

NOT
an official
Amstrad
publication!!

STARSTRUCK!

Three Dee Blast Off with Starstrike II



THE MOULD-BREAKING MEGAZINE FROM FUTURE PUBLISHING

AMSTRAD

ACTION

PARLEZ VOUS FRANCAIS?

Amstrad Action across the channel – five page special

BIG DISC DRIVE ADD-ON

Full 800K storage and 5¼-inch discs for the CPC

PROGRAMMING IN PASCAL

Three versions of this powerful language compared

PLUS

- CAULDRON II MAP
- LEARNING BASIC
- CP/M TUTORIAL
- LETTER PUZZLER LISTING
- GAME PREVIEWS
- THE PILGRIM
- CHEAT MODE
- SPECIAL OFFERS
- AND MUCH MUCH MORE

SPECTRUM COMMODORE 64 AMSTRAD
7.95 £8.95 £8.95

MIAMI VICE™



ocean

CHILL OUT
WE'RE CRUISIN' YOUR HIGH STREET NOW

OCEAN SOFTWARE
OCEAN HOUSE · 6 CENTRAL ST.
MANCHESTER · M2 5NS
TELEPHONE: 061 832 6633
TELEX: 669977

*TM and © 1984
Universal City Studios, Inc.
All Rights Reserved.
Licensed by Merchandising Corporation of America, Inc.

A MISSION YOU CAN NEVER COMPLETE?

GALVAMAN



...the name
of the game

SPECTRUM
£7.95
SPECTRUM

Imagine Software (1984) Limited
6 Central Street · Manchester M2 5NS
Tel: 061 834 3939 · Telex: 669977

AMSTRAD
£8.95
COMMODORE 64

A M S T R A D

ACTION

FRONT END

EDITORIAL ● NEWS ● LETTERS

7 ED-LINES

Amstrad Action is ONE YEAR OLD today! News of the celebrations live by satellite from Somerton, plus the mystery of the vanishing Toot – was he kidnapped? Turn to page Seven.

8 REACTION

Your news, views, blues and... well, anything else you fancied telling us about enough to put pen to paper. Four full pages of it too.

12 AMSCENE

All you need to know to keep your finger on the racing pulse of Arnold and Joyce.

SERIOUS SIDE

REVIEWS ● ARTICLES ● PROFILES

19 PARLEZ VOUS FRANCAIS?

Our roving reporter has been out and about sur la continent – sampling the wine, relaxing in the bistro and sniffing out the French software scene. See the Previews on page 58 too.

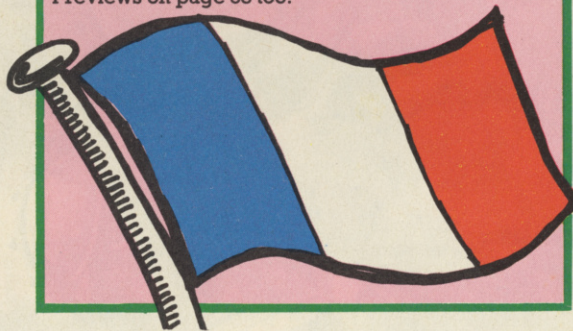

22 ABSOLUTE BEGINNERS – Part 5

Everything you wanted to know about programming in Basic but were far to embarrassed to even suggest that you weren't the definitive wisdom on.

24 BOOTING UP CP/M – Part 3

It came free with your machine so you might as well use it. Matt moves on to the STAT command this time round.

26 THE BIG DISK DRIVE

Andy Wilton looks at a 5¼-inch disc drive add-on that enables Arnold to read discs written in almost any format – including IBM PC – and provides 800K of storage.

28 IMAGER & SDISC

A system for transferring tapes to discs which discourages pirates too, and a device that lets you in on that unused 64K of RAM.

32 MICRODRAFT

Computer-Aided-Design (CAD to you) for your Arnold.

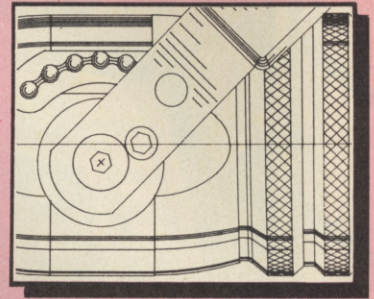

35 THE IMAGE SYSTEM

A Colour Drawing package comes under the scrutiny of Andy Wilton.

36 PASCAL

Three versions of this powerful alternative to Basic compared.

38 DATA GALORE!

A powerful database and Book reviews wind up Serious Software.

ACTION & ADVENTURE

GAMES ● MAPS ● THE PILGRIM

41 ACTION TEST STARTS HERE!

Turn to this page for a full list of the games reviewed in the next 19 pages, and your Top Ten Chart. These are just the Raves...

42 JACK THE NIPPER

Nappy naughtiness in cartoon graphics from Grem-lin Graphics.

44 GHOSTS'N GOBLINS & STORM

Spook the spooks in this great title from Elite, and genuine two-player arcade adventure action from Mastertronic.

46 3D STARSTRIKE II

Real Time/Firebird hit the Mastergame slot with this excellent sequel. solid 3D graphics – need I say more?

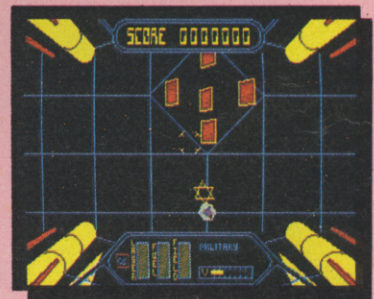

Colour Origination: Wessex Reproductions, 325a Wells Road, Bristol BS4 0QL Printing: Redwood Web Offset, Yeomans Way, Trowbridge, Wilts. Distribution: Seymour Press, 334 Brixton Road, London SW9 7AG
(Distribution & subscriptions in the Netherlands: INFO-DATA COMPUTERS, Postbus 97, 3800AB, Amersfoort. Phone: 033-630187. Retail price: Hfl 7.90)

Editor: Matt Nicholson Software Editor: Bob Wade Technical
Editor: Andrew Wilton Art Editor: Trevor Gilham Assistant
Art Editor: George Murphy, Jane Toft Toot's Wardrobe:
supplied by Dunlop Production Assistant: Diane Tavener
Subscriptions Assistant: Jane Farmer Publisher: Chris
Anderson.
Advertisement Manager: Mike Carroll Phone: 01-221 3892

Amstrad Action
Future Publishing Limited
The Old Barn
Brunel Shopping Precinct
Somerton
Somerset TA11 5AH
Phone: (0458) 74011

52 NEXUS & THRUST

An unusual run-around and search'em-up from Nexus, and superb vector graphics space action from Firebird - it almost made Mastergame!

54 KNIGHT GAMES

Maiming Mediaeval Action from English Software.

58 PREVIEWS

An early look at some great titles from over the Channel, and an interesting variation of the Trivia theme.

70 PILGRIM'S PAGES

The cowled crusader brings you news, reviews and views from the world of Adventures - including Pilgrim's Post, the Lords and Ladies of Adventure and a new section this month - The Clue Cauldron.

76 CAULDRON II MAP

All your Pumpkin problems solved with our full-colour map of the Witch's Castle.



Yes folks, Amstrad Action is one year old today, and boy hasn't it grown! Much passing of the bubbly and blowing out of candles has been going on in the Old Barn, but in the midst of it all we have still managed to bring you an Action packed issue. And for a so-called 'quiet' month there has been much action in Arnold's playpen.

As usual Bob Wade has brought you all the best in 19 packed pages of Action Test. *Starstrike II* came in early in the day, and had us fighting for joysticks for many a long night. All seemed hunky-dory, with some nice pre-running to our French phrase-books, and plenty of sure-fire raves. And then, at the last minute, *Thrust* dropped quietly through the letter box. And it was good. What could we do? All the colour was gone but we had to bring you the game so please, please check it out!

On the more serious side Andy has been looking at some powerful packages for bringing the best out of your machine, with an 800K second disk drive that really lets Arnold talk to the Big Boys, a whole host of versions of Pascal for the dedicated programmer, and a powerful drawing package for the really creative. For the beginners, check out our series on CP/M and Basic - there's more to this machine than you think. Stick around, and you might join us for our second birthday too!

Matt

INTERACTION

THE SECTION CREATED BY AND FOR YOU

40 VOICE OF THE PEOPLE

Your comments on the latest games for Arnold.

66 CHEAT MODE

Your Pokes, cheats and tips for doing the impossible in your favourite games.

78 MAIL ORDER

Order software from your armchair and save yourself pounds.

80 SPECIAL OFFERS

We bring you games, software and gadgets at tempting prices.

82 TYPE-INS

An age old game brought up to date on the Arnold - you wrote it, you type it!

84 COMPETITION TIME

More fabulous prizes up for grabs to the lucky winners.

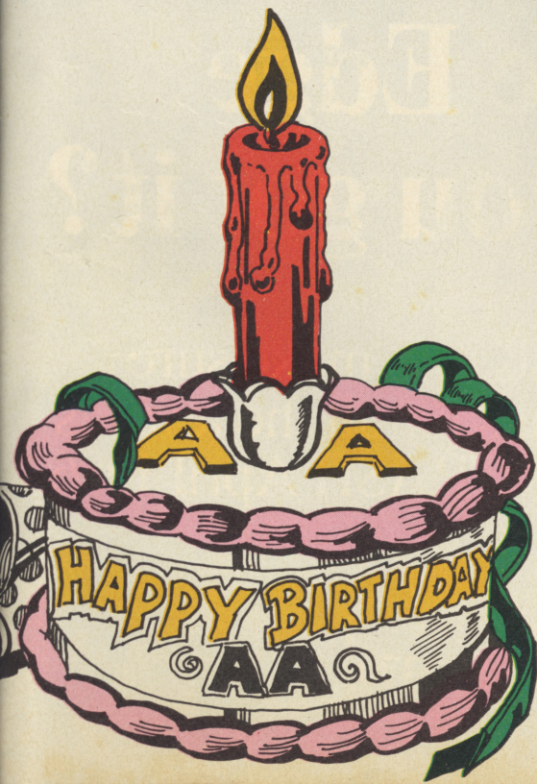

First to the street
with 3D graphics and sound
out now!
PCW 8256/8512 VERSION

Fairlight

by
Bo Jangeborg



THE EDGE



The Edge have you got it?

“The Edge’ll have to move to new premises to make sure that they’ve got room on their office walls for all the awards they have won (for Fairlight)...”*
(P.S. — We’ve moved!) CRASH April 1986

The Edge, 36-38 Southampton Street, Covent Garden,
London WC2E 7HE. Tel: 01-831 1801 (4-lines). Tlx: 892379.

*Crash Readers voted Fairlight ‘Best Graphics,’ ‘Best Music,’
Best Arcade Adventure,’ ‘State of the Art Award’ for 1985.

NEW MAGAZINE AT THE OLD BARN

The pace of life has increased here at the Old Barn - and new faces have appeared at Somerton's hottest publishing house. Why? The answer is simple. Future Publishing is expanding! To the founding title *Amstrad Action* is to be added a new title.

The new magazine is to be edited by Chris Anderson with the help of newcomer Ben Taylor, and will be the only magazine dedicated totally to owners of the PCW 8256 and 8512. Like *Amstrad Action* it will be produced totally using Amstrad micros, and Ben is an owner and expert in this field. It will feature news, reviews and plenty to help you make the most of your machine; and will be written with the same care and style as *Amstrad Action*. The first issue is due out on Thursday 11th September, so watch out for it in your newsagents. If it's not there, then order it. Joyce owners - this one's for you!

Amstrad Action therefore becomes the only magazine dedicated to CPC owners, and will change accordingly. The only real difference will be in the Serious Software section though, which will concentrate more on the diverse applications of the Arnold; with features on making music, communications, graphic tools, programming tools and much else.

HARVEY HEADBANGER COMPETITION (July issue)

FIRST FIVE WINNERS

Rhys Jones, Peterborough; Ben Teasdale, Cambridge; Ellenore Stewart, Frome, Somerset; Nicola Paton, Rugeley, Staffs; Max Bartlett, Shrewsbury, Shrops.

OTHER PRIZE WINNERS

Stephen Miller, Halesworth, Suffolk; Simon Forrester, Wigston, Leicester; Dominic Hegarty, Cork, Eire; Iain Bage, Sunderland; B Stuart Bruce, Cumbria; David Hartley, Harrogate; Mrs Z J Gibbs, Peterborough; Mr P G Newman, Co Tyrone, N Ireland; Nick Priest, Blackpool; Damon Querry, Sunderland, Tyne & Wear.

FIGHTING FIT COMPETITION (July issue)

Mr J Dixon, Kenley, Surrey; Asif Aziz, Glasgow; Nicholas Purser, Harrogate; Richard Sullivan, Cosham, Portsmouth; Alistair Irving, Ayr, Scotland; David Hartley, Harrogate; A Stephens, Farnham, Surrey; Major V J Reed, BFPO 15; Bhupinder Singh, Glasgow; Gaynor Rees, Gwent; Euan Walker, Glasgow; Peter Taylor, Stratford-upon-Avon; Stephen Williams, Luton; Mr G Simpson, Richmond, N Yorks; Damon Querry, Sunderland; R J Newton, Bromley, Kent; Toby Briant, Saffron Walden, Essex; S N Franks, Shaldon, S Devon; Mr M Lambert, Gosport, Hants; Russell Franklin, Oxford; Steven Phillipps, Leicester; Andrew Crawford, Tiverton, Devon; K Kosniowski, Somerset; Rhys Jones, Peterborough; K Gibbons, Leeds; Wayne Learoyd, Leeds; Stan Powell, Dagenham, Essex; Mr R P Mundin, Portsmouth; O Lawless, Dublin; Martin Crisp, Totnes, Devon.

Precognition

A rather strange press release came through the other day from Elite Systems Limited, concerning their game *Ghosts n' Goblins*. The press release stated that this game had 'already been awarded...an *Amstrad Action* Rave'. Nothing unusual about that, you might think; but the funny thing is that the press release arrived before we had given it the Rave! In fact, it gets an AA-Rave in this issue, which, as you can see, is only just out!

So, what's been going on? Either Elite are employing psychics or they've been jumping the gun somewhat. We suspect the latter...

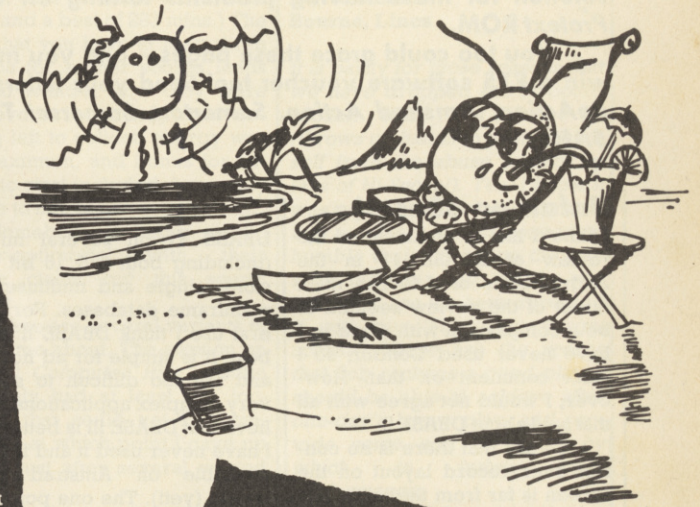

WHAT HAPPENED TO TOOT?

We've had a lot of letters about that! It has even been suggested that we ate him - as if we would (George - stop munching!). Nothing could be further from the truth. Toot simply decided that it was about time he had a holiday - so he packed his shades and bermuda shirt and hitched a ride on a passing seagull to sunnier climes. We understand that somewhere in the Azores was the planned destination, so we were hoping to scoop the dailies on news of the Royal honeymoon, but no such luck. It appears that the seagull had relatives in Miami, so that is where Toot ended up. Watch out for his starring role in the next episode of *Miami Vice*.

Please tell us

If you are using your Arnold in an unusual way, and you feel that others might be interested in what you are doing - then let us know. We are interested, and we'd like to let others in on the diverse applications of this powerful machine. Just send us a description in less than 500 words and we'll print it if it is unusual enough.

So whether you're running a weather station, or storing your family tree on Arnold, write to:

Unusual Applications,
Amstrad Action, The Old
Barn, Brunel Shopping
Precinct, Somerton, Somerset
TA11 5AH

APOLOGIES!

Our apologies are due to Micro Peripherals as we printed the wrong phone number in our 'Crafty Plotting' feature in the August issue. Their correct phone number is (0256) 473232 - Sorry!

NEXT ISSUE

The October issue of *Amstrad Action* will be in your newsagents on **Thursday 4th September**, so buy it then - and ask for it if it's not there!

Re-ACTION

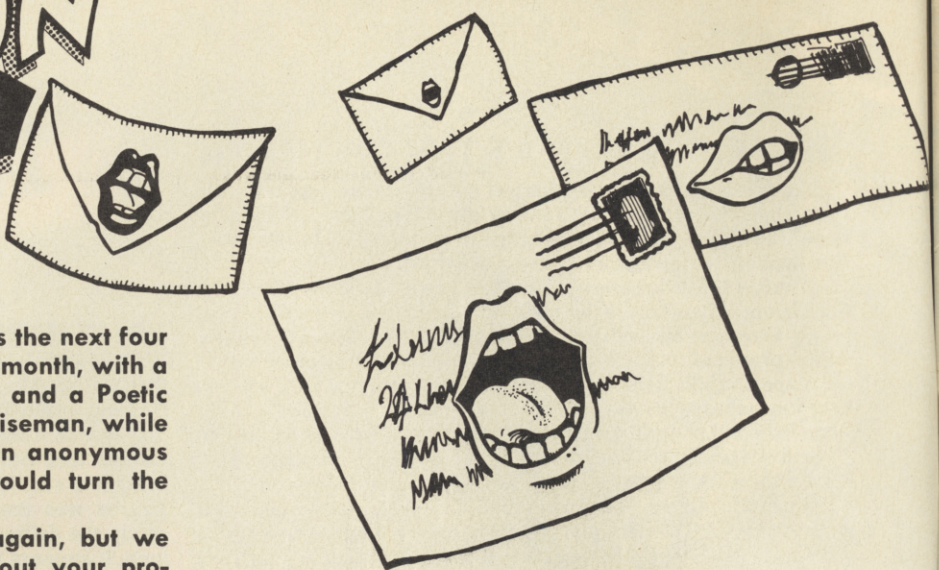

Once again the letters have poured in, as the next four pages show. Poetry is the flavour of the month, with a Birthday Greeting from James Moloney and a Poetic Problem with *Spindizzy* from Stephen Wiseman, while controversy comes from Greece, with an anonymous report on rife software piracy that would turn the stomachs of any staunch programmer.

Problem Attic has been flooded again, but we have manned the pumps and sorted out your problems. In particular Arnor have come through with a solution for those having problems turning off their *Protex* ROM.

You too could grace these pages – and you might win a £15 software voucher too! Send your letters to: *ReAction*, Amstrad Action, Somerton, Somerset TA11 5AH.

Unfair on dBasell

I should like to comment on the review of DBASE 11 in the August issue of *AA*. The main thrust of the review seemed to be a comparison with *Condor*. I have never used *Condor*, so I can't comment on that. However, I would not agree with all that said about DBASE II.

To say that there is no control over record layout on the screen is far from the truth. Not only does the command for doing so (@) have the largest section in the reference guide, but a separate utility (ZIP) is provided to create screen layouts.

The manual is also criticised for not even being CP/M specific never mind Amstrad. The manual does not need to be machine or even operating system specific. One of the advantages of DBASE II is that it behaves exactly the same on ALL machines, 8 & 16 bit, CP/M, MSDOS or PCDOS. Even the command to invoke it is the same, you just type DBASE on any system. Also the database, index, command, report and format files are all portable across different operating systems (except that the type of command file is .CMD on 8 bit and .PRG on 16 bit). Assuming a common disc format, it is possible to take a DBASE 11 database created on any office machine and work on it at home with an Amstrad computer.

I have used several databases ranging from *Masterfile* and *Delta* on a CPC 464, through

DBASE 11 on several micros (including both 8 & 16 bit versions, single and multiuser) to mainframe databases. For general use I think DBASE II is the best. It is simple for ad hoc use and not too difficult to set up very complex applications. I believe that DBASE III is better, but I have never used it and it is not available on Amstrad computers (yet!). The one point that I would quote against it was not mentioned in the review, and that is it can be very slow producing reports of data from more than one database (ie where both primary & secondary databases are in use).

May I also suggest that an article or series of articles on database design, attribute analysis, normalisation etc. might be a good idea. For efficient and best use of a database, especially in business, proper database design is essential. The micro magazines seem to ignore completely this aspect of database use. Not only is no guidance given, but the potential user is not even told that such a discipline exists. May I recommend the book 'An introduction to Database Systems' by C J Date, published by Addison Wesley, as a good all round introduction to the subject of databases.

Graham Murray
Southampton

While we may agree that the *Bad News* point 'Can't define the layout of the record card' in

our review of DBASE II is misleading when read in isolation, we still stand by the point. *Condor 1* prompts you to define the layout of the data-entry screen as part of the process of creating a data file, using control-key combinations to move around the screen placing fields and prompts where you wish. DBASE II, as we understand it, uses the command @ in a similar fashion to the way the PRINT command is used in BASIC, and as such is really a programming tool. As for ZIP, this is really a programming utility which is used to make the design of input and output screens easier.

It is evident from your letter that you have some experience using a variety of database systems on a variety of machines. However, our review of DBASE II, and indeed all our reviews of business software on the Amstrad machines, are aimed at the novice user coming to business computing for the first time. It is in this context that we looked at both screen design and the manual. It is commonly accepted that DBASE II is not the friendliest database system around – its strengths lie elsewhere. DBASE III does indeed provide both power and friendliness, but as you state it is not yet available for the Amstrad models.

On your last point, I would just like to add a recommendation for the book 'Working with dBase II' by M de Pace. I have



found this to be an ideal companion to DBASE II, making it a lot easier to use.

Clubbing down under

Herewith I enclose a complimentary copy of the latest magazine published by AMSWEST Amstrad User Group, Perth, Western Australia.

Would you please publish our name in your magazine asking for correspondents. We are very interested to know how other groups manage, and what they offer their members.

Our group, currently numbering nearly 200, are at present doing Basic and Machine code courses, with guest speakers on various other as-

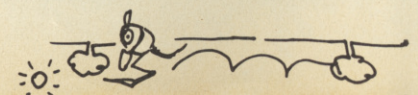

Birthday Greetings

Happy Birthday Amstrad Action,
Your mag is really great,
I've stuck with you since issue
One,
You've become my Arnold's
mate.

Amstrad Action has many items,
Including all the game reviews,
Hardware, offers and cartoons,
And the latest Amstrad News.

A little character roams the
pages,
I think he's really cute,
He's a head upon two legs,
And the fellow's name is Toot.

Bob Wade reviews the latest
games,
These are his favourites
(just to name a few)
Elite, *Get Dexter* and *Exploding
Fist*,
And don't forget *Spindizzy* too.

Hear ye all ye fellow pilgrims,
The hooded man will save the
day.

If a Balrog blocks your path,
The Pilgrim will clear the way.

There's also a high-score table,
For nearly every game,
And if your score is good
enough,
You can win some fame.

A last word to all you Arnold
owners,
This you must be told,
This is a month of celebration,
Amstrad Action is One Year
Old.

James Moloney
Co Tipperary, Ireland

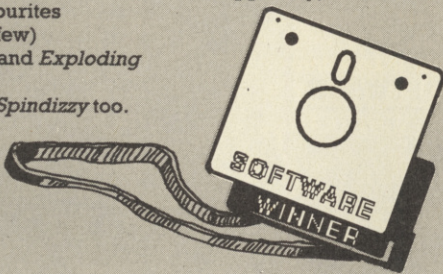

pects of the Amstrad, such as
Microfile, Tasword, etc.

Thelma Ardron
"Amswest"
PO Box 1099
East Victoria Park, 6101
Perth
Western Australia
Tel: Perth 361-8975

Cheating at Chess!

A warning about Amsoft's *Cyrus Chess* - it cheats! On a number of occasions now when using the technique of forcing the computer's king onto the edge of the board with, for example, two rooks, the computer has cheated. At the 'mate in one' position it takes its move, then replaces the king to its original position, and swaps sides. I mean how underhanded can you get? Has anyone else had this problem?

Now I will sing the praises of Arnor for their *Protext* word processor, on which this letter was produced. The word processor is fast, easy to use, and very well thought out. I would recommend it to anybody, from beginner to expert. I use the ROM-based version, which also has the advantage of making the disc drive on my 464 easier to use; in fact I now switch on the word processor to do most of my disc editing since you don't need to use the awful procedure of defining a string for the filename, you just type it straight out!

I must also give a mention for the Micro Peripherals MP-

165 printer which I could so easily review in this letter. As it is I shall restrict myself to say that not only is it by far the quietest printer I have come across, but the NLQ print, in my opinion, is unrivaled by any other dot matrix printer I have seen. When you consider that the NLQ is produced at 75 cps (165 cps draft quality), what more could you want from a printer?

Paul Tansom
Portsmouth



"WOULD YOU MIND BLOWING
INTO THIS BAG, SIR?..."

Invisible Ghosts

I would like to offer a few lines in response to points raised in your July edition concerning *The Covenant*.

I think Robert Carter's reference to a ghost may contain a misprint; he writes 'if I re-enter a segment after just leaving it'. I think this should read 'after just SAVING it'. This happened to me on numerous occasions. The ghost is invisible, but you know it is there because there is an audible energy drain. You can even stun it with a lucky shot and pick it up! Alternatively, if you leave the segment, clear the adjacent one, and then re-enter, it will probably rematerialise.

I sent in a claim for *Covenant* Hi-score of 55,288, as did Brian Smith (in fact I've now completed the game three times, with the same score each time and a best of 283 mins.) The fact that you have at least three claims for higher scores leads me to wonder how they were achieved. I certainly had nothing left to collect, energy was at maximum, and bonus for return to start included. I can only come to one of two conclusions:

(1) Somebody is being a little 'over-optimistic' with their score claim, but this seems unjust.

(2) There are several variants of the game about. The version on the *10 Computer Hits* cassette certainly had at least two locations that could not be completed, at which point I gave up in disgust after several wasted hours.

This of course raises the point that, if there are several versions of the game about, some of us poor consumers

have little or no hope of getting to the top of the Hi-Score table, even if we play till Arnold starts steaming. Perhaps through your 'high level' contacts with PSS you are now in a position to reveal what the potential top score for *The Covenant* really is. It has to be a definite figure as the task is clearly defined and there appear to be no variables.

Finally a word on the long running 'free' cassette saga. You really only have yourselves to blame, since you insist on using the word 'free' at various points in the mag. If instead you pointed out that what you are offering was an absolute bargain at a mere 50p everyone would shut up! At which point so will I!

David Sizmur
Bourne, Lincs

It is partly for these reasons that we have dropped the Hi-Score section from this issue on (throws up hands to protect himself from the abuse hurled by fans of Hi-Score!). Yes, I know it was popular with many readers, but to others it just served to humble their efforts on the joystick and...no, wait, not the rotten eggs!...so we have replaced it with our 'First Day Target scores'. These are the scores that Bob reckons a good player should be able to achieve after one-day's heavy play, and provide some sort of guide by which to judge your performance.

As to your last point, I think quite enough has been said about the 'free' cassette offer too.

Poetic Problem

Dear Sirs I write to you this day,
To help me out, I beg, I pray,
Alone, helpless and
dumbfounded,
With the game they call
Spellbound.

I know you've given hints and
tips,
But try and try, I'm falling to
bits,
A nervous wreck have I
become,
Why even the cat is drinking
rum.

My name and address you'll
have to print,
So friendly readers can send me
a hint.
Your mag is ace, I think it's fab,
I have but one more thing to
add,

Last issue (Aug) did Toot I see,
But only twice, how can this be?

What have you done to him, you
cruel lot?
You've probably cooked him in
a pot.

Have you eaten him for tea?
Or sacked him for acting
irresponsibly?
Bring him back AA or else!!!

My 464 is one today,
No problems yet, all is OK.
Now to end this little rhyme
And type in progs on this
computer of mine,
Readers out there please take
heed
Knowledge of SPELLBOUND is
what I need.

Stephen Wiseman
57 Davidson Place
Northfield
Aberdeen
Grampian AB2 7RD

Toot? yum yum!



Your loftier questions answered



PROBLEM ATTIC

Greeks bearing gifts...

We are writing to you because we think you might be interested in the Software condition in Greece. It is really like Wild West (no laws...) We are aware that some of your readers will be envious of this, and others might want to kill us, but here it is difficult to find someone who owns ONE original tape or disc.

Computer shops pirate programs and sell them at various prices ranging from £2.50 (Give me your disc to write you a game) to £45 (CP/M languages). Of course there are ads for Pirated software which sell from 25p to £2. There are many people who own well over 300 titles. Personally we have more than £1800 worth of Pirated software that we got almost free (to be honest, we payed around £18) and shall get much more. Piracy here has reached a record level that only Italy can surpass (maybe...).

In Greece, many professional programs have been transferred from other CP/M machines to the Amstrad before the Arnold version was released in UK. Have you ever heard of Fortran-80, MBASIC, SBASIC, DBASE 11, COBOL-80 and Turbo Pascal, all custom installed on the machine since December 1985? This job has been done here with help from a 5 1/4-inch second drive.

Please excuse us for being anonymous, but DO print this letter just to inform you lovely readers (we mean this) on what happens outside UK.

This letter was written using Micropro's WordStar which we bought at a... discount for £0.00 (!\$\$%'&'&&?**) .

Psychopath Intruders from Planetary systems of the Goon Galaxy... Greece

From what you've told us, I doubt if there are any flourishing software houses in Greece! (maybe I'm wrong, but I doubt it) After all, programmers need to eat just like the rest of us, and if they are not making any money from their work because it keeps being pirated then they'll probably just earn a crust at something else.

There's a lesson here for us all.

Locating the Loki

My Spectrum (friend) has 'warned' me of a new Amstrad/Spectrum Computer called the LOKI. Unless someone out there doesn't know about this new thing, I will let you reveal this to them. I can

Type-in trouble

As a newcomer to computers, I have had my 464 for a couple of months now. I thought I'd try out some of the user magazines for the Amstrad micros. Unfortunately I didn't try yours until last. If I'd bought AA first I need not have wasted my money on the others, which might as well have been written in a foreign language. Come to think of it, it was a foreign language!

Anyway, to the point of my letter. After reading my second copy of AA (July) I decided that your 'type in' Blitter was definitely the most impressive graphics display my Arnold was going to get his bits around since I'd bought him. So I began to prod away. An hour later with finger and eyeballs recuperating I plucked up the courage and ran the program. To my surprise, instead of the usual screenful of syntax errors, the grid unfolded and a multi-coloured football started plotting and apparently flashing and spinning (what happened to the red and white ball?) Then just as I was getting interested it all stopped after the ball was fully plotted and the Ready message came up. The grid and football were still there. There was also no sound and yes, I did have the volume turned up. The second attempt at running the program produced a red and white striped football; again this stopped when fully plotted and the Ready message appeared again - still no sound, and what happened to all that bouncing and spinning?

I did notice, however, that pressing Key 1 listed the whole program in Mode 2 and even after deleting line 430 it still did not disable this function. I think the computer had taken control by this point. I can only assume that line 430 was somehow the cause of my problems, especially considering that the next line seems to be concerned with the sound which I never heard.

So please can you help? Is it me, Arnold, your listing, or did my typing finger stray where he shouldn't?

**Andrew Staples
Worcester**

It sounds as though your typing finger strayed I'm afraid. Line 430 simply defines that function key to list the program in Mode 2. Unfortunately, deleting it won't make any difference as the program itself doesn't re-define the function key, so it stays as defined until you reset Arnold. It sounds as though you might have made a mistake in line 490 or 600 - otherwise we

are totally bewildered, though the mistake is almost certainly to be found after line 430.

It looks like you will have to check your typing again. The program printed in the magazine is a photographic copy of the listing produced on a printer from a working program, so I'm afraid it's your mistake.



"I TOLD YOU NOT TO BUY THE CHEAP VERSION..."

Interference

I've had my Amstrad CPC 464 for more than a year, and have not solved this problem: every time I switch on the computer it makes the radio unbearable to listen to.

Is there anything I can do to stop this interference? (And please don't say 'switch off the radio' - this is far from helpful!)

**T Davies
Dyfed**

We have encountered this problem, particularly while listening to VHF radio. The interference doesn't seem to occur to anything like the same extent if you listen to MW or, better still, LW - but if it still persists you could fit a suppressor to Arnold's mains plug. These cost a few quid in your local electrical store, and should solve the problem. If it doesn't you'll just have to... (whispers quietly)...turn off the radio.

Using Draw screens

First I want to congratulate you on a mega mag as it is the best that I have yet read.

I own a CPC 464 with green monitor and I have recently purchased Melbourne Draw. I think that it is an excellent package, but I find it difficult to use the colours on my green monitor. My only complaint is with the booklet which accompanies the program. In some parts it is unclear. I am able to use my pictures as loading screens in my games, but I do not know how to use the pictures within my games and call them up onto the screen. I write my games in Basic and they are mostly adventures. Please could you provide me with a short listing or tell me how to get my pictures stored in memory and then called back again.

Oh, and thanks for last month's 3K loader. It was very much appreciated.

**Justin Grimley
Co Armagh, N Ireland**

Unfortunately, unless you have a friend fluent in machine code, there is no easy way of using Melbourne Draw pictures in your Basic adventures. This is because they take up around 16K RAM for each screen, so you wouldn't have room for much else. If you want to put pictures into adventure programs, either draw them in Basic or use a package such as Incentive's Graphic Adventure Creator (£22.95 on cassette). If any readers have another solution, let us know!

Locoscripting a film

I recently purchased an Amstrad PCW 8256 and am very happy with it. One of the tasks I bought it for was script-writing. Since a film script tends to have a number of recurring characters, one of the things I would like to be able to do is to replace names with initials, or at least fewer keystrokes. In an average script I might have to write out 'Stephanie' four or five hundred times. Would it be possible to do this using Locoscript, or would someone have to design a special program?

**Kevin Hoyes
London N1**

What you need is what is generally known in the business as 'Search and Replace', but what

AMSCENE

XEVIOUS

US GOLD AIM TO MASTER THE UNIVERSE

US Gold are going for a massive 20 per cent of the games market for Christmas with at least eight releases scheduled and possibly more to come.

Top of the billing comes the official *Masters of the Universe* game, launched under agreement with Mattel. Based on the top selling toy, cartoon, TV series, teeshirt etc., there will actually be two versions. The first is an arcade game, scheduled for October release - the second is a graphic adventure due out in November and programmed by Adventuresoft. In

both games you become He-Man 'by the power of Greyskull', to battle against the evil Skeletor.

Also scheduled for October release is the Amstrad version of that arcade classic *Gauntlet* from the Atari Games Corporation. This is a multi-player role-

playing game involving cooperation between the players. You can choose to be a Valkyrie, Warrior, Wizard or Elf; each with different strengths and weaknesses.

Other games due through Autumn and Winter include *Xevious*, a shoot-em-up featuring vertical scrolling; *Express Raider* which involves fighting karate-style on carriage roofs; and *Breakthru*, a game from the US arcades that is 'like a sideways Commando in a flying jeep' and involves five stages in mountain, prairie, bridge, city and airfield settings.

From Epyx through the US Gold label are promised first *Super Cycle*, a bike racing game very similar to the arcade

machine 'Hang On' and due in October; and *World Games* - eight 'wacky' events set in their country of origin. These include Acapulco cliff-diving, German barrel-rolling and Scottish Caber-tossing - and the package is due out by December.

Of the rest, perhaps the most notable is US Gold's signing of the British company Vortex Software. The first title to come out of the match will be *Revolution*, a 3D animated game that sounds to be in the *Spindizzy* mold.

Oh, I almost forgot - *Impossible Mission* is reportedly finished and approved by Epyx. Official launch date for the Arnold version is now August 28th. Let's hope that their other titles stick to a tighter schedule than this did!

£1,000 to be won!

Micronet have joined forces with PHAB to bring you the chance to win £1,000 and save your conscience at the same time. PHAB is an organisation that promotes better understanding between the Physically Handicapped and the Able Bodied, so it is appropriate that the competition should be about just that.

What you have to do is write a piece of software that is designed to increase our awareness and understanding of the problems that society creates for the physically handicapped - so this is a chance to put your programming skills to good use. The competition is open to all UK residents, and the closing date is 30th November '86. Entries must be clearly marked with the author's name and address, together with the

target computer (Amstrad CPC or PCW) and the instructions if necessary. Your programs must run on a 'totally standard configuration', so printers, light pens, mice and speech boxes musn't be essential. Joysticks are fine, provided there is a keyboard option as well.

With a prize of £1,000 this has got to be a good one! Further details from Micronet on 01-278 3143, or PHAB on 01-388 1963.



Name changing

It appears that the trend for last-minute changes of names is catching on. Design Design have just announced that their forthcoming title *Nemesis* is no more - instead they are launching *Nexor*. The reason? There is already a game called *Nemesis*. Design Design's new title involves the defence of a weapons system developed at a base called *Nexor* against Androids, so the new title is quite appropriate.

Also announced is *Taking Tiger Mountain*, a deep space battle game featuring high resolution colour screens and fast 3D vector graphics. It is reported to need strategy and quick thinking as well as Magellan-bashing, and to be 'the most advanced battle simulation available'. Design Design produced the classics *Dark Star* and *Tank Busters*, so we wait in anticipation.

Arnold speaks his mind

Out now is *SPEECH!*, an unusual speech synthesiser from Superior Software. It is unusual because it requires no extra hardware at all - all the action takes place in the software. It is supposed to be very easy to use; you simply type in *SAY followed by the sentence in English and Arnold sounds forth on any subject you want. It is also very cheap at £9.95 on cassette and £14.95 on disc. Let's hope it is also comprehensible!

Superior Software can be contacted on (0532) 459453.

THE PC GUESSING GAME

Enough of this pussyfooting on the fence - it's time for *AA* to join every other magazine in the PC GUESSING GAME! Yes folks, it's easy to play: all you need is a vivid imagination and a suitable publication. Good contacts might help, but are not essential. The name of the game is to guess the specification, launch date and price of the PC-compatible that Amstrad might (or might not) be bringing out. There are no prizes for getting it right, except a warm feeling of smugness at the others who got it wrong.

So what's our prediction? We on *AA* are going for a specification of 512K RAM, single 5 1/4-inch disc drive, a non-Hercules standard graphics card, built-in joystick, and three spare IBM-compatible expansion slots. On the software side we reckon it will come with both MS-DOS and DOS-PLUS operating systems, plus the *GEM* graphic environment package from Digital Research. We are going to put our necks on the line and say that it will be packaged with *GEM Write* and *GEM Paint* as well, and it will definitely come complete with a mouse.



"DON'T HANDCUFF ME TO HIM - I'M NOT PC COMPATIBLE..."

As to launch date and price, we are predicting three versions to be launched to the pub-

lic at the PCW Show in Olympia on September 3rd. All models are reckoned to come with monitor but without printer - the cheapest at £399 being mono display and single disc drive, the second with twin drives costing £499, and the top model at £599 complete with colour display. All prices exclude VAT, and we don't think there will be a hard disc version yet.

There. That's our (late) entry to this fascinating competition. Find out next month whether we've got a smug expression or egg on our face - but if we're right it will be some machine, both at home and in the office.

Full IBM PC compatibility will give you access to the vast range of business software already available on the market, and there are plenty of games for it too. PC-compatible software is very pricey by Amstrad standards, but we've heard rumours that prices could be dropping here too. After all, *dBase II* is now available for the PCW range at less than half its original price; and if this happens to any great extent it could make for exciting times ahead!

MICRONET MEETS ARNOLD

Another reason for buying a modem has been supplied by Micronet with an Amstrad-specific database (if you can afford the phone bills, that is!).

Users of the Micronet on-line service will be aware of the existing special areas aimed at the BBC, Commodore and Spectrum micros, and probably feel a little left out. Micronet have at long last recognised the popularity of the Arnold, and are setting aside 500 Prestel pages just for us. Services provided include news, reviews of hardware and software, soft-shop and a helpline for both Arnold and Joyce. Telesoftware - programs that can be downloaded by phone and saved on cassette - will follow shortly; but this is the place to meet other Amstrad owners.

Membership of Micronet includes access to the whole of Prestel, and the Amstrad area will be unusual in that routes from its pages will lead directly to the more business-orientated sections of the database, such as Biznet, Citiservice and Telex services. For further details contact Micronet on 01-278 3143.

Tolkien Blockbusters

In case you didn't know, Melbourne House decided that July was to be 'Tolkien Blockbuster Month', and are celebrating it in two ways.

First of all, and of great interest to PCW owners, they are launching their adventure version of *Lord of the Rings* on Joyce, together with the classic *The Hobbit*. Both versions are obviously on disc.

Also to mark this auspicious month comes a drop in price for *The Hobbit* on cassette. This will be available, without book, for £9.95. £14.95 buys the book as well.

DRAGON'S LAIR

Yes, the first game to use Laserdisc display in the arcades will soon be available and showing at your local Arnold - but without the laserdisc of course.

Basically an action/adventure game *Dragon's Lair*-arcade version featured by far the most spectacular graphics seen at the time. Whether this version can match the original in any way has yet to be seen, but Software Projects have developed a new multi-loading technique which allows the next screen to load while the game is being played. It is worth remembering that they were the authors of *Manic Miner* and *Jet Set Willy*, so they have a reputation to maintain!

GOLDMARK SYSTEMS SOFTWARE FOR THE AMSTRAD

LORD OF THE RINGS

Side 1 of our conversions cassette will *AUTOMATICALLY* transfer the three games to disc including the screen. Side 2 is for *NON-DISC* owners and will reduce the loading time of around 15 mins. to just under 3 mins. This program is very useful if you are in the habit of getting killed!

Cassette £4.00

SPEED-TRANS

SPEED-TRANS is specifically designed to transfer most programs that have been protected with the SPEEDLOCK protection system. Contains full instructions to convert to disc.

Cassette £5.50

VIEWTEXT

This utility will allow you to see the text in a BINARY file. It is particularly useful for games that require passwords (e.g. Hacker and other adventure games). This utility is TRANSMATTABLE to disc.

Cassette £3.00

WHY WAIT AGES FOR YOUR PROGRAMS TO LOAD -- let us help you to convert them to disc. Please telephone or write for further information and other services we offer (large SAE appreciated).

UK prices shown. EUROPE add £1.00 per title. REST OF WORLD add £1.50 per title. We accept EUROCHEQUES. Please make your cheques payable in sterling.

GOLDMARK SYSTEMS, 51 Comet Road, Hatfield, Herts, AL10 0SY, England. Tel: 07072 71529. Up to 9 pm.

NEXUS ON PCW

Nexus, from Nexus Productions Limited and an AA-Rave in this issue, is to be released for Joyce as well as Arnold in the near future. prices haven't yet been fixed, but the disc version for the Arnold costs £14.95, which should give some indication.



PIRANHA

Macmillan, the book people, are sinking their teeth into the games market with their Piranha label and several new titles scheduled for the next few months. Programs are being developed with the help of companies such as Design Design and Delta 4.

First on the agenda in September are the Amstrad version of *Popeye*, based on the famous comic hero; and *The Colour of Magic*, based on a book of which Isaac Asimov's Science Fiction Magazine said: 'This is not just the funniest fantasy I've ever come across; it's one of the

funniest books', so it can't be bad! *Popeye* will cost £7.95 and *The Colour of Magic* £9.95. Also due in September is *The Trap Door*, another funny based on a new TV series from Terry Wogan Productions. It features bumbling Berk (and Terry?) and will be priced at £7.95.

October should see three titles. *Rogue Trooper* at £8.95 is an arcade battle featuring the character from 2000AD; while at £9.95 is *Nosferatu the Vampire*, a graphic adventure after the movie of the same name, and *Strike Force Cobra* - featuring 3D perspective colour graphics, four independent team members and over 250 locations.

Trivial Pursuits

Well, it had to happen. The most successful board game of the Eighties has arrived on computer, and in two very different versions. From Domark comes the official version, and it is supposed to be pretty faithful to the original with many of the questions from the Master Genius Edition. But new questions have been added too, that are supposed to take advantage of the Arnold's graphics and sound. It will be priced at £14.95.

The other version comes from Arcana Software Design, and is previewed on page 58 of this issue. Suffice it to say that it is set in Ancient Greece, is not that faithful to the original but features over 2,000 questions, and involves you playing one of the Greek gods. It will cost £9.95 on cassette and £14.95 on disc, and you could win a holiday in Greece! One copy released before Christmas will contain a special message that will be displayed at some point during the game. If you get this message contact Arcana straight away - you might not have to save up for that holiday next year!

enough set in a Russian nuclear power station - but this time you are trying to save it rather than blow it up (should do wonders for East/West relations!). It is an arcade shoot-em-up featuring isometric 3D graphics.

On to October, and the release of a game that 'makes Rambo look like Bambi': *The Vikings*. This 'saga of abject greed in the face of manic ferocity' involves axing your way through lowlands, burning and pillaging villagers and horse rustling. Cue the follow-up *Rambo meets the Vikings*. Also scheduled is *The Big 4* - a com-



Boldly going Beyond

Beyond, the company who produced *Lords of Midnight* amongst other successes, have been appointed by film company Paramount to produce the first official computer version of *Star Trek*. It will be an arcade/strategy game, and is to be written by a team headed by Mike Singleton, the creator of those astounding graphics in the

Lords of Midnight.

This year is the 20th anniversary of *Star Trek*, and celebrations abound. Countless conventions for the dedicated Trekkers are taking place around the world, and the launch is scheduled to coincide with the re-run of the series on BBC television in September. Let's hope they make it.

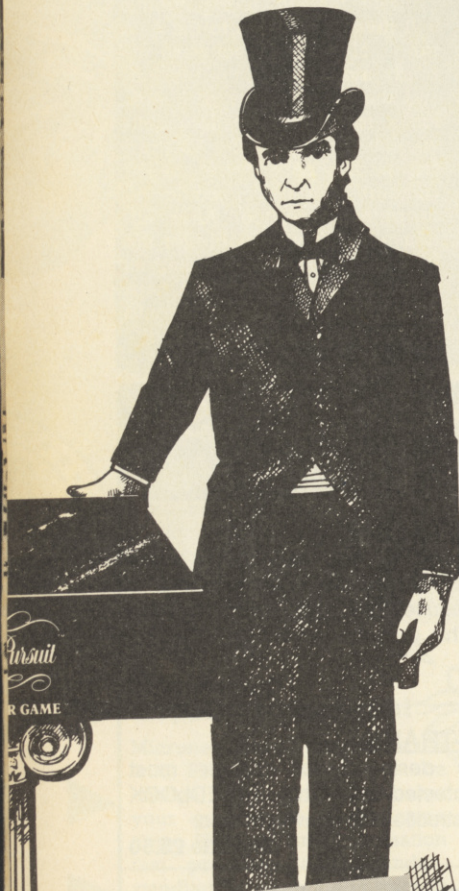

GAMES GALORE!

Durell Software Limited are preparing for a good Christmas with a mammoth list of new games. Congratulations are due if they keep to this schedule:

September should see the release of *Thanatos*. This is the name of a dragon who flies, walks and burns its way through the underworld in search of its arch enemy Eros. On the way it gobbles maidens and smashes knights, all against a landscape featuring a new panoramic scrolling technique. Also due is *Chain Reaction*, predictably



pilation of *Saboteur*, *Turbo Espirit*, *Combat Lynx* and *Critical Mass* on a single disc, possibly priced at just £11.95.

Durell are busy this month, with the release of a third game called *Killer DOS*. Based on the concept of the 'worm' program, you play a software worm that is sent down-line by modem to cripple a computer installation. Again a new form of graphics display is promised, with 3D views of the computer architecture seen from above.

November sees *Saboteur II* - *Avenging Angel* cashing in on the current 'Ninja' craze, except

that you play the Ninja's beautiful sister out to revenge your fatally wounded brother. Over 200 screens and plenty of action promised here. Also due is *Sigma Seven*, a seven stage arcade game with three distinct sections to each stage. First is a 3D space battle, followed by a 3D platform game and rounded off with an arcade puzzle.

And finally, December should see the sequel to *Combat Lynx*, called *Deep Strike* it is supposed to blend smooth scrolling landscapes with simpler controls.

What about January then?

YOUR AMSTRAD NEEDS

GREMLIN



DISC
£13.95
CASSETTE
£8.95



BOUNDER
"10 levels of fun make this torture excellent value for money. Nova rating. Definitely one of those 'just another go' games. Game of the month February" - Computer Gamer.
"The most compulsive game I've ever played. If you don't buy it you'll never know what you've missed." says Gary Penn. Zzap! 64.
Gold Medal Award 97% overall.

DISC
£12.95
CASSETTE
£8.95



MONTY ON THE RUN
Super fit and desperate for freedom our frightened hero finds refuge with the criminal underworld who offer him his chance to breathe fresh air and bask in the sunlight once again. Monty must select the correct five elements of his freedom kit from the many he's offered and not miss out on the hidden gold coins that will make him a mole of leisure.

DISC
£14.95
CASSETTE
£9.95



THE WAY OF THE TIGER
Enter the world of Avenger, a Ninja warrior of unparalleled skills and deadly powers, as he battles the forces of evil in defence of his faith and protection of the weak.
Be calm and stay silent as the outstanding animation and unrivalled combat routines take you to levels of action you'd never have thought possible.
Experience the stunning effects of triple scrolling action as you master the techniques of Hand to Hand combat, Pole Fighting and the skills of the Samurai Sword.
And when you believe you've succeeded in overcoming all the odds, the next in this thrilling series of adventures will beckon you forward to a further challenge of death.

DISC
£14.95
CASSETTE
£8.95



JACK THE NIPPER
He's wicked. He's evil. Can he ever be stopped? Jack the Nipper plays the tricks and creates the havoc we all would have liked to have enjoyed. So why wait any longer.
Jack was tired of all the wimps in his town, their boring games and goody goody ways sent him to sleep. So Jack being of a rather naughty disposition set about livening things up a bit, he picked up his trusty pea-shooter and scarpared off to cause some trouble.
This is where you come in to take on the role of Jack and use your imagination to be as naughty as possible doing the things you always wanted to do but dare not (YOU WIMPI!). Jump on things, pick them up and drop them, use your pea-shooter to create smashing effects and toot your horn at the cat.
Use the items you pick wisely then you must work out where you have to drop them to cause ultimate havoc. For instance what could you do with a tube of glue?



Compumart

Special Limited Offer
ONLY 10-AMSOFT 3" CF2 MICRODISKS
£32.00 +£1p&p
 Suitable for All Amstrad Drives



NEW 5 PACKS
5-AMSOFT 3" CF2 Microdisks
ONLY £17.00 +£1p&p
 SUITABLE FOR ALL AMSTRAD DRIVES

Printer Ribbons For
DMP 2000 Printers £5.50 ea.
8256,8512 Printers £5.50 ea.
Ribbons-POSTAGE FREE
 Please Specify Printer

Same Day Despatch On ALL Orders Before 4pm
 All Prices inc. VAT

24 Hour Credit Card Order Line
0509-233893

Please send cheques/postal orders to:

Compumart, (Dept AA)

Unit 8, Falcon Street, Loughborough, Leics, LE11 1EH

Compumart
0509-262259
 HOTLINE



pride utilities



UNIT 14, WHITE HILL HOUSE, 6 UNION STREET, LUTON, BEDS LU1 3AN
 THE UTILITY PEOPLE TEL (0582) 411686

FOR YOUR AMSTRAD 464-664-6128

£12.95 DISC £19.95 ROM

ODDJOB

STILL THE BEST DISC UTILITY PACKAGE
 A complete disc utility with all the programs YOU have told us you wanted all together in one amazing package. A total of 39k of disc space used.

- Just look at some of the features:
- A complete directory editor with which you can examine the disc directory and easily alter the contents.
 - Recover erased programs.
 - Hide programs from the directory.
 - A complete sector editor to examine and/or alter the contents of files in HEX or ASC11.
 - Map out your disc and locate where files are on the disc.
 - Prevent programs from accidentally being erased.
 - An intelligent disc copier that can copy those damaged/non standard sectors on a single or twin drive system.
 - Format in half the time on either drive. Ideal for 5.25 inch second drives.
 - Transfer your little used programs/files from disc onto tape to reclaim expensive disc space.
 - Increase the speed of your disc drive by up to 20%.
 - Load and list protected BASIC programs.
 - All instructions are supplied on disc on a separate help menu.
 - Simple to use with single key selection.
 - Makes full use of the disc drive. A to A, A to B, B to A, etc.
 - Compatible with all Amstrad CPC computers.
- All this for the incredible price of £12.95 on disc only
 ODDJOB is constantly upgraded — check with us the current version No. and if you wish, return the disc with £2 for upgrade.
 NOW A ROM VERSION ODDJOB AVAILABLE — £19.95.

£7.95 CASS £11.45 DISC

TRANSMAT

Easy tape to disc transfer. This professionally used and respected utility has set the standard in tape to disc transfer that others attempt to mimick. Rated highly by the computer press.

- Transmat's many features include
- Easy Operation • Auto or non auto modes • Relocator for programs which overwrite the disc area • Erase • Catalog files • Rename • Disc header reader • Select user area • A or B drive working • Transmat's itself.
- Also available on ROM only £19.95.

£5.95 CASS

SPIRIT

The perfect advanced software complement to Transmat or those knowledgeable in computing—Spirit offers all the tools you need in one economic package to transfer those genuine headerless programs onto disc.
 To use Spirit you need a disassembler and some knowledge of machine code.

£7.95 CASS £11.45 DISC

PRINTER PAC 11

The screen copier. The complete printer utility for most popular dot matrix printers, including the DMP 2000 • Full proportional shading • Full size dumps • Variable buffer option to release the computer • Text dumps • all models catered for.

NEW!

NEW!

£11.95 DISC

FIDO

A general file and disc organiser. If you have a lot of discs and you can never find the program you want, then FIDO is your answer. Its many features will allow you to completely organise all your files/discs and manipulate them using a specially designed database. This menu-driven disc can store up to 200 discs or 2150 programs • Full disc utility section • Security password system (to protect your database) • Separate programs runner • Will search and list • Sort into alphabetical order • Printer option • Find free space • Very easy to use • Well up to Pride's usual high standards.

NEW!

£7.95 CASS £11.45 DISC

SUPER SPRITE

Creates fast moving animated games easily. An extremely powerful and versatile piece of software at a realistic price. SUPER SPRITE is a menu-driven friendly program which will offer you hours of enjoyment designing your own sprites. Included is a demo to show you the possibilities of designing and writing your own animated software. The complete instruction book gives examples of how to create and animate sprites for your own programming.

IF YOU'VE WRITTEN A UTILITY UP TO OUR HIGH STANDARDS PLEASE CONTACT US.

ORDER FORM

All prices include VAT and P & P. For Europe add £1 per title. For Australasia add £1.75 per title. For rest of world add £1.50 per title. INC AIR MAIL.

NAME _____

ADDRESS _____

Cass Disc Rom Port

TRANSMAT				
SPIRIT				
FIDO				
PRINTER PAC II				
SUPER SPRITE				
ODDJOB				

The 5th official

AMSTRAD COMPUTER SHOW

Organised by
Database Exhibitions

Home users... business users... educational users... this is YOUR show!

Champagne Suite &
Exhibition Centre

**NOVOTEL
HAMMERSMITH
LONDON W6**

Friday, October 3, 10am-6pm
Saturday, October 4, 10am-6pm
Sunday, October 5, 10am-4pm

- ★ Two whole floors of the Novotel, easily reached by tube, bus or car.
- ★ All that's new from Amstrad and leading hardware and software suppliers.
- ★ Unrepeatable bargains to be found right round the show.
- ★ Free advice from the experts about all your computing problems.
- ★ Non-stop demonstrations and videos in the Amstrad Theatre.
- ★ Electronic mail in action – the 'world comes to your fingertips.

Confirmed bookings from:

Amstrad	Loadplan
Amstrad Computer User	MicroLink
Amstrad Professional	Micronet 800
Computing	Minerva
Advanced Memory Systems	Miniature Tool Co
AK Marketing	MML Systems
Amor	Newstar Software
Bernard Babini	Overbase
Boume Educational	Quest International
Software	Pace Microtechnology
Cambrian Software Works	PCS
Caxton Software	Preston Software
CDS Software	Pride Utilities
Celcom	Professional Data Services
Compact Software	Robert Edwards & Co
Computer Manuals	Sagesoft
Computing with the	Sandpiper Software
Amstrad	Saxon Software
Connect Systems	Setanta
Comix	Shekhana
EG Computer Graphics	Siren Software
Fineground	Software Plus
Garwood Software	Sunshine Books
GEM Distribution	Tasman Software
Gultronics	The Electric Studio
HSV Computer Services	Timatic
Interlock Services	Transform
KDS Electronics	Velda Publishing
LCL Educational Software	Videx Case Co
Load and Run	Willberry

Don't miss it!

**Avoid the
queues!**

**Get your
ticket in
advance
and...**

**SAVE £1
A HEAD!**

Advance ticket order

Please supply:

- Adult tickets at £2 (save £1) £ _____
- Under-16s tickets at £1 (save £1) £ _____
- TOTAL £ _____
- Cheque enclosed made payable to
Database Publications Ltd.
- Please debit my credit card account:

Access _____

Visa _____

Admission at door:
£3 (adults), £2 (under 16s)

POST TO: Amstrad Show Tickets, Europa House,
68 Chester Road, Hazel Grove, Stockport SK7 5NY.



Champagne Suite & Exhibition
Centre, Novotel, Hammersmith, W6
October 3-5, 1986

Name
Address
.....
..... Signed

PHONE ORDERS: Show Hotline: 061-456 8835
PRESTEL ORDERS: KEY *89, THEN 614568383
MICROLINK ORDERS: MAILBOX 72:MAG001

Please quote credit card number and full address + Ref. AA9

MANDRAGORE

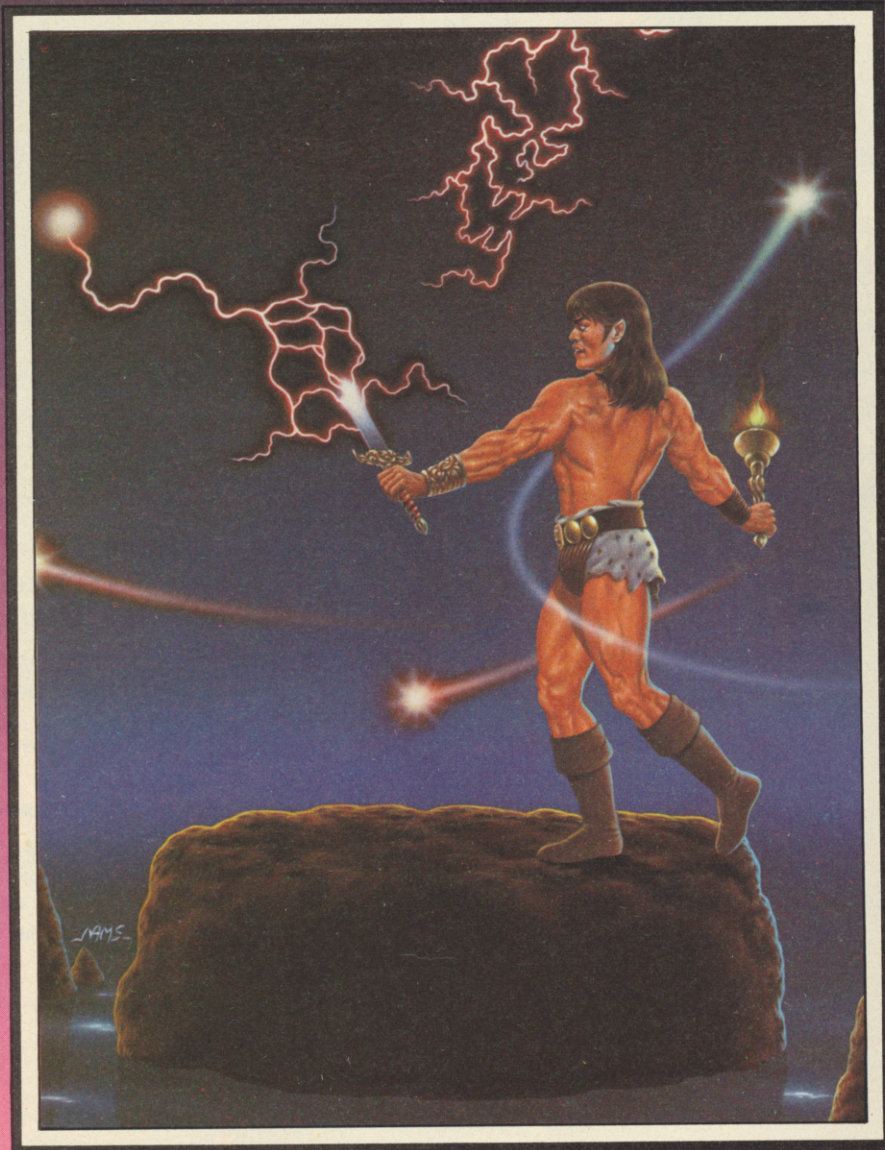

THE MAKING OF A LEGEND

France's award winning, role playing epic now available in English

Available for:

Amstrad (Disk and Cassette)

CBM 64 (Disk and Cassette)

Apple II (Disk)

MSX and **Spectrum**

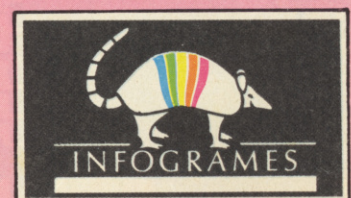

Would you buy a computer from a company whose logo was a crocodile? No, I thought you wouldn't. But the French have gone for it in a big way – perhaps because they all seem to wear those expensive Lacoste shirts with the same toothy beast on the chest.

The computer company, naturellement, is Amstrad France. The crocodile has slithered its way into over 200,000 French homes and is now firmly established as the top-selling micro in the country.

We've seen the benefits over here. AA readers will be only too aware of games like *Get Dexter* and *The Fifth Axis*. Is there more to come across the Channel? Are we facing the biggest French invasion threat since Napoleon? Read on to find out.



VIVE LA DIFFERENCE!

In the beginning was the PSS/Ere Informatique link up – the one that brought you *Crafton et Xunk* and *Eden Blues*, alias *Get Dexter* and *Doomsday Blues*. And the French saw that it was good, and they sold many copies of their games, for they were good too. And it came to pass that Loricels signed an agreement with Activision, and lo, *Le Cinquieme Axe* became *The Fifth Axis*, and that sold well too.

And other French software houses looked on and saw that they were missing out on a very good thing indeed if they did not get their games over to Britain pretty sharpish. And so it came it to pass that a company called Infogrames decided to go the whole hog and establish a UK company to translate and market their games.

That's why this issue of AA has got a Pilg review of *Mandragore*, the first Infogrames game to be released here. The first of many, and not just from Infogrames – look out for games from Rainbow, Ubi Soft, Cobra Soft, Ere and Loricels in the next few months.

Obviously then, there's a pretty lively Amstrad scene in France. Possibly – dare I say it? – livelier than over here. You only have to go into a computer shop such as General, in Paris, to see that Amstrad hardware and software are in demand. Herve Collin, the manager, told me that they sell around 200 programs a day in the one shop. It's a little more understandable when you realise that they've sold around 12,000 Amstrads since September '85, largely 6128s with colour monitors.

The reasons for such a success are not very different from those that created the Amstrad boom in the UK. As Marc Andre Rampon of Ere Informatique puts it; 'people were attracted by the all-in solution'. And, indeed, the price – although a 6128 with green screen in France is going to cost the equivalent of around £470. Still, it's a lot less than any comparable system. And, as far as Herve Collin can predict, 'there's no foreseeable competition.' No wonder that Gallic crocodile's sporting an enormous grin.

THE MAGS

French micro enthusiasts are spoilt for choice, particularly on the Amstrad front. *Amstrad Magazine*, *CPC*, *MicroStrad* and two more launches planned for the autumn. As well as these specialist titles all the general magazines, such as *SVM* and the games mag *Tilt*, carry hefty Amstrad sections.

Inside the mags you'll find pretty much the same sort of stuff as over here – although without AA's unique blend of wit, style, good design and hard information. Outside the mag, though, you might get a shock: they all cost around £2!

CPM is a hardy perennial, listings go over in a big way – some of the mags still publish special listings issues – and games review are, of course, obligatory. Funnily enough, the French devote nowhere near as much space to games as we do. And they don't give same sort of detail or eye-catching ratings.

One feature English Amstrad owners will recognise – if they read French – is the tales of woe in the letters pages: where are the discs? why can't I find a 464 anywhere? why is software house X advertising this game although it's nowhere near finished?

Plus ça change, plus c'est la meme chose.

L'Affaire Hebdogiciel

Wackiest French mag by far is the weekly *Hebdogiciel*, a bizarre cocktail of strip cartoons, film and music reviews, games reviews and listings.

Some of the cartoons feature the sort of 'adult' topic you'd be very surprised to see in a computer mag over here, while the games reviews are written in a curious slang that must be virtually incomprehensible to anyone over the age of 20 e.g. 'And now, for your eyes only, a games review. You're happy, you're overjoyed, you burst into laughter, youpiieeee. Hop. Ecstasy. You smile as you should, your lips curl up to your ears, in short, you're in heaven'.

Hebdo seems to have taken something of a dislike to Amstrad and Mr. Sugar, but he surely didn't deserve the treatment they handed out to Amstrad in June.

'EXCLUSIVE: AMSTRAD CPC 5512' blared Hebdo's headline. They went on to give details of the 'new' machine: 512K RAM, 5¼-inch drive, price slightly higher than the 6128. The extraordinary thing is that the French fell for it, to the extent that 6128 sales fell, a software house announced that it's going over to 5¼-inch disks and Amstrad France sent an urgent message off to Brentwood HQ. Sugar replied with characteristic terseness: 'Rubbish!'

End of story? Not quite. The editor of *Hebdogiciel* is called in to see Amstrad. They don't sue, but he is forced to repay the price of the issue – just over £1 – to any unhappy readers.

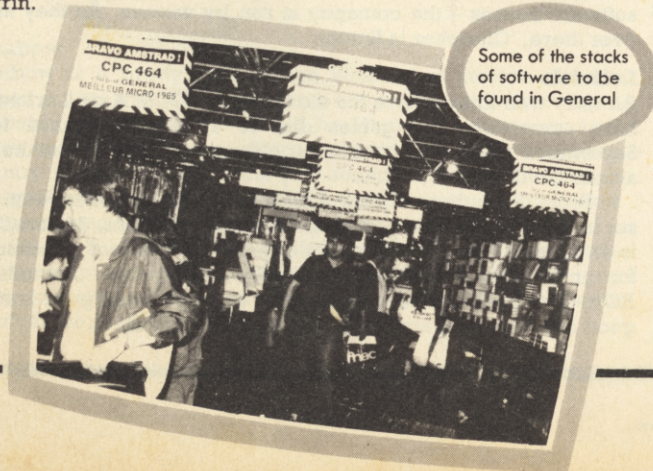

THE SOFTWARE HOUSES

Ere Informatique

The first French games house to make a big impact over here – with the best-selling *Get Dexter*. The company was started by Emmanuel Viau and Marc Andre Rampon – both of them still disgustingly young – in June 83. They started out with a flight simulator written by Marc on the ZX80, *Intercepteur Cobalt*. In three years the program has sold around 55,000 copies in its various incarnations.

Their first Amstrad prog was the excellent pinball simulation *Macadam Bumper*, written by software star (and also author of *Get Dexter*) Remi Herbulot.

The next two games from EI to appear in the UK, in conjunction with PSS, will be *Contamination* – a strategy game AA readers should know all about – and *Pacific*, a submarine arcade adventure with an alleged 32,000 screens (and an AA-Rave in our August issue).

Marc characterises Ere as a company who 'love anything to do with Z80 – it allows you to create beautiful graphics.'

Certainly, the other games I saw at Ere's offices bore out that statement. *Tension*, an animated strip poker game to send the shivers up Samantha Fox, features three characters on screen, all of whom can change expression as they try to bluff each other – and you. And the strip sequence is, well, something else. Accompanied by some suggestive music, the female player wriggles and simpers while the 'camera' zooms in on various parts of her anatomy. It could just be a little too hot for us over here.

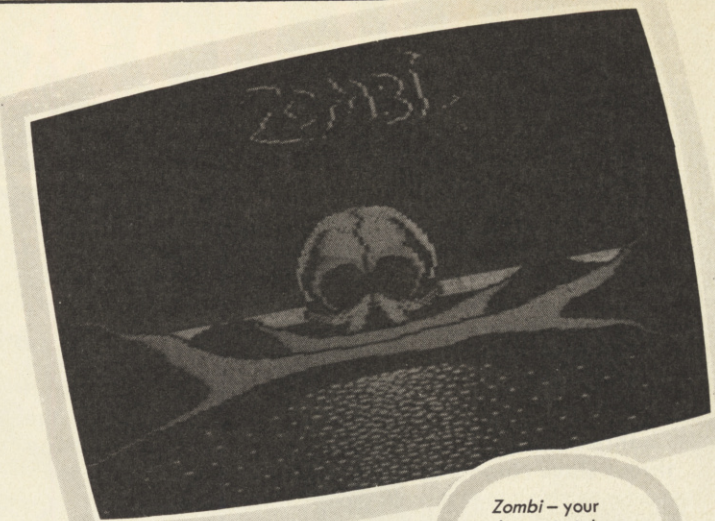
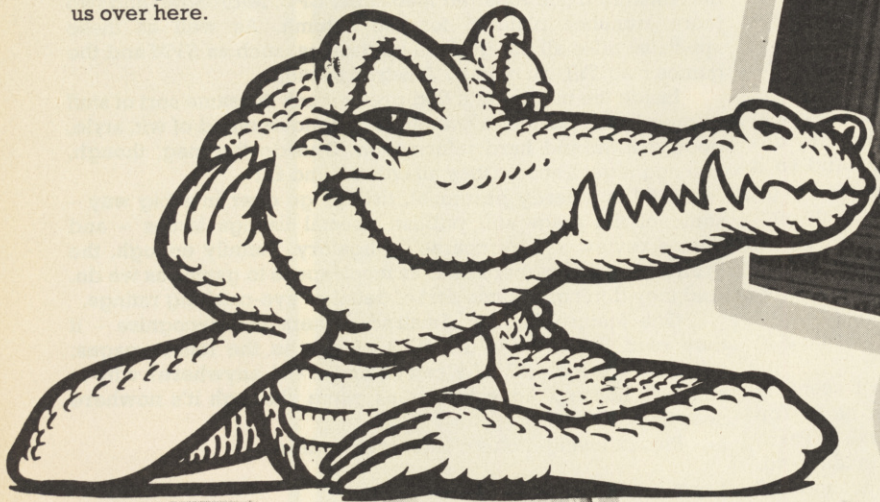

Zombi – your chance to take part in a night of the living dead.

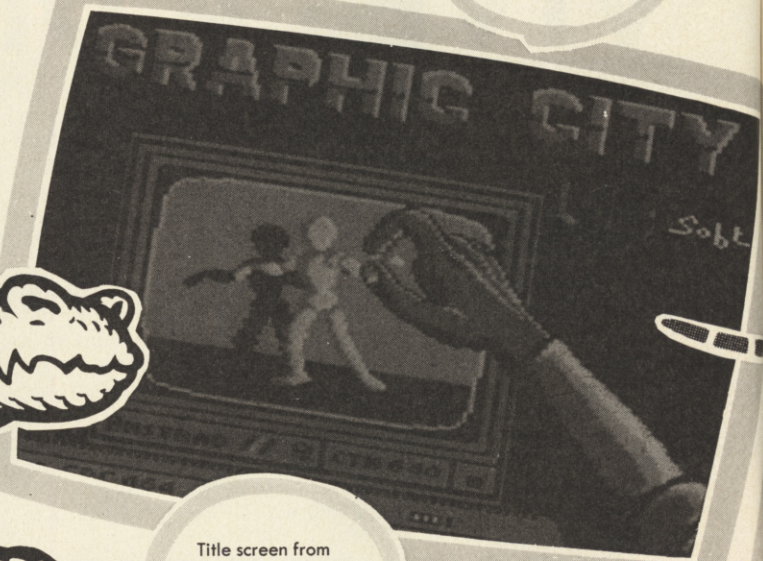

Title screen from *Graphic City*, Ubi Soft's forthcoming sprite editor

Ubi Soft

If you ever saw the film *Night of the Living Dead*, then you'll appreciate *Zombi*, a disk-only Amstrad game from Ubi Soft. You can choose to play one of four characters who have to find enough petrol to escape from the zombie hordes on their tail. The game has those familiarly excellent French graphics – influenced by strip cartoons – and is icon-driven.

Future releases from Ubi include *Graphic City*, a sprite designer which, they claim, is better than *Laser Basic*, and *Fer et Flamme* (Iron and Flame), a role-playing game set long long ago.

Ubi Soft may well be unique in the history of games software houses – the company is run by women. As they say over there, 'Cherchez la femme'.

Loriciels

Already well-known here for the intriguing *Fifth Axis*, Loriciels have some tempting games due to appear in France for September – although it's not yet clear how many will make it across the Channel.

From the authors of *Fifth Axis* comes *Sapiens*, an adventure set in prehistoric times which uses fractal graphics. *Maracaibo* is an arcade game which poses you the problem of searching for underwater treasure, while *Billy-la-Banlieue – Suburban Billy* – has the bizarre scenario of a greaser looking for some good old-fashioned arcade games. I know the feeling.



The lads of one of Infogrames' many programming teams. They'd like to say 'Bonjour' to you



Nelly Desclaux, 50 per cent of Ere's in-house graphics team

Infogrames

If you start seeing armadillos all over the place, don't worry. This is a perfectly normal reaction to the entry of Infogrames into the British market. The Armadillo - le tatou - is Infogrames' logo and, boy, do they make the most of it. You may even be getting 'The Daily Armadillo' shoved through your letter box one of these days, telling you about their latest games.

The first release here is *Mandragore*, for news of which see the Pilg's column. This is to be quickly followed by *Omega*, an interplanetary role-playing game, and then *The Vera Cruz Affair*, a murder mystery with superb graphics, previewed on page 58 of this issue. In this line too is *Murder on the Atlantic* which, as the name suggests, is set aboard one of those big ships full of characters escaping from an Agatha Christie novel. La *Geste d'Artillac* is also one for the Pilg; if the gameplay gets anywhere near the quality of the graphics it should be something pretty special.

Infogrames have something like 30 programmers working in-house at their Lyons offices. They're a young company - the co-founders only total 54 years between them - with a lot of ambition; in an interview given recently with a French magazine Bruno Bonnell said that Infograme's ambition was 'to become the international leader in interactive media. To make Infogrames a Metro-Goldwyn-Mayer of computing.'

The whiz-kid founders of Infogrames: Christophe Sapet - in the unfinished cardigan - and Bruno Bonnell, with the armadillos running up his tie



Scene from Infogrames' *Heritage*



MINITEL 23 PRESTEL 1

That's the proportion by which the French are leading us in the comms field. It's not really something in the French character, just the fact that hundreds of thousands of Minitel terminals were given away to get the system going. There are now 1.3 million systems installed.

So now, if you've got the gear, you can get access to any amount of weird and wonderful information. For instance, nearly all the popular magazines and papers are on Minitel. Not only can you read the paper, but you can get in touch with like-minded readers and discuss the football results or the latest films, or even where you'd like to meet for dinner.

So all in all the French have really got their act together as far as the Arnold is concerned, and in certain aspects are way ahead of us - vive la difference!

STOP PRESS

See page 58 for hot previews of new software soon to be available in your shops, and page 84 for a great competition in which you can win the first of an Infogrames game to appear in this country!



Title screen from *Murder on the Atlantic* gives a clue to the game's location

Rainbow

Rainbow is a pretty new games house, but they've already signed a deal with CRL over here. The first prog to come out - probably in September - should be *Warrior*, a dungeons-and-dragonsish, menu-driven affair in which you have to liberate a country from its tyrant. If the plot sounds all too familiar, then the quality of the graphics should compensate. And Rainbow are promising a much bigger disk-only version.

Future releases in France include *Goliath*, a Zaxxon-style shoot-em-up and graphics adventure *Attentat*, in which you have to defeat a terrorist conspiracy. As yet it's uncertain whether they will appear in the UK.

Absolute Beginners

More loops and variables from Andrew Wilton, and a few pictures too in Part Five of our crash course in Basic

Last time we saw how we can use letters to represent numbers in the commands we give to Arnold. These letters are called *variables*, and are an essential feature of BASIC. In fact, variables needn't just be single letters – words will do just as well. Thus, where we had 'a=599:MOVE a,180' last time we could have put 'elephant=599:MOVE elephant,180' instead. Arnold would have understood and obeyed the command in exactly the same way – that is, he would have performed a 'MOVE 599,180'.

We also saw that we can alter the number attached to a given variable name – the *value* of the variable – using an *assignment* command. Thus, the command 'MOVE a,180' can mean different things depending on what the last 'a=...' command was. Take a look at this program:

```
10 CLS
20 a = 130
30 PLOT a,100
40 a = 210
50 PLOT a,100
```

The PLOT commands in lines 30 and 50 are identical, but they do different things. This is because line 40 assigns the new value of 210 to 'a', wiping out the old value which line 20 had set.

We rounded off last time with a program that used the new commands FOR and NEXT. We saw there that these commands were very powerful, but we didn't see precisely what they did. We're going to find that out right now – with a little help from one of the first commands you learnt.

PRINTING VARIABLES

Right back in *Absolute Beginners* Part 1 we saw how PRINT could be used to display text on screen. In fact, PRINT can do a lot more than that. Try typing in these immediate commands:

```
a = 593
PRINT "a"
PRINT a
```

You should find that the first PRINT produces the letter 'a', while the second produces the number 593 – the value of the variable 'a'. The difference between the two is just a matter of punctuation: the first has quotation marks to tell Arnold that 'a' is a piece of text to be printed; the second, on the other hand, has no quotation marks. Because of this, Arnold assumes you're trying to PRINT the value of the variable 'a'. You previously

assigned the value 593 to 'a', so that's what Arnold displays on screen.

FOR-NEXT LOOPS

That may have seemed like a bit of a diversion but, believe me, it was necessary. PRINT is vital for monitoring what happens to the value of a variable, and we'll need to do a fair bit of PRINTing to understand the FOR and NEXT commands.

Let's start off with a simple program which just prints a message repeatedly:

```
10 FOR a = 1 TO 5
20 PRINT "Line 20"
30 NEXT a
```

Lines 10 and 30 together make Arnold perform the PRINT command in line 20 not once but five times. RUN the program to see this for yourself. Then add to it by typing in new lines so that it looks like this:

```
5 PRINT "Line 5"
10 FOR a = 1 TO 5
15 PRINT "Line 15"
20 PRINT "Line 20"
25 PRINT "Line 25"
30 NEXT a
35 PRINT "Line 35"
```

Now RUN this. You should find you get a series of messages, each of them referring to the line that PRINTs it. Thus, if you get the message "Line 25" on the screen, you know Arnold has just performed the command in line 25. In practice Arnold does this sort of thing very fast, so you won't have time to think about each line as it pops up on screen. That doesn't really matter. We're interested in the order Arnold performs the lines in, and the number of times he repeats them.

Okay, you've got a whole series of messages on the screen. Let's take a look first of all at which messages crop up more than once. You should have only one "Line 5" message and similarly only one "Line 35". The middle three, however, each occur five times. They're not just in any old order, either. They come in five groups of three, each one like this:

```
Line 15
Line 20
Line 25
```

That is, they're in numerical order within these groups. Can you see what FOR and NEXT are doing here?

If you look back to the listing you'll see that the repeated lines are the ones between the FOR command in line 10 and the NEXT command in line 30. The combined effect of the FOR and the NEXT is to make Arnold repeatedly run through the lines in between them. As you may remember from last time, this repetition is called *looping*. The FOR and NEXT commands and the lines between them form what's called a *loop* - that is, a bit of the program which gets repeated. For obvious reasons, this kind of loop is usually called a *FOR-NEXT loop*.

HOW MANY TIMES?

It's all very well me showing you how FOR and NEXT can make a bit of your program repeat itself, but you'll also need to know what controls the number of times it repeats.

Get rid of the old program using NEW, and type this one in its place:

```
10 CLS
20 FOR a= 1 TO 10
30 PRINT "Hello"
40 NEXT a
```

If you RUN this you'll get the message "Hello" appearing on your screen ten times. Clearly line 30 is being repeated ten times, so that's the number of times Arnold's going through the loop. Change line 20 to read:

```
20 FOR a= 1 TO 5
```

Now you should only get the message appearing five times. Before you jump to any conclusions about what this second number does, try running the program again with line 20 modified as follows:

```
20 FOR a= 2 TO 5
```

Now you only get the message four times. If you can't work out why, don't worry. Remember that business earlier about printing the value of a variable? Well, that's what we're going to do right now, and it'll show you exactly what's going on.

You see, that 'a' between 'FOR' and '=' in line 20 is a variable name. The FOR command needs a variable to count the number of times it's gone through the loop, and the 'FOR a=' tells Arnold to use 'a' as that variable. Modify your program so it looks like this:

```
10 CLS
20 FOR a= 2 TO 5
30 PRINT a
40 NEXT a
```

When you RUN this you'll get a series of numbers running from 2 to 5. Each of the numbers is the value of the variable 'a' for one pass through the loop - one performance of the PRINT command in line 30. As you can see, the value of 'a' starts off as 2, and goes up by one each time until it gets to 5. When Arnold finds the command 'FOR a=' he sets 'a' equal to the first operand, runs through the loop, increases the value of 'a' by one, runs through the loop again and so on. He'll only stop once 'a' is larger than the second operand.

In this program, then, he sets 'a' equal to 2 first time through. The NEXT command tells him to run through the loop again using the NEXT value of 'a' - which he gets by adding one to its current value. Thus he runs through the loop again, this time with 'a' equal to 3. The same thing happens for 'a' equal to 4 and 5. After the pass through the loop with 'a' set to 5, the NEXT tells Arnold to find the NEXT value of 'a' again, ready for another pass through the loop. The NEXT value of 'a' would be 6, however, and that is greater than the second operand of the FOR command. So, instead of running through the loop again, Arnold carries on with the rest of the program. In this case there isn't any more program to carry on with so Arnold puts up 'Ready' to let you know he's finished.

We can show what goes on even more clearly by adding these lines to the program, and running it again:

```
50 PRINT "That's the end of the loop"
60 PRINT a
```

You should now find that it PRINTs out the numbers 2 to 5, the end-of-loop message and then the number 6. This last is the value of 'a' after Arnold has finished with the loop. As we said we said before, this means Arnold carries on with the rest of the program. So when he reaches the 'PRINT a' command in line 60, 'a' still has the value 6 from the last time Arnold performed the NEXT in line 40 - so that's the number he PRINTs on the screen.

PUTTING THIS TO WORK

At the very end of last month's *Absolute Beginners* there was a program which dragged a square from one side of the screen, very slowly. It went as follows:

```
5 FOR a= 0 TO 599
10 CLS:MOVE a,180
20 DRAW a + 40,180,1
30 DRAW a + 40,220,1
40 DRAW a,220,1
50 DRAW a,180,1
60 NEXT a
```

You should have some idea of how this works now. We haven't covered that 'a + 40' business in lines 20 and 30, but this is more or less self-explanatory. It just tells Arnold to use 40 more than the value of 'a' for the first operand of the DRAW command.

THE LAST STEP

There's just one more thing I want to cover this month, and that's the STEP command. Modify line 5 of the program above to read:

```
5 FOR a= 0 TO 599 STEP 10
```

Notice how much faster the square moves now? That's because Arnold is increasing 'a' by 10 every time it goes through the loop, instead of the usual 1. That's what that STEP does for you - it tells Arnold how much the loop's NEXT command should increase 'a' by.

FOR-NEXT LOOPS

The commands FOR and NEXT work together to form *loops*. Arnold will perform the program commands in between the FOR and the NEXT repeatedly.

The FOR command needs a variable-name and two operands. These are laid out in the form 'FOR variable= TO '. When Arnold comes across the FOR command he makes the variable equal to the first operand. The variable is used to control the number of times Arnold performs the loop. Because of this it is called the *loop variable*. The second operand is an upper limit for the loop variable, and Arnold stores it away for future reference.

The NEXT command just needs a variable name, but it must be the same one you used in the FOR statement. When Arnold reaches the NEXT com-

mand he adds 1 to the loop variable, and compares it to the upper limit - the second operand of the FOR command in other words. If the loop variable is still less than the upper limit, he runs through the loop again; otherwise, he carries on with the rest of the program.

If you're using the loop variable as an operand of a command in the loop, like the way the moving-square program uses 'a' in those MOVE and DRAW commands, the STEP command can come in handy. This lets you change the *step-size* of the loop - that is, the amount by which the NEXT command increases the loop variable each time. Arnold assumes you only want to add one each time, unless you use STEP to tell him otherwise. Using STEP, the FOR command takes the form 'FOR variable= TO STEP '.

BOOTING UP CP/M

Last month's episode of this series was dominated by the DIRectory command, and the wonderful things it could do for CP/M PLUS users. Users of CP/M 2.2 can get their revenge now, because most of this episode goes into the depths of the STATus command, which is not even implemented for CP/M PLUS. But Matt Nicholson covers something for everyone, so read on...

Before we start, let's make a backup of your CP/M system disc. This means copying the contents of the master system disc on to a blank disc, and using the copy for day-to-day work so that if anything goes wrong you've still got a working master disc. This is something that you should do with all your program discs, otherwise you could have an expensive problem when your only copy of a program gets corrupted!

Fortunately Amstrad supply a program file on your master disc for this very purpose: called DISCKIT2.COM on CP/M 2.2 and DISCKIT3.COM on CP/M PLUS. The program is run by entering DISCKIT2 or DISCKIT3 as appropriate, and following the on-screen

instructions. Remember to press the function keys to select an option, and select 'copy' at the first menu. Also remember to copy both sides of the discs. Once you have successfully copied your master discs, put them away somewhere safe and use your copies in future.

Last month we showed you how to use the STAT command to give you a directory of the contents of a disc - something which is done in CP/M PLUS with the DIR command. However this is just part of the STAT command's function, as it can also show you the full STATus, or vital STATistics, of your micro.

DEVICE ASSIGNMENT

As far as the operating system is concerned the disc drive is just one of the elements of your micro that has to be taken care of. Other elements are the keyboard and screen, and any interface ports. On the Amstrad these are the Centronics port for your printer and, if you have one fitted, the RS232 or Serial port used for communicating with other computers.

However CP/M was not designed specifically for the Amstrad range: it was designed long before Arnold was just a twinkle in Alan Sugar's eye; and to be portable - i.e. to work on a wide range of makes and models, with a wide range of keyboards, screens and interface ports. CP/M takes care of this by distinguishing between 'Logical' devices and 'Physical' (or actual) devices. Physical devices are best regarded as the actual keyboard, screen and interfaces of your computer. Logical devices are part of the CP/M operating system, and are the same regardless of the computer itself. CP/M operates by assigning the logical devices to the actual, physical devices of your micro.

CP/M 2.2 has four logical devices, and their names reflect the vintage of the operating system: CON: stands for 'CONsole', and usually covers both the keyboard and the screen; RDR: stands for 'paper tape ReaDeR', and covers the serial input device; PUN: stands for 'card PUNch', and covers the the serial output; and finally LST: stands for 'LiST device', and is usually a parallel or centronic printer. CP/M PLUS is a little more up to date, dividing the console between CONIN: and CONOUT: for the keyboard and the screen respectively, and using AUXIN: and AUXOUT: for the serial input and output. LST: remains for the printer output, giving five logical devices in all.

The physical devices are named differently, and again reflect the vintage. The actual keyboard and screen are called CRT:, standing for 'Cathode Ray Tube'. The serial interface is called TTY: in CP/M 2.2, standing for 'TeleTYpe', and the more reasonable SIO in CP/M PLUS, standing for 'Serial Input Output'. Finally the printer is labelled LPT: in both versions of CP/M, standing for 'Line PrinTer'. CP/M itself supports a lot more Physical Devices than these, including such things as Paper Tape Reader, Batch processing and User Defined Punches, but these are not applicable to the Amstrad machines as they stand.

Anyway, back to the 20th Century and down to work. Turn on your Arnold and boot up CP/M 2.2 as described in Part One of this series (PCW owners hang on!). On the A-prompt type **STAT DEV:** and hit return - remember the colon, otherwise it won't work. The result will look like this:

```
A>stat dev:
CON: is CRT:
RDR: is TTY:
PUN: is LPT:
LST: is LPT:
```

This command shows you the STATus of your DEVICES, listing the logical devices on the left and their assigned physical devices on the right. So this listing tells you that CON: is indeed mapped to the keyboard and screen, RDR: and PUN: are the input and output of the serial port respectively, and LST: is the centronic printer port. Now enter **STAT VAL:**, and you should get something like this:

```
A>stat val:
Temp R/O Disk: d:=R/O
Set Indicator: d:filename.typ $R/O $R/W $SYS $DIR
Disk Status : DSK: d:DSK:
User Status : USR:
Iobyte Assign:
CON: = TTY: CRT: BAT: UC1:
RDR: = TTY: PTR: UR1: UR2:
PUN: = TTY: PTF: UP1: UP2:
LST: = TTY: CRT: LPT: UL1:
```

What is shown here is a complete list of the VALid entries and formats for STATus assignments. Ignore the top bit for the moment, and concentrate on the bit below the words 'Iobyte Assign'. Listed here are all the possible physical devices that can be mapped to the four logical devices. It is quite possible, using the STAT command, to assign CON: to the serial port, in which case Arnold would take all information coming through the serial port as though it was keyboard input, and would send its display through the serial port instead of to the screen.

To do this enter **STAT CON:=TTY:**. The result will be unspectacular, as nothing you enter on the screen will appear on the keyboard. Luckily this is not permanent, but you will have to reset Arnold and re-boot CP/M to regain control.

If, however, you had another micro connected to your Amstrad via serial interfaces on each machine, you would have found that the second micro had taken control of Arnold. Andy and I managed to do this, using the Pace RS232 interface on our Arnold, and an NEC lapheld micro in the office. When we entered STAT CON:=TTY: on Arnold's keyboard, Arnold's screen went blank, and his keyboard died, but Arnold's A-prompt appeared on the NEC's screen and we were able to use the NEC's keyboard to do directories of the disc, and use other CP/M commands.

BACK TO THE DISC DRIVE

All of this probably seems singularly useless, which indeed it is at this stage, but devices come into their own later in this series. The final use of STAT that we shall cover here is concerned with the disc files.

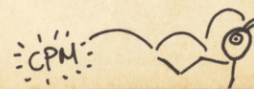

From CP/M 2.2 enter the command **STAT *.***, as we did last month. On the screen should appear a complete list of the files on your disc. Notice the fourth column, headed 'Acc' for Access. All entries in this column should stand at 'R/W', standing for Read/Write which means that you can both read or use the contents of the file, and change it by writing to it. Now enter the command **STAT XSUB.COM \$R/O**, followed by **STAT *.***. The new directory listing reveals that the bottom file, XSUB.COM, is now read-only, which is a useful way of stopping the accidental corruption or erasure of important files. Enter **STAT XSUB.COM \$R/W**, and list the directory again, and the file reverts to read/write. Once again wildcards can be used, so **STAT *.COM \$R/O** sets all COM files to read-only status, and **STAT *.COM \$R/W** sets them back to read/write files.

[COLUMNS = nn LINES = nn], where nn is any full number. Try playing around with it for a while, and see you next month when we will look at the PIP command for copying files, and start creating files of our own. ■

OVER TO CP/M PLUS

As we said at the beginning, none of this is implemented in CP/M PLUS. However there are two other files, DEVICE.COM and SHOW.COM which, between them, cover the functions provided by STAT in version 2.2. Although they do the same thing, needless to say they do it in a different way! If you own an Arnold both these files are on the main system disc, Side 1. If you own a PCW, then you will find SHOW.COM on the system disc, Side 2, but the DEVICE.COM file is on the second disc, Side 3. Remember that the active side faces left when you put the disc in Joyce's drive.

the SHOW command is of limited use at this stage. Just entering **SHOW** has a similar result to the STAT command on its own in CP/M 2.2: it simply shows the amount of free disc space. More useful is DEVICE.COM. Try entering **DEVICE** on the A-prompt:

```
A>device
Physical Devices:
I=Input,O=Output,S=Serial,X=Xon-Xoff
CRT NONE IO LPT NONE O

Current Assignments:
CONIN: = CRT
CONOUT: = CRT
AUXIN: = Null Device
AUXOUT: = Null Device
LST: = LPT

Enter new assignment or hit RETURN
```

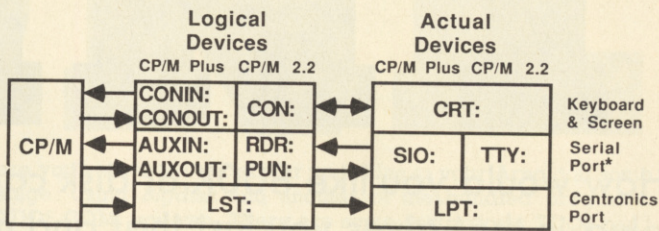

*If you have an RS232 add-on fitted.

This is how the logical devices of CP/M map onto the actual devices of the micro, for both CP/M PLUS and CP/M 2.2

STATUS - CP/M 2.2 Only

The STAT command is a powerful way of examining the STATUS or STATISTICS of your machine. Used by itself it looks pretty puny, but used with qualifiers it enables you to examine and alter the whole nature of your machine. These are the most useful variations:

- STAT** Simply shows you the amount of space left on the disc, and whether the disc is 'R/O' (read-only) or 'R/W' (read/write).
- STAT filename** Gives you full details of the named file on the disc, including its size and status. Wildcards can be used, so *.* would give full details of all the files on the disc.
- STAT VAL:** Provides a list of the

valid formats for the various STAT qualifiers.

STAT DSK: Lists the full characteristics of the current disk drive. STAT B:DSK: would give the characteristics of Drive B.

STAT DEV: Lists the current assignment of Physical (Actual) devices to the CP/M Logical devices.

STAT logical: = physical: Assigns the specified logical device to the specified actual device.

STAT filename \$R/O Sets the specified files to read-only status. Again, wildcards can be used.

STAT filename \$R/O As above, but setting files back to read/write status.

SHOW & DEVICE - CP/M PLUS Only

The CP/M PLUS operating system does not use the STATUS command, however it shares the facilities over three other commands: DIR, DEVICE and SHOW. We covered the DIRectory command and all its options last month. The SHOW command covers the remaining disc specifications, while DEVICE covers the input and output characteristics of your micro:

- SHOW** Like the bare STAT command, this simply shows the amount of disc space left on the active drive and whether it is Read/Write or Read Only. It can be followed by a disc letter, so SHOW B: would show you the amount of space left on the disc in drive B.
- SHOW [SPACE]** As above, but for all the disc drives connected, not just the one you are logged on to.
- SHOW [DRIVE]** Like STAT DSK: this gives the full characteristics of the active drive. Again, SHOW B:[DRIVE] would

give the characteristics of drive B.

DEVICE This shows the current assignment of Physical devices to Logical devices, and certain characteristics of the Physical devices.

DEVICE NAMES Just shows the characteristics of the Physical devices.

DEVICE VALUES Just shows the current assignments.

DEVICE logical: = physical Assigns the specified logical device to the specified physical device. More than one physical device can be assigned to each logical device by separating their names with commas.

DEVICE logical: = NULL Disconnects that particular logical device.

DEVICE CONSOLE[PAGE] Shows the current number of columns and lines that can be displayed on the screen.

DEVICE CONSOLE [COLUMNS = nn LINES = nn] sets a new format for the screen display.

Like STAT DEV: this lists the current assignments of logical device to physical device, but with a prompt allowing you to alter the assignments there and then, or exit by hitting RETURN. Note also the different names used for the devices by the PLUS version of CP/M. This command is also a little more intelligent than STAT: if you do not have a serial interface it lists AUXIN: and AUXOUT: as being assigned to 'null device'; but if you do have a serial interface you will find them assigned to SIO.

Another difference is that you can assign the logical devices to more than one physical device. At the prompt within the DEVICE program, try entering **conin: = crt,lpt**. A very understandable error message comes up pointing out your mistake: you can't assign CONIN: to the printer LPT: because the printer is not an input device, only output. Enter **DEVICE CONOUT: = CRT,LPT** this time. If you have a printer connected, and on-line, then anything you enter on the keyboard is also sent to the printer and printed out. If you do not have a printer connected you get a scrolling error message - hit the C key to cancel. This format that can be used for any combination of device assignments.

Finally, and something that PLUS owners will be glad to know is not implemented in CP/M 2.2, try entering **DEVICE CONSOLE[PAGE]** at the A-prompt:

```
A>device console[page]
Console width set to 89 columns
Console page set to 31 lines
A>
```

What you see is the format of your display - and you can alter it too! The format for doing this is DEVICE CONSOLE

THE BI

How would you like 800K of disk capacity? Andy Wilton looks at a plug-in that gives you just that and more

Imagine you've just bought an Amstrad FD-1 second drive for your 6128. You get it unpacked, plug it in and boot up CP/M PLUS. When you pop a freshly formatted disk into the new drive and do a SHOW B: you'll find you have just under 180K in the way of free space. Nothing surprising about that, you might think. Well, I've got a second drive on my 6128, but when I do a SHOW B: Arnold tells me I've got 796K free.

And that's not all. When you bought your 360K disk it probably cost you the best part of a fiver - maybe as little as £4 if you really shopped around, or bought in bulk. When I bought my 800K disk it cost me £2.50, and I simply bought the first one I saw. That's 800K I can get at in one go, remember, whereas you can only use yours in two separate 180K chunks.

As you've probably gathered my second drive isn't an FD-1, and it doesn't use 3-inch disks. Instead I've got Timatic's new 6128 *Bigdisk* drive, also known confusingly as the 6128 1 megabyte drive, which takes 5¼-inch floppy disks.

THE DISKS

Unlike the 3-inch disks that Amstrad drives need, 5¼s have been around a long time. They're cheap, easy to find and were until recently the universal standard for microcomputing. They are also, it has to be said, vulnerable. The disk itself is poorly protected by its flexible vinyl sleeve, and the disk surface is actually exposed in places. Whereas the 3-inch's tough case and metal shutter can take a lot of punishment, 5¼s must be handled with care.

The fact that most micro disk-drives still use 5¼s makes for other advantages as well as the availability of blank disks. With the right software, a 5¼-inch drive can allow Arnold to read files from other computers' disks. Timatic provide suitable software for several major 5¼-inch formats, so there's another reason why you might be interested in the *Bigdisk*.

THE DRIVE

Compared to the FD-1 the *Bigdisk* is wide, flat and heavy. The weight is accounted for in part by its outer case, a cream-enamelled steel effort which could certainly cope with all the rough handling you could give it. The drive sits on four little rubber feet which certainly stop it from sliding. The on/off switch is on the back panel, along with a 40/80 track select switch and the slot which the ribbon cable comes out of.

The drive door arrangement at the front seems sturdy and practical. Inserting a disk is a two stage process. First you push the disk deep into the slot, a section of the slot's lower lip hingeing inwards to allow for the fattest of fingers. Then you pull a latch down across the slot, clamping the disk in place. To remove the disk again, you simply push the hinged portion of the lower lip. This releases the latch and ejects the disk quite forcibly.

Below the drive slot is a red LED which acts as a 'power on' indicator. There's no 'disk access' indicator, but that's not what I'd call a serious omission. Firstly, the one on our FD-1 has never worked properly, which has never caused me any problems. Secondly the *Bigdisk*, while quiet by 5¼-inch standards, makes a lot more noise than the Amstrad built-in drives. Thus you can tell fairly easily the difference between motor running and motor idle. As for actual disk access, that's

perfectly audible even in the din of the AA office so you shouldn't have any problems at all.

SETTING UP

The drive comes fitted with a mains plug and an Amstrad cable. All you need to do is plug it in, slot the ribbon connector into the 'DISK DRIVE 2' socket on the back of your 6128, and set the 40/80 switch to 80 track. Then you just switch everything on, pop a disk in the *Bigdisk*, boot up CP/M PLUS and you're ready to go - almost.

Although CP/M PLUS signs on as having two disk drives, it can't use the *Bigdisk* straight away because it expects the second drive to be an FD-1 or similar. Instead you have to run a program to let CP/M PLUS know what format the second drive actually is.

Timatic provide two such programs, HDENS.COM for high-density (800K) and S80TRK.COM for low-density (400K) operation. These both come on a 3-inch disk supplied with the drive, along with a few other goodies we'll be taking a look at a bit later on. Under normal circumstances you'll only want to use HDENS, so you could just put this on your boot-disk - the one you use to boot up CP/M PLUS from. If you do this you just have to boot up using |CPM, type HDENS <return> and the *Bigdisk* is now a fully fledged drive B.

You can make things even easier on yourself. Timatic have thoughtfully provided a file called PROFILE.SUB which runs HDENS. Just put the HDENS, PROFILE and SUBMIT files onto your boot disk and every time you boot up CP/M PLUS it'll automatically set the *Bigdisk* up for you.

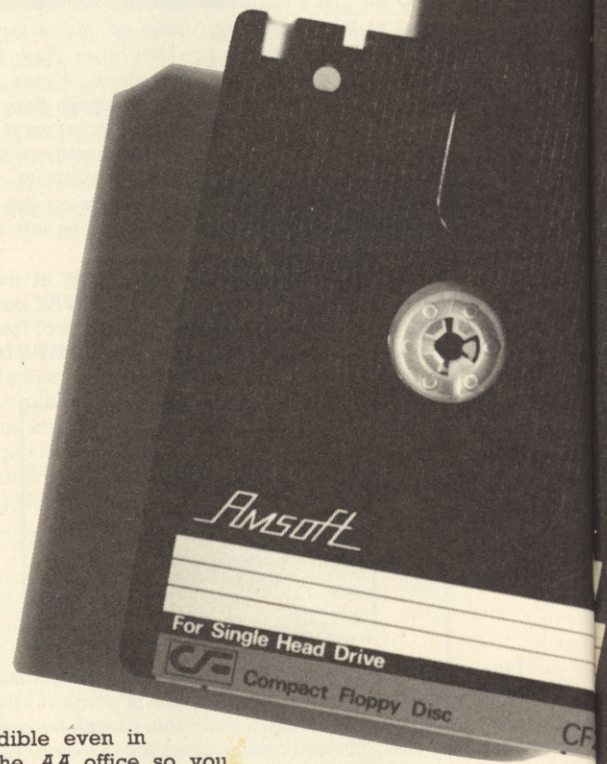

BIG ONE

are you've wanted to transfer your files to your Arnold at some stage. Using *Bigdisk* and another of the bundled programs, TDOS.COM, you can. There are some restrictions: TDOS can't cope with directory paths, and demands double-sided disks. It's worth bearing in mind too that you can't transfer MS-DOS applications programs - only the files they produce. So you'll need a CP/M application that can cope with the given file structure.

In practice you're most likely to want to transfer text as an ASCII file, and that presents no problems at all. TDOS is a very flexible tool allowing you to transfer files either way, catalogue drives A: and B: or erase files from the MS-DOS disk. It's very friendly too. When I tried to transfer files from drive B: to drive B:, it told me that I'd set up "silly drive assignments" - and of course it was right.

CAMELION

If you want still more freedom and don't mind spending an extra £49, Timatic sell a very powerful format selection utility called *Camelion*. I'm not sure, but I think the spelling error's deliberate - after all, CHAMELION.COM is too long to be a legal CP/M filename.

Anyhow, I've not seen the package myself but it sounds very impressive indeed. It offers a host of different pre-set formats, or lets you define your own if you can't see the one you want. The latter option does involve 'getting your feet wet', but Timatic do offer to help you find the settings you need. If you've got a lot of info you want to transfer one way or the other, it could well be worth it.

VERDICT

If you can spare the £249 asking price, *Bigdisk* is wonderful just as a second drive. The feeling of freedom you get from knowing you've got 800K to work with is amazing. It can transform some programs in a way that a normal second drive can't hope to.

Take Digital Research's *Pascal/MT+*, for instance. Under normal circumstances you need one disk for the compiler and editor, another for the linker and at least one more for the debugging tools, library routines and everything else. Even with this arrangement the compiler/editor disk soon starts to nudge 180K - and that's with a small, no-frills editor. With a *Bigdisk* on the other hand you could fit the whole lot onto one disk, use *WordStar* as your editor, and still have several hundred K for your own program files - without touching drive A:, that is.

As for transferring files to and from other machines, that depends entirely on your needs. Only you can work out whether it's worth the price, but it does seem straightforward and reliable from the file-transfers I tried. Bear this in mind: even if you buy *Bigdisk* chiefly for transferring files, you can still use that great big HDENS format when you use the machine normally. ■

While you're sorting out what you want on your boot disk you'll need to give some thought to *FORMAT.COM*, another of the programs supplied with the disk. As you might expect, it's a utility for formatting 5¼s. It takes quite a bit longer than *DISCKIT3* does on a 3-inch, but that's hardly surprising when you think about the size of its task.

That's about it in terms of using *Bigdisk* as a big, cheap drive B. All the programs supplied for this purpose are simple to use and require nothing in the way of technical knowledge. But there's more to *Bigdisk* than this, as I've already hinted.

CP/M 2.2, AMSDOS AND BEYOND

If you're sharp-eyed, you'll have noticed I mentioned *S80TRK.COM*, and said it was used to set *Bigdisk* up as a 400K drive - but didn't say why you'd want to do that. You can't use *Bigdisk* to its full under CP/M 2.2 or AMSDOS, hence all the specific references to CP/M PLUS so far. But you can use it from both operating systems as a 400K drive. Under 2.2 you use *80TRK.COM* to set it up and under AMSDOS you use *80TRK.BAS*, both files coming on the bundled disk. Timatic provided *S80TRK.COM* so that you can get at these low-capacity files under CP/M PLUS, if you need to. This common standard across operating systems is a nice touch, and could come in very handy.

Bigdisk can cope with a much wider range of formats than this, though. If you want to set it up to read CP/M 86 files written by an IBM PC, *Bigdisk* can do it. It can also cope with FTS and ICL format CP/M files. Far more important, it can read from and write to MS-DOS and PC-DOS disks.

Thanks to the PC and its compatibles, MS-DOS is the operating system for serious computing today. If you use an MS-DOS computer in the office, at school or in college, the chances

GOOD NEWS

- ▶ Huge (800K) capacity.
- ▶ Cheap, readily available disks.
- ▶ Friendly software.
- ▶ Easy to use.
- ▶ Can read MS-DOS and other non-Amstrad disks.

BAD NEWS

- ▶ £250 is a lot of money.
- ▶ You only get a 400K capacity under CP/M 2.2 and AMSDOS, though that's still pretty big.

FREEZE FRAME

Andy Wilton plugs-in a novel approach to tape-to-disc transfer

If you thought having a disc drive meant fast-loading games, you probably reckoned without all those problems of three-inch disc shortages, titles only available on cassette, and the extra £5 a time that disc-based games tend to cost. For those of you who just have to have your lengthy games on disc, the choice has always been one of buying a tape-disc transfer utility or learning some serious machine code.

Neither of these two methods are exactly ideal. Tape-disc utilities have a bad reputation for encouraging piracy; and a worse one for simply not working. There's an undeclared war between people who write transfer utilities and people who write turbo-loading routines. The latest games will always stay one jump ahead, and keeping up with advances in copier design can get pretty costly.

As for the hacking approach; this too has its problems. Even dealing with simple headerless loaders needs a sound grasp of machine code and a pretty good idea of the way Arnold's laid out inside; and as for the latest turbo-loading protection schemes: these take effort, skill and a great deal of mental juggling. If you're not already equipped for the job, it could be an expensive business too. Just the firmware manual and a decent set of hackers' utilities - *PyraDev*, for example - could set you back the best part of £50.

For the same sort of price, Mirage now offer a third and much simpler solution to the tape-disc problem in the *Imager*. It handles tricky loaders and other protection schemes with ease because, unlike all the other transfer systems currently available, it's a piece of hardware.

WHAT IT IS

The *Imager* takes the form of a chunky expansion-port module, designed to hug the back of a 464. For the benefit of 664 and 6128 owners the package includes a ribbon-connector so that the unit can stand free of the machine. Also included are a couple of photocopied sheets of paper by way of instructions, and that's it.

The most prominent feature of the *Imager* module is a single red button on the top of the casing. Indeed, aside from the through-connector and the Mirage label, it's the module's only feature.

This button is used to activate the *Imager* when you need it.

Plugging in is quite straightforward on the 464, but 664/6128 owners have to be a bit careful. With most expansion-port plug-ins, Arnold finds any connection problems on power-up. The *Imager* is an unconventional peripheral, however, and a normal power-up screen doesn't necessarily mean all is well. You may well find that, even with an apparently healthy start-up, pressing that red button produces the usual bad-connection mess on screen. As ever you have to switch off and plug in again, making sure the metal strips of the connectors line up, and then switch Arnold back on. Repeat this until everything behaves itself.

WHAT IT DOES

Once the *Imager* is set up properly you can go ahead and load the game you want to transfer. At this stage Arnold behaves exactly as normal because, quite simply, he doesn't know the *Imager* is even there. Once the game has reached the point where you want it saved, you just hit the red button and the *Imager* swings into action.

Immediately the game action freezes, and the top two lines of the screen are replaced by the *Imager*'s sign-on message. With most games you'll also find the colours on the rest of the screen go haywire, and quite possibly the display ends up scrolled rather strangely. If you now hit <Enter> on the keyboard the sign-on message is replaced by a prompt and a list of possible commands.

The emphasis here is on ease of use. The only options available are Save, Load, Run, New and Cat - all very familiar command ideas. You just type the first letter of the command you want and hit <Enter>. If you type 'S' for 'Save' the *Imager* prompts for a file name, asks which drive you want to save to and then goes to work writing the program to disc. The 'Load' command leads to a similar filename prompt, after which the saved game loads in to memory. You can now restart the game where you left off by using 'Run'.

As for the other commands; using 'New' before you load the game from its original can save you a lot of disc space, especially on the 6128; and 'Cat' just catalogues the disc - though at the cost of losing any program you had in the memory. There are plenty of possible error messages, but they're mostly self-explanatory and the documentation covers them pretty well anyway.

HOW IT WORKS

Provided there's room on the disc and you don't make any silly



mistakes, the set-up works every time. It's hard to imagine a protection system that could stop the process - conventional turbo-loaders or Lenslok-type systems certainly don't. That's because the *Imager* works by brute force, and makes no attempt to understand the code that it's dealing with.

When you press that red button and choose the Save command, the *Imager* stores the entire contents of Arnold's memory and the precise state the Z80 is in at the point where the game got frozen. In theory, then, it can make a record of everything about Arnold's state at the point when you pressed the red button, and restore him to that state some time later.

Unfortunately, there are some aspects of Arnold's 'state of mind' - colours and screen size in particular - which the *Imager* can't record. This meant that *Ghosts and Goblins*, while playing fine, adopted a very funny set of colours after imaging. As for *Starstrike II*, screen size problems made the imaged version unplayable. Mirage are working on a replacement ROM to get round the screen-size problem, which should be available by the time you're reading this. Existing users will be offered a free upgrade.

That still leaves colour problems - though most games reset these back to normal if, for example, you leave the room, move to a new screen or get killed. Others can be ugly but are rarely unplayable. Indeed, imaging *Ghosts and Goblins* cured it of its green-screen visibility problems.

Other drawbacks are rather more serious. Imaged games take a long time to load compared to conventional disc-games,

and eat up disc space like nobody's business. A typical imaged game is the best part of 60K long, and takes something like a minute to load. This is still a worthwhile improvement over the enormous loading times of tape games these days, but it's not exactly all you could hope for.

DISCOURAGING PIRACY

Some people will also be disappointed to hear that you can only reload imaged games with the *Imager* present, and that the imager actually encodes its files to keep things that way. To my mind this shows a responsible attitude. Any product of this type is bound to come under attack for encouraging piracy, and the case for legitimate disc-tape transfer needs all the support it can get. Mirage are working on improvements that would mean you could only reload files with the same *Imager* that was used to save them, and it's good to hear that too. ■

IMAGER

Mirage Microcomputers Ltd All CPC machines, price £49.95

GOOD NEWS

- ▶ Works every time.
- ▶ Very simple to use.
- ▶ Takes steps to discourage piracy.
- ▶ Lets you save a game at any point you like.
- ▶ The cure for screen-size problems is on its way.

BAD NEWS

- ▶ You're stuck with colour problems.
- ▶ Takes its time, and your disc space.
- ▶ £50 isn't exactly peanuts.



THE FULL RAMIFICATIONS

DK'tronics plugs you in to that wasted RAM - Andrew Wilton checks the claims

With this new plug-in DK'tronics, a firm best known for offering add-on memory expansions, are going into the business of helping you use the memory you've already got. If you've got a 6128, you've got an extra 64K of memory compared to 464 and 664 owners. But unless you use CP/M Plus this 64K probably hasn't done you a whole lot of good up till now. The 64K Silicon Disc just might change that - for a price.

Like its 256K big brother, reviewed in the May issue of *AA*, this package offers you a ramdisc for your CPC. A ramdisc is a section of memory which behaves like a disc drive: you can save and load files just like a real drive, only much faster. Unlike the 256K version the new Silicon Disc, or *sDisc* for short, doesn't actually come with RAM of its own. It simply enables you to use that extra 64K of RAM as a ramdisc, something it wouldn't be too easy to do otherwise.

SETTING UP

The *sDisc* is a single unit which plugs onto the expansion port. As such it makes a much more reliable connection than that of the twin units of the 256K version. There is no noticeable wobble on the unit, and it behaves well even with quite a few other peripherals hanging on the through connector. The only connection problem came when I tried to connect it at the same time as a Pace RS232 interface - and there was a good reason

for that, as we'll see later.

Once you've got the *sDisc* plugged into the back of your Arnold you can set the thing up for use under AMSDOS. To do this you simply type the external command |SDISC. The *sDisc* ROM responds by telling you which drive it's going to be: drive B if you've got the bare 6128, or drive C if you've got an add-on drive as well. If you want to use it in the normal AMSDOS way, you can now switch to it using |B or |C as appropriate. The commands CAT, |ERA and the like will all work just as if you were dealing with a genuine disc drive.

You can also use the 64K *sDisc* with CP/M 2.2 from side 4 of the 6128 system discs, but you'll have to go to a bit more trouble. It's all set out step-by-step and there's nothing too hard about it so long as you follow the instructions, but you'd have to be pretty well up on CP/M to have the faintest idea what it all means.

DRAWBACKS

If the reliable connection made a pleasant change from the old 256K Silicon Disc, there are several minus points worth bearing in mind. An obvious one is the smaller capacity. Once you've made room for the directory there's only 62K available, and that's really not very much at all. If you want to run an application from the Silicon Disc and keep data on the normal

drive you'll probably be okay, but even there you are limited in what you can do. WordStar will fit, for example, but you'll have to leave the help file out.

Worse still, for my money, is that you can't use the 64K *sDisc* under CP/M Plus. The lack of CP/M Plus compatibility was a serious drawback to the early 256K *sDiscs*, and DK'tronics wasted little time in bringing out an improved, compatible version. They won't be able to do that with the 64K version, however, because of the very way the thing works.

The 64K *sDisc* is, after all, not a ramdisc in its own right. Instead it turns the extra 64K of memory already in the 6128 (or expanded 464/664) into a ramdisc. Unfortunately, CP/M Plus needs that extra 64K for its own purposes - which is why you can't use CP/M Plus with the unexpanded 464 or 664. If you were to try and use the *sDisc* and CP/M Plus simultaneously, the clash would be disastrous.

In addition to these you've got the standard problems of ramdiscs. They may behave like discs, but they're really just RAM, the same as normal computer memory - literally, in this case. So you lose the contents of a ramdisc when you switch your computer off. Any data you put on the *sDisc* has to be backed up on a genuine, three-inch disc if you want to keep it safe. The things are only really useful, then, for keeping programs and overlay files on.

Connected with this is the problem of getting your programs etc onto the *sDisc*. When you switch on the *sDisc* is empty - anything you want to reside there has to be transferred across. To make things easy, the *sDisc* ROM has a couple of bar-commands to move programs and data around. |SAVEDISC stores the entire contents of the *sDisc*, and is very useful for making backups of precious data held there. |LOADDISC does the reverse, and is very handy for putting an application onto the *sDisc*; it does, however, have an unpleasant habit of crashing if there's more than 62K of data on the disk.

DOCUMENTATION

DK'tronics have combined all their product documentation into one 80-page manual. The 64K and 256K *sDiscs* have only eight pages between them, but this is room for a thorough coverage of the their use plus some interesting technical notes. As for the

other 72 pages; they make pleasant enough reading and do no harm, though the packing was designed with a thinner manual in mind and makes for a bit of a tight fit.

To their credit, DK'tronics are at pains to point out the incompatibility of the *sDisc* with CP/M Plus. The only thing that the manual lacks is a mention of the thing's ROM number. It is in fact ROM number 4, so you won't be able to plug it in with the Pace RS232 for example.

VERDICT

If the review has been a bit on the negative side so far, that's because I've left out the most important factor - the price. At just under a hundred pounds the 256K version was, I felt, somewhat overpriced. Cheap non-Amstrad drives make this look even more the case now.

With its sub-thirty pound price tag, the 64K model is a much more attractive proposition. If you can't afford a second drive for your 6128 this new *sDisc* does represent a viable low-cost alternative. It's got a very low capacity and it can't do some of the useful things that a real drive can do - make back-ups, for example - but it is both cheap and fast. ■

64K SILICON DISC

DK'tronics, £29.95

CPC6128, or 464/664 with 64K add-on RAM

GOOD NEWS

- ▶ A lot cheaper than a second disk drive.
- ▶ Quite a bit quicker than a conventional drive, especially for CP/M applications.
- ▶ Makes a reliable connection without you having to open Arnold up.
- ▶ Pretty good value for money.

BAD NEWS

- ▶ Doesn't work under CP/M Plus.
- ▶ Has a low capacity.
- ▶ Volatile - switch off, and you lose anything stored on it.
- ▶ 664 owners will need an extra 64K of RAM, while 464 owners will need that plus a first disc drive.

SERIOUS SOFTWARE TOP TEN

The chart created by AA readers

This month	Last month	% of votes	Title	Software house
1.	1	24.6%	GRAPHIC ADVENTURE CREATOR	Incentive
2.	3	10.8%	MINI OFFICE 2	Database
3.	2	8.6%	AMX MOUSE	AMS
4.	8	6.8%	EASI AMSWORD	Amsoft
5.	10	6.1%	TRANSMAT	Pride Utilities
6.	5	5.7%	LASER BASIC	Ocean
7.	4	5.3%	TASWORD	Tasword
8.	7	5.1%	DISCOVERY	Siren
9.	-	4.3%	THE QUILL	Gilsoft
10.	-	4.1%	MELBOURNE DRAW	Melbourne House

Laser Genius hasn't appeared in the charts yet, but Easi Amword has climbed up four places! How could you!

Graphic Adventure Creator maintains its hold on the top position, and the Quill makes a re-entry at number nine - you must be writing loads of adventures out there!

The other new entry is Melbourne Draw, showing that there is plenty of life left in those older packages.

Remember, these are your charts, so if you want to have a hand in them the voting form is on page 86, along with all the other forms.

REVOLUTION

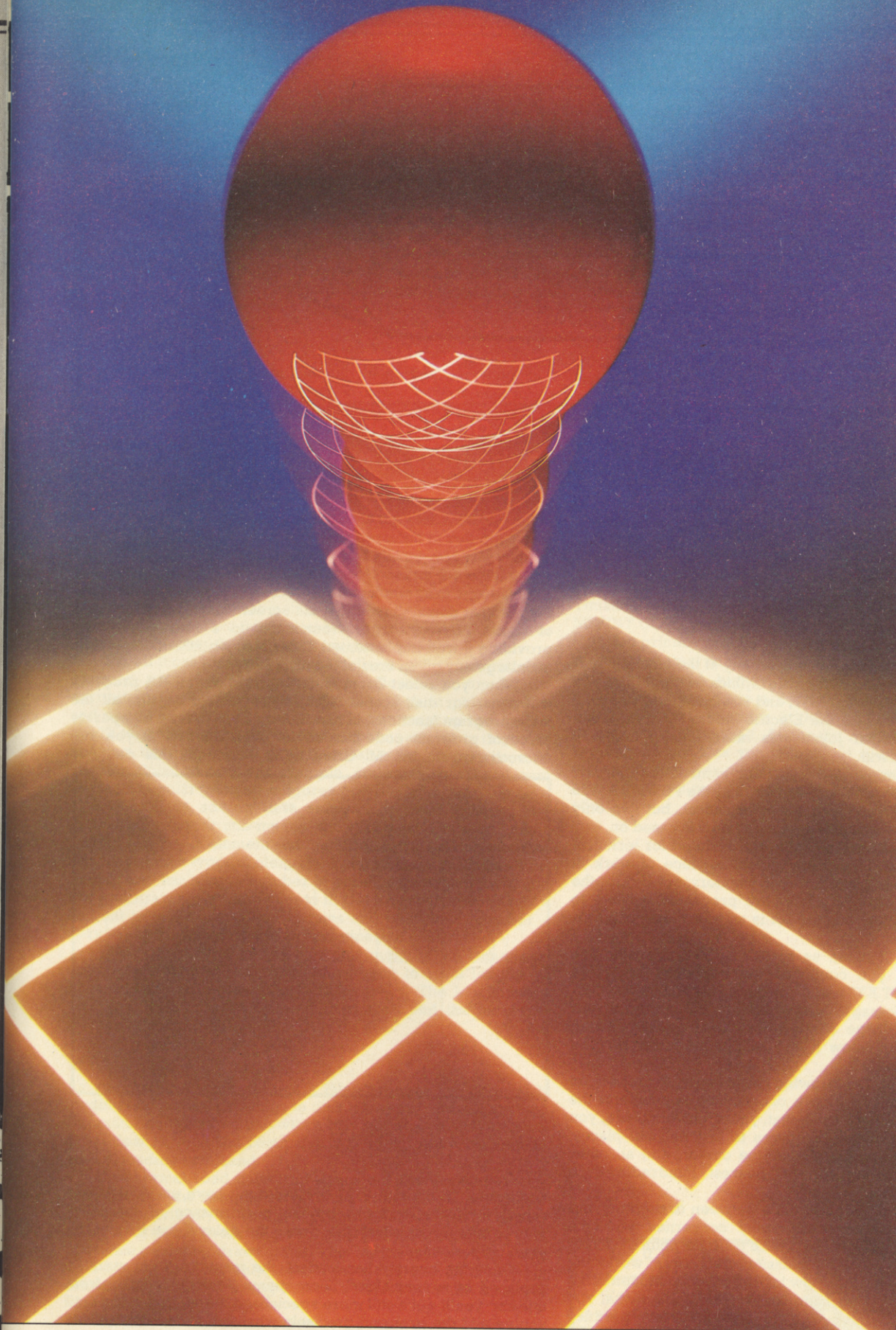

...REACH NEW HEIGHTS IN TENSION!



Manufactured and distributed by
U.S. Gold Limited
Unit 2/3 Holford Way
Holford
Birmingham B6 7AX

AMSTRAD CASSETTE	£9.95
AMSTRAD DISK	£14.95
SPECTRUM CASSETTE	£9.95

Vortex Software Ltd.,
Vortex House
24 Kansas Avenue
off South Langworthy Rd.,
Salford M5 2GL



Drawing to perfection

Andrew Wilton celebrates the arrival of a graphics package which is more than pixel perfect.

MICRODRAFT

Timatic Systems
PCW 8256 /8512, CPC 6128, £79.95 disc

Timatic Systems are an innovative company at the moment, and not just in the field of plug-ins. This graphics package of theirs is something of a first for the PCW, and stretches the machine's capabilities considerably. If the Electric Studio PCW Lightpen didn't convince you that Joyce was more than a text-only computer, *Microdraft* will.

I must make a couple of things clear immediately. Firstly, *Microdraft* is available for the 6128 as well as the PCWs. Timatic tell me that the 6128 version is almost identical, but I've only used the PCW version so that's what the review is based on.

Microdraft is not an art package. It's intended for technical drawing, and as such is a pretty complex piece of work. It doesn't manipulate a chunk of screen memory dot by dot the way an art package does. It's far more precise than that - to *Microdraft*, an individual screen dot is an enormous, cumbersome thing.

You'll see what I mean as soon as you start using the system. To do this you configure the keyboard using the SETKEYS file MDRAFT.KYS and then run the file MDRAFT.COM. After a copyright message, *Microdraft* sets the screen up for drawing. There's a large window for viewing the drawing through, a status line below it and an options menu running down the right-hand side.

In the middle of the drawing window is a cross-hairs cursor, and a readout of its x-y coordinates appears on the status line. Nothing strange about that, you might think, until you realise that the coordinates are given to two decimal places. *Microdraft* measures the position of the cursor, and all other points on your drawing, to the nearest hundredth of a millimetre.

This is the heart of the difference between draughting and art packages. Art packages are only concerned with the appearance of things on screen. There'd be no point in giving an art package the sort of precision *Microdraft* works to, because the screen just can't show hundredths of millimetres.

Microdraft on the other hand isn't worried about what you can or can't show on screen. The aim here is for it to produce the most accurate finished drawing it possibly can. Since the finished drawing might well be produced on a high-precision plotter, that accuracy really is necessary.

ZOOMING IN

That still leaves us with the screen resolution to cope with. Just

because the program needs to work in hundredths of millimetres, that doesn't mean that the screen can display that kind of detail. *Microdraft* gets round this to a large extent by providing a well-implemented Zoom function which allows you to enlarge any given area of the drawing.

When you select Zoom from the main menu, the program will pause for disk access. This is because Zoom, like all the main program functions, is handled by an *overlay* - a separate piece of program code loaded in when needed. If you run *Microdraft* from the M: drive as is intended, this delay is

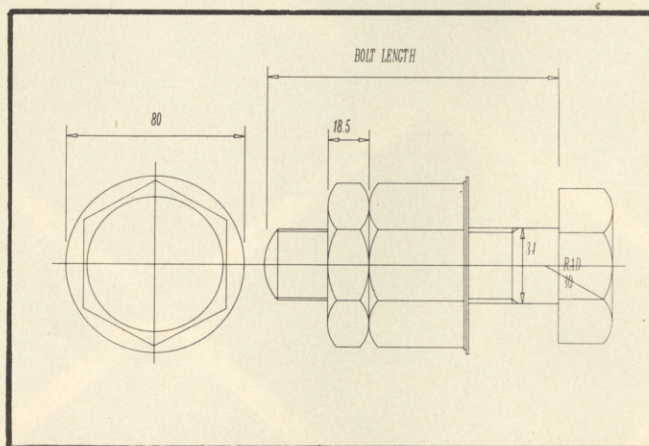

Picture created on an IBM PC using AutoCad, and then transferred to *Microdraft* for further manipulation

negligible. Of course, 6128 owners don't have an M: drive to run it from but, judging by the performance of the PCW *Microdraft* on a physical disk drive, the delay there isn't going to be too serious.

Once the overlay has loaded, the main program menu is replaced by a specialised Zoom menu. Select a function from this and you'll get a still more specialised menu, and so on until you've told the program precisely what you want it to do. This 'menu-tree' system is used for all the program functions.

Selecting 'In' from the Zoom menu allows you to enlarge an area of the drawing centred on the cursor. This enlargement is nothing like an art package's zoom-in: it doesn't simply blow up the dots that the original screen picture was made of, nor does it increase the thickness of the lines in the enlarged area. Instead

it shows the contents of the area in greater detail. Where two points are separated by 0.1mm they will probably appear to be in the same place on the normal size picture. As you zoom in, however, they become separate points. Minute differences at normal size can become enormous when you use zoom to look at them close up.

You can carry on zooming in until the screen resolution is the same as *Microdraft's* level of accuracy – until you can see all the detail there is to be seen, in other words. You can switch back to normal size, pan the zoom window across the drawing or enter a precise ratio you want to magnify by, all from the Zoom menu.

ELEMENTS

Of course there's no point zooming in on your drawing until there's something there for you to see. To start creating a drawing, you'll need to select the 'Elements' option from the main menu.

After the usual overlay load, you're presented with a menu covering all the kinds of thing you might want to add to your drawing: you can choose from straight lines, circles, arcs, markers and dimensions.

For most of these the procedure is the same. Once you've selected the type of element you're interested in you get a sub-menu. From this you select 'New' to indicate that you want to add a new element. Now you'll have to define the element by selecting points. If you're adding a line, for instance, you'll have to give the start and finish points. If you're defining an arc you'll also need to specify a third point that the arc passes through, or alternatively enter the radius of curvature.

For all those elements that are defined with points there's a common point-selection menu. This allows you to use the current cursor position, enter cartesian (x-y) or polar (radius and angle) co-ordinates, use the end of an existing line and so on. Though the cursor and cartesian options are likely to get the heaviest use, the others are all valuable for one purpose or another. Polar co-ords, for example, are invaluable if you want to create regular geometric figures.

As well as adding new elements to your drawing the individual element sub-menus allow you to 'Get' – in other words, select – an element and then 'Delete' it. You can also Get and Move some types of element. When it comes to the line sub-menu, 'Get' has a large number of possible uses. You can Get a line and draw a perpendicular to it, Get a circle and construct a tangent to it, or even Get two lines and fillet them together – very useful for rounding off corners nice and neatly.

The odd one out on the elements menu is the Dimension option. This marvellous option allows you to label lengths of lines in mm, or angles of arcs in degrees. The labels come complete with little arrow-head lines/arcs, and the measurements are worked out automatically for you.

FILES, BLOCKS AND MACROS

As you would expect, there's a Files sub-menu to cope with loading and saving drawings to disk. However, there's another command on the sub-menu which may not immediately mean a great deal to you. The command is 'Macro', and it's a special kind of loading command.

The normal Load command wipes out any drawing previously held in the computer's memory and replaces it with the drawing previously stored in a given file. The Macro command loads a drawing from a given file, but without wiping the previously existing drawing out. This means that you can build up a library of commonly-used objects and add them to your drawings at will. A drawing in such a library is called a macro, hence the command's name.

On its own this would certainly be very useful. Architects could add tree symbols to plans, electronic engineers could add logical gates or standard components, indeed most potential *Microdraft* users could find sub-drawings they could profitably store for later use with Macro. There is, however, rather more to the command than this.

When you save to disk, *Microdraft* records the size of the

drawing – the scale, in effect. This information is used by Load to make sure that your drawing stays the size you originally drew it. Macro ignores this information: whatever level of zoom you're using, a given macro will always appear the same size on screen. Use Macro on a high magnification, and you'll reduce the size of the macro loaded in.

You can apply a more powerful scaling action – plus rotation and reflection if you want – to groups of elements already part of the current drawing. To do this you have to define them as a block. This involves stretching a 'rubber box' cursor around the elements concerned. You can then delete them en masse, manipulate them as mentioned above, move them together or produce a duplicate block. Obliging, *Microdraft* treats all the elements in a macro as being a block, and whisks you straight from the Macro command to the block manipulation sub-menu rather than returning you to the main menu.

One feature the package doesn't have as yet is the ability to exchange files with other draughting and CAD (Computer Aided Design) packages – but this is coming soon. For an expected price tag of £24.95 there'll be an additional utility which will allow *Microdraft* to read DXF files. If you use a CAD system that can store drawings in DXF format – and most of the main systems can – then you can load and manipulate those files on *Microdraft*.

HARD COPY

Timatic provide two different utilities for producing hard copy. MPRINT.COM will print your drawing out on the PC's bundled printer, and the results it produces should be adequate for most informal purposes.

If you need higher precision or presentation quality, MPLOT.COM can drive a Hewlett Packard-compatible plotter. You'll need a Centronics or RS232 interface for this and, of course, the plotter itself. As for the results this produces, they are only as good as your plotter of course – but usually that means they're very good indeed. They're almost certainly better than you could produce by hand, and they take a lot less effort.

VERDICT

Microdraft is a very complex and powerful piece of software. Its flaws are relatively minor. The 'user-interface' – the way in which you make *Microdraft* do what you want it to – seems cumbersome at first. This is not really surprising, given the enormous range of options you have to choose between. What is surprising is how rapidly using the package becomes second nature. Timatic have worked hard to keep the user-interface consistent throughout the program so that different features are controlled in similar ways – and the effort pays off.

If there is a problem it's with the program's error trapping. Trying to save to an unformatted disk or an empty drive gets you the usual 'Retry, Ignore or Cancel' message, but cancelling here will exit from *Microdraft* and lose your current drawing. Moral: always correct the problem and retry.

Overall though, the package does extremely impressive things with the Joyce. Up till now this kind of drawing power has cost more than an 8256 just for the software, let alone the machine you'd need to run it on. It's got just about all the drawing features you could ask for, and a thorough manual to document them.

GOOD NEWS

- ▶ Very powerful indeed.
- ▶ Works to a very high level of accuracy.
- ▶ Can drive a plotter, or just use the bundled printer.
- ▶ Clear, helpful manual.
- ▶ Utility available soon to read .DXF files from other packages.

BAD NEWS

- ▶ Could be better error-trapped.
- ▶ Exiting from an option can be difficult.
- ▶ Needs a plotter to really do its stuff.

WORLD DOMINATION BY FRIDAY

...for only £79.95

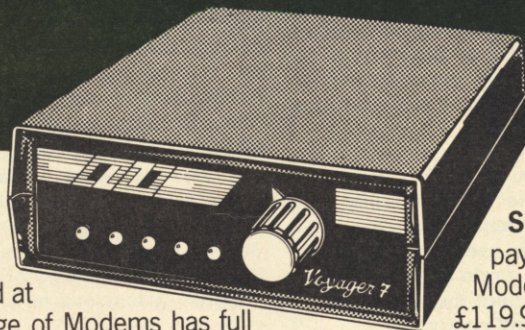

...or Tuesday...or Thursday...
the sooner you send off the
coupon, the sooner you'll have
the entire knowledge of the world at

your fingertips. The Voyager range of Modems has full
BAPT approval and is fully compatible with just about any
micro throughout the world. And you could pay twice the
price for a modem and still not get these features:

- Multi Speed – including 300/300, 1200/75, 75/1200
full duplex, and 1200/1200 half duplex
- Full Function
LED Display
- More software support than any other
Modem – and the best.

The Voyager CPC range of Software gives you:

- Auto Dial/Auto Answer
- Full Colour Prestel/
Viewdata Emulation
- Full Prestel/Viewdata Graphics
Emulation
- Full Telesoftware support
- Full Upload/
Download and/or Spooling to Cassette, Disk, Memory
and/or Printer
- X-Modem File Transfer
- Bulletin
board Software available soon
- The total software on
ROM package for just £39.95 (ex-VAT)
- PCW
Software available – the most powerful and best-selling
pack – £75.00 (ex-VAT).

With Voyager 7 you can link Prestel, Micronet, Viewfax,
Amsnet, BT Gold, Microlink – and most other data
bases – and for 98% of the country it'll cost you only
around 40p per hour (cheap rate) to run (Assuming

Prestel local call access).

Special Introductory offer: We'll
pay your VAT. A complete CPC pack –
Modem and Software – for just
£119.90. PCW Pack (Voyager II and Serial
Interface) £119.95.

Fill in the coupon then stand by to access mainframes
and micros – worldwide.

MODEMHOUSE

THE SINGLE SOURCE SOLUTION

Modem House,
70 Longbrook Street, Exeter,
Devon EX4 6AP

As Stocked by *Boots*



Please send me:

(Tick which required)

1. Voyager 7 Modem £91.94 (inc VAT)
2. Complete Amstrad CPC pack inc. Software & Modem £119.90
3. Complete PCW Pack (Voyager II Software & Serial Interface) £199.95

I enclose cheque/PO payable to 'Modem House' for _____

OR Access No: _____

NAME _____

ADDRESS _____

Post to: Modem House, 70 Longbrook Street, Exeter,
Devon EX4 6AP Tel: (0392) 213355

AA/9/86

ALTERED IMAGES

Andy Wilton looks at an ambitious art package

You may have thought that the Arnold market was awash with art packages, but CRL clearly don't. They've just brought out a new one called *The Image System*, and the price tag on it suggests they're going for the top end of the market.

Its major selling point is its ability to distort pictures - to zoom, move, copy, scale, rotate and even twist or fold (them) in 3D space' as the inlay so eloquently puts it. While these features certainly are available, they do have some serious drawbacks. Indeed, the package as a whole has its problems right from the start.

DRAWING

The whole screen area is available for drawing, but in normal use an area of it is covered by a status/command window showing the position of the cursor in x-y coordinates, and the current palette set-up. There are always 16 colours on the latter, because the system only works in Mode 0.

Using the cursor keys you can move the drawing cursor around the screen one pixel at a time. Holding the <shift> key down accelerates things somewhat. Holding down the <caps lock> key while moving the cursor lets you draw freehand. Pressing 'L' puts you into rubber-band mode: you pin one end of a line using <copy>, stretch the other end to your chosen position using the cursor keys, and then use <copy> again to fix the whole line.

The only other drawing method is the circle/ellipse function, called up by the 'C' key. Instead of the traditional centre-radius method, you use the cursor to fix the two opposite corners of a box. The program then draws a circle or ellipse to exactly fit inside the box, either in outline if you press <copy> or solid colour if you press <shift> and <copy>. The problem with this method is that it only gives you a true circle if you get the defining box perfectly square - no easy matter, that.

FILLING IN

Once you've created an enclosed area using one of these three drawing methods you can fill it with a solid wash of colour. To do this you just move the cursor inside the chosen area, hold down <shift> and press <copy>. The fill is fast and thorough, though it does occasionally make mistakes. Given that it is thorough, and will leak out at the slightest opportunity, it should be used with care - there is no way to undo it afterwards.

Rather than filling with a solid colour you can define a texture of your own if you prefer. This resembles the texture fill of *Melbourne Draw*, but is much less flexible. It only works on a fixed size (16x32 pixels) of texture which you have to put together in the top-left corner of the screen. That's an awfully large area to work on if you're trying to create a fine pattern. To make matters worse you can't fill an area of colour with a texture if you've used that colour in the texture itself.

So far we've seen nothing amazing - certainly nothing that other packages couldn't do better. Unfortunately this is all that *The Image System* can do in the way of creating pictures. All its other features are dedicated to manipulating pictures that you've already created.

SPECIAL EFFECTS

The different things you can do with your pictures all revolve around saving your pictures in memory. Having pressed 'S' for

save, you use the cursor keys to define a box around some section of your picture. *The Image system* then squirrels that picture section away in Arnold's memory, compressing it so that it takes up as little space as possible. The compression is a slow process, and not terribly efficient either - but it's a lot better than nothing.

You can store lots of pictures in this way. There's a gauge in the status window to show you how much picture-memory you've got left, and you get a warning message if you try and store too much.

Using the view command you can add stored pictures to the screen. When you call up the command by pressing the 'V' key an outline box appears on screen, showing you where the edges of the picture will come when it reappears. You can move this box around with the cursor keys so that you can control the final position of the picture.

You can alter the colours that the stored picture will sport, or set them to 'transparent'. In this way you can 'trim' the background from some picture element if you want to.

While you could do all of this with *Melbourne Draw*, there are other effects you can get with the view command which are unique to *The Image System*. When that outline box appears to show you where the stored picture will go onscreen, you can do a lot more than just move it. You can also rotate, stretch and generally distort it.

Whatever shape you twist the 'view' box into *The Image System* will force the stored picture into it. This is extremely ambitious stuff for an Arnold program, but I'm afraid it isn't really very successful. The distortion process is not only slow but also pretty inaccurate - the finished picture usually looks quite badly mauled, and tends to be full of little one-pixel holes.

VERDICT

There are quite a few other features of the package that I just don't have the time to cover in detail. Notable among these are a very nice zoom window, a printer dump routine and the ability to use the various program routines as RSXs from Basic.

I don't think these are really relevant however, because to my mind, *The Image System* is fatally flawed. The whole emphasis of the program is on manipulating pictures that you've created. Unfortunately it lacks most of the features necessary to create these pictures in the first place. The package really cries out for a paint or airbrush function.

To make matters worse, those precious manipulation functions are none too satisfactory either. They are really too ambitious for Arnold, and certainly much too ambitious for Mode 0 resolution. You can see it as heroic failure or plain gimmickry, but I don't think it's worth the money - or the effort it would take to get the results. ■

GOOD NEWS

- ▶ Some unusual, ambitious features.
- ▶ Can use program routines from BASIC.
- ▶ Compresses stored pictures to save memory.

BAD NEWS

- ▶ Lacks important drawing functions.
- ▶ Picture rotation and distortion don't work very well.
- ▶ Only works in Mode 0.
- ▶ Pretty expensive.
- ▶ No joystick option.

PROGRAMMING

Let's face it, BASIC isn't the most powerful computer language in the world. It might be friendly and docile, but it's very slow. If you're looking for a second language which is both useful and easy to learn, you could do a lot worse than PASCAL.

The difference between BASIC and PASCAL goes a lot deeper than the commands used. They are different kinds of languages: BASIC is an *interpreted* language whereas PASCAL is *compiled*. To understand the difference we need to take a look at how your computer understands program commands.

All the computing that goes on in either Arnold or Joyce is done by a chip called the Z80. This is the 'brains' of your machine. When you want to program your machine - to tell it what to do, in other words - you have to speak to the Z80. Unfortunately the Z80 only understands a language called *machine code*, and machine code is very difficult to learn. Machine code commands are just numbers, and it takes an awful lot of them to do anything impressive.

The alternative most people choose is to use a *high-level language* like BASIC or PASCAL. High-level language commands are much easier to understand than their machine-code equivalents, and tend to be based on English words or mathematical symbols. That's fine as far as we're concerned, but now our programs don't make any sense to the Z80 - because it can only cope with machine code commands.

This is where the high-level language earns its keep. It translates the high-level commands (which made sense to you) into machine code commands (which make sense to the Z80). If this sounds like a pretty good way of keeping everybody happy, you'll see why high-level languages have caught on in such a big way.

COMPILERS AND INTERPRETERS

That's not quite all there is to it, though. This translation business can be done in one of two ways. Some languages are translated as they go along: the computer translates an instruction, performs it, then translates the next instruction and so on. This is called *interpreting*, and the section of the language that does the translation is called the *interpreter*. As I said earlier on BASIC is interpreted. This makes it a very friendly language, but it also makes it very slow.

The alternative system works like this: you translate the entire high-level program in one go, so that you end up with a pure machine code program. This process is called *compiling*, and the machine code program produced by it is called the *compiled code*. Because the compiled program is in machine code the Z80 can understand it without the need for an interpreter. PASCAL is a compiled language, and this makes it (potentially) very powerful and very fast.

USING PASCAL

If you're programming in PASCAL, the first thing you're going to want to create is your *source code*. That's the proper name for the actual text of your program - the PASCAL commands. For this you need an *editor*, and I'm not talking about the magazine variety here.

Since BASIC generally comes with a built-in editor, it tends to get taken for granted. It's the thing that lets you type in, list and delete lines of your program. With PASCAL you normally use a separate text-editor. It doesn't have to be a purpose-written source code editor - if you have WordStar or NewWord, for example, either of them would be fine if you use 'non-document mode'.

Once you've written your file using the editor and saved it

OXFORD PASCAL

Systems Software (Oxford) Ltd
CP/M PLUS (6128 and PCWs), £24.95

This is the cheapest of the packages covered here and also the most beginner-orientated; two facts that may not be unrelated. It comes in two different forms, a standard disk-resident compiler PAS.COM and a memory-resident compiler/editor/trace utility PASCAL.COM. The first of these works in pretty much the usual way - you type in PAS PROGRAM and it compiles the file PROGRAM.PAS into the P-code file PROGRAM.OBJ. You can run this as is with the interpreter RUN.COM, or turn it into a stand-alone program with LOCATE.COM. So much for PAS.COM, at least for the moment. PASCAL.COM is rather more unusual.

It's a major point in favour of most BASIC systems that the editor and interpreter are *memory-resident* - that is, you load them into memory at the start of a session and they're both on call there until you've finished programming. (I'm talking here about CP/M BASICs like Mallard and MBASIC - Locomotive BASIC doesn't even need to be loaded in.) If you write a BASIC program you can run it, find an error, edit it till it's correct and run it again, all within BASIC.COM.

In contrast, with most PASCAL systems you'd have to write your program with the editor, exit to CP/M, run the compiler and find the errors, exit to CP/M, enter the editor again and so on until you get it right. For beginners this is arduous to say the least - especially if you don't really know what the compiler's having problems with. What *Oxford Pascal* offers you in the form of PASCAL.COM is the BASIC-like ability to switch between editing, compiling and actually running your program.

It must be pointed out that the system has its drawbacks. The compiler is a cut-down version of PAS.COM, and still needs to access the disk for its error message file. It actually falls through into the system if you've not got that on the disk, but there is a handy utility called RECOVER.COM which lets you salvage any source code in memory.

More seriously, the PASCAL.COM editor is very unfriendly and quite poorly thought out. To edit a line you need to refer to it by number. But unlike BASIC, lines in PASCAL programs aren't given numbers by the programmer: they're automatically numbered as lines 1,2,3 and so on. When you list your source code by the clumsy '1,\$p' command the line numbers aren't shown. You just have to count down till you reach the line you're interested in. This unfriendliness is a real shame. The editor has some quite powerful features, but it's such a hard

GOOD NEWS

- ▶ Very nice price.
- ▶ Optional resident system.
- ▶ P-code system makes for short programs.
- ▶ Manual caters well for beginners.

BAD NEWS

- ▶ Rotten built-in editor.
- ▶ Aggravating colour protection scheme.
- ▶ Needs an extra locating stage to get stand-alone programs.

slog getting to them I'd sooner use WordStar and forget about the memory-resident system altogether.

Turning to PAS.COM reveals other problems. The system as a whole uses a system of colour protection to avoid piracy. If you're using PASCAL.COM you only have to go through this rigmarole once in each session, but PAS.COM insists on checking your credentials every time.

It works like this: you're given a 40x26 grid with numbers up the side and letters along the bottom. In each cell of the grid

MINING POWER

is a coloured dot. Every time you run the compiler, it asks you for the colours of the dots in each of four cells of the grid. Get one wrong and it unceremoniously dumps you back into the operating system.

The theory is that you can't reproduce the grid on a photocopier, so a pirate copy is unusable. In practice honest users get extremely annoyed at having to waste their time like this, get locked out of the system when they lose their grid or

are stranded from the word go thanks to colour-blindness; while pirates get out their felt pens or trot off to the nearest copyshop that has a colour photocopier.

This really puts me right off using the package in a serious way - I mean, it's just too much effort to go through all that every time you want to compile something. And some enterprising hacker is bound to work out a poke to get round it...

```

1
2 program bounce (input, output);
3 const thecowscomehome = false;
4     DELAY = 30;

```

PASCAL 80

Hisoft, CP/M 2.2 & Plus (All CPCs and PCWs) price £39.95

Hisoft's *Pascal 80* has long been the standard package to recommend. It's solid, dependable and very short on gimmickry. It also costs £15 more than *Oxford Pascal*.

For your £40 you get the standard Hisoft editor ED80.COM and a disk-resident compiler HP80.COM. You also get a fair few other files, but we can take a look at these later on.

As usual, the first thing you'll be doing is writing your source code. You could use your favourite CP/M word processor/text editor for this, but ED80 will meet most people's needs handsomely. ED80's a full screen editor, and it uses almost the full set of WordStar control key combinations. This does strike me as a little strange - after all, if you know WordStar the chances are you've already got a copy of it, and won't need ED80. That said, ED80 only takes up 12K of disk and so is a lot more convenient on single-drive systems.

In use ED80 is straightforward and, for a CP/M editor, quite fast. It doesn't behave exactly like WordStar, but that's not going to bother too many people. It can be configured for the larger 8256/8512 screen without too much difficulty, and its size makes it a natural for the M: drive.

As for HP80, it's just a good practical compiler. You call it up from disk in the usual way, so that typing HP80 PROGRAM will compile the file PROGRAM.PAS into PROGRAM.COM. It's pretty fast, and quite fussy. A missed semi-colon, for example, will produce an avalanche of errors on the next line.

Pascal 80 would be the grand old man of Amstrad PASCALS if it wasn't for the way Hisoft keep adding to it. Since it was first launched it's gained not only random access filing but also a fascinating library of GSX graphics routines. Both of these come as PASCAL source code and are thoroughly documented. You can use them as procedures within your own programs, or read through them to study the techniques used - the latter being well worth the effort.

The smart ring-bound manual also contains support material for these files, plus a great deal of information on the *Pascal 80* implementation. It doesn't cover PASCAL for beginners, as the authors are at pains to point out. You may be able to pick up what you need to know from the manual and some experimentation, but you're probably going to need a book of some sort to help you over the more difficult points. To this end, the manual's bibliography lists a few suitable introductory books.

This is all starting to add to the price of the system as far as beginners are concerned, but it does mean that the manual can give more experienced users the information they need. That's very important, and not just for hardened PASCAL fanatics. If you buy a package you're going to learn with, you don't want one you're going to outgrow too soon; nor do you want one that restricts you.

It may not be aimed at beginners, but I'd still recommend *Pascal 80* to anyone starting out. Beginners need the best and, for the price, I'd say that's *Pascal 80*.

GOOD NEWS

- ▶ Nice editor and good solid compiler.
- ▶ Thorough manual.
- ▶ Nice, well documented GSX routines.
- ▶ Compiles to true Z80 code.
- ▶ Runs under both CP/M systems.
- ▶ Takes up very little disk space.

BAD NEWS

- ▶ Not too cheap.
- ▶ Manual doesn't cater for beginners.

to disk as, say, PROGRAM.PAS, you'll then want to compile it. To do this you have to run the compiler. If the compiler was called, say, COMPILE.COM then you type something like COMPILE PROGRAM at the A> prompt. Assuming you haven't made any mistakes the compiler then produces a new file called PROGRAM.COM. This is the compiled version of your program, and behaves just like any other .COM file. That is, you can run it simply by typing PROGRAM at the A> prompt.

The chances are that things won't go anywhere near so smoothly at first. PASCAL is very fussy, particularly about punctuation. If you make a mistake, it'll probably be spotted during compilation. The compiler will report the kind of mistake you've made, but it's not always very precise. Often you'll get several different error messages all set off by one mistake. There's also a tendency for the messages to crop up some way after the actual error, which only adds to the general confusion.

P-CODE

Some implementations of PASCAL don't work in quite the way that's described above. Instead of converting your commands into Z80 machine code, they translate it into a special language called P-code. Then an interpreter translates this P-code once the program is running. There are theoretical advantages to

this. In particular, the same program is usually much smaller in P-code than it would have been in machine code.

There are also several drawbacks to P-code compilation. A major problem is that P-code programs need the interpreter to be present when they run. If you want to turn a P-code program into a *stand-alone* program – something that can run without an interpreter – you'll need to put it through an extra processing stage. Turning a P-code program into a stand-alone .COM file usually makes it a great deal bigger. It could easily end up being larger than the file a normal compiler would have produced.

JENSEN & WIRTH

PASCAL is a highly standardised language – much more so than BASIC. A program written for one version of PASCAL should, in theory, need very little modification to compile on another.

For the purposes of standardisation, PASCAL implementors refer to a specification drawn up by *Jensen* and *Wirth* back in 1975. PASCAL packages usually boast about how accurately they conform to the appropriate standard, but it doesn't actually mean that much these days. For what it's worth, neither of these packages could compile the other's demonstration files without considerable modification. ■

A flexible friend

INSTANT ACCESS

Minerva Systems
All CPCs with disk drives, £29.95

Programmer Wilton explains how Minerva's utility can help you remember things faster

If you've got a disk-equipped CPC and you program in Locomotive Basic, you've got a lot of features available to you in the way of graphics and sound commands that PCW owners and their Mallard Basic don't have. Mallard does have one feature, though, that Locomotive can't match – and that's random access file-handling.

THE PROBLEM

When you want to read files in Locomotive Basic, you can only get at your information *sequentially* – in the order you stored it in the first place, that is. If you've stored 100 phone numbers and want to get at the 50th one, you have to open the file and read in and discard 49 phone numbers to get the one you're after. If you now want to read the 38th number you have to close the file, reopen it and start the read/discard process again.

This is very inefficient, so most people end up just reading the whole file into an array and working on it there. That's fine, so long as you can fit your program and your data into memory in one go. Otherwise, you've got problems.

THE SOLUTION

What you need is a way of getting at the precise piece of information you want without having to plough through all the data up to that point. This is called *random access* and as I said earlier, Locomotive Basic can't do it. Till now, the answer has been to work in CP/M – both of the CP/M Pascals reviewed this issue offer random access, or if you prefer Basic you could buy a copy of Mallard. That does mean learning a new language, though, or at least a new implementation of Basic.

Now Minerva Systems have come up with a way of getting random disk access in Locomotive Basic. It's called *Instant Access* and it's a spin off of their successful *Random Access Database*. They've taken the disk-handling routines out of that and packaged them up as RSXs – functions you can call from Basic by using bar-commands.

THE ROUTINES

There are nearly 40 RSXs in the package, a third of them

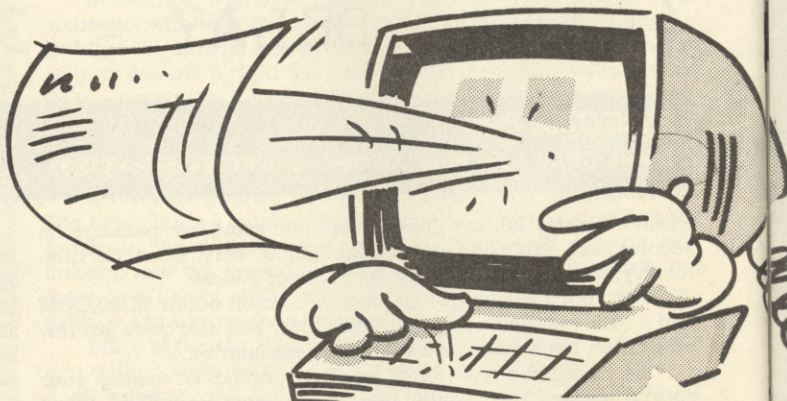

actually dealing with random access. The key ones are |CREATE to set up a new random access file, |OPEN and |CLOSE for existing files, |PRINT to write data and |INPUT to read it.

As with all RSX systems, information is passed to an *Instant Access* routine as a series of parameters after the relevant bar-command. If you wanted to read a piece of information in from a file you'd opened, you'd give a command of the form '|INPUT, tstringname\$, number1%, number2%'. Here 'stringname\$' is a string you've previously defined.

The routine starts reading in characters from the random access file, putting them into stringname\$ until it's full. If you've previously defined stringname\$ as a string of 10 blanks then, after the routine has done its job, the string will instead contain 10 characters read in from the file.

The two numbers in the example tell the routine which part of the file you wanted to read from. If you don't bother to give them, the routine will carry on reading where it left off last time – just like a sequential system. |PRINT works in a similar way and, helpfully, can be freely used alongside |INPUT. You don't have to open a file specifically for input or output, in other words: if you read the data and find it needs updating you can rewrite it without the need to close and reopen the file – another advantage over Locomotive Basic.

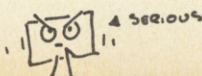

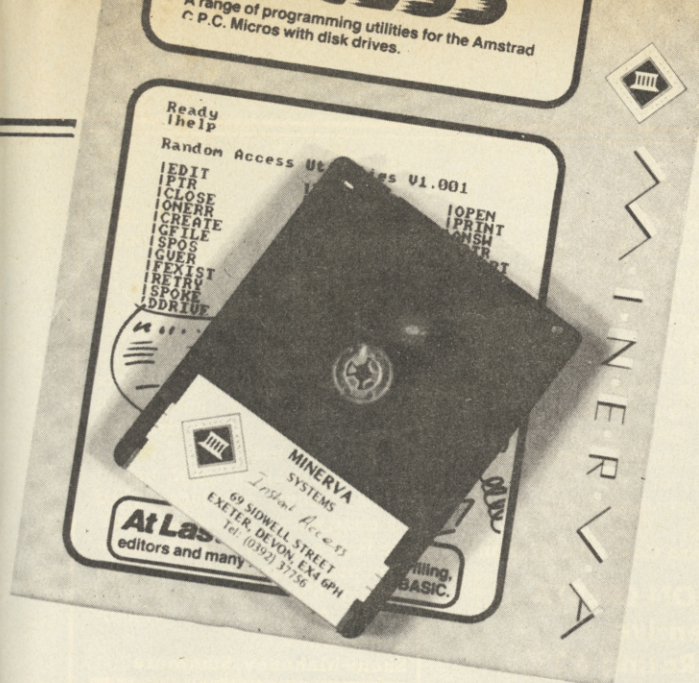

Non random-access RSXs in the package include commands for direct sector editing, inputting data from the keyboard, disk-error handling, and executing the contents of a string as a Basic command. These are all interesting, though some of them need to be used with a little care.

VERDICT

The real advantage of this system is the way it gives you random access file and other advanced disk features within Locomotive Basic. With a reasonable knowledge of Basic and the aid of a helpful, clearly written manual you should find the routines quite easy to use. Setting up all the parameters for the bar-commands can get laborious, especially on the 464, but the effort required to write your own routines would be in a different league altogether.

The real drawback with the system is the amount of space it takes up - somewhere in the region of 10K - but a data-handling program will probably save much more than that by keeping data on disk rather than in memory.

GOOD BOOK

THE DIGITAL RESEARCH CP/M PLUS MANUAL

Heinemann NewTech, price £25
CPC 6128 and PCW machines

Let's get one thing clear before we start: this book is not for beginners. If you shy away from memory maps and assembly language you're unlikely to find it comprehensible, never mind actually useful. Quite simply, it's the only book you'll ever need on the technical side of CP/M Plus - and that means it's very technical indeed.

If you're a bit of a machine code buff and want to start delving in CP/M 2.2, there are plenty of books available from

Sybex and the like. If it's CP/M Plus you're out to gen up on, you've got much less choice. In fact, the only really helpful book up till now has been MML's *The Amstrad CP/M Plus* by Andrew Clarke and David Powys-Lybbe. So how does Digital Research's official effort measure up?

In terms of presentation, the DR manual is a lot slicker. The typesetting is certainly much easier to read and that's a major advantage to my mind. In practical terms it loses out however, as its chunky ring-binding weakens its pages and the thin covers give it inadequate protection for a reference work.

As far as content goes, the Digital Research manual is really quite narrow. It concentrates on the structure of CP/M Plus in its Amstrad implementations, the workings of the DR/Amstrad utilities and the techniques used in writing applications of your own. This is all very theoretical stuff, and needs to be read slowly. MML's guide quite definitely set out (amongst other things) to teach beginners how to do useful things with CP/M Plus. It covered a wide variety of programming and hobbyist topics in a friendly, even chatty way.

In contrast, the DR book is formal and precise. Though it starts from basics, the emphasis is on the technicalities of CP/M Plus on the Amstrad machines rather than on how to do what you want to. Each section starts off with a brief summary of what lies ahead, and terms are carefully defined before they are used. The authors waste no time getting stuck into the nitty-gritty of BDOS entries, RSXs (which they explain extremely well) and the two Amstrad CP/M Plus implementations. For the beginner this is of no use at all, but for the seasoned machine code programmer intent on learning to hack in CP/M Plus it's just about ideal.

It's partially a question of the sort of approach you like, but I found the writing style of the Digital Research book much more straightforward and easy to read than Messrs Clarke and Powys-Lybbe. To be sure, the subject matter is pretty complex stuff. All the more reason, to my mind, to set things out plainly as the DR manual does. There's no chat or waffle to get in the way; just detailed information. That said, you might well find it a little too clinical and prefer the MML manual's style - it's a matter of taste.

GOOD NEWS

- ▶ All the details you need.
- ▶ Clear and concise style.
- ▶ Thorough explanation of techniques.
- ▶ If DR don't know the technical ins and outs, who does?

BAD NEWS

- ▶ £25 is on the pricey side.
- ▶ Definitely not for beginners.

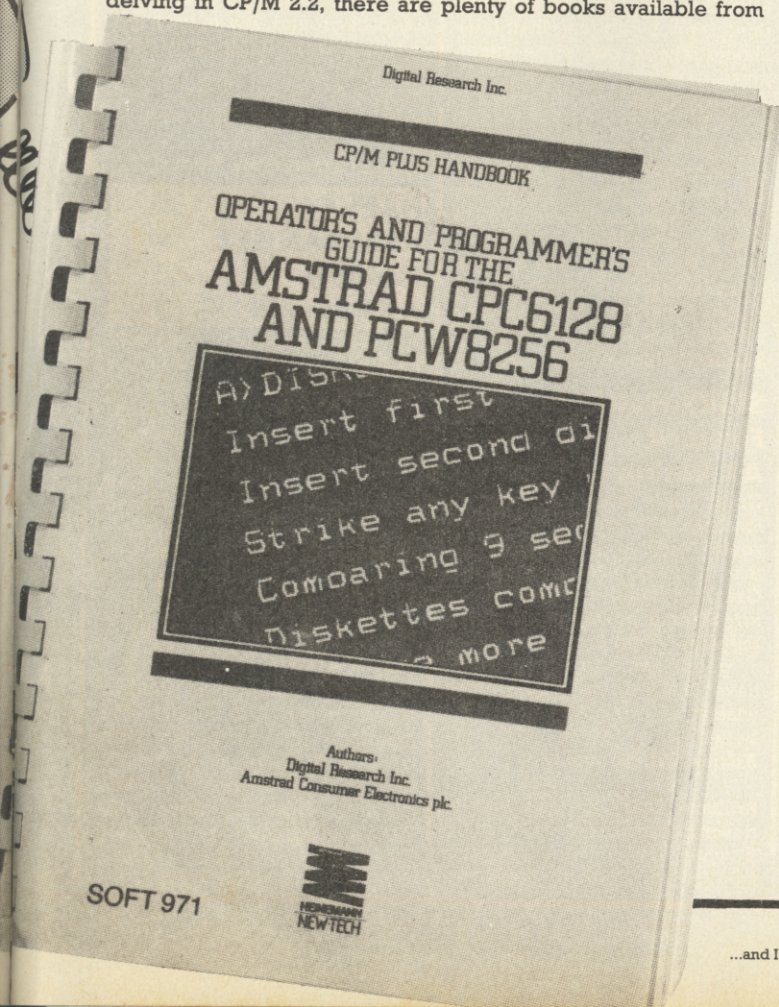

VOICE OF THE PEOPLE



Hope you didn't miss us too much last month, but pressures of space meant something had to go. Anyway the People are back with a vengeance this month, praising and pillorying software houses for their efforts.

Tomahawk and *Kane* both get a definite thumbs up, while *Meltdown* gets a very cool reception from the dynamic duo in *Sidcup*. Shane Mahoney really flipped over *Spiky Harold* for which no praise is too good as far as he's concerned.

If you've just got your hands on a new game and feel a desperate urge to tell someone how good, bad or average it is, then this is the place to do it. Send your comments on the back of a postcard or stuck down envelope to: *Voice of the People, Amstrad Action, The Old Barn, Somerton, Somerset TA11 5AH.*

KANE Mastertronic AA Rating 80%

If you work in a computer shop you see a lot of programs for the Amstrad. Most pass without a lot of notice, but not *Kane*. It's one of the most colourful and graphical games I've seen. Addictive is just not in it - just try to stop playing it.

Alan Segar, Wallasey

A very good game indeed. Colour is used well throughout the game, as is sound. The game is tough when you start out but it soon gets easier. All in all a great game and well worth £1.99.

Craig Munro, Loanhead

The graphics and animation are very good, especially the running character. The game is difficult at first but becomes easier, especially if you use the practice mode. If you like Westerns then you'll love it, although it might not hold some peoples interest for long. On the whole a good game, and worth the £1.99 asking price.

Clive Hopkins, Eastleigh

I must admit I was quite impressed with this game. Although it has only four screens it is fairly good fun to

play and quite challenging. The graphics are very nice and the sound effects are great. The only problem is that it is very easy. I completed it on my second go. Still for a couple of quid it is definitely worth getting.

Richard Connelly, Crofton

TOMAHAWK Digital Integration AA Rating 92%

One of, if not the, greatest flight simulators on the Amstrad. Yet it is not difficult to fly. The vector graphics are excellent, but best of all are the variety of options available to you, such as night flying and cloud base. If you are in the slightest bit interested in simulations, this is a must.

Daniel Castle, Marlborough

Digital Integration have come up with the perfect flight/combat simulation with this program. Control of the chopper is realistic and there are plenty of battle opportunities for the more bloodthirsty. Best of all though is the infra-red night time scenario.

Gerry Hughes, Cranleigh

This is definitely the best flight simulation around at the moment. It's the best combination of simulation and shoot-em-up. Unlike most others it is fairly

easy to fly the helicopter, so you won't spend most of the time on the ground, unable to take off. But to fly it properly it will a long time to master.

Once you're up in the air there's plenty to shoot at, including tanks and helicopters. There are loads of options to make the game as easy or as difficult as you want. You can fly by day or night, in cloud or in clear weather. Definitely worth buying.

Richard Connelly, Crofton

MOON CRESTA Incentive

AA Rating 62%

This is a completely unoriginal, mindless shoot-em-up - and I love it! All the addictiveness of the arcade original has been captured in this version. You need a quick trigger-finger and lightning reflexes to survive. A great piece of nostalgia for ageing arcade addicts like myself.

Gerry Hughes, Cranleigh

MELTDOWN

Alligata

AA Rating 67%

PSS need not worry that this game will take *Get Dexter's* role - it's naff. The graphics are pathetic, as is the animation. Also the screen update is, well, s-l-o-w. The music by WE MUSIC is about the only decent thing and I suggest that they should check out some other companies who need them.

Emmet Masterson, Sidcup

This must be one of the most hyped games for ages, it is just so *£!*. The graphics are useless, the sub-games are, well if you can call them games, terrible. Playability too is terrible with everything going at a snail's pace. The only redeeming feature is the music.

Simon O'Connell, Sidcup

SPIKY HAROLD Firebird

AA Rating 66%

Great music while the game is loading. The sprites all follow routes so that it's experience that will complete the game. Graphics could have been better. Staying power lets it down but some good features make it a good game. Colour could have been used much more wisely to make it so much better.

Adrian Sill, Doncaster

Brilliant! That's the only way to describe this game. How could it score only 56% on sonics in your rating. I loved listening to

its version of 'An English Country Garden', and the sound effects are great. There are so many features on screen it's amazing - I found birds, flies, bees, mice, puffs of smoke, drops of water, ghosts, spiky balls, snails, a tortoise, ducks and spiders. The humour of getting drunk after drinking wine is immense.

If you want a tough timing game, pretty graphics, good humour, excellent use of colour, loads of screens and a magnificent price, buy *Firebird's Spiky Harold*. It should have at least got an AA Rave if not Master-game award.

Shane Mahoney, Stanmore

THE FIFTH AXIS

Loriciels

AA Rating 83%

This game really is boring. It has rubbish graphics and sound that really grates after a while. This wouldn't matter if the gameplay was good, but it isn't. All you do is kick neverending numbers of monsters and pick up things, then when you've got about a 1,000,000 you jump spears, boring.

Simon O'Connell, Sidcup

This is another great French game with some really terrific animation. Scrolling is also good, as is the atmospheric catchy tune which plays along in the background. My only gripe is that it lacks a bit in variety which means it can get boring. All in all a great game which none of my mates seemed to like.

Emmet Masterson, Sidcup

HARVEY HEADBANGER Firebird

AA Rating 91%

Brilliant, absolutely brilliant! This game is just so addictive and playable. The graphics are stunning, real cartoon quality. There are plenty of options so you can make the 'game suit your needs. It is just great. The bonus is that it is only £1.99, so you can't go wrong.

Richard Connelly, Crofton

KUNG-FU MASTER US Gold

AA Rating 72%

This game is almost as good as all the ads led us to believe. The graphics and animation are great BUT there is no music (shock amongst arcade players). However this is US Gold's only good game so far and probably their best.

Simon O'Connell, Sidcup

Featuring the world's greatest game reviews

MASTERGAME

3D Starstrike II (Realtime)..... 46

AA RAVES

Jack the Nipper (Gremlin)..... 42
 Ghosts'n'Goblins (Elite)..... 44
 Storm (Mastertronic)..... 44
 Nexus (Nexus)..... 52
 Thrust (Firebird)..... 52

OTHER GAMES TESTED

Mission Elevator (Micropool)..... 50
 Room Ten (CRL)..... 50
 Knight Games (English)..... 54
 Star Firebirds (Firebird)..... 54
 Gladiator (Domark)..... 54
 Soccer 86 (Loricels)..... 55
 Mah Jong (Liffsoft)..... 56
 Doppleganger (Americana)..... 57
 Amstrad Shuffle (Alpha-Omega)..... 57
 Helichopper (Firebird)..... 64
 Night Gunner (Digital Integration)..... 64
 Trashman (New Generation)..... 64

GAMES PREVIEWED

Powerplay (Arcana)..... 58
 The Vera Cruz Affair (Infogrames)..... 59
 The Inheritance (Infogrames)..... 59
 Stainless Steel (Mikro-Gen)..... 63

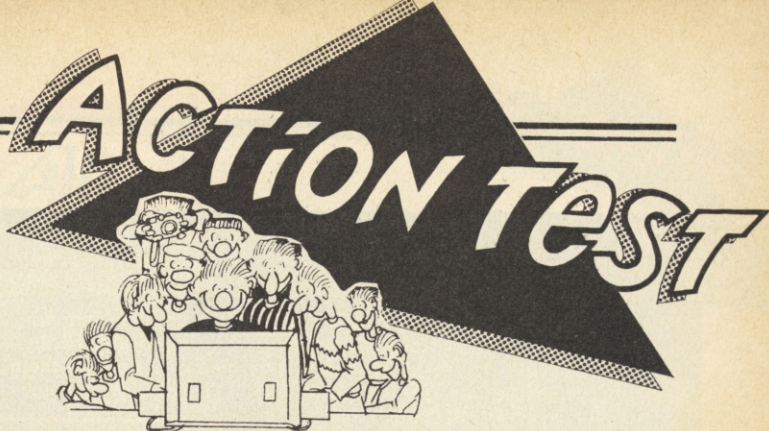

FIREBIRD IN FORCE

Firebird really take the laurels this month with both Mastergame and an AA-Rave that scores an AA-Rating of 94 per cent! Is this a record?

The Mastergame is *3D Starstrike II* and the AA-Rave is *Thrust*. If *Thrust* had come in sooner it might well have made Mastergame - as it was it had to make do with black-and-white, but do check it out on page 52.

The French flavour this month is not supplied by garlic but by our look at the French scene on page 19, and a preview of some colourful forthcoming titles on page 59. As far as we could tell with our limited French they look pretty good.

Don't forget the Special Offers on page 80 either. You can pick up both the Mastergame and *Jack the Nipper* and save yourself up to £6 too!

COMPATIBILITY

All the games reviewed this month are compatible across the whole CPC range. None work on the PCW I'm afraid.

TOP 20 AMSTRAD GAMES

The chart created by AA readers

This month	Last month	% of votes	Title	Software house	
1.	1	10.4%	GET DEXTER	PSS	Top three games <i>Get Dexter</i> , <i>Spin Dizzy</i> and <i>Elite</i> maintain their reign of power, just showing how good these AA Mastergames really are. <i>The Covenant</i> from PSS shoots in to the number six spot, making it a game to watch! <i>Batman</i> looks like a game to watch too - can it hang on to fourth position for long? And what about the battle going on between 10th, 11th and 12th place? Remember, the outcome is up to you - these are your charts, so if you want a hand in them get voting on our voting form on page 86.
2.	2	10.2%	SPIN DIZZY	Electric Dreams	
3.	3	8.7%	ELITE	Firebird	
4.	8	6.1%	BATMAN	Ocean	
5.	5	5.8%	BOMB JACK	Elite	
6.	-	4.6%	THE COVENANT	PSS	
7.	10	4.4%	TAU CETI	CRL	
8.	4	3.2%	SORCERY PLUS	Virgin/Amsoft	
9.	-	3.2%	COMMANDO	Elite	
10.	15	2.8%	HIGHWAY ENCOUNTER	Vortex	
11.	13	2.8%	RAMBO	Ocean	
12.	16	2.7%	GREEN BERET	Imagine	
13.	6	2.5%	WHO DARES WINS 2	Allgata	
14.	20	2.2%	FAIRLIGHT	The Edge	
15.	-	2.1%	MARSPORT	Gargoyle	
16.	-	1.9%	STARION	Melbourne House	
17.	-	1.6%	3D GRAND PRIX	Amsoft	
18.	12	1.5%	SPELLBOUND	Mastertronic	
19.	-	1.4%	SWEEVO'S WORLD	Gargoyle	
20.	9	1.0%	YIE AR KUNG FU	Imagine	



JACK THE NIPPER

Gremlin Graphics, £8.95 cass, £14.95 disc, joystick or keys

Young Jack is every parents worst nightmare - he's not just a naughty little boy, he's positively evil. His main aim in life is to smash anything he can get his hands on, drive adults up the wall, throw a spanner in the cogwheels of industry and generally cause as much trouble as possible. You'll be glad to know that far from having to try to stop Jack...you are Jack. All aboard for second childhoods, kiddie psychopaths and revenge wreaking parents.

All the action takes place in Jack's home town, which he's intent on livening up a bit. To do that he's got to use a number of objects in the right places to cause havoc. The town is made up of several streets containing shops, houses and gardens, nearly all of which contain some potential mischief. Each location is shown in pseudo 3D and is packed with moving characters who really do deserve the phrase 'cartoon graphics'. There may not be much animation but the variety and detail of each character gives them real personality and humour.

All of the characters pose a danger to Jack because whenever he runs into anybody his 'rash rating' goes up until he loses a life due to a very sore bum. Extra hefty scoldings will be handed out if he performs one of his acts of mischief and gets caught by the unfortunate victim. This sort of rough justice will also be meated out if he shoots people with his trusty pea-shooter.

SECOND OPINION

For once here's a game with real cartoon graphics - the characters look like they've stepped straight out of The Beano, and there's a plot to match. It's a totally breakable game, and you just won't be able to resist it. Go on, give 'em hell!

AW

As Jack moves about the town he can enter the doors of shops and buildings to do mischief, or move into another street through the top of some screens. He can't move back through the bottom of a street, but has to carry on through the screens until the street wraps around back to the starting position. This isn't much of an inconvenience since there are only a few streets, but it means that a good knowledge of the street layout is helpful.

The pranks that Jack can perpetrate are fairly straightforward but aren't always easy to complete without getting a bad spanking. Dropping things from a great height so that they smash and shooting things with the pea-shooter are fairly obvious, but using some of the other objects is more fun. Many shops are vulnerable to attack, by overloading the launderette's washing machines with powder, for example, or shorting out all the computers in the 'Just Micro' computer shop. Only two objects can be carried at once, but after they've been used they can be disposed of in the most destructive manner you can think of.

This isn't a particularly tough game on

the adventuring side, but while you're still trying to find all the objects and work out what to do with them it's tremendous fun. The cartoon graphics really are good and

THIRD OPINION

As the proud father of a two-year old, I could really feel for this game. The graphics are excellent and the humour funny for once, but whether it'll keep the dedicated player involved for long is another matter.

MN

add a great deal to the game's impact. You'll fall in love with this little horror straight away and the great beauty is that, unlike the real thing, you can turn him off whenever you like.

BW

FIRST DAY TARGET

50 per cent, or 'Prankster'

GOOD NEWS

- ▶ Very attractive cartoon graphics.
- ▶ Plenty of humour.
- ▶ Most tasks are pleasantly destructive.
- ▶ Enough locations and objects to present a reasonable challenge.
- ▶ Most kids aren't quite this bad.

BAD NEWS

- ▶ Loses interest once you've solved most puzzles.

GREEN SCREEN VIEW

For a game with such great use of colour, this one looks pretty good in green - certainly no visibility problems.

AW

GRAPHICS	86%	
SONICS	69%	
GRAB FACTOR	86%	
STAYING POWER	77%	
A A RATING	81%	

Nipper's naughty hints

Here are a few clues on how to use objects to their most mischievous:

SOAP POWDER: gets Mum into a lather.

FLOWER KILLER: Dad's busy weeding the garden so why not give him a hand.

BATTERY: someone will blow his top when you blow his fuse.

BOMB: 'ello, 'ello, 'ello, now you've blown it.

HORN: not a hot tin roof but just as lively.

FLOPPY DISC: production will grind to a halt when you corrupt somebody's computer.

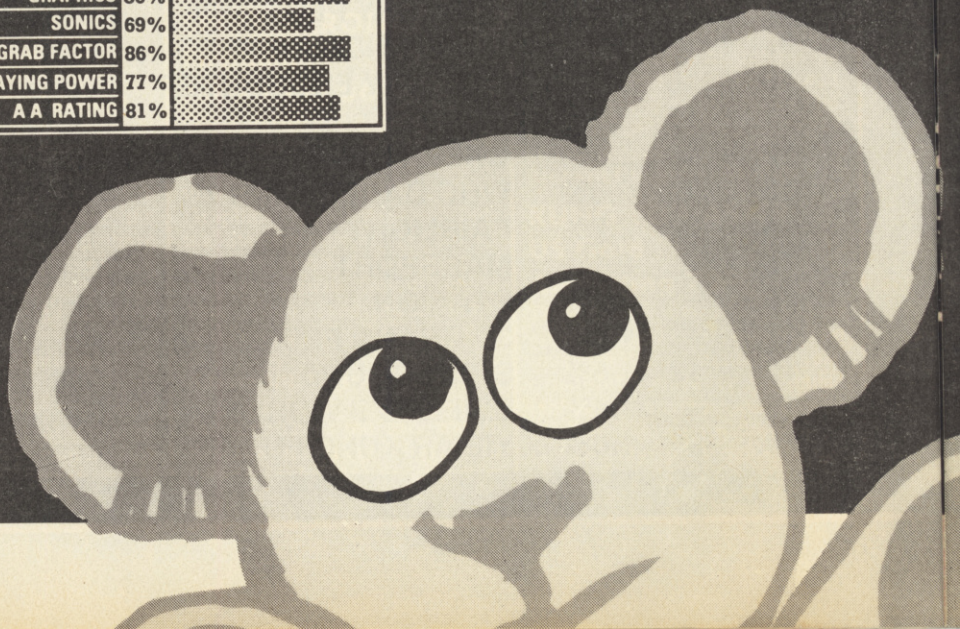
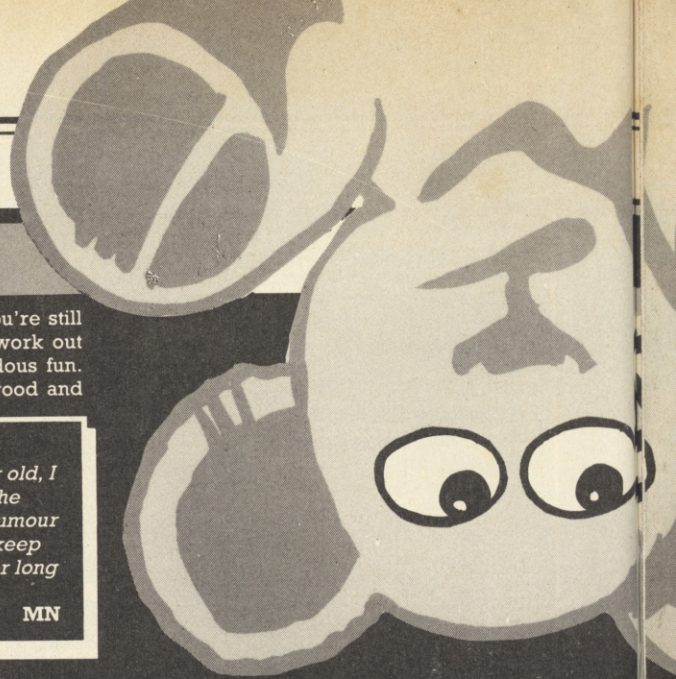



Jack's out and about and up to no good

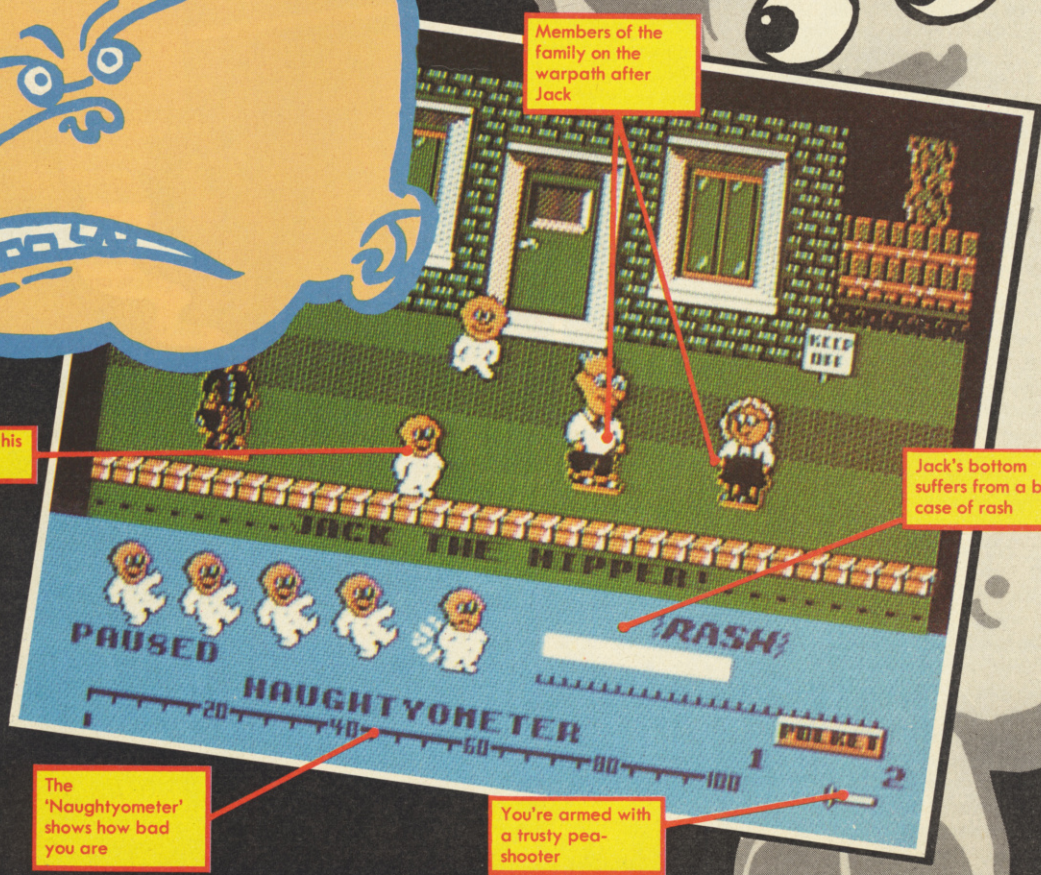

Members of the family on the warpath after Jack

Lovable Jack in his romper suit

Jack's bottom suffers from a bad case of rash

The 'Naughtyometer' shows how bad you are

You're armed with a trusty pea-shooter

STORM

Mastertronic, £1.99 cass, keys only

You just can't seem to match Mastertronic's production of high quality, regular and cheap games at the moment. This one's a version of the arcade game *Gauntlet* and stands out because of the option of a two player game in which the participants have to actively co-operate to get anywhere in the game.

As a one player game this is a fairly straightforward arcade adventure in which

SECOND OPINION

If this was a one-player game, it would be pretty good. Weak graphics and difficult controls would put it some way below Mastertronic's usual high standards, but it would still be good value. It earns its Rave with the two-player option, however – the cooperative gameplay is great stuff, and very unusual.

AW

you rush around lots of locations picking up as many objects as possible and fighting hordes of creatures. However, when you play with two players it becomes a unique exercise in co-operation and dual action that you won't find in any other Amstrad game. So if you've got a friend who you'd like to get closer to then read on.

The game revolves around two characters, Agravain Undead and Storm, who are searching the castle of Una Cum for Storm's wife. In the one player game you control Agravain and have to complete the task on your own, while in the two player game Storm is also thrown into the action.

The castle is composed of rooms connected by doorways, the rooms and everything in them being viewed from above so that you only see the head and shoulders of each character. Storm's wife is in Una Cum's laboratory, and to get inside you'll need to collect three snake brooches hidden in the maze of castle rooms.

As you enter each room a description of it scrolls across the top of the screen which may or may not prove useful. More helpful are messages that appear informing you of events and the status of the characters. Each room usually contains a number of features such as walls or other static objects. Some of these can be picked up, others shot and some examined.

In every room there are generators that produce creatures varying from armed guards to amoeba-like fungi. These can be shot, and when they come into contact with you they drain energy. The generators can also be destroyed, stopping them from producing creatures, but they reappear if you re-enter a room. These are the only other things that move but they are a

serious threat because the generators can spew them out at great speed to create a seething mass of monsters.

Objects that can be picked up include scrolls, amulets, masks and cabbalas. Masks will destroy all the generators in a room, but scrolls and amulets will just destroy all the monsters. Cabbalas will remove or create traps, and you only find out which by trial and error. Other helpful

THIRD OPINION

I am a real sucker for two player games, if only because genuine two player action is so rare, and most games are very anti-social. This one really succeeds because to get anywhere the two players have to co-operate rather than compete for a change.

MN

objects are food and restorative fluid that replenish energy, and armour that protects you against the creatures.

If you are playing the two player game then when one player exits the room the other player has to follow through the same door. This, combined with the difficulty of the game, makes co-operation essential – if players try to compete against each other then disaster is certain.

GHOSTS'N GOBLINS

Elite, £8.95 cass, £14.95 disc, joystick or keys

Yet another of Elite's very popular arcade conversions, which will probably leap to the top of the charts quicker than you can say 'pots of money'. It's very short on instructions, but anyone who's seen it in the arcades or played *Green Beret* will quickly get the idea.

You control a knight, sporting a fiery orange beard, who's trying to do what knights do best – rescue a damsel in distress. To do that you've got to overcome all manner of spooks, ghouls, goblins and things that go AAAAAARGH in the night. You have to get through a number of screens, moving left to right across them. When you near the right hand edge of the screen it scrolls to reveal more of the spooky scenario.

The knight is armed with a limitless supply of swords you throw horizontally to dispatch foes, but you can also take evasive action when necessary by jumping, ducking or climbing. The first problem encountered are zombies, which rise up from gravestones and head towards you with arms outstretched. They zombies have to be hacked down with the swords so that you can leap over the gravestones.

The background soon becomes more detailed with the knight able to climb ladders up to a plateau. On this section there are more zombies, birds that flap up and down, and plants that spit rocks at you. All of these are deadly to the touch but can be killed with swords. If you do lose a life you return to an intermediate starting point, depending on how far you've got. These points are quite a way apart and take some



A zombie staggers towards you

The orange bearded knight has just thrown a sword

Ghostly ghost group

Here's a run down on the first few ghouls you'll face and how they behave:
ZOMBIES: appear out of the ground and walk towards you. Can be laid low with your sword.

KILLER PLANTS: Don't move but spit killer rocks at you. Plants can be killed by a sword but rocks have to be jumped, ducked or otherwise avoided.

KILLER BIRDS: Take off from gravestones and flap up and down. Can be shot with a sword but you may have to jump up to do it.

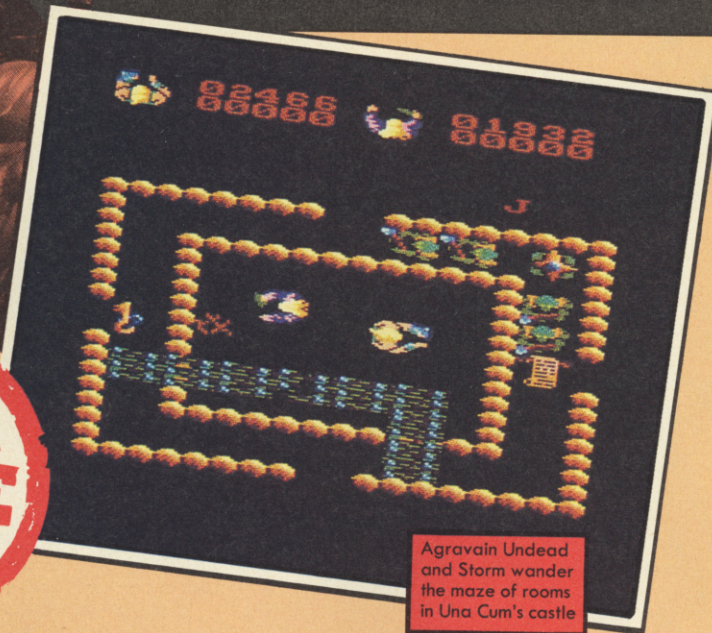

Agravain Undead and Storm wander the maze of rooms in Una Cum's castle

GREEN SCREEN VIEW
It didn't look too good in colour, but this game's just ugly in green. Still plays fine though.
 AW

G O O D N E W S

- ▶ Plenty of rooms to explore.
- ▶ Colourful graphics viewed from an interesting overhead position.
- ▶ A very tough one player challenge.
- ▶ Unique two player game requiring co-operation.
- ▶ Nice features like traps, masks and scrolls.

B A D N E W S

- ▶ Keyboard control only, which is rather awkward at times.
- ▶ Odds can be overwhelming.

GRAPHICS	65%	
SONICS	41%	
GRAB FACTOR	84%	
STAYING POWER	80%	
A A RATING	84%	

The graphics are quite nicely done although overlaid sections of scenery can make it difficult to see what's going on at times. The action is very hectic and you won't have much time to stop and think in either player mode. The use of objects and traps adds an interesting element to the

gameplay that make this more than just a mapping task. In one player mode it's just a good, tough arcade adventure, but in two player mode it's unique and will provide many hours of enjoyment.

FIRST DAY TARGET
 One Snake Brooch

BW

getting to - that's just on Level One, and there are four Levels in all!

The next starting point takes you into a different section of the game, where things get really tough. First you have to hop on a raft to cross a stretch of water, and then avoid some nasty flying ghosts while trying to jump over more pools. If you've got this far you'll be starting to wonder just how

SECOND OPINION

This game runs on frustration. Die at the end of a section and you start your next life a long, long way back - always assuming you've got a life left, that is. The obstacles keep getting meaner, and you've got to take each one a new way. It drives me up the wall, but I can't stop playing it.

AW

A bird waits evily to pounce

long Level One is, but the toughest part is yet to come.

The last adversaries include a winged demon, flying ghosts with spears, another rock spitting plant, and a guardian demon who leaps up and down, trying to stomp on your head. Pools of water also make life difficult, so you'll need all your skill and timing to get through. If you can make it to the end of Level One the game opens out, giving multi-directional scrolling instead of just left and right. The action also becomes more platform orientated and certainly no easier.

THIRD OPINION

Needless to say I didn't get anywhere like as far as Bob with this one, which is one reason I'm not usually that keen on this type of game. But this is one with a sense of humour, and just the right level of difficulty to keep me coming back for more. Better than Green Beret and a lot less bloodthirsty too.

MN

experts will find it tough to get past Level Two. Like me, you'll keep coming back to it to see if you can just crack one more section...and another...and another.

FIRST DAY TARGET SCORE
 Just get to Level Two!

BW

GREEN SCREEN VIEW

The rocks that the plants spit at you are almost invisible, and they're tough enough to dodge when you can see them. This game really doesn't need to be any more difficult.

AW

G O O D N E W S

- ▶ Four very tough levels.
- ▶ Variety of ghastly, ghostly enemies.
- ▶ Extremely addictive gameplay.
- ▶ Good music while you're playing.
- ▶ Not just horizontal scrolling, multi-directional action from Level Two on.

B A D N E W S

- ▶ Long gaps between starting points.
- ▶ Almost too tough in places.

GRAPHICS	67%	
SONICS	82%	
GRAB FACTOR	89%	
STAYING POWER	83%	
A A RATING	86%	

FLYING KNIGHTS: Whizz up and down the screen and can only be avoided by running under them.

WINGED DEMON: Rushes across the screen at you and has to be jumped over.

FLYING GHOSTS: Carry spears which they may throw, and float gradually down the screen towards you. Can be shot with a sword.

LEAPING DEMON: Leaps up and down and has to be shot several times before you can progress to the next level.

Each level comes with different scenery and all are exceptionally tough. The graphics and animation are reasonable, if not outstanding, but the music is very catchy and the gameplay tremendously addictive. If you've played *Green Beret* you'll be at home straight away, but it is a much more varied, complicated and tougher game. Some players may take time to really get to grips with it and even



MASTERGEAR

STARSTRIKE II

Realtime Firebird, £9.95 cass, joystick or keys

The predecessor to this was one of the earliest big games on the Amstrad, and it still looks good even today. That was a 'vector' graphics shoot-em-up with all the ships line-drawn and empty. Now everything has been filled in with colour, and has more varied stages and an overall task. If you've got the original then you already know what Realtime is capable of, and this latest offering sets new standards in graphics.

SECOND OPINION

This one takes shoot-em-up graphics into a whole new league. The enemy ships are so beautiful it seems a shame to shoot them, and they're just a small part of the game. If docking with space-wheels doesn't amaze you, you should try the tunnel sequence at full speed - it's dazzling. The gameplay's tough and varied, but who cares.

AW

The game is a battle against the invaders of the original game, who have been driven back to their own planetary systems which you now have to conquer. There are five systems, each with between three and six planets which have to be neutralised by overcoming a number of defence zones and destroying their control centres. The planets come in three types, military, industrial and agricultural, and this determines the sort of opposition you're likely to encounter.

Starstrike stages

In a little more detail, here is what you have to do at each stage of your attack:

SPACE WHEEL: Shoot five pods off the edge of the wheel and then dock with it by spinning to match rotation. Once inside destroy the ship and the three control pods - the third one freezes the iris door and allows you to escape.

The ship is based at a support module from which you travel to each of the five systems. Supplies can be taken on at the module to replenish fuel and forcefield levels before taking on the planets. Once at a system you can choose to attack any of the planets, basing your decision on the cost in fuel and the strength of their defence. When you hyperspace to the planet you may encounter your first problem - a hyperspace storm. This consists of an awful lot of coloured blocks flying straight at you, which have to be avoided if you don't want to suffer a lot of shield damage.

Having reached the planet you could come across a space wheel. These always appear at military planets and sometimes at industrial ones. These can be ignored, but provide quite a challenge. After that comes a series of defence forcefields, each passed through a diamond-shaped gap. These are defended by various spinning objects and gun emplacements that fire six-pointed stars. Getting through them unscathed is very tough and takes good timing and positioning.

After getting through the defence fields you've got to deal with the planet's orbiting fighter cover. This involves ship-to-ship fighting, very similar to *Starion* and using similar scanners to locate the enemy. When the enemy comes into view the scanners disappear and leave you to marvel at the amazing solid, full colour spaceship twisting and turning in front of you. Shoot it a few times and it explodes, often leaving a fuel pod for you or an enemy scavenger ship to pick up.

Once you've destroyed enough ships you descend to the planet surface, and a trench which you fly through, shooting some of the ground targets and avoiding others. At the end of the trench you enter a ventilation duct full of blocks and obstacles, including rotating fans and opening and closing iris doors. Finally you'll come to the

THIRD OPINION

If you fancy a change from Elite, this is the one for you. It doesn't quite have the same thrill as racing your souped-up Cobra MkIII against a couple of Vipers - it doesn't quite have the feel - but it's pretty hot. And the graphics are astounding too.

MIN

room containing the pod that has to be destroyed to neutralise the planet. Blast that and it's off to tackle another one.

ORBITAL FIGHTERS: To get them in your screen use the two scanners. When shot they usually leave a fuel pod - be careful not to shoot it, but fly quickly towards it before a scavenger ship picks it up.

DEFENCE FIELDS: The gap in the field is blocked by spinning squares and triangles. The triangles can be shot, but the squares have to be avoided. Examine their movement and positioning to find a route through.

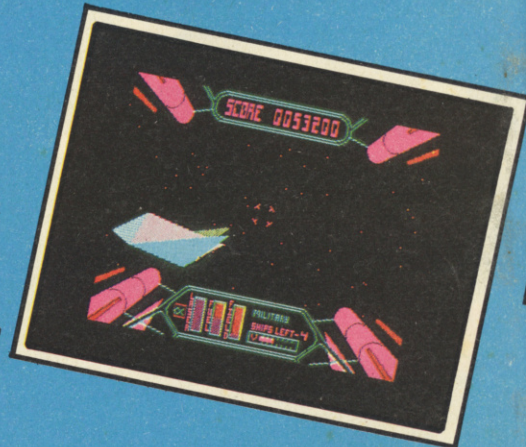
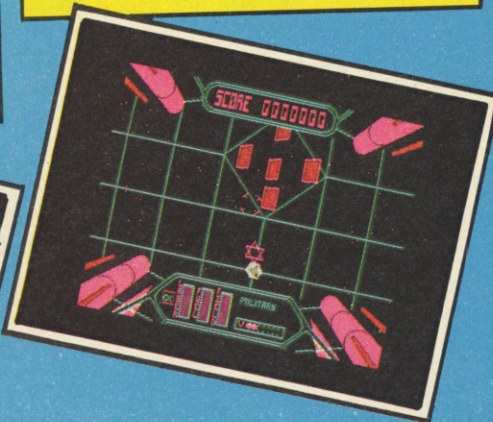
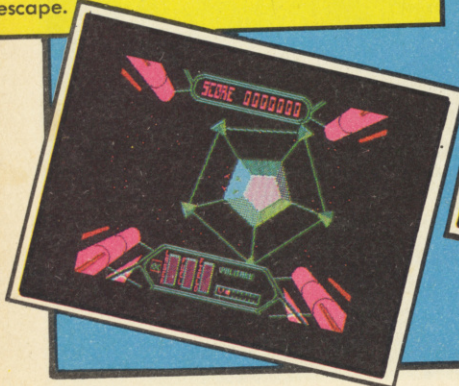

Not every planet has all these stages, and some are harder than others. Whichever one you choose you find your shields under heavy pressure and a need for plenty of skill and practice. The solid 3D graphics are absolutely stunning, combined with demanding, addictive gameplay and terrific variety in the stages and opponents. It's certainly the best action shoot-em-up of the year so far, and those 3D, solid, colour graphics are absolutely incredible.

FIRST DAY TARGET
200,000 points

BW

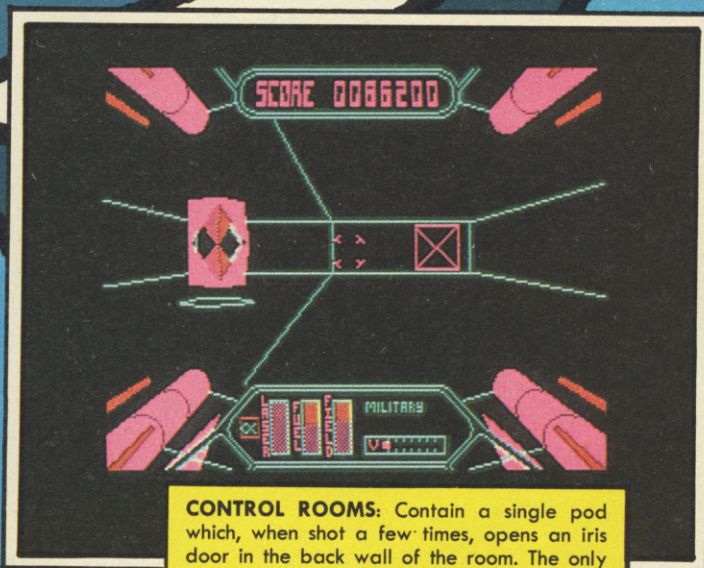

CONTROL ROOMS: Contain a single pod which, when shot a few times, opens an iris door in the back wall of the room. The only difficulty is in manoeuvring to shoot the pod and then getting back to the door in time. If you miss it then it's back to the ground attack stage.

VENTILATION DUCT: Contains blocks across your path on all sides of the duct. Some oscillate up and down, others from side to side. Fans rotate, while iris doors and sliding doors open and close across the whole of the duct. You can vary your speed, and at full speed it's lethal but very impressive.

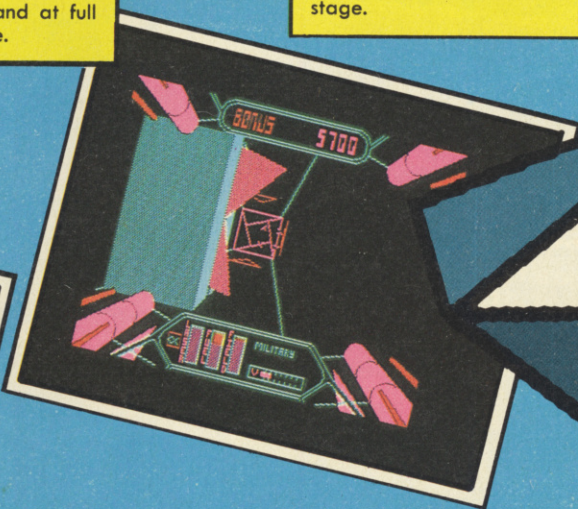

GREEN SCREEN VIEW
Looks great to me, and I do mean great.

AW

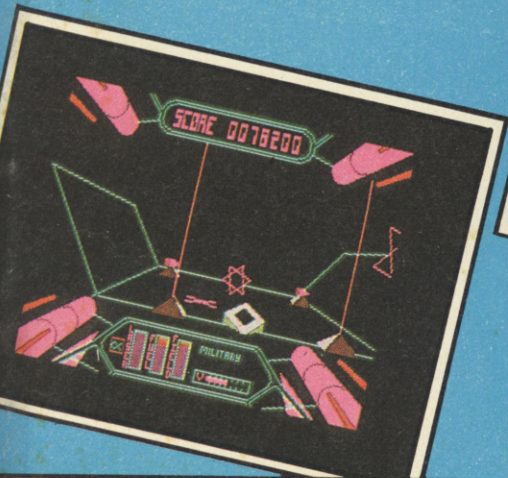

GROUND ATTACK: Dangers include gun emplacements that fire stars, vertical beams and bouncing squares. A cursor on the ground shows where you can shoot, its position being controlled by your height and sideways movement.

- ▶ Very addictive and fast gameplay.
- ▶ As a pure shoot-em-up it knocks everything else into deep space.
- ▶ A long term aim besides a high score.

B A D N E W S

- ▶ Only if you don't like shoot-em-ups.

G O O D N E W S

- ▶ Astounding graphics.
- ▶ Easy to get into the action.
- ▶ Large variety of sections and enemies.
- ▶ Some very tough stages.

GRAPHICS	96%	
SONICS	65%	
GRAB FACTOR	96%	
STAYING POWER	92%	
A A RATING	94%	

the Perfect Addition to Your **AMSTRAD** *Computer*

MAESTRO



THIS PACKAGE CONTAINS: ONE AMPLIFIER
ONE PAIR STEREO HEAD PHONES
TWO 3" SUSPENDED POD SPEAKERS
ONE DEMONSTRATION CASSETTE

- Powerful stereo amplifier which utilises the Amstrads full sound capabilities.
- Compatible with the 464, 664 and 6128 computers.
- Very easy to use. Demonstration software included.
- Enhances most existing software in wonderful stereo.
- No external power supply needed.
- Works with ALL add on's.
- Complete with two high quality 30 watt double cone air suspension speakers in pod mounts, for group listening and a pair of lightweight headphones for personal listening.

- Range of music tapes which complement the Maestro perfectly.
- Can be used with your own Hi-Fi speakers.
- A must for all music lovers
- Designed by experts.



A Vanguard Leisure Product

VANGUARD LEISURE LTD.
CHURCH ROW CHAMBERS, FRANKLANDS,
LONGTON, PRESTON PR4 5PD
Telephone (0772) 617665

**ONLY
£39.95**

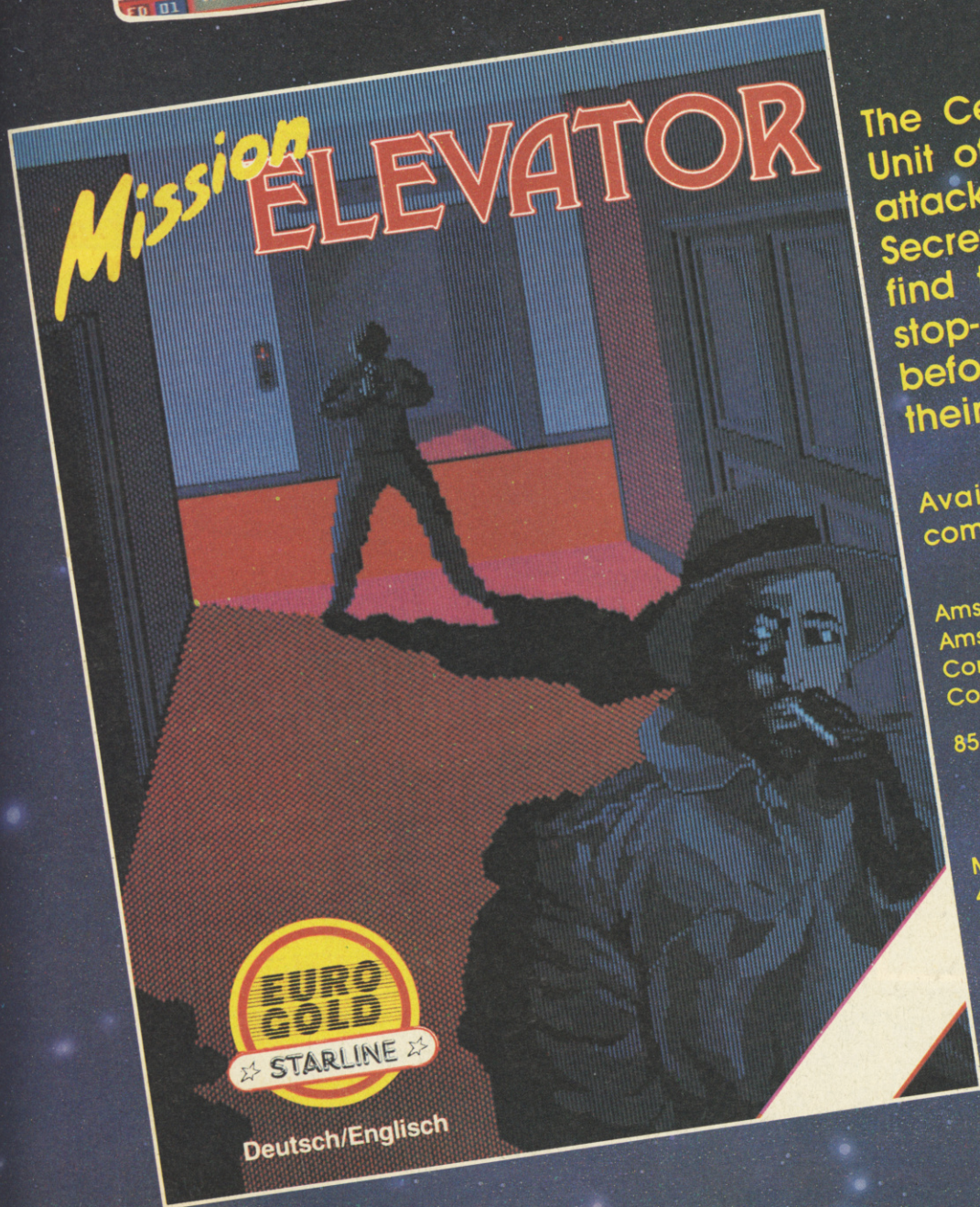

Deutsch/Englisch

The Central Intelligence Unit of the FBI has been attacked by a hostile Secret Service, you must find the bomb and the stop-codes for the timer before the enemy lose their patience

Available from all leading computer stores

- Amstrad CPC Cassette £9.95
 - Amstrad CPC Disc £14.95
 - Commodore 64/128 Cassette £9.95
 - Commodore 64/128 Disc £12.95
- 85% Overall - Happy Computer, Germany

Micropool International Ltd,
 4, Mercury House,
 Calleva Park,
 Aldermaston,
 Berkshire. RG7 4QW
 Tel. Tadley (07356) 77486

ROOM TEN

CRL, £7.95 cass, joystick or keys

It may be from the same author who produced *Tau Ceti*, but this certainly isn't a sequel in any way. *Room Ten* draws a lot on the scenario that produced *Tau Ceti*, but the game is in fact a hi-tech development of those old 'pong' (tennis) games. Remember the days when you'd go brain dead watching a white dot bouncing off two bats? Well now it's in 3D and there's a very mean computer opponent to go with it.

This new sport is called 'glyding', and the name of the game comes from the fact that it takes place in room number 10 at each Gal Corp leisure complex. The game

SECOND OPINION

The idea of 3D, zero-gravity pong may not sound like a natural, but this one really works. It's gripping, infuriating stuff, and at top speed can really get quite manic. The split screen makes for great two-player action, and the computer opponent's no slouch either. Wouldn't have minded a more interesting scoring system, though.

AW

takes place inside a large rectangular box, and under zero gravity conditions so that the ball doesn't have a curved trajectory. The two players control transparent bats –

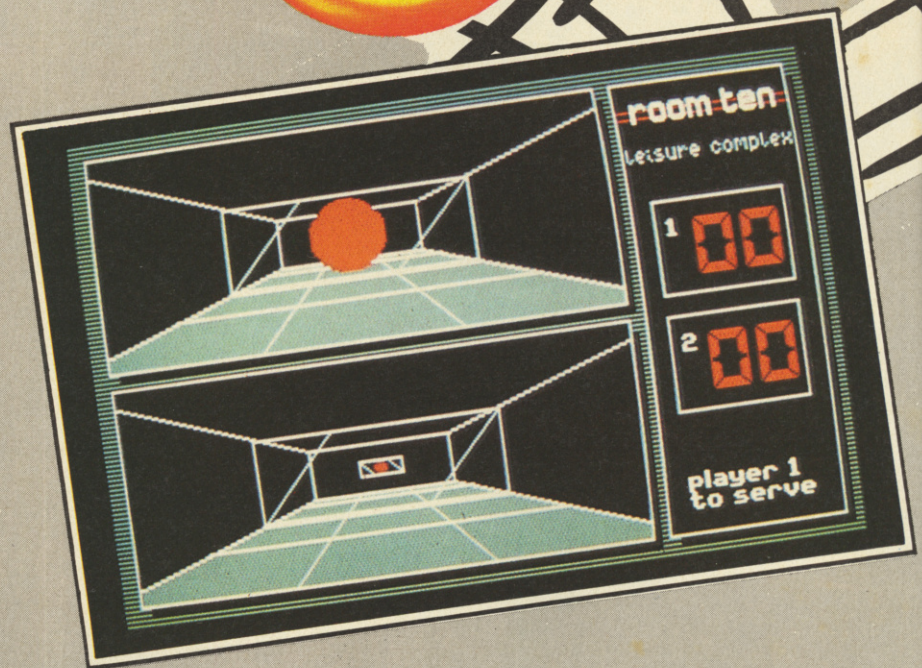

MISSION ELEVATOR

Micropool, £9.95 cass, £14.95 disc, joystick or keys

This is one of the first games to come out of the thriving German Amstrad market, and it shows that they may well emulate the French with a similar software invasion. This isn't terribly original in concept but it's well implemented, looks good and features some testing gameplay.

The game takes place in a hotel in which a bomb has been planted on the 62nd floor. The aim is to get to the bomb by using the many elevators in the building, and then to defuse it. Naturally things are a good deal more complicated than that, and there are plenty of obstacles in your path.

SECOND OPINION

It's always nice to see the Arnold market in Europe feeding software back into the UK, even if it isn't all exactly to the standard of Get Dexter. This German lift-em-up (sorry!) has the fresh and unusual approach of recent French games, with nice touches galore. All that shooting, ducking and jumping can get a bit tiresome, but at least it's different.

AW

The agent you control is called Trevor, and in order to defuse the bomb he needs to find 16 codes hidden in the building. The building itself is split into groups of eight floors, each group containing two keys and two codes. The first key is to be found at a reception desk, and allows you to open the

hotel rooms in that group of floors. In one of these rooms is a porter with the key that takes Trevor past an emergency door into the next group of eight floors.

Three floors are shown on screen at a time and each is only one screen wide, but all are packed with furniture and objects.



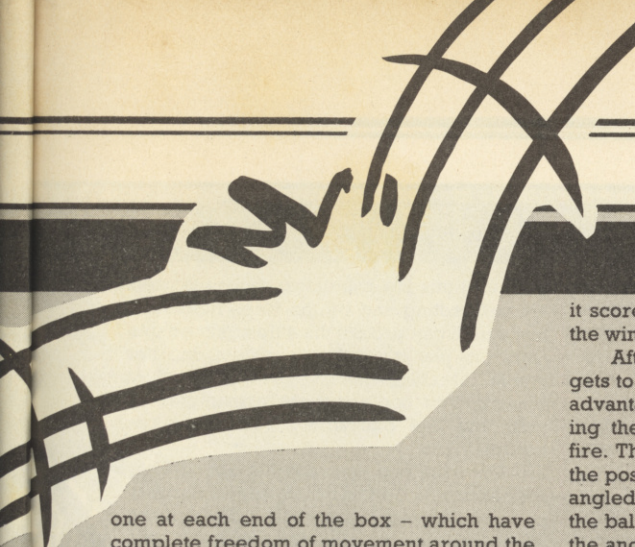

one at each end of the box - which have complete freedom of movement around the back walls. The aim is to strike the ball so that it misses the opponent's bat and hits the back wall instead.

THIRD OPINION

This game just goes to show that the old favourites still have life in them even now. An old idea, but a great perspective and great graphics - and really two player, though the computer is a pretty mean opponent. It's just a shame that they didn't take the idea further.

MN

The screen is split into two so that each player has a view of the court from behind their back wall. The view moves so that the bat is kept centre-screen, providing a constantly changing perspective of the court. Every time the ball hits the back wall

it scores five for the player who last hit it, the winner being the first to score 35.

After every point the player who lost gets to serve, and therefore gains the initial advantage. A serve is performed by placing the bat behind the ball and pressing fire. The direction of the serve depends on the positioning of the bat; so the ball can be angled up, down, left or right. The nearer the ball is to the edge of the bat the greater the angle achieved, but also the higher the risk of missing.

The game has quite an impressive 'front end', with many options and scene-setting instructions to help you along. You can choose whether you play the computer or a human opponent, what standard the computer player is, the game speed and the screen colours. There's also a comprehensive key/joystick selection feature, the rules of glyding, an introduction to the Galcorp Leisure Complex, a high score table and a choice of languages.

The graphics move smoothly and look good, particularly when the game is being played at top speed. The computer puts up a good opposition but much the best way to play the game is against another human. The only real disappointment is that there isn't more depth given to the game by having a series of games or different shaped courts, for example. That limitation aside you'll have plenty of fun with the two

player game, trying to follow a bouncing ball as it goes crazy all over the court.

BW

G O O D N E W S

- ▶ Smooth, fast, 3D graphics.
- ▶ Good computer opponent.
- ▶ Two player option is great fun.
- ▶ Can vary computer skill and game speed.

B A D N E W S

- ▶ Little depth to the action with just single games.
- ▶ Doesn't have different shaped courts.

GREEN SCREEN VIEW

There's a colour-changing option, though the default colours were perfectly visible anyway.

AW

GRAPHICS	70%	
SONICS	31%	
GRAB FACTOR	82%	
STAYING POWER	67%	
A A RATING	73%	

Everything can be searched to find the pieces of code, which have to be remembered in the right order for use later when defusing the bomb. Popping out from the lifts and from behind curtains are the bad guys, who are your main problem. They come after you and will shoot, costing you a life. You can jump or duck bullets, but the baddies can duck and shoot as well so you need to stay constantly alert. Trev can shoot back and kill, but they keep coming however many he wastes.

Opening hotel room doors can prove hazardous, as usually you won't find the porter but instead a bad guy who you'll have to shoot before he shoots you. This reflex action at a door can prove unfortunate because sometimes a lady in a night-dress answers, and if you press the fire button all her clothes fall off and you lose 100 points. This last bit of rather tacky, sexist rubbish obviously must have amused

the programmers because it serves no other purpose.

THIRD OPINION

Initially I loved this game, and wasted several nights trying to get to floor 20; but interest waned when I realised that all the floors are basically the same - there's just an awful lot of them. Good graphics, good action and some nice touches - but is that really enough?

MN

As you explore the hotel you discover various special features that can help or hinder your quest. Examining an armchair pauses the game while Trev sits down for a rest; while examining a small table gives you the chance to gamble on a dice roll that could enhance your financial position. Other nice features include a bar from which you can buy drinks in return for information from the barman, but causing you some problems with control; mains sockets that can prove very hazardous; fire extinguishers that put the lights out, and pot plants that put them back on.

If it weren't for the special features this would be a fairly ordinary game in which a lot of time is spent running, searching and shooting. However these features do give it that extra something and combine with the tough gameplay to make a good game. The graphics are colourful and detailed, although the scrolling between sections of

three floors is jerky. A good effort from Germany with hopefully even better to come.

BW

G O O D N E W S

- ▶ 62 floors is a lot to get through.
- ▶ Colourful and detailed graphics.
- ▶ Tough gameplay so you can't afford to relax.
- ▶ Good features such as the bar, chairs and fire extinguishers.

B A D N E W S

- ▶ Becomes repetitive.
- ▶ Controls are a little awkward for searching.

GREEN SCREEN VIEW

Most of the time it's fine in green. Putting out the lights will cause visibility problems, but then it is supposed to.

AW

GRAPHICS	74%	
SONICS	52%	
GRAB FACTOR	73%	
STAYING POWER	71%	
A A RATING	71%	

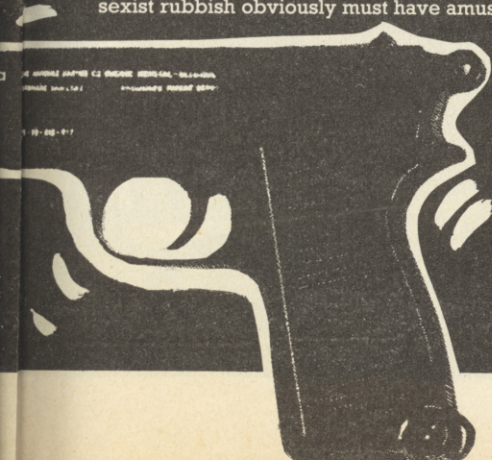

THRUST

Firebird, £1.99 cass, keys only

This game dropped onto my desk very late on in the issue, which is why we had no time to give it a colour page – but it's so good that we just had to tell you about it. Who knows, if it had come in earlier it might even have pipped *Starstrike II* for the Mastergame title. It's a superb vector graphic game that has its origins in the arcade game *Gravitar*, and features some of the most addictive gameplay in an arcade game, never mind a budget Amstrad title.

SECOND OPINION

The gameplay on this is just unbelievable. The controls are stunning, the obstacles are formidable, and that pod is so amazingly heavy you can almost feel the strain on the tractor beam. It's too good to be true. At £8.95 it would have been second only to Spindizzy, but at £1.99 it's unmissable.

AW

THIRD OPINION

This is what I like. A space ship that really lets you feel the thrust of burners against gravity – and moves like a ten-ton articulated when you've got a pod in tow. The graphics aren't stunning, but that doesn't matter. This is a real simulation, and with plenty of action too.

MN

At first sight it looks like nothing special, with just a few insubstantial vector graphics and a very simply drawn planet surface, but as soon as you start playing it's obviously something special as you delight in the control of the spaceship. The task is quite straightforward – to pick up a power pod from the surface, and then destroy the planet by shooting up the main reactor. Completing it can be a whole different matter.

are very nice to use and, unless you panic or get disorientated, aren't too difficult. The ship is equipped with a tractor beam that attaches to the power pod and tows it, which brings new control problems with the pod's weight and inertia affecting the ship's movement as well. If the pod is destroyed you go with it, so you have to be careful with the precious cargo.

The ship can pick up fuel from fuel dumps in the same way as it picks up the

pod, and this is essential since fuel is used when thrusting and by the force field. The force field can protect the ship against shots from the planet's defence system, but not against crashing into the ground or other objects. You can shoot the armaments as well, but like everything else this takes accuracy.

Once the pod is in tow you can go after the reactor, which has to be shot a number of times before it starts to flash. This means it's going to explode any moment, and you've only got a short time to fly straight up and away from the planet. You can leave without destroying the reactor but the next



NEXUS

Nexus, £9.95 cass, £14.95 disc, joystick only

A new software house with their first game, and packaged in some very 'alternative' packaging. It certainly doesn't look like a cassette or disc box, but it does look attractive. The game is set in the HQ of a drugs ring which you have to smash, and combines several familiar themes to create quite a different game.

The screen is split into several areas which you need to be familiar with before getting very far into the game. The top third is the area where you can see the man you control and part of the level of the building he is on. Below are various windows that show communications from other characters, a radar display of characters and objects on your building level but off screen, the direction of someone or something interesting, facial pictures of friends and enemies, and a list of possible moves or actions. To understand most of what's going on you have to read the instructions carefully, but eventually the basically simple aim reveals itself.

Supposedly you are searching the eight floor levels of the building for a friend of yours and the answers to 32 questions. Each question is composed of four scrambled fragments which you have to rearrange, but first you've got to find them – all 128 if you're going to complete the game. The pieces are found in rooms all over the eight levels of the complex, which have to be systematically searched in order



The HQ
drugs ri

planet will be alerted and have its armaments ready.

If you complete the first six planets, with things getting tougher all the time of course, weird things start to happen as the planets repeat but with heavier defences and some other strange effects.

There may not be much to the graphics but what's there is superbly done, and of course the real clincher is the gameplay. You just can't afford to relax for a minute with the amount of control needed, but even if you crash it just draws you back for another game. This would be a good full

price title but at £2 it's an absolute steal. Go and buy it now or you'll regret it.

FIRST DAY TARGET SCORE
20,000

BW

GREEN SCREEN VIEW
Best thing since sliced bread.

AW

GOOD NEWS

- ▶ Excellent vector graphics.
- ▶ Well designed, devious caverns.
- ▶ Marvellous ship control.
- ▶ Great effects on later levels.
- ▶ So simple yet so addictive.
- ▶ Amazing price.

BAD NEWS

- ▶ It's just possible you may not like the control (only just, mind).

GRAPHICS	89%	
SONICS	47%	
GRAB FACTOR	96%	
STAYING POWER	91%	
A A RATING	94%	

Not much too look at but great to play

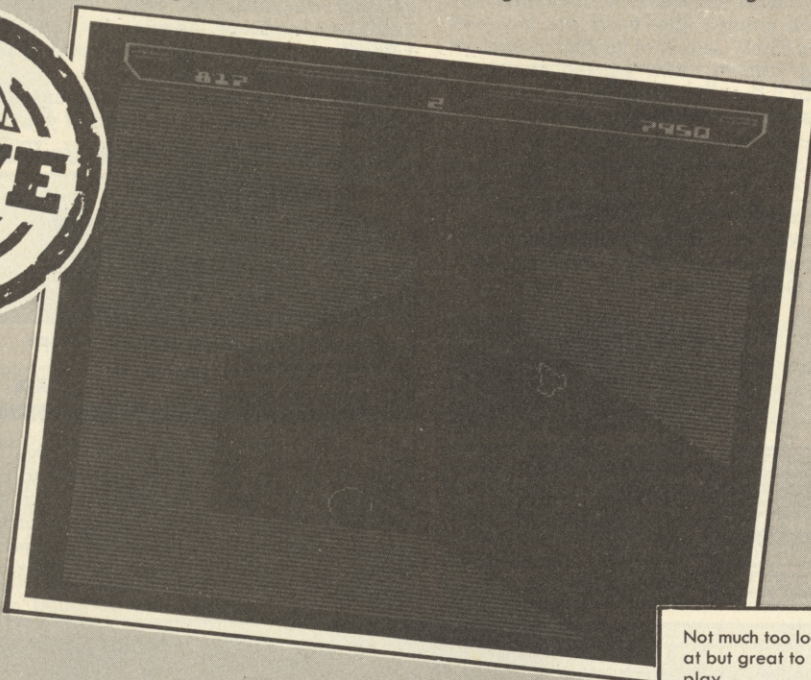

to find the information.

Your character has a large number of possible moves and actions, including karate kicks and punches for fighting and some acrobatic avoidance measures. He can also get hold of guns and grenades to

SECOND OPINION

A cut above the usual run-around-searching-rooms stuff, but the puzzles are still pretty puny and the graphics aren't all that hot either. It's well presented and the digitised faces are great if you squint a bit, but it doesn't feel very satisfying. I do wonder how long it's going to keep people hooked, truth to tell.

AW

to be safe from attack in some areas you need pass cards which can be got from Nexus personnel. Once you're familiar with the layout and action involved the game becomes mostly a matter of keeping out of trouble and searching the whole complex for pieces. Once you've got plenty of pieces you can edit them in a special room to discover the answers to the 32 questions, and then transmit the answers from the

THIRD OPINION

The plot is corny, the instructions complicated and the packaging totally over the top - but I liked this one. It has a nice balance of action and adventure, but could become repetitive quite quickly.

MN

give him more firepower. The characters you meet are pretty tough too, and if they get nasty they can beat you up pretty good. There are also friendly characters who are members of Nexus and can provide you with help, as long as you stay on the right side of them.

To get between levels you use lifts, but

'transmission' room. Another room allows you to locate and examine the skills of the members of Nexus when you need their help.

The graphics and animation are quite good, with a very nice screen layout and use of windows. There's music too that tootles along with the game but it isn't very inspiring. Initially it takes time to get to grips with things, but once you're under-way the gameplay varies between repetitive searching of rooms and bursts of fight-

ing action. There's plenty here to get to grips with but it may wear thin after you've found and edited most of the messages.

FIRST DAY TARGET SCORE
250 points

BW

GREEN SCREEN VIEW

Colour coding on terminals and guards' uniforms causes some serious problems.

AW

GOOD NEWS

- ▶ A large, interesting playing area.
- ▶ Tough task requiring strategy and skill.
- ▶ Good screen design and graphics.
- ▶ Nice features like the computer terminals and the Nexus personnel.

BAD NEWS

- ▶ Gameplay may become repetitive.

GRAPHICS	77%	
SONICS	68%	
GRAB FACTOR	84%	
STAYING POWER	82%	
A A RATING	81%	

STAR FIREBIRDS

Firebird, £1.99 cass, joystick or keys

Originally released by Insight at a price of £7.95, this game has quickly made its way into the ranks of budget games where it rightly belongs. It's a simple shoot-em-up similar to many others on the Amstrad, but you've only got to shell out a few pennies for it.

The familiar scenario involves a laser base at the bottom of the screen that you control to blast away at several types of alien birdie things flying down the screen. There are two common types of bird that whizz around screen in curving patterns; one of which shoots single bullets, while the other shoots a scatter of them. These are dealt with by a single shot.

SECOND OPINION

Great blast for a couple of minutes, but there are none of the tough patterns that these left-right-fires really need. Fun, and graphically quite appealing – but where's the staying power?

AW

Bombs come in from the top of the screen and slowly descend, but when shot they explode into dangerous fragments. The last and toughest of the adversaries is a big bird that has to be hit several times before it dies.

If the base gets into real trouble it can 'warp' a limited number of times. Warping causes it to move automatically up screen while invulnerable to the birds which you can kill on the way. When it goes off the top it reappears at the bottom of the screen, and you need to be ready so that it doesn't reappear in a hail of enemy fire.

THIRD OPINION

Great in the arcades a few years ago, but wearing a bit thin now. It's a good version though and not exactly expensive at £1.99.

MN

The graphics are very colourful and move at a reasonably challenging pace.

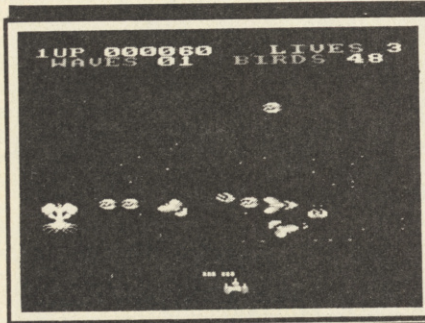

What's that those alien birds are firing?

There is little variety in the bird's action and mostly it's just a matter of blasting away with a tiring finger at the same old formations. It's only £2 so you could do worse if you're looking for a mindless blast.

BW

FIRST DAY TARGET SCORE

10,000

G O O D N E W S

► Colourful graphics.

B A D N E W S

- Not many varieties of alien.
- Little change in movement patterns.
- Completely and utterly mindless (or is that Good News?)

GREEN SCREEN VIEW

No problems here (except for those damned birds!).

AW

GRAPHICS	61%	
SONICS	27%	
GRAB FACTOR	41%	
STAYING POWER	32%	
A A RATING	37%	

KNIGHT GAMES

English Software, £8.95 cass, £14.95 disc, joystick or keys

The mediaeval muckabout is a new concept in combat games, with knights battling to knock the rivets out of each other in eight contests of brute force and skill. There are six combat events here where two knights go head to head and two shooting events – crossbow and archery.

The eight events all load separately but fortunately this doesn't take long and is handled by means of a convenient menu. The whole thing starts with a very impressive loading screen involving eight characters all doing their thing in superb animation. You can then load one of the eight events; with Swordfight 1, Quarterstaff, Archery, and Ball and Chain on the first side, and Swordfight 2, Pike Staff, Crossbow and Axeman on the other.

SECOND OPINION

The events look amazing, but I'm afraid the gameplay is very dreary. Even hardened combat-game freaks will feel disappointed. You'll load each of the events once just for the graphics and music, but I don't think you'll actually play any of them much.

AW

All the events take place against beautifully detailed backgrounds drawn with superb use of colour. The participants are delightfully animated using many separate frames of action and manoeuvre. Not only that but the background music is varied, atmospheric and enjoyable. So if it looks so good and sounds so good why isn't it the Mastergame you ask? The answer lies in the gameplay, which is very similar and

GLADIATOR

Domark, £8.95 cass, joystick or keys

As if to prove that you can't keep a good idea down here's yet another combat game. It's set in the first century AD where, armed with a nasty assortment of body splitting weapons, you enter the Roman arena as a gladiator. As ever it's a case of kill or be killed, so you had better start sharpening those blades.

You can take part in a battle against the computer or against a friend and, if you do well enough against the computer, you'll

SECOND OPINION

This must be the naffest combat game we've had all year. The action looks ridiculous, sounds feeble and plays dismally. There's no attempt at realism or playability, and the whole thing ends up rather more like Life of Brian than Spartacus.

AW

later get the chance to bet on the result of other fights. The first thing you have to do is choose your three weapons from the 45 on offer. These include shields, swords, spears, tridents, nets, bolas and daggers, which can all be used in different combinations.

repetitive in all the six combat events and isn't much better in the shooting contests.

The six combat events are basically just a matter of the two players, either both human or one computer, standing toe to toe and beating the pulp out of each other until time runs out or one of them gets knocked out. Time is measured by a burning candle.

THIRD OPINION

Great graphics, but I'm not really that interested in beating the whits out of someone on a computer screen.

MN

while the hits on the fighters are registered by disappearing roses and shields. Even short fights last a long time, so those with plenty of stamina will survive the longest.

The archery and crossbow contests require more skill. Shots are aimed using a cursor, which tends to wobble about to make things difficult. These contests are also against the clock, sorry candle, and for all events the more hits you score the more points you get. The high score for each event is shown on a menu, and is carried over when you load a new event.

It's a shame there isn't more variety to the gameplay but the graphics, music and humour will keep you interested for a while – and beating the tar out of someone in a two player game can be most satisfying. Fun for a while but will soon lose your interest.

BW

FIRST DAY TARGET SCORE

Beat the computer at the combat events

Hack, lunge, thrust, slice, yawn

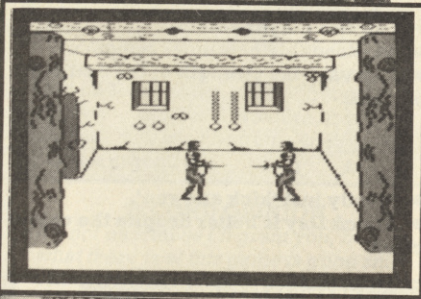

THIRD OPINION

I never liked this sort of game anyway, and this example is certainly not going to change my mind.

MN

your freedom. Unfortunately, right from the start you are faced with fighters who are incredibly difficult to defeat. There may be a trick to beating them which I haven't found yet, but it's pretty obscure if there is. You can hack, lunge, thrust, throw and charge as much as you like, but in this sort of pitched battle you're dead meat every time.

The only way I found of winning was to get a couple of early hits in and then keep

G O O D N E W S

- ▶ Large choice of weapons.
- ▶ It's certainly a tough challenge.

B A D N E W S

- ▶ Not enough variety in the action.
- ▶ Very difficult to get anywhere against the computer.
- ▶ Action for hits, misses and blocks isn't clear enough.
- ▶ Not really much different to any other combat game.

The weapons are supposed to affect your performance and tactics in a fight, but it will take you a very long time to find out how because the difference is not at all clear. They all look different as you swing them around in the arena, but that's just about all. Your opponent is fairly conventionally armed to start with so at least you can have an even match on that score.

Once in the arena you have to win 15 fights before gambling on other games, the aim being to gain enough money to win

running away from my opponent until he keeled over from exhaustion just before me. The arena is shown in pseudo 3D but most battles occur purely in 2D.

The fighters are quite well drawn, but it's usually difficult to see exactly what's going on. The arenas change and can look quite good, but are always very yellow (sand probably). The action itself is very tough but not really much different from all the other combat games that have come and gone before it. Nothing special I'm afraid, and bound to cause plenty of frustration with countless deaths.

BW

FIRST DAY TARGET SCORE

Beat one opponent

GREEN SCREEN VIEW

Can be hard to tell who's landing the hits, but I can't really say I'm bothered.

AW

GRAPHICS	60%	
SONICS	34%	
GRAB FACTOR	41%	
STAYING POWER	32%	
A A RATING	35%	

SOCCER 86

Loriciels/Activision, £9.99 cass £14.99 disc, joystick or keys

There are several football games already out on the Amstrad, so this offering from across the Channel has plenty of competition - most notably from Ocean's *Match Day*. It's a simulation along similar lines in which you can play six-a-side football with four of Europe's top nations on a horizontally scrolling pitch.

The pitch is about four screens long and scrolls rather jerkily as the players move about. The only markings are the goals, centre line and the six yard box. Each team has five outfield players and a goalkeeper, and their are four choices of team: England, France, Germany and Italy. You control the outfield player who is either in possession of or nearest to the ball. The goalkeeper is operated automatically and is good, but not perfect.

You can play against the computer or against another player, but you are limited to one game since there is no cup competition system. The computer opponent plays

Over 'ere Brian, on me 'ead

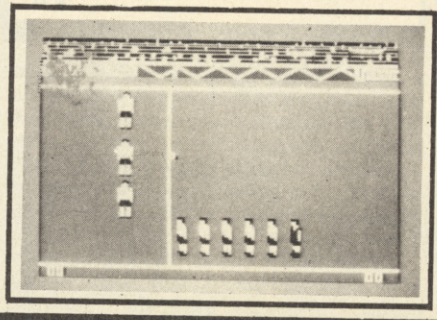

G O O D N E W S

- ▶ Eight events.
- ▶ Superb graphics and animation.
- ▶ Great music to accompany each event.
- ▶ Archery and crossbow require some skill and timing.

B A D N E W S

- ▶ Six combat events are very similar in gameplay.
- ▶ The initial appeal wears off quite fast.

GREEN SCREEN VIEW

Visibility's fine, but those colours really are worth seeing.

AW

GRAPHICS	94%	
SONICS	90%	
GRAB FACTOR	80%	
STAYING POWER	62%	
A A RATING	72%	

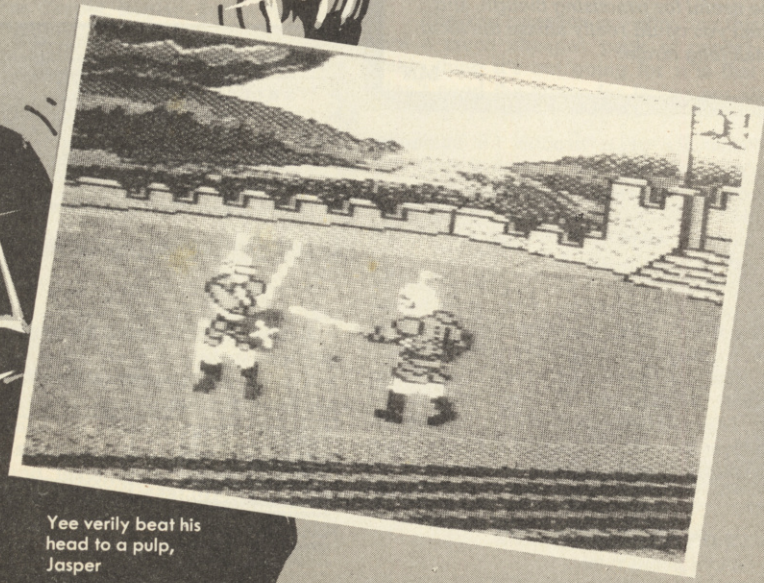

Yee verily beat his head to a pulp, Jasper

well but, as with all these games, it is best played with two players. The computer can be set at different skill levels but a bit of practice should master any of these.

The five outfield players are allocated power ratings that determine their speed in the game. There are 100 units in all and a player can have a maximum of 30, so you can have the teams strength up front or in defence. On the pitch the controls are simple: just directional for where you want the player to run and the fire button to kick the ball in the direction you're facing.

SECOND OPINION

Considered on its own merits this one's quite fun and pretty reasonable value. Put it up against Matchday though, and it looks a bit shallow - a bit too short on variety, really. It's nice, but I'm not sure it'll last the 90 minutes.

AW

The game recognises throw-ins, corners and goal kicks (and goals of course), and also allows players to head the ball if they position themselves correctly. The teams change ends at half time, each game lasting about ten minutes. There's no unseemly colour clash when players overlap

and you can't run 'through' them. There also isn't too much skill involved - it's mostly just a matter of hoofing the ball up field and chasing after it. Passing is possible but plenty of practice is needed before you can expect any sort of accuracy.

I don't think there's much between this and *Match Day*, except that this doesn't have a cup competition or as many options

THIRD OPINION

I'm not that into football anyway, let alone a small-screen version, so I'm afraid this one left me a little cold. Not enough action for me.

MN

as the *Ocean* game. If you haven't got *Match Day* and fancy a football game (without colour clash) then this is better than most.

BW

FIRST DAY TARGET SCORE

Beat computer by 3 clear goals

GREEN SCREEN VIEW

I'm over the moon about the visibility on this one, Brian.

AW

GOOD NEWS

- ▶ Quite good player movement (no colour clash).
- ▶ Fun two player action.
- ▶ A reasonable computer opponent.
- ▶ Can vary the strength of the outfield players.

BAD NEWS

- ▶ Mostly just 'kick and run'.
- ▶ *Match Day* is better despite the colour clash.

GRAPHICS	62%	
SONICS	41%	
GRAB FACTOR	64%	
STAYING POWER	58%	
A A RATING	61%	

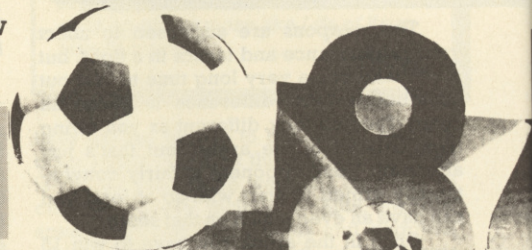

Mah Jong

Liffsoft, £6.95 cass, joystick or keys



This classic Chinese tile game isn't one you expect to appear as a computer game - but this new software house has come up with a version that may interest anyone who can't get together a foursome for the real thing. It's a one player game with the computer playing three hands against you.

The first thing to be said is that this is definitely not a game for the newcomer to Mah Jong. It is possible to work out what is going on from the instructions and the screen layout, but it would be painstaking and unrewarding. This is because the game is text only and lacks a comprehensive instruction booklet for the beginner. However, for anyone who knows how to play and just can't get four people together it's absolutely perfect.

SECOND OPINION

I've never played Mah Jong, and I can back Bob up on one thing - it certainly is unplayable unless you already know the game. The problem isn't so much the program itself as the impenetrable set of instructions. More care here would have opened the game to a much wider market.

AW

The computer handles all the complicated layout of the game so that you just have to worry about playing your own hand. All the tiles are denoted by a two digit/letter code, for example B6 is bamboo six and GD a green dragon. Once you're familiar with that the action is fairly easy to follow.

There is a menu of instructions at the bottom of the screen that allow all the normal choices; including declaring

Chows, Pungs and Kongs, taking a tile from the wall or last discard, declaring Mah Jong, discarding and viewing what the other players have declared. Above this menu line is your hand - the main part of the screen being used to show the whole discard pile as it grows.

The computer players are good, and you'll have no problem continuing very long series of games as the computer also keeps track of the scoring. It recognises special hands and concealed Pungs and generally can't be faulted.

THIRD OPINION

Mah Jong is a classic game, but it's also a social occasion. This version would be useful for practising though, and then you could really amaze the local Mah Jong circle.

MN

This is a great product for someone who's played Mah Jong, even though the screen display is unattractive. For the newcomer it's much more confusing since without having played the real thing all this talk of tiles and walls and so on will be completely baffling. It's a great game so if you want to find out more just borrow a real set to learn the rules, then you can visualise what's going on in the computer version.

The game is available mail order from: Liffsoft, 52 Garretts Green Lane, Yardley, Birmingham B26 2HP. The ratings are from the point of view of someone who can already play Mah Jong.

BW

FIRST DAY TARGET SCORE

A positive points total

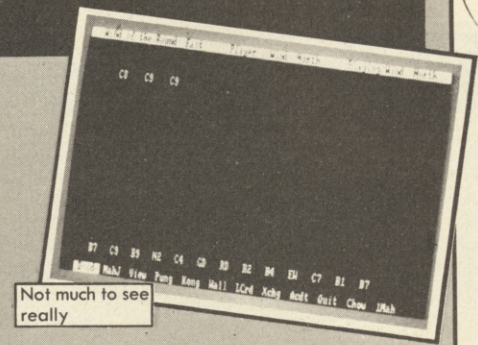

Not much to see really

GREEN SCREEN VIEW

Loses nothing at all, but then it wasn't exactly a graphic masterpiece to start with.

AW

GOOD NEWS

- ▶ It's a one player game.
- ▶ The three computer hands play very well.
- ▶ The program recreates the game very accurately.
- ▶ If you know the rules it's very easy to use.

BAD NEWS

- ▶ Extremely difficult for a beginner to get into.
- ▶ The all-text display makes things hard to visualise.

GRAPHICS	5%	
SONICS	5%	
GRAB FACTOR	65%	
STAYING POWER	74%	
A A RATING	70%	

DOPPLEGANGER

Americana/Alligata, £2.99 cass, joystick or keys

Another game that saw its first incarnation as a full price title and is now experiencing a second lease of life at a budget price. It's a 25 room arcade adventure featuring a sorceress and her alter ego, both of whom you have to control.

SECOND OPINION

It's not enormous I'll grant you, but what there is of this game is good stuff. There's quite a bit of originality to the gameplay, and that price is pretty appealing.

AW

The 25 rooms are in 'isometric' 3D and are connected by a number of doorways with different coloured frames. The significance of this is that the sorceress can only pass through some of the doors and her alter ego through others. This means that you need to use both characters to complete the game.

THIRD OPINION

Controls are difficult, and it's a small game, but the graphics aren't bad and it's a nice idea. Not bad for the price.

MN

The task is to collect various ingots of gold, silver and bronze and return them to the location where the two characters start. There are plenty of problems along the

way; including locked doors for which you need a colour coded key, energy sapping spiders, monster heads and other things which can be stopped with particular ob-

jects - which objects you have to discover as you play.

Many things sap the energy of the two characters, but energy can be replenished in the right room. The graphics are pleasant and atmospheric and, although the game is quite small and not too complicated, it provides some fun and challenge for a while. Definitely good value as a budget title.

BW

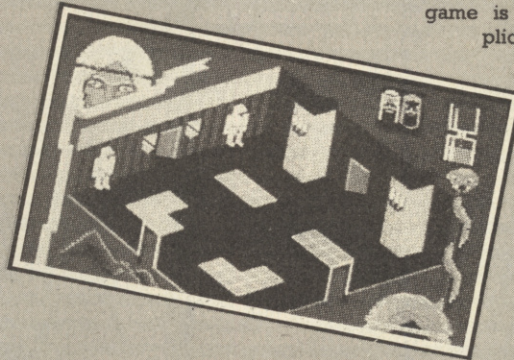

Sorceress and alter ego in the starting room

G O O D N E W S

- ▶ Good graphics.
- ▶ Use of two characters.
- ▶ Some puzzling and exploration needed.
- ▶ Much better value at £3.

B A D N E W S

- ▶ Not very big or complicated.
- ▶ Character movement can be awkward.

GREEN SCREEN VIEW

Colour coding problems on the doors I'm afraid. Still playable, but only with difficulty.

AW

GRAPHICS	68%	<div style="width: 68%;"></div>
SONICS	52%	<div style="width: 52%;"></div>
GRAB FACTOR	66%	<div style="width: 66%;"></div>
STAYING POWER	62%	<div style="width: 62%;"></div>
A A RATING	70%	<div style="width: 70%;"></div>

AMSTRAD SHUFFLE

Alpha-Omega/CRL, £4.95 cass, keys only

At £4.95 this game is neither one price nor the other, which is a shame because it would be good as a real budget title. It's a compilation of seven games of Patience and a game of Blackjack, which load in two sections. The first side contains Column, Clock, Row and Pairs Patience, and the second has Carpet, Raglan, Sultan Patience and Blackjack.

SECOND OPINION

It's quite nicely presented, but it's really no match for the real thing, half-price or no. Buy a pack of cards and a good Patience book - and save Arnold for Starstrike II

AW

The seven games of Patience are all fairly well known, but for those who aren't familiar with them there are instructions on how to play them. Each one is played on a single screen with an appropriate green background and easy to identify cards. In all the games the computer does the hard work of shuffling, dealing and moving cards around, leaving you to decide where the cards should go.

All the games are well laid out and easy to follow and every bit as brain calm-

ing as Patience games usually are. Blackjack can be played by one to three players with the house as dealer. It's played exactly as in a casino, and the house certainly doesn't let its money go easily.

THIRD OPINION

As far as I'm concerned, if you want to play card games buy a pack of cards.

MN

The key question is - why buy this and not a much cheaper pack of cards? The main thing it's got going for it is that you don't need the space for laying out all the cards and there's no danger of having them scattered all over the place. It also stops

you cheating, which I've always considered half the fun of Patience, after all who's to know? Not a bad little package of games but I'd still like to have seen it £2 or £3 cheaper.

BW

GREEN SCREEN VIEW

I miss the red and black of the real thing, myself - but you can still tell the cards apart okay.

AW

G O O D N E W S

- ▶ Seven games of patience and blackjack.
- ▶ Good screen design.
- ▶ No mess and all the hard work done for you.
- ▶ Very soothing.

B A D N E W S

- ▶ Except for Blackjack you could play them all for the price of a pack of cards.
- ▶ You can't cheat!

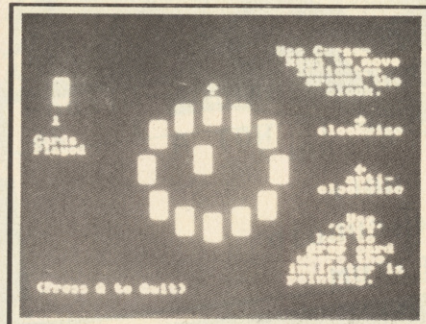

The clock patience layout

GRAPHICS	38%	<div style="width: 38%;"></div>
SONICS	13%	<div style="width: 13%;"></div>
GRAB FACTOR	69%	<div style="width: 69%;"></div>
STAYING POWER	66%	<div style="width: 66%;"></div>
A A RATING	68%	<div style="width: 68%;"></div>

Powerplay

Arcana is a new name in Amstrad software, and from what we've seen of this first game it could quickly become a big name. The game is very loosely based on all those Trivia board games, but uses the Amstrad's facilities far better than previous quiz games.

Instead of just relying on a bunch of silly questions to hold your interest, there's actually an absorbing game here too. It takes place on an 8x8 grid of squares, each in one of five different colours, four of which represent different subjects and the fifth a special square. Two, three or four players can take part, and the more players the better the action.

Each player controls a team of four warriors who start the game in one of the corners of the board. The warriors can be of four different strengths: Hercules, Cyclops, Minotaur and Satyr in ascending order of power. On each player's turn you have to answer a trivia question on the subject of the square your selected warrior is currently standing on. You're given four possible answers, and if you get it right then the warrior can move one square.

The aim is to destroy all the opponents' warriors by trying to move onto their square and thereby challenging them. The challenge is resolved by the two players trying to answer another question, the winner being the one who gets it right first. The loser has his warrior demoted a level and destroyed completely if it was already a Hercules.

Points are awarded for getting questions right; more points being given for the harder questions set when a warrior is in

the form of one of the stronger beasts. Enough points allow a warrior to mutate into a more powerful form and therefore increase survival chances in challenges.

There are four ready prepared batches of questions, each containing over 500 questions. These are very cleverly put together and organised so that even if the same questions recur the game still retains its interest through the need for tactics and speedy response.

There's also a very slick question compiler that allows you to put together your own question sets, and is easy to use. The version of the game we looked at still had to undergo final testing but the combination of excellent graphics, good questions, multi player action and tactical gameplay make this look very good indeed. It's a mile ahead of other trivia games so far and should prove the producers right in their aim of a big Christmas hit.



The Powerplay game screen with one of its questions below

CRUZ AFFAIR PREVIEWS INHERITANCE PR

Infogrames

The French labels Ere Informatique and Loriciels have already made their mark on the UK software scene and now Infogrames look set to do the same. Their first release, *Mandragore*, is an adventure that you'll find reviewed by the Pilgrim this month, but is being followed by two other products, *The Vera Cruz Affair* and *Inheritance*.

These aren't adventure games but they can't be described as arcade games either, they're a very original combination of the two that should stir up a good deal of interest. The copies of the games that we looked at were the French versions, but the English translations are well underway.

Inheritance

This is another product that really stands out for originality, both in presentation and gameplay. It's a three-part quest, the goal of which is to inherit your Aunt's fortune by winning one million dollars in one night at Las Vegas.

In the first part of the game you have to get down from your 17th floor hotel room, avoiding various people that you owe money or possessions. The second part takes you to the airport where you have to get the flight to Las Vegas and the third part, in which you have to play the

various games to make your million. The two latter parts are accessed by codes obtained by completing the previous stage.

In the hotel room there are a number of objects that you need to collect to help you get out of the hotel. You can get down the 17 floors using the lift and the stairs, but the inhabitants will get in your way as much as possible. They appear on screen, drawn in cartoon style and with animated mouths, delaying your progress until you give them money or the correct object.

Many of the inhabitants always require the same object, so with repeated games you can find out how to get rid of them quickly. Once again this should have a wide appeal since it's unlike any other game I've seen on the Amstrad. Watch out for full reviews of the English versions of the game and in the meantime admire the screen shots of the superb graphics that feature in these games.



MR STONE, EMPRUNTE
RENDEZ-MOI CE QUE VOUS M'AVEZ

ctif de votre appareil en
s touches curseur. COPY
ier et ENTER pour finir



One of the caricatured inhabitants of the block of flats in Inheritance

Vera Cruz lies dead in her flat. You have to investigate the grisly, atmospheric scene

The Vera Cruz Affair

You are a Sergeant in the St-Etienne police force and have to deal with a tricky case that starts out looking like a suicide and turns into something more sinister. The investigation begins at the scene of the crime which you have to examine for clues to set you on your way.

The initial scene is depicted very well and provides plenty of atmosphere to get you into the game. Having examined all the effects present you can move onto the next stage of the

game, where everything is handled through the police computer. This isn't as graphically interesting as the opening screen but contains some excellent facial pictures of the various suspects and witnesses.

Through the computer you can perform six basic tasks to get additional information or to identify the guilty party. Messages can be sent to and received from other police bodies; statements can be ob-

tained from witnesses and suspects; the facts can be compared with the statements; examinations made on the evidence or the body; printouts taken of information gained; and of course an arrest made when

SIREN SOFTWARE

1.**DISCOVERY**

The tape-to-disc transfer program. Transfers some turbo loaders, alters BASIC loaders to get programs running without alteration. "HIGHLY RATED", Amix! "Discovery does it best across the widest range of games." AA, Feb '86. "Probably the best of the tape-to-disk copiers." AA, Mar '86. Featured in the serious software chart, AA March '86. On 464, 664, 6128. Disc £11.99, tape £7.99

2.**MASTER DISC** *NEW*

The only disk utility package you will ever need, this program really does it all.

IMAGE - make backups of your disks (inc. funny formats, etc)

DIRECTORY EDITOR - unerase files, show hidden files, secure files, etc.

SPEEDFORM - format your disks lightning fast.

SECTOREDITOR - complete sector editor.

DEPROTECTOR - deprotect a Basic program.

DISK HEADER - display start, length, type, etc of files.

TAPE HEADER - as for disk header, but for tape.

TRANSFILE - transfer individual files from disk to tape or disk to disk.

DISKMAP - shows how files are stored on disk.

TYPESTYLE - display on screen or printer any ASCII file.

DUMPFIL - display Hex/ASCII format for contents of a file.

DISK - speed up your disk drive by up to 20%.

This disk does it all!

On 464, 664, 6128. Disk only £12.99.

OVERSEAS PLEASE ADD £1.00 FOR POSTAGE AND PACKING

SIREN SOFTWARE
76 BRIDGE ST
MANCHESTER M3 2RT
TEL 061 796 6874



SIREN SOFTWARE

SELECTED AMSTRAD PROGRAMS

CASSETTE SOFTWARE

TITLE	RRP	OUR PRICE
WINTER GAMES.....	9.95	7.50
BOMB JACK.....	8.95	6.95
YIE AR KUNG FU.....	8.95	6.95
EXPLODING FIST.....	9.95	7.50
BRUCE LEE.....	9.95	7.50
BRUCE LEE.....	9.95	7.50
COMMANDO.....	9.95	7.50
10 COMPUTER HITS 2.....	9.95	7.50
RAMBO.....	8.95	6.95
DUN DARACH.....	9.95	7.25
FRANK BRUNO.....	8.95	6.95
FAIRLIGHT.....	9.95	7.50
HYPERSPORTS.....	8.95	6.95
GREEN BERET.....	8.95	6.95
3D STUNTRIDER.....	8.95	6.95
GET DEXTER.....	9.95	7.50
ROCK 'N' WRESTLE.....	9.95	7.50
3D GRAND PRIX.....	9.95	7.50
SPITFIRE 40.....	9.95	7.50
BARRY McGUIGAN.....	9.95	7.50
ALIEN HIGHWAY.....	8.95	6.95
MOON CRESTA.....	7.95	6.95
SABOTEUR.....	8.95	6.95
RED MOON.....	6.95	5.50
KNIGHT LORE.....	9.95	7.50
MONOPOLY.....	9.95	7.50
D. THOMPSON SUPER.....	8.95	6.95
D. THOMPSON DECATH.....	8.95	6.95
SOLD A MILLION.....	9.95	7.50
BATMAN.....	8.95	5.95
TASWORD 464.....	19.95	10.95

DISC SOFTWARE

TITLE	RRP	OUR PRICE
MINI OFFICE 2.....	19.95	16.95
TASWORD 6128.....	24.95	19.95
SORCERY.....	13.95	11.95
BIGGLES.....	14.95	12.95
SCRABBLE.....	14.95	12.95
3D BOXING.....	13.95	11.95
SOLD A MILLION.....	14.95	12.95
SOLD A MILLION 2.....	14.95	12.95
FIGHTER PILOT.....	13.95	11.95
GLEN HODDLE.....	13.95	11.95
HYPERSPORTS.....	12.95	10.95
ELITE.....	19.95	17.50
3D STUNT RIDER.....	13.95	11.95
YIE AR KUNG FU.....	12.95	10.95
MARSPORT.....	13.95	11.95
SPITFIRE 40.....	14.95	12.95

PCW 8256

PRO-SPELL.....	29.95	23.95
HITCHHIKERS GUIDE.....	28.75	22.95
LORD OF THE RINGS.....	24.95	20.95
BALLY HOO.....	28.75	22.95
ENCHANTER.....	23.00	19.95
PLANETFALL.....	23.00	19.95
BRIDGE PLAYER.....	19.95	16.95
COLOSSUS CHESS.....	15.95	13.95
GERMAN MASTER.....	19.95	16.95
FRENCH MISTRESS.....	19.95	16.95
ZORK 1.....	23.00	19.95

ALL PRICES INCLUDE VAT AND POSTAGE & PACKING
(Overseas orders add £1 per item)
Cheques/PO associate to:

C & F ASSOCIATES

and send to:

C & F ASSOCIATES (AA), P O BOX 2, BIDEFORD, EX39 3RE
Tel: (023 72) 619

Orders normally despatched within 24 hours of receipt but maximum of 7 days.

AMSTRAD GRAND SALE

AMSTRAD SOFTWARE

MANIC MINER.....	£2.95	QUACK A JACK.....	£2.50
CRAZY GOLF.....	£2.50	JET BOOT JACK.....	£2.50
LASERWARP.....	£2.50	ALIEN BREAK-IN.....	£2.50
ATOM SMASHER.....	£2.50	SNOOKER.....	£2.50
GEMS OF STRADUS.....	£2.50	HOME BUDGET.....	£8.95
HARRIER ATTACK.....	£2.50	STEVE DAVIS SNOOKER.....	£5.95
BEACH HEAD.....	£4.50	RAID!.....	£4.50
ALIEN.....	£2.95	BOUNTY BOB.....	£3.95
HIGHWAY ENCOUNTER.....	£4.95	MUTANT MONTY.....	£2.50
RING OF DARKNESS.....	£2.95	CODENAME MAT.....	£2.50
AMERICAN FOOTBALL.....	£3.95	HEROES OF KARN.....	£3.50
T.L.L.....	£4.95	JEWELS OF BABYLON.....	£3.50
CHUCKIE EGG.....	£3.95	FOREST AT WORLD'S END.....	£3.50
TRIPODS.....	£3.95	STOCKMARKET.....	£2.50
CODENAME MAT II.....	£3.50	HUNTER KILLER.....	£2.95
GREMLINS.....	£3.50	SABRE WULF.....	£4.95
CAULDRON.....	£4.25	BATTLE FOR MIDWAY.....	£4.95
VIEW TO KILL.....	£3.50	ALIEN 8.....	£4.95
BLAGGER.....	£2.50	EVERYONE'S A WALLY.....	£4.95
STAR COMMANDO.....	£2.50	INCA CURSE.....	£2.50
ASTRO ATTACK.....	£2.50	ESPIONAGE ISLAND.....	£2.50
SNOWBALL.....	£5.95	PLANET OF DEATH.....	£2.50
DARK STAR.....	£4.50	SHIP OF DOOM.....	£2.50
TRIAL OF ARNOLD BLACKWOOD.....	£2.95	FANTASIA DIAMOND.....	£3.95
FOOTBALL MANAGER.....	£5.95	GRAND PRIX DRIVER.....	£2.95
LUCKY FRUITS.....	£2.95	AMSGOLF.....	£2.95
BATTLE OF THE PLANETS.....	£4.95	CLASSIC ADVENTURE.....	£2.50
TECHNICIAN TED.....	£3.95	HEATHROW A.T.C.....	£3.95
ALEX HIGGINS WORLD POOL.....	£4.95	FU KUNG IN LAS VEGAS.....	£2.50
ALEX HIGGINS WORLD SNOOKER.....	£4.95		
ANDROID 2.....	£3.95		
ON THE OCHE.....	£2.95		
SPACE HAWKS.....	£2.50		
SPANNERMAN.....	£2.50		
3D INVADERS.....	£2.50		
ELECTRO FREDDIE.....	£2.50		
MASTER CHESS.....	£2.95		

Anything currently available in software or peripherals we can supply - just phone us for a quote.

LOGIC SALES LTD

6 Midgate Peterborough Cambs PE1 1TN

24 hour ordering on 0733 313870

SHEKHANA COMPUTER SERVICES

	RRP	OUR PRICE
ELITE-D4.....	14.95	12.95
BOMB JACK-D2.....	8.95	6.75
GHOST AND GOBLINS-D2.....	8.95	6.75
COMMANDO-D2.....	9.95	7.50
*PAPER BOY-D2.....	9.95	7.50
CASCADE 50-D2.....	9.95	7.50
EQUINOX-D2.....	9.95	7.50
LORD OF THE RINGS.....	15.95	12.95
SOUTHERN BELLE.....	7.95	5.95
V-D2.....	8.95	6.75
NIGHT GUNNER-D1.....	8.95	6.75
ARNEHAM.....	9.95	7.50
WINTER GAMES-D2.....	9.95	7.50
JACK THE NIPPER-D2.....	8.95	7.50
MASTERFILE.....	24.95	22.50
YIE AR KUNG FU-D2.....	8.95	6.75
MINI OFFICE 1.....	5.95	4.99
SCRABBLE-D2.....	9.95	7.50
MINI OFFICE 11-D4.....	14.95	12.95
LAZER BASIC-D2.....	14.95	12.95
WAY OF THE TIGER-D2.....	9.95	7.50
DESERT RATS.....	9.95	7.50
GHOSTBUSTERS-D2.....	10.99	8.50
SABATEUR-D2.....	8.95	6.75
TURBO ESPRIT-D2.....	8.95	6.75
TAU CETI-D2.....	9.95	7.50
AZIMUTH (HEAD ALIGN).....	8.95	7.95
SOCCER 86-D2.....	9.99	7.95
THEATRE EUROPE.....	9.95	7.50
BIGGLES-D2.....	9.95	7.50
SPINDIZZY-D2.....	9.95	7.50
RESCUE ON FRACTULUS-D2.....	9.95	7.95
HIGHWAY ENCOUNTER-D1.....	8.95	6.75
IAN BOTHAMS CRICKET.....	7.95	5.95
3D GRAND PRIX-D1.....	9.95	7.50
ESP LIGHT PEN.....	19.95	17.95
BRIDGE PLAYER 3-D2.....	12.95	10.95
3D CYRUS CHESS.....	9.95	7.50
MONOPOLY-D2.....	9.95	7.50
COLOSSUS CHESS 4.0-D2.....	9.95	7.50
FAIRLIGHT-D2.....	9.95	7.50
TOMAHAWK-D2.....	9.95	7.50
GREEN BERET-D2.....	8.95	6.75
NICK FALDOS GOLF.....	9.95	7.95
THE FIFTH AXIS-D2.....	9.95	7.50
HEAVY ON THE MAGIC-KD2.....	9.95	7.50
SHOGUN-D2.....	9.95	7.50
LAZER GENIUS-D4.....	14.95	12.95
GET DEXTER-D2.....	9.95	7.50
DOOMSDAY BLUES-D2.....	9.95	7.50
KNIGHT GAMES-D1.....	8.95	6.75
DOOMSDARK REVENGE-D2.....	9.95	7.95
BATMAN-D2.....	8.95	6.75
GLADIATOR-D3.....	8.95	7.50
STARQUAKE-D1.....	8.95	6.75
SPITFIRE 40-D2.....	9.95	7.50
NODES OF YESODS-D2.....	9.95	7.95
GLASS-D2.....	9.95	7.95
SPLITTING PERSONALITIES-D3.....	8.95	7.50
SAI COMBAT.....	8.95	7.50
FIGHTER PILOT-D1.....	8.95	6.75
SWORDS AND SORCERY-D2.....	9.95	7.95
LAST V8.....	2.99	2.99
THE PRICE OF MAGICK.....	9.95	7.50
BOUNDER-D1.....	9.95	7.50
MOVIE-D2.....	8.95	6.75
STRIKE FORCE HARRIER-D2.....	9.95	7.95
PRO TENNIS-D2.....	9.95	7.95
KNIGHT TYME.....	2.99	2.99

D=DISK VERSION AVAILABLE. D1=AT £11.95, D2=AT £12.95, D3=AT £14.95, D4=AT £17.50.

Special offer while stocks last. 3" disks box of 10 only £38.00. Inc P+P.

FOR MAIL ORDER: CHO/P O PAYABLE TO

S.C.S. (AA) P.O. BOX 394 LONDON N15 6JL. TELEPHONE 01-800 3156.

P+P INCLUDED IN U.K. EUROPE ADD £1 PER TAPE. ELSEWHERE AT COST. S.A.E. FOR FULL LIST.

If you would like to pick up your discount software please bring along this advert to:

S.C.S. UNIT 5, 221 TOTTENHAM COURT ROAD, LONDON W1R 9AF.

(NEAR GODDGE ST TUBE STN) OPEN 6 DAYS A WEEK 10.00 AM - 18.00 PM

ACCESS AND VISA HOT LINE PLEASE RING 01-631 4627

CREDIT CARD OWNERS DESPATCHED SAME DAY - SUBJECT TO AVAILABILITY.

*FOR NEW RELEASES, PLEASE RING TO CONFIRM AVAILABILITY.

WAR

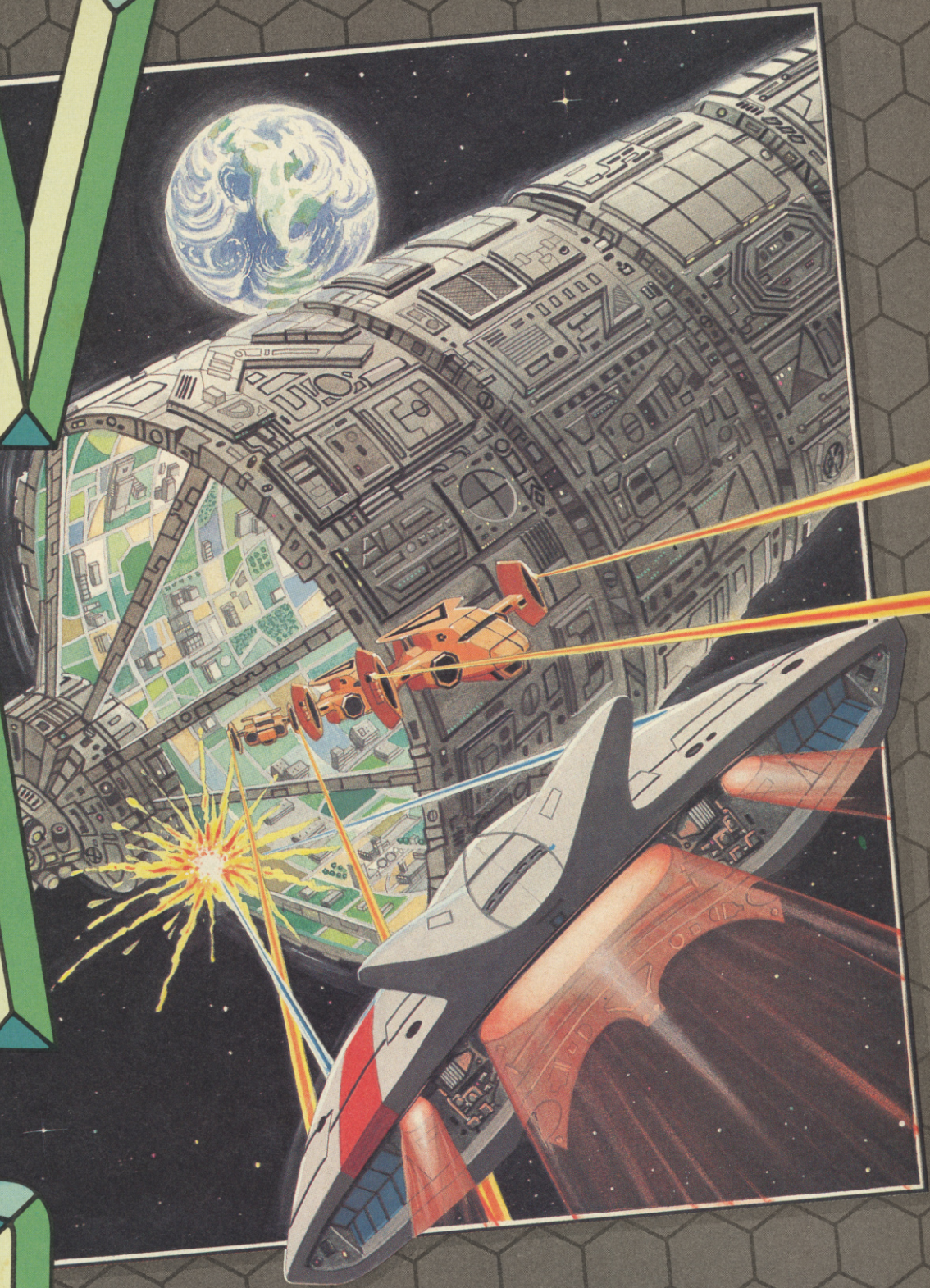

BEING A HERO IS EASY.
STAYING ALIVE IS MORE DIFFICULT!

Spectrum 48K/128K
Amstrad 464/664/6128
CBM 64/128
MSX

£7.95
£8.95
£8.95
£8.95

martech

Martech is the registered trade mark of
Software Communications Limited, Martech House,
Bay Terrace, Pevensey Bay, East Sussex BN24 6EE

TRADE ENQUIRIES WELCOME. PHONE: (0323) 768456 TELEX: 878373 Martec G



NODES OF YESOD[®]

Odin
COMPUTER GRAPHICS LTD.

SPECTRUM - COMMODORE 64 - AMSTRAD -
© "NODES OF YESOD" IS A COPYRIGHT OF B.T.PLC



SALES 01-379 6755
01-240 9334
INTERNATIONAL 44-1-379 6755

PREVIEWS STAINLESS STEEL PREVIEWS

you think you have enough evidence.

There's plenty of investigating and deducing to absorb you here. It's difficult to know exactly how it will play in English (my French isn't that hot!), but it's certainly different to anything you'll have seen before and will really put your powers of deduction to work. Should have a wide appeal to both adventurers and arcade players alike.



Brigade de Recherches ST-ETIENNE
GENDARMERIE NATIONALE
AUDITION

LAFEUILLE Madine
nee le 1.2.56 a VALENCE (07)
demeurant 2 rue Balay a ST-ETIENNE.

--Je suis une amie d'enfance de Vera CRUZ. Je l'ai rencontrée la veille de son deces. Elle m'a dit qu'elle en savait trop sur une sale affaire et avait peur d'un certain 'manouche'.

M = message
E = examen

D = deposition
C = comparaison

I = imprimante
A = auteur

One of the printouts of a suspect's statement in the Vera Cruz Affair with their picture on it

Stainless Steel

Fresh from their hit with *Equinox* Mikro-Gen's latest game is based around a 'teenage hero', Ricky Steel. The version of the game we were sent was still some way off completion, with one of the four main game sections still to be added on and several other minor alterations to be made to the existing sections.

The four sections of the game involve you in first trying to locate a flying car, using it to cross a hostile desert, fly down a waterway on a submarine hunt, and then trying the unseen fourth section. Each section consists of a route a single screen wide that is viewed from above and scrolls as progress. The first one is completed on foot along a roadway, pitted against

helicopters and tank defenders. You can move forwards and backwards along the route, which is well drawn but lacks much use of colour at the moment.

The second and third sections are faster and tougher than the first, with the flying car being harder to control than the walking man. You encounter enemy missiles, planes and obstacles that have to be shot down or avoided to continue making progress. Again these stages are pretty much single colour but have some good graphics. On all three stages there's a radar scanner to indicate progress and the problems approaching.

Although the use of colour looks uninspiring at this stage the gameplay already looks like it's going to be fairly addictive and tough. Fast action, shoot-em-up fans should keep an eye open for the full review coming soon (we hope!).

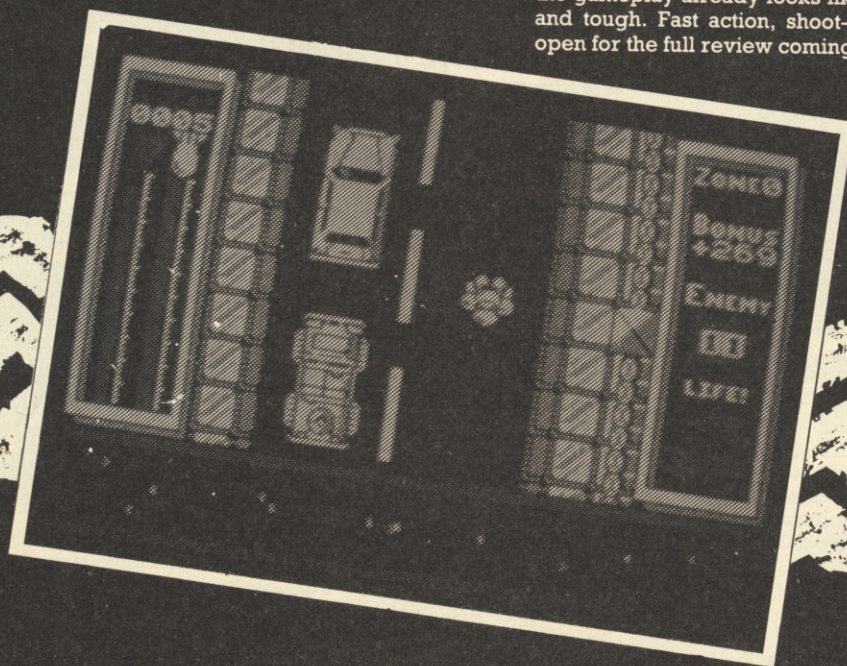

Ricky Steel searches for his flying car on the first of the four stages

HELICOPPER

Firebird, £1.99 cass, joystick or keys

Not one of the more original titles I've seen lately and unfortunately the same can be said of the game itself. It's a one screen effort in which a helicopter has to rescue clones from various swamp creatures. There are 23 waves of creature so the opposition changes even if nothing else does.

On the left hand side of the screen are a number of ledges and in the bottom right is a man standing by a fence. Your helicopter appears roughly in the middle of the screen and has to fly down to the fence, pick up the man, and then drop him off on one of the ledges. Several men have to be deposited; how many depending on which level you're on. Trying to stop you are the various creatures that appear on each of the 23 levels.

SECOND OPINION

I find it hard to believe this comes from the same house as Thrust. The game is absolutely diabolical, no two ways about it. Puny graphics, pointless gameplay and feeble sound effects make this the sort of thing that gives budget games a bad name.

AW

These appear from the edges of the screen, some following fixed movement patterns while others move around aimlessly - some even home in on the helicopter. You can bomb them if you can get them underneath you, and you have an infinite supply of bombs to blast away with.

Each screen has to be completed within a set time limit, and every time the chopper hits one of the creatures or sinks into the swamp at the bottom of the screen a life is lost. Most of the screens are fairly easy, though there is the occasional one that needs careful timing - but with a little practice even these won't hold you up for long.

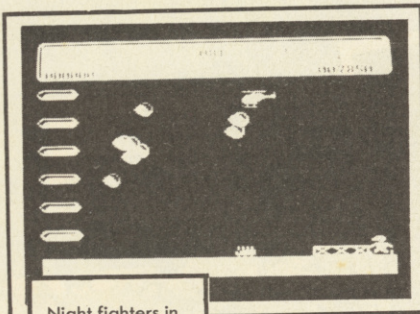

Night fighters in your sights

Not very inspiring at all, with very crude use of graphics and colour, and boring gameplay that won't interest anyone for long. The best thing about it is the loading music and screen.

FIRST DAY TARGET SCORE
Screen 23

BW

GREEN SCREEN VIEW

You can hardly see some of the nasties, but that's a small price to pay for getting rid of those revolting colours.

AW

THIRD OPINION

You must be joking.

MN

GOOD NEWS

► 23 screens of various creatures to beat.

BAD NEWS

- Crude graphics and colour.
- Boring, repetitive gameplay.
- Not even worth £1.99.
- Monotonous game sound.

GRAPHICS	33%	
SONICS	32%	
GRAB FACTOR	24%	
STAYING POWER	17%	
AA RATING	21%	

NIGHT GUNNER

Digital Integration, £7.95 cass, £13.95 disc, joystick or keys

Don't be misled into thinking this is a flight simulator just because it comes from the people who brought us *Tomahawk* - it is in fact just a shoot-em-up, bomb-em-up, strafe-em-up arcade game. It puts you in a Lancaster bomber that is set a series of missions deep into enemy airspace where it will have to cope with both air and ground forces.

SECOND OPINION

Digital Integration might be respectable simulation publishers these days, but once upon a time they turned out silly arcade games like this one. Why they've chosen to convert Night Gunner now I really don't know, because it really creaks. It's fun for a few minutes, but it's not worth anywhere near £7.95.

AW

Each mission begins with a flight to the target in which you have to battle enemy night fighters and barrage balloons. Your view is out of the gun turret and a cursor guides the machine gun bullets around. You have limited ammo and you'll need to save some for the flight back. Meanwhile the enemy is scoring hits on you which gradually build up and can prove fatal.

Once at the target you're set one of two types of mission, a high level bombing run or a rocket attack. The bombing run gives you an overhead view of various ground

TRASHMAN

New Generation/Virgin, £7.95 cass, joystick or keys

It's been a long wait for the conversion of this game, which is all about the problems faced by Britain's bin men. It involves a never ending battle against the hazards that lie in wait in what at first seems to be a quiet suburban street.

Initially you're set the task of emptying five bins in a single street before the bonus time limit runs out. The screen shows a vertical roadway with detached houses on either side. Each house has a gate and a

SECOND OPINION

Very simple and quite old, but it's nicely done. The time limit's quite tough, and those dogs'll drive you up the wall. Nothing to get excited about I'll admit, but quite fun.

AW

path, on which is placed a dustbin waiting to be emptied. You control a little stick-man bin-man who has to get the bin and empty it into the back of the waste lorry that slowly makes its way up the left hand side of the road.

After emptying, each bin has to be put back in place before moving onto the next one. Bins have to be collected from the houses on both sides of the road, and the ones on the right hand side are particularly hazardous because you have to brave the

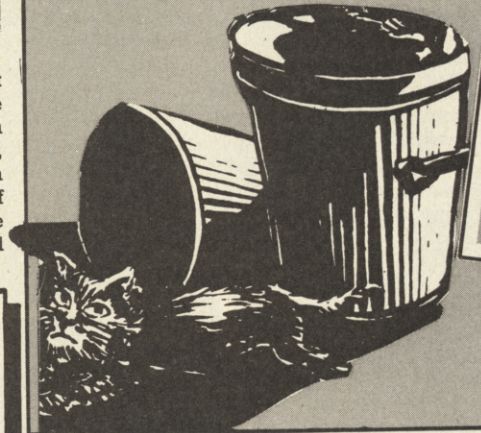

You'll be asleep in charge of this helicopter

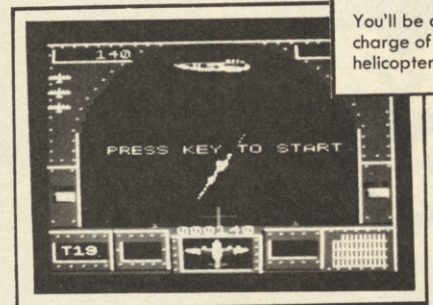

vehicles including tanks, lorries, tracks and artillery. The rocket attack shows the vehicles in front of you as you dive, release the rockets and then pull up to avoid crashing.

At first the vehicles don't move, but on

dangers of the traffic. You can even be killed by your own waste lorry if you're not careful.

Each house is drawn in pseudo 3D with gardens, garages, and hedges, and if you avoid trampling on anything the householder appears at the door as you're leaving. If you pop in through the front door you'll get extra bonus time and a very old and corny joke. If you stray onto the grass at some houses a dog comes out and bites you, causing you to limp. This makes you

THIRD OPINION

A nice gentle game that's not too complicated and not too taxing. Shame the jokes are so corny though.

MN

travel slower, as does carrying a laden bin as opposed to an empty one. Other dangers include bicycles that race down the footpaths and can also slow you down if they hit you.

If you successfully get all the bins emptied then you have to tackle another street with more bins and more hazards: bins are placed in more awkward places, bikes and dogs appear more frequently, cars travel nearer the edge of the road and grass verges appear on the footpaths.

The graphics look quite good although the 3D is very unconvincing, and better use could have been made of Arnold's colour. The gameplay is quite addictive, with what is still a novel and original task. It's a shame the game wasn't converted sooner, but now it's here it's certainly worth a look.

FIRST DAY TARGET SCORE

10,000

BW

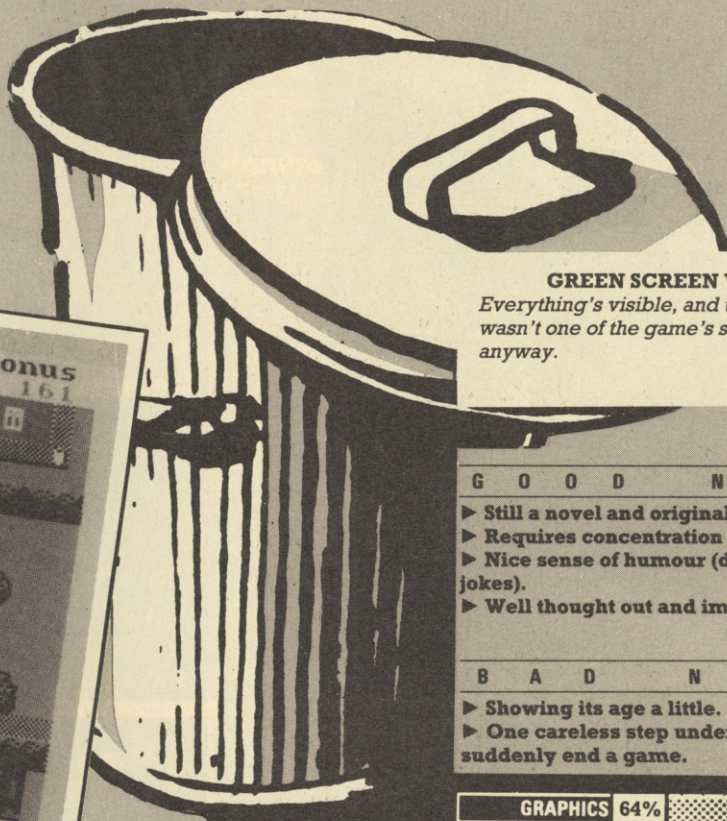

GREEN SCREEN VIEW

Everything's visible, and use of colour wasn't one of the game's strengths anyway.

AW

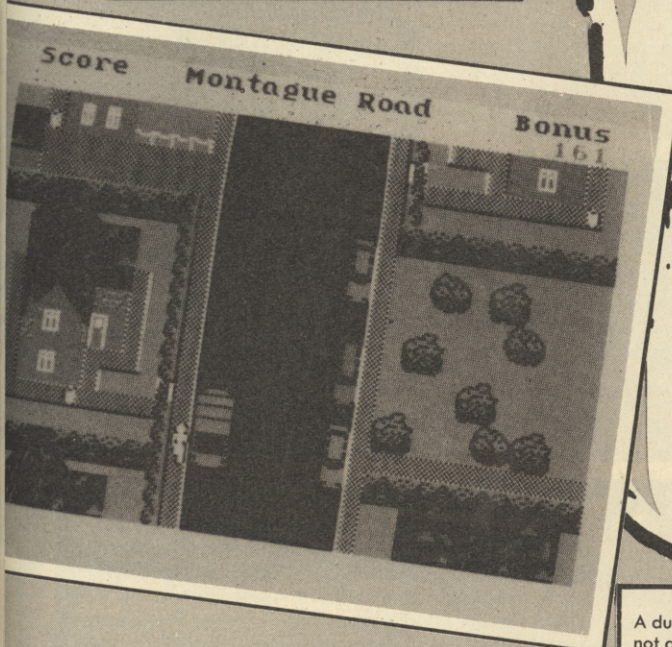

A dustman's life is not a happy one

GOOD NEWS

- ▶ Still a novel and original game.
- ▶ Requires concentration and skill.
- ▶ Nice sense of humour (despite corny jokes).
- ▶ Well thought out and implemented.

BAD NEWS

- ▶ Showing its age a little.
- ▶ One careless step under a car can suddenly end a game.

GRAPHICS	64%	
SONICS	22%	
GRAB FACTOR	77%	
STAYING POWER	75%	
A A RATING	73%	

later missions they do, so you have to fire your weapons ahead of the target to score a hit. The same happens on the machine gunners screen where the tracer has to be aimed ahead of the moving target.

THIRD OPINION

Good for some mindless zapping, and it's nice the way the tracers curve through the sky. At around £2 it might have been worth it, but it really is overpriced at £7.95.

MN

may take more hits on specific areas which can affect its handling. Survival means the plane gets completely patched up and sent off on another tougher mission.

The graphics are very colourfully done with some good planes and vehicles, and some equally pleasing explosions. The gameplay tends to get repetitive very quickly so you'll need to be pretty mindless and bloodthirsty to stay with it for long.

FIRST DAY TARGET SCORE

10,000

BW

GREEN SCREEN VIEW

No problems here.

AW

GOOD NEWS

- ▶ Some good multi-coloured plane and vehicle graphics.
- ▶ Lots of explosions, things to shoot and loud bangs.

BAD NEWS

- ▶ Repetitive so you'll quickly tire of it.
- ▶ Apart from the planes and vehicles there's not a lot else to see.
- ▶ Never much impression of movement.

GRAPHICS	66%	
SONICS	65%	
GRAB FACTOR	55%	
STAYING POWER	44%	
A A RATING	49%	

After the bombing run you have to survive the trip back home, and the plane

CHEAT MODE

Bob Wade checks out your tips, pokes and game-busting ploys. The best ones win a tenner – so why not send YOUR latest gem to: Cheat Mode, Amstrad Action, Somerton, Somerset TA11 5AH

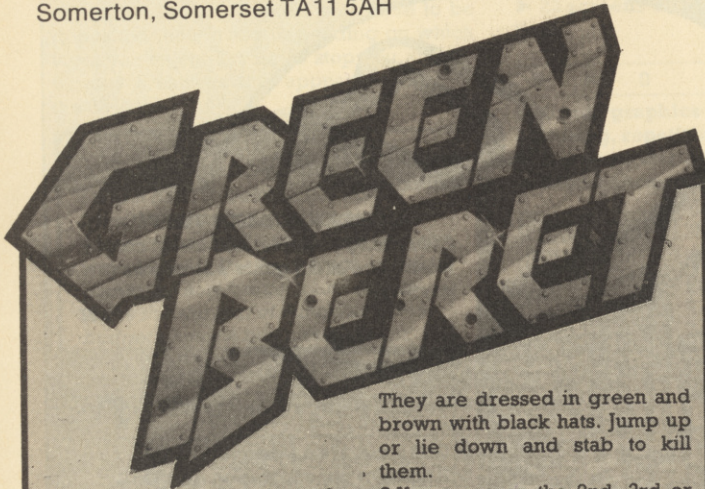

Here are some tips for Imagine's stab-em-up from J(?) Lawless of Cabra in Ireland. Using these you should be able to get a lot further into the game.

First some general tips for all the levels, followed by some details on levels two and three.

1. Never stand at the very edge of a screen.
2. If you see a Commandant (blue uniform), position yourself by the bottom of the first ladder he will come to. If he is not already on the bottom level he will climb down and you can stab him to get his weapon.
3. Only Commandants and Rifle Carriers follow you around. To beat them off just climb a ladder, lie down and knife them as they come after you.
4. If the enemy is right behind you, run right. As the screen scrolls jump left over their heads. Face right and, if you have a weapon, blow'em away.
5. If you have a weapon don't be miserly with it. If you are close to the right hand edge of the screen when you fire it, it will scroll with the screen and you get twice the killing power.
6. If you don't have a flamethrower at the end of the first level than lie down and stab the enemy.
7. Karate troops are a real pain.

They are dressed in green and brown with black hats. Jump up or lie down and stab to kill them.

8. If you are on the 2nd, 3rd or 4th levels try to get on one of the higher platforms. Get two enemy troops running along below you (one will do, three is a gift). When you drop down follow them along since only three enemy troops appear at a time except at the end of a level. This way you will easily get to the end of a level.

Level 2: At the end of this you will come to a submarine. Lie down in the centre of the screen, or slightly left of centre, facing left. Four dogs will come after you. You must lie down and stab these because the rocket launcher is useless against them. When these four are dispatched turn right and, still lying down, kill another four dogs. Repeat this twice more.

Level 3: This is very tough. Take a step or two right, jump left over the mine and climb on the wall. If you see a rifle Carrier throwing a grenade (you'll hear a warbling noise), jump at him. On this level it is vital that you use your bazooka when two men are ahead of you.

When you come to the fence get up on to it as soon as possible because it's much easier up there. At the end you come up against a small helicopter that I've yet to beat.

664/6128 Pokes

Compatibility problems have struck again, this time with Phil Howard's pokes. Because of the particular way he gets round one of the common protection systems, it means the pokes don't work on a 664 or 6128. However to the rescue comes Richard Hodges from Barnet who has discovered the necessary changes to make them work. We're printing fully corrected listings for the 664 and 6128 that are all entered using Method 1, but here are the necessary technical changes from the originals for those in the know.

In the data statements these changes (system variables) need to be made: B807 becomes B11F, B1EA becomes B7E5, B1D9 becomes B7D4 and an additional call, CALL &3A6A, needs to be added.

```
,88,21,74,22
30 DATA 36,05,23,36,bb,21,40
,20,11,40,00
40 DATA 01,36,02,ed,b0,21,40
,00,e5,21,00
50 DATA bb,e5,21,36,02,e5,21
,1f,b1,e5,21
60 DATA bb,02,e5,f1,21,e5,b7
,11,d4,b7,f3
70 DATA c9
80 MEMORY &2000
90 LOAD""
100 CALL &3A6A
110 LOAD"!",&2040
120 FOR x=&BE00 TO &BE42
130 READ a$
140 POKE x,VAL("&"+"a$)
150 NEXT
160 MODE 1
170 POKE &BE0F,255
180 CALL &BE13
```

Nomad

```
10 DATA 21,3a,22,36,00,c3,dc
,3a,21,40,22
20 DATA 36,25,23,36,9b,21,40
,20,11,40,00
30 DATA 01,06,02,e6,b0,21,40
,00,e5,21,00
40 DATA bb,e5,21,06,02,e5,21
,1f,b1,e5,21
50 DATA bb,02,e5,f1,21,e5,b7
,11,d4,b7,f3
60 DATA c9
```

Sabre Wulf

```
10 DATA 21,2c,97,36,19,23,36
,0f,23,36,11
20 DATA 21,c3,9b,36,04,c3,1a
```

Poke methods

This is the section where we explain how to input the majority of Cheat Mode pokes. There are two different methods – the instructions for each poke tell you which one to use. If you have a 664 or 6128, you'll have to type |tape before using either.

Method 1: Make sure that you've rewound the game tape to the beginning. Now type in the poke listing. Then type RUN and press the 'Enter' key. (Don't use the key marked 'CTRL' or 'CONTROL', that will stop the poke from working.) Press the PLAY key on the cassette deck, and hit any key on the main keyboard – the space bar will do nicely. The tape should now start to play through in the normal way.

Method 2: For this method, you have to skip the first bit of the game program. To do that, start by rewinding the game

tape to the beginning. Now type in the listing. Then type CAT, and press the 'Enter' key. Start the tape by pressing PLAY and hitting a key, and then watch the screen.

After a little while you'll get the message "Found SOMETHING block 1". It doesn't matter what the SOMETHING actually is – this will vary from one game to another. If the instructions with the poke just tell you to skip the first block you should stop the tape here. If the instructions tell you to skip several things, stop the tape when the 'Found' message comes up for the last thing you're trying to skip.

Once you've stopped the tape press the ESC key, type RUN, and press the 'Enter' key. Now press PLAY on the tape deck, and hit a key on the keyboard to start the tape running.

70 MEMORY &2000
 80 FOR x=&BE00 TO &BE37
 90 READ a\$
 100 POKE x,VAL("&" + a\$)
 110 NEXT
 120 LOAD""
 130 CALL &3A6A
 140 LOAD"!",&2040
 150 CALL &BE08

Batman

10 DATA 21,90,1c,36,00,c3,00,
 ,01,21,2d,22
 20 DATA 36,d3,21,40,20,11,40,
 ,00,01,f2,01
 30 DATA ed,b0,21,40,00,e5,21,
 ,00,bb,e5,21
 40 DATA f2,01,e5,21,1f,b1,e5,
 ,21,bb,02,e5
 50 DATA f1,21,e5,b7,11,d4,b7,
 ,f3,c9
 60 MEMORY &2000
 70 FOR x=&BE00 TO &BE34
 80 READ a\$
 90 POKE x,VAL("&" + a\$)
 100 NEXT
 110 LOAD""
 120 CALL &3A6A
 130 LOAD"!",&2040
 140 CALL &BE08

TLL

10 DATA 21,8a,90,36,00
 20 DATA 21,a2,a6,36,00

30 DATA 21,c8,a8,36,00
 40 DATA 21,9b,a9,36,00
 50 DATA 21,7a,91,36,00
 60 DATA c3,f5,8f,21,77,22,36,
 ,25,23,36,e2
 70 DATA 21,40,20,11,40,00,01,
 ,3a,02,ed,b0
 80 DATA 21,40,00,e5,21,00,bd,
 ,e5,21,3a,02
 90 DATA e5,21,1f,b1,e5,21,bb,
 ,02,e5,f1,21
 100 DATA e5,b7,11,d4,b7,f3,c
 9
 110 MEMORY &2000
 120 LOAD""
 130 MODE 1
 140 CALL &3C6A
 150 LOAD"!",&2040
 160 FOR x=&BF40 TO &BF88
 170 READ a\$
 180 POKE x,VAL("&" + a\$)
 190 NEXT
 200 CALL &BF5C

Jet Set Willy (TSAM)

10 DATA 21,25,22,36,73,23,36,
 ,6a,21,40,20
 20 DATA 11,40,00,01,eb,01,ed,
 ,b0,21,40,00
 30 DATA e5,21,00,bb,e5,21,eb,
 ,01,e5,21,1f
 40 DATA b1,e5,21,bb,02,e5,f1,
 ,21,e5,b7,11
 50 DATA d4,b7,f3,c9,21,b7,57

,36,00,23,36
 60 DATA c3,23,36,11,23,36,75,
 ,c3,66,4d,f5
 70 DATA cd,09,bb,fe,0d,ca,33,
 ,54,f1,c3,bb
 80 DATA 57
 90 MEMORY &2000
 100 LOAD"":CALL &3AB1:LOAD"!":
 :CALL &7070
 110 LOAD"!",&2040
 120 FOR x=&74D0 TO &751D
 130 READ a\$
 140 POKE x,VAL("&" + a\$)
 150 NEXT
 160 CALL &74D0

Rambo

10 DATA 21,9c,8e,36,00,23,36,
 ,00,23,36,00
 20 DATA 21,ab,8e,36,00,c3,00,
 ,8f,21,2d,22
 30 DATA 36,f8,21,40,20,11,40,
 ,00,01,f2,01
 40 DATA ed,b0,21,40,00,e5,21,
 ,00,bb,e5,21
 50 DATA f2,01,e5,21,1f,b1,e5,
 ,21,bb,02,e5
 60 DATA f1,21,e5,b7,11,d4,b7,
 ,f3,c9
 70 MEMORY &2000
 80 FOR x=&9500 TO &953F
 90 READ a\$
 100 POKE x,VAL("&" + a\$)

110 NEXT
 120 LOAD""
 130 CALL &3A6A
 140 LOAD"!",&2040
 150 CALL &9513

Highway Encounter

10 DATA 21,40,00,11,00,9c,01,
 ,40,00,ed,b0
 20 DATA 21,00,00,11,40,00,01,
 ,00,99,ed,b0
 30 DATA 21,77,00,36,03,21,00,
 ,9c,11,00,00
 40 DATA 01,40,00,ed,b0,c3,f2,
 ,01,21,74,22
 50 DATA 36,0f,23,36,a0,21,5d,
 ,22,36,5b,21
 60 DATA 40,20,11,40,00,01,37,
 ,02,ed,b0,21
 70 DATA 40,00,e5,21,00,bb,e5,
 ,21,37,02,e5
 80 DATA 21,1f,b1,e5,21,bb,02,
 ,e5,f1,21,e5
 90 DATA b7,11,d4,b7,f3,c9
 100 MEMORY &2000
 110 LOAD""
 120 MODE 1
 130 CALL &3A6A
 140 LOAD"!",&2040
 150 FOR x=&9300 TO &935D
 160 READ a\$
 170 POKE x,VAL("&" + a\$)
 180 NEXT
 190 CALL &9329

ZOIDS

Daniel Castle from Marlborough has some tips for anyone trying to get into Martech's game of these plastic dinosaurs.

When you come to a city complex, call up the base and tell them to launch a missile on the power station. The zoid's heart beat will go up and you should now fire a short range missile at either the mine or the beacon. Repeat this procedure but go for the city domes.

To pick up extra power cells, destroy an installation and move to where it was standing. Turn on the scanner and any object around will show up on it

and be automatically picked up.

When you're moving the best tip is to go to the missile icon once you begin to move. That way there is a red zoid creeping towards you. You can despatch a short range missile to turn it into a pile of zoidar scrap.

It is easy to be destroyed by incoming red missiles. You should really spend a few games practising shooting against them. You can do this by switching to the gun icon and pressing fire. You're then in gunnery practice mode where no missiles will harm you if they hit you.

TOMBSTOWNE

Keith Morris from Grantham has got some additional tips for the Amsoft arcade adventure, which lead on from those in issue 10.

1. After collecting the grey key from the upstairs bathroom, collect the book from the adjoining Master Bedroom.

2. Take the book to the Library and then walk to the far left of the room, avoiding the phantom.

3. When safe walk towards the right and jump, and you will enter the Secret Passageway.

4. Follow the passageway and you will enter the Armoury.

5. Collect the blue page, then climb the barrels to collect the shield at the top.

6. With the shield and the grey key go to the End of the Battlements outside the castle of Tombstowne. You will now be

able to pass the flying arrow and enter the Hut, and retrieve another blue page for the book of spells.



Meltdown

These tips come from Ben Lower of Wadhurst, who starts off with some general tips and then gives advice on how to complete the first six mini games on the disc version.

1. Always make sure you are standing still when firing or you will do a somersault. If you land on a cyberman you will die.
2. Don't stand still and let a cyberman come to you. Move into its line of fire and shoot it, because it will have less time to shoot you.
3. After releasing a bullet, sidestep to avoid incoming bullets.
4. In rooms which are cut in half by two storey computer stacks you can always shoot one of the stacks to make it explode. Only one will explode but it's always the same one for a particular screen.
5. In the room with a row of cybermen, try to stand behind them because as they turn round you can shoot them easily and quickly.
6. In any room before a gamma radiation room you will find a stationary cyberman in the top right hand corner of the room. Touch it and the cyberman suit will transfer to you so that you can safely pass through the

gamma radiation. On the other side you will be able to remove the suit in the same way you acquired it so that you can leave.

MINI GAMES

Terminal 1: Move the joystick diagonally for a second, then just fire until all nasties are killed.

Terminal 2: Give top priority to side missiles as they move twice as fast.

Terminal 3: Fire, then move slightly diagonally, then fire and repeat the process. This must be done to avoid shooting yourself.

Terminal 4: Line up with the top target and shoot when the gap is a few squares away, then move to avoid ricochets.

Terminal 5: Move to the top then come down in horizontal rows. By doing this you don't overlap or leave the screen. When you've got all the numbers the password is obtained.

Terminal 6: When you press the button to start the game fire instantly and you will get the A. Then it just takes practice to get the word ALIVE. Fire when the letter required is about 4 or 5 squares away.

Heavy on the Magick

A nice bonus for fans of the Gargoyle game - tips from C Hoare from Denham on summoning Demons and a poke from Darren Jones of Bryn giving you 99 per cent skill, stamina, luck and experience. The poke should be typed in and saved. Load the game as normal. Press 5 to restore Axil and enter version A. You'll also have all the spells and be grade 10.

Astarot: Drop the sword and stand well clear. Invoke Astarot. Astarot can now transport you to any place. Just type "Astarot, place". Eg: type "Astarot, Trollwynd".

Magot: Use same procedure as above but using the sunflower

instead of the sword. He can tell you where an object is by typing "Magot, object".

Belezbar: Invoked in the same manner but using the Mantis. Can tell you what an object really is.

10 POKE 43090,1
 20 POKE 43091,150:POKE 43092,150:POKE 43093,150
 30 POKE 43094,10
 40 POKE 43095,150
 50 POKE 43096,47:POKE 43097,102:POKE 43098,128
 60 POKE 43099,170:POKE 43116,248
 70 SAVE"AXIL-A",3,43090,27

Turbo Esprit

Infinite lives for the drug chasing, racing game, from Paul Robson of Middlesbrough. Enter using Method 2 to get past TITLE block 1 (be careful since there is only a small gap between this and the section you want to load.)

10 MODE 1:MEMORY 2015
 20 FOR F=2016 TO 2027

30 READ a:POKE f,a:NEXT
 40 DATA &21,0,&40,&11,&68,&42,&3e,&16,&cd,&a1,&bc,&c9
 50 CALL 2016:CALL 32768
 60 a=2017:POKE a,0:POKE a+1,8
 70 POKE a+3,&54:POKE a+4,&a1
 80 CALL 2016:POKE 34409,0:CALL 6496

Sabre Wulf

Another poke for a disc game, this time the TSAM version of Sabre Wulf. It's from Conor McCooey and John Keane of Dundalk and gives immunity to all animals. Just type in the listing, insert the TSAM disc and **SAVE"SABCHEAT",** then **RUN"SABCHEAT** and the game will load automatically.

10 BORDER 1:FOR i=0 TO 3:INK i,1:NEXT i
 20 MODE 1
 30 loc=&1000
 40 RESTORE 70:GOSUB 170
 50 DATA 3e,01,cd,0e,bc,06,0a,21,00,11,11,00,d0,cd,77,bc,21,00,13,cd,83,bc,cd,7a,bc
 60 DATA 06,0a,21,00,12,11,00,d0,cd,77,bc,21,00,c0,cd,83,bc,cd,7a,bc,c9,end
 70 loc=&1100

80 RESTORE 110:GOSUB 170
 90 DATA 53,41,42,47,52,46,2e,53,42,46,end
 100 loc=&1200
 110 RESTORE 140:GOSUB 170
 120 DATA 53,41,42,50,52,47,2e,53,42,46,end
 130 CALL &1000
 140 GOTO 240
 150 READ a\$
 160 WHILE a\$("end")
 170 POKE loc,VAL("&"a\$)
 180 loc=loc+1
 190 READ a\$
 200 WEND
 210 RETURN
 220 POKE &DD60,0:POKE &DD56,&18
 230 CALL &C000

KUNG-FU MASTER

Emmet Masterson and Simon O'Connell from Sidcup have been knocking the stuffing out of the five levels of US Gold's martial arts game - here are their tips to get you through them.

Level 1: just henchmen to beat on this floor, and Master of Stick is no trouble. Using punch move right up close to him and crouch. Then let him have it.

Level 2: it's best to use kick for the first part of this level as punch can sometimes be inaccurate. Avoid floating globes when they appear, as they are hard to destroy. When dwarfs somersault into you, jump up in the air to knock them off. To beat Boomerang Man use sweep. Move in and let him throw his first boomerang, duck or jump it, and then hit him. Remember to avoid his boomerang when it returns.

Level 3: it's just henchmen, knifemen and dwarves on this level so be careful with timing of punches and kicks. Strongman is again easy to beat, just move in and sweep.

Level 4: To kill bees on this level it's best to use punch. The

wizard is a hard opponent, as you must destroy each image of him until you face the real wizard. Duck each fireball and then keep on sweeping. With luck you should just have enough energy to pull through.

Level 5: Again just henchmen, knifemen and dwarves on this floor. Real skill is needed to reach the last opponent, and he is mean. Keep on punching and kicking and watch out because he kicks and punches back. We haven't been able to beat him yet so keep on trying.



"GET DEXTER!"

Phil Howard from Mapperley has slaved long and hard to bring you this poke which gives Dexter infinite energy. it's entered using Method 1, and you should ignore the odd colours on the loading screen and any funny noises near the end of the load - they're unavoidable.

```
10 DATA 21,22,b2,06,c3,e5,c5
,21,97,c2,e5
20 DATA c5,21,5e,02,06,cf,e5
,c5,21,ff,bb
30 DATA 06,08,e5,c5,21,55,7b
,3e,04,11,05
40 DATA 7c,c1,fd,e1,f5,cd,13
,79,38,fb,f1
50 DATA 3d,20,f0,21,5e,7b,36
```

```
,fa,21,4e,40
60 DATA 11,fb,7b,01,13,00,ed
,b0,f3,21,55
70 DATA 7b,11,31,b9,01,c0,00
,ed,b0,c3,31
80 DATA b9,21,16,b3,36,e2,23
,36,b9,c3,12
90 DATA b3,21,d1,7e,36,00,c3
,da,6b
100 MEMORY &3000
110 FOR x=&4000 TO &4060
120 READ a$
130 POKE x,VAL("&"*a$)
140 NEXT
150 LOAD""
160 POKE &7924,&c9
170 MODE 0
180 CALL &4000
```

Alien Break-In

Another one for infinite lives from Ian Grainger of Wingate. Enter it using Method 1.

```
10 MEMORY &5500:LOAD "part2"
:POKE &740C,0:POKE &70C8,60
20 FOR f=&9000 TO &9003:READ
a:POKE f,a:NEXT:READ a,b:PO
KE a,b
30 CALL 29658
40 DATA 71,63,21,47,29736,0
```

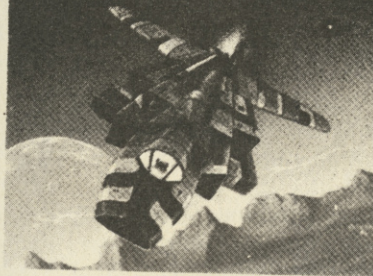

How to win an ENTIRE ISSUE'S Rave software!

The standard of pokes, maps and playing tips you've been sending us has been so high that we've decided to up the stakes. From now on we'll be setting you challenges each month to produce a particular poke, map or set of playing tips. All you have to do is find the solution and let us know about it within a month of the issue being published.

The best solution to one of the problems will win a stunning prize - a copy of every single Rave and the Mastergame in the issue in which the solution is printed. The number of these games will vary of course, but in past issues there have been six Raves or more - that's over £50 worth of software, and some months it will be over £100! The prizes will normally be supplied on cassette, but if you prefer you may ask to have disc software of equivalent value.

We'll also be giving out up to five runners-up prizes every month of one of the Raves/Mastergame in that issue. You don't necessarily have to solve one of the problems we set to win a prize - if you come up with something even better that'll suit us fine.

At the time of writing the first set of challenges set last month are still being worked on and we should see the results and the first prizes from that in the next issue. For this issue we've got five more testing challenges for you to get to work on.

1. A poke to allow joystick/dual joystick control on *Storm*.
2. A poke to make *Jack the Nipper* invulnerable to rash.
3. A poke to give invulnerability or the ability to start at any level on *Ghosts'n Goblins*.
4. A playing guide/tips on the helicopter simulator in *Biggles*.
5. Playing tips on *Cauldron II*.

Under the old system we've got three more £10 winners this month. J Lawless for his *Green Beret* tips, Richard Hodges for enabling 664 and 6128 owners to use a host of pokes, and Phil Howard for slaving over a poke for *Get Dexter*.



RADZONE

This poke from Paul Robson of Middlesbrough is entered using Method 1 and gives you infinite lives.

```
10 FOR f=&BB48 TO &BB4D
20 READ a:POKE f,a:NEXT
30 DATA &21,&ee,&09,&36,&67,
&c9
40 RUN"
```

Jet Set Willy

Good to see people coming up with pokes for disc versions of games, this ones for the TSAM disc version of *JSW*. It comes from Peter Millar of Aberdeen, and to use it you just type in the listing, type *SAVE"CHEAT* followed by hitting enter, then enter *RUN"CHEAT* and it will automatically load *JSW* with infinite lives.

```
10 MEMORY &2000
20 LOAD"jetset.sbf",&1260
30 FOR n=&9C40 TO &9C48
40 READ n
50 POKE n,n
60 NEXT
70 DATA 33,96,18,17,96,2
80 DATA 1,134,128,237,176,20
1
90 CALL &9C40
100 POKE &57B7,0
110 CALL &4D65
```

Chuckie Egg

This one from Paul Wilton of Mold speeds up the game (line 30) and removes monster detection (line 40). You may find it possible to get 'stuck' in a falling loop at times but you may be able to get out of this, or just abort the game currently in progress. Entered using Method 2 to get past the first block of the program.

```
10 OPENDOUT"d":MEMORY 1000
20 LOAD""
30 POKE 39557,201
40 POKE 39698,0:POKE 39699,0
50 CALL 39575
```

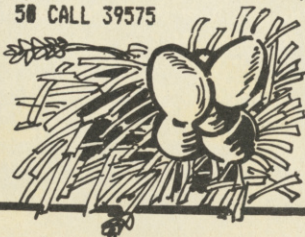

The Covenant

If you transferred our May cover game to disc with the listing in the June (9) issue then this poke from An Dat Phung of Dunfermline will help. It stops everything but your own shooting draining your energy. Just type in the listing, insert the disc with the game saved on it and type *RUN* (no quote marks).

```
10 :DISC:MEMORY 4999:LOAD"CO
V",5000:POKE 12828,0:POKE 12
848,0:POKE 12849,0:POKE 1285
0,0:CALL 10887
```

ADVENTURE

This month the Pilg goes where no 'modo has gone before in Hunchback – the Adventure, comes perilously close to giving Mandragore a Pilgrim Pasting, brings you the first of a new series of special tips sections (on Level 9's Price of Magik), and dips another toe into the hazardous world of MUD.

And if that's not enough for you, there's still the monthly readers' chart (with a chance of winning a free game), a host of correspondents, the World-Renowned Lords and Ladies of Adventure, and the dizzy delights of the Clue Pot.

MANDRAGORE

Infogrames, £14.95 disc, all CPC models

'Twas only a few weeks back that a younger and less experienced Pilg penned the following immortal lines:

'Brill graphics and some truly original gameplay. Mandragore promises 250K of adventure, up to four players, and a ten chapter 'booklet' for £14.95. The Pilg reckons this could be a very impressive petit gamette, so watch this space.'

Well, here's the space to watch, here's the game up on my Arnold, and here's my initial reaction...

Ugh!

Okay, okay, if there's anyone from Infogrames reading, don't have a heart attack. I'm not going to slam the game – in fact, I quite like it – but the problem is that it just doesn't LOOK too good. The gameplay is fine, but the graphics certainly don't impress at first sight and may well have the effect of putting a few people off altogether. Let's delve a little futher into the game and see what we have.

Mandragore is a role-playing game for up to four players. That means that each player creates a character and allocates it specific values for intelligence, wisdom, and so on. You then sally forth and explore the world of Mandragore; doing battle with monsters, finding treasure, exploring castles, and trying to stay alive.

The point of the characterisation is that, in theory, your attributes should determine the manner in which you play the game. If you play on your own you can create four different characters and control them all yourself. A group of characters is called a team and its success or failure depends to a certain extent on the manner in which the different team-members play together and use their respective abilities.

A character may belong to one of five different races: Dwarf, Elf, Mi-Orc, Obbit (ie Hobbit), or Human. In Mandragore each character possesses six attributes – constitution, strength, intelligence, wisdom, dexterity, and appearance. The last struck the Pilg as being a bit odd until I realised that it meant 'charisma' – a lesser-known but fairly traditional role-playing attribute that (I think) basically determines how likely you are to sweet-talk the next Balrog.

When you determine the attributes of your character, you are given 80 points to distribute, and must allocate between five

and 20 points to each attribute. During the game two other attributes, Experience and Life, come into play. The first simply increases as you solve puzzles, find treasure, or defeat monsters; the second starts at 50 points and decreases in battle or strenuous exertion (attempting to open locked doors, for example). Once its life points reach zero a character dies, and life points can only be increased by eating or by casting one of the few spells available (such as cure).

So much for 'team creation'. One of the nice things about Mandragore (especially nice for disc owners) is that you can SAVE a team at any time during play, to resume later on where you left off. If you wanted to, you could use this option to create different teams with different qualities, SAVE them right at the start of the game, and then run through the game with each one to see how the different attributes affected gameplay. More about this later.

On to the actual gameplay itself. Mandragore has four basic 'modes' of play. The first is 'MAP' mode. In this mode you see a fairly crude representation of the surrounding terrain. A small figure in the middle of the screen represents the position of your team and you can move about by entering commands at the keyboard.



The whole command structure is rather complex at first glance, but is in fact very simple to master. There are about 30 verbs allowing you to instruct your character(s) to perform actions such as INSPECT (an object), PARALYSE (a monster), BARTER (exchange cash or food for goods) and so on. Compared with other games of this type (and there aren't many on Arnold) this is quite a creditable range of options. You enter them by typing the first two or three words, and the parser then completes the command for you appropriately.

In giving commands you will of course have to specify the character and in some cases the object, person, or monster involved, as in SYRELA ATTACK TICKEL WITH KNIFE. All the characters have a number for use in this instance, as do all objects carried. Objects and monsters in view at the time have a code letter displayed on the side of the screen for reference purposes. You soon get used to it and, in conjunction with a 'repeat command' option, it can speed things up no end - very useful when repeatedly attacking someone.

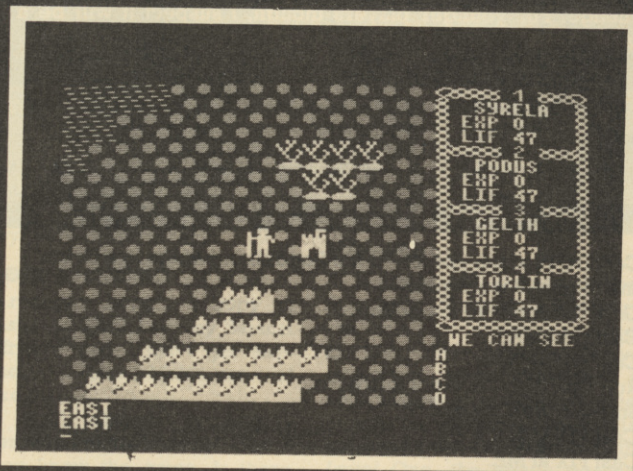

The scrolling map of Mandragore

Whilst in MAP mode you can wander around and the landscape scrolls appropriately. From time to time you are confronted by a monster which throws you into 'Wandering Monsters' mode. The screen clears and shows you the immediate location complete with resident nasty (or nasties). You must then either vanquish the opposition or flee, which you can do by pressing M to change back into MAP mode - but this carries a heavy penalty of ten life points for each character.

Alternatively you may come across a village or chateau (this is a French game, remember). Chateaux are the key to the game. They hold treasure, puzzles, weapons, food, and (of course) monsters. Chateau mode is entered by moving in MAP mode to a Chateau symbol and then pressing C. You must then load the relevant data for that Chateau from disc or tape.

As you explore the Chateau each location and its contents are displayed on screen. The same happens in Village mode, which is entered in a similar manner from Map mode (though you don't have to load a separate data file). Villages are generally a far safer place, and give you the opportunity to trade and replenish your supplies. There isn't a lot of point, however, in making for a village until you've ransacked a nearby chateau for treasure.

So what's it like to play? Well, once you get over the disappointment of the graphics, it's really not too bad. The only competitor that I can think of is *Ring of Darkness* from Wintertsoft (now a bargain on Global's *Fourmost Adventures* collection) but the scale of *Mandragore* is of course far greater. The chateaux are all very different from one another and some of them pose extremely difficult puzzles indeed; quite apart from the hazardous business of defeating their inmates. But after a while you work out which actions do most to increase your

character's experience, and where to find food and weapons.

Apart from the graphics, my other major quibble with the game is the lack of detail in the different situations. There is only one line available for the program's textual responses on the screen, and 'Inspecting' objects usually gets a curt response like 'No danger' or 'Booby trapped', but not much else. This being the case the weakness of the graphics, and in particular the pathetic way in which the characters move about the screen, becomes even more disappointing.

Finally, it's not altogether clear during the game to what extent each of your carefully chosen character attributes are having any effect. Experience seems to count for quite a bit, so it's worth taking note of the particular situations which increase it most; and I noticed that the Thief was better than others at stealing - but then that's an obvious one. However, to really pass judgement on this side of the game you would have to play for a very long time, and it's to the credit of the game that I think I'll probably be making time to do just that.

But then I've got a free review copy! Should you go out and actually buy it? At £14.95 it's not cheap, certainly. It doesn't LOOK like a program that's worth anything like that amount. However there's a fair amount of monster bashing here and, although there aren't that many chateaux to explore, the Pilg reckons that together they offer sufficient variety to keep you busy for some time. And of course there are all the villages and wandering monsters in between.

HUNCHBACK - THE ADVENTURE

Ocean, £9.95 cass, £14.95 disc, all CPC models

NeverEnding Story from Ocean has consistently achieved high ratings in our readers' adventure chart, so what news is there of this latest release from Ocean?

Hunchback - the adventure gives you the romantic role of Quasimodo in a race to rescue the divine Esmeralda from the Evil Cardinal. Like its predecessor, *NeverEnding Story*, the game comes in three parts with four separate loads - an intro screen and three data files. Each load brings a new set of

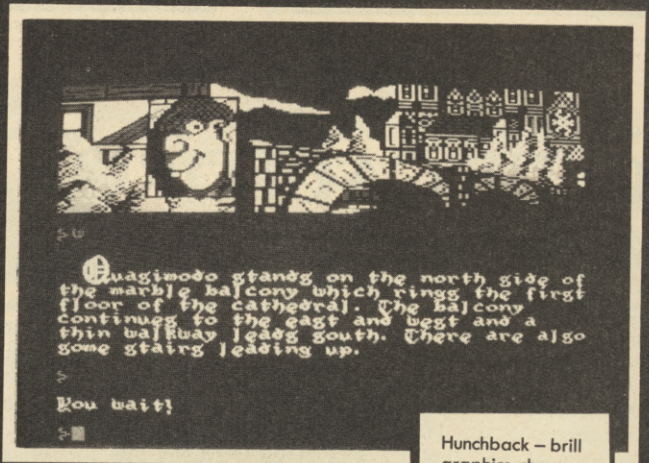

Hunchback - brilliant graphics, shame about the limited challenge. And you have to wait eight minutes for it to load

locations - the first being the Cathedral itself, the second taking you beneath the city of Paris, and the last dumping you in the Cardinal's mansion where you must find and rescue your lady-love. You can't begin a new part until you've completed the previous one.

Hunchback has been programmed by the same team as *NES* and its pedigree is very apparent. You have the same Mode 0 horizontal graphics window at the top of the screen with some excellent graphics and good use of colour. There are three main elements to the graphics display: a colourful

backdrop; cameo pictures of the items you are carrying; and slightly larger cameos that depict scenes reflecting the current location or events. For example, if you are fighting a guard, a small window bearing the words Pow! Biff! etc will appear. If your struggle is successful, you will then be rewarded by a mug-shot of the dead guard.

Beneath the graphics display is a scrolling text window with the same attractive alternative character set as was used in NES. When it comes to entering text however, the picture isn't quite so rosy. There are only about 25 verbs (not including the twelve direction commands which as well as NE etc. also offer IN and OUT) and EXAMINE is conspicuous by its absence. Even then, one of the words (SMASH) doesn't seem to figure in the game at all - at least the parser doesn't understand it! Words like USE and GIVE are also absent so that although objects and characters abound, the actual potential for interacting with them is pretty small. But then this was also true of NES and didn't seem to detract from its popularity.

My own feeling is that *Hunchback* - the adventure is on about the same level as its predecessor. To start with the locations are more meaningful and better laid out. The program doesn't always list all possible exits from a location, and since twelve directions are allowed there are times when experimentation may reveal a new route. There are also occasions when the location lay-out is not entirely logical (e.g. a corridor that runs east-west but in fact doubles back on itself) so care has to be taken in mapping. Given the fact that you won't find that many locations in each part, one might say that the more difficult it is the better.

The real trouble with *Hunchback* is the same as that with NES. Really, the game is too easy - certainly in the first part anyway. As you wander round the Cathedral you frequently encounter guards, but their attacks seem for the most part to be ineffectual and I managed to kill every one with my bare hands without much trouble. What's more, on two occasions I was rewarded with the message 'Your attack fails! You have killed the guard!'

In the whole of the first section there are only about 30 locations but more seriously there is only ONE puzzle worth speaking of, and it's pretty obvious at that! Any experienced adventurer will polish this section off in about one hour of play, and that's not really sufficient for my tastes. Things brighten up a bit as you go on and there's a half-decent maze in the second half, but even that surrenders its secrets after you drop a couple of objects.

The Pilg didn't have time to make it to part III, but it does look as if this game is very much on a par with its predecessor. Which means that for the experienced adventurer it offers pretty graphics and an amusing scenario but is pretty short on challenge. For younger players though, I suspect it will be a huge success.

GAME	ATMOSPHERE	INTERACTION	CHALLENGE	AA-RATING
Mandradore	60%	58%	87%	70%
Hunchback	82%	50%	58%	70%

More from Mud...

Well, actually, no! Last month I promised you more about the wonderful world of MUD - Multi-user dungeons. However, MUD is changing all the time, and the Pilg reckons that the subject is deserving of an article all on its own. So next month the Pilg will be reporting to you

direct from MUD mission control, somewhere in a dark hole in Ealing, side by side with a couple of VAX mini-computers (or something like that). Meanwhile, if your Mudding and see the Pilg passing by, SHOUT HELLO!

1. Cast DOW at the object - if the Pendulum swings in a circle then the object is magikal.
2. Give the robes to the golem.
3. Carry the BAT.
4. Cast FLY at ME.
5. Rub eyebright flowers into eyes.
6. Smash it with the sword.
7. Cast FIN at ME.
8. Cast FIX at ME.
9. Touch the moon - but beware, you can only do this a few times.
10. Bury the bones, skull, and knucklebone.

CLUE CAULDRON

What price Magik?!

What price indeed, fellow Pilgs. This very popular gamette from Level 9 has been torturing many followers of the Path recently, so it deservedly receives the honour of being the first of the Cowed Crusader's Clue Cauldrons. In this occasional series, a single game gets the in-depth sniff treatment for the benefit of all you poor lost souls who escaped from the Goblin's Dungeon only to fall foul of the infamous Giant Slug.

One of the problems with giving so many tips on a single game is that there is always the danger of giving too much away. For this reason, each Clue Cauldron features a series of problems followed by a single number. The number is then used to refer to a list where the relevant tip will be found.

- Can't fly upwards (4)
- To get past the giant bloodworm (3)
- To check for magikal properties (1)
- To cure thyself (8)
- To become a fish (7)
- Having trouble seeing in the dark? (5)
- Getting rid of the curtain (6)
- If old age is getting you down (9)
- Need your daily mail? (2)
- Can't get the armour? (10)

FOR DISC OWNERS

How to transfer *Price of Magik* to disc:

Type in the first listing and RUN it to transfer the files from tape to disc, then type in the second listing and save it on the disc with a filename of your choice - you can then run the game by entering RUN"filename". Note that all SAVES during the game are still done to tape.

```
10 REM Tape-to-disc transfer for The Price of Magik
20 REM Creates 2 files MAG2.BIN and MAG3.BIN
30 FOR A=&B000 TO &B052: READ B$: B=VAL("&"+B$):POKE
A,B:COUNT=COUNT+B:NEXT
40 IF COUNT<>7908 THEN PRINT "Data Error!":STOP
50 CALL &B000
60 DATA 21,0,40,11,FC,0D,3E,44,CD,A1,BC,06,04,21,4B,B0,
CD,8C,BC,21,0,
40,11,FC,0D,01,0,40,3E,2,CD,98,BC,CD,8F,BC,21,70,0,11,
90,99,3E,54,CD,A1,BC,6,4,21,4F
70 DATA B0,CD,8C,BC,21,70,0,11,90,99,1,70,0,3E,2,CD,98,
BC,CD,8F,BC,C3,0,0,4D,
41,47,32,4D,41,47,33
```

```
10 REM Loader for The Price of Magik
20 FOR A=&B000 TO &B03A: READ B$: POKE A,
VAL("&"+B$):NEXT
30 CALL &B000
40 DATA 6,4,21,33,B0,CD,77,BC,21,70,0,CD,83,BC,CD,7A,
BC,6,4,21,37,B0,CD,
77,BC,21,0,CO,CD,83,BC,CD,7A,BC,CD,37,BD,21,0,CO,11,0,
9A,1,FC,D,
ED,B0,C3,90,86,4D,41,47,33,4D,41,47,32
```



PILGRIM'S POST

Out of the Question!

Derick Murdoch of Kilmarnock has come up with an idea for a competition:

'I have thought up a pretty good competition for your adventure pages. It has two simple questions about you: (1) What does the Pilg look like under his cloak? and (2) What is his real name? I think the winner should be the sender of the most imaginative drawing and name.'

Well, Derick, just two teeny little snags with this otherwise excellent suggestion:

1. Anyone submitting a drawing of what I look like under my cloak would be liable to immediate arrest. I suspect you have committed a serious crime even by suggesting it!
2. My real name, The Handsome Dashing One From West London, is of course already well known to everyone. Any more bright ideas?

Help wanted

'I recently bought a copy of Castle of Skull Lord by Samuri Software and I can't get anywhere.' John McMeiken of Wrexham.

Well, John, you've got further than I have, because I don't even know the game. Is there anybody out there from Samuri who could send me a copy? Otherwise I'm afraid I'll have to throw this one open to the house. In the meantime, anyone who can help John should write to him at 19 Woodlands Road,

Marford, Wrexham, Clwyd, LL12 8SP.

Down the Plug...

'Now for a quick plug for the Isle of Wight Amstrad Computer Users Group. This user group is dedicated to all Amstrad machines and their users who live on the Isle of Wight. We can offer lots of detailed courses including: Ron's BASIC course, Steve and Simon's Machine Code Course, Nick on CP/M, and Faz on GAC Programming. All this and lots more for only £5.00 per annum plus 25p per meeting. The meetings are held at the Vectis Hall, Melville Street, Ryde, IOW, every first and third Wednesday.'

From M.I. Farrell, Haylands, Ryde.

Of Capes and Wraiths

'I noticed an error', writes Smurfy the Warlock of Accrington, 'in a clue you gave relating to The Never-Ending Story, which was in the clue "drop a coin without hesitation near the wraith." If, however, you wear the cape from the quicksand in Level One, the wraith doesn't appear. The cape is found by going to Morla in the Swamps of Sadness, then going West then South-West. You are now (a) in the quicksand and (b) where the cape is. But note - you have only two moves, then you die.'

A short list of spells (by no means complete - we don't want to spoil ALL the fun, do we?):

Spell	Focus number	Result
FIX	7	Maximum hitpoints
FLY	6	Fly upwards
DOW	5	Detect magik
ZEN	4	Fast movement
IBM	3	Terrify creature
FIN	2	Creature is turned into a fish
BOM	1	Wakes up

FOCUS OBJECTS:

1 trumpet, 2 silver mail, 3 blue box, 4 small mirror, 5 pendulum, 6 broom, 7 valerian plant

Get into the big time!

This month's Clue Cauldron was filled to the brim with goodies by **Geronimo** of Peterborough (playing tips) and **Alistair Irving** of Ayr (disc transfer routines). When you've finished worshipping this sharp pair of Reverendi Pilgrimissimi (or Red

Hot Pilgs), how about applying yourself for this rare privilege? If you've finished a game and want to give others the low-down, then send in a list of problems, together with their solutions, plus other helpful info on the game.

CLUE-SNIFFING

Yes, Pilgs, here we have another session with the good old Clue Pot. Just because I'm really spoiling you now with the Clue Cauldrons (see elsewhere in this month's column) doesn't mean that the Pot shall be overlooked. Far from it - here are this month's timely tips, and if you haven't sent in your tips for the pot this month, why not do so right now? On the back of a postcard please, and marked **Pilgrim's Clue Pot, c/o Amstrad Action**, at the address in the front of the mag.

The Boggit

Chuck the goodies out of the window. Your share isn't worth much, I'm afraid. Speak up and be friendly for lunch.

The Beer Hunter

JUMP from the roof of the Barbican to the roof of the Ferret. In jail? Move the bed and dig.

Heroes of Karn

Knight doesn't like acid.
Hydra doesn't like spears.
Vampires don't like crosses.
Pirates don't like daggers, but make sure the little one wields it.

Seabase Delta

To get the disc from the lift shaft, tie the washing line to the magnet from the speaker and lower it down shaft. Speared octopus will give you something to write about.

Mordon's Quest

Move churns to find ring.
Persevere with the Admantium barrier.
Break pyrites into small pieces.
Turn out the light to get past the Octopus.

Forest at the World's End

Wear ring in hovel to get key.

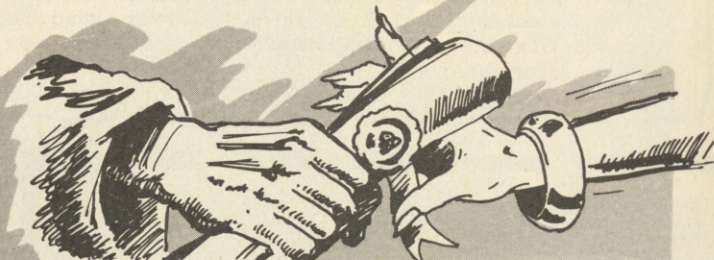

The Lords and Ladies of Adventure

Come on, Pilgs, let's hear it for the Undying Ones, these immortal Wanderers who have returned from the Dark Corners of the World to bring you help and friendship. To enter this column is to aspire to the very heights of glory, so if you've finished a game and would like to render assistance unto others, then write to the Pilg giving full details of your honourable self, and I shall consider you for inclusion in this hallowed column. And if you haven't written in, just look at yourself in the mirror and ask yourself how long you can carry on living the life of a nobody! Fame, fortune, and friends from around the world await you for the cost of a postage stamp!

If you're contacting the Lords or Ladies, don't forget to include an SAE, and if you telephone please ensure that you do so at a reasonable hour, and certainly not after 10pm.

All Interceptor games, *Castle Blackstar*, *Mordon's Quest*, *Robin of Sherwood*, *Lords of Time*, *Never-Ending Story*, *Arnold Goes to Somewhere Else*, *The Wise and Fool of Arnold Blackwood*, *The Trial of Arnold Blackwood*, *Fantasia Diamond*
Graham Wheeler, 2 Burford Close, Southdown, Bath, BA2 1JF

Dun Darach, *Colossal Adventure*, *Bored of the Rings*, *Zork 1*, *Dungeon Adventure*, *Snowball*, *Lords of Midnight*, *Never-Ending Story*, *Dragonlore*, *Hobbit*, plus limited help on *Hitchhiker's Guide*, *Return to Eden*, *Lord of the Rings*, *Adventure Quest*, *Heavy on the Magick*
C. Hoare, 127 Tilehouse Way, Denham, Bucks (tel: Denham 833924)

MUD, *The Hobbit*, *Planet of Death*, *Ship of Doom*, *Inca Curse*, *Espionage Island*, *Lord of the Rings Part 1*
Ric Emeran, 4 Eagle Lane, Snaresbrook, London, E11 1PF



Erik the Viking, Return to Eden, Red Moon, The Hobbit, Forest at the World's End
Peter C Cusack, 15 Oldtown Park, Santry, Dublin 9

Message from Andromeda
Judith McGowan, 1 Milverton House, Perry Hill, Catford, London, SE6 4HA

Gremlins, Forest at the World's End, Message from Andromeda, plus limited help on Heroes of Karn
Blane Traynor, 11 Moyness Park Cres, Blairgowrie, Scotland, PH10 6LY

Fantasia Diamond, Heroes of Karn, Message from Andromeda, Forest at the World's End
Paul Martin, 56 Marshall Road, Oldbury, Wazley, West Midlands, B68 9ED

Warlord, Forest at the World's End, Message from Andromeda, Return to Eden
Alan Stewart, 11 Craigpark Street, Failley, Clydebank, G81 5BS

Never-Ending Story (levels one and two)
Smurfy the Warlock, 25 Craven Street, Accrington, Lancs, BB5 0SE

Jewels of Babylon, Forest at the World's End, Warlord, Heroes of Karn, Message from Andromeda, Espionage Island, Planet of Death
P A Ferris, 6 Ferdinand Walk, Colchester, Essex, CO4 3TS

IMPORTANT NOTICE!

Tony Treadwell's Questline adventure club and helpline which was featured in earlier Lords of Adventure columns, is now for members only. A fee of £5 gets you the Questline Chronicles plus access to the helplines, though if you don't want to pay the £5 there are alternative membership arrangements. For full details send a SAE to Tony at 17 Headley Way, Headington, Oxford, OX3 0LR. The Pilg thoroughly endorses Tony's service, which is now very well established, so if you're looking for a club to join and there isn't anything on offer locally, this could be a good bet for you. And of course the Hotlines can be a real help if you're absolutely stuck in a game.

Red Hot Charts...

One of the strange things about adventures – as opposed to arcade games – is the way they never seem to lie down and die. Most arcade titles rocket onto the supermarket shelves and then, after a frantic few weeks in the charts, disappear again. Not so with adventures.

And certainly not this month! Ocean's *Never-Ending Story* is enjoying a mid-summer boom in popularity according to our readers' poll. This game topped our charts a few months back and has been consistently popular, and this month a sudden influx of votes has put it back in the Number One position.

And then look who's at number 2! None other than Bilbo Baggins himself. Melbourne House is busy having a Tolkien Month at the moment – looks as if they've chosen the right time.

Heavy on the Magick makes a well-deserved first showing in the chart this month. And even old *Fantasia Diamond* (a Pilg personal favourite, though looking a bit worn nowadays) is still in the running.

Don't forget to get your votes in as early as possible. This month's free program goes to an anonymous reader at Northlands Avenue, Orpington, in Kent, who was so struck by *Heavy on the Magick* that he 'had to stop his jaw from hitting the ground!'. One copy of Level 9's excellent *Price of Magick* is on its way, Mr (or Ms) Anon.

- 1 **Never-Ending Story** (Ocean)
- 2 **The Hobbit** (Melbourne House)
- 3 **Heavy on the Magick** (Gargoyle)
- 4 **Red Moon** (Level 9)
- 5 **Return to Eden** (Level 9)
- 6 **The Worm in Paradise** (Level 9)
- 7 **Hitchikers Guide to the Galaxy** (Infocom/Softsel)
- 8 **Lord of the Rings** (Melbourne House)
- 9 **Heroes of Karn** (Interceptor)
- 10 **Fantasia Diamond** (Hewson Consultants)

To The Pilgrim.

My favourite three adventures are:

1. Game: _____

Company: _____

2. Game: _____

Company: _____

3. Game: _____

Company: _____

The reasons for my first choice above are:

The free game I would like is:

My address is (BLOCK CAPITALS ONLY).

Contact the Pilg!

The Pilg is particularly interested from hearing from all you Wandering Souls out there and will do his best to include your correspondence in these columns whenever space permits. Contributions to the Clue Cauldron and the Clue Pot are especially welcome, particularly for lesser-known games which may not be getting the coverage they deserve.

Please remember that I'm

not a Helpline and cannot give help on individual adventurers' problems – that's what the Lords and Ladies are for, so use them well! But for the rest of you, I'm contactable *c/o Amstrad Action, The Old Barn, Brunel Shopping Precinct, Somerton, Somerset, TA11 7PS*, or if you have a modem, on BT Gold 83:JNL251 or on Prestel/Micronet 919994854.

NOW

ON THE AMSTRAD/
COMMODORE 64/128

TO HEAR THE FULL
STORY RING: 00771 1156
AVAILABLE IN THE LONDON AREA CHARGED AT ST RATE.

DOOMDARK'S REVENGE



BEYOND

by Mike Singleton

R.R.P.
9.95

**FEATURING A SPECIAL AUDIO CASSETTE
WITH THE FULL STORY OF DOOMDARK'S REVENGE**

Doomdark's Revenge is more than adventure, mightier than a wargame. 6,144 locations, 48,000 screen views, 128 characters and 128 objects to collect. There are icelords, barbarians, dwarves, fey and giants to meet. Bitter weather conditions and welcoming torches to guide you through caverns. Its a game for one or more players whose skill alone will determine victory or defeat.

Doomdark's Revenge is available now from software dealers everywhere. In case of difficulty write to: Beyond, British Telecom, Wellington House, Upper St. Martin's Lane, LONDON WC2H 9DL.

CALDOZ II

ARMY

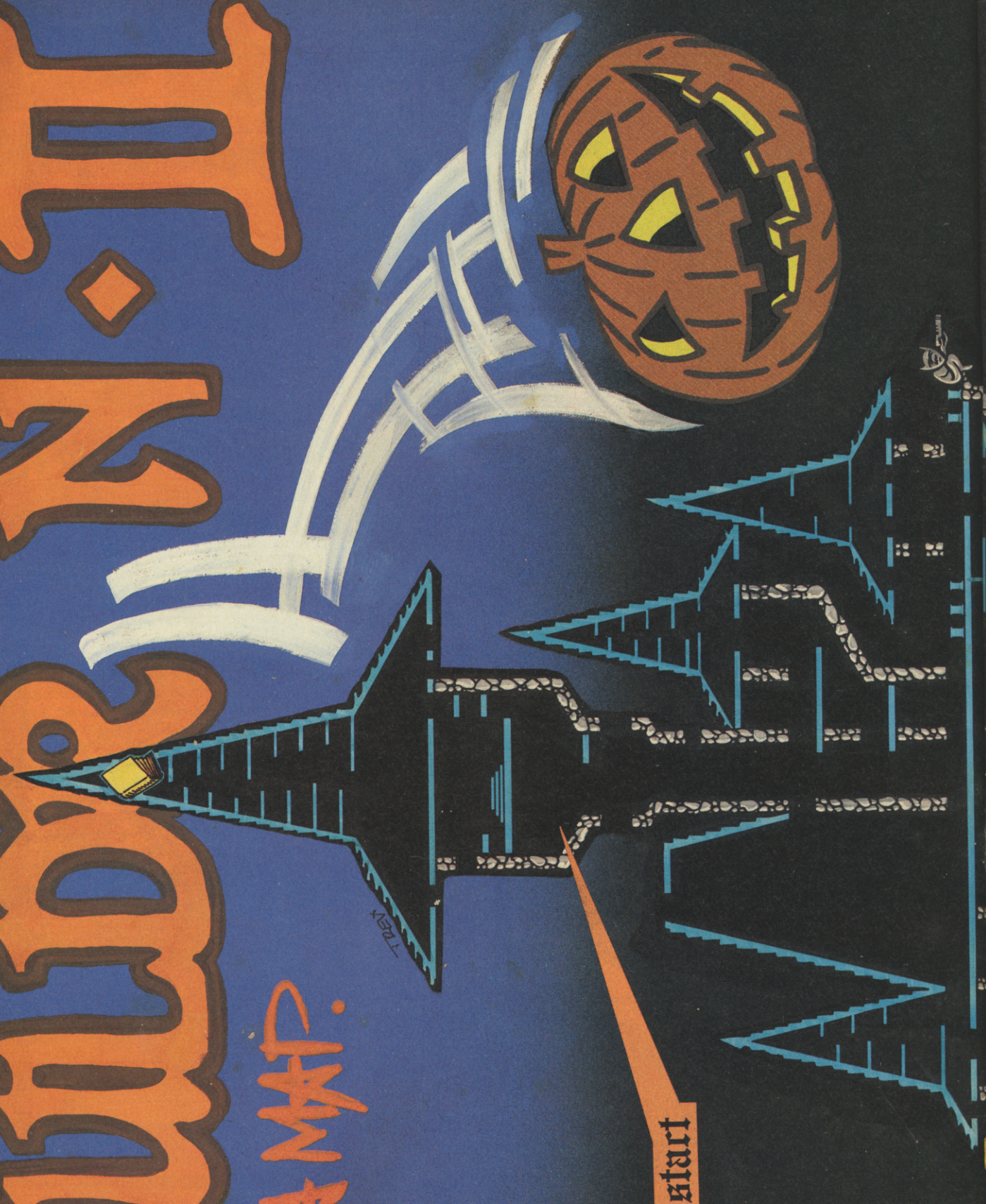

start

- AXE
- GOBLET
- SHIELD
- CROWN

SHIELD

CROWN

CAULDRON

BOOK

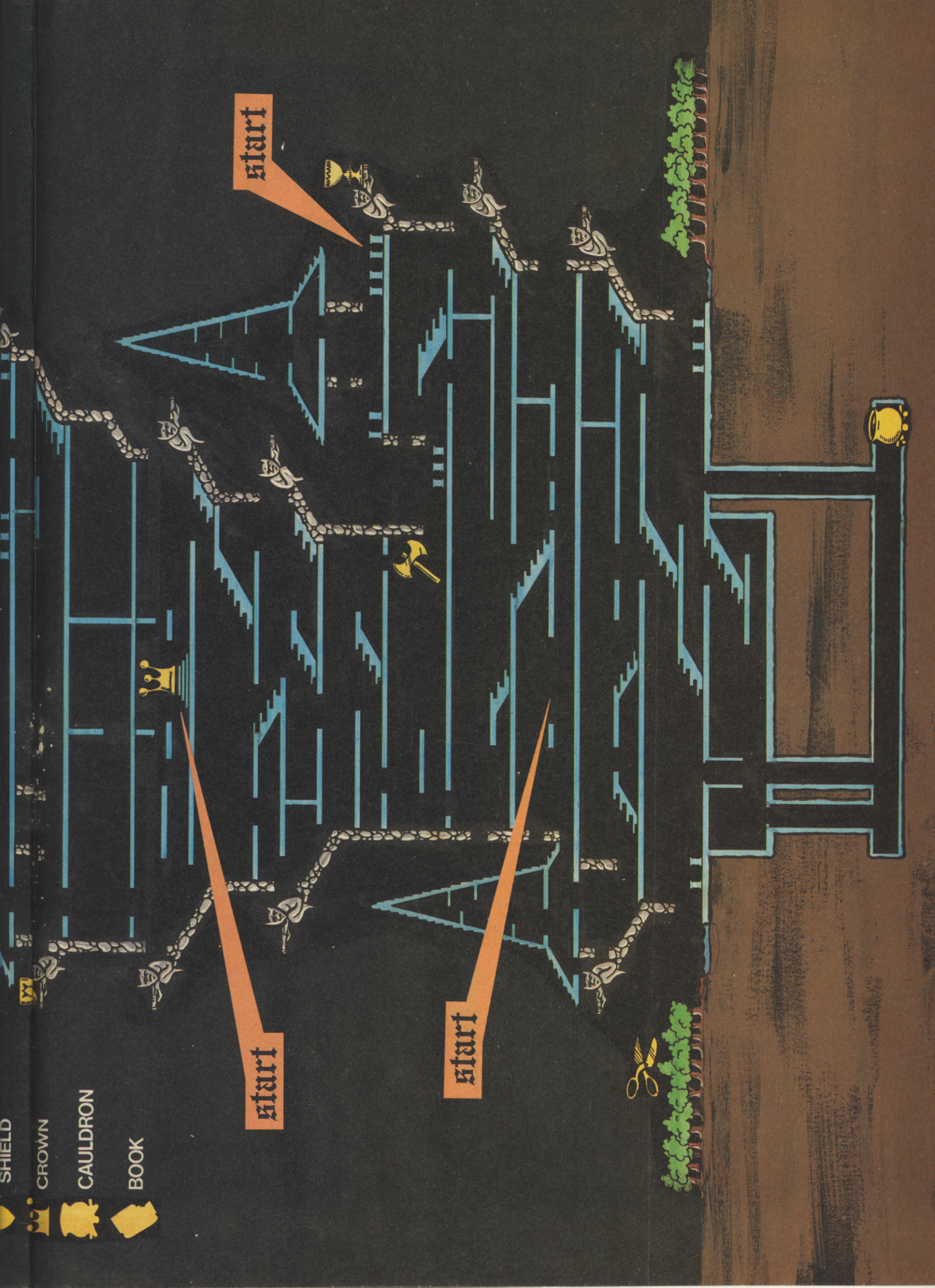

start

start

start



AA MAIL ORDER

BUY YOUR SOFTWARE FROM YOUR ARMCHAIR!

Let Amstrad Action's unique mail order service do the walking.

By the time you've reached this part of the magazine, chances are you'd love to get your hands on some of the software we've reviewed. And that's just what you can do. Our mail order service allows you to order virtually ANY piece of software for the Amstrad micros reviewed in the magazine. What's more you can save yourself a good sum of money on shop prices AND qualify for great free gifts. Hey, it's a wonderful way to buy your software!

AA MAIL ORDER

The double-A triple-F service

▶ FAST delivery

▶ FAT discounts

▶ FREE gifts

SUPER-GIFTS

Here's the great range of bits and pieces you can get FREE with your order - most of them would normally cost £8-10! If your total order is over £15 you select any one you like. If it's over £30 you can select any TWO. Just enter the numbers of the gifts you want, together with your second preferences, in the order form.

1. KUNG FU / NUMBER 1.

Two great Ocean games on one tape, given away with the Christmas issue of AA. If you missed 'em then, get 'em now. CPC 464/664/6128.

2. THE COVENANT + DEMOS

This tape featured on the cover of our May issue. It contains a full version of the AA-raved PSS game, together with demos of four other PSS programs. Supplied with instructions for transferring The Covenant to disc. CPC 464/664/6128

3. AMERICAN FOOTBALL

An impressive simulation from Amsoft/Argus - CPC 464 only.

4. CHUCKIE EGG

Hugely addictive, high-scoring platform game. CPC 464/664/6128.

5. ELECTRO FREDDY

Frantic, humorous fun. CPC 464/664/6128.

6. WRIGGLER

The best version of the arcade classic Centipede. CPC 464/664/6128.

7. LASER WARP

Smooth, colourful, classic shoot-em-up. CPC 464/664/6128

8. CLASSIC ADVENTURE

The great adventure that started it all. CPC 464/664/6128

9. PYJAMARAMA

The first of Mikro-Gen's challenging Wally games. CPC 464/664/6128

10. MASTER CHESS

Worthy multi-level chess program. CPC 464/664/6128

11. SPACEHAWKS

Version of the shoot-em-up Galaxians. CPC 464.

12. SPANNERMAN

Panic action as you try to stop the water-flow. CPC 464/664/6128.



VOUCHER

For use with orders from £5.00-£9.99 (max. one voucher per order)



VOUCHER

For use with orders from £10.00-£19.99 (max. one voucher per order)



VOUCHER

For use with orders from £20.00-£49.99 (max. one voucher per order)



VOUCHER

For use with orders over £50.00 (max. one voucher per order)

HOT STUFF

FREE!

with any order over £5

A C15 data cassette containing high-quality tape specially designed for computer users. It comes in a library case with blank inlay card.

FREE!

with any order over £15

Your pick of any one of the games featured in the Super-gifts box. Most would normally cost £8-10!

FREE!

with any order over £30

A blank 3" disk OR your pick of any TWO of the games featured in the Super-gifts box.

HOW ORDERS ARE DEALT WITH

Amstrad Action Mail Order is run here in Somerton by the super-efficient SUE TAYLOR, the woman who gets more mail in a day than most people get each year!

Unless your order includes programs which our suppliers cannot get hold of for some reason, Sue despatches all packages by first class mail within two or three working days of receiving the orders. Therefore, you can normally expect to receive your parcel about a week to 10 days after ordering.

If it's delayed beyond that chances are you've ordered a true which hasn't yet been released or is temporarily unavailable. In which case a phone call from you WON'T speed things up. (In fact the reverse - phone calls are very time-consuming.) If a long delay were likely we'd let you know.

PLEASE BEAR IN MIND

1. The fact that a program is reviewed in the magazine does not guarantee its availability since some software is reviewed BEFORE it has actually been released.

2. We are happy to refund your order at any time up to the despatch of the goods. But because of the possibility of copying software, no refund or exchange to an alternative piece of software can be given after they have been despatched. Software which does not load may be returned for a replacement cassette or disc containing the same software either to us or directly to the software house concerned.

3. We try to be as accurate as we can with details of price, compatibility and disk availability, but cannot accept liability for any errors that creep in.

OVERSEAS READERS WELCOME

Readers in the Republic of IRELAND can order any of these goods at the same rates as British readers provided that payment is made in pounds Sterling. If you wish to pay in Irish pounds you must add a IR3.50 surcharge IN ADDITION to allowing for the current exchange rate - that's what it costs us to pay in your cheques or postal orders.

Readers elsewhere in EUROPE must add £1 per software item to the cost of their order. Payment must be in pounds Sterling.



Send this form plus payment to: AA Mail Order, 18 Pinewood Drive, Somerton, Somerset, TA11 6JP

MAIL ORDER FORM

Name.....Telephone no. (if poss).....

Address.....

.....Post code.....

Machine owned: CPC 464 CPC 664 CPC6128 PCW 8256 PCW 8512

Enter the programs you wish to order in the spaces below. Under 'PRICE' you must enter the full retail price. If you want more than five items, you should list them on a separate piece of paper.

SOFTWARE TITLE	SOFTWARE HOUSE	DISC/CASS	PRICE
1			
2			
3			
4			
5			
PRE-DISCOUNT TOTAL			

Tick one of the following according to your PRE-DISCOUNT TOTAL and enter the number(s) of any free gift(s) you are entitled to claim:

- Under £5 £5-9.99. I enclose a 50p discount voucher. £10-14.99. I enclose a £1 discount voucher.
- £15-19.99. I enclose a £1 discount voucher and claim free gift number _____. (Second choice ____.)
- £20-20.99. I enclose a £2 discount voucher and claim free gift number _____. (Second choice ____.)
- £30-40.99. I enclose a £2 discount voucher and claim a 3" disc* OR free gifts* Nos. ____ and _____. (3rd choice ____.)
- Over £50. I enclose a £5 discount voucher and claim a 3" disc* OR free gifts* Nos. ____ and _____. (3rd choice ____.)

*Delete as necessary

TOTAL PAYABLE FOR MAIL ORDER (=PRE-DISCOUNT TOTAL minus discount): £

Add this total to the amount payable on any special offers ordered on reverse side.

Half Price!

HERBERT'S DUMMY RUN, BOUNTY BOB STRIKES BACK & THE DEVIL'S CROWN

Three cassette games reduced from £9.95 to just £4.95 each

Herbert's Dummy Run from Mikro-Gen was an AA-Rave in our December '85 issue, with an AA-Rating of 81 per cent. Bob Wade reckoned that 'The graphics are every bit as good as *Everyone's a Wally* and even more colourful, while the gameplay and tasks you face are just as absorbing...'

Another AA-Rave in the same issue was *Bounty Bob Strikes Back* from US Gold. This one got 84 per cent, and was the successor to the 'original' platform game [*Miner 2049'er*, starring the same Bounty Bob. Pete Connor reckoned it was 'one of the best I've ever played', and Bob called it 'A truly superb game', so it can't be bad.

And finally, *The Devil's Crown* from Probe Software achieved Rave status in November '85 with 87 per cent. This arcade adventure is reminiscent of the acclaimed *Sorcery*, but is set aboard a sunken pirate galleon. The aim is to recover seven jewels from the bowels of the ship and replace them in the *Devil's Crown*, which 'won't be easy to complete', to quote Bob from the review. It features stunning graphics too, and is a real bargain at less than a fiver!

Save £5 on...

PYRADEV!

Just £24.95 on disc for any CPC model

'The price is very reasonable considering what you get - a complete development system', is what Andy said of this package at £29.95 from Gremlin Graphics. Imagine what he would have said if the price had been a fiver less, but that is just what we're offering you.

The package consists of five separate modules. First is an Editor for creating your source code, followed by a powerful Assembler offering everything you could wish for, and allowing you to write the resulting machine code on your disc in either AMSDOS or CP/M format. Next comes the Monitor and the Disassembler - 'a similarly thorough piece of work' - to help you debug your programs; and finally Disk Nurse provides a powerful utility for inspecting and modifying the contents of a disc.

All in all a powerful package for anyone interested in professional programming, whether a novice or an expert. And a price that's hard to beat!

SPECIAL

Save chaos!

MAGAZINE B

Only £3.95

You asked for them and now you've got them. No more piles of Amstrad Actions cluttering up your living room carpet and getting, sob, battered to pieces in the process. Instead a superb, custom-built binder specially designed to take 12 copies of AA and preserve them in pristine condition for prosperity (and easy future reference).

Save upto £4!

GREEN BERET

Just £6.95 on cassette and £10.95 on disc

An AA-Rave only last month, and already it's high in our Top Ten Charts! *Green Beret* from Imagine is one of those games you just can't put down - as Andy said, 'It's got real two-fisted arcade action that you just can't tear yourself away from'. It involves fast reactions, and quick thinking too as you pit your commando against the enemy lines. The action comes in four stages, which get harder and harder all the time. It got an unreserved Rave at £8.95 and £14.95 on disc - at our prices it's unbeatable!

WANT TO GET INTO MACHINE CODE?

SPECIAL OFFER FORM

Fill in your name, address and machine type on the reverse of this form. Then place a tick next to those items you wish to order.

1. Speedking Joystick

Just £9.99

2. 3D Starstrike II

Cass £6.95
 Disc £10.95

3. Pyradev

Disc £24.95

4. Green Beret

Cass £6.95
 Disc £10.95

5. Jack the Nipper

Cass £6.95
 Disc £11.95

6. Half price offer

£4.95 each on cass
 Herbert's Dummy Run
 Bounty Bob
 The Devil's Crown

7. Magazine binders

£3.95

8. Subscription

12 months £16.50

9. Back issues

Number 3 £1.35
 Number 4 £1.85
 Number 5 £1.35
 Number 8 £1.85
 Number 9 £1.35
 Number 10 £1.35
 Number 11 £1.35

(Those at £1.85 include a cover mounted cassette containing superb game software)

TOTAL NUMBER OF ITEMS TICKED

TOTAL AMOUNT PAYABLE ON SPECIAL OFFERS

£

SUBSCRIBE!

Ensure that you get the next 12 copies of *Amstrad Action* with the minimum of fuss. £16.50 will make sure that every issue materialises on your doormat without you having to lift a finger.

I enclose a cheque or postal order for this amount, plus the total payable for mail order on the reverse of this form. The payment is made out to FUTURE PUBLISHING LTD.

OFFERS

BINDERS

These binders look every bit as good as the magazine, and include the name 'Amstrad Action' embossed in blocked Newvap Gold on the spine. Individual magazines are held in place by being slotted behind one of 12 wires

Loyal readers, don't delay. Request your binder right away!

Save £3!

3D STARSTRIKE II

Yours for just £6.95 on cassette

Just a glance at this month's front cover shows you how much we rate this game. It offers stunning 3D space combat in a style reminiscent of *Elite*, but those vector graphics are filled in with glorious colour! The aim of the game is to break through the enemy's defences, destroy the central reactor, and escape fast. But there are a variety of planets, each with ever more powerful and varied defences, each of which have to be destroyed.

The defence of the galaxy is in your hands. At £9.95 this game merited Master-game - at £6.95 it could be yours.

Save up to £3

JACK THE NIPPER

Just £6.95 on cassette and £11.95 on disc

Just turn to page 42 of this issue if you want to know what we thought of this excellent Gremlin Graphics game. And just look at those graphics - full cartoon colour and cartoon action. Help Jack make life difficult for the grown-ups - smash those plates, fuse those computers and submerge the launderette in soapsuds; but don't get caught or you'll get a sore bot. Relive your childhood and save pounds too. At £8.95, and £14.95 on disc, these games were good. At our prices they're beautiful!

Save £3!

KONIX SPEEDKING JOYSTICK

Yours for just £9.99

This is the stick that won enthusiastic praise in our April issue, and this is the stick that we use in the AA offices for all our reviews. Unlike most joysticks which work best standing on a table top, this one is cleverly designed to fit neatly in your hand with your index finger comfortably over the fire button.

Chief games-tester Bob Wade wrote of the Speedking: 'The grip is very comfortable and should enable long hours of play...the internal contacts are micro-switches which give a positive clicking action. This makes it ideal for platform and wagging games, but it is also suitable for

many others.'

The Speedking is built solidly and should stand up to months of use - ours is still performing as good as new even after several gruelling issues of AA! It normally sells for the bargain price of £12.99. At £9.99 it's a steal.

PLEASE NOTE

These offers are separate from the rest of our mail order scheme. You cannot use the vouchers on the mail order page to obtain further discounts and free gifts - we've already knocked off the most we can! However if you prefer, you may order any of the items on this page at their **NORMAL FULL PRICE** through the ordinary mail order scheme on the previous page. You can then use the relevant voucher and, if the price is over £15 claim a free gift. This could make sense if you are ordering other goods at the same time.



LETTER PUZZLER

Two very nifty and very different programs this time to keep your type-in fingers nimble. *Letter Puzzler* is an interesting variation on a very old game that can keep you puzzling through to the next issue, while *Manuscript* could save any musicians a lot of money! Keep them coming, but don't forget our new form.

LETTER PUZZLER

Another game this month, but you'll need to use your brains a bit more on this one. You know those little plastic puzzles where you slide little lettered tiles around to make words? Well, this brain-taxing type-in gives you the same kind of puzzle on Arnold - only bigger. Its author, **Simon Watson** from St. Austell in Cornwall, wasn't satisfied with the usual 4x4 or 5x5 grid. He went for a huge 8x8 grid, and that means 63 tiles to get in the right order.

The program scrambles the tiles in a different order each time you play. You then have to unscramble them using either the cursor keys or a joystick. 'Up' will move a tile up into the empty space, 'left' will move one left, and so on. The screen display shows you not only the order the tiles are in now, but also the order you have to get them into and the time you've taken so far.

When typing the listing in be sure that you finish line 460 properly. It ends with a comma, a space and then a second comma. That's about all you need to know for you to use the program. Now, the sooner you get typing the sooner you can get puzzling. What are you waiting for?

MODIFYING THE PROGRAM

If you've played the program for a little while, you might like to try making a few modifications to it. The nice thing about type-ins is that you can usually alter them without having to be an out-and-out hacker.

The lines 390-460 hold the data for the words formed by the

puzzle. If you decide to change them, bear in mind that they must all have eight letters and the last letter of the last word must be a blank. Using numbers, lower case letters and other symbols, you could make all the tiles different. If you think this would make the game a lot harder, you're quite right - in fact it would make the thing impossible roughly half the time. Because of the way the thing works, you should always duplicate a few of the tiles. If you make the last two identical, this'll do the trick.

You may have noticed that you always get the same sequence of puzzles the first time you use the program after resetting the machine. If you've saved the program to disk, you'll be able to check this out rather quicker than cassette users could. This repetition happens because the game doesn't seed the random number generator - it doesn't have a statement of the form *variable = RND(negative number)* anywhere in it, in other words. You'll probably have to experiment a bit to get this one to work the way you want, though.

The most obvious modification would be to enlarge the grid - to 12x12, say. To do this you'll really have to modify the program quite considerably. Aside from some cosmetic alterations to the graphics, for the most part you'll just need to replace 8 with 12 throughout. Obviously, not every occurrence of the number 8 is a reference to the grid size - the reference in line 100, for example, shouldn't be changed.

Similarly, there are some references to the grid size that don't involve the number 8. In line 380, 'X%=7' should be changed to 'X%=11' for a 12x12 grid. You'll just have to look through the program carefully for this sort of thing.



```

10 ' *****
20 ' ** Tile Game **
30 ' *****
40 ' By S. Watson
50 MODE 1:INK 0,0:BORDER 0:INK 1,26:INK 2,11:INK 3,3:DIM L
$(8,8),S$(8,8)
60 WINDOW#1,16,32,5,21:PAPER#1,2:CLS#1:WINDOW#2,2,13,8,19:
PAPER#2,1:CLS#2
70 WINDOW#3,3,12,9,18:PAPER#3,3:CLS#3:WINDOW#4,16,32,1,3:P
APER#4,1:CLS#4
80 PEN 3:PAPER 2:LOCATE 20,8:PRINT"Joystick":LOCATE 23,10:
PRINT"or ":LOCATE 20,12:PRINT"Keyboard":LOCATE 18,16:PEN 1
:PRINT" (K/J)?"
90 IF INKEY(45))-1 THEN K(1)=72:K(2)=73:K(3)=74:K(4)=75:GO
TO 120
100 IF INKEY(37))-1 THEN K(1)=0:K(2)=2:K(3)=8:K(4)=1:GOTO
120
110 GOTO 90
120 RIGHT=0:CLS#1:LOCATE 19,12:PEN 3:PRINT"P L E A S E":LO
CATE 21,16:PRINT"W A I T":FOR N=248 TO 504 STEP 32:MOVE N,
70:DRAW N,324:NEXT:FOR N=70 TO 346 STEP 32:MOVE 248,N:DRAW
504,N:NEXT
130 GOSUB 340:CLS#4:PAPER 1:PEN 0:LOCATE 17,2:PRINT"TIME :
"
140 FOR Y%=1 TO 8:FOR X%=1 TO 8:LOCATE X%+3,Y%+9:PAPER 3:P
EN 2:PRINT S$(X%,Y%):LOCATE (X%*2)+15,(Y%*2)+4:PAPER 2:PEN
3:PRINT L$(X%,Y%):NEXT:NEXT
150 FOR Y%=1 TO 8:FOR X%=1 TO 8:IF L$(X%,Y%)=S$(X%,Y%) THE
N RIGHT=RIGHT+1

```

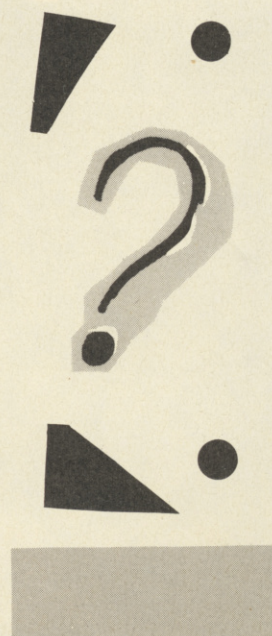

```

160 NEXT:NEXT
170 FOR Y%=1 TO 8:FOR X%=1 TO 8:IF L$(X%,Y%)=" " THEN A%=X
%:B%=Y%:GOTO 190 ELSE NEXT:NEXT
180 END
190 PEN 1:PAPER 0:LOCATE 10,25:PRINT"Press SPACE to start"
:WHILE INKEY$(<)" ":WEND:LOCATE 10,25:PRINT"
"
200 PAPER 1:PEN 0:LOCATE 17,2:PRINT"TIME : ":PRINT CHR$(7)
:TIC=TIME/300
210 IF INKEY(K(1))>-1 AND Y%<8 THEN A%=X%:B%=Y%+1
220 IF INKEY(K(2))>-1 AND Y%>1 THEN A%=X%:B%=Y%-1
230 IF INKEY(K(3))>-1 AND X%<8 THEN A%=X%+1:B%=Y%
240 IF INKEY(K(4))>-1 AND X%>1 THEN A%=X%-1:B%=Y%
250 TICKER=ROUND((TIME/300)-TIC,2):LOCATE 23,2:PAPER 1:PEN
0:PRINT TICKER
260 IF A%=X% AND B%=Y% THEN 210
270 SOUND 3,14,1,14:A%=L$(A%,B%):B%=S$(A%,B%):C%=S$(X%,Y%)
280 IF A%=B% THEN RIGHT=RIGHT-1
290 IF A%=C% THEN RIGHT=RIGHT+1
300 L$(X%,Y%)=A%:L$(A%,B%)=" ":PAPER 2:PEN 3:LOCATE (X%*2)
+15,(Y%*2)+4:PRINT A%:X%=A%:Y%=B%:LOCATE (X%*2)+15,(Y%*2)+
4:PRINT " "
310 IF RIGHT=63 THEN GOTO 470
320 FOR N%=1 TO 4:IF INKEY(K(N%))>-1 THEN GOTO 330 ELSE NE
XT:GOTO 210
330 TICKER=ROUND((TIME/300)-TIC,2):LOCATE 23,2:PAPER 1:PEN
0:PRINT TICKER:GOTO 320
340 RESTORE
350 FOR Y%=1 TO 8:FOR X%=1 TO 8:READ A%:L$(X%,Y%)=" ":S$(X
%,Y%)=A%:NEXT:NEXT
360 FOR Y%=1 TO 8:FOR X%=1 TO 8:A%=S$(X%,Y%)
370 A%=INT(RND*8)+1:B%=INT(RND*8)+1:IF L$(A%,B%)<>" " THEN
370
380 L$(A%,B%)=A%:IF X%=7 AND Y%=8 THEN RETURN ELSE NEXT:NE
XT
390 DATA A,M,S,T,R,A,D,S
400 DATA S,P,E,C,T,R,U,M
410 DATA J,O,Y,S,T,I,C,K
420 DATA H,A,R,D,W,A,R,E
430 DATA C,A,S,S,E,T,T,E
440 DATA P,R,I,N,T,E,R,S
450 DATA K,E,Y,B,O,A,R,D
460 DATA M,O,N,I,T,O,R,
470 FOR N=1 TO 100:INK 1,INT(RND*26)+1:INK 2,INT(RND*26)+1
:INK 3,INT(RND*26)+1:NEXT
480 INK 1,26:INK 2,11:INK 3,3:CLS#1:CLS#2:CLS#3:GOTO 80

```

MANUSCRIPT

Just a little extra for all you music lovers out there, courtesy of Colin Powell. If you've got a DMP2000 or Epson-compatible printer you can use this listing to churn out cheap manuscript paper. All you have to do is pop a sheet of blank A4 paper into the printer, make sure the printer's on-line, and run the program. How useful it is depends on how much manuscript paper you get through, but you've got to admit it's a bit different.

```

10 REM MANUSCRIPT CREATOR
20 REM (c) COLIN POWELL
30 REM *** JULY 1986
40 PRINT#8,CHR$(27);CHR$(49);
50 PRINT#8,CHR$(27);CHR$(45);CHR$(1);
60 PRINT#8,CHR$(27);CHR$(69);
70 GOSUB 170
80 FOR stave=1 TO 10
90 FOR lines=1 TO 5
100 PRINT#8,"
":REM 79 SPACES
110 NEXT lines
120 GOSUB 170
130 NEXT stave
140 PRINT#8,CHR$(12);
150 PRINT#8,CHR$(27);CHR$(64);
160 END
170 FOR space=1 TO 5
180 PRINT#8
190 NEXT space
200 RETURN

```

SENDING IN TYPE-INS

We're always pleased to get programs for the type-ins pages, and we pay for those we publish. It makes things a lot easier for us if you use the nifty **Type-Ins Form** on page 94. It also cuts down the risk of the careless old type-ins editor losing your address, your program, or both.

CAN YOU SOLVE...

THE VERA CRUZ AFFAIR?

Find out by entering our great competition for this new game from just across the channel

The Vera Cruz Affair, or *L'Affaire Vera Cruz* as it is called by French publisher Infogrames, is at present a totally French game, and as a graphics and text based adventure, that makes it pretty hard to play unless your French is pretty good. But fear not, we are giving you the chance to win the first five fully English copies to come off the production lines when it is translated.

And that's not all - for the first 50 entries to this competition will receive a voucher worth £3 that can be used to buy any Infogrames title from the publisher. There, what more can we do for you?

The game's pretty good to, as you will see from Bob's preview on page 59 of this issue. *The Vera Cruz Affair* is basically a game of detection. The opening screen, and a work of art it is too, shows a dead body and various clues as to who did the dastardly deed. Using the police computer and all your powers of deduction it is up to you to solve the mystery. This game certainly looks a little different, and we look forward to reviewing it in the next issue.

The Competition:

All you have to do to win is answer the following questions correctly. The first five correct entries out of the hat on September 12th will receive the first five English translations of *The Vera Cruz Affair*. The first fifty will get a £3 voucher against any Infogrames game ordered direct from Infogrames.

The Questions:

1. What is the significance of July 14th to the French?
2. Which famous French footballer plays for Italy?
3. What is the name of the arch built for Napoleon to celebrate his victory entry into Paris?
4. In what famous event does the yellow jersey play an important part?
5. What is or are Boules?

Entries:

The closing date for this competition is Friday 12th September. Entries should be on a postcard or the back of a sealed envelope. The address is: Vera Cruz Competition, Amstrad Action, The Old Barn, Somerton, Somerset TA11 5AH



MIRRORSOFT

BY MAIL ORDER

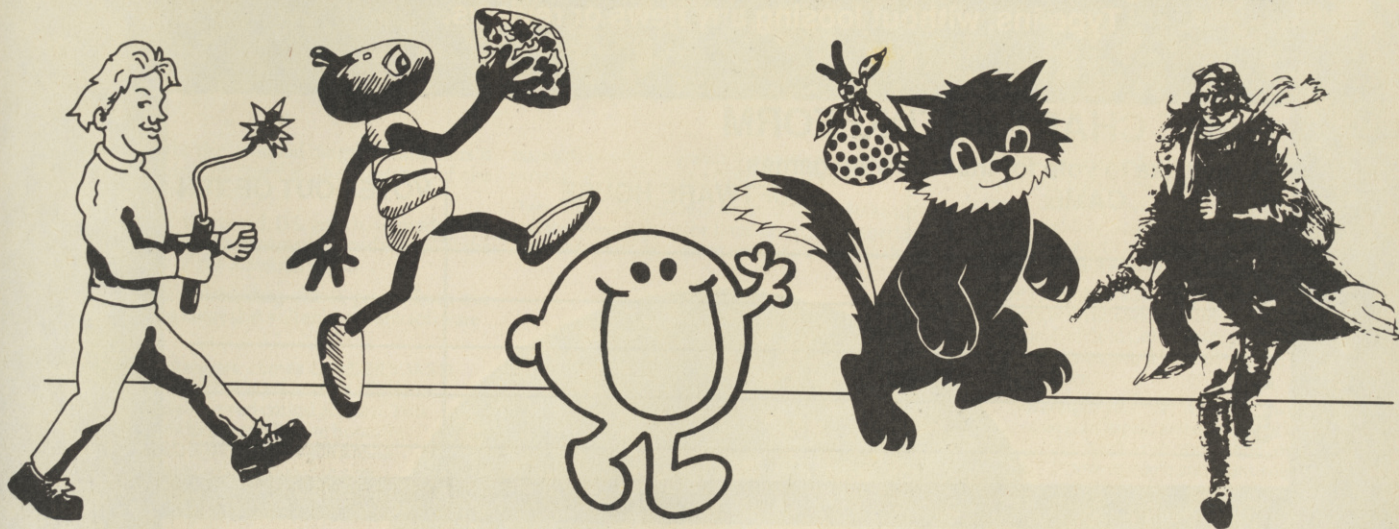

You've always known that Mirrorsoft produces high-quality Amstrad CPC games and children's software – but did you also know that the entire range is available by mail order direct from our warehouse, with no extra charges for postage and packing?*

We accept cheques, postal orders, Access, VISA, and American Express cards. Please allow 28 days for delivery.

GAMES

EARLY LEARNING/CHILDREN'S ENTERTAINMENT

	Tape	Disk
ASHKERON! Challenging text/graphics adventure	£6.95	N/A
BIGGLES Sopwith Camels and police helicopters!	£9.95	£14.95
BOULDER DASH The all-time arcade strategy classic	£9.95	£14.95
DYNAMITE DAN A platform game with real style!	£8.95	£13.95
SAI COMBAT Martial arts with a new twist	£8.95	£13.95
SPITFIRE 40 Relive the Battle of Britain	£9.95	£14.95
STRIKE FORCE HARRIER The ultimate flight/battle simulation	£9.95	£14.95

	Tape	Disk
FIRST STEPS WITH THE MR MEN Ages 3-6 Fun for the youngest pre-reader	£8.95	£13.95
HERE & THERE WITH THE MR MEN Ages 4-7 Early Logo skills for little ones	£7.95	£12.95
CAESAR'S TRAVELS Ages 3-9 Animated storybook and software	£8.95	N/A

Also available:

BIGGLES:	Posters	Free!
	T-shirts	£3.95 (S/M/L)
	Scarves	£4.95
SAI COMBAT	Posters	Free!
SPITFIRE 40	Posters	Free!
STRIKE FORCE HARRIER	Posters	Free!
COMPLETE COLOUR CATALOGUE	Posters	Free!

*Free postage and packing applies to UK and BFPO orders only

MIRRORSOFT

MIRRORSOFT, Dept AM, FREEPOST BS4382, Paulton, Bristol BS18 5BR

THE ALL-IN-ONE ACTION FORM

This form has been created by the Save-Your-AA-From-Being-Overhacked-Department. You can use it to register your votes for Games and Serious Software, or to send in your Type-ins, without loosing any news or reviews.

GAME CHART VOTING FORM

I would like to vote for the following games:

	GAME	SOFTWARE HOUSE	VOTES OUT OF TEN
1.			
2.			
3.			
4.			
5.			

SERIOUS SOFTWARE VOTING FORM

I would like to vote for the following packages:

	PROGRAM	SOFTWARE HOUSE	VOTES OUT OF TEN
1.			
2.			
3.			
4.			
5.			

TYPE-INS

You can help us out at AA, and give your type-ins a far better chance of being published, by filling out this form and wrapping it around your cassette with a rubber band. It would also be an idea if you send it in a jiffy bag as an awful lot of cassettes arrive here damaged.

Name.....

Address.....

.....

.....

.....Postcode.....

TITLE.....

DESCRIPTION:

I hereby declare that the program on the attached tape is all my own work, and that it has not been sent to any other publication, nor been published in any form, or submitted to a software house for consideration as part of a commercial package.

Signed.....Date.....

OUR SOFTWARE WAS MADE FOR IT.

Without doubt the Amstrad range of computers is rapidly establishing itself at the forefront of the personal micro industry.

In response to this trend, U.S. Gold have produced a series of stunning conversions designed to exploit the best features of the Amstrad micro.

Here are four outstanding classic games from our ever increasing range that will enhance any software collection.

Direct from America comes LEADERBOARD; a golf simulation that is truly state of the art, and has already received critical acclaim. This is what ZZAP 64 had to say: "Quite honestly, LEADERBOARD makes all other golf simulations look clumsy and antiquated in comparison. This is the sports simulation of the year—if not the decade!"

LEADERBOARD features all the skills, techniques and elements of the game, right from amateur status to touring

management skill to ensure the physical and economic survival of the PSI-5 TRADING COMPANY!

Direct from the arcades of America, KUNG FU MASTER will test your skills to the limit. Martial art experts and demons of every description are your obstacles in this fast

paced video action thriller. To travel through the Wizard's Temple and rescue the fair maiden you must avoid demons, dragons, snakes and killer bees. Beware of weapon wielding henchmen and defeat each of the deadly guardians to advance to each of the five floors. Your only defence is your martial art skills!

LAW OF THE WEST'S astounding interactive adventure puts you right in the middle of turbulent Old West action. As the sheriff of Gold Gulch, as tough a Wild West town as there ever was, you'll have all you can do to survive 'til sundown.

Standing in your way will be all manner of hard-case gunslingers, and desperados looking to rob the bank, run roughshod over innocent townspeople and plant you in Boot Hill!

Ultra-large graphics and lifelike action deliver excitement so real you can almost smell the gunpowder! All these games are available now especially for the Amstrad at better computer stores, nationwide.



LEADER

professional. Stunning graphics and multiple courses ensures that LEADERBOARD is strokes ahead of its rivals!

If you don't fancy a sporting challenge, then how about the life of a high flying space entrepreneur? Command your ship through one of the great edge-of-your-seat adventures of the 35th century. Choose your cargo, lot your course. You'll need courage and

BOARD

AMSTRAD

DISK £14.95

CASSETTE £9.95

PSI-5 TRADING COMPANY

WEAPONS - FIRING ORDERS LIST				
D	Shots	Weapon	Target	Pri Status
3		Missiles	at B	3 out-range
7		Blasters	at E	3 in-range
3		Cannons	at A	4 broken
5		Thermos	at C	6 no power
9		Blasters	at G	8 in-range
9		Cannons	at D	9 broken

PSI-5 TRADING COMPANY

Commscore 64/128

KUNG-FU MASTER

THE OFFICIAL COIN-OP GAME

LAW OF THE WEST

YOU THE MARSHALL OF THIS TWO-BIT TOWN

WHAT'S IT TO YOU, PUNK? YOU GOT A SURR UNDER YOUR SADDLE. BOY YES, SON, AND IT'S A PRETTY NICE TOWN YOU. WHAT HAV I DO FOR YOU?

LAW OF THE WEST



Selected U.S. Gold products are available from all good computer stores & selected branches of:



John Menzies

WHSMITH

DOUBLER

HAVING PROBLEMS BACKING UP THE LATEST LOADING TECHNIQUES?

DOUBLER+ Will solve ALL your problems

After enormous success on the CBM 64 and spectrum we now have "Doublor" available for the CPC464. Designed by DRAYSOFT, inventors of the infamous "Interface III", this superb unit will operate with 100% success guaranteed. It requires the use of an auxiliary cassette deck.

Simply plug in the "Doublor" on the expansion port, connect a tape player to it with the lead supplied. LOAD the software supplied in the normal way and you are ready to start. Using digital techniques "Doublor" will create a brand new machine back up of ALL software. 100% success GUARANTEED.

As a bonus "Speedcop" is included in the package. This is a superb conventional back up copier that will handle all normal AMSTRAD loaders. It has all the usual options like choice of save speed deprotect basic etc.

Solve all your back up problems in one move, remember we guarantee success.

ONLY £16.95

DISCMASTER V1.0

At last a **POWERFUL disc backup and utility** package for the 464/664/6128 series incorporates the following:

"DUPLICATOR" . . . A new standard of protected disc backup for the Amstrad. A very powerful program that will operate with one or two drives. We aren't saying that it will copy every disc available but our extensive tests have been **unable to find one that it won't**. We are sure that the DUPLICATOR is the **best disc backup program available**. Make no mistake many similar utilities are very limited. Future updates will be available as and when necessary at nominal cost.

"MENU MAKER" . . . A tremendously useful utility that allows you to make a menu on all your own discs **completely automatically**. You select which files are to be included on the finished menu and all the rest is done for you.

"RECOVER" . . . This program allows you to recover any files that may accidentally be erased from a disc. Very useful in case of accident.

"EXTENDED CATALOGUE" . . . Gives an extended CAT that includes the start address and length in bytes of both BASIC and machine code files.

ONLY £19.95

WARNING: Do not be misled by other adverts. There is only one "DUPLICATOR", it is the most powerful program of its type.

Evesham Micros

THE UTILITY SPECIALISTS

3" DISCS Usually Available @ £39.00 for 10 inc. P. & P.

TAPE TO DISC MADE SIMPLE

At last, a hardware "device" that will allow you to transfer those tediously slow loading cassettes to disc. "Disc Wizard" operates on the working memory of the computer, hence it is unaffected by the loading method used. It is brought into operation by the **simple press of a button**. A working version of the program in memory is then saved to disc and the program will restart. The saved version in memory is then saved **useful**. In most cases the process is then complete. With some programs it will be necessary to make one or two adjustments to the saved programs using a simple routine supplied. However, this will also allow you to make certain custom alterations to the programs, e.g. screen size, windows, etc.

"Disc Wizard" is a hardware interface that fits the expansion or floppy disc port of the **464/664/6128**. It is equipped with a through port and is supplied complete with simple instructions. **At the time of going to press we have been unable to find even one, memory resident, program that the "Wizard" has been unable to handle.**

ONLY £39.95

Please Note: This product is intended for archival purposes only. Programs transferred require the unit to be present for reloading. Software to enable saved versions to stand alone will be available in the future.



SUBJECT TO AVAILABILITY. ALL ORDERS DESPATCHED THE WORKING DAY AFTER RECEIPT

All prices include P&P and VAT. Send cheque, Postal Order or Credit Card No. Credit Card orders accepted by phone. Callers welcome. Wide range of goods stocked. Trade enquiries welcome. European orders send price as advertised. Outside Europe £2.00 for airmail. Mail order to Evesham please.

EVESHAM MICROS
BRIDGE STREET, EVESHAM,
WORCS. WR11 4RY.
Tel: 0386 41989

MICRO CENTRE
1756 PERSHORE ROAD,
COTTERIDGE, BIRMINGHAM.
Tel: 021-458 4564

In Australia contact: **MICRO ACCESSORIES S.A.**, 39b Anderson Walk, Smithfield, South Australia 5114. Tel: (08) 254 6284

SOFT INSIGHT DISCOUNT SOFTWARE

3 STATION CRESCENT, WESTCOMBE PARK, BLACKHEATH SE3 7ER.

Access orders/enquiries tel: 01-305-0521.
ALL PRICES INCLUDE FREE FAST DELIVERY IN THE U.K. ONLY. PLEASE ADD 70P PER TAPE ON EUROPEAN ORDERS AND 1.00 PER TAPE ELSEWHERE.
New titles arriving every day, please ring for details.

Alien Highway.....8.95 6.71	Worm in Paradise.....9.95 7.46	Doomsday Blues.....14.95 11.50
Kung Fu Master.....9.95 7.46	Theatre Europe.....9.95 7.46	Spindizzy.....14.95 11.50
Green Beret.....8.95 6.71	Lord of the Rings.....15.95 12.00	Masterfile.....29.95 24.95
Ghosts 'n' Goblins.....8.95 6.71	Cluedo.....9.95 7.46	Mastercalc.....29.95 24.95
V.....8.95 6.71	Computer His 10.....14.95 11.50	Graphic Adv. Creator.....24.95 19.95
Gunright.....9.95 7.46	Bomb Jack.....8.95 6.71	Sold a Million.....14.95 11.50
Meltdown.....8.95 6.71	Dun Darach.....9.95 7.46	Computer His 9.....14.95 11.50
Boulderash III.....9.95 7.46	Ping Pong.....8.95 6.71	Battle of Britain.....14.95 11.50
Fifth Axis.....9.95 7.46	Mike.....8.95 6.71	Theatre Europe.....14.95 11.50
Equinox.....9.95 7.46	The Music System.....14.95 11.50	Spy vs Spy.....14.95 11.50
G. Gooch Cricket.....9.95 7.46	Here & There with Mr Men.....8.95 6.71	Fighter Pilot.....14.95 11.50
Heavy on the Magic.....9.95 7.46	First Steps with Mr Men.....8.95 6.71	Cyrus Chess.....12.95 10.50
Price of Magic.....9.95 7.46	Writer Games.....9.95 7.46	3D Grand Prix.....12.95 10.50
Batman.....8.95 6.71	Contraption.....8.95 6.71	Tau Cell.....14.95 12.00
Hills 10 Vol II.....9.95 7.46	Rescue on Fractalus.....9.95 7.46	Lazer Basic.....19.95 15.95
Sold a Million II.....9.95 7.46	Spin Dizzy.....9.95 7.46	Lazer Compiler.....24.95 20.95
Strike Force Harrier.....9.95 7.46	Rambo.....9.95 7.46	Elite.....17.95 13.95
Tomahawk.....9.95 7.46	Runesone.....7.95 5.96	Mini Office.....19.95 15.95
Doomsday Blues.....9.95 7.46	Back to the Future.....9.95 7.46	
Cauldron.....8.99 7.46	Critical Mass.....8.95 6.71	
Snowball.....9.95 7.20	Saboteur.....8.95 6.71	
Lords of Time.....9.95 7.20	Turbo Espirit.....8.95 6.71	
Return to Eden.....2.95 7.20	Forbidden Planet.....8.95 6.71	
Emerald Isle.....6.95 5.40	2112AD.....8.95 6.71	
Red Moon.....6.95 5.40	Spillie 40.....9.95 7.46	
Bridge Player (CP).....9.95 7.40	Lazer Basic.....14.95 12.00	
Fighter Pilot.....9.95 7.46	Lazer Compiler.....19.95 15.95	
Battle of Britain.....9.95 7.46	Doors of Doom.....9.95 7.46	
Get Doctor.....9.95 7.46	Mini Office 2.....14.95 12.00	
They Sold a Million.....9.95 7.46	3 Weeks in Paradise.....9.95 7.46	
Elite.....14.95 11.21	Battle of Planets.....9.95 7.46	
Way of the Tiger.....9.95 7.46		
Room 10.....7.95 5.96		
Scrabble.....9.95 7.46		
Monopoly.....9.95 7.46		
3D Grand Prix.....9.95 7.46		
Cyrus Chess.....9.95 7.46		
Zoids.....8.95 6.71		
Wie Ar Kung Fu.....8.95 6.71		
World Series Baseball.....8.95 6.71		
Hypersports.....8.95 6.71		
Southern Belle.....7.95 6.20		
Frankie G T Hollywood.....9.95 7.46		
Matchday.....9.95 7.46		
Nightshade.....9.95 7.46		
Skyfox.....9.95 7.46		
Who Dares Wins 2.....9.95 7.46		
Commando.....9.95 7.46		

* DENOTES NEW TITLES THAT ARE AVAILABLE IN THE NEAR FUTURE. PLEASE RING FOR CONFIRMATION.
WHY NOT COME AND PICK UP YOUR SOFTWARE PERSONALLY FROM OUR DISCOUNT SHOP AT 3 STATION CRESCENT, WESTCOMBE PARK, BLACKHEATH, LONDON SE3 7ER. RIGHT OUTSIDE WESTCOMBE PARK RAILWAY STATION ON THE SOUTHERN REGION. OPEN ON SATURDAYS ONLY FROM 10.30 'TIL 6.00 PM.

SUPA SOFT DISCOUNT SOFTWARE

GAMES	R.R.P	OUR PRICE	OUR SHOGUN (DISK).....14.95 10.95	BEEBSOFT TOOLKIT.....14.95 10.95
WAY OF THE TIGER.....9.95 6.95	SAGE	POPULAR ACCOUNTS.....99.99 79.99	BEEBSOFT TOOLKIT (DISK).....17.95 14.95	MUSIC SYSTEM.....15.95 11.95
KUNG FU MASTER.....9.95 7.25	POPULAR ACCOUNTS +149.99 119.99	POPULAR INVOICING.....69.99 49.99	MUSIC SYSTEM (DISK).....19.95 15.95	
KUNG FU MASTER (DISK).....14.95 10.95	POPULAR PAYROLL.....69.99 49.99	POPULAR COMBO.....149.99 129.99	DIGITAL	
SOLD A MILLION 2.....9.95 6.95	POPULAR SUPER COMBO.....199.99 169.99	CHT CHAT E-MAIL.....69.99 49.99	PASCAL/ MT.....49.95 44.95	
SOLD A MILLION (DISK).....14.95 10.00	CHT CHAT VIEW DATA.....69.99 49.99	CHT CHAT COMBO PACK.....99.99 79.99	C BASIC COMPILER.....49.95 44.95	
SPIREFIRE 40.....9.95 7.25	CHT CHAT VIEW DATA.....69.99 49.99	SAGE DATABASE.....69.99 49.99	DR GRAPH.....49.95 44.95	
SPIREFIRE 40 (DISK).....14.95 10.95	MONOPOLY.....9.95 7.25	TASMAN	DR DRAW.....24.95 19.95	
ELITE (DISK).....19.95 14.00	MONOPOLY (DISK).....14.95 10.95	TASWORD 6128.....24.95 19.95	PRO MERGE.....24.95 17.95	
PRO TEXT.....26.95 19.95	SCRABBLE.....9.95 7.25	TASWORD 464.....19.95 14.95	PRO SPELL.....49.95 35.95	
	WINTER GAMES.....9.95 7.25	TASWORD 464 D.....24.95 19.95	SCRATCH PAD +.....69.99 55.95	
	WINTER GAMES (DISK).....14.95 10.95	TASPRINT 464 D.....12.90 9.90	SUPERCALC II.....49.95 39.95	
	TURBO ESPRIT.....8.95 6.75	TASPELL (DISK).....16.50 11.50	AMSOFT 3" DISC X 10 101 E36.95	
	SORCERY + (DISK).....14.95 10.00	TASPODY (CAS).....9.90 7.95	3D CLOCK CHESS (8256).....19.95 15.95	
	GET DEXTER.....9.95 6.50	TASPODY (DISK).....14.95 10.95	BRIDGE PLAYER (8256).....19.95 15.95	
	V.....8.95 6.25	LASER BASIC (DISK).....19.95 14.95	MINI OFFICE II (CAS).....14.95 11.95	
	ALLEN HIGHWAY (DISK).....13.95 9.50	LASER COMPILER.....19.95 14.95	MINI OFFICE II (DISK).....19.95 14.95	
	BATMAN.....8.95 6.25	LASER COMPILER (DISK).....24.95 19.95		
	SHOGUN.....9.95 7.25			

P & P included. Overseas orders add 75p per item. Mail order only.
Make cheques / PCs payable to Discount Software (Sterling only) and send to DISCOUNT SOFTWARE, DEPT 2, 210 NICHOLLS TOWER, HARLOW, ESSEX, CM18 6EF

ADVERTISERS' INDEX

Ambyte	ibc	Modem House	34
Beyond	75	Ocean	ifc
C & F Associates	60	Odin	62
Database	17	Shekhana	60
Design Design	89	Siren	60
Evesham Micros	80	SJB Disks	16
Gremlin Graphics	15,88	Soft Insight	90
Imagine	3	Softek	6
Infogrames	18	Supasoft	90
Logic Sales	60	US Gold	31,87,
Martech	61		bc
Micropool	49	Vanguard Leisure	48

GET YOUR NAME ON THE LEADERBOARD

If you have ever bought another golf simulator – shoot yourself!
If you are ever considering it – save yourself a bullet!
ZZAP64

Quite honestly, leaderboard makes all other golf simulations look clumsy and antiquated in comparison.
ZZAP64

This is the sports simulation of the year – if not the decade!
ZZAP64

Multiple 18 hole golf course

Amazing sound

The most realistic 3D golf simulation available

Practice Driving Range

**TAPE £9.95
DISC £14.95**

GOLD MEDAL AWARD

U.S. GOLD American Software

And swing your way to a record round

Now you can become a golf pro and experience the thrill of having your name up on the "Leaderboard".
With this amazingly realistic simulation you get a true perspective view of your golf game.
As you play on different 18 hole courses on levels varying from amateur to touring professional you'll need skill concentration and control to come in under par.

Features:

- Choice of club, distance, type of shot (hook, slice, putting) and more
- Realistic Sound
- Practice Driving Range
- Joystick Controlled
- Multiple 18 Hole Golf Courses
- Automatic Scoring



AMSTRAD Coming soon for Spectrum

