

BRITAIN'S BEST SELLING MAGAZINE
FOR THE AMSTRAD CPC 464 ● 664 ● 6128
ISSUE 48 • SEPTEMBER 1989 • £1.45

NOT
an official
Amstrad
publication!

FROM FUTURE PUBLISHING COMES THE MAGAZINE THAT LEADS THE FIELD

AMSTRAD ACTION

PRESS FOR ACTION!

The expert guide to publishing
newsletters, fanzines
and booklets on your CPC

plus WIN a £750 Mannesmann Tally
24 pin printer to enhance
your creativity!

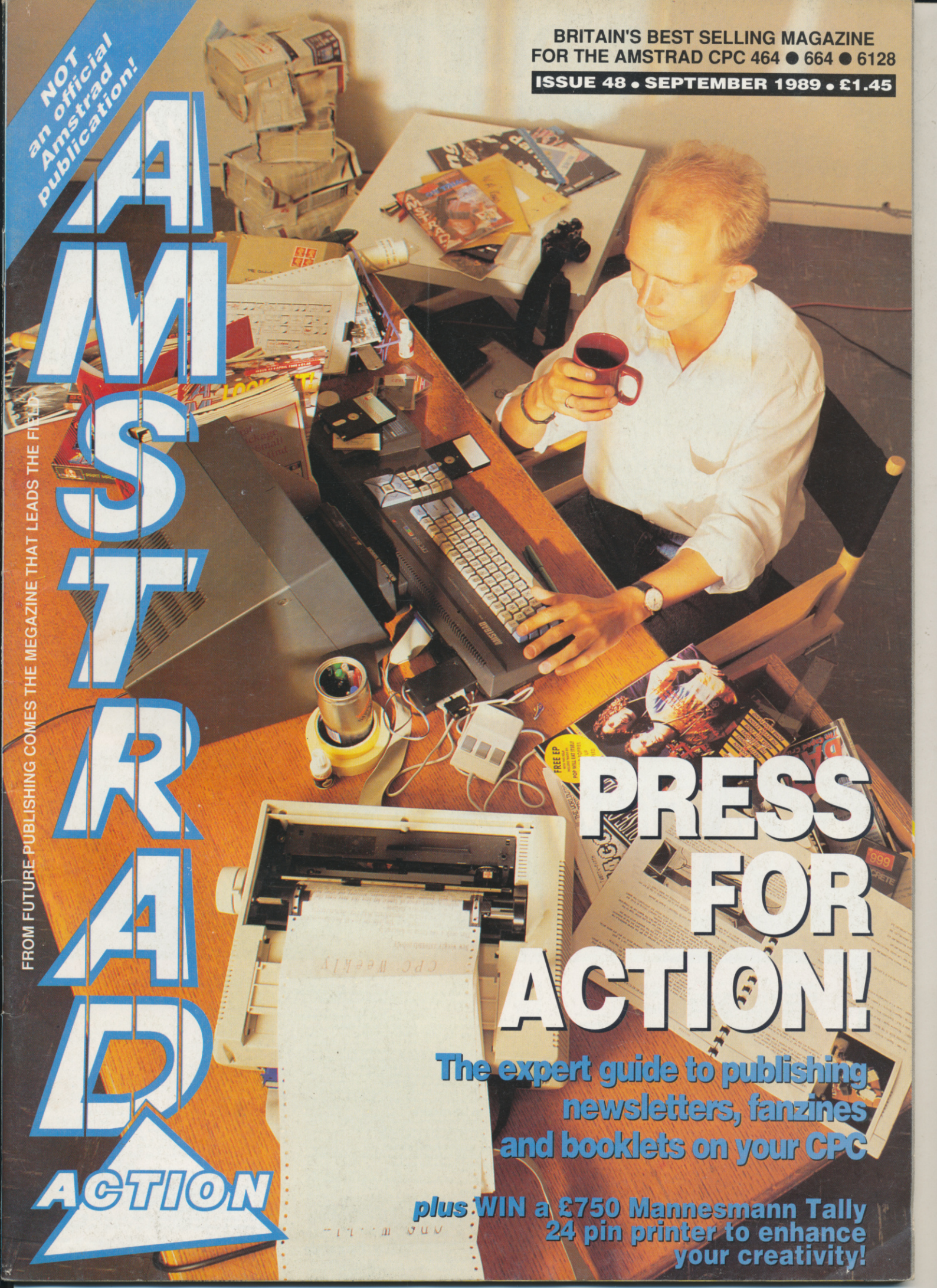

CHECK OUT THE NAMES.

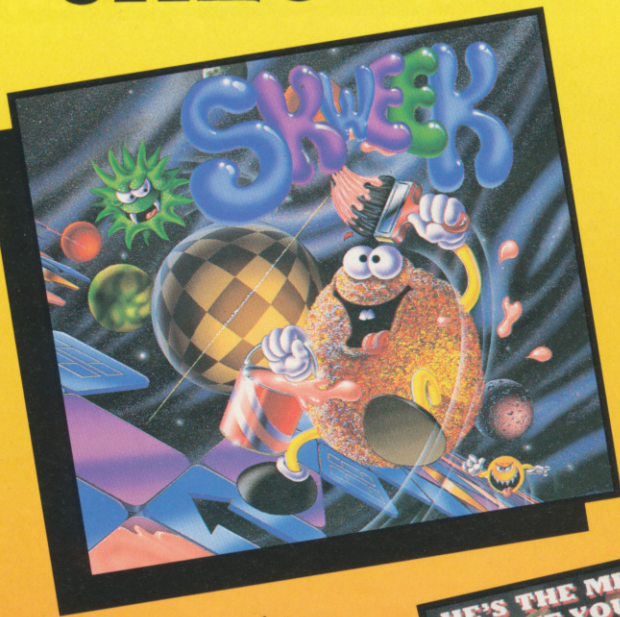

SKWEEK™ – Manic action, compulsive fun as hyperactive Skweek sweeps through the 99 continents of his mother planet decontaminating them on his way. Skweek is fun. Skweek is action. Skweek will last forever. Skweek is a charming action sensation.
Amstrad £9.99c, £14.99d.



FORGOTTEN WORLDS™ – Two cool dudes, one hot situation, eight megalithic adversaries .. it all adds up to a whole lotta trouble.
Amstrad £9.99c, £14.99d.



HKM™ – From Holland to Spain, from Germany to Palestine, no matter the odds, no matter the scene – he's tough, he's mean, he's the Human Killing Machine.
Amstrad £9.99c, £14.99d.

TM & © 1989 LUCASFILM LTD., (LFL) INDIANA JONES, INDY AND LUCASFILM ARE TRADEMARKS OF LUCASFILM LTD. ALL RIGHTS RESERVED.

SEE **SEE** APPOINTED DEALERS BELOW

AT YOUR LOCAL

- AVON**
Ace Computers 42 Cannon Street, Bedminster, Bristol. Tel: 9272 637981
Ace Computers 3 North Street, Bristol. Tel: 0272 666341
Virgin Games 18 Merchant Street, Bristol, Avon. Tel: 0272 294779
- BEDFORDSHIRE**
Dowling Computers 3 Harpur Centre, Lower Floor, Harpur St, Bedford. Tel: 0234 273090
Software Plus Unit 11, The Boulevard, Harpur Centre, Bedford. Tel: 0234 66598
- BUCKINGHAMSHIRE**
Aylesbury Computer Centre 38 Kingsbury Square, Aylesbury. Tel: 0296 89480
- CAMBRIDGESHIRE**
Software Plus 43 Bureleigh Street, Cambridge. Tel: 0223 353643
- CHESHIRE**
Northwich Computers 79a Witton Street, Northwich, Cheshire. Tel: 0606 47883
Tim's Megastore 29/31 Sunderland Street, Macclesfield, Cheshire. Tel: 0625 34118
- CLEVELAND**
C.H.I.P.S. Computer Shop 151 Linthorpe Road, Middlesbrough. Tel: 0642 219139
C.H.I.P.S. Computer Shop Silver Court Shopping Centre, Silver Street, Stockton on Tees. Tel: 0642 618256
Computer Shop 14 West Row, Stockton on Tees. Tel: 0642 606166
Topssoft 3 Hambletonian Yard, Stockton on Tees. Tel: 0642 670503
- CORNWALL**
Truro Micro Ltd. Bridge House, New Bridge Street, Truro, Cornwall TR1 2AA. Tel: 0872 40043
- COUNTY DURHAM**
C.H.I.P.S. Computer Shop Charles Yard, Darlington. Tel: 0325 381048
Topssoft 6 Wellington Court Mews, Grange Road, Darlington. Tel: 0325 486689
- DERBYSHIRE**
DK Sound & Vision 7 Lightwood Road, Buxton, Derbyshire. Tel: 0298 72066
Gordon Harwood 69 – 71 High Street, Alfreton, Derbyshire. Tel: 0773 836781
- DEVON**
Computerbase 21 Market Avenue, City Centre, Plymouth. Tel: 0752 672128
Judya Computers 7/9 Exeter Road, Exmouth, Devon. Tel: 0395 264593
The Games Cupboard 5 New Bridge Street, Exeter. Tel: 0392 214128
The Model Shop 11 Old Town Street, Plymouth. Tel: 0752 221851
- DORSET**
Columbia Computers 17 Columbia Road, Exbury Park, Bournemouth. Tel: 0202 535542
Computerbase 5 Great Gazona Street, Weymouth, Dorset. Tel: (0305) 781745
- EAST SUSSEX**
Computerware 22 St Leonard's Road, Bexhill-on-Sea, East Sussex TN40 1HT. Tel: 0424 223340
Software Centre 31/32 Churchill Square, Brighton, East Sussex. Tel: 0273 776576
- ESSEX**
Computer Leisure Centre, 6 Lower Mallow Street, Limerick, Ireland. Tel: 010 35361316488
Cork Microcomputer Centre Ladins Quay, Cork, Ireland. Tel: 021 273330
Virgin Games 14 – 18 Aston Quay, Dublin 2. Tel: 0001 777180
- GLoucestershire**
G. D. Computer Software 9 Market Parade, Gloucester. 0452 307108
The Model Shop 79 Northgate Street, Gloucester. Tel: 0452 410693
The Model Shop 22 High Street, Stroud. Tel: 0433 65920
- Greater Manchester**
Microbyte Unit 176, Halle Mall, The Arndale Centre, Manchester. Tel: 061 832 1438
The Computer Shop Unit 121, Market Way, Manchester. Tel: 061 832 0878
Vudata 203 Stamford Street, Ashton-under-Lyne, Lancashire. Tel: 061 339 0326
- Hampshire**
Micro Centre 13 London Road, North End, Portsmouth. Tel: 0705 697802
G.B. Microland 7 Queen's Parade, London Road, Waterlooville. Tel: 0705 239911
Software Plus Unit 8, The Boulevards, Wellington Centre, Aldershot. Tel: 0252 29862
Ultima 118 East Street, Southampton. Tel: 0703 639419
- Hereford & Worcester**
Antics 16 St. Swithin Street, Worcester. Tel: 0905 22335
G. D. Computer Software 37 Upper Tything, Worcester WR1 1JZ. Tel: 0905 726259
- Hertfordshire**
Foxminster 23 Market Square, Hemel Hempstead, Herts. Tel: 0442 55044
Software Plus Unit 94, Inshops, The Mallings, St. Albans. Tel: 0727 64347
- INDIA**
Video City 45 – 47 Fisher Green, Stevenage, Herts. Tel: 0438 353808 (ST & AMIGA SPEC)
Video City 10 Station Road, Letchworth, Herts. Tel: 0462 672647 (ST & AMIGA SPEC)
- LANCASHIRE**
Computer Leisure Centre 117 High Street, Orpington. Tel: 0689 21101
Silica Shop 1 – 4 The Mews, Hatherley Road, Sidcup. Tel: 01 302 8811
Software Plus 35 High Street, Gravesend. Tel: 0474 333162
Software Plus Unit 2, 4 – 6 Orange Street, Canterbury. Tel: 0227 438112
Video Machine 194/196 Canterbury Street, Gillingham, Kent. Tel: 0634 56460
- Lancashire**
Alan Heywood 174 Church Street, Blackpool. Tel: 0253 21657
Bits & Bytes 11th Barn Street, The Rock, Bury. Tel: 061 764 1989
PV Computers 100 Abbey Street, Accrington. Tel: 0254 35345
PV Computers 97 St. Albans Road, St. Anne's. Tel: 0253 722969
- Leicestershire**
May's Computer Centre 57 Churchgate, Leicester. Tel: 0533 22212
- LONDON**
Doubtvision 32 High Street, Ealing, London. Tel: 01 566 1004
Erol Computers 125 High Street, Walthamstow, London. Tel: 01 520 7763
Logic Sales 19 The Broadway, The Bourne, Southgate. Tel: 01 882 4942
Microtek Grove Green Road, Leytonstone. Tel: 01 566 2275
Shekhana 211 Tottenham Court Road, London. Tel: 01 631 4627
Shekhana Computers 2 Gladstone House, Gladstone Avenue, High Road, Wood Green. Tel: 01 631 4267
Silica Shop 52 Tottenham Court Road, London. Tel: 01 580 4000
Software Plus Inshops, 37 – 43 South Mall, Edmonton Green Shopping Centre. Tel: 01 803 8581
Virgin Games 100 Oxford Street, London. Tel: 01 637 7911
Virgin Games 527 Oxford Street, London. Tel: 01 491 8582
Virgin Games Store 14-22 Oxford Street, London. Tel: 01 631 1234
- Merseyside**
Bits & Bytes 18 Central Station, Ranelagh Street, Liverpool. Tel: 051 709 4036
Computer Adventure World Bank Buildings, 1a Choring Cross, Birkenhead, L41 6EL. Tel: 051 666 1132
Micro Snips (Mail Order), 37 Seaview Road, Wallasey, Merseyside. Tel: 051 630 3013
- Middlesex**
J.K.L. Computers 7 Windsor Street, Uxbridge, Middlesex. Tel: 0895 51815
- NORFOLK**
Computer Plus 40 New Conduit Street, Kings Lynn, Norfolk. Tel: 0353 774550

CHECK OUT THE GAMES.

INDIANA JONES™ AND THE LAST CRUSADE – The Action Game

THE MAN WITH THE HAT IS BACK! on a new quest and in a deadly race against the evil forces of Nazism. Re-live the greatest action scenes from the greatest Indy™ movie of them all. Capture the cross of Coronado, overcome a savage rat attack, fight your way out of a giant Zeppelin, survive the deadly tests of the Grail Temple ... and much much more!
AMSTRAD £9.99c, £14.99d.



THE GAMES SUMMER EDITION™ – The complete test of body co-ordination, muscle power and speed as you exhaust your limbs on the widest combination of eight exciting events ever compiled for human competition. Pole Vault, Parallel Bars, Cycling, Hammer Throw, Diving, Hurdles, Archer, Gymnastic Rings. Become your own sporting hero.
Amstrad £9.99c, £14.99d.



STAR DEALER

- Software Emporium 77/87 Magdalen Street, Norwich, Norfolk. Tel: 0603 633362.
- Viking Computers Ardrey Rise, Cotton Green Road, Norwich. Tel: 0603 425209
- NORTHAMPTONSHIRE**
- A-Z County Supplies 23a Lower Mall, Weston Fovell Centre, Northampton, NN3 4JZ. Tel: 0604 414528
- Complete Computing 1 Central Buildings, Railway Terrace, Rugby. Tel: 0788 72309
- Softspot 42 High Street, Daventry, Northants. Tel: 0327 79020
- NORTH YORKSHIRE**
- The Computer Store 14 St. Sampson's Square, York. Tel: 0904 646934
- York Computer Centre 9 Doggate Centre, Doggate, York. Tel: 0904 651862
- NOTTINGHAMSHIRE**
- Belshaws Computer Shop 51 Belderrate Gate, Newark, Notts. NG24 3EQ. Tel: 0636 72503
- The Computer Shop Unit 230, Victoria Centre, Nottingham. Tel: 0602 410633
- Micro Byte 27 Goosegate, Hockley, Nottingham. Tel: 586454
- Microbyte Unit 109, Upper Broadwalk, Broadmarsh Shopping Centre, Nottingham. Tel: 0602 586454
- North Notts Computers 23 Quorn Street, Sutton in Ashfield, Notts. Tel: 0623 556686
- Virgin Games 6-8 Wheeler Gate, Nottingham. Tel: 0602 476126
- OXFORDSHIRE**
- Club Computers 6 Evans Yard, Sicester, Oxon. OX6 7ST.
- Panther Computers 2 Regents Arcade, Wantage, Oxon. Tel: (02357) 4831
- Softspot 5-6 Broad Street, Banbury, Oxon. OX16 8BN. Tel: 0295 68921
- Winney Computer Centre 105 High Street, Witney, Oxfordshire. Tel: (0993) 778294
- PETERBOROUGH**
- Logic Sales & Midgate, Peterborough. Tel: 0733 49696
- SCOTLAND**
- Capital Computers 12 Home Street, Tlcrross, Edinburgh. Tel: 031 228 4410
- Computer Centre 32 Primrose Street, Alloa. Tel: 0259 722932.
- Computer Centre 50 Bannion Street, Stirling. Tel: 0786 64175.
- Database Computers 42 East Port, Dunfermline. Tel: 0383 724597
- Database Computers 93 Graham Street, Jordon. Tel: 0236 47097
- Falkirk Computers 242 Graham Road, Falkirk. Tel: 0324 612989.
- Greiffix 304 High Street, Kercady, Tel: 0592 265569
- Greiffix 9 Albert Street, Leith Walk, Edinburgh. Tel: 031 553 6155
- Inverness Computers 15 Market Arcade, Inverness. Tel: 0463 226205
- The Computer Shop 75 Rosemount Viaduct, Aberdeen AB1 1NS. Tel: 0224 647875
- The Micro Shop 271/275 Dumbarton Road, Glasgow. Tel: 041 339 0832
- Vic's Computer Store 31-33 South Street, Perth, Scotland. Tel: 0738 36704

- Virgin Games 131 Princes Street, Edinburgh. Tel: 031 225 4583
- Virgin Games 28 - 32 Union Street, Glasgow. Tel: 041 204 0866
- Virgin Games Centre Argyle Street, Glasgow. Tel: 041-221 2606
- SOUTH HUMBERSIDE**
- The Computer Store 42 High Street, Southport. Tel: 0724 857985
- SOUTH YORKSHIRE**
- Crazy Joes 145 Ellingham Street, Rotherham, South Yorkshire. Tel: 0709 829286
- Just Micro 22 Carver Street, Sheffield. Tel: 0742 732732
- Microgame 20 Cleveland Street, Doncaster. Tel: 0302 329999
- Micro Fun Unit 12, Guardian Centre, Rotherham. Tel: 0709 360000
- Micro Fun 10 Peel Street, Barnsley. Tel: 0226 207063
- Micro Fun 83 Holme Lane, Hillsborough, Sheffield. Tel: 0742 345002
- The Computer Store 44 Market Street, Barnsley, S. Yorkshire. Tel: 0226 284124
- The Computer Store 21a Printing Office Street, Doncaster. Tel: 0302 325260
- STAFFORDSHIRE**
- Burton Software 31/2 High Street, Burton on Trent, Staffs. Tel: 0283 34388
- Miles Better Software 219/221 Cannon Road, Chaddamoor, Cannock. Tel: 0543 466377
- Software City 59 Forsgate, Stafford. Tel: 0785 41899
- SUFFOLK**
- Bits & Bytes 47 Upper Orwell Street, Ipswich. Tel: 0473 219961
- Bits & Bytes 45 Orwell Road, Felixstowe, Suffolk. Tel: 0394 279266
- Softsellers 5a Dogs Head Street, Ipswich. Tel: 0473 37158
- Software Plus 22 St. Matthews Street, Ipswich. Tel: 0473 54774
- SURREY**
- The Model Shop 89a Woodbridge Road, Guildford. Tel: 0483 39115
- Ultima White Lion Walk, Guildford. Tel: 0483 506939
- TYNE & WEAR**
- Microbyte 56 Garden Walk, The Metro Centre, Gateshead. Tel: 091 468 6054
- Microbyte The Green Market, Newcastle-upon-Tyne, Tyne & Wear. Tel: 091 261 9050
- Sunderland Computer Centre 29 Crowtree Road, Sunderland. Tel: 091 565 3711
- The Computer Shop 7 High Fries, Eldon Square, Newcastle. Tel: 091 261 6260
- The Computer Shop 9 Maritime Terrace, Sunderland. Tel: 091 310 8142
- WALES**
- Allsorts 39 Cross Street, Abergavenny, Gwent. Tel: (0873) 6903
- Bud Morgan 22/24 Castle Arcade, Cardiff. Tel: 0222 229065
- E.C. Computers Glamorgan House, David Street, Cardiff. Tel: 0222 390286
- Tandy Pier Street, Aberystwyth, Dyfed. Tel: 0970 625491
- Wrexham Computer Centre 24 Abbott Street, Wrexham, Chwyd LL11 1TA. Tel: 0978 358832

- WARWICKSHIRE**
- Spa Computer Centre 68 Clarendon Street, Leamington Spa. Tel: 0926 337648
- WEST MIDLANDS**
- Bull Ring Computers 7 Waterloo Terrace, Bridgenorth. Tel: 0746 766839
- Comtazia 204 High Street, Dudley, West Midlands. Tel: 0384 239259
- Comtazia Shopping Mall, Merryhill Shopping Centre, Brierley Hill. Tel: 0384 261698
- Microbyte 424 Grand Parade, Bull Ring Centre, Birmingham. Tel: 021 616 1036
- Mr. Disk 11 - 12 Three Shires, Oak Road, Beavwood, Warley. Tel: 021 429 4995
- Mr. Disk 8 Smallbrook Queensway, City Centre, Birmingham B5 4EN. Tel: 021 616 1102
- Software City 1 Goodall Street, Wallall. Tel: 0922 24821
- Software City 3 Lichfield Passage, Wolverhampton. Tel: 0902 25304
- Venture TV Broad Street, Sidemore, Bromsgrove. Tel: 0527 72650
- Virgin Games 98 Corporation Street, Birmingham. Tel: 021 236 1577
- Watchdog Comp 40 Queen Street, Wolverhampton. Tel: 0902 313600
- WEST SUSSEX**
- Crawley Computers 62 The Boulevard, Crawley. Tel: 0293 37842
- Worthing Computers 7 Warwick Street, Worthing. Tel: 0903 210861
- WEST YORKSHIRE**
- Atom Software 495 Great Horton Road, Great Horton, Bradford. Tel: 0274 373788
- Microbyte 1 Kirkgate Mall, The Kirkgate Centre, Bradford. Tel: 0274 308829
- Microbyte 29 Queen Victoria Street, Leeds. Tel: 0532 450529
- Microbyte 33 Kirkgate, Wakefield. Tel: 0924 376556
- The Computer Store 34/36 Negate, Bradford. Tel: 0274 732094
- The Computer Store 10 Square, The Woolshops, Halifax. Tel: 0422 69077
- The Computer Store 4 Market Place, Huddersfield. Tel: 0484 514405
- The Computer Store 40 Trinity Arcade, Bond Street Centre, Leeds. Tel: 0532 429284
- The Computer Store 13 Westmorland Street, Wakefield. Tel: 0924 290139
- Virgin Games 94 Baggate, Leeds. Tel: 0532 432606.
- WILTSHIRE**
- Antics 8 Regent Circus, Swindon. Tel: 0793 611253



IN-STORE MARKETING
2/3 Holford Way, Holford,
Birmingham B6 7AX.
Tel: 021 625 3388

BRUCE SPRINGSTEEN, superstar of rock, says "Make sure you don't miss out on AA Fall - I never do!"
JED-GOP!

THE LINE UP

AMSTRAD ACTION ● SEPTEMBER 1989

FRONT END

NEWS●LETTERS

7 AMSCENE

All the CPC news and previews

11 REACTION

Once more into the postbag dear friends... Readers' letters on all matters CPC

14 EMMA BROADLEY

Ms. B: she's quietly spoken, gentle and reasonable - believe that and you'll believe anything!

SERIOUS SIDE

CPC USES●HARDWARE●PROGRAMMING

16 DTP SPECIAL

● This smashing **Mannesmann Tally 24 pin printer** must be won - see our DTP special beginning on p. 16!

This month we take a close look at what can and can't be done in the way of Desktop Publishing with the CPC. We

- REVIEW a brand new *Stop Press* enhancer;
- INTERVIEW the people behind *The House of Dolls*, a music fanzine that started;
- SURVEY the CPC fanzine scene;
- BEGIN a brand new series on the five major aspects of DTP - writing, artwork, printing, distribution - and
- ANNOUNCE a great AA competition to find the best new fanzine around written on the CPC.

16 STOP PRESS ACCELERATED!

PAT McDONALD reviews a brand new enhancer for the ever-popular *Stop Press*, and expresses a personal reason for welcoming it

AMX MOUSE
 FOR THE AMSTRAD
 CPC 6128

THE ACTION BEGINS ON 40!

THE VERY BEST IN CPC ENTERTAINMENT

40 GEMINI WING

The latest Tecmo arcade conversion from Virgin Games



42 PURPLE SATURN DAY

It's French, it's frantic - it's fantastic!



18 HOUSE OF DOLLS

An inspiration if ever the budding fanzine editor needed one - ADAM PETERS talks to the team that watched a mag grow from 30 copies and issue to 20,000

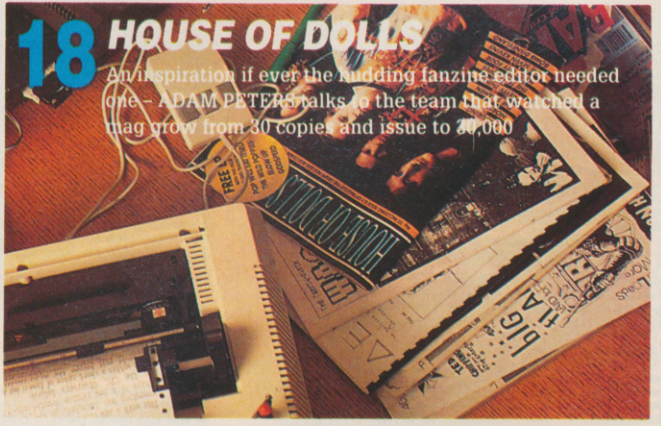

ACTION TEST: page 40!

- Gemini Wing, p. 40
- Purple Saturn Day, p. 42
- Red Heat, p. 46
- Rick Dangerous, p. 47
- Dominator p. 48
- Compilations p. 48
- Eliminator, p. 50
- Bob's Full House, p. 53

46 RED HEAT

Arnie: no brains but a whole lot of brawn!

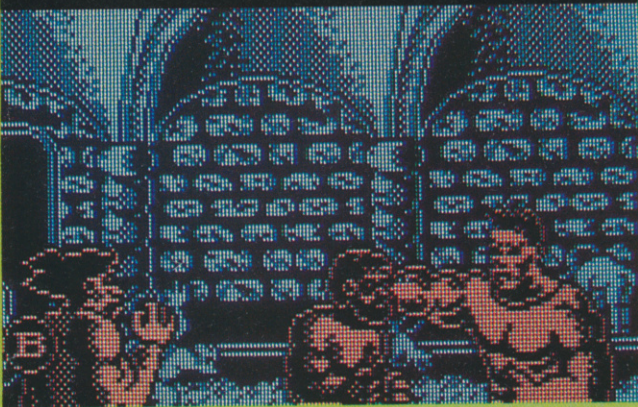

47 RICK DANGEROUS

A cross between Indie Jones - and Charlie Chaplin!



21 FIRST EDITION

Our expert guide to CPC DTP begins here

22 ENCLOSE SAE...

JEFFREY DAVY surveys the thriving CPC fanzine scene

25 FORUM

Technically speaking, PAT McDONALD gets worked up

30 GETTING IN ON THE ACT

PHIL CRAVEN investigates the "Black Boxes" and those other mysterious utilities the Copyright Bill seeks to kill

33 ARE YOU NOW OR HAVE YOU EVER...?

£100 of software just for filling in a questionnaire? Yup!

Get into print mode - now!

The vast majority of CPC owners know all about its abilities as both a games machine and a word processor. Many use it at work, too, for keeping tabs on accounts, stock and so on. What we've been missing out on, however, is its potential for Desktop Publishing.

Now no-one is going to pretend that a home machine, even one as good as the Amstrad, can compete with micros costing several thousands of pounds. But if it's an affordable, durable workhorse you're after, perhaps you've already got it! (It has the added advantage, too, that you can play a mean arcade game to relax in between pages.)

We've decided to do our bit to encourage CPC users everywhere to develop their creative talents. So turn to page 16 and get cracking!

Steve



PS This month there's a questionnaire on page 33. We're giving away £100 of software to encourage you to fill it in. But the real reason we're so keen is that this is your magazine, and this is your opportunity to shape it for the year to come. Your voice counts!

36 THE LOOK

That spritely PAT McDONALD uses more graphic language



55 SMALL ADS

Selling couldn't be cheaper or easier - nor could buying!

58 INSIDE OUT

The CPC bares its innards for STUART McCOLL

60 HELPLINE

Get in touch, get out of trouble - bumper edition

62 TYPE INS

The way to learn is to do: and there's plenty to do here

67 CHEAT MODE

We can give you the secrets of eternal life - for free!

70 INSIDER DEALING

The secret diary of A. Hacker, alias PHIL HOWARD

72 PROTECT AND SURVIVE

Just how are games protected? MIKE WONG reports

75 BUYERS GUIDE

What, where and how much - do nothing without it!

78 AFTERTHOUGHT

We'll think of something, we hope!

79 SPECIAL OFFERS

The juiciest offers, the tastiest prices!

Future Publishing Limited
4 Queen Street, Bath BA1 1EQ

- ☎ 0225 446034 ● Fax 0225 446019 ● Editor Steve Carey
- Technical editor Pat McDonald ● Games editor Trenton Webb
- Art editor Ollie Alderton ● Additional design Martin Parfitt
- Contributors Emma Broadley, Super Phil Craven, Phil Howard, Stuart McColl, James Wilson, Steve Palmer
- Publisher Greg Ingham ● Production Diane Tavener ● Subscriptions Christine Stacey ☎ 0458 74011 ● Mail Order Clare Bates ☎ 0458 74011 ● Advertisements Elaine Brooks ☎ 0225 446034 ● Distribution Comag

© FUTURE PUBLISHING LTD 1989 Amstrad Action is an independent publication. The company producing it - Future Publishing Ltd - has no connection with Amstrad plc. We cannot guarantee to return material submitted to us, nor can we enter into personal correspondence. We take great care to ensure that what we publish is accurate, but cannot be liable for any mistakes or misprints. No part of this publication may be reproduced in any form without our explicit written permission.

ABC

MEMBER OF THE AUDIT BUREAU OF CIRCULATIONS

38,457

July-December 1988

NOW THE FIRST EVER UTILITY TO TRANSFER "GO!" LOADERS TO DISC

This type of loader has previously been considered impossible to transfer to disc with an automatic utility but now we have developed a
** FULLY AUTOMATIC PROGRAM **

to transfer the game and loading screen with a massive saving in disc space used, due to compressing not only the screen but also the game code.

Among those tested are:- 720 DEGREES, ATF, HEROES OF THE LANCE (main file & screen), INDIANA JONES (Main file & screen), TRANTOR (main file & screen), BLACK BEARD, COLOSSEUM, WIZARD WARZ (main file), SIDE ARMS, CHICAGO 30's, RAMPARTS, LAZER TAG, ECHELON (main file), JACKAL, SOLOMONS KEY and HERCULES (main file).

** This utility is written to only work in a CPC6128. It will not work in a CPC464 or CPC664 even with memory expansion unless fitted with a 6128 ROM as it uses direct ROM addresses. However, the transferred game will run on your 464/664.

With Indiana Jones, Trantor, Heroes of the Lance, Hercules, Wizard Warz and Echelon we supply details of how to complete the transfer of the remaining game code.

Added Utility To Dump Any Screen Saved With Goldtrans To Four Different Types of Printers

GOLDTRANS PRICES: UK - £15.00 EUROPE - £16.25 REST OF WORLD - £17.00

! SPEEDTRANS PLUS - NOW EVEN FURTHER AHEAD OF ITS RIVALS! SPEEDTRANS PLUS - 3

For CPC6128 (or 464/664 with DK Tronics 64K (or larger) Memory)

Once the program has been transferred to disc It Will Run On your 464/664

Fully automatic - Just One Keypress * Only One Program To Run Which Finds The Speedlock Type Automatically * Transfers Many Original And Today's Speedlock Programs * No Meddling - Written With The Amateur In Mind * Automatic Disc Filenames * No Wasted Disc Space - Saves The Correct Amount Of Game Code * Saves 99% Of Opening Screens * Screens Saved In Their Correct Colours * Compresses Screen Code To Save Even More Disc Space * A Normal Data Format Disk Will Hold Six Standard Games. * Faster Loading Times From Disc Because Of Shorter File Lengths *

SPEEDTRANS handles all Speedlock types **Automatically**. No need to hold a key down at anytime during loading. **SPEEDTRANS** has only one program to run - no time wasting running several alternatives making transfers that do not work. **SPEEDTRANS** makes all transfers direct to your destination disc - does not need the **SPEEDTRANS** disc whilst working. **SPEEDTRANS** transfers more Speedlock protected programs to disc than any of its competitors. It also transfers ALL the speedlock protected programs we say it will - we make no unsubstantiated claims.

SPEEDTRANS transfers over 200 programs to Disc, some of the latest it will do are MADBALLS, FREDDY HARDEST (both games) BASKET MASTER, MATCHDAY II, PHANTOM CLUB, GRYZOR (main program) OUT RUN (main prog) SUPER HANG ON, ATV SIMULATOR, R TYPE, REVOLUTION (Including screen) in only 43K, SUPERHERO in only 48K and Wizzball in only 55K compared with 61K when transferred with another Speedlock utility.

SPEEDTRANS is the only utility that will transfer Mutants 64K. **SPEEDTRANS** is the only utility that will transfer Revolution automatically without meddling.

Added Utility To Dump Any Screen Saved With Speedtrans To Four Different Types of Printers.

SPEEDTRANS will transfer many other titles - some better known ones are:

All Titles From Konami's Coin-Op. Hits From Konami Arcade Collection: Nemesis - Jackal - Jailbreak
Summer Gold By US Gold: Dambusters - Beach Head II - 10th Frame - Bruce Lee - Impossible Mission. From They Sold A Million: Sabrewulf - Beach Head - Jet Set Willy - Daley Thompsons Decathlon. From They Sold A Million 3: Fighter Pilot - Ghostbusters - Daley Thompsons Decathlon

3D Starfighter, Ace Of Aces (Main Program), Acrojet, Advanced Pinball, Alien Highway, Arkanoid, Arkanoid 2, Revenge Of Doh (Main Program), Armageddon Man, Army Moves (1 & 2), ATV Simulator, Brain Clough's Fortunes, Barry McGuigans Boxing, Basket Master, Batman, Beach Head, Beach Head II, Black Magic-Both Parts, BMX Simulator, Bounty Bob, Bounty Bob Strikes Back, Brain Ache, Breakthru, Bruce Lee, Catch 23, Crystal Castles, Cluedo, Cobra (Stallone), Combat School, Copout, Cosmic Shock, Daley Thompsons Decathlon, Daley Thompsons Olympic Challenge (Main Program), Daley Thompsons Super Test, Dambusters, Dan Dare 2,

Desert Fox, Dizzy, Donkey Kong, Elektra Glide, Express Raider, Eye Spy, F15 Strike Eagle, Fighter Pilot, Football (Codemasters), Frankie Goes Hollywood, Freddy Hardest, Fruit Machine Simulator (Main Program), Galactic Games (Main Program), Galvan, Game Over (Both Parts), Ghostbusters, Goonies, Grand Prix Simulator, Green Beret, Gryzor (Main Program), Gunfight, Gyroscope, Hacker, Head Over Heels, Highlander, Highway Encounter, Hunchback II, Hypersports (Main Program), I Spy, Impossible Mission, Its A Knockout, Jackal (Compilation Ver), Jailbreak (Compilation Version), Jet Bike Simulator (Main Program), Jet Set Willy, Juggernaut, Killed Until Dead (Main

Program), Knight Games (Main Program), Knight Rider, Konami Golf, Kong Strikes Back, Kung Fu Master, Leaderboard, Leaderboard Tournament, Leaderboard Worldclass, Legend Of Kage, Leviathan (Main Program), Madballs, Mag Max, Mario Brothers, Match Point, Matchday, Matchday II, Metrocross, Miami Vice (Ocean), Mikie, Minder, Mindshadow, Mission Jupiter, Monopoly, Nemesis The Warlock, Never Ending Story (Main Program), Nigel Mansells Grand Prix (Main Program), Nomad, Out Of This World (Main Program), Outrun (Main Program), Phantom Club, Ping Pong, Platoon, Pro Ski Simulator, Pulsator, Race Against Time, Raid, Rambo First Blood II, Renegade (Imagine) (Main

Program), Rescue On Fractalus, Return To Oz, Revolution, Road Runner (Main Program), Rocco, Sabre Wulf (Later Version), Samantha Fox Poker, Saracen, Scalextric, Scrabble, Shadow Skimmer, Shao-lins Road, Short Circuit, Silent Service, Slain, Slapfight, Space Shuttle, Spy Trek, Street Hawk, Super Cycle (Main Program), Super Hang On, Super Hero, Super Stunt Man, Tenth Frame, Terrormolinos, The Great Escape, The Race Against Time, The Way Exploding Fist, Topgun, Transmuter, Tubaruba, Uchimata, V, Vampire, Vixen, Warlock, Winter Games, World Games (Main Program), World Series Baseball, Xarq, Xevious, Yie Ar Kung Fu, Zoids (Martech), Zorro and many more.

SPEEDTRANS is, without doubt, the best Speedlock transfer utility on the market today and is capable of transferring more Speedlock games to disc than any of its competitors.
TRY IT AND SEE FOR YOURSELF UK £15.00 -- Europe £16.25 -- Rest Of The World £17.00 Upgrade your Speedtrans Disc - send your disc together with UK £3.00 - Europe £4.25 - Rest Of The World £5.00 Upgrade your Speedtrans Tape send your tape together with UK £12.00 - Europe £13.25 - Rest Of The World £14.00

DMP 2000/2160 PRINTERS

The printer buffer presently in the DMP 2000 series is a 2K RAM. Most of this RAM is used by the printer's operating system leaving an average 1/2K as buffer space. Our upgrade kit contains a new static RAM chip which will increase the printer buffer by 6K (about 4 pages of text). This upgrade allows all Download Characters to be re-defined allowing the user to design special characters for use with scientific and other programs. The kit is supplied with full pictorial instructions to allow the amateur to carry out his own modification (the DMP2160 takes about 7 minutes). If you don't think you are up to it your local TV shop can do the job in approximately 15 minutes

UK £14.50 - EUROPE £15.75 - R. of W. £16.50

COMPACTOR

COMPACTOR will allow you to load a standard 17K screen, set the mode, border and ink colours and then save it as a compressed screen containing its own mode and ink colour information. Most screens compact down to an average of 9K which is an enormous saving on disc space. Loading time of compressed screens is also proportionately reduced.

TAPE:- UK £5.00 - EUROPE £6.25 R. of W. £7.00
DISC:- UK £8.50 - EUROPE £9.75 - R. of W. £10.50

UTILITIES DISC NO. 1

This utility disc contains 5 programs, all menu driven. They are SAMSON, TRANSIT, QCLONE, VIEWTEXT and the fast disc FORMATTER.

DISC:- UK £15.50 - EUROPE £16.75 - R. of W. £17.50
ROM:- UK £17.25 - EUROPE £18.50 - R. of W. £19.25

UTILITIES DISC No. 2

This utility disc contains nine programs. They are Samson, Delilah, Playtrans, Firetrans, Screen Compactor, Address Label Printer, Epson Screen Dump, Schinwa Screen Dump, Cito Screen Dump.

DISC:- UK £20.00 - EUROPE £21.25 - R. of W. £22.00
ROM:- UK £25.00 - EUROPE £26.25 - R. of W. £27.00

NIRVANA

Have you tried backing up your original expensive disc software and failed? Use NIRVANA before its too late! NIRVANA (meaning enlightenment) is an extremely powerful disc handling utility which has the following features: Disc to disc back-up copier which will handle most of the commercially protected discs available today. File copier for individual files. Disc formatter, much easier to use than CPM. Change file attributes. Erase files. Change filenames. Will handle all disc drive combinations

DISC:- UK £15.00 - EUROPE £16.25 - R. of W. £17.00

CHARACTER DESIGNER

(All CPC's)

- * REDEFINE YOUR PRINTER DOWNLOAD CHARACTERS
- * REDEFINE THE COMPUTER SCREEN FONT
- * REDEFINE ANY/ALL KEYBOARD KEYS (ASWERTY)
- * DESIGN SPECIAL SCIENTIFIC CHARACTERS/FONTS

Takes all the hard work out of character designing making it a pleasure. The printer part of the program will only work if your printer is capable of DOWNLOADING and is EPSON compatible - see your printer manual. Works with 7-bit or 8-bit output (8-bit port). All the designing is done "On-Screen" so you can see exactly what you are doing. You can save your newly designed characters to disc and reload them at any time into a basic program and into most Word-Processors. The program also allows the user to redefine any or all of the keys on the keyboard. This feature will be useful for those who require an ASWERTY keyboard. The disc also contains twelve sample fonts for experimentation

TAPE:- UK £7.99 EUROPE £9.25 - R. of W. £10.00
DISC:- UK £12.00 - EUROPE £13.25 - R. of W. £14.00

Please send your cheque (£ Sterling) Eurocheque or UK P.O. to:
GOLDMARK SYSTEMS, 51 COMET ROAD, HATFIELD, HERTS
AL10 0SY ENGLAND

Please write or telephone 07072 71529
for full brochure on our many other tape to disc products

AMSCENE

releases... updates... previews... new releases... updates... previews... new

Cheetah: "No CPC market for lightgun"



● Virgin/Mastertronic's Magnum: having things all its own way

Attention!
Turn to page 9 for an important announcement about AA

Cheetah, the company that produces CPC joysticks, the *Amdrum* and music keyboards, have admitted that they have no plans to launch their multi-format lightgun in a CPC version.

The announcement follows the launch last month of the Virgin/Mastertronic *Magnum*, licensed by Amstrad and bundled with six games including the best-selling *Operation Wolf*.

The news that the gun, which is being developed in conjunction with CPC budget specialists Code Masters, comes as a blow to some observers who had been rel-

● Cheetah's Amdrum and joysticks: but no lightgun forthcoming

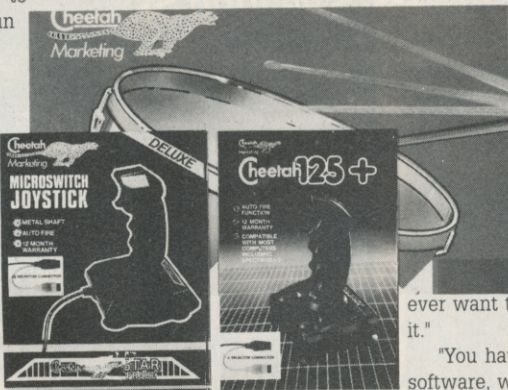

ishing the prospect of a stand-up fight between the two companies.

Cheetah's boss Howard Jacobson was scathing about the CPC's future prospect, claiming that there is no market for a lightgun.

"We've produced peripherals for the CPC before, and they haven't been supported. People go out and buy the CPC because they can get a package, and they don't ever want to buy anything else for it."

"You have to go out and create software, which costs a lot of mon-

ey that you have to get back by selling product. Something like the Commodore version we're going to sell 200,000: on the CPC we'd be lucky to sell 2,000.

"It's the same on the Atari: we've actually got the hardware, but I just don't think there's a market there for it.

Are you running scared of the Virgin/Mastertronic Amstrad-licensed *Magnum*, which would be a direct competitor your gun?

"If you look at the rest of the market, and sees what happens to it very, very shortly you'll see that we're not," he replied, cryptically.

What does that mean, Howard? "No comment."

Is it to do with what Amstrad are doing, or with what Cheetah are doing?

"We don't like competition, OK? So we always win, and make sure we do. That's one side... the other side, you'll just have to wait and see. But we're certainly not scared of anyone, we just make sure no-one can beat us."

Do you know something about the CPC the rest of us don't?

"No, not at all, it's just that I don't believe it's a market worth getting into. Amstrad are probably going to get involved because they want to sell packs. I would imagine that the CPC hasn't got very much longer to live.

"Yes there's a lot of them out there, but the owners either shove them up in the loft or their parents won't buy them any more, and they've bought them a system and don't want to spend any more on them."

New Amstrad show "will be world's biggest"

A giant new Amstrad show, claimed to be "the world's largest event for Amstrad users" has been announced.

The three day Computer Shopper Show, organised by Database Exhibitions and taking place at the Great Hall, Alexandra Palace, is claiming to expect 40,000 visitors and some 250 stands, more than 100 of which will be dedicated to selling CPC, PCW and PC products.

Amstrad have already committed themselves to the show, and other major household names pledged to it include Amnor, Rombo Productions and Tynesoft, with many more expected to follow suit.

A special feature is the sickeningly entitled "Wonderful World of Amstrad," allegedly a "major exhibition in its own right" within the main show.

"For three days in November," Michael Meakin, head of Database Exhibitions claims, "Computer Shopper will transform Alexandra Palace into the number one Christmas computer gift hypermarket in the world. The number of Amstrad products will never have been greater -

nor will the number of special show offers. It will be a bonanza for all Amstrad CPC users: I guarantee it!"



Spectravideo invent better mousetrap

This extraordinary-looking thing is the new AS-118F Wizmaster Games Controller. Spectravideo, the company behind the phenomenally successful Quickshot series, are claiming that its features make it "unique."

"There was a time," reminisced boss Ashwin Patel, "when a phrase commonly used by marketin people in this industry was that 'A joystick is a joystick is a joystick.'

"This is no longer the case. The end user now demands a much wider range of choice. Spectravideo intend to meet this more sophisticated demand with innovative new designs; QS-118F Wizmaster is the first of many to follow."

What, though, makes this beast unique, apart from its decidedly odd appearance?

"Well, it has features that I'm not aware have appeared on any other joystick," claimed a Spectravideo spokesperson. Such as? "Apart from the autofire on-off button, there's the three different control mechanisms."

Ah yes, the three different control mechanisms. The *what?* "If you look on the left hand side of the joystick you'll see a short lever: this is removable, so that

Ralph Waldo Emerson (1803-1882), I believe, who asserted that "If a man write a better book, preach a better sermon, make a better mousetrap or do something novel with

a joystick, the world will beat a path to his door." Well, maybe he didn't say that bit about joysticks, but he said the rest of it.

That nice man in your local computer shop will be only too pleased to accept £11.95 from you in exchange for the Wizmaster.



● The Wizmaster: Spectravideo's "better mousetrap"

if you're one of those players who prefer finger-and-thumb operation you can have it.

"And if you require a longer lever you can screw that in its place."

So there you have it. It was

● Meanwhile Konix are releasing yet another world beating designer joystick. Well, sort of: their ultra cheap *Megablaster* (rated as a Bargain Buy in our AA44 joystick survey) is being revamped internally and it's £2 more expensive at £8.99.

The difference is that rather than using leaf spring switches (which warp, making control more difficult), the new *Megablaster* depends on microswitches, which are much tougher and give a more consistent performance.

Mini office II counts down to 500,000!

Database Software's *Mini Office II*, one of the most popular CPC software packages ever, is about to reach a remarkable landmark: its 500,000th sale. The lucky purchaser will win a state

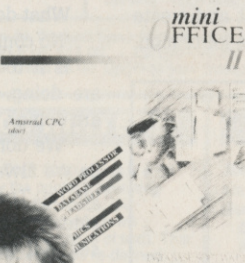

of the art £500 video recorder.

The integrated word-processor, database, spreadsheet and comms package is claimed to be "the bestselling small business package of all time," according to

Database's marketing manager Chris Payne. "To celebrate, we're giving away a brilliant Sony video recorder, with slow motion digital effects, perfect pausing, picture-in-picture and editing - it's got everything!"

Launched originally as *Mini Office* back in October 1984, just six months after the first 464, the package was revamped as *Mini Office II*, currently selling at £21.95, and has been a best-seller ever since.



● *Mini Office II*: 500,000 and still going strong. Chris Payne's not complaining

Swearing Skweek gets the chop!

Twisted pranksters have corrupted US Gold's cuddly *Skweek*, the central character of a recently released Loricels game (*Raved* in AA last issue).

A highly embarrassed US Gold have been forced to withdraw copies of the game, which have been interfered with so that the lovable children's friend becomes a foul-mouthed fiend. Although few copies have been found Gold have taken the line that it's better to be safe than sorry.



More French lessons soon

Flushed with the success of the extraordinary *Purple Saturn Day* (see page 42 for the full review) Infogrames have announced their next project, *Action Service*, which the player in a fictional commando school somewhere in Europe, training to join the elite Cobra Force.

Your aim is to train your player up to the peak of physical fitness (*cough, wheeze, stop you're killing me*). It boasts a vast array of joystick driven commands - over 20 - to help you learn the trade. All the action is viewed through a split screen system that also boasts a slow motion facility to help you improve your kill ratio.

It's also rumoured that a second game is being planned which will let you take the character built up in *Action Service* on active service! Sound impossible? Well, so did a *Purple Saturn Day* conversion for the CPC, and that's simply outstanding, so who knows? Watch this space... (why, what's it going to do? - ed)



● *Action Service* - from the people who brought you the rather splendid *Purple Saturn Day*



US Gold hype for the best

The launch of the latest *Indiana Jones* demo copies have been circulated to give us all a foretaste of the most hyped game of the year so far. As *Indie*, you play through four different stages of his life in an arcade adventure. First in

same breath as *Out Run* and *Leaderboard*, two of the biggest sellers of all time.

On 16 bit formats the concept is being so aggressively pursued that not one but two games – an arcade style and a pure adventure – are springing from the one licence! Luckily we are spared such over-exposure and only have the higher paced, literal interpretation of the movie.

To further boost sales the US Gold team are splashing the cash for both the press and the public. Journalists were softened up with a preview screening in Leicester Square and a

party at Stringfellows. The public are to be inundated with T-shirts, signed poster competitions and a whole host of other associated goodies. The book of the film, the launch of *Indiana Jones and the Temple of Doom* as a sell-through video as well as a massive advertising campaign in movie, computer and sundry other mags are all opportunities for US Gold to remind us; in case we'd forgotten, that the game is coming. Advertising and promotion costs are being split between the various Licencers and licencees.

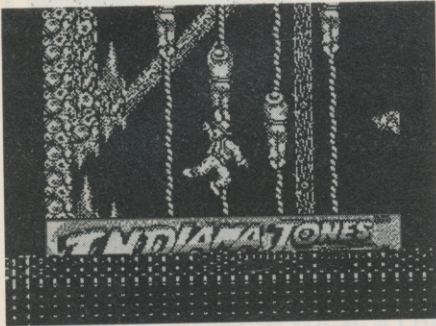

search of the Cross of Coronado, then scrambling across the roof of a speeding train, face to face with rats in sewers of Venice, even playing spiderman on the walls of a Castle.

The game is getting some major muscle from the marketing people at US Gold, who are predicting that this one game alone could turn around the traditionally sluggish summer sales figures. This is seen as so important that Gold have spent more than ever before on a non-Christmas release. Sales expectations are high – Gold are talking of *Indiana Jones* in the

Are you the next AA TECHNICAL EDITOR?

This is a golden opportunity for someone with sound technical knowledge to make the break into magazine journalism, working for one of Britain's fastest expanding publishing companies.

But do you fit the bill?

- You have a thorough knowledge of the CPC's hardware and software.
- You write well, communicating your understanding and enthusiasm clearly in a way that both Amstrad buffs and newcomers will find entertaining and informative.
- You relish the prospect of living in Britain's most beautiful city.

You have these qualifications? Good! Write to The Editor, *Amstrad Action*, 4 Queen St, Bath BA1 1EJ. Enclose a formal letter of application; personal details and qualifications; and a piece of writing (about 300 words) demonstrating your abilities. Review a piece of serious software; analyse a program or explain a routine – whatever. But it must show that you are the person for this demanding and satisfying job.

Share the excitement!

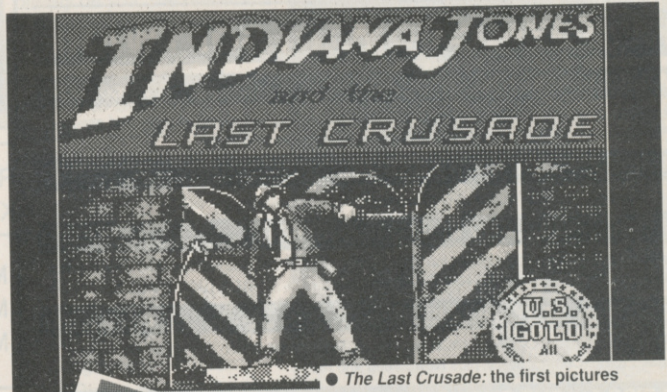

• The Last Crusade: the first pictures

Laser Squad lands at last

At long last *Laser Squad* is about to be released. Target Games, who bought you *Rebelstar*, are up and gunning again, this time with a choice of up to six different scenarios for you to blast your way through.

In a game of tact, diplomacy and mindless violence you control a group of rebels taking on various evil intergalactic corporations and law enforcement bodies. You have a wide choice of weapons and armour to tool up with, creating a highly flexible and always changing battle simulator. A cross between *Airborne Ranger* and the movie *Aliens*, it gives you the chance to try and outwit either your CPC or a friend. A quick recon-

naissance mission has reported that war may be hell, but it sure looks fun (ideologically unsound state-



• They took their time, but Now It Can Be Told: *Laser Squad* gets here

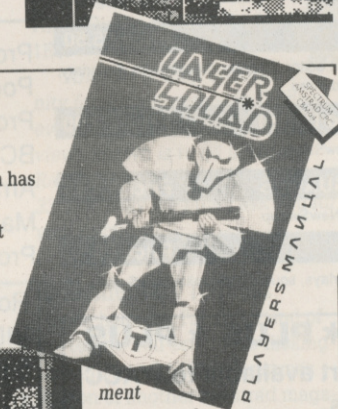

ment of the month, or what? – ed). A full briefing follows in next month's dispatches, together with an exclusive interview with Adrian Gollop, the game's programmer.

This puts all US Gold's summer eggs firmly in one basket, and leaves them dependent upon the movie's success or failure at the box office before any customers even get to see the game. All the evidence from what we've seen so far of the CPC version suggests that game's tie-in to the game has been very well done, creating what looks to be a highly effective licence. So far so good.

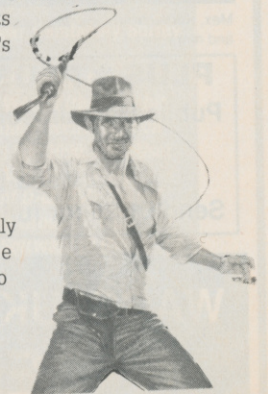

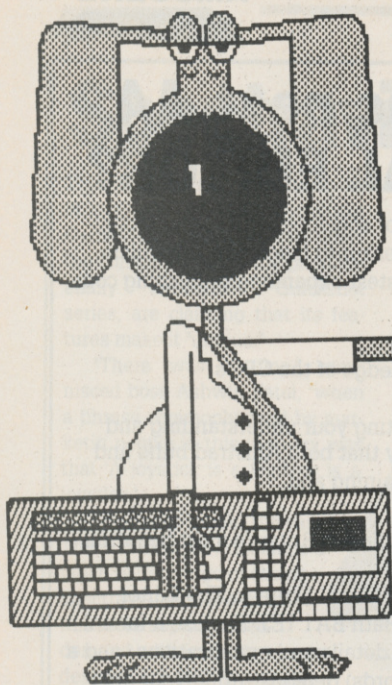

WACCI

unbeatable prices, unbeatable service

ANNUAL SUBSCRIPTION RATES

UK.....	£15.00
Europe	£22.50
Overseas	£30.00
Current issue	£1.25

- * Fully illustrated
- * Over 20,000 words per month
- * Proper A4 format

Letters, Basic, Comms, Mcode, Hardware projects and much more.

A truly
Alternative
Fanzine

CASPELL RIBBON REFRESHER
An 8oz can does up to 30 ribbons
ONLY £7.95 PER CAN

THE PUBLIC DOMAIN SOFTWARE

CPM DISC 1 – MACHINE CODE TOOLS Price £5.50

Z80 and 8080 assemblers, Z80 to 8080 to Z80 code translator, Debugging monitor and assembler, Reverse assembler, Binary file comparer, plus NewSweep and more.

CPM DISC 2 – COMPUTER LANGUAGES Price £5.50

Small-C, Prolog, Lisp, EBasic, Small-C-Interpreter plus NewSweep.

CPM DISC 3 – FILE AND DISC MANAGEMENT Price £5.50

Library utilities, Disc quality checker, Unix GREP command, PCW disc reader, Disc sector editor, Text file sorter, Word counter, plus NewSweep and more.

CPM DISC 4 – AT YOUR LEISURE Price £5.50

Cave Adventure, Chess, Othello, Golf, Word search, Biorhythms, Maze generator, On-screen calculator, Prolog, Comms utility, plus NewSweep and more.

CPM DISC 5 – THE BUSINESS Price £5.50

Scrivener spreadsheet, Inventory database, Powerful text editor, Spelling checker with dictionary, Sorter, Word counter, Comms utility, plus NewSweep and more.

CPM DISC 6 and 7 – PASCAL PLUS (Two Discs) Price £9.00

Pascal, SCI, Cobol, EBasic, Powerful text editor, plus NewSweep.

CPM DISC 8 – MORE COMPUTER LANGUAGES Price £5.50

Forth, Stoic, Cobol, Expert 86, Powerful text editor, plus NewSweep

CPM DISC 9 – COMMUNICATIONS Price £5.50

Mex, Kermit, Kermode, Interface and Smart-Modem, overlays, source code, plus NewSweep and more.

PLUS * PLUS * PLUS * PLUS * PLUS

Public Domain software support available to WACCI subscribers.

Mega-big homegrown library

Send £1.25 for full catalogue and details (E and OE).

THE SPECIAL OFFERS



Advanced OCP Art Studio — £18.95

OCP Art Studio — £15.95

The Advanced Art Studio, bundled together with the Genius Mouse, Interface and Mouse Mat — £49.95

Ram Delta Joystick	7.99
Kador Seal 'n' Type covers	7.95

MasterCalc 128	24.95
MasterFile III	29.95
MasterCalc AND MasterFile	49.95

Protex (CP/M+)	47.00
Pocket Protex (CP/M+)	23.25
Protex Filer	19.50
BCPL (CP/M+)	19.50
Arnor C (CP/M+)	39.00
Maxan 1.5 (ROM)	£23.25
Protex Office (Disk)	£27.25

Rombo Rom Box	27.00
VIDI-CPC digitiser	68.00
5 x CF2 discs (yes we've got them!)	11.95
10 x CF2 discs	22.95
20 x CF2 discs	44.95
DMP 2000/3000 Printer Ribbons (each)	£2.95

WACCI UK, 9 SOUTH CLOSE, TWICKENHAM, MIDDX TW2 5JE
Est. 1986 — Phone 01-898 1090



REACTION

Yet another brimming postbag spills across the editor's desk

● Long live The Pilgrim!

Like many Amstrad CPC owners I am getting used to being a member of a minority group. As an adventuring addict I should also be used to belonging to a group not only even smaller, but one that gets only a token of the level of support given by some software houses to other makes of computer.

However, as a regular reader of AA since issue 1 who has always appreciated and fully supported its campaign for a better deal, I must raise my voice in protest when without warning the Adventure Column has been dropped and the magazine no longer appears to be on the side of the adventurer.

From my experience on the Adventure Helpline since November 1985 talking to and corresponding with adventurers everywhere, including some from as far away as Australia and New Zealand, I know that not only are there a great number of you out there, but also that the column is both popular and very helpful in its various ways.

My message to fellow adventurers everywhere is to read the AA answer to Mark Watson in issue 47 and follow the suggestion: write a letter to AA. But do it immediately to join me in saying "We want our column back!"

If we are successful in getting AA to resurrect the Adventure Column I shall continue to give it my support, but either way the helpline (what The Pilgrim calls *Lords and Ladies of Adventure*) will go on. If you are having trouble with an adventure drop me a line (don't forget the SAE) or ring me between 1pm and 10pm on 0305 784155. If I can't help I will probably be able to put you in touch with someone who can.

Joan Pancott
Weymouth, Dorset

AA: Magazines must evolve, clearly, or else they die. In the

Get your point across to the world of CPC readers. Write to: Reaction, AA, 4 Queen St, Bath BA1 1EJ.

There's a £15 software voucher for the letter of the month, too!



past year the Hot Tips, Words Work and Problem Attic columns have all been compressed into Forum; we have turned Buyers Guide into a regular all-round shopping list; and added columns such as Broadley Speaking and series such as Phil Howard's Insider Dealing and Stuart McColl's Inside Out.

The Pilgrim, however, is different. When the author - The Pilgrim himself - moved on to pastures new (where the grass was greener) it was decided that we would drop the column as an experiment. There are after all, as Joan implies few adventure software houses left who consider the CPC important to their plans. What I hoped would happen is that people would want to fight for its survival, write in and complain, send petitions, beseege the office, demand an Adventure column in AA.

Well, at last it's started. Joan's is not the only letter I've had from angered adventurers. Now, since

there are
so few
new



● The mysterious disappearing Pilgrim: gone - but not for long!

adventures released for us, it makes sense to re-organise. What I propose is that we have a regular column of Lords and Ladies of Adventure, so that adventurers can get in touch with each other; and also featuring playing tips (but probably not complete solutions). On those occasions when new adventures are released, of course, we shall review them at length either in The Pilgrim or in Action Test.

The size of the all new Pilgrim column, however, depends completely on you, the readers. If it is clear that Joan is the only person prepared to put any effort into it then it's unlikely to last very long. If, on the other hand, I'm inundated with replies, adventure tips, entries for the Lords and Ladies and so on, then there's no reason why it needn't expand...

So let us have your contributions, ideas and observations as soon as you can to: Long Live the Pilgrim!, AA, 4 Queen St, Bath BA1 1EJ.

Another golden opportunity for adventurers - and indeed everyone else - to make their views known is to fill in the Readers' Questionnaire on page 33. Don't say we never ask you for your opinion!

● Elementary request

Please help me, I'm at the end of my tether. You see, I was flicking through my old 1986 Christmas edition of another Amstrad magazine when I came across a game called *Zombi*, by Ubisoft. As I read the review I soon realised that it was based on my favourite film, *Zombies, Dawn of the Dead*. At that moment I knew I had to have this game at any cost. So my search began in software houses and in high street shops, but after

all my efforts I could not find it, so I decided to write to the greatest mag in the universe, because I know if any one can find this missing piece in my life it's AA.

Matthew Sherlock
25 Rosehill Ave
Woking
Surrey GU21 4SO

AA: I'd be inclined to agree that anyone whose favourite film is *Zombies: Dawn of the Dead* is indeed in need of help, but where you might find Ubisoft's *Zombi* I'm not too sure.

It's no longer available, as you've found, in the shops, but there must be a number of people out there who could put Matthew out of his misery. Go on, put the poor chap out of his misery!

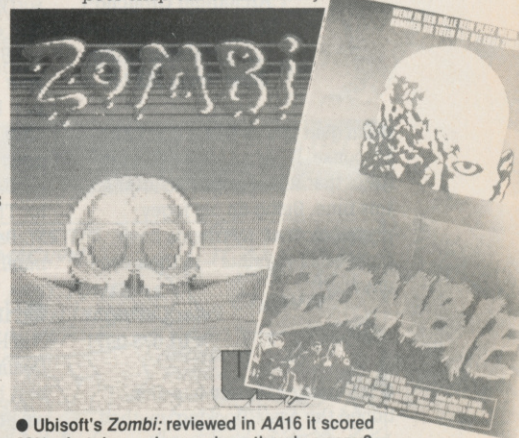

● Ubisoft's *Zombi*: reviewed in AA16 it scored 69% - but do you know where there's a copy?

● Domain request

I'm writing to you to ask if there are any Public Domain clubs around. If so, I would be grateful if you could supply me their addresses.

B Bear, Camberley, Surrey

AA: Absolutely! In the first instance try WACCI (there's a bit more about these weird guys on page 22) ☎ 01 898 1090; CPM User Group (☎ 72 Mill Rd, Hawley, Dartford, Kent DA2 7RZ); United Amstrad User Group (☎ 0329 281324); PD Software (☎ 08926 63298); and PD-SIG (90 Braybourne Close, Uxbridge, Middlesex UB8 1UJ).

Any additions to that list we should know about?

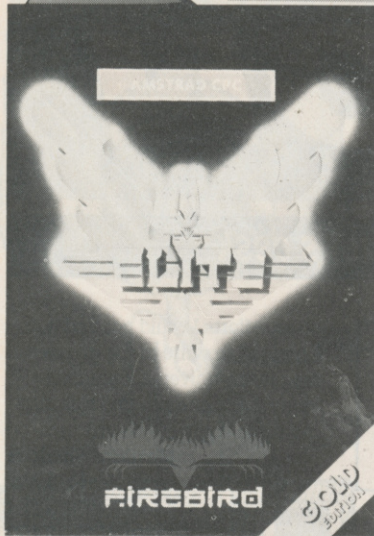

● The *Elite* club: join up now!

● **Elite club kicks off**

I think that the *Elite* Club is a great idea! I'm sure that I'm not the only player who would like to contact other commanders and Archangels.

I achieved *Elite* status only recently, after two years of play, and have only had two missions, so count me in.

Kevin McAspurn
("Archangel Groucho")
52 Highfield Crescent
Hebden Bridge
West Yorks HX7 8LA

● I'm glad you've had a good *Elite* response. It says a lot for this program that it still grips folk after all this time. Being an old fogey myself most of my friends have more adult pursuits – in their eyes anyway!

Peter Cartright
☎ 01 673 0971

● I'm amazed no-one has mentioned the easy "Docking" method. Just hyperspace to the planet you want to go to, press DEL to pause then 1 to quit.

Press Y to go to file screen. Press 3 (or 4) to exit. Press SPACE, et voila! No fuss, no risk.

Adrian 'Elite' Forbes
37 Victoria Rd
Gourcock
Scotland PA19 1DF

● I stopped playing *Elite* several months ago now due to lack of interest, but your suggestion of an *Elite* club has given me the incentive to start again.

Lawrence Gilson
☎ 0705 262984

● My rating is Competent but I'd like to join anyway.

Commander A. Lawrence
☎ 0344 51109

● Mark Gibson from West Bromwich wrote in to ask about help with *Elite* (I know the feeling – my wife won't speak to me either!) After what started out as a very promising reply, listing several back numbers that contained 'A large number of *Elite* tips', you then went on to say that they were sold out...

As I am in a situation that is not too different from Mark's, is there any chance of a reprint (perhaps a small leaflet that we could send off for) of some of the hints that you have included in the past for now classic games, *Elite* being a prime example. It could be the first in a whole series...

Tim Holyoake
Tythe Farm Cottage
Arnesby Lane
Peatling Magna
Leicestershire LE8 3UP

AA: I'm slightly confused, Tim. Do you mean to say that your wife had stopped talking to Mark Gibson of West Bromwich before she stopped talking to you? No, sorry, can't get my head round that one at all.

But the answer to the part of your letter I can understand is: yes. We shall be reprinting all the *Elite* stuff again, so great has been the demand.

Send entries to the *Elite* Club to: The *Elite* Club, AA, 4 Queen St, Bath BA1 1EJ. Add phone number if possible.

● **Hack into AA**

Phil Howard, author of *Insider Dealing*, is obviously one of the best hackers around, and I think we are fortunate that he has seen fit to reveal "his secrets" to us readers.

However there appears to be little response from readers showing interest and response in this fascinating subject. Mr Howard has taken the trouble to show us how to hack, and I think we all owe him some response.

Mr P Haii
Basildon, Essex

AA: Yes indeed. Mike Wong has taken the plunge this month with a fine contribution on methods of copy protection (see p.72), but others appear to be shy. Why, I wonder? Apart from the glory there's money involved. And if you're really worried about Bob Hay bringing a few of the boys round, you can even write under an assumed name (eg *Cracker*

● **Erm... Hang on, I know this one, um, aahm..**

Having seen (and been baffled by) your Adventure games competition, I think you should do a similar competition, but using arcade (or rather non-adventure) games.

There are many more of them, for a start, and I can think of several gruelling questions. Here's just five examples:

- 1 What happens when you finish *Jet Set Willy*?
- 2 Which two moves score the most points in *Way of the Exploding Fist*?
- 3 What is the message at the end of *Gryzor*?
- 4 What is the weapon on the 5th stage at *Target Renegade*?

Jeremy Congley
Tonbridge, Kent

AA: I quite sympathise with you, because I too found the Adventure competition beyond me. A games competition, now that's an idea...

Meanwhile, a crisp Amstrad Action bacon, lettuce'n'tomato flavoured tenner for the first set of correct answers to Jeremy's questions out of the AA top hat.

Write to: I Know This One, AA, 4 Queen St, Bath BA1 1EJ. Winner next month.

Jack or some other such non-sense).

feed the paper through the printer.

I spoke to Richard Moss, who told me: "Well, Colouredump can achieve perfect registration, which manual rewinding of paper on a printer may not.

"It also offers user defined shadings, and for LC10 owners in particular it is fully compatible and uses all the printer's colour facilities. There is no other commercial program available for the LC10."

By the way, Richard wishes to point out a slight mistake in our review: Colouredump takes ten minutes per colour ribbon, not per screen ink. So the longest a print-out can take is 40 minutes, not three hours as we stated.

As for the Pandora giveaway, I'm afraid the advert was wrong. The price really is £29.95, so by entering the competition you can indeed save yourself a fiver.

We would like to take this opportunity to apologise publicly to Swift Software (☎ 061 456 0926) for cocking up their advert.

● **It's a-mazing!**

The trouble Adrian James of Deeside has running *Sultan's Maze* (AA47) may be because he's trying to run it on a 6128.

If he does he will get "memory full in 30." I run mine by first running a short program to re-organise the 6128 into a 464. He – and indeed anyone else – can have a copy if he gets in touch at this address.

Cyril L. Baxter
78 Byron Avenue
New Malden
Surrey KT3 6EY

● **Big deal?**

In your August edition there is a review of a program called "Colouredump" which claims to be able to make colour printouts on a single-colour printer such as the DMP2000 from screens created with the *Advanced Art Studio*.

I have a DMP2000 and the *Advanced Art Studio*, and I have found it quite easy to produce colour printouts without any additional expense except coloured ribbons, which I would have to buy anyway.

All that it is necessary to do is to edit the palette so that the colours to be printed appear black or in dark colours on the screen, and wind the paper back manually and change ribbons between print runs

Some screen colours render the menus invisible, but with practice this can be overcome.

Why should anyone pay £9.50 for a program to do something they are already equipped to do? Perhaps the publishers would care to comment.

There is another strange offer in the same magazine, where all entrants to a competition are offered a voucher to entitle them to buy *Pandora* at £24.95.

Turning to page 29 I see that the publishers of that program are advertising it at £24.95 anyway! So what's the big deal?

R J F Stewart
Liverpool, Merseyside

AA: You're right, insofar as anyone could sit down and edit the palettes and manually reverse-

●Put the record straight

In AA46's *Amscene*, previewing *Pandora*, you say that *Laser Genius* was the effort of Oasis/Ocean to produce sprite handling in Basic.

I just thought I'd set the record straight. That package was in fact *Laser Basic* and was quite reasonable for its price of £14.95 (tape) and £19.95 (disk).

Laser Compiler was a (not very good) basic compiler which had the *Laser Basic* commands so if you wanted, you could produce stand alone programs using *Laser Basic*.

Laser Genius was, however, a very comprehensive editor-assembler-monitor-disassembler package. If it wasn't for its size (assembler = 6500 bytes) it would probably have been one of the best machine code packages out. The monitor was and still is the best out, with a FORTH-like programming language in which (the 130-page manual claimed) it was almost possible to write a simple space invaders game!

However, about three months after their release, Oasis went bankrupt and the products dissolved.

My copy of *Laser Genius* is

rapidly becoming a valuable collector's item. (I now use *Maxam 1.5* for assembling, but the monitor of *Laser Genius*, to debug my programs.)

Jeremy Congley
Tonbridge, Kent

AA: H'm. I can't honestly say I know *Laser Basic* well enough to comment. Is it really that good?

●Complete compilations

I wish to complain that the documentation supplied with compilations is really appallingly sparse, inadequate, and incomplete. For example, *Elite* (*Supreme Challenge*) is covered by four pages of minute printing, whereas the original takes a 60 page manual; *Flight Ace* is covered by one instruction page with the fold over the 'Access Code' (now unreadable) for ATF; *Matchday 2* instructions are skimpy and actually erroneous in places.

Yes, I know we are getting a lot of game for our money but some of the material is now quite elderly. We who are buying them now did not have the opportunity to buy them when they were first issued; we do not set the price and I am sure most would be pre-

pared to pay a few pence more to receive proper instructions and get full enjoyment from these reissued 'classics'. Come on compilers - give your customers a fair deal!

Roy Disney
Bury St Edmunds, Suffolk

AA: Couldn't agree more, Roy, except in one respect. I don't see that you or indeed anyone should have to pay "a few pence" more for adequate documentation. Compilation purchasers have every right to expect full instructions on how to load and play their games.

●Sounds: a good idea

I find that sound and music are very poorly catered for in *Type Ins*. Apart from the excellent "Rocking CPC" in AA33 I can't recall seeing very much at all.

Ian Sinclair, in his book *Music and Sound on Your Amstrad* writes that "the possibilities are so great that no-one could claim to have created, listened to and catalogued every possible sound effect."

Perhaps you could incorporate in *Type Ins* readers' examples of envelopes, amplitude and tone, with a little sound to see what

●AA beater?

I'm hoping to set up a CPC fanzine and I'm looking for artists, programmers, reviewers and writers.

Don't worry, though, I'll still keep reading AA to see what the competition is like! (Only kidding.)

Simon Williams
24 Chalcot Drive
Hednesford
Staffs WS12 4SF

AA: Glad to help Simon. Hope you're going to read our DTP series beginning inside on p.18.

interesting noises would ensue.

You may even find you get such a response that you need a corner of AA to cover sound itself. *Sounds Write* might be an apt title, or even *Amstrad-i-Various* (ouch!).

I rather like Ian Sinclair's rapid disappearance sound. Ta-ta,
1Ø ENV 1, =14, 5ØØØ
2Ø ENT 1, 2ØØ, -4, 2
3Ø SOUND 2, 5ØØ, Ø, Ø, 1, 1, 1

Arthur Lewis
Newtown, Powys

AA: Excellent idea Arthur. Contributions, anyone?

Sugarman

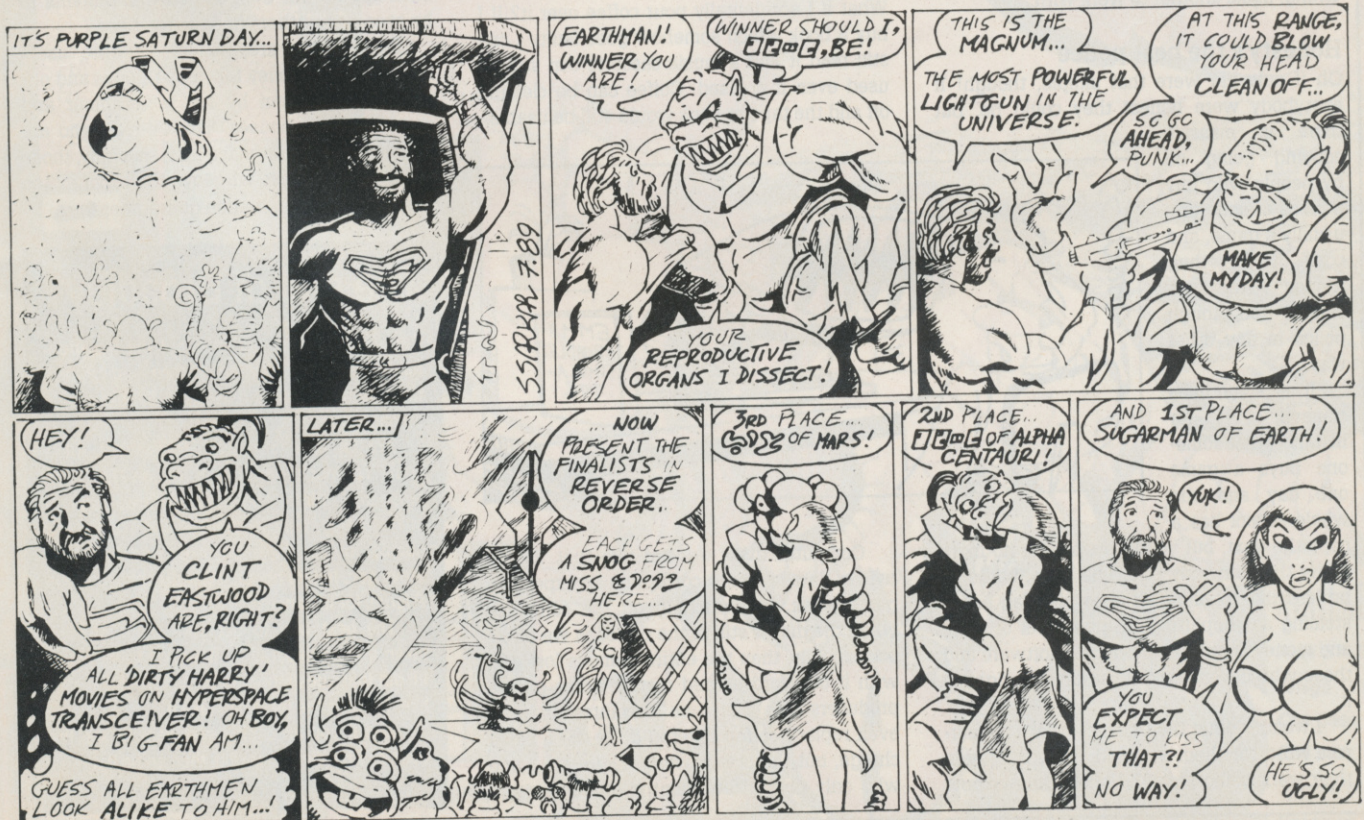

BROADLEY SPEAKING

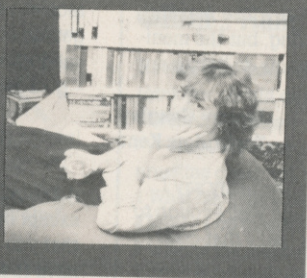

Another page with EMMA BROADLEY, the woman who calls a gardening implement consisting of a flat rectangular steel blade attached to a long wooden handle a spade.

If like me you own Hisoft's Devpac80, turn to the first page of the manual, which has three paragraphs pertaining to copyright. It states that you must not reproduce or transmit any part of the manual, and that to copy the program for reasons other than to make a security back-up infringes the copyright.

Fine. I totally agree. People have full rights over their own work, and if others wish to use it then a charge is perfectly justified. I can think of no valid reason to make a photocopy of the manual unless two working copies are needed for two separate computers, in which case two charges should be paid. The copyright statement allows for a back-up copy of the program and that's how it should be. You pay your money, make a back-up, use it as the working copy and, if it goes wrong, make another to work with.

Honesty's the best police

Oh if only life were that simple, though! If everybody were honest they could be, but there is massive copying going on by people who buy a piece of software, usually a game, and copy it for their friends. And it's simply too tough police in any other way.

It is sometimes claimed, for instance, that someone buys a game one day and the whole school has a copy the next, but young people are no more guilty than anybody else. This little "fiddle" is no less than stealing. It is as plain an act of stealing as shoplifting. A great deal of work and money is put into producing software and those who haven't paid for it have no right to it.

I wonder what the thieves - that's the correct word for them - would think if it were their work being stolen? Nobody knows how

much money is lost to the industry because of it. The idea that, for each game sold, ten people have a copy, therefore nine sales have been lost, doesn't add up. Not many of the other nine would have bought it anyway. Even so, the loss must be huge.

Getting people backups

All right, nobody expects everyone to stop making copies of the latest games, and soft-

“ We honest software users have our money taken by thieves and our moral rights taken by the government and even software houses... ”

ware houses have tried to prevent it by putting anti-copy routines in their software.

But just a minute. I understand their reason for doing it, but now they are preventing honest users from making genuine back-ups and that's not on. What if I buy a game today and in a year from now it becomes corrupted? What if it goes wrong in five years time? What if I accidentally pour coffee over it? If I buy a book which somehow goes faulty I can still read it and a music cassette can still be used even if creased. Coffee can be cleaned off and the tape or book would still be usable.

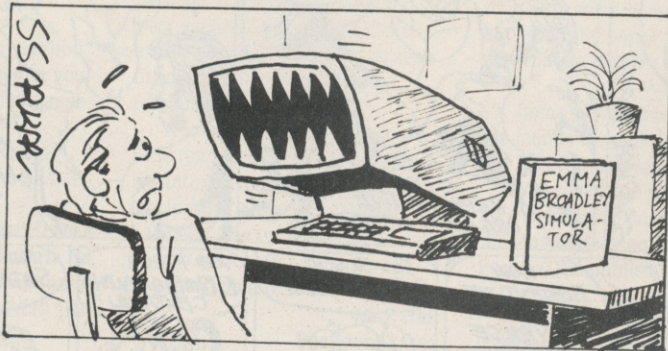

Computer disks are not like that. If one byte of data becomes corrupt on an expensive games disk, by switching off the computer while the disk is still in the drive, as we all do occasionally, then the entire game is lost and with it our hard earned money. Some games producers give a lifetime guarantee and will even replace coffee covered disks, for a small charge, but the others won't. There are some who only give a few months guarantee and

that's that. They don't seem to care about the customers who put bread on their tables and roofs over their heads. Their priority seems to be to stop anybody taking what's theirs and to heck with the rest of us. The mentality is not much different from that of the thieves. Money is the only motive.

Buy rights

Furthermore, if I buy something, it is *mine*. I can do with it what I will. Whatever I buy is always someone else's work but, when I've bought it, it is my property to do with as I see fit. If I want to lend or give it to somebody, whether it's a book, a car, a toaster or a computer program, I can. I have paid for the use of one copy of the item and I own the rights to use one copy. If I make multiple copies for security reasons, I can still only use one at a time, so I strongly object to any copy protection put on any software by companies who are not prepared to give a lifetime guarantee. Copying utilities, such as those by Nemesis and Goldmark, help us to do what is ours to do, but, if the producers were all honorable, these would not be necessary.

Enter the government in the form of the new copyright laws which seem not to uphold morals but to uphold money. It would be fine if the law stated the illegality of copying to increase the usership of an item and left it at that. Alas, it goes for means of copying rather than the act and seeks to outlaw the ability to copy as well as the practice. As we would expect, out goes the bath water, baby and all. Our morally right, protection beating copiers may well be doomed. Already we seem to have seen the demise of the Multiface II, a product which helped us make legitimate back-ups for our own use only. It remains to be seen if the others find life too risky.

So here we are, honest software users who have our money taken by thieves and our moral rights taken by the government and some software houses. The thieves who are to blame in the first place and, secondly, those software producers who love their money too much to give us a lifetime guarantee. ●

The end of Broadley?

Can I just put my oar in about the questionnaire this month? (Oh go on then - ed.) Please take the few minutes it needs to fill it out - it's on page 33.

We all have our own ideas about AA. I know I'd much prefer it if *Action Test* was reduced a little to about two or three pages - only kidding, only kidding! - and I believe a number of you have pet likes and loathings Steve gets letters about. (What happened to the *Pilgrim*, for instance?)

The best way to get your point of view taken into consideration, it seems to me, is to fill out that questionnaire. Be as forceful as you like: I'm sure the team can take it.

And if you all decide you want to see the back of *Broadley Speaking*, then so be it...



Gemini Wing

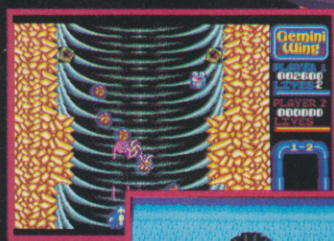
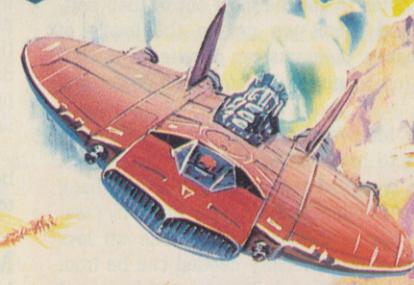

AMIGA



ATARI ST



AMSTRAD



SPECTRUM

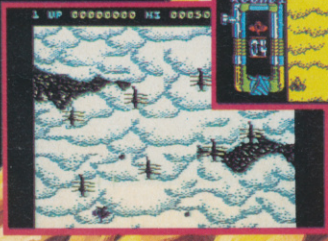

COMMODORE 64

AVAILABLE ON

- Atari ST £19.99
- Amiga £19.99
- C64 Cass £ 9.99
- C64 Disk £14.99
- Spectrum £ 9.99
- Spectrum +3 £14.99
- Amstrad Cass £ 9.99
- Amstrad Disk £14.99

Express yourself!

Now *Stop Press* can do more, faster. PAT McDONALD (motto: do less, slower) gets his finger out.

X-PRESS

£30 disk: *Stop Press* required. Available from Medway/King - but see also AA back pages, where it is on offer at £20

The CPC is not widely regarded as adequate for real desktop publishing, and has the dubious honour of being the least sophisticated machine capable of achieving such ends.

The problem lies not in the software - *Stop Press* and *Micro Design* are well done - but in the memory. True, 128K of usable memory in the case of the 6128 seems a lot, especially if you have the 464 or 664. But machines more often associated with DTP have at least 512K, and some (such as the Amiga) really need a million bytes to get the most out of their software. And when we get to the levels of Macintoshes, programs can require up to 1MB just to run - and that's before you create any files!

Now Medway and King have produced a program to help get around these limitations. *X-Press*, designed to get around the "one page at a time" problem of *Stop Press* works by compacting pages. That way they take up less space on a disk. Memory needed can be from as little as 6K, although 24K plus is the general average.

By altering the **USER** number (that is, the

directory area) that pages are saved in, you could have four or five pages per 3" disk side, as opposed to two.

These compacted pages can have another section added to them, either at the bottom or at the top. If you print out such a condensed page at the standard A4 size, then it will be squeezed vertically, allowing more detail. Alternatively (and perhaps more usefully) the page can be printed as that old fashioned but still much loved size, foolscap.

These tricks are nothing in terms of improving versatility compared with what it can do in conjunction with *Ramos* or *Rodos*, the alternative disk operating systems from Romantic Robot and KDS.

So you can take *Stop Press* pages off standard Amstrad 3" disks and transfer them to 5.25 or 3.5" disks, saving the amount of tedious and time-consuming disk swapping immensely.

Of course, having the pages on a funny sized disk is not much use unless you can print them out - and again, *X-Press* can cope. There are five different print modes: high resolution (just like *Stop Press* NTQ, except it uses seven pins at once rather than just one); high resolution condensed (for those squashed pages); draft; draft condensed (similar but coarser than high resolution); and draft high speed, which will whip out at a page in about six minutes.

Pages being printed can be queued up behind each other, removing *Stop Press'* need to load each one before printing it.

Manual dexterity

It is much more important to have the manual to hand than with many other programs. Because none of the options explains itself to

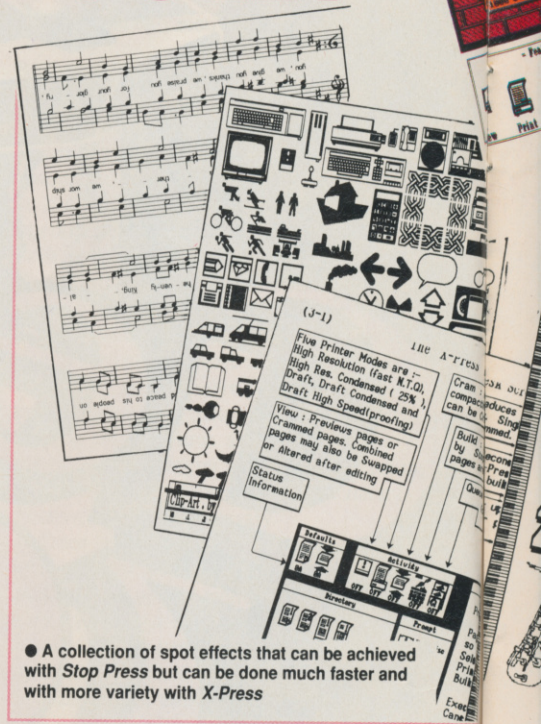

● A collection of spot effects that can be achieved with *Stop Press* but can be done much faster and with more variety with *X-Press*

any degree, it's vitally important to get to know what everything does before you manage to garble your "oh so pretty" pages. The authors seem well aware of the fact, because the manual goes through every option click by click. Even though many processes are similar in operation, everything is painfully well documented.

Although this makes the manual a bit off-putting for those of us who've worked out how programs tend to work, I'd stake my reputation (*big deal - ed.*) that people unused to computers will find it a great help to have someone holding their hand all the way in this manner. The letdown of the manual, however, is that it doesn't explain in enough detail exactly why you'd want to use the particular features.

X-Press feels very similar to *Stop Press*, using either an AMX mouse or the F4/F5/F6 plus cursor keys combination. F4 is used to **Execute** operations, and F6 **Cancel**s them. F5 is **Reduce** (rather than **Move**) and either takes off the last page on the printer queue, or decreases the **USER** number when clicked over the right icon.

The program is also similar to *Stop Press* in that every function is presented on just one screen. You move a cursor around in the time old fashioned way, and click on various functions. Where it differs is that none of the features is "pull down" in nature: none brings down lists of selections, and no part of the screen ever overlaps another.

The final touch

It should be borne in mind that *X-Press* cannot be used actually to create or edit pages. That

Let this be a warning...

How Chris Medway found *X-Press* sneaking up on him

X-Press was never intended to become a fully-fledged commercial program.

It began when Chris Medway, a member of the Solent Amstrad Computer Club, wrote a utility to save disk space and speed up printing on his DMP 2000.

Then an idea occurred: he could make it mouse and icon based.

Later, demonstrating it to fellow SACC founder member Nigel King, they agreed that it

would be useful to have the program work with Nigel's 5.25" disk drive so that pages could be archived onto the bigger, cheaper format.

That was the beginning of a 14 month project that saw Chris and Nigel working sep-

arately and meeting regularly to compare results. Several

times they had to restructure the whole thing to include extra essential features.

Were it not for the ZX81 making Chris a "memory miser," and what he calls Nigel's "disciplined and meticulous programming" (he's certainly to be congratulated for his clearly commented source code) the program might never have been finished.



● Nigel King and Chris Medway - got more than they bargained for!



● Now Stop Press gets a boost up the diskdrive with X-Press

job is left to *Stop Press*, so if you discover a mistake on one of your published efforts you'll have to go back to the DTP system and correct it.

Stop Press is perfectly capable of creating all the artwork and inserting all the text on a page: *X-Press* is therefore only useful for the final two stages – arranging the final product (such as a book or, more likely, a fanzine) and printing out all the pages.

● General status window

● Here's where it all happens: View, Printer, Cram, Build and printer Queue

● The Preview area, where pages are checked before loading/saving

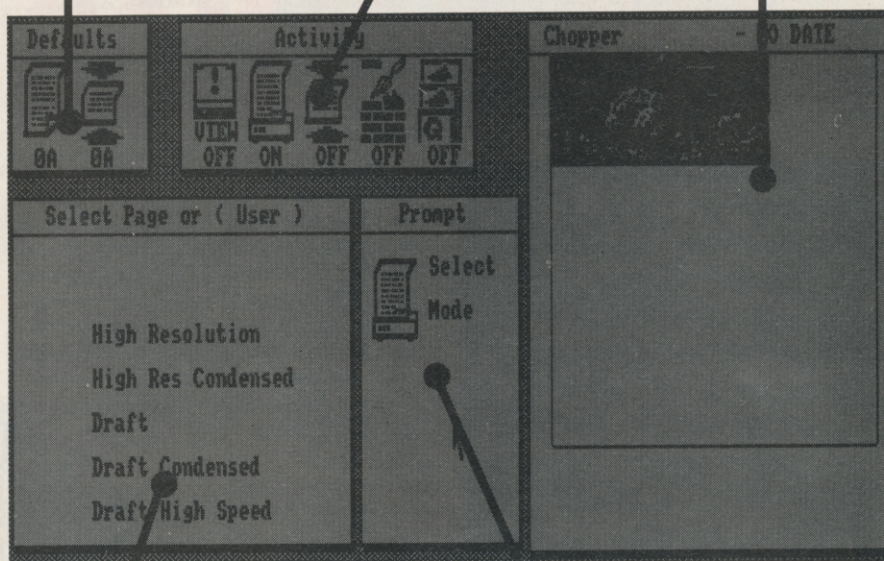

● Disk directory information goes here

● Xpress gives prompts on what to do next in this box

Clearly, *X-Press* is neither a toy nor a simple bunch of utilities. Its purpose, is to "super-charge" *Stop Press*, and at that task it is outstanding. Here's a program that's genuinely useful, and DIY CPC DTP should be AOK. And that's not to mention the cramming and print enhancement capabilities which make pages look even better.

On the down side, it must be said that, at

£30, the program is not particularly cheap. Neither is *Stop Press* at £69.95. There's also the problem that it takes some time to become fully conversant with all the different processes.

Nonetheless I think that Medway and King are onto a winner. The number of times I've edited a picture, only to discover I've run out of room at the bottom or the top of a page... ●

GOOD NEWS

- Certainly enhances *Stop Press*.
- Big disks are now OK too.

BAD NEWS

- Takes time to learn well.
- Not cheap.
- Specialised, naturally!

This time it's war!

PAT McDONALD confesses to an unusual hobby (no, not that one) that uses *Stop Press* – and now *X-Press*, too

ECWS, The English Civil War Society, is dedicated to re-enacting the sights and sounds of conflict between Parliament vs Charles Stuart & Son which raged through the mid-17th century.

The society is divided between the King's Army and the Roundhead Association, which is further divided into brigades composed of individual regiments.

When you join, you sign up with an individual regiment – and most regiments have a newsletter or "fanzine" (in the loosest possible use of the word) which informs members of the various meetings or "musters" of troops held throughout the year.

I edit the *Rattes Tayle*, regimental magazine of the Norfolk Trayned Bandes (evidently there were no spell checkers in the early 17th century), using my 6128 and *Stop Press*.

What I've learned laying out pages is that *Stop Press* is fine for playing about with pages, but is an absolute pain when it comes to actually arranging all of them into some sort of document. The difficulty is the nasty and very frustrating habit *Stop Press* has of taking ages and ages to print a single page.

Then there's the limit of two pages per disk side. *Rattes Tayle* is always at least ten pages long and sometimes 20, the average being

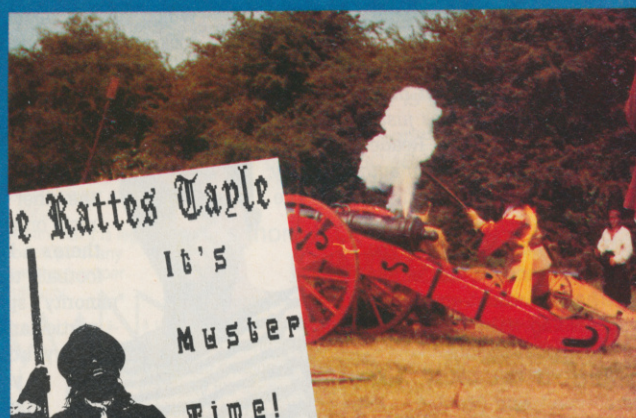

● The Norfolk Trained Bandes' *Rattes Tayle*; and ECWS members at play

about 14. That's three to five disks for the data alone, entailing lots of disk swapping on a one drive system.

With *X-Press*, *Ramos* and a 5.25" second drive, I will now be able to transfer all my pages onto a single

drive. *X-Press* can get on with the printing stage, leaving me much more time to work on the actual process of compiling the pages into the right shape and keeping track of their order.

And drinking tea.

First edition



Welcome to a major new series that shows you how to go about creating a magazine using your CPC.

In the next few months we'll be covering all the important areas: text, artwork, layout, printing and distribution.

On p.21 the editor of more than one fanzine in his time (see *Day in the Life*, AA39), takes a look at *The House of Dolls*, a fanzine success story.

On p.22 JEFFREY DAVEY looks at some CPC fanzines, and on p.24 we announce the great AA £750 fanzine competition.

But first of all ADAM PETERS wonders why more people don't do it for themselves.

Mr A.A. Reader looked up irritably. "Come in," he muttered. His secretary entered. "Good morning, sir."

"Good morning, Miss Stereotype."

"I have some more money for you to count, sir, and we've just had the latest ratings lists. Reader TV has just topped a billion viewers, The Daily Reader now sells ten million copies, and your autobiography, A Reader's Life, has just outsold The Bible."

"Thank you, Miss Stereotype."

"Oh yes, and, er, this came."

She handed the envelope over, holding it by the corner somewhat snootily.

"That is all, Miss Stereotype," said Mr A.A. Reader, eagerly ripping open the envelope.

"Honestly sir, I don't know why you still get that. Lots of grown men playing silly games and such all day long."

"Thank you, Miss Stereotype. That is all."



● The name Adam Peters (pictured left) may be familiar to you. If so you're either a relative of his, or you read *Day in the Life* last year (AA39). Or possibly both, perhaps?

The door slammed shut, and Mr A.A. Reader began to run his hands up and down the cover. Five years ago I was spotty and fat, he thought, and now I'm spotty, fat and rich. And it's all thanks to reading that series on fanzines. At first, I only did it for a laugh, but then things began to get serious. Here I am now. I own seven newspapers, five television stations, most of Scandinavia and one of those dishwashers with a variable temperature control....

There's lots you can do with your CPC. You can play mindless games, break into the NATO computer and start a war, or you can throw it at your brother (and then write to Pat McD. asking how to put it back together again). But one of the most gratifying - and least practised - of all is the production of magazines.

Yoof movement

Fanzines - magazines produced by and for a specific group - first appeared in the early seventies. Photocopiers had brought down production prices and made small-circulation papers financially viable. There was also a new youth movement developing at the time, which ancient readers may recall as punk rock, that was demanding its own medium.

Though music fanzines are less prominent now, the proliferation of football fanzines has brought the medium back into the public eye. You can produce a fanzine (or magazine, if the other word brings you out in a rash) on virtually any topic. Maybe there's a band, a style of music, a football team, a rugby team, a "minority" sport, or a hobby you're particularly interested in? Perhaps you'd like to start a magazine at your school or workplace? Maybe you want to produce a magazine to protest about the Channel Tunnel, acid rain or the price of butter?

From little acorns...

And you don't need much money to start out. Perhaps you'll run off only five or six copies on the photocopier in your local library. Then, if there is a good response you can run off more.

At least three magazines on the newsstands today - *House of Dolls*, *When Saturday Comes* and *Viz* - began life in this way, found a market, and now sell thousands of copies.

All you need is a CPC (and if you haven't got one of those, what are you doing reading AA?), a printer and some software. Obviously the better the equipment the better the final product can be, though that too is down to you.

Someone with a 464, DMP 2160, *Mini Office 2* and lots of imagination will come up with a better result than someone with a 6128, a posh 24-pin printer,

Protex, *Stop Press*, and the imagination of a cabinet minister.

You'll also need paper, pens, Tippex, glue - all that stuff: don't think you can get by without stationery, just because you're using a computer. And you'll need friends. The more friends you get to help you, the better.

Over the next five months we shall be discussing various elements of producing a magazine: text, artwork, layout, printing, and distribution. Follow us and you should be able to produce something worthwhile at the end of it.

If you disagree with what I say, write in and say so - or ignore it. It is your ideas, however simple they may seem, that will "carry" what is after all your magazine. That's the great thing about it. If you wish there was an article about fish strangling in Outer Mongolia, write one! ●

Do the write thing

Next month we look at text: what to write, and how. In particular we consider the usefulness of various word processing packages for the fanzine editor. Contain your excitement if you can!



A SMALL SELECTION FROM OUR WAREHOUSE

Hardware & Peripherals (Offers while stocks last)	RRP	WAVE
Amstrad CPC6128 Green with Joystick & Software	299.99	254.99 ANC
Amstrad CPC6128 Colour with Joystick & Software	399.99	339.96 ANC
MP-2 Modulator/Power Supply - CPC464/664/6128	29.95	23.96 C
DDI-1 1st 3" Drive Inc. Interface & Cable - CPC464	159.95	126.36 B
FD-1 2nd 3" Drive - CPC/+3 (6128/+3 Also Req. DL-2)	99.95	85.14 C
DL-2 Cable - FD-1 to CPC6128/+3	6.95	5.56 E
PL-1 Lead, Printer Centronics Parallel - CPC/+3/+2A	14.95	7.48 F
Star LC10 Parallel F&T NLQ Printer (Reqs. PL1 Lead)	297.85	158.01 A
Computer Labels 89mm X 36mm 1 across	Box 1000	9.20
Croxley 11" x 9.5" Listing Pater 606	Box 2000	24.93
2482RN Ribbon Re-inking Nylon - DMP2000/3000 series	Pkt 2	11.90
Fabric Ribbon Re-inking Fluid (Aerosol)		8.95
Microtext Teletext Adaptor Inc: Tuner - CPC		114.80
Amstrad JY2 Jystick - CPC		14.95
AMX Mouse Inc: Interface & AMX Art S/W - CPC464/664/6128		69.99
AMX Mouse Inc: Interface & Stop Press S/W - CPC6128		79.99
DK 'Tronics 464SDS 256K Silicon Disc - CPC 464/664		149.95
DK 'Tronics 256SDS 256K Silicon Disc - CPC6128		149.95
DK 'Tronics A005 Graphics Lightpen - CPC464 Limited Stocks		29.95
Trojan Light Pen & Graphics Software - CPC464 Colour		19.95
Trojan Light Pen & Graphics Software - CPC6128 Colour		23.95
Dust Cover Set 2 Piece Set - CPC (State Model)		8.63

DO YOU WANT TO SAVE MONEY, THEN SEND FOR OUR TRADE PRICE LIST

(State for which products and enclose 3 x 19p stamps)

Blank Discs & Software

Amstrad Amscase Library Case Holds 10 x 3"	7.95	3.98 E
Amsoft 3" Discs DS/ALL 3" Drives	Box 10	29.90
Maxell 3" Discs DS/ALL 3" Drives	Box 10	29.90
JVC 3.5" DS/DD 135TPI Bulk Discs	Pkt 25	62.50
Verbatim 5.25" DS/DD 40/80T Bulk Discs	Pkt 25	27.27
YU-DS80L D.8. Lockable Storage Box Holds 50 x 3"/80 x 3.5"		23.77

CAPTAIN CAVEMAN BBS NOW ON LINE 4PM TO 9AM 0229-473609

Eng. Mainland post & ins.: (A) £5.75 (B) £4.60 (C) £3.45 (D) £2.30 (E) £1.15 (F) 58p
(ANC) 3 Day £10.35 Next Day £13.80, COD+ £2.30, Max UK post chg. £6.90 per 20kg/£500.
All Prices include VAT. All sales subject to our Trade Terms of Trading.

W.A.V.E. (Trade Dept. AA 989)

Walney Audio Visual & Electrical Distribution

1 Buccleuch Street, Barrow-in-Furness, Cumbria, LA14 1SR
Tel: 0229-870000 (6 lines) Hours: Mon - Fri 10.00-5.00

50 GOOD REASONS TO SHOP AT CRAZY JOE'S

10 Computer Hits 5	£4.99	R-Type (Disc)	£7.99
10 Great Games 3	£6.99	Roland in Time (464)	£0.99
1942	£2.99	Roy of the Rovers	£3.99
Answer Back Junior Quiz	£4.99	Silent Service	£4.99
Armageddon Man	£1.99	Silicon Dreams	£4.99
Army Moves	£2.99	Split Personalities	£1.99
Bard's Tale	£2.99	Spy Hunter	£2.99
Bombjack 2	£1.99	Star Wars	£3.99
Daley Thompson Decathlon	£2.99	Supreme Challenge	£6.99
Dynamic Duo	£4.99	Tetris (Disc)	£4.99
Fernandez Must Die	£3.99	Tiger Road	£4.99
Fernandez Must Die (Disc)	£4.99	Time Scanner	£6.99
Forgotten Worlds	£6.99	Trio Hit Pak (3 Games)	£2.99
Game Over	£2.99	Triv Pursuits Baby Boomer	£3.99
Gauntlet 2	£2.99	Triv Pursuits Young Players	£3.99
Gothik	£1.99	Typhoon	£4.99
H.A.T.E.	£6.99	Victory Road	£4.99
History in the Making	£12.99	Vixen	£2.99
Human Killing Machine	£5.99	Cheetah 125+ Joystick	£7.99
Hunt for Red October	£6.99	Cheetah Mach One Joystick	£9.99
Inc. Shrinking Sphere (Disc)	£4.99	Konix Megablaster	£6.50
Jack the Nipper	£2.99	Konix Speedking	£9.50
Leaderboard	£2.99	Konix Navigator	£12.50
Prodigy	£0.99	CF2 3" Discs	Each £2.50
Ranarama	£1.99	CF2 3" Discs	For Ten. £22.50

Crazy Joe's, Dept. AA, 145 Effingham St.,

Rotherham, South Yorkshire S65 1BL

Visa and Access Orders Taken on (0709) 829286

Please make Cheque/P.O. Payable to "Crazy Joe's"
P&P FREE in U.K. on orders of £5 or over. Under £5 please add 50p.
Europe (inc. Eire) add £1 per item. Rest of World add £1.50 per item.

NEMESIS - The Original Meddlers

BONZO SUPER MEDDLER

"A REAL ALTERNATIVE to the Superface II BLACK BOX.", A.A JAN '89.
"The best TAPE TO DISC transfer utility available", WACC1 6/88.

THE 1989 EDITION

BONZO SUPER MEDDLER continues as the most complete TAPE TO DISC transfer utility. Recently revised, it now includes a database of all verified transfers - currently 980 TRANSFERS! GUARANTEED to TRANSFER MORE games than any other program - POSITIVELY!

BONZO DOES THE TRANSFER AUTOMATICALLY - YOU PLAY THE GAME

"GO" loaders are just one of the many types of tape protection handled by BSM - this could cost you £15.00 from another source and still leave you lost for means to cope with over 900 other programs - but BONZO SUPER MEDDLER does them all!

RECENT REPORTS FROM USERS INDICATE THESE TRANSFERS TO DISC:
GARY LINEKER HOTSHOTS, TIGER ROAD, H.A.T.E., BLACKBEARD, 19, LAZARUS, THE SIDEARMS, A.T.F., MARAUDER, GRAND PRIX SIMULATOR II, MOTOR CRO, SIMULATOR II, MIG 29, TOM CAT, ANDY CAPP, NINJA COMMANDO, PULSARDS, CRAZY CAT, HUGHES FOOTBALL, TITAN TRACKSUIT MANAGER, RYGAR, 720, B1 SOLOMON'S KEY, TURF FORM, OFF SHORE WARRIOR, TASK FORCE, OCTOPLEX, SUPER TROLLEY, DANGERMUSE IN DOUBLE TROUBLE etc.

OVER 900 OTHERS!

Isn't it time you got the BEST? Send your disc-based utility to be transferred HACKPACK for just £8.00. If you haven't got one, then the BSM instructions, details of over 900 transfers, and our current NEWSLETTER. **£12.50 inclusive. Supplied on disc.**

BONZO BLITZ - SPEEDLOCKS TO DISC "HIGHLY RECOMMENDED" - WACC1, 12/88

BONZO SUPER MEDDLER will cope with a large number of SPEEDLOCK. An enthusiast we developed BONZO BLITZ - the first to deal with all forms of SPEEDLOCK need an expanded CPC - works on 464/664/6128 - and still EQUALS any other utility in juggling or fussing. A database on this one too! A FEW: ALIEN HIGHWAY, ARMY MESS, SIMULATOR, BEACH HEAD 1 & 2, CATCH 23, DEATHSTALKER, DIZZY, ELEK, FRAGLE, FRUIT MACHINE SIM, F15 EAGLE, GAMEOVER 1 & 2, GREAT ESCAPE, HIGHWAY ENCOUNTER, MATCHDAY I & II, MADBALLS, METROCROSS, REVOLUTION, SALAMANDER, SLAINE, SCRABBLE, SCALEXTRIC, SUPERHERO, TRANSMUTERS, WIZBALL, WEC LE MANS, etc. WORLD CLASS LEADERBOARD and ROADRUNNER although "multi-loaders" will completely transfer if you have BSM to assist! Other "multi-loaders" main file only. BLITZ was first in with the "NEW" SPEEDLOCK variation - and there's dozens of compilation tapes using this, like MAGNIFICENT SEVEN & GAME, SET & MATCH II. **£12.50 inclusive. Supplied on disc.**

UPGRADES BSM or BLITZ, £3.00 [return original disc]

B/BOARD INFO CYNOTEL 01 346 2816 [1200/75]

The long-awaited CPC PROCOPY, developed by Kevin McCaughey is available EXCLUSIVELY from NEMESIS.

You will have noticed that your present disc-copier is becoming less efficient, due to the extensive protection now employed on many commercial discs. This is particularly apparent on "Speedlocked" discs. CPC PROCOPY can "clone" these, and other heavily protected discs. By employing semi-Z80 EMULATOR techniques CPC PROCOPY can reach sectors that other copiers cannot cope with! CPC PROCOPY will "out-ology" your present "cloner" - whatever it is!

PROBABLY the BEST "cloner" in Europe?
NO! CPC PROCOPY IS the BEST!!

- (1) FULL A/B DRIVE CAPABILITY.
- (2) CAN ALSO ARCHIVE TO TAPE.
- (3) MAPPING & GAP 3 ANALYSIS.

There's more! CPC PROCOPY includes,

MINIDOS

to get rid of the cumbersome CPM for routine disc functions. MINIDOS also handles many non-standard routines, and can be readily copied to VENDOR DISKS. MINIDOS commands are friendly, useful and POWERFUL.

- 1 CAT - full catalogue of ALL files on a disc - including "hidden" files.
- 2 CAT any file for type and parameters.
- 3 FORMAT RENAME, and COPY files
- 4 Make files READ/WRITE, READ ONLY, SYSTEM.
- 5 An intelligent UNERASE facility!

All this sounds pretty expensive, but NEMESIS are able to offer this professional utility at their regular price - whilst they can legally do so.

CPC PROCOPY just £12.50 on DISC

NEMESIS A.A

ALL ORDERS sent by return: Cheque/P.O./Access

TEL: (0933) 623967

10, Carlow Road, Ringstead, Kettering, Northants NN14 4DW

AUSTRALIA: C. BOSWELL, 62 MARMONG STREET, MARMONG POINT 2284, NSW.



Access **G-TEN LIMITED** **Access**
The Mail Order Software House

AMSTRAD CPC	TAPE	DISC	
Action Service	£7.90	£12.25	LED Storm.....£7.90 ..£12.25
Afterburner	£7.90	£12.25	Mind Stone.....£6.75 ..£10.50
Barbarian II	£7.90	£12.25	Night Raider.....£7.90 ..£12.25
Batman	£7.90	£12.25	Out Run.....£7.90 ..£12.25
Carrier Command	£12.90	£17.25	Parisian Knights.....£10.50 ..£12.25
Cybernoid II	£7.90	£12.25	Red Heat.....£7.90 ..£12.25
Dominator	£7.90	£12.25	Robocop.....£6.75 ..£12.25
Dragon Ninja	£7.90	£12.25	Soccer.....£12.25 ..£17.25
Eliminator	£7.90	£12.25	Special Action.....£10.50 ..£15.50
Espionage	£6.75	£12.25	Thunderbirds.....£10.50 ..£12.25
Final Assault	£7.90	£12.25	Technocop.....£7.90 ..£12.25
Flight Ace	£12.25	£16.50	Vigilante.....£7.90 ..£12.25
G.I. Hero	£6.75	£12.25	
Giants	£10.50	£17.25	
Hill 19	£7.90	£12.25	
I.S.S.	£7.90	£12.25	
Jinks	£7.90	£12.25	
Karate Ace	£10.50	£12.25	
Last Ninja II	£10.50	£12.25	

PERIPHERALS (CARRIAGE FREE)

Dust Cover CPC	£7.50
Amstrad Joystick I/F	£5.95
Quickshot II Turbo	£13.95
Pro 8000 Joystick	£14.95
Mouse Mats	£4.95

Please Specify Computer Model. Strictly Mail Order.
 Allow 14-28 days Delivery
 P.O. or Access Credit Card Orders Despatched within 48 hours.
 P&P Inc. UK/EC/BFPO. Elsewhere add £3.00 per item.
 Cheque or P.O. (sterling only) made payable to:- **G-Ten Limited.**

Send Your Orders To:-

G-Ten Limited
Dept AA2
FREEPOST (no stamp needed UK/BFPO)
5A Sunnyside Terrace
Edgware Road
London NW9 9YP
Or Tel 24 hr Telesales: 01 200 4858

Buy 2 Games, Get One Mystery Game FREE!!

ONLY POOLS AND HORSES

Football Boxform £14.95 (+ £2 for 3" disc)
 ● The **ONLY** pools program written by a **GENUINE EXPERT** who has been professionally employed as such by the leading pools company.
 ● The **ONLY** program dealing with football form that has its team merit ratings published in a national sporting magazine.
 ● The **ONLY** program that uses machine code and advanced statistical methods to analyse true odds for every match. Covers league & non-league clubs
 ● The **ONLY** program to claim **50% MORE DRAWS** than obtained by chance.
BOXFORM & HANDICAP WINNER £14.95 (+ £2 for 3" disc)
 Two programs for the price of one. Easy to use and they never go out of date. All you need is a few minutes with a daily paper. **BOXFORM** weighs up a race by considering the many facets of form. Easily amended to suit the user's ideas. **HANDICAP WINNER** shows the value for money bets. **OVER 600 WINNERS** in handicaps this year at prices up to 25/1.
SPECIAL PRICE of £24.95 (+ £2 for 3" disc) for all of the above programs
RACING TOOL KIT £49.95 tape or disc
 A package of 7 programs for the racing enthusiast. **BOXFORM & HANDICAP WINNER** plus programs to produce ratings and time figures, update private handicaps or form your own, keep records, work out almost any bet etc. etc.
 Why pay inflated prices? **BOXoft CLEVER** and get the **BEST**
 Available on tape or disc for SPECTRUM, CMD C64/128, AMS CPC's, BBC B. from:
BOXoft (AA), 65 Allans Meadow
Neston, South Wirral. L64 9SQ
Credit card holders may phone : 051-336-2668 (24 hours)

STRATEGY SOFTWARE
 Strategy games for the Amstrad CPC

THE FINAL CONFLICT - the game is a conflict between Nato and the Warsaw Pact in Europe. Options are either two player or solitaire against the computer, 25 different countries involved, over 160 units, infantry, corps, parachute, armoured, cities helicopters, different strengths, effects, supplies, fuel, casualties status, different seasons, city production levels, millions of troops involved, game lasts for weeks, save game, 18 page manual plus sounder.

SOCCER 6128 - football strategy game which lets you manage any team in the 4 divisions. Options are buy players, sell players, league programme, fixtures, opposition, play match, instructions, league table, accounts, playing staff, save game, 10 different positions, skill, form, goal scorers, injuries, up to 20 players in squad, sackings, over 2000 players, 80 English clubs, 60 European clubs, FA Cup, League Cup, European Cup, UEFA Cup, Cup Winners Cup plus much more. Reviewed in AMSTRAD ACTION July '88. (For 6128 only, on disk only).

KURSK the clash of armour - was the biggest tank battle of WW2 in which the Germans had to beat the Soviet army to stand any chance of winning the war. The options are two player or solitaire against the computer. There are over 125 units which are infantry, armoured, corps, artillery, anti tank plus cities which all have different effects in combat. There are also supplies like troops, provisions and fuel. The object of the game is to capture the key cities or destroy enemy units. Also save game plus much more.

SOFTWARE HIRE CLUB - we hire out top game titles of strategy and simulation games for the Amstrad CPC. Send a large S.A.E for details.

Title	disk	tape
THE FINAL CONFLICT	£8.00	£7.00
SOCCER 6128	£8.00	£8.00
KURSK the clash of armour	£8.00	£7.00

Cheques or Postal orders Payable to **STRATEGY SOFTWARE**
 Send to - **STRATEGY SOFTWARE, 32 Albert Street, Seaham, Co Durham SR7 7LJ.**

IRENIX SOFTWARE

ADD AN 800K DISC DRIVE TO YOUR CPC

Our 80 track double sided 3.5 inch disc drive will allow you to store 800K on a single 3.5 inch disc. The drive is a slimline 1 inch high citizen mechanism (as used on the Amiga and ST) and comes complete in a steel casing and with a power supply and cable to connect to the computer (please specify 464/664/6128). We have three different software packages that complete the system, RAMDOS & ROMDOS by KDS software (ROMDOS is a ROM version of RAMDOS) or RODOS by ROMANTIC ROBOT. 464 owners must already own a first drive and interface before they can use our drive.

NEW LOW PRICES! SAVE £15.00 ON ALL DRIVES

Disc drive with RAMDOS	£109.99
Disc drive with ROMDOS	£119.99
Disc drive with RODOS	£119.99
Blank 3.5 inch disc	£1.00
ROMBOARD (holds 6 ROMS)	£24.99

All prices include VAT and postage

Access



TELEPHONE
061 228 1831



84-86 PRINCESS ST. MANCHESTER M1 6NG.

Welcome to The House of Dolls

Not all magazines start off big. Many, like *House of Dolls*, begin as a newsletter, grow into a fanzine and just keep on growing. And it none of it would have been possible without the CPC. ADAM PETERS reports.

The story of *House of Dolls* is an inspiration, proving that people armed with nothing more than enthusiasm and a CPC can break into the cut-throat world of national magazine journalism.

So if you've ever wished you could read about your hobby in a mag that really feels as if the people writing it shared your interest, why not write it yourself – as they did?

Nightclub catering

House of Dolls was the brainchild of 23 year-old Londoner Andy Allen. Having tendered his services as a DJ at numerous venues, he realised that there was no nightclub catering for the growing number of people who shared his somewhat esoteric taste in music.

House of Dolls was set up in early 1986 as a club dedicated to the "indie" music scene (ie groups not signed to huge record companies), and converged every week on a venue in the city after all the stockbrokers had gone to bed. The club's popularity grew with the emergence of this new "scene" as yet unrepresented in the media, and the idea of setting up a magazine began to germinate.

CPC glee

The first issue of *The House of Dolls* newsletter appeared in March 1986, consisting of two photocopied sheets given out free to club members. It opened with the prophetic line: "Welcome to what we hope will become the first of a multitude of issues."

The publication developed rapidly. Over the first six months eight issues appeared,

and the publication moved on from being a manually typed two-sheet newsletter, to being a 36-page magazine with a circulation of several thousand.

Fundamental to this development (and this is where we come in, folks) was *HOD's* acquisition in October 1986 of their first computer: an Amstrad CPC 464.

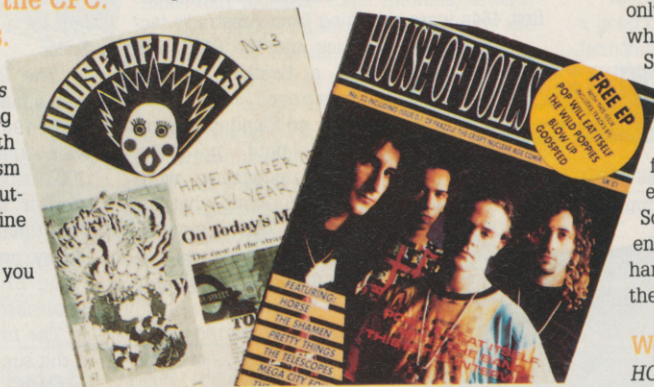

● What a difference: *House of Dolls* issues 3 (the tatty bit of paper in the background) and 22 (the highly professional glossy – with a free EP!)

Promotions Manager Ginni Brown, who has been with the magazine since the early days, recounts the computer's arrival with some glee: "It was a godsend. The presentation improved with justification, and we no longer had to re-type the whole piece when we wanted to change bits.

"The CPC is ideal if you're starting off doing something like that," she says. "You don't need anything more sophisticated to begin with. It's very user-friendly and reasonably priced, and if you get bored you can always play a few games – though we were far too busy to do that!" (Funny how everyone always says they're too busy to play games...)

Good for the circulation

House of Dolls has been such a success story that it is now produced on Apple Macintoshes costing several thousands of pounds each, has national distribution, a colour cover, and circulation claimed to be approaching 30,000.

Their *raison d'être*, however, has remained the same. The mission is an admirable one – "we want to give unknown bands the opportunity to put themselves across to a wider audience" – and their attitude unrepentantly positive ("we try not to waste space slagging bands off"), in an industry where being nega-

tive is usually considered obligatory.

The *HOD* offices currently stretch to several rooms and a roof in Barking High Street. There are four telephones in constant use; two cats constantly at each other's throats; a mass of electrical equipment; and a steady procession of eager worker-bees. No-one, however, gets paid for their services, with the only reward being that unique feeling you get when you look at the magazine racks at W. H. Smiths and see your own work.

"That feeling is the same now as it was when we started," insists Ginni: "the sense of achievement when you get the finished product back in your hands; printed or photocopied, twenty copies or 20,000. Something is always better than last time. It encourages you to carry on, and work even harder on the next one. With a computer, there are so many possibilities to explore."

We, fail?

HOD hope to increase their UK circulation to 60,000 and expand into the US market (a few copies have been shipped out there since the start). They want to go monthly, and then colour throughout.

Though similar publications have come to sticky ends, the *HOD* staff won't even consider the possibility, not while there's still always a record company at the other end of the line, wanting to arrange an interview or place an advert. You feel their ambition, and enthusiasm, might be all they need to succeed.

In these days of Maxwell and Murdoch expansion it is refreshing to know that there is at least one magazine on our newstands, which began life as a scrappy newsletter; a

magazine whose staff and contributors work for pleasure rather than pay; a magazine that exists to provide a service for "people like us." With your CPC, your printer, a smattering of ideas, some helpful colleagues and a bit of loose change, you really do have everything you need to start up a magazine for "people like me."

Today the CPC – tomorrow the world? ●

● Next month we introduce you to another fanzine success, *Arnold* - dedicated to the CPC itself (as if you hadn't guessed). Meanwhile our fanzine special continues over the page. See you there!



● A messy office is a busy office – or so at least the *HOD* staff claim!

The write stuff: CPC fanzines

New CPC fanzines seem to be springing up every week.

JEFFREY DAVY, himself the veteran of one of the best computer fanzines, *The Bug*, surveys the scene.

There is a clichéd image of CPC fanzines as a few wonkily-duplicated sheets turned out by people who spend their days hunched over computers blasting aliens and their nights hunched over computers writing about blasting aliens, surrounded by coffee cups with things growing in them.

Yet in my experience fanzine writers are nearly normal. They have something to say, after all, and how better to say it than with your own magazine?

Most contain what you'd expect to find in a big mag such as AA, but with an edge and frankness that's often missing from the "glossies." It seems that, being new to the business, they fear neither software house nor lawyer, and because of their limited and almost underground distribution, they can get away with stating opinions and

giving judgments that would have AA's ed on the dole queue within the fortnight!

True, they may not always be able to compete with the major publishers but the best are a damn good read...

Bitten by The Bug

The Bug, which claims to be the first computer fanzine, started way back in 1984 when the first 464s were emerging from Amstrad's factories and the 6128 was but a twinkle in Alan Sugar's eye.

As co-founder Jaron Lewis puts it: "The 'glossy' magazines were putting forward what we saw as a biased view of the industry: games we thought were terrible got great reviews."

The Bug started with coverage only of the Spectrum selling 50 copies an issue, but has expanded over its five

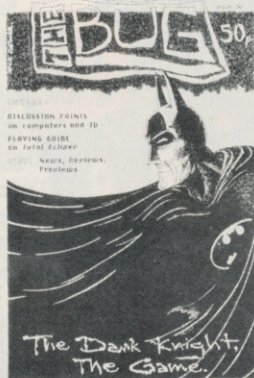

year existence to cover CPC, Amiga, and PC too and now sells around 300. It regularly runs to eighty pages of news, reviews, discussion articles, offers and competitions.

Although it is a multi-format fanzine, *The Bug* manages a good coverage of all things CPC, with arguably the best Amstrad games

coverage of all fanzines (but then, I am biased). Reviews are concise and informative with a critical style – contributors aren't afraid to say what they think, something that has led to disagreements with software houses and led to a few TV appearances.

The Bug has had more than a fair share of controversy. In 1987, for instance, software and distribution giant CSD became the magazine's sponsor and boosted circulation to 1,500. Unfortunately the company ran into severe money problems and finally went bankrupt owing £1.5 million, nearly taking an entire unreleased issue of *The Bug* with them!

The final issue, number 37, was released in the summer and featured a cover-mounted cassette – a highly ambitious project by fanzine standards.

The Bug, 55p: 28 Leaside Avenue, Muswell Hill, London N10 3BU.

AEMing for the top

AEM, or to give it its full title, *The Amstrad Enthusiasts' Magazine*, claims to be "The serious CPC fanzine for serious CPC users." Editor

WACCI: funsters indeed

AA regulars will already know of the organ of the "Worldwide Amstrad CPC Users Club." WACCI, which stretches the very term fanzine, has the club's resources behind it, giving a considerable advantage over more narrowly based publications.

In 1986, founder Jeff Walker – who has since worked at ACU – spotted a gap in the market for CPC enthusiasts. Three years on the club has a steadily rising membership of several hundreds. Current editor Steve Williams tells the story of one person thinking of setting up a club who took a look at WACCI and just gave up, joining instantly!

The magazine runs to thirty odd (and occasionally very odd) pages of technical articles on Basic, Pascal, and hardware additions for your Amstrad – all daunting to the novice. But there are also articles on leisure software – simulations and adventures in particular. WACCI dropped games reviews altogether since, as Williams says, somewhat dismissively, "you can get them from the big mags."

WACCI is crammed with articles and letters written by folk apparently suffering from the delusion that the entire universe revolves around the CPC. Indeed the magazine itself is produced on CPC with the aid of *Protex* and

Promerge, so in that sense perhaps it's no delusion after all.

WACCI's distinctive brand of irreverence – fools are not suffered gladly, and sometimes not all – and the off-beat nature of their articles has invited controversy: ex-Code Masters press officer Bruce Everiss was not pleased when they dared to take the mickey a few months ago. As Williams tells it, Everiss was on the point of suing when he realised that they had no money! Instead he issued a blanket ban on sending Code Masters software to fanzines, a move which hurt them



all and did Code Masters themselves no favours.

Serious users have an additional motive for joining WACCI – the huge Public Domain library

with all the homegrown software "exclusive to WACCI." What more could you want?

WACCI, £1.25
9 South Close,
Twickenham,
Middlesex TW2
5JE

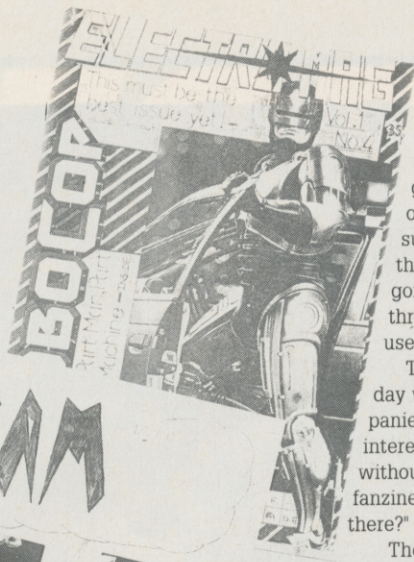
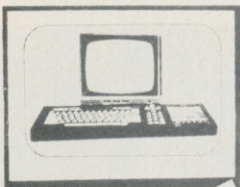

RAM

Neil Selwyn and Sub-Ed Paul Hopkinson have set out to produce a magazine about "homebrew" software with not a games review in sight.

Selwyn's view of the CPC's future is gloomy: "In these days of 16-bit dominance", he suggests, "the *only* way that CPC computing is going to survive is through user groups and user interaction.

There's going to come a day when all the major companies will no longer be interested in the CPC, and without user groups and fanzines where do we go from there?"

The mag, still in its infancy with only two issues out so far (issue 3: September), is packed with all manner of articles. Its first issue contains Basic and Machine Code tutorials, articles on the CPC's future, licences and the exploitation of the consumer (it's against it, by the way) as well as news.

AEM welcomes "homebrew" software, and hopes to set up a PD library. It's readable and well-written and shows signs of great potential. What it needs now is readers willing to make a commitment to it. And, of course, as a young publication it offers budding journalists and would-be fanzine contributors the ideal opportunity to get involved.

Common ground: a brief introduction to the pleasures and perils of publishing

Whatever your publication, if you've already written, produced, printed and distributed something you will probably already know what's contained in this short introduction to the subject. If, however, you've never had this particular agony and ecstasy, here's what's involved.

Whether what you're planning to publish is a four page newsletter on the exploits of the Cotton College Cricket Team, a 16 page CPC fanzine of games reviews and contacts (as some on these pages are) or a nationally distributed magazine that will sell (you hope) in Smiths and Menzies, getting it out of your head and into the hands of your readers can still be divided into a number of key positions and tasks.

The *publisher* has overall control of the publication, supervising budgets, hiring and firing staff and guiding the direction of the title. The *editor* commissions articles (or "copy" as it is

called), writes others, and cajoles, bullies and begs his writers to get their work done – not always successfully. In practice, however, the jobs of publisher and editor are often done by the same person.

Other major roles include that of *sub-editor*, who funnily enough spends his time sub-editing (ie attempting to turn the ravings of others into decent, well spelt prose); the *artist*, who lays out and designs the pages and commissions illustrations; the *writers*, who may be either "in-house" or "freelance" (ie commissioned to write a particular article); and the *advertising sales person*, whose job it is to

get as high a price as possible from advertisers. And then of course there are printers and distributors.

There is, as I say, no reason why all these jobs can't be done by the same person – except the health and sanity of whoever would attempt it! What's more, one of the most pleasant parts of being involved in a publication is the fun of working with other people on a common task.

Adam Peters' series on publishing using the CPC, *First Edition*, which begins this month on page 18, will feature each month one of the key tasks involved, kicking off next month with text and then moving onto artwork, layout, printing and distribution.

Follow it, and you will build up a considerable knowledge of what's needed to turn a good idea into a great idea into a great publication.



AEM, 60p & large SAE: Highfield, Coombe Keynes, Nr Wareham, Dorset BH20 5PS.

RAM-packed

Yet another recent arrival to the fanzine scene is RAM. It's a dedicated games mag full of reviews for most computers, including, of course, the CPC. They even have a full-colour cover!

RAM would appear to be produced by a cast of thousands, under the benign dictatorship of Alex Edwards and a cat (!). All of them are still at school, with the possible exception of the cat.

Articles and reviews are in a bouncy, knockabout style, yet underneath there seems to be a strong understanding of what makes a good game. And they are themselves representative of a large section of the games buying public: teenagers.

More than one software house could learn a good deal about the tastes of its customers from subscribing to RAM.

The magazine undoubtedly has a long way to go before it rivals *The Bug* or *WACCI*, but it is none the worse for that.

RAM, 30p: 21 The Farthings, Marcham, Abingdon, Oxon, OX13 6QD

Just out: Print-Out

It's heartening to see new CPC magazines appearing all the time, and all the more so when they're as well thought out and produced as the first issue of *Print-Out*.

Produced by Thomas Defoe, Mark Gearing and Jonathan Haddock, *P-O* deserves to succeed. Issue one contains 42 pages of well written information for those who are keen to learn about their CPC and how to program it.

There's also a questionnaire and even a special offers page. Well worth investigating.

Print-Out, 70p (plus large SAE & 26p stamp): Thomas Defoe, 8 Maze Green Rd, Bishop's Stortford, Hertfordshire CM23 2PJ.

Why didn't we include the fanzine you edit? Because you didn't tell us about it, that's why! We intend to run a regular contact list of names and addresses for CPC fanzines, so let us know. Write to: Fanzines, AA, 4 Queen St, Bath BA1 1EJ

Create and win!

Be sure not to miss out on the smashing Mannesmann Tally 24 pin printer we're giving away for the best newsletter, booklet, fanzine or other publication created using the CPC. Turn to 24 for details now!

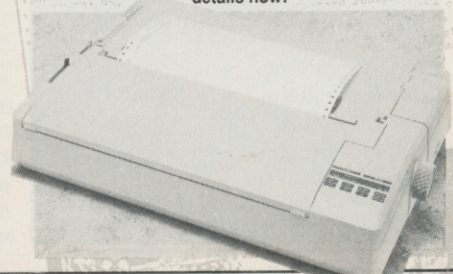



CREATE AND WIN!

● This is Mannesmann Tally's MT222, a 24 pin printer with a recommended retail price of £750. But it could be yours for free!

You really should get on and start that magazine/newsletter/booklet – you know, that idea that's been nagging away in the back of your mind for ages. Perhaps you're involved with a local cricket or football team, and they need to know what's going on. Or you're the biggest fan of a band. Or the company you work for or run doesn't have any means of communicating good news other than a notice-board.

It does involve hard work, but we here at AA reckon that creating a publication about something you're really interested in (like the CPC, in our case) is one of the most enjoyable and rewarding of activities.

Over the next few months AA

will be showing you the best ways to harness the power of the CPC to create your publication.

But there's a bigger incentive than that, too: the £750 Mannesmann Tally MT222 24 pin printer, pictured in all its glory here. Publish and be damned lucky and this superb printer could be yours!

The performance of the MT222, as you'd expect, is impressive: 220 characters per second in draft, 72 in letter quality. You can switch at a keystroke between continuous and single sheet stationery. And the results are a dream. (We've just got our hands on the MT222: review coming up soon.)

So how do you enter? Well, follow our series on DTP, *First Edition* (read all about it on page 18), create your newsletter, fanzine or whatever kind of publication you wish, and send it to us. We shall decide which is the best in all areas: subject matter, design, content and so on. We're not looking for a magazine of 76

colour pages. What we want to see is wit, imagination, creativity, hard work and that extra something that makes readers keep reading.

In addition we shall be asking five questions, one a month, while the series runs. Then at the end we'll tell you how to submit your entry.

(To tell the truth we've actually devised this competition so that we could be entertained by your work. The CPC fanzines we received as part of the survey carried out by Jeffrey Davy on page 22 impressed us so much we thought we'd try and get more of you at it.)

So read *First Edition* every month, keep a note of the questions as you go along and get working on your own publication.

Who knows, it could be the start of something big – and if you're half as good as you think you are, you'll be in with a great chance of winning £750's worth of printer, too! ●

Question one

Not a difficult one, this:

Who is the author of AA's new series on DTP,

First Edition? Is it

a) Pat McDonald;

b) Adam Peters, or

c) Jeffrey Davy?

FORUM

Problems, solutions... and fireworks with PAT McDONALD?!

Welcome to *Forum*, where Pat answers your questions and passes on your CPC computing tips.

● All together now: "Oh yes it can!"

In AA44 Phil Craven's article "ABBA," states that the Multiface II cannot save programs to the B drive. Oh yes it can! Here's how.

When prompted for a filename, enter B: plus the name – only five letters can be used, unfortunately. To get round this limitation, enter the following and save it to the B drive with a filename of up to eight letters:

10 |b

20 RUN"five letter filename here

Optionally, if you don't want to see lots of obscure filenames when you cat the disk, then

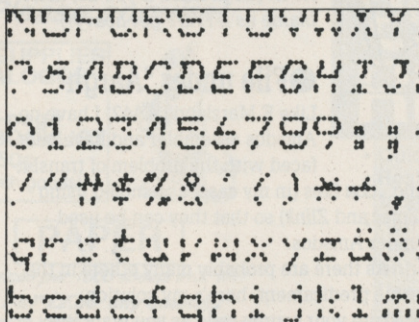

● The case of the missing pin: Andy Brown asks whether software could be to blame ("Pin Down")

with *Stop Press*, and it worked wonderfully, except that when I tried to print a document with *Tasword 6128*, the results were as shown. Pin five on the print head seems to have been permanently turned off. Should I send my printer back, as it's still under guarantee, or is there a control code or dip switch to get it working again?

Andy Brown, BFPO 23

Looks to me as if the printer has failed, rather than Stop Press messing it up. Send it back for replacement, because turning printer pins on or off just isn't implemented on any printers that I know – including the DMP2160.

● Fixer

I've just spotted a mistake in my program on re-defining printer characters way back in AA36. Line 150 instructs the printer to treat the unused control codes as printing characters. The codes for this are ESC "I1". As printed it's ESC "|1", which the printer ignores. Hence it won't work.

M. Catton, Gosport

Thanks, I'm sure a lot of frustrated readers appreciate your continued efforts.

By the way, I wonder why so many correspondents to this part of the mag insist on being known by an impersonal initial, rather than the friendly first name I know I'd rather see?

● Inner secrets

Recently I acquired an Amstrad CPC6128 plus a few other odds and ends secondhand. Discovering that the autofire on the joystick didn't work I opened the computer up and discovered huge amounts of dust and grime. When I cleaned these out I also found that the

previous owner had been interfering.

There are two extra wires: pin nine of the printer port is connected to pin 12 of the 8255 chip, and leg 22 of the 40025 chip had been cut, only to be reconnected with the second piece of wire.

Are these harmless? What are they meant to do?

D Sudell, St. Annes

The previous owner of your 6128 was obviously an Amstrad Action reader – the 8255 modification was in AA26, with the program for it in AA26. It gives CPC's an eight bit (rather than seven bit) printer port, allowing the (normally unavailable) control codes from 128-255 to be sent the printer.

As for the other wire, it sounds to me as though it's a simple repair: leg 22 didn't connect properly, and so was bypassed. Whatever it's for – as that's the ROM chip – if something was wrong, it would be drastically wrong and your machine wouldn't work at all!

Oh yes, nearly all joystick autofires don't work with the CPC. It's just a fact of life, I'm sorry to say.

● Alternative alternative

The program *Alternative Bank Manager*, featured in AA46, unfortunately caters only for 6128 owners. Below is a patch to allow 464 and 664 users with a 64K memory expansion to use all of the *Alternative Bank Manager* commands. (It replaces the firmware call KL_BANK_SWITCH with some OUT commands to do the same task.)

Just retype the following lines and resave the program.

```
50 FOR lin=0 to 37
1220 DATA DE80CD1881C93E00, 971
1230 DATA CD1881C93EC0CD08, 1026
1350 DATA 43C5D6044FE60347, 865
1360 DATA 79E61C87B0F6C401, 1133
1370 DATA 007FED79C1C90000, 879
```

David Hughes, Monaghan

Nice tip, David. £10 on the way.

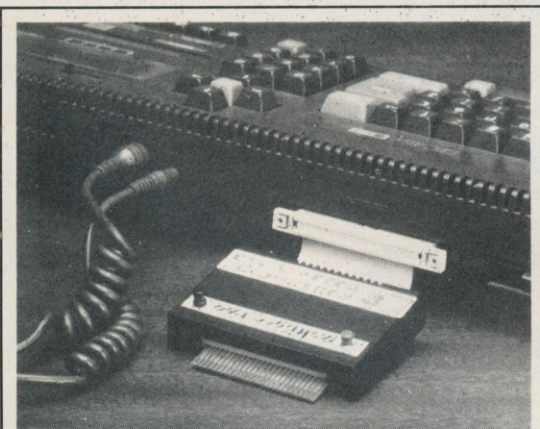

● You could be breaking the law just for owning one of these (see p30). But never mind, Tony Culshaw shows how to use the Multiface II to save to a B drive, so that's alright then (*huh? – ed*)

use a disk editor (such as *Discology*) to give the Multiface files into a different USER area.

Tony Culshaw, Penwortham

There you have it, a simple answer to a common problem. Cheers Tony!

● Pin down

Something has gone drastically wrong with my Amstrad DMP2160 printer, as you can see! I decided to test out my new 64K RAM pack



● Now 64K memory owners get ABM

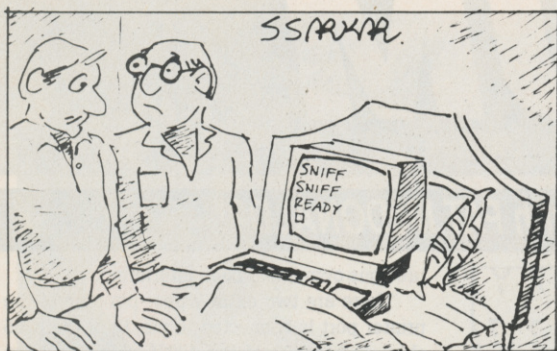

"I think it's got a virus."

● Truth at last

I have just bought *Protect* on ROM. I want to write a disk program to program the function keys with various options, amongst other things. However I have run up against the 128 character limit for key expansions. Looking back through previous issues of AA, I notice in AA31 that you printed a short program to increase the limit to 1,280 characters.

It crashes on my ROM version. Was it for tape users only? When I have my program finished, I want to transfer it to ROM. The intention is to set up the options and then run *Protect*. Is it possible to call one ROM from another?

Since Graduate software will transfer CPM+ to ROM seemingly without express permission, does this mean that we can legally do the same to other commercial programs that we have bought?

M. Ball, Chelmsford

There have been a number of requests for a program that works: unfortunately the original wasn't very satisfactory, because it didn't. Here's an environment friendly version that should be acceptable to just about everyone:

```
10 a=HIMEM:MEMORY a-1280
20 a=HIMEM+1:b=INT(a/256):c=a-(b*256)
30 FOR t=&BF00 TO &BF09:READ a$
40 POKE t,VAL("&"+a$):NEXT
50 POKE &BF01,c:POKE &BF02,b:CALL &BF00
60 DATA 11,00,00,21,00,05,cd,15,bb,c9
```

*As for the backing up question, the sticking point is whether you have to crack a protection in order to get at the program. The fundamental rule of the 1988 Copyright, Patent and Design Act is that if something is protected, you're not supposed to touch it unless it's for your own private use (see last month's *Amscene* and the article this month on page 30 for more information).*

If a) you have bought the original soft-

● No escape!

Can you give me a poke that disables the ESC key so that people can't break into my programs?

J. Hepi, Braintree

Yes – or rather, T P Cheung can: POKE &BDEE, &C9.

ware, b) it was transferred without breaking protection, ie it was still fingerprinted in some way, and c) the ROM copy was for your own personal use, ie you didn't make lots of copies for all your friends, then that should be OK. But we certainly aren't legal eagles round here, so don't go taking our word for it! (Or at least, if you do, don't blame us if FAST get heavy!)

● File under "Aargh"

Like E Marsland (AA42) I have no Amsdos assembler and have been faced with the problem of translating

.COM files (in my case, assembled using *Zmac* and *Zlink*) so that they can be used under Amsdos.

As there are probably many others in the same predicament, here's my solution:-

1. Write your source code as you want it to operate under Amsdos, using the normal Amsdos firmware calls if required.
2. Assemble it to give a .COM file in the normal way (I use *Zmac*, a good PD assembler from Wacci). I assemble the code to &100 using *aorg* 100h, then use *Zlink* to produce the .COM file.
3. Exit CPM to Amsdos and LOAD "filename.com" – at this stage you might get a Direct command found message, but don't worry!
4. SAVE "filename", b, &967C, length – where length is the length of the file. You should now have a .BIN file which can be used under Amsdos.

Finally, what's the structural differences between .COM, .HEX, .OBJ and .BIN files?

M S Vann, Richmond

I've tried it, although it doesn't seem to work if the file is over 2K long. As for the others, the point about .COM and .OBJ is that there isn't any difference, except that the header file on the disk is different: to Amsdos they are both Ascii files. .HEX files are different, using Intel Hex code to represent binary numbers, and also look like Ascii to Amsdos. .BIN files have different headers again, and Amsdos sees it as machine code.

Confused? So am I! The fundamental reason for the strangeness is that Amsdos and CPM are totally different operating systems. Just about the only thing they have in common, in fact, is that they can both write to and read from 3" disks.

● Stationery vehicle

So you want to get continuous A4 stationery to work with *Tasword*, do you? Here's how: send these codes to the printer (customize the printer setup option): 27, 51, 42 and 27, 67 60. The first one sets the paper feed to 42/216", and the other sets the page length to 60 lines.

You mentioned recently that "third party" 3 inch second disk drives are scarce. Well, I got mine from J N Bull Electrical Ltd (they're in Brighton – 0273 430380). It was uncased and with no power supply, but a techie with a Maplins catalogue should have no problems finding a PSU and a box – mine cost me about £55 plus a few hours work.

A G Cameron, Aberdeen

Just goes to show, there's always somebody making a living in any market. Anybody know of a company that sells the power supply, case, drive and connecting lead in one box?

● Len's solution

Len Phillips requests a routine for a 16 character file name (AA43). This is unnecessary if on each side of disk a standard eight character filename is stored, together with explanations of their meanings. I use the following routine:

Type in Mode 2 this listing.

```
1 'DISC 2A
2 MODE 2:LIST 10-
```

AUTO will now give the listing numbers in increments of 10. Against each insert the single quote character ('), which is a shorthand for REMARK. Then put all the filenames on the disk, plus the length and explanation of file as follows:

```
10 ' ANAGRAMS.BAS 5 Anagrams of word entered.
```

```
20 ' BARCHART.BAS 2 Simple entry barchart.
30 ' ELECTYPE.BAS 3 Electric Typewriter.
```

Initial numbering in tens allows you to enter additional filenames if you happen to save them

```
150 'M .BAS 1 "
160 'GRAPHICS.DMP 2 Graphics dump. Printer manual 2.7
170 'SCREEN .DMP 3 Text screen dump. Printer manual 2.4
180 'RECORDS .DOC 3 List of Dads records (Mini office)
190 'TELETEXT.DOC 8 Teletext numbers (Mini office)
200 'THIMBLES.DOC 3 List of thimble collection
210 'TYPE .BAS 1 Typing tutor giving one endless line
220 'UNERASE .BAS 2 File uneraser (faulty listing)
230 'XTRAFNTS.BAS 2 Extra fonts CPC Computing Sep 88 (Arthur) ? operation
```

● Geoff Stott's solution to a demand for 16 character filenames may not be elegant, but it is... er, cheap!

onto the disk later. Then type RENUM to tidy up the line numbers.

When you've finished end with the filename CAT. Now, when you want to look at what all the programs on a disk do, just type

```
RUN"CAT. To dump a disk's contents to a printer just enter LIST#8.
```

Using this method allows up to 230 characters of explanation for each filename although keeping to single line entries gives a shorter list. Geoff Stott, Sutton Coldfield

Well, at least it's free, Geoff! I guess for anyone short on pennies and long on spare time it's ideal.

Printout Specialists

CASPELL COMPUTER ☎ 0202 666155 [24 hr]

RIBBONS

Amstrad DMP 2/3000 series	2482	A
Amstrad DMP 4000	2426	E
Amstrad PCW8256 (L/Life)	*2741	D
Amstrad PCW9512	*2746	B
Brother HR15/25/40	*2696	B
Canon PW1080A	2223	D
Centronics GLP	2412	D
Citizen 120D/180E/LSP10	2488	B
Citizen MPS801	2477	D
Epson FX/LX-80	2273	B
Epson LX/GX-80	2454	B
Epson LQ-500	2477	D
Epson RX-80	2273	B
Epson EX-800	2774	D
Epson Full Width	2320	D
Juki 6100 Daisywheel M/S	2563	B
NEC Pinwriter P1/P2	2254	D
NEC P2200	2844	D
NEC P6+/P7+	2870	E
Panasonic KXP-1081/1180	2228	B
Seikosha GP100	2317	B
Seikosha SL80 (L/Life)	*2741	D
Seikosha 500/550	2236	D
Shimwa CP80/MT80	*2698	D
Tatung/Commodore CP80	*2698	D
Star LC10	2861	B
Star LC24-10	2868	B
Star NL10	2761	D

* = Avail. in Fabric Nylon or M/Strike Film.
Please choose!

(Fabrics offer longer life and may be used with Ribbon Refresh!)

PRICE STRUCTURE

	1 off	2 off	5 off
A	£2.95	£5.75	£12.95
B	£3.95	£7.45	£16.95
C	£4.45	£7.95	£18.45
D	£4.95	£8.95	£19.95
E	£5.95	£10.95	£24.95

Prices include VAT & post

WE ALSO HAVE DISKS

and a Technical Library of 1500 BOOKS!

Please enquire!

FREE SUPPLIES CATALOGUE

24-page FULL BOOKLIST 50p (Only with goods)



PAPER

All prices per 1000 sheets incl. VAT

* P&P £2.50 any quantity

11/9.5 60gsm Listing	£6.45
11/9.5 70gsm Microperf	£7.95
11/9.5 85gsm Letter Qual	£9.95
A4 size 70gsm Microperf	£9.70
A4 size 85gsm Letter Qual	£10.95
11/9.5 2 part NCR	£19.40

A5 size Letter Quality paper, Upright (Portrait) Orientation, £13.95
Microperf all edges for letter-writing

Address Labels

3.5/1.5, 1- or 2- across
£3.75 per 1000 (+£2.50 P&P)

At last - a unique new ink spray that restores ribbons in seconds

SAVE £££s ON RIBBONS

- Quick & Convenient.
- Restores & Re-inks faded ribbons in seconds!
- Refreshed ribbon lubricates print head for smoother running & enhanced printer life.
- Use on any fabric ribbon... again and again!
- Pays for itself the first two times you use it.



ONLY £8.95 inc VAT & post

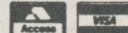

Cheques/POs (no stamp needed)

CASPELL COMPUTER SERVICES

Dept AA, FREEPOST, Poole Dorset BH15 1BR
Tel: 0202 666155 or 0202 35650 (24-nr)
TRADE ENQUIRES & LOCAL AUTHORITY ORDERS WELCOMED
Account enquires: 43 Emerson Rd., Poole Dorset BH15 1QS

SOFT EXCHANGE

HISTORY IN THE MAKING CASS£6.99

SUPREME CHALLENGE CASS£5.95

SUPERMAN CASS £2.99

WIZARDS LAIR I CASS £2.99

WIZARDS LAIR II CASS£2.99

GO CRAZY CASS..... £5.95

MOTOR MASSACRE CASS £2.99

INDOOR SPORTS CASS£2.99

SUPER SPORTS CASS£2.99

NEVER ENDING STORY DISC£4.99

3D BOXING CASS.....£2.99

MOVIE DISC£4.99

VOLLEYBALL SIMULATOR DISC£3.99

MAD BALLS DISC£3.99

EVE DISC.....£4.99

RAMPAGE DISC£4.99

Blank Discs at £2.20 each or 10 for £19.95

All Recent Budget Titles at Discount £1.99 = £1.60 or £2.99 = £2.49

To Order send Cheque/P.O. to:

SOFT EXCHANGE LTD
101 CLIFTON ROAD
SOUTH NORWOOD LONDON SE25 6QA

EDUCATIONAL SOFTWARE NOW AVAILABLE

COMPUTER CROSSWORDS

EXCLUSIVE FROM AKOM LIMITED

Featuring

THE TIMES Volumes 1, 2, 3, 4, 5, 6 & Jubilee Puzzles 1932-87

and

The Sun Volumes 1, 2, 3, 4, 5 & 6

Prices of software with NEW Team Option are as follows:-
For Amstrad 5 1/4", IBM 5 1/4", IBM 3 1/2", Archimedes, Atari ST Times discs are £19.95, Sun discs are £18.95
For Amstrad 3", RM Nimbus 3 1/2", BBC 3 1/2", Electron +3, BBC Master 128 ADFS, BBC DFS 40, DFS 80 Times discs are £18.95, Sun discs are £17.95
For Spectrum +3 Sun discs are £17.95. Note: no Times version
For all Acorn, Spectrum, Amstrad cassettes (No Team Option) Times £9.95 (Vols. 1-3, +Jubilee only), Sun £7.95 (Vols. 1-4 only)
Prices include postage, packing and VAT (£1 surcharge ex UK)

Please send me:

The Times Computer Crosswords Volume(s).....

The Times Jubilee Puzzles 1932-1987.....

The Sun Computer Crosswords Volume(s).....

my system is: (delete as appropriate) IBM/Amstrad/BBC/Spectrum/Atari ST/Nimbus/disc/cassette/3"/3 1/2"/5 1/4"

Computer model (details).....

Name:..... (BLOCK CAPITALS)

Address:.....

Postcode.....Tel.....

I enclose cheque/postal order for £.....(payable to):

AKOM LIMITED 51 MANOR LANE, LONDON SE13 5QW TEL: 01-852 4575

● Full up

I was interested in the letter on page 34 of the July magazine. I typed in page 55 of the June AA on my 6128 and got **Memory full** in 50 – so that was that! Haven't a clue how to sort it out.

Could someone do a 10 line firework display?

C Russell, South Harrow

Er, I haven't much of a clue either. Supposing that you're having a problem with Typewriter from AA45, then I recommend that you disconnect any peripherals such as ROM boxes and try again. It's not the easiest program to type in, but it makes future Type-Ins seem easy by comparison, because you have the checking system then.

As for a ten line firework display, here goes:

```
10 PRINT "BANG"
20 PRINT "WHIZZ"
30 PRINT "WHOOOSH"
40 PRINT "SPARKLE"
50 PRINT "BOOM"
60 PRINT "FIZZ"
70 PRINT "KABLAMM! KABLAMM! KABLAMM!"
80 PRINT "WHEE"
90 PRINT "PHUT"
100 PRINT "That's all folks"
```

Anyone with an even better effort than this should send it to Type-Ins. Don't worry about the ten line limit, just try and keep it so that it will fit on a page of the magazine.

● Easy way out

Could you please reprint the Artist listing from AA16 in next month's issue of your brilliant magazine?

Lee Martin, Gloucester

We may indeed reprint the listing, Lee, but in the meantime there's an alternative that will save you lots of typing: turn to the back of the magazine, and buy a back issue of AA37. This included the Smart 2 art program on the cover tape, and it's much better than Artist.



● What a turn off

After several disks of mine have been corrupted, I feel that I must warn other people of the pitfalls of using a disk drive. This has mainly been caused by switching off the computer with a disk in the drive, or more dramatically having a powercut.

The reason for this is as follows: one type of disk drive has a head solenoid, and other types don't. A head solenoid is a coil of wire that acts like a magnet when an electric current flows through it. It prevents the drive head from touching the disk surface when the disk is inserted (??).

CPC drives do not have a head solenoid. Therefore the read head in these drives is constantly touching the disk if one has been inserted (??). If a surge of electricity comes plummeting through the drive head (??? – surge, I thought you said cut?) there are possibilities that the magnetic patterns on the disk will be corrupted.

So always make a backup disk and never turn your computer off with a disk in the drive. I also use my Epson LX86 printer with Mini Office 2.



When I printed out pie charts, they didn't look like circles. Because my printer has something called a "one to one plotter mode" the problems was solvable.

When the computer and printer are setup, but before loading Mini Office 2, type in this command:

```
PRINT
#8, CHR$(27); "?K"CHR$(5)
Then run Mini Office 2 as normal. Note that CHR$(5) is the Epson code: other models may need a different code here to select the plotter mode.
```

T P Cheung, Ipswich

Well, you were close in your analysis of why disks corrupt. The solenoid doesn't stop the

disk touching the head, it's used to read and write the magnetic patterns. Now, if the computer is switched off, then the sudden change in current causes a small magnetic pulse from the solenoid – sudden changes in electricity supply do this to magnetic coils, which is one of the components of a solenoid.

Anyway, it's that pulse which causes the corruption on the disk. As you say, it doesn't happen often and is easily avoidable if you never leave a disk in the drive. Incidentally, 464 owners (with disk drives, naturally) don't have nearly so many problems as 664 and 6128 owners, because 464 drives have their own power supplies and don't depend on the monitor.

Can't fault you on the plotter bit, though.



● What a turn off: why leaving a disk in your drive when you switch off is such a bad idea

● Getting stuck in...

I've just started programming in machine code, using Des Daly's assembler from the AA37 cover tape. I have written a program which copies the screen at &C000 to &4000, but it's quite slow, slower than other copiers that I've seen. Am I doing something wrong?

```
LD HL-&C000
LD DE-&4000
XLoop LD A (HL)
LD (DE) A
INC DE
INC HL
LD A H
CP-&FF
JP Z-Xcheck
JP-XLoop
XLoop LD A L
CP-&FF
RET Z
JP-XLoop
```

Also, using machine code, how do I draw a diagonal line on the screen?

Nicholas Keeling, London



Well, for a start you're testing HL on each loop to see if the routine's finished. It would be

better to assign a counter, and when the counter is zero, the copy is complete. If you use the LDIR command (load, increment and repeat command), this is done automatically:-

```
LD BC-&4000
LD DE-&4000
LD HL-&C000
LDIR
RET
```

As for drawing a diagonal line, what you have to do is take the start and finish coordinates, find the difference between them, and then plot all the pixels on that line (that's the most blasé answer I've ever heard from you, McDonald, and that's saying something – ed).

OK, OK! Having been offered sufficient encouragement (ie he can keep his job if he behaves – ed), here's an example. It uses the firmware graphics jumpblock, the inbuilt machine code routines with which Basic copes. I suggest you obtain a copy of the jumpblocks: take a look at the Helpline for people who can help you.

WATCH YOUR SCREEN – SEPTEMBER

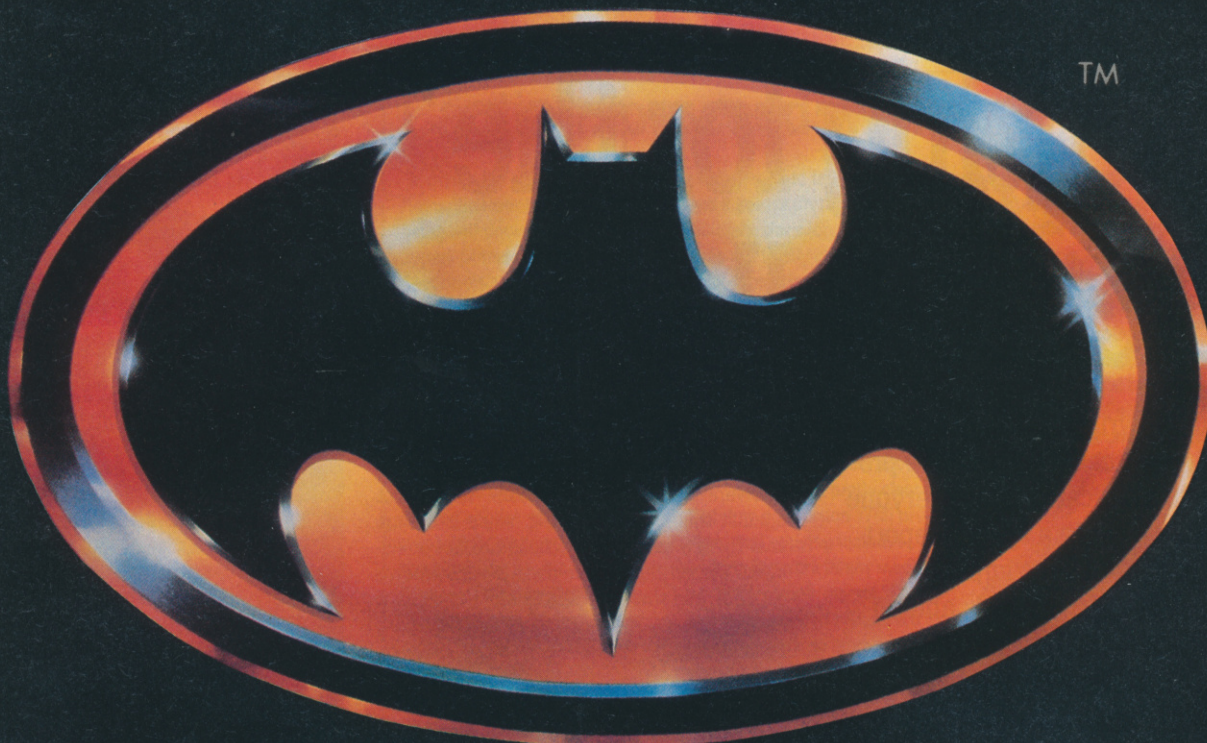

TM



TM & © 1964 DC Comics Inc.

First the graphics cursor is moved to where you want it. Load HL with the Y coordinate, DE with X and jump to &BBC0 for an absolute position, &BBC3 for a relative position.

Then load DE and HL with the coordinates of where you want to draw to, and jump to &BBF6 for an absolute line, or &BBF9 for a relative draw.

Here's a couple of examples (don't type in the comments to the right of the semicolons):

```
LD DE-&0
LD HL-&0
JP-&BBC0 ; move cursor to 0,0
LD DE-&639
LD HL-&12C; hexadecimal for
                X639, Y400:
JP-&BBF6 ; draw absolute line ●
```

●Psion of the times

I have a 6128 with an RS232 interface and a modem. I also have a pocket diary/computer known as the Psion Organiser II-CM. I would like to connect the two together for transfer of data. To do this I need a COMMS package from Psion (which includes the RS232 cable) which isn't cheap, but what about the CPC end?

Now here's a little tip. One bugette of the AA *Sprite Editor* is that when loading mode and inks, the program neglects to change the numbers in *stepno* and *noinks* for different modes. To correct it, type in these lines:

```
510 NEXT:inkselect=1:mflag=1:GOSUB
940:RETURN
955 If mflag=1 THEN mflag=0:GOTO 1010
Fred de Laszlo, London
```

Thanks for the tip. I don't know the *Psion Organiser*. Does any kind reader know details of the transfer protocol (or a comms program for the CPC if the protocol is unique to the Psion)? I'm sure that Fred would be a lot happier. And that would make me a lot happier.



● This peculiar object is a Psion Organiser, identical to the one Pat has never seen: can anyone help? ("Psion of the times")

Nice little earner

Forum is designed to do the jobs previously done by *Words Work*, *Hot Tips* and *Problem Attic*, which always overlapped to some extent anyway. It will be as big as you want it to be – depending on your reaction and the number and quality of letters we receive.

To encourage you we're giving away £40 each and every month to the writers of the hottest tips and the best questions. So if you have a problem, or a solution, get it in writing now. Send it to: *Forum*, AA, 4 Queen St, Bath BA1 1EJ.

We're very sorry but we simply haven't the time to reply personally to your letters: so no SAEs please!



Waiting for the Act to fall

The Copyright Designs and Patents Act 1988 may have profound implications for everyone with a CPC. In a special report PHIL CRAVEN attempts to unravel the confusion; and on the right J.E.J. Altham, an academic who has studied the Act in detail, comments.

On August 1st the Act came into force. Since then confusion has reigned, with companies such as Romantic Robot, who produce the Multiface II, advertising "last ever opportunities" to buy their product. Utilities too have been threatened, and questions have even been raised about *Disckit's* PIP command!

The Act itself is a massive and complex piece of legislation that runs to some 200 pages and 306 sections. It includes such bizarre items as a clause to exclude *Peter Pan* from its provisions! (Sir James Barrie bequeathed all royalties from the play on the Hospital, which has come to depend to a large extent on them.)

Court out

Clearly, there are fierce difficulties of legislating for a medium of information storage and communication that was only in its infancy when the Act which the present one builds upon was drawn up in 1956. It seems unlikely that statements can be made with absolute conviction until test cases have been brought. As last month's *Amscene* amply demonstrated, not only the managers at Romantic Robot but even the staff of the Federation Against Software Theft (FAST) are unwilling to make categorical statements about the Act's implications.

What does seem clear is that, despite what has been printed in some sections of the press, all software – games or otherwise – is protected by copyright and it is an offence to make back-up, archive or working copies without the permission of the copyright holder. The fact that an item of software has not been protected against copying does not in any way imply that permission has been given, no more than leaving your front door unlocked grants permission to a burglar to empty your house's contents.

On the other hand an offence of copying in this instance is a civil rather than a criminal act, and would go before a civil court. Software houses I have spoken to are not against this kind of copying, since it doesn't cost them a sale: court actions are not envisaged. United States law does permit archive copying, and there are moves afoot to allow it here in the EC – though it is meeting with resistance.

Falling foul

The most relevant section of the new Act is 296, which seeks to make illegal not only the act of copying without permission but also the *means* of copying copy-protected software (*this section is quoted below – ed.*)

It certainly appears as if disk to disk and tape to disk utilities, which are designed to get around protections like Speedlock, and Multiface II hardware, which breaks into a running game for the purpose of making a back-up copy, all fall foul of this section.

But do they? The key phrase is "used to make *infringing copies*." Obviously copying in itself cannot be illegal, or we would not be allowed to making working copies even when permission is given, or copy our own files



from disk to disk, and software houses would not be able to produce copies for us to buy.

There is an interesting parallel here, which funnily enough concerns Amstrad. In *CBS Songs Ltd v Amstrad Consumer Electronics plc* [1988], the House of Lords threw out a claim that Amstrad's dual cas-

"The House of Lords accepted quite happily that the machine not only could and would be used to make such illegal copies: they even seem to have conceded that the main use of it would be illegal!"

sette recorders were offering an authorisation to buyers of the hardware to make illegal copies of cassettes. Now this is very interesting indeed, because the House of Lords appeared to accept quite happily that the machine not only could and would be used to make such illegal copies: they even seem to have conceded that the *main* use of it would

That historic Act in full

(well, not really. But, er, *bits* of it in full...)

24. — (1) "Copyright in a work is infringed by a person who, without the licence of the copyright owner –
(a) makes,
(b) imports into the United Kingdom,
(c) possesses in the course of a business, or
(d) sells or lets for hire, or offers or exposes for sale or hire,
an article specifically designed or adapted for making copies of that work, knowing or having reason to believe that it is to be used to make infringing copies."

56. — (2) "If there are no express terms –
(a) prohibiting the transfer of the copy by the purchaser, imposing obligations which continue after a transfer, pro-

hibiting the assignment of any licence or terminating any licence on a transfer, or
(b) providing the terms on which a transferee may do the things which the purchaser was permitted to do,
anything which the purchaser was allowed to do may also be done without infringement of copyright by a transferee; but any copy, adaptation or copy of an adaptation made by the purchaser which is not also transferred shall be treated as an infringing copy for all purposes after the transfer."

[In other words you can sell a program, or a copy of a program: but if any copy you keep of that program infringes copyright.]

296. — (1) "This section applies where copies of a copyright

work are issued to the public, by or with the licence of the copyright owner, in an electronic form which is copy-protected.

(2) The person issuing the copies to the public has the same rights against a person who, knowing or having reason to believe that it will be used to make infringing copies –
(a) makes, imports, sells or lets for hire, offers or exposes for sale or hire, or advertises for sale or hire, any device or means specifically designed or adapted to circumvent the form of copy-protection employed, or
(b) publishes information intended to enable or assist persons to circumvent that form of copy protection as a copyright owner has in respect of an infringement of copyright."

be illegal. Amstrad actually advertised that it could be used for recording "your favourite cassette"! Admittedly they also included a wee notice stating that copying of copyrighted material without permission was against the law.

The act of copying

Now it would seem that there are parallels in the present case. As long as a utility can be genuinely used without infringing copyright then it is not illegal in itself. Software houses, for instance, have a perfectly legitimate use

The thing in detail

If you would like to investigate the Act further you should find that your local reference library has a copy. But a more useful guide is *Blackstones Guide to the Copyright, Designs and Patents Act 1988*, by Gerald Dworkin and Richard D. Taylor. It includes a copy of the Act, as well as 17 chapters on various aspects of it. More specifically there is an excellent summary on Computer Technology as covered by the Act. The book, published this year by Blackstone Press of London (ISBN: 1 85431 023 2), costs £18.95 in paperback.

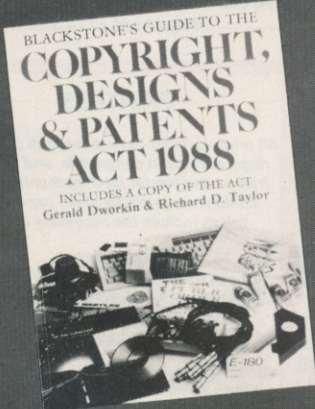

for such utilities or hardware. One of the major companies to whom I spoke stated that they sometimes buy rights to a foreign game and then have to break into it themselves so they can produce it for different machines.

Computer magazines – *Amstrad Action* among them – use the device for "grabbing" screenshots from games for use in reviews.

And of course the Multiface II's main use is for breaking into games

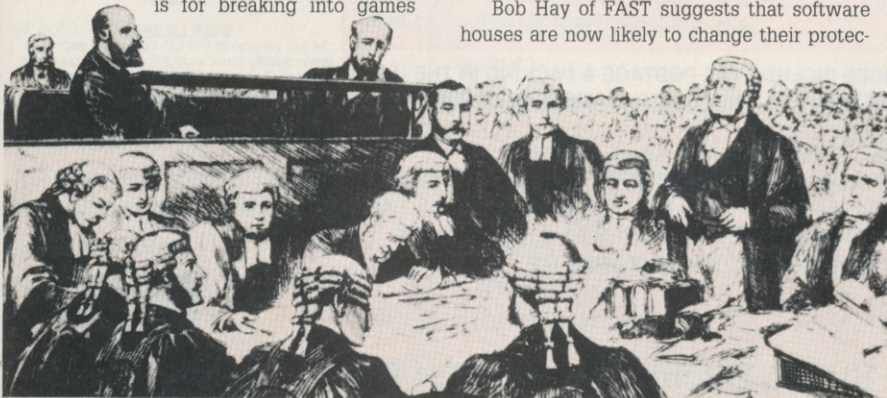

Caution: proceed with care...

"In giving the reason why Romantic Robot's Multiface is being withdrawn from sale, you appeal (*Amscene, AA47*) to Section 24(1) of the Act (*quoted in the box on facing page - ed.*).

"I agree with you that it is not clear that a case against Romantic Robot based on this Section would succeed. But Section 296 of this complicated Act is also highly relevant. This section applies where copies of a copyright work are issued to the public, by or with the licence of the copyright owner, in a form which is *copyrighted*. (*again, quoted on facing page - ed.*).

"When you've worked through the considerable complications you realise that this is a powerful section. Various tape to disk transfer utilities

seem clearly to fall foul of it, and it seems probable that the Multiface does too. Multiface does not totally circumvent copy-protection, because it must be connected to make the copies run, but the Act does not say that the circumvention must be total to be illegal.

"You also wondered whether Multiface back-ups constitute copies under the new law. It seems pretty clear that they do. Section 17(2) provides that copying includes 'storing the work in any medium by electronic means.' The fact that you need a Multiface to make the work so stored usable appears to be legally irrelevant.

"It must be agreed that until the courts have decided some relevant cases uncertainty will remain.

"Meanwhile, Romantic

Robot's caution in withdrawing the Multiface seems amply justified by the wording of the new Act. Sections 24 and 296 both include prohibitions on making as well as selling, so it is very difficult to understand Alex Goldscheider's suggestion that the Multiface might be manufactured here and sold abroad.

"If it's illegal under one of these sections to sell it here, it's also illegal to make it here."

● JEJ Altham, a Cambridge University lecturer in the faculty of Philosophy, has recently co-ordinated a course on professional practice and ethics for the Cambridge Computer Science degree

which have the interrupts disabled. One reason is to poke cheats into them; another is to study the programming. Interrupt disablers are not protected by law, of course, and breaking into a program isn't illegal. But the Multiface II also has the facility of then saving the game to disk and, in doing so, getting round "the form of copy protection employed." As long as there are people making legal use of the Multiface II it appears to fall within the law, though it looks as if Mr Goldscheider is unwilling to risk having the matter taken to the courts.

Living in interesting times...

Goldmark Systems, producers of several copying utilities, may withdraw one or two items from sale if they feel that their legality cannot be demonstrated. Colin Harris, who runs Nemesis (a name that tempts fate, if ever there was one!), feels that genuine working copies should not be illegal. Their new CPC Pro-Copy disk utility suite is going ahead as planned.

Bob Hay of FAST suggests that software houses are now likely to change their protec-

tion methods: if utilities change to follow them, prosecutions could ensue.

So how do you stand if you already own a copy-protection breaking utility? In a nutshell, section 296, sub-section 3 states that if you have it in your "possession, custody or control *with the intention that it should be used to make infringing copies of copyright works...*" (my italics) then you fall foul of sections 99 and 100 which mean that certain articles – presumably the utility itself, along with any illegal copies – can be seized. It follows that if you have no such intention then everything is fine and dandy. Probably.

The Act is now law, but it may be difficult for a case to be made that any utility or hardware is subject to it. On the other hand, it may well be that some commonly used utilities – such as you may very well already possess – could have a hard time justifying their legality and may disappear.

For those of us who can afford to, the present legislation and its applicability or otherwise to computer technology provides food for fascinating thought and discussion. It has been a pleasure to watch proposals and debates as the Bill progressed through the House and hardened into the Act we now have.

Others, however, are finding out just how damning is the old Chinese proverb: "May you live in interesting times..." ●

● What do you think? Has the Act got it right? Should Romantic Robot's Mr. Goldscheider be flung in gaol and the key thrown away? Or should mass piracy be legalised and those greedy software houses shown the door?

DISCOUNT SOFTWARE

SWIFT, HOW LOW
CAN YOU GO?

from M.J.C. SUPPLIES

DISC GAMES

3D Pool	11.95
Dominator	12.95
Obliterator	11.95
Time and Magic	11.95
Lancelot	14.95
Forgotten Worlds	12.95
Silk Worm	12.95
Xybots	12.95
Skweek	12.95
Navy Moves	12.95
Storm Lords	12.95
Emlyn Hughes International Soccer	11.95
Microprose Soccer	15.95
Time Scanner	12.95
Renegade III	11.95
Vindicators (by Domark)	12.95
Game Set and Match	13.95
Tank Attack	11.95

MJC SPECIAL:

3D Pool
RRP 14.95 OURS 9.95
OFFER ENDS 31st AUGUST

CORNIX SOFTWARE

CARD INDEX: Easy to use filing system
CASS: 19.95
DISC: 24.95

SIMPLE ACCOUNTS: easy to use accounts ideal for small business includes VAT. **CASS:** 34.95
DISC: 39.95

JOB ESTIMATOR: useful tool for contractors. **DISC:** 39.95

PRODUCT COSTING: DISC: 39.95 Full specifications on all of the above programs on request.

EDUCATION

Animal Veg. Mineral	11.95
Answerback Junior Quiz	11.95
Factfile Arithmetic	7.95
Factfile Spelling	7.95
Factfile Sports	7.95
Fun School for 2-5 years	7.95
Fun School for 5-8 years	7.95
Fun School for 8-12	7.95
Fun School 2 for under 6 yrs	9.95
Fun School 2 for 6-8 yrs	9.95
Fun School 2 for over 8 yrs	9.95
World Wise	11.95
German Master (12 to adult)	14.95
French Mistress (12 to adult)	14.95
Spanish Tutor (12 to adult)	14.95

Note: Factfiles are question packs only and require the Answerback Junior Quiz.

DISC SERIOUS

Protext	17.95
Prospell	16.95
Promerge	16.95
Arnor Filer	18.95
Arnor Office Suite	26.95
Tasword 6128	19.50
Taspell	12.95
Tasprint	10.95
Tascopy	10.95
Tasdiary	10.95
Tassign 6128	23.95
Qualitas Plus	12.95
Qualitas Pica Font Pack	8.95
Qualitas Clarion Font Pack	8.95
Qualitas Newsroom Font Pack	8.95
Qualitas CPM + Utilities Disk	8.95
French Mistress	16.95
German Master	16.95
Spanish Tutor	16.95
Masterfile III Database	29.95
Mastercalc 128	25.95
Matrix Spreadsheet Plus	29.95
Stop Press Desktop Publishing	29.95
Extra Extra	19.95
Maxam (Assembler/Diss)	18.95
Poke Easy Plus	14.95
Mini Office II	15.95
Rodos Extra Disk	8.95
Advanced Art Studio	19.95

CPM BASED

At Last Plus	29.95
Supercalc 2	44.95
Arnor C Compiler	39.95
Maxam II	39.95
Fortran	39.95
Nevada Cobol	39.95
Hisoft Devpac 80	39.95
Hisoft Pascal 80	39.95
Hisoft C Compiler	39.95
lankey 2 Finger Typing	19.95
lankey Crash Course	19.95

MJC SPECIAL

Protect CPM: including
Spellchecker & Mailmerge
RRP £59.95 OURS £41.95

CASSETTE BASED

Maxam 464	15.95
Protect 464	15.95
Tasword 464	15.95
Answerback JNR Quiz	8.95
Italian Tutor	14.95

**ALL ABOVE PRICES INCLUDE VAT, POSTAGE & PACKING IN THE U.K.
THE ABOVE SOFTWARE IS ONLY FOR THE AMSTRAD CPC RANGE**

ACCESSORIES

AMX Mouse + Interface	Only 34.95
Printer Lead 1M	8.95
Printer Lead 1.5M	9.95
Printer Lead 2.0M	10.95
3" Disc Cleaner	6.95
Amstrad R232 Interface	55.95
Mono Screen filter	12.95
Colour Screen Filter	14.95
Comp Pro 5000 joystick	13.95
Quickshot Turbo joystick	11.95
Cruiser joystick	9.95
464 Monitor ext Leads	6.95
6128 Monitor ext Leads	7.95
1000 Fanfold Labels	6.95
Second Drive Lead	7.95
AMX Mouse + Art Software	49.95
AMX Mouse + Stop Press	54.95
464 Dust Cover (mono/col)	7.95
6128 Dust Cover (mono/col)	7.95
KDS 5 1/4" 800K disc drive (state 464/6128)	159.95
KDS 8 Bit Print Port	18.95
DKTK Memory Expansion	45.95

RIBBONS

Printer	1	2	5
DMP 2000/2160	3.50	6.00	14.00
Panasonic 1080/1081	3.95	7.00	16.00
Citizen 120D	3.95	7.00	15.00
Star LC10 (Black)	3.95	7.00	15.00
Micro-P165/200	4.95	8.00	18.00
Star LC10 Colour	5.95	11.00	—
CF2 Disc (Amsoft/Maxell)		10	
PLEASE CALL FOR AVAILABILITY		for	£25.95

BOOKS/MANUALS

Adv Amstrad Graphics	7.95
Mastering Machine Code	8.95
Programming the Z80	19.95

ROM BASED

Protect	27.95
Prospell	22.95
Promerge +	23.95
Maxam	27.95
Maxam 1.5	20.95
Utopia	20.95
BCPL	21.95
Rodos	28.95
Cage Rom (state which I/Face)	31.95
Rombo (if purchased with Rom)	28.95
KDS Rom Board (Holds 6)	24.95

Quali Pack

The Print Enhancement Package
Qualitas Plus, KDS 8 Bit Port
Display Font Pack
R.R.P £44.45
Package Price £34.95

Quali Pack Extra

Plus Clarion, Pica, Newsroom, Font Packs,
R.R.P £54.95
Package Price £44.50

PRINT COLOUR GRAPHICS

At last it is possible to get colour screen dumps from a 6128!

COLOUR DUMP 2 is available exclusively from M.J.C Supplies and will take a standard screen file from **Advanced Art Studio** or created with **AMX Art**, and print it out in full colour on a **Star LC10** colour printer. You choose which colours on paper, represent which inks on screen for total control and variation.

COLOUR DUMP 2 - £12.95

ADVANCED ART STUDIO - £19.95

All Star LC10 colour orders before 31st August just £214.95!

PRINTERS

All printers listed have a ten inch (A4) carriage, are Epson compatible, and feature friction and tractor feed mechanisms for continuous or single sheet paper. All prices include the necessary cable

CITIZEN 120-D

Cheap Epson FX-80 compatible giving a range of text sizes and effects in draft mode. Limited sizes and effects in NLQ
£139.95

PANASONIC KXP - 1081

Offers all the draft mode text sizes of the D.M.P. 2160, but is better built, more reliable, and offers N.L.Q. in all sizes and effects, for only £10.00 extra! Highly recommended.
£159.95

STAR LC-10

As well built and reliable as the Panasonic. Has four N.L.Q. fonts (typefaces), in combination with all sizes and effects. New low prices makes it well worth considering
£174.95

STAR LC-10 COLOUR

All the features of the LC-10, but with a seven colour option for colourful text. If you want colour graphics please call first for advice.
£214.95

STAR LC 24-10

24 pin version of the LC-10. Has 5 excellent letter quality fonts available with all sizes and effects. Two extra effect, outline and shadow are also featured. Good value.
£339.95

Overseas Orders Welcome - Please write for details

WE ARE NOW IN OUR FIFTH YEAR OF SPECIALISING IN AMSTRAD MAIL ORDER, OUR POLICY IS TO PROVIDE THE WIDEST RANGE AT DISCOUNT PRICES WITH A FAST TURN AROUND TIME - TRY OUR SERVICES WITH CONFIDENCE

CALLERS WELCOME: Mon-Fri 9 to 5 Sat 10 to 4

PLEASE SEND CHEQUES/POs TO:

M.J.C SUPPLIES, (AA)

40a Queen Street, Hitchin, Herts. SG4 9TS.

Tel: (0462) 32897/420847 or 421415 for enquiries/Credit Card orders

VISA

Access

Proprietor M J Cooper

PLEASE CUT ALONG DOTTED LINE

AA Questionnaire 1989

We often receive letters suggesting ideas for new series, features or refinements to existing sections of the magazine. Recently, for example, Phil Howard's hacking series and the new one on fanzines beginning this month originated in suggestions from readers. So you see, we do take notice of what you think!

Now is your big chance to make your voice heard. This is, we believe, the most in-depth and detailed survey of the interests of our readers we've ever carried out. We are very keen indeed to know what type of person you are, what you own, what your buying habits are, what you like - and dislike - about AA, and what exactly we can do to improve it. We've

also left plenty of room for your own comments. So please take the time to fill in this questionnaire. The direction the magazine takes in the next year depends on you!

You don't have to fill in your name and address, but if you do you'll be entered for a free draw, with prizes of two £50 packs of mystery software! Fill in the questionnaire now and post it off to: AA Questionnaire, 4 Queen St, Bath BA1 1EJ. We shall make the free software draw on the 1st of October, but you're welcome to submit your answers any time.

**£100
TO BE
WON**



1. Name _____
Address _____

2. Sex
 Female
 Male

3. Age
 Under 14
 15-20
 21-30
 31-50
 51 or over

4. Occupation _____

5. Are you a games player, a "serious" user (word processing, accounts, programming) or both?
 Just a games player
 Just a serious user
 I'm both a games and serious user

6. How long have you owned your CPC?
 Less than six months
 More than six months, less than a year
 1 year - 2 years
 2 years - 3 years
 More than 3 years

7. Which of the following do you own (tick left column); or intend to buy in the next year (tick right column)?

	I own	I intend to buy
CPC464	<input type="checkbox"/>	<input type="checkbox"/>
CPC664	<input type="checkbox"/>	<input type="checkbox"/>
CPC6128	<input type="checkbox"/>	<input type="checkbox"/>
Colour monitor	<input type="checkbox"/>	<input type="checkbox"/>
Green screen	<input type="checkbox"/>	<input type="checkbox"/>
TV modulator	<input type="checkbox"/>	<input type="checkbox"/>
Printer	<input type="checkbox"/>	<input type="checkbox"/>
464 disk drive	<input type="checkbox"/>	<input type="checkbox"/>
2nd disk drive	<input type="checkbox"/>	<input type="checkbox"/>
Modem	<input type="checkbox"/>	<input type="checkbox"/>
Memory upgrade	<input type="checkbox"/>	<input type="checkbox"/>
Multiface	<input type="checkbox"/>	<input type="checkbox"/>
External speakers	<input type="checkbox"/>	<input type="checkbox"/>

8. What type of printer do you own or intend to buy?
Make: (eg. Star, Amstrad, Epson, Brother) _____
Model: _____

9. Which word processor do you use?
 Protect
 Tasword
 Brunword
 Other (please specify) _____

10. Approximately how many hours a week do you spend using your CPC?

Less than 2 hours 2-5 hours
 5-10 hours 10-15 hours
 20-30 hours Over 30 hours

11. In the last three months how much have you spent on:
Hardware? _____
Games software? _____
Serious software? _____

12. What proportion of this expenditure has been through mail order?
 All 75-99% 50-75%
 25%-50% 1%-25% None

13. In the last two months which three pieces of software have been in most common use on your CPC? (in descending order)
1) _____
2) _____
3) _____

14. How many times have you bought *Amstrad Action* in the past year?
 Every month
 About every other month
 Occasionally
 I subscribe
 None - I borrowed/stole this one/read it in the newsagent

PLEASE CUT ALONG DOTTED LINE

15. What issue of *Amstrad Action* was the first you bought or read? (Just an approximate month, eg January 1987)

16. How do you rate *Amstrad Action* (out of ten)?

Out of ten I rate it at _____

17. Do you think the magazine is improving, getting worse or is about the same?

18. What other computer magazines have you bought in the past three months? If any, name and rate out of ten:

- _____
- _____
- _____
- _____

19. What newspaper do you read most often?

- Mail
- Express
- Mirror
- Sun
- Today
- Star
- Sport
- Times
- Telegraph
- Independent
- Guardian
- None of these

20. And what's your favourite non-computer magazine?

21. Do you ever have trouble finding a copy of *Amstrad Action*?

- No: I subscribe
- No: I ask my newsagent to reserve me a copy every month
- Yes: it's sometimes there, sometimes not
- No: there's always a copy

Comment:

22. In order, what are the three main reasons you buy *Amstrad Action*? (So if you buy the mag for *Line Up*, the *Buyers Guide* and *Action Test* in that order, put 1,2,3 against those sections.) And put a cross against the section of the magazine you would most like to see dropped.

- What's on the cover
- News
- Reaction (letters)
- Hardware reviews
- Serious reviews
- Tutorial features (how to hack, how to write a fanzine with your CPC, hardware projects and so on)
- Forum
- Games reviews
- Type Ins
- Cheat Mode
- The Look
- Pilgrim
- Adverts (eg. to hunt for bargains)
- Small ads
- Helpline
- Mail order pages (at the back)
- The tone and spirit of *Amstrad Action*

23. Do we

- concentrate too much on games?
- concentrate too much on "serious" uses?
- have the balance about right?

24. Do you find the cover cassettes we do a special attraction?

- Yes
 - Not especially
 - Hate 'em (please explain why) _____
- _____

25. Have you bought anything from the AA Mail Order pages in the past three months?

- Yes
- No

26. If you answered no, please say why not (tick as many boxes as you like):

- Nothing there that suited me
- Forms were confusing

- Prices didn't attract me enough
 - Other reasons (please explain)
- _____
- _____

27. What items would you like to see sold in the back pages?

- Games and lots of 'em
 - Serious software
 - Big hardware items (disk drives, printers and so on)
 - Other (please state) _____
- _____
- _____

28. Would you be prepared to pay, say, 50p extra every month if there was a cover cassette?

- Yes
- Not really
- If it meant paying 50p more, I would definitely not want a cover cassette

29. If there are features you would like to see in the magazine, please tell us about them. You can be as specific or general as you wish - so if you'd like more hacking say so, and if you'd like to see a particular hardware project tell us what it is: _____

30. Finally are there any other comments you'd like to make which aren't catered for in this questionnaire?

● Thank you for filling in this questionnaire. It will be read carefully and the results noted. Look out for an analysis in a couple of months. Meanwhile, good luck with the software draw!

PASSING SHOT™

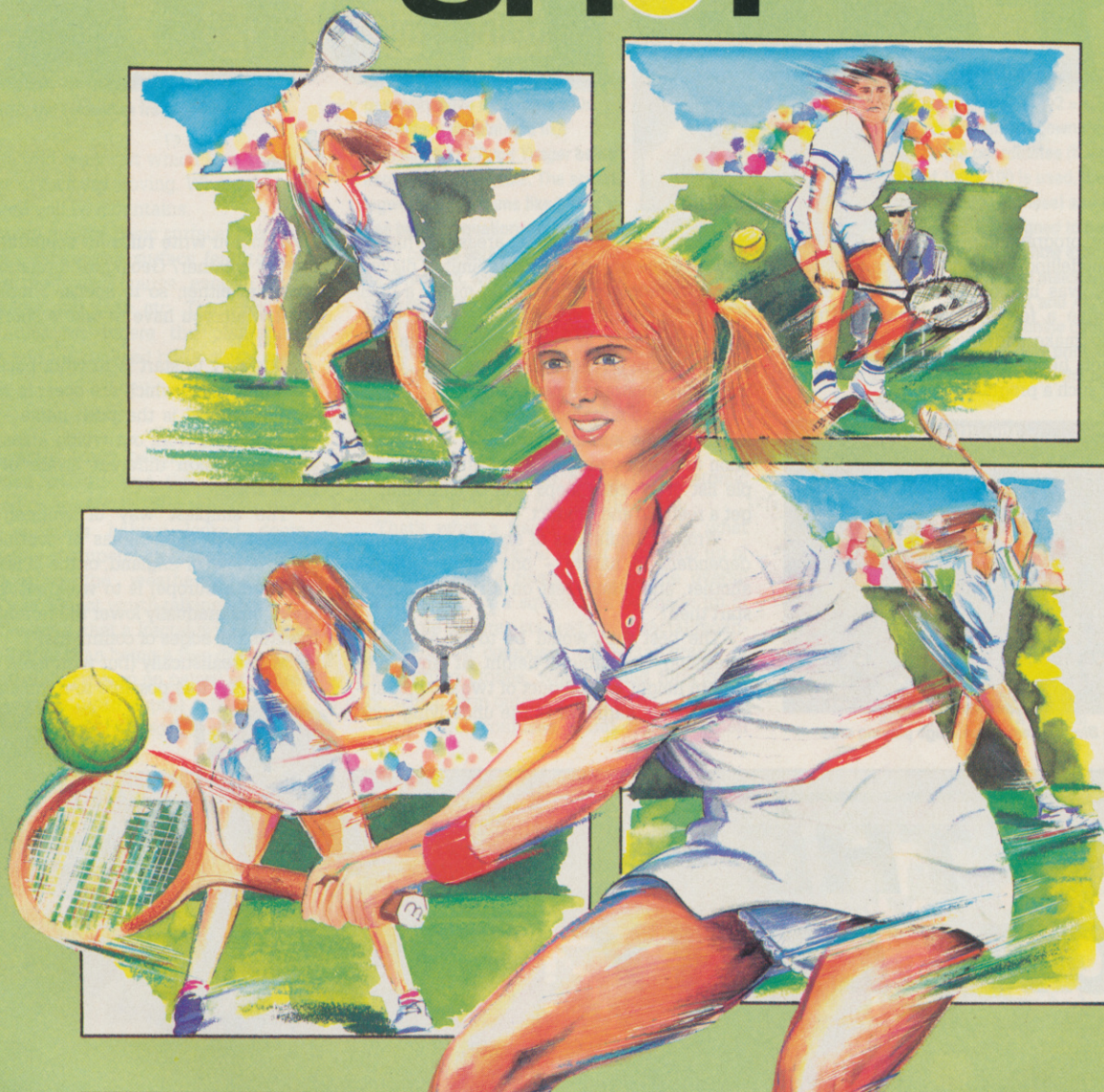

Anyone for tennis?

Not 'alf! Image Works serves up another ace with this conversion of the Sega® coin-op smash.

Featuring tennis-ational singles or doubles action on clay and grass courts from around the world, Passing Shot™ is the most accurate simulation of the noble sport to appear since the real thing!

Game, Set and Match to Image Works!

"It's rally volley good!"
Doris Decker

"I can't fault it!"
Ivor Lentil

Image Works, Irwin House, 118 Southwark Street, London SE1 0SW.
Tel: 01-928 1454.

PASSING SHOT™ HAS BEEN MANUFACTURED UNDER LICENSE FROM SEGA® ENTERPRISES LTD., JAPAN, AND "PASSING SHOT™" AND SEGA® ARE TRADEMARKS OF SEGA® ENTERPRISES LTD.
©1988 SEGA ENTERPRISES LTD. MANUFACTURED BY MIRRORSOFT LTD.

Available soon on:

Amiga
Atari ST
Commodore 64 (cassette)
Commodore 64 (disc)
Amstrad CPC (cassette)
Amstrad CPC (disc)
Spectrum (cassette)
Spectrum (disc)
MSX (cassette)

Screenshots from Atari ST version

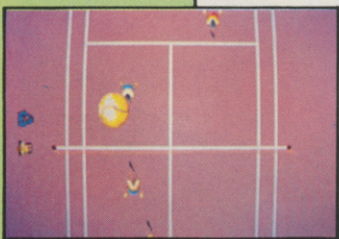
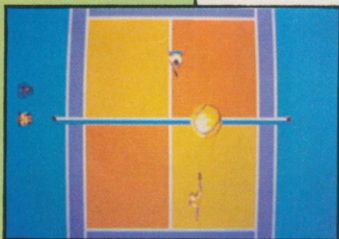

SEGA®



THE LOOK

Chaos programming? PAT McDONALD's an expert!

Chaos programming continued! The idea of modelling a planet's surface using the CPC was introduced last month, and I hope to give a few ideas to those intrepid enough to make the programming attempt. First though, here's a few thoughts on the usefulness of such a program.



● Captain Blood: great game, huge playing area

Computer games rely on areas in which to play. Imagine having almost unlimited playing space! A program which could model a planet's surface could spawn some really deep, intriguing efforts, as opposed to the innumerable vertical-scrolling-shoot-'em-ups which infest the Amstrad games scene.

A common misconception along these lines is that all the surface features of such a creation are merely random in nature, and a simple list of IF-THEN loops will be sufficient to get a realistic end product.

Wrong! Simulations of any kind are interdependent in nature - one factor rests on another, and others rest on it. Where do you start then?

The best way would be to fix a rule for determining the ground height at any level. Terrain height is a product of two factors, erosion and the hardness of the underlying rock.

How do you write rules for something as random as weather? Geological formations are no pushover either, so to speak. There comes a point when you have to take a short cut, and this is it.

One way to start is to work backwards. If you input areas which are oceanic sea beds - "abyssal plains" is the posh name - then the computer can work out which areas are land, and can assign different strata of rock for those areas.

The simplest way of working out the mountainous spine areas of continents (like the Pennines of England, or the Massif Central of Western Europe) is to work out the central areas, and gradually lower the terrain contours towards the edges of continents.

More realistically (but with more complexity) it is possible to fragment the surface

THE GALLERY



● Fancy yourself as an artist? Then get cracking! Let us have your very best work at the AA office, and you could earn yourself £20! Send entries - together with a short note telling us which art package you used, and an SAE if you want the pictures back - on disk or tape to:

Pat McDonald's *The Look*
Amstrad Action
Future Publishing
4 Queen St
Bath BA1 1EJ



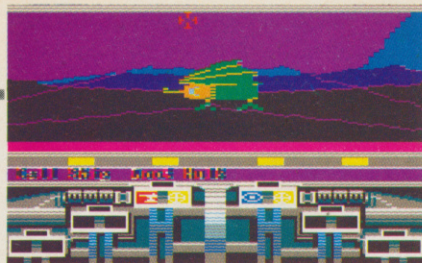

● Koronis' *Rift*: the Lucasfilm fractal hit

of the world, and work out which way the different plates of rock are moving. Where there is an edge, there will be mountains.

Once you've got the basic surface, then you can work out where the surface features go: rivers follow the lowest course, enough water will form lakes and seas etc. Then you can write the rules for where the plants and wildlife are, and the civilised bits – cities, roads and so on.

Confusion

But what exactly, you're asking, is the difference between fractals and the above bits? What, indeed, is a fractal? Why are they mentioned in whispers behind locked doors, between people of stupendously high intellect? Possibly because the weather's been so remarkable that it's not worth talking about...

The low down is that a fractal is a fractional dimension. Rather than being a two dimensional shape (something drawn on paper) or a three dimensional shape (with depth) a fractal is in between: although it has edges and can be

Sims unlimited

Computer models of the real world generally have little to do with graphics – simulations like *Gunship* and *Chuck Yeager* being exceptions to the rule. The actual legwork of programs like this is to use built-in equations to alter the flight path of aeroplanes, allowing for thrust, lift, wind and drag. What you see on the screen is the result of all these varying influences.

Enough theory, how do you get fractals on your CPC monitor? The idea behind the Mandelbrot set is that a grid is set up, with x and



● *Chuck Yeager* – not quite what you'd expect

y coordinates. The base equation is $x^2 + y^2 = 4$. The set is scanned down through all the coordinates (if a grid of 100 X 100 is used, there'll be 10,000 of these) and a colour is assigned to them, depending on how exactly the equation is matched.

In AA's XX and XX, a Basic and machine code

Mandelbrot generator program were printed. The former took about five hours to work, the latter was faster at 40 minutes.

infinitely magnified (no atoms or subatomic particles in infinity) it has no true depth.

That's what a fractal looks like, but what makes a fractal a fractal is that it is made up of parts that bear a relationship to the overall shape. So just as a square can be made up of lots of little squares stacked up, a fractal mountain would be composed of fractal grains of sand forming stones, which would form boulders, which form outcrops, and so on.

People get confused about fractals when

they see computer generated graphics of real life objects and think, "hmm, must be a pretty big program to do all that." In the case of fractals, what the computer produces generally has little to do with "reality," and the vast majority of fractals are incredibly complex abstract patterns. ●

● Next month in *The Look* we look at some fractal graphics programs – plus, at last and about time too, AA sprites!

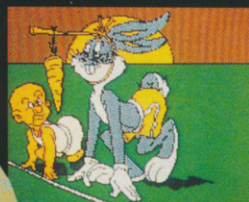

13

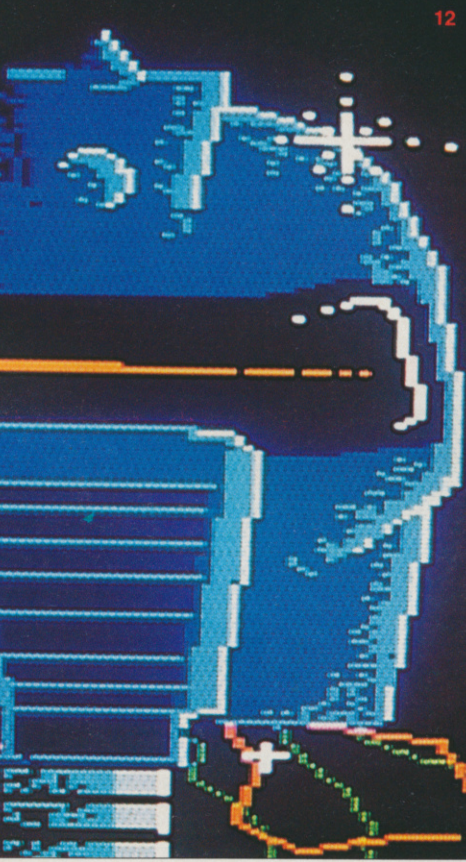

12

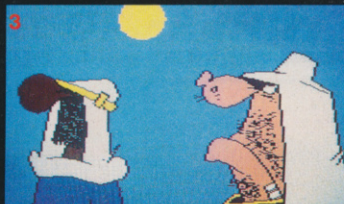

1. Thank JONATHAN DAVENPORT of Ipswich for this inscrutable robotic portrait (*Smart 2*) 2,3. Who's the *Smart 2* Beau fan? MARK SAORBUTTS from Leigh, that's who! 4. More zany SAORBUTTS' (are all Leigh people so strange?) 5. PATRICK BELL, an Australian and another *Smart 2* reader 6. JEAN PAUL MICHEL from Terway can sure churn them out with *Graph X!* 7. Remember M S BROWNING of Blackpool? After Queenie comes Fergie! (*CRL Image System*) 8. Not

again! Another Garfield, this time (with the *Image System*) by BROWNING 9. *Spiderman* – step forward JEAN PAUL MICHEL 10. Sale pokester MIKE WONG uses *Amsoft Screen Designer* 11. JEAN PAUL again! 12. The Gunman, by MICHAEL J BLYTH of Ross-On-Wye (*Smart 2*) 13. And a final effort from JEAN PAUL, trying to give Bugs some incentive 14. Another BROWNING bash, Not Much Cop – no, that's the name of the picture!

DATEL ELECTRONICS

MIDI COMPATIBLE



music machine

THE RAM MUSIC MACHINE IS PROBABLY THE MOST EXCITING MUSIC ADD-ON AVAILABLE FOR ANY COMPUTER.

FREE MICROPHONE AND HEADPHONES!



- ▼ It's a full sound sampling system allowing any sound to be recorded digitally into computer RAM. Once stored the sound can be replayed at different pitches with many varying effects.
- ▼ It's an echo chamber & digital delay line. Create very interesting effects.
- ▼ Various sampled sounds are provided to get you going.
- ▼ The Music Machine can be used as a drum machine - eight drum sounds are provided, but you can easily produce more of your own.
- ▼ The powerful software allows you to compose tunes from individual bars of music. You can edit on screen & Save/Load sounds, instruments & rhythms.
- ▼ It's a two voice music/sound synth.

- ▼ Fully MIDI compatible. The Ram Music Machine supports full MIDI In, MIDI Out & MIDI Thru.
- ▼ Output through your Hi-Fi or Headphones. Comes complete with Microphone.
- ▼ Use a full size MIDI keyboard to play the Music Machine.
- ▼ Sounds produced by the Music Machine can be mixed with a MIDI Synthesiser's own sounds.
- ▼ On screen Sound Editor can produce MIDI data from your own compositions.
- ▼ No other product can offer so much in one unit - it's the total solution!!

ONLY £49.99 (Cassette)
ADD £5 IF DISK REQUIRED



LIGHTPEN/GRAPHICS SYSTEM

- ▼ Complete Lightpen and graphics system lets you create a whole range of effects on screen.
- ▼ It can magnify, shrink, colour fill and create circles, rectangles, lines and curves.
- ▼ Pictures can be edited at pixel level using a scratch pad which is magnified to full screen.
- ▼ Picture storage and retrieval, and a pen calibration feature.
- ▼ Printer dump utilities for Epson/Amstrad printers supplied (on cassette).

ONLY £14.99 CASSETTE

OR £24.99 WITH SOFTWARE ON ROM - NOTHING TO LOAD

464 or 6128 (Please state which)

MEMORY EXPANSION

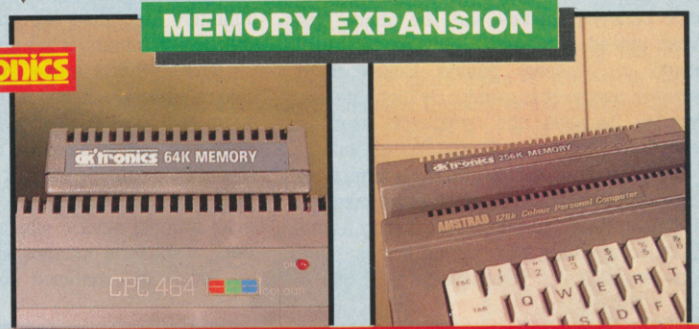

64K AND 256K MEMORY EXPANSION

- ▼ Simple plug in memory expansion gives instant extra memory.
- ▼ Features bank switching software for easy use by the programmer or for use as a data storage area.
- ▼ Ideal for use with the CPM 2.2 etc.
- ▼ The software also features some extra BASIC commands.
- ▼ 64K unit brings 464 up to CPC 6128 memory configuration making a much larger software base available. Will work straight off with many programs designed

- ▼ for this unit (including OCP Art Studio - see Ad.).
- ▼ 64K unit expands 464 to 128K. The 256K unit takes your 6128 to a massive 320K!!
- ▼ All bank switching done automatically by supplied software (cassette 464 - disk 6128).

ONLY £49.99

64K for 464

ONLY £99.99

256K for 464 or 6128 (Please State)



REALTIME CLOCK

- ▼ A simple but highly useful device.
- ▼ Easy to use realtime clock - battery backed to give the correct time and date always.
- ▼ Also features extra 8bit I/O port for external control applications - very useful.
- ▼ Comes complete with full instructions and set-up software.

ONLY £19.99

464 or 6128 (Please state which)



SILICON DISK 464/6128

- ▼ This is the fastest storage system available for the Amstrad CPC computers and is compatible with CPM 2.2, CPM+ and all DK Tronics peripherals.
- ▼ The 2516K Silicon Disk is designed to be used in conjunction with at least one normal Disk Drive attached to the system.
- ▼ When the 2516K Silicon Disk is fitted only 2K is used for the Silicon Disk directory, leaving 254K for storage - that's 70K more than a normal Disk Drive.

- ▼ Data and programs can be exchanged between Silicon Disk and normal Disk, application programs can then work on their data at vastly increased speeds.
- ▼ Software is on ROM (nothing to load) and can be used in two modes - Basic under AMDOS with normal LOAD, SAVE CAT MERGE commands etc. and within CPM 2.2 CPM+ where commercial programs are designed to run on multi-drive systems.

ONLY £129.99

464 or 6128 (Please state which)

SPEECH SYNTHESISER & STEREO SOUND BOOSTER

- ▼ This easy to use Speech Synthesiser includes a powerful Stereo Amplifier and two Pod Speakers which is a great improvement on the sound of the internal mono speaker.
- ▼ Using the SPO/256 Speech Chip the unit has an almost infinite vocabulary.
- ▼ Text to speech software is provided in ROM to make speech output simplicity itself.
- ▼ Voicing is transparent to the user and the computer can carry on with other program tasks.
- ▼ Speech output is mono directed to both speakers. Booster gives stereo to internal sound output.

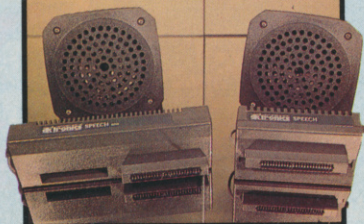

ONLY £29.99

464 or 6128 (Please state which)

DATTEL ELECTRONICS

THE ULTIMATE GRAPHICS PACKAGE...

SPECIAL OFFER PACK!

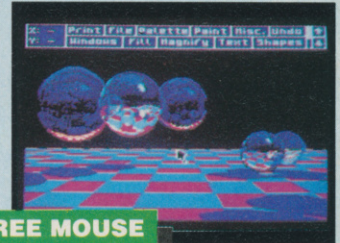

INCLUDES FREE MOUSE MAT/HOLDER WORTH £12.99

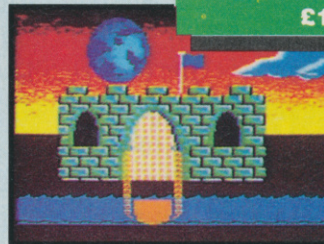

Genius Mouse

COMPLETE WITH

**OCPC
ART STUDIO™**

- ▼ Genius Mouse is a high resolution two button mouse featuring optical counting, teflon guides, microswitches, rubber coated ball and high quality interface.
- ▼ When combined with OCP Art Studio this graphics package is quite simply the best system available. The features are unmatched...
 - ▼ Create an image - shrink it, expand it, move it, rotate it, copy it, colour it etc., etc.
 - ▼ Spray patterns or shades, make elastic lines - stretch and manipulate shapes.
 - ▼ Zoom in to add detail in fine mode.
 - ▼ Pulldown/icon driven menus for ease of use.
 - ▼ Mouse operation, plus joystick and keyboard control.
 - ▼ 16 pens, 8 sprays, 16 brushes - so flexible anyone can create superb graphics easily.
 - ▼ Full cut and paste facilities plus excellent printer support.
- ▼ Pixel edit, font editor, flip, invert, rotate, solid or textured fill and professional manual make Art Studio simply the best graphics package for the Amstrad CPC.

**TAPE OR DISK FOR 464 OR 6128 (PLEASE STATE WHICH REQUIRED)
N.B. 464 NEEDS DK' 64K RAM PACK**

**ONLY £49.99
TOTAL PACKAGE INCLUDING GENIUS MOUSE/INTERFACE MOUSE MAT/HOLDER AND OCP ART STUDIO**

NEW SLIMLINE DRIVE



800K 3.5" DISK DRIVE

- ▼ Now you can add a superb top quality 3.5" drive to your CPC Amstrad.
- ▼ 800K of data storage on disks that cost less than £1.00.
- ▼ No need to flip disks.
- ▼ 3.5" disks are fast becoming industry standard.
- ▼ Comes complete with power supply and cables.
- ▼ We supply our drive with the RODOS operating system, giving not only this vast disk capacity but also over 50 new bar commands plus a printer buffer, etc.
- ▼ Easily fitted - full instructions.

464 owners must already have at least one Amstrad drive.

Only £119.99 for Drive and RODOS including PSU/Cables

- ▼ Turn your Amstrad Monitor into a full feature TV set with our TV Tuner System.
- ▼ Latest chip technology gives crystal clear reception on all channels.
- ▼ Built-in speaker.
- ▼ On/Off volume controls.
- ▼ Brightness and colour controls.
- ▼ Channel selector.
- ▼ Attractively styled to match your computer.
- ▼ Why not realise the full potential of your monitor?

ONLY £69.99

TV TUNER SYSTEM

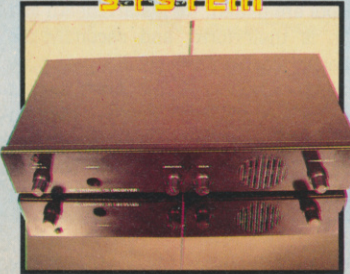

PCW 8256/8512



PCW 8256/8512 COMMUNICATOR

- ▼ Complete RS232 and Centronics/Parallel interface for the PCW Amstrad.
- ▼ Simply plugs into rear expansion slot.
- ▼ Attractively styled in computer colours.
- ▼ Full instructions supplied.

Only £49.99 complete

ALL ORDERS NORMALLY DESPATCHED WITHIN 48 HRS

HOW TO ORDER ...

<p>BY PHONE</p> <p>0782 744707 24hr Credit Card Line</p>	<p>BY POST</p> <p>Send cheques/POs made payable to "Datel Electronics"</p>	<p>FAX</p> <p>0782 744292</p> <p>UK ORDERS POST FREE EUROPE ADD £1 OVERSEAS ADD £3</p>
--	---	--

PRICES AND SPECIFICATIONS CORRECT AT TIME OF PRESS AND SUBJECT TO CHANGE WITHOUT NOTICE

CALLERS WELCOME - Please reserve goods by telephone prior to visit.



DATEL ELECTRONICS LTD., FENTON INDUSTRIAL ESTATE GOVAN ROAD, FENTON, STOKE-ON-TRENT, ENGLAND.

**SALES ONLY
0782 744707**

**TECHNICAL ONLY
0782 744324**

ACTION TEST

The latest games get the **TRENTON WEBB** treatment...

Two Raves for your delectation this month: the excellent, if none too original, *Gemini Wing*; and the hilarious *Rick Dangerous*, which the redoubtable Ms Broadley demanded to be allowed to review. And what she wants she invariably gets – turn to page 47 to see her first effort in the games department (should she get another chance?).

The real event of the month, however, is *Purple Saturn Day*, without a doubt the hottest game we've seen in a long time – those French programmers certainly know their onions!

MASTERGAME

Purple Saturn Day 42

RAVES	
Gemini Wing	40
Rick Dangerous	47

Also reviewed this month

Bob's Full House	53
Dominator	48
Eliminator	50
Red Heat	46
Story So Far, The (Vol II)	48

GEMINI WING

Virgin Games ● £9.99 cass, £14.99 disk joystick/keys



"Eat white hot laser death, alien slime sucker," pilots were heard to mutter as the briefing concluded. The Gemini Wing pilots were incensed, and you can see why, because just about the whole of creation had declared war on Earth – and all because of a joke! To make matters worse, it would definitely ruin their chances for a quiet weekend as well.

Admitted, it wasn't the best joke you've ever heard. One Tuesday the news had been slow, so some creative journalism at the *Sunday Spirit* had been called for. They hit upon the headline "Die Alien Mutant Scum!" Though it was only a prank, and little worse than a lot of what scumbag tabloid so-called "journalists" do all day every day, for some inexplicable reason it irritated those green scaly items so much they promptly declared their intention to wipe the smile off our faces, and

our faces off the Cosmos. Being a peace loving race, we humans relished the chance to try out some new hardware on a full sized set of space invaders.

The *Gemini Wing* project has just been completed, a fearsome new battle craft that can turn the war in our favour and have us home in time for tea. The Aliens, it appears, were too busy landing B-52 bombers on the moon and doing strange things with Hitler clones to notice its development. Now their fleets marshal above our heads and our new wings are all a flutter, because the bug eyes have one big surprise waiting for them, Earthside.

The *Gemini Wing* is a revolution in the science of blowing other living beings into small smouldering pieces. It fires and moves the same way as any ordinary ship, but if you pull back on the joystick as you fire, a superweapon is unleashed. "So what?" the populace cried,

"we've played *R-type!*" But with the Gemini series the weapons include such darlings as the Windscreen wiper of death.

So it's down into the trenches and to war. The nasty bug eyed aliens swoop down across the surface of the planet spreading doom and death. Living pill box maggots dig in quickly, and flies the size of small trucks patrol the airways. The Gemini pilots are miffed: for a start, death and destruction is their forte, and secondly the aliens seriously clash with the wallpaper.

The corps battle cry – "Die alien mutant scum!" – echoes through your radios as you charge down on your foes. The first few are easily dispatched in

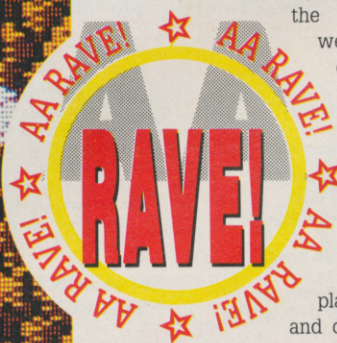
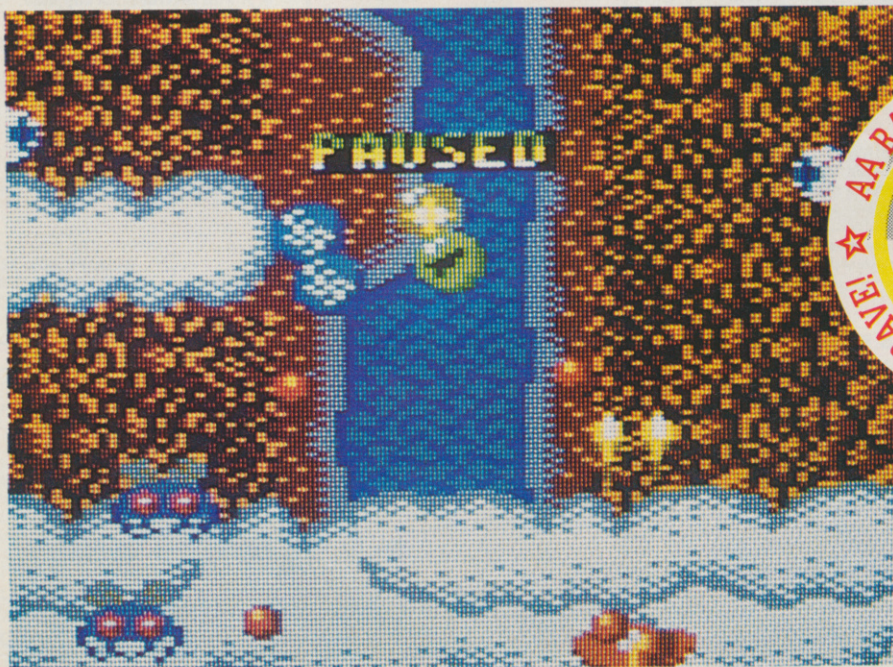

● Fly over those gun-balls to get added firepower

standard fire mode and drop to the floor in the shape of gunballs. Curious, as any vengeance crazed fighter pilot would be, you fly over their remains and find they stick to your tail. Pull that trigger and yank your joystick back to find out what effect this has. The colour and design of the corpses (or gunballs as they've now become) determine the effect. Normal blue gunballs give you three way shots, some circling defenders, others a curtain of fire that cleanses all in its path. The best by far, though, is the aforementioned 'Wiper of death. Waving in front of you it forms a chain of fireballs that roasts everything you touch. Righteous action indeed for the Gemini pilots of xenophobe battalion.

Your opponents come thick (they must be



● The Windscreen wiper of death!

dense to try it on with a Gemini Fighter!) and fast. Some of the off-world creatures buzz down and are easily swatted with a quick squeeze of the trigger, but many need a specific sort of shot to fry their evil invading insides. So it's time to look to your ever growing tail, which waves majestically behind you, and use a 'ball. You've no choice as to which you release but firing off two or three at once does the trick. Used at the right moment, your tail can turn a humble trench into cemetery central. Just love this job or what?

As you progress toward the end of level one you meet more and more Things From Another World, such as the flying beast which spawns small scorpions. *Shoot these boys instantly!* Leave them more than a couple of secs and the scorps are homing in on your port side: and when they bite, they kill!

The craft is easily controlled but it's the co-



● Blue gunballs with anchors give you triple shots



● A well timed fire curtain kills everything on screen - hot stuff indeed!

SECOND OPINION
"GW won't win awards for originality, but what the heck it's great fun anyway. I'm not usually the world's greatest shoot-em-up fan - I like something with a little more to it - but I must admit to having spent more time playing this one than I really needed to. I don't think you'll be disappointed." SC

GREEN SCREEN
Invisible alien scum - not recommended in green

ordination of shooting and collecting gunballs that's difficult - the dead alien mutant scum invariably fall on the other side of the screen. Similarly when you're trying to dodge shots the wagging tail distracts you temporarily from wreaking megadeath. The colours tend to mask some of the foreign fiends from your view, which results in a nasty surprise when they finally pop up.

On the plus side, though, completing a level once gets you a password to the next stage. In a similarly pleasant vein, being shot means you just lose a life and all your hard won balls. You restart from the place you got zapped, so it's possible to grab 'em back off the floor and start again.

Gemini Wing is a refreshing change from the hi-tech norm, and brings new interests and challenges to the world of CPC blasting. Following *Silkworm*, the re-launched Virgin

Games label is showing something of a real shoot'em up pedigree. So if the aliens and evil beings of this universe want a fight, they've got one. The *Gemini Wings* are fuelled up and ready to roll, 'cause it ain't so much a war out there, just a party. And we're ready to rock. **TW**

FIRST DAY TARGET SCORE

Complete level one

The Verdict

GRAPHICS **73%**
 Bright and bold...
 A tad shaky?

SONICS **53%**
 Underwhelming.

GRAB FACTOR **67%**
 Tough to start.
 And fun too.

STAYING POWER .. **84%**
 Gets difficult quickly.
 Seven layers of mayhem.

AA RATING **81%**
 Original shoot out with a humorous plot.

PURPLE SATURN DAY

Infogrames • £14.99 cass, £19.99 disk joystick/keys

"Ham tot zoglo hulu hulu," as they say on Saturn. And let us give thanks to Exxos one big heap for what he has seen fit to bestow on the meagre world of humanoid sport.

No more running up and down strips of astroturf trying to kick an inflated plastic sphere into a net for us, no sirree. Never again the rigours of hitting leather balls with lumps of willow. For today is Purple Saturn

and plain crazy from every planet in the known universe gather to challenge each other in a battle of wits, intuition and guts: a slalom pursuit through the rings of Saturn, a head to head on trionic sliders, a race to rebuild a gigantic brain and eventually capture enough stars to hurl you beyond the bounds of time itself.

● **The Ring Pursuit** is a breathtaking drag race through the rings of Saturn, asteroids and all. You must circumnavigate the planet keeping the correct side of wrecked space craft marker buoys. Points are gained for good



● Your opponents' abilities: vital info

ship spins on anti-grav axis allowing instant 180 degree turns as you both chase an energy ball. Once you've tracked it down the ball must be shot and the pieces collected.

As the game progresses more and more obstacles appear on the rink, preventing your mad, high-speed charges from side to side.

Using the ship's instruments you soon learn to combine stealth with speed, caution with insane cornering and total spins to shake off the opposition. Trionic sliders are little dodgems for grown-ups with a taste for speed, but who play for keeps.

● **The Brain Bowler** is one of the ultimate tests for cerebral fitness. Using an electroball you have to reactivate half a computer brain. 18 chips must be created from energy and current guided across them. To achieve this you must guide a charge by way of switches, condensers and resistors through a maze of circuitry. To make life more difficult you have six electrical pulses to control at once, and an eye must be kept on the other guy, because you can tamper with each other's circuitry. Curses fill the air as a whole bank of chips is de-activated in a few quick moves, or the enemy steals your condenser's power just when you really need it. You're forced to think of twelve

things at once and still plan ahead. A mind twistingly evil game even on the practice level, it makes boxing and juggling simultaneously seem easy.

● The final contest is the **Time Jump**, a feat achieved by catching shooting stars to power your space catapult. As they scream past the cabin window you guide your energy collector with crosshair sights. When the shower's over you winch up the old machine and launch into deep space. A good performance hurls you into hyperspace: the cabin inverts, the sky explodes in white light and you are left marvelling at the beauties of hyperspace (the better you play, the prettier the picture) while your score is totalled. Truly rapture of the void.

Purple Saturn Day graphics is of a standard where each section could have been released individually. The stunning appearance is not merely cosmetic, though, because there

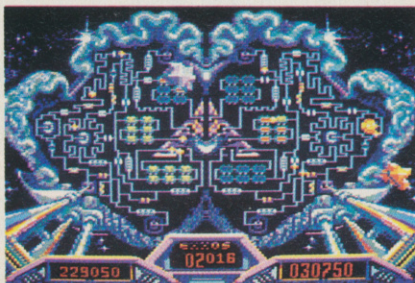

● Above: meet and greet, if you will, the Purple Saturn Princess; (inset) the brainrace, in which you have to reactivate a computer brain. Tricky indeed – especially against an opponent

Day, the one day in the calendar when the planet turns a royal purple (a sort of purple reign?), and heavy duty action is here to stay.

What we have here is a mindtwisting fingerflexing synapsesnapping stargazing time-jumping deathdefying speciestspecific rip-snorting gutwrenching nervejangling hair-raising fullblooded charge for glory in the ultimate sporting contest. All this and more has to be endured if you are to win that prize of prizes, the goal of goals (*oh all right Webb get on with it – ed*), a kiss from the Purple Saturn Princess.

Once every year, the brave, the reckless

flying and lost for bad. If you're in the lead and overshoot one of the gates you score points for the opposition!

Such a dry mechanical description, though, is an injustice. The biggest danger is not collision, but getting carried away by the speed you travel. Joysticks get a bashing, being wrenched from side to side in a desperate bid to keep on course, the ship travelling faster than a mere human could ever react. Luckily the craft are tough, surviving direct hits from debris, so it's not a matter of staying alive but staying ahead on points. But even if all is lost, wind it up and dive into the asteroids for one last blast at the ultimate reflex test. No average race, this is *WEC Le Mans* times a hundred with speeds to dazzle the eyes and obstacles to stretch the nerves.

● Round two is the **Trionic Slider** test. Here you and your competitor are alone in a rink. Your



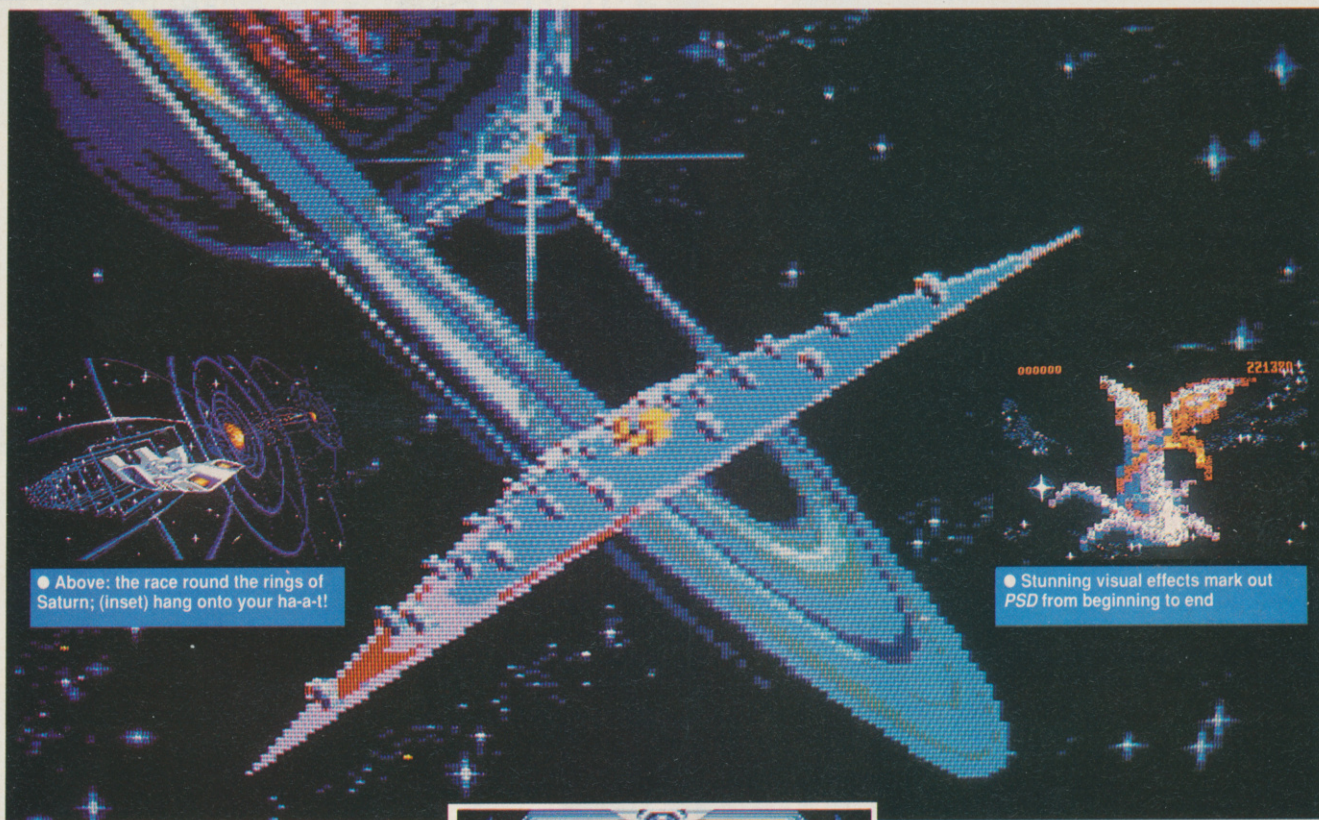

● Above: the race round the rings of Saturn; (inset) hang onto your ha-a-!

● Stunning visual effects mark out PSD from beginning to end

are highly complex games here which stress gameplay and skill. The illustrations and animation grab you instantly and serve to bind the whole concept together. Incidental work reinforces the overall effect. As you charge around Saturn in the ring pursuit, for example, the planet spins gently and quietly. It serves no purpose other than squeezing the most out of the CPC's capabilities, a refreshing mark of pride in the programmer's work.



● A whole universe of differing effects and games



● Hang on, we're going in!

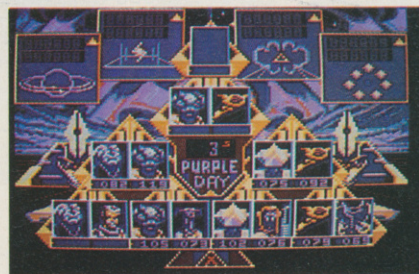

● Meet the folks - what a gruesome collection!

SECOND OPINION

"I think I've just fallen in love with the Purple Saturn Princess. And PSD must be the most sophisticated game to appear on the CPC this year. These French programmers certainly know their stuff alright.

"There's so much to this game that you'll be playing it, like us, for months to come." SC

GREEN SCREEN

Well, Green Saturn Day doesn't have quite the right ring about it, but it's still perfectly playable

Purple Saturn Day is so much more than a mere compilation of space games. The tournament is complex enough to keep everything fresh for many Purple Days to come. Each species of alien, many of whom Captain Blood fans will already have met, has strengths and weaknesses which you can swot up on before a day's competition. Do this every game because the little devils actually

evolve and develop new skills!

When, on one wonderful Purple Saturn Day you finally win, you'll see yourself in full colour in the arms of the beautiful Purple Saturn Princess receiving a great big wet smacker on the chops. The many defeats fade into the mists of time and you know it was all worthwhile. TW

FIRST DAY TARGET SCORE

Reach level two

The Verdict

GRAPHICS 99%

- Simply awesome...
- ... a truly stupendous achievement.

SONICS 78%

- Quality music and effects.

GRAB FACTOR 72%

- Four very difficult games...
- ... amusingly and informatively explained in the manual.

STAYING POWER .. 83%

- Four games and eight constantly evolving competitors!

AA RATING 94%

- A French revolution for games!

SWIFT SOFTWARE

061 477 8405

PANDORA TAPE £24.95 DISC £29.95

The program that takes the lid off your micro!

- ★ Write arcade games - in Basic!
- ★ Multi-featured sprite designer
- ★ Animated sprites
- ★ Compatible with all WPs
- ★ Free games and examples
- ★ Comprehensive manual



KEYWORD

DISC £29.95

The dynamic wordfinder for home and business use

- ★ Over 10,000 synonyms and antonyms
- ★ Nearly 1,000 main subject headings
- ★ Extra rapid word search
- ★ Can select over 70 words at a time
- ★ Simple operation
- ★ Flexible 'roam' facility
- ★ Can be used as a Thesaurus
- ★ Compatible with Protex rom

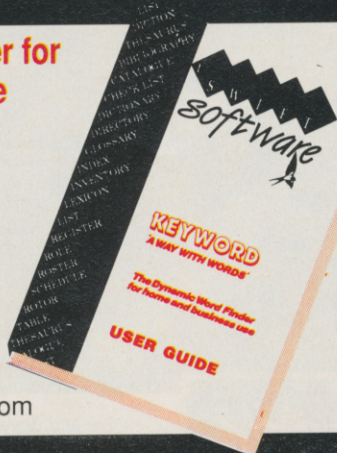

ΩMEGA

DISC £14.95

It's like having two CPCs for the price of one!



When you switch your CPC on load in Omega first and you'll find you have two program environments.

How does it do it? Simple. Omega takes over both 64K banks of ram and swaps between them.

So, for example, you can load your wordprocessor into one bank and a game into the other.

Then at the press of a key you can swap between the two.

This program has to be seen to be believed.

KEYPAD

DISC £9.95



A unique program designed specifically for physically disabled people.

With it, using just a joystick, you can write complete documents on the rom version of the Protex wordprocessor.

THE ARNOR COLLECTION

Don't forget, we've the cheapest prices on Arnor discs and roms.

If you see them cheaper elsewhere in this magazine we'll beat the price on the spot. This offer is valid until the end of the month on this issue's cover.



5 Machine-code arcade games for only £9.95!

- Arcadians Revenge
- Leaper
- Munchies
- Panic
- Zareba

Space Invaders like you've never seen them before
Guide the frogs to safety across the road and river
Fill in all the squares before the munchies get you
Fast-action version of the classic ladders and levels game
Brain damaging, joystick busting arcade-adventure

ONLY £9.95

Please send me the following (please tick)

	Tape	Disc	Rom
Protex & Rombo	—	—	£49.50 ()
Protex	—	£18.50 ()	£28.50 ()
Promerge	—	£17.50 ()	—
Promerge Plus	—	—	£23.50 ()
Prospell	—	£17.50 ()	£23.50 ()
Utopia	—	—	£21.50 ()
Maxam	—	£18.50 ()	£28.50 ()
Maxam 1.3	—	—	£21.50 ()
BCPL	—	£18.50 ()	£22.50 ()
Pandora	£24.95 ()	£29.95 ()	—
Keyword	—	£29.95 ()	—
Omega	—	£14.95 ()	—
Keypad	—	£9.95 ()	—
Swift Selection	—	£9.95 ()	—

ORDER FORM

I enclose a cheque/Euro cheque/PO made payable to:
SWIFT SOFTWARE

Name _____

Address _____

Postcode _____ Tel. _____

SWIFT SOFTWARE AA9, 347 LONDON ROAD, HAZEL GROVE, STOCKPORT, SK7 6AA. 061-477 8405

Emlyn Hughes



INTERNATIONAL



GAME

OF THE YEAR!

WINNER OF CCI OSKARS FOR
BEST SPORTS SIMULATION
AND BEST GAME OF THE YEAR!

The best football game ever
Commodore Computing

Now available for your Amstrad CPC
Tape £9.95 Disc £14.95

"Excellent graphics... highly enjoyable gameplay...
marvellous way to play football 91%" A.C.U.

"You ain't played footie on your CPC till you've mastered
Emlyn!" Amstrad Action Mastergame

Audiogenic

Audiogenic Software Limited, Winchester House,
Canning Road, Harrow HA3 7SJ, England

Order by phone on 01 861 1166



RED HEAT

Ocean ● £9.99 cass, £14.99 disk joystick/keys



Police officer Arnold Schwarzenegger has been put in charge of traffic control. But it ain't traffic warden duty, for this is drug traffic we're talking! So now Arnie has the chance to kill, mutilate and maim for fun and profit – your fun and his profit.

Following one of the weakest plots in cinema history *Red Heat* packs Arnie (the man with muscles in places I haven't even got) off on the rampage. You send him wading knee deep through bashed and blasted bodies in pursuit of Victor Rostavili, an international drug smuggler (oh very *glasnost!*). Let loose in both Mother Russia and the US of A he can get away with murder – and does so, frequently. Four levels of mindless mayhem are the result.

SECOND OPINION

"There's absolutely nothing to be said in defence of this game. It's a sick and empty plot with no redeeming features."

"It's also great fun, dammit." SC

GREEN SCREEN

"Green Heat" is just as good/bad

Drawn in shaky Spectrum outlines the chief sprite gets five whole movements on Level One: punch, duck, left, right and head-butt. None of this gameplay lark for Arnie, oh dearie me no, let's just damage people. This is all he wants to do, all he can do, and all that's required for a game so gratuitously violent it has to be fun.

In a sauna somewhere in snowy Siberia Ivan Danko (Mr S's character) is set upon by Rostavili's hordes. He has to work his way through the hothouse only stopping off to collect extra energy and the occasional wagging sub-game (game, they call that a game?).

In his path are three kinds of fist fodder: punchers, butters and ballers. Boxer types come on all showy with their fists but a Glasgow kiss soon has them "stitching that, Jimmy." Bearded head-butt freaks with rubbery necks amble towards the man mountain, only to be discouraged by one of your perfect crossing rights to the chin. Worst of all are the

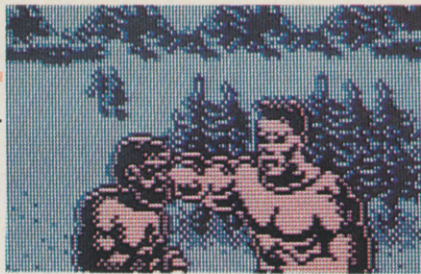

● Punch the headbutter before it's too late

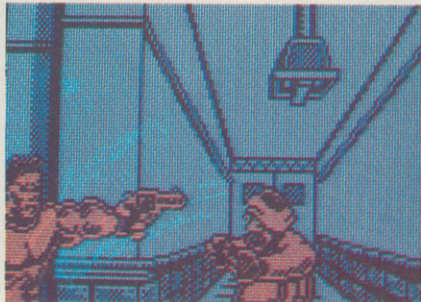

● Go ahead punk, make my day

manic snowballing hippies, who race around oblivious to everything. When they catch Arnie standing they release a snowball of epic proportions, quite knocking you back, destroying the rhythm essential for success. The only course of action is ducking Arnie out of sight until they run on past. Realistic it ain't: a fifteen stone six footer built like a brick outhouse crouches slightly and he becomes invisible? I should coco!

Lacking in everything that makes a game good *Red Heat* Level One grabs you with its brutality and sound effects. Anyone who ever thought Schwarzenegger had a brain should forget it now. Listen to the sound he makes when he butts somebody and you just know his head is hollow. The blows land with a satisfying crunch, having you in howls of sadistic laughter and his opponents in stitches.

Level Two is where everything gets seriously sick. Having left the USSR it's off to hospital, which is not entirely surprising considering the pasteing you've just taken. The poor chap must have a bruised bonce, because his

head-butt ability has been swapped for a small howitzer. Along the cinematic-style screen (who are they trying to kid?) scroll Arnold and enemies. In the background sit demented patients oblivious to the carnage and listening to Radio Lollipop. Nurses are having their brains blown out and

these people just sit there and grin!

Wm A A C Smith OBE, Cycling Proficiency with Bar, get your pen ready. To progress you must either shoot or punch patients and staff. The size of the screen means that to blast

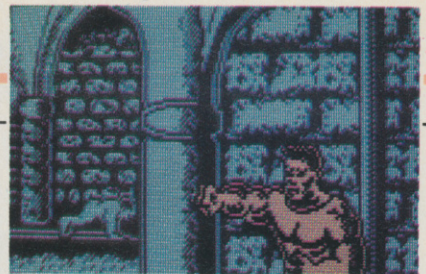

● Where'd he go? Where'd he go?

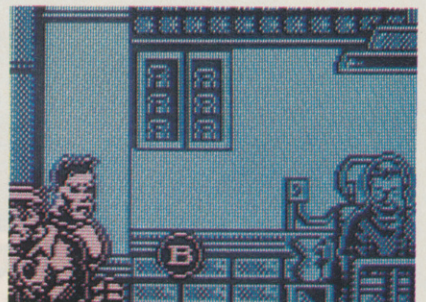

● In the hospital – watch out for the mean granny!

someone you virtually have to put the gun to their temple – good, clean, sick fun or what? Age, sex or condition count for nothing as every hospital stereotype known to man is systematically wasted: busty nurses, invisible man bandage freaks, people on crutches, and even whingeing old grannies eat lead in the head. Mrs Brady old lady – say your prayers!

Not one good thing can be said for *Red Heat's* theme or presentation. Killing people should not be fun, especially when the graphics and sound are so unimaginative. But if you've got a spare tenner and want enough nasty, vindictive fun to keep that Broadley woman in shocked silence for a month, get *Red Heat* and start reaping.

TW

FIRST DAY TARGET SCORE

Reach level two

The Verdict

GRAPHICS 58%

- Disappointing and dull.
- Three colours. Is that all?

SONICS 77%

- Good effects...
- But not enough variety.

GRAB FACTOR 64%

- Simple violent fun.

STAYING POWER 57%

- It does seem possible to complete
- Too repetitive.

AA RATING 67%

- Duff graphics, dull sound, no gameplay – and still great fun!



● From *Red Heat*, the film: Arnie gets tough



● The guy on the left throws a mean snowball

RICK DANGEROUS

Firebird ● £9.99 cass, £14.99 disk
joystick/keys

"I think you should do some work this month, Broadley," said Steve, "to justify that six figure sum we're paying you." So here I am, joystick at the ready to dive into the depths with Rick, or Rick Dangerous as our hero prefers to be known.

He stars in a platform adventure complicated by dozens of puzzles. Make a wrong move and a spear flies out of the wall, or a huge stone lands on Rick's head, or he lands on a collection of spikes in such a way as would most definitely bring tears to the eyes. Beware crumbling, bouncing floors and the lava pits!

The character Rick, a less muscular version of Indiana Jones meets Wild Bill Hickok, uses a gun, dynamite and stick to blast, shoot and poke his way out of trouble. His adventures take place in exotic locations such as South American temples and an Egyptian tomb, and involve passing through four different levels by dodging spears, natives and other nasties. The emphasis is very definitely



● A tricky one: jump from the ladder onto the platform, which sets off the spears; the baddie gets the spear right in the nappies; you jump off again; and then jump back on and crouch under the spears



● That box of ammo is guarded by the gun-toting bad guy. You've got to shoot him without shooting the ammo. Lots of platform bouncing required!

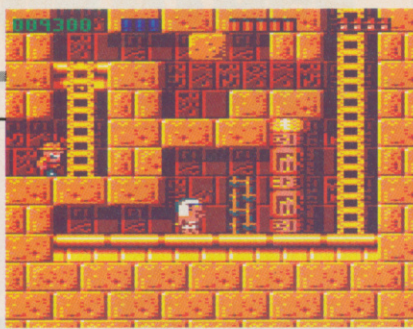

● Rick watches the enemy walk like an Egyptian

on humour, and the characters are more like cartoon figures than war heroes. The natives, far from being revolting, even die laughing!

Action commences when Rick descends into an Aztec temple hotly pursued by a rolling rock (Indie fans take note). Bounding out of the way Rick moves into the main temple area, which looks more like a mine than a temple. Be prepared to hone your joystick skills, because much bending, leaping and lunging is required to move from screen to screen and escape the guards. Each move upwards or sideways onto the next wooden ladder or walkway is prevented by natives, who have to be shot or, to save bullets, jumped over. There are also traps triggered by Rick moving past them, so beware!

Along the way Rick collects gold masks which bump up his score, though since there's no high score table it's not always worth bothering: saving bullets is more important, and the natives usually have to be killed to gain the booty.

Ammunition stores are replenished if Rick loses one of his six lives, but more bullets and dynamite sticks can also be obtained along the way. Part of the skill of the game is to remember where these are and to use ammunition frugally. Doing away with a guard adds 50 points to your score (100 if you blow him away with the dynamite - make sure you don't do Rick in at the same time!). It's much more interesting, however, to progress through the levels rather than accumulating some irrelevant high score.

The game's strongest feature is its graphics, full of very amusing little cartoon characters. The Amazonian indians, for instance, resemble squat Popeyes, who for some odd reason lose their clothes when they are killed, and fly across and down the screen wearing only nappies and blue goggles!

Even better are the Egyptians, doing a hilarious sand dance in full Pharaoh headress and leaping spectacularly when zapped. These guys really crack me up, and rank with the more gruesome monsters of *Barbarian II*.

Graphics in general are excellent, as is the use of colour, with the dark blue, damp and mysterious temple contrasting neatly with the yellow and red Egyptian tomb that actually makes you feel all hot and sandy.

Rick Dangerous requires an enquiring mind and a good degree of skill, since combining the accumulation of points with keeping Rick alive and finding out how to get through the levels means remembering how the traps are triggered and solving the puzzles to progress further. If you found *Barbarian II* funny, or enjoyed games such as

SECOND OPINION

"I'm not being ageist when I say this is a great fun game that younger players especially will enjoy, because I love it too. The only people who won't like it will be those who like gore and blood and hate humour. It's excellent!" SC

GREEN SCREEN

Just as funny, just as much fun

Bubble Bobble or Skweek you'll love *Rick Dangerous* as much as I do. As I mentioned, though, I've been stuck in the Egyptian tomb for eons trying to figure out to get past the invisible ladder and the deadly spike. If you figure out the solution let your pal Em know - it's driving me absolutely crackers!

Emma Broadley

FIRST DAY TARGET SCORE

Reach level two

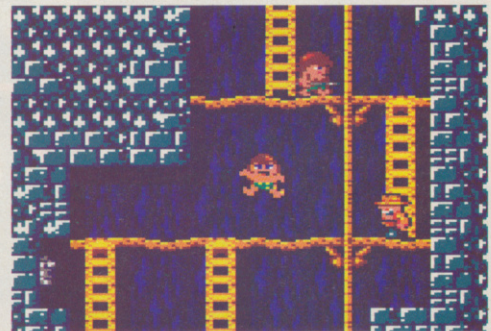

● Another nappy-clad (?) baddie bites the bullet

The Verdict

GRAPHICS 92%

- Exceptionally good sprites.
- And the funniest sprite movement of the year.

SONICS 72%

- Amusingly done footsteps and "Aargh!" type sounds.
- And that's about all.

GRAB FACTOR 83%

- Not hard to make progress.
- And you restart where you got to.

STAYING POWER ... 85%

- Four missions should keep you going for some time.

AA RATING 83%

- A great action game with tons of puzzles and oodles of humour.

DOMINATOR

System 3 ● £9.99 cass, £14.99 disk joystick/keys



Picture the scene: there's the most awesome eating machine in history just about to lunch on Earth. And you, the *Dominator*, have just flown down its throat! You're trying to find a weakness, any weakness so you can kill it and save Earth. You have five lives, four special weapons to pick up and a funny feeling today's going rapidly downhill. Can you do it? No problem!

Wave after wave of internal defence mechanisms attack, you blast away, watching out for protruding bits of intestine that may



● In the mouth of the beast: kill, kill, kill!

pierce its Achilles heel. Particularly clever and nasty bits of gut guard the entrance to deeper and more vulnerable zones.

Your ship shows its age, and is easily out-paced by the defending antibodies. All you've got to do is blow things out of the way, and a strange mixture of things they are too, never quite convincing you that they belong in the belly of an intergalactic mega muncher – but

SECOND OPINION

"So what if Dominator's a bit 'ho-hum'? I enjoy it, though I guess I'll soon tire. No awards for originality, but it will certainly keep you busy for a while." SC

GREEN SCREEN
Dark but clear

then what could?

Rudimentary sounds (shots, explosions) accompany this tricky if not exactly innovative vertical shoot 'em. You sit there and blast, move a bit and blast some more. Fine if that's what you're into, but limited if you're not a die hard trigger artist. TW

FIRST DAY TARGET SCORE

15,000 points



● No enemies to kill on this screen – but watch out for the those

The Verdict

GRAPHICS 65%

- Clear and bright.
- Nothing we haven't seen before.

SONICS 46%

- Bang and blip and that's your lot.

GRAB FACTOR 67%

- Natural arcade appeal.

STAYING POWER 54%

- Hard core blasters will stay the course.
- Normal people won't.

AA RATING 57%

- Acceptable arcade action lacking that original something to make it special.

THE STORY SO FAR, VOL 2

Elite ● £12.99 cass, £14.99 disk joystick/keys



Elite's second compilation in this series has all a player could reasonably demand: a decent price, four respectable games out of five and not

a real dog in sight.

Live and Let die is a routine chase through the florida swamps in the super powered boat of James "My Name Is" Bond. Lots of bangs and flash as you dash from bank to bank picking up fuel

SECOND OPINION

"There can be no better way to build up your games collection cheaply and fast than by investing in a couple of good compilations. You could do worse than start with this one, which is worth the asking price for *Space Harrier* alone!" SC



● The excellent *Space Harrier* gets *The Story so Far* off to a fine start

and extra ammo. It's no great shakes on the gameplay front, but an enjoyable way to spend a few hours.

Beyond the Ice Palace is a heavy duty arcade adventure with lots of levels. The smooth scrolling and pacey action is slightly impaired when you get caught in certain sectors and just have to wait to die, but still a sound way to spend the occasional wet Sunday.

Hopping Mad and *Overlander* are the weakest links in the chain: both are still creditable efforts and will keep you riveted if only for a short while. *Overlander* is the better of the two, although the controls make it more than a mite irritating to begin with.

Streets ahead of them all though is the excellent *Space Harrier*, a long time favourite in the AA office. As a conversion it manages to convey the same destructive elements of fun as the arcade without the aid of a massive hydraulic sys-

tem (or even a safety net). You take on the guise of a jet packed gun freak who wastes everything foolish enough to stray in his path: a slick and fast blast from the past.

The Story so Far is great package for those with a liking for higher speed in gaming, but who demand a little originality and thought to maintain interest. A fair price with a varied selection, well worth thinking about. TW

Beyond the Ice Palace	80%	AA39 Rave
Hopping Mad	62%	AA35
Live and Let Die	80%	AA39 Rave
Overlander	61%	AA37*
Space Harrier	90%	AA17 Rave

* Eagle-eyed AA readers may notice that we originally got this score wrong. It's OK, but certainly ain't worth the 81% we gave it at the time!

The Verdict

AA RATING 82%

- Solid collection well worth the asking price.
- Straightforward but enjoyable arcade selection.

NOW THE HIT NAMES · THE HIT GAMES
From

The HIT SQUAD



"What a game!... the presentation is superb... the best hard guy game there is... buy it now" **CRASH Smash**

STALLONE COBRA

©1986 Warner Bros. Inc. All rights reserved.



"will keep you playing for hours" "Very fast" **COMMODORE USER** "A great game... Playable and addictive... Compulsive... Faster than Out Run (!)" **CRASH**

CRAZY CARS™



"This is programming of the highest order on any machine" **AMSTRAD USER** "You'll want to play it again and again" **SINC. USER Classic** **CRASH Smash**

BATMAN™

BATMAN and all characters, logos, and related indicia are trademarks of DC Comics Inc. ©1986 DC Comics Inc. All Rights Reserved.



"All American razzamatazz - cheer leaders - giant screen and fantastic action." "Loved it... Excellent... Top baseball simulation" - **ZZAP Sizzler**

WORLD-SERIES BASEBALL



"playable from the first volley" "A few untouchable aces add to the excitement!" - **C & VG** "Fast, playable and graphically superb" **YC**

KONAMI TENNIS!

match point

AMSTRAD & COMMODORE ONLY

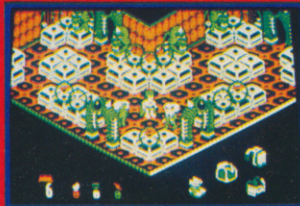

"Miss this and you're missing the finest release of the year. Wizball is simply brilliant" **ZZAP SIZZLER** **AA MASTERGAME** **SU CLASSIC 10/10** **CRASH SMASH** **CCI - GAME OF THE YEAR**

WIZBALL

HIT NAMES HIT GAMES · HIT SQUAD

SIX MORE SUPERB GAMES AT INCREDIBLE PRICES
ASK FOR THEM BY NAME AT YOUR COMPUTER SOFTWARE STOCKIST
ONLY £2.99

ELIMINATOR

Grandslam ● £9.99 cass, £14.99 disk joystick/keys

Living on the ceiling is where all hip and trendy *Eliminator*s want to be. None of this run-of-the-mill-float-along-the-floor nonsense: any game can have that. *Eliminator*s like to mix it up, a quick blast in floorland followed by rooftop mayhem. Variety after all is the spice of life – and in some cases a cause of death too.



● Hit that thing in front and you shoot over the fire

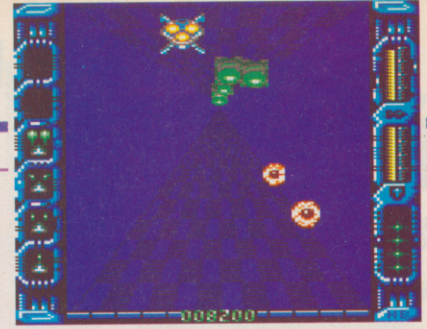

● Dancing on the ceiling (what a feeling)

a space Skoda! Even the ships' guns are slow and unpredictable.

Sure, they've a lot of variations, but the fire rate is pitiful.

As you continue into tube city, the first things you see are two beasties apparently holding hands.

The natural reaction of any gamer is understandably to blow 'em right away. Unfortunately this doesn't quite seem to do the trick and as they jerk ever closer you'll have to scramble to the centre fast to get between them.

defences as well the whole emphasis of the game switches from *Eliminator* to *Stay-out-the-way-until-later*.

Speed is sadly lacking, though, totally depriving *Eliminator* of any chance of becoming quite the hair-raising charge it promises to be. The ship doesn't so much swoop from side to side as list, and shots take too long to launch. You often find yourself sailing into obstacles simply because of a lag between control movements and sprite reaction. This has the endearing quality of making *Eliminator* a shoot'em up for the common man or woman who's not an arcade freak. Everyone can get a fair distance into the game, with the result that it does get boring in the opening stages.

Graphically and sonically *Eliminator* fares well enough, but ultimately lacks that crazy devil-may-care magic that encourages you to throw caution to the wind and go in all guns blazing. The trouble is, even dying is no fun: explosions are more squibs than climatic ends to a promising career, just six cotton wool fireballs and no earth shaking bangs. And when I go down I wanna go down in flames. **TW**

SECOND OPINION

"Playing on a colour monitor is not a great challenge, more a simple case of patience. Green screen owners will probably find it much more difficult – I know I did!"

PMcD

GREEN SCREEN
The tunnel disappears!

Hot (well, warmish) on their heels come a horde of hovering horrors with big bug eyes and little dangling legs. These guys try to kill you by spitting large blue balls in your general direction. There is a lot less bother with the hovers, however, as they disintegrate easily with just one blast.

So, ho hum, everything unfolds pretty much as you'd expect: yes, special weapons are there for collecting, as of course are refills of energy; the aliens do indeed get more devious and numerous, which inevitably results in death on the first few passes.

Then you collect another gold blend bean (seriously, that's what they look like!) and suddenly WHAMMO: you're on the roof.

Disorientation city!

Now everyone's used to bombing along at ground zero but on the ceiling is another story altogether. Perspective is so different it takes a whole game getting used to it.

Points scoring opportunities are strictly limited by the availability of weapons and energy for both your shields and

guns. Due to a low fire rate it's hard to let the enemy close in and then get trigger happy, whereas indiscriminate long range pot shots deplete reserves of laser power, rendering you armless. With easily knocked out

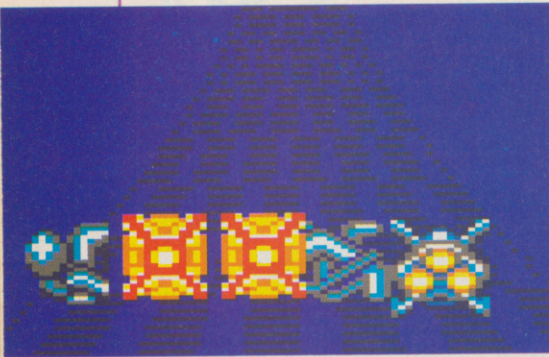

● That thing on the right is your ship: shoot those flame barriers!

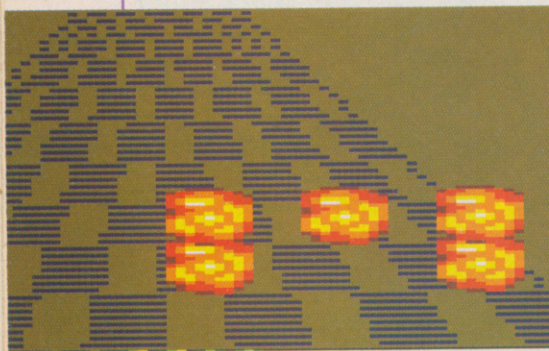

● Great walls of fire!

Charging down a chequered chute your *Eliminator* starcruiser weaves merrily from side to side, alone at the moment but safe in the knowledge that hordes of curious creatures and craft are getting ready to pile out in kill frenzy. Tail fins are wagged in a quick test of manoeuvrability and the trigger squeezed, purely for research purposes you understand.

It's at this point you begin to realise that your mission may be just a tiny bit more tricky than you were led to believe in the *Eliminator* recruiting office.

For a start off the ship, tool of any shoot'em up artist's trade, is duff. It looks like a dream, it sounds like a dream and handles like a cow. Yup, of all the hi-tec death dealing devices in the wide realms of the cosmos you had to get

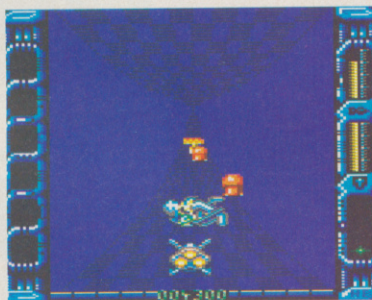

● Down the corridor of death...

FIRST DAY TARGET SCORE

Reach level two

The Verdict

GRAPHICS 65%

- View from the ceiling is great!
- Slow and jerky scrolling.

SONICS 69%

- Good title tune – nice one Nick Jones!
- Limited in-game effects.

GRAB FACTOR 58%

- Quickly picked up...
- Soon becomes repetitive.

STAYING POWER 45%

- Difficulty doesn't increase – it gets to one level of toughness and stays there.

AA RATING 57%

- Above average treatment of a below average concept.

Cheetah STAR PROBE

THE
**EMPIRE
STRIKES
BACK**



DIRECTLY
COMPATIBLE
with Sinclair
+2, +3

- Eight highly sensitive light touch **MICROSWITCHES**
- Unique ergonomically designed control handle
- Built in **AUTO FIRE** • Indestructible **METAL SHAFT**
- +2, +3 Selector Connector • Four fire buttons • 12 month warranty • Automatic Centering
- High impact robust body • Heavy duty base with strong stabilising suction cups
- Eight directional control • On table or in hand operation • Compatible with ZX Spectrum 16k, 48k, 128k (Interface sold separately), +2, +3, Commodore 64, Vic 20, C64, Plus 4 (adaptor sold separately), Amstrad, Atari, etc.

**ONLY
£14.99**

THE NEW ROYAL EDITION



- Two ultra sensitive fire buttons
- Ergonomically designed control handle • 12 month warranty
- Automatic centering • High impact robust body • Heavy duty base with strong stabilising suction cups
- Eight directional control • On table or in hand operation • Compatible with ZX Spectrum 16k, 48k, 128k, (interface sold separately) Commodore 64, Vic 20, Amstrad, Atari, etc.

**Cheetah
CHALLENGER
ONLY £4.99**

DELUXE

A Right Royal Joystick



Cheetah **MACHI** MICROSWITCH JOYSTICK

- **AUTO FIRE**
 - **METAL SHAFT**
 - **12 MONTH WARRANTY**
- ONLY....
£10.99**

- Deluxe, robust construction • Comfortable rugged hand-grip, 8 directional control with automatic centering • Heavy duty base with strong stabilising suction cups • Highly sensitive light touch **MICRO SWITCH** fire buttons • Ergonomically designed control handle with indestructible **METAL SHAFT** • Built in **AUTO FIRE** function.
- Mach I Joystick compatible with: • Sinclair ZX Spectrum 16K, 48K, 128K (Interface sold separately), +2, +3 • Amstrad Computers • Commodore 64 and Vic 20 Computers • Commodore C16 & plus 4 Computers (adaptor sold separately) • Atari 2600 & Atari 5200 Video Game Systems • Atari Home Computers etc.

All specifications and prices subject to change without notice

Prices include VAT, postage & packing.
Delivery normally 14 days.
Export orders at no extra cost.
Dealer enquiries welcome.



Cheetah products available from branches of **Argos** **Dixons** **Harrods**

LASKYS **WHSMITH**

High St. Stores and all good computer shops or direct from Cheetah.

CHEETAH MARKETING LTD
Norbury House, Norbury Road,
Fairwater, Cardiff CF5 3AS.
Telephone: Cardiff (0222) 555525
Telex: 497455 Fax: (0222) 555527

THE TOP PEOPLES CHOICE



125+
The
Explosive Joystick

- Compatible with ZX Spectrum, 16k, 48k, 128k (Interface sold separately), +2, +3, Commodore 64, Vic 20, C16, Plus 4 (adaptor sold separately), Amstrad, Atari, etc.
- Four extremely sensitive fire buttons
- Uniquely styles hand grip
- Auto fire switch • 12 months warranty
- +2 Selector Connector

**ONLY
£8.99**

DIRECTLY
COMPATIBLE
with Sinclair
+2, +3



AMSTRAD SPECIAL OFFERS	AMSTRAD SPECIAL OFFERS	CASSETTE	CASSETTE	CASSETTE	DISKS	AMSTRAD SPECIAL CASS
Artura.....3.99	Convoy Raider.....1.99	ISS.....3.95	Road Blasters.....6.50	Trivial Pursuit (Standard) 4.95	Ballyhoo.....6.00	Big Foot.....1.99
Action Force.....1.99	Chall. Gobots.....0.99	IK+.....1.99	Rolling Thunder.....3.95	Trivial Pur. (Baby Boomer) 4.95	Station Fall.....6.00	Inter Rugby Simulator.....1.99
Afterburner.....5.99	The Centurions.....0.99	The Inheritance.....0.99	Runestone.....0.99	Trivial Pur. (Young Players) 4.95	Cut Throat.....6.00	Pro Golf.....1.99
Austerlitz.....3.99	Dan Dare II.....2.79	Jackal.....1.99	Ramparts.....1.00	Thunderblade.....5.95	Suspect.....6.00	3D Starfighter.....1.99
Auf Wiedersehen Monty 2.99	Dandy.....0.50	Johnny Reb 2.....2.99	Return of the Jedi.....3.99	Target Renegade.....5.95	Hollywood Hijinx.....6.00	Ace.....2.50
Andy Capp.....1.99	Dragon's Lair.....1.99	Indoor Soccer.....1.99	Roy of the Rovers.....3.99	Tobruk.....3.95	Sorcerer.....6.00	Flinstones.....2.99
Army Moves.....2.79	Dragon's Lair II.....1.99	Karnov.....1.99	Red Scorpion.....0.99	Venom Strikes Back.....2.95	Microprose Soccer.....12.99	Wizball.....2.99
Batman.....6.99	Dambusters.....1.99	Kinestik.....0.99	Spy V Spy Trilogy.....3.99	View to a Kill.....1.99	R-Type.....8.95	Techno Cop.....3.99
Battlefield Germany.....5.99	Dark Sceptre.....1.99	Killed Until Dead.....1.99	Strip Poker II+.....3.99	Wonderboy.....4.95	Rampage.....4.95	Vulcan.....3.99
Blastroids.....6.99	Emlyn Hughes Soccer.....6.99	Krypton Factor.....3.99	Super Hang On.....3.99	West Bank.....2.99	Karnov.....4.95	Pink Panther.....2.99
Ball Blazer.....0.99	Empire Strikes Back.....3.99	Leaderboard.....2.99	720°.....2.99	Xarq.....0.50	Predator.....4.95	Grand Prix Simulator.....1.99
Black Magik.....0.99	Eidolon.....0.50	Lazer Tag.....1.00	Super Sprint.....1.99	Yogi Bear.....1.50	Cholo.....2.99	BMX Simulator 2.....1.99
Bedlam.....1.99	Every Second Counts.....3.99	Mega Apocalypse.....1.99	Star Raiders II.....1.99	Zynaps.....2.99	Terror of the Deep.....2.99	Into the Eagles Nest.....1.99
Bride of Frankenstein.....0.99	Flunky.....0.50	Mutants.....1.99	Street Machine.....1.99	Xelon.....2.99	Sai Combat.....2.99	Joe Blade 2.....1.99
Bubbler.....0.99	Fernandez Must Die.....2.99	G.G. Match Cricket.....1.99	Scalextric.....3.99	Cyberoid.....3.99	Dynamite Dan 2.....2.99	Operation Wolf.....5.95
Blood Brothers.....3.99	Future Knight.....1.99	Monopoly.....3.95	Slane.....1.99	Garfield.....3.99	Football Director II.....5.95	
Baseball.....1.99	G.F.L. Football.....2.99	Nebulus.....2.99	Spy Hunter.....2.79	Skate Crazy.....3.99	Wonderboy.....6.95	
The Big Sneeze.....1.99	F.Ball Manager II.....4.99	Nomad.....0.99	Survivor.....0.99	Gnome Ranger.....3.99	Waterloo.....5.95	
Bionic Commando.....4.99	The Fury.....2.99	Nexor.....0.50	Sea Base Delta.....0.50	Tau Ceti.....2.99	Mario Bros.....4.95	
Blockbusters.....3.99	G.B. Air Rally.....1.99	North Star.....1.99	Star Wars.....3.95	Waterloo.....3.99	Afterburner.....9.95	
Bullseye.....3.99	GreyFell.....0.99	Nosteratu, The Vampire.....1.99	4 Soccer Simulators.....4.95	Rex.....3.99	Thing Bounces Back.....1.99	
Battle of Britain.....2.99	Gliderider.....1.99	Nemesis (Final Challenge) 1.99	Starglider.....3.95	Typhoon.....5.99		
Battle for Midway.....2.99	Gothik.....1.99	Nemesis Warlock.....1.99	Sorcerer Lord.....5.95	Thing on a Spring.....0.50		
Cylu.....0.50	Gauntlet II.....2.99	Out Run.....6.50	Spitfire 40.....3.95	Gunship.....9.50		
The Colour of Magik.....1.99	Gladiator.....0.99	Out of this World.....0.50	Techno Cop.....5.95	BMX Sim. 2.....2.99		
Crazy Cars II.....6.99	Guadal Canal.....0.99	Premier II.....2.99	Total Eclipse.....3.95	Equinox.....0.99		
California Games.....2.99	Gunsmoke.....2.99	Pulsator.....0.50	Through the Trap Door.....1.99	Caves of Doom.....0.99		
Cluedo.....3.99	Heroes of the Lance.....5.95	Prodigy.....0.50	Terramex.....1.99	Chicken Chase.....0.99		
Clever & Smart.....0.99	Hercules.....3.99	Pegasus Bridge.....5.99	Thundercats.....3.95	Challenger.....7.95		
Champ Sprint.....2.99	Hijack.....0.50	Predator.....3.95	Throne of Fire.....0.99			
Captain America.....1.00	Hive.....0.50	Paperboy.....3.95				
		Quartet.....2.99				
		Road Runner.....1.99				
		Rygar.....1.99				

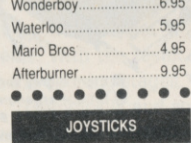

TAITOS COIN OPS
 Rastan, Flying Shark, Slap
 Fight, Arkanoid, Arkanoid 2,
 Bubble Bobble, Renegade,
 Legend of Kage
ALL 8 GAMES
SPECIAL PRICE £5.99

GO CRAZY
 Bad Cat, Jinks, Side Arms,
 Bedlam, Shackled, Desolator
ALL 6 GAMES
ONLY £4.99

All orders under £5 please add 50p towards Postage & Packing.
All orders over £5, Postage & Packing FREE
No Overseas orders please.
All in stock items despatched by return

CASSETTE COMPILATIONS	CASSETTE COMPILATIONS	CASSETTE COMPILATIONS	CASSETTE COMPILATIONS	AMSTRAD COMPILATIONS
<p>BEST OF ELITE VOL 2</p> <p>Paperboy, Ghost & Goblins, Battleships, Bombjack 2</p> <p>ONLY £4.99</p>	<p>1,2,3.</p> <p>BMX Kidz, Ninja Master, Rock Wrestle</p> <p>ONLY £2.99</p>	<p>4 SMASH HITS</p> <p>Zynaps, Exolon, Rana Rama, Euridium+</p> <p>ONLY £4.99</p>	<p>KNIGHTORK</p> <p>Loosed Orc, Horders of Mountain Kings, A Kind of Magik</p> <p>ONLY £3.95</p>	<p>GRAND PRIX SELECTION</p> <p>Championship Sprint, Super Sprint, Super Hang On</p> <p>ALL 3 FOR £4.99</p>
<p>GIANTS</p> <p>Rolling Thunder, Gauntlet II, Outrun, 720° California Games</p> <p>ONLY £5.95</p>	<p>SUPREME CHALLENGE</p> <p>Elite, Ace II, Tetris, Starglider, Sentinel</p> <p>ONLY £5.95</p>	<p>TEN GREAT GAMES VOL 2</p> <p>Auf Wiedersehen Monty, Samurai Trilogy, The Duet, Mask, Convoy Raider, Jack Nipper II, Deathwish III, Basil Mouse Det, The Final Matrix, Thing Bounces Back</p> <p>ONLY £5.95</p>	<p>COMPUTER CLASSICS</p> <p>Into the Eagle's Nest, Dynamite Dan, Zynaps, Alien, Cauldron II</p> <p>ONLY £2.99</p>	<p>UNBELIEVABLE ULTIMATE</p> <p>Alien 8, Sabre Wulf, Nightshade</p> <p>SPECIAL PRICE ONLY £1.99</p>
<p>GOLD, SILVER, BRONZE.</p> <p>Summer Games 1, Summer Games 2, Winter Games</p> <p>ONLY £7.95</p>			<p>MAGNIFICENT SEVEN</p> <p>The Great Escape, Wizball, Arkanoid, Short Circuit, Frankie, Stalone Cobra, Head Over Heels, Yie Ar Kung Fu</p> <p>ONLY £5.95</p>	<p>THEY SOLD A MILLION</p> <p>Beach Head, Sabre Wulf, Jet Set Willy, Decathlon</p> <p>REDUCED TO ONLY £3.99</p>

MANY THANKS TO ALL THE PEOPLE WHO ORDERED FROM US LAST MONTH

BOB'S FULL HOUSE

Domark/TV Games ● £7.95 cass keys



Bob's Full House will not go down in history as one of the high points of British broadcasting. In fact most people in the country have a loathe/hate relationship with it. It's real edge of sleep stuff - all those

crushing puns, cute bingo lingo and of course Mr Monkhouse himself, whom we'd all dearly love to shake warmly by the throat. Love him or loathe him, you can't love him.

So what hope is there for a computer game based on (one could hardly say inspired by) the show? It claims, although you can't be too sure why, to be an accurate representation of the programme. Both style and format are the same, giving you a chance to imagine you've won a new dishwasher, CPC, TV or even a dream holiday - so called because even if you win, a dream it will stay.

After an eternity of loading time the game finally presents itself. It looks promising. You're invited to type in your name, which appears above your very own bingo card, along with a little person who mutters silently away throughout the whole show. Even the

The bizarre tale of the hunt for Bob's autograph

At one time it looked as if Bob's Full House would never open its door to the world of CPC games (see Amscene AA43). As the game was nearing completion Bob's decision to leave the Beeb threw all the carefully laid plans into disarray. The licence as it stood had never been signed by Mr Monkhouse, and therefore his name couldn't be used on the game, and A.N. Other's Full House just wouldn't sound quite right.

Domark - producers of TV Games - hurried round to Bob's agent's house to clear things up

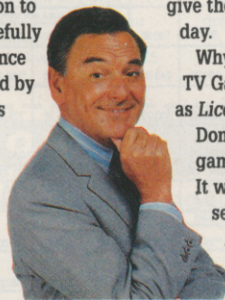

and to try and salvage something from the project. To their relief they found Mr Monkhouse more than willing to sign up and give the game the go-ahead thus saving the day.

Why all the fuss though? Admittedly the TV Games licences may not be as glamorous as Licence to Kill but they are important to Domark who balance their "trendier" games against slower but steadier sellers. It would not be surprising to see Bob still selling at Christmas when the interest in Licence has evaporated, providing a steady flow of delicious dosh for Domark.

man in the shiny grey suit and the brylcreem smile is there, so all is set and it's time to get your eyes down for a full house.

The first round, as you know (come on, admit it!), is a race to answer four questions and light the cornermost numbers of your bingo card. As soon as Bob has popped the question it's a sprint to your bell, each player having a different key. If you play the computer, watch out: its players are quick but thick, not much competition but they get in the way. To answer a question you not only have to know the answer, but you've got to type it in: no trouble when the answer is something

type in the correct answer, rather than choosing from four options, as is the case in multiple choice quizzes such as Question of Sport. The spelling also gives each question a longer shelf life, because when the computer answers you don't get to see what it writes to

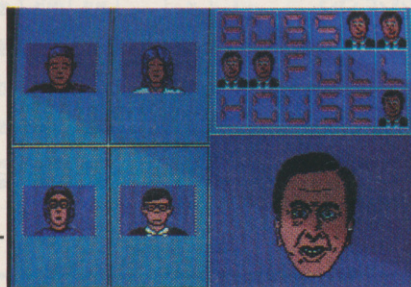

● Don't you just love Bob Monkhouse? (A: no.)



● He's going for the car! (Well, kettle actually)

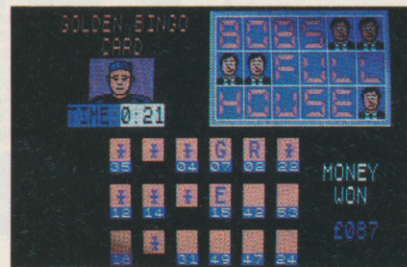

● What a card Bobby is

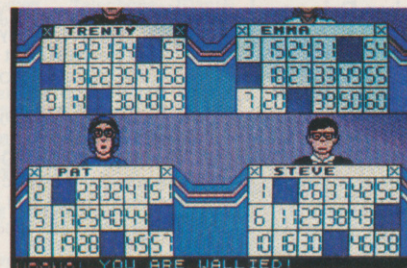

● A bad bingo joke

simple like "blue," but when it comes to "Who was India's first female Prime Minister?" you may know the answer but can you spell it?

The spelling element frees more memory for question storage, since you are required to

itself. You could, for example, remain forever in the dark as to the identity of the youngest member of the House of Lords!

Rounds progress as in the show: light the middle line of your card and then illuminate all your remaining numbers. The winner chooses from a range of wonderful household appliances: fridges, stereos and kettles, golly gosh I can hardly contain my excitement.

The champion gets the chance for a go at Bob's Golden Bingo Card to win a holiday.

SECOND OPINION

"If you're a Bob Monkhouse fan then a) you're ill, and b) you'll probably enjoy BFH. Not my thing, but it can't be denied that Domark have done a good job, as always." SC

GREEN SCREEN

Fine great super (insincere grin)

You've one minute to reveal the letters spelling out a dream destination. This final lap is really tough, with over twenty questions in under a minute.

The prize sequence sounds daft, but surprisingly it does give the game a well rounded feel. I cannot deny that since I despise the TV show and its slick host I was expecting to have to do a hatchet job.

Yet such is the skill and attention to detail with which the licence has been translated that you may be as pleasantly surprised as I was. Put together with the usual Domark professionalism, Bob's Full House is hardly a classic. It's better than the telly, but then, is that enough? TW

FIRST DAY TARGET SCORE

Beat the computer

The Verdict

GRAPHICS 73%

Entertaining presentation of a visually limited concept.

SONICS 52%

TV-style tune, buzzers and little else.

GRAB FACTOR 55%

Accessible quiz game.
 Limited initial appeal.

STAYING POWER .. 59%

Over six hundred questions.
 Format limits the games.

AA RATING 58%

Not as unwatchable as the TV game.

Matrix Software Hire

The cheapest way to play them all.

Top games titles for Amstrad, Commodore, Spectrum and Amiga.

Please state system

Please send large SAE for details to

Matrix Leisure Club, Dept AA,
271 Stansted Road, Bishops Stortford
Herts CM23 2BT

ZEDASM ROM £19.95
The professional Z80 Text Editor/Assembler and System monitor. Superfast Z80 assembler (200 lines second). Supports page switching on 6128 machines, up to 80k of text source in memory at the same time.

DEMON DEVELOPMENT CARTRIDGE £19.95
The Ultimate machine code tool. Stop Any program Anytime by a press of a button, the memory remains intact and can be saved to Tape/Disc, debugged, traced, moved, disassembled etc.

EPROM PROGRAMMER KIT £27.50
Transfer your favourite programs (Basic/Machine Code) onto Eprom. Programs 2764/27128 12.5 or 21 volt Eproms. Powerful but easy to use software, Rom to Rom copy, Editing, Verification, Single or block programming.

PCB DESIGNER CARTRIDGE £59.95
Design double sided printed circuit boards quickly and easily. Output to standard printer 1:1 or 2:1 scale. Predefined DILS & IDC connectors. Auto Routing. Zoom Editing etc. Too many functions to list here.

PASCAL COMPILER ROM £15.00
Our pascal compiler is easy to use, suitable for the absolute beginner and produces stand alone Machine code. Does NOT require CPM.
(Note cartridges have no through connector for 464 with Disk Drive)

John Morrison Dept (AA)
4 Rein Gardens, Tingley, West Yorkshire, WF3 1JR
Telephone (0532) 537 507 S.A.E for further information

VSE Technical Services

High Quality Repairs
Low Inclusive Prices
The Logical choice!

REPAIRS		All repairs guaranteed 4 months, prices quoted apply to any single fault ★ and are inclusive of parts, labour and VAT. Free return carriage for UK mail order customers. CPC 6128 Rom installation service available, only £8.00. ★ Excludes replacement of complete keyboard or disk drive assemblies (free estimate given).
Amstrad CPC 464.....	£21.90	
Amstrad CPC 6128.....	£24.90	
ACCESSORIES		
CPC 6128 Rom	£16.90	
64K Ram Pack.....	£43.90	
MP2 Modulator.....	£27.90	
Printer Cable.....	£8.80	

VSE Technical Services (Dept 104), Unit 6,
8 Nursery Road, London SW9 8BP. Tel 01-737-0234

MAKE YOUR AMSTRAD EARN

Yes making money with your Amstrad becomes incidental when you know how. Your micro is, if only you knew it, a gold mine. The size and make is irrelevant. Make the initial effort **NOW** by starting your own

HOME BASED BUSINESS

This may be the most important move you will ever make!
REMEMBER: You'll never get rich by digging someone else's "ditch". Anyone in the country, including YOU, can become very rich in a relatively short period of time just by doing a few basic things! It's more rewarding than playing games. The benefits are many and varied. Full or part time. For **FREE** details send S.A.E. to:

HOME BASED BUSINESS

31, PILTON PLACE (AA4)
KING AND QUEEN STREET,
WALWORTH, LONDON SE17 1DR



Escroe plc

11 Mundells Court,
Welwyn Garden City,
Herts, AL7 1EN, England

Telephone UK: (0707) 334460 Intl: (44) 707 334460

DISKS, DISKS AND MORE DISKS AT TRADE PRICES
DIRECT TO THE PUBLIC AND COME COMPLETE
WITH USER SETS AND ENVELOPES. **LIFETIME
GUARANTEE.**

PRICES INCLUDE POSTAGE, PACKING AND V.A.T.

PAYMENT, CHEQUE OR ACCESS



ORDERS WELCOME FROM GOVERNMENT,
LOCAL AUTHORITY, EDUCATIONAL &
CORPORATES

BULK	2 807	D/S CF2	D/S CF200	D/S 3.50	D/S800 3.50	HD 3.50	D/S86 5.25	HD 5.25	S/S 8.00	D/S 8.00	BULK	BULK
10	NOT	21.85	29.90	7.95	8.95	23.00	N/A	N/A	23.00	24.00	10	BULK
25	AVAILABLE	51.75	66.13	20.00	22.00	50.00	11.50	23.00	51.75	54.00	25	BULK
FREE 100 LOCKABLE BOX WITH ANY OF THESE PURCHASES												
50	IN	97.75	130.00	*35.00	*40.00	*90.00	*17.25	*44.00	97.75	102.75	50	BULK
100	BULK	184.00	245.00	*68.00	*78.00	*180.00	*28.75	*70.00	184.00	194.00	100	BULK
250	FORM	430.00	800.00	140.00	165.00	375.00	68.00	170.00	430.00	455.00	250	BULK
500		850.00	1100.00	265.00	315.00	740.00	115.00	330.00	850.00	900.00	500	BULK
ALL MIMIC DISKS ARE PREFORMATTED TO ENSURE PERFECT PERFORMANCE												
2 80		D/S CF2	D/S00 CF200	D/S00 3.50	D/S800 3.50	HD 3.50	D/S86 5.25	DS HD 5.25	S/S 8.00	D/S 8.00		
IN PLASTIC CASES												
10	**24.15	**24.15	**32.20	8.95	11.50	25.00	5.75	11.50	25.00	27.00	10	MIMIC
20	**47.00	**47.00	**62.00	17.00	21.00	48.00	11.00	23.00	38.10	41.10	20	MIMIC
40	**92.00	**92.00	**120.00	33.00	40.00	94.00	21.00	44.00	73.80	81.80	40	MIMIC
80	**182.00	**182.00	**230.00	64.00	72.00	185.00	41.00	85.00	138.00	154.00	80	MIMIC
100	**220.00	**220.00	**275.00	77.00	85.00	225.00	50.00	100.00	165.00	185.00	100	MIMIC
2 80		CF1	CF80	CF100	CF150	CF200	CF250	CF300	CF350	CF400		
10	5.95	5.95	5.95	3.95	3.95	3.95	3.95	3.95	17.95	17.95		MIMIC
20	24.15	24.15	48.00	18.50	18.50	38.00	9.50	18.50	25.00	26.00	10	
40	47.00	47.00	90.00	28.00	28.00	75.00	18.00	38.00	49.00	50.00	20	
80	92.00	92.00	175.00	50.00	50.00	148.00	35.00	70.00	94.00	95.00	40	
100	182.00	182.00	345.00	96.00	96.00	290.00	68.00	135.00	178.00	180.00	80	
200	220.00	220.00	425.00	105.00	105.00	350.00	84.00	180.00	215.00	220.00	100	

SUBSCRIBE

NOW TO AMSTRAD ACTION

YOUR MAGAZINE DEDICATED TO YOUR MACHINE

Only £17.95 for 12 action-packed issues (and we even pay the postage for you!)

Ring 0458 74011 NOW, quoting the order code AA396 and having your credit card handy or use the order form on Page 82. Why not order some of the latest and cheapest products from The Amstrad Action Special Offers at the same time!

Remember our unique guarantee: we will refund the cost of all unmailed issues, if you are not completely satisfied with our subscription service.

- ★ Hotline Number 0458 74011
- ★ Order Form on Page 82
- ★ Be sure you get your copy before the newsagent sells out
- ★ Get our regular quarterly "UPDATE" of extra-special savings on products that we didn't quite manage to squeeze in the magazine!

BRITAIN'S BEST SELLING MAGAZINE
FOR THE AMSTRAD CPC 464 • 664 • 6128
ISSUE 48 • SEPTEMBER 1989 • £1.45

NOT an official Amstrad publication!

FROM FUTURE PUBLISHING COMES THE MAGAZINE THAT LEADS THE FIELD

AMSTRAD

PRESS FOR ACTION!

The expert guide to publishing newsletters, fanzines and booklets on your CPC

plus WIN a £750 Mannesmann Tally 24 pin printer to enhance your creativity!

ACTION

ONLY **£17.95** FOR 12 ACTION-PACKED ISSUES

Inside out



In the fourth part of his series on what's inside your CPC and how it works, **STUART McCOLL** unravels the mysteries of multiplexers – and explains what buses have to do with it.

T Well, have you reached a solution to the problem I left you pondering last month? Whaddya mean "What problem?" OK, for those who consider a month a long time, and for the one or two (no more than that, surely) who may be lagging behind, I'll elaborate.

Last time we looked at the hardware configuration of a simple microprocessor, and discovered the need to be able to connect a chosen register to a bus, while simultaneously disconnecting the other unwanted registers. This difficulty, however, is not unique to microprocessor design. Indeed, digital systems - microcomputers or otherwise - are littered with such situations. What is required is something

has a single output which is representative of the data on one of its 2^n data inputs, as chosen by n control inputs. Figure 1A illustrates the construction of a small two input multiplexer, the symbol of Figure 1B being more commonly used.

Each data input has its own enabling/disabling AND gate, the outputs of which are fed into an (often large) collecting OR gate. For the correct operation of a multiplexer it is imperative that exactly one gate is enabled while all the others are disabled. To understand how this is done, think back to last time. You should recall that a decoder is a device with n inputs and 2^n enable outputs, only one of which will be logically TRUE at any given time (award yourself a pat on the back if you spotted last month's misprints in the decoder truth table). Thus an integral part of any 2^n input multiplexer is an n input decoder – as annotated in Figure 1A. The decoder simply enables the correct AND gate. The truth table of Figure 1C illustrates which input is passed to the multiplexer output for each configuration of control inputs.

demultiplexer is the decoder, used to enable the correct data output. Figure 2C illustrates which output receives the data input for the various control input configurations.

It should be obvious by now that within a simple microprocessor such as that illustrated last month, multiplexers are used to feed (or gate) the contents of a register associated with one device onto a bus, while demultiplexers will be used to route the contents of the bus into a register associated with another chosen device. Figure 3 illustrates this concept with a system wide view – try drawing a table showing how information flows through the system. In fact, multiplexers and demultiplexers are indispensable in any circuit which involves a selection process – for example, choosing which particular operation an Arithmetic Logic Unit should perform. We will, incidentally, see how multiplexers are actually used in ALU design when we build our own (admittedly small) arithmetic logic unit – more of which later.

Buses: all aboard

Computer literature and associated paraphernalia are riddled with references to the ubiquitous "bus" – but what exactly is one?

As we've observed before, a bus is really nothing more than a collection of wires. This is quite true (would I lie to you?), but there is in fact more than one way in which a bus may be implemented. There are actually two very popular techniques, each with its own advantages, and Figure 3 introduced you to one of them.

Here, the fixed links from the output of the multiplexer on the left to the input of the demultiplexer on the right comprises the data bus, or – popularly – the highway (thus the four wheel analogy). By applying the correct combination of control signals to the multiplexer and demultiplexer, any device whose outputs appear on the left may be connected to any of the devices whose inputs are routed through the demultiplexer on the right.

This type of bus structure, however, is rarely found in microcomputer systems. The reason is best explained by an example. Suppose that the microcomputer of Figure 3 were to be expanded to accommodate a plotter, say, or a mouse – this not being entirely unreasonable. The problem is immediately obvious: all the inputs to the multiplexer and all the outputs of the demultiplexer have already been allocated to a system component.

There is simply no way in which the existing system can be expanded, without first tak-

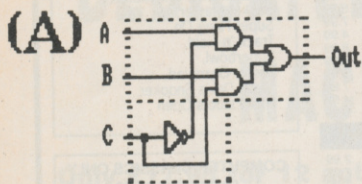

(B) Multiplexer schematic

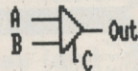

(C)

C	Out
F	A
T	B

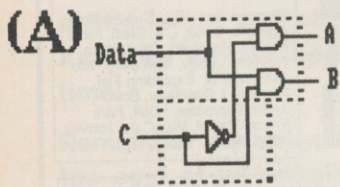

(B) Demultiplexer schematic

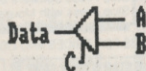

(C)

C	Out
F	A
T	B

● Figures 1 and 2: the multiplexer (top)... and the demultiplexer (below)

which will pass a chosen signal through to a common output (in our case a bus), while ignoring the other input signals. Fortunately, there is a device with just such properties...

Multiplexers? Couldn't be simpler!*

Despite the daunting name, multiplexers - like practically everything in computer design - are essentially very simple devices. A multiplexer

A very similar device is used to pass a single input to any one of 2^n outputs. It is called a demultiplexer, and a simple 2 output demultiplexer is illustrated in Figure 2A, along with its corresponding schematic symbol in Figure 2B. As with multiplexers, an essential part of every

* You're perfectly right, of course. It could be a lot simpler. My mistake - ed.

ing it to bits and rebuilding it using larger multiplexers and demultiplexers - which is of course, quite unacceptable. Although ideal for processor design, an alternative is then clearly required for microcomputer system buses.

The solution almost universally adopted is so simple it's "pure genius." Considered generally, a peripheral must be able to receive and transmit data over the data bus. So each device simply has its inputs and outputs connected to the data bus (normally a single set of connections serve as both input and output lines from the peripheral), ready to receive or transmit data as per the control bus.

However, if the bus is nothing more than a collection of wires (or tracks of plated copper), there is clearly a problem with respect to electrical shortcircuits. This is overcome by using what's known as tri-state devices. Such devices have the usual outputs of 5 volts and 0 volts (TRUE/FALSE). However, they have an

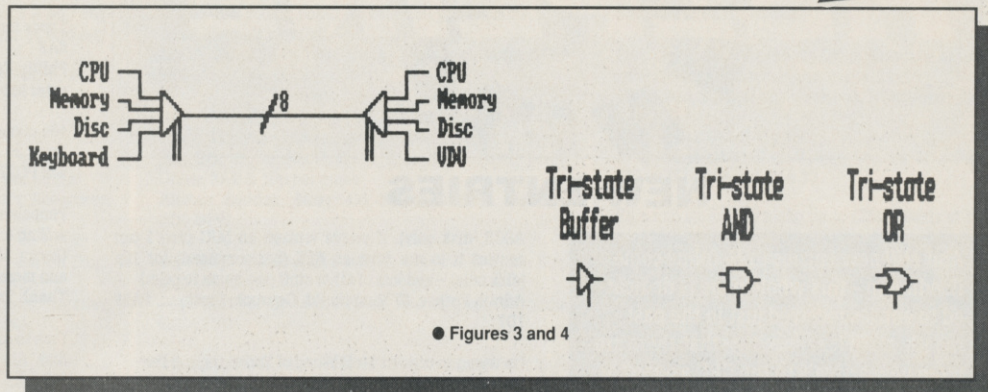

of sixteen wires, conventionally labelled A₀ - A₁₅. From our knowledge of binary arithmetic it is clear that such machines have an address space of 2¹⁶ = 65536 unique addresses. When the micro wishes to communicate with anything external to the actual processor, ie., main memory - in which programs are stored, the keyboard, screen, printer etc. - it must place the address of the appropriate peripheral or

Decoding your address

So what is address decoding? Well, it's rather like giving a unique name to every system component - a name which may be easily recognised and spoken by both the component and processor. This name is ultimately an address, and address recognition is commonly called address decoding.

Each device belonging to a memory mapped microcomputer system will remain idle until it recognises the contents of the address bus as being an address which it has been allocated.

Such allocation is done both at the system design stage and later when the operational system is being expanded. The recognition process is performed by the device interface and is called an address decoder.

To illustrate: suppose we allocate address 21₁₀ to a peripheral - a printer, say. Thus the register which holds the character to be printed will be loaded with data from the data bus whenever the control bus indicates a WRITE operation, and the address bus holds the binary information 00000000001010₂.

Figure 5 illustrates an appropriate address decoder - although again it fails to take into consideration any timing aspects which ultimately depends on both the processor and the nature of the interface.

Notice how simple it is? The logical expression for the address decoder, using the notation introduced last month, is also given.

It is clearly imperative that no two devices attempt to drive the data bus at the same time, as this would inevitably result in a shortcircuit, with possibly disastrous results for the entire computer.

Such catastrophes are avoided by ensuring that no two address decoders generate a device-enable signal simultaneously. For larger systems this can be achieved only by careful planning and a comprehensive well organised memory map or/and peripheral map.

It is to this subject we shall be turning next month. ●

● Stay tuned for another *Insider Outing* next month, CPC innards fans!

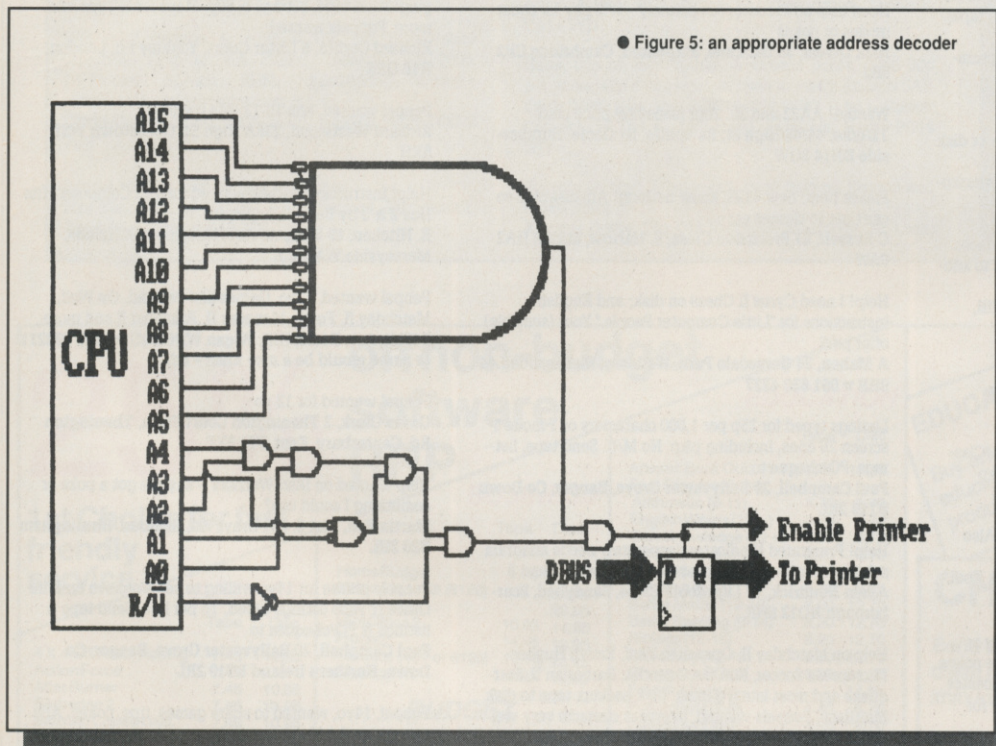

additional third state, which is referred to as the *high impedance output* or *z-state*.

This essentially places an infinitely high resistance on the output - effectively disconnecting the device from the bus and thereby eliminating the possibility of short circuits. All tri-state devices have a control input, which when TRUE, will switch to the z-state. Figure 4 illustrates a few such devices.

Address and a matter of status

Now we're ready for the second part of last month's teaser. I invited you to think about how decoders might be used with respect to a microcomputer's address bus.

The address bus of most small microcomputers (including your CPC) typically consists

memory location onto the address bus.

The status of the Read/Write line on the control bus will then be set to indicate in which direction information should flow, and (setting aside timing vagaries) the information will be placed onto the data bus by the CPU (Write) or peripheral device (Read).

As I've remarked before, it becomes the responsibility of the peripheral device to recognise that the CPU is communicating with it, and to take the correct action.

The CPU depends on the integrity of the system into which it is connected and will behave peculiarly, or even crash, if it is compromised by either the peripherals themselves or by the address decoding.

HELPLINE

NEW ENTRIES

And still new entries to *Helpline* come flooding in - this whole page is dedicated to entries received just in the past month or so! It seems, too, that there are more new arrivals to the CPC asking for help than ever before - which must be a good thing. Why don't you find yourself a pen-pal from this lot? - Steve

Help wanted for Captain Blood, Wiggler, Driller and Dizzy: a list of 125 pokes, from which you may choose five, if you help me with at least two of these
Ross McClintock, 109 Crawfordsburn Rd, Bangor, County Down, N. Ireland BT19 1BJ

Help with Basic M/Code; will debug programs. Send on tape (for M/Code, send as ASCII source listing, on tape). Will write M/Code programs. All free
Thomas Jolly, 5 Trinity Terrace, Corbridge, Northumberland NE45 5HW
☎ 043471 2804, evenings only

Basic programs written for your needs. Send tape or disk with a PO for £1
S. Giddins, 31 Lulworth Walk, Merry Hill, Wolverhampton, West Midlands WV4 4YS

Advice wanted on selection of suitable midi interface, keyboard/synth & software. Also what's the limit to add-on devices hung on 6128?
Derek Tatam, "Littlecroft," Stanton Rd, Forest Hill, Oxford OX9 1DT ☎ 08677 3226

Penpals wanted: 9 - 11
Hadyn Hughes, 15 Chase View, Ettingshall Park, Wolverhampton WV4 6QN

Two text-only adventures (150 locations) in early 'Classic Adventure' tradition. Only £1.50, including p&p
Bill Clows, 33 Beresford Rd, Blackburn BB1 8BG

Listings and basic screens printed, 8p per page. Also will print out letters &c 25p each. Send SAE
Andrew Byles, Tweedmount, Lower Rd, Hartlip, Kent ME9 7ST

Super Robin Hood and Vampire wanted - will buy or exchange. Help on Dizzies, Wiz Ball and lots more pokes.
Paul Harris, 50 Stonechat Ave, Abbeydale, Gloucester GL4 9XE ☎ 0452 414925 (PS his sister wrote this for him)

Type in any Type In from AA16 onwards (or from any accurate listing) for 1p per line and debug programs at same price. Also addresses of many important Amstrad companies
Christopher Street, 43 Ridgedale Rd, Bolsover Derbyshire S44 6TX ☎ 0246 827135 after 5pm

Pokes for Xevious, Tempest, Light Force, Grand Prix Sim, Short Circuit, Thrust, Into Oblivion, Ollie & Lisa and Combat Zone. Send SAE, tape & 30p per game
159 Rawreth Lane, Rayleigh, Essex SS6 9RN (- a name would be nice! - ed)

Basic programs written (price on application); pokes for all games (send large SAE for details)
Graham, 63 Outland Gardens, Leeds, West Yorks LS7 1SL

Malbordus Software tape-disk for 40p. Basic unprotected for 10p (tape-disk), files unerased for 10p (Basic, binary,

ASCII, disk only). If you've written an M/C prog I can convert it to run from an RSX (bar command) for 10p (disk only) - and lots of other stuff (too much to print)
Adrain Forbes, 37 Victoria Rd, Gourrock, Scotland, PA19 1DF

I'm trying to contact Mr D Wong of Yorkshire, but I've lost his address
Christopher Bowler, 318A Wrythe Lane, Carshalton, Surrey SM5 1AF (you're sure you don't mean Mike Wong, Chris?)

Penpal wanted to share tips, pokes, games (Renegade, Game Over and many more). All letters answered
Nicholas Gee, 125 Cuckoo Lane, Stubbington, Fareham PO14 3TR

Lots of help on Logo (advice, printouts), 20p per help. Send SAE
Vincent Lahiff, Ballykeeffe, Mungret, Limerick, Ireland

Need help on Predator desperately - will pay for cheat modes or pokes
Nick Owers, 35 Bar Lane, Stapleford, Cambridge CB2 5BJ

Wanted! AA22 and 30. Your (sensible) price paid
J Drake, 44/46 High St, Rawcliffe, Nr Goole, Humberside DN14 8QW

Please help: new 6128, know nothing! Am disabled so can't get to classes etc
C Russell, 57 Brookside Close, S. Harrow, Middx HA2 9AW

Help! I need Cyrus II Chess on disk; and English instructions for "Little Computer People." Your (sensible) offer paid
A Mahon, 34 Gorsedale Park, Wallasey, Merseyside L44 9HB ☎ 051 630 4337

Listings typed for 25p per 1,000 characters or 1 mode 1 screen 26 lines, including p&p. No M/C. Send tape, listings, PO/cheque to
Paul Campbell, 20 Ballyvester Grove, Bangor, Co Down BT19 2RL

Help! Frustrated Vindicator desperately needs anagram solutions for level 1 and passwords for levels 2 and 3
Adam Nendrick, 17 Lightfoots Close, Sandybed, Scarborough & O12 SNR

Help on Matchday II, Operation Wolf, Emyln Hughes, Microprose Soccer, Run the Gauntlet, Barbarian II, Starquake and most latest games. Disk backup, tape to disk, Multiface. Penpals wanted, overseas contacts very welcome
Y. Pang, 12 Rheingold Way, Wallington, Surrey SM6 9NA

Penpal wanted between 10 and 14
Sandip Rao, 76 Mellitus St, East Acton, London W12 ODS ☎ 01 749 5231 (between 6.30-8.30pm weekdays)

Tape/tape, disk/disk, tape/disk, disk/tape (yes I think we get the idea - ed). Send SAE, blank tape/disk cheat disk one, send SAE £2 & blank disk to get 125 pokes for tape
Carl Wilson, 64 Fishponds Rd, Kenilworth, Warks, CV8 1EZ

Anyone got an AA17 they're willing to part with? Penpals needed age 12-14. All letters answered. 6128 owner
Mark Berbezier, 47 Lakeen Rd, Intake, Doncaster, South Yorkshire, DN2 5HB ☎ 0302 323266 (6-9pm)

Whole listings, documents & reports typed in for you! Anything printed, high quality results. Quick, reliable,

1p per line, send copy of text, blank tape (optional), SAE to J Hale, 8 Witcombe Close, Kingswood, Bristol BS15 4RY ☎ 0272 611987

Tapes for taping only 10p or will swap for taping, send SAE
Phillip Kenna, 10 Jubilee Terrace, Middleton, Manchester M24 2LU ☎ 061 654 8326 after 6pm

464 owner wants female penpal, 19+ (photo required)
Tony, 30 Foxes Croft, Barnham, Bognor Regis, W. Sussex PO22 0JT

Penpals wanted, all over the world, regardless of sex, willing to teach me M/Code. I also have Cheats to swap, Gryzor, Metal Army, Arkanoid, Zoids, Target Renegade and more
Thanh Truong, 36 Stanley St, Burwood 2134, Australia

Disk to disk: just send 50p (3 for £1), SAE, game and disk. Also loadsa Multiface pokes, send 50p plus SAE for full list
Brian Doyle, 18 Doyle Road, Turners Cross, Cork, Ireland

Maps for copying - over 60 including Dizzy, Thrust, Driller, Dark Side, Exolon, Trantor & others. Send 10p per map for photocopying. Penpals wanted too! Can anyone get me a good deal on Galactic Games or Knight Games 2? Anyone wanna buy Laser Basic?
Anthony Treacy, 60 Ruskin Rd, Kingsthorpe, Northampton, NN2 7SY ☎ 0604 716057

Help on Crazy Cars I & II, N. Mansell Grand Prix, Twin Turbo V8, Typhoon, Barbarian II and more. Basic debugging: send tape, listings & 50p. Maps for R-Type and more. Penpals wanted!
Richard Corbin, 5 Lister Court, Yoakley Rd, London N16 0BE

Penpal wanted, age 10-12, 464 owner
Richard Westwood, 238A High St, Chasetown WS7 8XH

Help! Instruction leaflets wanted for Ten Computer Hits Nos 2 & 3 by Beau Jolly
E. Hitchen, 19 Wingate Ave, Nutgrove, St Helens, Merseyside WA9 SLE

Penpal wanted, 12yo. Games like Pacland, Op Wolf, Matchday II, Footie Manager II, Arkanoid II and more
2 Lilac Ave, Beech Hill, Wigan WN6 8QU ☎ 0942 493211 (a name would be a nice idea! - ed)

Penpal wanted for 12 yo
Gavin Clark, 2 Thanington Court Farm, Thanington Rd, Canterbury, Kent CT1 3XF

Help wanted on Ikari Warriors - anyone got a poke or something I could use?
Martin Fan, Flat 6, 251 Brays Rd, Sheldon, Birmingham B20 2UL

Penpals please for 14yo willing to send/receive on Mini Office II. Also listings typed, 1p per line. Send tape & listings & PO/cheques to
Paul Campbell, 20 Ballyvester Grove, Bangor, Co Down, Northern Ireland BT19 2RL

Penpal, 14yo, wanted to share games, tips, pokes. Anyone got an AA17?
David Lee, Antigmor Rising Sun, Harrowbarrow, Callington, Cornwall PL17 8JE

AMX Stop Press users! Send £3 and blank disk for 4 pages of excellent clip art and extra fonts. Listings printed 10p per page (send tape/disk)
James Garside, "Talesin," Rhodfa Anwyl, Rhuddlan, Rhyl, Clwyd, LL18 2SF

Anyone got Donkey Kong (Ocean, tape) to sell?
Colin Watson, 8 Woodside, Dailly by Girvan, Ayrshire KA26 9EQ

Help! New to 464, seeking pen pals over 20yo
S. Neill, 125 Eli Bank Rd, Eltham, London SE9 1ON

Maps for photocopying: Wizball, Race v Time, Dizzy II, Game Over II, Ghost Hunters, Platoon. Send 25p & SAE. Need help on some games
Stephen Cumb, 14 Highlees Rd, Mixenden, Halifax, West Yorkshire HX2 8TF

Please please please (*that's enough pleases - ed.*) anyone interested in games & reading AA. I'm 14 and anyone will do
Simon Williams, 24 Chalcot Drive, Hednesford, Staffs WS12 4SF

Basic programs written (price on application). Basic & Pascal programs debugged: send disk or tape stating program. (10p per K of program tape; 15p per K disk)
Craig Willcocks, 105 Kent Avenue, Minster, Sheerness, Sheppey, Kent ME12 2DX

Help! I need a picture digitised ready to use on Stop Press. I'll send the picture to you with an SAE
Stephen Thompson, 5 Pendragon, Great Lumley, Chester-le-Street, County Durham, DH3 4NA

Will supply any help for Mirage Imager and supply any digitized video picture for Advanced Studio. Loads games/utilities
Matthew Clover, 10 Lacon Rd, Bramford, Ipswich, Suffolk = 0473 43811

Loads of maps, pokes and tips for new and old computer games
Mark Watson, 106 Mountain Rd, Thornhill, Dewsbury, West Yorkshire, WF12 0BP

Help on disk drives, printers, Protex, disk backup, tape to disk Multiface and tape loading problems
 Someone from Thanet who forgot a vital bit of information: name and address! Wake up matey! - ed.

Will print listings & screens 10p per page, send tape/disk. Help on AA Studio, Tasword, DMP2000, DKTronics Speech ROM, customising cassette recorders/ joysticks/computers etc.
David Carter, 28 Mt Hermon Rd, Woking Surrey GU22 7UH

Penpal wanted to share tips and pokes
Iain Thomson, 13 Millhill Ave, Kilmours, Kilmarnock, Ayrshire, Scotland KA3 2TA

Maps, tips, codes, pokes on over 250 games, AMX Stop Press. Penpals wanted!
Jay Redfern, 10 Oaktree Close, Mansfield, Notts NG18 3EN

Tips & cheats (no pokes) on Asphalt, Get Dexter I&II, Dizzy, Wizball, Ghosthunters, Super Stuntman, Grand Prix Sim, Super Robin Hood, Sorcery +, Green Beret, Driller. SAE & 10p per game
Alistair London, Maryfield, Strath-martine, Dundee, DD3 0PW

19yo 6128 owner wants penpal who can program M/C so he can learn
John Mullen, 62 Lonsdale St, Workington, Cumbria, CA14 2YD

Ireland only: utilities: disassembler, real time clock, disk search, 6128 extra memory commands. All m/c. Send tape/disk & padded SAE to
D.J.Daly, 'Amber Pines', Annmount, Glounthaune, Cork, Eire

Tape to disk, 464 loading problems, CPC firmware and hardware, disk drive problems, Multiface Two, Hackit (Siren), 6128 tape recorders, Epson compatible printers, simple M/C, computer repairs. And penpals, m/f, over 15 please for 19yo
Rob Scott, 22 North St, Leatherhead, Surrey, KT 22AT = 0372 377443 6.30-11pm except Sunday

Penpal wanted, all letters answered
John Mullen, 62 Lonsdale St, Workington, Cumbria CA14 2YD

Hints, tips on most games & various pokes. Send 30p per game, 45p if you want it typed in ready. Enclose SAE
Keith Meakings and WW (who's WW? - ed.), Corner Cottage, 15 Old St, Hill Head, Fareham, Hants PO14 3HT

Penpals wanted. Desperately need help on Platoon and Green Beret
Alastair Davis, The Old Vicarage, Meerbook, Nr Leek,

Staffs ST13 8SJ
 Penpal wanted - especially UK or Germany to teach me machine code & swap cheat modes. I'm 15
Paul Chen, PO Box 126, Burwood, NSW, Australia 2134

Penpals wanted of any age
Amz Hijazi, 94 Mellitus Street, London W12 OAS = 01 743 6607 between 4.30-8.30

Free info on how to make up to £250 weekly at home in your spare time. Send large SAE
Christopher Bowler, 318A Wrythe Lane, Carshalton, Surrey, SM5 1AF



Feeling helpful? Just send your name, address, phone number (say if you don't want it printed) and subjects on which you're offering help to: **Helpline**, Amstrad Action, 4 Queen Street, Bath, BA1 1EJ.
 Please write on a postcard or the back of a stuck down envelope and keep it short or you won't get in (or you'll get cut to 'load-sagames').
 If you want help contact the appropriate Helpliner - not us. By post include a self-addressed, stamped envelope for the reply - or you won't get one. And phone only in decent hours!
 Piracy is not welcome: don't try it, you'll get booted off. Keep it legal. And if you receive SAE's, for heaven's sake return them with some acknowledgement. If you want to come off **Helpline** just write and say so.
 All comments are the editor's.

25%

off non-budget software RRP

1st Choice for fast friendly service

EDUCATION

	Tape	Disc
Answer Back Quiz (6-11)	7.45	10.45
Fact Files for above		
Arithmetic (6-11)	3.70	6.70
English Words (12+)	3.70	6.70
Gen. Knowledge (12+)	3.70	6.70
Gen. Science (14+)	3.70	6.70
Nat. History (10+)	3.70	6.70
Spelling (6-11)	3.70	6.70
Better Maths (12-16)	8.20	12.70
Better Spelling (9-14)	8.20	12.70
Biology (12-16)	8.20	12.70
Chemistry (12-16)	8.20	12.70
Chemistry GCSE	10.95	14.95
French Mistress		14.95
Fun School (2-5)	4.45	6.70
Fun School (5-8)	4.45	6.70
Fun School (8-12)	4.45	6.70
Fun School 2 (Under 6)	7.45	9.70
Fun School 2 (6-8)	7.45	9.70
Fun School 2 (Over 8)	7.45	9.70
German Master		14.95
Magic Maths (4-8)	8.20	12.70
Maths Mania (8-12)	8.20	12.70
Maxi Maths (9-14)	8.20	12.70
Physics (12-16)	8.20	12.70
Physics GCSE	10.95	14.95
Spelling		6.70

BUSINESS

	Tape	Disc
HomeBudget	1.75	
Mastercalc 128 (6128)		24.70
Masterfile 3		29.95
Mini Office 2	10.95	14.95
Protex	14.95	19.95
Tasword (464 or 6128)	18.70	22.45
Tascopy	8.95	10.95

BUDGET

Choice Cheats 1	2.99	4.99
Choice Cheats 2	2.99	4.99
Big Foot	2.99	
Commando	2.99	
Football Manager	2.99	
Footballer of the Year	2.99	
Gauntlet	2.99	
Moto Cross Simulator	2.99	
Pro Snooker	2.99	
SAS Combat	2.99	
Street Gang Football	2.99	
The Hit Squad	2.99	
Treasure Island Dizzy	2.99	
Twin Turbo V8	2.99	
Zorro	2.99	
Air Wolf	1.99	
B. McGuigan's Boxing	1.99	
Bomb Jack	1.99	
Bubble Bobble	1.99	
Dynamite Dan	1.99	
Dun Darach	1.99	
European 5 a Side	1.99	
Ghostbusters	1.99	
Gun Boat	1.99	
Joe Blade 2	1.99	
Shanghai Karate	1.99	
Steve Davis Snooker	1.99	
Thing	1.99	
Yabba Dabba Doo	1.99	
Yogi Bear	1.99	
Xeno	1.99	

LEISURE & SPORT

E. Hughes Int. Soccer	7.45	10.95
Football Manager 2	7.45	10.95
Game Set and Match 2	9.70	13.45
G. Lineker Sup. Skills	7.45	10.95
Gold Silver Bronze	10.95	18.70
Tour de Force	7.45	
Triv. Pursuit New Beg.	10.95	14.95
Triv. Pursuit Genius	10.95	14.95
Triv. Pursuit Young	10.95	14.95
Wec le Mans	7.45	10.95

EDUCATION EXTRA

Buy any 2 educational products

£1 off next order

BUDGET BARGAIN

Save over a £1

3 @ £1.99
or
2 @ £2.99

only £4.99

CHEAT for only

**Tape £2.99
Disc £4.99**

Bend the rules! Play your games until dusk, with cheat options such as infinite weapons and immunity.

CHOICE CHEATS 1

Cheat at: By Fair Means or Foul, Cybernoid, Karnov, Operation Wolf, Flying Shark, Radius, Tanium, Advanced Pinball Simulator, Joe Blade 2, Star Trooper, Reflex and Shanghai Karate.

CHOICE CHEATS 2

Cheat at: Dragon Ninja, Hopper Copper, Arkonoid, Arkonoid 2, Dynamite Dan, Solomon's Key, Dizzy 2, ATV Simulator, Empire Strikes Back, Pro Ski Simulator, Batman and Head Over Heels.

Many more items in stock than listed phone us for **DISCOUNT PRICES**

All prices are inclusive of VAT and P & P in UK.
To order send cheque or PO to

1st Choice Software Ltd
 Dept AA/9
 4 Paul Row, Temple Lane
 Littleborough, Lancs. OL15 9QG

phone **0706 72728**

Please state Name, Address, Title, Disc or Cassette and price

ARCADE

	Tape	Disc
4 X 4 Off Road Racing	7.45	10.95
Action Force	7.45	
After Burner	7.45	10.95
Barbarian 2	7.45	10.95
Batman Caped Crus.	7.45	10.95
Command Perf	9.70	10.95
Crazy Cars 2	7.45	10.95
Cybernoid	7.45	
Dan Dare 2	5.95	
Dark Side	7.45	10.95
Dark Fusion	7.45	10.95
Dragon Ninja	7.45	10.95
Driller	10.95	13.45
Fire Trap	7.45	
Gothic		10.95
Giants	9.70	14.95
Marauder	7.45	
Netherworlds	7.45	10.95
Operation Wolf	7.45	10.95
Obliterator	7.45	
Pacland	7.45	10.95
Real Ghostbusters	7.45	10.95
Robocop	7.45	10.95
Running Man	7.45	10.95
Run The Gauntlet	7.45	10.95
Samurai Warrior	6.70	10.95
Skweek	7.45	10.95
Storm Lord	7.45	10.95
Thunderbirds	7.45	10.95
Venom Strikes Back	7.45	

ADVENTURE

Game Over 2	6.70	9.70
Ingrid's Back	10.95	14.95
Lancelot	10.95	14.95
Realm of the Trolls	7.45	9.70
Time and Magic	10.95	10.95

TYPE-INS

Roll up, roll up, get your typing practice here with PAT McDONALD

MODULE DESIGNER

Been reading *The Look* and getting anxious for that program to let you build up icons with redefined characters? Well, here it is! Rather than filling up your Basic listings with lots of SYM-BOL commands and LOCATE statements, use this instead...

The program lets you draw large blocks of characters (called modules). If you've been using the *Symbolizer* to create strange character sets, then you can use those in your modules.

It's mostly menu driven and self explanatory, but in any case here's a brief guide. Alter the mode to suit your tastes: it's only used for actually drawing the sprites. The first usable character should be set to the first one you've altered - so if you've edited 0 set it to 0, if you've only messed about with

200-255 then set it to 200, and so on.

Loading a character set is simple. When drawing a module, enter how high and wide you want it: it can be as big as the current screen. Use the cursor keys and space or a joystick to move the cursor around. Press s to select a different character. CLR wipes the character under the cursor, and RETURN finishes off the process.

Discard the character if you don't want it, or assign a number from 1-255 to it. Characters can be edited again if you want to change them, and loaded or saved to tape or disk. If you accidentally retain a module that you don't want, then you can delete it, and there's also a status option to see just what you've got.

```
{BvBm} 10 'FOR n=40593 TO 40705:PRINT n,PEEK(n):
      NEXT:END
{GoAq} 20 'AA Module Designer
{OxAp} 30 'By Pat McDonald
{GuBq} 40 'Public Domain - Amstrad Action September
      1989
{AxCx} 50 SYMBOL AFTER 0: memfin=HIMEM:MEMORY
      (HIMEM-10240):memstart=HIMEM+1:SYMBOL
      0,0,0,0,0,0,0,0
{GiEn} 60 firstchar=240:charflag=0:tempx=0:tempy=0
      :select=240:modeno=1:xwidth=40:pixwidth=
      16:DIM modnum(255):transfer=1000:
      transfer$="XXXXXXXXXXXXXXXX"
{LxAp} 70 RESTORE 110
{FwAo} 80 FOR n=0 TO 11
{EkAt} 90 READ a:POKE &BE80+n,a
{OwAj} 100 NEXT
{CnBn} 110 DATA 33,0,0,17,0,0,1,0,0,237,184,201
{NwAr} 120 WHILE aafolded=0
{GxAAn} 130 GOSUB 220
{FuBk} 140 LOCATE 10,1:PRINT "AA Module Designer"
{GxAq} 150 RESTORE 170
{IxBu} 160 FOR n=1 TO 8:READ a$:LOCATE 7,2+(n*2):
      PRINT n;" " ;a$:NEXT
{KlEp} 170 DATA Set Mode,Set First Character,Load
      Character Set,Draw Module,Edit Existing
      Module,Load/Save Modules>Delete a Module,
      Status of Modules
{NvCv} 180 LOCATE 1,21:PRINT "Free memory:";memfin
      -memstart-2048;" First Character:";
```

```
      firstchar
{CwCj} 190 LOCATE 3,24:CALL &BB00:INPUT "Please
      enter your selection:";n
{PuBo} 200 ON n GOSUB 1050,280,330,380,1270,1410,
      1670,1720
{PwAk} 210 WEND
{FoBn} 220 MODE 1:INK 0,0:INK 1,26:PEN 1:RETURN
{AtBq} 230 MODE modeno:INK 0,0:INK 1,26:PEN 1:
      RETURN
{EkCk} 240 GOSUB 220:LOCATE 5,10:PRINT b$;" " ;:
      CALL &BB00:INPUT transfer
{JmAo} 250 b$="":RETURN
{FuCl} 260 GOSUB 220:LOCATE 5,10:PRINT b$;" " ;:
      CALL &BB00:INPUT transfer$
{BsAp} 270 b$="":RETURN
{EpBk} 280 WHILE transfer <0 OR transfer >255
{EvBr} 290 b$="First redefined character?":GOSUB
      240
{GuAk} 300 WEND
{KlAx} 310 firstchar=transfer:transfer=1000
{DlAn} 320 RETURN
{KiBp} 330 WHILE LEN(transfer$) > 8 OR LEN
      (transfer$) <1
{FtBp} 340 b$="Filename of character set?":GOSUB
      260
{DiAl} 350 WEND
{HiCr} 360 filename$=transfer$:transfer$=
      "XXXXXXXXXXXXXXXX":LOAD filename$,
      memstart+10240
{PpAm} 370 RETURN
{PjBj} 380 WHILE transfer <1 OR transfer >25
{AuBt} 390 b$="How tall will the module be?":
      GOSUB 240
```

● Next month there'll be a machine code printing routine to use modules in your own programs, plus *AA Sprites*. Don't miss it!

```

{JvAk} 400 WEND
{DkAu} 410 tempy=transfer:transfer=1000
{HsBk} 420 WHILE transfer <1 OR transfer >xwidth
{ApBq} 430 b$="How wide will the module be?":GOSUB
240
{DjAl} 440 WEND
{OsBi} 450 FOR n=memstart TO memstart+2047
{GpAq} 460 POKE n,0:NEXT
{DwAv} 470 tempx=transfer:transfer=1000
{CoAt} 480 posy=tempy*16-2:posx=0
{HrBv} 490 GOSUB 680:GOSUB 730:MOVE posx,posy:TAG:
PRINT CHR$(select);
{LiAq} 500 MOVE posx,posy
{NrAr} 510 WHILE INKEY(18) <> 0
{OuBq} 520 IF INKEY(60) = 0 THEN GOSUB 790: REM
select
{AmBq} 530 GOSUB 1030:IF fire =1 THEN GOSUB 880:
fire=0
{NlBx} 540 IF INKEY(16) = 0 THEN GOSUB 1400: REM
wipe character
{LjAp} 550 GOSUB 910:WEND
{NrBr} 560 b$="Do you want to discard this?":
GOSUB 260
{GoBm} 570 c$=transfer$:transfer$="XXXXXXXXXXXXXXXX"
{FmBt} 580 IF LEFT$(c$,1)="y" OR LEFT$(c$,1)="Y"
THEN RETURN
{EnBk} 590 WHILE transfer <1 OR transfer >255
{HjBo} 600 b$="What number module is this?":GOSUB
240
{IoAk} 610 WEND
{OsAv} 620 w=transfer:transfer=1000
{PiDm} 630 IF modnum(w) <> 0 THEN GOSUB 220:LOCATE
10,1:PRINT "Module already exists!":
CALL &BB18:GOTO 590
{CiBk} 640 GOSUB 1140:REM poke header information
{ArAw} 650 RETURN:REM end of drawing
{AqAn} 660 RETURN
{DwAt} 670 'draw temporary memory
{HtAr} 680 GOSUB 230:w=0:TAG
{BuBi} 690 FOR z=(tempy*16)-2 TO 14 STEP-16
{NrBo} 700 FOR q=0 TO ((pixwidth*tempx)-pixwidth)
STEP pixwidth
{FqBn} 710 MOVE q,z:PRINT CHR$(PEEK(memstart+w));
{KxBs} 720 w=w+1:NEXT:NEXT:TAGOFF:MOVE posx,posy:
RETURN
{DjBk} 730 TAGOFF:PRINT CHR$(23);:PRINT CHR$(1);
{OxA} 740 RETURN
{BuBk} 750 TAGOFF:PRINT CHR$(23);:PRINT CHR$(0);
{FxA} 760 RETURN
{OlBk} 770 z=((tempy*16)-2)-posy)/16:w=posx/
pixwidth
{OkAv} 780 memcoord=(z*tempx)+w:RETURN
{AxBi} 790 GOSUB 230:startchar=select
{ImAv} 800 GOSUB 750:WHILE fire=0
{IuBv} 810 TAG:MOVE 320,200:PRINT CHR$(startchar);
" ";startchar;" ";
{NpCs} 820 GOSUB 980:IF left=1 AND startchar>
firstchar THEN startchar=startchar-1:
left=0
{PsCk} 830 IF right=1 AND startchar<255 THEN
startchar=startchar+1:right=0
{AiAo} 840 GOSUB 1030
{OwAk} 850 WEND
{GwAw} 860 fire=0:TAGOFF:select=startchar
{AuCr} 870 GOSUB 680:GOSUB 730:MOVE POSX,POSY:TAG:
PRINT CHR$(select);:TAGOFF:MOVE POSX,
POSY:RETURN
{EvEk} 880 GOSUB 750:TAG:MOVE posx,posy:PRINT CHR$(
select);:TAGOFF:GOSUB 730:TAG:MOVE
posx,posy:PRINT CHR$(select);:MOVE posx
,posy:TAGOFF
{GqBn} 890 GOSUB 770:POKE (memcoord+memstart),
select
{HjAn} 900 RETURN
{AjCp} 910 GOSUB 980:IF left=1 AND posx>0 THEN
GOSUB 970:posx=posx-(pixwidth):GOSUB 970
{OpCu} 920 IF right=1 AND posx<(tempx*pixwidth)-
pixwidth THEN GOSUB 970:posx=posx+
pixwidth:GOSUB 970
{IkCm} 930 IF up=1 AND posy<(tempy*16)-16 THEN
GOSUB 970:posy=posy+16:GOSUB 970
{OsCk} 940 IF down=1 AND posy>16 THEN GOSUB 970:
posy=posy-16:GOSUB 970
{LlBk} 950 down=0:up=0:right=0:left=0:fire=0
{AvAn} 960 RETURN
{KmCq} 970 GOSUB 730:TAG:MOVE posx,posy:PRINT CHR$(
select);:TAGOFF:MOVE posx,posy:RETURN
{BpBr} 980 IF INKEY(8) = 0 OR INKEY(74) = 0 THEN
left=1
{OtBo} 990 IF INKEY(1) = 0 OR INKEY(75) = 0 THEN
right=1
{GxBp} 1000 IF INKEY(0) = 0 OR INKEY(72) = 0 THEN
up=1
{ImBq} 1010 IF INKEY(2) = 0 OR INKEY(73) = 0 THEN
down=1
{DtAo} 1020 RETURN
{FtBp} 1030 IF INKEY(47) = 0 OR INKEY(76) = 0 THEN
fire=1
{FvAo} 1040 RETURN
{JuBi} 1050 WHILE transfer <0 OR transfer >2
{BlBo} 1060 b$="Which mode do you want?":GOSUB
240
{DjAl} 1070 WEND
{DxA} 1080 modeno=transfer:transfer=1000
{HwBn} 1090 IF modeno=0 THEN
pixwidth=32:xwidth=20
{MqBm} 1100 IF modeno=1 THEN
pixwidth=16:xwidth=40
{JmBl} 1110 IF modeno=2 THEN
pixwidth=8:xwidth=80
{PjAn} 1120 RETURN
{GuAw} 1130 'Header information plus data

```

I'm sorry Dave
I can't do that!

● Perfect for 2001 obscure error messages

**FUN FROM DOWN UNDER
THAT WILL HAVE YOU STANDING
ON YOUR HEAD**

TAITO

**THE
NEWZEALAND
STORY**

**CHVG
HIT!**

SPECTRUM
8.99
CBM/AMSTRAD
9.99
ATARI ST
19.99
AMIGA
24.99

TAITO'S ARCADE HIT **POUNCES**
ONTO YOUR MICRO SCREEN WITH
A BURST OF ZANY ACTION.

Wally Walrus has captured his tea - 20 of Joey Kiwi's friends from the New Zealand zoo, and if Joey doesn't rescue them all by tea-time they'll be stuffed, served and swallowed at Wally's table. Joey has to search Wally's domain which is just how you would expect it to be - FAT with danger!

Armed only with a bow and arrow, Joey can accumulate more weapons along the way. Beware of the malicious rabbits, boomerang throwers, deadly frogs, blood-sucking bats and many, many more villainous creatures.

ocean

Ocean Software Limited · 6 Central Street · Manchester · M2 5NS
Telephone: 061 832 6633 · Telex: 669977 OCEANS G · Fax: 061 834 0650



Mostly harmless

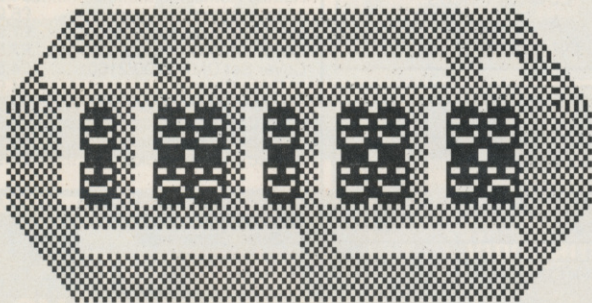

```
{EpAp} 1170 POKE z+2, tempy
{GwAn} 1180 memfin=z-1
{ErAl} 1190 q=0
{JmAr} 1200 FOR n=1 TO tempy
{IvAq} 1210 FOR m=1 TO tempq
{IvAt} 1220 a=PEEK(q+memstart)
{ImAs} 1230 POKE z+3+q, a:q=q+1
{BoAl} 1240 NEXT
{MtAl} 1250 NEXT
{HtAo} 1260 RETURN
{NsBj} 1270 WHILE transfer <1 OR transfer >255
{LtBk} 1280 b$="Edit which module?":GOSUB 240
{LtAl} 1290 WEND
{AjAu} 1300 a=transfer:transfer=1000
{FuAx} 1310 b=modnum(a):c=PEEK(b)
{BtCs} 1320 IF a <> c THEN GOSUB 220:LOCATE 10,1:
PRINT "No such module!":CALL &BB18:
RETURN
{ApAl} 1330 q=0
{PnBk} 1340 tempq=PEEK(b+1):tempy=PEEK(b+2)
{GmEn} 1350 IF memfin-(memstart+2048) < (tempy*
tempq) THEN tempq=0:tempy=0:GOSUB 220:
LOCATE 10,1:PRINT "Not enough
memory!":CALL &BB18:RETURN
{IpBj} 1360 FOR n=1 TO tempy:FOR m=1 TO tempq
{PkAx} 1370 POKE (memstart+q), PEEK(b+3+q)
{HwAs} 1380 q=q+1:NEXT:NEXT
{FiAn} 1390 GOTO 480
{NnFo} 1400 MOVE posx, posy:GOSUB 750:TAG:MOVE posx
, posy:PRINT CHR$(0):MOVE posx, posy:
PRINT CHR$(select):MOVE posx, posy:
GOSUB 770:MOVE posx, posy:POKE
(memcoord+memstart), 0:RETURN
{PmCr} 1410 b$="Save or Load ( S or L?:":GOSUB 260
:z$=transfer$:transfer$="XXXXXXXXXXXXX"
{DuBp} 1420 WHILE LEN(transfer$) <1 OR LEN(
transfer$) >8
{JuBi} 1430 b$="Filename?":GOSUB 260:WEND
{MvBq} 1440 filename$=transfer$:transfer$=
"XXXXXXXXXXXXX"
{KoBx} 1450 IF LEFT$(z$, 1)="S" OR LEFT$(z$, 1)="s"
THEN GOSUB 1560:RETURN
{NqBj} 1460 w=memstart+2048:LOAD filename$, w
{MsBo} 1470 stemp=PEEK(w):FOR n=1 TO 255:modnum
(n)=0:NEXT
```

● Left: why have boring old traditional green men?

```
{KwAs} 1480 WHILE stemp <> 0
{CmAp} 1490 stemp=PEEK(w)
{CrAq} 1500 modnum(stemp)=w
{NsAx} 1510 b=PEEK(w+1)*PEEK(w+2):w=w+b+3
{OsAk} 1520 WEND
{HkBj} 1530 w=w-3:GOSUB 1580:FOR n=1 TO 255
{DpBq} 1540 IF modnum(n) <> 0 THEN modnum(n)=
modnum(n)+u
{HjAn} 1550 NEXT:RETURN
{FlBu} 1560 SAVE filename$, b, memfin+1, (memstart+
10240)-(memfin+1)
{OiAn} 1570 RETURN
{DwBo} 1580 q=memstart+2048:r=w-q+1:s=w:q=q+8192
{JwAq} 1590 'r=w-q:REMq=de, r=bc
{LkAu} 1600 's=w-1:q=q+8192:REMhl
{HjBx} 1610 GOSUB 1620:memfin=q-r:u=memfin+1-
(memstart+2048):RETURN
{NwAw} 1620 z=s:where=&BE81:GOSUB 1660
{GuBi} 1630 z=q:where=&BE84:GOSUB 1660
{KsBj} 1640 z=r:where=&BE87:GOSUB 1660
{JoAs} 1650 CALL &BE80:RETURN
{DrCj} 1660 w=INT(z/256):v=z-(w*256):POKE where, v
:POKE where+1, w:RETURN
{KxBm} 1670 IF memfin=memstart+10239 THEN RETURN
{PxBl} 1680 WHILE transfer <1 OR transfer >255
{BjBr} 1690 b$="Module to delete?":GOSUB 240:WEND
{MxCq} 1700 s=modnum(transfer)-1:r=PEEK(modnum
```

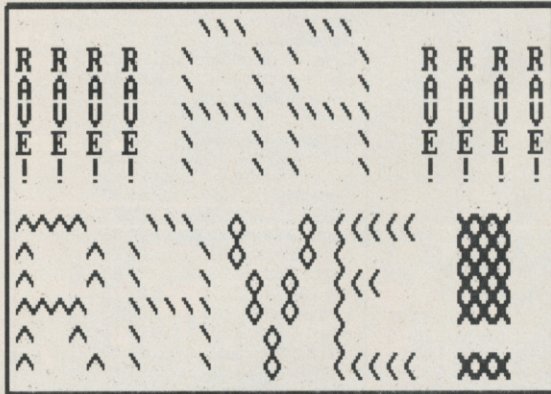

● New rave logo? No problem!

```
(transfer+1)*PEEK(modnum(transfer)+2)
+3:q=s+r
{HiBx} 1710 GOSUB 1620:modnum(transfer)=0:transfer
=1000:memfin=memfin+r:RETURN
{LwCo} 1720 GOSUB 220:LOCATE 10,1:PRINT"Module
Status":PRINT"Number Width
Height"
{ILDj} 1730 FOR n=1 TO 255:IF modnum(n) <> 0 THEN
PRINT PEEK(modnum(n)); " ";PEEK
(modnum(n)+1); " ";PEEK(modnum(n)+2)
{LsAn} 1740 NEXT:RETURN ●
```

K & M COMPUTERS

THE LEADING AMSTRAD MAIL ORDER SPECIALISTS

ADVENTURE	CASS	DISC
Time and Magik	£11.25	£11.25
Gnome II: Ingrid's back	£11.25	£14.75
Pawn (6128)		£14.75
Jinxter (6128)	phone	£14.75
Corruption (6128)	phone	£14.75

COMPILATIONS		
Soccer Spectacular	£10.50	Phone
Special Action	£10.50	Phone
The Story So Far (Vol. 1) Phone		
The In Crowd	£11.25	-
History in the Making	£15.95	£21.50
Taito Coin-op (inc. Rastan)	£9.90	
Supreme Challenger (Inc Elite)	£9.90	£13.10
Gold Silver & Bronze	£11.25	£21.50
Giants	£10.50	£15.95
Flight Ace	£11.25	£13.95
Arcade Muscle	£10.50	Phone
Command Performance	£9.90	£15.95
Frank Brunos Big Box	£9.90	£13.10
We are the Champions	£7.75	£13.10
Fists N Throttles	£9.90	£13.10
Game Set & Match II	£9.90	£13.10
Space Ace	£10.50	£11.25
KidsPlay	£2.99	

STRATEGY / SIMULATION		
Kenny Dalglish	£7.75	
Football Manager II	£7.75	£11.25
F.ball Man.II Expansion Kit	£6.25	£7.25
Football Director II		£14.75
Gunship	£11.25	£14.75
Ancient Battles	£11.25	
Micropose Soccer	£11.25	£14.75
Times of Lore	£7.75	£11.25
Chuck Yeagers Ad Trainer	£7.75	£11.25
3D Pool	£7.75	£11.25
Bards Tale	£2.75	£6.25
Question of Sport	£9.99	£14.75
Football Director (464)	£7.75	
Roy of the Rovers	£7.75	£11.25
The National	£7.75	
War in Middle Earth	£7.75	£11.25
Heroes of The Lance	£7.75	£15.90
Airborne Ranger	£11.25	£14.75
Trivial Pursuit (New Edition)	£11.25	£14.75
Emlyn Hughes Soccer	£7.75	£11.25
Track-Suit Manager	£7.75	£11.25
Laser Squad	£7.75	£11.25
4 Soccer Simulator	£7.75	£11.25
Archon Collection	£2.75	£6.25
Classic Games 4	£7.75	£11.25
Carrier Command	N	£Phone

EDUCATIONAL		
Answer Back Jnr	£7.95	£11.95
Facfile 500s	£3.75	£6.75
Fun School (U5s, 5-8, 8-12)	£5.50	£7.95
Maxi Maths (Geometry)	£8.50	£13.95
The Three Bears (6128)		£15.95
Giant Killer (9-14)		£12.95
Happy Breathing (12-16)		£13.95
Magic Maths (4-8)	£8.50	£12.95
Maths Mania (8-12)	£8.50	£12.95
Chemistry GCSE	£11.90	£14.95
Physics GCSE	£11.90	£14.95
Biology 1 (12-16)	£8.50	£12.95
Wordhang	£7.50	£11.95
Happy Writing	£7.50	£11.95
Physics 1 (12-16)	£8.50	£13.95
Mapwork Geography Quiz	£8.50	£13.95
Spanish Tutor	£12.95	£15.95
French Mistress	£12.95	£15.95
German Master	£12.95	£15.95
Iankey Crash Course (6128/PCW)		£19.90
Iankey Two Finger (6128/PCW)		£19.90
Fun School 2 (U6s, 6-8, 8+)	£7.99	£9.99
Happy Fractions (12-16)		£13.95

ARCADE	CASS	DISC
Thunderbirds	£10.25	£11.25
All New Ghostbusters	£7.75	£11.25
Run The Gauntlet	£7.75	£11.25
Dominator	£7.75	£11.25
Vigilante	N	£7.75 £11.25
H.A.T.E.	£7.75	£11.25
Robocop	£7.75	£11.25
Skweek	£7.75	£11.25
StormLord	£7.75	£11.25
New Zealand Story	£7.75	£11.25
Indy (Last Crusade)	N	£7.75 £11.25
Super Scramble	£7.75	£11.25
Barbarian II	£7.75	£11.25
Forgotten Worlds	£7.75	£11.25
Red Heat	N	£7.75 £11.25
Crazy Cars II	£7.75	£11.25
1943 (Midway)	£7.75	£11.25
Afterburner	£7.75	£11.25
Navy Moves	£7.75	£11.25
Munsters	£7.75	£11.25
WEC Le Mans	£7.75	£11.25
Silkworm	£7.75	£11.25
Vindicators	£7.75	£11.25
APB	N	£7.75 £11.25
Purple Satin Day	N	£7.75 £11.25
Operation Neptune	N	£7.75 £11.25
Licence To Kill	N	£7.75 £11.25
Blasteroids	£7.75	£11.25
Batman (New)	£7.75	£11.25
Dragon Ninja	£7.75	£11.25
Superman	£7.75	£11.25
SuperTrux	£7.75	£11.25
Rick Dangerous	N	£7.75 £11.25
Butcher Hill	N	£7.75 £11.25
Titan (SPECIAL PRICE)	£6.99	£10.25
Renegade III	£7.75	£11.25
Xybots	£7.75	£11.25
High Steel	N	£7.75 £11.25

BUDGET	CASS ONLY
Spy Hunter	£2.75
Battleships	£1.80
Quest / Golden Eggcup	£1.80
Split Personalities	£1.80
Frank Bruno Boxing	£1.80
Super Trolley	£1.80
Trantor	£2.75
Turbo Esprit	£1.80
BMX Simulator II	£2.75
Ghostbusters	£1.80
720	£2.75
Formula Grand Prix	£1.80
A.T.V. Simulator	£2.75
Rugby Boss	£1.80
Mig 29	£2.75
Moto X Sim.	£2.75
Ace II	£2.75
Bombjack	£1.80
Twin Turbo V8	£2.75
Shockway Rider	£2.75
B.M.X. Freestyle	£2.75
Roadrunner	£2.75
Kickstart II	£1.80
Rocky Horror Show	£1.80
Postman Pat	£1.80
Jocky Wilson Darts	£2.75
Grand Prix Sim 2	£2.75
Green Beret	£2.75
Treasure Island Dizzy	£2.75
Fast Food	£2.75
Adv. Pinball Sim.	£2.75
Gauntlet II	£2.75
1942	£2.75
Blackbeard	£2.75
Street Cred Boxing	£2.75

Lowest Prices
Available on
Printer Ribbons

Special prices on
A.M.S. Software

StopPress	£39.95
StopPress & Mouse	£72.95
Mouse & Art	£61.95
Mouse Mats	£4.95
Max	£16.95
Extra Extra	£21.95

KDS Electronics
Special Offers

Rombox	£24.95
5 1/2 Second Drive	£158.95
8 Bit Pr. Port	£18.75
Serial Int + Rom	£44.95
Printer T Switch	£24.95
Screen Master	£14.95
Ramdos (Disc)	£23.95
Ramdos (Rom)	£27.95

KDS Modems are no
longer available

Mini Office II
Still our No1 Seller
Cass £11.25 Disc £14.75

Amsoft/Maxell 3" Discs

One	£2.50
Five	£12.50
Ten	£24.95
5 1/2 Discs TEN	£3.90
3 1/2 Discs TEN	£9.50

A Swift Reduction on
Armor Products

Protect Disc	£18.45
Protect Rom	£28.45
Promerge Disc	£18.45
Promerge+ Rom	£23.45
Prospell Disc	£17.45
Prospell Rom	£23.45
Maxam Disc	£18.45
Maxam Rom	£28.45
Maxam 1.5 Rom	£21.45
Utopia Rom	£21.45

All Prices Include Vat & P&P
in U.K.
In stock items sent by
return of post.

SPECIAL OFFER
ORDER ANY FIVE
£1.80 Budget games
and pay only £8.00

DMP 2000/2160/3000
Ribbons
£3.25 each
£5.99 for Two
£13.50 for Five

ACCESSORIES

Rombox Rombox	£34.95
464 Keyboard Ext Leads	£6.99
6128 Keyboard Ext Leads	£7.99
Cover Set 464 or 6128	£7.50
Cover Set DMP 2000/2160	£4.50
3" Drive Cleaner	£4.99
Cassette Player & Leads	£19.99
6128 Cassette Leads	£3.50
Lockable 3" Disc Boxes	£9.99
3" Disc Cabinet (Holds 10)	£5.95

JOYSTICKS

Superboard	£18.95
Cheetah Starfighter	£13.95
Konix Navigator	£13.95
Gunshot	£5.75
Quickjoy II Turbo	£10.50
Cheetah 125+	£7.95
Supercharger	£12.95
Cheetah Challenger	£4.75
Konix Autofire	£11.95
Konix Speedking	£9.99
Cruiser (Microswitch)	£9.50
Delta	£9.50
Wico Ergostik	£17.75
Amstrad JV2	£13.95
Cheetah Mach I	£10.95
Quickjoy II	£8.50
Quickjoy Turbo	£10.50

BUS/UTILITIES

Adv. Art Studio	£19.99
Joystick Splitter	£7.95
Tasword 6128	£19.95
Money Manager	£24.95
Mastercalc 128	£27.95
Qualitas+	£12.95
Masterfile III	£32.95
Plan-It	£14.75
Professional Adv. Writer	£24.95
Art Studio & Mouse	£49.95
Tasspell	£13.95

HARDWARE ETC

2160 Printer	£159.95
DDI Disc Drive	£159.95
MP2 Modulator	£29.95
FD1 Second Drive	£99.95
64K Memory Expansion	£47.95
Screen Filter	£19.99
Eprom Storage Box	£1.99
Cont. Paper 2000 60g	£18.50
Cont. Paper 2000 80g	£20.50
Mouse Mats	£4.95
Surge Plug	£12.50
C15 Cassettes	£45
Fanfold Labels (1000)	£5.90
Mouse House	£3.95
RS232 with Commstar	£55.95
Printer Cable	£9.99

NEW LINES AT LOWEST PRICES

Atari ST Super Pack	£360.00
Amiga A500 Inc Mod.	£370.00
PCW8256 (Inc VAT)	£389.00
PCW8512 (Inc. VAT)	£499.00
PCW9512 (Inc VAT)	£510.00
PPC512 (Inc VAT)	£449.00
PC1512 (Inc VAT)	from £449.00
PC1640 (Inc VAT)	from £550.00
PC2086 (Inc VAT)	from £675.00
Utax GRP. 3 fax (Inc VAT)	£999.00
DMP 4000 Printer	£375.00
DMP 3250 Printer	£220.95
LQ 3500 Printer	£375.00
Epson LX800 Printer	£299.00
Commodore PC 1	from £349.00
80 C Printer Muffler	£85.00

PCW Owners
write or phone for
new catalogue.
PC200 Software available.
Prices in this advert
are for Amstrad 464/6128

All items are subject to availability

Access orders by phone or Mail
N = New release
Please Phone for availability
and other new releases

K & M Computers (AA)
140, Sandy Lane Centre
Skelmersdale,
Lancs, WN8 8LH

24 Hrs Phone 0695 29046

When ordering please state make of computer.
Please make cheques & P.O. payable to K & M Computers.
Overseas inc. Eire add £1.00 per item of software.
We supply government & educational establishments.

Shop Open 9-6 Mon-Sat



Prop. K. Fairhurst

CHEAT MODE

And in a packed programme tonight (© Two Ronnies, 1948)..., Let 'em have it, TRENT!

THE REAL GHOSTBUSTERS

When there's something strange in your neighbourhood, who ya gonna call? The Real Phil Howard, that's who! You can really get busting now with infinite lives to stop you joining the spook crew too! Tape method 1

```
{EkAs} 1 'REAL GHOST BUSTERS
{FrAj} 2 'by Phil Howard, AA48
{EpAs} 3 'INFINITE LIVES
{FtAj} 4 '
{BlAt} 10 DATA 21, 09, be, 22, 4f, 30
{CjAs} 20 DATA c3, 00, 30, af, 32, bc
{NkAr} 30 DATA 65, c3, 80, 4e
{IqAr} 40 MEMORY &2000:y=0
{GwAr} 50 FOR x=&BE00 TO &BE0F
{KiAt} 60 READ a$:a=VAL("&" + a$)
{PiAs} 70 y=y+a:POKE x,a:NEXT
{KwAt} 80 IF y<&60F THEN 110
{OxAm} 90 LOAD"RGB"
{ExAo} 100 CALL &BE00
{KnAr} 110 PRINT"data error!" ●
```



Lost? Here's the way...

If you'd dearly like to input one of these pokes, but don't know how, despair not! Two things to help you:

- 1) The four characters in the funny brackets at the end of each line aren't to be typed in. They're part of an error-checking program we printed in AA45. If you don't have a copy, it's best just to ignore them until we reprint the program (soon, honest!).
- 2) Yes, you're saying, but how do I get the blasted pokes to run? Turn over...

Vindicators

Is *Vindicators* too hot to handle? Do your tin machines ending up as smoulder wrecks in some distant Tangent land? No more, as Phil Howard of Mapperly conjures up weaker opponents and immortality for tank commanders with a seriously destructive bent. Tape method 1

```
{EnAp} 1 'VINDICATORS
{FrAj} 2 'by Phil Howard: AA48
{KvAq} 3 'WEAKER OPPONENTS
{FtAj} 4 '
{NiAs} 5 'INFINITE LIVES
{FvAj} 6 '
{CrAs} 10 DATA 21, 23, 41, 36, c3, 23
{HkAt} 20 DATA 36, 0e, 23, 36, be, c3
{AnAt} 30 DATA 00, 40, 3e, 3e, 32, 72
{PmAu} 40 DATA 2D, 3E, C9, 32, 58, 06
{CsAo} 50 DATA C3, 00, 04
{CjAq} 60 MEMORY &3000:Y=0
{CLAp} 70 FOR X=&BE00 TO &BE1A
{OkAs} 80 READ A$:A=VAL("&" + A$)
{IoAs} 90 POKE X,A:Y=Y+A:NEXT
{CvAu} 100 IF Y<&7AA THEN 130
{NpAo} 110 LOAD"VIND"
{HlAp} 120 CALL &BE00
{ErAt} 130 PRINT"DATA ERROR!" ●
```



RENEGADE III

Set your *Renegade III* free with infinite lives! So no need to worry about little red cavemen, mummified birds, knights in shining armour or bug eyed space men. Kick some butt and rescue your girl courtesy of Phil Howard, Nottingham's very own poke vigilante. Tape Method 1

```
{OkAo} 1 'renegade III
{FrAj} 2 'by Phil Howard: AA48
{GuAu} 3 'infinite time + lives
{FtAj} 4 '
{KmAt} 10 DATA 21, 16, BD, 36, C3, 23
{DkAt} 20 DATA 36, 0E, 23, 36, BE, C3
{BuAu} 30 DATA a5, 99, 21, 17, BE, 22
{PvAs} 40 DATA 4f, A6, C3, 08, A6, DD
{EsAv} 50 DATA 21, b9, a8, 11, ab, 00
{GtAr} 60 DATA CD, 48, a8, 21, 2A, BE
{NpAu} 70 DATA 22, 62, a9, C3, e3, a8
{AwAv} 80 DATA 3E, c9, 32, df, 4d, af
{IpAu} 0 DATA 32, 89, 2b, c3, b3, 64
{CkAp} 100 y=0:MEMORY &5000
{LLAs} 110 FOR x=&BE00 TO &BE35
{PxAu} 120 READ a$:a=VAL("&" + a$)
{MmAt} 130 POKE x,a:y=y+a:NEXT
{OjAt} 140 IF y<&181A THEN 170
{DmAp} 150 LOAD"renegade
{LtAo} 160 CALL &BE00
{BjAs} 170 PRINT"data error!" ●
```

● Look out for next month's huge whacking great enormous Cheat Mode special!

"How do I get the blasted pokes to run?"

The three pokes printed on the previous page are all for tape versions of the games only: they won't work if you have the disk version.

There are two methods of loading tape pokes, but since this month's are all **Method 1** you don't need to know about the other kind.

Simply follow these steps...

- 1) Rewind the game tape to the beginning;
- 2) Type in the poke listing exactly as printed

here. Change absolutely nothing.

- 3) Now type **RUN** and press the Enter key. (Don't use the key marked CTRL or Control, or the poke won't work.)
- 4) Press the Play key on the cassette deck, then any key on the main keyboard – the spacebar's as good as any.
- 5) The tape should now play through as normal, except that hopefully you'll find you have infinite lives – or whatever effect the poke has on the game.

What if it still won't work?

If you've followed these instructions and nothing happens, it's possible you've not typed in the program absolutely accurately. Get a friend to check it over, telling them you'll give them £1 (or 1p, if you're mean) for every mistake in your typing they can find.

- Failing that, get hold of a copy of AA46 and read "Bug Killer" on p.71. We'll reprint it soon. ●

— Black box —

K. Wood of Blyth, Graham Smith of Somerset, Newland Andrews of Devon and J. K. Young of Sussex have all been boxing clever and their collective effort has pro-

duced this big brave bunch of bold beauties for brilliant black box boffins and something else beginning with b.

Game	Address	Poke	Effect
<i>Bad Dudes</i>			
<i>vs Dragon Ninja</i>	13c0	00	infinite time
	1d54	00	infinite lives
<i>Operation Wolf</i>	29e7	ff	255 magazines
	2a4e	80	128 grenades
<i>Paperboy</i>	05ac	00	infinite lives
<i>Robocop</i>	3f23	00	infinite energy
<i>SAS Combat</i>			
<i>Simulator</i>	3286	ff	100 lives
<i>Storlord</i>	6b8b	00	infinite lives
<i>Thunderblade</i>	0fa2	00	infinite lives (part 1)
	0fe1	00	infinite lives (part 2)
<i>Zynaps</i>	5f7e	ff	255 lives

Multiface pokes: what they are, how to do them

- Most games are heavily protected these days, resulting in longer pokes.
- Many of you have one of the infamous black boxes that can be used to stop programs – the Multiface 2 from Romantic Robot for example.
- Often the only thing that they're used for is transferring games from tape to disk, but they can also be used to hack games for infinite lives etc.
- This occasional section is for owners of the Multiface 2 and similar devices so that they can poke games

without typing in huge listings.

- Here's how you enter them:
- Plug the Multiface into the expansion slot at the back of your keyboard.
- (Multiface 2 owners: make sure that the switch on the front is in the up position.)
- Load the game that you want to poke in the usual manner following the instructions supplied with it.
- (Multiface 2 owners: move the switch to the down position after it has loaded.)
- Press the red button on the

Multiface and a menu appears at the bottom of the screen. Press 'T' for tool and then 'H' to change input to hexadecimal.

- Press the spacebar and type in the number under the Addr column. Next type in the number under the Poke column.
- Repeat this process until you've entered all of the pokes that are listed for the game and then press 'ESC'.
- Press 'R' to return to the game. It then runs with the pokes that you've just entered.

BARBARIAN II

The Barbarian from Delmonte, he say 'Uuuggghhh!' to this map of Drax's lair. Now Princess Mariana and the Barbarian II get the max from their axe as GAVIN BLANN of London tells them where to go and how to get there.

- ⊙ PIT THING
- ⊙ LAVA OR SLIME
- ⊙ SKULL
- F FINAL SCREEN
- S START
- PIT
- ⊙ PORTCULLIS

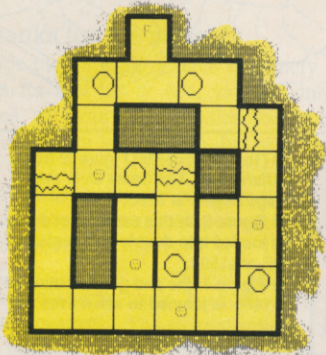

LEVEL 1

N
↑

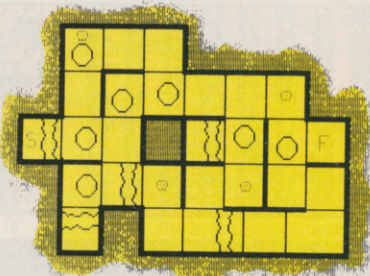

LEVEL 2

W
↑

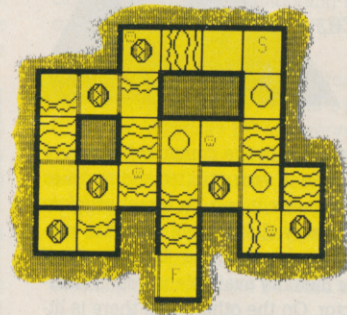

LEVEL 3

S
↑

PORTSMOUTH'S LEADING SOFTWARE/MAIL ORDER CLUB

SUPER SOFTWARE SALE

AMSTRAD BARGAINS

Monopoly50p	} PACK 1	3D Chess.....50p	} 75p
Trivial Pursuit ...50p		3D Boxing.....50p	
Scrabble.....50p		Daley Thompson Day 1	
Scalectrix50p		Daley Thompson Day 2	
Cluedo.....50p		Plus Many Others @ 50p	

SPECIAL OFFER PACKS

PACK 1
£2

PACK 2
15 games
£5

PACK 3
17 games +
joystick
£6.50

Prices include VAT. Please add £1.50 Post & Packing. Cheques/PO/Cash to

PARKER ASSOCIATES
Dept M, 272 Grafton Street,
Buckland, Portsmouth.
Tel: 0705 831538

**SCREENVISION
TURNS YOUR
MONITOR INTO
A COLOUR TV!**

AT THE AMAZING OFFER PRICE OF £64.95
Door to Door Insured delivery add £6 INC VAT

USE YOUR AMSTRAD CPC464, CPC664 & CPC6128 MONITOR AS A COLOUR TV SET!

Screenvision is a modern 'State-of-the-Art' TV Tuner which simply connects to your monitor, using the existing lead and converts it to an outstanding colour television.

Screenvision has more features than any other TV Tuner and costs less! Each tuner has seven pre-select push button channel selectors, separate controls for brightness, colour, tone and volume and has built in Speaker, Colour and Automatic gain control.

Unlike other products, Screenvision also connects to a host of other Monitors should you change your system.

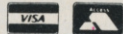

SCREENS

DEALER & EXPORT ENQUIRIES WELCOME

MICROCOMPUTERS & ELECTRONICS

MAIN AVENUE · MOOR PARK
SALES 09274 20527 EXPORT 09274 20664

MIDDLESEX · HA6 2HJ · ENGLAND
TELEX: 929224 SCREEN G FAX: 0923 835421

Insider dealing

In the fourth part of his series on hacking, **PHIL HOWARD** boldly journeys into space, the final frontier.



Poking, peeking and pinching

The memory from £0040 up to about £A700 is available to the user, and is where the programs generally sit. There is little of interest between these locations, except to note that generally Basic programs start at £0170. If you don't have a disk-drive there is more space to play with, up to about £AC00. (Some Basic instructions affect these areas, as do extra ROMs.)

From £AC00 up to £BB00 is the computer's own bit, where it stores information it needs



Finding space in the computer's memory to squeeze in your utilities and routines is difficult, for it can be a real problem to choose memory that is safe from the ravages of the incoming program. The amount of free space or memory available to you is clearly a vital factor. On the other hand there is little in hacking terms you can achieve on a 6128 that can't be done on a 464 or a 664, with slightly more effort. (Mind you, an extra 64K of memory expansion is worth its weight in gold – more of that later.)

It's very useful to be able to find your way around the computer's insides, and for this you need to consult the memory map, a graphic representation of the computer's useable memory, ranging from £0000 to £FFFF (0 to 65535) – your working space. The computer itself takes up a bit in order to keep control, but the whole lot is RAM-based, meaning that it can be altered, should you desire to do so.

The memory map is well documented already, but there are a couple of interesting features in each area worth a look.

The lowest part of the memory from £0000 to £003F contains the RESTARTS, destinations for the one byte M/C code instructions (RST 0-7). They are processor rather than M/C specific and include low level functions such as system reset, user restart, interrupt vector and so on. Programs do not generally overwrite this area, and the restarts can be patched to re-direct control to you. A one byte instruction which brings you from any point in the memory can be very useful.

1 ' THIS ROUTINE DUMPS	50 DATA 00,11,00,40,01,00	150 DATA ED,49,C7
2 ' THE ENTIRE "FRONT"	60 DATA 40,ED,B0,01,C6,7F	160 y=0:MODE 1
3 ' MEMORY INTO "BACK"	70 DATA ED,49,21,00,80,11	170 FOR x=£BF00 TO £BF56
4 ' MEMORY WHEN CALLED	80 DATA 00,40,01,00,40,ED	180 READ a\$:a=VAL("£"+a\$)
5 ' AT £BF00.	90 DATA B0,01,C0,7F,ED,49	190 POKE x,a:y=y+a:NEXT
6 ' 100 DATA 21,00,40,11,00,C0	110 DATA 01,00,40,ED,B0,01	200 IF y<>£1EE4 THEN 220
20 DATA F3,01,C7,7F,ED,49	120 DATA C5,7F,ED,49,21,00	210 PRINT"SAVE FIRST":END
30 DATA 01,00,40,ED,B0,01	130 DATA C0,11,00,40,01,00	220 PRINT"data error!" 1
40 DATA C4,7F,ED,49,21,00	140 DATA 40,ED,B0,01,C0,7F	

● Figure 1:

```

01A4 9F 21 HH LD FB C3 00 32 1 * C. 2
01AC 47 41 4D 45 20 4F 56 45 GAME OVE
01B4 5E 54 4F 45 57 49 4E 44 RESEMINO
01BC 20 54 4F 45 53 49 44 45 TO SIDE
01C4 20 42 20 53 54 41 52 54 B START
01CC 5F FF 4F 45 4E FF 21 15 THEN!!
01D4 42 11 02 67 CD 3C 83 06 B. GM<..
01DC F0 C5 CD 49 94 C3 FD 26 92 PEMI.M&:
01E4 8D 2E 18 C1 10 F3 FD 21 M. A. s;
01FC 40 47 21 05 4E 01 10 34 G! B. 4
01F4 C3 82 8A ED 53 86 47 CB C. S. G!
01FC 13 BA CB DE CB E6 FD CB /N> .XG/
0204 32 CE 3E 1F C1 47 32 88 2. :2AG2.
020C 32 12 52 43 C0 22 88 01 2. :2AG2.
0214 32 12 52 43 C0 22 88 01 2. :2AG2.
    
```

- (Top downwards) Figure 2: from Afterburner. The Game Over message begins at £1AC;
- Figure 3: in this case the address is loaded into double byte register DE at £1500;
- Figure 4: the end-game routine at &14F6 is jumped to when lives run out

```

014F6 47 41 4D 45 20 4F 56 45 LD HL,4785H
014FE CB 0E 8E RES S,(HL)
014FB CB C6 SET S,(HL)
014FD CD 77 01 CALL 0177H
01500 CD AC 01 LD DE,01ACH
01503 CD D8 41 LD HL,41D8H
01506 CD 3C 83 CALL 8383H
01509 CD 61 06 CALL 6106H
0150C CD 00 0E LD BC,0E00H
0150F CD 1B 1E CALL 1E1BH
01512 CD 8C 83 EI
01515 CD 8C 83 CALL 838CH
01518 CD B C LD B,C
0151B CD D D LD D,D
0151E CD H H LD H,H
01521 CD 38 RST 38H
    
```

```

020A1 C3 81 1E JP 1E1H
020A4 3A BE 47 OR A,(4785H)
020A7 87 B1 1A JR NZ,2055H
020AA FD F8 1A DEC (Y+81H)
020AD YD CB 62 7E JP M,14F6H
020B0 3E 5E BIT 7,(Y+62H)
020B3 38 01 LD A,80H
020B6 38 01 JR 2,20B6
020B9 32 11 BA XOR A,(8BA1H),A
020BC 32 0F BA LD A,(8BA0FH),A
020BF DD 1E FE LD A,IVALID
020C2 CD 8C CALL 838CH
020C5 CD B C LD B,C
020C8 CD D D LD D,D
020CB CD H H LD H,H
020CE CD 38 RST 38H
    
```

to function, system variables, interrupt routines, header data and so on. It is possible to PEEK some of these numbers to find a considerable amount out about the system.

The locations from £BB00 to £BE00 are

termed the jump blocks. There are nearly 200 of these three byte instructions, which are the "way in" to the ROM routines, and can be patched, altered, erased, copied, or just used to make the hacker's lot easier. Each jump is used to perform a single task. CALL £BB18 (KM WAIT KEY), for instance, waits for a key press, and £BC6E (CAS START MOTOR) turns the cassette motor on. (Should you happen to mess up this area it can be rewritten from ROM by calling £BD37 (JP RESTORE).)

You will notice that nearly all the cheat routines run up from £BE00 to £BFFF. (The disk operating system pinches a bit of this space, so if a cheat runs at £BE80 the owner has a disk). This area was originally designated as the stack (where the computer stores its

RETURN addresses), but as the stack works its way downwards from **&BFFF** and rarely reaches further than about **&BF00** or so, it is an ideal place for small routines. An added bonus is that all code in this area will survive a soft reset (**CTRL+SHIFT+ESC**).

Above this from **&C000** to **&FFFF** is the screen memory. This is ordinary RAM that is scanned and displayed on your TV or monitor. It is possible to load and run a program into this area, so long as the screen isn't cleared or printed on. Many programs do this in fact: next time you're staring at a blank loading screen console yourself with the thought that it's probably sticking some code on there. Clearing the screen resets all the memory locations to zero.

Thanks for the memory

If you own a 6128 or have a memory expansion for the 464 or 664, you not only have place to store the graphics for multi-level games, extra screens etc. but you also own the CPC's greatest hacking tool.

Any Z80 computer can only deal with 64k of memory at a time. At power-up you effectively access to the "front" 4 X 16K blocks of memory (bank 0=**&0000-&3FFF**, bank 1=**&4000-&7FFF**, bank 2=**&8000-&BFFF**, bank 3=**&C000-&FFFF**). The system can be instructed, however, to swap bank 1 (**&4000-&7FFF**) for one of the "back" banks. This swapping is not a physical swap of the contents, but a hardware change that fools the computer into believing the new bank is really bank 1, while the original bank 1 is ignored. Any data that is subsequently loaded into the area **&4000-&7FFF** is really being put in the one of the "back" memory banks, likewise any data in a "back" bank before the "swap" appears to be in the 16K beginning at **&4000**.

The Video Gate Array is the hardware device that instructs the computer which combination of four banks it is "looking" at, and can be reached via the port at **&7F00**. This may sound complicated, but it is really very simple, and can be implemented from Basic by using the following OUT instructions.

- OUT **&7F00, &C4** swaps in the first bank of the "back" memory to **&4000** "front."
- OUT **&7F00, &C5** swaps in the second bank.
- OUT **&7F00, &C6** swaps in the third bank.
- OUT **&7F00, &C7** swaps in the fourth bank.
- OUT **&7F00, &C0** resets to the original configuration.

One major importance of the "back" memory is that like the stack, it will survive a soft reset: data that is in the "back" memory banks will be preserved, and can be accessed.

Naturally all of these instructions can be implemented in M/C code. The program supplied (figure 1) puts a small routine at the **&BF00** which will dump the entire "front" memory into the "back". The routine has a **RST 0** (soft reset) at the end so when called (**CALL &BF00/ &CD, &00, &BF**) the system copy, then reset. This can be changed to **&C9** (return) if you wish. Subsequent use of **OUT &7F00, &C4-&C7** puts the appropriate "back" bank at **&4000** "front" for examination - mirror imag-

ing, software style!

Secrets of eternal life

Meanwhile, back on the ranch, er, game poking front, we have reached the third and final type of system, the remaining 50% in the matters of life and death. This lot, however, is not strictly speaking a type. It is anything at all that is left over, and which cannot be categorised into the other two. It is where the going gets tough, where great cunning is required and where three lives suddenly seems like they might be enough after all. It is the "Wing and prayer" section.

Actually, it's not all that bad, more a question of isolating subroutines within the program, or using some other indicator to point to the area you are looking for. You will notice that the words "usually", "often", "mainly" etc. crop up on an all too regular basis, please remember that there are no hard and fast rules, and it is only the concepts that are contained here, so expect variation.

The first one entails back tracking from a recognisable landmark in the program. You remember originally I spoke about looking through the code for screen messages, "GAME OVER", "TIME OUT" etc. and noting the addresses? This is why.

First locate the final message, for instance "GAME OVER" in the memory (see figure 1) and note its starting address, ie. **&01AC**. In order for the program to display this message on the screen, it must use a printing routine, which first, must be told where the message is.

Using the BYTE SEARCH locate any references to this start address. It is worth searching for two or three numbers previous to the location you think, just in case there are

Absolute and relative

The Z80 processor supports two sorts of addressing, ABSOLUTE which specifies exactly where in the memory the program should go next. ie **&C3, &BC, &9A** Jump to memory location **&9ABC**. And RELATIVE which specifies how many bytes backwards or forwards from the present location to jump. ie. **&18, &05** : jump forwards by 5 bytes or **&18, &FB** : jump backwards by 5 bytes. If the number is in the range **&00** to **&7F** the jump is FORWARDS. If it is in the range **&FF** to **&80** the jump is BACKWARDS. Just to add insult to injury, backward jumps count down instead of counting up; jump back 1 byte is **&FF**, back 2 bytes is **&FE** etc. (aren't you pleased you started this?).

Each of these types have a number of CONDITIONAL (decision making) forms. ie **&CA, &BC, &9A** : If the result (of the previous calculation) is zero jump to **&9ABC**, and **&28, &05** : If the result is zero jump forwards by 5 bytes.

Join in!

Dear A. Hacker,
You are hereby invited to contribute to *Insider Dealing*. Dress as you like, bring a bottle if you wish, but what we're really after are your contributions. So far this column has been dedicated to the work of Phil, who may be brilliant but would never claim to know everything (*wouldn't I?* - Phil Howard).

Let us in on what you know, and we'll pay you handsomely! Write in the first instance to *Insider Dealing*, AA, 4 Queen St, Bath BA1 1EJ.

ctrl. characters for positioning the message, or just blanks ie. "GAME OVER" to be printed.

You will find that the address should be loaded into one of the double byte registers, HL or DE (normally BC is reserved for counting, but don't count on it). In this case it is loaded into DE at **&1500** (see Figure 3), ready for printing in a later sub-routine. This part of the program is *only* accessed when the end of the game arrives, so the decreasing and checking routines must be close at hand.

Loop before you leap

When the program decreases the number that is your lives, time, energy etc. it must also make a decision, whether to loop around and give you another chance, or to leap off into the END-GAME routine that you have just located. To trace back you will need to find the start address of this end-game routine. This one is obvious **&14F6** (see figure 3), but don't expect it always to be so, you may have to make a couple of guesses at it.

There are two alternatives here, depending on whether the programmer has used a conditional absolute jump or relative jump (see box) for the decision making. Using the BYTE SEARCH to locate references to **&14F6**, this will turn up any absolute jumps. Whilst using the disassembler to examine the instructions from this address minus **&80** bytes to this address plus **&80** bytes (this is their maximum span) you can check for relative jumps to **&14F6**.

In the example an absolute jump has been used. The instruction **JP M, &14F6** at **&20AA** has detected that the previous calculation (dec **IY+97**) was negative ("M"inus), decided the lives have expired, and jumped off to inform you that the game is over. The instruction **&FD, &35, &61** (dec **IY+97**) needs removing, or as in the actual cheat (see AA46), altering to render it harmless. ●

Stay tuned for more Hacking secrets in next month's *Insider Dealing*, featuring Phil's amusing sun-tan. Meanwhile, there's two more whole pages for hacking fans overleaf, when MIKE WONG spills the beans...

Protection racket

As one of *Cheat Mode's* regular contributors, MIKE WONG knows a thing or two about protection. Now for the first time he reveals the secrets of making software secure from prying eyes.

There are some devilishly tough protection systems in operation these days, as you'll know if you've ever tried hacking into a game. Newcomers, however, may be surprised that it hasn't always been thus. Back in the good old days when the CPC and Phil Howard were young there was hardly any protection. Why? Software houses weren't bothered; games weren't worth protecting; protection wasn't good enough; and last but not least, piracy was minimal. In fact it could even be argued that protection developed as an exercise of programming ability, rather than protecting anything.



It continues today as a fearsomely complex art, where the author of the protection may even give his phone number on the protected disk either as a sign of confidence, or a gesture of acknowledgement to the invader.

The argument is that it prevents piracy. Yet mass pirates ignore protection and find other means. And any hacker worth his salt can crack the protection himself.

Protect and survive

A protected game usually has of a small file called a LOADER of length £800 to £1000 bytes long which loads in the rest of the game (hence the name, I suppose - slow ed.). Normally all hacking involves intercepting the loader after it has loaded the game, and directing it to your own routine, eg, to poke it, and then to continue where you left off. But what can prevent you following this simple line of approach?

(i) The latest line of protection systems consist of long routines which decode an encrypted loader - anything up to 100 times! Thus what initially looks like garbage eventually makes sense. Such complex systems require separate consideration.

Eg: US Gold, GO!; Ocean, Speedlock.

(ii) Other forms involve loading in a lot of game code (or useless packing) - nearly 64K in fact. The loader loads in an impossibly huge file completely overwriting your own little program. The solution is to place it in an unused area, close to the loader itself.

Eg: Gremlin Graphics; Titus.

(iii) Some protections are extremely trying, and overwrite certain areas of memory set aside by the computer for its own use. These areas (JP block, disk drive area, systems variables and routines), when overwritten, may cause a crash. So even if you have intercepted the loader, you're left with a crippled machine. The best way is to let the loader overwrite the areas, but when we gain control, we use instructions to return everything to normal.

Eg: Gremlin Graphics; Old Speedlocks.

(iv) Even more bizarre are those which load programs in a special way, or load in games saved by special format.

Eg: Firebird musical and countdown loaders; Ocean 24-sector disk loaders.

Hacking cough

There are 4 main ways:

(i) Manually. This, the hardest and most satisfying, involves hard work, patience, care and attention. This is the case for the long decoding loaders. It can take hours or even days,

The mark of XOR

Perhaps the most commonly used opcode in protection systems is the XOR instruction, which alters the value of the A register in conjunction with another register, a number or the contents of the HL or index registers.

These XOR routines run in sequence, one after the other, so that each routine XORs the rest of the loader, revealing the next routine which it runs into (see Fig 1 below). Eventually the whole loader is decoded. Two typical XOR routines are shown in Fig 2 below.

● Note the use of the R (refresh) register, which provides the next seed for every XOR of the routine. The R register changes with each instruction, thus any alteration in the program alters the R

register, leading to corruption of the rest of the loader.

● Notice in the second routine that the number is XORed twice before being put back into (HL). And D is altered to the result for the next XOR. Also, the routine alters the last byte of itself (£9A64) from £XX to £9A, to complete the routine. This is added protection.

● The rest of the routine checks for end of XORing and if not, continues to XOR the next number.

● The first routine contains relative jumps, eg JR NZ.

Therefore, why not relocate it,

and execute it under your control? This will reveal the next XOR, which you can then relocate after the first... The second uses absolute jumps, eg JP, but can still be relocated provided you alter the important absolute addresses.

● Some routines XOR against the screen contents. Therefore, try not to alter the screen before it has finished XORing.

● Some seemingly complex loaders consisting of XOR routines can be completely revealed by alteration of a few bytes of the loader.

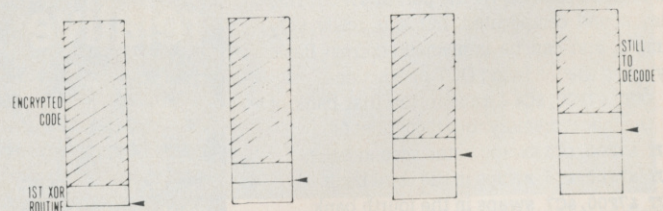

● Fig 1: the XOR routine

98AE LD HL, 98BE	9A4C LD HL, 9A64
LD DE, 0C39	LD BC, 0D6F
more LD A, R	LD D, 50
XOR (HL)	9A54 LD A, R
LD (HL), A	XOR (HL)
INC HL	XOR D
DEC DE	LD (HL), A
LD A, D	LD D, A
OR E	INC HL
JR NZ, more	DEC BC
98BE	INC D
	LD A, C
	OR B
	JP Z, next
	9A62 JP XX54
	next

● Fig 2: two typical XOR routines

A loader rubbish?

What about loaders without XOR routines? These usually rely on the intrinsic protection provided by the format in which the game is saved, thus necessitating the special loader. How do we recognise such loaders? Within the loader is a routine that does the actual loading. Entry to this routine is usually by a CALL with parameters set in registers IX (start), DE (length) and sometimes A with an additional sync byte. Alternatively HL replaces IX. Thus you can find the start and length of the code. These 'simple' loaders end with a JP to the execution address, for example:

```
BC55 LD IX,003F
      LD DE,39F7
      CALL BCD9
      LD IX,55B4
      LD DE,667C
      CALL BCD9
      JP 003F
```

Others have additional protection by use of a routine that loads in a huge file of nearly 64K in length. They usually load from &C000 to &FFFF, through 0 to &XXXX, or backwards from &FFFF to &C000, past &C000 to

&8000 and eventually to &XXXX (the difference is shown in figure 3 below). These loaders overwrite the JP block and other important areas. Since these programs are dealing with the computer in a raw

state, they must perform elementary tasks such as switching the motor on or off themselves (see fig 7). And since the loader generally stops the motor after it has finished loading...

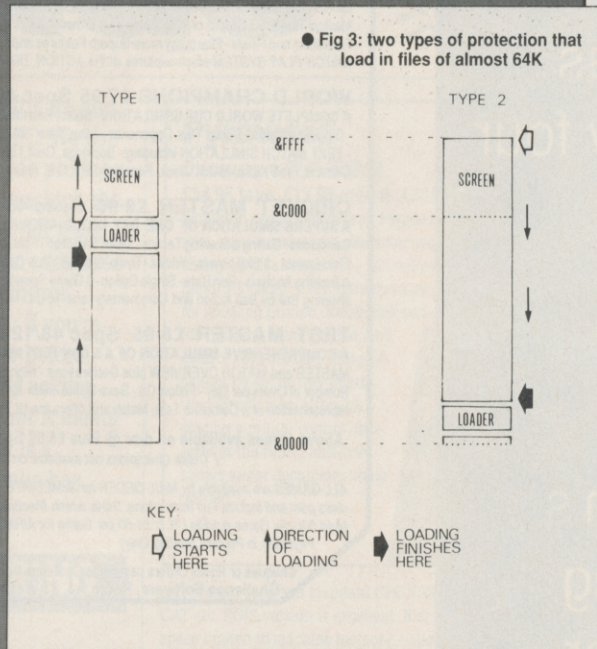

```
LD BC,F600 LD BC,F610 XOR A LD A,1
OUT (C),C OUT (C),C LD BC,FA7E LD BC,FA7E
OUT (C),A OUT (C),A

tape_off tape_on disc_drive_off disc_drive_on
```

● Fig 4: elementary tasks such as motor switching have to be included. And the loader generally stops the motor after loading...

especially when encountering a new loader. Several similar loaders later, however, it is easier, and you can even write a program to do the work for you!

(ii) **Interception.** These include replacing an area, where the loader is known to jump to, with something else (see below). Alternatively it may involve altering the loader so it jumps somewhere else. Most forms of small-time pokes owe their existence to this technique. Pressing the red button on a Multiface is really an interception.

If we have a loader which changes the screen mode like this: -

```
...
0450: LD A,1 ) Firmware call for screen
0452: CALL BC0E ) mode - here, for Mode 1.
...
```

- we know it will go to &BC0E. So we alter (or "patch") &BC0E with our own:

```
BC0E: JP BE80) Address of our routine
```

Now, instead of altering mode, the program goes to &BE80, which is the address of our own program.

(iii) **Write your own loader.** We ignore the protected loader and devise our own simpler loader, which enables us to poke the game after loading and execute it. This is true for only a small minority of, eg, headerless, or very long binary, programs like *Critical Mass* at 40+ blocks.

(iv) **Cheat.** Look in *Cheat Mode*, type in and disassemble the poke for games: all the information required is there in the program. It's a great way to learn, and helps you play the game as well. (The *Type-in "Hacker"* can also be used, but it works on only unprotected games).

After hacking protection

It is necessary to save the program in a form we can readily examine and investigate. This is *not* saving out a complete copy for piracy

This article cannot tell you how actually to break into the latest protected game, concentrating on information about how programs may be protected. Note that all program listings shown are actual routines.

means - far from it.

What is saved out is used to find pokes. Then, using the knowledge gleaned from breaking into the system, we can install the poke into the original game and thus help other readers.

The only other alternative is to use Insider with a Multiface, but then that doesn't give you any clues on how actually to break into the system. And it wouldn't be very useful for people without one - especially now that it seems unlikely those without will be able to acquire one, thanks to this daft law. ●

The deviousness of programmers

Most loaders have now added protection against prying eyes. Thus we have:

● Routines to detect the Multiface:

```
LD BC,FEE8
OUT (C),C
LD A,(0000)
CP F3
JP Z,destruction_routine
... rest_of_loader
```

● Routines that erase memory as the program XORs itself, leaving nothing to examine (mainly for Multiface owners).

Even when the program has finished XORING, it completely erases memory above and below itself, wiping out any prying routines you may have placed there!

● Routines like XOR, but using the SP (stack pointer) with PUSHes and POPs to move the program on a larger scale. Also, difficult to follow LDIs in association with RET PO are used.

● Some programs overwrite the JP blocks. These run from &B900 to &BE00 approximately, and consist of 3 byte RST instructions which contain CF (RST 8) or C3 (JP) followed by an address of a standard ROM call. The 3 byte areas can be relocated anywhere, even in your own program, but if the whole JP block is overwritten, the computer may crash when a ROM call is required. A useful call is JP RESTORE at &BD37 which restores the JP block to normal if overwritten. But wait! What if &BD37 is itself overwritten? Well, you didn't forget to relocate the 3 byte instruction for &BD37 did you? (NOW he tells us! - ed)

● Programmers delight in fooling hackers, leaving messages in loaders ranging from the author's name (one calls himself "The Master Hacker!") to telling you to, er, go away in no uncertain terms! Some even have greetings to hackers (who's *Justin* anyway?) and other people (Hi Sam), whilst some include red herring messages. When you see such messages you know you're in...

Q

What comes out

of the same offices as Amstrad Action, only four times as often?

A

Britain's leading

news-stand computer weekly magazine.

Look what it offers!

- **Weekly** packed news pages covering all the latest developments in computing.
- **Weekly** product reviews, features, technical tips, letters, analysis.
- **Weekly** CPC section written by AA's editor Steve Carey.
- **Weekly** shopping bargains including a special voucher scheme guaranteed to save you money.

Only **58p!**

Out every Thursday
in all good newsagents.

NEW COMPUTER EXPRESS

First news, best buys – every week

CHALLENGE

GREAT STRATEGY GAMES

A superb range of Football & Cricket games

SOFTWARE

for the Spectrum, Commodore & Amstrad

From Challenge Software (formerly E & J Software)

TREBLE CHAMPIONS £9-95 Spec 48/128 : Com 64/128 : Ams CPC
A STUNNINGLY REALISTIC FOOTBALL STRATEGY GAME - Can you Win The League, The F.A. Cup & The League Cup - 4 Divisions of 20 Teams + 1 Div. 20 Non League Teams - Details of OVER 1500 Players - Results & Leagues ALL Divisions - League Cup with 1st, 2nd Rnds - S/Finals over 2 Legs - F.A. Cup includes Non League - Transfer Market buy ANY PLAYER ANY DIVISION - 3 Skill Levels - Start ANY Division - SAVE GAME - Time Management - Reserves - 2 In-Match Subs - Coaching + Fitness Training - PLUS MUCH MORE.

EUROPEAN CHAMPIONS £8-95 Spec 48/128 : Ams CPC
THE INTERNATIONAL CHALLENGE OF THE EUROPEAN NATIONS CUP - Genuine Nations Cup Format with full Random Draw of 32 Seeded Teams - Fixture List, Results and League Tables of ALL 8 Groups - Discipline & Medical Reports - Squad of 22 Players plus Other Players - 17 Month Itinerary of Qualifying Group, (Arrange Friendlies) and Finals - Plus many more Superb Features and Options. EUROPEAN CHAMPIONS includes E & J's MATCH PLAY SYSTEM which captures all the ACTION, DRAMA & TENSION of International Football.

WORLD CHAMPIONS £7-95 Spec 48/128 : Com 64/128 : Ams CPC
A COMPLETE WORLD CUP SIMULATION - Select Friendlies - 25 Players - Qualifying Group - 2 In-Match Subs - Discipline Table - Select Tour Opponents - Extra Time - final Rounds - Players Gain Experience - 7 Skill Levels - TEXT MATCH SIMULATION including: Bookings, Goal Times, Named & Recorded Goal Scorers, Injury Time, Corners, Free Kicks, Match Clock, Penalties - PLUS many more Features.

CRICKET MASTER £8-95 Spec 48/128 : Com 64/128 : Ams CPC
A SUPERB SIMULATION OF ONE DAY INTERNATIONAL/COUNTY CRICKET - Weather, Wicket & Outfield Conditions - Batting & Bowling Tactics - Team Selection - Fast, Medium & Spin Bowlers - 4 Types of Batsmen - Select Field Layout - 3 Skill Levels - Wides - Byes - No Ball - Run Out - Misfield - Dropped Catches - Scoreboard - Batting & Bowling Analysis - Run Rate - Single Option - 3 Game Speeds - STAR FEATURE a complete MATCH OVERVIEW showing Ball by Ball Action and Commentary and MUCH MORE!

TEST MASTER £8-95 Spec 48/128 : Ams CPC
A COMPREHENSIVE SIMULATION OF A 5 DAY TEST MATCH - Includes most of the Features of CRICKET MASTER and MATCH OVERVIEW plus Declarations - Nightwatchmen - Light Meter - Rain Stops Play - Varying Number of Overs per Day - Follow On - Save Game - New Ball - Bad Light Interruptions - TEST MASTER is a True representation of a Complete Test Match and offers the ULTIMATE CHALLENGE to All Cricket Enthusiasts.

Above games available on disc @ Plus £4-00 Spec & Ams or Plus £2-50 Com PER GAME
(Treble Champions not available on disc for Commodore 64/128)

ALL GAMES are available by MAIL ORDER for IMMEDIATE despatch by 1st class post and include Full Instructions. State which Machine & Tape or Disc.
(Add 50p per Game outside UK or £1-50 per Game for AIRMAIL outside Europe.
Payment in Pounds Sterling Only)

Cheques or Postal Orders payable to Challenge Software, SEND TO:
Challenge Software, Room A1, 37 Westmoor Road, ENFIELD, Middlesex, EN3 1LE

FANTASTIC DISCOUNTS
FULL PRICE GAMES ONLY
Buy 2 games deduct £3-00
Buy 3 games deduct £5-00
Buy 4 games deduct £7-00
Buy 5 games deduct £12-00

MODE-ONE

21 Orchard Drive
Burton-upon-Stather
Scunthorpe DN15 9EF
South Humberside.

0724 721204

Amstrad
CPC

Amstrad
CPC

★★★ LOOK!! NEW LOW PRICES ★★★

TITLE	CASS	DISC	TITLE	CASS	DISC
Afterburner	7.40	10.65	Skweek	7.40	10.65
Blasters	7.40	10.65	Taito Coin-ops	8.50	10.65
Bloodwych	NR	6.90	Thunderblade	7.40	10.65
Chuck Yeagers APT	6.90	10.65	Titan	7.40	10.65
Crazy Cars II	6.90	10.65	Timescanner	7.40	10.65
Command Performance	9.99	14.05	Thunderbirds	NR	6.90
Dragon Ninja	7.40	10.65	Vindicators	6.90	10.65
Dominator	6.90	10.65	Vigilante	NR	6.90
Dark Fusion	6.90	10.65	Wanderer (+3D Specs)	7.40	10.65
Emelyn Hughes Soccer	7.40	10.65	War in Middle Earth	6.90	10.65
Forgotten Worlds	6.90	10.65	Wec Le-Mans	6.90	10.65
Fist n' Throttles	9.00	12.99	Xybots	6.90	10.65
Game Over II (+1)	6.80	10.50	4 Soccer Simulators	6.90	10.65
Guerrilla War	6.80	10.50	3D Pool	6.90	10.50
Giants	10.40	15.90			
Game Set & Match II	9.80	12.99			
H.A.T.E.	6.90	10.65			
High Steel	6.90	10.50			
H.K. Machine	6.90	10.65			
I.S. Sphere	6.90	10.65			
Jaws	6.90	10.50			
Licence to Kill	NR	6.90			
Last Duel	7.40	10.65			
Led Storm	7.40	10.65			
Navy Moves	6.90	10.50			
Netherworld	6.90	10.50			
Oblierator	7.40	10.65			
Operation Wolf	7.40	10.65			
Outrun Europa	NR	7.40			
Paciland	6.90	10.65			
Pacmania II	6.90	10.65			
Running Man	7.40	10.65			
Run the Gauntlet	7.40	10.65			
Robocop	7.40	10.65			
Real Ghostbusters	7.40	10.65			
Renegade III	7.40	10.65			
Red Heat	7.40	10.65			
Ric Dangerous	NR	6.90			
Rock Star	NR	7.40			
Stormlord	7.40	10.65			
Silkworm	6.90	10.65			
Special Action	9.25	12.95			
Super Scramble	6.90	10.50			
Airborne Ranger	10.80	13.95			
Barbarian II	6.95	10.50			
Batman II	6.90	10.50			
Bubble Ghost	6.50	9.99			
Cybernoid II	6.95	10.50			
Echelon	10.50	12.99			
Fernandez Must Die	6.50	9.99			
Galactic Conqueror	6.90	9.99			
Gunship	9.80	13.95			
Live and Let Die	6.50	9.99			
Motor Massacre	6.90	10.50			
Roy of the Rovers	5.99	9.99			
Return of the Jedi	5.99	9.99			
Rambo III	6.90	10.50			
R-Type	6.90	10.50			
Road Blasters	6.90	10.50			
Savage	6.50	9.99			
Spitting Image	6.25	9.99			
Supreme Challenge	8.50	12.45			
S.D.I.	6.90	10.25			
Total Eclipse	6.90	9.99			
Typhoon	6.25	9.99			
1943 Midway	6.50	9.99			
4 x 4 Off Road Racing	6.50	9.99			
Victory Road	5.99	9.99			

★★SPECIAL OFFERS★★ CASS ★ DISC★

ALL £2.99 BUDGETS ONLY £2.60
ALL £1.99 BUDGETS ONLY £1.75
Any game not listed please write or phone. All in stock titles sent by return. New releases sent on the day of release.

All our prices include P&P & VAT
Eire & Europe please add £1.20 per item.
NR = New release at the time of press
- Phone for availability

Please make cheques or postal orders payable to 'MODE ONE'

AA Buyers Guide

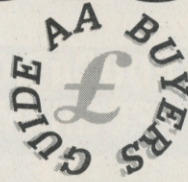

This is the place to find what software and hardware is available for your CPC. We list programs by category, and provide producer; phone number; price; issue in which the item was reviewed; and last but not least, a brief description of the program's features and, where appropriate, shortcomings.

But don't take our word for it: if you're in doubt read the original review before you splash out, and make sure by asking the person you're buying from that it meets your particular needs. Best of all is a try-out, if you can find a friend who has what you're thinking of buying.

WORD PROCESSING

Brunword 6128

Brunning Software ☎ 0245 252854

£16.50 tape, £25 disk ● AA24

40 or 80 column mode; spell checker loaded into extra memory. Suitable for expanded 128K machines. Superscript/subscript effects on-screen. Includes Datafile. Available as 'Junior Brunword' at £12.95 in slightly cut-down version.

Pendown

Logotron ☎ 0223 323656

£19.95 disk ● AA18

A complete tutorial in the theory and practice of word processing - it's great fun, too. Open system, owing much to expensive DTP packages.

Protex

Arnor ☎ 0733 68909

£19.95 tape, £26.95 disk, £39.95 ROM ● AA3

Lightning fast on all tasks involving screen. True merging from separate files and disks to the cursor position is easy,

Pyraword

Discovery ☎ 0742 753423

£14.95 tape, £17.95 disk ● AA18

Similar in use to Discovery's Pyradev. It loads a profile of inks, printer codes and character set. Word counting, changing disk drives etc - "housekeeping" tasks - are handily located. Uses extra memory of 128K machines for spooling printed documents and storing text. True file merging is impossible, and control keys are odd. Margins cannot be set further apart than 80 columns, although placing a printer control character at the right hand side allows wider documents to be printed.

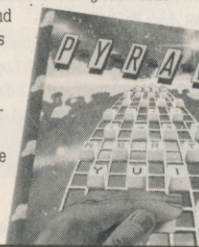

and Protex supports standard CPC RSX's like DISC, TAPE, CAT etc. ROM version is excellent. Bad points: maximum file space limited to machine memory - about 22K on disk, 38K for the ROM version. As used by AA, if that's any recommendation (don't answer that).

Tasword

Tasman Software ☎ 0532 4388301

464, 464D, 6128, £19.95 tape, £24.95 disk ● AA1

464 is the tape based version (the same as *Amsword*). 464D has enhancements for a disk drive. 6128 makes full use of a 6128's extra memory. The latter pair include mailmerge facility. Easy to get to know: comprehensive help screens. Screen operations are slow, but may be customised for greater speed.

Wordstar

Micropro/Cumana ☎ 0483 571666

£49.95 disk (CPM) ● AA1

Files can be as big as the space available. A professional program, with huge manual and a layout like mission control. If you want a function, it is in there... somewhere. Not fast.

PRINTERS

Manufacturers' recommended retail prices are listed as guidelines, but heavy discounts are offered by retailers.

Amstrad DMP/2160

☎ 0279 454555

£149 including VAT ● AA6

Load through front: printer must be above paper; but loading continuous stationery is easy. Poor NLQ mode. £5 for ribbons. Low priced, rather than a bargain.

Amstrad DMP3160

☎ 0279 454555

£199 + VAT ● AA29

Similar to but faster than DMP2160. Accepts all IBM and Epson printing codes. NLQ is front loading system. Good buy.

Amstrad DMP4000

☎ 0279 454555

£349 + VAT ● AA20

A real text cruncher. Wide carriage, and really flies across the paper, up to about 200 cps (in NLQ about 50 cps). Fonts available: standard 9 pin Pica, Elite, condensed etc. - but they are different, rather than just adjusted spacing for the same characters.

Amstrad LQ3500

☎ 0279 454555

£349 + VAT ● AA31

Cheapest 24-pin printer. Paper loaded from the rear - more time consuming. 30 cps in letter quality mode, and 62 cps in draft. Print quality excellent: plenty of different type-styles built in. Not ultra fast.

Citizen 120D

☎ 0800 282692

£199 + VAT ● AA43

Dimensions: 3.7 kgs, and 370mm x 90mm x 238mm. Draft quality is 'dotty,' and poor, but NLQ is sharp and simple. A quiet beast, with cable to the computer connected on the side. Manual includes a complete written breakdown of all the printer control commands, and their effects.

Epson LX800

☎ 01 902 8892

£279 + VAT ● AA29

Very fast for 9 pin. Control panel for style selection, and Epson compatible. Reverse winding sheets requires care, though.

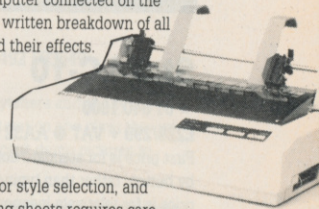

Epson EX800

☎ 01 902 8892

£629 + VAT ● AA29

Upgradable in 101 ways - cut sheet feeds, serial ports, longer life ribbons. Quiet, with respectable printing speed. Sans Serif/Roman NLQ fonts incorporated. Control panel to select fonts - just the same font with different spacings.

Epson LQ500

☎ 01 902 8892

£399 + VAT ● AA29

Features galore and price to match. Handles both Sans Serif and Roman styles of NLQ, for instance. Colour-printing upgrade kit available. 24 pin printer, offering excellent quality printing. Control panel to select from many available fonts (ie. the same font at different widths).

Panasonic KXP3131U

☎ 0753 73181

£335.25 (discont.) ● AA29

Daisywheel therefore superb quality - but can't print bit graphics (no trendy screen dumps), and if you want different fonts, you have to plug in a different Diablo-compatible one. Not quiet.

Mannesmann Tally MT81

☎ 0734 788711

£149 + VAT ● AA43

Dimensions: 70mm x 100mm x 265mm; weight, 4.5 kgs. Prints Epson and IBM graphics. Draft mode print quality is good: square printhead pins put ink onto greater areas. The printed output is more ornate than the Citizen. Manual is superb, but falls down in failing to explain control codes: for that you have to buy the applications manual. Certainly a very good buy.

Mini Office II

Database Software ☎ 0625 878888

£14.95 tape, £19.95 disk ● AA6

If you don't need full specification *Mini Office II* is for you.

Remarkably cheap for word-processor, database and spreadsheet, plus comms software and more. Packaging and documentation is good, and programs work in a menu environment.

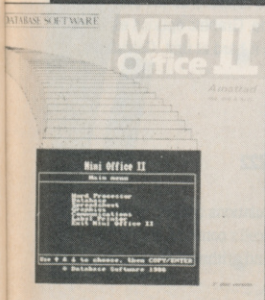

Panasonic KXP1081

☎ 0753 73181

£219 +VAT ● AA29

Similar to DMP2000/2160: chunky, 9 pins, 10 inch carriage and compatible with Epson codes. Thorough A4 manual, good NLO mode – better than DMP – and condensed, draft and NLO modes.

Star LC 24-10

☎ 01 840 1800

£399 + VAT ● AA47

A low-cost 24 pin, 10 inch, 80 column Letter Quality printer: 8 resident fonts, all operable from the front control panel and 3 print variations. See the review in this issue, page 22.

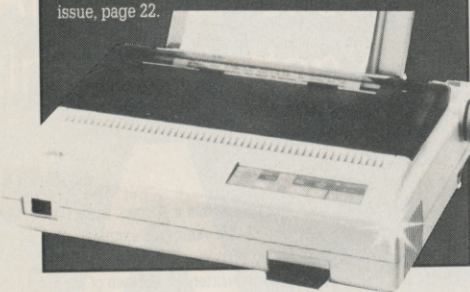

Star LC-10

☎ 01 840 1800

£229/299 + VAT ● AA32

First price is for standard dot matrix printer. Fonts selected by button, rather than typing in fiddly control code. Second price is for relatively inexpensive colour model. Uses multi-colour ribbon to produce different mixes, though there are currently no commercial programs to take advantage of this capability (but see the *Colour Dump* review in AA46, page 24).

INTEGRATED PACKAGES

Info-Script

Brunning ☎ 0245 252854

£46 disk ● 128K/256K only ● AA35

Billed as the "complete database with word-processor and spelling checker," it's best with 256K. Well set up, easy to use and allows for changes in layout and content. Manual could be clearer.

Mini Office II

Database ☎ 0625 878888

£14.95 tape, £19.95 disk ● AA6

Astonishingly cheap word processor, database, spreadsheet, graphics, comms and label printer all-in-one, it's continued to sell, and sell, and sell... Not full specification, but at this price who's complaining?

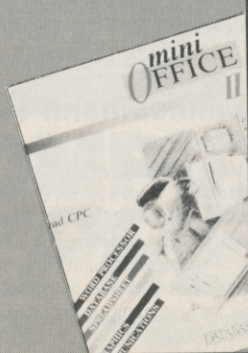

Protex Filer/Office

Arnor ☎ 0733 68909

£24.95/£34.95 disk ● AA34

Database that works comfortably with Protex, has powerful sorting options and comprehensive invoice printer. Can be slow, but good value.

EDUCATIONAL PROGRAMS

Amstrad Selection

Fernleaf Education ☎ 0474 359037

£25.95 disk/tape ● AA32

For age range 7 to 12+: Eight programs – including *Fletcher's Castle*, *Market Stall*, *The Perfume Hunter*, *The Raiders*, *Ferry Captain*, *Treasure*, and *Thorn Sea*.

Arc Master Pack Plus

Arc Education ☎ 0472 812226

£48 disk ● AA32

A massive pack of 70 programs: Junior; Primary; a parent/child adventure; DR Logo and word games. Each set available at £9 tape and £12 disk. Well presented with good graphics, reasonable musical ditties and plenty of options.

Kosmos

Kosmos ☎ 05255 3942

£9.95 tape, £13.95 disk ● AA32

Answer Back Junior Quiz lets you either answer the question; make a choice from a number of options; or say whether something is true or false. There's also *Factfile 500*, sets of additional questions for the program: arithmetic, spelling, sport and natural history.

The other range from Kosmos: vocabulary tutors in French, Spanish, German and Italian.

Funschool 2

Database Software ☎ 0625 878888

£9.95 tape, £14.95 disk ● AA43

So rare is it that educational software gets into the charts that it made the news pages of the weekly computer press. Actually there are three great packages here: under sixes, six to eights and over eights.



Wordhang

Bourne Education ☎ 0794 523301

£9.95 tape; £14.95 disk ● AA32

One of Bourne's range of ten programs. Others include *Happy Letters*, *Numbers and Writing* (all Infant); *Timeman One/Two* and *Map Rally* (all Junior); and the excellent *Chemistry* and *Physics Revision* (Senior).

BUSINESS/ACCOUNTS

● See also Pendown in 'Word Processing'

Protex Office

Arnor ☎ 0733 68909

£34.95 ● CPM+, 6128 only ● AA34

Requires *Protex* and *Promerge* to run. Information inputted using *Protex*. Mail merge templates included, and very well implemented invoice printing feature. A genuinely useful business system.

SD Microsystems range

SD Microsystems ☎ 0462 675106

General Ledger ● £19.95 ● AA32

Sales Invoicer Pack ● £19.95 ● AA26

Small Traders Pack ● £24.95 ● AA26

Stock Accounting System ● £39.95 ● 6128 only ● AA32

SD Microsystems have a range of quality small business systems. Consult original reviews for in-depth explanations of what each does and how it differs from the others – or better still, ring them and ask.

DATABASES

AtLast Plus

Rational Solutions ☎ 056681 511

£39.95 ● CPM+, 128k machines only ● AA30

Powerful: developed into user's requirements. Data capacity restricted only by disk size, and splitting fields into smaller elements possible. Printed output impressive. Beefy processing.

Masterfile III

Campbell Systems ☎ 0378 77762

£39.95 CPM+ ● AA30

With parent/child records – enabling tying together of records, saving space and time. Screen layouts and reports menu selected; not for faint hearts, but good results.

Random Access Database

Minerva Systems ☎ 0392 437756

£29.95 disk ● AA6

40 or 80 column screen. Good mathematical and string operations. Random disk accessing gives speed and power.

● See also Info-Script in '4. Integrated Packages'

SPREADSHEETS

Mastercalc 128

Campbell Systems ☎ 0378 77762

£33 disk ● 128K machines ● AA4

Can show two parts of spreadsheet at once. Includes notepad and calculator. Easy to use, but the mathematical formulae can only consist of the four basic arithmetic options. Slows down as more data is entered.

Matrix

Audiogenic Software ☎ 01 861 1166

£34.95 disk ● AA18

Uses disk to store data – so good capacity on the plus side, but poor speed on the minus side. Graphic options excellent. Onscreen prompts rare, making it hard at first. Calculating power good.

Supercalc II

Amssoft/Sorcim ☎ 0277 230222

£49.95 CPM+ ● AA4

First class documentation. Calculations can be determinative – performed on whether or not cell's contents match given value. Excellent help prompts and arithmetic functions.

Cracker

Newstar Software ☎ 0277 229509
£49.00 disk CPM+ ● AA9
 Spreadsheets must be created from scratch. Documentation good, command sequences soon learned. Mathematical functions well done, with random numbers catered for. Files limited to 17K - and formulae programming not well implemented.

The Cracker
 user's manual

■ SOUND

Amdrum

Cheetah ☎ 0222 555525
£34.95 ● AA13
 Digital drum machine. Editor comprehensive. Not Midi compatible: to hear output you plug it into amplifier.

DHCP Midi Interface

DHCP ☎ 0440 61207
£69.95 interface, £34.95+ disk s'ware ● AA33
 DHCP produce Midi software for various Midi interfaces for CPC, which are incompatible with each other.

Micro Music Creator

First Byte Software ☎ 0225 765086
£9.95 tape, £14.95 disk, £24.95 ROM ● AA38
 A music composer that lets you put staves and notes onscreen and play tune back. Accents can't be inserted, though. Other side is sampler to capture sounds from tape and play them through CPC. Excellent.

Miditrack Performer

EMR ☎ 0702 335747
£49.95 interface, £79.90/£89.90 tape/disk s'ware ● AA13
 Midi interface plus sequencing software to drive Midi equipped instruments. Records each instrument then plays them all at once. Onscreen layout similar to multi-track recorder. Excellent.

Sound Blaster

Siren Software ☎ 061 228 1831
£34.99 ● AA23
 Amplifier and pair of loudspeakers that plug into CPC for maximum 2 watts sound effects.

Midi Interface

Silicon Systems ☎ 061 848 8959
£59.95 interface, £59.95 software ● AA26

Useless alone, but software you can use with it - DX7, FB01, MT32, D50 and CZ101 - is diverse. Software prices vary, and lack presentation of EMR sequencer. High performance.

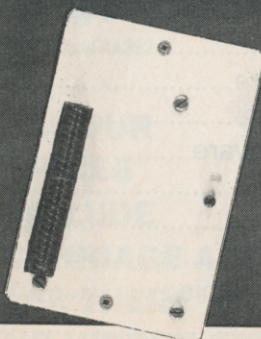

Ram Music Machine

RAM Electronics (Datel) ☎ 0782 744707
£49.99 tape, £59.99 disk ● AA17
 All in one music package: Midi interface, sound sampler and music editor. Sampler can handle one sample of just over a second. Midi controller software and music editor comprehensive. No through port, though, so 464 users must use tape version. And you can't edit live played Midi compositions.

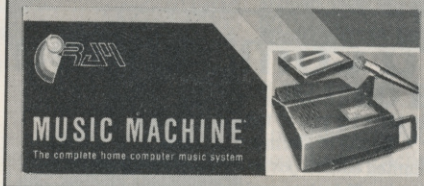

Speech Synthesizer

DK'tronics (Datel) ☎ 0782 744707
£29.99 ROM
 Add-on producing speech by RSX's: loudspeakers supplied. Cannot include speech in program for someone else's CPC, though. Even so, excellent speech quality and value.

■ VISION

AMX Art

Database ☎ 0625 878888
£69.95 disk (includes mouse) ● AA7
 User friendly, if little unsophisticated compared to *Advanced Art Studio*, but mouse helps greatly. Colour, spraycans, textures, circles and host of other features.

Cherry Paint

Siren Software ☎ 061 228 1831
£9.99 disk ● AA20
 WIMP controlled - ie mouse moves pointer to various icons to pull-down menus. B/W mode 2 only, but fun. Curves are difficult, but this is a bargain.

Advanced Art Studio

EEC ☎ 0753 888866
£24.95 disk ● AA21
 Recently revitalised, this is the user-friendly, best and most powerful art package: works in all three modes. Can cycle through inks, and cut and paste different areas, transformations and reflections. Fill routines in coloured patterns. Available as a standard version for £15.95.



DART Scanner

Dart Electronics ☎ 0502 513707
£79.95 ● AA22
 Attach reading device to your DMP2000, 3000 or 3160. Feed in picture to printer: device reads in picture as B/W image. Quality onscreen isn't amazing, but it works and it's fun.

The Informer

Treasure Island Software ☎ 0492 593549
£29 disk ● AA33
 For creating animated displays, suitable for classroom and shop window: takes text, graphics and animated displays and produces slide show. Works best but not only with *Parrotty Plus* (see below).

CRL Image System

CRL ☎ 01 533 2918
£14.95 disk/tape ● AA12
 Boasts range of picture manipulations and distortions, but lacks art options. Best on finished pictures - like a mini Quantel box.

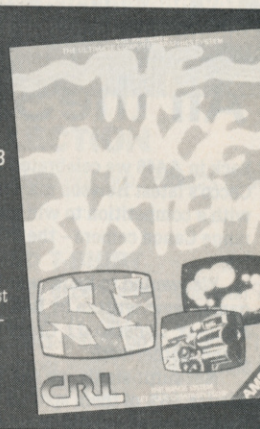

Parrotty Plus

Treasure Island Software ☎ 0492 593549
£19.95 disk ● AA30
 Rather than lots of effects used anywhere and at any time, *Parrotty Plus* 'remembers' every alteration and plays through the list to create animation. Note: can't dump pictures to printer without external program.

Electric Studio Light Pen

Electric Studio ☎ 0462 420222
464D £24.99, £14.99 ROM ● 6128 £24.99 ROM only ● AA1
 Excellent drawing software, including rubber-banding shapes and lines, filling areas, spray-can etc. Accepts software written for it.



Vidi Digitizer

Rombo Productions ☎ 0506 414631
£89.95 ● AA15
 Grabs picture from video recorder or camera and puts it on CPC screen, allowing you to alter it with an package. Easy to use. Software on tape, disk or ROM includes superb printer dump routine.

● Corrections, additions or ideas for sections to be included are welcome. Drop a line to: **AA Buyers, Amstrad Action, 4 Queen St, Bath BA1 1EJ**

Don't miss out!
AA's special fourth
birthday issue is out
on 14 September. It's
sure to sell out fast:
reserve a copy today!

AA Afterthought

Have we got a special issue for you lined up next month! Well, *have we?*

All the Stormlord competition winners!



Back in AA46 we celebrated the launch of Raff Cecco's latest Hewson masterpiece *Stormlord* with a competition to win a superb top-of-the-range Canon camera – the EOS 750, to be precise.

We wanted to know which of the following games were written by Raff Cecco: *Exolon*, *Equinox*, *Cyberoid I*, *Crazy Cars II*, *Cyberoid II* and *Netherworld*.

Not surprisingly we had heaps and heaps of entries, 95% of them spot on with the answers. One or two of you did imagine that Raff was responsible for *Crazy Cars II* (hard luck IAIN BROWN of Farnham in Surrey); two or three forgot to put their name and address (tough cheese, WHOSIT of Whereveritis); and about a dozen put their answers *inside* an envelope, thereby disqualifying themselves.

But as Trenton plunged his arm up to the elbow in the AA Whacking Great Competition Box, the first name out was KEITH TODD of Waterloo on Merseyside. Well done Keith, we hope you enjoy your prize and hope it arrived

in time for you to take on holiday.

Copies of *Stormlord*, together with a special limited edition poster of the game, go to the following 25 lucky people: J. Anderson, Aylesbury; D. Rees, Brynamman; Gurvinder Singh Sandha, Edgbaston; Alan Robinson, Preston; L. Thompson, London; V. Gwilym, Brynamman; Gary Conway, Huntingdon; Simon Waters, Poole; Matthew Woods, Orpington; Paul Carthy,



● Keith Todd, of Waterloo, Merseyside Judging by the photo the Todd household could do with a decent camera!

Clonmel; Rev B. Yellowley, Wombwell; Philip Jones, Ellesmere Port; Paul Wright, Kilcullen; Brian Keaveney, Dublin; Jagdeep Bhaura, Hounslow; Richard Ormson, Bury; M. Ahmad, Newcastle-upon-Tyne; R. Whelan, Coventry; Harry Lingard, Guildford; S. McSkimming, Hatfield; Alistair Hamilton, Harrogate; Adam Chazanow, Glasgow; C. Carter, Swansea; Whoever Lives At, 78 Home Park Rd, Wimbledon; and last and certainly not in way whatsoever least, goodness me no, Stuart Carter, Swindon. Well done one and all, and we hope you enjoy *Stormlord* as much as we do.

● If you're quick you may still be in time to enter our mega-splendiferous Electronic Arts *Skate or Die* and Virgin/Mastertronic *Magnum Lightgun* competitions: entries by the 31st August, details in last month's issue.

Stop him – he's reserved himself a copy of AA!

To the newsagent: Amstrad Action is distributed by COMAG

Dear newsagent,
Please reserve me a copy of the special fourth birthday issue of *Amstrad Action*, due out on Thursday 14 September

Name:

Address:

Telephone number:

If you're under 16, please get your parent or guardian to sign here:



Next month is AA's fourth birthday issue, and as usual we invite you to celebrate it with us. We are in the process of putting together a special cover cassette packed with entertainment, utilities and one or two special surprises. The birthday issue traditionally sells extra fast, and you'd be well advised to reserve a copy with your newsagent now. We cannot be held responsible for any disappointment or unhappiness caused by shortages!

ADVERTISERS INDEX

Akom	27	Goldmark Systems	6	Screens	69
Audiogenic	45	Home Based Business	54	Siren Software	20
Boxoft	20	John Morrison	54	Soft Exchange	27
Caspell	27	K&M Computers	66	Strategy Software	20
Castle Computers	52	MJC Supplies	32	Swift	44
Challenge Software	74	Matrix	54	US Gold	2-3
Cheetah	51	Mirrorsoft	35	VSE	54
Crazy Joe's	190	Mode One	74	Virgin/Mastertronic	15
Datel	38-39	Nemesis	19	Wacci	10
Escroe	54	Ocean	29, 49, IBC, OBC	Wave	19
First Choice	61	Parker Associates	69		
G-Ten	20	SDC	57		

THE ACTION OFFERS

BUY PRODUCTS FROM YOUR FAVOURITE CPC MAGAZINE.

All the prices include postage, packing and VAT. You can trust us, we don't intend to leave the planet for quite some time!

LIMITED EDITION COLLECTION

For a limited period only we are offering the following two products to add to your Amstrad Action Designer Collection.

RED BINDER

This smart Red Binder with the Amstrad Action logo embossed in blue on the spine and front. Holds 12 issues safe and secure from dangerous sources.

ONLY £4.95

Order Code AA417R

OR

£9.00 FOR TWO

Order Code AA4172R

RED T-SHIRT

A truly excellent red American T-Shirt with the official AA logo in three colours printed on the front. This summer wear yours with pride (and please the Ed!).

ONLY £4.99

Medium

Order Code AA361R

Extra Large

Order Code AA362R

OR

WHY NOT BUY

TWO T-SHIRTS

ONLY £9.00

(ONE in white and ONE in red, just quote the two relevant order codes!)



THE ORIGINALS...

AA BINDERS

The fabbo AA binder is the ideal item in which to store your growing collection of the world's most popular CPC magazine! Holds 12 issues, this royal blue binder with gold embossed logo on side and front is an essential purchase for even half-serious readers.

JUST £4.95 EACH

Order Code AA217

OR BUY TWO FOR £9.00

Order Code AA2172

**CALL OUR HOTLINE
ON 0458 74011 NOW
OR SEE THE ORDER
FORM ON PAGE 82**

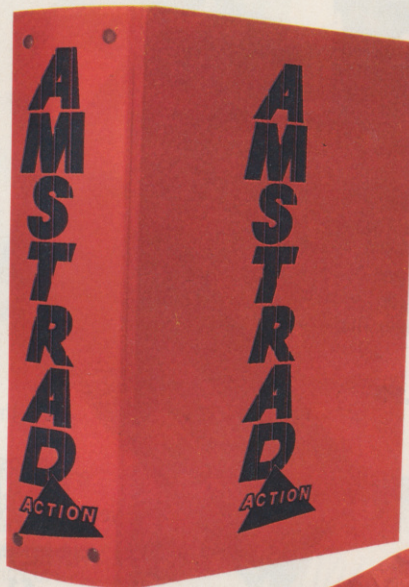

T-SHIRT

The amazing AA T-shirt is here! The sparky red and blue AA logo is printed on a white cotton T-shirt which you can buy for £4.99 in either medium or extra large sizes. Get this and you'll have AA even nearer your heart than ever before!

JUST £4.99

Medium

Order Code AA361

Extra large

Order Code AA362

**ALL OUR
PRICES
INCLUDE
CARRIAGE AND
VAT, THERE ARE
NO HIDDEN EXTRAS!**



THE ACTION OFFERS

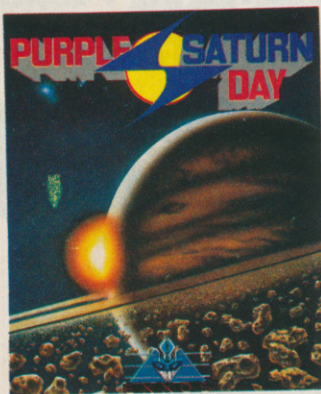

**CALL OUR HOTLINE
ON
0458 74011
OR SEE THE
ORDER FORM ON
PAGE 82**



PURPLE SATURN DAY

from Infogrames
The ultimate challenge.
See your way through the most difficult contests with the prize being a luscious kiss from the Purple Saturn Princess herself.

"There's so much to this game that you'll be playing it, like us, for months to come"

AA Issue 48

CASSETTE RRP £9.95

AA PRICE £6.95

Order Code AA600

DISC RRP £14.95

AA PRICE £9.95

Order Code AA601



SPECIAL ACTION

from Ocean
The latest superb compilation of games from the masters of software, Ocean.
It consists of:-
Captain Blood, S.D.I., Daley Thompson's Olympic Challenge, The Vindicator and Driller.

CASSETTE RRP £12.99

AA PRICE £8.95

Order Code AA602

DISC RRP £17.99

AA PRICE £12.99

Order Code AA603

AA DUST COVERS

A set of dust covers provides a neat solution to dust, tea and other potential computer disasters.

These specially-commissioned Amstrad Action covers are made from high-quality, water (and coffee) proof PVC. They're coloured a gentle beige with smart blue trimming and matching AA logo. You can order a 2-piece set tailor-made for your CPC system - just choose the correct order code from the list below.

2-PIECE SET ONLY £6.95

Order Codes

464 mono - A208 colour - A209

664 mono - A210 colour - A211

6128 mono - A212 colour - A213

HIGHLIGHTER PENS

For bringing out those key phrases, there's nothing like



**THREE FOR
£1.50**
Order Code AA266

these AA-embossed pens in red, yellow and green.

MONEY MANAGER

From Connect Systems

Money Manager is an easy-to-use system for recording all financial transactions, and for analysing them in a number of very powerful ways in order to facilitate sound financial management. Ideal for controlling small businesses, or for users wishing to control their personal finances in a business-like way.

- Full detailed statements, showing each transaction for any month or for the whole year.

- Bar graphs, pie charts etc.

- Standing order facility

- Full telephone support
CPC 464 (with disk drive) / 6128

RRP £29.95 AA PRICE

£18.95

Order Code AA291AD

more adventures including clashes with the infamous "Hood". All the characters are here, including Lady Penelope with her pink Rolls Royce and loyal chauffeur, Parker.

"Thunderbirds has the kind of depth and long term appeal that I find really rewarding"
Steve Carey, AA Issue 47.

AMS CASS RRP £12.95

AA PRICE £8.95

Order Code AA295AC

AMS DIS RRP £14.95

AA PRICE £9.95

Order Code AA295AD

GERRY ANDERSON'S THUNDERBIRDS

From Grandslam



"Calling International Rescue, calling International Rescue!"
Play the game and listen to the theme on the audio tape. Taken from the Gerry Anderson classic TV series you must attempt to save some miners that have fallen to the bottom of a shaft. Using your superb Thunderbird range of aircraft and machinery, send the Tracy clan on this dangerous mission. With three

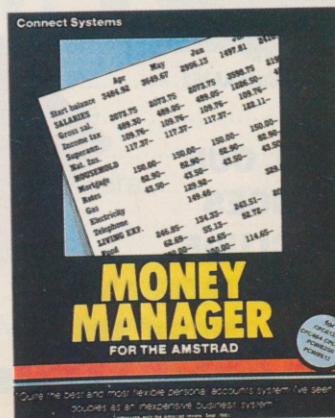

THE ACTION OFFERS

FUN SCHOOL 2

From Database/Mandarin
Bumper packages of educational software for infant and primary school age children. Fun School 2 comprises of three complete suites of eight programs.

"Fun School 2 lives up to both parts of its title. It is fun, and your child will almost certainly learn too."

AA Issue 43.

RRP £9.95/£12.95

AA PRICE £6.95 TAPE £8.95
DISK

Teddy Bear

FOR UNDER-6'S

Teddy Count, Teddy Bear Picnic, Colour Train, Find the Mole, Pick a Letter, Spell the Word, Shape Snap and Write a Letter.

Ams Cass Order Code AA292AC

Ams Disk Order Code AA292AD



Robot

FOR OVER-8'S

Logic Doors, Build a Bridge, Passage of Guardians, Unicorn, Escape, Souvenirs, Code Boxes and Mystery Machine

Ams Cass Order Code AA294AC

Ams Disk Order Code AA294AD



Frog

FOR 6-8 YEAR OLDS

Number Train, Maths Maze, Caterpillar, Shopping, Packing, Treasure Hunt, Number Jump and Bounce.

Ams Cass Order Code AA293AC

Ams Disk Order Code AA293AD



**SUBSCRIBE NOW!
SEE PAGE 56
FOR SOME
EXCELLENT
REASONS WHY!**



X-PRESS

from Medway/King

X-Press for owners and potential owners of Stop Press. There have always been limitations with programs running on the CPC machines, due to lack of memory. Now we can offer extra space and speed with this superb add-on package. (see full review, issue 48.).

AA PRICE ONLY £19.99

Order Code AA605

AMS 30L DISKS BOX

High quality anti-static storage box
Finished in high impact resistant plastic.
Hinged smoked plastic lid
Key operated security lock
Stepped base for easy disk selection

Attractive design for convenience and security

Capacity:

30 x Uncased 3" discs

15 x Cased 3" discs

AA PRICE £14.95

Order Code AA604



STOP PRESS AND MOUSE

Desktop publishing — doing page design and printing on a computer instead of the old cut-and-paste and linotype printing method — is the boom area of low-cost computing. All the national dailies are switching over to DTP methods — and so are thousands of CPC users, to produce everything from newsletters to menus, from posters to invoices.

ONE MONTH ONLY

ONLY £49.95,
AN AMAZING
SAVING OF
£30.00!!

THE RRP IS £79.99

Please note that this price cannot be held after 25th September, at which time the price will return to £64.99. (CPC6128 or 464 with upgrade and disk drive)

Order Code
AA605

**ALL OUR
PRICES INCLUDE
CARRIAGE AND VAT,
THEY'RE THE CHEAPEST AROUND!**



SQUEEZING



OVER A DOZEN



CHART-BUSTERS
INTO TWO
PACKS WASN'T
EASY —



BUT NOW HERE THEY ARE . . . THE TOP-SELLING COMPILATIONS THAT NO PLAYER SHOULD BE WITHOUT. **EXPAND** YOUR PLAYABILITY.

THE IN CROWD



SPECIAL ACTION

A M S T R A D
 C O M M O D O R E
 S P E C T R U M
£ 1 4 . 9 5
 D I S K

A M S T R A D
 C O M M O D O R E
 S P E C T R U M
£ 1 2 . 9 9
 C A S S E T T E

Ocean Software Limited · 6 Central Street · Manchester · M2 5NS
 Telephone: 061 832 6633 · Telex: 669977 OCEANS G · Fax: 061 834 0650

ACTION RATING-99%



MOSCOW'S TOUGHEST DETECTIVE. CHICAGO'S CRAZIEST COP. THERE'S ONLY ONE THING WORSE THAN MAKING THEM MAD. MAKING THEM PARTNERS.

The heat is on ... and the chase is in full cry as East and West join forces to hunt down a Soviet drugs dealer. The two detectives; one Russian, one American have very different methods of capturing their prey, but together they face the worst of Chicago's underworld – street fights, the 'Cleanheads' gang, gun fire – the hottest film tie-in to date – it's all action with stunning graphics – feel the heat – RED HEAT.



RED HEAT



THIS IS THE CLIMAX ...

THRILLING ACTION THROUGH TIME AND SPACE

When a guy loses his girl – he loses his mind! Now, in the Final Chapter, Renegade must summon all his strength and lightning reactions as he chases his girlfriend's captors through time itself. Fight against neolithic man, mediaeval knights, and the tormented undead from within the tombs of Ancient Egypt. Your quest finally takes you BEYOND the present – to a time you'll never forget! ... but remember ... your girl wants to see you alive!



RENEGADE III THE FINAL CHAPTER

NOW FOR THE ATARI ST & AMIGA

9 EXPLOSIVE EVENTS

JET SKIS · HOVERS · QUADS · BUGGYS · THE HILL · METEORS · SUPERCATS · SPEEDBOATS · INFLATABLES

Hot from the Television series – the toughest, most exciting, multi-machine assault course to hit your screens! Simulating the skills of controlling the Jet Skis, the speed of the buggys, the sheer guts and stamina required for The Hill and much, much more! Run wild – Run The Gauntlet!



RUN THE GAUNTLET

(THE OTHER 1% IS FOR LOADING)

SPECTRUM
£8.99 EA
CASSETTE



COMMODORE
AMSTRAD
£9.99 EA
CASSETTE