

**NOT**  
an official  
Amstrad  
publication!

BRITAIN'S BEST SELLING MAGAZINE  
FOR THE AMSTRAD CPC 464 ● 664 ● 6128

ISSUE 49 ● OCTOBER 1989 ● £1.95

FROM FUTURE PUBLISHING COMES THE MEGAZINE THAT LEADS THE FIELD

# AMSTRAD

# D ACTION



"AAh... so!"

## BUT WHERE WILL YOU PUT IT ALL?

We celebrate our fourth birthday  
by giving away thousands of pounds  
worth of CPC goodies!

**DISK? YES!  
ALL UTILITIES  
TRANSFER EASILY  
TO DISK!**

How to load:  
turn to  
p.16

## SHINOBI - PLAY IT NOW!

- On the brilliant birthday cover cassette...
- SHINOBI - special fully playable mission!
- DATA CREATOR - Basic from nowhere!
- WORDSEARCH - pleasing puzzler!
- SELF-DESTRUCT - hilarious practical joke!
- DALEKS - classic CPC fun!
- EASISHEET - complete spreadsheet!



**BATMAN** is a shadow in the darkness, as elusive as a dream. High above the seamy streets of GOTHAM, he is a criminal's nightmare. The only hope for a desperate city – BATMAN.

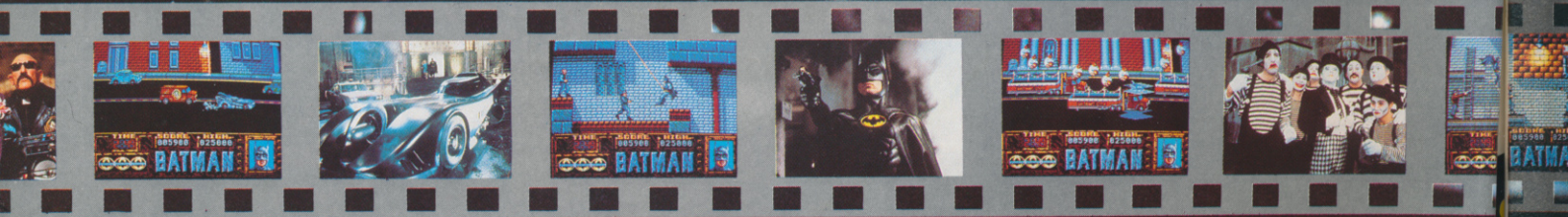

AMSTRAD  
**£9.99**  
COMMODORE

SPECTRUM  
**£9.99**  
SPECTRUM

ATARI ST  
**£19.99**  
ATARI ST

AMIGA  
**£24.99**  
AMIGA

TM

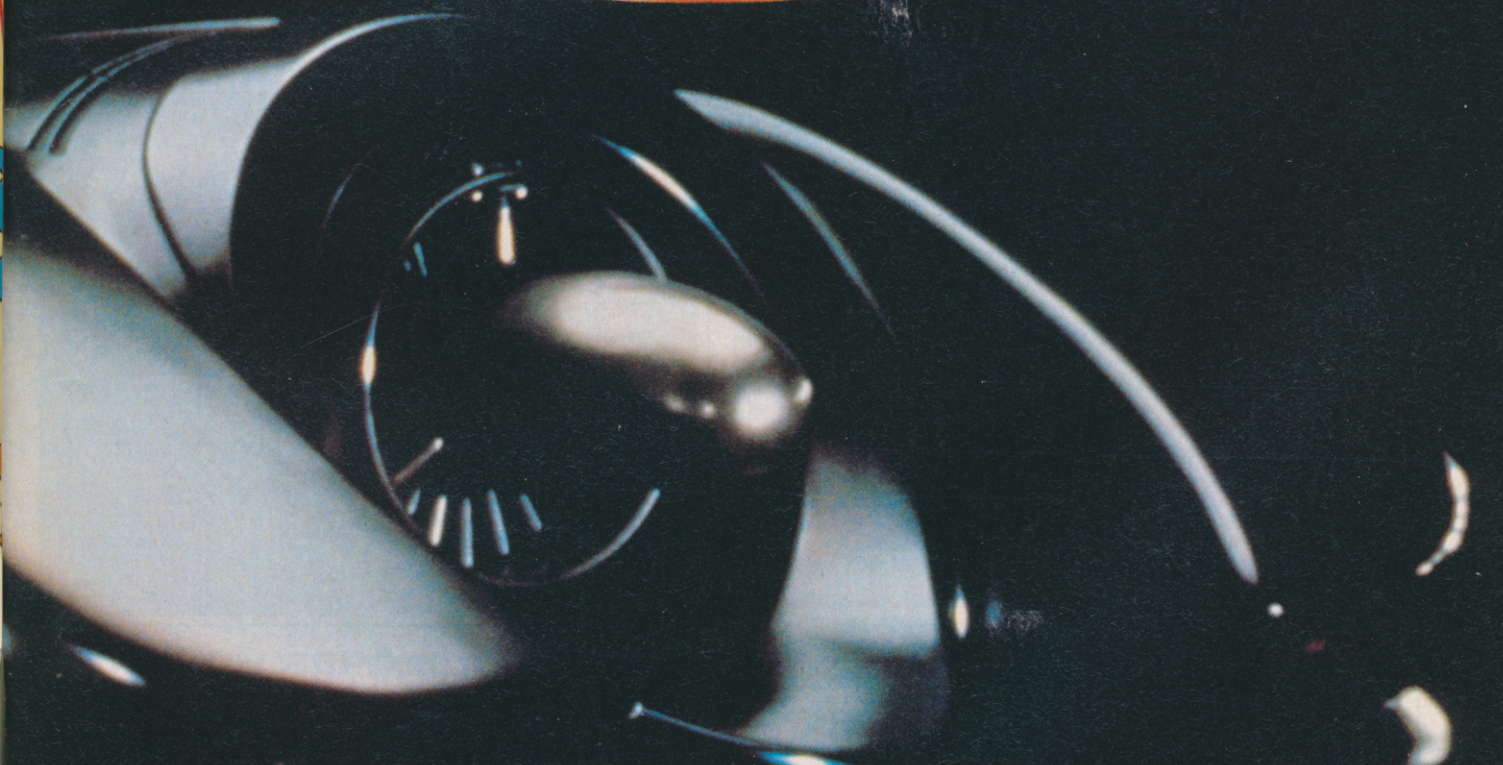
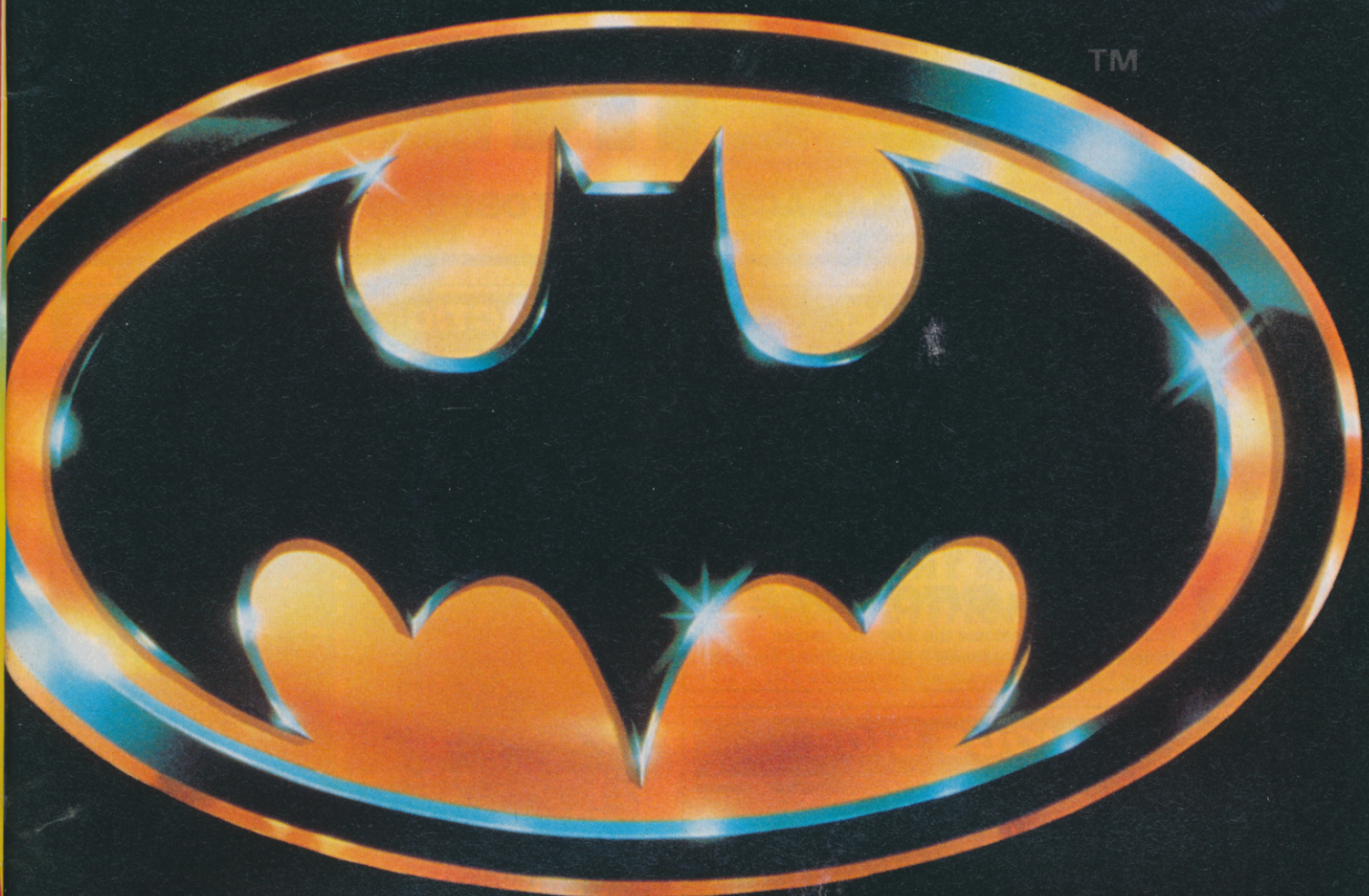

**ocean**<sup>®</sup>

TM & © 1989 DC Comics Inc.  
All Rights Reserved.

Ocean Software Limited · 6 Central Street · Manchester · M2 5NS  
Telephone: 061 832 6633 · Telex: 669977 OCEANS G · Fax: 061 834 0650

# THE LINE UP

AMSTRAD ACTION ● OCTOBER 1989

## FRONT END

NEWS ● LETTERS

- 7 AMSCENE**  
All the CPC news and previews
- 11 REACTION**  
Once more into the postbag dear friends...  
Readers' letters on all matters CPC
- 14 EMMA BROADLEY**  
Will you please welcome the lady who makes  
*Renegade* look like *Skweek*... No? Oh please yourself.

## SERIOUS SIDE

CPC USES ● HARDWARE ● PROGRAMMING

### 16 THE AA COVER TAPE!

Boy, have we a cover cassette for you! We have a MAJOR Amstrad exclusive in the form of Virgin/Mastertronic's conversion of the brilliant coin-op *Shinobi*, and a veritable TON of other utilities and entertainment...



● The utterly, utterly, brilliant, fabulous and wonderful *Shinobi* - play it!

Future Publishing Limited  
4 Queen Street, Bath BA1 1EJ

☎ 0225 446034 ● Fax 0225 446019 ● Editor Steve Carey

● Technical editor Pat McDonald ● Games editor Trenton Webb

● Art editor Ollie Alderton ● Additional design Martin Parfitt

● Contributors Emma Broadley, Phil Howard,

Stuart McColl, James Wilson, Adam Peters ● Photography Stuart Baynes

● Publisher Greg Ingham ● Production Fiona Milne ● Subscriptions

Christine Stacey ☎ 0458 74011 ● Mail Order Clare Bates ☎ 0458 74011

● Advertisements Elaine Brooks ☎ 0225 446034 ● Distribution Comag

© FUTURE PUBLISHING LTD 1989 *Amstrad Action* is an independent publication. The company producing it - Future Publishing Ltd - has no connection with Amstrad plc. We cannot guarantee to return material submitted to us, nor can we enter into personal correspondence. We take great care to ensure that what we publish is accurate, but cannot be liable for any mistakes or misprints. No part of this publication may be reproduced in any form without our explicit written permission.

ABC

MEMBER OF  
THE AUDIT  
BUREAU OF  
CIRCULATIONS

38,457

July-  
December  
1988

## THE ACTION BEGINS ON 48!

THE VERY BEST IN CPC ENTERTAINMENT

### 50 LASER SQUAD

The long wait is finally over: Target Games triumph!

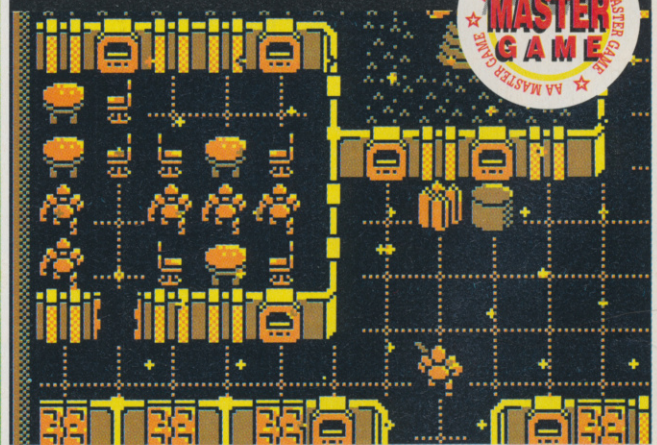

### 52 LICENCE TO KILL

Domark's word is their Bond...



### 18 THE LOOK

Oh my goodness me it's a graphics series!

### 21 NEVER A CROSSWORD

World's best CPC mag (7,6) reviews crossword prog.

### 23 KING OF PRINTERS

Whew, and we said we were giving it away? Must be mad!

### 24 MICE AND EASY DOES IT

Resident rodent expert PAT "The Cat" McD. sorts 'em out

### 26 FORUM

Page after page of hints, tips and problem solving.

**ACTION TEST:  
page 48!**

- Xenon, p. 48 ► Laser Squad, p. 50
- Licence to Kill, p. 52 ► Passing Shot, p. 54 ► Dragon Spirit, p. 55 ►
- Kenny Dalglish Soccer Manager, p. 56 ►
- Treble Champions, p. 56 ►
- Rockstar Ate My Hamster, p. 58 ►
- Indiana Jones, p. 62 ► Strider, p. 64
- Running Man, p. 66

**58 ROCKSTAR**  
Codemasters' Ate My Hamster simulator



**62 INDIANA JONES**  
US Gold whip up the hysteria...



- 32 MATCH REPORT**  
Two AA footie fans recall a great day out at Wembley.
- 40 FIRST EDITION**  
Our DTP series continues apace.
- 42 DAY IN THE LIFE**  
A Judge offers his verdict on the CPC.
- 44 HEAR, HEAR!**  
Let's hear it for the CPC beginner's tutorial.
- 70 THE PILGRIM IS BACK!**  
By popular demand, three pages of adventuring!

**Many more to come!**

Surely it can't be our birthday *already*? It seems only a few months since we were celebrating AA's third year. Now, a whole 12 months later on, here we are! And as we head out of the supposedly "slow" period of summer and towards the always frantic winter/Christmas time, things are looking much better than anyone could have predicted.

Sadly, however, it's not all good news. After some 17 issues in-house and heaven knows how many before that as freelance, Pat McDonald, Technical Editor extraordinary, is heading back home towards Frome. I shall miss him, and I'm sure you will too.

On a happier note, next month sees the arrival of the new Technical Editor, whom we shall be showing off proudly next month - stay tuned!

*Steve*



**34 THE AA FOURTH BIRTHDAY MEGA-COMPETITION!**

We have lined up what we believe to be the biggest ever CPC competition. For heaven's sake, *don't miss out!*

**COMPETITION**



- 72 FIRST EDITION**  
Read all about it, write your own fanzine, read all about it!
- 74 TYPE INS**  
Let your fingers do the walking to programmer's nirvana.
- 80 INSIDE OUT**  
STUART McCOLL'S CPC conducted tour comes to an end.
- 83 CHEAT MODE**  
A five page special, including THE ELITE CLUB!
- 88 INSIDER DEALING**  
Hackers' hacker PHIL HOWARD mucks about some more.
- 90 HELP LINE**  
Stuck? Here's the place to head for help!
- 91 BUYERS GUIDE**  
You'd be mad to buy before you check it out here...
- 95 SPECIAL OFFERS**  
Psst! Just don't ask how we can afford to sell so cheap!

# DISCOUNT SOFTWARE



from M.J.C. SUPPLIES

## DISC GAMES

3D Pool	11.95
Dominator	12.95
Obliterator	11.95
Time and Magic	11.95
Lancelot	14.95
Forgotten Worlds	12.95
Silk Worm	12.95
Xybots	12.95
Skweek	12.95
Emlyn Hughes International Soccer	11.95
Time Scanner	12.95
Renegade III	11.95
Vindicators (by Domark)	12.95
Running Man	11.95
Licence To Kill	11.95
Rick Dangerous	11.95
Supreme Soccer Challenge	12.95
The Story So Far	11.95
Thunderbirds	11.95

## M.J.C. SPECIAL:

Indiana Jones and the Last Crusade  
RRP 14.99 OURS 10.95  
OFFER ENDS 30th SEPTEMBER

## CORNIX SOFTWARE

**CARD INDEX:** Easy to use filing system  
**CASS:** 19.95  
**DISC:** 24.95

**SIMPLE ACCOUNTS:** easy to use accounts ideal for small business includes VAT. **CASS:** 34.95  
**DISC:** 39.95

**JOB ESTIMATOR:** useful tool for contractors. **DISC:** 39.95

**PRODUCT COSTING:** DISC:39.95 Full specifications on all of the above programs on request.

## EDUCATION

Animal Veg, Mineral	11.95
Answerback Junior Quiz	11.95
Factfile Arithmetic	7.95
Factfile Spelling	7.95
Factfile Sports	7.95
Fun School for 2-5 years	7.95
Fun School for 5-8 years	7.95
Fun School for 8-12	7.95
Fun School 2 for under 6 yrs	9.95
Fun School 2 for 6-8 yrs	9.95
Fun School 2 for over 8 yrs	9.95
World Wise	11.95
German Master (12 to adult)	16.95
French Mistress (12 to adult)	16.95
Spanish Tutor (12 to adult)	16.95
Italian Tutor (12 to adult)	16.95

**Note:** Factfiles are question packs only and require the Answerback Junior Quiz.

## DISC SERIOUS

<b>Protext</b>	<b>17.95</b>
Prospell	16.95
Promerge	16.95
Arnor Filer	18.95
Arnor Office Suite	26.95
<b>Tasword 6128</b>	<b>19.50</b>
Taspell	12.95
Tasprint	10.95
Tascopy	10.95
Tasdiary	10.95
Tassign 6128	23.95
<b>Qualitas Plus version 2</b>	<b>14.95</b>
Qualitas Font Library	11.95
Qualitas CPM + Utilities Disk	8.95
<b>French Mistress</b>	<b>16.95</b>
German Master	16.95
Spanish Tutor	16.95
Italian Tutor	16.95
<b>Masterfile III Database</b>	<b>29.95</b>
Mastercalc 128	25.95
Matrix Spreadsheet Plus	29.95
Stop Press Desktop Publishing	29.95
Extra Extra	19.95
Maxam (Assembler/Diss)	18.95
Poke Easy Plus	14.95
<b>Mini Office II</b>	<b>13.95</b>
Rodos Extra Disk	8.95
Advanced Art Studio	19.95
Stockmarket	25.95

## CPM BASED

At Last Plus	29.95
Supercalc 2	44.95
Arnor C Compiler	39.95
Maxam II	39.95
Fortran	39.95
Nevada Cobol	39.95
Hisoft Devpac 80	39.95
Hisoft Pascal 80	39.95
Hisoft C Compiler	39.95
lankey 2 Finger Typing	19.95
lankey Crash Course	19.95

## M.J.C. SPECIAL

Protext CPM: including  
Spellchecker & Mailmerge  
RRP £59.95 OURS £39.95

## CASSETTE BASED

<b>Mini Office II</b>	<b>9.95</b>
Maxam 464	15.95
Protex 464	15.95
Tasword 464	15.95
Answerback JNR Quiz	8.95

**ALL ABOVE PRICES INCLUDE VAT, POSTAGE & PACKING IN THE U.K.  
THE ABOVE SOFTWARE IS ONLY FOR THE AMSTRAD CPC RANGE**

## ACCESSORIES

AMX Mouse + Interface	Only 34.95
Printer Lead 1M	8.95
Printer Lead 1.5M	9.95
Printer Lead 2.0M	10.95
3" Disc Cleaner	6.95
Amstrad R232 Interface	55.95
Mono Screen filter	12.95
Colour Screen Filter	14.95
Comp Pro 5000 joystick	13.95
Quickshot Turbo joystick	11.95
Cruiser joystick	9.95
464 Monitor ext Leads	6.95
6128 Monitor ext Leads	7.95
1000 Fanfold Labels	6.95
Second Drive Lead	7.95
AMX Mouse + Art Software	49.95
AMX Mouse + Stop Press	54.95
464 Dust Cover (mono/col)	7.95
6128 Dust Cover (mono/col)	7.95
KDS 5 1/4" 800K disc drive (state 464/6128)	159.95
KDS 8 Bit Print Port	18.95
DKTK Memory Expansion	45.95

## RIBBONS

Printer	Quantity		
	1	2	5
DMP 2000/2160	3.50	6.00	14.00
Panasonic 1080/1081	3.95	7.00	16.00
Citizen 120D	3.95	7.00	15.00
Star LC10 (Black)	3.95	7.00	15.00
Micro-P165/200	4.95	8.00	18.00
Star LC10 Colour	5.95	11.00	-
CF2 Disc (Amsolf/Maxell)	10	for	

**PLEASE CALL FOR AVAILABILITY £25.95**

## BOOKS/MANUALS

Adv Amstrad Graphics	7.95
Mastering Machine Code	8.95
Programming the Z80	19.95

## ROM BASED

<b>Protex</b>	<b>27.95</b>
Prospell	22.95
Promerge +	23.95
<b>Maxam</b>	<b>27.95</b>
Maxam 1.5	20.95
Utopia	20.95
BCPL	21.95
Rodos	28.95
Cage Rom (state which I/Face)	31.95
Rombo (if purchased with Rom)	28.95
KDS Rom Board (Holds 6)	24.95

## Quali Pack Version 2

The Print Enhancement Package  
New Qualitas Plus version 2  
KDS 8 Bit Printer Port  
**R.R.P £36.90**  
**Package Price £34.95**

## Quali Pack Extra Version 2

As above plus new Qualitas font library  
**R.R.P £51.85**  
**Package Price £44.50**

## PRINT COLOUR GRAPHICS

At last it is possible to get colour screen dumps from a 6128!

**COLOUR DUMP 2** is available exclusively from M.J.C. Supplies and will take a standard screen file from **Advanced Art Studio** or created with **AMX Art**, and print it out in full colour on a **Star LC10** colour printer. You choose which colours on paper, represent which inks on screen for total control and variation. Also works on Epson compatibles inc. **DMP 2000/2160** with coloured ribbons.

## COLOUR DUMP 2 - £12.95

**ADVANCED ART STUDIO - £19.95**  
All Star LC10 colour orders before 30th September just £214.95!

## PRINTERS



All printers listed have a ten inch (A4) carriage, are Epson compatible, and feature friction and tractor feed mechanisms for continuous or single sheet paper. All prices include the necessary cable

## CITIZEN 120-D

Cheap Epson FX-80 compatible giving a range of text sizes and effects in draft mode. Limited sizes and effects in NLQ  
**£139.95**

## PANASONIC KXP - 1081

Offers all the draft mode text sizes of the D.M.P. 2160, but is better built, more reliable, and offers N.L.Q. in all sizes and effects, for only £10.00 extra! Highly recommended.  
**£159.95**

## STAR LC-10

As well built and reliable as the Panasonic. Has four N.L.Q. fonts (typefaces), in combination with all sizes and effects. New low prices makes it well worth considering  
**£174.95**

## STAR LC-10 COLOUR

All the features of the LC-10, but with a seven colour option for colourful text. If you want colour graphics please call first for advice.  
**£214.95**

## STAR LC 24-10

24 pin version of the LC-10. Has 5 excellent letter quality fonts available with all sizes and effects. Two extra effect, outline and shadow are also featured. Good value.  
**£269.95**

Overseas Orders Welcome - Please write for details

WE ARE NOW IN OUR FIFTH YEAR OF SPECIALISING IN AMSTRAD MAIL ORDER, OUR POLICY IS TO PROVIDE THE WIDEST RANGE AT DISCOUNT PRICES WITH A FAST TURN AROUND TIME - TRY OUR SERVICES WITH CONFIDENCE

**CALLERS WELCOME: Mon-Fri 9 to 5 Sat 10 to 4**

PLEASE SEND CHEQUES/POs TO:

# M.J.C. SUPPLIES, (AA)

40a Queen Street, Hitchin, Herts. SG4 9TS.

Tel: (0462) 32897/420847 or 421415 for enquiries/Credit Card orders

Proprietor M J Cooper

VISA

ACCESS

# AMSCENE

releases... updates... previews... new releases... updates... previews... new

## Enhancements all round!

To bring to a successful close a summer that has been an exceptionally active period for the CPC, companies are hastening to release substantially upgraded versions of best selling utilities and programs.

Swift Software have taken *Pandora* (the games creating aid) up to version 1.01. Manager Robin Nixon was very happy about his product's success.

"We've sold between 600 and 700 copies," he claimed, "and feedback has been very encouraging indeed. With our help lots of people have had been able to solve serious problems with programs."

### Sound judgment

So what does the new version contain? "We had one or two people who told us about some minor bugs - there was quite a nasty one in the scroll routines, for instance. Users also mentioned many improvements to the original program, and naturally we were glad to incorporate those."

In fact, the new *Pandora* can handle saving out sound envelopes (tone or volume) as separate data blocks, rather than depending on



● Pandora is getting better all the time, while Speech gets an encore



you saving the whole lot. It allows access to the stack for variables, loops, PEEKing and POKEing memory and running your own machine code routines too.

### Uphill struggle

Swift are also working hard to improve the distribution of *Pandora*. "We're still trying to get distribution of the program into the shops," explained Robin: "but quite frankly it's an uphill struggle. I can however say that *Pandora* will almost certainly be available through WH Smiths' Home Computer Club by the New Year."

The version of *Pandora* available then, Version 2, will incorporate extras such as music creators

and sequencing, envelope editors, new sprite handling and intelligent compilation, so that memory is used as efficiently as possible. For existing users the price of upgrading (from V1.00 to V1.01 or, when available, V2.00) is £4.95. Swift are on ☎ 061 477 8405.

● Swift have recently acquired

the rights to sell *Speech!*, the fun program that lets your CPC speak up for itself in pure English. On top of this is a tutorial, and a utility to speak out ASCII files - all for a mere £4.95 on tape and £7.95 on disk.

● And Swift's £30 Keyword utility is reviewed in this issue on p. 20.

## Price of progress

SD Microsystems have announced that their popular *General Ledger* is now available on tape. Steve Denson, the brains behind SD, told AA, "We have no doubt that businesses won't be able to use a tape based *General Ledger* very well. That wasn't the idea at all."

"The reason is that people want to see the program at work before they upgrade to disk. It's a big step for a small business just starting out, and they need to see that it's worthwhile and will do what they need."

Another change to the range is a special *General Ledger* program for the 6128. This uses the extra memory to store up to twice as many transactions as before, as well as having more features, such as a trial balance report, standing orders and

direct debits (automatically posted to the account on the right day) and ten extra expense accounts. The "look and feel" of the program have also been enhanced.

Neither has the *Stock Accounting System* been ignored. Version 3.15 now features a routine which logs all transactions as they happen for Stock Analysis purposes. So you don't have to do a batch run to get a report of what's selling well. Instead, the information is available at any time, and the Sales Ledger can be updated instantly. SD Microsystems can be contacted on ☎ 0462 675106.

● Readers on the other side of the world now have a local (well, relatively local) dealer: Strategy Software, PO Box 11, Blackmans Bay, Tasmania 7512 ☎ 002 29-4377.

## New look Prestel and Brunword

Prestel and its micro-computer special interest group Micronet 800 have acquired a much improved electronic mailbox facility - mostly as a result of protest over the original system.

Rather than just sending one mailbox frame to one person, whose identity number you must know, you can now send five frames to up to 12 people at a time. You will be informed when the mailbox is read, and there's a notepad area which lets you edit and store mailboxes.

Perhaps most useful of all is the directory, which lets you find out details of other Prestel customers, which can be automatically cap-



● Prestel: goes from strength to strength

ured for addressing your electronic mail.

This all costs - naturally: 1p per usage of mailbox, plus 4p for receiving a pre-addressed mailbox. Advertising and promotional messages cost 20p per time for mailshots. And of course there are the dreadful VAT charges on top of that...

● Brunning Software's *Brunword Elite* is currently undergoing fine pre-release tuning. "We have no doubt that when it is released it will be very well received," predicted Peter Brunning confidently.

Meanwhile, Brunning's *100 Letters* utility for *Infoscript* is reviewed in this issue on p. 20.

# Star pins its hopes on new models

The second biggest importer of printers into the UK (that "second" must hurt) is making a bid for the low cost end of the printer market.

Star's excellent LC24-10 (reviewed in AA47) has been reduced by £100 to £299, and an LC24-10 with a carriage wide enough to take A3 size paper (labelled the LC24-15) has been introduced at £499.

Furthermore a new intermediate printer between the LC10 colour and the LC24-10 is on its way. Known as the Star LC15, it costs £399 and has a wide carriage.

It also has the unconventional feature of the paper feeding through the bottom of the printer, which means that it takes up less space than a normal printer. Finally, the LC10 is to be updated to the LC10 II, minus the colour option but with a 20% faster printing rate. It costs £229.

Discuss your needs with Star on ☎ 01 840 1800.

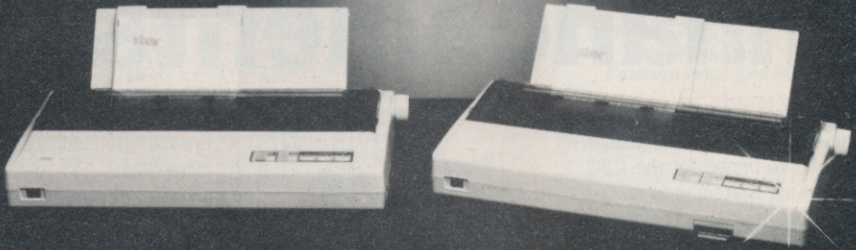

● We're going to make you a Star...

## AA lines up massive Shopper spree!



● Get out of your trolley in the AA/Shopper competition!

● AA has joined forces with mighty Database to organise a great competition to publicise *The Computer Shopper Show*, which opens at Alexander Palace on Wednesday November 22nd. The lucky winner will be given a shopping trolley, a map of the CPC exhibitors and five minutes in which to grab as much as possible!

CPC exhibitors already pledged to support the show and the competition include famous names such as Amstrad, Database themselves (of course), Rombo Productions, Computer Manuals, Kempston Data and Tynesoft. Others less well known, such as A&S Distribution, A1 Computer Supplies, B Bytes, Caspell Computer Services, Computer Store, Graft Vent, Manor Court Supplies and Margin Maker will all be there as part of what it is claimed will be "the biggest Amstrad show ever."

So get into training, and be sure to grab a copy of next month's AA!

## Lifetime drive arrives for CPC

The Miles Gordon Technology "Lifetime" drive is now available to the public. By merely setting a few dip switches to a different configuration, you can plug it into nearly every disk based microcomputer on the market.

The Lifetime Drive costs £129.95, but to this must be added the cable for the CPC, which is £18.50. Then you need a second drive operating system, such as *Ramdos* from KDS (☎04853 2076) or *Rodos* from Romantic Robot (☎01 200 8870), bumping up the price by another £20 to £30.

The Lifetime Drive also fits the BBC, QL, Plus D, Disciple Spectrum Interface, ST, Amiga, IBM PC, Spectrum +3 and for all we know your dad's old Austin 40.

Miles Gordon Technology are on ☎0792 791100.

● Watch out for the full and definitive CPC review in next month's AA, and a competition to win one all for yourself!



● All together now: and next month they're making another one!

## Rad on

Not content with capturing the Marvel signature (see story on p. 9), The Edge have also entered the cutthroat budget market with *Rad*, a new label instantly noticeable for its dayglo spine.

*Soldier of Light* and *Alien Syndrome*, two arcade conversions, are first out of the bag, though *Rad* promises a heady mix of previously unreleased material, established classics and mini-compilations, all at £2.99. Radical it ain't, but if *Rad* games put up as good a fight as the label is talking we'll be well happy.



## 'Op: for the best?

It's called *Operation Gunship* - and that's about all we can tell you until the full review next month.

We can reveal that it's by the self-styled "famous" Oliver Twins, the team behind *Dizzy*, *Treasure Island Dizzy*, *Fast Food*, *Advanced Pinball Sim*, *Race Against Time*, *GhostHunters*...



● Op Wolf meets Gunship, perhaps?

# The Edge: close to The Punisher

The Punisher is coming! Yes folks, the he-man with the taste for ultra violence and justice blasts his way onto the CPC around Christmas. After almost a year of negotiations The Edge have managed to capture the licence to produce Marvel Comics characters in computer game form.

Punisher, also to feature in a movie starring He-Man meathead Dolph Ludgren, is the new Marvel sensation. Tooled up with an Uzi machine pistol and a weapons laden battle van, his mission is the elimination of organised crime. He looks the ideal game character: light on conversa-

tion and heavy on action, thick as a brick but twice as tough.

The Edge have also acquired rights to create a game around the *The Uncanny X-Men*. Led by cult hero Wolverine, three games are planned around the adventures of the mutant/superhero band. *The X-Men* are the biggest selling Marvel title and The Edge are predictably banging the gong.

"You name the Marvel character," challenged an Edge spokesperson, "and we probably have a game planned!" (OK, what about *Lockjaw?* - ed.) That's not to say The Edge don't recognise the dangers of "quick buck" licence abuse: "We're not doing either a Spiderman or a Hulk game for a while, because there have been some appalling kick-em-ups based on these characters that should kill them off for quite some time!"



EDGE



## Heroes: sequel promised

*Heroes of the Lance*, US Gold's Advanced Dungeons and Dragons bash-'em-up, is claimed to have passed the 150,000 sales mark. Now things are once again stirring in the mythical world of Krynn, for *The Dragons of Flame* is, as they say, Coming Soon to your CPC.

Much more than a sequel (more a way of life), *Dragons* promises even higher levels of roleplaying, with added features such as extra magic, more monsters, wilderness mapping and three tasks to be completed in a time limit set by yourself. Predicted launch date is late November, but after the epic saga of delays on *Heroes*, beating the time limit set by US Gold could be an adventure in itself. Wait and see...



● *Heroes*: sequel promised. Breath holding unwise

## Gazza lends weight to Empire footie game

With the football season well into its stride, Spurs superstar Paul Gascoigne has thrown his not inconsiderable weight behind Empire's new football sim *Gazza's Super Soccer* (let us be the judge of how super it is, if you don't mind). The game's twist is that there is not just one, not even two, but *three* perspectives from which to view the game!

On the centre of the pitch the view is from the side, but when you get near the goalmouth the perspective switches to an end-on view to help with



● *Gazza*: over 'ere son, on me 'ead!

control of the set pieces and the goalie's movements.

Further control is helped with a "boot-o-meter" (sounds more at home on the terraces than the pitch) which helps you control the power of the kick.

*Gazza Super Soccer* has a team database which allows you to play any team from any English division and the Scottish Premier. Each team is based on that particular squad as it starts the 89/90 season, with varying

skill factors and formations reflecting real life. Naturally, on the it's-my-game principle Paul Gascoigne is the most skilful computer opponent, so it might be wiser to play *with* Spurs rather than against them!

● *Gazza's Super Soccer* gets the full treatment in next month's issue. We're having a ball - don't miss it!

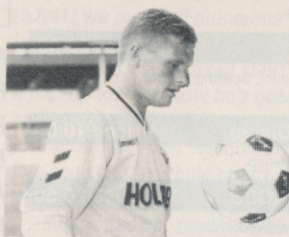

## 'Copter load of this!

Microprose's *Mr Heli*, a cute shoot-'em up with a distinct Raff Cecco look, carries on where the excellent *Rick Dangerous* left off.

As the pilot of a small helicopter you buzz around a multi-directional maze, blasting anything that moves with guns, missiles and bombs. To make life interesting there are bonus

weapons and points hidden away in the brickwork which have to be blasted out and collected. The levels are short but difficult, and include one starting in the dark!

● Full review in next month's AA (available from all good newsagents on Thursday, October 12: order your copy now!).



● *Mr Heli*: nice gameplay, shame about the title?

## Aow! Who's, hic, baaaaad, aow!? Hic!

Well known warbler, hooper and squeaker Whacko Jacko is about to moonwalk across your screen going "Aow!" and "Hic!" rather a lot. Jackson's fantasy film *Moonwalker* is being given the US Gold treatment even as you read this, and they claim, somewhat predictably, to be using all the best transformation, battle and chase sequences.

No doubt US Gold expect tabloids' favourite Jackson's charisma and talent to generate massive sales, but it will be, um, interesting to see whether an essentially musical film can translate successfully into a computer game. Where might it end? *Pro South Pacific Simulator II?* *Oklahoma*. *The Arcade Adventure?* *An American Gunship in Paris?*

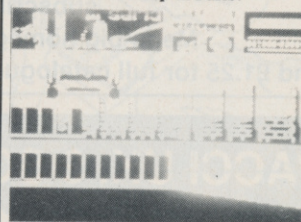

● *Moonwalker*: it'll end in "hic" noises

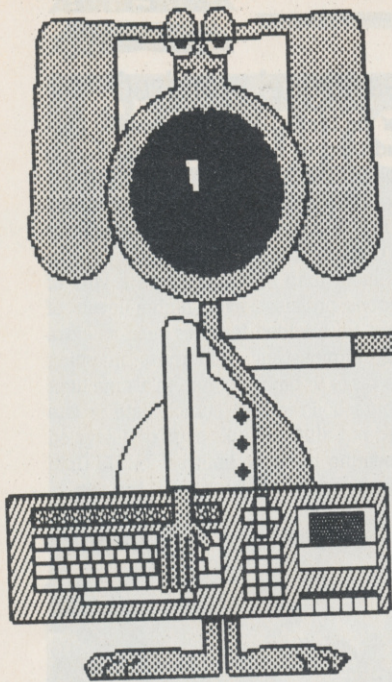

# WACCI

unbeatable prices, unbeatable service

## THE FANZINE

### ANNUAL SUBSCRIPTION RATES

UK.....	£15.00
Europe .....	£22.50
Overseas .....	£30.00
Current issue .....	£1.25

- \* Fully illustrated
- \* Over 20,000 words per month
- \* Proper A4 format

Letters, Basic, Comms, Mcode, Hardware projects and much more.

A truly  
Alternative  
Fanzine

**CASPELL RIBBON REFRESHER**  
An 8oz can does up to 30 ribbons  
**ONLY £7.95 PER CAN**

## THE PUBLIC DOMAIN SOFTWARE

### CPM DISC 1 – MACHINE CODE TOOLS Price £6.50

Z80 and 8080 assemblers, Z80 to 8080 to Z80 code translator, Debugging monitor and assembler, Reverse assembler, Binary file comparer, plus NewSweep and more.

### CPM DISC 2 – COMPUTER LANGUAGES Price £6.50

Small-C, Prolog, Lisp, EBasic, Small-C-Interpreter plus NewSweep.

### CPM DISC 3 – FILE AND DISC MANAGEMENT Price £6.50

Library utilities, Disc quality checker, Unix GREP command, PCW disc reader, Disc sector editor, Text file sorter, Word counter, plus NewSweep and more.

### CPM DISC 4 – AT YOUR LEISURE Price £6.50

Cave Adventure, Chess, Othello, Golf, Word search, Biorhythms, Maze generator, On-screen calculator, Prolog, Comms utility, plus NewSweep and more.

### CPM DISC 5 – THE BUSINESS Price £6.50

Scrivener spreadsheet, Inventory database, Powerful text editor, Spelling checker with dictionary, Sorter, Word counter, Comms utility, plus NewSweep and more.

### CPM DISC 6 and 7 – PASCAL PLUS (Two Discs) Price £10.00

Pascal, SCI, Cobol, EBasic, Powerful text editor, plus NewSweep.

### CPM DISC 8 – MORE COMPUTER LANGUAGES Price £6.50

Forth, Stoic, Cobol, Expert 86, Powerful text editor, plus NewSweep

### CPM DISC 9 – COMMUNICATIONS Price £6.50

Mex, Kermit, Kermode, Interface and Smart-Modem, overlays, source code, plus NewSweep and more.

### PLUS \* PLUS \* PLUS \* PLUS \* PLUS

Public Domain software support available to WACCI subscribers.

Mega-big homegrown library

Send £1.25 for full catalogue and details (E and OE).

## THE SPECIAL OFFERS



Advanced OCP Art Studio — £18.95

OCP Art Studio — £15.95

The Advanced Art Studio, bundled together with the Genius Mouse, Interface and Mouse Mat — £49.95

Ram Delta Joystick .....6.99  
Kador Seal 'n' Type covers.....7.95

MasterCalc 128 .....24.95  
MasterFile III.....29.95  
MasterCalc AND MasterFile .....49.95

Protex (CP/M+) .....47.00  
Pocket Protex (CP/M+) .....23.25  
Protex Filer.....19.50  
BCPL (CP/M+) .....19.50  
Arnor C (CP/M+) .....39.00  
Maxan 1.5 (ROM).....£23.25  
Protex Office (Disk) .....£27.25

Rombo Rom Box.....29.95  
VIDI-CPC digitiser .....69.95  
5 x CF2 discs (yes we've got them!) .....11.95  
10 x CF2 discs .....22.95  
20 x CF2 discs .....44.95  
DMP 2000/3000 Printer Ribbons (each).....3.20

**WACCI UK, 9 SOUTH CLOSE, TWICKENHAM, MIDDX TW2 5JE**  
**Est. 1986 — Phone 01-898 1090**

# REACTION

Yet another brimming postbag spills across the editor's desk

## ●Not such a grim pill to swallow after all!

I have sweated and walked miles to get a petition together to bring back the Pilgrim. Scan the list and you will see that a lot of famous people are upset because the adventure column in AA has disappeared.

J Stiles	Pr G Bush
Ron Reagan	Kate Bush
Dr Spock	M Thatcher
Granny Smith	Dr Doolittle
Level 9	Hank Marvin
J Henderson (local corner shop)	
Michael Jackson and Bubbles	
Joe Longthorne	Joan Pancott
Terry Wogan	Capt Birdseye
Eric Bristow	Clint Eastwood
Lee Trevino	Willie Carson
HRH	Frank Bruno
Clive Sinclair	Tom and Jerry
Mother Theresa	Michael Fish
Eddie Murphy	Ronnie Corbett
Shakin' Stevens	Mel Gibson
Bros	Lech Walesa
Paul McCartney's son	
	Shergar

Anyway, I think you get the point!  
**Jim Struthers,**  
 Blyth, Northumberland

**AA:** Jim, I hate to sound sceptical, but I know for a fact that Bubbles (to name but one) has trouble doing the joined up writing. You wouldn't be telling a teeny, weeny porkie pie by any chance, would you?

Never mind, you and all the other Pilgrim fans have made your wishes known. Turn to page 70 and all your birthdays will arrive at once!

Incidentally, I hope that this encourages other AA readers to put their own preferences into writing. You see, it really does make a difference.

## ●Copy and be damned!

My letter concerns Phil Craven's article on software copying and the new Copyright Law (AA48). Due to the ever-present threat of corruption (from which I have twice suffered), I have formed the habit of making backups wherever possible. It is plain common sense.

Software manufacturers seem

A letter can make all the difference (it brought the *Pilgrim* back!). So write to: *Reaction*, AA, 4 Queen St, Bath BA1 1EJ. There's a £15 software voucher for the letter of the month, too!

to be divided into three camps. There are the producers of serious programs who recognise this need and positively encourage the creation of backups, or give a lifetime's replacement guarantee. Closely allied to them are the producers of budget labels and compilations. The third camp contains the selfishly-motivated games creators.

Let me make my own position clear. I am opposed to piracy. The fact is that if you copy someone's lawful copyright property, whether it be article, artwork, musical score or computer program, for personal gain, or to pass on to someone else who might otherwise buy a copy, then you are a thief. So is the recipient.

However, I am also opposed to rip-offs. When Amstrad disks were reduced in price, it was reasonable to expect software houses to follow suit, at least part way. But the thought of all that extra loot was too big a temptation, so they jumped onto the profiteering bandwagon. As I dislike being fleeced, I only buy a game on disk if it is a multi-loader.

My own sequence of actions are, then, quite clear, the Copyright and Patents Act 1988 notwithstanding. I shall continue to attempt to transcribe software on cassette to disk on the basis that the tape and its contents are legitimately mine for me to do with as I please, as long as I do not rob the originators of their just dues (or ill-gotten gains, as the case may be). If sophisticated protection cannot be bypassed, even though the game may be to my

taste I will not buy the disk version. If the product is a disappointment, then it will be put out for a rummage sale. In this respect, the software company loses out, because somebody will pay 25-50p, instead of purchasing a full-priced, brand-new copy – and

I say good luck to him, and serve them right!

**Wm A C C Smith**  
 Windsor



PS Incidentally, your contributors seem to be fond of quoting my name at frequent intervals, usually with derogatory remarks. I would be obliged if they would at least show me the courtesy of getting my initials right. Not too much to ask, is it?

**W A C C S**

**AA:** Oh dear, now what do we do? After two of Mr Smith's previous contributions to *Reaction* (AA41) we received numerous letters from readers of the opinion that WACCS was a token short of a pop-up toaster. Now he's gone and spoiled their fun by writing just about the most sensible letter I've seen on the whole piracy debate.

Seems like our readers will have to find someone else to be unpleasant about... Ah! An idea! Emma, come out here, I think the good people have something to say to you...

## ●I could do with 3D!

Since writing to you last month about obtaining a package that would allow me to turn 2D drawings in to 3D, I have run into several problems. You suggested I try *Model Universe* from Arnor, so I decided to give them a ring.

After three attempts I finally got through only to be told that

they had stopped producing and selling the program. I am therefore writing to you once again, not to complain but to print the following plea to the other 35,000 or so readers:

Is there anyone out there who would sell me *Model Universe* on disk for the Amstrad CPC, please give me a ring on (061) 789 2294.

I would also like to thank you for publishing my previous letter. Could you also include my name and 'phone number for the *Elite* Club that you mentioned last issue.

**Andrew Manning**  
 29 Kingswood Road,  
 Winton, Eccles,  
 Manchester M30 8HN

**AA:** This is a little odd, since I personally rang Arnor and checked that they still had copies of *Model Universe*. They said they weren't publicising the fact, but yes, they did have a few copies left. Perhaps they've all gone now. Anyway, if some kind reader could help Andrew out he'd be very grateful.

And we'll be glad to enter you in the *Elite* Club roster, which incidentally kicks off in this month's *Cheat Mode* on p. 84.

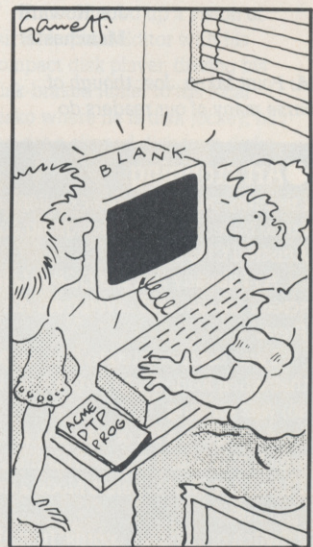



●In the club

At last, after 12 months of treading water with my wellies on, I have at last reached a rating of "Dangerous."

Unfortunately, I keep getting "zapped" by a ship, which appears to have a cloaking device.

Any ideas, suggestions or pokes? (I don't have a little black box, nor do I have the cassette poke from AA20.)

Elite Club could be just the ticket for intrepid space cadets like me, especially if it helps me zap this disappearing pirate before he zaps me.

By the way, let's get back to basics with Cheat Mode: we don't all have a little black box or disk drives.

Yours dangerously,  
**Joe Howard**  
Manchester

AA: Point taken, Joe: though of course many of our readers do

have little black boxes and disk drives. We try to strike a balance, and suggestions such as yours help us to do so.

●All that glisters

The Elite Club seems a good idea, particularly if we can get some ideas for the "Gold" version of this superb game.

I've been playing the "Gold" version for about two years now, am Elite status, have Cloak and Jammer, got 5.6 million credits and can carry 150 ton cargo. All the questions, tips, hints, etc I've read to date relate to the "routine" game. Can anybody answer:-

- 1 How do you get the 8 digit code to access side 2 of the disk (I have 200+ "Rt On Cmdrs")?
- 2 How do you get to the "hidden" planets, eg Celees in galaxy 8 (there are others)?
- 3 Why can you make suns and planets disappear?
- 4 Why can you move suns and planets?
- 5 How do you safely enter the non-rotating stations? - I've entered the "flashing" stations and destroyed up to 250 ships at one station.
- 6 How do you increase Hyper space range without going via witch space with fuel scoops on?

The "Gold" version objective seems to be to get a bigger ship and extra armaments (Right Lobster, etc). To see this, load Commander Elite and ignore the "Disk Error" message.

R. Chandler  
Worcester Park, Surrey

AA: Can anyone help this possessor of coolest name of the month? He or she signs off as simply "Chandler," so it's quite impossible to tell if there's any connection with the immortal Ray.

●The games quiz: we pick the lucky winner

Last month Jeremy Congley presented these posers:

- 1 What happens when you finish Jet Set Willy?
- 2 Which two moves score the most points in Way of the Exploding Fist?
- 3 What is the message at the end of Gryzor?
- 4 What is the weapon on the 5th stage at Target Renegade?



Now MARC FREE of Tendring in Essex has come up with what we reckon to be fairly plausible answers:

- 1 Mr Willy walks from the master bedroom to the bathroom and then enters a new room called: 'Oh \$#!+! The Central Cavern!' where he jumps up and down indefinitely. (This is also the first level of Manic Miner).
- 2 Flying kick + roundhouse.



- 3 "Congratulations... You have saved the Earth from the Alien threat. Unfortunately... Destroying the heart activates a self-destruct Mechanism which blows up the Planet... HOW SAD...."
- 4 Snooker cue. "PS," he adds, "I think that a games competition is a great idea and look forward to seeing one soon..."

AA: Congrats, Marc! You've just won yourself a crisp (salt 'n' vinegar flavoured) AA tenner, signed by the entire team, some even in joinedupwriting.

As for a games competition: what do you think you've just won, the Kentucky Derby?

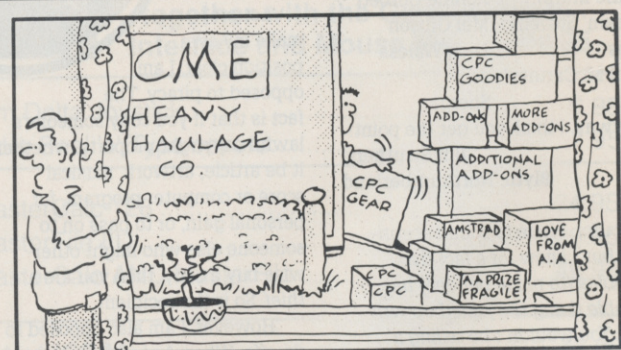

"LOOKS LIKE YOUR AA PRIZE IS HERE, SON"

● This could be you - turn to p. 34 this instant!

●Art stopping

I recently purchased the excellent AMS Stop Press, as I hope to start a home based business designing and printing posters etc using my Amstrad CPC 6128.

As I already had the OCP Advanced Art Studio I decided to see if a screen created and saved from Art Studio could be imported into Stop Press.

I was disappointed to find, as possibly others have already found, that when loaded into Stop Press the top part of the picture (an inch or so) was missing.

After quite a bit of messing around I have come up with a solution which may assist others with the same problem.

- 1 Load Art Studio. Select Mode 2 and click the bottom arrow box 3 times.
- 2 Switch on 'Display coords' from the "Input Devices" menu.
- 3 Return to the main menu and pull down the "Shapes" menu. Set the "Elastic" switch to on and select Rectangles.
- 4 Draw a rectangle from the co-ordinates X:8, Y:320 to X:631, Y:8 (the

top LH and bottom RH corners respectively).  
5 Save the screen as "Stopress."

You now have a box the exact size for Stop Press, and any time you need to use Art Studio, simply load the 'STOPPRESS' screen, create your design within the box and save it to your Stop Press screen disk as "Filename.PMS".

I haven't tried the using modes 0 or 1, but as Stop Press used only two colours there doesn't seem to be any point.

David Swales,  
Gainsborough, Lincs

AA: Brilliant, David! I reckon you've earned the undying gratitude of anyone faced with the same problem.



● Art stopping: AMX Stop Press and Art Studio in open dialogue!

● **Sphinx Jinx: thanx!**

Now for a nice letter! I telephoned Incentive Software Ltd today to enquire if they had a hint sheet for *Total Eclipse 2 - Sphinx Jinx* as I needed help with one room to enable me to finish the game. The receptionist very kindly put me through to Mr Ian Andrew himself, who was only too pleased to help me. So I would like to say a very big "thank you" to Mr Andrew as I have now managed to complete the game, all thanks to him after I had been tearing my hair out all week! Also thank you to the receptionist who very kindly made enquiries for me.

Sarah Drummond  
Ayr, Ayrshire

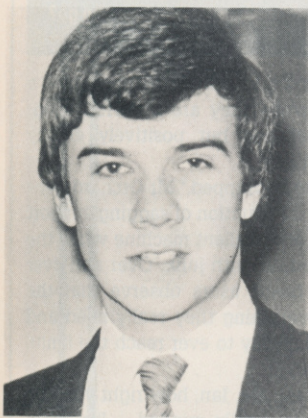

● *Sphinx Jinx* thanx: Ian Andrew is a further Incentive to buy *Freescape* games, says Sarah D.

AA: Well, it's good of you to take the time to say thanks, Sarah. I'm probably going to make him blush now, but I'll say it anyway: Ian is one of the nicest and kindest people I've dealt with as AA's editor. There you are, I told you it would make him blush!

By the way, I don't think I'm breaking any confidences in telling you that there will be another *Freescape* epic in time for this Christmas: details as soon as we get them.

● **Sounding off**

I agree with Arthur Lewis (AA48) on his point about more sound and music programs for the CPC. With the ever decreasing size of *Type-Ins* it shouldn't be too hard to list a few.

I would like to learn "machine code" on my 464, but don't know how to go about it. The User Manual says that I need a Z80 assembler program and recommends the *Amsoft assembler*, with editor, disassembler and monitor. I would be grateful if you would

● **Is it true that Rave=Grave, and Mastergame=Masterlame?**

I am worried by the apparent lack of success of your Mastergames. Not since AA16 *Mastergame Gauntlet* has an AA Mastergame reached the top position in the Amstrad Gallup Chart, and in fact very rarely do they appear in the top 10. Is there something notorious about them? Also, the recent chart-toppers like *Robocop* and *Last Ninja 2* have not even been reviewed by you! Is there something sinister lurking near Sugarman? Who knows, only you can tell I suppose.

Derek Wong  
Thornton Heath, Surrey

AA: We've just received an announcement from US Gold, which claims that *Heroes of the Lance (Mastergame, AA37)* has sold "more

than 150,000 copies." That's not all on Amstrad, of course, but even so it's a fair old turnover. What do you say to that, then, Derek?

Secondly, let's come clean about *Last Ninja 2*: we looked at it, and decided it was the biggest load of old rubbish since *Psycho Pigs UXB*, and that we'd much rather review some better games.

As for *Robocop* - which incidentally we liked very much - we had such problems getting a review copy out of Ocean at the time that we thought, "Stuff 'em, we'll review something else." We don't usually have this problem, and are at a loss to explain why the normally helpful and enthusiastic Ocean crowd should have suddenly turned so shy.

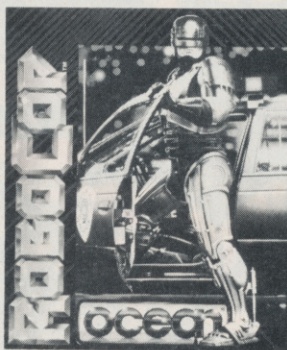

● *Mystery of the disappearing Robocop* - we tell all!

advise me on which program to buy, and a "Machine-Code For Beginners" type book. I'm 14 years old and have had my ever faithful 464 for four years, and have had lots of experience in Basic.

Antony Bennett  
Romford, Essex

PS Do I need an *Advanced User Guide for the 464* ?

AA: Point taken about *Type Ins*, Anthony, though our new *Technical Editor* may have something to say on the subject.

For an assembler, try *MJC Supplies* ☎ 0462 32897 for Maxam, at £15.95 all in for the tape version. Book: try Daniel Martin's Amstrad *Advanced Users Guide (Glentop, 1986)*, or consult our book guide in AA46

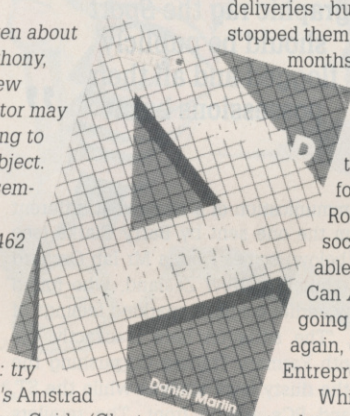

Two or three months ago I decided to upgrade my 464 (as in AA 30). CPC Ltd could supply neither ROM nor CPM+ disk. K & M Computers likewise, but they expected deliveries of the ROMs "tomorrow" (sounds familiar?) A recent check shows no change, though K & M now admit they don't know when they can expect deliveries - but that hasn't stopped them screaming for months, "464 UPGRADE ROM NOW AVAILABLE" in their adverts. And then there's the adverts for "The amazing Romboard extra with socket for" (unobtainable) "upgrade ROMs." Can AA tell us what's going on? Is it Sugarman again, or a Great British Entrepreneurial cock-up?

While I'm writing, is it too late to comment on those round flat things? Your comments on the spelling intrigued me, as I thought the English spelling was with a "c," "k" being a cheap American import. I consulted my 1983 *Chambers Dictionary* and found: "disk, see disc. disc; disk. a quoit thrown by ancient Greeks..."

disc file (comput)... disc player... etc, etc [Gr diskos], Eric Partridge's *Origins* has: "disc, disk; see dish. dish; disk; disc, discus, discoik; 1. Dish comes from OE disc, a plate, from L discus, dish, disk, quoit... L discus represents Gr diskos, a platter, quoit..."

As this was hardly clear support for your case I eventually consulted the local library *OED (1933)*. This resulted in - "Disk, disc: [L discus, Gr diskos quoit, dish, disk: The earlier and better spelling is disk, but there is a tendency to use disc in some scientific senses (not in the botanical)]." No reason is given for the preference for "k" and the many examples of use given divide roughly half 'k', half 'c', with not one from the 20th cent. I wonder what the latest edition says?

This conjured up a vision of our diskophile Editor with his compact disk player, driving his disk-braked Roller to the local disko where he is disk-jockey, having got a slipped disk from diskodancing!!

As all dictionaries are only as good as the whims of their editors, and they are by nature always years out of date, the ultimate authority is what native speakers adopt.

In this case it seems to depend on whether you favour the Greek, as our Editor does, or the Latinate. Personally I also prefer the ancient Greeks to all things Latin, so I shall be saving this to a disk file!

Len Martin  
Stubbington, Hants

● **ROM for improvement?**

What's happened to all the 464 to 6128 upgrade ROMs?

● **So long, and fishtanks for all the fish**

I would just like to ask one question, and that question is this: was comment on page 79 of AA 48, "You can trust us, we don't intend to leave the planet for quite some time!", a reference to the book *The Hitch Hikers Guide To The Galaxy* (about the dolphins) or to the book *Stark* by Ben Elton?

Andrew Manning  
Manchester

AA: Oh yes. Very definitely yes... What was the question again?

AA: This discussion is now konkluded. ●

# BROADLEY SPEAKING

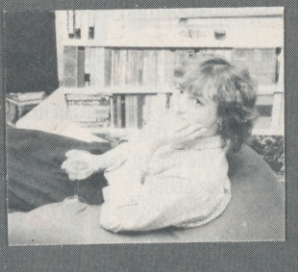

It's the well known stunt columnist and general risk taker **EMMA BROADLEY**, for once in rather mellow mood.

Well, comparatively.

If you ever read other computer mags beside AA – though why anyone should want to is beyond me – you can't have failed to notice that the CPC does not figure very strongly. Small business, guv? PC, a'course! No daht abaht it, squire.

Makes you wonder if they really know what they're talking about. OK, so if you really had to have a PC you could probably cobble together a low-end base model with single floppy drive and mono monitor for about £400 (somewhat more than you would pay for a 6128 with colour monitor). Remember at this end you're still in Skoda city: to get anything that would turn heads you'd be spending telephone numbers.

But – and here I think is the big but – the expense has only just begun when you unpack your nice new PC. Take three of the best selling titles among the business fraternity, *WordStar* (word processor), *Accountant Plus* (accounts) and the spreadsheet *Supercalc*.

Now for your word processor, depending on which version you require, we're talking between £70 and £300. For a fraction of that sum you could get *Infoscript 6128*, or *Tasword 6128*. Indeed you could get the entire *Prottext* suite on ROM and still have enough change to buy either of the other two as well!

*Supercalc* would set you back £220 for the latest version.

Accounts? Well, *Accountant Plus* is an integrated stock control/invoicing/ledger system. It's something like SD Microsystems' *Stock Accounting System* with knobs on – except that the PC program costs £249.

Oh, and don't forget the VAT.

Consider the set-up of someone with a colour (colour, mind) 6128, *Mini Office II*, *Prottext* and business software virtually bought to your requirements by mixing and matching from what SD Microsystems have to offer.

You might get your leg pulled by someone with £2,000's worth of the latest 386 and several hundreds of pounds' worth of software. But then, who's the real winner?

“ The staff of that pornographic rag the *Sport* should be publicly flogged and all their possessions burnt ”

● A communication of a somewhat different kind from the one sent by Barry Clarke (see the box below) comes from a Mr Ian Orchard of Christchurch in New Zealand, who found one of my earlier columns sparking feelings of *deja vu*. "The situation here is exactly the same, with Farmers Trading Co pushing the CPC to the dusty back shelves while the ST, Amiga and PCs are up front. The retailers protest that the 8-bit machines are dead and

## A question of time

Steve has asked me to thank the many hundreds of you – possibly over a thousand – who sent back their completed questionnaires so promptly. I've had a look at a few, and I'm surprised and delighted to see that some of you actually named this column as your favourite thing in the whole mag. (If you don't believe me, tough: but it's true, believe me!)

Admittedly there were also one or two hot-heads who named this as their *least* favourite part of AA. Steve tells me he and his team of dedicated professionals (well, Trent and Pat – and not Pat for much longer) are slaving away to produce a full analysis of the results, which should appear in next month's issue. Until then I'll have to wait in suspense, with bated breath and on tenterhooks, itching to hear the verdict... Broadley: does she stay or does she go?

they are not going to sell old technology – a hollow claim when they are cheerfully flogging off repackaged but positively elderly C64s and Atari XEs.

"We seem to be trapped," Mr Orchard goes on, "in a Catch-22 situation of sagging support slowly stifling an excellent machine while the public is flogged off with junk. Over and over again I have heard users observe that the CPC can do everything they really need and that they are unlikely to ever reach the limits of the machine."

How right you are, Ian, how right you are. I'm not very technically minded – I'm much more interested in what computers can do than in how they do it – but it seems to me that such is the pace of modern computer technology that it is far outstripping applications of it. If you read the more techno-babble obsessed publications of the computer market, such as *PC Plus*, you'll find people overcome with excitement because the latest PC 386 can run so many more million instructions per second. Yet is there a word processor for the PC than can load as fast and yet work as simply as *Prottext* on ROM for the CPC? I don't think so, chums, I really don't think so. ●

## Flog 'em till they beg for mercy, then flog 'em some more

"Dear Emma," writes Mr Barry Clarke of Sittingbourne in Kent: "Plain speaking by all means, but I find it pretty amazing that you should think it right to defend *rubbish* in our society.

"Don't you think there is plenty enough muck, porn and general exploitation of the worst in human nature already without the need to defend even more?

"And what is the 'standard' by which you judge morality? The *Sport*?"

Now I'm not too sure what Barry's talking about, actually, because he doesn't specify. But

I'd guess he's having a go at me for what I said in this column a few months ago about *Barbarian II* and "sex'n'violence" in computer games.

And what I said was, "when so many people are exposed to the *Sport* every week, what harm can computer games featuring quarter inch sprites do?"

No reference to standard, you notice, and I hope no imputation that the *Sport* is either praiseworthy or harmless. I find it filthy and degrading, and if the fat creep who owns it were to get himself severely beaten up by Mary Whitehouse and her host of loonies I wouldn't

mind a bit.

That the *Sport* is classified as a newspaper and finds its way into thousands of homes where children can see it is as good an argument in favour of state censorship and book-burning as I can think of. The staff of this pornographic rag should be publicly flogged and all their possessions burnt.

Satisfied, Barry?



● *Barbarian II*, minus the deformed Maria Whittaker

# LASER SQUAD



BUY THE BEST

## BLADE

"Laser Squad is one of the best games to appear."

Commodore user



"It's one or two player tactical warfare situation... with great graphics, sound, playability and hookability to boot. One player it's great, two players it's unbeatable."



BLADE SOFTWARE LIMITED

AA

BROOKLANDS NEW ROAD, ST. IVES, CAMBRIDGESHIRE PE17 4BG. TELEPHONE 0480 496497

Available: Amiga £19.95, Atari ST £19.95, P.C. £24.95, Archimedes £24.95, C64 cass. £9.95, C64 disk £19.95, Amstrad CPC cass. £9.95, Amstrad disk £19.95, Spectrum cass. £9.95, Spectrum disk £19.95 and MSX £9.95.

## BIRTHDAY GIFT PACK

Amstrad CPC 464 • 664 • 6128

## OTHER SIDE

- SPRITES DRIVER
- DATA CREATOR
- MICROBLANCH
- SELF-STRUCT
- DALEKS
- EASISHEET

SAVES ALL PROGRAMS TO DISK! - see p.16

# The AA fourth birthday tape

Everything you need to know about the greatest cover tape in the history of er... cover tapes.

## Daleks

by Mike Wong

● To load: run tape & select (4) from menu

This superb little program is a one screen game that promises loads o' fun for everyone.

Your task is to defeat the Daleks on their home planet Skaro. Either make them crash into each other, or use your trusty sonic screwdriver (which has a limited number of uses and only works at point blank range). Also, the Daleks cannot touch the Tardis.

You move using the cursor key pad as a sort of clockwork movement tablet: f6 is East,

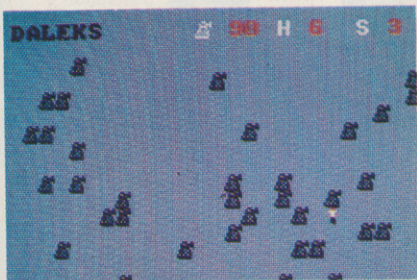

● Crumbs, rather a lot of Daleks to deal with here!

f1 is South-West, and so on. To use the sonic screwdriver, use the S key. But be warned - the Daleks track you relentlessly!

If things get tight use your compact random hyper space generator (H key) to get out quick. In dire emergencies enter the Tardis - but then the Daleks win, and you must beat them again on the same level. Daleks is a tough, thought-provoking game with some cute effects and an addictive quality that's often not present in commercial games.

## SelfDest

by Rufus Cable

● To load: run tape & select (7) from menu

We're not going to show you what this looks like: let's just say it's totally harmless but great fun! When it's loaded get someone who doesn't know you've done so to come along and press a key. Then just watch their face...

## DataMaker

by Richard Carr

● To load: run tape & select (5) from menu

Ever written code directly into memory? It can be a real pain trying to turn it into a list of DATA statements for use in a Basic program. Some people even resort to putting it all in by

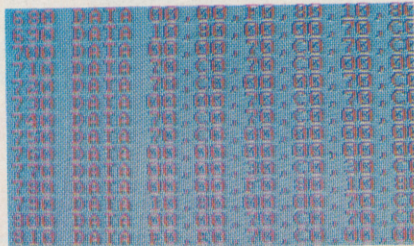

● The data lines that Came From Nowhere!

hand, a nightmare for long lists of binary that inevitably results in errors.

That's where this DataMaker comes in. Load the program, then the code; enter the start and end addresses and a filename. The program creates a Basic program with data neatly put into DATA statements. Re-LOAD the new file and then SAVE it again, because it's created in ASCII format, not the quickest file type for loading and saving. Re-SAVE and your CPC uses much faster Basic format.

## WordFinder

by Jason Birkitt

● To load: run tape & select (6) from menu

You will surely have come across a word-search puzzle - a grid of apparently random letters which conceal hidden words. Now you can create them onscreen. Simply enter the words (don't use spaces: that's a dead giveaway!) and the program merrily goes along, inserting them in a random grid. You can either print it out, rearrange the grid (sometimes the words appear in rather obvious places), or start on a new grid.

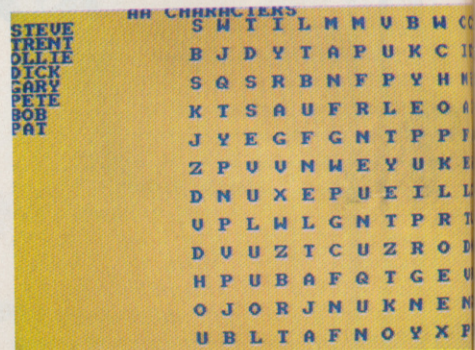

● The AA word puzzle, free with this page

## Easisheet

by Andrew Hodgson

● To load: run tape & select (3) from menu

A spreadsheet is a utility used for mathematical simulation. By entering values onto a "sheet" of electronic paper, the computer can work out calculations between the values, and store the results further down on this "sheet."

Uses might include seeing how much money flows through your hands during a year, or costing some complicated project, or perhaps seeing how

Easisheet						
	Jan	Feb	Mar	Apr	May	
1276	103.30	79.30	456.80	509.40	837.30	
1277	100.30					
1278	14.00					
1281	80.00					
1282						MIS-CHARGE
1283						
1285		1898.1	CRU-CHARGE			
1287						
1288						
1289						
1290						

● Cut calculations down to size with Easisheet

### Key

Cursors

f9

f8

f7

f6

f5

f4

CTRL,Shift,B

TAB

● All other keys enter text into the cell where the cursor is.

### Purpose

Move around spreadsheet from cell to cell

Reveal/Hide equations

Help page

Enter Formula

SAVE the spreadsheet

LOAD a spreadsheet

Calculate the spreadsheet

Return to Basic

Go straight to a specific cell

much time a process takes.

The electronic "page" is laid out in a series of rows and columns, which divide it into cells. Numbers can be entered into these cells, as can text - to help explain what process the spreadsheet is at. Calculations are also entered into these cells.

# Side A: *Shinobi*, Master Ninja!

### ● Important warning: joystick and ultra-fast reactions required

The first side of the AA Fourth Birthday Cassette is entirely given over to a great fully-playable taster of the brilliant new Virgin Games coin-op conversion *Shinobi*.

you enjoy it as much as we do!

Almost certainly this is the best cover game that we at *Amstrad Action* have ever had: one complete level of *Shinobi*, the furious martial arts arcade adventure from Virgin Games.



The storyline is simple: a terrorist network led by five evil Ninjas called the Ring of Five have kidnapped the children of various world leaders. Tut, tut. They now have a black-mail capacity far in excess of any previous nasty. Only you, as a Master Ninja with so much *Shinobi* (a Japanese word meaning stealth, by the way) it's coming out of your ears, can rescue the children.



There's lots to do: one level, one end of level guardian and the bonus level. On a 128K machine there's a full sound track, as well as various digital samples. But everyone gets the same level of frenetic gameplay. The most difficult of the various movements open to you difficult is jumping up to a ledge: press up and fire at the same time. Down and fire brings you back down again.

● Due to the sheer mammoth size of the *Shinobi* demo, there isn't a routine to transfer it to disk. Load it and leave it loaded!

Look out for the definitive, two page review of this exciting new game in next month's AA - and see if you agree with our verdict!



## Taking the easy way in

We've included a little menu program at the beginning of the tape. From it, you can use all of the programs available on the tape - including backing up the B side to disk! To run it, type

|TAPE  
(to get the bar, hold down [Shift] and press the key with the @ sign to the right of the P key).  
Now type  
RUN^AATAPE

Simply type the number on the menu opposite the program you want to see, and the computer will obey.

If you're intending to save the B side to disk (and if you can it's a good idea), you'll need a formatted disk ready to use. Here's how you do it...  
Load up the menu by

playing the tape as explained above. Press (1) and then, following the instructions, press the [Play] key on your tape recorder and any key on the keyboard to set it running (making sure your disk drive is connected and switched on). You should see on the screen information about which files are being loaded and saved (eg, Loading ONDISK block 1 and so on).

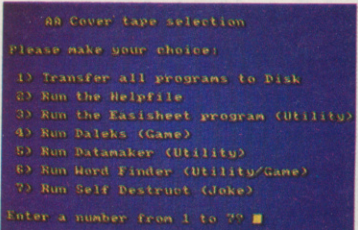

● Choose from our delicious menu

## STUCK? DON'T PANIC (YET)!

- Are you stuck? Unsure of what to do? Try using the Help program. It prints some information about the tape as well as each of the programs. If you have a printer attached, then the helpfile can be printed out instead, giving you some clues about the purpose of each program.
- To load the help file, first make sure the tape is rewound to the beginning. Now, if you have a 464 hold down the [CTRL] key to the right of the spacebar and tap the small [ENTER] key on the numerical keypad. Then press [PLAY] on the tape recorder and press any key on the keyboard to start it playing.
- The menu (see box, "Taking the easy way in") should come up. Press (2) to run the helpfile and when you're asked, "View instruction file (y/n)?" press y (for yes, see?). When you're asked, "Printer or screen?" press s (for screen

- do it all again and press p for printer if you want a hard copy).
- When you've finished reading the helpfile, turn off your computer and turn it on again, rewind the tape and follow the instructions as in the "Taking the easy way in" box (above).
- If, rather than loading the tape and not knowing what to do next, you find you can't load the tape at all, don't despair. Inevitably, in any run of duplication of over 50,000 there will be one or two "rogues" that are going to get damaged in distribution or whatever.
- Return your faulty tape to this address: AA Cover Tape Returns, Interceptor Ltd, Mercury House, Calleva Park, Aldermaston, Berks, RG7 4QW.
- There's nothing we here at AA can do - unless you've returned your tape and had no reply.

## Now it's your turn!

Have you written a program suitable for inclusion on an AA cover tape? We're looking for serious applications, games, fun programs - anything our readers would find entertaining, educative or just good value for money.

Send your programming masterpiece to: AA Cover Tape Evaluation, 4 Queen St, Bath BA1 1EJ. We pay, of course, and who knows, your work may be the beginning of a glittering career as a programmer!

One or two hints. Send it on disk if you can, with a brief explanation of what your program does, its length and how to run it. Send a good, detailed helpfile with it, too, so we don't have to do it. And remember space is tight: a 38K program that changes the screen border colour is not what we're after!

Keep a copy. Label everything with your name and address, and finally, if you want to see your creation again, enclose an SAE!

# THE LOOK

The continuing story, by one PAT McDONALD. Tell it like it is, Pat!

This month we examine some of the techniques of getting fractal pictures onto the screen of your Amstrad. The first thing to remember is that the idea of such a program is to get your computer to do most of the work.

A fractal shape is composed of smaller shapes which are similar to the overall shape. Now although it's perfectly possible to draw a huge fractal, and then magnify to see all the detail, it makes more sense to build them up from the smallest areas. The reason is that it's simpler to program, and therefore easier to understand.

## Shifting positions

Imagine for a moment, if you will, a square in which the length of the sides is exactly divisible by four. Such a square can be split into 16 smaller squares, and if all these are numbered, you end up with something like figure 1.

13	14	15	16
9	10	11	12
5	6	7	8
1	2	3	4

● Fig 1: your common, everyday square

Fascinating, I'm sure you'll agree. To make an even more interesting shape, let's suppose that we're going to shift the positions of some of the squares - numbers two, eight, nine and sixteen - and form a shape not dissimilar to a swastika (figure 2).

Now assuming that this is our "building brick," so to speak, here's the program that

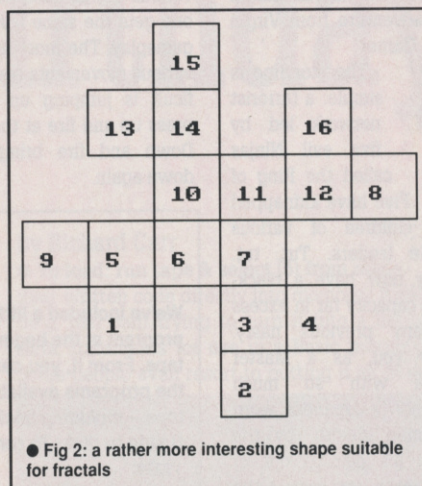

takes the shape and repeats it into a true fractal shape.

```

10 MODE 2
20 DIM x(16):DIM y(16)
30 FOR a=1 TO 4
40 FOR b=1 TO 4
50 c=4*a+b-4
60 x(c)=b-3:y(c)=a-3
70 NEXT: NEXT
80 x(2)=0:y(2)=-3
90 x(8)=2:y(8)=0
100 x(9)=-3:y(9)=-1
110 x(15)=-1:y(15)=2
120 FOR d=1 TO 16
130 FOR e=1 TO 16
140 FOR f=1 TO 16
150 FOR g=1 TO 16
160 xx=64*x(d)+16*x(e)+4*x(f)+x(g)
170 yy=64*y(d)+16*y(e)+4*y(f)+y(g)
180 PLOT 320+xx,250+yy
190 NEXT: NEXT: NEXT: NEXT
    
```

This works by going to the highest resolution graphics mode, and then defining the shape of the fractal - in lines 20-110. The size of the fractal depends on lines 120 to 190: for each extra loop, the size grows by a factor of four.

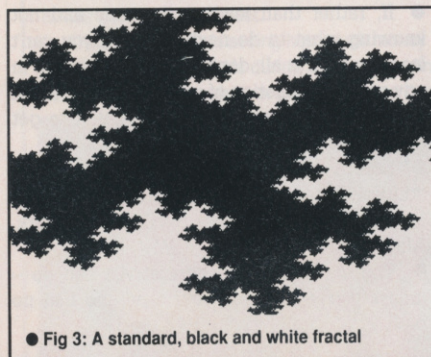

## Stay in control

There are lots of possibilities for the shape in figure 3 (it's called a Julia plot, in case you're wondering). To change the basic fractal shape would be a simple matter of perhaps adding a few more alterations to lines 80-110.

A challenging idea is to add colour to the fractal, and the more the better. So change line 10 and add these too:

```

10 MODE 0
15 INK 0,26:FOR i=1 TO 15
17 INK i,i+5:NEXT
    
```

To change the colour on the paper, use this line 180 plus and additional you get. Figure 4 is an example of the effect you get:

```

180 h=(xx*yy) MOD 14 + 1
182 PLOT 320+xx,250+yy,h
    
```



There are plenty ways of altering different colours in different areas. The easiest to understand is to change the colour for the plotting routine at the beginning of the loops. To do this for the largest fractal variation, put in this line:-

```

125 h=(h+1) mod 14 + 1
180 PLOT 320+xx,250+yy,h
    
```

For more subtle colour variations put the line which alters h (125) just after each loop. So, for very subtle tonal variation, rather than 126 it would be:

```

155 h=(h+1) mod 14 + 1
    
```

Try it out and see what the effect is. ●

● Next month we leave the subject of fractals to return to the real world, and learn about scrolling the display in all sorts of directions. Stay in touch!

## Geometry of nature

Fractal freaks swear by B.B. Mandelbrot's classic *Fractal: Geometry of Nature* (published by WH Freeman at a whacking great £39.95: ISBN 0716711869, try your nearest Waterstone's). But a word of warning to numerophobes (is there such a word? There is now!): as fractals are mathematical in nature, a good grounding in maths (understanding of equations, matrices and a bit of calculus) is desirable, not to say essential.

# THE GALLERY

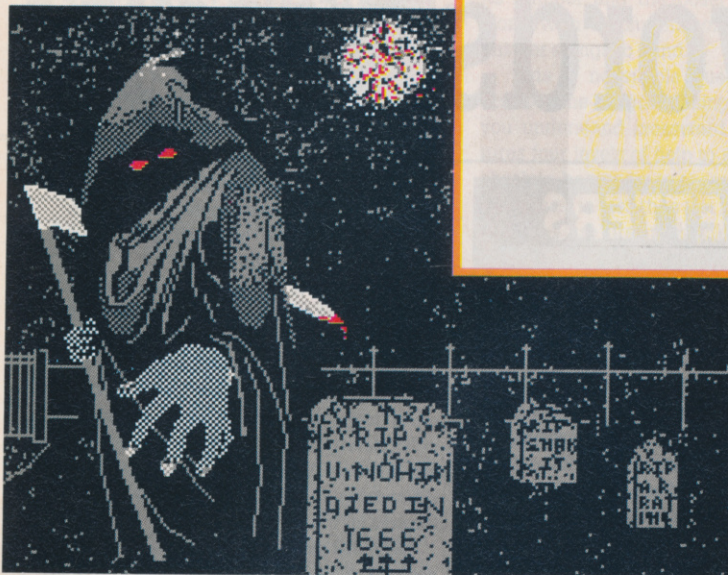

● James Saull of Hambleton must have spent hours perfecting this on the Advanced Art Studio



● Mike Wong and the AAS really are a special combination (above) - as is James Garside from Rhuddlan (below). Excellent shots from two regular contributors.



● Mike Wong from Sale again, with a nasty piece of work called Claws: not the sort of thing to bump into on a dark and lonely night.

On the right, we have an excessively good picture of C3PO which wins the £20 prize for James Garside. What a stunner!



● Fancy yourself as an artist? Then get cracking! Let us have your very best work at the AA office, and you could earn yourself £20! Send entries - together with a short note telling us which art package you used, and an SAE if you want the pictures back - on disk or tape to:

Pat McDonald's *The Look*  
Amstrad Action  
Future Publishing  
4 Queen St  
Bath BA1 1EJ

# Making words work

On the right, crosswords on your CPC: NO BENT TWERB (anag.) gets down and come across with the goods; while on this page STEVE CAREY looks at two new utilities that put words in your mouth.

## KEYWORD

£29.95 disk ● keys only  
Swift Software ☎ 061 477 8405

Swift Software, a relatively new name in the CPC world, have very quickly made their mark. First release was the admirable *Pandora* (reviewed in AA47), a compiled version of Basic designed to allow non-Machine Code experts to write commercial quality programs. (Version 1.01, with substantial improvements, is already out - see *Amscene*).

Now we have *Keyword*, a "word finder." It's a doddle to use: insert and type RUN\*DISC. *Keyword* is now installed as an RSX, accessed by typing |KW. The dictionary is on side B, so you have to have the disk in your drive whenever you wish to use the program.

This is a nuisance if you're looking for a word while you are using your word processor. It's no problem, of course, if you have *Protexit* on ROM.

*Keyword* claims to have over 10,000 synonyms and antonyms and nearly 1,000 main subject headings, and you can well believe it.

But in truth that's not a great deal, though it sounds a lot. Trenton's tatty old Penguin paperback thesaurus contains vastly more than 10,000 entries, and my new hardback Collins revision of Roget's standard work has many more again (except that some swine, knave, varlet, vagabond, wretch, rascal, rogue, rapsallion or criminal has nicked it!).

Suppose, having already used the word "believe" in a previous paragraph, I wanted to use it again but preferred to avoid the repetition. I tap |KW, enter "believe" and press [Return] twice. Up comes... nothing. There are no entries for believe. Other categories where *Keyword* proves useless include amaze, bland, condemn, diagnose, emend, feature, grill, hip...

Perhaps this is unfair, since it took me three or four goes to find a word that produced nothing. But, on the other hand, these are not particularly rare or unusual words, and it doesn't speak very highly for the data

## 100 LETTERS

£15 disk ● Needs 128K and *Infoscript*  
Brunning ● 0245 252854

The CPC is exceptionally well served for word processors, for besides *Tasword* and the superb *Protexit* there is Brunning's *Brunword* and its bigger brother *Infoscript*. And one thing that sets *Infoscript* apart, it should be noted, is Brunning's continuing project of upgrading and "supercharging" the program. We reviewed it in AA35, for instance, and shortly after that it was speeded up considerably.

Now Brunning has added *100 Letters*, a utility that works within *Infoscript*. Its purpose is to provide a library of over 50 standard letters that can be edited, amended and added to, so that your own individual needs are catered for.

To put things simply (if you own and use *Infoscript* you'll appreciate that a program that does so much needs to be complex), you begin by loading *Infoscript* and then loading *100 Letters*. Now you select your letter from the list available, and with a couple

of keypresses you're in *Brunword*, with your letter ready for editing.

The key combinations and method of working will be familiar to anyone who has used *Brunword* or *Infoscript*. But what about

people new to this computing lark? It's all very well saying, "Reset the computer, CAT the disk and load the INFO file," but if you don't know a reset from a CAT, what do you do?

What you do is consult the manual. One criticism levelled at *Infoscript* was that the documentation was insufficiently detailed for the novice, and that shortcoming has been admirably corrected for *100 Letters*. You're taken first on a "walk round" tour of what you can do with the program, which cleverly takes you through *Infoscript* and into *Brunword*. So, without knowing exactly what you're doing, you've already been actively involved in "this computing lark."

After that there's a well written and carefully explained tutorial that shows you how to print out the summary (so you know what letters there are), and sections on updating the LABELS file, creating new files and using existing ones, using library letters and creating single ones, and so on.

To be honest it's rather a lot to take in at one sitting, and you'd be well advised to go out for a brisk walk to clear your head. But if you have gone to the trouble of shelling out £50 for *Infoscript*, and have perhaps found it not as easy as you'd hoped, why not make the little extra effort to try again with *100 Letters*? ●

041	LET04	Sad Loss	Her	None
050	LET05	Get well		None
060	LET06	Congratulati	Boy	None
061	LET06	Congratulati	Girl	None
062	LET06	Congratulati	Exams	None
063	LET06	Congratulati	Engagement	None
070	LET07	Advert	For Sale	17 Descript
071	LET07	Advert	Personal	None
072	LET07	Advert	Wanted	17 Descript

### GOOD NEWS

- Useful utility.
- Very good introductory manual.

### BAD NEWS

- Requires *Infoscript* and 128K of memory.

file if that's the best it can do.

For this you're asked to stump up £29.95, considerably more than the price of a damn good hardback thesaurus.

It seems such a great deal of money to pay for something so weak. ●

Press ESC to quit

KEYWORD

```

abstract
brain
conceive
conception
conscience
conscious
critical
ego
note
perception
personality
psyche
psychiatry
psychic
psychology
rational
    
```

● One of *Keyword*'s better moments

### GOOD NEWS

- Simple, sturdy "background" program.

### BAD NEWS

- Expensive.
- 10,000 words is not enough.

# SUN COMPUTER CROSSWORDS: 5

£17.95 disk ● keys only  
Akorn Ltd ● 01-852 4575

A cracking crossword is not something you'd expect in the Sun, but living modestly beneath the bingo and right next door to the star signs is a decidedly enjoyable cerebral assault course. These puzzlers, having been compiled into countless books, are now making their presence felt on the CPC.

Akorn Ltd, under licence to News Group Newspapers Ltd, have released *The Sun Computer Crosswords Volume 5* ("Now That's What I Call Crosswords Vol 5," perhaps?), an ideal way for budding cryptographers to cut their teeth. Not that the seasoned campaigner should feel left out, because there's enough wordplay here even for the crossword freak who just lives for idiograms and synonyms.

The best thing about this package is the gentle way it introduces novices to the intriguing world of the anagram, word split and palindrome. An analysis of the first puzzle is included in the manual, for example, as is a list of the abbreviations used in the clues.

The puzzle is presented in a simple and easily understood format. The crossword sits

at the top of the screen, you select a clue by its number and the poser is printed below along with a solution box – just in case an answer spings to mind.

This is no simple question and answer session, the program being designed to help you understand crossword dynamics. It features four levels of help to suit everyone from absolute beginners to those swine who finish the *Times* in less than ten minutes.

Clues are first presented in cryptic form, and the help option may be employed to determine the way to the question should be attacked: *An* signifies an anagram, *Do* for an action, *Du* meaning word division and so on. This breakdown helps you work out what clues to look for in the question itself. Even if you get completely stuck the learning curve is enhanced when the solution is revealed. You won't get the hang of it straightaway, but you'll soon pick up the technique for cracking the toughest of crosswords.

*Times* crosswords are also available on the CPC as are the previous four volumes of *Sun* brain teasers. The later modules all contain a team game feature, but that's not what crosswords are about: it's the duel of wits between the puzzler and the puzzled, a brain battle for pride, not points. ●

## HAL & me

The Computer Crosswords project has been a labour of love for author David Akenhead. David, son of Edmund, Editor of *Times* crosswords from 1964-1983, has now published across some 14 formats, having begun in BBC Basic.

It was the film of Arthur C. Clarke's *2010*, curiously enough, that gave David the clue he needed. In it the Americans and the Russians devise a docking communications system to enable them to rescue a US module disabled near Jupiter. The method – a compiler program with a stacking device that lets it out in chunks, and a different program to unload it – gave



● David Akenhead: labour of love

David the inspiration to solve the complexities of fitting 50 crosswords onto a single disk.

Did you know, by the way, that the "modern" crossword was invented by a silent order of French monks in the 15th century?

### GOOD NEWS

■ Educational, challenging and fun.

### BAD NEWS

■ Expensive.



## AA prize crossword... AA prize crossword... AA prize crossword...

By special arrangement with Akorn, we bring you a crossword taken directly from the volume reviewed here. We've given you a couple of solutions to start you off, and explained how they work. Entries to: AA Crossword, *Amstrad Action*, 4 Queen St, Bath BA1 1EJ, by 31st October 1989.

### Across

1A Diets can disturb for the duration (8)  
*Solution: Distance* ("disturb is an anagram indicator for "Diets can". DISTANCE is associated with duration, esp. in boxing)

7A Russian for whom I get the vehicle (4)

*Solution: IVAN* ("get" means joined to; hence I with a word meaning "vehicle" – VAN)

8A Control of pleasures on the never-never! (8)

*Solution: JOYSTICK* (JOYS, "pleasures." TICK means credit. JOYSTICK is a form of control)

9A Stroke treatment on ship (6)

10A Headgear manipulated by Svengali (6)

11A Part of foot to note (8)

12A Flat in either direction (5)

14A Engineers go to a church on part

of a river (5)

16A Mark or Dorothy? (3)

18A Old Bob has plenty enough for a specimen (6)

20A Complaint about the bowler's triumphant call? (6)

22A He raises unnecessary fears of a mistral storm (9)

23A Stamp on animal (4)

24A Street on which a politician gets point of French flight!

### Down

1D Abandon original plan and evade it, perhaps? (7)

2D Carol has energy to burn (5)

3D Notice fair change (6)

4D Animal shy, with broken toe

5D A cold task outside for Biblical favourite (5)

6D Hit by withdrawal of labour (6)

13D Die in river: epitaph put up inside (6)

15D Slaughter by a band of sailors in prison (7)

16D One gets cold in department show (6)

17D Vehicle test to reverse twice with instrument (3-3)

19D Everything put up the old lane (5)

21D Discrimination in another state (5)

The Sun Crossword 1										Score
1		2		3		4		5		
7				8						
9						10				
12				13				14	15	
18	19					20		21		
22								23		
				24						

Insert clue number :

Name \_\_\_\_\_

Address \_\_\_\_\_

\_\_\_\_\_

\_\_\_\_\_

# 25%

## off non-budget software RRP

1st Choice for fast friendly service

	Tape	Disc
<b>ARCADE</b>		
4 X 4 Off Road Racing	7.45	10.95
Action Force	7.45	
After Burner	7.45	10.95
Barbarian 2	7.45	10.95
Batman Caped crus.	7.45	10.95
Command Perf	9.70	10.95
Crazy Cars 2	7.45	10.95
Cybernoid	7.45	
Dan Dare 2	5.95	
Dark Side	7.45	10.95
Dark Fusion	7.45	10.95
Dragon Ninja	7.45	10.95
Driller	10.95	13.45
Fire Trap	7.45	
Gothic		10.95
Giants	9.70	14.95
Marauder	7.45	
Netherworlds	7.45	10.95
Operation Wolf	7.45	10.95
Obliterator	7.45	
Pacland	7.45	10.95
Real Ghostbusters	7.45	10.95
Robocop	7.45	10.95
Running Man	7.45	10.95
Run The Gauntlet	7.45	10.95
Samurai Warrior	6.70	10.95
Skweek	7.45	10.95
Storm Lord	7.45	10.95
Thunderbirds	7.45	10.95
Venom Strikes Back	7.45	
<b>ADVENTURE</b>		
Game Over 2	6.70	9.70
Ingrid's Back	10.95	14.95
Lancelot	10.95	14.95
Realm of the Trolls	7.45	9.70
Time and Magic	10.95	10.95

### BUSINESS

	Tape	Disc
HomeBudget	1.75	
Mastercalc 128 (6128)		24.70
Masterfile 3		29.95
Mini Office 2	10.95	14.95
Protext	14.95	19.95
Tasword (464 or 6128)	18.70	22.45
Tascopy	8.95	10.95

### BUDGET

Choice Cheats 1	2.99	4.99
Choice Cheats 2	2.99	4.99
BigFoot	2.99	
Commando	2.99	
Football Manager	2.99	
Footballer of the Year	2.99	
Gauntlet	2.99	
Moto Cross Simulator	2.99	
Pro Snooker	2.99	
SAS Combat	2.99	
Street Gang Football	2.99	
The Hit Squad	2.99	
Treasure Island Dizzy	2.99	
Twin Turbo V8	2.99	
Zorro	2.99	
Air Wolf	1.99	
B. McGuigan's Boxing	1.99	
Bomb Jack	1.99	
Bubble Bobble	1.99	
Dynamite Dan	1.99	
Dun Darach	1.99	
European 5 a Side	1.99	
Ghostbusters	1.99	
Gun Boat	1.99	
Joe Blade 2	1.99	
Shanghai Karate	1.99	
Steve Davis Snooker	1.99	
Thing	1.99	
Yabba Dabba Doo	1.99	
Yogi Bear	1.99	
Xeno	1.99	

### EDUCATION

	Tape	Disc
Answer Back Quiz (6-11)	7.45	10.45
Fact Files for above		
Arithmetic (6-11)	3.70	6.70
English Words (12+)	3.70	6.70
Gen. Knowledge (12+)	3.70	6.70
Gen. Science (14+)	3.70	6.70
Nat. History (10+)	3.70	6.70
Spelling (6-11)	3.70	6.70
Better Maths (12-16)	8.20	12.70
Better Spelling (9-14)	8.20	12.70
Biology (12-16)	8.20	12.70
Chemistry (12-16)	8.20	12.70
Chemistry GCSE	10.95	14.95
French Mistress	14.95	
Fun School (2-5)	4.45	6.70
Fun School (5-8)	4.45	6.70
Fun School (8-12)	4.45	6.70
Fun School 2 (Under 6)	7.45	9.70
Fun School 2 (6-8)	7.45	9.70
Fun School 2 (Over 8)	7.45	9.70
German Master	14.95	
Magic Maths (4-8)	8.20	12.70
Maths Mania (8-12)	8.20	12.70
Maxi Maths (9-14)	8.20	12.70
Physics (12-16)	8.20	12.70
Physics GCSE	10.95	14.95
Spelling		6.70

### LEISURE & SPORT

E. Hughes Int. Soccer	7.45	10.95
Football Manager 2	7.45	10.95
Game Set and Match 2	9.70	13.45
G. Lineker Sup. Skills	7.45	10.95
Gold Silver Bronze	10.95	18.70
Tour de Force	7.45	
Triv. Pursuit New Beg.	10.95	14.95
Triv. Pursuit Genus	10.95	14.95
Triv. Pursuit Young	10.95	14.95
Wec le Mans	7.45	10.95

**EDUCATION EXTRA**  
Buy any 2 educational products

£1 off next order

**BUDGET BARGAIN**  
Save over a £1  
3 @ £1.99  
or  
2 @ £2.99  
**only £4.99**

### CHEAT for only Tape £2.99 Disc £4.99

Bend the rules! Play your games until dusk, with cheat options such as infinite weapons and immunity.

#### CHOICE CHEATS 1

Cheat at: By Fair Means or Foul, Cybernoid, Karnov, Operation Wolf, Flying Shark, Radius, Titanium, Advanced Pinball Simulator, Joe Blade 2, Star Trooper, Reflex and Shanghai Karate.

#### CHOICE CHEATS 2

Cheat at: Dragon Ninja, Hopper Copper, Arkonoid, Arkonoid 2, Dynamite Dan, Solomon's Key, Dizzy 2, ATV Simulator, Empire Strikes Back, Pro Ski Simulator, Batman and Head Over Heels.

Many more items in stock than listed phone us for DISCOUNT PRICES

All prices are inclusive of VAT and P & P in UK. To order send cheque or PO to

1st Choice Software Ltd  
Dept AA/10  
4 Paul Row, Temple Lane  
Littleborough, Lancs. OL15 9QQ



Please state Name, Address, Title, Disc or Cassette and price

# NIRVANA v1.1

## The Ultimate Disc Management Suite

A POWERFUL SUITE OF DISC UTILITIES WITH THE FOLLOWING FEATURES

#### SELECTABLE DRIVES

Any combination of disc drives can be selected

#### FAST DISC FORMATTER

Formats a disc in under 20 seconds. Formatting is possible in drive A or B with a choice of DATA or VENDOR formats.

#### RENAME FILES

NIRVANA supports single and multiple renaming of files.

#### ERASE FILES

NIRVANA supports single and multiple erasing of files

#### DIRECTORY EDITOR

On-screen directory allows alteration to any part of a disc's directory.

#### SECTOR EDITOR

On-screen editing of any sector is possible allowing alterations to be made directly to the disc's code. To help guide you round a data formatted disc a Data Sector Map is included in the instruction manual.

#### DISC MAP

Maps a disc with the option of printing the map to screen or printer. The map shows the name of each file together with the tracks & sectors it occupies.

#### FILE ATTRIBUTES

Four options are available allowing files to be READ ONLY or READ WRITE and DIRECTORY or SYSTEM.

#### FILE COPY

A unique and intelligent file copier allows single or multiple transfer of files from one disc to another. This option will check for and use any additional memory including D K'tronics memory packs up to 256K. With a 256K pack it will transfer one side of a disc in a single pass (only one disc change for single drive users.) Full On-screen reporting of how the transfer is progressing.

#### DISC COPY

This option allows single or multiple tracks to be transferred from one disc to another. Full on-screen reporting shows tracks and sectors being transferred.

The ROM version of NIRVANA has insufficient room for some features. These are, however, supplied on disc

NIRVANA IS CAPABLE OF BACKING-UP SOME COMMERCIAL DISCS. AUTHORITY MUST BE OBTAINED FROM THE COPYRIGHT HOLDER BEFORE A COMMERCIAL DISC IS BACKED-UP.

### Simply the best Disc Management Suite available today

Upgrade your early Disc version	UK £3.00	Europe £4.25	Rest of the World £5.00
Upgrade your ROM (incl disc)	UK £6.00	Europe £7.25	Rest of the World £8.00
Disc to ROM upgrade (inc. disc)	UK £13.00	Europe £14.25	Rest of the World £15.00
Disc version	UK £15.00	Europe £16.25	Rest of the World £17.00
ROM version (includes disc)	UK £26.00	Europe £27.25	Rest of the World £28.00

### AMSTRAD DMP2000/3000 PRINTERS

The printer buffer presently in the DMP2000/3000 printers is a 2K RAM. Most of the RAM is used by the printer's operating system leaving around 1/2K as buffer space. Our upgrade kit contains a new static RAM chip which will increase the available buffer by about 6K (approximately 4 pages of text). This upgrade also allows all downloadable characters to be redefined enabling the user to design special characters for use in scientific and other programs. The kit is supplied with full pictorial instructions to allow the amateur to carry out his own upgrade (the DMP2160 takes about 7 minutes). If you don't think you're up to it your local TV shop can do the job.

UK £14.50 EUROPE £15.75 REST OF WORLD £16.50

### CHARACTER DESIGNER

- \* REDEFINE PRINTER DOWNLOAD CHARACTERS \*
- \* REDEFINE COMPUTER SCREEN FONTS \*
- \* DESIGN SPECIAL SCIENTIFIC CHARACTERS \*

This utility takes all the hard work out of character designing making it a pleasure. All designing is done on screen so you can see exactly what you are doing. You can save your newly designed characters to disc and reload them into basic programs and most word processors. The program disc also contains twelve fonts for experimentation.

UK £15.00 EUROPE £16.50 REST OF WORLD £17.75

Please send your cheque (£ Sterling) Eurocheque or UK P.O. to:  
**GOLDMARK SYSTEMS, 51 COMET ROAD,  
HATFIELD, HERTFORDSHIRE, AL10 0SY, ENGLAND**

Write or Telephone  
(0707) 271529  
for a brochure

# Prince of printers?

Can the Mannesmann Tally MT222 really be worth all of £800? PAT McDONALD takes some convincing.

## MT222

£799.25

Mannesmann Tally ● 0734 788711

You certainly get your money's worth with this one! Open the box and you find a wealth of bits and pieces to plug in and attach. There's a cut sheet feeder, tractor assembly (already fitted but detachable) and the front cover. Everything fits very well - no rattling or tendency to fall apart. Obviously a lot of design work has gone into the moulding.

Since this is a wide carriage printer, you can fit paper up to 15" wide into it. As a result it does grab a fair bit of your desk space. The paper is, as usual, fed into the back, and that's where the printer cables go (either the normal centronics parallel or RS232 serial connectors can be used). Add to this the power lead, and you'll need an square area of about 70cms on a side.

### Start print

Once you have the whole thing connected up, you'll appreciate that the motor drive in it is not exactly underpowered. After spending all of five seconds fitting the paper, the printer whipped it out of my hands and fed it through.

Printing speed is excellent. The claimed printing speed is 220 characters per second in

## Yours for the asking

Why is AA reviewing a printer twice as expensive as the CPC itself? For the simple reason that we're giving this big beauty away in our *First Edition* DTP series (see p. 40). Some lucky blighter is going to be giving some poor postman a hard time, courtesy of Mannesmann Tally and *Amstrad Action*.

Besides, we intend to review a whole range of printers for all pockets, and, as the best that money can buy, the MT222 provides a standard against which lesser - but more affordable - printers can be measured.

Incidentally, a while back it was doubtful whether the MT222 was ever going to be on sale in this country (see *Amscene*, issue 44). Due to a technical design fault, the printer had to be put on hold until the problems were ironed out. Now at last it's available, if you have the necessary readies.



● The MT222: chunky and solid

draft mode: I timed it at about 170 cps, still fast indeed. It's much faster than the Seikosha SL80, and shows the Star LC24-10 a clean pair of heels too.

Getting good quality print out of the MT222 is not straightforward. It emulates the Epson LQ (letter quality) or the IBM XL standards, which means that most computer users must buy a separate font cartridge to get good looking characters. Five are available, Courier, Serif and Gothic among them. Luckily for us CPC owners, *Qualitas* does nicely.

You can download fonts into the MT222 very nicely indeed. Once there, you can do all the normal tricks on the text: superscript and subscript, double strike, emphasized, double height and underline.

### You get what you pay for

The graphics printing of the MT222 is formidable, because not only can you do the normal 24 pin printer stunts, you also have 360 dots per inch horizontally and vertically. A one-to-one scale of the Amstrad screen would print out at under two inches wide and just over one

MT 222	24 WIRE	DOT	MATRI
ROM(1)	.....	(8482)	4¢
ROM(2)	.....	(8482)	4¢
ROM(FONT)	.....	(8374)	4¢
COLOUR-OPTION	.....	NO	
OPTIONAL-RAM	.....	NO	
OPTIONAL ROM	.....	NO	
FONT-CARTRIDGE	.....	NO	
EE-ROM(DUMP)	.....	38 30 8E	
		20 00 00	
		00 00 00	
		4A 4A 4A	

### ● Speed, quality and dependability: examples of the MT222's good work

Emphasize your dramatic points!

v a r i a b l e

s p a c i n g

condensed proportional pica -

one of my favourites

inch high.

The normal print routines, good as they are, in programs such as *Advanced Art Studio* and *Stop Press* are simply not up to exploiting this kind of capability properly. Nonetheless the results are stunning, and it's only a matter of time before some genius comes up with 24 pin printer routines.

There are two manuals supplied with the printer. One is the operators manual, and is written in a very clear, informative style. The other is the applications manual which contains the codes needed to get the most out of it. Both manuals assume that you have never used a printer before, and serve as an excellent introduction.

There is one problem, in that none of the example programs in the manual work without modification. If you ignore the **OPEN** commands, replace **LPRINT** with **PRINT #8** and **LLIST** with **LIST #8**, you'll be fine.

The finesse of this product has to be seen to be believed. You pay for quality, but if you want a printer that's going to last you years and years, or do some serious zine work, then it's a real investment. ●

### GOOD NEWS

- Wonderful graphics capability.
- Beautifully put together: you won't be upgrading.

### BAD NEWS

- Cost.
- You'll probably need font cartridges or *Qualitas*.

# Rodents running all over your table

Of mice and mice software: at a glance, everything you ever wanted to know about mice but were afraid to ask in case people thought you really believed a mouse was a small furry rodent.

STEVE WILLIAMS assesses the brand new value-for-money bundle from Datel Electronics, while PAT McDONALD makes comparisons with the other two currently available.

## DATEL MOUSE BUNDLE

£49.99 with *OCF Art Studio*  
 Datel ☎ 0782 744707  
 Disk and tape, 128K memory required  
 (Note: available with *OCF Advanced Art Studio* from WACCI)

Datel Electronics' new package consists of:

- the Genius Mouse (long available for other computers); a mouse mat;
- *OCF Art Studio*, generally ranked second only to the *Advanced Art Studio* as the best ever graphics package for the CPC;
- a mouse holder;

- and – last but most important of all – an interface that enables the CPC to interpret the signals from the mouse, without which nothing would be possible.

A sleek little cream coloured beastie (10 by 6 by 3cms) with a nice solid feel to it, the Genius has two buttons on its surface that give a satisfying audible click when pressed. The cable is a generous 180cms long with a joystick plug. The rollerball (the ball on which the mouse travels across your desk) is medium-sized and coated in a soft plastic shell. The unit has an optical rotary encoder which has a speed of up to 500mm per second.

The Datel mouse interface has a very familiar look to it, bearing a striking resemblance to a Dk'tronics memory expansion pack and even sporting the Dk'tronics logo. Surprising? Not if you have been keeping up

## Comparison: AMX MOUSE

£49.95 with *AMX Art*  
 £74.95 with *Stop Press*  
 Database Software ☎ 0625 878888  
 Disk and tape: all CPCs  
 Reviewed AA7  
 Stop Press reviewed AA28

When it was released three years ago, the AMX mouse was the only one of its kind available. Since then, a number of utilities have been made available that work with it in perfect harmony. The best is *AMX Stop Press*, the most user friendly and powerful desk top publishing program for the CPC.

The interface is about the size of a packet of Swan Vestas and plugs directly into the joystick port jutting out from the side of the computer by about 80cms. The i/f draws its power from the five volt line by interrupting it with a plug and socket arrangement. It is always in the back of my mind that one day I am going to inadvertently going to catch something on the protruding i/f unit and send a nasty

power spike to the computer via the interrupted five volt line with disastrous consequences.

If only for this reason I prefer Datel's package. The i/f sits nice and tight on the back of my computer out of harm's way and there's no messy fiddling with plugs and sockets to provide a power supply. That's the way to design add-ons correctly.

The mouse has three buttons which have a very soft feel and don't punish your fingertips. The feel of the mouse in the hand is comfortable, though most people find that the palm is held above it, rather than on it. It's impossible to please everyone, I suppose.

*AMX Art*, the main drawing program supplied with the mouse,

has several disadvantages compared to other art programs. It only allows you to edit a portion of the available screen. You can only edit pictures in the four colour Mode 1. And the manner in which the pictures are loaded and saved means that a special program (also supplied with the mouse) is needed to use them in your own programs.

Having given it a right slagging, however, I should make it plain that it's loads of fun to use. The mouse control is by far the most responsive I've seen with any art program, and you'll find yourself spending hours perfecting pictures on your CPC.

There are two design programs on the disk to let you create your own fonts, icons and patterns for use in *AMX Art*. They're all easy to use and understand.

Another excellent extra is the control program. With it, any halfway competent Basic programmer can set up a WIMP desk top with a mouse pointer, and some icons too. And of course, pull down menus too! So writing your own programs to work with the *AMX* mouse is no problem at all.

The manual for the whole shebang is easy enough to read, but because it covers all the various programs the detail isn't quite there for the absolute beginner. It must be said though that you really learn how to use a mouse system by playing around with it, and so the *AMX* (overall) is a good choice for any Amstrad owner.

The rollerball in the *AMX* unit is made of plastic and consequently is very light. In use this means that it does not have such a positive "feel" as the *Genius* mouse. The buttons on the *Genius* also have a better action than those of the *AMX*, which seem to have a weak return to the normal position. In addition the *Genius* mouse glides over the mat more easily than the *AMX* one (I had always thought the *AMX* one was pretty free up until I did this review.) At the end of the day it is going to be the *Genius* mouse that will outlive the *AMX* mouse.

Software	7
Comfort	8
Value	7
Overall	8

# Comparison: MASTER MOUSE

£49.99 with *Cherry Paint*  
 £64.99 with *Micro Design*  
 Siren Software ☎ 061 228 1831  
 Disk only: all CPCs  
*Cherry Paint* reviewed AA20  
*Micro Design* reviewed AA28

Billed as "compatible with all AMX software," the Siren Master Mouse is another three button effort that does indeed mimic all the actions of the AMX offering.

There are two options: you can either buy it with *Cherry Paint*, a French art program distributed

exclusively by Siren; or with *Micro Design*, a Siren program that almost - but not quite - makes the claim of being a DTP package.

*Cherry Paint* works in mode 2 only, and is stunning when used for the first time: icons, pull down menus and so on are executed so

well you might think that it was running on an Apple Macintosh.

The program does have flaws: pixel accuracy is difficult, the documentation is skimpy and the patterns to paint on the screen cannot be edited. Nevertheless *Cherry Paint* has lots of charm.

*Micro Design* is different in that it has lots of potential power and so is tricky to get to know. Mouse control works quite well with it: you could easily knock out a newsletter or poster on the setup.

As for producing a fully fledged fanzine with lots of different fonts - it would take a dedicated user indeed to find the time for all the

tweaks necessary.

Although it cannot really be matched with the AMX or Datel products, the Siren mouse has one advantage: it's compatible with the AMX, and is cheap! If you already own some mouse software (*Advanced Art Studio* and *Stop Press*) then this will be the best way to have the best control. Good for somebody who just wants a mouse.

Software	7
Comfort	7
Value	8
Overall	7

with *Amscene*, and recall that Datel is the company that bought up the company that bought up Dk'tronics (many moons ago), and now they are putting their circuit board in the self same boxes.

The Dk'tronics box on a 6128 has a through connector for the expansion port, and (a nice touch) a small tunnel passing through the lower left part that allows the printer cable to pass through. The 464 pack is about half as wide as the 6128 one and therefore doesn't need the little through tunnel. On the left hand edge of both packs there is a joystick socket and emerging from the box below it is an 18cm cable with a joystick plug at the other end.

The interface plugs snugly onto the expansion port at the rear of the computer. The joystick plug from the unit curls around the side of the computer and fits into the 6128's port. The plug from the mouse then fits into the socket on the side of the interface pack.

## Mouse magic

Ah, the joys of free-hand drawing with a mouse! It allows you to sit away from the monitor and view the design from a distance.

From the keyboard, for instance, you can't create "artistic masterpieces" such as the one in Fig 1. The Genius mouse has a nice precise control over the cursor and the action is very smooth. The only limitation is one's artistic ability - or in my case, artistic liability.

When you switch to zoom (or "magnify") mode the advantages of using a mouse

become manifest. Touching up the errant pixels that have somehow found their way into your work of art ceases to be a boring chore and becomes an occasion for joy and happiness.

There is, however, bad news for those of you with *Stop Press* and dreams of compatibility. The pointer moves around the screen alright, but the lack of a third button means you can't click onto icons. Perhaps the technobots at Datel might consider making *Stop Press* compatible?

## But is this rodent up to scratch?

The complete package - *Art Studio*, mouse, interface, mouse mat and holder - costs £49.99. Considering that *The Art Studio* alone retails at £18, and that the mouse mat and holder are worth, say, about £13, you're getting the mouse and interface for a mere £19.

If Datel had just boxed the *Advanced Art Studio* (saving it from obscurity) with a mouse and interface allowing CPC owners to use that excellent program, they would have earned my approval. They have done both these things, added extra goodies and bundled them in an excellent graphics package at a keen price.

If you don't yet own either art package or mouse then Datel's Genius Mouse kit warrants serious consideration.

Software	10
Comfort	8
Value	9
Overall	9 ●

## Living in hope - and a note of caution

● Datel Electronics have done CPC owners a great service by releasing *Advanced Art Studio* from the "Twilight Zone." Is it too much to hope that the excellent and much sought after *Advanced Music System* might reappear on the

market?  
 ● The interface reviewed here as a component of the Datel mouse is the one designed for the 6128. The only difference between this and the 464 version is the shape of the box it is housed in (the

design of the back of the 464 is different from the 6128.) Please note that 464 owners will need the Dk'tronics 64K RAM pack as well.

● Finally, note that you can't run *Art Studio* on a 464, even an expanded one.

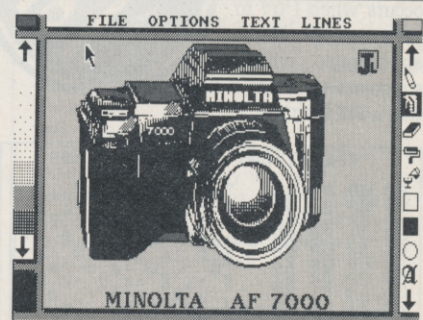

▲ OCP Art Studio is simply the best there is

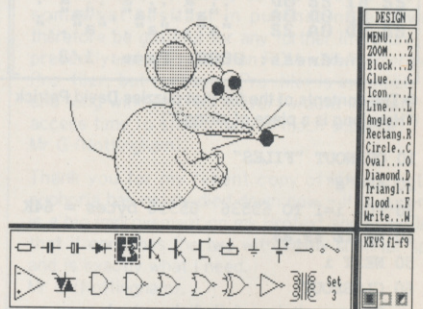

▲ The Master Mouse can also be used with Stop Press

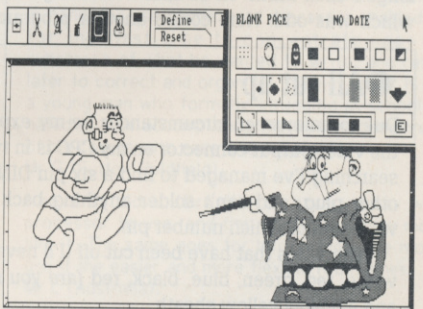

▲ AMX Art doesn't let you edit the whole screen

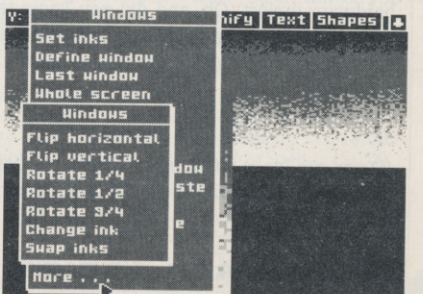

▲ Micro Design, included with the Master Mouse

# FORUM

Three pages packed with powerful problem-solving from the pen of PAT McDONALD

## ●How long is a piece of string?

I'm writing a database program on my 6128, and have come across a problem. I'm using the second 64K of memory for storing fields, and arrays for storing record titles and field titles.

My problem occurs when I try to save the file. Here's an example, which is supposed to create a file that's 64K long:-



```

Track: 001 Sectors: 009
22 0D 0A 22 " " " " " " " " " " " " " " " "
0D 0A 22 61 " " " " " " " " " " " " " " " "
0A 22 61 22 " " " " " " " " " " " " " " " "
22 61 22 0D " " " " " " " " " " " " " " " "
61 22 0D 0A " " " " " " " " " " " " " " " "
22 0D 0A 22 " " " " " " " " " " " " " " " "
0A 22 61 22 " " " " " " " " " " " " " " " "
22 61 22 0D " " " " " " " " " " " " " " " "
0A 22 61 22 " " " " " " " " " " " " " " " "
61 22 0D 0A " " " " " " " " " " " " " " " "
22 0D 0A 22 " " " " " " " " " " " " " " " "
Address: 0000 Page: 1/2

```

● The contents of the file that puzzles David Patrick ("How long is a piece of string?")

```

10 OPENOUT "FILES"
20 a$="a"
30 FOR i=1 TO 65536 ' 65536 bytes = 64K
40 WRITE #9,a$
50 NEXT i
60 CLOSEOUT

```

The result is a full disk, which was previously formatted, and the file was over 64K long. I then went on to find something else which was odd. Here comes another program

## ●All cut up

Due to unforeseen circumstances (ie my *expletive deleted* little cousin) the video output connector on my CPC is in two pieces. After four weeks searching I've managed to find a six pin DIN plug, but now I've lost the other plug, and can't solder anything back until I know which colour wire goes to which number pin.

The wires that have been cut off (I'll never forgive him!) are coloured white, red, green, blue, black, red (are you sure that's two reds? - Pat) and a hollow yellow sheath.

By the way, I have a green GT65 monitor. I'd love to see a modulator hardware project. Oh, and did you know that if you set your video to camcorder, ie source mode and connect pins 6 and 4 of the computer to video in, then you get a pretty good black and white picture that you can video?

Michael Heys, Nelson

(Steve, can I take apart one of our moni... Definitely no! - ed). Assuming that you're telling fibs about the two red wires, Michael, then black

should be GND, and the white and yellow wires (you'll probably have to extend the latter) are SYNC and LUM, though which is which, who knows...

What I'm saying is you'll just have to try all the combinations once black is connected to GND: you can't hurt the monitor by getting them wrong. You don't actually need the red, green and blue signals on a green monitor.

Anyway, the connections as available in your ever friendly CPC manual are shown in the accompanying picture.

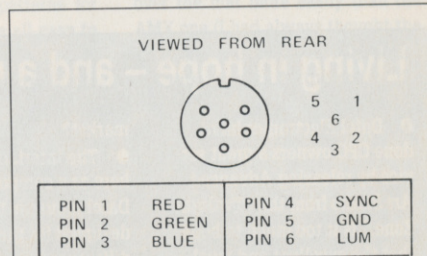

● This illustration may prevent Michael Heys ("All cut up") from strangling someone

## ●Desperately seeking help

Could you tell me where to get the manufacturer's data sheets dealing with the chips inside the CPC, as mentioned in the Firmware Guide? I haven't got the foggiest idea where to go and I need to know how to make sounds, read the keyboard/joysticks and also use the tape deck, without resorting to the firmware. It's for a game that my friend and I are writing.

John Girvin, Belfast

Hmm. The only company that I know of for data sheets are RS, who don't sell to the public. They have a setup called Electromail who do help out individuals ☎0536 204555.

Mind you, I don't really think that data sheets are going to help you much. What you really need to know is how to drive the hardware of the CPC directly, and no book currently available tells you about it. That may, however, change in the not-too-distant future...

as an example:-

```

10 OPENOUT "FILES"
20 a$=STRING$(10,"a")
30 FOR i=1 TO 6554
40 WRITE #9,a$
50 NEXT i
60 CLOSEOUT

```

The result of this was a 90K file. I then went on to search for an answer to this, so I used a sector editor and looked at track 01, sector C1. Results were as shown in the accompanying picture.

I understand that the 22s on the disk are the " character, and the FF's are for the . characters, but what are the 0D and 0A for? Is it some kind of control character that tells the computer to stop when it gets to this point? Is there any way around this without messing about with machine code?

David Patrick, Sheffield

ELECTRICAL PRODUCTS SERVICE



● RS will supply anyone with technical data through Electromail (Soviet Embassy take note!)

## BrunWord 6128 £30

BrunWord 6128 is specially written for the Amstrad CPC6128. Months were spent just optimising the routines into their smallest, most efficient form. The result is the fastest, most convenient word processor for this computer, complete with the fastest spelling checker and a card filing programme for mail merging. Whether you are writing a few letters or a complete novel, you will find no better assistant than BrunWord.

The word processor, spelling checker and 30,000 word dictionary, are all loaded into memory by typing RUN "BRUNWORD". The disc drive is then completely free for your data disc.

All other word processors, even the ROM versions, need to access the programme disc to test the spelling. (ROM versions have the dictionary on disc). This is slow and can involve many disc changes. For example, Protext needed the disc to be changed eight times to check the spelling of our test file, whereas BrunWord needed no disc in the drive.

The 40 page BrunWord manual has several detailed examples, starting with step by step instructions to produce and print a simple letter. But your very first step is to load the TUTOR file into BrunWord. This takes even the complete novice straight into word processing and demonstrates the powerful editing and formatting features of BrunWord. There are also examples of printer control, showing how to create headings, to underline or to emphasise, and five deliberate spelling errors for you to correct. The tutor takes about 20 minutes to run through and after that you will feel confident to type in your own text.

### BrunWord Features

\*40, 80 or 128 column display \*Touch typing speed over 200 words/min \*True insert or overwrite \*Justify or unjustify paragraph or whole text \*Justified text has balanced appearance \*Instant word wrap \*Block save, move, copy, insert and delete \*Local editing with word delete/undelete \*Adjustable margins and TABs \*Column/Line/Page display with file name \*True word count \*Find and replace \*Help menus \*Memory filing system \*Single character embedded printer commands (18 with 3 printer codes and 21 with 10 printer codes) \*Page throw markers \*Multiple copies \*Odd/even page headers/footers with page numbers \*Multi file printing (new page or continuous) \*Print specified pages \*Works with any printer \*True display superscript and subscript numbers \*User defined print characters \*Load ASCII files from other word processors \*Save ASCII files for other word processors \*Files can be encrypted \*Maximum file size about 9 pages of text.

### BrunSpell Features

\*Memory resident with word processor \*Checks 4,000 words/min \*30,000 word dictionary \*No American spellings \*Add up to 5,000 of your own words \*Instant lookup \*Helps to find correct spelling \*Automatic correction.

### DataFile Features

\*Alphabetical, numerical, date sorting on any field \*User defined headings \*Search routine \*Data merging into BrunWord \*Label printing.

## BrunWord Junior

Low cost version of BrunWord 6128 on 3 inch disc, including the spelling checker, 30,000 word dictionary, TUTOR file and manual. Holds just one page of text and cannot save words to the dictionary. Otherwise as BrunWord 6128. Cost £18. Upgrade later to BrunWord 6128 for £14.

## Tasword Upgrade

Send your original Tasword 6128 disc (not the packing or manual), and £23.00. We will return your programme together with the full version of BrunWord 6128 with BrunSpell and DataFile.

# BrunWord

## Info-Script £50

The great power of any database is only realised when the data can be put to use. A database system is centred around saving, sorting, finding and displaying the data. Obviously, very essential features but only if there is a purpose to storing the data. That purpose might be names and addresses for mail merging, a stock list of items being sold that generates a buying list, a catalogue of your compact disc recordings so that you can take a printout with you to the shop, a catalogue of recipes so that you can have a print out in the kitchen of the in-season treats, a catalogue of garden activities that gives you a reminder list to hang in the garden shed.....

The common element being the need to take the data away from the computer, in a form that suits your immediate requirement.

We gave considerable thought to this and concluded that the only solution was a proper text handling system within the database itself. In other words, a word processor. We looked into designing a special word processor but quickly realised that BrunWord, with its memory filing system, is ideal.

This is the exciting concept of Info-Script. A comprehensive relational database integrated with a powerful word processor, giving total flexibility to the way that the data is printed. A fast, user friendly combination that has the depth of power to keep up with your needs. A mail shot, a restaurant wine list, a summary of expenses.....

## BrunWord Upgrade

Send your BrunWord 6128 disc, BrunWord manual (not the packing) and a cheque for £22.00. We will record Info-Script, test the disc and return with a new manual.

## BrunWord Elite £90

A superb programme which has printed this advertisement but the release date has been put back while we resolve problems with certain 24 pin printers. Meanwhile don't despair, buy Info-Script.

Our booklet BrunWord & Printer will need a few changes to the conclusions, so is also delayed.

## Comparisons

We have tested BrunWord 6128, Protext (disc) and Tasword 6128 with the same file of 3366 words.

BrunWord scrolled 40% faster than Protext which in turn scrolled 19% faster than Tasword.

Protext was the fastest to justify but needed a separate operation to see the result. BrunWord produced the best appearance of all three and was 30 times faster than Tasword.

Our simulated typing test reached 218 words per minute. Both BrunWord and Protext had no trouble at this speed but Tasword was very slow inserting text into the start of a paragraph and could only handle 16 words per minute.

The spelling test checked all 3366 words. BrunSpell took 52 seconds and needed no disc changes. Prospell took 6 min 24 sec and needed 8 disc changes. Taspell took 18 min 46 sec and needed 3 disc changes.

## 100 Letters £15

This is a utility for use with Info-Script. It is supplied with over 50 pre-written letters and has a special format that will allow you to add hundreds of your own letters.

For example, you want to place a 'Wanted' advertisement to buy another CPC6128. Insert the Info-Script disc. Type RUN "INFO". Insert your data disc and load your name and address file. Insert the 100 Letters disc. FIND the 'Yellow Advertiser' record from your own file (now in memory). Type LET072 into the ACTION field and CPC6128 into field 17. Press T for Transfer. Info-Script will load letter 072, personalise it with the address of the paper and insert the 'Wanted' item. The letter is then in the word processor and can be edited in the normal way to be exactly what you want, and then printed out. When that is done press <ESC> \* and you are back in Info-Script, with the 'Yellow Advertiser' record still selected, ready to address the envelope. You can write as many letters as you like without changing the disc and you will never wait more than a few seconds.

100 Letters is supplied with an operating manual which takes you easily into writing letters and explains, in simple terms, how to create your own letter patterns. An average CPC6128 owner, using easy patterns, can expand the library to about 100 letters but there is no limit.

## Letters

I am extremely interested in the sound of your Info-Script. However, as the cost is £50 I am somewhat hesitant in purchasing and would therefore be grateful for any further literature. I am presently using Protext on ROM with Promerge and Pro-filer, but accessing Pro-filer is incredibly slow and long winded. Your advert would indicate that access time to stored data is much superior. Mr G (Nottingham).

Thank you for my recent copy of Info-Script. My euphoria has nearly died down now - it is superb. It is a big improvement on my Protext and Pro-filer in that it combines the two with vastly superior speed and is exactly what I need. Mr G (Nottingham).

May I take this opportunity to express my appreciation of BrunWord. My son has been the main user. After years of torture in school with pen in hand, the use of the word processor enabled him for the first time to concentrate upon the substance of what he wanted to write, and return later to correct and organise. The net result is that a young man who formally struggled at school and hated it, now accomplishes the written components of his course with ease and satisfaction. Mr G (Sutton Coldfield).

I have found it (BrunWord) a very easy word processor to use, and the more I use it the more I like it. The same goes for Info-Script, the more I use it the easier and more flexible it becomes. Mr L (Australia).

Please supply BrunWord 6128. I have both Tasword (used for his letter) and Protext. Why do you think I deserve the discount offered..... my age 76. Mr S (Glasgow). (see ACU Aug 89)

Send cheque/PO/Access number/Visa number to:

## Brunning Software

34 Helston Road,  
Chelmsford, Essex, CM1 5JF  
Telephone (0245) 252854 (24 Hours)

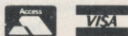

BrunWord 6128 with BrunSpell & DataFile. . . £30.00  
BrunWord 464 with BrunSpell & DataFile. . . £25.00  
BrunWord Junior 6128 with BrunSpell. . . . . £18.00  
Info-Script 6128 with BrunWord & BrunSpell. . £50.00  
100 Letters (needs Info-Script). . . . . £15.00  
BrunWord Elite and Info-Script include backup disc.  
(All supplied on 3in Disc - state which computer)

All prices are inclusive for UK. Overseas orders sent insured air mail - Europe add £2.50 - Rest add £7.50

# POOLSWINNER II

THE ULTIMATE POOLS PREDICTION PROGRAM

- MASSIVE DATABASE** Poolswinner is a sophisticated Pools prediction aid. It comes complete with the largest database available - 22000 matches over 10 years.
- PREDICTS** Not just SCOREDRAWS, but AWAYS, HOMES and NO SCORES.
- SUCCESSFUL** SELEC guarantee that Poolswinner performs significantly better than chance.
- ADAPTABLE** Probabilities are given on every fixture - choose as many selections as you need for your bet. The precise prediction formula can be set by the user - you can develop and test your own unique method.
- SIMPLE DATA ENTRY** All team names are in the program. Simply type in the reference numbers from the screen. Or use FIXGEN to produce fixture list automatically (see below).
- LEAGUE AND NON-LEAGUE** All English and Scottish League teams are supported, and also the non-league sides often used on pools coupons.
- PRINTER SUPPORT** Full hard copy printout of data if you have a printer.



Based with detailed instruction booklet

PRICE £24.00 (all inclusive)

**NOW AVAILABLE**

## FIXGEN 89/90

AT LAST! No more struggling for hours to get the fixture list into the computer. FIXGEN has been programmed with all English and Scottish League fixtures for 1989/90. Simply type in the date, and the full fixture list is generated in seconds. Fully compatible with Poolswinner. Yearly updates available.

POOLSWINNER with FIXGEN £26.50 (for both)



## COURSEWINNER V3

THE PUNTERS COMPUTER PROGRAM

You can develop and test your own unique winning system by adjusting the analysis formula, or use the program in simple mode. Coursewinner V3 uses statistical analysis of major factors including past form, speed ratings, course statistics, prize money, weight, going, trainer and jockey form etc. etc. It outputs most likely winners, good long odds bets, forecasts, tricast etc. The database includes vital course statistics for all British courses. You can update the database - never goes out of date. FULL PRINTER SUPPORT.

PRICE £24.00 (all inclusive) includes Flat AND National Hunt versions.

NOT JUST A TIPSTER PROGRAM. Coursewinner V3 can be used by experts and occasional punters alike.

AVAILABLE FOR

AMSTRAD CPCs  
BBCs  
COMMODORE 64/128  
SPECTRUM

AMSTRAD PCW  
IBM Format  
COMMODORE AMIGA  
ATARI ST

Please state tape or disc  
(add £2.00 for disc).



Send Cheques/POs for return of post service to...

62 ALTRINCHAM RD, GATLEY, CHEADLE, CHESHIRE SK8 4DP. ☎ 061-428 7425  
(Send for full list of our software)

# SOFT EXCHANGE

Special Offers Cassette only	720 <sup>0</sup>	Title	Cass	Disc
History in Making .....6.99	Hardball .....2.60	Purple Saturn Day 7.99 ...12.99		
Go Crazy .....4.50	Yir Ar Kun Fu .....2.60	Quarterback .....7.99 ...12.99		
Super Sports .....2.99	Match Point .....2.60	Rainbow Island ..7.99 ...10.99		
Motor Massacre .....2.99	Summer Games .....2.60	Risk .....7.99 ...10.99		
Supreme Challenger .....5.50	Pro Power Simulator .....2.60	Shinobi .....7.99 ...12.99		
Superman .....2.50	Turbo Espirit .....2.60	Skate or Die .....7.49 ...10.99		
Wizards Lair I .....2.50	Black Beard .....1.99	Star Wars Trilogy 8.99 ...16.00		
Wizards Lair II .....2.50		Vigilante .....7.99 ...12.99		
Indoor Sports .....2.99	<b>Title</b>	Xenophobe .....7.99 ...12.99		
3-D Boxing .....3.99	Rick Dangerous .....7.49 ...10.99	A.P.B. ....7.99 ...12.99		
Sai Combat .....1.60	Forgotten Worlds ..7.49 ...10.99	Navy Moves .....7.99 ...12.99		
5 A Side .....1.60	Silk Worm .....7.49 ...10.99	Dragon Ninja .....7.99 ...10.99		
Shadowy Skimmer .....1.60	Microprose Soccer 10.99 ...14.99	After Burner .....7.99 ...12.99		
123 .....1.99	Red Heat .....7.49 ...10.99	Command Performance 8.99 ...14.95		
Rally Simulator .....1.99	Robocop .....6.99 ...9.99	Bionic Commando 7.99 ...12.99		
Jokey Wilson Darts .....1.99	Treble Champs .....7.49 ...10.99	Fun School 2 (6-8) 7.25 ...9.25		
Rod Pikes .....2.25	Indiana Jones .....7.49 ...10.99	Fun School 2 (6-7) 7.25 ...9.25		
	Thunder Birds .....7.49 ...10.99	Fun School 2 (6-6) 7.25 ...9.25		
	Carrier Command ..7.49 ...10.99	Mini Office .....10.99 ...13.95		
	Kenny Daghish .....7.49 ...10.99	Stop Press .....35.99		
<b>Disc only</b>	Emlyn Hughes .....6.99 ...10.99	Stop Press + Mouse .....66.99		
Eye .....3.99	Dominator .....7.49 ...10.99	Mouse + Art .....58.99		
Rampage .....3.99	Phobia .....7.49 ...10.99	Extra Extra .....18.99		
Madballs .....3.99	Run the Gauntlet ..7.49 ...10.99	Protext .....17.45		
Volleyball Simulator .....6.99	Operation Wolf .....7.49 ...10.99	Promerge .....16.99		
Never Ending Story .....4.99	Soccer Squad .....7.49 ...10.99	Prospect .....16.99		
	3-D Pool .....7.49 ...10.99	Fleet St Editor .....28.99		
	Spy Hunter .....2.60	Masterfile III .....28.99		
	Battleships .....1.75	Time Scanner .....35.99		
	Tr Islands Dizzy .....2.60	Dr Draw V 1.0 .....35.99		
	Blackbeard .....2.60	At Last Plus .....26.99		
	Adv Pinball Sim .....2.60	Supercalc 2 .....42.99		
	ACE II .....2.60	Arnor C Compiler .....36.99		
	BMX Simulator II .....1.60	Maxam II .....36.99		
	Kickstart II .....2.60	lankey 2 Finger Typing ..16.99		
	Green Beret .....2.60	lankey Crash Course .....16.99		
	Bomb Jack II .....2.60	Hisoft Devpac 80 .....36.99		
	Mr Hell .....7.50 ...11.99	Hisoft C Compiler .....36.99		
	Road Runner .....2.60			
	New Zealand Story ..7.50 ...10.99			
	Passing Shot .....7.99 ...10.99			
	Rambo .....2.60			

Orders under £5 include 50p postage.

All orders despatched within 7 days of receipt.

To Order send Cheque/P.O. to:

SOFT EXCHANGE LTD

101 CLIFTON ROAD

SOUTH NORWOOD LONDON SE25 6QA

Orders from Govt. or Educational Depts. are Welcome Please Write



## HSV COMPUTER SERVICES LIMITED

23 Hampstead House, Town Centre, Basingstoke RG21 1LG (AA)

ALL OUR PRICES INCLUDE CARRIAGE & VAT

Personal  
Organiser  
Stationery  
85gsm  
£7.95  
for 250 sheets

### Stationery . . . Stationery . . . Stationery . . .

	500	1,000	2,000
9.5" x 11" 60gsm Micro-Perf all edges	-	£9.50	£15.95
True A4 70gsm Micro-Perf all edges	£8.50	£12.95	£23.95
True A4 90gsm Micro-Perf all edges	£9.75	£14.95	£27.95
True A4 100gsm Micro-Perf all edges	£16.95	£31.95	-
(coloured - Cream, Blue, Grey or White)			

### Dust Covers

- \*CPC 464 2pce set £7.95
- \*CPC 6128 2pce set £7.95
- DMP 2000 Printer Cover £4.95
- \*State Mono or Colour

### Printer Ribbons

- DMP 2000/3000 Black £2.95
- DMP 2000/3000 Colours\* £3.95

\*Colours Available are:-  
Red, Blue, Green, Brown.

**NO EXTRAS  
TO PAY**

**Credit Card Hotline  
(0256) 463507**

**Faxline  
(0256) 841018**



Orders under £8 in value carry a small order charge of £2

Amsoft 3" disks (uncased): One £2.85; Five £13.50; Ten £25.95

Maxell 3" disks (cased): One £2.85; Five £13.50; Ten £25.95



## ● Whole lot of questions...

If I:

- buy a silicon disk and turn it into a memory pack, as well as a silicon disk. Then I:
  - buy a ROMboard Xtra with a 40025 6128 ROM chip in the appropriate slot. Then I:
  - buy the 40015 Amdos ROM chip and stick it slot number 7. And finally, supposing I:
  - built a disk drive using the J N Bull Hitachi jobbie...
- would I have converted my 464 into a fully operational 6128?

I am having trouble with my Cheetah Amdrum. Either it crashes the computer or no sound comes out. It does work the odd time, which is odd. What's going on?

Last but not least: is there a hard card or some other type of instant access memory for the 464 or 6128 if my first point is valid?

Simon McCartney, Ballinderry

*So you have a CPC plus 6128 ROM with a disk ROM and a disk drive eh? Is it a 6128? Not quite! You've forgotten all the little controller chips which are also in the DDI-1 first disk drive for the 464. I'm surprised that no one has come up with an alternative first drive for the 464, but until they do the J N Bull device can only be used as a second drive.*

*As for the Amdrum, it sounds like a loose connection or a dry solder joint to me - send it back to Cheetah.*

*As for an instant memory area, the only one I can think of is the Amram 2 from Silicon Systems. It's a 16K sideways RAM device which lets you store ROMs and bits of machine code in. If there is an actual hard drive for sale that plugs straight into a CPC, I've never heard of it. But that's not to say it doesn't exist...*

## ● Midi assistance

Here are a few pointers which may help S D Green of Woking (*Forum AA47*) who wasn't having much luck with a Yamaha DD-10 connected to his *RAM Music Machine*. While I don't own a DD-10, I have had quite a lot of experience with various Midi instruments and I can't see any problems.

On my faithful Roland TR-505 drum machine, as well as assigning different drum sounds to different Midi channels, the note at which each sound is triggered can be altered. The Music Machine's samples start at middle C: in Midi terms this is note 60. So sample 1 sends Midi 60, sample 2 is 61, and so on. If the DD-10 offers the same facility, try checking which notes the sounds are set to trigger on.

If it's impossible to change the DD-10, then use the bar editor of the *Music Machine* for the rhythm. This will allow a much greater range of notes to be sent, from C2 to C2: some if not all of the sounds must be in this range.

As well as sending (and receiving) on a specific channel try setting the DD-10 into Omni-on (mode 1 or 2) to receive on all 16 Midi channels.

If all else fails, check the connections (are they pushed in all the way? Is IN connected to OUT? And so on). I know it sounds obvious but it has been known... Long or extended leads can sometimes cause a weaker Midi signal. Hope this helps.

G W Heslington, Sheffield

*On behalf of the Green of Woking: ta!*

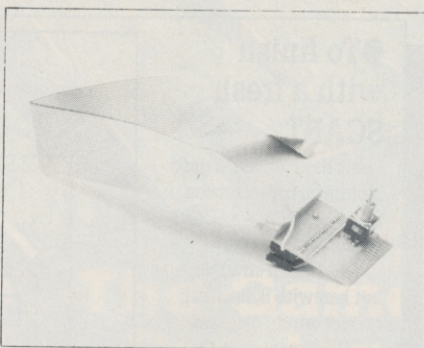

● 6128 connectors are shaped differently

expansion or the drive switcher?

As the chip is soldered in, I want to buy the Microstyle Romboard Xtra, so I can just plug in the 6128 ROM. Can I load a 6128 only game with all the external ROMs turned off? Some games need this, you see.

M Parker, Knutsford

*The problem with 6128 hardware is that the case and second drive connections are differently shaped to the 464. So in most cases you'll have to get the 464 versions of hardware. As for the ROMs, that'll be fine.*

## ● Bearer of bad news

I have just purchased a Multiface 2 for my 6128. I do not know a lot about computers. How do I save games from tape to disk that load in many parts, such as Gauntlet?

Andrew Skinner, Bridgnorth

*Bad news, Andrew: you can't. A multi-load game is a one-off, so you would need a custom program for each one. (I hope you noticed, by the way, everyone, how for once we managed to resist illustrating this letter with yet another picture of a Multiface. Truth is, we wore the last one out. Normal service will be resumed shortly.)*

## ● Helping hand

I'd like to offer some assistance with A K Kirk's problem in AA47's *Forum* regarding *Mini Office* and *Easi-Amsword*: While I can't help with the former the following bits of info may help, bearing in mind the problem of altering a copyrighted program.

This letter was written with *Easi-Amsword* on disk. The first thing to realise is that *Easi-Amsword* is written in Basic and consists of two files: a 2K loader and the 21K main file *Eamsword*. These two files must first be listed. For disk only purposes I find the loader unnecessary, and the main file needs lines 10-40 deleted and this line added:-

```
3760 CLS:CLS #1:INPUT "DOCUMENT
```

```
NAME";N$:N$=LEFT$(N$,8):PR#=1:RETURN
```

This can be improved upon, because disk operations need different parameters. In other words, file names are limited to eight characters and features such as save speed are redundant. Here are the changes to give a disk-only *Easi-Amsword*.

First, delete lines 960, 1920, 3830 and 5070.

```
1930 LOCATE #4,1,7:PRINT #4,"..... etc
```

```
3720 ME$="CENRSPD":CT$="AR":PN$="
```

```
,":TB$=SPACE$(80):
```

```
..... etc
```

```
3910 CLS:CLS#2:LOCATE #2,17,1:PRINT
```

```
#2,
```

```
"DISC MENU"
```

```
3920 WINDOW #7,9,9,11,18:FOR I%=1.....
```

```
etc
```

```
3850 LOCATE 10,14:PRINT "eady (Disc in Drive)"
```

```
5010 ON INSTR("CENRSPD",Z$) GOTO
```

```
5020,5025,5030,
```

```
5040,5050,5060,5080
```

It would perhaps be more useful to keep the option of using tapes to store data on. This only requires the alteration of several lines as per the following listing. Beware that the tape print option may not work.

```
3720 ME$="CENRSPD":CT$="TARD":
```

```
etc
```

```
3855 LOCATE 10,16:PRINT "isc drive
```

```
(disc in drive)
```

```
3860 GOSUB 3780:FOR I%=1 TO
```

```
LEN(CT$):IF
```

```
Z$=MID$(CT$,I%,1) THEN 3865 ELSE
```

```
NEXT:GOSUB 3770:GOTO 3860
```

```
3865 IF I%>2 THEN GOSUB 4400
```

```
4400 REM DISC OR CASSETTE CHOICE
```

```
4410 IF I%=3 THEN |TAPE:RETURN
```

```
4420 IF I%=4 THEN |DISC:RETURN
```

The define colour routine is held in line 1740-1830 and it's easy to change one or more for your own preferences. I hope this information is useful as over the years I have learnt quite a number of hints and tips from your magazine.

Peter Shepherd, Warrington

*Cheers Peter: your helping hand is much appreciated.*



● Ram's Music Machine, now being sold by Datel: still the same cheap 'n cheerful package

### ● Bag full of tips

If you enter a command such as **SOUND 1, 50, 30000, 7** you get a high tone that goes on for ages. To stop such, simply press the **DEL** key which issues a **CHR\$(7)** control code - in other words, a beep!

This flushes the sound queue, stopping any tone in its tracks.



Poking illegal numbers into **&B2BF** while in modes one or zero can give multicoloured characters. Try this listing (for mode 1 change line 30 to **POKE &B2BF, 85**):

```
10 SPEED INK 1,1
20 MODE 0
30 POKE &B2BF, 238
40 INK 3, 26, 0
50 INK 15, 0, 26
60 LOCATE 1, 10
70 PRINT "You have a serious case of
shaky-sightitis!"
80 WHILE 1:WEND
```

Putting a **!** at the start of the name of a file when saving or loading suppresses all those boring **FOUND** Block cassette loading messages.

The simplest way to change the graphics pen colour on a 464 is **CALL &BBDE, x, x, x** where the number of **x**'s is the pen colour. So for graphics pen 5, **CALL &BBDE, 5, 4, 7, 3, 2** would do the trick. **CALL &BBE4** for changing the graphics paper colour.

Oh, and did you know that you get a free Magnum light gun with a Spectrum +2 from Tandy's for £149? You don't get one with a new CPC. Send all complaints to: Alan Sugar, Amstrad PLC, 169 Kings Road, Brentwood, Essex.

Shabaz Yousaf, Slough

*Thank you for those words of wisdom, Shabaz. If Mr Sugar's lawyers could direct all writs and so on to Shabaz rather the AA offices we'd be very grateful!*

### ● Too big for its bootsectors

I have an Amstrad 6128 and a *Multiface II+*, and I've been having problems copying games from tape to disk. On tape the game uses three blocks of unprotected Basic, followed by 13 blocks of unprotected binary code. I can get all this onto a disk and it uses 29K of space. Trouble is, I can't run it without getting an error message: **Improper argument, Memory full or Bad command**. What am I doing wrong?

If I use the *Multiface*, then I get a working disk game but it uses 46K of space. Is there a way to compress *Multiface* files?

W R Blunt

### ● To finish with a fresh SCART

I now have, at last, a good picture on my television from the CPC via a SCART socket.

It's been a struggle, but herewith is the final, correct wiring diagram.

Only problem is that the colours are a bit dull. Can you comment, or should I leave well alone? Incidentally the problem with the letters AV on the screen has solved itself.

Once the TV receives a decent signal on the SCART input the letters disappear after a few seconds.

John D Copley,  
Rickmansworth

*Thanks John. You do, I take it, have the matching resistors, of about 56 Ohms, connected between the colour signals: red-red, blue-blue etc?*

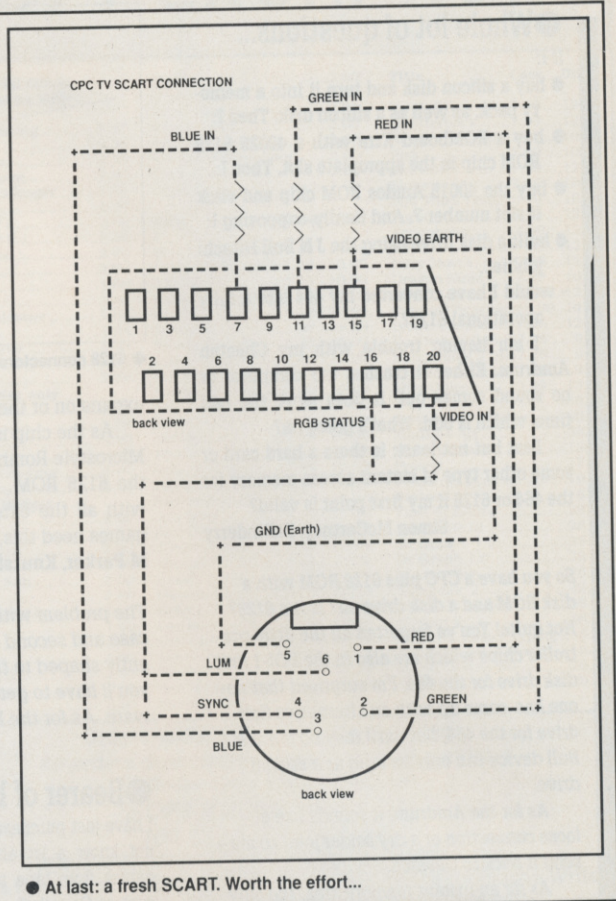

Drive A: user 0

GAME	.BIN	1K	GAMES
GAME1	.BIN	16K	GAME6
GAME2	.BIN	14K	GAME7
GAME3	.BIN	5K	GAME8
GAME4	.BIN	4K	

70K free

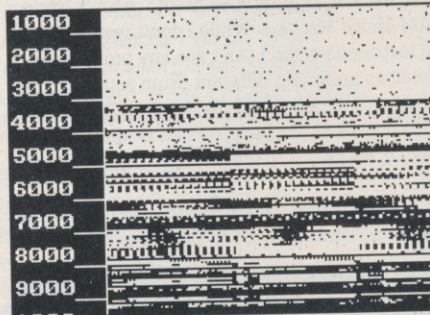

● A game may take up something like 40K on a memory map (shown above in the memory map) ... but much more on a *Multiface* disk (CATted, top). It ought to be possible to compress *Multiface* files - any takers?

Tape games are quite often tape only, in that they won't run from a disk drive without some modification. As for compressing *Multiface* files, it's almost certainly possible - any listings (M/C if poss)? Otherwise I'm afraid it's either learn to program machine code, or buy lots of disks. Or invest in a large capacity second drive.

### Write now, make £££s, open Bank Holidays!

*Forum* is designed to do the jobs previously done by *Words Work*, *Hot Tips* and *Problem Attic*, which always overlapped to some extent anyway. It will be as big as you want it to be - depending on your reaction and the number and quality of letters we receive.

To encourage you we're giving away £40 each and every month to the writers of the hottest tips and the best questions. So if you have a problem, or a solution, get it in writing now. Send it to: *Forum*, AA, 4 Queen St, Bath BA1 1EJ.

We're very sorry but we simply haven't the time to reply personally to your letters: so no SAEs please!



# The Game Creator



## Blow the Lid off your Micro!

The highly acclaimed program creator now gets even better!

Pandora has been greeted as a breakthrough in program development. It was specially written to drive the CPC's unique features to the limits, and now incorporates many new functions suggested by enthusiastic owners.

Here are some of the power-packed features from version 1.00

- Uses simple Basic commands
- Needs no knowledge of assembler
- Up to 48 standard or animated sprites
- Automatic animation and movement of sprites
- Super fast multi-featured sprite editor
- Compiles to stand-alone programs
- Can compile to memory for quick debugging
- Works with Basic or all wordprocessors that produce Ascii files
- Can compile directly from Protex text menu
- Extensive graphics and sound facilities
- Comprehensive manual with examples
- Several demonstrations and working games included
- You can sell programs written with Pandora

But that's just for starters. Remember that Pandora is unique in that it has the features YOU want. At the request of many delighted owners, the latest version is now supplied with the following extras:

- Local variables
- Facility to call machine code routines
- Load files anywhere in memory
- Load and save sound envelopes
- Hex constants supported
- Simple use of logical operators
- Nested "FOR NEXT" loops
- Even more flexible sprite editor

Because Pandora is evolving all the time, we'll keep you up to date with enhancements, and for just £4.95 you'll be able to upgrade to the latest version! Also including the new version 2.00 due out in November and featuring numerous new enhancements.

**Order your copy today and very shortly you'll be writing your own professional games in a fraction of the usual time, and without the fuss.**

### What the Press say

"This could be the start of something big" - New Computer Express, June 1989

"Easy to use sprite editor... Commands which any Basic programmer will understand... Writing your own games on the CPC has never been easier" - Amstrad User Club Newsletter, July 1989.

"You'd be astonished at what you can do with Pandora... The sprite handling offers exciting possibilities to the games writer... Pandora's advantage is its superior flexibility... looks like becoming an important addition to the CPC software catalogue" - Amstrad Action, August 1989.

### ORDER FORM

Please send me the following:

- Pandora Tape £24.95
- Pandora Disc £24.95
- Upgrade from version 1.00 £4.95
- (Enclose your master disc as proof of purchase)

Name.....

Address.....

Postcode.....

Tel.....

I enclose a Cheque / Eurocheque / Postal order made payable to Swift Software.  
Swift Software, 347 London Road, Hazel Grove, Stockport, Cheshire, SK7 6AA.



**£24.95**  
Tape



**£29.95**  
Disc



# AA goes down Wembley way

Back in our "Football Special" issue (AA45) we ran a super competition to celebrate the launch of Audiogenic's *Mastergame*, Emlyn Hughes *International Soccer*. The lucky winners tell it like it was.

**W**e had an inkling that a visit to Wembley to watch Arsenal play Liverpool for the Charity Shield might be a popular prize. And the fact that the winners were to have a special tour of the stadium the day before and get to stay at the exclusive Hilton National overnight could only add to the excitement. (Unfortunately, however, the otherwise lucky winners *did* have to share the weekend with Steve and Trent. Still, every silver lining has a cloud.)

What we weren't prepared for was the sheer number of entries: we're used to receiving hundreds, but this was ridiculous!

Eventually we whittled down the winners to JOHN GORDON of Blackheath in London, and CHRISTIAN HALL of Stetchford in Birmingham. John brought twin James (otherwise he'd never have been forgiven), while Christian's dad made it clear that he would need to accompany his son on the long and arduous journey (so thoughtful of him, don't you think?). Co-ordinating events was Beverley Gardner of Audiogenic, though boss Peter Calver was also around to ensure things ran smoothly.

## Early bath

But rather than us telling you about it, let's hand the rest of the page over to our special reporters John and Christian for the full and uncensored story of What Happened When AA Went to Wembley...

"We arrived at the Hilton," AA reporter John Gordon writes, "at about 2.45pm on the Friday, ready for the tour of Wembley, to be met by Steve and Trenton in the bar" (*I thought I told you not to mention that bit - ed.*). "We all had a drink, which must have been quite expensive, as I saw someone pay by credit card."

"Hello," said Steve, 'the first prize is meeting me.' And the second is meeting him twice, I thought.

"Trenton thought we should wear something with *Amstrad Action* on it, so Steve put-teth his hand into a plastic bag and saith, 'Let

there be *Amstrad Action* T-shirts,' and lo! there were *Amstrad Action* T-shirts. And Steve saith, 'Lo, put them on,' and lo! they were put on.

"We were shown around Wembley and saw a film on its history. Trenton took lots of photos of us. 'That's right, smile. I'm good at taking these photos, aren't I?' he said, with the lens cap of his camera still on."

What John fails to mention is that he and James had previously done the Wembley tour, so whenever the guide, smiling through gritted teeth, launched into another joke routine, the terrible twins stole his punchlines!

"The Wembley guide showed us some old footballers' shirts," writes special AA correspondent Christian Hall, "including Emlyn Hughes' old Liverpool shirt. He also showed us the crossbar Geoff Hurst hit in a famous goal from the 1966 World Cup."

"Going into the changing rooms was best. We even went into the bath, which was empty. It's just as well it was, because it was 5'6"!"

## No match for Liverpool

"The next day we had lunch in a nearby restaurant," John recalls, "and heard a speech by the ex-England player Peter Osgood, and then went on to Wembley to see the match. I entered Wembley with my West Ham supporters kit (scarf, hat, broken bottle, knuckle-dusters), and we took our seats just past the halfway line."

"Before the match the band came on. Personally I think they should have been - banned, that is. The match was good, though I don't why it's called a friendly. The highlight was a Peter Beardsley's goal which I, hating Liverpool, called a 'lucky chance which anyone could have scored.' My brother James, a Liverpool fan, labelled the goal a 'brilliantly controlled masterpiece of a shot.'"

Christian agrees that Liverpool deserved to win: "From the press seats we saw Liverpool dominate the match. Ian Rush put the ball wide of the Arsenal keeper John Lukic, but although we all thought it had gone in the ball hit the post and bounced out into Lukics' arms. Peter Beardsley make no mistake after half an hour. Liverpool were definitely the better team on the day."

"Arsenal were definitely cheated," John claims: "according to an Arsenal fan in front of us who showed us his watch. On it the digital display read 44.48. I'm not saying we could have won," he said, 'but it's unfair the ref not playing the last 12 seconds!'"

Let the last word be John's (it usually is): "I'm relieved the game didn't end in a draw. Both teams would have had to hold the trophy for six months."

"Wouldn't Kenny Dalglish's arms be a bit tired by Christmas?" ●



● Christian, James, John and Damien, AA's guests



● Trent tells his joke



● The teams emerge to the famous Wembley roar



● Steve and Bev muscle in on the attention



● Steve passes the cup to Christian and co

# MODE - ONE

21 Orchard Drive  
Burton-upon-Stather  
Scunthorpe DN15 9EF  
South Humberside.  
☎ 0724 721204

Amstrad  
CPC

Amstrad  
CPC

TITLE	CASS	DISC
Airbourne Ranger.....	10.80	13.95
Afterburner.....	7.40	10.65
A.P.B.....	6.90	10.50
Bloodwych.....	6.90	10.50
Butcher Hill.....	7.40	10.65
Batman the Movie.....	7.40	10.65
Beach Volley.....	7.40	10.65
Crazy Cars II.....	6.90	10.65
Double Dragon.....	NR	
Dragon Ninja.....	7.40	10.65
Dark Fusion.....	6.90	10.65
Echelon.....	10.50	12.99
Emlyn Hughes Soccer.....	7.40	10.65
Forgotten Worlds.....	7.40	10.65
Fist N Throttles.....	9.00	12.99
Fernandez Must Die.....	6.50	9.99
Gunship.....	9.80	13.95
Game Over II (+1).....	6.80	10.50
Guerrilla War.....	6.80	10.50
Gilbert.....	6.90	10.50
Gemin Wing.....	6.90	10.50
H.A.T.E.....	6.90	10.65
High Steel.....	6.90	10.50
H.K. Machine.....	6.90	10.65
Heatwave.....	6.90	12.95
Indiana Jones.....	7.40	10.65
Jaws.....	6.90	10.50
Licence to Kill.....	6.90	10.50
Lone Wolf.....	NR	
Navy Moves.....	6.90	10.50
New Zealand Story.....	NR	
Obilator.....	7.40	10.65
Operation Wolf.....	7.40	10.65
Purple Saturn Day.....	7.40	10.65
Pacland.....	6.90	10.65
Paranoia Complex.....	NR	
Running Man.....	7.40	10.65
Run the Gauntlet.....	7.40	10.65
Robocop.....	7.40	10.65
R-Type.....	6.90	10.50
Renegade III.....	7.40	10.65
Red Heat.....	7.40	10.65
Rick Dangerous.....	6.90	10.50
Rock Star.....	7.40	10.65
Rainbow Island.....	NR	

TITLE	CASS	DISC
Silkworm.....	6.90	10.65
Special Action.....	9.25	12.95
Super Scramble.....	6.90	10.50
Skweek.....	7.40	10.65
Stormlord.....	7.40	10.65
Thunderblade.....	7.40	10.65
Typhoon.....	6.25	9.99
Treble Champions.....	7.40	10.65
Titan.....	7.40	10.65
Timescanner.....	7.40	10.65
Thunderbirds.....	9.90	10.50
Vindicators.....	6.90	10.65
Vigliante.....	6.90	10.65
Wanderer (-3D Specs).....	7.40	10.65
Wec Le Mans.....	6.90	10.65
Xybots.....	6.90	10.50
4 Soccer Simulators.....	6.90	10.65
3D Pool.....	6.90	10.50

### \*BUDGETS CASS ONLY\* \*RRP \*OUR\*

ATV Simulator.....	2.99	2.60
Bigfoot.....	2.99	2.60
BMX Freestyle.....	2.99	2.60
Chuckie Egg (I or II).....	3.99	3.80
Commando.....	2.99	2.60
Crazy Cars.....	2.99	2.60
Dan Dare II.....	2.99	2.60
Death Stalker.....	2.99	2.60
Eagles Nest.....	1.99	1.75
Footballer of Year.....	2.99	2.60
Gauntlett I (or II).....	2.99	2.60
Ghostbusters.....	1.99	1.75
Glider Rider.....	1.99	1.75
Grand Prix (I or II).....	2.99	2.60
International Rugby.....	2.99	2.60
Mooncresta.....	1.99	1.75
Protector.....	2.99	2.60
Roadrunner.....	2.99	2.60
SAS Combat.....	2.99	2.60
Spook.....	2.99	2.60
Treasure I. Dizzy.....	2.99	2.60
Who Dares Wins II.....	1.99	1.75
Yabba Dabba Doo.....	1.99	1.75

We cannot possibly list everything we stock here. So if it's not listed, it doesn't mean we haven't got it! New releases sent on the day of release.

All our prices include P&P & VAT, in England, Scotland, Wales & N. Ireland.  
Ire & Europe add £1.20 per item.  
Rest of world add £3.00 per item.  
NR = New Release - phone for availability.

Please make cheques or postal orders payable to "MODE ONE"

## STRATEGY SOFTWARE

Strategy games for the Amstrad CPC

**THE FINAL CONFLICT** - the game is a conflict between Nato and the Warsaw Pact in Europe. Options are either two player or solitaire against the computer, 25 different countries involved, over 160 units, infantry, corps, parachute, armoured, cities helicopters, different strengths, effects, supplies, fuel, casualties status, different seasons, city production levels, millions of troops involved, game lasts for weeks, save game, 18 page manual plus more.

**SOCCER 6128** - football strategy game which lets you manage any team in the 4 divisions. Options are buy players, sell players, league programme, fixtures, opposition, play match, instructions, league table, accounts, playing staff, save game, 10 different positions, skill, form, goal scorers, injuries, up to 20 players in squad, sackings, over 2000 players, 80 English clubs, 80 European clubs, FA Cup, League Cup, European Cup, UEFA Cup, Cup Winners Cup plus much more. Reviewed in AMSTRAD ACTION July '88. (For 6128 only, on disk only).

**KURSK** the clash of armour - was the biggest tank battle of WW2 in which the Germans had to beat the Soviet army to stand any chance of winning the war. The options are two player or solitaire against the computer. There are over 125 units which are infantry, armoured, corps, artillery, anti tank plus cities which all have different effects in combat. There are also supplies like troops, provisions and fuel. The object of the game is to capture the key cities or destroy enemy units. Also save game plus much more.

**SOFTWARE HIRE CLUB** - we hire out top game titles of strategy and simulation games for the Amstrad CPC. Send a large S.A.E for details. Disk not available for 464 disk drives. When ordering state which machine.

Title	disk	tape
THE FINAL CONFLICT.....	£8.00	£7.00
SOCCER 6128.....	£8.00	-
KURSK the clash of armour.....	£8.00	£7.00

Cheques or Postal orders Payable to STRATEGY SOFTWARE  
Send to - STRATEGY SOFTWARE, 32 Albert Street, Seaham, Co Durham SR7 7LJ.

## DISCBASE

The only fast disc-file organizer for CPC machines...  
"99% of disc users will find DISCBASE indispensable" AA Apr 89

DISCBASE is a specialised database for keeping track of your disc collection and the files on them.

To build up your database, simply insert each of your discs in turn and the program automatically reads them. Then you can search to find any file in UNDER 1 SECOND!

- ★ Flick through discs as CATs
- ★ Comprehensive file and disc lists
- ★ Automatic disc update
- ★ Hard copy of lists or CATs

Rrp £11.95. P&P UK free, please add £1 for Europe, £2 for Rest of World.

## GREYHOUND SOFTWARE (AA)

Kennel Cott, Hockley Lane, Wingerworth, CHESTERFIELD S42 6QQ  
Telephone enquiries: 0246 235233 Mon-Sat 6pm-8pm

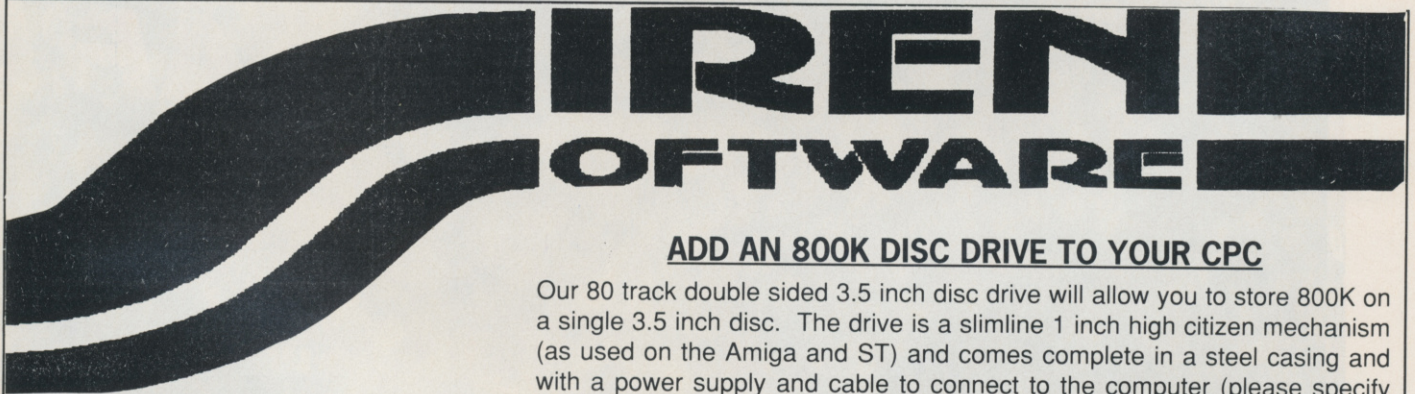

### ADD AN 800K DISC DRIVE TO YOUR CPC

Our 80 track double sided 3.5 inch disc drive will allow you to store 800K on a single 3.5 inch disc. The drive is a slimline 1 inch high citizen mechanism (as used on the Amiga and ST) and comes complete in a steel casing and with a power supply and cable to connect to the computer (please specify 464/664/6128). We have three different software packages that complete the system, RAMDOS & ROMDOS by KDS software (ROMDOS is a ROM version of RAMDOS) or RODOS by ROMANTIC ROBOT. 464 owners not already own a first drive and interface before they can use our drive.

### NEW LOW PRICES! SAVE £15.00 ON ALL DRIVES

Disc drive with RAMDOS.....	£109.99
Disc drive with ROMDOS.....	£119.99
Disc drive with RODOS.....	£119.99
Blank 3.5 inch disc.....	£1.00
ROMBOARD (holds 6 ROMS).....	£24.99

All prices include VAT and postage

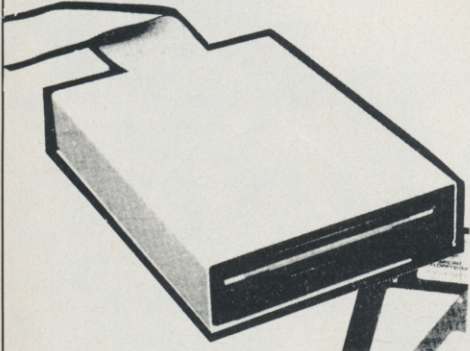

TELEPHONE  
061 228 1831



84-86 PRINCESS ST. MANCHESTER M1 6NG.

# The Amstrad Action fourth birthday competition!

COMPETITION CO



Regular readers will need no reminding that we like to celebrate our birthdays with rather more than a novelty card and a bowl of jelly and custard. And what better way than with the world's biggest CPC competition?

It seemed such a good idea at the time, as most ideas that turn out to be rotten ideas do. "Look," said Steve, "we're going to have a mega-competition, aren't we?" "Yes, Oh Mighty One With The Power To Make

Our Life Hell," chorused Pat and Trenton. "So we want to give a way thousands of pounds worth of CPC goodies, don't we?" "Yes, Your Deliciousness," they dutifully replied. "Well, why don't we get all the stuff in, so we can photograph it and show the good people what they're getting?" "Er... but..." "But me no buts - just do it!"

46 phone calls and two weeks later and no-one can even get into the AA office, let alone attempt to sort the stuff out. "WHY DIDN'T ANYONE HAVE THE INTELLIGENCE TO POINT OUT THAT WE HAVEN'T ROOM IN THIS OFFICE?" bellowed Steve. "Er... sorry boss," muttered Pat and Trenton, risking only the tiniest of tuts at this latest example of editorial incompetence. You know what he's like when he's in the wrong.

## Securicor cares!

Hence the call to those nice (but not soft, no not for a moment soft) people at Securicor. They agreed to hold the stuff until ten lucky and one *extremely* lucky prize winners take all the assorted hardware, serious and games software off our hands.

Just look at all this kit - a Star printer, a Siren 3.5 inch disk drive, the entire *Protex* collection on ROM, just about all of Database's wide range of CPC software, not to mention great items from Datel, Seven Stars and many others (plus, of course, 200 odd brilliant games)... the list is just about endless. You wouldn't believe how much it hurts us to have to hand over all this beautiful bounty without us getting even a teeny weeny bit of it!

Thanks to Securicor Ltd and in particular to their guards Mike and Eddie



# EDUCATION

**FREE** Catalogue Amstrad CPC, PCW, PC1512, Commodore, BBC, IBM PC  
 Amstrad PCW - Business Software, School Admin. PC. 24 Hr. Visa/Access Hotline. Ring UK 010353-614977 (Office Hours) (Irl. 061-27994) 010 353-6145399 (UK 24 Hr.)

**MAXI-MATHS**  
 Amstrad PC, IBM PC, Amstrad 464, 664, 6128.  
 1. Triangles, 2. Angles, 3. Sin Cos Tan, 4. Rectangles, 5. Circles.  
 A highly interactive program such as Basic Geometry provides a very stimulating learning environment.

**MAGIC MATHS (age 4-8)**  
 CBM 64, All Amstrads, IBM PC  
 Additions and Subtraction. "A serious challenger to similar BBC programs and a good example of its type." Primary Teaching and Micros UK.

**MATHS MANIA (age 8-12)**  
 All Amstrad/CBM 64/IBM PC  
 Multiplication and Division. "It appeals to the age group. My son has been sneaking downstairs before breakfast to play." BBC CEEFAX review.

**BETTER SPELLING (age 8-adult)**  
 All Amstrads/CBM 64/BBC/IBM PC  
 "Well Organised Lessons. Educationally it is very strong." 8000 Plus.

**BETTER MATHS (age 12-16)**  
 All Amstrads/CBM 64/BBC/IBM PC  
 Rated in the top five in Amstrad Action educational survey.

**CHEMISTRY (age 12-16)**  
 All Amstrads/CBM 64/BBC/IBM PC  
 Very ambitious in terms of the range of topics. High standard of questions." 8000 Plus.

**BIOLOGY (age 12-16)**  
 All Amstrads/CBM 64/BBC/IBM PC  
 "A very good excuse to play with your computer and have fun while revising." Your Computer.

Mapwork Quiz (9-Adult) CPC, BBC, CBM 64

The Three Bears (5-10) CPC & PC

Physics (12-16) CPC/PCW/PC

School Administration PC1512/IBM

CPC & PCW DISKS £16.95

PC DISKS £22.95

CASSETTES £10.95

Send Cheque Visa/Access/and Exp. Date (£1.00 P&P)

School Software

Tait Business Centre, Dept A, Dominick Street, Limerick, Ireland

Tel: (UK) 010-353-61 49477 (IRL) 061-27994



**MATHS MANIA**



**Biology 1**



**SCHOOL SOFTWARE**

**BETTER SPELLING**



**Physics 1**



**SCHOOL SOFTWARE**

**MAGIC MATHS**



**CHEER UP!**  
 we've got you covered!

Now for CPC range **£8.95**



Patent pending and Registered Design

**SEAL 'n TYPE**™

- \* Protective keyboard cover through which you can type.
- \* 24hr dust/spill cover
- \* Removable, washable, re-usable.
- \* Can be custom-made for any keyboard. Ring for details

Ring or Write for our FREE catalogue

- Re-inking Service ..... £1.90
- Ring for transporter SAE
- DMP re-inking kit ..... £10.00
- VDU Screen (Colour/Mono) ..... £14.50
- Mouse Mat ..... £5.95
- Dust Cover (Col/Mono) £7.50
- Plonker Box ..... £2.30
- Dextette Copy Holder A4 ..... £8.50 A3 ..... £10.00
- Surge Protectors ..... £12.00
- Acoustic Boxes ..... £38.95

All prices exclude VAT  
 Cheques/P.O. payable to:  
**KADOR**  
 Unit 4  
 Pontcynon Industrial Estate  
 Abercynon  
 Mid Glamorgan CF45 4EP  
 Tel: 0443 740281  
 Computer Accessories Manufacturer



## ONLY POOLS AND HORSES

- The **ONLY** pools program written by a **GENUINE EXPERT** who has been professionally employed as such by the leading pools company. **HE KNOWS HOW TO IMPROVE YOUR CHANCES.**
- The **ONLY** program dealing with football form that has its team merit ratings published in a national sporting magazine.
- The **ONLY** program that uses machine code and advanced statistical methods to analyse football form. Lists homes, aways and draws in order of merit and gives true odds for every match. Covers league & non-league clubs
- The **ONLY** program to claim **50% MORE DRAWS** than obtained by chance.

**BOXFORM & HANDICAP WINNER** £14.95 (+ £2 for 3" disc)  
 Two programs for the price of one. Easy to use and they never go out of date. All you need is a few minutes with a daily paper. **BOXFORM** weighs up a race by considering the many facets of form. Easily amended to suit the user's ideas. **HANDICAP WINNER** shows the value for money bets. **OVER 700 WINNERS** in handicaps this year at prices up to 25/1.

**RACING TOOL KIT** £49.95 tape or disc  
 A package of 7 programs for the racing enthusiast. **BOXFORM & HANDICAP WINNER** plus programs to produce ratings and time figures, update private handicaps or form your own, keep records, work out almost any bet etc. etc.  
 Why pay inflated prices? **BOXOFT CLEVER** and get the **BEST**  
 Available on tape or disc for SPECTRUM, CMD C64/128, AMS CPC's, BBC B. from:  
**BOXOFT (AA), 65 Allans Meadow**  
**Neston, South Wirral. L64 9SQ**  
 Credit card holders may phone : 051-336-2668 (24 hours)



# Escroe plc

11 Mundells Court,  
 Welwyn Garden City,  
 Herts, AL7 1EN, England

Telephone UK: (0707) 334460 Intl: (44) 707 334460

DISKS, DISKS AND MORE DISKS AT TRADE PRICES  
 DIRECT TO THE PUBLIC AND COME COMPLETE  
 WITH USER SETS AND ENVELOPES. **LIFETIME  
 GUARANTEE.**

PRICES INCLUDE POSTAGE, PACKING AND V.A.T.

PAYMENT, CHEQUE OR ACCESS



ORDERS WELCOME FROM GOVERNMENT,  
 LOCAL AUTHORITY, EDUCATIONAL &  
 CORPORATES

BULK	2 80'	D/S CF2	D/S CF200	D/S 3.50	D/S880 3.50	HD 3.50	D/S96 5.25	HD 5.25	S/S 8.00	D/S 8.00	BULK	BULK
10	NOT	21.85	29.90	7.95	8.95	23.00	N/A	N/A	23.00	24.00	10	BULK
25	AVAILABLE	51.75	66.13	20.00	22.00	50.00	11.50	23.00	51.75	54.00	25	BULK
50	IN	97.75	130.00	*35.00	*40.00	*90.00	*17.25	*44.00	97.75	102.75	50	BULK
100	BULK	184.00	245.00	*68.00	*78.00	*180.00	*28.75	*70.00	184.00	194.00	100	BULK
250	FORM	430.00	600.00	140.00	165.00	375.00	68.00	170.00	430.00	455.00	250	BULK
500	FORM	850.00	1100.00	285.00	315.00	740.00	115.00	330.00	850.00	900.00	500	BULK
ALL MIMIC DISKS ARE PREFORMATTED TO ENSURE PERFECT PERFORMANCE												
2 80'	D/S CF2	D/S500 CF200	D/S500 3.50	D/S880 3.50	HD 3.50	D/S96 5.25	DS HD 5.25	S/S 8.00	D/S 8.00			
IN PLASTIC CASES												
10	**24.15	**24.15	**32.20	8.95	11.50	25.00	5.75	11.50	25.00	27.00	10	MIMIC
20	**47.00	**47.00	**82.00	17.00	21.00	48.00	11.00	23.00	39.10	41.10	20	MIMIC
40	**92.00	**92.00	**120.00	33.00	40.00	94.00	21.00	44.00	73.80	81.80	40	MIMIC
80	**182.00	**182.00	**230.00	64.00	72.00	185.00	41.00	85.00	138.00	154.00	80	MIMIC
100	**220.00	**220.00	**275.00	77.00	85.00	225.00	50.00	100.00	165.00	185.00	100	MIMIC
2 80'	CF2	CF200	CF200	CF200	CF200	CF200	CF200	CF200	CF200	CF200		
	3.00	3.00	3.50	3.50	3.50	5.25	5.25	8.00'	8.00'			
5 95	5.95	5.95	3.95	3.95	3.95	3.95	3.95	17.95	17.95			
10	MABEL	MARBY	MARBY	SOBY	SOBY	SOBY	MABEL	MABEL	VERBYN	VERBYN		
	CF2	CF2	CF200	CF200	CF200	CF200	CF200	CF200	CF200	CF200		
	24.15	24.15	48.00	16.50	16.50	38.00	9.50	18.50	25.00	26.00	10	
20	47.00	47.00	90.00	28.00	28.00	75.00	18.00	36.00	49.00	50.00	20	
40	92.00	92.00	175.00	50.00	50.00	148.00	35.00	70.00	94.00	95.00	40	
80	182.00	182.00	345.00	96.00	96.00	290.00	68.00	135.00	178.00	180.00	80	
100	220.00	220.00	425.00	105.00	105.00	350.00	84.00	180.00	215.00	220.00	100	
	MABEL	MARBY	MARBY	SOBY	SOBY	SOBY	MABEL	MABEL	VERBYN	VERBYN		

So, how did we go about selecting all these scrumptious prizes? Well, it was clear from the beginning that what we wanted was the very best in each category. We also wanted to publicise the vast amount of equipment, hardware and software, serious applications, education and games, utilities and peripherals, available for the CPC. And remember, many of these items are available exclusively for the Amstrad CPC.

We had no hesitation in deciding what printer to go for. The Star LC10 colour we gave away in last Christmas' issue of AA attracted a huge response, and we were convinced that at the price it cannot be beaten. *Qualitas Plus*, just released in Version 2, gives it that extra edge of elegance and choice.

And Siren Software's 800K 3.5 inch disk drive has a long and distinguished record as a hard wearing and reliable item.

Similarly in the word processing department we had no hesitation in choosing *Protex*. It's what we use here at AA, so perhaps it has an unfair advantage (but then, we chose it in the first place because we thought it was the best). And if you're talking absolute luxury you're talking the entire *Protex* suite on ROM. So that's that sorted!

DTP on your CPC? Easy: *Stop Press*, simply the best there is. Not cheap at £90 including mouse, but then on this particular occasion we knew we had to

have the best – and besides, you can sometimes find it at less than list price.

And as for games... well, we knew the people we definitely wanted to talk to. Incentive, of course, for their superb *Freescapes*, *Driller*, *Dark Side*, *Total Eclipse* and *Total Eclipse II*, *Sphinx Jinx*. And we definitely wanted Ocean's *Renegade* trilogy, as well as something from Electronic Arts, Activision, US Gold and Hewson – all of



**PROTEXT**  
WORD PROCESSOR

## Those ten runner-up prizes in full...

Crkey oh Reilly!

1 Amstrad (Virgin/Mastertronic) Magnum lightgun  
*Fun School II* (Database) ● *Arctic Fox* (Electronic Arts) ● *Cybernoid* (Hewson) ● *Cybernoid II* (Hewson) ● *Stormlord* (Hewson) ● *Exolon* (Hewson) ● *Total Eclipse* (Incentive) ● *Total Eclipse II*, *Sphinx Jinx* (Incentive) ● *Lancelot* (Level 9) ● *Time and Magik Trilogy* (Level 9) ● *Silkworm* (Virgin) ● *Time Scanner* (Activision) ● *Renegade* (Ocean) ● *Renegade II* (Ocean) ● *Renegade III* (Ocean) ● *Anarchy* (Rack-It/Hewson) ● *Gauntlet II* (Kixx) ● *Real Ghostbusters* (Activision) ● *Zynaps* (Hewson) ● *Impossaball* (Hewson) ● *Bards Tale* (Electronic Arts)

... and last but certainly not least, a year's subscription to AA, a binder to put them in and an AA T-shirt to wear while you read them.

# HOW WOULD THIS LITTLE LOT SUIT YOU?

Here's a complete check list of what one lucky reader will soon be receiving. At current retail recommended prices, the value of the prize is close on £1,000 – and that's *without* the more than 20 games we've gathered together too, which themselves must be worth some £200.

*Note: Future Publishing Ltd, the publishers of AA, cannot be held responsible for any building work that may be needed to strengthen or expand your house to contain all the following equipment.*

- 1 LC-10 Star colour printer (Star: recommended retail price, £299)
- 1 Siren 800K 3.5" second disk drive (£119.95)
- 1 *Qualitas Plus* Version 2 (Seven Stars, £14.95)
- 1 *Mini Office II* (Database, £21.95)
- 1 *Stop Press* (Database, £79.99)
- 1 *Stop Press Utilities* (Database, £19.95)
- 1 *MAX* (Database, £19.99)
- 1 *Fun School II* (Database, £12.95)
- The *Arnor Protex* collection –
  - Protex* on ROM (£39.95)
  - Promerge* on ROM (£34.95)
  - Prospell* on ROM (£39.95)
- ... and of course a ROMBO ROM box to hold all these wonderful ROM goodies! (£34.95)
- Utopia* on ROM (£29.95)
- Thompson Computers *Mailmerge* tutorial (disk, £9.95)
- MAXAM* version 1.5 on ROM (£29.95)
- The RAM Music Machine (Datel, £59.99)

Soundblaster, including Harvard stereo speakers and Boxer stereo headphone equipment

- (Siren, £34.99)
  - 1 Amstrad (Virgin/Mastertronic) Magnum lightgun (£34.95)
  - Arctic Fox* (Electronic Arts)
  - Cybernoid* (Hewson)
  - Cybernoid II* (Hewson)
  - Stormlord* (Hewson)
  - Exolon* (Hewson)
  - Dark Side* (Incentive)
  - Driller* (Incentive)
  - Total Eclipse* (Incentive)
  - Total Eclipse II*, *Sphinx Jinx* (Incentive)
  - Lancelot* (Level 9)
  - Time and Magik Trilogy* (Level 9)
  - Silkworm* (Virgin)
  - Time Scanner* (Activision)
  - Renegade* (Ocean)
  - Renegade II* (Ocean)
  - Renegade III* (Ocean)
  - Anarchy* (Rack-It/Hewson)
  - Gauntlet II* (Kixx)
  - Real Ghostbusters* (Activision)
  - Zynaps* (Hewson)
  - Impossaball* (Hewson)
  - Bards Tale* (Electronic Arts)
  - ... and last but certainly not least, a year's subscription to AA, a binder to put them in and an AA T-shirt to wear while you read them.
- That should be enough to be going on with!

whom were very keen indeed to get involved. "Amstrad Action is the CPC magazine, and we want to do anything we can to help you celebrate your fourth birthday!" was how just one of them put it.



So we took them at their word – and helped ourselves to more than 200 games! Trenton was posted on the door of the AA office to frisk anyone leaving (that gave him some pleasure, I can assure you!).

The rest, dear readers, is up to you. You've got to be in it to win it, so turn over immediately and get cracking. You have nothing to lose but your desk space! ●

● *Note: some of the software listed among these prizes is provided on cassette and some on disk. Also, some items work best, and one or two work only, on a 6128 or 464/664 with 64K memory upgrade.*



And now, the moment you've all been waiting for. Ladies and gentlemen won't you give a big hand please for...

# THE AA FOURTH BIRTHDAY COMPETITION ENTRY FORM!

This competition has three parts. Answer them all correctly and you will WIN in the great *Amstrad Action* birthday celebration.

**PART ONE:** Tick one of the following boxes:

- YES I really do want to get the most out of my CPC. I realise its potential is much underrated, and that this competition gives me the once-in-a-lifetime opportunity to tool up my Amstrad so it can really do its stuff.
- No I'm not really interested in the CPC in fact I was thinking of selling it except I couldn't find a pen to write the advert I mean it's not as if it is a very good computer really is it I mean it's not as if you can do word processing and play games on it is there anything on the telly I'm really bored (and boring)?

Did you tick the *first* of these two boxes?  
Congratulations! You're already well on the way to winning one of the ten runners up prizes in our fourth birthday competition, and you could even win first prize!

**PART TWO:** OK now, keep calm, keep calm, don't let the nerves get to you. You're doing fine. Just a few simple answers and you're almost there. What we'd like you to do now is to answer the following questions about the CPC and the companies that supply hardware and software for it.

(a) Which company recently moved into the CPC

market and sells a wide range of CPC peripherals, such as the dk'tronics range, *OCP Advanced Art Studio* and the *RAM Music Machine*? Is it:

- (i) Joe Bloggs Ltd?  
(ii) Arthur Daley Enterprises (Est. 1987)?  
(iii) or is it Datel Electronics?  
(Clue: this company advertises in *Amstrad Action*)

(b) Which large company, based in Manchester, sells the enormously popular *Mini Office II*, as well as the education program *Fun School II*? Is it:

- (i) London Computing Softwear?  
(ii) 16 Bit Only Ltd (sorry, no CPC stuff)?  
(iii) or is it Database Software?

(c) Which of the following is *not* a producer of high quality, exciting games for the CPC?

- (i) Incentive Software  
(ii) US Gold  
(iii) Electronic Arts  
(iv) Hewson  
(v) Audiogenic  
(vi) The Non Playtested Dodgy Games Outfit Co  
(vii) Virgin

(d) And finally (keep calm, keep calm!)... What is the name of Britain's best-selling and only independent magazine for the Amstrad CPC 464, 664 and 6128?

(If you need a clue you probably wouldn't know what to do with the prizes anyway.)

**PART THREE:** Gosh, that was a bit on the tough side, wasn't it? Never mind, you're within sight of your goal. All you have to do now is to complete this sentence in an apt and original way in 15 words or less:

"I would like to win one of the fabulous collections of prizes in the AA fourth birthday competition because \_\_\_\_\_

Finally, cut out this completed entry form (or photocopy it, if you don't want to spoil your copy of *AA*), fill in your name and address and send it to: The AA Fourth Birthday Competition, 4 Queen St, Bath BA1 1EJ to arrive not later than Tuesday, 31st October, 1989. Entries received after that date will be thrown away (except for overseas readers – see box above).

Name: \_\_\_\_\_  
Address: \_\_\_\_\_

Overseas reader (please tick if appropriate – see box above).

## Rules and conditions of entry

- All entries must be submitted by 31st October 1989, except for overseas entrants, for whom two second prize bundles are being held back. These bundles will be awarded as and when the judges decide and there's an end to it.
- No correspondence can be entered into and the judges' decision is final.
- Because of the large number of prizes being awarded Future Publishing can accept no responsibility if the prizes the winners receive do not exactly match their descriptions here. However the organisers do guarantee to make every effort to make sure that winners receive everything to which they're entitled. Honestly though, Steve had a heck of a job sorting all this gear out, especially after Ollie and Stuart had photographed it all and then chucked it back in the boxes any old how. I don't know, these art people...
- All entries become the property of Future Publishing to dispose of as we wish. If you wish to have your entry destroyed after this competition closes you must send a request to this effect with your entry. A condition of entry to the competition is that these rules are accepted.

● We would like to take this opportunity to thank all those companies who responded so quickly and generously in providing us with prizes for this competition: Datel, Star, Arnor, Database, Seven Stars, Siren, Electronic Arts, Hewson, US Gold, Incentive, Virgin, Level 9, Activision and all the others too. (If we've missed you off this list because of lack of space, sorry and it's nothing personal!)

## Overseas readers: this one's for you!

We often get complaints from our loyal readers overseas that by the time they've received their copy of *AA* our competitions have often closed. Unfortunately there's often nothing we can do about that: we know from experience that people in the UK don't much want to see a closing date four months after the issue has gone out, because that means even if they win they won't see their prize for at least five months and possibly longer.

What we've decided to do is to hold back two of the second prize bundles for our overseas readers. So whether you live in Ireland or

Australia, Greece or New Zealand, Spain or Denmark – wherever you live (as long as it's not England, Scotland or Wales!) your entry will go into your own special competition.

We shan't specify a closing date for overseas entries: anticipating the vagaries of international post isn't something we'd care to attempt.

So get your entry in as soon as you possibly can – copy your answers onto an airmail letter if you think it may help (don't forget your name and address!). Good luck, everyone!

# Computer shopping is fun at the Computer Shopper Show!



Yes, for three exciting days in November, Computer Shopper will turn Alexandra Palace into the world's greatest computer show. Everything you need for business and leisure computing will be available under one roof – with experts to help you make the right choice!

The Computer Shopper Show is your chance to meet the dealers with the bargains, the manufacturers with the latest machines – and to take away the things you buy on the day!

Auctions, demonstrations, competitions . . . everything that you've ever wanted from an exhibition will be happening at the Computer Shopper Show – the only show for the direct buyer and the ultimate computer shopping experience!

And, with Computer Shopper you know you'll save money!

Why not start right here! By ordering your tickets in advance you will save £££s! Simply complete and return the coupon with your payment or telephone the Credit Card Hotline on 051-357 2961 to place your order.

## The Computer Shopper Show

Alexandra Palace, London

10am-6pm Friday, November 24

10am-6pm Saturday, November 25

10am-4pm Sunday, November 26

**COMPUTER SHOPPER SHOW '89**  
NOVEMBER 24-26, ALEXANDRA PALACE

### SAVE £££s WHEN YOU BUY OUR TICKETS IN ADVANCE!

Yes! Please send me my tickets for the Computer Shopper Show! £

- Adult tickets at £3 (Save £1!) \_\_\_\_\_  
 Under 16s tickets at £2 (Save £1!) \_\_\_\_\_  
 Family tickets - admits up to 2 adults and 2 children - £9 (Save £5!) \_\_\_\_\_

TOTAL \_\_\_\_\_

I would like to pay by -

- Cheque made payable to Database Exhibitions Ltd  
 Credit card  Access  Visa Expiry Date \_\_\_\_\_

No. \_\_\_\_\_

Signed \_\_\_\_\_

Name \_\_\_\_\_

Address \_\_\_\_\_

Postcode \_\_\_\_\_

Please return your completed order form to -  
 The Computer Shopper Show Ticket Office, Database Exhibitions Ltd, PO Box 2, Ellesmere Port, South Wirral L65 3EA.

A811

- ★ Over 250 stands serving every major make and model – the ultimate computer hypermarket, packed with pre-Christmas bargains and offers.
- ★ Incorporates the Amstrad Computer Show, the Atari Computer Show, the Electron & BBC Micro User Show and much, much more!
- ★ On-site car parking for hundreds of cars – ideal for taking away your computer bargains on the day!
- ★ Excellent public transport network with courtesy coach link to the local British Rail station.
- ★ Special show features and entertainment to make your shopping experience fun!
- ★ Special discount tickets for under 16s and family groups.

Sponsored by **COMPUTER SHOPPER**

Organised by **DATABASE EXHIBITIONS**

Prestel or Microlink

To place your order by Prestel, Key +89, then 614568383. Microlink users should key 72:MAG 001. Please quote your credit card numbers and your full name and address when you place your order.

**TELEPHONE HOTLINE**  
 Place your orders for tickets by calling  
**051-357 2961**

# First edition

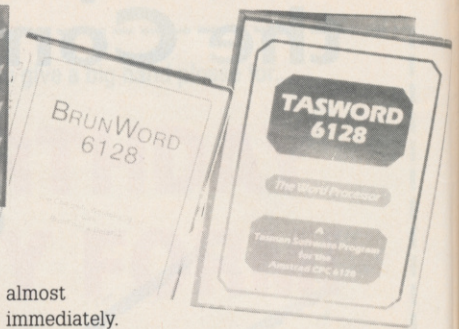

Last month we began a series on using your CPC to create newsletters and fanzines. In this second instalment ADAM PETERS considers the revolution of the word according to Amstrad.

**S**o you've finally decided to get down to it and make a go of that brilliant idea for a publication you've been thinking about last thing every night for the past few months. You were prompted to this bold and brave decision, no doubt, by the story of one fanzine, *House of Dolls*, as revealed exclusively in the first instalment of *First Edition* last month, and by the promise of this series.

The *House of Dolls* gang found that the CPC was quite sufficient to take them from blurred four page photocopied typed effort with a "print run" of less than 50, to a professionally produced and printed high street magazine with a colour cover and a circulation in the thousands. Play your cards right and the same could happen to you!

The first thing you'll need in your publication is a bit of text (ones without words are rarely huge successes). Obviously, if you're planning to do a "comic" style magazine, consisting entirely of picture strips, any words present probably won't have been typed in on

a word processor (which just goes to prove that I can't win).

For the rest of you budding editors, however, here is the *First Edition* guide to choosing a word processor.

## Cheap and cheerful

There are certain features magazine and newsletter editors need in word processors that types who just write "the odd letter" can live without: columns, for a start. Unfortunately, no package provides the best of everything. It's more a matter of selecting the most suitable from those available.

*Mini Office 2* is the best-selling piece of CPC software ever - in fact, across the formats it's just sold its 500,000th copy! It's very cheap and features a number of different business programs. Most CPC owners probably have a copy lying around somewhere already. If you haven't got a word processor, and are considering buying one to start up a magazine, then my advice to the would-be editor-cum-publisher is: *avoid Mini Office 2 like the plague!* Its much vaunted versatility is in fact so limited you will feel the need to upgrade

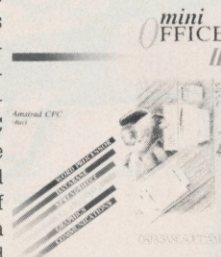

almost immediately.

Let me just point out a few of its many drawbacks. Printer control codes, for one thing, must be entered in full, and are replaced by spaces in the printout. WYSIWIG (= what you see is what you get) it ain't! In other words you can't emphasise, underline, or italicise individual words. Even more annoying is that once you start to enter text, you can't change the ruler length.

When producing magazines, you will occasionally have situations when the width of the text is dependent upon the length; you'll often want text to run around illustrations. With *MO2* these functions could involve retyping whole pieces several times, or pasting together lots of little sections. Aaargh!

Having said that there are some nice features, such as a "real time clock," so you can see at a glance exactly how long you have been slaving away on a particular piece and how long past your deadline you are already (a sobering experience). And perhaps it is useful to have some of the other features, such as the graphics module. The word processor, however, is, I'm afraid, a joke that anyone trying to get out a real publication won't find in the least bit funny.

## If something's worth doing, it's worth copying

Whatever the nature of the publication you're embarking on, you'd better get used to the idea that you'll be "nicking" ideas. Look at last month's cover and you'll see that Trenton (for it is he) as the small magazine editor is doing just that!

This "theft" isn't as sinister as it sounds. Everyone "borrows" from other people. The *House of Dolls* dudes (see *AA* last month), for instance, showed me examples of *Melody Maker* having blatantly stolen their graphic ideas. Yet they themselves admitted that nothing they came up with in the way of graphics, interviewing and writing styles was ever original: "You tend to take ideas from all around you."

"We'll steal ideas from anywhere," as the editor of a CPC magazine based in Bath once remarked to me (*ahem -ed.*).

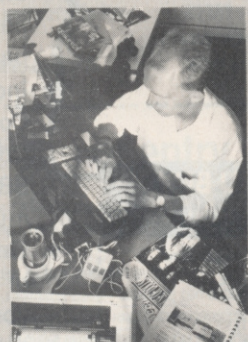

● Our own, our very own, T. Webb demonstrates the gentle art of nicking ideas - it's more common than you think!

There are two main arenas in which you can hunt out "inspiration." The first is those established High Street magazines concerned with the same subject as your fanzine. For a CPC fanzine you should flick through *AA* and see what it contains - news, games reviews, letters pages, type-ins,

a wonderful series on fanzines, and lots of other stuff.

When I say "nicking" things from other mags, that doesn't mean lifting Trent's review of *Silkworm* and sticking it in your own magazine! If you do you'll get all sorts of legal hassles, and I'll get a thick ear from Mr Carey. It's simply the "concept" that you steal.

Games reviews are an important part of *AA*. Maybe you'd like to do some reviews of games you own. For a sports fanzine, look at every part of the sporting press. Reports on sporting events are common, as are interviews with sportspeople. Most minor public figures are happy to spend a few minutes chatting to a spotty little oik, for a magazine with a circulation of six (well, there's no harm trying). For a local magazine, read the local press.

Motto: be shameless.

## Slow on its feet

*Tasword 6128* is a full specification package, but nothing to write home about, or indeed with. The annoying "one word at a time" formatting operation can actually be "turned off," but the speed of all screen functions still falls sadly short of *Protex*. One consolation is that ownership of *Tasword* does open up the whole world of *Tasman* products to you. *Tasprint*, for instance, is a multi-font printout package which can be integrated with *Tasword* (useful in the world of fanzines, where every font counts!).

A complete chart of "in text" functions can be easily accessed, and there is a comprehensive (and unbelievably dull) interactive tutorial file to accompany the manual. There is also a mail-merge facility (absent from 464 version).

*Brunword 6128* has a superb mail-merge utility which enables the computer to deal with the "top" of the letter by itself (it even selects Dear Sir/Dear John as appropriate). Most fanzines aren't likely to find themselves sending out lots of "circulars," except when subscriptions expire. If you've already got your

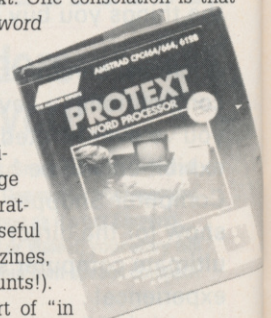

## Revealed! What's inside the ZX Spectrum...

As for *Arnold*, an 8-page (16, 24 and 32 pages are the best sizes for fanzines) imaginary mag dedicated to the CPC, we've gone for: a spoof letters page; a spoof problem page (the easiest concept to write comedy in); an editorial (on the current state of the CPC world); a page of serious ranting (sex and violence in games is not "just harmless fun"); a comic strip (on the back page); a page of hardware/software reviews; a guide to 'What's Inside a ZX Spectrum' (you can work that one out for yourself); and last but not first, if you see what I mean, the front cover (which makes eight).

Having gone on about stealing ideas, it's worth pointing out that these ideas are just "springboards" for your own imagination and originality.

One idea of your own, is worth a dozen borrowed ones. Personally, I've never nicked the merest smidgeon of an idea. Never. Well...

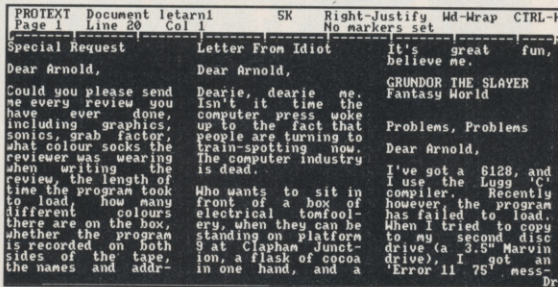

● The letters page from the imaginary *Arnold*: note *Protext* is quite happy coping with columns in CPM+, though when they're this narrow you get some odd "rivers" (bit of publishing jargon for you there, my name's Adam Peters thankyou goodnight)

subscribers stored on *DataFile* (the *Brunword* utility), it's a simple operation to run off some "send us more cash" letters. There are even separate programs for printing addresses onto labels or envelopes. Brilliant!

The spell checker, *BrunSpell*, is also included. It's the fastest, and most "intelligent" spell checker available. A word about spell checkers in general though: they are no substitute for proof-reading. They don't spot punctuation errors, or your/you're style mistakes, which are the most common (and easily made). Also, be warned that the dictionaries supplied are limited (around 30,000 words usually), and tend to reject a lot of perfectly-spelt 'simple' words (*BrunSpell* rejects "hello," for a start!). This often means you waste a lot of time looking up in a "real" dictionary, to check that you are indeed more intelligent than the computer.

### Which wrod (sic) processor?

Whenever word processors are compared in AA, *Protext* always comes out on top, and rightly so. It's the fastest and most comprehensive package available on the CPC. There are none of your fancy menus on *Protext*. All commands are entered in as part of the text, so you can actually change from continuous to single sheet printing (for instance) in the middle of a

document. Quite why you'd want to do something like that I don't know, but it's possible.

A few months back someone wrote to AA, pointing out that they'd said they used *Protext* to do the mag, yet columns weren't possible. In fact, columns are possible on the CPM+ version of the program (as narrow as you want, and as many as you like across the page). The CPM package includes mail-merge and an a-g-o-n-i-s-i-n-g-l-y slow spell checker.

There are though disadvantages to the CPM environment. Files can't be as large as available disk space. Only a small amount of text (around four and a half pages) can be held in memory at any one time, so the program starts making all sorts of limbo files once this size has been exceeded. When you start messing around with columns, the figure drops to just over a page. Unless you have three times the necessary space on the disk, you can get into all sorts of trouble.

A further warning: when you mess around with columns (moving blocks around and so on), it occasionally confuses the computer ("available memory" and all that), and the hugely upsetting message "Fatal Error 10 79" sometimes appears at the top of the screen. I've lived through this unwelcome experience myself a few times, and you'll be relieved to know that all it means is that only half the block (column) was moved into position. It's an easy operation to pick up the remainder, and put it where it should be.

Comparing prices as well as features, *Brunword* almost comes out on top. But the "Box Mode" (column-producing) feature on its own is enough to guarantee the indispensability of *Protext* CPM to the fanzine editor. The £60 price tag is more than a little daunting, of course, and you'd be well advised to check out the ads in your friendly neighbourhood AA before you shell out the full whack. ●

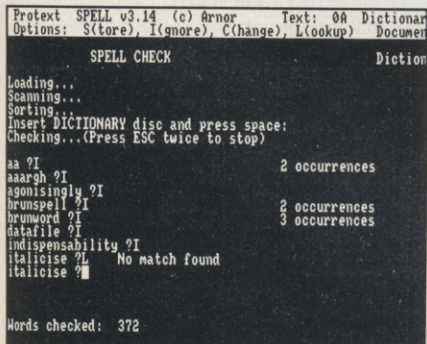

● *Prospell*, the *Protext* spell checker that's even slower than an extremely tired tortoise that's carrying a heavy load and isn't that much of a hurry anyway (don't try to copy Adam Peters' dangerous caption writing technique at home, will you, readers? - ed.)

● Don't miss next month's *First Edition*, in which we consider the role of artwork in your publication

# CREATE AND WIN!

You really shouldn't need any more encouragement than *First Edition* to get cracking with that magazine/newsletter/bulletin or whatever it is you've been driving your friends crackers about for months.

But we thought you might appreciate it if you had an extra teeny, weeny bit of motivation.

So we arranged with Mannesmann Tally, the printer people, to give away their £750 (yes, £750!), 24 pin MT222 printer!

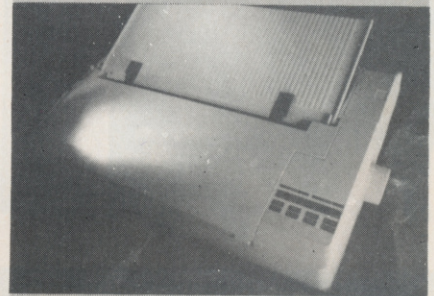

To win this beautiful beast you'll need to do two things:

**THING THE FIRST:** follow *First Edition* every month (this is part two: another three parts to go), and answer the simple question we'll be asking each month.

Last month, for instance, we wanted to know who wrote the series. (Clue: look at the top of the page, under the headline!)

**THING THE SECOND:** following *First Edition* should give you some brilliant ideas for creating your very own publication.

Whatever your interest - sport, the CPC, your local club and so on - there's always room for a witty, incisive and intelligent publication.

Send in yours, whether it's the first issue or the hundred and fifth, and you stand a real chance of picking up The Printer They're All Talking About!

So keep your eyes on *First Edition*, note the answer to each month's question and get ready to send in your entry. Don't rely on us to reprint the questions (but we might if we feel like it)...

## Question two

According to this month's *First Edition*, who was on last month's cover? Was it:

- a) Bros?
- b) An alien from outer space?
- c) or Trenton Webb?

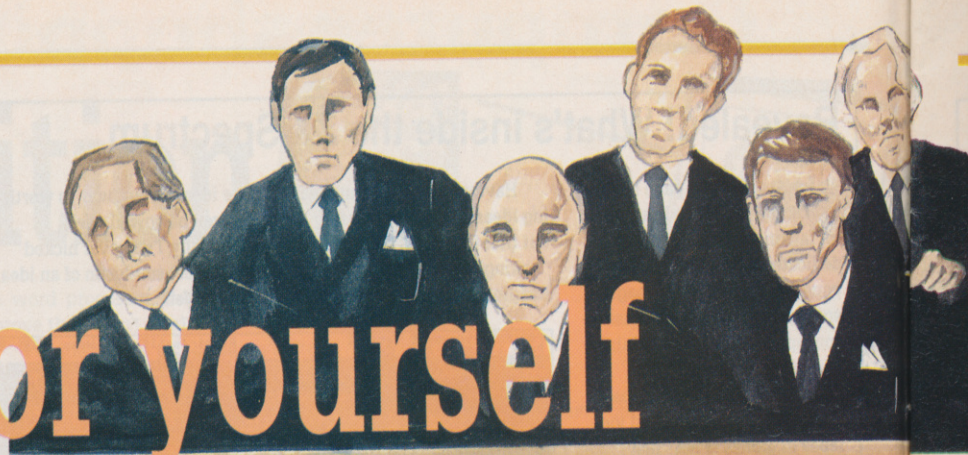

# Judge for yourself

*Day in the Life returns, at last, with Michael S. R. Maxton's finely judged verdict of the CPC's role in court.*

I very much doubt that the number of *Amstrad Action* readers who use the CPC 6128 as I do wouldn't fill the dock in my court - or even overflow from the witness stand! For I use my CPC for crucial judicial tasks. Also, as an author, I find that it can cope with books of 100,000 words.

From an early age I could touch-type at a furious rate, thanks to playing jazz piano, and an Army typing course. I wrote my first book on an IBM Golf Ball typewriter. Naturally, errors and second-thoughts bred like rabbits.

To a moderate perfectionist, avoiding blemishes means either bathing in Tipp-ex fluid or typing a manuscript about five times. I did both. When inexpensive word processors appeared, guess who saw them as a must?

I bought my CPC 6128, knowing nothing of the innovative PCW 8256 - launched a week later as a specialised word processor. I was underwhelmed with satisfaction. But my disappointment vanished with experience. The CPC was fine for me, a user whose limitations the machine has been graciously pleased to overlook.

## Guilty of jargon

I find most of the text of the manuals for my CPC and my software incomprehensible, exquisitely painful and superfluous. I have

read only a fraction. There are probably wonderful facilities of which I do not dream. Yet I have never had to ask the suppliers for help. After my solitary struggles, every new insight

**"I find most of the text of the manuals for my CPC and my software incomprehensible, exquisitely painful and superfluous..."**

into how to operate makes me feel like Christopher Columbus.

I have no interest in the technicalities of computing, or in writing programs. Spreadsheets and databases are a mystery. I don't play games. I have not added any bells and whistles, such as extra memory or a Serbo-Croat dictionary.

I don't use the machine for correspondence as I find it a nuisance to disconnect continuous stationery and to feed in single letterheads.

Therefore, it is a tribute to my CPC that a computer-illiterate like myself can use it successfully for massive word processing. In four years of almost-daily and heavy bashing, my CPC 6128 has been up to every task, without malfunction or breakdown in either the equipment or myself. I have not received any electric shocks. The monitor has never overheated. The keyboard copes with my typing virtuosity. The screen is easy to read.

## Fine sentences

My only complaint is that, exploiting my weakened state in the small hours of the night, the CPC sometimes commits contempt of court by making cheeky or critical comments on my text. But next day, on reflection, I usually agree with them.

For word processing, as distinct from hunting aliens, juggling figures and such trifles, what more can one ask of a computer? It is to the software that one must then look.

*Tasword*, my first word processing program, was user-friendly and coped with large-sized files, but it was slow. I switched to *Protect*. Although it limits the size of files, large amounts of text can easily be split up. The outstanding speed and flexibility of *Protect* make it a pleasure to use.

My set-up includes a Canon PW-1080A dot matrix printer, a reliable work-horse. Its NLQ mode has been found acceptable for manuscripts by more than one publisher.

Word processors excel as tools for organising existing text into a new structure. This is how I use my CPC in judicial work. An example is how I prepare my charge to a jury in a criminal trial. For days or weeks I have to take full notes of testimony about some serious offence such as an assault or a robbery. The official shorthand record is of little help here. The notes accumulate into a mass of detailed, and conflicting evidence. It is a judge's duty to analyse this, to extract the issues, and to present them to the jury for decision, accurately and fairly, with directions in law. Usually the evidence is reviewed overnight to prevent delay in the daily progress of the trial.

## Verdict: the evidence speaks for itself

Drafting the charge to the jury is a two stage process. My first draft includes everything important and relevant in the evidence, in the order in which I noted it. I insert comments, references to legal authorities, intended directions in law and so on. This is easy to compile on a word processor, since it can be changed later.

**"It is a tribute to my CPC that a computer-illiterate like myself can use it successfully for massive word processing. In four years of almost daily and heavy bashing, my CPC 6128 has been up to every task, without malfunction or breakdown in either the equipment or myself..."**

The second stage is to edit and arrange the material for presentation in the most clear and appropriate way. The charge to the jury is not a mere summary of the evidence. It must focus all the questions for their decision, while fulfilling all the legal requirements, including fairness, so that the jury may reach a proper verdict.

The value of a word processor for such tasks is clear. I also use my CPC for other court duties including chamber work. These are personal applications of my own equipment. But courts are now introducing computers for word processing, administration, reference to the law, recording decisions, and other functions.

My CPC 6128 is also fully able to handle the books I write of up to 100,000 words. It often looks smug about the results - one book, pro-



moted in 30 countries and another, published last year, and to be printed for the third time. I constantly expect the screen message, "Could a PCW do better?"

The pleasure of using the machine, and of editing and polishing, does much to overcome the usual writer's inertia on facing a blank sheet - or worse, a roll of blank continuous stationery.

I learned that it was essential to divide chapters into short files for flexibility, to save after every page, to make back-ups each time I switched off, and to use continuous 100 gsm paper for ease of handling.

I have no plans to replace my tried and trusted CPC. Indeed I am just embarking on a

new series of books, and it shows every sign that it will last the course! ●

● That's the judge's story, and he's sticking to it. We'd be delighted to hear from you if your CPC has an equally unusual and exciting life: *Day in the Life* exists to demonstrate the variety of uses to which this versatile and underestimated machine is being put. Send your account of how you use the CPC to run a medium-sized country to: *Day in the Life*, AA, 4 Queen St, Bath BA1 1EJ. The editor is always happy to receive short outlines, in case you don't want to risk writing the whole thing straight off.

PS Oh yes, there's one other thing. We pay you too, handsomely!

# Special Show Offers from Dynamics

## ON CURRENT RANGE OF JOYSTICKS

**New Home Games Starter Pack**  
Competition Pro PC and A/D Games Card and 4 Games. A unique combination of hardware and software in one.

**COMPETITION PRO PC** Joystick in light grey suitable for Atari, Amstrad and Commodore computers. Top selling joystick with arcade quality and reliability, incorporating these amazing features:-

- Super sensitive microswitches - for precision control.
- Dual fire buttons for left or right hand control.
- Firm non-slip base pads.
- Robust steel shaft and rubber return for smooth movement. Go with the Pro!

Special PC Show price **£10.00** RRP £14.95

The Dynamics **A/D GAMES CARD** combined games card and analog/digital changer allows the use of the Competition Pro PC Joysticks or other digital joysticks with IBM-PC, AT, XT and compatible machines and with Schneider Euro PCs.

Buy the **PRO PC JOYSTICK** and **A/D GAMES CARD** in the **DYNAMICS STARTER PACK** and we will include an exciting OCEAN SOFTWARE 4 games selection featuring the best selling ROBOCOP, worth at least £80.00.

Special PC Show price **£40.00** RRP £49.95

Also available at the Show our current range of superb joysticks.

**COMPETITION PRO 5000**  
The top selling arcade quality joystick.

Special PC Show price **£10.00** RRP £14.95

**COMPETITION PRO - EXTRA**

The ultimate in the Competition Pro series.

Special PC Show price **£12.00** RRP £16.49

### A/D GAMES CARD

- Use any good quality digital joystick on your IBM.
- Enjoy a whole new world of 2 joystick games.
- Now with slow motion facility.

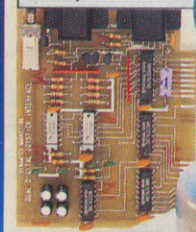

See us on stand **3451** at the PC Show

**SUPERB OCEAN 4 GAME PACK** with **Competition PRO PC** and **A/D GAMES CARD**



**ROBOCOP**  
BRITAIN'S TOP SELLING COMPUTER GAME

**DYNAMICS marketing Ltd**

A British Leader in Joystick manufacturing

COIN HOUSE NEW COIN STREET ROYTON OLDHAM OL2 6JZ ENGLAND  
TELEPHONE: 061 626 7222 TELEX: 669705 COING

**Additional £1.00 off the PC Show Price**  
You can save an additional £1 on these special offers at the PC Show. Cut out this voucher and take it to our stand where we will take £1 off the special show price

- Only one voucher per purchase
- Valid only from 30th Sept to 1st Oct, 1989
- This voucher is valid against the Competition Pro PC and A/D Games card.
- This voucher is not redeemable against cash or other substitutes.

**£1 OFF**

C.V.G. A.A.

# To begin at the beginning

If you've just acquired a CPC, and don't know the first thing about this computing lark, perhaps you should get some nice man to tell you all about it. Step forward Head-Line. TRENTON WEBB explains all.

## THE COMPLETE INTRODUCTION - AMSTRAD 6128

£33.50 disk ● 6128 only  
Head-Line ☎ 0432 271598

Have you ever wanted to be more familiar with your CPC? Do you want to know its most intimate secrets, just what makes it tick? Head-Line Communication would like to introduce you to your 6128. So sit down, say "Hello, CPC" ("Hello, CPC"), and if you're sitting comfortably we'll begin.

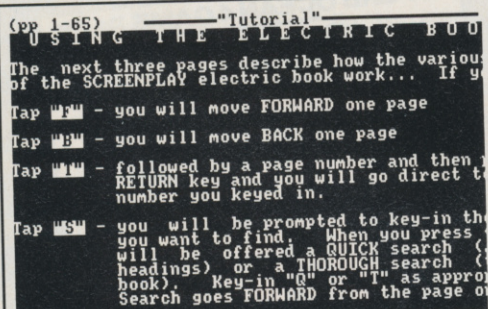

● Assaulting your senses, visual and auditory: a brief taster of *The Complete Introduction*

The package consists of four audio cassette tutorials on two tapes and a work disk which contains exercises and an "electronic book." Using the system disks supplied with your 6128, the aim is to take you from setting the computer up, through to using CP/M.

The whole course has been designed to alleviate "technofear" and introduce the CPC as a powerful processing and computing tool.

So, simply slap the tape in your walkman and do what the nice man tells you. After plugging all your wires into the right holes (yes, it really is that basic!), you're taken through the very fundamental steps of programming in basic.

This is not intended to tell you how to pro-

gram, but familiarise you with the terms and concept involved.

### Delving deeper

After a headlong rush at Basic, the tutorial now changes tack and goes straight for the CP/M jugular. In no time at all you've started up CP/M Plus, digested the marvels of an operating system and are ready for some *real* action.

The rest of the first tutorial is used to make you comfortable moving around this strange new world that your CPC has entered. DIR commands, switching drives, filenames and resetting are all covered, but the most rewarding part is using DISCKIT and actually creating something.

Tutorial two delves deeper into CP/M with exercises in which you chop and change the system disk backup created in Lesson one. EDIT, SHOW, even SUBMIT are all dealt with in a clear and informative manner, leaving the student relaxed with CP/M but aware that there are many more secrets to be discovered. Rather than plough ahead though, the operating system is dropped and you are plunged back into Basic.

This time you flick through the "Electronic Book" supplied on the other side of the tutorial disk. This is dull stuff indeed, with the narrator talking at you and you flipping screens following the onscreen text.

In tutorial three, things start to go awry. Everything starts nicely with some more exercises in CP/M. Then, as an example of some applications and programs, you are taken into a spreadsheet. Nothing wrong with that: this is after all a complete introduction to the 6128, and spreadsheets are an important and useful application.

However, this general introduction soon turns into a precise guide of how to work this particular spreadsheet. All this is very informative, but not much use when you're up to your neck *Supercalc II*, which follows the same principals but a totally different operating procedure.

### Falling between two stools

The same problem occurs in the fourth tutorial, where you're introduced to databases. The only useful information apart from the general guide to databases is the introduction to "the electronic book" for recap purposes.

*The Complete Introduction* starts by guid-



● What you get for your £35: a book, two tapes and a disk

ing the proud owner of a shiny new 6128 through the minefields of Basic and CP/M. The lessons are well constructed and lay solid foundations for later learning, but just when they start to get into some real detail the whole scheme is abandoned.

In the final tutorials examples are given of some of the serious applications of the computer. Both are good, but running them in the same package means that neither concept is fully followed through.

If the idea was to show the various software applications of the CPC, why were only spreadsheets and databases included? What about word processors, art packages, DTP or even a playable game?

The very flexibility of the CPC makes the "complete introduction" to the various software options a no go project. Whereas in the CP/M and basic tutorials you are led into new fields and the scope for learning is defined by the logical steps that are prevalent in the two systems; so more can be learned and at least then two areas could be completely introduced. This way solid foundations are being laid for later, more specialised study.

Nice try Headline, but possibly too hard a try. It's an impractical task to cover completely all the possible operating methods and applications of a machine like the 6128 in four half hour sessions.

The course is split between the way the 6128 works and what it can do, and it should concentrate on one or the other. Admittedly, it could not then claim to be "complete," but at least it would have the potential to be more thorough than its present form allows. ●

#### GOOD NEWS

- Effective teaching method.

#### BAD NEWS

- Not as complete as claimed.
- Expensive.

*The Printout Specialists*

**CASPELL COMPUTER ☎ 0202 666155 [24 hr]**

**RIBBONS**

Amstrad DMP 2/3000 series	2482	A
Amstrad DMP 4000	2426	E
Amstrad PCW8256 (L/Life)	*2741	D
Amstrad PCW9512	*2746	B
Brother HR15/25/40	*2696	B
Canon PW1080A	2223	D
Centronics GLP	2412	D
Citizen 120D/180E/LSP10	2488	D
Citizen MPS801	2477	B
Epson FX/LX-80	2273	B
Epson LX/GX-80	2454	B
Epson LQ-500	2477	D
Epson RX-80	2273	B
Epson EX-800	2774	D
Epson Full Width	2320	D
Juki 6100 Daisywheel M/S	2563	B
NEC Pinwriter P1/P2	2254	D
NEC P2200	2844	D
NEC P6+/P7+	2870	E
Panasonic KXP-1081/1180	2228	D
Seikosha GP100	2317	B
Seikosha SL80 (L/Life)	*2741	D
Seikosha 500/550	2236	D
Shirawa CP80/MT80	*2698	D
Tatung/Commodore CP80	*2698	D
Star LC10	2861	B
Star LC24-10	2868	B
Star NL10	2761	D

\* = Avail. in Fabric Nylon or M/Strike Film.

Please choose!

(Fabrics offer longer life and may be used with Ribbon Refresh!)

**PRICE STRUCTURE**

	1 off	2 off	5 off
A	£2.95	£5.75	£12.95
B	£3.95	£7.45	£16.95
C	£4.45	£7.95	£18.45
D	£4.95	£8.95	£19.95
E	£5.95	£10.95	£24.95

Prices include VAT & post

**WE ALSO HAVE  
DISKS**

**and a Technical  
Library of  
1500 BOOKS!**

*Please enquire!*

**FREE SUPPLIES  
CATALOGUE**

**24-page  
FULL BOOKLET  
50p**  
(Only with goods)



**PAPER**

All prices per 1000 sheets incl. VAT

\* P&P £2.50 any quantity

11/9.5 60gsm Listing	£6.45
11/9.5 70gsm Microperf	£7.95
11/9.5 85gsm Letter Qual	£9.95
A4 size 70gsm Microperf	£9.70
A4 size 85gsm Letter Qual	£10.95
11/9.5 2 part NCR	£19.40
<b>A5 size Letter Quality paper,</b> Upright (Portrait) Orientation,	£13.95
Microperf all edges for letter-writing	

**Address Labels**

3.5/1.5, 1- or 2- across

**£3.75 per 1000** (+£2.50 P&P)

At last - a unique  
new ink spray that  
restores ribbons in  
seconds

**SAVE  
£££s ON  
RIBBONS**

- Quick & Convenient.
- Restores & Re-links faded ribbons In seconds!
- Refreshed ribbon lubricates print head for smoother running & enhanced printer life.
- Use on any fabric ribbon... again and again!
- Pays for itself the first two times you use it.



**ONLY  
£8.95**  
inc VAT & post

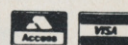

Cheques/POs (no stamp needed)  
**CASPELL COMPUTER SERVICES**

Dept AA, FREEPOST, Poole Dorset BH15 1BR  
Tel: 0202 666155 or 0202 35650 (24-hr)  
TRADE ENQUIRES & LOCAL AUTHORITY ORDERS WELCOMED  
Account enquires: 43 Emerson Rd., Poole Dorset BH15 1QS

**TASWORD 6128**

The Word Processor - with Mail Merge

The established, powerful word processor for the Amstrad CPC 6128. TASWORD 6128 has been specially developed to use 64K of memory as text space. This means a text file can be a massive 60,000 characters long, enough room for over 10,000 words! Featuring all standard and many extra word processing facilities TASWORD 6128 includes sophisticated print options, on-screen help, notepads and a built-in data merge facility. Extensive customisation options allow many facilities to be changed to your requirements and then saved into the program. Combining power with ease of use, TASWORD 6128 is the complete word processor for the CPC 6128.

TASWORD 6128 Disc £29.95



PERFECTION IN PROFESSIONAL SOFTWARE

Springfield House, Hyde Terrace, Leeds LS2 9LN Tel (0532) 438301

**TASWORD 464**

The Word Processor

Your 464 becomes a professional standard word processor with TASWORD 464. Supplied complete with a comprehensive manual and a cassette which contains the TASWORD 464 TUTOR to teach you word processing using TASWORD 464.

TASWORD 464 cassette £24.95

**TAS-SIGN**

The Sign Maker for the CPC 6128 and PCW

Produce and print your own signs, banners and large notices to get your message across with maximum impact. A complete sign making package including four distinctive lettering styles and character heights from one inch to the full width of the paper. Signs may be printed across the paper or along the length of the paper to produce large eye-catching banners and notices.

TAS-SIGN (dot matrix printers only) disc £29.95

Use the clip coupon below and send for our FREE brochure describing these and other products for the CPC range.

If you do not want to cut this magazine, simply write out your order and post to:

TASMAN SOFTWARE LTD, DEPT AA, SPRINGFIELD HOUSE, HYDE TERRACE, LEEDS LS2 9LN

I enclose a cheque/PO made payable to Tasman Software Ltd OR

charge my ACCESS/VISA number: \_\_\_\_\_

Card expiry date: \_\_\_\_\_

NAME \_\_\_\_\_

ITEM \_\_\_\_\_

PRICE £ \_\_\_\_\_

ADDRESS \_\_\_\_\_

£ \_\_\_\_\_

£ \_\_\_\_\_

Telephone Access/Visa orders: Leeds (0532) 438301



Outside Europe add £2 per item airmail TOTAL £ \_\_\_\_\_

Please send me a FREE Tasman brochure describing your products for the IBM/Amstrad PC  Amstrad PCW  Amstrad CPC

All prices include VAT and post and packing

# DATEL ELECTRONICS

**MIDI COMPATIBLE**

## music machine

**THE RAM MUSIC MACHINE IS PROBABLY THE MOST EXCITING MUSIC ADD-ON AVAILABLE FOR ANY COMPUTER.**

**FREE MICROPHONE AND HEADPHONES!**



- ▼ It's a full sound sampling system allowing any sound to be recorded digitally into computer RAM. Once stored the sound can be replayed at different pitches with many varying effects.
- ▼ It's an echo chamber & digital delay line. Create very interesting effects.
- ▼ Various sampled sounds are provided to get you going.
- ▼ The Music Machine can be used as a drum machine - eight drum sounds are provided, but you can easily produce more of your own.
- ▼ The powerful software allows you to compose tunes from individual bars of music. You can edit on screen & Save/Load sounds, instruments & rhythms.
- ▼ It's a two voice music/sound synth.

- ▼ Fully MIDI compatible. The Ram Music Machine supports full MIDI In, MIDI Out & MIDI Thru.
- ▼ Output through your Hi-Fi or Headphones. Comes complete with Microphone.
- ▼ Use a full size MIDI keyboard to play the Music Machine.
- ▼ Sounds produced by the Music Machine can be mixed with a MIDI Synthesiser's own sounds.
- ▼ On screen Sound Editor can produce MIDI data from your own compositions.
- ▼ No other product can offer so much in one unit - it's the total solution!!

**ONLY £49.99 (Cassette)**  
**ADD £5 IF DISK REQUIRED**

## MEMORY EXPANSION

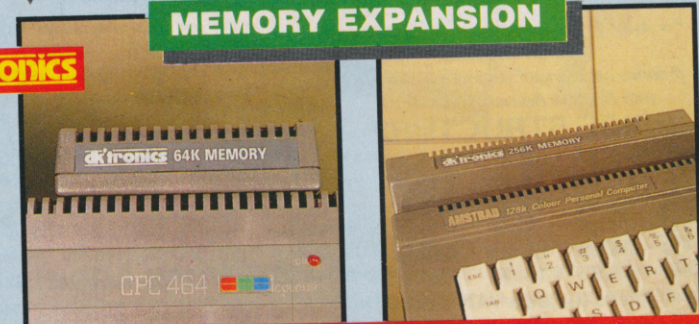

## LIGHTPEN/GRAPHICS SYSTEM

- ▼ Complete Lightpen and graphics system lets you create a whole range of effects on screen.
- ▼ It can magnify, shrink, colour fill and create circles, rectangles, lines and curves.
- ▼ Pictures can be edited at pixel level using a scratch pad which is magnified to full screen.
- ▼ Picture storage and retrieval, and a pen calibration feature.

- ▼ Printer dump utilities for Epson/Amstrad printers supplied (on cassette).

**ONLY £14.99 CASSETTE**  
**OR £24.99 WITH SOFTWARE ON ROM - NOTHING TO LOAD**  
464 or 6128 (Please state which)

## 64K AND 256K MEMORY EXPANSION

- ▼ Simple plug in memory expansion gives instant extra memory.
- ▼ Features bank switching software for easy use by the programmer or for use as a data storage area.
- ▼ Ideal for use with the CPM 2.2 etc.
- ▼ The software also features some extra BASIC commands.
- ▼ 64K unit brings 464 up to CPC 6128 memory configuration making a much larger software base available. Will work straight off with many programs designed

- ▼ for this unit (including OCP Art Studio - see Ad.).
- ▼ 64K unit expands 464 to 128K. The 256K unit takes your 6128 to a massive 320K!!
- ▼ All bank switching done automatically by supplied software (cassette 464 - disk 6128).

**ONLY £49.99**  
64K for 464  
**ONLY £99.99**  
256K for 464 or 6128 (Please State)

## REALTIME CLOCK



- ▼ A simple but highly useful device.
- ▼ Easy to use realtime clock - battery backed to give the correct time and date always.
- ▼ Also features extra 8bit I/O port for external control applications - very useful.
- ▼ Comes complete with full instructions and set-up software.

**ONLY £19.99**  
464 or 6128 (Please state which)

## SPEECH SYNTHESISER & STEREO SOUND BOOSTER

- ▼ This easy to use Speech Synthesiser includes a powerful Stereo Amplifier and two Pod Speakers which is a great improvement on the sound of the internal mono speaker.
- ▼ Using the SPO/256 Speech Chip the unit has an almost infinite vocabulary.
- ▼ Text to speech software is provided in ROM to make speech output simplicity itself.
- ▼ Voicing is transparent to the user and the computer can carry on with other program tasks.
- ▼ Speech output is mono directed to both speakers. Booster gives stereo to internal sound output.

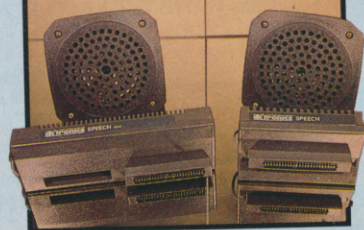

**ONLY £29.99**  
464 or 6128 (Please state which)

## SILICON DISK 464/6128

- ▼ This is the fastest storage system available for the Amstrad CPC computers and is compatible with CPM 2.2, CPM+ and all DKTronics peripherals.
- ▼ The 2516K Silicon Disk is designed to be used in conjunction with at least one normal Disk Drive attached to the system.
- ▼ When the 2516K Silicon Disk is fitted only 2K is used for the Silicon Disk directory, leaving 254K for storage - that's 70K more than a normal Disk Drive.

- ▼ Data and programs can be exchanged between Silicon Disk and normal Disk, application programs can then work on their data at vastly increased speeds.
- ▼ Software is on ROM (nothing to load) and can be used in two modes - Basic under AMDOS with normal LOAD, SAVE CAT MERGE commands etc. and within CPM 2.2 CPM+ where commercial programs are designed to run on multi-drive systems.

**ONLY £129.99**  
464 or 6128 (Please state which)

# DATTEL ELECTRONICS

**THE ULTIMATE GRAPHICS PACKAGE...**

**SPECIAL OFFER PACK!**

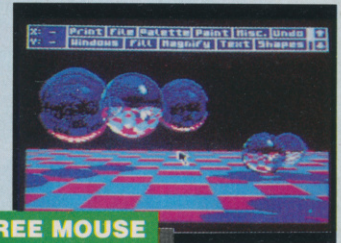

**INCLUDES FREE MOUSE MAT/HOLDER WORTH £12.99**

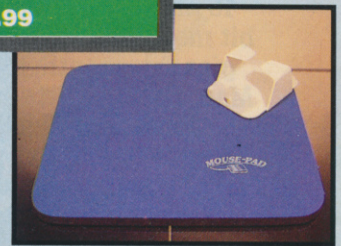
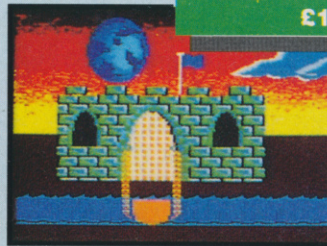

## Genius Mouse

**COMPLETE WITH**

## OCF ART STUDIO™

- ▼ Genius Mouse is a high resolution two button mouse featuring optical counting, teflon guides, microswitches, rubber coated ball and high quality interface.
- ▼ When combined with OCP Art Studio this graphics package is quite simply the best system available. The features are unmatched...
  - ▼ Create an image - shrink it, expand it, move it, rotate it, copy it, colour it etc., etc.
  - ▼ Spray patterns or shades, make elastic lines - stretch and manipulate shapes.
  - ▼ Zoom in to add detail in fine mode.
  - ▼ Pulldown/Icon driven menus for ease of use.
  - ▼ Mouse operation, plus joystick and keyboard control.
  - ▼ 16 pens, 8 sprays, 16 brushes - so flexible anyone can create superb graphics easily.
  - ▼ Full cut and paste facilities plus excellent printer support.
- ▼ Pixel edit, font editor, flip, invert, rotate, solid or textured fill and professional manual make Art Studio simply the best graphics package for the Amstrad CPC.

**TAPE OR DISK FOR 464 OR 6128 (PLEASE STATE WHICH REQUIRED) N.B. 464 NEEDS DK' 64K RAM PACK**

**ONLY £49.99 TOTAL PACKAGE INCLUDING GENIUS MOUSE/INTERFACE MOUSE MAT/HOLDER AND OCP ART STUDIO**

**NEW SLIMLINE DRIVE**



## 800k 3.5" DISK DRIVE

- ▼ Now you can add a superb top quality 3.5" drive to your CPC Amstrad.
- ▼ 800K of data storage on disks that cost less than £1.00.
- ▼ No need to flip disks.
- ▼ 3.5" disks are fast becoming industry standard.
- ▼ Comes complete with power supply and cables.
- ▼ We supply our drive with the RODOS operating system, giving not only this vast disk capacity but also over 50 new bar commands plus a printer buffer, etc.
- ▼ Easily fitted - full instructions.

464 owners must already have at least one Amstrad drive.

**Only £119.99 for Drive and RODOS including PSU/Cables**

- ▼ Turn your Amstrad Monitor into a full feature TV set with our TV Tuner System.
- ▼ Latest chip technology gives crystal clear reception on all channels.
- ▼ Built-in speaker.
- ▼ On/Off volume controls.
- ▼ Brightness and colour controls.
- ▼ Channel selector.
- ▼ Attractively styled to match your computer.
- ▼ Why not realise the full potential of your monitor?

**ONLY £69.99**

## TV TUNER SYSTEM

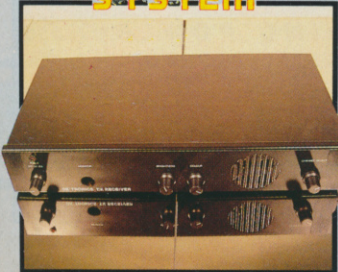

## PCW 8256/8512



## PCW 8256/8512 COMMUNICATOR

- ▼ Complete RS232 and Centronics/Parallel interface for the PCW Amstrad.
- ▼ Simply plugs into rear expansion slot.
- ▼ Attractively styled in computer colours.
- ▼ Full instructions supplied.

**Only £49.99 complete**

## ALL ORDERS NORMALLY DESPATCHED WITHIN 48 HRS HOW TO ORDER ...

### BY PHONE

**0782 744707**  
24hr Credit Card Line

### BY POST

Send cheques/POs made payable to "Datel Electronics"

### FAX

**0782 744292**

UK ORDERS POST FREE  
EUROPE ADD £1  
OVERSEAS ADD £3

PRICES AND SPECIFICATIONS CORRECT AT TIME OF PRESS AND SUBJECT TO CHANGE WITHOUT NOTICE

CALLERS WELCOME - Please reserve goods by telephone prior to visit.

# DATTEL ELECTRONICS

DATTEL ELECTRONICS LTD., FENTON INDUSTRIAL ESTATE GOVAN ROAD, FENTON, STOKE-ON-TRENT, ENGLAND.

**SALES ONLY**  
**0782 744707**

**TECHNICAL ONLY**  
**0782 744324**

# ACTION TEST

Heap big pile of games, brought to you by (among others) **TRENTON WEBB**

15 pages of *Action Test* – now that's a bit more like it! We've got some real biggies this month, too: there's *Running Man*, *Rockstar Ate My Hamster*, *Indiana Jones and The Last Crusade* and *Licence to Kill*. But pick of the pack this month is undoubtedly *Laser Squad*, one of the longest awaited games of all time. And it was worth the wait, too!

## MASTERGAME

Laser Squad 50

### RAVES

Dragon Spirit 55

Strider 64

Indiana Jones 62

## Also reviewed

Xenon	48
Licence to Kill	52
Passing Shot	54
Kenny Dalglish Soccer Manager	56
Treble Champions	56
Rockstar Ate My Hamster	58
Running Man	66

## AA interviews

Colin Jones ( <i>Rockstar</i> )	60
Julian Gollop ( <i>Laser Squad</i> )	69

## XENON

Virgin Games ● £9.99 cass, £14.99 disk joystick/keys

Somewhere across the bounds of space and time a great adventure is taking place. A lone fighter is battling to survive against awesome odds, his only weapon a fantastic craft that can transform from a tank to a plane at the touch of a button. Enemies are massing, though, for one final assault. This is the world of *Xenon*, and a battle's coming down.

The aim of the game is simple: victory by the complete obliteration of the enemy. Your tank/plane is a tough armour-plated beast that can rip up the opposition easily on a one to one basis. But of course, like buses, they only ever arrive in threes. This forces you to be constant-

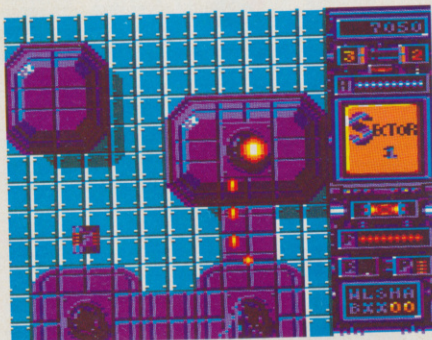

● You'll have to change to tank mode to collect the fuel drum

ly switching from shape to shape to maximise kill power and minimise the risk factor.

On the ground you're immune to aircraft shots, but are slow and attract fire from enemy armour and gun emplacements. When you're a fighter plane, speed and range improve but you're vulnerable to shots from everybody and can't pick up the extra power packs dropped by retreating tanks, so a balance must be struck.

You scroll up this hi-tech tiled corridor, with turrets protruding out of the floor. One quick shot (or even a near miss) soon has them

exploding beautifully, and the trip continues.

Next, gun emplacements on a higher level require quick change to plane mode, or avoiding the shells they send crashing down around you.

That's just about it: differing formations of tanks, planes and fortifications getting ever more dangerous until big bad end of level beasties come out of hiding and give you a short sharp lesson in the art of dying. The side effect is that you are returned right back to the beginning and the whole battle starts again, amid much gnashing of teeth.

The whole point of a shoot'em up is that you don't even have time to think, and it's instinct and reaction speed that see you through. On this score, *Xenon* fails to deliver. The whole game moves at the speed of a slug with a sprained ankle. Even in plane mode, which allows you a modicum more pace, everything's in slow motion.

In a way the slowness is a relief, because if everything was at normal blasting speed the survival time would be measured in microseconds: it's tough enough as it is! The graphics and sound are both excellent conversions from their 16 bit cousins and the scrolling is smooth if slow.

The blasting, however, isn't enough to sustain any lasting interest. Tough it may be, interesting it ain't. *Xenon* just doesn't set the blood on fire the way *Silkworm* did, there's not the mad and confused scramble that makes shoot'em ups so exciting.

It's a shame, a crime even, that such good work has been squandered in such a game.

Apart from speed it's

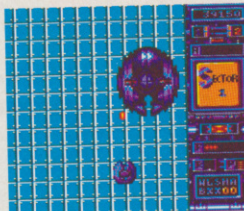

● A really tough end of level guardian

● Only a plane can shoot elevated turrets

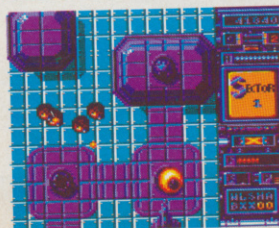

## SECOND OPINION

"Trenton's absolutely spot on, as usual. *Xenon* is a brilliant-looking conversion, lacking just that one element no shoot-'em-up can survive without: speed. Thanks, but no thanks."

SC

GREEN SCREEN  
Crystal clear

got everything: good graphics, sounds, smooth scrolling and even a reasonable plot premise for a shoot out. But it is just not enjoyable enough to warrant spending £10 on!

In years gone by scientists thought the element xenon was inert. I think they were probably right.

TW

## FIRST DAY TARGET SCORE

50,000 points

## The Verdict

GRAPHICS ..... 79%

- Crisp, clear tanks and planes.
- Exceptionally accurate arcade lookalike.

SONICS ..... 63%

- Great tune.
- So-so spot effects.

GRAB FACTOR ..... 58%

- Low-key pace makes it easy to play.

STAYING POWER ..... 33%

- Too slow to be interesting at all.

AA RATING ..... 57%

- Looks good... but it's all so slow...

**ARCADES · MOVIES · SPORTS**



**THE HIT NAMES · THE HIT GAMES**

**THE HIT SQUAD**

**Only 2.99**

**WE'VE GOT THEM ALL**

**FOR SPECTRUM AMSTRAD COMMODORE**

**HIT NAMES · HIT GAMES**  
**HIT SQUAD**

# LASER SQUAD

**Bladesoft/Target Games**  
**£9.95 cass, £14.95 disk**  
 (Note: expansion modules included on disk;  
 cost £3.95 for cassette)  
 joystick/keys

A droid crosses in front of Corporal Hansen. He's been waiting for this, and takes a carefully aimed shot, but the M4000's bullets skitter off its armour. Hansen's in trouble and the rest of the laser squad will have to get there pretty quick if he's to avoid becoming a smouldering lump of laser fodder. It may be war, but that droid's getting personal.

*Laser Squad* is a game of tactics and violence accurately simulating the one-to-one combat of rebel space marines. A wargame in essence, it takes you down to the level where you can almost feel a victim's last breath. You've got to organise the men to achieve an objective within a specified number of turns, and when the strategy has been decided the shooting starts.

All movements and combat relate to the action points total of each trooper, which is calculated with regards to encumbrance, wounds and physical stamina. Every activity from an aimed shot to priming a grenade uses a predetermined number of action points, forcing you – the commander – to carefully consider each and every action. There's nothing more frustrating than having an enemy in your sights and no energy left to pop off a grenade and frag him.

The style of play is completely in the hands of the commander right down to choosing the arms and the armour for the team. The range on sale at the local munitions store is enormous and vicious: battle armour in four different grades, a multitude of rifles and lasers, as well as sundry explosives are all on offer. The only

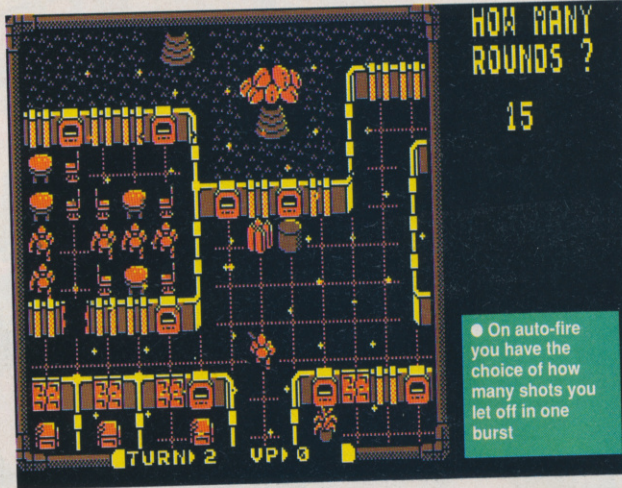

● On auto-fire you have the choice of how many shots you let off in one burst



● In Paradise Valley the trees sometimes offer cover from hostile fire – but are there aliens hiding in them as well? There's only one sure way to find out...

limit is the generous budget which forces few compromises on the easier levels.

Tooling up the lads takes a few minutes – double check everyone's got spare ammo – because when the action starts you'll need all the firepower you can put your trigger finger on. Different missions need different weapons and some guns become positively dangerous to the user as well as the target if used in a rash moment of panic (rocket launchers in small rooms, for instance).

Armed and dangerous, the Squad are ready to beam down to the mission start points (or LZs as we used to call them in 'Nam).

Remember you are so totally in control that you even have to tell them to pick up their rifles when you land!

The first mission sends you in pursuit of Sterner Regnix, a man the rebellion want pushing up daisies and not repressing the masses. The attack you have to lead on his house is no quick "nip round the back and poison his cocoa" job, but more a convincing impersonation of Beirut. Battle droids patrol

everywhere and Sterner is killed out in the best armour money can buy. Subtly, though, soon gives way to overkill when you start loosing off your rocket launcher in his living room.

Mission two sends you on an S&D patrol to a lunar computer station. This system has been gathering too much in depth info on the rebels: your job is to go into the moonbase and blow it chip from chip. Once again the base is defended by some mean hombres (watch out for Trooper Sol) who must be persuaded with laser pistols to let you trash their hardware collection.

Mission three casts you as the rescuers of fellow revolutionaries incarcerated in a mine complex. Long twisting corridors push your nerves to the limit as you never know what you'll bump into at the next junction. Accuracy is of prime importance here, which can be a real test on the nerves and the patience.

Expansion one puts you in defence of a planet's geothermal core taps which are being attacked by war droids – which



● Top: when arming the team get a variety of weapons, and don't forget extra ammunition!  
 ● Bottom: if the enemy fire at your men, you see their stats too – nice touch

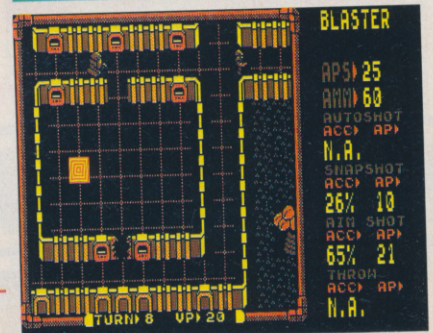

**Main games screen**

Action points remaining

Direction indicator

Action points needed to get opportunity fire

The cursor on screen is your troop selector

Terrain and its cover value: this often dictates where and how you get to your objective

Laser Squad trooper

If any enemies cross your line of sight this box flashes and tells you how many. What it won't tell you is where...

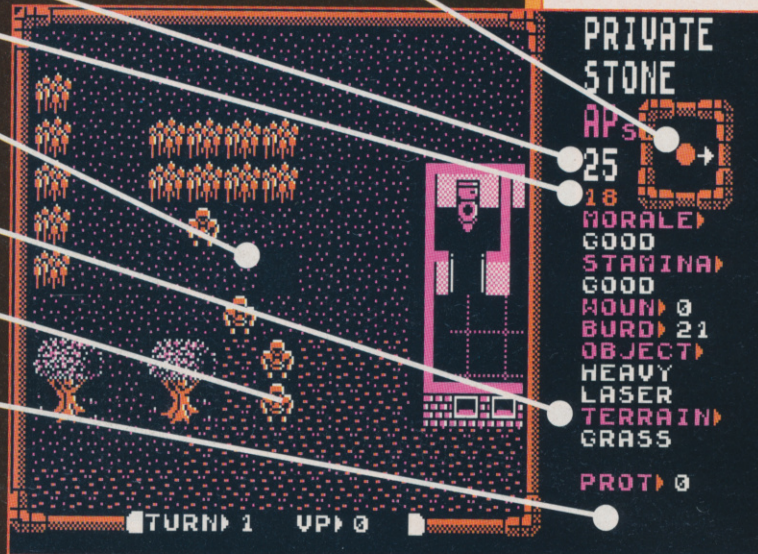

**Scanner screen**

A map is always on hand for checking enemy positions



**'Fire' screen**

Move the cursor to identify target...

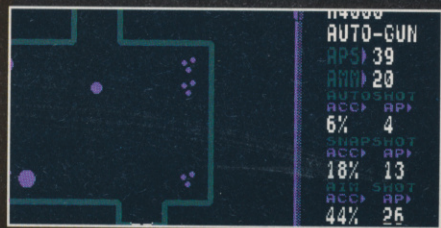

The various fire options, and cost in action points

would result in a hole clean through the planet and not just the ozone layer. Expansion two places you in Paradise Valley, a nice place for a venom spitting alien, but downright terrifying for space grunts. Guess what you meet though as you stroll across the valley floor escorting a top spy to safety? Yup, venom spitting aliens – big and nasty ones!

Two things add excitement and great

appeal to the package: a two player mode and the element of luck. In two player, one side controls the LS boys, the other player the evil empire's soldiers. If you can exercise enough self restraint to avoid looking as your opponent directs his forces then a truly intriguing battle of wits ensues. So now you've a chance to hunt friends down, hound them till they're begging for mercy, and still shoot them!

Luck has the largest part to play of all factors in any successful Squad campaign. Sometime you'll find your troops unable to even see the barn let alone hit its broadside! And since all the combat is random, even if you aim at point blank range there is still a slight possibility you may miss, a chance magnified for a snap shot at medium distance and a near certainty for spray fire at long.

Similarly, to surprise an opponent and get opportunity fire as they enter your line of sight you must have more action points left than them. But how do you know? You can be waiting hidden in an alcove and still be denied a shot by a particularly active robot. Worse still, if you get a crack at a bad guy and miss there's a strong possibility you've frittered away all your action points and you're about to be introduced to the business end of

a pump action shotgun.

The fun in Laser Squad stems from its flexibility and its playability. With two players and four levels of difficulty (seven on the expansion modules) the games playing life is a long one indeed. It's the armaments on offer that really make the whole show worthwhile, because even when you've beaten a scenario you can give fresh life by tackling it with over the top or completely inappropriate weapons.

With the addition of "add on" modules this one will run and run – who knows where the next mission will take us? With the two current expansion modules new weapons have been added and the difficulty has been stepped up. Laser Squad as it stands now will have any "intelligent aggro freak" coming back time and time again. You'll love the smell of Auto Cannon in the morning. It smells of Victory. **TW**

**FIRST DAY TARGET SCORE**

Kill Sterner Regnix

**The Verdict**

**GRAPHICS** ..... **85%**

- Clear, detailed maps.
- Instantly understandable screens.

**SONICS** ..... **30%**

- Poor sound effects and no music.

**GRAB FACTOR** ..... **94%**

- Tooling up is fun...
- ... but using it's even better!

**STAYING POWER** ... **96%**

- Up to five different war zones to visit.
- Learn the tactics, win the war.

**AA RATING** ..... **91%**

- Detailed and intriguing one-on-one wargame.
- When two friends go to war, fun is all that you can score!

● Turn to page 69 for an exclusive interview with the author of Laser Squad!

**SECOND OPINION**

"It's apparent from the word go that this is no ordinary computer game. The sheer satisfaction of blowing your opponents (especially a friend) all over the scenery is an impressively good experience."

"Playing two player stretches the life of the game, but there are two scenarios that I still can't beat the CPC on."  
**PbM**

**GREEN SCREEN**

Green screen Laser Squad is just as clear and just as totally addictive

# LICENCE TO KILL

**Domark ● £9.95 cass, £14.95 disk joystick/keys**

What was Felix Leiter thinking of when he invited long time friend and colleague James Bond to be best man? Everyone knows anywhere Bond goes trouble always follows – in *On Her Majesty's Secret Service* James couldn't even get to the honeymoon hotel before his own bride got killed! And sure enough the gunfire starts before you can say "I do, aaarghh!" and the would-be Leiter family get all messed up.

Never one to live and let live, James resigns from Her Majesty's Secret Service and goes off like a thunderball to scare the living daylight out of the drug smuggler – Sanchez – who orchestrated the attack. There are a number of steps to tracking down such a master criminal, the first being to hit him where it really hurts, right in the shipments.

So it's up in a chopper to start destroying the narcotics factories and chase down Sanchez, who's doing a runner in a jeep. The dealers don't seem too keen about being bombed and fire back forcing you to use both height and speed to line up the sheds for demolition. Like *Thunderblade* it's a case of swooping in at just the right moment with guns blazing to keep the damage counter from ticking into critical.

Having made your way through the valley of death you've got to nip out of the 'copter and get down to a gun fight. You see Bond



● Level One: chase the jeep and destroy it

from above, sighting the gun with a floating cursor. You've only a limited amount of ammunition and so dead traffickers must be looted for extra bullets – ammo can also be preserved by shooting the barrels of aviation fuel which litter the airfield, making them explode.

Sanchez escapes in a plane, and so to employ his *Licence to Kill* the world's favourite secret agent has to go up in the helicopter once more. This time you're not trying to shoot anything down but latch onto the plane's tail. Yes that's right never happy to do

## The men with the golden licence

Domark have come along way since they announced they'd won the licence to produce Bond movies as computer games.

This then tiny company has progressed through a whole batch of licences to become one of the young pretenders to the twin thrones of US Gold and Ocean.

It's good to see that their commitment to the concept

that launched them (*View to a Kill* and other movies) is not waning. Indeed Domark are about to release a complete trilogy of their *Star Wars* games. How long will it be before they take the plunge and bring us a collection of the greatest moments of 007 on the CPC ?

With the current threat to coin-op conversions from the console manufacturers, films

could well be the way ahead for the tie-in games.

Things are definitely going that way: *Robocop* number one in the charts for just about ever, *Indy and the Last Crusade* hyped beyond belief, and of course a little-known film tie-in called *Batman* will soon be hitting our screens courtesy of Ocean.

Maybe the times they are a changing?

things the easy way and get on at the airport, you've got to try and hitch a lift – at 10,000 feet!

Next you visit a drug drop zone and take a quick dip with some particularly vicious divers, gunboats and harpoons. Then it's time to steal a seaplane and go for the finale: a chase with 18 wheeler trucks as they make a dash for the border. Life is never as simple as it should be, because the trucks have that everyday extra motoring necessity, *Stinger missiles!*

### SECOND OPINION

"Without a doubt this Bond is the best of the bunch. It's finishable, which makes a change." SC

### GREEN SCREEN

Nothing to complain about

*LTK* is a compilation of themed games, rather than one scenario that tries to capture the feel of the movie. The music comes straight from the original score and establishes atmosphere for the adventure. And all the best and most spectacular scenes of the film have been carefully chosen and recreated by Domark's goldfingered programmers.

The game is not graphically stunning, but the action and characters are clear. Mostly drawn in a *Gauntletesque* style, *Licence to Kill* is the most impressive Bond yet: not exactly innovative, but highly enjoyable to play.

The war against drugs takes on a whole new slant as James helps you say Dr. No to drugs.

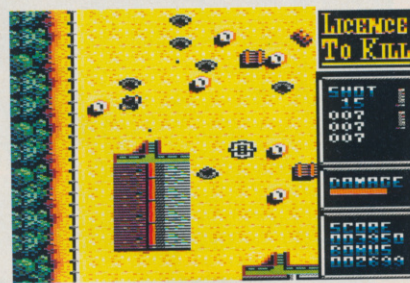

● Level Two: fight your way across the

*Licence to Kill* is a game which you'll see the end of without a poke, as it's intended to be completed, with you then going round again, improving your score.

In the competition for the best movie licence of the summer, Domark have certainly made their pitch with a strong contender. Just when you thought that you'd played every sort of Bond game under the sun, this is proof positive that you'll never say never again (that's enough bad puns on Bond film titles – ed). TW

### FIRST DAY TARGET SCORE

10,000 points

### The Verdict

**GRAPHICS** ..... 65%

- A great selection of different playing screens.
- A bit blocky.

**SONICS** ..... 83%

- Brilliant film music conversion.

**GRAB FACTOR** ..... 77%

- Simple games, well executed.
- Six different games in one.

**STAYING POWER** 62%

- A bit too easy for the hard player.
- Only four levels.

**AA RATING** 76%

- Great film conversion: best Bond yet!



P R E S E N T S

©1988 SEGA ENTERPRISES LTD.

# SHINOBI™

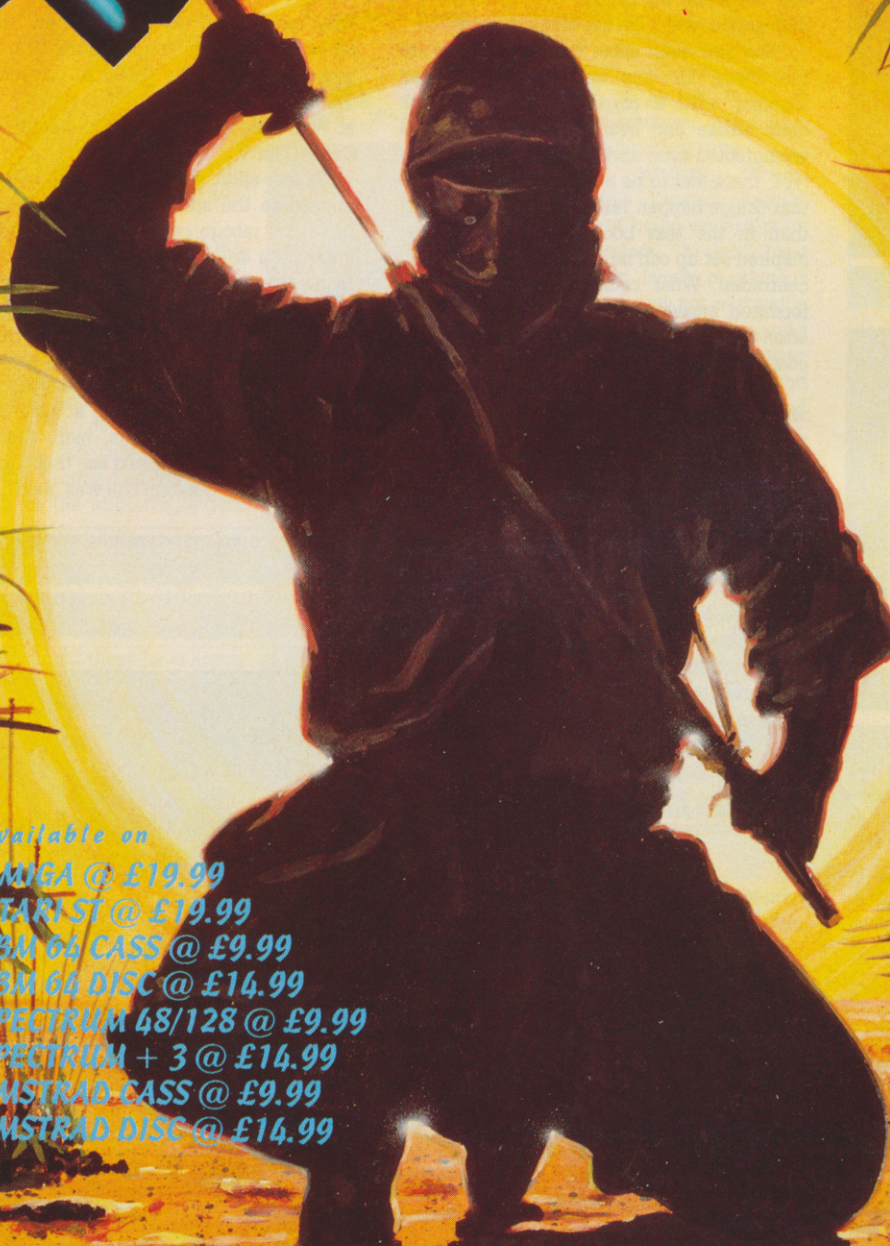

AMIGA



ATARIST



CBM 64



SPECTRUM



AMSTRAD

available on

AMIGA @ £19.99

ATARIST @ £19.99

CBM 64 CASS @ £9.99

CBM 64 DISC @ £14.99

SPECTRUM 48/128 @ £9.99

SPECTRUM + 3 @ £14.99

AMSTRAD CASS @ £9.99

AMSTRAD DISC @ £14.99

VIRGIN MASTERTRONIC LTD.

2-4 Vernon Yard - 119 Portobello Road - London W11 2DX

"This game has been manufactured under license from Sega Enterprises Ltd., Japan, and "SHINOBI" and "SEGA" (or "SEGA") are trademarks of Sega Enterprises Ltd."

Produced by The Sales Curve Ltd.

# PASSING SHOT

Imageworks ● £9.99 cass, £14.99 disk joystick/keys

It's just like the Des 'n' Gerry show at Wimbledon, as all the world's best tennis talent bay for a crack at yet another British hopeful - you! Only, unlike the real thing, you actually stand a chance of achieving glory, even winning the Grand Slam! So limber up, put on those Reeboks and drink plenty of that yukkie barley water stuff. It's time for a knock up.

Out on the court you take over just as the last set is about to begin, so this is for the

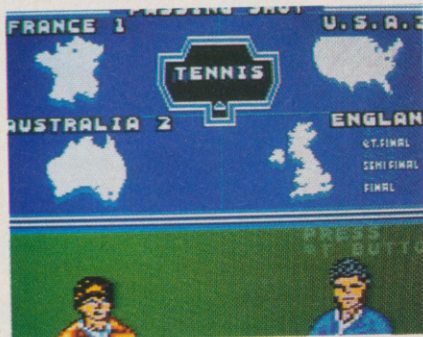

● Which tournament will you play in first?

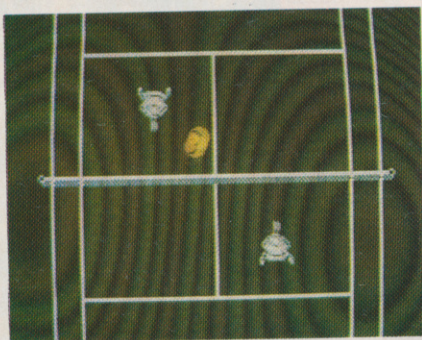

● The rallies are seen from overhead

match. You get to serve first and the drama is all set to unfold. The spectators are hushed (either that or asleep) and the two players are busy psyching each other out, gunfighters in white cotton shorts.

Service couldn't be easier, all you do is bung the ball up and belt it. It always goes in - a touch of realism healthily ignored. Once the game's underway, you can send your player scurrying around in any direction to line up your back and forehand shots. All you've got to do (on the easy level at least) is just get near enough to hit the darned thing, and Robert is your mother's brother.

What's that you say? Sounds so simple it's bound to be boring? You couldn't be more wrong! In no time at all you'll find yourself planning a couple of shots in advance and trying to outwit the computer opposition. Even complete tennis haters (like myself) are soon wooed into the complexity of this "simple" sports sim. You'll be waiting for that moment

when the other guy makes a slip and you charge into the net poised for the kill, eager to smash the ball back so fast they're not even going to see it, let alone hit it!

Doubles adds yet another dimension to the gameplay. The challenge of playing with a friend is offset by the merry confusion caused when two identical players are on the same side of the net. Once positional problems have been overcome, though, careful and conservative play results in you becoming an almost unbeatable (well I did say almost!) team.

The four main shots in your armoury are the volley, lob, top and back spin. Used together with a correctly timed fore/back hand stroke and even a computer can be wrongfooted time and time again. The hitch (yes, there had to be a hitch, didn't there?) is that things happen rather faster on the court than in the text book, so even the most inspired set up can be ruined by a lack of concentration. What could have been a great forehand smash to the left hand corner so often turns into a backhand headed for row G seat 13.

The controls are simple on a joystick: forward to come over the top of the ball, backward to strike it underneath, with the trigger to tell the player when to make contact. Forehand and back is simply a matter of hold-

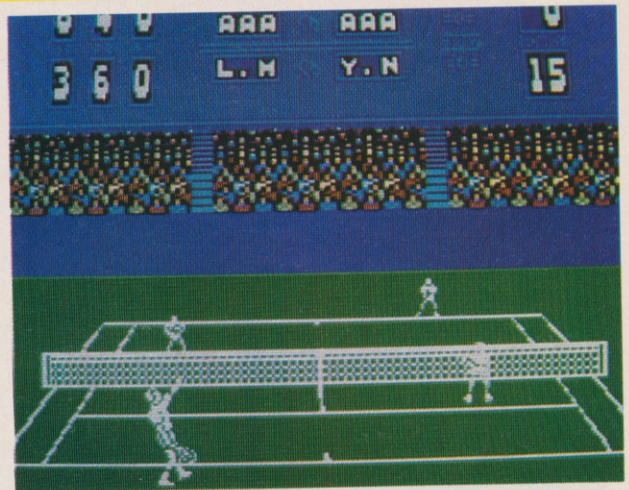

● Serves are seen from behind the player, just throw the ball up and hit it!

new tactics and so a whole new learning curve begins when you reach the 'States, and you switch from the green to the red stuff. The series concludes in a three match thriller at Wimbledon, which takes us neatly back to Des 'n' Gerry.

A real sport sim, this actually makes you appreciate the sport rather than ripping off the most recognisable bits and calling it a game. You will soon develop enough skill to bypass the easy opponents and go for the real tough stuff, where speeds increase and every shot is just that little better disguised. Will you win and get that revolting plate they keep trying to foist on people at Wimbledon? Or will you be left shouting at your monitor that it cannot be serious, man, there was chalk dust, everyone could see that there was chalk dust, the goddam ball was good? **TW**

## SECOND OPINION

"Passing Shot serves up an ace: at a forehand stroke it takes over from the much harder Matchpoints. Game, set and match to Passing Shot!" **PMcD**

### GREEN SCREEN

Bad light won't stop play!

### FIRST DAY TARGET SCORE

Win a match

## The Verdict

**GRAPHICS** ..... 65%

- Player sprites move well.
- Mostly just white and green.

**SONICS** ..... 70%

- Brilliant theme - just like the TV!
- No crowd or tennis-type noises.

**GRAB FACTOR** ..... 80%

- Much easier than the real thing!
- Six different games in one.

**STAYING POWER** 72%

- Four tournaments to play in.
- Four levels of skill.

**AA RATING** ..... 76%

- A great sporting moment for the CPC.

ing the 'stick to the respective side. But remember that holding the racquet on the left means you'll drive the ball across the court to the right, so be careful when lining up your line drives and it's match point.

Better than the real thing in many respects, a *Passing Shot* game win sees a tennis ball creature burst into tears of frustration (not that real pro's would behave in such childish fashion, surely?). Line calls are decisive, but you can't help feeling that the machine has been programmed to make the occasional odd decision just to add spice, but always on your points!

The tour takes you through four different locations which means you've to play on both clay and grass. The different surfaces require

# DRAGON SPIRIT

Tengen/Domark ● £9.99 cass, £14.99 disk joystick/keys

Historically dragons have had a tough time of it. St. George skewered a big lizard and became a national hero, while fantasy writers have painted them as fire breathing demons with human blood dripping down their fangs and a malicious smile on their scaly lips. Truth is that they've just got a bad press. To see how they *really* behave look at the one in *Dragon Spirit*. He risks his neck(s) just to help save some poor Princess who's had the bad luck to be kidnapped by an evil devil.

Now although this Dragon may have the best intentions, his methods are highly suspect. All he can do is fly all over the kingdom boffing all the bad guys he meets with a quick bit of the old napalm breath – unsubtle, maybe, but effective! All you do is follow the trail of the malevolent monsters right back to the lair of Zawell, the devil serpent.

Zawell's forces, mythical beasts created with black magic, are almost as powerful (if not as dexterous) as the dragon. Lizards patrol the rivers, phoenixes hide in volcanos for sneak attacks and dragonflies – what else! – swarm in waves to overwhelm their enemy. To dissuade them, our friend the Dragon has his breath weapon for the airborne rangers, and bombs for those trying navy moves or land movement.

The breath can be made more effective by bombing dragon eggs which release a ball of magic power. If caught these have highly beneficial effects: more heads and more range on the firepower, and even baby dragon drones to help you on your way. If you're really lucky a final capsule of enchantment will transform your three-way shots into one huge



● Three heads are better than one when you're fighting the phoenix!

fireball which cleans the corridor of all flying foes, allowing you to concentrate on avoiding ground fire.

Eight levels of apocalyptic destruction are the product of these magical powers, with the volume of assailants threatening to breach your defences at all times. Chaos reigns in the land of *Dragon Spirit* when melee is joined, enemies coming at you from all angles as well as firing from below. Some try kamikaze runs into your wings, bats hang at the top of the screen and then scream down intent on impact, while on later levels big blue creatures attack from behind in bombing runs.

The fantasy theme strengthens *Dragon Spirit's* chances of being an exception to the general "hi-tech" blast outs: eight levels of glorious destruction and not a starship in sight! Magic explains away the extra weapons and gives the programmers a free hand for those beasties not included in the coin 'op conversion brief. Another shootout it may be, but it is far from predictable.

For a hard day's wiggling you would be hard pressed to find anything that'll make your trigger finger ache as much as *Dragon Spirit*. Intense is the word that comes to mind. Its depth will have most wilting

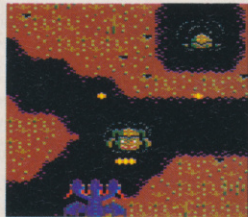

● Just some of the many monsters on levels 2 and 3



● Above: bomb those fire spitting lizards to get to the impressive (and dangerous) Level One guardian (right)



## SECOND OPINION

"Fast, frantic and furious, *Dragon Spirit* will have you blowing on your joystick hand to cool it down. Tengen and Domark do it again!" SC

### GREEN SCREEN

True to the spirit of the game

under the pressure and pace. The ranks of high quality shoot 'em ups have been swelling in recent months and it's the originality and the accuracy of the conversion that sets this one apart. You'll discover fire can fight fire... but then, you've got a *Dragon Spirit* on your side! TW

### FIRST DAY TARGET SCORE

20,000 points

### The Verdict

**GRAPHICS** ..... 71%

- Strong sprites, fast action...
- Small playing area.

**SONICS** ..... 54%

- Theme tune is well out of character.

**GRAB FACTOR** ..... 82%

- Great shoot-'em-up appeal.

**STAYING POWER** 82%

- Eight long, enemy packed levels.

**AA RATING** ..... 81%

- Another stonking coin-op conversion from Domark!

## KENNY DALGLISH'S SOCCER MANAGER

Cognito ● £9.95 cass, £14.95 disk joystick/keys

Q. How do you make a management game look exciting?  
 A. Slap on the box the name of the most successful football manager of the eighties, that's how.

The man whose rare words of wisdom have inspired thousands (understood by dozens) has put his impressive image to work for this new game from Cognito.

An icon driven game, *Kenny Dalglish* does exactly the same as every other management sim, but with pretty pictures rather than boring titles. Everything's there, even a boardroom crew that includes trainers, scouts, accountants and bank managers (you really



● Click on the 12 shirt to swap the team around

want to play a game that stars your bank manager?).

Nothing new has been done to take the genre forward except for the icons. Everything develops at snail's pace, with you filling in the time between matches balancing the club's books, looking around for new talent and swapping the team about. The only real influence you can bring to bear is the side you select and their playing formation.

So you wade through the season, constantly checking your job security rating, aware that runs of bad luck only ever end in the dole office. When your league position solidifies everything gets a bit dull, as you're unable to find any more players of quality to buy - borrowing the money's no hassle, but try spending it!

### SECOND OPINION

"I don't quite see the attraction of football management games. But if you do, this is the one to get alright."

PMcD

**GREEN SCREEN**  
 Nicely suited - just like Kenny himself!



● Placing your team before a match

As a fourth division side you eventually get knocked out of the cup and life just carries on. There comes a time in the season when either promotion is in the bag or out of the question and the cup competitions are memories. What else can a manager do apart from sit around and just wait for the axe to fall?

*Kenny* is a well done example of a stagnant game form. There are no rough edges, but there's no magic either. Even the screens with their slow redraw speed eventually become an irritant, because with no direct influence on the field of play you end up feeling the helpless pilot of a prearranged course - a spectator and not a player. Nice try Cognito, but it needs something other than a big name to carry this genre.

TW

## TREBLE CHAMPIONS

Challenge ● £9.95 cass, £13.95 disk keys

Inside everyone who watches football there's a Ron Atkinson, or even a football manager, struggling to get out. And every touchline general dreams of glory by winning the triple: League and FA Cups, as well as the first division title. Challenge Software want to know: can your team become *Treble Champions*?

### SECOND OPINION

"You'd be a real fan of footie-strats to want this one. And to enjoy it you'd have to be the number one fan."

SC

**GREEN SCREEN**  
 No pictures, so no loss

With nothing more than boxed titles to look at you're launched into a league season with very little idea of what's going on or what to do about it (sounds like Bobby Robson!). The instructions supplied are abbreviated into a deconstructed morass of senseless jargon, made all the more incomprehensible by tiny print, so your first game is bound to be an unmitigated disaster.

The game must go on, though, and you soldier through gradually getting the hang of what to do and when. There is an allotted amount of time between games which must be spent coaching and training players, as well as going poaching from teams in other leagues.

### The Verdict

**GRAPHICS** ..... 64%

□ Good icon usage.

**SONICS** ..... 0%

■ The hills aren't alive with the sound of nothing.

**GRAB FACTOR** ..... 62%

□ Icons are user friendly.

**STAYING POWER** ..... 58%

■ The season stagnates if you're not up for the cup.

**AA RATING** ..... 60%

□ Good example of its type...

■ ... but hardly earth shattering.

Excitement almost sneaks in during a match, as you watch a ball by ball commentary, but is again stymied by your lack of real influence (two subs per game and that's your lot!). But watching the other team chalk up a 9-1 victory with no indication as to how to avoid such thrashings in the future soon gets aggravating.

Just another management simulator, its main feature - efficient programming - not being enough to make it noteworthy. Outclassed by the likes of *Kenny Dalglish*, this game has arrived too late.

TW

ARSENAL	HOME TO
8	G/KEEPER
51	DEFENCE
16	MIDFIELD
7	FORWARD
32	FIT/FORM
8	POSSESSION
0	SHOTS
0	GOALS

ARSENAL SHOOT

● A match being played, exciting

### The Verdict

**GRAPHICS** ..... 40%

■ Just names in boxes.

**SONICS** ..... 0%

■ What sonics?

**GRAB FACTOR** ..... 30%

■ Slow starter with poor instructions.

**STAYING POWER** ..... 62%

□ Five divisions, hours of play.

**AA RATING** ..... 49%

□ Staid, but does the job.

# K & M COMPUTERS

## THE LEADING AMSTRAD MAIL ORDER SPECIALISTS

ADVENTURE	CASS	DISC
Time and Magik	£11.25	£11.25
Gnome II: Ingrid's back	£11.25	£14.75
Pawn (6128)		£14.75

### COMPILATIONS

Heatwave	£10.50	£13.99
Soccer Spectacular	£10.50	£13.10
Special Action	£10.50	£13.99
The Story So Far (Vol. 2)	£10.25	£11.25
The In Crowd	£11.25	
History in the Making	£11.25	£21.50
Taito Coin-op (inc. Rastan)	£9.90	
Supreme Challenger (Inc Elite)	£9.90	£13.10
Gold Silver & Bronze	£11.25	£21.50
Giants	£10.50	£15.95
Flight Ace	£11.25	£13.95
Arcade Muscle	£10.50	£15.95
Command Performance	£9.90	£15.95
Par 3	£11.25	£15.95
We are the Champions	£7.75	£13.10
Soccer Squad	£7.75	£11.25
Game Set & Match II	£9.90	£13.10
Space Ace	£10.50	£11.25
KidsPlay	£2.99	

### STRATEGY / SIMULATION

Kenny Dalgleish	£7.75	
Football Manager II	£7.75	£11.25
Fball Man.II Expansion Kit	£6.25	£7.25
Football Director II		£14.75
Gunship	£11.25	£14.75
Ancient Battles	£11.25	
Micropose Soccer	£11.25	£14.75
Times of Lore	£7.75	£11.25
Chuck Yeagers Ad Trainer	£7.75	£11.25
3D Pool	£7.75	£11.25
Bards Tale	£2.75	£6.25
Passing Shot	N. £7.75	£11.25
Football Director (464)		£7.75
Treble Champions	£7.75	
The National	£7.75	
War in Middle Earth	£7.75	£11.25
Heroes of The Lance	£7.75	£15.90
Airborne Ranger	£11.25	£14.75
Trivial Pursuit (New Edition)	£11.25	£14.75
Emlyn Hughes Soccer	£7.75	£11.25
Track-Suit Manager	£7.75	£11.25
Laser Squad	N. £7.75	£11.25
4 Soccer Simulator	£7.75	£11.25
Archon Collection	£2.75	£6.25
Championship Golf	£7.75	
Carrier Command	N. £Phone	

### EDUCATIONAL

Answer Back Jnr	£7.95	£11.95
Factfile 500s	£3.75	£6.75
Fun School (Us, 5-8, 8-12)	£5.50	£7.95
Maxi Maths (Geometry)	£8.50	£13.95
The Three Bears (6128)		£15.95
Happy Breathing (12-16)		£13.95
Magic Maths (4-8)	£8.50	£12.95
Maths Mania (8-12)	£8.50	£12.95
Chemistry GCSE	£11.90	£14.95
Physics GCSE	£11.90	£14.95
Biology 1 (12-16)	£8.50	£12.95
Wordhang	£7.50	£11.95
Happy Writing	£7.50	£11.95
Physics 1 (12-16)	£8.50	£13.95
Mapwork Geography Quiz	£8.50	£13.95
Spanish Tutor	£12.95	£15.95
French Mistress	£12.95	£15.95
German Master	£12.95	£15.95
Iankey Crash Course (6128/PCW)	£19.90	
Iankey Two Finger (6128/PCW)	£19.90	
Fun School 2 (U6's, 6-8, 8+)	£7.99	£9.99
Happy Fractions (12-16)	£8.95	£13.95

**The Magnum Light Gun**  
With Six Free Games Including 'Operation Wolf'  
Please State 464 or 6128  
Only £32.95 from us.

ARCADE	CASS	DISC
Thunderbirds	£10.25	£11.25
All New Ghostbusters	£7.75	£11.25
Run The Gauntlet	£7.75	£11.25
Dominator	£7.75	£11.25
Vigilante	£7.75	£11.25
Rainbow Island	N. £7.75	£11.25
Robocop	£7.75	£11.25
Skweek	£7.75	£11.25
StormLord	£7.75	£11.25
New Zealand Story	£7.75	£11.25
Indy (Last Crusade)	£7.75	£11.25
Super Scramble	£7.75	£11.25
Barbarian II	£7.75	£11.25
Forgotten Worlds	£7.75	£11.25
Red Heat	£7.75	£11.25
Crazy Cars II	£7.75	£11.25
Gemini Wing	N. £7.75	£11.25
Skate or Die	£7.75	£11.25
Navy Moves	£7.75	£11.25
Munsters	£7.75	£11.25
WEC Le Mans	£7.75	£11.25
Silkworm	£7.75	£11.25
Vindicators	£7.75	£11.25
APB	£7.75	£11.25
Purple Satin Day	N. £11.25	£14.45
Xenophobe	N. £7.75	£11.25
Licence To Kill	£7.75	£11.25
Blasteroids	£7.75	£11.25
Batman (The Movie)	N. £7.75	£11.25
Dragon Ninja	£7.75	£11.25
Bloodwyche	N. £7.75	£11.25
Gilbert	£7.75	£11.25
Rick Dangerous	£7.75	£11.25
Butcher Hill	£7.75	£11.25
Titan (SPECIAL PRICE)	£6.99	£10.25
Renegade III	£7.75	£11.25
Xybots	£7.75	£11.25
High Steel	£7.75	£11.25

### BUDGET

### CASS ONLY

Spy Hunter	£2.75
Battleships	£1.80
Quest / Golden Eggcup	£1.80
Split Personalities	£1.80
Frank Bruno Boxing	£1.80
Super Trolley	£1.80
Trantor	£2.75
Turbo Esprit	£1.80
BMX Simulator II	£2.75
Ghostbusters	£1.80
720	£2.75
Formula Grand Prix	£1.80
A.T.V. Simulator	£2.75
Rugby Boss	£1.80
Mig 29	£2.75
Moto X Sim	£2.75
System 8	£2.75
Bombjack	£1.80
Twin Turbo V8	£2.75
Shockway Rider	£2.75
B.M.X. Freestyle	£2.75
Roadrunner	£2.75
Kickstart II	£1.80
Rocky Horror Show	£1.80
Postman Pat	£1.80
Jockey Wilson Darts	£2.75
Grand Prix Sim 2	£2.75
Green Beret	£2.75
Treasure Island Dizzy	£2.75
Fast Food	£2.75
Adv. Pinball Sim.	£2.75
Gauntlet II	£2.75
1942	£2.75
Blackbeard	£2.75
Street Cred Boxing	£2.75

Lowest Prices  
Available on  
Printer Ribbons

Special prices on  
A.M.S. Software

StopPress	£39.95
StopPress & Mouse	£72.95
Mouse & Art	£61.95
Mouse Mats	£4.95
Max	£16.95
Extra Extra	£21.95

KDS Electronics  
Special Offers

Rombox	£24.95
5 1/2 Second Drive	£158.95
8 Bit Pr. Port	£18.75
Serial Int + Rom	£44.95
Printer T Switch	£24.95
Screen Master	£14.95
Ramdos (Disc)	£23.95
Romdos (Rom)	£27.95

KDS Modems are no  
longer available

Mini Office II  
Still our No1 Seller  
Cass £11.25 Disc £14.75

### Amsoft/Maxell 3" Discs

One	£2.50
Five	£12.50
Ten	£24.95
5 1/2 Discs TEN	£3.90
3 1/2 Discs TEN	£9.50

A Swift Reduction on  
Armor Products

Protex Disc	£18.45
Protex Rom	£28.45
Promerge Disc	£18.45
Promerge+ Rom	£23.45
Prospell Disc	£17.45
Prospell Rom	£23.45
Maxam Disc	£18.45
Maxam Rom	£28.45
Maxam 1.5 Rom	£21.45
Utopia Rom	£21.45

All Prices Include Vat & P&P  
in U.K.  
In stock items sent by  
return of post.

SPECIAL OFFER  
ORDER ANY FIVE  
£1.80 Budget games  
and pay only £8.00

DMP 2000/2160/3000  
Ribbons  
£3.25 each  
£5.99 for Two  
£13.50 for Five

### ACCESSORIES

Rombo Rombox	£34.95
464 Keyboard Ext Leads	£6.99
6128 Keyboard Ext Leads	£7.99
Cover Set 464 or 6128	£7.50
Cover Set DMP 2000/2160	£4.50
3" Drive Cleaner	£4.99
Cassette Player & Leads	£19.99
6128 Cassette Leads	£3.50
Lockable 3" Disc Boxes	£9.99
AMS 30L Disc Box	£12.50

### JOYSTICKS

Superboard	£18.50
Cheetah Starfighter	£13.95
Konix Navigator	£13.95
Gunshot	£5.75
Quickjoy II Turbo	£10.50
Cheetah 125+	£7.95
Supercharger	£12.95
Cheetah Challenger	£4.75
Konix Autofire	£11.95
Konix Speedking	£9.99
Cruiser (Microswitch)	£9.50
Delta	£9.50
Wico Ergostik	£17.75
Amstrad JV2	£13.95
Cheetah Mach I	£10.95
Quickjoy II	£8.50
Quickjoy Turbo	£10.50

### BUS/UTILITIES

### DISC

Adv. Art Studio	£19.99
Joystick Splitter	£7.95
Tasword 6128	£19.95
Money Manager	£24.95
Mastercalc 128	£27.95
Qualitas+	£12.95
Masterfile 3	£32.95
Plan-It	£14.75
Professional Adv. Writer	£24.95
Art Studio & Mouse	£49.95
Taspell	£13.95

### HARDWARE ETC

2160 Printer	£159.95
DDI Disc Drive	£159.95
MP2 Modulator	£29.95
FD1 Second Drive	£99.95
64K Memory Expansion	£47.95
Screen Filter	£19.99
Eprom Storage Box	£1.99
Cont. Paper 2000 60g	£18.50
Cont. Paper 2000 80g	£20.50
Mouse Mats	£4.95
Surge Plug	£12.50
C15 Cassettes	£45
Fanfold Labels (1000)	£5.90
Mouse House	£3.95
RS232 with Commstar	£55.95
Printer Cable	£9.99

### NEW LINES AT LOWEST PRICES

Atari ST Super Pack	£360.00
Amiga A500 Inc Mod.	£370.00
PCW8256 (Inc VAT)	£389.00
PCW8512 (Inc. VAT)	£499.00
PCW9512 (Inc VAT)	£510.00
PPC512 (Inc VAT)	£449.00
PC1512 (Inc VAT)	from £449.00
PC1640 (Inc VAT)	from £550.00
PC2086 (Inc VAT)	from £675.00
Utah GRP, 3 fax (Inc VAT)	£999.00
DMP 4000 Printer	£375.00
DMP 3250 Printer	£220.95
LQ 3500 Printer	£375.00
Epson LX800 Printer	£299.00
Commodore PC 1	from £349.00
80 C Printer Muffler	£85.00

PCW Owners  
write or phone for  
new catalogue.  
PC200 Software available.  
Prices in this advert  
are for Amstrad 464/6128

K & M Computers (AA)  
140, Sandy Lane Centre  
Skelmersdale,  
Lancs, WN8 8LH

24 Hrs Phone 0695 29046

All items are subject to availability

When ordering please state make of computer.  
Please make cheques & P.O. payable to K & M Computers.  
Overseas inc. Eire add £1.00 per item of software.  
We supply government & educational establishments.

Shop Open 9-6 Mon-Sat

Access/Visa orders by phone or Mail  
N = New release  
Please Phone for availability  
and other new releases



Prop. K. Fairhurst

# ROCKSTAR ATE MY HAMSTER

Codemasters • £9.99 cass, £12.99 disk joystick/keys

Rock stars have unsavoury reputations: the Eagles urged us to "party till you puke," the Sex Pistols spat on their audience and one or two have had a penchant for parking Rolls Royces in swimming pools. But none has achieved the ultimate headline which banners across the *Stun* sleazepaper in Codemaster's latest full price offering: *Rockstar Ate My Hamster!*

You've been left 50 grand by a grannie and rather than investing it wisely (like on the 3.30 at Kempton!) you let Cecil Pitt use it to start a rock group. This band, you hope, will make your fortune, by becoming the greatest musical phenomenon this side of Kylie and Jason.

Holding auditions, you view 49 of the most gifted people ever to hold a guitar - make that 50, if you're foolish enough to believe Wacky Jacko has talent! Each tells you their price and you have to weigh their current popularity against your ability to pay their wages. You

## SECOND OPINION

"Colin Jones has succeeded in what seemed an impossible task: creating a funny and playable rock management game. But the question remains whether enough people want to play it. It's great fun for a while, but you may find its long-term appeal limited."

**GREEN SCREEN**  
Perfectly playable

can build a band of up to four would-be megastars (eg. Ms Maradonna, String, Dorrisey and Witless Houston) or concentrate your resources on a rock dinosaur like Bruce Stringbean to bid for the top.

As soon as the band and a name have been decided it's time to start on the campaign trail.

You've one year to get four silver records and rake in as much dosh as is immorally possible. There are three ways of making money: sponsorship, touring and record deals, the relative success of which lies in how much press coverage you attract.

The first choice is whether you're good enough to pack in the fans on January 1st or whether you'll need a little practice. Of course exposure brings offers of recording contracts - but too many nights playing stadiums crammed with six people soon leads to



Below: an ugly manager contemplates an ugly band. Above that the ugly manager and his ugly sidekick sit on the coach while the ugly band are out there "gigging," "spanking planks" and so on. Note the four silver records waiting to be lit up (score so far: nil!); the date (still alive at the end of the year - quite an achievement!); the record sales curve; and last and by no means least the cash from chaos. Millions accumulated, but you're still accounted a failure if you haven't amassed those all-important silver records!

bankruptcy. You've a choice of venue (pubs to mega-sized football grounds) and the admission price (£2 to £20). Careful financial juggling can leave you seriously rich, but if the fans stay away you'll need publicity to cram 'em in.

Ask your trusty sidekick Clive to arrange a publicity stunt, and the very next day you see the headline in the *Stun*. Trouble is, while all publicity is good publicity, some can prove fatal. Results range from "Rockstar ate my wife" (good), through "Rockstar's life of train spotting" (bad) to "Rockstar killed in nuclear war" (ugly). Of course landing the latter with a one man band can bring a promising career to a sudden end. So only dabble with the press when it's absolutely necessary or you have spare band members!

Eventually you sign a recording contract

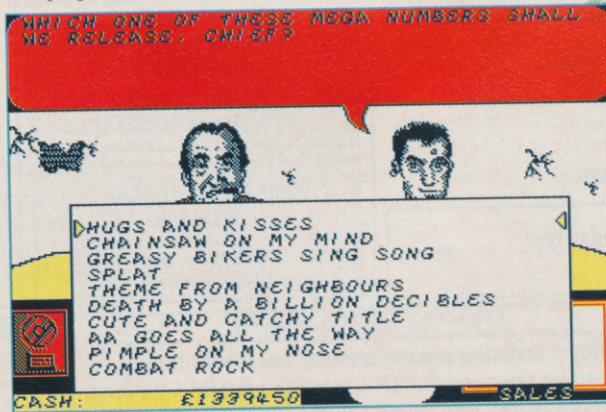

Decisions, decisions... can you choose a winner, "pop pickers"?

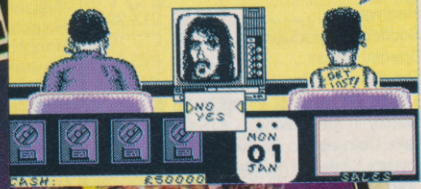

Day one, and an important decision to be made. I'd suggest no, actually, but it's your band!



and it's off to a studio to work the album. You name the tracks as tastelessly as possible until you've a whole host of classic songs ready to whip the great British public into buying frenzy. Upon release you have the option to make a video and there are various expensive locations and directors to choose from - so it's worth having a fair wad of notes available, because if you let Clive shoot it in Cricklewood for £55, it'll never chart.

Once you start releasing the vinyl it's time to keep in the public eye with tours and headline stunts. A bar graph shows how record sales are going, and once a week you get a nailbiting chart countdown as you see if you have at last managed to make the break.

A strategy game based on the music biz may sound about as exciting as Bros in concert, but it's not that bad, and the humour (noticeably tamer in parts than it could and perhaps should have been) gives the game impact. Even when you've finally seen all the snide comments between Clive and Cecil, read all the headlines and made up as nasty a name as possible for your group it remains challenging. It's tough to get those four records high in the charts, especially with the publicity feature killing off your meal-ticket(s) at random intervals!

The caricatures are well observed, with each star having a different appeal and personality - Rotten Johnny always storms out of my groups demanding crates of caviar! The sound

# Bloodwych



**ARGUE! BARTER!  
LIE THROUGH  
YOUR TEETH!!!**



Atari ST Screen Shots



Amiga	£24.99
Atari ST	£24.99
Spectrum (tape)	£9.99
Spectrum (disc)	£14.99
Amstrad CPC (tape)	£9.99
Amstrad CPC (disc)	£14.99
Commodore 64 (tape)	£9.99
Commodore 64 (disc)	£12.99

As the people of the Bloodwych awake to a new dawn, they find a stranger in their midst – from one of many races he has come. His task; to halt the demon that lies dormant within the Castle of the Bloodwych.

Unification of the Crystals of Sanguis will secure the Behemoth in his lair for all eternity. Should they remain separate, then he shall rise to bring darkness into the world.

This unique role-playing fantasy game allows greater interaction with the environment than has ever been seen before. Argue, barter, negotiate – even lie through your teeth! The fully implemented personalities of all the characters in Bloodwych allows a rich style of role-playing that has only been dreamt of.

With one or two player simultaneous mode, this is the game that you've been waiting for. Bloodwych for those that dare!

is basic but changes with each artist and actually improves during the year as the band members begin to gel.

Once you win it's odds on you'll be unlikely to rush into another game, unless being a self centred manager playing Russian roulette with others' lives is the bag you're into. How quickly can you drive someone to their grave for the sake of a buck? Answer: very, especially if it was your hamster the rockstar ate in the first place! **TW**

**FIRST DAY TARGET SCORE**  
Two silver records

**The Verdict**

**GRAPHICS** ..... **79%**

- Limited number of different screens to see.
- 50 excellent caricatures.

**SONICS** ..... **81%**

- The band actually *does* get better with practice!

**GRAB FACTOR** ..... **70%**

- Playing spot the stars is fun.
- Death is too easy for a one man band.

**STAYING POWER** ... **72%**

- Fiendishly difficult to get those silver records.
- One level of difficulty only.

**AA RATING** ..... **76%**

- At last, a management/strategy game that gets away from sport.
- A witty and original look at the record industry.

**"CODE MASTERS PAID ME MONEY!" - SHOCK CLAIM**

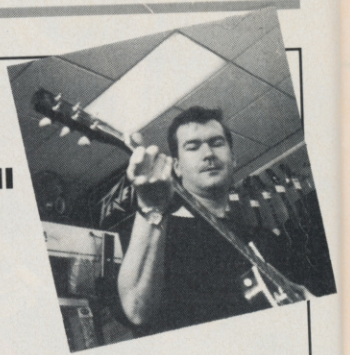

**Rockstar author COLIN JONES tells all to our man with the concealed microphone and the tears in his eyes, STEVE CAREY.**

The rock'n'roll industry has been left REELING from the revelations of *Rockstar Ate My Hamster*, an **OUTRAGEOUS** new game that uncovers the **REAL** truth behind the glitter and glitz of the music biz.

In an **EXCLUSIVE** interview with your caring, sharing, stark staring bonkers super soaraway *Amstrad Action*, *Rockstar's* author (and secret Page Three stunna) Colin Jones has **SPOKEN** OUT for the umpteenth... er, sorry that should read for the very first time. He tells of his secret **FEARS** and **DESIRES**, his **JOY** and his **GRIEF**, his **BREAD** and his **BUTTER**. Now it can be told...

**SELF-CONTROL AND SATISFACTION**

"This game has been the most satisfying project I've worked on," Jones says, "because I designed and wrote it 100% myself, and had complete control. Codemasters gave me free range, and at no time did they step in and say, 'We want this kind of game.'"

"After we'd agreed on the idea for the game I just went away for about six months and came back with the finished game... I don't know why, but they just trusted me for some reason!"

Jones liaised with the music programmer, Paul Highley, and the graphics artist (for all versions), Chris Graham, giving him virtually complete say over the "look and feel" of the game. This degree of control is unusual, at *Code Masters* and elsewhere. "With Chris I came up with some storyboards, the layouts of the screens and all the spoof names of the rockstars I wanted to put in. He's very good at these cartoony caricatures. He'd send the graphics to me and then I'd ring him up and we'd chat about any alterations that might be needed."

**LOOKING AND FEELING**

He is very pleased with the *Amstrad* version of *Rockstar*, calling it "graphically the best of the 8-bits." For one thing, he says, you don't get "those silly attribute square problems." He likes what he calls the "cleanness" of the *CPC* graphics: "and most people will be watching it through the

*Amstrad* monitor and listening to it through the *Amstrad* sound chip. So you have a standard machine to work with. When you work with other computers you don't know what *TV* they're going to be playing it on, and the result can look and sound completely different."

Jones was surprised at how easy it was to find the jokes that make the game. "Once you get a basic framework - groups, songtitles and the rock'n'roll industry - it's very easy to make jokes about it." In retrospect the idea seems stunningly obvious, and perhaps one of the greatest compliments one can pay the game is that it is surprising it hasn't been attempted before. In fact, as Jones discovered, it has: "I was up in Manchester doing a promotional thing and I met Frank Sidebottom's manager, who revealed that Sidebottom had made his debut in a rockstar management game he'd written for *Virgin*." Unlike *Rockstar*, however, Sidebottom's effort sank without trace.

**"BAN THIS SICK GAME"**

The game has created its own controversy, being banned from major chainstores, principally because of what's in the manual. Jones, however, absolutely denies any suggestion that this might have been a deliberate attempt to attract publicity, and insists that the banning was not only unexpected but unwelcome. "The game is non-sexist, non-racist and non-violent, even though it does use cartoons of page three girls. It's poking fun at them." (This argument - it's only a bit of fun - is exactly the one used by the pornographic *Sunday Sport*. Still, *Rockstar* is nowhere near as offensive as that. You'd have to be a nun or a prude to be shocked by it.)

**GET YOUR ROCKSTAR OFF, SAYS MAD MULLAH MRS W!**

But that's not to say that Jones has been careful to avoid contra... controv... er, offending people: "I want some people to be offended by *Rockstar*. Mrs Whitehouse, for one. It would make her day, wouldn't it? That's what she does, she gets offended."

And as Jones left to return to his secret hide-away somewhere in Wales, he had this warning for the stars, many of whom are said to be terrified that *Rockstar* may

bring to a sudden end their life of luxury: "Look out you rockstars - your days are numbered!" ●

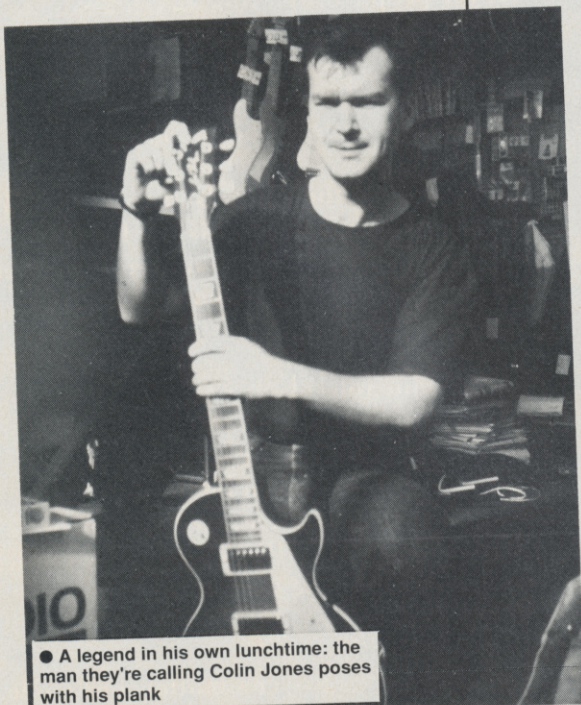

● A legend in his own lunchtime: the man they're calling Colin Jones poses with his plank





# INDIANA JONES AND THE LAST CRUSADE

US Gold ● £9.99 cass, £14.99 disk joystick/keys

The man with the hat is – well, you know the rest. Summer 1989 may go down in history as The Summer of Hype, with Batman way out in front and Bond and Jones fighting for second. And no film hype is complete these days without a computer game tie-in. There's nothing wrong with that – except perhaps that so much money is invested in the licence that little may be left over to spend on developing a decent game.

We are fortunate, then, that both *Licence to Kill* and *Indiana Jones and the Last Crusade* prove well up to the mark. And although it is a great pity US Gold have compromised on a cheap Spectrum port to Amstrad, at least they are continuing wholeheartedly to support our machine, realising that there's still gold for Gold in these here CPCs! (I wonder how they feel, incidentally, about *Rick Dangerous*, a game remarkably similar in look and feel?)

As with *Licenced to Kill*, *Indy* is devised as four separate sequences taken from – or perhaps that should be "inspired by" – scenes from the film. It's not necessary to have seen it, though if you liked the first *Indy* film and loathed the second you'll find *III* a return to form.

Those who have shelled out will know that what makes it is the presence of retired Bond Sean Connery, turning in a sardonic and yet affectionate performance as *Indy's* old man (though in reality only 11 years separates



● *Indy*: "Say, Miss Broadley, I reckon we may have found a copy of AA1!"  
Emme Broadley (for it is she): "Ah shut up and get your kit off ya big lummoz!"



● That's The Cross of Coronado, above *Indy* – but how will he get there?

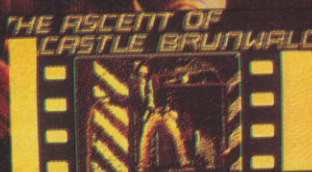

● Made It through mission one! Now for part two...

him from Ford!). It's unfortunate, then, that in the game there's no sign of *Indy* senior.

Still, what you get is not bad, not bad at all. The first of the four arcade-type adventures finds Jones attempting to recover the Cross of



● Above the Zeppelin (mission three)

Coronado. In the film it's the young Jones (played by the bizarrely named River Phoenix), doing his priggish Boy Scout bit ("That artifact belongs in a museum!"). Here the brief scene in the caves is drawn out into an enormous, and very

difficult, subterranean sequence. *Indy* has to brave knife-throwing thugs, falling rocks, poisoned swamps, knife-throwing thugs, disintegrating bridges, knife-throwing thugs and knife-throwing thugs. He also needs his whip – and has a strictly rationed number of cracks with it – a firebrand (he left the torch in his other trousers) and a memory much better than most of us possess in order to find his way around an amazing

labyrinth. (The firebrand, by the way, is just a fancy time-limit, because if you hang around too long it starts to get dark: keep moving, especially if you have a green screen!) This geographical confusion isn't helped by the fact that the landmarks are compiled of about half-a-dozen items that reappear every few screens. They are much like the backgrounds you see cycling round in cartoons: a barrel, a rock, a pile of rocks; a barrel, a rock, a pile of rocks... And the guys who seem to spend all their time shinning up and down the very ropes *Indy* was hoping to shin up and down bear an uncanny resemblance to the man himself. What is this, some kind of cunning disguise?

Despite a superb series of loading and title screens and that instantly recognisable John Williams theme, however, early signs are not good. He's somewhat jumpy, is our *Indy* (as who wouldn't be, with all these knife-throwing thugs about?), and displays a distressing tendency to mistime his jumps and end up plunging 30 feet or more onto the rocks below. Naturally this tends to sap the

old strength somewhat (represented by what looks like a stick of rock or a barber's pole at the bottom left of the screen). Still, after a couple dozen inglorious deaths he starts to get the hang of things, knowing when to avoid the – you guessed it – knife-throwing thugs and suchlike.

You'll soon get heartily sick of starting from the beginning, but despair not: once you've got up to the poisoned swamp

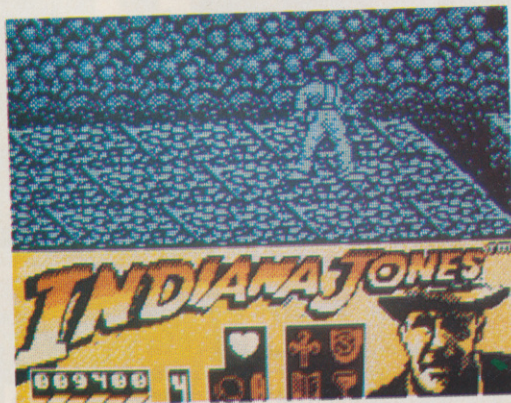

● The devilish opening screen on the fourth and final mission

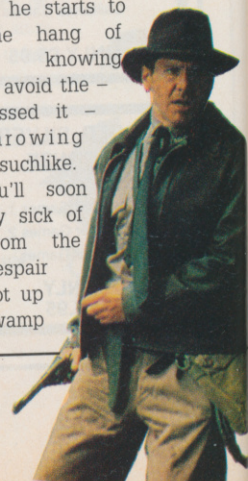

you don't have to start again (until you've lost your last life, that is). Each level has about four or five "restart" points, helping you to guess how far you've progressed.

One of the things that's best about *Indy* is Indy the sprite. He runs! He jumps! He hangs onto his hat! He falls (quite frequently, unless you're careful!) And if you can't quite decide what to do, he turns towards you and shrugs in that "Handsome" Harrison Ford way that turns Emma Broadley into a lovesick girlie (yeuch!). All in all *Blue Turtle* (for it is they) have done a remarkable job in capturing the crumpled charm of Indy, a man not afraid of looking afraid and unlike old smoothiechops Bond in that he sometimes looks as if the pressure's getting to him.

As indeed it is. Manage to recover the Cross of Coronado and your mission is only starting. Next it's time to try and find the Crusader's Shield. Here you'll find a copy of the *Byzantine Crusader* comes in handy - you know, the piece of paper that came with the game, the one you lost... Ah. Oops! Assuming you find it again you'll need to look up the "Grail Diary" page to check the code. Otherwise you may find yourself wandering for eternity inside an archway that doesn't even contain the shield. Even assuming you do choose the correct archway, it's a fair bet you will be spending what seems like eternity looking for the blasted thing. I dare say two or three smartarse gamers will be writing in to *Reaction* saying they finished it before it had even loaded, but for most of us mere mortals *Indy* should only be attempted when there's a whole lot of time between you and bedtime.

Mission three takes you to the Zeppelin (a scene I recall as being possibly the worst special effect since *Batman* was a TV programme), which is notable chiefly for a sickening wobble that's meant to suggest an airship and succeeds only in suggesting a visit

to the optician. Once again a cunning time limit is imposed, in the form of flimsy paper passes that disintegrate after a while. Keep moving or the alarm will be raised! The final mission, which as we go to press I have barely begun to explore, finds Indy attempting to get to the Holy Grail in order to save his old man, whose heart is gradually turning to stone (sounds like Trenton talking about me, but don't believe a word of it!). The first screen appears to have a break-dancing

**SECOND OPINION**

*"Much as I lust after Harrison Ford, and much as I enjoyed this latest film, I found Indiana Jones and the Last Crusade the computer game dull and uninspired."*

*"I think US Gold deserve to fall into a poisoned pit themselves for doing a Spectrum port. To my mind, Indy never gets going."*

Emma Broadley

**GREEN SCREEN**

*Very dodgy indeed when the light goes - keep moving fast!*

(remember break-dancing?) and ice-skating Indie, and is a real pig to get off until you learn the trick. Clue. press fire and push joystick up. Enough said.

If the idea of a game that involves platforms, problem solving, punching and whipping, knife-throwing thugs (mustn't forget the knife-throwing thugs) and climbing ropes appeals to you, *Indy* is just your Grail of tea. Don't be discouraged too soon: there's lots to do, and progress at first is slow. But take my word for it: once you get the hang of things you'll find plenty here to keep you in fast heartbeats for heaven knows how long. SC

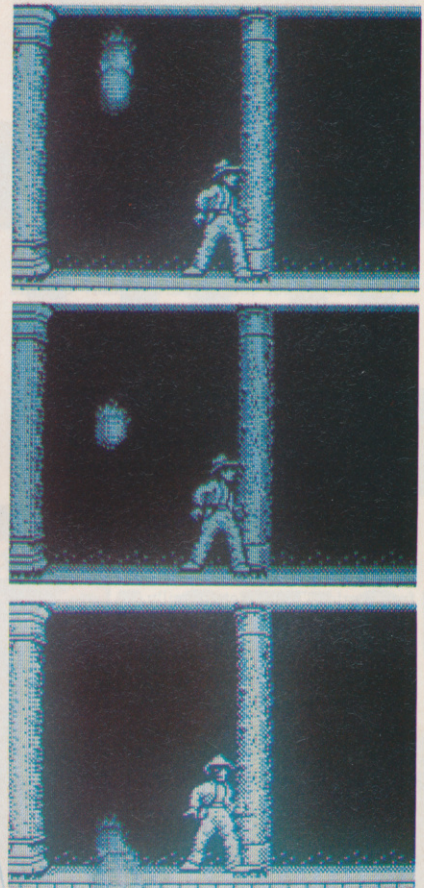

● For mission two the overhead perils become cascading balls of fire. Note on the bottom picture how Indy looks to you for help - as if you knew what to do!

**FIRST DAY TARGET SCORE**

Spot the Cross of Coronado!

● From mission two, *The Ascent of Castle Brunwald*. At the bottom on the left (looking like a stick of rock), is Indy's "healthometer" and score (he's 100% fit, but hasn't scored yet - oooer).

Next to that are his remaining lives (5): the icecream is his torch, and the ring thingy is his whip, plus the number of cracks left.

And to the right of that are the four objects he's after: the Cross, the Shield, the Diary and the Grail itself.

Such a lot of info for poor Indy to carry in that pretty little head of his! (Well, Emma B. fancies him!)



**The Verdict**

**GRAPHICS** .....82%

- Indy moves well and looks good.
- Spectrum (boo!) conversion.

**SONICS** .....74%

- Music is well done.
- But the effects are not so special.

**GRAB FACTOR** .....61%

- Difficult to get going.
- More restart locations would be appreciated.

**STAYING POWER** .....87%

- Four massive levels keep you busy.
- Time limits pile on the pressure.

**AA RATING** .....83%

- Enough to keep you busy for a long time.

# STRIDER

US Gold ● £9.99 cass, £14.99 disk joystick/keys

*Strider* hates US Gold. They always try to weave a story into their arcade conversions, but this time they've gone too far. He's been landed with the daftest excuse for a plot since last night's *Neighbours*. How will he ever face his arcade nutter counterparts again? Oh, the shame of it!

The plot on this outing has this sword-wielding nutter sent to attack the Red Army and save the western world (*glasnost?* *Wossat* then?). All starts well enough as he fights his way around Moscow and then zips up to Siberia to mix murder and a spot of skiing. But then he goes to the jungles of deepest Russia (?) and eventually battles the Master Soviet mutant (!?) to save the free world. This is getting silly.

So when you play *Strider* just get into the game, because it's good violent fun and no reasons are really needed. The screen ain't big enough for both of you so something's got to give, and it ain't going to be the *Strider*. You fly into Moscow on a hightech hanglider and drop down on to the red rooftops with a smile on your face. After all, *Strider* is a professional and he enjoys dusting people.

The first few waves are little more than limbering up exercises: a guard all kitted up in body armour and a real wimpy gun gets a quick appendectomy and a hovering weapons carrier can be persuaded to drop a protector 'droid for you. Want more? No problem, there's a whole army of these guys (literally) out there all

possibility of defeat, he's too busy looking good.

The battles continue, not particularly trickily, until you start encountering the level nasties. A big guy flies at you and must be sent into a cowering crouch before escape is possible. A laser turret forces you to up the strike rate and make like Michael Jackson between laser beams in an attempt to dent more than its pride. The worst of all is the ringworm (a sabre flashing worm created out of rings!) who bounces all over the place trying to to cause you grief.

Roasting opponents is generally a matter of having seen each part before and knowing

have you making those strange martial arts noises that Ninjas are so found of in the movies. Not as intensive as *Forgotten Worlds*, it requires more brain work as well as deft waggling and wiggling to help the last hope for freedom strike a few blows for life, liberty and the way of the warrior.

The trips through the various Russian backdrops (including a rainforest - news to me!) leads to four levels of senseless violence, which is really its strong point. *Strider* is put together with real thought and skill, suggesting strongly that the Capcom boys are working up to a real classic to make them legends in the computer aggro world. *Strider's* great but falls short of that classic grade - although a firm grounding in their style of gameplay will be required when their day of glory comes. Pass the blade Stevie, I've got a ringworm problem and I think I know how to cure it!

TW



● Fighting the ringworm, try to find his weakspot

where to stand and strike those darned Ruskies. It's not the concept that makes *Strider* memorable - it's little more than a "grew up platform game" - but the technical execution and fiendish blend of problems and foes. Is it best to jump and run, duck and cover or stand or fight? Only time and plentiful practice will tell if you've got what it takes to rock with these guys.

The only failing in this arcade cut-'em-up is the feeling that with the bigger foes you don't really know whether you're causing them pain or wasting effort until they disappear in a puff of smoke (always bad for your health). This seems to be a feature of Capcom's work, as anyone whose tried to top Bios in *Forgotten Worlds* will know. This is purely a personal gripe and the game will no doubt build a even stronger following among fans of Capcom's new programming superstars.

Graphically the leaps and bounds almost

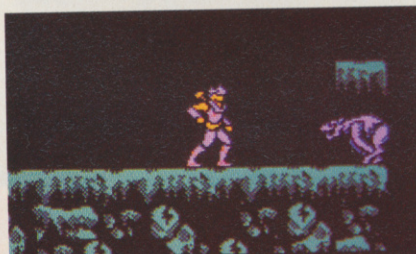

● Watch out for the wolves on level two, they bite!

### FIRST DAY TARGET SCORE

20,000 points

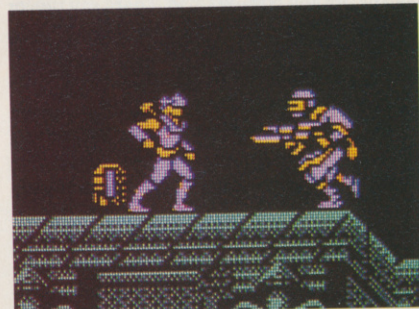

● If hit these pods release a protector droid

### SECOND OPINION

"This, the latest in a growing genre of platform Ninja games, is one of the best of its kind. You want to kick? You want to leap outrageous distances? Become *Strider* and you won't look back!"

SC

**GREEN SCREEN**  
Very visible

spoiling for a fight. More wasting awaits you as your progress along the rooftops is hindered by sword fodder.

All's well until you meet an obstacle that even your trusty katana can't destroy, a huge chasm. So you wind him up to jump across and "yo mama!" Has this boy got style, or what! None of this half-hearted Fosby flop nonsense, *Strider* flips a huge somersault 15 feet up and 20 forward, to land deftly on the other roof. He don't even think about the

### The Verdict

**GRAPHICS** ..... 83%

- Athletic sprites.
- Purple and orange - lovely mix!

**SONICS** ..... 72%

- Brilliant music, OK effects.

**GRAB FACTOR** ..... 84%

- Simple controls launch you into an ever more complex game.

**STAYING POWER** 81%

- A sprinkling of nasties per level help to maintain the pressure.
- Only four levels.

**AA RATING** ..... 80%

- Great arcade slashing fun.

# SUBSCRIBE

## NOW TO AMSTRAD ACTION

### YOUR MAGAZINE DEDICATED TO YOUR MACHINE

Only £17.95 for 12 action-packed issues (and we even pay the postage for you!)

Ring 0458 74011 NOW, quoting the order code AA396 and having your credit card handy or use the order form on Page 98. Why not order some of the latest and cheapest products from The Amstrad Action Special Offers at the same time!

Remember our unique guarantee: we will refund the cost of all unmailed issues, if you are not completely satisfied with our subscription service.

- ★ Hotline Number 0458 74011
- ★ Order Form on Page 98
- ★ Be sure you get your copy before the newsagent sells out
- ★ Get our regular quarterly "UPDATE" of extra-special savings on products that we didn't quite manage to squeeze in the magazine!

**NOT an official Amstrad publication!**

BRITAIN'S BEST SELLING MAGAZINE FOR THE AMSTRAD CPC 464 ● 664 ● 6128  
ISSUE 48 ● SEPTEMBER 1989 ● £1.45

**AMSTRAD ACTION**

FROM FUTURE PUBLISHING COMES THE MEGAZINE THAT LEADS THE FIELD

**PRESS FOR ACTION!**

The expert guide to publishing newsletters, fanzines and booklets on your CPC

plus WIN a £750 Mannesmann Tally 24 pin printer to enhance your creativity!

**ONLY** **£17.95** **FOR 12 ACTION-PACKED ISSUES**

# THE RUNNING MAN

Grandslam ● £9.99 cass, £14.99 disk joystick/keys

In 1919 the nightmare of corporate empires has become all too true. One man dares to say no to the totalitarian system, a police officer named Ben Richards - alias Arnie Schwarzenegger - and he is about to pay the price. Richards is to become a *Running Man*.

The *Price is Right* gone crazy, *The Running Man* sends convicted prisoners into a maze to fight for their lives against a crack squad of flashy assassins. Watched by millions, this is the most successful show ever to hit the crystal bucket and viewing figures are going to be high tonight because the "Butcher of Bakersfield" is about to run.

Little do the poor defenceless TV promoters know that they've made two big mistakes. Firstly, Richards, the aforementioned "Butcher," is actually innocent (well surprise, surprise) and is rather keen to get even with the people who framed him. And secondly they've transgressed the unwritten law of movies - never play a villain opposite Arnie if you want to walk again!

So down the chute you shoot with Uncle Ben into the arena. The show takes place in four different locations, each with a different assassin, or stalker, taking on the man mountain. First comes Subzero, an ice hockey player who uses his stick and pucks to great effect, tripping and beating runners into submission (or more often the after life). Stalker number two is Buzzsaw, who specialises in a chainsaw - not very sporting but it gives him an edge (*ouch*). Next it's Dynamo who uses a special electrified suit to zap people, so punching him isn't really a smart move. Last but not least comes Fireball, who uses fireballs (these Schwarzenegger movies are so full of surprises) to cut opponents down before he wades in with his fists.

If Ben survives all these little tests it's time to go back live to the studio for a word from our sponsors and some physical violence for Killian, the show's sadistic host. An

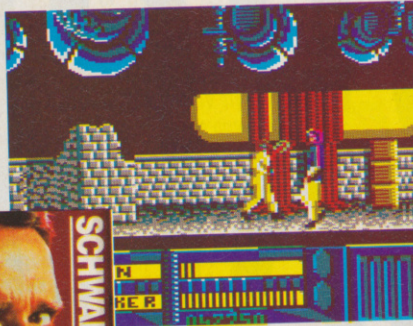
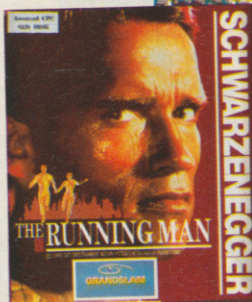

● On Level Three you meet Dynamo

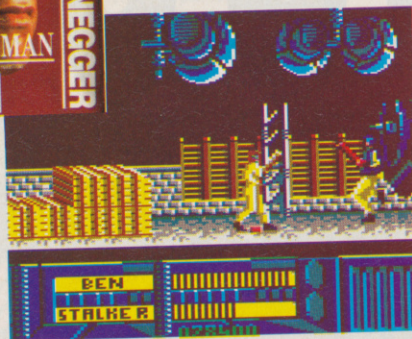

● Buzzsaw uses a chainsaw, you use a stick!

ideal formula for both a film and a computer game, one would think, but then again have you seen the movie? OK, so it's not *that* bad but it's more than ropey in places. The game, on the other hand, is just ropey all the way through - with the possible exception of the loading screen!

Your attention is first grabbed by the attempt at parallax scrolling. Good idea, shame it doesn't work. The effect that this

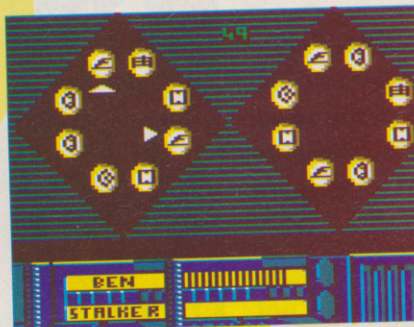

● Line up the symbols to get extra energy

has on the game is remarkable: touch any part of the scenery and the whole screen wobbles like a *Crossroads* set. I know the game is set in Los Angeles, but this many earthquakes? The sprites themselves have to be seen to be believed: indefinite, sketchy outlines and a very limited number of animated poses. The unintentional highlight of the game being the Ben Richards waddle. Due to the way he's been animated every third step his rear end becomes so pronounced you'd swear it was Ankeka Rice and not Arnie out there.

The combat is limited to say the most. You

control your player with the options jump, kick and punch. Occasionally you can pick up a weapon but even here Arnie prods at the stalkers as if he's trying to tickle them to death, not beat them up good and proper.

The only saving graces are the sub-games, where you're trying to find the combination to a satellite beaming station by jiggling a set of symbols. In the story it allows you to broadcast to the nation and declare your innocence; in the game it's for points and full health. After a few games this becomes irrelevant as the stalkers are easily defeated wimps, with the only energy loss

## SECOND OPINION

"Oh dear, oh dear, oh dear. You'd honestly have more fun playing noughts and crosses. Cheaper, too." SC

**GREEN SCREEN**  
Just as awful in green

coming from falling into or off the scenery.

Overall *The Running Man* is a poor excuse for computer entertainment. It's not fun to play, the technical execution is atrocious and it gives every indication of being put together piecemeal fashion. It doesn't do the film justice (and that's saying something) and yet like *Red Heat* it will sell simply on the strength of the Schwarzenegger image. Arnie is a perfect subject for computer games: let's see someone use that potential and create a game (based on the *Terminator* for instance) that you wouldn't feel nervous about showing to the man himself. TW

## FIRST DAY TARGET SCORE

Not reformatting the disk!

## The Verdict

**GRAPHICS** ..... 28%

- Nice loading screen.
- Appalling scrolling, bad sprites.

**SONICS** ..... 69%

- Great rendition of film music.
- Average sound effects.

**GRAB FACTOR** ..... 35%

- Very easy...
- In fact, far too easy.

**STAYING POWER** 10%

- Finish it on day one, then forget it.

**AA RATING** 29%

- Nice box, shame about the contents.

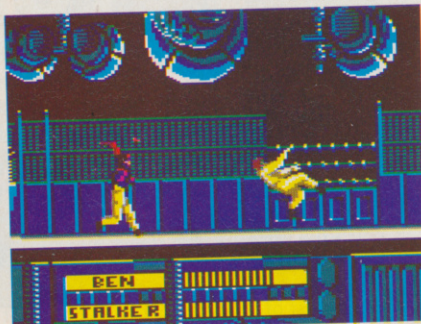

● Subzero fires pucks to trip Richards



Smogware  
Systems

20 Grove Avenue, New Costessey, Norwich, Norfolk, NR5 0HN, ENGLAND

## RSX - LIB (1.0)

The RSX Library Utility

### DON'T YOU JUST HATE RSX'S?

- Great in theory, but a waste of time in practice?
- All that messing around with machine code? With RSX-LIB, YOU'LL LOVE THEM!
- Select the ones you need from RSX-LIB's library
- Run them from anywhere in memory (self-relocating)
- 52 RSXs supplied free!
- Add more yourself (automatically) using assembled code, binary type-ins, RSX type-ins, etc
- Simple to use utility, with comprehensive (and friendly) manual

Suitable for all CPC machines,  
but supplied on DISC ONLY

Cheques (£ sterling),  
Eurocheques, or UK P.O.s for  
£19.95 (UK), £21.45 (Europe),  
£21.95 (Rest of World)



## BIT - 7 Computer Software

221 Rockingham Road, Kettering,  
Northants, NN16 9JB

### The Tiny Desk Top Publisher.

Complete DTP package. Includes 6 extra fonts, cut & paste and graphics.

REVIEW IN AA41 6123 disc only  
Only £8.00

### The Learning Pack

A set of educational but enjoyable programs for young children.

- 1) Text to pix : turns words into colour pictures.
- 2) What time ? : teaches hands to hours/minutes.
- 3) Simple sums : numbers are printed as they would be written.

Plus more.

For any CPC £8.00 tape/disc

COMING SOON !!! Page Setter 64

The first 64K DTP !

First on disc - later on 4 tapes.

Fully featured ! Just £10.00

## 3 1/2" DISC DRIVE £89.95

800K STORAGE CAPACITY

This quality drive is just 1" high and, when used with Rodos (ROM), Romdos (ROM) or Ramdos (DISC), can store 800K of files without flipping the disc. It is supplied cased. Power supply and cables are included. Please state 464/664/6128.

When supplied with Rodos, price is £119.90

When supplied with Romdos, price is £124.90

When supplied with Ramdos, price is £114.90

464  
Only

The amazing  
ROMBOARD XTRA  
including  
6128 UPGRADE SOCKET

FEATURES  
plus -

6 Standard ROM Sockets  
Put a 6128 ROM in the 7th socket and you have a working 6128 operating system. Upgrading is as simple as that!

plus -

464/6128 selector

plus -

Cold start RESET BUTTON

plus -

Through connector for further expansions

ALL THIS FOR JUST £20

6128 ROM £19.50

64K RAM PACK £49.95

6128/  
664

### THIRD DRIVE SWITCHING CABLE

Connect to any combination of 5.25", 3.5" or 3" disc drives.

ONLY £8.50

(Please state makes of drives if known)

We buy and sell quality used computers and peripherals.  
Give us a ring and we might have it.

MICROSTYLE

DEPT AA, 212 Dudley Hill Road, Bradford BD2 3DF

Tel: 0274 636652

# 50 GOOD REASONS TO SHOP AT CRAZY JOE'S

10 Computer Hits 5.....£4.99	Prodigy .....£1.99
10 Great Games 3.....£6.99	R-Type (Disc).....£7.99
3D Pool.....£6.99	Roland in Time (464).....£0.99
4 Soccer Simulators.....£4.99	Roy of the Rovers.....£2.99
Answer Back Junior Quiz.....£4.99	Runestone.....£1.99
Bard's Tale.....£2.99	Scraples.....£4.99
Bombjack 2.....£1.99	Skweek.....£6.99
Daley Thompson Decathlon.....£2.99	Spy Hunter.....£2.99
Fernandez Must Die.....£3.99	Star Wars.....£3.99
Fernandez Must Die (Disc).....£4.99	Starglider (Disc).....£6.99
Forgotten Worlds.....£6.99	Supreme Challenge.....£6.99
Game Over.....£2.99	Tetris (Disc).....£4.99
Gauntlet 2.....£2.99	Thunderbirds.....£6.99
Geoff Capes Strongman.....£0.99	Tiger Road.....£4.99
Gothik.....£1.99	Time Scanner.....£6.99
Grand Prix Selection.....£4.99	Trio Hit Pak (3 Games).....£2.99
Harrier Attack.....£0.99	Triv Pursuits Baby Boomer.....£3.99
History in the Making.....£12.99	Triv Pursuits Young Players.....£3.99
Hunt for Red October.....£6.99	Twin Turbo V8.....£0.99
Inc. Shrinking Sphere (Disc).....£4.99	Victory Road.....£4.99
Jack the Nipper.....£2.99	World Series Baseball.....£0.99
Last Ninja 2.....£7.99	Cheetah Mach One Joystick.....£9.99
Monopoly.....£4.99	Konix Navigator.....£12.50
Pacland.....£5.99	Konix Speedking.....£9.50
Pacmania.....£4.99	Maxell CF2 3" Discs (10).....£22.50

## Crazy Joe's, Dept. AA, 145 Effingham St., Rotherham, South Yorkshire S65 1BL

Visa and Access Orders Taken on (0709) 829286

Please make Cheque/P.O. Payable to "Crazy Joe's"

P&P FREE in U.K. on orders of £5 or over. Under £5 please add 50p.  
Europe (inc. Eire) add £1 per item. Rest of World add £1.50 per item.

## A SMALL SELECTION FROM OUR WAREHOUSE

Hardware & Peripherals (Offers while stocks last)	RRP	WAVE
Amstrad CPC6128 Green with Joystick & Software.....	299.99	254.99 ANC
Amstrad CPC6128 Colour with Joystick & Software.....	399.99	339.99 ANC
MP-2 Modulator/Power Supply - CPC464/664/6128.....	29.95	23.96 C
DDI-1 1st 3" Drive Inc. Interface & Cable - CPC464.....	159.95	126.36 B
FD-1 2nd 3" Drive - CPC/43 (6128/+3 Also Req. DL-2).....	99.95	85.14 C
DL-2 Cable - FD-1 to CPC6128/+3.....	6.95	5.56 E
PL1 Lead, Printer Centronics Parallel - CPC/+3/+2A.....	14.95	7.48 F
Star LC10 Parallel F&T NLO Printer (Reqs. PL1 Lead).....	297.85	158.01 A
Computer Labels 89mm X 36mm 1 across.....	Box 1000	9.20 6.44 D
Croxley 11" x 9.5" Listing Paper 60G.....	Box 2000	24.93 9.76 B
2482RN Ribbon Re-inking Nylon - DMP2000/3000 series.....	Pkt 2	11.90 3.92 F
Fabric Ribbon Re-inking Fluid (Aerosol).....	8.95	6.91 E
Amstrad JY2 Joystick - CPC.....	14.95	9.72 E
AMX Mouse Inc: Interface & AMX Art S/W - CPC464/664/6128.....	69.99	46.79 D
AMX Mouse Inc: Interface & Stop Press S/W - CPC6128.....	79.99	54.56 C
RAM Electronics Music Machine (Tape Ver.) - CPC.....	49.95	42.46 C
RAM Electronics Music Machine (Disc Ver.) - CPC.....	54.95	50.55 C
Trojan Light Pen & Graphics Software - CPC464 Colour.....	19.95	14.96 E
Trojan Light Pen & Graphics Software - CPC6128 Colour.....	23.95	17.96 E

### DO YOU WANT TO SAVE MONEY, THEN SEND FOR OUR TRADE PRICE LIST

(State for which products and enclose 3 x 19p stamps)

Blank Discs & Software		
Connect Money Manager - CPC/PCW.....	29.95	19.47 E
Supercalc 2 ! NEW VERSION ! - CPC/PCW.....	69.95	48.96 C
Tasword 6128 (Word Processor) - CPC6128.....	29.95	20.96 D
Amstrad Amcase Library Case Holds 10 x 3".....	7.95	3.98 E
Amsoft 3" Discs DS/ALL 3" Drives.....	Box 10	29.90 20.93 E
Maxell 3" Discs DS/ALL 3" Drives.....	Box 10	29.90 18.99 E
Verbatim 3.5" DS/DD 135tpi Bulk Discs.....	Pkt 25	62.50 20.63 D
Verbatim 5.25" DS/DD 40/80T Bulk Discs.....	Pkt 25	27.27 7.36 D
AMS30L Storage Box Holds 15 Cased/30 Uncased 3" ! NEW !.....	14.95	9.72 D

### CAPTAIN CAVE MAN BBS NOW ON LINE 4PM TO 9AM 0229-473609

Eng. Mainland post & ins.: (A) £5.75 (B) £4.60 (C) £3.45 (D) £2.30 (E) £1.15 (F) 58p  
(ANC) 3 Day £10.35 Next Day £13.80, COD+ £2.30, Max UK post chg. £6.90 per 20kg/£500.

All Prices Include VAT. All sales subject to our Trade Terms of Trading.

W.A.V.E. (Trade Dept. AA 1089)

Walney Audio Visual & Electrical Distribution

1 Buccleuch Street, Barrow-in-Furness, Cumbria, LA14 1SR

Tel: 0229-870000 (6 lines) Hours: Mon - Fri 10.00-5.00



# Target renegades

Just who do Target Games, the team responsible for this month's *Mastergame*, *Laser Squad*, think they are? We sent JEFFREY DAVY to find out.

**K**ERRUNCH! The *Laser Squad* assassins burst through the front door of Sterner Regnix, multi-millionaire head of the Marsec Corporation, the most unscrupulous arms firm in the Universe. Their mission? To eradicate him once and for all, of course.

Such is one of your missions in Target Games' *Laser Squad*, already a hit in its Spectrum form. Julian Gollop is the programmer and creator of this and several other hit strategy games.

Julian didn't start on the programming ladder in the normal way: "I was never into computers," he admits: "my main interest was, and still is, game design. But having got hold of a Sinclair ZX81 in my sixth form, it wasn't long before I tried programming games on it because I thought that computers would be quite a good vehicle for the games I wanted to create."

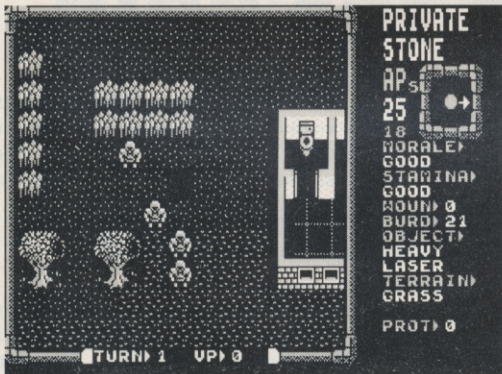

■ A scene from an instant classic: Gollop and Target Games' *Laser Squad*: for the full review, see p. 50

## Timelords gentlemen please

He wrote his first proper game on a BBC: "It was called *Timelords*, written for Red Shift, a group of friends of mine all interested in [board] wargames who decided to produce similar games for computer. It's the most original game I've done and it still fascinates me."

The game, with its Doctor Who-type plot, was a far cry from the blow-away-the-aliens products of today. Your aim was to act as a Timelord in a randomly-generated computer universe. This universe had alien races all vying for power. You could change the outcome of events, and so change time itself!

"It created some rather great logical problems!" Julian recalls. You could even find yourself destroyed before you'd ever existed and affected anything and reincarnated through the time-tamperings of others. The arguments over the results of changing time are enough to leave anyone totally confused.



His second game, more like the games we see now, was *Nebula* for the Spectrum, in which you play an alien whose eventual aim is to dominate the universe. Unsurprisingly, others were out to do the same, and random events such as plague, rebellions and earthquakes didn't help your imperial aspirations one bit.

The next project, the original *Rebelstar Raiders*, was written quickly. The aim was "individual, tactical warfare involving anything it's possible to zap" for two players. It was to have three scenarios - Sci-Fi, Castles, and World War II. Only the Sci-Fi one ever got completed.

## Debt on arrival

Red Shift then died, and Julian went on to Games Workshop where he wrote the much-neglected *Chaos* and part of *Battle Cars* after finishing two more BBC games called *Islandia* and Version 2 of *Timelords*. *Chaos* is an enthralling game of spell-casting, mystical and mythical monsters, and all-powerful wizards - re-released as a Firebird budget game.

It wasn't until Summer 1985 that his next game, the best-selling budget game *Rebelstar* (Firebird) appeared - yet he's still bitter about it! Why? "Well, it sold thousands of copies, and all I got was £1,000 for ten months work. You'd be crazy to choose to do ten months work for £1,000!" he says.

*Rebelstar* is a development of the original *Rebelstar Raiders*. It is set in a Moonbase and has two sides - Raiders and Operatives.

It is the Raiders' mission to storm the base and destroy a computer while the Operatives' attempt to stop them. It has a bit more razzmatazz and action than most strategy games.

*Rebelstar* was his first game on the Amstrad, which according to Gollop has several

problems.

He cites memory limitations as an example, but argues that the major difference between the Amstrad and Spectrum is the graphics. Despite its lack of colour, he produced some quite detailed graphics in the machine's four colour mode. He was also able to add many features that were not present in other versions, including a scanner and a new playing area.

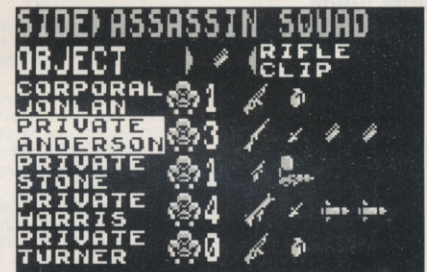

■ OK men, you know your mission: let's do it!

It was some time until his next project, which only came about after a period of heart-searching over whether his future lay in programming. He made a choice, and *Rebelstar II* was the result. Firebird, damn their eyes, didn't feel the need for an Amstrad version.

## To boldly go it alone

Dissatisfied with working for other peoples' software companies, Julian, Nick, and Peter Gollop set up Target Games in March 1988 with the aim of "producing high quality strategy games designed to go beyond the middle mark... to produce something original and keep that standard up". *Laser Squad*, their first release, is billed as a "tactical warfare simulation" involving a band of fighters in three initial missions - with more to follow. It's a considerable advance on *Rebelstar*, is just as much fun and is set to become an instant classic (see Trent's review on p. 50).

The Amstrad version is truly something special, with detailed four colour graphics like those in *Rebelstar*, improved Artificial Intelligence, and - inevitably for a quality Amstrad version - more and better sound with a variety of special effects.

His only problems were, of course, cramming everything in and making the graphics smooth and fast enough. "I'm very proud of what I've achieved in the Amstrad version," he says: "I honestly believe I've got as much out of it as anyone can."

He could be right. ●

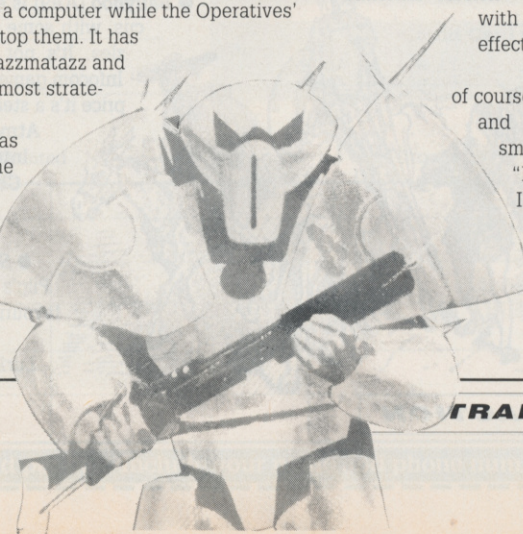

# PILGRIM

Making a triumphant return, it's the best adventure column in the world!

Oh 'tis indeed passing good to be back, my fellow adventurers!

By overwhelming public demand (thanks all), a rejuvenated and changed Pilgrim returneth with a veritable host of new ideas.

But don't let this column die: get writing!

## A word from our sponsor

“ I've been surprised and delighted at the number of people who've written demanding the return of the Pilgrim,” writes AA's editor Steve. “To be frank the two month 'holiday' was an experiment: I wanted to discover the strength of feeling about the column. Adventurers galore have made their feelings known, and the future of this section is now secure – if you keep writing. Well done all!”

## Scapeghost is coming!

Level 9's *Scapeghost* is about to be unleashed on the adventure playing market. You're a murdered detective who has become a ghost and it's your task to hunt down within three nights the gang responsible for your death.

The detective/ghost combination allows for some tricky puzzles – you have psychic powers from the ghostly world but you also still have your detective powers. Some of the puzzles require that you use your dual skills to the limit.

Level 9 boss Pete Austin claims that the graphics (disk version) are “the best yet” (we shall see) confides that *Scapeghost* won't have the same humour as *Gnome Ranger* and *Ingrid's Back* (the Pilg isn't too sure that he finds Level 9's style of humour

funny), though one of the main non-player characters (the characters controlled by the computer) does wander around making awful puns! The game uses the same system as *Ingrid's Back* in that it has three parts, a powerful parser supporting OOPS, GO TO etc and graphics on disc versions. Austin reveals that “the graphics are hand drawn by the same artist who drew *Ingrid's Back*. The graphics are of the highest quality, but very moody and realistic” which certainly makes a change from the cute gnomish graphics in *Ingrid's Back*.

*Scapeghost* is due imminently at £14.95 (tape) and £19.95 (disk). Look out for the definitive review, written in the Pilg's own fair hand, in next month's splendid AA.



# Infocom titles up for sale

Castle Computers, now the only suppliers of Infocom games on the Amstrad, are selling their few remaining stocks at rock bottom prices – £6 apiece when normally Infocoms are over £20 each.

Stocks are low, so hurry! Games still available include:

● **Stationfall** (AA27), one of the Pilg's faves, follows on from where *Planetfall* left off: funny and atmospheric (*Stationfall*, not the Pilg. Oh I don't know though). It has one of the cutest of all non-player characters, a hopeless robot called Floyd who follows you everywhere.

He's joined by Plato, a suitably philosophical robot. Discover the secrets of the deserted Space Station!

Atmosphere 90%  
Interaction 89%  
Challenge 89%  
Overall 90%

● **Cut Throats** is set on the open seas, diving for treasure in ship wrecks. An oceangoing atmosphere prevails.

Atmosphere 87%      Interaction 89%  
Challenge 90%      Overall 88%

● **Hollywood Hijinx** (AA20) requires you to locate ten treasures in one night at your deceased Aunt's mansion to inherit her millions - superb game, with a brilliant maze and excellent and original problems.

Atmosphere 89%      Interaction 90%  
Challenge 92%      Overall 90%

● **Ballyhoo** (AA9) is set in the circus, with some difficult puzzles. It's not the best of Infocom games, but at this price it's a steal.

Atmosphere 89%  
Interaction 90%  
Challenge 90%  
Overall 89%

● **Suspect** is the Pilg's all-time joint favourite adventure (along with *Lurking Horror*).

It's a murder mystery set at a fancy dress party where you are suspected as the murderer of the hostess. Tons of interaction with other characters, with nearly everybody acting as suspicious as each other!

Atmosphere 90%      Interaction 95%  
Challenge 93%      Overall 94%

● **Sorcerer**: one of the best of the 'Enchanter' series, with weird spells to cast, and an errant magician, Belboz, to track down. Experience exquisite psychic tortures, explore deserted realms, and generally have yourself a great time!

Atmosphere 88%      Interaction 90%  
Challenge 93%      Overall 90%

The last two are fiercely difficult and will occupy you for centuries.

A word of warning though: all these games are disk only and, although Infocom games have very large vocabularies and are great fun to play, they have no graphics and are slow, since the fact that the disk is accessed after every command.

The Pilg suggests you ring Castle today (0782 575043) to make the most of this exceptional offer: stocks are low, and you'd do well to check before you send your cheque!



# AA SMALL ADS

## FOR SALE

**Power Print.** Stylish WYSIWYG poster maker. 25+ dump sizes, 300+ timesteps, 20+ fonts and designer. 6128 only. Disc £12.95 cheques only to: **Rocksoft, 62 The Rise, Mount Merrion, Dublin, Ireland.** Tel 855912.

**Why buy £10 games** when you can buy excellent condition secondhand games half price or less. £2 games for sale. As well as Green Screen Monitor £40. Phone **Paul Turner (0992) 589696**

**Amstrad CPC464**, colour monitor, 25 games, many magazines and joystick £175. Call **Milton Keynes (0908) 70113** (at weekends only please).

**CPC6128** colour monitor, Shinwa Dot matrix printer, 8-bit printer port, joysticks, numerous books, magazines, games programming languages etc. Bargain at £500. Telephone **Martin on (0274) 502987 (Bradford) evenings and weekends.**

**CPC6128** Colour monitor disk drive over 60 games 30 disc games, over 40+ mags (ACE, AA) tape games, tape recorder (to play tape games) Games. Sell for £250. Tape leads. Comes complete with manuals. Phone **01-878-4481 ask for Jonathan 6pm-9pm.**

**CPC464** colour monitor. Two joysticks, manual, eighty popular games including Driller, Starglider, Barbarian, many strategic games included. Mint condition closest to £400 takes the lot. Phone **0670 519524 now!**

**Pixelmania II** 35 more brilliant graphics programs. Monster exploding fun! Just send £2.00 sae and blank disc to **D G Hooper, 32 Pounds Park Road, Peverell, Plymouth. PL3 4QR.** Don't delay! Super Speedy Service!

**Amstrad 64K** computer. Mono monitor MP1

TV connection joystick 54 games including Gunship, A Ranger, Barbarian II. Good condition worth £400. Sell for £250 ono. **Kingswinford 295279.**

**Maxam II (CPM+)**, new £30 Amstrad MP-2 modulator, for 464 or 664. £20. Phone **01-367-2109. Ask for Colin.**

**CPC6128**, colour monitor, Built-in d/drive, joystick, numerous games, advanced art studio, magazines. Excellent condition £245.00. Tel **01-852-0242.**

**Master Tipster Horse Race Predictor** for Amstrad CPC disc only full instructions £6.50 disk only. Write for details, **S Booth, 122 Meadow Lane, Dunston, Gateshead Tyne + Wear NE11 9PP.**

**S.P.R.O.G** can you battle your way through a hostile Labyrinth, capture the six-headed, Plasma Spitting, grotesque Squergly, and return? (Tape game £7.99) from **PRF Software, 26 Olton Road, Mickleover, Derby DE3 5PL.**

**CPC464** colour monitor, RAM music machine, joystick and games. £150. Telephone **Marlon 06284 75698.**

**CPC464** fully upgraded to 6128, mono monitor, 20 discs (some PD) plus RS232 (Ams/Pace) Prism 2000 modem £250 or Computer £200 RS232/Modem £60 **(0252) 23872.**

**CPC6128** colour monitor, second drive, DMP2000, discs, datacorder, Maxam rom, lightpen, over £700 software (games and utilities) books, magazines, firmware guide £650. Telephone **Jason, Burton on Trent (0283) 760404 weekends.**

**All computer bits and pieces**, memory expansion units. Fully assembled plus many other pieces of equipment very cheap. For details send SAE to **40D Freeland Road,**

**Clacton-on-Sea, Essex C015 3LW.**

Football program with all results for division 1-4 season 88-89 including team colours, League Tables etc. Full menu driven (250K) only £1.99. **Tahir Ghani, East Tarbert, Isle of Harris. PA85 3DB.**

**CPC 6128** mono monitor, 2nd disk drive, DMP2000 printer, cassette recorder, dustcovers, joystick, Mini Office II, Tasword, Brunword, Matrix Firmware manual, software, books, magazines £375. Phone **036287 340.**

**CPC6128** colour monitor, DMP2000 printer, tape recorder, 2 joysticks, as new, boxed. Plus:- 25 games (tape and disk), extension leads, books, well over £850. Sell for £500. Tel **0204 691455.**

**CPC6128** green screen monitor, nearly new £85 contact Charles after 6pm. 21 Carr Hill Grove, Calverley, Leeds LS28 5QB. Tel **Leeds 609869.**

**CPC464** colour monitor good condition, loadsa games from Chuckie Egg to Vindicators, Konix joystick, manuals, loadsa Amstrad Action's 86-89 even scarce ones, in Binders £350 offers near. Phone **Tim 0536 710769.**

**Amstrad 6128** colour monitor, printer, joystick, cassette player, game, serious software £300 ono. **Bob 0702 556180.**

**Rombo Rom** - Box with disable switch containing Protex, Utopia, and Maxam 1-5 £75.00 DMP 2160 printer with Qualitas Plus £90. **Steve 32 Lycett Road, Wallasey, Merseyside. Messages taken 051 630 5245.**

**CPC464** colour monitor, DK-Tronic speech synthesiser, DK-Tronic TV Tuner (receives TV Programs), joystick, 29 tapes, (over 60 games), magazines, books. Best offer over £300. Split possible. **Laura Flint 0509 674562.**

**CPC 6128** with colour monitor DMP2000 printer £250 of software including Elite, Matchday 2, ATF. Magazines, books and blank discs. Worth £940. Sell for £320 ono. Phone **0923 242196.**

## WANTED

**Wanted Multiface Two** for Amstrad CPC464 offering up to £15. Telephone **Kim 0625 612229** or write **Kim Manli, 2 Harewood Way, Macclesfield Cheshire SK11 7YF**

**Any one wishing to share Multiface pokes** that have not been published. Any game,

any age very welcome. Please send them to **Carl Surry, 37 Fairfield Way, Barnet, Herts EN5 2BQ.**

**CPC 464 users!** Information required. Would you like the same opportunities as 664/6128 users, to win a boring prize, money. No information no TRANCE-fer! Get into a TRANCE Telephone **06527 584 (Monty).**

**Colour monitor for CPC 464.** Any reasonable price paid. Also green screen and/or modulator for sale/swap. Contact **Mark on Colchester 0206 43018.**

## SERVICES

**Confused by the CUBE?** Bored by bar charts? Alienated by your computer? Lost your sense of adventure? Instant relief, get into a TRANCE. Ozone friendly. Cash prize! Telephone **065 27-584 (Monty)**

**CP/M services.** Public Domain software for all machines. Format translation service. Recovery of data from corrupt discs. SAE for details. **Mick Reed (AA) 11, Older Way, Angmering, Sussex BN16 4HQ.**

**Phoenix Tape to disc 464/6128** 85p per game, Multiloader £3.50 add 30p if tape(s) to be returned, enclose disc(s) Tape(s) **PHOENIX 10 Walter St, Draycott, Derby DE7 3NU. Tel 03317 4490.**

## OTHER

**Revolutionary new game (puzzle)** for imminent release. RemonSTRANCE Endless hours of amusement and the opportunity to win **LARGE CASH PRIZE!** Get into a TRANCE! Enquiries Telephone **065 27 584 Monty Remon.**

**"Hello Fred, have you gone Comatose yet?"** No Dave, maybe tonight. I see John is walking about like a zombie. He would feel better if he got into a TRANCE, **065 27 584.**

**Make money with your computer**, entails work, persistence, little outlay. Results big, depending on effort made. Send for details, no money. **Ford West, 36 Lower Quay Road, Hook, Haverfordwest. Pembs SA62 4LR.**



This section offers you a really cheap and effective opportunity to speak direct to 38,000 CPC owners - or would be owners. Users report excellent results. You can place an ad up of up to 30 words for just £5.

So you could use it to sell a printer, launch a user group or advertise a piece of software you've written. One thing you can't advertise is the sale or swap of software. Such ads can be misused by pirates.

Fill in the application form and send it to us together with payment. We'll place the ad in the next available issue (published 2-7 weeks after we receive your order).

## ORDER FORM

SEND TO AA SMALL ADS, PRODUCTION DEPT, FUTURE PUBLISHING LTD, 4 QUEEN STREET, BATH BA1 1J

Please place the following advertisement in the next available issue of **Amstrad Action**

Name \_\_\_\_\_

Address \_\_\_\_\_

Telephone \_\_\_\_\_

I enclose payment of £5.00 by Cheque/ P.O./ Access/ Visa

Credit Card number \_\_\_\_\_

Credit Card expiry date \_\_\_\_\_

Classification. Tick  For sale  Wanted  Services  User Groups  Other

Write your advertisement here, one word per box. Include your name and phone number if you want them

# Clue Pot

Brought to you by Joan Pancott (HPilg), Jerome Young, Wendy Watters, Stuart Whyte (AA's Adventurer of the Year), Howard Swaines and of course ye Pilgrim himself.

## Heroes of Karn

To kill the lizard, light the gas (need tinder box), get frog, kiss frog. Kill the barrowright with the bible (to get money). To cross the chasm, "Istar Wave Wand", play flute, "Istar Wave Wand". Water ashes to kill phoenix.

## Venom

After leaving the cove, venture to the inn and talk to the customer. Before leaving the tap-room open the barrel, put berries in it, and fill the wineskin. Don't drink it yourself unless you feel like a sheep. Wear mask.

## Big Sleaze

To blow the safe stuff the dynamite into the lock, light it and retreat. In the hotel push the Obelisk to find the way into the air vent.

## Return to Eden

Don't kill the figure that you meet in the shadow lands - fight until you are told that he is badly wounded then "gethood".

Give the old man in the engraving room some bread and he will open a secret passage. Wait by the chest until someone comes and offers to pull it up for you. Tie rope to chest, wait until he comes back for you, grab rope, he will pull you up and give you a staff.

## Hitchhikers Guide to the Galaxy

To open the screening door you must first have moved your common sense particle in your brain. Then go to the door, drop tea, get tea (no tea dropped), get no tea. The door is so impressed it opens for you!

## The Pawn

To get past the boulder, tie the shirt to the rake and hoe then lever the boulder. Ask Kronos about the wristband and he will give you a chest to give to the adventurer. Examine the horse for a laugh. Mix the red with the blue and the green to make white. You will find them in a pouch in the forest clearing after giving the guru the bowl of snow.

## Leather Goddesses of Phobos

To avoid the ion beam shooting machine, don't travel down the river. To avoid the alligator in the maze - NW, N, NE, E, clap, NE, NE, SE, hop, clap, say kweepa, go down, NW, NE, clap again, N, S, hop, say kweepa, clap, NE, up, NW into store-room. Get the directory, clap, NW, hop, S, say kweepa, clap, SE, SE, down, E, clap, hop, N, W, say kweepa, clap, E, W, S, hop, clap, SW into burial chamber. Get the raft, N, say kweepa, clap, NE, hop, E, clap, NW, NE, SE, say kweepa, clap, hop, up, NW, to the well bottom. Go circle.



● Mag Scrolls' *Corruption* and *Guild of Thieves*: hints and tips, anyone? Write to: *The Pilgrim*, Amstrad Action, 4 Queen St, Bath BA1 1EJ



## Coming soon to *The Pilgrim*

- The *definitive* review of *Scapeghost*
  - Childs play: adventures for youngsters
  - Homebrew adventures: are they ever up to "professional" standards?
  - Exclusive interviews with famous adventure personalities and companies
  - A round up of adventure writing systems
- ... and so much more. Reserve your copy now - or why not subscribe?

## Programming for the future?

Remember "Programming with the Pilgrim"? It was abandoned partly because of lack of space, and partly because certain people didn't like writing adventures in BASIC. Let the Pilg know if you would like the feature to return, and in what form - written in BASIC, PAW, Quill or GAC. Write to Pilg programming, *The Pilgrim*, Amstrad Action, 4 Queen St, Bath BA1 1EJ.

# Honorary Pilgrim the First

"Well done everyone, thanks to your many letters *The Pilgrim* is back, and what better way could there be to celebrate AA's Fourth Birthday!" writes Joan Pancott, famous Witch of Wessex.

Joan reminds fellow travellers that people *must* send a self stamped addressed envelope (or an international reply coupon) when seeking

help from a Lord or Lady of Adventure - who, after all, are working on your behalf for free. She also suggests that, when you phone her or other Lords and Ladies, you specify what games you are calling about at the start to save time and money.

The Pilgrim hereby introduces a new honour to reward Amstrad adventurers who have excelled them-

selves in their efforts. Joan Pancott is hereby dubbed the first "Honorary Pilgrim," and as such can place the letters HPilg after her name. Congratulations Joan - you deserve it! Suggestions for Honorary Pilgrims are welcome: who merits such a prestigious title? Write to, HPilg Nominations, *The Pilgrim*, Amstrad Action, 4 Queen St, Bath BA1 1EJ.

# Pilgrim Post

The Pilgrim has received a strange and mystifying letter from Bob Adams: "Oh dear, so now I am forced to finally come out of the closet!" he writes, worryingly.

"After years of secret adventuring it has come to this. Either reveal myself to one and all or

support on the Amstrad. "With Infocom having dropped the CPC, Magnetic Scrolls with no distributors and Level 9 changing to 16 bit machines, there doesn't seem much hope for the Amstrad," he complains.

I have to disagree, Stuart. True, Infocom (who have some serious problems) have dropped the CPC, but Level 9 and Magnetic Scrolls will still *definitely* continue support. Level 9's new arcade adventure system is only available on the Amiga and ST, but they will still produce 8 bit adventures, such as *Scapeghost* (see the news story). Many other smaller companies and authors still support the Amstrad, too.

Finally, Ian Reynolds writes: "I live in Coventry and my local software supplier closed down, so please could you tell me some mail order firms that stock adventures like the *Hobbit*, *Bards Tale*, *Hitchikers Guide to the Galaxy* and other titles?"

The Pilg has received many similar letters recently, so watch out for the round up of adventure clubs and magazines soon...



## Wanted!

- "Home brew" games
- Cheat Modes for adventures
- Cluepot contributions (but not complete solutions!)
- Ideas
- Feedback, letters of encouragement and advice, and *big cheques*

face the wrath of the Pilgrim! I certainly have no wish to antagonize you further and taste your staff, but after all, Skrimball?"

I think this translates as: "Can you put my name in the Lords & Ladies column?" The Pilg is not so pleased about the Skrimball bit, either. Watch out for the large hungry Balrog with razor sharp teeth coming your way soon Bob!

I also received a pessimistic letter from Stuart Whyte, AA Adventurer of the Year, complaining about the lack of adventure

## CONTACTING THE PILGRIM

The Pilgrim welcomes correspondence from all readers on matters of adventure. Write to him c/o *Amstrad Action*, 4 Queen St, Bath BA1 1EJ, marking your letter clearly for the attention of The Pilgrim.

I'm afraid that it's usually impossible for me to write personal replies to letters, but rest assured that I will do my best to answer, either in this column or by post.

# The Lords and Ladies of Adventure

Souls of Darkon (thanks Joan!), Kobayashi Naru, Venom, Mystery Indus Valley and Gnome Ranger

Wendy Watters, 82 Booth Road, Stacksteads, Bacup, Lancashire, OL13 OSF ☎ (0706) 877518

Message from Andromeda, Heroes of Karn, Forest at the Worlds End, DAA n Everything, Trial of Arnold, Jewels of Babylon, Mordons Quest, Hobbit, Lord of the Rings & Planet of death

Bob "I love Probe" Adams, 81 Uplands, Welwyn Garden City, Herts. AL8 7E8

Adventure Quest, Aftershock, Apache Gold, Arnold Blackwood Trilogy, Beer Hunter, Boggit, Bored of the Rings, Brawn Free, Buggy, Colossal Adventure, Circus, Classic Adventure, Cutthroats, Dodgy Geezers,

When writing to a Lord or Lady of Adventure enclose a SAE and please keep those phonecalls to sociably acceptable hours!

The all new Lords and Ladies is to be run like AA's *Helpline*, so that the names change each month but reappear eventually. This way people such as Stuart Whyte, Darren Stephens and Joan Pancott don't use up all the Pilgrim column with their long lists of completed games! If the game you want isn't mentioned, write and Your Old Pal the Pilgrim will his level best find someone who can help you.

Dracula, Dungeon Adventure, Dungeons Amethysts Alchemists n Everything, Emerald Isle, Enchanter, Escape from Koshima, Espionage Island, Fantasia Diamond, Forest at

the Worlds End, The 4th Protocol, Football Frenzy, Gems of Stradus, Gnome Ranger, Gremlins, Haunted House, Heroes of Karn, Hitch Hikers Guide, Hobbit, Hunchback adv, Imagination, Inca Curse, Jewels of Babylon, Kentilla, Knight Tyme, Kobayashi Naru, Leather Goddesses of Phobos, Lords of Time, Lurking Horror, Message from Andromeda, Mindshadow, Mordons Quest, The Mural, Necris Dome, Never Ending Story, Nythyhel, Pawn, Questprobe III, Rebel Planet, Redhawk, Red Moon, Return to Eden, Return to Oz, Rigels Revenge, Robin of Sherwood, Robin of Sherlock, Seabase Delta, Snowball, Sorcerer, Souls of Darkon, Spytrek, Sphinx adventure, Star Wreck, Stolen Lamp, Subsunk, Theseus, Tomb of Kuslak, Very Big Cave adventure, Warlord, Woodbury End & Zork 1

Darren Stephens ☎ (0795) 473490

# TYPE-INS

Close encounters of the keyboard kind with that PAT McDONALD character

## MULT-ART

Here's an excellent utility for all the people who've ever wanted to edit the screens from games. Supposing that you have a *Multiface II* and *Advanced Art Studio*, this listing will convert the screens saved by the Multiface into .SCR files for your art package to play with.

It can be used with other art programs too, because it tells you all the ink and border colours, as well as the correct screen mode. The only thing it can't do is cope with screens that are different to the conventional size. Rob Munlin from Portsmouth is the person to thank.

```
[DpAp] 6 REM Mult-art
[IsAq] 7 REM By Rob Munlin
[ErBk] 8 REM Amstrad Action October 1989
[CpAo] 10 MEMORY &3FFF
[GqAv] 20 DEFINT b-z:DIM i(15),hc(31)
[DrAx] 30 FOR x=0 TO 31:READ hc(x):NEXT
[CvDn] 40 DATA 13,0,19,25,1,7,10,16,0,0,24,26,6,8,15,17,
0,0,18,20,0,2,9,11,4,22,21,23,3,5,12,14:
[PwBn] 50 cr$=CHR$(13)+CHR$(10):pr$=cr$+"then press
a key"
[KmCk] 60 MODE 2:PRINT"Put disc containing MULTIFACE
screen in drive A"pr$
[GsAm] 70 GOSUB 3000
[OjAl] 80 CLS:CAT
[OtBp] 90 INPUT"Enter filename of MULTIFACE screen -> ",
scr1$
[BpBp] 100 IF scr1$="" OR LEN(scr1$)>11 THEN 90
[CnBn] 110 PRINT:PRINT"Loading "UPPER$(scr1$)"...."
[PiAo] 120 LOAD scr1$
[FqBr] 130 'Get screen colours and mode number from
MULTIFACE screen
[FmBt] 140 bordcol=PEEK(&8067):modenum=PEEK(&8088) AND
&X11
[FwBl] 150 FOR x=0 TO 15:i(x)=PEEK(&8068+x):NEXT
[HsCj] 160 PRINT cr$"Do you wish to Save the screen"cr$
TAB(13)"or View data (s/v)?"
[PoBl] 170 WHILE NOT(a$="s" OR a$="v"):GOSUB 3000:WEND
[CtBo] 180 IF a$="s" THEN GOSUB 1000 ELSE GOSUB 2000
[IjBj] 190 PRINT cr$"Another Screen (y/n)?"
[KtBl] 200 WHILE NOT(a$="y" OR a$="n"):GOSUB 3000:WEND
[JqAt] 210 IF a$="y" THEN 60
[CnAl] 220 END
```

## Module Designer

Oops! Sorry about last month's *Module Designer*. Unfortunately three lines were cut off by one of the pictures. Here they are:

```
{NxAx} 1140 z=memfin-(tempx*tempy)-2
{AjAu} 1150 modnum(w)=z:POKE z,w
{NjAq} 1160 POKE z+1,tempx ●
```

```
[KtAq] 1000 'Set up .PAL file
[IkAx] 1010 PRINT cr$cr$"Thinking..."
[KxBv] 1020 POKE &8809,modenum:POKE &880A,&FF:POKE &880B
,&19
[AnBk] 1030 FOR addr=&88D8 TO &88F8:POKE addr,0:NEXT
[HwAo] 1040 addr=&880C
[DkAp] 1050 'Poke ink colours
[OjAp] 1060 FOR x=0 TO 15
[BnBp] ExAm] 1070 FOR a=addr TO addr+11:POKE a,i(x)+64:NEXT
[MsAo] 1080 addr=addr+12
[ExAm] 1090 NEXT x
[ApAv] 1100 'Poke border colours
[BsBr] 1110 FOR a=addr TO addr+11:POKE a,bordcol+64:NEXT
[GvAx] 1120 'Save .SCR and .PAL files
[NqBx] 1130 CLS:PRINT"Put disc to save screen to in drive
A"pr$
[MkAn] 1140 GOSUB 3000
[CtAm] 1150 CLS:CAT
[NkAr] 1160 d=INSTR(scr1$,".")
[JrBq] 1170 IF d THEN scr1$=UPPER$(LEFT$(scr1$,d-1))
[PuCn] 1180 PRINT"Enter filename to save to"cr$TAB(8)"
(default "UPPER$(scr1$)");
[MuAq] 1190 INPUT" -> ",scr2$
[IxAx] 1200 IF LEN(scr2$)>8 THEN 1180
[FwBl] 1210 IF scr2$="" THEN scr2$=scr1$
```

## TYPE WRITER

Those four characters in square brackets at the beginning of each line are not meant to be typed in. They're part of our typing checker, which originally appeared in AA45. We're reprinting it this month, due to popular demand, on p. 78.

```
[KtBp] 1220 PRINT cr$"Saving "UPPER$(scr2$)".SCR...."
[LrBi] 1230 SAVE scr2$+".SCR",b,&4000,&4000
[PnBq] 1240 PRINT cr$"Saving "UPPER$(scr2$)".PAL...."
[PlBl] 1250 SAVE scr2$+".PAL",b,&8809,&EF
[HtAo] 1260 RETURN
[JpAt] 2000 'Display screen data
[OmBn] 2010 CLS:PRINT"Screen or Printer (s/p)?"
[FvEm] 2020 WHILE NOT(a$="s" OR a$="p"):GOSUB 3000:WEND
[FuAx] 2030 IF a$="s" THEN st=0 ELSE st=8
[DvBk] 2040 PRINT#st,cr$"Screen mode ="modenum
[DmBm] 2050 PRINT#st,"Border colour ="hc(bordcol)
[Glbq] 2060 FOR x=0 TO 15:PRINT#st,"Ink"x="hc(i(x)):NEXT
[JjAn] 2070 RETURN
[AvBj] 3000 'Clear input and get keypress
[ClAt] 3010 WHILE INKEY$<"":WEND
[GlbO] 3020 a$="":WHILE a$=""a$=LOWER$(INKEY$):WEND
[EwAo] 3030 RETURN ●
```

# SWIFT Software

061 477 8405



## PANDORA TAPE £24.95 DISC £29.95

The program that takes the lid off your micro!

- ★ Write arcade games - in Basic!
- ★ Multi-featured sprite designer
- ★ Animated sprites
- ★ Compatible with all WPs
- ★ Free games and examples
- ★ Comprehensive manual



## KEYWORD

DISC £29.95

The dynamic wordfinder for home and business use

- ★ Over 10,000 synonyms and antonyms
- ★ Nearly 1,000 main subject headings
- ★ Extra rapid word search
- ★ Can select over 70 words at a time
- ★ Simple operation
- ★ Flexible 'roam' facility
- ★ Can be used as a Thesaurus
- ★ Compatible with Protex rom



## ΩMEGA

6128 ONLY

DISC £14.95

It's like having two CPCs for the price of one!



When you switch your CPC on load in Omega first and you'll find you have two program environments.

How does it do it? Simple. Omega takes over both 64K banks of ram and swaps between them.

So, for example, you can load your wordprocessor into one bank and a game into the other.

Then at the press of a key you can swap between the two.

This program has to be seen to be believed.

## SPEECH! TAPE £4.95 DISC £7.45

Your CPC can now talk back for as little as £4.95!



Speech! is an incredible piece of coding. Needing no extra hardware and taking up just 8K of memory, it converts your CPC's sound chip into a full-blown speech synthesiser!

Once installed you can call it from your programs with a single RSM - plus you can fully configure it to speak in any accent or pitch, through any of the three sound channels.

Due to a bulk purchase we can offer this unique program to you for less than half price. But place your order soon as they're sure to be in high demand.

	Tape	Disc
RRP	£9.95	£14.95
Our Price	£4.95	£7.45

## SWIFT SELECTION



5 Machine-code arcade games for only £9.95!

- Arcadians Revenge
- Leaper
- Munchies
- Panic
- Zareba

Space Invaders like you've never seen them before

Guide the frogs to safety across the road and river

Fill in all the squares before the munchies get you

Fast-action version of the classic ladders and levels game

Brain damaging, joystick busting arcade-adventure

DISC ONLY £9.95

Please tick the program(s) you require

### ORDER FORM

	Tape	Disc
Pandora	£24.95 ( )	£29.95 ( )
Keyword	—	£29.95 ( )
Omega (6128)	—	£14.95 ( )
Keypad	—	£9.95 ( )
Swift Selection	—	£9.95 ( )
Speech!	£4.95 ( )	£7.45 ( )

I enclose a cheque/Euro cheque/PO made payable to:  
**SWIFT SOFTWARE**

Name \_\_\_\_\_

Address \_\_\_\_\_

Postcode \_\_\_\_\_ Tel. \_\_\_\_\_

SWIFT SOFTWARE AA10, 347 LONDON ROAD, HAZEL GROVE, STOCKPORT, SK7 6AA. 061-477 8405

# 10 PIN BOWLING

Here's an excellent little public domain game from the hand of Cambridge resident Rowland Jack. You start by selecting a direction with the joystick, and then pressing fire. Now you have to waggle like fury for five seconds, to work up the speed of the ball. Put it at the proper angle and the pins will tumble - stand clear and let's go!

```
[DqAr] 5 `Public Domain
[LLAq] 6 `10 Pin Bowling
[PrAp] 7 `By Rowland Jack
[KoBi] 8 `Amstrad Action October 1989
[EwAl] 10 MODE 1
[LmBo] 20 INK 1,25:INK 2,6:INK 0,0:BORDER 6:PAPER 0:PEN 1
[IpAu] 30 LOCATE 31,18:PRINT"10 Pin"
[JwAw] 40 LOCATE 30,19:PRINT"-----"
[GjAv] 50 LOCATE 31,20:PRINT"Bowling"
[JvAx] 60 LOCATE 30,21:PRINT"-----"
[NvBi] 70 LOCATE 30,22:PRINT"By R.Jack"
[FqBi] 80 LOCATE 29,23:PRINT"-----"
[IqAr] 90 WINDOW #1,3,7,3,3
[LvAn] 100 PAPER #1,3
[LiAm] 110 CLS #1
[NmAt] 120 WINDOW #2,34,38,3,3
[DpAo] 130 PAPER #2,3
[GsAm] 140 CLS #2
[JsAs] 150 WINDOW #3,30,39,12,12
[LjAn] 160 PAPER #3,3
[LqAm] 170 CLS#3
[EnAu] 180 WINDOW #4,2,11,15,16
[CtAo] 190 PAPER #4,3
[DtAm] 200 CLS #4
[CtAr] 210 GRAPHICS PEN 1
[AqAv] 220 MOVE 232,1:DRAW 232,400
[OtAu] 230 MOVE 390,1:DRAW 390,400
[BiAm] 240 GOTO 700
[KrBl] 250 CLS #4:PRINT#4,"Press a":PRINT#4,"key"
[CmAq] 260 CALL &BB18
[JiAm] 270 CLS #4
[GtAx] 280 CLEAR INPUT:'464 Users omit!
[HwAp] 290 FOR t=-16 TO 16
[PkAu] 300 FRAME:CLS #1:PRINT#1,t
[OxAw] 310 IF INKEY(76)=0 THEN 350

[JnAr] 320 FOR y=1 TO 20:NEXT y
[CuAk] 330 NEXT
[GwAl] 340 GOTO 290
[CxAn] 350 ang=t
[DmAv] 360 CLS #4:PRINT#4,"Ready,"
[LvAr] 370 FOR t=1 TO 600:NEXT
[AlAv] 380 CLS #4:PRINT#4,"Steady,"
[InAt] 390 FOR t=1 TO 600:NEXT
[KxAt] 400 CLS #4:PRINT#4,"GO!"
[MkAl] 410 t=TIME
[PqAk] 420 chk=0
[EtAl] 430 spd=0
[BqBi] 440 IF TIME>t+1500 THEN 480
[PkBq] 450 IF INKEY(74)=0 AND chk=0 THEN chk=1:GOTO 440
[PiCp] 460 IF INKEY(75)=0 AND chk=1 THEN chk=0:CLS #2:spd
      =spd+1:PRINT#2,spd:GOTO 440
[OvAm] 470 GOTO 440
[BjAn] 480 spd=spd\3
[OsAm] 490 CLS #4
[MmAt] 500 PRINT#4,"Round: ";tu
[CiAt] 510 PRINT#4,"Throw: ";throw
[IiBi] 520 CLS #3:PRINT#3,"Score: ";score
[KxAn] 530 RETURN
[OuBj] 540 CLS #3:PRINT#3,"Score: ";score
[MoAs] 550 FOR t=17 TO 23 STEP 2
[NrAv] 560 LOCATE t,1:PRINT CHR$(143)
[AuAk] 570 NEXT
[DqAv] 580 FOR t=18 TO 22 STEP 2
[JrAv] 590 LOCATE t,3:PRINT CHR$(143)
[OlAj] 600 NEXT
[BiAt] 610 FOR t=19 TO 21 STEP 2
[HiAw] 620 LOCATE t,5:PRINT CHR$(143)
[HqAk] 630 NEXT
[AsBi] 640 LOCATE 20,7:PRINT CHR$(143)
[KkAm] 650 CLS #4
[FxAt] 660 PRINT#4,"Round: ";tu
[KuAt] 670 PRINT#4,"Throw: ";throw
[BjAk] 680 TAG
[JvAm] 690 RETURN
[KqAq] 700 TAGOFF:GOSUB 250
[HtBl] 710 IF gonum=0 THEN TAGOFF:GOSUB 540
[FlAo] 720 TAG:gonum=1
[BnAl] 730 y=16
[DvAq] 740 GRAPHICS PEN 1
[lsAv] 750 FOR x=234 TO 372 STEP 8
```

## STOCKMASTER

THE Stock Control System for the Amstrad range of computers.

Stockmaster is a highly advanced stock control system written specifically for the Amstrad CPC & PCW series computers. It is fully menu driven and is extremely easy for even the absolute beginner to use. It incorporates highly advanced ordering sub-systems, allowing orders to be printed in a format suitable for direct mailing to the supplier indicated. File updating is done by a separate batch program, which may be run at a quiet point in the day.

Its file sizes are limited only by disc drive capacity, allowing the system to grow as your company grows. Options also exist to print various reports, to calculate total stock value etc. etc. **STOCKMASTER** is supplied complete with a detailed 43 page user manual, and requires CP/M Plus to run. It also needs at least one disc drive. Full system specs available on req. To order:- Send a cheque/PO for £29.95 to:

**Williams Software Services,**

11 Howard Close, Romiley, Stockport, Cheshire, SK6 3BH.

Tel: 061-430-5307. Please allow 21 days for delivery.

65 Woodfoot Rd.  
Rotherham.

## MICROGENIC SYSTEMS

AT LAST THE HOME COMPUTER ENTHUSIAST CAN HAVE PROFESSIONAL HIGH QUALITY ACCESSORIES FOR ALL CPC COMPUTERS  
Our programmer is not fussy about which brand of EPROMs you buy, it programs them all! Easy to use menu driven software which is supplied on ROM, the ZIF socket and many other special features and you have a professional unit  
**FOR ONLY £69.95.**

Our successful 8 socket ROM board also has a host of features and uses on board switches to provide the following benefits:-

- \* Easy bank switching 0-7 to 8-15
- \* Fast ROM selection
- \* Convenient board enable/disable
- \* Useful computer hardware reset

This no-compromise ROM board only costs **£34.95**

Both products use the latest technology high quality components and can be left safely and permanently connected to your CPC, using their built in flow-through connector.

Additional items to complement your computer system:-

EPROM ERASER £22.50 WITH TIMER £27.50  
EPROMS 27C64 £5.95 27C128 £6.95  
EPROM ANTI STATIC BOX £2.50

**P&P UK FREE EUROPE £1 ANYWHERE ELSE. £2**  
CHEQUES AND POSTAL ORDERS MADE PAYABLE TO:  
**MICROGENIC SYSTEMS**  
PO BOX 41, WATH UPON DEARNE, ROTHERHAM, S63 7PS.



PRE-SCHOOL, PRIMARY, JUNIOR  
**Education**

Designed by  
Experienced Teachers  
For use in School and Home

Wide range of programs  
For AMSTRAD CPC - PCW - PC1512  
- ATARI ST - SPECTRUM +3

CASSETTE £9.50 per set  
DISC £12.50 per set  
Send SAE for List. Stating Amstrad  
model and child's age.

ARC (ACT10), 51 Coniston Crescent, HUMBERSTON,  
SOUTH HUMBERSIDE DN36 4BA. (0472) 812226

# COMPUTER CROSSWORDS

EXCLUSIVE FROM AKOM LIMITED

Featuring

**THE TIMES** Volumes 1, 2, 3, 4, 5, 6 &  
Jubilee Puzzles 1932-87

and

**The Sun** Volumes 1, 2, 3, 4, 5 & 6

Prices of software with NEW Team Option are as follows:-  
For Amstrad 5 1/4", IBM 5 1/4", IBM 3 1/2", Archimedes, Atari ST  
Times discs are £19.95, Sun discs are £18.95  
For Amstrad 3", RM Nimbus 3 1/2", BBC 3 1/2", Electron +3,  
BBC Master 128 ADFS, BBC DFS 40, DFS 80  
Times discs are £18.95, Sun discs are £17.95  
For Spectrum +3  
Sun discs are £17.95. Note: no Times version  
For all Acorn, Spectrum, Amstrad cassettes (No Team Option)  
Times £9.95 (Vols. 1-3, +Jubilee only), Sun £7.95 (Vols. 1-4 only)  
Prices include postage, packing and VAT (£1 surcharge ex UK)

Please send me:

The Times Computer Crosswords Volume(s).....

The Times Jubilee Puzzles 1932-1987.....

The Sun Computer Crosswords Volume(s).....

my system is: (delete as appropriate) IBM/Amstrad/BBC/Spectrum/  
Atari ST/Nimbus/disc/cassette/3"/3 1/2"/5 1/4"

Computer model (details).....

Name:.....

Address:..... (BLOCK CAPITALS)

Postcode..... Tel.....

I enclose cheque/postal order for £..... (payable to):

AKOM LIMITED 51 MANOR LANE, LONDON SE13 5QW TEL: 01-852 4575

**NEW**

## Jackson Software BFG DATAFILE

CPC 464 - 664 - 6128

Fax Available - Ring 0228 42373 ext. 38

**Disc £15.95      Cassette £10.95**

Cheques/PO Payable to:

**Jackson Software (1989) Ltd**  
Unit 32, Carlisle Enterprise Centre,  
James Street, Carlisle CA2 5BB

Access/Visa available shortly

## NEMESIS - The Original Meddlers

### GOOD GRIEF! GREETINGS!

Yes, it's a very strange advertisement - but it's time to have a few words with you all. The "new" law has confused many of us, those that "don't know" AND those that profess to know.

It comes down to extremes of interpretation, the most extreme being that BACK-UPS even though only used by the owner of an original piece of software are illegal! That means that there are several hundred thousand CPC users due to get a visit, a writ, or something unpleasant!

Here, at NEMESIS, we have always believed that the owner of an original item of software has the perfect right to do what the hell he/she likes with it - provided that by doing so the Copyright Owner is not deprived of another source of income. Many fair-minded people agree with this; if you have thirty thousand BACK-UPS of MANIC MINER they'll do nobody any harm provided that they remain in your hands.

By custom and practice ( a term not to be used lightly ) computer owners have safeguarded their collection by making BACK-UPS of software from their own originals.

Another "extreme" side of the new law MAY be that in order to make a BACK-UP legally you need the expressed permission of the Copyright holder or his agent.

NEMESIS utilities, well known for their power on backing-up the majority of software are still available - and remain at the same low prices.

The "extreme" side of the interpretation of the law means that you need the permission of the copyright owner to make a BACK-UP, but you'll need the means to do it!

On the basis that you may need such permission, we offer the utilities shown on the right.

If you have doubts about your right to make back-ups, then don't do it! Just to set the record straight, ALL NEMESIS SOFTWARE can be backed-UP as many times as you wish - but.....

FOR YOUR OWN USE ONLY.

**UPGRADES** BSM or BLITZ, **£3.00** [return original disc]

B/BOARD INFO **CYNOTEL 01 346 2816** [1200/75]

## BONZO SUPER MEDDLER

" A REAL ALTERNATIVE to a Multiface II BLACK BOX ", A.A. JAN'89.  
" The best TAPE TO DISC transfer utility available ", WACCI 6/88.

## BONZO BLITZ - ULTRA-TRICKY TAPES TO DISC.

" HIGHLY RECOMMENDED " - WACCI 12/87.

## CPC PROCOPY & MINIDOS

The most recent and best utility for disc-housekeeping. Back-ups, file transfers, status changes, and much more!

**EACH DISC £12.50 inclusive.**

**ALL THREE £35.00 inclusive.**

**NEMESIS A.A** ALL ORDERS sent by return: Cheque/P.O./Access **TEL: (0933) 623967**

10, Carlow Road, Ringstead, Kettering, Northants NN14 4DW

AUSTRALIA: C. BOSWELL, 62 MARMONG STREET, MARMONG POINT 2284, NSW.



```
[PoAx] 760 FRAME:MOVE x,y:PRINT CHR$(231);
[GjAw] 770 IF INKEY(76)=0 THEN 810
[PoAs] 780 FRAME:MOVE x,y:PRINT" ";
[IuAk] 790 NEXT
[EnAm] 800 GOTO 750
[PxDx] 810 throw=throw+1:IF throw>3 THEN throw=1:tu=tu+1:
    GOSUB 940:CLS #4:PRINT#4,"Round:";throw:
    PRINT#4,"Round:";tu:TAGOFF:GOSUB 540
[NvBr] 820 CLS #4:PRINT#4,"Round:";tu:PRINT#4,"Throw:"
    ;throw
[JiCj] 830 IF x+ang>372 OR x+ang<234 THEN FRAME:MOVE x,y
    :PRINT" ";:GOTO 700
[GqBj] 840 IF TEST(x+ang+16,y+spd)=1 THEN 860
[MrBn] 850 IF TEST(x+ang,y+spd)=1 THEN 870 ELSE 880
[KjDq] 860 TAGOFF:LOCATE (x+ang)\16+2,25-((y+spd)\16):
    PRINT" ";score=score+1:CLS #3:PRINT#3,"Score:"
    ;score:TAG:GOTO 840
[NkDp] 870 TAGOFF:LOCATE (x+ang)\16+1,25-((y+spd)\16):
    PRINT" ";score=score+1:CLS #3:PRINT#3,
    "Score:";score:TAG:GOTO 840
```

```
[KxAt] 880 FRAME:MOVE x,y:PRINT" ";
[HnBp] 890 spd=spd-0.11:IF spd<0.1 THEN y=16:x=312:GOTO
    700
[HkAs] 900 IF y>384 THEN 700
[NpAt] 910 x=x+(ang\3):y=y+spd
[FuAx] 920 FRAME:MOVE x,y:PRINT CHR$(231);
[BqAm] 930 GOTO 830
[HiBm] 940 IF tu=11 THEN 950 ELSE RETURN
[OpAx] 950 LOCATE 16,10:PRINT"GAME OVER"
[DxAs] 960 FOR t=1 TO 2000:NEXT
[NaAk] 970 CLS
[AoCl] 980 LOCATE 1,1:PRINT"After your 30 throws you
    have a total score of";score
[LtDu] 990 PRINT"Which represents an average of";score
    /10;:PRINT"points in every round or";score/30
    ;:PRINT"points for every throw."
[DtBo] 1000 PRINT:PRINT"Press any key to play again."
[ChAq] 1010 CALL &BB18
[PmAl] 1020 RUN ●
```

# TYPE WRITER

Newcomers to *Type-Ins* complain that, because they don't understand what the lines do, they don't know how to debug (correct) their programs. What's needed is a means to ensure that absolutely anybody can put in a listing and be sure it's right. Hence *AA Type-Righter*.

Start typing in the program now (don't bother running it until you've read the page). Once it has worked, two interception routines are set up to intercept printing to the screen and printer.

Every time the computer notices a carriage return, it adds up all the characters it has printed since the CR, and produces a checksum figure.

So every time you type in a line for a *Type-In* (don't forget to enter *NEW* to get rid of *Type-Writer!*) you can compare the checksum figure with what's printed in the magazine. If they're the same, then all is well. If they're different, then what you've typed is not the same as what's in the magazine, and is probably not what the program wants or needs.

However, to help stop you typing them in accidentally as part of a program, we'll print them - in a column - before the program lines. Do remember that when you're typing in the listings, the numbers will appear last.

## Daft Question

When first run, the program asks if the machine you are using is a 464. If it isn't, or you have a 6128 ROM fitted, then do not answer yes! The program will get terribly confused.

If you get a Data Error message, then carefully check lines 200-310. Not getting such an error does not necessarily mean that the data is correct - if two values were transposed the computer would not notice.

When, after typing in the whole listing you finally get checksums appearing after everything you type, type *LIST* to compare the values in the magazine with those on the screen (*LIST #8* for a printer copy works fine too).

## DON'T PANIC!

When you get a checksum that's different from the one printed in the magazine, here's what you do:

### DON'T PANIC!

*Type-Writer* is very, very sensitive, and even takes note of swapped characters and embedded spaces in lines...

The spacing in *Type-Ins* has been designed to make the listing as easy as possible. The text never joins back onto the line number: instead a complete block of text appears after the line number.

When a line is too big to run continuously along the page, it breaks at either a space or a punctuation mark: colon, semicolon, comma, bracket or full stop.

All the characters are the same width in the listings. You can count up the number of spaces or whatever used in a string, simply by counting them on a line either below or above the one you want.

```
{LxAn} 10 'Type-Writer
{NkBj} 20 'by Pat McDonald
{BqAw} 30 'Amstrad Action June 1989
{EiBp} 40 flag=0:PRINT:INPUT "Am I a 464 (Daft
    question!";h$
{IsBj} 50 a=HIMEM-93:MEMORY a-1:RESTORE 200
{PjAr} 60 FOR b=a TO a+5D
{ArAv} 70 READ c$:d=VAL("&"+c$)
{AsAr} 80 POKE b,d:e=e+d
{IqAl} 90 NEXT b
{BkBx} 100 IF e <> 10566 THEN PRINT "Error in data.
    Please Check." :END
{MpBv} 110 IF LEFT$(h$,1)="y" OR LEFT$(c$,1)="Y"
    THEN POKE a+8,&A4
{AkAo} 120 z=a+34:e=0
{AlAs} 130 f=ABS(INT(z/256))
{DwAq} 140 g=ABS(((z/256)-f)*256)
{NqAx} 150 POKE a+40,g:POKE a+41,f:POKE a+45,g
{CtBm} 160 POKE a+46,f:POKE a+57,g:POKE a+58,f
{NkBi} 170 POKE a+65,g:POKE a+66,f:POKE a+77,g
{LxAx} 180 POKE a+78,f:POKE a+85,g:POKE a+86,f
{FiAu} 190 POKE a+90,g:POKE a+91,f
```

```
{JmAv} 200 DATA e5,c5,f5,fe,0d,20,18,21
{NpBi} 210 DATA 8a,ac,01,00,06,51,59,7e
{ClAw} 220 DATA fe,00,28,11,47,81,10,fd
{ErAv} 230 DATA 4f,eb,09,eb,23,18,f0,f1
{PrAv} 240 DATA c1,e1,cf,fe,93,3e,20,cd
{GvAx} 250 DATA 22,90,3e,7b,cd,22,90,7b
{KvAt} 260 DATA 07,07,07,07,e6,0f,c6,41
{CxAv} 270 DATA cd,22,90,7b,e6,0f,c6,69
{ExAv} 280 DATA cd,22,90,7a,07,07,07,07
{KvAu} 290 DATA e6,0f,c6,41,cd,22,90,7a
{IpAv} 300 DATA e6,0f,c6,69,cd,22,90,3e
{JrBj} 310 DATA 7d,cd,22,90,18,c1,4d,61
{NuAl} 320 g=g-34
{GkBm} 330 IF flag=0 THEN flag=1 ELSE GOTO 370
{DvBo} 340 POKE a+35,PEEK(&BB5B):POKE a+36,
    PEEK(&BB5C)
{CsBo} 350 POKE &BB5A,&C3:POKE &BB5B,g:POKE
    &BB5C,f
{FwAm} 360 GOTO 50
{DpBp} 370 POKE a+35,PEEK(&BD2C):POKE a+36,
    PEEK(&BD2D)
{IqBn} 380 POKE &BD2B,&C3:POKE &BD2C,g:POKE
    &BD2D,f ●
```

NO PRIZES IF YOU SPOT MORE THAN 52 SPELLING ERRORS

# A & A (ANY & ALL) COMPUTERS

## COMPUTERS

DAKTARI ST & Monitors etc  
AMIGAS & Monitors etc  
AMSTRAD 6128's (COLOUR or MONO)  
AMSTRAD 464's (COLOUR OR MONO)  
PCW 8256, 8512 & 9512's  
PCW 9512 with Auto Sheet feeder  
AMSTRAD PC1512 & 1640's  
(Also replacement keyboards)

## PRINTERS

AMSTRAD Dot Matrix & Daisy wheel  
STAR DM & DW  
EPSON SALTS DM & DW  
CITIZEN DM & Lazy printers  
ATARI DM & DW  
CODDAMORE DM (Col. Mono) & DW  
SEIKOSHA DM  
(Please ring for details)

## AMSTRAD CPC PERIPHERALS

STEREO SPEECH SYNTHESISER  
256K SILICON DISCS  
256K MEMORY UPGRADE  
3.5" DISC DRIVES WITH SOFTWARE  
STOP PRESS WITH MOUSE  
AMX ART WITH MOUSE (Trap extra)  
LIGHT PENS  
JOYSTICKS (No comment)  
PRINTER CABLES/CASSETTE LEADS ETC ETC  
CPC to SCART (Television) LEADS  
A 464,664, or 6128 connected to a  
SCART TV with one of our leads,  
affectively gives a superb colour monitor  
(Great for playing games).

## SERIOUS SOFTWARE

Loads, & loadsa utilities & specialist or  
general business software.

GAMES, GLORIOUS, GLAMOUROUS & GRIZZLY GAMES

(WE DO-NOT SELL "TURKEYS")

VISA



	DISC	CASS
BATMAN (New Ocean Version)	PHONE	PHONE
INDI JONES / LAST CRUSADE	PHONE	PHONE
PURPLE SATURN DAY	11.50	7.50
ROBOCOP	11.50	6.75
GEMINI WING	11.50	7.50
3D POOL	11.50	7.50
SULTANS MAIZE		
BARBARIAN 2	11.50	7.50
STORMLORD	11.50	7.50
THUNDERBIRDS	11.50	9.75
LICENCE TO KILL	PHONE	PHONE
RENEGADE 3	11.50	7.50
LOADSACOMPILATIONS	PHONE	PHONE

LOWDS AN LOWDS OV UVERS. IF YA WONT IT, AN ITS GOOD NUFF, YA KAN AVIT; NICE'N  
CHEEP LIKE, AN KWIKK TU. JUS GIV US A BELL, OR SOME DOSH IN A BAG WIV A STAMP  
ONIT. WEAL SEND YA WOT YA WONTED WIV LOADSA DETAILS OV OWER CRAZI COMPU  
GRUB. YA KAN RITE LETTERS IF YA WONT, AN WEAL SEND YA DETAYLS OV LOADSASTUFF.  
WEY TEK AKSESS, VEESA AN DIOMOND SENTERD CAMAL DROPPINGS. BUTT IFF YA WONT  
IT KWIKK, THEN NOK A QWORTA (25%) OFF THU PROPPA (rrp) PRYCE, AN POST THU  
CHECKS TU USS, WIV YA DETAYLS. WEYAL PRAY THA PASTEMAN.

A&A COMPUTERS, Unit 38 Telford Ind Ctre, Stafford Park 4, Telford, Shropshire. TF3 3BA.  
(CALCULATION METHOD = GAMES ONLY).

Telephone 0952 290547

# TRANCE

£££££  
ARE YOU

# TRANCE

Confused by the CUBE? Bored by bar charts? MUGged methodically? Finding yourself locked  
in strange rooms for weeks on end? Zapped Out? Alienated by your computer? Lost your sense  
of adventure?

Should the answer to any of these questions be YES, and you have taken to watching  
Crossroads videos you really should be into a ..... TRANCE

Do not delay. Act immediately, remorseance is the only solution to your problem, can YOU find  
the solution to ..... Remon's TRANCE?

Anyone can crack it, so you have no need to HACK it, the solution is in your hands, not in  
the program. You will not have seen the film, read the book, worn the T-shirt or tried the  
soup yet, because CPC 664/6128 users are to be the first to succumb to its Spell.

THE PRIZE is proportional to all TRANCEactions

In other words ..... for every TRANCE puzzle sold within twelve months from  
the first sale the PRIZE fund INCREASES by £1! Submit your answer on the enclosed  
enTRANCE form. DRAW in twelve months to find the winner, if it is not won, then every month  
following until won. Watch the prize grow, GROW, GROW in AA!



© M.REMON. 1989

Did you know that the AA sales exceed 38,000?

Introductory price £9.99 inc. P&P ex. asprin

Cheques/POs to "TRANCE". Stonehaven, Nth., End,

S.Kelsey, Lincoln. LN7 6PG.AA Tel: 06527-584

## LERM SOFTWARE - Z80c TOOLKIT.

THE UTILITY FOR ALL MACHINE CODE USERS - ONLY £9.99

"Excellent value for money", "Brilliant package",  
that is what Your Sinclair said about the Spectrum version of our Toolkit,  
now available for the Amstrad 464, 646, and 6128. 3 programs in 1. Copies to disc.

**HAS OUR FULL MONEY BACK GUARANTEE - NOTHING TO LOSE!**

★ SUPERB ASSEMBLER - full screen editor - like a word processor.

Very fast - has its own monitor.

★ TOOLKIT - shows what happens to registers when running  
m/code, plus disassembler, debugger, etc.

★ CTOS - reverse assembler - changes machine code back into  
a source file - relocate your m/code!

IDEAL FOR BEGINNERS. MANY UNIQUE FEATURES. INCLUDES  
HEX/DEX, LOADER MODE, SINGLE STEPPER. HALF THE PRICE OF  
MANY RIVALS! SAE FOR DETAILS. ALL INCLUSIVE PRICE

LERM, DEPT AA, 11 BEACONSFIELD CLOSE, WHITLEY BAY,  
TYNE AND WEAR. NE25 9UW. TEL 091 - 2533615.

CHALLENGE

## GREAT STRATEGY GAMES

A superb range of Football & Cricket games

for the Spectrum, Commodore & Amstrad

From Challenge Software (formerly E & J Software)

**TREBLE CHAMPIONS £9-95 Spec 48/128 : Com 64/128 : Ams CPC**  
A STUNNINGLY REALISTIC FOOTBALL STRATEGY GAME - Can you Win The League, The F.A. Cup & The  
League Cup - 4 Divisions of 20 Teams + 1 Div. 20 Non League Teams - Details of OVER 1500 Players - Results  
& Leagues ALL Divisions - League Cup with 1st, 2nd Rnds +S/Finals over 2 Legs - F.A. Cup includes Non League  
- Transfer Market buy ANY PLAYER ANY DIVISION - 3 Skill Levels - Start ANY Division - SAVE GAME - Time  
Management - Reserves - 2 In-Match Subs - Coaching + Fitness Training - PLUS MUCH MORE.

**EUROPEAN CHAMPIONS £8-95 Spec 48/128 : Ams CPC**  
THE INTERNATIONAL CHALLENGE OF THE EUROPEAN NATIONS CUP - Genuine Nations Cup Format with  
full Random Draw of 32 Seeded Teams - Fixture List, Results and League Tables of ALL 8 Groups - Discipline &  
Medical Reports - Squad of 22 Players plus Other Players - 17 Month Itinerary of Qualifying Group, (Arrange  
Friendlies) and Finals - Plus many more Superb Features and Options. EUROPEAN CHAMPIONS includes E & J's  
MATCH PLAY SYSTEM which captures all the ACTION, DRAMA & TENSION of International Football.

**WORLD CHAMPIONS £7-95 Spec 48/128 : Com 64/128 : Ams CPC**  
A COMPLETE WORLD CUP SIMULATION - Select Friendlies - 25 Players - Qualifying Group - 2 In-Match Subs  
- Discipline Table - Select Tour Opponents - Extra Time - final Rounds - Players Gain Experience - 7 Skill Levels  
- TEXT MATCH SIMULATION including: Bookings, Goal Times, Named & Recorded Goal Scorers, Injury Time,  
Corners, Free Kicks, Match Clock, Penalties - PLUS many more Features.

**CRICKET MASTER £8-95 Spec 48/128 : Com 64/128 : Ams CPC**  
A SUPERB SIMULATION OF ONE DAY INTERNATIONAL/COUNTY CRICKET - Weather, Wicket & Outfield  
Conditions - Batting & Bowling Tactics - Team Selection - Fast, Medium & Spin Bowlers - 4 Types of Batsmen - Select  
Field Layout - 3 Skill Levels - Wides - Byes - No Ball - Run Out - Misfield - Dropped Catches - Scoreboard - Batting  
& Bowling Analysis - Run Rate - Single Option - 3 Game Speeds - STAR FEATURE a complete MATCH OVERVIEW  
showing Ball by Ball Action and Commentary and MUCH MORE!

**TEST MASTER £8-95 Spec 48/128 : Ams CPC**  
A COMPREHENSIVE SIMULATION OF A 5 DAY TEST MATCH - Includes most of the Features of CRICKET  
MASTER and MATCH OVERVIEW plus Declarations - Nightwatchmen - Light Meter - Rain Stops Play - Varying  
Number of Overs per Day - Follow On - Save Game - New Ball - Bad Light Interruptions - TEST MASTER is a True  
representation of a Complete Test Match and offers the ULTIMATE CHALLENGE to All Cricket Enthusiasts.

Above games available on disc @ Plus £4-00 Spec & Ams or Plus £2-50 Com PER GAME  
(Treble Champions not available on disc for Commodore 64/128)

ALL GAMES are available by MAIL ORDER for IMMEDIATE despatch by 1st  
class post and include Full Instructions. State which Machine & Tape or Disc.  
(Add 50p per Game outside UK or £1-50 per Game for AIRMAIL outside Europe.  
Payment in Pounds Sterling Only)

Cheques or Postal Orders payable to Challenge Software, SEND TO:  
Challenge Software, Room A1, 37 Westmoor Road, ENFIELD, Middlesex, EN3 7LE

FANTASTIC  
DISCOUNTS  
FULL PRICE GAMES ONLY  
Buy 2 games deduct £3.00  
Buy 3 games deduct £5.00  
Buy 4 games deduct £7.00  
Buy 5 games deduct £12.00

SCREENVISION  
TURNS YOUR  
MONITOR INTO  
A COLOUR TV!

AT THE AMAZING OFFER PRICE OF £64.95  
Door to Door Insured delivery add £6 INC VAT

## USE YOUR AMSTRAD CPC464, CPC664 & CPC6128 MONITOR AS A COLOUR TV SET!

Screenvision is a modern 'State-of-the-Art' TV Tuner which simply connects  
to your monitor, using the existing lead and converts it to an outstanding  
colour television.

Screenvision has more features than any other TV Tuner and costs less!  
Each tuner has seven pre-select push button channel selectors, separate  
controls for brightness, colour, tone and volume and has built in Speaker,  
Colour and Automatic gain control.

Unlike other products, Screenvision also connects to a host of other Monitors  
should you change your system.

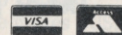

DEALER & EXPORT ENQUIRIES WELCOME

SCREENS

MICROCOMPUTERS &  
ELECTRONICS

MAIN AVENUE · MOOR PARK  
SALES 09274 20527 EXPORT 09274 20664

MIDDLESEX · HA6 2HJ · ENGLAND  
TELEX: 929224 SCREEN G FAX: 0923 835421

# Inside out



In the fifth and final part of this series, **STUART McCOLL** concludes his examination of the CPC's entrails – and ventures a guess at what the future holds.

In the past four months we've covered many of the key subjects of computer architecture, and – we hope – served to demystify that "black box" you find yourself hunching over well into the wee small hours. From a firm understanding of binary arithmetic and its significance, up through logic gates and into the more complex computing areas such as flip-flops and decoders, you've glimpsed just how simple – and I really do mean *simple* – a micro-computer can be.

In this, our last instalment, we start with something approaching the realms of myth. There was a time when introductory computing texts assured the reader that their software, however erroneous, could do nothing to their computer which couldn't be put right with a flick of the power switch. Although still largely true, such remarks should really be qualified thus: "providing your system is unexpanded, and that the peripherals attached do not clash with any existing device."

Last month we considered the problem of how devices are able to ascertain when the CPU wishes to communicate, and reached a solution with the introduction of the address decoder. Each device belonging to the system is allocated an address, and an address decoder is constructed which generates an enable signal when the system control and address lines indicate that the CPU wishes to instigate some form of data transfer with the device.

When designing computer architecture, assigning addresses to devices is initially a largely arbitrary process – often considered from the viewpoint of minimising the hardware required for building the address decoders. When adding a peripheral to an established system, however, it is imperative that the address space of the new decoder is unique to that device.

### Beware!

What would happen if two decoders clash? Suppose you buy a wonder box – a real time clock, say, which interfaces to your computer at address F000<sub>16</sub>, which returns the time with a READ operation, and sets the time with a WRITE operation.

Unknown to you, however, your ultra-fab serial joystick port (which is input only), has also been assigned this address, and has been designed to return the state of the joystick with a READ operation, while ignoring all WRITE operations. Perhaps you can see that

we're heading for trouble...

You switch on your computer. All is fine. The joystick and clock interfaces are sitting idle, waiting for the CPU to chat with them. Following the instructions in the manual, you set the time on the clock with either one, or more OUT (&F000),time operations. Now, to check it's working, you type PRINT INP (&F000) or something similar, expecting the time, accurate to so many microseconds, to be displayed in glorious technicolour. Instead, alarming wisps of smoke curl lugubriously from the back, and – if you're lucky – your joystick and clock interfaces are dead. If you're luck is out, you'll be reaching for the nearest mail-order computer mag. So the old adages

about it "not mattering how bad a programmer you are" go out the window the moment you stick your first black box onto the expansion bus.

But what happened? Both the joystick port and clock port attempted to drive the highway (data bus) simultaneously. Result: short circuits and beautiful blue smoke galore.

### Address maps

Some processors fail to distinguish any difference between addressing main memory and hardware. Although simpler, this approach restricts the address space which can subsequently be used by memory, in which your programs are eventually stored – and when it comes to marketing computers, the Ks count. The smarter processors (including the Z80 family) provide additional control signals indicating whether memory or an I/O device is currently being addressed. The Z80 in your CPC actually has two such signals, and if you look at a pin-out (back of your user manual), you'll see them listed as IORQ and MREQ. If you're in doubt as to the nature of a processor, consult its machine instruction set. The smarter chips have different instructions for accessing memory and hardware, the latter often via INPUT/OUTPUT.

Memory, peripheral, or I/O maps are used to keep track of where each device is to be found in the available address space. Although the names are often used synonymously, "I/O" and "peripheral" become obsolete when using a processor which doesn't distinguish hardware from memory – for example the popular 6800/6802 microprocessors have a single 64K address space which has to include ROM, RAM and the usual collection of external paraphernalia. Conversely many processors, such as the Z80, have two distinct maps: a peripheral map which shows device address allocation, and a memory map which illustrates how the external memory is organised by the operating system.

Even on an unexpanded CPC there are many inner peripherals attached to the CPU, each accessible via their assigned addresses. Figure 1 illustrates the basic CPC I/O address map, "xx" meaning the value of the lower byte doesn't really matter – anything in the range 00-FF addressing the peripheral indicated by the upper eight bits. It may seem complicated, and it's certainly not an "ideal" peripheral map from the user viewpoint, but it's arranged this way to minimise the amount of hardware used in the address decoding – after all, more hardware often means a bigger and ultimately more expensive computer.

Those considering constructing their own peripherals have to find some way to interface it with the computer system – and that means finding an address which hasn't already been allocated. With the CPCs this, unfortunately, is

FFxx	Not Used
FExx	Do Not Use
FCxx	Expansion Bus
FBxx	
FAxx	
F9xx	
F8xx	
F7xx	PPI Control
F6xx	PPI Port C
F5xx	PPI Port B
F4xx	PPI Port A
F3xx	Do Not Use
F0xx	Print Latch
EFxx	
EExx	
E0xx	Expansion ROM Select
DFxx	
DExx	
C0xx	CRTC Data In
BFxx	
BExx	
BDxx	
BCxx	
BBxx	Do Not Use
80xx	Video Gate
7Fxx	
7Exx	
00xx	Do Not Use

● Figure 1: inner peripherals

not the end of the story. There are actually further restrictions imposed on user peripheral interfacing, resulting from the way the lower byte of the address is decoded. These are listed in the box on User Peripheral Address Spaces – along with the addresses which satisfy these criteria and are safe to use in your projects.

We now know where to put our peripherals, and how to interface their registers to a microprocessor based computer system, which is simply (that word again) a CPU, memory, and external peripheral devices accessed via a multitudinous collection of address decoders. Since peripherals, whether a keyboard or state of the art video-chip, clearly make a computer, before concluding this introduction, we'll take a brief look at the two very distinct categories into which most peripherals fall.

**Fast and faster**

Consider the conditions required for effective data transfer with memory. Two popular peripherals, falling nicely into each category, are the keyboard and disk drive – and we'll begin with the simple *Programmed I/O* keyboard and its modest requirements.

*Programmed I/O* actually refers to the way in which data moves between memory and peripherals. Devices employing this method transfer data under control of a program, or sequence of machine instructions, which the CPU executes.

At this point let's introduce another "bit" of the control bus: INTR – the Interrupt Request. This is an input (with respect to the CPU), the status of which is reflected in an internal CPU register. This register is inspected by the CPU at the end of each instruction cycle: if it finds an interrupt to have occurred, it halts execution of the current program, stores the program

counter (PC) onto the stack and jumps to a special address in memory at which is stored a sequence of machine instructions, or, more commonly, an Interrupt Service Routine (ISR).

So, you press a key on the keyboard. The keyboard hardware first works out which key you pressed, and then stores this character in a register devoted to the task. The interface then raises an interrupt by making the INTR line TRUE. The CPU – recognising an external device wants to interrupt – stores the PC (and, depending on the particular processor, perhaps the general registers, too) before branching to the ISR.

What the ISR does depends on the particular system, but it's generally a short subroutine which polls – in order of priority – the status registers of all recognised devices. When it encounters a device requiring attention – this probably being the one which originally interrupted – it branches to a further subroutine dedicated to managing that particular peripheral. Continuing the keyboard example, its ISR typically consists of an INPUT instruction to read the external keyboard register and a WRITE instruction to send this character to a keyboard buffer maintained in RAM by the OS.

Because all data is routed through the CPU, when servicing such devices there is often a high drop-off in overall system performance. Luckily, an alternative is available, in the guise of Direct Memory Access (DMA).

**Direct Memory Access**

Consider the I/O requirements of a disk drive. It spins so fast that even if the transfer was given 100% of CPU time, a computer would be unable to match the rapid transmission speeds. To circumvent this restriction, DMA is used. DMA interfacing uses two further bits of the control bus: BUSRQ and BUSAK, standing respectively for Bus Required and Bus Acknowledge. Peripherals such as disk drives use these control lines to eliminate the CPU from the data transfer operation. That's why it is known as *Direct Memory Access*.

When a device interface makes BUSRQ true, the CPU places all its outputs into the high impedance z-state, effectively disconnecting them from the system

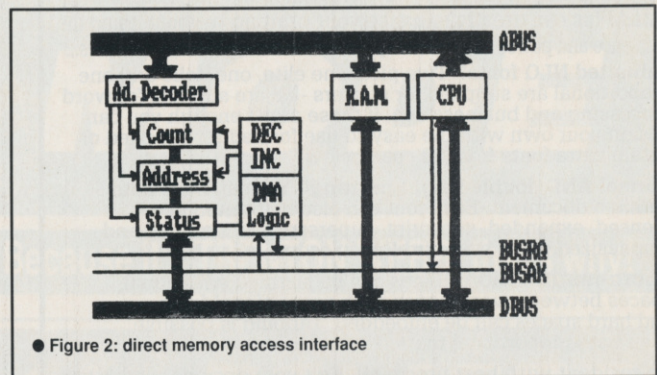

● Figure 2: direct memory access interface

busses. All that is, but BUSAK, which it makes true, thereby informing the peripheral that it now has control over the busses. A typical DMA peripheral interface is illustrated in Figure 3.

It normally consists of a simple processor, a few programmed I/O registers and, of course, an address decoder. When the interface obtains control of the busses, the dedicated processor transfers the data between memory at high speed. Upon completion, it returns control to the CPU by making BUSRQ false.

**Last but not least**

You may have noticed that the Arithmetic Logic Unit (ALU) hinted at in AA48 has not, in fact, been discussed. Instead, we thought a little teaser would do you good, and test how closely you've been paying attention. Figure 4 illustrates the problem, and the solution is plastered throughout the contents of this serialisation. Good luck – but you don't really need it. ●

**Shape of things to come?**

It used to be the case that a programmer needed a strong technical knowledge of the host machine and its language.

However, things are changing. Fast, high level languages (HLLs) are now almost universally accepted, allowing programmers to work on a variety of machines with the minimum of translation difficulties – from a CPC to an 80386 state of the art PC.

A similar revolution in hardware design is surely due. A good computer will then become the result of true creativity and originality, not just ponderous technical achievements by the boffins.

Software packages may soon display banners such as "Design your own computer – no technical background necessary"!

For computers can be as complicated or as simple as we choose to make them. Designers, after all, just bend to the clamour of public demand. AA could easily be filled with technical bits and bobs – but who would read it? Certainly not as many as do now!

On the other hand, our whistle stop tour gives you a firm technical foundation, and – I hope – a desire to unearth more copper clad secrets.

**User peripheral address spaces**

There are three User Peripheral Interfacing restrictions:

- (1) If bit 7 is LOW the disk drive is selected
- (2) If bit 6 is LOW a reserved function is selected
- (3) And if bit 5 is LOW a communications channel is selected.

The addresses available for user address decoders are:

- FBE0 – FBFF
- FAE0 – FAFF
- F9E0 – F9FF
- F8E0 – F8FF

If you analyse the bit patterns for the available addresses, you'll see that bits 0,1,2,3,8,9 may be used freely, providing up to 64 I/O channels. If simple bit-related partial decoding is used, 6 channels are available.

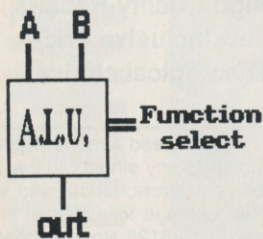

F1	F0	Result
F	F	A+B
F	T	B-A
T	F	INC A
T	T	DEC A

HINT: (B-A) = (-A+B)

● Figure 3: ALU dilemma. A simple CPU has an ALU with four operations, two input busses and an output bus. The required operations are listed in the table. Can you design the logic? You can if you've been following *Inside out!*

## QUALITAS PLUS

Your printer was an expensive buy - why not make the most of it? Qualitas Plus can greatly enhance - your printing, without losing the convenience and power of your word processor. Just look at these features...

- **Unlimited NLO fonts!** Two pica, one elite, one italic and one proportional are supplied for starters - all are suitable for word processing and business use. If these aren't enough you can design your own with the easy-to-use font editor supplied or obtain extra fonts from us - see below.
- **Normal AND double height printing!** You can have both within a document. Each font can also be printed in condensed, expanded, subscript, superscript, underlined and emphasized using standard Epson codes - all in NLO
- **Micro-justification!** Lines can be justified with equal spaces between words, even with proportional fonts, and hard spaces can be embedded. Tabbing is possible even with proportional fonts.
- **Co-resident with host program!** Edit your document and then just print it, using all the powerful features of your word processor, eg print formatting, character redefinition, and even mail merge (try doing this with a desktop publisher!) You do NOT have to save files to disc first!
- **Very compatible!** Works with nearly all 9-pin Epson-compatible printers, including the CP80 and the MT80, but not the DMP1 or HR5. Compatible with Advanced Amword, Masterfile III, Mini-Office II (CPC6128 or equivalent only), Protex (except CP/M Plus but see below), Tasword, and your own BASIC programs.

Qualitas Plus (NEW improved version 2) is just £16.95. The NEW Qualitas Font Library adds an amazing 30 extra fonts for only £14.95 (requires 8-bit printer port). The Utility Pack for CP/M Plus allows Qualitas to run under CP/M Plus (eg with Protex) and costs £9.95. Latest KDS 8-bit printer port MK3 - £18.95. Upgrades (send us your master disc): Qualitas Plus version 1 to version 2 - £4.95; any Font Pack to complete Font Library - £6.95.

All programs disc only. Please state your computer, printer and word processor. UK orders post free (Europe add £1, elsewhere add £2 airmail).

"I can't stand the DMP2000's ugly NLO print, and many other printers have the same problem. The definitive cure is Qualitas Plus. Provided your printer is compatible, it is one of the best buys you will ever make." - WACCI May 1988

**SEVEN STARS**

Seven Stars Publishing, Dept AA,  
34 Squirrel Rise, Marlow,  
Bucks SL7 3PN. Tel: 06284 3445



## POOLS AND HORSES WIN WITH COURSEMASTER AND POOLSMASER

(formerly 'Pools Predictor' by Cowen Computer Systems)

### The Computer Horseracing Programme

- \* RATES ANY RACE IN SECONDS - ANY DAILY NEWSPAPER IS ALL YOU NEED
- \* NEVER out of date - Both N. Hunt and Flat - Fast data entry
- \* AMAZING ACCURACY!! - Now you CAN BEAT THE BOOKIE!
- \* Works on the simple principle that **FAST HORSES BEAT SLOW ONES!!!**
- \* Clearly identifies best selection in every race plus these **AMAZING** Features:-
- \* First, Second and Third choice shown for Forecasts and Tricasts. etc. Recommends most suitable type of bet.
- \* Actually works out your **WINNINGS** on most popular bets including **SINGLES** and **DOUBLES**, win and each way **PATENTS**, **YANKEES**, **CANADIANS**, **HEINZ** etc. Good **EACH WAY** and **LONG ODDS** bets clearly shown.
- \* Will **PRINT** out your **BETTING SLIP** for you.
- \* Maintains a **BANK ACCOUNT** - **BET** like **PROFESSIONALS** do! Records all your bets in any number of accounts. Keep a complete record of your betting or compare Coursemaster against your favourite tipster.
- \* **PLUS!!! - THE AMAZING COURSEMASTER SYSTEM** This superb betting system is included in the programme. A system which regularly produces huge wins from small stakes. Try it! Can pay for itself many times over on the first day!
- \* Supplied with 20 page **BETTING GUIDE** and **MANUAL**.

**FREE HOT TIP OF THE MONTH TO EVERY PURCHASER**

Supplied on **TAPE** at £16.95 for:-  
All Spectrums, Commodore 64/128, Amstrad  
CPC's, BBC & Electron. Also available for  
Sinclair QL on Microdrive at £16.95.

Supplied on **DISC** at £18.95 for:-  
All Spectrums, Commodore 64/128 Amstrad  
CPC's, Amstrad PCW's, BBC & Electron,  
IBM/PC compatibles. All Amstrad PC's etc.

Please state machine and disc size

### The Computer Football Pools Predictor

- The amazing **POOLSMASER** programme is by far the best Pools predictor that we have ever seen. In just 10 weeks of trying this programme ourselves we won 12 dividends the largest being nearly £300. **POOLSMASER** is simple to use and requires only that you keep the league tables up to date using your usual newspaper.
- The result of many years research into the Football Pools by the programmer Martin Evans of C.C.S. the programme is a masterpiece of expertise and is simplicity itself to use.
- \* Predicts Homes, Aways and Draws.
  - \* No fiddly typing in of teams etc. and no redundant databases.
  - \* Instant read out or Hardcopy if you have a Printer.
  - \* Uses scientific formula based on recent form home and away, league position, goals scored etc. It has long been realised that certain combinations of these factors return a much higher average of draws than the laws of average would expect. **POOLSMASER** looks for these factors and analyses their significance to give you the best possible chance of a win.
  - \* Also has a 'Sequence Predictor' option. Many people believe that certain numbers on the coupon come up more often than others and over a season patterns do seem to develop. The programme analyses these patterns and predicts the numbers most likely to come up next. Certainly more scientific than sticking a pin in or family birthdays etc!

If you do the **POOLS** then this is the programme for you.

SUPPLIED ON TAPE AT £16.95  
FOR ALL SPECTRUMS, AMSTRAD CPC'S  
COMMODORE 64/128.

SUPPLIED ON DISK AT £18.95 FOR ALL  
PCW'S, SPECTRUMS, COMMODORE  
64/128, AMSTRAD CPC'S, AMSTRAD/IBM  
COMPATIBLE PC'S.

British and Australian version available please state which. Please state disc size.

\* **SPECIAL COMPENDIUM DISK OR TAPE CONTAINING \***  
**BOTH COURSEMASTER & POOLSMASER - TAPE £31.95 - DISK £34.95**

INTRASET LTD, (DEPT AA) FREEPOST NO. 10 Woodside Ave,  
Clayton-Le-Woods, Chorley, Lancs, PR6 7QF

### ZEDASM ROM £19.95

The professional Z80 Text Editor/Assembler and System monitor. Superfast Z80 assembler (200 lines second). Supports page switching on 6128 machines, up to 80k of text source in memory at the same time.

### DEMON DEVELOPMENT CARTRIDGE £19.95

The Ultimate machine code tool. Stop Any program Anytime by a press of a button, the memory remains intact and can be saved to Tape/Disc, debugged, traced, moved, disassembled etc.

### EPROM PROGRAMMER KIT £27.50

Transfer your favourite programs (Basic/Machine Code) onto Eprom. Programs 2764/27128 12.5 or 21 volt Eproms. Powerful but easy to use software, Rom to Rom copy, Editing, Verification, Single or block programming.

### PCB DESIGNER CARTRIDGE £59.95

Design double sided printed circuit boards quickly and easily. Output to standard printer 1:1 or 2:1 scale. Predefined DILS & IDC connectors. Auto Routing. Zoom Editing etc. Too many functions to list here.

### PASCAL COMPILER ROM £15.00

Our pascal compiler is easy to use, suitable for the absolute beginner and produces stand alone Machine code. Does NOT require CPM.

(Note cartridges have no through connector for 464 with Disk Drive)



John Morrison Dept (AA)  
4 Rein Gardens, Tingley, West Yorkshire, WF3 1JR  
Telephone (0532) 537 507 S.A.E for further information

## MAKE YOUR AMSTRAD EARN

Yes making money with your Amstrad becomes incidental when you know how. Your micro is, if only you knew it, a gold mine. The size and make is irrelevant. Make the initial effort **NOW** by starting your own

### HOME BASED BUSINESS

*This may be the most important move you will ever make!*

REMEMBER: You'll never get rich by digging someone else's "ditch". Anyone in the country, including YOU, can become very rich in a relatively short period of time just by doing a few basic things! It's more rewarding than playing games. The benefits are many and varied. Full or part time. For **FREE** details send S.A.E. to:

## HOME BASED BUSINESS

31, PILTON PLACE (AA5)  
KING AND QUEEN STREET,  
WALWORTH, LONDON SE17 1DR



## Matrix Software Hire

The cheapest way to play them all.

Top games titles for Amstrad, Commodore,  
Spectrum and Amiga.

Please state system

Please send large SAE for details to

Matrix Leisure Club, Dept AA,  
271 Stansted Road, Bishops Stortford  
Herts CM23 2BT



High Quality Repairs  
Low Inclusive Prices  
The Logical choice!

### Technical Services

#### REPAIRS

Amstrad CPC 464.....£21.90  
Amstrad CPC 6128.....£24.90

#### ACCESSORIES

CPC 6128 Rom .....£17.90  
64K Ram Pack.....£43.90  
MP2 Modulator .....£27.90  
Printer Cable.....£8.80

All repairs guaranteed 4 months, prices quoted apply to any single fault \* and are inclusive of parts, labour and VAT. Free return carriage for UK mail order customers. CPC 6128 Rom installation service available, only £8.00.  
\* Excludes replacement of complete keyboard or disk drive assemblies (free estimate given).

VSE Technical Services (Dept 104), Unit 6,  
8 Nursery Road, London SW9 8BP. Tel 01-737-0234

# CHEAT MODE

They don't call him PAT McDONALD... Why? Because it's TRENTON WEBB, that's why!



"Kiss me Hardy" will never be the final words of Captain Ace Gunn again, because MIKE WONG of Sale has come up with a nifty little pokette for immortality.

Time to get mean with those big blue boys in tin, because with this poke you become a dapper zapper in Tengen's Xybots. DISK.

```
1 ` XYBOTS Disk
2 ` by Mike Wong
3 ` Amstrad Action Oct 89
10 MODE 2:PRINT"Insert ";
20 PRINT"XYBOTS disk..."
30 FOR n=&BE80 TO &BEA9
40 READ a$:a=VAL("&"a$)
50 POKE n,a:c=c+a:NEXT
60 IF c<>3335 THEN 150
70 CALL &BB18:CALL &BE80
80 DATA 21,8d,be,11,40,00
90 DATA d5,01,1d,00,ed,b0
100 DATA c9,21,00,01,e5,11
110 DATA 00,00,0e,41,df,5a
120 DATA 00,21,53,00,22,05
130 DATA 01,c9,af,32,1f,72
140 DATA c3,b0,04,3c,c0,07
150 PRINT"Error..." ●
```

XYBOTS



Time and tide wait for no man, unless, that is, Julian Page of Somerset has gotten to them first. Thirst no more, and always have infinite time on your hands to complete *Total Eclipse* by

Incentive. Don't get so excited it's only a poke, and anyway he's stopped any heart attacks and made you immune to poison gas as well! Disk

```
1 `TOTAL ECLIPSE Disk
2 `By Julian Page
f3 `For Amstrad Action Oct 89
10 MODE 1
20 MEMORY &1B15
30 PRINT"INSERT TOTAL ECLIPSE"
40 PRINT"DISC AND PRESS A KEY"
50 CALL &BB03:CALL &BB06
60 LOAD"TECODE"
70 A$="No Heart Failure"
80 GOSUB 200:IF NOT a THEN 110
90 POKE &7609,0:POKE &6A4C,0
100 POKE &6BAC,0
110 a$="No Time Limit"
120 GOSUB 200:IF NOT a THEN 160
130 b=&3CA9:POKE b,0
140 POKE b+1,0:POKE b+2,0
150 POKE &6770,&18
160 INK 0,0:INK 1,0
170 INK 2,0:INK 3,0
180 LOAD"tecon.scr",&C000
```

```
190 CALL &1B16
200 PRINT:CALL &BB03
210 PRINT a$;" Y/N ?"
220 b$="":WHILE b$=""
230 b$=LOWER$(INKEY$)
240 WEND
250 a=(b$="y"):RETURN ●
```

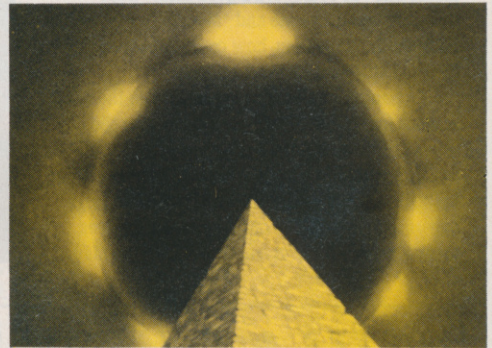

## NETHERWORLD

Have a smashing time courtesy of Sale's very own MIKE WONG. *Netherworld* from Hewson will nether (geddit) be the same again, with the gift of infinite smashers/killers, bags of time and immortality too.

What more could a cursor dream of? Tape Method 1.

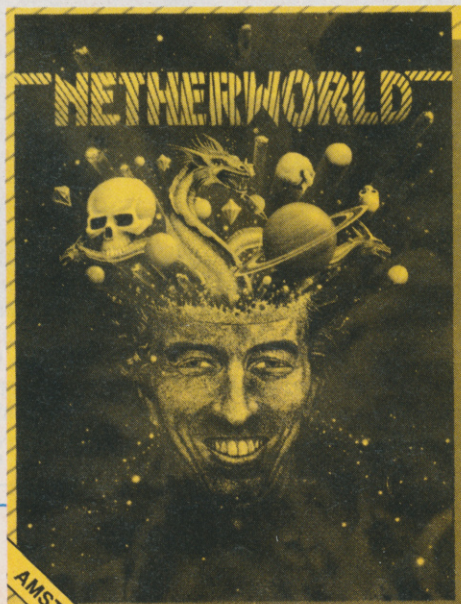

```
1 ` NETHERWORLD Tape
2 ` METHOD 1
3 ` by Mike Wong
4 ` Amstrad Action Oct 89
10 MODE 2:MEMORY &3FBF
20 FOR n=&BE80 TO &BEB7
30 READ a$:a=VAL("&"a$)
40 POKE n,a:c=c+a:NEXT
50 IF c<>3885 THEN 250
60 FOR n=1 TO 3
70 READ a$,p,q:PRINT a$;
80 INPUT" (y/n)";a$
90 IF a$="y" THEN 110
100 POKE &BE90+p,q
110 NEXT:LOAD"":CALL
&BE80
120 DATA
21,8d,be,11,40,00
130 DATA
d5,01,2b,00,ed,b0
140 DATA
c9,21,49,00,22,5b
150 DATA
41,c3,c0,3f,3e,a7
160 DATA
32,74,21,32,28,23
170 DATA
3e,00,32,bf,27,18
180 DATA
00,06,0a,21,18,a7
190 DATA
36,09,23,36,09,11
200 DATA
04,00,19,10,f5,c3
210 DATA 00,01
220 DATA INF
SMASHERS/KILLERS
230 DATA 7,&3d,INF
LIVES,15,1
240 DATA 990 TIME,20,16
250 PRINT"Error..." ●
```

# THE ELITE CLUB

Space, the final front ear (*shurely shome mishtake ?- ed.*)... Now AA boldly goes in search of all those Commanders - from harmless, through above average, right up to elite - willing to share their knowledge. Take it away, TRENTON!

Since the idea of an *Elite Players Club* was mooted back in AA46 we've been deluged with mail detailing adventures in Firebird's galaxy spanning epic. So welcome to The Elite Players Club (EPC), officially launched in this historic issue. May God bless her and all who sail in her.

*Elite* (Mastergame, naturally) was first reviewed way back in AA5, but the sheer longevity of the game and reputation it has continued to enjoy has astonished everyone. Faced with comments like "Of course it's a good idea!" from Commander McQuarrie and "Megawicked!" by Commander Rouyheen, how could AA not start the EPC and still hold its head up high?

Archangel Dan Dare identified one of the many reasons for the EPC: "I can just remember the day when I came across the message 'Mayday Corolius in danger!' At the time (not so long ago) it was like being in space, I was frantic with nowhere to go and with no one to call on for assistance! I was lucky, I passed the test and made 'Elite' on May

20th, 2100hrs, Anbedi, Galaxy Five and I'd only joined the ranks of harmless traders in September the previous year.

"Since then I've ploughed my way through the galaxies and life has been very quiet... I am now in galaxy Eight. What I'd like to know what comes next? What are the other two missions? When do you finish?"

The EPC exists to fill the gap that left Commander Dare vulnerable. The club has the potential to build up into a network of Elitists throughout the country. Over the months there will also be a series of reprints of all the old *Elite*

hints and tips so you can build up the ultimate space traveller's guide to life, the universe and thargoid dietary habits.

The EPC is your club, so tell us what you want! To get things rolling we've compiled a list of Elitists who want to spread the word, share tips, advice and the like. Featuring The Mega Poke this month means there's no room for tips, but they will most definitely form a regular part of the column. We'll be giving away £15 pounds' worth of software for the best advice/cheat each and every month, so send in your tips when you sign up for the EPC. If you want your name added to

the *Elite Roster* all we need to know is you and your commander's name, your rating and, if you can, telephone number. Of course if you want to tell us more we'll be eager to read it.

With the game's re-emergence on Ocean's *Supreme Challenge* compilation, there are a whole new generation of commanders out there venturing into space. The EPC is both for the "deadly" pilots and for harmless traders, so regardless of your rating write in now!

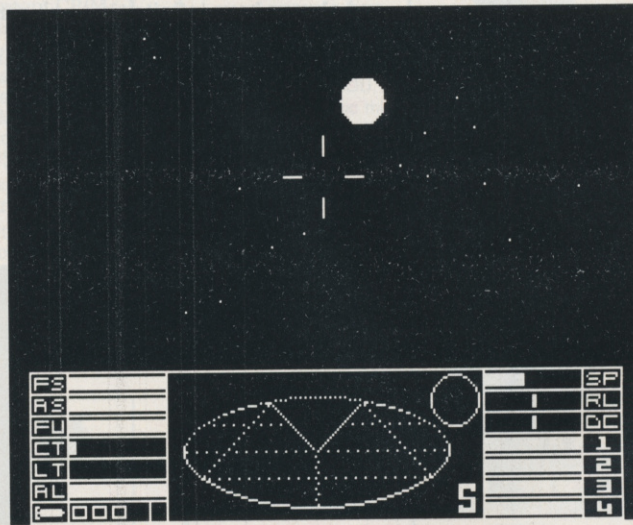

## ROSTER ● ELITE ROSTER ● ELITE ROSTER ● ELITE ROSTER

**Commander Gibson**  
Rating: Unknown  
Alias: Lawrence Gibson  
Portsmouth, Hants.  
☎ 0705 262984

**Commander: The Evil One**  
Rating: Dangerous  
Alias: Jonathan Pearson,  
44 Lavinia Rd,  
Gosport, Hants.  
"I need some tips to get past the flashing ships I think they're pirates, perhaps?"

**Archangel Dan Dare**  
Rating: Unknown  
Alias: Colin Kirkwood  
Ayr, Scotland  
☎ 0292 287348  
"Hello to Ytootie, in galaxy three."

**Commander Sturgess**

Rating: Dangerous  
Alias: James Sturgess  
110 Tadburn Rd,  
Romsey, Hampshire  
SO51 8HS

**Commander Piranha**  
Rating: Deadly  
Alias: Richard Townsend  
London SW18.  
01 874 366  
"What are missions three and four about?"

**Commander Prang**  
Rating: Deadly  
Alias: Kevin Thomas  
Exeter, Devon.  
0392 61 938  
"Why do I always seem to find Thargoid Invasion Fleets in the next system I hyper-space to?"

**Commander Doohier**  
Rating: Dangerous

Alias: T Doohier  
Leicester.  
0533 872293  
"Ring after five."  
**Commander Rouyheen**

Rating: Dangerous  
Alias: C Rouyheen  
Manchester.  
061 7751814  
"What's an Archangel?"

**Commander Hawkeye**  
Rating: Dangerous  
Alias: Graham Crabb  
London IG8.  
01 5057315

"Where's planet Solega on Galatic chart two?"

**Commander Boba Fett**  
Rating: Deadly  
Alias: SB Roberts  
Cardiff.  
Cardiff 614126

**Commander Douglas**

Rating: Deadly  
Alias: Craig R Douglas  
Seaham, Co. Durham.  
091 5260635

**Archangel Street**  
Rating: Elite  
Alias: Chris Street,  
43 Ridgedale Rd,  
Bolsover, Chesterfield,  
Derbyshire S44 6TX

**Commander Bloggs**  
Rating: Deadly  
Alias: Simon Fogiel  
Aberdeen, Scotland.  
0224 635812  
"Call between 4 and 10 pm."

**Commander Swindells**  
Rating: Harmless  
Alias: Adam Swindells  
Peusey, Wilts.  
0672 63465

**Commander McQuarrie**  
Rating: Unknown

Alias: James Grant  
McQuarrie  
Fife, Scotland.  
041 9425922

**Commander Honka**  
Rating: Dangerous  
Alias: Chris Hayes  
Southampton, Hants.  
0703 583175

"Dangerous in three days play, not bad eh!"

**Commander Walters**  
Rating: Deadly  
Alias: David Walters  
0405 69240

"Advice given for mission one, two and on the cloaking device"

**Commander Ryder**  
Rating: Unknown  
Alias: Richard Beafoy  
Walsgrave, Coventry.  
0203 619564  
"Ring evenings only."

# ELITE GETS THE ULTIMATE POKE!

Here, Commanders one and all, is the ultimate in *Elite* pokes. First featured way back in AA20, and now reprinted by popular demand (petitions, requests, begging letters - but precious few cheques), gives you the power to do almost anything you wish in Firebird's classic. Type in lines 1-130 inclusive to get into the program. Then select the pokes you want operative and type them in using the corresponding line number (if you choose you can ignore the REM statements, which just indicate what the poke statement does). When you've typed in the lines you want finish off the poke with line 520. Then put the game disk in the drive and type RUN.

```

1 ' Elite - disk
10 ' Amstrad Action Oct 89
20 ' Thanks to Adrian Forbes
30 '
40 MODE 1: BORDER 0: INK 0, 0
47 | USER, 0
50 INK 1, 24: INK 2, 15: INK 3, 6
60 WINDOW #1, 14, 26, 12, 12
70 WINDOW #2, 14, 26, 12, 14
80 LOAD "common2x", &C000
90 OPENOUT "d"
100 MEMORY &83F
110 CLOSEOUT
120 LOAD "largeaxx", &840
130 LOAD "commonxx", &1A40

```

```

140 '**** Instant hyperspace ****

```

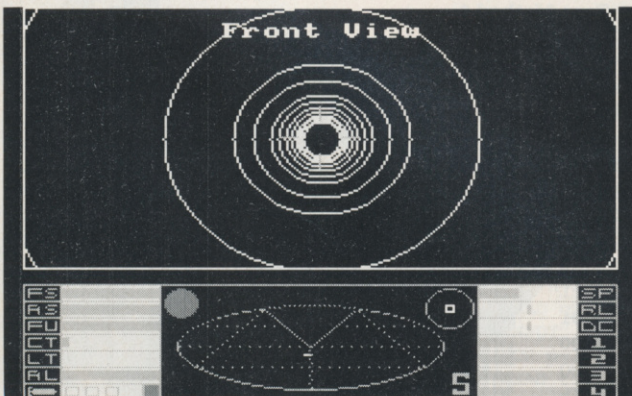

```

145 POKE &4C56, 24
146 POKE &507F, 0
150 '**** Inf fuel ****
170 POKE &4F02, 0
180 '**** Inf miss ****
190 POKE &382D, 0

```

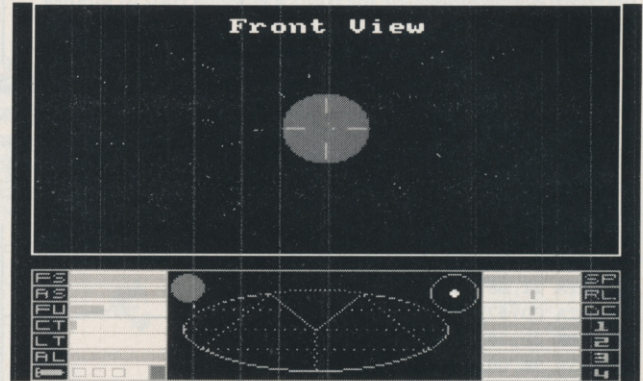

```

200 '**** no hyp range limit ****
210 POKE &4C08, 0: POKE &4C12, 0
220 '**** const galac jump ****
230 POKE &4BFA, 0
240 '**** const escap pod ****
250 POKE &3849, 0
260 '**** No cargo loss on use of esc *
270 POKE &3866, 0
280 '**** No energy loss ****
290 POKE &35CB, 0
300 '**** No laser temp rise ****
310 POKE &7A4F, 0
320 '**** One hit to destroy ships ****
330 POKE &7AA8, 0
340 '**** Spast launch thargoids ****
350 POKE &896B, 0
360 '**** Miss able to blow up spst **
370 POKE &8A8F, 0
380 '**** Cloaking (Y) ****
390 POKE &4902, &21: POKE &4906, &F6: POKE &4908, &0
400 '**** Inf credits ****
410 POKE &FE78, 3: POKE &FE86, 18
420 '**** ECM jammer ****
430 POKE &8932, &18: POKE &48C3, 0
440 POKE &48CD, 0
450 '**** Const energy bomb ****
460 POKE &2F6A, 0
470 '**** Remove flash ****
480 POKE &2F7A, &C9
490 '**** Make indestructable ****
500 POKE &787C, &0: POKE &7B61, 0: POKE &1E63, &C3
510 '**** Start prog ****

```

```

520 CALL &1C82

```

## CALLING ALL THE HEROES!

You've worked hard to acquire your knowledge: why not share it? And while you're at it, why not register for the Elite roster? Write now to: The Elite Club, Amstrad Action, 4 Queen St, Bath BA1 1EJ.

# SILKWORM

Helping the worm to turn PHIL HOWARD of Mapperley gives the flyboys and jeepsters a chance to strike back in Virgin's great shoot'em up *Silkworm*. Just to be fair both warriors get immortality, for a silky smooth trail to victory. Tape Method 1

```

1 `SILKWORM tape
2 `by Phil Howard
3 `INFINITE LIVES
4 `Amstrad Action Oct 89
10 DATA 21,16,BD,36,C3,23
20 DATA 36,0E,23,36,BE,C3
30 DATA D9,99,21,17,BE,22
40 DATA 4E,A6,C3,08,A6,DD
50 DATA 21,B8,A8,11,C2,00
60 DATA CD,47,A8,21,2A,BE
70 DATA 22,78,A9,C3,E2,A8
80 DATA 3E,00,32,69,4D,C3
90 DATA FE,99
100 y=0:MEMORY &5000
110 FOR x=&BE00 TO &BE31
120 READ a$:a=VAL("&"+a$)
130 POKE x,a:y=y+a:NEXT
140 IF y<&1623 THEN 170
150 LOAD"SILKWORM"
160 CALL &BE00
170 PRINT"data error!" ●
    
```

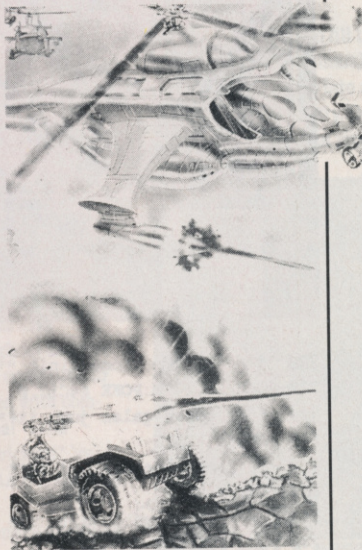

# RED HEAT

Red Cheat on *Red Heat* as Arnie Schwarzenegger gets some real muscle in the form of infinite energy and bullets. PHIL HOWARD helps us all to stop the traffic in drugs and increase the traffic to the morgue. Tape Method 1

```

1 `REDHEAT tape
2 `by Phil howard
3 `INFINITE ENERGY
4 `Amstrad Action Oct89
5 `INFINITE BULLETS
6 `
10 DATA 21,16,BD,36,C3,23
20 DATA 36,0E,23,36,BE,C3
30 DATA 9E,9A,21,17,BE,22
40 DATA 56,A6,C3,0F,A6,DD
50 DATA 21,C0,a8,11,B2,00
60 DATA CD,4F,A8,21,2A,BE
70 DATA 22,70,A9,C3,eA,a8
80 DATA AF,32,EC,4C,32,0B
90 DATA 56,32,12,56,C3,00
100 DATA 20
110 y=0:MEMORY &5000
120 FOR x=&BE00 TO &BE36
130 READ a$:a=VAL("&"+a$)
140 POKE x,a:y=y+a:NEXT
150 IF y<&16A1 THEN 180
160 LOAD"REDHEAT"
170 CALL &BE00
180 PRINT"data error!" ●
    
```



# BAD DUDES VS.

# DRAGONNINJA™

Bad news for *Dragon Ninja* with this tasty poke from MIKE WONG of Sale. It gives Ocean's quite naughty dudes the chance to turn real mean: the options are infinite lives, ener-

gy, time and/or credits. Is rescuing the President that important though? Chew it over when you finish the game! Tape Method 1.

```

1 `BAD DUDES tape
2 `by Mike Wong
3 `Amstrad Action Oct 89
10 MODE 1:MEMORY &99BB
20 FOR n=&BE80 TO &BEE8
30 READ a$:a=VAL("&"+a$)
40 POKE n,a:c=c+a:NEXT
50 IF c<>10100 THEN 360
60 FOR n=1 TO 4
70 READ a$,p,q
80 PRINT"Inf "+a$+" (y/n)";
90 INPUT a$
100 IF a$="y" THEN 120
110 POKE &BE00+p,q
120 NEXT:CLS
130 LOAD"!":CALL &BE80
140 DATA 3e,c3,21,8e,be,32
150 DATA 16,bd,22,17,bd,c3
160 DATA bc,99,cd,37,bd,21
170 DATA 00,00,22,4d,a6,21
180 DATA a0,be,22,50,a6,c3
190 DATA 00,a6,dd,21,ba,a8
200 DATA 11,ab,00,cd,49,a8
210 DATA 21,b3,be,22,63,a9
220 DATA c3,e4,a8,3e,a7,32
230 DATA 16,1f,32,51,22,3e
240 DATA a7,32,54,1d,3e,00
250 DATA 32,cf,13,32,d8,13
260 DATA 3e,a7,32,07,15,21
270 DATA db,be,11,45,5b,01
280 DATA 0e,00,ed,b0,c3,00
290 DATA 80,4d,49,4b,45,20
300 DATA 57,4f,4e,47,20,5b
310 DATA 20,41,41
320 DATA energy,&b4,&3d
330 DATA lives,&bc,&3d
340 DATA time,&c1,1
350 DATA credits,&c9,&3d
360 PRINT"Error..." ●
    
```



# DOMINATOR

Penetrate. Dominate. Conquer. *Cheat!* If you've failed to master System 3's *Dominator* then rejoice because PHIL HOWARD is here to save the world. Immortality is yours to help defeat the beast with an appetite for anything planet-sized or smaller. Tape Method 1

```

1 'DOMINATOR tape
2 'by Phil Howard
3 'INFINITE LIVES
4 'Amstrad Action Oct89
10 DATA 21,16,BD,36,C3,23
20 DATA 36,0E,23,36,BE,C3
30 DATA 9E,9A,21,17,BE,22
40 DATA 4E,A6,C3,08,A6,DD
50 DATA 21,B8,A8,11,AB,00
60 DATA CD,47,A8,21,2A,BE
70 DATA 22,61,A9,C3,E2,A8
80 DATA 3E,00,32,36,07,C3
90 DATA 00,05
100 y=0:MEMORY &5000
110 FOR x=&BE00 TO &BE31
120 READ a$:a=VAL("&"+a$)
130 POKE x,a:y=y+a:NEXT
140 IF y<>&13B0 THEN 170
150 LOAD"DOM"
160 CALL &BE00
170 PRINT"data error!" ●

```

# RICK DANGEROUS

WE'RE NOT HERE TO EAT.

Firebird's Rick Dangerous, explorer extraordinaire, had better change his name to Rick Quite Safe, Actually: MIKE WONG of Sale gives the alternative Indy everything he could ever dream of: infinite lives, bullets and bombs. Let the good times - and that large stone - roll! Disk.

```

1 'Rick Dangerous - Disk
2 'Amstrad Action Oct 89
3 'Mike Wong
10 FOR n=&BE80 TO &BEA4
20 READ a$:a=VAL("&"+a$)
30 POKE n,a:c=c+a:NEXT
40 IF c<>3183 THEN 220
50 FOR n=0 TO 2:READ a$
60 PRINT"Inf ";a$;" (y/n)";
70 INPUT a$
80 IF a$="y" THEN 100
90 POKE &BE96+n*3,&21
100 NEXT
110 PRINT"Insert RICK..."
120 CALL &BB18:MODE 1
130 CALL &BE80
140 DATA 21,00,01,11,00,00
150 DATA 0e,41,df,a2,be,21
160 DATA 94,be,22,25,01,c3
170 DATA 00,01,3e,a7,32,c3
180 DATA 88,32,35,9f,32,90
190 DATA 9f,c3,50,50,3c,c0
200 DATA 07,lives,bullets
210 DATA bombs
220 PRINT"Error..." ●

```

## Real Ghostbusters

Do you wanna be a *Real Ghostbuster*? Get those fingers typing, because MIKE WONG has gone disk-busting and brought back the secret of infinite lives from the other side. (Disk.)

```

1 'RGB - Disk
2 'Amstrad Action Oct 89
3 'Mike Wong
10 PRINT"INSERT DISC..."
20 CALL &BB18:MODE 2
30 PRINT"1. DISC TO NORMAL"
40 PRINT"2. INF LIVES"
50 FOR n=&BEFB TO &BF17
60 READ a$:a=VAL("&"+a$)
70 POKE n,a:c=c+a:NEXT
80 IF c<>2552 THEN 230
90 PRINT:INPUT n
100 IF n=2 THEN 130
110 POKE &BF07,&80
120 POKE &BF08,&4E
130 CALL &BEFB
140 POKE &BF15,&3F
150 CALL &BEFB
160 IF n=2 THEN |CPM
170 PRINT"DISC OK..." :END
180 DATA 21,00,40,11,00,00
190 DATA 0e,41,df,15,bf,21
200 DATA 0d,bf,22,ab,40,c9
210 DATA 3e,a7,32,b1,65,c3
220 DATA 80,4e,3c,c0,07
230 PRINT"Error..." ●

```

# BARBARIAN II

Did you follow last month's map for *Barbarian II* to Drax's lair, only to get chopped down in a few quick hacks? Fear not, for hacking hero MIKE WONG comes to your aid with infinite lives, energy and the mysterious megapower. What does it do? There's only one way to find out! (Disk.)

```

1 'Barbarian II - disk
2 'Amstrad Action Oct 89
3 'Mike Wong
10 DATA 21,00,40,11,00,00
20 DATA 0e,00,df,0c,80,c9
30 DATA 3c,c0,07
40 DATA INFINITE LIVES
50 DATA 24,66,&af,61,&a7
60 DATA 24,66,&af,61,&a7
70 DATA INFINITE ENERGY
80 DATA 23,72,278,50,58
90 DATA 23,72,402,50,58
100 DATA MEGAPOWER
110 DATA 23,72,146,&b7,&d6
120 DATA 23,72,147,&91,&10
130 FOR n=&8000 TO &800E
140 READ a$:a=VAL("&"+a$)
150 POKE n,a:NEXT:MODE 2
160 PRINT"INSERT BARB 2..."
170 PRINT"WRITE PROTECT OFF!"
180 CALL &BB18
190 FOR n=1 TO 3
200 READ q$:PRINT q$;
210 INPUT" (y/n)";a$
220 FOR p=1 TO 2
230 READ t,s,a,b,r
240 POKE &8005,t
250 POKE &8007,s
260 POKE &800C,&3C
270 CALL &8000
280 x=&4000+a
290 IF a$="y" THEN POKE x,r
300 IF a$="n" THEN POKE x,b
310 POKE &800C,&3F
320 CALL &8000
330 NEXT p,n
340 |CPM ●

```



# Insider dealing

Part five of PHIL HOWARD'S series on the joys of hacking finds him with a bag of chips.

It always amazes me – but then, I am easily amazed – how at the lowest levels of computing, hardware and software are practically indistinguishable, in that both retain the birthmarks of an earlier electronic theory. Electronics never was my strong point, but it's true to say that the better you understand internal structures, the easier and more logical software and hardware manipulations become. I'm lucky to have Stuart McColl's hardware series running along side by side. It certainly is a bonus, since it lays a great deal of the ground work for many programming techniques.

Right, that's enough crawling. This month we're going to have a bash at the keyboard, and that means straying into hardware territory (not strictly my patch). But then, as I said, at the lowest level it's all the same...

## Bag of chips

Inside the CPC, all merrily ticking along to the synchronised rhythm of the system clock, are a number of individual, off the shelf silicon

chips. Each has been selected to perform a specific task, and for the most part they act independently. The Central Processor Unit runs the show, crunching the numbers and interpreting the instructions. The Programmable Sound Generator creates the noises, while the Cathode Ray Tube Controller deals with the visuals etc. In order for the computer to work, though, there needs to be some contact between these functions. This is dealt with by the CPU, which communicates by sending instructions out to the chips and getting information about the system back in from them.

These in and out instructions are the lowest form of language that you are likely to encounter, and while it's essential to know that this is going on, it's very much easier to use the higher level implementations (Basic and ROM routine), and not get personally involved. If you want to understand the full picture, however, there's a lot to be said for spending a little time and effort finding out not only the way they work, but also what they are capable of doing for you. Some damage may be caused if these instructions are executed imprudently, so don't use them at random (just to see what they do).

Basically each chip is linked to the CPU

and each other via a series of electrical connections known as the bus (don't ask me – just read last month's instalment from Stuart McColl!), which you can see an extension of, labelled "expansion socket," sticking out of the back of your keyboard. Each chip has its own address, called a port, which is, as it were, its telephone number. By sending data out to a specific port you can write new information into that chip, and, by receiving data in you can read what

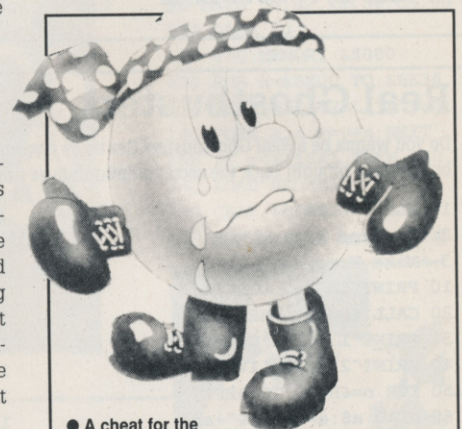

● A cheat for the Oliver twins' *Treasure Island Dizzy*: press Q,A,S,C,P and SPACE together to start, keep them pressed until he disappears, then Z,X,M and K move location

## Rotten cheat!

The Oliver twins' method and style in programming makes them, in my opinion, the best of the "cheap'n'cheerful" teams. Technically they may not be the most proficient operators in the world, as I'm sure they themselves would admit, but they seem to have an uncanny ability to anticipate what it is their target audience wants from them.

Symptomatic of their craftsmanship are the password-driven cheat routines they build into their games. I know, however, that they feel that revealing their cheat words shortens the life of their games.

Bob Adams of Welwyn Garden City (hi Bob!) has similarly indicated his concern that cheats spoil games. "Although I am mainly an adventure fan," he writes, "I've noticed that my children stop playing a game once they have used a cheat on it."

I am in two minds. On the one hand difficulty levels are often pitched rather too hard for my liking, but on the other there are some games which really are ruined by cheats, even if they are the exception rather than the rule. Do you remember *Sorcery*, *Total Eclipse*, *Way of the Exploding Fist*? Having said that how many of you have got even near to finishing *Renegade III* or *Afterburner*? I know I haven't!

In the end it comes down to personal choice – but of course that means there must be a choice. I have long thought it would be useful if games writers could build in cheats which enhance play at all skill levels, complementing the game yet allowing an easier version for the average player.

What do you think? Write and give your views to: Phil Howard's A Cheat!, Amstrad Action, 4 Queen St, Bath BA1 1EJ.



that chip is up to.

In and out instructions can be executed from Basic or from M/C code. You may remember last month sending new data out to the Gate Array at port &7F00 and altering the computer's memory configuration.

## Press for action

Superficially the keyboard is very strangely constructed: being split up into 10 blocks (0 to 9) each having 8 keys (0 to 7), it can be thought of as 10 separate keypads. If you've ever looked at the key number diagram (6128 owners have it printed on top of the disk-drive; 464 owners will find it in the manual) you will have noticed that the numbers appear randomly distributed. This is due to the way the 10 X 8 matrix fits onto the rectangular keyboard. The key numbers are specified by which block they are in, and their number within the block, using the formula Block No. times 8, plus the number in the block. Thus:

In block no. 5, the 7th. key (5x8+7), is key number 47 (space bar)

In block no. 0, the 2nd. key (0x8+2), is key number 02 (cursor down)

In block no. 2, the 0th. key (2x8+0), is key



● Here's one for all you *Advanced Pinball Simulator* fans: pause, then type H.E.N.L.E.Y. - now J,X and C do strange things to the ball...

number 16 (Clr)  
Information from the keyboard is supplied to the CPU by another chip, the Parallel Peripheral Interface, using those same low level in and out instructions. The method of accessing the data is rather complex, as the chip has to be set up before use. It is also used for other things, such as reading and writing data to/from the cassette, controlling the tape motor, acting as an auxiliary to the sound generator etc. The Firmware Manual attempts an explanation, but in true Amsoft tradition, doesn't give much away. So here is a brief run down.

The PPI chip has three channels: A (Input and Output) at port &F400; B (Input only) at &F500; and C (Output only) at &F600; there is also a control for channel A at &F700, which tells the chip if the data will be in or out.

- The sequence to read the keyboard is:
- 1) Configure data IN by setting bits 1, 4 and 7 on the control channel.. out &F700,&92
  - 2) Tell the chip which BLOCK you want to look at on channel C.. out &F600,BLOCK (BIT 6 needs to be SET)
  - 3) Check if any keys in that block are being pressed on channel A.. IN &F400
- This returns a number that must be examined in binary to make sense of it:  
The bit number reset (0) indicates which key is being pressed:

- &EF = 11111110 = key 0
- &FD = 11111101 = key 1
- &FB = 11111011 = key 2
- &F7 = 11110111 = key 3
- &EF = 11101111 = key 4
- &DF = 11011111 = key 5
- &BF = 10111111 = key 6
- &7F = 01111111 = key 7

As I said before, this is a very complicated procedure and really only of interest to a commercial programmer, which is why I've explained it. You don't have to be able to write this sort of code, just to know what it looks like. Keyboard/Joystick detection is one

of the best orientation devices within a program, as you're always sure it will be there.

**Might as well jump**

If the program doesn't use the jump blocks things get slightly more complicated, as there will be a custom built routine buried somewhere in the code. Finding that would be difficult if you didn't already know about accessing the PPI

chip with in/out instructions (at last!).  
The incidence of in instructions within most programs is very low. Sound and cassette/routines routines do use it, but there is very little input a game needs, other than yours. A search through the memory for the instruction &ED,&78 (In A,(C)), (or less usually one of the other in instructions) should turn up the keyboard routine. If you can then find the routines start address, any calls to that location will check a keypress.

It just so happens that up until recently the Oliver twins' games have always used the jump block method. I told you in AA46 about the cheat words for *Dizzy* and so on. Lately I have had a chance to look at the *Advanced Pinball Simulator* and *Treasure Island Dizzy*, by the same authors. It is clear that they have changed to using the direct chip method, but have kept their built-in cheats (well done lads!). After buying *Fast Food*, however, solely for the cheat, I find that there isn't one! Such is life. Still, the game's pretty good.

I've gone on a bit this month, so next time we will give the CRTC chip an outing and attempt to change your screen into a Spectrum - gasp, just what you've never wanted!

**Check your pulse**

Deep within the CPU lurks what is known as the system clock. It is a device which pulses at a regular speed - in the case of the CPC's Z80A processor at 4 Mhz, or, 4 million pulses per second.

Each instruction takes the CPU a specific number of clock pulses to process, so logical-

**Key to cheating**

There are in essence two styles of M/C code programming on the Amstrad. The first makes use of the machine's built in facilities in the shape of ROM routines accessed via the jump blocks. They are extremely flexible, but are for that reason slow and mainly of use to amateurs who want some help with basic M/C functions, but who aren't terribly worried about the final speed of the program.

The second style is to ignore the M/C's routines, and write your own specifically for the program. These tend to be less flexible but suit the needs better. The benefits are vast increases in speed and efficiency.

If you have a program that uses the jump blocks (they are in the minority), locating where it scans the keyboard is easy. The ROM routine performing that function is at &BB1E (KM TEST KEY): all calls to &BB1E read a keypress. The method is to load the "A" register with the key number and then call &BB1E. If the selected key is being pressed then on return the zero flag will be false (RESET). Looking through the program and noting all values in "A" when &BB1E is called will tell you which keys are being checked for.

But so what? Well, you remember originally (months ago) I told you that it is worth looking through programs for built-in cheats? If you find the program is scanning for keys that aren't in fact supposed to be used, the chances are that they are there to access/manipulate routines not usually visited. Such as cheats...

ly, each takes a finite time to execute. Individually the processing of these instructions is timed in micro-seconds, but as a group, or program, the time taken soon adds up.

Programmers mostly work within very tight constraints of time. If a game runs too slowly then it is dull, so there is a trade off between what goes on and how long it takes. There is a constant battle to shave off those few vital micro-seconds which make the difference between a bore and a vital, exciting game you'd rush out to buy and play to death.

The CPC's unique internal ROM routines, excellent as they are, perform much too slowly to be a serious proposition in most commercial games. The relatively slow speed and 8 bit architecture of the Z80 chip is responsible for limitations when compared to games on the 16 bit Atari and Amiga.

Despite what you may think, and what others may tell you, an equivalent quality game on the CPC is in fact perfectly possible. But... It... Would... Play... In... Slow... Motion! ●

Fearless Phil continues to hack his way into the undergrowth in next month's *Insider Dealing*. Don't miss it!

● The *Dizzy* pause routine (right) calls to &BB1E and checks numbers pressed against what's stored at &75A7 (pointed to by IX). (Numbers at &75A7 are &33, &32, &22, &3B, &36, &32, &23, &3D, &34, &3A and &FF.)

```

7494 DD 21 A7 75
7498 3E 1B          L7498:
749A CD 1E BB
749D 20 14
749F DD 7E 00
74A2 FE FF
74A4 CC 35 75
74A7 BB 7E 00
LD IX,75A7
LD A,1BH
CALL 0BB1EH
JR NZ,L749A
LD A,(IX+4)
CP 0FFH
CALL Z,7535F1
LD A,(IX)

```

```

1244 ED 49          OUT (C),C
1246 06 F6          LD B,0F6H
1248 4F             LD A,A
1249 ED 78          IN A,(C)
124B 81            ADD A,C
124C 4F             LD C,A
124D F6 C0          OR 0C0H
124F ED 79          OUT (C),A
1251 ED 49          OUT (C),C
1253 04            INC B
1254 3E 92          LD A,92H
1256 ED 79          OUT (C),A
1258 05            DEC B
1259 CB F1          SET 6,C
125B ED 49          OUT (C),C
125D 06 F4          LD B,0F4H
125F ED 78          IN A,(C)
1261 01 82 F7      LD BC,0F7H
1264 ED 49          OUT (C),C

```

● *Pinball Sim* (left) is slightly different. It uses the hardware port at &F600 to read the keyboard, and has the key numbers built into the program. Port &F600 is selected at &1246: Port &F400 is selected at &125D: then the IN A, (C) at &125F gets the keyboard info.

# HELPLINE

## NEW ENTRIES

And still new entries to *Helpline* come flooding in - this whole page is dedicated to entries received just in the past month or so! It seems, too, that there are more new arrivals to the CPC asking for help than ever before - which must be a good thing. Why don't you find yourself a pen-pal from this lot? - Steve

Help wanted for Captain Blood, Wriggler, Driller and Dizzy: a list of 125 pokes, from which you may choose five, if you help me with at least two of these  
**Ross McClintock, 109 Crawfordburn Rd, Bangor, County Down, N. Ireland BT19 1BJ**

Help with Basic M/Code; will debug programs. Send on tape (for M/Code, send as ASCII source listing, on tape). Will write M/Code programs. All free  
**Thomas Jolly, 5 Trinity Terrace, Corbridge, Northumberland NE45 5HW**  
= 043471 2804, evenings only

Basic programs written for your needs. Send tape or disk with a PO for £1  
**S. Giddins, 31 Lulworth Walk, Merry Hill, Wolverhampton, West Midlands WV4 4YS**

Advice wanted on selection of suitable midi interface, keyboard/synth & software. Also what's the limit to add-on devices hung on 6128?  
**Derek Tatam, "Littlecroft," Stanton Rd, Forest Hill, Oxford OX9 1DT = 08677 3226**

Penpals wanted: 9 - 11  
**Hadyn Hughes, 15 Chase View, Ettingshall Park, Wolverhampton WV4 6QN**

Two text-only adventures (150 locations) in early "Classic Adventure" tradition. Only £1.50, including p&p  
**Bill Clows, 33 Beresford Rd, Blackburn BB1 8BG**

Listings and basic screens printed, 8p per page. Also will print out letters &c 25p each. Send SAE  
**Andrew Byles, Tweedmount, Lower Rd, Hartlip, Kent ME9 7ST**

Super Robin Hood and Vampire wanted - will buy or exchange. Help on Dizzies, Wiz Ball and lots more pokes.  
**Paul Harris, 50 Stonechat Ave, Abbeydale, Gloucester GL4 9XE = 0452 414925 (PS his sister wrote this for him)**

Type in any Type In from AA16 onwards (or from any accurate listing) for 1p per line and debug programs at same price. Also addresses of many important Amstrad companies  
**Christopher Street, 43 Ridgedale Rd, Bolsover Derbyshire S44 6TX = 0246 827135 after 5pm**

Pokes for Xevious, Tempest, Light Force, Grand Prix Sim, Short Circuit, Thrust, Into Oblivion, Ollie & Lisa and Combat Zone. Send SAE, tape & 30p per game  
**159 Rawreth Lane, Rayleigh, Essex SS6 9RN (- a name would be nice! - ed)**

Basic programs written (price on application); pokes for all games (send large SAE for details)  
**Graham, 63 Oatland Gardens, Leeds, West Yorks LS7 1SL**

Malbordus Software tape-disk for 40p. Basic unprotected for 10p (tape-disk), files unerased for 10p (Basic, binary,

ASCII, disk only). If you've written an M/C prog I can convert it to run from an RSX (bar command) for 10p (disk only) - and lots of other stuff (too much to print)  
**Adrain Forbes, 37 Victoria Rd, Gourrock, Scotland, PA19 1DF**

I'm trying to contact Mr D Wong of Yorkshire, but I've lost his address  
**Christopher Bowler, 318A Wrythe Lane, Carshalton, Surrey SM5 1AF (you're sure you don't mean Mike Wong, Chris?)**

Penpal wanted to share tips, pokes, games (Renegade, Game Over and many more). All letters answered  
**Nicholas Gee, 125 Cuckoo Lane, Stubbington, Fareham PO14 3TR**

Lots of help on Logo (advice, printouts), 20p per help. Send SAE  
**Vincent Lahiff, Ballykeeffe, Mungret, Limerick, Ireland**

Need help on Predator desperately - will pay for cheat modes or pokes  
**Nick Owers, 35 Bar Lane, Stapleford, Cambridge CB2 5BJ**

Wanted! AA22 and 30. Your (sensible) price paid  
**J Drake, 44/46 High St, Rawcliffe, Nr Goole, Humberside DN14 8QW**

Please help: new 6128, know nothing! Am disabled so can't get to classes etc  
**C Russell, 57 Brookside Close, S. Harrow, Middx HA2 9AW**

Help! I need Cyrus II Chess on disk; and English instructions for "Little Computer People." Your (sensible) offer paid  
**A Mahon, 34 Gorsedale Park, Wallasey, Merseyside L44 9HB = 051 630 4337**

Listings typed for 25p per 1,000 characters or 1 mode 1 screen 26 lines, including p&p. No M/C. Send tape, listings, PO/cheque to  
**Paul Campbell, 20 Ballyvester Grove, Bangor, Co Down BT19 2RL**

Help! Frustrated Vindicator desperately needs anagram solutions for level 1 and passwords for levels 2 and 3  
**Adam Nendrick, 17 Lightfoots Close, Sandybed, Scarborough & O12 SNR**

Help on Matchday II, Operation Wolf, Emlyn Hughes, Microprose Soccer, Run the Gauntlet, Barbarian II, Starquake and most latest games. Disk backup, tape to disk, Multiface. Penpals wanted, overseas contacts very welcome  
**Y. Pang, 12 Rheingold Way, Wallington, Surrey SM6 9NA**

Penpal wanted between 10 and 14  
**Sandip Rao, 76 Mellitus St, East Acton, London W12 ODS = 01 749 5231 (between 6.30-8.30pm weekdays)**

Tape/tape, disk/disk, tape/disk, disk/tape (yes I think we get the idea - ed). Send SAE, blank tape/disk cheat disk one, send SAE £2 & blank disk to get 125 pokes for tape  
**Carl Wilson, 64 Fishponds Rd, Kenilworth, Warks, CV8 1EZ**

Anyone got an AA17 they're willing to part with? Penpals needed age 12-14. All letters answered. 6128 owner  
**Mark Berbezier, 47 Lakeen Rd, Intake, Doncaster, South Yorkshire, DN2 5HB = 0302 323266 (6-9pm)**

Whole listings, documents & reports typed in for you! Anything printed, high quality results. Quick, reliable,

1p per line, send copy of text, blank tape (optional), SAE to **J Hale, 8 Witcombe Close, Kingswood, Bristol BS15 4RY = 0272 611987**

Tapes for taping only 10p or will swap for taping, send SAE  
**Phillip Kenna, 10 Jubilee Terrace, Middleton, Manchester M24 2LU = 061 654 8326 after 6pm**

464 owner wants female penpal, 19+ (photo required)  
**Tony, 30 Foxes Croft, Barnham, Bognor Regis, W. Sussex PO22 0JT**

Penpals wanted, all over the world, regardless of sex, willing to teach me M/Code. I also have Cheats to swap, Gryzor, Metal Army, Arkanoid, Zoids, Target Renegade and more  
**Thanh Truong, 36 Stanley St, Burwood 2134, Australia**

Disk to disk: just send 50p (3 for £1), SAE, game and disk. Also loadsa Multiface pokes, send 50p plus SAE for full list  
**Brian Doyle, 18 Doyle Road, Turners Cross, Cork, Ireland**

Maps for copying - over 60 including Dizzy, Thrust, Driller, Dark Side, Exolon, Trantor & others. Send 10p per map for photocopying. Penpals wanted too! Can anyone get me a good deal on Galactic Games or Knight Games 2? Anyone wanna buy Laser Basic?  
**Anthony Treacy, 60 Ruskin Rd, Kingsthorpe, Northampton, NN2 7SY = 0604 716057**

Help on Crazy Cars I & II, N. Mansell Grand Prix, Twin Turbo V8, Typhoon, Barbarian II and more. Basic debugging: send tape, listings & 50p. Maps for R-Type and more. Penpals wanted!  
**Richard Corbin, 5 Lister Court, Yoakley Rd, London N16 0BE**

Penpal wanted, age 10-12, 464 owner  
**Richard Westwood, 238A High St, Chasetown WS7 8XH**

Help! Instruction leaflets wanted for Ten Computer Hits Nos 2 & 3 by Beau Jolly  
**E. Hitchen, 19 Wingate Ave, Nutgrove, St Helens, Merseyside WA9 5LE**

Penpal wanted, 12yo. Games like Pacland, Op Wolf, Matchday II, Footie Manager II, Arkanoid II and more  
**2 Lilac Ave, Beech Hill, Wigan WN6 8QU = 0942 493211 (a name would be a nice idea! - ed)**

Penpal wanted for 12 yo  
**Gavin Clark, 2 Thanington Court Farm, Thanington Rd, Canterbury, Kent CT1 3XF**

Help wanted on Ikari Warriors - anyone got a poke or something I could use?  
**Martin Fan, Flat 6, 251 Brays Rd, Sheldon, Birmingham B20 2UL**

Penpals please for 14yo willing to send/receive on Mini Office II. Also listings typed, 1p per line. Send tape & listings & PO/cheques to  
**Paul Campbell, 20 Ballyvester Grove, Bangor, Co Down, Northern Ireland BT19 2RL**

Penpal, 14yo, wanted to share games, tips, pokes. Anyone got an AA17?  
**David Lee, Antignor Rising Sun, Harrowbarrow, Callington, Cornwall PL17 8JE**

AMX Stop Press users! Send £3 and blank disk for 4 pages of excellent clip art and extra fonts. Listings printed 10p per page (send tape/disk)  
**James Garside, "Talesin," Rhodfa Anwyll, Rhuddlan, Rhyl, Clwyd, LL18 2SF**

Anyone got Donkey Kong (Ocean, tape) to sell?  
**Colin Wason, 8 Woodside, Dailly by Girvan, Ayrshire KA26 9EQ**

Help! New to 464, seeking pen pals over 20yo  
**S. Neill, 125 Eli Bank Rd, Eltham, London SE9 1QN**

Maps for photocopying: Wizball, Race v Time, Dizzy II, Game Over II, Ghost Hunters, Platoon. Send 25p & SAE. Need help on some games  
**Stephen Cumb, 14 Highlees Rd, Mixenden, Halifax, West Yorkshire HX2 8TF**



# AA Buyers Guide



This is the place to find what software and hardware is available for your CPC. We list programs by category, and provide producer; phone number; price; issue in which the item was reviewed; and last but not least, a brief description of the program's features and, where appropriate, shortcomings.

But don't take our word for it: if you're in doubt read the original review before you splash out, and make sure by asking the person you're buying from that it meets your particular needs. Best of all is a try-out, if you can find a friend who has what you're thinking of buying.

## WORD PROCESSING

### Brunword 6128

Brunning Software ☎ 0245 252854  
£16.50 tape, £25 disk ● AA24

40 or 80 column mode; spell checker loaded into extra memory. Suitable for expanded 128K machines. Superscript/subscript effects on-screen. Includes Datafile. Available as 'Junior Brunword' at £12.95 in slightly cut-down version.

### Pendown

Logotron ☎ 0223 323656  
£19.95 disk ● AA18

A complete tutorial in the theory and practice of word processing - it's great fun, too. Open system, owing much to expensive DTP packages.

### Protect

Arnor ☎ 0733 68909  
£19.95 tape, £26.95 disk, £39.95 ROM ● AA3

Lightning fast on all tasks involving screen. True merging from separate files and disks to the cursor position is easy.

### Mini Office II

Database Software ☎ 0625 878888  
£14.95 tape, £19.95 disk ● AA6

If you don't need full specification Mini Office II is for you.

Remarkably cheap for word-processor, database and spreadsheet, plus comms software and more. Packaging and documentation is good, and programs work in a menu environment.

### Pyraword

Discovery ☎ 0742 753423  
£14.95 tape, £17.95 disk ● AA18

Similar in use to Discovery's Pyradev. It loads a profile of inks, printer codes and character set. Word counting, changing disk drives etc - "housekeeping" tasks - are handily located. Uses extra memory of 128K machines for spooling printed documents and storing text. True file merging is impossible, and control keys are odd. Margins cannot be set further apart than 80 columns, although placing a printer control character at the right hand side allows wider documents to be printed.



and Protect supports standard CPC RSX's like DISC, TAPE, CAT etc. ROM version is excellent. Bad points: maximum file space limited to machine memory - about 22K on disk, 38K for the ROM version. As used by AA, if that's any recommendation (don't answer that).

### Tasword

Tasman Software ☎ 0532 4388301  
464, 464D, 6128, £19.95 tape, £24.95 disk ● AA1

464 is the tape based version (the same as Amsword). 464D has enhancements for a disk drive. 6128 makes full use of a 6128's extra memory. The latter pair include mailmerge facility. Easy to get to know: comprehensive help screens. Screen operations are slow, but may be customised for greater speed.

### Wordstar

Micropro/Cumana ☎ 0483 571666  
£49.95 disk (CPM) ● AA1

Files can be as big as the space available. A professional program, with huge manual and a layout like mission control. If you want a function, it is in there... somewhere. Not fast.

## PRINTERS

Manufacturers' recommended retail prices are listed as guidelines, but heavy discounts are offered by retailers.

### Amstrad DMP/2160

☎ 0279 454555  
£149 including VAT ● AA6

Load through front: printer must be above paper; but loading continuous stationery is easy. Poor NLQ mode. £5 for ribbons. Low priced, rather than a bargain.

### Amstrad DMP3160

☎ 0279 454555  
£199 + VAT ● AA29

Similar to but faster than DMP2160. Accepts all IBM and Epson printing codes. NLQ is front loading system. Good buy.

### Amstrad DMP4000

☎ 0279 454555  
£349 + VAT ● AA20

A real text cruncher. Wide carriage, and really flies across the paper, up to about 200 cps (in NLQ about 50 cps). Fonts available: standard 9 pin Pica, Elite, condensed etc. - but they are different, rather than just adjusted spacing for the same characters.

### Amstrad LQ3500

☎ 0279 454555  
£349 + VAT ● AA31

Cheapest 24-pin printer. Paper loaded from the rear - more time consuming. 30 cps in letter quality mode, and 62 cps in draft. Print quality excellent: plenty of different type-styles built in. Not ultra fast.

### Citizen 120D

☎ 0800 282692  
£199 + VAT ● AA43

Dimensions: 3.7 kgs, and 370mm x 90mm x 238mm. Draft quality is 'dotty,' and poor, but NLQ is sharp and simple. A quiet beast, with cable to the computer connected on the side. Manual includes a complete written breakdown of all the printer control commands, and their effects.

### Epson LX800

☎ 01 902 8892  
£279 + VAT ● AA29

Very fast for 9 pin. Control panel for style selection, and Epson compatible. Reverse winding sheets requires care, though.

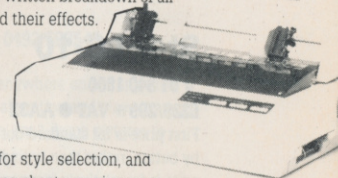

### Epson EX800

☎ 01 902 8892  
£629 + VAT ● AA29

Upgradable in 101 ways - cut sheet feeds, serial ports, longer life ribbons. Quiet, with respectable printing speed. Sans Serif/Roman NLQ fonts incorporated. Control panel to select fonts - just the same font with different spacings.

### Epson LQ500

☎ 01 902 8892  
£399 + VAT ● AA29

Features galore and price to match. Handles both Sans Serif and Roman styles of NLQ, for instance. Colour-printing upgrade kit available. 24 pin printer, offering excellent quality printing. Control panel to select from many available fonts (ie. the same font at different widths).

### Panasonic KXP3131U

☎ 0753 73181  
£335.25 (discont.) ● AA29

Daisywheel therefore superb quality - but can't print bit graphics (no trendy screen dumps), and if you want different fonts, you have to plug in a different Diablo-compatible one. Not quiet.

### Mannesmann Tally MT81

☎ 0734 788711  
£149 + VAT ● AA43

Dimensions: 70mm x 100mm x 265mm; weight, 4.5 kgs. Prints Epson and IBM graphics. Draft mode print quality is good: square printhead pins put ink onto greater areas. The printed output is more ornate than the Citizen. Manual is superb, but falls down in failing to explain control codes: for that you have to buy the applications manual. Certainly a very good buy.

**Panasonic KXP1081**

☎ 0753 73181  
£219 + VAT ● AA29

Similar to DMP2000/2160: chunky, 9 pins, 10 inch carriage and compatible with Epson codes. Thorough A4 manual, good NLO mode – better than DMP – and condensed, draft and NLO modes.

**Star LC 24-10**

☎ 01 840 1800  
£399 + VAT ● AA47

A low-cost 24 pin, 10 inch, 80 column Letter Quality printer: 8 resident fonts, all operable from the front control panel and 3 print variations. See the review in this issue, page 22.

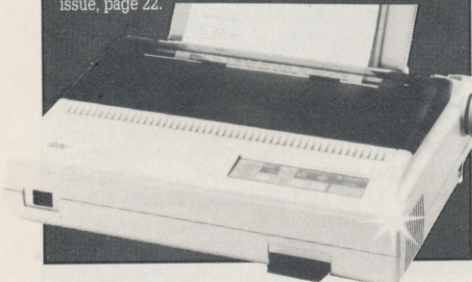

**Star LC-10**

☎ 01 840 1800  
£229/299 + VAT ● AA32

First price is for standard dot matrix printer. Fonts selected by button, rather than typing in fiddly control code. Second price is for relatively inexpensive colour model. Uses multi-colour ribbon to produce different mixes, though there are currently no commercial programs to take advantage of this capability (but see the *Colourdump* review in AA46, page 24).

**INTEGRATED PACKAGES**

**Info-Script**

Brunning ☎ 0245 252854  
£46 disk ● 128K/256K only ● AA35

Billed as the "complete database with word-processor and spelling checker," it's best with 256K. Well set up, easy to use and allows for changes in layout and content. Manual could be clearer.

**Mini Office II**

Database ☎ 0625 878888  
£14.95 tape, £19.95 disk ● AA6

Astonishingly cheap word processor, database, spreadsheet, graphics, comms and label printer all-in-one, it's continued to sell, and sell... Not full specification, but at this price who's complaining?

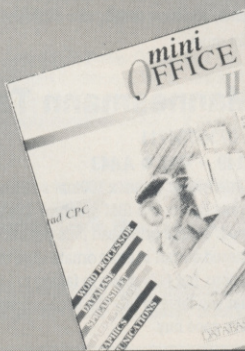

**Protect Filer/Office**

Arnor ☎ 0733 68909  
£24.95/£34.95 disk ● AA34

Database that works comfortably with Protect, has powerful sorting options and comprehensive invoice printer. Can be slow, but good value.

**EDUCATIONAL PROGRAMS**

**Amstrad Selection**

Fernleaf Education ☎ 0474 359037  
£25.95 disk/tape ● AA32

For age range 7 to 12+: Eight programs – including *Fletcher's Castle*, *Market Stall*, *The Perfume Hunter*, *The Raiders*, *Ferry Captain*, *Treasure*, and *Thorn Sea*.

**Arc Master Pack Plus**

Arc Education ☎ 0472 812226  
£48 disk ● AA32

A massive pack of 70 programs: Junior; Primary; a parent/child adventure; DR Logo and word games. Each set available at £9 tape and £12 disk. Well presented with good graphics, reasonable musical ditties and plenty of options.

**Kosmos**

Kosmos ☎ 05255 3942  
£9.95 tape, £13.95 disk ● AA32

*Answer Back Junior Quiz* lets you either answer the question; make a choice from a number of options; or say whether something is true or false. There's also *Factfile 500*, sets of additional questions for the program: arithmetic, spelling, sport and natural history.

The other range from Kosmos: vocabulary tutors in French, Spanish, German and Italian.

**Funschool 2**

Database Software ☎ 0625 878888  
£9.95 tape, £14.95 disk ● AA43

So rare is it that educational software gets into the charts that it made the news pages of the weekly computer press. Actually there are three great packages here: under sixes, six to eights and over eights.

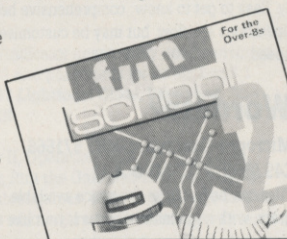

**Wordhang**

Bourne Education ☎ 0794 523301  
£9.95 tape; £14.95 disk ● AA32

One of Bourne's range of ten programs. Others include *Happy Letters*, *Numbers and Writing* (all Infant); *Timeman One/Two* and *Map Rally* (all Junior); and the excellent *Chemistry and Physics Revision* (Senior).

**BUSINESS/ACCOUNTS**

● See also Pendown in 'Word Processing'

**Protect Office**

Arnor ☎ 0733 68909

£34.95 ● CPM+, 6128 only ● AA34

Requires *Protect* and *Promerge* to run. Information inputted using *Protect*. Mail merge templates included, and very well implemented invoice printing feature. A genuinely useful business system.

**SD Microsystems range**

SD Microsystems ☎ 0462 675106  
General Ledger ● £19.95 ● AA32  
Sales Invoicer Pack ● £19.95 ● AA26  
Small Traders Pack ● £24.95 ● AA26  
Stock Accounting System ● £39.95 ● 6128 only ● AA32

SD Microsystems have a range of quality small business systems. Consult original reviews for in-depth explanations of what each does and how it differs from the others – or better still, ring them and ask.

**DATABASES**

**AtLast Plus**

Rational Solutions ☎ 056681 511  
£39.95 ● CPM+, 128k machines only ● AA30

Powerful: developed into user's requirements. Data capacity restricted only by disk size, and splitting fields into smaller elements possible. Printed output impressive. Beefy processing.

**Masterfile III**

Campbell Systems ☎ 0378 77762  
£39.95 CPM+ ● AA30

With parent/child records – enabling tying together of records, saving space and time. Screen layouts and reports menu selected; not for faint hearts, but good results.

**Random Access Database**

Minerva Systems ☎ 0392 437756  
£29.95 disk ● AA6

40 or 80 column screen. Good mathematical and string operations. Random disk accessing gives speed and power.  
● See also Info-Script in '4. Integrated Packages'

**SPREADSHEETS**

**Mastercalc 128**

Campbell Systems ☎ 0378 77762  
£33 disk ● 128K machines ● AA4

Can show two parts of spreadsheet at once. Includes notepad and calculator. Easy to use, but the mathematical formulae can only consist of the four basic arithmetic options. Slows down as more data is entered.

**Matrix**

Audiogenic Software ☎ 01 861 1166  
£34.95 disk ● AA18

Uses disk to store data – so good capacity on the plus side, but poor speed on the minus side. Graphic options excellent. Onscreen prompts rare, making it hard at first. Calculating power good.

**Supercalc II**

Amsoft/Sorcim ☎ 0277 230222  
£49.95 CPM+ ● AA4

First class documentation. Calculations can be determinative – performed on whether or not cell's contents match given value. Excellent help prompts and arithmetic functions.

## Cracker

Newstar Software ☎ 0277 229509  
**£49.00 disk CPM+ ● AA9**  
 Spreadsheets must be created from scratch. Documentation good, command sequences soon learned. Mathematical functions well done, with random numbers catered for. Files limited to 17K – and formulae programming not well implemented.

**The Cracker**  
 user's manual

## SOUND

### Amdrum

Cheetah ☎ 0222 555525  
**£34.95 ● AA13**  
 Digital drum machine. Editor comprehensive. Not Midi compatible: to hear output you plug it into amplifier.

### DHCP Midi Interface

DHCP ☎ 0440 61207  
**£69.95 interface, £34.95+ disk s'ware ● AA33**  
 DHCP produce Midi software for various Midi interfaces for CPC, which are incompatible with each other.

### Micro Music Creator

First Byte Software ☎ 0225 765086  
**£9.95 tape, £14.95 disk, £24.95 ROM ● AA38**  
 A music composer that lets you put staves and notes onscreen and play tune back. Accents can't be inserted, though. Other side is sampler to capture sounds from tape and play them through CPC. Excellent.

### Miditrack Performer

EMR ☎ 0702 335747  
**£49.95 interface, £79.90/£89.90 tape/disk s'ware ● AA13**  
 Midi interface plus sequencing software to drive Midi equipped instruments. Records each instrument then plays them all at once. Onscreen layout similar to multi-track recorder. Excellent.

### Sound Blaster

Siren Software ☎ 061 228 1831  
**£34.99 ● AA23**  
 Amplifier and pair of loudspeakers that plug into CPC for maximum 2 watts sound effects.

### Midi Interface

Silicon Systems ☎ 061 848 8959  
**£59.95 interface, £59.95 software ● AA26**  
 Useless alone, but software you can use with it – DX7, FB01, MT32, D50 and CZ101 – is diverse. Software prices vary, and lack presentation of EMR sequencer. High performance.

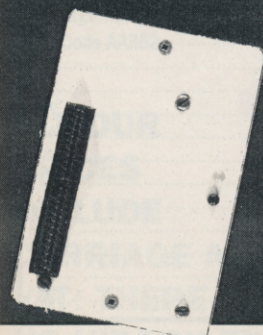

## Ram Music Machine

RAM Electronics (Date) ☎ 0782 744707  
**£49.99 tape, £59.99 disk ● AA17**  
 All in one music package: Midi interface, sound sampler and music editor. Sampler can handle one sample of just over a second. Midi controller software and music editor comprehensive. No through port, though, so 464 users must use tape version. And you can't edit live played Midi compositions.

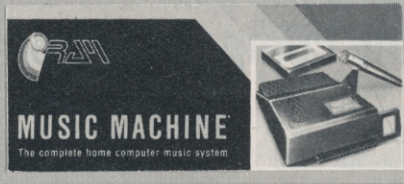

## Speech Synthesizer

DK'tronics (Date) ☎ 0782 744707  
**£29.99 ROM**  
 Add-on producing speech by RSX's: loudspeakers supplied. Cannot include speech in program for someone else's CPC, though. Even so, excellent speech quality and value.

## VISION

### AMX Art

Database ☎ 0625 878888  
**£69.95 disk (includes mouse) ● AA7**  
 User friendly, if little unsophisticated compared to *Advanced Art Studio*, but mouse helps greatly. Colour, sprays, textures, circles and host of other features.

### Cherry Paint

Siren Software ☎ 061 228 1831  
**£9.99 disk ● AA20**  
 WIMP controlled – ie mouse moves pointer to various icons to pull-down menus. B/W mode 2 only, but fun. Curves are difficult, but this is a bargain.

### Advanced Art Studio

EEC ☎ 0753 888866  
**£24.95 disk ● AA21**  
 Recently revitalised, this is the user-friendly, best and most powerful art package: works in all three modes. Can cycle through inks, and cut and paste different areas, transformations and reflections. Fill routines in coloured patterns. Available as a standard version for £15.95.



### DART Scanner

Dart Electronics ☎ 0502 513707  
**£79.95 ● AA22**  
 Attach reading device to your DMP2000, 3000 or 3160. Feed in picture to printer: device reads in picture as B/W image. Quality onscreen isn't amazing, but it works and it's fun.

## The Informer

Treasure Island Software ☎ 0492 593549  
**£29 disk ● AA33**  
 For creating animated displays, suitable for classroom and shop window: takes text, graphics and animated displays and produces slide show. Works best but not only with *Parrotty Plus* (see below).

### CRL Image System

CRL ☎ 01 533 2918  
**£14.95 disk/tape ● AA12**  
 Boasts range of picture manipulations and distortions, but lacks art options. Best on finished pictures – like a mini Quantel box.

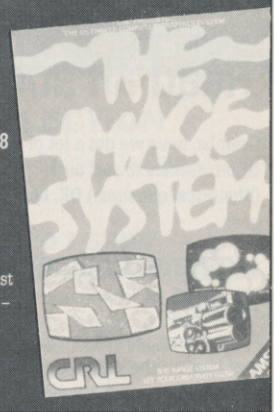

## Parrotty Plus

Treasure Island Software ☎ 0492 593549  
**£19.95 disk ● AA30**  
 Rather than lots of effects used anywhere and at any time, *Parrotty Plus* 'remembers' every alteration and plays through the list to create animation. Note: can't dump pictures to printer without external program.

### Electric Studio Light Pen

Electric Studio ☎ 0462 420222  
**464D £24.99, £14.99 ROM ● 6128 £24.99 ROM only ● AA1**  
 Excellent drawing software, including rubber-banding shapes and lines, filling areas, spray-can etc. Accepts software written for it.

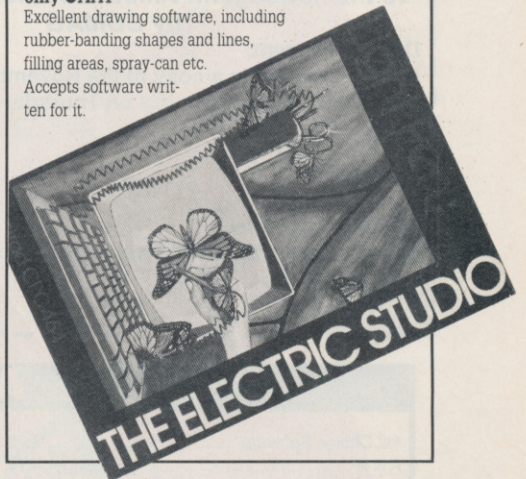

### Vidi Digitizer

Rombo Productions ☎ 0506 414631  
**£89.95 ● AA15**  
 Grabs picture from video recorder or camera and puts it on CPC screen, allowing you to alter it with an package. Easy to use. Software on tape, disk or ROM includes superb printer dump routine.

● Corrections, additions or ideas for sections to be included are welcome. Drop a line to: **AA Buyers, Amstrad Action, 4 Queen St, Bath BA1 1EJ**

Don't miss out!  
AA 50 - an extra  
special unbrithday  
issue - is out on  
Thursday October 12:  
reserve a copy now!

# Afterthought

Oh we *did* have a luvly birthday, thanks very much (pass the jelly and custard, Pat)

## Read all about it... all the competition winners! Read all about

Crumbs, have we got a lot of competition winners to sort out! (Rhetorical question.) OK, here goes...

### Lightgun Competition (AA47)

What games, we asked, would convert best for the Virgin/Mastertronic Magnum lightgun? Among an avalanche of entries, some were, erm, interesting: *Elite*, *Gauntlet* and *Frank Bruno's Boxing*, to name but three! Anyway, here's the ten winners who came up with *sensible* answers: each receives some heavy dooty shootin' irons for the CPC, pardners: Paul Clancy, Cork - *West Bank*, *SDI*, *Prohibition*; Neil Montgomery, Fife - *180*, *West Bank*,

*Aliens*; John Bryant, Broadstairs - *Robocop*, *Platoon*, *Gryzor*; David Wilke, Strathaven - *180*, *Trivial Pursuit*, *3D Starfighter*; John Gordon, London - *3D Pool*, *Space Harrier*, *Starglider*, Kwokwah Chung, Windsor - *Roadblasters*, *Space Harrier*, *Leader Board*; David Chew, Dublin - *Prohibition*, *180*, *Aliens*; James Howells, Pontypridd - *The Train*, *SDI*, *Prohibition*; Elizabeth Glyn Jones, Kew - *Prohibition*, *West Bank*, *Space Harrier*; Craig Fritzsche, Plymouth - *SDI*, *Blasteroids*, *Afterburner*. Nice ones, people, prizes with you soon!

### Skate Or Die (AA47)

We asked: who wrote Electronic Arts' *Skate or Die*? It was of course

Michael Kosaka, Stephen Lundrum and David Bunch. The two winners of the complete skateboard outfits are DANIEL MAKIN of Leigh on Sea and TRACY HADLEY of Hurworth-on-Tees.

### Pandora giveaway (AA47)

We asked you either to create a game concept which could be written using *Pandora*, or to suggest a new feature for the program. The following impressed us mightily: Rowland Jack, Fen Ditton, Cambridge; D. Williams, Orpington, Kent; Fiona Richins, Iver Heath, Bucks; J. Burton, Altrincham, Cheshire; Nicholas Kouladis, Southampton; Anonymous,

Aberdeen; Steven Cook (no relation), Silverstone; Iain Cameron, Moray; Piyush Jethwa, Leicester; Dayle Major, Auckland, New Zealand; Steven Stewart, Presall, Lancs; Andrew Stannard, Bridlington; Paul Carthy, Clonmel, Tipperary, Eire; Neil Montgomery, Fife, Scotland; Sean McManus, Stevenage; Hans Vanhellemont, Belgium; Christopher Smith, Blackburn, Lancs; Alan Ogilvie, Roundyhill by Forfar; Shabaz Yousaf, Slough; and S. Bonner, near Doncaster. Well done all!

● All unsuccessful entrants receive a £5 voucher off the price of *Pandora*.

## Stop him - he's reserved hissself a copy of AA!

To the newsagent: Amstrad Action is distributed by COMAG

Dear newsagent,  
Please reserve me a copy of the November issue of *Amstrad Action*, due out on Thursday 12 October

Name:

Address:

Telephone number:

If you're under 16, please get your parent or guardian to sign here:



## Filler Comp #2 (AA47)

Q. Who helped us tidy the office?  
A. Step forward, Alisdair Swanney!  
The first correct entry out of the hat, and winner of a crisp AA tenner is CHRISTOPHER MURPHY of Tamworth - the cheque's in the post!

● This month's filler: who in the AA office has the high score on *Shinobi*? A tenner's up for grabs: write to, Filler Comp #3, AA, 4 Queen St, Bath BA1 1EJ. Comp. closes end of October. Get to it!

## ADVERTISERS INDEX

1st Choice Software .....	22	Greyhound Software .....	33	School Software .....	36
A & A .....	79	Home Based Business .....	82	Screens Vision .....	79
Akom .....	59	HSV Computer Services Ltd .....	28	Selec Software .....	28
ARC Education .....	59	Intraset Ltd .....	82	Seven Stars .....	82
Bit-7 .....	67	Jackson Software 1989 Ltd .....	59	Siren Software .....	33
Blade Games .....	15	John Morrison .....	82	Smogware .....	67
Boxoft .....	36	K&M Computers .....	57	Soft Exchange .....	28
Brunning Software .....	27	Kador .....	36	Strategy Software .....	33
Caspell Computer Services .....	45	Lerm Software .....	79	Swift Software .....	31, 75
Castle Computers .....	61	MJC Supplies .....	6	Tasman Software .....	45
Challenge Software .....	79	Matrix .....	82	Trance .....	79
Crazy Joe's .....	67	Microgenic Systems .....	76	U.S. Gold Ltd .....	OBC
Database Exhibitions .....	39	Microstyle .....	67	VSE Technical Services .....	82
Datel Electronics Ltd .....	46-47	Mode One .....	33	Virgin Mastertronic .....	53
Dynamics .....	43	Nemesis .....	59	W.A.V.E .....	67
Escroe plc .....	36	Ocean Software .....	IFC, 3, IBC, 49	Wacci UK .....	10
Goldmark Systems .....	22	S.D.C. .....	68	Williams Software Services .....	76

# THE ACTION OFFERS

**BUY PRODUCTS FROM YOUR FAVOURITE CPC MAGAZINE.**

**All the prices include postage, packing and VAT. You can trust us, we don't intend to leave the planet for quite some time!**

## LIMITED EDITION COLLECTION

For a limited period only we are offering the following two products to add to your Amstrad Action Designer Collection.

### RED BINDER

This smart Red Binder with the Amstrad Action logo embossed in blue on the spine and front. Holds 12 issues safe and secure from dangerous sources.

**ONLY £4.95**

Order Code AA417R

**OR**

**£9.00 FOR TWO**

Order Code AA4172R

### RED T-SHIRT

A truly excellent red American T-Shirt with the official AA logo in three colours printed on the front. This summer wear yours with pride (and please the Ed!).

**ONLY £4.99**

Medium

Order Code AA361R

Extra Large

Order Code AA362R

**OR**

**WHY NOT BUY TWO T-SHIRTS?**

**ONLY £9.00**

(ONE in white and ONE in red, just quote the two relevant order codes!)



## THE ORIGINALS...

### AA BINDERS

The fabbo AA binder is the ideal item in which to store your growing collection of Britain's most popular CPC magazine! Holding 12 issues, this royal blue binder with gold embossed logo on side and front is an essential purchase for even half-serious readers.

**JUST £4.95 EACH**

Order Code AA217

**OR BUY TWO FOR £9.00**

Order Code AA2172

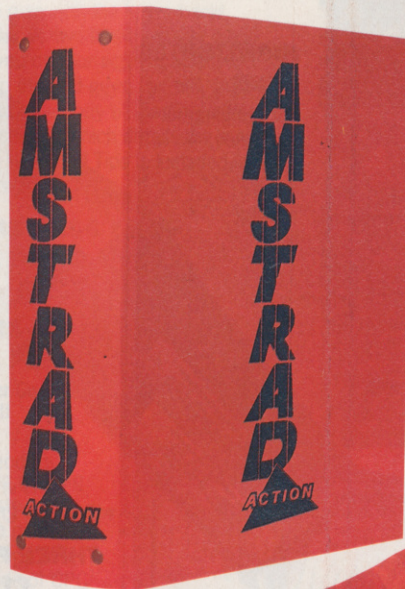

**CALL OUR HOTLINE ON 0458 74011 NOW OR SEE THE ORDER FORM ON PAGE 98**

### T-SHIRT

The amazing AA T-shirt is here! The sparky red and blue AA logo is printed on a white cotton T-shirt which you can buy for £4.99 in either medium or extra large sizes. Get this and you'll have AA even nearer your heart than ever before!

**JUST £4.99**

Medium

Order Code AA361

Extra large

Order Code AA362

**ALL OUR PRICES INCLUDE CARRIAGE AND VAT: THERE ARE NO HIDDEN EXTRAS!**



# THE ACTION OFFERS

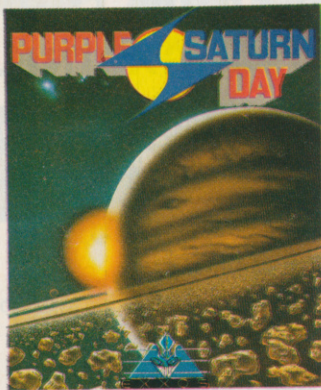

**CALL OUR HOTLINE  
ON  
0458 74011  
OR SEE THE  
ORDER FORM ON  
PAGE 98**



## PURPLE SATURN DAY

from Infogrames

The ultimate challenge. See your way through the most difficult contests with the prize being a luscious kiss from the Purple Saturn Princess herself.

*"There's so much to this game that you'll be playing it, like us, for months to come"*

AA Issue 48

**CASSETTE RRP £9.95**

**AA PRICE £6.95**

Order Code AA600

**DISC RRP £14.95**

**AA PRICE £9.95**

Order Code AA601

## GERRY ANDERSON'S THUNDERBIRDS

From Grandslam



"Calling International Rescue, calling International Rescue!"

Play the game and listen to the theme on the audio tape. Taken from the Gerry Anderson classic TV series you must attempt to save some miners that have fallen to the bottom of a shaft. Using your superb Thunderbird range of aircraft and machinery, send the Tracy clan on this dangerous mission. With three



## SPECIAL ACTION

from Ocean

The latest superb compilation of games from the masters of software, Ocean.

It consists of:- Captain Blood, S.D.I., Daley Thompson's Olympic Challenge, The Vindicator and Driller.

**CASSETTE RRP £12.99**

**AA PRICE £8.95**

Order Code AA602

**DISC RRP £17.99**

**AA PRICE £12.99**

Order Code AA603

## AA DUST COVERS

A set of dust covers provides a neat solution to dust, tea and other potential computer disasters.

These specially-commissioned Amstrad Action covers are made from high-quality, water (and coffee) proof PVC. They're coloured a gentle beige with smart blue trimming and matching AA logo. You can order a 2-piece set tailor-made for your CPC system - just choose the correct order code from the list below.

## HIGHLIGHTER PENS

For bringing out those key phrases, there's nothing like



these AA-embossed pens in red, yellow and green.

**THREE FOR  
£1.50**

Order Code AA266

more adventures including clashes with the infamous "Hood". All the characters are here, including Lady Penelope with her pink Rolls Royce and loyal chauffeur, Parker.

*"Thunderbirds has the kind of depth and long term appeal that I find really rewarding"*

Steve Carey, AA Issue 47.

**AMS CASS RRP £12.95**

**AA PRICE £8.95**

Order Code AA295AC

**AMS DIS RRP £14.95**

**AA PRICE £9.95**

Order Code AA295AD

## 2-PIECE SET ONLY £6.95

Order Codes

464 mono - A208 colour - A209

664 mono - A210 colour - A211

6128 mono - A212 colour - A213

## MONEY MANAGER

From Connect Systems

Money Manager is an easy-to-use system for recording all financial transactions, and for analysing them in a number of very powerful ways in order to facilitate sound financial management. Ideal for controlling small businesses, or for users wishing to control their personal finances in a business-like way.

- Full detailed statements, showing each transaction for any month or for the whole year.

- Bar graphs, pie charts etc.

- Standing order facility

- Full telephone support

CPC 464 (with disk drive) / 6128

**RRP £29.95 AA PRICE  
£18.95**

Order Code AA291AD

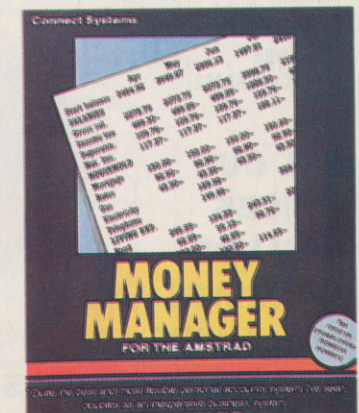

# THE ACTION OFFERS

## KEYWORD

from Swift Software

The dynamic word finder for home and business use.

It's so easy to use. Just type in a word and straight away you'll be offered a huge list of alternatives. Then, using just the mouse, you can select a word that's nearer to your requirement. Or if it's not quite what you're looking for, just click on Search to see another set, more closely related to the new word — and so on.

- Over 10,000 synonyms and antonyms
- Nearly 1,000 main subject headings
- Extra rapid word search
- Can be used as a Thesaurus
- Simple Operation

RRP £29.95

AA PRICE £19.95

Order Code AA515

(6128 or 464 with disk drive and upgrade)



## LASER SQUAD

from Bladesoft

A game of tactics and violence accurately simulating the one-to-one combat of rebel space marines. Superb flexibility and playability make this one of the most brilliant war games.

"Laser Squad will have any intelligent aggro freak coming back time and time again."

Trenton Webb AA Issue 49

AMS CASS £9.99

AA PRICE £6.99

Order Code AA513

AMS DISK £14.99

AA PRICE £9.99

Order Code AA514



## INDIANA JONES AND THE LAST

CRUSADE from US Gold

The man with the hat is back!

A classic two fisted arcade game played on four action packed levels. Whip the bad guys...as only Indy can! Includes a copy of the "Byzantine Crusader" which details the storyline and Hints and Tips is included in the software.

AMS CASS £9.99

AA PRICE £6.99

Order Code AA511

AMS DISK £14.99

AA PRICE £9.99

Order Code AA512

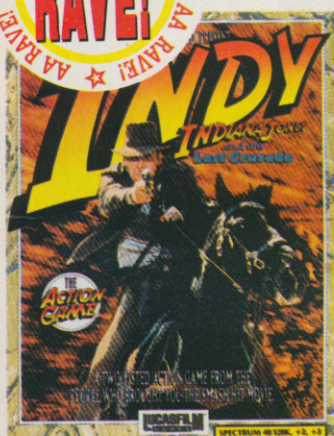

## STOP PRESS AND MOUSE

Desktop publishing — doing page design and printing on a computer instead of the old cut-and-paste and linotype printing method — is the boom area of low-cost computing. All the national dailies are switching over to DTP methods — and so are thousands of CPC users, to produce everything from newsletters to menus, from posters to invoices.

ONLY £64.99,

THE RRP IS £79.99

If you order before 25th September it is still only £49.95

(CPC6128 or 464 with upgrade and disk drive)

Order Code AA605



**ALL OUR PRICES INCLUDE CARRIAGE AND VAT — THEY'RE THE CHEAPEST AROUND!**

**SUBSCRIBE NOW!  
SEE PAGE 65  
FOR SOME  
EXCELLENT  
REASONS WHY!**



## X-PRESS

from Medway/King

X-Press for owners and potential owners of Stop Press. There have always been limitations with programs running on the CPC machines, due to lack of memory. Now we can offer extra space and speed with this superb add-on package. See full review, issue 48.

AA PRICE ONLY £19.99

Order Code AA606

# BACK ISSUES

**ISSUE 1-22 • SOLD OUT!**

**ISSUE 23 • £1.25**

Launch of Word-Processing series. Utility Type-ins.

**ISSUE 24 • £1.25**

Two years of AA!  
Exolon. Word processors.  
Tas-Sign. More WIMPs.

**ISSUE 25-28 • SOLD OUT!**

**ISSUE 29 • £1.25**

Six top printers reviewed.  
Spreadsheets.

**ISSUE 30 • £1.25**

Discovering databases. How to upgrade a 464 to a 6128.

**ISSUE 31 • £1.25**

CP/M software section starts. Basic programming reaches part five.

**ISSUE 32 • £1.25**

Educational software survey.

CP/M on ROM. Word processing.

**ISSUE 33 • £1.25**

Loads of hardware projects! - joystick, splitter, I/O port etc. Comms.

**ISSUE 34 • £1.25**

Simulation software from space shuttles to bike..

**ISSUE 35 • £1.25**

Joy of hacking scrutinised!  
Buyers guide to computer books.

**ISSUE 36 • £1.25**

Micronet - worth it? Code Masters? Printer selection.

**ISSUE 37-40 • SOLD OUT**

**ISSUE 41 • £1.50**

Databases for all, Hard drives, Pilgrim special, Batman, Jedi

**ISSUE 42 • £1.25**

Wec Le Mans and Airbourne Ranger reviewed. How to write a best seller! Loads of Hot tips!!

**ISSUE 43 • £1.25**

The Amstrad Entertainment Centre. Citizen v Mannesman Tally Printers. Educational Software, the latest offer

**ISSUE 44 • £1.25**

Joystick Jury. Barbarians II. Professional music programmers, interviewed.

**ISSUE 45 • £1.25**

DTP a new, cheap package reviewed. Massic AA Soccer Spectacular. Guide on Midi Systems.

**ISSUE 46 • £1.45**

Forgotton Worlds and Stormlord, two brilliant games! Your best book guide. Whats really inside the CPC?

**ISSUE 47 • £1.45**

The Magnum lightgun, on trial. How to write a best seller, the Pandora package examined for potential game programmers. The latest stock control update from SD Microsystems.

**ISSUE 48. £1.45**

DTP special, various add-ons reviewed in depth. Gemini Wing, Red Heat and Purple Saturn Day, all great games. How to create a magazine using your CPC.

**Expand your Amstrad Action Collection!**  
**If you're one of the thousands of readers who've joined Amstrad Action only recently, you'll want to catch up on some of the good things you've missed. Here's how to do it. We have limited numbers of the back issues listed below, which we're selling at cover price with post and packing free.**

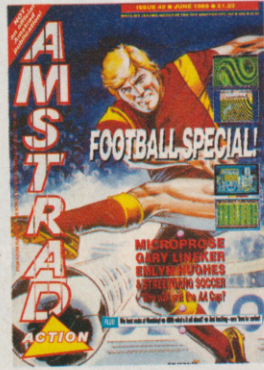
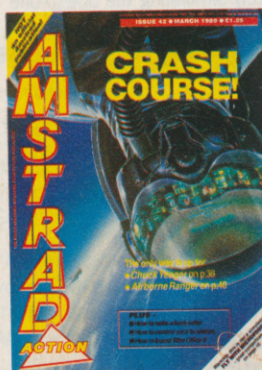

## THE ACTION OFFERS

### ORDER FORM 49

CODE	DESCRIPTION	PRICE
<b>TOTAL PAYABLE</b>		

Please send me the above item(s) from the Amstrad Action Special offer pages.

Make cheques & postal orders payable to  
**FUTURE PUBLISHING LTD.**

If paying by credit card, please enter details

CREDIT CARD NUMBER  EXP. DATE

Method of payment (please circle)  
ACCESS • VISA • CHEQUE • PO

Send this form plus payment to **SPECIAL OFFERS, AMSTRAD ACTION, THE OLD BARN, SOMERTON, SOMERSET TA117PY**

Name

Address

*Please remember the post-code, it is essential!*

Date of Order

Tel Number (if possible)

## SUBSCRIPTIONS

New subscribers welcome! As well as getting your 12 issues posted directly to you from the printers, we have a unique Subscriber Scheme. This is how it works: immediately you subscribe we send you £20 worth of vouchers for our mail order section. This offer entitles you to a £20 saving on mail order products from these pages over the next 12 months. For every £10 spent you save £1. Plus by subscribing look out for our up-to-the-minute super duper exclusive AA Mail Order Update, which will be posted to you in the next few weeks.

**ONLY £17.95**  
Order Code AA396

## OVERSEAS SUBSCRIPTIONS

**AIR-MAIL EUROPE £33.95**  
Order Code AA397

**SURFACE EUROPE AND REST OF WORLD £23.50**  
Order Code AA398

THE SUN'S BEATING DOWN,  
ROCK 'N' ROLL MUSIC'S PLAYING . . .

See us at the  
PC SHOW  
27th Sept-1st Oct



# Beach VOLLEY

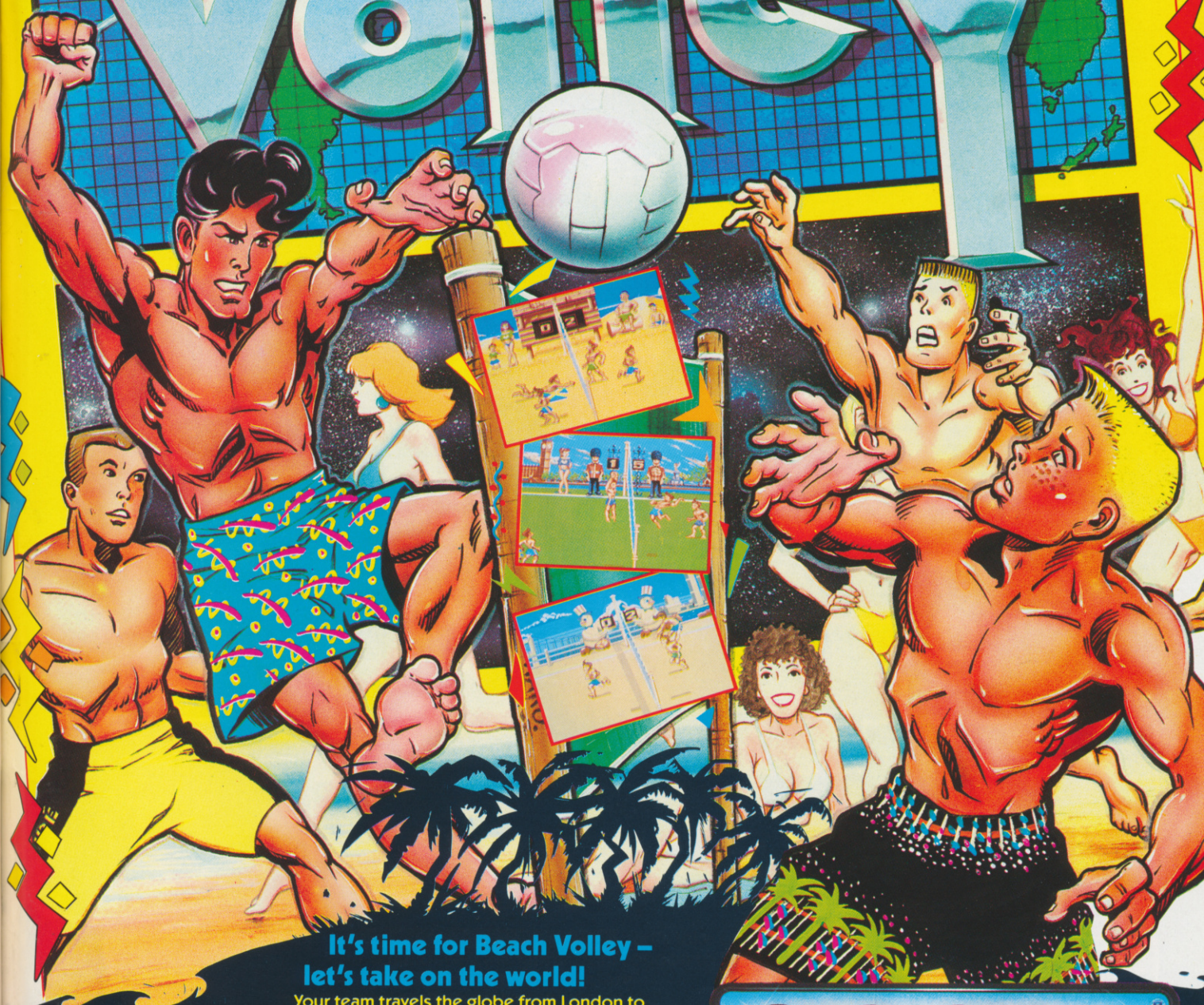

It's time for Beach Volley –  
let's take on the world!

Your team travels the globe from London to Sydney challenging all comers in the latest craze that's sweeping the beaches.

Fantastic action with variable service and play controls as you lob the defences, try a lightning reflex smash to win back your service, jump block to defend your match winner.

This is Beach Volley . . . you may even catch a tan!

SPECTRUM AMSTRAD  
8.99 9.99  
SPECTRUM COMMODORE

CASSETTE

ocean<sup>®</sup>

Ocean Software Limited · 6 Central Street · Manchester · M2 5NS  
Telephone: 061 832 6633 · Telex: 669977 OCEANS G · Fax: 061 834 0650

WHEN LAW FAILS...VIGILANTE PREVAILS

# VIGILANTE

TM

1994 NEW YORK ..... The police dare not patrol the streets. The army cannot control the city. Law and order no longer exists. .... When street gangs dominate a city. When ordinary citizens no longer defend themselves for fear. And when law enforcement agencies are powerless to help. Your last chance is .....

**VIGILANTE**  
..... THIS  
TIME IT'S  
WAR

Atari St & Amiga  
£14.99  
IBM PC  
£19.99  
Spectrum 48/128K  
£8.99c, £12.99d  
Amstrad  
£9.99c, £14.99d  
CBM 64/128  
£9.99c, £14.99d

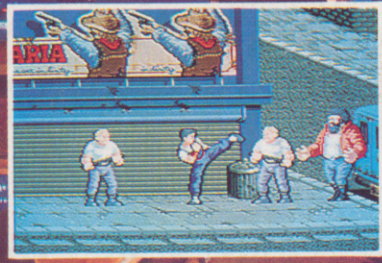

© 1989. Licensed from Irem Corp. All rights reserved.  
Manufactured and distributed under license by U.S. Gold Ltd.,  
Units 2/3 Holford Way, Holford, Birmingham B6 7AX. Tel: 021 625 3388

NOT  
an official  
Amstrad  
publication!

FROM FUTURE PUBLISHING COMES THE MEGAZINE THAT LEADS THE FIELD

# AMSTRAD

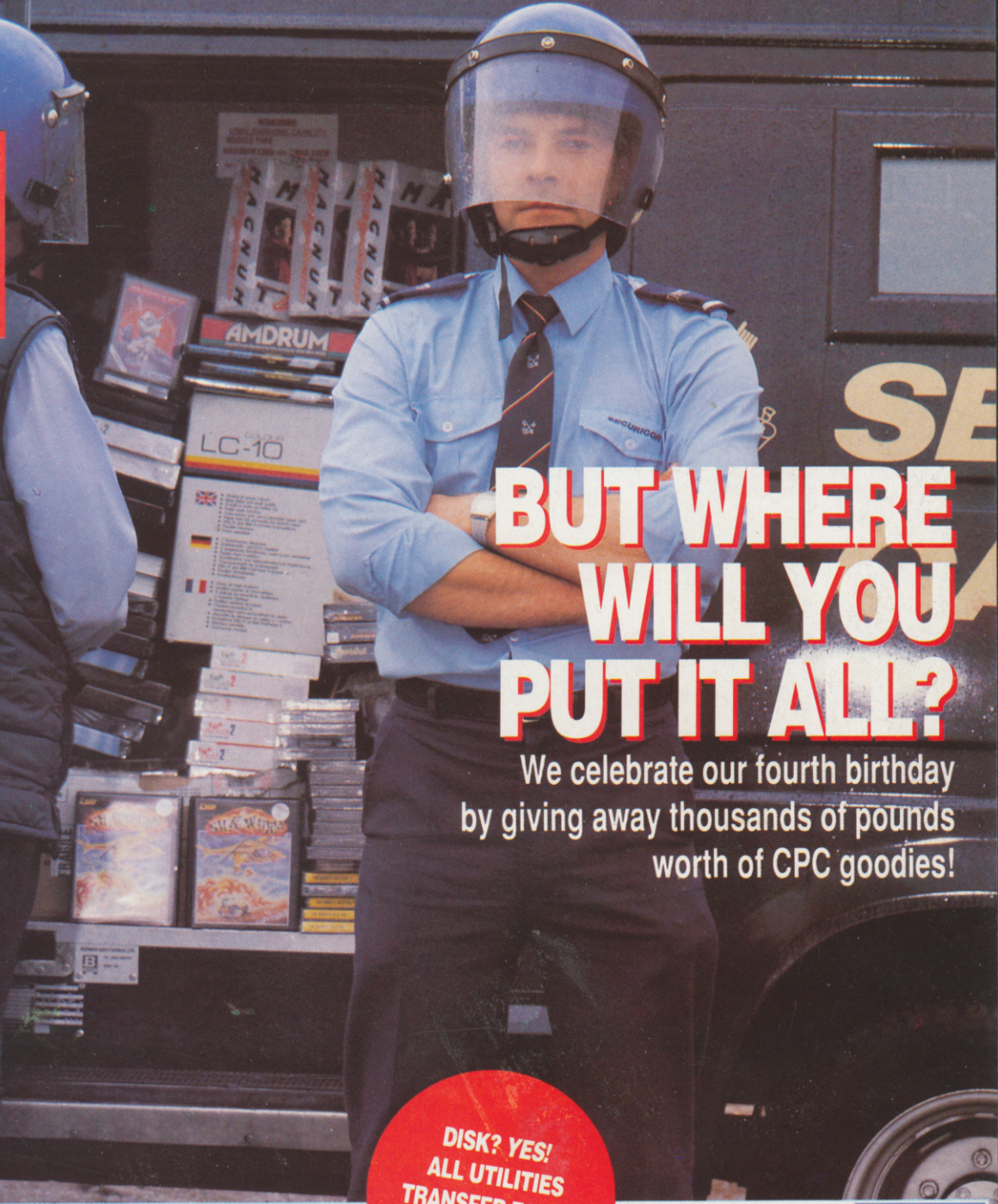

## BUT WHERE WILL YOU PUT IT ALL?

We celebrate our fourth birthday  
by giving away thousands of pounds  
worth of CPC goodies!

**DISK? YES!  
ALL UTILITIES  
TRANSFER EASILY  
TO DISK!**

How to load:  
turn to  
p. 16

## SHINOBI - PLAY IT NOW!

The brilliant birthday cover cassette...  
SHINOBI - special fully playable mission!  
CREATOR - Basic from nowhere!

- VSEARCH - pleasing puzzler!
- SELF-DESTRUCT - hilarious practical joke!
- DALEKS - classic CPC fun!
- EASISHEET - complete spreadsheet!

# D ACTION



"AAh... so!"

