

Free!
cassette
tape head
cleaner

TOP TIPS • FIRST REVIEWS • BEST ADVICE

ISSUE No.87 DECEMBER 1992 £2.50

CPC



PLUS



Future
PUBLISHING
Your guarantee of value



NOT an official Amstrad publication!

**A
M
S
T
R
A
D**

**Dizzy: this
is your
life!**

A toast to
the CPC's
biggest star



Portable power
Is the Amstrad NC100
the perfect peripheral?

It's kickin'
Can Football Manager 3
improve on the great FM2?

Oi, where's
the free tape
head cleaner
then?



FREE
tape head
cleaner

ACTION

If you can read this it means
your covertape is missing!
Make sure you ask your
newsagent where it is.

ALSO ON DISK!

Want a disk version of the covertape?
(6128 Plus owners take note) See the
tape pages for ordering details.

Line

Serious

20 Public Image

The latest news, views and reviews from the booming public domain software world, including reviews of a top disk copier and binary file crunching utility

22 A portable Amstrad?



Amstrad's new NC100 Notepad is an interesting little machine - not least to CPC owners! Its word processor looks a lot like PROTEXT...

24 Technical Forum

More technical queries answered by Richard 'Doc' Fairhurst, and Alex van Damm's regular section for complete computing beginners. Plus the third and final part of our exclusive PowerPage tutorial, the excellent complete DTP package given away on a past AA covertape.

38 Type-ins

A calendar program, maths calculators and an etch-a-sketch art program - the month's best readers' contributions and your regular BASIC tutorial. Don't forget - each program we publish earns its author £20!



Main feature

30

Dizzy: this is your life

The history of the most successful game character ever - from his embryonic beginnings to his life as a hard-boiled adventurer

44

Football Manager 3

FOOTBALL MANAGER 2 was one of the most successful footie games ever. But is FM3 better still? We put it to the test

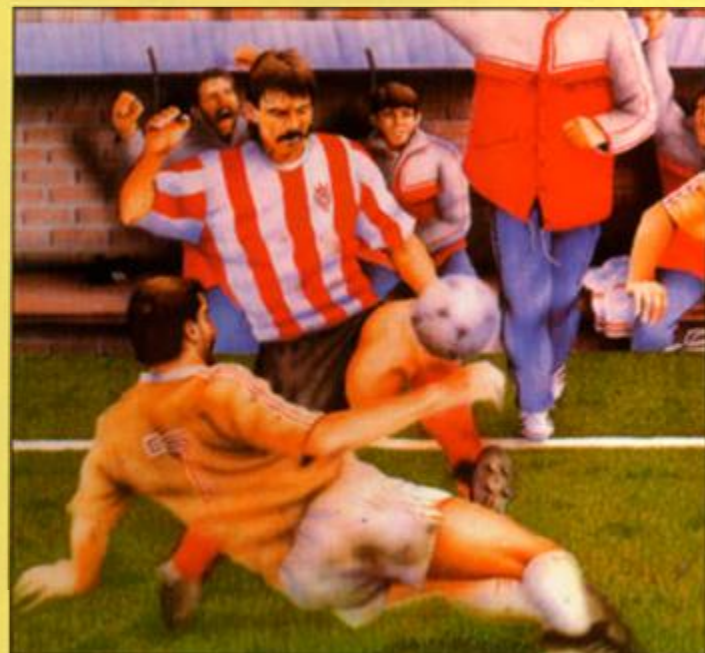

Games

36 Balrog

Part two of the definitive Cluepot index, plus a review of TREASURE ISLAND and news of ADVENTURE PROBE...

43 Power up

The Gallup charts, the full run-down on this month's games coverage PLUS what the team's been up to

46 Super Seymour

Codemasters' little potato-head stars in his own compilation. Dizzy watch out!

48 Count Duckula 2

It's taken us ages to get hold of this cartoon licence sequel - should we have bothered?

51 Cheat Mode



101 game cheats! Phil Howard presents a Christmas cornucopia of keypress cheats PLUS a map of CASTLE MASTER

MP

56 Replay Run-down

Part two of our exhaustive run-down on CPC budget re-releases. 50 GAMES REVIEWED AND RATED!

Regulars

4 The Tape Pages

All the instructions and info you need to get stuck into this month's covertape progs

8 Reaction

Don't write to your MP, write to us! (Unless it's about the drains outside your house). Oh, and no more poems...

10 Amscene

ATTACK fails! AA's rival bites the dust after six issues. Plus all the other Amstrad news

12 Action Zone

Win over 100 games! And that's just one of this month's special competitions

18 Special Offers

Missing any back issues? Now could be your last chance to complete your collection - they sell out fast! And don't miss our regular selection of bargains on other goodies...

28 Subs

Why make that journey to your newsagent each month when you can have AMSTRAD ACTION delivered to your door?

42 Small Ads

How could we make them better? By making them FREE!

ACTION PACK

They don't write games like this any more! Play NEXOR on this month's tape and you'll be hooked. PLUS we have a nifty little PACMAN clone, two excellent utilities and fine batch of readers' progs...



1 Nexor

Wow, this is a tough little puzzler. Or rather a tough BIG puzzler, actually, seeing as you've got to assemble the various bits and pieces to build a bomb and blow up an entire planet (a planet full of baddies, thankfully)

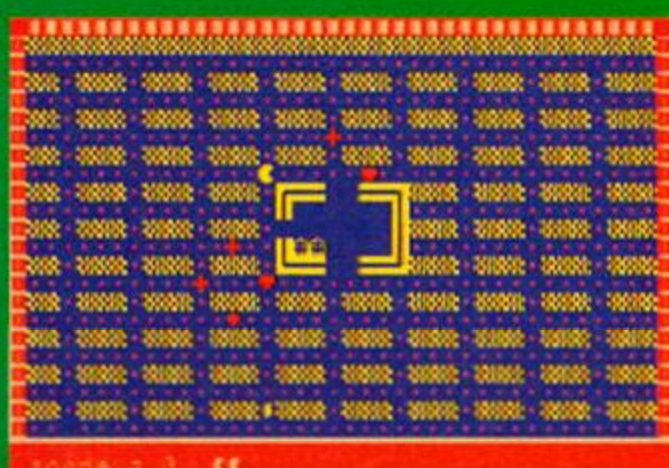

2 Pakman

Yes, we know PACMAN is an old game, but it's such a goodie, isn't it? Which is why we found a little corner to slip in this BASIC version. It takes up only 7K but it features a very BIG (and horrible) maze

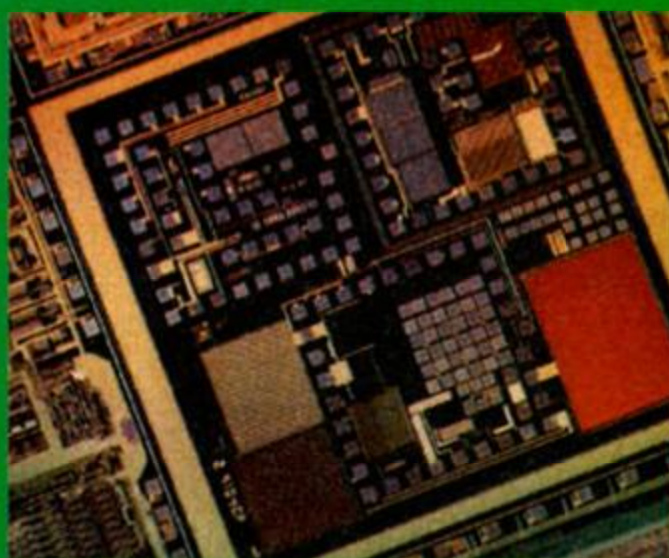

3 MPAck

128K owners and programmers have to use BANKMAN.BIN, the memory-handling utility supplied with their machines, to use the extra RAM. Unfortunately, BANKMAN.BIN is copyright and therefore you're not supposed to include it. It's also not perfect. Which is where MPAck comes in...



4 Pilot

You thought BASIC was easy, huh? Well this interpreted programming language is easier still - there are only five commands! PD programmer David Wild has produced this Amstrad version of the program, plus instructions

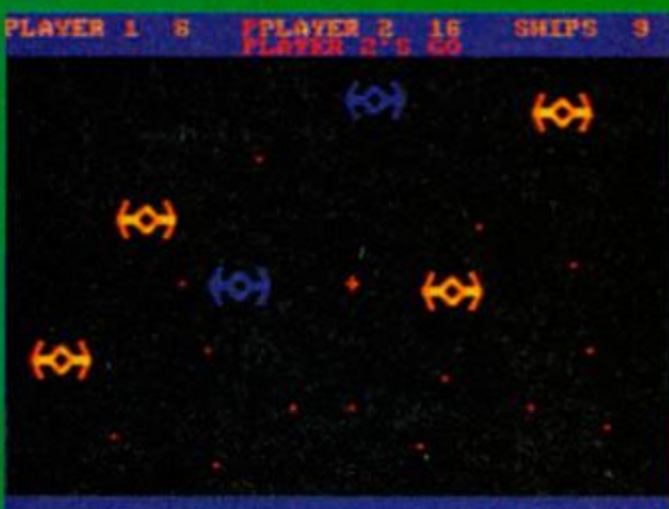

5 Type-ins

All the readers' progs from the October issue!

- DISK NURSE: a menu-drive disk and file-handling utility
- SHIPS: a CPC version of the Battleships boardgame
- RSX SPEECH: a digitiser that uses the cassette port
- TENNIS: old-style fun!
- TEXT: ASCII text editor

Just turn the page for all the details

ACTION PACK

Loading: Rewind to the start of side 1, then press CTRL + SMALL ENTER key. The covertape menu will load. Select Nexor, and the game will then load.



Machines are going to take over the world. They already decide when your toast is ready in the morning, they tell us what the weather's going to be like tomorrow, they predict who's going to win the general election... they even run the European Exchange Rate Mechanism (oh, sorry, that's vegetables).

In *Nexor*, things have got worse still. A nation of robots is poised to take over the galaxy and only you, as a brave human rebel, can stop them.

Some of your rebel mates, you see, have nicked the uniform of a slave worker, allowing you to sneak into the robot complex and... and... well exactly what are you going to do?

Easy. Scattered about the complex are the bits of a 'Nemesis' machine which, when assembled, will blow the complex and all those rotten robots into a black hole.

That's not your only job, though. You've also got to find some important blueprints and then find a teleport device to escape from the doomed complex (pretty essential, that bit).

Sounds easy enough, doesn't it? Except that finding your way around robotville isn't very easy. The complex is made up of loads and loads of individual rooms joined by doorways (or not at all). Your first job, then, is to start working on a map.

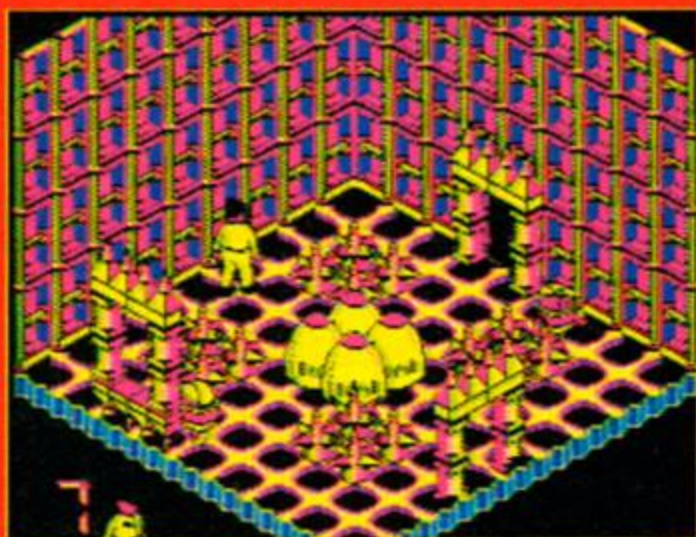

This is not a nice screen. If you don't get spiked or blown up, the robots will get you!



Aha, how do we get out through that doorway half way up the wall on the left then?

Nexor

Fancy a bit of planetary pyromania do you? (That's blowing things up, by the way.) Well then you want to play Nexor...

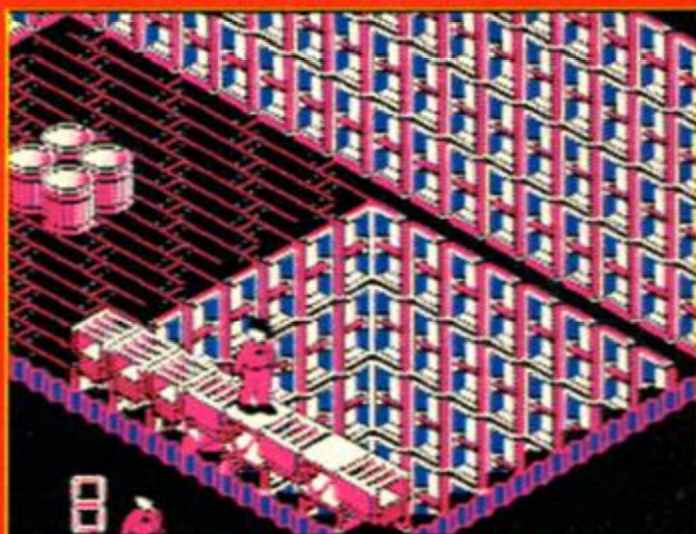

Here we are at the start of the game. You will mind that bottomless shaft, won't you?

Snag number one: you can't do much of a map if you can't get out of the first room. That doorway is just too high to jump to. The answer? Aha, you can push objects around the floor – you can even pick some objects up by jumping on them and then using the pick up/drop command. However, not all objects can be picked up or pushed.

There are worse problems too. The complex has a system of security cameras and if you linger too long in one place you get spotted and the robotic guards zoom into action. These can be little things on wheels which trundle around in regular patterns. They're OK because, basically, they're thick as a brick. Not so nice are the horrible bouncy noisy things that move about five times faster than you do, even if it does seem to be at random.

Oh, and there are the conveyor belts, too. These just look like slatted grilles in the floor, but they trundle you off in the direction of the slats, so unless you want a one-way trips to doomsville, keep jumping as you cross them.

Worried yet? Well worry some more, because there's a large central shaft to the complex which is easy to fall down, but not so easy to get back up unless you can time those jumps on to the elevator blocks. You're going to have to be a bit nimble, because most of the places you have to get to can only be reached from this shaft.

Oh, and we didn't mention the bombs, did we?

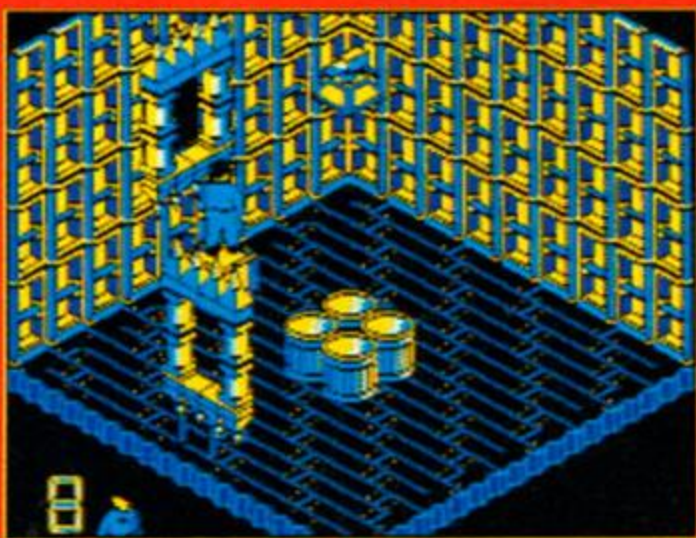

Simple. Grab that packing case in the left hand corner and plonk it under the door...

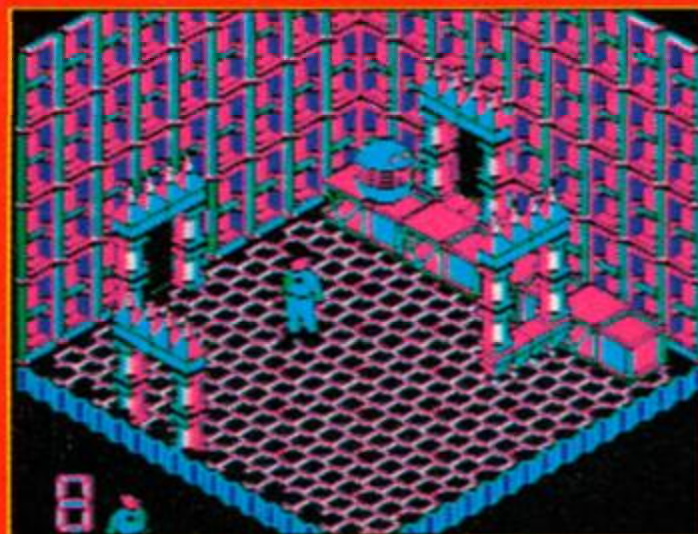

To go through that doorway behind you, first you must dodge the guard...

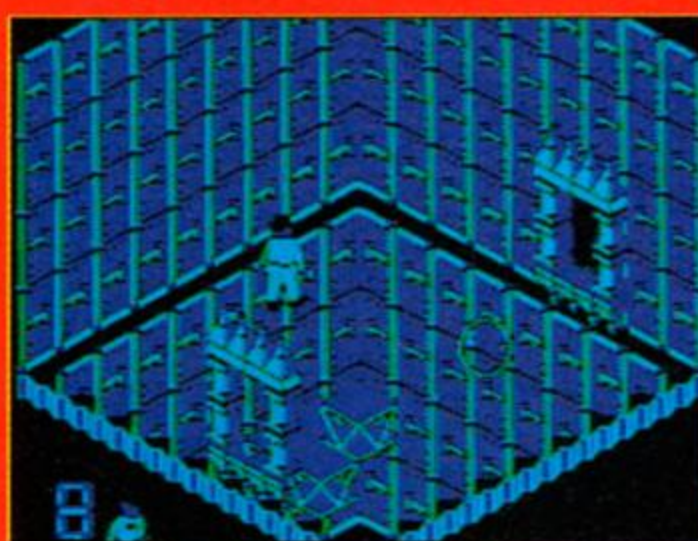

The main shaft isn't actually bottomless, but it is a long way down.

Never mind, you'll come across those soon enough...

Nexor doesn't move at the speed of light, but it is a puzzler as much as an arcade game. There's a lot of ground to cover, and a lot of thinking to be done, so you'd better get started, hadn't you?

Nexor Controls

Keyboard or joystick control

ZLeft
XRight
NForwards
MBackwards
, (comma)Jump
. (full stop)Pick up/drop

(keys can be redefined)

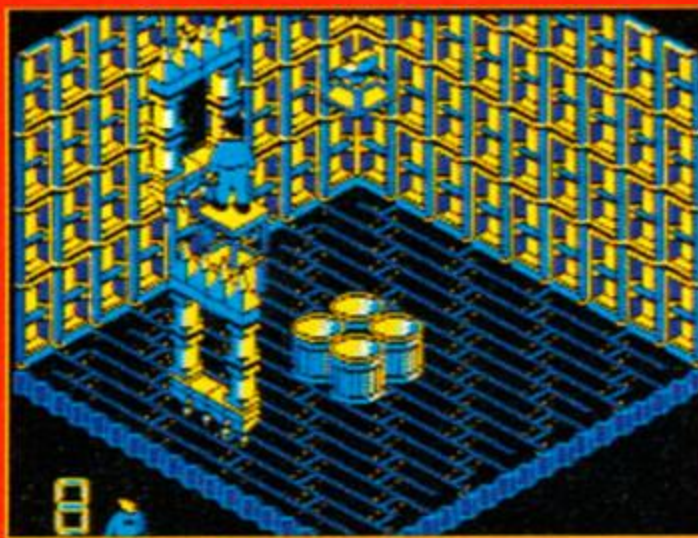

...then grab the little table under the doorway to the left, climb up and jump out!

Pakman

They drive you mad, those blasted ghosts, don't they? Well the ones in this Pac-man clone will, anyway!

Loading: Pakman must be run from BASIC. To load it, rewind to the start of side 1 of the tape, type RUN"PAKMAN.BAS" then sit back and wait.



There's only one problem... ach!... with this game... oh no!... it's so, darned... eeeekkk - I'm dead!... difficult. If we don't stop playing it we're going to go bonkers.

The thing is, there are only two ghosts but the maze is designed in such a way that they can always close in on you - and they never turn back. It's simply not fair.

Pakman is yet another Pacman clone, but it's a toughie. As a matter of fact, we want to hear from anyone who manages to clear the screen, 'cos we're not sure it's possible. (Of course, it might just be that Rod is rubbish - Adam)

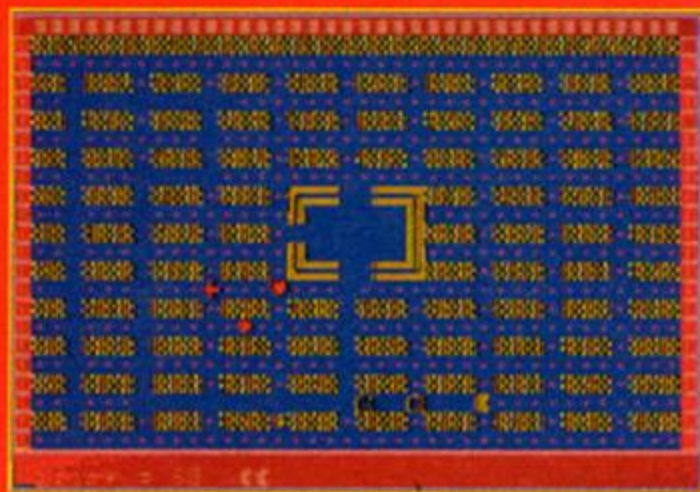

Just look at the size of that maze! And you've got those two ghosts at your heels...

Anyway, we've got reader J Bennet of Sheffield to thank for this rather challenging little BASIC game.

There's only one thing, JB... you couldn't make it any easier, could you?

Utilities

Two excellent programs for you this month - a memory bank manager and a very different programming language...

MPack is principally a utility for disk owners, since it can only be used by 128K machines. Pilot works from both tape and disk.

MPack (128K only)

Loading: MPack only works with 128K machines (obviously), and although it can be run from tape, just about everyone will be running it from disk. Once all the covertape files are transferred to disk (using the transfer option on the menu), type RUN "MPACK.BAS". (This file is the loader. There is another file, MPACK.BIN, which is the program itself.)

The Z80 chip inside the CPC organises its memory in 64K 'banks'. The 464 only has 64K of RAM, so it only has one 'bank'. The 6128, though, has two banks of 64K each. Using the

extra memory isn't always as easy as it might be, even though Amstrad supplied a special utility with the machine - BANKMAN.BIN ("Bank Manager") to let you do it. The other problem with BANKMAN.BIN is that the copyright belongs to Amstrad, so although you can use it in programs for your own use, you can't incorporate it in programs for sale (or even for the public domain).

The solution? MPack, which is supplied on this month's covertape. It's designed to replace BANKMAN.BIN and supports loads of commands to aid memory management. Full instructions are provided on-screen as part of the program.

Pilot

Loading: Pilot can be run either from tape or disk. To run it, type RUN"PILOT.BAS". To explain more about the program, we've enclosed a documentation file (PILOT.DOC) which can be loaded and displayed with PILOTINF.BAS.

Pilot is an extremely simple 'interpreted' language (like BASIC) and PD guru David Wild has now produced a version for the CPC, including a documentation file to explain how it works.

Basically, there are only five commands in Pilot! Nevertheless, you can use them to build up quite complex programs. Developed for use in education, Pilot is quite a fun language to try, and much easier for youngsters than BASIC.

How to load your covertape

Just pop the tape into your machine, making sure it's rewound to the start of Side 1, and then press CTRL + ENTER (or type RUN""), then press any key and the tape will start loading.

Within a few moments you get a menu screen. Choose the program you want using the Spacebar, then hit the Return key.

Nexor, Pakman and MPack are on Side 1 of the tape. The Pilot programming language and type-ins can be found on Side 2.

● Note that Pakman, the two utilities and type-ins are not loaded directly from the menu. Instead, you have to quit back to BASIC and use the RUN"(filename)" command.

● If you have a disk drive either built into your machine or plugged in, you will first have to type ltape to switch the computer to tape loading. You get the l character by pressing SHIFT+@. Then just proceed as normal.

Duff tape?

We go to great lengths to make sure that our covertapes work properly. However, if you still have difficulty, try this:

● Loading at several different volume levels if you're using an external tape recorder ● Cleaning the tape heads. This can be done with any commercially available cleaning kit ● Adjusting the cassette recorder's head alignment. The alignment screw is located just to the left of the tape head, and is usually accessible through a small hole. Turn it a fraction at a time with a jewellers screwdriver. When the crispest sound is heard, the alignment is spot on. ● Tapping the cassette gently against a table edge - the spools may be sticking or jammed.

If you still can't get the tape to load then send the tape, along with a brief description of the problem and an SAE to:

**AA87 Covertape Returns,
Ablex Audio Video Ltd,
Harcourt, Halesford 14,
Telford, Shropshire
TF7 4QD**

Want a disk version?

The covertape contains its own tape-disk copying program. To transfer the programs to tape, simply follow the instructions on the tape.

● 464 owners with external 3-inch drives will have no problems, but 6128 owners will need a cassette player with a REM socket. Stopping and starting the tape manually is difficult.

● 6128 Plus owners who've had their machines modified to load from tape can transfer the programs to disk, but must rewind to the start of the tape again before the transfer starts.

You can also order a disk version of the covertape from our duplicators, Ablex. Snip off the coupon on the corner of this page and send it with a cheque/PO for £2.00 to:

**AA87 Disk Offer, Ablex
Audio Video, Harcourt,
Halesford 14, Telford,
Shropshire
TF7 4QD**



MPack is designed as a replacement for BANKMAN.BIN on the 6128.

**Disk 87
Token**

Type-Ins

Here we are, all those excellent type-ins from issue 85, just in case you couldn't get them working when you typed them in...



Loading: All these programs consist of single files which must be run from BASIC. They will work either from tape or disk (except Disk Nurse, which is disk-only - obviously). Simply type RUN"FILENAME".

DN.BAS

With a name like "Disk Nurse" it sounds as if this program, from John Adamson, is for repairing damaged disks and files. It does let you 'unerase' erased files and rename files too, but principally it's a disk handling utility. You can change user areas and format disks AND display ASCII files.



Disc Nurse is a handy little disk and file managing utility from John Adamson.



Ships is a version of that old boardgame classic Battleships, from Graham Smith.

SHIPS.BAS

This game, from Graham Smith, is a bit like that old boardgame Battleships, where you have to drop bombs on the sea, trying to hit invisible ships (they only become visible when you hit them). In this game, though, the players don't place their own ships and then try to bomb each other's. Instead, there are a certain number of 'computer' ships placed at random around the screen, and the two players compete to see who can hit most...

SPEECH.BAS

This novel little program, from Neil Hopkinson, lets you input music or speech via your cassette machine so that the Amstrad can replay it via its built-in sound chip. Bits of sound can be stored and used in your own programs, for example. Full instructions are included in the program.

TENNIS.BAS

This addictive little game is from Polys Pilvanas, and is a version of that old video game that you could plug into your TV. Each player has a 'bat' and you have to keep the ball in play as long as possible. Player 1 uses a joystick, player 2 uses the cursor keys. From the title screen you can zero the scores with R and play a new game by



Tennis gave us the most fun we've had this month! It's from Polys Pilvanas.

RSX SPEECH SYSTEM

```
Commands:
ION   This turns the tape recorder on.
IOFF  This turns the tape recorder off.

[RECORD, [start], [length]

This command records anything that is playing through the CPC tape recorder. For best results the sound should be quite loud.

[start] = Address to store speech
[length] = Length of speech
```

Make sure you don't record over the RSX speech system!
(ENTER)

RSX Speech, from Neil Hopkinson, lets you digitise sounds for use in your own progs.



Text, from Derek Payne, is a basic text-editor with a friendly front end.

hitting G. (Don't worry when the screen goes blank - the machine hasn't crashed. You just have to hit any key to 'serve'.)

TEXT.BAS

We've also included a little extra this time - a program from Derek Payne called Text. This a very simple text-editing program which nevertheless lets you edit old text, save text files and print it out too. You can view your work either in mode 1 or mode 2, and there's even an on-line help system! It also works from both tape or disk.

Calling all programmers!

Don't forget that Amstrad Action has its own programming section (Type-ins, p38 this issue). If you're a bit of an ace at BASIC, why don't you send in some samples of your work? Each program published earns its author £20!

Apart from including programs for you to type in yourselves, the section also has an ongoing BASIC tutorial for those who want to learn a little more about their machines.

What are you waiting for?

Exciting news and reviews from around the world in this month's MBUK

WIN A CANNONDALE WORTH £925

- The World Championships
- Double trouble or double fun - defying gravity on duelling tandems
- Take our advice on warm winter gear - so you don't end up looking like a walrus
- Metrotrekking in Newcastle - why-aye pet!
- PLUS Isle of Skye - the most rugged landscape in Britain

This and loads more action for only £1.95

Mountain Biking UK

Britain's best-selling bike magazine

MBUK is produced by
Future PUBLISHING

November issue on sale October 22



3.5" Mega Drive £79.95

(Including FREE MS800)

FEATURES

- ★ 800K per disk when used with MS800 (supplied FREE), RAMDOS, ROMDOS, or RODOS.
- ★ DUAL MODE: Mode 1.—The Mega Drive is a complete alternative B drive. Mode 2.—The Mega Drive will also format up to 800K per disk
- ★ SIDE SWITCH switches the disk between side A and side B of your 3.5" disk.
- ★ EXTERNAL PSU. the power supply is external, and should the need ever arise is easily replaceable.
- ★ MULTI-COMPATIBLE The Mega Drive is compatible with almost all other computers, so that if you change computers you can transfer your MegaDrive. Only a different lead and connector required.
- ★ COMPACT SIZE The Mega Drive measures only 7" x 4" x 1".
- ★ RELIABLE The Mega Drive uses the most reliable TEAC mechanism, and assures you of trouble free operation. Full 12 month RTB guarantee.

FD1 Disk Drive£79.95

Trade Enquiries Welcome

Overseas Orders Welcome

MS800 - the STANDARD in 800K storage£9.95

MS800 enables the Dual - Mode disk drive to store up to 800K per disk. Since it was introduced in 1991 it has become the biggest selling software of its kind, by far. So much so that many people have converted their earlier 3.5" and 5.25" drives to dual mode capability, and switched to MS800.

FEATURES INCLUDE:-

360K, 400K, or 2 x 180K per side. Compatible with all CPC's and CPC+'s CP/M+, MF11, Stop Press; and all other software. 64 or 128 directory entries; verify disk; disk copy; file and batch copy. Unlike most alternatives each disk initialises the computer for its own format without using up any of the storage space. Once a disk has been formatted, MS800 itself is not needed.

Formatting up to 400K each side needs a SIDE SWITCH on the drive. We can supply a side switch and simple fitting instructions, suitable for 3.5" or 5.25" disk drives

Side Switch with instructions£3.00

SPECIAL OFFER
50 X 3.5" Disks & Disk Box
!!! £29.95 !!!

MP3 TV Tuner.....£29.95

CT1 Clock/Radio/Alarm£14.95

MP3 & CT1£39.95

6128 ROM.....£24.95

MAXIDOS (with FREE PROCOPY)—£13.95

THE MOST COMPREHENSIVE & EFFECTIVE GENERAL DISK UTILITY AVAILABLE FOR THE CPC

MAXIDOS is fully compatible with RAMDOS, AMSDOS, and CPM formats.

COPY files/disks; VERIFY disks; RESURRECT erased files; FAST FORMAT Amsdos/Ramdos/Romdos; IDENTIFY format; CAT files (including erased ones) optional status/address/length/etc; ALTER user areas; MAKE/UNMAKE system or read only; DISPLAY or PRINT filesand MUCH MORE. BEST sector editor EVER for the CPC. All standard editing facilities, PLUS file mapping to screen or printer, auto step by step movement through a file, string and byte. SEARCH through file/disk. FILE ARCHIVER backs up disks to tape; variable baud rates. SPEED up your disks! Unique optimise, re-arranges your crowded disks, making them load up to 50% faster.

BONZO SUPER MEDDLER.....£13.95

now includes the BONZO HACKPACK - FREE! The most comprehensive tape to disk utility. Supplied on disk with a huge database of verified transfers. Produces stand alone transfers.

BONZO BLITZ.....£13.95

now includes BONZO'S DOODAH and 4 adventure games - FREE! Tape to disk transfers. Deals with all forms of SPEEDLOCK. Works on all CPC's and produces stand alone transfers. Huge database of verified transfers.

BONZO BIGBATCH.....£9.95

FAST, FLEXIBLE database. Superb football pools predictor, plus a user friendly memory saving SCREEN & SPRITE DESIGNER.

BONZO FLASHPACK£9.95

"The best all round BASIC extension program" WACCI. FLASH BASIC adds around 70 extremely useful RSX's to use in BASIC programs. The resulting progs will run on any computer without the presence of FLASH BASIC. Includes a database and other excellent example programs.

ABBA switch (6128/664)£12.95

3rd drive switch (6128/664)£12.95

(Including fitting instructions)

FILE TRANSFERS

CPC To/From PC's, PCW's and Others

2 in 1£24.95 MFU£29.95

(Both programs run in CPM+ NOT CPM 2.2)

464/464+ OWNERS

Want a DISK DRIVE? Cannot find a DDI-1?

Exchange your 464 for 6128£129.95

Exchange your 464+ for 6128+£99.95

It's cheaper than buying a DDI-1, Rampack, & ROM

OTHER ITEMS

3.5" Disks (Gold Master Branded) (10)£7.95

3" Disks (Amsoft) (10)£19.95

Plastic Cases for CF2 3" Disks (10)£5.95

3.5" Disk Box (Holds 50)£7.95

3"/3.5" Disk Drive Head Cleaner (state size)£4.95

Printer Lead£7.95

64K DKtronics RAM PACK£39.95

6128+/464+ Adapter£9.95

Phone your order before 3.00pm for same day dispatch

All prices include VAT, postage & insurance for U.K. & BFPO.
Overseas orders charged at the cost of airmail postage. Trade enquiries welcome.

CREDIT CARD ORDERS
(24 HR SERVICE)

Phone 0772 701248

G.V.L. Microform (Dept AA12)
191 Watling Street Road, Fulwood, Preston PR2 4AE
Phone 0772- 701248 Fax 0772 703131

MICROFORM
G.V.L.

Reaction



Write to us if you've got something to say about the CPC, computing, AMSTRAD ACTION or life in general (we don't always print the last type). There is just one thing. Please, PLEASE, no more poems. We really don't think we can bear it...

Subs Club suggestions

Here's a suggestion. We all know that with the specific number of pages in AA, not everybody can get everything they want in it. For example, I would like more adventure games coverage. Now, all us subscribers get the AA Subs Club newsletter, which is at the moment filled with information about how the magazine is made etc. Why don't you put this information on one side, and on the other side have a specialist page where, for example, one month the Balg could review a new adventure that's come out? The next month there could be a machine-code article, the next a hardware project... I don't know what percentage of the readership subscribes, but this would certainly encourage those of a more serious mind to do so.

If you can't do that, then for us poor adventure fans why not put adventure game reviews into the games review pages? With the decreasing number of games available you must surely have space for the odd half-page or page when a new adventure comes out, depending on how

good it is, and the Balg could devote all of his two pages to hints and tips.

I ask this particularly because I am in the middle of writing a game myself and intend to have it reviewed in AA. And maybe, since every reader now has a copy of GAC, we'll see an increase in the number of 'home-brewed' adventures?

Steven Haddon
West Lothian

An interesting idea, Steven, but it does present a few problems. For a start, although AA has a very high subscription level (many more people subscribe to the mag than is normal for a newsstand magazine), they have a wide range of interests. So it would be a mistake to assume that all (or most) subscribers are 'serious' users. When writing the Subs Club newsletter, we have to cater for as many different interests as we do when writing the magazine.

I'm currently thinking of ways to further improve the value of the Subs Club newsletter, and your suggestions have made me think...

...It would be silly to get the Balg or other

contributors to write stuff for the newsletter and not the magazine itself, but it may well prove interesting to run material from the archives – popular type-ins, for example, or hardware projects.

For those who haven't cottoned on yet, by the way, all AA subscribers get a special newsletter with each issue giving them the inside story on each issue, the chance to win prizes and general CPC chat.

As for putting adventure game reviews in the main body of the magazine – I'm not sure they're popular enough! Sorry, Steven, but it seems that for every committed adventure fan, there are a dozen readers who hate the things! I think we'll stick to the current arrangement of keeping adventure game reviews within the Balrog section... of course, if you've got a strong opinion either way and want to drop us a line, we may have our minds changed!

Small Ads success!

In the Small Ads section of AA82 I advertised my

Deaf Poets' Society

We just can't stop people sending in their poems (if you can call them that)...

Trolling along

In *Reaction*, AA79, you stated, and I quote, that: "taking photos of camera-shy people is exactly the sort of anti-social behaviour we like to see our readers getting up to". I wonder if this includes sending other people's poems in for publication? My sister wrote this gem about trolls. In case you don't know, trolls are little plastic dolls in sad need of a haircut and a diet plan.

I love my trolls, they are so cute
I even covered one in Brut
Just to make it smell much nicer
Not like a mouldy apple slicer

Trolls are cool they are so lush
I wish I had a very large slush
To drink whilst watching a funny movie
Featuring THE TROLLS, they are so groovy

Here I end my story of trolls
Little furry plastic dolls

They sit on a pencil or on a badge
Once I got called 'Little Troll Spadge'

Rachael Munns
Penarth

Rachael, I was inspired by your sister's poem. It's not often you come across such a carefully-crafted piece of prose. I too have come across these charming little plastic dolls. With this in mind, I decided to write a poem of my own about these cute little creatures...

*One day I ran over a plastic troll
Left tyre-marks over its brain
I liked it so much I backed up the car
And did it all over again*

Songs of praise

I was reading through my AA as usual when I felt an urge to write a poem. When I finished it I thought it was pretty good, so here it is:

Amstrad Action is the best
Amstrad Action beats the rest
Rod, Adam, Lam, Tracy, Jackie, Colin too
Put it together for me and you
Once a month it comes to me
The only thing that stops insanity
AA eighty-five
Just the thing to survive
The next month until a new one comes
Nothing to do except twiddle my thumb
Roll on December I cannot wait
I hope my mag doesn't come too late.

John 'Pathetic Poet' Briggs
Roade

I was reading through our readers' letters as usual when I felt an urge to write a poem. When I finished it I thought it was pretty good, so here it is:

*I wakened from a gentle nap
To read your poem. It was cr... (snip – publisher)*

om

General Knowledge Quiz. The response to my advert was overwhelming. I am writing to thank all the people who ordered a copy of my quiz.

Carlton J. Young
Huddersfield

Good for you! Incidentally, in case you didn't notice last time, the Small Ads section has been changed. Not a major change, though, just that all the ads are now... FREE! Just one more step towards making Amstrad Action the complete solution for all CPC/Plus owners.

Virtual information

In AA84 in the Cyberspace feature you mentioned two videos: *Dr Devious* and *The Fractals Experience*. Where can you get them from? Also, what is the ISBN of that book *Glimpses of Heaven, Visions of Hell?*

P.S. I have never, and will never buy *CPC Attack!*

Daniel Johnson
Leytonstone

The two videos you mention should be available at any 'proper' music store - try an HMV or Virgin shop. The

ISBN no of *Glimpses of Heaven, Visions of Hell* is 0 340 56905 0.

P.S. I know for a fact you never will buy *CPC Attack*, Daniel. Neither will anyone else, for that matter. It ceased publication with the November issue (see *Amscene* this month).

Querying copyrights

HELP! I have written a piece of software for the BBC Master and the Amstrad CPC464 that I think would sell. The program language is the same in both versions and I was wondering how I go about obtaining a copyright for the program and if I will need a separate copyright for each computer?

David
Somewhere in Paisley

You don't have to worry to much about how to get a copyright, David, because you've already got it! As the author of the program, you have full copyright automatically. The only complications

that might arise would be if portions of anyone else's code were used in the program. Assuming that's not the case, you don't have to worry about it any more. Each version you produce (for different computers) will have its own copyright but, again, this will automatically belong to you the moment you put finger to keyboard.

The only thing you need to make sure of is that you can provide documentary evidence that you wrote the program, including evidence of when you wrote it. This is in the unlikely event that anyone should dispute your copyright.

Programming Pluses

We all know that cartridges were a total flop. But recently Codemasters saved all Plus owners from committing suicide from either getting bored with *Burnin' Rubber* or not being able to get hold of any other carts from software shops by releasing *Stryker*.

So, the question is: Isn't it about time Ocean, Domark or US Gold released their own Plus-busting games? If Codemasters can and they didn't even release a cartridge, then surely Ocean and other could? Even if they re-released 'old' games, but with the Plus graphics, it would be a start. Ocean could put 'Plus' graphics into their *Hit Squad* games and US Gold into their *Kixx* games.

This might mean the major software houses that have dropped out of the Amstrad market would come back.

Duane Saunders
Colchester

If only things were that simple, Duane! *Stryker* was programmed by a team that already knew more than a bit about the Plus hardware - they'd developed cartridge games already. Which means they had a bit of inside info and used it in the game.

I doubt US Gold or Ocean would follow suit, though. Not because they didn't have the expertise (they obviously do!), but because they're not really convinced that the Plus market is worth re-entering. There's more money to be made in the console markets, with less risk attached to doing it - it makes sound business sense!

Your idea about giving old games Plus-style graphics is a non-starter, I'm afraid. It's not just a case of tarding up the graphics code - the games would have to be largely re-programmed and it just wouldn't be worth it.

Write on!

Come on, don't be shy! If you've got something to say, send us a letter.

The address to write to is:

Reaction
Amstrad Action
Beauford Court
30 Monmouth Street
Bath
Avon BA1 2BW

Fluffy animals vs laser death the follow-up

We stirred up a real hornet's nest in AA84. It was hanging just inside the garage door and we poked it with a stick and... oh yes, and there was that other hornets' nest, too. We asked you to write in with your opinions about violent games. In the blue corner (with a kind a cerise chiffon drape) was Maryanne, who believed that games should not involve killing things and that cute, fluffy little animals were lovely. And in the red corner? Well, that was what we wanted to find out. Our conclusions? There are some sick people out there...

"I totally disagree with Maryanne. If everybody had 'nice' games they would end up vomiting on their CPCs." (That explains why our keyboard's sticky, then - Ed)

James Brisco
Ashford

"I totally agree with Maryanne that all these shoot-em-ups etc are absolutely mindless. They also have nasty effects on the brain, take Adam for example! Personally, I reckon that Maryanne should get the biggest ozone-friendly cannon in the vicinity and give Adam a one-way ticket to the moon with enough oxygen for one hour to give him time to think about all the poor little fluffy animals that have been killed by guys like him!" (Actually, I'd spend that hour trying to find some more twiggling oxygen - Adam)

Peter Hetherington
Shaftesbury

"I disagree with Maryanne. I like playing games like this - e.g. *Turrican 2*, *Final Fight*, *Smash TV* - but I don't go round punching people's heads in or blowing them into oblivion in real life." (Nice to know you have principles, Neil - Ed)

Neil Forbes
Yarnton

"Games should not involve violent killing as young children can be influenced by them and try the same thing on their poor old dog." (It was the dog that did the violent killing in our house - Ed)

Teresa Millam
Dunsfold

"I'd rather blow some stranger's head into oblivion than squeeze a little bunny with pink, fluffy ears." (People don't go to Milton Keynes much - Ed)

Iain Heard
Milton Keynes

"I do agree with Maryanne's point of view because I'm a fan of fluffy animals too and games which have brainless killing are not my cup of tea. Plus, the world would be a much better place if everyone was nice to each other." (You've obviously never been to Bognor Regis - Ed)

Richard Avery
Farnborough

Amscene

All the latest news from the Amstrad world is right here. If you have some news for us, send it off to: Amscene, Amstrad Action, Beauford Court, 30 Monmouth Street, Bath, Avon BA1 2BW.

Future launches Gamesmaster mag

Channel Four's computer games show *Games Master* now has a magazine to go with it – and it's published by Future Publishing! Future is producing the magazine under licence from Hewland International (the makers of the TV show) and will be printing 350,000 copies of the first issue.

This is Future Publishing's biggest launch (since *Amstrad Action*, that is... ahem) and will be backed by ad campaigns and promotions. Issue one will carry an exciting covermount, too.

Visitors to the Future Entertainment Show will already have picked up a copy FREE. The rest of you will just have to wait until it appears in the shops. (Bet you wish you'd gone to the show now, don't you?)

All Formats fairs keep growing

These All-Formats Computer Fairs just keep going from strength to strength! Three new venues have been added in Edinburgh, Leicester and Cardiff, for a start, and extra bookings have been added to the lists for the existing sites. Basically, it seems that except for summer holidays and Christmas, there is a Fair somewhere in

Attack called off!

Six months after its launch, *CPC Attack* (AA's newest rival) has ceased publication. A spokesman for publishers HHL stressed the magazine had been 'suspended' not closed, but conceded that it was unlikely to reappear.

The news broke as readers calling the mag were referred to staff on a sister title who told them *Attack* was no longer being produced and editor Pat Kelly had left the company.

This means that AA is the only remaining UK title devoted specifically to the CPC and Plus. It was also one of the first to appear when the CPC was launched, making it one of the industry's most enduring successes. We've always tried to provide Amstrad owners with the best information, the most authorita-



tive reviews and the most up-to-date Amstrad news. Ultimately, though, it's up to the readers to decide which magazine does it best.

It looks like they have.

the country every Saturday and Sunday!

The All-Formats Fairs are not grand showcases for the industry, exactly, more like computer jumble sales. Although that's not really fair, because many of our readers have reported picking up some good bargains – from blank disks to games to whole CPCs!

There are now too many Fair dates to list, so if you want to find out when there's going to be one near you, call the organisers on 0608 662212.

CPC gets a video link

Those clever people at Campursoft (who brought us *MicroDesign Plus*) have an even more exciting development in the pipeline. It's a lead which will let you connect your CPC's monitor output to the SCART input of any domestic video recorder.

Indeed, if you're lucky enough to own one of the very latest televisions, that too should have a SCART socket, meaning that you can bypass the video recorder altogether and plug your CPC

straight into your TV!

The advantages are obvious. Domestic TVs can offer a much larger picture than the Amstrad monitor – great for games fans. It goes a bit further than that, though. You see the Campursoft lead could be an inexpensive way of converting your mono system to colour. The trouble with the CPC is that it's always been sold as a complete package. So that those people who bought a mono machine, thinking they would use it principally for serious applications, subsequently find it difficult to upgrade to colour. Well, not so much difficult as impossible. The only way to do it is to sell your entire system and buy a colour one!

Amstrad did for a while offer an alternative in the form of their CPC TV modulators. These are no longer manufactured, however, and getting hold of one can be very hard (although advertisers WAVE sometimes have them in stock).

The potential of Campursoft's lead is huge, and we'll be exploring it more fully in the next issue with a special review. Look out for it!

Robot sends a bulletin...

Richard Fairhurst, leading light at Robot PD and also, as it happens, *Amstrad Action's* resident technical boffin, is to set up a bulletin board called Real World BBS. We'll have more news for you modem fans out there as soon as we get it.

Got your free head cleaner?

You'll have noticed a little extra on the front of this month's ish – a free tape head cleaner, no less! This is suitable for use in both ordinary tape players and in your 464s built-in tape deck. It should cut down on those frustrating 'read errors' some users get when loading covertapes.



Bargain of the century? A mono 464 Plus with loads of games for only £120! See the blurb on the right for full details...

Cheap Pluses spotted!

Reader Ian Thompson phoned us up to tell us about a company selling mono 464 Plus machines for an amazing £120!

This is all the more amazing given that they are being sold with ten free tape games – plus, of course, *Burnin' Rubber*, the game supplied on the machine's cartridge.

We expected the price of the Amstrad Plus machines to fall, given their disappointing sales in the shops, but this has to be a bargain by any standards.

The name of the company offering the bundle is Universal Trade Surplus, and you can call them on 0630 655797.

ULTRA SOFTWARE

**UK ORDERS
POST/PACK
FREE UNTIL
30/11/92**

STAR COMMAND

COMMAND A VAST FLEET OF SPACE CRAFT IN THIS FUTURISTIC STRATEGY GAME. PLAY THE COMPUTER OR A FRIEND. OVER 90 CRAFT OF 5 TYPES, ANTI-RADAR CRAFT, & MORE! CAN YOU SAVE/DESTROY EARTH?

FORMULA GRAND PRIX

THE PINNACLE OF MOTOR SPORT IS BROUGHT TO YOU IN THIS FORMULA 1 SIMULATION. 16 TEAMS, 8 TRACKS, RAIN, SPINS, CRASHES, PIT STOPS, CHAMPIONSHIP & KNOCKOUT SYSTEMS etc. etc

OTHER PROGS AVAILABLE

PROGRAM FEATURED
TEN PINS AA85
DOWN THE DRAIN AA86
HORSEIN' AROUND
STABLES ED'N AA86
MIST ISLAND AA84
MUSIC MASTER AA84
CROSS-IT AA86
EDITOR AA83

ZAP 'EM ACADEMY

THE BEST STAR FIGHTER ACADEMY IN THE UNIVERSE HAS OFFERED YOU A PLACE. YOU WILL BE PUT THROUGH TRAINING - AND IF YOU PASS THIS THEN YOU WILL BE REQUIRED TO HELP SAVE PLANET EARTH!

HORSEIN' AROUND PUNTERS EDITION

THIS IS THE ULTIMATE BETTING GAME! CHOICE OF BOOKIES AND TYPES OF BET (EG WIN/PLACE), FORM/PADDOCK GUIDES, PLAY FRIENDS/COMPUTER, RACE GRAPHICS...

CATALOGUE

FOR A COPY SEND YOUR NAME, ADDRESS AND AN 18P STAMP.

PRICES

TAPE - \$3.49
DISK - \$5.49

POST PER ORDER

U.K. - 50P
EUROPE - \$1.20
OTHERS - \$2.00

IMPORTANT

PLEASE MAKE P.O.s & CHEQUES OUT TO R.F. TAYLOR

Proprietor: R.F. Taylor

TAPE: 64K VERSION ONLY

DISK: 128K & 64K VERSIONS

CHRISTMAS PRESSIES

ANYONE ORDERING 2 OR MORE PROGRAMS WILL BE SENT A FREE GIFT-WRAPPED PROGRAM (PICKED AT RANDOM) ON THE SAME FORMAT AS THOSE ORDERED OR BUY ONE - \$2.49/TAPE \$3.99/DISK. OFFERS END 14/12/92

ULTRA SOFTWARE (AA87), FULLING MILL BROUGHTON, BANBURY, OXON. OX15 6AP

464/464+ DISK DRIVES

We are now selling a 3.5" disk drive along with a DDI-1 interface for the 464/464+. The package includes the 3.5" disk drive, DDI-1 interface, power supply, disk drive cable, Master Disk and instructions. This is the only disk drive being produced for the 464/464+. Available now priced £159.99 (plus £5.00 postage and packing).

VERY LIMITED STOCKS LEFT, ORDER NOW!



FREE MULTIFACE II for transferring your cassette based software onto disk. Supplied free with every DDI-1.



3.5" DISK DRIVE

FREE 10 BLANK DISKS WITH EVERY 3.5" DISK DRIVE

Our stylish no-nonsense 3.5" disk drives are the only ones available that come complete with all the necessary leads, power supply & software to enable you to use 800K per disk without the need to change any manual side select switch.

Other disk drives will only allow you to access 400K at a time, whereas our superior drives come complete with RAMDOS or the new ROMDOS XL that allows the full 800K to be accessed even under CPM!

Our SONY disk drives come complete and ready to plug in. Included is a full 15 page printed user manual and a FREE DISK CONTAINING RAMDOS, RAMDISK DRIVE, SECTOR EDITOR, DIRECTORY EDITOR, FAST FORMATTER etc.

ROMDOS XL

ROMDOS XL is an enhanced ROM version of RAMDOS. This disk operating system is the only one available for the CPC that enables 800K on line disk space under Amsdos and CPM! It also has built into it many useful features such as file copying, disk formatting, batch file erasure etc, etc. It is available on ROM priced £29.99, in its own unique cartridge priced £44.99 or with a 6 socket rombox priced £49.99. It is also available complete with our 3.5" disk drives.

PRICES

3.5" DISK DRIVE WITH RAMDOS.....£74.99
3.5" DISK DRIVE WITH ROMDOS XL.....£94.99
3.5" DISK DRIVE WITH ROMDOS XL CARTRIDGE.....£99.99
3.5" DISK DRIVE WITH ROMDOS XL
& 6 SOCKET ROMBOX.....£109.99

How to order:

Telephone orders on
061-724 7572

Mail orders to:

SIREN SOFTWARE, Wilton House, Bury Road, Radcliffe, Manchester M26 9UR.



AMSTRAD GAME CARTRIDGES FOR 6128+/464+/GX4000

TITLE	BOXED WITH INSTRUCTIONS	UNBOXED NO INSTRUCTIONS
Klax.....	£24.99	£14.99
Pro Tennis Tour.....	£24.99	£14.99
Batman.....	£24.99	£14.99
Operation Thunderbolt.....	£24.99	£14.99
Barbarian II.....	£24.99	£14.99
Navy Seals.....	£24.99	£14.99
Robocop II.....	£24.99	£14.99
Pang.....	£24.99	£14.99
Switch Blade.....	£24.99	£14.99
No Exit.....	£24.99	£14.99

* Special offers: 10 Unboxed games (all different) £100.00 *

Amstrad GX4000 Games Consoles

with free game £59.99

Amstrad Paddle Controller £8.99

Burnin' Rubber + Locomotive Basic Cartridge £19.99

Amstrad MP3 Modulator/TV Tuner, for use with CTM644 monitor.....	£29.99
Amstrad 464 Light Gun & Games Cassette.....	£19.99
Amstrad 6128 Light Gun & Games Disk.....	£19.99
Amstrad CT1 Clock Radio.....	£14.99
Amstrad CPC464 Cassette Mechanism with tape head and motor.....	£29.99
Amstrad 464 Head Alignment Tapes.....	£9.95
Tape Head Demagnetizer.....	£9.99

Prices include VAT, postage and packing

All orders by return: Cheque/Visa/Access

Trade-In-Post, Victoria Road,
Shifnal, Shropshire TF11 8AF

Tel/Fax (0952) 462135





Win all this

Take a deep breath and put on your strongest reading glasses. AA presents an opportunity to win the following games (on tape), both as individual games and also on a few budget compilations:

Academy • Aftermath • Aliens (US Version) • Andy Capp • Army Moves • Australian Rules Football • Axiens • Bangers & Mash • Big Trouble in Little China • BMX Ninja • Captain 'S' • Championship Baseball • Championship Sprint • Combat Zone • Confusion • Count Duckula • Count Duckula 2 • Crazy Er'bert • Cricket Crazy • Cricket International • Dandy • Danger Mouse in Double Trouble • Danger Mouse in Making Whoopee • Dead or Alive • Double Dare • Endzone • Everyone's a Wally • Fireman Sam • Football Frenzy • Formula Grand Prix • Freddy Harvest • Galactic Games • Game Over • Game Over 2 • Gee Bee Air Rally • Gilbert - Escape from Drill • Gold or Glory • Graham Gooch's Match Cricket • Grebit • Grid Iron 2 • Gun Boat • Hideous • High Steel • Hijack • Hi-rise • Howard the Duck • Huxley Pig • Indoor Soccer • Invaders • Jaws • Judo Uchi Mata • Kentucky Racing • Life-Term • Mad Flunky • Meganova the Weapon • Metalyx • Micro Ball • Mini Office • Missile • Moon Cresta • Mountain Bike • Muncher • Mystery of the Indus Valley • Neil Android • Nigel Mansell's Grand Prix • Nosferatu the Vampire • Oink! • Operation Hormuz • Pegasus Bridge • Pentomania • Popeye • Popeye 2 • Postman Pat • Postman Pat 2 • Pro Mountain Bike Simulator • Punch & Judy • Rally Driver • Red Arrows • Rescue from Atlantis • Revolver • Rex • Rik the Roadie • Rogue Trooper • Rugby Boss • Run for Gold • S*M*A*S*H*E*D • Samantha Fox Strip Poker • She Vampires • Slug • Snodgits • Soccer Boss • Soccer Challenge • Sooty & Sweep • Space Trooper • Spindizzy • Spitfire '40' • Splat • Star Wreck • Strike Force Cobra • Strike Force Harrier • Stunt Experts • Superted • Swords & Sorcery • Tarzan • The Colour of Magic • The Last Commando • The Munsters • The Rocky Horror Show • The Wombles • Theatre Europe • Thomas the Tank Engine • Through the Trap Door • Trap Door • Turbo Bike • Up for Grabs • US Basket Master • Vixen • Who Dares Wins 2 • Wiz Biz

PLUS: Lovely sports bag • Alternative newsletter • Dalek poster • Some most excellent Dalek stickers

See right for competition questions and entry details

AMSTRAD ACTION December 1992

Action Zone

Christmas is coming, the geese are getting fat, maybe you can win some stuff, in this month's ACTION ZONE competition special.

(ER, THAT DOESN'T RHYME ADAM - ED.)

Win 119 games (and a bag)

ALTERNATIVE
COMPO

This looks like being one of the biggest competitions we've ever run. There's only one prize, but it's a prize that consists of over 130 items and is worth over £500! Yep, our top chums at Alternative have got together every game they've ever produced (119 games plus about 10 compilations) and bunged them together in a sports bag.

There are enough games in here to last you a lifetime! Here's a brief idea of what our winner can look forward to...

Golden Oldies: classics like *Spindizzy*, *Academy* (the sequel to *Tau Ceti*), *Judo Uchi Mata* (a martial arts game), the incredible blasting action of *Army Moves*, and much more.

Sports Games: management games like *Soccer Boss* and *Rugby Boss*, adventures like *Cricket Crazy* and *Football Frenzy*, simulators like *Grid Iron 2*, *Soccer Challenge*, *Australian Rules Football* and *Nigel Mansell's Grand Prix* (the game we don't like talking about).

Cartoon Fun: Alternative are famous for their

TV licences, and there's tons of those here; *Danger Mouse*, *Count Duckula*, *Gilbert*, *Superted*, *Postman Pat*, *The Munsters*... what are you going to do to keep up?

"So how do I go about entering the compo then, Adam me old chum."

It's easy, dude. Somewhere on this page (depending on where Lam felt like putting them) you'll find four screenshots, numbered 1-6, sorry 1-4. These come from four of the games up for grabs. Using your skill and judgement, a bit of luck and the list of games (wherever Lam's put that), work out what the games are. They're all quite easy if you think a bit.

Then simply jot down your answer (eg '1) Cricket International, 2) BMX Ninja', etc), together with your name and address, on the back of a postcard or sealed-down envelope. Send the whole shish kebab off to: Alternative Bumper Compo, Amstrad Action, 30 Monmouth Street, Bath, Avon BA1 2BW, to arrive by 11th January 1993. The winner wins.

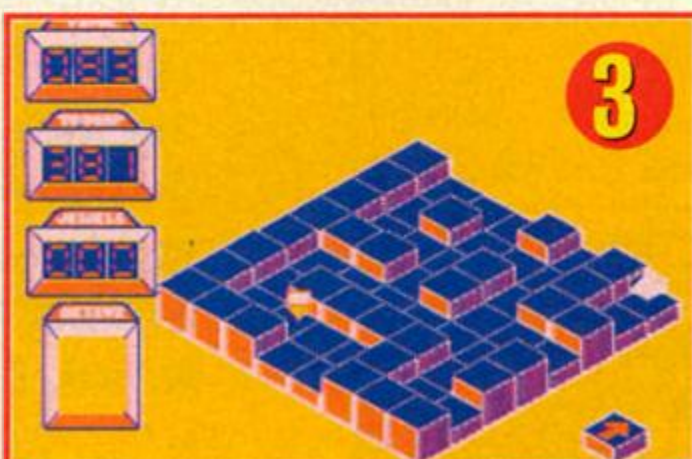

CODEMASTERS COMPO

Win a load of Dizzy stuff

It's official Dizzy month here at AA Towers. Turn to the centre pages for the start of our bumper Dizzy life story feature, and when you've done that turn back to here for an opportunity to win a whole pile of Dizzy stuff. We've got tape versions of both Dizzy

compilations (*Dizzy Collection* and *Excellent Adventures*), plus individual tapes of nine of the games contained therein. We've also got the whole range of Dizzy merchandise; a sports bag, a wall clock, a mug, a T-shirt and a baseball cap.

In a few weeks a lucky chap or chappess out there in AAland will be greeting a postie bearing almost £100

worth of Dizzy stuff. Crikey!

"So," you say (with a tremble in your voice), "how can I win all this gurt lush Dizzy gear?"

It's dead easy, chums. You know how Dizzy hangs around with those Yolk Folk bods (Daisy, Dylan, Denzil, Dozy, Dora and Davidbellamy)? Well, we want you to come up with an idea for another member of the Yolk Folk. Think up your own character, but make sure that (a) it's egg-shaped, (b) its name begins with 'd', and (c) the name is fitting for the character of the character (if you see what we mean).

Just draw a picture of your new Yolk Folk character, together with the character's name and a bit of info about what sort of things they could get up to in Dizzyland. Bung it all in an envelope, together with your name and address, and get it to us by January 11th 1993 at this address: Dizzy Competition, Amstrad Action, 30 Monmouth Street, Bath, Avon BA1 2BW. Then pray. The winner wins.

Win all this

The following games (on tape) – both as individual games and also on compilations:

Bubble Dizzy • Dizzy • Dizzy down the Rapids • Dizzy Panic • Dizzy Prince of the Yolk Folk • Fantasy World Dizzy • Fast Food • Kwik Snax • Magic Land Dizzy • Spellbound Dizzy • Treasure Island Dizzy • PLUS: The complete set of Dizzy collector cards • Fab Dizzy sports bag • Dizzy mug • Dizzy clock • Groovy baseball cap (with Dizzy on it) • T-shirt (bearing Dizzy's picture)

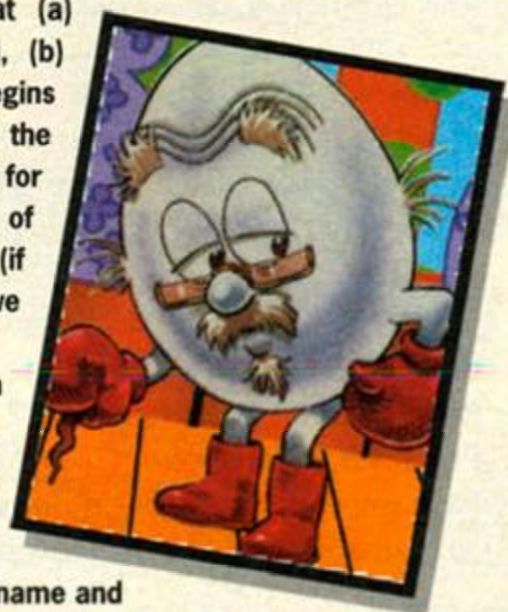

Photo compo

Bribery certainly seems to work. Our offer of £20 for any photos of bonafide celebrities reading AA has lead to lots of you trying your luck with a variety of pathetic little cons. Here's just a few of your pitiful attempts to get your hands on some free money. You must think we fell off a tree...



Rob Waugh from Market Weighton in East Yorkshire (yeah, say no to Humberside!) has provided possibly the most pathetic attempt of all, sending in this picture from AA79. Apart from the fact that none of the people pictured are bonafide celebrities (especially not Maryanne) we're not even reading the blimmin' magazine, we're just looking at a test sheet for a recent redesign. Pathetic, Rob. Your entry's so bad that we've decided that you should send us £20 for even daring to submit it.



Similar, but a little better, is this entry from Gavin Craddock in Stoke-on-Trent. At least there's a magazine in this picture, but until we see Rod snogging Liz Taylor in one of the Sunday supplements, we refuse to recognise his 'celebrity' credentials. (*How did you find out about me and Liz Taylor? - ed.*) Try again Gavin.

Some of these entries really plumb the depths, but at least the pictures actually exist. Chancer of the Month award goes to Gemma Fernandes of Romford who tells us that her friend lives next door to Tony Adams, the Arsenal captain. Tony, apparently, "does not possess an Amstrad. He prefers to

play with his daughter's Sega. The scum!" [The views of our contributors do not necessarily reflect those of the editor, Amstrad Action or Future Publishing. Or the Pope.] "Please could you send me £20 because I would have got a photo of Tony Adams reading AA but I didn't." What is she like?



Oh dear! When he's not making some of the worst records in modern history, Bryan Adams likes nothing better than to read *Amstrad Action*. Or at least according to Amy Kernahan of Stornoway he does. Anyone out there suspicious that instead of a detailed colour picture, Amy has sent us a crappy two-tone photocopy? Do you suspect she might have doctored the photo a bit? Really? Surely not. Amy also enclosed a letter of support for the neolithic Canadian's dissing of modern music as "this computerised crap". As opposed to "that guitar crap" that Bryan knocks up. Yeah, like let's leave popular music stuck permanently in 1969. Minus several hundred points on every count there, Amy.



This is a little more like it. According to Damien Kirwen of Dunlavin in Ireland, his five year old brother Ross (pictured) is

number five junior karate finalist in the World Pro Kickboxing Tournament. And there were we thinking that someone had just got him out of bed and stuck a frozen chicken to each hand. Not astonishingly convincing to be honest, but have a tenner anyway Damien. Just in case your brother really is a martial arts expert (we're all incredible cowards here at AA Towers).



My God! A celebrity! A real life celebrity! William Gaunt is an actor who has starred in TV series like *Sergeant Cork*, *The Champions*, *No Place Like Home* and *The Practice*. He's also been in loads of stage plays; *The Flip Side*, *Boys in the Band*, *When did you last see your trousers?*, *Run for your Wife*, and currently, *Murder by Misadventure*. And here he is reading a copy of AA that has been thrust in his hands by Ann Frodsham of Harlow, Essex. Ann wins £20. See, it's easy! So come on the rest of you: nab a star, win some cash!

WIN YOURSELF SOME MONEY

Send your pictures of celebrities holding AA to: Photo Compo, Amstrad Action, 30 Monmouth Street, Bath, Avon BA1 2BW. There are loads of crisp £20 notes (OK, cheques) on offer.

Here are some places where celebrities often hang out: stage doors of theatres, West End nightclubs, tropical islands, their homes, fêtes and parish days, supermarket openings, hotel foyers, TV studios, Soho restaurants, signings in book and record shops, and loads of other places (keep your eyes peeled).

And remember dudes, we know what constitutes a 'real' celebrity. We're not stupid you know. (*Sniffle wurble plip - ed.*)



Lam Tang's wonderful world of art

Hello readers! My name's LAM TANG. I'm the AA art editor (page designer) and I'm great. I'm possibly one of the greatest artistic hopes of my generation. The world art community worships at my feet. I make Van Gogh look like a girl. Here's what you can do...



EARLY RELEASE

Crystal Kingdom Dizzy

He's back, and this time he's got a whip! The egg's gotten mean. Let's get the crap puns out of the way right at the beginning; egg-cellent, egg-citing, egg-sactly, egg-scruciating, it's no yolk, family albumen, er... and any others you can think of. (This is really sad Adam, you should be shot - Jon Pillar, Your Sinclair.) But I'm just listing all the crap puns to show how sad they are. (But you're reinforcing them just by using them - Jon.) No I'm not, I'm showing them up for how sad they are. (Egg jokes are pathetic - Lam Tang.) (I've just seen what you're doing. Don't use my name in this at all, I don't even want to be associated with eggs - Jon.) (Why not Jon, did you have a nasty experience with an egg when you were young? - Rod.) (No, I just really hate Dizzy and all the Dizzy games - Jon.) Why? They're great. (But they're all the same game. CodeMasters are destroying computer games with rubbish like this - Jon.) (They are pathetic. They're all the same - Lam.) You can say that about any type of game. Beat-em-ups are all the same, and at least Dizzy games require a bit of intelligent thought. (No they don't, they're really easy - Jon.) You might find them easy, but plenty of other people don't or they wouldn't be selling that well. (The games are all the same - Lam.) But why change a winning formula just for the sake of it? If the games are crap, people won't buy them. (But look at Take That records - Linda Barker, Your Sinclair.) (Exactly. Everyone knows that Stock, Aitken & Waterman records are crap, yet they sell millions - Jon.) Wrong. Opinionated, pretentious middle



class journalists and TV presenters think that SAW records, together with TV programmes like 'Allo, 'Allo and You've Been Framed, are crap. A large part of the population doesn't agree. Do you really believe people go out and buy things they don't like? Why would they do that? (It's all just marketing - Jon.) Marketing can make people buy things, it can't make them like them. All the evidence of readers' letters, Cheat Mode and Helpline suggests that a lot of our readers see Dizzy games as their favourite games.

(Have you ever bought a Dizzy game? - Jon.) I got the original Dizzy on an AA covertape a few years ago and I've played them all since joining the magazine. How many Dizzy games have you played? (I've played one, but I can't remember which one - Jon.) So can you really diss the games then?

(I can't remember how it came about that I built up this big hatred of Dizzy. I think I just see Dizzy as a symbol for all that's wrong in the software industry at the moment - Jon.) It's easy, lazy, simple programming, but if that's what the people want, why change it? (People are being asked to pay £9.99 for Crystal Kingdom. What extra are they getting for the extra six quid? A blinkin' poster? - Jon.) Yeah, I have to agree with you on that one.

Software house: CodeMasters
Release date: December 1992
Price: £9.99 cassette
First impression: Dizzy games - love them or loathe them. It's your choice.

AA HEROES

No 1 • Rolf Harris



The brilliance of Rolf Harris truly knows no bounds. After escaping from an Australian prison in the mid 70s, Rolf arrived in Britain and soon established himself as the nation's number one TV presenter. His artistic style has inspired a whole generation. Not only has he given us some classic cartoons to savour, but he is also responsible for the world's biggest TV promotion of computer art packages, which he has regularly featured on the seminal Rolf's Cartoon Club. It is no exaggeration to say that, without Rolf, Lam Tang's Wonderful World of Art would be a sad and desolate place. Sir Rolf is appearing in panto in Bath this winter, and you can bet your bottom the AA staff will be in the big crowd outside the stage door every night. Rolf Harris, guru for a nation's youth, we salute you.

This is the first in a series of special cut-out-and-keep cards, featuring some of the great icons of the late 20th century.

DATEL Electronics

NOW A TOTAL MOUSE/ GRAPHICS PACKAGE FOR YOUR AMSTRAD AT A TRULY UNBEATABLE PRICE!!

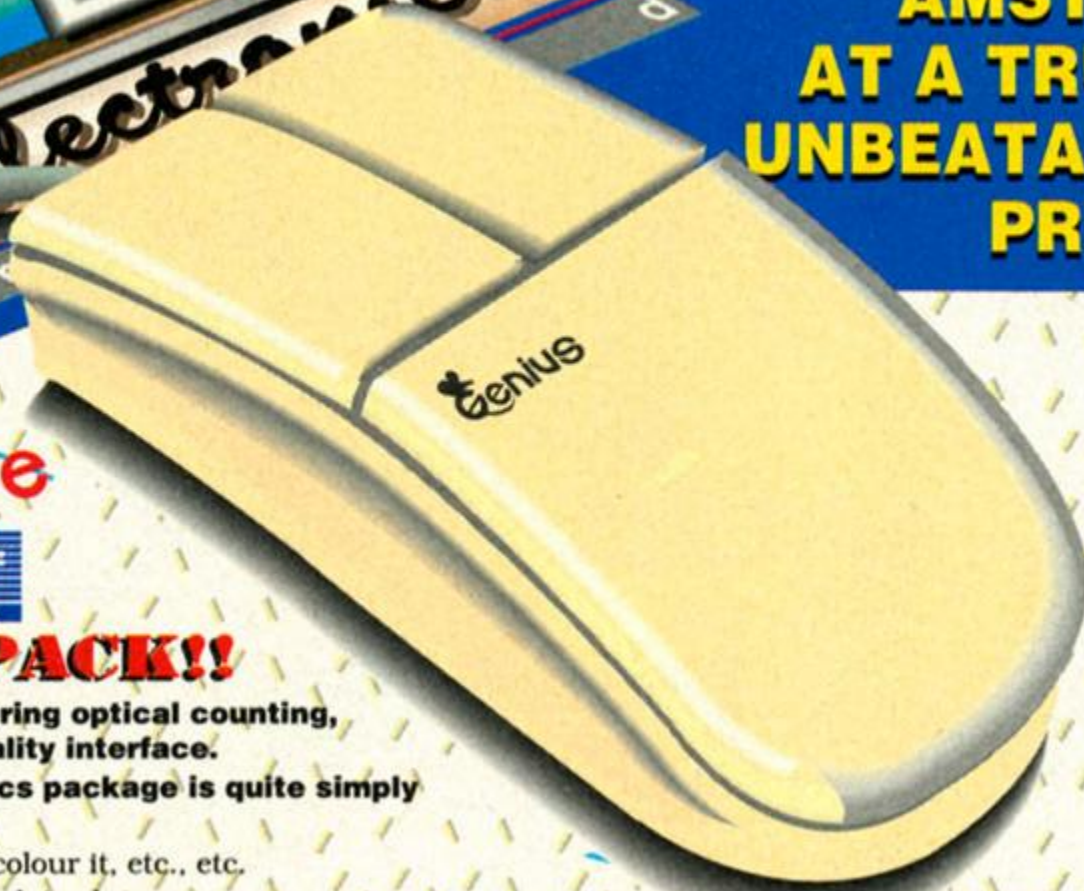

Genius Mouse

COMPLETE WITH



SPECIAL OFFER PACK!!

- Genius Mouse is a high resolution two button mouse featuring optical counting, teflon guides, microswitches, rubber coated ball and high quality interface.
- When combined with OCP Advanced Art Studio this graphics package is quite simply the best system available. The features are unmatched...
- Create an image - shrink it, expand it, move it, rotate it, copy it, colour it, etc., etc.
- Spray patterns or shades, make elastic lines - stretch and manipulate shapes.
- Zoom in to add detail in fine mode.
- Full cut and paste facilities plus excellent printer support.
- Pulldown/Icon driven menus for ease of use.
- Mouse operation, plus joystick and keyboard control.
- 16 pens, 8 sprays, 16 brushes - so flexible anyone can create superb graphics easily.

TAPE OR DISK FOR 464 OR 6128 (PLEASE STATE WHICH REQUIRED) N.B. 464 NEEDS DK'TRONICS 64K RAM PACK

COMPLETE WITH MOUSE INTERFACE



- The Genius Mouse Graphics System comes complete with the special Mouse Interface to allow super smooth control.
- Attractively styled to match your 464 or 6128 design and colour. Simply plugs into Expansion/Joystick port.

ONLY £49.99 TOTAL PACKAGE INCLUDES GENIUS MOUSE, INTERFACE, OCP ADVANCED ART STUDIO PLUS FREE MOUSE MAT AND HOLDER

FREE! MOUSE MAT AND MOUSE HOLDER (WORTH £12.99) WITH EACH PACKAGE



NEW

LC 200 COLOUR PRINTER PACKAGE

- NOW YOU CAN PRINT OUT YOUR PICTURES IN FULL COLOUR!**
- The Star LC200 Colour Printer not only prints in Near Letter Quality for your regular jobs but also prints out your pictures from Art Studio, etc., in genuine colour!
 - LC200 is a full Centronics printer so it works with other computers (Amiga, ST, etc.).
 - Made possible by Datel's unique colour printer driver - now you can have a hardcopy in up to 16 colours!!
 - No more to buy - just plug in and print!!

**PACKAGE INCLUDES... STAR LC200 COLOUR PRINTER RRP £299.00
CENTRONICS PRINTER LEAD RRP £9.99
DATEL COLOUR PRINTER DRIVER SOFTWARE RRP £19.99
NORMALLY £327.98
COMPLETE PACKAGE NOW ONLY £239.00**

COLOUR PRINTER DRIVER AVAILABLE SEPARATELY ONLY £19.99
● If you already have an LC10 or LC 200 Colour Printer we can supply the Driver separately.

dkitronics



- Simple plug in memory expansion gives instant extra memory.
- Features bank switching software for easy use by the programmer or for use as a data storage area.
- Ideal for use with the CPM 2.2 etc.
- The software also features some extra BASIC commands.
- 64K unit expands 464 to 128K.
- 64K unit brings 464 up to CPC 6128 memory configuration making a much larger software base available. Will work straight off with many programs designed for this unit (including OCP Art Studio - see Ad.).
- Bank switching done automatically by software (cassette 464).

64K MEMORY EXPANSION

ONLY £49.99 64K FOR 464

DATEL Electronics LIMITED

HOW TO GET YOUR ORDER FAST!
TELEPHONE [24Hrs] **0782 744707** CREDIT CARD ORDERS
ORDERS NORMALLY DISPATCHED WITHIN 48 Hrs. ALL CHEQUES/POSTAL ORDERS MADE PAYABLE TO...
DATEL ELECTRONICS
GOVAN ROAD, FENTON INDUSTRIAL ESTATE, FENTON, STOKE-ON-TRENT, ST4 2RS, ENGLAND. FAX 0782 744292 TECHNICAL/CUSTOMER SERVICE 0782 744324



THE BEST COMPILA

THE DREAM Team

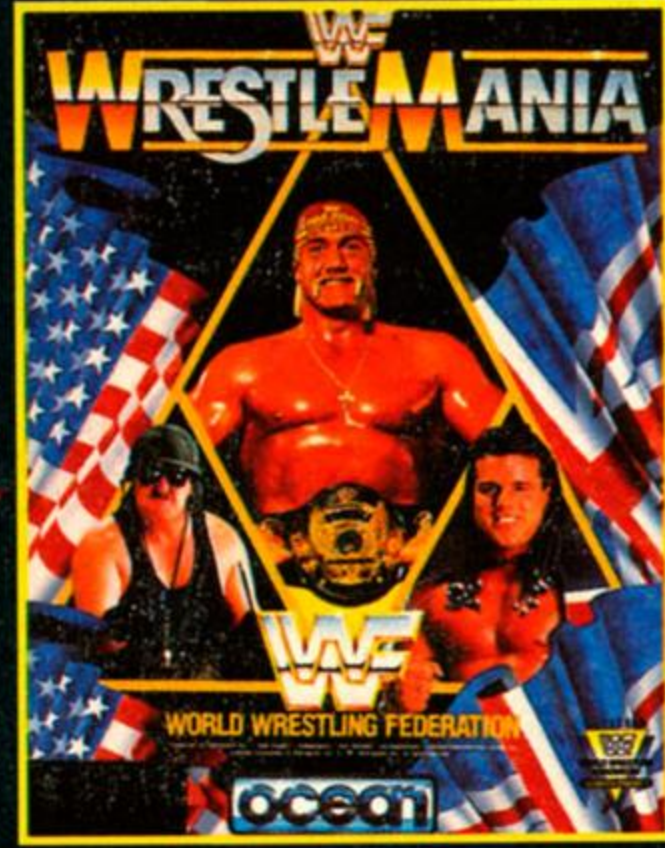

BART, ARNOLD & HULKSTER IN ONE GIANT COMPILATION
THE THREE BEST SELLERS
OF 1991-1992
ALL REACHING NUMBER **ONE** THROUGHOUT THE YEAR

ATION OF ALL TIME

THE SIMPSONS™ BART VS. THE SPACE MUTANTS



"A hit, pure and simple. Excellent opening animation. Once you've played it you'll be hooked."



ACCLAIM® AND BART VS. THE SPACE MUTANTS™ ARE TRADEMARKS OF ACCLAIM ENTERTAINMENT, INC. THE SIMPSONS™ TM & © 1991 TWENTIETH CENTURY FOX FILM CORPORATION. ALL RIGHTS RESERVED.

TERMINATOR™ 2



"You'll keep coming back, just like the Terminator itself. Get hold of this one, it's almost as mean as Arnie!"
COMMODORE Magazine
94%
"Variety is definitely the winning ingredient with Terminator2."
COMMODORE FORMAT



LIN® IS A REGISTERED TRADEMARK OF LIN LTD. © 1991 CAROLCO INTERNATIONAL N.V. ALL RIGHTS RESERVED.

WWF* WRESTLEMANIA*



"Where other wrestling games fail WWF succeeds. WWF is more realistic than the real thing and that's official. Brilliant presentation, convincing and colourful graphics throughout, spot on control method makes everything feel perfectly natural - a must for all WWF fans."



*TRADEMARK OF TITANSPTS, INC. © 1991 ALL RIGHTS RESERVED. ALL DISTINCTIVE CHARACTER NAMES, LIKENESSES AND LOGOS ARE TRADEMARKS OF TITANSPTS, INC. © 1991 ALL RIGHTS RESERVED. **HULK HOGAN, HULKAMANIA AND HULKSTER ARE TRADEMARKS OF MARVEL ENTERTAINMENT GROUP, INC. LICENSED EXCLUSIVELY TO TITANSPTS, INC. © 1991 ALL RIGHTS RESERVED.

ocean®

OCEAN SOFTWARE LIMITED · 2 CASTLE STREET · CASTLEFIELD · MANCHESTER · M3 4LZ
TELEPHONE: 061 832 6633 · FAX: 061 834 0650

Amstrad Action Superstore

Back issues



ISSUE 79 • £2.50
New-look issue. Brand new Technical Forum section starts. Ranarama and Maze Mania on the covertape. Blues Brothers mastergame, plus compilations.



ISSUE 80 • £2.50
Stryker and the Crypts of Trogan – a budget game which uses the cartridge hardware of the Plus! (Demo on the covertape) New series on how a game is made, plus poll results.



ISSUE 81 • £2.50
Fanzine special: what they are, how to produce them, the best DTP progs and more. Addams Family demo plus Forbidden Planet on the covertape. The best French software reviewed.



ISSUE 82 • £2.50
Lemmings, The Addams Family and Bonanza Bros reviewed. DTP program PowerPage on the covertape and playable Lemmings demo. Buyers' Guide to art packages.



ISSUE 83 • £2.50
On the tape: Tetris game, music composer, Defenders of the Earth full game. In the mag: Report on a software shopping trip to France, footie strategy games, AA82's Type-ins.



ISSUE 84 • £2.50
Famous Five on the covertape, lightpen hardware project, colour printing special and three-page Hideous review. Plus Virtual Reality special & the best 3D CPC games of all time.



ISSUE 85 • £2.50
Music-making on the Amstrad – a special feature. PowerPage tutorial, MicroDesign Plus review plus two full games on the covertape (On the Run and Link) and a WIMP interface!



ISSUE 86 • £2.50
Special feature on kids TV licences from Alternative Software, Picasso art package reviewed, Glider Rider on the covertape plus MIDI demo and three great utilities

Sorry, sold out!

Issues 1-54, 56-65

ISSUES STILL AVAILABLE:

Issues 55, 66, 68, 71, 72, 73, 74, 75, 76, 77, 78

UK price original cover price

OVERSEAS PRICES Europe £5, Rest of world £7

Postage & Packing £1 per order*
*Regardless of size of order

LEMMINGS

Psygnosis

Can you stop hundreds of furry little mammals from doing themselves in? It starts off easy, but gets harder and harder. A brilliant, original game that's utterly addictive – 60 levels of frantic action.



Description	Price	Order No
Lemmings Cass	£13.99	AALEMC
Lemmings Disk	£16.99	AALEMD

PROTEXT

Arnor

Protext is arguably the best word processor you can buy for your Amstrad (it's the one that is used by the AA editorial team). It's very fast and is packed with features. It also allows comprehensive file-handling (full disk management) from within the program. Can be 'expanded' with Prospell, Promerge and Prototype packages, available from Arnor. Works on 464 and 6128 • DISK ONLY.



Description	Price	Order No
Protext Disk	£19.95	AA674D

MINI OFFICE II

Database Software

Word processor, database, spreadsheet, label printer, graphics and communications – a fabulous all-in-one pack at an amazing price!



Description	Price	Order No
Mini Office II Cass	£13.99	AA670AC
Mini Office II Disk	£15.99	AA670AD

AA BINDER

Keep your valued Amstrad Action magazine collection together in this fabulous bright red binder. Equally at home on a brass mantelpiece or the floor of a dingy bedsit; buy a binder and treasure your magazines for life...



Description	Price	Order No
One binder	£5.99	AA417R
Two binders	£11.00	AA4172R

HOTLINE 0458 74011

AMSTRAD ACTION BACK ISSUES/MAIL ORDER

Name

Address

Postcode Phone number

Method of payment (please circle) Access • Visa • Cheque • PO

Credit Card No

Expiry date

Please make all cheques payable to Future Publishing Limited

Description Price Order No

TOTAL ORDER

Please send me the following back-issues.....Total

• For overseas orders call Claire Bates for prices on 0458 74011

SEND THIS FORM TO: Amstrad Action, Future Publishing Ltd, Freepost, Somerton, Somerset, TA11 7BR

No stamp required if posted in the UK, Channel Islands or the Isle of Man

Watchdog with Lynn Folds-Paper

It sounds all very good to run a PD library, doesn't it? Hey! The opportunity to make loads of money out of other people's hard work doesn't crop up every day, so when it comes grab it! "I'll start a library, charge £1 for a side of a disk and not only get rich in the process but also be famous!". It might sound ridiculous, but that is actually the way many new librarians think.

There are a number of different reasons why there are now too many libraries on the CPC. Firstly, there are not enough PD programs to comfortably accommodate them all and secondly, quite a lot of the new libraries are just plain crap.

The true meaning of PD (as repeated an infinite number of times, it never seems to sink in) is not to have the biggest library, but to provide a service to CPC users. As Richard Fairhurst rightly said last issue, if you are making a decent profit, you're charging too much. To give yourself the title of a 'really nice librarian', you must:

- Compile your own collections.
- Introduce new programs into the library from either Britain or overseas.
- Have a relatively speedy delivery time (about two weeks is the usual maximum waiting time).
- Charge no more than 50p per disk side.

Incidentally, if anybody out there is thinking of opening a library now, I think I speak on behalf of the entire CPC world when I say that that you really shouldn't bother.

And so, suprisingly as it may seem, these libraries are a potential death-trap... [cue a manic grin.] Hur, hur, hur...

PD Charts

...sponsored by **ARTIFICIAL INTELLIGENCE**, for all your PD needs (am I allowed to say that, Rod?). (SORRY, WHAT? I WASN'T LISTENING - ED.) These charts are guaranteed to have no rave music trash in them! (WATCH IT TIM - ADAM.) This month, we feature **DOMAIN PD**. Hurrah!

- 1 SER1: The JL Copying Suite.
- 2 CLP2: Er... Lots of clip art.
- 3 DEM8: Adults Only 2.
- 4 APP8: I-Spell by Paul Dwerryhouse.
- 5 VAR6: Polish Stuff.
- 6 CLP7: More funky clip art.
- 7 SER2: Printer Utilities.
- 8 VAR8: Digitizers, Quiz Master
- 9 GAM7: Games...
- 10 VAR1: STD Codes database.



Public Image

Recession? What recession? That lad TIM BLACKBOND is all right, he knows loads of places you can get excellent CPC software for next to nothing. Fortunately for us, he shares his knowledge on a monthly basis...

UTILITIES

Crime

By Crown • Available from Robot PD and Sheepsoft (Disk 52)

Crime has got to be the greatest disk copier it is possible to get in the public domain. Written by Crown of the Band European News Group (BENG), the actual code for the program is kept as small as possible (8K) for allow for a really big buffer. In fact, a huge 112K is at your disposal for either disc or file copying.

Not only does it have the biggest buffer, but also the fastest copying time. A full disk can be transferred from Drive B to Drive A in about (no more than) thirty seconds. Unfortunately, it does have a minor drawback: It only accepts Data format disks, but other than that if you want to mass produce copies at a startling rate, this is the one for you.

89%

Crunch

By Crown • Available from Robot PD and Sheepsoft (Disk 52)

This Crown really likes to show off his programming talents in a big way! *Crunch*, as if you haven't already guessed, compresses binary files

so they take up less disk space. It works a lot like the crunch option on *Newsweep* (*Newswhat? - ed*) with one minor difference: The compressed files can then be loaded and executed without having to de-compress them! As an example of the power of *Crunch*, the main code file of *Karl's Treasure Hunt* came to an amazing 13K from 27K! A utility like this could revolutionise the PD scene!

86%

GAMES

Karl's Treasure Hunt

By Neil Kolban • Available from GD PD (Games 11)

It has to be said, there is some doubt about this actually being public domain. If anyone can remember that far back, it was released by Software Projects in the early days of the CPC. Whether Software Projects have given this game permission to be PD isn't known. Are Software Projects still around? Do they care?

The idea of the game is simple. You are Karl, a man with a mission. There's treasure to be found and Karl doesn't mess around when riches are involved. You must make your way through forty screens and collect a key from each one.

Loose talk

3 Causeway House, Kelstedge, Ashover, Chesterfield S445 ODW.

...and even more fanzines!

Well, almost. One other fanzine due to make and appearance (using the cult package, *PowerPage*. There, it is better than *Stop Press*) called *CPC Now*. Like *Extreme*, it will be an all-round fanzine covering everything the CPC is remotely linked with. Phew! No competitors for me there!

Ozone friendly, paper free fanzines

With Matt Gullam's move to Neath, he finds the concept of PAYING for photocopying too much handle and so has moved *Presto News* on to disk.

Stop the world!

Robert Masson wrote me a very nice letter informing me of his forthcoming fanzine, named after the rock band, *Extreme*. Apparently, it will cover all major topics that encircle the CPC such as the GX4000, commercial software and Public Domain and loads more. Look out for it. Write to Rob at: 28 Spring Street, Hucknall, Notts, NG15 7BZ

Street-fighting years

Another forthcoming fanzine to have strong music links in the title is *Alive And Kicking* (named after the re-release from Simple Minds). The magazine, edited by a Lee Ouane, caters for those who use their CPC for games only. The first issue is coming out on the 1st of November (and will be produced with the ever-popular *PowerPage*). Write to Lee at:



See that little man down the bottom right of the screen? That's you, that is. OK, so we're not exactly talking state of the art graphics.



The Strangely Blocky Big Eyeball People are out in force on this screen. Lots of well-timed jumps required here, we reckon...

When you have every key you can make your way to the exit, open the treasure and live the rest of your life on a beach with scantily clad girls bowing to your every whim.

The only major problem is, it's incredibly easy to play but very difficult to complete. Karl moves at an alarming speed and there are hundreds, nay millions of baddies, ranging from space invaders to Rubik's Cubes, out to stop you. Some rooms have the key positioned so that a child of three could get it no problem, but others are precariously balanced on the edge of a large drop with four or five nasties flying around it on floor that crumbles away when you step on it.

There are all sorts of platforms and hazards for you to confront: the place is littered with everything from ladders and conveyor belts to dissolving steps and killer things. It's very difficult. Let's face it, if you don't like it, the young 'uns will!

71%

Matt assures me that it will be nothing like the presentation of *CPC Domain*, in fact he has roped several demo coders into writing a smart disk fanzine system with graphics and music. With a new layout comes a new name, *Grace Under Pressure* does seem a little silly, but the editor's decision is final.

Zap T' Balls latest

Yes! *Zap T' Balls*, the really excellent *Pang*-like reviewed here last month, has been unleashed! I thought Mr. Fairhurst was the only one who had it, but I was wrong (as usual). It can be found on the Sheepsoft disk number 123. Be warned, the disk also contains a program by myself which was intended for an AA covertape over a year ago. It's deeply sad.

Rogues gallery

Hands up all those who think that this looks just a little bit like **PRIVATE AND CONFIDENTIAL**. Well, give yourselves extra pocket money to buy a faintly amusing PD fanzine, because it is, only we talk to the exciting cream of the CPC, PD librarians! This month, a friendly, intimate chat with the zany founder of *Dartsma PD*: Adam Shade! What do you mean, "who?"

Full name (including embarrassing middle names)

Adam Lee Shade.

Have you ever had any silly nicknames?

My nickname was, and still is, Shelly. This is because I used to wear a lot of shell-suits. I don't now but the name just stuck. I do have a pseudonym, which is Roodolph.

What are your top five PD programs?

Erm, let me think... [Adam ponders on this for what seems like forever: it wasn't forever of course, but at least he was paying for the telephone call...]. *TREE.CUT*, *CHICKEN.CUT*, *TURKEY.CUT*, *AARDVARK.CUT* and *AI.CUT*. Did you know that *Dartsma* has the biggest selection of clip art on the CPC?

What is your favourite band?

I generally listen to anything, but given the choice it would be Jean Michel Jarre or the remarkably popular *Asda FM*, which you can pick up on Sky Movies, frequency six or something.

What is your favourite film and actor/actress?

I haven't really got a favourite actress, but I like Arnold Schwarzenegger. My favourite film is *The Champ*, which I doubt anybody has ever heard of. It's a very old film.

If a brick is travelling at the speed of light, what to the power of R is its mass density?

Sulphuric Acid.

What's the best and worst bit of running a PD library?

The worst bit is getting orders and the best bit is getting really big plugs like this one now.

If you had a pet aardvark, what would you call it?

Something with ant in it... Anty.

If your house was on fire, what one item

would you take with you?

I'd take my Coke, my money and my bedroom. So to take just one item, I'd throw the Coke and money in my bedroom and take the lot at once.

Who should be Prime Minister and why?

My pet pErple oRrange. No-one can see him and he's still got a bigger IQ than the previous PMs put together. This pet pErple oRrange was invented by a scientist in Greenland. He's like a Telethon bug only bigger and is invisible to everybody but me. Even the strange men with white coats and sleeping-tablet syringes can't see him.

How did you come up with the name 'Dartsma'?

I simply ran the word *Amstrad* through an anagram program I had and *Dartsma* came out more often than others. So now you know. It could quite easily have been *Kullock PD* or even *Queesy PD*. (You must have a very bugged anagram program, Adam - Adam.)

Finally, are there any questions you're glad I haven't asked you?

Yes, I'm glad you didn't ask if a PD library makes money and what colour underpants I'm wearing.

Does a PD library make money?

Not if it's run properly. Money only goes above the break-even point if it isn't run properly. Black with white bits, if you really must know.

And finally...

We want your mail! If you have anything at all to say about any aspect of the public domain scene, don't bottle it up. Write it down and send it to:

**PUBLIC IMAGE, Amstrad Action,
30 Monmouth Street, Bath,
Avon BA1 2BW**

PD library directory

ADVENTURE PD • 10 Overton Road, Abbey Wood, London SE7 8HF

DARTSMA PD • 47 Kidd Place, Charlton, London SE2 9SD

DOMAIN PD • 44 Echilne Grove, South Queensferry, West Lothian EH30 9RU

GD PD • 49 Woodville, Barnstable, North Devon EX31 2AY

PRESTO PD • 36 Whittington Street, Neath, West Glamorgan SA11 1AW

ROBOT PD • 2 Trent Road, Oakham, Rutland LE15 6HF

SHEEPSOFT • 39 Woodlands Road, Barry, South Wales CF6 6EF

WACCI • 12 Trafalgar Terrace, Long Eaton, Nottingham NG10 1GP

Amstrad Notepad

£199.00 ■ Amstrad ■ 0277 228888

PROTEXT fans ahoy! How often have you wished your CPC was portable so that you could write while on the move? Well Amstrad's new NC100 Notepad isn't a CPC, but it's the next best thing. ROD LAWTON finds himself on some familiar ground...



The whole philosophy behind the NC100 is simplicity. Right from the foreword to the manual (written by Alan Sugar himself) to the easy-peasy main menus you go through when you switch the machine on.

Once you're using a program, most of the commands are accessed via keyboard shortcuts... but what's this? A menu key to the right of the spacebar will call up a list of possible commands at any one time.

The LCD display is blue-on-green and, although it doesn't have a backlight feature (that would do horrible things to battery life), it's clear enough and easy to read. What is good is that the word processor displays bold text, for example as bold and italics as italics! It's not a truly WYSIWYG ('What You See Is What You Get') display, but it goes a long way towards it.

For such a reasonably-priced (read 'cheap') machine, the NC100's keyboard really is excellent. It's far better than than on the Cambridge Z88 (it's main rival), heaps better than the CPC464's, loads better than the 6128's and miles better than the Plus's. In other words, it's just about the best keyboard we've used.

Batteries are expensive things, and nobody who's ever forked out for a pack of Duracells will

relish the prospect of doing it regularly. Fortunately, the NC100 can squeeze an amazing 60 hours of use out of one set! Even if you use standard zinc/carbon batteries, you should expect to get about 20 hours. There is also a RAM back-up battery which is good for two years, even when the main batteries are exhausted. That should give you long enough to get a new set, we think...

Word processor

Loading up the word processor from the main screen is dead easy. Just follow the on-screen instructions, pressing the yellow and red keys together, and you're given a new document to start typing into. (The screen obligingly tells you to 'start typing here' - are potential owners really that simple?)

From here on in, things look very familiar. Isn't that a very *Protex*-like text ruler we see at the top of the page? It certainly is. A little detective work reveals that much of the software for the machine was written by Arnor. In fact the word processing software really is *Protex*, albeit without the command-line. (It's like being in editing mode all the time.) Many of *Protex*'s special commands can be carried out from the Edit

mode anyway, and on the NC100 keyboard commands take care of any function you need to carry out.

What about saving and loading files when you haven't got a disk drive? Well, first of all, you don't have to save files at all. The machine's RAM is also its storage system - all you're doing when you Save a document on the CPC is transferring it from the RAM to a disk. On the NC100 it just stays in the RAM. So when you decide you've done enough typing, just switch off! When you switch the machine on again you get the Main Screen. Select the word processor and you will get the option to start a new document, list the existing ones or print a document. Your document will be on the list - guaranteed!

In many ways (this is the main one) the NC100 is a darned sight simpler to operate than a conventional computer - the documentation and the machine's design are already pitched heavily towards the computing novice.

Protex (the CP/M version) comes with a spellchecker - and so does the NC100. It's

What's in the box?



● The machine

The NC100 Notepad is a rather attractive, slim little beast. It's lighter than the tiniest PC-compatible notepad - but then so it should be, with no disk drives built in. True, it all looks a bit gaudy, what with the colour-coded keys and list of commands printed under the display, but the machine itself feels well-made.

● Soft case

The NC100 kit gives you everything you need, including a soft case. The Cambridge Z88 (the NC100's nearest rival) was generally supplied without a soft case - an essential item unless you want your computer to look like it has been through a sand-blasted within a month.

● Batteries

The NC100 is supplied with four batteries - another nice touch. If only more manufacturers sold their products ready to use straight away...

● Mains adaptor

Battery life is pretty generous on the NC100 (unlike the infamous power consumption of the Z88), but you get a mains adaptor anyway. Very useful if you spend long periods at your desk.

● Manual

A well-produced paperback that guides you carefully through the machine's functions. It's simplistic for someone who owns a computer already, but ideal for beginners.

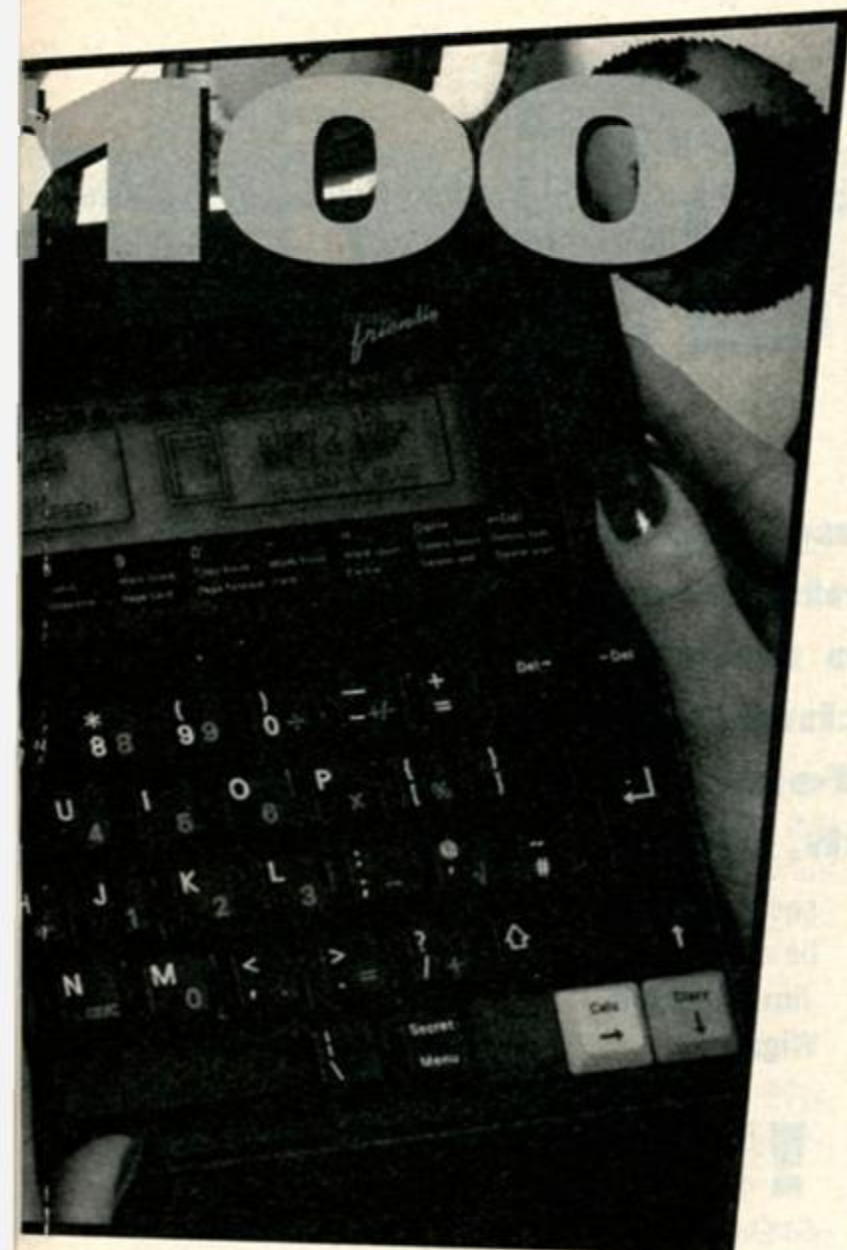

stored in the machine's in-built ROM and uses a massive 48,000-word spellchecker. The usual options apply: Lookup, Store, Ignore and Edit. As well as checking your spelling at the end of a typing session you can also look up words as you go along.

The best thing about this word processing software, though (perhaps we'd better not keep calling it *Protext*), is that you can also write 'macros' (automated sets of keypresses that stop you having to type them over and over again). And you can also insert a wide variety of 'stored commands' (listed in an appendix at the back of the manual) to control margins, layouts and printing – just like, er, *Protext*, in fact.

Calculator

Why oh why did Cambridge Computer bother putting a calculator on the Z88? Who on earth is going to use a dirty great A4-sized machine to do sums on when they can use something the size of the credit card? The same criticism can be levelled at the NC100

A Calculator function is, of course, an extra selling point, but apart from making the adverts look good it is, arguably, a waste of time.

Admittedly, in Calculator mode the NC100 displays huge numbers you could see a mile off – much better than the tiddly characters normally used. But ordinary calculators are still much easier to use – and this despite the fact that the NC100 has a special cluster of 'number' keys picked out in green for quicker calculating. The system doesn't work at all well, and it makes the keyboard much more cluttered and confusing.

Diary/clock/address book

The NC100 stores the correct time even while the machine is switched off. But you'll have to set it initially when you take the machine out of the box. From then on, the NC100 works like one of

those wonderful little electronic organisers that you can slip in your jacket pocket.

Mind you, if you can slip the NC100 into your jacket pocket you should change your tailor.

The Diary/Clock/Address Book software is accessed from the main screen by pressing the yellow and blue keys. You now get the choice of using the Address Book, the Calendar/Diary or the 'Time Manager'.

The Address Book is really a card index-style database. It's pretty simple, but useful enough for storing names, addresses and telephone numbers.

The Calendar/Diary option displays a whole month at a time, with dates on which you've made appointments marked with an asterisk. To make a note for any particular day, just move the cursor to that date on the Calendar screen, then press Return.

The Time Manager is a little more complicated. Choose this option and you get three more: Alarm, Edit Alarms, Set/Edit time zones. The NC100 has a decent enough little alarm and setting/cancelling it is pretty easy. The International Time Zones business looks very flashy, but few of us are jetsetting travellers, and fewer still would pack an NC100 on the trip. For most purposes this is just a bit of gloss (like the calculator – only more so).

Interfaces

Because the NC100 has no built-in disk drive, you're going to have to transfer documents by cable. To transfer stuff to your CPC (assuming you've already got an RS232 interface for the thing) you need to use the serial interface on the back of the Notepad. Unfortunately, it's one of the tiddly 9-pin plugs, but getting or making up a lead shouldn't be a problem. Once you've done that, transferring stuff is a doddle, thanks to the NC100's built-in comms software.

Most printers these days are worked via parallel interfaces, and the NC100 features a standard parallel port on the back for trouble-free connection. The machine won't just print to Epson-compatibles, though – it can also be set up to drive IBM 24-pins, Canon BJ10es (the rapidly emerging standard for bubble-jet printers) and Laserjets.

There's more...

Although the NC100 comes equipped with only 64K of RAM (which is quite adequate, actually), this can be expanded with memory cards. A slot in the left-hand side of the machine accepts industry-standard SRAM cards (JEIDA/PCMCIA cards) of up to 1Mb capacity!

These not only allow the storage of much more data than the RAM alone could accommodate, they also provide the potential for non cable-based links with other machines which can use these cards.

More immediately interesting, though, is a new 3.5-inch disk drive from Ranger Computers (the RangerDisk NC100 drive) which lets you swap files with PC-compatibles. Unfortunately, the RangerDisk costs £299, which is 50% more than the NC100! (Ranger Computers are on 0604 589200.)

The perfect CPC add-on?

Bizarre though it may sound, people have tried to produce 'portable' versions of the CPC! These range from standard machines bunged into specially-designed backpacks to CPC innards being stuffed into converted shoe-boxes... basically, it can't be done.

The Amstrad NC100 is about the closest thing you can get to a portable Amstrad – particularly for writers. We haven't yet fully investigated the compatibility between documents produced on the NC100 and Protext on the CPC, but we wouldn't be surprised to find that margins and text formats were carried across perfectly... and if not, a simple macro at either the NC100 or CPC end should put things right.

Similarly, we haven't investigated the compatibility between BBC BASIC and the version installed on the CPC. We're sure lots of people have, though...

The best news of all about the NC100 is the price. At £199.00 it represents terrific value. For games players it is, obviously, a dead loss. But for serious users forced all too often to part company with their CPCs for long periods of time, it's an excellent purchase.

The competition

The Cambridge Z88 is about the most serious competitor for the NC100. Its rubber membrane dead-flesh-feel keyboard, although effective enough, is nothing like as good as the NC100's, and the battery life is substantially worse. The Z88 doesn't have a back-up battery, either, which makes changing the main batteries a bit fraught (you've got about 45 seconds)! Finally, the Z88's built-in *Pipedream* software makes a much weaker word processor than that in the NC100.

On the other hand... the Z88 is slimmer still than the Amstrad, it also has spreadsheet and database facilities, and the display is marginally clearer (although the characters are smaller).

Basically, the NC100 wins by a country mile. With *Protext* built in plus BBC BASIC installed, it really is the closest thing yet to a portable CPC.

VERDICT

GOOD NEWS

- Excellent value
- PROTEXT installed as standard
- 48,000-word spellchecker on ROM
- Has both serial and parallel ports

BAD NEWS

- If only Amstrad/Locomotive BASIC had been built-in!
- The other built-in software is OK, but a bit of a waste of space

An excellent performer and superb value for a portable computer

RATING 92%

Technica

Sounds like trouble

? I seem to have partially broken my CPC 6128. I think I did it by holding down the reset button on my Multiface whilst I switched off the computer. I didn't see how this could damage it, but it has: 10 keys are now dead. I tried doing the same thing again and I got an electric shock off the back of the Multiface, so I'm sure that it was me that did the damage. I have a vague recollection of someone once writing in with a similar query and an even fainter recollection of the answer being that the sound chip was damaged. I hope you can give me an idea of what I've done to my faithful computer and how much it will cost to get it repaired.

David Gittins
Sharpenhoe

! Yep, that's the sound chip all right: it sounds like a whole row in the keyboard matrix has gone. However, your Multiface really shouldn't be doing things like that: if it's under guarantee, send it back, and if not, send it along with the 6128 to be repaired. As far as cost goes, I'd estimate that you'd be charged £15 for an hour's labour, plus five to ten quid for the parts that need replacing and a bit on top for postage.

Computers can be trying things, can't they? Thankfully, AA's technical expert RICHARD FAIRHURST is on hand to sort your little troubles out. Write to: Technical Forum, Amstrad Action, Beauford Court, 30 Monmouth Street, Bath, Avon BA1 2BW

'Phone a friendly repair company (R&C, 081 552 8900, have just successfully repaired my own 664) who know about Amstrad CPCs and ask them for a quote.

Stuff and nonsense

? With reference to your column in issue 85 regarding the mapping in of the 64k RAM pack. Well, for eighteen months now I have tried to do this, and it's a myth, lies, stuff and nonsense, it don't mean bo-diddley, in fact it can't be done. I have tried your way, the handbook's way, a few of my own ways, and I have even made numerous 'phone calls to Mr. Tronics and he assures me that after mapping in the RAM everything I do is stored in the RAM. I do not believe him at all!

When I use the RSXs with the RAM pack it is excellent, but try to use it from BASIC and you

see nothing at all. I am convinced that it cannot be done.

Jim Mousdell
Wigan

! I think you're getting confused as to what the method printed in AA85 actually did. BASIC can't take advantage of the 'direct mapping' method (i.e. OUT &7F00,&Cx), except by use of the PEEK and POKE command. What the OUT does is select an area of memory (&C0 for standard memory, or &C4 to &C7 for one of the four extra banks of 16k) to be addressed between &4000 and &7FFF by the POKE and PEEK keywords in BASIC.

Just to show that it works, here's an example of putting 4 into bank &C4, address &4000, and 237 into &C7 at the same place:

OUT &7F00,&C4: POKE &4000,4
OUT &7F00,&C7: POKE &4000,237

Beginners' Questions

Are you baffled by the basics, boggled by binary? ALEX VAN DAMM is here to help with all your beginners queries...

Aaaaargh!

Michael Walsh from Rochdale has had a slight accident.

? "I recently transferred a utility called 'Fast Formatter v1.7' to disk. I ran it and on the menu it said 'Format type: 1 CP/M (system), 2 CP/M (vendor), 3 Data, 4 IBM, 5 BigK (206k)'. I was confused and just pressed number 3, then something happened..."

I got worried and so switched the computer off. I then typed in CAT and all my disk games had been erased, and all it said was 178k free. Please tell me what happened and how I can get my disk games back."

! I don't know quite how to tell you this, Mike, but your games are gone forever...! What a formatter does is to set up the disk so that it can be used by the computer, and in doing so wipes absolutely everything off the disk - this is known as 'formatting'.

Unlike simply ERAsing files, once you've formatted a disk, you can't get the old data back - it's gone forever. Sorry!

Although you've learnt the hard way this time, I can help you to avoid this in the future. If you're about to do something you're not sure about, 'write-protect' your disk so that the contents can't be changed - there is a little plastic lever in the top left-hand corner of each disk to do this. Move it until it fills the hole, and your disk is safe! from accidental erasure!

Printer please

Mrs. L. Harris of sunny Eastbourne is at her wits end.

? "Please could you help me! I own a 6128 and, until a few months ago, an Amstrad DMP 3000 printer. Sadly the printer is now 'dead', and I am desperately trying to find another printer which will run alongside my existing computer (using 'Tas-sign', 'Tasword' and 'Tasprint'). The few computer shops there are in Eastbourne cannot help. I am lost without my printer, but at the same time, I'm a simpleton where computers and printers are concerned!"

! One of the nice things about the CPC is that Amstrad decided to fit a standard printer interface (known as 'parallel' or 'Centronics'). So any printer which says it has this interface will work with your 6128. However, not all of them will work with the programs you use. Make sure the printer you pick is 'fully Epson-compatible', which means it understands the instructions used by Tasword, etc. These days, you can get a good printer for under £200. Don't buy an Amstrad DMP 2000 or 3000 - I had one once, and sold it after a few months - the high-quality mode is scruffy! Star, Citizen, Panasonic and others make a good range of low-price printers.

Forum

If we map each bank back in again, and put the result in a variable each time, we can print the values and see that they're different:

```
OUT &7F00,&C4: first=PEEK(&4000)
OUT &7F00,&C7: second=PEEK(&4000)
```

Now type PRINT first,second and you will see that the two values are different, and that it can be done! One word of warning: remember to set HIMEM below the address you'll be PEEKing and POKEing, by MEMORY &4000-1, first.

Techie trio

? 1. How do I emulate the GRAPHICS PEN, CLEAR INPUT and FRAME commands on my 464?

2. How can I make a screen show up instantly?

3. How can you imply that *Tubular Bells II* isn't interesting (on the back page of the latest AA) when Adam Peters' rave track on the covertape is boring, repetitive trash?

Bob James
Surbiton

! 1. For GRAPHICS PEN, try PLOTR -800,-800,colour: MOVER 800,800. For CLEAR INPUT, CALL &BB00 will do (although be careful - this can turn ESCape off!). FRAME is a simple CALL &BD19.

2. Before you start drawing the screen, try OUT &BC00,1: OUT &BD00,0 (which tells the computer that the screen is 0 columns wide). When it's finished, OUT &BC00,1: OUT &BD00,40 will display it instantly.

3. Don't blame me, I think TB2 is an incredible piece of music - blame Adam!

Disgusted of Hampshire

? In AA84, you comment that a lot of people have experienced difficulties in loading the disc versions of your covertapes. I have received disc copies of the August and September '92 issues, and on side A both times I have tried RUN"DISC, RUN"MENU and RUN"MEN - 'not found' is always printed. CAT displays 'DISC.BIN 1k' followed by '168k free'.

This is most frustrating as it was the games on side A that I particularly wanted. The tape version of the *Famous Five* is words only, and *Defenders of the Earth* takes half an hour to load from tape! Surely you could insist that disks from Ablex should be 'as advertised'.

Disgustedly yours,
Phyllis King
Waterlooville

! First of all, I should say that in any large duplication run there are bound to be a few

faulty disks. However, from what you say your discs sound perfectly OK.

If CAT says 'DISC.BIN' is present, then it is present. If you then attempt to run the program and it says that it's not present, then you've done something wrong. It sounds very much like you're not using the same spelling of 'DISC' as the computer - sometimes it's spelt DISC, sometimes DISK. Follow the spelling in the catalogue.

By the way, any more "Mr (or Mrs) Angry" letters, as well as condescending ones - and this particularly goes for the user areas problem on covertapes, which was dealt with last time - will be thrown in the Techie Forum bin immediately from now on!

Six of the best

? 1. I am, after the AA85 covertape, considering buying an EPROM programmer. Do I have any hope of blowing 'Worktop' onto ROM? Or, for that matter, anything else such as 'Notepad' or 'Disk Nurse'? If so, how? And is it wise to have it done professionally by Avatar's ROM programming service?

2. How do you load protected BASIC programs on a 6128?

3. How do you copy a file from tape to disk under CP/M and PIP?

4. I have an AZERTY keyboard (poor you - Richard). Type-Righter prints an 'a' with an acute accent instead of a squiggly bracket. How do I change this?

5. Do you know if the MP-3 modulators advertised in AA will work in Eire? It's still PAL, but should be UHF instead of VHF, I think.

6. Which PD library is 'Flik' available from?

Mark McCormick
Galway, Ireland

! 1. 'Notepad' and 'Disk Nurse' should be possible: you may get a program that converts BASIC programs into a ROM downloadable format with your EPROM programmer, in which case you won't need to fork out for the 'professional' service. 'Worktop' won't work from ROM, unfortunately (although I could be persuaded to write a new version); a better alternative is SD Microsystems' (0462 675106) 'Front-Runner' desktop, specifically designed for ROM.

2. Use a special de-protection program, or a copier with the option to remove protection.

3. You don't. Instead, watch out for a cunning little program coming to next month's covertape!

4. The different character doesn't make any difference to the actual code. Grin and bear it!

5. The UK is UHF, too, so it should be OK.

6. Well, I do know that Robot PD have a copy...! Alternatively, watch out for a future AA covertape (any more requests? Send 'em in!).

TOP TIPS

The saga continues

I have found an alternative phototransistor for the light pen project, available from RS Components. The stock number is 585-220 and the price is 58p, considerably cheaper than the Maplin one.

Chris Gilmour
Manchester

A long speech

I am writing to suggest a way in which you can extend the length of samples produced with the RSX Speech type-in. It works by sampling sound into a 16k area of RAM, then paging in a 'fresh' area from the banked RAM available on 128k CPCs. In this way the sample length can be increased to about 80k. Note that there is no noticeable click as banked RAM is paged in and out of main memory.

To sample:

```
10 MEMORY 16383
20 ISPEED,5
30 ION
40 OUT &7F00,&C0
50 IRECORD,16384,16384
60 FOR a=&C4 TO &C7
70 OUT &7F00,a: IRECORD,16384,16384
80 NEXT: IOFF
```

To playback, simply replace IRECORD by ISPEECH. Note that the speech machine code must be loaded and set up before the program is run.

Mark Stewart
Belper

AA: Thanks Mark! To save, use the following prog:

```
10 OUT &7F00,&C0: SAVE
   "speech.1",b,&4000,&4000
20 FOR n=&C4 TO &C7: OUT &7F00,n
30 SAVE "speech."+
   STR$(n-&C2),b,&4000,&4000: NEXT
40 OUT &7F00,&C0
```

To load, use the same program, but replace SAVE by LOAD, and remove the 'b,&4000,&4000' in both cases.

Hidden Message 2

I have another hidden message for you. To view this, you must first run CP/M, insert your Mini Office disk and then enter TYPE KNIFE.BIN - rather sad, really.

Rajni Mistry
Harwich

AA: I've seen this one about eighty times before, but it's worth repeating. Thanks Raj.

MIND YOUR LANGUAGE

Logo is a very strange little programming language that you probably didn't even know you had! It's supplied with the CPC6128, lurking quietly on one of the CPM utility disks. Generally despised, Logo is actually not a bad little language...

No 3 LOGO

"Goo goo", "me want teddy bear", and "Forward 100 Right 90". These are all perfectly common children's expressions: the third one is in Logo.

Used almost exclusively in the early stages of education, Logo is a language most well-known for its 'turtle graphics' facilities, where either an imaginary turtle on the screen (usually represented by an arrow-head), or a plastic buggy on the floor, is moved about using simple commands leaving a trail of ink or phosphor. You can tell it to go forward or back, to rotate left or right, to repeat a process as many times as you like (great for Spirograph style drawings), and even to put its pen up or down. An example Logo program, to draw a square, would be:

```
REPEAT 4 [ FORWARD 100 RIGHT 90 ]
```

This tells the language to go forward 100 steps, right 90 degrees – and then repeat this three more times. Changing the repeat counter and the angle (to 5 and 144, for example) can produce more interesting shapes, in this case a star. Long programs can be written using the language's built in text editor.

Such features have tended to obscure its other main prowess, a feature present since its invention by Seymour Papert in the 1970s – list processing. You can create lists of 'items' (such as 'cat', 'dog', 'hippopotamus' and 'Adam Peters'), pick random items from them, and manipulate them in any which way you choose. A combination of the two aspects of Logo's 'split personality' can actually produce some quite powerful programs – an arcade-type game was even printed for the CPC running Logo a few years ago.

In fact, every disk-based CPC you buy comes with a copy of Logo – which, although running under CP/M, uses graphics and sound facilities. Implementations are present for both versions of CP/M (many programmers have been known to roast Amstrad for squandering 8K of disk ROM space on a chunk of code for a kiddies' language), with the Plus version being more powerful.

To be honest, Logo isn't much use. As a beginners' language it's severely restricted, and doesn't offer a logical route into 'proper programming'.

As a language to waste countless school computing lessons on, though, it's proved very useful to teachers in the past...

PowerPage tutorial

PART 3

By now you should have a good grasp of POWERPAGE's text and graphics facilities. In this instalment we aim for mastery...

You've probably noticed that, in AA, a subtle (or, more usually, sarcastic) aside in an article or letter is written in brackets. To make it clear that the aside is from a different writer, it's in a different style – italics. *PowerPage* is capable of italic text, too: if you're simply typing directly onto the page, then you can use the Style menu (on the right of the menu bar). Press I, and a tick will appear next to 'Italic' – RETURN to exit. Follow the same process to turn it off again.

Using the same method, but pressing a different letter, you can also select bold, underlined or thin text. Don't use too many at once, though – and be consistent. Using bold text for emphasis in one place, and underlining in another, just looks messy. By the way, you can do this in 'Text layout' (although not 'External headline') mode, too: insert CTRL-X (an hourglass symbol will appear) followed by B, T, I or U at the place where you want to toggle a style on or off. (Don't forget that you might have a style already selected when you enter this mode!)

Go with the flow

Another professional feature available on *PowerPage* is 'autoflow'. This makes the text you enter flow automatically around any headlines, graphics or such like in the way. It's particularly effective in Text layout mode, although it doesn't operate in either headline mode. To select it, venture into the Options menu, and along the bottom line of the screen, you should see 'Autoflow off' displayed. Pressing A will replace the 'off' with a number, increased by one every time you press A, until it reaches 16 – at which point it starts again. This number determines the number of pixels to be left between graphics encountered and your text – a setting around 8 gives the best effect.

Making a space

In fact, the Options menu is full of undiscovered goodies. One of these is 'Forward spacing' – as with most options on *PowerPage 64*, selected with its initial letter. As the standard width of an Amstrad character is 8 pixels, the default value for this (which determines how far to move on after each character) is 8. However, if you're using a thinner font, then you may want to reduce this (in which case, keep on pressing F until the

value you want appears). The best option, which covers any font at all, is proportional spacing ('PR' will be displayed). This moves on only by the width of each character entered – the classic example is how an 'i' will take up less space than an 'm'. The standard Amstrad font, though, has space to the left of the character as well as to the right, so this still leaves ugly spaces in the text. Instead, load (using the Import menu) a proportional version of the font, stored on the disk as 'AMSPROP.CHR'.

Another spacing option on this menu is 'Down'. This, surprisingly enough, controls the number of pixels that the program moves down after each new line – and, as above, the default is a setting of 8. If you're using a shorter font, you may want to use a setting of 6 and 7. For a really professional look (as used in world-famous fanzine *Artificial Intelligence*), try setting it to the height of the characters plus one – giving 9 for a standard size font. This leaves a line of space in between each line of text, ensuring that the 'descenders' on characters such as 'g' and 'p' don't touch with the tops of letters, and generally giving the page a much less crowded look.

Back to front

Two useful features remain on the Options menu: the facility to select Normal or Inverse (press N or I), so that you can draw white lines over black backgrounds etc, and the graphics set. This refers to the extra characters available by pressing CTRL-A to CTRL-P (try it!). To select which characters these are (they're drawn from ASCII codes 128 to 255), change the value from 128 to something different – it moves up in steps of 16.

One loose end remains to tie up: the File menu. As well as Save and Load page options, lets you catalogue the disk (due to memory restrictions, it appears line-by-line at the bottom of the display, advanced by any key) in either drive. It also allows you to save out the current screen as a 17k picture file (press P). 'Quick save' stores the page on disk as an uncompressed pair of files, but this really isn't very useful except for maintaining compatibility with early versions of *PowerPage* – and as everyone has the latest version (from the AA covertape) now, there's no problem there anyway!

So that's *PowerPage*. I haven't attempted to describe the utilities on the disk – that would require a 3-part series of its own. (Oh yeah? – ed) Using the techniques outlined in this series,

though, in time you should be able to create really professional-looking pages: you may even want to upgrade to the more flexible *PowerPage 128*, available from... (snip – ed!)

MJC COMPUTER SUPPLIES

Suppliers of Discount Software since 1984

HOW TO ORDER:

All prices include VAT & delivery
Please allow 5 days for cheque clearance.
Send cheques or postal orders made payable to:
MJC SUPPLIES (AA)
Unit 2, The Arches, Icknield Way, Letchworth,
Herts, SG6 1UJ

Or telephone with Access or Visa debit
and credit cards on:

0462 - 481166

Overseas Customers: write for quotation
Educational Bodies, Local Authorities, Govt.
Departments: send written order
FAX US ON 0462 670301

NEW - MICRODESIGN PLUS

This superb Desktop Publishing program is now available from MJC Supplies. MD+ offers superb page layout features along with probably the best printouts you will see on a CPC. MD+ can import Stop Press pages & cut-outs along with the cut-outs on Extra Extra. MD+ files are also compatible with MD2 on the PCW and PC. The program is also compatible with the AMX mouse. Contains too many features to list here!

REQUIRES 128K AND A DISK DRIVE
MJC PRICE ONLY £28.95

MICRODESIGN PLUS & AMX MOUSE

Buy the Microdesign+ program together with the AMX Mouse

MJC PRICE ONLY £59.95

GOLDMARK PAGE PRINTER

Contains printer drivers to enable you to print out your Microdesign Plus pages on your 24 pin or Bubble Jet printer

MJC PRICE ONLY £9.95

AMX MICE & INTERFACE

We now have CPC mice and Interfaces back in stock.

CPC MOUSE & INTERFACE £34.95
(Plus owners please call before ordering)

PRINTER RIBBONS

Printer	Quantity		
	1	2	5
DMP 2000/3000	3.00	5.50	12.00
Panasonic KXP1081/1180	3.95	7.00	15.00
Citizen 120-D	3.95	7.00	15.00
Star LC-10 Mono	3.95	7.00	15.00
Star LC24-10 Mono	4.95	9.00	20.00
Panasonic KXP-1124	3.95	7.00	15.00
Star LC-10 Colour	5.95	11.00	-
Star LC200 Mono	5.50	10.00	-
Star LC200 Colour	10.95	19.95	-
Star LC24-200 Mono	4.95	9.00	-

CASSETTE SOFTWARE

Fun School 3 for 2-5 years	8.95
Fun School 3 for 5-7 years	8.95
Fun School 3 7-11 years	8.95
Fun School 4 for 2-5 years	9.95
Fun School 4 for 5-7 years	9.95
Fun School 4 for 7-11 years	9.95
Mini Office 2	9.95
Protex 464	15.95
Advanced Art Studio (128k)	15.95

CF2 DISKS

5 for	£8.95
10 for	£15.95
20 for	£29.95

SERIOUS DISKS

PROTOTYPE

Arnor's excellent print enhancer - a must for all Protex users (not CPM)
MJC PRICE £21.95

Protex	19.95
Prospell	17.95
Promerge	17.95
Matrix Spreadsheet Plus	29.95
Masterfile 3	29.95
Mastercalc 128	25.95
Stardump	14.95
Stockmarket	29.95
Extra Extra (Fonts & Clip Art)	14.95
Money Manager	21.95
Nirvana	14.95
Maxam Assembler	19.95
Mini Office 2	14.95
Advanced Art Studio (128K)	17.95
Advanced Art Studio & AMX mouse	49.95

COLOURDUMP 3

After a lot of feedback on ColourDump 2, we are now pleased to announce the latest version of the best colour screen printing program for the CPC range. Requires Star LC-200 or compatible 9 pin colour printer.

Improved use with Advanced Art Studio. Will automatically read in palette file and set screen mode to ensure your page is the same as your screen. Uses compressed or uncompressed files.

Bigger printouts. In addition to the original 13 cm x 9 cm image, a large print out at 22cm x 15cm is available at single or double density.

Use Multiface screens. A conversion routine is supplied to allow most Multiface screens to be used.

NO OTHER COLOUR SCREEN DUMP OFFERS SO MANY FEATURES.
COLOURDUMP 3 £15.95 DISK ONLY

GAMES DISKS

COMPILATIONS

Capcom Collection	17.95
Gary Lineker Collection	10.95
Max Pack	17.95
Soccer Stars	13.95
Super Sega Collection	17.95
Super Sim Pack	17.95
G-Loc	12.95
Hero Quest Double Pack	12.95
Hudson Hawk	11.95
Lancelot	14.95
Lemmings	15.95
Manchester United Europe	10.95
North & South	12.95
Outrun Europa	11.95
Pit Fighter	11.95
Rodland	11.95
Sim City	12.95
The Simpsons	11.95
Smash TV	11.95
Snowstrike	10.95
Space Crusade	11.95
Space Gun	11.95
Space Control	11.95
Terminator 2	11.95
Titus The Fox	11.95
Tusker	10.95
WWF Wrestlemania	11.95

EDUCATIONAL DISKS

LCL SOFTWARE

Primary Maths (3-12 years)	19.95
Micro Maths (11-GCSE)	19.95
Micro English (8-GCSE)	19.95
Mega Maths (A-Level)	19.95

KOSMOS SOFTWARE

French Mistress (12 to adult)	15.95
German Master (12 to adult)	15.95
Italian Tutor (12 to adult)	15.95
Spanish Tutor (12 to adult)	15.95
Answerback Junior Quiz (6-11 years)	10.95
Factfile Arithmetic (6-11 years)	7.95
Factfile Spelling (6-11 years)	7.95

(Factfiles require Answerback Junior Quiz)

THE FUN SCHOOL RANGE

Fun School 2 8 programs per disk

For 2 to 6 years	3.95
For 6 to 8 years	3.95
For 8 to 12 years	3.95

Fun School 3 6 programs per disk

For 2 to 5 years	11.95
For 5 to 7 years	11.95
For 7 to 11 years	11.95

Fun School 4 6 programs per disk

For 2 to 5 years	11.95
For 5 to 7 years	11.95
For 7 to 11 years	11.95

ACCESSORIES

DKT 64K Memory Expansion	39.95
8 bit printer port (inc. lead)	24.95
CPC to parallel printer lead	9.95
CPC Plus to parallel printer lead	6.95
464 keyboard-monitor ext leads	7.95
6128 keyboard-monitor ext leads	8.95
6128+ keyboard to monitor ext leads	7.95
FD1 Disk Drive lead (664/6128)	7.95
464/6128 dust covers	7.95
464/6128 Plus dust covers	8.95
Quickjoy Python Joystick	9.95
Competition Pro 5000 Joystick	13.95
Topstar Joystick	19.95

CPM BASED

Protex CPM	39.95
At Last Plus	24.95
Supercalc 2	39.95
Hisoft Pascal 80	36.95
Hisoft C Compiler	36.95
lankey Crash Course Typing	18.95
lankey Two Fingers Typing	18.95

PRINTERS

All prices include a cable, ribbon, VAT, postage & packing. A courier delivery service is available, just add £5.00.

Using a colour printer with the Amstrad CPC requires additional software.

FEEL FREE TO CALL FOR ADVICE

9 PIN PRINTERS

STAR LC-20

Star's new replacement for the popular LC-10 is sure to be a winner

MJC Price £159.95

PANASONIC KXP-1170

Replacement for the very popular KXP-1180. Still

NEW - STAR LC-100 COLOUR

The new budget 9 pin printer from Star. 8 NLQ fonts, 180 cps in draft mode and 45 cps in NLQ. Paper parking with push feed tractor. Excellent value for money.

MJC Price £189.95

PANASONIC KXP-2180

A new 9 pin colour printer from Panasonic. Offers 7 colours and 6 different fonts. Very good quality output

MJC Price £214.95

STAR LC-200

The latest colour printer from Star. Not only very fast but offers new paper handling features. Best value for money.

MJC Price £219.95

24 PIN PRINTERS

When printing graphics from 24 pin printers results will be distorted without using some extra software. Please call for advice before ordering.

STAR LC24-20

Excellent value budget 24 pin printer offering 5 letter quality fonts and additional effects such as quad size, outline and shadow.

MJC Price £209.95

PANASONIC KXP-1123

Panasonic's entry level 24-pin printer, offering a better print quality than the Star models, but with 4 LQ fonts and fewer effects

MJC Price £219.95

PANASONIC KXP-1124i

Replacement for the excellent 1124, offering excellent text quality, build quality, paper handling and control panel. Now offers shadow & outline effects, 7 LQ fonts and a new Super LQ font.

MJC Price £279.95



Card holders can order now on: **0462 481166**



Subscribe to Action!

– choose
packages...



Cheetah Bug

One of the best joysticks we've ever used! Short, responsive 'stick, positive Fire buttons and a superbly 'ergonomic' design make it the office favourite... and it can be yours with an AA sub!

Complete the coupon and return it today. Alternatively, call our Credit Card Hotline on **0458 74011**

**YOUR
NO-QUIBBLE,
NO-RISK
GUARANTEE**

You can cancel your subscription at any time in the future and we will refund you in full for all unmailed issues.

You just can't lose out!

– the magazine that brings you
ALL THIS!

● A superb covertape

Packed with software including complete games, demos of new releases, serious utilities, readers programs and game cheats

● Top game reviews

We don't just give you an opinion, we give you **FACTS** – plus maps, annotated diagrams, tips and more info than you'll get anywhere else

● Budget games latest

Many top games are now being re-released at budget prices. We make sure you don't miss any of them!

● Game cheats

Stuck in a game? Every month we print pages of tips, hints, help, cheats, passwords, maps and solutions sent in by our readers

● The latest news

New products, game previews, industry interviews, reader opinions and show news

● Technical help

Pages and pages of help, tips and info for those who want to do more than just play games... **PLUS** full reviews of all the latest serious products

● Top features

On music, desktop publishing, games, art and more – all the background you need to getting the very best from your CPC

● BASIC programming

Learn how to use your machine's built-in programming system to write your own programs **AND** see what our readers can do in our four-page Type-Ins section

...and there's much, much more!

IF YOU'VE GOT A CPC OR A PLUS, GET AMSTRAD ACTION!

DIZZY: THIS IS YOUR LIFE

Dizzy doesn't know it yet. He thinks we're just here to talk about his upcoming game, CRYSTAL KINGDOM DIZZY (his twelfth). But what's that big red book ADAM PETERS is holding? Could this be the full, uncensored Dizzy history? Did the life of Britain's favourite egg really begin like this...

"I didn't want them to do it," declares CodeMasters boss David Darling, dramatically. "We'd done a couple of games that were selling nicely, and I wanted them to do a grand prix game. They came up with this funny egg thing and I didn't think much of it."

"There was a bit of conflict at the time," admits Philip Oliver, one half of 'the famous Oliver twins'. "We were writing a lot of simulators back then, but we thought it was a bit boring just doing simulators. We thought it would be good to do something a little more creative."

And so Dizzy was born. Hail Britain's most famous egg adventurer!

"We wanted something with character, which meant having something with a big face," says Philip in response to the 'why an egg?' question. "He needed to move around, so we added legs and arms. Before you knew it, we had an egg-shaped thing." He waves around some photos of Dizzy wandering round the 1992 Computer Entertainment Show in Chicago.

"We thought that costume was going to be really good," David laughs, remembering Chicago Dizzy. "We got the same people to do it that did the Hofmeister bear for the TV ads. It was far too baggy, and just looked ridiculous. Sega's Sonic costume isn't any better, though."

"Most games are just for kids. Dizzy games appeal to the whole family"

PHILIP OLIVER

"Dizzy? You mean Mr Easy-to-draw," sarcasms Paul Ranson, Dizzy's valet since 1990.

"I'm not a very good graphic artist," admits creator Philip.

"Dizzy is an egg," adds creative director Shân Savage, helpfully.

All right, let's start again...

The birth of Dizzy

1987: CodeMasters, only a few months old, is already well established as an 8-bit budget software house. The early success story is mainly down to the efforts of two sets of brothers; the Darling brothers (Richard and David) who set the whole thing up and wrote some of the early games, and the Oliver twins (Andrew and Philip) who soon established themselves as the Codies' most prolific programmers. The Olivers wrote a whole host of games, most of which featured the word 'simulator' in the title.

"With simulators you're just trying to portray a really popular sport so that the player can control it," says Philip. "You're simply translating the sport across onto the computer, rather than doing something original."

The Olivers decided they wanted to do something original. What they came up with was a game of exploration and puzzle-solving, starring a giant egg.

"They showed me this screen with an egg

The Games: Eggs by the dozen – we review and rate Dizzy's



Dizzy

The game that started it all. Dizzy looks quite primitive compared to later games, and it's not all that big. It's still highly playable though, and a bit of a legend. The game also features one of Dizzy's rare recourses to violence; the objective is to kill (yes, kill!) the evil wizard Zaks. Appeared on AA37 covertape.

61x



Treasure Island Dizzy

The second Dizzy title offers no major changes from the original (except that all the screens and objects are different, of course). Dizzy is stranded on a desert island and has to somehow find his way off the island and back home. Probably the best Dizzy plot. An OK game.

62x



Fast Food

Dizzy's first non-adventure game. Originally titled *Happy Eater*, the game was going to be sponsored by the fast food restaurant chain of the same name: that's why this jolly *Pac-Man* clone features burgers, shakes and so on. *Happy Eater* pulled out at the last minute though, and the name was changed to *Fast Food*.

66x

rolling around," declares David Darling, "and I wasn't impressed. But once they started developing the game, it began to look really interesting. We decided to put it out and see how it did."

The game was released in September of that year and sold moderately well. Initial sales were about average for a CodeMasters game, but then things started going a bit strange. The game continued to sell in the same numbers. There was no fall off in sales. CodeMasters were puzzled and interested to see what happened when they released the follow-up.

Philip: "We were going to call it *Dizzy 2*, but we'd just released *Grand Prix 2* and that hadn't done very well, with the original *Grand Prix* having stopped selling altogether. We decided that with *Dizzy* we were going to give each game its own title. Like the James Bond films, each new release would be part of a series but would have its own name and identity. You can play one without having played any of the others.

"We released the second game as *Treasure Island Dizzy*. It sold very well, better than the first game.

More curiously, its release didn't affect the sales of the first game, which continued to sell as well as ever. Very surprising."

Even at that stage, CodeMasters were aware they had a cult phenomenon on their hands.

Egg: on his face

"*Dizzy* has aged five years in the last three months." Shân Savage, CodeMasters creative director (in charge of the inlays and illustrations) points to the artwork for the *Crystal Kingdom* cover. "The illustration for the first *Dizzy* game was terrible – so bad that we had to change the illustration for the second game. We've really

changed the character's appearance with this illustration for the new game. He'll appeal to older teens now, rather than six year olds."

"He looks evil," pipes up Stephanie, AA regular Richard Eddy's glamorous assistant.

"He certainly looks spooky," admits Shân, "especially with the whip."

The whip? Crikey!

The simplistic little ovoid character we know and love now bears the look of an egg who has been to hell and back, if only on a day trip. There's something just slightly unnerving about that look in his eyes, and he's also taken to sporting a tattoo.

DIZZY GETS TOUGH SHOCKER: The Twiggins family of Wiggly Road, Burnley were in a state of shock last night over the change in behaviour of their ten-year-old son Terry's favourite playmate. *Dizzy*, a five year old egg hailing from the Leamington area, used to be "such a sweet old soul" said Mrs Twiggins, "a happy smiling egg. We felt comfortable knowing our son was up their playing with Mr *Dizzy*."

THEN THINGS CHANGED.

In the past few weeks *Dizzy* has become "a whirlwind of evil". He has taken to:

- sporting a tattoo of a tiger's face on his arm
- carrying a large whip
- smiling in a sinister manner
- wearing a safari hat, possibly "to cover a violent punk rock haircut".

"It's been so sudden," Mrs Twiggins told AA, "and I don't know what to make of it. Certainly I won't be so quick to leave Terry and *Dizzy* playing alone now. Who knows what mischief they'll get up to. Swinging from the lampshades and all. There's expensive china in the living

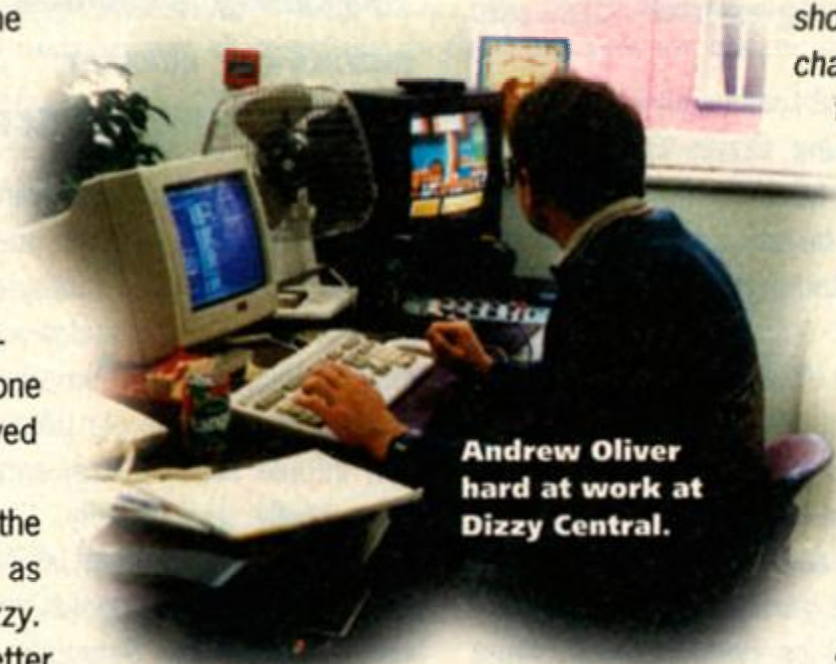

Andrew Oliver hard at work at *Dizzy Central*.

Remember me?

"There are a lot of people you have met on your travels, *Dizzy*. You thought that they were all still in the *Crystal Kingdom*, but they're not. No. They're here tonight..."



Daisy

"Oh *Dizzy* darling, we've been going out for three years now but I still go all gooey every time I see you. Every time I get kidnapped, I just know you'll be rushing to save me. My hero! But you haven't finished washing the dishes yet, have you, you lazy tyke!"



Dylan

"Hey man, chill out, wow what a groovy page. Dig those game screen shots down the bottom there. Yeah! That *Kwik Snax* picture is great, there's so much happening in it. You know, we should all just love each other. Love is all you need. Peace and respect, man."

first twelve outings (seven adventures and five arcade games)



Fantasy World Dizzy

The first of the new generation of *Dizzy* games, and also the last programmed by the Olivers. The first appearance of those lovable old misfits, the *Yolk Folk* (*Daisy*, *Dylan* and co). The idea is to rescue your true love, *Daisy*. Tree huts, castles, dungeons: one of the best.

80%



Kwik Snax

Based on the golden oldie *Pengo*, *Kwik Snax* is a damn fine maze game. You've got to collect collectables and avoid avoidables (enemies). You can push bits of the maze around to squash the bad-dies, and there are four separate lands, each containing five screens. Topper fun in one of *Dizzy*'s best arcade outings.

76%



Magic Land Dizzy

The Olivers passed the *Dizzy* baton on to Big Red Software, who kicked off their reign with this neat game. The evil wizard *Zaks* is back from the grave, *Daisy*'s been kidnapped (again), and there's a lovely big castle there for you to explore. Oh yes, and some tree huts (as usual). Beautiful graphics and lots to do.

78%



David Darling

"You're very important to us, Dizzy. Software houses don't need characters to create an identity the way that console manufacturers do, but if people associate Codies with Dizzy, that's great."



Evil wizard Zaks

"Damn you Dizzy, you odious little egg-shaped thing of indeterminate origin. You foil my dastardly plans, but I'll get you in the end, wait and see. You'll be in a sandwich before you know it."



Denzil

"Safe. Chillin'. Big shouts. Make some noise. 'Nuff respect from the Yolk Folk in the area. Givin' it up. Respect is due. Jumpin' and pumpin'. You're pukka!" (Translation - "Hello Dizzy.")

room, you know"

Asked about his behaviour, Dizzy was nonchalant. "Shân made me do it," he said.

"We're a bit limited in what we can do," says egg corrupter Shân, without a hint of remorse, "because of the oval shape. We had to retain the character's identity: basically, an egg wearing red boxing gloves and red shoes. We've tried to make him more believable though. A real hero.

"Previously Dizzy looked very young. You couldn't really believe that he'd be able to embark on any of those adventures without having to be home by 8 o'clock. He's cuter now, but in a mischievous rather than a childish way."

"He's a lot sexier now," adds Richard Eddy.

"He's more butch," double-adds Paul Ranson.

"You could parallel his development with that of Jason Donovan growing up from *Neighbours* to the present day."

We could Richard, but I rather think we won't.

Asked about the 'new' Dizzy, Terry seemed impressed. "Yeah, he's much more wicked now," he told AA, "but he'd be even better if he had fangs." Fangs? "Yeah. And a gun."

Question time

Are you at all surprised by Dizzy's success?

Philip Oliver: "Yeah, definitely. Very."

David Darling: "We certainly didn't expect the character to do so well at the outset."

Why do you think the games are so popular?

Philip: "They appeal as family games. Most games are just for kids. They go and sit in their bedrooms with the game and everyone else forgets about them. With Dizzy games the whole family can sit round and take part. You may be holding the joystick but the other people are there making suggestions.

"Dizzy games are the ultimate word-of-mouth games. People get talking about them in playgrounds, asking round to see who knows how to get past a certain problem they're stuck on. More people get involved in the discussion and it encourages others to go and buy the game."

David: "He's such a unique-looking character. The way he always tumbles and the fact he's always in really playable games are two reasons for the success. If we'd put him in bad games it wouldn't have worked."

Philip Oliver, you now have thirty seconds on your specialist subject, Dizzy the Adventuring egg. Starting... now. What's the reasoning behind putting Dizzy into non-adventure games (ie *Dizzy Panic*, *Bubble Dizzy*)?

"We'd done *Treasure Island* and it was really successful. We wanted to show that the games were based on the character rather than the style of game. To illustrate that we decided to have a go at putting Dizzy into a different style of game. Hence *Fast Food*."

Have the arcade games been as successful as the adventures?

"Yes. People get more involved in the adventures but the arcade games sell just as well."

"Dizzy looks a lot sexier now"

RICHARD EDDY

All the Dizzy adventures are the same.

"We keep the control method the same to keep things familiar to people. Lots of programmers throw in every technique they can think of, making things really complicated for the person playing. We use simple programming and styles that people are used to, aiming to make everything really user-friendly. Dizzy games are no more 'all the same' than James Bond films."

Or Famous Five books, as Linda Barker said in her *Wild West Seymour* review last month. Which reminds me... so far I've managed to resist the temptation to ask that question, but it needs to be asked. The window is dangerously ajar. Philip Oliver could well be a psychotic schizophrenic for all I know. Oh dear. Formulating a whole question would be extra dangerous: I think I'll just say the word...

Seymour.

Time stands still. A vicious glint appears in Philip's eye. The window slides threateningly open. Oh my God, I'm going to die...

"Seymour arose out of quite strange circumstances [see previous AAs for the full story]. *Seymour Hollywood* was going to be the next Dizzy game, that's how the character came about. We would have preferred him to be a bit more different though."



Panic Dizzy

This is a terrible game, based on the *Tetris/Klax*-style 'move and drop' puzzler, *Columns*. There are only two controls at your disposal - left and right - and you've got to get shapes to fall in the right holes. It's like watching a toddler playing with their top postbox, only much more expensive and much more boring.

12%



Spellbound Dizzy

The biggest Dizzy game ever, but sadly not the best. It's so big and complicated that CodeMasters had to produce four separate four-minute helpline messages on their 0898 service. *Spellbound* is full of extras (Dizzy snorkelling, Dizzy in a coal cart, etc) but there's too much boring walking and it's far too difficult. Gah!

65%



Prince of the Yolk Folk

The best Dizzy adventure, and that's official! *Prince of the Yolk Folk* is only 30 screens big, but there's plenty to get your teeth into and lots of nice logical puzzles to try and solve. Even King Arthur makes a guest appearance. This is the definitive Dizzy game. Totally good.

84%



Dizzy Enterprises: Andrew Oliver, Philip Oliver, Pogie the fluffie, and various dodgy looking blokes. I'm sure I've seen one of the chaps in the back row on Crimewatch UK...

Richard Eddy pops up with a bit of diplomacy: "The gameplay relies on the same thing but the styles are moving further apart. Dizzy appears in 'serious' adventures set in a fantasy land, whereas Seymour appears in more humorous adventures set in the real world."

"Good," says Philip, calming down a little, "the further apart they get, the better." The window slams shut. Phew, survived that one.

Now the world...

Dizzy looks set to be still wending his way through fantasy landscapes well into the next century. A lot of Dizzy games have been released on the Nintendo NES in America, and there are plans for Dizzy titles on the Super NES and Megadrive. Word is that Dizzy games will also be appearing on multi-media machines (such as the Philips CD-i) in the near future.

"Dizzy games would then become what we've always dreamt of them being," says Philip, "fully interactive cartoons, set in a magical land where everything is possible. Games will also have much longer lives. They'll last for years."

And that's not all, Dizzy fans. Chances are you'll be seeing your ovoid chum in action on the TV within the next few years. Discussions have already taken place with Hanna-Barbera over the possibility of producing a Dizzy cartoon series. (United Artists have also shown an interest.)

Hanna-Barbera say the character isn't yet big enough worldwide to go ahead with the project. The production of Dizzy cartridges for the ever-growing world console market means that the time could be drawing near.

The NES game *The Fantastic Adventures of Dizzy* (*Bubble Dizzy* and *Dizzy down the Rapids* were both lifted from it) recently won 'Best Graphic Adventure of the Year' in a prestigious American video games awards ceremony. Surprising really, considering that CodeMasters aren't officially licensed by Nintendo: the company has consequently found it difficult both getting their games into the shops and getting them reviewed in magazines.

Whatever happens in computing, it seems that Dizzy is here to stay. But let's leave the last word to Paul Ranson, designer of recent titles starring the infamous egg: "While we were programming *Magic Land Dizzy* at Big Red, we spent a lot of time eating Donahue's balm cakes. They're the biggest balm cakes in the world, and they only cost 80p each. They were served by a woman who only had one eye. She'd be pointing at you and you wouldn't know where she was pointing. You'd go into the shop and..."

Er, scratch that. Let's leave the last word to Andrew Oliver, who, along with brother Philip, started this whole big egg thing off.

"Dizzy."



Pogie the fluffie

"Squeak squeak squeak squeak." (Translation - "Though I'm purple and small, you never mocked me at all. You patted my head, I found it surprising. You're a decent egg, though patronising.")



Philip Oliver

"I could never have guessed you would become this famous: Britain's favourite computer game character. Kids love you, parents love you, whole families love you. And of course, i love you."



Grand Dizzy

"Hello there, young Dizzy. You're not a kid any more. Isn't it about time you got rid of that tattoo, got yourself a proper haircut and decent clothes, and went out and found a job? Eh? Eh?"



Dizzy down the Rapids

What is the point? Why go about ripping off a really crap game (*Toobin'*) instead of a good one? Why release it when it's even slower than the original? Travel down some rapids, throwing things at crocodiles, or save your money and buy something decent instead.

20x



Bubble Dizzy

Probably the best of the Dizzy arcade games, this is a version of ye olde game *Underwulde*. Dizzy has to travel from the sea bed to the surface on air bubbles, jumping from bubble to bubble and using ledges where available. There's a tight time limit and loads of frantic, addictive arcade action. Looks dull, plays fab.

79x



Crystal Kingdom Dizzy

The new Dizzy game (a full pricer) should be hitting the shops within the next couple of weeks. Full review next month. In the meantime, we'll tell you that the game is made up of four separate lands to explore, and has a lot of speech in it. Is it worth £9.99? We'll see...

99x

GAMES MASTER

THE GREATEST SHOW ON TV...



... IS NOW ON PAPER!

Every issue, GamesMaster magazine will deliver a whole month's worth of concentrated GamesMaster excitement. We'll have the first and finest reviews of the big games, the most enormous competitions, thrilling challenges and tips from The GamesMaster himself.

It's our aim to cover everything that moves on the games scene each month. First.

The very special first issue comes with three rather splendid gifts:

- A 100-page tips book with codes, cheats and tactics for over **250** games.
- A **GIANT** double-sided calendar-poster.
- **3** sets of smart GamesMaster stickers.

FIRST ISSUE IS ON SALE THURSDAY 3RD DECEMBER

MEGA DRIVE, SUPER NES, AMIGA, NEO GEO, PC ENGINE, MEGA CD, GAME BOY, GAME GEAR AND LYNX!

Balrog's Postbag

THE BALROG rips open another sack of readers' mail with his razor sharp fangs (he now owes the GPO £243.92)...

Revenge wanted!

Could you tell me if *Doomdark's Revenge* is still available? I've just finished *Lords of Midnight* and am itching to get my hands on the sequel.

Captain Faramir
Aradoria

Sorry Captain Faramir (?!), *Doomdark's Revenge* is no longer available. However if any readers out there have a copy they want to sell then why not write in to the usual *Balrog* address.

Fantasy found!

I have tracked down a mail order company that supplies one of the three fighting fantasy games (*Forest of Doom*, *Rebel Planet* and *Seas of Blood*). Mark Cocerdale asked where he could get them so here's his chance to pick up *Rebel Planet* (the hardest of the three). The game costs £6.29 plus £1 p&p on cassette and the company is called Anneva Leisure Ltd on 0890 3232.

Tony Hutchinson
Saltney

Thanks Tony!

Adventure Rebirth?

I'm writing to agree with your comments in AA79. The 8-bit adventuring market is undergoing a rebirth, but as we have Joan Pancott's *WoW* software and Debby Howard's *Adventure PD*, we have nothing to worry about. I've been investigating the world of 16-bit adventuring, but if you strip away the flashy graphics and sound effects there is no game left. Any 16-bit adventure worth playing is just as easy to play on an 8-bit - most of the stuff was written on an 8-bit originally anyway. Infocom, Level 9, Magnetic Scrolls... We've seen them all on the old CPC before. As soon as someone realises that flashy technical routines do not make a game enjoyable then we 8-biters will have as much backing from the commercial adventure houses than the 16-bit adventures.

Thomas Christie
Grangemouth

You're right Thomas, many of the 16-bit games look very flashy but really have no gameplay at all. The Amstrad is capable of some fantastic games - *Suspect*, *Lurking Horror* and *Lords of Chaos* to name but three and it seems a shame that software houses are turning away from the CPC. The major reason is that of money - the companies can make a lot more money selling ST and Amiga games. However as long as *Wow*, *Adventure Workshop*, *FSF* and the other companies stick with the CPC the adventure scene will live on!

Balrog

Welcome, fellow Balgs, to another exciting instalment of adventure gossip, reviews, hints and tips in this latest missive from the monstrous Balrog!

THANKS this month to Simon Avery, Nick Carter, Brendan "Legolas" McGoldrick and Daniel Pooley for their adventurous hints and tips - if you have any then please send them to: **The Balrog, Amstrad Action, Beauford Court, 30 Monmouth Street, Bath, Avon BA1 2BW.**

Black Fountain - Part 2

- Give the slimy creature the meat.
- Say laughter to the sprite.
- Charm snake with pendant.
- Steam the mirror with the jug then wipe it with the cloak.
- Give the fish to the men then dig.
- Give the gold to the guard.
- Show the mirror to the abhaldos.

How to be a Complete B*****

- Get the sheet and do ghost impressions (be sober).
- Eat the compost.
- Don't eat the frozen pizza or chicken.
- Don't kill anyone with the chainsaw.
- Watch the Sicko 3 video on TV.
- Tie someone up with the hose (be drunk)

- Place the rake on the ground (be sober)
- Dig a hole with the shovel (be drunk)
- Don't watch the dirty video
- Don't read the dirty mag
- Zap the furry pet in the microwave (be drunk)
- Don't reset the computer
- Stab somebody with the pen (be sober)
- Place the tyre about somebody (be drunk)
- Do big farts if the room is crowded
- If you can only see one person, go next to them and do a little fart
- Do not fart if you've eaten curry or coal
- Do not open the umbrella
- Smash furniture with the hammer

Lord of the Rings

- Location of the elfstones:
 - Tell Merry to climb into the silver lake (two elfstones will be thrown at him)
 - Climb the climbable tree in the forest and get the elfstone.
 - Pippin gets two elfstones when he is trapped in the fissure.
 - Look in the flowerpot.
- To use the elfstones say Elbereth.
- Use the ring to get past the hobbit guard then follow Strider.

Clue Cauldron: Castle Master

THIS MONTH'S clue cauldron is for *Castle Master* and is written by Edward Fitzpatrick from Ellesmere - thanks Edward!

To kill the spirit in the 'Dragons Lair', which is the ultimate baddie, you must first kill all the other spirits in the castle (there are 20 in all). If you're stuck on trying to find the last few remaining spirits and have nine keys, then you'll find the last key in the cavern beneath the hot baths. You must activate the box in the cavern; this will then tip over and you will be able to walk on top of it and get on top of the blue barrier next to it. Once on the blue barrier, turn 90 degrees to the right, now walk along the barrier, making sure you don't fall off it. Keep walking along it until you hit the wall in front of you. Look straight up and you'll see a hole near the ceiling - this is the key to the 'Spirits Abode'. Aim your sights on it, make sure you have rock travel and then press fire and activate it. At first you may not get the key but keep

trying as you will eventually get it.

Get out of the caverns and go to the 'Guard Room', here is a door to the 'Spirits Abode' which you can now unlock. Kill the three spirits in there. You should now have killed all twenty spirits and have ten keys collected, if you still don't have all of them killed yet, then look for the one that is hidden by the flag in the courtyard, shoot the flag and then shoot the spirit by it.

With all the spirits killed you can now go to the 'Dragons Lair'. Unlock the door, once in here aim your sights on the dragon's forehead and keep firing until it is destroyed. Now a pathway is opened to a door on the left. Go through it and you will be in 'Magister'. Activate the two boxes on the walls, they will then disappear and the barrier blocking the door on the left will also disappear. Go toward this door and activate the knob, the door will open, go through it and you will have freed the captive.

Treasure Island

£5 disk (CPM 2.2 & CPM +) • The Adventure Workshop, 36 Grasmere Road, Royton, Oldham, Lancashire OL2 6SR. Tel: 061 652 7565

TREASURE ISLAND is based on the classic book by Robert Louis Stevenson with the player acting the role of the cabin boy Jim Hawkins. The game is faithful to the storyline of the book – you'll meet most of the characters (including the Doctor, Squire and the infamous Long John Silver) and fans of the story will feel right at home.

PAWEd in two parts, *Treasure Island* was originally written on the Spectrum and has been converted by Phil Reynolds, the head honcho at TAW.

The puzzles are mostly very well done, although there are a couple of time-related puzzles that can

be annoying to complete as the time allotted is very short. Make one wrong move or mistype a command and you're dead!

Treasure Island has all the ingredients of a good game – plenty of atmosphere (especially for adventurers who have read the original book), good puzzles that aren't too difficult, some well-designed mazes and a large number of locations. Well worth seeking out.

VERDICT

ATMOSPHERE

Atmospheric, especially if you've read the original story

72%

INTERACTION

The parser works fine, often a stumbling block in adventures

72%

CHALLENGE

Two parts and some tough puzzles means there's plenty to do

75%

A well-written game, and definitely worth trying

RATING 79%



Panic Beneath the Sea

- To get money from the bank you need to go to small wooden cabin, move table, open trap-door, down, get and search uniform. Get both cards. Use plastic card found in your office then go to cash dispenser and get money.

Shadows of Mordor

- Kill the skinny orc to get the fishing line.

Seabase Delta

- Get magnet from speaker and the washing line from the kitchen. Then tie the magnet to the line, get the key and unlock the hatch in the lift shaft. Drop line, pull line, get the disk and insert it into the computer, push joystick, pull joystick. The tiger missile's co-ordinates are degrees bearing 104, elevation 199.

Smirking Horror

- Fill cup with water and go outside. Wait till water turns to ice and throw ice at Arthur.
- Cut the bar with the boltcutters.
- Wedge open elevator with the bar.

Cluepot Index part 2: N-Z

(the numbers relate to AA issues)

Necris Dome	74	Runestone	30	Suspect	51	64
Never Ending Story	6 8 10 20	Scapeghost	52 55 66 76	Talisman of Power	73	
	38 61		81 84	Terrormolinos	73	82 84
Not a Penny More, Not a Penny Less	74 81	Scary Tales	35 66	Test	64	
Panic Beneath the Sea	51 64	Seabase Delta	10 12 13 15	Theseus	76	
Pawn	21 27 56 58		20 38 59 66	Times of Lore	61	
	61 67 74	Search for Largo Grann	69 72	Tombestowne	64	
Planetfall	27 73 80		55	Total Reality Delusion	80	
Price of Magic	10-14 16 17	Seastalker	35	Trial of Arnold Blackwood	80	82
	26 29 43 64	Secrets of Ur	72	Use your loaf	80	
	65 79 80 84	Secret of St Brides	15	Venom	30	33 49 61
Quad X - II	85	Shadows of Mordor	25 66 68 72	Very Big Cave Adventure	33	61 62 82
Quest for Golden Egg Cup	65 79 81		74 81		84	85
Questprobe III	25 54	Sharpe's Deeds	79	Videoworld	82	
Rebel Planet	27 54	Simply Magic	74 81 84 85	Warlord	3	4 7-10
Red Moon	11 20 29 65	Slaine	30 57		17	27 57 74
	68 74 76	Smashed	63 84	Well adventure	73	
Redhawk	14 17 20 59	Snowball	1 2 6 22	Wise & Fool of Arnold Blackwood	75	
	70 74	Sorcerer	52 66 74	Wishbringer	75	
Return to Eden	2 3 11 14	Sorcery +	85	Witness	60	
	17 18 49 50	Souls of Darkon	33 63 66	Wizbiz	60	80
Revenge	85	Spellbreaker	25 27 35	Wolfman	40	50 61 62
Rigels Revenge	29 30 33 35	Spiderman	4		66	75 76 85
	37 40 43 55	Spiro Legacy	81 84	Worm in Paradise	29	35 52
	57 62 72 81	Spytrek	20 25 35 43	Yarkon Blues	82	
Ring of Darkness	4		66 80	Zork	6	8 43
Robin of Sherlock	17 27	Star Wreck	29	Zork II	73	
Robin of Sherwood	8 15	Stationfall	35 51 60	Zork III	27	65
Roy of the Rovers	61	Subsunk	10 17 62 65			

TYPE-INS

Maths Processor

**£20
WINNER**

He's a very useful bit of code with some startling fun and novel additions. *Maths Processor* helps all budding Einsteins to solve everything from square roots to exponentiation simply by selecting the required function from a menu and inputting the data. But that's not all, a very original screen clearing routine will have you doing sums just to see it again and again. What happens? You'll have to type it in to see. Fortunately, the program's only 2K long so there's not much work involved. Andrew Ruddick of Bolton is the programmer behind *Maths Processor* and he's earned a well-deserved £20. Menu driven, no instructions needed.

```
{CIBi} 10 ON BREAK GOSUB 930: BORDER 0: MODE 2
{HnBo} 20 CLS: LOCATE 25,2: PRINT "COMPUTER
      CALCULATOR"
{HtBj} 30 LOCATE 5,5: PRINT "1...PROBABILITY"
{MrBj} 40 LOCATE 5,7: PRINT "2....INTEREST"
{DmBk} 50 LOCATE 5,9: PRINT "3..SQUARE ROOT"
{NpBl} 60 LOCATE 5,11: PRINT "4...CUBE ROOT"
{OIBl} 70 LOCATE 5,13: PRINT "5..EXPONENTIATION"
{KjBk} 80 LOCATE 5,15: PRINT "6....DIVISION"
{JpBn} 90 LOCATE 5,17: PRINT "7..MULTIPLICATION"
{HmBk} 100 LOCATE 5,19: PRINT "8....SUBTRACTION"
{FtBm} 110 LOCATE 5,21: PRINT "9.....ADDITION"
{OpCj} 120 LOCATE 25,24: PRINT "ENTER CHOICE BY
      TYPING NUMBER AT BEGINING OF OPTION"
{EvBi} 130 LOCATE 45,5: PRINT "H...HELP?"
{BnBv} 140 LOCATE 45,7: PRINT CHR$(164): LOCATE
      47,7: PRINT "ANDREW RUDDICK"
{IpBj} 150 LOCATE 45,8: PRINT "4,OAKWOOD Dr"
{NlAv} 160 LOCATE 45,9: PRINT "HEATON"
{IpBi} 170 LOCATE 45,10: PRINT "BOLTON"
{MrAv} 180 LOCATE 45,11: PRINT "1992"
{OnBl} 185 LOCATE 45,15: PRINT "C...CREDITS"
{LiAv} 190 K$=INKEY$: K$=UPPER$(K$)
{ImBj} 195 K$="" : WHILE K$="" : K$=INKEY$: WEND
{KuBj} 200 IF K$="1" THEN GOTO 310: K$=""
{OsBl} 210 IF K$="2" THEN GOTO 360: K$=""
```

Your CPC doesn't just RUN programs, it lets you WRITE them! And here to show you how is JERRY GLENWRIGHT. PLUS another four brilliant readers' programs for you to type in and use...

```
{CkAx} 220 IF K$="3" THEN GOTO 410: K$=""
{LnBj} 230 IF K$="4" THEN GOTO 460: K$=""
{PqBi} 240 IF K$="5" THEN GOTO 510: K$=""
{CiBj} 250 IF K$="6" THEN GOTO 560: K$=""
{MwAx} 260 IF K$="7" THEN GOTO 610: K$=""
{OtBi} 270 IF K$="8" THEN GOTO 660: K$=""
{KnBj} 280 IF K$="9" THEN GOTO 710: K$=""
{GqBl} 290 IF K$="C" OR K$="c" THEN GOTO
      880: K$=""
{HtBo} 300 IF K$="H" OR K$="h" THEN GOTO
      760: K$=""
{KtBo} 305 IF K$ (<) "" THEN SOUND 1,40,20: GOTO
      10
{LwBn} 310 CLS: INPUT "ENTER NO. OF FAVOURIBLE
      OUTCOMES"; A
{OoBn} 320 PRINT "Pr": INPUT "ENTER NO. OF
      POSSIBLE OUTCOMES"; B
{CvBu} 330 PRINT "ANSWER=": PRINT A/B: PRINT
      "PRESS ESC' TWICE"
{IsAp} 340 GOTO 340: K$=""
{LqAo} 350 'INTEREST
{EsAv} 360 CLS: PRINT "SIMPLE INTERST"
{OjAw} 370 INPUT "ENTER INTEREST RATE"; R
{ItAw} 380 INPUT "ENTER INVESTMENT"; I
{BrCs} 390 INPUT "ENTER TIME IN
      YEARS"; T: PRINT "INTEREST=": PRINT
      I*T*R/100: PRINT "PRESS ESC' TWICE"
{FoAm} 400 GOTO 400
{OqAn} 410 'SQUARE ROOT
{KrAu} 420 CLS: PRINT "SQUARE ROOT"
{IrBj} 430 INPUT "ENTER NUMBER TO BE SQUARED"; S
{MwBu} 440 PRINT "SQUARE ROOT=": PRINT
      SQR(S): PRINT "PRESS ESC' TWICE"
{MqAn} 450 GOTO 450
{FvAn} 460 'CUBE ROUTE
{IiAv} 470 CLS: PRINT "CUBE ROOT"
```

```
{CpBj} 480 INPUT "ENTER NUMBER TO BE CUBED"; C
{DrBu} 490 PRINT "CUBE ROOT=": PRINT
      C^(1/3): PRINT "PRESS ESC' TWICE"
{DqAl} 500 GOTO 500
{MwAp} 510 'EXPONENTIATION
{GvBx} 520
      CLS: PRINT "EXPONENTIATION": INPUT "ENTER
      NUMBER TO BE RAISED"; RA
{FvAw} 530 INPUT "ENTER 'THE POWER'"; P
{MrCi} 540 PRINT RA "TO THE POWER OF"; P "=": PRINT
      RA^P: PRINT "PRESS ESC' TWICE"
{BmAn} 550 GOTO 550
{KxBv} 570 CLS: PRINT "DIVISION": INPUT "ENTER
      NUMER TO BE DIVIDED"; ND
{AqBl} 580 INPUT "ENTER NUMBER TO BE DIVIDED
      BY"; DB
{BIBx} 590 PRINT ND "DIVIDED BY"; DB "=": PRINT
      ND/DB: PRINT "PRESS ESC' TWICE"
{BsAl} 600 GOTO 600
{IvAq} 610 'MULTIPLICATION
{HkBw} 620
      CLS: PRINT "MULTIPLICATION": INPUT "ENTER
      NUMBER TO BE TIMED"; TI
{FwBo} 630 INPUT "ENTER NUMBER TO BE MULTIPLIED
      BY"; MB
{CsCl} 640 PRINT TI "MULTIPLIED BY"; MB "=": PRINT
      TI*MB: PRINT "PRESS ESC' TWICE"
{GiAm} 650 GOTO 650
{CkAo} 660 'SUBTRACTION
{EkCi} 670 CLS: PRINT "SUBTRACTION": INPUT "ENTER
      NUMBER TO BE SUBTRACTED"; SU
{MjBk} 680 INPUT "ENTER NUMBER TO BE SUBTRACTED
      BY"; SB
{GjBt} 690 PRINT SU "MINUS"; SB "=": PRINT SU-
      SB: PRINT "PRESS ESC' TWICE"
{PuAl} 700 GOTO 700
```

Basic tutorial... Basic tutorial... Basic tutorial... Basic tutorial.

Who was it said that loops accounted for 95 per cent for bugs in computer programs? Some schmuck who wanted five minutes of fame no doubt, but it is true – as you're probably aware now that you've had a chance to play with them a little. Anyway, enough of loops for a while, let's move on to a deeper look at ON BREAK encountered last month.

As we've seen ON BREAK is a ready-made Amstrad BASIC construction used to determine whether a user has pressed the Break key and stopped your program. If that's the case, then by attaching another BASIC keyword to ON BREAK such

as GOSUB, GOTO, or STOP, you can ensure appropriate action is taken.

Here's an example. Let's say you're not satisfied with simply trapping out bad string information in your version of the string counting example code from a month or two ago. You'll remember the original code looked like this...

```
10 REM This is a program to count the
      characters in a string
20 FOR CNT=1 TO 5
30 A$=""
```

```
40 INPUT "Please type a string"; A$
50 IF A$="" THEN 40
60 IF ASC(A$)<65 OR ASC(A$)>122 THEN PRINT
      "Invalid input. Try again\": GOTO 30
70 PRINT "The string 'A$' is "LEN (A$)
      "characters long."
80 NEXT CNT
90 END
```

Line 60 traps most invalid input, but what happens if the user of the program hammers on the Break key,

ms

```
{OuAm} 710 'ADDITION
{OuBs} 720 CLS:PRINT"ADDITION":INPUT"ENTER
NUMBER TO BE ADDED";AD
{BuBj} 730 INPUT"ENTER NUMBER TO BE ADDED";ADD
{GoBv} 740 PRINT AD"PLUS";ADD=":PRINT
AD+ADD:PRINT"PRESS ESC' TWICE"
{KuAm} 750 GOTO 750
{LtAl} 760 'HELP
{PuAr} 770 CLS:PRINT"HELP?"
{JlBr} 780 PRINT"ANDREW RUDDICK":PRINT:PRINT"
PRESENTS":PRINT
{GtBx} 790 PRINT"          MATHAMATICS AT
YOUR FINGERTIPS!":PRINT:PRINT:PRINT
{ArBx} 800 PRINT"SELECT OPTION BY TYPING THE
BEGINING NUMBER/LETTER."
{JuCl} 810 PRINT"IN CASE OF EXTENSIVE DATA, THE
COMPUTER MAY INSTEAD OF PRINTING"
{IxBn} 820 PRINT"A LOAD OF ZERO'S, GIVE IT IN
SHORT FORM."
{PxBw} 830 PRINT"IF THIS OCCURS IT WILL GIVE A
NUMBER FOLLOWED BY AN 'E'"
{BmCi} 840 PRINT"FOR EXAMPLE: 9999999
MILTIPLIED BY 9999999=1.00000E+14"
{JtBm} 850 PRINT"WHICH ACTUALLY MEANS
1.000000000000000000000000"
{FmBv} 860 PRINT:PRINT:PRINT
CHR$(164):PRINT"1992":PRINT"PRESS ESC'
TWICE"
{JuAk} 870 GOTO 870
{EKBs} 880 CLS:PRINT"ANDREW
RUDDICK":PRINT"4,OAKWOOD DRIVE"
{PxBo} 890
PRINT"HEATON,BOLTON":PRINT"MANCHESTER"
{DnBn} 900 PRINT"BL1 SEE":PRINT"TEL. 0204
45653"
{CuAt} 910 PRINT"PRESS ESC' TWICE"
{CqAn} 920 GOTO 920
{FsAv} 930 ' VDU "SPECIAL EFFECT"
{BqAp} 940 FOR f=0 TO 40
{OqAr} 950 FOR g=0 TO 12:NEXT
{MlAv} 960 OUT &BC00,1:OUT &BD00,F
{XlBn} 970 OUT &BC00,2:OUT &BD00,46-(20-
INT(f/2))
```

```
{BwBq} 980 OUT &BC00,6:OUT &BD00,25-INT((40-
f)/1.6)
{AtBt} 990 OUT &BC00,7:CALL &BD19:OUT &BD00,30-
((40-f)/3.2)
{BwAk} 1000 NEXT
{GlAl} 1010 RUN
```

Art Studio



Art Studio turns your poor old CPC into one of those fiendishly difficult nut nonetheless addictive Etch-a-Sketch machines. You know, those plastic screens bearing two knobs which you use to move a 'cursor' around. As the cursor moves, a trail of graphite is left behind and produces a picture - of sorts! Run *Art Studio* by Trevor Jones of Morpeth, Northumberland, and the an almost clear screen is presented with only a single pixel in the middle representing the moveable cursor. You use a joystick to move this cursor and so ceate a picture.

Pressing the Fire button changes colour, and you can draw pre-computed squares and circles by pressing 1 and 2 respectively. Key 3 produces a fill pattern and 4 and 5 save and load your pictures. Plenty of scope for additional routines.

```
{JvAn} 1 'ART STUDIO
{KsAv} 2 '***PRESS 7 FOR HELP***
{FuBi} 10 MODE 0:INK 1,26:INK 0,0:BORDER 0
{DmAx} 20 INK 2,6:INK 3,2:INK 4,15:INK 5,16
{BoAu} 30 INK 6,18:INK 7,24:INK 8,3
{LjAr} 40 WINDOW 1,20,1,1
{MiAn} 50 COLOUR=1
{MoAl} 60 X=320:Y=200
{EiAm} 70 ORIGIN 0,0
{MsAt} 80 PLOT 0,380,1:DRAW 640,380,1
{MnAo} 90 PLOT X,Y,COLOUR
{MjAp} 100 PLOT X,Y+2,COLOUR
{FtBm} 110 LOCATE 1,1:PRINT"DRAW YOUR PICTURE "
{ErAn} 120 Q$=INKEY$
{IiAu} 130 IF Q$="↑"THEN Y=Y+4
{HwAs} 140 IF Q$="→"THEN X=X+4
{GvAs} 150 IF Q$="↓"THEN Y=Y-4
{NvAr} 160 IF Q$="←"THEN X=X-4
{HvAu} 170 IF Q$="1"THEN GOTO 320
{LiAu} 180 IF Q$="2"THEN GOTO 540
{AxAv} 190 IF Q$="X"THEN COLOUR=COLOUR+1
{DsAt} 200 IF Q$="3"THEN GOTO 870
{JtAt} 210 IF Q$="4"THEN GOTO 1050
{DvCp} 220 IF Q$="5"THEN LOCATE 1,1:PRINT"
":PLOT 0,380,0:DRAW
640,380:LOAD"!SCREEN"
{IsAt} 230 IF Q$="6"THEN GOTO 10
```

Win £20!

That's what we're offering: five minutes of glorious fame, and masses of cash (well, your name in print and twenty quid, anyway...). So if you're a brill BASIC programmer writing code which knocks spots off anything published here - send it in! Your name in lights and big prize money is a-waiting...

Here's a few dos and don'ts to help you on your way:

- DO include your name and address with your tape or disk
- DO include a SAE if you want material returned
- DO include a written description of your program and details of its operation - on-disk doc files won't do!
- DON'T include instructions saying "...here's my program Hot-Dots, the name speaks for itself...", because it doesn't! If you can't be bothered to describe what it does, I can't be bothered to load it up, OK?

The address to write to with your programs is:

**Type-Ins,
Amstrad Action,
Beauford Court,
30 Monmouth Street,
Bath, Avon BA1 2BW**

```
{NmAu} 240 IF Q$="7"THEN GOTO 1120
{HpAr} 250 IF X<1 THEN X=1
{FpAt} 260 IF X>638 THEN X=638
{FiAu} 270 IF Y>378 THEN Y=0
{LxAu} 280 IF Y<0 THEN Y=378
{LqAv} 290 IF COLOUR>8 THEN COLOUR=0
{MvBt} 300 IF COLOUR=0 THEN PLOT X,Y,1:PLOT
X,Y+2:PLOT X,Y,COLOUR:PLOT X,Y+2
{FwAn} 310 GOTO 90
{IuBp} 320 PEN 1:LOCATE 1,1:PRINT"SELECT SQUARE
SIZE"
{DvAl} 330 B=0:C=0
{IpAo} 340 A$=INKEY$
{BtAr} 350 CO=TEST(X+B,Y+C)
{NvAr} 360 PLOT B+X,C+Y,COLOUR
{ImAp} 370 PLOT B+X,Y+C,CO
{AqAu} 380 IF A$="↑"THEN C=C+4
{KvAu} 390 IF A$="↓"THEN C=C-4
{GnAv} 400 IF A$="→"THEN B=B+4
{AnAt} 410 IF A$="←"THEN B=B-4
{DkAu} 420 IF A$="X"THEN GOTO 440
{OmAl} 430 GOTO 340
{CqBo} 440 PEN 1:LOCATE 1,1:PRINT"SQUARE BEING
```

Basic tutorial... Basic tutorial... Basic tutorial... Basic tutorial...

stopping the software in its tracks? Nothing, if you've included this little line at the beginning

```
10 REM This is a program to count the
characters in a string
15 ON BREAK CONT
20 FOR CNT=1 TO 5
30 A$=""
40 \etc
```

After encountering line 15, BASIC sets an indicator so that, when a user presses the Break key, BASIC

checks the indicator, sees that it's set, and performs the instruction passed to it with the ON BREAK construct - in this case CONT.

And what does CONT do? Tells BASIC to CONTINUE (what else?) when it's stopped by someone pressing Break.

Now before we CONT, let's digress briefly to talk about indicators or 'flags' as they're known. Without getting into a big discussion of the internals of the Amstrad CPC, flags are registers - physically, one location in the computer's RAM memory, for example, which, if it contains the value 1 is

considered to be 'set' and a 0, reset.

By setting these flags (it may help to think of them as real-world flags, raised translating as set, and lowered, reset), BASIC can determine whether a particular criterion has been met, or some happening beyond its control carried out or what have you. It's rather like BASIC tying a knot in the corner of its handkerchief in order to remember an event! Flags, right? Back to the action...

So. By including ON BREAK CONT at the beginning of a program, you can trap users pressing the Break key and attempting to stop your program,

```

DRAWN"
{PnBl} 450 IF Y+C<Y THEN GOTO 500 ELSE 460
{EuAs} 460 FOR E=Y TO Y+C STEP 2
{MuAx} 470 PLOT X,Y,COLOUR:DRAW B+X,E:DRAW X,E
{KwAl} 480 NEXT E
{IoAm} 490 GOTO 70
{DoAs} 500 FOR E=Y TO Y+C STEP -2
{FiAx} 510 PLOT X,Y,COLOUR:DRAW B+X,E:DRAW X,E
{GIAI} 520 NEXT E
{GuAm} 530 GOTO 70
{AnAw} 540 LOCATE 1,1:PRINT" "
{LIBj} 550 LOCATE 1,1:PRINT"SELECT CIRLE SIZE "
{GpAn} 560 F=0:G=0
{HIAo} 570 A$=INKEY$
{HjAq} 580 CO=TEST(X+F,Y+G)
{HrAr} 590 PLOT X+F,Y+G,COLOUR
{GkAo} 600 PLOT X,Y,COLOUR
{JwAp} 610 PLOT X+F,Y+G,CO
{AjAv} 620 IF A$="↑"THEN G=C+4
{DrAu} 630 IF A$="↓"THEN G=C-4
{JtAu} 640 IF A$="→"THEN F=F+4
{IvAt} 650 IF A$="←"THEN F=F-4
{HsAt} 660 IF A$="X"THEN GOTO 680
{PmAl} 670 GOTO 570
{BoAv} 680 LOCATE 1,1:PRINT" "
{DpAw} 690 LOCATE 1,1:INPUT"SOLID OR NOT ";A$
{PjAv} 700 IF A$="Y"THEN GOTO 730
{EvAx} 710 IF A$="N"THEN GOTO 800
{GuAm} 720 GOTO 700
{ApAt} 730 FOR R=1 TO 360 STEP 2
{PsAj} 740 DEG
{CtAp} 750 PLOT X,Y,COLOUR
{EuBl} 760 DRAW X+F*COS(R),Y+G*SIN(R),COLOUR
{BjBi} 770 IF INKEY$=""THEN GOTO 70
{AoAl} 780 NEXT R
{EmAm} 790 GOTO 70
{OpAs} 800 FOR R=0 TO 360 STEP 1
{DmAl} 810 DEG
{JoAo} 820 PLOT X,Y,COLOUR
{JsBi} 830 PLOT X+F*COS(R),Y+G*SIN(R),COLOUR
{NwBi} 840 IF INKEY$=""THEN GOTO 70
{AmAm} 850 NEXT R
{HIAI} 860 GOTO 70
{AvBk} 870 LOCATE 1,1:PRINT"FILLING SHAPE "
{NtAm} 880 X=X:Y=Y
{JjAq} 890 Y=Y+2:TE=TEST(X,Y-4)
{EtAr} 900 PLOT X,Y,TE:PLOT X,Y+2,TE
{FkAm} 910 P=TEST(X,Y)
{JwAp} 920 CEN=X:GOTO 940
{OxBp} 930 Y=Y-2:IF TEST(X,Y)<>P THEN
    Y=Y+2:Y=y:X=x:GOTO 70
{LxBw} 940 X=X-4:IF TEST(X,Y)=P THEN GOTO 950
    ELSE XL=X:GOTO 970
{MrBj} 950 IF X<4 THEN XL=X:GOTO 970
{KnBp} 960 IF INKEY(68)=0 THEN GOTO 70 ELSE

```

```

GOTO 940
{FvAk} 970 X=CEN
{EuBt} 980 X=X+4:IF TEST(X,Y)=P THEN GOTO 990
    ELSE XR=X:GOTO 1010
{EvBj} 990 IF X>636 THEN XR=X:GOTO 1010
{BrBp} 1000 IF INKEY(68)=0 THEN GOTO 70 ELSE
    GOTO 980
{GnBk} 1010 MOVE XL+4,Y:DRAW XR-4,Y,COLOUR
{GkAs} 1020 CEN=((XR-XL)\2)+XL
{EqAr} 1030 X=((XR-XL)\2)+XL
{HsAm} 1040 GOTO 930
{AwAv} 1050 LOCATE 1,1:PRINT" "
{DjAs} 1060 LOCATE 1,1:INPUT A$
{KsBm} 1070 IF LEN(A$)>20 THEN A$=LEFT$(A$,20)
{MjAv} 1080 LOCATE 1,1:PRINT" "
{OxAu} 1090 LOCATE 1,1:PRINT A$
{FrAx} 1100 SAVE"SCREEN",B,&C000,&4000
{ItAm} 1110 GOTO 70
{JoBn} 1120 LOCATE 1,1:PRINT"1.SQUARE 2.CIRCLE "
{CnBi} 1130 FOR HELP=0 TO 1000:NEXT HELP
{AiBo} 1140 LOCATE 1,1:PRINT"3.FILL4.SAVES.LOAD "
{GtAx} 1150 FOR HELP=0 TO 1000:NEXT HELP
{GxBi} 1160 LOCATE 1,1:PRINT"6.CLEAR 7.HELP "
{LjAx} 1170 FOR HELP=0 TO 1000:NEXT HELP
{IiAm} 1180 GOTO 70

```

Times Tables



Staying with a mathematical theme is this handy wee snippet from C Urquhart of Bognor Regis, West Sussex. *Times Tables* does nothing more than print the times tables, from 1 to 10, on screen at the press of a key. Each table is accompanied by squeaks and buzzes and there's a tune or two at the end. Full instructions contained within.

```

{InBj} 5 BORDER 0:PAPER 0:INK 0,0:INK 3,14
{LIAI} 6 MODE 1
{BvBr} 7 LOCATE
    11,1:PRINT"*****"
{AtBp} 8 LOCATE 11,2:PRINT"*** TIMES TABLES
    ***"
{GvBs} 9 LOCATE
    11,3:PRINT"*****"
{DnBr} 10 LOCATE 11,4:PRINT CHR$(250)+"By C
    Urquhart.1991"+CHR$(251)
{MmBt} 11 LOCATE 5,25:PRINT"PRESS ANY KEY
    ONCE!...TO CONTINUE"
{NkFu} 15 WINDOW 14,30,9,20:SOUND
    7,300,100,7:SOUND 7,200,75,7:SOUND
    7,100,50,7:SOUND 7,75,150,7:SOUND
    7,200,100,7:SOUND 7,37,50,7:SOUND
    7,50,50,7:SOUND 7,37,50,7:SOUND
    7,50,50,7:SOUND 7,37,100,7

```

```

{DmBi} 20 IF INKEY$="" THEN GOTO 20
{HuBk} 25 a$=INKEY$:CLS:SOUND 7,1200,80,7,1,1
{BsAj} 30 '
{JjAo} 40 FOR a=1 TO 12
{CnAq} 50 PRINT a"* 1 ="a*1
{FnAk} 60 NEXT a
{NwAi} 70 '
{EwBi} 75 IF INKEY$="" THEN GOTO 75
{LjBj} 80 a$=INKEY$:CLS:SOUND 7,1100,80,7,1,1
{IoAo} 90 FOR a=1 TO 12
{JxAq} 100 PRINT a"* 2 ="a*2
{CjAl} 110 NEXT a
{JmBi} 115 IF INKEY$="" THEN GOTO 115
{PuBj} 120 a$=INKEY$:CLS:SOUND 7,1000,80,7,1,1
{JwAj} 130 '
{HoAo} 140 FOR a=1 TO 12
{IpAp} 150 PRINT a"* 3 ="a*3
{PtAk} 160 NEXT a
{AuBj} 165 IF INKEY$="" THEN GOTO 165
{CwBk} 170 a$=INKEY$:CLS:SOUND 7,900,80,7,1,1
{HqAj} 180 '
{FiAo} 190 FOR a=1 TO 12
{OuAp} 200 PRINT a"* 4 ="a*4
{IIAl} 210 NEXT a
{KiBj} 220 IF INKEY$="" THEN GOTO 220
{FrBj} 230 a$=INKEY$:CLS:SOUND 7,800,80,7,1,1
{CnAj} 240 '
{CwAo} 250 FOR a=1 TO 12
{IuAr} 260 PRINT a"* 5 ="a*5
{BnAl} 270 NEXT a
{MmBi} 280 IF INKEY$="" THEN GOTO 280
{JsBi} 290 a$=INKEY$:CLS:SOUND 7,700,80,7,1,1
{EsAj} 300 '
{ImAp} 310 FOR a=1 TO 12
{CjAs} 320 PRINT a"* 6 ="a*6
{MvAk} 330 NEXT a
{BoBj} 340 IF INKEY$="" THEN GOTO 340
{GIBk} 350 a$=INKEY$:CLS:SOUND 7,600,80,7,1,1
{AKAk} 360 '
{DuAo} 370 FOR a=1 TO 12
{OpAp} 380 PRINT a"* 7 ="a*7
{InAl} 390 NEXT a
{FqBj} 400 IF INKEY$="" THEN GOTO 400
{KmBi} 410 a$=INKEY$:CLS:SOUND 7,500,80,7,1,1
{MnAi} 420 '
{DiAo} 430 FOR a=1 TO 12
{BsAr} 440 PRINT a"* 8 ="a*8
{NtAl} 450 NEXT a
{BmBj} 460 IF INKEY$="" THEN GOTO 460
{KjBj} 470 a$=INKEY$:CLS:SOUND 7,400,80,7,1,1
{KIAj} 480 '
{AwAp} 490 FOR a=1 TO 12
{MnAq} 500 PRINT a"* 9 ="a*9
{KrAk} 510 NEXT a
{JkBj} 520 IF INKEY$="" THEN GOTO 520

```

Basic tutorial... Basic tutorial... Basic tutorial... Basic tutorial.

to examine it for instance. Trouble is, what happens when you want to stop it? Short answer is, you can't! At least, not without resetting the computer or switching off and on again. The CPC, unfortunately, cannot differentiate between valid and invalid ESC attempts! There is, however, a way to do just that.

Instead of putting ON BREAK CONT at the beginning of the program, insert this line

```
ON BREAK GOSUB 500
```

so that the code now looks like

```

5 REM This is a program to count the characters
    in a string
10 VALID$="valid"
15 ON BREAK GOSUB 500
20 FOR CNT=1 TO 5
30 A$=""
40 \etc

```

And at the end (i.e. after the BASIC keyword END) you put in the following

```
500 REM This code checks for a valid program
```

```

access
510 CLS: LOCATE 15,7
520 PRINT "ACCESS ATTEMPT - ENTER PASSWORD"
530 LOCATE 20,10
540 INPUT "Enter password:"; PASS$
550 IF PASS$="" THEN 540
560 IF ASC(PASS$)<>ASC(VALID$) THEN CLS:LOCATE
    15,15:PRINT "INVALID PASSWORD": NEW
570 RETURN

```

The complete program should look like this
5 REM This is a program to count the characters

Using Type-writer

If you're a comparative newcomer to *Amstrad Action* you're probably wondering about those funny four-letter codes in the curly brackets printed at the start of each line of a listing. These are here to help you type the programs in without making any mistakes. To use the system, first of all you have to run the *Type-Writer* program (printed in this box). From now on, for every line that appears on the screen, a four-digit 'checksum' is displayed too. So that when you type in a line printed on this page, your computer should display on-screen the same code as the one printed in the magazine. If it doesn't, you know you've made a mistake!

10 'Type-Writer
20 'Public Domain, by Pat McDonald
30 'Amstrad Action June 1989

```
40 flag=0:PRINT:INPUT"Am I a 464 (Daft
question!);"h$
50 a=HMEM-93:MEMORY a-1:RESTORE 200
60 FOR b=a TO a+85D
70 READ c$:d=VAL("&"c$)
80 POKE b,d:e=e+d
90 NEXT b
100 IF e(<)10566 THEN PRINT"Error in data.
Please Check.":END
110 IF LEFT$(h$,1)="y"OR LEFT$(h$,1)="Y"THEN
POKE a+8,&A4
120 z=a+34:e=0
130 f=ABS(INT(z/256))
140 g=ABS(((z/256)-f)*256)
150 POKE a+40,g:POKE a+41,f:POKE a+45,g
160 POKE a+46,f:POKE a+57,g:POKE a+58,f
170 POKE a+65,g:POKE a+66,f:POKE a+77,g
180 POKE a+78,f:POKE a+85,g:POKE a+86,f
```

```
190 POKE a+90,g:POKE a+91,f
200 DATA e5,c5,f5,fe,0d,20,18,21
210 DATA 8a,ac,01,00,06,51,59,7e
220 DATA fe,00,28,11,47,81,10,fd
230 DATA 4f,eb,09,eb,23,18,f0,f1
240 DATA c1,e1,cf,fe,93,3e,20,cd
250 DATA 22,90,3e,7b,cd,22,90,7b
260 DATA 07,07,07,07,e6,0f,c6,41
270 DATA cd,22,90,7b,e6,0f,c6,69
280 DATA cd,22,90,7a,07,07,07,07
290 DATA e6,0f,c6,41,cd,22,90,7a
300 DATA e6,0f,c6,69,cd,22,90,3e
310 DATA 7d,cd,22,90,18,c1,4d,61
320 g=g-34
330 IF flag=0 THEN flag=1 ELSE GOTO 370
340 POKE a+35,PEEK(&B5B):POKE
a+36,PEEK(&B5C)
350 POKE &B5A,&C3:POKE &B5B,g:POKE &B5C,f
360 GOTO 50
370 POKE a+35,PEEK(&B2C):POKE
a+36,PEEK(&B2D)
380 POKE &B2B,&C3:POKE &B2C,g:POKE &B2D,f
```

```
{BiBk} 530 a$=INKEY$:CLS:SOUND 7,300,80,7,1,1
{AmAk} 540 '
{KiAo} 550 FOR a=1 TO 12
{BrAs} 560 PRINT a"* 10 ="a*10
{KvAk} 570 NEXT a
{JsBj} 580 IF INKEY$="" THEN GOTO 580
{MiBi} 590 a$=INKEY$:CLS:SOUND 7,200,80,7,1,1
{NvAi} 600 '
{KsAo} 610 FOR a=1 TO 12
{EmAt} 620 PRINT a"* 11 ="a*11
{BrAl} 630 NEXT a
{FmBi} 640 IF INKEY$="" THEN GOTO 640
{EiBj} 650 a$=INKEY$:CLS:SOUND 7,100,80,7,1,1
{ApAj} 660 '
{NmAo} 670 FOR a=1 TO 12
{FwAr} 680 PRINT a"* 12 ="a*12
{EiAk} 690 NEXT a
{PwBi} 700 IF INKEY$="" THEN GOTO 700
{DjAq} 710 a$=INKEY$:CLS
{HwAj} 720 '
{CoAq} 730 CLS:GOTO 15
```

Calendar



Jo Castleton of Lowestoft has prettied up the traditional on-screen calendar printing theme to produce a program which is a pleasure to use. Run *Calendar*, and you're prompted for a year and month. Enter both as numerics so that, for example, February, 1962 would be 62 for Year and 2 for month. *Calendar* then draws a colourful year and month display with a complete calendar for the chosen month between them.

```
{FIAm} 10 'enter info
{DwCm} 20 MODE 1:DIM m(12),m$(12):BORDER 0:INK
0,0:INK 1,26:INK 2,24:INK 3,6
{FtBo} 30 PEN 1:LOCATE 11,2:PRINT"COMPUTER
CALENDER "
{NtBn} 40 PRINT:PRINT" Copyright 1992
J.D.Castleton"
{AtAp} 50 PRINT:PEN 2
{MnAo} 60 INPUT"Year ",y$
{MtAn} 70 INPUT"Month ",u
{LwAk} 80 CLS
{AlAm} 90 PEN 1
{Ckbn} 100 LOCATE 11,9:PEN 3:PRINT"Su Mo Tu We
Th Fr Sa
{HmAn} 110 'date info
{CxCn} 120
m(0)=28:m(1)=31:m(3)=31:m(4)=30:m(5)=31:
m(6)=30:m(7)=31:m(8)=31:m(9)=30
{NjAu} 130 m(10)=31:m(11)=30:m(12)=31
{OmBv} 140 y=VAL(y$):IF (y/4)=(y\4) THEN
m(2)=29 ELSE m(2)=28
{LjBp} 150
m$(1)="JAN":m$(2)="FEB":m$(3)="MAR":m$(4)
)="APR"
{LrBr} 160
m$(5)="MAY":m$(6)="JUN":m$(7)="JUL":m$(8)
)="AUG"
{JjBt} 170
m$(9)="SEP":m$(10)="OCT":m$(11)="NOV":m$
(12)="DEC"
{IkAo} 180 'cal calender
{PnAq} 190 y1=(y\4):ys=y+y1
{NxBm} 200 IF ys>7 THEN ys=ys-7:GOTO 200 ELSE
```

```
210
{PmBm} 210 FOR mm=0 TO u-1:tm=tm+(m(mm)-
28):NEXT
{AkBr} 220 IF tm>7 THEN tm=tm-7:GOTO 220 ELSE
230
{JuAo} 230 s=ys+tm-1
{AxBi} 240 IF (y/4)=(y\4) THEN s=s-1
{KjBi} 250 IF s>7 THEN s=s-7:GOTO 250 ELSE 260
{EpAr} 260 IF s=7 THEN s=0
{OtAs} 270 'print year and month
{MnBp} 280 PEN 1:LOCATE 1,25:PRINT y$:yg=4*(5-
LEN(y$))
{NiB1} 290 FOR y=0 TO 15 STEP 2::FOR x=0 TO 79
STEP 2
{AjCu} 300 IF TEST(x,y)=1 THEN PEN 2:LOCATE
(x/2)+yg,(25-(y/2)):PRINT CHR$(143):PEN
3:PRINT CHR$(133)
{KrBi} 310 NEXT:NEXT:LOCATE 1,25:PRINT" "
{DjBk} 320 PEN 1:LOCATE 1,25:PRINT m$(u)
{CpB1} 330 FOR y=0 TO 15 STEP 2:FOR x=0 TO 47
STEP 2
{KjCu} 340 IF TEST(x,y)=1 THEN PEN 2:LOCATE
(x/2)+9,(8-(y/2)):PRINT CHR$(143):PEN
3:PRINT CHR$(133)
{DrBi} 350 NEXT:NEXT:LOCATE 1,25:PRINT" "
{LlAq} 360 'print dates
{OvAr} 370 WINDOW 11,31,11,18
{BiB1} 380 PEN 3:FOR n=1 TO s:PRINT" ";NEXT
{OvBx} 390 FOR p=1 TO m(u):PEN 1:PRINT USING
"##";p;PEN 3:PRINT" ";NEXT
{PmAp} 400 CALL &BB18
{FsAk} 410 RUN
```

```
in a string
10 VALID$="valid"
15 ON BREAK GOSUB 500
20 FOR CNT=1 TO 5
30 A$=""
40 INPUT "Please type a string"; A$
50 IF A$="" THEN 40
60 IF ASC(A$)<65 OR ASC(A$)>122 THEN PRINT
"Invalid input. Try again\": GOTO 30
70 PRINT "The string '"A$"' is "LEN (A$)
"characters long."
80 NEXT CNT
```

```
90 END
500 REM This code checks for a valid program
access
510 CLS: LOCATE 15,7
520 PRINT "ACCESS ATTEMPT - ENTER PASSWORD"
530 LOCATE 20,10
540 INPUT "Enter password:"; PASS$
550 IF PASS$="" THEN 540
560 IF ASC(PASS$)<>ASC(VALID$) THEN CLS:LOCATE
15,15:PRINT "INVALID PASSWORD": NEW
570 RETURN
```

Here's what's happening. Line 10 sets up a valid password, in this case the word 'valid' (note lower case...). Line 15 sets BASIC's ON BREAK flag and offers BASIC the GOSUB construct as a valid action following the pressing the Break key. The rest of the code is normal until, that is, line 500. There to line 570 consist of a subroutine to handle the input of a password, checking it, and taking appropriate action should it be the wrong password.

And unfortunately, that's all we've got space for this month. Play with the extra code, and I'll give you full details of what's going on next time. Have fun!

AA SMALL ADS

For Sale

Amstrad GT64 Green screen monitor. Ideal for Word Processing, Database etc. £35 o.n.o. Phone Tony on 021-426 1686 after 5pm.

Original games 1986-91, 70 disks, 69 tapes, plus Multiface II, mouse, Maxam, Fleet Street Editor, Gac, Head Over Heels, Elite, Deflektor, Spindizzy. Lots more, worth £2,200, can split. Will consider any offers. Tel (0225) 469677.

Amstrad 6128, with mouse and mouse-mat, Lightpen, 2 joysticks, TV Modulator, arial, leads and manuals. Tape deck and over £2,000 worth of games, £1,100. May split. Phone Daniel on (0245) 284101.

Amstrad CPC 6128 with colour monitor, manuals, DMP 2000 printer, disk games, including Robocop, 28 tape games including Turtles. Comes with tape player. Software includes stop Press. £320 o.n.o. Phone (0526) 860144.

Amstrad CPC6128 with colour monitor, joystick, games, Mini Office II, user instruction manual. Excellent condition £230 o.n.o. Tel (0202) 533453.

Amstrad CPC464 with colour monitor, DDI-1 disk drive, Multiface II, modulator, new joystick, games on tape and disk - including 3D Construction Kit - manuals. £350, no splits. Phone (0303) 812777 after 5pm (Kent).

Cassette games, compilations and single games. Approximately 200 games, just £100 o.n.o. Also an FDI Second 3.5" disk drive. £50 o.n.o. Phone Gordon on (0259) 51062.

Student needs CPC6128, colour monitor, 3.5" drive, ROM DOS, Protet (ROM), ROMbox, printer (9 pin B/W), printer cable, all system disks etc. Buyer collects. Contact D.R Cantrell, Room Q3, Clifton Hall, Brunel University, Uxbridge.

CPC464 mono DDI Modulator, 64K expanded memory, Art Studio, mouse mat, joysticks, Brother printer, Multiface Two, Tasword II. All leads included. Many games, disk and tape. Bargain at £225. Phone Harwood on 081-942 9934.

CPC6128 plus Cartridge/disk drive, colour monitor. Excellent condition, complete with joy-pad, user manual, Burnin Rubber + Basic Cartridge, Grand Prix Circuit disk. Only £275. Tel: 081-443 1936.

CPC6128 colour monitor, DMP2160 printer, 3.5" disk drive. Dart Scan Multiface 2, Lightpen, mouse, tapedeck, joystick, games. Serious : Ocpart, Amxart, Stop Press, Protex, Prototype, Tassign, Mini Office 2 etc. Operating manual and other manuals £400 o.n.o. Tel (0325) 362808.

CPC464 with mono monitor, modulator, disk drive, 64K upgrade. 26 disks, cassette software, Multiface 2+ , AA and ACU magazines, Stop Press, mouse and colour plotter. All boxed for £499 o.n.o. Phone Andy on 091-413 3550. Can deliver.

CPC6128 colour, complete with manual, CP/M etc, boxed £200. Multiface 2 £25. Cassette, joysticks. Lots of software (games/serious) on tapes/disks, mostly as new. Books and magazines. Tel (0276) 34720 for list/details.

CPC6128 colour and mono monitors. 3.5" drive, modem, MFII, mouse, joystick, Maxam II, Sprites Alive, GAC. Many games, educational software and much more. £400 o.n.o. Phone (0780) 721356 after 5pm.

Amstrad Action magazines. Issues 1 to latest (inc. 5 binders). All cover mounted cassettes/specials £65 o.n.o. Amix magazine issues 0 to 18 (last published) plus 2 binders £25. Tel: 071-822 3727 and ask for Roger.

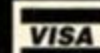

SD MICROSYSTEMS



NEW! Front-Runner.....£14.95 **3 1/2" Maxi Drive.....£79.95**

The ultimate WIMP Desktop manager for the CPC! Full control of your disks by joystick/mouse and drop-down menus, single or batch file selection, copy/erase/unerase/run/fast format and more! Supports PC-style sub-directories, 3.5" drives, ROMDOS, RAMDOS, MS800, XFORM and our 400KS! A must for all 128K CPC users with disk drives.

Other Serious Software disks for the CPC:
 BOO-TRACKER, music soundtrack creator.....£14.95
 HOME ACCOUNTS, personal finance system £14.95
 2 IN 1, CPC-PC data transfer software.....£19.95
 PAGE PUBLISHER, the best all-round DTP.....£24.95
 PICTURE DISKS 1 & 2, clip-art collection.....£12.50
 GENERAL LEDGER 6128, business accounts.....£29.95
 STOCK/INVOICER 6128, fully integrated.....£39.95

This top-quality unit formats to 800K per disk with our special software as well as operating in standard 180K mode. Comes complete with a fitted side-select switch, all cables/connectors and a heavy-duty power supply ready to plug-in and go! A FREE starter pack of five 3.5" disks and a powerful RANDOM ACCESS disk file, sold separately at £14.95, are included. The ideal second drive for the 464 & DDI-1, 664/6128, 6128 PLUS (add £5.00) Please order early for Christmas/New Year and remember to state computer type. Extra Packs of Ten 3.5" disks £6.50. UK DELIVERY: £1.00 Software, £5.00 Drives



Send cheques, POs or stamped SAE for our current CPC catalogue to: DEPT AA SD MICROSYSTEMS, PO BOX 24, HOLBEACH, Lincs PE12 7JF. TEL: (0353) 862678

Wanted

Wanted urgently - DD-1 disk drive interface to Amstrad CPC464. Walding, 14 Park Way, Northampton NN3 3BS or phone (0604) 401733.

Tele Text tuner for Amstrad 6128. Ring Ray on (0472) 357523 9 - 5pm.

Wantet Elite for CPC464 tape. Will pay your price or swap 5 of my games for it. Tel (0222) 567698 and ask for John.

Any books on programs for the 464+. Any hardware considered. Example: disk drive, printers, software also considered. Call Ian on (0209) 218080 evenings.

Type-ins for CPC464. Tape only please. Doesn't have to be recent. Games, serious, graphics, demos - anything. Send to: Mrs A. D Rowe, 79 St. Dunstons Coffee Hall, Milton Keynes, Bucks MK6 5DW.

Amstrad DMP-I printer or similar wanted for CPC464. Will pay postage. Ross Robertson, 1 Back Dykes Terrace, Falkland, Fife KY7 7BA.

Wanted: Amstrad CPC magazines. ACU, Amix and Computing with the Amstrad CPC. All issues. If you have any issues of the above magazines, please phone James on (0256) 880557 (Silchester, Berkshire). Reasonable prices paid.

PD Library wants your original work. Program of the month receives £7. Please send a 1st class stamp to get your programs back, to: PD Library, 18 Felton Close, Matchborough East, Redditch, Worcs B98 0AG.

Other

I would like to swap Turrican II, The New Zealand Story and Altered Beast for Captain Dynamo, Moonwalker and Turrican. Simon Graham, 29 Beaufort Walk, Nords, County Down, Northern Ireland BT23 4RP.

CPC Now! Fanzine. 32 pages with games, news, listings, cheats and lots more. 95p monthly. Cheques payable to CPC Now! 3 St. Ethelwolds Close, Ely, Cambridgeshire CB6 3AX.

Tuck PD - for a stock list and more details send an SAE to: Tuck PD, 15 Ravencar Road, Eckington, Sheffield S31 9GJ. Now with over 50 disks full!

Wanted for Albania. CP/M programs. Must be legal and with documentation. We have donated old computers, we would like YOU to donate the software. Contact Anderson High School, Lerwick, Shetland ZE1 0BA for details.

Probird: Professionally programmed birdwatchers' Database. Now available for 6128. It's fast, efficient and field tested. Excellent manual, user support back up. Details: Probird, 37 Essex Road, Stamford, Lincs PE9 1LG.



ORDER FORM

SEND TO AA SMALL ADS, AD PRODUCTION, FUTURE PUBLISHING LTD, BEAUFORD COURT, 30 MONMOUTH STREET, BATH, AVON BA1 2BW

Please place the following advertisement in the next available issue of *Amstrad Action*

Name _____

Address _____

Telephone _____

Classification. Tick box: For sale Wanted Services User Groups Other

Write your advertisement here, one word per box. Include your name and phone number if you want them

FREE READER ADS!
 It's true - from now on you can advertise in Amstrad Action for NOTHING! It's all part of our continuing efforts to provide you with the best value magazine possible.

Power Up

ACTION TEST pages 44-48 • **CHEAT MODE** pages 51-54 • **REPLAY RUNDOWN** pages 56-57

FOOTBALL MANAGER 3 arrives at last! Quick, stick it in the tape deck, load it up and... oh dear. ADAM 'FOOTBALL MAD' PETERS is not a happy man. Why not? Read the review...



Rod Lawton

What's going on here? Wanton destruction of a computer? "Er, no." Yes it is. We're not stupid, we can see what you're doing. You're pouring sulphuric acid over that PC someone's accidentally left in the new AA office. "No I'm not, I'm... er... watering the plants." That's not a plant. "Isn't it? Oh. In that case, I've become a surrealist street entertainer. Look out Mrs Bronedsky, the orange Mackerel is flying tonight. Twenty seven. Blip."



Adam Peters

Another suspect caught in the act. What are you playing at, Peters? "Ah, now I'm glad you asked me that. I'm actually on a sponsored ninja to raise money for charity. I've been ninjain'g solid for over 53 hours. This was the only place there was enough space." So you're not trying to smash the PC up then? "Oh dearie me, no." And ninjas use umbrellas then, do they? "Er... no... not always. But this is a special ninja umbrella." Is it? "Yes."



Linda Barker

So what pathetic excuse have you got for your blatant piece of vandalism, Linda? "What blatant piece of vandalism?" We can see what you're doing, attacking that poor keyboard with a pair of scissors and a bar of soap. "I'm cleaning it." Cleaning it? "Yes. This is a brand new cleaning technique from Scandinavia." What's it called then? "Er... Professor Volvo's Scissorsandsoap PC Cleaning Technique." Really? "Definitely."

Reviewed this month

COUNT DUCKULA 2.....3%



FOOTBALL MANAGER 338%



SUPERSTAR SEYMOUR.....80%

The hit parade

1 WILD WEST SEYMOUR
CodeMasters • 82% (AA86)

2 TURBO THE TORTOISE
CodeMasters88% (AA83)

3 NEW ZEALND STRY • Hit Squad .76% (AA73)

4 RAINBOW ISLANDS • Hit Squad .89% (AA78)

5 DIZZY: YOLKFOLK • C/Masters..84% (AA87)

6 ROBOCOP • Hit Squad.....84% (AA78)

7 ITALIA '90 • Tronix73% (AA87)

8 SPELLBND DIZZY • C/Masters...65% (AA87)

9 MULTIMIXX 1: GOLF • Kixx86% (AA73)

10 TAG TEAM WRESTLG • Zeppelin.74% (AA85)

11 DIZZY: RAPIDS • C/Masters.....29% (AA82)

12 MAGIC LND DIZZY • C/Masters..85% (AA64)

13 F16 COMBAT PILOT • Action 16 92% (AA68)

14 BATMAN - MOVIE • Hit Squad94% (AA74)

15 GOLDEN AXE • Tronix58% (AA75)

16 BUBBLE DIZZY • C/Masters79% (AA87)

17 SEYMOUR H'WOOD • C/Masters 88% (AA87)

18 BUBBLE BOBBLE • Hit Squad71% (AA74)

19 DOUBLE DRAGON 2 • Tronix.....27% (AA86)

20 CYBERBALL • Hit Squad.....71% (AA84)



Action replay

RUNDOWN PART 2

Another massive pile of re-releases this month: INDIANA JONES & THE LAST CRUSADE • INTERNATIONAL 3D TENNIS • ITALIA 90 • ITALY 1990 • JANAGHIR KHAN'S SQUASH • KLAX • LAST DUEL • LAST NINJA 2 • LED STORM • LICENCE TO KILL • LOTUS ESPRIT TURBO CHALLENGE • MANCHESTER UNITED • MATCHDAY 2 • MATCHDAY • MIAMI VICE • MICROPROSE SOCCER • MIDNIGHT RESISTANCE • MIKIE • MONTY PYTHON • MOONWALKER • MYTH • NARC • NARCO POLICE • NAVY MOVES • NEMESIS • NEW ZEALAND STORY • NIGHTBREED • OPERATION THUNDERBOLT • OPERATION WOLF • OUT RUN • PLATOON • POWER DRIFT • PUFFY'S SAGA • PUZZNIC • QUARTET • R-TYPE • RAINBOW ISLANDS • RAMBO 3 • RASTAN • RED HEAT • RENEGADE 3 • RETURN OF THE JEDI • RICK DANGEROUS • ROBOCOP • RUN THE GAUNTLET (Loadsagames!)

Football

Addictive ■ 081 804 8100 ■ £10.99 cassette, £15.99 disk

I like football management simulators. There, I've said it. Whole civilisations will pour scorn on me now. Young children will laugh at me in the street. (*They do that already though, Adam - ed.*) But I'm not ashamed. I will say it loud and proud: I like footie management sims. I've served my time with ten season stretches on Soccer Boss and Football Manager 2. I led a play-by-mail team through to League Cup success in their first season. I'm not one of those people (and there are plenty of them reviewing computer games) that disses all management sims as "boring reems of

statistics for trainspotters only". Not me. I know the score.

All of which means that the following words are said neither lightly nor joyfully... *Football Manager 3* is crap. Unutterable crap.

But how can this have happened? *Football Manager 2* was probably the best footie manager game ever (only *Kenny Dalglish Soccer Manager* pushes it close). It featured loads of options, sensibly detailed player attributes, a transfer market at just the right level of buoyancy, plenty of scope for tactical thought, and - best of all -

match highlights that were genuinely exciting (at least some of the time): real on-the-edge-of-your-seat stuff.

Football Manager 3 has none of these. It has very few options, tons of totally unnecessary - and frankly, over the top - guff about the individual players: yeah, like people have got the patience to move all those little bars around to train their players.

The transfer market is crap: you have to pay above, rather than below, the asking price. There is virtually no scope for any sort of thought at all,

Can you 'manage' this little lot?



THE OFFICE

This is where it all happens. Or at least, this is the starting point for making things happen. The office is the equivalent of a main menu: from here you can select items like the diary or the filing cabinet which lead you to the separate option and information screens. Sadly it's not an real iconed-up menu system: you don't click on your chosen item, you just have to lug the joystick left and right to highlight the item that is required.

Accounts		
20 Tue August		
b/f		0
Credits		
Bank Interest		0
Gate Receipts		0
Sold Player		0
Debits		
Bank Interest		0
Buy Player		0
Player Salaries		0
Ground Expenses		0
Appearance Fees		0
New Balance		0
Overdraft Limit		124880
Funds Available		124880

FINANCES

The Board (a lot of grumpy old men in ill-fitting suits) look after the cash. Well they should do, but you don't need to ask them before you spend it all. Beware that overdraft limit - sneak just a smidgeon over it and the game's over (we're not talking the Friendly Bank here). The screen also gives a breakdown of the profit and loss that's occurred since you last had a look at the books. It's purely an information screen, this one.

Contract	
Expiry Date	2/12/91
The Manager	

THE FILING CABINET

The filing cabinet contains records of all your players. Not criminal records sadly, the cabinet probably isn't big enough. What you get is info like their wage, their age, details of all their different skills, a lovely little picture of them, and much, much more. And if you get bored of snooping on your players, there's a manager's record in here too. It details your performance to date. Chances are it won't make for pleasant bedtime reading.

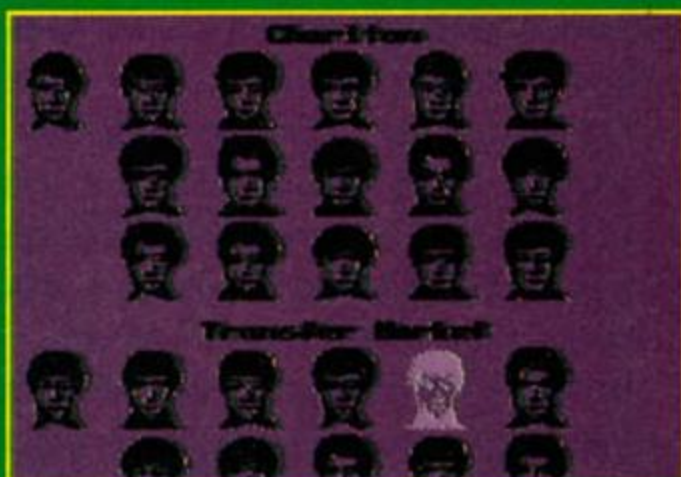

THE TRANSFER MARKET

What a motley collection of young men this lot are. The ones in the top half of the screen are your team, hoping that you won't click on them (to put them up for sale). In the bottom half of the screen are the Prima Donnas and old codgers that you could buy if you had enough money. Click on your target, check out their vital statistics, then jiggle about with those figures (transfer fee, player's wage, appearance fee) to strike a deal.

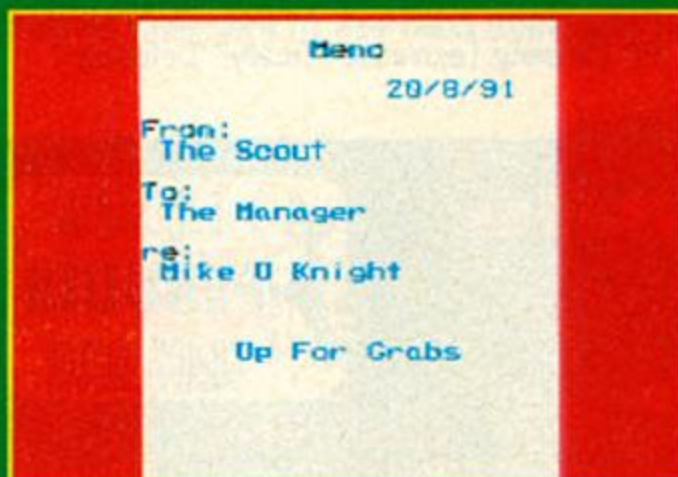

MEMOS

Hmm, not a lot happening here really. You've got to read the memos, otherwise they just stay cluttering up your desk, but mostly it's just the scout telling you who's on the transfer market ("we already know mister scout, we've looked") and the bank manager informing you that your overdraft has been increased by £6 ("cheers, mister bank manager"). Important memos ("you're sacked", "you've died horribly") pop up automatically.



TEAM FORMATION

An opportunity to fiddle about with your team (oo-er). You can move players about, trying them in different positions... er, on the field... er, in the team: midfield, defence and stuff. If you want to add someone to the team, you've got to kick someone else out of it first. Click on the little icons and you can drag players around the pitch. It's almost a game in itself. (In fact, it might even be a better game than the one you've bought.)

Manager 3

let alone tactical. And the match highlights? Don't make me cry. Tiny sprites jerking around in slow motion for hours on end with nothing at all happening (you probably wouldn't be able to see it if anything was happening).

As a special bonus, the end of the game comes instantly unless you keep an eagle eye on your cash. Bust your overdraft limit and that's it. No warnings. No re-negotiations. A little memo pops up telling you to load the game again as you've just lost. Twig off.

The masterful hand of Kevin Toms is no

longer at the wheel, and the *Football Manager* series careers off course ignominiously. Like the Beatles reforming to perform Kylie Minogue songs or James Dean returning from the grave to star in a *Carry On* film, this kind of thing is both unthinkable and very sad. The bottom line is: *Football Manager 3* is virtually unplayable. Buy *Football Manager 2* (available for £3.99 on the electronic duplication system at large John Menzies stores) instead. And if you've already got it, then that's even more reason to give FM3 a wide berth.

4th Division
31 Sat August

Barnford	Gillingham
Lincoln	Doncaster
Midstone	Crewe
Mansfield	Chestrfld
Wthampton	Carlisle
Rochdale	Cardiff C
Rotherham	Burnley
Scarboro	Blackpool
Walsall	Brexham
Charlton	Scunthorpe

The weekend's fixtures... hmm, some interesting tussles there between some of the big guns of international soccer. My money's on Scunthorpe...

4th Division
31 Sat August

	P	D	L	F	A	Pts	
9 Mansfield	1	1	0	0	1	0	3
10 Cardiff C	1	1	0	0	1	1	1
11 Rochdale	1	1	0	0	1	1	1
12 Halifax	0	0	0	0	0	0	0
13 York	0	0	0	0	0	0	0
14 Scarboro	1	1	0	0	1	1	1
15 Wthampton	1	1	0	0	1	1	1
16 Brexham	1	1	0	0	1	1	1
17 Chestrfld	1	1	0	0	1	1	1
18 Midstone	1	1	0	0	1	1	1
19 Doncaster	1	1	0	0	1	1	1
20 Gillingham	1	1	0	0	1	1	1
21 Rotherham	1	1	0	0	1	1	1
22 Charlton	1	0	0	0	1	0	0

8 Sun September	12 Thur September Fred R. Smith
9 Mon September League Match Gillingham Home	13 Fri September
18 Tue September	14 Sat September League Match Crewe Away
11 Dec September League Cup	Notes Birthdays

Name: Nigel D Knight
Age: 26 Years Old
Status: Playing

PHYSICAL: Speed, Fitness, Stamina
SKILLS: Dribbling, Passing, Tackling, Shooting, Keeping

Contract Length: 3 Year
Annual Salary: 21000
Appearance Fee: 44
Offer Price: 103000
Make Offer

What are we bid for this slightly geeky looking young man? We'll start the bidding at two Polos and a photo of Joanna Lumley. Do we hear three Polos and a Donovan LP?

THE COMPUTER

It's terribly hi-tech in the world of domestic soccer now you know. Vital information such as the league tables, fixtures and the club history are stored on a database on your trusty old PC. As long as we can get through the season without the machine crashing or catching a virus, I'll be happy... Incidentally, First Division Manager from CodeMasters was the first CPC footie sim to go for both the computer and the graphic menu screen.

Name: Ian A Morris
Age: 36 Years Old
Status: Playing

PHYSICAL: Speed, Fitness, Stamina
SKILLS: Dribbling, Passing, Tackling, Shooting, Keeping

TEAM TRAINING

Well it's called team training, but each player undergoes their own individual routine. Select a player and a screen like this appears. Jiggle about the blue bars to specify the amount of training in each separate area (and the amount of rest). The red bars show the player's current level of ability in each area. Giving extra training in the areas that they're weakest in seems like a pretty sensible tactic to me. What do you reckon, readers?

THE DIARY

Where would a football manager be without his diary? Probably in the wrong place at the wrong time. This useful little book keeps track of all those important little events. (Like football matches and stuff.) You can flick back and forth through the pages for the whole season, in case you ever feel the need to know who you're playing on March 7th. Strangely enough, the game begins in the 1991-2 season (pre-Premier League). Hmm, curious...



THE MATCH

Aha! The animated match action sequences. Hurrah! Um... so has the game started yet then? Unfortunately the match sequences in FM3 are almost stunning bad. Lots of tiny little sprites jerking around the screen for what seems like eternity. Frankly, I don't care if we win or lose, I just want this over with. These bits should be the most exciting part of the game. They're not. They are truly irritating, and the biggest nail in FM3's coffin.

VERDICT

GRAPHICS 46%
Class 3B of Hinchley Wood Primary School have done a terrific job! A bit garish and quite primitive.

SONICS 2%
Not a lot going down in this department, but what do you expect? It's a management game, dudes.

GRAB FACTOR 28%
Well, the graphic menu screen looks hell of a lot more inviting than most management sim menus...

STAYING POWER 15%
...but the moment you have to sit through some match highlights, you'll give up and go and watch TV.

FOOTBALL MANAGER 3 will give GONE WITH THE WIND a good run for its money in the tearduct stakes.

RATING 38%

Superstar

CodeMasters ■ 0926 814132 ■ £12.99 cassette

The first compilation starring Mr Lardball offers five blobtastic games. Here's big reviews of the two newies and mini-reviews of the three oldies. Courtesy of ADAM PETERS, your lardacious host...

Seymour goes to Hollywood

The game that started it all. *Dizzy in Movie Land* hits a snag when the Oliver Twins say they don't want Dizzy taken out of a fantasy setting. A few minor tweaks to the Dizzy sprite and *Seymour goes to Hollywood* (or *Seymour at the Movies* as it's also known) is born.

OK, so it's difficult. Difficult to an almost *Spellbound Dizzy* degree. (The complete solution



SEYMOUR GOES TO HOLLYWOOD is still a favourite here in the AA offices. Tons to do, tons to see, tons in general really. We lurve it.

fills several pages of A4.) And there are a few nasty instant death situations (the *Flash Gordon* set is particularly annoying). But at the end of the day, this is easily the best arcade adventure CodeMasters have produced to date.

There's tons of variety in the different sections (treehuts, offices, various film sets) and a lot of very clever puzzles. The last of these games to slip through before the backlash started.

88%



SUPER SEYMOUR "saves the planet" we are told. Hmm... From a bevy of giant fans and a mouldy peanut, by the look of things.

Super Seymour

Some people rate this *Bombjack* clone very highly. Not us. Sure it's fun, but this really is gameplay at its most simplistic. Seymour has to leap his way round the screen, bedecked in his finest Dick Turpin outfit, collecting radioactive things. (Oh great, another environmental computer game - I wonder how much packaging they've used for this one.) Enemies try to get in his way, but he can jump on their heads a few

Sergeant Seymour Robotcop

Even the most hardened Seymour-basher will have pleasant words to say about this one. *Robotcop* is a brilliant mazy shoot-em-up, with only a measly quota of lives (three) going against it. Oh yeah, and a really naff name. *Sergeant Seymour Robotcop*... I ask you!

We love innovative maze games here at AA Towers and *Sergeant* gives Hi-Tec's classic *Insector Hecti* a good run for its money in our affections. The game begins in the Ice Zone where a giant snowman gives birth to snowballs, Eskimos and assorted wintery things. Once the screen is cleared of enemies you can progress to the next level.

To wax the enemies you need to first catch them with your handy Black & Decker extend-

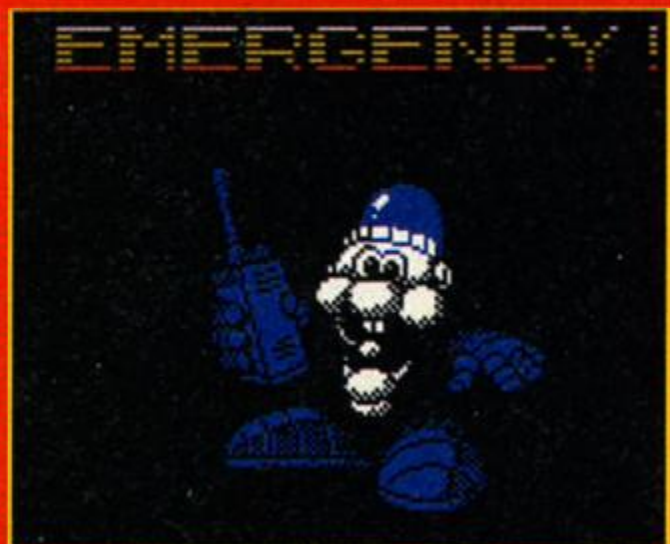

For various technical reasons we couldn't get any grabs of **SERGEANT**. Plan B: some Spectrum grabs nicked off YOUR SINCLAIR.

able arm, then throw them against a wall (ouch). There are loads of excellent power ups to be had, including various weapons (laser, rocks), different types of invincibility, some food and lots of letters of the alphabet, which you collect to try and spell 'Robotcop' (for untold bonuses).

It's great fun grabbing enemies and throwing them at other enemies, but the distinct lack of enough lives is a major problem. There are a total of 50 levels, split into five zones, but no-one in the Future Publishing offices (and we're talking some of Britain's most experienced gamers) has got past level eight. Three lives simply isn't enough for a game as strewn with hazards as this one.

There are actually a number of opportunities to prolong your life, though: if a telephone on screen starts ringing, get to it quick for a bonus screen and safe passage to the next level; collect all the letters of the word 'Robotcop' and... er... you probably get an extra life or something. (You haven't managed to collect all the letters yet then? - ed.) No, but I've come really close. The last six times I've played I've only needed one more letter to complete the word.

Nick Ross: So what does happen when you collect all the letters of the word? Have you or a relative seen this event occurring? If so, we'd like to hear from you on Seymourwatch UK. And don't have nightmares. Have really nice dreams. About flowers and chocolate cake.



SERGEANT SEYMOUR ROBOTCOP looks funky on the Speccy. It's even funkier on the CPC. It's not a Speccy port. It's fab, trust us.

Sergeant Seymour is great fun. The sarge's extendable arm is the key to hours of baddie-hurling, power up-snatching lardball hi-jinks. *Insector Hecti at the Interchange* is still the best maze game of the '90s, but *Sergeant Seymour* comes in a fairly creditable second. If only it wasn't so... yikes, damn, wooh, oops, lost again... darned difficult.

Incidentally, I will gladly marry the first person to supply *Cheat Mode* with a cheat for extra lives. (Don't all rush at once, readers - ed.)

An excellent maze game with loads of nice touches. The programmers were a little stingy on the lives side, frankly, but I'm sure it won't be long before some committed cheater finds a way round that.

81%

Seymour



WILD WEST SEYMOUR is full of in jokes which will no doubt have all the Codies staff (and their immediate families) in hysterics.

times to kill them and blag himself a power up or two from their lifeless corpses.

What do you get? You get Spectrum style graphics, big clumsy slow-moving sprites, and one of the most mindless game styles ever. "Gameplay may become repetitive and requires no thought" said AA of *Bombjack* back in 1987. Five years on and I, for one, am not going to argue.

47%

Fun for a while. A short while.

Wild West Seymour

There's nothing like a happy medium (and we don't mean Doris Stokes with a smile on her face). And this is nothing like a happy medium. On the one hand, there's the hyper-difficulty of *Seymour goes to Hollywood*, a game you'll still be trying to finish from the grave. And on the other hand, there's *Wild West Seymour*, a game that you'll finish within a matter of hours.

Remember *Seymour Take One*, the mini-game on the AA77 tape? *Wild West* is the same sort of thing as far as difficulty goes, only bigger.

Poor old Codies. People complain when the games are too difficult, and people will complain that this one's too easy. If only the programmers could find that happy medium. We'd still complain, because we enjoy complaining. But we'd be happy.

75%

OVERALL VERDICT

Grumbles and gripes aside, *Superstar Seymour* is a bit of a bargain, as long as you haven't already got too many of the games. More varied and of better overall quality than either of the Dizzy compilations. Fairly recommended.

80%

Stuntman Seymour

Who is the star of this game? Seymour? It doesn't look anything like him. Seymour is a potato (no he's not, he's a lardball - Codies) but the character in this game looks more like a pebble. The game itself is something not unadjacent to *DJ Puff* with different sprites.

DJ Puff, let's be honest, isn't the most inspiring of games. A slow and jerky platform shoot-em-up with less than a tenth of the appeal of, say, *Cauldron*: a game which featured the same sort of jumping-round-a-castle gameplay, but with added excitement. Excitement is a bit thin on the ground in *DJ Puff* and thinner still in *Stuntman Pebble*.

There are cowboys and indians pacing round the place in set patterns (none of that intelligent enemy movement nonsense here) and your Seymour-esque hero has bullets and bombs to despatch them with. When they die they turn into bags of money, extra bombs, food and such like.

This is something that has always troubled me. I cannot believe that these characters really do turn into things like that when you kill them. As far as I'm concerned, if something is a banana when it's dead, then all it could possibly have been when it was alive is... a banana.



STUNTMAN SEYMOUR is a platform game in the mould of DJ PUFF. Not that we're saying DJ PUFF is mouldy or anything.

One that walked and talked maybe, but a banana nonetheless.

The only other alternative is that the pick up objects actually fall out of the enemies pockets when they cop it. A more convincing argument, but there are still problems with it: objects are often too big to fit in even the most generous of pockets, and (far more spookily) it still doesn't explain where the bodies go.

I have my own theory on that (oh dear, I don't want to hear this - ed). My theory is that some kind of spiritual entity similar to the tooth fairy is at work. The tooth fairy, as you will all be aware, takes your teeth and gives you some cash. The computer sprite fairy, on the other hand, takes computer sprites that are no longer needed (ie an enemy that's been killed) and in return gives you something nice that will be of use to you within the game. The most common objects you're given are sweets and ice creams - maybe the computer sprite fairy has got a deal going with the tooth fairy.

It gets creepier. We all know the tooth fairy collects teeth to make pianos out of (she sells pianos to fellow fairies for a living), but what does the computer sprite fairy do with all the dead computer sprites? Does the idea of zombie sprites gathering as an army in the fifth dimension, ready to invade our world and slay us in act of bloody revenge, scare you at all? It certainly scares me.

Some of you might think this theory is a load of ill thought-out, childish, pointless nonsense. Strangely enough, that's also exactly what *Stuntman Seymour* is.

A dull and repetitive platform game, with boring walking, boring shooting, boring jumping and not much else. DJ Puff with less to do and graphics that don't give you migraine.

38%



Who is this? Seymour? It looks more like my Aunt Nellie. (Is NELLIE THE AUNT OF YOURS THAT LOOKS LIKE A POTATO? - Ed.) Yeah. So.



Things are all chaotic near the saloon. Seymour's found himself in the middle of a cowboys and indians fight. Whoops.

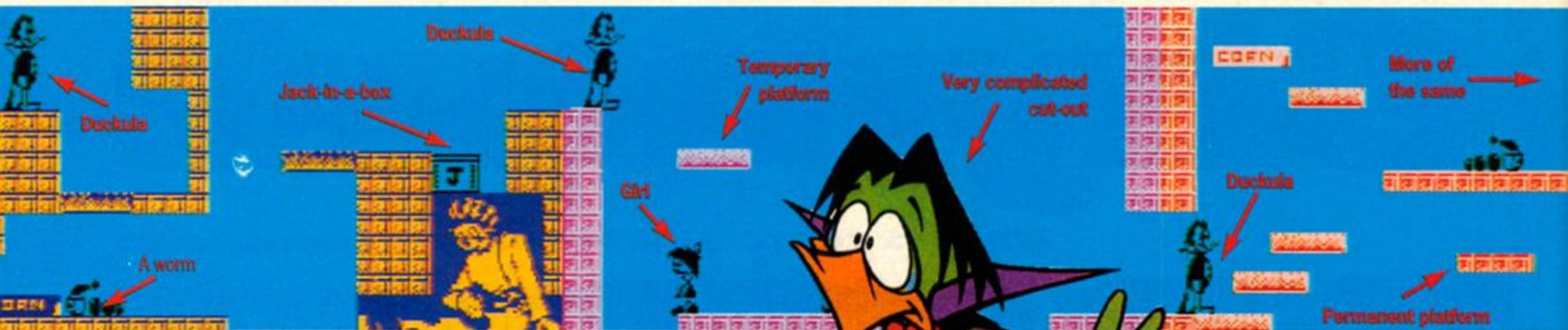

Count Duckula 2



Alternative ■ 0977 797777 ■ £3.99 cassette



Hurrah! When things get tough call up Tremendous Terence for a helping hand.

The vultures are gathering. You can hear them flapping overhead. Down below, fifty feet below, Rod Lawton stares at his computer screen in disbelief, then wails in despair, "this is dreadful, absolutely dreadful." The vultures stare down, sharpening their beaks, preparing to pounce. It's not the cheery, bearded editor they're after, but the small rectangular box of audio tape resting in the 464.

Blocks appear and disappear on screen, very slowly. It's slow motion. The vultures laugh. Someone says something about nought per cent. Someone else ponders exactly why Alternative refused to send us a review copy. We hold a quick straw poll round the office and *Count Duckula 2* is officially recognised as THE WORST CPC GAME OF ALL TIME. The vultures leap into action, ready to tear the tape apart.

But we're not a lynch mob. We're not, and don't you dare say we are. We understand that a game has rights. A fair trial is called for.



Oh look! A worm, a jack-in-the-box, a ketchup bottle, and loads of platforms.

Wigs are glued to heads, Lam grabs the gavel and starts beating the vultures round the head with it. In the blue corner, the prosecution sit playing with their elastic bands: Adam Peters, Rod Lawton, Jon Pillar from *Your Sinclair*, and anyone who happened to wander into the office while the game was running. And in the yellow corner: Alternative Software, suppliers of computer games to the youth of Britain. Seconds out.

CASE FOR THE PROSECUTION

"M'lord, ladies, gentlemen, all evidence points to *Count Duckula 2* being a criminally poor game, the worst ever unveiled on the CPC community.

"Your character must jump from block to block, through loads of levels. Blocks appear and disappear, and the game moves slower than any other commercial release. We were genuinely amazed to learn it was programmed in machine code. It looks like it's written in BASIC. We wouldn't use this if it was submitted as a type-in.

"The graphics would have been laughable in 1984, let alone now. Colour clash graphics from hell and zero animation. Duckula doesn't jump through the air, he stands through the air. What's the point of the game? There isn't any. You jump your way across a few screens, firing at people with your tomato sauce gun if you feel like it (it isn't necessary). And the shoot-em-up section from the Commodore 64 version has been left out. Jezebels! Philistines!

"What makes this game even more damnable is the shame it brings upon the name of Count Duckula, Britain's most wickedest cartoon char-



Ha ha! Mr Teddy Bear doesn't look too clever now that he's covered in ketchup...

acter. This game should be sent into the eternal pain and loathing of the ungodly fires that fill the seventh level of hell. It should be hung, drawn, quartered, halved, tarred, feathered, whipped, poached, fried, scrambled, beaten, smashed, trashed, ripped, torn, shredded, stamped on, spat on,

kicked, punched, thrown, shot, stabbed, drowned, looked upon disdainfully, and finally LEFT TO THE RAVENOUS BEAKS OF THE VULTURES THAT STALK THIS DAWN. We want the highest sentence this court is authorised to carry out: a nought per cent verdict. Nothing else will do. Nothing else would adequately serve the CPC community and the public at large. So there."

CASE FOR THE DEFENCE

"It was rushed."

THE SENTENCE

"As judge it is my duty to weigh up the evidence. It weighs two hundred tons. It is fresh, it is steaming and it leaves me with no other option. CD2 should be locked away, lest it fall into the hands of (disappointed) children."

Adam Peters

VERDICT

GRAPHICS Just look at the screenshots for as long as you can bear. Then step outside and scream very loud.	5%
SONICS A reasonably funky title tune, plus some pretty sad (and very limited) in-game effects.	32%
GRAB FACTOR Slow. Jerky. Basic. Frustrating. Dull. Pointless. Repetitive. Requires great patience. Easy with practice.	4%
STAYING POWER Basic. Jerky. Pointless. Repetitive. Frustrating. Dull. Slow. Easy with practice. Requires great patience.	2%

If there's a worse game than **COUNT DUCKULA 2** anywhere in the world, we've never seen it. And we'd rather not.

RATING 3%

ROM PRODUCTS

DISK DRIVE PRODUCTS

SOFTWARE

ROMBO ROMBOARD £25.00
The most widely used of all CPC romboards. 8 sockets, each with an on/off switch; low or high slots selectable; provision for ZIF socket and 16K ramrom add-ons; boxed with through connector.

EPROM PROGRAMMER £30.00
The Rolls Royce of eprom programmers. Programs 8K, 16K and 32K eproms (32ks allow 2 programs in 1 eprom), 21 and 12.5 volt types. handles most eproms, including CMOS, at its fast (105 seconds) speed. Programs all or part eprom; ROM to ROM copying. Includes a PD games ROM and utilities to turn Basic and machine code programs into ROM files plus instructions on ROM layout and how to use the 2 program 32k eprom.

BLANK EPROMS
16K and 32K new - £3.50 each or 5 for £15.00
32K used and erased - £1.00 ea. (minimum 5)

32K RAMROM £14.95
32K of RAM that behaves like two 16K ROMs. When loaded with ROM programs, each 16K block acts as a ROM until the computer is turned off - even surviving resets. Ideal for writing, editing and testing ROM programs without the need to blow and erase eproms. Links allow choice of ROM slots. Three switches control operations.

ROMONOFF SWITCH £7.95
Connects to the CPC's expansion port to turn all external ROMS ON or OFF as desired. Not suitable for a 464 with disk drive.

6128 UPGRADE ROM £24.95
Supplied with full instructions of several different fitting methods.

ROM SOFTWARE

PROTEXT	£30.00	UTOPIA	£25.00
PROPELL	£25.00	MAXAM	£30.00
PROMERGE	£25.00	MAXAM 1.5	£25.00
PD GAMES ROM (2 games and utilities)	£3.50		

3 1/2" DUAL-MODE DISK DRIVE

£79.95 inc. carriage

Includes MS800 on disk and ROM plus TEN 3 1/2" disks FREE!

MODE 1 - works as a standard B drive storing 180K per side.
MODE 2 - stores up to 800K per disk when used with MS800, Ramdos, Romdos or Rodos.

NOTICE - Do not be deceived by unscrupulous statements. No CPC 3.5" drive needs a side switch to store up to 800K per disk. Those that have one provide EXTRA facilities for the user.

Our ultra quiet, super slim drive is housed in a sturdy metal casing and is supplied complete with everything you need to use it immediately. Its off the desk power supply allows it to fit neatly on top of the 6128's internal drive. It is fitted with a side switch to allow Mode 1 operation and the use of the number 1 high capacity formatter - MS800.

This drive is suitable for all CPCs including the Plus machines but the 464s also need a disk drive interface. Please state your computer model.

ABBA SWITCH £12.95

Swaps the internal A and external B drives around so that the A becomes the B and vice versa. 6128 (not Plus) and 664 only. Works with any external drive. NOTE: MS800 is the only high capacity formatter that can recognise its disks in drive A.

3rd DRIVE SWITCH £12.95

Allows two B drives to be connected to the 6128 or 664 and switch between them at will. Allows B to B copying.

DRIVE ADAPTORS Various

Short extensions that allow any CPC drive to work on other computers. Computers catered for are:- ST, Amiga, PCW and PCs. Write or phone for details.

3" Amsoft disks 10 for £20.00
3.5" disks 10 for £7.50
FD1 second 3" drive £79.95
ROMDOS (ROM only) £9.95
Side switch kit £3.00

MS800 ROM

for existing MS800 disk owners - £5.50.
Proof of ownership is required.

BONZO SUPER MEDDLER £13.95

Transfers a large percentage of games from tape to disk. Produces stand-alone transfers. Inc. a very large database of verified transfers.

BONZO BLITZ £13.95

Transfers all known varieties of SPEEDLOCKS from tape to disk. Stand-alone transfers. Large database of verified transfers.

BONZO'S FLASHPACK £9.95

Fast, flexible database; superb football pools predictor; screen and sprite designer.

MS800 disk or ROM £9.95; both £14.95

MS800 is the number 1 in high capacity formatters allowing up to 800K storage on each 3.5" disk. It is the ONLY one that doesn't need to be present for its disks to be used - stand alone disks. It is the ONLY one that is compatible with all software since it uses no memory. It is the ONLY one that can recognise its disks in drive A - good for ABBA switch owners. It comes complete with its own copying utility and a menu program that allows many transferred games to run on drive B. Or, to put it another way, IT'S THE BEST.

MAXIDOS £13.95

The most comprehensive and effective disk utility available with far too many features to list.

464 PLUS UPGRADES

We now offer the following low cost upgrades for the 464 Plus:-
EXTRA 64K RAM.....from £15.00
DISK DRIVE INTERFACE.....from £30.00

Please write or phone for full details

AVATAR

39 CROSSFELL ROAD,
LEVERSTOCK GREEN,
HEMEL HEMPSTEAD,
HERTS, HP3 8RG

MAJOR CREDIT CARDS
ACCEPTED

0442 - 251705

Monday to Friday
No callers please

THIS IS YOUR LAST CHANCE

Get a MULTIFACE Two for ONLY £34.95

ROMANTIC ROBOT are moving away from 8-bit computing. The MULTIFACE will always remain the BEST thing that has ever happened to the Amstrad CPC - but it's time to move. If you haven't got a MULTIFACE 2, make YOUR move NOW. This is our BIG CLOSING SALE - get the fabulous MULTIFACE 2 with a fab DISCOUNT while you can!

(PLEASE ADD £2.00 P&P)

Do you need to know what happens ANY TIME INSIDE a RUNNING CPC program?

Get INSIDE INFORMATION!

Install INSIDER into MULTIFACE, RUN a program, let Multiface FREEZE it and the INSIDER tell you everything: it will fully disassemble, find text or code, show/alter RAM and the Z80 registers, dump to printer. All this & more for £14.95.

Now HALF-PRICE: £7.95 on disk!

Invaluable tool for machine code users!
Unique de-bugging/development aid.

You MUST NOT use our products to copy, reproduce or infringe in any way any copyright material without the permission of the copyright owner. We do neither condone nor authorise the use of our products for the reproduction of copyright material - to do so is ILLEGAL! All prices are already discounted and apply to Mail Orders to 21/12/92 only.

I order a MULTIFACE 2 for CPC 464/6128 £47.95 **£34.95** or for CPC+ £49.95 **£34.95** PLUS P&P per item: UK / Europe £2 Overseas £3.
RODOS £29.95 **£14.95** RODOS XTRA £9.95 **£4.95** INSIDER £14.95 **£7.95**

I enclose a cheque/PO/cash for £..... or debit my Access/Visa No. Card Exp.....

Name/address.....

ROMANTIC ROBOT, 54 Deanscroft Ave, London NW9 8EN ☎ 24 hrs 081-200 8870 AA

COMPUTER REPAIRS

★ AMSTRAD AUTHORISED ★

Quality Assured!



- ★ Fixed price repairs on many machines
- ★ Over 2500 square foot engineering complex
- ★ Top quality technicians at your disposal
- ★ All work warranted
- ★ Fast turnaround
- ★ Simply post or hand deliver your machine and we will do the rest

Amstrad 464	£37.00
Amstrad 6128	£41.00 (extra if disk drive needs complete replacement)
All monitors	£15.00 Diagnostic charge plus quote
Others	P.O.A.

Please supply evening and daytime telephone numbers

WTS Electronics Ltd reserve the right to refuse machines that in their opinion are beyond reasonable repair. Full charge applies.

Tel: 0582 491949 (4 lines)

WTS Electronics Ltd, Chaul End Lane, Luton, Beds LU4 8EZ

FRENCH TEST

- suitable for beginners and advanced alike -

£14.95 (Disc only)

- * Over 2500 words organised into more than 80 different topics and 40 dictionary tests plus dozens of useful phrases.
- * Flexibility - select from GCSE topics (Basic and Higher) or enter own vocabulary and merge a term's homework for revision.
- * Two levels - Quick Test for rapid revision and Full Test for language learning with inbuilt PROGRESS ASSESSMENT.

"Accurately and slickly presented, Guillotine game very well done" AA

"An excellent utility which puts the fun back into learning" ACU

NOTE: Using this program ensures success at GCSE - pass or we guarantee to refund your money in full.



Including LA GUILLOTINE



(cheques etc. to:) GMF Programs, Dept ACU, 21 Northwick Park Road, Harrow, Middx. HA1 2NY Tel. 081 861 2891 + Evenings & Weekends.

\$1000
USE YOUR VOICE
TO OUTDRAW THE GUNFIGHTER
WIN BIG CASH PRIZES

0891 313578

TERMINATION

Win A Mega Drive

0891 313589

TREASURE ISLAND

USE YOUR VOICE TO LOCATE THE TREASURE

0891 313586

If you are under 18 years of age please obtain permission of whoever pays the phone bill. Max cost of call £2.70 Cheap £3.60 All Other Times. INFODIAL PO Box 36 LS1 4TN Call charges 36p Per Min Cheap 48p Per Min All Other Times.



(0257)
421915

O.J. SOFTWARE

Fast Friendly Service



(0257)
421915

ADVENTURE	COMPILATIONS	EDUCATION	PRINTERS																																																																																																																																																								
<p>ADVENTURE</p> <table border="0"> <tr><th>CASS</th><th>DISK</th></tr> <tr><td>Acheton.....</td><td>£11.95</td></tr> <tr><td>Avon (with Murdac).....</td><td>£11.95</td></tr> <tr><td>Countdown to Doom.....</td><td>£11.95</td></tr> <tr><td>Return to Doom.....</td><td>£11.95</td></tr> <tr><td>Last Days of Doom.....</td><td>£15.95</td></tr> <tr><td>Kingdom of Hamil.....</td><td>£11.95</td></tr> <tr><td>Philosophers Quest.....</td><td>£11.95</td></tr> <tr><td>Lancelot (128K).....</td><td>£15.95</td></tr> <tr><td>Time & Magic (128K).....</td><td>£12.95</td></tr> <tr><td>Hero Quest + Ret W/Lord.....</td><td>£10.95</td></tr> <tr><td>War in Middle Earth.....</td><td>£11.95</td></tr> <tr><td>Famous Five on Tr. Island.....</td><td>£9.50</td></tr> <tr><td>Giant Killer Maths Adventure.....</td><td>£15.95</td></tr> </table>	CASS	DISK	Acheton.....	£11.95	Avon (with Murdac).....	£11.95	Countdown to Doom.....	£11.95	Return to Doom.....	£11.95	Last Days of Doom.....	£15.95	Kingdom of Hamil.....	£11.95	Philosophers Quest.....	£11.95	Lancelot (128K).....	£15.95	Time & Magic (128K).....	£12.95	Hero Quest + Ret W/Lord.....	£10.95	War in Middle Earth.....	£11.95	Famous Five on Tr. Island.....	£9.50	Giant Killer Maths Adventure.....	£15.95	<p>COMPILATIONS</p> <table border="0"> <tr><th>CASS</th><th>DISK</th></tr> <tr><td>2 HOT 2 HANDLE: Golden Axe, Sup. Off Rd, Tot. Recall, Shad. Warriors.....</td><td>£12.95</td></tr> <tr><td>FISTS OF FURY: Shinobi, Double Dragon II, Ninja Warriors, Dyn. Dux.....</td><td>£9.99</td></tr> <tr><td>HOLLYWOOD COLLECTION: Bman Movie, Robocop, Gbusters II, I. Jones L.C.....</td><td>£11.95</td></tr> <tr><td>LINEKER COLL: Italy 1990, G.L.H./Shots, G.L. Sup Skills, Sup Star Soccer.....</td><td>£9.95</td></tr> <tr><td>MEGA SPORTS: 30+ Sporting Events.....</td><td>£15.95</td></tr> <tr><td>MINDSTRETCHERS: Monopoly, Scrabble, Cluedo.....</td><td>£12.95</td></tr> <tr><td>MOVIE PREMIERE: Turtles, Gremlins II, Back Fut II, I. Jones L.C.....</td><td>£11.95</td></tr> <tr><td>SOCCER STARS: Kick Off II, Gazza II, Emlyn Hughes, Microprose Soccer.....</td><td>£11.95</td></tr> </table>	CASS	DISK	2 HOT 2 HANDLE: Golden Axe, Sup. Off Rd, Tot. Recall, Shad. Warriors.....	£12.95	FISTS OF FURY: Shinobi, Double Dragon II, Ninja Warriors, Dyn. Dux.....	£9.99	HOLLYWOOD COLLECTION: Bman Movie, Robocop, Gbusters II, I. Jones L.C.....	£11.95	LINEKER COLL: Italy 1990, G.L.H./Shots, G.L. Sup Skills, Sup Star Soccer.....	£9.95	MEGA SPORTS: 30+ Sporting Events.....	£15.95	MINDSTRETCHERS: Monopoly, Scrabble, Cluedo.....	£12.95	MOVIE PREMIERE: Turtles, Gremlins II, Back Fut II, I. Jones L.C.....	£11.95	SOCCER STARS: Kick Off II, Gazza II, Emlyn Hughes, Microprose Soccer.....	£11.95	<p>EDUCATION</p> <table border="0"> <tr><th>CASS</th><th>DISK</th></tr> <tr><td>Fun School III or IV U5.....</td><td>£10.95</td></tr> <tr><td>Fun School III or IV 5-7.....</td><td>£10.95</td></tr> <tr><td>Fun School III or IV 7-11.....</td><td>£10.95</td></tr> <tr><td>The Shoe People 4-6.....</td><td>£8.95</td></tr> <tr><td>Lets Play with Words 4-8.....</td><td>£12.95</td></tr> <tr><td>Fun with Words 7.....</td><td>£8.50</td></tr> <tr><td>Read Right Away 1 5-8.....</td><td>£9.95</td></tr> <tr><td>Read Right Away 2 6-9.....</td><td>£9.95</td></tr> <tr><td>Read Right Away 3 7+.....</td><td>£9.95</td></tr> <tr><td>Better Spelling 9+.....</td><td>£8.95</td></tr> <tr><td>Lets Play Numbers 4-8.....</td><td>£12.95</td></tr> <tr><td>Lets Play Money 4-8.....</td><td>£12.95</td></tr> <tr><td>Primary Maths 3-12.....</td><td>£24.95</td></tr> <tr><td>Fun with Numbers 7.....</td><td>£8.50</td></tr> <tr><td>Target Maths 6-13.....</td><td>£10.95</td></tr> <tr><td>Micro Maths 9-16.....</td><td>£24.95</td></tr> <tr><td>Better Maths 12-16.....</td><td>£8.95</td></tr> <tr><td>Mega Maths 15+.....</td><td>£24.95</td></tr> <tr><td>Biology 1 12-16.....</td><td>£8.95</td></tr> <tr><td>Chemistry 1 12-16.....</td><td>£8.95</td></tr> <tr><td>Physics 1 12-16.....</td><td>£8.95</td></tr> <tr><td>French Mistress 11+.....</td><td>£15.95</td></tr> <tr><td>German Master 11+.....</td><td>£15.95</td></tr> <tr><td>Italian Tutor 11+.....</td><td>£15.95</td></tr> <tr><td>Spanish Tutor 11+.....</td><td>£15.95</td></tr> <tr><td>Micro English 8-Ad.....</td><td>£24.95</td></tr> <tr><td>The Three Bears 5+ (6128).....</td><td>£12.95</td></tr> <tr><td>Five on Treasure Island.....</td><td>£9.50</td></tr> <tr><td>Granny's Garden 6-10 (6128).....</td><td>£16.95</td></tr> <tr><td>Dragon World 6-10 (6128).....</td><td>£20.95</td></tr> <tr><td>Giant Killer Maths Adv 9-14.....</td><td>£15.95</td></tr> <tr><td>Answer Back Jr Quiz 6-11.....</td><td>£11.95</td></tr> </table>	CASS	DISK	Fun School III or IV U5.....	£10.95	Fun School III or IV 5-7.....	£10.95	Fun School III or IV 7-11.....	£10.95	The Shoe People 4-6.....	£8.95	Lets Play with Words 4-8.....	£12.95	Fun with Words 7.....	£8.50	Read Right Away 1 5-8.....	£9.95	Read Right Away 2 6-9.....	£9.95	Read Right Away 3 7+.....	£9.95	Better Spelling 9+.....	£8.95	Lets Play Numbers 4-8.....	£12.95	Lets Play Money 4-8.....	£12.95	Primary Maths 3-12.....	£24.95	Fun with Numbers 7.....	£8.50	Target Maths 6-13.....	£10.95	Micro Maths 9-16.....	£24.95	Better Maths 12-16.....	£8.95	Mega Maths 15+.....	£24.95	Biology 1 12-16.....	£8.95	Chemistry 1 12-16.....	£8.95	Physics 1 12-16.....	£8.95	French Mistress 11+.....	£15.95	German Master 11+.....	£15.95	Italian Tutor 11+.....	£15.95	Spanish Tutor 11+.....	£15.95	Micro English 8-Ad.....	£24.95	The Three Bears 5+ (6128).....	£12.95	Five on Treasure Island.....	£9.50	Granny's Garden 6-10 (6128).....	£16.95	Dragon World 6-10 (6128).....	£20.95	Giant Killer Maths Adv 9-14.....	£15.95	Answer Back Jr Quiz 6-11.....	£11.95	<p>PRINTERS</p> <p>All printers listed below are suitable for use with Amstrad CPC, Atari ST, Commodore Amiga, IBM PC & Compatibles When ordering please state computer</p> <table border="0"> <tr><td>Citizen 120D + 9 pin mono.....</td><td>£139.95</td></tr> <tr><td>Star LC20 9 pin mono.....</td><td>£149.95</td></tr> <tr><td>Panasonic KXP 1170 9 pin mono.....</td><td>£159.95</td></tr> <tr><td>Star LC100 9 pin mono/colour.....</td><td>£199.95</td></tr> <tr><td>Star LC200 9 pin mono/colour.....</td><td>£219.95</td></tr> <tr><td>Panasonic KXP2180 9 pin m/col.....</td><td>£209.95</td></tr> <tr><td>Star LC24-10 24 pin mono.....</td><td>£209.95</td></tr> <tr><td>Star LC24-100 24 pin mono.....</td><td>£219.95</td></tr> <tr><td>Panasonic KXP1124i 24 pin mon.....</td><td>£219.95</td></tr> <tr><td>Star LC24-200 24 pin mono.....</td><td>£259.95</td></tr> <tr><td>Star LC24-200 24 pin mon/col.....</td><td>£289.95</td></tr> </table> <p>All prices include cable & delivery</p> <table border="0"> <tr><td>Printer Ribbons No 1 2 5</td><td></td></tr> <tr><td>DMP 2000/3000.....</td><td>£3.75 £7.00 £16.25</td></tr> <tr><td>Citizen 120D.....</td><td>£3.75 £7.00 £16.25</td></tr> <tr><td>Panasonic KXP10/1180.....</td><td>£3.75 £7.00 £16.25</td></tr> <tr><td>Star LC10/20.....</td><td>£3.75 £7.00 £16.25</td></tr> <tr><td>Star LC24-10/20.....</td><td>£3.95 £7.50 £17.50</td></tr> <tr><td>Panasonic KXP1124.....</td><td>£3.75 £7.00 £16.25</td></tr> <tr><td>Star LC200 Mono.....</td><td>£4.95 £9.50</td></tr> <tr><td>Star LC200 Colour.....</td><td>£9.95 £18.95</td></tr> </table> <p>Other printer ribbons please phone Ribbons refresh.....£8.95</p>	Citizen 120D + 9 pin mono.....	£139.95	Star LC20 9 pin mono.....	£149.95	Panasonic KXP 1170 9 pin mono.....	£159.95	Star LC100 9 pin mono/colour.....	£199.95	Star LC200 9 pin mono/colour.....	£219.95	Panasonic KXP2180 9 pin m/col.....	£209.95	Star LC24-10 24 pin mono.....	£209.95	Star LC24-100 24 pin mono.....	£219.95	Panasonic KXP1124i 24 pin mon.....	£219.95	Star LC24-200 24 pin mono.....	£259.95	Star LC24-200 24 pin mon/col.....	£289.95	Printer Ribbons No 1 2 5		DMP 2000/3000.....	£3.75 £7.00 £16.25	Citizen 120D.....	£3.75 £7.00 £16.25	Panasonic KXP10/1180.....	£3.75 £7.00 £16.25	Star LC10/20.....	£3.75 £7.00 £16.25	Star LC24-10/20.....	£3.95 £7.50 £17.50	Panasonic KXP1124.....	£3.75 £7.00 £16.25	Star LC200 Mono.....	£4.95 £9.50	Star LC200 Colour.....	£9.95 £18.95
CASS	DISK																																																																																																																																																										
Acheton.....	£11.95																																																																																																																																																										
Avon (with Murdac).....	£11.95																																																																																																																																																										
Countdown to Doom.....	£11.95																																																																																																																																																										
Return to Doom.....	£11.95																																																																																																																																																										
Last Days of Doom.....	£15.95																																																																																																																																																										
Kingdom of Hamil.....	£11.95																																																																																																																																																										
Philosophers Quest.....	£11.95																																																																																																																																																										
Lancelot (128K).....	£15.95																																																																																																																																																										
Time & Magic (128K).....	£12.95																																																																																																																																																										
Hero Quest + Ret W/Lord.....	£10.95																																																																																																																																																										
War in Middle Earth.....	£11.95																																																																																																																																																										
Famous Five on Tr. Island.....	£9.50																																																																																																																																																										
Giant Killer Maths Adventure.....	£15.95																																																																																																																																																										
CASS	DISK																																																																																																																																																										
2 HOT 2 HANDLE: Golden Axe, Sup. Off Rd, Tot. Recall, Shad. Warriors.....	£12.95																																																																																																																																																										
FISTS OF FURY: Shinobi, Double Dragon II, Ninja Warriors, Dyn. Dux.....	£9.99																																																																																																																																																										
HOLLYWOOD COLLECTION: Bman Movie, Robocop, Gbusters II, I. Jones L.C.....	£11.95																																																																																																																																																										
LINEKER COLL: Italy 1990, G.L.H./Shots, G.L. Sup Skills, Sup Star Soccer.....	£9.95																																																																																																																																																										
MEGA SPORTS: 30+ Sporting Events.....	£15.95																																																																																																																																																										
MINDSTRETCHERS: Monopoly, Scrabble, Cluedo.....	£12.95																																																																																																																																																										
MOVIE PREMIERE: Turtles, Gremlins II, Back Fut II, I. Jones L.C.....	£11.95																																																																																																																																																										
SOCCER STARS: Kick Off II, Gazza II, Emlyn Hughes, Microprose Soccer.....	£11.95																																																																																																																																																										
CASS	DISK																																																																																																																																																										
Fun School III or IV U5.....	£10.95																																																																																																																																																										
Fun School III or IV 5-7.....	£10.95																																																																																																																																																										
Fun School III or IV 7-11.....	£10.95																																																																																																																																																										
The Shoe People 4-6.....	£8.95																																																																																																																																																										
Lets Play with Words 4-8.....	£12.95																																																																																																																																																										
Fun with Words 7.....	£8.50																																																																																																																																																										
Read Right Away 1 5-8.....	£9.95																																																																																																																																																										
Read Right Away 2 6-9.....	£9.95																																																																																																																																																										
Read Right Away 3 7+.....	£9.95																																																																																																																																																										
Better Spelling 9+.....	£8.95																																																																																																																																																										
Lets Play Numbers 4-8.....	£12.95																																																																																																																																																										
Lets Play Money 4-8.....	£12.95																																																																																																																																																										
Primary Maths 3-12.....	£24.95																																																																																																																																																										
Fun with Numbers 7.....	£8.50																																																																																																																																																										
Target Maths 6-13.....	£10.95																																																																																																																																																										
Micro Maths 9-16.....	£24.95																																																																																																																																																										
Better Maths 12-16.....	£8.95																																																																																																																																																										
Mega Maths 15+.....	£24.95																																																																																																																																																										
Biology 1 12-16.....	£8.95																																																																																																																																																										
Chemistry 1 12-16.....	£8.95																																																																																																																																																										
Physics 1 12-16.....	£8.95																																																																																																																																																										
French Mistress 11+.....	£15.95																																																																																																																																																										
German Master 11+.....	£15.95																																																																																																																																																										
Italian Tutor 11+.....	£15.95																																																																																																																																																										
Spanish Tutor 11+.....	£15.95																																																																																																																																																										
Micro English 8-Ad.....	£24.95																																																																																																																																																										
The Three Bears 5+ (6128).....	£12.95																																																																																																																																																										
Five on Treasure Island.....	£9.50																																																																																																																																																										
Granny's Garden 6-10 (6128).....	£16.95																																																																																																																																																										
Dragon World 6-10 (6128).....	£20.95																																																																																																																																																										
Giant Killer Maths Adv 9-14.....	£15.95																																																																																																																																																										
Answer Back Jr Quiz 6-11.....	£11.95																																																																																																																																																										
Citizen 120D + 9 pin mono.....	£139.95																																																																																																																																																										
Star LC20 9 pin mono.....	£149.95																																																																																																																																																										
Panasonic KXP 1170 9 pin mono.....	£159.95																																																																																																																																																										
Star LC100 9 pin mono/colour.....	£199.95																																																																																																																																																										
Star LC200 9 pin mono/colour.....	£219.95																																																																																																																																																										
Panasonic KXP2180 9 pin m/col.....	£209.95																																																																																																																																																										
Star LC24-10 24 pin mono.....	£209.95																																																																																																																																																										
Star LC24-100 24 pin mono.....	£219.95																																																																																																																																																										
Panasonic KXP1124i 24 pin mon.....	£219.95																																																																																																																																																										
Star LC24-200 24 pin mono.....	£259.95																																																																																																																																																										
Star LC24-200 24 pin mon/col.....	£289.95																																																																																																																																																										
Printer Ribbons No 1 2 5																																																																																																																																																											
DMP 2000/3000.....	£3.75 £7.00 £16.25																																																																																																																																																										
Citizen 120D.....	£3.75 £7.00 £16.25																																																																																																																																																										
Panasonic KXP10/1180.....	£3.75 £7.00 £16.25																																																																																																																																																										
Star LC10/20.....	£3.75 £7.00 £16.25																																																																																																																																																										
Star LC24-10/20.....	£3.95 £7.50 £17.50																																																																																																																																																										
Panasonic KXP1124.....	£3.75 £7.00 £16.25																																																																																																																																																										
Star LC200 Mono.....	£4.95 £9.50																																																																																																																																																										
Star LC200 Colour.....	£9.95 £18.95																																																																																																																																																										
<p>ARCAD</p> <table border="0"> <tr><th>CASS</th><th>DISK</th></tr> <tr><td>Addams Family (128K).....</td><td>£10.95</td></tr> <tr><td>F16 Combat Pilot.....</td><td>£3.75</td></tr> <tr><td>Final Fight (128K).....</td><td>£13.95</td></tr> <tr><td>G-loc (128K).....</td><td>£13.95</td></tr> <tr><td>Gauntlet III.....</td><td>£13.95</td></tr> <tr><td>Lemmings.....</td><td>£12.95</td></tr> <tr><td>Outrun Europa.....</td><td>£9.50</td></tr> <tr><td>Paperboy II.....</td><td>£9.50</td></tr> <tr><td>Space Crusade.....</td><td>£12.95</td></tr> <tr><td>Space Gun (6128+ Only).....</td><td>£12.95</td></tr> <tr><td>Simpsons.....</td><td>£9.50</td></tr> <tr><td>Smash TV.....</td><td>£9.50</td></tr> <tr><td>Super Space Invaders.....</td><td>£9.50</td></tr> <tr><td>Terminator II.....</td><td>£9.50</td></tr> <tr><td>Titus the Fox.....</td><td>£9.50</td></tr> <tr><td>WWF Wrestlingmania.....</td><td>£10.95</td></tr> </table>	CASS	DISK	Addams Family (128K).....	£10.95	F16 Combat Pilot.....	£3.75	Final Fight (128K).....	£13.95	G-loc (128K).....	£13.95	Gauntlet III.....	£13.95	Lemmings.....	£12.95	Outrun Europa.....	£9.50	Paperboy II.....	£9.50	Space Crusade.....	£12.95	Space Gun (6128+ Only).....	£12.95	Simpsons.....	£9.50	Smash TV.....	£9.50	Super Space Invaders.....	£9.50	Terminator II.....	£9.50	Titus the Fox.....	£9.50	WWF Wrestlingmania.....	£10.95	<p>STRATEGY/SIMULATION</p> <table border="0"> <tr><th>CASS</th><th>DISK</th></tr> <tr><td>Colossus 4.0 Chess.....</td><td>£3.75</td></tr> <tr><td>Cluedo.....</td><td>£2.99</td></tr> <tr><td>Monopoly.....</td><td>£2.99</td></tr> <tr><td>Scrabble.....</td><td>£2.99</td></tr> <tr><td>Scrabble De Luxe 6128.....</td><td>£12.95</td></tr> <tr><td>Trivial Pursuits.....</td><td>£2.99</td></tr> <tr><td>F16 Combat Pilot.....</td><td>£3.75</td></tr> <tr><td>Manchester Utd Europe.....</td><td>£12.95</td></tr> </table>	CASS	DISK	Colossus 4.0 Chess.....	£3.75	Cluedo.....	£2.99	Monopoly.....	£2.99	Scrabble.....	£2.99	Scrabble De Luxe 6128.....	£12.95	Trivial Pursuits.....	£2.99	F16 Combat Pilot.....	£3.75	Manchester Utd Europe.....	£12.95	<p>ACCESSORIES</p> <table border="0"> <tr><td>AMX Mouse & interface.....</td><td>£34.95</td></tr> <tr><td>AMX Mouse + Adv Art + mouse mat.....</td><td>£54.95</td></tr> <tr><td>Amstrad MP1F (464 to Scart TV).....</td><td>£25.95</td></tr> <tr><td>Amstrad MP2F (6128 to Scart TV).....</td><td>£29.95</td></tr> <tr><td>AMS 30L disk box (30 3" disks).....</td><td>£12.95</td></tr> <tr><td>Cassette lead (not 6128+).....</td><td>£3.95</td></tr> <tr><td>Cassette Rec + leads (not 6128+).....</td><td>£23.95</td></tr> <tr><td>Cover Set (state mach & mon).....</td><td>£8.95</td></tr> <tr><td>Disk drive cleaner 3".....</td><td>£5.95</td></tr> <tr><td>Genius Mouse & Adv Art.....</td><td>£49.95</td></tr> <tr><td>Memory expansion 64K for 464.....</td><td>£44.95</td></tr> <tr><td>Printer cable..... 1 mtr £8.95 2 mtr £10.95</td><td></td></tr> <tr><td>Printer cable 464+/612+ 2mtr.....</td><td>£7.95</td></tr> <tr><td>Joystick Splitter.....</td><td>£8.95</td></tr> <tr><td>Kboard ext leads 464+/6128+.....</td><td>£8.95</td></tr> </table>	AMX Mouse & interface.....	£34.95	AMX Mouse + Adv Art + mouse mat.....	£54.95	Amstrad MP1F (464 to Scart TV).....	£25.95	Amstrad MP2F (6128 to Scart TV).....	£29.95	AMS 30L disk box (30 3" disks).....	£12.95	Cassette lead (not 6128+).....	£3.95	Cassette Rec + leads (not 6128+).....	£23.95	Cover Set (state mach & mon).....	£8.95	Disk drive cleaner 3".....	£5.95	Genius Mouse & Adv Art.....	£49.95	Memory expansion 64K for 464.....	£44.95	Printer cable..... 1 mtr £8.95 2 mtr £10.95		Printer cable 464+/612+ 2mtr.....	£7.95	Joystick Splitter.....	£8.95	Kboard ext leads 464+/6128+.....	£8.95	<p>WAR GAMES</p> <table border="0"> <tr><td>Avalanche (Italy WW2).....</td><td>£10.95</td></tr> <tr><td>Battle of Bulge.....</td><td>£10.95</td></tr> <tr><td>Crete 1941.....</td><td>£10.95</td></tr> <tr><td>Desert Rats.....</td><td>£10.95</td></tr> <tr><td>R.T.Smith Compendium.....</td><td>£12.95</td></tr> </table>	Avalanche (Italy WW2).....	£10.95	Battle of Bulge.....	£10.95	Crete 1941.....	£10.95	Desert Rats.....	£10.95	R.T.Smith Compendium.....	£12.95	<p>JOYSTICKS</p> <table border="0"> <tr><td>AMSTRAD JY2.....</td><td>£7.95</td></tr> <tr><td>CHEETAH Bug.....</td><td>£13.95</td></tr> <tr><td>CHEETAH Mach 1.....</td><td>£11.95</td></tr> <tr><td>POWERPLAY Terminator.....</td><td>£14.95</td></tr> <tr><td>QUICKSHOT Python 1.....</td><td>£9.95</td></tr> <tr><td>QUICKSHOT Python 1 microswitch.....</td><td>£11.95</td></tr> <tr><td>ZIPSTICK Super Pro.....</td><td>£4.95</td></tr> <tr><td>464+/6128+/GX4000 Games Paddle.....</td><td>£8.95</td></tr> </table>	AMSTRAD JY2.....	£7.95	CHEETAH Bug.....	£13.95	CHEETAH Mach 1.....	£11.95	POWERPLAY Terminator.....	£14.95	QUICKSHOT Python 1.....	£9.95	QUICKSHOT Python 1 microswitch.....	£11.95	ZIPSTICK Super Pro.....	£4.95	464+/6128+/GX4000 Games Paddle.....	£8.95	<p>BUSINESS/UTILITIES</p> <table border="0"> <tr><td>Advanced Art Studio 6128.....</td><td>£19.95</td></tr> <tr><td>Crash Course Typing Tut 6128.....</td><td>£20.95</td></tr> <tr><td>Masterfile III.....</td><td>£29.95</td></tr> <tr><td>Mini Office II.....</td><td>£12.95</td></tr> <tr><td>Money Manager (+PCW).....</td><td>£24.95</td></tr> <tr><td>Protext.....</td><td>£16.95</td></tr> <tr><td>Prospell.....</td><td>£21.95</td></tr> <tr><td>Stop Press (DTP Package).....</td><td>£39.95</td></tr> <tr><td>Supercalc II (6128+PCW).....</td><td>£29.95</td></tr> <tr><td>Tasword 464/464D.....</td><td>£20.95</td></tr> <tr><td>Tasword 6128.....</td><td>£24.95</td></tr> <tr><td>Tas-Spell [For Tasword].....</td><td>£20.95</td></tr> <tr><td>TasDiary.....</td><td>£20.95</td></tr> </table>	Advanced Art Studio 6128.....	£19.95	Crash Course Typing Tut 6128.....	£20.95	Masterfile III.....	£29.95	Mini Office II.....	£12.95	Money Manager (+PCW).....	£24.95	Protext.....	£16.95	Prospell.....	£21.95	Stop Press (DTP Package).....	£39.95	Supercalc II (6128+PCW).....	£29.95	Tasword 464/464D.....	£20.95	Tasword 6128.....	£24.95	Tas-Spell [For Tasword].....	£20.95	TasDiary.....	£20.95	<p>AMSTRAD MP3 TV TUNER USE YOUR MONITOR AS A COLOUR T.V. WORKS WITH CTM644 MONITOR £29.95</p>	<p>FACTFILE SERIES FOR ANS BACK JNR QUIZ</p> <table border="0"> <tr><td>Arithmetic 6-11.....</td><td>£7.95</td></tr> <tr><td>Spelling 6-11.....</td><td>£7.95</td></tr> <tr><td>World Geography 6-11.....</td><td>£7.95</td></tr> <tr><td>Natural History 6-11.....</td><td>£7.95</td></tr> <tr><td>English Words 6-11.....</td><td>£7.95</td></tr> </table>	Arithmetic 6-11.....	£7.95	Spelling 6-11.....	£7.95	World Geography 6-11.....	£7.95	Natural History 6-11.....	£7.95	English Words 6-11.....	£7.95				
CASS	DISK																																																																																																																																																										
Addams Family (128K).....	£10.95																																																																																																																																																										
F16 Combat Pilot.....	£3.75																																																																																																																																																										
Final Fight (128K).....	£13.95																																																																																																																																																										
G-loc (128K).....	£13.95																																																																																																																																																										
Gauntlet III.....	£13.95																																																																																																																																																										
Lemmings.....	£12.95																																																																																																																																																										
Outrun Europa.....	£9.50																																																																																																																																																										
Paperboy II.....	£9.50																																																																																																																																																										
Space Crusade.....	£12.95																																																																																																																																																										
Space Gun (6128+ Only).....	£12.95																																																																																																																																																										
Simpsons.....	£9.50																																																																																																																																																										
Smash TV.....	£9.50																																																																																																																																																										
Super Space Invaders.....	£9.50																																																																																																																																																										
Terminator II.....	£9.50																																																																																																																																																										
Titus the Fox.....	£9.50																																																																																																																																																										
WWF Wrestlingmania.....	£10.95																																																																																																																																																										
CASS	DISK																																																																																																																																																										
Colossus 4.0 Chess.....	£3.75																																																																																																																																																										
Cluedo.....	£2.99																																																																																																																																																										
Monopoly.....	£2.99																																																																																																																																																										
Scrabble.....	£2.99																																																																																																																																																										
Scrabble De Luxe 6128.....	£12.95																																																																																																																																																										
Trivial Pursuits.....	£2.99																																																																																																																																																										
F16 Combat Pilot.....	£3.75																																																																																																																																																										
Manchester Utd Europe.....	£12.95																																																																																																																																																										
AMX Mouse & interface.....	£34.95																																																																																																																																																										
AMX Mouse + Adv Art + mouse mat.....	£54.95																																																																																																																																																										
Amstrad MP1F (464 to Scart TV).....	£25.95																																																																																																																																																										
Amstrad MP2F (6128 to Scart TV).....	£29.95																																																																																																																																																										
AMS 30L disk box (30 3" disks).....	£12.95																																																																																																																																																										
Cassette lead (not 6128+).....	£3.95																																																																																																																																																										
Cassette Rec + leads (not 6128+).....	£23.95																																																																																																																																																										
Cover Set (state mach & mon).....	£8.95																																																																																																																																																										
Disk drive cleaner 3".....	£5.95																																																																																																																																																										
Genius Mouse & Adv Art.....	£49.95																																																																																																																																																										
Memory expansion 64K for 464.....	£44.95																																																																																																																																																										
Printer cable..... 1 mtr £8.95 2 mtr £10.95																																																																																																																																																											
Printer cable 464+/612+ 2mtr.....	£7.95																																																																																																																																																										
Joystick Splitter.....	£8.95																																																																																																																																																										
Kboard ext leads 464+/6128+.....	£8.95																																																																																																																																																										
Avalanche (Italy WW2).....	£10.95																																																																																																																																																										
Battle of Bulge.....	£10.95																																																																																																																																																										
Crete 1941.....	£10.95																																																																																																																																																										
Desert Rats.....	£10.95																																																																																																																																																										
R.T.Smith Compendium.....	£12.95																																																																																																																																																										
AMSTRAD JY2.....	£7.95																																																																																																																																																										
CHEETAH Bug.....	£13.95																																																																																																																																																										
CHEETAH Mach 1.....	£11.95																																																																																																																																																										
POWERPLAY Terminator.....	£14.95																																																																																																																																																										
QUICKSHOT Python 1.....	£9.95																																																																																																																																																										
QUICKSHOT Python 1 microswitch.....	£11.95																																																																																																																																																										
ZIPSTICK Super Pro.....	£4.95																																																																																																																																																										
464+/6128+/GX4000 Games Paddle.....	£8.95																																																																																																																																																										
Advanced Art Studio 6128.....	£19.95																																																																																																																																																										
Crash Course Typing Tut 6128.....	£20.95																																																																																																																																																										
Masterfile III.....	£29.95																																																																																																																																																										
Mini Office II.....	£12.95																																																																																																																																																										
Money Manager (+PCW).....	£24.95																																																																																																																																																										
Protext.....	£16.95																																																																																																																																																										
Prospell.....	£21.95																																																																																																																																																										
Stop Press (DTP Package).....	£39.95																																																																																																																																																										
Supercalc II (6128+PCW).....	£29.95																																																																																																																																																										
Tasword 464/464D.....	£20.95																																																																																																																																																										
Tasword 6128.....	£24.95																																																																																																																																																										
Tas-Spell [For Tasword].....	£20.95																																																																																																																																																										
TasDiary.....	£20.95																																																																																																																																																										
Arithmetic 6-11.....	£7.95																																																																																																																																																										
Spelling 6-11.....	£7.95																																																																																																																																																										
World Geography 6-11.....	£7.95																																																																																																																																																										
Natural History 6-11.....	£7.95																																																																																																																																																										
English Words 6-11.....	£7.95																																																																																																																																																										
<p>SPECIAL OFFERS</p> <table border="0"> <tr><td>New York Warriors.....</td><td>£6.99</td></tr> <tr><td>Super Off Road.....</td><td>£6.99</td></tr> <tr><td>Off Shore Warrior.....</td><td>£6.99</td></tr> <tr><td>Wild Streets.....</td><td>£6.99</td></tr> </table>				New York Warriors.....	£6.99	Super Off Road.....	£6.99	Off Shore Warrior.....	£6.99	Wild Streets.....	£6.99																																																																																																																																																
New York Warriors.....	£6.99																																																																																																																																																										
Super Off Road.....	£6.99																																																																																																																																																										
Off Shore Warrior.....	£6.99																																																																																																																																																										
Wild Streets.....	£6.99																																																																																																																																																										
<p>FULL RANGE BUDGET SOFTWARE STOCKED</p>																																																																																																																																																											
<p>PRICES INCLUDE POSTAGE & PACKING IN U.K PLEASE MAKE CHEQUES & POSTAL ORDERS PAYABLE TO: O.J. SOFTWARE AND SEND TO O.J. SOFTWARE, 273 MOSSY LEA ROAD, WRIGHTINGTON, NR. WIGAN, LANCs WN6 9RN(MOST ORDERS DESPATCHED BY RETURN) ACCESS & VISA ORDERS TELEPHONE/FAX ON (0257) 421915 OR SEND DETAILS TO ABOVE ADDRESS OVERSEA ORDERS WELCOME (SOFTWARE ITEMS OVER £10.00 EACH POST FREE, OTHERS ADD £1.00 EACH)</p>																																																																																																																																																											

What better way to end the year in true CHEAT MODE style, than with a round-up of every keypress known to man brought together in one mammoth issue? PHIL HOWARD is the man to do it...

Cheat Mode

The Untouchables Type HUMPHREY BOGART into the hi-score table and TEST MODE ACTIVE will light up in the top left hand corner of the screen. Then by pressing the keypad keys "9","6","3",".", and "right arrow" together you will move on to the next level.

Stormlord Type BRINGONTHEGIRLS (quickly and without spaces) while the title screen is displayed (a number 12 appears at the top left if you do it in time). Then selecting 1 to 4 will allow you to play that level with infinite lives.

Exolon Redefine the keys as Z,O,R B,A.

Cybernoid Redefine the keys as Y,X,E,S.

Cybernoid II Redefine keys as O,R,G,Y.

New Zealand Story Type FLUFFY very slowly on the title screen and you get infinite lives. Press the large ENTER/RETURN key you can move to the next level.

Druid Type THE COVENANT into the hi-score table - all the monsters will now removed from the game.

Ghostbusters II For infinite stuff on the first level, press P to pause the game, then Type AYKROYD (get it?) and then press P to return to the game.

Super Stuntman Type LIVEWIRE into the hi-score table for a never ending supply of everything.

Indiana Jones and the Last Crusade

Press the keys "T","O" and "D" all together on the title screen ONLY to turn the cheat on and off - the border should flash. During play SHIFT + "1" returns to start of the level. SHIFT + "2" moves you to the next restart. SHIFT + "3" moves you to the next level.

Chase HQ Re-define the keys as S,H,O,C,K,E,D and "TEST" will appear at the bottom right. At any time during play press "1" to restart level, "2" to move to the



next level, "3" (should I be telling you this?) to see the end game display, and "4" to get an extra life.

Bedlam Press COPY on the title screen to start on the level you died on.

Jinks Press ESC to replay the level you died on.

Tempest Press "Q" and "A" on the "Enter to Start" screen to raise or lower the start level.

Supertank Simulator

Press ESC to pause then type STANK then ESC to return, and you have infinite lives.

P-47 Thunderbolt Type ZEBEDEE into the hi-score table, for invulnerability, also press "L" to advance a level.

Super Stunt Bik Simulator Press TAB whilst playing to go to the next level.

Little Puff Pressing the keys DRAGON will get you into the cheat mode and give you invulnerability. By pressing "SHIFT" plus the arrow keys you can move location. Pause "DEL" then "F4", "F5" and "LEFT ARROW" will change the background colour (great for green screens), Also, "F4","F5" and "COPY" will alter the border colour.

Real Ghostbusters Press the keys C H E A T at any time during play

and you will advance to the next level and get infinite lives.



X-Out To get as much money as you like, simply take a ship etc. and instead of buying it, give it to the Melob (bottom right of the select screen) your score will increase each time you do so. Having done this a few times you can buy as much as you like, but keep an eye on your score.

Into the Eagles Nest

Type DAS CHT into the hi-score table for infinite energy, DAS MAP for map mode, MAP OFF to turn it off again, and DAS NME to play without enemies.

Turbo Boat Simulator To advance a level press PAUSE and CLR together.

Turbo Chopper Simulator Pause the game by pressing CTRL, then to enter thecheat mode press "M", "B", and "1" keys together, you now have infinite lives. Also, from now on, by pressing CTRL followed by ESC you can advance a level.

Operation Wolf (Lightgun version) Hold down CTRL SHIFT and ESC keys and you will move to the next level.

Grand Prix Simulator On the title screen type TRACK followed by your selection A to M. Type the following into the hi-score table - COMPLEX, CHEAT, HELP, PANDA, SPECTRUM, SOMEBODYTRACK, HEREROBIN.

➔ **Bounty Hunter** Press ESC to pause the game then type FIZBANG for infinite lives.

Nuclear Heist Type EGDROLE (or is it EGDIRDLE) into the hi-score table for infinite lives.

Thrust press keypad keys "2", "5", "8", "UP ARROW" and "ESC" together at any time to advance a level.

Impossamole Pause the game with "H", hold down the keys "M", "O", "L", "E" and (at the same time) press "H" to restart, each time you do this the energy goes to a maximum.

Human Killing Machine As you start the game press the keys "G" and "O" (that's O not zero), then at any time pressing "X" raises you to the next level.

Grid Iron when asked for your name type OVERLORD and you will get extra cash.

Grand Prix Sim 2 Change the name of player 1 to INTEGRA and it will stop you being knocked out. For a laugh, try COMPUTER.

Jungle Warfare Press SHIFT + P to pause the game then press the keys A, S, Z, X, C, U, J, M and SHIFT down simultaneously, when you return to the game you will have infinite lives.

Strider On the title screen, press "Z" and "0" (zero) together, the border will flash. Then, whilst playing the game, press "H" to pause, SHIFT and "1" will advance you to the next stage. (but don't try to skip the end of level guardian, the game will crash). Also SHIFT and "0" will restart the level you are on, each time you use the cheat your lives and time are reset.

Equinox Collect the PETE object, move to the extreme top left of the start screen, then press "R", "N" and "C" keys together for infinite lives.

Slug By pressing "L", "*", ">", "?" and SPACE you can move to the next level.

Three Weeks in Paradise Get killed, then immediately press the keys "K", "A", "T", "H" until you obtain infinite lives.

BMX Freestyle Type TAEHC (that's CHEAT backwards) into the hi-score table, and guess what happens.

Dynasty Wars Press SHIFT and ZERO when playing and you move to the next level.

E-Motion Type MOONUNIT on the title screen then "R" will advance 1 level, "F" will advance 10 levels, "T" moves back 1 level, "G" moves back 10 levels and "V" will self destruct (back to level 1).

Pro Powerboat Sim Press ESC to pause the game, then by pressing the keys "1", "2", "Z", "X", and "SPACE" you get infinite lives

Ruff and Ready Hold down the keys "D", "Y", "L", "A", "N" on the title screen and the message CHEAT ON will appear just below the title, you now have infinite lives.

Solomons Key Type CAZZ into the high score table for infinite lives.

Midnight Resistance On the title screen press the keys "R" "G" and "N" and you can turn an infinite lives cheat on and off

Deliverance On the picture title screen (before it changes) type in ILIKE, the music will disappear and the border will let you know that the cheat is active. You will then be invulnerable.

Turrican At the start press "H" to pause the game, then hold down the keys "V" "O" and "N" together you will get 99 of everything... Press "ESC" to advance a level.

Indiana Jones and the Temple of Doom Type in JIMBO on the title screen then start the game and press "3" to advance a level.

Enduro Racer If you find you are getting behind during the first 3/4 stages, reduce your speed to 0 mph then press the keypad keys "0", "1", "4", "5" and "LEFT ARROW" suddenly you will be whizzing invulnerably past the competition. When you reach the next level press the keys once again and it's back to normal. You can do this at the start and be transported, without effort, to the 5th level!

Hong Kong Phooey To get infinite energy hold down the keys Y,O,G,I on the options table.

Blazing Thunder To get infinite lives, hold down the keys S,L,I,M,E on the options table.

Yogi Bear in The Greed Monster To get infinite lives press down the keys S,T,A,R,E,D on the options table.

Xenon Start the game, press Esc to pause, then hold down the keys T,I,N,Y, A message will appear to tell you your craft is now invulnerable.

The crypt: Last month you got the solution, this time check

Ground level

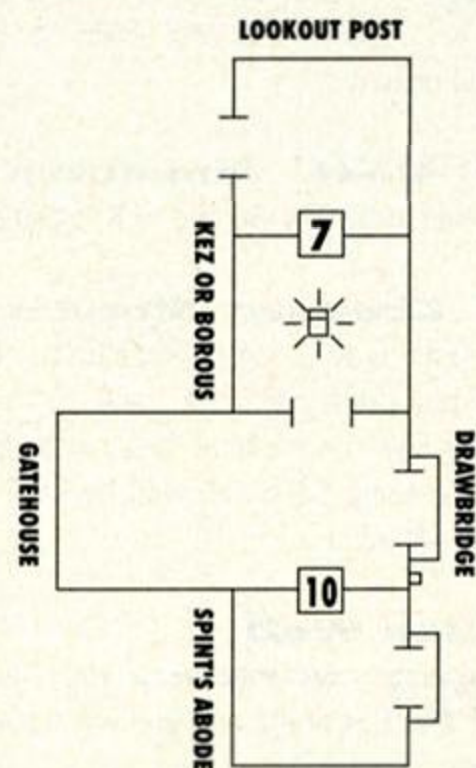

Level 2

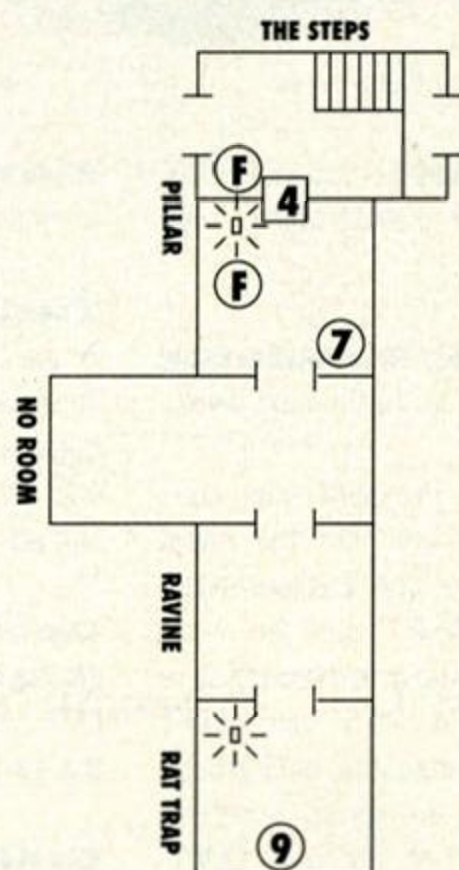

Level 3

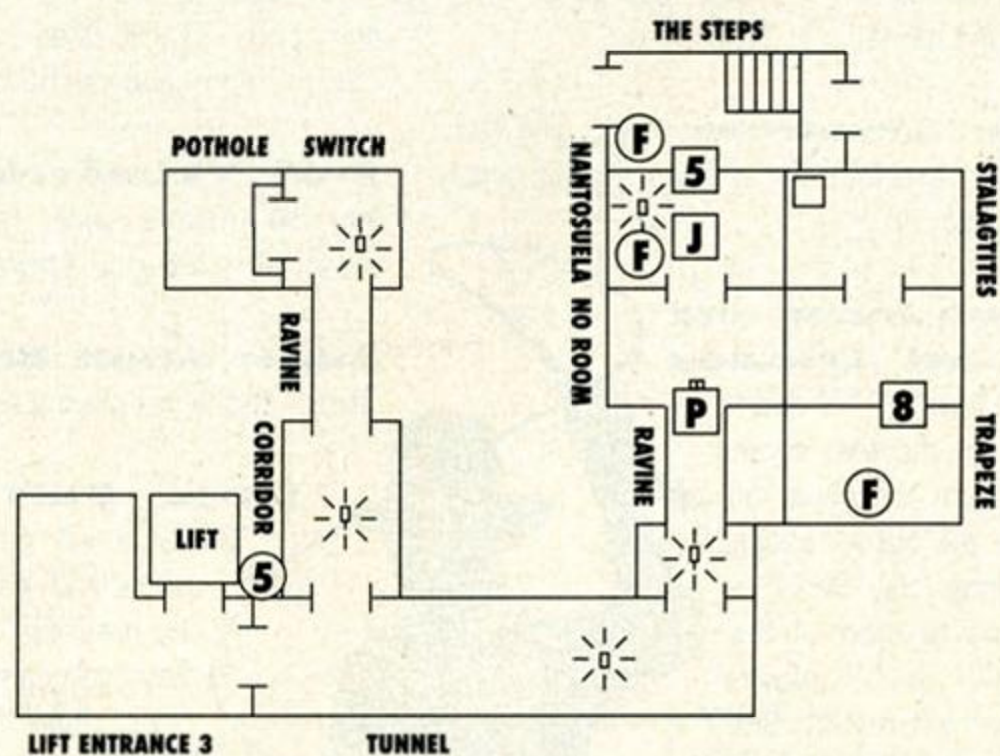

Key

⊥ Door P Padlocked door 8 Locked door F Food K Key J Jewels

Hammerfist Pause the game with "ESC" then press down the keys "Y", "U", "I", "O" with one hand and "C", "V", "B" and "N" with the other, then when you unpause the game "ESC" you will be able to skip through the levels by pressing "L".

Killapede At any time press DEL to pause the game, then pressing the keys A,6,P together give extra lives, CLR to restart.

Back to the Future II Type HEADBUTT slowly on the title screen and you will activate the infinite energy cheat, also by pressing "ESC" you will be able to move to the next level. In levels 2 and 4, at the question TRY AGAIN Y OR N, pressing Y will give you another chance and extra lives each time.

Yogi's Great Escape Redefine the keys to I C E and you get infinite lives.

Super Robin Hood At any point during the game press the keys A,6,P together and you will get called a cheat, before the sign disappears press (and keep pressed) E for extra energy, K to start the lifts, or H to collect Hearts. The border changes colour to let you know you've cheated.

Ghosthunters At any time during the game press DEL to pause, a sign saying pause mode active will pop up. Type C,O,M,P,L,E,X and the pause sign will disappear, then pressing different keys on the keyboard will move location. Pressing Space will resume play and top up your energy.

Dizzy (no 1) This is a bit awkward! On the title screen press SPACE to start the game.

Keeping your finger on SPACE press Q to quit, continue keeping your finger on SPACE and the game will restart. Then pause the game with P and type T,R,O,W,B,R,I,D,G,E, after the last letter Dizzy should disappear (if not, something went wrong!). Use the keys Z,X,K and M to move location, use ENTER for extra lives, and, use the SPACE to restart in your chosen location.

Advanced Pinball Sim Press P to pause the game then type H,E,N,L,E,Y the game will automatically restart on the final letter, you can then manipulate the ball with the keys X,C and J.

Treasure Island Dizzy (no 2) On the title screen use the keys Q,A,S,C,P and SPACE (or joystick FIRE if you are using the joystick) to start the game. Whilst playing pressing C will cause Dizzy to disappear, the keys Z,X,K and M then move location. Press SPACE (or joystick up) to restart at your chosen location.

Fantasy World Dizzy (no 3) Press down the keys D,Y,L,A,N and SPACE to start the game, then once again pressing C will enter the cheat mode Z,X,K, and M move location and SPACE resumes the game.

Race Against Time Pause the game with P and type in I,N,T,E,G,R,A,L, then you can move location once again using the direction keys X,Z,M and K or the joystick. Restart the

game by pressing SPACE / FIRE.

Total Recall Type THE END IS NIGH (including spaces) into the hi-score table, then pressing f4, f6 and the down cursor will transport you totally to the next level. Also, type INACTIVE MINDS (two spaces between the words) into the hi-score table, you will become invulnerable... very flickery, but invulnerable.

Puzznic While playing press R to enter the Retry menu, then type HELPM and you will get infinite retries.

Teenage Mutant Hero Turtles Whilst playing the game press down the keys "G", "ZERO", "1" and "SHIFT" together and the screen tells you the cheat mode is on - you then become invulnerable.

The Light Corridor Pause with RETURN, then type in LOS ANDROLLOS COMEN POLLO for infinite balls, or, pause the game and type SOMORMUJO VECTORIANO to see the light at the end of the tunnel.

Dark Fusion If, on the title screen, you type ULTRAGEN, after the last letter you will hear a sound (crshhhggsh - or something similar); you have entered the cheat mode. Then during play pressing 1, 2, or 3 will advance you to different points in the game, pressing 4 at the same time will put your number of lives up to 8.

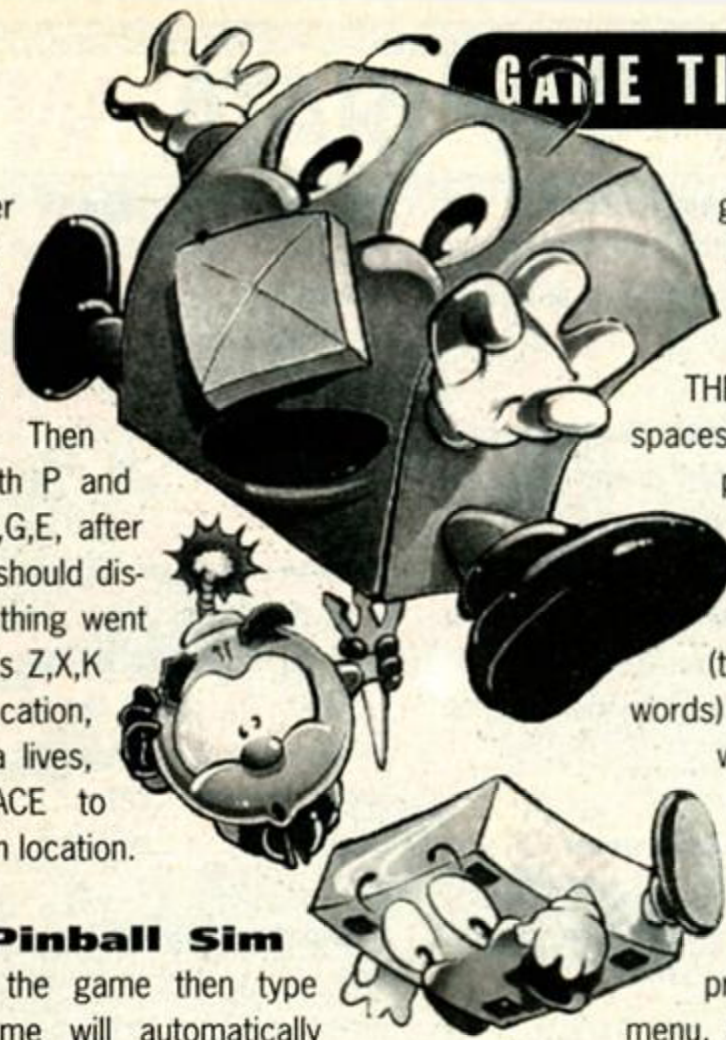

out the map! If you can't finish it now, you must be a cabbage...

Level 4

Level 5

Level 6

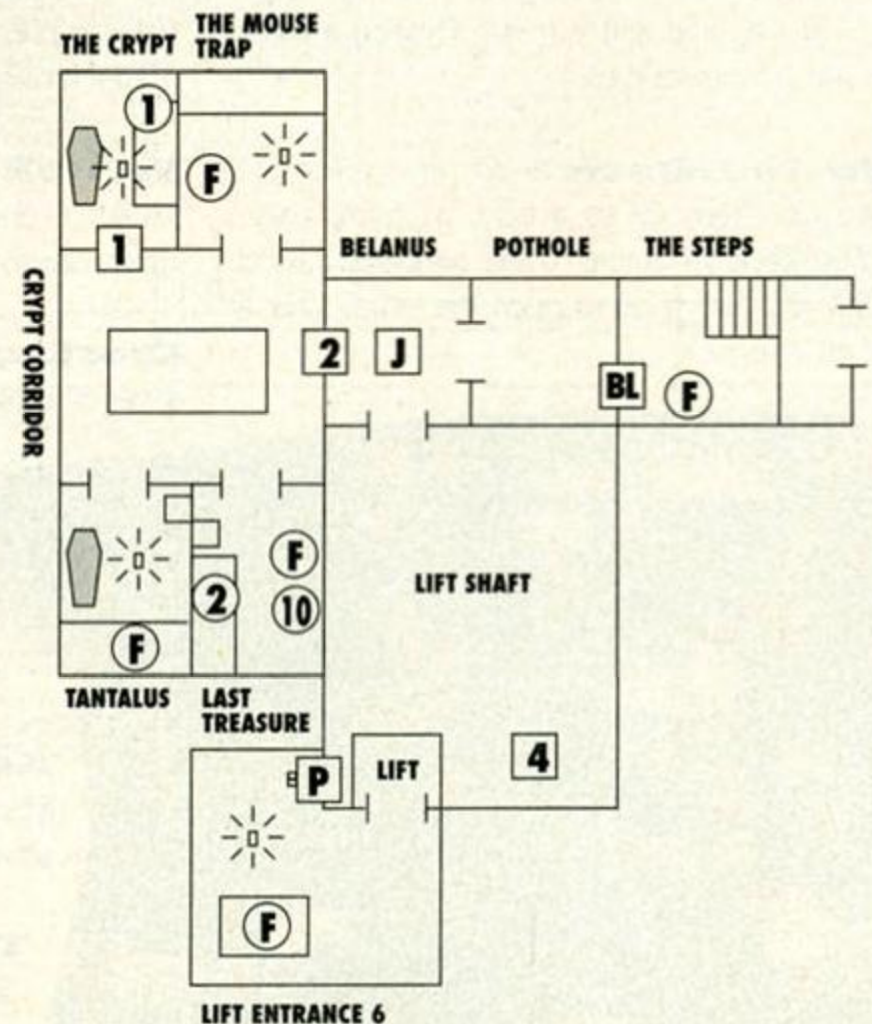
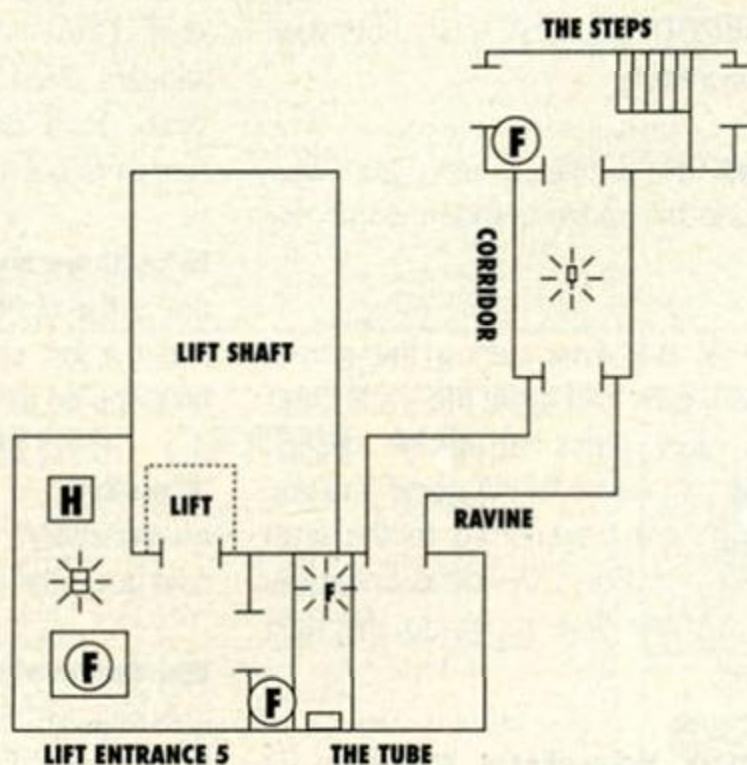
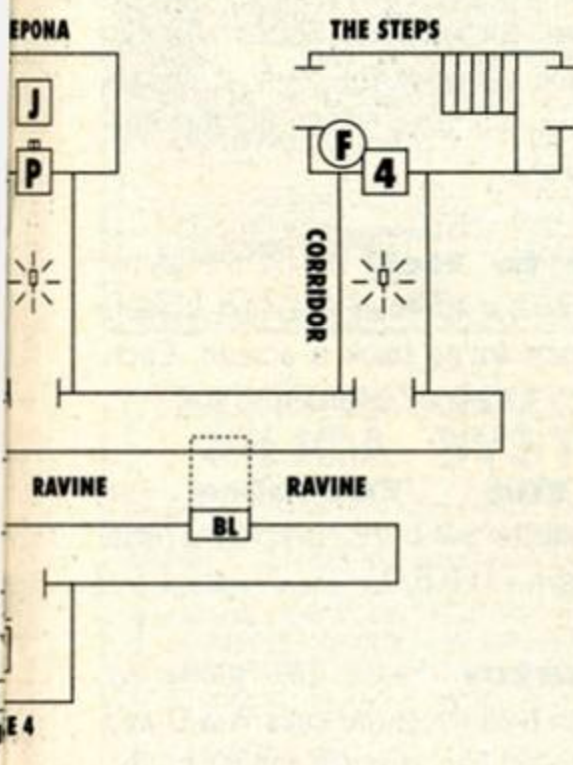

BL Block ☀ Nasty ☠ Coffin

➔ **Operation Thunderbolt** put EFI into the Hi-score table, then at any time press the keys "J", "P", "D" and you will be transported to a higher level.

Scooby Doo and Scrappy Doo On the options screen press the keys HELP and you will get infinite lives.

Topcat in Beverly Hills Cats On the options screen hold down the keys SERFPUK until the screen lights up, then you will get infinite lives.

Quick Draw McGraw On the title screen press the keys "W" "A", "R", "T" and you get infinite energy (it only works on the outside of the train though).

Combat Zone Recently re-released on the Alternative's 4 Most Action compilation. Press CLR to pause the game (it will say PAUSED on the screen) Then press the keys SHIFT, CAPS LOCK, and TAB, a sign will tell you the cheat mode is ready. Then keeping your fingers on SHIFT, CAPS LOCK, and TAB, Pressing S changes the scenery, pressing H initiates a Smart bomb system (Space), "I" ups the lives to 255, and "F" ups the fuel. A sign on the screen tells you that the cheat mode has been activated.

Back to the Future 3 Type the following during play:

- Level 1: ROTTEN CHEAT
- Level 2: LOUSY CHEAT
- Level 3: LOW DOWN CHEAT

Continental Circus Press CLR then redefine the keys C,H,E,A,T,SPACE. Once you start the game, keep pressing "C" for loads more credits. Excellent!

Hunchback 2 Type LAZY JONES in the hi-score table.

Renegade 3 Hold down the keys Q,U,I and T at any time and you will advance a level, also you get infinite lives.

Edd the Duck At any time press the keys F,I,Z. There will be a burst of music – you will now be invulnerable to the baddies. Careful though you may have to re-do the cheat after a level change.

Narco Police Into the Personal Intercom Unit type NOENEMIG for no enemies, COMMENTARZAR to bring back the enemies, MUNICION to give yourself more ammo.

Destructo Press P to pause the game and type CAVE CARNEM, then return to the game, the following time you pause the game you can press Z to skip a level.

Predator 2 Press the keys Q,A,O and P at the same time to advance to the next level.

Impossaball On the title screen press the keys C,H,E,A and T (what else?) all together, and a message will appear at the bottom of the screen saying START LEVEL 1, then press L to alter the level number.

Turbo Kart Racer Press CTRL to get the next track.

Turrican 2 Get a hi-score (finishing level one is usually enough). Fall down the holes on level 2 until you get the game over message, but don't continue. Enter your name as WIMPON and press Return. The border should flash briefly, start the game and press the CTRL key to move to the next level.

Periscope Up Hold down the COPY key then start the game by pressing Fire on the joystick to get yourself infinite lives.

Moving Target In the hi-score table type GARETH BAKER leaving a space between the words) for invulnerability.

Moontorc On the title screen type KINDERLEBE OBIZUTH BE GONE (space between words) for invulnerability.

Superkid On the title screen, type I LUV ATLANTIS (include the space between words) for invulnerability.

Crackup At any time during the game, press H to pause, then hold down the small Enter key, press Fire on the joystick to return to the game and you are transported to the level 2. Press the small Enter key at any time to go to the next level.

Astro Marine Corps By typing CREEP into the hi-score table on either part you will become invulnerable.

The Hit Squad In the hi-score table type BIGTHING for invulnerability.



Cobra Force Pause the game and type OPTIMUS to get infinite lives. Plus the RIGHT CURSOR will advance you a level.

Rambo 3 Redefine the control keys as C,H,E,A,T,SPACE. Then, whilst playing the game, press all the cursor keys down to skip a level.

Havoc At any time during the game hold down the keys ARN all together for invulnerability.

Shark During the game hold down Z and the point "." on the keypad to load the next level.

Jungle Warfare Press SHIFT and P to pause the game, then type JASON. Pressing P will restart the game with infinite lives.

Megabucks At any time during the game hold down the keys "M", "<" and ">" and press any cursor key to see the screens.

Tomcat On the title screen hold down the keys GDAY and a message GDAY BRUCE appears, then you can play the Tomcat upside down. Hold down the keys again on the title screen to put it right.

Stairway to Hell During the game press the right cursor to enter the next screen and the left cursor to go back a screen. Each time you do this a life will be awarded to you

Turbo the Tortoise For Invulnerability, infinite lives and everything else hold down the keys T,U,R,B,O.

Exterminator Pause the game by pressing "H" then hold down the keys W,S,D and C. Then a completed blue row will appear on the floor and you will be taken to the next room.

Lemmings Hold down the keys SHIFT,Z,E and X on the screen displaying the current level, and the level will increase, do not extend it past 60 (it does not return to normal).



FREE! FROM SILICA



When you buy your new Atari 520, 1040 or Mega ST-E computer from Silica Systems, we will give you an additional £324.75 worth of software FREE OF CHARGE, including some great entertainment and productivity programs. These free gifts will introduce you to the world of ST computing and help you to get off to a flying start with your new ST. Plus, with every ST and TT, we will give you 16 nights holiday hotel accommodation for you and your family to enjoy a break at home or abroad.

16 NIGHTS HOLIDAY HOTEL ACCOMMODATION
Every Atari ST from Silica comes supplied with a free 72 page colour brochure with accommodation vouchers. These entitle 2 people to stay up to a total of 16 nights in any of 250 hotels with accommodation FREE. All you have to pay for are your meals (prices are listed in the brochure).

TENSTAR PACK:

ASTERIX	£24.99
CHESSE PLAYER 2150	£24.95
DRIVIN' FORCE	£19.95
LIVE AND LET DIE	£19.99
ONSLAUGHT	£24.99
PIPE MANIA	£19.99
RICK DANGEROUS	£24.99
ROCK 'N' ROLL	£19.99
SKWEEK	£19.99
TRIVIAL PURSUIT	£19.95

PRODUCTIVITY PACK:

1st WORD*	£59.99
Word processing package from GST	
SPELL IT	£19.99
Spelling checker to complement 1st Word	
ST BASIC	£24.99
Basic programming language with tutorial	

TOTAL VALUE: £324.75

WORTH NEARLY £325!
*Not supplied with STs where Atari pack already includes 1st Word

NEW ATARI ST PRICES



PLUS! FREE GIFTS FROM SILICA!
SEE PANEL TO LEFT

NEW! REVISED PACK 520ST-E DISCOVERY XTRA

HARDWARE:

520ST-E COMPUTER	£249.99
8MHz 16-Bit 68000 CPU, 512K RAM, Mouse, TV Modulator, Internal PSU, 1Mb Disk Drive	

SOFTWARE - ARCADE GAMES:

Final Fight - A superb street fighting game	£25.99
9 Lives - Cartoon quality platform romp	£24.99
Robot Monstres - Arcade Shoot 'em Up	£19.99
Sim City - Take control of your own city	£29.95

BONUS ARCADE GAMES:

Missile Command	£9.99
Crystal Castles	£9.99
Super Breakout	£9.99
Battlezone	£9.99

SOFTWARE - PRODUCTIVITY:

Neochrome - Art package	£29.99
1st Word - Word processor	£59.99
First BASIC - Programming language	£49.99
ST Tour - Tutorial Disk	FREE
ANI ST - Animation Package	£29.95

PLUS! FREE FROM SILICA:

Silica Productivity Pack*	£44.98
TenStar Games Pack	£219.78

Total Value: £825.55
Less Pack Saving: £576.55
SILICA PRICE: £249.00

PLUS! 4 BONUS
BATTLEZONE
CRYSTAL CASTLES
MISSILE COMMAND
SUPER BREAKOUT
ARCAD GAMES WORTH £39.96

*Does not include 1st Word

£249

Inc VAT - Ref: STC 6300

ATARI TT



NEW LOW PRICE

- 32MHz 32-Bit 68030 Processor
- 3 1/2" 1.44Mb Double Sided Disk Drive
- 2/4/8Mb RAM Versions
- Stereo 8-Bit PCM Sound Output
- 4096 Colour Palette
- Built-in 68882 Maths Co-Processor
- Up to 1280 x 960 Resolution
- VME + SCSI Expansion Ports
- Expandable to 36Mb RAM
- Hard Drive Expansion Options
- FREE 16 Nights Holiday Accommodation**

2Mb RAM	4Mb RAM	8Mb RAM
£899	£1199	£1499
STC 8925	STC 8939	STC 8977

MEGA STE



NEW LOW PRICE

- 16MHz 16-Bit 68000 processor
- 3 1/2" 1.44Mb Double Sided Disk Drive
- 2Mb RAM
- Hard Drive Options Available
- 4096 Colour Palette
- Stereo 8-Bit PCM Sound Output
- FREE Silica Productivity Pack**
- FREE TenStar Games Pack**
- FREE 16 Nights Holiday Accommodation**

SPECIAL PROMO PRICE!
2Mb MEGA ST-E (No hard drive)

RRP	SILICA PRICE
£708.83	£449
	Inc VAT - Ref: STC 8433



The new Atari Falcon 030 is here! It is a powerful, versatile, multipurpose home computer, offering unmatched performance for its price. Included in its advanced specification are multiple co-processors for sound and graphics, true colour displays from a pallet of over a quarter of a million colours and 16-bit stereo sound input for speech recognition and sound sampling. These all combine to provide a new computer capable of running unrivalled sound, graphics and multimedia applications. The Falcon is an ideal upgrade for Atari ST owners who are looking for a more powerful model, as it is compatible with the majority of ST application software.

1040ST-E MUSIC MASTER

The Music Master Pack features one of the most popular computers used by musicians combined with the renowned MIDI package PRO 24 III to provide a perfect environment for novice and professional alike. The acclaimed MIDI Recording and Editing System from Steinberg, PRO 24 III is used by many top musicians including Dire Straits and PWL. Using any MIDI keyboard, PRO 24 offers the ability to write and compose music to a very high standard. You can record up to 24 tracks simultaneously, and then apply real time editing to remove mistakes.

HARDWARE:

1040ST-E COMPUTER	£299.99
8MHz 16-Bit 68000 CPU, 1Mb RAM, Mouse, TV Modulator, Internal PSU, 1Mb Disk Drive	

SOFTWARE:

PRO 24 III	£150.00
------------	---------

PLUS! FREE FROM SILICA:

Silica Productivity Pack	£104.97
TenStar Games Pack	£219.78

Total Value: £774.74
Less Pack Saving: £475.74
SILICA PRICE: £299.00

NEW! LOW PRICE

£299
Inc VAT - Ref: STC 1261

The Falcon Has Landed!

- 16MHz 32-bit 68030 Processor
- 32MHz Motorola DSP and BLITTER co-processors
- DSP capabilities for voice recognition, speech synthesis and numerous audio special effects
- True colour display: 768 x 480
- 65,000+ colours on screen at once
- Record 8 channel, 16-Bit stereo sound and play back 4 channel, 16-bit stereo simultaneously
- SCSI II, DMA, MIDI IN & MIDI OUT, Stereo audio & microphone ports
- 1.44Mb Floppy Disk
- 1, 4 or 14Mb RAM
- Optional 65Mb Hard Disk
- Built-in ADC & DAC convertors

HARDWARE:

ATARI FALCON 030	£899
16MHz 32-bit 68030 CPU, 1Mb RAM, 3 1/2", 1.44Mb FDD	

SOFTWARE:

CALAPPT - Personal Information Manager - Enhanced version calendar allowing import/export & printing	
PROCALC - Calculator	
SYSTEM-AUDIO-MANAGER - An Auto Folder! Desk Accessory combination that allows the user to record sounds from a microphone and assign various system functions	
TALKING CLOCK - Announces the time at preset intervals	
AUDIO FUN MACHINE - A revolutionary audio program using DSP	
LANDMINES & BREAKOUT - Two fully featured games	

1Mb RAM, 4Mb HD - Ref: STC 7000
4Mb RAM 65Mb Hard Disk - Ref: STC 7046

NEW! 1040ST-E FAMILY CURRICULUM II



HARDWARE:

1040ST-E COMPUTER	£299.99
8MHz 16-Bit 68000 CPU, 1Mb RAM, Mouse, TV Modulator, Internal PSU, 1Mb Disk Drive	

SOFTWARE MODULES:

PLAY AND LEARN - A Game with Words and Sentences	£76.59
JUNIOR SCHOOL - Answer Back/General Knowledge Quiz, Spelling and Primary Maths	£58.54
GCSE - Micro Maths, French, and Geography Quiz	£55.54
HYPHER PAINT - Full Colour Paint Package	£39.99
MUSIC MAKER II - Music Creation Software	£49.99
FIRST BASIC - Powerful Programming Language	£49.99
1st WORD - Very easy-to-use Word Processor	£59.99
ANI ST - Animation Package	£29.95

GAMES

9 LIVES - The ultimate in playability! - help Bob Cat save Claudette	£24.99
PRINCE - Do battle in this tenth century game of warfare	£24.95

PLUS! FREE FROM SILICA:

Silica Productivity Pack*	£44.98
TenStar Games Pack	£219.78

Total Value: £1035.27
Less Pack Saving: £736.27
SILICA PRICE: £299.00

PLUS! 16 NIGHTS HOLIDAY HOTEL ACCOMMODATION

ALL PRICES INCLUDE VAT - FREE OVERNIGHT COURIER DELIVERY IN THE UK MAINLAND

SILICA SYSTEMS OFFER YOU

- FREE OVERNIGHT DELIVERY:** On all hardware orders shipped in the UK mainland.
- TECHNICAL SUPPORT HELPLINE:** Team of technical experts at your service.
- PRICE MATCH:** We normally match competitors on a "Same product - Same price" basis.
- ESTABLISHED 14 YEARS:** Proven track record in professional computer sales.
- £12 MILLION TURNOVER (with 60 staff):** Solid, reliable and profitable.
- BUSINESS + EDUCATION + GOVERNMENT:** Volume discounts available 081-308 0888.
- SHOWROOMS:** Demonstration and training facilities at our London & Sidcup branches.
- THE FULL STOCK RANGE:** All of your requirements from one supplier.
- FREE CATALOGUES:** Will be mailed to you with offers + software and peripheral details.
- PAYMENT:** Major credit cards, cash, cheque or monthly terms.

Before you decide when to buy your new computer, we suggest you think very carefully about WHERE you buy it. Consider what it will be like a few months after you have made your purchase, when you may require additional peripherals and software, or help and advice with your new purchase. And, will the company you buy from contact you with details of new products? At Silica Systems, we ensure that you will have nothing to worry about. We have been established for almost 14 years and, with our unrivalled experience and expertise, we can now claim to meet our customers' requirements with an understanding which is second to none. But don't just take our word for it. Complete and return the coupon now for our latest FREE literature and begin to experience the "Silica Systems Service".

MAIL ORDER HOTLINE
081-309 1111



MAIL ORDER: 1-4 The Mews, Hatherley Rd, Sidcup, Kent, DA14 4DX
Order Lines Open: Mon-Sat 9.00am-6.00pm No Late Night Opening
Tel: 081-309 1111 Fax No: 081-308 0608

LONDON SHOP: 52 Tottenham Court Road, London, W1P 0BA
Opening Hours: Mon-Sat 9.30am-6.00pm No Late Night Opening
Tel: 071-580 4000 Fax No: 071-323 4737

LONDON SHOP: Selfridges (1st Floor), Oxford Street, London, W1A 1AB
Opening Hours: Mon-Fri 9.30am-7.00pm (Sat close 6.30pm) Late Night: Thursday - 8pm
Tel: 071-629 1234 Extension: 3914

SIDCUP SHOP: 1-4 The Mews, Hatherley Rd, Sidcup, Kent, DA14 4DX
Opening Hours: Mon-Sat 9.00am-5.30pm Late Night: Friday - 7pm
Tel: 081-302 8811 Fax No: 081-309 0017

ESSEX SHOP: Keddies (2nd Floor), High Street, Southend-on-Sea, Essex, SS1 1LA
Opening Hours: Mon-Fri 9.30am-5.30pm (Sat 9.00am-6.00pm) No Late Night Opening
Tel: 0702 462426 Fax No: 0702 462363

To: Silica Systems, AMACT-1292-79, 1-4 The Mews, Hatherley Rd, Sidcup, Kent, DA14 4DX

PLEASE SEND A BROCHURE ON THE ST RANGE

Mr/Mrs/Miss/Ms: Initials: Surname:

Company Name (if applicable):

Address:

Postcode:

Tel (Home): Tel (Work):

Which computer(s), if any, do you own? 79E

E&OE - Advertised prices and specifications may change - Please return the coupon for the latest information.

Hurrah! – it's part two of ADAM PETERS' giant guide to re-releases. £3.99 for a game that sold for three times as much a year ago has got to be a bargain, huh? Maybe, maybe not...

INDIANA JONES & THE LAST CRUSADE

Kixx • 72%

Nasty Spectrum graphics will put you off from the start. But if you stick with it, you'll soon discover a very deep and highly playable arcade adventure. And it makes a nice change to see an arcade adventure where the hero isn't egg-shaped.

INTERNATIONAL 3D TENNIS

GBH • 78%

True-to-life 3D. That means lots of strangely animated stick people. This is a game that looks off-puttingly stupid at first glance, but turns out to be the most realistic (and generally funky) tennis sim available. Even tennis incompetents can play it.

ITALIA '90

Tronix • 73%



The official 1990 World Cup game switches from overhead view to head-on the moment someone gets in the penalty area. All the controls then change. You and the ball are separated. You swear loudly. That apart, not a bad footie sim.

ITALY 1990

Kixx • 91%

The best football game ever! Hang on, that's what

we said about *Emlyn Hughes* last month. OK, if it's strategy and build-up you want, go for *Emlyn*: but if you're after incredible speed and non-stop action, embrace *Italy 1990*. It's turbo-charged!

JANAGHIR KHAN'S SQUASH

GBH • 70%

An OK-ish squash game. It would be nice if things moved a bit faster, but this is a decent enough opportunity to sample a sport rarely re-created on computer.

KLAX

Hit Squad • 74%

The world's favourite computer puzzle game (er, after *Tetris*, that is). Catch coloured blocks on a bat and pile them up in matching colours for points and stuff. Hectic and great fun.

LAST DUEL

Kixx • 39%

A shoot-em-up best played with two players (one in a car, one in a plane). Still not very good though. Very colourful, but jerky and crap.

LAST NINJA 2

Hit Squad • 31%

Tiny sprites in a Speccy port black and white isometric 3D game zone. This translates as: you cannot see what the frog is going on. Which is a shame, since this is a beat-em-up and there are loads of obstacles in your way. So ideally you need to see what's going on. Aaargh.

LED STORM

Kixx • 32%

Similar to *Last Duel* (dissed above), *LED Storm* involves driving down a road shoot-

Action replay

RUNDOWN PART 2



ing at other vehicles. It also involves pacing round your room angrily shouting, "what a crap game. I don't believe how crap it is." Be warned.

LICENCE TO KILL

Hit Squad • 58%

A very difficult game. Bond starts off in a helicopter, shooting machine gunners whilst chasing a car. He then gets to walk a bit. Then in a plane. Then swimming. Then in a car. Difficult and uninspiring.

LOTUS ESPRIT TURBO

CHALLENGE

GBH • 90%

An excellent drive-em-up, with a stonking split-screen two-player mode. You get a driver's seat view of the road (limited colour, but that don't matter) and you need your wits about you. Only skilful steering will see you through. Puts the skill back into racing games.

MANCHESTER UNITED

GBH • 69%

Half-decent football game, combining management and arcade sections. The management bit is the superior section, with loads of team selection, wheeler dealing and training. The

arcade bit's jerky, but nothing to start a petition about. Quite good fun.

MATCHDAY

Hit Squad • 61%

Superseded in most people's affections by *Matchday 2*, this was the first big footie game on home computers. Looks a bit nob now, mind.

MATCHDAY 2

Hit Squad • 82%

OK, so it looks a bit wrinkly and doesn't have the full complement of moves (dirty tackles and the like), but *MD2* is still one of the greatest footie sims ever written. It's just as much fun to play today as it ever was.

MIAMI VICE

Hit Squad • 11%

Drive around the city, get messages telling you where the villains are, go there and shoot them. Or better still, don't bother. A nice idea let down by everything else (apart from the idea) being stunningly crap.

MICROPROSE SOCCER

Kixx • 81%

As you'd expect from Microprose, a company famous for its realistic simulators, the way the ball spins is calculated to mathematical precision. Limited colour and a very small area on screen. Includes eleven-a-side and five-a-side games.

MIDNIGHT RESISTANCE

Hit Squad • 86%

Spectrum-style graphics do minimal damage to a brilliant lone-soldier-against-the-enemy-army shootie. Your hero runs from left to

right, jumping on the occasional platform, shooting away at a host of people with big guns he's not friends with. Mindless games be fun, and this one is fab!

MIKIE

Hit Squad • 72%

You're an American school kid avoiding baddies in a series of single screen levels. Collect tulips for your girlfriend, collect weapons to bash the enemies, and keep any eye open for nude women: this was apparently the first game to feature them. Despite this (and its easiness and its age), *Mikie* is quite a good game.

MONTY PYTHON

Tronix • 80%

Supreme nonsense in a platformy arcade adventure that captures the spirit of the TV show brilliantly, and consequently defies any sort of rational explanation. So instead here's some music: parp, parp, bum, bum, dee, bum, parp...

MOONWALKER

Kixx • 68%

Michael Jackson: is he mad then or what? (No, he's not mad at all, he's perfectly sane – *Future Publishing Legal Dept.*) This is a tie-in with Wacko's silly film of the same name. Varied game styles: level one is crap, levels two to four are OK, levels five and above don't exist.

MYTH

Kixx • 92%

If arcade adventures are your thing, give *Dizzy* a break (he's gone full price now anyway, the turncoat). *Myth – History in the Making* is quite an old game. The

graphics are a bit of a colour-free zone. But the game itself is one of the best arcade adventures ever, set across four different historical periods. Most good.

NARC

Hit Squad • 29%

Graphics so poor you almost feel like giving them 10p for a cup of tea. A game so mindless you almost feel like entering it as a contestant on *Strike it Lucky*. We don't think much of this, basically.

NARCO POLICE

GBH • 56%

Typically over-difficult fare from Spaniards Dinamic. Untypically, it's a 3D vector graphics style shootie (rather than a horizontal scroller). Quite good fun, but nothing spectacular. And don't expect to get very far in it.

NAVY MOVES

Hit Squad • 52%

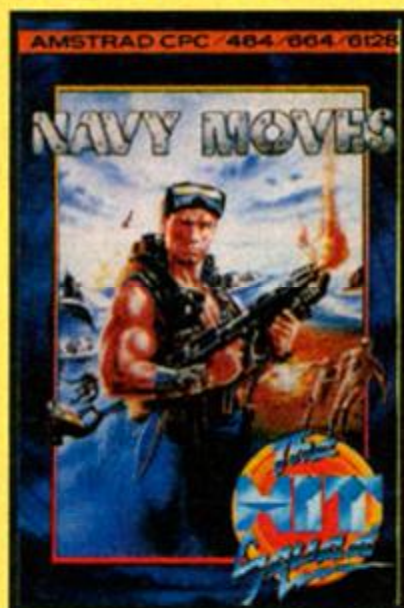

Either Spanish game players are far superior to their British counterparts or Dinamic are off their heads. Probably the latter: once again the Iberian softie provides a brilliant shoot-em-up (this time with the hero seated in a dinghy) only to spoil it with extreme difficulty verging on sheer impossibility. Silly people.

NEMESIS

Hit Squad • 58%

Distinctly average horizontally-scrolling sci-fi shoot-em-up. The graphics haven't aged well, and neither has the gameplay, which is most repetitive. Hard to love (or even like, actually).

NEW ZEALAND STORY

Hit Squad • 76%

Graphics that re-define the word 'awful' do large amounts of damage to a very good platform game. You're a kiwi. You have to rescue your kiwi chums. You have to avoid snails. The first problem is trying to work out which are the snails and which is the kiwi.

NIGHTBREED

Hit Squad • 43%

Bog standard beat-em-up. It's impossible to avoid taking hits. Wonderfully garish colours win some cred, but not enough. Hopelessly boring and predictable.

OPERATION THUNDERBOLT

Hit Squad • 91%

The sequel to *Operation Wolf* (which comes after it in this list – strange thing, the alphabet) means even more mindless destruction. Crosshair on screen, enemy soldiers all over the place, well prepared Fire button finger... the two-player mode is even more manic (but you need two players).

OPERATION WOLF

Hit Squad • 85%

Slightly eclipsed by its more bloodthirsty sequel, *Op Wolf* is an absolute classic that set some very serious standards in shoot-em-up gameplay. It's also a brilliant game, and always will be. Mindless, but brilliant.

OUT RUN

Kixx • 17%

One of the worst coin op conversions ever. Tortoise racing is faster and more competitive than this. File under 'Low Points in the History of Computer Games'. Gawd help us all.

PLATOON

Hit Squad • 69%

Dated, but quite enjoyable, shoot-em-up with a hint of strategy too. There's lots of killing to be done in a game based on one of the most ideologically un-sound films ever. Oh well.

POWER DRIFT

Hit Squad • 85%

An excellent drag racing game. And when we say *drag*, we mean it. Be very careful taking the corners – your car skids out of control at the slightest invitation. It's a real race. You have to finish in the top three. Not easy.

PRO TENNIS TOUR

Hit Squad • 54%

A very difficult tennis sim that requires lots of the old p-r-a-c-t-i-c-e. There's a serving machine on hand, and it's best to wait until you can return a ball from that before playing a real match. An average tennis sim once you've got the hang of it.

PUFFY'S SAGA

Hit Squad • 76%

A cutesie maze game (as in big, rather than single screen, mazes). Puffy runs about a castle avoiding enemies and hazards, whilst eating all the food he can get his hands on. Not bad, but not brilliant.

PUZZNIC

Hit Squad • 87%

A quite excellent puzzle game that involves moving about blocks with pictures of fruit on them. Sounds like the sort of thing people are forced to do in secure institutions, but this is actually supreme fun. 144 different puzzles also means a seat at the table for Mr Long Term Appeal. Pukka!

QUARTET

Hit Squad • 16%

Why on earth did they re-release this? It should have been left well alone. A platform game that was worth 38% in 1987 ("the graphics are appalling and the gameplay monotonous"). What's the verdict today? Shoot on sight.

R-TYPE

Hit Squad • 65%

A coin-op conversion. Limited colour, slow scrolling, repetitive gameplay: similar to most other coin-op conversions, really.

CPC *R-Type* is a reasonable, if rather predictable, attempt.

RAINBOW ISLANDS

Hit Squad • 89%

Those dodgy haircuts on *Amiga Power* reckon this is the best computer game ever made. Hmm, well... it's quite good fun. You have to make your way up through various screens, climbing on rainbows and waxing cutesie enemies. But you knew that already.

RAMBO 3

Hit Squad • 64%

Reasonably varied shoot-em-up, containing all the unleashed firepower you'd expect with the name 'Rambo' in the title. The film was a complete flop. The game is reasonable.

RASTAN

Hit Squad • 73%

Medieval four-way scroller in which you have to chop things to bits. (When we say 'Medieval', we mean it's set in Medieval times, not programmed then.)

RED HEAT

Hit Squad • 58%



A punch-em-up with a very strange taste in graphics (it's hard to explain – you have to see it running). A nice bit of close-up mindless violence in a game that should, for what it is, score about 30%. But it's strangely good fun. (And it's got that nice Mr Schwarzenegger in it.)

RENEGADE 3

Hit Squad • 71%

The final game in the *Renegade* series is a jaunt

through history. It's over-difficult though. Over-difficult beat-em-ups are just as annoying as over-easy ones, but this is an OK game.

RETURN OF THE JEDI

Hit Squad • 72%

The best of the *Star Wars* games. Something of a rarity: a diagonal scroller that isn't crap (and from Domark, too!). It's a bit jerky, the graphics are chunky, and it's one of those shoot-em-ups we like to call 'mindless'. But it's still good for the odd game. So there.

RICK DANGEROUS

Kixx • 93%

The best platform game of all time, according to official AA figures (our review and your readers' poll entries). Rick runs and jumps his way, Indiana Jones style, through five different game zones. Avoid enemies. Avoid rocks. Don't avoid this classic game.

ROBOCOP

Hit Squad • 84%

This one sold millions. Must have been thanks to the film. The game itself is pretty good (with horizontal shootie, puzzle and *Op Wolf* sections) but not earth shattering. A worthwhile buy if you like a bit of action.

RUN THE GAUNTLET

Hit Squad • 64%

A multiloop from hell! It consists of eight different races; four on land, four in the water (each in a different vehicle). It's quite good, but it really isn't worth bothering with on tape. You'll spend more time loading and rewinding the tape than you will playing the game.

GBH • 0742 753423

Hit Squad • 061-832

6633

Kixx • 021-625 3388

Touchdown • 0268

541126

Tronix • 081-960 2255

Future Publishing Limited,
Beauford Court, 30
Monmouth Street,
Bath, Avon BA1 2BW
Tel: 0225 442244
Fax: 0225 446019

Editor Rod Lawton

Staff Writer Adam Peters

Contributors Stuart Whyte, Phil Howard,
 Jerry Glenwright, Richard Fairhurst,
 Tim Blackbond

Art Editor Lam Tang

Senior Ad Sales Executive Jackie Garford

Publisher Colin Campbell

Promotions Manager Michele Harris

Promotions Assistant Tamara Ward

Group Publishing Director Greg Ingham

Production Tracy O'Donnell

Subscriptions Christine Stacey,
 tel: 0458 74011

Circulation Director Sue Hartley,
 tel: 0225 442244

● **Reader calls:** We regret we have to restrict reader calls to Tuesday afternoons.

© **Future Publishing Ltd 1992** Amstrad Action is an independent publication. The company producing it - Future Publishing Ltd - has no connection with Amstrad plc. We cannot guarantee to return material submitted to us, nor can we enter into personal correspondence. We take great care to ensure that what we publish is accurate, but cannot be liable for any mistakes or misprints. No part of this publication may be reproduced in any form without our explicit written permission.

Printed in the UK



'Your guarantee of value'

This magazine comes from Future Publishing, a company founded just seven years ago, but which now sells more computer magazines than any other publisher in Britain. We offer:

Better advice. Our titles are packed with tips, suggestions and explanatory features, written by the best in the business.

Stronger reviews. We have a cast-iron policy of editorial independence, and our reviews give clear buying recommendations.

Clearer design. You need solid information fast. So our designers highlight key elements by using charts, diagrams, summary boxes, annotated photographs etc.

Greater relevance. At Future, editors operate under two golden rules:

- Understand your readers' needs.
- Satisfy them.

More reader interaction. We draw strongly on readers' contributions, resulting in the liveliest letters pages and the best reader tips. Buying one of our magazines is like joining a nationwide user group.

Better value for money. More pages, better quality: magazines you can trust.

Home of Britain's finest computer magazines.

Amstrad Action • Your Sinclair • Commodore Format • PCW Plus • PC Plus • PC Answers • PC Format • Amiga Format • ST Format • Sega Power • Total! • Amiga Power • Amiga Shopper • Super Play • Mega and also Classic CD • Mountain Biking UK • Cycling Plus • Photo Plus • Needlecraft • Cross-Stitch Collection • Today's Vegetarian and others

ABC 35,298

Member of the Audit Bureau of Circulations January-June 1992

Next Month

The Christmas issue of AA is on its way. Here's what to expect...

Christmas shopping

Want to get hold of some serious software or hardware for your machine? Want to know what's available and where to get it? AA presents a Christmas guide to the stuff to buy to get the best out of your machine. Completely indispensable.



Still a little Dizzy

We've given you the full family history this month. Next month the first full-price release starring the egg, *Crystal Kingdom Dizzy*, gets the complete POWER UP treatment. Check out the AA verdict before investing a crisp tenner in the game.

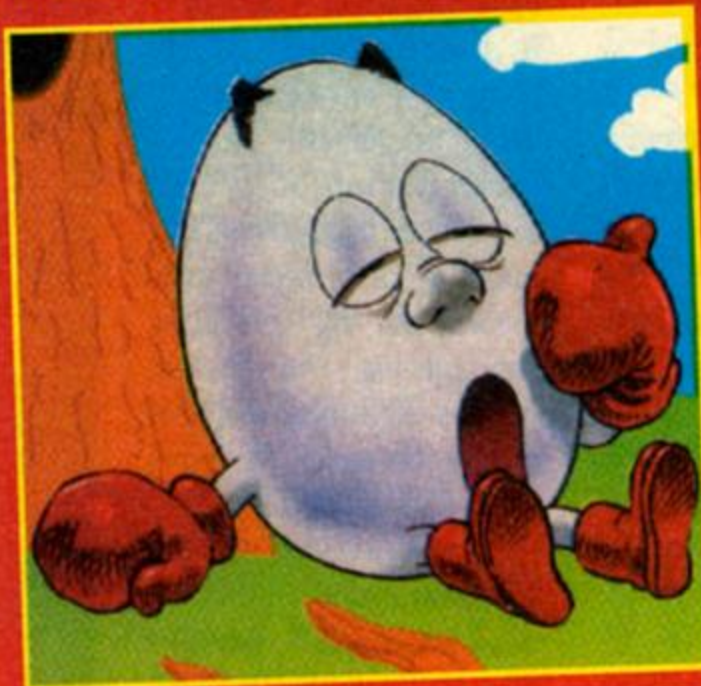

It's educational

Some of you complain that AA doesn't review enough educational software. You're right. Next month we make amends by putting new packages *The Shoe People* and *Playdays* through their paces, along with *Fun School 2* (re-released on budget). Read it - you might learn something.



Drivin' or what?

Nigel Mansell's *World Championship* is Gremlin's eagerly awaited new racing game. The January AA features a detailed review that will leave no hub cap unturned. Oh yes, and there's a fully playable demo on the covertape! Speed junkies, order your copy today. Oh, er, and this isn't actually Nigel Mansell in the photo. We couldn't find a picture of Nigel. This is someone else.



**January issue
 on sale
 December 17th**

Don't miss it!

Dear Newsagent, since this is the place I always come to buy stuff, do you think you could order a magazine for me? It's called *Amstrad Action*, and I want it every month, starting with the January issue - out on Thursday 17th December. Cheers. By the way, you can get it from your wholesalers.

My name

My address

.....

.....

.....

FREE! ZOOOL PACK WITH EVERY AMIGA

500 or 600 FROM SILICA SYSTEMS

PLUS!
PHOTON PAINT 2 AND GFA BASIC

WORTH OVER
£265

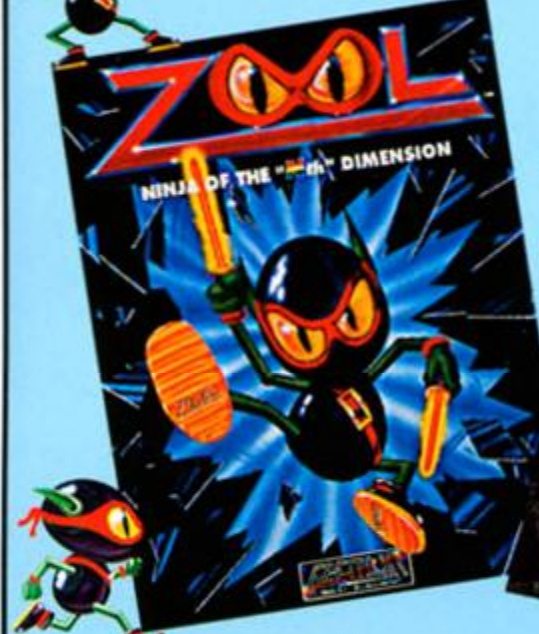

Silica are pleased to offer THE Software Pack of the Year FREE with every Amiga purchased. It includes the sensational new title ZOOOL which has received rave reviews as the most original game ever seen on the Amiga.
ZOOOL - "Knocks the socks off Sonic." - 97% - Amiga Computing - Nov '92
STRIKER - "Footballer of the Year - and no mistake..." - 94% - CU Amiga - June '92
PINBALL DREAMS - "It's quite simply superb" - 94% - AUI - Sept '92
TRANWRITE - Premier word processor (UK version) with a 90K spell checker.
 Plus, with every Amiga from Silica, we will give you Photon Paint 2 paint package and GFA Basic programming language. A total of over £265 worth of free gifts.

ZOOOL PACK:
 ZOOOL - platform title of the year £25.99
 STRIKER - soccer simulation £25.99
 PINBALL DREAMS - pinball simulation £25.99
 TRANWRITE - word processor £49.95
PLUS!
 GFA BASIC v3.5 - programming language £50.00
 PHOTON PAINT 2 - paint package £89.95
£267.87



AMIGA 500 Plus CARTOON CLASSICS

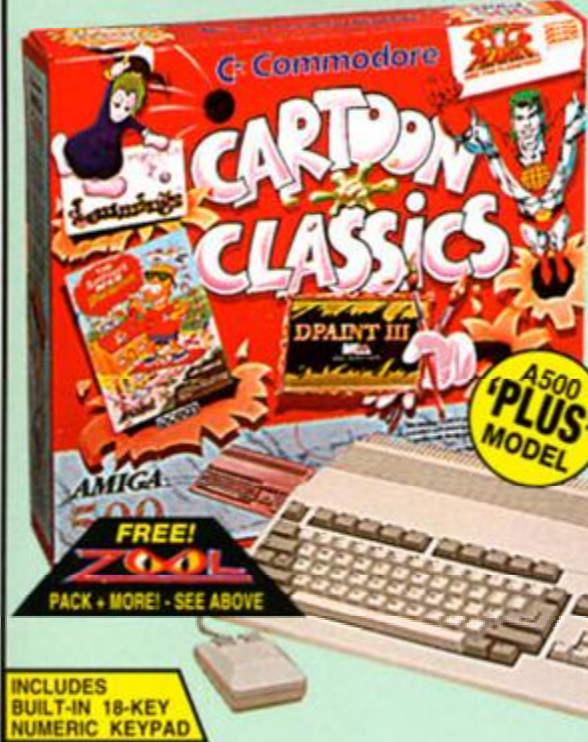

PACK INCLUDES:
 • 1Mb AMIGA 500 PLUS £399.99
 • BUILT-IN 1Mb DRIVE FREE
 • ASIO TV MODULATOR FREE
 • THE SIMPSONS £24.99
 • CAPTAIN PLANET & THE PLANETEERS £25.99
 • LEMMINGS £25.99
 • DELUXE PAINT II £79.99
PLUS! FREE FROM SILICA
 • ZOOOL PACK £127.92
 • PHOTON PAINT v2.0 £89.95
 • GFA BASIC v3.5 £50.00
PACK VALUE: £824.82
PACK SAVING: £525.82
SILICA PRICE: £299.00

INCLUDES BUILT-IN 18-KEY NUMERIC KEYPAD

£299
INC VAT - AMC 0592

AMIGA 600



AMIGA 600 COMPUTER WITH FREE! ZOOOL & DELUXE PAINT III PLUS! FREE GIFTS FROM SILICA
SEE PANEL ABOVE

The new Amiga 600 uses state-of-the-art surface mount technology, for maximum reliability and features a 3 1/2" floppy drive, mouse, TV modulator and smart card slot all as standard. The innovative smart card slot accepts games, ROM or RAM cards (from 1Mb up to 4Mb) and will take advantage of many future new developments. The very latest version of the operating system, Kickstart/Workbench v2.05 is used in the Amiga 600 and its enhanced chip set facilities include improved graphics resolution, increased genlock support and the facility for up to 2Mb of chip memory. The Amiga 600 is fully compatible with the A670 CD-ROM Drive and Interface which will give it access to a full range of CDTV titles and audio CDs. The Amiga 600 is available from Silica in several configurations including a special 2Mb RAM upgrade optional extra - see the chart below.

£299
INC VAT - Ref: AMC 0666

NEW! AMIGA 600 PACKS

WILD, WEIRD & WICKED

EPIC 'HARD DRIVE' PACK



The Wild, The Weird and The Wicked (WWW) is the title of Commodore's new Amiga 600 games pack. Priced at £349, it comes complete with Amiga 600 computer and mouse, plus a range of high quality entertainment software. For pack contents, plus a list of the FREE gifts from Silica with every Amiga 600, see the chart on the right.
£349
INC VAT - AMC 0649

For the more serious user, the £499 Epic Language Pack is based around the A600HD, the A600 with 20Mb hard drive. It includes challenging adventure games and software for the linguistically minded! Details are shown on the chart on the right along with a list of the FREE gifts from Silica with every Amiga 600 purchased.
£499
INC VAT - AMC 0799

AMIGA 600 COMPUTER OPTIONS

- 1Mb AMIGA 600 + MOUSE, 3 1/2" Disk Drive, TV Modulator, Smart Card Slot
- 20Mb HARD DISK - Very fast, mass storage for programs and data
- DELUXE PAINT III - Award winning graphics and animation package
- LEMMINGS - Save the Lemmings as they drop into 100 screens of danger
- MICROPROSE GRAND PRIX - Racing Sim with all the thrills & spills of the track
- SILLY PUTTY - The pliable arcade game of immense playability
- PUSH OVER - A game of puzzles. Can G.I. Ant save Colin Curly's Quavers?
- EPIC - A Sci-fi adventure. Can you guide a space fleet across the solar system?
- ROME - Your goal is to become Emperor in this role playing adventure
- MYTH - Can you stop the spread of evil and question the judgements of the gods?
- TRIVIAL PURSUIT (in 3 languages) - The great trivia quiz game for the Amiga
- WORD PROCESSOR + DICTIONARY (in 5 languages) - For creating documents
- 1 YEAR ON-SITE WARRANTY

	NO HARD DRIVE	20Mb HARD DRIVE
LEMINGS	£299.99	£299.99
WWW PACK	£79.99	£79.99
EPIC PACK	£25.99	£25.99
	£34.99	£34.99
	£25.99	£25.99
	£25.99	£25.99
	-	£29.99
	-	£25.99
	-	£19.99
	-	£29.99
	-	£29.99
PLUS! - FREE FROM SILICA		
• ZOOOL PACK - Four top Amiga titles - see panel above	£127.92	£127.92
• PHOTON PAINT v2.0 - An art package with numerous features & special effects	£89.95	£89.95
• GFA BASIC INTERPRETER v3.5 - A language for programmers of all levels	£50.00	£50.00
TOTAL PACK VALUE:	£673.84	£734.82
LESS PACK SAVING:	£374.84	£385.82
SILICA PRICE:	£299	£349
2Mb RAM	PRICE OF UPGRADE TO 2Mb RAM WITH BATTERY BACKED CLOCK	PRICE OF UPGRADE TO 2Mb RAM WITH BATTERY BACKED CLOCK
	+£45	+£45
	RAM 0610	RAM 0610

ALL PRICES INCLUDE VAT - DELIVERY IS FREE OF CHARGE IN THE UK MAINLAND

SILICA SYSTEMS OFFER YOU

- **FREE OVERNIGHT DELIVERY:** On all hardware orders shipped in the UK mainland.
- **TECHNICAL SUPPORT HELPLINE:** Team of technical experts at your service.
- **PRICE MATCH:** We normally match competitors on a "Same product - Same price" basis.
- **ESTABLISHED 14 YEARS:** Proven track record in professional computer sales.
- **£12 MILLION TURNOVER (with 60 staff):** Solid, reliable and profitable.
- **BUSINESS + EDUCATION + GOVERNMENT:** Volume discounts available 081-308 0888.
- **SHOWROOMS:** Demonstration and training facilities at our London & Sidcup branches.
- **THE FULL STOCK RANGE:** All of your requirements from one supplier.
- **FREE CATALOGUES:** Will be mailed to you with offers + software and peripheral details.
- **PAYMENT:** Major credit cards, cash, cheque or monthly terms.

Before you decide when to buy your new Amiga computer, we suggest you think very carefully about WHERE you buy it. Consider what it will be like a few months after buying your Amiga, when you may require additional peripherals or software, or help and advice with your new purchase. And, will the company you buy from contact you with details of new products? At Silica Systems, we ensure that you will have nothing to worry about. We have been established for almost 14 years and, with our unrivalled experience and expertise, we can now claim to meet our customers' requirements with an understanding which is second to none. But don't just take our word for it. Complete and return the coupon now for our latest FREE literature and begin to experience the "Silica Systems Service".

MAIL ORDER HOTLINE 081-309 1111

SILICA SYSTEMS

MAIL ORDER: 1-4 The Mews, Hatherley Rd, Sidcup, Kent, DA14 4DX Tel: 081-309 1111
Order Lines Open: Mon-Sat 9.00am-6.00pm No Late Night Opening Fax No: 081-308 0608

LONDON SHOP: 52 Tottenham Court Road, London, W1P 0BA Tel: 071-580 4000
Opening Hours: Mon-Sat 9.30am-6.00pm No Late Night Opening Fax No: 071-323 4737

LONDON SHOP: Selfridges (1st Floor), Oxford Street, London, W1A 1AB Tel: 071-629 1234
Opening Hours: Mon-Fri 9.30am-7.00pm (Sat close 6.30pm) Late Night: Thursday - 8pm Extension: 3914

SIDCUP SHOP: 1-4 The Mews, Hatherley Rd, Sidcup, Kent, DA14 4DX Tel: 081-302 8811
Opening Hours: Mon-Sat 9.00am-5.30pm Late Night: Friday - 7pm Fax No: 081-309 0017

ESSEX SHOP: Keddies (2nd Floor), High Street, Southend-on-Sea, Essex, SS1 1LA Tel: 0702 462426
Opening Hours: Mon-Fri 9.30am-5.30pm (Sat 9.00am-6.00pm) No Late Night Opening Fax No: 0702 462363

To: Silica Systems, AMACT-1292-80, 1-4 The Mews, Hatherley Rd, Sidcup, Kent, DA14 4DX

PLEASE SEND A 64 PAGE AMIGA COLOUR CATALOGUE

Mr/Mrs/Miss/Ms: Initials: Surname:

Company Name (if applicable):

Address:

Postcode:

Tel (Home): Tel (Work):

Which computer(s), if any, do you own? 80G

... E&OE - Advertised prices and specifications may change - Please return the coupon for the latest information.

THE HARD-HITTING BIG THREE JOIN FORCES TO BRING YOU
THE WILDEST
COMPILATION PACK
OF ALL TIME

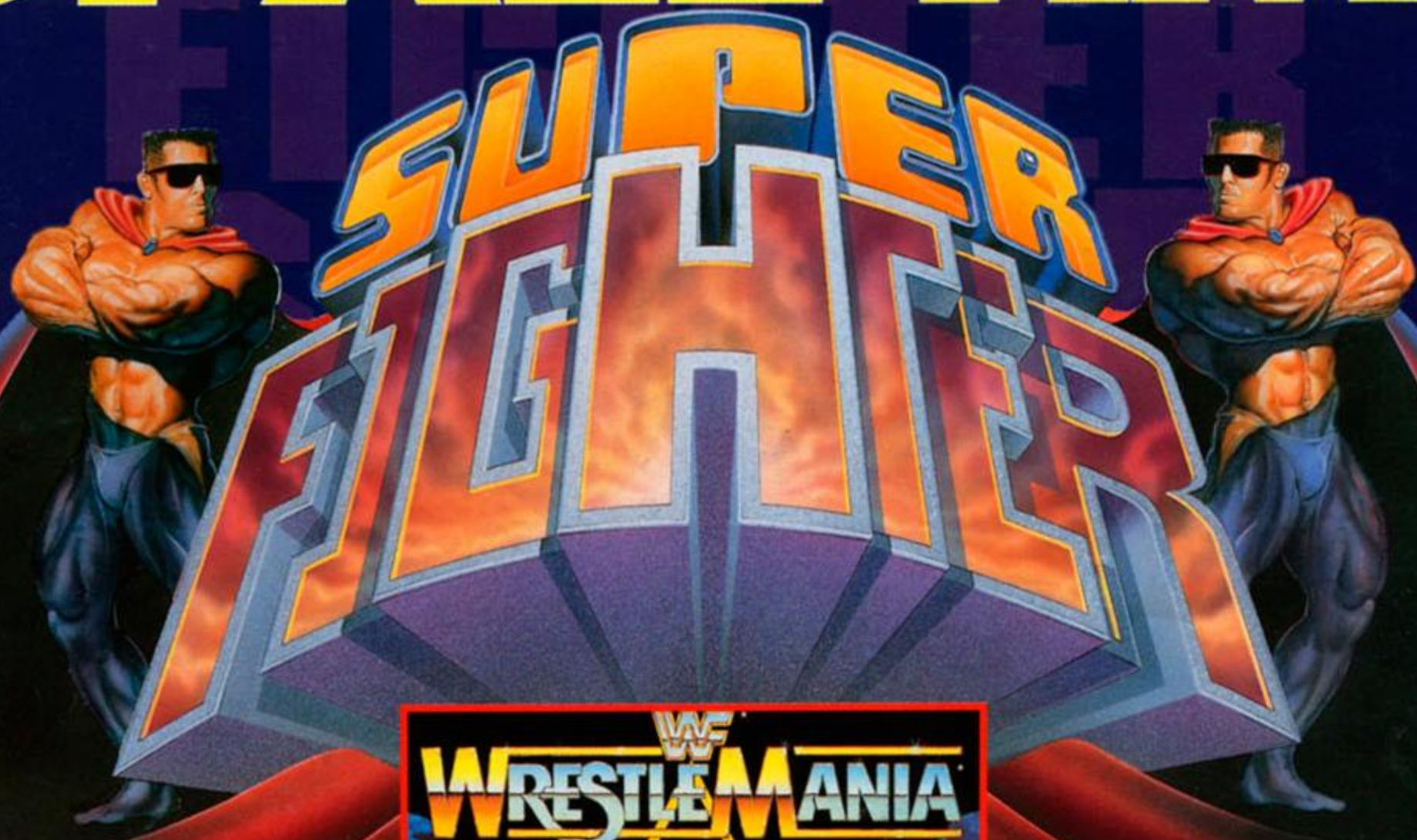

FINAL FIGHT™ ©1991 CAPCOM USA, INC. ALL RIGHTS RESERVED.
 CAPCOM® IS A REGISTERED TRADEMARK OF CAPCOM USA, INC.

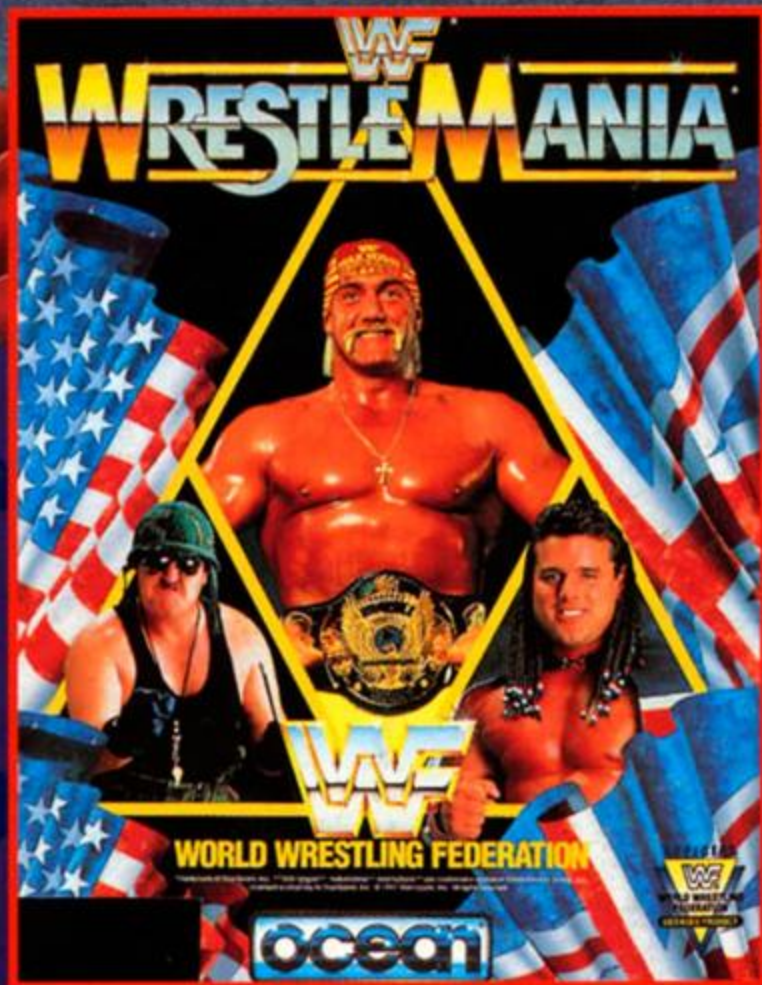

*TRADEMARK OF TITANSPTS, INC. © 1991 ALL RIGHTS RESERVED. ALL DISTINCTIVE CHARACTER NAMES, LIKENESSES AND LOGOS ARE TRADEMARKS OF TITANSPTS, INC. © 1991 ALL RIGHTS RESERVED. **HULK HOGAN, HULKAMANIA AND HULKSTER ARE TRADEMARKS OF MARVEL ENTERTAINMENT GROUP, INC., LICENSED EXCLUSIVELY TO TITANSPTS, INC. © 1991 ALL RIGHTS RESERVED.

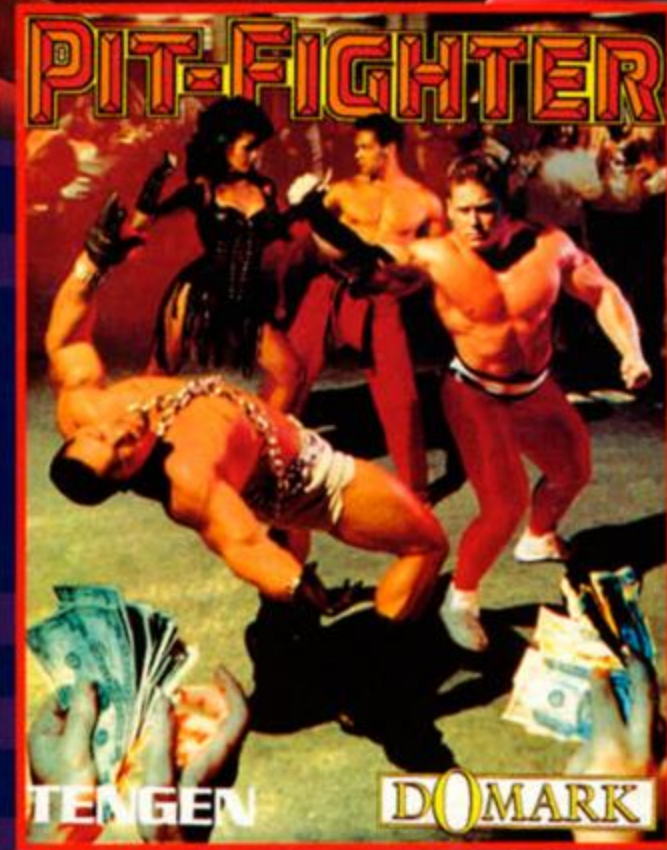

©1991 TENGEN INC. ALL RIGHTS RESERVED. TM ATARI GAMES CORPORATION.



CBM AMIGA · ATARI ST
 SPECTRUM · AMSTRAD
 COMMODORE 64