

May 1987

£1.00

AMSTRAD COMPUTER USER

Painting with numbers using
Rainbird's Advanced Art Studio

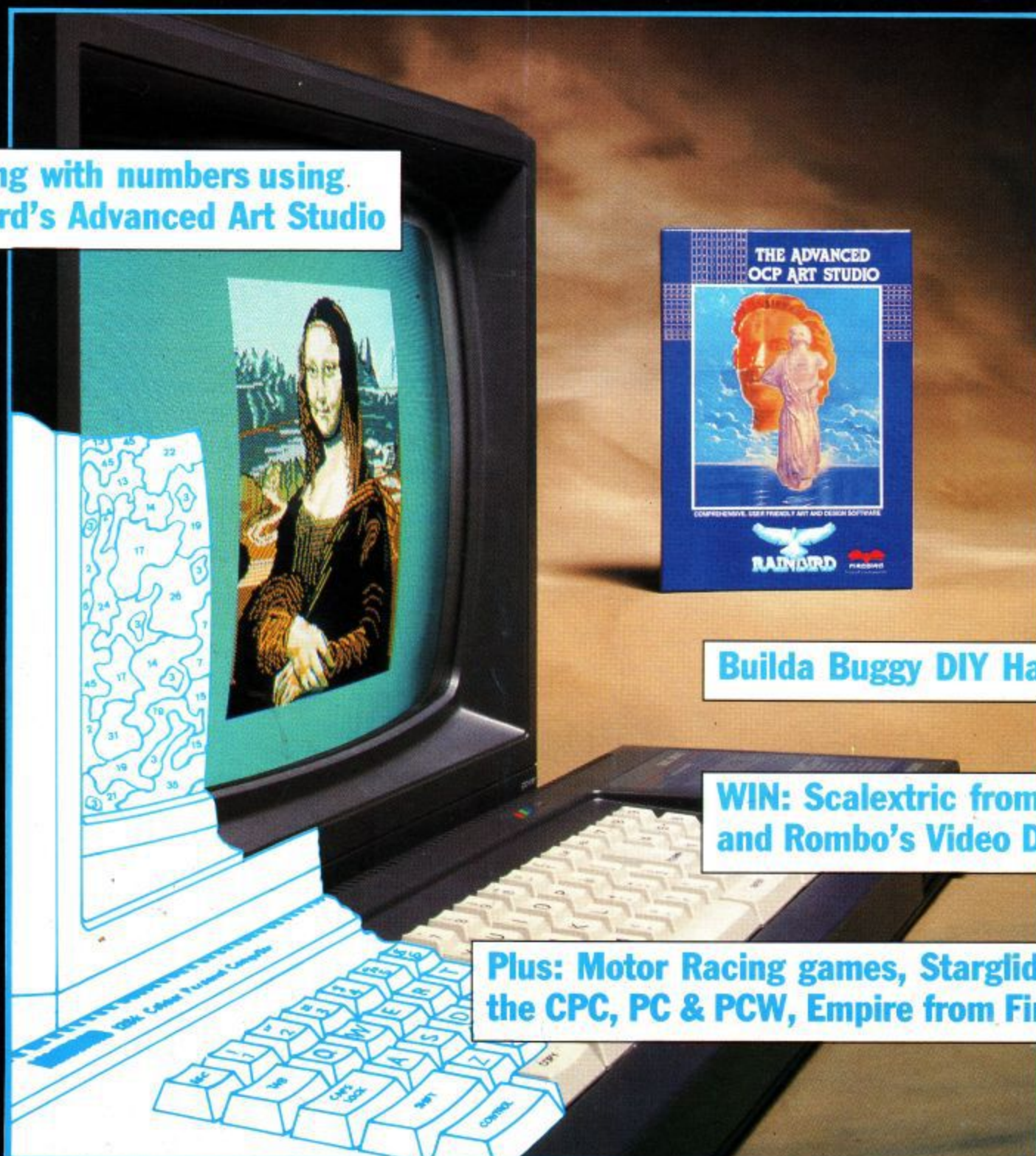

Build a Buggy DIY Hardware

WIN: Scalextric from Virgin
and Rombo's Video Digitizer

Plus: Motor Racing games, Stargliders for
the CPC, PC & PCW, Empire from Firebird

Official Amstrad Home Computing Magazine

Norway NOK 20.00
Spain 300 Ptas
Turkey 1650 TL
Denmark Kr. 31.00
New Zealand NZ\$4.95 Rec.

* And presentation quality graphics, so ask about DR GRAPH and DR DRAW packages £49.95 each

AMSTRAD PROFESSIONALS
FROM DIGITAL RESEARCH

Your Amstrad has 256k or 128k to play with.

The Amstrad 8256 and 6128 are extraordinary machines with random access memory that lifts them far above the home computer norm.

Now Digital Research, creators of the CP/M operating systems bundled with these business calibre Amstrads, offer serious users professional program development power and applications portability via two high level Digital Research languages: PASCAL/MT+ and CBASIC COMPILER.

Both languages come as complete packages of standard Amstrad 3" disks with full documentation.

The most complete PASCAL £49.95.

PASCAL/MT+ is full ISO standard PASCAL, extended to provide a comprehensive professional programming environment for industrial, business and educational applications.

It's faster, more versatile, more portable and easier to use in sophisticated applications demanding segmented development.

The package includes a compiler to generate relocatable object files; a linker to generate executable files from compiler outputs; a run-time support library covering transcendental functions, machine interrupts and other tasks; a disassembler and a symbolic debugger.

As well as standard ISO numerics, PASCAL/MT+ supports BCD and floating point real numbers for arithmetic precision. Special features reduce program size and enhance I/O capabilities. PASCAL/MT+ is the fully implemented PASCAL you can start with, stay with and never outgrow.

It seems a pity just to play.

Ten times faster with CBASIC £49.95.

CBASIC Compiler is a native code compiler that allows separate modules to be written, tested and combined to create a complete program. And it combines machine code speed with BASIC ease to produce programs that execute eight to ten times faster than the same interpreted programs.

A fully integrated set of device independent graphics statements and functions permits direct output to any graphics peripheral without recompiling.

Extended precision 14-digit decimal arithmetic ensures that fractional parts of pound amounts are exact and ledgers balance to the penny.

CBASIC Compiler also supports integer arithmetic, so you can use integer variables to increase execution speed.

Multiple line function capability with multiple parameters provides features found in block-structured languages. Local variables can be declared in an MLF. MLF functions may be declared as external, belonging to an entirely different program module.

Development Potential.

PASCAL/MT+ and CBASIC Compiler run on the Amstrad CPC 6128, PCW 8256, CPC 664 and CPC 464 with DD-1 disk drive. Use of graphics with CBASIC Compiler is only available on CPC 6128 and PCW 8256.

The Amstrad Professionals from Digital Research will allow you to explore and exploit your Amstrad computer's program development potential to the full.

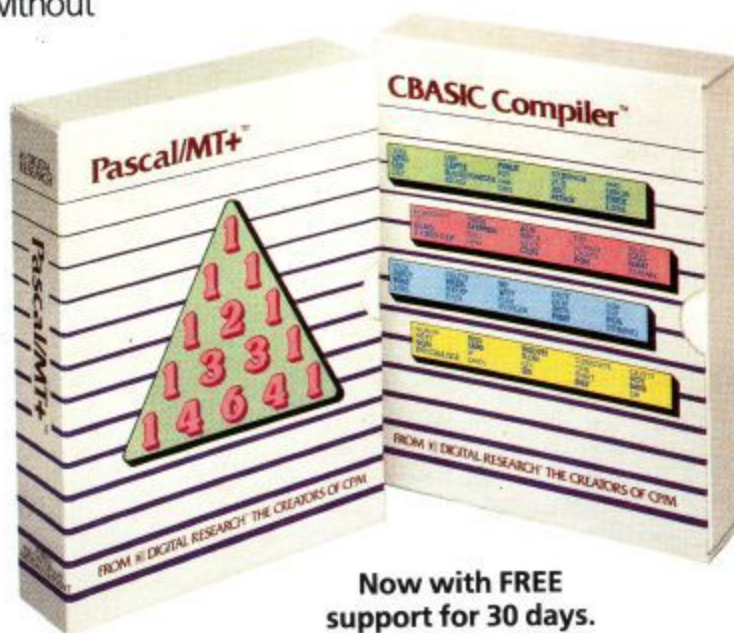

Now with FREE
support for 30 days.

Amstrad Professionals from Digital Research. Now Professionalism begins at home.

To place an order, send cheque to: Amstrad Sales, Digital Research (UK) Limited, Oxford House, Oxford Street, Newbury, Berkshire RG13 1JB. Or telephone Newbury (0635) 38787 or 38783, with your credit card details. Or contact your local Amstrad dealer.

*FREE telephone support for 30 days following receipt of registration card. Thereafter a full year's on-line telephone support is available for just £15.00 + VAT. Full details will come with your software.



*Prices include
Packaging, Postage and VAT.

**DIGITAL
RESEARCH**

The creators of CP/M™

REGULARS

- 5 News
- 11 Letter
- 23 Hairy Hackers Haunt
- 36 Seek and Ye Shall Find
- 20 Gallup Chart
- 98 LSB

REVIEWS

- 18 **Advanced Art Studio**
With more facilities and a higher price. Does the former justify the latter? Jill Lawson found out.
- 32 **PlanIt**
Sort out your finances, software style. But getting organised needs more than just some clever software.
- 77 **Empire**
Firebird is hiding its light under a bushel and has kept quiet about the new space strategy game. It may be difficult, but it is also very addictive.

FEATURES

- 64 **Elite, the software house which cares**
Some software houses will release any old program, but Elite is too fussy for that, as Jerry Muir found out.
- 44 **AMBUG**
Build your own number 5... a robot which runs under the control of your CPC. So get out your soldering iron, dust off those wire strippers and get going...



- 81 **Games Reviews**
Colin, Nigel and Liz try out Muncher, Sigma 7, Cobra, Into The Eagles Nest, and Shockway Rider.

COMPETITIONS

- 43 **Rombo Compo**
Let your video and computer become friends with a Vidi interface. A simple, free-to-enter competition for all Arnold owners.
- 31 **Scalextric Compo**
You are never too old to play Scalextric. Win a full set from Virgin or a runners-up prize of the computer version.

PROGRAMMING

- 57 **Plumberdroid**
The pipeline is leaking, you must dodge the alien and repair the pipe before it's too late. Go for it!
- 68 **Assembly Point**
Pete Green presents a routine which features one of the classic principles of assembler coding.

AMSTRAD

COMPUTER USER

The official magazine for all users of Amstrad computers

Cover photo: Martyn Howlett

Editorial and Advertising offices:
169 King's Road, Brentwood, Essex CM14 4EF.
Tel: 0277-234459 (Editorial); 0277 234434 (Advertising)
Telecom Gold: 72:MAG021

Published by Avralite Ltd, 36/38 St. Petersgate, Stockport SK1 1HL.

News trade distribution: Diamond-Europress Sales & Distribution Ltd,
Unit 1, Burgess Road, Ivyhouse Lane, Hastings, East Sussex TN35 4NR.
Tel: 0424 430422.

Editor: Simon Rockman
Advertisement Manager: Jane Nolan
Advertisement Assistant: Lorraine Day

Amstrad is a registered trade mark, and with the title Amstrad Computer User, is used with the permission of Amstrad Consumer Electronics plc. No part of this publication may be reproduced without permission. While every effort is made to ensure the accuracy of all features and listings we cannot accept any liability for any mistakes or misprints. The views and opinions expressed are not necessarily those of Amstrad or Amsoft but represent the views of our many readers, users, and contributors. Material for publication is only accepted on an all-rights basis. We regret that Amstrad Computer User cannot enter into personal correspondence. © Avralite Ltd 1987.

MASTERFILE III

FOR THE AMSTRAD CPC 6128 (ALSO CPC 464/664 WITH DK 'TRONICS 64K RAM)

FIRMLY ESTABLISHED ...

MASTERFILE III is now firmly established as THE filing system for the CPC6128. It has received rapturous reviews and we could paper the walls of our new offices with our customers' letters of appreciation.

For the benefit of newcomers to the CPC machines: MASTERFILE III is a powerful and flexible data filing and retrieval system. All "database" systems require that your data is organised into fields and records. Unlike most, MASTERFILE does not commit you to field lengths or formats, since ALL data is variable-length and optional. Files are not pre-formatted, and only used bytes are saved to disc. Also, unlike the rest, MASTERFILE allows multiple user-defined ways of viewing/printing your data. And unique in its price range, MASTERFILE offers RELATIONAL FILE options, whereby common data can be entered just once and shared by many records. Maximum field size is 240, maximum fields per record is over 50, and maximum file size is 64K. Room for 1,000 full names and addresses, for example. Only one disc drive is required. It is menu-driven throughout, and comes with detailed illustrated manual, and example files.

SO VERY VERSATILE ...

Just about ANY kind of information can be handled by MASTERFILE. You can EXPORT the data to other systems (e.g. PROTEXT/MERGE and TASWORD). You can even merge your own USER BASIC to MASTERFILE for customised file processing, or build new files from other computer sources. The speed of SEARCH of MASTERFILE is second to none. Records can be sorted ascending/descending, character or signed numeric, even embedded keys such as surnames. Other functions are field-to-field calculations, and several-across label printing. We simply don't have room to list all the features; give us a call if you are still in doubt of the power of MASTERFILE III.

ALL THIS POWER ...

This is no toy thrown together in BASIC and half-tested, but real machine-coded computing power professionally constructed. We have had IBM and Apricot users beg us for a MASTERFILE for their machines — when they had seen the earlier CPC MASTERFILE. All this power is yours for ... **£39.95.**

For those who already have an earlier MASTERFILE, we offer updates; please telephone for details. You will be amazed at the performance improvements and extra functions.

★★★ PCW users: be patient, MASTERFILE 8000 will be ready early in 1987 ★★★

MASTERCALC 128 SPREADSHEET

We also have one of the fastest and friendliest spread-sheet programs around, MASTERCALC 128. Its unique features include: individual tailoring of column widths and precision; relocatable formulae; split-screen option; automatic cursor advance; text output to printer, or to disc for interface with PROTEXT or TASWORD; hi-res graphic histogram of any three rows. MASTERCALC 128 runs on CPC6128, or CPC464/664 with DK'tronics RAM. The price is just **£33.00.**

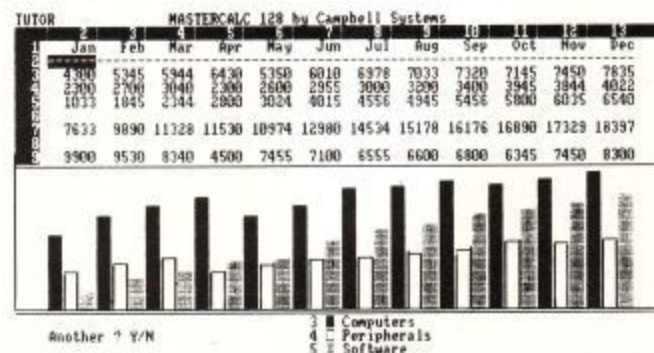

SPECIAL OFFER

You can save £10 by taking MASTERFILE III and MASTERCALC 128 for a combined price of just **£62.95.**

Prices include VAT and P&P to anywhere in Europe. Elsewhere please add 20% for air-mail service. ACCESS/VISA/MASTERCARD welcome, written or telephoned, quoting card expiry date. Make cheques payable to "Campbell Systems". Our normal response is return of post, 1st class.

CAMPBELL SYSTEMS Dept. (ACU)
7 Station Road, EPPING, Essex CM16 4HA,
England. Tel: (0378) 77762/3.

Summary of Business Assets			
Description	Maker	Model	Value
Microcomputer, 64K RAM + 32K ROM	Amstrad	CPC 464	£199.00
Microcomputer, 128K RAM + disc	Amstrad	CPC 6128	£299.00
Disc interface and 1st drive, 3"	Amstrad	DDI-1	£149.95
Dot-matrix printer 50cps 80col	Amstrad	DMP-2000	£159.95
Executive briefcase	Antler	AT0109	£42.00
Wire paper clip	British Steel	BMC	£0.01
Answering machine	British Telecom	BT2836	£185.00
Photocopier, single-feed	Canon	PC-10	£650.00
String ball of	IBM	8005-Exec	£0.00
Executive jet aircraft	Lear	Cloud-Cuckoo	£5,200,000.00
Typewriter, electric	Olivetti	Leterra 36	£130.00
Dictation machine	Philips	510	£190.00
Coffee maker	Philips	HD5349	£30.00
Parcel scale	Salter	250P	£119.00
Microcomputer, 48K	Silicarn	Trumpspec	£129.95
Letter scale	Waymaster	375KL	£10.00
Totals:			£5,202,294.26

Top record = 0001 [H] for menu
File: FILE2 Records:0016 Selected:0016 Parents:0000 RAM used:02K from 64K



New comms package for CPC 6128

A new terminal package is to be launched by Monflair for the CPC 6128 range of computers. The disc based software will work with all interfaces built to the specification outlined in the Amstrad firmware manual. These include the Pace, Honeysoft and both the new and old Amstrad serial interfaces.

The package is referred to by the authors as being a full workstation. Written with Hi-Softs' Devpac, the program has been two years in the making and runs under CP/M+.

The full spec viewdata terminal supports telesoftware, double height, flashing, a full eight colours, conceal and reveal and we expect dynamic frames. It is possible to write mailboxes off line and send them at high speed when you log in. This saves time and cuts down on telephone bills.

Two screen dumps are available, a rapid text dump and a shaded Epson screen dump. The software will be available shortly and cost £39. For more details contact Monflair on 01-367-1777.

DK'Tronics clock on

Two years ago Amstrad user ran its first hardware project. The second one is in this month! Now DK has launched a peripheral for the CPC which does the same job as that ancient project, only with a bit more finesse.

It is a battery backed-up clock, just like the one Amstrad include with the PC 1512. It stores information when you switch the computer off. This includes a clock which can be switched from 12 to 24 hour notation. End of month and leap years are catered for in the calendar function and you can have a daily alarm.

It also includes 50 bytes of battery backed-up ram for important data and will work with CP/M and CP/M+. There is an 8 bit I/O port for control applications. The battery is re-charged from the Amstrad, so providing you use your Amstrad occasionally the data should be safe. More details from DK'Tronics on 0493 602926



Michael Caine, star of The Fourth Protocol, outside the Cabinet office.

The second and third 4th Protocols

Someone, somewhere in Britain is building an atomic bomb. He is a top KGB agent, the smartest they've got. With only a deep belief that this is what's going on, and the slightest of clues, you must find and stop him.

An excellent new film telling the story is doing the rounds. Go and see it, if only to watch a transit van being driven like a rally car. The hero is John Preston, played by Michael Caine, who solves the crime with the help of a BBC Micro.

Sounds ideal for a computer game really. And indeed it is. The fourth Protocol – the game is an adventure using icons and ciphers rather than text. Ariolasoft produced the first Amstrad version of this adventure quite a while back. It runs on the CPC and is worth looking out for.

To coincide with the film release Ariolasoft has launched PCW and PC versions of the game. Ideal for some cerebral exercise.

CRL reveal a warped mind

In the never ending quest for a new approach to software, CRL has announced a number of new programs. The most mundane of these is Sun Star. According to the press release 'You are destined for the Xxarian Star Corporation solar energy grid to collect energy' (what else – Ed).

It goes on 'However, due to a build up of unstable energy pulses, that task is far from easy'. Basically it's a jolly good shoot-em-up which will cost £7.95 on tape and £14.95 on disc.

The releases continue as the gore sets in. 'Gothic Horror from CRL'. This is a three part Frankenstein adventure with reportedly terrifying sound effects and a price tag reading £9.95 on the tape or £14.95 on disc.

Then the bumf plumbs the depths.

'CRL licenses Oink!'. This is not a particularly horrific press release. It tells of a game in which you play the part of Uncle Pigg, the world-famous editor of the magazine and have to be promoted from tea boy to editor. (Same thing in this place – Ed). What is horrific is that they keep sending copies of the magazine. It's sick, vile and absorbing.

No one fooled

Amstrad User's scoop news feature on Amstrad's sky rocket in the April issue of ACU does not seem to have fooled anyone. It was of course an April Fool. But how many of the clues did you spot? The acronyms APRIL, LOCOSCRIPT and even April FOOL worked into the script. Little touches like the date at the bottom and large hints like the satellite footprint should have helped you twig.



Jailbreak winner

Johnathan Morrice of Great Yarmouth is the winner of the Konami Jailbreak machine. The full size arcade machine is now sitting in his hall. The response to the competition was fantastic. Thank you to everyone who took part.

The correct answers were 1. b, 2. c, 3. a, 4. c. To award the prize to Johnathan, Luther De Gale of Konami UK, Hiro Maruo of Konami Europe and Mike Daniels of NMC (the company which handled the home computer conversion) came into the office. Our photograph shows Johnathan and Mr Maruo with the prize.

Starlight dawns

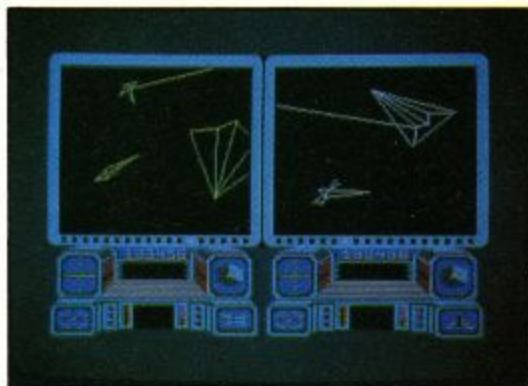

Dogfight

Two new games will be out soon from Starlight, the sister company to Ariolasoft. The first game is Dogfight 2187 and looks a little like Top Gun. The 3D vector graphics portray your role as Dexter. You must search the skies for pieces of the Spatial Generator. This will prevent an attack by hordes of marauding alien invaders.

The second title is Deathscape, which uses the old sci-fi plot of two nations putting up a champion in one-to-one combat rather than fighting an all-out war.

You play the hero volunteered by the Sol Federation, put into battle against a single Varg ship. Unfortunately the Varg's cheat and have sent a squadron against you. The arena is known as the Deathscape, and only one ship will escape alive. Make sure that ship is yours.



Rupert Bowater and Paul Norris of Binary Design

Tropical quest at the Palace

Well not actually *the* Palace, more a Palace. In this case Palace Software. They will be releasing Stifflyp & Co. The game is described as "a multi-role action back-packed adventure". It consists of two parts, "Out For The

Count" and "The Final Countdown".

Programmed by Binary Vision, Veterans of Zoids and The Fourth Protocol, the game centres around Sebastian Stifflyp and his quest for Count Chamelion.



Deathscape

DAVE and PAM

by ALEX & SPITAL

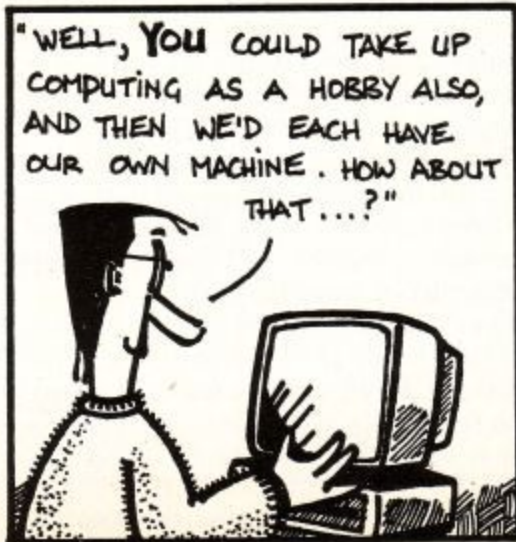
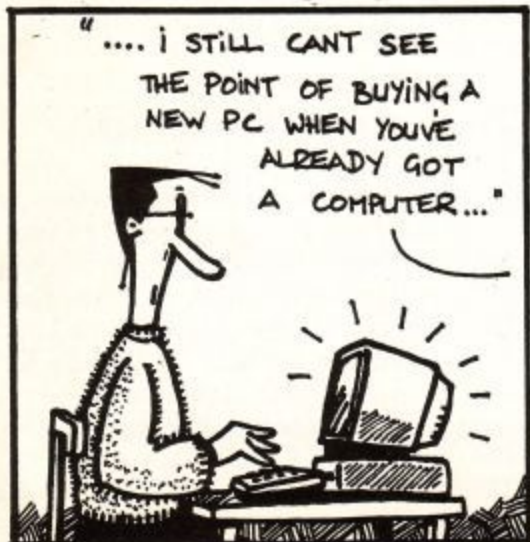

The 7th official

AMSTRAD COMPUTER SHOW

Organised by
Database Exhibitions



Friday July 10 10am-6pm
Saturday July 11 10am-6pm
Sunday July 12 10am-4pm

Alexandra Pavilion

London N22

The BIGGEST Amstrad event ever!

If you've an Amstrad computer – or thinking of getting one – you just **HAVE** to visit this mega event in the computing world.

The move to Alexandra Pavilion – one of London's largest and most prestigious venues – means there is 50% more space – with many more stands and many more exhibitors than ever before. It's the fastest growing computer show of them all!

FREE THEATRE PRESENTATIONS

To meet the exceptional demand, we've **DOUBLED** the number of seats in the Amstrad Theatre. In continual sessions every day of the show, Britain's top experts will be there to answer your questions – and help you make the correct choice from the multitude of new products you'll see on display at the show.

HOW TO GET THERE

It's so easy to get to the show – by car, rail, underground or bus. Alexandra Palace has its own British Rail station, whisking visitors to and from King's Cross in just nine minutes. And there's a free bus service shuttling between station and show every 10 minutes. If you're travelling by road the show is only 15 minutes away from Junction 25 on the M25 – and all car parking is free.

Advance ticket order

Please supply:

- Adult tickets at £2 (save £1) £
- Under-16s tickets at £1 (save £1) £
- Total £ _____
- Cheque enclosed made payable to Database Publications Ltd.
- Please debit my credit card account:



Alexandra Pavilion
Alexandra Palace, Alexandra Park
Wood Green, London

July 10-12, 1987

Post to: Amstrad Show Tickets,
Europa House, 68 Chester Road,
Hazel Grove, Stockport SK7 5NY.

Name

Address

Signed

Access/Visa
[] []

Admission at door:
£3 (adults), £2 (under 16s)

PHONE ORDERS: Ring Show Hotline: 061-480 0171
PRESTEL ORDERS: KEY *89, THEN 614568383
MICROLINK ORDERS: MAILBOX 72:MAG001
Please quote credit card number and full address + Ref. ACUS5

**This advance ticket
saves £1 a head –
and cuts the queues**

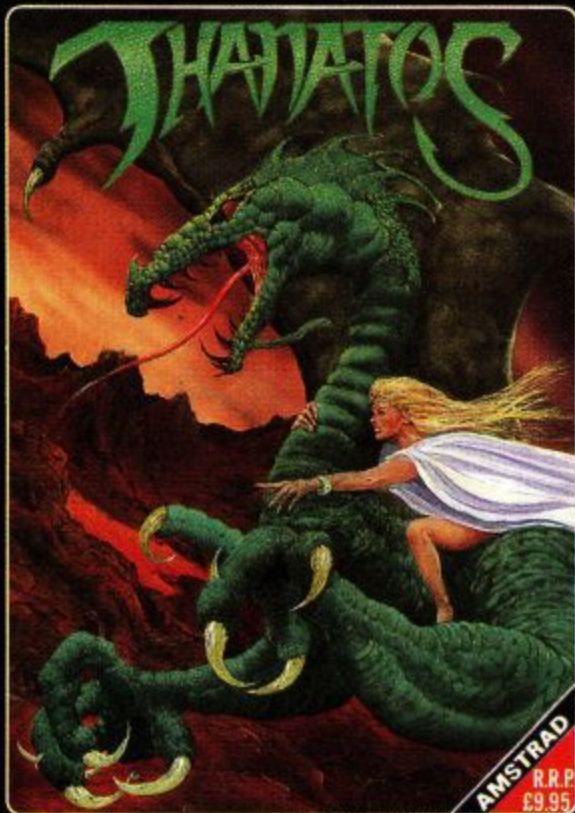

AMSTRAD
RRP
£9.95

THANATOS

In this magical game you take control of a dragon, Thanatos the destroyer, whose eternal destiny lies in conflict with the forces of the underworld. The dragon which is very large and superbly animated, flies, walks, swims, and burns its way through the landscape. The game features fantastic landscapes with a totally new panoramic scrolling action.

"Wow! This game is really amazing; stunning, astounding, brilliant! The tune on the title screen is very nice, but the graphics are absolutely superb." CRASH, December 1986 (overall rating 93%)

£9.95 Spectrum cassette
£9.95 Amstrad cassette, £11.95 Amstrad disk (£9.95 by mail order)
£7.95 Commodore 64 cassette, £9.95 Commodore 64 disk



DEEP STRIKE

At last an opportunity to try your luck against the Red Baron and his flying circus of World War I flying aces. This game not only lets you take-off in a fully armed fighter, but also gives you control of the four bombers of your DEEP STRIKE attack force. It uses the latest techniques to bring you a smooth-scrolling and tilting 3D landscape viewed from the cockpit in full colour.

"...after a few games I really got into it. The way you can bomb the ground features (especially churches) makes the game much more enjoyable than if you just had to shoot planes! Overall a game that you should come back to quite a lot in the future." AMTIX, February 1987 (overall rating 71%)

£9.95 Spectrum cassette
£9.95 Amstrad cassette, £11.95 Amstrad disk (£9.95 by mail order)
£7.95 Commodore 64 cassette, £9.95 Commodore 64 disk

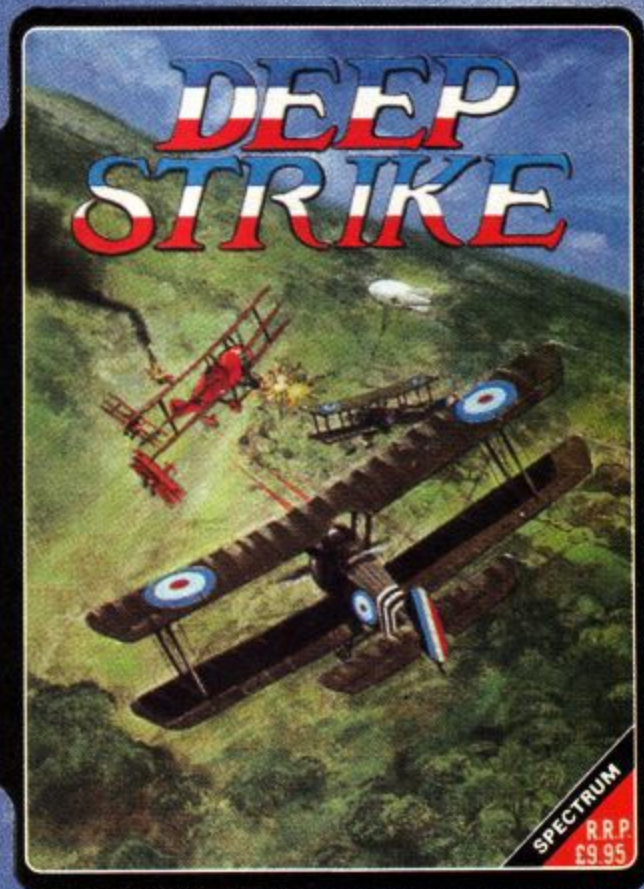

SPECTRUM
RRP
£9.95

SIGMA

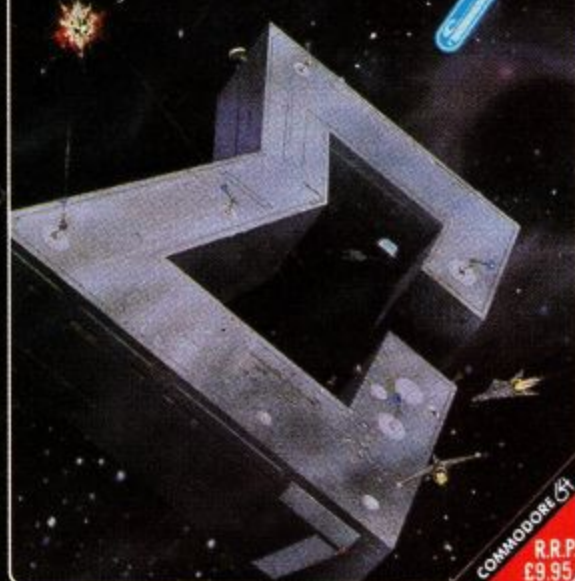

COMMODORE 64
RRP
£9.95

SIGMA SEVEN

An all-action arcade game featuring imaginative state-of-the-art 3D graphics and exciting synthesised sound. There are seven increasingly more difficult stages to the game which starts-out easy but ends-up almost impossible. Each stage is split into three phases: first take a space-fighter and blast your way to the next station through swami-mine defences, then free that station's internal pathways of killer-robots and radioactive deposits, to finally reach the remote-controlled main panel which must be reset within a critical few seconds.

"I really like this - it has three neat mini-games all of which are very playable and addictive. The graphics are really crisp and clear with a beautiful starry backdrop..." ZZAPP, February 1987 (overall rating 70%)

£7.95 Spectrum cassette
£7.95 Amstrad cassette, £11.95 Amstrad disk (£9.95 by mail order)
£9.95 Commodore 64 cassette, £9.95 Commodore 64 disk



DURELL

DURELL Sales Dept.,
Castle Lodge,
Castle Green,
TAUNTON, TA1 4AB
Som, England.

Telephone: (0823) 54489

FAT WORM BLOWS A SPARKY

Now for something completely different. You are an insidious little wormie being chased through a Sinclair Spectrum by creepers in sputniks and crawlers on feet. Defend yourself by shooting burper sparkies at the crawlers, and blaster sparkies to take-out the sputniks. You'll see the computer board in a smooth-scrolling 3D viewed from above, as you crawl around in search of a disk drive on which to clone yourself.

"Playability and addictiveness are of the highest standard, but as for the graphics - well, what can I say? As far as animation and solid 3D goes, this is probably the best I have ever seen" CRASH, November 1986 (overall rating 95%)

£9.95 Spectrum cassette only

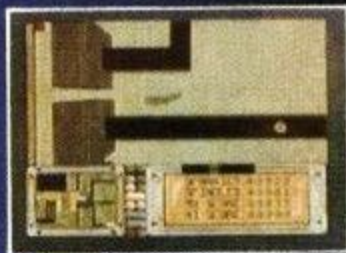
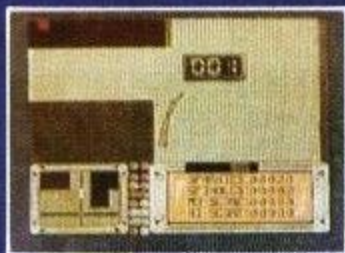

EAT WORM

blows a sparky



SPECTRUM
R.R.P.
£9.95

DURELL



SABOTEUR II Avenging Angel

SABOTEUR II - Avenging Angel

A follow-up by the original author, where as the Ninja's beautiful sister, your mission is to revenge your fatally wounded brother. The rebels have found that the disk he stole in "SABOTEUR" also contains data for one of the dictator's missile silos. Your job is to fly in by hang-glider, fight your way through the security guards, pumas, dogs and radio-controlled robots, to seek out some top secret punched tape to activate the missile's launch control. Launch it, disable the electric perimeter fence, then break-out by motor-bike. Over five hundred locations, three buildings, underground caverns, intelligent guard dogs and stupid guards.

£7.95 Spectrum cassette
£7.95 Amstrad Cassette, £11.95 Amstrad disk (£9.95 by mail order)
£7.95 Commodore 64 cassette, £9.95 Commodore 64 disk



BIG 4

A compilation of Durell's four great smash hits - COMBAT LYNX, SABOTEUR, TURBO ESPRIT, and CRITICAL MASS.

"All of these megagames charted, all of 'em are winners. If you've spent the last eighteen months begging, borrowing and swopping trying to get hold of these titles, now you can relax! Only Beethoven's Quartets beat this fun foursome - Gimme! Gimme! Gimme! YOUR SINCLAIR, December 1986 (overall rating 9 out of 10)

"Unlike most compilations where one title carries the others, the BIG 4 are actually four big games... A collection worth collecting." C & VG, December 1987

£9.95 Spectrum cassette
£9.95 Amstrad cassette, £11.95 Amstrad disk (£9.95 by mail order)
£9.95 Commodore 64 cassette (also on two "Duo-Disks" at £9.95 each)



DURELL BIG 4



R.R.P. £9.95

4 Smash Hits
In one pack
for any
SPECTRUM

MAIL ORDER

All Durell games are also available by mail order, with no charge for postage or packing. Just include a postal order or cheque made payable to "Durell Software Ltd", along with your name and address, your computer, and the title of the game you wish to purchase. Your game will be sent by return-of-post. **Note: Amstrad disks are only £9.95 by mail order!**

**NOW FROM THE AUTHORS OF BATMAN
COMES...**



DOUBLE TROUBLE

Hi! My name's Mr. Head. Some say I'm the one with the brains but I don't think my flat footed friend would agree. I'm a real sharp shooter, but without fast...or slow! I can jump like a flea and even glide but Heals is the Daley Thompson of the two of us - he's FAST! Together, if we can find each other, we really do make an awesome twosome, and that's the only way we can overcome the emperor Blacktooth. The last time we entered Castle Blacktooth we found the crowns of THREE of the suppressed kingdoms but by that time I'd run out of doughnut ammunition and my buddy was lost somewhere in the Safari world - it was the closest we had come to defeating that rascalion - we were jumping for joy, splitting our sides, dying with laughter... we were Head over Heals!

SPECTRUM
£7.95

MSX
£8.95

COMMODORE
£8.95
AMSTRAD

Ocean Software · 6 Central Street · Manchester · M2 5NS
Telephone: 061 832 6633 · Telex: 669977 Oceans G

ocean

Hi, I'm Lance Davis, your letters editor. If there is anything you think Amstrad computer users ought to know about then drop me a line. I can't deal with individual problems and this isn't really the place for programming tuition but it is the place for bouquets and brickbats, views and opinions. Write to me at the address in the front of the magazine or on Telecom Gold System 72:mag012. Remember that some writers will be sent free software, so let me know which computer you have.



New leaf needed

After all the delays, the Advanced Memory Systems AMX Pagemaker finally appeared for the Amstrad computers.

After all my big expectations, I was very sadly let down when I received my copy and tried using it on my 6128.

The program appears to have been put on the market without even the most basic quality control and it can only be described as useless, since some of the most elementary functions do not work of work incorrectly.

For example, Text Windows are inoperative and any attempt at a print-out produces a picture that is a distorted blur. It is certainly not my Manesmann Tally that is at fault since it is listed by AMS as compatible.

Considering that it costs £50, I think it disgraceful that software is put on the market in such condition. It reminds me of some of the bad untested software that was available in the early days of home micros.

I have returned my disc to AMS and hope that they can come up with a new page(maker).

C.R.Grey,
Rio de Janeiro,
Brazil.

LD: We've had a copy of Pagemaker in for review, and as you say it is often lacking. We have decided to wait until the bugs are fumigated.

Both Mirrorsoft and AMX announced desktop publishing programs for the CPC a long, long time ago. They both underestimated the time it would take and have failed to come up with the goods.

If you are desperate for a DTP package then what works of Pagemaker is excellent, and they will upgrade it for you later.



Live long and prosper

I am writing to the person who created the cover photograph for the March '87 issue of ACU. Did you make that spacecraft, and did you create the laser beams by printing over the photograph? Are you an artist who uses a camera instead of paints? How did you manage to use half a dozen shiny new computers in your picture - I doubt that you own them all?

Patrick Lee,
Cheshunt.

LD: Genius behind the lens is Martyn Howett who does most of the photography in ACU including last month's fabbo cover. He is the one standing between the chips on page 54 of the April issue. The spaceship was built by Daniel Shandrake and the laser beam was put on by cutting a shaped hole in the background and covering it with a red film. The machines in the photo are not so new and you can see the scratches. We had to borrow some of them.



The Rainbird has flown

Readers like myself who took advantage of your recent offers for Rainbird software are in for a nasty shock should they find problems with their disc, or wish to update their music system (as I did).

Rainbird tell their users to return their discs to a particular address. The Post Office promptly sends them back as 'address gone away'.

Faced with this, and noting that Rainbird belong to British Telecom, I duly presented the problem to the local telephone operators who did their best.

I eventually ended up talking to a puzzled but courteous chap in London who tried hard and eventually came up with a telephone number.

So I got the people at last, and extracted their new address from them. It is the same as Firebird, who also don't advertise in your journal, and it was changed last May.

I eventually got my update. And, oh yes, Rainbird still gives the wrong address on the new package. They didn't apologise either. When you are



attached to a big company, why bother about the customer?

Rainbird address is: 74 New Oxford St. London, W31A 1PF

James McKnight,
Cheshire.

LD: I spoke to someone at Rainbird. He said that Wellington House is the head office for New Information Services (NIS) and that Rainbird is part of Telecomsoft which is part of NIS. So all the post to Wellington House should be redirected.

The number is in the London phone book, so directory enquiries should have been able to tell you that you need 01-240-8838.

In Defence of Prottext

(As if it needed defending - Ed)

I would like to congratulate you on the review of the CP/M version of Prottext. On the whole I found it to be a fairly accurate assessment of its capabilities.

I appreciate that it is very hard to provide a 100 per cent accurate review of such a complete program as Prottext in the limited time available to a reviewer.

As the author of the manual and therefore well acquainted with Prottext, I feel that one or two points mentioned in the review might need clarifying.

Prottext does in fact know exactly where page breaks fall at all times, and the information on the status lines gives full details of page, line, and column numbers at all times.

These figures are corrected automatically to allow for changes in line spacing, whether headers or footers are on. The figure on the status lines is always the true line number as it will be printed.

Reference is made to the fact that the Undelete command can be used to mimic a block move. This might give the impression that Prottext does not support block moves, when in fact it has very simple commands to move, copy and delete, as well as undelete, blocks of text.

Reference is made to the fact that mail merging can result in a lot of wasted paper if you make a mistake. The manual mentions that the PRINTS command (to print to screen) is particularly useful for checking that a mail merge file is correctly arranged, before you commit it to paper.

PRINTS is a very useful option at any time, as it gives a good indication of how any document will appear on the paper.

From personal experience, I would doubt the validity of the statement that Prottext's spell is slower than LocoSpell if you are to compare their use in similar situations. Perhaps if you were to compare the stand alone version of Prospell, where you have to save the file, leave Locoscript, load Prospell and then carry out the spelling check, there may be some validity in the statement, but Prottext's Spell enables you to check a document in memory very much more quickly.

While I can see the point about being able to check a single word with LocoSpell, in many ways this defeats the object of a spelling checker, which is not only to check for incorrectly spelt words, but also for typing errors, which can only be done by checking through

the whole document.

I do not see the inability to read Locoscript files directly to be a major failing, as normally, once a document is completed, it is merely archived for possible future reference. One would therefore only bother to transfer those Locoscript documents which you needed to use again, which can easily be done via the Make Ascii option and then can simply be loaded into Prottext and reformatted as a normal Prottext document.

Control codes and any other codes, such as soft hyphens, may be hidden at any time by use of the ALT-V V command.

Handling disc, loading and saving operations from command mode, rather than from a LocoScript menu is actually far quicker, as it allows multiple operations to be carried out. For example, to copy all .DOC files from one drive to another simply requires the command COPY a:*.DOC B, rather than having to select each one individually and then confirm it.

One particular use for the typewriter mode is as a quick and easy way to add individual postscripts to letters after the main part has been printed.

I hope you will find the above information useful

David Foster,
Cumbria.

LD: The real test is yet to come. Prottext vs LocoScript 2. I spoke to Locomotive about the speed tests they ran on Prospell and they sounded very fair, but I doubt there is that much in it.

Looking up Great Aunt Ethel

In the February edition of ACU you published a letter from G.K. Armstrong who had written a data filing system for his genealogical records. I am also in the process of researching my family history and would welcome a contact from anyone who could provide such a program.

S. Rowden,
16 Howard Gardens,
Guildford,
Surrey,
GU1 2NX

Worthy cause

I am currently researching any project that are using computers with severely handicapped people with a view to starting a project in East Sussex. I would be grateful if you would publish

What's so special about the Mac, the Atari St, the Amiga, Windows and Gem?

It's no surprise that nearly all new 16 bit 'state of the art' micros now come with a Mouse and Wimp environment (Windows, Icons, Menus and Pointers) as standard.

With the AMSTRAD CPC you already own one of the classic micros and by simply adding AMX software you can achieve the same ease of use, freedom and versatility of much more sophisticated computers.

The AMX Mouse and compatible software – it's what you and your AMSTRAD micro have been missing.

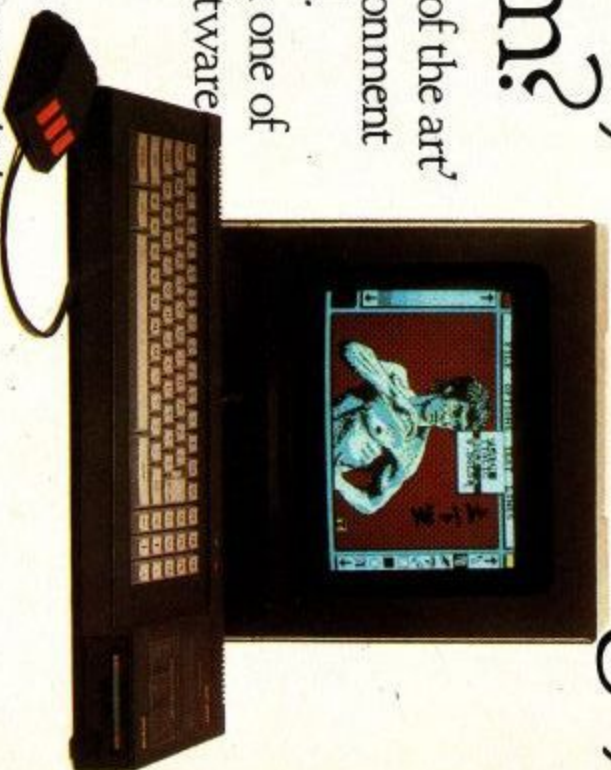

ART AND MOUSE OPERATING SYSTEM

AMX MOUSE PACKAGE Tape and 3" Disc

£69.95

There's not much joy in a joystick and keyboards can be all fingers and thumbs. Acclaimed by the press as 'the best input device', already over 50,000 micro users have adopted an AMX Mouse. The Mouse comes with fantastic Art Software and AMX control which enables you to create a Mouse environment in your own programs. Available for Amstrad CPC 464, 664, 6128.

GRAPHIC DFS FRONT END

MAX 3" Disc

£19.95

MAX provides an easy to use graphic based front end to your computer's disc filing system including a comprehensive set of disc management operations such as cataloging, copying, deleting and re-naming, also included are disc utilities such as sector editing, recovering erased files, formatting, verifying and faster tracking. You can also run programs from within MAX. Available for Amstrad CPC, 464, 664, 6128.

DESKTOP PUBLISHING

AMX PAGEMAKER 3" Disc

£49.95

Produce professional documents and newspapers with text and graphics, supplied with 16 variable typefaces it has many graphic functions including cut, copy, paste, etc. Available Now.

EXTRA! EXTRA! 3" Disc

£24.95

300K fantastic clip art, over 25 fonts. Available February 1987. For use with the Amstrad CPC 6128, CPC 664 (+ 64K min add on Ram), CPC 464 (+ 64K min add on Ram + Disc Drive)

AMX MAGAZINE MAKER 3" Disc

£129.95

A combination of AMX Pagemaker and the Rombo Vidi-Video digitiser. Using any video and the digitiser, images from a camera or TV can be converted into a graphics screen with Pagemaker to illustrate magazines or newsletters.

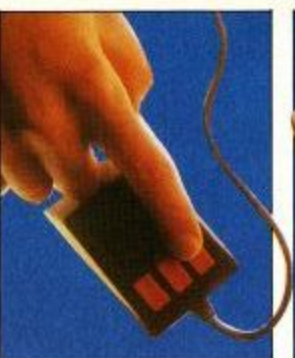

There is also a growing list of AMX support software including: AMX 3D Zicon (3" Disc) **£24.95** with Zicon you can transform vector data into on screen graphics. Printers and plotters are fully supported, AMX Utilities (3" Disc) **£19.95**. Utility software for the original art program supplied with the AMX Mouse. A Mouse and interface (only) can be purchased for **£34.95** direct from AMS using the order form enclosed in MAX, AMX Pagemaker and AMX 3D Zicon. These superb products are available from all good computer dealers or direct by cheque, Access or Visa. All prices include VAT and post and packaging.



FOR INSTANT ACCESS/VISA ORDERS TELEPHONE (0925) 413501/2/3



AMX SOFTWARE

IMAGINATION AT YOUR FINGERTIPS.

+ JKM
ALL THESE
PROGRAMS WORK
WITH JOYSTICK
KEYBOARD OR
MOUSE

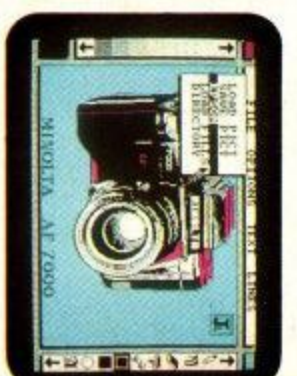

ADVANCED MEMORY SYSTEMS LTD. 166/170 WILDERSPOOL CAUSEWAY, WARRINGTON, WA4 6QA. TELEX 628672 AMSG. FAX 0925 58039.

TUBELINK ON PRESTEL PAGE 2582182 SUPPORTS THE AMX MOUSE AND ALL AMS SOFTWARE.

Macintosh is a licenced trade mark of Apple Inc. Atari St. is a trade mark of Atari Inc. Amiga is a trade mark of Commodore Business Machines Inc. Windows is a trade mark of Microsoft Inc. Gem is a trade mark of Digital Research Inc.

Use your Amstrad to talk to the world!

MicroLink

in association with **TELECOM GOLD**

Join MicroLink - and use your micro to send and receive electronic mail, telexes, telemessages, go teleshopping, book theatre and rail tickets, read the latest micro news, form your own exclusive closed user group ... even go via satellite to the USA to chat in real time to other users with similar interests as yourself. And it's all as easy as making a phone call! All you need to access MicroLink with your micro is a modem, appropriate software and a telephone.

How much does it cost?

• Standing charge of £3 a month. • Connect charges of 3.5p a minute (between 7pm and 8am weekdays and all Saturday and Sunday), or 11p a minute during office hours. • Cost of local phone call (London area) or cheap-rate PSS (extra 2.5p a minute).

These are basic charges. Most MicroLink facilities are free, including sending messages to other people on the system. Extras are:

Telex: 5.5p per 100 characters (UK), 11p per 100 (Europe), 18p per 100 (N. America), £1.25 per 400 (rest of the world), £2.75 per 400 (ships at sea). Plus a once-only telex registration fee of £10.

Telemessages: £1.45 for up to 350 words. An illustrated greetings card (for weddings, birthdays, etc) costs an extra 75p. Delivered anywhere in Britain first post the following day.

Overseas mail: 20p (Germany, Denmark), 30p (USA, Canada, Australia, Singapore, Hong Kong, Israel) for first 2,048 characters. For additional 1,024 characters, 10p and 15p.

To join MicroLink simply fill in and return the form below. Within days you will receive your personal mailbox number and password, an easy-to-understand Quick Guide to MicroLink, and the phone number of the Helpline where you can get additional assistance should you require it.

Your personal passport to the wide world of communications

Application Form

Name

Position

Company

Address

Postcode Daytime tel:

Commencement of Service

Please indicate month of commencement
Allow 7 days for validation of mailbox

19

Date of first payment to be on 15th of month following commencement. Please complete billing authorisation form A, B or C.

* Telecom Gold is a trademark of British Telecommunications plc.

I/We hereby apply to join MicroLink

I enclose my cheque for £5 payable to Database Publications as registration fee to MicroLink.

I also wish to use Telex. I authorise you to charge an additional £10 to my initial bill for validation.

I confirm that I am over 18 years of age.

I confirm that I accept the terms and conditions for the time being in force, copies of which are available on request

I intend to use the following computer model

Signature

Date

A. Direct Debiting Instruction (Enter full postal address of UK Bank Branch) to:

I/We authorise you until further notice in writing to charge to my/our account with you on or immediately after 15th day of each month unspecified amounts which may be debited thereto at the instance of Database Publications Ltd - MicroLink by Direct Debit. Bills are issued 10 days before debit is processed.

Name of Account to be debited

Account Number Sort Code

B. Please debit my/our Access/Mastercard/Visa/ *American Express

No.

*Overseas subscribers only

I/We authorise you until further notice in writing to charge to my/our account with you on or immediately after 15th day of each month unspecified amounts which may be debited thereto at the instance of Database Publications Ltd - MicroLink. Bills are issued 10 days before charge is applied to your account.

Signature Date

C. Please invoice the company/authority.

If you select this option, which is ONLY AVAILABLE to government establishments and Public Limited Companies, we will require an OFFICIAL ORDER to accept unspecified amounts.

Send to: MicroLink,
Database Publications,
Europa House,
68 Chester Road,
Hazel Grove,
Stockport SK7 5NY.

FOR OFFICE USE ONLY:

Mailbox assigned

Start date

Password

this letter in case any of your readers have experiences they would like to pass on to me. The aim of the project in Brighton would be to investigate whether computers can be used as a tool to facilitate communication, possibly as a very low level, with mentally handicapped adults who otherwise have no communication at the present time. In particular I am interested in any programs geared towards adults rather than children and in your readers experiences and the hardware they use.

Mark Tennent,
Social Worker,
Hollingdean & Coldean Office,
62 Brentwood Rd,
Brighton,
East Sussex.

Listing lament

AHGRR! The DUSJL (Dreaded Un-Standard Jump from line 30 to line 75 in Listing) has struck once more. I refer to the line numbering system in the April issue of *ACU*. Instead of, like most other ordinary minded humans, numbering their program lines in steps of 10, 1 or 5 or so on, they chose to confuse all us proggy-enterers and use oddly numbered lines. Please could you RENUM listings.

Excellent April Fools Day trick! After seeing no immediate clues to the presence of a trick, I started to read the article entitled Amstrad's Going into Orbit and I honestly believed it.

When I read that the main rocket consisted of three Aprils I became very suspicious. I finally knew that I'd been fiendishly tricked when I saw that the satellite would be called the AF-1!

Jason Anderson,
Portmead,
Swansea.

LD: There was a lot wrong with *Quoite* - if you send me a stamped addressed envelope I'll let you have a corrected (and renumbered) listing. Thanks for the April Fools compliment; the thanks should go to Rupert, Vax and lunchtime lubrication.

Postal programs

With reference to the enquiry in the letters section of the last issue, from Mr. Johns of Dorset concerning the use of the CPC6128 in sub post offices, we supply Sub Office Software, a suite of programs currently in use from Aberdeen to Penzance which process daily Post Office transactions and weekly balance.

If you can put us in touch with Mr.



Johns, we can let him know of the post offices in this area which are already running the system.

C.E.Cope,
Geotechnical Monitoring,
Birmingham.

Locked away

I am writing to you at this moment in deep agony over a small and seemingly easy problem. How do I use my extra 64K? Ever since I got my 6128 computer it has been pure agony for me as I slave away compacting when I know that locked away deep inside my computer there is an extra 64K. How do I use it? Bank Manager will do the job but it has many limits and boundaries. Recently in my attempts I ventured into machine code in the hope of a solution but to no result.

So here I am, writing to you on my hands and knees begging that you will end my agony and show me how to use

my extra memory without using Bank Manager.

Simon Nursey,
Essex.

LD: The extra bank of ram is tricky to access, that's why Amstrad supply Bank Manager. You will have to use machine code to do it yourself and I suggest you get a copy of SOFT 968 - the technical firmware manual but you may find it heavy going. DK Tronics sell a Rom which turns the extra ram into a silicon disc. This may solve your problems.

More tape troubles

I own an Amstrad CPC464 with a disc drive. Recently, my tape deck gave out completely due to rather heavy use and much rough treatment. The majority of my games and utility software is on tape because disc space is so expensive, and as a result I am left with a pretty useless machine on my desk.

I have tried returning it for repair,

but the warranty has run out, the machine has been tampered with (oops!) and the quote I received was £30 for several months wait.

I have tried wiring in an external tape deck but I am unsure which wires I should disconnect and plug the external wires into. The wires directly beneath the built in deck are red, black, white, blue, green, brown, grey, and yellow from top to bottom.

I have tried to replace these wires at random, but alas, no success.

I have therefore written to you with an urgent plea for information and meanwhile I have to sit staring at my machine with its entire library of CP/M, DR Logo, and Roland in Space, with 80 other games and utilities on tape. Arghh!

Michael Fin,
Chiswick.

LD: You really should get your tape deck fixed, there is no excuse for a long wait, since it is a fairly routine job. I'd have thought that £30 was a little steep but not amazingly so.

The leads you need to worry about are the blue and green. Blue is for data in (load) and green for data out (save). Now that blank discs are so much cheaper, the price of disc-based games ought to come down.

Foul play

A while ago I purchased a game titled The Boss by Peaksoft for £8.95. Although it was never a biggie game, for some reason I bought it. Earlier this year I bought Soccer Boss by Alternative Software for £1.95 at a nearby computer shop thinking that might be better.

To my amazement and anger Soccer Boss seemed exactly the same as The Boss so I thought "Hmmm, something not quite right here" (but in a stronger,

foreign language). Is this just an unlucky coincidence or have I been cheated of £7? Is this sort of copying legal?

Martin Fancourt,
Up-minster,
Essex.

LD: Repackaging football games does seem to be a bad habit among software companies. Even Virgin is at it with Soccer '86 being updated to Soccer '87. I'm not sure what went on between Peaksoft and Alternative Software but thanks for warning all ACU readers.

Called to the bar

Had a CPC464 for Christmas, great. Bought ACU, great. Decided to type in K. Freeman's program 'Combat'. Took ages, run, error line 200, !SPRITE! What's !SPRITE?

Don't know, fetch Dad, now Dad was found long ago among a row of turnips, error, error, delete turnip.

Have re-checked Type In error. Now line 1490. Can anyone tell me what went wrong?

Kirk Guest,
Birmingham.

LD: The bar command signifies an RSX. Look at the keyboard, find the symbol. This shares a key together with @ and the world is your RSX.

Prestel proggies

I have a CPC464, a modem and am registered with Prestel. I want to do some of this downloading of programs I hear so much about. How do I go about it?

Kenneth Allen,
Warlingham

LD: Amsnet and Micronet offer tele-software for the CPC's but you need the

right software to get at it. Amstrad, KDS and Pace have software which will work, but the Cirkit interface software was written before the standard had been established. You need to be a member of Prestel Microcomputing to get to the important pages. It's fun, so have a look.

Programming Mousterpiece

A little help for any fellow AMX mouse owners who have painstakingly typed in the game Sniper in February's ACU and have found the cursor key control clumsy and difficult to handle (like I did), which enables a mouse to be used to move the gun sights.

An extra feature, HOLD: by pressing <EXECUTE> the game freezes until <CANCEL> is pressed, is included - free of charge.

All that is necessary is to modify some lines as shown below. The remainder of the program should be left as it is. When the game is run the mouse files DEMLOA.BIN, DEMO.RS, VDUTAB.O, and ROM.ICN should all be on the same disc (or same tape - in that order), as these will load automatically.

David Clark, Doncaster.

```

40 PRINT "Please wait"
50 SYMBOL AFTER 32:MEMORY &5FFF
60 LOAD "!demloa.bin",&6000:CALL &6000:CLOSEIN:GOSUB 970
70 INMOUSE,1:BORDER 3:MODE 0:SOUND 4,300,10,10
80 DEFINT a-z
.....
etc
.....
560 keyPress
570 IF INKEY(78)=0 AND sh>0 THEN GOSUB 760
y
590 x=x/8:y=50-(y/8)
600 x=x mod 40:y=y mod 24
610 IF INKEY(77)=0 THEN WHILE INKEY(76)<>0:WEND
620 IF x=a AND b=y THEN 650
.....
etc
    
```

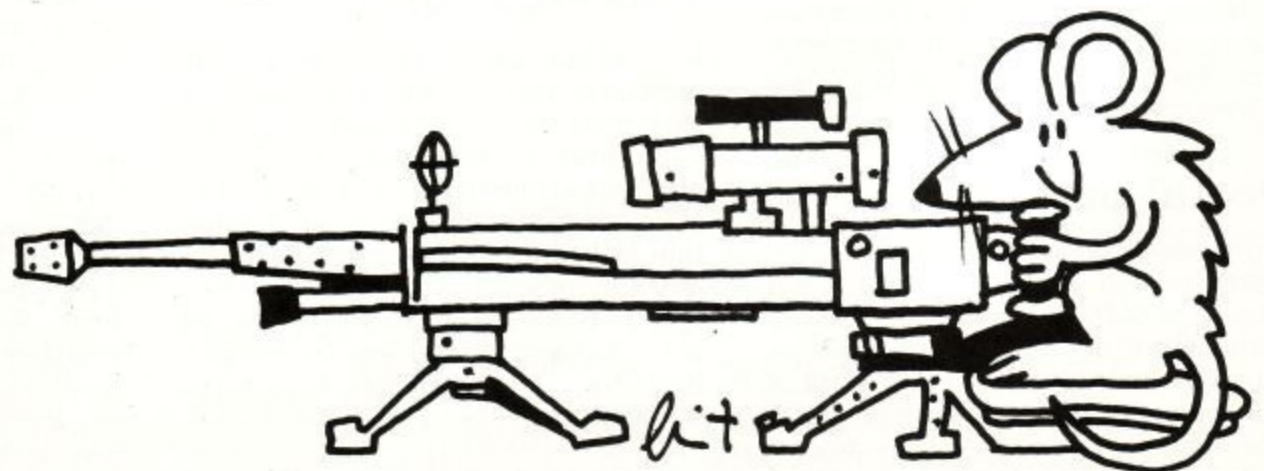

Another Great Compilation from Beau Jolly!

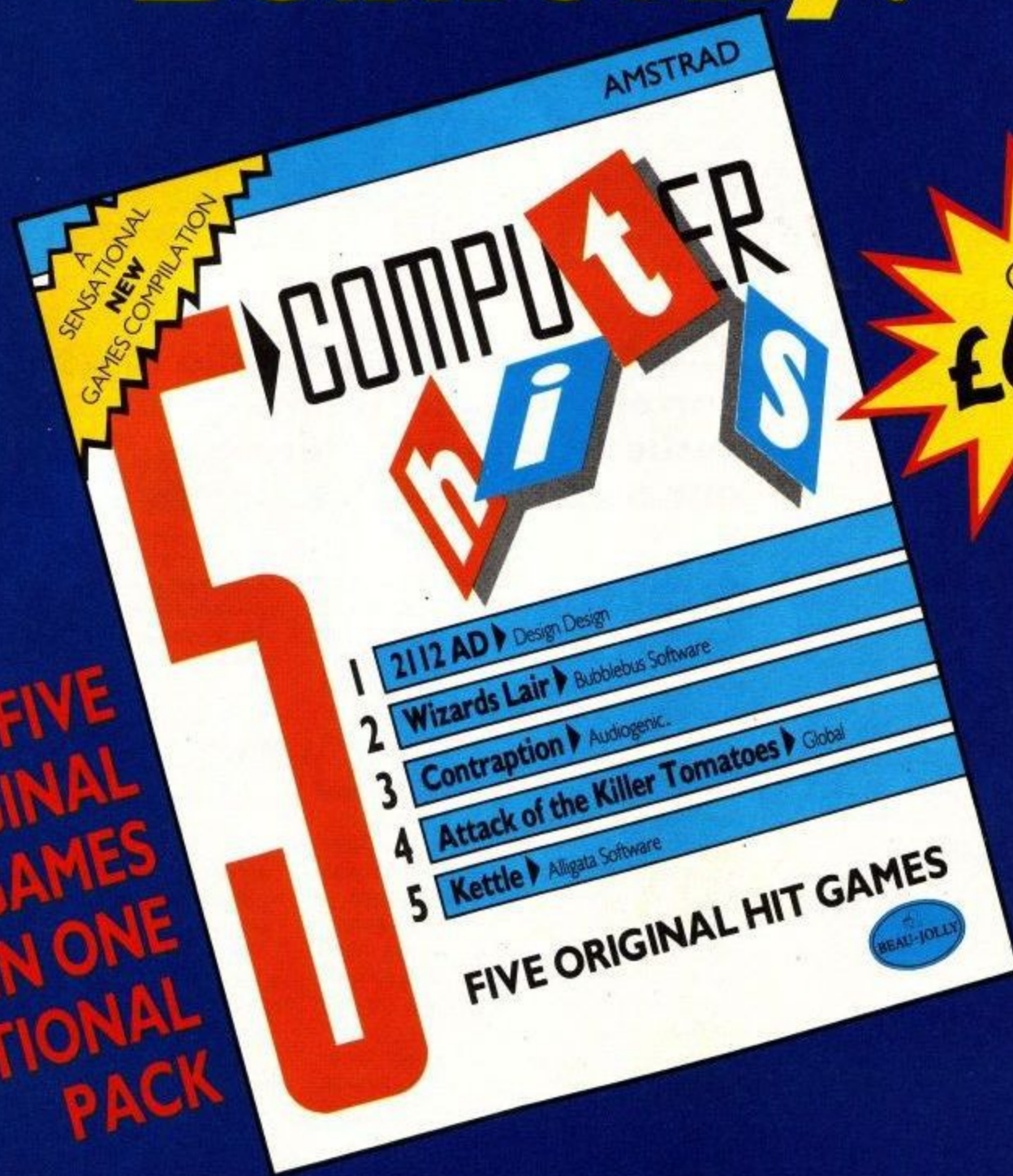

Only
£6.95

**FIVE
ORIGINAL
HIT GAMES
IN ONE
SENSATIONAL
PACK**

Spectrum/Commodore/Amstrad – Cassette **£6.95**

Commodore/Amstrad – Disk **£11.95**

Tell your friends also available for BBC, Electron & C16/Plus 4 Computers

(Titles may vary by format)



The name behind the great games

Beau Jolly Ltd., 29A Bell Street, Reigate, Surrey RH2 7AD. Tel: 07372 22003

Advanced ART STUDIO

Rainbird's original OCP Art Studio became available for CPC 6128 possessors in the latter part of 1986. Incorporating many sophisticated features, it provided excellent value for money (*ACU* November 1986). Now Rainbird has come up with Advanced Art Studio, which offers all the capabilities of the original version, plus many new and exciting characteristics.

The screen layout is the same, with a double row of drop-down menu boxes. Selection is via the cursor keys and spacebar, but there is an option to define one's own choice of keys, use a joystick or mouse. The program comes with an extensive manual, but the majority of available functions are self-explanatory.

Duplicate dump

No alterations have been made to the printer dump section, and the file handling is similar, but now screens can be compressed when saved, allowing several more pictures to a disc.

As before, patterns and text files can be saved or loaded with similar files accessed via the appropriate menu, and an innovation is the ability to save and compress individual windows.

The Advanced Art Studio aims to correct the shortcomings of the earlier Rainbird offering. Jill Lawson, our own digital Dali, takes a peek.

Colour palette selection is one of the areas where some of the most radical changes have taken place. As one would expect, two inks may be selected in Mode 2, four in Mode 1, and 16 in Mode 0, which is newly supported in this Advanced version.

Now, however, there are 12 vertical scroll bars associated with every ink.

Each bar may be set to any one of the Amstrad's 27 colours, so that an ink may sequence through a maximum of 12 different colours at a speed determined by an indicator on a horizontal bar near the top of the screen. The colour of the border may be set in a similar fashion.

Colour choices may be further manipulated with the cycle and rotate switches, allowing an infinite variety of animated palette effects.

Under the paint heading the choice of 16 pens remains the same, as do the spray sizes, but now spray can be fast, giving a thin distribution of dots, medium, or slow - which gives the densest coverage.

The brush option is quite different to that in original Art Studio. The brush patterns and the textured fill patterns are linked, with a single pattern element available as a brush, or multiple elements "tessellated" to form a fill texture.

A total of 15 new patterns may be designed at any one time, but frequently-used textures, such as stipple fills could be saved as separate files and re-loaded as necessary.

A pattern element (brush) is designed on a grid of height and width variable between one and 16 pixels.

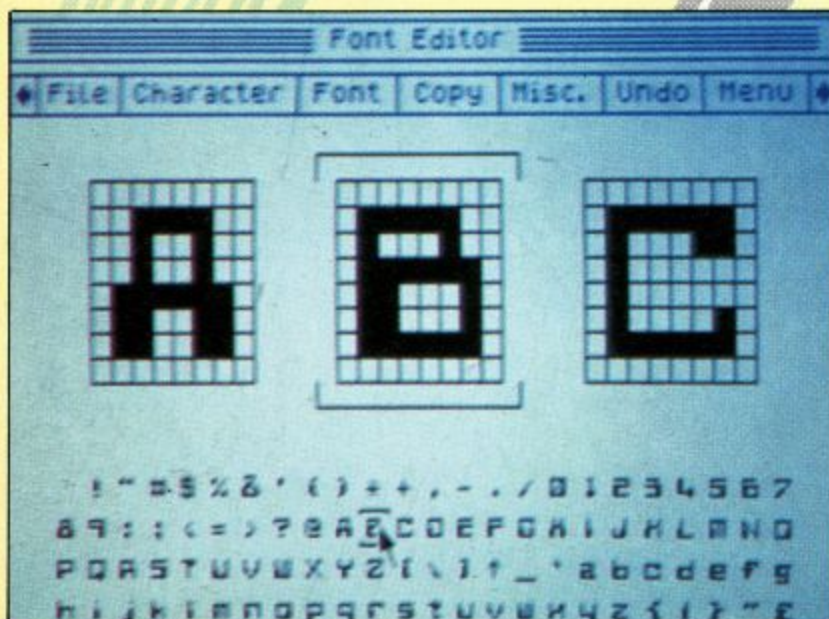

The font editor is easy to use



One computer inside another, inside another, inside ...

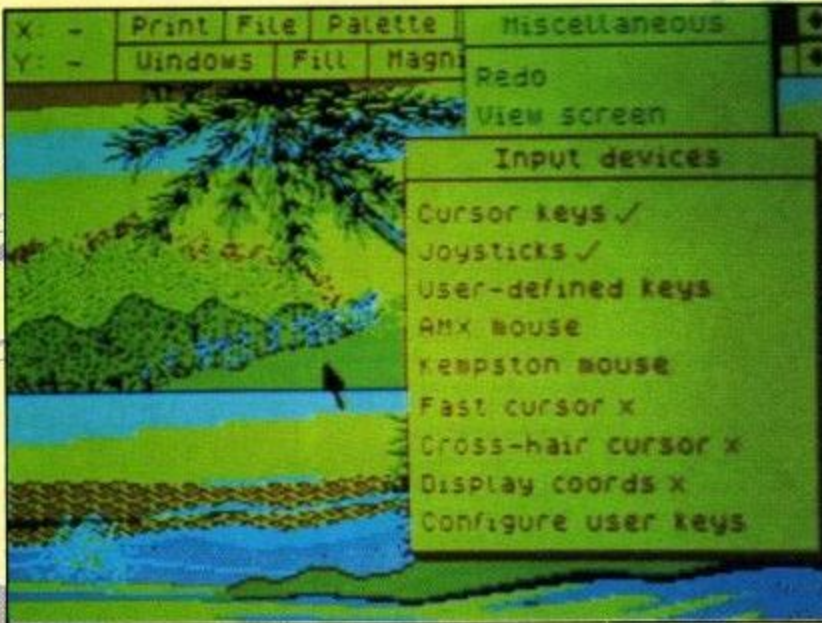

Flexible entry

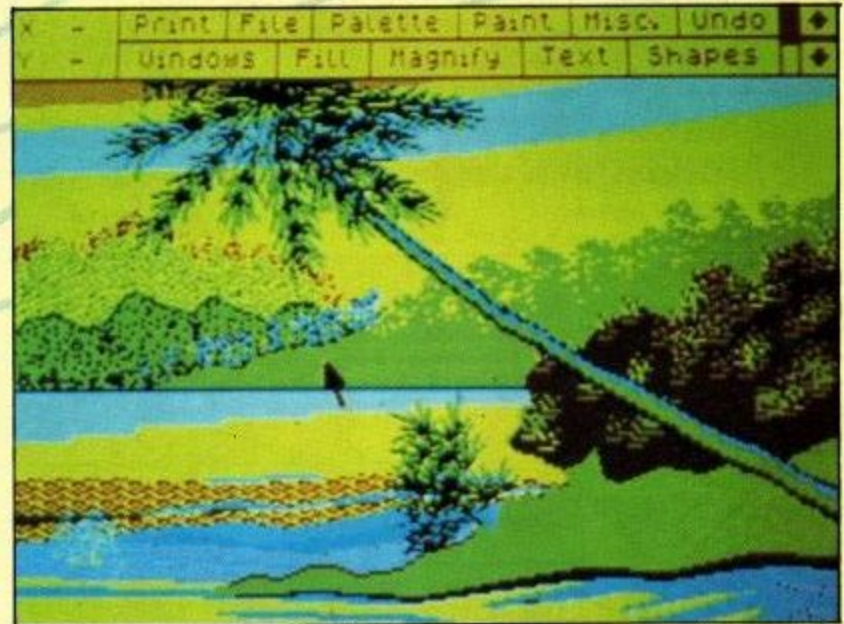

Mode 1 still produces best results

Multi-coloured mixtures are possible, backgrounds can be transparent, and an existing design can be copied to another pattern box, flipped, rotated and scrolled. In addition, an area of the picture can be captured and used as a pattern.

This is by far the most advanced and versatile system I have come across for pattern design, and is a delight to use.

The shapes menu has been extended to include ellipses. These and the circles can now be filled as well as unfilled, but this facility does not apply to rectangles or triangles.

As previously, one can choose an elastic preview for lines and shapes. It is perhaps surprising that this is not the default choice, and I would have appreciated an on-screen reminder of the current foreground colour when in drawing mode.

Extra extras

Along with the new screen mode 0 there are two significant extras in the miscellaneous section. Firstly redo, which complements the undo function by allowing a preview of what will be undone.

Although this is a valuable plus, I

would have preferred a change to the undo, which, unlike other utilities, does not just remove what was drawn in the immediately previous operation, that is the last line or last area filled, but takes out everything back to the last drawing mode selection.

Consequently a small error in drawing a single line could result in a loss of a great deal of correctly drawn picture if it has all been produced since the last pen change, or, more seriously, a leak in a final fill could necessitate a restart to filling a number of separate areas. It is necessary to reselect the same mode frequently to avoid frustration of this kind.

The second item is the very useful ability to protect inks. Basically, this means that anything drawn in a "protected" ink is not obscured when drawing over it in a different colour. So scenery, for instance, can be drawn behind an object in the foreground so long as care is taken to do it in a colour not used in the object.

Ink protection can apply to all drawing on screen, whatever the function, but it should be remembered that a protected ink does not constitute a boundary when performing a fill. Used with care, this is an extension which

could prove invaluable.

Layout of the windows menu has been revised, but only the ability to save and reload windows is new.

I believe that the finished version will be changed so that the current drawing ink will automatically become the current plot colour in the zoom modes.

Addition of text in a choice of sizes, styles and directions, with a choice of several fonts and an editor to allow creation of new fonts, now lets one change the spacing within a range of 4 to 15 pixels.

Conclusion

In the space of only a few months this version of Art Studio succeeds in making the original "best buy for the CPC 6128" art studio look old-fashioned and out-dated.

It is an absolute must for any aspiring artist, either as a stand-alone utility or as an excellent add-on to your favourite existing drawing program, because of the ease with which one can now swap pictures between studio and other utilities simply by saving or loading with an appropriate file name.

If you own a CPC 6128 buy it. If you don't, buy a 6128!

ACU



The three magnify levels remain excellent



GALLUP

SOFTWARE

CHART

Last month
Market strength

Rank	Change	Title	Description	Last month	Market strength
1	▲	Ninja Mastertronic	The fist fiends fight on, this time with a more vicious trait and at a lower price. You have to fight off the many using a variety of weapons. A bit like Kung Fu Master.	11	100
2	▲	Konami's Coin Op Hits <i>Imagine</i>	Save all your pennies for some day by avoiding the arcade and playing Green Beret, Ping-Pong, Hyper-sports, Mike and Yie Ar Kung-Fu at home.	3	93
3	▼	Gauntlet <i>US Gold</i>	Excellent conversion of the multi-player arcade smash. Impressive use of the 16 colour mode and high speed animation.	1	87
4	▼	180 Mastertronic	Digital darts, a budget game based on the non-intoxicating bar-room skill.	2	70
5	●	Feud <i>Bulldog</i>	The first game on the new Mastertronic label. Chunky sprites and a mystic plot go to make up this 2D maze game.	ne	61
6	▼	Computer Hits 10 Vol. 3 <i>Beau Jolly</i>	All your fave raves on one tape. A bargain compilation from the various artists of the computer industry.	4	59
7	▼	Five-a-Side Soccer <i>Mastertronic</i>	Football games have been around since the days of Pong, now a cheapie for the CPC keeps the trend alive.	5	50
8	▼	Five Star Games <i>Beau-Jolly</i>	Good bargain compilation as seen on TV. Ideal first buy for the new computer user. Worth £9.95 for Spindizzy alone.	7	49
9	●	Ghost Hunters <i>Code Masters</i>	This game is absolutely nothing to do with Ghost-busters, it isn't trying to cash in on the name but it is sold at budget prices.	ne	48
10	▲	Mini Office II <i>Database</i>	A full suite of business software at a low, low price. Ideal first look at sensible software but lacks the power for major applications.	17	46
11	▼	Hit Pack <i>Elite</i>	Compilation of games for the price of one, oldies but goldies, still with a plethora of compilations you can pick and choose.	6	44
12	▲	Footballer of the Year <i>Gremlin Graphics</i>	Deep thought is needed in the football futures game from Gremlin. Has the added bonus of good graphics.	18	43
13	▼	Donkey Kong <i>Ocean</i>	One from the vaults. Save your girl from a gorilla in the game which was the arcade hit of yesteryear. Odd actually, a Kong game for the 64 was one of Ocean's early titles.	6	42
14	▼	Trivial Pursuit <i>Domark</i>	Quirky questions and polished presentation give you as many endless hours of fun as the board game. Also available for the PC and PCW.	9	41
15	▼	Space Harrier <i>Elite</i>	Ace Amstrad version of the Sega arcade buster. When the real thing costs up to 50p a throw this game looks super cheap but plays like nothing you've seen.	8	41
16	●	Short Circuit <i>Ocean</i>	Let number five come alive in your Arnold. A pretty 3D maze adventure with a mission to seek out and be cute. Based on the film of the same name.	ne	39
17	▲	Ikari Warriors <i>Elite</i>	Excellent conversion of the coin-op game. Commando style for two players. Excellent graphics and great fun.	re	39
18	●	Riding the Rapids <i>Players</i>	Aquatic sports simulation at a low price, guide your canoe through gates and boulders. Mediocre Mode 0 sprites. Requires a supple wrist.	ne	37
19	▲	Dragons Lair <i>Software Projects</i>	Atari Laser disc classic. Just as challenging if not quite as pretty on the Amstrad. Large sprites well animated. Part II now available.	re	36
20	▼	They Sold A Million (3) <i>Hit Squad</i>	Fighter Pilot, Kung Fu Master, Rambo and Ghostbusters go to make up this compilation of past classics.	16	35



Non-mover



Up



Down



New entry

APRIL 1987

Chart compiled by
Gallup/MicroScope

GARWOOD SOFTWARE

☎ Chelmsford (0245) 460788 (3 lines)

Telex: 99468 GARWD G

Freeport: Garwood (Wholesale) Ltd, Freeport, BRENTWOOD, Essex, CM15 OBR
FREE 24 Page Colour Catalogue includes software for IBM PC & Compatible machines

Orders placed before 4pm. despatched same day (subject to stock availability)

PCW Software

FINANCIAL MODELLING:

SUPERCALC 2 £49.95
 CRACKER 2 £49.00

WORD PROCESSING:

NEWWORD 2 £69.00
 POCKET WORDSTAR £49.95
 LOCOMAIL or LOCOSPELL £39.95

SPECIAL:

BRAINSTORM £49.99
 ROTATE £24.95

GRAPHICS:

DR DRAW £49.95
 DR GRAPH £49.95

ACCOUNTS/PAYROLL:

CAMSOFT (from £49.95) Details on application
 M.A.P. (from £49.00)
 SAGE (from £69.99)

TRAINING:

TOUCH 'N' GO £24.99
 IANKEY £24.95
 AUDIO TUTORIALS £9.95

GAMES:

3D CLOCK CHESS £15.95
 BRIDGE PLAYER £19.95

DATABASE MANAGEMENT SYSTEMS:

CAMBASE 2 £49.95
 CARDBOX £59.99
 CONDOR 1 £99.99
 DBASE II £119.00
 SAGE RETRIEVE OR MAGIC FILER £69.99

COMMUNICATIONS:

SAGE CHIT-CHAT (from £69.99) See Catalogue

PC1512 Software

FINANCIAL MODELLING:

CRACKER 3 £69.00
 SUPERCALC 3 £69.95
 PC PLANNER £113.85

WORD PROCESSING:

WORDSTAR 1512 £69.95
 NEWWORD 2 £99.00
 PC WRITE £113.85

DATABASE:

CAMBASE £49.95
 CARDBOX £59.99
 CONDOR JR £99.99
 dBASE II £119.00
 DELTA 4 £99.95
 REFLEX £69.95
 RETRIEVE £113.85

ACCOUNTS/PAYROLL:

CAMSOFT (See Catalogue for details)
 M.A.P.
 SAGE

COMMUNICATIONS:

CHIT.CHAT £113.85

GAMES:

AMSTRAD (See Catalogue) £19.95

BOOKS:

PC1512 TECHNICAL REFERENCE £19.95
 LOCOMOTIVE BASIC2 USER GUIDE £9.95

Hardware & Supplies

PCW8256 (+ free spreadsheet, database and W/P mailmerge software worth £99.90) £458.85
Printer Stands (from) £42.15
Amstrad Modem £99.95
CPS8256 Interface £57.50

Disc Storage Boxes: 3" (up to 50) or 5 1/4" (up to 60) £19.95

Acco library file: 3" (up to 7) 5 1/4" (up to 10) £3.33

Screen filter (PCW or PC) £37.67

Acco Easystrip: £11.38

Dust cover sets: PCW 8256/8512 or PC1512 £11.45

DMP 2000/3000 Printer £4.95

Discs (Box of 10): Amsoft 3" CF2 £29.90 3M D/S, D/D (PC format) £20.70

Ribbons: DMP1 (per 2) £9.90 DMP2000/3000 £5.50 PCW8256/8512 £5.50

Labels: 1,000 3 1/2" x 1 1/16" LABEL TRACK IN FLIP TOP DISPENSER - £6.90

2,000 3 1/2" x 1 1/16" LABEL TRACK (2 ACROSS) IN PLASTIC TRAY - £11.00

CONTINUOUS LISTING PAPER

2000 sheets of 11" x 9 1/2" 1pt. 60g. Plain with micro perforations £15.95

2000 sheets A4 1pt. 70g. Plain with micro perforations £21.45

1000 sheets of A4 1pt. 90g. Plain with micro perforations £14.95

SPECIAL OFFER:

£5 voucher with every software order over £50
 (£10 voucher over £100 or £25 voucher over £200)
 Vouchers can be exchanged with any future order over £10.



ALL PRICES INCLUDE VAT & POSTAGE

Special Offers Close 2nd May



BRENTWOOD OFFICE SUPPLIES

Stationery · Printing · Office Equipment · Computer Products

149A HIGH STREET, BRENTWOOD, ESSEX CM14 4SA

TEL: (0277) 224099

HARDWARE

PCW 8256 £458.85
 PCW 8512 573.85
 CPC 464 Colour Monitor plus Free Games Pack 299.95
 CPC 6128 Colour Monitor 399.95
 (FREE £25 Credit Voucher with above Computers)

PC 1512 Computers P.O.A.

PCW SOFTWARE

Microfile/Microword 43.50
 Pocket Wordstar 42.50
 Pocket Wordstar D/L 59.95
 Supercalc 2 42.50
 Locomail 34.50
 Locospell 34.50
 dBase II 101.95
 Condor 1 84.95
 Cambase 42.50
 Cardbox 51.95
 DR Graph 43.50
 DR Draw 43.50
 Database Manager (At last) 27.50
 3D Clock Chess 13.95
 Colossus Chess 13.95
 Bridge Player 16.95
 Trivial Pursuit 18.50

PC 1512 SOFTWARE

Wordstar 1512 59.95
 New Word 2 84.50
 Cracker 3 58.95
 Supercalc 3 59.95

PC 1512 SOFTWARE (Continued)

Sidekick £26.50
 Cambase 42.50
 Condor 84.95
 Cardbox 51.95
 Retrieve 96.95
 Comsoft Delta 4 87.50
 Comsoft Domino 87.50
 Comsoft Bookworker 175.00
 Compact Accounts Programs P.O.A.
 M.A.P. Accounts Programs P.O.A.
 Sagesoft Accounts Programs P.O.A.
 Gem Programs P.O.A.
 Digital Research Programs P.O.A.
 Fleet Street Editor 132.50
 Open Access 132.50
 G Base 87.50
 Volkswriter de Luxe 39.50

MANY OTHER TITLES AVAILABLE - ALL AT DISCOUNT PRICES

PC 1512 Games now in stock
 CPC Games Latest titles available

SUNDRIES

PCW Joystick Interface 13.95
 PCW Printer Extension Lead 10.95
 464/6128 Monitor Ext. Lead Kit 9.95
 Twin Joystick Lead 4.95
 Autofire Interface 8.95
 AMX Mouse (Cassette & Disc) 62.50
 Mouse Mat 4.95
 Euromax Joysticks (Full range available) from 9.95

We also stock:- PCW, DMP1, 2000 & 3000 Ribbons, Listing Paper: (Micro Perf) 60 gsm 11 x 9 1/2 / 70, 80 & 90 gsm A4, Computer Labels - All at competitive prices. Send S.A.E. for supplies price list. Prices include VAT but not carriage. Personal callers - Please telephone for availability. Access and Visa accepted. Postage: Programs £1, all other items at cost.

APRIL 1987

TYPESETTING

with your

AMSTRAD COMPUTER

from £1.50 per 1000 characters

Enter your data onto your computer and key in the data, tables etc. in the position you would wish the final typeset version to be, no need to enter special and confusing typesetting commands, our system requires raw text only.

The text is then sent to our page make-up facility where each individual page is made up to your specifications.

We have four years experience typesetting from disk.

We specialise in books, magazine typesetting, reports - especially computer manuals and foreign language manuals.

For more information or if you wish to discuss a specific job please contact

Kim or Milan at

KAMSET

34 Rayleigh Road, Hutton, Brentwood, Essex
 Telephone (0277) 218676

"Without a doubt Siren Software have produced some of the best disc utilities ever seen on the Amstrad range of computers." Amix! January 1987

★ NEW ★ DISCOVERY PLUS ★ NEW ★



The ultimate tape to disc transfer program

"Discovery Plus must be the most advanced and probably most efficient tape to disc transfer utility to date" Amstrad Action December 1986

This program will transfer more games to disc than any other transfer program. The first person who can prove otherwise will receive twice his money back!!

Discovery Plus consists of 4 easy to use programs that together will transfer an extremely high proportion of your software onto disc.

Also included is details on how to transfer over 100 games.

Silver Screwdriver Award Amix! January 1987

Discovery Plus only £14.99 on disc for the 464/664/6128

Updates

If you have our old Discovery program send it back to us and we will send you the New Discovery Plus for only £5.99 (or £8.99 if you have discovery on tape).

Transmat owners, send us your Transmat to receive a £2.50 discount if you have the disc version of Transmat or £1.00 if you have the tape version of Transmat.

★ NEW ★ HANDYMAN ★ NEW ★

FORMAT YOUR DISCS TO 416K

Handyman the unique disc enhancement package allows you to manage, use and get more from your discs. Look at these unique features:

- Format your discs to 416K (208K per side on a standard CF2 disc)
- Save unwanted discs onto tape to release expensive disc space
- Full disc/file search and edit. Find and alter messages in programs
- Superb menu maker puts a menu selection system on your discs
- Filemate displays ASCII files, finds text in files, prints files etc etc

"Siren has come up with another marvellous piece of software" Amstrad Action December 1986

"This is just about the best disc utility that I have had to use" Amix! Jan 87

Amix! Golden Screwdriver Award Jan 87

Handyman on disc for the 464/664/6128 only £12.99



MASTER DISC
+HANDYMAN
ON SAME DISC
ONLY £21.99



★★ MASTER DISC ★★

THE DISC USERS UTILITY

Master Disc contains a disc copier, directory editor, fast formatter, sector editor, deprotector, disc and tape header readers, trans disc, trans tape, disc map, typefile, dumpfile & zipdisc.

"The package seems to work very well on the full range of machines" Amix! June 86

"Each section is fully documented with clear and precise instructions" Amix! June 86

"This Siren package really does offer you quite a lot for your money" Amstrad Action June 86

"So far we have yet to find a disc that it cannot copy from, it even copies unformatted discs" Amix! June 1986

Master disc available on disc only £12.99 for the 464/664/6128

TAPE UTILITY

464 OWNERS, LOAD IN YOUR SOFTWARE AT UP TO 4 TIMES THE NORMAL SPEED

Tape Utility will allow you to make back up copies of your tape base software that will load at up to 4 times the normal speed.

- ... So easy to use, simple one key operation
- ... Handles up to 42K (Approx) in one go
- ... Will copy normal, headerless, speedlock & flashloaders
- ... Tests have shown that it will back up about 90% of all Amstrad software
- ... Choice of 10 speeds up to 4000 baud
- ... Removes protection from basic & speedlock programs

"Simply the best, the tape to tape backup copier to beat all tape to tape backup copiers".

AMSCUB

... Written specifically for the 464, this is not a Spectrum conversion

TAPE UTILITY ON TAPE ONLY £6.99. AMSTRAD CPC464 ONLY

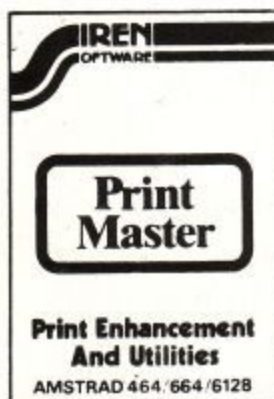

PRINT MASTER

The printer utility and enhancement package. No printer owner should be without this.

This unique suite of programs will allow you to make the most of your DMP2000 or any Epson compatible printer.

- Superb large 16 shade printer dump of any mode 0 screen
- Large black and white dump of any screen in any mode
- Fast character dump of screen
- Amazing 16K interrupt driven printer buffer
- Print out files from most wordprocessors (Protext, Tasword etc) in a variety of fonts, sizes and styles.
- Include screen dumps as illustrations
- 10 great fonts included
- A terrific font designer allows you to create your own fonts

This spectacular package is available on disc only for your Amstrad 464/664/6128. Only £12.99 on disc.

Siren Software, 2/4 Oxford Road,
Manchester M1 5QA Tel: 061 228 1831



HAIRY HACKERS HAUNT



First off, thanks to Madame Cyn for throwing that really great party on the Ed's birthday last month. He loved the cake, but the girl didn't like it when he bit into her.

Last month: Sell-by soup. This month, sniff-by soup. This is really last month's sell-by soup that's getting a bit dubious.

Some of the soup has developed quite well, biologically speaking. We wondered if it might have developed any form of intelligence yet, so we devised a test for the intelligence of soup. It's called: The Tureen Test.

Straight in then, with a very silly one from Steve Clarke of Ipswich. He has noticed that if you hold down Caps Lock, Up Cursor, f2, f5, f7 and f8 while playing Thrust, your score increases at about 40,000 points a minute. This also boosts your lives up to about 20 after five minutes with your fingers spreadeagled over the keyboard, like some evangelist laying on hands.

Now a brief interval, during which Justin will play the West Bank Infinite Lives concerto with a major checksum.

Hairy Hacker coding bright In the darkness of the night As thou peer deep to see Magic pokes in disassembly

Rewind, run and enjoy:

```
10 MODE 1:MEMORY &1FFF
20 LOAD "",&2000
30 tot=0
40 FOR n=&BE00 TO &BE20
50 READ a$:a=VAL("&"+a$)
60 POKE n,a:tot=tot+a
70 NEXT n
80 IF tot<>2693 THEN PRINT"summing wrong
  with that there data.":END
90 CALL &BE00
100 DATA 21,00,20,11,00,01,01,00
110 DATA 02,ed,b0,21,19,be,3e,c3
120 DATA 32,82,01,22,83,01,c3,00
130 DATA 01,af,32,dd,92,c3,8c,91
140 DATA 4a
```

A Mrs. April Rigby, no fooling, has written in (in a recycled Visa envelope) asking for Fairlight pokes; for a Joyce.

Well, when you have a device called a Z80 emulator, pokes are easy to find and just as easy to get in.

Unfortunately, putting pokes into Joyce games is a bit tricky at your end. If anyone beats me to the Fairlight Joyce hack, it should be worth Hack of the Month...

Speaking of which, we have a letter here from a certain El Hosko, post-marked in Germany and with a return address in Berkshire. Are you trying to confuse me or what? No matter, the letter contains two pokeyettes which might interest you.

One is for Heartland (which I haven't got and can't test), the other is for Gauntlet. Yes I know we've had Gauntlet before, but this one's different.

So, here's the poke for the disc ver-

Plan It

... the COMPLETE personal organiser

Now there's a simple way to keep track of your money, plan your budgets, sort out your files and manage your time far more effectively.

PlanIt's three main modules – Personal Accounts, Financial Diary and Card Index – take care of all

your day-to-day activities and help you rationalise your future financial position.

And there are two extra utilities – a Loan Calculator and a Calendar – to complete this remarkable package.

Personal Accounts Gives you up-to-the minute facts about your financial position at any time. Keeps separate accounts of your banking, cash transactions, credit card payments. Allows 24 individual accounts, up to nine different credit cards (and warns you when you reach your cash limit) and as many as 400 different transactions a month. Sets up your standing orders. Automatically updates relevant accounts with each transaction.

Card Index Create your own address book, phone directory, tape library title list. Use the flexible editor to enter or amend data. Sort and search. Call up detailed reports on contents in any form. Produce mailing labels on your printer.

Financial Diary All the features of the best desktop diary – plus much more. Enter up to 15 items per day and have them automatically sorted in time order. Add your expenses and have them totalled in separate categories. Speed search for entries, then mark them for future manipulation or replication.

DATABASE SOFTWARE

Please send me: PlanIt CPC on tape £14.95*() disc ££19.95*()
PlanIt PCW on disc £24.95 *()
*Europe add £2 Overseas Airmail add £5.

- I enclose cheque payable to Database Software 'or
 Please debit my Access/Visa card number

Name _____

Address _____

Signature _____

Send to: Database Software, Europa House, 68 Chester Road,
Hazel Grove, Stockport SK7 5NY.

ACUP5

sion of Heartland:

```

10 MEMORY &1FFF:LOAD "kim",&2990
20 INPUT "Infinite energy (y/n)";a$:IF U
  PPER$(a$)="Y" THEN POKE
&4FEE,&FF
30 INPUT "Infinite time (y/n)";a$:IF UPP
  ER$(a$)="Y" THEN POKE
&2CE5,0:POKE &2CE6,0:POKE &2CE7,0
50 CALL &2990
  
```

Run that, and I am assured that the accompanying maps will almost guarantee success.

Not only but also, we have pokettes for the fabled Gauntlet. This poke will run the game (running the Gauntlet?), but with options to dissable generators, freeze the monsters and the time, and – of course – infinite lives.

Type in the listing below (kindly retyped by the Wife), save it on a different disc (Gauntlet gets unhappy when

you save things on it) and run. Put the real Gauntlet disc in when it asks for it, or you won't get too far.

```

10 MEMORY &20FF
20 FOR i=41000 TO 41041:READ a:POKE i,a:
  NEXT
30 DATA
&21,&4e,&a0,&cd,&d4,&bc,&22,&4f,&a0,&79
,&32,&51,&a0,&1e,&00,&16,&00,&0
e,&41
40 DATA
&21,&00,&31,&df,&4f,&a0,&1e,&00,&16,&00
,&0e,&42,&21,&00,&33,&df,&4f,&a
0,&c9,&84,&00,&00,&00
50 PRINT"Insert "+CHR$(24)+"GAUNTLET"+CH
  R$(24)+" disc & press
  enter":WHILE INKEYS="" :WEND
60 CALL &A028
70 FOR i=&30F2 TO &30FF:READ a:POKE i,a:
  NEXT
80 DATA &21,&00,&31,&11,&00,&01,&01,&40,
&02,&ed,&b0,&c3,&00,&01
90 add=&32D0:POKE add,&AF:POKE &319E,&D0
:POKE &319F,&2
100 INPUT"Disable generators [Y/N]";b$
110 IF (b$="Y") OR (b$="y") THEN FOR i=1
  TO 8:add=add+1:READ a:POKE
add,a:NEXT
120 DATA &21,&3a,&85,&77,&23,&77,&23,&77
130 INPUT"Freeze monsters [Y/N]";b$
140 IF (b$="Y") OR (b$="y") THEN FOR i=1
  TO 8:add=add+1:READ a:POKE
add,a:NEXT
150 DATA &21,&bf,&a3,&77,&23,&77,&23,&77
160 INPUT"Freeze time [Y/N]";b$
170 IF (b$="Y") OR (b$="y") THEN FOR i=1
  TO 16:add=add+1:READ a:POKE
add,a:NEXT
180 DATA
&21,&f5,&99,&77,&23,&77,&23,&77,&21,&05
,&9a,&77,&23,&77,&23,&77
190 POKE add+1,&C3:POKE add+2,&0:POKE ad
d+3,&84
200 CALL &30F2
  
```

special. Windo forwardo past la firsto fileo sed runo la routineo.

```

10 MODE 1:MEMORY &13FF
20 LOAD "!",&8000:CALL &8000
30 LOAD "!",&1400
40 LOAD "!",&C000
50 POKE &9631,0:POKE &9632,0
60 POKE &963A,0:POKE &963B,0
70 POKE &96A3,&18
80 POKE &A462,0
90 POKE &A465,0:POKE &A466,0
100 CALL &8200
  
```

Who sent me two sheets of blank paper?

While everyone fails to admit it, have another one from Justin's selected finest pokes box. This one's for escalating prospects in Elevator Action:

Wind forward past the first file.

```

10 MODE 0:OPENOUT "d":MEMORY &FFF
20 BORDER 0:FOR p=0 TO 14:READ a:INK p,a
  :NEXT
30 LOAD "!scn",&C000
40 LOAD "!act"
50 POKE &148E,0:POKE &148F,0
60 POKE &1490,0:POKE &1493,0
70 CALL &59A2
80 DATA 0,26,14,13,24,6,2,9,3,16,1,10,18
  ,0,7
  
```

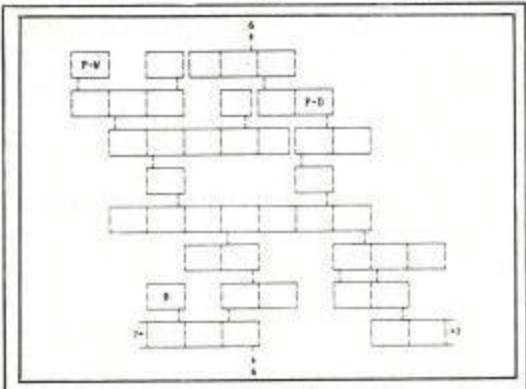

Castle

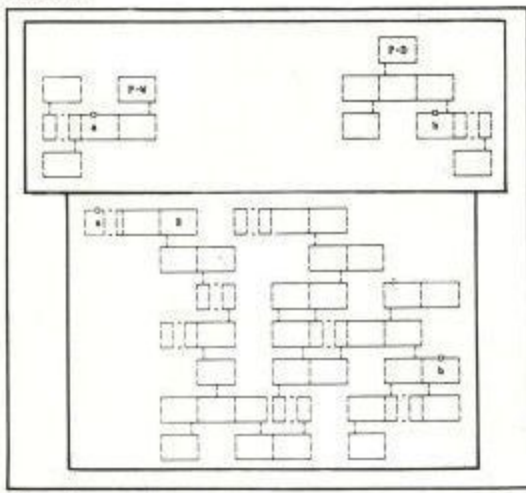

Garden

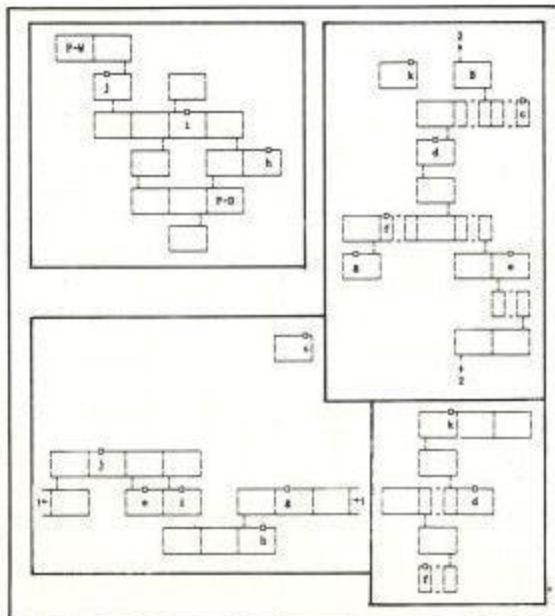

Moonbase

KEY
 B..... bed
 P-W..... page - white
 P-D..... page - dark
 □(a-s)..... lifts
 ↑ ↓ (1-8).... connections

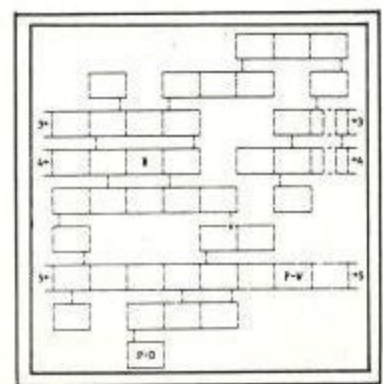

Village

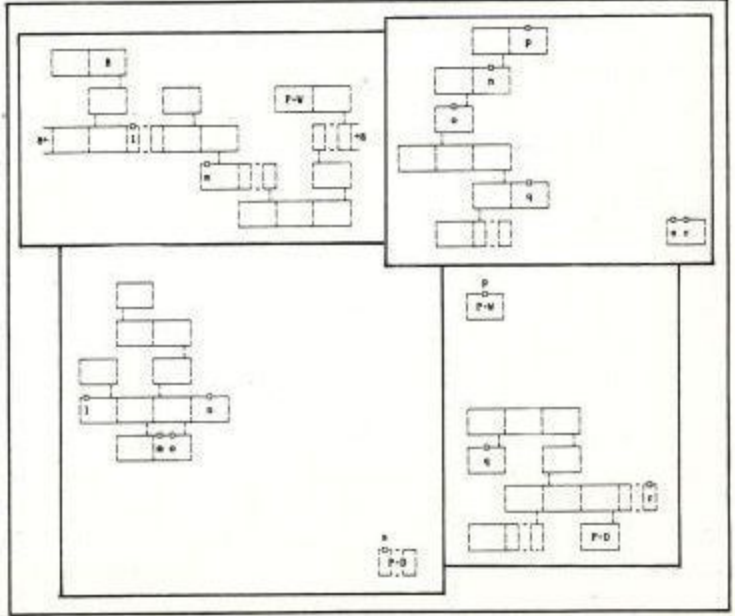

Caves

You're probably still waiting for Cliff's infamous map editor and stuff for Street Machine, aren't you? Well, waiting time is over. After much sweating over a hot keyboard (thank God for sealed switches), here it is.

First type ye famouse listing. Remember that the artwork department has been known to mis-label stuffs, so see which one looks right. Stick in a blank tape/disc, and save the program. If you don't save it, you'll have to type it in every time. Great typing practise, but lousy gameplay.

If all goes well (unlikely), you'll get a message suggesting that now is probably a very good time to put in your real Street Machine tape and press play and so on. The proggy doesn't load

```

10 REM ** Cliff "One pop, two pushes" La
   wsons
20 REM ** famous Street Machine poke, sl
   ightly
30 REM ** polluted by the "Small furry
40 REM ** creature from the Crab nebula"
50 REM ** special loader.
60 REM **
100 MODE 1:LOCATE 1,23
110 Loc=88000:l=1000
120 READ a$,a:cs=0
130 IF a$="*" THEN 230
140 PRINT "Line ";l;CHRS(13);
150 IF LEN(a$)<>32 THEN 270
160 FOR j=1 TO 32 STEP 2
170 x=VAL("8"+MID$(a$,j,2)):cs=cs+x
180 POKE Loc,x:Loc=Loc+1
190 NEXT
200 IF cs<>a THEN 270
210 cst=cst+cs:l=l+10
220 GOTO 120
230 IF cst<>66867 THEN 290
240 CALL 88000
250 PRINT "Type TAPE and run again."
260 END
270 PRINT:PRINT"Check line for errors"
280 PRINT "and SAVE IT.":END
290 PRINT "I think you miss a line."
300 END
1000 DATA 21108011000C01FF03EDB0C3000C00
   00,1085
1010 DATA 21080F06051100C0CD77BC210012CD
   83,1178
1020 DATA BCCD7ABC3EC9324F233EC932412D21
   27,1625
1030 DATA 0C22552AC30012F5E5D5C53E3ACD1E
   BB,1812
1040 DATA 280CAFC00EBCCD5C0CCDEF0C18163E
   3C,1567
1050 DATA CD1EBB2805CD2B0E180A3E24CD1EBB
   28,1323
1060 DATA 03CD480EC1D1E1F1CD0DBDC9010000
   C5,1968
1070 DATA CDC80CCDD40CCDEABB010321C044AF
   ED,2373
1080 DATA 4220ECCD870CC9C5E101000011A000
   AF,1662
1090 DATA ED520330FB19C9212EFC119EC70614
   3E,1640
1100 DATA C07712231310F83E40212DFCCDB80C
   3E,1566
1110 DATA 802142FCCDB80C2150FD1140C60650
   3E,1673
1120 DATA C07712231310FAC906527711000819
   30,1155
1130 DATA 041150C01910F3C9217F38097ECDE6
   0C,1576
1140 DATA CDDEBBC9CD770C2929EBC5E129E5C1
   21,2386
1150 DATA 9001AFED42C921890E5F1600197EC9
   21,1510
1160 DATA B02222070F22090FCD4B0DCD06BBFE
   FC,1521
1170 DATA CA0012FEF02818FEF12822FEF2282A
   FE,2179
1180 DATA F3282FFEF6CA010EFEF7CA160E18D9
   2A,2069
1190 DATA 070F11A000AFED5222090F18CB2A07
   0F,1042
1200 DATA 11A0001922090F18BF2A070F2B2209
   0F,640
1210 DATA 18B62A070F2322090F18AD2A070FE5
   C1,1046
1220 DATA CDC80CCDD40CCDEABB2A090F22070F
   E5,1823
1230 DATA 3E01CD59BCC1CDD40C3E0FCDEBBCD
   EA,2297
1240 DATA BB3E00CD59BCCD7D0DCD5D0EC92A07
   0F,1651
1250 DATA 2B2B017EC4CDB10D2A070F2B0182C4
   CD,1443
1260 DATA B10D2A070F0186C4CDB10D2A070F23
   01,1080
1270 DATA 8AC4CDB10D2A070F2323018EC4CDB1
   0D,1597
1280 DATA C9117F381911C0FE193E05F57ECDC9
   0D,1771
1290 DATA 11A00019F13D20F3C9FE7E38023E19
   E5,1734
00 DATA 6F2600292929292911407D19EBC5E1
   ,1283
1310 DATA CDE70DE5C1E1C90610C506041A7723
   13,1725
1320 DATA 10FA01FC07093005AF0150C009C110
   E9,1487
1330 DATA C92A070F22090F117F38197E3CFE7E
   20,1146
1340 DATA 01AF77C3F80C2A070F22090F117F38
   19,1097
1350 DATA 7EB720023E7E3D77C3F80C21100F06
   06,1242
1360 DATA 1100C0CD8C8C217F38112044010000
   3E,1138
1370 DATA 02CD98BCCD8FBCC921100F06061100
   C0,1569
1380 DATA CD77BC217F38CD83BCCD7ABCC92A07
   0F,2032
1390 DATA 117F38197ED60701A1C51E07CD750E
   3C,1364
1400 DATA 01D3C51E07D5F5C5C0C90DC1210400
   09,1759
1410 DATA E5C1F13CD11D20EDC9020102020202
   02,1444
1420 DATA 0202020C0C0C0C0808080C0C0C08
   08,142
1430 DATA 080801010606010C0C0C0C0C010101
   02,96
1440 DATA 0A020B04040B0B0B0B040C01010101
   02,97
1450 DATA 010102010102010308080903010205
   09,57
1460 DATA 0701010F0F0F0F0D0D0D0404040404
   0E,142
1470 DATA 0B040B050505050A0A08080A0A0A0C
   0C,136
1480 DATA 0A0C0C020C06060606010606080000
   00,93
1490 DATA 000000050500000000000040434F44
   45,370
1500 DATA 4E45574D41500000000000000000
   00,456
1510 DATA *,0

```

anything off the tape until the fourth program, called "MCODE". If you want to save a bit of time, scribble down the point at which this bit starts on an old fag packet, your filofax or whatever.

The game needs a buffer in which to put the data. Cliff used the screen, so don't worry about the technicolour effects inflicted upon the screen during loading.

When the game loads up and dumps the score table on the screen, you can start playing as normal, but you won't be troubled by minor breakdowns.

However, should you feel like redesigning the map to something approaching the complexity of spaghetti junction, press the E key. Before your very eyes, and anyone else's if they're watching, the whole shape of the map will be revealed. Eventually.

Also appearing on the screen is a small bright dot, which you will soon learn is capable of being moved about by the cursor keys. You've learned now, 'cos I just told you.

Anyways, once dot is learnedly moved to the right point on the map,

you can scroll through all the pretty curves, hedges, cars, sheep and other possible shapes with the shifted left and right keys. Clever eh? Even cleverer is the provision whereby you return to the front screen with the Escape key.

All very well, I hear you say, but how do us mortals save the result to tape? Haha, you hear me answer, press the S key when in the front screen. It'll then save the map to tape.

If you don't want the messages all over the screen from the tape routine, add line 70 CALL &BC6B,1. This is in fact one of those cunning uses of putting n parameters after a call to pass the number n to a subroutine.

OK, so you've saved your megatricky map. Now I suppose you want to load it in again later? How did I guess? Well, hit the L key while in the front screen and it'll start looking.

Sorry that the lives aren't infinite, but if you couldn't get to the menu you couldn't get to the screen designer, could you?

Ho hum, back to Just-a-poke. One I could do with here, infinite macho

energy for ghost hunter. Got any Ego boosters Justin?

```

10 MODE 1:MEMORY 12345
20 LOAD ""
30 FOR n=&A4FC TO &A502
40 READ a$:POKE n,VAL("8"+a$)
50 NEXT n
60 CALL &A4A0
70 DATA af,32,c1,82,c3,73,61

```

Phrase of the month: As user-friendly as a cornered rat.

Next we have a few helpful tints and hips here for Dan Dare fans, courtesy of Alexis, Edward, and Martin of Sunderland:

- Don't go down a lift until you've blasted everything on a level as you can't go back up again.

- When you're getting the fourth bridging piece, or heading for the Mekon's rocket, don't shoot the things that look like telegraph poles. These block your path and you'll never win.

- Never try to duck or jump a Tree, although it's OK to do this with floor guns.

Your key to communications!

**NEW AMSTRAD
DATABASE**



FREE Electronic Mail . . . International Telex . . . 10 National Chatlines (Interactive Bulletin Boards) . . . 70,000 users across the UK . . . Teleshopping . . . Multi-User Interactive Strategy Games



Instant computer news . . . Hardware and software reviews . . . Technical features . . . Hints and tips . . . On-line business advice and features



FREE and discounted quality software to download direct to your micro - **24 hours a day**

PRESTEL

PRESTEL is a trademark of British Telecommunications

300,000 pages of information on the huge Prestel database

for just 20p a day

Micronet 800-
The ultimate peripheral

Micronet 800
8 Herbal Hill, London EC1R 5EJ
Telephone: 01-278 3143

To: Micronet 800, 8 Herbal Hill, London EC1
Please send me a brochure on Micronet 800

Name _____

Address _____

_____ Telephone No. _____

Age _____ Micro _____

AMU 5/87

Amdrum Digital Drum system for the Amstrad 464, 664, 6128.

'Peripheral of the Year' (Readers poll PCW)

AMDRUM

INSTRUCTION MANUAL



£34.95

Mach I+ Joystick

Probably the best Joystick in the world.

- Auto Fire
- Microswitch Fire Buttons
- Metal Shaft
- Microswitch 8 directional controls
- 12 Month warranty.



£14.95

Peripheral Power

125+ Joystick

- 4 extremely sensitive fire buttons
- Auto fire switch
- Strong base suction cups
- Uniquely styled hand grip
- 12 Month warranty.



£8.95

MK5 Midi Keyboard



A full size 5 octave polyphonic keyboard containing a sophisticated and very powerful computer, suitable for a wide range of uses

£99.95

KITS AVAILABLE FOR AMDRUM

Latin Kit & Editor.....**£3.99**
 Electro Kit & Editor.....**£4.99**
 Afro Kit.....**£4.99**
Mini Interface to connect MK5 keyboard to 464,664, 6128.....**£29.95**

Aerial Splitter



Cheetah's neat splitter unit complete with

self-adhesive pad allows you to keep your T.V. and computer aerial leads plugged in without disturbing the picture.

£2.25

Split Extension Connector



Enables 2 Amstrad peripherals to be connected to the computer bus.

£11.75

Cheetah, products available from branches of
Dixons **John Menzies** **LASKYS**
WHSMITH High St. Stores and all good computer shops.

Prices include VAT, postage & packing.
 Delivery normally 14 days.
 Export orders at no extra cost.
 Dealer enquiries welcome.



Cheetah
 Marketing



CHEETAH MARKETING LTD.
 1 WILLOWBROOK SCIENCE PARK
 CRICKHOWELL ROAD, ST. MELLONS, CARDIFF
 TEL: CARDIFF (0222) 777337 TELEX: 497455
 FAX: 0222 779404

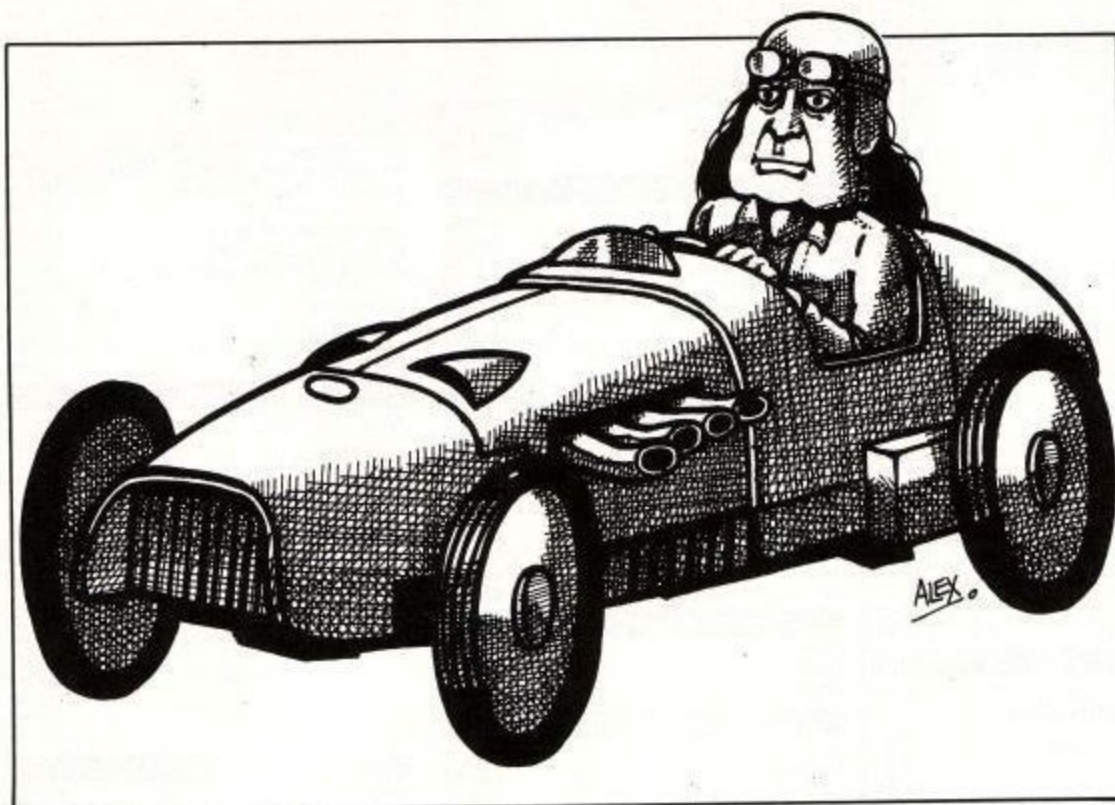

● When you've just given Digby a bridging piece, never try to shoot the gun that moves up and down the edge. You'll be more likely to fall off.

Who knows, maybe you'll be able to do it without the pokes.

For those of you who use Borland's Turbo Pascal on the Airo, the following procedure behaves much like the normal draw procedure in high res mode. The clever bit is that it lets you use all 16 colours available on the PC1512. It doesn't break any records for speed in the line-drawing stakes, but it works:

```

Procedure CDraw(x1,y1,x2,y2,c:integer);
const
  r_plane=$3de;
  w_plane=$3dd;
var r,w :integer;
begin
  r:=0 ; w:=1 ;
  repeat
  begin
    port[r_plane]:=r ; port[w_plane]:=w ;
    if (c AND w)=0 then
      Draw(x1,y1,x2,y2,0)
    else
      Draw(x1,y1,x2,y2,1);
    r:=succ(r) ; w:=w*2
  end;
  until w=16;
  port[r_plane]:=0 ; port[w_plane]:=15;
end;

```

I have been asked "Why does Turbo Pascal compile faster to disc than to memory?" Answer: it doesn't but if you've just compiled it in memory, compiling to disc just writes the bit in memory off.

C has been described as an encryption system for assembler. Arnor is bringing one out for the CPCs and Borland is about to release a version (aversion?) of it for the PC1512 soon. As soon as I get a copy, I'll rig graphics stuff for that too.

But enough, those of you not on ACU salaries will only have humble 464s, so here's infinite lives for that amazingly complex - and slightly familiar - Classic Muncher from Bubble Bus.

```

10 MODE 1:OPENOUT "d":MEMORY &4FF
20 LOAD "",&500
30 POKE 3561,0
40 POKE 3562,0
50 POKE 3563,0
60 POKE 3564,0
70 FOR n=&70 TO &7D
80 READ a$:POKE n,VAL("&"+a$)
90 NEXT n
100 DATA 21,00,05,11,00,01,01,00
110 DATA 94,ed,b0,c3,03,01
120 CALL &70

```

Now the Oz spot. Robbie Noordzy (alias: The Hopeless Hacker) has written in asking for a Ghosts 'n' Goblins pokeykin. Well, too late. It was in the September '86 issue (wasn't it ed?).

Remember, replies only come through the column, which doesn't cost me anything. I'm not in to sending letters to the land of Fosters, as this would be detrimental to the Hairy Hacker's bank account (I get 50 per cent of the Ozzie mailbag). You keep on sending 'em to me, OK?

Now Justin time for a really snakey poke for infinite lives in Oceans Cobra: (The quick may note that this routine is almost identical to that of Xevious.)

```

10 MODE 1:MEMORY 12345
20 LOAD ""
30 tot=0
40 FOR n=&A700 TO &A748
50 READ a$:a=VAL("&"+a$)
60 POKE n,a:tot=tot+a
70 NEXT n
80 IF tot<>7305 THEN PRINT"have a look at the data, its wrong!":END
90 CALL &A734
100 DATA dd,21,00,bf,11,4f,00,cd
110 DATA 4e,bc,21,c3,1a,11,a7,af
120 DATA 22,1b,bf,ed,53,1d,bf,c3
130 DATA 00,bf,21,00,00,22,ca,4e
140 DATA 22,cc,4e,c3,00,41,3e,a8
150 DATA 21,67,fc,32,00,02,22,01
160 DATA 02,f3,f1,c9,3e,c3,21,26
170 DATA a7,32,e2,39,22,e3,39,21
180 DATA ff,ab,11,40,00,c3,af,39
190 DATA 4a

```

Two more left from Justin and I can go to sleep. So in rapid succession, here's infinite lives for Durrell's SIGMA 7:

```

10 MODE 0:OPENOUT "d":MEMORY &BFF
20 FOR n=0 TO 15:READ a:INK n,a:NEXT
30 FOR n=1 TO 3:READ a,b
40 OUT (&BC00),a:OUT (&BD00),b
50 NEXT n
60 BORDER 0
70 LOAD "!sigscn",&C000
80 LOAD "!",&C00
90 FOR n=1 TO 3:READ a
100 POKE a,0:POKE (a+4),0:POKE (a+5),0
110 NEXT n
120 MODE 1:INK 1,18:INK 3,6
130 CALL &8236
140 DATA 0,6,1,26,24,3,2,13,25,14,26,11,3,18,3,6
150 DATA 1,32,2,43,6,24
160 DATA 21251,32026,32348

```

If you looksie into the basic file at the start of Sigma 7 it tells you how to remove the copyright shmear. On, in quick succession, with infinite lives for Disc and Cassette versions of Bombjack 2.

Either rewind to start of tape or forward past first file, or insert the disc then run the program, take your pick:

```

10 MODE 0:MEMORY &175B
20 BORDER 0
30 FOR n=0 TO 15:READ a:INK n,a:NEXT
40 LOAD "!b2screen.bin",&C000
50 LOAD "!b2code.bin",&175C
60 POKE &18EA,0
70 POKE &31BA,0
80 CALL &1770
90 DATA 0,26,1,8,11,10,14,5,20,15,21,25,6,3,12,24

```

Before collapsing into a deep slumber (like some of you probably have already), a small quiz: Q. How many programmers does it take to change a light-bulb? A. None, it's a hardware problem.

Bye! Luv VAX

ACU

THE BUSINESS CENTRE

PC 1512 SOFTWARE

ACCOUNTS PACKAGES

Compact Daybook	£69.00
Compact Accounts	£179.00
Compact Sales Invoicing	£80.00
Compact Sales Ledger	£79.00
Compact Purchase Ledger	£79.00
Compact Nominal Ledger	£79.00
Compact Reporting	£49.00
Sage Book-keeper	£99.00
Sage Accounts	£148.00
Sage Accounts Plus	£198.00
Sage Financial Controller	£299.00
Intuitive Bookkeeper	£89.00
Map Integrated	£138.50
Money Power	£90.00
Bookworker	£179.00
DAC Easy	£95.00
DAC Easy Mate	£49.95
DAC Easy Tutor	£29.95
DAC Easy Port	£39.95

SPREADSHEETS

Supercalc 3	£54.95
Supercalc 4	£349.00
Scratchpad +	£49.50
Sage PC Planner	£98.50
VP Planner	£90.00
Planners Choice	£34.99
Multiplan Junior	£59.95
Sage Desktop	£69.95

DATABASES

Sage Retrieve	£98.00
Delta 4	£84.00
Cardbox	£49.50
Condor Junior	£84.00
Cambase	£39.50
Reflex	£54.95
VP Info	£90.00
d Base II	£99.00
Files Choice	£34.99
PC Promise	£59.99
DAC Easy Base	£49.95
Superbase Personal	£89.95
G Base	£89.95

WORD PROCESSORS

Wordstar 1512	£54.95
Sage PC Write	£98.50
Word Perfect Junior	£88.00
Tasword PC	£22.00
Volkswriter	£44.95
GEM Write	£89.00
1st Word Plus	£69.95
Word Junior	£59.95
DAC Easy Word II	£49.95

INTEGRATED SOFTWARE

Logistix	£90.00
PSION PC Four	£69.00
Able I	£90.00
Ability	£89.95
Open Access	£139.95
Words & Figures	£89.00

LANGUAGES

Turbo Pascal	£69.95
Turbo Tutor	£29.95
Turbo Prolog	£69.95
Zorland C	£29.95
Lisp MS DOS	£220.00
C Compiler	£345.00

COMMUNICATIONS SOFTWARE

Datataik	£150.00
Crosstalk	£169.00
Chit Chat	£99.00
Gem Corn	£69.95

DESKTOP PUBLISHING

Ventura	£899.00
Fleet Street Editor	£139.00
Print Master	£29.95
Autosketch	£69.00

LEISURE SOFTWARE

Borrowed Time	£22.00
Mindshadow	£18.00
Alter Ego Male	£22.00
Championship Golf	£22.00
Hacker	£18.00
Hacker II	£18.00
Leather Goddess	£26.00
Cyrus II Chess	£18.00
Pitstop II	£18.00
Alex Higgins Snooker	£18.00
Archon	£18.00
Strip Poker	£18.00
PSION Chess	£22.00
Arcade Classics	£18.00
Solo Flight	£18.00
Spitfire Ace	£18.00
Crusade in Europe	£18.00
Silent Services	£22.00
F15 Strike Eagle	£18.00
Hellcat Ace	£18.00
Tigers in the Snow	£24.00
Dambusters	£18.00
Alternative Reality	£18.00
Gauntlet	£18.00
Trivial Pursuit	£18.00
Summer Games II	£18.00
Winter Games	£18.00
Pitstop II	£18.00
Mean 18 Golf	£18.00
Zork I	£25.00
Witness	£25.00
Tracer Sanction	£18.00
Shanghai	£18.00
Enchanter	£25.00
Cross Check	£18.00
Flight Simulator II	£45.00
Jet	£46.00
Sargon III Chess	£46.00
Boulderdash I	£14.95
Boulderdash II	£14.95

PC 1512 BOOKS

Technical reference manual	£19.95
Locomotive Basic 2 User Guide	£9.95
Using DOS+	£9.95
Using Gem on the PC 1512	£12.95
DOS Manual	£17.50
MS DOS bible	£16.95
MS DOS Handbook	£19.95
MS DOS Users Guide	£18.45
The Wordstar Handbook	£11.95
Getting Started with Wordstar	£9.95
8086/8088 Assembly LangProg	£10.95
Programming the 8086/8088	£16.95
8086 Book	£23.95
C for Beginners	£10.95
Introducing the Amstrad PC	£7.95
Word Processing Using Gem	£9.95
Advanced MS-DOS	£19.95
Intro to Turbo Pascal	£14.95
Turbo Pascal Handbook	£19.95
Using Turbo Pascal	£19.95
Users Guide to MS DOS	£45.00

COMMUNICATIONS SOFTWARE

Datataik	£150.00
Crosstalk	£169.00
Chit Chat	£99.00
Gem Corn	£69.95

PAYROLL

Compact	£90.00
Sage	£99.00
Map	£43.50

GENERAL UTILITIES

Sidekick	£27.00
Brainstorm	£39.00
Gem Draw	£84.00
Gem Graph	£84.00
Gem Diary	£32.00
Designers Pencil	£24.00
Music Studio	£24.00
1-up	£49.00
Touch 'n' Go	£22.00

PCW SOFTWARE

ACCOUNTS PACKAGES

Compact Daybook	£45.00
Compact Accounts	£170.00
Compact Accounts Plus	£199.00
Compact Sales Ledger	£59.99
Compact Purchase Ledger	£59.99
Compact Nominal Ledger	£59.99
Compact Nom Led. Reporting	£44.95
Compact Stock Control	£59.99
Camsoft Accounts SIS	£84.00
Camsoft Accounts SPN	£84.00
Camsoft Accounts SISPN	£114.00
Sage Popular	£75.00
Sage Popular Plus	£114.50
Map Integrated Acts	£125.00

DATABASES

d Base II	£89.00
Cambase	£39.50
Cardbox	£47.00
Sage Retrieve	£54.00
Locomail	£37.00
Pocket Datastar	£35.00
Condor I	£89.95
Pocket Matchbox	£29.95
Dataflow/Mailflow	£39.00

WORD PROCESSING

Protect	£74.00
Prospell	£24.00
Pocket Wordstar	£37.00
Tasword 8000	£19.50
Tasprint 8000	£12.50
Tasprint 8000	£14.50
Locospell	£37.00
Newword	£52.10
Tasword and Tasprint	£29.95

PAYROLL

Compact	£89.95
Camsoft	£43.95
Sage	£54.00

GENERAL & UTILITIES

DR Draw	£39.50
DR Pascal	£39.50
DR C Basic	£39.50
Pagemaker	£45.00
Fleet Street Publisher	£64.50
Write Hand Man	£25.00
Smartkey	£39.95
Brainstorm	£39.95
Rotate	£22.95

PC HARDWARE

Printer Lead Parallel	£18.00
Printer Lead Serial	£18.00
Dust Cover	£9.35
5.25 Disc Pack of 25	£20.00
Arcade Joy Stick	£16.95
PC Memory Upgrade	£39.95
FD 3 Floppy Drive	£149.00
3.5" Floppy Drive	£280.00
Light Pen	£19.95
HD 10 10Mb Hard Disc	£430.00
HD 20 20Mb Hard Disc	£530.00
3.5" 20Mb Hard Disc	£460.00
40Mb Tape Streamer	£575.00

MODEMS

Amstrad V21/V23	£99.00
Miracle WS2000	£120.00
WS3000 V21/V22 Hayes	£330.00
WS3000 V21/V22 N/23	£550.00
WS3000 V21B15/V22 N/23	£699.00
Quattro	£795.00
Amstrad AD/AA	£169.95

COMPUTERS

PCW 8256 with 5 free discs	£440.00
PCW 8512 with 5 free discs	£555.00
CPC 464 Green	£179.95
CPC 464 Colour	£279.95
CPC 6128 Green	£279.95
CPC 6128 Colour	£369.95

SPREADSHEETS

Supercalc 2	£41.95
Cracker II	£41.95
Scratchpad Plus	£49.50
Pocket Calcstar	£34.95

PCW BOOKS

Amstrad CP/M Plus	£12.95
Mastering the Amstrad PCW	£8.95
Step by step guide to Locoscript	£4.95
Using the PCW 8256	£9.95
Program Your PCW	£6.95
CP/M Bible	£16.50
CP/M Plus Handbook	£13.95
GSX Handbook	£19.95
Starting Logo	£6.95
Advanced Amstrad Basic	£12.95
Amstrad Mallard Companion	£7.95
Program Your PCW	£6.95
Understanding dBase II	£22.95
dBase Prog. Language	£14.95
dBase II for the first user	£16.95
Soul of CP/M	£16.50
Using CP/M	£5.95
Mastering CP/M	£17.95
Intro to CP/M Plus	£7.95
Practical Logo	£6.95

LEISURE SOFTWARE

Colossus 4 Chess	£17.00
Tomahawk	£17.00
Trivial Pursuits	£19.00
Scrabble	£18.00
Strike Force Harrier	£18.00
The Pawn	£22.00
Silicon Dream	£18.00
Classic Collection	£12.00
3D Cyrus II Chess	£18.00
After Shock	£15.95
Annals of Rome	£22.95
Batman	£14.95
Black Star	£14.95
G. Gooch Test Cricket	£17.95
Lord of the Rings	£22.95
Monsters Of Mordac	£17.95
SAS Raid	£14.50

EDUCATIONAL

Touch 'n' Go	£19.50
Locoscript Tutorial	£8.95
Ian Key Typing Course	£22.95
Hands on CP/M Plus	£19.95
Hands on Supercalc	£19.95
Hands on d Base II	£19.95
Teach Yourself Locoscript	£14.95

PCW HARDWARE

Thingl	£5.95
Electric Studio Lightpen	£64.00
Electric Studio Mouse	£114.00
Electric Studio Digitiser	£92.00
Graph PAD3	£139.00
Joystick Controller	£22.50
FD 2 Second Disc Drive	£149.00
FD2 & Memory Upgrade	£170.00
8256 Memory Upgrade	£29.95
RS232/Centronics Upgrade	£57.00
V21/V23 Amstrad Modem	£95.00
2 PCW Printer Ribbons	£9.95
Lockable 3 Disc Storage	£11.00
10 Mb Hard Disk	£499.00

PRINTERS

MP165	£239.00
CPA80	£189.00
MP 200	£325.00
MP 201	£410.00
Panasonic P1080	£179.00
DMP2000	£159.00
DMP3000	£179.00
DMP4000	£399.00
Star NL10	£259.00
Juki 8000 Daisy wheel	£199.00
Juki 6100 Daisy wheel	£299.00
EPSON LX86	£270.00
CITIZEN 1200	£199.00

● AMSTRAD PC 1512's NOW IN STOCK ● PHONE FOR LATEST PRICES ● ALL SINGLE & DUAL DRIVE SYSTEMS AT PRE-INCREASE PRICES WHILST STOCKS LAST

ALL PRICES INCLUDE VAT, POST & PACKING TO UK.

Comtec Systems

58a Wellingborough Road Northampton NN1 4DN Tel: (0604) 24463

- ALL PRICES INCLUDE VAT & POST & PACKAGING
- We are fully authorised Amstrad Repair Centre, with 'in-house' repair facilities.
- Phone now for details of our service contracts and repair costs.
- County Council, Local and Education Authorities. Orders Welcome.
- Corporate and Export Orders welcome.

OVERSEAS ORDERS

Please add the following to your order and make all payments in Sterling.

Software, Books, Discs, Leads	£2.00
Printers, Disc Drives	£20.00
Computers	£40.00

Please send me the following items:

Qty Product Price (inc VAT)

M/C TYPE 8256

1512 6128 8512 TOTAL _____

Name Mr/Mrs/Miss _____

Address _____

Postcode _____ Tel. No. _____

I enclose (please tick) cheque/p.o. or, please debit to my

Access Visa Card EXPIRY DATE _____

Send to: FREEPOST

Comtec Systems

NORTHAMPTON NN1 4BR. Tel: (0604) 24463

Win SCALEXTRIC®

Accelerate up to Paddock, sweep down the right-hander to Druids, hard on the anchors, tight out of the bend, accelerate, line up for the corner, don't lose it! Quite remarkable.

Recreate the excitement of Brands Hatch in your front room. Virgin offers you the chance to do this in two ways, either behind the screen or over the carpet.

Unfortunately building a large layout at home is limited by finance and the size of the front room – besides Mum gets a bit peeved when you want to move the aspidistra to make space for a scale model of Dingle Dell.

Virgin to the rescue . . . do it with an Arnold. With the new game you can build your own circuit on the screen, using all the bits of track you want, then race a friend. You don't have to worry about the cat walking on the track and it is far easier on the pocket.

The Grand Prix

One lucky reader of Amstrad User will drive off with a full Scalextric set including power supply, two cars and controllers. The winner and 25 qualifiers will take the chequered flag to walk away with a copy of Virgin's video version.

Prepare to qualify

Life in the fast lane requires sharp sight – you need to look out for blue lights. Our unfortunate bacchanalian wheelbender has obviously failed this test, but he has offered to blow into a bag for his friend in blue just to prove that he is sober. You may think that you are seeing double, but look carefully: Things are not quite what they seem. The two pictures below have some minor differences – spot them to win the prize.



Rules

1. Circle the differences on the illustration and enter the total number on the coupon. The sender of the first correct entry drawn on May 10th (sorry Australia) will win the Scalextric set and a copy of the Virgin game.
2. Twenty five runners-up drawn on May 10th will win a copy of the Virgin game.
3. You may photocopy the form but only one entry is allowed per reader.
4. The judges decision is final, no employees of ACU may enter.
5. FISA cannot change the rules to make sure a French entry wins.

SCALEXTRIC ENTRY FORM

I spotted differences.

Name:

Address:

Send your entry to:
Scalextric Competition, Amstrad Computer User,
169 Kings Road, Brentwood, Essex CM14 4EF.

PlanIt is a collection of three individual programs called Personal Accounts, Card Index and Financial Diary. In addition, a Loan Calculator is provided and a Calendar is an integral part of the Diary.

It is available on tape and disc for the CPC range and this review is about the disc version. It appears that the only difference is that the disc version has the three main programs linked by a common menu. (A PCW version is also available and is very similar in operation).

What can PlanIt do for you? Well, if you expect it to make instant order out of your chaos, you will be in for a disappointment. To get any worthwhile results from any program you have to be meticulous in the way in which you input the information.

This means that you have to get yourself organised into a routine to regularly enter all the information that the programs require. If you are prepared to do this, PlanIt may suit you well.

The answer to your problems?

PlanIt is supplied on a single disc, complete with a manual, in the all but mandatory "library case". The manual covers both the CPC and PCW versions, but as they are so similar, this causes no problems or confusion. It is well written and describes most features clearly, but is rather short on facts regarding the storage capacities of the various programs.

The three main programs are accessed by typing RUN "PLANIT", which results in a master menu to select which of the three main programs you want to use. The loan calculator seems to be a bit of an afterthought, as it is loaded separately with RUN "LOAN".

The disc is protected and the programs take a long time to load, largely due to the devious protection methods used.

The manual tells you that any roms must be disabled before using PlanIt and a program is provided to disable them if required. If you forget to do this, PlanIt does not warn you and proceeds to load, apparently normally. Only at a later date do you encounter problems, when it is too late to do anything about it.

The first impression of the programs is very good, with a well laid out and presented menu. Instructions are constantly given in a panel in the lower part of the screen and menu selection is by use of the cursor keys to highlight the required option and then by pressing Return.

Selection of options throughout is mostly by use of the cursor keys, and

The complete personal organiser

Yuppies do it with a filofax, techies use a computer. If your finances are a mess then a computer system can help you to learn to be organised. But if you don't change you'll still be in trouble, as David Foster found out.

while this is fine when there are only one or two options, it soon gets tedious when you may have to press the cursor 10 or 11 times and then Return to select an option near the bottom of the menu, when it could have been done with a single keypress of a letter or number key. Ideal as a method for selecting with a mouse, but not from the keyboard, and PlanIt does not have provision to work with a mouse.

Personal Accounts

This is perhaps the main part of the PlanIt suite for most people, and is intended to provide the facility to analyse your expenditure, bank and credit card accounts, month by month.

Before using the program for the first time you must specify details of the bank account and any credit cards, together with opening balances. This is

where we come across one of the many inbuilt compromises. There appears to be no provision to handle more than one bank account or a building society account, though provision is made for handling up to nine credit cards.

Transactions can be analysed into 24 different categories of expenditure, but there is no way to break down the value of a single payment into more than one category, so don't pay your electricity bill and buy a computer with the same cheque!

Individual statements for bank and credit card accounts can be viewed, printed or sent to a file on disc. There appears to be some slight problem with this part of the program, in that it is possible for credit card statements to not show all the entries, though they are shown elsewhere in the reports and are included in the summary totals.

Transaction reports and cumulative

The main menu which appears when you load PlanIt



Bank: Royal National		Statement of Account		
Branch: Hereford		Account Number 000323		
Date	Particulars	Debited	Credited	Balance
b/f				345.01
02/08	000001 Telecom	38.76		307.05
02/08	000002 H Low Ltd	12.00		294.25
02/08	Cash Dispenser	15.00		279.25
04/08	000002 Garage Shop	32.17		247.08
09/08	St Ord NBS	198.71		48.37
15/08	000004 Sport Shop	19.95		28.42
16/08	Credit		88.13	116.55
19/08	Cash Dispenser	25.00		91.55
20/08	000005 Elec Board	51.31		40.24
21/08	000006 Micro Store	18.11		22.13
23/08	000007 Water Rates	90.65		68.52
24/08	Credit Salary		480.00	411.48

Press any key ...

A clearly laid-out statement of account

expenditure reports are available at any time, so that you can see your individual transactions for the month to date and also expenditure by category since the start of the accounting period, together with the overall state of your finances.

At the month end you carry out a Month End update, to transfer all standing orders and balances forward to the next month.

Card Index

The Card Index is a very simple database and is ideal for simple names and addresses, but the maximum length of any one field is 22 characters and a maximum of seven fields. The default field headings are names, addresses and telephone numbers, but these can be changed as long as the wording is no more than eight characters long.

If your requirements fit within these dimensions the Card Index works well. Data can be entered, amended and deleted at any time and records may be scanned, viewed one after another or you can jump to a specific record.

Search facilities are provided, and searches may be made on the key (first) field, or all fields. This is fairly rudimentary and it is not possible to search on multiple criteria.

Records may be sorted into ascending order and you can select on which field the sort is to be carried out.

Financial Diary

The concept of the Financial Diary is that you may enter dates and times of appointments, together with details, for any date in the future and these are retained in the activity file for as long as required.

You are limited to 200 entries (maximum, depending on the size of each entry) in the activity file at any one time, but it is possible to store past dates and times in separate files,

month by month and these can be referred to and, for some strange reason, altered at a later date by loading them in to the diary.

You must select the date first and then state the time, followed by the appointment or notes. There is also a column to allow you to enter monetary figures and I assume that the intention here is that you can insert expenses at a later date once the appointment has passed.

The maximum size of any one entry is 50 characters, plus the time, and any "money" figure, but you can also add "notes" to include further comments.

Each entry may be marked with a character, and reports may be called to display any or all marked entries for any range of dates covered by the activity file. The money figures may also be totalled. Output can be to the screen or a printer, but not to a disc file.

Entries may be altered or moved to different dates without the need to retype the complete entry.

Incorporated within the diary is a calendar, and this can display any month from 1900 to 9999. I now know that in 9999, my birthday falls on a

At any time you can find out the exact state of your finances

Expense Heading	Total Expenditure		
Mortgage	198.71	Total Receipts	568.13
Rent	42.11	Charges/Interest	0.00
Rates	0.00	Expenditure	715.07
Electric	51.31		
Gas	38.90	Period Balance	-146.94
Water	90.65	Opening Balances	
Telephone	38.76	Credit Cards	-12.31
Groceries	41.29	Bank Account	345.81
Clothing	12.00		
Hobbies	22.95	Balance	186.56
Vehicles	32.17		
Garden	0.00	Current Bank Bal.	364.04
Social	34.00	Current Cash Bal.	-2.11
Gifts	41.56	Credit Card Bal.	-175.37
House	0.00		
Travel	28.50	Balance as at 22/12/86	186.56
Misc1	13.44		
Misc2	0.00		
Misc3	8.92		
Misc4	0.00		
Misc5	19.00		
Misc6	0.00		
Misc7	0.00		
Misc8	0.00		

Press any key

Monday, or at least I think it does, but the calendar doesn't seem to take account of the rules for leap years according to the Gregorian calendar.

Loan Calculator

For some reason this seems to have funny ideas about what ranges of figures are acceptable, and it will not take interest rates less than 1 per cent. The loan period must be stated in years, which can be awkward if you want to work it out for intermediate periods, though it will accept decimal fractions of a year, assuming you know what they are.

Overall impressions

Visually PlanIt is good, though the more I used it, the more irritated I became with the need to make multiple selections from a number of menus in order to carry out the simplest task.

There are a number of inconsistencies in the use of keys. Sometimes Esc may be used to back out to a higher level menu, but on other occasions, with a similar menu, it doesn't work. Sometimes you select by moving the cursor, but other times you have to type in your selection.

I ended up with the feeling that PlanIt was one person's idea of what he wanted from personal accounting and diary programs and that no one else had been consulted as to whether it suited them, though I am sure that Database Software must have carried out considerable marketing research before producing PlanIt.

Will PlanIt suite your needs? If they are simple and straightforward and you are prepared to be meticulous about entering everything, PlanIt may well be what you are looking for, but I can't help but feel that at the end of the day I could have done it a lot more quickly with pen, paper and a diary.

ACU



THE AMSTRAD 8256. MORE THAN A WORDPROCESSOR,

The Amstrad 8256 offers you more than the average wordprocessor for less than the average typewriter.

Its incredibly low price includes a monitor, disc drive, keyboard, word-processing software and a printer.

And with the 8256 you don't just get quantity, you get quality too.

A high speed RAM disc facility means you can store and retrieve information instantly.

The high resolution, green screen monitor can show 90 columns and 32 lines of text at the same time.

That's 40% more useable screen area than most PCs.

Special function keys on the keyboard save you memorising complicated codes.

And because all the necessary wordprocessing software comes free, you

FOR LESS THAN A TYPEWRITER.

won't have to pay for any hidden extras.

What's more the enormous 256K memory means you're also getting a powerful personal computer.

(If you want even more wordprocessing and computer power there's now the 8512 model, with two disc drives and 512K of memory.)

But what makes the Amstrad even more of a bargain is the fully integrated printer, with its automatic paper loader, tractor feed and choice of letter quality or draft speeds.

The 8256 is also backed up by numerous extras and services.

You can add an optional combined serial and parallel interface to gain access to modem, additional printers and other peripherals.

And business users can take advantage of our nationwide service and maintenance contracts, not to mention the many advanced training courses.

All this for a machine that costs just £399 plus VAT.

Which is less than you'd expect to pay for many other wordprocessors. Or obsolete typewriters.

Please send me some more information about the PCW 8256.

Home user Office user (Please tick)

Name _____

Address _____

Tel _____

ACU 5.87

Company _____

AMSTRAD PCW 8256

Amstrad plc., PO Box 462, Brentwood,
Essex CM14 4EF. Telephone: (0277) 230222.

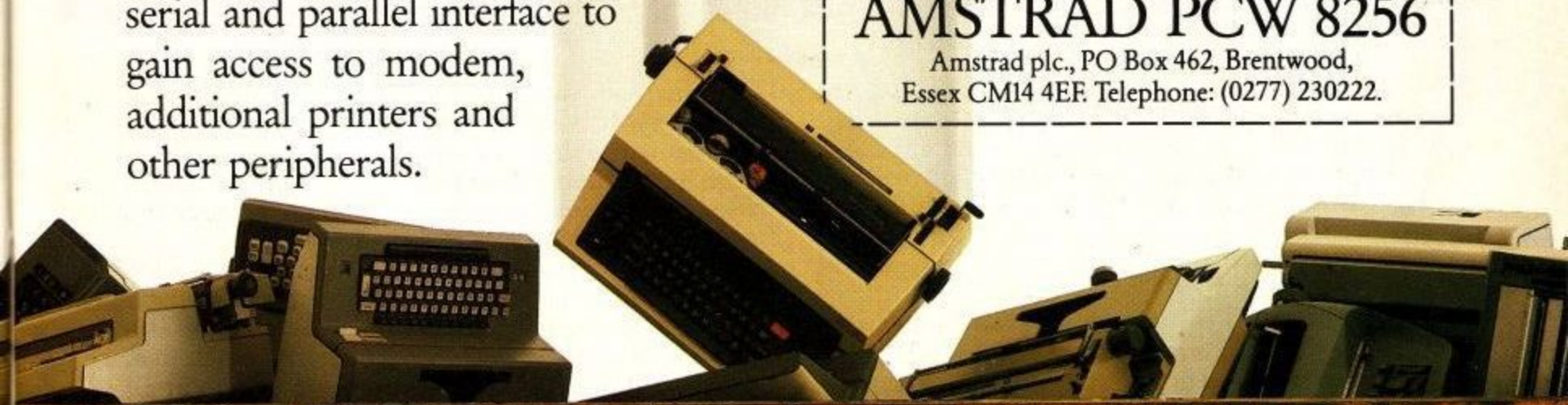

ASJ BULL LTD



Seek and ye shall find..

Into adventures with Bill Brock



Want a very good place

One question which turns up in the mailbag at regular intervals is: "How do I learn more about adventures?" This is usually accompanied by a brief explanation that the writer has thoroughly enjoyed his or her first game but has found it difficult to learn the tricks of the trade, and often ends with the plea: "Which adventures would you suggest for beginners in this field?"

The first game often stands out as a highlight, in that it will last in your memory for a lifetime. Because it was something new to you, you will have explored it with all the delight and wonder of an expectant child. The despair felt at each setback is completely overcome by the jubilation on each successful move.

Providing that this first game was not too difficult and that you have progressed well into it, either by yourself or with a little help you are likely to be hooked for life. It was something special, with every few steps an adventure in itself.

Now you know some of the difficulties that are hidden for the unwary and have some idea of how much there is to learn.

There is only one certain way of becoming more proficient at solving adventures and that is practice.

This may narrow the field for the choice of the next few games. It would not be sensible or enjoyable to choose a particularly difficult adventure.

What you need is one that CAN be solved with a reasonable degree of persistence, or one for which you can get some useful hints to its problems.

A great deal can be learnt playing a game for which there is a good hint sheet. The best of these that I have come across are those from Level Nine. All Infocom adventures have an optional "invisiclues" hint book, but these are exorbitant and provide full solutions.

The hints are just that. They do not give an answer to a problem but point you in the right direction for YOU to solve it. This way you learn how to tackle an adventure and not just how to cheat your way to the end.

There are several small circulation publications which provide regular hints, tips and solutions. They can be very useful if you are utterly stuck, but they usually consist of the barest essentials.

There is a temptation to simply type in the directions, and although you will complete the adventure, you will not learn a great deal in the process. There is



to start?

no substitute for your very own "brain think".

The following adventures are not just my recommendations, but also feature fairly heavily in your letters. They have all been out for some time and all represent good training grounds. You may very well find that some of the older ones are at reduced prices – especially at exhibitions – and represent even better value for money.

So if you are starting out and don't know which path to take, have a look at:

- The Jewels of Darkness – three classic Level Nine adventures distributed by Rainbird (01-240 8838).
- Jewels of Babylon and Forest at Worlds End – Interceptor (07356 77421).
- Mordons Quest – Melbourne House (01-943 3911).
- Mindshadow – Activision (01-431 1101).
- Neverending Story – Ocean (061-832 6633).

Hints for Jewels of Darkness are available from Rainbird and the others are covered in back issues of The Adventurers Handbook – H & D Services (061-370 5666).

Another adventure specific publication that may help is Adventure Probe. More info from Sandra Sharkey, 78 Merton Road, Wigan WN3 6AT.

Rapid access

One thing about most adventure games that is double edged is their large size. This means that you should get good value for money – either lots of text, plenty of graphics, or a reasonable mixture of both. Unfortunately this is balanced by what often seems to be a very long loading time.

Those of us with disc drives can occasionally buy disc versions but these are rare and cost a lot more than their more common cousins on cassette.

Strong shoes needed

The success of Incentive's Graphic Adventure Creator has resulted in no end of adventure games seeing the light of day. The arguments about whether GAC or Quill is best for you will undoubtedly rage for ages. In the meantime adventurers can only benefit by their use.

Incentive Software has launched the Medallion range of adventures for titles that are written using GAC. The first was Apache Gold and the second, Winter Wonderland, is certainly a good game for the beginner. The puzzles are, on the whole, quite logical and there are plenty of locations to explore and map.

It is also a perfect example of one particular type of adventure writer's ploy – the "go back and get it" stratagem. This means that having started at point A, you have to go to point B to get something you needed at A. You can only then

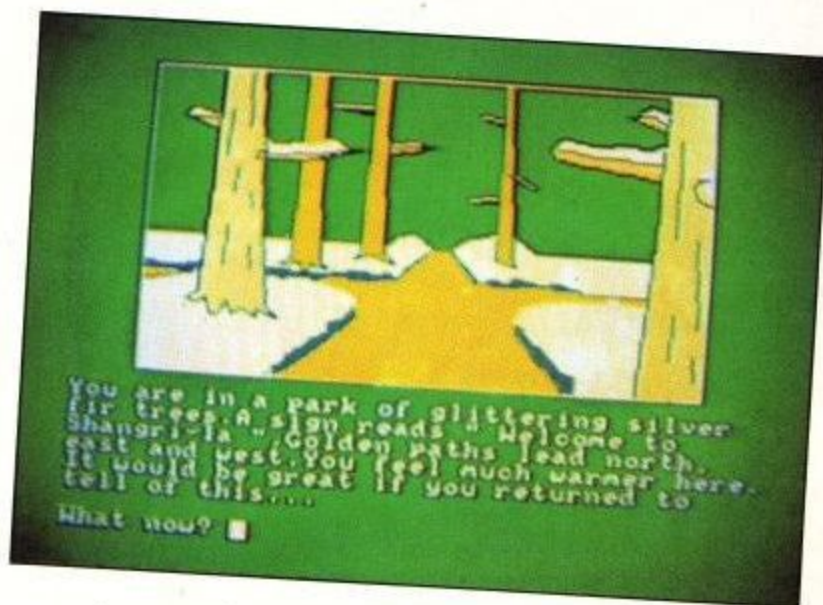

get something at A which is needed at B to enable you to go back to A for something needed at C!

Obviously the variations on this theme are limitless, and in Winter Wonderland a certain amount of patience and a good map are needed to sort out what to give to whom and when. I hope your shoes will stand up to all their walking around.

You take the part of an anthropologist who has got wind of a hidden civilization buried deep in the Himalayas. In the rush to reach the friend who has discovered evidence to support this find, you take a risky last leg flight in an old Cessna aircraft. Bad weather intervenes and you are swept into the mountains by a freak snowstorm.

The plane crashes but you get out alive only to find

yourself in the middle of a snow-swept plain. Eventually you stumble across the lost civilization, and although you are fascinated by the amazing similarities to the modern world outside, your main aim is to escape and report your find.

The idea of the plot is OK, but its interpretation is a bit dubious – with a hotel receptionist telling you that you were expected, dry Martini on sale in the off license, credit cards, postmen and the odd hang glider all appearing within this long-lost Shangri-La.

The best bet is to forget the plot altogether and just get stuck into solving the adventure. Look on it as a series of interlocking puzzles that you must solve.

Inputs are pretty much limited to verb/noun format, but multiple commands separated by comma, AND or THEN are accepted. The responses to examining many objects is simply "Nothing worth reporting back about" but do not be put off – examining things will pay off.

For all this lack of textual atmosphere, Winter Wonderland is good fun and will keep many advertisers busy for a long time. There are a number of good graphics, and beginners will have plenty to explore and discover.

Pictures are drawn to the screen quite quickly but they may be turned off to speed things up by the TEXT command.

Regular use of the SAVE command is to be recommended, as many red herrings will be caught and you will want to return to a known position. If you get stuck Incentive will send you a hint sheet on receipt of a stamped addressed envelope.



there is an ancient tank, an aged bomber and a seventh dan black belt Japanese soldier who disputes your right of passage.

If at any time you want to return to sanity, sitting in front of your computer, just type PINCH ARM and you are back in the opening sequence, all set to enter another one of the worlds. It will become obvious very quickly that to solve any of the puzzles you must zip backwards and forwards between the four sections – to get items which will be useful elsewhere.

The concept of four totally different sections linked in this way is interesting. This game could represent good value for money for the beginner even though there are not many locations to explore.

The puzzles are logical and reasonably obvious, but the depth of interest is not likely to be maintained for the more experienced player.



Just imagine

Another game requiring a fair amount of travelling backwards and forwards to get various objects is Firebird's latest adventure in their £1.99 Silver range, Imagination.

This starts with you finding an old, unnamed disc in your local computer shop. Taking it home and running it on your computer, you find a menu appearing on the screen. Four options are displayed and keying in your choice transports you into that scenario. The sensible and logical selection of ONE will give you a hint to your mission.

The first scene will take you to a spaceship, supposedly of gigantic proportions but with apparently only eight accessible locations. The second produces a frozen landscape with an imposing citadel, that you must find out how to enter. Again with a limited number of locations.

The third takes you to a world containing malevolent sprites, grim mines and, if you have played many ladders and platforms games, the distinct feeling that you have been here before.

The final option is a deserted airport at Margate where



OPUS WILL MAKE YOU A BETTER ORGANISER FOR ONLY £60

If your micro system is starting to get out of hand a smart organiser could be the solution to your problems.

At just £59.95 the Organiser desk from Opus Supplies will help to organise your system beautifully. It's purpose built to provide plenty of storage space and because it's produced alongside our range of executive computer desking it offers a level of quality you'll appreciate.

Shelving accommodates your monitor, printer computer, disc drive or cassette recorder and software, and the teak-finished unit is fitted with castors to make it fully mobile. The Organiser's assembled dimensions are: H. 31", W. 40¼" and D. 26".

And our price includes VAT and FREE DELIVERY.

The Organiser desk is suitable for use with all leading home micros including the BBC, Amstrad, Commodore and Sinclair computers.

Getting organised couldn't be easier. Phone us on 0737 65080 or simply post the coupon below.



To: Opus Supplies Ltd,
55 Ormside Way, Holmethorpe Industrial Estate, Redhill, Surrey.

Please rush me the following:
(PRICES INCLUDE VAT AND CARRIAGE)

_____ Organiser Desk(s) at £59.95 each (inc. VAT)

I enclose a cheque for £_____ or please debit my

credit card account with the amount of £_____

My Access Barclaycard (please tick) no. is: _____

Name _____

Address _____

Telephone _____

The continuing saga

The first computer game featuring that mixed-up teenager Adrian Mole went down rather well. Those that follow his adventures and feel personally for all his problems should now be lining up to buy the sequel, *The Growing Pains of Adrian Mole*.

This is not strictly an adventure game, but comes more into the category of Bookware. The screen lists excerpts from the daily life of your young friend and you have the onerous task of choosing one of three actions for him to take.

This leads to the result of that choice, and the poor lad then has to sort out the next critical decision in his life with your help.

There are a few random happenings, so the game will appear slightly different when you play again. The aim, apart from enjoying the story, is to increase your score and hence Adrian's popularity.

The program is written by Level Nine and follows the book's ideas and feelings as faithfully as possible. It comes in four parts - do not rewind the tape when you have loaded each section.

Although there are graphics, they are not exactly plentiful or very inspiring, and once or twice the text scrolled too fast to read.

Each part takes from between five and twenty minutes to play. You can, of course, repeat a section to find the results of alternative answers.

As each part takes about five minutes to load there may be a slight question about the overall value. For those who are already hooked on Adrian Mole it may be worth the money; for others I would suggest reading the book first.



Scores	Winter Wonderland	Imagination	Adrian Mole
Plot	60	65	65
Atmosphere	60	57	60
Addiction	65	55	45
Difficulty	57	45	0
Overall	63	57	55

ACU

PRINTER STAND FOR AMSTRAD 8256 AND 8512

An essential requirement for all Amstrad owners.

Now you can make printing so much easier and release valuable desk space with this superb new printer stand designed specifically for the Amstrad 8256 and 8512 printers.

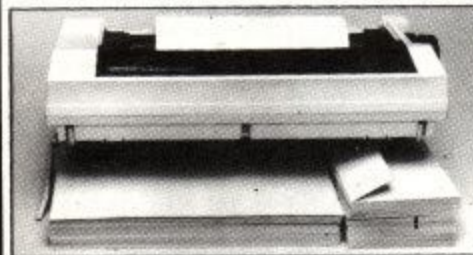

The printer sits perfectly on top and there's plenty of space beneath to store paper, accessories and even the computer keyboard.

Tried and tested it is now in use in Hospitals, Universities and some of the UK's busiest office environments.

Manufactured in the UK and made of sturdy 6mm steel, the stand is finished in pale grey PVC to match the computer and keyboard.

Available now at a special price of just £9.95 inc postage and packing. (Allow 14 days for delivery).

TRADE ENQUIRIES WELCOME. MONEY BACK IF NOT DELIGHTED.
CTC LTD., PO Box 4, Knebworth, Herts SG3 6EP

£9.95 ONLY INC. P&P



"A real must for any busy office"
K.H. Jefferies, Bath, Avon
"Thank you for sending the Printer Stand so promptly, it has made a tremendous difference to our small office."
R. Gibbs, Ipswich
"I am extremely pleased with it as it is a very simple and elegant design, and just what was required."
R.J. Upton, Reading

Patent Pending

Please send me _____ printer stands at £9.95. I enclose cheque/PO payable to: Clifton Trading Company

Name _____

Address _____

To: CTC Ltd., PO. Box 4, Knebworth, Herts SG3 6EP

AU2

Software hotline fills the gap

A REVOLUTIONARY support package for business and communications software users which includes membership of MicroLink has been launched by systems consultancy and software design firm Interlex.

It will provide previously unavailable support for the lower-priced – generally under £150 – software packages.

In addition, MicroLink will provide Interlex users with the bonus of electronic mail, telex and other communications facilities and databases.

Interlex managing director Mike Lane said: "As the trend toward low cost hardware and software has gathered momentum, the traditional dealer network has moved upmarket.

"Consequently the bulk of new business micro users have been left totally unsupported because the High Street and volume sellers supplying them are not geared up for the task.

"Interlex will fill the vacuum by supplying support at a price the new generation of users can afford.

"Initially this will be provided through a telephone hotline, but we are pushing ahead with plans for an Interlex bulletin board on MicroLink to extend the service to comms users".

MicroLink on the rates

BRITAIN'S 105-year-old Rating and Valuation Association has taken a giant stride into the 20th Century with the help of MicroLink.

Previously, the professional organisation for property experts in local government and private practice depended on phones and letters to communicate. It didn't even have telex.

Now its 5,000 members – town hall finance and

housing administrators, and chartered surveyors and valuers – will benefit from not only telex, but also electronic mail and Telemessages.

The Association conducts a four year course leading to professional exams, provides an information service, publishes text books, and holds between 70 and 80 conferences a year.

Assistant secretary Julian Price said: "Micro-

Link will give us the means to speed up our organisational communications, moving documents to and fro between our Council members who are located all over the country, contacting our members and exchanging information with our affiliates in the US.

"It will also help us organise our conferences, book hotels and speakers and make travel arrangements for delegates".

Japan comes to Salop

MICROLINK was the catalyst for language school proprietor Duncan Baker's latest venture – teaching Japanese to British business people.

The new addition to the curriculum at Lydbury English Centre in Shropshire developed from a sociable electronic mail exchange on MicroLink

with antiquarian bookseller Tony Swann.

Swann revealed a long cherished ambition to study Japanese and suggested that Baker organise a course.

This has now been done, and after being advertised on MicroLink half the places were filled within a week.

High peak, low tech in Tibet

ACCORDING to crack mountaineer Chris Bonington, "it's only a small trip compared to climbing Everest and I'm looking forward to coming home and getting to grips with MicroLink".

He was speaking a few days before leaving for Tibet, hoping to add the unconquered peak of Menlungste to his own collection of Himalayan "scalps".

When he's not climbing mountains Bonington can often be found at a computer keyboard writing one of his numerous

books and articles or simply mastering the latest micro technology.

A self-confessed computer buff, he has joined MicroLink because it will help him organise his expeditions.

"The telex facility will be absolutely invaluable in this respect", he said. "At present I have to rely on the generosity of my accountant and use his office telex machine if I want to send and receive messages, but obviously this isn't always convenient for either of us.

"Transmitting text to

my publishers is a definite possibility. They are a rather old-fashioned firm, but who knows, I may be able to convert them to Email. As a newcomer to MicroLink I'm also looking forward to exploring its many sections just for the fun of it.

"Unfortunately I won't be able to use MicroLink to keep in touch with home while I'm in Tibet. Where I'm going is so remote that my messages will have to be carried by runner for three days before they reach the nearest road".



£169.95

Special Offers

THE NEW GLP II +

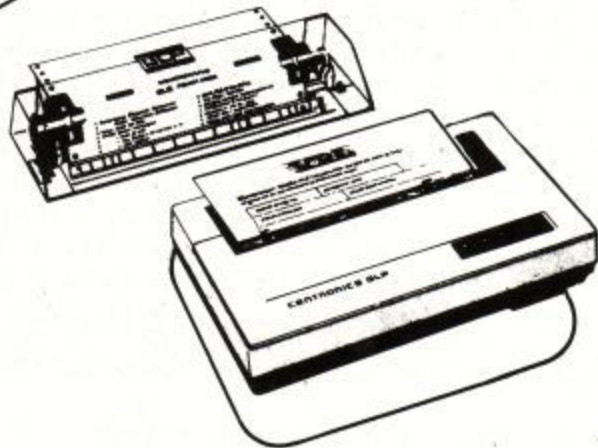

FREE
£45 worth of ACCESSORIES
FREE Tractor Feed and Paper
FREE Special Printer Stand
FREE Roll Feed and Paper
FREE Cable

The new GLP II Dot Matrix Printer plus accessories now replaces the highly successful GLP Printer. At the special offer price it gives incredibly value for money. Just look at these features:-

- ★ 100 CPS Draft printing.
- ★ 25 CPS Near letter quality.
- ★ Parallel and serial interface as standard.
- ★ 2K Buffer.
- ★ Epson and IBM compatible through DIP switch settings.
- ★ Epson compatible mode including, elite, emphasised, double strike, condensed, superscript, italis, plus others.
- ★ NLQ Mode can be selected by external hardware switch.
- ★ Prints 80 column on normal paper (A4 sheets, continuous stationery or roll paper.)
- ★ Bi-directional logic seeking.
- ★ Dot matrix 9 x 9 (Draft) 18 x 23 (NLQ).

Offer includes:

- GLP II Printer Plus
- FREE Tractor Feed Unit with Paper.
- FREE Roll Feed Unit with Paper.
- FREE Printer Cable.
- FREE Specially Designed Metal Printer Stand.

No extra's needed, just plug in and use.

Stock Code	Description	Price inc. VAT
VA409	GLP II Plus accessories	£169.95

Please add £8.00 for insured courier delivery.

SEND OFF YOUR ORDER NOW!

Viglen

Viglen Ltd.,
Unit 7,
Trumpers Way,
Hanwell, London. W7 2QA
Telephone: 01-843 9903
Telex: 919 304 VIGLEN G
Fax: 01-574 5126



SALES HOTLINE
01 843 9903

HOW TO ORDER

Simply fill in the coupon or write to us with your requirements enclosing a cheque/postal order or your credit card no. for the total amount. Don't forget to add the cost of delivery. Allow 7 to 10 days for delivery. Credit card holders may order by telephone on our sales hotline 01-843 9903 (8 lines). Orders from overseas should be exclusive of VAT (Please deduct 15% from the total cost).



Dealer and Trade Enquiries
Welcome:

OFFICIAL ORDERS

Official orders from education establishments, Government departments and Plc companies accepted. Viglen has a special education department to process orders and queries from schools, colleges, universities and Local authorities so please ask for our education department when you call. Being one of the major suppliers to the Education market, the experienced Viglen team will be able to understand and help you with your requirements.

Showroom Opening Times
By appointment only

Items marked ☆ are special offer products.

Fill in and post to Viglen Ltd., Unit 7, Trumpers Way, Hanwell, London W7 2QA. Tel. No. 01-843 9903. Please make cheques and postal orders payable to Viglen Ltd.

STOCK CODE	DESCRIPTION	QUANTITY	TOTAL PRICE

Please find enclosed a cheque/postal order

I prefer to pay by VISA ACCESS

* Tick one please.

Card No. _____ Signature _____ Expiry date _____

Name _____

Address _____

Postcode _____ Tel. no. _____

Viglen Viglen



Lights! Camera! Action!

Imagine an Electronic Eastenders, a Digital Den, a pixellated Pauline or a computerised Colin. You can create all these characters with the help of a video recorder and a Rombo Vidi digitiser.

The Vidi takes a television signal from either a video recorder or camera and turns the output into numbers. The computer then turns the numbers into a picture which can be edited by using something like Art Studio. Coupled with the Rombo Romboard the digitizer is an excellent package and you have a chance to win the set-up of a Vidi and Romboard. You will have to supply the video, the computer and the creative genius.

How to Win!

Answer these three questions about television and you could win the Vidi.

- 1: Who invented television?
 (a) John Logie Baird. (b) Alexander Fleming.
 (c) Graham Bell.
- 2: Which is the odd one out
 (a) VHS. (b) Betamax. (c) Polaroid.
- 3: Where was the first television transmitter in Britain?
 (a) Crystal Place (b) Ben Nevis
 (c) Westminster

Rules

1. The sender of the first correct entry drawn on May 10th (sorry Australia) will win a Rombo Productions Vidi interface complete with Rombo romboard and software.
2. You may photocopy the form but only one entry is allowed per reader.
3. The judges decision is final, no employees of ACU may enter.

ANSWERS

- 1 _____
- 2 _____
- 3 _____

NAME _____
 ADDRESS _____

Send your entry to: Vidi Competition,
 Amstrad Computer User, 169 King's Road,
 Brentwood, Essex CM14 4EF.

Constructing Ambug

The roboteer's route map

Before you can build your robot, you'll have to have all the requisite bits. These include not just the guts of the beast, but the tools to do the job with. Although it is possible to knock together Ambug with just a pair of scissors and a knitting needle heated over the gas stove – how the author's very first project was hung together – it's not recommended. What you'll definitely need in the way of tools includes:

- A soldering iron. 15-25 watts, with a fine tip will do nicely. Available at almost any DIY/hardware/electronics shop.
- Wire cutters. The most appropriate kind are called side snips or side cutters. Found in the more specialist (Tandy's, say) shops.
- Scissors (cardboard chassis, for the cutting out of).

A list of desirables, which will make your job a lot easier but can be left out if finance so dictates, will include:

- Desoldering pump. This can remove solder if a component needs to be replaced or moved.
- Long nosed pliers. These make bending component leads much easier and more accurate.
- A small bench vice. If you've never done it before, you'll soon find that soldering needs at least one extra hand – two are just not enough!

The budding roboteer will also need to beg, borrow but not steal (only the truly dedicated need buy) a test meter. This needs to measure up to 15 volts, check resistance and measure direct current of up to an amp or so.

If access to a secondary school or higher educational establishment is available, the physics/IT staff are usually more than happy to help out seekers after truth with a dead droid. And they've got test meters.

Got the lot? Good. Before you start sticking diode A into hole B, let's get a few of the basics of electronic down pat.

First, there's the gentle art of soldering, or how to make the perfect

There is more to computing than just pounding on the keyboard. Rupert Goodwins presents Ambug, a robot for you to build and run from the back of your CPC.

joint (calm down Vax). A joint, by the way, is a soldered connection.

In theory, it sounds quite simple. Heat two bits of metal up, pour molten solder over them, and allow to cool. But there's a few things to watch.

First, all the metal surfaces must be clean and free of grease or corrosion. As you'll be using new bits, that shouldn't be a problem, but if you can see grunge adhering to your wiry bits the trick is to pull the wire through a piece of folded sandpaper a couple of times.

Second, there's the technique. Some people push solder on to the end of their irons and just dump it on the connection.

Wrongo. The trick is to apply the iron first, allow the connection to get nice and warm, and then push the solder on.

Another fatal no-no is to use too much solder. Just put enough on to cover the surfaces around the area of the joint. It should flow on easily, if it doesn't then either the connection is too cold (let the iron stand for a few minutes), or one of the surfaces is dirty.

Practice on a few stray bits of wire until you get the feel of glueing with molten metal. When it comes to soldering stranded wires into place, it helps if they're tinned.

Tinning isn't an Irish calorie-controlled diet, it's the method of coating connections individually with solder before bringing them together. To tin a bit of wire, strip off about 5mm of insulation, twist the strands together, and apply to a soldering iron.

Push a little solder on. You should

aim for an end result where the wires are no thicker than before the solder was applied, but are stuck together by a fine veneer of liquid engineering.

If you do this to both ends of the ribbon cable (after separating the strands, of course), you'll find it a lot easier to solder them to the PCB when the time comes. You'll notice that the PCB comes ready-tinned. No expense has been spared . . .

Now the fun begins. Take the PCB and put in all the wire links. These are best done by cutting a piece of wire about 1 cm longer than the length needed on the board, and bending the ends through 90 degrees so that the link just fits into the board.

Then solder both ends, and trim off the spare bits as close to the board as possible. Then solder in the IC sockets and the ribbon cable.

Next, solder in the capacitors and the resistors – see the ID chart supplied with the kit to tell which is which.

The resistors and small capacitors can be soldered in either way round, but the big capacitor needs to be plugged in correctly.

Put the diodes, transistors and the ICs in last. The transistors need a little bit of extra care during soldering – don't hold the iron on the joint for longer than five seconds, and allow everything to cool for ten seconds between soldering each leg.

Make sure that those trannies are aligned correctly, and that the right types are in the right place. Ditto for the diodes. The ICs should be soldered

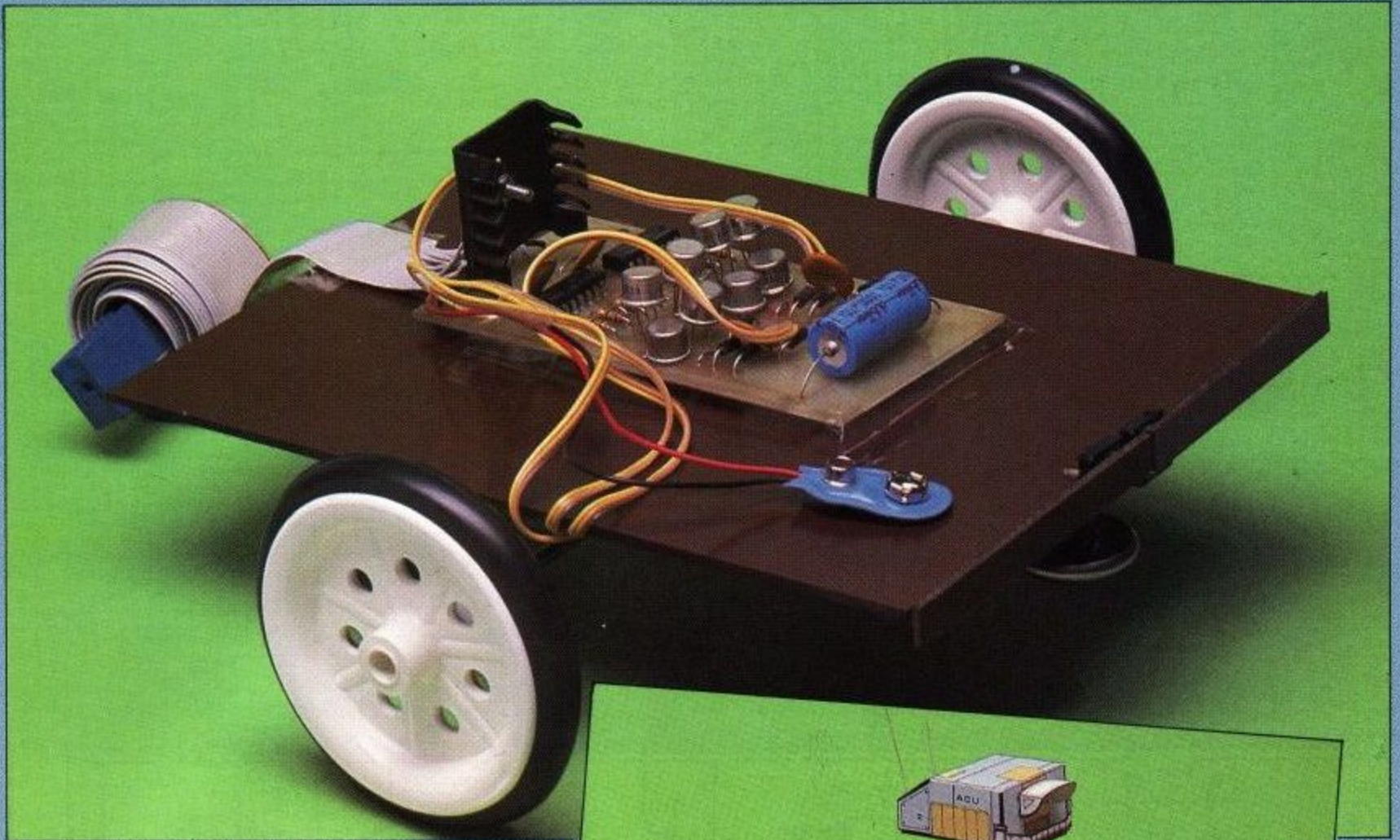

A fully built Ambug (above) and shown wearing its new clothes (right)

in last. The two long flat ones are the same as each other, but make sure that the notch in one end matches the diagram.

Solder on the joystick connector and the printer port connector. Connect the two sensor lines to pins 1 and 2 of the joystick plug, and the common earth wire to pin 8.

Similarly, connect the lines M1-M4 on the PCB to pins 2-5 of the printer port, and L1-L2 to pins 6 and 7, with the earth wire going to 22. You'll find pictures of the connectors in the back of your Amstrad user manual.

Then solder in the 7805 IC – the one with a black body, three legs and a metal plate. Screw on the heatsink to this plate, making sure it doesn't touch anything else. Then solder in the battery connector.

Finally for now, solder on the switches – don't bother to glue them on to the baseboard for now, and just plug in the joystick connector. Turn your Amstrad on.

Try the test program:

```
10 PRINT JOY(0); " "; GOTO 10
```

You should get a screenful of 0s, which change to 1s, 2s and 3s as the sensor switches are pressed.

If you only get one or two numbers check your wiring for short circuits, and make sure that you've got the numbering on the joystick plug right.

Amstrad User May 1987

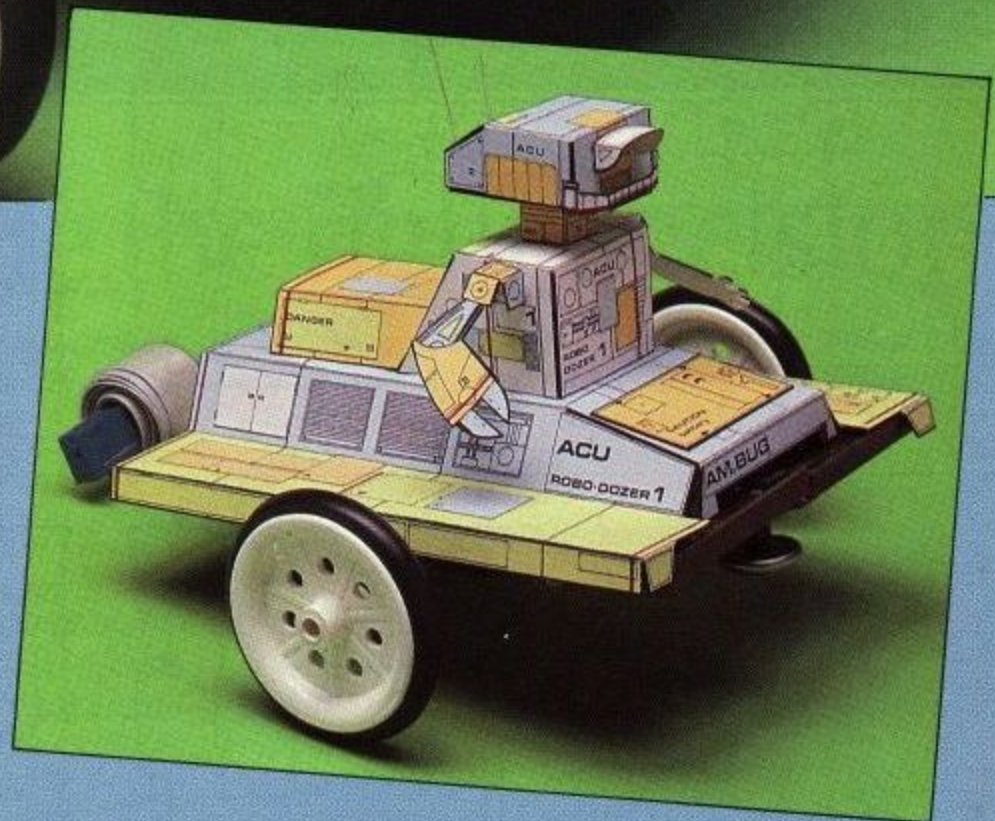

Getting it wrong can't hurt anything, and it's a good check to make sure that you've understood the elementary aspects of construction.

Next, switch everything off and con-

nect the motors and the light emitting diodes. The LEDs have to be soldered in the right way round, as they don't work (ever again) if you get it wrong.

Don't bother hooking up the gear-

Motors never turn	IC3, battery polarity.
Motor 1 turns in one direction only	TR1, TR2, TR5, TR6 and IC1.
Motor 2 turns in one direction only	TR3, TR4, TR7, TR8 and IC2.
Motor turns sluggishly and transistor overheats	Resistor connected to transistor, IC1 or 2, diodes connected to motor.
D9 stays on continually	TR9, R11.
D9 never lights	R9, R11, TR9
D10 stays on continually	TR10, R12
D10 never lights	R10, R12, TR10.
Motors judder or change direction randomly	C3, C4, C8.
<i>Always check connections to the computer and battery state before suspecting electronic foul play!</i>	

Table 1: Possible problems and how to diagnose them

boxes yet. Plug in the printer port connector and the battery box. Switch on again.

If one or other of the motors starts try switching on again. If the condition persists switch off and check the wiring around ICs 1 and 2, the area around the transistors and the arrangement of the diodes. Make sure you've remembered all the wire links.

If that proves nothing, then there's a faint chance that you damaged one of the transistors when soldering them in.

Assuming that the motors stay satisfactorily silent, then try OUT #EFFF,1 from Basic. One of the motors should start. OUT #EFFF,2 should reverse it, and OUT #EFFF,0 should stop it again.

The other motor can be likewise tested by OUT #EFFF,4, OUT

#EFFF,8 and OUT #EFFF,0. To make the motors both do something at the same time add the numbers together, so OUT #EFFF,5 should get both turning.

Similarly, OUT #EFFF,16, OUT #EFFF,32 and OUT #EFFF,48 should turn the lights on. If the motors start up when this happens you've got a crossed line; either there's a short in the plug or PCB end of the ribbon cable, a short on the PCB, or a miswiring. Turn off, unplug and check everything carefully.

If one or the other of the motors or lights won't work have a look at Table I, which should help you diagnose your disaster.

A little logical thinking, together with a read of the "How it works" bit, should help you sort out your problems.

Debugging hardware is much like debugging software, as long as you have an idea of what should happen!

Try to use an alkaline battery or batteries, or even better, rechargables. Ambug takes quite a lot of juice when belting along on its mission to save the world, and not an inconsiderable amount just sitting there. Unplug the batteries whenever you're not using Ambug.

It all works? Great! Now you can mount the hardware. If you're using the kit of bits full instructions come with it. If you're busking it (brave fellow/lass), then any old bit of wood should serve as a baseboard as long as it's not too flexible.

The official way of putting the gearboxes and bumpers on is with nuts and bolts. Personal experience has shown

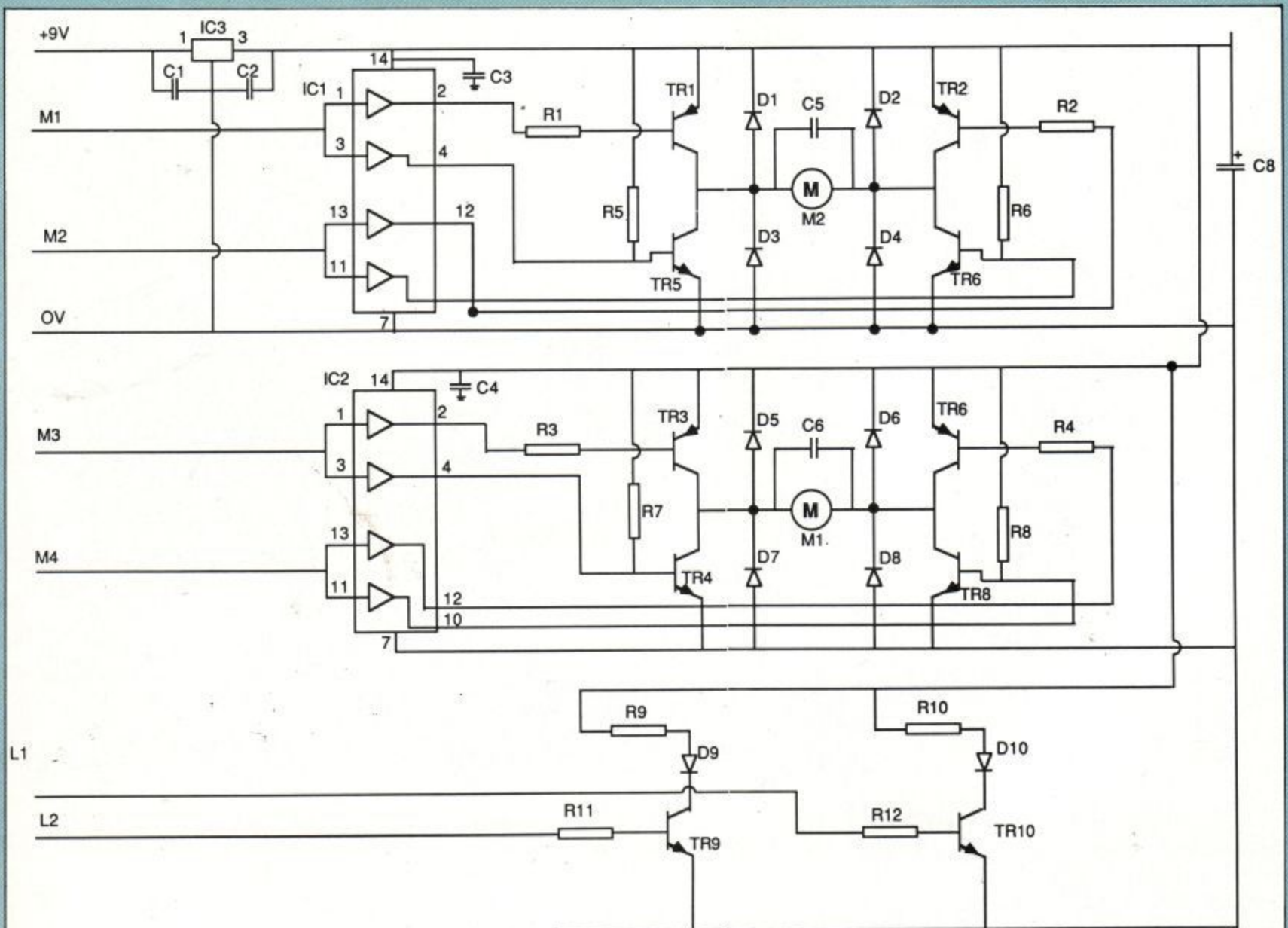

- | | |
|--------------------------------------|---------------------------------------|
| IC1, IC2 = 7417 | TR9, TR10 = BC108 |
| IC3 = 7805 | D1-8 = IN4001 |
| C1, C2, C3, C4, C5, C6 = 0.1μF, 25vw | D9, D10 = LED |
| C8 = 1000μF, 6vw | R1, R2, R3, R4, R5, R6, R7, R8 = 150Ω |
| TR1, 2, 3, 4 = BFX88 | A11, R12 = 1K |
| TR5, 6, 7, 8 = BFX51 | R9, R10 = 470Ω |

Circuit diagram for DIY fans

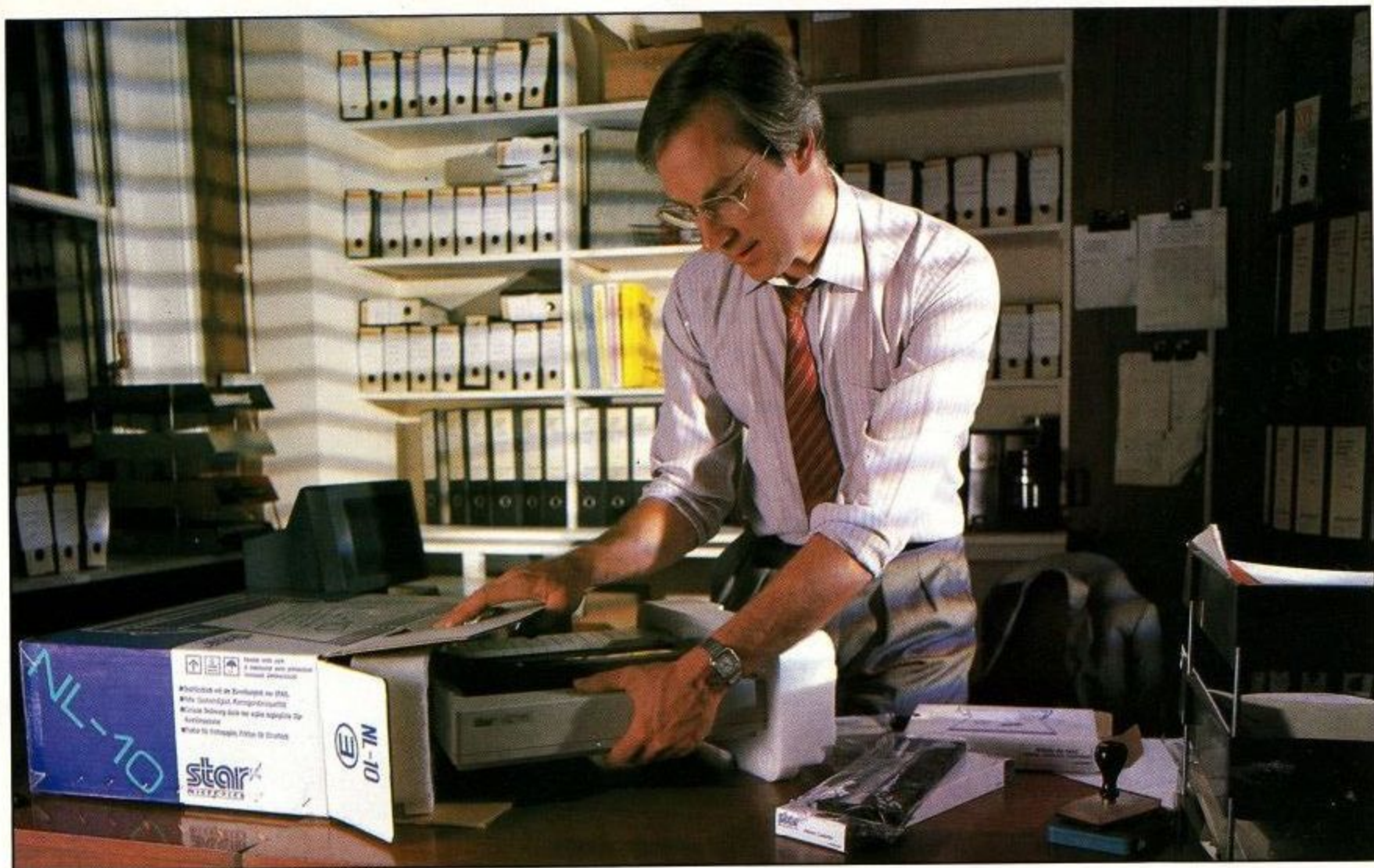

You've made the right decision

Star makes it easy to choose the right printer when it comes to those difficult decisions. From the small business or enthusiast user through to the highly demanding corporate buyer, there's a printer in our range to suit every need.

Take the NL-10 for example. You need to choose a printer that's compatible with the computer you're using today and the one you might upgrade to later. With the NL-10's modular interface that's no problem, just select the interface you need when you buy the printer. If you need to change later it only takes a moment to swap the cartridges over.

You'll want to choose a printer that's easy to operate. On the N series printers Star have all but done away with those fiddly little DIP switches. Almost every control you need for daily use is on a single touch panel. Select print quality, character size, margins and a host more options without ever having to lift the lid.

You want to choose a printer that looks after all your paper requirements; tractor, single sheet or multiple copies. The NL-10 has tractor feed as standard for continuous printing and an automatic single sheet feed to make letterheads really easy. There's even the option of a low-cost cut-sheet feeder.

Your ultimate choice is print quality. Print quality isn't often expected of dot matrix printers but the NL-10 provides it as standard. Whether you're printing at 120cps in draft mode or 30cps in Near Letter Quality every character is crisp and clear. And the range of character options is unbeatable.

Star is making it easier to choose the right printer when it comes to service and backup. Our pedigree is inherited from many years in the manufacture of precision machine parts and a long history of producing computer printers. This means you can rely on Star's wealth of experience in advanced design and manufacturing.

Countless users have made the right decision – why not join them?

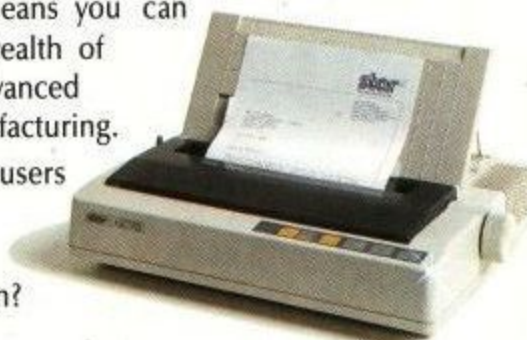

Star Micronics U.K. Ltd.
Craven House,
40 Uxbridge Road,
Ealing, London W5 2BS.
Telephone: 01-840 1800.

THE
Star
PRINTERS FOR BUSINESS

A division of Star Micronics Co., Ltd., Japan.

I would like to be sure I'm making the right decision. Please send me details on the Star range of printers.

Name _____

Company _____

Address _____

Postcode _____ Telephone _____

Or just call Belinda on 01-840 1829.

NL AU5

that superglue does the job just as well, if correctly applied.

Them that know reckon that the hardware's only as good as the software. With Ambug, the hardware's pretty good, but the software depends on exactly what you want to do with the poor thing.

However, owners of buggys invariably seem to take a delight in making their beasts bash against the nearest solid object and turn away in a daze. What the psychologists call a conditioned response.

Others take great pleasure in persuading their hardware to engage the cat in hot pursuit. Shrinks everywhere know this as out-and-out nastiness. So here are two programs to give the proud possessors of Ambugs a chance to sample the joys of dubious droidery.

Programs to try

Program I is a very basic Basic maze-learning program. Even that's being a bit grand; all it does is trundle Ambug forward until it hits something bigger than it is. It turns until it gets an all clear ahead, and then continues.

The clever bit comes when its master deigns to press the s key on the Arnold. With heartwarming faith and Mensa-like intelligence, Ambug will return to it's starting point, without hitting anything. At least, that's the theory.

The second program is a bit simpler. All it does is make Ambug obey the keyboard - Q for left, W for right, P for forward and L for back. If you're feeling particularly bright you might like to combine the two, so that you can teach Ambug a path with the old keyboard.

Depending on exactly how your Ambug is wired, you might need to swap the values for Goforward and Goback in line 50 of both programs. Similarly, Goleft and Goright, Left and Right might need a little juxtaposition.

```

10 REM AMBUG DRIVER PROGRAM
20 REM by Rupert Goodwins
30 REM      1987
40 REM
50 AMBUG=&EFFF:n%=1:right=1:left=2:both=
  3:goright=9:goleft=6:goforward=10:gob
  ack=5:halt=0
60 l1=16:l2=32
70 DEF FNti=TIME-datum
80 motor=goforward:lights=l1
90 EVERY 25 GOSUB 510
100 DIM a(200),b%(200)
110 datum=TIME:exploring=1
120 REM Now store up to 200 changes in d
  irection
130 WHILE n%<200
140 press=JOY(0):IF press<>0 THEN GOTO 1
  70
150 IF INKEY$<>"s" THEN GOTO 140
160 GOTO 280
170 REM Work out new direction for Amby
180 REM If both switches are pressed
190 REM it's a head-on crash. Reverse
200 REM for a second, and then turn 90 d
  egress
210 IF press=both THEN MOTOR=goback:GOSU
  B 400:delay=1:GOSUB 470:MOTOR=gorigh
  t:GOSUB 400:delay=1:GOSUB 470:MOTOR=
  gpforward:GOSUB 400:GOTO 260
220 REM IF one switch is pressed, just t
  urn
230 IF press=left THEN MOTOR=goright:GOS
  UB 400:delay=1:GOSUB 470:MOTOR=gofor
  ward:GOSUB 400:GOTO 260
240 REM if the other switch is pressed,
  turn t'other way
250 IF press=right THEN MOTOR=goleft:GOS
  UB 400:delay=1:GOSUB 470:MOTOR=gofor
  ward:GOSUB 400

```

Program I

Incidentally, Amstrad Basic is rather good for this sort of control program. You might notice the use of EVERY... to flash the eyes at a fixed rate - with a little more work the rate could change according to the direction Ambug is moving in.

Making Ambug learn a maze so it can find the shortest route would take a lot more programming. If enough Ambuggers (ahem) pester the Ed an article on how to do it might be forthcoming. Go on - it's what he's there for.

The easy option

Dedicated hardware hackers will sneer at this bit, so stop reading and go and plug in your soldering iron. The rest of you will want the soft option.

A kit is available which contains all the parts for a buggy for £21 plus £1 post and packing. If you wish to order from overseas please call for details.

The Ambug kit includes all the parts you'll need such as the PCB, motors, baseboard and wheels. You may order the kit directly from Magenta Electronics on 0283 65435 or by filling in the form alongside.

```

ward:GOSUB 400
260 WEND
270 REM That's all the moves recorded
280 REM Now do the changes in direction,
  backwards.
290 datum=TIME:exploring=0
300 FOR fx=1 TO n%
310 b%(fx)=15 AND (b%(fx) XOR 15)
320 NEXT fx
330 FOR fx=n%TO 1 STEP -1
340 motor=b%(fx):GOSUB 400
350 nextmove=TIME+(a(fx)-a(fx-1))
360 IF TIME<nextmove THEN GOTO 360
370 NEXT fx
380 REM And stop!
390 MOTOR=HALT:GOSUB 400:STOP
400 REM Send a command to Ambug and reme
  mber it
410 DI
420 LET command=motor OR lights
430 OUT ambug,command
440 IF exploring=1 THEN a(n%)=FNti:b%(n%
  )=motor:n%=n%+1
450 EI
460 RETURN
470 REM wait for DELAY seconds
480 LET oldtime=TIME
490 IF (TIME-(300*delay))<oldtime THEN G
  OTO 490
500 RETURN
510 REM Flash lights, but don't record i
  t as an event
520 IF lights=l1 THEN lights=l2 ELSE lig
  hts=l1
530 oldexp=exploring:exploring=0
540 GOSUB 400
550 exploring=oldexp
560 RETURN

```

```

10 REM AMBUG DRIVER PROGRAM II
20 REM by Rupert Goodwins
30 REM      1987
40 REM
50 AMBUG=&EFFF:goright=9:goleft=6:goforw
  ard=10:goback=5:halt=0
60 l1=16:l2=32
70 motor=halt:lights=l1
80 EVERY 25 GOSUB 200
90 IF LOWER$(INKEY$)="q" THEN LET motor=
  goleft:GOSUB 140
100 IF LOWER$(INKEY$)="w" THEN LET motor
  =goright:GOSUB 140
110 IF LOWER$(INKEY$)="p" THEN LET motor
  =goforward:GOSUB 140
120 IF LOWER$(INKEY$)="l" THEN LET motor
  =goback:GOSUB 140
130 IF INKEY$="" THEN LET motor=halt:GOS
  UB 140
140 REM Send a command to Ambug and reme
  mber it
150 DI
160 LET command=motor OR lights
170 OUT ambug,command
180 EI
190 RETURN
200 REM Flash lights
210 IF lights=l1 THEN lights=l2 ELSE lig
  hts=l1
220 GOSUB 140
230 RETURN

```

Program II

To: Magenta Electronics
135 Hunter Street
Burton-on-Trent
Staffs
DE14 2ST

I would like to order.....Ambug
kits at £22 each. I enclose a cheque
for.....or debit my Access/
Barclaycard

Expiry date.....

Name

Address.....

Please allow 28 days for delivery.

FOR AS LITTLE AS £159 YOU CAN BE THE HOME SECRETARY.

There's more to home computers than fun and games. Just add a printer (and the necessary software) and your computer becomes a word processor. And you become a very efficient secretary.

If the printer you add is the Amstrad DMP 2000 your efficiency will even extend to saving quite a lot of money.

Because the DMP 2000 costs just £159 (incl. VAT).

Yet it will print draft quality text at an impressive 105 characters per second. And Near Letter Quality at 26 characters per second.

As you would expect it is compatible with all Amstrad home computers. But it is also compatible with Epson and any other make that has the same Centronics Parallel Interface.



If you've already graduated to a PC there's the Amstrad DMP 3000 printer.

It's compatible with all the Amstrad PC 1512's as well as Epson and all other IBM compatible PC's. It costs just £169 (plus VAT).

Both printers have easy front loading and both will take ordinary A4 paper. One of them is bound to be right for your particular home office.

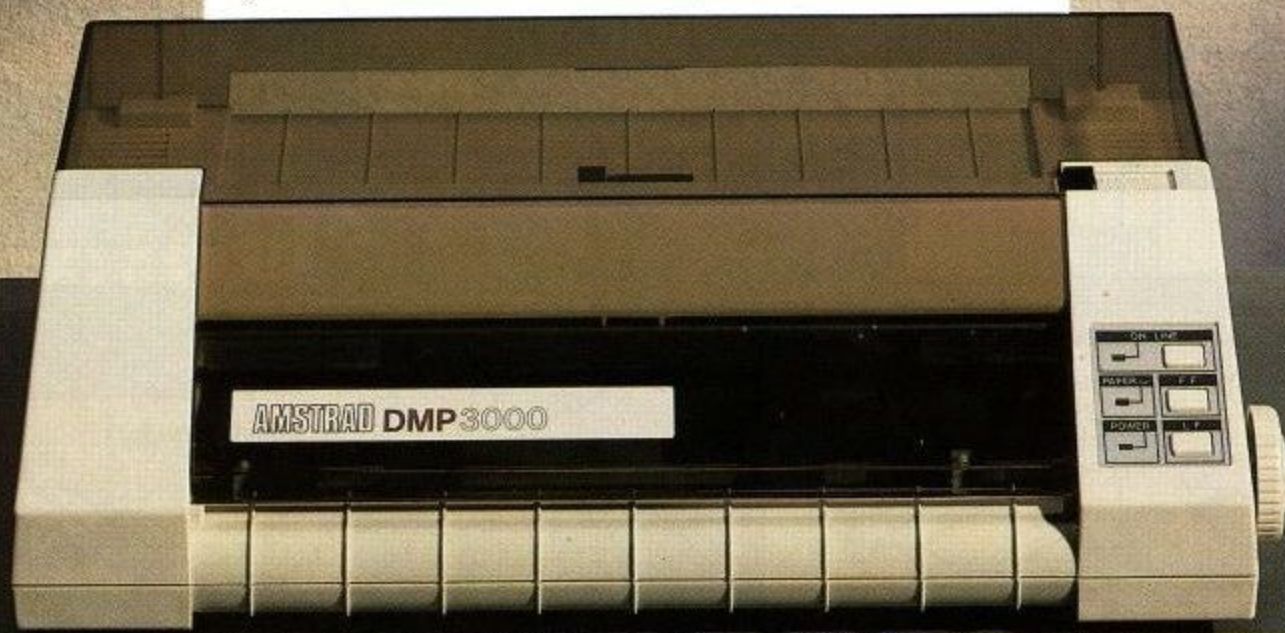

Please send me further information on the DMP 2000 and DMP 3000

ACU 5-87

Name

Company Telephone

Address

AVAILABLE AT: CPS · DIXONS · IBL · LASKYS · JOHN LEWIS · MBS · NORBAIN · NORTHAMBER · OFFICE INTERNATIONAL · P&P · RYMANS · SANDHURST · VISTEC · WILDINGS · AND GOOD INDEPENDENT COMPUTER STORES

AMSTRAD PRINTERS

Amstrad plc., PO Box 462, Brentwood,
Essex CM14 4EF. Telephone: (0277) 230222.

Now build
your own

AM.BUG ROBODOZER

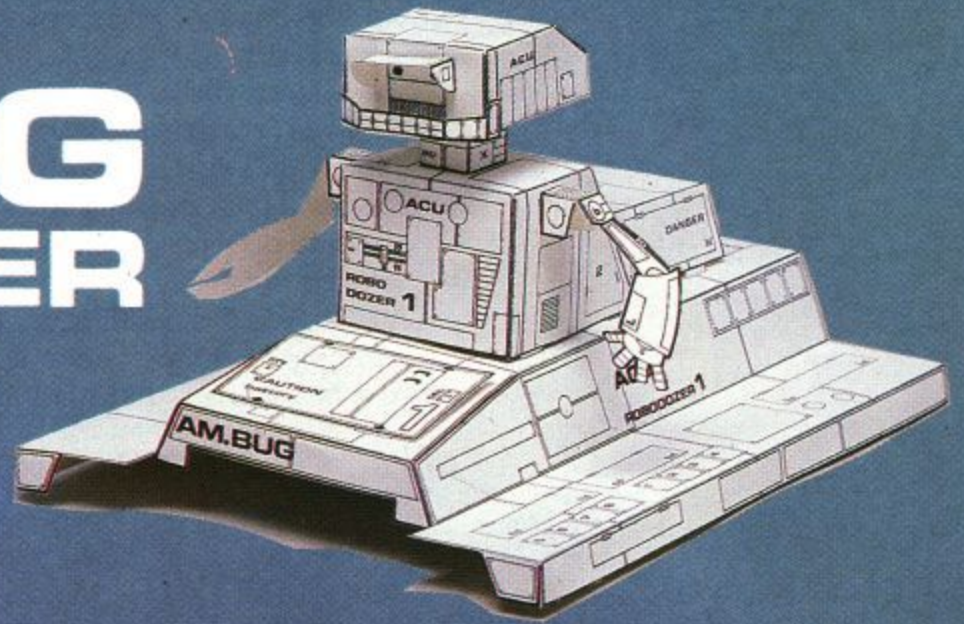

head

CUT-OUT EYE SLOTS TO FIT LEDS + GLUE IN PLACE BEFORE ASSEMBLY

assembly instructions

- 1 REMOVE THESE PAGES FROM THE MAGAZINE
- 2 PASTE PAGES ONTO CARD
-CARD OF CEREAL PACKET THICKNESS IS IDEAL
- 3 CUT-OUT INDIVIDUAL COMPONENTS
- 4 CUT-OUT SLOT HOLES + LIGHTLY SCORE ALONG FOLD LINES
- 5 ASSEMBLE AS SHOWN BY DIAGRAMS

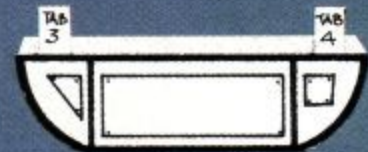
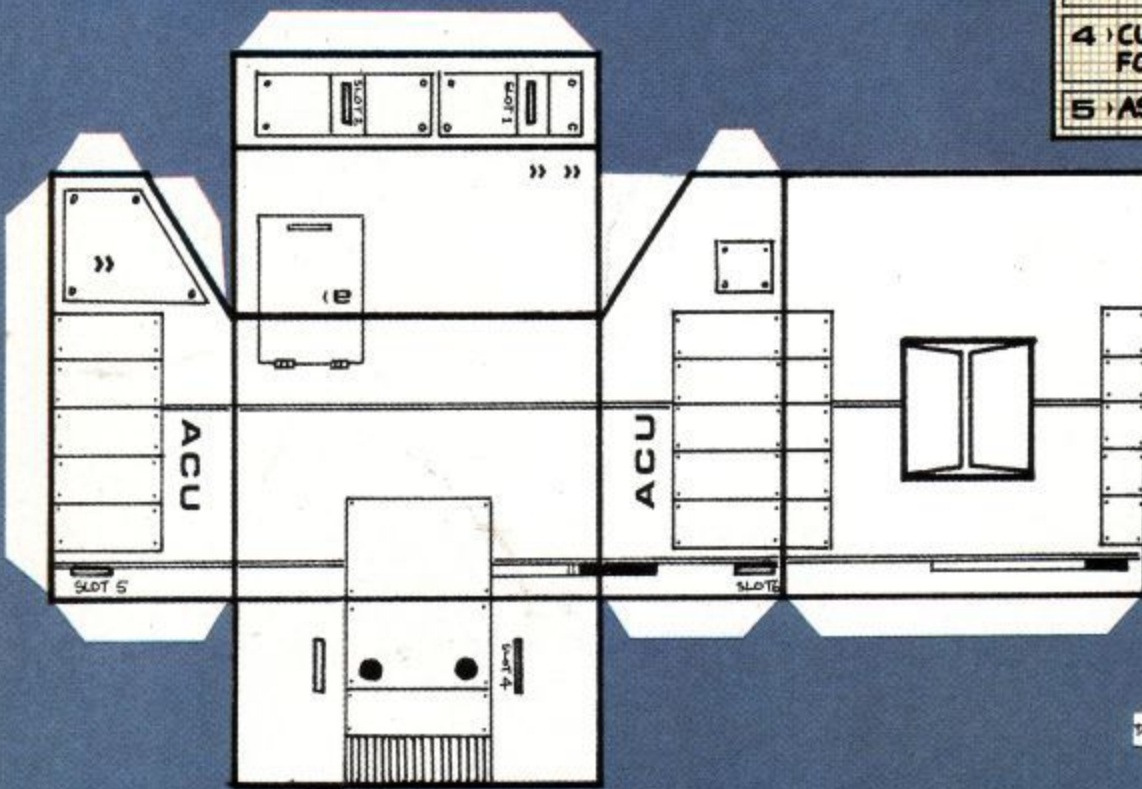

head

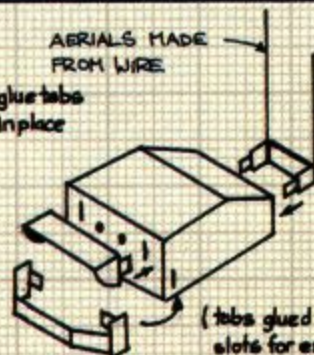

CUT EYE HOLES IN HEAD + GLUE IN LEDS (WIRES RUN THROUGH NECK INTO BODY)

main body



Glue tabs in place

assembly notes

LABELLED TABS LOCATE INTO APPROPRIATE SLOTS - ie TAB 1 into SLOT 1

UNLABELLED TABS SHOULD BE GLUED IN POSITION - DOUBLE SIDED TAPE OR A SUITABLE ADHESIVE SHOULD BE USED

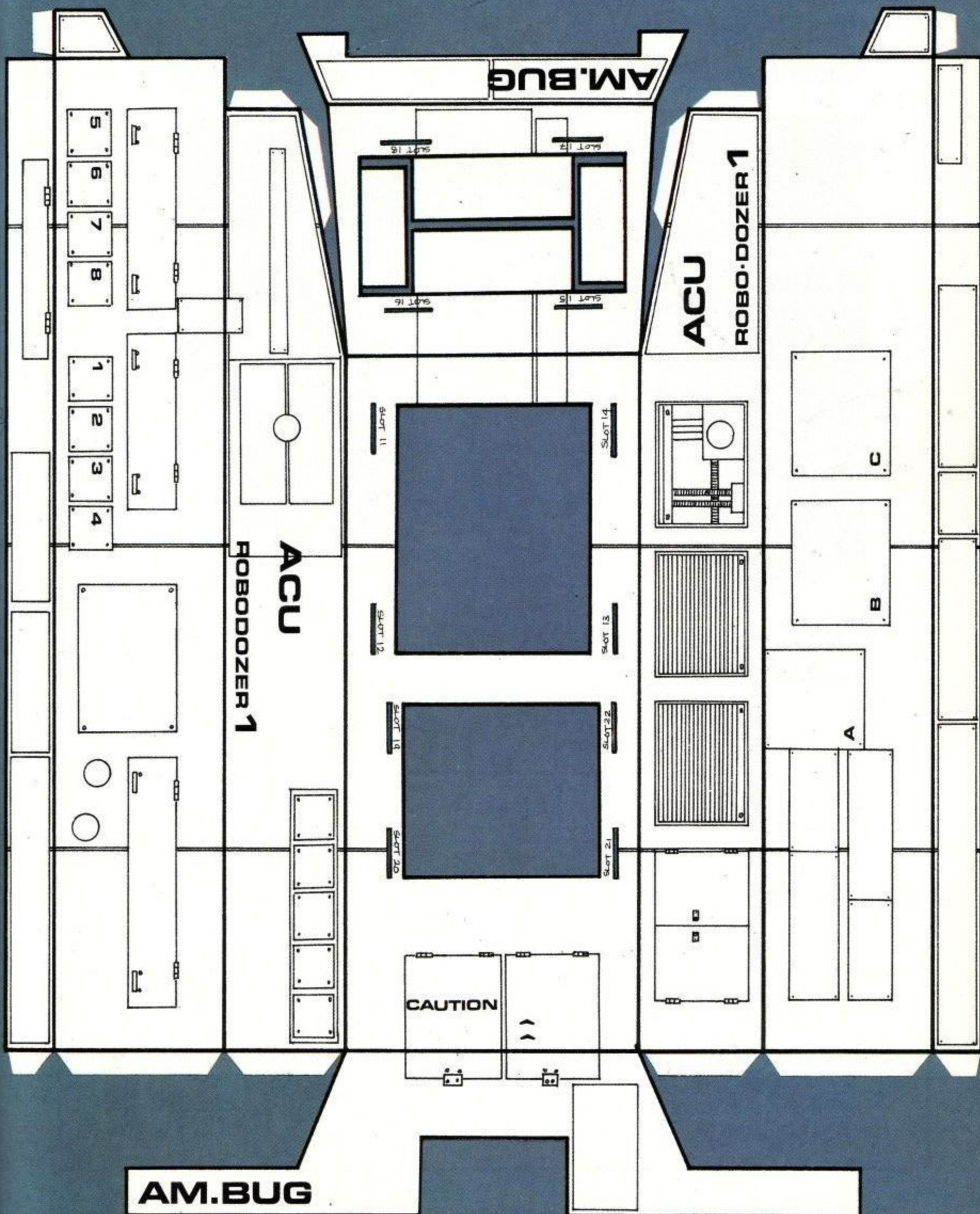

SCALEXTRIC®

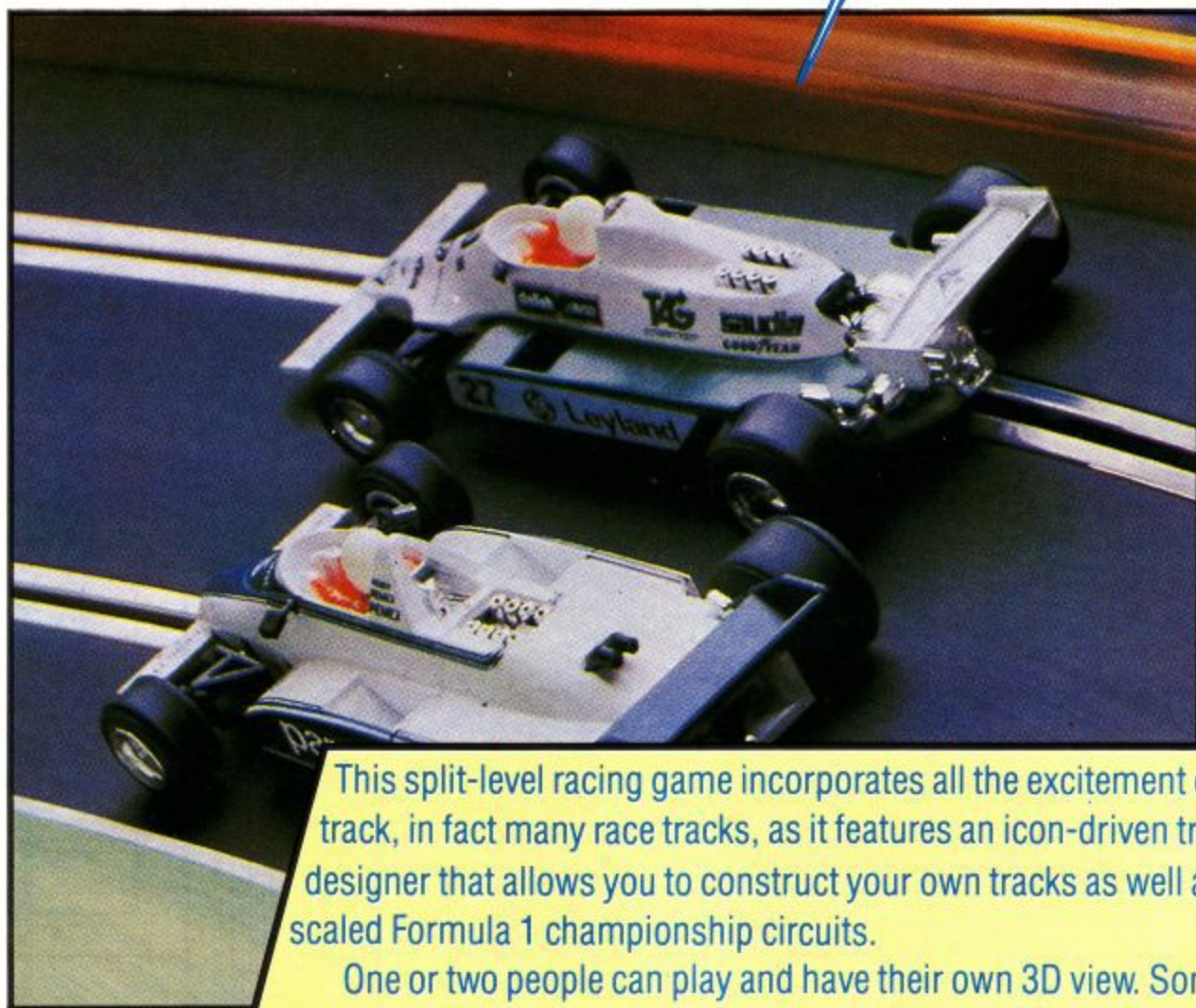

This split-level racing game incorporates all the excitement of the race track, in fact many race tracks, as it features an icon-driven track designer that allows you to construct your own tracks as well as select scaled Formula 1 championship circuits.

One or two people can play and have their own 3D view. Some ingenious programming has made the feel of controlling the cars very realistic, and you can even bump and push your opponent's car if you want to play dirty!

NOW AVAILABLE FOR
AMSTRAD CPC

£9.95

Also available for **Spectrum 48/128** and
Commodore 64/128

£9.95

SCALEXTRIC® IS A REGISTERED TRADE-MARK OF HORNBY HOBBIES LTD. © ALL COPYRIGHTS RESERVED Leisure Genius® is a wholly owned subsidiary of Virgin Games Ltd.

Please send me a copy of **SCALEXTRIC®** AMSTRAD CPC cass **£9.95** disc **£14.95**
SPECTRUM 48/128 cass **£9.95** COMMODORE 64/128 cass **£9.95**

Name _____

Address _____

Please make cheques and postal order payable to **Virgin Games Ltd.**, and post to
Virgin Games, 2/4 Vernon Yard, Portobello Road, London W11 2DX. Please do not post cash.



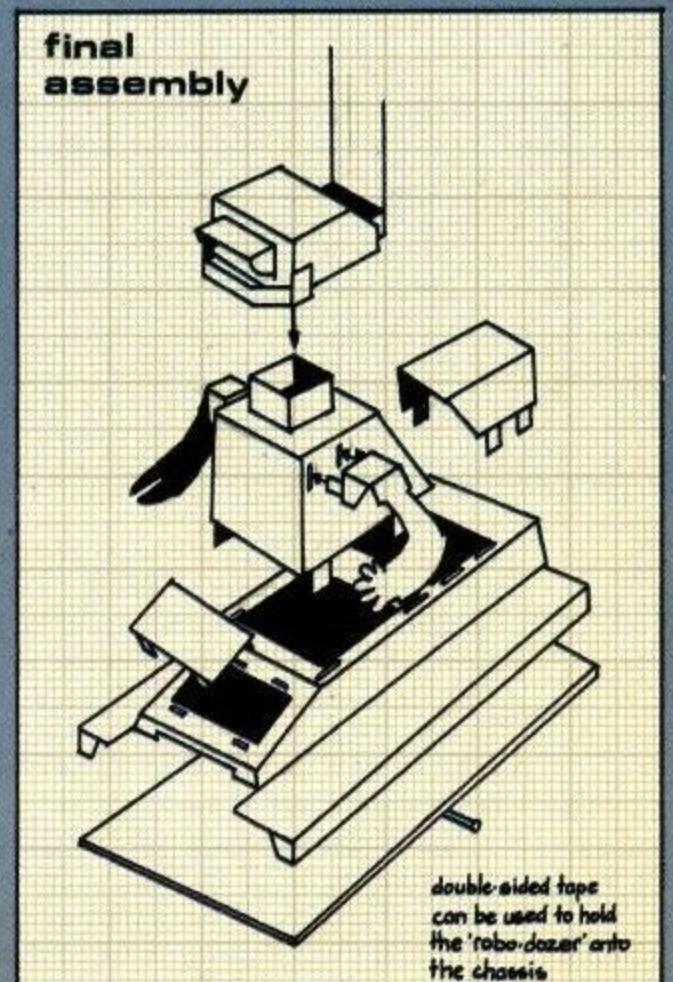
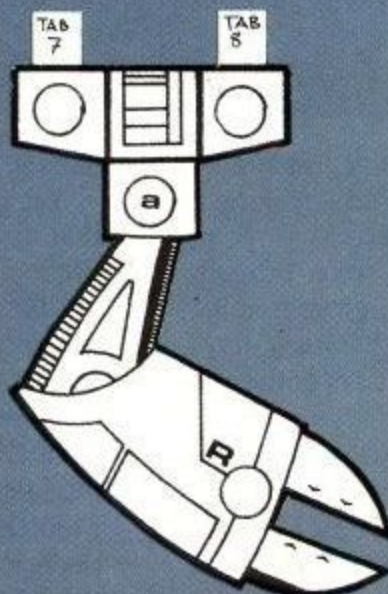
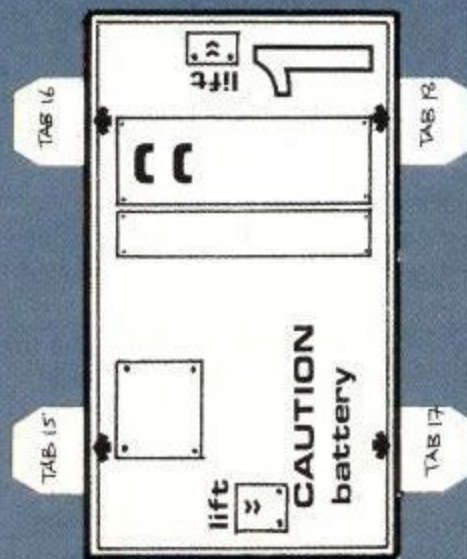
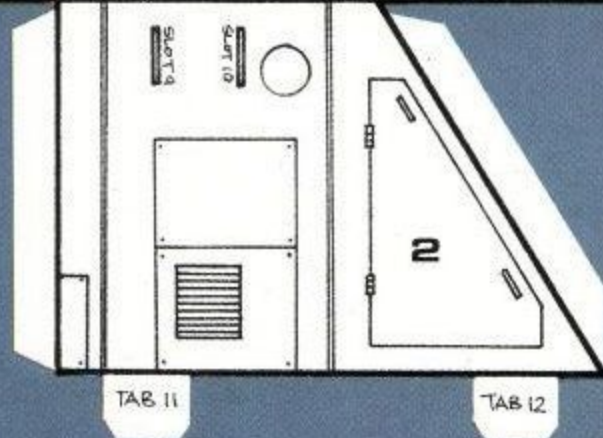
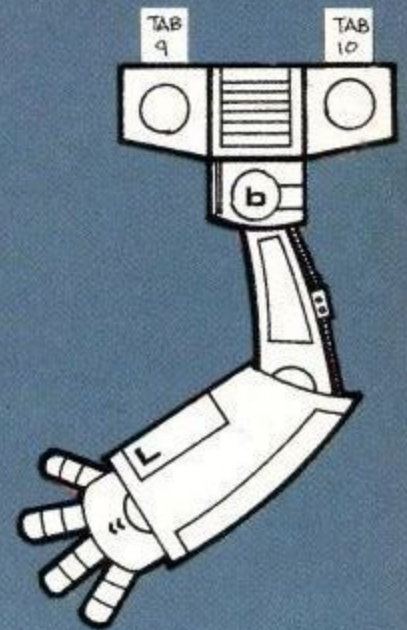
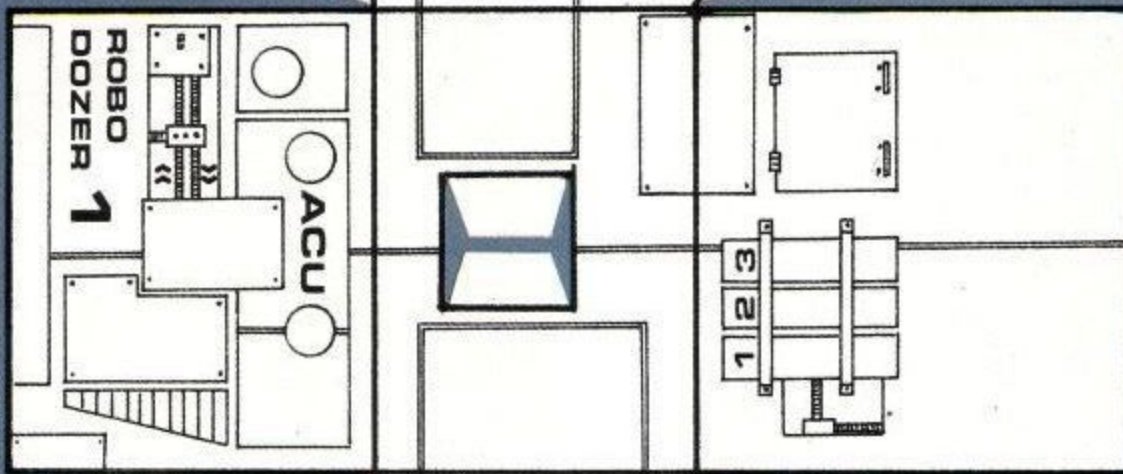
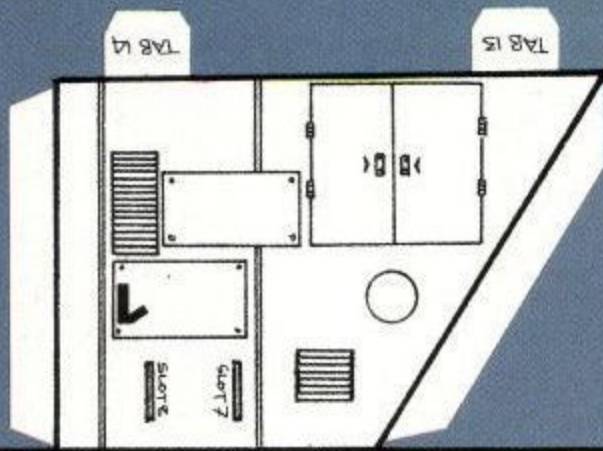
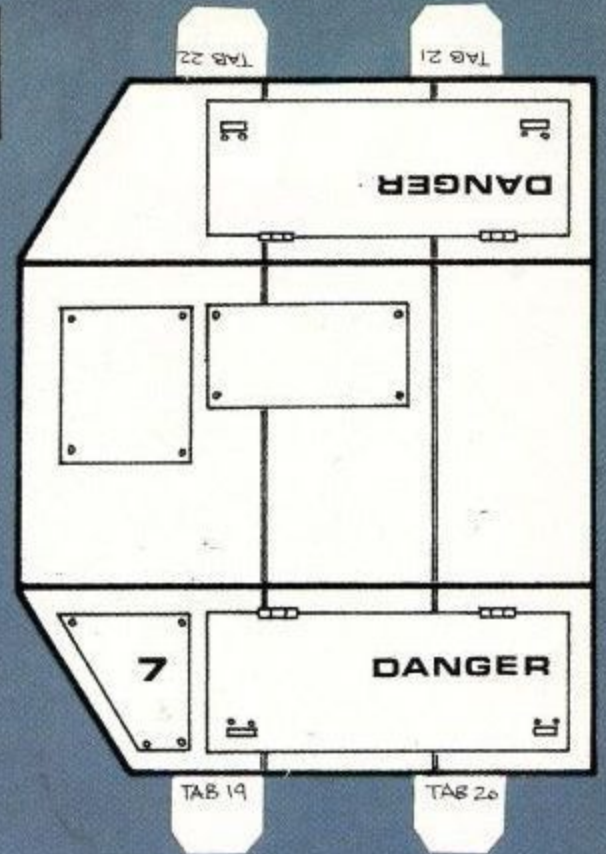
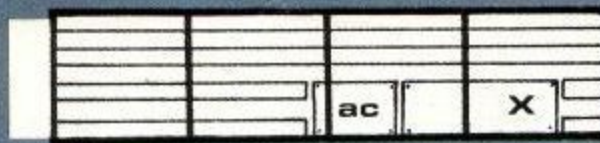
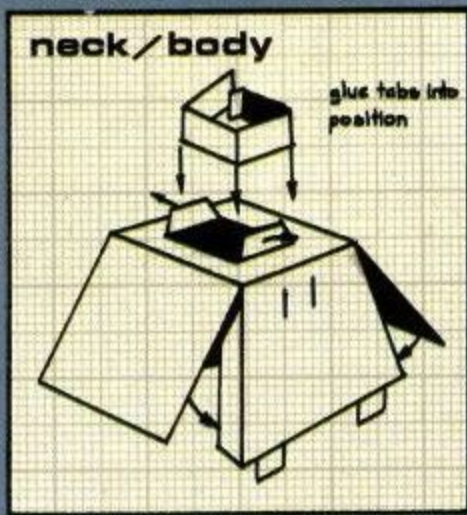

All this in just



WORD PROCESSOR

Compose a letter, set the print-out options using embedded commands or menus, use the mail merge facility to produce personalised circulars – and more!



DATABASE

Build up a versatile card index, use the flexible print out routine, do powerful multi-field sorting, perform all arithmetic functions, link with the word processor – and more!



LABEL PRINTER

Design the layout of a label with the easy-to-use editor, select label size and sheet format, read in database files, print out in any quantity – and more!

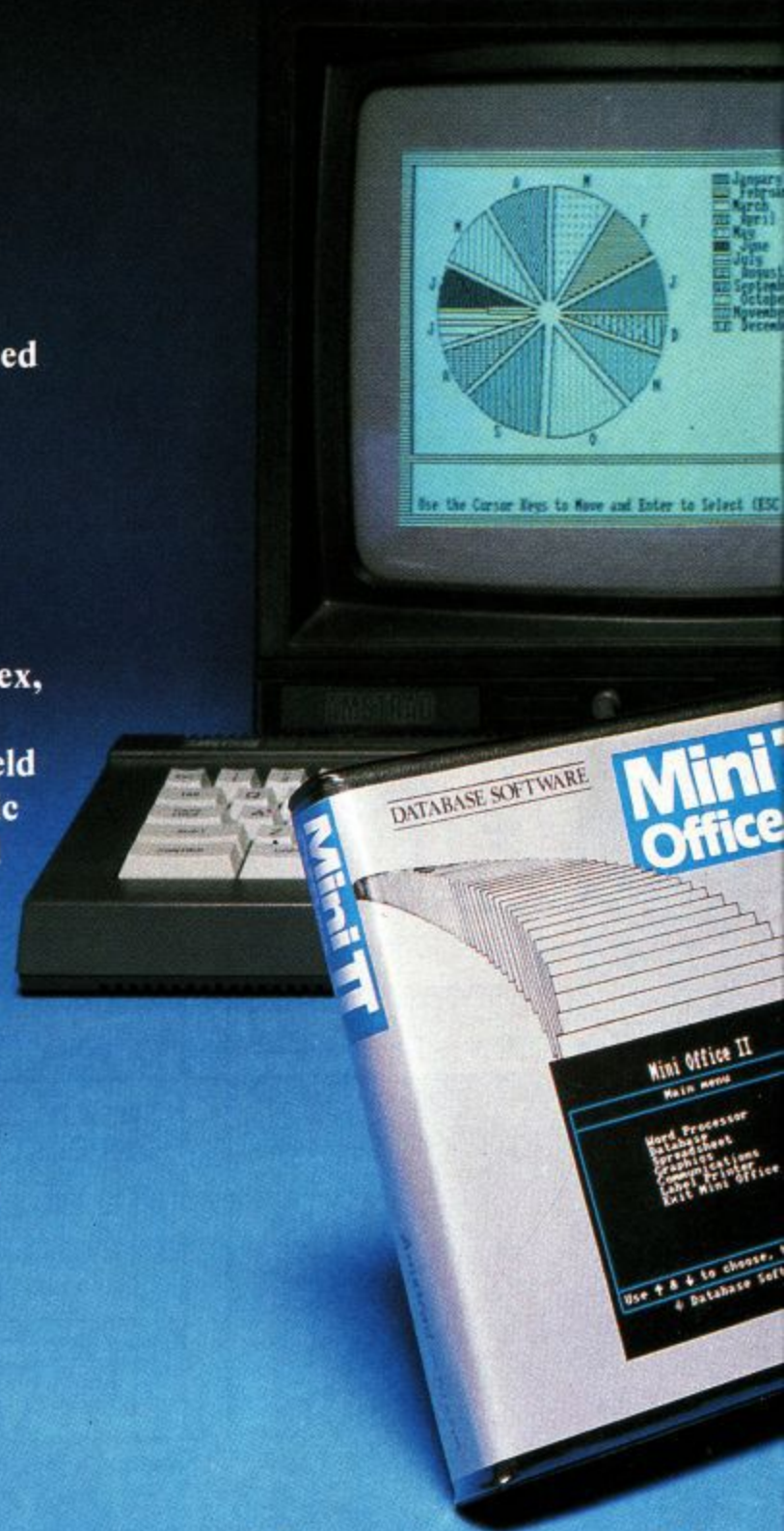

...and at a price

Mini Office II offers the most comprehensive, integrated suite of programs ever written for the Amstrad – making it the most useful productivity tool yet devised.

A team of leading software authors were brought together to devote a total of 26 man years of programming to the development of Mini Office II. What they have produced is a package that sets new standards in home and business software.

The sample screenshots above illustrate just a few of the very wide range of features, many of which are usually restricted to software costing hundreds of pounds. Most are accessed by using cursor keys to move up and down a list of options and pressing Enter to select.

Is it that easy to use? Several leading reviewers have

already sung its praises on this very point.

Yet possibly the best advertisement for Mini Office II is that it comes from the same stable that produced the original Mini Office package back in 1984.

That was so successful it was shortlisted in two major categories of the British Microcomputing Awards – the Oscars of the industry – and sold in excess of 100,000 units!

It was up to Mini Office II to take over where the first Mini Office left off, with 32 extra features, two additional modules, a program to convert existing Mini Office files to Mini Office II format, and a 60 page, very easy to follow manual.

This is the package thousands of Amstrad owners have been waiting for – and at a price everyone can afford!

ONE package!

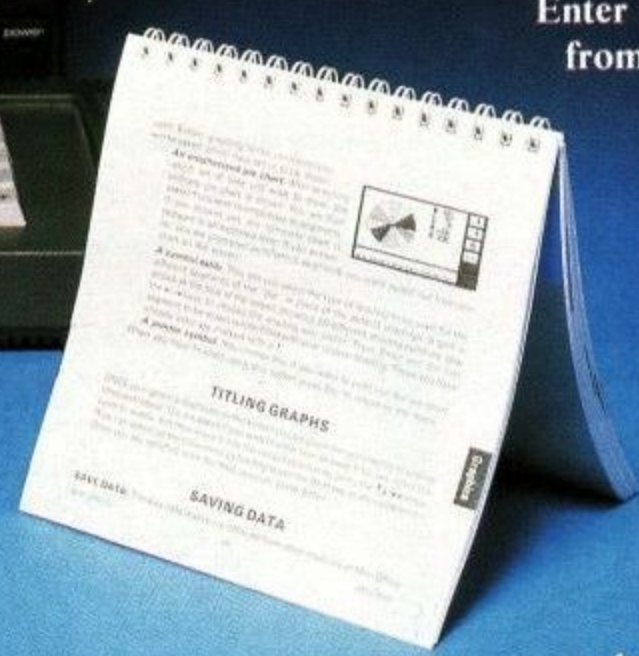

SPREADSHEET
Prepare budgets or tables, total columns or rows with ease, copy formulae absolutely or relatively, view in either 40 or 80 column modes, recalculate automatically – and more!

FreeSpace: 10072 Auto Down
Cell: B9 (locked) FormulaContents: B9:R2007

	Jan	Feb
1		
2		
3	Electric 60.00	50.00
4	Telephone 130.00	125.00
5	Salaries 2450.00	2400.00
6	Postage 375.00	360.00
7	Carriage 420.00	380.00
8		
9	TOTALS: 3635.00	3645.00
10		

GRAPHICS
Enter data directly or load data from the spreadsheet, produce pie charts, display bar charts side by side or stacked, overlay line graphs – and more!

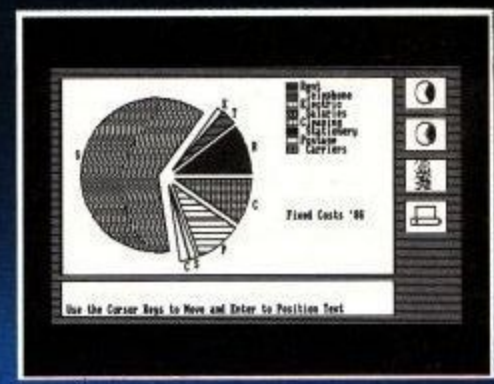

COMMS MODULE
Using a modem you can access services such as MicroLink and book rail or theatre tickets, send electronic mail, telex and telemessages in a flash – and more!

```

>?r
=====
British Rail Service
Tickets / Fares / Timetable
=====
* Ticket Bookings
* Pullman/Steam Bookings
* Seat Reservations
* Sleeper Reservations
* Pullman Rail
* Steam Excursions
* Electric Express - Newsletter
Timetable and Fares from May 12th

* Ho for HELP
1-8 Redisplay @Quit
Select 1
    
```

that can't be matched!

DATABASE SOFTWARE

Amstrad CPC 464, 664, 6128

Cassette £14.95
3" disc £19.95

Database Software,
FREEPOST,
Europa House,
68 Chester Road,
Hazel Grove,
Stockport SK7 5NY.

Order at any time of the day or night

Telephone Orders:
061-429 7931

Orders by Prestel:
Key *89, then 614568383

MicroLink/Telecom Gold
72:MAG001

Don't forget to give your name, address and credit card number

ENQUIRIES ONLY: 061-480 0171 9am-5pm



Please send me **Mini Office II**

*Add £2 for Europe
*Add £5 for Overseas

Cassette £14.95* 6086
3" disc £19.95* 6087

Payment: please indicate method (✓)

Access/Mastercharge/Eurocard/Barclaycard/Visa

Expiry date
/

Card No.

Cheque/PO made payable to Database Publications Ltd.

Name _____ Signed _____

Address _____

Tel: _____

Please allow 28 days for delivery

ACU 5

The ultimate choice in computer supplies for Amstrad Computers

THE "NEAT-N-TIDY" SOLUTION FOR THE PCW 8256/8512

No risk
Trial offer
7 day money back guarantee

£39.95



THE TOTAL
PACKAGE ONLY
£74.95 INC.

NEW

£44.95

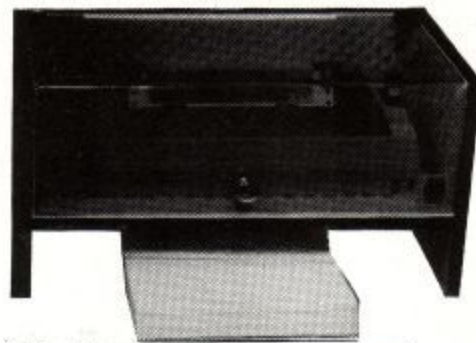

"Tidy" is a PCW stand that puts your screen at eye level. It provides space for your keyboard and has a shelf for storing of disks etc. It can be locked to ensure security and privacy. Since the keyboard can be safely stored away when not in use extra desk space is then made available. Slotted in the top to connect the keyboard cable to the PCW.

"Neat" is a printer stand and acoustic cover combined. No more annoyance to colleagues at work or at home. Designed to handle both continuous and sheet fed paper with slots at rear and top.

Available separately or as a pair for an unbeatable price, another new value for money product from SBS, the ultimate choice.

TOP QUALITY

NO EXTRAS TO PAY

BEST PRICES

3" CF2 DISKS

£25.50 for 10
£69.50 for 30

BEST
PRICES

5 1/4" PC1512/DISKS

PLAIN LABEL
IN PLASTIC CASE **£10.17** incl. for 10
MAXELL
BRANDED **£13.60** incl. for 10

DISK STORAGE



◀ DIAL A DISK
10 x 3" DISKS
PROTECTED AND
DISPLAYED

£5.95 incl.

3" DISC BOX
HINGED LID ▶
Cap 25 Discs
(uncased) 15 cased
£9.50 incl.



NEW

"THINGI" COPY HOLDER



FITS TO TOP OF
PCW WITH
VELCRO STRIP
PROVIDED.

£6.99 incl.

PLEASE SPECIFY LEFT/RIGHT REQD.

PERSPEX VDU FILTERS FOR PCW 8512 & PC 1512

- ▶ REDUCES EYESTRAIN
- ▶ REDUCES GLARE
- ▶ REDUCES HEADACHES
- ▶ IMPROVES CONTRAST

ONLY
£14.95 incl.



NEW

FITS TO VDU WITH VELCRO PADS PROVIDED
PLEASE SPECIFY IF MONO/COLOUR VDU (PC 1512 ONLY)

DUST COVERS	PCW 8256/8512	Full set	£10.35
	PC1512	Full set	£9.50
RIBBONS	PCW 8256/8512/DMP 2000/3000		£4.95
	PCW 8256/8512 (Carbon)		£5.50
	DMP 4000		£8.03
LISTING PAPER	11" x 9 1/2" 60 gsm ruled/plain	£14.24/2000	
	A4 continuous 70 gsm plain	£9.64/1000	
	A4 continuous 90 gsm plain	£12.89/1000	
	(Micro-perforated on all 4 edges)		
LABELS	3 1/2" x 1 7/16" 1 across the web	£31.56/8000	

▶ Call for sizes not listed.

BARGAIN
CORNER

ALL PRICES INCLUDE VAT — PLUS — FREE NATIONWIDE DELIVERY

SBS Computer Supplies Ltd.

UNIT 3 · CLARKS INDUSTRIAL ESTATE · NEWTOWN ROAD
HOVE · SUSSEX · BN3 7BA · TEL (0273) 726331 TELEX 878226

FOR IMMEDIATE DESPATCH ☎ OUR 24 HOUR



HOT LINE (0273) 726331

COMPANIES
WHY NOT
ASK FOR OUR FREE
64 PAGE CATALOGUE

PLEASE SEND ME

DESCRIPTION

QTY.

VALUE

I ENCLOSE A CHEQUE PAYABLE TO
SBS Computer Supplies Ltd.

NAME _____

ADDRESS _____

TEL _____

LARGE STOCKS
AVAILABLE
ACCESS AND VISA
CARDS ACCEPTED

ACU 5

TOTAL ORDER VALUE

COMPUTER
SBS
SUPPLIES



A game for CPC computers
by Kevin Freeman

plumber droid

DARE you enter the chamber of an earthquake-damaged chemical processing unit? Hazardous acidic gases have been released, and you must use the plumber craft to reconnect the pipelines, which will be displayed for a time in their correct positions.

Avoid the roaming disruptor droid - any contact and it will be transported to the start position. This must be completed before the gases eat their way through the shell of the plumber craft.

You have the option of using joystick or keyboard.

This program creates its own machine code and checks for typing mistakes, but cannot check for some errors. If you get the message "Type mismatch in 2620" you have made a mistake in the DATA. By typing GOTO 2770 when you get the error you should get a rough idea of where the mistake is.

Have fun!

```
10 Pipeline Plumber by K.Freeman
20
30 MODE 0
40 DEFINT a-z
50 SYMBOL AFTER 256:MEMORY 88FFF
60 SYMBOL AFTER 32
70 GOSUB 2730
110 MOVE 500,20:DRAWR 30,10
120 MOVE 500,20:DRAWR 30,-5
130 MOVE 514,7:DRAWR 0,25
140 PEN 8:LOCATE 6,10:PRINT "Pipeline
150 LOCATE 8,12:PRINT"Plumber
160 GOSUB 2580
170 DIM grid(20,12),start(20,12)
180 'position of disruptor
```

```
360 FOR y=1 TO 12
370 READ n$
380 FOR x=1 TO 20
390 s=(ASC(MID$(n$,x,1)))-97
400 SPRITE,(x-1)*2,(y-1)*2,s
410 grid(x,y)=s:start(x,y)=s
420 NEXT x
430 NEXT y
440 FOR t=1 TO 1000:SOUND 1,t,1,9:SOUND
2,1000-t,1,9:NEXT
450 'time left box
460 PLOT 370,0,2:DRAW 639,0
470 PLOT 370,10:DRAW 639,10
480 GOSUB 1580
490 GOSUB 1520
500 'variables
510 x=2:y=11:o=11:a=x:b=y
520 dx=dx(scr):dy=dy(scr):GOSUB 1130:da=
dx:db=dy
```

```
190 RESTORE 200:FOR t=1 TO 6:READ n,m:dx
(t)=n:dy(t)=m:NEXT
200 DATA 17,7,14,3,15,11,10,5,6,4,14,5
210 FOR t=200 TO 60 STEP -1:SOUND 4,t,1,
9:NEXT
220 'default control keys
230 up=0:dw=2:lf=1:rt=8:hv=47
240 GOSUB 680
250 scr=1:sc=0
260 SOUND 2,2000,7,13:MODE 0
270 BORDER 0
280 IF scr=1 THEN RESTORE 1790
290 IF scr=2 THEN RESTORE 1920
300 IF scr=3 THEN RESTORE 2050
310 IF scr=4 THEN RESTORE 2180
320 IF scr=5 THEN RESTORE 2310
330 IF scr=6 THEN RESTORE 2440
340 'show screen
350 l=0:q=0
```

```
530 grid(dx,dy)=17
540 w=370:hold=0
550 'keypress
560 IF INKEY(rt)=0 AND x<19 THEN px=1:py
=0:s=11:GOTO 850
570 IF INKEY(lf)=0 AND x>1 THEN px=-1:py
=0:s=12:GOTO 850
580 IF INKEY(up)=0 AND y>1 THEN px=0:py=
-1:s=9:GOTO 850
590 IF INKEY(dw)=0 AND y<11 THEN px=0:py
=1:s=10:GOTO 850
600 IF INKEY(71)=0 AND hold=1 THEN SOUND
2,1000,2,,,5:GOSUB 1240
610 IF INKEY(63)=0 AND hold=0 THEN SOUND
2,1500,3,,,8:GOSUB 1400
```

AMSTRAD
COMPUTER USER

Exclusive
READER
OFFERS

Save up to £16
on both these
eagerly-awaited
additions to the
LocoScript family!

**The latest (and best!)
mail-merging program . . .**

LocoMail

What you get with LocoMail:

- ★ Sends out any number of personalised letters.
- ★ Use your recipient's name twice in every sentence if you wish!
- ★ Insert data into your letters completely automatically.
- ★ Take data from LocoScript or from any Ascii database system.
- ★ Allows you to specify categories of people to receive your mail.
- ★ Facilitates automatic production and printing of invoices.

Normal price

£39.95 each

Reader price

£32.95 each

£63.90 for both

What you save

£7 each

£16 for both

**The latest (and best!)
spell-checking program . . .**

LocoSpell

What you get with LocoSpell:

- ★ Huge 78,000 word dictionary by Longman
- ★ Build your own dictionary of names, common words, etc.
- ★ Use it as an electronic dictionary to look up difficult words as you type.
- ★ Corrects all your misspelt words.
- ★ Check as much or as little spelling as you want.
- ★ No disc changes needed to correct spelling.

Read what the experts have to say!

‘I wouldn't hesitate to recommend LocoMail to anyone who has the need to produce circulars, club newsletters, invoices, invitations, contracts and the like . . . I can't wait to see what LocoSpell has to offer’

– Cliff Lawson, APC.

‘LocoSpell does the job admirably. Like, LocoMail, its easy integration with LocoScript makes it very easy to use. If you use your Joyce at all regularly then it MUST be an essential purchase’

– Rupert Goodwins, ACU.

To order please use the form on Page 95

```

620 GOSUB 960
630 v=v+1:IF v=55 THEN GOSUB 1540
640 IF q=l THEN 780
650 IF w<639 THEN 560 ELSE GOSUB 660:GOT
0 260
660 FOR t=2000 TO 1000 STEP -10:SOUND 1,
t,1,7:NEXT:MODE 0
670 LOCATE 5,12:PEN 1:PRINT"Game over";
680 LOCATE 5,17:PEN 10:PRINT"P to play";
690 PEN 7
700 LOCATE 5,18:PRINT "C set Controls"
710 IF sc>h THEN h=sc
720 LOCATE 10,21:PEN 6:PRINT"Hi=";h
730 scr=1:sc=0
740 IF INKEY(27)=0 THEN RETURN
750 IF INKEY(62)=0 THEN GOSUB 3790
760 IF INKEY(46)=0 THEN END
770 GOTO 740
780 FOR t=60 TO 200:SOUND 4,t,1,10:NEXT
790 sc=sc+640-w:GOSUB 1520
800 scr=scr+1:IF scr<7 THEN 260
810 MODE 0
820 LOCATE 3,12:PEN 1:PRINT"game complet
ed";
830 GOSUB 680:GOTO 260
840 'move/hover
850 SOUND 4,s[2,5,5,,,1
860 GOSUB 960
870 IF INKEY(hv)=0 THEN IF s<>o GOTO 900
ELSE 630
880 IF grid(x+px,y+py)>16 THEN x=x+px:y=
y+py
890 IF a=x AND b=y AND o=s THEN 560
    
```

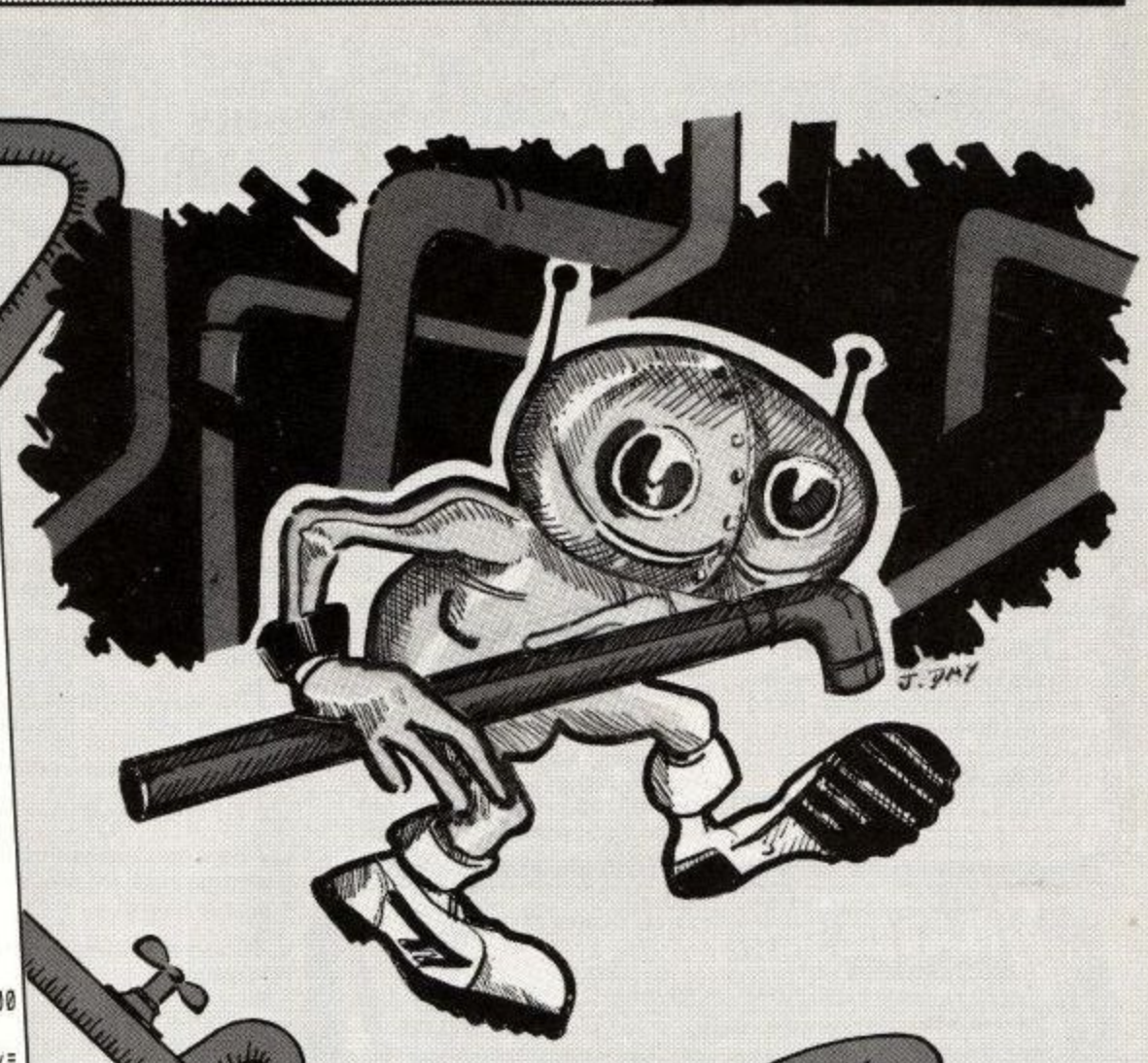

```

900 SPRITE,(a-1)*2,(b-1)*2,o
910 SPRITE,(x-1)*2,(y-1)*2,s
920 a=x:b=y:o=s
930 IF x=dx AND y=dy THEN GOSUB 1060
940 GOTO 630
950 'move disruptor
960 mv=mv+1:IF mv<3 THEN RETURN ELSE mv=
0
970 gr=grid(dx+du,dy+dn)
980 SOUND 1,300,5,5:SOUND 4,200,3,3
990 IF gr<16 THEN 1130 ELSE dx=dx+du:dy=
dy+dn
1000 SPRITE,(da-1)*2,(db-1)*2,14
1010 SPRITE,(dx-1)*2,(dy-1)*2,14
1020 da=dx:db=dy
1030 IF dx=x AND dy=y THEN 1060
1040 RETURN
1050 'disruptor contact
1060 FOR wt=100 TO 120:SOUND 4,wt,2,wt/1
0:BORDER wt/5-10:NEXT
1070 SPRITE,(a-1)*2,(b-1)*2,o
1080 x=2:y=11:o=11:a=x:b=y
1090 SPRITE,(x-1)*2,(y-1)*2,o
1100 BORDER 0
1110 RETURN
1120 END
1130 r=RND*7+1
1140 ON r GOTO 1150,1160,1170,1180,1190,
1200,1210,1220
1150 du=-1:dn=0:RETURN
1160 du=-1:dn=-1:RETURN
1170 du=1:dn=-1:RETURN
1180 du=1:dn=1:RETURN
1190 du=0:dn=-1:RETURN
1200 du=1:dn=0:RETURN
1210 du=-1:dn=1:RETURN
    
```

```

1220 du=0:dn=1:RETURN
1230 'drop pipe
1240 d=grid(x+px,y+py)
1250 IF d<17 THEN RETURN
1260 grid(x+px,y+py)=p
1270 hold=0
1280 IF start(x+px,y+py)<>p THEN 1360
1290 BORDER 6:INK 0,6
1300 FOR wt=1 TO 50:NEXT
1310 SOUND 1,1000,5,14
1320 BORDER 0:INK 0,0
1330 q=q+1:GOSUB 1500
1340 sc=sc+1:GOSUB 1520
1350 'display/erase pipe
1360 SPRITE,(x+px-1)*2,(y+py-1)*2,p
1370 SPRITE,38,22,p
1380 RETURN
1390 'pick up pipe
1400 p=grid(x+px,y+py)
1410 IF p>5 THEN RETURN
1420 grid(x+px,y+py)=17
1430 hold=1
1440 IF start(x+px,y+py)<>p THEN 1360
1450 SOUND 1,3000,5,14
1460 q=q-1:GOSUB 1500
1470 sc=sc-1:GOSUB 1520
1480 GOTO 1360 'jump to erase/display pi
pe
1490 'no. connected
1500 LOCATE 9,25:PEN 7:PRINT q;
1510 RETURN
1520 LOCATE 1,25:PEN 3:PRINT sc;
1530 RETURN
1540 w=w+3:v=0
1550 MOVE w,2:DRAW w,9,12
1560 RETURN
1570 ' move pipeline
1580 FOR y=1 TO 12
1590 FOR x=1 TO 20
1600 IF start(x,y)<6 THEN GOSUB 1650
    
```

```

1610 NEXT x
1620 NEXT y
1630 GOSUB 1500
1640 RETURN
1650 p=grid(x,y)
1660 grid(x,y)=17
1670 l=l+1
1680 SPRITE,(x-1)*2,(y-1)*2,p
1690 a=RND*19+1:b=RND*11+1
1700 IF grid(a,b)<>17 THEN 1690
1710 IF start(a,b)=p THEN 1690
1720 grid(a,b)=p
1730 SPRITE,(a-1)*2,(b-1)*2,p
1740 SOUND 2,500,2,6
1750 LOCATE 6,25:PEN 10:PRINT l;
1760 RETURN
1770 ' data for screens
1780 'screen 1
1790 DATA hhhhhssssssshhhhh
1800 DATA hrrrrhhiiiiihrrrih
1810 DATA iibddfrrrrhhrrrrri
1820 DATA inaharrrrrhhrrrbgri
1830 DATA iechharrrrrrrrrarri
1840 DATA irrrharrrrrbdddcri
1850 DATA irrrrarhhrrrrrrrri
    
```

```

1860 DATA irrrrarhhrrrrrrri
1870 DATA irrrredddddchrrrih
1880 DATA hsirrrrrrrhhrrrih
1890 DATA hlrrrrrrrrrrrrrshs
1900 DATA hhhhhiiiiiiiiihss
1910 'screen 2
1920 DATA iinhssshiiiiiiisss
1930 DATA irarrshrrrrhirhhhh
1940 DATA hrefriiirrrrorirrrh
1950 DATA hrrarhrrrrrrrrirri
1960 DATA sirarhbdddfrirhbdgi
1970 DATA sirarhrarhrraiharri
1980 DATA hireddchrriarrarii
1990 DATA irrrhrrrrrraihbciii
2000 DATA irrrhrrrrrrrabdcrrri
    
```

**IT'S
HERE**

THE ULTIMATE BACKUP DEVICE FOR THE 464/664/6128



Now you can stop the action of your game and make a complete backup to TAPE or DISK.



TAKE AIE TO THE HEART OF YOUR COMPUTER!

POST FREE

ONLY £34.99

THERE'S NO NEED TO PAY MORE!

VERY SIMPLE TO USE!!

Available NOW!!

It does not matter how your program was loaded – at normal or turbo speed – from tape or disk.

Through bus connector for other add-ons.

Programs are saved under normal DOS – unlike some products which need specially formatted disks.

100% SUCCESS? In our recent tests we could not find any memory resident game that we could not backup.

Simply load your game as normal then press the button to 'freeze' the action.

The whole program is then saved to tape or disk.

Program will reload and run from the point where it was frozen.

When the program save is complete that's it – no need to "repair" the program on reload like our competitors' products.

**DATTEL
ELECTRONICS**

**USUALLY SAME DAY
DESPATCH ON ALL ORDERS**
SEND CHEQUES P O'S TO
UNITS 8/9
FENTON INDUSTRIAL ESTATE,
DEWSBURY ROAD, FENTON,
STOKE-ON-TRENT TEL: 0782 273815
FAX: (0782) 264510

24 HR CREDIT
CARD LINE



FOREIGN ORDERS
ADD £2 POSTAGE

A FULL DIGITAL SOUND SAMPLING SYSTEM

FOR 464/664
OR 6128

**ONLY
£44.99**



Complete hardware/software package including free microphone.



The sampler allows you to record any sound into memory digitally and then replay it at variable pitch, forwards, backwards, ascending, descending, with echo, reverb, etc., etc.

Professional full 8 bit A to D and D to A conversion.

MIC input and line output.

On screen frequency plotting.

Live effects menu.

Through port.

Real time sequencer to produce musical pieces from a single sound.

Load and save sound features.

Available now – please state tape or disk software.

NOW ROBOTICS + MODEL CONTROL



Made Easy

FOR 464/664
OR 6128

ONLY £29.99
POST FREE

Connect your computer to models, lights, sensors, etc., etc.

4 onboard relays.

8 fully buffered inputs.

Using very simple basic commands, outputs can be controlled by inputs to form "artificial intelligence".

Complete with ribbon connector and cable to allow coupling to models etc.

Through bus for expansion/disk interface etc.

No more to buy.

Available now!

Advantage

The Independent Computer User Group

Advantage (U17) 33 Malyns Close, Chinnor, Oxfordshire OX9 4EW.
Tel: 0844 52075



AUTHORISED PC-SIG DEALER



ORDERING – Prices include VAT and UK postage. Cash with order please, cheque, money order or bankers draft. VISA and ACCESS accepted by post or telephone. Send a stamped, addressed envelope for our latest catalogue.

PLEASE STATE WHICH COMPUTER YOU ARE USING



PC OWNERS – SEND JUST £2 FOR OUR NEW CATALOGUE - ON - A - DISC WHICH INCLUDES SAMPLE GAMES AND UTILITIES.

PCW & CPC SOFTWARE

EACH DISC £8.95 (Advantage Members £6.95)
Overseas add £1 per disc.

The six discs below contain Public Domain software plus Advantage user notes.

COMPLEAT UTILITIES – Selective file copy erase, hide, rename and print, Sector Editor, Z80 Assembler/Disassembler, Z80 Debugger, Erased File Find and Recovery (CP/M 2.2), Sorted Directory, File Scanner, Splitter, String Finder, Bad Sector Eliminator, Typewriter Emulator.

GAMES COMPENDIUM – Chess, Colossal Cave Adventure, Othello, Mastermind, Awari, Life, Golf, Polish Pong, Maze, Biorhythms, Word Search Puzzle Maker, Calendar Generator, Noughts & Crosses, Banner Printers.

APPLICATIONS – Inventory/Database, Library Utilities, Word Count, Alphabetic Sort, Simple Spelling Checker, Easy to edit Starter Dictionary, Disc Catalogger, File Squeeze/Unsqueeze (saves up to 40% disc space), Password Protection.

COMMUNICATIONS – UK MODEM 7, Kermit, MEX, BINARY – HEX Converter and other utilities.

AMUSEMENTS & DIVERSIONS – 25 games and 8 utilities written in unprotected MALLARD BASIC, including Star Trek, Merchant, Hangman, Nim, Baseball, American Football, Calculator, Home Budget and Label Printer

SMALL C COMPILER – produces machine code programs and includes 25k of documentation

PC SOFTWARE

EACH DISC: £9.95 (Advantage Members £7.95)
Overseas please add £1 per disc

We have an extensive library of over 600 PC-SIG public domain and user-supported discs. Here are some of the favourites

PC-WRITE – Multi-function Word Processor 60k file size. 100 page on – disc manual.

PC-FILE III – Fully user definable Database 32,767 records. 100 page on – disc manual.

PC-CALC – Spreadsheet similar to 123 (64 column x 256 row). 30 page on-disc manual

PC-TUTOR – Course in computers and DOS

CASH-TRAC – Household budget organiser

PRO-COMM – Comprehensive Communications

PC DESKTEAM – more features than Desk Mate

ULTRA UTILITIES – Powerful Disc Doctor with disc mapper, unerase, sector editor

BEST UTILITIES – Selective delete and copy, print spooler, file Browse, super TYPE

BEST GAMES – Two classics: Space Invaders & Pacman plus Life, Bugs, Castle (adventure).

ASSORTED GAMES – Pinball, Catch The Baby, Frogger, Multi-maze, War Game

ARCADE GAMES – 3-Demon, Donkey Kong, Golf, Fortune, Breakout, Pango, Pitfall, Pyramid

PC-CHESS – Full feature, on-screen board

OTHELLO – Reversi game with graphics

COLOSSAL CAVE ADVENTURE – Extensive STAR TREK – Large graphics version

TRIVIA QUIZ – A two disc set £15.95

MONOPOLY – The board game on computer

CAVE QUEST – Dungeons & Dragons game

Q-BERT – fast square-jumping arcade game

HANGMAN – Well presented graphics version

FUNNELS & BUCKETS – A fun learning maths game for over 7's

MIX C COMPILER

- Full Kernighan-Ritchie implementation
- Fast Linker to build an executable program from separately compiled files
- Supports all data types, floats, bit fields, doubles, structures and unions
- Unix C compatible
- Extensive library of 175 functions
- Optimisation tools for speed and space
- 450 page manual describing compiler operation, C programming and tutorial
- UK technical support from Advantage

"Outstanding value for money" – CWA 2/87
Available for CP/M+ and MSDOS. Second drive or RAM disc is recommended for CPC owners.

£38.95 Overseas please add £5

MIX C TRACE

A powerful aid to fast program debugging with four-window monitoring and animated trace which highlights each statement as it executes. Single step and continuous functions with dynamic monitoring of source, output, variables, symbols and memory. Unlimited breakpoints. Comprehensive manual.

MSDOS only

£38.95 Overseas please add £3

MIX SPLIT SCREEN EDITOR

£29.95 Overseas add £3

MIX ASSEMBLER UTILITY

£10.95 Overseas add £1

*Buy any 2 MIX packages – deduct 10%
any 3 – deduct 15% all 4 – deduct 20%
Advantage members may deduct £2 per item

BORLAND TURBO PASCAL

The fastest Pascal compiler with programming environment, editor, error detection, window procedures, sound, colour and graphics.

"Runs like magic" – PC Magazine

Amstrad CP/M Version: £65.95

Overseas add £3 PC MSDOS

Version £78.95 (Members

deduct £2)

NEVADA & UTAH COBOL

Features runtime error messages, random access and sequential files and integration of assembly language using DR MAC.

CP/M or MSDOS

£38.95 (Members £36.95)

Overseas add £3

NEVADA & UTAH FORTRAN

Random I/O file, assembly language support, function library + real time error reports. CP/M or MSDOS "Outstanding Value" – CWA 11/86

£38.95 (Members £36.95) Overseas

add £3

FULL SCREEN TEXT EDITOR

Suitable for generating compiler source code – CP/M and MSDOS versions available.

£10.95 (Members £8.95)

Overseas add £1

INDEPENDENT USER GROUP

Choose either Group-8 (CPC & PCW) or Group-16 (PC1512) for monthly newsletter user support and software discounts.

Annual membership: £10.95 (UK)

£13.95 (Europe)

£16.95 (Rest of World)

PROGRAMMING

```

2010 DATA ishhrriiraahrhii
2020 DATA ilhrriisirecrrriss
2030 DATA iiiiiissiiiiiiiss
2040 'screen 3
2050 DATA sssiiiiiiiiihhh
2060 DATA sshrrrissirrhrrrrh
2070 DATA ihrrrrisirbdddfrri
2080 DATA irrbddcishrahhrahi
2090 DATA irrhahhhihrahrrari
2100 DATA ihredddddcbdddcrri
2110 DATA irrrrrrrrrrarrhhri
2120 DATA irrrrbfrrrrrarrhhri
2130 DATA irrrhaeddddccrrrri
2140 DATA hshrhgrrrhrhrrhiii
2150 DATA hlhrhrrrhhrrorhiss
2160 DATA hhhiiiiiiiiihhiss
2170 'screen 4
2180 DATA sssshiiiiinihihh
2190 DATA sssshrbddfhharrrrh
2200 DATA ssssirarrharrhhri
2210 DATA ssiirrahreddcrrrri
2220 DATA sshhbcrhorbdddfrri
2230 DATA sshhefhrrefrarrri
2240 DATA hiirrahbfrarahrri
2250 DATA irrrhhahaahrabchhri
2260 DATA irrrhharaahaegrhri
2270 DATA ishiiredceddcrrrii
2280 DATA ilhrrrrhhrrrrhiss
2290 DATA ihiiiiiiiiihhiss
2300 'screen 5
2310 DATA siiiihhhhiiiiihhs
2320 DATA ihhrrrrrbddfrhrrhs
2330 DATA irhbddfharrahirris
2340 DATA irbcroanhahreddfiih
2350 DATA ihfrrraahrrrarrhi
2360 DATA siharaedchrrhrefri
2370 DATA ssharrarhhrrrhahri
2380 DATA hhhegrefrhrrrbcrh
2390 DATA irrrrrredfrhrrrahhh
2400 DATA ishrrrrhreddddchii
2410 DATA ilhrrrrrrrrrrrhss
2420 DATA ihhhiiiiiiiiihhss

```

```

2430 'screen 6
2440 DATA iiiihhhiiiiihhiih
2450 DATA ihrrriirrrrrheddfh
2460 DATA hnhrrrrrrbdddiddch
2470 DATA iarrrrhrhrrrriihh
2480 DATA iarrrhhhrarohriss
2490 DATA iedddfbdddfarrhhss
2500 DATA irhhhaegrhccrrrrii
2510 DATA ichrrrrrrhrrrrri
2520 DATA irhiredddddfrrrri
2530 DATA hshrrrrhrrrrregrii
2540 DATA hlhhhhrrrrrrrrhss
2550 DATA hhhssiiiiiiiiihhss
2560 'poke code into memory
2570 @ 89000-89400
2580 RESTORE 2790:mem=89000
2590 BORDER 0
2600 FOR dl=1 TO 96:READ d$,ck:rs=0
2610 FOR by=1 TO 24 STEP 2
2620 a=VAL("8"+MID$(d$,by,2))
2630 rs=rs+a
2640 POKE mem,a
2650 mem=mem+1
2660 NEXT by:IF rs<>ck THEN 2750
2670 SOUND 4,300,3,10
2680 IF ab=12 THEN ab=11 ELSE ab=12
2690 DRAW 0,0,ab:MOVE dl*6,332:DRAW -8,18
2700 NEXT dl:CALL 89000
2710 RETURN
2720 'set pens

```

```

2730 RESTORE 3760
2740 FOR t=0 TO 15:READ k:INK t,k:NEXT:R
RETURN
2750 SOUND 4,600,6,15:BORDER 6
2760 MODE 1:INK 0,1:INK 1,26
2770 PRINT"data error in line.":dl*10+2610
2780 END
2790 DATA 010E90210A90CDD1BCC90A90,1303
2800 DATA 0E901390C31A905350524954,1088
2810 DATA C500DD4602DD4E04DD7E00FE,1394
2820 DATA 10D0076F2600117090197E5F,899
2830 DATA 237EFEFFC85778FE19D0D504,1781

```

```

2840 DATA 11500021B0BF1910FDD179FE,1375
2850 DATA 280007D55F160019D11A4713,935
2860 DATA 1A4F13C5E51AAE77231310F9,1188
2870 DATA E10100080930040150C009C1,770
2880 DATA 0D20E8C99090D29014915691,1516
2890 DATA 9891DA911C925E92A092E292,1752
2900 DATA 24936693A893EA933894FFFF,1842
2910 DATA 041000736F0000736F000073,587
2920 DATA 6F0000736F0000736F000073,678
2930 DATA 6F0000736F0000736F000073,678
2940 DATA 6F0000736F0000736F000073,678
2950 DATA 6F0000736F0000736F000073,678
2960 DATA 6F0000736F00041000000000,357
2970 DATA 000000000000000000000000,0
2980 DATA 00113333003333330073F3F3,873
2990 DATA 0073F3F30073F3F30073F3F3,1083
3000 DATA 00736FCF00736FCF00736F00,1092
3010 DATA 00736F0000736F0000736F00,678
3020 DATA 041000736F0000736F000073,587
3030 DATA 6F0000736F0033736F003373,780
3040 DATA 6F00F3F36F00F3F36F00F3F3,1431
3050 DATA 6F00F3F36F00FCFCFCFCFCFC,1383
3060 DATA 8A0000000000000000000000,138
3070 DATA 00000000000000041000000000,20
3080 DATA 000000000000000000000000,0
3090 DATA 3333333333333333F3F3F3F3,1380
3100 DATA F3F3F3F3F3F3F3F3F3F3F3F3,1476
3110 DATA CFCFCFCFCFCFCFCFCFCFCFCFC,1656
3120 DATA 000000000000000000000000,0
3130 DATA 041000736F0000736F000073,587
3140 DATA 6F0000736F0000736FCF0073,885
3150 DATA 6FCF00733F3F00733F3F0073,915
3160 DATA F3F30073F3F3003333330033,1291
3170 DATA 333300000000000000000000,102
3180 DATA 000000000000041000000000,20
3190 DATA 000000000000000000000000,0
3200 DATA 333330033333300F3F3B300,971
3210 DATA F3F3B300F3F3B300F3F3B300,1275
3220 DATA CF9FB300CF9FB300009FB300,1428
3230 DATA 009FB300009FB300009FB300,1014
3240 DATA 04100051AACF0055E7DB0055,1098
3250 DATA 22A200005500220077003345,554
3260 DATA E7AAB3153322F3739BA23F73,1539
3270 DATA 9BA26FB39BA2CF339BA29B67,1757
3280 DATA CF73459B4573453345DB0022,1172
3290 DATA 45CF000051CF0410030F1E3C,692
3300 DATA 030F1E3C57FFFBE570F1EBE,1217
3310 DATA 570F1EBE57FFFBE030F1E3C,1217

```

```

3320 DATA 57FFFBE030F1E3C57FFFBE,1682
3330 DATA 570F1EBE570F1EBE57FFFBE,1431
3340 DATA 030F1E3C57FFFBE030F1E3C,1003
3350 DATA 0410CCD000FFCCD000FF9C3C,1986
3360 DATA 3C7D9CD0007D9CD0007D9C3C,1795
3370 DATA 3C7DCCD000F5CCD000F59C3C,2131
3380 DATA 3C7DCCD000F5CCD000F59C3C,2131
3390 DATA 3C7D9CD0007D9CD0007D9C3C,1795
3400 DATA 3C7DCCD000FF041000281400,1140

```

```

3410 DATA 0028140000020100000020100,66
3420 DATA 00F4780000F4780045FCBC8A,1375
3430 DATA 45FCBC8A453C3C8A453C3C8A,1301
3440 DATA 459E6D8A459E6D8A00458A00,1155
3450 DATA 00458A000000000000000000,207
3460 DATA 041000000000000000000045,89
3470 DATA 8A0000458A00459E6D8A459E,1046
3480 DATA 6D8A453C3C8A453C3C8A45FC,1222
3490 DATA BC8A45FCBC8A00F4780000F4,1581
3500 DATA 78000020100000201000028,166
3510 DATA 140000281400041000000000,100
3520 DATA 00000000CF8A0000CF8A00,690
3530 DATA 009EF816009EF816453CF000,1237
3540 DATA 453CF000453CBC00453CBC00,1015
3550 DATA 009E7816009E781600CF8A00,945
3560 DATA 00CF8A000000000000000045,89
3570 DATA 041000000000000000000029F4,1162
3580 DATA CF000045CF0029F46D0029F4,1133
3590 DATA 6D0000FC3C8A00FC3C8A007C,1133
3600 DATA 3C8A007C3C8A29B46D0029B4,1071
3610 DATA 6D000045CF000045CF000000,661
3620 DATA 0000000000000410C3C3C3C3,800
3630 DATA C3C3C3C312736F8112736F81,1526
3640 DATA C3FFAFC312736F8112736F81,1566
3650 DATA C3FFAFC312736F8112736F81,1566
3660 DATA C3FFAFC312736F8112736F81,1566
3670 DATA 12736F8147736F8B47736F8B,1245
3680 DATA 000000000000000000000000,0
3690 DATA 0410000000015373F2A0000,201
3700 DATA 0000003F372A000000000000,160
3710 DATA 2A00003B3F00003B3F00003B,345

```

```

3720 DATA 3F00000000000002A000011,122
3730 DATA 3F0000113F000002A001537,261
3740 DATA 3F3F00152A00081800000000,221
3750 'pen colour
3760 DATA 0,24,19,21,25,9,6,15,16
3770 DATA 8,7,2,11,23,26,10
3780 'select keyboard/joystick
3790 PEN 1:MODE 1
3800 LOCATE 5,1:PRINT "Control"
3810 PEN 2:LOCATE 5,5:PRINT "j Joystick"
3820 PEN 3:LOCATE 5,7:PRINT "k Keyboard"
3830 PEN 1
3840 IF INKEY(37)=0 THEN 3870
3850 IF INKEY(45)=0 THEN 3940
3860 GOTO 3840
3870 rt=1:rt$="Cursor right"
3880 lf=8:lf$="Cursor left"
3890 up=0:up$="Cursor up"
3900 dw=2:dw$="Cursor down"
3910 hv=47:hv$="Space Bar"
3920 LOCATE 5,5:PRINT SPC(10);
3930 GOTO 4000
3940 rt=75:rt$="Joystick right"
3950 lf=74:lf$="Joystick left"
3960 up=72:up$="Joystick up"
3970 dw=73:dw$="Joystick down"
3980 hv=76:hv$="Fire"
3990 LOCATE 5,7:PRINT SPC(10);
4000 LOCATE 5,10:PRINT "right" ;rts
4010 LOCATE 5,12:PRINT "left" ;lfs
4020 LOCATE 5,14:PRINT "up" ;ups
4030 LOCATE 5,16:PRINT "down" ;dws
4040 LOCATE 5,18:PRINT "hover" ;hvs
4050 PEN 2
4060 LOCATE 5,20:PRINT "pick-up" X
4070 LOCATE 5,22:PRINT "drop" Z
4080 PEN 3:LOCATE 10,24:PRINT "p to play"
4090 RETURN

```

Arnor
LTD

PROGRAMMERS!!! READ ON.....

THE ARNOR

“C”

THE 1st FULL IMPLEMENTATION

of the K&R standard on the Amstrad. Features include: optimising compiler★linker★PROTEXT program mode editor★I/O & math. libraries★full floating point★32 & 16 bit arithmetic★conditional compilation★macros★complete operators guide.....

£79.95 (incl. VAT & P&P)



MAXAM II

THE BEST ASSEMBLER

on the Amstrad, now under CP/M+ (as used by all the leading software houses.) **PLUS** the most powerful monitor ever seen under CP/M **AND** the PROTEXT program mode editor. Features include: Z80 assembler, now with macros★single stepping★conditional breakpoints★full expression evaluation★examine **ALL** memory banks★links to C★complete operators guide and much more...

£79.95 (incl. VAT & P&P)

BCPL “FOR HUMANS NOT COMPUTERS”

(CWA MARCH '87)

The system programming language that is easy to learn and easy to use, the ARNOR BCPL is a full implementation, compiling to Z80 M/C code and is extremely fast. Also includes: debugging routines★I/O libraries guide★CP/M and AMSDOS version in same pack!

(incl. **FREE** ROM for CPC owners).

£39.95 (incl. VAT & P&P)

ALL THREE PROGRAMS ON DISC FOR AMSTRAD PCW8256/8512 OR CPC6128

AVAILABLE NOW IN ALL GOOD COMPUTER SHOPS OR DIRECT...

24 HOUR CREDIT CARD NUMBER 01-684 8009 (6 LINES)

OR WRITE FOR FREE CATALOGUE

118 WHITEHORSE ROAD, CROYDON CR0 2JF

Arnor
LTD



NEW FOR PCW AND PC



AMSTRAD PCW 8256/8512

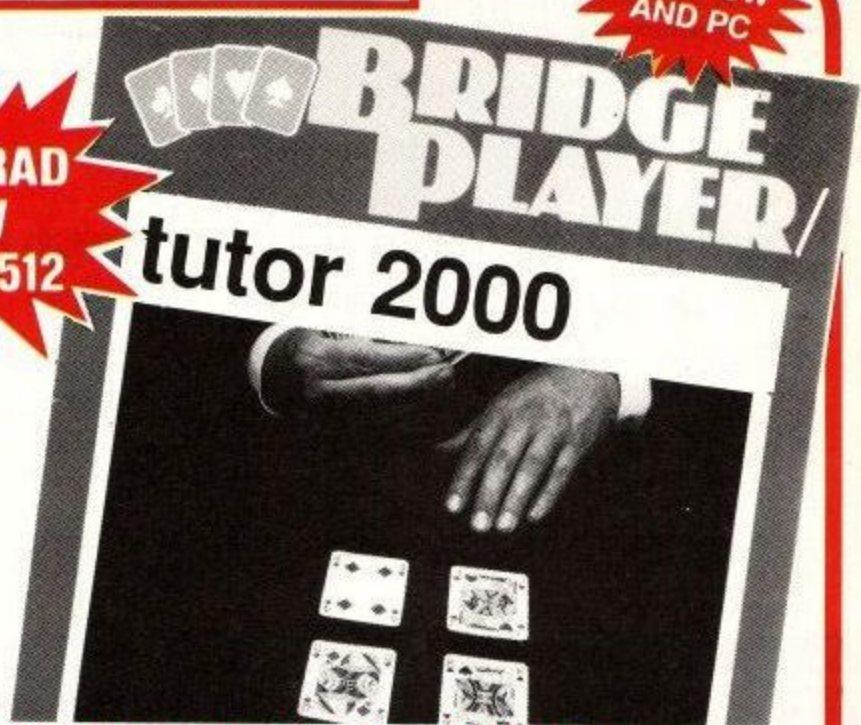

3-D CLOCK CHESS

NOW AT £15.95

Created in consultation with International Grandmaster and British Chess Champion Jon Speelman.

- FAST** with unique method of setting levels by time. 'Play against the clock' and 'matching time' modes.
- PENETRATING** at tournament levels - looks at least seven moves deep.
- FRIENDLY** - every possible feature. Ideal tutor for beginner and expert alike.

...VERSUS COLOSSUS CHESS: "3-D Clock Chess plays a stronger game" - PUTTING YOUR AMSTRAD TO WORK SEPT. 1986

"Excellent chess program... far too good for me... will test even stronger players" - AMSTRAD ACTION

BRIDGE PLAYER

£19.95

A challenging and realistic program for all bridge enthusiasts. **VERSATILE** bidding routines give you a really worthy opponent. **POWERFUL** bidding and play to appeal to the most experienced player. **COMPREHENSIVE** on-screen displays, keep you informed at all times. **EXCLUSIVE TUTORIAL OPTION** for beginners and improvers, with twenty set hands and expert guidance to bidding and play. The ultimate refinement in home computer versions of this sophisticated card classic. **NEW FEATURES INCLUDE:** bidding in ACOL system with STAYMAN and BLACKWOOD conventions *post mortem facility *rebid/replay *bias deal *claim rest of tricks *restart play of cards *input contract *tutorial section.



"All you ever wanted to know about GRAPHICS, THE UNIVERSE AND EVERYTHING on the PCW 8256/8512 ...but were afraid to ask."

£19.95

50+ routines and 100% PCW 8256/8512 compatibility—the ultimate PCW Toolkit. ★ Create DEVASTING GRAPHICS OUTPUT including fast smooth sprites. ★ Make direct use of RAM disc. ★ Create User Defined graphics. ★ Modify character set and send enlarged characters and UDG's to printer. ★ Experiment with sound routines. ★ Directly access video RAM system. ★ Discover hitherto unpublished hardware information—Port specifications and Edge connector diagram. ★ Access CP/M functions with ease. **ROUTINES INCLUDE:** Line draw/erase - Pixel plot/erase - Flood fill - Create sprite - Plot sprite - Move sprite - Change Character set - User defined graphics - Turn screen off/on - Invert screen - Sound - Send UDG's and Double height/double width characters to printer - Wait for Frame flyback - Delay - Randomiser - Move cursor anywhere - Read joystick - Disc motor off/on - Full software reset - Save/Load Memory from disc or RAM disc - Find system Clock - Save/Load screen from disc...AND MUCH MORE!

"Versatile... wide range of useful functions... good manual... excellent package" - 8000 PLUS JANUARY 1987

AMSTRAD CPC 464/6128

3-D VOICE CHESS

Cassette... £12.95 Disc... £15.95
Unique program brings you all the playing power of the original Amstrad Superchess, plus SPEECH and 3-D graphics. Beginners to expert levels with classic helpful features:
★ Analyse mode ★ problem solving ★ large opening library ★ help menu ★ change colours ★ recommended move

DRAUGHTS/ CHECKERS

Cassette... £5.95 Disc... £9.95
Complete with strategic hints, Kings and several challenging levels of play.

BRIDGE PLAYER 3

Cassette... £12.95 Disc... £15.95
Continuing the tradition of quality, this exceptionally strong bridge player will give even highly skilled players an engrossing game. **FEATURES** include bidding in ACOL system with STAYMAN and BLACKWOOD conventions ★ post mortem facility - rebid/ replay ★ bias deal ★ claim rest of tricks ★ restart play of cards ★ input hand/contract

BACKGAMMON

Cassette... £5.95 Disc... £9.95
Dice classic with fast moving graphics - easy to learn but hard to beat!

PINBALL WIZARD

Cassette... £5.95 Disc... £9.95
Colourful, fast-action graphics and sound give this game the feel of a real arcade pinball. Realistic launch, flippers, bumpers, high-score, bonus scores and freeball features.

SUPERCHES

Cassette... £5.95
The original Amstrad chess program - with seven levels of play to challenge you.

MAIL ORDER by cheque, postal order or ACCESS/VISA number (with expiry date). Telephone for instant credit-card orders. Send SAE for catalogue. DELIVERY is by soonest post. Post free in UK; Europe add 80p per program. All other places add £1 for surface mail or for Airmail add £2 for first program and £1 for each additional.

cp software STONEFIELD, THE HILL, BURFORD, OXFORDSHIRE OX8 4HX Tel: 099382 3463 Tlx: 57784 MCCL G

From the people who brought you Frank Bruno's Boxing, Space Harrier, Ikari Warriors and Bombjack, Jerry Muir brings you . . . The interview.

elite

If you draw up a league table of software houses, there's no question who the big boys are. Ocean and US Gold sit on high, churning out a mixture of resounding hits and the odd damp squib

But just under these giants lies a wealth of smaller companies who, far from being hidden by their shadows, are bright lights in their own right. They may be producing fewer games every year, but they've developed a reputation for consistent quality and house style.

In many ways it's more interesting to follow their fortunes than those of the apparently unshakable duo, because, as the proverb has it, mighty oaks from little acorns grow.

In fact a lot of software houses which are now household names began as very small acorns in the earliest days of home micros. Mikro-Gen copied arcade classics such as Centipede and Invaders; Hewson produced flight simulators; and the origins of Elite lie in a back-bedroom operation in the Midlands.

Second division?

Nowadays Elite is one of the most important of the "second division" companies, with a line of successful coin-op conversions to its name. But its rise has been gradual, hampered by occasional setbacks, and constantly enriched by a process of learning from its successes and failures, as company boss Steve Wilcox told me on my recent visit to the company's Walsall headquarters.

"Elite has been trading for two and a half years now. We started in September, 1984, as a completely self-financed software house. Before that I'd been involved as a retailer though, selling software and hardware since '83. It was just an opportunity that I spotted".

This route into the software industry contrasts with the origins of many of the smaller companies, which were founded by amateur hackers, working

late into the night to produce their first, mail-order efforts. But though Steve trained as a chemist, the mysteries of coding weren't entirely alien to him.

"My younger brother, Richard, put out a game called Blue Thunder.

"It was a straightforward back bedroom job. He wrote it while I was running the shop and got involved in putting the thing on the market.

"At that stage it was all very primitive, of course. Distributors were only just starting to operate. But it did well, and I decided that we should take on some more people to write some more products".

The first title to appear under the Elite banner was Kokotoni Wilf. "I don't know if you remember that?" Steve asks me. Indeed I do. This Jet Set Willy style game was a particular favourite of mine at the time.

There was nothing particularly revolutionary about the gameplay, apart from the fact that Wilf flew instead of

running and jumping, but the humorous scenery, set throughout the history of the earth, was well drawn and amusing.

The game appeared on the Spectrum, but never made it to Amstrad. I asked Steve why. "It was written for the Amstrad", he said, "but it wasn't particularly good, so we decided not to release it."

This concern about the quality of Elite programs is something that cropped up throughout our conversation. It's obviously very important to Steve to get things right. This has caused the delay in the release of the Amstrad Paperboy - the first version was scrapped when it failed to reach the mark.

So Elite started as what Steve calls the "typical thousand pounds finance job". Kokotoni Wilf sold fairly well. "Not a bad first effort", Steve says modestly. The next move was an ambitious one though. Elite was among the first companies to get involved in licensing TV shows.

Mixed reactions

"It was Ghostbusters that inspired us", Steve recalls. "Three or four months after the huge success of that game we recognised that there were other tie-ins that could be done and we went out and bought three at that stage - Fall Guy, Dukes of Hazard and the most successful of the three, Airwolf".

I can't help thinking he makes it sound like nipping down the market to buy five pounds of Kind Edwards.

Reactions to the first two tie-ins were rather mixed, though looking back at them, at least they resemble their originals, which is more than can be said for some recent tie-ins.

Airwolf wasn't without its controversial aspects either. A wall at the very start, which had to be shot away, made it difficult to get going. In retrospect, Steve reckons that this was a mistake,

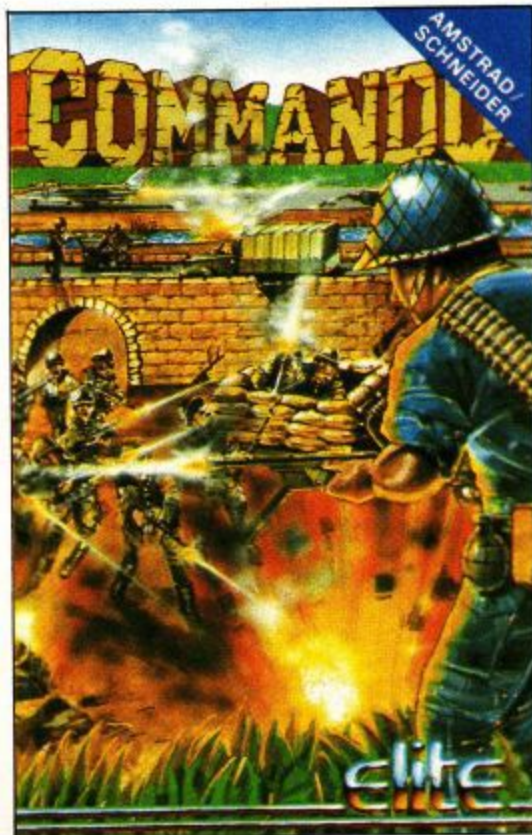

but that if you persevered you faced a very reasonable game.

After these three programs Steve decided not to follow the path any further. "The image of these games got tainted fairly quickly, and it seemed to us that some of the added value of the license disappeared from the product. But that's not to say that we won't do them again".

Good sports

So Elite began to look around for something else, and for the next three programs they bought sporting names. First up was an official Grand National game which was well received but which failed to spark the public imagination.

Its sequel, a rally driving game linked to Dunlop tyres, re-used some of the programming ideas, but turned out to have a flat as far as critics and punters were concerned.

"There was a stage between the purely character merchandised product and getting involved with the coin-ops where, I freely confess, we got a little bit lost. We agonised for some time over Dukes of Hazard as to whether to actually release it.

"But I think that we learnt a lot at that stage about the necessity to get product right. We had a couple of things which were really quite disappointing. But we were a very young company and we didn't know much about the business".

That ignorance included how long it takes to produce a game – something that still causes a number of companies to trip up.

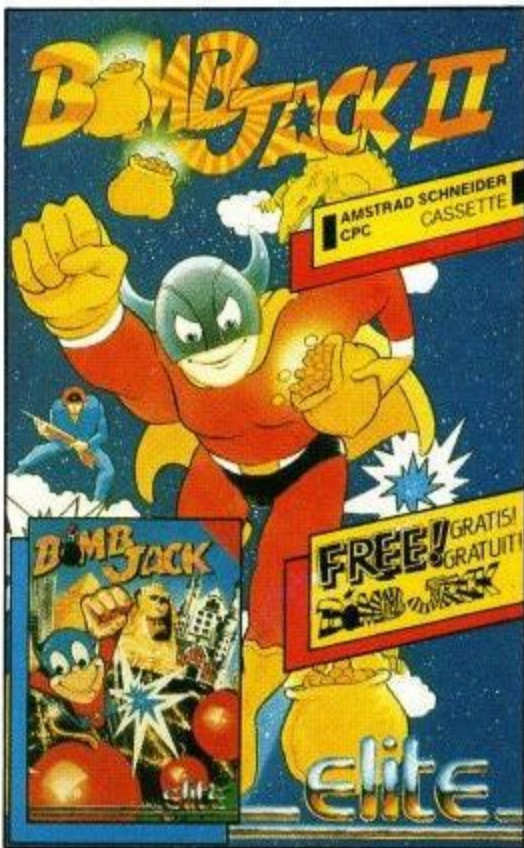

"That led to a product gap in the second quarter of '84. We'd made a decision at the start of the year that, rather than follow the trend to bang out as much product as possible, we'd go for the quality end. Which meant that between February or March and August '84, we didn't release anything".

But despite the resulting loss of cashflow, following a healthy Christmas period Elite was far from dead. Steve saw the real danger to the company not in terms of being forgotten, but in churning out bad product. A couple of projects were scrapped when they didn't make the grade.

The game that heralded the re-emergence of Elite was the third of their sporting tie-ins, Frank Bruno's Boxing. "We spent a long time developing it and there was a spate of boxing games, so we had to make the decision whether to rush it out.

"We took the longer term view and decided to develop it properly, wait the two months, and put out a good program". This philosophy worked, and Frank Bruno became micro champ immediately. He's still there, battling away, though looking rather queasy, on the Joyce.

There was another three month gap before the first game that was to launch the series for which Elite is probably best known, its coin-op conversions. Commando shot out of the arcades when Elite observed the success of titles such as Hypersports. But, as I pointed out to Steve, it's very easy to imitate the style of a machine without going to the expense of obtaining official permission.

"Yes", he agreed, "but the name is important. It's the only way you can produce a perfect copy of the game. There were a number of Commando clones out but the only way to do it properly is to take out a license".

Gut feelings

I was interested in how you go about choosing a machine from the arcades, then obtaining permission from its manufacturer. Steve's formula for success is to look for a degree of originality mixed with playability. "But it's a mixture of gut feeling and talking to people in the coin-op business", Steve explained.

Coin ops are big business. There's even an annual trade fair at Olympia in London. Steve tells me that there's a lot of competition for the best titles. However he reckons that there are more machines than could be converted in a year, so the supply shouldn't dry up just yet. Elite has licensed games from

eight or nine different publishers so far.

Once he's decided on his title the negotiations begin, and it can be an expensive business. "There are a number of significant interested parties, and it does force the prices up". Some of the companies have UK offices, but Steve can find himself dealing directly with the USA or even Japan.

Some companies are more concerned with how the conversion works out than others, but Elite always sends out demos as programming progresses and there is always the right of approval as an incentive to get things right.

Programmer education

That process is helped by making the programmers get to know the game, so one of Elite's first moves is to buy a machine and set it for free play. This can then be used by the people who will do the coding, so that they know every

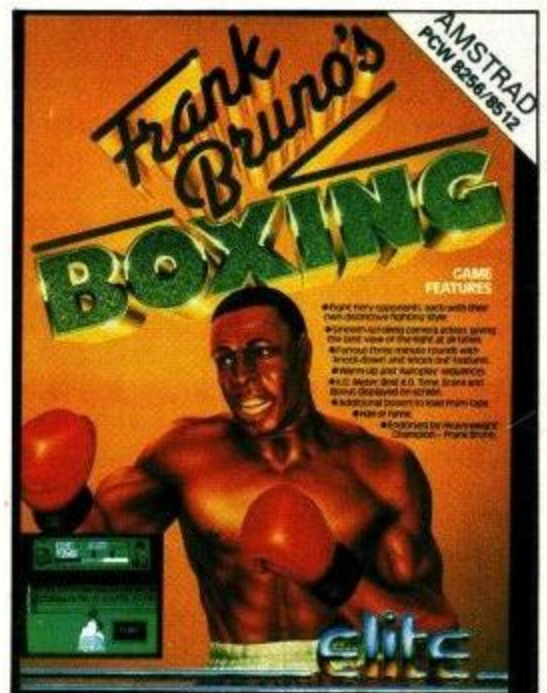

little detail – a job which sounds like heaven or hell, depending on your attitude to arcades.

While much of Elite's programming has been done on a freelance basis away from Walsall, one of the moves in '87 is to recruit a team of programmers, graphic artists and a musician. "Not a very large number to begin with, but we want people who can do the job properly".

But the program development houses will continue to play a vital role, and Elite frequently deals with three or four teams, plus individuals.

Once the team has taken the original to bits, they're in a position to submit a proposal to Elite, detailing what they think they can include in the game and how they intend to tackle its problems. Target dates are set, and after that

work in progress is submitted every two to three weeks.

Lack of computer training is no setback for Steve. He's absorbed enough information about what is and what isn't possible on the various micros. So when the prototype is evaluated back in Walsall it can be returned to the programmers with a report which details suggestions for alterations, whether they're major changes or mere fine tuning.

Development usually takes something over six months, but Elite hopes to have a finished version six weeks to two months before it appears into the shops. *Bombjack II*, which has only just appeared, was completed on two systems before Christmas.

It's not all coin-op conversions at Elite. *Scooby Doo* was a return to the tie-in formula. It also appeared long after it had been announced, and in a very different form to its original concept. I asked Steve why.

"We'd bought the license quite a time ago, in early '85", he said. Originally it was meant to be something akin to *Dragon's Lair*, with events in one episode shaping what happened next. "It was meant to play very similarly to that, but we ran into memory problems. At that stage we were very unsophisticated as far as program development was concerned".

So the project was re-designed, this time by the more than capable Gargoyle team, and Steve is now pleased with the product, though I detect a certain amount of regret that the original, ambitious and innovative idea never came to pass.

The one area where Elite was left with egg on its face in '86 was the £2.99 Classics range of budget re-releases. "We recognised that there was a section of the market that was growing. But I think, on reflection, that we didn't have the management capacity at that stage to administer the project. It was a lesson very well learnt, even if it was a rather embarrassing one".

However they've not given up on the idea of value for money software.

Following the success of last year's four program *Hit Pack*, this year will see a compilation from various sources, including *Scooby Doo*, *Antiraid*, *Fighting Warrior*, *Split Personalities*, *1942* and *Jet Set Willy II* - all for only £9.95.

1987 will also see a slight shift of emphasis from the coin-op conversions. In fact the year's first release, *Bombjack II*, is half way to being an original.

Instead of just having to collect the bombs, Jack now has to get them in order. And the nasties have become more vicious, metamorphosing into

tougher threats the longer he leaves them. The only way to deal with them is to push them off the ledges. New backdrops range from Sydney Opera House to Stonehenge.

Future plans

Out of the 12 titles that Elite plans to release in the year - the limit of the company's programming resources, according to Steve - four or thereabouts will be wholly or semi-original.

These could include licenses, because Elite owns some tie-ins which they plan to sit on for a while. "But we're not willing to do what some of our competitors do", Steve says, in uncompromising tones, "and buy up 25 properties then put them out, even if they are crap".

Elite now boasts 14 permanent staff, spread over two floors. The only problem that I can see with their premises is that the warehouse space is on the first floor and there's no lift. This means that Scott and Mark, whose realm is the stockroom, have to shift as many as 150 parcels a day up and down the stairs.

But constant movement of product is important, and the newly computerised system ensures that there is a fast turnover to suppliers.

"It's a very tight little operation", Steve says. "Overheads are very small". But with a turnover of around £3 million last year, it's become necessary to take on a couple more administrative staff, if only to ease the burden on Steve's father, Brian, who has handled this side from the start.

Elite's growth, based on quality, will be an organic affair, not a sudden flash in the pan though.

Looking forward to the next year, Steve is quite happy about the position of the Amstrad. "It's an important machine to us. It's also a machine that we're able to produce some extremely pleasant games on, so we like it in that respect too". He quotes

Ikari Warriors as a good example of Amstrad's capabilities.

Amstrad software is also doing its bit

for the export drive. It's very popular in France and Germany, where Elite has subsidiary companies, and in January foreign sales exceeded UK figures.

But Steve laments the cost of discs, which he claims makes a market for disc based software economically unviable in the UK at least.

One of the big questions for the coming year is whether games consoles will take a bite out of the computer market. Steve thinks that they'll complement each other, but reckons that the pricing structure at the moment is all wrong.

"We wouldn't publish a game for these machines if it has to sell for £15 or £20 a piece. It's going to depend on those prices".

Finally I ask Steve about his plans for games for the PCW and PC.

In both cases he says that any moves would be "toe in the water operations".

So while you shouldn't be surprised by an equally green successor to Frank Bruno, or the Elite logo on a 5¼in disc, you can be sure that Steve and his team will have looked long and hard at the potential market before playing their best shot.

You don't get rich by ripping off the customers or throwing money around. Caution is the way you join the Elite.

ACU

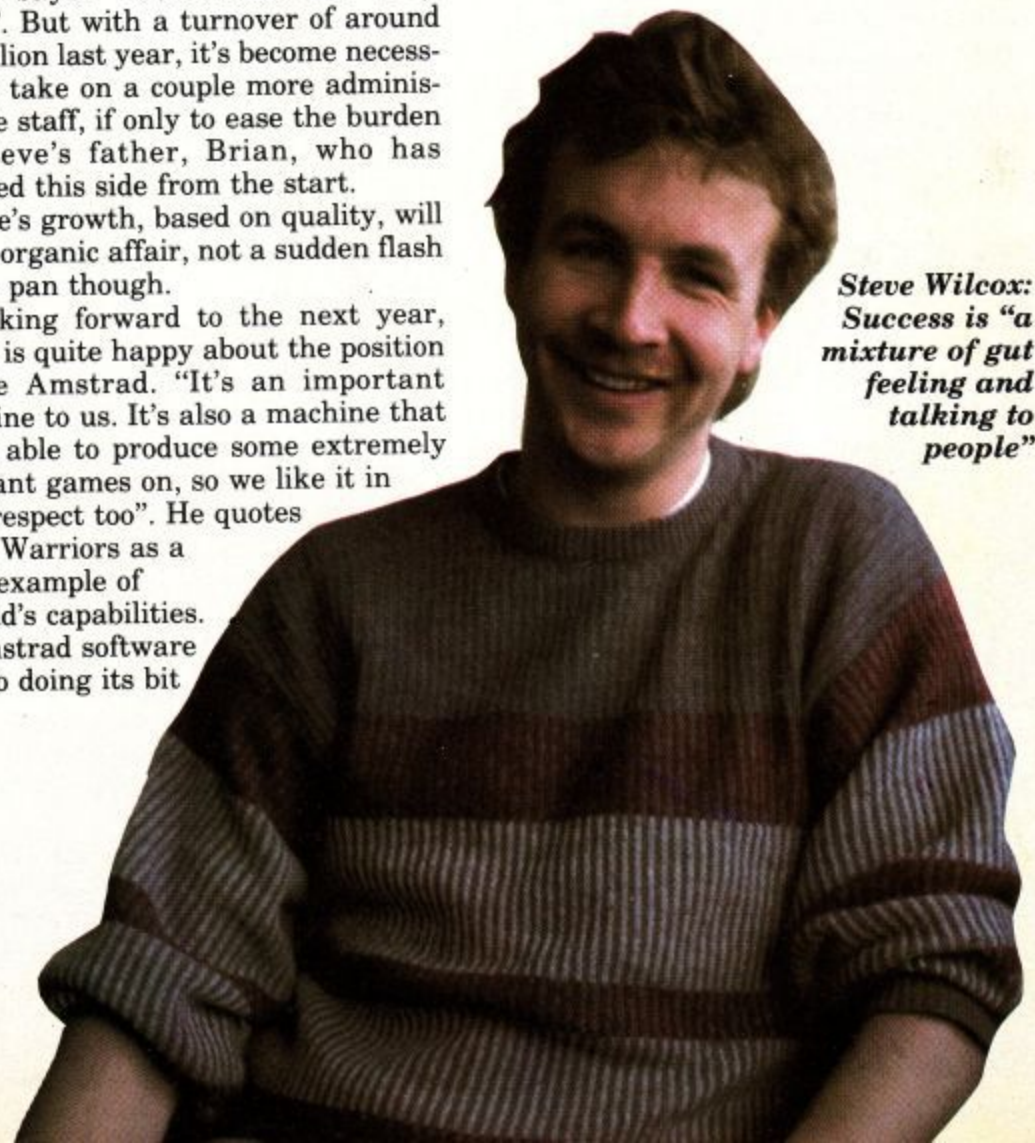

Steve Wilcox: Success is "a mixture of gut feeling and talking to people"

R.S.D. WILL SEE YOU'RE WELL CONNECTED

AMSTRAD

Printer Cable	
664/464/6128 1m	£8.95
2m	£9.95
Extension Printer Cable	
1m plus power. (PCW)	£9.95
Monitor Extension Lead	
664/6128 1m	£8.50
PCW Cable from Interface to	
Centronics Printer	£12.75
Expansion port extension lead	
6" Single F/M	£10.50
6" Double F/2m's	£14.75
Suitable - 664 & 6128	
Second drive lead	
1m 664 & 6128	£6.95
Cassette lead	£2.20



NEW
PC 1512
PRINTER LEAD

1.8m
£12.75

RS232 GENDER CHANGERS

Avoid modifying or replacing incompatible cables. m/m, f/f.

Our Price only £8.50

RS232 CABLES
MODEM LEADS
MADE TO ORDER
FOR ALL TYPES
OF COMPUTER
AND MODEMS

DISK HEAD CLEANERS

5.25" Wet type for use with single or double-sided disks, including 6 cleaning sheets £8.95

DATA SWITCHBOXES



This new range of slimline switchboxes enables you to switch quickly and easily between micros and printers

RS232 (Serial) metal cased	
25-way 'D1' to 2-way	£49.00
25-way 'D1' to 3-way	£59.00
25-way 'D1' to 4-way	£69.00
Centronics (Parallel) metal cased	
36-way Centronics 1 to 2-way Para	£54.00
36-way Centronics 1 to 3-way Para	£69.00
36-way Centronics 1 to 4-way Para	£79.00

All cables at discount prices when purchasing Data Switchboxes



TELEPHONE EXTENSION CABLE

Plugs into your phone socket enabling you to take your phone up to 50ft away - no need to pay for extensions! Enclosed in neat case with moulded carrying handle. Approval No. NS/2236/3F/450927. British made.

£9.95

TELEPHONE CONNECTORS

Surface master jack socket	£3.75
Surface Extension socket	£2.50
Dual outlet adaptor	£4.25
Line jack cord 3m	£1.85
4 core cable per metre	.15
BT plugs	.48

3" DISKS

BOX OF 10 CF2's
£29.90

AMSTRAD

NEW... JOYSTICK SPLITTER

Play with a friend! Splitter enables 2 joysticks to be used independently

ONLY £6.95

Twin port Joystick £6.50

DUST COVERS

PC1512	£9.50	All covers
6128	£7.25	clear with
PCW sets 3	£9.50	Grey piping

MONITOR LEADS

Fidelity (Scart) to: BBC/QL/Commodore/	
Sony/Spectrum 128 & Plus 2/Amstrad	£4.95
Microtec to: BBC/QL/Spectrum 128 & Plus	
2/Amstrad	£2.75
Ferguson to: BBC/Commodore 64/MSX/QL/	
Spectrum 128 & Plus 2/Amstrad	£3.50
Hitachi to: BBC/Commodore 64/QL/Spectrum 128	
& Plus 2/Amstrad	£3.50
Sony Kaga to: BBC	£5.95
Green screen to: Commodore 64/BBC	£2.95
Green screen to: QL	£1.95
Green screen to: Commodore 128	£4.95
Phono to Phono	£1.50
Philips to: BBC/Commodore 64	£2.95

DISTRIBUTION SOCKET

4-WAY MAINS
TRAILING SOCKET
ONLY £9.50



RIBBON CABLE (per ft)

10-way	15p	20-way	30p
26-way	45p	34-way	60p
40-way	70p	60-way	£1.10

CASSETTE HEAD CLEANERS

Wet type. Set includes Pin-wheel demagnetizer & full instructions £2.50

75p P&P IN UK, Access & Visa accepted. Please add 15% VAT to all orders. Cheques made payable to:

R.S.D. CONNECTIONS LTD Dept AU5, PO Box 1, Ware, Herts

Tel: 0920-5285/66284



HSV COMPUTER SERVICES LIMITED

CONTINUOUS STATIONERY - MICRO PERF ALL EDGES

	250	500	1,000	2,000
9.5" x 11" 60 GSM WHITE	£2.95	£4.95	£8.95	£14.95
TRUE A4 90 GSM WHITE	5.25	8.75	14.95	—
TRUE A4 100 GSM WHITE BOND	6.50	9.95	16.25	—
TRUE A4 100 GSM COLOURED BOND - CREAM, BLUE, GREY	7.25	13.50	25.50	—
LABELS 3.5" x 1.5" (1 across)	—	2.95	4.95	9.50
LABELS 4.0" x 1.5" (1 across)	—	3.25	5.50	10.50
LABELS 4.0" x 1.5" (2 across)	—	3.75	6.50	11.95
LABELS 2.75" x 1.5" (3 across)	—	2.75	4.50	8.50

**NEW
PRICES**

PRINTER RIBBONS

AMSTRAD 8512/8256	Each
AMSTRAD 8512/8256 (Red, Blue, Brown, Green, Purple, Orange)	£3.95
AMSTRAD DMP2000/DMP3000	£4.95
AMSTRAD DMP2000/DMP3000	£3.95
DUST COVERS PCW8512/8256	Set of 3 £8.50
PC1512	Set of 2 £9.50
CPC6128	Set of 2 £8.50
DMP2000 Printer	Set of 1 £4.50

DISKS

3"CF2 AMSOFT/MAXELL ... 1 - £3.10	5 - £14.95	10 - £27.95
5.25" DS/DD 48tpi ... 10 - £6.95	20 - £13.00	30 - £19.00

DISK STORAGE BOXES (3" Disks)

10 x 3" HINGED LID - Holds 10 (cased)	Price Each
20 x 3" HINGED LID - Lockable - Holds 20 (cased)	5.95
50 x 5.25" HINGED LID LOCKABLE	9.95
100 x 5.25" HINGED LID LOCKABLE	7.95
	11.95

**CREDIT CARD
HOTLINE**

(0256) 463507



ALL OUR PRICES INCLUDE CARRIAGE & VAT - NO EXTRAS TO PAY!

HSV COMPUTER SERVICES LIMITED, 40-42 New Market Square, Basingstoke, Hants RG21 1HS (0256) 463507

In virtually any machine code routine you see published there will be a number of program lines using the PUSH and POP instructions. People who have only programmed in Basic may not have come across these terms as there are no Basic keyword equivalents. However, Basic does use them in a hidden way, as you'll see in a moment.

PUSH and POP are used to manipulate data on a type of structure called a stack, which is simply a list of numbers stored in the computer's memory, but which can only be "got at" in a special way. The analogy usually made – and who am I to break with tradition? – is of a stack of plates.

You can add (PUSH) plates on to the top of the stack, and later remove (POP) them off again, but the first plate you POP off must obviously be the last one you PUSHed on. You can't get at the plates further down the stack until the ones higher up have been removed. This is why stacks are also known as Last-In First-Out (LIFO) buffers.

What kind of jobs can we do with a stack? Basic uses one to keep track of the return addresses of GOSUBs. Remember that in Basic, subroutines can be nested; that is, one subroutine can call another, which can call yet another and so on. All the GOSUBs are ended by the same command, Return, and yet each time the return is made to the correct place in the program.

What Basic does, when it finds a GOSUB command, is to PUSH the address of the next command onto a stack, and then go to the subroutine. When it finds a Return, Basic POPs whatever is on the top of stack and uses that as the return address. So each Return goes back to the most recently-called GOSUB; the stack structure automatically ensures the correct program flow.

Since computers don't have an infinite amount of memory, PUSHing without POPping will eventually fill the stack. That's why there's a limit to the depth that subroutines may be nested – about 50 on the Amstrad ("about" 50 because other functions may use some stack space, too).

On the Z80, as in any other micro-processor I know of, the programmer is provided with a "hardware stack", that is the stack function is built into the chip. Since we're dealing with numbers

Pushin' an' poppin' round the stack

For those people who have not had their fill of machine code, Peter Green fearlessly discusses the joy of stacks

held in memory, not china plates on a table, we need a 16 bit pointer to keep track of the position of the top of the stack. This, not unreasonably, is called the stack pointer, and in op-code mnemonics which refer to it directly it is called SP. For example, the Z80 stack can be anywhere in the 64k address space, so to place the stack at &C000 you write:

```
LD SP,&C000
```

This is where the Amstrad firmware, and most applications, initialise the stack pointer. Now alert readers will be saying "Wait a minute! The Amstrad screen memory starts at &C000. Using the stack will corrupt the screen".

Well, if the stack behaved like our china plates and grew upwards, you'd be right. Luckily, as numbers are added to the stack its top moves downwards in memory. We say that the stack "grows downwards", so that when a number is PUSHed, SP decreases, and when a number is POPped, SP increases.

This is not just bloody-mindedness on the part of the chip designers. Since the program instructions start in low memory and run upwards, if the stack starts in high memory and runs downwards you minimise the risk that they will try to use the same memory, corrupting either the program or the stack contents and crashing the machine.

Use and abuse

So what is the Z80 stack used for? The most obvious answer is for storing subroutine return addresses, just like Basic. Whenever you CALL a routine, the address of the next instruction after the CALL is automatically PUSHed on to the stack, and the Z80 jumps to the routine.

When a RET is executed, the return address is POPped off the stack and into the PC (program counter) register, and the program continues running at the instruction after the CALL.

However, the PUSH and POP instructions also allow the programmer to store any of the 16 bit register pairs on the stack and retrieve them later. As I've pointed out before in this series, in machine code the registers are heavily used, and data has to be continually moved in and out of them.

Values that need to be saved temporarily while a register is used for something else could be loaded directly into a memory and retrieved later, but such op-codes must include the memory address and use three or four bytes.

PUSH and POP automatically use SP as a memory pointer, so they need only one or two bytes, making the program smaller and faster.

You have to be careful how you use the stack, because mucking it up is easy to do, and always disastrous. For example, remember you can't PUSH a set of variables on to the stack, CALL a subroutine and then POP the values back off as parameters for the routine to use.

The first thing you POP will be the return address that the CALL placed *on top of your* data, so the subroutine will be working on the wrong numbers and has also thrown away its correct return address. This is a common mistake among machine code beginners (it took me ages to stop doing it!).

Another point is that when using the stack to store temporarily register values that a CALLED subroutine would otherwise corrupt (we do this a lot in the example program this month), the registers must be POPped off in the reverse order that they were PUSHed remember LIFO! Get into the

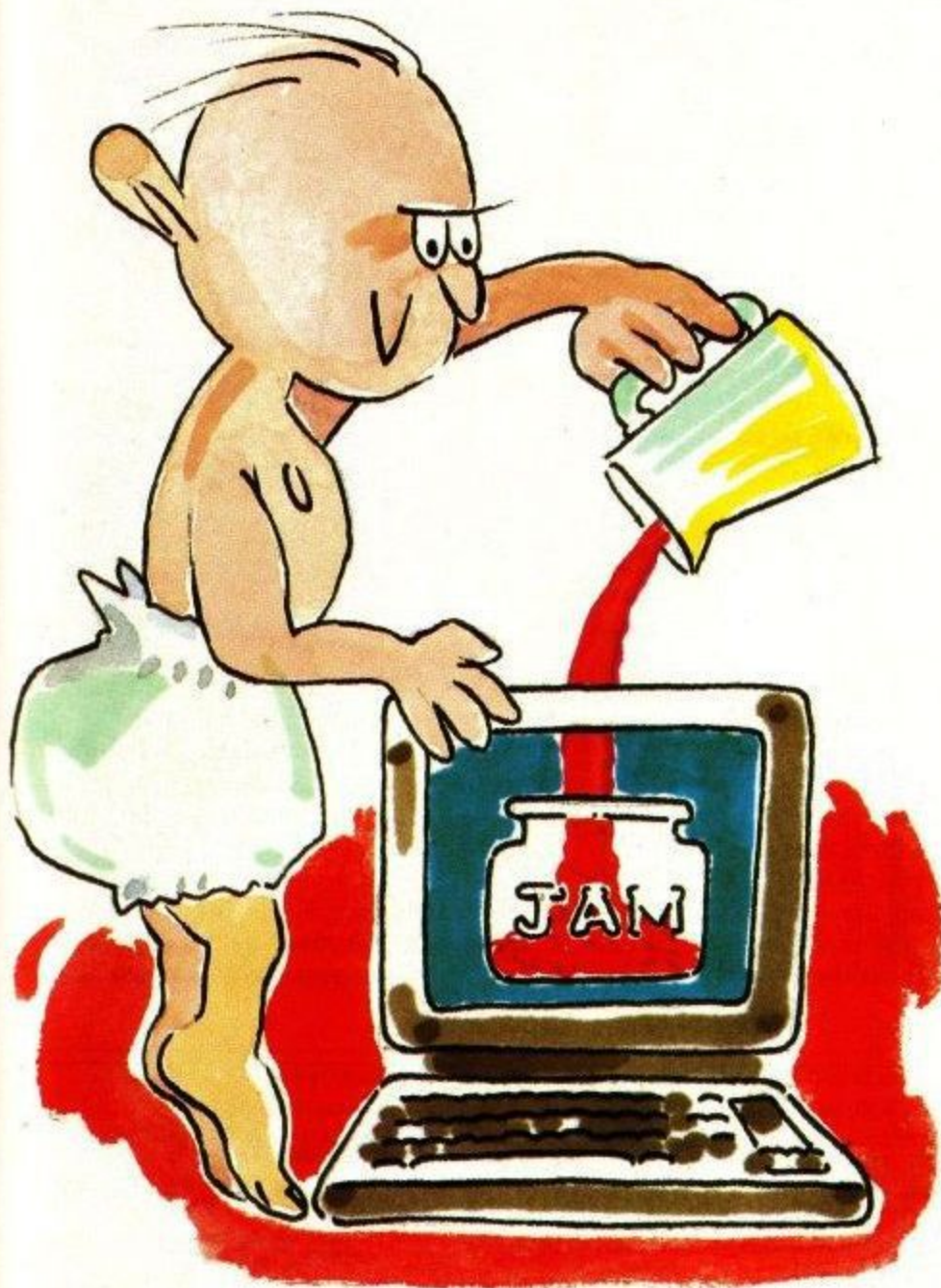

```

background_colour=TESTR(0,0)
IF background_colour=fill_colour THEN RETURN

LET graphics_foreground_colour=fill_colour
dx=21(2-mode)
stack_pointer=-1
PUSH start_x:PUSH start_y

WHILE1 stack_pointer>-1
  POP y:POP x
  MOVE x,y

  WHILE2 TESTR(dx,0)=background_colour AND x+dx<640
    x=x+dx
    WEND2

  top=1:bottom=1

  MOVE x,y

  WHILE3 TESTR(0,0)=background_colour AND x>-1
    PLOT x,y
    LET test_colour=TESTR(0,2)
    IF y>396 THEN top=0
    IF test_colour<>background_colour THEN top=1
    ELSE IF top=1 THEN PUSH x:PUSH y+2:top=0

    LET test_colour=TESTR(0,-4)
    IF y<2 THEN bottom=0
    IF test_colour<>background_colour THEN bottom=1
    ELSE IF bottom=1 THEN PUSH x:PUSH y-2:bottom=0

    x=x-dx
    MOVE x,y
    WEND3

  WEND1

```

habit of ordering such a sequence alphabetically, thus:

```

PUSH AF
PUSH BC
PUSH HL
CALL something-or-other
POP HL
POP BC
POP AF

```

That makes it easier to spot any silly errors when debugging. Some programmers use PUSH reverse-alphabetically and POP alphabetically. Well, there's no accounting for taste.

Of course, you might want to swap registers deliberately using the stack. The only op-code provided for a register swap is EX DE,HL, which puts the contents of register pair DE into HL and vice versa. But if you needed, say, the equivalent of EX DE,BC, then:

```

PUSH BC
PUSH DE
POP BC
POP DE

```

will do the trick. This is also the only

(legal) way of copying values between the general register pairs (AF,BC,DE,HL) and the index registers (IX and IY). Again, both these techniques feature in the example listing.

Finally, there's no reason to limit yourself to the machine stack. A stack is just a block of memory, a top-of-stack address pointer and a defined rule for accessing the data. The Z80 has plenty of 16 bit registers, so why not use one to set up your own user stack for certain applications? You've guessed it - see the example listing!

Filling you in

The example program this month is an area fill based on an algorithm that guarantees every nook and cranny of a closed shape will be reached. It makes heavy use of the machine stack, mainly to preserve registers through CALLs to the Amstrad's graphics firmware routines (most of which corrupt most of the registers). It also sets up a user stack, with the IY register as a stack

pointer, to store the screen coordinates of any unfilled areas it will need to process later.

Listing I is a description of the fill algorithm in pseudocode (that is, English-like but not corresponding exactly to any real programming language).

Listing II is the equivalent translation into Amstrad machine code. The pseudocode uses three WHILE-WEND loops which are not available in machine code, but there's nothing to stop us simulating them by using conditions and machine code GOTOs, that is JR and JP, in the right way.

Structured programming doesn't mean never using GOTO; it means using it properly. In machine code, GOTO and GOSUB are all we've got to work with.

To show how the loops translate into machine code, I've numbered them as WHILE1-WEND1, WHILE2-WEND2 and WHILE3-WEND3 in Listing I, with similar labels in Listing II.

If the colour of the starting point is the same as the required fill colour, the

routine quits immediately. Then the value dx is set up, which is the number of user coordinates/pixel in the x direction. This reduces the testing overhead on the lower resolution screens.

The algorithm works by treating a closed figure to be filled as a series of horizontal lines, each one pixel high. The routine moves to the extreme right hand end of a line segment, then moves to the left, filling the line pixel by pixel. As it goes, it also checks above and below, and if it finds a new, unfilled line segment (that is a pixel still in the background colour), it adds a coordinate from that segment to the user stack. The flags "top" and "bottom" are used to ensure that only one point (all we need) from each unfilled line segment is added to the stack, to avoid wasting stack space.

When the extreme left hand end of the line segment being filled is reached, the program POPs a new point off the user stack, moves to that coordinate and repeats the whole procedure.

The routine fills either as far as the first non-background colour in any direction or the edge of the screen. Note that the coordinates for the edges (0-639, 0-399) assume that the origin (point 0,0) is at the lower left hand corner of the screen. Use ORIGIN 0,0

or the machine code equivalent (GRA_SET_ORIGIN) if in doubt.

The fill is started by picking a point within the area to be filled and "priming" the user stack with that point. It finishes when the user stack is empty, that is all line segments within the boundary have been identified and filled.

The price to pay is speed, though. To guarantee not missing a point, every pixel in the figure is tested at least twice, and sometimes three or four times.

The user stack can't shrink indefinitely, because when it's empty we've finished filling. It can't grow indefinitely, because we test the user stack pointer and abort the PUSH if the stack is full. Since the stack can't escape from its fixed allocation of 256 bytes of memory, it doesn't matter much whether it grows up or down. So for variety, I've arranged for the user stack to grow upwards.

Also note that a single "push-user" stores the four bytes from DE and HL on the stack, whereas the machine stack stores two bytes (that's why all data storage on the stack is in register pairs like AF, BC and so on). You can tailor user stacks to suit your application.



As a stiff test, the demo in Listing II prints the words "Pan-galactic Gargleblaster" (the editor's favourite tippie), draws a box round them and fills the box. This example uses up about half the user stack space. If the stack should fill up, any further points are simply not added, so parts of the figure won't get filled.

```

ORG 88000

TXT_OUTPUT      EQU 88B5A
TXT_SET_CURSOR  EQU 88B75

GRA_MOVE_ABSOLUTE EQU 88BC0
GRA_SET_PEN      EQU 88BDE
GRA_PLOT_ABSOLUTE EQU 88BEA
GRA_TEST_ABSOLUTE EQU 88BF0
GRA_TEST_RELATIVE EQU 88BF3
GRA_LINE_RELATIVE EQU 88BF9

SCR_SET_MODE    EQU 88C0C
SCR_GET_MODE    EQU 88C11

LD A,1
CALL SCR_SET_MODE ;Set Mode 1 for demo
LD HL,80410
CALL TXT_SET_CURSOR ;Move text cursor to middle of screen
LD HL,string
CALL print ;It seems I've heard that song before...

LD A,2
CALL GRA_SET_PEN ;Set graphics pen colour (cant do this in BASIC!)

LD DE,30
LD HL,170
CALL GRA_MOVE_ABSOLUTE ;Move to top left hand corner of a box

LD DE,450
LD HL,0
CALL GRA_LINE_RELATIVE
LD DE,0
LD HL,-36
CALL GRA_LINE_RELATIVE
LD DE,-450
LD HL,0
CALL GRA_LINE_RELATIVE
LD DE,0
LD HL,36
CALL GRA_LINE_RELATIVE ;Draw a box round the text

LD A,3 ;Fill the box in PEN 3
LD DE,34 ;Start x coord for fill (in user coords)
LD HL,168 ;Start y coord for fill (in user coords)
CALL fill ;Fill the box
RET ;and quit

.print
LD A,(HL) ;Well, you all know how this one works by now
INC HL
OR A
RET Z
CALL txt_output
JR print

.string
TEXT "Pan-Galactic Gargleblaster",0

.fill
;-----
;Entry conditions: A=required fill colour
; DE=user x coord of start point
; HL=user y coord of start point
;Exit conditions: All registers corrupt
;-----

PUSH AF ;Save required fill colour
PUSH DE ;Save fill start x coord
PUSH HL ;Save fill start y coord
CALL GRA_TEST_ABSOLUTE ;LET A=colour at start position
LD IX,background_colour
LD (IX+0),A ;Store background_colour
POP HL ;Restore fill start y coord
POP DE ;Restore fill start x coord
POP AF ;Restore fill colour
CP (IX+0) ;Same as background?
RET Z ;Quit if same

CALL GRA_SET_PEN ;LET graphics_foreground_colour=fill_colour

CALL SCR_GET_MODE ;What mode are we in?
LD A,4 ;dx is 4 for Mode 0
JR C,set_dx ;dx is 2 for Mode 1
LD A,2 ;dx is 1 for Mode 2
JR Z,set_dx
LD A,1 ;dx is 1 for Mode 2

.set_dx
LD (IX+1),A ;Store dx (= 2[(2-mode)])
LD IX,stack-1 ;LET stack_pointer=0
CALL push_user ;PUSH start_x and start_y

.while1

```

JACKSON COMPUTERS LIMITED JOIN OUR DISCOUNT CLUB!

Life membership for £8.50

Software/Hardware Discounts of 5-20% off RRP

All AMSTRAD and other leading makes of software available

Complete computer system, Printers, modems, cables

AMSTRAD CPC464 with colour monitor

£279.90

AMSTRAD CPC6128 with colour monitor

£379.90

PCW8256/512

£419.95/£545.00

NEW AMSTRAD IBM compatible PC1512 mono/single floppy

PC1512 HD 20MB Hard disk & colour screen

PC1512 HD 10MB Hard disk & colour screen

Ring for details

Tandon 20 Meg add-on Disk Drive for PC 1512

£456.00

All prices include VAT, Postage + Packing

Also free Life Membership when you purchase any AMSTRAD computer

Visitors by arrangement only

TEL: 01-651 6244

Send for full Price List & membership form to:
25 Spring Lane, Woodside, South Norwood,
London SC25 4SP

Have you heard about the

HFP

- for Amstrad CPC 6128 and PCW 8256/8512
- a new approach to home finance • a program that helps you to save
- save for your holidays ... a new car ... a new house ... you name it!
- designed especially for the home
- easy to use • no codes • comprehensive manual
- up to 15 accounts • personalised program • reliable

Only £24.95

Send sae for further details and order form

Datavise (ACU)

20 Drumnaquoile Road, Castlewalian
Co Down BT31 9NT

3" HITACHI DISK DRIVES

Suitable for use on the Amstrad 6128, 664, Tatung Einstein, BBC with DFS. 40 track, double density. 3 ms track access time. Unformatted capacity — single sided 250k; double sided 500k. Shuggart interface. Plug compatible with 5 1/4 inch drives.

PRICE:
£29.95 + VAT
Single sided
£39.95 + VAT
Double sided



Cables available for connection to:
Amstrad — £7.50 plus VAT.
BBC — £10.00 plus VAT.
Tatung — £10.00 plus VAT.

Carriage £3 + VAT

FOR FURTHER DETAILS SEND S.A.E. TO:

MATMOS Ltd., Unit 11, Lindfield Enterprise
Park, Lewes Road, LINDFIELD,
West Sussex, RH16 2LX. Tel. 0444-73830

Or Computer Appreciation,
111 Northgate, CANTERBURY, Kent. CT1 1BH.

The UPGRADES

The specialist PCW magazine '8000 Plus' selected our Upgrade as
"BEST VALUE D-I-Y MEMORY UPGRADE"

"Instructions are clear and concise ... easier than you think".

Our simple, comprehensive instructions require skills similar to replacing a fuse.
We supply tested, TOP QUALITY, fast (150ns) chips which are jig preformed for ease of insertion - NO
BENDING REQUIRED - plus a spare 'practice' chip.

PCW 8256 256K internal Memory Upgrade £23.90
Internal DS/DD 2nd Disc Drive £135
Memory Upgrade plus 2nd Disc Drive £155

PC1512

128K Memory upgrade to 640K, essential for many recent
application programs, or to create a RAM Disc of 360K on
single drive machines.

£23.95

Prices include VAT and P&P. Delivery is normally by return.
Send Cheques/PO/LA orders to:



SILICON CITY

Dept. A, Mithian, St. Agnes, Cornwall TR5 0QE
Access/Visa orders: Telephone 087 255 2112



"Quite the best and most flexible personal accounts system I've seen - doubles as an inexpensive-business system" Computing with the Amstrad September 1985

"Money Manager is good enough to make most programs of this type give up in shame" Popular Computing Weekly 17-23 April 1986

Unbeatable value

CPC464

CPC664

CPC6128

MONEY MANAGER

SAVE £5 on RRP of £29.95 when you order direct from Connect Systems

ONLY £24.95 Incl. VAT, p&p

Unrivalled features

PCW8256

PCW8512

Financial management software for personal and/or small business use.

Money Manager is an easy-to-use system for recording all financial transactions, and for analysing them in a number of very powerful ways in order to facilitate sound financial management. It is ideal for controlling the finances of a small business, or for users wishing to control their personal finances in a business-like way. Use it to check bank statements, keep track of expenditure, monitor cash flow, make budgeting forecasts, prepare business financial statements, pacify your bank manager, convince the tax and VAT inspectors, avoid nasty surprises, etc. etc.!

12 months of entries are kept in a file stored on your disc. At any time, you may load a file into the computer memory, add to or edit the entries, analyse them, print statements, and then save the updated file for later use. Entries may be historic (for record keeping) or forecast (for budgeting). You may have any number of separate files, and make copies of files for archive purposes. You may advance the period covered by a file month by month.

Up to 100 separate transactions may be entered per month. Each entry consists of:

- The day of the month, e.g. 23rd of June.
- An account number, one of up to 9 defined by you to suit your circumstances e.g. 1=Barclays, 2=Visa, 3=Halifax etc.
- Reference, e.g. ABC123 for a cheque number or invoice reference.
- A class code, one of up to 50 defined by you to suit your circumstances e.g. h0=Household expenses, h1=Mortgage, h2=Rates or p0=Production, p1=Raw materials, p2=Assembly, p3=Packing, etc.
- A description so that you can see what each transaction was for, e.g. "New gearbox" or "Box of 10 discs".
- An optional single character mark which you may include for further classification, e.g. b=business, p=private, etc.
- The amount of the transaction, which may be plus or minus.
- A marker to indicate whether the entry is exempt, zero rated or taxable for VAT, or alternatively the actual VAT paid.

You may select categories according to account, class and mark (e.g. all entries, or all motoring expenses for business using a credit card, etc.) and produce reports on the screen or printer as follows:

- Full detailed statements, showing each transaction for any month or for the whole year.
- Detailed monthly VAT statement showing input and output amounts excluding VAT, the actual VAT and the total amount, plus totals and net VAT due.
- Tables showing the totals in each class for each month of the year.
- Tables showing the totals in each class for each account.
- Tables showing monthly maximum, minimum, average balances, turnover, cashflow etc.
- Bar graphs of any category month by month.
- Pie charts of annual totals for various categories (CPC version only).

Plus: standing orders - entries optionally sorted into date order - item search facility. Comprehensive manual and full set of practice data included.
Full telephone support.

Send cheque or credit card number or phone for immediate despatch.



Connect Systems

3 Flanchford Road, London W12 9ND 01-743 9792 8am-10pm 7 days a week



```

PUSH IY
POP HL ;Copy user stack pointer to HL (via machine stack!)
LD DE,stack
OR A ;Clear the carry flag
SBC HL,DE
JP C,wend1 ;Jump out of WHILE1 if stack_pointer=-1

LD H,(IY+0)
DEC IY
LD L,(IY+0)
DEC IY ;POP y
LD D,(IY+0)
DEC IY
LD E,(IY+0)
DEC IY ;POP x

PUSH DE ;Save x
PUSH HL ;Save y
CALL GRA_MOVE_ABSOLUTE ;MOVE x,y
POP HL ;Restore y
POP DE ;Restore x

.while2
PUSH DE ;Save x
PUSH HL ;Save y
LD D,0
LD E,(IX+1) ;DE = dx
PUSH DE ;Save dx
LD HL,0
CALL GRA_TEST_RELATIVE ;A=TESTR(dx,0)
POP BC ;BC=dx
POP HL ;HL=y
POP DE ;DE=x
CP (IX+0) ;IF TESTR(dx,0)<>background_colour
JR NZ,wend2 ;THEN quit the while2 loop

EX DE,HL ;x to HL, y to DE
PUSH HL ;Save x
ADD HL,BC ;HL=x+dx
PUSH HL ;Save x+dx
LD BC,640
SBC HL,BC ;(The ADD will have cleared the carry flag)
POP BC ;BC=x+dx
POP HL ;HL=x
EX DE,HL ;Swap x and y into proper registers
JR NC,wend2 ;IF NOT (x+dx<640) THEN quit the while2 loop

LD D,0
LD E,C
JR while2 ;LET DE=x+dx
;and loop back as per normal WHILE condition

.wend2 ;Come here when WHILE2 conditions are FALSE
SET 1,(IX+2) ;LET top=1
SET 0,(IX+2) ;LET bottom=1

PUSH DE ;Save x
PUSH HL ;Save y
CALL GRA_MOVE_ABSOLUTE ;MOVE x,y
POP HL ;Restore y
POP DE ;Restore x

.while3
PUSH DE ;Save x
PUSH HL ;Save y
LD DE,0 ;Set relative x
LD HL,0 ;and relative y to zero
CALL GRA_TEST_RELATIVE ;LET A=colour at current cursor position
POP HL ;Restore y
POP DE ;Restore x
CP (IX+0) ;IF TESTR(0,0)<>background_colour
JP NZ,wend3 ;THEN quit while3 loop

BIT 7,D ;Has DE gone negative?
JP NZ,wend3 ;IF yes, THEN quit while3 loop

PUSH DE ;Save x
PUSH HL ;Save y
CALL GRA_PLOT_ABSOLUTE ;PLOT x,y
LD DE,0 ;Relative x
LD HL,2 ;Relative y
CALL GRA_TEST_RELATIVE ;LET A=TESTR(0,2)
POP BC ;LET BC=y
POP DE ;LET DE=x
LD HL,397
OR A
SBC HL,BC ;LET HL=397-y
LD H,0
LD L,C ;LET HL=BC-y
JR NC,not_top_line ;IF y<398 THEN skip

RES 1,(IX+2) ;otherwise set top=0

.not_top_line
CP (IX+0) ;IF test_colour=background_colour
JR Z,check_top ;THEN check top
SET 1,(IX+2) ;ELSE LET top=1

JR check_below ;and skip over code for first IF TRUE

.check_top
BIT 1,(IX+2)
JR Z,check_below ;IF NOT (top=1) THEN check line below

INC HL ;ELSE LET HL=y+2
INC HL ;Push x and y coords on user stack
CALL push_user
DEC HL ;Restore old y
DEC HL ;LET top=0
RES 1,(IX+2)

.check_below
PUSH DE ;Save x
PUSH HL ;Save y
LD DE,0 ;Relative x
LD HL,-4 ;Relative y
CALL GRA_TEST_RELATIVE ;LET A=TESTR(0,-4)
POP HL ;Restore y
POP DE ;Restore x
LD BC,2
OR A ;Clear the carry flag
PUSH HL ;Save y
SBC HL,BC ;LET HL=y-2
POP HL ;Restore y
JR NC,not_bottom_line ;IF y>1 THEN skip

RES 0,(IX+2) ;ELSE LET bottom=0

.not_bottom_line
CP (IX+0) ;IF test_colour=background_colour
JR Z,check_bottom ;THEN check bottom

SET 0,(IX+2) ;ELSE LET bottom=1
JR move_left ;and skip over code for first IF TRUE

.check_bottom
BIT 0,(IX+2) ;IF NOT (bottom=1)
JR Z,move_left ;THEN move cursor left

DEC HL ;ELSE LET HL=y-2
DEC HL ;Push x and y coords on user stack
CALL push_user
INC HL ;Restore old y
INC HL ;LET bottom=0
RES 0,(IX+2)

.move_left
EX DE,HL ;Move x to HL, y to DE
LD C,(IX+1) ;LET BC=dx
LD B,0
OR A
SBC HL,BC ;LET HL=x-dx
EX DE,HL ;Move x-dx to DE, y to HL

PUSH DE ;Save x
PUSH HL ;Save y
CALL GRA_MOVE_ABSOLUTE ;MOVE x,y
POP HL ;Restore y
POP DE ;Restore x
JP while3 ;Loop back as per normal WHILE construction

.wend3 ;Come here when WHILE3 conditions are FALSE and
;loop back as per normal WHILE construction

.wend1 ;Come here when WHILE1 conditions are FALSE
;and quit the FILL routine

.push_user
PUSH HL ;Save y
PUSH IY
POP HL ;Copy user stack pointer to HL
LD BC,stack+256-4 ;Make sure room for four bytes on 256-byte user stack
OR A ;Clear the carry flag
SBC HL,BC ;Do a 16-bit compare
POP HL ;Restore y
RET NC ;Quit if no room on stack

INC IY
LD (IY+0),E
INC IY
LD (IY+0),D ;ELSE PUSH x on user stack
INC IY
LD (IY+0),L
INC IY
LD (IY+0),H ;and PUSH y on user stack
RET

.background_colour
BYTE 0 ;Store background colour here
.dx
BYTE 0 ;Store no. of user coords per pixel
.top_bottom
BYTE 0 ;Store two flags, top and bottom, in two bits
.stack
RMEM 256 ;User stack for fill

```

TYPESETTING

For the first time a major suite of Typesetting software is available to the Amstrad user.

AMSET £199.98 + VAT

PC SET £249.00 + VAT

For Amstrad PCW's, PC1512 & other IBM compatibles.

PROFESSIONAL TYPESETTING

Package includes H & J, kerning, indents, multicolumn, depth count, character count, rules.

20 FOUNTS

From 4 1/2-72 point. Digital setting on Linotron 202N.

QUALITY

Typeshare — The nation's biggest bureau service.

TUTORIAL

Comprehensive manual & friendly help line.

EXPANSION

Error free comms. Counting Ad. Pack.
Advanced typography, 1000 founts available.

TRIAL OFFER

AMSET £40.00, PC SET £50.00 + VAT for trial pack.
Phone for brochure.

Typeshare

Typeshare Ltd, Alan House, 55-59 Saffron Hill, Hatton Garden,
London EC1N 8DX. 01-405 7937.

Save more with the

HFP

- for Amstrad CPC 6128 and PCW 8256/8512
- a new approach to home finance • a program that helps you to save
- save for your holidays . . . a new car . . . a new house . . . you name it!
- designed especially for the home
- easy to use • no codes • comprehensive manual
- up to 15 accounts • personalised program • reliable

Only £24.95

Send sae for further details and order form

Datavise (ACU)

20 Drumnaquoile Road, Castlewellan
Co Down BT31 9NT

AMSTRAD HARDWARE

PC1512 DD CM	£783.00
PCW8512	£530.00
PCW8256	£425.00
CPC6128 Colour	£375.00
CPC464 Col. (£100 software free)	£275.00
DMP3000 printer	£180.00
DMP2000 printer	£157.00
FDI-1 disc drive	£93.00
3" discs DS DD (box of 10)	£28.50
RS232 interface for CPC or PCW	£55.00
DKtronics TV Tuner	£65.00
JY-2 Joystick	£9.30
Competition Pro 5000 joystick	£13.95

AMSTRAD SOFTWARE

	TAPE	DISC	PCW
MINI OFFICE II	11.40	14.99	N/A
PROTEXT	15.00	18.50	56.90
MASTERFILE III	N/A	29.95	N/A
SUPER CALC 2	N/A	N/A	41.50
PLAN IT	11.40	14.99	19.99
TASWORD-6128	N/A	19.00	N/A
TOUCH-N-GO	N/A	19.95	19.95
JEWELS OF DARKNESS	11.50	15.60	15.60
TOMAHAWK	7.20	11.70	15.90
THEY SOLD A MILLION 3	7.90	11.90	N/A
TRIVIAL PURSUITS	11.50	15.50	15.90
FAIR LIGHT	7.90	N/A	11.90

ALL PRICES INCLUDE VAT & DELIVERY IN UK ONLY.

Overseas customers please add £1.00 for Europe add £3.00

For rest of the world per software. We specialise in AMSTRAD HARDWARE & SOFTWARE. Please ring for details or send an S.A.E. for our catalogue.

CUSTOMERS PLEASE MAKE CHEQUES PAYABLE TO:

NEWCROWN COMPUTERS LTD

98-100 Hightown Road
Luton, Beds LU2 0DQ (UK)
Tel: (0582) 455684



NEW MIRAGE IMAGER MK III

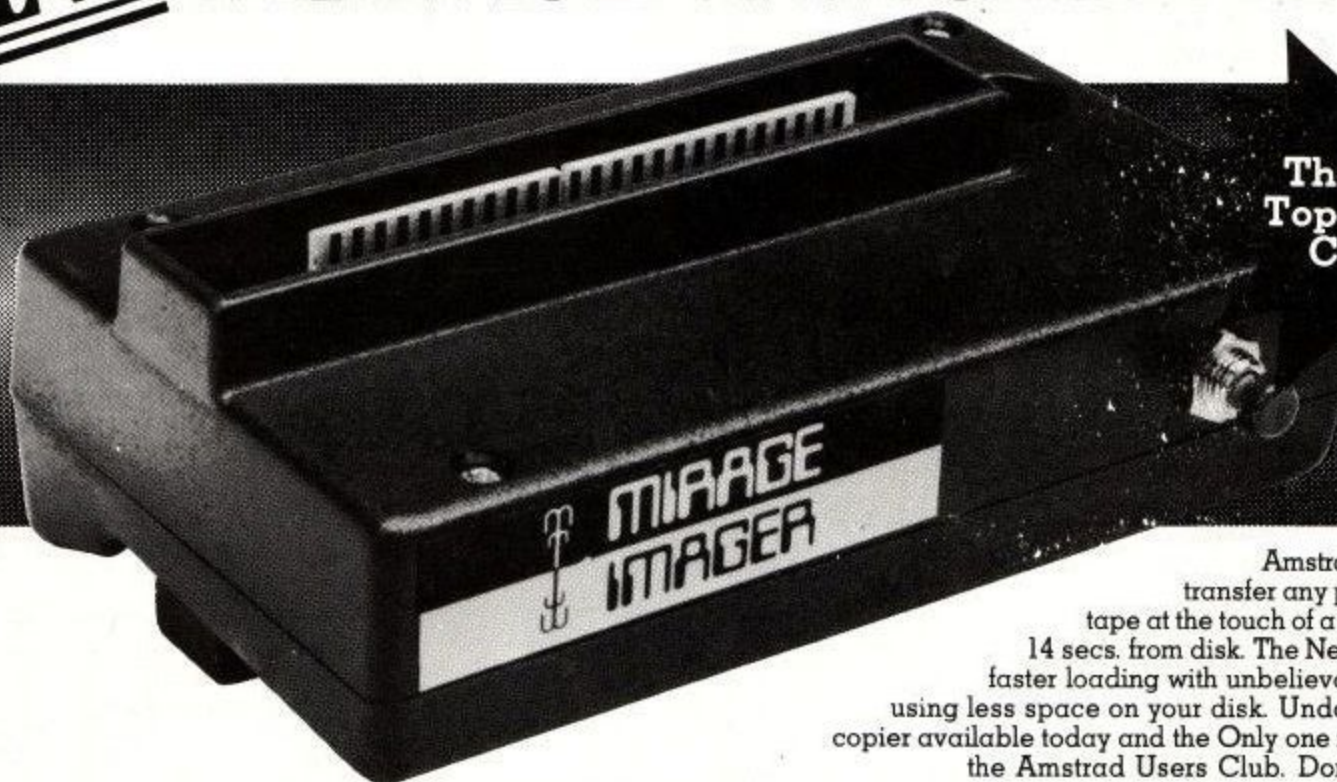

The UK's
Top Selling
Copier

Amstrad owners can now transfer any program to disc or tape at the touch of a button. 64K in just 14 secs. from disk. The New MK111 is much faster loading with unbelievable compression using less space on your disk. Undoubtedly the best copier available today and the Only one recommended by the Amstrad Users Club. Don't settle for less.



Available from good retailers everywhere

£49.95

Existing Mirage Imager Owners
Update your model for just £5.95.

Please state your Amstrad No. CPC464, CPC664 or CPC6128



In case of difficulty order directly from:
Mirage Microcomputers Ltd.
24 Bank Street, Braintree, Essex CM7 7UL
Tel: Braintree (0376) 48321
Telex No. 937400 Ref. 28238001

TASWORD 6128

THE WORD PROCESSOR FOR THE AMSTRAD CPC 6128



TASWORD 6128
The Word Processor
© Tasman Software Ltd 1985

Print text file	P
print with Data merge	B
Save text file	S
Load text file	L
Merge text file	M
Return to text file	R
Customise program	C
save Tasword	T
Erase file from disc	E
into Basic	B
check spelling	K
Install Tasprint	I

0 words 0 characters Drive A
1 lines 86276 characters free

Ⓜ move text left Ⓜ delete word Ⓜ start of text Ⓜ fast scroll up
 Ⓜ centre line Ⓜ delete line Ⓜ end of text Ⓜ fast scroll dn
 Ⓜ move text right Ⓜ undelete line Ⓜ start of line Ⓜ word right
 Ⓜ rejustify para (Ⓜ) Ⓜ clear text Ⓜ end of line Ⓜ word left
 Ⓜ rejust line (Ⓜ) Ⓜ insert line/char Ⓜ scroll up Ⓜ scroll down

Mr J H Shears
17 High Street
Lockton Bay
Leicestershire LE17 6LX

2nd February 1986

Dear John,

Thank you for your letter of the 31st January. I have corrected the first draft of the article and incorporated your suggested changes. It is a good thing TASWORD has a find and replace facility! You will see from the enclosed print out of the corrected draft that I have also made some other changes and I hope that you agree that they are an improvement. g

Line 16|Col 50|N|J on |M|W|n |Insert off|Paging off|ESC for help|NORMAL CHARS

TAS-DIARY THE ELECTRONIC DIARY

TAS-DIARY for the Amstrad CPC 6128, 664 and 464 with disc drive disc **£12.90**

Keep an electronic day-to-day diary on disc! TAS-DIARY features a clock, calendar and a separate screen display for every day of the year. Each year stored on disc includes a memo pad and several note pages. TAS-DIARY is an invaluable aid to keeping records, reminders, and any other data which is related to that most valuable commodity of ours - time!

TASWORD 6128 THE WORD PROCESSOR

TASWORD 6128 for the Amstrad CPC 6128 disc **£24.95**

Brilliant value for money.

AMSTRAD ACTION December 1985.
A powerful and easy to use word processor and a superb data merge program.

AMTIX December 1985.

TASWORD 6128 is the word processor especially developed to utilise the extra memory in the CPC 6128.

The program uses ALL the additional 64K of memory in the CPC 6128 as text space. This means that text files can be around ten thousand words long. TASWORD 6128 includes a built-in data merge program. Mail merge, in which a letter is printed any number of times, each individually addressed to a different person, is just one of the applications of this powerful facility.

The notepads are a unique feature of TASWORD 6128. Four separate notepads are available. Typing reminders and storing letter headings are just two possible applications for the notepads.

Up to one thousand characters can be stored in ten user definable keys allowing commonly used words, sentences, or even paragraphs to be typed with a single keypress.

TASWORD 6128 has comprehensive customisation features. These allow many of the program facilities to be changed to personal requirements. A customised program can be saved and includes the notepads and user definable keys.

TASWORD 6128 is fully compatible with TAS-SPELL and TASPRIINT. It will also read in data from Masterfile 6128. It can even be used to enter and edit your own Basic programs.

With all standard and many extra word processing facilities TASWORD 6128 is the most powerful of the TASWORDS, for the Amstrad CPC computers.

TASWORD 464-D

THE WORD PROCESSOR - WITH MAIL MERGE!

TASWORD 464-D disc **£24.95**

This is the new TASWORD especially developed to utilise the capabilities of the CPC 464 and 664 disc drives. The additional facilities include a larger text file size and automatic on-screen disc directories during save and load operations. A major new feature is the mail merge facility. This gives multiple prints of your standard letters, forms, etc., with each copy containing, for example, a name and address automatically taken from a disc file containing the data. This data can be entered using TASWORD 464-D, or created using the Masterfile Program Extension package. A powerful and useful conditional printing facility is included - parts of a document can be printed according to user-specified criteria. TASWORD 464-D will only run on, and is only supplied on, disc.

TAS-SPELL THE SPELLING CHECKER

TAS-SPELL disc **£16.50**
for the Amstrad CPC 464 and 664 running
TASWORD 464-D and for the CPC 6128 running
TASWORD 6128

Spelling mistakes and typing errors spoil any document whether it is a private letter or your latest novel. With TAS-SPELL you are free to be creative in the confident knowledge that your spelling won't let you down.

TAS-SPELL checks the spelling of TASWORD 464-D and TASWORD 6128 text files. TAS-SPELL has a dictionary of well over twenty thousand words which it compares with the words in your text. If a word is not recognised then the relevant part of your text is displayed with the suspect word highlighted. You can correct the word, ignore it (it might be a name), or even add it to the TAS-SPELL dictionary. Please note that TAS-SPELL will only work with TASWORD 464-D and TASWORD 6128.

TASWORD UPGRADES

TASWORD 464 and Amsword owners: send your original cassette or disc (not the packaging) as proof of purchase and £13.90. Your original will be returned together with TASWORD 464-D or TASWORD 6128 on disc.

TASPRIINT 464

THE STYLE WRITER

TASPRIINT 464 cassette **£9.90** disc **£12.90**

A must for dot-matrix print owners! Print your program output and listings in a choice of five impressive print styles. TASPRIINT 464 utilises the graphics capabilities of dot-matrix printers to form, with a double pass of the printhead, output in a range of five fonts varying from the futuristic DATA-RUN to the hand-writing style of PALACE SCRIPT. TASPRIINT 464 drives the dot-matrix printers listed below and can be used to print AMSWORD/TASWORD 464 text files. TASPRIINT 464 gives you output originality and style. Completely compatible with the 664 and 6128.

TASWORD 464 THE WORD PROCESSOR

TASWORD 464 cassette **£19.95**

"There is no better justification for buying a 464 than this program"
POPULAR COMPUTING WEEKLY,
NOVEMBER 1984

Your 464 becomes a professional standard word processor with TASWORD 464. Supplied complete with a comprehensive manual and a cassette which contains both the program and TASWORD 464 TUTOR. This teaches you word processing using TASWORD 464. Whether you have serious applications or simply want to learn about word processing, TASWORD 464 and the TUTOR make easy and enjoyable.

TASCOPY 464 THE SCREEN COPIER

TASCOPY 464 cassette **£9.90** disc **£12.90**

A suite of fast machine code screen copy software for the CPC 464, 664 and 6128. Print high-resolution screen copies in black and white and also large 'shaded' copies with different dot densities for the various screen colours. TASCOPY 464 also produces 'poster size' screen copies printed onto two or four sheets which can be cut and joined to make the poster.

TASPRIINT 464 and TASCOPY 464 drive the following dot-matrix printers:

AMSTRADDMP1 MANNESMANN STARDMP501/5/515 SHINWACP-80
EPSONFX-80 TALLYMT-80 BROTHERHR5 COSMOS-80
EPSONRX-80 BROTHERM1009 DATA PANTHER AMSTRADDMP20
EPSONMX-80TYPEIII NECPC-80238-N DATA PANTHERII

ROMANTIC ROBOT

present



Multiface two

Nº1 AMSTRAD MULTIPURPOSE INTERFACE with

- 1) FULLY AUTOMATIC, UNIVERSAL and PROFESSIONAL back-up facility to tape and disc for Amstrad CPC 464, 664 and 6128.
- 2) MULTI TOOLKIT to study/modify/develop software/hardware
- 3) 8K RAM EXTENSION
- 4) RESET BUTTON for "warm" reset

All at an AMAZING PRICE of £46.95!

"The cleverest hardware device at present" Amstrad Action

MULTIFACE TWO is UNIQUE both in unbeatable value and features:

**GOLDEN
SCREWDRIVER
Award**



"AMTIX NOV 86"

- * It is the only truly automatic back-up device - the programs are RELOADED exactly as they were STOPPED and SAVED, incl. the colours and sound - no other peripheral can RESTORE COLOURS AUTOMATICALLY and some programs will not RELOAD & RUN properly then - BEWARE! and use MULTIFACE TWO only.
- * Does not occupy any part of the Amstrad RAM and requires No additional software - has internal 8K ROM and 8K RAM.
- * STOPS ANY program ANYTIME. You can just PAUSE or SAVE or use MULTI TOOLKIT, etc. Programs will CONTINUE from the same point when you RETURN or RELOAD next time - everything is FULLY and AUTOMATICALLY RESTORED.
- * MENU-DRIVEN, fully ERROR-TRAPPED with prompts and one-touch commands turning complex tasks into a trivial procedure - all you need to do is to push the button and select from the menu:
SAVE - to name & SAVE a program to disc, tape or hypertape.
RETURN - to CONTINUE a program after any operation.
JUMP - not to return but to JUMP to another address, say to your own routines in the 8K RAM extension.
TOOL - to access MULTI TOOLKIT routines.

- * MULTIFACE 2 is EXTREMELY FAST in both SAVING & RELOADING - its INTELLIGENT COMPRESSING and TURBO saving to disc/tape makes a standard 64K program reload typically in up to 20 SECONDS from disk or just over 5 minutes from tape. The most EFFICIENT COMPRESSING also results in minimal space used on disc or tape.
- * MULTI TOOLKIT is the only existing combination of hardware and software capable of displaying & modifying EVERYTHING you may wish to know about a program and current state of computer. You can PEEK/POKE the entire AMSTRAD contents incl. extra 8K RAM, Z80 registers, colours, etc. You can open a WINDOW and scroll through 56 byte blocks in decimal, hex and even ASCII representation (ie. everything seen as text to reveal messages, etc) with full on-screen editing. You get INFO on screen mode/start address, interrupt mode, no. of characters per line, horizontal sync. position, lower and upper ROM and RAM bank status, ROM type, etc. And ALL can be changed...
- * COMPATIBLE with expansion ROMS, RAMS and any other devices.
- * PLUGS DIRECTLY into CPC 464, 664, 6128 - no need for extras.
- * Save PROGRAM or a full 25-line SCREEN ONLY.
- * THROUGH extension BUS for connecting other peripherals.

No other back-up device can compete with MULTIFACE TWO on any front:

MULTIFACE TWO is the ONLY AUTOMATIC one

MULTIFACE TWO is the FASTEST one

MULTIFACE TWO takes the LEAST ROOM

MULTIFACE TWO is the only one with a RESET button

MULTIFACE TWO is the only one with a TOOLKIT to study/modify programs

JUST COMPARE THE FACTS FROM AN INDEPENDENT TEST ON MICRONET:

MICRONET tested all four back-up devices currently on the market: ACTION REPLAY by Datel, DISC WIZARD by Evesham Micros, IMAGER by Mirage and MULTIFACE 2 by Romantic Robot. They were all tested on the TOP 10 GAMES for the week ending January 1987. Each copier was tested at the same point in each game and in the event of a failure the reviewer tried twice more. These are some of the results:

Out of overall 100% success claimed, the actual percentage was:

ACTION REPLAY - 20%	DISC WIZARD - 40%	IMAGER - 50%	MULTIFACE - 100%
---------------------	-------------------	--------------	------------------

MULTIFACE was confirmed as the ONLY TRULY AUTOMATIC back-up device - all other copiers require manual setting of colour, screen mode, windows, etc. - provided they do not crash in the first place! This when tested on 10 games took altogether:

ACTION REPLAY - 15 mins	DISC WIZARD - over 175 mins	MIRAGE - over 66 mins	MULTIFACE - not applicable
-------------------------	-----------------------------	-----------------------	----------------------------

The Actual SAVING time was in seconds:

ACTION REPLAY - 33.4	DISC WIZARD - 44.5	IMAGER - 36.6	MULTIFACE - 32.5
----------------------	--------------------	---------------	------------------

Naturally, you should add the SAVING time and the SETTING UP time together to get a true saving time per each game:

ACTION REPLAY - over 2 mins	DISC WIZARD - over 18 mins	MIRAGE - over 7 mins	MULTIFACE - 32.5 seconds
-----------------------------	----------------------------	----------------------	--------------------------

The loading time took on average in seconds:

ACTION REPLAY - 21.7	DISC WIZARD - 40.7	MIRAGE - 36.6	MULTIFACE - 19.7
----------------------	--------------------	---------------	------------------

Each device made a back-up of a different file size - on average:

ACTION REPLAY - 68K	DISC WIZARD - 89K	MIRAGE - 53K	MULTIFACE - 49K
---------------------	-------------------	--------------	-----------------

The summary of the tests on MICRONET?

"MULTIFACE TWO from ROMANTIC ROBOT wins easily on all features! It is faster, more convenient, more successful, uses less space and has more facilities!"

Multiface two THE ESSENTIAL AMSTRAD CPC COMPANION

Please send me a MULTIFACE TWO at £46.95 plus p&p - UK £1.00. Europe £2.00. Overseas £3.00

I enclose a cheque/PO for £ or debit my No. Card exp

Name & address

ROMANTIC ROBOT UK LTD 15 Hayland Close London NW9 0LH 24 hrs **01-200 8870** ACU 5/87

Empire - the thinking man's Elite

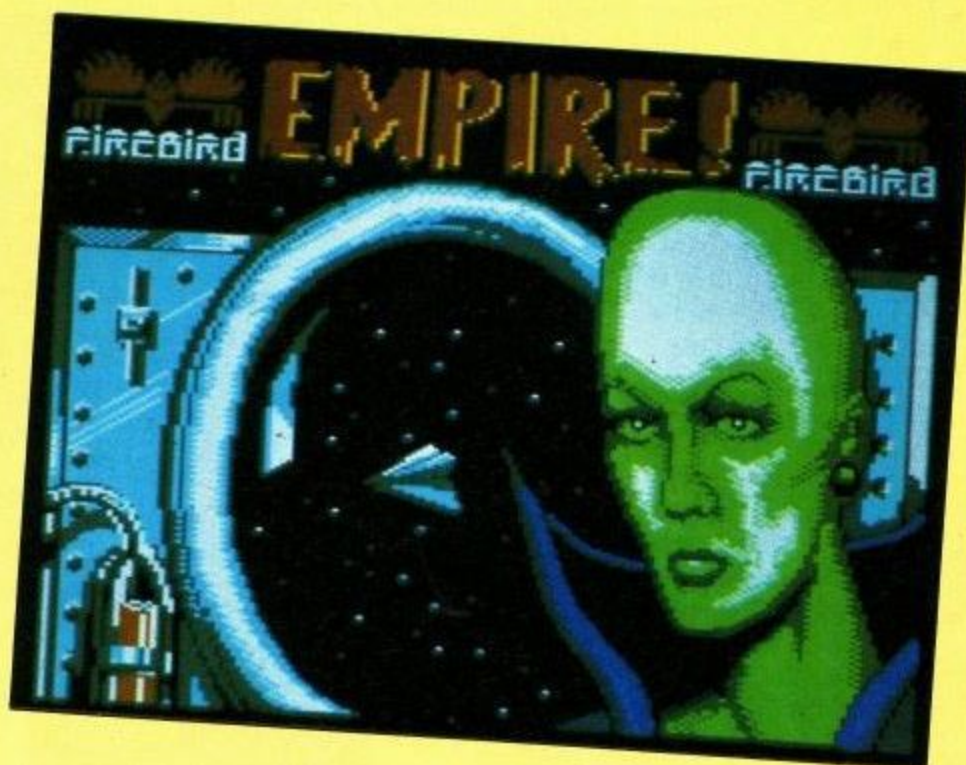

Simon Rockman joins the fight for the Federation

Empire is the new game from Firebird, and it will appeal to all megalomaniacs as you start with a small ship and work up to become master of your own empire.

It is a game of Elite-type proportions, and as with Elite you can progress by either fighting or trading. There are missions and medals, but the early part of the game centres on using pods.

The pods

Your cub ship is equipped with two tow ropes; these can be extended to carry pods, but must be withdrawn before you can dock. There are three basic types of pod – cargo, ship's extras and specials.

The cargo takes the form of ore, minerals or people. Special pods do things like fill starbases ready for trading, and

there are energy pods which can be dropped to replenish shields and plague antidotes.

Most important are the ship's extras – the correct use of the right pod at the right time is the key to building the empire.

Ship's extras include a better laser, extra cargo ropes, a go-faster module, shield generators, hyperspace pods and galaxy jump pods.

Initially you can only carry two pods at a time, so it is important to earn the extra cargo ropes which allow a further two pods to be carried.

It is unfortunate that you cannot choose which pod to drop, but you need to withdraw the ropes until the pod you want to lose falls. This will certainly mean dropping two pods, and may mean dropping all four.

Starbases

You dock with starbases by flying between the two orbs and rotating so that the bow of your ship points to the centre of one globe and the stern to the centre of another.

This is quite a difficult skill to master, but as the programs' author, Andrew Glaister, remarked "it takes a week to learn to dock in Elite".

You cannot dock with your tow ropes extended, which means that you have to drop all your pods – ropes appear from the starbase and drag in the goodies.

The base will store ship's extras and add cargo to its deposits.

The starbase rewards your depositing of cargo by offering you more ship's extras as pods, and these drift outside the starbase for later collection.

When you have filled the ore, people and minerals categories – and freed the system of aliens and plague – you have the option to buy the starbase. This is the first step to building your Empire.

Bouncing into a starbase damages your shields, but you are safe from aliens if you are close enough to see the base. Wait outside for the shields to build up before trying to dock.

Improve yourself

Shortly after starting the game you will get the radio message 'The Empire will award medals for shooting lots of aliens'. This roughly translates to around 100 aliens for the first medal, 200 for the second, 800 for the third and 1500 for the fourth.

With the fourth medal you get a supership, fitted with all mod cons and capable of storing eight pods internally. It is with this craft that you set about your empire building.

This is a grand position to reach, starting from a humble cub ship without even a trading pass.

Winning your wings is essential, and you must prove your worth before the Empire will allow you to have a trading pass. This is done by rescuing a pod



You are offered a mission. It's wise to accept it.

Docking is difficult

which has been stolen by some aliens and returning it to the home starbase. Armed with a trading pod you should aim for a warp hole.

Planet bound

Most of Empire is played in 2D, but the planet sequence enters the third dimension. Re-entry on to a planet means finding a warp hole, which is shown on the system map as one pixel dots. Place a locator over the warp hole then use the ships pointer to fly there.

The glide slope is shown by series of rings, a bit like those in Dark Star or Hive. Missing the rings has an adverse effect on your shield and it takes quite some mastering before you can get on to the planet in one piece.

Once there your troubles are not over – green spiky fuzz balls come for you, then you can pick up the ore, people and mineral pods. Finally you head for an exit which takes you near the warp hole, where you can collect your booty and take it back to the starbase.

Be careful when carrying radioactive ore – it'll cause your ship to heat up with fatal consequences if you transport too much for too long. You should beware of making Icarus's mistake – flying too close to a sun will melt your ship and even getting close causes the laser to play up.

Having found your feet it is then time for some intergalactic travel. There are missions to perform in other solar systems and aliens to fight. The galactic map shows where you can fly to and unlike Elite you don't have to mess about with hyperspace to get there.

You can fly, but this is slow – a Galactic jump pod is the recommended mode of transport. Curing plagues and saving solar systems from aliens will toughen your fighting skills ready for the final hurdle of building a frontier. Then with the help of some frontier generators, you can box in your own bit of the galaxy and live happily ever after.

Opinion

Empire is an epic game and generally underrated – but it is difficult, perhaps too difficult.

It took me a while to master the first mission. You have to fly towards the aliens with your ropes out and hit the two escorts and the main alien before more enemy ships can appear. You can then swing the rope over the pod and

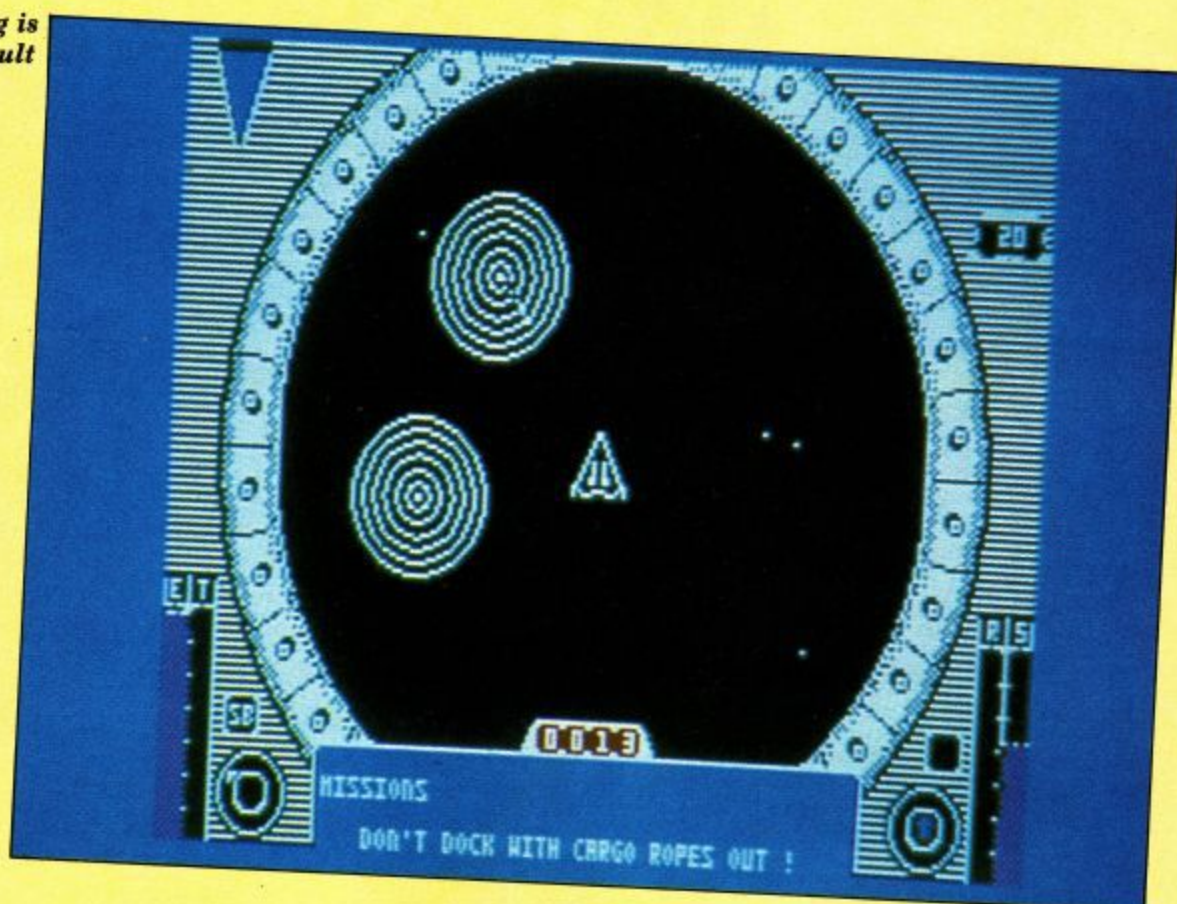

leg it back to the starbase as quickly as possible. It is a good job that you can outrun the other ships.

The planet scene is spectacular and very different – it could well be another game. This change of pace left me breathless as I emerged from the warp hole.

The plot was devised by Fouad Katan and Andrew Glaister. Fouad wrote the Commodore 64 version, Andrew the Spectrum and Amstrad versions. They have been over ambitious: There is so much to know that you cannot simply sit down and have a blast – even getting past the initial stages is pretty tough.

There are some nifty programming tricks. The Empire logo bounces around on the title page and the whole game is played through a porthole. This helps to give the game a 50's Buck Rogers feel.

In some ways I get the impression

that Empire is trying too hard to be different from Elite. There are more missions and a bigger goal but in many ways Empire could be classed with Elite, Space Trader and the old teletype Star Trek as a different space trading game.

The documentation is poor – an Elite/Starglider style novella would have been a worthwhile addition – and the sound is unimaginative. The disc version I tested required you to save your game to the supplied disc, something I was a little unsure of.

The game commits what one of my friends claims to be a sin – it starts in keyboard mode if you press the joystick fire button and doesn't document the key to leave the starbase.

Yet for all these faults it is the game I have played most this month. Empire is curiously addictive, very frustrating and requires a bit of planning. The thinking man's Elite.

ACU

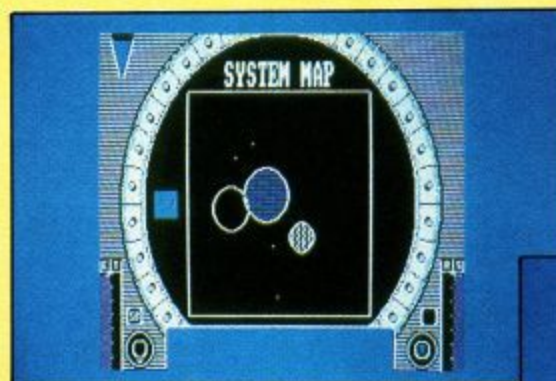

Local movements are planned on the system map

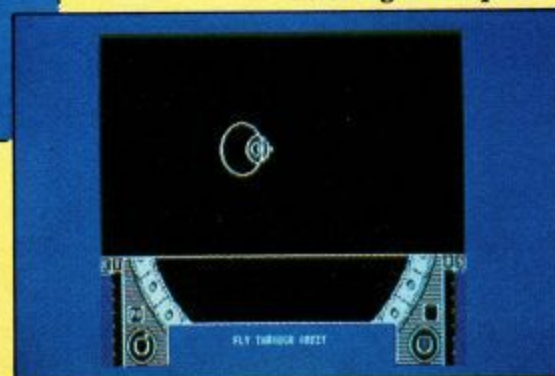

Entering a warp hole

The truth about TELEX

How much does it cost to go on Telex?

You could go the conventional way and buy a dedicated Telex machine. The cheapest will cost you £1,604 (the Whisper), the dearest £2,892 (the Cheetah). You will also need a separate telephone line, costing £101 to install, plus £404 a year rental. That's a total outlay over the first year of a minimum of £2,109. (All prices include VAT.)

Or you could do what more and more Amstrad users are doing – use your CPC, PCW or PC to double as a Telex machine. And just use your ordinary telephone!

How do I turn my Amstrad computer into a Telex machine?

All you need is a modem and appropriate communications software (see the advertisements in this issue), a telephone, and a subscription to *MicroLink*.

Telex is just one of a growing number of services available to Amstrad users on *MicroLink*. With it you can also read the news as it happens, go teleshopping, create your own closed user group, send telemessages and electronic mail right round the world, download free telesoftware programs directly into your micro ... and much more.

But why use Telex?

Because it's a standard means of instant communication between businesses. Today there are 150,000 Telex machines in use in Britain – and more than 2 million worldwide. They need it to dramatically speed up business communications – just as quick as using the phone but far more efficient, because you have a hard copy of every "conversation" for your records.

But there's a big bonus you get when you use *MicroLink* for Telex that the conventional way doesn't offer.

With *MicroLink* you don't HAVE to be in your office to send or receive Telex messages. You can just as easily use your computer at home (or even a portable). So now you can check whether there are any Telex messages waiting for you – anywhere, anytime.

How's that for your business efficiency?

MicroLink application form: Page 14

DMP-2000/3000 BUFFER UPGRADE KIT

The printer buffer presently in the DMP2000/3000 is a 2k RAM. Most of this RAM is used by the printer's operating system, on average, .5k as buffer space. Our upgrade kit contains a new static RAM which will increase the printer buffer by 6k (about 4 pages of text). This upgrade will also allow all of the Download Character Set to be re-defined thereby allowing the user to design his own special characters for use in scientific and other purposes. The kit is supplied with full pictorial instructions to allow the amateur to carry out his own modification.

Prices: \$5.50 (UK) \$6.75 (EUROPE) £7.50 (REST OF THE WORLD)

SPEEDTRANS (V1.43)

This is an enhanced version of the original SPEEDTRANS which will now transfer many more games AUTOMATICALLY all transfers are now made DIRECTLY TO DISC.

SPEEDTRANS is specifically designed to transfer those programs that have been written using the SPEEDLOCK protection method.

SPEEDTRANS will transfer both normal length (43k) games and also long (47k) games automatically.

SPEEDTRANS transfers the main program and, in most cases, the opening scene. SPEEDTRANS also offers the possibility of saving the screen of the longer games (RAID for example.)

SPEEDTRANS contains a unique INKS program which will automatically find the MODE, BORDER and INK colours used in the opening screen.

SPEEDTRANS will transfer the following SPEEDLOCK programs to disc: Barry McGulgans Boxing, Batman, Bounty Bob Strikes Back, Bruce Lee, Hacker, Doby Thompsons Decathlon, Kong Strikes Back, Jet Set Willy, Nomad, Ping Pong, Rambo First Blood II, Way of the Exploding Fist, Yie or Kung Fu, Gyroscope, Frankie goes to Hollywood, Winter Games, Dambusters, Scrabble, Kung Fu Master, Samantha Fox, Raid, Impossible Mission, World Series Baseball, Green Beret, Rescue on Fractalus, Monopoly (includes playing screen), Cluedo, Matchday, "V", Hunchback II, I Spy, Spy-Trek, etc.

Prices: \$5.50 (UK) \$6.75 (EUROPE) £7.50 (REST OF THE WORLD)
UPGRADE YOUR EARLY SPEEDTRANS...\$2.50 (UK) - \$3.75 (EUROPE) - \$4.50 (R. of W.)

LOOK

VIEWTEXT
(ON TAPE)

Reduced to £2.00
while stocks last.

Viewtext will allow you to get more pleasure from games and adventures etc. You can find the word tables in binary files which help you get more enjoyment from your programs.

GOLDMARK SYSTEMS

51 COMET ROAD, HATFIELD, HERTS. AL10 0SY
Please telephone for further info. (07072) 71529

ARE YOU IN A RUT??

Then climb out by learning to use your **AMSTRAD** to its full potential with our unique correspondence courses for any age or interest. Including software, texts and full HELP service to answer your enquiries.

COURSE 1 – INTRODUCING BASIC: For the newcomer to computing and using BASIC.

COURSE 2 – CONTINUING BASIC: More detailed use of BASIC and applications.

COURSE 3 – NUMBERS, MATHS & FUNCTIONS: Number systems and maths applications.

COURSE 4 – GRAPHICS & SOUND: Use of graphics and sound in your programs.

COURSE 5 – FILES: Creating and reading files for general/database applications.

Cassette: £17.90 each or Disc £19.90 each

Send course(s) _____ I enclose £ _____

or debit   No. _____

Name _____

Address _____

Send or write NO STAMP REQUIRED for further details to:

MICROWISE UK

FREEPOST, COLCHESTER CO3 4BR

ACU 5

SOFTWARE REVIEWS

CLASSIC MUNCHER

OK kiddies, let's play a little game. I'll start describing the scenario of this cute little original game by Bubble Bus, and you tell me when you think you can guess the game before it loads. All right? Here we go:

"... Living in a haunted mansion isn't much fun, especially when the ghouls take over. Muncher man must gather up all the food before the ghouls get him!"

No, Muncher Man does not come from Munich, and I don't know why he doesn't get his food from the nearest McDonalds. Maybe he's a trendy veggie? I see you're going to need further clues.

Muncher Man's house looks suspiciously like a maze, with lots of little round bits of food in it (Not yet! Wait a bit). You have to wander about the maze, eating the food, and avoiding the ghouls (now you can start guessing).

When you eat a special pill (left over from a previous police raid), you can chase and eat the ghouls (but go easy on the spirits), getting a large bonus from your local exorcist as you do so. (You must have it by now). Fruits pop up in the maze at random...

What do you mean, "I haven't got it yet?" Insert tape in ear, press any key and re-read from start. This flippin' well is Pac Man, however deceptive the picture of the dinosaur might be on the cover. Mind you, with names like Classic Muncher, Back Man, or Ghost Gobbling or some such, waddya expect? Asteroids?

You certainly don't get many hints from the loading screen - there isn't one. Another missing link is the sound effects - not exactly stunning, to say the least. At least you can use your own idea of keyboard and/or



joystick layout.

The sneaky bit that got me at the end of the first screen was that they went and changed the maze around. You don't see that on many Pac Man clones, though this one certainly swiped enough memory for several different maps.

If you're into being grabbed by the ghouls in the hedges with some fruit, then you could do worse than buy this one. Bubble Bus are currently running a competition on the high scores. The prize, more software. But don't let that influence you unnecessarily.

Price: £1.99
Author: Bubble Bus

Nigel

Simple ideas are often the best and you don't get much simpler than Pac Man. Bubble Bus may call this Classic Muncher, but no one else will. Still, I don't think they need to worry about Atari Coin-Op taking them to task.

Coin-Op IS still owned by Warner Bros, which isn't as litigation happens Mr Tramiel's outfit.

The game (*oh that - Ed*) is what you'd expect, the sprites are smooth, the gameplay a shade different to the arcade version but it is essentially the same thing. Graphics acceptable, sound unadventurous but all in all it is a reasonable Pac Man. The question is do you want to play a late '70s game in the late '80s?

10/
20

Liz

Software history lesson #37: Pac Man was invented in Japan, was bought by Atari and is probably the most profitable arcade game ever. The name derives from *pacu* the Japanese verb to eat and not - as is often claimed - from Alfred Packer the last American cannibal.

Part of the reason for the success of Pac Man was the non-violent theme, making it popular with girls.

As is the Americans' wont, a huge culture grew up around Pac Man with parades, a hit record and high score charts.

The reserved Brits didn't take to the game in quite the same way, but still it is surprising that this is all that remains of a video legend. A nifty cheapo game to bring back memories.

15/
20

Colin

As this is unashamedly a rip-off of Pac Man, I'm going to be ruddy critical of it. If you rip stuff off, you've got to do it right.

While loading, you get one of the "No Expense Spared Loading Screens plc." specials, that is, none at all. It's been said that games are best left without

loading screens, as it takes quite a while to load 'em in, but some message would be welcome.

The mazes are different, but a wee bit on the small side. On the plus side, it's all very smooth and colourful. Sound could have been a bit better though.

10/
20

INTO THE EAGLES NEST

Ach so, der Britischer/Amerikanischer schwein are invading der strongholdings of der commander of der glorious armed forces. Vehaff already captured three of zem, but zis vun has der magic shootenbangen machine-gun mit der 300 round capacity magazines.

Ve must not make life too hard for him, und zo ve leave plenty of der boxes of ammunition lying about. Ze people who really need it on ze front vill haff to wait.

He need not worry too much about being schott. Der guards hardly ever use der guns, und even if zey did hit him, he vould not know it. Zis is probably vy dercursed Kaptain K.E. Parker of der dreaded Pandora Software squad has not put in ze screen any vay of telling der health of der Britischer.

Der guards are so dim zat zey lock der doors und leave der keys lying on der floor, just vere der Britischer can find zem. Zis is probably just as vell, or zey vould vander away und get lost.

To keep him up on ze end of der toes, ve haff lots of der locked interesting boxes lying about too. Ven der looting Britischer finds vun, he shoots off der lid. Inside is maybe der jewels, der gold . . . or maybe der dynamite. Ho ho. Mit der sprengstoffenuppenstufen und gamen ended.

As vell as shooting der holes in der guards und der boxes, some of der doors (by some oversight) haff been made of ordinary wood und are schotten through mit der shootenfiren machine gunnen. Der person responsible for zis oversight vill be found und deprived of next months ACU after joining der three other Britischers vehaff caught for ein little torture party. Ve haff



vays of making you buy ACU!

For ein Britischer, Lt. R. A. Chapman has surpassed himself und a few others mit der qualitaat of zer graphics. All ze aktion is seen from zer bird's eye view (or is zat der eagle's eye view? Ho ho, eine kleine joke). Zer guards are looking like from zer Colditz, zer enemy is looking like zer Robert Redford.

Schould der Robert Redford lookalike successfully release der prisoners und detonate zeir explosivstoffe zat ve haff carelessly left vere zey put it, ve vill be in der schtuck.

Zis style of writing der reviews is not intendings to insult any of der German or Austrian peoples. It is being done to vind upzer spelling checker of der glourious editor.

Author: Pandora

Price: £8.95 (tape), £12.95 (disc)

Nigel

Some games grow on you. Others grow best in compost. This one definitely is for me, and I think, possibly for you too. I could sit in the ed's office for ages playing this with his nifty joystick, and probably would have if I'd not got hungry.

This is a good shoot-up and a mazy adventure game to boot. If only there had been more of a status line. The end sneaks up suddenly on you, and you don't know when to start heading for the nearest first aid box. Apart from that, brilliant.

18/20

Liz

Well it had to happen – a Gauntlet clone with a change of scene. Into the Eagles Nest is WWII Gauntlet, it is one player only and splendid with it.

The enemy sprites are much larger and better animated than those in the US Gold game, the shaded

mode 0 graphics look great and the scrolling smooth.

This is the first game from Pandora and it looks to be a winner. So if you fancy a challenge, a really good shoot em up with nifty graphics then venture into the Eagles Nest

18/20

Colin

I don't usually like World War II games, but this is an exception. Lots of action, a megamaze, realistic sprites and a true sense of danger. From the loading screen to the game over prompt, Into the Eagles Nest reeks of professionalism.

There is a bit of a Rambo – one man against impossible odds – flavour to it but every time I bit the dust I went back for more.

18/20

COBRA

Enter Sylvester "Stallion" Stallone in possibly his biggest movie flop yet: Cobra. The cassette inlay has a big macho picture of Stallone on the front, swinging a laser-sighted HK about, and with a Colt .45 jammed down the front of his trousers. Better be careful on quick draws with that, and when replacing the hot barrel. "Squeaky-voiced" Stallone, they'd call him.

At any rate, forget the shooter for the moment – when you start the game you begin with the humble fist. Weaponry comes off your opponents, via (no, I didn't believe this either) hamburgers.

Kinda hard to swallow is that. Mind you, so are the first Casey-burgers of the morning at Liverpool Street. Like I said, you do for a baddie or a booby-trapped window and it gets replaced by a hamburger. Go past said snack and your weapons and ammunition are miraculously replenished. I've heard they're full of iron, but shome mishtake shurely.

Nevertheless, bash in your sniper or offensive French window and there will be a pulsating hamburger waiting there. Hang on, hamburgers don't pulsate, not even at Casey's.

You'll never guess what the windows are booby-trapped with either. No? OK then, it's a parrot. It is an ex-parrot, it has . . . hang on, wrong sketch. This parrot is an excreting parrot. Get my drift, or should I be dropping more hints?

Apart from the flashing burgers and the pooping parrot, the scenery is just mediocre (for games that is, not the real world), consisting mostly of brick wall with the occasional staircase or window bunged in it.

Oh yes, and the not-so-occasional whore in the background. These can be shot, especially by the wife, but you lose 500 points in the process.

Other colourful inhabitants of this typical American township are knife, RPG, pistol and machinegun toting thugs, and a head-butting duck. I kid you not.

As Stallone, you have an extremely sound constitution, and can take several direct hits from an RPG,



bullet, psychotic duck or whatever, but it's much healthier to dodge them.

Being a veteran of many "Rocky" movies, you can leap, punch and duck with ease. Unfortunately, so can the duck. What you really need is a large-bore orange shooter. That'll fix the beggar. Further evidence of the Rocky heritage is the fact that lives remaining is counted in boxing gloves.

The point of this all? There is one, you know. You have to rescue the traditional blonde WAFF (if you're not into acronyms, read weak and feeble female here), she's called Ingrid, as if it mattered.

The contemptible dirty rotten ratfink who swiped her is called The Night Slasher, which is equally unimportant, but makes for a better storyline. And the story is all you'll get, 'cos there's no high-score table to impress your friends with.

Essentially, this is a good old-fashioned piece of mindless violence that you might pick up more than once to relieve boredom. Just thought I'd give you a snake preview.

Author: Ocean
Price: £8.95

Nigel

The streets of America may be dangerous but nowhere can they be this unsafe. It's a good job that you can kill assailants with your bare fists and withstand the force of a rocket launcher. Confronted by such hazards I'd run away very fast.

Unfortunately whichever way you run you are confronted with more of the same. Overall Cobra is monotonous, boring and poorly designed. Another licence exploitation prog. Don't let it exploit you.

8/20

Liz

Standard procedure for every game is to pick up the joystick and start playing. Then when you get stuck – and only after you've pressed every key on the keyboard to see if anything happens – you read the instructions.

I started playing Cobra and it seemed reasonable. I figured out the hamburger bit and was confused by the way you need to jump first up and then sideways

to get on to a higher ledge. So it seemed reasonable to read the instructions and sort out what was supposed to be happening.

Then my opinion changed. There was no more to it. Worraripoff. The sprites are poor and jerky, the plot as credible as your average Stallone movie and the whole thing overpriced.

14/20

Colin

Wot a load of old cobras, I've never seen such confused trash in all my life. Hamburgers my armpit! I know Stallone's supposed to be a bit of a beefcake, but this is ridiculous.

I couldn't help noticing that the screen occasionally went into a quivering fit after passing booby-trapped

windows. Also it seemed to halt for a while at it's own convenience. Nothing about that in the instructions.

This looks a bit like someone took Green Beret and ran it through some kind of zanification process. The result? For some peculiar reason I found it enjoyable.

6/20



PRE-SCHOOL, PRIMARY, JUNIOR

Education

By a Teacher. Tested by Pupils

Approved by Parents and Schools

For All AMSTRAD Computers. CPC/PCW and PC
Cassette £7.00 Disc £11.00
LargeSAE For Lists (Please indicate CPC/PCW or PC)

ARC (ACU11) 53 Bentley Street, CLEETHORPES,
South HUMBERSIDE DN35 8DL. (0472) 699632

Save 50% with TXTPAK

TXTPAK, for the Amstrad CPC range, stores string data in a packed form which requires 30-50% less space, so up to 100% more data can be stored. It adds 31 commands to Basic. Best results are achieved with English text (eg. letters, reports etc.) or numeric strings. All possible character codes (0-255) are valid. Data is packed into string variables which may be saved on disc using Basic commands. TXTPAK also supports RAM files containing variable or fixed length records. Records can be read, written or deleted at any position in the RAM file. The RAM file can be searched for a sub-string (even if the RAM file contains packed strings) and strings can be sorted into ascending order during input. TXTPAK (16K ROM or Disc) Introductory price £13.75 (Normal price £20)

BACKUP (CPC464/664/6128, requires TXTPAK)

BACKUP is a set of utility programs which simplify the taking of security copies of data files. It used TXTPAK to reduce the size of the backup files. BACKUP, RESTORE or VERIFY can be selected from a menu. Backup files can be placed on tape or disc, using 2 drives if available. Wildcards can be used when selecting files for backup and the list of selected files is held for re-use. On a CPC6128 with one disc drive a disc containing 178K of text can usually be secured with only one disc change. In tests 90K of text was packed into 40K. BACKUP (Disc) £12.50 (£10 if supplied on same disc as TXTPAK)

All prices include P&P etc. Enquiries and payments to:
T.D.J. KIRK, 'Oatlands', Ballinerry Upp., Lisburn, N.Ireland BT28 3EP.

From NEMESIS (The Original Meddlers) BONZO SUPER MEDDLER (FOR ANY CPC)

THE dedicated TAPE TO DISC utility

Recalling that AMTIX said of the BONZO MEDDLER,
"A VERY GOOD and USEFUL set of utilities..." Aug. 1986
It is no surprise that BONZO SUPER MEDDLER is SUPERB!
BONZO SUPER includes the full BONZO MEDDLER & RAM DAM to make a most powerful combination.

- ★ TRANSFERS ALL BASIC, BINARY, and ASCII files.
- ★ CAN TRANSFER MOST "SPEEDLOCKED", and HEADERLESS.
- ★ AUTO RELOCATOR - RENAMES to suit AMSDOS - EXTENDED 'CAT'.
- ★ VIRTUALLY AUTOMATIC - 'CUTEDISC' included.
- ★ RAM DAM transfers a wide range of TURBO and "FUNNY" LOADERS at the PRESS of a KEY > MO renaming or "juggling" needed.
- ★ IMPORTANT - ALL TRANSFERS "STAND ALONE" - no massive "host" files needed by BONZO!

THERE IS NO DOUBT - BONZO SUPER MEDDLER DOES MORE for LESS,
DETAILS OF 300 TRANSFERS supplied.

BONZO BEATS THE "ULTIMATE"
TAPE £7.50 DISC £11.00

NEW! BONZO'S DOO - DAH

This totally new and comprehensive DISC package was produced to meet the demands of discerning "meddlers" who wanted improvements on the common basic and "string" packages:

FEATURES: BIGBONZO FORMAT

A REALLY USABLE 203K per SIDE FORMAT, complete with the essential disc file transfer facility without irritating restrictions - files of over 42K READILY transfer between any mix of FORMATS. FORMATS RAPIDLY including all standard.
A "NOTHING HIDDEN" FULL CATALOGUE. COMPLETE DIRECTORY EDITOR.
TRAC/SECTOR EDITOR - in HEX or ASCII. (A FULL SECTOR or DIRECTORY displayed to the screen, with easy EDIT mode).
FILE LOCATIONS by TRAC/SECTOR. RAPID DISC SEARCH - HEX-ASCII A WIDE RANGING DISC TO DISC COPIER, PRINTER OUTPUT etc. etc.
ALL WORK ON NORMAL, ENLARGED, AND most "funny" formats. FULL USE OF DRIVE A/B where fitted - no problem with one.
MANY UNIQUE FEATURES. supplied on DISC £11.50

BONZO CLONE ARRANGER - the "disc miser" -

still available, AUTO DISC/TAPE for archives - easy recovery. RECOVER that little used disc, and store the content on tape! Fast format, excellent DISC-DISC facility - supplied on tape, easy transfer to disc, just £6.00 (tape)

ALL WITH FULL INSTRUCTIONS. We give FULL after sales support and a regular NEWSLETTER. Overseas please add £1.00 to total.

ORDERS with cheque/postal, sent by return post:

NEMESIS (ACU)

10 Carlow Road, Ringstead, Kettering, Northants NN14 4DW.

A/W
Needed

JERSTAD IMPORT

N - 4448 GYLAND
NORWAY

SE HER

RAM UTVIDELSER
TALESYNTETISATOR
DISK HJELPEPROGRAMMER
SPILL
MIRAGE IMAGER
BUCANOT REGNSKAPSPROGRAM

NORGES
RIMELIGSTE DISKETTER
TIL DIN AMSTRAD
Kun kr 45,- pr. stk
ved kjøp av 5 stykk.

SKRIV ELLER RING OSS

TLF 043 76494

BE OM KATALOG

TELETEXT

A world of information
at your fingertips

Now you don't need a special TV for Teletext, you can receive it on your Amstrad 464 or 6128. The Microtext Teletext Adaptor gives you a full colour display of any of the free pages from Ceefax or Oracle. There's the latest news and software reviews, sports results and gardening tips, what's on TV plus much more, hundreds of pages constantly updated to give you the very latest information, at the touch of a button.

It's easy to use but powerful too, a page from Teletext like a recipe or a weather map may be saved for later reloading or printed out and Teletext may even be accessed by your own programs to plot graphs of share movements or load the latest results into a pools predictor, the possibilities are endless. The adaptor will load telesoftware too!

Supplied with a manual, the adaptor is cased and fits neatly on the expansion port. A connecting lead which could be extended as far as 100ft, goes to the 'VIDEO OUT' socket of your video recorder - this concept means an extra aerial is not required, channel selection is done on the video which saves us components, and saves you money!

"very powerful tools indeed." - BBC Ceefax, 'Next' magazine

Just £69.95 inc P/P, only from

MICROTEXT

7 Birdlip Place, Horndean, Hants PO8 9PW
Telephone: (0705) 595694

A M S T R A D U S E R S



Now you can get your training direct from Amstrad

When it comes to making the most of your Amstrad 8256 and 8512, who else would you turn to for guidance than Amstrad themselves? Clearly we're the undisputed experts on our products - and on passing on their benefits to you.

NEW TRAINING COURSES

Our new one day training sessions have been designed to give you the most comprehensive knowledge of your computer and how to get the most out of it. Unlike many other courses, we insist on no more than eight per training group. And every participant is given his or her own Amstrad Computer to work from.

REAL VALUE FOR MONEY

A full one-day training course at our convenient Newcastle-under-Lyme Training Centre costs just £79 (including VAT). And

the price includes a delicious lunch and refreshments.

BOOK NOW

The training courses which are running now are just one more example of our outstanding aftersales service (an Advanced Amstrad User course is also following shortly).

We'd like to advise you that space is limited. So why not avoid the risk of disappointment and phone Miss Katherine Edge right now on 0782 610011 (ext. 208) to book your places (or for further details).



Amstrad Distribution Ltd
PO Box 299, Newcastle, Staffs, ST5 7QS.

SIGMA 7

After *Combat Lynx*, Durell games earned a reputation of taking three hours to play, and an obligatory university degree to comprehend the instructions. Not this one. This is a shooty-uppey game with some of the slickest graphics yet.

The opening sequence (once you're through with all the anti-piracy tosh) of your little gunship is breathtaking. So much so that it takes you a while to realise that the default playing option is via the keyboard, and you have to abort the game to select joysticks.

Things soon get moving, the space-station-cum-runway scrolls off and aliens resembling green sandwiches fly on in formation. Knocking off these is a piece of pizza, once you get used to moving the stick up and down instead of left to right. Most of the people I saw playing it turned the joysticks through 90 degrees.

Firing fast and furious, it's possible to completely obscure the view ahead with bits of disintegrating alien. This is a bit of a problem, 'cos sometimes they sneak up on you unawares through the bits of savage sandwich filling and banners proclaiming "100 points".

At the end of the invasion of the sarnie-snatchers is an automated docking sequence to sit through while you bandage the old trigger finger.

Stage two is completely different, but still viewed in perspective. Your character now plays the part of a creature that is not sufficiently unlike K9 for it to be pure coincidence. K9 moves along a maze-like pathway eating up flashing smarties, not entirely unlike Pac Man. You don't seem to get much of a score for smartie nibbling, though.

Some smarties are completely inedible to K9's electronic innards. The pattern these form is used in the third (and final) part. The baddies this time take on the shape of whole rounds of green sandwiches, appearing and disappearing at random in a psychedelic DNA-type spiral. You can toast these sarnies with K9's snout-laser, and gain points. Wot do points make? (prizes?) Soon the little countdown alarm flashes à la cheeping

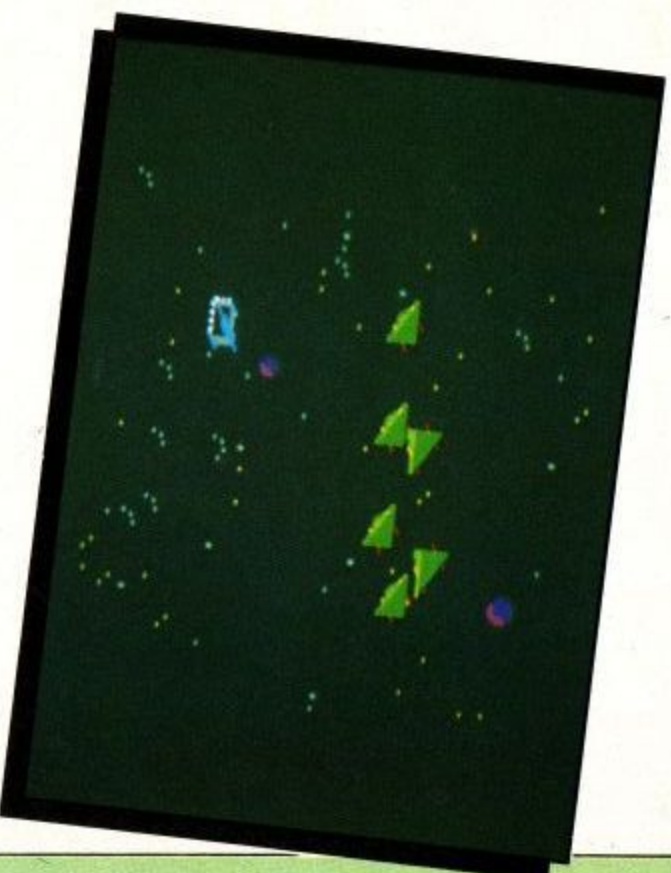

LED alarm clock. Now is the time for all good doggies to come to the aid of the third stage. Bad dogs can hang around and do some sandwich-blasting for a few extra points before legging it.

The third stage is a bit strange. K9 transmutes into a gobstopper, and has to push buttons in when they go yellow. Remember the bit about the inedible smarties? Well, that is the pattern you have to form on the buttons.

Difficult enough, so the sparkley thing that tails you round the board doesn't help a lot. You see, if you bounce him instead of a button, your gobstopper goes to that big sweetie jar in the sky. Not only that, but there's a time limit on it.

All in all, a very satisfying game. Part 3 is a bit dull, but parts 1 and 2 make up for it. Of course, if you complete it, you go round and round and round and...

Author: Durell
Price: £7.95

Nigel

The graphics on this ain't half bad, in fact they make it. If the thing wasn't in perspective, it would all be rather boring. I never got to play it on a monochrome monitor, but

177/20

Iain

This is a cross between *Zaxxon* and *Crystal Castles*. I found the space scenes a trifle dull, but the shooty Pac Man bit was fun. As with any 3D game the controls take some mastering. The boxed scores look a bit comic and the explosions

121/20

Colin

Since Arnold was born, software houses have complained about the 16k of screen memory being difficult to scroll. This shows in *Sigma 7*, the large objects, like your launch pad, scroll jerkily — not Durell's fault, more the mistake of attempting

the impossible.

Zaxxon offers a height gauge and a shadow in the planet scenes. This is missing from *Sigma 7*, making it hard to judge your relative position. A bit samey.

141/20

SHOCKWAY RIDER

Question: How do you get ahead in this game? Answer: You pick it up off the shockway.

Yeah, this is one game of really mindless, gutsy, bloodthirsty violence (so why did I score so badly?). It's all about spoiling innocent civilians' Sunday afternoon strolls on the moving walkways round the city. Not only spoiling them, but knocking seven kinds of whatever out of them while you're at it.

The overall effect is rather like rush-hour on the tube.

Some of the local yokels are just as bad as you are, noggin on the pavement. In true yobbo tradition, the opposition can be eliminated with uppercuts, bottles and bricks.

So can innocent bystanders. All disintegrate with appreciable clouds of naive smoke and appropriate guiltless noise, even the punks.

Some erks are dumb enough to sit in your way: they should get what's coming to them (... another one bites the dust, hey hey).

When the wrong one, that is you, gets decapitated (head hits the sidewalk, blood trickles in thick rivulets), all vigilantes present turn and do a creditable "Yar boo sucks" gesture in your general direction. This doesn't help us sore losers any.

As you progress through the mess of freshly de-bodified heads, things get trickier. Some bright spark decides it's a fun thing to build razor-edged barriers across the shockway. Not being an exponent of the



ancient art of limbo dancing, you get de-nutted on impact (that means yer head, mate).

In the demo, targets flash by on the higher levels. In practice, it takes a while to get that far. I didn't make it. Any way you do it, etiquette practically dictates that you make a complete circuit of the city, and if the devil doesn't take the hindmost, the shockway riders certainly will.

Author: FTL

Price: £8.95 (tape), £13.95 (disc)

Nigel

Sounds like the scenario of the walkways in Asimov's Caves of Steel, except more gruesome and there aren't so many cops. There only being all of three lanes, you don't get a lot of room to manoeuvre in, so your timing is critical. Mine is terrible.

Amazingly smooth scrolling on this; not a hint of

flicker, even while changing lanes or passing people. And I love the spare heads, heavily garnished with tomato ketchup. Once mastered, this one is going to brighten up the lives of many a potential jaywalker, mugger, thug, punk...

18/20

Liz

Yuk! This game is sick, putrid, rank, foul and in the worst possible taste. If CRL's Dracula was awarded a 15 Certificate then this wouldn't pass an 18. The idea of half a skull laying on the moving walkway is horrid. And yet despite my revulsion I returned for more.

The catchy tune, bright graphics and addictive qualities had me going for days. I am ashamed to admit that I enjoyed playing this game. Buy it if only to disgust your parents.

16/20

Colin

Imagine Infodroid in 3D and you get an idea of what Shockway Rider is about. Out goes the strategy and planning, in comes the gore. Travel around the city of the future avoiding muggers but earning bonus points for lobbing the odd half brick at an unsuspecting granny. Later you graduate

to mail bags and target practice.

Throwing missiles across the tracks is a difficult skill to master, and not needed until the later levels. Ideologically unsound, actually very good.

19/20

PRINTER OWNERS

Save Money on Printer Ribbons

Have your ribbon re-inked at less than half the price of a new one.

TRIAL OFFER

£1.50

Send your ribbon(s) and payment to:

ALADDINK

(Dept AU), 4 Hurkur Crescent, Eyemouth, Berwickshire TD14 5AP

Telephone 08907 50965 for colour

ASTROLOGY for beginners

Teach yourself astrology using your Amstrad

A Starter Pack comprising a simple program to calculate a horoscope, an introductory booklet and 2 self-teaching programs (how to interpret the horoscope)

£11.50 cassette £15.50 disc (£13.50 for 1512)

No previous knowledge required

Also many other programs for more experienced astrologers

Please send the Astrology Starter Pack for my Amstrad 464/664/6128/8256/1512. I enclose a cheque/PO, UK, for £11.50/£15.50/£13.50 (Inc p&p). Outside UK add 50p; or, I enclose a large sae for free catalogue.

Name _____

Address _____

ASTROCALC (DeptA) 67 Peascroft Road
Hemel Hemstead, Herts HP3 8ER Tel: 0442 51809

Reach the top with . . .

LCL

Educational Software

Amstrad (CPC + PCW) (Disc/tapes)

Electron, BBC (tape/disc)

Spectrum Commodore 64
(Apple, VIC, ZX81, NEC PC8201A)

AS

SEEN ON TV

★ WORLD LEADERS ★

★ At all Major Shows ★ ★ Hons. Graduate Authors ★

COMPLETE SELF-TUITION GCSE/GCE COURSES

(Each contains 24 programs)
£5 off total for 2, £10 off total for 3,
£17 off total for 4

PRIMARY MATHS COURSE (CPC)

Course taking beginners (from 5 years) to secondary school entrants in 35 programs divided into 18 lessons/tests.

All animated graphics 2 discs/tapes £24

MICRO ENGLISH (CPC+PCW)

Course taking beginners to English Language GCSE. Incorporates real speech, no extras required. 2 tapes/disc £24

MICRO MATHS (CPC+PCW)

Course taking beginners (from age 8 yrs) to O-Level/GCSE. 24 programs on 59 topics on 2 tapes/disc + 2 books £24

MEGA MATHS (CPC)

A-Level course for mature beginners, A-Level Students or Micro Maths users. Covers 105 topics on 2 tapes/disc + books £24

NEW

IMMEDIATE DESPATCH



Send coupon or phone orders or requests for free colour catalogue to:
LCL, (Dept. AU), Melody House, Greys Road,
Henley-on-Thames, Oxfordshire

Tel: 0491 579345 (10am-10pm)

Name _____

Address _____

Title _____

Computer _____ Disc/tape _____

Use your micro to speed up your mail . .

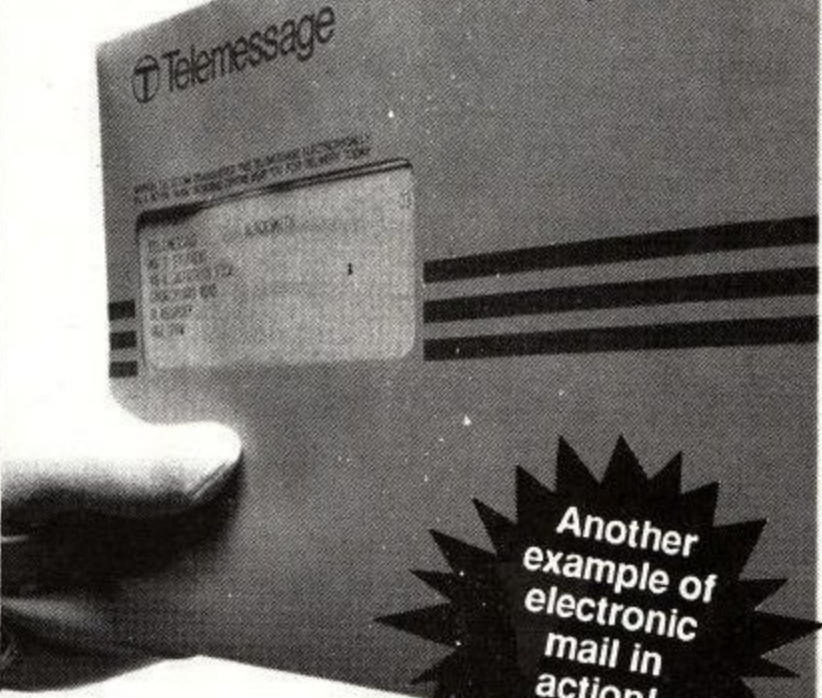

Another example of electronic mail in action!

and next-day delivery is guaranteed!

Everyone knows that "first class" mail is far from perfect. The Consumers' Association reported in June that two out of every five first class letters fail to be delivered the day after they are posted.

So if you have an urgent letter that just HAS to be delivered tomorrow, what do you do?

If you have a home or business computer the answer is at your fingertips.

You compose the letter on your computer. Then, in a simple operation that takes only a few seconds, you send it down the telephone line to MicroLink, the electronic mail service operated in association with Telecom Gold.

That's the end of your part in the story. From now on electronics take over. Your letter is fed automatically into the national British Telecom Telemessage service. It's switched to the delivery office nearest the recipient's address, where it's printed out on a letter-quality printer and put into a distinctive yellow envelope. And providing it was sent any time up to 8pm, it is delivered by the local postman by breakfast time the next day. Exactly as you'd typed it out the day before.

And how much does this ultra-fast service cost? From just £1.25 to send a letter of up to 350 words to any address in the UK (and an extra £1.70 to any address in the USA). You can also have it accompanied by a colourful greetings card (choose from 16 different varieties) for another 65p.

Telemessages is just one of many services offered by MicroLink that are designed to speed up communications. Find out more by returning the coupon below.

Please send me more information about your speedy Telemessage service and other aspects of MicroLink.

Name _____

Address _____

MicroLink
in association with
TELECOM GOLD

Send to: MicroLink,
Europa House, 68 Chester Road,
Hazel Grove, Stockport SK7 5NY.

ACU5

If you're a business or professional user of Amstrad computers you won't want to miss the May issue of . . .

AMSTRAD PROFESSIONAL COMPUTING

STOCKS AND SHARES: Dave Osborne examines two programs, available on all Amstrad machines, that help computerise share trading. And Iolo Davidson explains how to make a profit on the Stock Market – with someone else's computer.

EDUCATION: Rex Last offers improvements to a primary school software package.

STATISTICS: Dr Peter Morris evaluates a set of scientific and management statistical packages.

DATABASES: Kathy Lang finds out if the Amstrad version of PC Promise keeps its word.

PROGRAMMING: Peter Pavely looks at the ground rules for tweaking commercial software.

CHIT-CHAT: Cliff McKnight reviews Sagesoft's foray into the PC communications market.

. . . And much more. In-depth reviews of hardware and software, plus regulars and specials.

On Sale APRIL 15

SPECIAL OFFER FOR ACU READERS!

Subscribe to *Amstrad Professional Computing* using the coupon below and we'll send you a FREE binder worth £3.95.

ORDER FORM

Subscription

£15 UK and Eire	4001	<input type="checkbox"/>
£25 Europe	4002	<input type="checkbox"/>
£40 Overseas	4003	<input type="checkbox"/>
Free binder (UK only)	4006	<input type="checkbox"/>

Commence with _____ issue

Payment: please indicate method (✓)

Access/Mastercard/Eurocard/Barclaycard/Visa

Expiry date

No.

Cheque/Eurocheque made payable to Amstrad Professional Computing.

Name _____ Signed _____

Address _____

Tel: _____

Post to: Amstrad Professional Computing, FREEPOST,
36 St Petersgate, Stockport SK1 1HL
Order at any time of the day or night

Telephone Orders:
061-429 7931

Orders by Prestel:
Key *89, then 614568383

MicroLink/Telecom Gold
72:MAG001

Don't forget to give your name, address and credit card number

ENQUIRIES ONLY: 061-480 0171 9am-5pm

ACU5

CYCA LTD.

287 CALEDONIAN ROAD, LONDON N1 1EG
TELEPHONE:01-700 4004

AMSTRAD

Amstrad PC Compatibles	P.O.A. + VAT
CPC 464 Green	£173 +VAT
CPC 464 Colour	£260 +VAT
CPC 6128 Green	£260 +VAT
CPC 6128 Colour	£350 +VAT
DMP 2000 Printer	£139 +VAT
DMP 3000	£169 +VAT
PCW 8256	£399 +VAT
PCW 8512	£499 +VAT
Amstrad V21/23 Modem	£86 +VAT
CF2 Floppy Disc	£2.60 + VAT
CF2 DD Floppy Disc	£4.50 +VAT
Printer Ribbon DMP 2000	£4.00 +VAT
Printer Ribbon 8256/8512	£4.50 +VAT
JY2 Joystick	£11.00 +VAT
RS 232 Serial Interface	£43.00 +VAT
CPS 8256 RS 232 (use with PCW 8256)	£59.00 +VAT
Amstrad DDI 1	£139 +VAT
Amstrad FD 2	£139 +VAT
MP1 Modulator/464	£17.00 +VAT
Sony 3.5" S/S DD	£1.90 + VAT
Sony 3.5" D/S DD	£2.90 + VAT
Sony 5.25 MD1D	£1.20 + VAT
Sony 5.25 MD2D	£1.70 + VAT
Sony 5.25 MD2DD	£2.75 + VAT
Sony 5.25 MD2HD	£3.00 + VAT

TLX 297761 BT1EQ G Relay to 01 700 4004

CYCA LTD

287 Caledonian Road, London N1 1EG



CREDIT CARDS HOTLINE

01-700 4004



The PCW 8256 & 8512 Desk Top Companion Printer Stand £9.50

Why Let The Space Taken by your Printer be lost
Primarily designed for continuous stationery.
You could tuck your modem or second disc drive under it

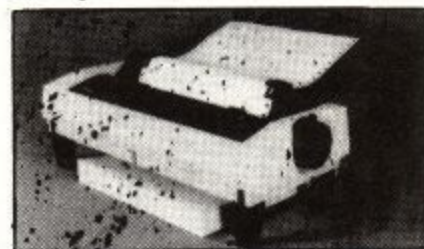

Top Mounting Printer
Stand £9.50

Top Mounting Monitor
Tray £15.00

A real space saver, put your printer on top of your monitor using our top mounting printer stand or why let the space taken by your monitor be lost, our tray recovers that lost space, vacuum formed in light grey to contrast with your keyboard.

All the products in the MEAC Designs Desk Top Companion range are designed specifically for your PCW to ensure that they blend in with the PCW's original design concept. Simple yet efficient. Desk Top Companions are injection moulded and simply plug into existing holes in your PCW, no screwing or glueing is required.

Our prices are all inclusive of VAT and P&P.

Memory Upgrade Scoop

PC 1512 Memory Upgrade kit £22.95
8256 Memory Upgrade Kit £18.95



Complete with easy to follow instructions & photographs.
Send your Cheque or Postal Orders made payable to MEAC Designs to

MEAC Designs, Dept AC
3 Little Croft, Yateley, Camberley,
Surrey, GU17 7BU. Tel: (0252) 879005

Trade enquiries
welcome

Patents
Pending

The AMSTRAD PC1512 is simply brilliant. With GEM™ Software it's brilliantly simple.

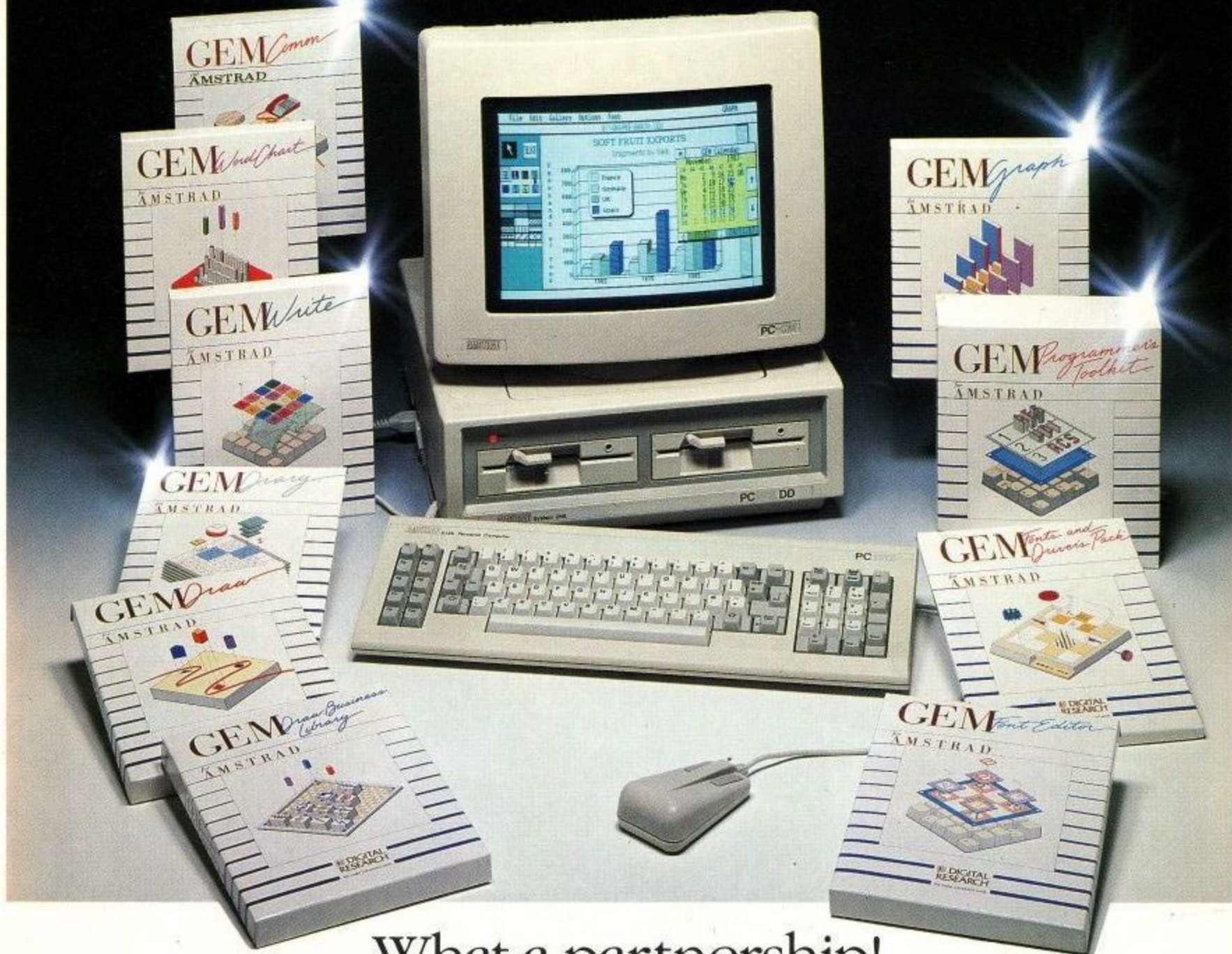

What a partnership!

First there's the brilliant new Amstrad PC1512.

Compatible with you-know-who. High speed 8086 processor. 512K memory. Full input/output system. High definition graphics...

...A mouse. A monochrome monitor. And a single disk drive. Fully loaded.

All for £449.

Then there's the software.

GEM makes the simply brilliant Amstrad PC brilliantly simple to use.

That's why you'll see GEM Desktop, GEM Basic2 and GEM Paint packed in free with your new PC1512. And more excellent GEM software is available.

That's also why we've added this coupon. Because, there's even more to GEM than first meets your eye.

Send now for details on the brilliantly simple GEM Software for the Amstrad PC.

GEM Diary £34.74 RRP – for perfect personal organisation, a perpetual calendar, diaries and card filer – all in one.

GEM Write £86.91 RRP – for full word-processing that mixes graphs and diagrams inside a letter or document.

GEM Graph £86.91 RRP – for the widest variety of graphs and charts to present numeric information.

GEM Draw £86.91 RRP – for anything from simple sketches to complex diagrams.

GEM Comm £60.83 RRP – for access to computer communications, including telex, electronic mail and Prestel services.

GEM WordChart £86.91 RRP – for crisp, clearly formatted text presentations and tables.

All prices mentioned are exclusive of VAT.

Name

Address

Postcode

Send to: GEM Amstrad Information,
Digital Research (UK) Ltd., Oxford House, Oxford Street, Newbury, Berks RG13 1JB

APC 3

GEM, GEM DESKTOP, GEM PAINT, GEM WRITE, GEM DIARY, GEM GRAPH, GEM DRAW, GEM WORDCHART AND THE DIGITAL RESEARCH LOGO ARE TRADEMARKS OR REGISTERED TRADEMARKS OF DIGITAL RESEARCH INC. AMSTRAD AND AMSTRAD PC ARE TRADEMARKS OR REGISTERED TRADEMARKS OF AMSTRAD CONSUMER ELECTRONICS PLC. Locomotive BASIC2 IS A TRADEMARK OF LOCOMOTIVE SOFTWARE LTD. © 1987 DIGITAL RESEARCH INC. ALL RIGHTS RESERVED

AMSTRAD
COMPUTER USER

**Exclusive
READER
OFFERS**

**FIVE powerful
modules at your
fingertips!**

- ★ Compose directly on to the staff with the feature-packed editor
- ★ Use your Amstrad keyboard to enter music in realtime and record it on the built-in multi-track recorder
- ★ Create and modify sounds with the synthesiser then feed them in to the sequencer
- ★ Link music files in any order to produce full-length compositions
- ★ Print out your masterpiece on to paper

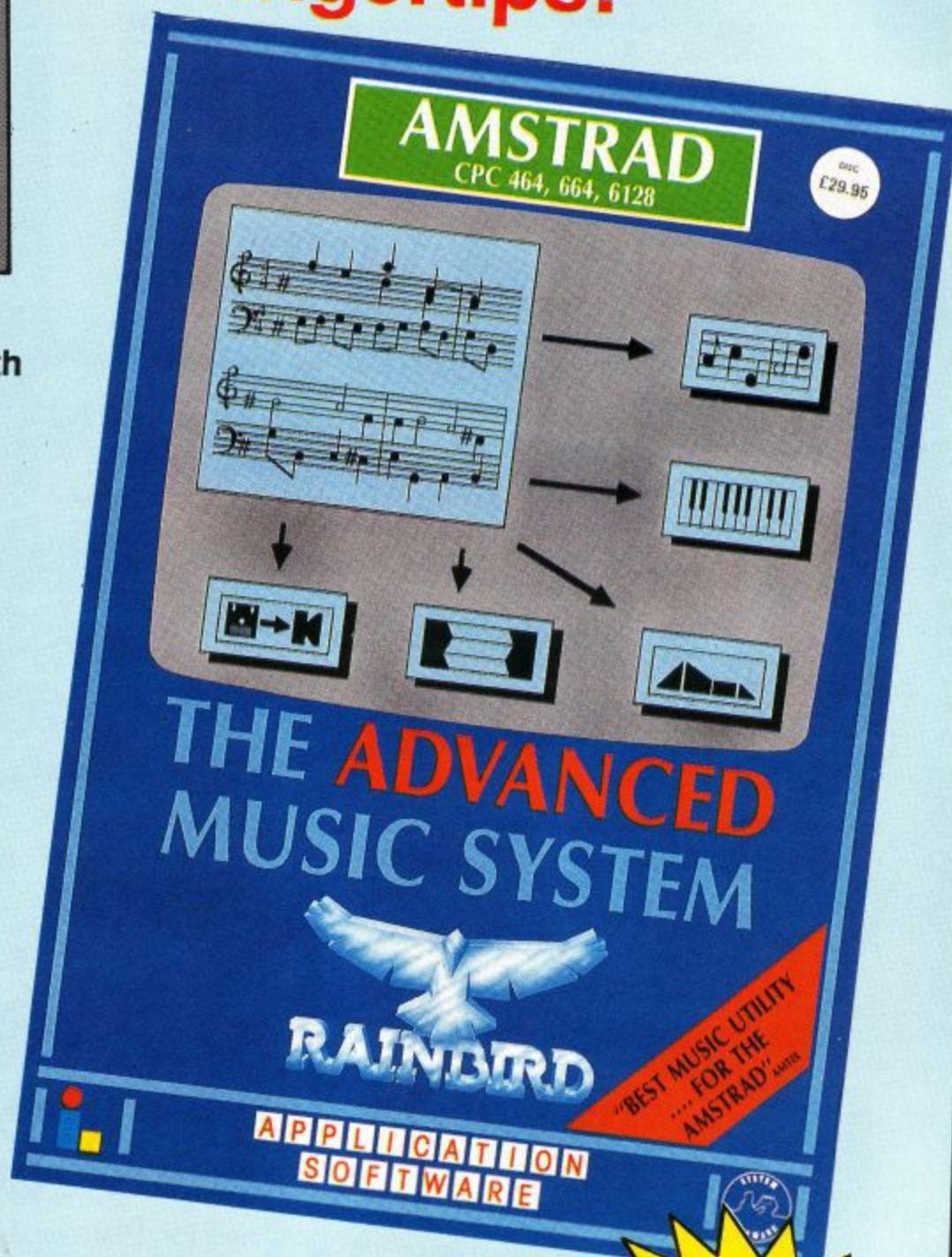

This is the most sophisticated music package ever created for the Amstrad CPC range – and now it's even better value!



Suitable for	Product	Format	RRP	Special reader offer	YOU SAVE	Offer including subscription	YOU SAVE
CPC 464, 664, 6128 (Disc only)	Music System	Disc	£29.95	£21.95	£8	£31.95	£10

To order please use the form on Page 95

**Exclusive
READER
OFFERS**

The OCP Art Studio was voted Best Utility of the Year. Now comes the Advanced OCP Art Studio with all the power and flexibility of its predecessor, and much more!



Its innovative features include:

- A colour priority facility so you can draw behind or mask particular areas of the screen.
- Eight random spray cans with three spray speeds for that professional finish.
- Three levels of magnification with sophisticated editing facilities.
- Cycle colours to produce simple animation effects.



You can also:

Design in Mode 0 (as well as Modes 1 and 2), paint with multicoloured patterns, display cursor x-y coordinates at all times, save windows to disc (or squash, stretch, flip, or rotate them), use keyboard, joystick, or mouse, and produce triangles, rays, rectangles, circles, filled circles, ellipses, and filled ellipses with ease. You can also add text in any of nine point sizes, in two directions, in normal, bold or italic, and with variable spacing.

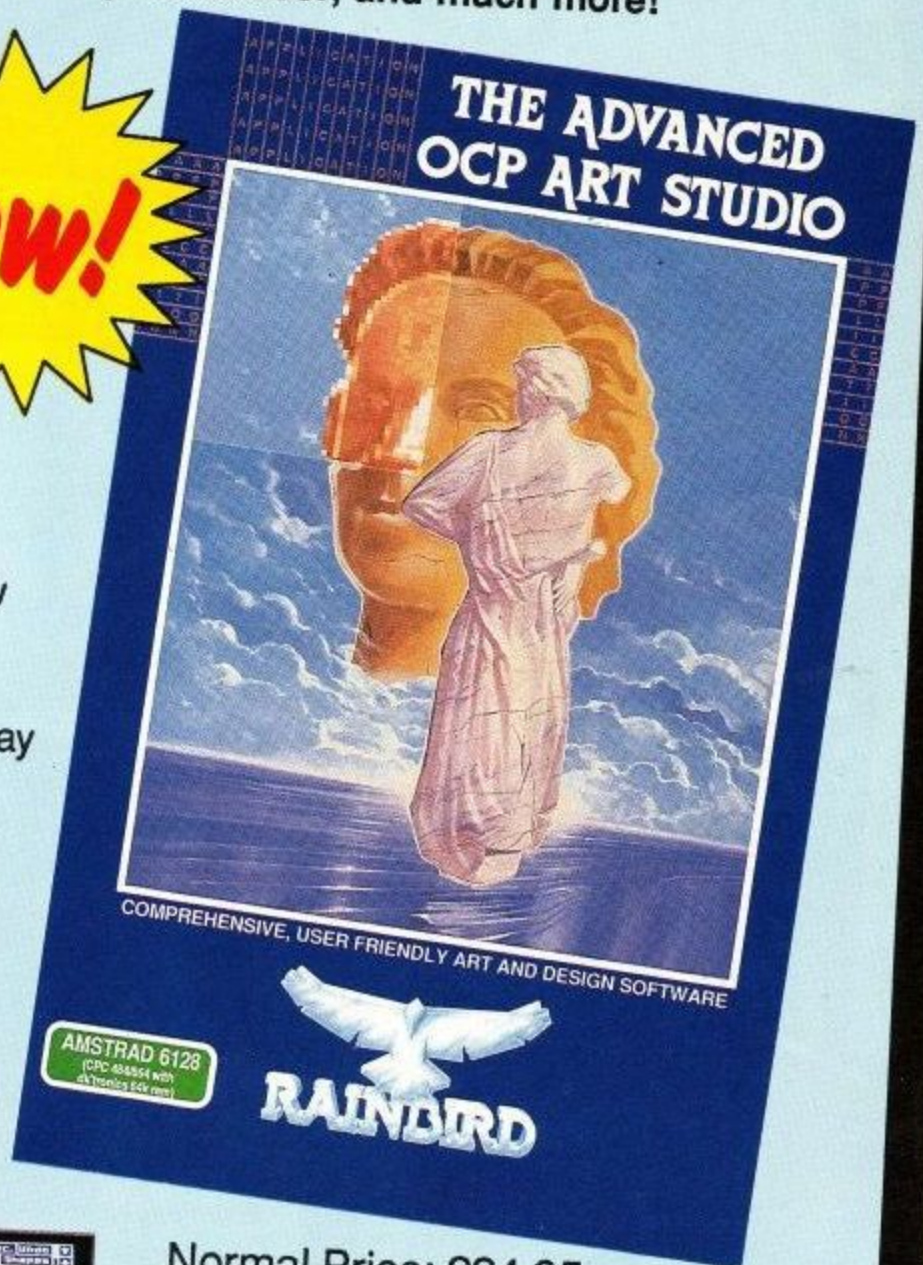

Normal Price: £24.95
Offer Price: £18.95

If you own a CPC664 or a CPC464 with disc drive, don't lose heart. You too can use this superb package if you purchase the DK'Tronics 64k ram cartridge which simply plugs into the back of your micro – and that's on special offer too!

Suitable for	Product	Format	RRP	Special reader offer	YOU SAVE	Offer including subscription	YOU SAVE
CPC Range*	Advanced Art Studio	Disc	£24.95	£18.95	£6	£28.95	£8
CPC 464, 664	DK'Tronics 64k Ram	-	£39.95	£31.95	£8	£41.95	£10
CPC 464, 664	Both the above	-	£64.90	£50.90	£14	£58.90	£18

*CPC 464 and 664 requires DK'Tronics 64k ram

To order please use the form on Page 95

AMSTRAD
COMPUTER USER

Exclusive
READER
OFFERS



only **£4.95**
UK

Binders

Your *Amstrad Computer User* is the ideal source of reference for every user of Amstrad computers. Keep your magazines tidy and in tip-top condition by using our top quality binder.

The *Amstrad Computer User* binder holds 12 issues. Each binder is black with the logo embossed in silver. Only £4.95.

Subscriptions offers



Cheap discs – WOW!

Discs are essential to anyone with an Amstrad disc drive so if you own a DDI-1, CPC 664, CPC 6128, PCW 8256 or even a PCW 8512 you will be interested in this special offer.

Our discs cost £2.74 each.

You could pay as much as twice that, the usual price is around £4 per disc. "There must be a catch". Yes, there is – you can only qualify for the offer when you subscribe to *Amstrad Computer User*.

These are official, thoroughly tested discs made by Panasonic. They are NOT the cheap, unreliable imports now coming on to the UK market.

See details on the order form alongside.

Dustcovers

Keep your equipment free from dust and grime with an *Amstrad Professional Computing* dustcover, made from clear pliable vinyl and bound by strong red cotton and sporting the logo.

NEW

DMP2000
Printer £3.95

CPC range
Keyboard £3.95
Monitor £5.95

DMP 2000/3000 Printer Cover	£3.95
CPC 464/664 keyboard cover	£3.95
CPC 6128 keyboard cover	£3.95
Green screen monitor cover	£5.95
Colour screen monitor cover	£5.95
PCW 8256 keyboard, monitor and printer set	£11.95

Back issues

1985 – May: CPC 634 review. Virgin interview. Using 5¼ inch discs.

June: Maxam assembler review. Rock Hopper listing. CP/M user group feature.

July: 664 (and 6128) to 464 conversion. Graphics toolkit listing. Speech synthesisers compared.

August: Screen designers compared. Technician Ted map. Knight Lore map and pokes.

September: Double height routine. *Unsung heroes* – MEJ. *Crazy legs* listing.

October: CPC 6128 review. Okimate 20 review. DK'tronics light pen.

November: Amgraph business graphics listing. DMP-2000 review. Life program.

December: Everyone's Wally map and pokes. Protext review. Enhanced trace utility.

1986 – January: Mode 3 revealed. Sorcery plus pokes and map. Shaded

dump listing.

February: Brainstorm review. Graphics adventure creator. DK'tronics ram expansion review.

March: Communications survey. Laser Basic reviewed. The Music system examined.

April: Using the 6845. Screen flipping on the 6128. Graphic packages reviewed.

May: Max Headroom. Joysticks compared. Teletext adapter reviews. Home spread listing. Dummy Run map. CPS review.

June: Batman Map. Biggles preview. Get Dexter Map. Music made simple. ABC Planner calc.

July: Palace interview, Activision, Load Spectrum screens into an Arnold, Battle of the cars program.

August: Equinox mapped, Printer mini-survey, Midi interface, Interceptor listing, Mastertronic interview. Last free issue of ABC.

September: Spindizzy map, detailed assembler survey, joystick reviews, PCW games.

Bargain bundles

Special Offer

An instant Amstrad Computer User Library

Are you new to *Amstrad User*? If so you've missed some great articles. Now there is a quick and easy way to catch up. We are offering two bumper bundles of Amstrad Computer Users which allow you to catch up.

Bundle 1: March 1985 to July 1985

This contains reviews of early software, Kuma's Zen and Arnor's Maxam assemblers, books, printers, the CPC 664, a plotter and speech synthesisers. There are games listings galore with such programming milestones as Rock Hopper, Cargo King, Froggie, Moonbase Alpha, Missile Attack and Trench. Seasoned programmers and raw beginners alike will enjoy articles on using the Arnold's music function, a machine code fill routine, writing adventures, simulating relative files from Basic, a graphics toolkit and a lot more besides.

Bundle 2: August 1985 to December 1985

This contains reviews of screen designers, Cobol, the first Amstrad RS232, The PCW 8256, CPC 6128, Okimate 20 DK Light Pen, DMP 2000, Epson LQ 1500. Help with Knight Lore, Technician Ted and Jet Set Willy II. Programs like 3D Maze, Splatch, Amgraph and Squash. Plus loads of interviews and features.

Each bundle costs £4.95, a substantial saving over the usual price of back numbers. Just to show how generous we can be you can have the lot - both bundles for £8.35. Can't say fairer than that!

PCW8256/8512
Keyboard, monitor
and printer set
only £11.95 set



October: PC 1512 reviewed, compilers tested, LocoMail, Basic 2 and Animator reviewed, Hacking help with joysticks.

November: Art package three-way test. Combat games compared. Using PIP. Mikro-Gen interview.

December: Heartland preview, Rombo Vidi full test, Dan Dare map, defining function keys under MS-dos.

1987 - January: Jailbreak, Starglider, Model Universe reviewed, PC games, Arnor interview, Frost Byte mapped, Crawler listing, Multi coloured CPC.

February: PC Programming, PCW Protex, CPC Listings. Top Gun and Gauntlet reviewed. The Secret of the Red Boxes plus all the regulars.

March: Nemesis preview, Music Machine - the ultimate Sound peripheral. Making the most of Protex, Machine Code manipulation, Elite Disc hack and US Gold interview.

April: Computer Journey - what makes your Arnold tick, the Men from Microprose, Amstrad RS232 reviewed, Sentinel from Firebird, back-up reminder program.

Back issues
£1.25 each

User May 1987

AMSTRAD COMPUTER USER

All Overseas items
despatched by
air mail

ORDER FORM

Valid to 31.5.87

Offers subject to
availability
All prices include
postage, packing &
VAT.

Subscriptions

	£	p	(✓)
£12 UK and Eire	8000		<input type="checkbox"/>
£25 Europe	8001		<input type="checkbox"/>
£40 Overseas	8002		<input type="checkbox"/>

Commence with _____ issue

Renewals

£12 UK and Eire	8811	<input type="checkbox"/>
£25 Europe	8812	<input type="checkbox"/>
£40 Overseas	8813	<input type="checkbox"/>

Subscription offer †

Five 3" discs (Europe add £2. Overseas add £5)	£13.70	8110	<input type="checkbox"/>
Ten 3" discs (Europe add £2. Overseas add £10)	£27.40	8111	<input type="checkbox"/>

†Only available if accompanied by subscription order.

Rainbird Advanced Music System

	With sub*	Without sub	
CPC 464, 664, 6128 Disc	£19.95	£21.95	8136/8137 <input type="checkbox"/>

*Only available if accompanied by subscription order or renewal
Add £2 for Europe/£4 for Overseas

Rainbird Advanced Art Studio

	With sub*	Without sub	
CPC 464, 664 Disc	£16.95	£18.95	8138/8139 <input type="checkbox"/>
CPC 6128 Disc	£16.95	£18.95	8140/8141 <input type="checkbox"/>
DK'Tronics 64k Ram	£29.95	£31.95	8142/8143 <input type="checkbox"/>
Disc + Ram	£46.90	£50.90	8144/8145 <input type="checkbox"/>

*Only available if accompanied by subscription order or renewal
Add £2 for Europe/£4 for Overseas

Back Issue Bundles

Bundle 1 - * March 85-July 85	£4.95	8146	<input type="checkbox"/>
Bundle 2 - * August 85-December 85	£4.95	8147	<input type="checkbox"/>
Bundle 3 - ** March 85-December 85	£8.35	8148	<input type="checkbox"/>

* Bundles 1 or 2 UK £4.95, Europe £6.95, Overseas £13.95

** Bundle 3 UK £8.35, Europe £12.35, Overseas £26.35

Back numbers

	£1.25 each	
1986	June 8019	December 8025 <input type="checkbox"/>
January 8014	July 8020	1987
February 8015	August 8021	January 8026 <input type="checkbox"/>
March 8016	September 8022	February 8027 <input type="checkbox"/>
April 8017	October 8023	March 8028 <input type="checkbox"/>
May 8018	November 8024	April 8029 <input type="checkbox"/>

Trivial Pursuit

	With sub*	Without sub	
PCW Series			
Genus Disc	£12.95	£17.95	8128/8129 <input type="checkbox"/>
CPC Series			
Genus Tape	£7.95	£12.95	8118/8119 <input type="checkbox"/>
Genus Disc	£12.95	£17.95	8120/8121 <input type="checkbox"/>
Young Players' Tape	£7.95	£12.95	8122/8123 <input type="checkbox"/>
Young Players' Disc	£12.95	£17.95	8124/8125 <input type="checkbox"/>
Extra Question Pack			
Young Players' Tape	£3.95	£6.95	8126/8127 <input type="checkbox"/>

*Only available if accompanied by a subscription order or renewal

Locospell/Locomail

PCW Series	Locospell	£32.95*	8132	<input type="checkbox"/>
	Locomail	£32.95*	8131	<input type="checkbox"/>
	Both	£63.90*	8133	<input type="checkbox"/>

*Add £2 Europe (£3 for both). Add £5 Overseas (£8 for both)

Dust covers

CPC 464/664 keyboard	£3.95	8100	<input type="checkbox"/>
CPC 6128 keyboard	£3.95	8101	<input type="checkbox"/>
CPC range green screen	£5.95	8102	<input type="checkbox"/>
CPC range colour monitor	£5.95	8103	<input type="checkbox"/>
DMP 2000/3000 Printer	£3.95	8105	<input type="checkbox"/>
PCW 8256 keyboard, monitor and printer set	£11.95	8104	<input type="checkbox"/>
PC 1512 Keyboard + colour monitor set	£9.90	8134	<input type="checkbox"/>
PC 1512 Keyboard + mono monitor set	£9.90	8135	<input type="checkbox"/>

Binders	£4.95 UK	8106	<input type="checkbox"/>
	£7.95 Europe		
	£11.95 Overseas		

European and Overseas readers, please
add £2 per item unless otherwise indicated

TOTAL _____

Send to
Amstrad Computer User,
FREEPOST,
36 St Peter's Gate,
Stockport SK1 1HL.

Telephone orders 061-429 7931 24 hours
Enquiries 061-480 0171 9am-5pm

PLEASE PRINT IN BLOCK CAPITAL LETTERS
Please allow up to 28 days for delivery

Please indicate method of payment (✓)

Access/Mastercharge/Eurocard/Barclaycard/Visa

Signature _____

Cheque made payable to Amstrad Computer User

Name _____

Address _____

ACUS

HOT FROM THE ARCADES

The MARIO BROS

are HERE

FEATURING MARIO

SIDESTEPPER

AND LUIGI

FIGHTERFLY

SHELLCREEPER

NEW!

SPECTRUM
£7.95

featuring Fireballs, Sidestepper, Shellcreeper and Fighterfly. Flip these pests and kick 'em off the pipes, but don't lose your footing on these slippery floors. Play as a team or against each other; either way you're in for a scream with Mario and Luigi — the MARIO BROS.

AMSTRAD
COMMODORE
£8.95

Nintendo

ocean

The Best! from HiSoft

Devpac80 Ver. 2

Devpac has always been a popular Z80 development system used by Software Houses all over the world since we first introduced it for CP/M over 6 years ago. Many regard it as a standard to work from. Now we have extended the standard to produce the most powerful Z80 development package yet seen and still at the same price as before, half the price of certain other systems!

- fully-integrated screen editor, remembers your assembly errors and takes you straight there for correction.
- standard Zilog macros with strings, nested conditionals & text include, full expression handling with absolute and relative values.
- produces standard .REL files or .COM files. .REL files allow you to link the output with the output of most other languages e.g. CBASIC™, ProPascal™, ProFORTRAN™, all MicroSoft languages etc. The REL format is a standard 8080/Z80 linker format, don't be fooled by substitute formats.
- assembler produces standard .SYM symbol table files for use with the symbolic debugger or with debuggers from MicroSoft and Digital Research.
- the debugger is symbolic i.e. you can see the labels you used when assembling in the code that you are debugging.
- debugger uses full conditional breakpoints and watchpoints so that you can even profile your program to highlight slow areas.

All this power with an extensive, quality ring-bound User's Manual for the incredible price of **£39.95**

HiSoft C/Aztec C

C is now a very popular and important language. We offer two entry points, one for beginners or casual users and one for the experienced C programmer.

HiSoft C £39.95

- fully-integrated editor, reports your error and takes you to the rogue line, ready for correction.
- super-fast and compact code.
- Kernighan/Ritchie without floating-point or linkage.
- Special Offer! Supplied with tutorial book C at a Glance *free!* Make sure you use the coupon below for this offer.

Aztec C Prime £79.95

- industry-standard compiler with upgrade path to developer and commercial versions.
- assembler, linker and object modules all supplied. Produces efficient, fast code.
- full Kernighan/Ritchie with floating-point.
- versions for CPC6128/PCW/PC1512 computers.

CPC and PCW Software

HiSoft Pascal80 £39.95

The best CP/M Pascal Compiler, with integrated editor. Compiles faster than anything else, and produces the fastest code. What more can we say. On Disc.

Nevada COBOL £39.95

The business programmers favourite, its based on ANSI-74 with some Level 2 features. Complete with 165-page manual, and free screen editor, ED80. On disc.

Nevada FORTRAN £39.95

A subset and superset to ANSI-66 with some 1977 features. Includes CHAINing with COMMON areas, TRACE debugging, random access and sequential files, and free screen editor, ED80. On disc under CP/M.

Write Hand Man £29.95

Sits in the background of your Amstrad and gives you a calculator, phone book, diary, macro key editor and much more. Now with status-line clock feature!

HiSoft FORTH £19.95

New from HiSoft is this powerful implementation of Fig-FORTH with extensions for the Amstrad CP/M Plus computers. HiSoft FORTH comes complete with an interactive screen editor, Z80 assembler, CP/M BIOS support and full GSX graphics. Fast and complete. HiSoft FORTH is incredible value for money!

PC1512 Software

Knife-86 £29.95

Knife-86 is the most powerful disc-recovery utility available for the Amstrad PC1512 computer. It allows you to examine any disc, floppy or hard, and change the contents of the sectors by simply moving the cursor over the top of the location you want to change. There's a host of features and utilities on the disc including UNDEL for recovering accidentally-deleted files, PAGE for sophisticated text pagination to printer, SHOWMAP to map your disc usage, GENSUB for easy generation of batch files and lots more.

Great value for money!

THE Index £49.95

On-line index generation the easy way! THE Editor from HiSoft works on Wordstar or NewWord files and allows you to create and alter indexes for your documents. It features a unique hot-key which allows to mark words for inclusion in the index at any time, even when typing them in. Fully menu-driven with examples and a comprehensive manual

FTL Modula-2 £54.95

Great value-for-money, this up-to-date and full implementation of the successor to Pascal is easy-to-use with an integrated editor, assembler and linker together with the source code for most of the predefined modules. Versions available for both CP/M (CPC6128 & PCW) and PC 1512 machines. 8087 support on the PC1512 is just £29.95 extra. The full source of this split-screen, macro editor is available separately at £39.95 or for £35 when purchased with the compiler. Go for Modula-2 today!

ZBASIC £49.95

ZBASIC is a fast BASIC compiler that works like an interpreter so that correcting mistakes is easy whilst compiling is a piece of cake! Compiles a full range of BASIC statements with floating-point precision selectable up to 54 significant figures so that you can control the accuracy/precision ratio. Full graphics support for the CPC and PC 1512 machines. Works on all CP/M and PC computers and there's even a version of the Apple Macintosh!

Please rush me the following HiSoft Software for my Amstrad:

Product	qty	price

Please charge my Access/Visa card:

Card No: _____ Expiry Date: _____

I enclose a Cheque / Postal Order to the value of £ _____

Name: _____

Address: _____

Post Code: _____ Signature: _____

HiSoft The Old School, Greenfield, Bedford MK45 5DE ☎ (0525) 718181

The Least Significant Bit

The Which? Computer Show brought the return of Sir Clive – you need to be careful not to call his machine a Sinclair. Amstrad owns his surname (but not his Sir name).

The foolish editor let nostalgia and his cheque book run away with him, producing an ink filled Parker to swell the coffers of the good knight. Since he had trekked to Brumm with instructions to buy a Z88 for a like-minded friend he made out the order for two, to include postage and packing.

Being as numerate as the average aardvark he failed the simple addition test and resorted to using the Z88 to do the calculation. Two machines each at £229.95, a Ram pack at £49.95, p&p £7.50. Right type that into Sir Clive's squidgy keyboard and write a cheque for: £517.3500001, Humm some debugging needed here I think.

Alan Sugar need not worry about the new black beast, so it is some surprise that he asked the techie wiz at a top Amstrad distributor what he thought about the Z88. "Well," replied the engineer, "it's small, so it's going to get hot. I think it needs a fan". Such *chutzpa* earned an unusual response from Mr Sugar – silence.

Fond memory

Many magazines have a page of chat at the back, a bit like LSB. PCW offers Chip Chat, Smash Hits has

Mutterings and Acorn User offers Acorn Abuser. It is this last column which caught the eye of Amstrad bigwigs shortly after the CPC launch, when Acorn were mighty and Amstrad were Audiophiles (who's laughing now Luigi?).

Abuser reviewed a Hi-Fi complete with twin speed disc drive (33 1/3 or 45 rpm), and tape interface. What annoyed the men at Brentwood towers was that the photo used was not of an Amstrad tower system but of a rival – not too distant in name from that of The Duchess of York.

Chart Busters

Never too proud to steal an idea – plagiarize, plagiarize remember why the good Lord made your eyes, but always call it research – LSB offers the top 10 games for 1999.

1. Computer Hits 10 Vol 97 – Beau Jolly
2. Bombjack 23 – Elite
3. Pong – official licence – Ocean
4. Naff James Bond game – Domark
5. Formula 1 Simulator – Mastertronic
6. Knight Tyme 1999 – Mastertronic
7. A little bit more advanced but not quite as advanced as next week's version Art Studio – Rainbird
8. Star Trek – Beyond
9. Blue Peter – the game – Macsen
10. Zaxxon – Amsoft

How to be a pest

If you want to annoy a PCW owner make it go beep. If you *really* want to annoy a Joyce owner then hold down a key, make it beep and pull out the keyboard plug. The machine won't stop beeping.

ADVERTISERS INDEX

Advanced Memory Systems	13	Database Software	24,54,55,58	M.J.C. Supplies	80
Advantage	60	Datavise	71,73	Nemesis.....	86
Aladdink	89	Datel Electronics	60	Newcrown Computers	73
Amsoft.....	83	Digital Research	2	Ocean Software.....	10,96
Amstrad	34,35,49,91	DK'Tronics.....	100	O.J. Software	85
Amstrad Distribution	86	Durell	8,9	Opus Supplies	39
ARC Education	86	Evesham Micros	80	Romantic Robot	76
Arnor.....	62	Garwood Software	21	Rombo Productions.....	85
Astrocalc	89	Goldmark Systems	79	R.S.D. Connections	67
Beau Jolly	17	HiSoft	97	SBS Computer Supplies.....	56
Brentwood Office Supplies	21	HSV Computer Services.....	67	School Software	85
Campbell Systems	4	Jackson Computers	71	Selec Software.....	85
Cheetah Marketing	28	Jerstad Import	86	Silicon City	71
Clifton Trading	40	Kamset.....	21	Siren Software	22
Compulink Services	80	LCL Educational Software	89	Star Micronics.....	47
Compumart.....	99	Matmos	71	Tasman Software.....	74,75
Comtec Systems.....	30	Meridian Software	80	T.D.J. Kirk.....	86
Connect Systems	71	Micronet 800	27	Typeshare	73
CP Software	63	Microtext.....	86	Viglen.....	42
Database Exhibitions	7	Microwise UK	79	Virgin Games.....	52
Database Publications .	14,41,79,89	Mirage Microcomputers	73		

YOU NEED A GOOD SENSE OF HUMOUR TO BUY FROM COMPUMART...

WITH OUR LOW PRICES YOU'LL BE LAUGHING ALL THE WAY TO THE BANK!

NEW
Low Prices!

BOX CLEVER!

BRAND NEW... Specially designed for Amsoft 3"CF2 Disks

Holds 20-3" Disks & Cases

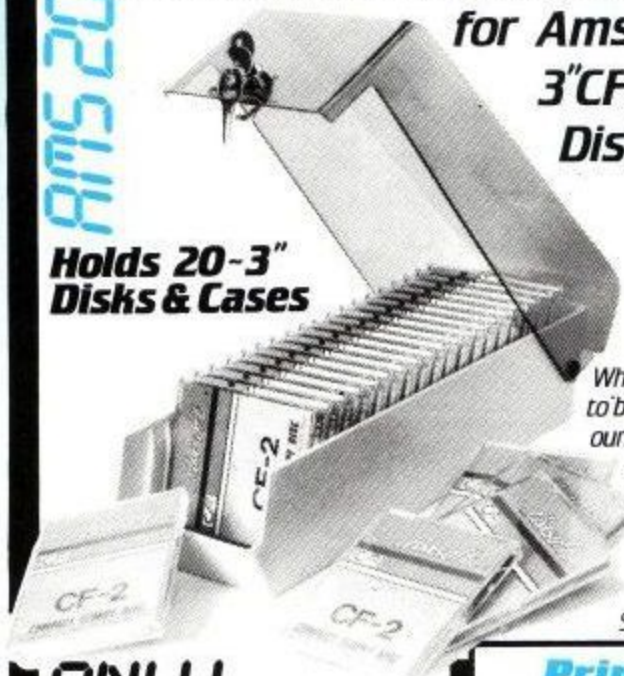

When it comes to 'boxing' you'll find ours a KNOCKOUT! Excellent quality Perspex, lockable.

Save on Accidental Damage from Spill, Drinks, Dust etc.

ONLY
£9.95
Post Free!

Amsoft 3" CF2 MICRODISKS

From the U.K.'s LARGEST Supplier

Individually packed in Plastic Cases - Boxed in 5's or 10's

ONLY 5-~~£14.95~~ / 10-~~£26.95~~
PACK +£1 P&P / PACK +£1 P&P
SAVE £3

Phone for Quantity Discounts

New From AMSOFT
'LOCOMAIL'
For PCW Machines
Latest version of Locoscript
with Superb Mailmerge Facility
Special Software Offer!
ONLY **£39** POST FREE

Buy Now & get
2 Blank Disks FREE

Printer Ribbons
for
PCW-8512/8256
DMP-2000/3000

ONLY... **£4.95** each
Post Free!

Please specify printer when ordering

ALL Products are covered by the Compumart Guarantee!

How to Order...

Simply post your order stating Name and Full Address, with either a Cheque or Postal Order (Made payable to Compumart) to the address opposite.

Phone any of our 3 Order Lines (24 Hours) and place your order using your Credit Card.

All Disks are usually despatched SAME DAY by First Class Post.

For a SPEEDY NEXT DAY Securox Delivery, just add £2 to Postage (e.g. £9.95 + £2 = £11.95) Send £3!

Overseas Orders: Please deduct 15% (VAT), then add 10% for Air Mail and Insurance.

We accept Official Purchase Orders from Government and Educational Establishments.

COMPUMART
A GREAT DEAL MORE · FOR A GOOD DEAL LESS!

3 ORDER LINES
(OPEN FOR 24 HOURS)
☎ ☎ ☎ 262259
(0509) 233893
266322

Please Send Cheques/P.O.'s to...
COMPUMART-Dept AM-Unit 8-Falcon Street
Loughborough · Leics · LE11 1EH

ALL PRICES INC. VAT AT 15%
PRICES AND DELIVERY SUBJECT TO AVAILABILITY

TURN YOUR MONITOR INTO A COLOUR T.V.



AMSTRAD

CTM 644
Colour Monitor

12V DC

power

POWER
ON-OFF VOL

DK'TRONICS

MONITOR

TV RECEIVER

BRIGHTNESS

COLOUR

CHANNEL SELECT

■ NOW YOU CAN USE YOUR MONITOR FOR BOTH COMPUTING AND WATCHING TELEVISION ■

■ Employing the latest chip technology the DK'Tronics receiver will convert your CPC monitor into a high quality television set, giving crystal clear pictures on all four channels.

■ HOW TO ORDER

DK'Tronics products are available in all good computer stores or may be obtained direct by telephoning and quoting your Barclaycard or Access number.

■ £69.95 including VAT

dk'tronics

POWER BEHIND YOUR AMSTRAD