

# COMPUTING

19 BOOKS 411  
22 1978  
30  
36 W/FBA REV  
45 COMP PHONIE NO.  
49  
48 BOOKS

## AGE

DECEMBER 1985 £1.00

# COMPUTER CRIME THE FACTS

BEST BUYS FOR XMAS

- INFRA-RED COMPUTER LINK
- SO WHY NOT THROW YOUR BBC AWAY?
- A-Z OF MICRO MUSIC
- GIZMOS FOR YUPPIES

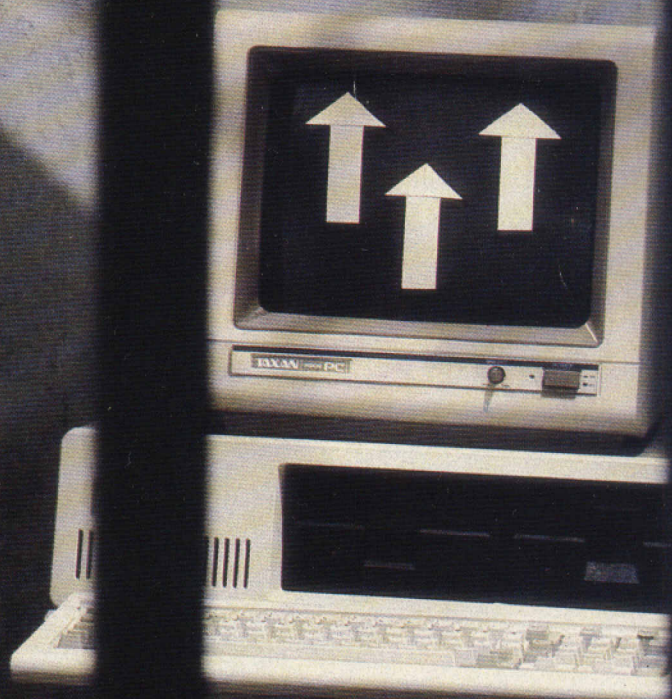

MAKING MORE OF YOUR COMPUTER

Volume 1 Issue 3 December 1985  
Computing Age  
Priory Court,  
30-32 Farringdon Lane,  
London EC1R 3AU  
Telephone all departments 01 251 6222  
Telecom Gold: 83JNL032  
Prestel/Micronet Systel: 01 314 3278

**Editor**

Gary Evans

**Deputy Editor**

William Owen

**Editorial Secretary**

Debbie Wood

**Advertising Manager**

Tony Herman

**Advertising Executive**

Tracey Keighley

**Advertising Production**

Serena Hadley

**Design**

Brian Cookman Design Associates

**Typesetting**

Time Graphics

**Publisher**

Terry Pratt

**Distribution**

EMAP National Publications

**Published by**

EMAP Business and Computer Publications

**Printed by**

The Riverside Press, England

**Subscriptions enquiries**

Telephone 0858 34567

Computing Age is normally published on the 13th day of each month.

Copyright EMAP Business and Computer Publications Ltd 1985. Reasonable care is taken to avoid errors in this magazine however no liability is accepted for any mistakes which may occur. No material in this publication may be reproduced in any way without the written consent of the publishers. The publishers will accept no responsibility for the safe return of any unsolicited manuscripts, listings, data tapes or disks.

Unfortunately we are unable to answer any telephone enquiries, any written enquiry requiring a personal answer must be accompanied by a stamped self addressed envelope - please allow up to 28 days for a reply

Subscription rate: UK £15.50 including post.

ISSN 0268-4934

# COMPUTING AGE

## FEATURES

- I, LOGO** 14  
Logo, more than just a means of pushing robots about.
- BBC add-ons assessed** 18  
One of the undoubted strengths of the BBC micro is the vast range of add-ons available for the machine. Clive Williamson looks at some of the best.
- Storming the Tower of Babel** 28  
Users of a wide range of computers are now able to program in BBC Basic. We take a look at how the language has been implemented on 'foreign' computers.
- Making micro music** 32  
A guide for those who want to get switched on to micro music.
- Infra-Red link** 36  
A novel means of hooking a computer up to home electronics - and you can build it yourself.
- 16 bits go to school** 40  
The days of the eight-bit micro may be numbered but the BBC micro still dominates the education scene. We assess the future of computers in school and the role that 16-bit computers can play.
- Computers in crime** 49  
Computer crime has been with us since the first computer.
- Gizmos for Christmas** 54  
A range of stocking fillers for the computer groupy who has everything.

## COMMUNICATIONS

- News** 43  
Micronet get busy with Bizznet plus other comms news of the moment.
- Conversation with Communique** 44  
When it comes to choosing a modem, Apricot users are hardly spoiled for choice. We review one of the few models designed for the range of Apricot's from the F series to the new XEN.
- Amstrad on-line** 46  
If the idea of a complete comms package for the Amstrad 464/6128 computers at a cost of around £30 appeals, then this is for you.

## REVIEWS

- Amstrad add-ons** 24  
The Amstrad peripheral industry is starting to gather momentum.
- Big drum sounds** 25  
A low cost drum synth designed for the CBM64 and C128 computers.
- Sanyo graphics card** 26  
Sanyo owners who demand IBM compatibility must fit a graphics card.
- Amstrad's Personal Wordprocessor** 34  
The PCW8256 wordprocessor system breaks new ground in terms of price vs performance. The system has in every way a professional specification yet costs less than many typewriters.
- Dragon Plus** 39  
Bleary eyed Dragon owners will be pleased to hear of a new board that offers them an 80 column display capability and an extra 64K of RAM.

## REGULARS

- News** 8
- Book Service** 42
- Letters** 11
- New Products** 52
- Subscriptions** 16
- Program Listings** 56
- Reader Services** 31
- Exit** 62

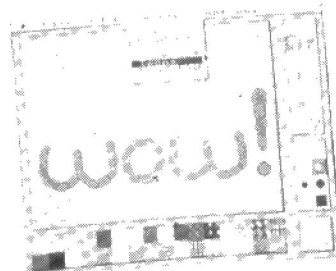

**18** We review the best buys in BBC hardware.

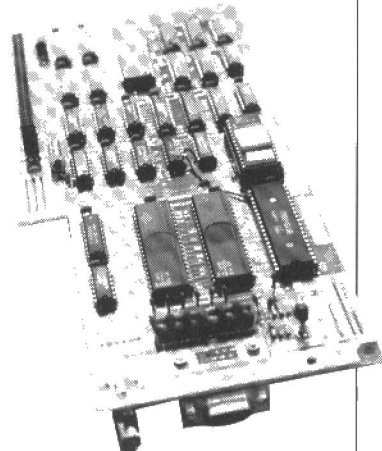

**26** IBM compatibility for Sanyo MBC owners.

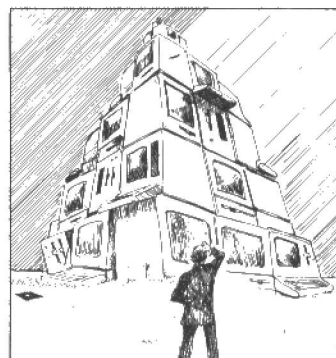

**28** BBC Basic is no longer the sole province of beeb owners.



**44** Apricot owner's get on line with Communique.

## Secret of success

Wineteen eighty five will hardly be remembered as a good year for the micro computing industry. It was, some will maintain, the year in which the micro computing bubble finally burst. For a plethora of reasons which have been extensively debated by industry pundits, many of the big names in the industry were plunged into financial crisis during the course of the year. Some survived to face the market in 1986, others were not so fortunate. Nearly every sector of the market has been forced to look at its growth predictions anew and in many cases once ambitious plans have been scaled down – it is the lean and fit that will survive in the future.

Amidst all this gloom and doom though it is refreshing to note that some companies are still able to identify and exploit lucrative gaps in the market. The most obvious exponent of this must be Alan Sugar the man in charge of Amstrad. This company at least managed to increase both profits and turnover to a significant extent when many of the companies around were fighting for survival.

What then is Amstrad's secret, if secret there is? The answer surely lies in the way in which the marketing department has been able to identify market needs and then to manufacture products designed to meet the perceived need. While other manufacturers are producing technically elegant hardware complete with a full range of bells and whistles, Amstrad sticks with tried and tested technology given a new lease of life by virtue of its application.

The latest Amstrad product, the PCW8256, is a prime example of this philosophy. On paper, the machine's specification looks boring: eight bit processor, mono screen and not a hint of mice or icons. Such an assessment of the 8256 belies the fact that it is marketed as a word processor system and in this application it offers an excellent performance. It is bound to succeed.

If the way to succeed is so clear, why do so few manufacturers manage to emulate this success? We don't pretend to have the answers – it can only be hoped that some of Amstrad's magic rubs off on the rest of the UK industry while there is still time.

## Next Month ON SALE DECEMBER 13

### Public domain software

There is a wealth of public domain software available, the trouble is that much of it is difficult to locate and is poorly documented. With a little help from Simon Craven, we show how this valuable source of free software may be tapped by anyone with a little determination.

### Simulation Systems

The UK leads the world in the technology of flight simulation. So realistic are the latest designs that the first time a pilot takes to the air in an unfamiliar plane there will be 400 passengers on board – all training will have taken place within a simulator.

Next month Alan Pipes looks

The features on colour printers and CP/M Plus scheduled for this month have been held over due to circumstances beyond our control. We hope to publish them in the January issue.

at the current generation of simulation systems and examines the future potential for Total Environmental Simulation.

### Atari comms

The Atari 520ST computer has communications built into its operating system. In theory users should be able to simply plug in a modem in order to get on line. We test the machine with one of the latest intelligent modems in next month's issue.

### 16-bit music

Do the latest, fast 16-bit computers offer any significant advances on the sound generation capabilities of the likes of the BBC micro? In most cases the answer, rather surprisingly, is no. Find out why in January's *Computing Age*.

## Teething troubles for Spanish Spectrum?

Take one Spectrum, one heat sink, one keypad, a level cupful of extra RAM chips, add fresh sound to taste and what have you got? The Spectrum 128, that's what – or, if you like, Paella y Sinclair: the long-awaited 128K has finally been launched, in Spain, and in considerable secrecy.

Manufactured in Madrid by Sinclair's Spanish agent Inves-tronica, the new machine operates in two modes. It can either emulate the old 48K Spectrum Plus, or access a full 128K plus extra facilities.

Those include a keypad which acts as on-screen editor and independent calculator, RAM disk facilities, and 3-channel sound fed through a television speaker. Also built-in are an RS232 interface and RGB monitor interface. It will sell at about £230; a UK model should go for around £170.

But the 128 will not be launched in the UK until early

1986, according to Sinclair Research, which is still refusing to release detailed information to the UK press. "The impetus to launch in Spain comes from the peculiar market forces there" says sales director Charles Cotton. More pragmatic Sinclair watchers suggest a no-competition deal with Dixons over the recent sale of 160,000 Spectrums and QLs for the Christmas market provides a better explanation.

That may be a blessing in disguise for British consumers. Pre-production models on show in Barcelona appeared to be undergoing typical Sinclair 'teething troubles' after a few days, and the claim of complete compatibility with 48K Spectrum software also looked shaky. At least one Spanish dealer reckoned OCP's Video Pool game wouldn't work on it – and suggested the same would go for some 15-20% of existing software.

## 520ST software hit by more delays

We had hoped to be able to present reviews of a number of applications software packages for the Atari 520ST in this issue of *Computing Age*. But despite our best endeavours during the early part of last month (October) we were unable to gather together enough products around which we could build such a feature. Some software houses had products they could send us, complete with finalised documentation and packaging, but these were the exception rather than the rule. Most of our enquiries met with the response, 'We'll have something for you in two weeks time.' We have no reason to doubt the good faith of companies offering to send us software in the near future, but the aim of the article was to review product that was available 'off the shelf'.

The availability of the soft-

ware Atari will bundle with the 520ST is difficult to determine. TOS, GEM and DR LOGO are, according to our information, in a finished form while DR BASIC is not ready for the public, at the time of writing, although we have seen a working version and provisional documentation. As yet we have not seen anything that resembles a finalised version of either DR GEM WRITE or DR GEM PAINT and it would appear that, at least in the short term, Atari is accepting that these will not be available. The company is supplying dealers with stop gap word processing and graphics software in the shape of Atari Write and Neo-Chrome. Our reports indicate that while some dealers have stocks of Neo-Chrome, Atari Write has not yet seen the light of day.

Purchasers of the 520ST who are supplied with early versions of the bundled software and

stop gap packages are being assured that they will receive copies of the promised GEM collection as soon as it becomes available. Dealers we spoke to said the question of just who would pay for this service was still rather vague.

While sales of the ST are said to be brisk, we cannot help but wonder just what proud owners of a new Atari 520 can do with their new machine. The option to create their own BASIC and LOGO programs is open to them and there is no shortage of development software for those wanting to write their own machine code or C programs complete with hooks to GEM. Dedicated programmers apart though, the machine would seem to have little appeal at present.

Until wordprocessors and spreadsheets, graphics designers, databases and perhaps comms software, including Prestel emulation, is readily available, the 520ST will remain a nice computer with nothing much to do.

We are not out to indulge in a spate of Atari bashing – the 520ST is a machine that lives up to the company's 'power without a price' slogan. But, for the average owner to release the power of the computer depends on the availability of good quality, low cost software. Until such packages can be pro-

duced, the power of the ST will remain caged. We hope that by next month we shall be able to report a more satisfactory state of affairs. In the meantime, we still have no hesitation in recommending the 520ST as good value for money, but we must add the rider that users must expect to face an as yet unknown period of waiting before they can expect to realise the full potential of the machine.

## Credit where credit's due

We have been asked to point out that the screen dumps used to illustrate the review of Timestep's weather satellite in last month's *Computing Age* were produced using Sat-Pack software. The copyright of this software is held by the Ground Track Project Team and is at present published by AMSAT-UK, 94 Herongate Road, Wanstead, LONDON E12 5EQ, telephone 01 989 6741. We are sorry that the article did not make this point clear and apologise for any confusion this omission may have caused.

## With a little help from the chip

In showing 'with a little help from the chip' at peak viewing time the BBC broke the long standing convention that there are certain things that are just not talked about. By focusing on the work being done for many handicapped people via the micro computer, the series certainly enhanced the image of the computer, but the format of the programmes was such that it was the general rather than the particular theme that was emphasised.

In fact, behind each of the items featured in the series is a phenomenal amount of work and ingenuity as the story of 'Christopher's Magic Cupboard', shown in the first broadcast of the series.

Christopher was crippled in an accident at the age of twelve months, since when he has lived in a ward at Great Ormond Street Hospital for Sick Children. Now four, he is paralysed from the neck down and is unable to breathe without the aid of a ventilator. He has full control of his facial muscles though and he can move his head and can speak. On the basis of these factors, Brian

Reeson, a bio-engineer at Great Ormond Street, is creating a computerised system centred around the child's wheelchair designed to give him mobility, a more stimulating environment and a limited degree of independence.

The wheelchair on which the hardware centres has to carry Christopher's oxygen cylinders and the gas-powered ventilator, with their attendant monitoring and alarm electronics, before ever the computer gadgetry is considered. To lighten the load, and make cannibalisation easier, Mr. Reeson has taken a BBC machine out of its case and used it as an intelligent terminal carried on the chair. It is attached to voice-recognition and speech-synthesis units, as well as operating control sensors and the wheelchair's movement. The whole thing is powered by sealed, re-chargeable batteries, located between the wheels, since mains power is out of the question on a wheelchair. The speech-synthesis unit is the DE-Talker and the recognition unit is an American system called SYS300.

*Continued over page*

## Flavour of the month

**S**ony, who bought the world the 3.5" disk drive, has developed a 2 megabyte (1.6M formatted) micro floppy unit by doubling the number of sectors per track. Using essentially the same magnetic technology as the original drives, the 2M drive features heads produced to higher tolerances to provide the increased storage capacity. An additional hole in the disk cartridge allows the drives to differentiate between 1 and 2M disks.

The drives should start appearing next year at prices that are only 20% higher than 1M units – another case of more bits per buck.

As Sony announced the 2M 3.5" drive **Toshiba**, not to be out done, has released details of a 4Mbyte drive that uses perpendicular recording techniques to achieve this impressive storage density. Evaluation units of

the 4M drive will be available next year with full production runs getting under way in 1986.

While on matters of magnetic storage units, **Hitachi** has demonstrated a 3.5" hard disk that holds 15Mbytes of data. Data transfer rate is twice that of a typical floppy drive at 625K bytes/second. Expect to see the new drive, designated the DK-301, appearing in portable computers within the next year.

Another example of the way computers can help the handicapped is the speaking hand developed by students at an American University. The hand accepts **ASCII text** from a terminal and then 'speaks' the words to people who are both deaf and blind.

The handicapped, and those among you that belong to the single finger school of typing, will find the idea behind a new **IBM PC** program of interest. The software is designed to make keyboards easier to use for those having limited use of their arms and hands. Running the software alongside many popular applications software removes the need to press two keys simultaneously. Instead of

having to press the **shift, ctrl** or **alt** keys at the same time as another key, the user can type the two keys sequentially.

Another candidate for the 1985 Yuppy **gadget of the year** is the View Control System (VCS) input device for the **Macintosh**. The device is worn on the head of the user and, by measuring the signals produced at three points on the headband, the VCS is able to move the cursor around the screen in response to movements of the user's head. We are told that exaggerated movement of the head is not required; cursor movement depends on the rate of head movement. By monitoring this rate of movement signal, the VCS is able to decide whether the screen is being scanned or the user is zeroing in on a specific area of the screen.

Types prone to nodding off at their computer should be warned this could have a terminal effect on their programming.

The development of the **laser printer** and the improved quality of the print produced by dot matrix printers means that demand for **daisy**

**wheel** printers is showing a dramatic downturn. A new printer to be featured in next year's Epson catalogue could, in addition to killing the daisy wheel market stone dead have some important implications for manufacturers and retailers holding stocks of current dot matrix models. The new Epson printer will sell for around the £200 price mark and will offer a quality of print that will be hard to distinguish from that produced by a daisy wheel.

The trade has been aware of these trends for some time and has been offering some real 'bargains' on dot matrix printers in recent months – not out of the kindness of their hearts but fear of unshiftable **Epson RX80s** etc.

Workers at **Tatung's** factory in Telford have been instructed that they are **not to laugh** while on the firm's premises for fear that they will damage the sensitive components that go into, among other products, the Einstein computer. A stern faced company spokesman was unable to say what Tatung workers found so funny – could it be, we ask, the sales figures for the aforesaid computer?

Continued from Page 9

As yet, the use of this equipment is highly experimental. The SYS300 is fast and efficient but it has to be taught its vocabulary, which involves three repetitions of each word. It must be programmed by the eventual user.

SYS300 works by decoding sounds spoken into a microphone. The sound is interpreted by the chair-borne micro, which translates instructions for a conventional BBC computer standing in the room. The results are then viewable by the user, displayed on the giant screen of the stationary micro's monitor. The system cost Project Christopher £1500, but until it is wholly reliable, the chair has been rigged up with proximity switches which can be activated by a movement of the head or even the tongue, and these at least allow Christopher to turn the power on and off by himself.

In addition, a joystick has been attached to a helmet which Christopher wears, the

idea being to enable him to move the cursor on his software programs by manipulating the joystick with his mouth. The degree of control is not as satisfactory as it will hopefully be with a voice-operated system, but it is not yet clear how much can be achieved.

With many things still in the experimental stage, the computer electronics demand constant modification. Because Christopher needs his chair to be available at all times, the devices are in four discrete units fixed to the top of the chair, and are easily removed. As the demands on the micro as controller become more complex, it may be necessary to incorporate more 6522 VIA chips into the system. At present, all the BBC's ports are dedicated, with joystick and proximity switches controlled via the analogue port, SYS300 connected to the RS423 and the chair itself being driven from the user port.

Part of this same port is used for an infra-red link between the two computers, and Brian Reeson intends to expand this to a two-way link, so that the

mobile BBC can receive data downloaded from the stationary machine's disk system. The user port bit has been programmed to simulate an RS423, a complicated piece of software which is needed because the keyboard emulator on the stationary computer, which enables Christopher to control his software programs remotely, only recognises an RS423 convention.

There is one more substantial piece of sophisticated hi-tech dedicated to Christopher's interests, and that is the Colne Robotics Armdroid. The controlling software has been written by Brian Reeson specifically to help Christopher to play. He uses proximity switches and mouth-joysticks to operate the arm, but again the intention is to put it under voice-control as soon as possible. Even so, the interim solutions have called for ingenuity.

A conventional joystick would be too large to position in front of the mouth, because it would obscure a third of Christopher's view. Mr. Reeson has therefore constructed a small unit which

houses two potentiometers, which provide a more or less standard 2-axis joystick, modified by op-amps designed to offset and amplify Christopher's own highly restricted movements. Some axis movement in the Arm has been locked up, including the rotating wrist action, because the child is both too young and too handicapped to cope with all the degrees of freedom offered. The Armdroid, left to itself, traces curves. For Christopher's benefit, it has been given a linear direction and is programmed to move on a grid, in two centimetre steps, identifying co-ordinates as it goes.

The ultimate aim is to enable Christopher to play with model animals, moving them about a farm layout, but it's not yet clear whether his inability to do that is due to his age or to his physical condition. The best he can do at the moment is knock building blocks over or off the table. It may not seem like much, but it's the beginning of childhood for him, and perhaps for others like him, courtesy of the micro-computer.

# HISOFT

## High Quality Microcomputer Software

### UPGRADES

We offer an upgrade service if you have an old version of a product and wish to get an up-to-date copy. Please write or call for more information. We cannot offer an upgrade from one product to another (eg if you change your computer or go from cassette to CP/M) because of the substantial effort which goes into creating each product.

### SPECIAL OFFERS

SHARP MZ700 DEVPAC cassette ..... £25.00 **£9.95**  
SHARP MZ700 Pascal cassette ..... £39.95 **£19.95**  
SHARP MZ700 Pascal & DEVPAC cassettes together £64.95 **£24.95**  
ULTRAKIT ordered with another product ..... £9.45 **£5.00**

### DISC FORMATS

CP/M software can be supplied in many different formats - call us if you are in any doubt. Amongst those available are:

8": IBM standard (Lifeboat A1); 5 1/4": Gemini Galaxy (QD 96tpi), Gemini (Pertec DDDS 48tpi), Gemini G805 (SD 48tpi), Nascom Lucas, NewBrain 40 track, Alphatronic, Torch CPN, Acorn Z80 second processor, Osborne single density; 3 1/2": MSXDOS; 3": Amstrad, Tatung; AND MANY, MANY MORE.

### ORDERING

All products are available directly from us by mail order or by telephone using Access or Visa. All prices are inclusive of VAT and postage and also include the relevant manual. We always despatch orders by first class post. Please enclose a cheque or postal order made payable to HiSoft. Be sure to tell us exactly **what computer** you have, **what product(s)** you want and **which disc format** you require.

Please 'phone or write for full technical details/export prices/credit card orders/friendly help - we want to hear from you.

**HiSoft, 180 High Street North, Dunstable LU6 1AT (0582) 696421**

### PRICE LIST of HISOFT PRODUCTS

The following price list applies from 16 Oct 85 within the United Kingdom ONLY.

Pascal80 for Z80 CP/M disc systems (including Amstrad and Tatung).....	£39.95
Spectrum 48K cassette (fully Microdrive compatible).....	£25.00
Spectrum 48K SPDOS disc.....	£25.00
Amstrad cassette (SOFT 155).....	£29.95
Amstrad AMSDOS disc for 464/664 (SOFT 1155).....	£34.95
(use Pascal80 on 6128/8256)	
SHARP cassette for MZ80K/A/B, and MZ700 (supports Quick disc).....	£39.95
MSX cassette (for 32K or above).....	£29.95

### DEVPAC

Devpac80 for Z80 CP/M disc systems (including Amstrad and Tatung).....	£39.95
Spectrum 48K cassette (fully Microdrive compatible).....	£14.00
Spectrum 48K SPDOS disc.....	£19.95
Amstrad cassette (SOFT 116).....	£21.95
Amstrad AMSDOS disc for 464/664 (SOFT 1116).....	£26.95
(use Devpac80 on 6128/8256)	
SHARP cassette for MZ700.....	£25.00
MSX cassette (for 32K or above).....	£19.95
Amstrad ROM version (464/664/6128) ROM only.....	£29.95

### C

for Z80 CP/M disc systems including Tatung (see below for Amstrad).....	£39.95
Spectrum 48K cassette (fully Microdrive compatible).....	£25.00
Amstrad cassette.....	£34.95
Amstrad disc for 464/664/6128/8256 (includes AMSDOS & CP/M & CP/M-PLUS versions).....	£39.95

### OTHER PRODUCTS

ED80 - CP/M disc - Wordstar compatible full screen editor (NB included with Pascal80, Devpac80 and CP/M/C).....	£29.95
The Colt - Spectrum 48K cassette - fast BASIC compiler.....	£12.95
ULTRAKIT - Spectrum 48K cassette - BASIC toolkit.....	£9.45
MONQL - QL microdrive - disassembler/debugger.....	NOW £14.95
The Torch - Amstrad CP/M disc - interactive CP/M tutorial.....	£12.95
The Knife - Amstrad CP/M disc - Disc/File sector editor.....	£12.95
Font 64 - Amstrad cassette - font editor/screen copier.....	£7.95
Font 64 - Amstrad AMSDOS disc for 464/664/6128 (NOT CP/M).....	£12.95
Font MSX - cassette - font editor.....	£9.95
SuperBasic Extensions - QL ROM - 70 useful procedures and functions.....	£29.95
Your Health Expert System - Amstrad/Spectrum 48K.....	£8.95
Your Horoscope Expert System - Amstrad/Spectrum 48K.....	£8.95
Your Hand Reveals Expert System - Amstrad/Spectrum 48K.....	£8.95

# Letters

Send your letters to  
The Editor,  
Computing Age,  
Priory Court, 30-32  
Farringdon Lane,  
London EC1R 3AU.

## Bernoulli drives

Mike James' article on storage devices ('More speed - more space', November issue) continues the excellent coverage which you give to the microcomputer user. In one respect, however, I found it less than adequate. In addition to the floppies and Winchester, there is a third disk configuration on the market: devices based on the Bernoulli principle. Without trying to go into any detailed description of these systems, it seems to me that Bernoulli drives combine the advantages of both flexible and fixed drives ie high density, high recording speed, complete elimination of 'crashes', removability (and hence greater security as they can be stored in secure places), easy handling (including their mailing) and, provided that one goes for the double disk drive version, fast and reliable copying. The initial cost of Bernoulli drives may be high but, as additional cartridges are priced around \$70.00 each, the cost of a functional and expanding system may, in fact, be cheaper than that offered by the Winchester option.

**D. M. Benda**  
W.I.C.O.

## Tea-break tattle corrected

You stated in your first issue that the Amiga 68000 can only handle 0.5Mb of memory, but if the person who wrote the report read a little harder in the hardware side of the 68000 and not facts he/she heard over a tea-break, then you find the 68000 has a 23-bit address bus plus a two bytes wide databus making a total of  $2^{23} \times 2 =$

16mb. One more thing, how do you get letters in your ever first issues or did I miss issue 0?

**Simon Dealey**  
St Helens, Merseyside

*The letters were sent to Electronics and Computing Monthly, as Computing Age was formerly known. OK?*

## Einstein users

I am attempting to set up a register of users for the Tatung Einstein computer, at present on a fairly informal basis. The object is an exchange of knowledge and provision of additional hardware and software support, of non-profit making nature.

Would anyone interested please send a stamped, self-addressed envelope to the address below.

Thank you.  
**Paul Burgess**  
24 Meredale Road, Liverpool,  
L18 5EX

## A let-down?

Where is Electronics & Computing? What have you done with it? You have taken the best computer magazine for the constructor off the stalls. In its place what? Computing Age! What is it? Previews... I can have that in any number of computer magazines.

You have let me, and the many like me, who enjoy building the projects you published, you have let us down. It would seem our support over the years has been of little value to you.

**J. M. Stevenson**  
Brentwood, Essex.

*We value the support of E&CM readers and will not let them down. We believe the new, and unique mix of features commands wide interest - already reflected in a 50% increase in circulation, and we shall continue to publish at least one computing project each month.*

## A boffin and a Spectrum

I am a Sinclair Spectrum owner and proud of it. However, having a lot of enthusiasm for computing, I am beginning to consider "upgrading" in order not to restrict my programming

experience to one machine. I would be grateful for advice on which second computer to buy. I am a Boffin, not a business or education user. As I see it, here is a list of requirements of the ideal boffin's computer: (in order of importance) 1. Great popularity - leading to huge software and hardware support; 2. A modern, yet widely used processor; 3. Unrestrictive user RAM; 4. Good BBC-like keyboard; 5. Parallel, serial and disk-drive interfaces; 6. Good friendly Basic and operating system. Good sound capability.

In view of these requirements, and the fact that I want to move **up** from the Spectrum and not **along**, there are only two machines in the running: The good-old BBC model B and the new Amstrad 128. Will someone please tell me what is so special about the BBC? There are three things I don't like about it: the old-fashioned 6502 processor, the pathetic amount of RAM and the ridiculous price. As a novice (Z80) machine-code programmer, the first of these factors is the most important. Do you agree with this?

Also, will someone tell me what is **wrong** with the Amstrad 128? For less than half the price of a BBC, disk-drive and monitor, you seem to get a machine which is equal if not superior in specification. As for popularity, do you think the Amstrad will be as popular in two years time as the BBC and Spectrum are now? I have seen no direct comparison between these two machines in the magazines although if you don't mind a second-hand BBC, they are very similar in cost.

Can you shed any light?  
**J. A. W. McOwan**  
Stowe-by-Chartley, Staffs

*So many questions - most of which you appear to have answered quite adequately. The BBC micro must be superior in terms of I/O and Basic, and also software support. However I will be most surprised if the 6128 doesn't retain its popularity. The price makes it an excellent buy.*

## Not bust nor active

I was concerned to note, in reading the 'Computerised Kaleidoscope' article in November's edition of *Computing Age*, that the

statement was made that Triple I had gone 'bust'. We are Triple-I's European subsidiary and I must tell you that this is very far from the case, as I trust the enclosed copy of our 1985 Annual Report and Corporate Profile will show.

It is the case that we sold off our 'Movie Group' fairly recently. However, we still manufacture 'Colour Movie Recorders' and have several of these devices in use with our customers.

Our main business is in the 'pre-press' for technical documentation, magazines and newspapers, where our expertise in image processing is applied to photographs and line art, and is combined with our expertise in text processing.

So, while we are no longer active in providing moviemaking services, we are very much alive and well in the 'pre-press' business.

**M. Daniels**  
Information International Grafix

## Wither Spectrum?

I have been reading your excellent publication for the past few months now, but there is one thing that really bugs me and that is the lack of features concerning the Spectrum. One of the reasons for purchasing your magazine in the first place was the support you gave for the Spectrum like the wordprocessor you featured not long ago. Now there is virtually nothing of any significance in *Computing Age*, apart from a passing comment in your Comms Column.

I suppose the Spectrum is an outdated computer but it is nowhere near dead. How about publishing comms software for use with a VTX modem so as to display 80 column text and so be able to connect to a wider range of databases, or a little project to convert the Spectrum's RS232 port into a MIDI interface. Now that would be nice!

I hope you can keep supporting the Spectrum as you did in *E&CM* and not overshadow it by the latest 16-bit gizmos that are not available yet. I wish you every success in the future with *Computing Age* and keep up the good work.

**M. Talianos**  
Epsom, Surrey

# I, LOGO

**Logo on 8-bit micros isn't fast enough for serious robotics, but equally it has a lot more to offer than the programming of 'toy' robots'**

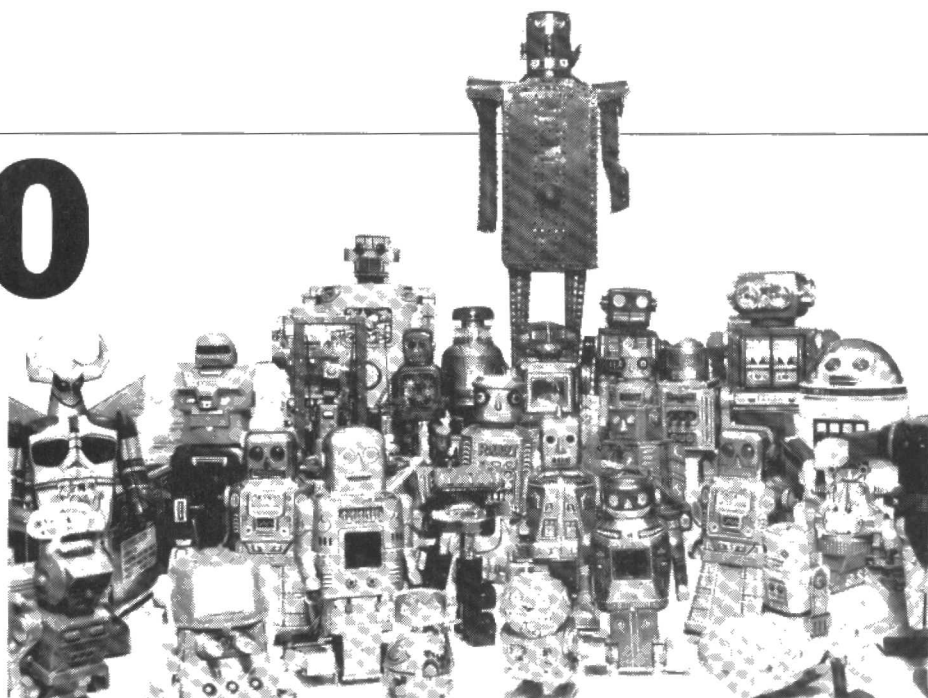

BOILERHOUSE PROJECT

Toy manufacturers are gearing up to offer children low cost robot construction kits, the modern equivalent of Meccano or train sets. The major entrants so far are Milton Bradley of the US, Fischer Technik of West Germany and Lego of Denmark.

The kits can be used with or without a computer. To convert the models into programmable robots, you need an interface board, a microcomputer, and suitable software. But so far, the toy manufacturers have shown little inclination to provide these items, which leaves a huge gap in the marketplace.

This gap is already being filled, with much of the technical work being done in schools, which have been moving in this direction for several years and were quick to see the potential of the new kits.

Milton Bradley has already scored a hit in British schools and homes with a programmable tank called Big Trak, which has been used as a low cost alternative to a floor turtle. Big Trak has its own mini-console into which one can punch a sequence of commands, which are then followed by the tank. But there is no way of storing programs, or building in conditionals.

**'Robotix can be used to build models which walk, and this offers a totally new programming challenge'**

Fischer Technik parts were used in the construction of the BBC Buggy, a versatile floor robot sold by the Sheffield firm Economatics Ltd, and Lego models have become increasingly motorised and sophisticated in recent years - Lego has financed a Lego Logo project at the Massachusetts Institute of Technology under the direction of Professor Seymour Papert.

There is now a growing variety of interface boards for the most popular educational computers, and Logo enthusiasts

have taken up the challenge. In the UK, there are at least a dozen major educational projects involving Logo and low cost robot kits. Several of them are using Logotron Logo on the BBC micro as the core software.

Logotron Logo is particularly suitable for this purpose because its authors made it completely extensible at machine code level. The command USE loads modules of specialised primitives from disk and treats them as if they were an integral part of the language. Julian Pixton of the MEP-run Walsall Logo Project used this feature to write Control Logo.

Control Logo gives the user full access to the different pins of the BBC micro input and output ports. The names of the primitives indicate how it is used: TURNON, TURNOFF, PULSE, TIME, ZEROTIME, SENSE, SETPORT, and so on.

## ADVANTAGES

There are advantages to using Logo rather than Basic for writing software of this kind. The first advantage is that it is easier. In schools, the robot kits are often to be found in the Craft, Design and Technology (CDT) departments, not in the computer room. Typically, Basic software has to be written by someone other than the end-user. Also, Basic programs generally have to be menu driven, with the user confined to a series of choices. The modular nature of the new kits is not suited to this approach, as the menus become too long to take account of the potential combinations.

Using Julian Pixton's Logo extension, quite young children in Walsall have been building properly sequencing traffic lights, automatic garage doors, chiming clocks, and robot arms. In Wales, schools have been using Logo to control models built from Milton Bradley's new Robotix kit.

In addition to the normal wheeled vehicles and grab arms, Robotix can be used to build models which walk, and this offers a

totally new programming challenge, as well as a new perspective on the mechanics of animal locomotion. It's easier to walk on rough ground with six legs than with four, or only two.

Later this year, the MEP National Primary project will be distributing a pack of materials and suggestions based on the work done with Logo and Control in schools.

## PROBLEMS

There are still plenty of problems. Logo on 8-bit microcomputers is not fast enough for serious robotics, and there is no concurrency, which means the robot cannot do two things at once. These problems will not last: compiled Logo offers concurrency on more powerful home computers.

This doesn't mean that Logo has nothing to offer the serious robotics hobbyist today. It provides by far the easiest method of prototyping a program, which may subsequently have to be laboriously written in assembly language. Logo is a dialect of Lisp, the language used to program many of the most advanced robots in use in the world today.

Two new books illustrate the emergence of a new interest in Logo at the top end of the market. The author of *Logo for Micros*, Professor Martin Lesser, heads the department of mechanical engineering in a major American University. He hardly mentions turtle graphics.

Professor Brian Harvey of the Massachusetts Institute of Technology, the author of *Computer Science Logo Style*, says flatly: "The truth is that Logo is by far the most powerful programming language available for home computers."

Its power is only now being put into the hands of computer hobbyists as the cost of memory drops. It is hard to say whether home robotics will win as wide a following as model trains and Meccano did 50 years ago, but if they do Logo will play a major part in the process.

**The design of the BBC micro looks rather dated when compared to the likes of the Atari 520ST. Does it still represent a sensible purchase? Clive Williamson discovers that the answer is both yes, and no.**

The BBC Model B, once the apple in every reviewer's eye, is currently getting quite a bit of flak for being under-powered and over-priced compared with the latest generation of home micros. Machines like the Amstrads and Sinclairs are much cheaper, while the Atari 520ST offers eight times the memory for a similar price, and all the advantages of 16-bit architecture. Adding insult to injury, some of the IBM PC look-alikes and the cut-down Apricot micros cost little more than a BBC B+ with disk drives. It seems a good time to look at the Beeb in the light of this onslaught, to see just how it fares against all the competition.

On the face of it the Beeb does look chronically over-priced at £499 for the 128K machine, £469 for the B+, and £399 for the Model B, though while stocks last the latter can be picked up in some shops for around £290, rather less if you buy second hand. A direct comparison with the Atari 520ST is a sobering experience which acutely shows up the BBC machine's lack of memory. Screen resolution and colour – once 'the bees knees' on the Beeb – have been put firmly in the shade.

The BBC Micro does though offer some advantages over certain of the newcomers to the micro market-place. The initial specification of the machine, with its large number of ports and interfaces, give it enormous expansion potential, and quite apart from Acorn themselves, many third party manufacturers can offer a huge range of hardware add-ons for the micro, enabling it to sense and measure its environment, record data and control external devices. It can be linked to a Buggy to aid teaching the concepts of space and an awareness of geometry and maths. Conventional uses include telecommunications, the establishment of private viewdata systems and networks, and the generation of custom graphics using systems like Bitstik, while the more adventurous are now decoding their own weather satellite pictures (see last month's *Computing Age*), or generating multi-part synthesised music on the Music 500.

Thus the Beeb has become a versatile and reliable work-horse for serious applications, finding its way into hospitals, industry and education. In addition, it has proved a good starting point for many a pure 'hobbyist', as a single machine that

# LIFE IN THE



can be used to experiment with a variety of different projects.

## LARGE SOFTWARE BASE

Another attraction of the Beeb computer system for both new and existing users is the vast range of software that has built up over the years. Acorn claims it to be the largest for any PC. Not that all of it is good, one might add, but a fair proportion is (or at least, seemed so up to now). Educationally the BBC Micro is particularly well supported (in pure numbers, if not in quality of software) and there is a good range of languages to encourage programming at all levels, including Logo, Comal, Pascal, Forth and Lisp. For the home user, there are countless games and adventures – many look weak by today's standards, but some are exceptional, like *Elite* and *Revs* from Acornsoft – and a handful of 'serious' programs successfully cross over into the small business area. The Beeb's own Ultracalc II spreadsheet is a very useful package for large and small scale calculations, while Acornsoft's VIEW family of word processor, spreadsheet and Viewstore database can offer a relatively low-cost entry into office computing for the more advanced home or small business user.

All is not roses in the BBC Micro's software garden however – the advanced nature of the machine's operating system has made protection a nightmare, and piracy of programs for the Beeb is now so rife that many software houses are desperately turning to other machines in order to maintain sales. At least one company has suggested that now is an ideal time to buy a BBC, because there is so much free software for it! Couple the pirate problem with the severe lack of memory on the B model, and the result is a whole host of programmers on the look-out for greener pastures. Those who remain faithful to the Beeb – and let's face it, there are about 350,000 machines out there to cater for – will probably concentrate on producing far fewer new programs, but making sure that each one is a real block-buster, no doubt published with lots of accompanying literature to make copying difficult!

## EXPAND-A-BEEB

A mitigating circumstance in the Beeb's favour is the potential to upgrade from a Model B to a B+, giving 20K of extra 'shadow' RAM for the screen display, and a further 12K available to programmers. This path gives a bit more scope for those using the BBC Micro as a word processor.

# OLD DOG YET

or handling lots of data in a high resolution screen mode that would normally consume a lot of memory. Aries Computers are the people who market the upgrade – called the B32 – and it sells for £92. Users of VIEW 2.1 should be warned that they will need a published software patch to make use of the extra memory.

**'Now could be an ideal time to buy a BBC, there's so much free software for it'**

Another expansion possibility is to fit a sideways ROM board, which augments the BBC Micro's normal compliment of four plug-in ROMs to a maximum of 16. A host of languages and utilities can then be installed, permanently on call, though taking up none of the machine's memory when dormant. An ideal way to buy things like word processors, spreadsheets, terminal emulators, and disk or printer utilities. The expansion boards often include the ability to download images of ROM software from disk into 16K of CMOS RAM – a facility which is great for the users – but a terrible headache for the people trying to sell software in sideways ROMs! A board that gives the full 16 ROM sockets in the machine is SIDEWISE by ATPL (£39 + VAT), and Aries makes the B12 board which, as its name suggests, allows up to 12 ROMs, and is fully compatible with the B32 upgrade. The Aries-B12 costs £46, and users not having the B32 or earlier B20 fitted will have to pay an extra £5.75 for an adaptor board.

## DISK UPGRADES

The BBC's disk system has always had its critics, because of its restriction to 31 files per drive. Thankfully this pitiful performance can now be improved upon. The BBC B+ has a different disk controller chip, which is much cheaper, and more flexible in operation. The 1770 controller now replaces the 8271 originally chosen by Acorn, and owners of the old Model B can upgrade to the new chip by purchasing a 1770 Disk Interface Kit for £49.99. On the face of it, this upgrade merely offers a few new disk commands for existing users, but there is method in Acorn's madness. The 1770 will support a new Advanced Disk Filing System (another £29.99), offering double density storage, and a hierarchical directory structure giving an almost unlimited number of files. It must also be said that there is also madness in Acorn's method, since the 1770 won't run any disk

which relies on the 8271 chip being present to give protection. This unfortunately includes Acornsoft's Elite, so another messy patch is necessary. Ah yes, the other thing is that the new ADFS is totally incompatible with software saved on the old system. But that's progress! Actually the ADFS would have been marvellous if it had come out a couple of years ago, but Acorn have left it too late now for the majority of users to benefit.

## SECOND PROCESSORS

The use of a Second Processor is another way to get round the restrictions of the BBC Micro's memory. First came the 6502 processor, giving the Beeb a dramatic increase in processing speed, and between 30 and 44K of memory to play with. Using this, serious word processing using VIEW became feasible, and Robocom were able to transfer the Bitstik graphics system onto the BBC, but as yet little else has been produced to take advantage of this upgrade.

Next on the scene was a Z80 Second Processor, designed to enable existing owners of the BBC Micro system to get at the vast library of programs already written for the CP/M operating system. In a classic move, Acorn released the Z80 add-on with an excellent bundle of software for £299,

then promptly realised that they hadn't allowed for a dealer margin to give the right support to the system. The price was upped another £100 – which still made it reasonable value – but the long-term effect has probably been a considerable reduction in sales. There has also been a marked reluctance on the part of third-party software houses to get involved, so very few of the major CP/M titles have been released in a format suitable for the BBC machine.

One good thing about the Beeb is that its 'Tube' interface – the one which deals with all the Second Processors – does provide for further extensions to the system in the future. How about an MS DOS add-on, or a 68000? Time alone will tell. The latest offering is based on the 32016 chip, but this is an expensive number crunching device aimed squarely at scientific users, and so far no dynamic software has been produced to attract the computer-user-in-the-street. The trouble is that no-one wants to put any effort into writing new software if the device it runs on has a limited market.

So should I throw my good old Beeb away? Should I go 16-bit, and upgrade to a new generation computer? I think the answer is unavoidably linked to how you use, or intend to use, your machine. Thanks to its sensible initial design, there does seem to be life in the old dog yet! The BBC Micro's future lies in people finding one or more specific applications for the same computer. It is still ideal for the hobbyist

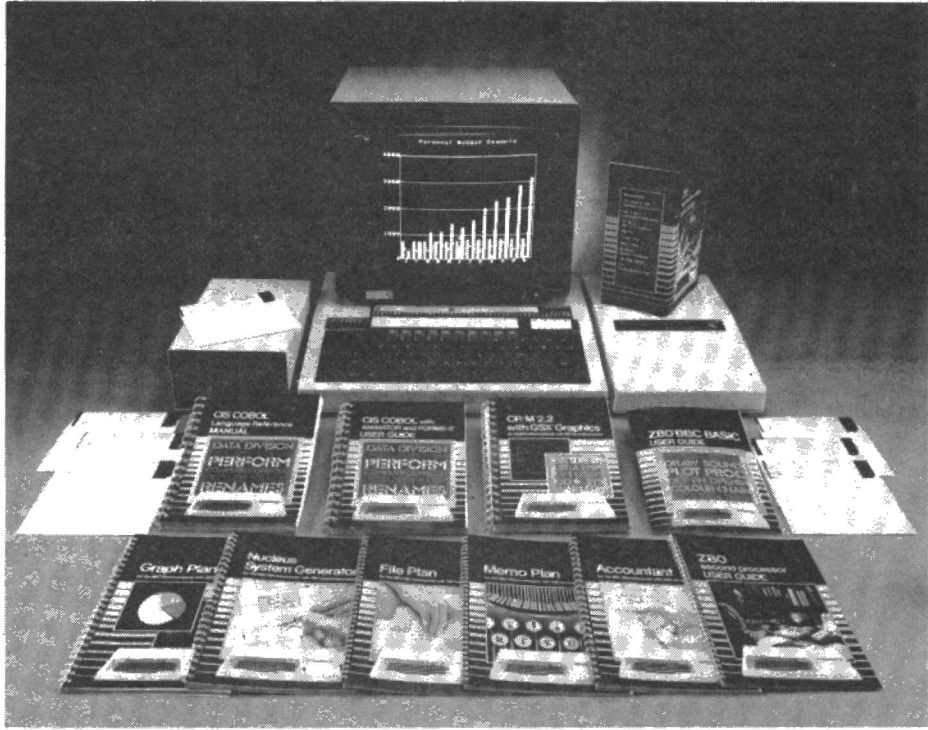

A wealth of software support.

who wants to dabble in a number of different areas – programming, games, telecommunications, graphics – and it wins hands down in most hardware-related applications, because of the support it has from small companies building add-ons for it. A new user may still choose a brand new Beeb as a result, but those who are simply fascinated by computer technology will undoubtedly go for a state-of-the-art machine like the Atari with its icons, mouse, and advanced graphics. The 520ST has its fair share of interfaces, and will inevitably build up hardware to match its already strong software base, so Acorn is certainly going to have a tough battle on its hands if Atari makes it through to '86.

There are an enormous number of BBC Micros in education, but the move there is definitely toward 16-bit technology, so Acorn may soon be forced to change with the times if they are to stay in business. And what about some more software of the Elite or VIEW quality from Acornsoft? Looking back on the development of the BBC system it is difficult not to see it as a string of missed opportunities, and good pieces of hardware delivered too late.

## MUSIC 500

Most people are aware of the limitations of the BBC Micro's sound chip: its OK for arcade effects, but useless as a serious device for generating music! Hybrid Technology has come to the rescue of all those who want to take music further on the Beeb, by producing an add-on synthesiser called the Music 500 for £200. It must be said straight away that the design concept for this device is quite revolutionary. Rather than rely on a knowledge of musical notation and theory to produce sounds from the unit, direct interaction and programming is done from the QWERTY keyboard, using a new music programming language called AMPLE. The add-on connects to the BBC machine via the 1MHz bus, and the output from the Music 500 is in the form of a normal stereo signal, which can be fed into a hi-fi amplifier.

The revolutionary part is that notes are entered as they are written... a lower case c will give middle 'c', b gives the note below C, while D (in capitals) is the note above C. What could be easier? Chords are written in the form c(GE) and other notation includes rests (^), pauses (/) and bar-lines ( ), while drum beats can be represented by variables (X and Y, for example). The tempo of play can be widely varied using a single command. AMPLE is a complete structured language, and allows small sections of a musical piece to be developed in real time at the keyboard, then incorporated as procedures into the final work. Loops can be used wherever repetitive sequences are needed (especially useful for pop pieces!), and AMPLE makes use of concurrent processing to give accurate synchronisation of multi-part

music.

In all, there are 16 sound channels available, which are digitally synthesised to 8-bit resolution (the same as the vastly more expensive 'Fairlight' Computer instrument) and these can be organised into eight musical voices. Each can be given one of seven positions in the stereo image. The channels cover more than 10 octaves, giving the unit a frequency range from 0 to 20kHz. Complex sound manipulation can be achieved by using amplitude and pitch envelopes, and frequency modulation of basic tones. The unit is capable of giving a truly enormous range of sounds, from pure imitations of real musical instruments to unearthly synthetic creations, so it should appeal to almost any musical taste.

The AMPLE language does take some grasping – just as learning Logo or Pascal from scratch would – but in its simplest form the beginner can experiment quite a lot, and there are a number of example pieces included with the unit to help you get started. Once mastered, the Music 500 is a very powerful device indeed, and it is currently only available for the Beeb. A music keyboard – the Music 400 – is due out soon for about £130, and there are plans for a matching MIDI interface, stereo amplifier and pitch analyser to go with the system.

## AMX MOUSE

There can't be many BBC Micro owners who didn't turn green with envy when they first saw the mouse-driven icon software for machines like Apple's Macintosh. What a stroke of luck then, that a company actually managed to launch something similar for the Beeb! The company in question was Advanced Memory Systems, and the beast in question the AMX Mouse. The original £89.95 starter package consisted of the mouse itself (a small black one, with three red buttons), a plug-in 8K ROM to service the thing, and two programs which made full use of the facilities provided by the system. Icon Designer helped you create your own on-screen symbols, and AMX ART, a graphics package, produced very attractive visual results mixing graphics and various text fonts. The programs all used the Beeb's Mode 4 display in black and white, giving a very similar screen output to that seen on the Mac and Atari machines.

Now, for the same price, AMS have released a more advanced 'Mark II' system – the mouse comes with a new 16K Super ROM, and Super Art, an expanded version of AMX ART that works in the four-colour Mode 1 on the Beeb. In both art programs, the patterned fill menus are particularly impressive, and a useful airbrush effect is also included. Finished artwork can be dumped to a printer, or saved as a complete screen for later use. More software is available separately: colour Paint Pot and Utilities increase the versatility of AMX ART, while AMX DESK adds diary, address

book and calculator functions to the system. A new range of programs has just been announced, including a database, 3D graphics package, an educational tool called AMX XAM, and 'Pagemaker', an interesting-looking text and graphics editor for budding journalists.

Apart from the proprietary software, which mainly sells for £14.95 or £24.95, you can write some yourself, as full instructions are included with the mouse on how to use its pull-down menus, windows, pointers and icons in your own programs. The end result is to make the 'front end' of the BBC Micro much easier to grasp for those who don't know all the ins and outs of the machine.

## ELITE

The definitive arcade game for the BBC Micro! Acornsoft's 'ELITE' is an amazing combination of flight simulator, arcade action and strategic adventure, and casts the player in the role of Captain of a Cobra Mk III trading and combat spacecraft. The object of the game is to make your fortune by trading – either legally or illegally – throughout known space. This stunning sci-fi game squeezes every ounce from the BBC machine – the amount of data held in the program is incredible – and the action portrayed by the screen display is very smooth.

The potential for adventure is enormous, as the eight galaxies you can visit each contain over 250 recognised planets with various life-forms and political climates. Don't expect to finish this one in a hurry! The cassette package costs £14.95, and there are some advantages in getting the disk version at £17.65, but these are minor. There are plans afoot to release a version which runs even faster, with more colour, on the 6502 Second Processor.

## WHITE KNIGHT MK 12

Although White Knight from BBC SOFT doesn't have the stunning graphics to be seen on the Psion QL chess program, it does have the advantage that its game-playing algorithm is very strong indeed, making the program difficult to beat. In fact the program won first prize in the home computer section of the 1983 PCW European Microcomputer Chess Championships.

A lot of care has been taken over the way White Knight looks on screen, and the result is tidy and functional. A good 2-D representation of the chess board and pieces is shown in pale blue, and the game offers a variety of extra facilities and playing modes, including an option which effectively provides thousands of 'levels' of play. Mark 12 is a disk version of the previous Mk 11.

**Suppliers:** Aries Computers 0223 862614, Hybrid Technology Ltd 0223 316910, Advanced Memory Systems Ltd 0925 602959/602690.

# AMSTRAD ADD-ONS

**A wealth of peripherals are now available to Amstrad 6128 users. Richard Sargent reports.**

Almost alone in the computer world, Amstrad has a reputation for not boasting about a new product before they're in a position to produce it.

By contrast, I suspect some peripheral manufacturers advertise their Amstrad products when they still only exist as prototypes, and buying mail-order in such circumstances can be a protracted business.

Seeing (and perhaps buying) the peripherals you need at computer shops is perhaps the safest way to equip your new micro: you can at least cross-question the manufacturer about his latest offering.

Some 8,000 people may have had this in mind when they descended on the Novotel Exhibition Centre in October to attend the first Amstrad Computer User Show. With 70 stands of assorted software, hardware and books to scrutinise, brand X could at least be compared with brand Y. So, if you already have an Amstrad 6128, or intend to get one shortly, what good peripherals can you look forward to?

**'Most Amstrad add-ons will function on any of the Amstrad machines and the choice is growing every week'**

Most Amstrad add-ons will function on any of the Amstrad machines and the choice is growing every week in the run up to the expected Christmas sales boom. The most expensive peripheral is the printer, or which Amstrad markets two of its own. The first, the DMP1, was not well received, but their latest, the DMP2000, is a 9-pin dot-matrix printer with Epson compatible control codes and gives a clear print-out in a wide choice of type-sizes.

Most software producers seem to assume that users will have an Epson FX/MX/RX series printer and supply primary routines for this eventuality. Routines for

the DMP1 are usually provided as the second option.

If you want your printer to do more than just print program listings, a DUMP and FONT utility are needed. There are a selection of such routines from various manufacturers, on tape, disk and ROM. Hisoft's 'FONT64' tape produces a large (225mm x 170mm) grey-scale screen-dump and has a font-designer; these work well enough although there seem to be a few bugs in the printer-option software which Hisoft has failed to comment on.

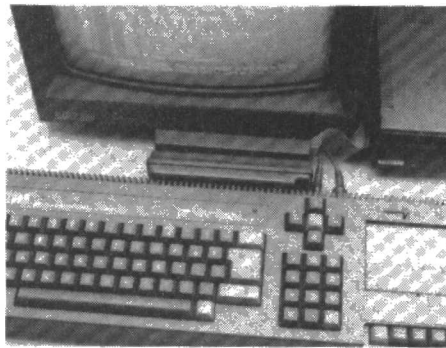

*The Superpower sideways ROM card.*

Micropower has a 'toolbox' ROM which produces, amongst other goodies, dumps in 200 x 140mm and 130 x 70mm sizes. It only exists in the CPC464 version at present, but if they maintain the same standard their 6128 utilities ROM should be worth investigation.

Tasman Software markets 'Screen Copier' (tape or disk), which produces grey-scale dumps and has a special facility to create, with help from scissors and glue, a giant poster-size dump. Another, separate, piece of software, also on tape or disk, prints special ready-made fonts, including a near-letter-quality style, and this will work with Basic's print-output or with the Tasman wordprocessor (of which more later).

On-screen painting and designer software is also available in some quantity. 'Screen Designer' by Amsoft requires no joystick, mouse or trackerball and is considered to be excellent for serious work because small portions of the picture can be magnified to allow finely-detailed pixel painting.

Slightly more expensive are the light-pen packages, of which there are currently four. The Dart Electronics offering is the pick of the bunch, with a fair amount of built-in intelligence (it intercepts the

monitor's vertical-sync signal) and a good range of drawing and painting facilities.

Mouse-lovers will appreciate the AMX Mouse package (which just made it to the Amstrad User Show), but if you prefer trackerball operation, then a delay has yet to be sorted out - the Central Trade Exchange 'Icon Art-star' program has, at the time of writing, not yet appeared. Both AMX and CTE have moved their equipment and software over from the BBC micro, and it will be interesting to see how these two icon packages fare on the Amstrad, with its lower screen resolution but higher memory capacity.

**'On-screen painting and designer software is available in some quantity'**

The BBC micro also introduced sideways ROM, with wordprocessors, disk-doctors, assemblers and utilities all available at switch-on, and one firm in particular is leading the field with similar products for the 6128. That firm is Arnor and their first product, the 'Maxam' assembler, is held in high regard amongst machine-code programmers. Their ROM software transfers well to the 6128, although they had to shave a few millimetres off their pcbs to make them fit the 6128 port. (Their ROM board or AD1 cartridge, partly fits inside the 6128).

Using the Honeysoft ROM extension board, another four ROMs may be fitted to the AD1 cartridge. Arnor already produces two other ROMs, the 'Protex' wordprocessor and the 'Utopia' utilities package, and has a graphics package in the pipeline. Protex is a friendly wordprocessor similar in many ways to the BBC's Wordwise, but with much more efficient disk handling. It can support a 40K document file, which is large enough to hold a book-chapter, for example. Documents can be passed to the Maxam assembler, and also to Basic (Protex adds the Basic line numbers if you haven't already typed them in). Utopia is a utility ROM intended for the serious Basic and machine code programmer. It can be used to format disks, copy disks and interrogate disk sectors, and to reveal tape-headers, Basic variables and free-memory space.

However, the award to the first software house to make use of the 6128's extra memory goes to Tasman. The Tasword wordprocessor, first written for the 16K Spectrum, has now grown to 32K in size and handles a document size of 62K. It therefore no longer competes with Protex, or for that matter Amsoft's 'Advanced Amword' (also written by Tasman) which can only handle documents of 13K.

Whichever way you look at it, the CPC6128 has a bright future. It's cheap enough, at 1986 income levels, to be a first computer, and yet it is sufficiently powerful and versatile to satisfy the most demanding 8-bit programmer.

# BEAT IT

**It lacks the glamour and guts of a full blown drum kit, but you can program up a storm on the Digidrum for only £65, writes Ian Waugh.**



Everyone would like to be a drummer. But drums are large bulky things, they're expensive and you have to spend hours and hours practising rolls and paradiddles (not in the front room, Johnny, please) to achieve even a small degree of competence.

Alternatively you can buy a drum machine. Most modern drum units are sampled sounds stored on a chip. They are small and very easy to play, but still quite expensive.

Enter Syntron and the Digidrum, which is small, easy to play and cheap. Digidrum I was launched a few months ago and Digidrum II is a result of improved software. The package consists of a disk and a small black box which plugs into the user port of a Commodore 64 or C128. A jack socket at the back of the box provides an audio output and must be connected to an amplifier or hi-fi system. A phono socket provides a trigger output so you can sync it up with other gear.

The menu page offers seven main options: 1 Program Rhythm Patterns; 2 Compose songs; 3 Directory Display; 4 Load Patterns + Songs; 5 Save patterns + Songs; 6 Load Sounds; 7 Save Sounds. There are also options here to set the tempo and erase all patterns and songs.

## FIRST STEPS

Drum tracks are built up in sections, like the more expensive machines. The first step is to create a number of patterns using option 1. Up to 51 different patterns can be created and they do not all have to contain the same number of beats (although they are all played at the same tempo). You can therefore produce all the odd time signatures you wish and build up pieces with complex time changes.

A pattern can consist of up to 38 individual beats, probably because that is the largest number of beats that will fit comfortably into the screen display. Movement around the screen is with the cursor keys. Eight different drums are available and are entered into the pattern by pressing the following keys: C (Crash cymbal), ? (Open

high hat), H (Closed high hat), D (Drum - small tom), S (Snare), G (Grand tom), F (Floor tom) and B (Bass drum). The keys are listed down the right of the screen and when you press one, a Commodore graphics character you never knew existed shows where a beat has been placed. F1 terminates the bar.

Up to three drum sounds can play on the same beat although some instruments are mutually exclusive, for example, the high hats and cymbal. The software won't let you program anything it can't play, however, which is very sensible. You can hear the pattern you've created by pressing F7.

## SONGS

With a few patterns in the machine, the next stage is to string them together to produce a Song with menu option 2. Songs are built up by entering a pattern number followed by the number of times it is to be repeated up to a maximum of 99 repeats. Up to 100 such sets of patterns can be entered, which is more than enough for most compositions, and up to 10 songs can be stored in memory at one time.

Options 4 and 5 let you save and load patterns and songs and option 3 shows you what's on your disk.

So far so good but let's cast a critical ear over the sounds. The little black box is actually a digital-analogue converter and the sounds are produced by clever software. Actually, no two people are likely to agree how a particular drum should sound - not even drummers - so evaluations are subjective. A couple of musician friends and I concluded that the high hats are good but the crash cymbal cuts off a little too

**'Up to three drum sounds can play on the same beat, though high-hats won't play with cymbals'**

soon; the snare and bass crack and thump quite nicely but the toms could be better.

However, the advantage of running a software- as opposed to hardware-based system is that software can be updated more easily and cheaply than hardware. Syntron has already produced other drum sets including Glass, Latin and Syn Drums sounds. Individual drum sounds have also been produced: cowbells, rim shots, shaker, hand clap, metal bars, umpteen different tom, high hat and cymbal sounds and a few other items of exotica thrown in for luck. Sounds can be loaded and saved in complete sets or individually so you can construct different drum kits by taking a ping from here and a rattle from there. A disk containing over 40 of these new sounds is available for an extra £16.50 and already another disk is in the making and will be available soon.

## Data

<b>Computers</b>	Commodore 64/SX-64/C128
<b>Output</b>	mono audio out via jack socket
<b>Sync</b>	one-pulse-per-beat via phono socket
<b>Storage</b>	51 Patterns 10 Songs
<b>Price</b>	£65 inc VAT (add £2.50 p&p). Disk of new samples: £16.50
<b>Supplier</b>	Syndromic Music, 35A Grove Avenue, London, N10 2AS Telephone: 01 883 1335

## In brief

- The quality of the output of Syntron's Digidrum is well up to recording standard although discerning ears may detect a little background noise.
- The Digidrum is comparable with many of the cheaper drum units - and generally outperforms them.
- All purchasers will receive details of new samples as they become available and a free subscription to a quarterly magazine on computer music.
- Syntron's R&D department is working on a MIDI conversion for their black box and a facility to incorporate your own sounds, both at nominal cost.
- Syntron obviously intends to support the Digidrum.

# IN SEARCH OF COMPATIBILITY

Sanyo's advertising somehow makes a virtue of the MBC 55X series' incompatibility with the IBM PC – but the company has submitted to the immovable object and released an IBM-type video RAM board.

The majority of IBM programs fail to run on the Sanyo because of video problems, but the new video board doesn't guarantee total PC compatibility – the makers say it enables the MBC 555 and 550 to run about 90% of IBM PC software, including Lotus 1-2-3, Supercalc 3, Electric desk (minus the comms facility) and Microsoft's Flight Simulator.

Some other programs will fail because they make illegal calls to the PC's BIOS. They won't run on a Sanyo with or without video board. Problems will also arise with autobooting software, which requires a software patch if it is to boot up on the Sanyo machine.

## 'The board is a neat piece of hardware engineering'

The board itself is a neat piece of hardware engineering which fits snugly inside the main unit, above the Sanyo processor board and below the disk drives. The board is provided with a short instruction manual, new operating software, GW Basic and manual, and various screws,

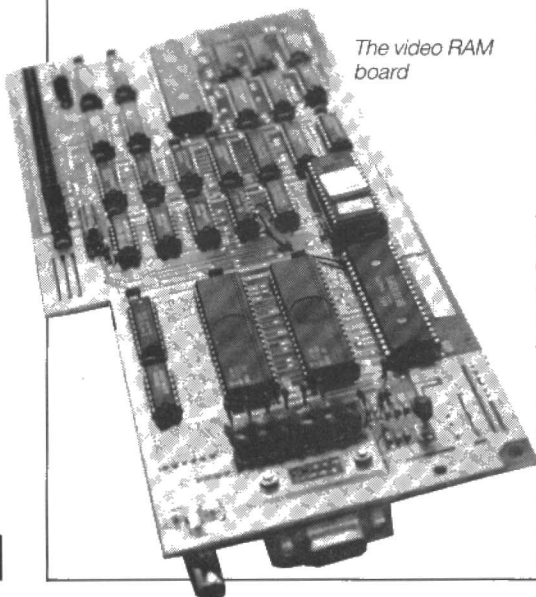

The video RAM board

**Sanyo's IBM type video board for their MBC 55x series of micros offers a high level of PC compatibility. William Owen sets out to discover just how close to IBM emulation the add-on comes.**

casing (held down by five screws), detaching three cables from the main board, and then sliding it carefully out. A metal plate, and plastic spacers, are then attached to the video board, which is then connected to the main board via an expansion socket and the spacers. Unfortunately the board with which we were supplied had inaccurately drilled screw holes and it was impossible to attach it firmly to the backplate of the main board. The fitting was however reasonably secure. The two boards are then replaced in the disk drive unit and cables refitted. That's all there is to it, and the manual is quite clear in all respects.

The board is booted up via the new ver-

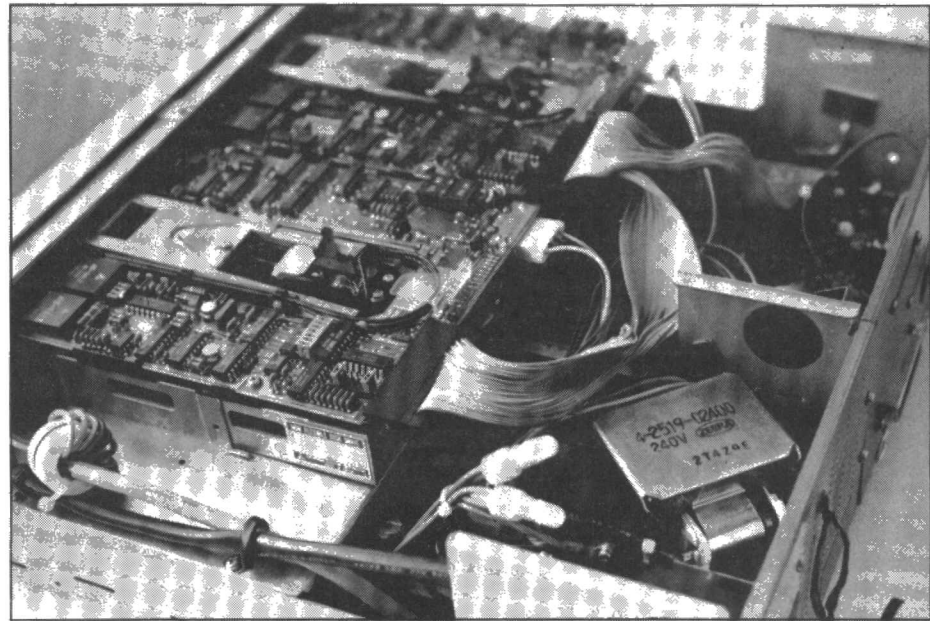

Inside the computer. Removing the case requires the extraction of just five screws.

and spacers and a new metal plate to fit into the back of the machine. Sanyo doesn't provide the special lead you will need to connect up a colour monitor, that will have to be made up by the dealer and costs extra.

## INSTALLATION

According to the manual, installation can be completed within fifteen minutes: it took me thirty, but that's still quick. The first step of the operation is removal of the upper

portion of the OS. Our machine is an 800K version running under Michtron's DSDOS Plus, which has been upgraded to include a VIDEO command by which it is possible to switch from video board to normal mode in software, and therefore run two monitors, one for each mode.

Video Board users will immediately notice the annoying flicker which occurs when it is used to run not only Wordstar (there is of course no need to run Wordstar in this mode) but also when running GW Basic. The flicker should disappear when PC software is run.

- The video RAM board is a useful and relatively inexpensive bolt-in accessory to the MBC series, but if you purchase it with the aim of running any specific PC software package, always consult your dealer first to ensure that the program will run, and preferably ask to see it in action.
- A full translation of Sanyo to IBM keys is given in the Sanyo user manual. Patches (eg that for flight simulator) will make the translation in software, saving you the trouble of searching between two manuals, as well as fooling the software.
- The GW Basic manual is just that – basic. It gives only the briefest description of the many commands available.
- Installation requires no thorough knowledge of computer hardware, just care and the ability to read instructions properly.

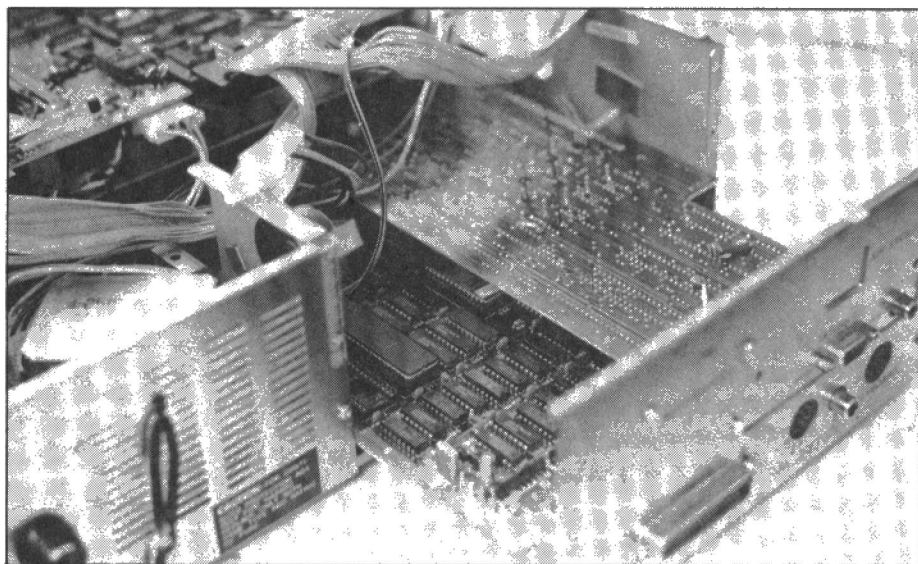

The video board installed, IC side facing down.

## BOOTING UP

The first product we tried to boot up was Flight Simulator; which stubbornly refused to boot. The reason, it was later discovered, is that Flight Simulator needs a software patch. The patch is public domain software and will be supplied by Sanyo. However if you want to run Flight Simulator take care that you buy the correct version of the board – two of the three versions won't run it at all.

**'Some autobooting software will require a software patch if it is to run on the Sanyo machine'**

Lotus 1-2-3 also requires a software patch in the form of a new command, GD.COM, which should be supplied by the dealer if Lotus is purchased with the board. Some users have found difficulty purchasing this patch and you may have to shop around for it.

The video board is priced at £95.00, Lotus 1-2-3 costs a further £200.00. To get the full benefit of GW Basic Sanyo recommends a memory upgrade to at least 192K (this will apply to other IBM compatible products which require more than the standard 128K, such as desktop overlays).

 **SANYO**  
Micro users  
association

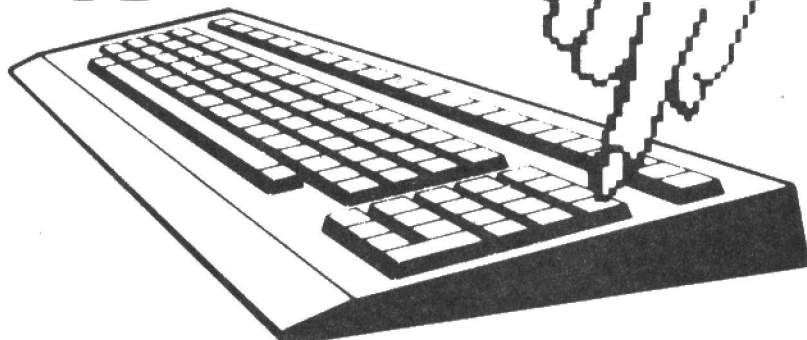

**Important  
News for**

 **SANYO**

**micro  
owners**

**EXTENDED OFFER.  
FREE GETTING STARTED PACK, VALUED AT  
£49.99. LIMITED NUMBER ONLY**

- ★ The SMUA has been formed to support YOU and your computer
- ★ Our services include unlimited telephone support
- ★ For further information on joining the SMUA dial 100 and ask for

**FREEPHONE SMUA**

# Storming the Tower of Babel

**BBC Basic could be the standard bearer in the struggle against the scourge of incompatibility, writes Mark Wells.**

There are as many different types of Basic as there are micros to run them, and several of them are referred to, confusingly, as standard Basic. This does not imply any degree of compatibility, nor even points of similarity between them. Any features in common are on the whole fortuitous and more an accidental bonus than an effort to help the user.

Microsoft has spawned a number of Basics, starting with the business version, MBasic, for micros such as the Apricot and the IBM-PC. The Macintosh variation involved special implementations to take account of the machine's sophistication and the original was soon so overlaid with extra facilities that it was almost unrecognisable. MSX and Commodore Basics also acknowledge MBasic parentage, and Digital Research came up with CBasic for the CP/M market.

Then came various non-starters, such as ANSI Basic, which took a decade of discussion before it was launched, and has emerged as IS-Basic on the Enterprise, the computer which took two years to see the light of day, a clear case of like attracting like. GWBasic, DEC Basic Plus and BLS (Basic Language System) all add their weight to the confusion, and it is with some relief that all but the most dedicated computer buffs come nose to microchip with the educational standard Basic, BBC-style. And it's this one which might one day give real meaning to the phrase 'standard Basic'.

M-Tec, a small firm in Norfolk run by Gerald Perry and Doug Mounter, has produced BBC Basics to run on extraordinary numbers of 8-bit micros, for schools and homes, and is now embarking on the 16-bit challenge with software designed for the IBM PC and compatibles. The Apricot F1 and F2 series are also under active consideration. With few exceptions, it has been possible to write BBC Basic for nearly every micro attempted, and now the only restraint is M-Tec's insistence that the machines chosen are of a good specifica-



tion, are reliable and worthwhile. So far, in the region of 100,000 copies of Z80 BBC Basic have been sold, and each user has access to the advice and problem-solving service which M-Tec offers as part of its sales back-up.

## REAL SALES SUPPORT

The company was set up in 1981, to sell and advise on computer systems, including M-Tec's customised software. At the time, the micro industry was beset by the sell-a-black-box mentality, when large warehouse-style stores handed cartons over counters to novices who were sold on the idea of computerisation but who discovered that interest in their problems as users stopped when the cheque changed

hands. Perry and Mounter set out to give sales support real meaning, and quickly established a clientele in the professional and small business sector.

Doug Mounter was acquainted with Richard Russell, BBC software engineer and editor of the original BBC micro specification, both firmware and hardware. Russell was interested in the principle of standardising languages between microcomputers, more as a principle than anything else, but it fitted M-Tec's practical approach to minimising user-confusion, and the ideal of BBC Basic for general application was launched. The BBC itself approved and co-operated, giving permission for M-Tec to use the term BBC Basic for their software – the specification of BBC Basic is within the public domain and anyone can write a version or copy the

original, but the title may not be used for marketing the results without permission.

## BUSINESS

Initially, BBC Basic was designed for CP/M machines which were essentially business machines, generally without graphics capability. M-Tec identified three factors necessary to the successful running of BBC Basic on these micros: first, they had to be CP/M 2.2 or a later version; second, they had to use a Z80 processor; and third, the CP/M had to be implemented correctly. Some machines with idiosyncratic configurations which did not match up to the manufacturers' manuals proved inimical to M-Tec's work, but on the whole, virtually any CP/M micro can be given BBC Basic. To prove it, M-Tec have their software running on a whole range of CP/M models, including Superbrains, NECs, Newbrains, Apples with Z80 cards, Equinoxes, Philips, Cromencos, Televideos and Dec Rainbows.

The Z80 version which became the basis of M-Tec's work was completed by Richard Russell at about the same time as the 6502 edition, which became the implementation adopted for the Acorn BBC. M-Tec sold Z80 Basic in its pure CP/M form for about six months.

Encouraged by success, they graduated to micros with graphics, and here, particularly on machines with an extensive graphics capability, special implementations involving rewrites of areas of the Basic were called for. The result was BBC Basic for the Torch (a logical starting point, since it is essentially a CP/M machine with graphics capability), the Wren, the Einstein and the Norwegian Tiki. Originally named the Kontiki, until anthropologist Thor Heyerdahl protested, the Tiki was adopted by schools under the Norwegian equivalent of the British MEP scheme, and BBC Basic was identified as being a valuable educational tool in Norway.

## EXPORTS

For the past two years M-Tec has continued to supply BBC Basic to Norwegian schools and colleges under contract to the manufacturers of the Tiki computer, to whom the education department had passed BBC Basic evaluation tapes they had received from M-Tec. Exports have also reached South Africa and Australia, and Gerald Perry says: 'We're becoming known for BBC Basic.' He is considering exporting to America next year, using the IBM version currently under development — though given the current attitude in the USA to British micro products, he suspects it might do better if marketed as Abe Lincoln Basic rather than BBC.

Once the Z80 version is running on a CP/M micro, without graphics, it requires only minimal configuration to achieve compatibility with any other CP/M machine.

M-Tec supplies instructions for users who wish to adapt the Basic to their own particular micro. For micros with graphics capability, M-Tec is usually approached by the manufacturer of a particular machine before attempting the Basic configuration, and will only do so then if it is confident that the end result will be worthwhile.

M-Tec's preoccupation at the moment is with the IBM and its compatibles. The BBC Basic for these is currently undergoing testing by various companies, and the final version will, it is hoped, be launched before Christmas. It will be available for the IBM, the Zenith, the Compaq and M-Tec's own imported IBM compatible, the M-Tec Professional with a twin disk system and a price tag of under £1,000 plus VAT.

The company plans to change the image of BBC Basic as a language solely for home and educational use. Perry says it is a very good language, well-structured and including many routines which can be of value in the business environment. He adds that many people who might use computers in the course of their work have experience of BBC Basic on BBC micros, through educational or home use, and efficiency is improved and time saved if the same programming language is available on the company micro. BBC Basic is used within the Ferranti organisation in connection with defence projects, because it was the language most familiar to the man concerned with the programming aspect of the work.

## AMSTRADS

Once Basic for the IBM style machines is dealt with, the Apricot 16-bit micros are earmarked for investigation. Then M-Tec plans to return to the 8-bit scene, with an evaluation of the Amstrad CPC464 and its big brother, the CPC6128, as well as the PCW8256, the Amstrad wordprocessor, shortly to be available through Dixons. These machines are perhaps more logical micros for Z80 Basic than some of the others which M-Tec has developed, but Perry says the company now believes that any Z80 or 16-bit micro which can run MS DOS is a potential host for BBC Basic.

If standardisation for the end-user is the criterion, it doesn't apply to the work of the software engineers at M-Tec. Each machine has different graphics drivers, addressing the monitor screens in different ways. Different screen dimensions affect the size of pixels, and each variation in a system imposes its own demands on the configuration of BBC Basic. Sound chips, too, add to the need to treat each implementation as a separate project with its own idiosyncracies. The aim of making all BBC Basics sound alike as well as run alike can be frustrated by physical differences between the different sound chips. The Einstein version, for example, is inferior in range and tone to the original BBC Basic, as a direct result of the AY-38910 sound chip Tatum uses.

## 8 TO 16 BIT

Changes between implementing 8-bit and 16-bit versions will probably only involve the commands used for the operating systems. For example, the Torch will accept \* commands, whereas the IBM PC does not recognise the same symbols in the same way. The much vaunted speed of operation of the 16-bit machines is not, says Perry tactfully, a problem. On a good day, with a following wind, most of the 16-bit models can almost hold their own against the best of the 8-bit machines when it comes to BBC Basic. It was always regarded as a fast interpreter, and neither the passage of time nor the advent of more sophisticated processors has diminished its virtues.

Perhaps the greatest restriction on M-Tec arises from the strict specification laid down for the original BBC Basic. Since M-Tec's work is marketed with the full approval of the holders of the copyright on the title, none of their versions may incorporate features not presented by the original. Potential improvements, in a specific M-Tec implementation or in the original, must be referred to the BBC, with a recommendation that it be considered for inclusion in a later version of BBC Basic. The BBC then either rejects the idea, or refers it to Acorn for consideration. M-Tec cannot implement any changes to the specification unilaterally, although they can if they wish include features which are in the BBC specification but were not implemented by Acorn. Mounter does not claim that BBC Basic is the best possible standard language. 'The minute that you freeze the design, some bright spark comes up with something better, but almost any standard is better than no standard, and the BBC Basic is a good language.'

**'Once the Z80 version is running on a CP/M micro, without graphics, it is easily configured for any other CP/M machine'**

The history of standardisation attempts has not been a happy one. The 8" disk standard was decimated with the advent of the 5¼" machines, resulting in everyone going their own way and creating literally hundreds of disk formats. The CP/M operating standard achieved some stability, but already the new generation of micros have Unix and MS DOS to choose from. M-Tec's work is aimed in the long-term at achieving a standard language which can be transferred from one micro to another as required, thus reducing the potential for chaos which faces unwary users at present. As Gerald Perry says, 'Wouldn't that be nice?'

# Reader Services

# COMPUTING AGE PCB SERVICE

## BBC EPROM BLOWER

### CONSTRUCTOR'S PACK

Computing Age has arranged for a complete kit of parts necessary to build this project to be made available to our readers. By taking advantage of the Constructor's pack offer readers can buy all the parts needed to construct the project from a single source. In addition, the Constructor's pack is accompanied by a set of detailed notes for constructors including some useful hints on fault finding.

**Complete kit £29.98 (including all components plus PCB but excluding software).**  
**Suitable Power Supply Unit £11.64 (provides +5V, +6V, +12V).**

60p handling charge must be added to all orders.

Send cheques/postal orders to  
 EPROM Blower Constructor's Pack, c/o Magenta Electronics,  
 135 Hunter Street, Burton-on-Trent, STAFFS, DE14 2ST.

<b>December 1983</b>		<b>January 1985</b>	
BBC Sideways RAM .....	£6.48	CBM 64 I/O Port .....	£3.55
Electron A/D .....	£3.78	Speedy EPROM Blower .....	£3.73
<b>February 1984</b>		<b>HOW TO ORDER</b>	
BBC Sideways ROM Board .....	£7.13	List the boards required and add 50p post and packing charge to the total cost of the boards. Send your order with a cheque or postal order to:	
<b>March 1984</b>		<b>Computing Age,</b>	
Spectrum Cassette Controller .....	£2.59	<b>c/o Magenta Electronics,</b>	
<b>April 1984</b>		<b>135 Hunter Street, Burton-on-Trent,</b>	
Commodore A/D .....	£2.15	<b>Staffs DE14 2ST</b>	
<b>May 1984</b>		<i>Please supply the following PCBs:</i>	
Memex .....	£7.55	.....	
Spectrum Diary .....	£4.26	.....	
Centronics Buffer .....	£7.41	.....	
<b>June 1984</b>		.....	
Mains Data Link (2 Boards) .....	£4.72	.....	
<b>July 1984</b>		.....	
IR Data Link (2 Boards) .....	£3.95	.....	
<b>August 1984</b>		.....	
Robot Wall Builder .....	£2.70	.....	
<b>September 1984</b>		.....	
Spectrum Frequency Meter .....	£3.61	.....	
<b>October 1984</b>		.....	
EPROM Simulator .....	£5.85	.....	
<b>November 1984</b>		.....	
Amstrad PIO .....	£5.65	.....	
<b>December 1984</b>		.....	
Amstrad CPC464 A/D .....	£4.10	.....	

**Post & Packing 50p**

TOTAL £

Signed .....

Name ..... (please print)

Address .....

**Please allow 28 DAYS for delivery**

# Start of term! Make sure you have the future of the class in the bag.

Educational Computing is the definitive magazine for educationalists. Whether it is at a primary, secondary or higher education level, Educational Computing ensures you are totally up to date with the applications for computers in teaching.

Find out for yourself. Return this coupon stating how you want to pay. If after reading Educational Computing

you find it is not for you. Simply cancel your order, and we will make a refund. No obligation; just an opportunity for you to find out why Educational Computing is so highly respected.

Send your completed coupon to Educational Computing, Priory Court, 30-32 Farringdon Lane, London EC1R 3AU.

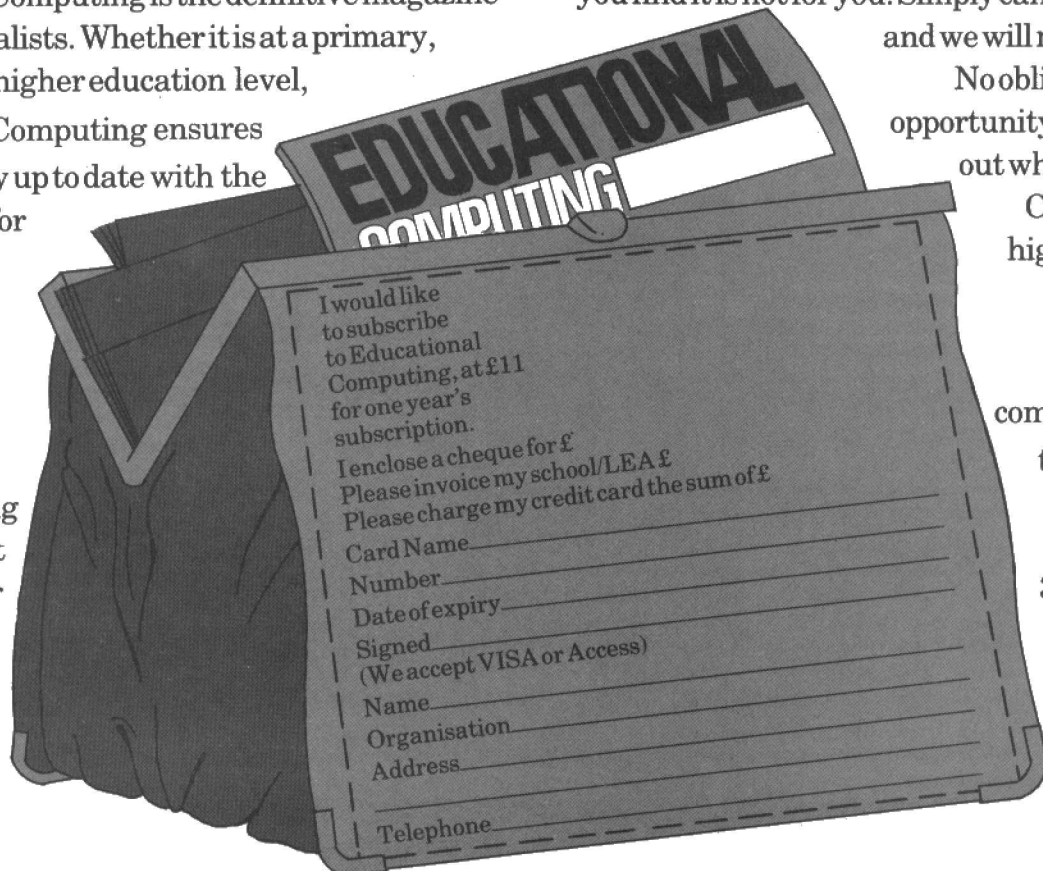

# THE A TO Z OF MICRO MUSIC

**Computerised studio recording equipment costs the earth – but you can do a fair job with a home micro and some add-ons, reports Wendie Pearson.**

Just as new technology has found its way into recording studios over the last few years, so the interest in home recording using micro-based systems has grown.

While you may not have the space or the cash for a £110,000 Synclavier or £100,000 SSL studio system in your drawing room, you may well be equipped to take a BBC-based UMI system, or any one of the MIDI systems you can build up around a Commodore, Apple, Spectrum or BBC. High-end systems used by the studios cost upwards of £9,000 with the exception of the Fairlite, which is £5,000. But a good home system can be had for as little as £1,000, including the micro. Interfaces such as the MIDI (Musical Instrument Digital Interface) have advanced home recording using micros such as the Apple, BBC and C64, which help compose, edit, write and play, with the MIDI interface transmitting information between the micro and the musical hardware.

Recording techniques these days turn sounds into strings of numbers, so, with the combination of a micro and a synthesiser, great things are possible.

MIDI hardware and software is available from specialist high street suppliers and the interface needed to drive MIDI has been likened to the RS423 (serial) port on the BBC. An alternative interface for any other micro with an RS232 port is available from MIDI consultants Hinton Instruments.

Remember that synthesisers and keyboards are not usually separate entities. Magazines go on about keyboards or synthesisers, but seldom explain to the uninitiated that 99% of synthesisers have built-in keyboards. If a synthesiser doesn't have a keyboard, it is known as an expander. You may want one or two other synthesisers linked up to the main one, although you'll only need one keyboard. The MIDI IN receives information from one synthesiser and MIDI OUT transmits control information to several synthesisers.

## BUILDING A SONG

MIDI software sequences and edits. Pieces of music can be rearranged and corrected and played in various sequences or combinations of sequences to build up a song. Some software also allows you to input music in real time rather than note by note, so if you could never read music, all is not lost.

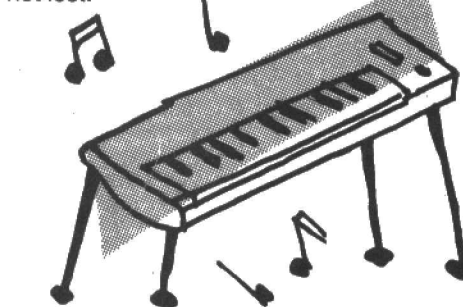

A typical system using MIDI would comprise an Apple IIe or C64, double disk drive, monitor and Yamaha DX7 keyboard (which costs £1,400). A cheaper keyboard is Casio's CZ101 at £395. Ritter Music in Edware supplies MIDI interfaces suited to both the IIe and the C64, in addition to another for MSX. It also supplies an array of MIDI software for the Apple II+, IIe and C64: MIDI 4, their first version of MIDI recording software, is £60. MIDI 4 Plus, for four track recording, has more sophisticated add-ons and costs £80. It also corrects mistakes without you having to go through the whole program (rather like a word processor). MIDI 8 Plus is for eight track recording and costs £120, and MIDI Player, a graphics package which creates patterns and artwork to go with the music (like Jeff Minter's Psychadelia for the C64) costs £64.

Polywriter, part of Ritter's MIDI Printing Software Range for Apple micros, costs £250. Manager Albert Elegino recommends as a basic system MIDI 4, Poly-

writer and MIDI Player (if you want graphics) assuming you already have an Apple system and a synthesiser and can play the piano. The MIDI interface itself is £119 for the Apple or £110 for the C64. For owners of the Yamaha CX5M MSX machine, Ritter sells PSG Musicwriter at £20.95 which lets you play back and correct music as you go along, while Odyssey K at £11.95 lets you record music in real time.

Siel (UK) Ltd in Horley, Surrey, sell a cheaper MIDI interface for the Commodore and Spectrum at £87.95 and another for the BBC at £99. They also sell a serial RS232/MIDI interface for £26. Other goodies are a DK70 programmable MIDI synthesiser at £499, the EX80 Synthesiser for £399, electronic pianos priced from £399 to £955 and 17 pieces of computer music software ranging from £12.95 to £65 for the BBC, C64 and Spectrum.

## FOR MUSICIANS

Another system you may have heard a lot about is the UMI. Designed by musician Lynton Naith to help other musicians, UMI needs a BBC B to function and is available from the London Rock Shop at £495. UMI consists of a piece of chip-based software which fits inside the Beeb, plus an interface box which sits on top. The interface connects to the BBC with one lead and to your synthesiser with the other. If you lack a BBC, the London Rock Shop will normally get you one, although they'd rather you got one yourself before bringing it round to be fitted. A new BBC plus UMI alone will set you back around £850, but if you use a second hand BBC, you can include a cheap keyboard for under £1,000.

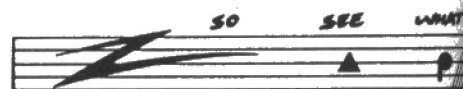

Those wanting a makeshift drum machine have been catered for by Vince Hill Associates, consultants to the music and computer industries. They make the £65 Syntron Digidrum for the C64/SX-64 and 128 which converts your micro into a makeshift digital drum machine (see page 25). This would cost around £250 commercially for the same sort of system. It consists of a small black box and software on disk or cassette and uses sounds sampled from real instruments – in this way it imitates the drum machines you would find in commercial studios.

## FOR CHILDREN

Yamaha's TYU 30 is a children's keyboard, for £39.95, so kids can record their own songs and music. The mike and keyboard are built into one unit and the price includes two music cartridges each with 10 songs including Jingle Bells, Auld Lang Syne and Silent Night.

At Trident Studios in London's Victoria, sound engineer Clive Martin said he thought home recording experience would be valuable to anyone wanting to pursue sound recording as a career. Currently handling a 24 track mixing desk which will soon increase to 48, Martin is a great fan of the mini-based SSL (Solid State Logic) system on which he works.

'Lots of people look for jobs using the SSL as it's so popular,' he said. 'It does all the work for you. In the old days you ran a tape and had to do it live but with the computer you can do one movement at a time and it will remember everything. For instance, if you want to make something louder, you move the fader and the computer then remembers to make it louder at certain points.'

**'Some software lets you input music in real time rather than note by note, so if you can't read music, all is not lost'**

Having a 24 track machine means you can record 24 separate things simultaneously or separately, with, for instance, vocals on one track, bass on another, sax on another and so on. A channel, on the other hand, is a long line of buttons, and each channel has its own graphic equaliser, like bass and treble on a home hi-fi but a lot more complicated, according to Martin. Also attached to the SSL is a small, oblong unit called a Lexicon which will, for instance, record you singing in the bath then make it sound as if you're singing in the Albert Hall. 'If you want to make it sound as if someone's singing in a small, carpeted room, you can do that too,' says Martin. The Lexicon, in other words, makes voices three-dimensional. Other gadgets on the desk are compressors, which com-

press noise, and gates, which let sound through. In the centre of this massive mixing desk is a tiny monitor measuring 6" x 4" set under a sloping piece of glass. Whatever appears on this monitor reflects on a TV screen above the desk, so that the engineer can see what's going on at any time.

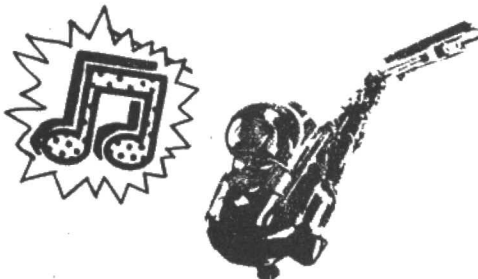

At Soho Studios in London W1, managing director Mark Teverson said he hopes to equip the studio with an SSL. Teverson is no stranger to using a micro to record music: he used the Apple based DS3 system by Greengate as long ago as 1981. 'The DS3 lets you sample any noise onto a floppy disk and play it back – then you can sequence it.'

## SYMPHONIES

The Fairlite is essentially a musical computer which remembers up to 16 instruments simultaneously. 'You can do everything on it – you could write a symphony on it using a keyboard and a typewriter,' said Pete Waterman, managing director of Vineyard Studios in south east London. He described it as a 'three foot by two foot square computer with disk drives, screen and lightpen'. It costs around £46,000 and the updated version, due out this winter, costs a whopping £70,000.

The Lin 9000, based around the IBM PC, is, Waterman said, 'basically a drum machine that is user friendly. It samples, records, plays the drums – it gives the producer facilities he hasn't had before, and I wouldn't say it affects the quality of the music.'

A drummer who doesn't much like working with systems like this is Dolphin Taylor from Sphere of Destiny, who is afraid the new technology will detract from the individual's creativity. 'In a studio situation, when it comes to mixing using a computer, you lose your creativity. Mixes take a lot longer on the computer because there are so many more things you can do. The element of choice is making it more expensive and studio time costs a lot, so unless you've got someone who understands computers, there's not much point in investing in the equipment,' he says. 'Fairly basic computers were brought in to aid the engineers over their mixes over the last few years. The only thing is the computers tend to break down, meaning you might have lost 12 hours studio time on the mix.'

Studio time varies in cost between £45 an hour for a really basic studio to around £110 an hour for a studio with an SSL.

Taylor does favour the SSL, despite his general misgivings, and records on one at Trident. An Amstrad owner, Taylor recommends home recording using hobby equipment, 'as long as you don't use an Amstrad.' 'The concept of home studios encourages more people to write songs and all you need is a tape recorder, channel mixing desk and speakers,' he says.

## THE KING

Vineyard Studios, who are weighed down with various computerised recording systems including the Lin 9000, Fairlite, and SSL, also have the mega-expensive Synclavier, the king of the recording world and the most expensive system available at £250,000.

'Synclavier was developed for NASA for the space shuttle program,' explained Waterman. 'It was designed for speech synthesis so that astronauts could talk to

**'Home recording experience is valuable if you want a career in sound recording'**

the ground, and there would be no distortion in their voices.'

The basic difference between Synclavier and SSL is that Synclavier records music rather than just remembering it. Commenting generally on computerised equipment in studios, Waterman said: 'It's added a new dimension to recording and it certainly hasn't turned people into brainless imbeciles. It gives you five times as many options as you had before.'

Numerous characters in the music world have turned to the micro to help them in their work. Kajagoogoo's keyboards player, Stuart Neale, uses a PPG computerised keyboard system with a MIDI interface so that he can operate nine keyboards simultaneously and use the equipment for recording and writing.

Other musicians who have succumbed to the charms of new technology include Stuart Copeland, Bill Wyman, Kim Wilde, Big Country, Marilyn, Stevie Winwood and Brinsley Ford of Aswad, all of whom own a home micro or use one for recording purposes. Many managers, too, have taken to running a band's business on a micro including Human League's manager Bob Last who also manages Scritti Politti and ABC.

**Contact:** Hinton Instruments 0865 721731; Vince Hill Associates 01 883 1335; Siel (UK) Ltd 0293 776153; London Rock Shop 01 267 5381.

Other suppliers: Electromusic Research (MIDI consultants) 0702 335747; Clef Products (Electronics) – makers of Clef Computer Music System 061 439 3297; Umusic, 17 Parkfields, London SW15 (MIDI interfaces/software).

# A PACKAGE TOUR

**Is Amstrad's PCW8256 really the best thing since sliced bread – or have we all been duped by the Brentwood hype? Stephen Ibbs finds out.**

For those who have not been inundated with leaflets praising this remarkable machine, it is a wordprocessor – but much more. For less than £400 (plus VAT) you get a 256K RAM computer, green screen monitor capable of resolving 90 characters horizontally, disk drive, printer, and the software!

And it's not made of cardboard. On the contrary, it looks and feels solid and well constructed – a recent survey showed that Amstrad have an impressive record in terms of machine reliability. Both the printer and the external keyboard plug into the monitor, which has a disk drive built in. This has an unformatted capacity of 500K, and a 1M drive can be added as an optional extra, as can an RS232 and a Centronics parallel interface.

The 256K is divided to provide a 112K silicon disk. For those unfamiliar with this term, it acts much like a built in disk drive, but without the disk, and much faster. However data is not retained when power is removed, so files must be transferred to a normal drive after use.

Setting up the system is easy, but make sure that the 'bail-bar' on the printer is down (in contact with the paper), as this is detected by the computer, and no printing will otherwise take place.

Inserting the disk and turning on causes the system to 'auto-boot', and eventually you will be presented with what they call the 'disk-management screen', displaying what files are stored, and in what groups. Each disk can hold up to eight groups of files, divided into, say, letters, memos, documents, etc.

The advantage of this method is that you can design blank 'templates' into each group, which automatically set up various parameters for that particular group: your blank letter template could have your address formatted correctly with page size set up, so that you don't have to do this every time – a most useful facility. Individual files can automatically override these default parameters when they are loaded.

The silicon disk comes into its own now, because files can be transferred into it using the function keys and the windows



that appear at various times to inform you of your options, or errors, or checks before actions are taken. Once in edit mode you will find that several facilities normally only found in 'professional' wordprocessors have been included, amongst them rulers, soft and hard hyphens/spaces, widows and orphans, headers and footers, etc.

The function keys are used time and again, and their role is always displayed at the top of the screen. As a key is pressed a small window of relevant information is displayed, for you to make your selection. 'f1', for example, allows you to display extra items of information while entering text. This includes rulers, printing codes, and blanks. This last option seems a bit odd, but it must be remembered that in wordprocessing there is a difference between spaces which are counted as actual characters, and blanks, which mean that nothing exists at that point.

Special keys have been added to the normal keyboard for cutting or pasting text and cancelling commands, as well as extra keys for movement through the text. These are on the right of the normal QWERTY layout, where there is also a numeric keypad. Some of the keys can be made to produce Greek and mathematical symbols, as well as accented characters used in other languages, by simply pressing ALT or

EXTRA with the appropriate key. They are also of course printed out correctly.

## PRINTING

Because the printer is part of the package the software writers have been able to incorporate the various printing codes into the system, and this must be one of the big advantages of this wordprocessor. They can be called in a variety of ways, and a description of three different ways shows how flexible the system is.

- f3 and f4 display small menus of the options, eg, underlining, centring text, superscript, double-strike, and the cursor keys are moved until the highlighted bar is over the desired line, and selected by pressing a special '+' key then ENTER. It is cancelled by pressing '-' when in the menu, then ENTER.

- Pressing + and a special key displays a huge window on the right of the screen with all the options listed. Again the highlighted bar can be moved with the cursor keys, or a combination of letters (shown in upper-case) which uniquely selects an option, followed by ENTER. This is much quicker than the first method.

- Once you have learned these letter combinations – C for centre line, RJ for right-justify – the code can be entered by

Figure 1. Sample print-out from PCW8256.

```
This is a test passage of text to see how simple the s
automatically adjust so that the text will fit the margi
'justification on' in the ruler design stage.
```

```
This is a test passage of text to see how simple the s
automatically adjust so that the text will fit the marg:
'justification on' in the ruler design stage.
```

```
This is now in enlarged mode to se
change in pitch style looks li
printed page.
```

```
This is now in enlarged mode to se
change in pitch style looks li
printed page.
```

keying + RJ (some codes needing ENTER afterwards). Thus as you get more used to the software, so you become much faster as you take the shortcuts, which have been most thoughtfully provided. The designers have scored heavily in this area.

TABS are defined via the ruler, and these can be normal, right, left, depending on how you want the text aligned. Decimal TABS aligns columns of figures on the decimal point. There is also an ALT TAB facility, which indents the whole paragraph, extremely useful, whereas a normal TAB merely indents that particular line.

You have a choice of pitch, 10, PS (proportional spacing), 12, 15, 17 characters per inch, and the computer knows how to adjust the text to fit into the margins specified. The default pitch is that specified in the 'base layout', the foundation of that particular document, but the ability to change pitch part way through, and know that it will still be formatted properly, is a great help to users.

## JUSTIFYING

In fact the system is even cleverer. It is very difficult to get text left AND right justified (ie both margins straight as seen in text in books) when the pitch style is 'proportional

## Technical Details

**If there is a secret to Amstrad's success** it is in producing machines with an advanced technical specification at very low cost. This they achieve by manufacturing the hardware in the Far East with low labour costs, and by taking advantage of economies of scale by manufacturing very high volumes of equipment – in the case of the PCW8256 this will be 40,000 units per month.

A further factor contributing to a low ex-factory, hence retail, price is the extensive use in the 82565 of custom integrated circuits. In fact the computer has less than 20 ICs doing all the work and of these eight are the 256K x 1 RAM chips. Of the remaining 10, the Z80 processor, disk and printer controllers account for three more devices along with a large custom IC from NEC which takes care of just about everything else. The rest of the electronics is responsible for tasks such as buffering the output to the computer's dedicated printer. There is no ROM within the machine: the bootstrap routine that loads the system software from disk is squeezed into one of the LSI ICs.

There are two important implications of the level of integration adopted by the designers of the PCW8256. The first is that the Z80 processor has a great deal of work to do and some of the time it has too much to do, meaning that some operations can take rather a long time to complete.

The other point to bear in mind is that any fault in the system is likely to cause the complete machine to go down. Contrast this to other WPs where a fault in the printer would not prevent the user from making use of the other parts of the system.

spaced'. This means that the amount of space varies for the character, so that the character 'i' or 'l' takes up much less room than 'w' or 'm'. To get the right margin straight the software has to take all these characters into account when it is adding extra spaces between the words. The PCW 8256 handles this well.

It must however be remembered that the screen display cannot cope with different pitch styles, so the display may sometimes look distinctly odd. For example if your base layout has a pitch of 10, and you then specify a whole section in a pitch of 17, the computer knows that it can squeeze in many more characters to the inch on the printer, but it can't do it on the screen, so your text apparently goes well off to the right past the margin – most disconcerting. Similarly in PS, even though you have justification selected via the ruler, the right margin appears ragged, though it will be printed out straight.

Rulers are inserted or edited to change the overall layout of sections of the text – and each document can have up to 99 rulers! You can define left/right margins, line-spacing and line pitch, italic (but this can be changed through the printing code menus) and right justification. To understand how these rulers work requires some tenacity, but the manual is helpful in this regard.

You are actually presented with two manuals, one covering Locoscript (the wordprocessor) and CP/M Plus (the operating system), and the other covering Basic. They are both impressive tomes, with numerous illustrations and examples, and provided you are prepared to work through them, you will learn a great deal. But in some ways it could be made a bit more friendly, and perhaps companion book of hints would be a useful addition.

The quality of the printout is excellent. You can select either 'high' or 'draft' quality, as well as specifying page length, gap amount (to jump over perforations in continuous fan-fold paper) and header and footer zones. Text can be automatically inserted at the top and bottom of each page, and the system is very flexible with regard to first and last pages, or odd/even pages for those writing books wanting different headers and footers on alternate pages.

- The PCW8256 is difficult to beat on a value for money assessment. Atari's 'power without the price' slogan perfectly sums up this computer.
- The eight bit Z80 processor works overtime to deal with all the computer's functions with the result that some operations can take some time to complete.
- The PCW8256 is much more than a dedicated wordprocessor. In theory the CP/M Plus operating system should mean that a wide range of commercial software will run on the computer. As yet though there is little evidence of widespread availability of such software on 3" disks.
- The RS232 interface, along with a modem will be an essential purchase for those wanting to use the 8256 with electronic mail services. This will also require the purchase of CP/M comms software. It should be noted though that it has been reported that CP/M will not read Locoscript files. Extensive users of e-mail would then also require a basic CP/M text editor.
- The range of software supplied with the machine is comprehensive although the inclusion of DR LOGO is strange in view of the intended applications of the computer.

**In brief**

## Data

<b>Processor</b>	Z80A 4MHz
<b>RAM</b>	256K expandable to 512K
<b>Mass storage</b>	180K (formatted) 3" disk drive
<b>Operating system</b>	CP/M Plus
<b>Keyboard</b>	Full QWERTY, numeric pad, five function keys (10 with shift), plus other keys dedicated to operation with Locoscript
<b>Display</b>	7620x256. 90 columns by 32 lines. Green phosphor
<b>Interfaces</b>	Expansion port, Amstrad printer port
<b>Bundled software</b>	CP/M Plus, Mallard Basic, DR GSX graphics extension, DR LOGO, Locoscript
<b>Supplier</b>	Amstrad Consumer Electronics PLC (0277 228888)

## BUG

There is a bug in the 'pages' menu whereby you can end up with a page length of 10, but a footer position of 63! Also some early versions of the software did not allow the insertion of the page number code when defining header and footer text.

If you have come to this processor from another professional system, say Wordwise Plus, you will be disappointed by the speed. The machine has only a single Z80 working overtime to do everything, and once a document gets over a few pages you will notice how long it takes to move a paragraph from the beginning to the end. Possibly the software writers were used to a mainframe system, and transferred it to a micro without taking account of the loss of speed. It should be possible to produce a faster wordprocessor whilst retaining all the features already provided.

In any package priced like this, it should be easy to 'nit-pick' and find fault – but it isn't, it's difficult. Provided you are patient, it will give you all you need in text handling. If however you don't like Locoscript, the adverts claim that several CP/M packages will work on the PCW8256, including Wordstar and dBase II (costing hundreds of pounds each). It can be faulted on one or two details and on its speed, but it is still one of the best value for money packages I know of.



one input of a voltage comparator, while the other input is fed with a (lower) reference voltage. This sends the output of the comparator high and activates a switching transistor at the output of the circuit.

The situation is very different in the absence of an input tone. The input signal is random noise which will sometimes be positive-going, during positive output cycles from the current controlled oscillator, but will just as often be negative-going. The output potential from the low-pass filter is the average of the input signal voltage, which in this case is roughly zero. This sends the output of the comparator low and switches off the output transistor. Thus the system gives what is effectively a DC coupling from the input of the transmitter to the output of the receiver.

### TRANSMITTER CIRCUIT

The transmitter is built around the ever useful 555 timer device, and the full transmitter circuit appears in **Figure 2**.

IC1 is a standard 555 astable oscillator circuit with an adjustable output frequency. VR1 is trimmed to bring the output frequency within the narrow lock range of the receiver. The inverter stage is based on TR1, and with a low input level this gives a high control signal to pin 4 of IC1 and enables oscillation. With a high input level, pin 4 is taken low, oscillation ceases, and IC1's output goes low. TR2 is an emitter follower buffer stage which enables the fairly high drive current of about 100 milliamps for D1 to be readily achieved. R6 is a current limiting resistor which controls the LED current.

### RECEIVER CIRCUIT

**Figure 3** shows the circuit diagram for the receiver unit.

D2 is the infra-red detector diode, and this is a sensitive device which has an integral infra-red filter to reduce interfer-

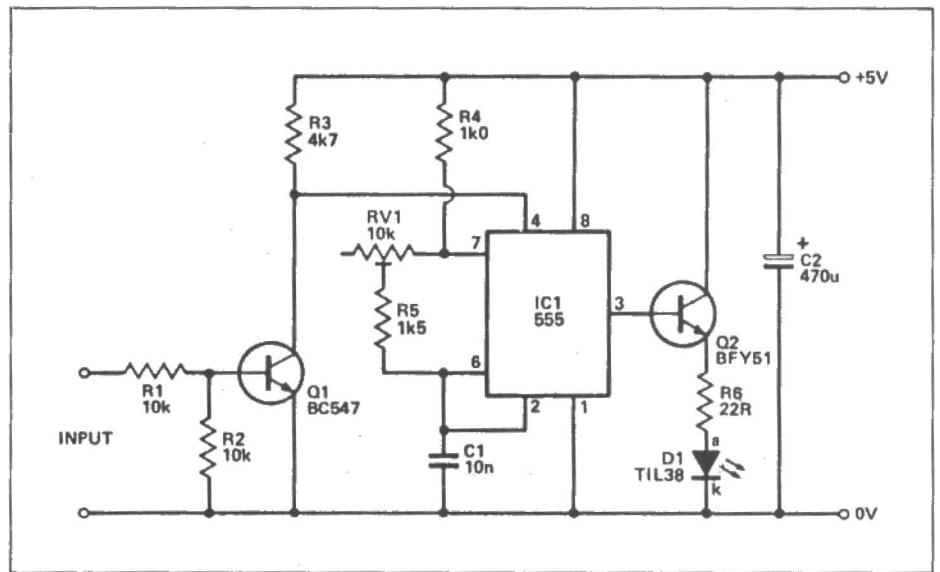

Figure 2. Circuit diagram of transmitter.

ence from visible light sources. It is connected so that it is reverse biased by R7, and the leakage current of the device depends on the infra-red level to which it is subjected (increased level giving increased leakage). Therefore the pulses of infra-red from the transmitter give small negative output pulses from the junction of D2 and R7.

TR3 is used as a common emitter amplifier, and R10 is used to give local negative feedback which reduces the otherwise excessive voltage gain of this stage. The amplified signal is coupled by C5 to two common emitter amplifiers which provide most of the circuit's voltage gain. The values of the coupling capacitors have been made as small as possible and are consistent with efficient coupling at the frequency of the input signal. This severely attenuates 100 Hertz mains hum which is generated by mains powered lighting, and which might otherwise greatly reduce the efficiency of the system.

IC2 is the NE567 phase locked loop tone decoder. R16 and C8 are the timing components for the current controlled oscil-

lator. C9 is the capacitor in the low-pass filter at the output of the phase comparator, and this operates in conjunction with an internal resistor of IC2. C10 is the smoothing capacitor at the output of the quadrature phase comparator. The internal switching transistor at the output of IC2 has an open collector output, and R17 is the discrete load resistor for this.

The output from the receiver will not directly control mains operated equipment. There are however a number of 'off the shelf' switches that will accept the TTL on/off signal as an input and use this to switch mains voltages.

The IR link is suitable for a wide range of applications. When installing the unit it should be noted that it is important that neither the transmitter nor receiver should be obscured during operation.

Readers wishing to construct the infra-red link should write to our offices for detailed construction notes to accompany the project together with details of where to obtain the components. Please ensure that you enclose an SAE and please mark the envelope 'IR link constructors notes'.

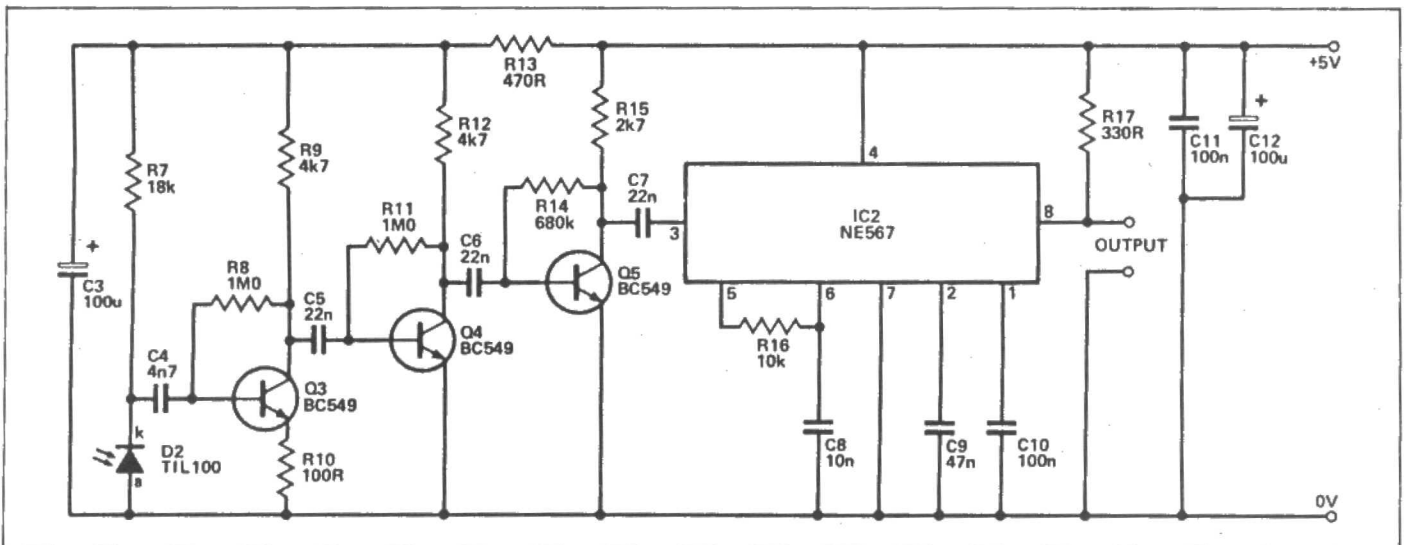
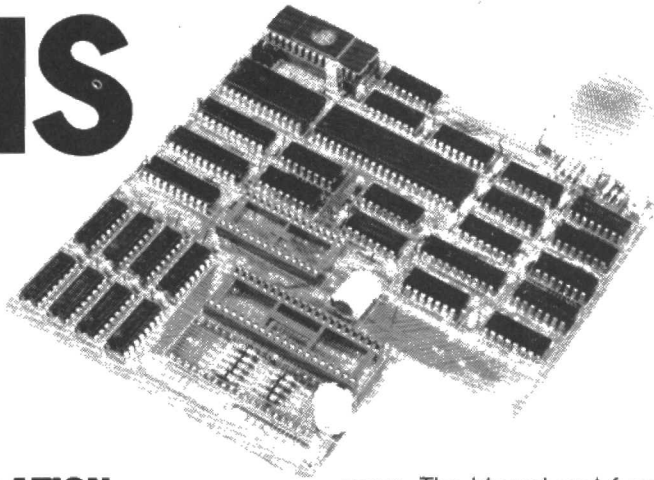

Figure 3. Circuit diagram of IR receiver.

# NEW WINGS FOR DRAGONS



**The Dragon's small RAM and lack of a full-width display mar an otherwise good machine. Now all that has changed, writes Michael Graham.**

The Dragon computer, although never a tremendous commercial success, has over the years built up a considerable base of loyal users. Dragon owners have a number of advantages over owners of 'lesser' machines such as the BBC micro. Of these, access to the FLEX and OS9 operating systems must be counted as the most important.

But it has to be said that the computer also has some major shortcomings. Of these, the lack of an adequate video display generator is the most serious. The Dragon is limited to a hardware generated video display of only 40 columns, only half that considered to be the minimum specification in any serious application. Both OS9 and FLEX go some way towards overcoming this restriction by providing a software generated 51 column mode that makes use of one of the computer's graphics screens to provide the character set. Apart from the disadvantage that this 'steals' some 6K from the available RAM workspace, the software generated display does not provide the quality in terms of definition that hardware driven displays are able to offer. In addition, other failings in the computer's video driver mean that the resultant display is barely acceptable. Couple this with the fact that much of the software written under OS9 and FLEX assumes an 80 column display, and thus produces some unpredictable results when operated with a restricted 51 column display, and the need for an 80 column add-on to the computer is obvious.

A new expansion system from Compusense offers the solution to both these problems. The Dragon Plus system provides users with both an 80 x 24 display capability and an extra 64K of RAM configured as two banks of 32K apiece. The expansion system comprises a single PCB which is installed within the Dragon's casing. Fitting the PCB is straightforward, but Compusense offers an installation service for users not confident of undertaking the work themselves.

## INSTALLATION

To fit the board, the cover of the Dragon is removed – it should be noted that this will invalidate any warranty in force on the computer – and the keyboard assembly disconnected from the computer's main PCB. The installation instructions cover both the 64K and 32K variants of the machine; in both cases it is necessary to remove two ICs from the computer (the SAM chip and a ROM IC) and to transfer them to vacant sockets on the Dragon Plus board. A ribbon cable from the Plus PCB terminates in a header plug which plugs into the socket from which the SAM was removed.

The only other connections to be made concern the video output from the expansion system. Compusense supplies a DIN socket of the same type as the existing video output on the computer. Compusense suggests that an additional hole is cut at the rear of the computer and that this is wired to the expansion board in the same way that the original video output socket is configured. The sound output from the computer should be connected to the new socket by running a single wire between the two.

To take advantage of the facilities offered by the expansion system, it will be necessary to use modified versions of the operating system – at present Compusense can supply a version of FLEX complete with the necessary screen drivers, and is planning to make OS9 drivers available in the future.

In addition to handling the 80 x 24 column display, the FLEX update software allows an area of the additional RAM to be configured as a RAM disk.

## QUALITY

The difference in the quality of the display produced by the new board and the original video driver circuitry will come as a pleasant surprise to hardened Dragon

users. The blurred and fuzzy characters they have been used to are replaced by a well defined 80 column display. The new version of FLEX ensures that all applications software that ran under the 51 column screen operates correctly, the only difference being that the screen displays the full 80 columns.

The RAM disk is initialised by a new command, VINIT. The RAM disk created by this command may be accessed as any drive number 0 to 3. Note that the VINIT command affects the way that all disks are assigned by mapping the FLEX drive number to the disk (physical or virtual). Entering the command ASN? will display the current allocations.

## APPLICATIONS

One of the most useful applications of the RAM disk is to copy frequently used commands, or commands that take a considerable time to load, to the RAM disk just after the system has been booted up.

The FLEX update disk supplied with the system includes two EXEC command files that initialise and set up the RAM disk for operation with either single or double drives. These command files may be modified by users to tailor the system to their exact requirements.

The Dragon Plus expansion system should be considered an essential purchase for serious users of the computer together with the FLEX operating system. The improvement to the display would be well worth the cost of the system to some users.

*Dragon Plus Expansion, assembled and tested, with installation kit, £103.50; update disk for new versions of FLEX/dBasic and Edit+ for FLEX, £5.00 (FLEX system disks must be returned).*

**Contact Compusense 01 882 0681/6936.**



The old . . .

**If colleges, and soon schools, are to prepare their students for the real world then 16-bit micros will have to take over from the BBC micro, says Mike Banner.**

For some time now, the BBC Micro has taken the lion's share of the education market, thanks to the impetus provided by the DTI's 'Micros in Schools' scheme. The Beeb accounts for roughly three quarters of the machines now owned by schools and colleges. But times change, micros change. There are moves afoot to oust 8-bit technology from its number one position, and replace it with the 16-bit hardware now in pole position in the business market and generating so much enthusiasm (if not actual sales!) among home PC users. But how likely is a change to a 16-bit 'standard' in education, and how suitable are the current machines for use in the classroom?

Research Machines' Nimbus, the Apricot F1e and the Atari 520ST are the leading contenders in the 16-bit attack on what is basically Acorn/BBC territory, and there is no doubt that their large memories, hi-res screen graphics and processing power could offer a great deal to the educational market. The advantage of lots of RAM is the ease with which a user-friendly screen graphics - using icons, windows, and mice - can be supported. This gives the 16-bit machine running something like GEM or Windows the potential to shine in any environment where students are not required to learn the ins and outs of computing, but rather make use of the computer as a tool. Having bags of memory also implies the ability to store and manipulate large amounts of data - a useful asset in most classroom applications where the micro is required to act as a pro-

cessor of information, rather than a computer-assisted-learning (CAL) device.

The 16-bit manufacturers are quick to point out another plus-point in their favour. Apricot's Group Marketing Manager, Jes Dorrell, thinks that schools and colleges of further education should be using business computers running MS DOS. 'If education is supposed to prepare people for the real business world, then they should be taught on a machine that will prepare them. Our F1e computers are being bought by a large number of polytechnics now, particularly for use in networks'. Apricot has set up a national purchasing scheme to encourage universities and colleges of further education to buy their systems - but they are willing to admit that things are happening faster in higher education - the take-up of 16-bit machines in schools is likely to be a much longer-term process.

### **FAMILIAR INTERFACE**

Apricot is first and foremost a business computer company. Research Machines, on the other hand, has a long standing association with educational computing. The RM380 and 480Z machines have been in competition with the BBC Micro for some time now, and they have had considerable success with for example, the Inner London Education Authority, where their machines are approved as a standard. RM recently surprised everyone with their Nimbus computer, a large but well-designed machine, similar in style to the IBM PC. Talking to the company's Managing Director Mike Fischer, you are immediately struck by the way he thinks in educational terms. 'The mode of use for computers in schools is towards information processing - the product is used as a tool to handle data - then comes word processing - and that is followed by Logo or Basic programming.' He says that 60% of RM's new business from secondary schools is for the Nimbus, and that there is a definite desire among primary schools to

# 16 BITS GO TO SCHOOL

go 16-bit to get the benefit of the machine's user-friendly interfaces, graphics, simulations and Logo. Not that there are many purchases from that sector - money is so scarce.

Mike Fischer is obviously thrilled by possibilities offered by 16-bit technology's ease of use. 'Education will benefit enormously from trends that make applications easier to drive. The Mac style is important, and we have Microsoft Windows on the Nimbus so that pupils have a good visual frame reference for what's going on. They soon get used to making selections from a menu with a single clicking push-button.'

That Mac style of interface is also to be found on the Atari 520ST of course, and Atari has not exactly been idle in the education area! In August they ran a special scheme offering 28% discount on a mono system to encourage educational establishments to buy an ST for evaluation. The company says a large number of universities now have one, and claim that from their dealings so far, many educational users now see the 520ST as the natural successor to the BBC Micro: similar in price but a vast leap in technology.

### **ACORN'S POSITION**

Acorn for its part is not unduly disturbed by what they call 'the current 16-bit hype'. Bob Coates of Acorn Education told me that they do recognise the importance of 16-bit trends, and that it would be naive of people to think that they did not have some kind of solution up their sleeves to satisfy the market. And he wasn't referring to the recently announced Acorn/Olivetti/Thompson initiative to establish a European educational computing standard: that project will take two to three years to produce results.

What is evident at Acorn is that the Education division has given considerable thought to what schools really need. Bob Coates is adamant that MS DOS is not the answer: that it is geared too much towards

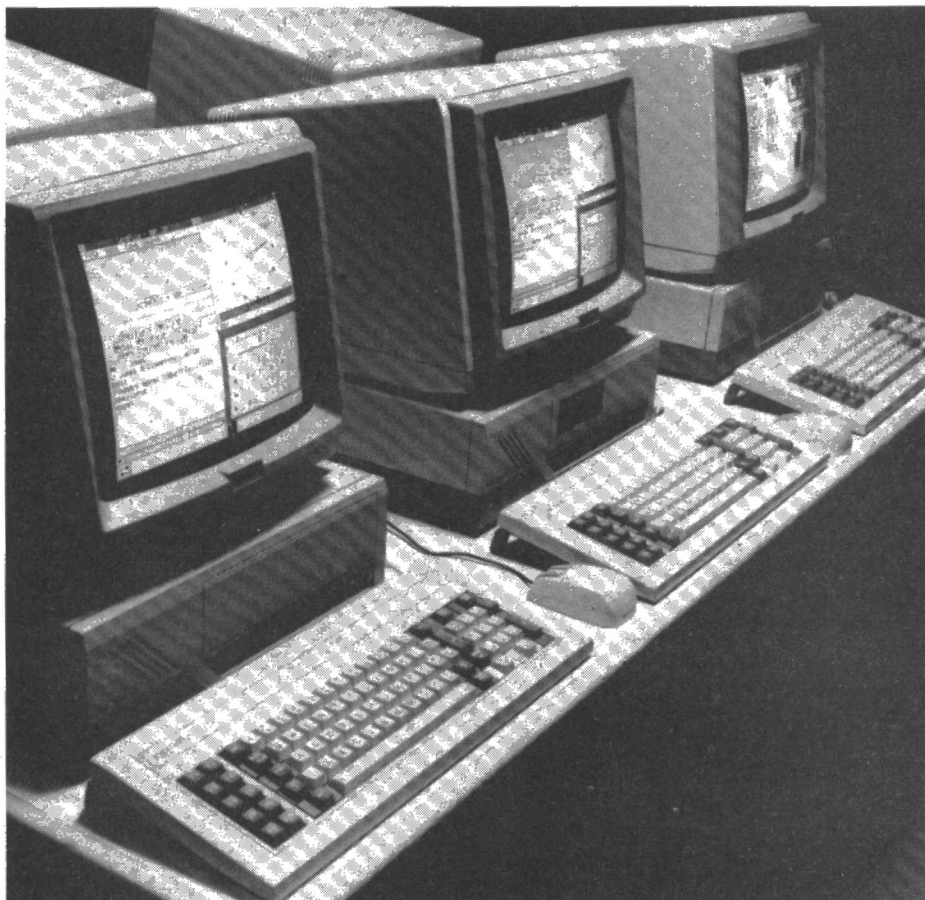

... and the new

business use, not education: and that it is likely to go the way of CP/M in a few years time. He says that Apricot and Nimbus machines are being bought for training, but they do not have the software base necessary for education. The business software available for the 16-bit machines is far too complicated for most people to use in the real world, let alone most classrooms.

**'If education is supposed to prepare people for the real business world, then they should be taught on a machine that prepares them – Apricot'**

He admits that things could change, once a few more people can actually get to grips with the business packages. In the meantime, there are already 160,000 Beebs in education, and nobody is going to want to throw away all the teacher training and the investment in software for those machines. Needless to say, he would not be drawn on whether the future Acorn initiative in education would revolve round an upgrade path, like a second processor, or an entirely new machine! All Bob would say was that ultimately in a classroom environment, memory and speed are not all-important. What matters is what the machine can do.

## THE GOVERNMENT VIEW

If the 16-bit manufacturers had hoped that the government might make some announcement about the future of educational computing, it looks as if they will be disappointed! A spokesman for the Department of Trade and Industry told me that there is no plan in the pipeline to regenerate the Microtechnology in Schools scheme to help schools buy 16-bit machines, although the DTI do agree that 16-bit microcomputers are better for any new purchase. DTI money is being used to encourage publishers in the educational software field at present, but government thinking is that the money can't go on forever, and that they can only try to help a sector develop until it can sustain itself. Obviously they feel that the previous pump-priming exercise was enough, and that the Local Education Authorities can look after themselves now.

It is plain that two major factors will control the future of computers in education: software and money (or the lack of them). The money side is straightforward: the irony is that the present government is seeking to promote new technology and educational software on one hand, and cutting back education budgets on the other, making it difficult for schools to replace hardware or buy any new software. The software is another matter. It has always been said that there are very few good programs written for education – the most popular seem to be things that can

act as a stimulating resource in any classroom, such as simple word processors and databases – and this is the area where people should be looking for improvements. Robotics and control experiments, and special languages like Logo, can be run quite happily on a BBC Micro. The Beeb is still a useful addition to many classrooms, but it cannot readily support the attractive graphics and ease of use of something like the 'Word' word processor running on the Nimbus.

## SOFTWARE TROUBLE

Where the 16-bit machines have trouble, is their almost complete lack of software suitable for use in primary and secondary schools, and the situation is unlikely to change in a hurry. Most manufacturers don't want to get directly involved in software development (I would exclude Research Machines here, who do publish their own programs like the Quest database), and none of the 16-bit software houses want to devote too much energy in developing a product with the relatively small potential sales offered by the schools market! The software situation looks even more bleak, now that government funding is being withdrawn from the Microelectronics Education Programme.

**'What is needed is something specifically designed for education. Teaching, not training, is the keyword – Acorn'**

There seems to be a general consensus (with the possible exclusion of Acorn) that most of the 8-bit machines sold to education from now on will be to expand existing networks, or as replacement plant. The shift towards 16-bit is well under way, but mainly in universities, and colleges where specific business software training is required. 16-bit machines cannot be universally accepted without a dramatic initiative in software development. I will leave the final word with the current market leaders: Bob Coates at Acorn reminded me that transporting pure business equipment into schools rarely works. What is needed is something specifically designed for education – teaching, not training, is the keyword – so the most important thing in designing a computer for school use is the philosophy behind it. Acorn has the philosophy, but no machine as yet. Apricot and Atari have the machines but little educational background and little or no software for the classroom. Research Machines has the philosophy, some of the software, and the Nimbus. Time alone will tell! More important than the 16-bit question at the moment must surely be, 'Who's going to write some really good educational software?'

## Copyright for Prestel

**B**T lawyers are quietly celebrating a couple of obscure clauses in the new Copyright Amendment Act, while staying carefully silent about the committal for trial of two men in a crucial case of alleged hacking.

Freelance journalists Rob Schifreen (erstwhile occupant of this page), and ex-Micronet columnist Steve 'Micromouse' Gold were arrested early this year under the 1981 Forgery and Counterfeiting Act after late-night swoops on their homes in London and Sheffield by detectives and BT officials investigating the Prestel 'Duke of Edinburgh' hack.

Reporting restrictions in force for committal proceedings at Bow Street have merged seamlessly into the sub-judice regulations pending until their trial to ensure that no public comment can be made about this use of the forgery laws, under which the alleged hack is being prosecuted because it involved the making of 'a false instrument, namely a device on or in which information is recorded or stored by electronic means with the intention of using it to induce the Prestel Development Test Computer to accept it as genuine and by reason of so accepting it to do an act to the prejudice of British Telecom'.

But although BT officials are forced to keep quiet about the 'Gold-freen' affair until the outcome of the trial at Southwark Crown Court – probably several months hence – they have meanwhile been able to comment with satisfaction on the plugging of an obscure but important gap in viewdata legislation.

The Copyright Amendment Act, now in force, was sponsored by the Federation Against Software Theft and sped through Parliament with full government support, on the strength of its attack on software pirates.

But the clause which protects software authors by extending the Copyright laws to cover material composed and stored on computers, has (perhaps by accident) established for the first time that dial-up databases will likewise be protected.

According to a Prestel execu-

# COMMS NEWS

*More gossip, news and essential information from our man in the switching system.*

utive: 'Copyright cover for material written and stored on a computer, with no existence on paper or other clearly protected media, has always been uncertain. The new Act will be a relief to Prestel Information Providers because it establishes that original material keyed directly onto an on-line database is definitely covered.

'Mind you, some JPs might regard the new Act as a mixed blessing, because it also makes clear that copying material onto a database from another medium is a form of reproduction which requires the permission of the copyright owner. We had one IP whose data was, let's say, somewhat closely derived from one of the better-known wire services. There were naturally complaints about this, but the IP decided it had nothing to fear because the material was being converted to viewdata form – which, until now, was thought not to be covered by copyright legislation.'

## War of the 'nets escalates

**A** plethora of press releases has marked a new stage in the rivalry of Compunet and Micronet for the allegiance of Commodore comms freaks – and indeed (when Compunet opens its services to other machines) for the cheque books of all micro owners.

From Compunet, there's been talk of local call access points and the opening of a real-time CB emulator. Meanwhile, no doubt entirely by coincidence, Micronet has seen fit to

announce a new mini-database for C64 owners, a further area on money management ('a decisive step away from exclusively computer-oriented coverage') and the expansion of its Gallery user-edited area.

Less publically, Compunet is (we hear) contemplating the selective abandonment of the error-checking which currently slows page access to near-Ceefax lethargy, and a source inside the Net has let slip plans for an eventual Micronet-rivaling MUD link.

Compunet's 50 new local access points, due in service about now, are designed to answer criticism that the existing 12 points are too few to protect the majority of users from long-distance calls – and to defuse destructive comparisons with Prestel's 92% local call access.

Paradoxically, though, the new nodes will themselves carry an additional time charge of 60p an hour, bringing on-line charges to around £1 an hour.

The two systems are also toe-toe in their offering of real-time CB emulators – though the new services are so radically different as to defy comparison.

Compunet's version is in US-style scrolling ASCII characters, though on one channel only, while the Micronet service (exclusively described on this page last month) is a re-jigging of Prestel's page-oriented format to provide auto-refresh, and a simultaneous display of a message-sending window inside the main receiving frame.

## Anti-porn overkill?

**A** judiciary sub-committee of the US Senate is wrestling with a proposed anti-pornography law aimed at bulletin boards used as an information exchange for paedophiliacs.

Although the spirit of the new law has been generally welcomed, many observers have objected that the legislation is so poorly drafted that it would threaten even on-line teen dating services.

Meanwhile, the massive Dialog system (provider of on-line information services like Knowledge Index) is discounting claims that Russian spies are using on-line networks to

pin-point companies working on sensitive defence contracts.

According to Dialog, all their data is in the public domain, though the report says that the 300 databases available through the service make life uniquely easy for inquisitive Rusksies, and that 'once you target a particular company, it's easy to figure out who's working on a specific project by hanging around in the nearest bar'.

## Illegal entry

**I**ntrepid Stateside hackers have been up to their usual tricks in recent weeks.

Salt Lake City police are seeking a red-neck hacker who broke into the computer at a community action programme and altered the tape on a dial-in advice service. Elderly and impoverished callers were alarmed when the usual helpful information on federal aid services was replaced by a message beginning 'Listen, you bums' which upbraided them for 'sleeping on park benches and leeching off taxpayers'.

A more acceptable face of capitalism was displayed by a couple of Nevada comms freaks who were so appalled at their colossal phone bills (and which of us can't raise a sympathetic sigh) that they hacked the phone company's billing computer and erased their own records.

Sadly, the two enterprising youngsters – respectively 15 and 16 years old – have been arrested after a four month investigation and charged with attempting to defraud Sierra Telecom of some £8,000.

## RFI in the sky

**R**ecent reports have connected the operation of portable computers on board civil aircraft to malfunctions of flight deck instrumentation. The Radio Technical Commission for Aeronautics in the USA is at present investigating the possible consequences of operating portable computers during flight might pose. The electronics are getting so sensitive that this correspondent was, in flight, asked to remove a Sony Walkman.

# APRICOTS GO ON-LINE

**Now Apricot users can take off their gags and join the hubbub in the wonderful world of comms, writes Ian Burley.**

Apricot rivals Torch Computers desisted on built-in comms right from the start – even on their home models. Micros with built-in modems are fast becoming the norm and although Apricots don't yet feature a modem as standard, a complete Apricot comms terminal package called Communique is available for £395 + VAT. Communique can be fitted to any Apricot including the PC, Xi, 5, Portable and the brand-new Xen models. Special discounts on BT Gold or Easylink accounts are being offered for purchasers of Communique, worth around £10.

Communique consists of a neat, compact modem card and disk-based software. The software is capable of handling both 'teletype' scrolling text services such as BT's Telecom Gold and full colour paged viewdata services like Prestel. Communique's modem is one of Apricot's range of Plus Pack compact upgrade cards. Designed by modem specialists Dacom, the card incorporates a world standard AMD 7900 modem chip as used in many stand alone modems such as the Miracle Technology WS2000, Pace Nightingale and the now defunct Demon modem. Communique can auto dial and log on; 300 baud and 1200/75 baud full duplex rates are supported and 1200/1200 half duplex is also possible. This latter option is becoming increasingly useful. Multistream will feature 1200/1200 next year. Tone dialling and US Bell-tones are not implemented even though the AMD modem chip has these capabilities, ensuring that the card gained full BABT approval. Dacom have packed a lot of modem into the small space provided for expansion cards – the 5" PCBs are sandwiched together. Fitting the card into my Apricot F1 was straightforward: two easily accessible screws release the F1's top revealing its single expansion slot.

F1 series Apricots with single expansion slots mean owners are faced with a dilemma if they wish to make use of other

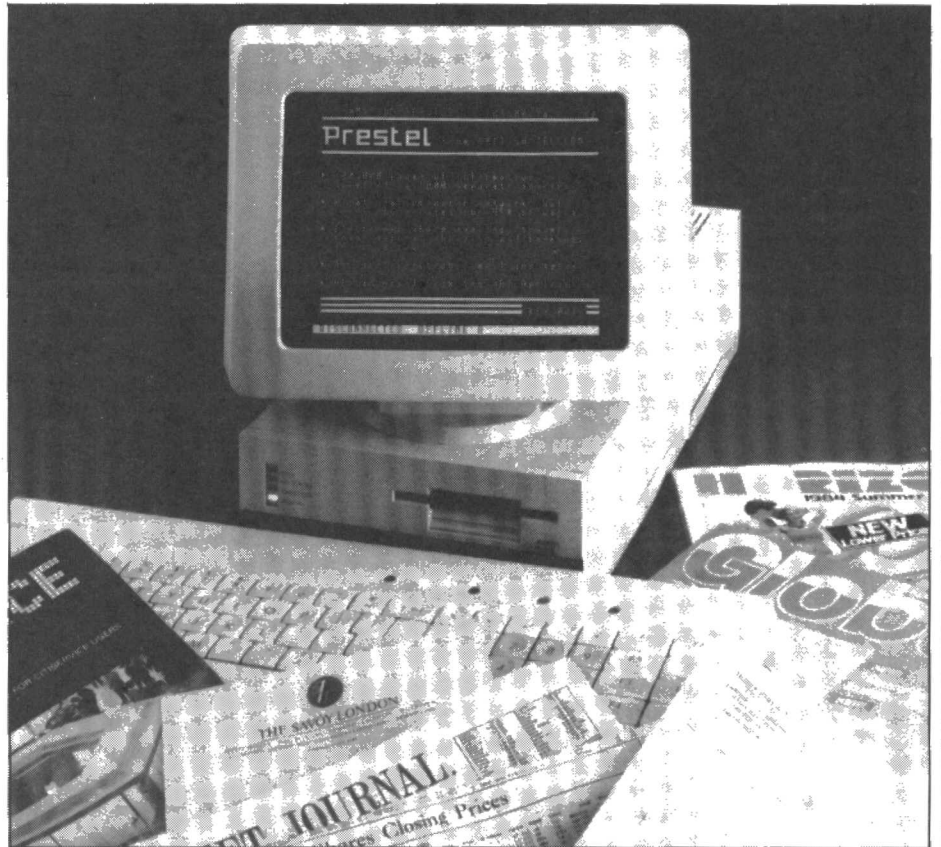

Plus Pack cards (a RAM upgrade board for example). Networked Apricots don't get on with Communique either – the networking and Communique Software uses the same machine-code interrupts. Apricot's Bristol office, where they developed Communique, say that future developments will resolve the networking problem.

## **'Communique provides a comprehensive intelligent terminal for one's Apricot'**

Communique's software comes supplied on a standard Apricot MS DOS disk which needs to be configured before use. Apricot PCs differ slightly from F series machines and different versions of the Digital Research GSX colour graphics environment exist for them. This is mainly because the more expensive PCs (and Xi's) feature a dedicated graphics chip and the MS DOS BIOS is loaded from disk, whereas budget PCs have a ROM based BIOS and more software intensive

graphics. As a result F series machines have particularly sluggish graphics, especially in full colour viewdata emulation mode. Configuration is quite simple; you're asked what machine the disk is to be configured for and whether you wish to use viewdata. If the viewdata option is not needed, extra space is made available on the disk. As F1 and Portable Apricots only have a single disk drive, it might be wise to create two backups: one for viewdata and the other for teletype services only.

Communique provides a comprehensive intelligent terminal for one's Apricot. No attempt has been made to offer host facilities allowing Communicated Apricots to be their own remote, auto-answering databases. However comms software specialists Metrotel offer a full viewdata (Prestel compatible) remote database with full IP (Information Provider) facilities for Apricot PC or X1 models. A configured Communique disk can be either auto-booted in the standard Apricot manner or called up via the command 'ACCESS' from MS DOS.

## MODULAR

Communique is a good example of modular software. Separate files containing comms protocols and log on sequences are supplied for a variety of existing databases. Twelve pre-prepared sets of connection parameters are supplied:

- Micromail (PSS)
- Micromail (Direct)
- Datastream
- Extel
- Textline
- Datastar
- Dun & Bradstreet
- Pergamon Infoline
- Prestel
- Eurolex
- Easylink
- Easylink Forced Delivery

The connection parameters in the attachment and sign on files may be called up and edited individually for each programmed service. New services may be added to the standard repertoire by the user too. One such service users might like to add is that of Apricot's own private viewdata system in Bristol, running on a telephone multiplexed Apricot Xi (using Micronet software). This can be done by altering the supplied Prestel telephone number to 0454 618 448 and entering a 10 digit identity of 4444444444 and four 4's for the

password (same as for Micronet's demo area on Prestel) in the sign on file.

A colour monitor is essential for easy viewdata usage in full colour 40 column mode although there is also a split screen 80 column monochrome display mode too. The viewdata screen's 40 columns is set in the left with the 40 columns to the right made available for prompt line. I was rather disappointed with Communique's online viewdata performance, especially with the F1. More and more Prestel IPs are using dynamic frames (specially animated Prestel Frames) and the way Communique interprets certain viewdata codes can leave these dynamic pages in a real mess with background colours obscuring text,

etc. Communique also seems to do a lot of error checking and so viewdata screens appear in a very sluggish manner.

Teletype services are accessible in a much more straightforward manner, there being no colour and graphics to interpret (although the user can choose a different fore and background colour for easier viewing of menus and online text). I'd like to have seen split screens for a teletype chat mode segregating incoming text and the text being entered by the user. Useful for chatting on BT Gold or especially when playing MUD (Multi User Dungeon) there being nothing more frustrating than something you're typing in being overwritten by someone else's drivel.

### In brief

- For comms orientated Apricot owners, Communique is something of a necessity – there aren't many alternative packages! Communique offers a comprehensive range of facilities but I found the multi-level menus and function key prompts tiresome to use. In some situations you are left with no option but to press reset – when the printer option is called and no printer is present for example.
- There is plenty of on screen help and errors are dealt with usefully in general. It's worrying to use a system which stores IDs and passwords on disk – not only because someone can look at this information on the disk (although there is a password protection option) but also because some public domain databases (bulletin boards especially) will extract IDs even when they're not required. This is a serious comms security point. In practice, I never use programmed IDs.
- Apricots aren't ideal machines for comms, especially the slower, cheaper models (but probably no worse than other MS DOS machines), although on the whole Communique is a sound system offering a wide range of facilities.
- At £395 it's quite pricey, but Apricot do offer a very good level of support from their Bristol office (tel 0454 617 617).

# COMMS NEWS

Continued

## Gold goes up

Telecom Gold has announced a revision of its charges schedule – in other words the service is going to cost more. The new charges come into effect on December 1 and relate both to connect time charges and to those applied for the use of the 'Gold NUI on PSS.

Charges for the standard rate of connect time charges are increased from 10.5p per minute to 11p per minute (these apply between 0800 and 1900 Monday to Friday). Cheap rate connect time charges remain unchanged at 3.5p per minute.

The cost of using Telecom Gold's PSS NUI are increased to 2.5p per minute at 300 baud (from 2p per minute) and to 3p per minute (from 2.5p) for operation at 1200 baud.

Note that the duration of all calls is rounded up to the nearest minute.

The new charges take the basic cost of using the system during the working day via a PSS access point at 1200 baud to 14p per minute. This is by no means a trivial charge and if business and private users are to avoid excessive bills from Telecom Gold they will have to develop good e-mail habits, planning their sessions on the system, spooling all incoming mail to a disk file in order to minimise charges, and so on.

## One-to-One

One-to-One is another in the increasing range of services available for those wishing to jump on board the electronic mail bandwagon. We've just been assigned an account and will be carrying a full report on One-to-One in the near future.

Briefly though, the service is designed to be attractive to business users, particularly those that make heavy use of telexes. On the technical side the service is very much like that

offered by Telecom Gold. London users of the service can gain access to the messaging computers via a series of direct lines offering a range of baud rates. Users in other parts of the country can make use of a series of PSS access points.

We opted for the 1200/75 half duplex line using a BBC computer with Communicator software and a Telemod 2 modem. This seemed to give acceptable results, although we'll reserve judgment on the optimum configuration based on a range of computers when we have had a chance to gain more experience of the system.

After signing on to One-to-One users are informed of any mail awaiting their attention and at this stage have the option of reading the mail, sending a message in the form of electronic mail, a telex or a priority message.

The system user manual is concise, being only six pages in length, including the front cover. This indicates that One-to-One is probably easier to use than to describe.

More details from One-to-One at Scorpio House, 102 Sydney Street, LONDON, SW3 6NL.

Telephone 01 351 2468. Those of you with access to One-to-One can e-mail us on account number 16176001.

## Education on-line

Following the success of their recent pilot, Prestel Education have announced the launch of their full telesoftware service.

Prestel Education users are now able to download a wide range of educational software, which can be saved to disk, ready to run on the school or college micros. Some programs come from publishers who are offering discounts of up to 50% off normal price. Further software packages written by local education authorities and schools, are free. Others are published directly by Prestel Education.

Software is available for the RML 380Z/480Z and BBC micros and covers a range of applications including curriculum support programs for primary and secondary schools, programmers' utilities and data files.

# CIRKIT ACOUSTIC COUPLER

**Peter Luke tries out an acoustic modem selling for only £30, complete with an Amstrad interface.**

One of the applications of micro computers to see significant growth in recent months is related to their use as communications terminals configured to access one of the many electronic mail and data base services now available. In recognition of the fact that many micro owners will wish to use their computer in this way, the latest computers are being supplied complete with basic comms software. Unfortunately, this doesn't include the Amstrad range of computers – the user must purchase an appropriate comms package.

Until recently adding a communications facility to a micro has been rather an expensive exercise, with typical packages retailing at more than £100. As this sort of figure is a significant proportion of the cost of a computer like the Amstrad CPC464, the cost of getting on line would obviously have to come down if it was to appeal to a large number of micro users. The 'Prestel Link' from Cirkit Holdings is just such a low cost route to the world of communications.

For about £30, the package provides the hardware and software necessary to log on to data bases operating at 1200/75 full duplex, a common format, or at 1200/1200 half duplex. The reason Cirkit is able to offer the package at such a keen price stems from the fact that the company produced the 1200 acoustic modem marketed by Protek. When Protek ran into financial problems earlier this year, Cirkit was left with a large number of modems that, as a stand alone item, would have been difficult to sell. Then Honeysoft Limited designed an interface that would allow the modems to be used in conjunction with Amstrad CPC464 and CPC6128 computers, making the unsold modems a far more attractive proposition.

## RELIABLE

Much has been written on the pros and cons of acoustic coupled modem units with many users preferring to use direct connect types on the basis that they are less prone to introducing interference, in the form of extraneous noise, to a comms link. Using an acoustic coupled modem intelligently though can give results that are as reliable as operation with a direct connect type. The Cirkit modem is BT

approved (even though acoustic coupled modems have no direct connection to the telephone network they must still be approved, according to the signalling frequencies they use).

The modem is powered by four AA sized batteries, two mounted in each of the cups, which should give about 30-50 hours of continuous use. The operation mode is selected by a three position switch, centre off, with 1200/1200 or 1200/75 selected in the two other positions. Other connectors include a 3.5mm jack socket for an earpiece, which is supplied with the modem. This allows the flow of data to be monitored without the need to break the acoustic link. This is useful as the modem lacks the usual carrier detect indicator. The other connector is the data I/O socket, a 180° 5 pin DIN type.

The interface unit is supplied in a small plastic case designed to plug into the expansion port of the 464 or 6128. It features a thro' connector making it possible to use other peripherals, disk drives etc, in conjunction with the unit.

**'Using an acoustic coupled modem intelligently can give results that are as reliable as the direct connect type'**

The interface converts the parallel data presented on the expansion port into a serial data stream suitable for transmission to the modem. The majority of the work is carried out by an 8251 UART, with some additional circuitry to interface to the computer's bus, to provide some additional decoding of control lines and to generate the appropriate system clocks.

## OPTIONS

The cassette based software supplied with the interface allows various options to be selected from a main menu. (See Table 1.)

TABLE 1

OPTION	MODE
1	PRESTEL
2	TERMINAL
3	RECEIVE FILE
4	SEND FILE
5	EXIT

Selecting option 1, Prestel, from the main menu provides a second menu from which more specific Prestel options are available. The Prestel data may be displayed in Amstrad modes 0 or 1 by selecting options 1 or 2 from the Prestel menu. As the Amstrad video circuitry does not support a mode that is directly compatible with Prestel, some compromises have had to be made in the way in which data is displayed. Mode 0 allows all eight colours, plus flashing and double height, to be displayed but because a horizontally compressed character set is used in order to display the full 40 character wide screen, definition of the display is slightly reduced.

For this reason the alternative Mode 1 display is provided. In this mode only four true colours are supported, but a stippling

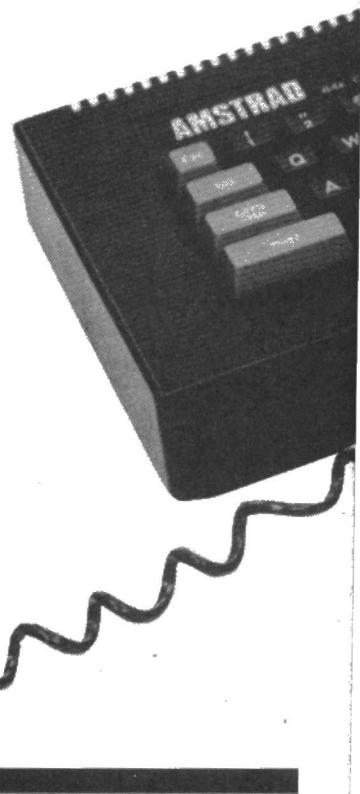



**'The system can easily be configured for operation with two of the most popular electronic mail services'**

technique provides four more colours, although these do not conform to Prestel standards. Mode 1 does not support flashing characters.

The software redefines the return key to generate the Prestel # character and the decimal point key on the function key pad to give the \* character. The copy key is used in conjunction with the reveal facility while the tab key is used to exit from either of the Prestel modes.

The software allows Prestel frames to be stored to the currently selected filing system and to be loaded back for later viewing.

## ELECTRONIC MAIL

Selecting option 2, terminal mode, from the main menu allows the computer to be used with services that do not operate on the Prestel standard. On entering this mode, a secondary menu is displayed together with a status line at the bottom of the screen. The information displayed on the status line shows the current configuration of the terminal. The various parameters, each separated by a horizontal bar are, baud rate (1200/1200, 1200/75 or 300/300 – note the hardware does not support 300/300 operation), data bits (5 to 8 supported), parity (none, odd or even), stop bits (1, 1.5 or 2) and echo (off or on).

The four options available from the terminal main menu allow the system to be easily configured for operation with two of the most popular electronic mail services, BT Gold (option 1) and Easylink (option 2). Option 3 allows the system to be used with most bulletin boards operating at 1200/75 while option 4 enters the terminal with the parameters shown on the status line – these can be set by invoking option 5.

The receive and send file options allow files to be exchanged between two users of the Cirkit interface by way of the 'phone system. By using a system of data exchange known as Automatic Repeat reQuest (ARQ), a high degree of reliability can be achieved.

## In brief

- There can be no doubt that the Cirkit interface offers excellent value for money.
- In such an inexpensive piece of equipment it is possible to excuse shortcomings – but in fact the interface suffers from few shortcomings.
- If users feel happy with the acoustic coupled modem and are not likely to want to use systems running at 300/300 baud then the package represents unbeatable value for money.

**Contact** Cirkit Distribution, Park Lane, Broxbourne, Herts EN10 7NQ Tel: (0992) 444111.

# COMPUTER CRIME AND THE TECHNO THIEF

Computer crime emerged soon after the computer. Once it was the private domain of the programmer in industry, but the advent of the terminal and the modem has created a new generation of potential computer criminals. Whether hardened criminals or victims of irresistible temptation, 'techno' thieves are highly successful – and they usually get away with it. Warren Lake investigates.

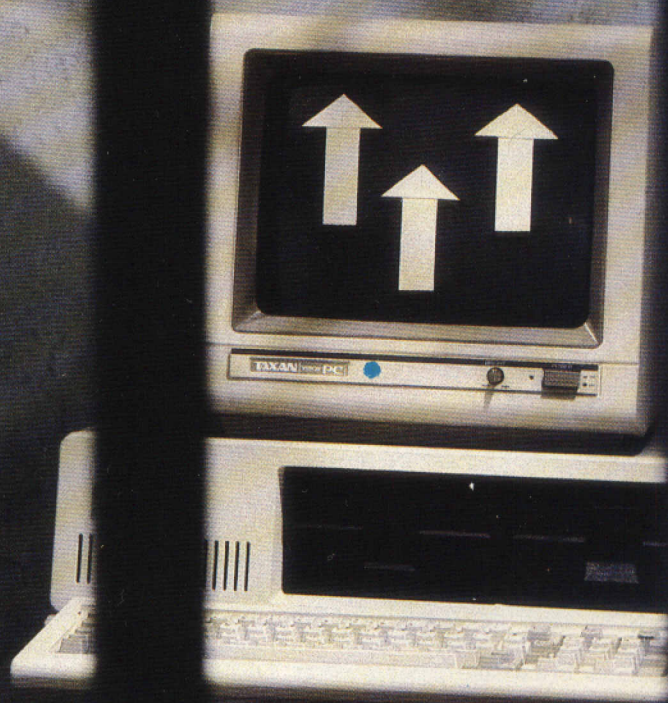

As bits of data replace paper as the principal stores of wealth and information in our society a new and multifarious breed of criminals is fast emerging. Popularly known as 'techno' thieves, the perpetrators of computer crime – if the few that have been discovered are anything to go by – defy any tidy classifications. They come from all walks of life, employ methods that are as diverse as they are numerous and in the main, are highly successful.

The minimum prerequisites for a 'techno' thief would appear to be a rudimentary knowledge of computer workings and criminal intent. Surprisingly, access to a computer is not vital, as a customer of a US bank demonstrated when he replaced the bank's paying-in slips with some with his own account number magnetically encoded upon them. After closing his account the following day having withdrawn the balance in cash, the villain made off with an estimated £75,000.

Information on computers is surprisingly easy to come by. Unlike, say, safe-cracking, the subject is taught in schools and covered by the popular press. Also documentation outlining operating procedures for specific machines is seldom locked away. Indeed, a misplaced reliance on safeguards built into computers themselves has meant the obvious is often overlooked. For example, where so-called 'secure' communications lines are installed the telephone number may be ex-directory and not listed within internal exchanges but they still appear on installation contracts, invoices and, on occasion, scribbled all over the installation engineer's notes.

As for criminal intent, it is often a matter of being unable to resist temptation. And where computers are concerned this can be very great.

## NOT VIOLENT

To begin with, computer crime, unlike a frontal assault on a bank for example, is seldom violent and is not self-revealing. Indeed, of late computer auditors have given up claims that they will be able to track down computer fraud outright. The sheer volume of data stored by large companies makes it impossible to check every transaction individually even if fraud is suspected. Company policy often appears to be merely to keep defalcations within acceptable limits.

For example, in the case of illegal use of credit cards, which trigger a vast number of electronic funds transfers, losses within 0.05% of gross income appear to be acceptable. Even where limits are exceeded the 'cost-effective' action taken is seldom aimed directly at the criminal. An example of this can be found with bank guarantee cards. To stem rapidly escalating losses the £50 limit has not been

increased for many years despite inflation, and, as European neighbours appear to be the worst offenders, the cards are being withdrawn from use overseas.

Social attitudes towards computer crime also enhance its appeal. Many place theft from a machine, especially when it involves small amounts of money, on a par with fiddling one's tax or expenses. It is regarded as trivial. Whether or not this attitude is reflected in the courts is not clear. However, sentences for computer crime are often very much lighter than those levied upon say, the sawn-off shotgun brigade. Take for example, the case of

## 'Company policy often appears to be merely to keep fraud within acceptable limits'

Jerry Neal Schneider, or the Famous Equity Funding Fraud.

In the former, Schnieder, an enterprising teenager living in Los Angeles, set up an electronics company with zero stock and then tapped into a local telephone company's IBM mainframe to steal stock from them to order. After several months the teenager was denounced by an accomplice he had taken on so that he might attend evening courses. However, despite having misappropriated close to a

million dollars' worth of goods, the offender received a £500 fine and a two month sentence, of which he served 40 days before going back into business as a computer security consultant.

The Equity Funding scandal (1972), billed 'The Fraud of the Century' was carried out exclusively by the top management of a 'fast' growing US corporation over the course of eight years. Computers were used amongst other things to issue over 64,000 bogus life assurance policies to sell to co-insurers. When discovered the fraud cost shareholders £600 million and insured lost policies with a face value of one billion dollars. Many of the victims were ruined but the 24 perpetrators received sentences varying from eight years down to fines and probation.

## COVERING UP

Even if a computer crime is discovered and the perpetrator identified prosecution is seldom automatic. The victims are often reluctant to go to court. Banks, a popular target, are apt to regard the publicity that accompanies a trial as more harmful than the fraud itself. Elsewhere, amongst company management in particular, a fraud may well be papered over to avoid accusations of negligence from shareholders.

Another deterrent is the cost of legal proceedings. Establishing the exact nature of the offence and proving guilt, especially in the case of sophisticated computer fraud,

## Protection

There are many ways to protect against computer crime and we examine a few here:

### Denying Physical Access

As more and more micros appear in offices as stand alone units or intelligent terminals the Fort Knox approach of locking up the computer and throwing away the key becomes steadily more impractical.

Even when the computer department is effectively isolated from the outside world the techno thief can always resort to tampering with input before it is entered onto the computer. The Equity Funding fraud is a case point. Here the programming department was supplied with entirely fictitious information by management and the corporation's customers made the mistake of taking computer print-out as gospel truth. Another example is that of the computer security consultant whose favourite ploy was to walk into a clerical department, fill out one of the many blank input forms left lying about and drop it on the floor. Invariably, the form which was usually a payment requisition made out to the company's MD but addressed to the consultant, would be picked up and processed. The consultant would then confront the MD with a cheque and thereby justify his services.

### Password or Personal Identification Numbers

Often to log onto a system the user is required to

type in a password. On some systems this is clearly visible as it is typed in. Here, the techno thief may simply spy on the user to obtain the relevant information, as VDU's emits signals just like any other electronic display device, he may simply tune into the log-on process.

Where the password fails to display on the screen and is not carelessly scribbled across manuals or installation notes, more sophisticated techniques must be employed. One, demonstrated by a Scottish student, was to write a phony sign-on procedure which would store away the password and then simulate a system crash. Unsuspecting users would first sign on to the phony system, assume that there was a fault on the system and then sign on once more, but this time onto the real thing.

Information databases over the telephone lines have refined password breaking to an art. Lists are available which given the top ten most popular log on names and complex algorithms have been developed to calculate the most likely permutations of alphanumeric characters.

### Electronic Keys

Usually this takes the form of a plastic card with data encoded upon a magnetic strip along its side. Various means exist for altering such cards. The most sophisticated is to use an electronic pantograph to extract the information stored. The least sophisticated (for cards which entitle one to a

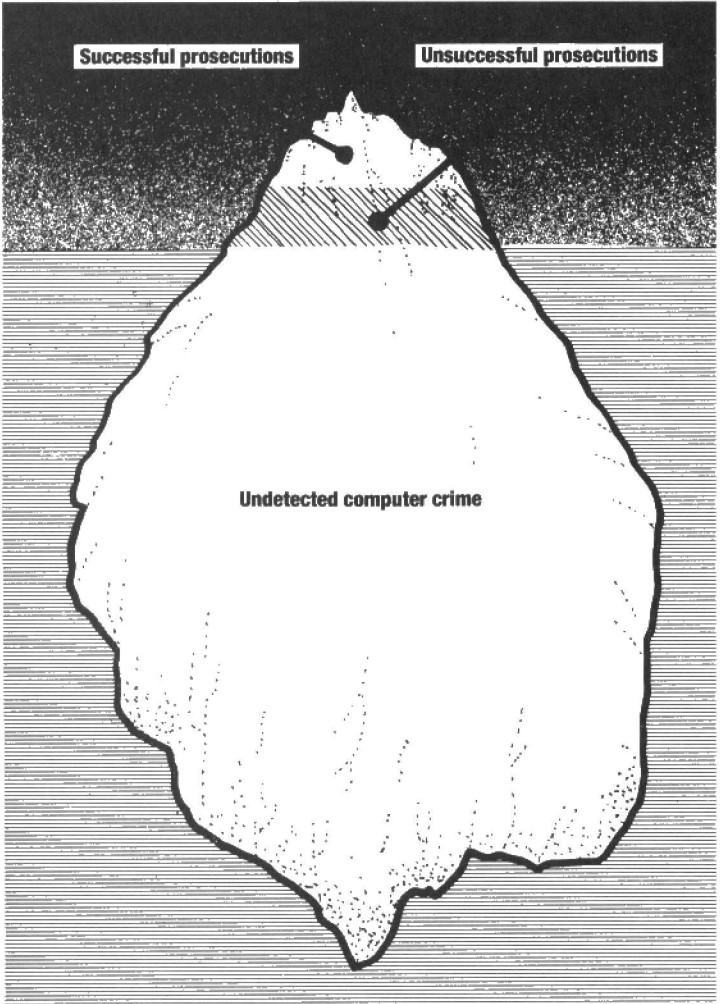

Computer crime, the tip of the iceberg. Only a tiny fraction of computer crime is detected resulting in a successful prosecution. Many detected crimes are not reported to the authorities.

by accident when the company PR, in order to demonstrate the wonders of the system, pulled out the first and last accounts.

**ERROR-PRONE**

The general acceptance of the idea that computers are by nature prone to error also works in the criminal's favour. For example, three employees of New Securities managed to milk customer accounts to the tune of at least half a million dollars over a period of several years. If a customer noticed the balance on his account was wrong the 'error' was blamed upon the computer system.

Also, and perhaps not surprisingly, where errors occur in the customer's

**'People see theft from a machine as a trivial matter, like fiddling one's tax or expenses'**

favour, few are inclined to report them. This can be taken to extremes, as it was by a self-employed book-keeper who accidentally had debited to his account close to a million dollars. The recipient managed to spend most of the money before the bank discovered its error. He was acquitted on the charge of theft.

Computer crime takes a myriad of forms and is not limited to straightforward cases of fraud and embezzlement. The target may for example be company property. In one city in the USA organised crime modified computer input so as to write off some 200 boxcars from a railway company's inventory. The perpetrators then promptly leased back the cars to the original owners.

Another form is the theft not of electronically stored funds but of information. Mailing lists are a favourite. One case records the sale by computer operators working for the Encyclopaedia Britannica of some two million names and addresses. The asking price was more than a million pounds. Even government census records are not inviolate.

Industrial espionage is also rife amongst the techno thieves. The ease with which data can be duplicated without trace lends itself to the theft of trade secrets, budget plans and management information which usually finds a ready market amongst a company's competitors. Computer programs themselves are often a target, particularly proprietary software which is the fruit of many man-years' development.

Finally, on the borderline between the illegal and unethical come the currently popular practices of theft of computer time (or electricity) and invasion of privacy as practiced by 'hackers'.

number of units of a service such as telephones or public transport) is to use a simple household iron to attach a new magnetic strip.

**Encryption**

Encryption is usually limited to the protection of sensitive information, especially information which has to be sent over public networks or as extra protection for private land lines. It involves encoding and decoding text using special algorithms and a unique key. Providing the latter remains known only to the recipient and sender of the information, even if the algorithms are known the code remains secure.

Encryption constitutes a formidable barrier to the techno thief in so far as code breaking requires considerable computing power. However, it is worth noting the government agencies do have the capability to decode and use it.

Encryption constitutes formidable barrier to the techno in so far as code breaking requires considerable computing power. However, it is worth noting the government agencies do have the capability and use it. For example, The National Security Agency has set a standard of seven digit encoding, which, it says, cannot be cracked using even the largest computer. However the truth is that the NSA's computers are capable of decoding information scramble seven times - but not eight. The NSA is simply ensuring that it can always read sensitive commercial information.

often requires an inordinate amount of time, effort and money. The 12 good men and true that make up a jury cannot be depended upon to be computer literate and usually have considerable difficulty acquainting themselves with the facts of a case.

Because computers are now so widespread the opportunity to commit computer crime has greatly increased. Clerks, secretaries, even office cleaners now have access to computers. Furthermore, where computer staff are being recruited employers tend to look for people whose qualities, an inquiring mind and a flair for accuracy, are those most likely to make them react to security measures as a challenge. Much computer crime is opportunist: people not seeking financial gain have had the opportunity thrust under their noses. Many programmers will break into a system as an act of harmless mischief, but once inside temptation often proves too great.

Again, computer crime is hard to detect. The much quoted Rounding Up fraud is a case in point. Here the perpetrator, working for a large bank, patched a program so that when interest was calculated on customer accounts the tiny amounts that arose from rounding up were not credited to individual accounts but accumulated in fictitious account at the end of the customer file. The fraud was only discovered

# Spy

Keeping a watch on the latest boxes of tricks to plug into your computer, plus all that's new in software.

## Software Selection

The QL's emergence from the doldrums continues apace with new software releases from Digital Precision and Microdeal, and Hisoft packages now in ROM. Digital Precision has produced improved versions of its **Super Sprite Generator** and **Super Monitor/Disassembler**, as well as four new products, including both games and utilities. **Supercharge** is a full SuperBasic compiler, which, says the makers, will speed up programs by a factor of between 20 and 200. An all-in-one Forth package, **Superforth and Reversi** is a standard Forth compiler and 'the strongest home computer version of the game yet produced'. The superstitious, or to be polite, lovers of the arcane, will appreciate **Super Astrologer**, which, ominously, gives 'a full personality readout for any location, date and time of birth'. QL Super Arcadia is two shoot-em-up machine code arcade adventures in one. The other new game on the market, this time from Microdeal, is an old chestnut, **Crazy Painter**. Surely the QL was made for better things than this? Hisoft, who might agree, has put its QL monitor, **MONQL**, into ROM for easier access. MC programmers be thankful.

Hisoft is another software house intent on turning us all into reincarnated flower children (this must say a lot about the origins of software programmers) and has produced **Your Health**, an 'organically-grown wholefood expert system' (**Spectrum** and **Amstrad**). The press release gloatingly begins, 'Are you another overweight, bad-tempered journalist living on junk food, black coffee and thirty a day?' The answer to all but the first is yet. If you want your review program back it can be found in the bins behind the office.

The **Atari 520ST** market has got off to a shaky start with many of the programs displayed at the PCW show

Continued opposite

## PC PRICE BUSTER

While the IBM PC and its look alikes have long been considered for use by individuals in the 'States, the high UK price has meant that in this country their use has been restricted to the business sector. Two recent developments mean that this situation could change dramatically in the coming year.

The first story concerns Unique Solutions who are set to launch a PC clone at only £555. The PC machine will be supplied with 256K of RAM, MS DOS, one floppy drive and a mono monitor. The computer is said to be compatible with a range of top selling PC software.

The second item of news which could have an impact on the PC market is that Chuck Peddle, father of the CBM64, has teamed up with Tandon, a US disk drive producer, with the aim of developing a PC compatible at a price that will establish new levels of price/performance.

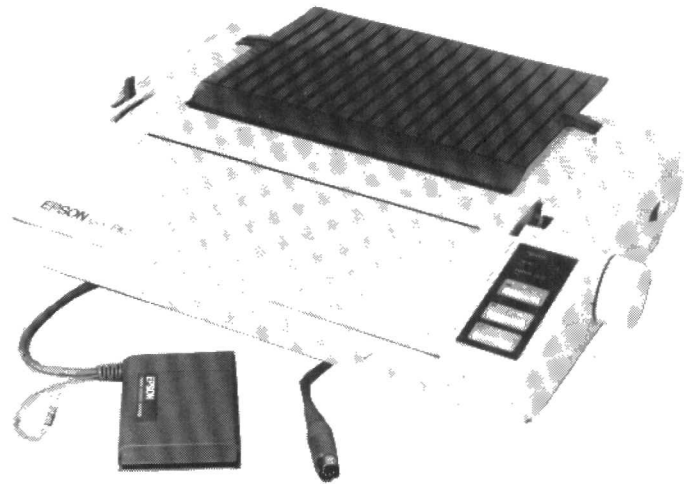

## SON OF LX80

Users of computers ranging from the Atari 600 to the IBM PC and clones will find the new GX-80 printer from Epson has been designed to cater for their needs. The printer, a derivative of the LX-80, reviewed in the October issue of *Computing Age*, is supplied complete with a PIC (Printer Interface Cartridge) that configures the printer for use with computers that lack

the standard Centronics port. At present PICs are available for the aforementioned Atari and IBM computers in addition to the Apple IIe. Plans are underway to introduce more PICs in the future.

The GX-80 costs £249 with additional PICs priced at £50. Optional extras include a sheet feeder at £55 and a tractor unit at £20.

The printer should be in stock at your local Epson dealer.

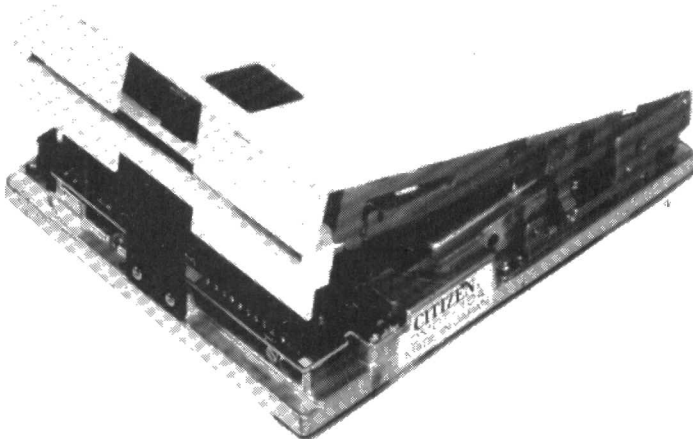

## QL DISK CONTROLLER

Cumana recently announced intentions to market a QL disk interface that offers signal buffering between the QL and itself. The interface plugs into the computer's expansion socket thus making installation straightforward. The unit is supplied with a suite of ROM-based utilities and resident spooler. Either 3", 3.5" or 5.25"

drives may be used with support for up to four drives in double density mode. Forty or 80 track operation with single or double sided drives is also supported.

The unit is priced at £82.95 inclusive or may be purchased as part of a package comprising the interface and a dual 3.5" drive (2M capacity) which retails for £279.95.

Contact Cumana on 0483 503121.

## TOP LOADING CITIZEN

Yet another Japanese company has announced that it is to enter the disk drive market. Citizen Europe, a subsidiary of the giant Citizen Watch Company, is to offer a top loading 3.5" micro floppy drive to OEMs in the portable market. Two versions of the drive are available with unformatted capacities of 500K or 1M. The new design offers a low power consumption combined with very small size, the drives are only one inch in height.

## COMBINATION CARD FOR QL

PCML has further demonstrated its commitment to the QL market with the launch of a new combination card that features 256K of RAM, some useful ROM based utilities and an industry standard disk interface capable of operation with either 5.25" or 3.5" drives. The card can be supplied with a twin 720K 3.5" drive at an all-in price of £475.

Contact PCML on 9372 67282.

## SIDEWAYS BOX

Another variant on the solution to expanding the BBC micro's sideways ROM capacity has been introduced by Voltmace. It is based on a large (5" x 3.5") cartridge that slots into a steel box forming the heart of the system. Under each slot there is a single sided edge connector—to ensure that a cartridge inserted backwards makes no electrical connections and thus suffers no damage.

Both of the connectors are fully buffered, the buffers being disabled if the cartridge in slot 1 is removed. This means that cartridges may be inserted while the computer is on without the risk of damage or loss of data.

In addition to the ROM cartridge holder, Voltmace can supply a RAM cartridge that features battery backup. The cartridge is supplied without RAM chips: the user has the option to

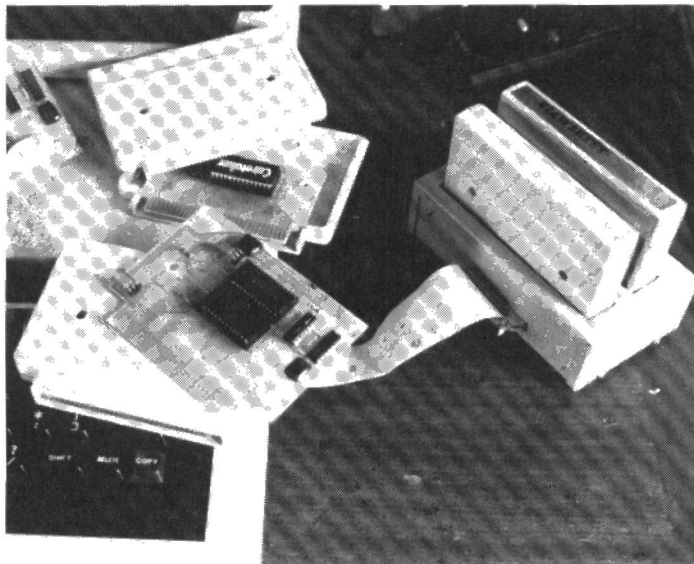

fit either 4K or 16K devices. The batteries will hold their charge for a period of up to a year and are trickle charged as soon as the computer is switched on.

Price of the buffer box plus one ROM cartridge is £29.95. Additional ROM cartridges are

available for £3.50. The RAM cartridge costs £9.95 without the battery backed option and £19.95 complete with the batteries — in both cases the RAM chips are extra.

Contact Voltmace on 0462 894410.

## HELPING HANDS

Flight Electronics has announced a robot arm aimed at the educational market. The arm, called ERIC (Educational Robot Incorporating Cybernetics), offers four degrees of freedom, the base rotates through 360 degrees, the shoulder moves the arm up and down, the elbow allows the gripper to move in and out and the gripper itself may be opened and closed. Eric uses direct drive DC motors that form part of a closed loop feedback system that offers a high level of control over the arm's move-

ments.

Price for the complete Eric package is £499. The arm costs £399, the control board £99, power supply £29.95 and a robotics experiment pack containing the firmware costs £39.

Eric bears a quite remarkable physical similarity to the 'Ogre' robot arm manufactured by L. W. Staines and Co. — at something like half the price. The specifications are also nearly identical. However Flight Electronics insists that theirs is an original design.

Contact Flight on 0703 227721.

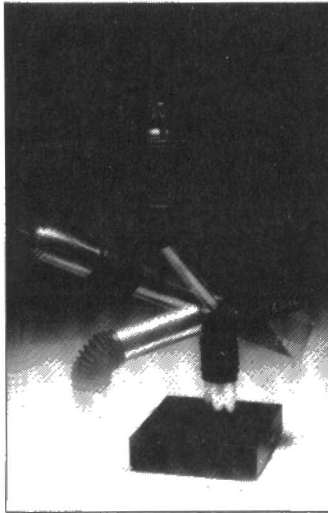

## FORTH PROTOCOL

The Eleven-Q Interfacing Control Learning Package has been designed for students learning about the application of micro-computers in industrial applications. The interfacing control hardware is based on a micro-computer widely used in OEM control applications and supports the FORTH language.

The package contains over fifty fully documented interfacing experiments and is supplied as nine printed circuit cards, together with connecting cables and a comprehensive manual.

Contact RCS Microsystems on 01 979 2204.



Continued from previous page

(see last month) still 'unfinished' or only in preview versions. A firm release date has been given for a twinpack of two adventures from Talent, transferred from the QL, namely **The lost kingdom of Zkul and West**. BOS software, a noted business software house, is busily at work transferring a number of its products to the ST, which must be some sort of mark of approval.

Watford Electronics' Christmas bonanza includes a utility for the famous BBC wordprocessor, Wordwise Plus, called **Word-Aid**. The Word-Aid ROM gives the Wordwise user the option of a new menu, accessed by a \* command, which opens up a range of new utilities. According to Watford, the ROM was designed in close association with, and approval by, **Computer Concepts**.

Word-Aid gives Wordwise Plus a number of new facilities, or makes some current facilities easier to use. Options include an alphabetical sort, which will sort entries in the main text area either by individual line or blocks of data.

Text transfer is made easier by the new ROM. Whereas Wordwise Plus can happily transfer text from the segments to the main text area, it can't do it the other way around. The Wordwise Plus facility will make this possible.

Wordwise Plus can cope with text files of up to about 24K in size, and will divide text into multiple files if anything longer is required. Using a 'continuous processing' option the user can keep track of a group of files forming one large document, treating them in much the same way as a single file.

There is an address finder and mail merger, and a label printing option. The address finder will insert an address belonging to any particular name within the text. Mail merge merges names and addresses with a master letter, and is used for circulars etc.

Word-Aid includes a facility to program the function keys for use during editing, for example to insert Epson printer codes, and has the ability to remove embedded commands from the text. Finally, there is also a search and display option.

Word-Aid requires Wordwise Plus to operate. The normal Wordwise doesn't contain the necessary routines. A DFS system must also be present, though Word-Aid will not access a disk drive unless requested to by the user. The Word-Aid menu occupies about 1K of the user memory. Other routines can take memory usage up to 4K.

# GIZMOS FOR YUPPIES

## Chris Bourne's tasteless ideas for a computer Christmas.

It's a lucky computer owner who's never been given a micro-related prezzie at Christmas. You're not convinced? Think for a moment of the number of small boys and girls who'll wake up on Christmas morning to discover Santa's latest wheeze – the joystick interface which zaps out half the RAM chips and melts the CPU into an unrecognisable blob of avant-garde jewellery as soon as it's plugged into the back.

Or how about the well-meaning Uncle who turns up on Boxing Day with the last word in mega-zap space opera from Tattsoft Ltd., purveyors of software to the terminally moronic, especially written for the Atari 520ST... imagine the joyous time the family will have picking over a rapidly-drying turkey wing and moodily eyeing the wreckage of the Commodore 64 the nephew's just hurled to the floor in tear-smitten fury at the incredible idocy of grown-ups.

machine transforms ordinary cheap single-sided floppy disks into double-sided disks. How does it do it? It cuts a small three millimetre notch in the disk, as a write-protect marker. Now all you do is turn the disk over and use the other side. Makes you wonder why they ever bothered with single-sided disks in the first place?

That will be of particular value to Commodore owners, who are compelled to use disk drives even slower than a tape load on a Spectrum. If Commodore supplies the Pentagon, Reagan won't even get a chance to hit the button before the bombs send him into orbit round Uranus. "What am I doing back home?" asks Ronnie, until he spots the 64 gracefully following him in zero gravity.

Activision has just the thing for bored Presidents in the outer solar system – **There's Someone Living in My Computer**. Load it up, and all

you see on the screen is a little house with somebody living in it. He gets out of bed, eats, drinks, brushes his teeth, does some computing, and so on. There's a dog in there as well, and since you can issue orders, try getting the man to put the dog in the fire. Personally, I think the RSPCA ought to know about all this, but the dog displayed great sense and ran out of the room and hid under the bed. Rumour also has it there's a transvestite living in the attic, but who do you complain to about that? Nobody's tried the closet yet...

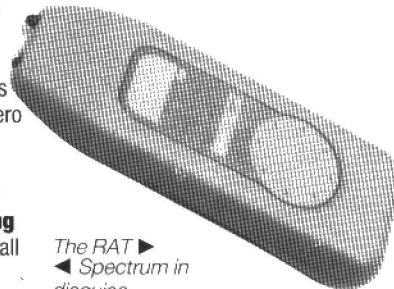

*The RAT* ▶  
◀ Spectrum in disguise.  
▼ Someone in my computer

Getting back to those melting joystick interfaces, how about the **RAT**? This repulsive joystick operates by sending signals to the interface on the infra-red spectrum, thus doing away with cables and the obnoxious habit excited friends sometimes have of pulling your whole system onto the floor at moments of stress. Cheetah made it, and should do penance. It's a vile light blue in colour, has a horrible spongy pressure-pad instead of a stick, and sends a remote-control telly bonkers.

For the Spectrum owner who wants to look serious, how about the **Elite Keyboard** from Saga? It looks so professional it's the ideal method of convincing friends that you are in fact a highly paid stockbroker with his own personal IBM compatible. A cunningly disguised microdrive – shove it in an old Cornflakes box and



▲ Pet Valve.  
Spray with off-white enamel – completes the illusion. As everybody knows microdrives are actually faster than IBM disk drives...

If, on the other hand, you're stuck with an IBM PC and can't think of anything to do with it except write memos on WordStar – not a pleasant task – how about impressing your boss with your clean and wholesome mind by buying **The Word**? This is nothing more or less than the complete King James bible on disk,

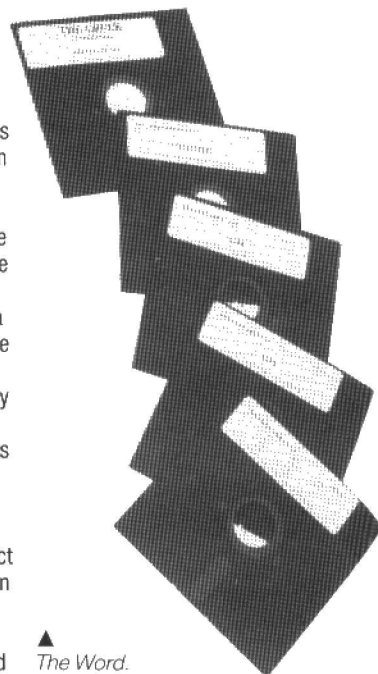

▲ The Word.

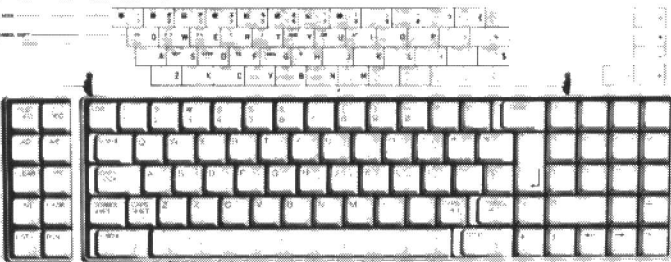

But if you're still determined to inflict technology on your friends and relations, here's a few ideas for reasonably acceptable gifts, along with some wonderfully useless products for the \*!?!\* down at the club who keeps upstaging you with the latest addition to his vast collection of black boxes.

We all know people like that, and it's ten to your hundred he's got a disk drive. Fine. You weren't going to buy him one anyway. But how about the **Disk Doubler**? This fascinating



and contains search facilities to find just the right pious sentiments or thunderous curses to suit those troublesome boardroom situations. Also ideal for vicars stuck for a snappy quote when writing sermons or drunken idiots who want to check who begat Methuselah because "I've got a pony riding on it" down the boozier. It beats writing to the Old Codgers in the Daily Maxwell anyway.

If your boss already has The Word, upstage the sanctimonious individual with The **Greek Transliterator**. This

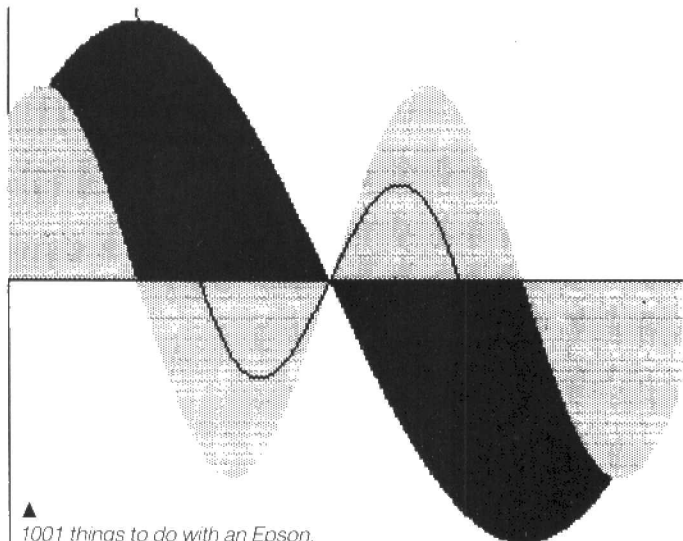

▲ 1001 things to do with an Epson.

contains the New Testament in Greek and English, and you can use it to ferret out inconsistencies of translation with which to confound him. It's also got a dictionary, so you can find out whether it really was the cheek you were supposed to turn – and if so, which one? Both programs are from Access, and can be bought for the Apricot and Apple II as well. I particularly liked the title screen, with the words 'Exodus 25:10 Thou shalt not steal' followed by an invocation against software pirates. Very classy.

The Bible may be good for the soul, but QL owners need more practical assistance than that. They've got microdrives to worry about. Talent's **Microdrive Doctor** is the answer – a piece of software that recovers just

about everything left on a damaged or corrupted cartridge. You could even chop a section out of a cartridge, stick it – badly – together again and the Doctor will sort out what's left, and let you alter it on the screen. Excellent for corrupted files, and if you know your way around the QL's contorted intestines, you can even recover files you accidentally deleted from the cartridge.

Some people spend more time reading about computers than doing things with them. To discharge such

activities, buy them a book. Not just any book, mind. One really numbing title is **Get More From the Epson Printer**, by Susan Curran, made all the more effective by the fact that Epson's own manuals are among the finest printer manuals ever written anyway. Pride of place must however go to the brilliantly conceived **Orbits for Amateurs** by D. Tasttersfield, which explains how to predict the orbits of planets using a micro. It starts with the self-evident statement 'Many amateur astronomers have in the past been inhibited from under-taking calculations associated with the orbits of comets'. Read the book and find out why.

Back to the mainstream again, and one present that's bound to please anyone with one of those dinky little electronic keyboards is a **MIDI interface**. MIDI is the standard for transmitting data for music, and it's essentially a very fast serial interface.

Siel produces a number for the Spectrum, Commodore and Atari computers, complete with Sequencers and hideously expensive synthesisers as well, and you'd better check with the people there for details regarding your machine, because it's not quite as simple as stuffing one up your RS232 and typing in the name of your favourite song. The glory of MIDI is you can make quite acceptable noises without understanding anything about music, and play them back properly as well. A full do-it-yourself recording studio will set you back a bit, but it still costs a helluva lot less than the tone of gear you needed before MIDI came along.

Real cool is not, alas, to be found among sweaty programmers of pseudo-Kraftwerk electronic noise, but on the wrists of such paragons of style as our otherwise tolerable Deputy Editor, William Owen. Yes folks, it's **Seiko Wristwatch** time!

The Seiko RC1000 is in fact a stunted computer, which you can plug in to pretty well anything with an RS232 port and disgorge or assimilate data. Not a lot – 80 lines of 24 characters apiece is your limit, but you can also have it trigger one of those messages at any given time or date for a year ahead.

Seiko Watch.

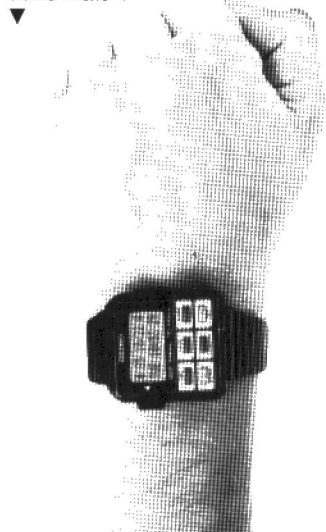

The sight of a bunch of salesmen queuing up to plug themselves into their BBC or Apple of a morning is the best reason for trying to ensure the spread of this weird gadget. It's equally amusing innocently asking William for the time – and then watching him try and find out.

Such advanced users may well be wrecking the cut of their suit by stuffing a **Psion Organiser** in one of their pockets. The Organiser is a perfectly respectable pocket computer which uses semi-permanent cartridges on which to construct databases. You can have your phone book, fave eateries and

latest figures on it, or a list of stamps you want to swap. Or you could even wander around warehouses looking officious. Marks and Sparks have bought a whole load of them to incorporate into cash tills, so it must be pukka.

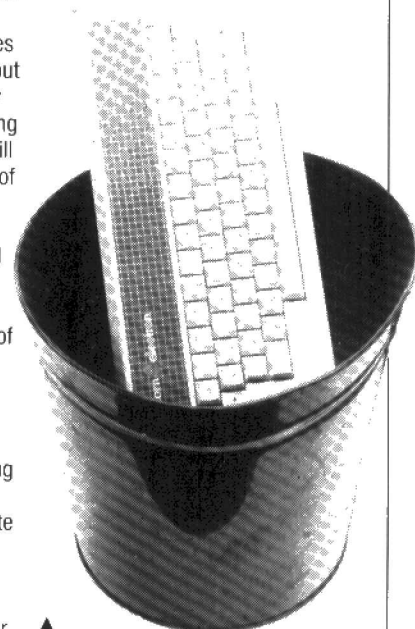

▲ Gift-wrapped Electron.

Best educational gift must surely be the new cut-price **Acorn Electron**. Utterly useless for anything else, its saving grace is the speed with which it teaches its proud owner a) what is wrong with Acorn, b) what is wrong with the people who gave Acorn the BBC contract, and c) what is wrong with the people who thought BBC machines would be great in schools.

Finally, if you are fink enough to stick an Olivetti budget special on anyone you know, you'd better throw in a **foam rubber foot** as well. These artifacts are ideal stocking fillers (sic and sorry) for any micro-owner, being specially designed to enable you to thump recalcitrant machines to your heart's content without doing any actual damage.

Lots of ideas then, some admittedly dubious, and if they don't work you'll get no sympathy from me. I'll be spending Christmas in an obscure Greek village getting plastered on treacle masquerading as brandy and if anyone so much as whispers the word 'Amiga', or even Omega, I'll... well, cheers, anyway.

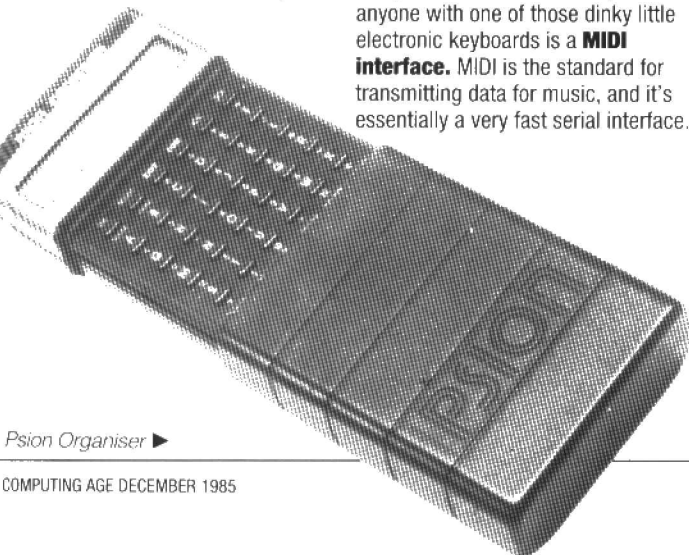
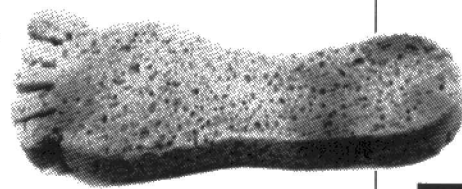

Psion Organiser ▶

Each month *Computing Age* publishes utility, graphics, communications or business software for a range of home computers, including the BBC Micro, Sinclair QL, Amstrad, CBM64, Atari 520ST, CP/M and MS DOS machines.

This month we feature an extensive listing for the BBC micro, Moneybox. The program is easy to operate and gives a monthly account of cashflow, taking into account regular income and outgoings.

Then two neat exercises in Basic/Logo by Richard Sargent, which give BBC and Amstrad Basic a Logo-like control ability. We want **you** to write for this column. If you have written software for any of the above machines then send it to *Computing Age*. We pay £75 per published page, as long as the listing meets the following requirements:

Listings should be set over a maximum width of 40 columns. Each listing should include an explanation of how the software operates, of between 200 and 400 words length. Your submission should be accompanied by a disk or cassette, and a clear printout of the listing. Please include a stamped self-addressed envelope so that the software can be returned if it is unsuitable for publication. *Computing Age* cannot accept responsibility for loss or damage to software submitted.

Send your software to: PRINTOUT, *Computing Age*, Priory Court, 30-32 Farringdon Lane, London EC1R 3AU.

## Moneybox

*A computerised account of personal transactions which will help even financial illiterates to maintain a cosy relationship with their bank manager.*

### BBC

This program is designed to keep track of standing orders, income and outgoings (cheques) for each month. It will also give an indication of how much to save each month to cover certain standing orders, and how much is available to spend next month.

The program consists of four arrays which hold control information, income, outgoings and standing orders. The control array holds information on what month and year is currently being processed, brought forward and carried forward values etc. Income and outgoings contain the values for income (pay) and cheques written for the month. The standing orders are split into two types: monthly and yearly; these two being identical except that yearly standing orders are used to calculate the amount that should be saved each month if they are to be met.

The limits on the four arrays are: control - 20, there are currently 6 spare for extra use; Income - 20; outgoings - 40, ie up to 40 cheques per month, if more than 40 are required use a negative value when inputting to income; standing orders - 40, 20 monthly and 20 yearly.

When replying to prompts the following convention applies: 'RETURN' by itself will always take you back to the main selection menu unless the prompt contains a value enclosed ie '<>', in which case the value in '<>' is used; this saves any retyping.

Each standing order has associated with it a month on which it is to be paid, this is held as a bit pattern, each bit being a month. There is a 13th bit which is used to indicate that the amount given is advisory and will not be used in any totalling, apart from savings. When setting up the required months these are input to the appropriate prompt in the following format: month number.month number. month number, eg 2.4.7 if order is for Feb, April and July. If advisory is required then '13' or 'A' may be used. If all the months are needed then 'ALL' is available, thus 'ALL.A' will be all months and advisory.

The control array also holds certain totals which, if any attempt at changing them is made will not take effect. The following calculations are made and displayed on the top 4 lines of the screen:

Carried forward = Brought forward + income - outgoings - tot S/Os for this month.

Savings = Min. savings(control(13) + (tot yearly S/Os)/12 - tot S/Os this month

Next month = Carried forward - min. in bank(control(5)) - tot S/Os for next month

The normal operating procedure would be to load last month's account, use selection 6 (move to next month ie this month), input income, outgoings, make any amendments then save this months account.

Within this program certain parts of the code are repeated with minor variations; it would be possible to reduce this but with a loss of clarity. It was felt that if small changes were required then it was better to leave in the 'duplicated' code.

Note that this program will not run under Basic 1 because of the depth of nesting in called procedures. Also statements of the form INPUT TAB(x,y);"string";variable produce a syntax error.

CHRIS KING

```

10 REM MONEY BOX a financial program.
20 REM Copyright Chris R. King - 1985
30 *TV255
40 MODE4
50 REM control - control functions
60 REM income - all income (pay)
70 REM outgos - all out goings (cheq
ues)
80 REM so,so%,so% - standing orders
90 REM 1-20 monthly ; 21-40 yearly
100 REM 'so' - amount
110 REM 'so%' - comment
120 REM 'so%' - for which month
130 REM
140 DIM month$(12),monmask%(13)
150 DIM control(20),control$(20)
160 DIM income(20)
170 DIM outgos(40)
180 DIM so(40),so$(40),so%(40)
190 REM
200 PROCinit:REM Initialise certain va
riables
210 err=1 : REM Enable error trapping
220 ON ERROR PROCerr
230 REM =====
240 REM Start main loop
250 REPEAT
260 PROCtopline
270 PROCmenu
280 IF sel%=1 PROCcancon
290 IF sel%=2 PROCaminc
300 IF sel%=3 PROCamout
310 IF sel%=4 PROCamsos(0)
320 IF sel%=5 PROCamsos(20)
330 IF sel%=6 PROCnextmonth
340 IF sel%=7 PROCloadacc
350 IF sel%=8 PROCsaveacc
360 IF sel%=9 PROCcat
370 IF sel%=10 PROCsumpage
380 UNTIL FALSE
390 END
400 REM =====
410 REM Initialiser
420 DEFPROCinit
430 FOR I%=0 TO 12
440 READ month$(I%),monmask%(I%)
450 NEXT I%
460 monmask%(13)=4096
470 FOR I%=1 TO 20
480 READ control$(I%)
490 NEXT I%
500 REM Set strings to max possible si
ze
510 FOR I%=1 TO 40
520 so$(I%)=STRING$(20," ");so%(I%)=""
530 NEXT I%
540 in%=STRING$(40," ");in$=""
550 ENDPROC
560 REM =====
570 DATA Undef,0,Jan,1,Feb,2,Mar,4,Apr
,8,May,16,Jun,32
580 DATA Jly,64,Aug,128,Sep,256,Oct,51

```

2,Nov,1024,Dec,2048

```
590 DATA Month,Year,Brought Forward,Carried Forward,Minimum in Bank
600 DATA total income,total outgoings,total monthly S/Os this month
610 DATA total monthly S/Os next month,total yearly S/Os this month
620 DATA total yearly S/Os next month,total yearly S/Os per month
630 DATA minimum to savings per month
640 DATA ,,,,,, : REM Spare
650 REM =====
660 REM Display top information
670 DEFPROCtopline
680 VDU28,0,3,39,0:CLS:REM Window for top information
690 PROCmoncalc : REM Work out next month
700 REM Calc C/F
710 control(4)=control(3)+control(6)-control(7)-control(8)-control(10)
720 @%=&020209
730 PRINT TAB(0,1),control(3);" B/F",TAB(0,2),control(4);" C/F"
740 savings=control(13)+control(12)-control(10)
750 IF savings>0 PRINT TAB(18,1),savings;" to savings"
760 IF savings<0 PRINT TAB(18,1),-savings;" from savings"
770 REM Amount for next month
780 PRINT TAB(18,2),control(4)-control(5)-control(9)-control(11)
790 @%=10
800 PRINT " for "jmonth*(nmon%)" "iyear%
810 PRINT TAB(10,0);"Accounts for "jmonth*(control(1));" "jcontrol(2)
820 VDU28,0,31,39,4:REM Window for other info.
830 ENDPROC
840 REM =====
850 REM Selection Menu
860 DEFPROCmenu
870 CLS:PRINT TAB(1,0);"Menu : please select 1-10"
880 PRINT TAB(1,2);"1 : Amend controls"
890 PRINT TAB(1,3);"2 : Amend income"
900 PRINT TAB(1,4);"3 : Amend outgoing"
910 PRINT TAB(1,5);"4 : Amend monthly S/O's"
920 PRINT TAB(1,6);"5 : Amend yearly S/O's"
930 PRINT TAB(1,8);"6 : Move to next month"
940 PRINT TAB(1,10);"7 : Load an account"
950 PRINT TAB(1,11);"8 : Save this month's account"
960 PRINT TAB(1,12);"9 : Account catalogue"
970 PRINT TAB(1,14);"10: Summary page"
980 REPEAT
990 INPUT TAB(1,18);"Please give selection "sel%
1000 UNTIL sel%>0 AND sel%<11
1010 ENDPROC
1020 REM =====
1030 REM Control amender
1040 DEFPROCamcon
1050 REPEAT:CLS
1060 PRINT TAB(0,0);"Amend control functions"
1070 FOR I%=1 TO 20
1080 PROCpline(I%,control(I%),control(I%)-1)
1090 NEXT I%
1100 PROCamendreq(20)
1110 IF amd%>0 PROCchcon:PROCretotal:PROCtopline
1120 @%=10
1130 UNTIL amd%=0
1140 ENDPROC
1150 REM =====
1160 REM Change controls
1170 DEFPROCchcon
1180 IF amd%>2 @%=&020208
1190 valid%=FALSE
1200 REPEAT
1210 PRINT TAB(5,2);control*(amd%);
1220 PRINT TAB(0,25);"<"control(amd%);";":INPUT in%
1230 IF LEN(in%)>0 control(amd%)=VAL(in
```

```
*)
1240 IF amd%=1 PROCvalmonth ELSE valid%=TRUE
1250 UNTIL valid%
1260 ENDPROC
1270 REM =====
1280 REM Check month is 1 to 12
1290 DEFPROCvalmonth
1300 IF control(1)>0 AND control(1)<13 valid%=TRUE ELSE control(1)=0
1310 IF NOT valid% PRINT TAB(0,23);"Month must be 1 to 12"
1320 ENDPROC
1330 REM =====
1340 REM Income amender
1350 DEFPROCaminc
1360 IF control(6)=0 PROCinput(20)
1370 REPEAT:CLS
1380 PRINT TAB(0,0);"Amend income"
1390 total=0
1400 FOR I%=1 TO 20
1410 PROCtotaler(income(I%),-1)
1420 PROCpline(I%,income(I%),",-1)
1430 NEXT I%
1440 @%=&020208
1450 PRINT TAB(2,21),total;" total"
1460 control(6)=total
1470 PROCtopline
1480 PROCamendreq(20)
1490 IF amd%>0 PROCchinc
1500 @%=10
1510 UNTIL amd%=0
1520 ENDPROC
1530 REM =====
1540 REM Change income
1550 DEFPROCchinc
1560 @%=&020208
1570 PRINT TAB(0,25);"<"income(amd%);";":INPUT in%
1580 IF LEN(in%)>0 income(amd%)=VAL(in%)
1590 ENDPROC
1600 REM =====
1610 REM Outgoings amender
1620 DEFPROCamout
1630 IF control(7)=0 PROCinput(40)
1640 REPEAT:CLS
1650 PRINT TAB(0,0);"Amend outgoings"
1660 total=0
1670 FOR I%=1 TO 40
1680 PROCtotaler(outgos(I%),-1)
1690 PROCpline(I%,outgos(I%),",-1)
1700 NEXT I%
1710 @%=&020208
1720 PRINT TAB(22,21),total;" total"
1730 control(7)=total
1740 PROCtopline
1750 PROCamendreq(40)
1760 IF amd%>0 PROCchout
1770 @%=10
1780 UNTIL amd%=0
1790 ENDPROC
1800 REM =====
1810 REM Change outgoings
1820 DEFPROCchout
1830 @%=&020208
1840 PRINT TAB(0,25);"<"outgos(amd%);";":INPUT in%
1850 IF LEN(in%)>0 outgos(amd%)=VAL(in%)
1860 ENDPROC
1870 REM =====
1880 REM Input income/outgoings
1890 DEFPROCinput(N%)
1900 CLS
1910 IF sel%=2 PRINT TAB(0,0);"Input income"
1920 IF sel%=3 PRINT TAB(0,0);"Input outgoings"
1930 I%=1
1940 REPEAT
1950 PROCinline(I%)
1960 IF sel%=2 income(I%)=in
1970 IF sel%=3 outgos(I%)=in
1980 I%=I%+1
1990 UNTIL in=0 OR I%>M%
2000 ENDPROC
2010 REM =====
2020 REM Input a value
2030 DEFPROCinline(N%)
2040 IF N%>20 X%=20 ELSE X%=0
2050 PRINT TAB(X%,N%-X%);N%;TAB(2);
2060 INPUT in
2070 ENDPROC
2080 REM =====
```

```
2090 REM Standing order amender
2100 DEFPROCamsos(off%)
2110 REPEAT:CLS
2120 PRINT TAB(0,0);
2130 IF sel%=4 PRINT "Amend monthly S/O"
2140 IF sel%=5 PRINT "Amend yearly S/Os"
2150 total=0:tottmon=0:totnmon=0
2160 FOR I%=1 TO 20
2170 J%=I%+off%
2180 PROCtotaler(so(J%),so(J%))
2190 IF T%="T" COLOUR 0:COLOUR129
2200 PROCpline(I%,so(J%),so*(J%),so*(J%))
2210 NEXT I%
2220 @%=&020208
2230 PRINT TAB(2,21),tottmon;" this month"
2240 PRINT TAB(21,21),totnmon;" next month"
2250 IF sel%=4 control(8)=tottmon:control(9)=totnmon
2260 IF sel%=5 control(10)=tottmon:control(11)=totnmon:control(12)=total/12
2270 IF sel%=5 PRINT TAB(21,22),control(12);" per month"
2280 PROCtopline
2290 PROCamendreq(20)
2300 IF amd%>0 PROCchsos
2310 @%=10
2320 UNTIL amd%=0
2330 ENDPROC
2340 REM =====
2350 REM Change standing orders
2360 DEFPROCchsos
2370 A%=amd%+off%
2380 @%=&020208
2390 PRINT TAB(10,27);"Value";
2400 PRINT TAB(0,24);"<"so(A%);";":INPUT in%
2410 IF LEN(in%)>0 so(A%)=VAL(in%)
2420 PRINT TAB(5,27);"Comment up to 20 characters";
2430 PRINT TAB(0,25);"<"so*(A%);";":
2440 INPUT LINE in%:IF LEN(in%)>0 so*(A%)=LEFT$(in%,20)
2450 mon%=so*(A%)
2460 M%="."
2470 FOR M%=1 TO 12
2480 IF mon% AND monmask%(M%) M%=M%+STR$(M%)+". "
2490 NEXT M%
2500 IF mon% AND monmask%(13) M%=M%+"A"+". "
2510 PRINT TAB(0,27);"S/O months (n.n.n) ALL=1-12 A=advisory";
2520 PRINT TAB(0,26);"<"M%";":INPUT in%
2530 IF LEN(in%)>0 so*(A%)=FNmonpack(in%)
2540 @%=10
2550 ENDPROC
2560 REM =====
2570 REM Pack up requested months
2580 DEFNmonpack(M%)
2590 M%="."+M%+"."
2600 IF INSTR(M%,".ALL.") M%=4095 ELSE M%=0
2610 IF INSTR(M%,".A.") M%=M% OR monmask%(13)
2620 FOR N%=1 TO 13
2630 N%="."+STR$(N%)+". "
2640 IF INSTR(M%,N%) M%=M% OR monmask%(N%)
2650 NEXT N%
2660 =M%
2670 REM =====
2680 REM Print information lines
2690 DEFPROCpline(N%,value,comment%,mon%)
2700 IF N%>20 X%=20 ELSE X%=0
2710 @%=02
2720 PRINT TAB(X%,N%-X%);N%;TAB(2);
2730 @%=&020208
2740 IF sel%=1 AND N%<3 @%=08
2750 PRINT value;" ";comment%;
2760 @%=&04
2770 IF mon%<0 PRINT ELSE PROCpmon
2780 COLOUR1:COLOUR128
2790 @%=10
2800 ENDPROC
2810 REM =====
2820 REM Print month info
2830 REM In inverse if T%="t"
```

```

2840 DEFPROCpmon
2850 PRINT TAB(33);
2860 IF T$="t" COLOUR0:COLOUR129
2870 PRINT A$;T$;N$,mon%
2880 ENDPROC
2890 REM =====
2900 REM Retotal income/outgoings/so's
2910 DEFPROCretotal
2920 PROCmoncalc
2930 total=0
2940 FOR I%=1 TO 20
2950 total=total+income(I%)
2960 NEXT I%
2970 control(6)=total
2980 total=0
2990 FOR I%=1 TO 40
3000 total=total+outgos(I%)
3010 NEXT I%
3020 control(7)=total
3030 total=0:tottmon=0:totnmon=0
3040 FOR I%=1 TO 20
3050 PROCtotaler(so(I%),so%(I%))
3060 NEXT I%
3070 control(8)=tottmon:control(9)=totnmon
3080 total=0:tottmon=0:totnmon=0
3090 FOR I%=21 TO 40
3100 PROCtotaler(so(I%),so%(I%))
3110 NEXT I%
3120 control(10)=tottmon:control(11)=totnmon:control(12)=total/12
3130 ENDPROC
3140 REM =====
3150 REM Product totals
3160 DEFPROCtotaler(value,mon%)
3170 A$="":T$="":N$=""
3180 total=total+value
3190 IF mon%>0 PROCmoncheck
3200 ENDPROC
3210 REM =====
3220 REM See if for this/next month
3230 DEFPROCmoncheck
3240 IF mon% AND monmask%(13) A$="A": R
EM Advisory
3250 IF mon% AND monmask%(tmon%) T$="t"
:IF A$=" " tottmon=tottmon+value:T$="T"
3260 IF mon% AND monmask%(nmon%) N$="n"
:IF A$=" " totnmon=totnmon+value:N$="N"
3270 ENDPROC
3280 REM =====
3290 REM Work out this/next month
3300 DEFPROCmoncalc
3310 tmon%=control(1):nmon%=tmon%+1:year%=control(2)
3320 IF nmon%>12 nmon%=1:year%=year%+1
3330 IF tmon%=0 nmon%=0
3340 ENDPROC
3350 REM =====
3360 REM Request a number for amendment

3370 DEFPROCamendreq(max%)
3380 REPEAT
3390 INPUT TAB(0,23);"Which one to amend"jand%
3400 UNTIL amd%>-1 AND amd%<max%+1
3410 ENDPROC
3420 REM =====
3430 REM Move to next month : clear out
3440 REM income and outgoings
3450 DEFPROCnextmonth
3460 control(1)=nmon%
3470 control(2)=year%
3480 control(3)=control(4)
3490 FOR I%=1 TO 40
3500 IF I%<21 income(I%)=0
3510 outgos(I%)=0
3520 NEXT I%
3530 PROCretotal : REM beacuse of month change
3540 ENDPROC
3550 REM =====
3560 REM Request an account to load
3570 DEFPROCloadacc
3580 CLS
3590 REPEAT
3600 INPUT TAB(0,4);"Give account month (1-12) "jin%
3610 UNTIL in%>0 AND in%<13
3620 account#=month$(in%)
3630 INPUT TAB(0,6);"Give account year "jln%
3640 account$=account#+STR$(in%)
3650 PRINT TAB(0,8);"OK to load "jaccounnt$;" <Yes> "j
3660 INPUT in$

```

```

3670 IF LEFT$(in$,1)="Y" OR LEFT$(in$,1)
)="y" OR in$="" PROCloader
3680 ENDPROC
3690 REM =====
3700 REM Load the account
3710 DEFPROCloader
3720 PRINT TAB(0,10);"Searching for "jaccount#
3730 file=OPENIN(account$)
3740 PRINT TAB(0,11);"Loading"
3750 FOR I%=1 TO 20
3760 INPUT#file,control(I%)
3770 NEXT I%
3780 FOR I%=1 TO 20
3790 INPUT#file,income(I%)
3800 NEXT I%
3810 FOR I%=1 TO 40
3820 INPUT#file,outgos(I%)
3830 NEXT I%
3840 FOR I%=1 TO 40
3850 INPUT#file,so(I%),so%(I%),so%(I%)
3860 NEXT I%
3870 CLOSE#file
3880 ENDPROC
3890 REM =====
3900 REM Save account
3910 DEFPROCsaveacc
3920 CLS
3930 account$=month$(control(1))+STR$(control(2))
3940 PRINT TAB(0,4);"OK to save "jaccountnt$;" <Yes> "j
3950 INPUT in$
3960 IF LEFT$(in$,1)="Y" OR LEFT$(in$,1)
)="y" OR in$="" PROCsaver
3970 ENDPROC
3980 REM =====
3990 REM Save the account
4000 DEFPROCsaver
4010 file=OPENOUT(account$)
4020 PRINT TAB(0,7);"Saving "jaccount#
4030 FOR I%=1 TO 20
4040 PRINT#file,control(I%)
4050 NEXT I%
4060 FOR I%=1 TO 20
4070 PRINT#file,income(I%)
4080 NEXT I%
4090 FOR I%=1 TO 40
4100 PRINT#file,outgos(I%)
4110 NEXT I%
4120 FOR I%=1 TO 40
4130 PRINT#file,so(I%),so%(I%),so%(I%)
4140 NEXT I%
4150 CLOSE#file
4160 ENDPROC
4170 REM =====
4180 REM Give account catalogue
4190 DEFPROCcat
4200 CLS
4210 err=0 : REM Disable error trapping
4220 PRINT TAB(0,1);"Account catalogue : escape to stop"
4230 %CAT
4240 ENDPROC
4250 REM =====
4260 REM Print summary page
4270 DEFPROCsumpage
4280 CLS
4290 PRINT TAB(5,2);"Summary page"
4300 @%=&020209
4310 PRINT TAB(5,5),control(3);" B/F"
4320 PRINT TAB(5,6),control(6);" + income"
4330 work=control(3)+control(6)
4340 PRINT TAB(5,7),work;" ="
4350 PRINT TAB(5,9),control(10);" - yearly S/Os"
4360 work=work-control(10)
4370 PRINT TAB(5,10),work;" ="
4380 PRINT TAB(5,12),control(8);" - monthly S/Os"
4390 work=work-control(8)
4400 PRINT TAB(5,13),work;" ="
4410 PRINT TAB(5,15),control(7);" - outgoings"
4420 PRINT TAB(5,16),control(4);" = c/F"
4430 @%=10
4440 INPUT TAB(5,20);"Press RETURN to continue" in$
4450 ENDPROC
4460 REM =====
4470 REM Error detected (escape?)
4480 DEFPROCerror
4490 IF err=0 err=1:ENDPROC : REM Inten

```

```

ded error
4500 CLS
4510 @%=10
4520 IF ERR=17 PRINT TAB(0,2);"Escape requested"
4530 IF ERR<>17 PRINT TAB(0,1);:REPORT:PRINT " on line "IERL
4540 INPUT TAB(0,5);"Do you wish to continue <Yes> "jin$
4550 IF LEFT$(in$,1)="N" VDU26:CLS:END
4560 ENDPROC

```

## Turtles in Basic

*Programs for two computers which turn Basic into a Logo-style turtle controller.*

Turtles which move only on the screen of their computer's monitor are best controlled by compass directions given in degrees from north, which is taken to be the top of the screen. Thus to follow the time honoured advice "go West, young turtle!", the juvenile amphibian must be given the instruction "BEARING 270, FORWARD 1000". This is not at all easy to do in Basic, which lays its screen out like graph paper and much prefers movement to be the "go from x1,y1 to x2,y2" instruction. Moreover, to assist directionally-insensitive turtles, and, it is said, help young children with their geometry, LOGO-style instructions turn lines, turtles and other motorised buggies LEFT or RIGHT relative to their direction of travel.

The code to do this varies according to how a computer's Basic draws its lines. The listings show the code for the BBC micro, and the Amstrad. Each program can drive a screen-turtle, and, using a suitable interface such as Cirkit's Centronics Interface (see *E&CM* July 1985 or the Cirkit catalogue), it is also possible to drive a simple two-motor floor buggy.

## AMSTRAD

The Amstrad turtle program is somewhat longer, though it does the same job. The computer is told to calculate in degrees (line 640) and a border to the graphics screen is drawn for a neat visual effect. The commands Left, Right, Forward and Wipe-screen are supported. The command loop is lines 200-280. The relative movement right or left is calculated from the absolute bearing in lines 310-330 and 520-540, and the move is performed using the equations on lines 420 & 430. As far as the screen turtle is concerned, movement left or right can be any angle, but the floor turtle will only ever turn through one set angle determined by length of the delay routine.

The real turtle can be easily operated through the special Centronics Control Interface marketed by Cirkit. The device works by appearing to the micro as a printer, hence the print statements of line

360 (one motor on) and 380 (all motors off). If the floor turtle is not required, variable H must be set to 0, otherwise the program will "hang up" when it reaches the printer statements and finds that no printer is connected.

Like the Enterprise program, forward motion is specified as time units, but appears on the screen as distance travelled. Variable SC is a scaling factor which can reduce the length of the lines drawn on the screen. The value of variable D determined whether the angles given will be interpreted as degrees (when D=1) or as minutes (when D=6). The minutes are those of a clock-face, so that, for example, R15 is taken as an "angle" of 15 minutes past the hour, or a right-angle.

```

100 REM CPC464 LOGO TURTLE
110 REM (c) R.SARGENT Sept 85
120 MODE 1:CLS:ORIGIN 0,0
130 WINDOW #1,1,40,22,25
140 WINDOW #2,1,40,1,2
150 GOSUB 660
160 GOSUB 640
170 SC=2.5:REM SCALING FACTOR
180 PR=20:PL=20:REM TURN TIMES
190 D=1:H=0:T=0
200 INPUT #1,A$:B$=LEFT$(A$,1)
210 N=LEN(A$):C$=RIGHT$(A$,N-1)
220 V=VAL(C$):VV=V
230 IF (B$="L" OR B$="R") AND (V=0 OR V>359) THEN GOTO 200
240 IF B$="R" THEN A=V*D:GOSUB 310
250 IF B$="L" THEN A=V*D:GOSUB 520
260 IF B$="F" THEN V=INT(V/SC):GOSUB 420
270 IF B$="M" THEN GOSUB 630
280 GOTO 200
290 :
300 REM GO RIGHT (SCREEN)
310 A=T+A:IF A>359 THEN A=A-360
320 CLS #2:PRINT #2,"COMPASS BEARING ";A
330 T=A
340 IF H=0 THEN RETURN
350 REM GO RIGHT (MOTOR)
360 PRINT #0,CHR$(&X11100001);
370 M=PR:GOSUB 720
380 PRINT #0,CHR$(&X11110000);
390 RETURN
400 :
410 REM GO FORWARD (SCREEN)
420 DRAW X+V*SIN(A),Y+V*COS(A)
430 X=XPOS:Y=YPOS:MOVE X,Y
440 IF H=0 THEN RETURN
450 REM GO FORWARD (MOTORS)
460 PRINT #0,CHR$(&X11000011);
470 M=VV:GOSUB 720
480 PRINT #0,CHR$(&X11110000);
490 RETURN
500 :
510 REM GO LEFT (SCREEN)
520 A=T-A:IF A<0 THEN A=ABS(A):A=360-A

```

```

530 CLS #2:PRINT #2,"COMPASS BEARING ";A
540 T=A
550 IF H=0 THEN RETURN
560 REM GO LEFT (MOTOR)
570 PRINT #0,CHR$(&X11010010);
580 M=PL:GOSUB 720
590 PRINT #0,CHR$(&X11110000);
600 RETURN
610 :
620 REM INITIALISE SCREEN
630 CLS #1:CLG
640 ORIGIN 0,0:DEG:GOSUB 660
650 X=320:Y=200:PLOT X,Y:RETURN
660 PLOT 24,400-16*3
670 DRAWR 36*8*2,0
680 DRAWR 0,-284
690 DRAWR -(36*8*2),0
700 DRAWR 0,284:RETURN
710 :
720 REM 90 DEGREE TURN DELAY
730 FOR N=1 TO W
740 FOR Z=1 TO 40:NEXT
750 NEXT N
760 RETURN

```

## BBC MICRO

The line numbers have been kept similar to the Amstrad program to allow comparison. The string slicing uses the standard LEFT\$ and RIGHT\$ operators. Notice too the difference in the data line 250 and the jump line 410. In the LOGO-movement routines, the turn angle is changed to radians (lines 502 & 552) because the SIN and COS functions can only handle radians. The VDU commands are really PRINTER commands in disguise, so the Cirkit interface can be used. VDU2 turns the printer on, while VDU1,x is the equivalent of PRINT CHR\$(x); and actually sends the byte to the printer (or Cirkit interface). VDU3 turns the printer off.

RICHARD SARGENT

>PRINT

>WIDTH 34

>LIST

```

100 REM LOGO TURTLE
110 REM (c)R.SARGENT
132 Q=6:REM Q=1
133 D=1:REM D=6
134 H=0:T=0:AA=0
135 PR=20:PL=20
136 MODE 1:CLG
140 PLOT 4,640,312
150 GOSUB 200
152 :
154 REM INPUT LOOP
160 PRINT TAB(1,2);"
162 PRINT TAB(1,2);
168 INPUT B$:IF B$="0" THEN STOP
170 GOSUB 300:GOTO 160

```

```

180 :
200 REM READ COMMAND TABLE INTO
201 REM ARRAYS A$ & A
202 RESTORE 250:READ COM
204 DIM A$(COM):DIM A(COM)
206 FOR N=1 TO COM:READ A$(N):RE
AD A(N):NEXT N
207 RETURN
250 DATA 3,"R",1,"L",2,"F",3
298:
299 REM PROCESS INPUT STRING
300 IF B$="" THEN RETURN
310 N=1:X=LEN(B$)
320 IF LEFT$(B$,1)=A$(N) THEN GO
TO 350
330 N=N+1:IF N>COM THEN RETURN
340 GOTO 320
350 B$=RIGHT$(B$,X-1):K=1
360 IF RIGHT$(B$,X-K)("<0" OR RI
HT$(B$,X-K)):" THEN GOTO 370
365 K=K+1: GOTO 360
370 K=K-1:IF K=LEN(B$) THEN V=VA
L(B$):GOTO 410
374 V=VAL(LEFT$(B$,X-K-1)):B$=RI
GHT$(B$,X-K-1)
409 VV=V
410 ON A(N) GOTO 500,550,600
420 :
499 REM GO RIGHT
500 V=V*D:V=T+V
501 IF V>359 THEN V=V-360
502 T=V:AA=RAD(V)
504 IF H=0 THEN GOTO 300
506 VDU2:VDU1,&E1:REM MOTOR ON
508 M=PR:PROCDELAY
510 VDU1,&F0:VDU3:REM MOTOR OFF
512 GOTO 300
514 :
549 REM GO LEFT
550 V=V*D:V=T-V
551 IF V<0 THEN V=ABS V:V=360-V
552 T=V:AA=RAD(V)
554 IF H=0 THEN GOTO 300
556 VDU2:VDU1,&D2:REM MOTOR ON
558 M=PL:PROCDELAY
559 REM GO FORWARD
560 VDU1,&F0:VDU3:REM MOTOR OFF
562 GOTO 300
564 :
600 PLOT 1,V*SIN(AA),V*COS(AA)
602 IF H=0 THEN GOTO 300
604 VDU2:VDU1,&C3:REM MOTOR ON
606 M=VV:PROCDELAY
608 VDU1,&F0:VDU3:REM MOTOR OFF
610 GOTO 300
612 :
624:
899 REM DELAY FOR V*0.1sec
900 DEF PROCDELAY
901 FOR J=0 TO W
902 FOR R=1 TO 20:NEXT R
904 NEXT J
906 ENDPROC
908:

```

It's easy to forget that the computer is inherently a logical rather than an electronic machine. And that processing doesn't have to be done by a chip. The essential components of a computer are switches capable of transmitting in two states, representing 0 and 1. Any form of matter which can rapidly change between two states, via any physical, chemical, or even biological process, and can be controlled, could be utilised as the core of a computer.

Just as the transistor replaced the vacuum tube, and the integrated circuit the transistor (an IC contains thousands of transistors), so in turn as silicon approaches its theoretical limits it could be replaced by another 'medium of exchange'.

We hear a lot about finer miniaturisation, gallium arsenide (an alternative to silicon) or superconductivity at low temperatures, but an entirely new method of processing information may become available in the near future, by using light. For a decade now it has been possible to build a computing machine in which signals are transmitted by transphasors, or optical transistors.

They would offer significant advantages. In terms of speed, fast transistors are now approaching their fundamental theoretical switching limit of a nanosecond (a billionth of a second), whereas a transphaser's processing time would be reckoned in picoseconds (a thousand billionth of a second). Transphasors are more versatile, because the basic operations, AND, OR, NOT, can be handled by one transphaser rather than a number of physically separate devices, which would also mean greater compactness. Finally, in certain circumstances there would be no need to convert visual data into another form in which it can be handled by the computer; and link-ups with other computers via optical fibres would be greatly simplified.

## LASERS

How does a transphaser work? An experimental device developed by three scientists from the United States, Abraham, Seaton, and Smith, uses an optical transistor switched by a small change in

## Exit Computing at the speed of light

*Optical processing  
isn't just a dream*

the intensity of an incident beam of laser radiation. The transphaser is 'based on a property of certain crystals' whose refractive index changes as the intensity of light increases.

With the right combination of crystalline material and laser wavelength the change in the refractive index can be used to construct a device in which a very small change in the intensity of the laser beam can produce a great change in the intensity of the transmitted radiation.

This property was first discovered in 1896, and demonstrated using the Fabry-Perot interferometer. This consists of two partially reflecting mirrors separated by a cavity. A beam of light is projected on the first mirror and, passing through the cavity, the light is transmitted via the second mirror at a much lower intensity. This seemed to offer the possibility of controlling an output of light with respect to a given input, but would be of little use in an optical computer as the transmitted beam could only be modulated by changing the characteristics of the mirrors. There are further difficulties. Interference within the cavity between the forward incident beam and light partially reflected back from the second mirror is uncontrolled, hence it affects the character of the transmitted beam.

The transmission of the interferometer can be changed by altering the length of the cavity or the wavelength of the incident light – both too clumsy for an optical transistor.

The problem was solved by using a powerful source of coherent light – the laser – and a

material (such as indium antimonide) within the cavity whose refractive index (the ratio of the speed of light in a vacuum to its speed in that material) is not fixed but varies with the intensity of the beamlength of the cavity.

The end result of this complicated interaction is an optical device which gives optical bistability, that is, there are two distinct stable states, within which the intensity of the transmitted light varies little with changes in the intensity of the incident beam. Thus it creates an optical switching mechanism.

## REVOLUTION

The simplest form of optical computer would process information in the same way as a conventional electronic computer – but about a thousand times faster. But it may be the case that the optical transistor will revolutionise the way in which a computer is organised. This is because a transphaser has the potential to switch between not two, but four or more states, introducing an alternative to the binary system of zeros and ones used in today's machines.

The crystals with which Abraham and his colleagues work can switch to successively higher levels of transmitted power with successive increases in the incident beam – the limit is greater than a mere two, stable, switchable states – creating the possibility of an entirely new form of computer logic.

Building an optical computer presents a number of difficulties – which would explain why no-one has done it yet, although the basic circuitry has already been devised.

Many optical circuit elements would have to be assembled and interconnected. In the 1970s thin films were developed through which laser radiation can be made to propagate, in a manner analogous to the path of electronic radiation through a silicon substrate. Such waveguides could form the connecting elements in integrated optical circuits: this idea is still on the drawing board.

As far as applications are concerned: apart from the superfast conventional machine, new designs may be

## 'Optical processing creates the possibility of an entirely new form of computer logic'

attempted. Whereas in a single transistor multiple currents become mixed, multiple beams can be passed through an interferometer and still remain separate. So it should be possible to use a single crystal for several separate switching operations. For example, five lasers beams could pass through a crystal, each forming one site of operation. And each operation could be different by selecting varied beam intensities. Two paths might function as AND gates, two as OR gates, and one in the basic transistor mode.

## PARALLEL

The five paths of light might be derived from a single source divided into five parts, and upon which five logical operations could be performed. This sort of parallel processing system would require circuits entirely different from those in an electronic machine.

So when will we see a working optical computer? Apart from a medium for the circuitry, such as the film mentioned above, it would require a crystal which could operate efficiently at room temperature – indium antimonide has a critically small band-gap energy which decreases with increasing temperature. This problem may be overcome by using carbon monoxide lasers. To achieve a low switching power (also a preoccupation of designers of electronic computers) requires materials which can produce a high light intensity incident upon the crystal from a small power source. New lasers and nonlinear materials are being developed which can achieve this aim; so can reducing the size of the device (but that in turn may result in overheating).

Formidable obstacles remain in the way of a workable optical computer. The key, says Abraham et al, is 'the selection of the right medium or the discovery of new nonlinear (refractive) materials'.

# Maplin

**WELCOME TO  
THE MAPLIN  
ADVENTURELAND  
IN 1986...**

The new Maplin catalogue for 1986 is a real adventureland for the electronics enthusiast. With hundreds of new lines and details of Maplin's new low low prices, it's the one event in the electronics year that no-one should miss. Packed with data and information on all the latest electronic products. Pick up a copy from any branch of W.H. Smith for just £1.45. Alternatively you can order your copy by post for just £1.85. For overseas customers the prices are as follows: Europe surface mail £2.50; Europe air mail £3.75. Outside Europe surface mail £2.50; Outside Europe air mail depending on distance £4.25/£5.50/£6.25. For surface mail anywhere in the world you may send eleven International Reply Coupons for payment in full.

Post this coupon now for your copy of the 1986 catalogue.  
Price £1.45 + 40p post and packing. If you live outside the U.K.  
send £2.50 or 11 International Reply Coupons. I enclose £1.85.

Name .....

Address .....

.....

.....

**ON SALE  
9th NOV  
1985**

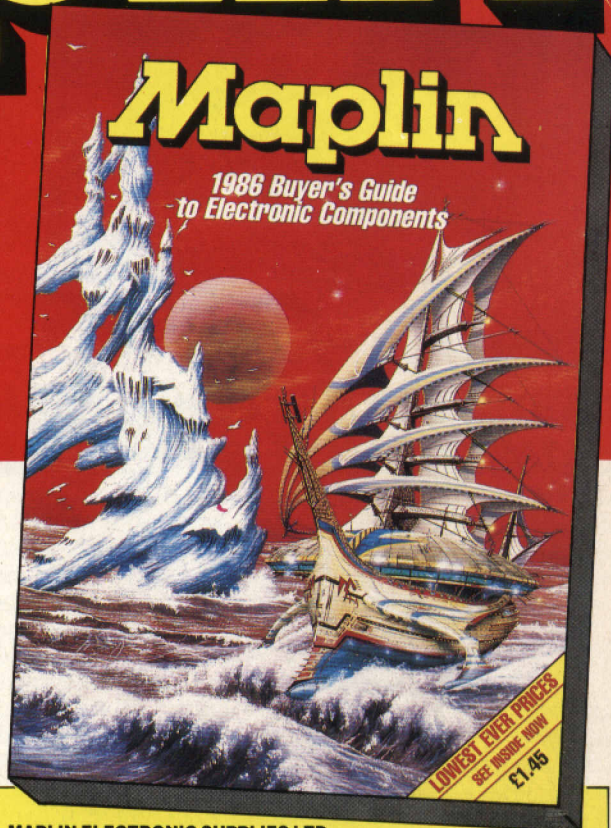

#### MAPLIN ELECTRONIC SUPPLIES LTD.

Mail Order: P.O. Box 3, Rayleigh, Essex SS6 8LR. Tel: Southend (0702) 552911  
SHOPS

- BIRMINGHAM Lynton Square, Perry Barr, Tel: 021-356 7292.
- LONDON 159-161 King Street, Hammersmith, W6. Tel: 01-748 0926.
- MANCHESTER 8 Oxford Road, Tel: 061-236 0281.
- SOUTHAMPTON 46-48 Bevois Valley Road, Tel: 0703 225831.
- SOUTHEND 282-284 London Rd, Westcliff-on-Sea, Essex. Tel: 0702-554000

*Shops closed all day Monday.*

**ORDER YOUR COPY NOW**