

# Personal Computer World

A GUIDE TO BUSINESS SOFTWARE

US \$2.00/FF8:80/LIRE 1700/DM 3.80/FL 4.00/BF 55  
DKr 10.75/Skr 7.65/Nkr 10.50/A Sch 28/S Fr 3.50/Pts 135

NOVEMBER 1979 50p



**SEE YOU AT THE SHOW!**

**The 2nd Personal Computer World show - preview issue**

Ask for our  
free colour  
brochure

DIAL  
NOW

031-225 2022  
(24 HOURS ANSWERING)

# MicroCentre are the UK

## Cromemco experts

Sample catalogue prices:

*System Two computer	1995
*System Three computer	3293
*Z-2H computer	4998
Extra 64K memory	893
3101 visual display unit	1147
3355 daisywheel printer	2297
HDD 11-mbytes hard disc	4022
ANSI Cobol compiler	55
ANSI Fortran IV compiler	55
16K extended Basic	55
Word processing system	55
Database management	55
Macro relocating assembler	55

Prices exclude VAT and  
delivery

MicroCentre also supply peripherals, applications software, and multi-user timesharing systems; a PROM programmer; analogue-digital interface; and much more. On site maintenance can be arranged throughout the UK.

\*Computer systems include fast 4MHz Z80A micro, S-100 bus (21 slots), 64K memory, dual floppy discs, peripheral interfaces, etc. CP/M compatible operating system CDOS free with software.

With our in-depth experience and total commitment to the reliable Cromemco range we are Cromemco's leading UK distributor. Rely on us, as many others do, for expert support with your routine or special micro-computer applications.

*Photo features Cromemco System 3 computer, 3101 VDU, and 3355 daisywheel printer.*

## Micro Centre

Complete Micro Systems Ltd.  
132 St. Stephen Street,  
Edinburgh EH3 5AA.  
Tel: 031-225 2022.

Look out for us at Compec '79, stand no. 756

# CONTENTS

**40 NEWSPRINT** (now featuring What's New) assembled and compiled by Guy Kewney.

**48 BENCHTEST** Spotlight this month on the Challenger C3.

**54 PREVIEW** of the 2nd Personal Computer World Show. . . see you there!

**60 COMPUTER ANSWERS** Readers pose the problems, Sheridan Williams — plus consultants — finds the solutions.

**63 SHAKESPEARE, BASIC** and the C.I.A. Now the micro art of detecting forgeries in literature.

**67 READERS SURVEY** Help us with the questions — and may be win a Sharp MZ-80K!

**71 BUZZWORDS** Peter Reynolds is back with us again with his 'computing dictionary'.

**72 THE COMPLETE PASCAL** Sue Eisenbach & Chris Sadler continue their series with Part 3 — loops.

**78 INTERRUPT A** clear indication of PCW's new, broader base is the respect being gained by this reader forum.

**80 SYSTEMS** Mike Knight and David Tebbutt present an overture to our new business software evaluation feature.

**82 BUGGING THE 6800** John Moore outlines a monitor program for the 77:86 system.

**86 CALCULATOR CORNER** This month Dick Pountain looks at the Casio FA-1 cradle, the Master Pack software package and the Sharp EL-5100.

**89 ON THE LINE** David Hebditch unveils his Personal Computer Network.

**92 HARD TIMES** David Broad of Comart presents some security solutions for the Winchester disc drive.

**94 BOOKFARE** Malcolm Peltu grabs 'The Systems Monster' by the throat.

**97 DIRECT ACCESS** PCW rationalises its information output by evolving this new department. It includes: *In Store, User Group Index, Fax, Transaction File* and *Diary Data*.

**105 COMPETITIONS ROUND-UP** A short resume of results outstanding.

**106 COMMUNICATION** Your letters, in double the amount of space.

**109 YOUNG COMPUTER WORLD** John Coll introduces another chapter from PCW's younger readers.

**110 PROGRAMS** The usual assortment of interesting listings, including REVAS plus *Blunders*, for errors that have crept through in past issues.

**117 LEISURE LINES** JJ Clessa turns his obsessions towards palindromic mileometers.

Founder  
Angelo Zgorelec

Editor  
Bruce Sawford

Technical Editor  
David Tebbutt

Regular Contributors  
Guy Kewney, Sheridan Williams, John Coll, Sue Eisenbach, Malcolm Peltu, Mike Knight, Dick Pountain

Consultants  
John Coll, Mike Dennis, Charles Sweeten, Patrick Sutton, Michael James, R.W.Davy, David Hebditch, Sheridan Williams, Dr. Stephen Castell, Dr. D.J.Hand

Advertising Manager  
Stephen England

Group Advertising Manager  
Richard Howell

Production Manager  
Dick Pountain

Art Director  
Paul Carpenter

Art Assistants  
Jimmy Egerton, Julia Davies



Cover Illustration  
Hunt Emerson

Typesetter  
Jane Hamnell

Published by SportsScene Publishers (PCW) Ltd., 14 Rathbone Place, London W1P 1DE, England. Tel: 01-637 7991/2/3. Telex: 8954139 A/B 'Bunch' G. London

Copyright notice  
Personal Computer World is published by SportsScene Publishers (PCW) Ltd. © 1979 Felden Productions. No

material may be reproduced in whole or part without written consent from the copyright holders.

Printed by Seymour Press Ltd., 334 Brixton Road, London SW9 7AG.

PCW welcomes all unsolicited material (written, photographic and illustrative) and although no guarantee can be given as to its safe return, reasonable care and attention will be exercised.

**Guidelines for contributors**  
PCW welcomes articles of interest. Don't be put off if your style of writing is 'under developed'. . . true worth lies in the content, and shaping features comes naturally to us! Manuscripts should not exceed 3,000 words and authors are asked to use triple-spaced lines with a wide left-hand margin; diagrams, listings and/or photographs should be included wherever possible. Please enclose a stamped, self-addressed envelope if you would like your article returned.

Because of the foregoing, it is necessary to add that the views expressed in articles we publish are not necessarily those of *Personal Computer World*. Overall, however, the magazine will try to represent a balanced, though independent viewpoint.

Finally, before submitting an article, please check it through thoroughly for legibility and accuracy.

**Subscription rates:** Britain £8.00 for 12 issues, USA \$20 for 12 issues (surface mail), Continent and elsewhere £9.80 for 12 issues. All prices include postage and packing. Supplies to specialist shops can be arranged by negotiation direct with the publishers.

Dr. Chris' Evans, psychologist and computer scientist, died of cancer early in October following a period of indifferent health. Although having been at the forefront of computer science for many years, it's doubly tragic that this should have happened at a time when Chris' was due to attract far wider recognition with the television serialisation of his best-selling book, "The Mighty Micro". With his interests firmly centered around the man/machine interface, his flair and energy are sure to be greatly missed. The staff of *Personal Computer World* extend their sympathy and condolences to his family.

## SEE YOU AT THE SHOW!

### The 2nd Personal Computer World show

1-3 November 1979  
West Centre Hotel  
Lillie Road London

# Rostronics present the Z-Plus Dual Floppy Microsystem

Price **£3750** plus VAT



## Features:

Over One Megabyte Disk Storage  
4 MHz Z-80 Processor      64k Memory  
Two Serial and Two Parallel I/O Ports  
An alphanumeric keyboard with 95 keys and  
numeric pad, character display (24 lines of 80  
characters per line) on a 15 inch screen

Including System Desk

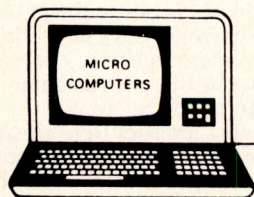

# ROSTRONICS

LIMITED

115-117 WANDSWORTH HIGH STREET, LONDON SW18 4JP

Telephone: 01-870 4805

Telex: 8813089 INTPRM G

Please mention *PCW* when replying to advertisers — it identifies you.

## DPS-1 MAINFRAME

Introducing the DPS-1 the full IEEE S100 bus computer system from Ithaca Intersystems — the S100 experts.

FOR EDUCATION, INDUSTRY, RESEARCH and all professional uses, including hardware and software development, low cost OEM systems, teaching applications etc.

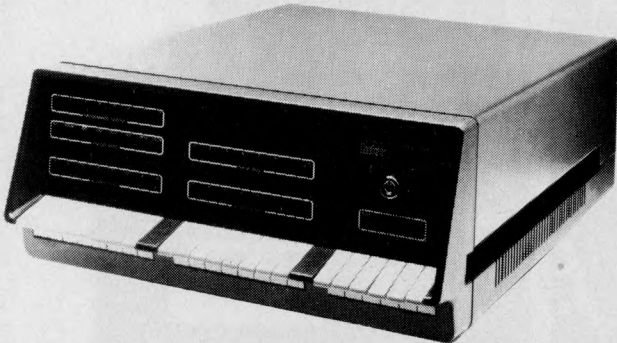

A MINI COMPUTER using MICRO technology at a ridiculous MICRO Price!!! The front panel with a backplane and power supply accepts S100 bus boards from many manufacturers.

# InterSystems

Just look at these professional features!

- ★ FRONT PANEL (we won't ask you to debug our hardware, but we will give you the tools to debug yours!) Has lights and switches to allow inspection and control of addresses and data. Other features include programmed input switches, and output lights. Examine. Examine next, deposit, deposit next, single or slow step (0.1 to 1000 IPS), hardware breakpoint on any data or address byte, repeat instruction and many other hardware diagnostic facilities.

- ★ 30 Amp, 8V power supply, 5 Amps on  $\pm 16v$  rails (all rails are separately fused)
- ★ 20 slot IEEE S100 Motherboard with active termination and shielding between bus lines
- ★ Guaranteed operation at 4MHz.

The DPS1 comes as a mainframe with front panel, Motherboard, power supply and 4MHz Z80A cpu board. The system is truly modular allowing the user to build up the system he requires in his own time.

S100 boards from a number of manufacturers will plug into the DPS1 IEEE S100 bus.

Just add S100 Memory Boards — S100 disk controller boards — S100 I/O boards — S100 video and/or graphics boards — S100 EPROM boards

All Ithaca Intersystems OEM products including K2 disk operating system and PASCAL/Z on 8" floppy drives will run in the DPS-1.

DPS-1 with S100 4MHZ Z80 cup board **£695**  
Fully assembled and tested

## SOFTWARE for your S100 system

**PASCAL/Z** The new language for Micros

CP/M Version **£165.00** (5 1/4" or 8")

K2 Version **£131.25** (8")

Runs under K2 operating system.

★ Compiler that produces Z80 macro assembler code — NO NEED for slow run time P-code interpreter. ★ Comes complete with Macro assembler. ★ Produces binary object modules — small and fast. ★ Modules are re-entrant and can be put into ROM. ★ IMBED, TRACE and ERROR debug facilities. ★ Recursion

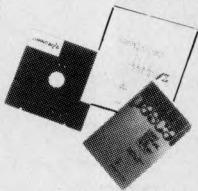

**K2 OPERATING SYSTEM** **£56.25**

8" disk based operating system — distributed on Shugart compatible 8" floppy disk  
★ TED — 52 command character orientated text editor with macros. ★ PIP — File and directory handler. ★ ASMBLE — full Z80 2 pass assembler. ★ HDT — Hex debug tool. ★ OCL — Utility overlay/command decoder. ★ SYSGEN — System builder. ★ COPY — disk to disk file copier. ★ DUP — disk duplicator.

## PASCAL MICRO DEVELOPMENT SYSTEM

*Are you still waiting for one?*

ITHACA Intersystems HAVE JUST  
ANNOUNCED AN IEEE S100 SYSTEM WITH A  
TRUE PASCAL COMPILER

FOR RESEARCH and DEVELOPMENT  
LABORATORIES and TEACHING APPLICATIONS

The PASCAL System



- DPS1 Mainframe with hardware front panel.

- Z80A 4MHZ Microprocessor.

- 64K Static RAM.

- 8" Shugart or DRI Floppy Disc Drive, Power Supply and Controller.

- K2 DOS Operating System.

- Pascal Compiler and Macro Assembler.

- I/O Board with 2 RS232 ports and 4 parallel ports

*While the others are talking about it, we are delivering!*

## OEM S100 boards from the experts!

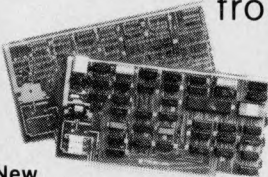

New products from Ithaca audio!

Assembled and tested

Disk controller (up to 4 single or double sided drives) **£131.25**  
I/O board (4 parallel and 2 serial ports) with interrupts **£210.00**  
I/O board (4 parallel and 2 serial ports) less interrupts **£180.00**  
S100 front panel (as used in DPS1) **£245.00**  
Analogue I/O board **£295.00**

Assembled and tested

8K Static RAM board (450ns) **£123.75**  
8K Static RAM board (250ns) **£146.25**  
16K Static RAM board (450ns) **£216.00**  
16K Static RAM board (250ns) **£234.00**  
64K Dynamic RAM board (250ns) **£540.00**  
Z80 cpu board (2MHz) **£131.25**  
Z80 cpu board (4MHz) **£153.75**  
2708/2716 EPROM board **£63.75**  
Prototype board (bare board) **£18.75**  
Video display board (64x16, 128U/L Ascii) **£108.75**

**AVAILABLE SOON:** ZBC-1 Single board computer for OEM market. Available in basic through to fully expanded. 4MHz Z80A, 64K RAM, memory mapped 4K screen buffer, composite video, up to 16K power on EPROM monitor, 4 parallel ports, 2 serial ports, 4 channel counter timer. 1 off **£895** — please phone for a quote for your needs. (quantity discounts available).

ALL MANUALS AVAILABLE SEPERATELY **£2.50 each**

### CONTACT THESE UK DEALERS

All prices quoted are exclusive of VAT.

**NEWBEAR COMPUTING STORE** (Newbury) (0635) 30505 Telex: 848507 **SIRTON PRODUCTS** (Surrey) 01-660 5617  
**DATAVIEW LTD.** (Colchester) (0206) 78811 **TRANSAM** (C.London) 01-402 8137 Telex: 444198  
**CODIFIED COMPUTER SYSTEMS** (North London) 01-226 1319 **MICRONEX** (Bristol) (027589) 3042  
**DATA SYSTEMS ENGINEERING** (Fife, Scotland) (03374) 469 **NORTEK SYSTEMS** (Merseyside) (0704) 67375  
**MICROPEOPLE** (Nottingham) (06076) 69117 **ENERTECH** (E. Sussex) (0323) 870814

ITHACA Intersystems  
(formerly ITHACA AUDIO of New York)

EUROPEAN SUBSIDIARY

58 Crouch Hall Road, London N8 8HG, England.  
Telephone: 01-341 2447 Telex: 895 4665 - Ref: ITHACA

# ALMARC

## NO.1 FOR

# VECTOR GRAPHIC

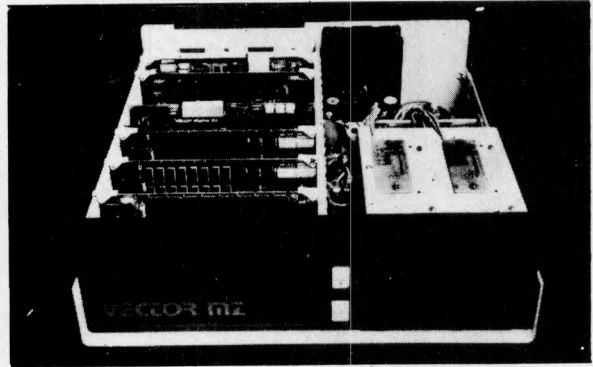

### OUR NEW EXTENDED RANGE OF PROFESSIONAL GRADE SYSTEMS

#### SYSTEM MZ

Z80 4MHZ CPU, 48K Ram, 630K bytes disc storage,  
Serial port & two parallel ports, prom rad board  
with monitor, 18 slot motherboard (S100),  
MDOS operating system, Z80 assembler, Basic interpreter

£2300.00

#### SYSTEM B

As MZ plus Vector mindless terminal, 24x80  
flashwriter board, MZOS North Star compatible DOS.  
CP/M configured by Almarc:

£2850.00

#### SYSTEM BG

As System B plus 240x256 graphics board, 8K memory.  
10" monitor.

£3240.00

#### SYSTEM BF

As System B plus Fast Fortran 80 compiler with hardwired  
floating point system which includes board and interface  
software for Fortran. This system uses the A.M.D. chip and  
provides breathtakingly fast floating point manipulation

£3595.00

#### SYSTEM BFG

Combines BG & BF plus 'Glib' graphics package for use with  
Fast Fortran 80 and 240x256 graphics board

£4190.00

We also sell a wide range of s100 boards and C/PM compatible software.

#### WE ARE THE SPECIALISTS

When you spend £2000.00+ on a microcomputer system you're entitled to support from people who understand the equipment and your problems. At ALMARC we don't sell systems from many different manufacturers, we specialise in Vector Graphic systems and supporting hardware & software. So if you want to just buy different makes of hardware then don't come to us, but when you decide that Vector Graphic is for you then contact ALMARC.

# ALMARC

ALMARC DATA SYSTEMS LTD., 29 CHESTERFIELD DRIVE,  
BURTON JOYCE, NOTTINGHAM. Telephone: 0602 248565

**MICRO  
COMPUTERS  
FROM  
COMART  
COME LIKE  
THIS!**



**comart**

**SPECIALISTS IN  
MICROCOMPUTERS**

**URGENT**

**SPECIALISTS IN  
MICROCOMPUTERS**

**comart**

**We care about what leaves  
our factory. After all it's got  
our name on it.**

The next time you want  
reliable microcomputer  
products – single card  
computers, floppy disk  
systems and disk systems –  
take a look at what we put in  
our boxes.

**A Comart Computer Catalogue will  
show you.**

Write to



**comart**

**Comart Ltd., P.O. Box 2, St. Neots,  
Huntingdon, Cambs.  
Or telephone (0480) 215005.**

# MacroFloppy™ goes twice the distance

Micropolis is rapidly becoming the industry standard in 5¼" floppy disc drives; they have been shipping double density drives for over 2 years, thus proving their outstanding reliability and performance.

By completely reassessing the engineering involved in 5¼" floppy disc drives, and using the most modern technology available, Micropolis achieve a formatted density of 315K bytes per single sided unit.

## Starter system

The 1041 / 1 Macrofloppy system includes a 143K byte double density drive with S100 controller card, MDOS and BASIC with a comprehensive manual.

This unit will successfully add on-line disc storage to a wide range of S100 computers at an unbeatable price per byte.

Add to your **Cromemco, North Star, Vector Graphic, Sol, Poly 88, Sorcerer, etc.**

Fully assembled, tested and burnt-in unit  
£439.00

Optional regulator for S100 raw power  
£14.00

## Also available

A full range of hardware and software including:

Mains powered add-on 143K bytes (Also suitable for **Tandy** expansion interface)  
£399.00

Single drive 315K byte system  
£663.00

Twin drive 630K byte system  
£1159.00

CPM  
£100.00

**North Star** compatible operating system  
£35.00

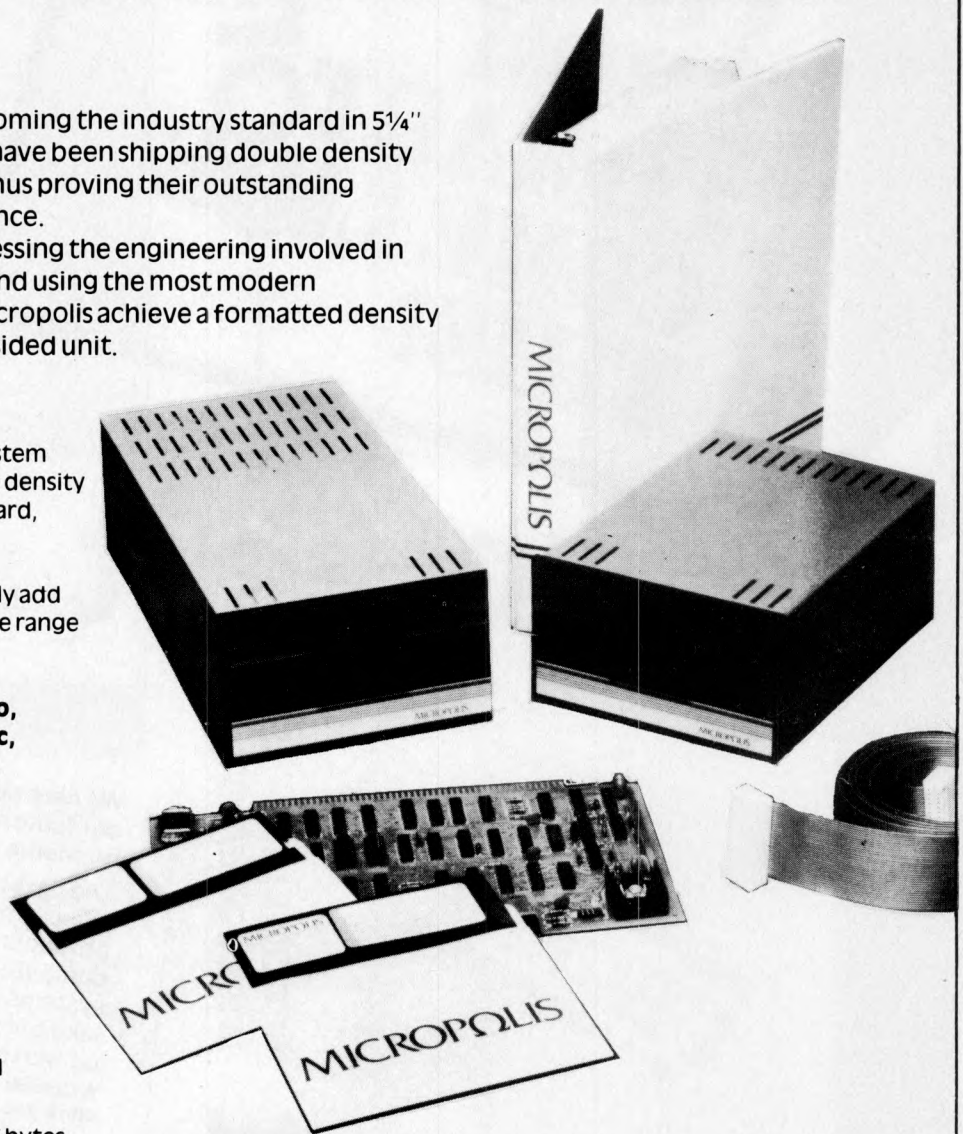

**Dealer enquiries welcome**  
**Ring Reading 85464 for further details**



## SINTROM MICROSHOP

14 Arkwright Road, Reading, Berks RG2 0LS  
Tel: Reading (0734) 85464  
TELEX: 847395 CABLES: SINTROM READING

**PET  
Z80/CPM  
6800**

# SOFTWARE

*This is how your business appears on the screen.  
Approx 60 entries update require only 1-2 hours weekly and  
your entire business is under control.*



**\*PROGRAMS ARE INTEGRATED**

- 1 = ENTER NEW NAMES ADDRESSES IN LINE!
- 2 = \*ENTER/PRINT INVOICES
- 3 = \*ENTER PURCHASES
- 4 = \*ENTER A/C RECEIVABLES
- 5 = \*ENTER A/C PAYABLES
- 6 = ENTER/UPDATE STOCKS REC'D
- 7 = ENTER ORDERS REC'D
- 8 = EXAMINE/UPDATE BANK BALANCE
- 9 = EXAMINE SALES LEDGER
- 10 = EXAMINE PURCHASE LEDGER
- 11 = EXAMINE INCOMPLETE RECORDS
- 12 = EXAMINE PRODUCE SALES

**SELECT FUNCTION BY NUMBER**

- 13 = PRINT CUSTOMER STATEMENTS
- 14 = PRINT SUPPLIER STATEMENTS
- 15 = PRINT AGENTS STATEMENTS
- 16 = PRINT QUARTERLEY TAX STATEMENTS
- 17 = PRINT WEEK/MONTH SALES
- 18 = PRINT WEEK/MONTH PURCHASE
- 19 = PRINT YEAR AUDIT
- 20 = PRINT PROFIT/LOSS ACCOUNT
- 21 = UPDATE ENDMONTH FILES
- 22 = PRINT CASHFLOW ANALYSIS
- 23 = ENTER PAYROLL

WHICH ONE (ENTER 1 TO 24)

EACH PROGRAM GOES IN DEPTH TO FURTHER EXPRESS YOUR REQUIREMENTS.  
FOR EXAMPLE (9) ALLOWS: a. list all sales; b. monitor sales by stock code; c. invoice search;  
d. amend ledger files; e. total all sales

**BUSINESS PROGRAM VERSION £275**  
(VERBOSE SIMPLE LANGUAGE AND UNITARY  
FILE HANDLING)

**BUSINESS PROGRAM VERSION 2 £375**  
(MORE IMPENETRABLE VALIDATIONS AND  
PROTECTION)

**MULTIMODE + MULTI-FUNCTION  
HANDLER 12 STRING £50**

**BUSINESS PROGRAM VERSION 3 £475**  
(SPACE SAVING AND MULTI MODE AND  
FUNCTION PROGRAMS)

**BUSINESS PROGRAM VERSION £575**  
(INCLUDING PAYROLL, YEAR AUDIT PRO  
LOSS CASHFLOW)

**MULTI-MODE 2 MULTI-FUNCTION, 12 STRING  
HANDLER & NUMERIC COMBINER £100**



# HARDWARE



**PET 2001 SERIES**

- PET Computer 2001 32K £795
- PET Printer 3022 Tractor Feed £645
- PET Floppy Disks 2040 £795
- PET IEEE Cables £ 45

**TERMINALS**

- HAZELTINE 1510 £895
- Interlube Video Terminal £595
- Soroc IQ120 £695

**PRINTERS**

- Teletype 43 Printer £895
- Centronics 779 Printer £950

**COMPUTERS**

**Intertec Superbrain**  
Dual Z-80A Vector Interrupt, 64 RAM  
pws 1K 2708 PROM Bootstrap, Two  
Double-Density 5in Floppy Disks  
£1,950

**Industrial Micro Systems Z-80 System**  
48K Expands to 594K; Twin D/D Disk  
included. Expands to 10 Meg and pro-  
grams are CPM compatible £2,500

**Smoke Signal 6800 System**  
32 K Expandable + twin D/S  
Discs £2,500

Please telephone for appointment — Tony Winter 01-636 8210

G.W. Computers Ltd., 89 Bedford Court Mansions, Bedford Avenue, London WC 1

See us on the Ensign stand (No. 51-52) at the PCW Show.

# HORIZON



## For Business, Scientific and Educational Uses.

### PROFESSIONAL HARDWARE

Use of the North Star Horizon for a short period will enable you to appreciate the professionalism in the product. There's a solid well-built chassis, a good power supply, a quiet fan and an attractive wooden case. There's a Z80A processor running at 4MHz with the 250ns static RAM boards.

There are dual integral Shugart minifloppy drives (capacity of about 360 KB on line, with an option for a further two drives), enabling easy and quick handling and copying of programs and data files.

And of course, there's the 12 slot S-100 bus which enables you to plug in many types of peripheral boards, including a hardware floating point board for increased "number crunching" performance.

### PROFESSIONAL SOFTWARE

North Star Computers built their professional reputation around their powerful, but simple, Disc Operating System and Disc Extended BASIC Interpreter.

The latter contains, in addition to the usual BASIC commands, random and sequential access disc files, strings, string operators, multiple dimensioned arrays, formatted output, machine language CALL, memory EXAMine and FILL, line editor, program chaining and more.

The CP/M operating system is also available as an option and provides access to a Macro Assembler, C BASIC Compiler and FORTRAN-80 and COBOL-80 Compilers. A standard UCSD PASCAL has now been implemented.

### TYPICAL APPLICATIONS SOFTWARE

- Financial
- Mathematical
- Statistical
- Educational
- Games
- Sales Ledger
- Purchase Ledger
- Stock Control
- Payroll
- General Ledger
- Estate Agents Package
- Incomplete Records
- Employment Agents

**HORIZON** with dual drives, 32K RAM, 2 serial + 1 parallel ports:- Dynamic RAM – £1545, Static RAM – £1905.

**COMPLETE HORIZON BUSINESS SYSTEMS** (hardware) with 32K RAM, dual mini-floppy drives, VDU and 8" printer – £3295; 48K RAM, dual mini-floppy drives, VDU and 150cps printer £4658.

Prices exclude VAT and carriage.

Dealer, OEM and Educational Discounts available.

## EQUINOX

COMPUTER SYSTEMS LTD.  
"KLEEMAN HOUSE"

16 ANNING STREET, NEW INN YARD,  
LONDON EC2A 3HB.

Tel: 01-739 2387/9 01-729 4460

# Thinking Computers?



## Then come to the number one micro-computer centre

If you're wondering if a micro-computer can help you, we are here to advise you. At Lion House—London's leading centre for micro-computers—you'll find:

- \* Experts who'll explain the equipment in a way you can easily understand, showing how and where it applies to *your* work.

- \* Demonstration areas where you can get immediate experience of using micro-computers yourself.

- \* Probably the biggest range of software in the UK.

- \* Programmes can be tailored for your particular commercial needs by our In-House Analysts and Programmers.

- \* Total service—including the availability of full maintenance after you've bought an installation.

- \* Leasing and H.P. facilities immediately available.

- \* A computer book section with publications that give you new insight into the world of micro-computers.

**How will micro-computers help you?** In thousands of ways—only a few can be mentioned here...

MICRO-COMPUTERS FOR BUSINESS



**For business and professional,** the versatility of compact micro-computers means that all the benefits of big computers are made available to all at low cost. The businessman can now computerise his accountancy, his stock control, his records and much more—cutting his overheads and improving his efficiency.

**For the home,** micro-computers have innumerable uses and considerable value too—sometimes in unexpected ways.

MICRO-COMPUTERS FOR THE HOME



Budgeting ... investments ... controlling heating or security ... storing information on things like recipes ... designing complex and fascinating games ... education ...

**Come and see.** We invite you to visit us and investigate the possibilities and the potential. If you're too far away, phone or write and we'll send you more information.

**You need a micro-computer.** We can supply it.



## LION MICRO-COMPUTERS

SMALL COMPUTERS—TO MAKE YOUR BUSINESS BIGGER

Lion Computer Shops Ltd, Lion House, 227 Tottenham Court Road, London W1 (First Floor). Telephone: 01-637 1601.

Telex: 28394 Lion G.

Open 9 to 6, Monday to Saturday (Thursday to 7).



# interface

# NASCOM'S NEW BIG DISTRIBUTOR

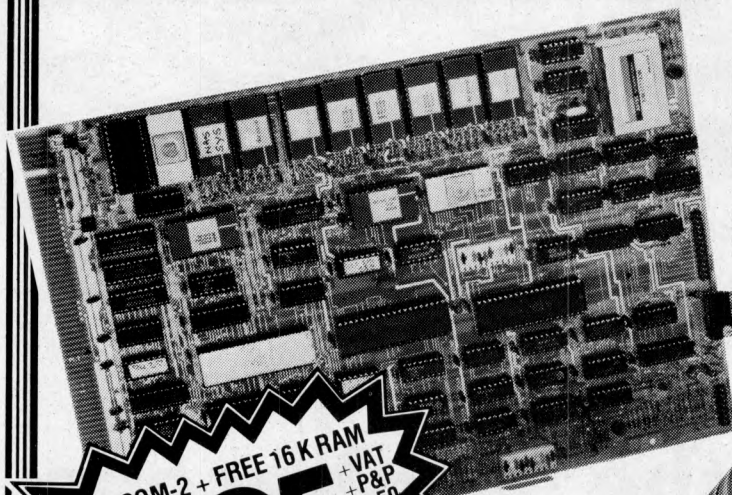

## NASCOM-2 + FREE 16K RAM

Here's an offer you can't refuse:

Because of the lack of availability of MK 4118 RAMs, Nascom Microcomputers is supplying its Nascom 2 without the 8 spare 4118s but with a FREE 16K dynamic RAM board.

When the 4118s become available, Nascom 2 purchasers can have them at the special price of £80 + VAT for the 8K.

So, for £295 plus VAT this is what you get:

### MEMORY

- 16K RAM board (expandable to 32K).
- 8K Microsoft BASIC.
- 2K NAS-SYS 1 monitor.
- 1K Video RAM.
- 1K Workspace/User RAM.
- Main board sockets for the 8x4118s or 2708 EPROMS.

### MICROPROCESSOR

- Z80A which will run at 4MHz but is selectable between 1/2/4 MHz.

### HARDWARE

- Industrial standard 12" x 8" PCB, through hole plated, masked and screen printed. All bus lines are fully buffered on-board.

### INTERFACES

- Licon 57 key solid state keyboard.
- Monitor/domestic TV interface.
- Kansas City cassette interface (300/1200 baud) or RS232/20mA teletype interface.

The Nascom 2 kit is supplied complete with construction article and extensive software manual for the monitor and BASIC.

NASCOM-2 + FREE 16K RAM  
+ VAT  
+ P&P  
£1.50

£295

No more slaving over a hot soldering iron - the Nascom 1 is now supplied BUILT!  
Britain's biggest small system is available fully constructed for you to slot into your own housing for the ridiculously low price of £175 plus VAT (kit price still only £165 plus VAT).

## nascom-1

12" x 8" PCB carrying 5LSI MOS packages, 16 1K MOS memory packages and 33 TTL packages. There is on-board interface for UHF or unmodulated video and cassette or teletype.

The 4K memory is assigned to the operating system, video display and EPROM option socket, leaving a 1K user RAM.

The MPU is the standard Z80 which is capable of executing 158 instructions including all 8080 code.

NASCOM-1 BUILT

£175

+ VAT  
+ P&P  
£1.50

### NASCOM FIRMWARE

- NASBUG T2: £12.50 + VAT + 30p P+P
- NASBUG T4: £25.00 + VAT + 30p P+P
- NAS-SYS 1: £25.00 + VAT + 30p P+P

### NASCOM HARDWARE

- Motherboard: £5.50 + VAT + 50p P+P
- Mini Motherboard: £2.90 + VAT + 50p P+P
- 3 amp PSU: £29.50 + VAT + £1.50 P+P
- VERO DIP board: £10.50 + VAT + 50p P+P

### NASCOM SOFTWARE

- 8K BASIC tape: £15.00 + VAT



# Take your first bite at computers with Apple



Starter System only

**£750\***

Typical Business System

**£2500\***

## WHY APPLE?

APPLE II Plus will change the way you think about computers. That's because it is specifically designed to handle the day-to-day activities of business, financial planning, scientific calculation, education, and even entertainment. It makes learning to use computers enjoyable and creative, by bringing to the user a new level of simplicity through design sophistication.

Apple Computer Inc. has produced a total system based upon the incomparable APPLE II Plus Computer, which has an unequalled range of accessories with superbly produced documentation.

## APPLE FEATURES

The basic APPLE II Plus can be used on its own (with your TV) or as the basis of a most comprehensive business computer system by adding such items as floppy disc drives and printers. Professionally written programs are available for a wide variety of tasks.

APPLE II Plus is easily programmed in BASIC but now has available for the first time—PASCAL, probably the most exciting new computer language around.

APPLE II Plus also has some futuristic accessories available today such as—programmed speech output—speech recognition—a superb music synthesiser that even displays the musical stave as it plays—a graphics input tablet—all this and high and low resolution colour graphics too!

Apple brings professional standards to personal computing. It gives you the features, appearance and "feel" for ease of use. The Apple name is your guarantee of satisfaction.

## APPLE RELIABILITY

Apple backs its quality with a solid warranty and the **Microsense Computers national network of Dealers** who can advise and help you in choosing the System and accessories to suit your particular needs whether for Business, Education or in the Home.

## APPLE IN BUSINESS

Apple is ideal for the small company run by forward looking Management. The Apple Computer System can, for example, help you run the company Payroll or handle the Stock Control for a Retail Store. Specialist applications include those for managing an Estate Agents records.

## APPLE IN EDUCATION

Computer literacy is rapidly becoming an essential part of the world in which we live. Real "hands-on" experience with the Apple allows teachers to be more effective in preparing their students for business, commerce and the professions where computers will soon be as common as typewriters.

## APPLE IN THE HOME

The computer can help you give your children a head start in understanding this modern business and scientific tool. Its very nature encourages learning and increases computer awareness. For the householder there are the advantages of easily handling home finance.

TRADE ENQUIRIES WELCOME—Please telephone (0442) 63561 Ext 52 or 57.

\*Prices exclusive of VAT and correct at time of going to press.

SOLE U.K. DISTRIBUTOR

**microsense  
computers**

Finway Road, Hemel Hempstead, Herts HP2 7PS  
Hemel Hempstead (0442) 41191 (3 lines)  
and 48151 (3 lines) 24 hour answering service

Telex: 825554 DATEFF G



© Apple is a trade mark of Apple Computer Inc., Cupertino, CA, USA.

I want to know more about how the Apple Computer can help me:

In my Business  In Education

In Science  In the Home

Name \_\_\_\_\_

Address \_\_\_\_\_

Postcode \_\_\_\_\_ Telephone \_\_\_\_\_

Please complete and send to Microsense Computers, FREEPOST, Hemel Hempstead, Herts. HP2 4BR. (No stamp required).

# TRANSAM COMPUTER PRODUCTS

## TRITON SINGLE BOARD PERSONAL COMPUTER

THREE NEW EXCITING EXPANDABLE SYSTEMS DESIGNED FOR EASE OF CONSTRUCTION AND FLEXIBILITY. KITS COME COMPLETE WITH CASE, POWER SUPPLY, FULL KEYBOARD, PCB. ALL COMPONENTS AVAILABLE SEPARATELY SEE CATALOGUE.



FULL HARDWARE AND PROGRAMMING MANUAL AVAILABLE. THE SYSTEM IS EASY TO EXPAND AND IS WELL SUPPORTED. FEATURES 2, 2.5 OR 7K BASIC IN EPROM (SEE CATALOGUE).

- SINGLE BOARD
- HOLDS UP TO 8K MEMORY
- VHF OR VIDEO OUTPUT
- CASSETTE INTERFACE
- THREE FIRMWARE OPTIONS
- BASIC IN EPROM
- 64 GRAPHICS CHARACTERS
- PLUS IN EXPANSION BOARDS

**Personal Computer £286 +VAT FROM**

## EXPANSION MOTHERBOARD

TRITON. Expand your Triton simply and easily with our new 8-slot motherboard; complete with its own P.S.U. takes 8 plug-in Euro cards. Plug-in 8K RAM card.

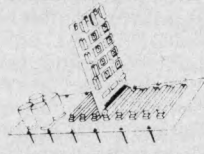

£50 + VAT

AND EPROM CARDS NOW AVAILABLE. KIT COMPLETE WITH PSU-1 SET CONNECTORS

## 8K RAM CARD

TRITON 8K STATIC RAM CARD KIT USES 2114 LOW-POWER 4V STATIC RAMS ON-BOARD REGULATION. NEW JUMP SELECT PCB ONLY £5. RAMS £5.50 KIT LESS RAMS £31 INCL SKTS COMPONENTS



COMPLETE KIT £97 + VAT

## 8K EPROM CARD

TRITON 8K EPROM CARD KIT COMPLETE TO TAKE UP TO 8 x 2708 EPROMS (1K x 8) AS RAM CARD PCB ONLY £15 KIT LESS EPROMS £31 EPROMS (BLANK) £9 PLUS VAT



COMPLETE KIT £97 + VAT

## BI-DIRECTIONAL MATRIX PRINTER

£595 + VAT

THE BD80 IS A LOW-COST, 80-COLUMN LINE PRINTER WITH MICROPROCESSOR CONTROL TO PROVIDE EXCELLENT AVAILABILITY AND PERFORMANCE.

- 5 x 7 Dot Matrix
- 10 Char. per inch
- 6 Lines/inch
- 400 Char. Buffer
- Full ASCII Char. Set
- 10 Lines/sec Paper Advance
- 112 Char./sec
- 82 Lines per minute
- Self Test
- Fully Cased

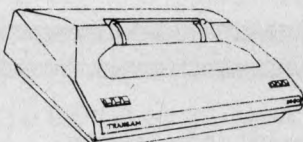

A UNIQUE PRINTER FAST AND RELIABLE

SWITCH-SELECTABLE BAUD RATE FROM 110 TO 9,600 ON A STANDARD V24 AND RS232 INTERFACE. SEND SAE FOR FURTHER DETAILS. IDEAL PRINTER FOR TRITON OR ANY SYSTEM REQUIRING HIGH-SPEED, RELIABLE HARD COPY. WE CAN SUPPLY CONSUMABLES

## S100 BOARDS

8K Static RAM board (450ns) £123.75  
8K Static RAM board (250ns) £146.25  
Z80 cpu board (2MHz) £131.25  
Z80 cpu board (4MHz) £153.75  
2708/2716 EPROM board £63.75  
Prototype board (bare board)  
Video display board (64x16, 128/L Ascii) £108.75  
Disk controller board £131.25  
KD disk operating system £56.25  
ASSEMBLE/Z Macro Assm £37.50

## ITHACA

PASCAL/Z build your own Pascal Micro Development system. IEEE S100 bus system using DPSI main-frame. Supports K2, ASSEMBLE/Z and PASCAL/Z on 8" disk. WE STOCK THE FULL RANGE OF ITHACA PRODUCTS

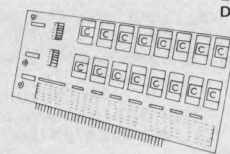

YOUR LONDON DEALER!

## PCB CONNECTORS

EDGE CONNECTORS GOLD CONTACT DOUBLE-SIDED PCB CONNECTORS

.1 in.	PRICE	.156 in.	PRICE
22/44	£3.20	6/12	£1.25
25/50	£3.60	10/20	£1.50
28/56	£3.90	12/24	£2.00
30/60	£4.15	15/30	£2.20
35/70	£4.60	18/36	£2.30
36/72	£4.75	22/44	£2.65
40/80	£5.00	28/56	£3.30
43/86	£5.50	36/72	£3.90
50/100	£5.80	43/82	£4.60 + VAT

## TRAP! Triton Resident Assembly Language Package

Links via the L6.1 monitor and new scientific basic to make Triton a stand alone development system. Trap is an 8K package in EPROM and resides on our EPROM card. Set of 8x2708 only £80 including document.

- EDITOR
  - ASSEMBLER
  - DISASSEMBLER
  - SYMBOL TABLE
  - CRYPSTALS
  - BREAKPOINT
  - SINGLE STEP
  - TRACE
  - PROGRAMME LOAD
  - MONITOR
- SEE CATALOGUE FOR FURTHER DETAILS

## COMPONENTS 74LSXX

SN74LS00N	18	SN74LS554N	21	SN74LS138N	75	SN74LS195AN	85	SN74LS325N	255
SN74LS01N	18	SN74LS563N	21	SN74LS139N	75	SN74LS196AN	85	SN74LS326N	255
SN74LS02N	20	SN74LS563N	50	SN74LS145N	20	SN74LS197N	20	SN74LS327N	255
SN74LS03N	18	SN74LS573N	35	SN74LS148N	175	SN74LS221N	125	SN74LS328N	135
SN74LS04N	20	SN74LS574N	40	SN74LS151N	85	SN74LS240N	220	SN74LS329N	150
SN74LS05N	26	SN74LS575N	46	SN74LS153N	60	SN74LS241N	190	SN74LS335N	85
SN74LS08N	20	SN74LS576N	35	SN74LS164N	60	SN74LS242N	190	SN74LS336N	85
SN74LS09N	22	SN74LS578N	35	SN74LS155N	125	SN74LS243N	195	SN74LS337N	65
SN74LS10N	18	SN74LS583AN	115	SN74LS156N	125	SN74LS244N	220	SN74LS338N	65
SN74LS11N	26	SN74LS585N	110	SN74LS157N	60	SN74LS245N	260	SN74LS339N	132
SN74LS12N	25	SN74LS586N	40	SN74LS158N	99	SN74LS247N	125	SN74LS337AN	170
SN74LS13N	55	SN74LS590N	65	SN74LS160N	115	SN74LS248N	195	SN74LS375N	72
SN74LS14N	89	SN74LS591N	99	SN74LS161N	115	SN74LS249N	130	SN74LS377N	132
SN74LS15N	25	SN74LS592N	99	SN74LS162N	115	SN74LS251N	145	SN74LS378N	132
SN74LS20N	20	SN74LS593N	65	SN74LS163N	99	SN74LS259N	125	SN74LS379N	140
SN74LS21N	26	SN74LS595AN	120	SN74LS164N	150	SN74LS257N	140	SN74LS381N	365
SN74LS22N	26	SN74LS596N	175	SN74LS165N	170	SN74LS258N	95	SN74LS386N	57
SN74LS25N	39	SN74LS107N	39	SN74LS166N	175	SN74LS259N	145	SN74LS390N	196
SN74LS27N	35	SN74LS109N	39	SN74LS168N	195	SN74LS260N	39	SN74LS393N	150
SN74LS28N	35	SN74LS112N	39	SN74LS169N	195	SN74LS261N	350	SN74LS395N	180
SN74LS30N	25	SN74LS113N	44	SN74LS170N	250	SN74LS266N	39	SN74LS396N	170
SN74LS32N	27	SN74LS114N	44	SN74LS173N	220	SN74LS273N	185	SN74LS398N	275
SN74LS33N	39	SN74LS122N	79	SN74LS174N	175	SN74LS281N	75	SN74LS399N	160
SN74LS37N	29	SN74LS123N	90	SN74LS175N	105	SN74LS280N	75	SN74LS424N	450
SN74LS38N	29	SN74LS124N	60	SN74LS181N	275	SN74LS283N	180	SN74LS445N	125
SN74LS40N	25	SN74LS125N	65	SN74LS190N	75	SN74LS290N	180	SN74LS447N	125
SN74LS42N	79	SN74LS126N	65	SN74LS191N	175	SN74LS293N	180	SN74LS490N	195
SN74LS47N	95	SN74LS132N	75	SN74LS192N	145	SN74LS295AN	220	SN74LS496N	95
SN74LS48N	95	SN74LS133N	39	SN74LS193N	175	SN74LS298N	220	SN74LS566N	95
SN74LS49N	109	SN74LS136N	40	SN74LS194AN	189	SN74LS324N	180	SN74LS567N	270

## MEMORY AND SUPPORT CHIPS

SUPPORT	RAMS	ROMS	OTHER	PRICES EXCLUDE VAT
8212	2 20 2101	2 32 745287	3 70 LM748CN-8	1 19 7912K 1 80 19M 2 90
8216	2 20 2102L-4	1 20 745472	12 00 LM748CH	0 45 7915K 1 30 20M 2 90
8221	2 80 2111	2 32 745770	8 00 LM1455H	0 72 DIL SKTS
8226	2 20 2112	2 46 745773	15 46 LM1458N-8	0 48 80IL 0 14 CD4011 0 15
8234	4 20 2110	4 08 745774	12 46 LM1458D	0 65 140IL 0 15 + full range
8238	4 20 2154	8 18 1 0 LM1499D	0 85 80IL 0 24 MISCLE	
8245	11 00 2114	5 50 2513	7 50 LM1499AD	1 25 240IL 0 27 2515 7 50
8246	11 00 2102L-3	1 80 96364	10 95 LM1495N-14	0 99 20JIL 0 30 TMS6011 5 00
8251	5 00 74C920	11 00 14412	12 90 LM3301N	0 65 240IL 0 30 MC14411 12 00
8253	11 00 74C921	11 00 14412	12 90 LM3403N	1 20 480IL 0 36 MC14412 12 90
8255	5 00 74C929	11 00 LINEARS	0 39 LM3900N	0 54 CRYSTALS
8257	11 00 4027	11 00 LM3014H	0 30 TL080CP	1 49 100K 3 00 CPU S
8259	12 50 4044	14 70 LM301AN-8	0 99 TL081CP	0 69 200K 3 70 8080
8292	18 00 4045	9 15 LM (MINI DIP)	0 30 TL082CP	1 29 1MHZ 3 60 6800
6820P	4 50 4048	7 00 LM308N	0 99 TL083CN	1 65 3 50 80 8 00
6821P	4 50 2107	7 80 LM309N	1 45 TL084CN	1 69 1843K 3 00 80A 15 00
6850P	4 50 4116	8 00 LM311H	1 45 VOLT REGS	6 00 7805K 1 50 8085 12 95
6852P	5 50 4118	20 00 LM318H	2 25 7812K 0 90 2457K 3 05	
AY-5-2376	11 50 280P10	10 00 LM324N	0 79 7815K 0 90 3278P 2 70	
MC14411	12 00 280C10	10 00 LM339N	0 54 7815K 0 90 3MHZ 3 05	
MS7109	12 43 280A01	14 00 LM555N	0 30 7824 2 10 9900 30 00	
MS7160	10 00 280A02	14 00 LM556N	0 75 7805K 1 50 4 43M 1 00	
MS7161	10 00 EPROMS	6 00 LM709CN	0 37 7812K 1 50 5MHZ 2 70	
TMS6011	5 00 1702	8 00 LM723CH	0 58 7815K 1 50 6MHZ 2 70	
81LS96	1 30 520K	9 00 LM723CN	0 43 7824K 1 50 7MHZ 2 70	
81LS96	1 30 2708	28 00 LM733CN	1 30 7915 1 10 7 168M 2 50	
81LS97	1 30 2516	22 00 LM739CN	1 30 7912 1 10 8MHZ 2 70	
81LS98	1 30 2716	22 00 LM741CN-14	0 33 7915 1 10 10MHZ 2 70	
16x21141 only £79		LM741CN-8	0 25 7924 1 10 10 7M 2 70	
8x4116 only £58		LM741CN-14	0 79 7905K 1 80 40DIL 0 95	

## TRITON DOCUMENTATION

- available separately as follows. prices include p & p
- Triton manual — detailed circuit description and constructional details + user documentation on level 4.1 monitor & basic £5.70
- L4.1 listing — listing of 1K monitor & 2K tiny basic £4.20
- L5.1 user documentation on level 5.1 firmware £1.20
- L5.1 listing — listing of 1.5K monitor & 2.5K basic £5.20
- L6.1 user documentation on 7K basic interpreter £1.80
- Motherboard, 8K RAM & 8K EPROM constructional details £5.00
- User group newsletter subscription £4 per annum
- Triton software — Send SAE for list of programs available for Triton.

## HOME COMPUTING CATALOGUE

If you're in town, visit our showroom in Chapel Street, next to Edgware Road tube station. We have Tritons on display plus a comprehensive range of components and accessories, specifically for personal computer users. Books, mags, tapes, data, cables plus much more. Showroom open 6 days a week. (Half day Thurs from 1.30 pm)

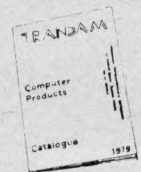

NEW A4 SIZE CATALOGUE FILLED WITH OUR LATEST PRODUCTS 40p + SAE ALL PRICES EXCLUDE VAT

# TRANSAM

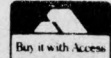

VAT ALL PRICES EXCLUDE VAT

TRANSAM COMPONENTS LTD. 12 CHAPEL STREET, LONDON, NW1 TEL: 402 8137

# Microcomputer Mail Order



All your microcomputer requirements can be bought with confidence by mail order from MICRODIGITAL, one of the largest and longest established computer stores.

Most orders are despatched same day as receipt, if not a note explaining what the supply situation is. If we cannot supply within 30 days we will, on request, make an immediate cash refund.

Access and Barclaycard orders are welcome either in writing or over the phone. Your account will not be charged until the goods are despatched.

Official orders of over £10 are also welcome. With normal 30 days trade credit extended to bona fide commercial and government organisations.

If you do not have our brochures, write or phone today for free copies by return.



## MICRODIGITAL

MICRODIGITAL LIMITED  
FREEPOST (No stamp required) LIVERPOOL L2 2AB  
TEL: 051-236 0707 (MAIL ORDER 24 HOURS A DAY)  
TEL: 051-227 2535

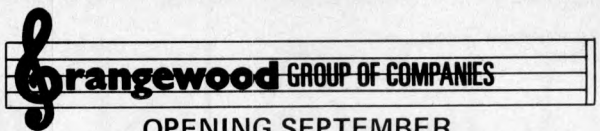

OPENING SEPTEMBER

HOME + BUSINESS COMPUTERS

"PET SHOP" FOR THE HOME AND SMALL BUSINESS MAN 8K-16K-32K

"THE QUICKNESS OF THE CHIP DECEIVES THE EYE" WITH SORCERER 32K OF MAGIC. THE IDEAL SYSTEM FOR THE MORE AMBITIOUS HOME USER AND THE BUSINESS MAN - FLOPPY DISKS PRINTERS - WORD PROCESSING

BOOKS, MAGS, TAPES GALORE!

Add a little colour to your life with APPLE/ITT 2020 what better use for your colour T.V.!!

WE ARE HERE

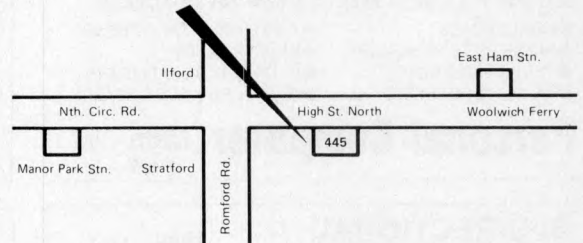

445, High Street North, Manor Park, London E12.  
Phone 01-472 5107 (24 Hr Ansaphone)

# 11 Megabyte Hard Disk for the Apple 2

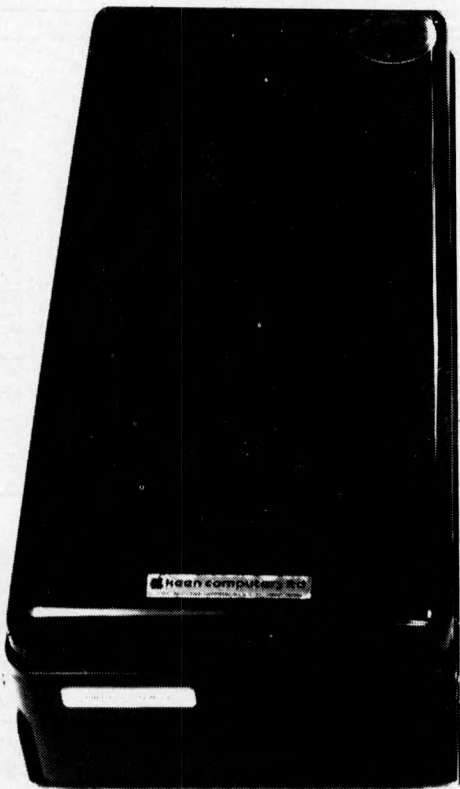

The Corvus 11A hard disk system for the Apple II is made by Corvus Systems Inc. and is imported exclusively by Keen Computers Ltd.

It has been specifically designed to work with the Apple Disk Operating System and plugs directly into anyone of the Apple's I/O ports, maintaining total compatibility with existing hardware and software.

The system consists of the IMI 7710 "Winchester" disk drive with Corvus intelligent controller, a complete power supply and an intelligent module for the Apple, consisting of an interface card and its associated software.

#### FEATURES:

- \* 11 megabytes unformatted storage
- \* Z80 controller and 16K RAM
- \* All Software in ROM
- \* Complete compatibility with existing systems
- \* 50K bytes/sec transfer rate
- \* Winchester heads

#### Prices:

Hard Disk and Controller £3500 - Slave Disk £2500

cut out and post today

Please send me more information on the Corvus hard disk

Name .....

Company .....

Address .....

.....

pcwoct



## Keen Computers Ltd

5b The Poultry  
Nottingham NG1 2HW  
Tel: 0602 583254

# HERE'S TREMENDOUS VALUE FROM COMPUTER CENTRE

## MINI KIT

The lowest priced CP/M Z80 Micro in U.K. Add your power and terminal. Minifloppy 16KB, RAM, Z80, CTC, Serial + Parallel I/O, S100 motherboard, connectors, manuals CP/M system FREE BASIC and ALGOL. Optional two drive case illustrated and power supply **£149**



## S100 KITS

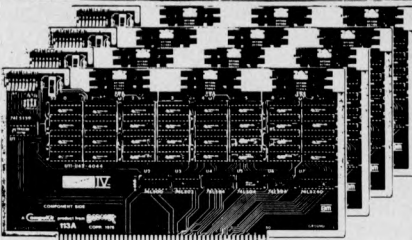

**8K Static Ram Kit**  
4MHz has run in Northstar, Cromenco, etc. **£79** ass. £94

**64K Dynamic Ram Kit**  
4MHz runs with 8080, Z80, uses 16kbit chips **£449** ass. £499

**SBC 100 Single board Z80**  
S100, Z80, CTC, USART 1K RAM, 4 ROM, Serial and Parallel I/O. **£155** ass. £215

**Eprom Programmer Kit**  
for 2708, or 2716 Eproms S100, Eprom sockets **£99** ass. £145

Also S100	kit	ass.
16K Econoram IV 4MHz	175	199
8080A with vector interrupt	69	104
I/O 2 Serial/Parallel	89	124
Tarbell disc controller	125	160
Versafloppy disc controller	99	140
VDB 80x24 Video	185	245
Motherboard (11 slot)	19	—
Prototype board	18	—

## MEGABYTE

**MEGABYTE MICRO KIT**  
CP/M disc based micro in kit form! Just add power and a terminal. Kit includes:  
Drive, 8in double sided double density, Z80, CTC, Serial and Parallel I/O, 16K ram (expandable to 64K), CP/M systems, connectors, manuals. Case and power supply extra £149. Assembled and Dual Drive versions available.



## SDS 100

Z80, 12" VDU, 1M. Byte, twin drives, Serial + Parallel outputs, numeric pad, CP/M system



## TRS 80

**16K bytes upgrade kits** - these are the IC's that even work in the 48k expansion. Excellent instructions, screw driver and common sense extra!

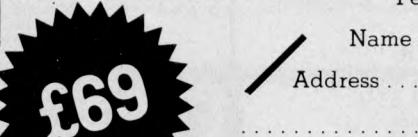

## MINI FLOPPY

Double/single density hard or soft sector used for TRS80 North Star etc.



## 8 INCH DRIVE

**DRI 7100 (Shugart Compatible)** single/dual density. British Made Assembled + Guaranteed. Double sided version. **£375**



## CP/M SOFTWARE

**CP/M Operating system + 6 manuals + Basic - E** **£64**

Extensive User group **£4.50**  
Library includes Basic 8" DISC compilers/interpreters Algol-60, Pilot, Stoic, utilities and games. 10 copies **£35**

### Proprietary software:

Microsoft Basic **£180**  
Fortran **£280**  
CIS Cobol **£380**  
UCSD  
Pascal **£150**

All advertised items generally in stock. Cash with order ensures same day despatch. Add 2% postage and 15% VAT to advertised prices.

Send:  Catalogue (please tick)

Send: .....

I enclose cheque for £ .....

Name .....

Address .....

# COMPUTER CENTRE

THE DISCOUNT COMPUTER STORE

9 De la Beche Street, Swansea, SA1 3EX. Tel: 0792 460023 Telex: 48638



For Hardware, Software, Peripherals, Consultancy and Competitive Prices.

# MICROCOMPUTERS ETC

Registered business name



## PET

**Pet 2001  
From £515**

NEW PET 2001 with large keyboard.  
From £ 630.00



commodore  
Authorized Dealers

PET 2001-16N (16K RAM and New Large Keyboard)	£630.00
PET 2001-32N (32K RAM and New Large Keyboard)	£750.00
PET 2001-8 (Standard PET with 8K memory)	£515.00
CBM 3040 (Dual Drive mini-floppy 343K User Storage)	£745.00
CBM 3022 (80 col. Printer with PET graphics—tractor feed)	£605.00
IEEE/RS232 Serial Interface 'A' Output only	£106.00
IEEE/RS232 Serial Interface 'B' Input/output	£186.00
IEEE-488/Centronics type parallel Interface	£45.00
PET C2N External Cassette Deck	£53.00
Interface to S100 (4 slot motherboard)	£112.00
IEEE to Pet Cable /IEEE to IEEE Cable	(Resp. £19/24
COMPUTHINK dual drive up to 800K storage from	£795

### Sorcerer

Now with the  
S100 Bus Expansion  
Interface and Dual  
Drive mini-floppy Disk



**E.I.**  
inc.  
Authorized  
Dealers

Sorcerer 16K RAM (inc.UHF Modulator)	£740.00
Sorcerer 32K RAM (including UHF Modulator)	£840.00
Exidy Video Monitor (High Resolution)	£240.00
Exidy Dual Drive mini-floppy Disk (630K storage)	£1195.00
Exidy S100 Bus with Interface+Motherboard+PSU	£200.00
Exidy Mini-floppy Disk Drive (143K Storage)	£495.00
CP/M for Sorcerer on Disk	£145.00

### apple computer

Computer with PALSOF in ROM (16K RAM) B/W	£750
Computer with PALSOF in ROM (16K RAM) Colour	£819
Apple mini-floppy Drive (116K storage) inc. Controller	£398
Parallel Printer Interface Card	£110.00
High Speed Serial (RS232C) Card	£110.00
RAM Upgrade (16-32K, 32-48K)	£69

ITT 2020 & EUROAPPLE Authorized Dealers

### Advanced Systems

Altair, Equinox, Billings, Heath, Rair, Horizon.  
Installations to include hard disk, and multi tasking

P. O. A.

### Terminals

(Most Brands)  
Pentland V1, 80 char./24 lines 2 page memory £580

**Ansaback** 'Phonemate' Telephone Answering Machine, voice operated twin cassette £190.00

### Software

<b>Petsoft COMPUSETTES</b> Personal Software	GEMSOFT
<b>Lifeboat Associates</b> (Authorized Dealerships, Send for Catalogues)	
PILOT (for TRS 80) text orientated language	£18.00
COMAC III Suite- Computerised Accounting for TRS 80	£75
STOCK CONTROL (TRS 80) Inventory, P/O & Invoicing	£125.00
CP/M for TRS 80	£95.00
CBASIC for TRS 80 & Sorcerer	£75.00
Estate/Employment Agency Systems, Fortran 80, Cobol 80, Pascal	

### Etc.

Diskettes 5 1/4 (blank) boxed (min. order 10) each	from £3.00
C12 Cassettes (Min. order 10) each	£0.45
Computalker Speech Synthesis for S100	£350.00
Books — Large range of Microcomputer related books & magazines.	

If you don't see it — ask if we have it.

**T & V JOHNSON (MICROCOMPUTERS ETC) LTD.**

Member of the TV Johnson Group of Companies

165 London Road, Camberley, Surrey GU15 3JS

48 Gloucester Road, Bristol BS7 8BH

148 Cowley Road, Oxford OX4 1JJ.

Branches at: Birmingham, Bristol, Edinburgh, Leeds, London, Louth, Newmarket, Nottingham, Oxford, Byfleet, Wokingham.

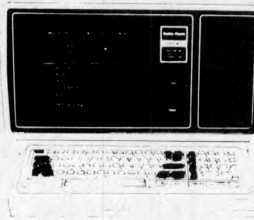

CAMBERLEY  
(0276) 62506  
BRISTOL  
(0272) 422061  
OXFORD  
(0865) 721461

## TRS 80 MODEL II

is coming...  
with up to 64 K RAM  
and 2-0 MB  
Disk Storage!

TRS 80, 4K Level 1 (Keyboard with 4K memory+ VDU+Cassette drive+240v PSU)	£365.00
TRS 80, 4K Level II (as above but with Level II basic)	£425.00
TRS 80, 16K Level II (as above but with 16K memory)	£499.00
TRS 80, Expansion Interface with 16K RAM	£275.00
TRS 80, Expansion Interface with 32K RAM	£360.00
Shugart Mini-floppy Disk Drive (including PSU)	£315.00
Micropolis Mini-floppy Disk Drive (including PSU)	£315.00
Percom FD200 Mini-floppy Disk Drive (inc. PSU) 110v.	£299.00
Micropolis Dual Drive (394K) (including PSU)	£1195.00
TVJ 232T Serial Interface for TRS 80	£45.00
TRS 80 Screen Printer (text+graphics) (110V)	£445.00
Centronics Parallel Printer Interface for TRS 80	£45.00
TRS 80 Voice Synthesizer	£345.00
TRS 80 Numeric Key Pad supplied & fitted	£69.00
New Radio Shack Micro Printer	£245.00
Radio Shack Phone Modem	£160.00
NEWDOS Super-enhanced TRSDOS	£49.00
Level III Super-enhanced BASIC	£34.00
RSM Assemble/Monitor on Disk	£19.95
MICROCHESS or SARGON CHESS Cassette/Disk	£14.00
UHF Modulators (encased with leads for 625 lines)	£20.00
RAM upgrade (4-16K, 16-32K, 32-48K) supplied and fitted at our premises (Kit £80)	£ 85.00
'Electric Pencil' text/word processing package (on cassette)	£65.00
'Electric Pencil' text/word processing package (disk version)	£109.00
'Electric Pencil' keyboard mod. to give lower case with text/word processing package.	£28.00
S100 Interface for TRS 80 (6 slots)	£375.00
'Library 100' — 100 progs for TRS 80 on cassette (Level II)	£39.00

NOW AVAILABLE

## Compucolor II

Computer with colour Monitor,  
Keyboard and Integral Disk Drive

From only £1058.00

Second Disk Drive £316.00

Programmed Diskette albums available from £9.00

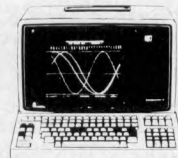

### Printers

Teletype 43 KSR Serial Printer	£825.00
Teletype 33 KSR Serial (110 Baud) Reconditioned	£550.00
Centronics 779 parallel (friction feed)	£750.00
Centronics 779 parallel printer (tractor feed)	£825.00
Anadex DP 8000 serial/parallel printer (112 c.p.s. bi-directional tractor feed)	£575.00
Centronics Micro printer (20, 40, 80 columns selectable)	£395.00
Black Box Printer (80 col.)	special offer £299
HEATH WH 14 serial (80, 96, 132 cols. selectable)	£510.00
TRENDCOM 100 (40 c.p.s. bi-directional, thermal)	£243.00
QUME or DIABLO daisy wheel serial printers	P.O.A.

PRICES EXCLUDE VAT, FREIGHT & HANDLING SEND OR PHONE FOR PRICE LIST & BROCHURES (All prices correct at time of compilation)

Directors: Dr. R.V. King, BA, MIEE.  
S.G. Johnson, BSc. (Hons.)  
T.S. Johnson, ABIBA, ACMB, FBSC, MBIM  
A.S. Barton, ACII, ABIBA, CdpAF.



CAMBERLEY  
(0276) 62506  
BRISTOL  
(0272) 422061  
OXFORD  
(0865) 721461

+ Ansaback eves  
and w/ends.

Telex 858893

Hours of business 9.30—5.30 Mon-Fri. 9.30—1.00 Sat.

# Everything you always wanted to plug into your PET, APPLE or TRS-80\*

TRS-80  
HARDWARE

TRS-80  
SOFTWARE

## DOUBLE DENSITY DISK STORAGE FOR THE TRS-80

(220% capacity of Radio Shack's)

TRS-80 owners can now increase their on-line mass storage capacity to 200K bytes. How? By using the 77 track Micropolis model 1033-II dual drives.

Cost: only £1195 for two drives, to give 394K on-line.

How does it work? By writing on 77 tracks (instead of the conventional 35) with precision head positioning.

How do I use it? TVJ Microcomputers Etc. provides you with a special program to let your TRS-80 DOS know there are extra tracks. This program was written especially by Randy Cook, author of TRS-80 DOS.

Will the double density disk work with my Radio Shack drives? Yes, except of course for copying an entire 77 track disk to a 35 track drive.

### NEW

Radio Shack Voice Synthesizer for TRS 80 provides the ability to speak in English and limited foreign languages. Capable of producing 62 phonemes (sound units) that are the building blocks of spoken language. Includes audio amplifier and speaker. . . . . £345.

TRS 80 Printer Interface Cable — allows you to connect a parallel printer (e.g. Centronics 700 series) directly to your Level II Keyboard, i.e. Expansion Interface not required. . . . . £54.

TRS 80 Numeric Keypad Mod. — Calculator Style Numeric editor, and linking loader. . . . . £244.  
Key pad which sits to the right of the standard keypad; has keys for 0 to 9, decimal point and ENTER. Both Keyboards active at the same time. . . . . £69.

Radio Shack Microprinter for TRS 80, 40 column 2 1/2" Parallel and TRS 80 BUS Interfaces . . . . . £245.

TRENDCOM Printers for TRS 80, PET or APPLE. 40 cps, 40 column Thermal Printer . . . . . £243.

TRS 80 Interface for Trendcom Printer . . . . . £29.  
PET/APPLE Interface for Trendcom Printer. . . . . £49.

### APPLE

SPEECHLAB — provides voice control for the Apple. Train your Apple to understand and act upon the spoken word (inc. microphone) . . . . . £165.00

REAL TIME CLOCK — 1/1000 sec. to 388 days with interrupt;

Software controllable, Rechargeable Battery back-up when A/C power off . . . . . £165.00

GRAPHICS LIGHT PEN. . . . . £165.00

PASCAL CARD — Powerful new language for the Business User with PASCAL, PALSOFT & Intertur basic . . . £296.

COMMUNICATIONS CARD, allows APPLE to exchange data with a remote computer over ordinary telephone lines through a modem . . . . . £140.00

AC line controller — allows APPLE to monitor and control AC devices remotely . . . . . £270.00

**T & V JOHNSON (MICROCOMPUTERS ETC) LTD.**  
Member of the TV Johnson Group of Companies  
165 London Road, Camberley, Surrey GU15 3JS  
48 Gloucester Road, Bristol BS7 8BH

DATA MANAGEMENT/REPORT GENERATOR — easily formats disk files, allows entry, edit, delete & list of records; and retrieves data for display or calculation on screen or printer . . . . . £200.

ELECTRIC PENCIL — powerful word processor allows full cursor movement, insert/delete, string search, block movement, adjustable line length, justification (on cassette) . £65.

LOWER CASE MOD KIT FOR ABOVE . . . . . £28

DISK BASED WORD PROCESSING PACKAGE. . . £124.95

RSM-2D DISK MONITOR — powerful system manipulates disk data, has Z-80 breakpoint routine. . . . . £25

ESP-1 EDITOR/ASSEMBLER . . . . . £29.95

RSM-IS MACH, LANGUAGE MONITOR tape base. £23.95

DCV DISK CONVERSION UTILITY — use with TAPE-DISK utility to save system tapes on disk (i.e.) Pencil. £9.95

UTILITY PACK 1 — a) Libloader merges from tapes  
b) Renumber (spec. mem. size); Statement analysis for debussing.....£9.95 ea. all 3 for £24.95

SARGON CHESS — 16K Iv II — the 1978 champ . . . . £14

MICROCHESS 1.5 by Jennings — 4K any lev . . . . . £14

LIBRARY 100 — an assortment of 100 programs for . . £39

MAZE — random maze on the TRS-80 graphics. . . . £14

**FORTRAN IV FOR THE TRS-80!** Finally, for high speed calculations on your micro, MICROSOFT's FORTRAN can speed up those computation-bound programs. Complete package includes compiler, relocatable assembler, text editor, and linking loader. . . . . £244.

CP/M + CBASIC for TRS-80 . . . . . £170.

NEW DOS — TRSDOS with corrections & enhancements £25

**NEW DOS +** — As above but with further facilities:- KBFIX, RENUM, Screen to Printer one step, DOS commands from BASIC, Level I in II, SUPERZAP, Disassembler, Open 'E' to end of sequential file, Load and Save faster, List variables . . . . . £49.

### PET

JOYSTICK PACKAGE — complete with connector, software, instructiond . . . . £39.95 single, . . . . £59.95 dual.

MICROCHESS 2.0 by Jennings . . . . . £14

ASTROLOGY/NATAL PACKAGE — sophisticated chart computation with PET graphics . . . . . £14.95

SUBS — best graphics yet — drop depth charges on the subs below you and rack up points. Complete adjustability for many same variations. . . . . £19.95

SUPER MAZE — 2 games in 1: Tunnel vision lets you travel through the maze in perspective with graphics, also Kat'n' mouse chase . . . . . £19.95

74 COMMON BASIC PROGRAMS on 1 tape . . . . . £15

PETACT BUSINESS SYSTEMS. . . . . P.O.A.



Branches at: Birmingham, Bristol, Edinburgh, Leeds, London, Louth, Newmarket, Nottingham, Oxford, Byfleet, Wokingham.



# Upgrade your PET...

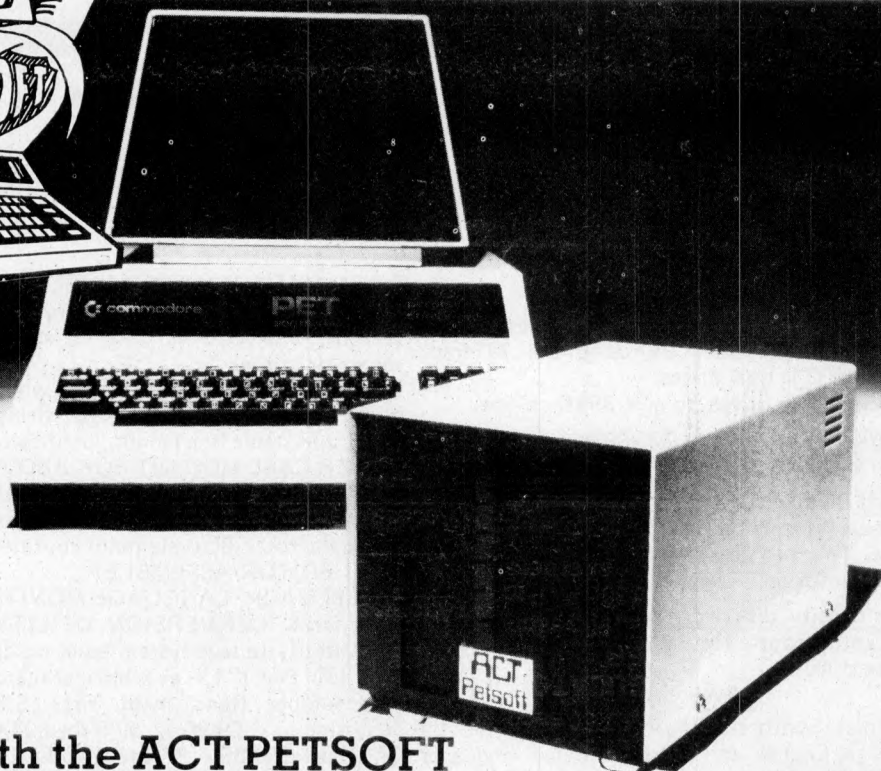

## ... with the ACT PETSOFT PROFESSIONAL DISK SYSTEM

A complete stand-alone system for the Commodore PET allowing up to 800,000 bytes of mass storage online. Designed by Compu/Think for business use, this powerful double density system offers complete random or sequential file access and support.

The Disk Operating System is in a ROM which plugs directly into 16K and 32K (new ROM) PETs, or via an Expandamem memory expansion board for 8K PETs. The Disk Operating System adds 16 extra easy-to-use commands to PETs BASIC. The Disk unit comes with a complete set of utility programs and a comprehensive manual.

- ★ Supported by PETACT Business Software: Sales Accounting, Invoicing, Purchase Accounting, and soon Stock Control and Payroll
- ★ More memory power for your money
- ★ Reliable and easy to use
- ★ Languages supported include BASIC, 6502 Assembler, FORTH, FIFTH, PLM, PILOT, CESIL, and soon FORTRAN and PASCAL
- ★ Wide range of PETSOFT programs including Payroll £50 + Stock Control £25
- ★ Supports the Pagemate Database £299

Prices exclude VAT

# ACT Petsoft

Radclyffe House, 66-68 Hagley Road, Edgbaston, Birmingham, B16 8PF. Telephone: 021-455 8686 Telex: 339396

Please send me details of the  
PETSOFT PROFESSIONAL  
DISK SYSTEM

My name is .....

I live at .....

..... Postcode .....

I have a new/old ROM PET

up to 800K online!

	MRP
<b>800K</b> Dual headed double density dual disk for 16K and 32K (new ROM) PETs	<b>£1,095</b>
<b>400K</b> Double density dual disk for 16K and 32K (new ROM) PETs	<b>£840</b>
<b>400K</b> Double density dual disk for 8K (old ROM) PETs. Requires Expandamem	<b>£795</b>
<b>24K</b> Expandamem internal expansion memory board	<b>£320</b>

Prices exclude VAT.  
PET is the trademark of Commodore who recommend PETACT Business Systems.

Try the ACT PETSOFT Professional Disk System and software at your PET dealer or write to us for full details and the name of your nearest stockist.



# comart

## ... the specialists

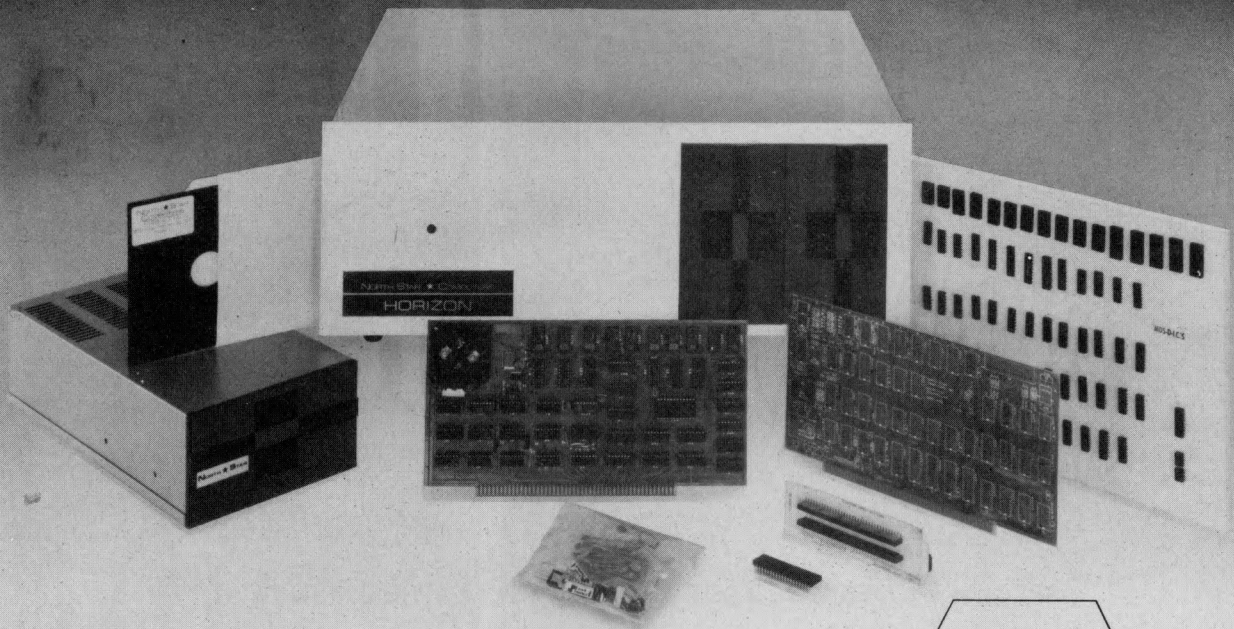

The complete range of North Star computer products in both kit and assembled form is offered by Comart: The Horizon computer, the Microdisk System, memory and floating point arithmetic board. And, Comart being S100 specialists, other items from our computer catalogue may be easily added to meet your requirements.

Teaching, Research, Engineering and Commerce .... each field has applications where this state-of-the-art technology provides cost effective processing of immediate benefit.

Comart quality. Each assembled module is final-tested by our own engineers. Take delivery of a computer system – plug in a wide variety of peripherals and use it.

Attractive prices, good delivery and a choice of Comart's factory repair or on-site service with a Computer Field Maintenance contract make the acquisition of a Comart computer a safe decision.

Find out more – ask us for the Comart catalogue of Computers.

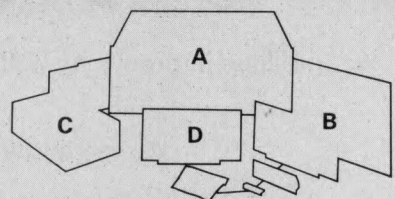

The North Star dual drive double-density Horizon computer **A** together with a typical kit product **B**, the Microdisk system drive **C** and hardware floating point board **D**.

Contact us direct or call your nearest Comart dealer

CAMBRIDGE  
CAMBERLEY  
ILFORD

LEEDS

LONDON  
LUTON  
MANCHESTER

NEWBURY

NEWPORT  
NOTTINGHAM

SHEFFIELD  
SOUTHAMPTON

**CAMBRIDGE COMPUTER STORE**, Cambridge (0223) 68155  
**MICROBITS**, Camberley, Surrey (0276) 34044  
**THE BYTE SHOP**, Ilford, Essex 01-554 2177

also at Tottenham Court Road, London 01-636 0647  
**HOLDENE LIMITED**, Leeds (0532) 459459

also at Wilmstow, Cheshire (0625) 529486

**DIGITUS LIMITED**, London W1 01-636 0105

**ISHERWOODS**, Luton, Bedfordshire (0582) 424851

**MICROCOMPUTERMART**, Manchester (061-832) 2269

also at West Park, Leeds (0532) 788466

**NEWBEAR COMPUTING STORE**, Newbury, Berks (0635) 30505

also at Stockport, Cheshire (061-491) 2290

**MICROMEDIA SYSTEMS**, Newport, Gwent (0633) 50528

**COMPUTERLAND LIMITED**, Nottingham (0602) 40576

also at Birmingham (021-622) 7149

Manchester 061-236 4737

Glasgow (041 332) 2468

**HALLAM COMPUTER SYSTEMS**, Sheffield (0742) 663125

**XITAN SYSTEMS LIMITED**, Southampton (0703) 38740



### comart specialists in microcomputers

Comart Ltd., P.O. Box 2, St. Neots, Huntingdon, Cambs, PE19 2AF. Tel: (0480) 215005 Telex: 32514

# micro BITS

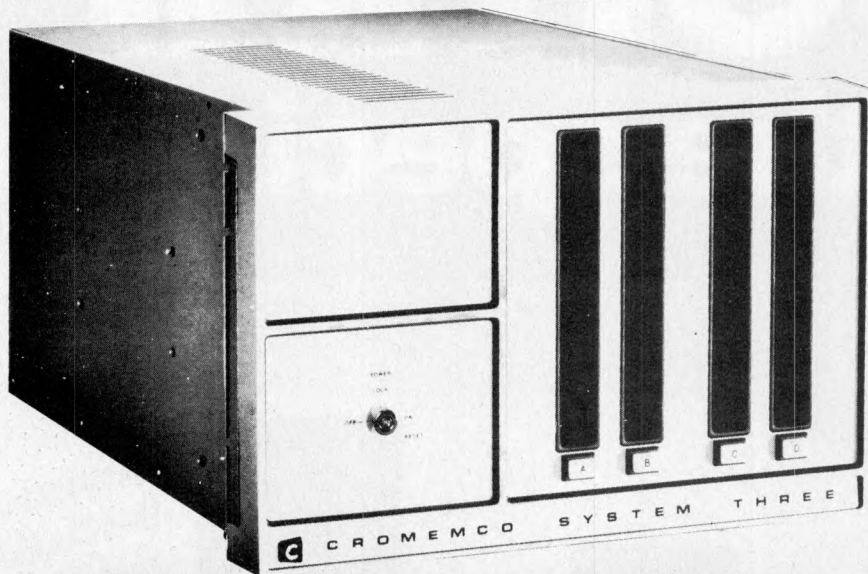

## CROMEMCO SYSTEM 3

- \*new low prices
- \*multi-user
- \*Fortran
- \*Word Processing
- \*early delivery
- \*Basic
- \*Assembler
- \*Mailing lists
- \*finance available
- \*Cobol
- \*Data-Base management
- \*Labels

SPECIALLY DESIGNED SOFTWARE NEED NOT BE EXPENSIVE

We specialise in producing well designed and constructed software with full documentation, user training and a guarantee.

We can quote on a fixed price or time and materials basis.

We require only one third payment on commencement of software projects, one third on delivery and one third AFTER the guarantee period. We can then provide an annual maintenance agreement.

Why buy unsupported, imported packages?

Also Sorcerer, Apple, Horizon systems, Dolphin, Printerm and OKII printers Elbit and Burnt Hill VDU's plus a vast range of books and all media requirements supplied.

# micro BITS

**SHOWROOM and OFFICES** open Monday - Friday 9 a.m. - 6 p.m.  
34B London Road, Blackwater,  
Camberley, Surrey. Saturday 10 a.m. - 5 p.m.  
Telephone: 0276 34044. Telex 858893 On Main A30  
SEE US AT COMPEC ON STAND 255

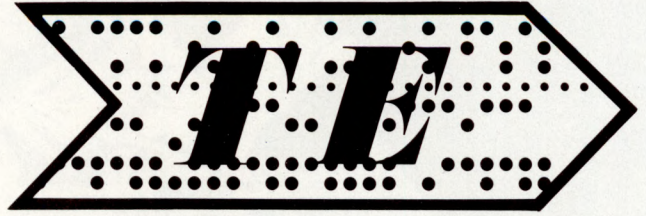

## TELEPRINTER EQUIPMENT LTD

### PAPER TIGER SPECIFICATION

<b>Controller:</b>	Microprocessor controller with both serial RS-232C and Centronics-compatible parallel interfaces.
<b>Power-on Diagnostics:</b>	Microprocessor program and buffer memory test performed each time power is applied. If a problem is found, the ONLINE indicator is extinguished and an attempt is made to print an error indication.
<b>Printing Diagnostics:</b>	Built-in, operator-initiated self-test prints repeating alphanumeric pattern.
<b>Maximum Print Speed:</b>	164 cps instantaneous, with sustained through-put to 79 cps at 16.5 cpi; 100 cps instantaneous, with 47 cps sustained through-put at 10 cpi.
<b>Through-put in Lines:</b>	228 lines per minute with short (10 characters) lines; 35 lines per min. with full lines (132 chars. at 16.5 cpi).
<b>Maximum Line Length:</b>	73, 80, 96, and 134 characters at 8.3, 10, 12.5 and 16.5 cpi respectively (8-inch print width).
<b>Paper Width:</b>	Maximum width of 9.5 inches to minimum width of 1.75 inches, including pinfeed holes.
<b>Paper Feed:</b>	Bottom or rear feed. Internal self-contained roll holder (optional) holds 4.5 inch diameter roll. Fan-fold paper stack of approximately 500 sheets can be housed partially within printer.
<b>Paper Form:</b>	Pinfeed roll or fanfold paper; widths from 1.75 to 9.5 inches.
<b>Paper Type:</b>	Ordinary paper. Single or multiple ply.
<b>Paper Drive:</b>	Stepper-motor-driven pinfeed tractor. Slew rate of approximately 3.5 inches per second.
<b>Forms Control:</b>	Eight switch-selectable form sizes and automatic perforation skip. Top of form control by operator switch (offline) and ASCII FF control code (online).
<b>Line Spacing:</b>	Six or eight lines per inch, switch selectable. Twelve lines per inch software selectable by ASCII VT code.
<b>Character Format:</b>	7-x-7 matrix normal mode. 8-x-7 matrix enhanced mode.
<b>Character Set:</b>	Full 96 ASCII characters, upper and lower case.
<b>Character Sizes:</b>	0.110 inch high; 8.3, 10, 12 and 16.5 characters per inch, plus enhanced (double width) characters at each density.
<b>Ribbon:</b>	Nylon ribbon, 0.5 inch wide on 2-inch spools with automatic re-inking mechanism.
<b>Print Head Life Expectancy:</b>	100 million characters.
<b>Graphics Dot Plotting:</b>	(Optional) Full dot pattern control for graphics. Includes expanded 2048-byte buffer.
<b>Electrical:</b>	Serial RS-232C interface with handshake control via Data Terminal Ready (DTR) signal. Centronics functionally compatible parallel interface.
<b>Connector Supplied:</b>	25-pin Male EIA (Cinch DB25P or equivalent). Interface cable optional.
<b>Serial Data Format:</b>	Asynchronous bit serial: 1 start, 8 data/parity, 1 or 2 stop bits.
<b>Character Codes:</b>	Full 96 ASCII characters, upper and lower case. 12 control codes standard. One optional.
<b>Line Buffering:</b>	Automatic multiple line buffering. Standard buffer size of 256 bytes; buffer size of 2048 bytes for full CRT screen and graphics buffering supplied with graphics option.
<b>Dimensions:</b>	15.75 inches wide x 12.25 inches high x 12.5 inches deep.
<b>Weight:</b>	20 pounds.
<b>Note:</b>	All specifications are for 50Hz operation. For 60Hz operation, through-put is increased by 17% and there is a 20% decrease in the density of selected character sizes.

# The Paper Tiger™ is here.

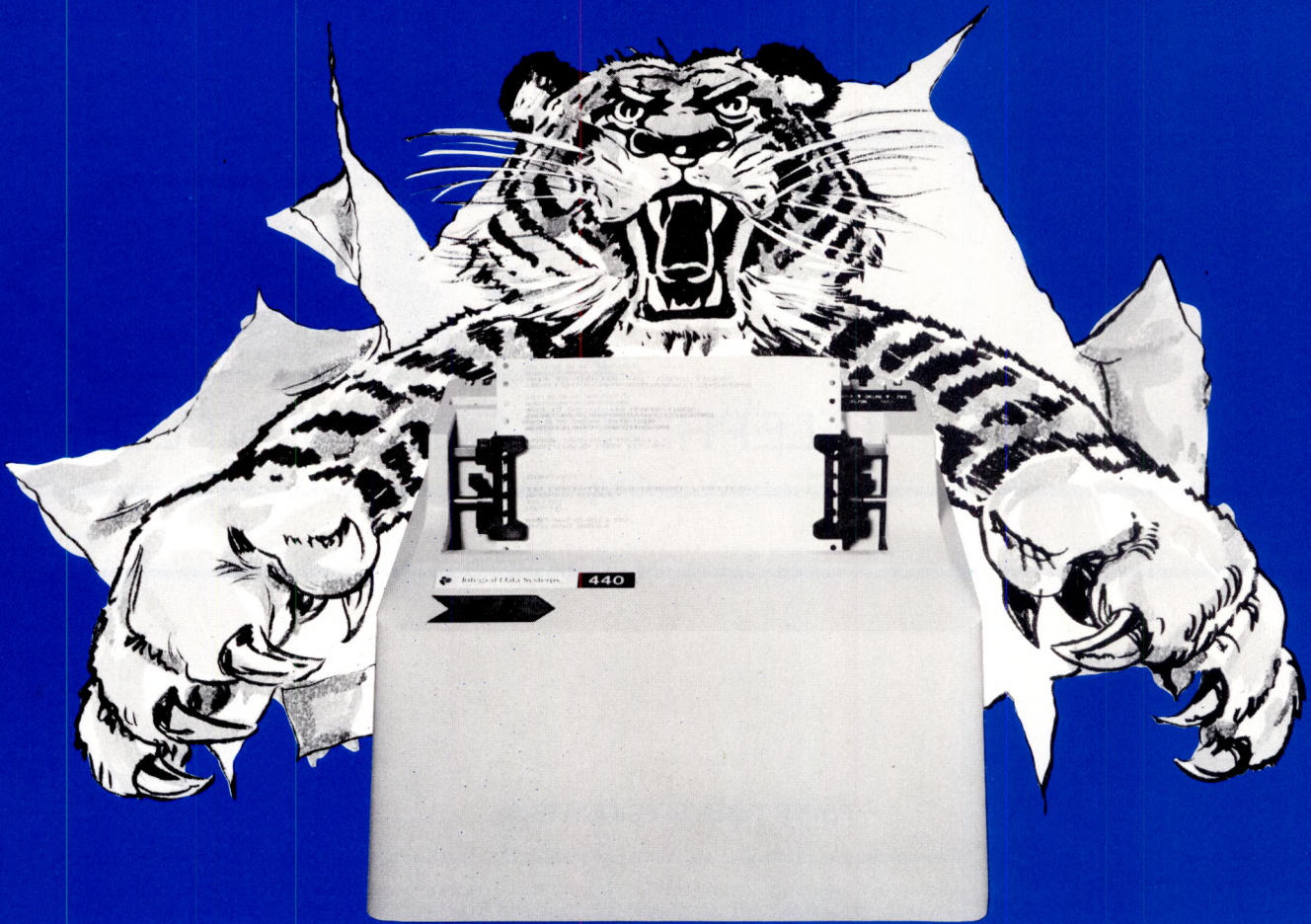

The Paper Tiger sets a new standard for low-cost impact printers. More capability. More versatility. For just **£585**.

You get a full upper and lower case 96-character set. Eight software-selectable character sizes. Plain paper, multiple copies. Forms length control. Parallel and serial interfaces. Multiple line buffer. Tractor feed. Automatic re-inking. 80 and 132 columns.

It's all standard with the Paper Tiger.

#### Unbeatable capability.

The Paper Tiger prints just about any paper form you need. From address labels to multicopy invoices and legal-size reports.

Adjust the tractor width from 1 3/4 to 9 1/2 inches. Choose from 8 switch-selectable forms lengths. Print 6 or 8 lines per inch.

#### Unmatched versatility.

Want graphics? Add the Paper Tiger's software-selectable full dot plotting graphics. Print illustrations, block letters, charts, graphs, and more.

Need a bigger buffer? The Paper Tiger features an optional 2K-byte memory that holds a full 24 by 80 CRT screen.

Printer Feature	Integral Data 440	Tally 1200	Lear-Seigler 300	Texas Instruments 810	Centronics 779-2
	96-character ASCII set, upper and lower case	YES	OPTION	YES	OPTION
Software-selectable character sizes	YES	NO	NO	OPTION	NO
Throughput, lines per minute @ 10 char./line @ 132 char./line	275 42	100 40	Data not available	440 64	130 21
Parallel and RS-232 serial interfaces standard	YES	NO	NO	NO	NO
CRT screen buffer	OPTION	NO	OPTION	NO	NO
Footprint (W x D = sq. ft.)	1.37	3.45	3.18	3.58	2.44
Weight (lbs.)	20	64	50	55	45
Forms length control	YES	OPTION	YES	OPTION	NO
Full dot plotting graphics	OPTION	NO	NO	NO	NO
Unit Price + VAT, P & P	£585	£1,500+	N/A	£1450	£995

Comparison data from manufacturers' current literature for 60 Hz operation.

#### And there's more.

The Paper Tiger is small, light-weight, and compact. That's because it's designed especially to work in small computer systems.

And it's built rugged and simple. For high reliability and easy maintenance. Just like the thousands of IDS printers already in the field.

#### See for yourself.

Check the comparison chart. Find out why this Paper Tiger sets a new standard for low-cost impact printers.

For more information, write or call:

**Teleprinter Equipment Ltd.**,  
70/82 Akeman Street, Tring, Herts.  
Telephone: (044282) 4011 (20 lines)  
Telex: 82362 BATECO G.



TELEPRINTER EQUIPMENT LTD



# BUY nascom-2 NOW AND GET A FREE 16K RAM BOARD

The lack of availability of the MK4118 RAMs has seriously delayed the launch of the Nascom 2, so we have decided to relaunch the product with an offer few will be able to refuse.

The Nascom 2 will be supplied without the optional user 4118s. Instead, we will supply a 16K dynamic RAM board and the interconnect for the NASBUS – absolutely FREE. This board allows further expansion to 32K. Also, when the 4118s become available, customers taking advantage of this offer can have the 8K for just £80 (plus VAT).

Meanwhile, the empty sockets on the Nascom 2 can be filled with 2708 EPROMs allowing dedicated usage, now with 16, or 32K of extra RAM. All the other features of the Nascom 2 are available and these include :

## MICROPROCESSOR

Z80A 8 bit CPU which will run at 4MHz but is selectable between 1/2/4 MHz.

## HARDWARE

12" x 8" PCB through hole plated, masked and screen printed. All bus lines are fully buffered on-board. PSU : +12v, +5v, -12v, -5v.

## MEMORY

- 2K Monitor-NAS SYS 1 (2K ROM)
- 1K Workspace/User RAM
- 1K Video RAM
- 8K Microsoft BASIC (MK 36000 ROM)

## INTERFACES

New 57-key Licon solid state keyboard  
Monitor/domestic TV

On-board UART provides serial handling for Kansas City cassette interface (300/1200 baud) or the RS232/20mA teletype interface.

Totally uncommitted PIO giving 16 programmable I/O lines.

The Nascom 2 makes extensive use of ROMs for on-board decoding. This reduces the chip count and allows easy changes for specialised industrial use of the board. On-board link options allow reset control to be reassigned to an address other than zero.

The 1K video RAM drives a 2K ROM character generator providing the standard ASCII characters with additions – 128 characters in all. There is also a socket for an optional graphics ROM on-board.

## NASCOM DISTRIBUTORS

Henrys Radio (London W2)  
Microdigital (Liverpool)  
Interface Components (Amersham)  
Comp Components (New Barnet)  
Electrovalue (Egham & Manchester)  
Lock Distribution (Manchester)  
Eley Electronics (Leicester)  
Target Electronics (Bristol)  
CC Electronics (Torquay)

Camera Centre (Barrow-in-Furness)  
Strathand (Glasgow)  
Byte Shop/Computerland Group  
Adda Computers (Ealing)  
Electronic Services (Sheffield)  
Business & Leisure Microcomputers (Kenilworth)  
A & G Knight (Aberdeen)  
P & O Computers (Belfast)

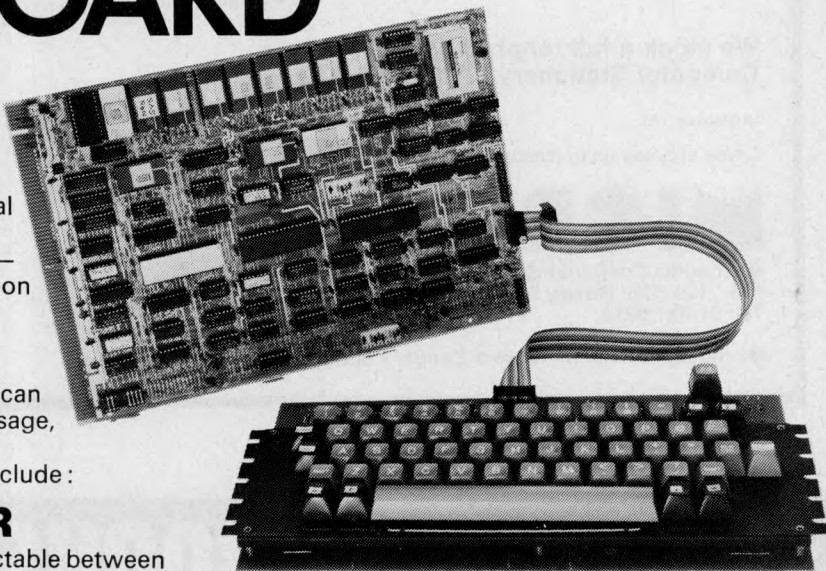

# £295 PLUS VAT

TO **NASCOM MICROCOMPUTERS LTD**  
**92 BROAD STREET**  
**CHESHAM**  
**BUCKS**

Nascom Microcomputers

Tel: 02405 75155  
NM/PCW/1

Please send me ..... Nascom 2 kits  
(complete with construction article and  
extensive software manual for the monitor and  
BASIC) at £295 plus VAT plus £1.50 p&p.  
And ..... 3A PSUs at £29.50 plus VAT  
plus £1.00 p&p. And ..... optional  
graphics ROMs at £15.00 plus VAT.

NAME \_\_\_\_\_

ADDRESS \_\_\_\_\_  
\_\_\_\_\_  
\_\_\_\_\_

ACCESS/  
BARCLAYCARD NO \_\_\_\_\_

# WE OFFER A COMPLETE SERVICE!

When you buy a computer from us — we don't give you the box and wave goodbye.

We realise this is a major purchase for a Company and take the time to find out your requirements, design your computer system and write the software, or if you prefer to write your own, we will always be available to advise you.

You can buy a wide range of fully-documented packages — Word Processing/Purchase & Sales Ledgers/Stock Control/Incomplete Records/Medical Systems/Teaching Programs etc. on Microcomputers such as—

**APPLE II** from £750  
(16K)  
A complete business system 48K  
Apple, 2 Disk Drives, VDU &  
Printer £2,500

**MICROSTAR** from  
£4,950  
Multi-user/Multi-task  
1.2/2.4 or 4.8 mb.  
A complete system with 2 VDUs  
& Printer £7,000

**ALPHA MICRO** from  
£9,950  
From 1 to 32 terminals.  
From 10 mb. to 90 mb. disk  
storage.  
16-bit processor, Multi-user  
operating system.

**We stock a full range of VDUs, Printers,  
Computer Stationery, Diskettes, Disk Boxes etc.**

all prices ex VAT.

Come and see us to discuss your requirements and have a demonstration.

## MICROSOLVE

Microsolve Computer Services Ltd.  
125 /129 High Street, Edgware, Middlesex.  
Tel: 01-951 0218

M1 junction 4 /20 mins from Central London.

e.g.

**LOW COST  
PRINTERM**

matrix printer £695

**LEAR SEIGLER**

200A matrix printer £1,650

**QUME Sprint 5**

daisywheel printer £2,115.

# BOOKS • BOOKS • BOOKS

**BOOKS** Our most popular titles:—

Introduction to Personal and Business Computing. £5.45

Microprocessors Chips to Systems. £7.95

Microprocessors — Interfacing Techniques. £8.75

Introduction to Microcomputers Vol 0 — The Beginners Book. £5.95

Vol. 1 — Application Techniques. £6.30

Microcomputer Prime. How they work for beginners. £6.35

Z80 Microcomputer Handbook. £6.95

Z80 Assembly Language Programming. £6.95

Z80 Prog. for Logic Design. £6.30

Illustrating Basic. £2.25

How to Profit from your Personal Computer. £5.50

6502 Applications Book £8.95

Programming the 6502. £7.95

Instant Basic. The fun way to learn. £7.20

Basic Basic. One of the most widely sold. £6.50

Advanced Basic. £6.00

How to Program Micros. Assembly Language for 8080, 6800 & 6502. £6.95

How to Build a Working Digital Computer. £4.60

How to Build a Computer-Controlled Robot. £5.95

Peanut Butter & Jelly Guide to Micros. £6.45

Small Computer Systems Source Book, for newcomers — practical knowledge. £6.10

Cobol with Style (proverbs) £5.40

Practice Problems in Number Systems, Logic and Boolean Algebra. £4.95

Some Common Basic Programs, 76 programs, finance maths etc. £6.45

Scelbi 6800 Gourmet Guide £7.95

Scelbi 8080 Gourmet Guide £7.95

Scelbi 8080 Standard Editor £9.95

Scelbi 8080 Standard Assembler £15.95

Scelbi 8080 Standard Monitor £9.95

Basic Computer Games £5.50

Computer Quiz Book £5.45

1976 U.S. Computer Chess Championships £6.25

Starship Simulation £5.45

Fun with Computers and Basic £5.45

Intro. to Computers and Basic

The Best of Byte £8.95

The Best of Creative Comp Vol. 1 or Vol. 2 £6.95

General Ledger £10.95

Accounts Payable/Receivable £10.95

ITT 2020 Handbook Set £20.00

Cromemco Catalogue £1.00

**NEW!**

Computer Capers. Tales of electronic thievery embezzlement and fraud! £5.95

David Lien. The BASIC Handbook. Virtually an encyclopedia! A Must! £11.50

A Colin Day. Fortran Techniques Spec. ref. to non-numerical applications. £2.25

Murray Laver. Intro to the Uses of Computers.

Includes appreciation of problems computers can handle outside purely mathematics £3.50

D. W. Barron. An Introduction to the Study of Programming Language. A comparison. £2.95

Donald M. Monro BASIC. Not to be confused with J. Coan's title. A must! A bargain! £2.00

Martin Whitbread Microprocessor. Applications in Business and Industry. Must for decision makers. £10.00

'Phone in your Access/  
Barclaycard No.  
0742-585490  
or complete this  
order form

Send s.a.e. for full list. Prices correct at going to press. Add 12p insurance on books if required.

**C Cromemco** **ITT 2020** **apple II** **PET**  
**TEXAS INSTRUMENTS** **nascom-I**

Please supply .....

I enclose:— £  
Cheque/Postal Order No. ....

Barclaycard/Access No. ....

Name: .....

Address: .....

Datron Micro Centre, Latham House, 243 London Road,  
Sheffield S2 4NF. Tel: 0742-585490

# COMPUTER WAREHOUSE

**NOW OPEN**  
MONDAY-SATURDAY  
9.30-5.30

## HIGH DEFINITION 9" VIDEO MONITOR

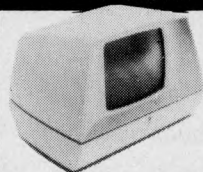

This superb ex computer video monitor was originally used as an information display on large computer systems. It features all silicon electronics, attractive style, housed in shatterproof two colour A.B.S. case with controls under flap. 240v operation, 625 lines, 75 or 50 ohm composite video input 50 hz - 20 mhz frequency response. Supplied complete in good condition but untested and unguaranteed.

Connect direct to your M.P.U. at only **£47.50** P.P. £68.00  
Supplied complete with circuit.

## DATA STORAGE MEDIUMS

RACAL C10 "Supergrade" cassettes complete with library cases 66p each 10 for **£5.45**

VERBATIM 5 1/4 soft sector mini disks **£3.45** each 10 for **£31.63**

## OPTO SMASH!

TIL 302/MAN 7 7 segment LED readout common anode direct drive (via resistors) from 7447 £1.10 each  
TIL 119/OC72 Darlington opto isolator 3 for £1.00  
TIL305 0.3" 7 x 5 matrix LED alphanumeric readouts £3.75 each.  
**PHOTO TRANSISTOR**  
Fairchild FPT-100 NPN silicon 30v 25ma. 4 for £1.00

## DISPLAY I.C. AND TRANSISTOR BARGAINS NEVER CHEAPER

All I.C.'s and Transistors by well known manufacturers and fully guaranteed. No fall outs. Comprehensive data on I.C.'s 15p per type.  
2N4351 N channel MOS FET.  
2N4352 P channel MOS FET.  
50p each £1.00 per pair.

**HIGH VOLTAGE NPN POWER SWITCHING** transistors BVcbo 600v BVceo 500v BVebo 15v Ic 5amps P<sub>c</sub> 125 watts HFE 60 typ ft 2.5 mhz ideal invertors, etc. TO3 £1.60 each 4 for £5.40.

**BF258 NPN** 250v @ 200ma 45p each 3 for £1.08.

**I.R. BSB01** 2.5 amp 100v bridge rec. P.C. mount long leads 35p each 4 for £1.08.

**IN4998** 4 amp 100v P.C. mount diodes long leads 14p each 10 for £1.10.

**LM309K** + 5v 1.2 amp regulator £1.10 each 6 for £5.35.

**2N1671B** unijunction 450mw 30v 48p each 3 for £1.00.

**IN4004 SD4** 1 amp 400v diodes 7p each 18 for £1.00.

**I.R. 12 amp BRIDGE RECS.** 400 volt £1.25 each.

**POWER DARLINGTON SCOOP!**  
**MJ1000 NPN** 60v 90w 8 amps TO3 95p each  
**2N6385 PNP** 80v 100w 10 amps TO3 £1.25 each  
**MJ4030 NPN** 60v 150w 16 amps TO3 £2.25 each

**PLESSEY EDGE STACKABLE DECADE THUMBWHEEL SWITCHES.** Gold plated contacts dimensions 2" x 2" x 1/8" 85p each 8 for £5.35.

**28 way 0.156"** double sided edge connector, easily cut £1.25 each.

**AMPHENOL 50Ω BNC** plug 50p. **50Ω BNC** plug right angled 60p.

**C90 Audio Cassettes** screw type construction 45p each 3 for £1.00.

**Bulbs** 24v 14 watt white frosted S.B.C. 8 for £1.00.

**Bulbs** 12v 100 watt clear, base similar S.B.C. 45p each.

**S.B.C. Bulb Holders** All steel cad. plated panel mount easily fixed via nut and round hole, ideal disco displays, scoreboards, etc. 4 for £1.10.

**Xtal filters** S.E.1 QC1121/B miniature low insertion loss P.C. mount. C.F. 10.7 mhz with B.W. of 7.5khz 2000Ω imp in-out. Brand new @ £7.99.

**Heavy Duty Flat Insulated Earth Braid** 100-200 amp braided tinned copper in heavy clear PVC sheath 50p per metre. £6 for 15 metres + PP £1 per 15 metres.

**BULGIN** miniature 6 way male chassis mount socket and matching free plug 60p each, 2 for £1.10.

**Red L.E.D.'s** full spec. 0.2" 14p each, 10 for £1.25.

**Dynamic Stick Mics** 600Ω with built in on/off switch complete with lead and min. jack plug £1.15 each, 10 for £10.00.

**TO5 HEATSINKS** "Thermalloy" black anodised press on aluminium finned type 18p each, 8 for £1.00.

**HARDWARE PACK** Don't be stuck for the right nut and bolt for the job. Pack contains B.A. Metric, Unified, Self Tap, etc. Nuts, Bolts, Screws, Washers, etc. in Brass Bronze and Steel. All steel items plated. Average contents 400-600 pieces.

Sold by weight, **£2.65** 2lb bag.

## MANY HUNDREDS OF TRANSFORMERS IN STOCK - SEND SAE FOR LIST

**1 ONLY DEC PDP8M**  
16k memory, auto restart, vk8 video set, serial/parallel, printer interface etc. Perfect order. **£850.00** + VAT + carriage.

## TELETYPES

**KSR33** 20ma loop from **£150.00**

**ASR33** 20ma loop from **£275.00**

## 4k x 12 RAM static Memory card

Complete 4K x 12 bit memory system on one PCB. This ex computer memory card contains all relevant decoding, read write and control logic for coupling to your M.P.U. or mini computer system. TTL in and out make interfacing a "cinch". We understand that by reading the outputs correctly, the memory can be organised as a 6K x 8! Features include fast 250ns max. access time. Standard +12v, -12v + 5v power rails compact construction, non volatile memory, data remains even when power switched off!  
Original cost over £800 each, supplied complete with full data and circuit manual, at an unbelievable price of **£39.95** P.P. £1.75  
Note: Memories are removed from working equipment but supplied untested, unguaranteed.

## HOW TO GET HERE

Victoria, London Bridge or Holborn Viaduct to Thornton Heath. 1 minute from Thornton Heath Station.

## MPU EXPERIMENTORS POWER SUPPLY

Once again we are very pleased to offer this superb Power Supply Unit, and hope to satisfy most of our previous customers who were disappointed when we sold out due to demand, last time they were advertised! These units may just have well been made for your lab., they consist of a semi-enclosed chassis measuring 160mm x 120mm x 350mm containing all silicon electronics to give the following fully regulated and short circuit proof outputs of:  
+5v @ 2 amps D.C. +12v @ 800ma D.C.  
-12v @ 800ma D.C. +24v @ 350ma D.C.  
and if that's not enough a fully floating 5v output @ 50ma D.C. which may be seriesed to give a host of other voltages. All outputs are brought out to the front panel via miniature jack sockets and are also duplicated at the rear on short flying leads. Units accept standard 240v AC mains input. They are ex GPO and may have minor scratches on the front panels, they are sold untested but in good internal condition. Our original price of £16.50 and the recent VAT increase makes these an absolute snip at only **£15.50** each + £2.25 P & P. Complete with circuit and component list.  
**HURRY WHILE STOCKS LAST!!**

**HY GRADE SMOOTHING CAPS**  
**MULLARD - PLESSEY - MALLORY - SPRAGUE**  
1500mf 100v 60p\* 3300mf 40v 50p  
3300mf 63v 70p\* 1mf 600v MYLAR 28p  
10,000mf 15v £1+ 22,000mf 16v £1.10+  
100mf 250v 45p 2100mf 200v £2.50+  
\*Ex equipment tested +P.P. 40p

## SEMICONDUCTOR 'GRAB BAGS'

Amazing value mixed semiconductors, include transistors, digital, linear I.C.'s, triacs, diodes, bridge recs. etc. etc. All devices guaranteed brand new, full spec. with manufacturers markings, fully guaranteed.  
50 + BAG **£2.95** 100 + BAGS **£5.15**

## MUFFIN FANS

ideal equipment cooling etc. tested, ex-equipment.  
240v 50-60 HZ **£6.15** + p.p. 45p  
110v 50-60 HZ **£5.05** + p.p. 45p

## ELECTRONIC COMPONENTS & EQUIPMENT 66% DISCOUNT

Due to our massive bulk purchasing programme which enables us to bring you the best possible bargains, we have thousands of I.C.'s Transistors, Relays, Cap's, P.C.B.'s, Sub-assemblies, Switches, etc. etc. surplus to our requirements. Because we don't have sufficient stocks of any one item to include in our ads., we are packing all these items into the "BARGAIN PARCEL OF A LIFETIME". Thousands of components at giveaway prices! Guaranteed to be worth at least 3 times what you pay plus we always include something from our ads. for unbeatable value!! Sold by weight  
**7lb £ 5.25 14lb £ 7.95**  
**28lb £13.75 56lb £22.00**  
PLEASE ADD P + P £1.25

## ISOLATED 240v 4 AMP & 10 AMP SOLID STATE RELAYS

Interface your MPU etc. with the outside world made by the famous "Astralux" Co. They consist of a miniature plastic module with mounting holes containing a relay for isolation, choke and triac. 12-20 volts D.C. at a few milliamps enable on/off control of A.C. loads up to 10 amps! The 100 amp version should be mounted on a heatsink. 100's of uses including power control, lighting, etc. etc.  
Dimensions: 4 amp, 1 1/2" x 1" x 1 1/2". 10 amp, 1 1/2" x 1 1/2" x 1".  
4 amp **£1.45** 10 amp **£2.10** complete with circuit

## SCOOP OF THE YEAR HAZELTINE H1200 V.D.U. TERMINAL

Due to a fantastic bulk purchase, we are now able to offer this superb terminal at a price almost below the cost of manufacture!! Features include: 12" screen, 55 key TTY keyboard, full ASCII, RS232 interface, adjustable baud rate 75 to 9600, 12 lines x 80 characters (upgradable to 24 x 80), cursor control, lower case option, plus many other features.

Brand new at only **£250** CARR. + VAT.  
FULL Technical Manual available

## POWER SUPPLY UNITS

**5 VOLT 2.5 AMP T.T.L. P.S.U.**  
Made for T.T.L. this compact ex computer systems unit features a 10 amp transformer with D.C. outputs of 5 volts @ 2.5 amps and 7.5 volts @ 5 amps. The 5 volt output is fully regulated and smoothed and has electronic current limiting. May be easily moded for 5 volts @ 7.8 amps, believed working but untested. 240v A.C. input  
Complete with circuit **£8.25** P.P. **£1.60**

## KEYBOARD

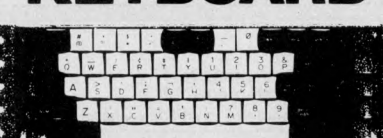

A special bulk purchase enables us to offer the above keyboard at a lowest ever price. 49 coded keys encoded into a direct TTL compatible 7 bit output. Features such as delayed strobe, 5 volt D.C. single rail operation and rollover protection make this an absolute must for the MPU constructor! Supplied complete with connection diagram and edge connector, at a secondhand price of only **£20.00** + P.P. **£1.60**

"no time to test" price of only **£20.00** + P.P. **£1.60**  
**SUPER CASED VERSION** Same as above spec. but housed in attractive two tone moulded, free standing case. Unit also includes an all TTL parallel to serial converter (no details) etc.  
**£27.50** + P.P. **£1.85**  
Note, super cased version matches 9" video monitor

## UNIVERSAL TOROID TRANSFORMER

Just what you have been waiting for, made for a major electronics co. this miniature toroidal transformer accepts 240v AC input and gives AC outputs of 0-10v @ 1.8 amps and 2 x 0-20v @ 750ma. Intended for an MPU supply of +5 and - and -12v its small physical size of only 2 1/2" x 1 1/2" and negligible hum field make it a snip at only **£4.25** + pp 60p.

## HIGH EFFICIENCY SMITHS RADIAL BLOWERS

Are your hot parts sweltering? Then keep them cool with our high efficiency radial snail type blowers. Made by Smiths, designed for continuous use in expensive electronic equipment very powerful and quiet, gives massive air flow to prolong component life and reliability. Easily mounted, air aperture 2 1/2" x 3". Ideal linear etc.  
Please state 240v or 110v operation. 50hz only.  
**£4.55** P.P. **£1.10**

# ELECTRONICS

Dept. P.C.W., 64-66 Melfort Road, Thornton Heath, Surrey  
Telephone: 01-689 7702

Unless otherwise stated all prices inclusive of VAT. Cash with order. Minimum order value £2.00. Prices and Postage quoted for UK only. Where post and packing not indicated please add 30p per order. Bona Fide account orders minimum £10.00. Export and trade enquiries welcome. Orders despatched same day where possible. Access and Barclaycard Visa welcome.

**MAIL ORDER & SHOWROOM**

EUROPE'S LARGEST SELECTION OF MICROCOMPUTER BOOKS, MAGAZINES AND SOFTWARE FOR THE HOBBYIST, EDUCATIONALIST, PROFESSIONAL AND RETAILER.

**BOOKS**
**SUMMER HOLIDAY BONUS: for the purchase of 3 books or more, and paying by cheque, P.O. or cash, give yourself a 10% DISCOUNT!**

Introduction to Microcomputers: by Osborne	
Vol 0: Beginners Book	£5.95
Vol 1: Basic Concepts	£6.30
Vol 2: Some Real Microprocessors (without binder)	£18.95
Vol 2: Some Real Microprocessors (with binder)	£24.70
Vol 3: Some Real Support Devices (without binder)	£11.95
Vol 3: Some Real Support Devices (with binder)	£17.70
Updating subscription (6 issues) for Vol 2	£18.95
Updating subscription (6 issues) for Vol 3	£18.95
Updating subscriptions for Vol 2 & 3	£30.00
1 Updating issue (specify for Vol 2 or 3)	£4.00
1 Binder (Specify for Vol 2 or 3)	£5.75

Microprocessors from Chips to Systems	£7.00
Microprocessor Interfacing Techniques	£8.75
Z80 Microcomputer Handbook	£7.50
TV Typewriter Cookbook	£7.50
Cheap Video Cookbook	£4.30
CMOS Cookbook	£7.50
IC OP-AMP Cookbook	£8.95
RTL Cookbook	£4.25
TTL Cookbook	£7.50
IC Timer Cookbook	£7.50
Ciarcias Circuit Cellar	£5.50
First Book of KIM	£7.00

6800 Programming for Logic Design	£6.30
8080 Programming for Logic Design	£6.30
Z80 Programming for Logic Design	£6.30

Introduction to Personal and Business Computing	£4.95
Getting Involved with your Own Computer	£4.75
Buyer's Guide to Microsoftware	£2.40
How to Profit from Your Personal Computer	£5.50
Microcomputer Potpourri	£1.75
Hobby Computers are Here	£3.95
New Hobby Computers	£3.95
Understanding Microcomputers and Small Computer Systems	£6.95
Understanding Microcomputers and Small Computer Systems plus audio cassette	£8.75

More BASIC Computer Games	£5.50
BASIC Computer Games (also see software section)	£5.00
What To Do After You Hit Return	£8.95
8080 Galaxy Game	£6.95
SUPER-WUMPUS — A game in 6800 Assembler code & BASIC	£4.25
Computer Music	£6.75
Computer Rage (A Board Game)	£6.95
Artist and Computer	£3.95
Games with a Pocket Calculator	£1.75
Games, Tricks & Puzzles for a Hand Calculator	£2.49
Introduction to TRS-80 graphics	£5.75
Take My Computer Please... (light hearted fiction)	£3.25

Instant BASIC	£6.95
Basic BASIC	£6.50
Advanced BASIC	£6.00
My Computer Likes Me . . . When I Speak in BASIC	£2.75
Calculating with BASIC	£4.95
Users Guide to North Star BASIC	£10.00
Introduction to PASCAL	£3.95

Z80 Instruction Handbook	£2.95
8080 Programmers Pocket Guide	£1.95
8080 Hex Code Card	£1.95
8080 Octal Code Card	£1.95

Accounts Payable and Accounts Receivable	£10.95
Payroll with Cost Accounting	£10.95
General Ledger	£10.95

Best of BYTE	£8.95
Scelbi BYTE Primer	£8.95
Best of Creative Computing Vol 1	£6.95
Best of Creative Computing Vol 2	£6.95
Best of MICRO (Issues 1-6 of Micro Magazine)	£5.50

Basic Software Library:	
Vol 1: Business and Games Programs	£17.50
Vol 2: Maths, Engineering and Statistical Programs	£17.50
Vol 3: Advanced Business Programs	£26.95
Vol 4: General Purpose Programs	£7.95
Vol 5: Experimenters Programs	£7.95
Vol 6: Miniature Business System	£32.50
Vol 7: Chess/Medbil/Wdproc Programs	£26.95

Z80 Assembly Language Programming	£6.45
6502 Assembly Language Programming	£6.45
Microcomputer Programming 6502	£7.95
6502 Applications Book	£7.95
8080A/8085 Assembly Language Programming	£6.45
6800 Assembly Language Programming	£6.45
8080 Software Gourmet Guide and Cookbook	£6.95
6800 Software Gourmet Guide and Cookbook	£6.95
8080/8085 Software Design	£6.75
6800 Tracer — An aid to 6800 Programme Debugging	£3.95
Program Design	£4.25
Programming Techniques: Simulation	£4.25

Some Common BASIC Programs	£6.30
Computer Programs that Work (in BASIC)	£2.55
32 BASIC Programs for the PET	£10.10

PIMS — A Database Management System	£5.95
Scelbal High Level Language + Supplements for the 8080	£15.00
Basex — A Simple Language + Compiler for the 8080	£5.50

8080 Standard Monitor	£9.95
8080 Standard Editor	£9.95
8080 Standard Assembler	£9.95
Special Package: 8080 Assembler, Editor, Monitor	£20.00
Bar Code Loader for 6800, 8080, Z80 and 6502	£2.25
Tiny Assembler for 6800 Systems, Version 3.1	£6.75
RA 6800 ML — An M600 Relocatable Macro Assembler	£15.95
LINK 68 — An M6800 Linking Loader	£5.50
MONDEB — An advanced M6800 Monitor Debugger	£3.50

**MAGAZINES**
**SUMMER HOLIDAY BONUS: For the purchase of 3 Magazine back issues or more, and paying by cheque, P.O. or cash, give yourself a 10% DISCOUNT!**

<b>Magazine Subscriptions:</b>		
Subscriptions start within 3 weeks		
MICRO 6502 Journal (12 issues)		
Personal Computing (12 issues)	UK Price	Overseas Price
Interface Age (12 issues)	£12.50	£12.50
Dr Dobbs Journal (10 issues)	£17.00	£17.00
Computer Music Journal (4 issues)	£25.00	£25.00
Recreational Computing (6 issues)	£13.50	£13.50
BYTE (12 issues)	£11.00	£11.00
Creative Computing (12 issues)	£8.50	£8.50
Kilobaud (12 issues)	£24.50	£24.50
On Computing (6 issues)	£16.50	£16.50
	£21.00	£21.00
	£6.60	£6.60

<b>Magazine Back Issues:</b>	
Micro-6502 Journal	£1.50
Personal Computing	£1.95
Interface Age	£2.95
ROM	£1.95
Dr Dobbs Journal	£1.95
Computer Music Journal	£3.75
People's Computers/Recreational Computing	£1.95
BYTE	£2.95
Creative Computing	£1.95
Calculators and Computers	£1.95
Kilobaud (reprints only)	P.O.A.
73	£2.25
Magazine Storage Box (Holds 12)	£1.25
On Computing	£2.25

**SUMMER HOLIDAY BONUS:** For the purchase of 2 or more software packages, and paying by cheque, P.O. or cash, give yourself a 10% DISCOUNT!

**SOFTWARE**

<b>Computers Plus Inc.,</b>	FMS-80 (File Management System) Demo Pack (includes manual & demo disc) <b>£35.00</b>
<b>Computer Services</b>	Bidirectional driver for Diablo Hytype printers for use on CP/M, CDOS & IMDOS systems. BI-DIRECT Complete System <b>£65.00</b> Manual only <b>£15.00</b>
<b>CP/M User Library</b>	40 Volumes (8" only) <b>£4.00 each</b>
<b>Creative Computing Cassettes:</b>	<b>Pet</b> CS-1001 Logic Games — 1 CS-1002 Number Games — 1 CS-1003 Logic Games — 2 CS-1004 Graphic Games — 1 CS-1005 Graphic Games — 2 CS-1006 Conversational Games — 1 CS-1007 Board Games — 1 CS-1008 Sport Games — 2 CS-1201 Simulations — 1 <b>Apple II</b> CS-4001 Space Games — 1 CS-4002 Sports Games — 1 CS-4003 Strategy Games — 1 CS-4201 CAI Programs — 1 CS-4301 Know Yourself <b>Exidy Sorcerer</b> CS-5001 Graphics Games — 2 <b>OSI Challenger 1P &amp; Superboard II</b> CS-6001 Graphics Games — 3 <b>SOL-20</b> Coming Soon <b>TRS-80</b> CS-2001 Games — 1 (level 1) CS-3001 Board Games — 1 CS-3002 Space Games — 3 <b>Each of these are £6.50</b> CS-3033 Adventure <b>£12.50</b> CS-3201 Ecology Simulations — 1 <b>£19.50</b>
<b>Creative Computing Discs:</b>	for CP/M CS-9001 BASIC Games, Volume 1, disc 1 CS-9002 BASIC Games, Volume 1, disc 2 CS-9000 Both discs purchased together <b>These cost £12 each, or £20 if purchased together.</b>
<b>Digital Research</b>	Operating Systems: <b>On 5" On 8"</b> <b>Name Discs Discs</b> CP/M for North Star <b>£105.00 N/A</b> CP/M for MDS-800 <b>N/A £65.00</b> CP/M on Cromemco <b>N/A £65.00</b> SID <b>£55.00 £45.00</b> MAC <b>£55.00 £55.00</b> TEX <b>£45.00 £45.00</b> DESPOOL <b>£30.00 £30.00</b> CP/M Manuals only <b>£15.00</b> TEX Manual only <b>£10.00</b> SID Manual only <b>£10.00</b> MAC Manual only <b>£10.00</b> DESPOOL Manual only <b>£2.00</b> CP/M Disc only <b>£85.00 £45.00</b> SID Disc only <b>£40.00 £40.00</b> MAC Disc only <b>£50.00 £50.00</b> TEX Disc only <b>£40.00 £40.00</b> DESPOOL Disc only <b>£29.00 £29.00</b>

<b>Information Unlimited Inc.,</b>	WHATSIT for North Star Horizon <b>£59.00</b> APPLE 2; 48K <b>£72.00</b> APPLE 2; 32K <b>£59.00</b> CP/M <b>£75.00</b>
<b>L.P Enterprises</b>	Diablo Driver runs 300/1200 baud with autoloader For CDOS <b>£25.00</b> For CP/M <b>£25.00</b>
<b>Micah</b>	CP/M for CDOS Users Program to Expand CP/M system to be compatible with Cromemco CDOS S/W. <b>£59.00</b>
<b>Michael Shrayer</b>	Electric Pencil A) SS II for TTY etc., <b>£175.00</b> b) DS II for a DIABLO <b>£215.00</b> c) TRS-80 Cassette <b>£60.00</b> d) TRS-80 disc (on cassette) <b>£130.00</b>
<b>Micropro</b>	WORD-MASTER <b>£90.00</b> manual only <b>£25.00</b> TEX-WRITER <b>£45.00</b> Manual only <b>£15.00</b> WORD-STAR <b>£260.00</b> Manual only <b>£2.00</b>
	SUPER-SORT Version 1 <b>£130.00</b> Version 2 <b>£106.00</b> Version 3 <b>£75.00</b> Manual only <b>£20.00</b>
<b>Northshare</b>	** A Multi-User system for Northstar User's Disc only <b>£24.00</b> Manual only <b>£22.00</b> <b>£5.00</b>
<b>Osborne associates</b>	Some Common Basic Programs for PET on cassette with book <b>£10.00</b> <b>£15.00</b>
<b>Software Systems</b>	CBASIC Disc & Manual <b>£65.00</b> CBASIC Disc Only <b>£70.00</b> CBASIC Manual Only <b>£15.00</b>
<b>Software Works</b>	On North Star Discs Inventory — 1 <b>£50.00</b> Inventory — 2 <b>£75.00</b> Mail Room <b>£50.00</b> Housekeeper <b>£35.00</b> Preventative Maintenance <b>£75.00</b>  Manuals Only <b>£10.00</b>
<b>Structured Systems Software</b>	Accounts Receivable (Sales Ledger) Disc & 222 Page Manual <b>£395.00</b> Accounts Payable (Purchase Ledger) Disc & 177 Page Manual <b>£395.00</b> General Ledger (Nominal Ledger) Disc & 150 Page Manual <b>£480.00</b> Inventory (Stock Control) <b>T.B.A</b> NAD (Name & Address System) <b>£50.00</b> QSORT (Sort Utility) <b>£50.00</b> Demo disc for SL, PL, NL, QSORT, NAD) <b>£25.00</b>

**STOP PRESS:**  
To be announced soon a Multi-User, Multi-Tasking operating System for use on Z80 Systems with a minimum RAM of 64K; maximum of 16M RAM.  
**STOP PRESS:**  
More Coming

**HOW TO ORDER**  
For Software please add £1.50 for postage and insurance (not the cassettes) plus 15% VAT.

Please note our book and magazine prices include postage and packing, but not insurance, if wanted add 12p for every £10. of books ordered. Make cheques, PO's etc. payable to:-  
**L.P. Enterprises.**  
CREDIT CARDS accepted  
**BARCLAYCARD VISA/ACCESS/DINERS CLUB/AMERICAN EXPRESS**  
Phone: 01-553 1001 for Credit Card orders (24 hr answering service)

THIS LIST CANCELS ALL PREVIOUS PRICE LISTS: EFFECTIVE JULY 1979  
DUE TO FLUCTUATIONS OF THE DOLLAR, PRICES SUBJECT TO CHANGE WITHOUT NOTICE

Send to address on other page All Orders must be Prepaid:  
Indicate Payment Method; and underline items required. Total Enclosed £ . . . . .

. . . . . My cheque, P.O., I.M.O. is enclosed in **Sterling on U.K. Bank**

. . . . . Charge to Barclaycard/Visa/Access/Diners/American Express

Credit Card No . . . . . Expiry Date . . . . .

Name . . . . .

Address . . . . .

. . . . . POSTCODE . . . . .

Signature . . . . .

All publications are published in U.S.A. and shipped into Britain air-freight by **L.P. Enterprises**. In unusual cases, processing may exceed 30 days.  
Prices subject to change without notice

**TRADE ENQUIRIES WELCOME, CALLERS WELCOME**

# Great news from Heath.



## WH-89 All-In-One computer.

The new All-In-One computer from Heath has the power, versatility, and built-in peripherals needed to meet the demands of the business user.

- \*'intelligent' video terminal \*2xZ80 microprocessors.
- \*floppy disk storage system.
- \*basic 16K RAM (expandable).

Easy to program. Simple to operate. It is capable of a multitude of high-speed functions and speaks the language of today's most popular software.

## Heath data systems

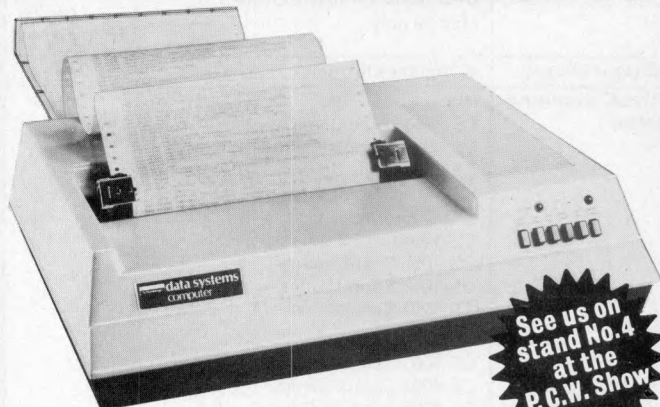

See us on stand No.4 at the P.C.W. Show

## WH-14 serial printer.

With a compact table-top configuration, the WH-14 is designed for a broad variety of uses in both the personal and business computing field.

- \*5 x 7 dot matrix impact printing \*96 character ASCII
- \*upper and lower case characters \*microprocessor-based electronics.

It combines speed, flexibility and ease of use with any computer providing standard RS-232 C or 20mA current loop interface connections.

For complete specifications of these and all Heath Data System products contact:

Heath (Gloucester) Limited, Dept. ( ), Bristol Road, Gloucester, GL2 6EE. Telephone: (0452) 29451.

## New Low-Cost ASCII Keyboards Ex Stock Delivery



**ALL THE ABOVE KEYBOARDS ARE FULLY TTL-COMPATIBLE PROVIDING THE FULL 128 ASCII CHARACTER SET, AND REQUIRING +5V -12V POWER SUPPLY. FULL TECHNICAL DATA AND CIRCUIT DIAGRAMS SUPPLIED.**

Model	Price	Mail Order	Optional Extras	Total
KB771 71 Keystations incorporating separate numeric/cursor control pad and installed in a custom built steel enclosure	£95.00	£115.00	Mail Order KB15P Edge Connector KB701 Plastic Enclosure KB702 Steel Enclosure KB710 Numeric Pad KB2376 Spare ROM	£4.31 £12.50 £25.00 £8.00
KB756 56-keystations, mounted on PCB	£49.50	£58.65	Encoder DC-512 DC/DC Converter	£12.50 £7.50
KB756MF, as above, fitted with metal mounting frame for extra rigidity	£55.00	£64.98	25-Way D-Type connector for KB771	£4.25

All equipment is refurbished second-user equipment unless otherwise stated. All prices subject to carriage & VAT. Trading conditions supplied on request.

<p><b>BALL MIRATEL VIDEO MONITOR</b></p>  <p>9in. diagonal P4 phosphor tube. Bandwidth 12MHz (-3dB). Input voltage 220V 50/60Hz 24W. Output voltage +15V DC (short circuit protected) +12kV DC, 12.6V r.m.s. Separate horizontal &amp; vertical sync. Supplied complete with high &amp; low voltage power supplies, amplifier, and attractive moulded plastic housing including space for keyboard. Full technical manual provided.</p> <p><b>PRICE: £95.00</b> (total including carriage and VAT £123.00)</p>	<p><b>DIGITRONIC PAPER TAPE PUNCH</b></p>  <p>Solenoid-actuated unit capable of punching 5 to 8 channel tapes asynchronously. Basic punch contains 8 data, 1 sprocket and 2 transport solenoids plus end-of-tape switch. Pulse amplitude 27VDC. Very compact unit measuring only 6in. x 8in. x 5 1/2in., weight 9 1/2lbs.</p> <p><b>Model P120 (20 cps) £75.00</b> (price including carriage &amp; VAT £92.00)</p> <p><b>Model P135 (35 cps) £95.00</b> (price including carriage &amp; VAT £115.00)</p>
<p><b>NEW SHUGART FLOPPY DISC DRIVES</b></p>  <p>SA400 Minifloppy — 110KB capacity, 35 tracks, transfer rate 125Kbits/sec AV access time 550msec. Power requirements +5VDC +12VDC</p> <p><b>PRICE: £195.00</b> (price including carriage &amp; VAT £235.00)</p> <p>SA800 Floppy — 400KB capacity, 77 tracks, transfer rate 250Kbits/sec. AV access time 260msec. Power requirements +24DC +5VDC -5VDC</p> <p><b>PRICE: £395.00</b> (price including carriage &amp; VAT £468.00)</p>	<p><b>RAYTHEON COSSOR UNITEL II VDUs — BRAND NEW SURPLUS</b></p> <p>Teletype-compatible display, 15in. diagonal green phosphor tube providing 15 lines of 80 characters (upper case ASCII character set). 6 switch-selectable baud rates (110-2400). Full/half Duplex and buffered mode. Detachable keyboard, Printer port. Dual interface enabling user to select either V.24 (RS232) or 20mA current loop connections. Supplied with operator's handbook and full technical manual.</p> <p><b>PRICE: £295.00</b> (price including carriage &amp; VAT £356.00)</p> 
<p><b>ELECTRONIC BROKERS LIMITED</b> 49-53 Pancras Road, London NW1 2QB. Telephone: 01-837 7781 Telex: 298694. Our showroom is open MON/FRI 9-1, 2-5 (2 mins. Kings Cross underground)</p>	

# Graham Knott & Jeff Orr have now moved....

to new premises due to expansion to accommodate larger stock and workshop facilities for the Microcomputer user. Our new number is

## 051-933 5511

ring us at any time for your requirements

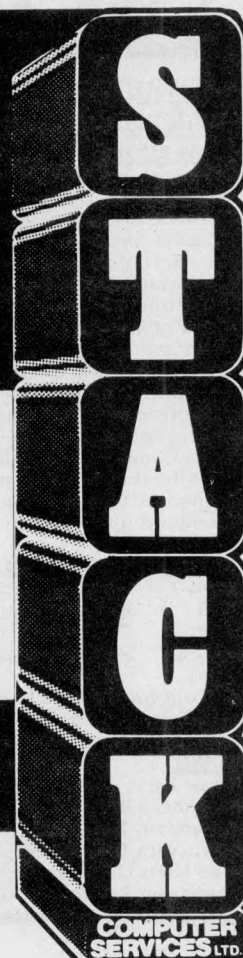

**NEW** Vastly improved 625 TV adaptor for Pet. Handles reverse field graphics, exceptional picture. **£25 complete plus VAT**

PET	
Pet 8k	£550
Pet 16k	£675
Pet 32k	£795
2nd Cassette	£55

Disk Units	
Computhink 400k Random and Sequential complete. to fit 8k Pet (via expandamem)	£795
to fit 16/32n Pet (direct fitting)	£840

Memory Expansion	
24k Exandamem for Pet	£320

Interfaces	
Uni-direc I-EEE to RS232	£89
Bi-direc I-EEE to RS232	£140
Bi-direc 2 ported I-EEE to RS232	£175

A/D Convertors	
AIM 161 16 channel A/D convertor for Apple, Aim, Nascom etc	£130
Petsset 1, AIM 161 including all interfacing requirements for Pet, complete	£166

Stack Peripherals	
Stack Joystick a balanced, calibrated unit supplied with software and examples of use, complete	£25
New 625 Video Adaptor a vastly	

improved 625 video convertor for Pet, works extremely well **£25**  
**Stack Page Printer Interface** copies screen contents onto 20m.a. loop complete with software **£25**

APPLE	
Apple II (colour) 16k	£985
Apple-plus (b&w) 16k	£830
ITT 2020 (colour) 16k	£950
16k RAM upgrade	£85
Printer Card	£110
Communication Card	£140
High Speed Serial Card	£110
Disk Drive with DOS	£425
Extra Disk Drive	£375
Diskettes (10's)	£30

SORCEROR	
Sorcerer 16k	£760
Sorcerer 32k	£859
AIM 65	£249.45
NASCOM	£165
KIMI	£99.95
MANUALS New Pet user manual	£5
6500 Programming manual	£5
6500 Hardware manual	£5

PRINTERS	
Teletype 43 pinfeed RS232	£860
friction RS232	£885
pin and friction RS232	£920
Anadex DP8000	£575

Perkins Elmer Pussycat CRT copier	£839
Also Centronics Range, Instruments, Lear Siegler	Texas
Ring us for a quote on individual models.	

### Consumables

(All paper add £5 carriage per box)  
**Anadex DP8000** paper (2000 sheets) 9.5" x 11" drop **£15**  
**Teletype 43** pinfeed paper (2000 sheets) 12" x 11" drop **£15**  
**8.5 inch friction roll** Box 'A' quality (12 x 3.5" diam rolls) **£20**  
 Box 'B' quality (12 x 3.5" diam rolls) **£15**  
 Box 'A' quality (6 x 5" diam rolls) **£20**  
 Box 'B' quality (6 x 5" diam rolls) **£15**

### Cassettes

**C15 cassettes**, high quality tape, 5 screw cassette cases, per 10 **£4.40**

### Disks & Diskettes

We supply 8" and 5.25" diskettes for all disk drives. Please state your machine and we can give you a quotation.

e.g. Pet 2040	£30 per 10
Computhink	£30 per 10
Apple	£30 per 10
Horizon	£30 per 10
Sorcerer	£30 per 10

Many others in stock, both hard and soft sector.

### Connectors

Pet User Port/I-EEE Port	£1.10 each
Pet 2nd cassette Port	85p each
Hoods for User/I-EEE connectors	£2.25
D.25 RS232 Connectors (State Male or Female)	£3.00
D.25 Hoods	£2.25

### Demagnetiser

Curved head **£4.00**  
**If any requirements are not listed please ring us as we may have them in stock.**

All prices are +VAT at 15% and include carriage (unless otherwise stated). Please make cheques payable to Stack Computer Services Ltd.

# Stack Computer Services Ltd

## 290-298 Derby Rd, Bootle

## Liverpool 20



**NEWBEAR MAIL ORDER:** 40 Bartholomew Street, Newbury, Berks. Tel: 0635 30505  
**NORTHERN SHOWROOM:** 220-222 Stockport Road, Cheadle Heath, Stockport Tel: 061 491 2290

### NEW BOOKS

Microprocessors & Microcomputers	Huggins	£ 4.95
Computers & Commonsense	Hunt & Shelley	£ 3.50
Business Data Systems	Clifton	£ 5.75
Finance for the Small Business	R. Ragan	£ 7.20
The Best of Computer Faires Vol. 3		£ 9.50
Reducing COBOL Complexity through Structured Programming	McClure	£11.30
Microprocessor and Microcomputer Systems	Rao	£19.85
Encyclopedia of Computer Science	Ralston	£48.60
Computer Approach to Introductory College Maths.	Scalzo	£11.30
Microcomputer Handbook	Sippl	£16.15
Data Communications Dictionary	Sippl	£16.15
Handbook of APL Programming	Weidmann	£ 6.50
Computer Output Design	Wooldridge	£ 9.70
Computer Input Design	Wooldridge	£ 8.85

### INTRODUCTORY BOOKS

Vol. 0 The Beginners Book	A. Osbourne	£ 5.95
Vol. I Basic Concepts	A. Osbourne	£ 5.95
Vol. II Some Real Products	A. Osbourne	£18.95
Vol. III Some Real Support Devices	A. Osbourne	£11.95
A Consumers Guide to Personal Computing		£ 5.65

### BASIC

Basic Basic	J. S. Coan	£ 5.00
Advanced Basic	J. S. Coan	£ 5.50
Illustrated Basic	D. Alcock	£ 2.25
Basic with Business Applications		£ 5.56
The Users Guide to North Star Basic	Rogers	£10.00
Basic and the Personal Computer	Dwyer	£10.36

### MISCELLANEOUS

Microprocessors C201	R. Zaks	£ 7.50
Interfacing Techniques C207	R. Zaks	£ 7.50
Best of Byte		£ 8.50
Scelbi Byte Primer		£ 9.95
A Dictionary of Microcomputing	P. Burton	£10.00
Small Computer Systems Handbook		£ 5.10
The Cheap Video Cookbook	Lancaster	£ 5.10
TV Typewriter Cookbook	Lancaster	£ 7.50
Active Filter Cookbook	Lancaster	£ 7.50

### PROGRAMMING

Top-Down Structured Programming Techniques		£12.76
Assembly Level Programming for Small Computers	Weller	£12.76
How to Programme Microcomputers	Barden	£ 6.95
6800 Programming for Logic Design	A. Osbourne	£ 5.95
8080 Programming for Logic Design	A. Osbourne	£ 5.95
8080 Assembly Language Programming	A. Osbourne	£ 6.95
6800 Assembly Language Programming	A. Osbourne	£ 6.95

### GAMES

32 Basic Programs for the Pet		£ 9.95
Chess & Computer	D. Levy	£ 7.16
Chess Skill in Man & Machine	P. Frey	£11.84
Basic Computer Games	AHL	£ 5.50
Game Playing with Computers	D. Spencer	£10.20
Game Playing with Basic	D. Spencer	£ 4.10

**Terms:** ALL BOOKS ADVERTISED ARE IN STOCK AT TIME OF PRINTING. OFFICIAL ORDERS (MIN £10), ACCESS & BARCLAYCARD WELCOME.

SEND FOR COMPLETE BOOK & MAGAZINE LIST.

# Micro-Facilities

127 High Street  
Hampton Hill  
Middlesex TW12 1NJ

01-979 4546  
01-941 1197

## MIDDLESEX & SW LONDON

As dealers for North Star Horizon and Commodore PET Microcomputers we provide a fully comprehensive service for all types of user:

★ Personal ★ Business ★ Education ★ Industry ★ Scientific  
We offer both a large range of software and the choice of supporting peripherals.

### Software Packages

Sales Ledger Purchase Ledger  
General Ledger Stock Control  
Incomplete Records  
Loan Accounting Mail Order  
Payroll Job Costing  
Text Processing CP/M

very low cost. Our programmers can write in BASIC, COBOL, RPG, or FORTRAN.

### Financing

In addition to purchasing, we offer you the choice of Rental, Leasing or H.P. (subject to references). Furthermore if you already have a micro system then why not ask us about part exchange. Commodore PET computers are available for hire from £4.75 per day, disks interfaces and printers are extra.

### Systems & Programming

A professionally experienced team of consultant analysts and programmers offer you a complete service for specifying, designing, writing and testing programs to your exact requirements. Our packages can be tailored to your needs at



NORTH STAR HORIZON

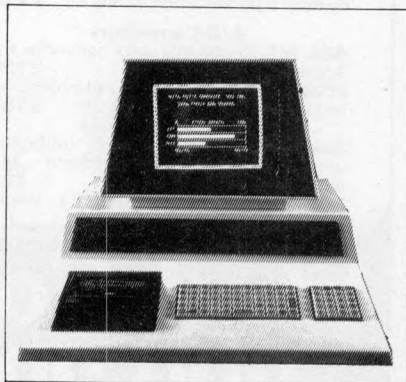

COMMODORE PET

If you have a computer problem then ask Micro-Facilities for the solution.

Association of Independent  
Computer Specialists

# SERIES I BUSINESS COMPUTER



- \* **Up to 4 Megabytes of disc storage**
- \* **64 Kilobytes of read/write memory**
- \* **Choice of dot matrix or NEC correspondence quality Spinwriter printers**
- \* **Choice of three different VDUs.**

## Software

In addition to CP/M, FORTRAN, BASIC, COBOL and PASCAL we offer the unique 'Insta' software which enables tailor-made applications packages to be configured in a very short time by the computer itself! 'Insta' applications programs can be altered to suit your changing requirements at any time by operators with no knowledge of computer programming but who know what they want it to do.

**If you have not seen 'Insta' software, ask for a demonstration. We promise you that you will have never seen anything that even comes close to matching it in business applications.**

 **compelec**

14-15 BERNERS STREET, LONDON W1P 3DE

Telephone 01-636 1392 (4 lines)



## 32K PET

The professional version ...  
some power!!  
Full size keyboard,  
easy-on-the-eye green display.  
Now at reduced price ...

only **£725!**

16K **£625!**

## EXIDY SORCERER

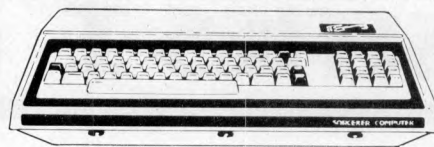

User-definable graphics. Plug-in interpreter ROMs. (Basic supplied).  
Sophisticated Z80 system! Plug into own TV or monitor and cassette.

32K now only **£790!**

16K **£690!**

## APPLE II

Best 6502 system! Up to  
48K RAM on-board ....  
Plug into own colour or  
B/W TV & cassette.

48K only  
**£1130!**

16K  
**£985!**



## OHIO CHALLENGER 2P



Sophisticated 6502 system!! Plug into  
own TV or monitor! 20K RAM.  
Interpreter Basic!  
Ex-stock, with single mini-floppy

only **£1200!**

with dual mini-floppies, save at

**£1530!**

Memory expansions, discs and printers  
for all above from stock.

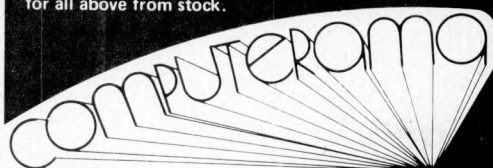

Computerama,  
Department P.C. W.2.,  
Harpers Kensington Showrooms,  
London Road, Bath, Avon.  
Telephone (0225) 28819.



Send for free list.

Add £6 Securicor carriage  
and 15% VAT to above prices.

Access and Barclaycard  
orders accepted by phone or  
letter, just quote number  
and print name and address.

## WORD PROCESSOR complete with printer for £1195

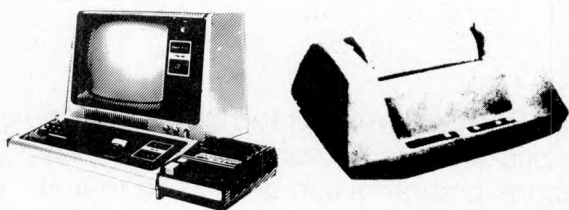

Based on TRS-80 Level II, 12" screen, 64 characters (A4)  
wide, upper/lower case, superb electric pencil software,  
Anadex 8000 DOT Matrix Printer or Qume Daisy Wheel  
Printer (option)

General business Software also available. To run on the  
above system.

Complete with Anadex Printer, 16K **£1195**

As above with Expansion Box & 48K **£1445**

Qume Daisy Printer in Lieu Anadex **£995**

Dual Floppy Disc Drives **£575**

All prices ex VAT

Write or phone for further details or demonstration

## LONDON COMPUTER STORE

43 GRAFTON WAY

Off Tottenham Crt. Rd., London W.1.

01-388 5721 OPEN 11-7 Mon-Fri 11-4 Sats.

## HEAVY DUTY PRINTER

FOR

PET · SWTP · HORIZON · APPLE  
SORCERER · CROMEMCO · TRS-80

ANADEX D.P. 8000

80 COL.  
FAST 112 CPS  
BIDIRECTIONAL-  
PRINTING.  
VERY GOOD PRINT  
QUALITY UPPER/LOWER CASE. £ SIGN.

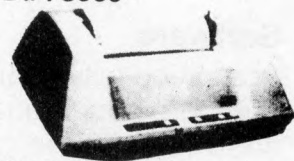

COMPLETE WITH PLUGS, CABLES & 500  
SHEETS OF PAPER

READY TO GO **£550 + VAT**

FOR PETS, ALL ABOVE + INTERFACE

DELIVERY

EX. STOCK

Also available:

COMPLETE BUSINESS SYSTEMS **£2700**

DIABLO HYTERM 1620 **£1800**

Write or phone for further details or demonstration

## LONDON COMPUTER STORE

43 GRAFTON WAY

Off Tottenham Crt. Rd., London W.1.

01-388 5721 OPEN 11-7 Mon-Fri 11-4 Sats.

# MoI MINE OF INFORMATION LTD MoI

1 FRANCIS AVENUE, ST ALBANS AL3 6BL ENGLAND PHONE 0727 52801 TELEX 925859

<b>SOCIAL IMPACT</b>		<b>BASIC</b>	
RENMORE C D	£2.50	ALCOCK Donald	2.30
1979 120pp		1979 134pp	
0 85969 292 2		0 521 21704 0	
OSBORNE Adam	3.50	DOERR Christine	4.90
1979 200pp		1979 177pp	
0 931988 28 4		0 8104 5113 1	
EVANS Chris	5.50	NEVISON John	5.40
1979 256pp		1978 151pp	
0 575 02708 8		0 201 05247 4	
BARRON/CURNOW	10.00	BOSWORTH/MAGEL	6.90
1979 244pp		1977 224pp	
0 903804 42 5		0 574 21090 3	
0 335 00268 4		LIEN David	11.00
ROTHWELL/ZEGVELD	8.50	1979 360pp	
NYP		0 932760 00 7	
0 903804 55 7		DWYER/CRITCHFIELD	11.90
SYBEX INC	2.50	1978 438pp	
1977		0 201 01589 7	
0 89588 002 4		LEE/BEECH/LEE	3.00
Scientific American	4.00	1978 100pp	
1977		0 905104 03 X	
0 7167 0066 2		AHL David (Ed)	5.50
LIPPIATT Arthur	4.20	1978 185pp	
1978 192pp		0 89480 052 3	
0 13 044750 1		AHL David (Ed)	5.50
LEWIS T G	4.80	1979 185pp	
1978 144pp		0 916688 09 7	
0 8104 5112 3		POOLE/BORCHERS	6.50
OSBORNE Adam	5.40	1978 193pp	
1979 300pp		0 931988 06 3	
0 931988 26 8		OSBORNE et al	8.05
OSBORNE Adam	5.90	1979	
1977 350pp		0 931988 25 X	
0 931988 02 0		POOLE/BORCHERS	8.50
WHITE James	5.90	NYP	
1977 235pp		0 931988 24 1	
0 918398 22 3		POOLE Lon	9.50
WILLIS Jerry	6.30	NYP	
1978 207pp		0 931988 23 3	
0 918398 54 4		OSBORNE Adam	5.90
ZAKS Rodney	6.90	1978 300pp	
1977 420pp		0 931988 04 7	
0 89588 001 8		LEVENTHAL Lance	6.30
<b>SYSTEMS DESIGN</b>		1978 400pp	
LANCASTER Don	4.40	0 931988 10 1	
1978 256pp		BARDEN William	6.50
0 672 21524 1		1978 256pp	
LOOFBOURROW Tod	4.90	0 672 21549 8	
1978 132pp		OGDIN Carol Anne	6.60
0 8104 5681 8		1978 224pp	
PEATMAN J.B	5.90	0 13 580985 1	
1979 544pp		LARSEN/RONY/TITUS	6.70
0 07 085554 4		1979 304pp	
LANCASTER Don	7.00	0 672 21541 1	
1976 336pp		McCRACKEN Daniel	8.50
0 672 21035 5		1978 262pp	
LANCASTER Don	7.50	0 201 04575 3	
1977 412pp		OSBORNE et al	5.90
0 672 21398 2		1978 372pp	
LESEA/ZAKS	7.90	0 931988 11 X	
1978 420pp		LEVENTHAL Lance	6.90
0 89588 003 2		1979 630pp	
LEVENTHAL Lance	9.50	0 931988 21 7	
1979 640pp		BARDEN William	6.90
0 13 487876 0		1978 304pp	
HUNTER R P	11.90	0 672 21500 4	
1978 412pp		SPRACKLEN Dan & Kathie	9.50
0 13 054302 3		1978 114pp	
GARRETT Patrick	14.60	0 8104 5155 7	
1978 248pp		ZILOG CORPORATION	11.90
0 87909 035 9		1979 350pp	
KLINGMAN Edwin	16.50	Z 03 30550 01	
1977 480pp		OSBORNE Adam	5.90
0 13 581413 8		1977 300pp	
OSBORNE et al	14.00	0 931988 05 5	
1978 1373pp		LEVENTHAL Lance	6.30
0 931988 15 2		1978 400pp	
0 931988 16 0		0 931988 12 8	
OSBORNE et al	11.00		
1978 652pp			
0 931988 18 7			
0 931988 19 5			
OSBORNE et al	19.00		
1978/1979			
Subscription			
OSBORNE et al	19.00		
1979/1980			
Subscription			

# P I P S

ackaged nformation rocessing ystems

We offer a variety of turnkey systems based on APPLE II, CROMEMCO and ZENTEC. It is our endeavour to give a complete service from problem determination through to the supply of computer based solutions. We will solve the problem either with a tailor made suite of programs for a ready written package from another famous software house, such as CAP-MICROSOFT or COMPUTECH.

We can also supply three excellent DEVELOPMENT SYSTEMS, namely NASCOM, ACORN and AIM65.

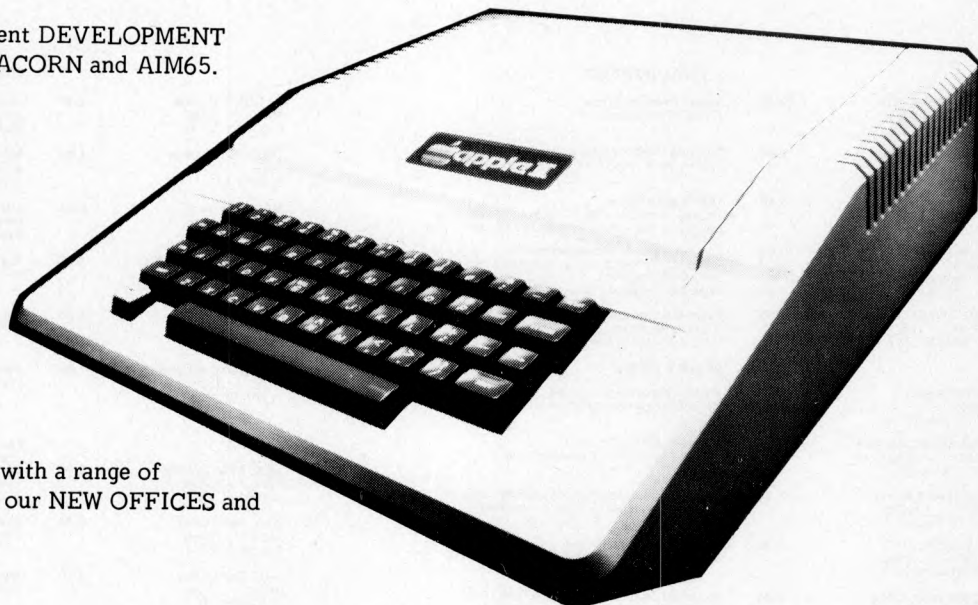

All the above equipment, along with a range of peripherals, will be on display in our NEW OFFICES and SHOWROOM

P.I.P.S. Computer Services  
(0632) 482359. Trade enquiries welcomed.  
See us on Stand 16 at the PCW SHOW.

## DATA BANK (SOFTWARE SERVICES)

PROGRAMS GALORE!!

### GAMES:-

Lost in Space	£8
Star Trek-1	£6
Star Trek-2	£8
Drag Racer	£4
Noughts & crosses	£6
Hangman	£4
Take your poison	£5
Battleships-1	£7
Nim	£4
Spook	£4
Card Dealer	£3
Ticktackoe	£4
Craps	£5
Space wars	£8
Pontoon (21's)	£5
Jet flight-1	£5
Dice thrower-1	£4
Oil tanker	£6
Bridge hand dealer	£4
Numbers battle	£4
One armed bandit	£4
Spies	£5
Racing car	£5
Lunar lander	£5
Mastermind-1	£5
Spook	£4

### EDUCATIONAL:-

Elementary Maths	£5
Advanced Maths	£7
Ele. Statistics	£5
Adv. Statistics	£7
Ele. Physics	£5
Adv. Physics	£7
Ele. Chemistry	£6
Hyperbolics	£4
Ele. Electronics	£5
Adv. Electronics	£7
Ele. Geometry	£5
Adv. Geometry	£7
Ele. Integration	£6
Vector analysis	£6

### BUSINESS:-

Payroll	£20
Sales & Purch. Led.	£20
Stock Control	£25
Std. letter printer	£15
Sim/Compound Int.	£10
Tax depreciation	£10
Bank account tally	£6

### MISCELLANEOUS:-

Calender printer	£5
Primes generator	£5
Racing analysis	£25

EXIDY SORCERER, COMMODORE PET, APPLE II, TRS-80 and NASCOM II

S.A.E. now: for catalogue with details of over 100 programs.

Prices include Post and Package.

Cheques/Postal orders to  
DATABANK

66, QUEENS ROAD, LOUGHBOROUGH  
LEICESTERSHIRE. LE11 1DH  
(Mail order only).

## PRODUCTIVITY UNLIMITED

DATA PROCESSING SERVICES

The Downs Austenwood Lane Gerrards Cross Bucks SL9 9DA  
Telephone (02813) 83626 Telex 847777 DELRAY G attn MANCON

### MEET US AT THE PERSONAL COMPUTER WORLD SHOW

Together, on Stand 47, we'll be demonstrating the MICROSTAR 45 PLUS Multi-user, Multi-task computer system in operation with QUME and Texas printers and TeleVideo VDU's.

COMPLETE SYSTEMS ARE AVAILABLE  
FROM £7000



access data communications ltd.

# XITAN SYSTEMS

The South's Premier Microcomputer Supplier.

**WE SUPPLY SYSTEMS – LOOK AT THESE  
TYPICAL CONFIGURATIONS!**

## **System A**

32K Commodore PET + Commodore model 2040  
Dual floppy drives and cable **£1610**



## **System B**

NORTH STAR HORIZON, 32K Ram, dual double  
density drives, 2 serial, 1 parallel port, DOS and  
BASIC, High quality Brand Name 24 x 80 char  
VDU **£2155**



## **System C**

CROMEMCO System 2, 4MHz Z80, 64K Ram,  
dual minifloppies, 21 connectors, 1 serial, 1  
parallel printer port, CDOS 1.07 and Extended  
Disk Basic, High quality Brand Name VDU etc.  
**£2655**

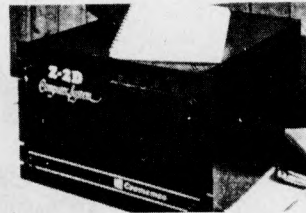

## **System D**

CROMEMCO Z-2, 4MHz, 1 MEGABYTE floppy  
disk storage, 64K Ram, 3 serial ports, 2 parallel  
ports, CDOS 1.07 and Basic, High quality 24 x 80  
char VDU **£4600**

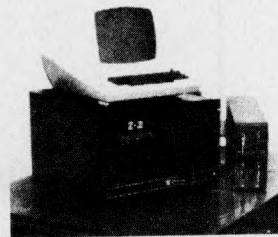

## **System E**

CROMEMCO System 3 (the "Rolls ROYCE")  
64K Ram, 4MHz, 1 MEGABYTE floppy disk  
storage, 1 serial and 1 parallel printer port, High  
quality Brand Name 24 x 80 char VDU etc, includ-  
ing CDOS and BASIC **£5130**

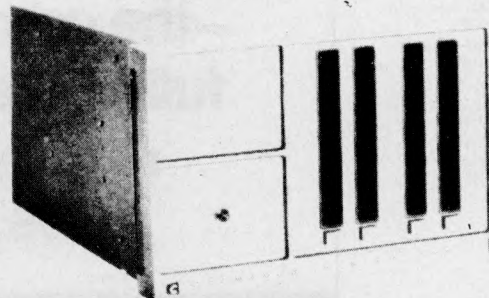

We supply Centronics, Teletype 43 and Diablo Printers, plus the normal range of ancilliary equipment. CP/M for Cromemco and Horizon systems is available from us, as well as Microsoft Fortran, Tex etc.

**23 Cumberland Place, Southampton SO1 2BB Tel: (0703) 38740 Tues - Sats.**

**AUTHORISED  
PET  
COMMODORE  
DEALERS**

**Birmingham**

Camden Electronics  
021-773-8240

CPS (Data Systems) Ltd  
021-707-3866

Taylor Wilson Systems Ltd  
Knowle 05645-6192

**Bolton**

B & B Consultants  
0204-26644

**Bournemouth**

Stage One Computers  
0202-23570

**Bradford**

Ackroyd Typewriter &  
Adding Machine Co  
0274-31835

**Brentwood**

Direct Data Marketing Ltd  
0277-229379

**Bristol**

Bristol Computer Centre  
0272-23430

Sumlock Tabdown Ltd  
0272-26685

**Cambridge**

Cambridge Computer Store  
0223-68155

**Cardiff**

Sigma Systems Ltd  
0222-21515

**Colchester**

Dataview Ltd  
0206-78811

**Derby**

Davidson Richards (Int) Ltd  
0332-366803

**Durham**

Dyson Instruments  
0385-66937

**Edinburgh**

Micro Centre  
031-225-2022

**Exeter**

A.C. Systems  
0392-71718

**Grimsby**

Allen Computers  
0472-40568

**Hemel Hempstead**

Data Efficiency Ltd  
0442-57137

**Hove**

Amplicon Electronics  
0273-720716

**Leeds**

Holdene Ltd  
0532-459459

**Liverpool**

Aughton Automation  
051-548-6060

Cortex Computer Centre  
051-263-5783

Dams Office Equipment  
051-227-3301

**London E2**

Ragnarok Electronic Systems  
01-981-2748

**London EC1**

Sumlock Bondain Ltd  
01-253-2447

# THE PET



**Britain's no.1  
micro-computer  
from**

 **commodore systems**

**the complete system  
full range of peripherals  
nation-wide dealer  
sales and service**

**In case of difficulty contact  
COMMODORE SYSTEMS DIVISION  
360 Euston Road, London. Tel: 01-388-5702**

**AUTHORISED  
PET  
COMMODORE  
DEALERS**

**London N14**

Micro Computation  
01-882-5104

**London NW4**

Da Vinci Computers  
01-202-9630

**London SW14**

Micro Computer Centre  
01-876-6609

**London W5**

Adda Computers  
01-579-5845

**London WC1**

Euro Calc Ltd  
01-405-3113

**London WC2**

TLC World Trading Ltd  
01-839-3893

**Manchester**

Cytek (UK) Ltd  
061-832-7604

**Executive Reprographic**

061-228-1637

**Sumlock Electronic Services**

061-834-4233

**Matlock**

Low Electronics  
0629-2817

**Morley, W. Yorks**

Yorkshire Electronic Services  
0532-522181

**Norwich**

Sumlock Bondain  
0603-26259

**Nottingham**

Betos (Systems) Ltd  
0602-48106

**Oxford**

Orchard Electronics  
0491-35529

**Plymouth**

JAD Integrated Services  
0732-62616

**Preston**

Preston Computer Centre  
0772-57684

**Reading**

CSE Computers  
0734-61492

**Southampton**

Business Electronics  
0703-738248

**Symtec Ltd**

0703-37731

**Xitan Systems**

0703-38740

**Sunderland**

Tripont Associated Systems  
0783-73310

**Woking**

P.P.M. Ltd  
Brookwood 04867-80111

**Betalact Ltd**

04862-69032

**Yeovil**

Computerbits  
0935-26522

**North Scotland**

Thistle Computers  
Kirkwall 0856-3140

**Northern Ireland**

Medical & Scientific  
Lisburn 08462-77533

**MICRO COMPUTER CENTRE,**  
314 Upper Richmond Road West,  
East Sheen, S.W.14 876 6609.  
Business Specialists/Authorised Dealers for

## PET

### Computers

Standard PET with integral cassette and calculator type keyboard. 8K bytes of memory £550.00  
PET with 16K bytes of memory and large keyboard. External cassette optional £695.00  
PET with 32K bytes of memory and large keyboard. External cassette optional £795.00

### Printers

Whymark 201 - 20 columns complete with interface £400.00  
Datac BD80 - 80 columns £750.00  
1-way Interface £106.00  
Teletype 43 - 132 columns - Upper and Lower Case Keyboard £900.00  
2-way Interface £186.00

### Memories

16K Memory Extension for 2001 - 8K £276.00  
24K Memory Extension for 2001 - 8K £337.00

### Disc Drives

Compu/Think Twin Floppy Disc Drive - double sided discs - 100K per side £833.00  
Pet Twin Floppy Disc Dual Drive including cable £815.00  
Cassette Recorder £55.00

The above prices are exclusive of VAT. All the above items are IN STOCK at time of going to press.

We stock all PET accessories and handbooks PETSOF and PETACT Programs.

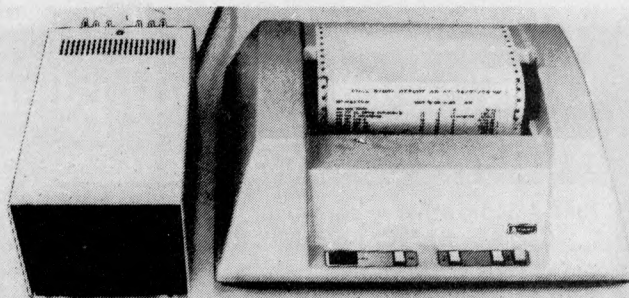

## OUR PET PICTURE IS NOT HERE

A Pet in the middle will galvanise this 'Computhink' disk drive and 'Anadex' printer into the finest micro-based business system we know. Especially if our COMPFER software is on it!

### 'Hardwearing' Software.

As we write quality software for many applications we look for the best in hardware. So we are: OFFICIAL PET DEALERS AREA ANADEX DISTRIBUTORS COMPUTHINK DISK DEALERS and deal in other quality equipment such as NASCOM & SWTPC.

### Prices?

Well - the new adjustable Anadex printer, 80 lines per minute, 80 characters full width with self testing facility and optional plug-in PROMS for special character and mode production is now supplied by us complete with parallel interface for a new reduced price of **£610**. Just plug into your Pet and go!

We sell the KIM at **£99.95** with a purpose built sturdy and reliable power supply for **£24**.

### Seen it before?

The text printed on the printer above is one of the facilities of our stock control package as seen on B.B.C's 'Look North'. We are rapidly achieving a reputation as standard setters in micro-application software.

### Still not impressed?

We have designed our own A/D converter with Fourier analysis software now in use internationally, we have a large stock of books and magazines and we have Pet interfacing to Oertling balances with software for Department of Trade standard quality regulations.

### IEEEEE?

Our IEEE parallel divider gives you two arms to your Pet IEEE port for **£12.50**

### Pet Life begins at PR-40

Hard copy for **£250!** Using ordinary till roll paper, prints results and program listings for your Pet.



### Preston Computer Centre

6 Victoria Buildings,  
Fishergate, Preston.

Tel: 0772- 57684

All the above prices are exclusive of V.A.T.  
Access and Barclaycard accepted.

## CAMBRIDGE COMPUTER STORE

We can help you select the right system for your application. Here in Cambridge your choice won't be limited - we'll demonstrate as comprehensive a range of microcomputers as you'll find anywhere in the U.K.

**CROMEMCO**  
**TANDY TRS-80**  
**COMMODORE PET**  
**APPLE II**  
**N-S HORIZON**  
**SORCERER**  
**ACORN**  
**NASCOM-1**

Stop press - dramatic reduction now in prices of TRS-8-, APPLE II and HORIZON systems. Where possible we deliver off-the-shelf to any location.

The store is open 6 days a week from 9-5.30 with demonstration systems always in operation. We offer a professional standard of advice and after-sales support and we're ready to discuss your application any time.

## CAMBRIDGE COMPUTER STORE

1 Emmanuel Street, Cambridge (0223) 68155

# U. K. — Micro Supplies — SCOTLAND

03374-795

## FLOPPY DISCS MICROPOLIS

1041-1 315K drive + controller Cable + BASIC, ASSEMBLER, + EDITOR only	£595.00
1015-11 315K drive — add-on other products on application	£395.00
DS525-10 Pack of 10 5¼ in. floppy disk	£30.00

## S100 BOARDS

SD Sales 32K Ram 375 ns Assm. + tested	£355
JADE Z80 2 mhz Assm. + tested	£140
MIKOS 15 slot Mother Board Assm. + tested	£110
MIKOS 2 Parallel/2 Serial Assm. + tested	£130
MIKOS 16K Erom (No 2708's) Assm. + tested	£110
MIKOS Extender Board Assm. + tested	£47
MIKOS Real time clock 2 interrupt Assm. + tested	£120
DSEL P.S.U. Kit +8v ±16v 4A Assm. + tested	£175

## V. D. U. s LIER SIEGLER

ADM 3A Introductory Offer	£560.00
---------------------------	---------

## SOFTWARE

CP/M for Micropolis	£90
MACRO for above	£60
TAILORED Software for all applications	

## PRINTERS CENTRONICS

Centronics 779	£785.00
Centronics 701	£1210.00
Centronics 703	£1894.00

## SYSTEMS

U.K. DISTRIBUTOR for  
SDS-200 (SD Sales) also HORIZON,  
CROMEMCO, DATA SYSTEM 800, 801

### FULL SERVICE & BACK-UP FACILITIES AVAILABLE

Telephone for all Non-Listed items  
OEM & DISCOUNTS on Application

ACCESS BARCLAYCARD  
Delivery at cost — Prices exclude VAT

## DATA SYSTEMS SUPPLIES LTD.

SHORE HEAD ROAD, INDUSTRIAL ESTATE,  
NEWBURGH, FIFE, SCOTLAND.

# 03374-795

# Nascom-2 from Adda

Available from Adda, Nascom-2 the mighty micro kit based on the powerful Z80A 4MHZ CPU and with the industry standard MICROSOFT basic in ROM. Nascom-2's 20K of on-board memory has 8K of user RAM, a 2K monitor, 1K Video RAM, 1K of work space RAM and the 8K basic ROM.

To order send a completed coupon with your remittance or phone an order quoting your Barclaycard or Access number. Personal callers are of course welcome.

Open 9.00 am - 6.00 pm Monday - Friday.  
10.00 am - 4.00 pm Saturday.

17/19 The Broadway, Ealing, London  
W5 2NH (Between W. H. Smith and  
Burtons). Telephone 01-579 5845

# adda

we add up to a great deal.

To Adda Computers Ltd., 17/19 The Broadway, Ealing, London W5 2NH

Please send me: Nascom-2  £295.00

3A Power Supply  £29.50

Tick your requirements. Please add VAT. Post and Packing are included

I enclose cheque/postal order for £

My Barclaycard/Access no. is

Name

Address

Signature



# nascom

## imp

# PLAIN PAPER PRINTER

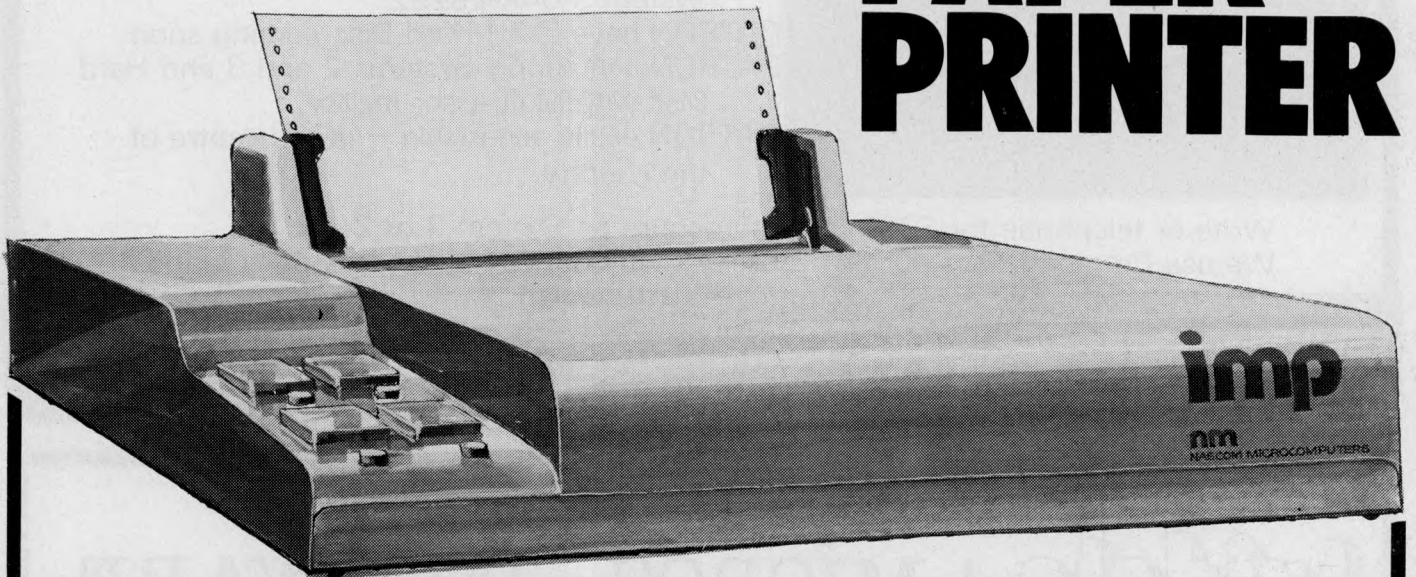

## BOXED AND BUILT FOR ONLY £325 PLUS VAT

### FEATURES

- Serial RS232 interface
- 80 characters wide
- Bidirectional printing
- 60 lines per minute
- 10 line print buffer
- 96 character ASCII set  
(includes upper/lower  
case, \$ # £)
- Automatic CR/LF
- 8½" paper
- Optional tractor feed
- Baud rate from 110 to 9600
- External signal for optional  
synchronisation of baud rate

The Nascom IMP plugs straight into a Nascom 1/2 but is usable with all other micro systems. Parallel option will be available shortly.

TO NASCOM MICROCOMPUTERS LTD  
92 BROAD STREET  
CHESHAM  
BUCKS  
Tel: 02405 75155

**nm**

Nascom Microcomputers

Please send me ..... Nascom IMPs at £325  
each plus VAT plus £2.50 p&p

NAME \_\_\_\_\_

ADDRESS \_\_\_\_\_  
\_\_\_\_\_  
\_\_\_\_\_

ACCESS/  
BARCLAYCARD NO \_\_\_\_\_

# DATRON of SHEFFIELD

for

**Cromemco** the ultimate name in micros



DATRON import direct from Cromemco, California.  
DATRON can supply Nationwide.

DATRON can provide maintenance nationally  
by C.F.M.

DATRON can give you the realistic prices.

DATRON have in stock:-

System 2 46K £1995

System 3 32K £2995

System 3 64K £3292

DATRON have Z-2H Hard Disc coming soon.

DATRON can supply Systems 2 and 3 and Hard  
Disc with Multi-User facility.

DATRON easily accessible - in the centre of  
the country.

Write or telephone for FREE colour brochure on System 3 or Z-2H.

We use Cromemco for our own business, why not call in for a demonstration.

**DATRON MICRO CENTRE**

Latham House, 243 London Road, Sheffield S2 4NF.  
Telephone 0742 - 585490. Telex 547151.

## Tridata + MICROS = SOFTWARE

Business systems available now for the TRS 80

Sales Ledger (OPEN ITEM/DEBTORS ANALYSIS/STATEMENTS/INVOICES/VAT/DAYBOOKS etc.) from £150

Purchase Ledger (OPEN ITEM/CREDITORS ANALYSIS/REMITTANCE ADVICE/VAT/DAYBOOK etc.) from £150

Invoicing (UPDATES SALES LEDGER/DOWNDATES STOCK/MAINTAINS BACK ORDERS) £75

Stock Control (ISSUES/RECEIPTS/MOVEMENT, USAGE, VALUATION, RE-ORDER REPORTS etc..) £200

Payroll (WEEKLY, MONTHLY, CASUAL STAFF/BONUS SCHEMES/COIN ANALYSIS/PAYSLIPS etc..) £218

Nominal Ledger (Available shortly)

12 MONTH WARRANTY ON ALL PACKAGES - TAILORED SYSTEMS TO YOUR REQUIREMENTS

FOR THE BEST IN PROFESSIONAL MICRO BUSINESS SOFTWARE CONTACT US DIRECT OR CALL YOUR NEAREST TRIDATA DEALER FOR A DEMONSTRATION.

CAMBRIDGE COMPUTER STORE (CAMBRIDGE)	0223 68155
COMPUTER DEVELOPMENT SERVICES (SWANSEA)	0792 26085
ELECTRON SYSTEMS (SANDY, BEDS.)	0767 81195
A. J. HARDING (BEXHILL, E. SUSSEX)	0424 220391
KATANNA MANAGEMENT SERVICES (CHELMSFORD)	0245 76127
OPTRONICS (TWICKENHAM)	01 892 8455
GPW ELECTRONICS LTD (PORTSMOUTH)	0705 693341

Tridata Micros Ltd.  
Smithfield House  
Digbeth  
Birmingham B5 6BS  
Tel: 021 622 1754

# Personal Computer World

## SUBSCRIPTIONS

Less than 2 years ago PCW became the first magazine in Europe to deal exclusively with the home and business use of Personal Computers. It has been an unqualified success. The current subscription list stands at well over 3000, with a staggering 70% renewal rate! PCW reader loyalty is already a byword in the publishing business. We aim to keep it that way. So if you are having difficulty in obtaining PCW at your newsagent, why not take out a subscription and have the magazine mailed to you direct? YOU KNOW IT MAKES SENSE!

### ANNUAL SUBSCRIPTION RATES

UK: £8.00  
USA: \$20.00  
Elsewhere: £9.80

Please send me the next 12 issues of PCW

NAME \_\_\_\_\_

ADDRESS \_\_\_\_\_

*(Block capitals please)*

I enclose cheque/P.O. for £ \_\_\_\_\_ made payable to Sportscene Publishers Ltd.  
Send coupon to PCW (Subscriptions), 14 Rathbone Place, London W1P 1DE. Allow at least 14 days for processing.

## BINDERS KEEPERS LOSERS WEEPERS

Half the people you meet today are not preoccupied with pollution, perversion or persecution. It's worse than that — they've lost a copy or two of PCW and don't know where to find replacements.

So keep *your* copies of PCW in a beautiful bright blue binder. £2.95 worth of smart security.

Just check the coupon at the foot of the page.

## BACK NUMBERS THINK OF THE FUTURE-LOOK BACKWARDS!

PCW has long been regarded as by far the most authoritative journal in its field. Every issue published has contained a wealth of detailed technical information on all aspects of the rapidly growing Personal Computer Market. Demand for our limited stock of back numbers has also become something of a rapid growth industry! Consequently, early back numbers of PCW are going to be increasingly difficult to get hold of, so make absolutely certain of getting yours by checking the coupon at the foot of the page.

### Volume 1 No. 1 May 1978

The launch of Nascom 1/77-68: The Mighty Micromite/The Gingerbread Mans Computer.

### Volume 1 No. 2 June 1978

PCW review Research Machines 380Z/Computer in the classroom/The debut of E78 — The Europa Bus.

### Volume 1 No. 3 July 1978

Buzzwords — The first A to Zzzz of computer terms/Pattern recognition/Johann Sebastian Byte.

### Volume 1 No. 6 October 1978

Minotaur — a new computer game/Computing in the Primary School/Time Tabling for schools.

### Volume 1 No. 8 December 1978

Computers and Art/3-D Noughts and Crosses/Meet Mickie — the micro with the bedside manner.

### Volume 1 No. 9 January 1979

Super Scamps VDU/Hexadecimal Conversion/TRS-80 Level II Basic/8-Bit Analogue input — putting your pet to work.

### Volume 1 No. 11 March 1979

Turning the Tables — a program for the T157/Motorola on sixteen cylinders/The SYM 1 - Computer on a board/Unraveling the Pet Bus.

### Volume 1 No. 12 April 1979

Breaking the Software Barrier with Nascom 1/A program for the Z80/Vector MZ review/The Learn Machine.

### Volume 2 No. 1 May 1979

Small computers for small organisations/The Sorcerers Wand/Chess Programming: Hints from an International Chess Master/Parkinsons Revas.

### Volume 2 No. 2 June 1979

PCW review the MSI 6800/Witbit — disassemble your programs/The Multilingual Machine/Polytechnical Processing.

### Volume 2 No. 3 July 1979

Vision link: Interfacing and Software for the Superscamp VDU/Pet Preening/The Soft Cursor — extended cursor graphics for the TRS-80.

### Volume 2 No. 4 August 1979

The North Star Horizon — A PCW review/High Speed Cassette Interface for the SWTP 6800/Garage Accounting Program/Apple Medical Application.

### Volume 2 No. 5 September 1979

New 10 part Pascal series/ESP — The ultimate interface?/Young Computer World with John Coll/Benchtest on the CompuColor

### Volume 2 No. 6 October 1979

In Store — the first complete micro — the SHARP MZ-80K/Bet on a Pet: Business feature/. Cromenco System Three takes the PCW Benchtest.

Any one issue 70p; Any two issues £1.20; Any three issues £1.60; Any four issues £2.00. All additional issues @ 40p each. Binders @ £2.95. All prices include post and packing. Cheque or P.O. payable to Sportscene Publishers Ltd., 14 Rathbone Place, London W1P 1DE. Please allow up to 3 weeks for delivery and don't forget to state clearly your name and full address with your order.

Please send me the following copies of PCW. I enclose a cheque P.O. for £

Volume 1                      Volume 2  
        /                          \*

Please send me — PCW Binder(s)

Name \_\_\_\_\_

Address \_\_\_\_\_

\*Tick appropriate boxes

*Newsprint (now incorporating What's New) is where Guy Kewney reports the happenings of the micro world. Product news, rumours, gossip, prediction and speculation. . . read Newsprint and stay ahead of events.*

## Aquack one?

It sounds like one of those old-fashioned quack cure-alls that relieves constipation, removes tar from teeth, dissolves kidney stones and cleans your spectacles. It's a £200 kit that uses either the Zilog Z80, or the Texas 9980 micro, and you can pull out one chip and replace it with the other, whenever you like.

My attitude is if it's true, I want one. There are few enough opportunities to get a cheap computer based on the TI chip family; the least expensive I know of is a board made by a Birmingham firm Brandauer, based on the 9900, a chip which has a full 16-bit data and address bus. It's really meant for the system builder, not the amateur (by this I mean you need an expensive terminal to get anything into or out of it). At the same time, there are so few Texas users that I'd be nervous of buying a computer that used only that chip. . . where would I go for help when things got stuck? And so, the option of the much more common Z80 attracts me.

So much for attitude, but what is it we're talking about? According to the preliminary specification it's a big board, a "double double Eurocard", with the processor section on one side, and the TV scanning circuit and keyboard interface which together provide input and output, on the other. You can cut this side off, and put the processor side in a standard Eurocard slot, says the designer.

If you don't cut it off, this side provides a display on a standard TV, and reads from a standard typewriter qwerty keyboard. On the TV side, it gives 16 lines of 64 characters, with a modulator described as 'on-board channel 36 wide-band UHF'.

Data is stored on/or retrieved from an audio tape recorder. The designer has modified the Kansas City computer users' tape standard (CUTS) to transmit in 64 byte blocks, with error checking. This is very important, although it does kill the possibility of compatibility on software or data from other systems.

So much for the more

interesting points of the boring detail. The designer also provides preliminary information on a similar level about software and memory mapping.

The really interesting bit is, how does he do it? From the fact that he recommends buying two forty-pin central processor sockets, both 'multiple insertion' types at £7.00 extra, you can safely deduce that he does not expect to plug the chips into the same socket. Just as well; it wouldn't work!

Yet, even allowing for the fact that the 9980 has a restricted data bus only 8 bits wide, rather than the full 16-bit bus of its big brother the 9900, there are fundamental differences between the Zilog and the Texas central processors.

For example, Texas provides an on-chip communications register unit which gives direct serial communications to outside teletype-writer devices. Can a system which is built round the Z80's need for universal asynchronous receiver/transmitters (UARTs) also accommodate a chip with a CRU output?

But hold it, you say: why are these questions appearing in print? . . . don't they know the answers?

No, not yet. The designer is one B.B. Leather of 1 Willow Way, Loudwater, High Wycombe, Bucks HP11 1JR. He has no traceable telephone, and our letter pleading for a chat had not reached him at press time.

By the time you read this, the mystery will have been resolved. Watch this space!

## As you were

We described the Philips MDCR as a diskette in the September issue. It is, of course, a cassette — a mini-cassette, in fact, as Philips rep Vic Drayton has been quick to tell me. He also points out that the bare device includes only read-write and motion control circuitry; software is needed for search ability, and a bit of logic for phase encoding; It is now available from two distributors: Swift Sasco of Gatwick Road, Crawley, tel: Crawley 28700; and Tekdata Electronics of Feder-

ation Road, Burslem, Stoke-on-Trent, Tel: Stoke 813631. It will be visible at Compec, the Wembley show, in a Pelco displayed Aim 65 system. Thank you, Vic.

## Sybex training system

From America, the publishing company Sybex has 'published' a computer. It costs \$300, and from that you can safely deduce that in the UK it will cost quite a bit more than £150.

Making this computer, (which uses the 6502 micro-processor) different from any other 6502 micro, is the fact that it is sold as a self study training system. Packaged with the machine — it looks astonishingly like a Sym 1 — are two books and two cassette tapes. One book is Programming the 6502, published by Sybex, and my friend Robin Bradbeer of the North London Poly tells me it is a good book. The other is a 6502 Applications book, also published by Sybex. On one tape, there is software, and on the other, a voice (probably human) giving instructions on how to use the board.

I'm afraid, on the basis of this information, I can't tell you why you should buy this package, rather than getting hold of the books separately, and buying a £75 Acorn which can be built up into a Eurocard system. If I hear of reasons, I'll print them. Sybex is at 2020 Milvia Street, Berkeley, California 94704.

## Memory aid

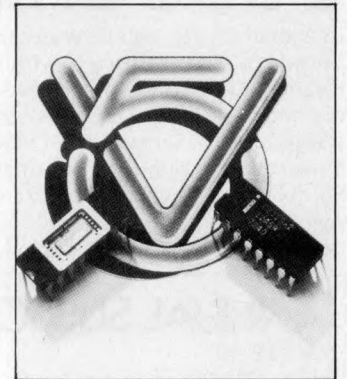

Intel's 2118S

A memory chip from Intel — just another 16K RAM, it would seem — is in fact being offered as a boon for the memory designer. The part is called the 2118, and it contains 16K bits, each addressable separately and singly. That means you need eight chips to make a useable memory for a machine with an 8-bit data bus, and you get a minimum of 16K bytes.

What makes it special, says Intel, is "It is the first 16K by 1 (ie singly selectable bits) RAM to operate with a single 5V power supply and to offer very low levels of power with 150 mW drawn in operation and 11 mW on standby". It is voltage and pin compatible with future 64K bit RAMs, so boards designed with this will carry four times the memory — that is, at least 64K bytes — when the 64s are out. But not this year. Intel also says that this chip is designed to work with its 8202 dynamic RAM controller, which makes it as easy to use as static RAM.

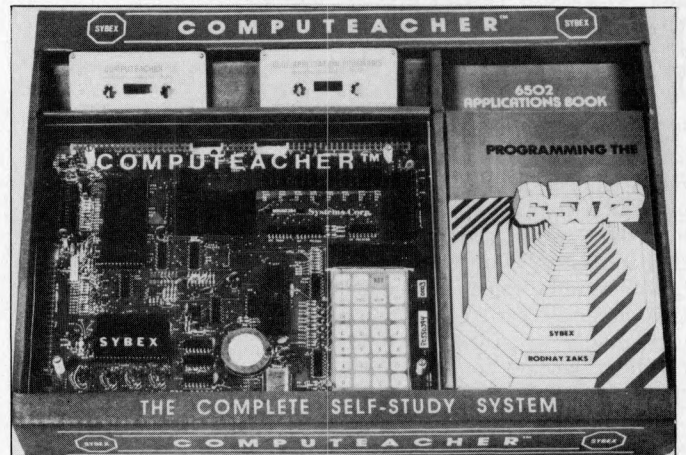

Sybex training system

## Tandy trick

Cramming 117,740 bytes onto a Tandy diskette with capacity for 89,600 is a trick done by software from AJ Harding (Molimerx) by the simple expedient of deciding that all the information on a Tandy diskette is BASIC (and therefore is not truly eight-bit hexadecimal code, but upper case ASCII – which can all be stored in six bit codes, not eight). Together with this new product, a new word: “as with the regular system this buffer can be configured as you wish”. One can only offer sympathise-ment. Details from Bexhill (0424) 220391.

## Floppy Power

Power supplies for floppy drives are not included in the average computer kit. You can make up one, or you can buy one, now, from HAL computers of Weybridge tel: Byfleet (09323) 45421.

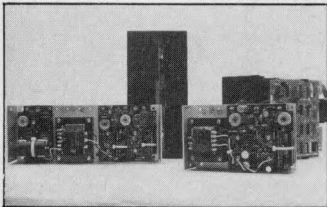

Floppy PSUs

## Owl's lisp

A new language? LISP is that, and costing £40 from Owl Computers it's probably a worthwhile experiment. Devotees claim that it's not so much a high level language as an assembly language for a high level machine, plus software to make your computer imitate that high level machine. Owl's version runs on the Apple II; it is supplied on disc or cassette, occupying 6K bytes of code, with a 44 page manual for a 16K byte or larger computer. Two demonstration programs are included.

It is aimed at “hobbyists who want hands on experience of the fundamental language of artificial intelligence research”, amongst others. Owl is in Bishops Stortford, on 0279 52682.

## Mass erase

You may never need to erase 104 programmable memory chips under ultra-violet – in fact statistics seem to show that most users of this form of read-only storage do just that – read only. Nonetheless, it may be worth your while knowing somebody who can cope with 104 at a time, because you may want to erase a u-v-e PROM that is soldered to a large board. That board will fit inside the big 100T PROM eraser now marketed by Microsystem Services. It's a fair bet that anybody who shells out the cost of a 100T will welcome the chance to recoup a bit by running an erasing service occasionally so if we hear of a sale – to a careless manufacturer of big EPROM systems who has to call back several thousand faulty boards, – we'll let you know. Meanwhile, back to the sun-ray lamp and guesswork timing. . .

## Friends of Pascal

People take languages very seriously, and nobody likes to hear his mother tongue insulted. Not surprisingly, then, the language Pascal found itself amply provided with friends when a slightly negative comment was made by Abacus, about the package as supplied by the University of California at San Diego. (UCSD).

Oddly, Derek Rowe of Abacus was not attacking Pascal; he was announcing that it was available on a system he sells – the TEI system. Rowe's original comment was apparently designed to please Pascal freaks: he said that in the UK the demand for Pascal is very tentative, and that he found this reluctance rather disappointing.

He then blotted his copy book by warning the unwary that UCSD Pascal is not really suited for the amateur until it has been processed from its raw state into a purpose built package for a particular machine. Some exception has been taken! Those who ‘speak Pascal’ already, long to

see others doing so too, and get very annoyed at anyone who seems to doubt their missionary zeal.

Yet the warning is worth repeating. What Rowe was trying to say was simple: if the inexperienced, BASIC-only programmer gets hold of the UCSD package, he won't have a clue how to select and tailor those portions that are dependant on the logical shape of your own computer.

“Most people who are looking to Pascal to give them a step up from BASIC are not systems programmers.” Rowe said, “and if they were, they wouldn't be looking to Pascal, but to assembler. I think all serious programming should be done in assembler.”

UCSD has now handed over the marketing of its Pascal to Softèch, a US software corporation which is not required to be a non-profit outfit (UCSD was having tax problems over the success of Pascal, it seems). It remains to be seen what shape the product will take in their hands, given a stronger marketing drive. Meanwhile, Abacus is at 62 New Cavendish Street London W1M 7LD.

## Off peak cheek?

The whole basis of the micro revolution has been the fact that you can have your own microcomputer for less money than the cost of a share in a large computer. So it takes a special kind of nerve for a London bureau to announce an ‘off peak’ time sharing service – for hobbyists. The bureau, Computer Time Sharing Services (CTSS), is prepared to let you use its machine for about a pound per hour. Quote from George Hertz, manager of CTSS:

“At these prices, many computer hobbyists will find time sharing more economical: all a user needs to get on to our system is a terminal with an RS-232C or V24 interface, a modem or acoustic coupler, plus his telephone. All this can be rented, or it can be purchased for less cost than most hobbyist computers. Yet it gives access to a system that is very much more sophisticated. No

longer is data storage restricted by the limitations of cassettes or small floppy disks; the CTSS user can have many megabytes of online data storage for instant access.”

All of which is very largely true. Exactly what it proves about the price of hobbyist systems in this country is probably unprintable. Until things change, CTSS is on 01-590 1155.

## Switch to bits

A sub-miniature rotary encoder switch which will convert its ten positions into a four-bit binary code from 0 to 10 – or rather, from 0000 to 1010 – has been produced by Impetron. You could use it as a monitor select switch, or as the simplest form of direct input to a system. Alternatively you can set it so that when it points to 5, it gives out 1100 instead, and so introduces a whole new series of bugs! Details on 01-992 5388.

## Solderless

Experimenters who do not rate their abilities as soldering operatives very highly will be pleased to see three ‘solderless Breadboard units’ from Lektrokit: two terminal strips, and one distribution strip. They have an adhesive on the back, or can be screwed down if you prefer. Details: Reading (0734) 669116.

## Connections

Having brought Lektrokit's solderless breadboard, you can also buy a kit of wires to connect components together. Each kit has 350 wires, comes in a neat box, and has fourteen different lengths, insulated, bent over, and ready to push into the holes.

## Photo-save

Your computer has just output a screen full of data onto a television. You know that if you write it down, you will acquire at least one error, and you can't afford any kind of printer. What do you do? Well it may seem obvious. . .

you take a camera and photograph the screen. A special Polaroid camera costs £128, and the supplier, John Davidson of GDS Ltd, will sell you a special hood to cut out reflections, for around £150 — or he will give you free designs and let you build your own hood. Phone Cambridge (0223) 51645 for details.

## Star bores?

American software for Apple II computers is sold with a certain lack of style that makes it irresistible. Virginia company, Soft-One, has announced a two-volume package at \$15 for each, with over a dozen programs on each volume.

But do we need things like 'Clock — turn your \$1200 computer into a \$5 clock with this program' and 'Story Teller tells simple stories; you supply the characters and the subject matter. Each one different' and 'Starwars — put the computer away Luke, and let the force be with you' and stuff? Yes? Somebody import it, then!

## Coloured acorns

A colour computer for under £200 can now be put together from Acorn parts. Some may think it almost impudent of Acorn's Chris Curry to announce a colour video display board for his £65 kit (£75 built) and apologise for for the fact that it costs £88. Veterans of the hobby business may recall, somewhat wryly, that it was the PAL colour output board which Apple told us, here in Europe was responsible for its high price compared with the US price. (PAL is the system of colour television we have, and it is much better than the US system, which is NTSC — that's all you need to know to enjoy the fight).

Acorn is 'cheating' a little by using the Mullard teletext chip for colour characters and graphics, and there is a hidden extra: £12 for a UHF modulator board to provide a signal that the aerial socket will be able to tune in to. It's not a lot of money, though.

Hidden extras are on the positive side too: the Acorn board can also give you a light pen facility.

## Quest micropad

For computer users who can't type, a hand-writing reader in the form of an intelligent writing pad has been announced by Quest. Originally the Datapad was a large mini-computer hidden under the table, watching the position and direction of movement of a pen on a pad. It was good, but the minicomputer cost several thousand pounds, and it didn't do anything with the information; it just turned it into the sort of output you would normally get from a keyboard.

Not surprisingly, the original Datapad did not take the world by storm. Its little brother may do. It has a microprocessor built into the pressure sensitive pad — the micro is the Texas 9900. It's a lot cheaper, and, says the Quest subsidiary which makes it, every bit as good.

Micropad recognises the full English alphabet, with alpha, numeric and special characters 'allowing for a wide tolerance in style and shape'. You need not interpret this as implying that it will cope with a scrawl, because it won't; there is a little display to show you what it thinks you have written, and that display isn't there just for show. It makes the occasional mistake even then. The Micropad also recognises where on the form you are filling in, you have entered data: so if the computer is properly programmed, you can enter (say) '33' under Age, '38 Bloggs Drive' under address, and the machine will interpret this correctly.

## Kits and bits

Kits and bits will be on show at the 'kits and bits' show, Breadboard '79 this Christmas. Last year, the first Breadboard attracted several micro-computer companies despite fears that it would prove to be the normal concoction of metal detectors and bad

# CPS

## DATA SYSTEMS

# The Midlands Micro Sales Centre

Established by CPS to ensure that you buy the micro best suited to your particular need.

During your visit you can see, and try at leisure a whole range of microcomputers.

Expert advice is always on hand to guide you through our hardware, software and back-up services.

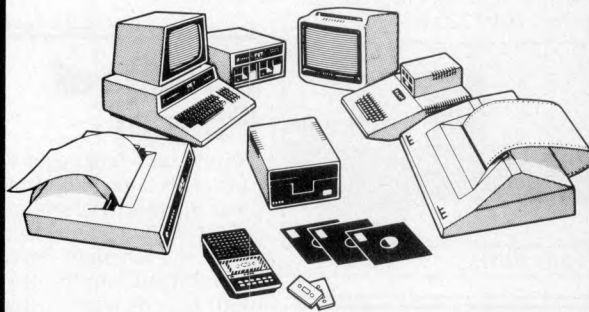

We're Authorised Dealers for **Pet, Apple, Rair** and **Transdata** microcomputers; **Decision Data** and **Datic** printers; and **Lear Siegler** terminals —all available off-the-shelf;

phone us today, to arrange your visit, or for product information

**Telephone: 021-707 3866**

 **CPS**  
DATA SYSTEMS

Third Floor, Arden House, 1102 Warwick Road, Acocks Green, Birmingham B27 6BH

A member of the CPS Group

# TRS 80 MICROCOMPUTER

The 'silicon chip' age is here, now, at your nearest TANDY store. TRS-80, the world's biggest selling microcomputer, is bringing high technology down to earth in shops, factories, offices, schools, laboratories and homes everywhere.

Teaching maths, storing essential information, making calculations for stock control, management accounts, financial analysis, personal finance and performing a-thousand-and-one other functions.

No prior knowledge of computing is required to operate a TRS-80 system using the comprehensive step-by-step 232 pg. users manual. Continuous computer demonstrations are featured at the stores listed below.

- \* TRS-80 is fully wired and tested – NOT a Kit.
- \* Designed and manufactured by TANDY CORPORATION.
- \* 'Level' refers to version of BASIC programming language offered by a particular system.
- \* 'K' factor relates to size of Random Access Memory and degree of program and data storage a particular system offers.
- \* TRS-80 is a modular system capable of expansion to suit your needs exactly. Get details of 'expansion interfaces', 'upgrades' and system capabilities from your local TANDY store.

## 16K LEVEL II



INCLUDES  
NUMERIC  
KEY PAD

REGULAR PRICE  
**£596.85** Inc. VAT

**£2519** PLUS  
VAT

## 4K LEVEL I



REGULAR PRICE  
**£431.25** Inc. VAT

**£2375** PLUS  
VAT

## 32K DISC SYSTEM

INCLUDING FREE GENERAL LEDGER PROGRAMME

SYSTEM INCLUDES

- 26 1162 DISK DRIVE (0)
- 26 1161 DISK DRIVE (1)
- 26 9503 DISK CONNECTOR
- 26 1006 16k LEVEL II
- 26 1141 16k RAM EXPANSION INTERFACE
- 26 1401 LINE PRINTER CONNECTOR
- 26 1301 SYSTEM DESK
- 26 1302 LINE PRINTER STAND
- 26 1403 INTERFOLD PAPER
- 26 1152 TRACTOR FEED PAPER
- 26 1103 NUMERIC KEY PAD
- 26 310 DOS DISKETTE
- 26 2104 DISK BASIC MANUAL
- 26 305 BLANK DISKETTES (10)
- FREE WORTH £69.95** Inc. VAT
- 26 1552 GENERAL LEDGER



REGULAR PRICE  
**£3,333.85** Inc. VAT

**£2,899** PLUS  
VAT

### Continuous computer demonstration stores

**WEDNESBURY** Bilston Road, (off Hollyhead Road);  
021-556 6429

**BRISTOL** 5 Badminton Road, Downend;  
0272 560234

**SOUTHAMPTON** Shopping Centre, 3 East Street;

**LEEDS** 72 Merrion Centre;  
0532 42520

**LEICESTER** Able Jack, Abbotsford Road,  
Humberstone Park; 0533 58011

**HENDON** 21 Sentinel Square, Brent Street, N.W. 1;  
01-202 7331

**WIMBLEDON** 124-126 The Broadway, S.W. 19;  
01-542 6389

**SALE** 13-15 The Mall Shopping Centre;  
061-973 0371

**TANDY**  
DEALER

Most items also available  
at Tandy Dealers. Look for  
this sign in your area.

Prices may vary at individual stores.  
Offers subject to availability.

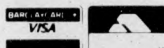

Instant credit available in most cases.  
Access, Barclaycard and Trustcard welcome.  
Check your telephone directory for your nearest store.

KNOWN AS RADIO SHACK IN U.S.A.  
MAKERS OF THE WORLD'S BIGGEST SELLING MICROCOMPUTER TRS-80.

# TANDY

BRINGING HIGH TECHNOLOGY DOWN TO EARTH

amplifiers, loved by electronics experimenters. This year the organisers, Trident Exhibitions, say over 90 exhibition stands will feature "microcomputer systems, analysers, logic test accessories, hi fi amplifier kits, modulators, etc, as well as a variety of exciting construction. . . ." (oh well, what do you expect. . .) "kits and TV games. . . visitors can construct their own lie detectors."

Trident, you should be warned, is a company with an uncanny knack of turning an exhibition into an astonishing success. The last one I know of was Compec (now owned by IPC).

At this stage, the alphabetical list shows Acorn, Commodore, Compshop, Crofton, Henry's Radio, Lektrokit, Lotus Sound, A Marshall, Microdigital, Newbear, Transam and Vero as the more obviously computing exhibitors. The dates are December 4 to 8, Tuesday to Saturday; and the location is Royal Horticultural Halls, Elverton Street, Westminster.

## Better BASIC structure

An 'extremely advanced' version of the BASIC language, called Structured Basic, is available from the big \$100 specialist distributor, Comart. The company introduced this new software tool as a way of allowing programmers to write structured (good) programs, rather than unstructured (bad) programs. Commands such as REPEAT, WHILE, IF...THEN...ELSE..., and PROCEDURE are believed to make clear program design easier: they do not make it inevitable, however, and you can write as badly structured a program as anybody — even using Structured Basic!

## Pascal for Elf

An unusual microprocessor, the RCA Cosmac 1802, has acquired a Pascal system through the Bicester firm, Golden River, which specialises in this device.

The micro is extraordinary in many ways: chiefly there's its use of complementary

metal oxide silicon technology. This takes very little current, and makes it possible to run quite large systems off a dry cell battery. It's also noteworthy for having an assembler language which makes Motorola and Intel assemblers look like voice recognition. The advantage of its fiddly assembler has always been that frighteningly efficient programs could be written, using only a little memory.

In the days when nobody could afford Cmos memory to go with the Cmos processor, that was an important advantage, and a Pascal system that needed 20K bytes of memory would have been meaningless for most amateurs. Now, however, Cmos is much cheaper, and even more important, standard dynamic memory chips are being sold that use as little power. All this is good news for users of the cheap Elf system, and eventually, the availability of Pascal will be reassuring to them. Golden River is on Bicester 44551.

## Elf prices down

Most of the items in the Elf II range have now been reduced in price. The Giant Board is £37.80, the 4K Static RAM board is £75.60, the ASCII Keyboard, £54.63 and the Kluge Prototype Board, £13.82. A video graphics board will be available soon, as will text editor, assembler and disassembler on cassette. Enquiries to HL Audio Ltd., 138 Kingsland Road, London E2 8BY (01-739 1582).

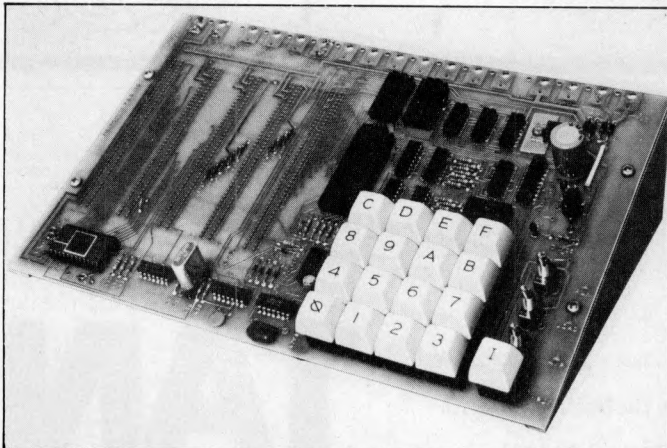

ELF II

## DIY fibre optics

Do-it-yourself fibre optics for experimenters has been announced by Burr-Brown, the analogue to digital company in Watford. Two packages are available, each with sufficient parts to form a complete link with the addition of a power supply and TTL level signals. The difference between them is speed. Details on 0923 338337.

## Look alike

Could Japan have struck at the hardest nut of all, the TRS-80? Being the most common computer in the world, a Japanese imitation makes sense, and a Matlock based company, Lowe Electronics, may have found one. They call it Genie and expect to sell it for £500 without video monitor. Supposedly, it runs all TRS-80 software.

## Danish soft

Denmark's personal computer industry has software for us. From a company called Lisco Micro Data in Kolding, comes a package of languages including Focal, Tiny BASIC, and some applications, aimed at users of the 6502 microprocessor.

Gunnar List claims that his Tiny BASIC will run in 4K byte systems on Kim-1 and Sym-1 from Commodore and Synertek, with a version for the Rockwell Aim 65 due out soon. Cost is £12.30 including

tape and manuals.

Focal costs more — £13.20 for the standard language interpreter, £17.60 for the extended interpreter, £4.70 for a mini manual and £9.40 for a 'user manual'. My typewriter won't cope with the subtleties of the Danish spelling, but as near as I can manage is: Lisco, Aprilvaenget 6, 6000 Kolding. The phone number is (05) 56 86 82.

## From the Centre

A British system builder has joined the long list of American names offering systems based on the standard \$100 layout. This is a £3,000 machine, so isn't for the user at home unless the user happens to have a generous employer.

The company, Computer Centre, is well known for the low prices it charges (especially on components such as memory boards) so it isn't surprising that boss Peter Norman has offered a 'basic kit form version for the scientific builder' at under £1,000.

The big machine is the OEM 2, with dual diskettes storing 2 million characters of data, a full 64K bytes of internal memory, and built-in software including the well respected CP/M operating system. This will allow the user to expand his external storage to 128 million characters without confusing the computer.

The basic kit version has only one diskette drive. Computer Centre is now in Swansea, at 9 De La Beche Street, Tel: 0792 460023.

## Tape basic

Very probably, most people who move from tape cassettes to diskettes could manage quite well on tape, if only the data loaded into the computer or stored out onto tape, were less liable to be wrong.

Nascom software expert Tony Rundle, now with his own company, Starbase, has added an error checking system to the way that computer handles mag tape. It comes with the new version

of BASIC for the Nascom 1. . . . only the Nascom 2, when it is available, will have BASIC as standard on the board. Rundle says that he was virtually forced to design a checksum cassette handling system because there was no other way of loading an 8K byte program.

Tape Basic costs £30 from Nascom itself; Tony Rundle is prepared to help and advise from his address at Waxhouse Gate, 15 High Street, St. Albans, Herts AL3 4EH.

## From Japan

Diskettes from Japan are to be marketed in this country by a new company: DRG Business Machines of Weston-super-Mare. Both five inch minifloppies and full 8-inch floppy drives are offered, data compatible on 8-inch with IBM drives. Details of these and a controller for the 8-inch, on 0934 415398.

## Please help

Ian Litterick was astonished to find that when he was first infected with the desire to become a computer owner, there was nobody to ask about pros and cons of different systems. Ian, a consumerist by nature and by training, instantly wrote off to MPs and civil servants suggesting that here was a hole that needed to be plugged.

"If you want information on big computers," he noticed, "you go to the National Computing Centre and pay for it. But if you want information on a micro, the sort of money the NCC wants for giving help can be almost as much as the micro."

His idea is a national Micro-computing Centre; and by dint of being a lot more energetic than the rest of us, he has bullied the NCC into studying the idea, and providing money for the study. The Department of Industry provides half the cost.

Litterick is compiling the informed opinions of people with informed opinions. . . . he has even asked me, for example. That can't be good enough. So, readers, please help with advice. What has

been most lacking when you were making your purchase decision? Would it help if the NMCC existed and put out a 'preferred specification' against which you could match your requirements, and compare prices? Send your opinions to PCW, or, if what you have to say is too harsh for our ears, to the NCC, which is at Oxford Road, Manchester M1 7ED.

## Pet sophistication

Pet owners usually go for the Pet in the first place because it has BASIC: after a while, they start wanting to do more sophisticated programming. The Pet Machine Language Guide, from Abacus Software in Michigan (not to be confused with Abacus Computers in the UK) is aimed at these ambitious people. Cost of the guide to us Britons is \$8.95.

Included are sections on using the Pet's input and output routines, clocks and timers, floating point, fixed point, ASCII number conversion routines, and other complex arithmetic functions. Payments by Visa card is accepted; Abacus is at PO Box 7211, Grand Rapids, Mich 49510.

## Cash in hand

It's competition time, and both Peterborough and the National Research Development Corporation have thousands of pounds ready to give away to those with bright micro ideas. Peterborough has a total of about £40,000 (that includes a free factory for a year in Peterborough). There are lots of details, musts and must-nots, all available from the organisers at Peterborough Council, and at the NCC respectively.

## Superbrain 2x Z80

Causing some interest amongst enthusiasts with £3,000 to spare, is a computer that uses two Z80 micros. The Superbrain, as it is called, uses the

second micro to control data coming in from the outside storage (two floppy disks) thereby speeding up the whole process.

The basic system is pretty big with a full quota of memory (64K bytes) and a wide variety of output methods. It will talk to standard computer terminals using the V24 protocol, and will drive an ordinary S100 bus from its S100 output port. Software includes the standard CP/M operating system, so the whole CP/M user library should be accessible to the user. The supplier, Computrade, is on Leatherhead (03723) 77374.

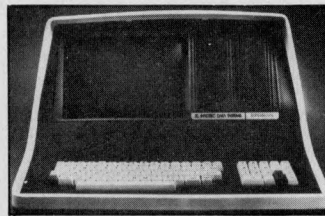

Superbrain — 2XZ80

## Comma to you

Comma Computers is now officially the name of Computer Marketing, the company which got itself known as a terminal supplier, and moved into micros by selling American ICS micro courses. News of micros with the Comma label has been given in the past, and the company felt that to have the same name for computer and company would 'give a clearer, crisper image to the combined operation'. It all arises out of Computer Marketing's takeover of Micro Software systems in July; the Companies Registrar is blamed for the delay in changing names.

Comma managing director George Macfarlane has astounded his competitors in the terminal market with his willingness to stick his neck out; they speak of him in hushed tones because of his willingness to trust Decwriter's delivery promises; no doubt they will also shake their heads over his decision to sell the new Alpha Micro 16-bit system.

He says he plans to shift more than £7 million worth of micros and terminals in just over a year, "and we are

celebrating the new name by announcing a novel micro-computer system called the Comma Copywriter". We look forward to seeing it, George, when can you bring it round?

## Supermicros, but when?

The supermicros, computers that would give us 'all the power of a middle sized mini-computer like Digital's PDP-11/34, on one chip', are knocking on the door.

The most encouraging news is of Motorola's big chip, the 68000, now 'available' on an evaluation board costing £1400. The word 'available' is a wild exaggeration, of course, with around a dozen of these boards so far sold, and with the UK micro people proudly displaying chip number 1065. Obviously the machine is not yet available to just anybody, so when will it be?

The best bet, from the point of the private buyer, is that it will remain a rare beast for at least another year, maybe two. Again, from the private buyer's viewpoint, this doesn't matter a lot. The biggest restraint on any private system is not the power of the processor. It is a question of how much memory it can control — both internal, and external. The Motorola 68000 will be able to control some 24M bytes of semi-conductor memory. . . . that's more internal storage than most private systems have disc storage. Couple a machine of that power, with its full quota of memory — or even a quarter of it — to a big, 50M byte disc, and it will eat anything on the market for £30,000 today.

But the same could be said of the humble Intel 8080, if one were to spend a little time and ingenuity giving it memory management; with a 50M byte disc, and a virtual disc storage system, to give the appearance of having more than the maximum 64K bytes internal storage (a neat trick, and an old, well proven one), it too could eat most small business systems. The problem is not the speed at which the processor can process data, but the slowness



**MSI 6800: At the root of every good system.**

**SEED**

Strumch Engineering Electronic Developments Limited  
Portland House, Coppice Side, Brownhills, Walsall, West Midlands. Telephone (279) 4321

with which data gets into it. A big, fast disc makes many times the difference of a big, fast processor.

That said, the signs are that inside two years, Motorola, Zilog and Intel will be able to offer chips (and support chips) with 16-bit architectures that will be attractive to private users. Motorola's is agreed to be the biggest and best; many, however, have disagreed as to whether it was not over-ambitious, with its 68,000 transistors on an area of silicon measuring 246 by 281 mills. Is it just too small for today's semiconductor expertise?

The most convincing argument that says 'yes, it can be built' has just been produced by Rockwell. Rockwell had a design for a supermicro of its own; it was going to be a descendant of the 6502, and it was going to be called the Super 65. Rockwell has abandoned Super 65 in favour of taking on the 68000. In exchange for the design, it will give Motorola its bubble memory designs.

Rockwell's decision tells us two things. First, it is convinced that it can make the 68000, and so the prospect of Motorola making it itself becomes that much more tenable. (Ones and twos don't count; hundreds per day would barely be convincing.) Second, it tells us that Rockwell is equally sure that it has time to learn the recipe for the 68000 before Motorola has got it down to a fine art and can make them for \$10 each.

## Courses

A new micro consultancy which wishes itself to be known by personal computing enthusiasts is Microsystems Consultants... for the reason that they run courses based on the Rockwell Aim 65. The courses are approved by Rockwell agent, Pelco, in the UK.

Managing director Markus Moser says he would like to help companies "with little or no knowledge of microprocessor applications", to get them to take the plunge and develop ideas and projects. Moser says he is an engineer with a degree in communi-

cations, and has worked for large companies like SCM, IBM and Data General on mini and micro projects.

For details of the courses, ring Camberley 27417, and to take the plunge, contact Fleet 29627.

## IBM on the move

"If there were any serious point to personal computing, then IBM would make a personal computer." Next time some computer industry know-all tries to put down personal computing as something for excessively open minded people - along with astrology and roulette systems - the comeback is a number: the 5105.

This machine will be announced by Christmas, and available at under £2,500 by Spring - in America at least. So says the California market research group Creative Strategies International (CSI) in a report costing some £500.

According to CSI, this will be the specification of the Entry Level System, or 5105 (assuming IBM doesn't change the name to prove them wrong): that's 500 nano-second cycle time, BASIC and monitor in read only memory, a minimum of 16K bytes memory, built-in video with 960 or 1920 character screen, mag tape cartridge for bulk storage and slow printer built in.

Options will include a language called ACL in firmware, memory extensions to 64K bytes or possibly 96K bytes; diskette storage up to 2M bytes; add on matrix printers and software, including word processing. A later option may be a 5M byte hard disc - probably a mini Winchester.

For those who got lost somewhere in the middle of that, it would be a pick up and carry home system rather like the Pet, with a printer and a better quality tape drive, possibly a little more powerful, and certainly priced at the top end of the market for what it is. The add-on list would take the price to around £10,000, for a system that would apparently compete with others based on



Sprint 5

the hobbyist, S100 bus, although at something of a price disadvantage. Software packages could give it an edge, however, for those needing something more than the IBM badge.

Final goodie: it may have an S100 bus adaptor.

## Get it right!

Last issue I said that a British Company, A J Harding (Molimerx), was responsible for Tandy software addition, Infinite Basic. How wrong I was! Freddy Nichols of Optronics (who also handles the product) tells me that in fact it was written in the States by Ron Johnson.

## At our show

Showing for the first time - and where else but at the 79 PCW Show? - are systems based on the Microstar 1.2 and 2.4 megabyte modules. Access Data are the appointed distributors and the two micro computer packages will have full software backup for both word and data processing. For the stand demonstration, one will be showing the word processing capabilities of the 55cqs Qume daisywheel printer, the other will be programmed for data processing using a Texas 820 dot matrix printer.

Access Data Communications are at 228 High Street Uxbridge, Middlesex.

# Personal Computer World

Personal Computer World is looking for a hard working Editorial Assistant to join its magazine production team.

Candidates for the post must:

- \*be able to write good English (often in a hurry)
- \*understand the jargon/implications of micro computing
- \*be able to work constructively under pressure
- \*be meticulous in his/her work
- \*maintain a sense of humour (most of the time!)
- \*be keen to learn the ways of magazine journalism

Salary is negotiable... please apply by letter to:  
The Editors  
Personal Computer World  
14 Rathbone Place  
London W1P 1DE

## BENCH TEST

# CHALLENGER C3-S1

*At about the time that the 6502, 6800 and Z80 were emerging as the "big three" 8-bit microprocessors Ohio Scientific, Inc. began to advertise its solution to the problem of program portability.*

*This was the Challenger CIII series — a range of systems centered on a novel MPU board which contained all those microprocessors and which could therefore utilize programs written to run on any one of the three. In designing this system, OSI have proved farsighted by predicting the decline in price of the actual processor chip relative to the accompanying hardware. To become really successful however, this scheme depends on the premise that people have a large number of assembly language programs which they need to transport from system to system. In the event, the arrival of BASIC (especially Microsoft's) and fairly widely implemented operating systems may have detracted from the original idea.*

*The Challenger III series offers a variety of memory sizes, peripherals and software configured around the basic board. Perhaps the most spectacular peripheral is the CD-74 74MB hard disc which comes with the top of the line system. Also catalogued are a voice I/O board, an A/D and D/A board, a multiplexing parallel board together with more standard serial and memory expansion boards. Also on offer are a variety of operating systems, starting with a simple DOS and graduating to a (not yet released) multi-user multiprogramming OS. CP/M is available, as are a Word Processing Package, Data Base Management System and a small business package.*

*The review machine, the S1 model, was a 56K RAM, twin floppy system with a Hazeltine 1410 terminal. Operating systems 65D, 65U, CP/M and application packages DMS (Data Base Management System) were provided on floppies together with most of the software documentation.*

## BY SUE EISENBACH

### Hardware

The Challenger III model C3-S1 is housed in two cases, a light one containing the computer itself, and the other, heavier one, the disc drives. To open either box the cover has to be unscrewed. Both boxes are well ventilated. The computer has no fan and the operating instructions state that it should be run in an air-conditioned room with 6" clearance for ventilation. The fan in the floppy disc drive is small and noisy; attached to the box, for some reason it clatters when it is running.

The outstanding feature of any Ohio Scientific C3 computer is its CPU board. Called the model 510, it contains three microprocessors, the 6502A, the 6800 and the Z80. A software switching program is on the board so that choice of microprocessor is under program control. The PROM contains the 6502 and 6800 monitors as well as a floppy disc bootstrap. An RS-232 port, eight parallel lines and a clock (which supplies 4MHZ, 2MHZ and 1MHZ signals) are provided.

The memory comprises two to four OSI 520 16K static RAM cards. The fourth is only half populated, giving a maximum of 56K (as in the review machine).

The disc controller is an OSI



470 which can support 1 or 2 single or dual headed 8" floppy drives with soft sectored, single density recording format. Capacity varies from 230K Bytes to 290K Bytes depending on the operating system used. The disc drives are Siemens FDD 120-8.

There were problems arranging the test. The machine came from Computerland in Birmingham and travelled by train and van to reach me. It hadn't fared well

during the journey. Inspection showed that not all of the PC boards were attached to the backplane of the computer. They could have been securely screwed down to the base of the box but this hadn't been done. After placing the loose boards back onto the bus and soldering up a few wires that had broken off in transit I turned my attention to the VDU. It failed to operate and investigation showed that a board was missing. Eventually, once equipped with a new VDU, the computer powered up successfully.

I experienced two hardware faults during testing. Firstly, the computer didn't always clear the memory when the reset button was pressed and secondly, when booting one of the CP/M discs, a few messages appeared on the screen and then the system crashed. This disc was however accessible (via the other CP/M disc) from the other drive.

My overall impression of the hardware was of a cleverly designed MPU board enclosed in a rather fragile mainframe.

### System software

According to the sales literature, there are four operating systems for the Challenger III. The review machine was supplied with three:

# BENCH TEST

OS-65D, OS-65U and OS-CP/M. OS-CP/M appeared to be a standard CP/M running on the Z80.

The other two operating systems were written by OSI and ran on the 6502. OSI do not provide an operating system to run on the 6800 as the fourth (a business/word processing system) also runs on the 6502.

65D is OSI's simplest operating system. It runs on any Ohio 6502 disc configuration (including those of the Challenger I and II) and is monitor type software. I was given two versions, one with BASIC and assembler, and one without. The disc without BASIC was designed for facilitating the execution of 6502, 6800 and Z80 machine code programs. It contains the operating system, a utilities package, I/O drivers and file handlers. The utility package provides software to use all three microprocessors. These include switches to the 6800 and 6502 monitors (in PROM on the MPU board), a Z80 monitor and Z80 and 6800 memory movers. For the 6800 there is also a MIKBUG simulator and 6800 LOAD and DUMP routines. MIKBUG itself cannot be executed on the C3 as it's not designed for such a large system. OSI explain how to alter MIKBUG programs for use under the OSI 6800 monitor and only provide the simulator for the execution of programs where there is no one available to do the alteration.

The utilities provided do not shield the user from the intricacies of data or processor transfers. To load 6800 or Z80 programs from disc the 65DOS must be entered, the utilities loaded, the program loaded and then the switch to the appropriate processor made. To save programs they must first be moved out of the way of the DOS, control switched back to the 6502, 65DOS booted in and finally the program saved. From

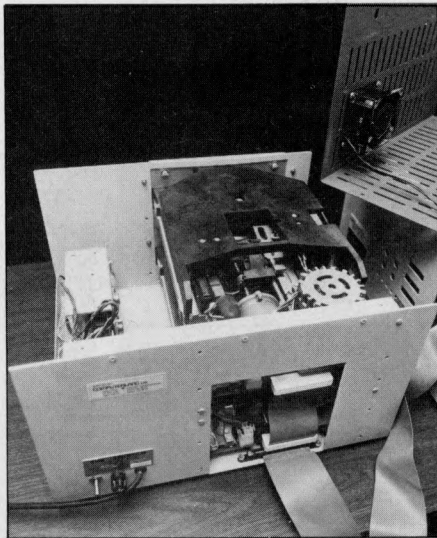

*Disc drives unveiled. Notice the large opening in the back and small fan on the cover.*

the documentation supplied, I could see no way of accessing disc files using the 6800. (The Z80 can access disc files under CP/M).

The second 65DOS disc supplied booted in BASIC along with the operating system. The BASIC utilities supplied are not provided with a 'LOAD and GO' facility and have to be explicitly executed — e.g. to see the disc directory one types RUN "DIR", to create a file RUN 'CREATE'. There are two ways of saving a BASIC program. The first is to exit from the BASIC system and then PUT the program onto a specifically named track (overwriting anything that might be there) and return to BASIC. The second method is to create a file before typing in any program. When creating the file its size must be declared and, unlike the previous method, the new file will be placed in free space. The user then types in a program and saves it in the usual manner. If the program is larger than the space allocated, nothing will be saved. In addition to the BASIC this 65DOS disc had an editor/assembler. Unfortunately

no documentation was provided for these so I could not evaluate them.

The other OSI operating system provided, called OS-65U, is a BASIC only system. In most respects it felt like OS-65D with the BASIC booted in. The data file facilities under 65D are not as comprehensive as those under 65U. Both however have random and sequential files; in addition 65U has indexed sequential files and a FIND command.

The two operating systems are sufficiently similar that it is surprising that Ohio Scientific decided not to write one operating system with the features of both.

## Basic

Each operating system came supplied with a BASIC — 65D and 65U BASIC occupy 9K. This includes 8K Microsoft BASIC and 1K of OSI add-ons (primarily file handling). The CP/M BASIC occupies 19K and is a slightly pared down version of 20K (Altair) Microsoft BASIC. Microsoft's BASICs are the industry standard and are upwardly compatible. Unfortunately OSI's file handling facilities are not the same as those written by Microsoft. The BASICs running under 65D and CP/M have comparable features (using different instructions) while 65U's are more sophisticated. The Data Base Management is written in 65U BASIC and utilizes its indexing instructions. For those readers with Pet experience 65D and 65U BASIC should seem familiar. In fact PET BASIC is easier to use with its screen editing.

65U BASIC contains a FLAG command which enables or disables a variety of system features, primarily error traps. Although there is no PRINT USING statement there is money mode output, which rounds to two decimal places with either left or right justification. File handling comprises: OPEN, CLOSE, PRINT%, INPUT%, INDEX and FIND. The INDEX is a pointer to a record in an open file which can be examined and altered. FIND searches from the current position of INDEX through the rest of the file for a given string (which can include 'don't care' characters). If found, INDEX points to the string; if not found it is set to 1,000,000,000.

### TECHNICAL DATA

CPU(S):	6502A 2MHZ, 68B00 2MHZ, (Sic) Z80 4MHZ.
MEMORY:	32K - 56K STATIC RAM
KEYBOARD: ]	HAZELTINE 1410
SCREEN: ]	
CASSETTE:	N/A
DISC DRIVES:	2 DRIVES, 1 OR 2 HEADS PER DRIVE, 8" DISCS, SINGLE DENSITY.
PRINTER:	N/A
BUS:	OSI 48-LINE BUS
PORTS:	1 SERIAL, 1 PARALLEL, EXPANDABLE.
SYSTEM SOFTWARE:	OS-65D, OS-65U, OS-CP/M, WP-1B
LANGUAGES:	6502, 6800, Z80 ASSEMBLERS, BASIC, EXTENDED BASIC, FORTRAN, COBOL

# BENCH TEST

CP/M BASIC with 65U & D marked U or D, B=Both

The CP/M BASIC is a language you would expect to find on a machine in this price range. It has in line editing, PRINT USING statement, IF . THEN . ELSE, AUTO line number and RENUM.

I would have preferred more expansive error codes on all three BASICs ("OM IN LN 100"); fortunately the messages are the same. The tables with the BASIC reserved words should illustrate the differences between the languages. OSI claim that the 6502 is a superior microprocessor . . . after running the benchmark programs I don't see much between them.

## Other software

Because CP/M runs on it, there is a large range of software available for the Challenger III. In particular, I was provided with two Microsoft compilers. . . one for 8080 Fortran IV and the second for Cobol-80. As these are completely standard (and good) software packages I will not describe them.

More interestingly, Ohio Scientific have written a comprehensive Data Base Management System designed to run under 65U O/S and aimed at the small business-man with no computer experience. OS-DMS boots in the DMS menu which is the first of several, the whole system being menu driven. The utilities, which can be altered by the programmer, are listed in the table below and show how comprehensive this system is. For security, passwords can be placed on any of the programs in the system. Unfortunately, the system might cause difficulties for a person without computer experience as most input is not checked for legality before being accepted. It is not difficult (contrary to statements in the documentation) to type in an answer that seems reasonable — only to get "SN IN LN 75" with no obvious way of getting back to the DMS system. Even when inputs are checked the user is just requested to type in another response — no range of acceptable data is offered. Before the non computer user would feel comfortable using this system, routines are necessary that buffer the operator from the programs and a rewrite of the documentation is needed.

### Commands:

AUTO	CLEAR	CONT(B)	DELETE	EDIT
FILES	LIST(B)	LLIST	LOAD(B)	MERGE
NEW(B)	NULL(B)	RENUM	RESET	RUN(B)
SAVE	SYSTEM	TRON	TROFF	WIDTH

### Program Statements:

DEF(B)	DEFDBL	DEFINT	DEFSNG	DEFSTR
DIM(B)	END(B)	ERASE	ERROR	FOR(B)
GOSUB(B)	GOTO(B)	IF . THEN(ELSE)	LET	NEXT(B)
ON . ERROR	ON . GOSUB	ON . GOTO(B)	OUT	POKE(B)
REM(B)	RESUME	RETURN(B)	STOP(B)	SWAP
WAIT				PEEK(B)

### Input/Output Statements:

CLOSE(U)	DATA(B)	FIELD	GET	INPUT
KILL	LINEINPUT	LSET	NAME	OPEN(U)
PRINT(B)	PUT	READ(B)	RESTORE(B)	RSET

### Arithmetic Functions:

ABS(B)	ATN(B)	CDBL	CINT	COS(B)
CSNG	ERL	ERR	EXP(B)	FRE(B)
INP	INT(B)	LOG(B)	LPOS	
POS(B)	RND(B)	SGN(B)	SIN(B)	SPC(B)
SQR(B)	TAB(B)	USR(B)	VARPTR	

### String Functions:

ASC(B)	CHR\$(B)	FRE(B)	HEX\$	INSTR
LEFT\$(B)	LEN	MID\$(B)	OCT\$	RIGHT\$(B)
SPACE\$	STRING\$	STR\$(B)	VAL(B)	

### Input/Output Functions:

LOF	MKDS	MKIS	EOF	LOC
			MKSS	

### Extensions

Both	65U	65D
IF . THEN	INDEX	EXIT
IF . GOTO	PRINT%	DISK!<STRING>
WAIT	INPUT%	DISK OPEN, <DEVICE>, <STRING>
	FIND	DISK CLOSE, <DEVICE>
	FLAG NN	DISK GET, <RECORD NUMBER>
	PRINT \$R,X	DISK PUT
	PRINT \$L,X	

## DATA BASE MANAGEMENT SYSTEM PROGRAMS

Create New Master File  
 Create New Key File  
 Edit Master File  
 Load Key File From Master  
 Edit Key File  
 Dump Key File  
 Generate Mailing Labels From Master File  
 Master File Merge or Load  
 Diskette Copier  
 Multi-File Multi-Format Report Writer  
 Multi-Conditional Report Writer with Statistical Functions  
 Multi-Conditional Statistical Package  
 Sort a File  
 Master File Record Inserter  
 Master File Record Delete and Repack  
 Inventory  
 Order Entry  
 General Ledger  
 Personnel  
 Payroll  
 Accounts Receivable  
 Accounts Payable  
 Query

## Benchmark

As well as running the Kilobaud benchmarks (see summary), I set up some disc tests.

These were run under OS-65U as Ohio Scientific state that this operating system provides the best file accessing facilities. All the files in these tests are 100 record files with 256 character records. Each record is composed of 8 fields (called A\$ — H\$). Tests 2 and 4 are designed to test the "randomness" of writing to and reading from files. If tests 2 and 4 take substantially longer to run than 1 and 3 then the operating system is probably using a sequential method for its random access. Test 1. Fill A\$ — H\$ with 32 "A"s each. Open a datafile; using a FOR-NEXT loop write to records 0 to 99; close the file. Test 2. As test 1 but writing the records to the file starting with the last record; that is the FOR-NEXT loop's step is -1. Test 3. Open "Datafile" using a FOR-NEXT loop, read each

# BENCH TEST

record out of the file, close the file.

Test 4. As test 3 but reading from the file starting with the last record.

Disc test 1	19.9
Disc test 2	21.9
Disc test 3	83.1
Disc test 4	83.1

## Business potential

The Challenger III is designed for use both as an end user system for running application packages and as a development system. For either use probably its greatest selling point is its hard discs. No other personal computer system on the market offers the possibility of nearly 300M bytes of on line storage. With a Challenger III, software can be designed or purchased for a floppy disc system and then run with hard discs as capacity grows.

### Business application

Looking at the Challenger III as an end user system, one ought to be able to run 6800, 6502 and Z80 packages on it. Unfortunately Ohio Scientific supply virtually no system software for running 6800 code. So either 6800 system software must be purchased first to run 6800 application programs or those packages purchased must be written in machine code. In either case, as standard 6800 MIKBUG code will not execute under the Ohio Scientific monitor, it is a safe bet that 6800 programs will not run without the attention of a system programmer.

Moving on to the 6502, Ohio Scientific have written three application packages. The review machine was only supplied with their Data Base Management System. It is a comprehensive package with the nice feature of optional passwords for reading and/or writing protection from unauthorized users. Unfortunately I had no difficulty in crashing (both accidentally and intentionally) DMS so any potential buyer should expect to experience some problems when it is first installed. The other two packages that Ohio Scientific supply are a Word Processor and a Small Business Package. Bearing in mind that Ohio Scientific's software is of variable quality, I cannot recommend software I haven't seen. In any case, I have serious doubts about the usefulness of the Small Business Package. It was designed in

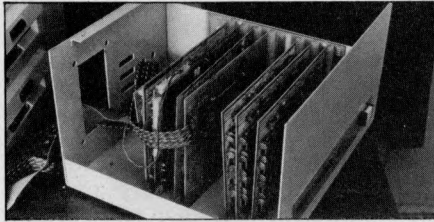

Inside the computer itself.

### Benchmarks

	CP/M	65U
BM1	2.3	1.7
BM2	7.9	13.1
BM3	21	21.6
BM4	21	23.7
BM5	22.5	29.2
BM6	37.5	39.6
BM7	59.6	58.3
BM8	9.9	17.6

(processor timings in seconds)

America, for an American market where business jargon is different and VAT is unheard of.

Finally, turning to the Z80, the user should experience few problems. As CP/M runs on this microprocessor and most disc based British application packages run under CP/M, the situation is most satisfactory.

### Development System

The Challenger III as a development system follows a similar pattern. Again the lack of systems software for the 6800 makes it difficult to use. On the other hand, the Z80 under CP/M gives access to a wide variety of system software. Translators for BASIC, FORTRAN, COBOL, PASCAL, Z80 Assembler and 8080 Assembler are on the market together with their corresponding debugging aids.

Looking at Ohio Scientific's own system software for the 6502 the kindest thing I can say is that it is of uneven quality. I have my doubts about the reliability of OS-65U. It crashed regularly throughout the period that I used it. Normally I would put this down to faulty hardware, but the system did not crash under CP/M and on the whole they use the same hardware. (I suppose there could have been something wrong with the 6502 chip itself). It has a few nice features such as a password system and good file handling facilities (including indexing) under OS-65U. On the whole Ohio Scientific's BASICs are less sophisticated than one would expect on a disc based system. It is also

irritating to have three different BASICs each with its own advantages and disadvantages.

### Summary

If a user either needs the large disc capacity or wants to run programs on more than one microprocessor, then the Challenger III has possibilities. If neither of these conditions apply, then the disadvantages inherent in the Challenger III probably outweigh its advantages. I cannot imagine the purchase of this machine for the developing or executing of 6800 programs. Ohio Scientific produce a less expensive range of computers, the Challenger II (6502 based only) for running their system software and Data Base Management System. There are a wide variety of other machines on the market that run under CP/M that are less expensive, more attractive and more robust.

## Educational potential

I have my doubts whether the hardware is sufficiently rugged to withstand student users. Also the large number of cabinet vents might lead to objects, such as pencils, "falling into the computer". A rack mounted version would be more secure against such accidents.

I was told that it was a good machine for education because it allows students to use a variety of microprocessors. However, for the price of a C3 one can purchase a CP/M system, a PET and a single board 6800 computer. Although this collection doesn't provide identical facilities, it probably provides those features of the C3 that students would utilize, with scope for more "hands on" experience.

On the other hand, programming needs could well be met by the multi-user system with hard discs but again it is debatable, given the small BASIC, whether several stand alone computers would not provide a more reliable installation for the money.

## Documentation

The documentation provided by Ohio Scientific Inc. was of variable quality. The OS-CP/M manuals (System, BASIC, FORTRAN, COBOL), written primarily by Microsoft Inc., are thorough, paginated, indexed and filled with examples.

The documentation that OSI

# BENCH TEST

write themselves is more difficult to praise. Several of the manuals supplied were photocopies of preliminary versions, but even their final efforts are not impressive. Pages are only numbered within sections and there are no indices. The manuals are both repetitious and incomplete. There are very few programming examples and most of those are full-sized programs that are rather daunting to scan right through for a single question of syntax.

OSI seem to have difficulty in finding the appropriate level for each type of manual. For example in the documentation for OS-DMS (the Data Management System that is "immediately usable for the untrained small businessman") there is a glossary of terms with definitions such as: "Index - the index is the virtual field address of an entry field, record or file". In the midst of a technical discussion about the memory, the OSI technical writer, in an outburst of enthusiasm says, "520 memory is by far the finest semi-conductor memory available in computing, regardless of price, considering both its superb reliability and outstanding speed/power product".

On the whole, I feel a little tentative about reviewing a system whose characteristics risk being obscured by such documentation.

## Expandability

Probably the largest personal computer system advertised is the Challenger III. A C3-S1 can be expanded to a full C3-B system with 768K bytes RAM, four 80M byte Winchester hard discs and 16 communication ports. Also announced is a multi-user version of 65U operating system.

## Conclusion

When the Challenger III was designed, there was virtually no software on the market. At that time, people producing software had to program in machine code and so had a thorough knowledge of the operation of their microprocessor. It was a clever idea to place all the major microprocessors on one board, so that all available programs could be run. Unfortunately for the designers of the Challenger III system, software developments in the micro

market have meant that programmers no longer need to learn machine code in order to use a personal computer. The overwhelming success of Microsoft BASIC, in which the majority of applications programs are coming to be written, means that the potential user who wants to fully exploit the C3 system will have to become more involved with the hardware than is necessary with other comparably priced systems.

My overall impression of the system was of a machine with some very clever ideas. However, I have the feeling that it was rushed into production, thus giving

a rather ragged feel to the package. In particular neither the OS-65D and U system software nor the overall documentation are up to the standards currently available in systems priced upwards of £2000. The 74M byte hard disc system sounds promising but experience (with the Superboards) leads one to expect an element of delay between product announcement and eventual availability.

*PCW would like to express its thanks to Computerland in Birmingham and the Byte shop in Ilford for the loan of equipment used in this test.*

## Prices

CS-S1	32K dual floppy in 2 cases with OS-65D	£2998
C3-OEM	32K dual floppies in 1 case	£2998
C3-A	48K dual floppies, 16 slot rack OS-65U	£4251
C3-B	C3-A with 74M byte hard disc	£9985
C3-C	C3-A with 29M byte hard disc	£7988
520	16K board	£ 385
	Centronics parallel interface board	£ 160
OS-65U	Single user	£ 200
OS-CP/M	With BASIC, FORTRAN and COBOL	£ 600
OS-DMS	Data Base Management System	£ 300
AMCAP	Small Business Package	£ 300
WP-2	Word Processing Software	£ 300

## FIRST IMPRESSIONS

Looks	**
Setting up	**
Ease of Use	***

*****	excellent
****	very good
***	good
**	fair
*	poor

## HIGH LEVEL LANGUAGES

BASIC (Ohio)	**
BASIC (CP/M)	****
COBOL	**
FORTRAN	****
PASCAL	n/a
System Software	***

## PACKAGES

Business	****
Education	n/a
Home	n/a

## PERFORMANCE

Processor	*****
Cassette	n/a
Disc	****
Peripherals	**

## EXPANDABILITY

Memory	****
Cassette	n/a
Discs	*****
Bus	***

## COMPATIBILITY

Hardware	**
Software	****

## DOCUMENTATION

	**
--	----

## VALUE FOR MONEY

	**
--	----

## MEMORY MAP UNDER 65D

DFFF	Source File Work Space
3178	OS-65D
2300	BASIC or Assembler
200	6502 Stack
100	6502 Page Zero
0	

## MEMORY MAP UNDER CP/M

B200	FDOS
A900	CCP
	TPA
0100	System Parameters & bootstrap
0000	

# EUROC

## Simplicity is the watchword



EUROC is a new simple to use, fast, powerful micro-computer system for business. It's British, the program tried and tested.

EUROC is already being talked about by bankers, accountants and businessmen. See it on Stand 642 at the International Business Show at the National Exhibition Centre, Birmingham from 23rd October to November 1st, 1979.

EUROC hardware is manufactured exclusively for Euro-Calc Ltd., by Plessey Microsystems Ltd. EURO-C will be on permanent display at Euro-Calc's branches

at 55 High Holborn, London WC1 and at 224 Tottenham Court Road, London W1.

EUROC looks after your day books (Cash-Sales-Purchase & Nominal).  
EUROC keeps your ledgers (Sales-Purchase & Nominal).  
EUROC prints out your Statements and Remittance advices.  
EUROC produces 8 vital REPORTS at your month end and to ensure you enjoy complete financial control. (I.E. Aged Debtors Report, Aged Creditors Report, Name and Address Report, Sales Analysis Report, VAT Report, Profit and Loss Report, Assets and Liabilities Report, Fund Report).

In addition optional Stock Control and Payroll programs will be available.

There are no hidden extras. EURO-C's price of £7,995 ex. VAT includes- Hardware, Software, Initial Supply of Stationery and Binders - in fact everything you need to computerise your business including the 1st year's Maintenance Contract - nationwide service is undertaken by Plessey Microsystems Ltd.

# EUROC

For further information and trade-distribution enquiries, talk to Peter Ingoldby, Managing Director, Euro-Calc Ltd., 55, High Holborn, London, W.C.1., telephone 01.405 3223 or Anthony Manton, Sales Director at Tottenham Court Road on 01-636 5560.

# THE 2nd PERSONAL COMPUTER WORLD SHOW

**1-3 November 1979  
West Centre Hotel,  
Lillie Road, London SW6**

Last year the vote was just about unanimous. . . The 1st Personal Computer World Show stood out above all others as Britain's major micro event of the year.

Now it's 1979 and although this time far bigger guns are being aimed at PCW's position of eminence, that in a way just makes us all the more determined to hold on to our first place. 'Bigger and Better' may be a hackneyed old phrase, but we are certain it will turn out to be an entirely apt description of The 2nd Personal Computer World Show.

We are happy to announce an over 50% increase in exhibitors this year — a sure sign of the continued growth of the micro industry. Indeed, so heavy has been the demand for site applications, the organisers have been forced to make special arrangements with the hotel to allow 'late-comers' to spill over into the foyer area.

Chess will again be a major highlight. Ever popular with the forces of the media,

David Levy takes charge of the first European Micro-computer Chess Championship — and what an enthralling contest that promises to be. 'Chess-nut' or not, don't forget to come by for David's commentary of this titanic struggle between rival programs. By the way, the winning owner picks up a cheque for £1,500.

Of special interest, David Hebditch (who's also one of our Conference speakers) will be demonstrating communication between personal computers. The display will stand as the fruition of his 'On the Line' series in PCW in which, issue by issue, he has taught the rudiments of this exciting new activity. Will McLuhan's concept of a 'Global Village' be finally realised? . . . talk to David

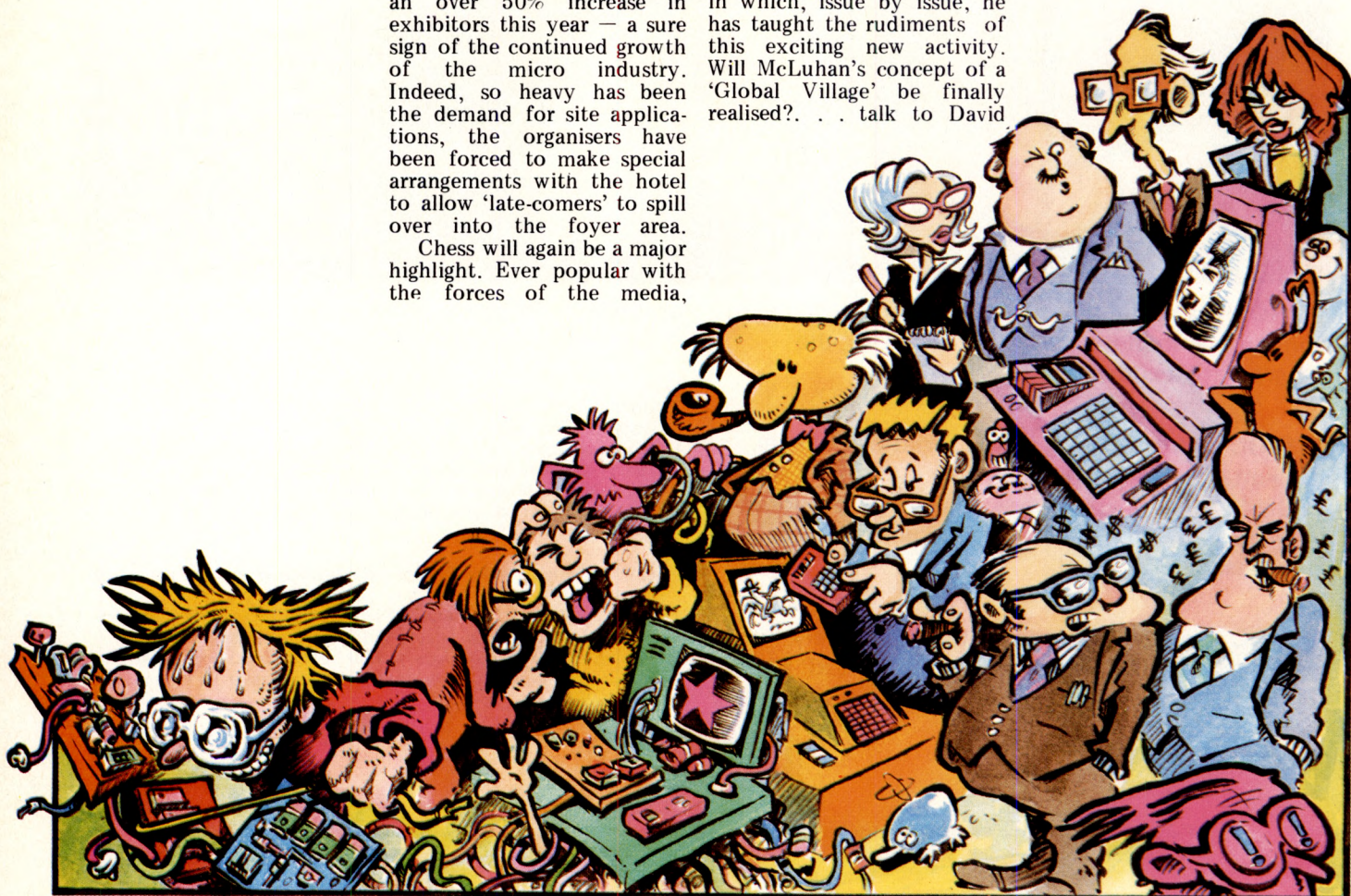

Illustration by Hunt Emerson

and see what he thinks. No PCW show could ever be complete without its accompanying 3-day Conference and this year's forum, with its carefully structured programme of subject matter, brings together some of the most skilled and knowledgeable speakers in their fields. Essentially the Conference breaks down into three main areas of interest. Day One caters for the businessman, Day Two for the industrialist and Day Three, the hobbyist.

Briefly, Day One looks at a businessman's decision to buy a micro, some possible uses for it, some first hand experience from a real user and, finally, an indication of the sort of return one might expect from the investment.

Next, the Conference switches tracks to look at the uses of microprocessors in the industrial environment. . . their place on the production line, their incorporation into the products themselves, the highly work-efficient world of the industrial robot and, to end, a session dealing with that thorny and emotive subject, the impact of micros on labour relations.

Day Three is 'hobby' day. First of all there'll be an overview of the current micro market, and that'll be followed by a look at the practicalities of dialling up other machines. The Conference then heads its way into the world of exotic peripherals and, to close, it strays across the Sci-Fi/Real Science border for a close-up investigation of the innards of fun robots.

Whatever else, The 2nd

Personal Computer World Show is intended to be a family occasion. Usually that means, 'dad, bring along the kids and show them what it's all about'. . . in this case it probably means, 'kids, bring along your parents and show them what it's all about'!

There'll be machines on show, books and magazines for sale, packages being demonstrated, consultants consulting, advisers advising; in fact, you name it and — if it's anything to do with micros — it'll be there. If you've never ever attended an exhibition like this before, The 2nd Personal Computer World Show is the one you simply cannot afford to miss. . . SEE YOU THERE!

#### GENERAL INFORMATION

##### Venue:

West Centre Hotel, Lillie Road, London SW6

##### Hours:

10:00-19:00 Thursday 1st November

10:00-19:00 Friday 2nd November.

10:00-17:00 Saturday 3rd November

##### Admission (Show):

£1.00 (advance booking), £1.50 at the door.

##### Admission (Conference)

Thursday & Friday — £45 plus VAT

Saturday — £14, VAT inclusive.

(Both the above prices include entry to the show)

##### Access:

Underground to either Earls Court or West Brompton (Beware, the latter station is closed on the Saturday). Also buses — 30, 74 and 74b.

---

**ACCESS DATA** 47  
**COMMUNICATIONS LTD**  
**& PRODUCTIVITY**  
**UNLIMITED**  
 228 High Street,  
 Uxbridge, Middx  
 0296 624887

A hardware supplier and a consultancy have teamed up to provide a complete service to the prospective micro buyer. The companies specialise in Microstar with Qume or Texas printers.

*They offer business analysis advice, guidance and software packages which they will customise if necessary or they will write a bespoke system. They provide hardware and software support and are planning training courses.*

---

**ACT PETSOFT &** 41 &  
**PETSOFT SOFTWARE** 49  
**SUPERMARKET**  
 P.O. Box 9  
 Newbury, Berks  
 0635 201131

This company specialises in servicing the needs of PET users. They sell a wide variety of software packages including business, games and training. They also sell PET peripherals and add-ons such as disc drives, memory expansion and plug-in programmers tool kit.

*On show will be a well-stocked PET-SOFT software supermarket, demonstrations of their packages including a non-stop presentation of their PETACT business system. They will be showing their 800K PET disc drive and their new stock control system written for use with this drive.*

---

**APPLIED DATA** A9  
**EDUCATION SERVICES**  
**LIMITED**  
 Suite 504,  
 Albany House,  
 24 Regent Street,  
 London W1R 5AA  
 01-580 6361

This company specialises in educational packages designed for Apple, PET and Tandy machines.

*On show will be their floppy disc based Little Genius self-instruction courses plus BASIC courses for the various machines.*

---

**B&B CONSULTANTS** A15  
 124 Newport Street,  
 Bolton, Lancs  
 0204 26644

This company sells hardware, software, support and training. They specialise in ITT 2020, Tandy, PET, Computhink and TECS equipment. They can hook up 2M Bytes disc storage to a PET if required. Their own packages include: Stock control, sales ledger, purchase ledger, nominal ledger and invoicing. A personalisation service is offered. Software is guaranteed and a hardware maintenance service can be provided.

*At the show they will have their PET and TECS equipment running demonstration programs.*

**For telephone  
 bookings or enquiries  
 call the organisers~  
 Montbuild Ltd  
 All exhibition and  
 conference enquiries  
 to Anne Reynolds  
 01-486 0067**



---

**THE BYTE SHOP LTD** 21 &  
426/428 Cranbrook Rd 22  
Ilford, Essex  
01-518 1414

This company sells a range of hardware and software, both off the shelf and tailor made. They sell about 20 different machines. They also provide a software service through their sister company - Computer Aided Systems - which has been in the software business for 10 years.

*On show will be a number of their more substantial systems aimed at the businessman. A range of financial and business packages will be demonstrated.*

---

**CS MICROCOMPUTERS** A16  
460 Cowbridge Road East,  
Cardiff  
0222 565012

This company provides hardware and software to your requirements. They cover England and Wales. Their speciality is in the North Star Horizon although they will provide other machines if required. They offer their own packages for collecting agencies, wages, stock control, sales statistics and word processing.

*Meet them at the show, discuss your needs and see their hardware and software in action.*

---

**COMPELEC ELEC-TRONICS LTD** 31,32,  
14/15 Berners Street, 33,35,  
London W1 36  
01-636 1392

This company provides both hardware and software backed up by comprehensive support services. They sell both to end users and OEMs. The packages offered are designed so that the person totally without experience can customise them in a few days. Applications are: sales ledger, nominal ledger, purchase ledger, order processing and invoicing; stock control; payroll; personal records and fixed assets. These all include 3 days training. Special business applications covered are: estate agents, insurance portfolio management and mailing lists.

*They will launch two new products at the show a 1MB,64K, VDU printer system and a word processing package which will also run their application software. They will also be showing Altair 300 systems - multiuser with 10 MB hard discs.*

---

**COMPSHOP LTD** C3  
14 Station Road,  
New Barnet, Herts  
441 2922

This company claims to be the largest discount microcomputer store in Europe. They stock Exidy, ITT, Compukit, TRS80 and PET products. They also sell software packages from PETSOFTE, A.J. HARDING and APPLE. They have a service company called Compucare.

*They will be demonstrating their basic range of machines and selling COMPUKIT UK 101. They will also be demonstrating colour add-on boards for this machine. The Video 100 and Hitachi monitors will be on display.*



---

**COMPUTER BOOKSHOP** 3  
Temple House,  
43-48 New Street,  
Birmingham B2 4LH  
021-643 4577

A wholesaler of microbooks to the microcomputer industry, Computer Bookshop sells books from 8 or 9 publishers. They are the sole Sybex distributor for the UK.

*A wide range will be on show including Sybex's books and cassette courses. They will also be bringing about 20 new books from Addison-Wesley.*

---

**3D DIGITAL DESIGN & DEVELOPMENT** 8-9  
43 Grafton Way,  
London W1P 5LA  
01-387 7388

3D are microprocessor interfacing specialists for industrial, medical and educational applications. They quote for custom interfacing packages which include both hardware and software.

*On show will be their serial and parallel printer interfaces for the new Sharp MZ-80K, a wide range of industrial interfaces e.g. Analogue/Digital converters, Relay drivers and Numeric Control tape preparation packages for PET.*

---

**DATAC LIMITED** A13  
Tudor Rd, Altrincham,  
Cheshire WA14 5TN  
061 941 2361

Datascall themselves "The Printer People". Indeed, that is their speciality. They also sell floppy disc drives.

*They will be showing most of their printer range and flexible disc drives. Printers on display will include: DB80 - an 80 column bi-directional sprocket feed matrix impact printer; 310 series, low cost 20 column printer which can be panel mounted or free-standing; and the 240/410 series of 16,20,32 and 40 column printers.*

---

**ELECTRONIC BROKERS LIMITED** A5  
49/53 Pancras Road,  
London NW1 2QB  
01-837 7781

This company specialises in the sale of secondhand computer equipment. The equipment is fully refurbished and offered with a warranty and full service backup.

*They will be showing a range of low cost ASCII keyboards and accessories, floppy disc drives, monitors, papertape equipment and VDUs.*

---

**ENSIGN LTD** 51 &  
13-19 Milford Street, 52  
Swindon, Wilts  
0793 42615

*Information not available at time of going to press.*

---

**EQUINOX COMPUTER SYSTEMS** 45 &  
46

Kleeman House,  
16 Anning Street,  
New Inn Yard,  
London EC2A 3HB  
01-739 2387

This company sells systems to scientific, business and educational users. The systems comprise hardware and system software and they offer a country-wide back-up service. They are well used to multi-user, multitasking systems incorporating hard discs.

*On show will be their Horizon series 5000 and 8000, CP/M based with 5 1/4" and 8" floppies, printer and VDUs. Software will include BASIC, FORTRAN, COBOL, PASCAL, ALGOL, Assemblers, Text and Word Processing.*

---

**A.J. HARDING (MOLIMERX)** 39  
28 Collington Avenue  
Bexhill-on-Sea  
East Sussex  
0424 220391

This company is one of the largest software suppliers for the TRS-80. Most of the packages are business and utility programs although they also sell some games. Their other activities include consultancy and custom design of systems.

*They will be selling their more important programs at the show but, most of all, they will be there to meet their customers - both existing and prospective.*

---

**HEATH (GLOUCESTER) LIMITED** 4  
11B Bristol Road,  
Gloucester GL2 6EE  
0452 29451

Two years ago in the USA this company introduced 8-bit computer kits to hobbyists - this led to a lot of business interest so they moved on to ready-built business systems based on the 16 bit DEC 8/11.

*Systems on show will be the WH89 - a 16K, 2 x Z80, integral disc plus VDU and the H8 - an 8080A based machine with an H19 intelligent VDU. A low-cost printer, the WH14 will also be on show.*

---

**ITHACA INTERSYSTEMS (UK) LTD** 34  
58 Crouch Hall Road,  
London N8 8HG  
01-341 2447

This company provides full technical and marketing support for Ithaca dealers throughout Europe. They sell a full range of IEEE S100 boards to OEM users.

*They will be launching their DPS1 IEEE S100 mainframe computer, a PASCAL/Z compiler, a single board computer, a 16K static RAM board and an I/O board. In addition they will be showing a full range of S100 boards such as Z80 CPU, EPROM, video disc controller etc. . .*

**KATANNA MANAGEMENT SERVICES LTD.** 54  
 22 Roughtons,  
 Galleywood,  
 Chelmsford,  
 Essex CM2 8PF  
 0245 76127

This company provides complete computer systems. They will install packages or tailor-made systems on any equipment although they do specialise in Tandy. They provide staff training and on-going post-sale support. They also sell a number of packages — both business and pleasure.

*On show will be a range of software including the Apparatus NEWDOS, their own packages and Tandy Business Systems. They will also have on the stand the Modata DSC-2 with 1.14M Bytes of floppy disc storage, a Hazeltine VDU and a choice of printers.*

**KEEN COMPUTERS** 13-  
**APPLE DEALERS** 18  
 c/o 5B The Poultry  
 Nottingham NG1 2HW  
 0602-583254

This is a network of companies comprising the Apple distributor and six dealers. They all specialise in Apple and its related hardware and software products.

*They will have a 'hospitality area' at the show and will be presenting all normal Apple systems plus hard discs, speech recognition and synthesis, A/C controllers, supercolour for home TV, Business and games software and a hardware driven PASCAL.*

**L. P. ENTERPRISES** C10 &  
 8-11 Cambridge House, C12  
 Cambridge Road,  
 Barking, Essex IG11 8NT  
 01-591 6511

This company distributes and retails books, magazines and microcomputer software. The software is supplied on cassette or floppy discs. Emphasis is on system software, applications and games packages.

*On show will be a wide range of products. Specific items on show will be the Wordstar word-processing system and the new Cromemco Series Three operating system. This operating system is multi-user (up to 16), multitasking for any Z80 with 64K RAM and interrupt handling facilities.*

**LEXICON TRANSLATORS A10**  
**& ELECTRONICS (UK) LTD**  
 Stewartson House,  
 691 Seven Sisters Road,  
 London N15  
 01-802 7970

This company markets the LK3000 — "your personal computer". This can be used as a computer or as a terminal. Different applications are contained on plug-in modules. There are 9 different language translators (with more to come), a calculator module, a computer terminal module, a user-programmable module and information modules.

*At the show they will be exhibiting all the modules, including a Winter Olympics information module containing details of previous Olympic records. This also includes a stop watch facility.*

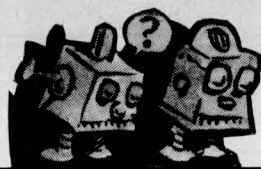

**LIFEBOAT ASSOCIATES** A3  
 30-32 Neal Street  
 London WC2H 9PS

*Information not available at time of going to press.*

**LONDON COMPUTER** 43  
**STORE**  
 43 Grafton Way  
 London W1P 5LA  
 01-388 5721

This company specialises in micro-computer based systems for business users and software houses. They market and distribute the Pegasus — a Z80 based micro built by the National Multiplex Corporation.

*On show will be a 10M Byte hard disc, a 2.4M Byte quad density 8" floppy disc drive and a low cost 80 column printer suitable for PET, Apple, TRS-80 etc. . .*

**LYNX COMPUTERS LTD** A19  
 Rotherglen,  
 Gerrards Cross Road,  
 Stoke Poges,  
 Bucks SL2 4EJ  
 Fulmer 2572

This company serves "software cottages" around the country. They provide Apples to system writers who, in turn, produce systems to their clients requirements. These systems are then publicised and distributed to the other cottages by Lynx. Lynx themselves are also a consultancy.

*On show will be 3 Apples. One with a daisy wheel printer attached for an embryo word processing system, another demonstrating standard commercial packages, the other demonstrating a stereo music synthesiser.*

**MBM (MICROCOMPUTER** 38  
**BUSINESS MACHINES)**  
 4 Morgan Street  
 London E3 5AB 01-981 3993

This company is a wholesale distributor of the entire Ohio range. They offer engineering and back-up support. They also offer software — tape and disc based.

*They will be showing the CI, CII and CIII. The CI will be cased and will include an extension board and a floppy disc drive. The CIII will come with a 29MB hard disc plus business and database software.*

**MEGAPALM LIMITED** A12  
 "Downderry"  
 Halton Road  
 Nether Kellet,  
 Carnforth,  
 Lancs LA6 1EU  
 0524 73 3801

A small flexible software consultancy who cover the whole spectrum of pre- and post implementation activities. They do consultancy work, systems analysis, system design and program writing especially for the first-time user. They hold dealerships in Commodore and CompuLink products and software packages. They run short resi-

dential courses in programming and allied topics.

*They will be exhibiting a small business system at the show.*

**MICRO COMPUTER** 25  
**CENTRE**  
 314 Upper Richmond West,  
 London SW14  
 01-876 6609

This firm offers PET based systems, either small applications for large businesses or large applications for small businesses. They offer a service from advice to designing and programming complete systems. They also sell standard packages which they are happy to customise. They supply PETs, CompuLink products and any other PET peripherals.

*On the stand they will be meeting clients, selling their range of hardware and software and demonstrating their business package.*

**MICRODIGITAL LTD** A22-  
 25 Brunswick Street A24  
 Liverpool L2 0BJ  
 051-227 2535

From hobbyist kits to full scale business systems they supply hardware, software, support, books and publications. As well as selling packages they develop their own and are happy to custom-build to your requirements. They also offer a hire service — the cost of which is deducted from purchase price.

*At the show will be books, a reed relay controller board for Nascom, some of their smaller systems and maybe even a surprise new computer???*

**MICROSOLVE COMPUTER** 6  
**SERVICES LTD**  
 125-129 High Street  
 Edgware, Middx  
 01-951 0218

This company offers a complete service encompassing hardware and software sales. They will conduct business investigations, design systems and produce solutions. They specialise in 3 machine ranges — Apple, Microstar and Alpha Micro — plus, of course, the usual range of add-ons, VDUs, printers etc.

*At the show they will be demonstrating some of their business packages.*

**MIKE ROSE MICROS** 42  
 67 Nova Road,  
 Croydon,  
 Surrey CR0 2TN  
 01-688 6013

This company specialises in consultancy, training and programming services. They think that systems should be matched to a businessman's needs, and to this end they offer business analysis, hardware recommendations, system design, programming, an implementation service, training and full post implementation support. They will also arrange hardware support on behalf of their clients.

*Meet them at the show. They will be happy to talk to prospective clients for their consultancy and training services.*

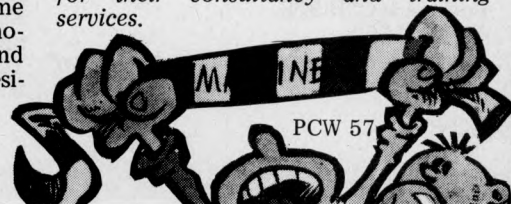

---

---

**NEWBEAR COMPUTING** 11 &  
**STORE LTD** 12  
40 Bartholomew Street,  
Newbury, Berks RG14 5LL  
0635 30505

They concentrate on the following machines: DPS1, Cromemco Series 3, Apple, North Star Horizon, printers, VDUs etc. Software is available for all these machines. The publication section boasts one of the biggest selections of books available. The components division sells chips, tools, kits, Jim-paks, UVEPROM erasing lamps etc.

*They will exhibit all their machines, a selection of books and any tools, Vero boxes etc. that can be carried away by visitors.*

---

---

**NEWTONS LABORATORIES** 19 &  
**TORIES** 24  
123 Wandsworth High Street,  
London SW18 4JB  
01-870 4248

The computer division sells micros direct to end users and to OEMs. They sell their own software — order processing, invoicing, sales ledger, purchase ledger, nominal ledger and payroll. They offer full customer support.

*They will be showing a 16 bit alpha micro with dual density dual sided 8" Shugart drives plus VDUs and a printer. They will also have 10MB and 90MB hard disc systems. They will be demonstrating their packages.*

---

---

**PERSONAL COMPUTERS** 30  
**LTD**  
194/200 Bishopsgate  
London EC2M 4NR  
01-283 3391  
01-626 8121

This company is a long-established Apple distributor dealing in Apple and compatible products. These include Teksim, full size floppy disc drives, printers, analogue to digital converters and a wide range of software products.

*They will have their full product range on show. Items of particular interest will be their Estate Agents software, their text processing package and the Milliken interactive medical education software.*

---

---

**PETALECT LTD** 5  
33-35 Portugal Road,  
Woking, Surrey  
048-62 69032

Last year they started selling PETS. They specialise in technical interfaces for the PET — electronic balances, spectrophotometers, light pens and so on. . . They produce the software and implementation service to back this up. In fact they are responsible for some very complex total systems.

*See them on the stand where they will have weighing machines hooked up to PETs, lots of laboratory equipment, bar code readers, demonstration packages and a selection of Computhink products.*

---

---

**RAIR LIMITED** 10  
30-32 Neal Street  
London WC2H 9PS  
01-836 4663

*Information not available at time of going to press.*

---

---

**RESEARCH MACHINES** 48  
**LIMITED**  
Chapel Street,  
Oxford  
0865 49792

A British microcomputer manufacturer, their product is the 380Z. The product is aimed at specialist markets such as research, education and the larger existing data processing user. They also supply system software. They offer systems and hardware support.

*They will be showing 380Z based systems with a mixture of peripherals. On display will be a 1MB 8" floppy disc system, VDUs — both memory-mapped and standard, high resolution graphics with the possibility of a new colour board.*

---

---

**ROSTRONICS** 7 &  
118 Wandsworth High Street A18  
London SW18  
01-870 4805

They sell the Z Plus system, TRS80 and associated packages. They provide services from the initial investigation to programming plus training and full support.

*On show will be their Z-Plus micro with its associated packages: Inventory, payroll, word processing, accounts receivable, and accounts payable. They will be showing the Paper Tiger printer, I/O boards, a double density, double sided disc controller and PASCAL-Z.*

---

---

**SOFTPRINT** A8  
The Vicarage, Kimpton  
Nr. Hitchin, Herts  
0438 832094

This company specialises in the production of tape-based magazines for the PET. They have just published issue 1 of their magazine "Lettercette".

*On show they will have Softwriter — a new word processor for the PET, with full editing and format facilities.*

---

---

**THE SOFTWAREHOUSE** A1 &  
146 Oxford Street A2  
London W1  
01-637 1587

They sell software, Apples and peripherals. They import, manufacture and distribute the software both wholesale and retail. They sell packages for almost every popular computer, covering a range of games and business applications.

*They will be exhibiting "Be Wary" — a new game from the USA by Leo Christopherson. They will be showing other games, including the Creative Computing range. PET, TRS-80 and Apple machines will be on the stand.*

---

---

**STRUMECH ENGINEERING LIMITED** 1 &  
2  
Portland House,  
Coppice Side, Brownhills,  
West Midlands  
05433 4321

This company holds the UK agency for Midwest Scientific Instruments and are European Master Distributors for Smoke Signal Broadcasting and Micro-Term International Inc. They offer a wide range of machines for use in educa-

tion, home computing and small businesses.

*On show will be a new multi-user BASIC interpreter and a graphic capability. Many microprocessors and peripheral devices based on the 6800 will be displayed.*

---

---

**TANDY CORPORATION** 26-  
**(BRANCH) UK** 29  
Bilston Road,  
Holyhead Road,  
Wednesbury,  
West Midlands  
021-556 6101

Tandy are the manufacturers and suppliers of the TRS-80 computer. They also provide a wide range of peripheral equipment. They will shortly open computer-only stores.

*On show will be two new line printers, a voice synthesizer, a P2 Quick printer and the new TRS-80 Model II. Other items on the stand will be the TRS-80 model I, expansion interface, printers, disc drives, system desk, software, voice synthesis peripheral and a range of books.*

---

---

**TRANSAM COMPONENTS** A6 &  
**LTD** A7  
12 Chapel Street,  
London NW1  
01-402 8137

Manufacturers and distributors of the British-designed TRITON system. They also sell firmware packages namely 7K Scientific BASIC and 8K TRAP — a system development package. . . They sell both wholesale and retail. Other products include components, books, connectors, cables, Ithaca products, Shugart drives and Compucolor.

*3 levels of TRITON will be on show as well as Compucolor, Ithaca and Shugart drives. They will be running their home-grown software and firmware.*

---

---

**V & T ELECTRONICS** 23  
82 Chester Road  
London N19 5DZ  
01-263 2735

This company sells chips, cassette players and a relocatable assembler for Nascom. With its associated software the cassette can perform high speed, bi-directional, searching at data rates of around 5K baud.

*On show will be a faster cassette mechanism (30K baud). They plan to have a cassette based BASIC which will provide the normal disc facilities but for cassette.*

---

---

**VERO ELECTRONICS** 40  
**LIMITED**  
Industrial Estate,  
Chandlers Ford,  
Hants  
04215 69911

This company produces a range of useful electronic equipment. Products include: Universal prototyping boards; power supplies — including an S100 sub-rack; card housing systems; interconnection and wiring systems; instrument cases; small enclosures; racks and cabinets.

*They will be displaying a wide range of their products.*



# ENSIGN

13-19 MILFORD STREET, SWINDON  
WILTSHIRE SN1 1DW  
Tel: (0793) 42615 Telex: 449703

Make more time available to  
enhance the quality of your  
life and improve your business

COMPUTER SALES • HARDWARE • SOFTWARE • CONSULTANCY • MEDIA • STATIONERY ETC

**For less than 25p an hour for just one year you can  
COMPUTERISE YOUR BUSINESS NOW!  
EVERYTHING YOU REQUIRE TO START  
COMPLETE - READY TO OPERATE.**

Incl. VAT, Pkg. & Delivery. Nothing extra to pay:

## £2,300

- MICROCOMPUTER WITH 48K RAM (Memory)
- DUAL DISK DRIVES (Storage up to 400K)
- DOS DISKETTE (Disk Operating System)
- BOX OF 10 BLANK DISKETTES
- PRINTER WITH TRACTOR FEED
- BOX OF CONTINUOUS STATIONERY/LABELS
- EVERYTHING COMPLETE WITH MANUALS

**+ FREE Programs worth over £500 +  
on Diskettes in a Library Case**

comprising:

SALES/PURCHASE LEDGERS QUOTE/ORDER/INVOICE  
BANK RECONCILIATION STOCKS / SHARES ANALYSIS  
STOCK CONTROL MAILING LIST GAMES PACKAGE

This package illustrates how to solve many of your business problems.  
They may or may not be suitable for your type of application but they will  
help you develop your own software for virtually any type of business.  
Worth over £500 this package is enclosed FREE.

### SOFTWARE

We are pleased to announce that we have been appointed  
Exclusive Distributor for UK, Europe & the World for  
**GRAMA WINTER SOFTWARE**  
for TRS 80, Apple, ITT 2020. Also dealer for Pet, Z80, SWTP.

Fully integrated suite of 30 complete business programs.  
Usual cost of such Quality Programs would be £2500+.  
Complete support, updates, NHI/Tax changes etc.  
Write for details.

Special introductory price . . . £575 . . . inclusive of VAT.

### CONSULTANCY

Please write or telephone if you require advice on  
BEGINNING or EXPANDING your computer installation.  
Software programs customised to your requirements.

**OUR BUSINESS EXISTS ON IMPROVING YOUR BUSINESS.**

We are continually adding new products to our range and would be  
pleased to receive your enquiries. ● Quantity Discounts available.

TRS 80		ex. VAT	inc. VAT
4K Level 2	(c/w K/bd, VDU, T/Rec)	434.78	500.
16K Level 2	(c/w K/bd, VDU, T/Rec)	500.00	575.
0K Interface	(to add printer & disk drives)	195.66	225.
16K Upgrade kits	(for k/bd or interface)	65.22	75.
Disk Drives, single	(up to 200K)	260.88	300.
Disk Drives, dual	(up to 400K)	608.70	700.
Disk Drives, dual	(up to 1000K)	1173.91	1350.
Disk Drives, dual	(up to 2000K)	1521.74	1750.
Disk Drives, cable 2 & 4 way from		21.74	25.
Anadex Printer, Tractor feed		434.78	500.
Printer cable for Anadex/Centronics		21.74	25.

### APPLE II ITT 2020

16K	(c/w Keybd & Palsoft ROM)	608.70	700.
16K Upgrade kits		65.22	75.
Disk Drive, single with cable		326.09	375.
Printer Interface		108.70	125.
Anadex Printer, tractor feed		434.78	500.
Colour TV ITT 340		239.13	275.

### COMMODORE PET

2001-32N	(New keyboard & 32K)	673.91	775.
2040 Dual Disk Drive 343K		673.91	775.
3022 Printer with graphics		521.74	600.
Printer interface and cables, each		21.74	25.

### MEDIA LIST

5¼" Verbatim	from (Qty 10)	17.39	20.
5¼" Dysan	from (Qty 10)	26.09	30.
8½" 3M	from (Qty 10)	30.44	35.

Blank 5¼" & 8½" Diskettes, Soft/Hard Secteded, Formatted/ Unformatted.  
We have Diskettes to suit many systems. When ordering please quote:  
SYSTEM MANUFACTURER, MODEL, MEDIA TYPE, AND DISK SIZE.  
Available in smaller or larger quantities.

### STATIONERY Listing Paper, Continuous Forms, Labels.

Listing paper 11" x 8½", white/green music ruled, boxed 2000 . . . £10  
Labels 2¼" x 17/16", white, fanfold, £5 per 1000 . . . 10,000 for . . . £40

Post/Packing/Insurance extra. Delivery by Registered Post, Securicor, etc.

Price List correct at time of going to Press, subject to change without notice. E.& O.E.  
Standard Warranties apply.

**Your enquiries assist us in forward purchasing.**

Please send Full Details & Price Lists		My requirements are for:		Requirements	Description	inc. VAT
HOME <input type="checkbox"/>	HOBBIES <input type="checkbox"/>	STUDENT <input type="checkbox"/>	BUSINESS <input type="checkbox"/>	Microcomputer	.....	.....
Name	: .....			Upgrade Kit	.....	.....
Street	: .....			Interface	.....	.....
Town	: .....			Disk Drive	.....	.....
County	: .....			Printer	.....	.....
Post Code	: .....			Cable/Interface	.....	.....
Telephone	: .....			Cluster System	.....	.....
Name of Co	: .....			Colour TV	.....	.....
Position	: .....			Media	.....	.....
PO/Chq No	: .....			Stationery	.....	.....
(Payment by Barclaycard / Trustcard / Access etc., can be arranged)				Software	.....	.....
				Post/Pkg/Ins	:(please tel. for cost).....	.....
				PC/PCW/L	TOTAL:	.....

# COMPUTER ANSWERS

Every month in PCW, Sheridan Williams assists readers with their hardware, software and systems difficulties. Some questions he deals with himself, other enquiries are directed towards members of his consultancy panel.



## STOCK DISCS

I have been told that I should not look at cassette based micros for business purposes. I do not see why, as even a C60 cassette should in my estimation be capable of holding more than 50,000 characters. My application is for stock control, and I would be unlikely to have more than 1000 items on file at any one time.

There are many reasons for rejecting cassettes in favour of discs.

1 Even the 5¼ inch mini-floppy discs hold more on each side than the average cassette. I have seen figures from 70K to 350K quoted. This would save you having to change cassettes in order to swap between programs and files.

2 You can hold many (usually up to 40) programs and files on a single disc, and they will be instantly retrievable.

3 Cassettes can generally be read at between 30 and 300 characters per second. Discs can be read at around 10,000 ch/s upwards. To read a 50K file from cassette could take up to 20 minutes, and yet only around 10 seconds from disc.

4 Discs tend to be more reliable... this is because of the nature of the Philips cassette format and the cassette drives used. If digital cassettes with full logic control were used, this statement would not be true and also search times would be significantly improved.

5 Discs are a 'direct access' medium, whereas cassettes are 'serial access'. The advantage of direct access is that any record on a file is available for immediate use; in order to access the 1000th record from tape the previous 999 must be read and discarded. With disc the read/write head can be moved directly to the relevant track.

When discs are used, program packages may be written as a 'suite' of programs — one program calling the other when required. It is preferable to write many small programs rather than one large one as each can be worked on and developed separately.

Even if discs are used in a serial access mode (and there are many applications suited to serial access), they are considerably faster than cassettes.

I suggest that you follow this by reading more on the subject of files. I have only just brushed the surface on one absorbing aspect of programming.

Sheridan Williams

## GIVE ME PROBLEMS

Is it possible for me to solve anything on my micro that no-one else has solved? I have found that I much prefer to program mathematical routines than ones related to data processing. Can you suggest any programs or ideas that I can look into?

You are obviously a person after my own heart. I agree that there is something very absorbing about manipulating numbers and expressions. However, I doubt whether you could do much with your micro as most of the pioneering work is carried out on machines that are a great deal faster. Don't let me put you off though; try and concentrate on finding better algorithms to solve common problems.

For example, to date I think that the highest known prime number is  $2^{123209}-1$ ; it is known as the 26th Mersenne prime. It took 8 hours 40 minutes on a CDC Cyber 174 just to prove that it is prime! That's a good starting point... try to do it more quickly with a more efficient algorithm. Don't waste your time in BASIC, however, unless you have a BASIC compiler.

Look through past editions of PCW and find competitions set by myself. These will provide you with ideas on programs. In the meantime how about looking deeper into the Ackermann function. This can be stated very elegantly by the following recursive definition:—  
 $A(0,n)=n+1$   
 $A(m,0)=A(m-1,1)$   
 $A(m,n)=A[m-1,A(m,n-1)]$   
Try building up a table for its values, and then try and find

a formula for each row: ie.  $A(0,n)=n+1$ ,  $A(1,n)=n+2$ ,  $A(2,n)=2n+3$ . (You can do this one in BASIC.) Can you define a function recursively in your version of BASIC? In fact, better languages for this would be ALGOL or PASCAL.

You will uncover further reading on the above two problems in *Dr. Dobbs Journals* of June/July 1979 and August 1979. Good luck, and write back with your findings.  
Sheridan Williams

## RANDOM CONFUSION

What is the point of 'random access' files? If the files are random, how do you know where each record is stored?

I think the reason that you are confused is because of the word *random*. I prefer the term 'Direct access' to 'Random access'; the two terms are synonymous. I can only imagine that the term *random* access was coined because it does not matter in which order you access the records in the file. I much prefer to think of the file as a *direct* access file because you can access any record directly without first having to read all the previous records.

Your question about how do you find a record — this is answered fairly simply now. You only need a way of linking the 'key field' in the record to the disc address. This is known as the 'randomising algorithm' (there's that word again). The disc operating system usually takes care of the track and sector numbers, and all you have to do is work out the relative address (relative to the start of the file and record length). An example would be if you had a file of part numbers. For certain goods you could make your part numbers run from 0001 to 9999 say, and hence part number 1234 would be found at record number 1234.

Problems arise where the key field is a name. Where on a file of 26000 people would you place SMITH. Well, if the file is fairly well balanced, one idea is to start each letter of the alphabet at intervals of

1000 records, and each second letter in the name could start at 1000/26 intervals. Hence Smith would be placed at a record calculated by  $19 \times 1000 + 13 \times 38 = 19494$  (S=19th letter, M=13th). This is just one of many ideas, although obviously it can be wasteful of space.

Sheridan Williams

## WHAT ARE THE PROSPECTS

I read your magazine regularly, and although I don't have my own system, I do intend to join the club one day. My immediate problem is my son. He is approaching 16 and will be leaving school next year with O levels (I hope). He expresses an interest in a computer career on the software side. What are his options as far as i) the course he should follow after school and ii) his choice of jobs within computing? And, as a matter of interest, how do the salaries compare?

Your son has a great deal to think about, and I would recommend that he talks to people, visits local colleges and libraries, and reads as much as possible.

As far as job choices are concerned, broadly the staff categories within a computer department are Systems Analyst, Programmer and Computer Operator. There are other categories and even subdivisions, but let us leave it at these three. Systems analyst is really only open to those with at least 5 years' experience and the approximate salary starts at £6500. Next comes a programmer; it's often from programming that people progress to systems analysis.

This is probably the best career to aim for; programmers' salaries start at £4500 for a trainee and can be as much as £250 per week for freelance contract work. A computer operator is the next category to aim for and it's worth saying too, that many companies give their operators time off from work to train as programmers. Computer operators often work shifts,

# COMPUTER ANSWERS

and as such get shift allowances, but in general their salaries start at £4000.

The question of courses must really be dependent on whether your son wishes to follow a career in scientific computing or data processing. If he desires the former then the best course of action is probably A level computing science followed by a degree. If he seeks the latter then this reduces to a further question... degree or not degree (pun intended). You can gain some very valuable experience by stopping at the stage of A level, City & Guilds 746/747, Royal Society of Arts Computers in Data processing, a Threshold scheme, or a British Computer Society award, and getting a job immediately; in the three years that you would have been studying for a degree you could have become very knowledgeable in a purely practical environment. Please seek further advice as there are many points that I have not covered. However, I hope that I have given you a starting point on which to base further questions.  
*Sheridan Williams*

*(We feel that we should mention the almost universal misuse of the term Systems Analyst. Sheridan is quite right when he says that this is often the next step for a programmer — it is, but it often comes as a disappointment. To illustrate why let's pretend that there is another progression for a programmer — to Systems Designer. This job would involve designing a computer system based on a statement of the business requirements of that system. This statement of requirements would be produced by someone who had studied the existing system in detail — usually by thoroughly interviewing users of that system and documenting the results. This would be followed by an analysis of the findings in order to establish the precise requirements of the system.)*

*You can see that the skills required for the two jobs described are quite different, yet they are frequently given the same description — systems analysis. The first, I imagine, would be a very satisfying next step for a programmer. The second may be extremely successful but, as well as a logical and analytical mind, it would also require a number of interpersonal skills which are not a natural adjunct to programming.  
Ed.)*

## BIG AND BEAUTIFUL

My computer has BASIC and it makes a great programmable calculator, but when I try to write large programs I always get tangled and can't get the program to work the way I

want. How can I learn to write big programs that work?

The mistake most beginners make is to jump straight into coding a program without designing it first. The problem with BASIC is that it makes coding very easy, but gives you no help at all in designing programs that are likely to do what was intended, or to be easy to test. Worse, beginners are usually taught flowcharting at the same time as BASIC, and though a well drawn flowchart is excellent for telling you which bit of the program is connected to which, it can still leave you clueless about the relationship between the program and the problem it was meant to solve. The art of programming is being able to go from a clear statement of the problem (a game, a calculation, handling a file), through several stages of refinement and definition, to a set of small, intelligible routines executed in the right order.

Many programmers use a structured programming technique to help them analyse a programming problem and record their stages of progress. There are several different forms. Some use pseudocode, a written problem definition language that looks like PL/1 or Pascal; some use a more pictorial technique such as a Warnier-Orr diagram, which brackets successive levels of the problem; some use structured flowcharts. All

methods are based on the same theory — that correct programs have three components: a set of input data, a set of output data, and a process to convert one into the other. If the process is too complex to comprehend in one go, it can be decomposed into simpler processes by applying straight forward rules.

1 There are only three basic processes; sequence — input process output; decision — IF condition THEN sequence A ELSE sequence B; iteration — WHILE condition REPEAT sequence. 2 Any sequence block can be decomposed into two sequence blocks, or a decision block, or an iteration block. By using this technique the programmer is able to concentrate his efforts on one area of the program at a time (knowing the relationship with other parts) and push each area in turn towards more detailed definition, until he reaches a level from which he can code the final program. By this stage the design is complete and hopefully, most of the logic bugs have been discovered before a single statement is coded. The design stages have been recorded, so that the functions of the various sections of the program can be understood and tested, and there is a very good chance that the program will perform as intended as soon as the inevitable keying errors are eliminated. If it doesn't, then the design documentation enables you to backtrack and find out why.

There are two very good

books for micro users: — "Software Design for Micro-computers" by Ogden (Prentice Hall, 1978); this will help you define program inputs and outputs, and design appropriate control structure for your applications. "Micro-processor Programming for Computer Hobbyists" by Graham (Tab, 1977); this teaches pseudocode, plus a wealth of information on arithmetic, data structures, searching and sorting.

The American hobbyist magazines frequently have articles on program design and documentation: — FLOWCHART — Ellis "Use of flowcharts to communicate" Kilobaud, Feb 1979 (for basic use of flowchart symbols). Dunn "Structural Decomposition" Interface Age June 1979 for structured flowcharting (strongly recommended). WARNIER-ORR — Higgins various articles BYTE Oct 77, Dec 77, Jan 78, Mar 79. PROGRAM DESIGN — Hearn "Top-Down Modular Programming" Byte July 1978. Weems "Designing Structured Programs" Byte Aug 1978. Schwartz "Pascal Versus BASIC: An exercise" Byte Aug 1978. And may all your bugs be little ones.  
*L.S. Warner*

## RAM DECODE

I found Mike Dennis' article "Practising a Little Micro-control" most enlightening but I am not sure how to decode RAM. Is it the same as for ROM?

In a nutshell, yes! Remember, any device connected to the data bus must only respond to either a specific individual address or a specific band of addresses. Address decoding achieves this and any device can be decoded to respond to any address. However, since the address bus doesn't always contain a valid address, it would be foolish to decode the device from the address bus alone. For this reason, the CPU provides suitably timed control signals that are present only when the address bus contains a valid address — MREQ (Z80) and VMA (6800); These control signals must be gated with each uniquely decoded address to provide the unique Chip Selection that each device needs. Some micros discriminate further with control signals for either I/O or memory operations ( $\overline{IORQ}$  and MREQ in the Z80). Other micros (6800 and 6502) do not and so any I/O port is simply treated as a specific memory address — all the devices are said to be "memory-mapped". There is no reason why the Z80 cannot be used in this mode as well.

*Mike Dennis*



"Sorry... but we already have 27 Russian roulette programs."

# The portable brain



## Sharp personal computer

- \* Z-80 based CPU
- \* 4K bytes monitor ROM
- \* Internal memory expansion up to 48K bytes of RAM
- \* 14K extended BASIC (occupies 14K bytes of RAM)
- \* 10 in. video display unit—40 characters x 25 lines display
- \* 80 x 50 high resolution graphics
- \* 78 key ASCII keyboard—alphabet (capital and small) plus graphics
- \* Built in music function
- \* Fast reliable cassette with tape counter—1200 bits/sec
- \* 50 pin universal BUS connector for system expansion—printers, floppy discs etc.

## Insist on



Audio, Video, Business Systems, Calculators,  
Cash Registers, Copiers, Microwave Ovens.

SHARP Electronics (UK) Ltd.,  
107 Hulme Hall Lane, Manchester M10 8HL. Telephone: 061-205 7321.

Amazing it may be, but that should come as no surprise since the 'Portable Brain' comes from Sharp, who produced the worlds' first equally amazing Portable Desk Top Calculator. Who else would you expect to be first again with the 'Portable Brain'—a micro-computer with some very remarkable features, made just by Sharp. Find out about the National Sales & Services Network which has been built-up by Sharp to look after this very special piece of advanced technology. Find out more about what it can do for you, by filling in this coupon right away!

## Trust Sharp to make it.

I would like to know more about the 'Portable Brain.' Send me the full facts now about how it can help me!

Name \_\_\_\_\_

Address \_\_\_\_\_

Tel: \_\_\_\_\_

Sharp Electronics (UK) Ltd., 107 Hulme Hall Lane,  
Manchester M10 8HL. Tel: 061-205 7321

PCW/1

# SHAKESPEARE, BASIC AND THE CIA

## Fingerprinting sentence structure

*A few miles out of Washington, approaching Langley, Virginia, there is a sign over the highway.*

*It reads 'C.I.A. Turn Right'. Shortly after making that turn a security barrier is encountered, and behind it a chain link fence. Identity documents are painstakingly checked against a list held by the guard, and your physical details verified with a computer housed in a large complex of buildings within the compound.*

*This is the first of a series of increasingly stringent checks that one meets on penetrating the heart of America's Intelligence machinery. And there, some six stories below ground, is a computer that plays with words. Exactly what this computer does, and indeed its very specification, remains a closely guarded secret. For at least part of the time, however, it is engaged in some fascinating literary detective work.*

*by Julian Allason.*

Literary detection is not a new science. Almost from the moment that Shakespeare was laid to rest, scholars have argued about the authenticity of various passages. In 1850 Spedding postulated that Shakespeare's disputed play, Henry VIII, was actually the result of a collaboration with Fletcher. This year Spedding's thesis was largely vindicated by Thomas Merriam — and a computer.

It was the Cold War, with its ceaseless propaganda battles, that generated the interest of the Intelligence community in computerised linguistics. Forgeries and plants abounded. They needed to know what was authentic — and what was not.

A celebrated case concerned the auto-

biography of Kim Philby, the Soviet double agent who had reached the top of the British Secret Intelligence Service. After his defection, a book entitled 'My Silent War' appeared, complete with foreword by Graham Greene. Philby claimed it was entirely his own work. SIS, knowing that it was a final attempt to smear them and damage Anglo-American relations, sent a copy to Langley. There, CIA specialists ran comparisons of 'My Silent War' with articles that Philby had written whilst operating as a Foreign Correspondent for the Observer. The tests showed that whole chapters had been written by others. The book is now regarded as highly suspect.

A similar thing hap-



pened when the memoirs of the West's top Kremlin agent appeared. Using similar methods, Soviet specialists swiftly "proved" the "Penkovsky Papers" a forgery. Penkovsky was shot and his book remaindered.

All methods of literary detection involve recognition techniques. The detective uses the computer to help establish an author's sub-conscious habits of speech or writing. Most Shakespearian scholars are capable of assembling a passable pastiche of the Bard's prose. To overcome vulnerability in this area, only very common "filler" words such as "and", or "it is" are tested. This is because use of these words is a matter of subconscious habit. Furthermore, they occur throughout written output whatever the mood or occasion. Position in the sentence is also held to be important.

Surprisingly, our syntactic habits are so ingrained that they show through even when an attempt is made to mimic the literary style of another. Usage of certain "filler" words remains fairly constant throughout a writer's work.

At the simplest level a literary detection program involves a series of string searches on text samples of established authorship. The incidence of certain strings, for example "such a", are noted. A profile of the author's literary style is then constructed. Similar tests are carried out on suspect text, and finally both profiles are compared. It should then be readily apparent whether or not all the samples were written by the same person.

Although fairly long samples of text are required for a definitive evaluation, it is possible to obtain reasonably accurate results from a short BASIC program. The routine I am working on for Petsoft uses less than 8K. The following simplified example illustrates a string search for the word "and".

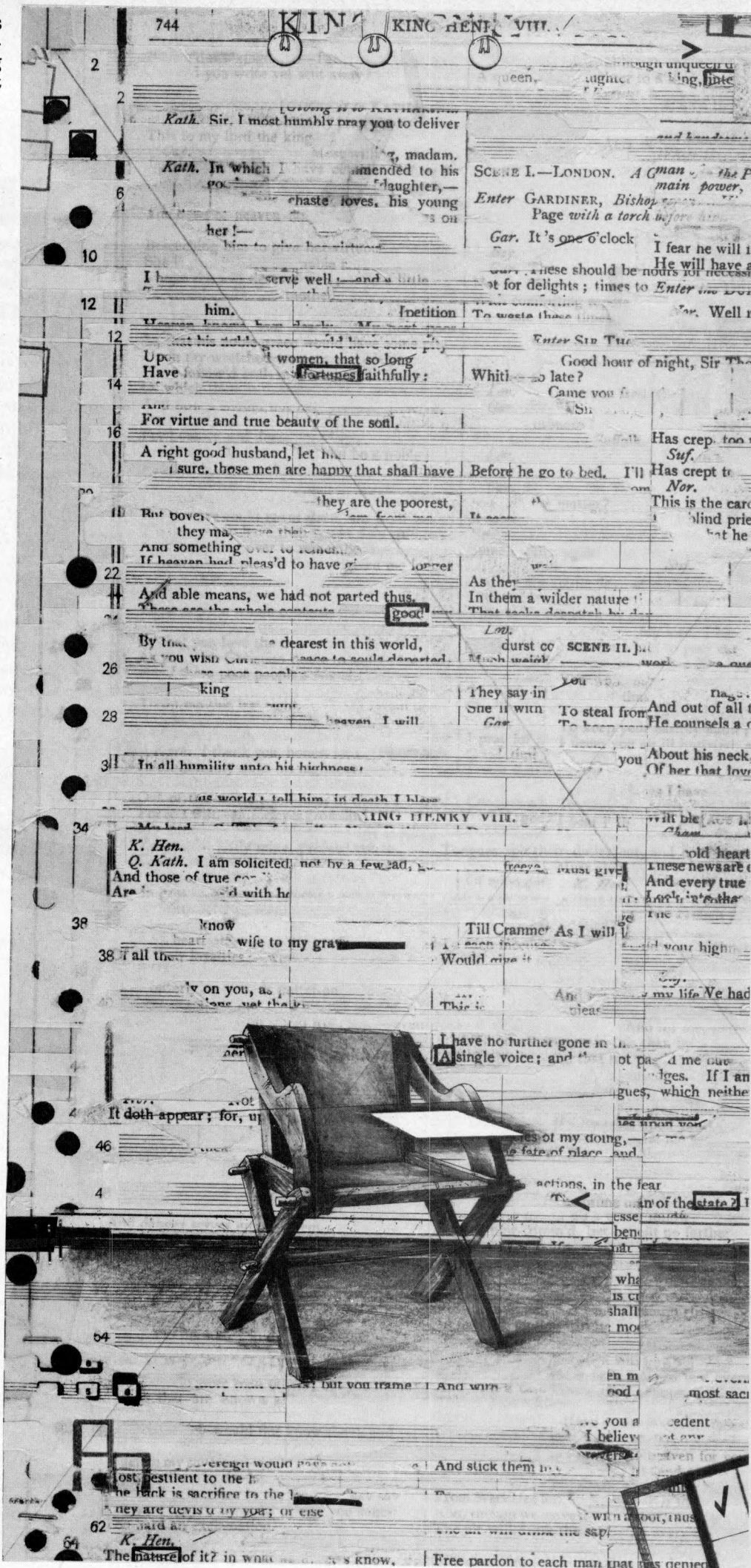

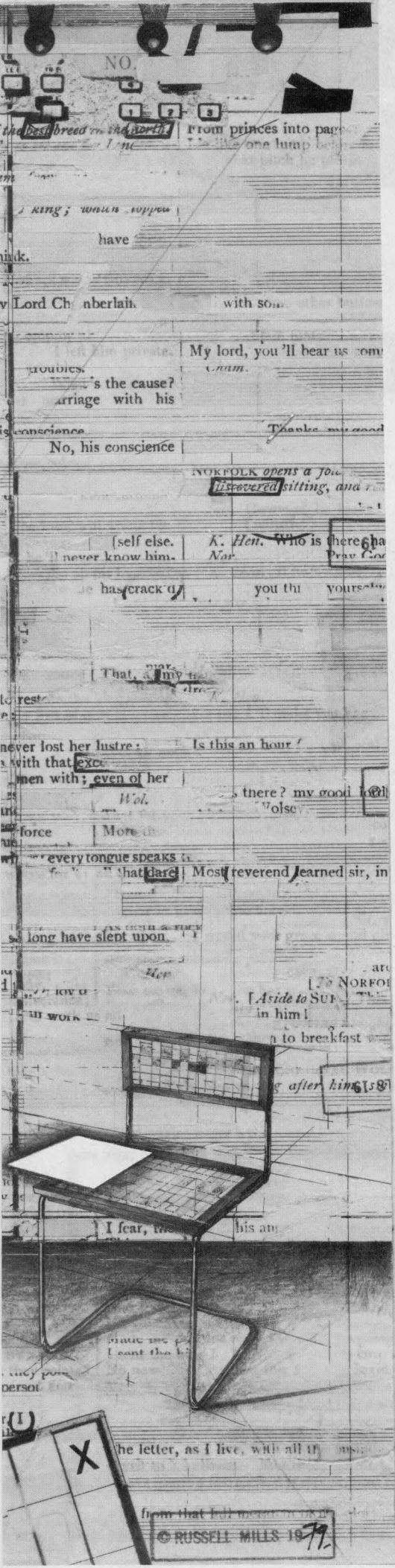

```

● 100 DATA "HANDSOME ANDREW AND HIS WIFE" : REM Text Sample
110 READ TS : REM Read Sample
120 FOR C=1 TO LEN(T$) : REM Set counter to no. of
: characters in string
● 130 IF MID$(T$,C,5)=" AND " THEN S=S+1 : REM Tests next five characters
: (including spaces)
● 140 NEXT C : REM Increments Character Counter
150 PRINT "AND'APPEARED 'S'TIMES"
160 PRINT "IN A STRING OF"LEN(T$)"CHARACTERS"
● 170 PRINT "ITS INCIDENCE WAS" S/(LEN(T$))*100 "%"
```

Note that five spaces are allowed for the string "AND" to avoid acceptance of "HANDSOME", "ANDREW" etc. An additional statement would be required to accept "AND" as the first word in a string.

In practice an expanded algorithm tests a much longer sample of text for the incidence and position of a number of such "filler" words and phrases.

At about the same time as the C.I.A. was trying to catch up on computerised literary detection they faced another problem. They needed English translations of all the scientific and technical information being published abroad. Their linguists could not keep up. Computers, it was argued, could provide the answer.

Early efforts at machine translation met with little success. The problem was the inadequacy of available syntactical analysis. Linguistics, the scientific study of language, was still in its infancy.

But in 1957, Professor Chomsky of the Massachusetts Institute of Technology, published a book called 'Syntactic Structures'. In it, he argued the existence of underlying or Deep Structures beneath the surface structure of the sentence. These defined and inter-related all the factors determining structural interpretation.

It is fair to say that not all linguisticians accept Chomsky's

thesis. But it has given the machine translation and literary detection specialists a good deal to think about.

Computerised linguistics is now finding a much wider, and academically more respectable range of applications. In 1974 Dr. Andrew Morton created a legal precedent with his evidence that only 7 of 11 police statements submitted in a case had been written by the defendant. The result was an acquittal.

In a recent book (*Literary Detection, Bowker, £10.50*) Dr. Morton examined the difference between Jane Austen and *The Other Lady*, who in 1965 completed the novel which had lain unfinished since Jane's death. Although in literary terms the imitation is quite good. Morton demonstrated that the probability of Jane Austen having penned the 4,000 words that were written by *The Other Lady* to be more than one thousand million against (see chart).

With the continuing evolution of linguistics and the rapid pace of micro-processor development, it is reasonable to project not only considerably more accurate machine translation than my pocket Craig translator offers, but the prospect of an infallible literary detective. *Post script: Having run this article through my PET, the computer confirms that it is almost certainly not written by Shakespeare. . .*

A comparison of Jane Austen and *The Other Lady*

Habit	Occurrences of the Habit in				Chi squared	
	<i>Sense and Sensibility</i>	<i>Emma</i>	<i>Sandition</i> (Jane Austen)	<i>Sandition</i> (The Other Lady)	(a)	(b)
<i>an</i>	25	26	11	29		
<i>a + an</i>	172	212	112	112	1.40	12.85
<i>a</i>	147	186	101	83		
P.B. <i>such</i>	14	16	8	2	0.20	3.92
<i>and</i>	253	299	151	154		
F.B.I.	12	14	12	1	2.45	6.84
<i>the</i>	270	271	229	221		
P.B. <i>on</i>	11	6	8	17	1.58	8.45
F.W.S.	22	26	19	8	0.43	6.34
<i>this</i>	32	39	15	15		
<i>this + that</i>	126	144	52	37	0.25	3.64
<i>with</i>	59	74	28	43		
<i>with + without</i>	77	84	38	47	5.02	3.71
<i>very</i>	37	68	26	27		
P.B. <i>the</i>	4	2	3	7	—	12.7

Notes: 1. The samples are: *Sense and Sensibility* — Chapters 1, 3, *Emma* — Chapters 1,2,3, *Sandition*, Jane Austen — Chapters 1,6, *Sandition*, The Other Lady — Chapters 12,24.  
2. The figures for chi squared are for the comparison of the three genuine samples, (a), and then for the comparison of these samples taken together for the comparison with The Other Lady, (b).

# If your Accounts are a problem- the solution could be on your desk.

You could use your telephone to call Comma Computers on Brentwood (0277) 811131.

Or you could use a pen and envelope to complete and return the coupon to us.

Later on, you could have a free copy of our 'no jargon' brochure on your desk from which you could see how Comma Computers have used advanced micro-processor technology to make business computers easy to understand, use and afford!

Still later, but not much later because Comma Computers are quick and simple to install, you

could have a Comma Aquarius, Aries or Leo business system on your desk – a complete system with computer, printer, keyboard, display, installation, 12 months maintenance and software to perform Payroll, Accounts, Invoicing and Credit Control applications and provide instant management information including Profit and Loss Statements and all from less than £6000.

Butchers, bakers, candlestick makers . . . can all, at last, enjoy the benefits brought to business by the silicon chip and increase the efficiency of dealings with customers and suppliers as well as accountants, auditors, HM Collectors of Taxes and Customs and Excise.

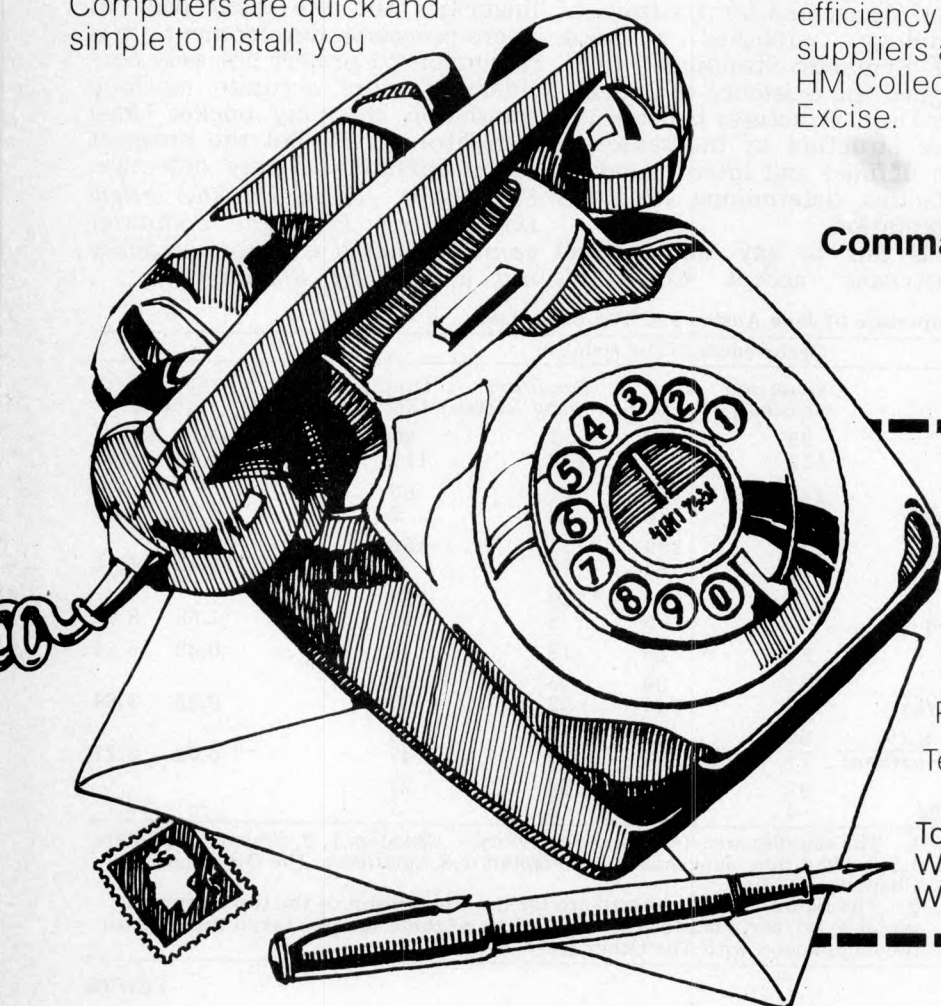

## Comma Computers Ltd.

West Horndon  
Industrial Park,  
West Horndon,  
Essex CM13 3XJ



Name \_\_\_\_\_

Position \_\_\_\_\_

Organisation \_\_\_\_\_

Address \_\_\_\_\_

Postcode \_\_\_\_\_

Telephone \_\_\_\_\_

To: Comma Computers Ltd,  
West Horndon Industrial Park,  
West Horndon, Essex CM13 3XJ

# READER SURVEY~AND WHAT A GIVEAWAY!

That's torn it — the secret's out. Our Star Prize in PCW's 1979 Reader's Survey is a 10k version of last month's "Mini Benchtest" machine:

## THE SHARP MZ-80K

What a surprise for the sender of the first completed questionnaire drawn out of the bag! And that's not all — to each of the first *twenty-five names selected* goes a year's free subscription to Personal Computer World.

Where appropriate please either write in block capitals or tick relevant box. Please feel free to tick more than one box, if appropriate.

## STAR PRIZE THE SHARP MZ~80K



1. Age \_\_\_\_\_

2. Address \_\_\_\_\_

3. Age \_\_\_\_\_

4. Occupation \_\_\_\_\_

5. Married or Single \_\_\_\_\_ months

6. Sex M  F  e) Once a year

7. Do you? f) Never

a) own your own home

b) rent your home

c) live with parents

8. Do you go to the cinema?

a) Once a week or more

b) More than once a month

c) Once a month

d) At least every 3

10. Do you watch television

a) More than 3 hours

b) More than 1 hour

c) Less than 1 hour

d) At least 3 days

e) At least 1 day per

f) Less than 1 day per

g) Never

9. Which ITV channel do you receive?

a) London

b) Southern

c) East of England

d) South West

e) Wales & West

f) Midlands

g) Lancashire

h) Yorkshire

i) North Eastern

j) Scottish/Grampian

11. Do you listen to radio on average?

a) More than 3 hours

b) More than 1 hour

c) Less than 1 hour

d) At least 3 days

e) At least 1 day per

f) Less than 1 day per

g) Never

12. Do you smoke cigarettes?

a) Yes

b) No

13. Which of the following newspapers do you read?

a) Daily Telegraph Every day

b) The Guardian Every day

c) Financial Times Every day

d) Daily Mail Every day

e) Daily Express Every day

f) The Star Every day

g) The Sun Every day

h) Daily Mirror Every day

i) Local morning Every day

j) Local evening Every day

3 times a week

Once a week

Sometimes

14. Which of the following Sunday Newspapers do you read?

a) The Observer Every week

b) Sunday Telegraph Every week

c) Sunday Express Every week

d) Sunday Mirror Every week

e) The People Every week

f) News of the World Every week

3 times a month

Once a month

Sometimes

15. Which of the following magazines do you read?

a) Radio Times Every week

b) TV Times Every week

c) Melody Maker Every week

d) Sounds Every week

e) The Economist Every week

f) Amateur Gardening Every week

g) Country Life Every week

h) The Listener Every week

i) New Scientist Every week

j) Punch Every week

k) Titbits Every week

l) Motor Cycle News Every week

m) Weekend Every week

n) Shoot Every week

o) Computer Talk Every week

p) Computer Weekly Every week

q) Computing Every week

r) Datalink Every week

3 times a month

Once a month

Sometimes

16. Which of the following monthly magazines do you read?

a) Car Mechanics Every month

b) Do It Yourself Every month

c) Family Circle Every month

d) House & Garden Every month

e) Ideal Home Every month

9 times a year

6 times a year

3 times a year

9 times a year

6 times a year

3 times a year

9 times a year

6 times a year

3 times a year

9 times a year

6 times a year

3 times a year

9 times a year

6 times a year

3 times a year

9 times a year

6 times a year

3 times a year

9 times a year

6 times a year

3 times a year

9 times a year

6 times a year

3 times a year

9 times a year

6 times a year

3 times a year

9 times a year

6 times a year

3 times a year

9 times a year

6 times a year

3 times a year

9 times a year

6 times a year

3 times a year

9 times a year

6 times a year

3 times a year

- f) Mayfair Every month  9 times a year  6 times a year  3 times a year
- g) Men Only Every month  9 times a year  6 times a year  3 times a year
- h) Motor Cycle Mechanics Every month  9 times a year  6 times a year  3 times a year
- i) Penthouse Every month  9 times a year  6 times a year  3 times a year
- j) Practical Motorist Every month  9 times a year  6 times a year  3 times a year
- k) Readers digest Every month  9 times a year  6 times a year  3 times a year
- l) Electronics Today International Every month  9 times a year  6 times a year  3 times a year
- m) Wireless World Every month  9 times a year  6 times a year  3 times a year
- n) Director Every month  9 times a year  6 times a year  3 times a year
- o) Investors Chronicle Every month  9 times a year  6 times a year  3 times a year
- p) Microprocessors and Microsystems Every month  9 times a year  6 times a year  3 times a year
- q) Which Computer Every month  9 times a year  6 times a year  3 times a year
- r) Management Today Every month  9 times a year  6 times a year  3 times a year
- s) Elektor Every month  9 times a year  6 times a year  3 times a year
- t) Omni Every month  9 times a year  6 times a year  3 times a year
- u) Video World Every month  9 times a year  6 times a year  3 times a year
- v) TV & Home Video Every month  9 times a year  6 times a year  3 times a year
- w) Practical Electronics Every month  9 times a year  6 times a year  3 times a year

17. Which of the following computer magazines do you read?
- a) Personal Computer World Every month  9 times a year  6 times a year  3 times a year
  - b) Practical Computing Every month  9 times a year  6 times a year  3 times a year
  - c) Computing Today Every month  9 times a year  6 times a year  3 times a year

18. Please specify the components of the system you own/have access to/are hoping to purchase. In the case of the Micro itself we are after the manufacturer and type, NOT the chip type or number.

	Owned	Have Access To	Hope to Buy Within 12 Months
Micro	_____	_____	_____
VDU	_____	_____	_____
Cassette Drive	_____	_____	_____
5 1/4" Floppy Discs	_____	_____	_____
8" Floppy Discs	_____	_____	_____
Hard discs	_____	_____	_____
Printer	_____	_____	_____
Other (Please Specify)	_____	_____	_____

24. What other topics would you like to see included?

\_\_\_\_\_

\_\_\_\_\_

\_\_\_\_\_

25. What topics would you like to see deleted?

\_\_\_\_\_

\_\_\_\_\_

\_\_\_\_\_

19. Please indicate your usage of computer media
- |                          | 1 per month              | 1-5 per month            | 5+ per month             |
|--------------------------|--------------------------|--------------------------|--------------------------|
| Ordinary cassettes       | <input type="checkbox"/> | <input type="checkbox"/> | <input type="checkbox"/> |
| Special length cassettes | <input type="checkbox"/> | <input type="checkbox"/> | <input type="checkbox"/> |
| Data cassettes           | <input type="checkbox"/> | <input type="checkbox"/> | <input type="checkbox"/> |
| Floppy discs (5 1/4")    | <input type="checkbox"/> | <input type="checkbox"/> | <input type="checkbox"/> |
| Floppy discs (8")        | <input type="checkbox"/> | <input type="checkbox"/> | <input type="checkbox"/> |

26. What activities would you like to see PCW sponsor?

- Exhibitions
- Conferences
- Courses
- Book publication
- Software publication
- Others (please specify)

20. Please indicate if you purchase the following
- Continuous stationary YES  NO
  - Special printed continuous stationary YES  NO

27. Are there any other comments you would like to make?

\_\_\_\_\_

\_\_\_\_\_

\_\_\_\_\_

\_\_\_\_\_

21. Please indicate the sections of the magazine that interest you most and least
- |                       | Most                     | Least                    |
|-----------------------|--------------------------|--------------------------|
| Newsprint             | <input type="checkbox"/> | <input type="checkbox"/> |
| Benchtests            | <input type="checkbox"/> | <input type="checkbox"/> |
| Computer Answers      | <input type="checkbox"/> | <input type="checkbox"/> |
| Transaction File      | <input type="checkbox"/> | <input type="checkbox"/> |
| Interrupt             | <input type="checkbox"/> | <input type="checkbox"/> |
| Calculator Corner     | <input type="checkbox"/> | <input type="checkbox"/> |
| On the Line           | <input type="checkbox"/> | <input type="checkbox"/> |
| Diary Data            | <input type="checkbox"/> | <input type="checkbox"/> |
| Checkout              | <input type="checkbox"/> | <input type="checkbox"/> |
| In Store              | <input type="checkbox"/> | <input type="checkbox"/> |
| Bookfare              | <input type="checkbox"/> | <input type="checkbox"/> |
| User Group Index      | <input type="checkbox"/> | <input type="checkbox"/> |
| Programs              | <input type="checkbox"/> | <input type="checkbox"/> |
| Leisure Lines         | <input type="checkbox"/> | <input type="checkbox"/> |
| Business Case Studies | <input type="checkbox"/> | <input type="checkbox"/> |
| Hardware Features     | <input type="checkbox"/> | <input type="checkbox"/> |
| Software Features     | <input type="checkbox"/> | <input type="checkbox"/> |
| Advertisements        | <input type="checkbox"/> | <input type="checkbox"/> |

22. I am interested in the following types of program:-
- BASIC  Games
  - Assembler  Subroutines
  - Machine Code  Business
  - Calculator  Engineering
  - Other  Education
  - (please specify)  Home Applications
  - Other
  - (please specify)

23. I am interested in the following software features:-
- Language descriptions
  - Programming efficiency
  - techniques
  - Systems design techniques
  - Descriptions of software products available
  - Others (please specify)

Please answer every question as accurately as you can, then post your completed Questionnaire to: PCW Reader Survey, 14 Rathbone Place, London W1P 1DE. The draw for the prizes will take place Monday 10th December, winners to be announced in PCW's February 1980 edition.

The staff of Personal Computer World would like to thank all readers who have taken the time to complete this questionnaire.

# Even More!

Super software from the world's leading microsoftware supplier.

## DIGITAL RESEARCH

Software with Manual / Manual Alone

- CP/M\* FDOS** — Diskette Operating System complete with Text Editor, Assembler, Debugger, File Manager and system utilities. Available for wide variety of disk systems including North Star, Helios II, Micropolis, iCOM (all systems) and Altair. Supports computers such as Sorcerer, Horizon, Sol System III, Versatile, Altair 8800, COMPAL-80, DYNABYTE DB8/2, and iCOM Attache. Specify desired configuration ..... **£75/£15**
- MAC** — 8080 Macro Assembler. Full Intel macro definitions. Pseudo Ops include RPC, IRP, REPT, TITLE, PAGE, and MACLIB. Z-80 library included. Produces Intel absolute hex output plus symbols file for use by SID (see below) ..... **£55/£10**
- SID** — 8080 symbolic debugger. Full trace, pass count and break-point program testing system with back-trace and histogram utilities. When used with MAC, provides full symbolic display of memory labels and equated values ..... **£45/£10**
- TEX** — Text formatter to create paginated, page-numbered and justified copy from source text files, directable to disk or printer ..... **£45/£10**
- DESPOOL** — Program to permit simultaneous printing of data from disk while user executes another program from the console ..... **£30/£1**

## MICROSOFT

- Disk Extended BASIC** — Version 5, ANSI compatible with long variable names, WHILE/WEND, chaining, variable length file records ..... **£155/£15**
- BASIC Compiler** — Language compatible with Version 5 Microsoft interpreter and 3-10 times faster execution. Produces standard Microsoft relocatable binary output. Includes Macro-80. Also linkable to FORTRAN-80 or COBOL-80 code modules ..... **£195/£15**
- FORTRAN-80** — ANSI '66 (except for COMPLEX) plus many extensions. Includes relocatable object compiler, linking loader, library with manager. Also includes MACRO-80 (see below) ..... **£205/£15**
- COBOL-80** — ANSI '74 Relocatable object output. Format same as FORTRAN-80 and MACRO-80 modules. Complete ISAM, interactive ACCEPT DISPLAY, COPY, EXTEND ..... **£325/£15**
- MACRO-80** — 8080/Z80 Macro Assembler. Intel and Zilog mnemonics supported. Relocatable linkable output. Loader, Library Manager and Cross Reference List utilities included ..... **£75/£10**
- EDIT-80** — Very fast random access text editor for text with or without line numbers. Global and intra-line commands supported. File compare utility included ..... **£45/£10**

## XITAN (software requires Z80\*\* CPU)

- Z-TEL** — Text editing language. Expression evaluation iteration and conditional branching ability. Registers available for text and commands. Macro command strings can be saved on disk for re-use ..... **£40/£12**
- ASM** Macro Assembler — Mnemonics per Intel with Z-80 extensions. Macro capabilities with absolute Intel hex or relocatable linkable output modules. New version 3 with added features ..... **£40/£12**
- LINKER** — Link-edits and loads ASM modules ..... **£40/£12**
- Z-BUG** debugger — Trace, break-point tester. Supports decimal, octal and hex modes. Disassembler to ASM mnemonic set. Emulation technique permits full tracing and break-point support through ROM ..... **£45/£12**
- TOP** Text Output Processor — Creates page-numbered, justified documents from source text files ..... **£40/£12**
- A4 package** includes Z-TEL, ASM, LINKER, Z-BUG, TOP ..... **£155/£30**

## EIDOS SYSTEMS

- KISS** — Keyed Index Sequential Search. Offers complete Multi-Keyed Index Sequential and Direct Access file management. Includes built-in utility functions for 16 or 32 bit arithmetic, string/integer conversion and string compare. Delivered as a relocatable linkable module in Microsoft format for use with FORTRAN-80 or COBOL-80. etc. .... **£275/£15**
- KBASIC** — Microsoft Disk Extended BASIC with all KISS facilities, integrated by implementation of nine additional commands in language. Package includes KISS.REL as described above, and a sample mail list program ..... **£495/£30**

## MICROPRO

- Super-Sort I** — Sort, merge, extract utility as absolute executable program or linkable module in Microsoft format. Sorts fixed or variable records with data in binary, BCD, Packed Decimal, EBCDIC, ASCII, floating, fixed point, exponential, field justified, etc. etc. Even variable number of fields per record! ..... **£125/£15**
- Super-Sort II** — Above available as absolute program only ..... **£105/£15**
- Super-Sort III** — As II without SELECT/EXCLUDE ..... **£75/£15**

- Word-Master Text Editor** — In one mode has super-set of CP/M's ED commands including global searching and replacing, forward and backwards in file. In video mode, provides full screen editor for users with serial addressable-cursor terminal ..... **£75/£15**
- Word-Star** — Menu driven visual word processing system for use with standard terminals. Text formatting performed on screen. Facilities for text paginate, page number, justify, center, underscore and PRINT. Edit facilities include global search and replace, read-write to other text files, block move, etc. Requires CRT terminal with addressable cursor positioning ..... **£255/£15**

## GRAFFCOM SYSTEMS

- PAYROLL** — Designed in conjunction with the spec for PAYE routines by HMI Taxes. Processes up to 250 employees on weekly or monthly basis. Can handle cash, cheque or bank transfer payments plus total tracking of all year to date figures. Prints emp master, payroll log, payslips and bank giro. Requires CBASIC-2 ..... **£475/£15**
- COMPANY SALES** — Performs sales accounting function. Controls payments of invoices and prints sales ledger and aged debtors report. Suitable for any accounting period. Comprehensive VAT control and analysis of all sales invoices. Requires CBASIC-2 ..... **£425/£15**
- COMPANY PURCHASES** — Performs purchase accounting function. Controls invoices, credit & debit notes. Prints purchase ledger, aged creditors report and payment advices. Comprehensive VAT control and analysis of all purchases. Interfaces with the NAD system. Requires CBASIC-2 ..... **£425/£15**
- STOCK CONTROL** — Maintains stock records, monitors stock levels to ensure optimum stock holding. Details include stock desc., product code, unit, unit price, quantity on hand/on order/minimum. Stock analysis reports can be weekly, monthly, quarterly etc. Interfaces with Order Entry Invoicing system. Requires CBASIC-2 ..... **£325/£15**
- ORDER ENTRY & INVOICING** — Performs order entry and invoicing function. Handles invoices for services and consumable items, part orders and part quantities. Sales Analysis report shows sales movements and trends for user-defined period. Interfaces with Stock Control, NAD and Company Sales systems. Requires CBASIC-2 ..... **£325/£15**
- NAD** — Complete control of all your names & addresses including suppliers, clients, enquiries etc. Assign your own coding system and select all output via the report generator. Will print anything from mailing labels to directories. Requires CBASIC-2 ..... **£225/£12**

## SOFTWARE SYSTEMS

- CBASIC-2** Disk Extended BASIC — Non-interactive BASIC with pseudo-code compiler and runtime interpreter. Supports full file control, chaining, integer and extended precision variables etc. .... **£75/£10**

## STRUCTURED SYSTEMS GROUP

- QSORT** — Fast sort/merge program for files with fixed record length, variable field length information. Up to five ascending or descending keys. Full back-up of input files created. Parameter file created, optionally with interactive program which requires CBASIC. Parameter file may be generated with CP/M assembler utility ..... **£50/£12**

## GRAHAM-DORIAN SOFTWARE SYSTEMS

- APARTMENT MANAGEMENT SYSTEM** — Financial management system for receipts and security deposits of apartment projects. Captures data on vacancies, revenues, etc. for annual trend analysis. Daily report shows late rents, vacancy notices, vacancies, income lost through vacancies, etc. Requires CBASIC. Supplied in source code. .... **£300/£25**
- INVENTORY SYSTEM** — Captures stock levels, costs, sources, sales, ages, turnover, markup, etc. Transaction information may be entered for reporting by salesman, type of sale, date of sale, etc. Reports available both for accounting and decision making. Requires CBASIC. Supplied in source code. .... **£300/£25**
- CASH REGISTER** — Maintains files on daily sales. Files data by sales person and item. Tracks sales, overruns, refunds, payouts and total net deposits. Requires CBASIC. Supplied in source code ..... **£300/£25**

## MICRO FOCUS

- CIS COBOL** — Version 3 is ANSI 74 subset with extensions which offer powerful interactive screen formatting and built in cursor control. Version 4 additionally offers full level 1 ANSI for Nucleus, Table Handling, Sequential Relative and Indexed I/O, Inter-Program Communication and Library ..... Version 3. **£295/£25**  
Version 4. **£395/£25**
- FORMS** — Interactive utility to create CIS COBOL source code to perform CRT screen handling in application programs. Supports full prompt text, protected fields and input validation against data type and range expected ..... **£65/£10**  
When purchased with CIS COBOL ..... **£55/£10**

## OTHER

Software with Manual / Manual Alone

- tiny C** — Interactive interpretive system for teaching structured programming techniques. Manual includes full source listings ..... **£45/£30**
- C Compiler** — Supports most major features of language, including Structures, Arrays, Pointers, recursive function evaluation, linkable with library to 8080 binary output. Lacks data initialization, long & float type and static & register class specifiers. Documentation includes "C" Programming Language book by Kernighan & Ritchie ..... **£65/£10**
- ALGOL 60 Compiler** — Powerful block-structured language featuring economical run time dynamic allocation of memory. Very compact (24K total RAM) system implementing almost all Algol 60 report features plus many powerful extensions including string handling direct disk address I/O etc. Requires Z80 CPU ..... **£110/£12**
- Z80 Development Package** — Consists of: (1) disk file line editor, with global inter and intra-line facilities; (2) Z80 relocating assembler, Zilog/Mostek mnemonics, conditional assembly and cross reference table capabilities; (3) linking loader producing absolute Intel hex disk file for CP/M LOAD, DDT or SID facilities. .... **£50/£12**
- Z80 Debugger**—Trace, break and examine registers with standard Zilog/Mostek mnemonic disassembly displays. Facilities similar to DDT £20 when ordered with Z80. Development Package ..... **£30/£7**
- DISTEL** — Disk based disassembler to Intel 8080 or TDL/Xitan Z80 source code, listing and cross reference files. Intel or TDL/Xitan pseudo ops optional. Runs on 8080. Standard CP/M and TRS-80 CP/M versions available ..... **£35/£7**
- DISILOG** — TEL to Zilog/Mostek mnemonic files. Runs on Z80 only ..... **£35/£7**
- TEXTWRITER II** — Text formatter to justify and paginate letters and other documents. Special features include insertion of text during execution from other disk files or console, permitting recipe documents to be created from linked fragments on other files. Ideal for contracts, manuals, etc. .... **£45/£3**
- WHATSIT?** — Interactive data-base system using associative tags to retrieve information by subject. Hashing and random access used for fast response. Requires CBASIC ..... **£70/£15**
- XYBASIC** Interactive Process Control BASIC — Full disk BASIC features plus unique commands to handle bytes, rotate and shift, and to test and set bits. Available in Integer, Extended and ROMable versions. Integer Disk or Integer ROMable ..... **£165/£15**  
Extended Disk or Extended ROMable ..... **£215/£15**
- SMAL/80** Structured Macro Assembled Language — Package of powerful general purpose text macro processor and SMAL structured language compiler. SMAL is an assembler language with IF-THEN-ELSE, LOOP-REPEAT-WHILE, DO-END, BEGIN-END constructs ..... **£40/£10**
- Selector II** — Data Base Processor to create and maintain single key data bases. Prints formatted, sorted reports with numerical summaries. Available for Microsoft and CBASIC (state which). Supplied in source code ..... **£105/£12**
- Selector III** — Multi (i.e. up to 24) Key version of Selector II. Comes with applications programs including Sales Activity, Inventory, Payables, Receivables, Check Register, Expenses, Appointments, and Client/Patient. Requires CBASIC. Supplied in source code ..... **£155/£12**  
Enhanced version for CBASIC-2 ..... **£185/£12**
- CPM/374X Utility Package** — has full range of functions to create or re-name an IBM 3741 volume, display directory information and edit the data set contents. Provides full file transfer facilities between 3741 volume data sets and CP/M files ..... **£125/£7**
- Flippy Disk Kit** — Template and instructions to modify single sided 5 1/4" diskettes for use of second side in singled sided drives ..... **£6**

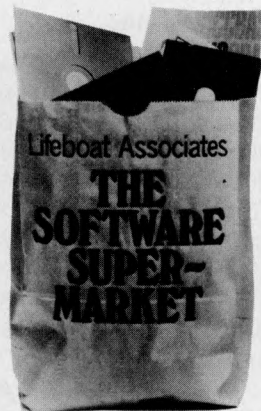

Orders must specify disk type and format, e.g. North Star Horizon single density.

Add VAT to orders for software (not manuals alone). Add 50p per item postage and packing (minimum £1).

All orders must be prepaid (except COD or credit card). Make cheques POs etc. payable to Lifeboat Associates.

Manual costs are deductible from subsequent software purchase.

The sale of each proprietary software package conveys a license for use on one system only.

## Lifeboat Associates

32 Neal Street, London WC2H 9PS  
01-379 7931

\*\* The Software Supermarket is a trademark of Lifeboat Associates

\* CP M is a trade name of Digital Research

\*\* Z80 is a trademark of Zilog, Inc.

EFFECTIVE 1 OCTOBER 1979

PCW 69

Software for most popular 8080/Z80 computer disk systems including **NORTH STAR HORIZON, VECTOR MZ, OHIO SCIENTIFIC, CROMEMCO, PROCESSOR TECHNOLOGY, RAI BLACK BOX, DYNABYTE, SD SYSTEMS, RESEARCH MACHINES, ALTAIR, EXIDY SORCERER, IMSAI, HEATH, and 8" IBM formats**

WALES LEADING  
SYSTEMS HOUSE



14 CHEPSTOW ROAD  
NEWPORT, GWENT.  
50528 / 841691 / 63310

Incorporating ( Microcourier)

At Micromedia we are usually asked for Complete Business Systems, here are a few examples.

	Purchase Price	Lease P/M
Accounting Package Sales Invoicing / Credit Controls Payroll on Alpha Micro, with 10 Megabyte Disk, visual display unit and printer.	17.950	448.75
Purchase Accounts, Sales Accounts, Payroll on Cromemco System III with work station, visual display unit and 180 c.p.s. printer.	7.950	198.75
Word Processing, Payroll, Accounts, on North Star Horizon with printer visual display unit and additional monitor.	5.500	137.50

Call us for a quotation on :

Cromemco II & III

North Star Horizon

Alpha Micro

Compucolour II

Commodore Pet

S W T P 6800

Microstar 45

APPLICATION SOFTWARE

Mailing Lists  
Data Base Management  
Accounting Suites  
Stock Controls  
Simplex Linear Programming  
Personel Records  
Fleet Maintenance Records  
Word Processing  
Pert (Critical Path Analysis)  
Purchase Ledger  
Sales Ledger  
Medical Records  
These are a selection from the range please call us to discuss your particular application.

We specialize in systems for Business Industry and Education and have specialist staff to discuss your applications.

Visual Display Units

	From £
Adds Regent 20	605
Adds Regent 25	645
Adds Regent 40	865
Cifer 2600	600
Dec VT 100	1100
Elbit 1920/30	725
Elbit 1920/30x	750
Infoton	610
Lear Siegler ADM 3A	595
Newbury Lab Range	
	From 495
Pericom 6801	985
Pericom 6802	1085
Pericom 6803	1285

Printers

	From £
Anadex DP800	575
S W T P PR 40	250
OKI E T 5200	485
Teletype 43 KSR	840
Dec LA 34	895
Dec LA 36	905
Dec LA 120 KSR	1675
Diablo 1640 RO	2098
Diablo 1640 KSR	2292
Texas 743	1195
Texas 810	1450
Tally Range from	1895

Odds 'n Sods

	£
M22 Paper Tape Reader	975
Punch	
M33 Paper Tape Reader	450
M63 Paper Tape Reader	
Punch	1495
Servogor Graphic Plotter	2750
Sigma Graphic Option	
Controller	2168
Single side mini Diskettes	
Per 10	30
Single side 8" Diskettes	35
Per 10	35
C12 Cassettes Per 10	475
Large range of computer books send SAE for list.	

OEM TERMS & QUANTITY DISCOUNTS AVAILABLE WRITE FOR DETAILS

# BUZZWORDS

Each month, Pete Reynolds takes us through the minefield of microcomputer terminology and jargon.



## J

### Jack Plug

A short rod-like connector whereby an electrical device (such as earphones) may be plugged into a jack.

### JCL

Job Control Language — specifying (typically for some mainframe computer) the input/output devices and other environmental variables before a program or 'job' is run.

### Jitter

Electrical instability, especially in the pattern of data displayed on a screen. Commonly due to inadequate voltage regulation.

### Job

A set of data processing tasks, including running programs, for a specified application — for example, "weekly payroll".

### Journal (tape)

A chronological listing, kept for backup, of all transactions and data entered to a computer system.

### Joystick

A small control device whose knob may be moved in any direction within two dimensions in order, for example, to move a dot on a screen.

### Jump

To depart from the normal sequence of program instructions. A jump instruction is often conditional. When a particular condition is satisfied (or not satisfied) the program instructions may be repeated in a loop, operating on each cycle on slightly modified data, until a pre-determined count has been exhausted. The condition allowing the jump will then cease to obtain and program instructions will be followed sequentially.

### Jumper

An electrical wire temporarily connecting two points on a circuit.

### Justify (1)

To arrange printed (or type-written) words so that the right-hand margin of each line forms a clear vertical line, as in most books and newspapers. There is usually no

difficulty about achieving justification of the left-hand margin, where each line of type begins, but to achieve the same effect along the right-hand edge of every line requires that words and letters must, to some extent, be spaced out more than they need be; this calls for a count of the characters and spaces required in each line and a calculation of the number of extra spacing inserts required and where they can best be placed. This can be a minor computing problem in itself.

### Justify (2)

To shift numeric characters to fill any spaces in the right-hand end of an accumulator or other area of computer storage, before an arithmetic operation.

## K

### Kilo (abbreviation)

Signifying 1000, as in kilometre or kilocycle. The internal storage of computers is commonly arranged by the manufacturer to hold a quantity of data which is some power of 2, for example, 4096 characters, bytes or words, which is  $2^{12}$ . The convention is to refer to this number as 4K. 64K, sixteen times as great, actually amounts to  $65536 (2^{16})$ . Note that the unit, bits, bytes or words is unstated. A '1K chip' probably holds 1K bits: to avoid ambiguity when referring to chips of greater capacity, the word size in bits may be shown after the K. Thus 1K8 means 1024 bytes, 16K1 means 16384 bits.

### Kansas City Standard

A way of recording binary data on cassette tapes in which 1 is encoded as 8 cycles of 2400 hertz and 0 as 4 cycles of 1200 hertz.

### Kb

1. Kilobytes, ie thousand bytes.
2. Kiloband, ie thousand cycles per second.
3. Kilobits, ie thousand bits.

### K/c

Kilocycle (abbreviation). One thousand cycles per second; now known as KiloHertz (KHz).

### KCS

Kansas City Standard.

### Key

A pattern of digits used to identify an item or record.

### Keyboard

The group of pushbuttons, as in a typewriter or calculator, whereby data or instructions may be input to a computer.

### Key-to-disc/tape

A system for computer data entry on a commercial scale which was introduced to obviate the need for punched cards originally selected for data entry by companies already in the punched-card business. In a key-to-disc (or key-to-tape) system the data-entry operators write their data on the relevant magnetic media for subsequent processing in batch mode. A limited validation check may be made on the data at the time of entry.

### Keyword

1. Same as key; a group of characters which identifies an item or record for data retrieval.
2. Same as password; a secret combination of characters which identifies an authorised user to a computer and may indicate which specific facilities are to be allowed or denied — eg to read data on the computer files but not to alter them in any way.

### KHz

KiloHertz (abbreviation).

### Kilo

Prefix signifying 1000 — but see entry under K.

### KiloHertz.

A frequency of 1000 cycles per second.

### KIPS

Kilo Instructions Per Second, describing the rate at which a processor can operate.

### Kit

A set of parts for assembly by the user. It may not include case, power supply or connecting leads and may be more expensive than equivalent mass-manufactured systems (if such existing). But for those who enjoy assembly, a kit can be more instructive and satisfying and easier to modify to one's personal design.

### Kludge

A local modification or patch in a computer program to overcome some error or design fault. Such patches make it difficult for others to follow the program or to deal with subsequent problems.

### Knock-Off

A device for automatically inhibiting some machine activity in certain circumstances. For example, a paper knock-off will stop a printer

when the paper supply is exhausted.

### KSR

Keyboard Send Receive. Descriptive of a printing terminal, such as a teletype, having keyboard and printer but no other media (such as magnetic or paper tape) capable of sending or receiving messages without manual intervention (Automatic Send Receive, or ASR).

### KVA

Kilo-Volt/Amps (abbreviation). A measure of electrical power, one KVA (or kilowatt) being equivalent, for example, to 4 amps at 250 volts or 5 amps at 200 volts. The consumption of one KVA for one hour (or 10 KVA for six minutes) is the familiar unit of the electricity bill.

## L

### L

1. Symbol for electrical inductance, eg of a coil, usually measured in Henries or Millihenries.
2. Low (state) in some bistable device.

### Label

One or more characters used to identify the location of an instruction (when line numbers are not used) within a program. The process of compiling such a program will replace each label with an absolute address.

### Lag

Delay between two successive events, such as reading a program instruction and completing its execution. The lag may be measured in clock cycles and knowledge of the interval used to advantage in advanced programming.

### Land

An internal electrical connection, eg. between an LSI chip proper and one of the pins in the package inside which the chip is supported.

### Language

Term used to describe a coding system by which instructions may be given, intelligible to a computer; for example, assembly language, BASIC, COBOL.

### Large Scale Integration

The fabrication on a small silicon chip of a circuit embodying several hundreds of semiconductor devices (normally between 100 and 10,000)

# 10 PART PASCAL SERIES

# THE COMPLETE PASCAL

BY SUE EISENBACH AND CHRIS SADLER

## CHAPTER 3 CONTROL STRUCTURES: 1. LOOPS

*In the last chapter, the procedure was presented as a means of performing the repetitive tasks so often required in computer programming. Thus program WALKING executed in "steps" LEFT and RIGHT alternately by successive calls to the procedures of those names. Some programs however have to repeat their procedures a large number of times, the precise figure often depending on conditions arising within the data or during the calculation, and hence not known in advance. In order to deal with these requirements, a programming device known as the loop exists in almost all languages.*

The function of the loop is to cause the execution of certain lines of code (the *body*) a certain number of times. Different types of loop may be distinguished by the way in which they decide how many repetitions (or *iterations*) are required. The process of deciding whether to repeat the body of the loop one more time or to continue with the rest of the program is called a *test*. Every loop therefore consists of a body and a test and is known as a *control structure* because it causes the program control or "flow" to differ from the normal sequential execution of program statements.

The most elementary type of loop is designed to execute the body a predefined number of times. This operation is controlled by an explicit *counter* variable and the test consists of comparing the value of the counter with the known finishing value. Depending on the outcome of the test, the counter is incremented (or sometimes decremented) and the body is repeated, or else program control passes to the code immediately beyond the loop.

In BASIC this structure is known as a FOR-NEXT loop and PASCAL has an equivalent called the FOR-DO loop. In addition, PASCAL has two loops for executing the body an unknown (or at least uncalculated) number of times. Here the test will depend on conditions arising within the body and a counter, if used at all, is not an explicit part of the loop. In the WHILE-DO loop, the test is made before the body is commenced whereas in the REPEAT-UNTIL loop, the test comes right at the end of the body. In the next few sections each of the above will be described, defined and exemplified in programs.

The body of a loop consists of either a single statement (now expanded to include the *compound statement*, as in the syntax diagram in Box 1) or in certain cases, a sequence of statements.

When laying out a program it is normal to indent the code between every BEGIN-END pair. When the body of a loop does not contain a BEGIN-END pair, however, by convention it is indented anyway, to emphasize that it is controlled within a loop.

context. Procedure RESTOFVERSE contains the parts of the song which are repeated in each verse. The loop, set up in line 11, ensures that the part that changes (CROWDS) is correct for each verse. This requires the special DOWNT0 reserved word to make the counter work backwards. Lines 13 and 14 actually produce each verse and line 15 sends the program control back to line 11 for the next verse — and so on. Line 16 finishes off the song. Lines 12

### The FOR~DO Loop

Program ROLLOVER in Box 2 illustrates a FOR-DO loop in a fairly typical

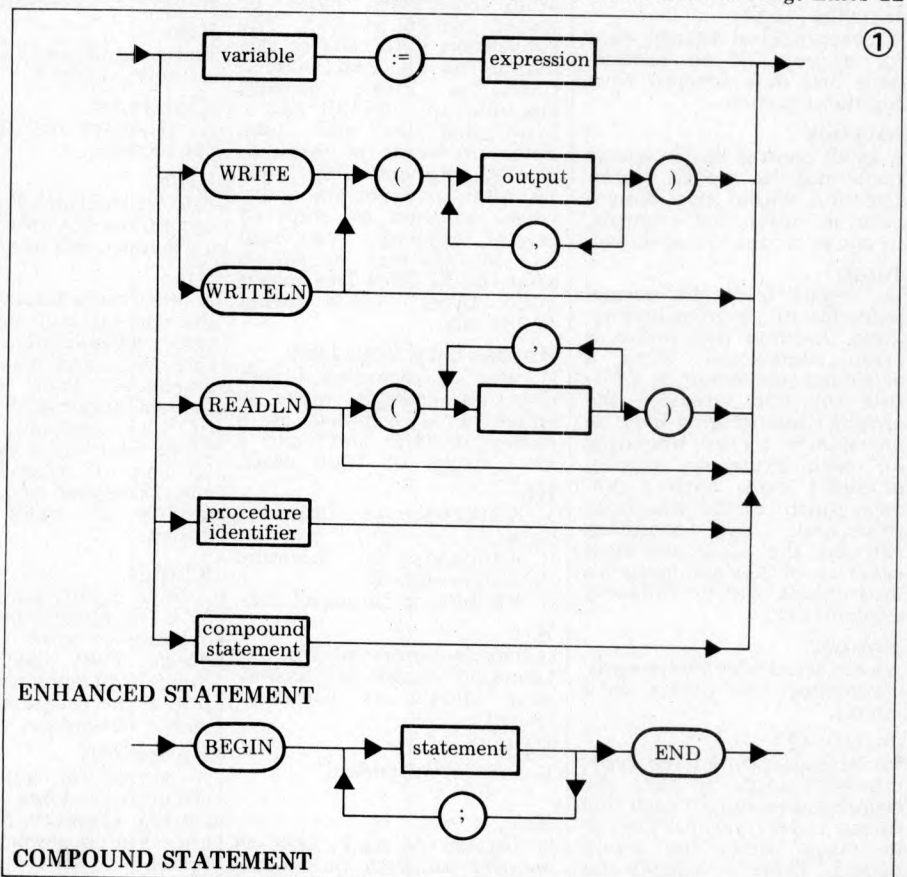

```

1 PROGRAM ROLLOVER ;
2 VAR CROWDS: INTEGER ;
3 PROCEDURE RESTOFVERSE ;
4 BEGIN
5   WRITELN(' IN A BED AND THE LITTLE ONE SAID' ) ;
6   WRITELN(''ROLLOVER, ROLLOVER'' ) ;
7   WRITELN('SO THEY ALL ROLLED OVER AND ONE FELL OUT.' ) ;
8   WRITELN
9 END ; (*RESTOFVERSE*)
10 BEGIN (*MAIN PROGRAM*)
11   FOR CROWDS:=10 DOWNT0 2 DO
12     BEGIN
13       WRITE('THERE WERE ', CROWDS) ;
14       RESTOFVERSE
15     END ;
16   WRITELN('THERE WAS 1 IN THE BED AND HE SAID 'GOODNIGHT''.')
17 END
-----
18 THERE WERE 10 IN A BED AND THE LITTLE ONE SAID
19 'ROLLOVER, ROLLOVER'
20 SO THEY ALL ROLLED OVER AND ONE FELL OUT.
21
22 THERE WERE 9 IN A BED AND THE LITTLE ONE SAID
23 ...
24 ...
25 ...
54 THERE WAS ONE IN A BED AND HE SAID 'GOODNIGHT' .

```

PROGRAM ROLLOVER

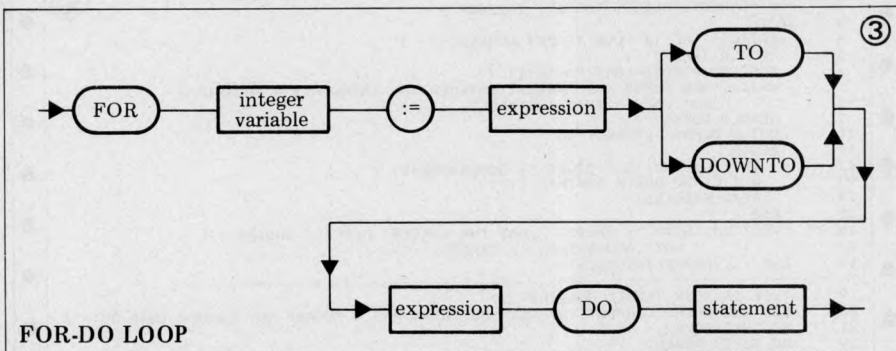

FOR-DO LOOP

to 15 provide an example of a compound statement. Finally, note PASCAL's solution to the problem of printing a ' mark. Since the quote (') is the text delimiter, the PASCAL compiler searches for pairs of quotes enclosing text. Two adjacent quotes will indicate that the text is not to be terminated but rather that a single quote is required for output.

The syntax diagram in Box 3 shows the precise structure of the FOR-DO loop. The different components appear as:

FOR (test) DO (body)

The counter is a variable (not a REAL) and must therefore, like any other variable, be declared explicitly in the declaration part. The starting and finishing expressions must be integer expressions. Because these expressions are evaluated before the loop commences, rather than during each iteration, there is no loss of efficiency in using quite complex expressions if required.

The counter increases or decreases (depending on whether TO or DOWNT0, respectively, is used) by 1 on each iteration. The restriction of the step size creates a loop-test requiring a minimal number of machine-code instructions. If a different step size is required, a "dummy" counter can be constructed within the body of the loop, but on no account should the value of the actual counter be changed inside the loop (for obvious reasons). The FOR-DO loop test will discontinue the loop when the value of the counter moves beyond the finishing value (in the indicated direction). This ensures not only that the body is executed the correct number of times, but also, if the counter is accidentally set up to move away from the finishing value, the body of the loop will be skipped over entirely.

When the loop has finished the counter variable loses any value it had (i.e. it becomes undefined). This feature

is included in PASCAL as a safety measure to guard against the tendency of some programmers to re-use a loop counter at a later stage of the program, without assigning a new value to it.

EXERCISE:

Write a program to print out the song "Ten Green Bottles".

### The Generalized Loop

Circumstances can often arise in programming where the use of a fixed-limit FOR-DO loop is too restrictive to allow for a fluent program style. As an example consider the problem of entering a list of numbers from a keyboard into a program. If you don't want to count how many numbers there are before you start, you need to have a way of telling the program when the list has come to an end. This is usually done with a "rogue" value - a number which couldn't possibly be a part of the list (eg. -9999). When the program detects the rogue value, this is an indication that the input list is complete and further processing can continue.

It would be nice to place the item-by-item reading of such a list in a loop, but if the length of the list is unknown, then the only way of doing this with a FOR-DO loop leads to awkward and error-prone code. Because circumstances such as this arise quite frequently, PASCAL has a more generalized loop form.

The distinguishing feature of the generalized loop lies in the nature of its test. Instead of a steady incrementation of a counter, the test checks the validity of some relationship which is (presumably) affected by the body of the loop. When the relationship holds, one course of action is taken and when events within the loop cause the relationship to change, a different course of action is embarked upon. Quite clearly, only two possibilities exist - the relationship holds or it doesn't (i.e. it is true or

false). Such a relationship is called a Boolean expression after the English mathematician George Boole who first studied the algebra of such expressions.

The syntax diagram in Box 4 fully defines the Boolean expression. Note that <> stands for "is not equal to". Consider a Boolean expression like A=B. This expresses the relationship "A is equal to B" and the = is known as a relational operator as are all the other symbols shown in Box 4. Compare this with the assignment statement A:=B which reads "A becomes equal to B". Here := is an assignment operator and it is this distinction which enables one to write X:=X+1 in a program where it would make no sense as an equation.

PASCAL provides two versions of the generalized loop. In the first, the WHILE-DO loop, the test is made before the body is commenced, and iteration occurs as long as the Boolean expression is true. If the expression is false when the program first encounters the loop, the entire loop will be skipped. The syntax diagram in Box 5 defines a WHILE-DO loop. As with a FOR-DO loop, the body is a single statement, generally compound.

The program in Box 6 illustrates the use of a WHILE-DO loop, which runs from lines 10 to 15, line 10 containing the test and the rest comprising the body. While this is not a very practical sort of guessing game, it does show the unlimited nature of the loop which will go on asking for new guesses until the right number turns up. It also shows the major danger of the generalized loop - suppose the test never fails? The program will stay in the loop forever. For instance, suppose TARGET was 16 while CORRECT and GUESS were REAL instead of INTEGER, and CORRECT became 3.99999 (as often happens). Any integer value guessed could never pass the test. This can happen quite easily especially when dealing with the mathematical functions with which rounding errors are associated. Consequently, it is good programming practice to check explicitly for realisable loop tests.

Examples of mathematical functions appear in line 6. SQRT(A) is a REAL value representing √A while TRUNC(B) is the largest integer less than B (when B is positive). In line 6 the above functions are nested so that CORRECT is the square-root of the largest perfect square less than TARGET. A list of all mathematical or standard functions available in PASCAL appears in the Look-Up Table at the end of this chapter.

The second generalized loop in PASCAL is the REPEAT-UNTIL loop defined in Box 7. The test comes at the end of the body and iteration occurs as long as the condition is false. PASCAL has two complementary loops to allow for a fluent programming style. Sometimes it will seem more natural to use a WHILE-DO loop and sometimes a REPEAT-UNTIL will suggest itself. In the latter case however, the body will be executed at least once, whatever state the Boolean expression is in, because the test comes after the body. Program ANOTHERGO in Box 8 illustrates the use of a REPEAT-UNTIL loop running from lines 22 to 26. Line 26 contains the test and the body lies above it.

The REPEAT-UNTIL loop has

reserved words which effectively bracket the body of the loop. This is not the case with the other two loops where the reserved word DO merely leads up to the beginning of the body. The PASCAL compiler needs to know where the loop body stops and the rest of the program begins. It is for this reason that the two DO loops restrict the programmer to a body consisting of a single statement (usually compound). Without the DO keyword possessed by the other loops, the REPEAT-UNTIL loop can contain more than one statement in its body (cf. syntax diagrams for the different loops). This means that one tends not to find BEGIN-END pairs following a REPEAT although the indentation convention is observed nonetheless.

The program from Box 6 has been converted into a procedure for ANOTHERGO. This is a sensible way to develop programs — writing a small, self-contained section as a separate program, testing it, and then incorporating it as a procedure in some larger program. This theme will be developed in more detail in the next section. Finally, line 2 introduces a new *data type*, the character type CHAR which consists of a single letter of the alphabet, digit or normal keyboard punctuation mark. The variable ANSWER can contain any one of these characters and can be compared with actual characters enclosed in 'quotes' as in line 26. Variables therefore can be declared as INTEGER, REAL or CHAR.

Each of the three control structures defined above is an extension of the definition of a statement, since it appears in the action part of a program. Consequently a complete syntax diagram for the statement must incorporate all of these, and this is shown in Box 9.

#### EXERCISE:

Computers (and calculators) are often tested for accuracy by computing a range of nested mutually inverse functions [eg.  $\exp(\ln[x]) = x$ ].

Write a program to input a sequence of (positive) numbers (rogue values could be 0 or less), in each case calculating  $\exp(\ln[x])$  and outputting this value, together with  $x$  and the difference between them before reading in the next one.

## Using Loops

As an everyday application of the use of loops, consider the construction of a mortgage repayment table. These are normally constructed by actuaries from formulae which give the monthly payment incurred by a loan assuming a fixed interest rate and where repayment occurs over a fixed time period.

This reputedly boring occupation seems ideally suited for rendering into machine soluble form, releasing the actuary for more valuable tasks (like estimating the insurance risks on a personal computer). Instead of employing the actuarial formula, however, the problem will be used to illustrate a common programming technique which consists of taking a guess at the likely value, working out the implications, comparing the results with the required outcome, improving the guess, working out the implications again, and repeating this process until an acceptable

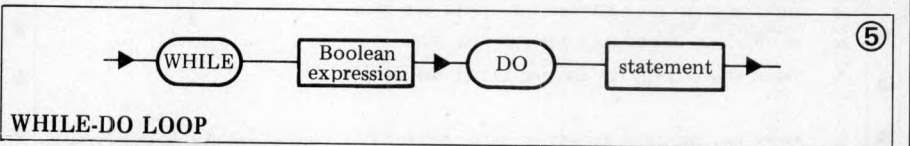
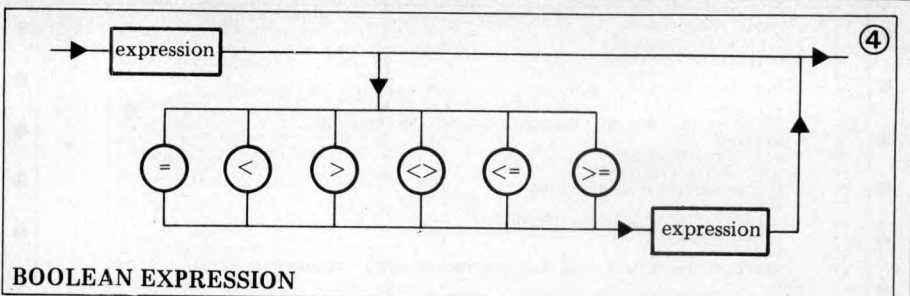

```

1 PROGRAM PERFECTSQUARE ;
2 VAR CORRECT, GUESS, TARGET: INTEGER ;
3 BEGIN
4   WRITE('TYPE IN YOUR TARGET NUMBER:-') ;
5   READLN(TARGET) ;
6   CORRECT:=TRUNC(SQRT(TARGET)) ;
7   WRITE('NOW GUESS THE LARGEST INTEGER YOU THINK HAS A SQUARE ',
8     'NOT LARGER THAN ', TARGET, ':-') ;
9   READLN(GUESS) ;
10  WHILE GUESS<>CORRECT DO
11    BEGIN
12      WRITELN('NO THAT GIVES ', GUESS*GUESS) ;
13      WRITE('SO GUESS AGAIN:- ') ;
14      READLN(GUESS)
15    END ;
16  WRITELN('GOOD ', GUESS, ' HAS THE LARGEST PERFECT SQUARE ',
17    'NOT LARGER THAN ', TARGET, '.')
18  END ; (*PERFECTSQUARE*)
-----
19 TYPE IN YOUR TARGET NUMBER:- 59
20 NOW GUESS THE LARGEST INTEGER YOU THINK HAS A SQUARE NOT LARGER THAN 59:- 6
21 NO THAT GIVES 36
22 SO GUESS AGAIN:- 7
23 GOOD 7 HAS THE LARGEST PERFECT SQUARE NOT LARGER THAN 59.

```

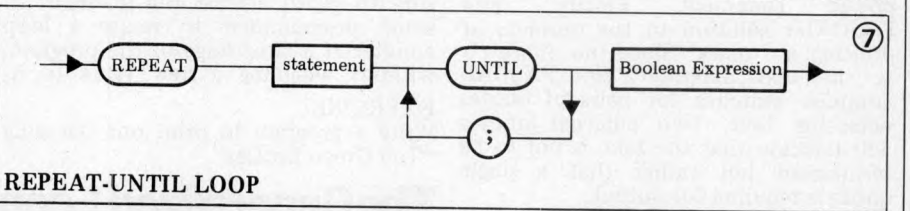

```

1 PROGRAM ANOTHERGO ;
2 VAR ANSWER: CHAR ;
3 PROCEDURE PERFECTSQUARE ;
4 VAR CORRECT, GUESS, TARGET: INTEGER ;
5 BEGIN
6   WRITE('TYPE IN YOUR TARGET NUMBER:-') ;
7   READLN(TARGET) ;
8   CORRECT:=TRUNC(SQRT(TARGET)) ;
9   WRITE('NOW GUESS THE LARGEST INTEGER YOU THINK HAS A SQUARE ',
10     'NOT LARGER THAN ', TARGET, ':-') ;
11   READLN(GUESS) ;
12   WHILE GUESS<>CORRECT DO
13     BEGIN
14       WRITELN('NO THAT GIVES ', GUESS*GUESS) ;
15       WRITE('SO GUESS AGAIN:- ') ;
16       READLN(GUESS)
17     END ;
18   WRITELN('GOOD ', GUESS, ' HAS THE LARGEST PERFECT SQUARE ',
19     'NOT LARGER THAN ', TARGET, '.')
20   END ; (*PERFECTSQUARE*)
21 BEGIN (*MAIN PROGRAM*)
22   REPEAT
23     PERFECTSQUARE ;
24   WRITE('DO YOU WANT TO TRY ANOTHER TARGET? ') ;
25   READLN(ANSWER)
26   UNTIL ANSWER='N'
27   END,
-----
28 TYPE IN YOUR TARGET NUMBER:- 44
29 NOW GUESS THE LARGEST INTEGER YOU THINK HAS A SQUARE NOT LARGER THAN 44:-
30 GOOD 6 HAS THE LARGEST PERFECT SQUARE NOT LARGER THAN 44.
31 DO YOU WANT TO TRY ANOTHER TARGET? N

```

answer is reached. Clearly, the loop provides a means of programming such an iterative solution — although it's unlikely to tempt any actuaries away from their formulae!

The approach we shall take in programming this problem is known as "Top-Down Design". The Top-Down designer begins by explicitly defining the problem, stating what results are expected from what initial information. The task is then coded by calling several procedures, each a distinct subtask or *module* which contributes to the solution of the total problem. Any consideration of the detail of these

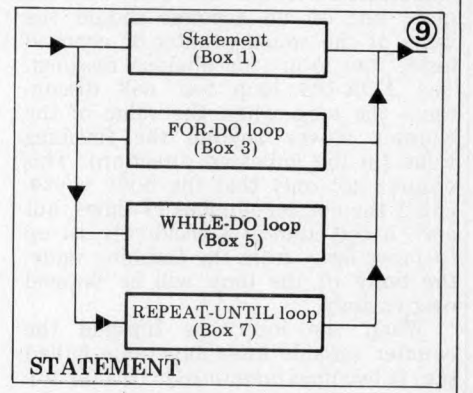

```

1 PROGRAM REPAYMENTS ;
2 VAR MIN, MAX, LOAN, REPAY: INTEGER ;
3 PROCEDURE GETINPUTS ;
4     (*READ IN INTEREST RATE, NUMBER OF YEARS,
5     MINIMUM AND MAXIMUM LOANS*)
6 PROCEDURE PRINTHEADINGS ;
7     (*PRINT OUT INTEREST RATE, NUMBER OF YEARS
8     AND TABLE HEADINGS-I.E.LOAN & REPAYMENTS*)
9 PROCEDURE CALCULATEREPAY ;
10    (*WORK OUT MONTHLY REPAYMENTS*)
11 BEGIN (*MAIN PROGRAM*)
12     GETINPUTS ;
13     PRINTHEADING ;
14     LOAN:=MIN ;
15     WHILE LOAN<=MAX DO
16     BEGIN
17         CALCULATEREPAY ;
18         Writeln(LOAN, ' ', REPAY) ;
19         LOAN:=LOAN + 1000
20     END
21 END. (*REPAYMENTS*)

```

**PROGRAM REPAYMENTS — FIRST ATTEMPT**

```

1 PROCEDURE CALCULATEREPAY ;
2 VAR TOTALMONTHS: INTEGER ;
3     MONTHLYINTERESTRATE, AMOUNTDUE: REAL ;
4 PROCEDURE TRYREPAY ;
5     (*WORK OUT THE ACTUAL AMOUNT A GIVEN REPAYMENT
6     WILL ACTUALLY PAY OFF*)
7 BEGIN
8     MONTHLYINTERESTRATE:=INTERESTRATE/12 ;
9     TOTALMONTHS:=12*YEARS ;
10    REPAY:=LOAN DIV TOTALMONTHS ;
11    REPEAT
12        AMOUNTDUE:=LOAN ;
13        REPAY:=REPAY + 1 ;
14        TRYREPAY
15    UNTIL AMOUNTDUE<=0
16 END ; (*CALCULATEREPAY*)

```

**PROCEDURE CALCULATEREPAY**

```

1 PROCEDURE TRYREPAY ;
2     (*WORK OUT THE ACTUAL AMOUNT A GIVEN REPAYMENT
3     WILL ACTUALLY PAY OFF*)
4 VAR MONTH: INTEGER ;
5 BEGIN (*CALCULATEREPAY*)
6     FOR MONTH:=1 TO TOTALMONTHS DO
7         AMOUNTDUE:=(AMOUNTDUE-REPAY)*(1 + MONTHLYINTERESTRATE)
8     END ; (*TRYREPAY*)

```

**PROCEDURE TRYREPAY**

```

1 PROCEDURE GETINPUTS ;
2 CONST IMIN=2 ; IMAX=50 ;
3     YMIN=5 ; YMAX=35 ;
4     LMIN=5 ; LMAX=200 ;
5 PROCEDURE GETINTEREST ;
6     (*READS IN INTEREST RATE BETWEEN IMIN AND IMAX AND
7     CONVERTS IT TO A DECIMAL*)
8 PROCEDURE GETYEARS ;
9     (*READS IN DURATION OF LOAN BETWEEN YMIN AND YMAX YEARS*)
10 PROCEDURE GETMIN ;
11     (*READS IN, IN THOUSANDS, THE MINIMUM LOAN VALUE BETWEEN
12     LMIN AND LMAX AND CONVERTS IT TO POUNDS*)
13 PROCEDURE GETMAX ;
14     (*LIKE GETMIN, BUT FOR THE MAXIMAL LOAN VALUE*)
15 63 BEGIN (*GETINPUTS*)
16 64     GETINTEREST ;
17 65     GETYEARS ;
18 66     GETMIN ;
19 67     GETMAX
20 68 END ; (*GETINPUTS*)

```

**PROCEDURE GETINPUTS**

```

1 PROCEDURE GETINTEREST ;
2     (*READS IN INTEREST RATE BETWEEN IMIN AND IMAX AND
3     CONVERTS IT TO A DECIMAL*)
4 BEGIN
5     Writeln('TYPE IN THE RATE OF INTEREST AS A PERCENTAGE.') ;
6     REPEAT
7         WRITE('A NUMBER BETWEEN', IMIN, ' AND', IMAX, ':-') ;
8         READLN(INTERESTRATE)
9     UNTIL (INTERESTRATE>=IMIN) AND (INTERESTRATE<=IMAX) ;
10    INTERESTRATE := INTERESTRATE/100 ; (* % -> DECIMAL *)
11 END (*GETINTEREST*) ;
12
13 PROCEDURE GETYEARS ;
14     (*READS IN DURATION OF LOAN BETWEEN YMIN AND YMAX YEARS*)
15 BEGIN
16     Writeln('TYPE IN NUMBER OF YEARS FOR WHICH MORTGAGE WILL RUN.') ;
17     REPEAT
18         WRITE('A NUMBER BETWEEN', YMIN, ' AND', YMAX, ':-') ;
19         READLN(YEARS)
20     UNTIL (YEARS>=YMIN) AND (YEARS<=YMAX)
21 END ; (*GETYEARS*)
22
23 PROCEDURE GETMIN ;
24     (*READS IN, IN THOUSANDS, THE MINIMUM LOAN VALUE BETWEEN
25     LMIN AND LMAX AND CONVERTS IT TO POUNDS*)
26 VAR LOANMIN: INTEGER ;
27 BEGIN
28     Writeln('TYPE IN THE SMALLEST MORTGAGE YOU ARE INTERESTED IN, '
29     ' IN THOUSANDS.') ;
30     REPEAT
31         WRITE('A NUMBER BETWEEN', LMIN, ' AND', LMAX, ':-') ;
32         READLN(LOANMIN)
33     UNTIL (LOANMIN>=LMIN) AND (LOANMIN<=LMAX) ;
34     MIN := LOANMIN*1000
35 END (*GETMIN*) ;
36
37 PROCEDURE GETMAX ;
38     (*LIKE GETMIN, BUT FOR THE MAXIMAL LOAN VALUE*)
39 VAR LOANMAX: INTEGER ;
40 BEGIN
41     Writeln('TYPE IN THE LARGEST MORTGAGE YOU ARE INTERESTED IN, '
42     ' IN THOUSANDS.') ;
43     REPEAT
44         WRITE('A NUMBER BETWEEN', MIN DIV 1000, ' AND', LMAX, ':-') ;
45         READLN(LOANMAX)
46     UNTIL (LOANMAX>MIN DIV 1000) AND (LOANMAX<=LMAX) ;
47     MAX := LOANMAX*1000
48 END (*GETMAX*) ;

```

**PROCEDURES GETINTEREST ETC.**

modules is deferred to a later stage of the design. In due course, each module will undergo the same treatment and thus the problem devolves into a hierarchy of more-or-less independent sub-problems until a level is reached at which only elementary programming functions are required. At this point the final coding can be done quickly and accurately, and the result should be a well-structured program.

Returning to the mortgage table program, the problem definition could be:

Given the interest rate and a time period for repayment, create a table showing the monthly payment due over a given range of loans.

The input data required is therefore:

1. interest rate (% p.a.)
2. repayment period (years)
3. maximum and minimum loans required (thousands of pounds).

The output should be a list of loans from minimum to maximum in steps of £1000, showing monthly repayments. The interest rate and repayment period should also be displayed.

The next stage is to decide on the method of solution in order to code the main program. At this level the tasks that must be accomplished include reading in the user's parameters, printing out the appropriate headings and, for each loan from the minimum to the maximum requested, calculating and printing the repayment amount. At this stage, the means by which the calculations are to be performed do not concern us and neither are we interested in the details of getting the input data or printing out the heading. The calculations will have to be performed in a loop which will stop when the maximum loan value is reached. In Box 10, we have called procedures named GETINPUTS and PRINTHEADINGS to handle the initial part of the problem, and introduced a WHILE-DO loop (lines 15 - 20) to control the calculation and output of the table. Procedure CALCULATEREPAY will actually perform the calculations.

The declaration part of this first attempt includes all identifiers used in the main program. These include the integer variables MIN, MAX, LOAN and REPAY, together with the procedures GETINPUTS, PRINTHEADINGS and CALCULATEREPAY. Notice that these procedures have not been fully defined at this stage but merely contain a comment indicating what each will eventually do.

#### EXERCISE:

Try re-writing this first attempt with a FOR-DO loop instead of a WHILE-DO loop.

We have now completed the highest level of the program design and are ready to proceed to the next level. The three procedures will be tackled in the same way that the whole problem REPAYMENTS was approached. The question arises as to which of the three should be dealt with first. We prefer to start with the "Heart" of the problem — CALCULATEREPAY (Box 11). The problem definition of CALCULATEREPAY could be:

Work out the monthly repayment as follows — first guess an obviously low value and calculate how much that

would pay off over the given time period, taking into account the interest charges. If there is still a debt by the end, the repayment value was not enough, so increase it and try again. Continue until the repayment amount pays off the loan.

Input data

1. duration of loan
2. interest rate
3. amount of loan

Output data is the calculated monthly repayment amount.

In the declaration part, the variables required in the calculation will have to be declared only if they are local to the procedure, since the global variables will already have been declared. Thus a check should be made that the input and output variables, YEARS, INTERESTRATE, LOAN and REPAY appear in the variable declaration of the main program. Some of these may be missing in a "first attempt" version and so should be incorporated.

To start coding CALCULATEREPAY the first step is to generate the working data from the input data. The repayment period, for instance, is in years but is here required in months, as is the interest rate. Therefore two new (local) variables TOTALMONTHS and MONTHLYINTERESTRATE must be declared and calculated. Next, the initial estimate should be made, in order to start the whole process off. Since repayments will be *increased* to improve the "guess", it is important to start with an estimate *below* the likely value. A reasonable first estimate would be the amount one would pay back interest-free. This is simple enough to code at this stage as can be seen in line 10 of Box 11. (Note that DIV has been used since REPAY is an integer. This program could be changed to give pounds and pence if the user were willing to trade some speed for such accuracy). Since the initial estimate must be too low, the next step should be to add £1 to the repayment and test whether that will pay off the loan.

The process of incrementing the repayment amount and testing will be repeated until a figure is reached which actually *does* pay off the loan. This has been coded in the REPEAT-UNTIL loop, lines 11 to 15, Box 11, but, just as this calculation was put off in the main program, so the job of calculating how much a given value of REPAY would actually pay off over the time-period is deferred to procedure TRYREPAY, which is the next problem to be tackled (Box 12).

The problem definition of TRYREPAY could be:

Evaluate how much a given value of REPAY would pay off over the given duration of the mortgage using the given interest rate, assuming monthly payments and the compounding of interest.

Input data

1. monthly interest rate
2. duration of loan (months)
3. value of loan (£)
4. value of repayment (£ per month)

Output data — amount of debt remaining when time period has elapsed.

What is owing at the end of one month? Suppose AMOUNTDUE contains the amount due at the beginning of one month and an amount REPAY is paid

back. At the end of that month, the amount due will be (AMOUNTDUE - REPAY) + interest accrued during the month. This figure will become the AMOUNTDUE for the next month; for N months, this calculation should pass through N iterations.

This is coded in the FOR-DO loop, Box 12, lines 6 and 7. The only variable needed that has not been previously declared is the loop counter, which is declared locally in line 4. This completes the definition of TRYREPAY which, in turn, completes the definition of procedure CALCULATEREPAY.

Having coded CALCULATEREPAY we now know exactly what information GETINPUTS must obtain. The problem definition could be:

Read in interest rate, duration of loan and maximum and minimum loans (in thousands of pounds). Convert interest rate to a decimal (instead of percentage) and loan values to pounds.

- Output data
1. interest rate (decimal fraction)
  2. duration of loan
  3. minimum loan
  4. maximum loan

An input procedure should usually check that the data it accepts is reasonable and unlikely to cause the program to crash. For instance, if the repayment period YEARS were zero, then TOTALMONTHS would also be zero. But we divide by TOTALMONTHS in CALCULATEREPAY, so that apart from zero being an unreasonable figure for years it will also crash the program.

Box 13 contains procedure GETINPUTS. In the action part the four procedures GETINTEREST, GETYEARS, GETMIN and GETMAX are called. The declaration part lays down limits

within which the input data should fall (lines 2 - 4). If one of these should later on prove restricting, it will be easy to change the CONST declaration.

The four individual input procedures (Box 14) are so similar that only one, GETINTEREST, need be considered in detail. Its problem definition could be:

Output a message asking for the rate of interest. Check whether the response is within the range of reasonable values. Keep asking until an acceptable reply is received. Then convert this number from a percentage to a decimal fraction.

Input Data

IMIN and IMAX — limits of "reasonable" interest rates (as a percentage).

Output Data

INTERESTRATE — actual required interest rate as a decimal fraction.

A REPEAT-UNTIL loop (lines 6 to 9) is used to accept input. The program remains in the loop until an acceptable figure is entered.

The other three input procedures are developed in a similar fashion. Note that in procedure GETMAX, the minimum value for a loan is not LMN but MIN DIV 1000 — the actual lower limit obtained from GETMIN (line 34).

Finally, PRINTHEADING is tackled (Box 15). Its problem definition could be:

Clear the screen, then print out a title followed by the required interest rate and the duration of the loan. Skip several lines and print the headings MORTGAGE (for the loan) and MONTHLY REPAYMENTS.

Input Data

1. yearly interest rate (%)
2. duration of loan (years)

Output Data — none as this procedure simply produces the headings.

Cont. on Page 81

```

1 PROCEDURE PRINTHEADINGS ;
2   (*PRINT OUT INTEREST RATE, NUMBER OF YEARS AND
3   TABLE HEADINGS-I.E. LOAN AND REPAYMENTS*)
4   CONST SPACE=' ' ;
5   BEGIN
6     WRITELN(SPACE, '**MONTHLY MORTGAGE REPAYMENTS**') ;
7     WRITELN(SPACE, '-----');
8     WRITELN ;
9     WRITELN('INTEREST RATE =', 100*INTERESTRATE, '% OVER ',
10    YEARS, 'YEARS') ;
11    WRITELN('  LOAN      REPAYMENTS') ;
12    WRITELN('  ----      -----') ;
13    WRITELN ;
14  END ; (*PRINTHEADINGS*)

```

PROCEDURE PRINTHEADINGS

## Look up table

### PASCAL STANDARD FUNCTIONS

Arithmetic:		
ABS(X)	Absolute Value	Real or Integer
SIN(X)	Trig functions	Answer Real
COS(X)		
ARCTAN(X)	Exponential	Answer Real
EXP(X)		
LN(X)	Natural Logs	Answer Real
SQR(X)	Square	Real or Integer
SQRT(X)	Square Root	Answer Real
Transfer:		
TRUNC(X)	Truncate	X real, Answer is integer part
ROUND(X)	Round to closest integer	

[ROUND(X) = TRUNC(X + 0.5) when X is positive]

### COMPUTING JARGON

Control Structure  
Counter  
Compound Statement  
Rogue Value  
Boolean Expression  
Relational Operator  
Module  
Iteration

### PASCAL RESERVED WORDS

FOR  
DO  
TO  
DOWNTO  
WHILE  
REPEAT  
UNTIL  
CHAR

### UCSD Exceptions

ATAN(X) instead of ARCTAN(X)  
Also LOG(X) is log to base 10.

### EXERCISE SUMMARY

1. Ten Green Bottles
2. Accuracy Test
3. Mortgage Table

# COMPUCOLOR II

Now available from:

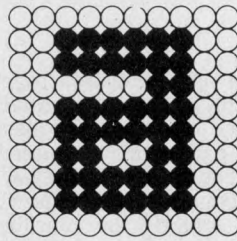
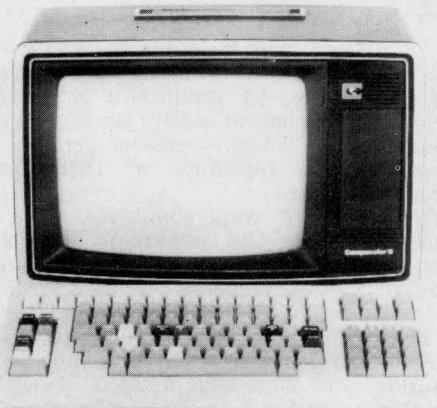

Abacus  
Computers  
Limited

62 New Cavendish St., London W1  
01-580 8841

"One of the best small systems we have reviewed" — Practical Computing

**Prices from £1058 ex. VAT**

and from

Micro-Media Systems  
14 Chepstow Road,  
Newport, Gwent.  
0633 50528

Trans Am  
12 Chapel Street,  
London W2.  
01-262 0814

Mektronic Consultants  
116 Rectory Lane,  
Prestwich,  
Manchester.  
061-798-0803

Kestrel Computing  
195 Bennetts End Rd,  
Hemel Hempstead,  
Herts.  
0442 50706

Tand V Johnson  
165 London Road,  
Camberley, Surrey.  
0276 62506

Protech Instruments  
224 Selbourne Road,  
Luton, Beds.  
0582 596181

Microshade  
1 Patford Street,  
Calne, Wiltshire.  
0249 815757

## ABACUS PASCAL SYSTEM



**£3850** Excluding VAT

**COMPLETE**

PURPOSE BUILT

PASCAL MAINFRAME FULLY CONFIGURED AND READY TO RUN.  
FEATURING AS STANDARD: 60K RAM; 3 SERIAL / 3 PARALLEL  
I/O PORTS; TWIN 8" DISC DRIVES; 12 SLOT S-100 FRAME, PLUS THE

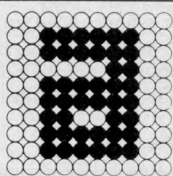

Abacus  
Computers  
Limited

62, New Cavendish Street, London W1M 7LD  
Telephone: 01-580 8841/2

**FULL UCSD PASCAL™**

SOFTWARE PACKAGE FULLY IMPLEMENTED  
BY ABACUS COMPUTERS LTD. IN THE UK.

FULL RANGE OF OPTIONS AVAILABLE.

MICROBASED EDITING TERMINAL

AVAILABLE FOR £600.

*Interrupt is the place in PCW where readers can unburden their grievances and air controversial views. New subjects are always welcome; the 'right of reply' shall be wielded at the discretion of the Editor. Please hold all contributions to within 800 words.*

## Future-What future?

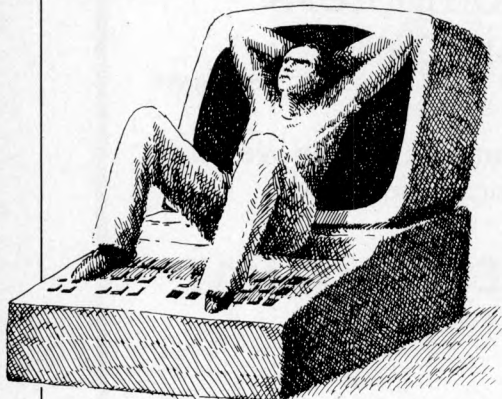

I am beginning to have strong suspicions that our leaders and the media are actively conspiring to keep the real implications of information technology from the general public. Having always held BBC documentaries in high regard, I was disturbed to see the recent three part production "The Right To Work?" brilliantly obscuring the most important issues.

There was the predictable argument regarding the amount of unemployment which may occur, and how best to minimise it, and a tantalising, albeit superficial, glance at the role of leisure in utilising the spare man hours. Unfortunately, however, any good intentions there may have been collapsed into a familiar political squabble between Sir Keith Joseph and two TUC representatives. The problem was one of approach. "The Right To Work?" provided an excellent example of that little known but highly pervasive phenomenon, best described as 'temporal chauvinism'. This is manifest in the inability of members of a society to envisage any future society without imposing their own contemporary political and economic structures upon it. The best, latter-day example, would be the persistent attitude of unions and government alike towards unemployment; they see it as a social evil to be avoided at all costs.

The real question posed by the present technological revolution was summed up by Peter Large of the *Guardian*; "Do we want to work anyway, if our jobs are unsatisfying or unpleasant, if we are there just for the money? Can we rethink the work ethic and find another way, by whatever political means, of distributing wealth?"

In the present social climate, however, resistance to such ideas is very powerful (A Nation of Scroungers? reads the headline). Even aside from the indignant abhorrence of the average man in the street towards 'living off welfare', there are many respectable academics who would argue that, for the individual, unemployment causes depression and psychological instability. The latter is, of course, bound to be true in a society where a person's educa-

tion and culture, together with the media and the inadequacy of many welfare payments, conspire to make the experience as miserable as possible.

Those of you familiar with the work of Ivan Illich will know that education can logically be considered as preparation for failure. The fact is that in national terms, educational institutions are designed to feed the needs of society. Thus, in a society where intellectual activities are accorded more status than manual, but where manual jobs greatly outnumber those requiring intellect, it is necessary to ensure that

---

**"...it is necessary to ensure that only a small minority of people finish their education feeling intellectually adequate."**

---

only a small minority of people finish their education feeling intellectually adequate. In order to achieve this end, examinations with a minority pass rate are held, and those who do not fall within the top twenty per cent or so are stamped 'failures'. Put simply, education is a subtle and apparently benign means of inducing people to accept their position within society.

Many young adults thus enter both manual and clerical jobs accepting that they are unlikely to be satisfying in any real sense, but nevertheless with an intense fear of the ultimate failure — unemployment. The middle class college student, with some sense of intellectual adequacy and personal confidence, will find long periods of unemployment much more acceptable than the individual whose dignity relies heavily upon being able to run a car and buy a round in the pub. Thus we are brought up to think of our status in society almost entirely in terms of the job we do.

This is even reflected in linguistics; when asked "what do you do?" the words "for a living" are immediately implied, and one describes a job. If you were jobless you might say "I'm unemployed at present but..."; you would be unlikely to say "I look for a job one day a week, play basketball, read science fiction books and newspapers, go for walks and make love to my wife". Thus although many people are presently unable to accept unemployment — in the conventional sense — this is clearly a result of learning rather than any innate predisposition towards "employment" as such. It should therefore be possible, through

changes in education and parental attitudes, to produce a situation where members of society are capable of achieving a high degree of personal satisfaction, regardless of their source of income.

But what about the profit motive, I hear you scream. Is not man really driven by greed, his career being merely an expression of an overwhelming desire to own more than his neighbour? How can we distribute wealth in a way which will satisfy this inner need without some kind of capitalist employment structure? Isn't the alternative a totalitarian state where nobody is really satisfied? True, one doesn't have to look far for confirmation of the intrinsic nastiness of human nature, and it would be foolish to suggest that this could change overnight, if at all.

Nevertheless, I cannot accept that mankind is incapable of achieving a higher degree of social awareness, or of maintaining a more egalitarian and humanistic social structure. Social evolution, which has long since superseded biological evolution as the major instrument of change in man, is difficult enough to understand — let alone control. The so called 'profit motive' is just one aspect of the complex relationship between the individual and his society which must be understood if we are to survive the hazardous future ahead of us.

I am not alone in the belief that we are entering a period of social change as dramatic and pervasive as the industrial revolution. This change will affect us all whether we choose to have any control over it or not. As individuals we can avoid the issue (and the headaches) by taking the view of Ron Condon (Editor of *Data Link*) that: "... as for the future, well, let it look after itself as it is so unpredictable anyway..."

I am sure, however, that many of you, feeling as I do, both excited and terrified by the social implications of information technology, will agree that we must at least attempt to direct the course of events if we are to avoid a catastrophic outcome. I am convinced that if we ignore the problems we will face inevitable social collapse and/or totalitarianism.

I have covered only a few of the most obvious points, and clearly there is much ground to be explored before any realistic plans can be made. Those of us already involved will have to carry the discussion across to the general public. Social change can only come from the people, since controlling bodies are, by their very nature, concerned only with social maintenance. Do you want your future to remain in their hands?

Dick Granby, Fitzrovia, London

---

## Grow your own

From the way microcomputer hardware is sold these days you'd think that

round every corner there were large forests of software trees tended by 'green fingered' programmers. In fact there's more likely to be giant sized briar patches tended by Weed Killer manufacturers.

"If we could only find skilled workers we could double our growth rate over the next four years".

"We've been looking for skilled workers for the past two years with no success".

These two comments were made by two exporters during recent television programs on the Malaise of British Industry.

It is, I suppose, a small comfort to see that the computer industry makes the same mistakes as the rest of British Industry. If you read the computer press, almost weekly you will see an article or letter bemoaning the 'lack of experienced programmers'. In fact, if you look at the job advertisements you see more and more companies offering larger and larger salaries to proportionally fewer and fewer programmers. On the other hand, one noticeable omission from the job advertisements is vacancies for trainee programmers. On those rare occasions when they do appear the response is normally overwhelming (one company reported 700 replies to one such advertisement).

As you can see our 'big' brothers in the mainframe business have already got a serious staff shortfall, (by the end of 1980 it is predicted that this shortfall will have reached 70% of the total requirements).

What are the prospects in micros?

**One noticeable omission from the job advertisements is vacancies for trainee programmers. On the rare occasions when they do appear, the response is normally overwhelming.**

Let's look at the numbers first: in 1978 the average monthly sales volume of microcomputers was larger than the total worldwide number of all computers installed before that year. This fact alone seems to indicate that microcomputers are already in a disaster situation. So what can be done about it.

Solutions to the software problem, available now, are to either use standard packages or to custom build.

The package approach is the one

which seems to have been adopted as 'standard'. Every month we see in the microcomputer press ever increasing numbers of software houses advertising ever increasing numbers of 'standard' packages. The problems associated with this are:

1. It gets increasingly difficult for small companies to evaluate these products. Many of the products on offer are poorly documented and little indication is given of their scope.

2. No joint standards have been agreed between software houses. So even if you get a package which meets your functional requirements it will need *customising* to interface with products from other software houses.

3. The products on offer are all *generalised* and in most cases, therefore, demand that you change your business to meet the requirements of the software rather than changing the software to meet your business needs.

The custom build approach would seem to be ideal since you will get exactly what you ask for. The problems associated with this approach are:

1. The obvious problem of the small number of programmers available.

2. The high cost of programmers. They usually cost between £5 and £10 per hour, so a customised system could turn out as much as 6 or 8 times the cost of the hardware.

3. Programmers know a lot about programming but they don't necessarily know about your business.

In my view the only satisfactory answer to the growing software problem is to combine both of these approaches. What is needed is industry specialisation. You, the businessman, bring your knowledge of your industry and its problems; the programmer brings his knowledge of computers. Together you provide an ideal combination which will lead to a standard package approach, but, since the package is specific to one industry, it is likely to meet the requirements of most companies in that industry. Obviously no two companies are exactly the same so some customisation is always going to be needed, although, only to a small degree. In addition, the cost of producing an industry standard package is offset by the higher likely demand for that product in that particular industry.

This all sounds ideal, but some of you will have noticed the slight flaw in my argument. I started by saying that we have a major shortfall in programming resource; how can this be overcome?

Well, the answer is in your own hands. It takes two years to develop a good programmer but programmers can be productive after six months. The answer then is to train your 'industry' knowledgeable staff to be programmers. The better software houses usually run training schemes (e.g. 'BASIC' programming courses) usually lasting 3-5 days and costing approximately £50 per day (a lot of this 'expense' can be recouped from your own industry training board). These courses will enable you to provide your own programming, although they

will need some direction. Once again, the better software houses should offer consultancy services so that the initial system design and program specification can be done by computer professionals with the bulk of the programming being done by your own staff. In addition, the same software house would probably undertake the marketing of the finished 'industry package' for you.

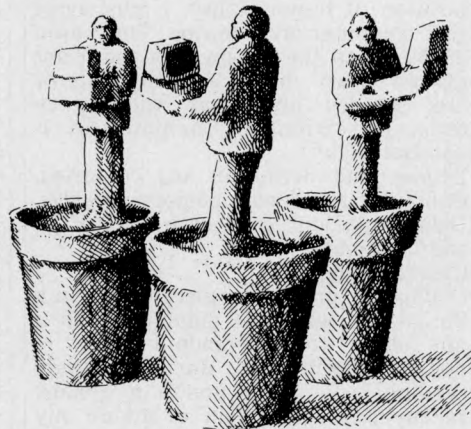

Illustrations by Ingram Pinn

In conclusion, one thing is certain — if you just sit there and do nothing the problem will not go away, it will just get bigger.

Mike Rose, Croydon

## Micro-mania revisited

I would like to challenge Mr Smith's view of personal computing in PCW volume 2 Issue 5, Interrupt column.

Mr Smith — I think you missed the whole point of the hobby. I would like you to show us the magazine or newspaper in which such fantastic claims were made for it. Or did you make them up for rhetorical effect? Because there is no hobby which can truthfully profess to fulfil any of your 'claims'.

Are you addicted, bored, dehumanised? Moreover, are you unable to justify . . . etc? Surely you had some reason for buying yours in the first place, some motivation? Or did you get it because it was the latest executive toy? Anyone who buys anything for such a reason deserves to be bored out of his/her tiny mind.

I am one of the genuinely poor people who cannot afford even the meanest computer kit. But already I have tens, even hundreds of ideas for my dream machine. None of them involves commercial equipment or software. The only reason I haven't tried to contribute to PCW is that I have not had the equipment to debug my ideas, and I doubt that the editor would enjoy reading any bug-riddled script, however valuable the core material.

As for your intro, we don't think of personal computers as liberating us in any sense. However the microprocessor *will* liberate a large proportion of the population, for a large proportion of their week, from the drudgery of work — whether in the typing pool or on a production line. Thus liberated there will have to be a cultural and educa-

## INTERRUPT

tional renaissance, in which personal computers could play a great part.

The pocket computer you describe will follow the development of the plasma screen or else the ultra miniaturisation of existing LED/LCD screens. Whether Woolworths will sell them is a matter of speculation.

The only requirement for the 'mental annihilation' you talk about is a weak, even sick mind. No such mind could insinuate its owner into any position of responsibility. I must agree that computer art is boring. The reason is similar to the reason why musicians disdain 'disco' music, as being more or less speeded up Musak with heavy drums/bass overlaid. Computer art is constrained by:

Display and definition and colouring.  
Computer speed and memory capacity.  
Display medium; most have just a VDU and/or printer

Character graphics.

Could you produce a piece of art on a 25x40 grid with PET graphics which is not either totally random (sorry - pseudorandom) or documentatively symbolic? If so - you're a genius! In any case, judgement of art on any basis other than technical exactness has to be subjective. Similarly 'disco' music is constrained to a dominant beat surrounded in time by audible-but-not-too-distractingly-brilliant music.

Lastly to your question about defence spending. The only way this could be stopped is by multilateral agreement, which would in turn be followed by multilateral distrust, and by a surge in spending on surveillance techniques, and secretion techniques. In any case, suppose some goodly invention does come from defence research; that is, an invention which, had it been sought from any other point on the 'knowledge map', would have had minimal chance of being found without a huge amount of extra expenditure? The ultimate aim of a scientific explorer is not as significant as the route taken and what he finds on the way. Example: The whole 'space race' was sparked off by military interest. Why don't you send for a catalogue of the valuable spinoffs that produced?

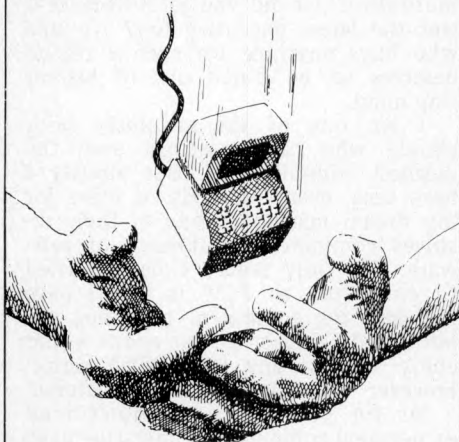

If you ever decide to drop your machine from your window, inform me beforehand. I'll be there with a butterfly net, and I promise to decapitate the first new enthusiast I see who even nearly imitates your attitude.  
T. Magee, Bradford.

## SYSTEMS

*PCW already has the most authoritative and comprehensive guides in the UK for hardware - namely our Benchtest and In Store contributions. Now, building on this success, we are pleased to introduce Systems. The brief for this new, monthly feature will be to take a different business application each issue and to report on some of the software packages available around it. PCW's David Tebbutt and Mike Knight of Mike Rose Micros take up the explanation.*

Perhaps before looking at the fine detail of our approach for the future we should examine the reasons for introducing Systems.

You've probably seen or heard business packages described in glowing terms. They are said to be complete, comprehensive or total. Sometimes they are not described in any terms at all; sometimes they are described in terms which only the writer understands. Somehow the prospective buyer must decide from this morass of inadequate information, which packages to consider buying.

Nor do the problems end there. Having selected a few possible packages, the potential buyer needs to know quite a lot more before making any final decision.

Is it well documented, for example? We can barely believe some of the apologies produced in the name of documentation. It can be inadequate in a number of ways. First of all it may simply not exist. . . not even instructions for operating the machine! Secondly, yes, it may exist, but in such a form as to be totally unintelligible to mere mortals - not to mention the prospective buyer/user. Thirdly, it may exist, but only in parts. The missing sections are usually the ones you need when you're burning the midnight oil and all the 'experts' are fast asleep in bed.

An exaggeration? In many cases we think not, although we have to point out that some companies do produce quite excellent documentation.

And here's something else to think about - bugs. What are bugs? .. well, in common parlance, they are errors existing in the application package which cause it to go wrong from time to time. Of course, ideally, one would like any problems resolved on the spot - time, after all, can be expensive. Here the difficulty may be that the firm from which you bought the package no longer exists. Perhaps (more likely) they aren't too interested, or don't have the staff to tackle any bugs. Again we don't want to paint an unduly miserable and pessimistic picture, but these are very serious matters and they need to be considered before any money is exchanged

for software. For the businessman it could mean his business crashing down alongside the programs.

Okay, enough of the horror stories, time now to take a look at some constructive action.

Each month when we report on a particular application area, the feature will be divided into the following sections:

Objectives

Tasks and volumes

Evaluations

Comparisons

New products

Let's look at each of these in turn.

### Objectives

In this section we shall define the objectives of the application. We shall also describe the application and explain any relationship with other applications. Failure to be very clear about objectives will lead any investigation to likely failure.

Taking 'payroll' as an example, we might describe the overall objective as 'to pay employees the amount due on time and to meet statutory requirements'. Then we might describe the application as follows:

- 1 Capturing information upon which payment will be based.
- 2 Using this information to calculate net payment.
- 3 Maintaining records of payments to each employee.
- 4 Producing appropriate documentation for company, employee and government records.

Finally, we might define the relationship with other applications as: 'information gathering - possibly the product of production hours recording. The payroll application will almost certainly create "transactions" for the accounting function'.

### Tasks and volumes

In this section we shall select, say, three packages and match them against the tasks to be performed. Staying with our payroll example, we might say something like this:

"Not only will this give a guide to three particular packages, it will also offer a framework against

# SYSTEMS

Tasks:	Package	A	B	C
Create employee records		●	●	●
Delete (suspend) leavers			●	
Maintain existing records		●	●	●
Build up to gross		●		
Gross to nett			●	●
Print payslips		●	●	●
payroll		●	●	●
cash analysis			●	
cheques or credit transfers		●		
bank reconciliation		●		
NI stamp analysis		●	●	●
Update employee records		●	●	●
Prepare P60s				●
Produce accounting transactions etc.		●		
<b>Maximum Volume/sizes:</b>				
Employee records		400	250	600
Record size		180ch	360ch	200ch

which to measure other packages of your choosing.”

## Evaluations

In this section we shall again focus attention on the selected packages. This part of the feature will be written as a structured narrative, describing each package in turn. The main elements are as follows.

- Availability
- Documentation
- System content
- System maintenance
- Costs
- Hardware required
- Support and training
- User comments

*Availability* covers number of suppliers, their distribution and whether the product is available ‘off the shelf’.

*Documentation* describes the scope, content and quality of the manuals and guides supplied.

*System content* will describe the programs involved in the package, their functions and certain aspects of their operation. For example, it may be that each program, on conclusion, automatically loads the next in sequence. On the other hand, there may be a need for a lot of disc or tape changing during the operation. We will try to give a picture of what will be involved in the day to day running of the system.

*System maintenance.* We shall be interested in whether the system has been designed to be changed easily. Examples which spring to mind are tax rates and discount terms. We shall also see if customisation is easy. Some packages are written with ‘hooks’ to enable customised routines to be added fairly simply. The language used is also important here. Finally, we shall check out who you have to go to to have these changes made.

*Costs* need little explanation. We shall give the costs for various versions of the package and, if applicable, the cost of any maintenance agreements.

*Hardware required.* We shall describe the different hardware configurations and relate these to the volumes which can be handled by each. We shall also give a guide to the hardware costs.

*Support and training.* If either of these areas are neglected, it’s likely that you’ll end up very disappointed with your new system. Training should, at the very least, teach you how to operate the system. Support is the on-going advice and guidance you will get from the supplier. It also covers their response to any problem you may encounter — a hardware fault, a software fault or perhaps an accident such as over-writing some important files. We shall assess the

services offered.

*User comments.* We shall contact users of each system and summarise their opinions and experience of the package.

## Comparisons

This section comprises a straightforward comparison chart showing all the packages notified to PCW, for the application in question. Each will be evaluated against the criteria discussed in this article. Because we cannot do an in-depth analysis of every package, this information will be based on that made available by the suppliers. If the publicity documentation fails to mention something, we shall not make assumptions and the column shall be marked N/A — not applicable.

## New products

Finally, and quite separately to the above, we shall provide information on any packages newly notified, for application areas already covered.

We’re sure that this structured approach to package evaluation will help readers in the selection of their business software. There are a lot of good and reliable suppliers of these products in the field, all of whom will give sound advice. But this series of articles, as much as anything, should help clarify your own thoughts on what can be a rather tricky subject.

*From time to time, PCW publishes business case studies. This involves spending a few hours with a user of a computer and chatting through their experiences. Last month, you will recall, we featured a betting shop system. If you would like to tell the world about your system, be it a standard package or custom-built, then please get in touch — other people’s successes (and failures) may offer invaluable information to businessmen working in similar areas.*

PASCAL... continued from P.76

The coding for this procedure appears in Box 15. The entire program can now be gathered together, incorporating the extra global variables (INTERESTRATE and YEARS) into the declaration part of the first attempt (Box 10) and filling out the details of the different procedures as they have subsequently been designed.

### EXERCISE:

Adapt REPAYMENTS to produce a

table showing the 15 year, 20 year, 25 year and 30 year monthly repayment figures for a given range of loans. The input should be the interest rate and range of loans (and *not* the loan period) and the output should be a table with 5 columns — one for the amount of the loan and one each for each repayment period.

## Conclusion

Loops control the repetition of a set of

statements within a program. Every language needs a loop — PASCAL has three, which enriches the language and makes it versatile. Loops can be distinguished by the type and position of the loop test relative to the loop body.

Just as a program can be built up from basic blocks into an ordered structure, so can the data on which the program operates be organised into efficient and powerful *data structures*. The next chapter will serve as an introduction to these.

# BUGGING THE 6800

*This article presents a monitor program developed by John Moore for the 77-68 system (described in PCW vol. 1 issue 1). This is a very flexible computer system sponsored by the Amateur Computer Club and designed for home construction. It uses the Motorola MC6800 processor for which there is a wealth of readily available cheap and sometimes free software of good quality.*

*The 77-68 hardware is usually configured with an interrupt driven parallel keyboard, and a memory mapped VDU with a Teletext compatible 24x40 format of upper and lower case characters. Users of other 6800 systems may also find ideas in this program that could be of use to them*

For those unfamiliar with machine code programming and debugging, or the function of monitors, a little explanation may be in order. A monitor serves three main purposes:

1. It includes routines to give the computer access to the outside world through input/output devices such as keyboards, VDUs and printers.
2. It is used as the executive or operating system to allow the user to run his own applications programs. For example it might support a BASIC interpreter which in turn runs user programs written in the BASIC language. Some monitors can support more than one user program simultaneously.
3. Used for machine code program development, it allows the operator to examine and alter memory contents one by one, to run sample programs, and generally to get them into working order.

Usually monitors are held in ROM so that they are available and running as soon as the computer is started. This particular one is unusual in that after switch on it has to be loaded from tape into a hardware determined 1K byte block of memory (address FC00 - FFFF).

Although this is inconvenient it only takes 5 seconds at 2400 Baud, and it does allow for easy program modification to

meet changing requirements. The 1K byte limitation meant there had to be some compromise between the three re-

quirements outlined above so, if anything, the emphasis was in favour of program development capabilities. In particular MIKBUG, the original standard Motorola 512 byte monitor, and similar related variations do not support modern I/O systems and have only slow and limited debugging facilities.

## MIKBUG™ Compatibility

The monitor described here retains a good number of MIKBUG compatible subroutines and although their coding and locations are different they do achieve the same end results. The following are included:

1. CONTROL, the normal re-entry point.
2. Output to VDU: OUT2H, OUTHL, OUTHR, OUT4HS, OUT2HS, OUTS, and OUTEEE. (Note that PDATA could not be squeezed in, but commercially available software usually has it built in).
3. Input: BADDR, BYTE, INHEX, INEEE. All these operate from keyboard or tape, so that a MIKBUG format tape can be loaded, if necessary, by use of a short routine relying heavily on the monitor.

## Input/Output

Looking at the program

```

0000 00 00 00 00 00 00 00 00 00 00 00 00
000C 00 00 00 00 00 00 00 00 00 00 00 00
0018 00 00 00 00 00 00 00 00 00 00 00 00
0024 00 00 00 00 00 00 00 00 00 00 00 00
0030 00 00 00 00 00 00 00 00 00 00 00 00
003C 00 00 00 00 00 00 00 00 00 00 00 00
0048 00 00 00 00 00 00 00 00 00 00 00 00
0054 00 00 00 00 00 00 00 00 00 00 00 00
0060 00 00 00 00 00 00 00 00 00 00 00 00
006C 00 00 00 00 00 00 00 00 00 00 00 00
0078 8E F0 80 4F 06 5F 86 55 8D 03 7E FE
0084 85 36 86 04 4A 26 FD 32 39 00 00 00
0090 00 00 00 00 00 00 00 00 00 00 00 00
009C 00 00 00 00 00 00 00 00 00 00 00 00
00A8 00 00 00 00 00 00 00 00 00 00 00 00
00B4 00 00 00 00 00 00 00 00 00 00 00 00
00C0 00 00 00 00 00 00 00 00 00 00 00 00
00CC 00 00 00 00 00 00 00 00 00 00 00 00
00D8 00 00 00 00 00 00 00 00 00 00 00 00
00E4 00 00 00 00 00 00 00 00 00 00 00 00
00F0 00 00 00 00 00 00 00 00 00 00 00 00
00FC 00 00 00 00 00 00 00 00 00 00 00 00
0108 00 00 00 00 00 00 00 00 00 00 00 00
17FF
  
```

1. Example of the display while using the Edit function. The simple program shown is as follows:

0078	8E	F080	LDS £F080
007B	4F		CLRA
007C	06		TAP
007D	5F		CLRB
007E	86	55	LDAA £\$55
0080	8D	03	BSR DELAY
0082	7E	FE85	JMP CONTROL
0085	36		PSHA
0086	86	04	LDAA £04
0088	4A		DECA
0089	26	FD	BNE \$1
008B	32		PULA
008C	39		RTS

The pointer is at location 007E.

listing, the section from FEF8 to FFDD is the VDU driver. As most of it has been described before in the ACC news it will not be covered again in detail. The reason for it being so long (230 bytes) is that the 24x40 format is not simply divisible by binary numbers, and therefore some calculation is necessary. The HOME routine can be used at any time, even when a user program is running, because it is called by a keyboard interrupt (see FED0) and and it is transparent, i.e. it saves and restores all registers that it uses so as not to disturb the user program.

The selections from FEB9 to FEBD and FEF4 to FEF7 handle the keyboard input. Its simplicity shows one of the advantages of using an interrupt driven keyboard. FEC8 to FEF3 handles the non-maskable interrupt itself, having been called by the vector at FFFC. The ability to break into a user program and escape from it (e.g. if stuck in a loop) is the other advantage of an interrupt driven system. The rather fiddly bit from FED9 to FEED (19 bytes) is necessary to cater for the situation where a user program has stopped at a WAI instruction, to await a keyboard input. Press the Home key; after homing the screen, it re-establishes the WAI condition, (without that the user program would press on regardless).

## Commands

To use the monitor for program development, commands are entered at the keyboard and decoded by FE8F to FEA5. In this case, the use of a keyed jump table is more efficient than successive comparison with a list of characters. It also allows easy modification and expansion; in fact, space has been left at FFF3 to FFF6 for the inclusion of your own defined command. This could even be a prefix to a whole group of commands, contained in another area of memory.

The following are available in this monitor:

**G XXXX** Go to user program at address XXXX. The user program runs in a stack whose pointer is extracted from TGTSTK (FOFA in the scratchpad RAM). After a system reset the stack will be from FOE0 down to F0DA, but after escaping from a user program this value could be indeterminate. It is thus good practice to make sure that your own programs set their stack pointer at an early stage.

**C** Continue from an escaped point in a program. This will only work properly if the target stack has been initialised to some area not used by the monitor (try LDS £\$F080 for example).

**L XXXX** Loads a binary tape into memory from address XXXX. In this mode the test of the data register switches at FEB9 is bypassed and their position is immaterial. When the tape has finished it is necessary to use the Escape key to return to CONTROL.

**D XXXX YYYY** Dump a binary tape from address XXXX to address YYYY. This routine can be used to dump any area of memory including the monitor itself. The program starts at FE13 by calling INADDS, a useful subroutine to get a pair of addresses from the keyboard. When the dump is finished it returns to CONTROL.

**E XXXX YYYY** Edit a block of memory from XXXX to YYYY. This routine is one of the central features of the monitor. It displays on the screen the first 276 bytes of memory contents starting from XXXX. The format is 23 lines and each contains the address at the start of line and 12 bytes of memory. A cursor, which is initialised to the first byte in the top left hand corner, points to one of the locations and may be moved left, right, up or down by the keys ←, →, ↑, and C/R. The byte

pointed to may be overwritten simply by typing the new value. Bytes can be removed by typing "R" or inserted by typing "I" followed by the new value.

In both cases, the succeeding memory contents close up or move out as necessary up to the end address (initially YYYY). The new end address is displayed for reference at the bottom of the screen. This system allows fast and easy interactive editing of machine code in small or large chunks. In the process it does away with the need for a number of separate commands to manipulate memory contents. The edit routine runs from FC5B to FCE1; it uses the MEMPRINT subroutine at FC20 to FC5A to print the display. It should be exited by typing a non-hex character, such as a space.

**M XXXX YYYY ZZZZ** Block move of memory from XXXX to YYYY

to a new area starting at ZZZZ. It is not necessary for the user to calculate the length of the block in advance. If desired, the effect of the move can be checked afterwards, with the Edit command. This routine (FDEA-FE04) is short and fast because it uses the stack pointer as a data counter in the absence of a second index register on the MC6800. You cannot, of course, move a block forwards to a new area which overlaps the old one. . . it will overwrite itself. In this case you have to move it first to a spare area and then to its destination.

**T WWWX XXXX YYYY ZZZZ** This is a software single step and trace routine that provides a powerful debugging tool. It traces a target program WWWX to XXXX, starting at instruction address ZZZZ. It needs a spare block of memory which you define to start at

0078	8E	F080	F9	FF	FF	FFFF	F080
0078	4F		F4	FF	00	FFFF	F080
007C	06		C0	FF	00	FFFF	F080
007D	5F		C4	00	00	FFFF	F080
007E	30		C4	00	00	F081	F080
007F	86	55	C0	00	55	F081	F080
0081	8D	03	C0	00	55	F081	F07E
0086	36		C0	00	55	F081	F07D
0087	86	04	C0	00	04	F081	F07D
0089	4A		C0	00	03	F081	F07D
008A	26	FD	C0	00	03	F081	F07D
0089	4A		C0	00	02	F081	F07D
008A	26	FD	C0	00	02	F081	F07D
0089	4A		C0	00	01	F081	F07D
008A	26	FD	C0	00	01	F081	F07D
0089	4A		C4	00	00	F081	F07D
008A	26	FD	C4	00	00	F081	F07D
008C	32		C4	00	55	F081	F07E
008D	39		C4	00	55	F081	F080
0083	7E	FE85					

2. An extra byte (30=TSX) has been inserted at 007E and then the program run in the single step and trace mode. The order of the columns is: address, opcode, operand if any, condition codes register (CCR), B,A,X,SP. Note the movement of the stack pointer on entering and leaving the subroutine and the further movement when pushing and pulling data onto the stack; also how the Z (=Zero) bit 2 of the CCR is set at 0089 when A has been finally decremented to zero. Details like these of the internal workings of the processor are clearly demonstrated by this sort of display.

YYYY and must be of the same length as the target. Any areas of data must be excluded from both and left intact as they are used by both the target program and the trace routine (or "host" program).

To understand how this routine works you should know that manual debugging of a user program uses the software interrupt (SWI, opcode 3F) as a breakpoint. The SWI is placed at a strategic point in the target so that, when the program gets to it, it responds to the artificial interrupt by dumping the processor registers on the stack and jumping to the address contained at FFFA. It is then possible manually to examine the stack to see what was happening at this point. There are some problems with this approach:

1. The program may never get to the SWI. You can counter this by placing several SWIs in different likely places in the hope of hitting one of them.

2. The process of substituting bytes of target with SWIs, remembering them, and replacing them afterwards is tedious and prone to error.

3. The whole business takes a long time and a lot of mental effort.

The solution adopted here is to extend this method to its logical conclusion by filling the whole of the target program, except for the instruction being executed, with SWIs. Whatever the instruction does it should now hit an SWI next. If it should jump right out of the target program this will be obvious from the display, so you will at least have located the problem instruction.

The trace, starting at FDOF, sets its own SP at FOCF, and the target's at FOB8 (to allow the target to run in an independent stack right from the start, and both target and host to be independent of the monitor stack). As soon as (or if) the target sets its own SP, this is used from then on. At FD32 the host calls the Transfer

routine to save a copy of the target in the area from YYYY, and to fill the original with SWIs. At FD37 it starts a line by line print by displaying the first instruction address. From FD48 to FD74 it measures the length of the instruction (1, 2 or 3 bytes), then displays it. At FDA7 the program waits for the single step command from the keyboard (→) and at FDB2 it executes the one instruction. Usually an SWI will be encountered next which will vector to FDB9 and fill the rest of the display line with the resulting register contents for your information. At FDE1 Transfer again prepares the target area and the program then loops round to the start again and waits for the next single step command.

The result is a line by line trace of the program flow that shows exactly what happens at each step. Apart from its diagnostic use this is a first rate educational tool for showing the internal workings of the micro-processor.

If the target gets into a long loop (e.g. a timing loop) you can skip to the end as follows:

1. Press the Escape key once. Do not press it again while you are temporarily out of the trace routine.

2. Knowing from the display where the target SP is, use the Edit command to examine the 7 bytes below it. These correspond to the CCR, B, A, X, and PC registers. You can then modify the CCR, B, A, and X registers (but not the PC) as necessary to shorten the loop. Press the space bar to leave Edit.

3. Alternatively you can modify areas of data in memory in the same way.

4. Press the continue key (←) to return to the Trace routine.

The only types of program that cannot be handled by the Trace are those with self modifying code or those with areas of data and program intermingled.

When you have finished, it is necessary to use the Move command to

shift the program copy from YYYY back to WWWW.

## Conclusion

This monitor has been in use for about six months now and has made it possible to tackle programs like 8K BASIC, study them and modify them to run on the 77-68 without too much difficulty. If you have more than 1K available for your monitor I suggest the following inclusions:

1. Automatic return of a traced program to its original location when finished.
2. Automatic decoding and display of the individual CCR flags during Trace.
3. Addition of the MIKBUG PDATA routine.
4. Inclusion of more

sophisticated tape dump and load formats with file names and error checking before transfer from a buffer to storage, unlike MIKBUG which loads each block first and then checks the address and data to see if it got it right!

5. An even bigger Edit display if you have a bigger VDU format.

6. Software vectoring of interrupts to allow more than one interrupt driven peripheral at a time, and also multi-programming.

Finally, may I add that suggestions for improvement of the existing monitor will always be welcome.

Copies of the monitor are available on 2708 EPROM at £14.10 + VAT. Contact John at 1 The Spinney, Fleet, Hants. Telephone: 02514 29553.

## Program

FC00	A6 00	OUT2H	LDAA X	
FC02	8D 05		BSR OUTHL	
FC04	A6 00		LDAA X	
FC06	08		INX	
FC07	20 04		BRA OUTHR	
FC09	44 44	OUTH	LSRA x 2	
FC0B	44 44		LSRA x 2	
FC0D	84 0F	OUTHR	ANDA £%00001111	
FC0F	8B 90		ADDA £\$90	Allison's algorithm - saves 2 bytes & average of 2 1/2 cycles per character
FC11	19		DAA	
FC12	89 40		ADCA £\$40	
FC14	19		DAA	
FC15	7E FE F8	OUTCH	JMP OUTEEE	
FC18	8D E6	OUT4HS	BSR OUT2H	
FC1A	8D E4	OUT2HS	BSR OUT2H	
FC1C	86 20	OUTS	LDAA £'space	
FC1E	20 F5		BRA OUTCH	
FC20	8D FF 1C	MEMPRINT	JSR HOME	
FC23	FE F0 F1		LDX STARTING	
FC26	FF F0 F6		STX TEMPX	
FC29	C6 17		LDAB £\$17	page length
FC2B	37	NEWLINE	PSHB	
FC2C	CE F0 F6		LDX £TEMPX	
FC2F	C6 0C		LDAB £\$0C	line length
FC31	8D CD		BSR OUT2H	
FC33	8D CB		BSR OUT2H	Print address
FC35	FE F0 F6		LDX TEMPX	
FC38	8C F0 EF	NEWBYTE	CPX MEMLOC	
FC3B	26 06		BNE MEM1	Print pointer against the byte
FC3D	86 5D		LDAA £' >	
FC3F	8D D4		BSR OUTCH	
FC41	20 02		BRA MEM2	
FC43	8D D7	MEM1	BSR OUTS	
FC45	8D B9	MEM2	BSR OUT2H	
FC47	5A		DEC B	
FC48	26 EE		BNE NEWBYTE	
FC4A	FF F0 F6		STX TEMPX	
FC4D	33		PULB	
FC4E	5A		DEC B	
FC4F	26 DA		BNE NEWLINE	
FC51	86 3C		LDAA £' >	
FC53	8D C0		BSR OUTCH	
FC55	CE F0 F3		LDX £ENDING	Print end address
FC58	8D BE		BSR OUT4HS	End of MEMPRINT
FC5A	39		RTS	
FC5B	8D FE 05	EDIT	JSR INADDS	
FC5E	8D C0	ED6	BSR MEMPRINT	
FC60	3E		WAIT	Get keyboard command
FC61	86 F0 FE		LDAA KBUFF2	
FC64	FE F0 EF		LDX MEMLOC	
FC67	81 5D		CMPA £' >	Cursor right?
FC69	26 03		BNE ED1	
FC6B	08		INX	
FC6C	20 2D		BRA ED2	
FC6E	81 5B	ED1	CMPA £' <	Cursor left?
FC70	26 03		BNE ED3	
FC72	09		DEX	
FC73	20 26		BRA ED2	
FC75	81 0D	ED3	CMPA £' >	Cursor down?
FC77	26 0F		BNE ED4	
FC79	86 F0 FU		LDAA MEMLOC LOW	
FC7C	8B 0C		ADDA £\$0C	
FC7E	B7 F0 F0		STAA MEMLOC LOW	
FC81	24 03		BCC ED5	
FC83	7C F0 EF		INC MEMLOC HIGH	
FC86	20 D6	ED5	BRA DE	
FC88	81 5E	ED4	CMPA £' >	Cursor up?
FC8A	26 14		BNE ED7	
FC8C	86 F0 F0		LDAA MEMLOC LOW	
FC8F	80 0C		SUBA £\$0C	
FC91	B7 F0 F0		STAA MEMLOC LOW	
FC94	24 03		BCC ED8	
FC96	7A F0 EF		DEC MEMLOC HIGH	
FC9B	20 C3	ED8	BRA ED6	
FC9D	FF F0 EF	ED2	STX MEMLOC	
FC9E	20 BE		BRA ED6	
FCAD	81 49	ED7	CMPA £' I	Insert?
FCAD	26 19		BNE ED9	
FCAD	8D FE 55		JSR BYTE	
FCAD	FE F0 F3		LDX £ENDING	
FCAD	08		INX	
FCAD	FF F0 F3		STX £ENDING	
FCAD	09	ED10	DEX	



Dick Pountain analyses and reports on the micro-associated world of programmable calculators.

## GETTING IT TAPED

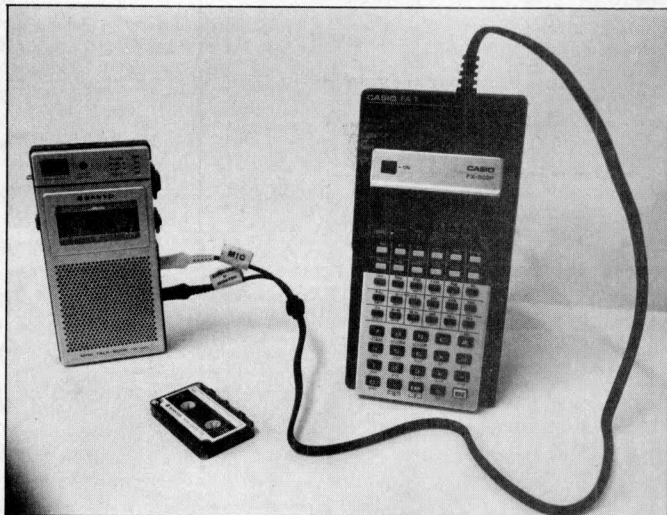

IN My glowing review of the Casio FX501/502P last month ("This one will run and run..."), I promised a follow up on the FA-1 adaptor. Here it is.

Tempus of Cambridge kindly supplied the adaptor and also exchanged the 501 for a 502 (which, as I suspected, is just like the 501, but more so).

The FA-1 is a small cradle into which the calculator slips, connecting via a gold plated, 7-pin socket. The cradle has a lead ending in two mini jack plugs which fit into the microphone and earphone sockets of a standard cassette recorder. Cassette radios, mono and stereo cassette decks and even mini cassette dictation machines will work. Some hi-fi cassette decks will require a 5-pin DIN plug to be substituted for the mini jacks.

Saving and loading are performed in the same manner as on a micro computer. The instruction SAVE is followed by a three digit file number, and is executed from the keyboard with the recorder running. Loading is by LOAD and the same file number. The calculator searches for the named file and displays, say, FP005 when a program file is found or F005 when a

data file is found.

For speed, it is best to first roughly locate the file using tape counter readings, but if necessary, the calculator will search a whole tape - displaying each file name as it passes, but loading only the designated one.

The maximum time for a LOAD is about 15 seconds... correspondingly shorter for smaller programs. Therefore a C-60 cassette can hold over 200 programs.

As alluded to earlier, program and data are stored in separate files, unlike most magnetic card calculators which store the whole program and data register contents on one card. The separate way is of much more use as the same program can be used with any number of different data sets. Also, execution of a program may be halted part-way through and a fresh data file loaded (manually, of course) which greatly increases the data handling facilities of the 502. In addition, the load instruction will fill all or any of the ten program registers. Therefore several different programs may be loaded into the machine simultaneously (size permitting), or parts of a large program may be loaded independently, or subroutines may be

stored on tape and added to existing programs in the machine.

I have used the adaptor with three different recorders including an 'electronic memo-pad' (which provides great portability) and found loading and saving very easy and reliable on all of them - provided the output volume is set as high as possible.

The FA-1 is also necessary for the music synthesizing function of the calculator, about which the less said the better. The world didn't need Rolf Harris and the Stylophone; it needs a robot Rolf Harris even less.

To summarise then, the Casio FX502P with the FA-1 and a mini cassette recorder provides a pocketable computing system which is in some ways unrivalled, even by the £150 plus Hewlett Packard and Texas machines, particularly in regard of ease of learning.

As a footnote, I must clarify a wrong impression my review last month may have given. I said that the 501/502 have only ten labels available for use in programs. Of course, since there are ten independent program registers, all ten labels may be used ten times over, if the program is broken down into modules (which is a habit the machine rapidly encourages). This gives a potential of 100 labels, which is quite sufficient.

### Master pack

Following on from the above, I have been informed by Premier Publications that they are launching the Master Pack, a software package for the Casios. It takes the form of a cassette containing over 160 programs and a 60 page manual which includes an introduction to programming, advanced programming, plus full program documentation. At press time I hadn't seen the whole

package, though extracts I have looked at from the manual suggest that it will be far superior to Casio's own User Manual. The programs include all of Casio's own library programs ready to load, plus a variety of educational, games and personal finance routines and general purpose subroutines for advanced programmers.

The pre-production sample contained some quite sophisticated games with ingenious use of the Casio's display formats, including one which scrolls a 10 by 10 field, line by line over the display. Another routine provides, via data packing techniques, the equivalent of 100 independent memories - each to store a single digit variable.

The Master Pack will be available from dealers after the middle of October and I shall report more fully when a production sample is available.

### Look sharp

A new pocket calculator from Sharp, the EL-5100, has reached me; although it won't interest PCW readers particularly, since it is not truly programmable, nevertheless it has some clever features which may give pointers to the future.

Immaculately presented in the inimitable Sharp fashion, it's distinguished from an ordinary scientific calculator by its unusually large LCD display. This display is alphanumeric (though only a part alphabet is provided).

When you enter a simple arithmetic calculation problem, the whole calculation is displayed, e.g.  $5.7 + 3.8 \times 6.4$ . On pressing = the answer is displayed. But more intriguing is the Algebraic Expression Mode. In this mode, algebraic expressions of any complexity may be written in stan-

Cont. on Page 93

# Four of a kind!

The most advanced VDU interface available at £88

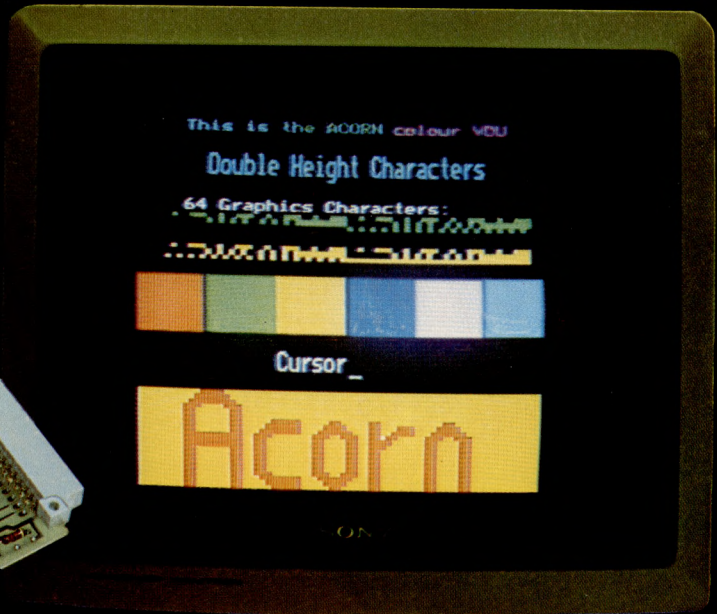
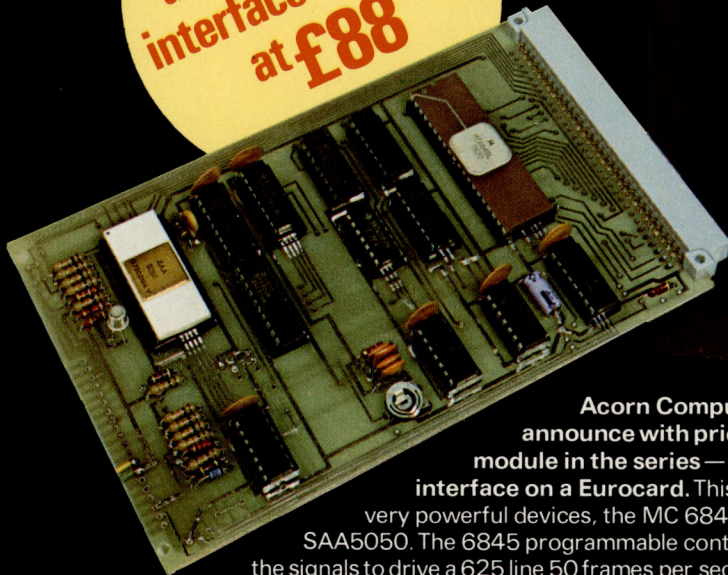

Acorn Computers announce with pride the fourth module in the series — a VDU interface on a Eurocard. This unit uses two

very powerful devices, the MC 6845 and the SAA5050. The 6845 programmable controller provides all the signals to drive a 625 line 50 frames per second VDU together with read addresses for the character RAM, the SAA5050 character generator then produces the necessary dot patterns to refresh the VDU. The SAA5050 produces standard teletext characters and graphics and has Red, Green and Blue outputs. This means that the Acorn system will be compatible with CEEFAX, ORACLE and PRESTEL transmissions.

The Acorn VDU module in kit form is complete with sockets and is supplied with listings for programs which set up the 6845, a miniature disassembler which displays 25 hex instructions (double or treble byte) and graphics programs. All these may be loaded and run using the Acorn system 1 monitor.

Options include:- VHF modulator for B.W. domestic T.V. and PAL colour encoder for domestic colour T.V.

- 40 characters per line
- 25 lines per page
- 5 colour graphics and characters
- Upper and lower ASCII
- Teletext graphics font
- Programmable cursor
- Hardware scroll
- Light pen facility
- Memory mapped
- Transparent access
- Single 5V supply

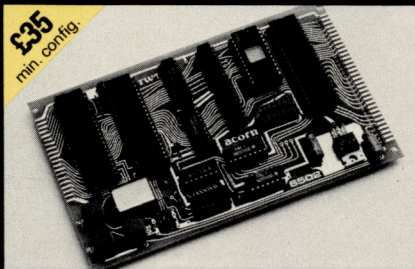

Acorn CPU

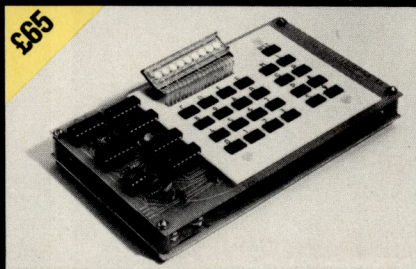

Acorn System 1

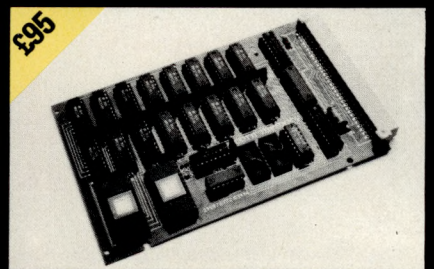

Acorn 8K Memory

**Order form** PCW 11

Send to: Acorn Computers Ltd., 4a Market Hill, Cambridge, Cambs.

<input type="checkbox"/> Acorn controller @ £35.00 plus VAT 5.25	_____
<input type="checkbox"/> Microcomputer @ £65.00 plus VAT 9.75	_____
<input type="checkbox"/> Assembled Microcomputer @ £79.00 plus VAT 11.85	_____
<input type="checkbox"/> Memory @ £95.00 plus VAT 14.25	_____
<input type="checkbox"/> Memory assembled @ £100.00 plus VAT 15.00	_____
<input type="checkbox"/> V.D.U. @ £88.00 plus VAT 13.20	_____
<input type="checkbox"/> V.D.U. assembled @ £98.00 plus VAT 14.70	_____
V.H.F. Modulator to be announced	_____
Colour Encoder to be announced	_____

Name \_\_\_\_\_

Address \_\_\_\_\_

**ACORN  
COMPUTER**

Acorn Computers Ltd., 4a Market Hill, Cambridge  
Telephone 0223 312772

FROM: KINGSTON COMPUTERS LIMITED.

TO: ALL PET OWNERS.

INFO: H.B. COMPUTERS  
ROBOX OFFICE EQUIPMENT  
STACK COMPUTER SERVICES  
TAYLOR WILSON SYSTEMS  
WEGO COMPUTERS

DATE: 15.10.79

REF: KC/PCW/9/1

KETTERING  
GLASGOW  
LIVERPOOL  
SOLIHULL  
SURREY

0536-83922.  
041-221-5401.  
051-924-1125.  
05645-6192.  
0883-49235.

HAVE PURCHASED 500 ADA 1200 RS232/IEEE INTERFACES  
AT UNBELIEVABLE PRICE — STOP — SUGGEST YOU RETAIL  
AT 65 POUNDS — STOP — WILL SUPPORT FULL ONE YEAR  
GUARANTEE — STOP — REGRET CANNOT REPEAT OFFER  
ONCE STOCK CLEARED.

REGARDS,

SANDRA V. OLIVER.  
SALES MANAGER.

KINGSTON COMPUTERS LTD.  
SCARBOROUGH HOUSE  
SCARBOROUGH ROAD  
BRIDLINGTON  
YO16 5NS  
0262-73036  
ONE OF THE DALE GROUP OF COMPANIES



# ON THE LINE

For almost a year now, David Hebditch in his 'On the Line' series has been expounding the basic concepts of using your personal computer to communicate with other systems over the public telephone network.



## HIGH-LEVEL PROTOCOLS

By the way of review, we have now explored the basic hardware and software mechanisms for interfacing personal computers to the public telephone network and for moving blocks of data between processors with a minimal level of error control.

This may well be adequate for most users to be able to establish simple point-to-point 'conversations'. However, in order to determine what to do with this capability it may be useful to return to base and consider our original ideas for the practical application of personal computer networking.

Let's forget (for the time being) the medium-term possibilities of using Prestel, Teletext and tele-

conferencing etc. The most practical (and useful) applications in the short-term are listed below.

1. **Conversations:** Simply sending messages between systems. The benefits of this are:

- a fast (and relatively cheap) way of sending someone a message - electronic mail?
- an effective way of using the telephone for deaf people.
- a means of setting-up calls for other purposes (see below)
- given the correct data link control, a basis for emulating a terminal for linking to another, larger computer (eg. a time-sharing service or data-base provider).

2. **Program Transfer**

- a means of swapping programs with another user.
- a means of sending the fixes to make the previous version of the program work.

It is technically feasible for software companies to use this as a method of distributing programs. Of course, the number of prospective customers with a communications capability needs to be big enough to make the investment on their part worthwhile and it may

be some time before this is achieved.

3. **File Transfer** is functionally very similar to program transfer but involves the shifting of data from one processor to another. This is more likely to be of use in a business system than in a domestic environment. For example, details of goods received at a warehouse could be transmitted to the order-processing computer for addition to the stock-on-hand file. The major difference between program transfer and file transfer is one of data format and this will be discussed later in the article.

I did consider including a category for interactive game-playing. The protocol required is, however, a function of the type of game involved. In the case of video games very little information needs to be sent (eg. the eight-bit value of a game-control) but it must be sent quickly (to avoid missing the ball!) In view of this and the relatively unimportant nature of the application, the use of a data link control with error handling would probably be too cumbersome. Other games like

## ANNOUNCING...THE PERSONAL COMPUTER NETWORK

The number of users with some form of communications capability has now reached a high enough level to justify the introduction of the 'Personal Computer Network'. The network will comprise a directory published in Personal Computer World (and periodically updated). The directory will include an entry for each reader who is interested in linking up to other enthusiasts and will list his name, telephone number, type of system, times available and applications. If you wish to partici-

pate, please complete the form below and send it to Personal Computer World.

During the Personal Computer World show, David Hebditch will be demonstrating data communications on a number of popular systems, including the Apple II, Pet and Nascom I. He will be available to provide assistance and answer any questions you may have about networking in general and the Personal Computer Network in particular.

Please register me as being interested in Personal Computer Networking.

I have the following type of communications interface:

I can transmit at the following speeds

Tick

110 bit/s   
300 bit/s   
1200 bit/s

I have a Post Office modem:

I use an acoustic coupler:

I can act as an originating station:

a receiving station:

both:

Other comments: \_\_\_\_\_

Date: \_\_\_\_\_

Signature: \_\_\_\_\_

Name: \_\_\_\_\_

Address: \_\_\_\_\_  
\_\_\_\_\_  
\_\_\_\_\_

Telephone No: \_\_\_\_\_

Computer System: \_\_\_\_\_  
\_\_\_\_\_

I do not yet have a communications interface, but would like to be kept informed of developments:

Tick

# 'We stock 20 different makes of computer. So our only vested interest is customer satisfaction'

*Bill Cannings, Managing Director*

Businesses can only improve their efficiency with computers if they buy exactly the right kind of equipment and software for their needs. The problem can be in matching their needs with what the market can supply at any one time.

At the Byte Shop and Computerland we have the widest range of computers available from any single source. We have deep-rooted systems know how going back over 10 years, so you get not only a refreshing breadth of choice, but also high level impartial advice from computer specialists on what to buy.

Our business is computers and only computers, so you will be talking to people who really understand their subject. Once you have taken the decision to visit us, you are already a good way towards choosing the right computer for your needs.

**Branches at:**

**Ilford**

426-428 Cranbrook Road,  
Gants Hill, Ilford, Essex IG2 6HW  
Tel. 01-554 2177

**London**

48 Tottenham Court Road,  
London W185 4TD  
Tel. 01-636 0647

**Birmingham**

94-96 Hurst Street,  
Birmingham B5 4TD  
Tel. 021-622 7149

**Nottingham**

92a Upper Parliament Street  
Nottingham NG1 6LF  
Tel. 0602 40576

**Manchester**

11 Gateway House,  
Piccadilly Station Approach,  
Manchester  
Tel. 061-236 4737

**Glasgow**

Magnet House  
Waterloo Street  
Glasgow  
Tel. 041-332 2468

**THE BYTE SHOP LTD**  
**COMPUTERLAND LTD**



# ON THE LINE

chess and simulations could be handled using the conversational mode. To cut a long story short, I don't think that any special protocol is needed for game-playing.

A major problem with the three modes identified above is that of transparency. This is caused by the transmission of characters in the text of a message which could be mistakenly identified at the receiving end as a data-link control character. For example if you sent ASCII ETX (3) in a message the receiver will treat this as the last character in the transmission and lose all the subsequent characters. The same thing could happen with EOT (4).

"Well", you might ask, "why do such a silly thing?" But it may be difficult to avoid. For example, in conversational mode, the user may inadvertently type a control-shift key which generates a protocol character. The solution here is relatively straight-forward; impose a rule which says that only displayable characters may be included in messages. This means that your dialogue control program must 'filter out' any illegal characters.

But what if you have to transmit the equivalent of a control character in a message? This could happen during the transmission of a program in object form, or of a data file containing integer values, or of a program in source form with 'funny' characters between the quotes in a PRINT statement.

The standard way of solving this problem is to employ some form of 'escape logic'. This involves the prefixing of each dubious character with ASCII ESC (27). This has to be inserted by the transmitting program and tells the receiving software that the next character is not really ETX (or whatever). The receiver will delete the ESC.

Now the smart guys amongst you are already asking, "What happens if you want to send 'ESC'?" Clearly a spurious ESC immediately prior to the real ETX will cause the ETX to be ignored. More problems. In this case, a further ESC prefix is also required and will cause the following ESC to be treated as a regular data character.

Phew! That's enough of escape logic. Now let's move on to the high level protocols (HLP) needed for the three application modes.

Byte No.	Name	Comments
0	Type	H: Handshake message D: Dialogue P: Program Transfer F: File Transfer etc.
1 - 3	Transmission Number	Sequential message number (incremented automatically by transmitting program)
4	Action code (Command/Response)	I: Initial transmission block S: Subsequent transmission block F: Final transmission block etc.
5 - 9	SPARE	(And anything else we can think of).

First of all, I have to make a disclaimer; there are no internationally agreed standards for HLP. Indeed there are no national standards, either. Whilst writing this article, I have a three-foot molehill on my desk of working papers from the various standards organizations (BSI, ISO, ECMA, CCITT, ANSI et al) as well as the manuals for many proprietary networking standards (IBM's SNA, Digital Equipment's DECnet and so on). I even have articles from BYTE and INTERFACE AGE describing the procedures used in the various US personal computer networks. And I plan to ignore them all.

The reasons are as follows:  
 1. They are too complicated.  
 2. Although we are talking about the establishment of a Personal Computer Network the network we are employing is the plain old telephone system rather than any sophisticated multi node grid, permanently interconnecting a large number of users. Only two processors will be connected at any one time.  
 3. Implementation of the HLP should be possible by the average home user.  
 4. Costs must be kept to a minimum.  
 5. Speed and reliability concerns are not so serious.  
 6. Which proposed 'standard' do we choose anyway?

Now having said all that, I would need an ego of enormous proportions to even consider that I might be able to come up with the definitive HLP for all future requirements. But as my ego is only of moderately large proportions (he says modestly) I am only going to suggest a possible protocol and then throw the floor open for discussion. In other words, we need a simple, minimal, easy to implement protocol with which we can play and experiment and

develop. HLP's are all based upon the use of a 'header' in each message which will contain all the necessary control information. A possible format is shown in Figure 1. The header occurs in every message of the exchange and comprises the following items: (Box 1). It is now necessary to consider how this header might be used for each mode. For example, I would suggest that the first message sent by each processor be a handshake message (Type 'H'). The action code would be set to 'I' and the transmission number to '001'. The data area might consist of:

- User name (20 bytes)
- Telephone number (15 bytes)
- System type (e.g. APPLE II 24 K) (20 bytes)

A handshake message must be received before any further communications can take place. At a later stage, a password might be incorporated in the message.

Immediately handshakes have been exchanged the system can enter dialogue mode to facilitate a conversation between the users. Subsequently, file or program transfer can be initiated.

We will look at these in more detail in another article. In the meantime, please send me your ideas and comments c/o The Editor, Personal Computer World.

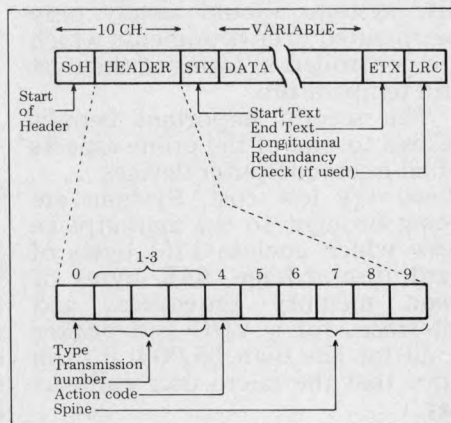

# HARD TIMES

## Winchester discs - secure or not?

*Comart Ltd. have just announced the Cromemco Z2H microcomputer system, incorporating a Winchester disc drive. David A. Broad, Managing Director and Chairman of Comart, gives a description of the device and presents some solutions to the data security problems imposed by it.*

The emergence of high capacity low-cost disc storage units housed in the physical space previously occupied by first generation floppy disc drives has opened up a whole new spectrum of applications for the small computer and intelligent controller. The technology of "Winchester" drives was first pioneered by IBM with their Piccolo fixed drive systems; they were designed to incorporate high reliability with high capacity. The essence of the concept is a disc pack fixed and spinning inside a sealed enclosure. Air within this enclosure is internally filtered by convection through a micro filter, with the effect that the disc drive has its own environment.

Another aspect of the Winchester concept is that the disc heads and carriage are of very low mass and inertia, allowing them to come within a very close proximity of the spinning disc surfaces. This results in a high sensitivity to flux changes which, in turn, enables a high storage capacity. Electronics are normally mounted outside the enclosure itself, to minimise dissipation and the necessity for access into it.

The concept of the fixed disc is particularly relevant to the microcomputer market. This is a market where the owner, operator and programmer of a computer system is often one and the same person and the environment that the system is intended to work in is that of a normal office, workshop or laboratory. Exchangeable disc systems should ideally only be operated in environments which are controlled in terms of the dust and temperature.

The second important benefit relates to one of the prime aspects of all microcomputer devices. . . . their very low cost. Systems are being brought to the marketplace now which enclose 11M bytes of hard disc storage, 64K bytes of main memory processors, and interfaces for a VDU and printer - all for less than £5,000; it's the price that the micro user wants to pay.

The other aspect is the very small size of the Winchester disc drives. They can be inserted in physical replacement of standard floppy drives and with very similar power supply requirements. Indeed their ability to work from DC supplies makes them not only very suitable for microcomputer applications, but also ideal for international use where there may be variations in mains frequencies and voltage. Of course the drives will find applications in the mini-computer industry and other types of small computer where low cost and compactness are desirable. But application areas will also open up in communications controllers, word processors and in other dedicated but intelligent devices where high capacity is required.

## Security aspects

One of the regular comments made on the fixed disc Winchester drives relates to their use in business applications. Here, the necessity exists for protecting and backing up the data in the event of a catastrophic failure and, indeed, advice is often sought from the suppliers on the best way for a customer to approach this problem.

---

**".. the necessity exists for protecting and backing up the data in the event of a catastrophic failure.."**

---

Let us first, however, consider the nature of the problem in relation to the design of the drives. Firstly, because of the light head mechanism and loading techniques, consideration of 'head crashes' is of lesser concern. The media itself is lubricated and in certain circum-

stances the heads will come in contact with the media (for example during powering up or powering down of the disc drive). Secondly, because of the enclosed environment, the ingress of dust and other foreign bodies is almost totally restricted and build-ups of material on the head is eliminated.

Electronic controller design also allows individual surfaces to be write protected and operating system design further allows faulty tracks to be interchanged in the event of corruption. So the problem of disc failures is greatly reduced. Write circuitry in the controllers is also normally designed for fail safe operation so that the incorrect combination of conditioned signals will result in no current passing through the disc head.

But of course failures can occur and the MTBF of the drives are commonly quoted at 10 thousand hours or so. To back up these disc drives several methods are often proposed by the manufacturers. Firstly, individual files or transaction records can be backed up to floppy discs. Careful systems design can enable the history of changes to the 10M byte data base to be recorded in concise form in transaction records. It is not necessary therefore for the entire disc to be saved in a back up procedure - the latest transactions are merely re-run to a different disc file.

Secondly, many suppliers propose the attachment of an auxiliary cartridge tape system. These systems often use high speed slewing of the tape across the head in order to record a very large amount of data in the shortest possible time. These devices, however, would still take some 15 minutes or so to back up a drive, and current deliverable versions of cartridge units average in the order of 4-5 M bytes total capacity. Also, the data rates proposed often exceed the design specifications of the cartridge media.

The conclusion on tape cartridge back-up media may therefore be



that, because of these limitations, it is not the best method of protecting valuable data. Indeed, it is the very occasion when you need to recover using back up media that the best possible reliability is required.

A third method of data protection is perhaps more practicable and certainly most reliable. That is the provision of a second disc drive which can often be run from the same controller in a daisy chain fashion and which may well have write protect key lock switches for operator protection. With the very high data rates that

these drives possess, it is often possible to do a complete back up of data in a minute or so.

It's not surprising that back up procedures are often only followed where the operation is quick and easy. Most will be content to wait a minute or two to undertake a back up, whereas 15 to 30 minutes is unpopular and hence often avoided.

## Conclusions

Winchester technology has brought a new impetus to the micro-computer revolution. Few people

would have envisaged with the introduction of the floppy disc drive that it would become an essential part of the standard microcomputer system of today. Now, many anticipate that the microcomputer system of tomorrow will include a Winchester drive as a standard feature. There is no doubt that whole new ranges of applications can be brought within the capabilities of the microcomputer and that many who up to now have been using a mini, on an OEM basis, are starting to consider the micro as an alternative tool.

### Calculated Corner Cont. from P. 86

standard algebraic form, e.g.  $A^2 + B^2 + \sin C^2 \dots$  up to 88 characters. On returning to the Computation Mode, the calculator asks you for the variable values ( $A = ?$ ) and evaluates the expression! Editing is via a flashing cursor, and expressions

longer than the display scroll off to the left. The eleven memories are non-volatile and a full set of scientific and statistics functions are provided.

The sophistication of this display is such that, surely soon, once large scale LCD displays are available, we will have a

hand held micro which is programmed in BASIC!

For a user who needs to evaluate many algebraic functions and doesn't want to trouble to learn a calculator "language" for programmed solutions, this calculator will be useful; anyway, it's certainly a status symbol.

But the impossibility of any sort of recursive operation limits its flexibility drastically and at a price of £69.90, it cannot compare well with various programmables in this cost range. Perhaps worse is that it takes away all the fun of playing computers!

Malcolm Peltu has made his name writing and lecturing about the nature and impact of computer-related technologies.



## In the grip of the systems monster

Why is it that a personal computing "amateur" can produce a multiprogramming operating system, compiler and utilities in a couple of years part-time work, whereas "professional" software suppliers can invest decades of man years to less avail?

"Perhaps it was because I didn't know that some problems existed, so I never encountered them", was the answer given to me by Tom Aschenbrenner who won the 1977 Personal Computer Fair competition at the US National Computing Conference (he had developed a message switching system for fellow radio hams in the Dallas area). As, another reason he added, "I did it because I enjoyed it — not because I had to, in order to earn a living." Aschenbrenner's comments would fit very pertinently into *Systemantics* by John Gall which tries humourously to analyse the behaviour of a beast which seems to run amok through so many aspects of modern life — The System. Written in a sometimes irritating, too-clever-by-half style, *Systemantics* offers a number of "laws" relating to systems behaviour, often paying homage to folk-lorish inventions like Murphy's Law that "If anything can go wrong, it will go wrong."

The Fundamental Theorem of *Systemantics* is that "New systems create new problems". According to Gall, one starts with a problem, like getting rid of rubbish. Then a system is set up to organise garbage collection and the main objective of that organisation is to manage the system rather than to solve the original garbage problem. In fact, Gall says, "for the practising systems-manager, the greatest pitfall lies in the realm of problems and problem-solving. Systems can do many things, but one thing they emphatically cannot do is to solve problems. This is because problem-solving is not a systems-function, and

there is no satisfactory systems-approximation to the solution of a problem. A system represents someone's solution to a problem but does not solve a problem.

"Solutions," he continues, "usually come from people who see in the problem only an interesting puzzle and whose qualifications would never satisfy a select committee." There could be no better proof of Gall's pudding than in the exciting tang of the home-brewing personal computer world. Aschenbrenner's remark about not being aware of the problems was true because many of the problems of software development are concerned with the complexities of managing large projects. A programmer in a Data Processing department or large software development team is likely to be less productive and less creative than a hobbyist.

Gall's most biting comments are lashed out at the dangers of trying to control complex systems. "Any large system is going to be operating most of the time in failure mode," he says, putting the boot in further with the Fundamental Failure Theorem that "a system can fail in an infinite number of ways" and that "the mode of failure of a complex system cannot ordinarily be predicted from its structure."

For programmers he has two special axioms: programs never run the first time, and complex programs never run. In a more general context, these axioms are summarised by his belief that complex systems designed from scratch never work; the only complex systems that do work are those which have evolved from successful simple systems.

I believe that computers are ideal models of Gall's system world. Operating systems which hog machine resources in order to sort out machine rather than user problems are perfect examples of how complex systems fail to tackle the problems for which they were initially created. The way in which the personal computing market has focused on the development of more human interfaces, such as colour graphics, has also shown that the computer industry as a whole proves another Gallism, "To those within a system, the outside reality tends to pale and disappear."

At the last National Computing Conference in New York, the hundreds of stands from the traditional computer industry paid lip-service to "user needs" but were still essentially displaying evolutions from the grey elephants which form

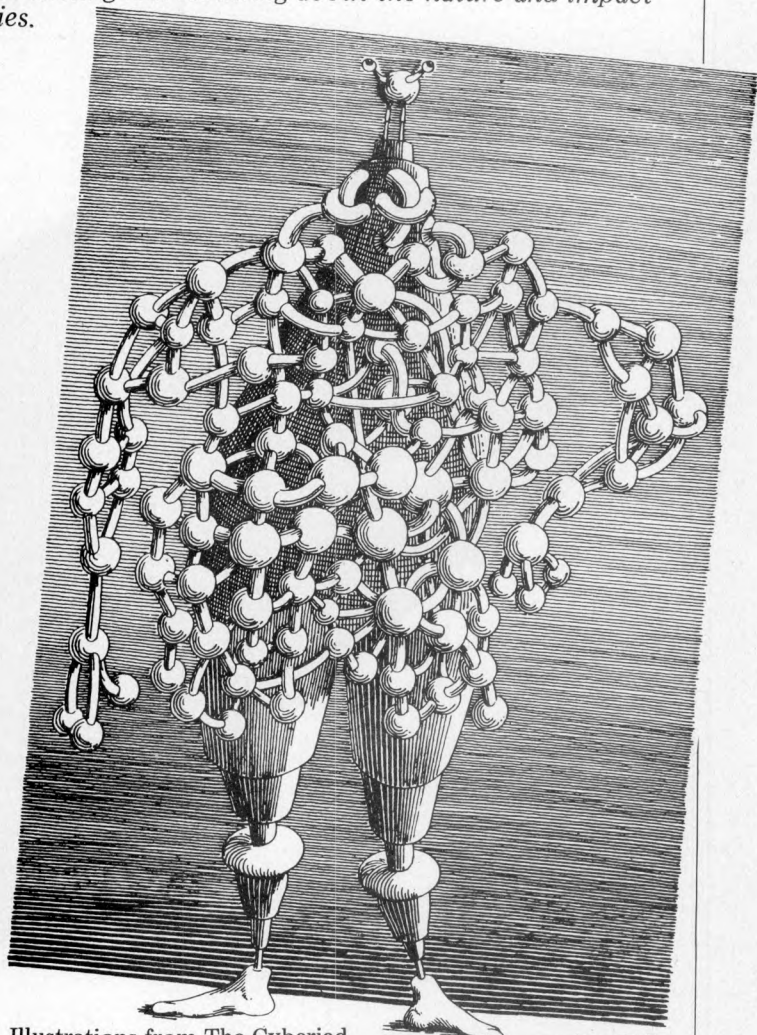

Illustrations from *The Cyberiad*



their "user base". The personal computing show at the same event was filled with colour graphics, voice synthesisers and other devices that offer a human window to the computer. And the reason is that the personal computer user is also a systems developer who focuses attention to the main goal of using the system.

For larger, established computer companies, the System has other goals, like growing and extending its administrative machine, its sales targets and all those other factors that have little to do with the user.

*Systemantics* is a book with a serious message and you'll find it if you scratch beneath its glossy, over-jokey veneer. Anyone working a bureaucracy whose purpose is to deal with people in need should, for example, spread the message "The dossier is not the person" which is Gall's extension of a sign he saw in a smallish hospital which said "The chart is not the patient".

The underlying strength of Gall's book is that it is based on a good appreciation of General Systems Theory and cybernetics. With tongue in cheek, Gall does in fact admit that the science of General Systemantics is a spoof of General Systems Theory, an idea inspired by one Ludwig von Bertalanffy (who coined the phrase *system* to describe the entity concerned with the organisation of a function rather than the function itself).

In *An Approach to Cybernetics* by Professor Gordon Pask, von Bertalanffy's work is cited as one of the sources that lead to the study of cybernetics. Where Gall provides some glib but perceptive insights into the complexities of Systems thinking, Pask, who is a professor of cybernetics at Brunel University, takes a more scientific and mathematical approach in trying to explain the background and scope of one of the major Systems "sciences".

For example, Gall and Pask both quote Le Chatelier's Principle, derived from chemistry, which states that any natural process tends to set up conditions opposing the further operation of that process; thus equilibrium can be maintained when various forces, such as chemical reactants, are mixed in certain concentrations in a closed vessel.

Gall turns this Principle into a corner stone of General Systemantics, that "Systems get in the way and Systems tend to oppose their own proper functions". He clarifies this by the example of a research worker who is asked to define his aims and objectives to satisfy various organisational Systems needs — like touting for research money.

So he makes up objectives that look good to the System, such as writing  $x$  papers in a year, even though his real objectives are different. But he then has to waste time meeting his Systems-inspired objectives. The System has therefore got in the way of real objectives.

For Pask, Le Chatelier provides a simplified analysis of what he regards as the crux of organisational Systems study — stability. "That which is stable can be described, either as the organisation itself or some characteristic which the organisation preserves intact". He writes "The trouble with cybernetics is that the very substance of its study is an entity as amorphous and generalised as the words 'organisation' and 'systems'."

Pask, however, makes a brave attempt at trying to explain in relatively simple terms the unique characteristics of a science which, as he says, "cuts across the entrenched departments of natural science; the sky, the earth, the animals, and the plants." The book is well worth reading as a first step towards a deeper understanding and involvement in a subject which both fascinates and confuses by its general applicability to anything — from running a company to developing a computer to studying the brain.

A mad and magnificent book which puts the whole Systems and cybernetics approach into an imaginative galactic context is *Stanislaw Lem's The Cyberiad*. A combination of science fantasy, political satire and mathematical impishness, *The Cyberiad* consists of a number of short fables, most of them loosely linked by the journeys of the 'constructors' Trurl and Klapaucius.

The starting point of each fable is often a superbly illogical logical idea like a machine that can create anything that begins with  $n$ , then causes havoc when asked to create Nothing. Or the stupidest eight storey thinking machine in the world which terrorises the constructors because they challenge its belief that  $2+2=7$ .

My favourite is Trurl's Electronic Bard, the poetry machine. In Lem's words "Whenever Trurl felt he just couldn't take another chart or equation, he would switch over to verse, and vice versa. After a while it became clear to him that the construction of the poetry machine itself was child's play in comparison with writing the program. The program found in the head of an average poet, after all, was written by the poet's civilisation, and that civilisation was in turn programmed by the civilisation that preceded it and so on to the very Dawn of Time. Hence,

in order to program a poetry machine, one would first have to repeat the entire Universe from the beginning. . ." and that is what Trurl does to Universe-shattering effect.

A trip on Lem's Cyberiad machine gives a whole new perspective to the real world of machines, people and organisations and helps to point to the farcical pimples on the bum of the Systems beast.

## Learning the lingo

One day Grace Hopper, one of the founders of the Cobol programming language, found herself lost in Tokio. And she managed to get back to her hotel merely by speaking Cobol words such as MOVE and GOTO because, she says, Cobol uses such basic universal commands.

It would be nice if a stranger lost in computerland could rely on a similar simple language. (In parentheses it is worth noting that Grace Hopper is said to have originated that descriptive computer jargon word 'bug', meaning an error. According to the story, one of the early computers with which she was working was giving a lot of trouble, until one day she opened a processor cabinet and a moth flew out. Hence the 'bug' came into being).

Meanwhile, back with the stranger in computerland, it is necessary to provide him/her with two forms of route finding assistance — firstly some guidance through the jargon used to describe the technology, and then help with learning the programming languages that get the machines doing something useful.

The problem with introductory books in computing is that they tend to be either too general, and therefore of little use in finding out about one system, or else they are far too specific to give a good perspective on the intrinsic points of the technology.

*Introduction to Microprocessors* by G. L. Simons offers a general overview of the hardware and software technology together with sufficient detail of some popular processors, languages and microcomputers to give the stranger some confidence and sense of direction; however it can in no way be taken as a training or reference book.

In addition to the systems, Simons provides a useful overview of design needs and the range of applications for micros, as well as a summary of some contemporary views on the social consequences of microcomputing.

When it comes to learning a computer language, one's choice is usually limited to

those available on the machine at hand. With microcomputers, the most widely available language is, of course, BASIC.

The trouble is each machine has its own restrictions and dialects for any given language. And this is the major drawback with the otherwise excellent *The BASIC Handbook* by David A Lien

The Handbook is aptly described by its subtitle as being an "encyclopedia". It clearly admits in the introduction, however, that it is not intended to replace the manufacturer's handbook which describes the language facilities for that machine. Instead it concentrates on simple, clear descriptions of the fundamental core words that are common to most machines using BASIC.

The aim is to provide some help to those who wish to adapt programs in a magazine like *Personal Computer World* into suitable forms to run on particular machines. Each BASIC word discussed starts at the top of page. They are listed alphabetically and an indication is clearly given whether the word is part of the American National Standards Institute (ANSI) BASIC standard.

Then there is a standard list of topics dealt with for each word, such as its word category, general description and variations that might be encountered. Test programs for the word and sample runs are also given as well as some very useful hints, including what to do if your computer does not have a particular word. Used as an encyclopedia, the Handbook will be exceedingly helpful in a variety of ways.

But, as Lien says, "like the expanding universe theory, BASIC keeps expanding; we can only chase it — but never catch it all."

So, although the BASIC Handbook will shine a guiding light through some unknown territory, it will still be necessary to get a more detailed and updated A to Z of any real system you want to use.

---

Books discussed in this month's Bookfare have been: *Systemantics* by John Gall (Fontana, 85p)

*An Approach to Cybernetics* by Professor Gordon Pask (Hutchinson's Radius Books, £1.00)

*The Cyberiad* by Stanislaw Lem (Secker & Warburg, £3.90)

*Introduction to Microprocessors* by G. L. Simons (National Computing Centre, £6.50)

*The BASIC Handbook* by David Lien (CompuSoft, available through Rostronics, 118 Wandsworth High Street, London SW18 — £11.00)

---

# THE ALPHA MICRO COMPUTER

Multi-User, Multi-tasking, Timesharing, Memory Management



Basic 64K RAM, 2·4Mb Floppy Disk System: £6,496.00  
 Basic 64K RAM, 10Mb Hard Disk System: £9,965.00  
 (Terminals & Printers to be added to user specification.)

ALPHA MICRO gives a new meaning to the words "Cost Effective." It combines a powerful 16 Bit processor with a proven time-sharing disk operating system to give you data handling and software sophistication parallel to that of high performance commercial minicomputers. It can be upgraded from a simple 64K single terminal floppy disk system up to a 24 terminal, multi-printer, system with 2400 Megabytes of disk storage and 1·02 Megabytes of Random Access Memory without any hardware redundancy.

#### ALPHA MICRO in Business

A fully integrated Accounting System is available "off the shelf." It includes Order Processing, Automatic Invoicing, Stock Control, Accounts Receivable, Accounts Payable, Nominal Ledger, Payroll, and Sales Analysis by Customer, Product or Salesman.

#### ALPHA MICRO Word Processing

Comprehensive word processing software is available which can run simultaneously with the accounting system (or any other program for that matter). It will handle anything from standard letters up to large and voluminous documents with automatic Index/Table of Contents generation.

#### ALPHA MICRO in Research & Education

Since the system can handle up to 24 terminals, where each user terminal has its own 32 or 48K memory partition, it is ideal in education or research since each user can do his own application, i.e. one can be running the BASIC Compiler whilst another runs LISP; again another can do programming in PASCAL or ASSEMBLER etc.

#### ALPHA MICRO Standard Features

- \* Multi-User, Multi-Tasking, Time-sharing Disk Operating System
- \* Memory Management from 64Kb-1·02Mb
- \* Disk storage from 2·4Mb-2400Mb

- \* Powerful WD16 16-Bit Processor
- \* S100 Bus Compatible
- \* Expands from 6-24 terminal ports
- \* Multi-Printer Spooler
- \* Adaptable to most RS232 peripherals
- \* Sequential, Index Sequential and Random Access files supported
- \* Comprehensive disk file management system and utilities
- \* Multi-User structured file system with programmer/project number and password protection
- \* Command file interpreter with parameter substitution
- \* Multiple level DMA and vectored interrupt system
- \* Multiple pass assembly programming system with linking loader
- \* ALPHABASIC Extended compiler and re-entrant runtime package
- \* Index sequential files supported in both Assembler and ALPHABASIC
- \* File management system with logical file I/O calls
- \* ALPHAPASCAL, one of the best UCSD implementations
- \* ALPHALISP, a textual data manipulation language

## THE ALPHA MICRO COMPUTER

**NEWTONS**  
LABORATORIES

PO Box 789  
123 Wandsworth High Street  
London SW18 4JB

Tel: 01-870 4248 Telex: 929222 (SLOTS G)

Request for ALPHA MICRO brochure	PCW 11
Name	
Title	
Company	
Address	
Postcode	Tel:

**DIRECT ACCESS**

**IN STORE**

Britain's most up-to-date and comprehensive guide to the selection of microcomputer equipment, compiled for PCW by Richard Olney of Heuristic Consultants.

Machine (Price from)	Main Distributor/s (No. of dealers)	Hardware	Software	Documentation	Miscellaneous
ALPHA MICRO (£5,700)	Alpha Micro Systems UK Ltd: 01-930 1991 (TBA)	64K-16M RAM: W/L 16 bits: Dual 8" F/D (1.2MB): 6 S/P: modular	multi-user O/S: BASIC: M/A: PASCAL: T/E: U: B/P	E	Expands to 1200 MB, 32 terminal system: average 10MB H/D system — £1,100
APPLE II (£810)	Microsense: 0442 63561 (80+)	16-48K RAM: 6502: 8 I/O slots: 15"x18"x5": options — single 5 1/4" F/D (116K), £425; C, £33; RS232 int, £110; 16K RAM, £110	O/S: BASIC: PASCAL: games	S	280x192 high resolution graphics: integer BASIC in 6K ROM
ATTACHE (£4,381)	Moncoland: 01-839 3661 (5)	48-64K RAM: 8080: dual 8" F/D (616K): 1 S/P, 1 P/P: two units: option — 9", 16x 64 b&w VDU, £250	ExBASIC: FORTRAN	S	Interfaces to Centronics 702 printer
CHALLENGER (£350)	Mutek: 0225 743289 Byte Shop: 01-518 1414. CTS: 0706 79332 (5)	4-8K RAM: 6502: RS232 port: 15"x16"x4": option — dual 5 1/4" F/D (160K), £550	O/S: BASIC: games: Ex-BASIC: Data Man: B/P (limited)	S	D/A conv: colour capability: 8K microsoft BASIC in ROM
CHALLENGER C3 (£2,450)	As above	32-56K RAM: 6502, 6800, Z80: dual 8" F/D (1.15MB): 2-16 S/P: 17"x22"x12"	OS65U O/S: CP/M BASIC: COBOL: FORTRAN: Data Man: B/P	S&H	Also C3B & C3P H/D modules: 74MB for about £10,000
COMMA VO3 (£4,200)	Comma: 0277 811131 (n/a)	32K RAM: LSI 11: dual 8" F/D (512K): 4 serial DLU11S ports: modular	RP11 O/S (£750): BASIC: COBOL: FORTRAN: B/P (limited)	H	Many configs possible: max 20 MB, H/D — about £27,000
COMPELEC SERIES (£2,400)	Compelec: 01-636 1392 (n/a)	64K RAM: Z80: dual 8" F/D (512K): 2 RS232 ports, 1 P/P	CP/M: A: CBASIC: COBOL: FORTRAN: PASCAL: W/P: B/P	S	Also with double density F/D, 1MB, £2,900; 1K EPROM
COMPU-CORP 625 (£6,000)	Compucorp: 01-952 7860 (15)	60K RAM: Z80: dual 5 1/4" F/D (700K): 9", 16x80 b&w VDU: 40cps printer 1 RS232 port: 20"x28"x10"	A: BASIC: U: W/P: B/P	B	Also available, 655 model with 315K F/D capability & 12", 20x80 VDU — £3,750
COMP WORKSHOP SYSTEM 1 (£1,600)	Comp Workshop: 01-491 7507 (n/a)	32K RAM: dual 5 1/4" F/D (170K): 9", 16x64 b&w VDU: modular	A: BASIC: FORTRAN: FLEX: PASCAL: PILOT: B/P	E	These systems are example configs from a fully compatible modular range
COMP WORKSHOP SYSTEM 2 (£11,000)	As above	128K RAM: 6809: dual 8" F/D (1.2MB): 3 intelligent 20x80 terminals; 80 col, 125cps printer: daisy wheel Sprint 3 printer	A: BASIC: FORTRAN: FLEX: PASCAL; PILOT: B/P	E	As above
COMP WORKSHOP SYSTEM 3 (£36,000)	As above	768K RAM: 6809: dual 8" F/D (1.2MB): 64MB H/D: 10 intelligent 20x80 terminals: 2 132 col, 120cps printers: 2 80 col, 125cps printers: 2 daisy wheel Sprint 3 printers: max 16 ports.	A: BASIC: FORTRAN: FLEX: PASCAL: PILOT: B/P	E	As above
COMPU-COLOUR II (£1,058)	Abacus: 01-580 8841 (6)	8-32K RAM: 8089: 13", 32x64 8-colour VDU: single 5 1/4" F/D (51K): RS232 port: 18"x15"x13"	ExBASIC (ROM): A: personal data base: games	I	16K module, £1,134; 34K, £1,137; maintenance & programming manual available.
CROMEMCO SYSTEM 2 (£1,995)	Comart: 0480-215005. Datron: 0742-585490. Microcentre: 031-225 2022 (20)	64K RAM: Z80: dual 5 1/4" F/D (180K): options — dual 8" F/D (512K), £1370; 11MB H/D, £3495; 22MB H/D, £5999	CDOS: BASIC: COBOL: FORTRAN (£55): multi-user BASIC	E	Expandable to multi-user system (2-7 users), £3,455-£6,400
CROMEMCO SYSTEM 3 (£2,995) (64K, £3,293)	As above	32-64K RAM: Z80: dual 8" F/D (512K): options as above: extra dual F/D, £1,200	CDOS: BASIC: COBOL: FORTRAN; multi-user BASIC	E	As above

<b>List of Abbreviations</b>	C/P Commercial package	I Introductory int Interface	P/P Parallel port	W/L Word length
A Assembler	E Extensive F/D Floppy disc	I/S Indexed sequential	S Software	W/P Word processor
B BASIC	G/C Graphics card	M/A Macro assembler	S/P Serial port	
B/P Business package	H Hardware	N/P Numeric pad	TBA To be announced	
C Cassette	H/D Hard disc	O/S Operating system	T/E Text editor	
			T/P Text processor	
			U Utility	

Please note: Software items listed in *italic* are not included in the basic price of the equipment. All prices are *exclusive* of VAT

Machine (Price from)	Main Distributor/s (No. of dealers)	Hardware	Software	Documentation	Miscellaneous
DIGITAL MICROSYSTEM DSC-2 (£5,395)	Modata: 0892 39591 (TBA)	64K RAM: Z80: dual 8" F/D (2.28MB); 4 RS232 ports: EIA port: 17"x21"x7"	CP/M: BASIC: E: CBASIC: COBOL: FORTRAN: PASCAL: CAP B/P	H	Up to 6 additional F/D units possible
DURANGO (£7,750)	Comp Ancillaries: 07843 6455 (12)	48K RAM: 8085x3: dual 5 1/4" F/D (1MB): 9", 16x64 green VDU: 132 col 165cps printer: N/P: options — add F/D £1,753; aux VDU £875	O/S: DBASIC: B/P	S	Takes up to 4 workstations: fully integrated system 15"x30"x24"
DYNABYTE DB8/1 (£1,500)	Dynabyte UK/Europe Ltd: 0723 65559 (6)	32-64K RAM: Z80: S100 bus; 2 RS232 ports: 1 P/P: 20"x18"x7": option — dual 8" F/D (1MB), £2,000	CP/M: BASIC: COBOL: FORTRAN: PASCAL: W/P: B/P	H	Expands to multi-user system: also DB8/2 with dual 5 1/4" F/D (400K), £3,000
EQUINOX 300 (£11,750)	Equinox: 01-739 2387 (n/a)	64-256K RAM: W/L 16 bits: 2MB H/D: 15", 24x80 b&w VDU: 150cps printer: 6 S/P	O/S: BASIC: COBOL: M/A: PASCAL: T/P: multi-user: B/P	S	Up to 1200MB of storage possible (4x300MB, Calcomp Tridents)
EUROC (£7,995)	Eurocalc Ltd: 01-405 3113 (TBA)	64K RAM: 8080A: dual 8" F/D (1MB): 15", 25x80 b&w VDU: 132 col, 14Ucps printer	CP/M: CBASIC: A: account system: U: B/P	S	A year's maintenance and stationary supply inc.
EXIDY SORCERER (£650) (16K, £760; 32K £859)	Factor One: 0736 66565 (10)	8-32K RAM: Z80: RS232: 1 P/P: S100 connector: 30x64 VDU I/O: options — dual 5 1/4" F/D (630K), £1,200; 12", 30x64 green VDU, £240; S100 chassis, £210	O/S: ExBASIC (ROM): W/P: Editor: A: games	I	High resolution graphics capability.
IMS 5000 (48K desk top £5,100)	Equinox: 01-739 2387 (20)	32-256K RAM: Z80: dual 5 1/4" F/D (320K): 15", 24x80 b&w VDU: 150cps printer: 2 S/P; 1 P/P: 18"x24"x3"	CP/M: BASIC: COBOL: FORTRAN: PASCAL: W/P: CAP B/P	S&H	Also available: IMS 8000 (dual 8" F/D); IMB desk top or stand alone models, £6,500
IMSAI VDP 42 (£3,900)	Computermart: 0603 615089. Corner Comp: 03727 41101 (2)	32-64K RAM: 8085: dual 5 1/4" F/D (400K): 9", 24x80 b&w VDU: 1 S/P: 1 P/P: 18"x27"x12"	IMDOS (CP/M comp): A: ExBASIC: U: CBASIC: COBOL: FORTRAN	H	Can support 8 additional F/D drives; also available, VDP 44 with F/D (780K), £4,400
IMSAUI VDP 80 (£6,200)	As above	32-64K RAM: 8085: dual 8" F/D (1.2MB): 12", 24x80 b&w VDU: 1 S/P: 1 P/P: 25"x15"x25"	IMDOS: A: ExBASIC: U: CBASIC: COBOL: FORTRAN: CAP B/P	H	
ITT 2020 (£867) (32K, £916; 48K, £995)	ITT: 0268 3040 (15)	16-48K RAM: 2020: 15"x18"x4": options — single 5 1/4" F/D (116K), £425, C, £33; 60cps printer, £825; 16K RAM, £110; RS232 port, £110	Monitor: A: BASIC: Dis-A: games	B	High resolution graphics capability: Integer BASIC in 6K ROM
LUXOR ABC 80 (£790)	CCS Microsales: 01-444 7739 (TBA)	16-40K RAM: Z80A: C: 12", 16x40 b&w VDU: 4680 bus: IEEE 488: RS232 port: option — dual 5 1/4" F/D (160K, own DOS), £895	DOS: BASIC: games: W/P: Database: Engineering & construction prog	S	Graphics loudspeaker with 128 effects: View-data compatible.
MEGAMI-CRO (£6,080)	Bytronics: 0252 726814 (5)	256K: 8080A: dual 8" F/D (1MB): 12", 20x80 b&w VDU: 120cps printer: 2 S/P: 2 P/P: option — printer stand, £100	CP/M: U: B/P	H&B	
MICRO-ENGINE (£2,080)	Pronto: 01-599 3041 (TBA)	64K RAM: MCP 1600: 2 RS232 ports: 2 P/P: 16"x13"x5": options — dual 5 1/4" F/D (1MB), £1,500; dual 8" F/D (2MB), £1,200	BASIC: PASCAL: File Manager: U	H&S	CPU has user written word set: PASCAL uses integral P code: available as board, £1,400
MICRO-NOVA (£12,000)	Digitus: 01-636 0101 (3)	64-1128K RAM: N601: 10MB H/D (5 fix, 5 rem): 12", 24x80 VDU: 132 col 60cps printer: 4 S/P: 1 P/P	DOS: M/A: U: T/E: I/S: debug: FORTRAN IV: BASIC: PASCAL: W/P: B/P	E	Larger configs usual: bus system for multi-user; smaller system possible with F/D
MICRO-STAR 45 PLUS (£4,950)	Data Efficiency: 0442 57137 (TBA)	64K RAM: 8085: dual 8" F/D (1.2MB): 3 S/P: RS232 port: 17"x26"x8"	STARDOS: CP/M: BASIC: COBOL: FORTRAN: UPDATE (database): B/P	E	

Machine (Price from)	Main Distributor/s (No. of dealers)	Hardware	Software	Documen- tation	Miscellaneous
MSI 6800 (£1,203)	Strumech: 05433 4321 (5)	16K RAM: 6800: C: (9", 16x64 b&w VDU: 1 S/P: option — PROM prog	BASIC: mini A T/E: U	H&S	Up to 8 serial or parallel interfaces possible.
MSI 6800 SYSTEM 1 (£2,175)	As above	32K RAM: 6800: dual 5¼" F/D (160K): 9", 16x24 b&w VDU: 1 RS232 port: option — dual 8" F/D (624K), £1,640	DOS, BASIC: U: A: <i>FOR-TRAN: T/E</i>	H&S	As above
MSI 6800 SYSTEM 2 (£7,500)	As above	56K RAM: 6800: Single 8" F/D (312K): 10MB H/D: 1 RS232 port: 9", 16x64 b&w VDU: options — dual 8" FYD (624K), £1,640 10MB H/D £4,250	DOS: BASIC: multi-user BASIC: A: B/P	H&S	Rack mounted
NORTH STAR HORIZON (£4,650 for 48K)	Comart: 0480 215005. Comma: 0277 811131. Equinox: 01-739 2387 (20)	24-56K RAM: Z80A: dual 5¼" F/D (360K): 15", 24x80 b&w VDU: 150cps printer: 2 S/P: 1 P/P	DOS: BASIC: CP/M: COBOL: FOR-TRAN: PAS-CAL: B/P	E	
PET 2001-8 (£550)	Commodore: 01-388 5702 (150)	8K RAM: 6502: C: 9", 25x40 VDU: IEEE488 (non standard) port: options — dual 5¼" F/D (353K), £795; 80 col 93cps printer, £645; expand to 32K RAM, £249	O/S: BASIC: A: <i>FORTH: PILOT: games</i>	I	Graphics facility: BASIC in 8K ROM: also available, dual 5¼" F/D (800K), £995 + £30 for operating ROM
PET 2001 - 16/32 (£675) (32K, £795)	As above	16-32K RAM: 6502: C: 9", 25x40 green VDU: IEEE488 (non standard) port: options — dual 5¼" F/D (353K), £795; 80 col 93cps printer, £645	O/S: BASIC: A: <i>FORTH: PILOT: games</i>	I	As above but disc operating ROM included.
POWERHOUSE II (£1,650)	Powerhouse Micros: 0442 48422 (TBA)	16-32K RAM: Z80A: 5", 27x96 b&w VDU: 1 S/P: 1 P/P: 17"x11"x7": options — IEEE488 int, £95; C, £150; G/C, £250	FDOS: BOS: BASIC: <i>games: C/P: ExBASIC (14K EPROM), £350</i>	I	
RAIR BLACK BOX (£2,300)	Rair: 01-836 4663 (n/a)	32-64K RAM: 8085: dual 5¼" F/D (160K): 2 RS232 port: 20"x16"x5": option — dual 5¼" F/D (520K), £1,000	CP/M: BASIC: COBOL: FOR-TRAN: M/A: T/E: B/P	H	16K RAM expansion, £250.
RESEARCH MACHINES 380 - Z (£1,048) (56K, £1,654)	Research Machines: 0865 49791 (n/a)	16-56K RAM: Z80A: C: RS232 port: 19"x16"x6": options — dual 5¼" F/D (168K), £895; dual 8" F/D (1MB), £1,695 (fitted in machine)	Tiny BASIC: <i>games: graphics: A: Ex-BASIC: CBASIC: COBOL: FOR-TRAN: ALGOL: CP/M: U</i>	S	Designed for education: high resolution graphics being developed
SDS 100 (£4,290)	Airamco: 0294 57755 (11)	64K RAM: Z80: dual 8" F/D (1MB): 12", 24x80 VDU: S100 bus: RS232 port: N/P: 1 P/P	CP/M: A: ExBASIC: COBOL: FORTRAN: CAP B/P	E	Facility for 8K PROM
SEMEL 1 (£2,900)	Strutt Electrical: 0822 5439 (n/a)	16-64K RAM: Z80: single 8" F/D (250K): 12", 24x80 b&w VDU: RS232 port: options — single 8" F/D (250K), £500; light pen	BASIC: COBOL: FORTRAN: B/P	I	Supports up to 8 drives
SHARP MZ-80K (£520-£740)	Sharp UK: 01-571 2157 (TBA)	6-34K RAM; Z80: C: 10", 24x40 b&w VDU	BASIC: A: <i>games</i>	B	Graphics: loudspeaker: BASIC in 14K RAM
SMOKE SIGNAL CHIEFTAIN 1 (£3,050)	Winrush Micro Designs: 069-24 5189 (TBA)	32-64K RAM: 6800: dual 5¼" F/D (160K): 12", 24x80 VDU: 112cps printer: RS232C port: option — 16K RAM expansion, £500	DOS: BASIC: DBASIC: RBASIC: A: FORTRAN: U: T/E: B/P	E	Also available, Chieftain 3 with dual 8" F/D (1MB), £3,950.

<b>List of Abbreviations</b>	C/P Commercial package E Extensive F/D Floppy disc G/C Graphics card H Hardware H/D Hard disc	I Introductory int Interface I/S Indexed sequential M/A Macro assembler N/P Numeric pad O/S Operating system	P/P Parallel port S Software S/P Serial port TBA To be announced T/E Text editor T/P Text processor U Utility	W/L Word length W/P Word processor
A Assembler B BASIC B/P Business package C Cassette				

Please note: Software items listed in *italic* are not included in the basic price of the equipment. All prices are *exclusive* of VAT

**DIRECT  
ACCESS****IN STORE**

Machine (Price from)	Main Distributor/s (No. of dealers)	Hardware	Software	Documen- tation	Miscellaneous
SOLITAIRE/ WP (£6,750)	Solitaire/KPG: 04252 71448 (TBA)	64K RAM: 8085: dual 5¼" F/D (700K): 14" VDU (with own CPU): 45cps printer: CPU	DOS: W/P: <i>BASIC</i>	S	All Solitaire systems are compatible: graphics on 11x13 dot matrix
SOLITAIRE/ BS200 (£7,950)	As above	64K RAM: 8085: dual 8" F/D (960K): 14" VDU (with own CPU): 45cps printer: CPU port	DOS: BASIC: W/P: <i>speciali- sed B/P</i>	S	As above
SOLITAIRE/ HBS100 (£9,500)	As above	64K RAM: 8085: 10MB Fix H/D: 14" VDU (with own CPU): 200cps printer: CPU port: option — up to 40MB H/D	DOS: BASIC: W/P: <i>speciali- sed B/P</i>	S	Up to 8 interface ter- minals can be used: also available, HBS200 with 20-80MB H/D.
SORD M100 ACE (£2,650)	Dectrade: 0602 861774 (TBA)	48K RAM: Z80: single 5¼" F/D (143K): 12", 24x64 colour VDU: RS232 port: option — single 5¼" F/D, £300	O/S: BASIC	I	With colour graphics: 8K ROM
SORD M223 (£3,500)	As above	64K RAM: Z80: single 5¼" F/D (350K): 12", 24x80 b&w VDU: S100 bus: RS232 port: option — extra F/D, £450	O/S: BASIC: <i>CAP B/P</i>	I	Other configs possible.
SUPER- BRAIN (£1,995)	Icarus: 0632 29593 (TBA)	64K RAM: 2xZ80: dual 5¼" F/D (320K): 12", 25x80 b&w VDU: S100 bus: RS232: TRS80 port: 21"x23" x14": options — dual 5¼" F/D (320K); dual 8" F/D (2.4MB); 8-120MB H/D	CP/M: A: <i>BASIC: COBOL: FORTRAN: APL: B/P</i>	H&S	Limited graphics: main- frame interface available
TAND- BERG EC10 (£5,000)	Tandberg: 0532 35111 (n/a)	50K RAM: 8080A: single 8" F/D (250K): 12", 25x 80 b&w VDU: RS232 port	ExBASIC (24K): multi- user BASIC: A: U: <i>COBOL</i>	H&S	Pascal available next year
TANDY TRS 80 LEVEL 1 (£380)	Tandy: 021 556 6101 (200)	4-16K RAM: Z80: C: 12", 16x64 b&w VDU	BASIC: games: I A	I	BASIC in 4K ROM: up- gradable to level 2
TANDY TRS 80 LEVEL 2 (£515- £1,005)	As above	4-48K RAM: Z80: C: 12", 16x64 b&w VDU: RS232 int: 1 P/P: option — single 5¼" F/D (78K), £478 (max of 4)	BASIC: games: I M/A: <i>FOR- TRAN: B/P</i>	I	16K machines include N/P: 4-16K upgrade, £120; without pad, £85
TECS (£1,600)	Technalogs: 051 724 2695 (TBA)	16-56K RAM: 6800: 8K PROM: RS232 port: C int: option — dual 5¼" F/D (320K), £800	BASIC	H	256 char graphics: Pres- tel compatible: plugs into standard TV
TEI 208 (£4,400)	Abacus: 01-580 8841 (5)	32-60K RAM: 8080/8085: dual 5¼" F/D 320K: 9", 24x80 green VDU: 3 S/P: 3 P/P: 17"x18"10": option — 150cps printer, £1,250	CP/M: <i>BASIC: COBOL: FOR- TRAN: PAS- CAL: ALGOL: B/P</i>	H&S	
TEI 212 (£5,067)	As above	32-60K RAM: 8080/8085: dual 8" F/D (1MB): 15", 24x80 green VDU: 3 S/P: 3 P/P: 17"x20"x17": option — 150cps printer, £1,250	CP/M: <i>BASIC: COBOL: FOR- TRAN: PAS- CAL: ALGOL: B/P</i>	H&S	
VECTOR GRAPHICS MZ (£2,300)	Almarc: 0602 248565 Sintrom Microshop 0734 84322 (5)	48K RAM: Z80: dual 5¼" F/D (630K): 1 S/P: 2 P/P: 20"x17"x8"	DOS: BASIC: A: <i>CP/M: CBASIC: COBOL: FORTRAN: PASCAL:</i>	E	4K PROM
VECTOR GRAPHICS SYSTEM B (£2,850)	As above	48K RAM: Z80: dual 5¼" F/D (630K): 12", 24x80 b&w VDU: 1 S/P: 2 P/P: 20"x17"x8"	DOS: BASIC: A: <i>CP/M: CBASIC: COBOL: FOR- TRAN: PASCAL</i>	E	With graphics and N/P
ZENTEC (£5,700)	Zigal Dynamics: 0753 71049 (1)	32-64K RAM: 2x8080: dual 5¼" F/D (280K); 15", 25x80 b&w VDU: RS232 port: options — dual 5¼" F/D (280K, £600; dual 8" F/D (1MB), £2,100 RS422 port, £105	O/S: A: U: <i>BASIC: micro COBOL: W/P</i>	S	User programmable character set

List of Abbreviations	C/P Commercial package	I Introductory	P/P Parallel port	W/L Word length
	E Extensive	int Interface	S Software	W/P Word processor
A Assembler	F/D Floppy disc	I/S Indexed sequen- tial	S/P Serial port	
B BASIC	G/C Graphics card	M/A Macro assembler	TBA To be announced	
B/P Business package	H Hardware	N/P Numeric pad	T/E Text editor	
C Cassette	H/D Hard disc	O/S Operating system	T/P Text processor	
			U Utility	

Please note: Software items listed in *italic* are not included in the basic price of the equipment. All prices are *exclusive* of VAT

Machine (Price from)	Main Distributor/s (No. of dealers)	Hardware	Software	Documen- tation	Miscellaneous
ZILOG MCZ1/05 (£4,200 - portable)	Micropower: 0256 54121. Memec: 084421 5471 (n/a)	64K RAM: Z80: dual 8" F/D (600K): RS232 port	Rio O/S: M/A: U: T/E: BASIC: COBOL: FORTRAN: PASCAL: B/P	H&S	Debug in 3K PROM: also available as desk top unit or R/M model, both £4,800.
ZILOG MCZ1/35 (£1,200)	As above	64K RAM: Z80: 10MB H/D (5 fix, 5 rem): RS232 port	Rio O/S: M/A: H&S U: T/E: BASIC: COBOL: FORTRAN: PASCAL: B/P	H&S	Internal disc control with own Z80
Z-PLUS (£4,000)	Rostronics: 01-874 3665 (TBA)	32-64K RAM: Z80: dual 8" F/D (1MB): 2 S/P: 2 P/P: 10"x29"x11"	CP/M: A: U: BASIC: COBOL: FORTRAN: PASCAL: Database: B/P	H&S	

In response to reader demand PCW will soon be extending In Store to include single board computers.

## USER GROUPS INDEX

*User Group Index is Britain's major, up-to-date listing of clubs, user groups and societies.  
The details published here were correct at the time of going to press;*

*if YOUR group hasn't been included, then please let us have all relevant information.*

*Send it to: PCW, 14 Rathbone Place, London W1P 1DE. Updates on changes would also be appreciated.*

### AVON

Bristol Computing Club.  
£3.00 p.a. Meetings 3rd  
Wednesday, monthly. Con-  
tact: Leo Wallis, 6 Kilbirnie  
Rd., Bridge Farm Estate,  
Bristol, BS14 0HY. Tel:  
Bristol 832453.

Brunel Technical College  
Computing Club. The club  
divides into two sections  
... the "skilled" and the  
"not skilled". They share  
alternate Wednesdays at the  
College. Contact S.W. Rabona  
at 18 Castle Road, Worle,  
Weston-Super-Mare, Avon,  
BS22 9JW (0934 513068).

### BEDFORDSHIRE

UK Intel MDS Users Group.  
Contact: Lewis Hard, 29  
Chaucer Rd., Bedford.

Cosmac Users Club (proposed)  
For People using the RCA  
1802, Cosmac ELF, ELFII,  
Super Elf etc. Those interested  
contact James Cunningham at  
7 Harrowden Court, Harrow-  
den Road, Luton LU2 0SR  
(enclose sae, please).

The 6502 Users Club. Hoping  
soon to hold regional and  
national meetings, they offer  
"support, encouragement and  
fellowship". Contact: Walter  
Wallenborn, 21 Argyll Ave.,  
Luton, Beds LU3 1EG.

### BERKSHIRE

77/68 User Group. Quarterly  
Newsletter. Free membership  
for 1st year if you buy the  
77/68 instruction manual,  
£1.50 thereafter. Contact:  
Newbar Computing Store,  
40 Bartholomew St.,  
Newbury, Berkshire.

The Thames Valley Amateur  
Computer Club. Meetings are  
on the first Thursday of every  
month and from November  
on, that will be at "The  
Southcote", Southcote Lane,  
off the Bath Road, Reading,  
Berks. Starting time, 7.00pm.  
Contact Brian Quarm (Cam-  
berley 22186) OR Brian Steer  
(Slough 20034).

### BUCKINGHAMSHIRE

TRS-80 Users Group. Con-  
tact: Brian Pain, 40a High  
St., Stony Stratford, Bucks.

### CHESHIRE

Anyone interested in starting  
a Chester club please contact:  
Mr. W. Collins, 37 Garden  
Lane, Chester, Cheshire.

### DERBYSHIRE

The Independent PET Users  
Group. IPUG. Secretary is  
Mike Lake of 9 Littlelover  
Lane, Derby (Derby 23127).

### DEVONSHIRE

Exeter and District Amateur  
Computer Club. General  
meetings 2nd Tuesday month-  
ly, specialist meetings 3rd or  
4th Tuesday. £5.00 p.a.  
Contact: Doug Bates, 3  
Station Road, Pinhoe, Exeter,  
Devon.

### DURHAM

Northeast PETS. Contact:  
Jim Cocallis, 20 Worcester  
Road, Newton Hall Estate,  
Durham. The group meets on  
the 3rd Monday of each  
month (at 7.30 pm.) in:  
Room A102, Ellison Bldgs,  
Newcastle Polytechnic,  
Newcastle-upon-Tyne.

### ESSEX

TRS80 User Club (Chelms-  
ford). Now part of the  
National TRS80 User Club.  
Contact Michael Dean, 22  
Roughtons, Galleywood,  
Chelmsford, Essex.

Amateur Computer Club.  
Membership now costs £3.50.  
Contact D. Ellis (the Member-  
ship Secretary), c/o 118  
Cambridge Avenue, Gidea  
Park, Romford, Essex RM2  
6RA.

The Colchester Micropro-  
cessor Group. Meetings held  
at the University of Essex on  
the second and fourth  
Wednesdays of each month -  
7.30pm start. Membership is  
open to all, on payment of £5  
annual sub £1 for full-time  
students). Contact the Infor-  
mation Centre at the Univer-

sity on the evening of the  
meeting.

### GLOUCESTERSHIRE

Cheltenham Amateur Com-  
puter Club. Meetings, 4th  
Wednesday monthly, 7.30pm  
start. Microprocessor work-  
shop starting October 2nd.  
Contact: Mr. M. Pullin, 45  
Merestones Drive, The Park,  
Cheltenham, GL50 2SU  
(Cheltenham 25617).

### 9900 Users Group, TI

9900 Users Group, TIMUG  
Contact: Chris Cadogan, 21  
Thistle Downs, Northway  
Farm, Tewkesbury, Glos.

### HAMPSHIRE

Southampton Amateur Com-  
puter Club. Meetings 1st  
Wednesday monthly (not  
July, Aug. or Sept.). Contact:  
Paul Dorey, Department of  
Physiology, University of  
Southampton, Southampton,  
SO2 3SU or Tel: Paul  
Maddison on Winchester  
4433 Ext. 6955.

### HERTFORDSHIRE

'11s Users Group. A sort of  
help service only. No meetings  
no newsletter. Contact:  
Pete Harris, 119 Carpenter  
Way, Potters Bar, Herts.,  
EN6 5QB. Tel: 0707 52091  
or 01-248 8000 Ext. 7065.

Harpenden Microprocessor  
Group. They hold meetings  
every fortnight, cover a wide  
range of interests and attract  
members from the area  
around Luton, St. Albans and  
Welwyn. Contact: David  
James, 5 Ox Lane, Harpenden,  
Herts AL5 4HH (05827  
5366).

### KENT

Medway Amateur Computer  
and Robotics Organisation.  
Contact: Tony Aylward, 194  
Balmoral Rd., Gillingham,  
Kent. Tel: Medway 56830.

North Kent Amateur Com-  
puter Club. Meetings, the  
second Tuesday of each  
month - usually at the

Charles Darwin School, Jail  
Lane, Biggin Hill, Kent.  
The sub is £2.50 per annum  
(£1 for students). More  
members are needed ... con-  
tact: Barry Biddles at 3 Acer  
Road, Biggin Hill, Kent  
(09594 71742).

### LANCASHIRE

Merseyside Microcomputer  
Group. Several sub-groups  
... Contact: J.S. Stout,  
Department of Architecture,  
Liverpool Polytechnic, 53  
Victoria St., Liverpool L1  
6EY or Tel: 051 236 0598  
or STEM Ltd., 19/23 Aber-  
crombie Sq., PO Box 147,  
Liverpool University, Liver-  
pool L69 3BX.

### LEICESTERSHIRE

The Leicestershire Personal  
Computer Club. Meetings  
held the 2nd Monday in each  
month, at Leicester Univers-  
ity and Loughborough Uni-  
versity alternately. They start  
7pm. Membership is £2 per  
annum (£1 for under 16s).  
Contact Miss Jill Olorenshaw  
(Club Secretary) c/o Arden  
Data Processing, Municipal  
Buildings, Charles Street.  
Leicester (0533 22255) OR  
Mr Dick Foden (Club Chair-  
man) at 11 Gaddesby Lane,  
Rearsby, Leicester.

### LINCOLNSHIRE

Lincolnshire Microprocessor  
Society. Various meeting-  
places. For up-to-date infor-  
mation, contact the Hon.  
Sec., Mr Eric Booth, Senior  
Common Room, Bishop  
Grosseteste College, Newport  
Lincoln.

### LONDON

MK14 Club. Bi-monthly  
magazine called "Comple-  
ment and Add". Contact:  
Geoff Phillips, 8 Podsford  
Rd., London NW9 6HP.

Southgate Computer Club.  
Meetings 1st Wednesday and  
3rd Thursday monthly  
during term time. Newsletter.  
Contact: Paul Woolley,

# USER GROUPS INDEX

Southgate Technical College, High Street, London N14 6BS. Tel: 01-888 6521.

UK Pet Users Club. Contact: Commodore Systems Division, 360 Euston Road, London, NW1 3BL.

East London Amateur Computer Club. Meetings 3rd Tuesday monthly. £2.50 p.a. (½ price to school students). Contact: Jim Turner, 63 Millais Rd., London E11.

The North London Hobby Computer Club. General meetings held on a Wednesday evening, once a month — specialised topics on three evenings each week. Location: The Polytechnic of North London. Contact: Robin Bradbeer (Chairman) at the Dept. of Electronic and Communications Engineering, Polytechnic of N. London, Holloway, N7 8DB (01-607 2789).

## MIDDLESEX

Harrow Computer Group. Meetings (term time) at the Harrow College of Higher Education and (other time) the "Traveller's Rest" Public House, in Kenton, Middlesex — on alternate Wednesdays at 7pm. Contact: Bazyle Butcher, 16 St. Peter's Close, Bushey Heath, Watford (01-950 7068) or P. Lecker, 23 Moss Lane, Pinner, Middx.

## NOTTINGHAMSHIRE

UK Apple Users Group. Contact: Andy Witterick (Keen Computers), 5 The Poultry, Nottingham. Tel: 0602 583254/5/6.

## OXFORDSHIRE

Research Machines Ltd. National User Group. Inaugural meeting 5th October. Contact: M.D. Fischer, PO Box 75, Oxford, OX4 1EY, for a registration form.

Oxfordshire Microcomputer Club. £5.00 p.a. Contact: S. C. Bird, 139 The Moors, Kidlington, Oxford OX5 2AF. Tel: Kidlington (08675) 6703

Microsoc, the Oxford University micro group holds shared meetings with the Oxford Microcomputer Club. Contact: M Bourla, St. John's College, Oxford.

## STAFFORDSHIRE

Central Program Exchange. Full membership £25 Europe, £40 overseas, provides 30 free programs p.a. Small User Service £10 Europe, £20 overseas) provides 10 free programs p.a. Contact: Mrs Judith Brown, The Polytechnic, Wilfruma St., Wolverhampton, WV1 1LY.

## SURREY

Exidy Sorcerer Users Group. Newly formed, and a division of the U.S. User Group. Fee is £5 p.a. Write, stating what hardware you own, to: Andy Marshall (Micro44), 44 Arthurs Bridge Road, Woking GU21 4NT (04862 66084).

Richmond Computer Club. Held the second Monday of each month at the Richmond Community Centre (20p per meeting), members have the

use of a good range of equipment. Contact: Robert Forster, 18a The Barons, St. Margarets, Twickenham, Middx (01-892 1873).

## SUSSEX

Independent PET Users Group — South. Free membership — meetings the first Wednesday of every month. £1.50 to receive monthly newsletter. Contact: John C Nuttall, 56 West Street, Shoreham-by-Sea, Sussex BN4 5WG.

## WARWICKSHIRE

ACC (Midland) Group. They meet every 3rd Saturday in room P109 at Lanchester College, Coventry. . . no sub, no magazine. Contact: Roy Diamond (Chairman), 27 Loweswater Road, Coventry, Warks (0203 454061).

## WEST MIDLANDS

West Midlands Amateur Computer Club. Newsletter . . . meetings 2nd Tuesday monthly. £2 p.a., or £1 if under 18, or a full time student. Contact: John Tracey, 100 Booth Close, Crestwood Park, Kingswinford, West Mids DY6 8SP. Phone Brierley Hill 70097.

## YORKSHIRE

South Yorkshire Personal Computing Group. (Please note, another publication has listed, incorrectly, a South Yorkshire Amateur Computer Club. It does not exist). For details of the SYPCG, contact Tony Rycroft, 88 Spinneyfield, Moorgate, Rotherham,

S. Yorks. (Tel: Rotherham 74889, eve).

## IRELAND

Computer Education Society of Ireland. A voluntary organisation that consists of a national body and an expanding number of local branches. Their brief is to monitor computer education in Ireland. *National CESI* (£3 p.a.) — Diarmuid McCarthy, 7 St. Kevin's Park, Kilmacud, Blackrock, Co. Dublin. *Cork branch* (£1 extra) — Michael Moynihan, Colaiste an Spioraid Naomh, Bishoptown, Cork. *Dublin branch* (£1.50 extra) — Jim Walsh, C.B.S. Naas, Co. Kildare. *Limerick branch* (£1 extra) — Sr. Lourda Keane, Convent F.C.J., Laurel Hill, Limerick. *Waterford branch* (£1 extra) — Mr. Hugh Dobbs, Newtown School, Waterford. *Kilkenny branch* (£1 extra) — Sr. Helen Lenehan, Presentation Secondary School, Kilkenny.

## SCOTLAND

Ithaca Audio S100 bus UK User Group. Contact Dave Weaver, 16 Etive Place, Cumbernauld, Glasgow G67 4JE. Phone 02367 36570.

## WALES

Gwent Amateur Computer Club. Covering the Gwent and Cardiff areas, the club has its own computer room and technical library. Meetings held once a week, Wednesdays, starting 7.30pm, at Room 149, Civic Centre, Newport. Contact: Peter Hesketh on Shirenewton 596.

# FAX

PCW introduces the first of a series of reference sheets with, this month, the 8080 instruction set. We plan to give you similar charts with the op-codes for all the common processors. Other areas we shall cover are standard codes — ASCII, EBCDIC, BAUDOT etc, hardware interface standards and protocols and anything else which lends itself to this format.

## THE 8080 MNEMONICS ARRANGED BY OP CODE

Compiled by John A. Coll.

MSB LSB	0	1	2	3	4	5	6	7	8	9	A	B	C	D	E	F	
0	NOP				MOV B,B	MOV D,B	MOV H,B	MOV M,B	ADD B	SUB B	ANA B	ORA B	RNZ	RNC	RPO	RP	0
1	LXI B	LXI D	LXI H	LXI SP	MOV B,C	MOV D,C	MOV H,C	MOV M,C	ADD C	SUB C	ANA C	ORA C	POP B	POP D	POP H	POP PSW	1
2	STAX B	STAX D	SHLD	STA	MOV B,D	MOV D,D	MOV H,D	MOV M,D	ADD D	SUB D	ANA D	ORA D	JZ	JNC	JPO	JP	2
3	INX B	INX D	INX H	INX SP	MOV B,E	MOV D,E	MOV H,E	MOV M,E	ADD E	SUB E	ANA E	ORA E	JMP	OUT	XTHL	DI	3
4	INR B	INR D	INR H	INR M	MOV B,H	MOV D,H	MOV H,H	MOV M,H	ADD H	SUB H	ANA H	ORA H	CNZ	CNC	CPO	CP	4
5	DCR B	DCR D	DCR H	DCR M	MOV B,L	MOV D,L	MOV H,L	MOV M,L	ADD L	SUB L	ANA L	ORA L	PUSH B	PUSH D	PUSH H	PUSH PSW	5
6	MVI B	MVI D	MVI H	MVI M	MOV B,M	MOV D,M	MOV H,M	HALT	ADD M	SUB M	ANA M	ORA M	ADI	SUI	ANI	ORI	6
7	RLC	RAL	DAA	STC	MOV B,A	MOV D,A	MOV H,A	MOV M,A	ADD A	SUB A	ANA A	ORA A	RST O	RST 10H	RST 20H	RST 30H	7
8					MOV C,B	MOV D,B	MOV H,B	MOV A,B	ADC B	SBB B	XRA B	CMP B	RZ	RC	RPE	RM	8
9	DAD B	DAD D	DAD H	DAD SP	MOV C,C	MOV D,C	MOV H,C	MOV A,C	ADC C	SBB C	XRA C	CMP C	RET		PCHL	SPHL	9
A	LDAX B	LDAX D	LHLD	J.DA	MOV C,D	MOV D,D	MOV H,D	MOV A,D	ADC D	SBB D	XRA D	CMP D	JZ	JC	JPE	JM	A
B	DCX B	DCX D	DCX H	DCX SP	MOV C,E	MOV D,E	MOV H,E	MOV A,E	ADC E	SBB E	XRA E	CMP E		IN	XCHG	EI	B
C	INR C	INR E	INR L	INR A	MOV C,H	MOV D,H	MOV H,H	MOV A,H	ADC H	SBB H	XRA H	CMP H	CZ	CC	CPE	CM	C
D	DCR C	DCR E	DCR L	DCR A	MOV C,L	MOV D,L	MOV H,L	MOV A,L	ADC L	SBB L	XRA L	CMP L	CALL				D
E	MVI C	MVI E	MVI L	MVI A	MOV C,M	MOV D,M	MOV H,M	MOV A,M	ADC M	SBB M	XRA M	CMP M	ACI	SBI	XRI	CPI	E
F	RRC	RAR	CMA	CMC	MOV C,A	MOV D,A	MOV H,A	MOV A,A	ADC A	SBB A	XRA A	CMP A	RST 8	RST 18H	RST 28H	RST 38H	F
	0	1	2	3	4	5	6	7	8	9	A	B	C	D	E	F	

# TRANSACTION FILE

The "Transaction File" is available for the free use of PCW readers (please, no companies). Buying, selling, exchanging, searching. . . whatever, just post your advertisement to: PCW Transaction File, 14 Rathbone Place, London W1P 1DE. We'd appreciate a maximum of around 50 words per insert.

## For Sale

77:68 CPU board. . . all complete — £20.  
77:68 MON 1 Board. . . all socketed and complete — £20.

77:68 VDU board. . . all socketed and complete — £25.

Apply Mr J K Newman, 2 Carlton Drive, Benfleet, Essex. Phone 0702 556891.

Applesoft floating point BASIC card. . . £80. Phone A Gleeson on Southampton (0703) 557538.

Cromemco Z2. . . computer system, 48K memory, 5" floppy (90K) drive, 16K extended BASIC and macro assembler included — £2200. Plus Hazeltine intelligent VDU 1510 — £800. Contact Paul Clarke, 32 Upper Mall, London W6 9TA. Phone 01-748 1176.

Triton micro. . . full on board RAM, with cassette recorder — £280.

Nascom 1. . . with T2 & B-Bug Monitors, complete in case with PSU — £150. Both units fully operational. Phone Ken on Shrewsbury (0743) 56698 (between 3 & 5 pm).

Motorola 6800. . . 12K words, cassette interface, ASCII keyboard for TV set, manuals. Offers — phone Ron James on 01-388 1827 (office hours).

Verbatim Soft Sector Discs. . . 5¼", unopened box of ten — £20. Ten used very briefly — £1.90 each. Contact D. Briers, 53a Newlands, Pershore, Worcs.

Nascom 1. . . PSU, B-Bug Monitor, graphics board, all neatly boxed in Vero case, fully tested and working, all documentation, 3 months old — £220. Phone 01-722 2039 or 01-249 6764.

IBM "Golfball" Typewriter. . . with punch and reader, box of spares & accessories & literature, metal case with tape holder. Z80 program for linking IBM printer to Exidy Sorcerer included (will require adaptation for this machine). Works, but needs overhaul to remove small faults. As is £290. Phone Porthowan 890688.

Pet 2001. . . 8K plus twenty or so programs (Petsoft etc). — £400 and free delivery in the London area. Contact Mr Forrester, 24 Connaught Avenue, Plymouth. Phone 0752 29638.

Texas T158. . . with PC100A printer, includes Master & Leisure libraries, electrical program "Pakette", programs & paper. £200 or S100 boards (RAM I/O A/D etc) in exchange. Phone Garelochhead (0436) 810605 evenings/weekends.

Pet 2001-8. . . nearly new, plus many games and programming aids. Only used in home — £500 o.n.o. Contact Mr Hounsell after 7pm on 031 332 8913.

MK.14. . . new keyboard, revised monitor, cassette interface, single step facility, instruction manual & amendments — £50. Phone K. Hones on Sandown (0983) 405256.

TRS-80 Level II 16K. . . with lower case, shift lock and control keys (Electric Pencil use), levels 1/2 and technical manuals, keyboard cover, video monitor, CTR-41 recorder with audible CLOAD/CSAVE and AUTO/MANUAL switch for rewind etc., "Electric Pencil" tape, "Tandy Personal Finance Package", output only RS232 interface, various other tapes — £600. Phone Dave Holloway on Asthall Leish (093 387) 241 (evenings/weekends).

Mikbug 6830 L-7 ROM. . . £8 o.n.o.

Also, anybody interested in implementing Pilot or Forth on 6502? — swap ideas, etc. Contact Mr Dunncliffe, 19a Hitchin Road, Henlow Camp, Beds. Texas T158. . . programmable calculator. Little used, too good for me, 240 and 110 volt adaptors — £45. Contact A. Park, Laburnum Cottage, Broomhall, Nantwich, Cheshire. Phone Crewe (0270) 780608.

Pet 8K. . . new in March 79. Inc sound-box, software, manuals, etc — £500. Phone Peter on 01-883 1560.

System 68 VDU. . . cards A&B, socketed & wired, never used: teleprinter type 28 KSR, 115V: Bunker-Ramo type 103A1 VDU, needs new main transformer: high speed Opto. paper tape reader, 8 or 5 holes. Will sell or swap for interesting/useful bits. Contact Chris Warwick G8DSO, 44 Wellington Road, Birmingham B20 2SB.

VDU. . . need a VDU? Come and see mine and make me an offer I can't refuse. Phone 01-794 8419.

16 Dynamic RAM chips. . . 4027, 250nS — £48. Phone 01-907 9065 any time.

T159. . . noughts & crosses program on mag card — £1.35. Contact M. Lancaster, 14 Barley Cote Road, Riddlesden, Keighley, W. Yorks.

PDP8-L. . . 4K mini-computer with TTY interface and full set diagnostics software. Ideal for emulation of Harris HM6100 12-bit micro. Seen working — £400. Additional 4K memory for above fitted and working in BA08 peripheral expander unit — £150. Phone Cobb on Portsmouth (0705) 385589.

Printer Mechanism. . . 80-col. impact, unused, no logic — £65.

Star devices. . . touch keyboard — £30. MK.14 computer. . . extra RAM, manuals, new keyboard — £30.

Phone David Pearce on Biggin Hill 73585.

TRS-80 Level II 16K. . . plus extra 16K chips, sound adapter and software, auto/manual tape control. Also software: Startrek III, X-Wing Fighter, T-Bug, and others — £500. Phone 0480 624286.

Flexowriter. . . electric typewriter with integral 7-hole paper tape punch and reader. All solenoid operated, requires 110 volt transformer, includes handbook and cct diagram — £40.

Card Reader. . . Burroughs, reads 200 80-col cards per minute, circuits and maintenance manuals included — £100. Maintenance manual. . . for IBM Selectric I/O typewriter — £8. Phone 01-449 1690, evenings.

PET 2001-32N. . . complete with cassette drive, dustcover and TIS workbooks 1-6. Commodore 2040 dual disc drive, just add printer for complete business system. Plenty of software included, both still under warranty. Cost over £1700 — open to offers. Anadex printer. . . DP-8000 80-col printer, RS232C and parallel interfaces, complete with CMC Pet interface for immediate use with any Pet. Cost over £700 — open to offers. Phone P. Wright on Blythburgh (050270) 252.

77:68 4K RAM boards. . . three, fully working — £50 each. Phone Leeds 771681 between 9 and 5.30 or write to David Thatcher, 2 Halfpenny Lane, Featherstone, Yorks.

Olivetti printer/terminal. . . 10cps with papertape punch/reader (similar to ASR 33), recently reconditioned — £250 o.n.o. Phone 01-455 3888, evenings.

Nascom 1. . . complete, fully socketed and working, with buffer board, cased keyboard, Cannon connectors — £180 o.n.o. PSU available if required. Phone Jon on 021 743 3442 (Solihull) evenings/weekends.

TRS-80 Level 1 4K. . . complete with monitor and cassette unit, plus program library — £300 o.n.o.

Olivetti TE 500. . . printer with tape punch/reader, believed good working order, but no documentation — hence £40 o.n.o.

Video writer. . . Practical Wireless design 7-bit ASCII in video /UHF out — £20 o.n.o. Phone Chelmsford 84732.

Pet 2001-8K. . . 6 months old, plus assorted games software and BASIC manuals — £475 o.n.o. Phone 01-572 4215, evenings.

Texas SR-56 calculator. . . programmable, 100 step, with operating manual and various sample programs — £25. Contact F. R. Applewhite, 252c Porchester Road, Nottingham NG3 6HE.

Apple II (ITT 2020). . . 32K RAM, cassette recorder, 30 various programs, as new with box and packing — £950 or take good Pet in part exchange. Phone Warrington (0925) 811191, after 6pm.

Sorcerer 32K. . . as new and complete with all cables, manuals etc. Also tape deck and technical manual. Save £150 plus by buying mine at £650. Phone Charles Thompson on 0438 832737 or 0438 032321 (Herts).

Sorcerer 16K. . . in excellent condition with all accessories — £615. Also available, TV monitor, cassette recorder, D/A and A/D converter, library of programs and cassettes, technical manual — £130. Together — £715. Phone Southport 65787/64809.

7/8" paper tape. . . to clear, £150 per 8" reel (includes p&p). Contact C. E. Brough, 21 Ashdene Gardens, Stourbridge, W. Mids DY8 5JQ.

Printer/terminal. . . ASR33 teletype (Westrex) with paper tape punch/reader, RS232 & SWTP MP-S interface — £300 o.n.o. Phone 01-764 5999.

Nascom 1. . . built and working, plus modulator, without PSU — £120. Phone Pete Overall on 0626 68975.

Nascom 1. . . built and tested, including PSU, mounted in stylish wooden cabinet, all manuals and programs supplied — £200 o.n.o. Contact T. D. Botterill, 48 Yardley Drive, Northampton. Phone N'ton 844338.

Kilobaud and Byte. . . exchange your unwanted copies — SAE list. Contact Geoff Smith, 84 Edenfield Gardens, Worcester Park, Surrey KT4 7DY.

Superboard II. . . with 8K RAM, fully operational, mounted in custom built and professionally finished metal cabinet. Supplied with all interface cables, diagrams and manuals and program tapes. Also UHF modulator. Needs 5V PSU — £280. Phone Mr A. D. Sellers on 0582 38581, 9am - 6pm. Comp 80. . . fully built and working Powertran W. W. Comp 80 — £300.

# TRANSACTION FILE

Phone 0632 650653 and ask for Geoff. Superboard II. . . with 8K RAM, complete with 5V 5A PSU and UHF modulator — £220 o.n.o. Phone Rod on Watford (0923) 20310, evenings. Ohio Disc System. . . C2-4P with TV monitor, as illustrated in the American Data adverts, complete with many business and games discs — £950 o.n.o. Phone Lichfield (Staffs) 54515. SC/MP II. . . in superb Vero case, 1K byte memory mapped VDU including cursor control, 2½K byte memory expandable to 64K, 5V PSU, 10 digit 7-seg LED O/P, cassette I/P & O/P interface, 16-bit I/O port with hand-shake mode, light touch keyboard, programs and all documentation — £125.

Contact U. Yoltay, 1 Grosvenor Gardens, London N10 (top flat).

Triton. . . includes full on board RAM (4K) and the new BASIC and monitor in (4K) of ROM; has sprayed front and rear panels, also includes cassette recorder — £400. Phone 01-805 1878, after 6pm.

Colour graphics kit. . . William Stuart Systems, for Nascom 1, complete with instructions, colour modulator and software — £38. Phone 0602 266748, weekends only.

Pet. . . new ROM set for 8K Pet. Update your machine for £25, or offer. Phone Sandwich (03046) 7209, evenings.

TRS-80 Level 2. . . numeric keypad,

32K interface — £750 plus VAT. Micropolis Dual Drive. . . 394K — £950 plus VAT. Only a few months old. Phone Henfield (Sussex) 3101.

## Wanted

Mite printer. . . any condition, any price considered. Contact Mr P. Spooner, 6 Ebor Close, West Parley, Dorset BH22 8LZ.

Software. . . copies of CP/M library programs on 5¼", 16 sector Micropolis quad density. Also programs for the Sorcerer: IN BASIC, machine language, on disc or cassette, or on CP/M format disc. Phone Garelochhead (0436) 810605, evenings/weekends.

# DIARY DATA

Moscow, Russia	Electronic Devices Production & Control Exhibition, 'Expocentre', 1a Sokolnichesky Val, 107113 Moscow, U.S.S.R.	Oct 11 - Oct 21
Budapest, Hungary	MIPEL — International Exhibition of Industrial Electronics. Hungarian Foreign Trade for Fairs & Publicity, Electronics, P.O. Box 44, H-1441, Budapest.	Oct 23 - Oct 28
Birmingham, England	International Business Show. BETA 109, Kingsway, London WC2B 6PU. Tel: 01-405 6233	Oct 23 - Nov 1
Harrogate, England	Management Services & Equipment Exhibition. Peter Mirrington Exhibitions, 1 The Coppice, School Rd., Kelvedon Hatch, Brentwood, Essex. CM15 6DL Tel: 0277 74290	Oct 25 - Oct 26
Frankfurt, W. Germany	Office Equipment Exhibition. Collins & Endress, 36 Sackville St., London W1X 1DB. Tel: 01-734 0543	Oct 30 - Nov 2
London, England	2nd Personal Computer World Show. Montbuild Exhibitions Ltd., 11 Manchester Sq., London W1M 5AB. Tel: 01-486 1951	Nov 1 - Nov 3
Cardiff, Wales	BEX — Business Equipment Exhibition. Douglas Temple Studios Ltd., 104B Old Christchurch Rd., Bournemouth, BH1 1LR, Hants Tel: 0202 20533	Nov 5 - Nov 6
London, England	COMPEC — Computer Peripheral & Small Computer Systems. Iliffe Promotions Ltd., Dorset House, Stamford St., London SE1 9LU. Tel: 01-261 8000	Nov 6 - Nov 8
Dublin, Ireland	ITRON — Irish Electronics Exhibition. SDL Exhibitions Ltd., 68 Fitwilliam Sq., Dublin 2, Ireland. Tel: Dublin 763871	Nov 6 - Nov 8
Helsinki, Finland	FINNTEC 79/ELKOM 79 — Electrical Technology & Professional Electronics Fair. ECL Ltd, 11 Manchester Sq., London W1M 5AB. Tel: 01-486 1951	Nov 6 - Nov 10
Munich, W. Germany	PRODUCTRONICA — International Exhibition for Electronics Production, ECL Ltd, 11 Manchester Square, London W1M 5AB. Tel: 01-486 1951	Nov 6 - Nov 10
Dunstable, England	The All Business Show. Luton and District Chamber of Commerce and Industry, George Street West, Luton LU1 2BT. Tel: 0582 23456	Nov 13 - Nov 15
Hamburg, W. Germany	Office Equipment Exhibition. Hamburg Fairs & Congress Co., 238 High St., Poole, Dorset BH15 1DY. Tel: 02013 4450	Nov 13 - Nov 17
Madrid, Spain	SIMO — International Office Equipment & Computers Exhibition. CITEMA, Plaza de Conde de Valle Suchil 8, Madrid 15, Spain	Nov 15 - Nov 23
Manchester, England	Minicomputers, Word Processors & Copying Machines Exhibition. Groundrule Exhibition Co. 7 Market St., Altrincham, Cheshire, WA14 2QW Tel: 061 928 2227	Nov 20 - Nov 21
London, England	Electronics '79 Show. Industrial & Trade Fairs Ltd., Radcliffe House Blenheim Court, Solihull B91 2BG. Tel: 021 705 6707	Nov 20 - Nov 23
Brussels, Belgium	International Electronics Exhibition. Brussels International Trade Fair, Palais du Centenaire, Parc des Expositions, B 1020 Brussels, Belgium	Nov 26 - Dec 1
Tokyo, Japan	Semicon Japan. Golden Gate Enterprises Inc., De Anza Office Center, 1307, So. Mary Ave., Suite 210, Sunnyvale, CA 94087 U.S.A.	Nov 28 - Nov 30
Bucharest, Romania	SYSTEMTECHNIK — International Electronics Exhibition & Trade Fair. Glahe. International GmbH & Co., Herler Strasse, 91-109, P.O. Box 800349, D-500 Cologne 80. W. Germany	Dec 3 - Dec 8
London, England	Breadboard Exhibition (Home Electronics). Trident International Exhibitions Ltd., 23a Plymouth Rd., Tavistock, Devon, PL19 8AU. Tel: 0822 4671	Dec 4 - Dec 8
Paris, France	International Electrical Equipment Exhibition. French Trade Exhibitions, 54 Conduit St., London W1. Tel: 01-439 3964	Dec 10 - Dec 15
Birmingham, England	TV MEX. Montbuild Ltd., 11 Manchester Sq., London W1M 5AB. Tel: 01-486 1951	Jan 15 - Jan 17
Wembley, England	Microsystems '80 Exhibition & Conference. Iliffe Promotions Ltd., Dorset House, Stamford St., London SE1 9LU. Tel: 01-261 8000.	Jan 30 - Feb 1
Leeds, England	BEX — Business Equipment Exhibition. Douglas Temple Studios Ltd., 104b Old Christchurch Rd., Bournemouth, Dorset. Tel: 0202 20533	Feb 6 - Feb 7
Milan, Italy	INTEL — International Electrical & Electronic Technology Exhibition. Intel, Via Luciano Manara 1, 20122 Milan, Italy	Feb 9 - Feb 13
Solihull, England	Mini Computers, Word Processors & Copying Machines Exhibition. Groundrule Exhibition Company, 7 Market Street, Altrincham, Cheshire WA14 2QW. Tel: 061 928 2227	Feb 12 - Feb 13

## DIARY DATA

London, England	Business Computing, Word Processing & Information Mgt., Exhibition & Conference. BED Exhibitions Ltd., Bridge House, Restmor Way, Wallington, Surrey. SM6 7BZ. Tel: 01-647 1001	Feb 12 - Feb 15
Wembley, England	INFO EUROPE — European Information Management Exhibition & Conference. Clapp & Poliak Europe Ltd., 232 Acton Lane, London W4 5DL. Tel: 01-995 4806	Feb 18 - Feb 21
Bournemouth, England	BEX — Business Equipment Exhibition. Douglas Temple Studios Ltd., 104b Old Christchurch Rd., Bournemouth, Dorset, Tel: 0202 20533	Feb 20 - Feb 21
Swansea, Wales	OFFEX — Office Equipment Exhibition. Phoenix Exhibitions Ltd., 1st Floor, Burrows Crumbers, East Burrows Rd., Swansea. Tel: 0792 460364	Feb 20 - Feb 22
Dortmund, W. Germany	HOBBYTRONIC — Electronic Hobby Exhibition. Westfalenhalle GmbH, Postfach 1130, Reinlanddamm 200, 4600, Dortmund, W. Germany	Feb 20 - Feb 24
Birmingham, England	IEA — International Instruments, Electronics & Automation Exhibition. Industrial & Trade Fairs Ltd., Radcliffe House, Blenheim Court, Solihull, West Midlands, B91 2BD. Tel: 021 705 6707	Feb 25 - Feb 29
Copenhagen, Denmark	TECHEX — World Fair of Technology Exchange. Dr Dvorkovitz & Associates, P.O. Box 1748, Ormond Beach, Florida 32074 U.S.A.	Feb 26 - Feb 29
Birmingham, England	Computermarket '80, Couchmead Ltd, 42 Great Windmill Street, London W1V 7PA. Tel: 01-437 4187	Mar 4 - Mar 6
Liverpool, England	Merseyside Business Efficiency & Office Equipment Exhibition. Gwen Shillaber Design, 81 Whiteladies Rd., Clifton, Bristol BS8 2NT. Tel: 0272 312850	Mar 4 - Mar 7
London, England	Microforum Europe. Business Equipment Trade Association, 109 Kingsway, London WC2B 6PU. Tel: 01-405 6233	Mar 11 - Mar 13
Sheffield, England	Business Efficiency & Office Equipment Exhibition. Gwen Shillabar Design, 81 Whiteladies Rd., Clifton, Bristol BS8 2NT. Tel: 0272 312850	Mar 11 - Mar 13
Manchester, England	Computermarket '80. Couchmead Ltd., 42 Great Windmill St., London W1V 7PA. Tel: 01-437 4187	Mar 11 - Mar 13
Bahrain, UAE	Middle East Business Equipment Show. Arabian Exhibition Management 11 Manchester Sq., London W1M 5AB. Tel: 01-486 1951	Mar 16 - Mar 20
Glasgow, Scotland	Computermarket '80. Couchmead Ltd., 42 Great Windmill St., London W1V 7PA. Tel: 01-437 4187	Mar 18 - Mar 20
London, England	Computermarket '80. Couchmead Ltd., 42 Great Windmill St., London W1V 7PA. Tel: 01-437 4187	Mar 25 - Mar 27
London, England	Viewdata '80. Online Conferences Ltd., Cleveland Road, Uxbridge, Middx UB8 2DD. Tel: 0895 39262	March 26 - March 28
Paris, France	International Exhibition of Electronic Components. French Trade Exhibitions, 54 Conduit Street, London W1R 9SD. Tel: 01-439 3694	Mar 27 - Apr 2

## COMPETITIONS ROUND-UP

One of the less appreciated inheritances for the new team at PCW was a collection of hitherto unresolved competitions. We believe, after some hours of research, that five (and possibly six) sets of results are outstanding (!) — please let us know if you spot others — and of those, at least two still require their instigators to pass judgement. They are: "Puzzle Dazzle 2", set in the February '79 issue; "Alphametics" set in the May '79 issue. Others, which we can deal with now, are: "Magic Squares", set by Sheridan Williams in the June '79 issue; "Knight's Tour", again set by Sheridan Williams, this time in the January '79 issue; finally, "Witbit 1" set by David Parkinson and Graham Trott in the June '79 issue.

It's obviously most unfair that the winners be kept waiting any longer. However, it'll come as no surprise to everyone to learn that the outlining of all these reports would take up far more space than any one PCW issue could possibly donate (not to mention the possibility of our readers going down with a nasty bout of 'competition overkill').

Therefore, this month we are restricting ourselves to little more

than a round-up of results although, through later issues, we hope eventually to publish a much fuller analysis.

### KNIGHT'S TOUR

The problem was to find a complete tour of the chessboard for a knight, so that the piece visits, in turn, every square on the board once, and once only.

Sheridan had purposely set a difficult competition. . . and yet the entries still came flooding in. Joint winners (£10 each) are Philip Crane of Romford in Essex and Brian Legg of Bishops Cleeve in Hertfordshire. The run times of the two programs were 3.87 seconds and 2.36 seconds, respectively.

### MAGIC SQUARES

The problem here was to find a magic square that satisfies the following conditions: (1) It comprises of 2-digit numbers (zeroes not allowed) (2) It's a 3x3 square (3) When the digits are reversed, another magic square is produced with none of the original numbers reappearing (4) The sum of the two magic constants is less than 200.

A prize was offered for the first correct entry supported by BASIC

program. The solution was as follows:

13 34 25	31 43 52
36 24 12	63 42 21
23 14 35 reversed	32 41 53

MC=72

MC=126

The winner is: Mr O. M. Dixon of Alverstoke in Hampshire, who receives £10. A consolation prize of £5 goes to Mr C. Palmer of Bradford, Yorkshire who, although not first out of the 'hat', submitted the best entry.

### WITBIT

The problem set was to write a short subroutine for an editor to execute a "Find string" command.

Solutions were accepted in Z80 and 6800 code, prizes to be awarded to the winners of each section. Z80. First prize (£10) goes to Mr J. Robertson of East Kilbride, Scotland for his neat solution which uses the minimum of temporary storage. Second prize (£5) goes to David Medland-Slater of Farnborough in Hampshire. 6800. Only four entries received in this section! Winner (£10) is Martin Bond of Didsbury, Lancashire and runner-up (£5), John Phillips of Saltash, Cornwall.

## Cryptic clue

Re September Issue 1979, Spaceship FX201-P. I have an entry for your diversions and puzzles page.

With reference to the above article:-

A Try and figure out how the list of step numbers applies to the program.

B Make a list of incorrect function signs.

C Fill in the missing line which would give answer 4 — your new radial distance.

I would be most grateful if you could send me the same copy that Dick Pountain wrote his review from. E. Fernie, Enfield, Middx Okay, pax... *Corrections to Spaceship FX201-P in Blunders at the end of our Programs section.*

## Faith healing

Further to my letter of 1st June, 1979, concerning difficulties I have experienced in obtaining a MPS 6550 memory chip for my Commodore PET. I now have the greatest pleasure to inform you of the remedy... a small shop in the town of Luton, Bedfordshire, called Isher-Woods. I rang them and explained my problem and was told that they had the devices in stock. I was invited to take my PET over to them where they could test the device in situ.

Once at the shop I was received by their Wizard, John Rees, who operates in a well-organised (you should see mine) workshop with an air of calm confidence and rather like a slow-motion Magnus Pyke. That he knows what he is doing is evident from the constant flow of people seeking his advice and leaving satisfied. I was invited to participate in the operation (painless) but the best part was enjoying the interesting chat seeded with snippets of valuable information.

The Wizard introduced me to the Vizier, Ian Wade who is their Divisional Controller and obviously knows a lot more about the aspects of hard and software than he is telling! If you wish to discuss the purchase of either he is in an ideal position to give you the "low down" on it. I wonder how many persons in his position can say the same.

Throughout my visit I was impressed with the atmos-

phere of friendly co-operation and enthusiasm and I strongly urge anyone in the vicinity, to drop in and say hello. This really is an unsolicited testimonial; unless Isher-Woods reads your worthy publication they will never know about it. S.R. Somers, Aylesbury *Well earned "plugs" we never mind repeating — Ed.*

## Punter postscript 1

I read with interest "The Programmed Punter" by Dr. M.R.J. Morgan in the July issue of PCW. I was surprised at the low limits on the value of the permutations he could calculate until I realised that he calculated them from three factorials.

This is a very long winded and restricting method as many terms in the fraction always cancel out. To take his example:

$$\frac{8!}{3! \times 5!} = \frac{8 \times 7 \times 6 \times 5 \times 4 \times 3 \times 2 \times 1}{(3 \times 2 \times 1) \times (5 \times 4 \times 3 \times 2 \times 1)} = \frac{8 \times 7 \times 6}{3 \times 2 \times 1}$$

The subroutine at line 1000 in the program below calculates the permutations this way cancelling the larger factorial on the bottom into the top.

```
10 REM *** BINOMIAL CO-EFFICIENTS ***
20 INPUT "M, N"; M, N
30 IF M=0 THEN END
40 GOSUB 1000
50 PRINT C
60 GOTO 20
1000 REM $1$ BIN CO $1$
1010 IF M-N >= N GOTO 1030
1020 N=M-N
1030 C=M
1040 IF N=1 GOTO 1090
1050 M1=M+1
1060 FOR I=2 TO N
1070 C=C*(M1/I)
1080 NEXT I
1090 RETURN
```

This program will allow your readers to see how large they can get M and N on their systems. With M=122 I can do all values of N although my RML380Z overflows at about  $10^{38}$ .

Hugh Williams (Past Chairman MUSE) West Bridgeford, Nottingham

## Punter postscript 2

In Dr Morgan's short article "The Programmed Punter" (July PCW) he used the formula  $M!/N! (M-N)!$  which gives the number of combina-

tions of N objects that can be chosen from M unlike objects. ABC and ACB are different permutations of the same combination of letters.

An alternative way of calculating the number of possible combinations, other than evaluating the three factorials as that program does, uses the fact that the coefficients of the binomial expansion  $(x+y)^M$ , are the number of combinations of 0,1,2,...,M objects from M objects. For example, the coefficients of the terms of  $(x+y)^7$  are 1,7,21,35,35,21,7,1 so there are 21 possible combinations of 2 objects from 7 objects.

Successive coefficients are related by:

$$\begin{aligned} mC_n / mC_{n-1} &= m! / n! (m-n)! \times (n-1)! (m-n+1)! / m! \\ &= (m-n+1) / n \\ {}^7C_3 / {}^7C_2 &= 35 / 21 = 5 / 3 = (7-3+1) / 3 \\ \text{so } mC_n &= mC_{n-1} \times (m-n+1) / n \end{aligned}$$

As  $mC_0 = 1$ , the number of combinations can be evaluated by successively multiplying by  $(M-I+1)/I$  where  $I=1,2, \dots, N$ . A program, assuming that the data is always correct being:

```
10 INPUT M,N
20 C = 1
30 FOR I=1 TO N
40 C = C*(M-I+1)/I
50 NEXT I
60 PRINT C
```

As  $mC_n = mC_{m-n}$  another line could be added to increase the efficiency of the program

```
15 IF M-N < N THEN N=
M-N
```

Using this algorithm, our RM 380Z, using DBAS12, can evaluate the number of combinations of N objects from 123 objects to an accuracy of 10 significant figures. Some results for values of M greater than this can be obtained, but the greater M is, the smaller N has to be. When M=300, N can only be 26 or less. Using the formula for the number of combinations directly, the greatest value of M is 33.

The formula for the number of permutations of N objects chosen from M unlike objects is  $M! / (M-N)!$  and a similar method of evaluation can be used that does not involve working out factorials.

As the order in which multiplication and division are executed does not matter, it is worth investigating to see if the equivalent statement

$C=C/I*(N-I+1)$  will enable greater values of M to be evaluated.

Peter Butt, Chadwell Heath, Essex.

## MK14 sound out

In musical or noise generating applications of the Science of Cambridge SC/MP based Mk.14 microcomputer, a crystal microphone insert may be used as a high impedance loudspeaker, driven directly by the logic levels at the flag outputs of SC/MP. The prototype used an ACOS type MIC-43 connected as shown below.

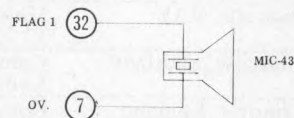

The brief program listed here may be used to generate a sound to test the set up. It operates by incrementing a store, loading the result to the Status (flag) Register, and also using the result as a parameter for a variable delay before jumping back to the start. The program is written in locations 0F20 to 0F26 inclusive with 0F1F as a store but it is relocatable to any eight contiguous locations in RAM. The type of output sound may be varied by altering the delay base number in location 0F24.

```
0F1F 00 Store:
0F20 A8FE Start: ILD Store
0F22 07 CAS
0F23 8F00 DLY
0F25 90F9 JMP Start
0000 .END
```

See the Mk.14 User Manual Music section for more ambitious programs using this circuit.

T. J. Spriggs, Havant

## Dodgy delays

The SC/MP micro-processor has a DELAY instruction (opcode 8F) which provides a pause, corresponding to a specified number of micro-cycles, with very simple software. (In the 6800 MPU, we have to write a short subroutine to achieve the same effect).

In the manual for the Mk.14 (which uses the SC/MP chip) there are programs (on Pages 65 and 66)

for Serial Data Input and Serial Data Output. These programs use the DELAY instruction. In a program I wrote, similar to the Serial Input program, I found that the constants for the DELAY operation suggested in the Mk. 14 programs, were not correct. My program worked correctly when the constants were changed to values which were found after some experiments guided by theory.

Page 64 of the manual gives a table for delay constants based on a frequency of 4 MHz. These constants are used in the Mk. 14 program for Serial Data Input. But the Mk. 14 works in association with a crystal which has a frequency of 4.433618 MHz (this is the value stamped on the casing of the crystal). It would therefore seem to be wrong to use the constants in the table.

In my project, I was working at 300 baud, the "bit time" is 3.333 milliseconds. For this condition, the table suggests

"C4 5E  
8F 03"

This means "Load 5E into the accumulator and set the displacement in the DELAY instruction to 06".

This leads to a delay of n microcycles, where n is given by  $13 + 2 \times (\text{accumulator}) + 2 \times \text{displacement} + 2^9 \times \text{displacement}$ ; i.e.

$13 + 2 \times 5E + 2 \times 6 + 512 \times 6$ .

This statement is somewhat confusing in that decimal numbers are mixed with hexadecimal. "5E" in hex means "94" in decimal. Thus n =

$13 + 188 + 12 + 3072$   
= 3285 microcycles.

At a frequency of 4 MHz, one microcycle lasts 1 microsecond. The delay is thus 3.285 milliseconds.

We require 3.333 milliseconds. This leaves 48 microcycles for the SC/MP instructions — a reasonable figure.

However, when SC/MP is working at 4.433618 MHz, the delay corresponding to 3285 microcycles is

$3285 \times \frac{4}{4.433618}$  microsecs

i.e. 2.9637 milliseconds.

For my project, I found that the program would work with

"C4 22  
8F 07"

The constants were chosen

by taking the mean of the upper and lower limits of the delays found to be satisfactory.

Because of the synchronising action of the START and STOP bits in the program, there is a certain range within which operation is satisfactory. With "8F 07" the program would work with values stored in the accumulator varying from 00 to 44 (in hex).

In addition to changing the constants for "bit time", I changed those required for "half bit time". To save space, those changes will not be mentioned here. The purpose of this letter is to suggest that values in a table intended for a frequency of 4 MHz should not be applied to an MPU working at 4.433618 MHz.

**Tom Palmer, Kew**  
*We rang Science of Cambridge who confirm your observations. They did point out, however, that since January they have incorporated a genuine 4MHz crystal. They also mentioned that their manual page numbers have changed following a recent update so you may find Tom's references different to your own. One last thing — they also told us that because the input and output routines use the same byte in memory, spurious data can find its way onto the output line as it is displaced by incoming data. You can work out your own solution to this by either dealing with the content of this byte before a read or by 'gate'ing the output. — Ed.*

## Pascal possibilities

Alex Cawley's letter in your September Issue gives incorrect information concerning the availability of PASCAL Compiler RAM requirements.

Our company has a 3 Pass PASCAL Compiler designed for the RCA 1802 Microprocessor which runs in a 20K RAM System with Floppy Discs. This Compiler, whilst designed for the 1802 family, can be adapted to other microprocessors by alteration of the 2K run time kernel to suit the required instruction set.

The 2K interpreter makes application programs as small as 3K a practical possibility;

the package is designed to appeal to the professional and industrial user looking for minimum read only memory costs.

M. J. Dagleish, Golden River Company, Bicester

## Routine business

I read an article in PCW recently describing Dr. Roger Quay's 380Z system at the National Hospital's Institute of Neurology. In it, Dr. Quay was quoted as saying that he had found PCW to be a useful source of assembler multiplication and division routines. As a fairly recent convert to PCW and a new user of a 380Z, I should like to track down these routines.

I wonder if you can quote me chapter and verse? I'd be very grateful.

Mrs A M Guenault, Lancaster  
*We rang Dr. Quay and, with his help, tracked down an article by Neil Harrison in volume 1 number 2. It's called 'Four Easy Pieces' and in it, among other things, he describes a multiplication routine. He thinks that his division routines came out of a hardware manual — Ed.*

## Was ist das?

I would be grateful if you could kindly inform me of any computer that translates German into English, it would also be a great help if you could supply the companies' names and addresses. PS I do take your magazine. H. Thomas, Shirehampton, Bristol.

*Nice to hear from another discerning reader! The company distributing translators in the UK is Lexicon. Their head office is in Parliament Street, London (Tel: 01-930 3030). They supply to shops all over the country — the nearest one to you is probably Communications Imports in Cheltenham. The phone number there is 0242 41173. It is probably worth noting that the translator has a repertoire of some 1500 words and translates word for word in the present tense, first person singular. Therefore, although it's no replacement for a human interpreter, it does provide a very useful means of communication. One last thing — price; a Lexicon*

*3000 with one language module of your choice costs £148 + 15% VAT. Each additional module costs £32.95 + 15% VAT. Each module plugs in and allows translation in either direction.*

*Stop Press: Lexicon have just announced that they are selling 'personal program' modules — you can store recipes, 'phone numbers jokes etc. — Ed.*

## Sorcerer tips

Despite claims to the contrary, there is no GET statement in Sorcerer BASIC. It is, however, possible to simulate a GET statement using a machine code routine that is POKE'd in from BASIC.

The statements are as follows:

```
firstly,
FOR X = 1 to 14
READ W
POKE 223 + X, W
NEXT X
DATA 62, 0, 50, 240, 0, 205,
9, 224, 200, 50, 240, 0, 201,
0.
then,
POKE 260, 224
POKE 261, 0
```

To use this routine:

V = USR (0) : A = PEEK (240)  
A now has the value of the ASC11 code of the last key to be pressed.  
If no key is pressed then A = 0.

An example is shown below:

```
10 PRINT "DO YOU WANT TO CONTINUE"
20 V = USR (0) : A = PEEK (240)
30 IF A = 0 THEN 20
40 IF A = ASC ("Y") THEN 80
50 IF A = ASC ("N") THEN 100
60 PRINT "RESPONSE INVALID"
70 GO TO 20
80 REM Do something
90 GO TO 10
100 END
```

To control a printer from BASIC, rather than from the monitor, USE the output vectors:

7FD0 H 32720 D  
and 7FD1 H 32721 D

The contents of these locations will change depending on the output option selected. To turn on the line printer (Centronics) POKE 32720, 147 and to switch it off again POKE 32720, 240. (A word of warning, we've found that if we mess about in the monitor before executing POKE 32720, 147 we lose our program entirely — some caution is needed). Rob Beynon, Liverpool University.



# SIRTON PRODUCTS

13 Warwick Road, Coulsdon, Surrey, CR3 2EF  
Telephone : 01 - 660 5617

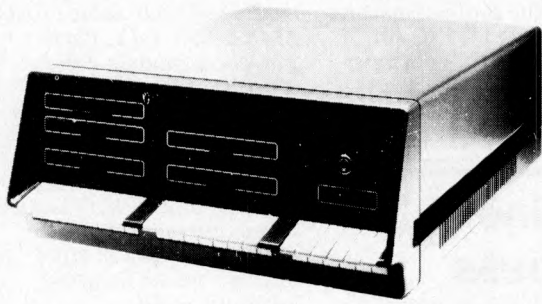

Professional versatile computer system with comprehensive front panel facilities and 20-slot motherboard. Units have substantial power supply etc. and come with 2 or 4 MHz Z80 CPU. BUS conforms to the IEEE S100 standard.

DPS.1 from £695

Available with K2 operating systems & PASCAL/Z. Companion Disc Drive Enclosure for on-line storage for 250K Bytes to 2 M Bytes.

## MIDAS

## MIDAS S.100 SYSTEMS

Substantial Mainframe to house your S100 system, with optional 5" or 8" disc drives. Special systems built to your requirements from Z80 CPU and other S100 boards held in stock

Mainframes from £228

MIDAS 1 : Z80 System from £625 (built)

MIDAS 2 : Z80 Disc System from £1100 (built)

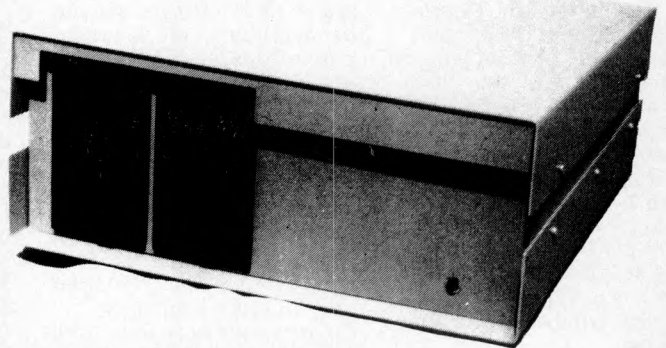

DOUBLE DENSITY recording available on MIDAS giving up to 2M BYTES of on-line storage. Software for MIDAS includes CP/M, FORTRAN, COBOL, PASCAL and several BASICS including XYBASIC for control applications.

### BOARD KITS — many also as bare boards

Z80 Starter Kit, featuring on board Keyboard, 2K Monitor, 1K RAM, 2x8 bit I/O Ports, Prom Programmer etc.	£145.00
Z80 CPU, 2 MHz, 1K RAM, up to 8K EPROM, Serial/Parallel I/O port, four channel counter timer	
— SBC 100	£155.00
Z80 CPU Board 4 MHz, jump-on-reset	£116.00
8080 CPU Board, jump-on-reset	£87.00
8K RAM Board, low power	
450 n Sec (21L02-1)	£79.00
16K RAM Board, low power	
250 n Sec. Static	
Dynamic RAM Board for 16-64K RAM (4116)	£195.00
2708 EPROM (16K) for 2708 or 2716 EPROMS	£91.00
2708/2716 EPROM Prog. Board,	
2 Textool A/T sockets	£63.75
I/O Board, 2/2, DIP switch selection	£86.50
I/O Board, 2/4 provision	£95.00
4K RAM/4K ROM	£135.00
Video Interface, 16 lines, 32 or 64 ch/line (60 frames)	£91.00
Video Interface, 16 lines, 64 ch/line (50 frames) A/T	£108.75
Video Display, 80 ch x 24 l, keyboard interface, 2K RAM, 256 available chars etc	£192.00
Motherboard (13 slot with four edge connectors)	£48.50
Motherboard (9 slot with four edge connectors)	£40.00
<b>FLOPPY DISCS</b>	
SHUGART SA400 Mini Floppy 5¼"	£190.00
SIEMENS 120 8" Disc Drive	£325.00
Disc Controller, 5" or 8"	£98.00
Double-Density Disc Controller	£280.00

### HARDWARE

EPROM Eraser (240V) :	
Erases up to 12 EPROMS at a time	£40.00
S100 Edge Connectors, solder tail	£2.45
S100 Edge Connectors, gold plated wire wrap	£3.50
Transformer Pri 110/240V; sec. 8V @ 10 amp & 25V CT @ 2 amp	£12.75
Bridge Rectifier 25 amp @ 50V	£3.75

### SOFTWARE

CP/M on 8" or 5" Floppy Disc	£76.00
C-BASIC 2	£74.00
Z80 Disc Based Assembler, Linker & Editor	£60.00
Microsoft BASIC V.5.	£160.00
XYBASIC — Extended	£220.00
FORTRAN 80	£210.00
COBOL 80	£325.00
PASCAL	£145.00
PASCAL/Z	£131.25
DISZILLOG Z80 Disassembler	£37.00

### PERIPHERALS

12" VIDEO MONITOR, green phosphor bonded tube, displays up to 80 ch/24 lines, 50/60 Hz operation	£215.00
PRINTER, Bi-Directional Dot Matrix; 112 ch/sec; 96 ch ASCII set, 80 ch/line; 900 ch buffer; RS232 or parallel input	£595.00
KEYBOARD set, 80 ch/line; 900 ch buffer; PERI	

### PERIPHERALS

12" VIDEO MONITOR, green phosphor bonded tube, displays up to 80 ch/24 lines, 50/60 Hz operation	£215.00
PRINTER, Bi-Directional Dot Matrix; 112 ch/sec; 96 ch ASCII set, 80 ch/line; 900 ch buffer; RS232 or parallel input	£595.00
KEYBOARD, 56-key Tri-mode ASCII output, with case & edge connector	£68.00
12V DC/DC Converter	£6.00

WRITE OR PHONE FOR CATALOGUE

# YOUNG COMPUTER WORLD

Young Computer World is the place where, each month, John Coll highlights the thoughts, ideas and contributions of PCW's younger readers.

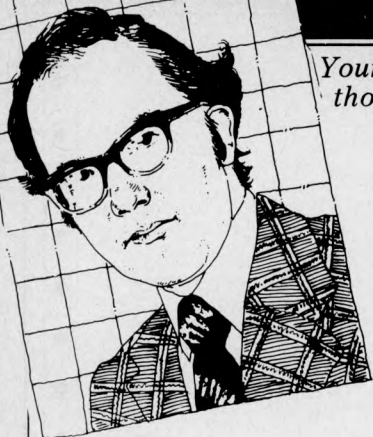

## Reactions

I can see that the major problem about this page is going to be finding space to print all the good stuff that comes in. We have given some thought to this problem and perhaps there is a place for publishing a whole selection of programs in book form in addition to the regular page in PCW. Anyway that remains to be seen. Also, of course, we are able to "overflow" into the Programs section.

However, I have only had one reply to my request for an idiot proof input subroutine, but I guess that may be because of the misprints which made the idea a little difficult to follow! I will leave that topic open for a while in the hope that others will try.

## Calculator programmes

I've been surprised at the number of calculator programs sent in. S.P Tait (17) is an apprentice with Marconi Communications Systems in Chelmsford and he has submitted five programs for the T157. One uses Kirchoff's and Ohm's laws, one plays pontoon. The other three deal with Matrix Multiplication, Number Base Conversion and a version of Mastermind. One of his programs is printed below.

## Number base conversion

STO 2	32 2
R/S	81
STO 0	32 0
R/S	81
STO 5	32 5
RCL 2	33 2
LBL 1	86 1
STO 2	32 2
1	01
STO 3	32 3
LBL 6	86 6
RCL 5	33 5
INV PROD 2	-39 2
X	55
RCL 2	33 2
INV INT	-49
INV SUM 2	-34 2
X	55
RCL 3	33 3
=	85
SUM 1	34 1
RCL 0	33 0
PROD 3	39 0
RCL 2	33 2
X=T	-66
GOTO 6	51 6
RCL T	33 1
INV SUM 1	-34 1
R/S	81
RST	71

The program converts any integer in any base 1 to 10 to decimal or any decimal integer to any base 1 to 10

To use the program enter the number then R/S. Enter the base of the first number then R/S, then enter the base of the result followed by R/S.

## CESIL

Undoubtedly the most interesting letter this month came from Richard Clyne (15) of London SW11. He has written a CESIL interpreter in BASIC. CESIL is a language which makes the computer behave like a very simple machine and

illustrates how an assembler works. Space does not permit a detailed explanation of how to work the program but it's fairly obvious. It was not the length of the program that was impressive but rather the fact that it was so clearly set out and easy to use. Richard's program was written to run on the ILEA RSTS System 6000 but it will be easy to alter the file handling for other systems. A fine piece of work.

See you at the show and in the meantime keep sending me useful bits and pieces. My address is Laxton House, Oundle, Peterborough PE8 4AQ. Thanks.

## Program listing

```

● CESIL 13:37 13-SEP-79
10 RANDOMIZE
20 PRINT " MODES AVAILABLE : "
● 30 PRINT TAB(10)," (1) INPUTING A PROGRAM"
40 PRINT TAB(10)," (2) LISTING A PROGRAM"
50 PRINT TAB(10)," (3) EDITING A PROGRAM"
● 60 PRINT TAB(10)," (4) RUNNING A PROGRAM"
70 PRINT TAB(10)," (5) RECALLS A SAVED PROGRAM"
80 PRINT TAB(10)," (6) INDEX OF ALL SAVED PROGRAMS"
● 90 PRINT TAB(10)," (7) SAVE A PROGRAM"
100 PRINT TAB(10)," (8) LIST OF VARIABLES"
110 PRINT TAB(10)," (9) LIST OF LABELS"
● 120 PRINT TAB(10)," (10) DELETING A PROGRAM"
130 DIM C$(3,200),L$(200),V$(200),VC(200),PS(100)
131 DIM D(100)
● 140 PRINT:INPUT "MODE":M
150 IF M>10 GOTO 20
160 M=INT(M)
● 170 IF A9>A6 THEN A6=A9
180 IF M>7 GOTO 1940
● 190 ON M GOTO 200,310,410,530,1530,1610,1710,1950
200 OPEN "KB:"FOR INPUT AS FILE #9
210 A9=1
● 220 INPUT #9,"L<":C$(1,A9)
230 IF C$(1,A9)="END"GOTO 290
● 240 INPUT #9,"C<":C$(2,A9)
245 IF C$(2,A9)="DATA" GOTO 301
250 INPUT #9,"A<":C$(3,A9)
● 260 PRINT
270 A9=A9+1
● 280 GOTO 220
290 CLOSE #9
● 300 GOTO 140
301 INPUT "HOW MANY DATA ITEMS":D:FOR D1=1 TO D:INPUT #9,D(D1):NEXT D1
● 302 D2=D
303 GOTO 140
310 ! LISTING PROGRAM (CESIL)
● 320 PRINT:PRINT
330 PRINT "CARD NUMBER",
● 340 PRINT "LABEL","COMMAND","LABEL/VARIABLE"
350 A9=1
● 360 IF C$(1,A9)="END" GOTO 140
375 IF C$(2,A9)="DATA" GOTO 401
● 377 PRINT A9,
380 PRINT C$(1,A9),C$(2,A9),C$(3,A9)
● 390 A9=A9+1
400 GOTO 360
401 PRINT "DATA",:PRINT D(D):FOR D=1 TO D2
● 402 GOTO 140
410 ! *****
420 A9=1
● 430 IF C$(1,A9)="END" GOTO 440 ELSE GOTO 460
440 INPUT "ADD MORE":YS
● 450 IF LEFT(YS,1)="Y" GOTO 220 ELSE GOTO 140
460 PRINT C$(1,A9),C$(2,A9),C$(3,A9)
470 INPUT "KEEP" ; ES
● 480 IF ES="E" GOTO 140
490 IF ES="C" GOTO 500 ELSE A9=A9+1:GOTO430
● 500 INPUT C$(1,A9),C$(2,A9),C$(3,A9)
510 A9=A9+1
● 520 GOTO 430

```



## COMMODORE PETS

Free file and record management program with every PET sold (limited period only).

Selection of Printers and Floppy Disks.

Large selection of software + programming service available. Few secondhand PETS available, e.g. 8K from £400.00 + VAT.

Call at: Davinci Computers Ltd., Classic Offices, Rear of Classic Cinema, Hendon Central, London NW4. Tel: 202 9630.

\*\*\* Wanted \*\*\* Part Time Programmers. Call above address.

## INTELLIGENT ARTIFACTS

Sale of S100 Memory Boards  
16K fully static, 2MHz £175 each  
4MHz £220 each. Also Z-80 CPU Boards  
4 MHz £150 each.

We also sell PETs, Challengers, AIM 65 etc. All imported direct from USA. Lowest prices in UK.

Send or call for Price List.  
Telephone: Arrington (022 020) 689  
Cambridge Road, Orwell,  
Nr Royston, Herts.

## PETS £400

4K VERSION IN STOCK. 8K £450  
etc. ALL PET PRODUCTS WAY  
UNDER UK PRICES. WE IMPORT  
DIRECT FROM USA AND CONVERT  
TO UK MAINS.

### AIM 65

WITH CASE, POWER SUPPLY AND  
4K RAM, BASIC AND  
ASSEMBLER £400

### AIM + KIM

EXPANSION CHASSIS AND 16K  
MEMORIES. NORTHSTAR BASED  
S100 SYSTEMS FROM £1,200.

SEND FOR PRICE LIST  
INTELLIGENT ARTIFACTS LTD  
CAMBRIDGE RD, ORWELL  
ROYSTON, HERTS.

## QWERTY COMPUTER SERVICES

Q.C. software; best quality budget priced programs:-

<b>FUN</b>	<b>LANGUAGES</b>
Torpedo Run	Q.Sil
Squash/cricket etc	Pilot
<b>EDUCATIONAL</b>	<b>BUSINESS</b>
Graph, plot	Stock control
Remedial Maths/	Cash Flow
English, Payroll	

Many more, send s.a. for listing.

We always require original programs and interfaces. If you have one send it to us for evaluation. Up to 35% royalty paid.

Q.C.Z. 20 Worcester Road, Newton Hall, Durham. Tel: 0385 67045

## PROGRAMS

```

530 L=1:D=1
540 FOR A8=1 TO A6-1
550 IF C$(1,A8)=""GOTO570
560 L$(L)=C$(1,A8):L(L)=A8:L=L+1
570 NEXT A8
580 L(O)=L
590 V=1
600 FOR A8=1 TO A6-1
610 V9$ =C$(2,A8)
620 IF V9$="STORE" GOTO 650
630 NEXTA8
640 GOTO 680
650 V9$=LEFT(C$(3,A8),1)
660 IF V9$="+" OR V9$="-" GOTO 630
670 V$(V)=C$(3,A8):V=V+1:GOTO 630
680 V(O)=V
690 P=1
700 A=INT(A)
710 X$=C$(2,P)
720 IF X$="IN" GOTO 890
730 IF X$="OUT" GOTO 920
740 IF X$="HALT" GOTO 950
750 IF X$="LOAD" GOTO 980
760 IF X$="JIZERO" GOTO 1090
770 IF X$="JINEG" GOTO 1120
780 IF X$="JUMP" GOTO 1140
790 IF X$="STORE" GOTO 1210
800 IF X$="PRINT" GOTO 1270
810 IF X$="LINE" GOTO 1290
820 IF X$="ADD" GOTO 1310
830 IF X$="SUBTRACT" GOTO 1340
840 IF X$="MULTIPLY" GOTO 1370
850 IF X$="DIVIDE" GOTO 1400
860 IF C$(2,P)="" GOT0140
870 PRINT C$(2,P);" IS NOT A LEGAL COMAND
880 PRINT"EDIT IT OUT!":GOTO140
890 A=D(D):D=D+1
900 P=P+1
910 GOTO 700
920 PRINT A;
930 P=P+1
940 GOTO 700
950 GOTO 130
960 P=P+1
970 GOTO 700
980 J$=C$(3,P)
990 IF LEFT (J$,1)="" OR LEFT(J$,1)="-" GOT01060
1000 FOR A9=1 TO V(O)
1010 IF C$(3,P)=V$(A9) GOTO 1040
1020 NEXT A9:P=P+1
1030 GOTO 700:NEVER REACHED
1040 A=V(A9)
1050 P=P+1:GOTO 700
1060 A= VAL(RIGHT(J$,LEN(J$)-1))
1070 IF LEFT(J$,1)="-" THEN A=-A)
1080 P=P+1:GOTO 700
1090 IF A=0 GOTO 1140
1100 P=P+1
1110 GOTO 700
1120 IF A<0 GOTO 1140
1130 P=P+1:GOTO 700
1140 FOR A8=1 TO L(O)
1150 IF C$(3,P)=L$(A8) GOTO 1190
1160 NEXT A8
1170 PRINT"LABEL ERROR CARD";P
1180 GOTO 140
1190 P=L(A8)
1200 GOTO 700
1210 FOR A7= 1 TO V(O)
1220 IF V$(A7)=C$(3,P) GOTO 1260
1230 NEXT A7
1240 PRINT "VARIABLE ERROR! CARD";P
1250 GOTO 140
1260 V(A7)=A:P=P+1:GOTO700
1270 PRINT C$(3,P);
1280 P=P+1 :GOTO 700
1290 PRINT
1300 P=P+1:GOTO 700
1310 GOSUB 1430
1320 A=A+T
1330 P=P+1:GOTO 700
1340 GOSUB 1430
1350 A=A-T
1360 P=P+1:GOTO 700
1370 GOSUB 1430
1380 A=A*T
1390 P=P+1:GOTO 700
1400 GOSUB 1430
1410 A=INT(A/T)
1420 P=P+1:GOTO 700
1430 J$=C$(3,P)
1440 IF LEFT (J$,1)="" OR LEFT (J$,1)="-" GOTO 1500
1450 FOR A7= 1 TO V(O)
1460 IF V$(A7)=J$ GOTO 1490
1470 NEXT A7
1480 PRINT" VARIABLE ERROR!!!!(MATH FUNCTION) CARD";P:GOTO140
1490T=V(A7):RETURN
1500 T=VAL(RIGHT(J$,LEN(J$)-1))
1510 IF LEFT (J$,1)="-" THEN T=-T)
1520 RETURN
1530 INPUT "PROGRAM NAME";P$
1540 OPEN P$ FOR INPUT AS FILE I%
1550 V=1
1560 INPUT #1,C$(1,V)
1570 IF C$(1,V)="END" GOTO 1590
1580 INPUT#1,C$(2,V):INPUT #1, C$(3,V):V=V+1:GOTO 1560
1590 CLOSE#1
    
```

## PROGRAMS

```

1600 GOTO130
1610 OPEN 'INDEX' FOR INPUT AS FILE 1%
1620 A=INT (RND*6)+7
1630 PRINT TAB(A),"CESIL PROGRAMS"
1640 INPUT #1,J
1650 FOR O5 = 1 TO J
1660 INPUT #1,PS
1670 PRINT PS
1680 NEXT O5
1690 CLOSE #1
1700 GOTO 130
1710 INPUT"PROGRAM NAME"PS
1720 OPEN PS FOR OUTPUT AS FILE 1%
1730 FOR A7=1 TO A6
1740 PRINT #1,CS(1,A7)
1750 PRINT #1,CS(2,A7)
1760 PRINT #1,CS(3,A7)
1770 NEXT A7
1780 PRINT #1,"END"
1790 CLOSE #1
1800 OPEN'INDEX' FOR INPUT AS FILE 1%
1810 INPUT #1,J
1820 FOR A=1 TO J
1830 INPUT #1,PS(A)
1840 NEXT A
1850 CLOSE #1
1860 PS(J+1)=PS
1870 OPEN.'INDEX' FOR OUTPUT AS FILE 1%
1880 PRINT #1,J+1
1890 FOR A=1 TO J+1
1900 PRINT #1,PS(A)
1910 NEXT A
1920 CLOSE #1
1930 GOTO 130
1940 ON M-7 GOTO 1950,2070,2110
1950 ! LIST OF VARIABLES
1960 Z=1
1970 FOR X=1 TO V(O)
1980 FOR Y = 1 TO X-1
1990 IF VS(X)=V9$(X) GOTO 2030
2000 NEXT Y
2010 V9$(Z)=VS(X):V9(Z)=V(X)
2020 Z=Z+1
2030 NEXT X
2040 PRINT "VARIABLE","CONTENTS"
2050 PRINT V9$(X),V9(X) FOR X= 1 TO Z-1
2060 GOTO 130
2070 ! LIST OF LABELS
2080 PRINT"CARD","LABEL"
2090 PRINT L(Z),LS(Z)FOR Z=1 TO L(O)-1
2100 GOTO 130
2110 !DELETEING A FILE
2120 INPUT"PROGRAM TO DELETE";PS
2130 OPEN'INDEX'FOR OUTPUT AS FILE 1%
2140 INPUT #1,J
2150 FOR X=1 TO J
2160 INPUT #1,PS(X)
2170 IF PS=PS(X) THEN 2210
2180 NEXT X
2190 PRINT"NO SUCH PROGRAM"
2200 GOTO 130
2210 INPUT #1,PS(X)
2220 FOR Y=X+1 TO J
2230 INPUT #1,PS(Y)
2240 NEXT Y
2250 CLOSE #1
2260 KILL PS
2270 OPEN'INDEX'FOR OUTPUT AS FILE1%
2280 PRINT #1,J-1
2290 FOR X=1 TO J-1
2300 PRINT #1,PS(X)
2310 NEXT X
2320 CLOSE #1
2330 GOTO 130
32627 END

```

## BELLS & WHISTLES

Recently PCW has received several cassette handling programs and subroutines. Here are two which should prove particularly useful.

### READ/WRITE ROUTINES

Thomas Turnbull, PETSOFI consultant presents a method for reading and writing PET data files without error.

This method gives close to 100% reliability. It involves two subroutines to increase the gap between data blocks written to tape, thus allowing the machine to read back all the data without dropping a single block. Remember, if a block that is lost contains an EOT or EOF the computer will crash with hardly any hope of recovery.

My subroutine starts at line 5000 for tape 1 and line 6000 for tape 2.

These subroutines need only be used on PRINT files (not READ files). Before opening a print file to CASSETTE 1 have the following POKE commands:

10 POKE 244,2:POKE 243,122:open 1,1,1

This is the POKE command for CASSETTE 2:

20 POKE 244,3:POKE 243,58:OPEN 3,2,1

## MICROMART

### COMPUTECH FOR APPLE SYSTEM APPLICATIONS SOFTWARE

Professional business software packages now available are turnkey systems with comprehensive manuals, built-in validity checks, interactive enquiry facilities, user options, satisfying accountancy. Inland Revenue and Customs and Excise requirements on diskette with DOS 3.2 and Space Utility. From £295 ea.

Not adaptations, written specifically as packages for the Apple System.

### COMPUTECH SYSTEMS

168 Finchley Road, London, NW3  
6HP Tel: 01-794 0202

Dealer enquiries welcome

### AZTEC

We have a growing selection of PET SOFTWARE for MANAGEMENT SCIENCE plus books, accessories etc.

Send for free catalogue.

We publish good, original programs and books on a royalty basis. Write now for details.

AZTEC 29 Royston Way  
Slough Berks. SL1 6EP  
Burnham (06286) 65408

## Vets for Pets

Anita Electronic Services (London) Ltd. are specialists in the repair and service of Commodore Pets.

We offer a fast on-site service, or alternatively repairs can be carried-out at our workshops should you wish to bring in your Pet.

Pet maintenance contracts are available at very competitive prices. Trade inquiries welcomed.

For further information tel. or write to:-

John Meade  
Anita Electronic Services,  
15 Clerkenwell Close, London EC1  
01-253 2444

\* We also specialise in the repair of all makes of office equipment.

## RACAL-ZONAL

### RACAL-ZONAL C-12 CASSETTES

Quality you can rely on  
Screwed shell, c/w library case  
5-£3.20, 10-£5.30, 50 £23.90

TDK HEAD DEMAGNETISER £11.75  
RACAL HEAD CLEANER £ 0.40

### BOOKS\*\*BOOKS\*\*BOOKS\*\*BOOKS

Computer programs that work £ 2.90  
Introduction to personal and  
business computing (ZAKS) £ 5.00  
Microprocessors - from chips  
to systems (ZAKS) £ 7.50  
Programming the 6502 (ZAKS) £ 8.00  
6502 Applications book (ZAKS) £ 9.00

CWO.£2.00min. Post & VAT included

DJM SERVICES 82 Hilden Park Rd  
Hildenborough KENT. Tel 0732 832815

# MICROMART

## BIAS POWER SUPPLIES FOR SYSTEM 64K EXPANSION

**BIAS 1** for general micro use  
+5 @ 10amps ±12v @ 2amps  
-5 @ 1amp KIT £42.50

**BIAS 3** for S100 systems  
+8v @ 10amps  
±18v @ 3.5amps KIT £40.20

Over Voltage Protection  
-optional B1-£12; B3-£9

**HEAVY ALLOY CASE**  
150 x 150 x 200  
includes switches, connectors,  
predrilled £12

Assembled & Guaranteed add £15

Mail order to:  
**TOOTING COMPUTING**  
p & p 157 ROBINSON ROAD  
£2.50 LONDON SW17  
Prices excluding VAT.  
Tel: 01-543 1398

**50 HZ  
SUPERBOARD  
£190**  
(BRITISH STANDARD)  
PLUS  
OFFICIAL  
Dealer Support  
PLUS

ASS/ED, EX/MON and other software  
and expansion available

CTS 1 Higher Calderbrook  
Littleborough, Lancs. OL15 9NL  
Tel: Littleborough (0706) 79332 anytime

### PETS!

Pets - new for old, part exchange  
your faithful Pet for a new model. We  
stock commodore or computhink discs,  
PET printers and teletypes etc.

We also by used Pets and peripherals  
for cash.

### HORIZONS!

32K static memory (the best) 2 double  
density discs (2 serial and 1 parallel port)  
From £1999

### HIRE!

PET 8K £4.75 per day  
PET 32K £6.95 per day  
Teletype 43 £6.00 per day  
HORIZON P.O.A.

### High Quality Cassettes!

C15 41p C30 55p including VAT  
Post 20p Orders over £4.00 free postage

Contact: Richard Mortimore or  
Chris Phelps at  
MICRO - FACILITIES  
01 979 4546/941 1197

## PROGRAMS

These POKE commands tell the PET  
which buffer it is to use and make sure  
that a proper tape header is written.  
If this is not done you will be unable  
to open that file for read operations.  
These POKE commands need only be  
put before the open statements and

nowhere else in the print file used.  
To use these subroutines you must  
GOSUB 5000 for tape 1 or GOSUB  
6000 for tape 2 after every print to the  
file.

Here is an example:

```

● 40 PRINT*1,AS:GOSUB5000:REM THIS IS FOR TAPE 1
●
● TAPE 1
● 5000 IF PEEK(625)<180 THEN RETURN:REM LOCATION
● 625 IS THE TAPE 1 BUFFER COUNTER
● 5010 POKE59411,53:T=TI:REM POKEING LOCATION
● 59411 WITH 53 STARTS TAPE 1 MOTOR RUNNING
● 5020 IF TI-T<6 THEN 5020:REM THIS SETS TAPE
● RUNNING FOR 1/10TH SECOND INCREASING GAP
● 5030 POKE59411,61:RETURN:REM THIS POKE COMMAND
● SWITCHES CASSETTE 1 OFF
●
● TAPE 2
● 6000 IF PEEK(626)<180 THEN RETURN:REM LOCATION
● 626 IS BUFFER FOR TAPE 2
● 6010 POKE 59456,207:T=TI:REM THIS STARTS CASSETTE
● 2 MOTOR
● 6030 IF TI-T<6 THEN 6030
● 6040 POKE 59456,223:RETURN
    
```

All PETSOF programs that use files  
have this subroutine included and they  
are very reliable in use.

The reason that the buffer is made  
to check the number 180, and not  
191 as you would expect, is because  
this keeps the motor running in small

starts until the buffer is finally emptied.  
Once empty, there is no need for the  
tape recorder to build up to writing  
speed as it will already be at the right  
speed and the data will be written at  
the correct rate.

## GLITCH FREE LOADING

by J. Luxford

This is written for NASCOM 1 users but  
the principles described may be easily  
applied to other micros.

### Problem:

You have a cassette written on another  
recorder which (due to incompatible  
head alignment, speed differences or  
poor tape quality) will not give error  
free program loading. You do not have  
listings in order to make manual correc-  
tions and, anyway, even if you did there  
may be too many. What to do?

### Solution:

1. Load the corrector program in a  
disused location.

2 Clean the tape recorder heads.  
3 Load as normal, (keep a note of  
errors). We will call the memory block  
just loaded block 1.

4 Copy block 1 to a free memory  
area. Call this area block 2.

5 Re-run the tape, reloading block 1  
to free memory area. Call this block 3.

6 Re-run the tape, reloading block 1

7 Execute the corrector program. If  
there are any remaining errors the faulty  
locations will be listed. If none are listed  
the program is loaded.

8 If errors still exist copy block 1 to  
block 2, reload block 1. Execute correc-

CP	Machine Code	Label	Mn	Op1	Op2	Comments
● 0D00	21000E	START	LD	HL	#0E00	] Initialise pointers to start of mem. blocks 1,2&3.
● 03	DD210016		LD	1X	#1600	
● 07	FD21001E		LD	1Y	#1E00	
● 0B	7E	NEXT	LD	A	(HL)	] Get the bytes for comparison
● 0C	DD5600		LD	D	(1X+d)	
● 0F	FD5E00		LD	E	(1Y+d)	
● 12	BA		CP	D		] Are blocks 1,2 same ? If so, good
● 13	2812		JR	Z	GOOD	
● 15	BB		CP	E		] Else compare blocks 1,3 If 1,3 same good
● 16	280F		JR	Z	GOOD	
● 18	7A		LD	A	D	] Else compare blocks 2 & 3
● 19	BB		CP	E		
● 1A	77		LD	(HL)	A	] Upgrade block 1
● 1B	280A		JR	Z	GOOD	
● 1D	E5D5		PUSH	HL	DE	] If data bad print bad addr. and scroll
● 1F	CD3202		CALL	TBCD3		
● 22	CD4002		CALL	CRLF		
● 25	D1E1		POP	DE	HL	] Set pointers to next byte
● 27	23	GOOD	INC	HL		
● 28	DD23		INC	1X		
● 2A	FD23		INC	1Y		
● 2C	010016		LD	BC	(# END BLK1+1)	] Check to see if finished
● 2F	B7		OR	A		
● 30	ED42		SBC	HL	BC	
● 32	09		ADD	HL	BC	
● 33	CA8602		JP	Z	PARSE	] Exit to monitor Else get next byte
● 36	1BD3		JR	NEXT		

## PROGRAMS

tor program.

9 If errors are still listed repeat step 8. Note: If insufficient memory is available to load the whole program in one go, split the program into segments. When each segment is cleaned up, DUMP on to scratch tapes, then assemble the individual good tapes to re-form the complete program.

Example:

1 The corrector is loaded at 0D00 — 0D37. (This may be relocated as only relative jumps are used). Our program to be loaded resides in 0E00 to 15FF so we define block 1 as 0E00 to 15FF, block 2 as 1600 to 1DFF and block 3 to 1E00 to 25FF.

Note: corrector lines 0D00, 0D03 and 0D07 are set to point at the start of these blocks and line 0D2C is a terminator set at [(END OF BLOCK 1) + 1]. Notice Z80 practice of putting Lo order

bÿte first.

2 Load block 1. Copy to block 2.

>CE00 1600 7FF NL

3. Reload block 1. Copy to block 3.

>CE00 1E00 7FF NL

4. Reload block 1

5. Execute corrector program, but because block 1 overlaps page 0 — 1 first modify R.SP. to 0C33 to prevent corruption of block 1. (see PCW March 1979 letters).

>M0C3D NL

33 0C. NL

>E0D00 NL

The monitor will now list any remaining errors. If none, the monitor will return a prompt (>) and the program is loaded.

Final note: This represents a very simple process of choosing any two from three, more sophisticated combinations may be used but it is doubtful if more complex and hence longer programs are justified on this application.

## FUN & GAMES

### APPLE WORMS

by Ray West, freelance programmer

TAPEWORMS: A KEYBOARD VIDEO GAME FOR THE APPLE

'Tapeworms' is a game for two players which uses the keyboard interactively. Each player has four allocated keys, which are identified by the keyboard PEEK function. Two shape tables are loaded by the program, and these give each 'worm' a different appearance. To improve the appearance of the display, the rotation feature of the shape table is used so that the direction of movement of the worm is matched by the rotation of the shape. A game ends either when a player crosses the rectangular border of the playing area, or collides with a previously plotted shape; the collision counter provides a way of checking for this event. For a detailed explanation of the listing, now read on...

Lines 510-640 are the main program control. There are essentially six subroutines which are called.

SUB 20000. This sets up a shape table of two shapes. Line 20000 sets up pointers in locations 232 and 233, the low and high bytes respectively. Since  $117 * 256 + 48 = 30000$ , the Apple expects the shapes to start at 30000. This works for a 48K or 32K machine. Line 20001 tells the machine there are two shapes in the table, and lines 20005 and 20010 give their addresses, offset from 30000. So shape 1 begins at  $30000 + 256 * 0 + 159 = 30159$ , for example. The two shapes are 'A' and 'V', and were used because they happened to be available. If you don't like them, try adjusting the table!

SUB 10000. This prints the title page onto the screen, enabling one of three playing speeds to be selected. In addition, variables are stored just after the program; line 10010 ensures that the coordinates and directions of each 'worm' are stored where retrieval time is minimised. Random start points and directions are generated for each player; in line 10220 they are checked to avoid starting too close to each other. Direc-

tions 1 to 4 are converted into the relevant keystroke equivalent for each player.

SUB 1000 & SUB 1400. This symmetrical pair of routines reads the keyboard. The point of the last statements of lines 1000 and 1400 is that the Apple seems sometimes to admit a low ASCII value. If on A's turn his part of the keyboard registers an input, its ASCII value is saved; and similarly on B's turn. In a fast game, only one peek at the keyboard is allowed.

SUB 2110 & SUB 2510. The x or y coordinate is incremented/decremented as required, and the direction indicator AD or BD set to correspond. Lines 2145 and 2545 test the new plot. If it is an acceptable move, the other person's score is increased by 1 and exit to the end-of-game routine occurs. The POP instruction removes the subroutine's return address from the stack: were this instruction omitted, after about 24 games the stack would fill up and an OUT OF MEMORY message appear. The formulae for ROT need to introduce multiples of 16, for which the values differ for the shapes plotted, so that lines 2147 and 2547 use different calculations. The direction is coded as 1 for north, 2 for east, and so on.

SUB 25000. This is entered only in a slow or medium speed game. It uses simple delay loops, which, however, have diminishing effect as the game proceeds. So the tempo accelerates towards the end.

SUB 26000. This routine displays the aggregate scores to date, the player sitting on the left having his score shown at the left of the screen and vice versa. The set of games can be terminated in order to change speed, or start afresh, by entering 'N'. Since some characters may remain in the buffer, line 26040 checks for the presence of an 'N' within it. If the set of games continues, line 26040 loops back to reset new starting positions and directions, before returning to the program's main control.

## MICROMART

### PETFOLIO

A New Book  
PET FOR BEGINNERS (£1)  
Also Book 2 £1.50

Also a new generation of  
Pet software  
Legible-fool proof-self-explanatory  
Educational, statistics, bibliography

Details from Morgan, Inis Beag,  
Blackhill, Colerains, BT51 4EU, N1

### HIRE

Pets Apples Horizon Floppy  
Disk and Printers etc.  
Some less than £12 per week  
inclusive.

01 368 9002

Monday — Sunday day — evening

Quality S100 Expansion for  
Pet 8K only £135  
01 368 9002

Top Prices for used Pets, Apples  
Working or not.  
Repairs undertaken.  
01 368 9002  
Promglow Ltd  
30 City Road E.C.1.

### INTENSIVE WEEKEND COURSES IN BASIC

including hands-on mini  
computer operation.

This short intensive course is intended to instruct from minimal knowledge to an operational capability of computer programming in BASIC high level language. The course is fully residential from Friday evening to Sunday afternoon.

Option of non-residential weekend, weekday evening and weekday courses available if required.

For further details of dates available, fees, etc:

Phone (0401) 43139, or write to  
CLEVELAND BUSINESS SERVICES  
Cleveland House, ROUTH  
Beverley, North Humberside

HIRE A PET MICRO  
WHY NOT TRY IT  
BEFORE YOU BUY IT  
£5 PER DAY OR £25 PER WEEK  
2ND HAND MICROS  
BOUGHT AND SOLD  
SPECIALISTS AVAILABLE FOR  
SOFTWARE DEVELOPMENT  
ESSEX COMPUTER SERVICES  
TEL: CANVEY ISLAND  
(037 43) 61663 OR 61926



# PROGRAMS

FC49	CD 11 F9	0703	CALL	COMMA	;"",
FC4C	A7	0704	AND	A	;CLEAR CARRY
FC4D	18 DE	0705	JR	LD1+2	;DO INDIRECT BIT
FC4F		0706			;
FC4F		0707			; ROTATE/SHIFT/BIT/SET/RESET
FC4F		0708			; NB. IF INDEXED THEN OFFSET PRECEDES OPCODE
FC4F		0709			;
FC4F	3A 0B 10	0710	CB:	LD	A,(HXYFLG)
FC52	A7	0711	AND	A	;INDEXED?
FC53	F5	0712	PUSH	AF	;SAVE FLAG
FC54	28 0B	0713	JR	Z,NOTXY	;NO,SKIP
FC56	11 34 10	0714	LD	DE,BUFFER+34	;YES,WRITE..
FC59	3E 06	0715	LD	A,6	:...REG. FIRST.
FC5B	CD C4 F9	0716	CALL	SREG	
FC5E	11 2D 10	0717	LD	DE,BUFFER+27	;RESET POINTER FOR MNEMONIC.
FC61	CD DB F8	0718	NOTXY:	CALL	BYTE ;GET OPCODE
FC64	F5	0719	PUSH	AF	;SAVE IT
FC65	FE 40	0720	CP	\$40	<\$40?
FC67	38 27	0721	JR	C,ROTATE	;YES,JUMP
FC69	21 A8 FC	0722	LD	HL,BRSTAB-3	;LOAD POINTER
FC6C	07	0723	RLCA		;SHIFT OPCODE DOWN
FC6D	07	0724	RLCA		
FC6E	E6 03	0725	AND	3	;ISOLATE ID
FC70	47	0726	LD	B,A	;MAKE 3,6,OR 9
FC71	07	0727	RLCA		
FC72	80	0728	ADD	B	
FC73	CD 2A F9	0729	CALL	FTADR	;FORM ADDRESS
FC76	CD 23 F9	0730	CALL	COPY3	;WRITE MNEMONIC
FC79	13	0731	INC	DE	;SPACE
FC7A	13	0732	INC	DE	
FC7B	F1	0733	POP	AF	;GET OPCODE
FC7C	F5	0734	PUSH	AF	;SAVE AGAIN
FC7D	0F	0735	RRCA		;PRINT BIT NUMBER
FC7E	0F	0736	RRCA		
FC7F	0F	0737	RRCA		
FC80	E6 07	0738	AND	7	;ISOLATE BIT ID
FC82	F6 30	0739	OR	\$30	;MAKE ASCII
FC84	12	0740	LD	(DE),A	;WRITE IT
FC85	13	0741	INC	DE	
FC86	CD 11 F9	0742	CALL	COMMA	;"",
FC89	C1	0743	TESTXY:	POP	BC ;RECOVER OPCODE
FC8A	F1	0744	POP	AF	;RECOVER HXY FLAG
FC8B	78	0745	LD	A,B	;LOAD OPCODE
FC8C	C0	0746	RET	NZ	;YES,RETURN
FC8D	C3 C4 F9	0747	JP	SREG	;NO,GO WRITE.
FC90	0F	0748	ROTATE:	RRCA	;SHIFT DOWN
FC91	0F	0749	RRCA		
FC92	C6 02	0750	ADD	2	;ROLL CODING ROUND
FC94	E6 0E	0751	AND	\$E	;ISOLATE ID
FC96	FE 0E	0752	CP	\$E	;IS IT 0E?
FC98	CA D6 FD	0753	JP	Z,NTVL	;YES,INVALID CODE
FC9B	47	0754	LD	B,A	;DO ID*3 AGAIN
FC9C	0F	0755	RRCA		
FC9D	80	0756	ADD	B	
FC9E	21 B4 FC	0757	LD	HL,ROTTAB	;LOAD BASE ADDRESS
FCA1	CD 2A F9	0758	CALL	FTADR	;FORM ADDRESS
FCA4	CD 23 F9	0759	CALL	COPY3	;WRITE MNEMONIC
FCA7	13	0760	INC	DE	
FCA8	13	0761	INC	DE	
FCA9	18 DE	0762	JR	TESTXY	;EXIT WRITING REGISTER
FCAB		0763			;
FCAB	42 49 54 52	0764	BRSTAB:	DB	'BITRESSET'
	45 53 53 45				
	54				
FCB4	53 52 4C 52	0765	ROTTAB:	DB	'\$R\$R\$C\$R\$R\$C\$R\$R\$R\$S\$A\$S\$R\$A\$'
	4C 43 52 52				
	43 52 4C 20				
	52 52 20 53				
	4C 41 53 52				
	41				
FCC9		0766			;
FCC9		0767			; AUTO CP LD IN OUT
FCC9		0768			;
FCC9	CB 57	0769	AUTO:	BIT	2,A ;TEST FOR VALIDITY
FCCB	C2 D8 FD	0770	JP	NZ,NOTVAL	;JUMP IF NOT
FCCF	F5	0771	PUSH	AF	;SAVE OPCODE
FCCF	E6 03	0772	AND	3	;ISOLATE OP ID
FCD1	07	0773	RLCA		;*
FCD2	21 B9 FC	0774	LD	HL,OPTAB	;LOAD BASE ADDRESS
FCD5	CD 2A F9	0775	CALL	FTADR	;FORM ADDRESS
FCD8	CD 25 F9	0776	CALL	COPY2	;WRITE PART OF MNEMONIC
FCD8	F1	0777	POP	AF	;RECOVER OPCODE
FCD8	21 F1 FC	0778	LD	HL,OPTAB+8	;LOAD BASE ADDRESS

To be continued

# BLUDNERS

## Basic Problem

You all spotted the Ss coming out as Ss in Bench Test and ESP didn't you? If not, why not!

## Puzzle

We've decided that Pythagoras was right after all — the area of a right-angled triangle is (once again)  $\frac{1}{2}B \times H$ .

## Spaceship

We think that we've had phone calls from every Fx 201-P owner! Just in case we haven't, ÷ came out as - in the following steps: 40,59,74, and 86 (the second one). Step 98 reads  $4 = 7 \div K2 + 9 + 4$ .

# MICROMART

## THE NEW uHEX 480 EPROM PROGRAMMER 2704 and 2708

Control programs for Z80, 8080, 6800, 6500. Please state machine.

Programs permit programming any length block into the eprom, so even unexpanded machines can now program eproms.

Needs only +5v, +12v, -5v.

Host computers require a PIO (PIA) complete kit ONLY £35 or ready built and tested £5 extra.

**PIO, PIA INTERFACE PANELS**  
Available for Z80/8080, 6800/6500

## THE uHEX 416 DELUXE EPROM PROGRAMMER Push Button Selection for 2704, 2708, 2716. STILL ONLY £65

All prices inclusive.  
SAE for further information about these products.

**MICRO HEX COMPUTERS**  
2, Studley Rise, Trowbridge, Wilts.

# SIGMA SYSTEMS

PETS, PERIPHERALS,  
PETSOFT PROGRAMS

and

A RANGE OF PRINTERS  
FOR THE PET

including

CENTRONICS, BD80, TELETYPE  
AND THE AXIOM. THE ONLY  
PET PRINTER AVAILABLE  
WITH GRAPHICS £575 cwo

**54 PARK PLACE**  
**CARDIFF 21515**

## APPLE AND PET IN DUBLIN

\*Come and see these fine computers in our new show room.

\*Try them and discuss your requirements.

### Sensible Software for Apple

- \*Sales Ledger, Financial Modelling.
- \*Fourier Analysis Shape Maker
- \*Educational Systems in Maths and Physics, Geography, Commerce.

### Softech Ltd

51 Lower Camden Street  
Dublin 2 Republic of Ireland  
Telephone Dublin 976279

## SORCERERS APPRENTICE

All kinds of software available for the Sorcerer. Send S.A.V. for full details. Full range of Exidy products.

7 Westbourne Grove  
Manchester 20  
Macclesfield (0625) 612818



# STOP PRESS

**...44 NEW PROGRAMS for the PET in the latest PETSOF T CATALOGUE including ...**

**167 PROGRAMS**

**6502 FORTH £30** FORTH is a unique threaded language that is ideally suited for systems and applications programming on a PET. The user may have the interactive FORTH Compiler/Interpreter system running stand-alone in 8K to 12K bytes of RAM. The system also offers a built-in incremental assembler and text editor. Since the FORTH language is vocabulary based, the user may tailor the system to resemble the needs and structure of any specific application. Programming in FORTH consists of defining new words, which draw upon the existing vocabulary, and which in turn may be used to define even more complex application. Programs written in FORTH are compact and very fast.

**PHOTOGRAPHY TUTOR £12** A comprehensive course developed by a professional photographer making full use of PET's dynamic graphics capabilities to demonstrate and explain the mysteries of exposure, focus, aperture, shutter speeds, interchangeable lenses, depth of field, etc. The theory and practice of photography are explored interactively, and progress tested. Multiprogram pack containing eight 7K lessons. Available on Disk £15.\*

**HUNT £10** A new concept in fantasy simulations which has achieved wide acclaim. The context is that of a search for a defined object, typically Atlantis or the Holy Grail. The objective, the names and natures of the searchers, their antagonists and the properties of the space in which the hunt is conducted are defined — by you!

**PAYROLL — 400 (Disk) £50** A totally new and complete disk based payroll system designed and written to meet the needs of small businesses. Up to 400 employees per disk are catered for. A 32K PET 2001-32 equipped with dual floppy, an Anadex DP800 or device 4 printer is required.

Facilities provided include Holiday Pay, Sick Pay, Bonus payments and two rates of overtime, as well as allowing a "standard week" to be specified for each employee. Weekly and monthly summaries are provided and amendments necessary because of a Budget (e.g. increasing employee's tax codes) are made very easy. Each week a wage slip is printed for each employee followed by an analysis of the coins/notes required for these employees paid in cash (payments by cheque and credit transfer are also allowed for). Tax and N.I. are computed automatically from a knowledge of the tax code and N.I. rate applicable to that employee. Update service available.

**JOB EVALUATION £25** Conducts the evaluation necessary to establish pay structures and grades. Program computes correct weightings for factors — education, training necessary, responsibility over other men and equipment, working conditions etc. — which comprise job value. A Job Evaluation Formula is created for use as a guide to the relative value of a job based on the thinking of the company or department concerned.

**STOCK CONTROL ON DISK £25** Facilities allow full or operational stock print out, total costing of items in stock and re-order level warning. Data is stored under Reference, Description, Supplier, VAT Rates, On order Quantity, Quantity in Stock, Unit of Quantity Designated, Minimum level, Stock allocated, Sale Price and Purchase Price. Approx 400 items per diskette.

**COURSE HANDLER £95** A must for School Timetablers. The program handles all the information relevant to creating a 4th, 5th or 6th year Option Scheme and is particularly useful where an "Open Choice" of subjects is offered to pupils. The program maintains, via a simple dialogue with the timetabler, a file of pupils and their requests and allocations and a file containing details of the Option Scheme. Facilities are provided for viewing the scheme, the classes, the pupils and the class clash matrix.\*

**CRYPTO PACK £8** This is the complete kit for all those interested in cryptography, codes, ciphers and cryptanalysis. Developed by Dr Michael Richter, the package includes Cryptosub, General Cipher, Cryptanalyser and New Cipher programs.

\*Send for a free Data Sheet.

**PLUS**

**The Original Cassette Magazine for the Commodore PET... CURSOR**

**CURSOR** — The cassette program magazine for PET owners. Mailed to you by first class post, each issue contains a dynamic graphic cover, table of contents and at least five new programs. There is a featured game which might cost £8 elsewhere, plus tutorials, programming aids and business routines, and of course CURSOR Notes with news and equipment reviews.

U.K.: £36 for one year's subscription (10 issues).

Overseas airmail: £45 for one year.

Send for a free Data Sheet.

**AND**

**PETSOF T PROGRAMMERS TOOLKIT**

"10 Powerful New Commands for your PET!"

The Toolkit is a machine language program which is provided in a 2 kilobyte ROM chip. Just plug it in — no tools are necessary — and your PET's BASIC has 10 new and very useful commands including:

AUTO, RENUMBER, DELETE, FIND, APPEND, DUMP, HELP, TRACE and STEP.

For the new 16K and 32K PETs, the toolkit consists of a single ROM chip which plugs into the left most empty socket inside the PET. Price £55 plus VAT. For 8K and other 'old ROM' PETs a small printed circuit board is attached to the memory expansion and 2nd cassette ports of the PET. Price £75 plus VAT. Send for a free Data Sheet

Recommended by Commodore

Programs are available on Commodore format cassettes. Some titles are available on disk for ACT PETSOF T and Commodore Disk systems.

PET is the trade mark of Commodore

# ACT Petsoft

Radclyffe House, 66-68 Hagley Road, Edgbaston, Birmingham B16 8PF. Telephone: 021-455 8585 Telex: 339396

My name is \_\_\_\_\_

I live at \_\_\_\_\_

Postcode \_\_\_\_\_

I have a new/old ROM PET  I have NO PET

Please send me a copy of your latest catalogue



# PUZZLES

## LEISURE LINES

With J. J. Clessa

Most of you spotted the deliberate (?) mistake in our first Leisure Lines — gulp!

Puzzle 1A involves some logical reasoning, and should not have proved much of an obstacle to our readers. The solution is that the pilot's name is SMITH.

Puzzle 1B was a bit tougher, and although it can be solved analytically, by anyone who's familiar with Diophantine analysis, it's a much simpler task to write a small program for desk calculator or micro-computer.

Since we made the error in defining the area of a triangle we decided we would accept either of the two possible solutions — many entries included both anyway.

Using our formula for triangle area (area =  $axb$ ), the smallest solution possible is a triangle with sides 36,48 and 60 units, which has a perimeter of  $12^2$  and an area (?) of  $12^3$ .

However, using the correct formula for area ( $axb/2$ ), the smallest solution is a triangle with sides 144,192,240, with a perimeter of  $12^2$  and an area of  $24^3$ .

Since there was no outright winner, we made a draw and the two lucky readers are: Puzzle 1A: D. E. Arnett of Grimsby. Puzzle 1B: Paul Durrant of Norwich.

Congratulations to both and stand by for a shower of chocolate bars (not to mention the subsequent visit to the dentist).

Just one puzzle for this month, but it's really a rather interesting one. Three friends, Alan, Bert and Colin each possess vehicles. Alan owns a big foreign car, Bert a small English car and Colin, a moped.

One day while discussing mileages, Alan reports that his mileometer, which gives 6-figure mileage readings, is currently showing a

palindromic reading of 006600 miles (for those that know not, a palindromic number is one which reads the same from right to left as it does from left to right).

"What a coincidence", explains Bert, "So is mine. The 5-figure reading at the moment is 18981 miles".

"Well I never", says Colin, "although the mileometer on my moped only shows 4-figures, it's reading 5335 miles, which is also palindromic".

"I wonder if we're ever likely to get such a coincidence again," says Alan.

Well, of course, since each vehicle does a different weekly mileage from the others, there's no way that the question could be answered. But, supposing all three mileometers were connected to just one vehicle, and also supposing that they were equally accurate, then what is the least number of miles that would elapse before a) Alan's and Bert's mileometers are both showing palindromic readings again? b) Alan's and Colin's mileometers are both showing palindromic readings again? c) Bert's and Colin's mileometers are both showing palindromic readings again? and d) all three mileometers are mutually palindromic?

Answers please on a post-card to Puzzle No. 3, *Personal Computer World*, 14 Rathbone Place, London W1P 1DE. Entries must reach our offices by November 30th.

### PRIZES FOR THIS MONTH

This month's prize is really cunning. In order to make sure the winner continues to send in entries to Leisure Lines, we intend presenting him/her with a hundred 10p stamps.

## Professional ASCII Keyboards

£39.50\*



**MODEL KB 756**

**FULLY ASSEMBLED & TESTED CASE AVAILABLE**

Accessories Available include:—

Edge Connector	KB15P	£1.95*
Numeric Key Pad	KB710	£7.50*
Plastic Case (Black)	KB701	£10.75*
DC to DC Converter	DC512	£5.00*

\* U.K. Orders add 15% VAT on Order total.

FULL DATA SHEET ON REQUEST

**Citadel Products Limited.**  
 Dept. PCW 50 High Street, Edgware,  
 Middlesex HA8 7EP. Telephone 01-951 1848

CARTER  
KEYBOARDS

# COLOUR YOUR NASCOM!



**DAZZLING COLOUR GRAPHICS FOR NASCOM 1**

Genuine bit-addressable "pixel" system for straightforward programming of pictorial or mathematical functions.

8 Colour display plus 8 colour independent background facility. Full documentation with FREE SOFTWARE: powerful sub-routines for vector generation, demonstration program for animated effects. All runs in Nascom 1 without expansion. Complete with UHF Colour Modulator for operation with normal colour TV set. Superior design allows connection to most other micro-processor systems — send us diagrams etc of your b & w video circuitry for free advice. Don't be fooled by the price: this is a top quality product which will transform your computer.

**NOW AVAILABLE FOR LIMITED PERIOD AT £45** Inclusive of VAT and postage.

**WILLIAM STUART SYSTEMS Ltd**

Dower House, Billericay Road,  
 Herongate, Brentwood,  
 Essex CM13 3SD.  
 Telephone: Brentwood (0277) 810244

"Stop Press:— UK101 Compatible"

**NRDC and NCC announce the**

# **BRITISH MICROPROCESSOR COMPETITION**

**A competition for the best invention  
incorporating a microprocessor**

**£20,000 total cash prizes**  
**First prize £10,000...**

... and NRDC will give favourable consideration to investing up to £½ million in any of the winning projects.

The competition closes on 14 December 1979. For full details, including entry form and rules and conditions, complete the coupon and post it to:

British Microprocessor Competition,  
c/o The National Computing Centre Ltd,  
Oxford Road,  
Manchester, M1 7ED.

Sponsored by the

**National Research Development Corporation**  
**and The National Computing Centre**

To: British Microprocessor Competition.

Please send me full details and entry form for this competition.  
BLOCK CAPITALS PLEASE.

Name \_\_\_\_\_

Address \_\_\_\_\_  
\_\_\_\_\_  
\_\_\_\_\_

PCW

# SORCERER™

Now becomes a professional word processor...as well!

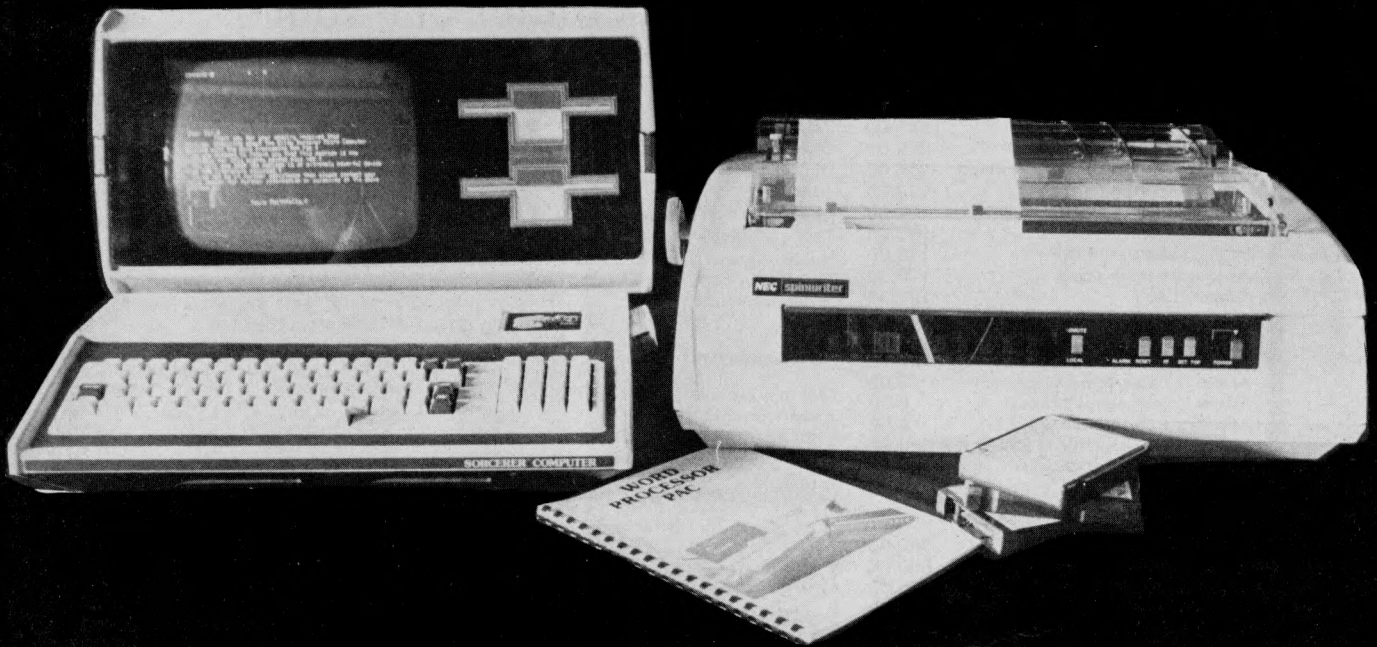

The Sorcerer Computer is a completely assembled and tested computer system ready to plug in and use. The standard configuration includes 63 key typewriter-style keyboard and 16 key numeric pad, dual cassette I/O, with remote computer control at 300 and 1200 baud data rates, RS232 serial I/O for communication, parallel port for direct Centronics printer attachment, Z80 processor, 4K ROM operating system, 8K Microsoft BASIC in separate plug-in Rom Pac™ cartridge, composite video of 64 chars 30 lines, 128 upper/lower case ASCII character set and a 128 user-defined graphic symbols, up to 32K on-board RAM memory, operators manual,

BASIC programming manual and cassette/video cables, connection for S100 bus expansion unit.

The Word Processor Pac creates, edits, re-arranges and formats text. Features include auto wraparound, dynamic cursor control, variable line length, global search and replace, holding buffer for re-arrangement of text, right justification, line width and line to line spacing, underlining or boldfacing, text merging and a macro-facility permitting tasks such as form letter typing, multiple column printing or automatic forms entry.

NOW CONTACT YOUR LOCAL DEALER



OR SEND COUPON FOR FURTHER INFORMATION



PRICES	£
8K Sorcerer	650.00
16K Sorcerer	760.00
32K Sorcerer	859.00
630K Dual Disc Drive	1,200.00
143K Single Disc Drive	500.00
S100 Expansion Unit	210.00
Line Printer	850.00
Video Display	240.00
Development Pack	70.00
Word Processing Pack	70.00
Technical Manual	8.95
Daisywheel type printer	1,900.00
Word processing pack	80.00
Video/disc unit	1,800.00
16K Memory expansion	110.00

- LANCASHIRE**  
051-2272535 MICRODIGITAL 25 Brunswick St., Liverpool L2 BJ
- WEST YORKSHIRE**  
0535 65094 BASIC COMPUTING Oakville, Oakworth Rd., Keighly
- SHEFFIELD**  
0742-668767 E.S. MICROCOMPUTERS 7 Berkley Precint, Ecclesall Rd., S11 8PN
- NORTH WALES**  
0248-52042 TRYFAN A/V SERVICES 3 Swifts Bldgs., High St., Bangor, Gwynedd
- AVON**  
0272-292375 ELECTROPRINT 5 Kingsdown Parade, Bristol BS6 5UD
- NORTH HANTS**  
0536-83922 H.B. COMPUTERS LTD. 22 Newland St., Kettering
- LONDON & Counties**
- BERKSHIRE**  
0635-30505 NEWBEAR COMPUTING STORE 40 Bartholomew St., Newbury RG14 5LL
- KENT**  
01-300 0380 INFORMEX 61 Harland Avenue, Sidcup, DA 15 7NY
- SURREY**  
0276-34044 MICROBITS 34b London Rd., Blackwater, Camberley  
0276-62506 T. & V.J. MICROCOMPUTERS 165 London Rd., Camberley

Geoff Wilkinson, **FACTOR ONE Computers Ltd.** 11-17 Market Place, Penzance.  
Tel: (0736) 66336 or 66565

Please send me details of the SORCERER COMPUTER

Name \_\_\_\_\_  
Address \_\_\_\_\_  
Tel. No. \_\_\_\_\_



Buy  
with confidence  
from the specialists  
**HB COMPUTERS**  
Stock a full range under one roof

**APPLE II**

Apple II	16K	750.00
Apple II	32K	819.00
Apple II	48K	888.00
Disk Drive with Controller		398.00
Disk Drive without Controller		355.00
Parallel Printer Card		110.00
Communication Card		132.00
Super Talker		190.00
High Speed Serial Card		110.00
Applesoft Rom Card		110.00
Speech Lab		127.00
Apple Clock		140.00
Carry Case		25.00
16K Ram Add-On Memory		69.00
Apple II Basic Manual		6.00
Apple II Reference Manual		6.00
Applesoft Reference Manual		6.00
Corvus II Fixed Disk (10 Meg)	3,500.00	
Super Sony 14" T.V.		300.00
Super Colour Interface		90.00

**COMMODORE BUSINESS SYSTEMS**

PET 2001-4	Computer	460.00
PET 2001-8	Computer	550.00
PET 2001-16N	Computer	675.00
PET 2001-32N	Computer	795.00
PET 2023	Printer	550.00
PET 3022	Printer	645.00
PET 2040	Dual Floppy Disk	795.00
IEEEE to IEEEE	Connector	25.00
PET to IEEEE	Connector	20.00
C2N	Cassette Deck	55.00
KIM 1	Micro computer	99.95
KIM 3B	8K Memory Expansion	129.95
KIM 4	Motherboard	69.95
PET Users Handbook		5.00
6500 Programming Manual		5.00
6500 Hardware Manual		5.00



Send S.A.E. for our extensive book list.

**PRINTERS RS232**

Micro Printer M879	695.00
Teletype 43 Pin Feed	850.00
Teletype 43 Dual Feed	950.00
Digital Decwriter LA 34	860.00
Digital Decwriter LA 36	850.00
Whymark 201 40 Column	395.00
Perkin Elmer "Pussycat"	
Thermal Page Printer	
N.E.C. Spinwriter	
Trendcom 100	
Trendcom Interface (Apple II or PET)	49.00

**PET ADD-ONS**

<b>Memory Boards</b>		
Expandamem	16K	295.00
Expandamem	24K	320.00
Expandamem	32K	392.00
<b>Interface</b>		
IEEE - RS232 Unidirectional		85.00
IEEE - RS232 Bidirectional		185.00
AIM 161 A/D Converter - 16 way		130.00
T.V. Interface		42.00
PET Set (AIM 161)		166.00
<b>Disk System</b>		
Compethink Dual Drive (Old Rom)		795.00
Computhink Dual Drive (New Rom)		840.00

**EXIDY**

Exidy Sorcerer	8K	650.00
Exidy Sorcerer	16K	760.00
Exidy Sorcerer	32K	859.00
S 100 Interface		210.00
Micropolis Dual Disk System (630K)		1200.00
Video Display Unit		240.00
1/0 Expansion Kit		99.00

**MISCELLANEOUS**

C12 Blank Data Cassettes (per 10)	3.98
5 1/4" Diskettes (per 10)	
Single side/Single density	30.00
Double side/Double density	35.00
B.A.S.F.	40.00
Continuous Single Part Paper	
8 x 12 (2,000 sheets)	15.00
9 x 11 (2,000 sheets)	16.00
<b>Edge Connectors</b>	
12 way	1.60
24 way	2.55
80 way	3.00
<b>Mains Power Adaptor</b>	
Input 240v 50Hz	
Output 6v/7.5v/9v DC-300MA	4.20
Co-axial Lead Connector (2 metre)	2.00
Aerial Splitter	3.60
RS232 Printer Connector Cable	25.00
Dust Covers (4 colours)	8.00
Sound Box	13.99

**A personal computer that  
opens the world of programming  
to your own fresh ideas!**



**78 Keys**  
ASCII standard  
Alphabet (capital and small letters)  
Graphic symbols

**Built-In Clock**  
Clock circuit, time is displayed according to program

**CRT Display**

This unit is equipped with a 25 cm (10") monochrome CRT for up to 1,000 letters (40 letters x 25 lines). Processing results can be displayed on the CRT, and it is possible to program and edit (addition, deletion, etc.) while watching the operation for confirmation.

**A Technical Masterpiece**

A personal computer that makes full use of the multi-functions of an 8-bit microcomputer (Z-80), this model is certainly one of the most advanced anywhere. It employs BASIC language, a feature which provides easy programming even to those totally unfamiliar with computer operation.

# HB COMPUTERS LTD

22 NEWLAND STREET, KETTERING, NORTHANTS.

Tel. (0536) 83922 & 520910 Telex 341297

*All prices are exclusive of VAT unless otherwise indicated. All items are sold subject to the Company's Conditions of Sale.*



# New Bear



### UPGRADE KITS : ITHACA

APPLE II . . . . .	16K . . . . .	£69.00
TRS 80 . . . . .	16K . . . . .	£69.00
SORCERER . . . . .	16K . . . . .	£69.00
★ SIMPLE TO FIT		
★ LIFETIME GUARANTEE		

### SPECTRONICS U.V. EPROM-ERASING LAMPS

PE14	Erases up to 6 chips, takes approx. 19 mins.	£ 56.00
PE14T*	Erases up to 6 chips, takes approx. 19 mins.	£ 76.58
PE24T*	Erases up to 9 chips, takes approx. 15 mins.	£111.22
PR125T*	Erases up to 6 chips, takes approx. 7 mins.	£237.84
PR320T*	Erases up to 36 chips, takes approx. 7 mins.	£384.09
PC1000*	Erases up to 72 chips, takes approx. 7 mins.	£842.83

### U.V. EPROM-ERASING CABINET

PC2000*	Erases up to 144 chips, takes approx. 7 mins.	£1 227.69
---------	---	-----------

\*Includes a 60 min. Timer.

## DISK DRIVES

☆ 5¼" SINGLE-SIDED		
SHUGART SA400 . . . . .		£190.00
B.A.S.F. 6106 . . . . .		£190.00
☆ 5¼" DOUBLE-SIDED		
B.A.S.F. 6108 . . . . .		£279.50
☆ 5¼" CONNECTORS		
34 way Edge Connector . . . . .	£	4.45
34 way Socket . . . . .	£	2.15
34 way Plug . . . . .	£	2.15
34 way Cable per foot . . . . .	£	0.80
☆ 8" SINGLE-SIDED		
DRI 7100 . . . . .	£	365.00
SHUGART 801 . . . . .	£	380.00
☆ 8" DOUBLE-SIDED		
DRI 7200 . . . . .	£	430.00
B.A.S.F. 6104 . . . . .	£	465.00
☆ 8" CONNECTORS		
AC Power Connectors . . . . .	£	0.80
DC Power Connectors . . . . .	£	1.65
50 way Edge Connector . . . . .	£	5.60
50 way Socket . . . . .	£	2.90
50 way Plug . . . . .	£	4.10
50 way Cable per foot . . . . .	£	1.20
☆ MEDIA		
5¼" Diskettes, Soft/Hard sectored		
Single Disk . . . . .	£	4.00
Box of 10 . . . . .	£	35.00
8" Diskettes, Soft/Hard sectored		
Single Disk . . . . .	£	4.00
Box of 10 . . . . .	£	35.00
☆ DISK STORAGE BOXES		
8" Boxes . . . . .	£	2.50
5¼" Boxes . . . . .	£	2.10
EACH BOX HOLDS 10 DISKETTES		

## ACORN

KIT £65  
6502 based

microcomputer on Standard Eurocard Modules

## SYM-1

- ★ 6502 Based
- ★ 4K Monitor
- ★ £160.00
- ★ Fast Cassette Interface

## OK TOOLS

### WIREWRAP CENTRE

BW-630 . . . . .	Battery Wirewrap Tool . . . . .	£25.17
------------------	---------------------------------	--------

### WIREWRAPPING JUSTWRAP

JW-1 . . . . .	Hand Wirewrap Tool . . . . .	£11.40
JWK-6 . . . . .	Hand Wirewrap Kit	
	(inc. sparewire & unwrap tool)	£19.13
JUW-1 . . . . .	Unwrap Tool . . . . .	£ 2.67
RHW-BLUE . . . . .	15 metre wirewrap spools . . . . .	£ 2.28

### WIRE

R30.B-0050 . . . . .	15 metre roll AWG-30 BLUE . . . . .	£ 1.38
DW-30B . . . . .	Dispenser . . . . .	£ 3.04

### WIRE WRAP SOCKETS

14 way . . . . .	£ 0.40
16 way . . . . .	£ 0.40
24 way . . . . .	£ 0.79
40 way . . . . .	£ 1.25

### TERMINAL POSTS

INS-1 . . . . .	Terminal Insertion Tool . . . . .	£ 1.85
WWT-1 . . . . .	Slotted Terminal Pack of 25 . . . . .	£ 3.46
WWT-2 . . . . .	Single Sided Terminal Pack of 25 . . . . .	£ 2.07
WWT-3 . . . . .	IC Socket Terminal Pack of 25 . . . . .	£ 3.46
WWT-4 . . . . .	Double Sided Terminal Pack of 25 . . . . .	£ 1.38

## VERO

SEND FOR LIST OF VEROBOARDS, BOXES AND INTERCONNECTING SYSTEM.

NEWBEAR SYSTEMS FOR APPLE II,  
HORIZON AND CROMENCO

## JIM PAK

FOR RESISTORS, CAPACITORS, CMOS, REGULATORS ETC. See Catalogue for list.

### TERMS AND CONDITIONS

All Mail Order to Newbury. Please add 15% VAT to all Hardware prices. Official Orders (minimum £10), Barclaycard & Access welcome.

SEND FOR OUR BOOK LIST

Head Office & Mail Order: 40 Bartholomew St., Newbury, Berks.

Tel: (0635) 30505 Telex: 848507 NCS

Northern Showroom: 220-222 Stockport Road, Cheadle Heath, Stockport

Tel: (061 491) 2290

# INTEX DATALOG LTD AGENTS FOR:- COMMODORE COMPUTHINK APPLE II PETSOFT

## \*\*\* P.E.T. MICROCOMPUTER

2001-4	£ 460.00
2001-8	£ 550.00
2001-16N	£ 675.00
2001-32N	£ 795.00

## \*\*\* KIM MICROCOMPUTER

KIM 1	£ 99.95
KIM 3B	£ 129.95
KIM 4	£ 69.95

## \*\*\* CASSETTE DECK

PET C2N	£ 55.00
---------	---------

## \*\*\* FLOPPY DISKS

CBM 2040	£ 795.00
COMPUTHINK 400K (OLD ROMS)	£ 795.00
COMPUTHINK 400K (NEW 16K)	£ 840.00
COMPUTHINK 800K (NEW 16K)	£ 995.00

## \*\*\* MEMORY EXPANSION

EXPANDAPET 24K	£ 320.00
----------------	----------

## \*\*\* PRINTERS

PET 2023	£ 550.00
CBM 3022	£ 645.00
ANADEX DP8000	£ 575.00
TELETYPE 43 - WITH KEYBOARD	£ 875.00
TRENDCOM 100 (INTERFACE EXTRA)	£ 243.00
CENTRONICS 779	£ 885.00
AXIOM MICRO PRINTER	£ 369.00
AXIOM GRAPHICS PRINTER	£ 749.00
TEXAS 810 - from	£1450.00
QUME SPRINT KSR45 - from	£2384.00

## \*\*\* CABLES ETC

IEEE TO PET CABLE	£ 20.00
IEEE TO IEEE CABLE	£ 25.00
DUST COVER	£ 5.75
NEW ROM SET FOR 8K	£ 35.00
TELETYPE 43 RIBBON	£ 7.72
ANADEX DP8000 RIBBON	£ 4.50
PR-40 RIBBON	£ 5.00

## \*\*\* APPLE MICROCOMPUTER

16K APPLE	£ 830.00
32K APPLE	£ 920.00
48K APPLE	£1010.00

## \*\*\* ADDITIONAL MEMORY

16K BLOCK	£ 90.00
-----------	---------

## \*\*\* ROM ADDITIONS

APPLESOFT	£ 110.00
PROGRAMMERS AID	£ 40.00

## \*\*\* FLOPPY DISK

SHUGART 5 1/4" 116K CAPACITY	£ 425.00
------------------------------	----------

## \*\*\* ACCESSORIES

CARRYING CASE	£ 25.00
---------------	---------

## \*\*\* INTERFACES

TV/VIDEO INTERFACE (PET)	£ 35.00
BAILEY OMNI-DIRECTIONAL (P)	£ 106.00
BAILEY BI-DIRECTIONAL (P)	£ 186.00
BAILEY PARALLEL (P)	£ 45.00
TNW 2000 BI-DIRECTIONAL (P)	£175.00
TRENDCOM (P/A)	£49.00
LIGHT PEN (A)	£155.00
PRINTER OR SERIAL CARD (A)	£110.00
CENTRONICS PRINTER CARD (A)	£125.00

## \*\*\*DISKETTES

SINGLE SIDED S/D (BOX 10)	£30.00
DOUBLE SIDED D/D (BOX 10)	£35.00
DISK LIBRARY CASE (HOLDS 10)	£3.15

## \*\*\*CASSETTE TAPES

C20 BLANK CASS IN CASES	£.40
-------------------------	------

## \*\*\*PAPER

TRENDCOM ROLL PAPER	£2.50
80 COL. (ANADEX/CENT.)	£15.00
132 COL. (TELETYPE 43)	£25.00
AXIOM ROLL PAPER	£5.70
PR-40 ROLL PAPER	£1.00

## \*\*\*MANUALS

TIS WORKBOOKS (SET 6)	£18.00
-----------------------	--------

\*\*\*\*\*  
PLEASE ADD 15% VAT TO PRICES SHOWN  
(UNLESS MANUALS)  
\*\*\*\*\*

INTEX DATALOG LIMITED  
EAGLESCLIFFE INDUSTRIAL ESTATE  
EAGLESCLIFFE, CLEVELAND TS16 0PN  
TEL: 0642 781193 - TELEX: 58252

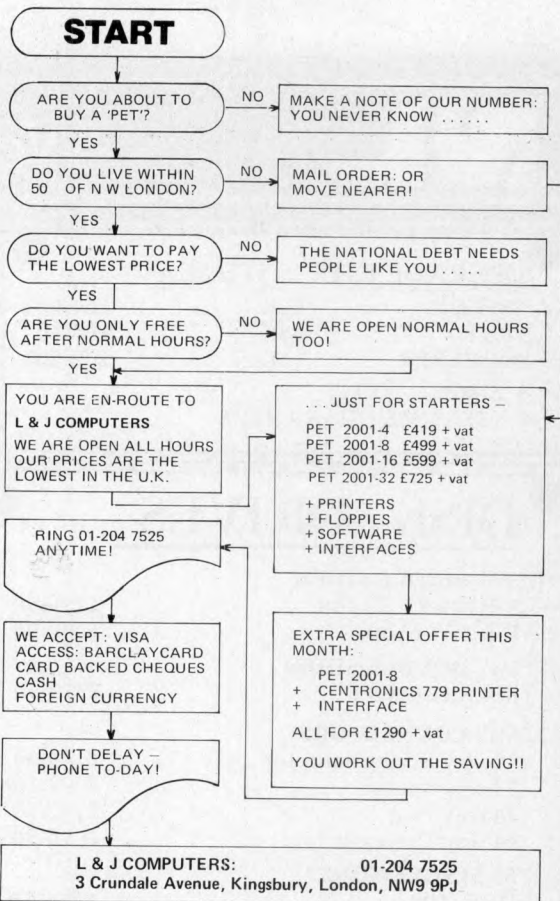

# V. & T. ELECTRONICS

## CPU CONTROLLED CASSETTE DECK

Connects to any 8 bit IO port & UART, full CPU control of fast forward, reverse, read and write, searches tape under software control for named files at up to 50 inches per second (Z80 software supplied) includes high speed CUTS interface - 2400 baud i.e. 1K bytes in 4.2 seconds. One C60 tape holds 860K bytes, ideal for NASCOM 1. Supplied ready built, not a kit, includes a.c. mains power supply. **£110 + 15% VAT**  
Postage & packing £2.00

Please call for demonstration

**FULLY Relocatable assembler for NASCOM 1** (easily converted to other systems) supports pseudo-ops + all Z80 opcodes, includes powerful text editor, uses approx. 3½K memory, all work areas programmable. Supplied on tape. **£10 + VAT**

2716 Eproms Intel Ex. Stock	1 off £23.50
4116 16K Dynamics 200ns	8 off £56.00
2114 4K Statics 200ns	2 off £10.00
Z80A	1 off £14.00
Z80 PIO	1 off £10.00

## NEW!

TRS-80 16K upgrade	£57.00
--------------------	--------

We are usually open 7 days a week until very late, please phone first before calling. **Please add 40p p&p.**

**82 CHESTER ROAD,  
LONDON N19  
01-263 2643**

DIODES/ZENERS			
QTY.			
1N914	100v	10mA	.05
1N4005	600v	1A	.08
1N4007	1000v	1A	.15
1N4148	75v	10mA	.05
1N4733	5.1v	1 W Zenner	.25
1N4749	24v	1W	.25
1N753A	6.2v	500 mW Zener	.25
1N758A	10v	"	.25
1N759A	12v	"	.25
1N5243	13v	"	.25
1N5244B	14v	"	.25
1N5245B	15v	"	.25
1N5349	12v	3W	.25

SOCKETS/BRIDGES			
QTY.			
8-pin	pcb	.16	ww .35
14-pin	pcb	.20	ww .40
16-pin	pcb	.25	ww .45
18-pin	pcb	.30	ww .95
20-pin	pcb	.35	ww 1.05
22-pin	pcb	.40	ww 1.15
24-pin	pcb	.45	ww 1.25
28-pin	pcb	.50	ww 1.35
40-pin	pcb	.55	ww 1.45
Molex pins	.01	To-3 Sockets	.35
2 Amp Bridge	100-prv		.95
25 Amp Bridge	200-prv		1.50

TRANSISTORS, LEADS, etc.			
QTY.			
2N2222M	(2N2222 Plastic)	.10	.15
2N2222A			.19
2N2907A	PNP		.19
2N3906	PNP (Plastic)		.19
2N3904	NPN (Plastic)		.19
2N3054	NPN		.55
2N3055	NPN 15A 60v		.60
T1P125	PNP Darlington		1.95
LED Green	Red, Clear, Yellow		.19
D.L. 747	7 seg 5/8" High com-anode		1.95
MAN72	7 seg com-anode (Red)		1.25
MAN3610	7 seg com-anode (Orange)		1.25
MAN82A	7 seg com-anode (Yellow)		1.25
MAN74	7 seg com-cathode (Red)		1.50
FND359	7 seg com-cathode (Red)		1.25

9000 SERIES			
QTY.		QTY.	
9301	.85	9322	.65
9309	.50	9601	.30
		9602	.45

C MOS							
QTY.		QTY.		QTY.		QTY.	
4000	.15	4017	.75	4034	2.45	4069/74C04	.45
4001	.20	4018	.75	4035	.75	4071	.25
4002	.25	4019	.35	4037	1.80	4081	.30
4004	3.95	4020	.85	4040	.75	4082	.30
4006	.95	4021	.75	4041	.69	4507	.95
4007	.25	4022	.75	4042	.65	4511	.95
4008	.75	4023	.25	4043	.50	4512	1.50
4009	.35	4024	.75	4044	.65	4515	2.95
4010	.35	4025	.25	4046	1.25	4519	.85
4011	.30	4026	1.95	4047	2.50	4522	1.10
4012	.25	4027	.35	4048	1.25	4526	.95
4013	.40	4028	.75	4049	.65	4528	1.10
4014	.75	4029	1.15	4050	.45	4529	.95
4015	.75	4030	.30	4052	.75	MC14409	14.50
4016	.35	4033	1.50	4053	.95	MC14419	4.85
				4066	.75	74C151	2.50

MICRO's, RAMS, CPU's, E-PROMS	
QTY.	
8T13	2.50
8T23	2.50
8T24	3.00
8T97	1.75
74S188	3.00
1488	1.25
1489	1.25
1702A	4.50
AM 9050	4.00
ICM 7207	6.95
ICM 7208	13.95
MPS 6520	10.00
MM 5314	4.00
MM 5316	4.50
MM 5387	3.50
MM 5369	2.95
TR 1602B	3.95
UPD 414	4.95
Z 80 A	22.50
Z 80	17.50
Z 80 P10	10.50
2102	1.45
2102L	1.75
2107B-4	4.95
2114	9.50
2513	6.25
2708	11.50
2716 D.S.	34.00
2716 (5v)	69.00
2758 (5v)	26.95
3242	10.50
4116	11.50
6800	13.95
6850	7.95
8080	7.50
8085	22.50
8212	2.75
8214	4.95
8216	3.50
8224	4.25
8228	6.00
8251	7.50
8253	18.50
8255	8.50
TMS 4044	9.95

- T T L -							
QTY.		QTY.		QTY.		QTY.	
7400	.20	7492	.45	74H20	.25	74LS76	.70
7401	.20	7493	.35	74H21	.25	74LS86	.95
7402	.20	7494	.75	74H22	.40	74LS90	.85
7403	.20	7495	.60	74H30	.30	74LS93	.85
7404	.20	7496	.80	74H40	.35	74LS96	2.00
7405	.35	74100	1.15	74H50	.30	74LS107	.90
7406	.25	74107	.35	74H51	.30	74LS109	1.50
7407	.55	74121	.35	74H52	.20	74LS123	1.95
7408	.20	74122	.55	74H53	.25	74LS138	2.00
7409	.25	74123	.55	74H55	.25	74LS151	.95
7410	.20	74125	.45	74H72	.35	74LS153	1.15
7411	.25	74126	.45	74H74	.35	74LS157	1.15
7412	.25	74132	.75	74H101	.95	74LS160	1.15
7413	.45	74141	.90	74H103	.55	74LS164	2.90
7414	.75	74150	.85	74H106	1.15	74LS193	2.00
7416	.25	74151	.95	74L00	.30	74LS195	1.15
7417	.40	74153	.95	74L02	.30	74LS244	2.90
7420	.25	74154	1.15	74L03	.35	74LS259	1.50
7426	.25	74156	.70	74L04	.40	74LS298	1.50
7427	.25	74157	.65	74L10	.30	74LS367	1.95
7430	.20	74161/9316	.75	74L20	.45	74LS368	1.25
7432	.30	74163	.85	74L30	.55	74LS373	2.50
7437	.20	74164	.75	74L47	1.95	74S00	.45
7438	.30	74165	1.10	74L51	.65	74S02	.45
7440	.20	74166	1.75	74L55	.85	74S03	.35
7441	1.15	74175	.90	74L72	.65	74S04	.35
7442	.55	74176	.95	74L73	.70	74S05	.45
7443	.45	74177	1.10	74L74	.75	74S08	.45
7444	.45	74180	.95	74L75	1.05	74S10	.45
7445	.75	74181	2.25	74L85	2.00	74S11	.45
7446	.70	74182	.75	74L93	.75	74S20	.35
7447	.70	74190	1.25	74L123	1.95	74S22	.55
7448	.50	74191	1.25	74LS00	.40	74S40	.30
7450	.25	74192	.75	74LS01	.40	74S50	.30
7451	.25	74193	.85	74LS02	.45	74S51	.35
7453	.20	74194	.95	74LS03	.45	74S64	.15
7454	.25	74195	.95	74LS04	.45	74S74	.70
7460	.40	74196	.95	74LS05	.45	74S112	.60
7470	.45	74197	.95	74LS08	.45	74S114	.85
7472	.40	74198	1.45	74LS09	.45	74S133	.85
7473	.25	74221	1.50	74LS10	.45	74S140	.75
7474	.30	74298	1.50	74LS11	.45	74S151	.95
7475	.35	74367	1.35	74LS20	.45	74S153	.95
7476	.40	75491	.65	74LS21	.45	74S157	.98
7480	.75	75492	.65	74LS22	.45	74S158	.80
7481	.85	74H00	.20	74LS32	.50	74S194	1.50
7482	.95	74H01	.30	74LS37	.45	74S196	2.00
7483	.95	74H04	.30	74LS38	.65	74S257 (8123)	2.50
7485	.75	74H05	.25	74LS40	.70	8131	2.75
7486	.55	74H08	.35	74LS42	.95		
7489	1.05	74H10	.35	74LS51	.75		
7490	.55	74H11	.25	74LS74	.95		
7491	.70	74H15	.45	74LS75	1.20		

I <sup>2</sup> L, LINEARS, REGULATORS, ETC.			
QTY.		QTY.	
MCT2	.95	LM320K24	1.65
8038	3.95	LM320T5	1.65
LM201	.75	LM320T12	1.65
LM301	.45	LM320T15	1.65
LM308	.65	LM323K	5.95
LM309H	.85	LM324	1.25
LM309 (340K-5)	1.50	LM339	.75
LM310	.85	7805 (340T5)	1.15
LM311 (8-14 Pin)	.75	LM340T12	.95
LM318	1.50	LM340T15	.95
LM320H6	.79	LM340T18	.95
LM320H15	.79	LM340T24	.95
LM320H24	.79	LM340K12	1.25
7905 (LM320K5)	1.65	LM340K15	1.25
LM320K12	1.65	LM340K18	1.25
LM320K15	1.65	LM340K24	1.25
		LM373	3.95
		LM377	3.95
		78L05	.75
		78L12	.75
		78L15	.75
		78M05	.75
		LM380 (8-14 Pin)	1.19
		LM709 (8-14 Pin)	.45
		LM711	.45
		LM723	.40
		LM725	2.50
		LM739	1.50
		LM741 (8-14)	.45
		LM747	1.10
		LM1307	1.75
		LM1458	.65

LM3900	.95
LM75451	.65
NE555	.45
NE556	.85
NE565	1.15
NE566	1.25
NE567	.95
TA7205	6.95
76477	2.95
95H90	9.95

CABLE ADDRESS: ICUSD

Telex #697-827 ICUSD SDG

HOURS: 9 A.M. - 6 P.M. MON. thru SUN.

## INTEGRATED CIRCUITS UNLIMITED

7889 Clairemont Mesa Blvd. • San Diego, California 92111 U.S.A.

NO MINIMUM

COMMERCIAL AND MANUFACTURING ACCOUNTS INVITED

ALL PRICES IN U.S. DOLLARS. PLEASE ADD POSTAGE TO COVER METHOD OF SHIPPING.  
ORDERS OVER \$100 (U.S.) WILL BE SHIPPED AIR NO CHARGE.

PAYMENT SUBMITTED WITH ORDER SHOULD BE IN U.S. DOLLARS.

ALL IC'S PRIME/GUARANTEED ALL ORDERS SHIPPED SAME DAY RECEIVED.

CREDIT CARDS ACCEPTED:

Phone (714) 278-4394 BarclayCard / Access / American Express / BankAmericard / Visa / MasterCard

Total Order	Deduct
\$35-\$99	10%
\$100-\$300	15%
\$301-\$1000	20%

# Happy Memories

21L02	450ns	83p	
21L02	250ns	100p	TRS-80 16K Upgrade Kit
2114	450ns	525p	
2114	250ns	575p	£69 for keyboard unit
4116	300ns	790p	
4116	150ns	840p	£63-50 for expansion box
2708	450ns	750p	

Floppy Discs by VERBATIM £27-50 box of 10  
(Mini soft sectored for APPLE, PET, TRS-80 etc.)

We stock the full NASCOM range of products  
Large quantity of 74LS stocked along with many  
other components. free lists sent upon request

TEXAS IC SOCKETS	8	14	16	18	20	22	24	28	40
Solder tail	pence: 10 11 12 16 17 19 21 27 37								
Wire wrap	- - 24 36 39 46 58 61 63 70 109								

Gold plated S100 edge connectors £3-25 each 3/£9-50  
4, 7 & 8 way DIP switches, all at 85p We keep a full range  
of wire wrapping equipment: Wrap-Strip-Unwrap tool £5-97  
50 foot reel of wire £1-64 Just-Wrap tool with 50 wire £12-21

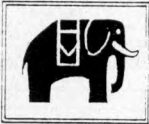

We've got Euroconnectors  
Educational & Government  
orders welcome Min £10

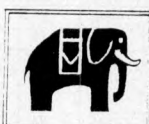

Shop open ten until six Access & Barclaycard  
Prices inc VAT, orders below £10 add 25p p & p

**19 Bevois Valley Road, Southampton,**  
**Hants. SO2 0JP Tel: (0703) 39267**

## Which Terminal?



**ELBIT - OF COURSE!**  
TTY & IBM compatible  
VDUs. Top quality, high  
reliability & low cost. EX  
STOCK. Phone Slough  
(0753) 26713 for details.

**Elbit**  
**DATA SYSTEMS LTD**  
295 Aberdeen Avenue  
SLOUGH BERKS SL1 4HQ

# New Low-cost Printer from PHIL

## Anadex DP8000

- 80 Columns
- 112 cps - 84 lpm bi-directional
- 1K Print Buffer
- Dual Interface - Serial & Parallel
- 96 ASCII set, 9 x 7 matrix

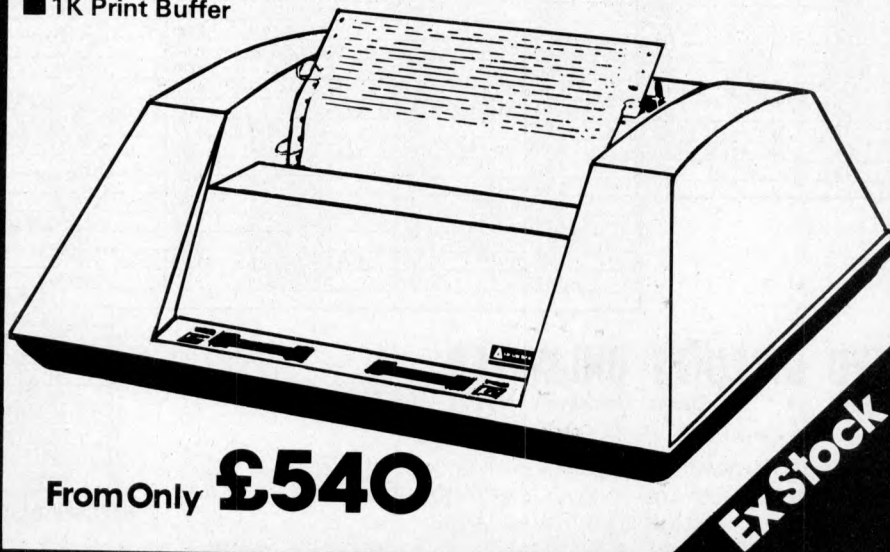

From Only **£540**

**EX Stock**

### Also available Visual Displays

Lear Siegler	
ADM - 3A	from only £ 571
ADM - 3A Graphics	from only £1395
ADM - 31	from only £ 809
ADM - 42	from only £1149

### Keyboard Printers

Teletype 43	
Pin Feed	from only £ 799
Friction Feed	from only £ 818
Typewriter Terminal	from only £ 825
Portable Models	from only £ 899
Digital	
LA 36	from only £ 849
LA 34	from only £ 911
LS 120	from only £1679

### Printers

Texas 810	from only £1392
SCI Rotary Printer	from only £ 747

### Data Storage

Techtran	
950 Microdisc Range	from only £ 955
815 Datasettes	from only £ 667

### Other Items

AJ 211 Acoustic Coupler	from only £ 199
-------------------------	-----------------



PERIPHERAL HARDWARE LIMITED  
Armfield Close, West Molesey  
Surrey England Telex 922175  
Sole UK distributor

South 01-941 4806 North Wetherby 61885 Ireland Dublin 971854

# THE RESEARCH MACHINES 380Z COMPUTER SYSTEM



## THE RESEARCH MACHINES 380Z A UNIQUE TOOL FOR RESEARCH AND EDUCATION

Microcomputers are extremely good value. The outright purchase price of a 380Z installation with dual mini floppy disk drives, digital I/O and a real-time clock, is about the same as the annual maintenance cost of a typical laboratory minicomputer. It is worth thinking about!

The **RESEARCH MACHINES 380Z** is an excellent microcomputer for on-line data logging and control. In university departments in general, it is also a very attractive alternative to a central mainframe. Having your own 380Z means an end to fighting the central operating system, immediate feedback of program bugs, no more queuing and a virtually unlimited computing budget. You can program in interactive BASIC or, using our unique Text Editor, run very large programs with a 380Z FORTRAN Compiler. If you already have a mini-computer, you can use your 380Z with a floppy disk system for data capture.

What about Schools and Colleges? You can purchase a 380Z for your Computer Science or Computer Studies department at about the same cost as a terminal. A 380Z has a performance equal to many minicomputers and is ideal for teaching BASIC and Cesium. For A Level machine language instruction, the 380Z has the best software front panel of any computer. This enables a teacher to single-step through programs and observe the effects on registers and memory, using a single keystroke.

### WHAT OTHER FEATURES SET THE 380Z APART?

The 380Z with its professional keyboard is a robust, hardwearing piece of equipment that will endure continual handling for years. It has an integral VDU interface — you only have to plug a black and white television into the system in order to provide a display

380Z/56K complete with DUAL FULL  
FLOPPY DISK SYSTEM FDS-2  
**£3266.00**

380Z/16K System with Keyboard  
**£965.00**

RESEARCH MACHINES Computer Systems are distributed by RESEARCH MACHINES LTD., P.O. Box 75, Chapel Street, Oxford. Telephone: OXFORD (0865) 49792. Please send for the 380Z Information Leaflet. Prices do not include Carriage or VAT @ 15%.

unit — you do not need to buy a separate terminal. The integral VDU interface gives you upper and *lower* case characters and low resolution graphics. Text and graphics can be mixed *anywhere* on the screen. The 380Z has an integral cassette interface, software and hardware, which uses *named* cassette files for both program and data storage. This means that it is easy to store more than one program per cassette.

Owners of a 380Z microcomputer can upgrade their system to include floppy (standard or mini) disk storage and take full advantage of a unique occurrence in the history of computing — the CP/M™\* industry standard disk operating system. The 380Z uses an 8080 family microprocessor — the Z80 — and this has enabled us to use CP/M. This means that the 380Z user has access to a growing body of CP/M based software, supplied from many independent sources.

380Z mini floppy disk systems are available with the drives mounted in the computer case itself, presenting a compact and tidy installation. The FDS-2 standard floppy disk system uses double-sided disk drives, providing 1 Megabyte of on-line storage.

\*Trademark, Digital Research.

Versions of BASIC are available with the 380Z which automatically provide controlled cassette data files, allow programs to be loaded from paper tape, mark sense card readers or from a mainframe. A disk BASIC is also available with serial and random access to disk files. Most BASICs are available in erasable ROM which will allow for periodic updating.

If you already have a teletype, the 380Z can use this for hard copy or for paper tape input. Alternatively, you can purchase a low cost 380Z compatible printer for under £300, or choose from a range of higher performance printers.

# GPW Electronics

## EXIDY SORCERER

8K — £650 : 16K — £760 : 32K — £859 : TV Mods fitted  
 S100 expansion £210  
 Printer 5 x 7 dot £595. Micropolis S100 Disk 143K £499 :  
 630K £1,200.

## TANDY TRS-80

Level I 4K £375 : 16K £480  
 Level II 4K £448 : 16K £519 : 16K Expansion kit £70.50  
**COMPUCORP**

655 System: 48K mem, 160K disk, CRT, S10 — £3,595  
 665 System: 60K mem, 315K disk, CRT, S10 — £4,540

## SOFTWARE

Large range of software available for all our computers.  
**S100 KITS**

Everything you need to build your own system, including:  
 808A; Z80; Z80A; Static and Dynamic RMAS; Mother-  
 boards; EPROM Boards; Disk Controllers; Tape and Video  
 Interface Boards, plus many, many more.

## BOOKS

Large range in stock. (No VAT on books)

## COMPONENTS

**RAMS** 6504 CMOS — £15.00; 2114 (450) Static —  
 £5.40; 5101 (45) CMOS — £4.50; TMS 4033  
 MOS — £1.50;

All other micros, memories, chips and components avail-  
 able.

Prices include post and packing. Please add VAT. C.W.O.,  
 Access or Barclaycard. Finance available.

146A London Road, North End, Portsmouth, Hants.

Tel: Portsmouth 693341

(for components — Portsmouth 697427)

# EQUINOX 300

A powerful multi-user  
 multi-tasking  
 multi-language

16-bit microcomputer time-sharing system

supporting

- \* BASIC
- \* LISP
- \* PASCAL
- \* Floppy discs
- \* Hard discs

including a powerful Text Formatter,  
 Assembly Language Development System  
 and disc-based Sort utilities.

Priced from under £5,000

Write or phone for further information

**EQUINOX COMPUTER SYSTEMS LTD**

16 Anning Street,

New Inn Yard

London E.C.2.

(Tel: 01-739 2387/8/9)



# CRYSTAL ELECTRONICS CC ELECTRONICS

## CRYSTAL/CC ELECTRONICS 'NASCOM' SOFTWARE

### XTAL BASIC — SPECIFICATION

This is an "8K Basic" Interpreter written for the  
 Nascom 1 system.

1. **COMMANDS:**— Call Clear CLoad Cont CSave Read.. Data.  
 Restore Def.. Fn Dim Edit End For.. To.. Step.. Next Gosub..  
 Return Goto If..Then Input List Nas Pop New On..Goto On..  
 Gosub Out Poke Print Rem Run Speed Stop Wait SPC ( )  
 Tab ( ) Print @

2. **VARIABLES:**— Names must start with a letter, but can be  
 up to any length. First two characters used to distinguish one  
 variable from another. Strings of up to 255 characters, also  
 Multi-Dim. Arrays and String Arrays. Numbers range from  
 +/- 1E+/-38, with an accuracy of six significant figures.

3. **FUNCTIONS:**— ABS ASC ATN CHRS COS EXP INT LEFTS  
 LEN LOG MID\$ PEEK POS RND RIGHT\$ SGN SIN SIZE  
 SIZE\$ SOR STR\$ TAN VAL

4. **OPERATORS:**— ARITHMETIC : + - \* / \*\* ("To the  
 Power of")

RELATIONAL: << < > >> = <=  
 ARITH-LOGICAL: And or Not  
 STRING : + (Concatenation)

5. **CASSETTE COMMANDS:**— CSave CLoad for Saving and  
 Loading Programs. Also CSave@ Cload@ for saving and loading  
 of Numerical Arrays.

6. **SPECIAL COMMANDS:** EDIT — Powerful Line Editor.  
 CALL — Machine-Code Subroutine Call, NAS — Return to  
 'Nasbug' Under Software Control, OUT, INP & WAIT — For  
 Control of I/O Ports.

7. **COMPATIBILITY:**— Tape Routine Provided for Use with  
 T2 Monitor. Fully compatible with T2, T4 & B-BUG Monitors.

8. **SIZE:**— Actually Fits in 7K of RAM (1000H — 2BFFH),  
 but recommend >= 16k expansion Ram in your system.

9. **AVAILABILITY:**— On C12 Cassette Tape, with documen-  
 tation.

10. **PRICE:**— £35 + VAT

NASCOM NATIONAL DISTRIBUTOR TRADE INFO WELCOME

WHY BUY AN IMITATION GREY WHEN  
 THE REAL CREAM IS AN

## APPLE THE SW AGENTS

APPLE II 16K (colour)	£920
128K MEMORY INCREM	£ 90 fitting & testing £10 extra
APPLE II 16K (B&W)	£830
APPLE SOFTWARE	ALL APPLE ADD ONS NORMALLY IN STOCK
STOCK CONTROL	MANY GAMES FROM £5-£15.00
NEW WORD PROCESSOR	£100
LETTER WRITER	£140, including lower case adaptor package

ALL PRICES EXCLUDE VAT & CARRIAGE

## DURANGO

THE FIRST FULLY INTEGRATED DESK-TOP SYSTEM  
 DUAL QUAD DENSITY MINI-FLOPPY DISCS FOR 1.5M BYTES ON LINE  
 9x9 DOT MATRIX BIDIRECTIONAL PRINTER 165cps, VARIABLE WIDTH  
 48K/64K RAM WITH 8085 CPU  
 FULL KEYBOARD WITH 10-KEY NUMERIC PAD  
 VDU WITH 24x80 or 16x64 CHARACTERS  
 POWERFUL DISC BASIC (14 DIGIT ACCURACY)  
 MULTI TASKING TO 4 USERS PLUS OPTIONAL 20 M-BYTE FIXED  
 APPLICATION SOFTWARE SMALL BUSINESS, A/C PAYABLE/RECEIVABLE  
 GENERAL LEDGER, ORDER ENTRY/INVENTORY CONTROL, INVOICE/SALES  
 ANALYSIS, PAYROLL, ETC. **PRICES FROM £7,500**

TEXAS TI PROGRAMMER A MUST FOR MACHINE LANGUAGE BUFFS  
 HEX/OCTAL/DECIMAL CONVERSION, ARITHMETICS OPS IN THREE BASES  
 SHIFT LEFT/RIGHT, IS COMPLEMENT, OR, AND, XOR, ETC.

SHOP OPEN	TEXAS T199/4 40 MAGDALENE ROAD	£46.25
0930-1730	HOME COMPUTER	TORQUAY
EXCEPT	PHONE	DEVON
WED & SUN	FOR DETAILS	ENGLAND
Closed for lunch		Tel: 0803 22699
1200-1300 hrs		

Shop open 0930-1730 except Wed. & Sun.

40 Magdalen Road, Torquay, Devon, England. Tel: 0803 22699

Access and Barclaycard welcome.





# CPS

## DATA SYSTEMS

# The Midlands Micro Sales Centre

Established by CPS to ensure that you buy the micro best suited to your particular need. During your visit you can see, and try at leisure a whole range of microcomputers. Expert advice is always on hand to guide you through our hardware, software and back-up services.

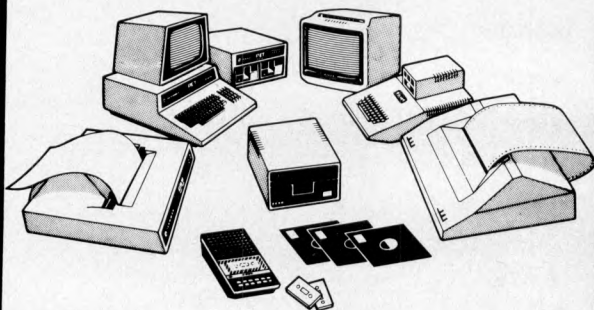

We're Authorised Dealers for **Pet, Apple, Rair** and **Transdata** microcomputers; **Decision Data** and **Datac** printers; and **Lear Siegler** terminals —all available off-the-shelf;

phone us today, to arrange your visit, or for product information

**Telephone: 021-707 3866**



Third Floor, Arden House, 1102 Warwick Road,  
Acocks Green, Birmingham B27 6BH

A member of the CPS Group

# GEMSOFT

BUSINESS SOFTWARE FOR ITT2020/APPLE

Payroll, Sales Ledger, Stock Control, Mailing List, Invoice printer, Price listing etc.,

**ALL AVAILABLE OFF THE SHELF.**  
at Gemsoft's amazingly reasonable prices. (All programs require ITT/Apple 32K, twin floppy disks & printer).

**VISIT OUR NEW SHOWROOMS**  
in Woking and see on demonstration:—  
Complete business systems from £2475 (ITT 32K, twin disks & printer). We are area dealers for the new superb INTERTEC SUPERBRAIN Business and research computer. (64K RAM, CPM twin disks, 12" VDU, full edit, printer interface, fully expandable S100, at only £1995. Just add a printer for a complete system (send for leaflet). We also sell ANADEX printers at £570 (variable width tractor feed). Teletype 43's at £825. Apple disks at £425 & £375, OHIO SCIENTIFIC C2-8P and many others.

**EXPERT IN-HOUSE PROGRAMMERS**  
to write your Business or Industrial Control System.  
Please send an SAE for our *Bumper Catalogue* of all our services and products, including over 100 programs for PET, EXIDY, and APPLE. Games, Educational, Business, Scientific etc., or come and chat to us. Open 6 days a week 9am to 5.30 pm.  
Add 15% VAT to all prices.

AERCO-GEMSOFT Ltd.,  
27, Chobham Road, Woking, Surrey. Tel: 04862-4667.

**WE MEAN BUSINESS**

## At last! Britain's very own monthly journal for Microsoftware, the LIVERPOOL SOFTWARE GAZETTE

ONLY 50p PER COPY

*First issue includes:*

SARGON meets the Nascom-1 — *J. Haigh.*  
Pascal and the PET — *J. Stout.*  
Programming practices and techniques — *Dr. M. Beer.*  
I'm Pilot, fly me — *D. Straker.*  
Letter from America — *D. Smith*  
Apple pips — *C. Phillips.*

Please subscribe 1st 12 issues of "Liverpool Software Gazette" I enclose cheque/PO for £6.00  
Access No \_\_\_\_\_  
Barclaycard No \_\_\_\_\_  
Name \_\_\_\_\_  
Org \_\_\_\_\_  
Address \_\_\_\_\_  
Post Code \_\_\_\_\_

Mail to: Microdigital Ltd. FREEPOST (No Stamp Required). Liverpool L2 2AB.

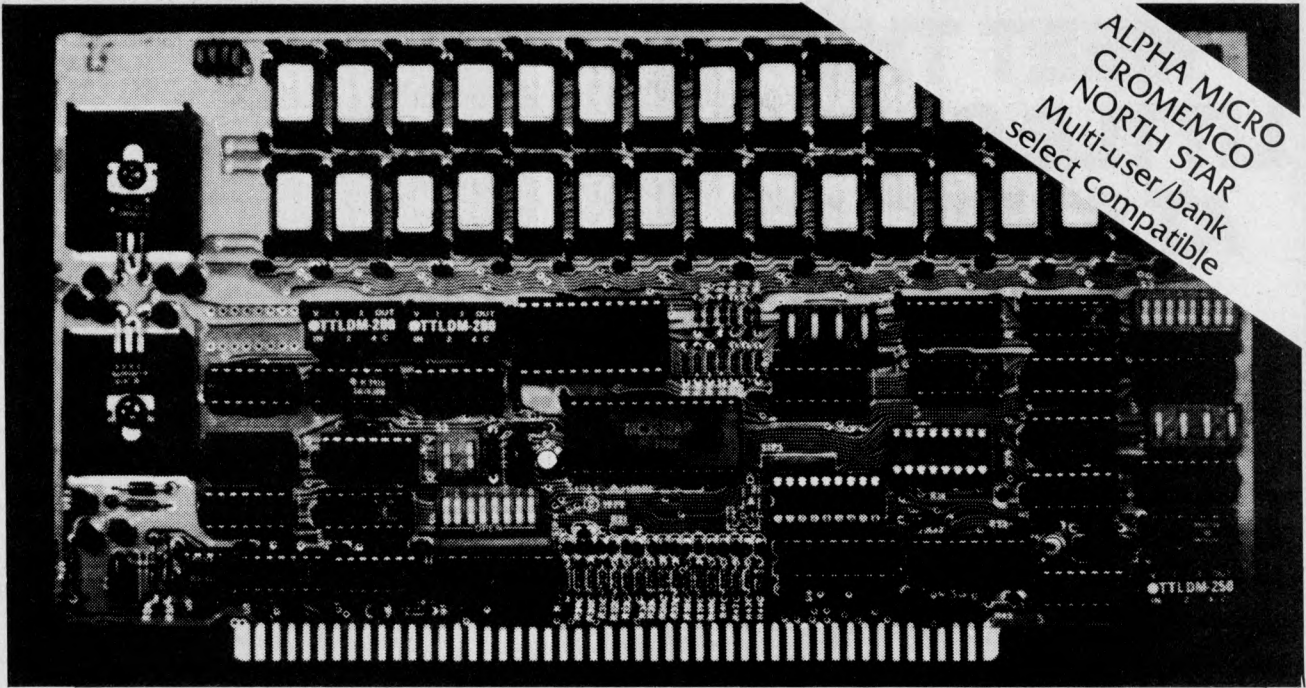

ALPHA MICRO  
CROMEMCO  
NORTH STAR  
Multi-user/bank  
select compatible

**Model DMB-6400 Series dynamic 64k byte RAMS incorporate the features which are standard in the DM-6400 Series and adds bank select for multi-user-timesharing applications.**

- ALPHA MICRO, CROMEMCO, and NORTH STAR output port bank select.
- Memory bank size can be incremented to 64k bytes in 16k increments.
- Four (4) 16k byte, functionally independent memory banks.
- Eight (8) 64k byte banks of memory per output port for expansion to 512k bytes for each output port.

**Model DM-6400 Series dynamic 64k memory boards feature IEEE S-100 compatible timing and on board transparent refresh.**

- Memory selectable and deselectable in 4k byte increments.
- 25 MHz on board crystal oscillator for independent timing.

**DMB-6400 and DM-6400 Common Features:**

- 4 MHz Z80 operation with no wait states.
- Tested and burned-in.
- Low power- 8 watts maximum.
- Reliable, expandable memories.

**ONE YEAR GUARANTEE**

	DM Series	DMB Series
64K	£487	£562
48K	397	472
32K	304	382

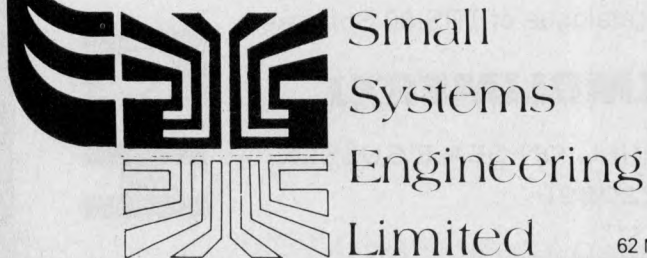

62 New Cavendish Street · London W1M 7LD Telephone: 01 637 0777

Personal Computer World Show

# MEET THE LITTLE GENIUS AT STAND A9

If you find self-instruction manuals difficult to follow, come and meet our Little Genius.

Little Genius floppy diskettes are the fastest, easiest way to master your micro.

Little Genius will save you time and effort, teaching you to exploit all your micro's facilities.

For a free demonstration of our first two courses visit Stand A9 at the PCW Show or phone Peter Brown: 01-580 6361.

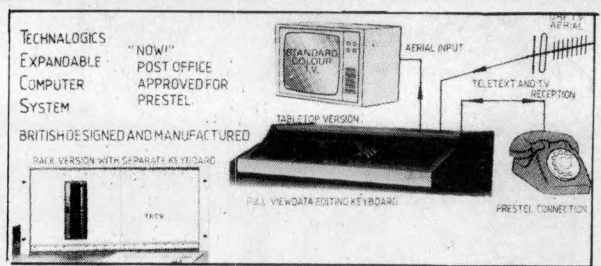

## TECS: FEATURES

- \*VIEWDATA AND PRESTEL DATABASE ACCESS
- \*STANDARD 7A KEY BOARD
- \*FULLY EXPANDABLE COMPUTER SYSTEM
- \*MEMORY-MAPPED TV DISPLAY RAM
- \*24 ROW x 40 CHARACTER, ALPHANUMERIC AND GRAPHICS PLUS B+W, ON UNMODIFIED COLOUR TV
- \*EXPANSION TO FULL 64K MEMORY
- \*SUPPORTS BOTH 5 1/4" + 8" FLOPPY DISCS
- \*GENERAL PURPOSE INTERFACE CARD FOR EXTRA RS232, 2 PARALLEL PORTS + 2 CASSETTE PORTS
- \*3K TECS MINI-BASIC, INTERVERSION WITH COLOUR DISPLAY
- \*8K TECS BASIC, FULL-FLOATING POINT VERSION OF ABOVE
- \*TECSBUG, POWERFUL MACHINE CODE MONITOR
- \*TECSOFT: OFFERS FULL SOFTWARE BACKUP FOR TECS. A RANGE OF SOFTWARE TO EXPLOIT THE FULL POTENTIAL OF THE TECS SYSTEM'S UNDER DEVELOPMENT
- \*FULL FACILITY TELE-TEXT RECEPTION (CEEFAX, ORACLE)
- \*INDUSTRY STANDARD MOTOROLA 6800cpu CHIP
- \*PROGRAM ACCESS TO TELESOFTWARE AND ON-SCREEN INFO DISPLAYED IN 6 COLOURS
- \*TO NEW TELETEXT/PRESTEL DISPLAY SPECIFICATION
- \*HIGH QUALITY PLUG-IN PCB'S, GOLD PLATED CONNECTORS, PT HOLES
- \*KANSAS CITY STANDARD CASSETTE INTERFACE

Kit	Build
*SYSTEM T1 Teletext, 3K Basic, 4K User RAM	£895 £1175
*SYSTEM T2 Teletext, monitor, 8K Basic, 4K User RAM	£1115 £1405
*SYSTEM T2a As T2 but + 16K RAM	£1335 £1635
*SYSTEM T2b As T2 but + 32K RAM	£1435 £1735
*SYSTEM T2c As T2 but + 48K RAM	£1535 £1835
*SYSTEM T4 'Prestel' System' Teletext, Prestel, 4K RAM, BASIC	N/A £1955

(Kits available direct from TECHNOLOGICS only)  
Please send for further details (Large S.A.E., 13p stamp please) or order now (specify rack or tabletop version) from your dealer or in case of difficulty direct from Tecs Sales Department.

**TECHNOLOGICS LTD.**  
8 EGERTON STREET  
LIVERPOOL L8 7LY  
TEL: 051-724 2695

All orders dealt with in strict rotation, carriage and insurance paid. All prices subject to 15% VAT.

# INNOVATIVE TRS-80 SOFTWARE

**NEW!!**

**INFINITE BASIC**

**NEW!!**

"Infinite Basic" adds over 70 new commands to your Level II or Disk Basic. Furthermore, these are modularised so that any combination may be loaded at any time, which makes the package very memory efficient. A sampling of the additions includes *complete* string functions, left & right justify, truncate, rotate, text justification, reverse strings, verify, string searches etc., etc. Complete Matrix functions are also included with inverse, transpose, simultaneous equations, multiply scalars, vectors; reshape, expand and delete arrays; change arrays in mid-program, zero and move arrays etc., etc.

"Infinite Business" is an add-on package to the above and includes multiple precision-packed decimal arithmetic, eliminating round-off errors with a 127-digit maximum accuracy. Also includes binary search of sorted arrays, automatic page headings and more!

Infinite Basic . . . **£29.95.** Infinite Business . . . **£16.95.** Both plus VAT & 50p p&p.

Send large SAE (12 1/2p) for our current catalogue of TRS-80 Software.



**A.J.HARDING (MOLIMERX)**

28 COLLINGTON AVENUE, BEXHILL-ON-SEA, E.SUSSEX.

TEL: (0424) 220391



# S.D. SYSTEMS inc. S100 COMPUTER CARDS & SYSTEMS

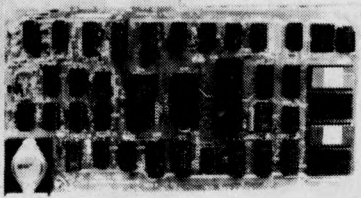

**SBC 100**  
 \* X-80 CPU  
 \* SERIAL I/O PORT  
 \* PARALLEL I/O PORT  
 \* 4 CHANNEL COUNTER TIMER  
 \* 1K RAM, 8K EPROM  
 \* S100 BUS  
 \* OPTIONAL VECTORED INTERRUPTS  
 PRICE: £135.00 KIT; £183.00 BUILT AND TESTED

**EXPANDORAM**  
 \* 8K TO 64K  
 \* WRITE PROTECT  
 \* INTERFACES WITH ALTAIR, IMSAI SOL-8, CROMENCO & SBC 100  
 \* S100 BUS  
 \* OPERATES WITH Z-80, 8080, 8085 CPUs  
 \* 2.5 MHz OPERATION  
 KIT  
 PRICE: 16K £145.00; 32K £205.00; 48K £265.00;  
 64K £325.00  
 BUILT & TESTED  
 PRICE: 16K £250.00; 32K £310.00; 48K £370.00;  
 64K £440.00

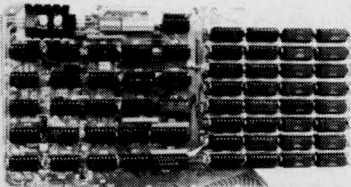

**EXPANDORAM II**  
 AS ABOVE BUT EXPENDABLE FROM 16 to 256K  
 \* COMPATIBLE WITH Z-80 CPU  
 \* 4MHz OPERATION

**PROM 100**  
 \* PROGRAMS THE FOLLOWING PROMS: 2708, 2758, 2716, 2732, 2516  
 \* PROGRAM PULSE GENERATED ON-BOARD  
 \* LOW POWER REQUIREMENT  
 \* S100 BUS  
 \* MAX PROGRAMMING TIME 100 SECS (16K)  
 \* PROGRAM VERIFICATION  
 \* SOFTWARE SUPPLIED  
 PRICE: £89.00 KIT; £123.00 BUILT AND TESTED

**AIRAMCO MIKRO 700**  
 \* S100 MAIN FRAME B&T  
 \* 12 SLOT MOTHERBOARD  
 \* CUTOUTS FOR 5 1/4" DRIVES (BLANKED ON DELIVERY)  
 \* FAN, POWER SUPPLY, KEY ON/OFF SWITCH, RESET BUTTON  
 \* COMPLETE WITH SBC 100 KIT  
 \* 16K EXPANDORAM KIT  
 PRICE: £650.00

**COMPLETE SYSTEM**  
 \* AS ABOVE BUT INCLUDING:  
 \* 2 SA 400s + POWER SUPPLY  
 \* 1 VERSAFLOPPY KIT WITH BIOS PROM  
 \* ALL CABLES AND CONNECTORS ETC AND INCLUDING CP/M  
 PRICE: £1295.00

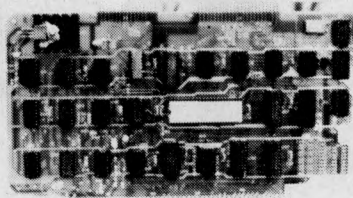

**AIRAMCO 1050 DISK BOX**  
 \* CONTAINS 2 MFE 750 8" DOUBLE SIDED DRIVES PLUS POWER SUPPLY AND CONNECTOR CABLES  
 PRICE: £1185.00

**VERO S100 RACK SYSTEM**  
 \* 6 SLOT MOTHERBOARD  
 \* POWER SUPPLY ETC  
 PRICE: £230.00

+ V.A.T. @ 15%

TRADE DISCOUNTS ON QUANTITY  
 PLEASE ADD £1.00 P&P FOR S100 ITEMS  
 THEN ADD V.A.T. @ 15%

**VERSAFLOPPY**  
 \* IBM 3740 COMPATIBLE  
 \* UP TO 4, 5 or 8" DRIVES  
 \* SINGLE OR DOUBLE SIDED  
 \* Z-80, 8080, 8085 CPUs  
 \* S100 BUS  
 \* USES FD 1771B-1 CONTROLLER CHIP  
 PRICE: £90.00 KIT; £145.00 BUILT AND TESTED

**VERSAFLOPPY II**  
 \* AS ABOVE BUT DOUBLE DENSITY & ANY COMBINATION OF DRIVE SIZES, UP TO 4 SIMULTANEOUSLY, USES FD1791-1 CONTROLLER CHIP  
 PRICE: £175.00 KIT; £224.00 BUILT AND TESTED

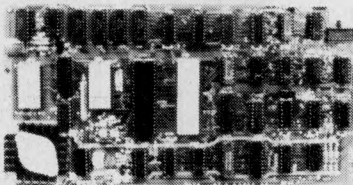

**VDB 8024**  
 \* FULL 80 x 24 DISPLAY  
 \* 7 x 10 MATRIX  
 \* KEYBOARD INTERFACE  
 \* VIDEO & TTL OUTPUT  
 \* 2K INDEPENDENT ON-BOARD MEMORY  
 8 ON-BOARD Z-80 CPU  
 \* 96 UPPER & LOWER CASE CHARACTERS  
 \* 32 SPECIAL CHARACTER SET  
 \* 128 ADDITIONAL PROGRAMMABLE CHARACTER SET  
 PRICE: £140.00 KIT; £236.00 BUILT AND TESTED

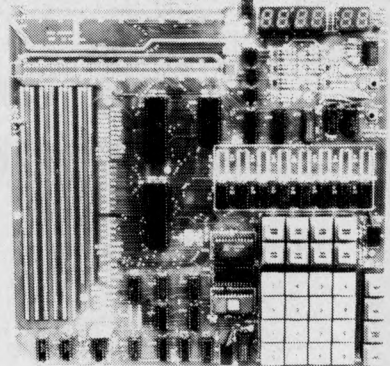

**STARTER KIT**  
 \* ON-BOARD KEYBOARD & DISPLAY  
 \* CASSETTE INTERFACE  
 \* PROM PROGRAMMER  
 \* 1K RAM, 6K EPROM, PI/O, CTC, MON.  
 PRICE: £140.00 KIT; £246 BUILT AND TESTED

COMPONENTS	
2708 1024 x EPROM	6.50
2716 2048 x 8 EPROM	37.50
1771B-1 FLOPPY DISK CONTROLLER	29.95
21LO2 1k x 1 (450ns) — per 8	7.50
21LO2 1K x 1 (250ns) — per 8	8.95
2114 1k x 4 (450ns)	4.99
4115 8k x 1 (250ns) DYNAMIC — per 8	25.00
4116 16k x 1 DYNAMIC — per 8	89.00
AY5 1013 UART	4.50
AY5 1014 UART (5V)	6.50
AY5 3600 ENCODER	9.99
8080A CPU	8.99
4044 4K x 1 (450ns)	7.45
4215 16K x 1 (250ns) — per 8	59.50

FOR COMPONENTS PLEASE ADD 40p P&P  
 THEN ADD V.A.T. @ 15%

**AIRAMCO LIMITED**  
 UNIT A2, 9 LONGFORD AVENUE, KILWINNING INDUSTRIAL ESTATE, KILWINNING Ayrshire KA13 6EX  
 TEL: 0294 57755. TELEX: 779808



Small  
Systems  
Engineering  
Limited

## COMMODORE APPROVED PET INTERFACES

### IEEE-488 Pet Disc Compatible

Serial Input and Output	£186.00
Serial Output only	£120.00
Parallel for Centronics, Anadex	£106.00
RS232C or 20mA Loop Output, Crystal controlled Baud Rates	
Special Code Conversion Chips available for non-standard Character Codes	

### Micro Based General Purpose Interface

Serial Input and Output with buffering	
Software Controllable Baud Rates	
Expansion Capability for additional RAM and I/O	
	Price £249

### PETE

Intelligent Terminal Software Package for PET  
Requires Bi-directional Serial Interface

### TV/Video Monitor Interface

Video and UHF output £ 35.00

### Expansion Memory Boards

Internally mounting — available with Prom Sockets:	
24K	£328.00
32K	£432.00

## NEW REAL-TIME AUDIO SPECTRUM ANALYSER

Internally mounting, 32 channels, 1K ROM routines on board for analysis and graphical display, USR functions linkage to PET operating system £450.00

## S100 BOARDS

### Dynamic Memory Boards

IEEE S100 Compatible timing and on board transparent refresh  
Available with Bank Select Feature, 64K, 48K and 32K  
64K £487.00 64K (Bank Select) £562.00

### P&T S100 IEEE-488 Interface Board

Controller, Talker, Listener capability  
CPM or North Star Software supplied,  
£350.00

All Prices exclude VAT  
P&P £5.00 (includes Securicor Express Delivery)

62 New Cavendish Street · London W1M 7LD  
Telephone: 01 637 0777 Telex: 8813085 (Abacus)

# the software house

COME & SEE US ON STANDS A1 & A2 AT  
THE P.C.W. SHOW! WE HAVE A WIDE &  
INTERESTING RANGE OF SOFTWARE FOR  
MOST POPULAR MICROS. NEW PROGRAMS :-

### TRS-80

* BEEWARY (WITH SOUND !)	£9.00
ADVENTURE (2 VERSIONS)	£8.50

### APPLE :

STOCKLOCK(1 disc stock control)	£50.
CITY MANAGER (RUN A CITY)	£10.

### PET :

* ALIENS ! (STOP THEM IF YOU CAN!)	£6.00
* UXB (DEFUSE BOMBS!)	£5.00
* MONSTERS (ZAP 'EM)	£9.00
U.K.MAP (C.A.I.GRAPHICS)	£12.00
* COMPENDIUM(SLOTS,TANK,ESCAPE)	£9.95
* BREAKOUT (with sound)	£5.00
ENLARGE (GRAPHIC AD DISPLAY)	£6.00
<u>SORCERER :</u>	
OTHELLO	£7.00
SI FI SAMPLER	£7.00
GENERAL KNOWLEDGE QUIZ	£6.00
BLOCKADE RUNNER(SPACE GAME)	£9.00
* <u>DENOTES PROGRAM WITH SOUND</u>	

WE ARE NOW APPLE DEALERS :  
APPLE II NOW ONLY £750. + VAT !!!!!  
ask for FREE LIST & SPECIAL OFFERS!

MORE PROGRAMS ARRIVING DAILY !!!!!  
OUR PRICES INCLUDE 15% VAT

ORIGINAL PROGRAMS WANTED FOR WORLD-  
WIDE DISTRIBUTION. WE PAY 15%  
ROYALTY ON GROSS SALES \*\*\*\*\*  
MOST PROGRAMS IN OUR CATALOG ARE  
AVAILABLE FROM STOCK

SEND FOR OUR FREE CATALOG.

THE JOURNAL "80-US" FOR THE TRS-80 IS  
AVAILABLE ON SUBSCRIPTION FOR £10 pa.  
& is published BI-MONTHLY - VERY good  
value for money! SAMPLE FREE TO USER  
GROUPS. PLEASE NOTE OUR NEW ADDRESS:  
146 OXFORD STREET, LONDON W.1.

# Research Resources Ltd

Micro-computers for Education, Science and Technology.

SWTP — New 16 Bit, 384K RAM Computer

## SWTP

- \* 6809 16/8 Bit CPU replacement card for Level 1/2
- \* Two new 6809 computers — up to 384K RAM
- \* New DMAF-2 8" Dual Floppy disks — 2.5 Megabyte
- \* Memory available in 4,8,16,32,128k Boards
- \* New Graphics VDU — CT82B — Improved 50Hz UK Standard
- \* New TSC BASIC — very fast!
- \* Plus LAB-BASIC, SAM, PASCAL, PILOT, FLEX, etc.
- \* A-D, D-A converters

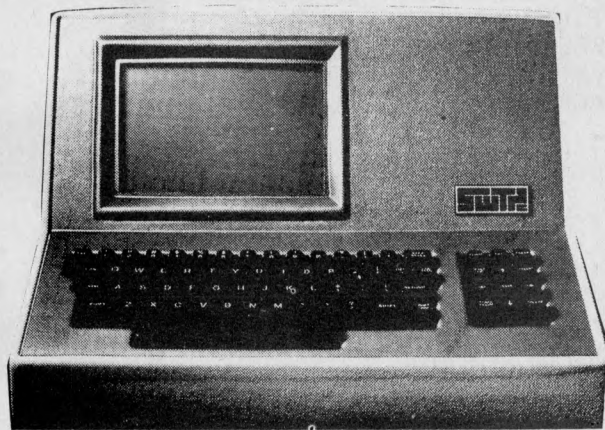

VECTOR MZ— up to 64k, S100, CP/M

## VECTOR

- \* Z80A CPU, S100 Bus
- \* 48k or 64k enhanced version
- \* Over ½ Megabyte of integral disk storage
- \* Improved Micropolis disk drives
- \* MDOS or CP/M operating system
- \* Hardware floating point board and software.
- \* Fast Fourier transform and digital filtering package.
- \* Plus LAB-BASIC, SAM, FORTRAN, BASIC Compilers

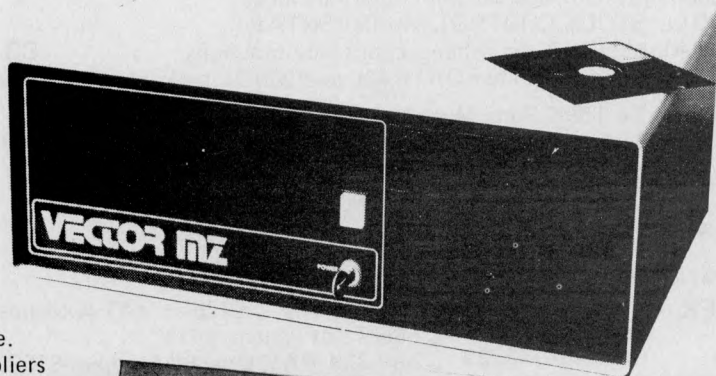

PET — New Models, Disc drives, Printers

## PET

- \* Up to 32k of user RAM
- \* 360k intelligent disk drives (CBM)
- \* 40 Column printer — only £250
- \* 80 Column Graphics printer
- \* RRL Special — use a SWTP chassis as a PET Memory/User port expander box.
- \* LAB-BASIC for Control



THE MATRIX IS COMING \* 16 Bit Machine with integral disk drives.

RRL specialises in designing micro-computer systems for educational and scientific use. We will supply the complete system — processor, VDU, printer, special interfaces, software etc. — to solve your problem.

For further information:

Tel: Welwyn Garden (07073) 26633

RESEARCH RESOURCES LTD, 40 Stonehills,  
Welwyn Garden City, HERTS. AL8 6PD.

# OSI for LESS than YOU EXPECT

IF YOU HAVE ALREADY DECIDED  
THAT YOU WANT AN OSI SYSTEM  
WE ARE  
OFFERING THE BEST PRICES  
AVAILABLE ON C2 AND C3 SERIES  
MACHINES

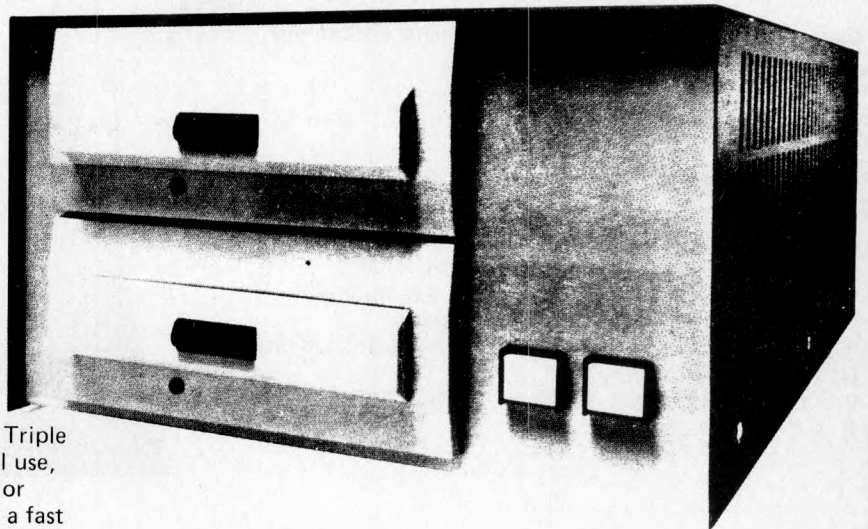

If you are undecided:-

**The C3-OEM** is an Ultra High Performance Triple Processor Machine for business or industrial use, providing advanced application packages. For information management OS-DMS features a fast file handling system, and program library includes PAYROLL, STOCK CONTROL and INVENTORY, GENERAL LEDGER and other accountancy functions. OS-CP/M offers a complete FORTRAN and COBOL package.

**C3 OEM**  
**£2450 + VAT**

**Expandable To T68K Ram, Multi User/Programming.**

C3-C with 23MB (formatted) hard DISC £POA. or C3-B with 74MB Hard Disc £8995 + VAT.

More memory? CM-3 16K static RAM £295 + VAT

INTERTUDE TERMINAL £675 + VAT

NEW! 13.4MB tape (cartridge) back up store POA.

## C2 SERIES PROCESSORS

**For Personal or Educational use**

C2-4P (4K RAM) £349 + VAT

extra 4K £ 29

CM-7 8K RAM £125! + VAT (expands to 24K)

C2-8P 8 slot system £475

C2-8P 32K RAM Dual 8" Floppies £1533

The OSI specialists:

**MUTEK** Quarry Hill,  
Box, Wilts  
Tel: Bath 743289

# NEW!

## MASTER PACK<sup>®</sup>

for Casio 501/502  
with FA-1

PRE-RECORDED CASSETTE AND USER MANUAL FEATURING :

- \* OVER 150 ready-to-run programs on cassette - with voice identification for fast access
  - \* Full CASIO PROGRAM LIBRARY ready for immediate use - PLUS
  - \* Extra GAMES - Lunar Lander, Codebreaker, Fruit Machine, Bomber Pilot, Reaction Timer, Wipeout, Roadrunner, math and strategy games
  - \* PERSONAL COMPUTER PROGRAMS - Bank account and credit card management, price comparator, biorhythm, diet and weight calculators
  - \* POWERFUL SUBROUTINES for use in your own programs - display formatting, user prompts, plus DATA-PACKING (gives 502 100+ special function memories - essential for statistics)
  - \* EDUCATIONAL PROGRAMS - Math Exerciser sets and marks problems in basic arithmetic
- PLUS USER MANUAL : **See preview in Calculator Corner**
- \* Basic and Advanced Programming - fact-packed articles to develop your programming skills; everything you need to know but can't find in the CASIO manual!
  - \* Full command key-code index for fast program de-bugging
  - \* Comprehensive documentation for all MASTER PACK programs
  - \* 'From Our Programmer's Notebook' - programming tips and tricks, special program sequences

## MASTER PACK

for Casio 501/502 with FA-1

**ONLY £17.95**

Available from selected CASIO retailers, or send £17.95 direct to PREMIER PUBLICATIONS  
15 Flaxman Road, London SE 5 (cheques/POs only - we pay p & p)

DEALER INQUIRIES INVITED - distributorships still available in some areas



# Happy Birthday PETDISK!

The U.K.-designed and manufactured Novapak disk system for Commodore's PET\*, first seen at Compec '78, has now entered its 2nd year of production. It's unique saddle configuration continues the integrated design concept of your PET, with no trailing wires or bulky desk-top modules.

Novapak Dual — disk system complete with PDOS and Utilities on disc £899 + VAT  
 Single-disk (stand alone) £499 + VAT  
 Pack of 10 mini-diskettes £30  
 Full cash with order is subject to 5% discount.

- \* Novapak may be used with any available RAM plane.
- \* May be used with both types of PET
- \* Data transfer takes place at 15,000 char/sec — effectively 1,000 times faster than cassette!
- \* Storage capacity is 125 K/bytes (unformatted) on 40 tracks per diskette side.
- \* Dual index sensors permit dual-side recording for 250 K/bytes per diskette.
- \* Easy operation full-width doors prevent media damage.
- \* System expandable to ½ Mbyte on-line storage (4 drives).
- \* Industry Standard IBM 3740 recording format for industry-wide media compatibility offered only by NOVAPAK.
- \* Dedicated Intel 8048 microprocessor and 1771 FDC minimise PET software overhead.
- \* Nationwide maintenance available.

Clear documentation and a range of Demonstration programs assist the first-time user, while for the experienced programmer full utilities are supplied to aid concise program development. The sophisticated, easy to use Disk Operating System supports multiple file handling and incorporates extensive error-recovery software for maximum data integrity. Optional password security for any file or any disk is provided.

Several standard software packages are available, and we will tailor any of these to match your specific requirement. Call now for details or a custom software quotation.

## analog electronics

47 Ridgeway Ave,  
 Coventry  
 Tel: (0203) 417761

## APPLE II comes to Glasgow

Why not call and see the fantastic Apple II the finest micro currently available.  
 Demonstration without obligation.

We also have in stock the following top quality items.

**High Speed Tape Cassette Interface.** Comes complete with instructions showing how to interface to Nascom giving 'normal' and high speed operation. 300, 600, 1200, 2400 baud. At the highest speed this will load our 8K basic in about half a minute.

Price (Kit) £17.50 + VAT

**Supercolour** — at last top quality colour for your Apple II. Converts apply signals to separate red, green, blue, and sync. signals. No modulator required. 14" colour monitors available. Send for details now.

**Also newly arrived** — Buy brand new games for Nascom, Snarkhunt, Chase + Trail, Bulls + Cows, Life, Four in a Row. Runs on minimum Nascom — Any monitor. £10.00 inc. VAT p+p.

**Printers** — High speed. 112 Char/sec. Top quality. User plain paper tractor fed £575 + VAT.

**PASCAL** — Now available, the most powerful micro language PET. Features too numerous to fit this ad. Full details by return post.

**Monitors** — Hitachi, top quality B/W monitors now available. Plug straight into Apple. No modulator required.

**Brand New Product.** Chiptester. Converts Nascom to a super powerful I.C. tester. Plugs in to existing ports. Send now for full details. £19.50 Inc. VAT p+p  
 Callers welcome

### STRATHAND

44 ST. ANDREW'S SQ.  
 GLASGOW G1 5PL  
 041-552 6731



Tel. order welcome with Access and Barclaycard  
 Now on Telex 777268. 24 Hours Service

## GODBOUT Computer Products

High quality, fast (4 MHz), reliable static S-100 memory boards and other products e.g. —

	Kit	Ass.
2708 EPROM chip	£6.25	n/a
2716 EPROM chip	p.o.a.	n/a
Econoram 2708, 16K EPROM (No EPROMS)	£45	£65
Econoram 2716, 16K EPROM (No EPROMS)		
8K RAM (No RAMs)	£55	£75
Econoram IIa, 8K	£80	£99
Interfacer 2 full RS232 serial I/O	£99	£125
Econoram IVa, 16K	£150	£169
Econoram VIIa, 24K	£230	£249
Econoram XIIIa, 32K	£315	£339

### EXTRA LOW PRICES ON QUALITY DISKS

Brand name diskettes stocked for most micros.  
 Pack of ten 5¼" disks, £19      Ten packs (100 disks), £175  
 Pack of ten 8" disks, £23      Ten packs (100 disks), £210

When ordering please specify whether you require hard or soft sectored diskettes, and if hard sectored, the number of sectors.

Anadax DP8000 Printer. Ready to go! Includes RS232 cable, 1,000 sheets continuous stationery and Securicor delivery within UK. Only £525.

All prices given include postage and packing (overseas add £10) Just add VAT. Send 10p stamp for details.  
 Quantity discounts available on application. Credit terms (nett 30 days) given to large companies and government establishments.

Mail Order 'phone: 01-828 1785

# Logic box

...Disks ... calculators ...  
paper ... printers ... magazines ...  
8K,16K,32K PET's ... Petsoft ...  
Petact ... Compelec Series 1 ...  
and accessories like our ...



... mains interference suppressor.  
This plug in suppressor helps stop  
interference from the mains which can  
be a threat to data in small business  
systems; no wiring and handles 1500  
Watts at 6 amps; reduces interference  
between 150 kHz and 100 mHz

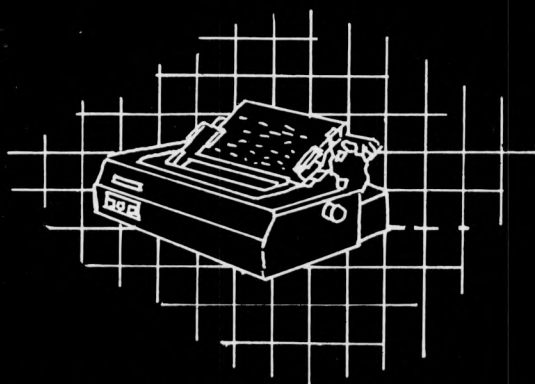

If you're after a Hewlett Packard calculator,  
a sales accounting package, a Teletype 43  
printer, a book on Basic or just a tape of  
'Microchess' ... drop in at 31 Palmer Street  
(by Caxton Hall) Westminster, London SW1.  
We are open Mon-Fri. and are right by St.  
James's Park tube near the  
Army and Navy Store.

31 Palmer St (by Caxton Hall) London SW1  
(01) 222 1122

also at:

Planer Bldg, Windmill Rd., Sunbury Middx (09327) 86262

Katanna  
Management Services Ltd

kms

&

COMPUT-A-CROP

WE ARE ON STAND 54  
of the PCW SHOW  
(1st - 3rd November)

0245-76127 01-677 3022

Come and discuss your requirements for Business  
Systems and Software:

Printers, Peripherals, and packages or individually  
written programs available:

For further information phone either of the above  
numbers or write to:-

22 Roughtons  
Galleywood  
Chelmsford  
Essex

'Tandy' Equipment from S. J. Trott Ltd.,  
(Franchise Dealer) - 01-969 6608

## Printers... Printers... Printers...

- \* 16,20,32,40,64,80 and 132  
characters per line.
- \* Impact, electrosensitive and  
thermal.
- \* O.E.M. mechanism/assemblies or  
complete packaged units.
- \* From only £149 for a printer  
mechanism with electronics.
- \* See them on stand A13 at the  
P.C.W. show.

**Dataac** LIMITED  
"The Printer People"

Tudor Rd, Altrincham, Cheshire, WA14 5TN  
Tel: 061-941 2361/2

EDUCATIONAL GAMES  
COMPUTERS  
SOFTWARE  
SYSTEMS  
PRINTERS  
PERIPHERALS  
CONSULTANCY  
TV GAMES  
CALCULATORS

CONTINUING  
B & B CONSULTANTS  
DISCOUNT  
DELIVERY  
SYSTEM

*Send large stamped  
addressed envelope  
for menu to:  
B & B Consultants,  
124 Newport Street,  
Bolton, Lancs. or  
Tel. Bolton  
(0204) 26644  
or see us on  
Stand A15  
at the PCW Show*

*DEFINITELY NO  
SERVICE CHARGE ON  
OUR MENU; THE  
PRICE YOU SEE IS  
THE PRICE YOU PAY*

ALL OUR PRICES  
INCLUDE CHIPS

MEGABYTES  
FOR  
YOUR  
PET!



**keen computers  
apple dealers stand**

- \* Keen Computers Ltd.
- \* P.I.P.S Computer Services Ltd.
- \* Arden Data Processing
- \* P.T.S. (Electronics) Ltd.
- \* Sumlock Bondain Ltd
- \* Pace Electronic Developments
- \* Furness Computer Services Ltd.

..... Starring

Apple II, Apple II+, Apple peripherals, Pascal  
Printers, Speechlab, Supertalker  
Supercolour, Corvus 11mb hard disk  
..... and Software for everyone

**COME AND TALK TO US  
STANDS 13-18  
PCW SHOW**

**and let apple have the last word**

I CAN'T AFFORD THE TIME|....

But if I did.....

Maybe I might find Microcomputers would assist me in my business

Maybe I may learn how to program a microcomputer

Perhaps I ought to afford the time to make just one 'phone call

Contact us on 01-546-9887 or see us on Stand 42 at The Personal Computer World Show, West Centre Hotel, Lillie Road, SW6 on November 1st-3rd 1979

TRAINING, SOFTWARE AND CONSULTANCY SERVICES

INTERAM  
Microsales

## North Star ★ COMPATIBLE HARDWARE

NORTHSTAR	£Kit	£Ass
Horizon-1-32K-D	995	1165
Horizon-2-32K-D	1195	1395
Horizon-1-32K-Q	1125	1335
Horizon-2-32K-Q	1425	1675
16K dynamic memory card	195	225
32K dynamic memory card	295	335
Hardware Floating Point card	145	195
Z80A CPU card	99	145
Dual density/Quad controller with REL5 S/W	225	275

### PERIPHERALS

Intertec Intertube II VDU (uses 280 + 6K EPROM)	n/a	575
Elbit DS1920, model 30 VDU	n/a	730
Anadex DP8000 printer	n/a	525
NEC Spinwriter 55 cps letter quality printer	n/a	1395
Digital equipment LA34 terminal	n/a	825

All prices given are exclusive of VAT and carriage, and are correct at time of going to press.

**ATTRACTIVE EDUCATIONAL, OEM AND DEALER DISCOUNTS AVAILABLE ON NORTHSTAR EQUIPMENT NOW!**

Please send 50p (inc. p+p) for our latest product catalogue which details the above and much more.

Telex: 925859

Telephone: 01-834 0261/2733

Interam Computer Systems Ltd  
59 Moreton St., Victoria,  
London S.W.1.

Telex: 925859

Telephone: 01-834 0261/2733

Interam Computer Systems Ltd  
59 Moreton St., Victoria, London SW 1

**INTERAM**

# COMPLETE COMPUTER SYSTEMS (CCS)



CCS Microsales

LEARN "BASIC" with a £50 Voucher towards the cost of a "BASIC" course when you buy a micro from us.

### ABC 80

Z80A based. Fastest in this price range. Fantastic 'BASIC' in 16K ROM plus Assemblers and FORTRAN (disc based) and over 35 Industrial I/O and memory boards.

### APPLE

48K Disc based WORD PROCESSING Turnkey System inc. IBM Printer only £1990 (ex. VAT). Also 12 extra boards from CCS as options to all the usual Apple boards.

### PET

Our own boxed S100 interface so you can choose from the 200+ index of S100 boards and use them with your PET.

### SORCERER

All sorts of S100 goodies available on order at costs which make it better than the hassle of getting them on your own.

We Know

### SEEING IS BELIEVING

and invite you to come and see the ABC80 and others at our new Letchworth shop (Open Nov.). Just clip the coupon and send it to: CCS MICROHIRE/MICROSALES FREEPOST (7 The Arcade) Letchworth, Herts.

### CCS Microhire

Still the Leading Microcomputer Hire Company with the best range of equipment:

PET (8K) now £4.20/day\*

APPLE (16K) now £5.70/day\*

Apple II; PET; Exidy Sorcerer;

SEED System One/MSI 6800;

NASCOM/MICROS; Research

Machines 380Z and Tandy

TRS-80

Over 500 million Bytes (half megabytes memory) available for hire in units from 4K to 48K.

Send for our NEW PRICE LIST giving the most attractive prices yet.

\* four day rates

**CCS MICROHIRE**

**FREEPOST (7 The Arcade)**

**LETCWORTH**

**Herts SG2 4YA**

I would like to come and see the ABC80, PET, APPLE  
Please call me back to arrange an appointment.  
NAME.....  
Company.....  
Location.....  
Tel..... Ext.....

# WHY BUY A MICRO-COMPUTER FROM **PETALECT**

**ELECTRONIC  
SERVICING LTD.**

## BECAUSE

- 1) Established company trading since 1971
- 2) Electronic servicing is our speciality
- 3) We have in house programmers/systems analysts
- 4) We have our own service engineers
- 5) We will demonstrate the PET at your premises
- 6) We can customise the PET to your requirements
- 7) We can arrange finance
- 8) We offer, after the three-month warranty, a **service contract from £69.50**
- 9) You benefit from our experience of having sold over 150 micro-computers to industrial, educational and business, personal users.
- 10) We specialise in programs and interfaces for weighing applications for average weight control and counting etc.

All 'PETS' sold with a Basic Tutorial Tape

8K £550.00 + VAT.  
16K £675.00 + VAT.  
32K £795.00 + VAT.

New Large  
Keyboard 'PETs'  
Now in Stock

In our showroom we sell  
Books, Programs etc.



## Also available:

24K Memory Expansion Boards (disk-compatible)  
only £320 + VAT

PET-compatible dual floppy disk unit  
with advanced operating system  
only £840 + VAT

Large Extension Keyboard for the PET £89.50 + VAT

Telephone for complete system prices.  
Wide Range of Printers Available.

If you require any more information or demonstration  
regarding the PET 2001/8 or any associated equipment,  
programs, etc., please contact Mr. P. J. A. Watts or  
Mr. D. W. Randall at:

### **PETALECT ELECTRONIC SERVICES LTD**

33/35 Portugal Road,  
Woking,  
Surrey.  
Tel. Woking 69032/68497

### Shop at:

### **PETALECT**

Chertsey Road,  
Woking,  
Surrey.

Tel. Woking 21776 23637

SEE US ON STAND 5 AT THE PCW SHOW

## ADVERTISERS INDEX

Abacus Computers	77	Lifeboat Associates	102
Acorn Computers	87	Lion House	9
Adda Computers	36	Little Genius	130
Airamco Ltd	131	L&J Computers	122
Almarc Data Systems	4	Logic Box	136
Analog Electronics	135	London Computer Store	30
Applied Data		Lotus Sound	127
Education Services	90	LP Enterprises	24/25
B&B Consultants	137	LTT Electronics	135
The Byte Shop	90	Micro Centre	IFC
Cambridge		Microcomputer Centre	35
Computer Store	35	Microdigital	14,128
Carter Keyboards	117	Micro-Facilities	36
CCS Microhire/ Microsales	138	Micromedia (Systems)	122
Comma Computers	66	Microsense Computers	12
Comart	5,19	Microsolve Computer Services	22
Commodore Systems	34	Mine of Information	29
Compelec Electronics	29	Mutek	134
Compfer Ltd	35	Nascom Micro- computers	10/11, 21,37
Comp Shop	140,IBC	Newbear Computing Store	28,121
Computerama	30	Newtons Laboratories	96
Computer Centre	15	NRDC	118
CPS (Data Systems)	128	Peripheral Hardware	124
Crystal Electronics	126	Personal Computers	OBC
Databank	32	Petalect Electronic Services	139
Datac	136	Petsoft/Petact	18,116
Data Systems		PIPS Computer Service	32
Engineering	36	Productivity Unlimited	32
Datron Interform	22,38	Research Machines	125
Display Electronics	23	Research Resources	133
Elbit Data Systems	124	Mike Rose (Micros)	32
Electronic Brokers	26	Rostronics	2
Ensign	59	Sharp Elec- tronics (UK)	62
Equinox		Sintrom Microshop	2
Computers	8,118,126	Sirton Products	108
Eurocalc	53	Small Systems Engineering	129,132
Factor One		The Software House	132
Computers	119	Stack Computer Services	27
Gemsoft	128	Strathand	135
GPW Electronics	17,126	Strumech (SEED)	46
GW Computers	31	Tandy Corporation	43
Happy Memories	70,124	Technalogs	130
A.J. Harding (Molimerx)	130	Teleprinter Equipment	20
HB Computers	120	Transam Components	13
Heath (Gloucester)	26	Tridata Micros	38
Home and Business Computers	14	TVJ Microcomputers	16/17
Integrated Circuits Unlimited	123	V&T Electronics	122
Interam Computer System	138	William Stuart Systems	117
Intex Datalog	122	Xitan Systems	33
Ithaca Intersystems	3		
Katanna Management Services	136		
Keen Computers	137		
Kingston Computers	88		

## TRS80 EXPANSION INTERFACE

Upgrade your system as your needs increase. Contains sockets for additional 16K or 32K RAM and a disk controller for up to 4-mini-disks. Software selectable dual cassettes can be used. Features a Centronics parallel port, real time clock, and a connector for an RS-232C interface or whatever. Requires Level-II Basic. 220/240V AC. Complete with 32 K RAM £299 plus VAT.



## ANADEX DP8000

ONLY £540 + VAT  
PET Connector — £49

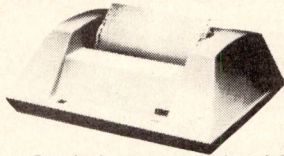

The DP 8000 prints the 96-character ASCII set in single or double width at 84 lines per minute. • The unit operates bi-directionally to print a 9 x 7 matrix on multiple copy, pin-lead plain paper. • This model accepts RS-232C or current loop serial data at baud rates switchable from 110 to 9600 and Parallel Bit data input at over 1000 characters per second. • Other features include Out of Paper Detector, Top of Form Programming and Skip Over Perforation Control.

- Standard storage capacity of 256 characters
- Other features include Out of Paper Detector, Top of Form Programming and Skip Over Perforation Control.

## THE NEW ITT APPLE (2020)



ITT MICRO COMPUTER

- ★ Full colour — UHF output
  - ★ Audio cassette tape interface
  - ★ Up to 48K RAM on board
  - ★ BASIC in ROM (graphics commands include COLOUR = VLIN, HLIN, PLOT and SCRIN)
  - ★ Built in loudspeaker
  - ★ Buckets of software available
  - ★ Disk System (110K byte per drive — includes controller)
- only £425 + VAT EX-STOCK

## THE TRS80 (Special Scoop) Low Priced, Ready to Go!



16K £399 + VAT

EXTENDED WARRANTY BY COMPUCARE

PLUGS INTO YOUR OWN TV Use your own cassette

LEVEL II BASIC WITH 16K USER RAM provides you with possibly the most powerful micro around. All our TRS80s are fully converted to English Television Standard and include a U.K. Power Supply, Cassette Leads, Sample Tape, Level I & Level II programming manuals, and special lead that enables you to connect direct into your own television.

Special features of Level II Basic enable you to: — Set or reset any point on the screen — Test for the presence of a point on the screen (these features enable easy animation) — Save or load data from cassette under program control — File handling capabilities on cassette using named files. — Graphics blocks as standard — design your own pictures and many many more features for only £399 + VAT

## PET COSTS LESS AT COMP and it's a pedigree

EXTENDED WARRANTY BY COMPUCARE

8K — Comes complete with integral cassette deck. Full manuals supplied. Powerful 8K Microsoft Basic in ROM. Masses of software available — £499 + VAT

16K — Same as above but with new improved keyboard and cassette supplied as extra. Machine code monitor on board so you can program in 6502 machine code — £590 + VAT

32K — for a little extra get 32K memory providing greater storage capacity for programs or data — £690 + VAT

External Cassette deck for 8K, 16K or 32K — £55 + VAT complete with cable and connector.



## HITACHI PROFESSIONAL MONITORS



9" — £129 + VAT  
12" — £199 + VAT

- Reliability Solid state circuitry using an IC and silicon transistors ensures high reliability.
- 500 lines horizontal resolution Horizontal resolution in excess of 500 lines is achieved at picture center.
- Stable picture Even played back pictures of VTR can be displayed without jittering.

- Looping video input Video input can be looped through with built-in termination switch.
- External sync operation (available as option for U and C types)
- Compact construction Two monitors are mountable side by side in a standard 19-inch rack.

## video 100

12" BLACK & WHITE LOW COST VIDEO MONITOR

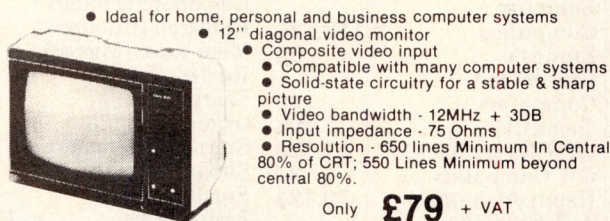

- Ideal for home, personal and business computer systems
- 12" diagonal video monitor
- Composite video input
- Compatible with many computer systems
- Solid-state circuitry for a stable & sharp picture
- Video bandwidth - 12MHz + 3DB
- Input impedance - 75 Ohms
- Resolution - 650 lines Minimum In Central 80% of CRT; 550 Lines Minimum beyond central 80%.

Only £79 + VAT

## SORCERER SPEAKS YOUR LANGUAGE

EXTENDED WARRANTY BY COMPUCARE

For personal or business use. The best value for money around.

- ★ 512 by 256 point screen resolution
- ★ 16K or 32K User RAM

- ★ Centronics Parallel Port
- ★ RS232C Serial Port
- ★ Composite IV peak to peak video output T.V. output supplied as extra.
- ★ 64 programmable graphics + 64 standard PEI graphics
- ★ 79 key keyboard including 16 key numeric keypad.
- ★ Expansion bus for connection to S100 Expansion Box.



Word Processing Pac and Development Pac now available.

16K Sorcerer — £690.00 + VAT  
32K Sorcerer — £790.00 + VAT  
S100 Expansion Box — £210 + VAT

Word Processing Pac — £70 Development Pac — £70

## Break the language barrier £138 + VAT



At a price equivalent to learning one language, LEXICON offers you, English, Spanish, French, German, Italian and Greek. The LK3000 comes to you with the person to person module which contains 6 languages, de-luxe carrying case and a charger adaptor using its own power source which will give you 4-5 hours continuous use, and can easily be re-charged from the mains supply, wherever you may be in the world. Every additional module carries a concise and understandable instruction book. Your deluxe carrying case has room for two additional modules.



(Part of the Compshop Ltd. Group)

Compucare is a company that has been set up to provide servicing and maintenance for the popular makes of micro-computers i.e. Sorcerer, Pet, Apple, TRS80, Nascom, CompuKit. Our charges are £7 per hour plus parts. Because of the extensive range of spare parts stocked you can usually expect your micro to be repaired within 10 days for an average charge of £14 labour. Emergency 24 hour repairs can be handled for a £10 surcharge where possible. CompuKits and Nascoms unsuccessfully constructed will be charged a standard £25. Maintenance contracts for these machines are available, see your local dealer for a Compucare Maintenance Application Form.

Please add VAT to all prices — Delivery at cost, will be advised at time of purchase. Please make cheques and postal orders payable to COMP, or phone your order quoting BARCLAYCARD, ACCESS, DINERS CLUB or AMERICAN EXPRESS number. OPEN — 10am to 7pm — Monday to Saturday CREDIT FACILITIES ARRANGED



AS SEEN IN  
P.E. AUGUST, SEPTEMBER  
OCTOBER 1979

EUROPE'S FASTEST SELLING ONE BOARD COMPUTER —  
JUST CHECK THE SPEC'S.

# COMPUKIT UK101

SAMPLE TAPE  
WITH EXTENDED  
MACHINE CODE MONITOR  
AND DISSASSEMBLER  
INCLUDED FREE

## LOW COST SUPERBOARD IN KIT FORM

The CompuKit UK101 has everything a one board 'superboard' should have.

- ★ Uses ultra-powerful 6502 microprocessor.
- ★ 50Hz Frame refresh for steady clear picture (U.S.A. products with 60Hz frame refresh always results in jittery displays)
- ★ 48 chars by 16 lines — 1K memory mapped video system providing high speed access to screen display enabling animated games and graphs.
- ★ Extensive 256 character set which includes full upper and lower case alphanumerics, Greek symbols for mathematical constants and numerous graphic characters enabling you to form almost any shape you desire anywhere on the screen.
- ★ Video output and UHF Highgrade modulator (8Mz Bandwidth) which connects direct to the aerial socket of your T.V. Channel 36 UHF.
- ★ Fully stabilised 5V power supply including transformer on board.
- ★ Standard KANSAS city tape interface providing high reliability program storage — use on any standard domestic tape or cassette recorder.
- ★ 4K user RAM expandable to 8K on board £49 extra.
- ★ 40 line expansion interface socket on board for attachment of extender card containing 24K RAM and disk controller. (Ohio Scientific compatible).
- ★ 6502 machine code accessible through powerful 2K machine code monitor on board.
- ★ High quality thru plated P.C.B. with all I.C.'s mounted on sockets.
- ★ Professional 52 Key keyboard in 3 colours — software polled meaning that all debouncing and key decoding done in software.

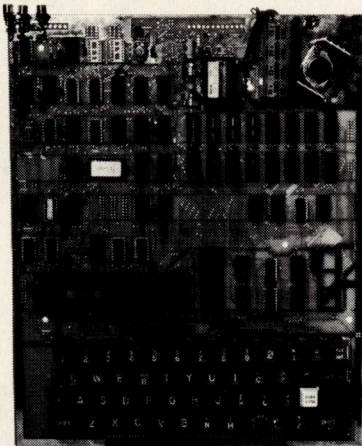

\*8K Microsoft Basic means conversion to and from Pet, Apple and Sorcerer easy. Many compatible programs already in print.

**SPECIAL CHARACTERS**  
@ Erases line being typed, then provides carriage return, line feed.  
. Erases last character typed.  
CR Carriage Return — must be at the end of each line.  
: Separates statements on a line.  
CONTROL/C Execution of a list is interrupted at the end of a line.  
"BREAK IN LINE XXXX" is printed, indicating line number of next statement to be executed or printed.  
CONTROL/O No outputs occur until return made to command mode. If an Input statement is encountered, either another CONTROL/O is typed, or an error occurs.  
? Equivalent to PRINT

Simple Soldering due to clear and concise instructions compiled by Dr. A.A. Berk, BSc.PhD

NO EXTRAS NEEDED JUST HIT 'RETURN' AND GO.

Build, understand, and program your own computer for only a small outlay.

KIT ONLY **£219** + VAT including RF Modulator & Power supply. Absolutely no extras.

Available ready assembled and tested, ready to go for **£269** + VAT

**COMMANDS**  
CONT LIST NEW NULL RUN  
**STATEMENTS**  
CLEAR DATA DEF DIM END FOR  
GOTO GOSUB IF.GOTO IF.THEN INPUT LET  
NEXT ON.GOTO ON.GOSUB POKE PRINT READ  
REM RESTORE RETURN STOP

**EXPRESSIONS**  
OPERATORS  
+ . / . ↑ NOT.AND.OR. >< . <> . >=< RANGE 10<sup>-32</sup> to 10<sup>+32</sup>

**VARIABLES**  
A,B,C,...Z and two letter variables  
The above can all be subscripted when used in an array. String variables use above names plus \$.e.g.A\$.

**FUNCTIONS**  
ABS(X) ATN(X) COS(X) EXP(X)  
LOG(X) PEEK(I) POS(I) RND(X)  
SPC(I) SQR(X) TAB(I) TAN(X)  
FRE(X) INT(X)  
SGN(X) SIN(X)  
USR(I)  
**STRING FUNCTIONS**  
ASC(X\$) CHR\$(I) FRE(X\$) LEFT\$(X\$,I)  
RIGHT\$(X\$,I) STR\$(X)  
LEN(X\$) MID\$(X\$,I,J)  
VAL(X\$)

## EXTRAS AVAILABLE SOON

**COLOUR ADD-ON** enables you to choose your foreground and background colour anywhere on the screen. Flash any character on the screen at will. Full documentation and parts in kit form.

**AD-A-RAM EXTENDER CARD** provides up to 32K Dynamic RAM Expansion, 8 Eprom sockets for 2708's or 2716's. Parallel Port (centronics compatible) and an RS232C serial port.

## WIN YOURSELF AN ANADEX DP8000 LINE PRINTER

There's never enough good software around. That's why **COMPUKIT LTD.** are sponsoring a software contest. There are 2 categories:

- 1) **Business and Education**
- 2) **Fun and Games**

One lineprinter will be awarded to the winner of each category. Send or bring along to the address shown below the following:

- 1) The program on cassette in the format used by the **COMPUKIT UK101**
- 2) Any documentation that you have for the program (source listing not necessary)
- 3) This coupon signed by you accepting the rules and conditions of the competition.

### RULES:

- 1) Entries, including documentation, must be printed by computer or typed double spaced, with your name on every page.
- 2) Send or bring your entries to the address shown below.
- 3) Entries must be received by midnight on 29/2/80, any received after this time are void.
- 4) You warrant by your signature that all programs and documentation material included is entirely your own creation, and that no rights to it have been given or sold to any other party, and you agree to allow **COMPUKIT LTD.** to use, publish, distribute, modify, and edit it as it sees fit.

- 5) All entries become the property of **COMPUKIT LTD.** No entries will be returned nor any questions answered regarding individual entries.
- 6) Judging will be by a selected panel chosen by, and including representatives of **COMPUKIT LTD.** Judges may assign programs to any of the categories as they see fit. Decision of the judges is final.
- 7) Employees of **COMPUKIT LTD.**, its dealers, distributors, advertising agencies and media are not eligible to enter.

Name \_\_\_\_\_

Address \_\_\_\_\_

I agree to abide by the above mentioned rules.

Signature \_\_\_\_\_

**COMP** COMPUTER COMPONENTS

14 STATION ROAD, NEW BARNET, HERTFORDSHIRE TEL: 01-441 2922 (Sales)  
CLOSE TO NEW BARNET BR STATION — MOORGATE LINE 01-449 6596  
OPEN — 10am to 7pm — Monday to Saturday TELEX: 298755



All Products Ex-Stock Please check availability

(Part of the Compshop Ltd. Group.)

# "My best Apple programs are on long-term deposit in the City... it pays rather well!"

We brought the first five Apples into the U.K. in November '77, with every penny we had. In November '79, we find several thousand throughout the country.

THANK YOU Apple owners.

Now we'd like to help you re-coup your investment by cataloguing and supporting the best Apple programs in the U.K. The Apple Software Bank is more like an old penny bank than a major clearing bank, but we know you'll help it grow. Telephone Stephen Derrick on 01-626-8121 to discuss your investment.

ATTENTION ALL Estate Agents, Employment Agencies, Yacht Brokers, Antique Dealers and Motor Traders.

Find out about *FINDER SOFTWARE!*

#### SOME BLUE CHIPS

**TESKIM.** This ROM will simulate the Tektronix 4010 family of graphics terminals. It's rather good!

**UPPER LOWER CASE ADAPTOR** A chip for the chap considering word processing.

#### NEW ISSUES

We are continually trying to bring the latest add-ons for your Apples. Please phone for the latest product information and data sheets.

#### NEW PRODUCTS

**8" SHUGART DISKS** giving 1.2 Megabytes A twin drive (with room for a third.) disk system with controller and software, give tremendous commercial possibilities. £2350 Excl. V.A.T.

**WORD PROCESSOR.** Ask about our Apple II Plus word processor package. Complete System with Diablo 1650 Daisy-Wheel Printer. £4250 Excl. V.A.T.

**PERSONAL COMPUTER PRINTERS.** Sensational 40 & 80 Character printer (graphics options) from £243 Excl. V.A.T. Interfaces for Apple, Pet & TRS 80. High quality silent printers. It's your choice!

**A/D BOARD** At last we have either an 8 bit or 12 bit A/D card for Apple. Excellent spec from £125 Excl. V.A.T.

**APPLE PASCAL** £296



## Personal Computers Limited

194-200 Bishopsgate, London EC2M 4NR.

Let us advise you about *COLOUR DISPLAY* on your Apple. Contact Technical Services.

