

# Personal Computer

HP85-TI 99/4-2  
ALLOS ACS 8000-2  
ALL BENCHMARKED

US \$2.00/FF8.80/LIRE 1700/DM 3.80/FL 4.00/BF 55  
S Fr 3.50/Pts 135 DKr 10.75/SKr 7.65/NKr 8.25/A Sch 28

World MAY 1980 50p

EUROPE'S LEADING MICRO MAGAZINE



**BUTTONING~UP THE INFORMATION AGE**

**Plus: 5th West Coast Computer Faire, an on~the~spot report**

# The best computers **PLUS** the best service

At MicroCentre, we're concentrating our resources on what we genuinely believe are the very best computers available today. . . . Cromemco computers, naturally. This way we can offer you the best deal possible.

## What we don't do

What we don't do is spread our expertise thinly amongst umpteen different systems, or try to stock every S100 product on the market. We don't claim to offer "impartial" advice on the best buy. And we don't sell from price lists or catalogues.

## The MicroCentre approach

Some micro-computer suppliers work like that, but we don't. Because we realise that when you're buying a computer you want more than the "brochures and boxes" approach. You want to see computers running; to try them out with different software products; to study the documentation; above all, you want expert answers to your most searching questions.

## Cromemco specialists

That's why we've specialised in Cromemco systems. Not simply because we think Cromemco systems are the best serious computers available at the price.



**Cromemco Model Z-2H hard disc computer. 10 megabyte hard disc, 2 floppy discs, Z-80 computer and 64K memory. MicroCentre price £5,326.**

But because by doing so we can dedicate our time, energy and resources to giving you the highest standard of Cromemco support possible.

demonstration; expect the full range of Cromemco peripherals; single-user and multi-user systems; and interactive graphics.

## Demonstrations

So when you visit MicroCentre expect to find Cromemco systems on permanent

## Software

Expect a choice of operating systems and compilers to evaluate; expect complete documentation; and expect the largest collection of Cromemco systems software in the UK.

## Expertise

Expect to find in-depth professional expertise at MicroCentre, the kind that is only acquired by installing Cromemco systems all over Britain. Expect a thorough appreciation of how Cromemco systems can be applied . . . in business, scientific research, industrial engineering, medicine and education.

## Support

Expect to get frank, accurate answers to your questions at MicroCentre. Above all, once you've bought a Cromemco system from us, expect to get a very high standard of technical support with your hardware enhancements and continuing software needs.

At MicroCentre, simply expect the best.



MicroCentre's Cromemco demonstration room, with the full range of Cromemco computers, peripherals, operating systems and software products on permanent exhibition. Why not pay us a visit? We're only an hour's Shuttle flight from Heathrow!

For  **Cromemco... call the experts**

**NOW IN SPACIOUS  
NEW SHOWROOMS**

Tel. 031-556 7354

**MicroCentre**

**STILL IN  
CENTRAL EDINBURGH**

Complete Micro Systems Ltd., 30 Dundas Street, Edinburgh EH3 6JN

# CONTENTS

Volume 3 No 5, May 1980

**36** **NEWSPRINT:** Guy Kewney with, this month, an additional Stateside supplement.

**45** **COMMUNICATION:** The letters this month.

**48** **BENCHTEST 1:** David Tebbutt covers the Texas TI 99/4 Home Computer.

**52** **BENCHTEST 2:** Sue Eisenbach reports on the Altos ACS 8000-2.

**55** **BENCHMARK ROUND-UP:** The timings for all machines tested since our September 1979 issue (plus a few more besides).

**57** **BENCHTEST 3:** Guy Kewney casts an eye over Hewlett Packard's HP85.

**60** **POWERING-UP THE POST:** PO or no PO, electronic mail is coming. David Hebditch evaluates some of the available modems.

**63** **VIEWDATA:** Part two of Adrian Stokes' introduction to the Information Age.

**67** **COMPUTER ANSWERS:** Sheridan Williams and friends handle another batch of reader problems.

**71** **FAIRE PLAY:** A special report, direct from the 5th West Coast Computer Faire.

**74** **SYSTEMS:** This month Mike Knight looks at Information Retrieval and Databases.

**76** **CHECKOUT:** John Moore examines the Microdata UV8 EPROM Eraser.

**77** **HARD COPY/SOFT PRICE:** A DIY teleprinter conversion feature — by YCW contributor, Tim Steele.

**80** **COMPUTER GAMES:** More complex evaluation functions — David Levy continues his series.

**86** **CALCULATOR CORNER EXTRA:** Calc AI. . . Peter Brooks puts some thought into programmables.

**88** **WAVE-MAKING ON A NASCOM 1:** Don Finlay describes a synthesis program — for acoustics or making music.

**91** **PET PRINTER PEP-UP:** J. C. Moore tells how he overcame the problems he found with the CBM 3022 printer.

**92** **PASCAL:** Sue Eisenbach and Chris Sadler explain some advanced programming techniques.

**96** **BOOKFARE:** So what if it works! Malcolm Peltu on writing with elegance.

**101** **RANDOM WRITINGS RESUMED:** What to do with random numbers. Michael James picks up the threads of a previous article.

**106** **CALCULATOR CORNER:** A TI59 accountancy application. . . where a calc provides a cost effective alternative to the micro.

**110** **INTERRUPT:** Watch out for monkey business! Also a warning to companies on accumulating micros.

**113** **YOUNG COMPUTER WORLD:** Taken over from this month by Derrick Daines.

**117** **DIRECT ACCESS:** Featuring IN STORE, TRANSACTION FILE, DIARY DATA and FAX

**132** **PROGRAMS** As well as those in YCW, this month we offer a superb backgammon program that features excellent graphics.

**135** **LEISURE LINES:** J. J. Clessa talks turkey and includes the most disgraceful "Quickie" yet seen.

**135** **BLUNDERS:** More "nasties" come creeping out of the woodwork.



Cover illustration  
Tony McSweeney

**Founder**  
Angelo Zgorelec

**Editor**  
Bruce Sawford  
**Technical Editor**  
David Tebbutt  
**Editorial Office:**  
01-637 7991/2/3

**Consultants**  
John Coll, Mike Dennis,  
Michael James, David Hebditch,  
Sheridan Williams,  
Dr. Adrian Stokes, Dr. Stephen Castell.

**Advertisement Manager**  
Stephen England  
(01-631 1786)

**Sales Executive**  
Liz Banks  
(01-631 1786)

**Micromart**  
Jacquie Hancock  
(01-631 1682)

**Group Advertising Director**  
Richard Howell (01-631 3187)

**Production Manager**  
Dick Pountain

**Art Director**  
Paul Carpenter  
**Art Assistants**  
Jimmy Egerton, Julia Davies

**Typesetter**  
Jane Hammell

Published by Sportscene Publishers (PCW) Ltd., 14 Rathbone Place, London W1P 1DE, England. Tel: 01-637 7991/2/3. Telex: 8954139 A/B 'Bunch' G. London.

Copyright notice  
Personal Computer World is published by Sportscene Publishers (PCW) Ltd. © 1980 Felden Productions. No material may be reproduced in whole or part without written consent from the copyright holders.

Printed by Riverside Press, Whitstable.

Distributed by Seymour Press Ltd., 334 Brixton Road, London SW9 7AG.

PCW welcomes all unsolicited material (written, photographic and illustrative) and although no guarantee can be given as to its safe return, reasonable care and attention will be exercised.

Guidelines for contributors  
PCW welcomes articles of interest. Don't be put off if your style of writing is 'under developed'. . . true worth lies in the content, and shaping features comes naturally to us! Manuscripts should not exceed 3,000 words and authors as asked to use triple-spaced lines with a wide left-hand margin; diagrams, listings and/or photographs should be included wherever possible. Please enclose a stamped, self-addressed envelope if you would like your article returned.

Because of the foregoing, it is necessary to add that the views expressed in articles we publish are not necessarily those of Personal Computer World. Overall, however, the magazine will try to represent a balanced viewpoint.

Finally, before submitting an article, please check it through thoroughly for legibility and accuracy.

Subscription rates: Britain £8.00 for 12 issues, USA \$20 for 12 issues (surface mail), Continent and elsewhere £9.80 for 12 issues. All prices include postage and packing. Supplies to specialist shops can be arranged by negotiation direct with the publishers.



# MICROCOMPUTERS ETC

For Hardware, Software, Peripherals, Consultancy and Competitive Prices.

Registered business name



## PET 2001



from  
£475

Commodore  
authorised dealers

## TRS 80



from  
£365

From Radio Shack Corp.

## APPLE II

from  
£750



Apple & ITT 2020  
authorised dealers

## SORCEROR

from £740



authorised dealers

## COMPUCOLOR

from  
only  
£999



for computer with colour monitor, keyboard and  
integral disk drive. Second disk drive £316.00

BASIC SYSTEMS		
PET 3016 (16K RAM and large keyboard)*	PET 2001;8 (PET with 8K memory + integral cassette)	£475.00
PET 3032 (32K RAM and large keyboard)*	PET 3008 (8K) with large keyboard	£475.00
	PET C2N External Cassette Deck	£53.00
ACCESSORIES		
IEEE/RS232 Serial Interface 'A' Output only	IEEE 448/Centronics type parallel Interface	£45.00
IEEE/RS232 Serial Interface 'B' Input/Output	IEEE to Pet Cable	£19.00
Programmers Toolkit - 10 powerful new commands for your Pet - plug in ROM chip 8K and 16/32K resp £75/£55	IEEE to IEEE cable	£24.00
	PETSET 1 16 Channel AD Converter c.w. all interfacing requirements	£166.00

BASIC SYSTEMS		
TRS 80, 4K Level I consisting of Keyboard with 4K memory, Video Unit, Cassette Drive and 240v power supply unit	TRS 80, 16K Level II (as above with 16K memory)	£499.00
TRS 80, 4K Level II (as above with Level II Basic)	TRS 80, Expansion Interface with 16K RAM	£275.00
TVJ 232C Serial Interface	TRS 80, Expansion Interface with 32K RAM	£360.00
Centronics Parallel Printer Interface (direct to keyboard)	ACCESSORIES	
TRS 80, Voice Synthesizer	Radio Shack Phone Modem	£160.00
TRS Voxbox - speech recognition system	UHF Modulators (encased with leads for 625 lines)	£20.00
TRS 80, Numeric Key Pad supplied and fitted	RAM upgrade (4-16K, 16-32K, 32-48K) supplied and fitted at our premises (Kit £80.00)	£85.00
	S100 interface for TRS 80 (6 slots)	£375.00
	TRS80 CPU 3 speed mod.	£26.00

BASIC SYSTEM		
Apple II Plus computer - APPLESOFT extended basic in ROM - (16K RAM) - video output		£695
ACCESSORIES		
Apple black and white modulator for domestic TV	Real time clock/calendar card - 1/1000 sec to 388 days with interrupt, software controllable	£128.00
Eurocolor card - provides colour on domestic TV	Speechlab - provides voice control for the Apple	£127.00
Parallel Printer Interface Card	Supertalker - adds human speech output!	£205.00
High Speed Serial (RS232C) Interface Card	ALF Music Synthesizer Card	£180.00
Communications Card	A1-02 Data Acquisition Card	£180.00
Centronics Card	Graphics Tablet	£462.00
Integer Basic Firmware Card	AC Line Controller	£270.00
PASCAL language system - includes language card to provide user with PASCAL, PALSOFT & INTEGER BASIC	RAM Upgrade (16-32K, 32-48K)	£69.00
	Hobby Prototype Card	£20.00
	Romplus - u./c. mixed text/graphics	£105.00

BASIC SYSTEMS		
Sorcerer 16K RAM (inc. UHF Modulator)	Sorcerer 32K RAM (inc. UHF Modulator)	£840.00
ACCESSORIES		
Exidy Video Monitor (High Resolution)	Exidy S100 Bus with Interface + motherboard PSU	£200.00
Exidy Video Disk Unit	CP/M for Sorcerer on Disk	£145.00

ADVANCED SYSTEMS		CORVUS 11mb Hard Disk for TRS 80 & Apple. Complete with interface & D.O.S.		TANDY Model II now available for demonstration at our Camberley Office. (by appointment only) P.O.A.	
Altair, Equinox, Billings, Heath, Rair, Horizon. Installations include hard disk and multi tasking. Prices on Application.		£3500.00			

SPECIAL OFFERS	
PET BUSINESS SYSTEM. Comprising CBM 3032 Microcomputer, CBM 3040 Dual Disk Drive, CBM 3022 Tractor Feed Printer and all cables - Total cost if items purchased separately	For only £1999.00
(limited period)	£2158.00
(Comprehensive business software available including: Sales, Purchase, Nominal Accounts; Stock Control, Word Processing etc.)	

DISKS	
PET CBM 3040 (dual drive) 343K User storage* storage	£795.00
Computhink (dual drive) 400K storage	£895.00
Computhink (dual drive) 800K storage	£1145.00
TRS80	
Shugart drive	£315.00
Micropolis drive	£315.00
Percom FD200 drive 110v	£299.00
Micropolis Dual Drive (394K storage)	£995.00
Corvus Hard Disk (11mb)	£3500.00
APPLE	
Apple Drive - 116K storage 1st drive	£349.00
Apple Drive - 116K storage 2nd drive	£299.00
Corvus Hard Disk (11mb)	£3500.00
SORCEROR	
Exidy - 143K storage	£495.00
Exidy Dual drive (630K storage)	£1195.00
Corvus Hard Disk (11mb)	£3500.00

## PRINTERS

PET CBM 3022 (80 col with PET graphics - tractor feed)*	£525.00
TRS80	
TRS 80 Screen Printer (text + graphics) (110v)	£445.00
New Radio Shack Micro Printer	£245.00
GENERAL	
Teletype 43 KSR Serial (pin or pinch feed, 132 cols)	£825.00
Teletype 33 KSR Serial (110 Baud) Reconditioned	£450.00
OKI - parallel/serial (pin or pinch feed, 40, 80, 132 cols selectable)	£499.00
Centronics 779 parallel (tractor feed, 132 cols)	£825.00
Anadex DP 8000 serial/parallel (112 cps bi-directional tractor feed, 40, 80 cols selectable)	£560.00
Centronics Micro Printer (20, 40, 80 cols selectable)	£395.00
Heath WH 14 serial (80, 96, 132 cols selectable)	£475.00
QUME daisy wheel printers TCM100/MICROHUSH Thermal Printer (40 cols) inc. interface for PET/APPLE/TRS80	£266.00

## ETC.

Disquettes 5 1/4" (blank) boxed (min order 10) each	from £3
C12 Cassettes (min order 10) each	£0.35p
Ansaback 'phonemate' telephone answering machine, voice operated twin cassette	£190.00
Pace E2 PHONE - Cordless Telephone	£225.00
Computalker Speech Synthesis for S100	£350.00
BOOKS - Large range of microcomputer related books and magazines	
TERMINALS	
Pentland V1, 80 char./24 lines 2 page memory	£580.00
PROGRAMMABLE CALCULATORS. TEXAS INSTRUMENTS. Business Programmable Calculators - complete range. Send for list + prices. (We are authorised TI dealers).	

IF YOU DON'T SEE IT - ASK IF WE HAVE IT

## SOFTWARE

PET PETSOFTE authorised dealers - over 160 programmes on cassette and disk. Send for catalogue.	
STAGE ONE COMPUTERS S/W dealers - PETAID, Stock Control, etc. Send for list.	
74 Common BASIC Programs on one tape	£15.00
PETACT Business Software - Sales and Purchase Ledger	P.O.A.
CBM DISK-BASED BUSINESS SOFTWARE -	
Commodore Word Processor powerful word processor package	£75.00
CSTOCK - STOCK CONTROL - gives complete stock report	£150.00
CBIS - BUSINESS INFORMATION SYSTEM - Storage & Retrieval of all types of company records	£150.00
COM ACCOUNTS - Full Financial Business Accounting System incl: Sales, Purchase, Nominal Ledgers (integrates with C Stock and C INV)	£610.00
PAYROLL - Handles hourly, weekly or monthly paid employees (Tape) (We are authorised CBM Business Software Dealers) Send for List.	£50.00
GD 1001 - Assembler Development System	£75.00
GD 010 - Lisp Interpretive Language (Artificial Intelligence)	£25.00
JOYSTICK PACKAGE - complete with connector software	
CAR INSURANCE QUOTATIONS - computerised car insurance quotation suitable for insurance brokers (TVJ S/W)	£25.00
MORTGAGE QUOTATIONS - suitable for agents/mortgage brokers (TVJ S/W)	£25.00
TRS 80	
COMAC III SUITE - computerised accounting for TRS 80 (TVJ SOFTWARE)	£75.00
STOCK CONTROL - complete inventory control - recorder level - P/O's etc.	£115.00
CP/M	£95.00
CBASIC	£75.00
FORTRAN includes compiler, relocatable assembler text editor and linking loader	£95.00
PASCAL - tomorrow's programming language today	£195.00
ELECTRIC PENCIL - powerful word processor allows full cursor movement, insert/delete, string search block movement, adjustable line length, justification on cassette	£65.00
ELECTRIC PENCIL as above - disk version	£115.00
LOWER CASE MOD KIT for Electric Pencil	£28.00
DATA MANAGEMENT/REPORT GENERATOR - easily formats disk files, allows entry, edit, delete and list of records and retrieves data for display or calculation on screen or printer	£200.00
RSM 2D DISK MONITOR - powerful system manipulates disk data, has 2-80 break routine	£25.00
ISAM - INDEX SEQUENTIAL ACCESS METHOD - sub routines to facilitate control of random data files	£45.00
STR80D communications software	£60.00
NEWDOS - TRSDOS with corrections and enhancements	£25.00
NEWDOS - as above but with further facilities - KBFIX, Renum, Screen to printer in one step, DOS commands from BASIC, Level II in II, Superzap, Disassemble, load and save faster, list variables	£49.00
LIBRARY 100 - an assortment of 100 programs	£39.00
SARGON CHESS - 16K Level II - the 1979 Champ Version I	£14.00
SARGON CHESS - 16K Level II - the 1979 Champ Version II	£24.00

APPLE	
A2PF FUNCTION PLOTTER - Comprehensive graph plotting	£18.00
U-DRAW II - High Resolution graphics editor. Create a figure then intake, expand, contract etc and store on disk	£27.00
LISP - programming language suitable for research in artificial intelligence	£30.00
3-MILE ISLAND - Complex disk based game simulating nuclear reactor	£27.50
VISICALC - Instant Visual Calculation - provides a powerful planning and forecasting tool	£95.00
APPLE WORD PROCESSOR - Complete text editing, storage and retrieval of text (disk based)	£42.00
LITTLE GENIUS - Comprehensive disk based Apple Soft Tutorial	£35.00
MUSE authorised dealers. Many programs on cassette and disk. Send for list.	
SORCEROR many programs available - send for list.	

\* 5% DISCOUNT ALLOWED FOR EDUCATIONAL ESTABLISHMENTS



## T&V JOHNSON (MICROCOMPUTERS ETC) LTD

Member of the TV Johnson Group of Companies

Camberley (Head Office)  
165 London Road, Camberley  
Surrey, GU15 3J5  
Telephone (0276) 62506

Oxford  
148 Cowley Road, Oxford  
OX4 1JJ  
Telephone (0865) 721461

Bristol  
48 Gloucester Road, Bristol  
BS7 8BH  
Telephone (0272) 422061

Hours of business  
Mon-Fri. 9.30 - 5.30  
Sat. 9.30 - 1.00  
+ Ansaback eves  
and w/ends.  
Telex 858893

Directors: Dr. R.V. King BA, MIEE  
S.G. Johnson, BSc (Hons)  
T.S. Johnson, ABIBA, ACMB, FESC, MBIM  
A.S. Barton, ACFI, ABIBA, CIPMAF

Branches at  
Birmingham, Bristol, Edinburgh, Leeds, London, Louth,  
Newmarket, Nottingham, Oxford, Byfleet, Wokingham

PRICES EXCLUDE VAT. FREIGHT & HANDLING SEND FOR  
\*PHONE FOR PRICE LIST & BROCHURES  
(All prices correct at time of compilation)

# TAKE CONTROL



**Advanced interfacing for micro-mainframe connection, control instrumentation and communications for the microcomputer user.**

We have interfacing experience with

#### **Mainframes**

IBM, ICL, Univac, Honeywell, DEC, Harris, Etc.

#### **Instrumentation**

Strain Gauges, Gas Chromatographs, Chart Recorders, Auto Analysers, Digital Oscilloscopes, Thermocouples, Accelerometers, Etc.

#### **Peripherals**

Punches, Readers, Discs, Tapes, Plotters, Bar Codes, Etc.

For further information please contact **Graham Knott** or **Jeff Orr** on **051-933 5511**

#### **Stack Computer Services**

290/298 Derby Road, Bootle, Liverpool 20.



# TANDY

## ANOTHER BREAKTHROUGH

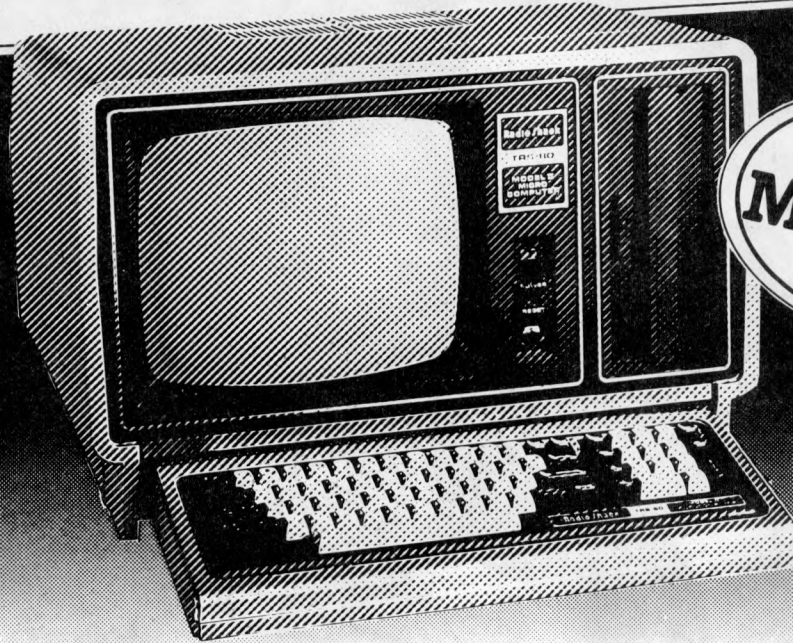

TRS.80  
MODEL II

### 5 FIGURE COMPUTING POWER AT A 4 FIGURE PRICE!

COMPLETE SYSTEMS FROM

# £1999

(Plus V.A.T.) Delivery 30-60 Days

- \* Built-in 1/2 Megabyte 8" Floppy Disk
- \* 32 or 64k Random Access Memory
- \* 12" High Resolution Video Monitor
- \* 24 Lines of 80 or 40 (wide) characters
- \* Upper/Lower Case
- \* Two RS-232C Serial Interface Ports
- \* "Power-Up" Self Testing
- \* One Centronics Parallel Interface Port
- \* Two Programmable Special Function Keys
- \* Direct Memory Access
- \* Vector Driven Interrupts
- \* Full 4 Megahertz operating speed
- \* Provisions for plug-in Expansion Boards

We've added a bigger, more powerful "brother" to the TRS-80 family. It's TRS-80 Model II - a completely new microcomputer whose capabilities begin where TRS-80 Model I approaches upper limits. Model II operates at twice Model I's speed, but it's not intended to replace - or compete with - the original TRS-80. It is designed specifically for the user who needs more data storage and versatility. Model II uses the enhanced Level III version of TRS-80's Level II BASIC and 27k Disk Operating System - automatically loaded into memory. System software is on diskette so future languages will permit maximum use of available memory. Operation is easy and requires no special training when our applications software is used. And like its little brother, Model II is completely modular, allowing easy-plug-in expansion. Listed above are some of Model II's sensational capabilities. See your nearest Tandy store or Computer Center for details. Discover how 5-figure computing - at a 4-figure price - can benefit you!

32k, 1-Disk TRS-80 Model II. 26-4001

## £2298.85\*

64k, 1-Disk TRS-80 Model II. 26-4002

## £2586.35\*

32k Memory Board. 26-4102

## £343.85\*

### THE EXPANDABLE TRS-80 MODEL II SYSTEM



Like TRS-80

Model I, Model II systems are expandable to meet changing - or growing - needs. Three expansion connectors (one parallel and two serial) allow you to connect printers, plotters, digitizers, telephone communications and many other external devices. Internal plug-in card slots allow for more expansion and enhancement options in the future... several are in the planning stages now.

Model II comes with a disk containing our expanded Level III BASIC programming language and our all-new command-compatible 'TRSDOS' operating system. This "system software" will be upgraded periodically with new features, and we plan to offer additional programming languages for Model II in the future.

Complete Model II packages can include up to 2 Megabyte Disk storage, advanced line printer for hard copy, system disk and more...

1 1/2 Megabyte System illustrated includes 26-4002, 26-4161, 26-4301, 26-1156

## £5,433.60\*

\*These prices are inclusive of V.A.T.

# NEW COMPUTER CENTERS OPEN!



## THE BIG NAME CENTRES FOR LITTLE COMPUTERS

Tandy are opening specialist TRS-80 micro-computer centers the length and breadth of Britain - many are already open and new ones will be appearing all the time. So you'll be able to drop in and experiment with the TRS-80 range, discuss your needs with a TRS-80 expert and buy one over-the-counter. Each store will be backed by a service engineer to iron out any problems you may encounter when commissioning your system.

## SHORT TEACHING COURSES

Every TRS-80 Computer Center has its own classroom where inexpensive practical short courses in TRS-80 use and programming take place regularly. Anybody can use a TRS-80 the courses are designed to prove it - fast.

- Level 1 Basic Course - 1 day
- Level 2 Basic Course - 2 days
- Level 3 (TRS-Disc operating system) - 2 days

## TRS-80 COMPUTER CENTRES NOW OPEN AT:-

**BIRMINGHAM**, Edgbaston Shopping Precinct, Hagley Road, **BRADFORD**, 2/4 Forster Square, **BRISTOL**, Colston Centre, Colston Avenue, **MANCHESTER**, 30 Market Place, Deansgate, **SOUTHAMPTON**, East Street Centre.

## NEW COMPUTER CENTRE/ AUDIO SUPERSTORES NOW OPEN AT:

**DOWNEND**, 5 Badminton Road, Downend, Bristol, **HENDON**, 21 Sentinel Square, Brent St., London NW4, **LEEDS**, 72 Merrion Centre, **LIVERPOOL**, 168 Market Way, St. John's Centre, **LONDON**, 1-2 Seacoal Lane, Ludgate Hill, London EC4, **WEDNESBURY**, Bilston Road, **WIMBLEDON**, 124-126 The Broadway, London SW19.

OVER 180 STORES AND DEALERSHIPS NATIONWIDE.

KNOWN AS RADIO SHACK IN U.S.A. MAKERS OF THE WORLD'S BIGGEST SELLING MICROCOMPUTER TRS-80.

## THE WORLD'S BIGGEST SELLING MICROCOMPUTER

TRS-80 MODEL 1 FOR BUSINESS, LEARNING & ENTERTAINMENT

4K LEVEL I  
**£385.25**  
26-1001

16K LEVEL II  
**£559.95**  
26-1006 (with green screen monitor)

Two years ago Tandy introduced the TRS-80, the wired, tested and ready-to-run computer that more people have bought than any other single computer. It has proven ideal for uses in school, business, lab and home, where a large computer is impractical.

Now available with new improved video monitor!



**TANDY**  
DEALER

# TANDY

THE BIGGEST NAME IN LITTLE COMPUTERS

Most items also available at Tandy Dealers. Look for this sign in your area. Prices may vary at individual stores.

Offers subject to availability. Instant credit available in most cases.



Access, Barclaycard and Trustcard welcome. Check your telephone directory for your nearest store.

# Sintrom Microshop

## The S100 computer centre

**Sintrom Periflex** microcomputer with both  
5" and 8" floppy disc drives

**Vector Graphic** microcomputers

**Micropolis** 5" floppy disc drives (now in stock)

**Micropolis** 8" Winchester / S100 systems

**Telema** computer systems

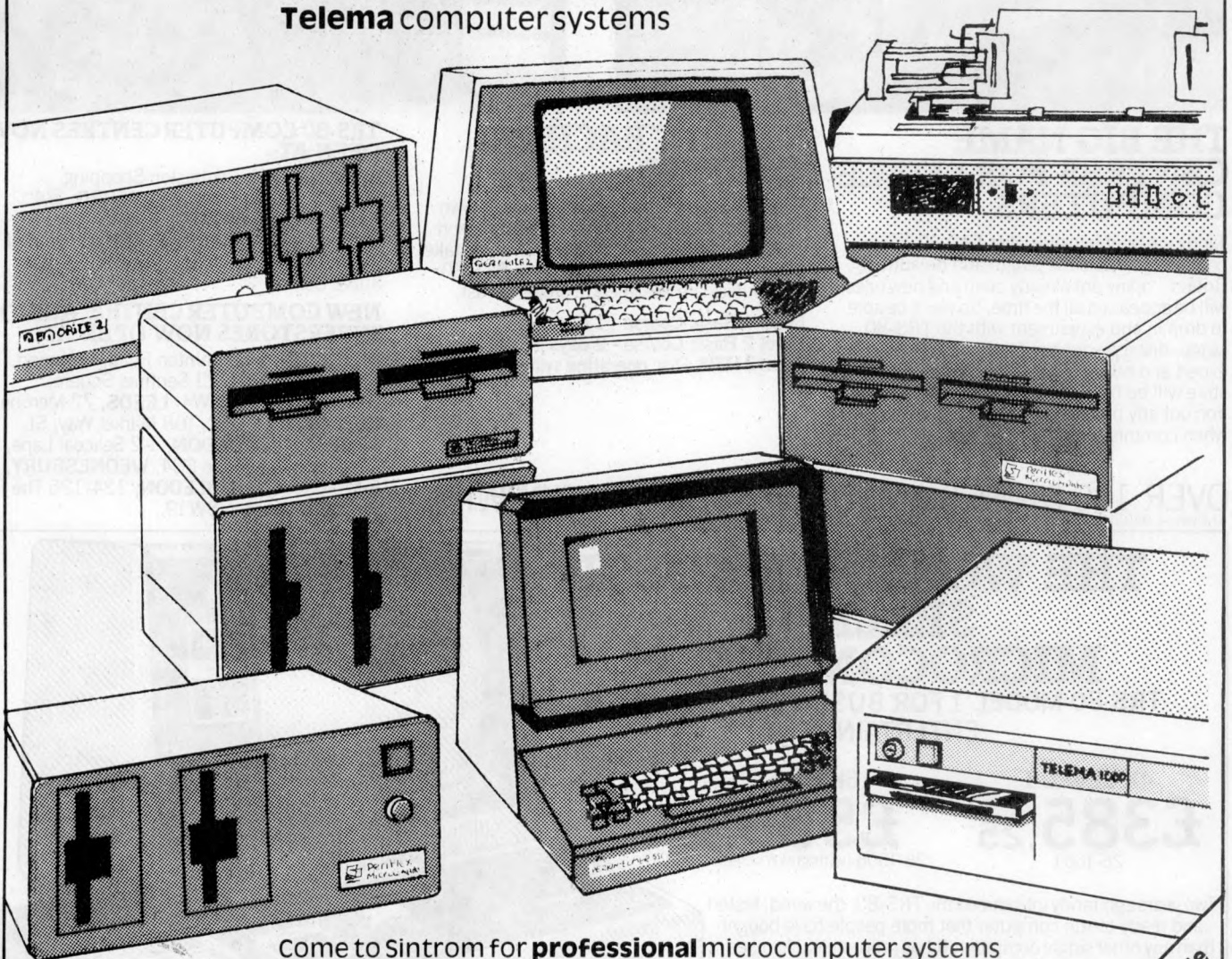

Come to Sintrom for **professional** microcomputer systems backed-up by the long established Sintrom Group, with years of experience in mini and micro computer systems and peripherals.



## Sintrom Electronics

14 Arkwright Road, Reading, Berks RG2 0LS  
Tel: Reading (0734) 85464 TELEX: 847395

Sintrom Microshop is a division of the  
Sintrom Group of Companies

**Very competitive terms available  
for dealers and OEMs**  
Phone Martin Whittaker  
on (0734) 85464  
for further details

# the software house

146 OXFORD STREET, LONDON W.1.

To Order simply photostat this page & circle items required and send with your remittance. ALL PRICES INCLUDE 15% VAT where applicable.

PLEASE SEND THE FOLLOWING PROGRAMS FOR MY MICROCOMPUTER:-

APPLE (I = Integer A = Applesoft)

APPLETALKER (I)	£15.00
APPLE LIS'NER (I)	£15.00
CITY MANAGER (A)	£ 9.00
STARWARS + SPACEMAZE	£ 9.00
APPLE 21 (I)	£ 9.00
MICROCHESS TAPE	£12.00
MICROCHESS DISC	£16.50
BRIDGE CHALLENGER (I)	£12.00
DOS 3.2 TUTOR (A)	£34.50
MAIL LIST/LABEL (A)	£57.50
STOCK CONTROL (A)	£80.50
VISICALC	£109.00
AIMS DATA BASE (A)	£140.00
DATA BASE UTILITY (A)	£50.00
FORTH	£40.00
LISP	£34.50
L. GENIUS APPLESOFT	£46.00
L. ADVANCED APPLESOFT	£46.00
KNOW YOURSELF	£ 6.00
SPACE GAMES	£ 6.00
SPORTS GAMES	£ 6.00
STRATEGY GAMES	£ 6.00
CAI PROGRAMS	£ 6.00
SPACE INVADERS	£12.00
APPLE INVADERS	£13.80
CONTRIBUTED V3/5	£69.00
REFERENCE MANUAL	£11.00
HIRES CHAR. GENERATOR	£19.00
SHAPE BUILDER	£19.50
MASTER CATALOGUE	£16.00
STATISTICS	£23.00
DATESTONES OF RYN	£15.00
TEMPLES OF APSHAI	£26.00
WIZARDS MOUNTAIN	£ 9.00
RELOCATED INTEGER (A)	£14.00

FOR APPLE/TRS 80 and SORCERER ADVENTURE!!!

ADVENTURELAND	£10.00
PIRATE ADVENTURE	£10.00
MISSION IMPOSSIBLE	£10.00
VOODOO CASTLE	£10.00
THE COUNT	£10.00
STRANGE ODYSSEY	£10.00
MYSTERY FUN HOUSE	£10.00
PYRAMID OF DOOM	£10.00

FOR APPLE OR TRS80

* SORCERERS CASTLE	£ 8.50
* KING TUT'S TOMB	£ 8.50
* HOUSE OF 7 GABLES	£ 8.50
* JOURNEY/CENTRE OF EARTH	£ 8.50
(ALL 4 above on disk for)	£28.00
ENCHANTED ISLE	£ 8.50
ATLANTIS	£ 8.50

TRS80

ANDROID NIM	£ 9.00
BEE WARY!	£ 9.00
LIFETWO	£ 9.00
SNAKE EGGS	£ 9.00
THE GREAT RACE	£ 5.00
LYING CHIMPS	£ 5.00
OWLTREE	£ 5.00
TRS80 OPERA	£ 5.00
NEWDOS +	£49.50
MTREK	£ 8.00

PET

ENLARGE (DISPLAY)	£ 6.00
TIME TREK	£12.00
DUCKSHOOT	£ 5.00

This is just a selection from our software range — we have the widest range of software and are adding new items daily. Send for our FREE catalogue.

NEW — APPLE UTILITIES DISC — single disc copy, patch zap etc. £19.50.

BUSINESS APPLICATIONS CONSULTANCY: we can offer help & advice — we specialise in the APPLE/ITT and offer tailored programs, complete systems and advice.

Send for details of our unique PROGRAMMERS COURSE & WORKSHOP (APPLE).

We also distribute the 80-US JOURNAL — a SUPERB magazine for the TRS80 £14.00 p.a.

Programs are in development for the SHARP and most popular micros.

If you don't see what you require — please ask — we regularly import the latest programs from most sources.

NAME.....

MICROCOMPUTER.....

ADDRESS.....

TOTAL FOR PROGRAMS £

(orders under £15.00 p&p 50p)

Cheque/P. Order/Cash enclosed.....

For 80-US subscription tick here

Items over £20.00 in value are sent by recorded delivery.

We welcome outside programs — our standard royalty is 15%.

The Softwarehouse is next door to OXFORD WALK (between Oxford Circus and Tottenham Court Road) and is open Monday to Friday 9.30 am to 5.30 pm

Reconditioned Olivetti Printers incl. paper tape reader/punch and transmission VDU's - 2000 ch buffered screens and Honeywell keyboards alone

250  
225  
180

**DDM HOBBY CORNER**

**MICROCOMPUTING**

**DDM DIRECT DATA MARKETING 44 High Street, Brentwood, Essex CM14 4AJ. Tel. (0277) 229379**

**Printers**

£ 550 Digital LA34 Decewriter  
795 Digital LA34 Decewriter with tractor feed  
645 PET Growth Products  
230 Disk Systems  
55 Computhink Dual Drives  
400 (Old Rom)  
800 (New Rom)  
Interfaces  
DDM's IEEE to RS232 bidirectional interface

£ 825 Apple  
905 Microsense Apple  
795 Apple II 16K  
840 Apple II 32K  
995 Disk Drive with Controller  
Disk Drive without Controller  
Corvus II Fixed Disk (10 Meg)  
130 New Apple Software  
Payroll, Stock Control and Comprehensive Accounting Systems.

£ 75.00  
81.90  
88.88  
33.55  
3.500

**DDM DIRECT DATA MARKETING**

**Commodore Pet**

Pet 2001-8  
Pet 2001-16N  
Pet 2022 tractorfed printer  
Pet 3022 tractorfed printer  
IEEE to Pet Connector  
IEEE to IEEE Connector  
C2N Cassette Deck

**Commodore Business Software**

Business Information, A/Cs, Word Processing  
Payroll and Mailing Systems.

Full product list available on application - please return the coupon for more details.

ALL PRICES EX. VAT.

**DDM POSTAL**

NAME.....  
COMPANY.....  
ADDRESS.....  
PHONE.....  
CURRENT MICRO.....  
PRODUCT INTEREST.....

SEND DIRECT TO DDM FOR PRODUCT LISTS & FURTHER DETAILS.

# Z-Plus Microcomputer System

- Over One Megabyte Disk Storage
- 4 MHz Z-80 Processor
- Two Serial and Two Parallel I/O Ports
- 64k Memory
- An alphanumeric keyboard
- Including System Desk



Price **£3950** plus VAT

THE Z PLUS SYSTEM IS MARKeted THROUGHOUT THE UK & EUROPE AND IS AVAILABLE THROUGH A NUMBER OF SELECTED DEALERS

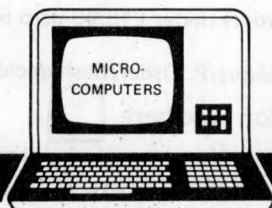

**ROSTRONICS**

LIMITED

115-117 WANDSWORTH HIGH STREET, LONDON SW18 4HY  
Telephone: 01-874 1172  
Telex: 8813089 INTPRM G

Scottish Office: 8 ROYAL CRESCENT, GLASGOW  
Telephone: 041 332 7642

Isaac Newton's

easy solution!



# Apple prices are tumbling at Microdigital!

A 48K Disk based computer system  
for only

## £1044

+ VAT  
For March,  
April, May and  
June only.



	Nett	VAT	Total
16K byte Apple Computer .....	£695.00	£104.25	£799.25
Disk System .....	£349.00	£52.35	£401.35
<b>Total with 32K free extra memory</b>	<b>£1044.00</b>	<b>£156.00</b>	<b>£1200.60</b>

## OFFICIAL ORDERS

We Welcome official orders from bona-fide commercial and government organisations. We require payment 14 days after invoice date.

Latest Apple II plus model with floating point basic and auto-start ROM.

Buy a 16K Apple with Disk drive and get 32K of memory Free.

Extras	Nett	VAT	Total
Second Disk Drive .....	£299.00	£44.85	£343.85
Pascal Language System .....	£299.00	£44.85	£343.85
Graphics Tablet .....	£462.00	£69.30	£531.30
Appletel System .....	£595.00	£89.25	£684.25
Black & White Modulator .....	£14.00	£2.10	£16.10
Eurocolour Card .....	£79.00	£11.85	£90.85
Joystick .....	£25.00	£3.75	£28.75

All Prices include courier delivery within U.K.



## MICRODIGITAL

25 Brunswick Street, Liverpool L2 0BJ Mail orders to: MICRODIGITAL LIMITED,  
Tel: 051-236 0707 (24 hour Mail Order) FREEPOST (No Stamp Required)  
051-227 2535 (All other Depts.) Liverpool L2 2AB

## Apple Business Systems

-ring Graham Jones 051-227 2535

Software Packages	£	Word Processor/Letter	£
Stock Control .....	£225.00	Writer .....	£130.00
General Ledger .....	£295.00	Book keeper Package	£295.00
Purchase Ledger .....	£295.00	Credit Control	
Sales Ledger .....	£295.00	Package .....	£150.00
		Payroll .....	£385.00
		+ VAT at 15%	



Please send systems as above at £1200.60 in addition please send:

Total Remittance \_\_\_\_\_

Name \_\_\_\_\_

Address \_\_\_\_\_

Access and Barclaycard welcome.



## BY OSBORNE

### Introduction to Microcomputers Series

Vol 0: Beginners Book	£ 5.95
Vol 1: BASIC Concepts	£ 6.30
Vol 2: Some Real Microprocessors (without binder)	£ 18.95
Vol 2: Some Real Microprocessors (with binder)	£ 24.70
Vol 2: Updating supplement set Nos. 1-6	£ 17.00
Vol 3: Some Real Support Devices (without binder)	£ 11.95
Vol 3: Some Real Support Devices (with binder)	£ 17.70
Vol 3: Updating supplement set Nos. 1-6	£ 17.00
1 binder (Specify for Vol 2 or 3)	£ 5.75
1 Updating supplement (Specify for Vol 2 or 3)	£ 4.00

See Subscriptions!

6800 Programming for Logic Design	£ 6.30
8080 Programming for Logic Design	£ 6.30
Z80 Programming for Logic Design	£ 6.30
Z80 Assembly Language Programming	£ 8.15
6502 Assembly Language Programming	£ 8.25
8080A/8085 Assembly Language Programming	£ 7.95
6800 Assembly Language Programming	£ 7.95

Accounts Payable and Accounts Receivable	£ 12.75	<b>Wang Basic</b>	£ 13.15	<b>C Basic</b>
Payroll with Cost Accounting	£ 12.95		£ 13.50	
General Ledger	£ 11.95		£ 12.25	
Some Common BASIC Programs			£ 7.95	

## GENERAL

### See Magazines and Subscriptions!

Microprocessors from Chips to System	£ 7.00	<i>See Osborne Books!</i>
Microprocessor Interfacing Techniques	£ 8.75	
Cheap Video Cookbook	£ 4.30	
CMOS Cookbook	£ 7.50	
IC OP-AMP Cookbook	£ 8.95	
RTL Cookbook	£ 4.25	
TTL Cookbook	£ 7.50	
Ciarcias Circuit Cellar	£ 5.50	
First Book of Kim	£ 7.00	
Buyers Guide to Microsoftware	£ 2.40	
Calculating with BASIC	£ 4.95	
Computer Programs that Work (In BASIC)	£ 2.95	
BASIC Software Library: (Listings)		
Vol 1: Business and Games Programs	£ 17.50	
Vol 2: Maths, Engineering and Statistical Programs	£ 17.50	
Vol 3: Advanced Business Programs	£ 26.95	
Vol 4: General Purpose Programs	£ 7.95	
Vol 5: Experimenters Programs	£ 7.95	
Vol 6: Miniature Business System	£ 32.50	
Vol 7: Chess/Medbil/Wdproc Programs	£ 26.95	
Vol 8: Homeowners Programs	£ 14.95	
Bar Code Loader for 6800, 8080, Z80 and 6502	£ 1.75	
Best of BYTE	£ 8.95	
Scelbi BYTE Primer	£ 8.95	
Best of Creative Computing, Vol 1	£ 6.95	
Best of Creative Computing, Vol 2	£ 6.95	
Program Design	£ 4.25	
Programming Techniques: Simulation	£ 4.25	
PIMS - A Database Management System	£ 5.95	
Numbers in Theory and Practise	£ 5.95	

## FOR THE Z80

### See Osborne books!

Programming the Z80 (Zacs)	£ 9.95
Z80 Instruction Handbook (Wadsworth)	£ 2.95
Z80 Microcomputer Handbook (Barden)	£ 7.50
Z80 Software Gourmet Guide and Cookbook	£ 7.95

## FOR THE 6800

### See Magazines and Subscriptions!

6800 Software Gourmet Guide & Cookbook	£ 6.95	<i>See Osborne Books!</i>
6800 Tracer - An aid to 6800 Program Debugging	£ 3.95	
Tiny Assembler	£ 5.75	
RA 6800 ML - An M600 Relocatable Macro Assembler	£ 15.95	
Link 68 - An M6800 Linking Loader	£ 5.50	
MONDEB - An Advanced M6800 Monitor Debugger	£ 3.50	

## CONCERNING LANGUAGE

SCELBAL - High Level Language Supplements	£ 15.00
Instant BASIC	£ 6.95
Basic BASIC	£ 6.50
Advanced BASIC	£ 6.00
My Computer likes me . . . when I speak in BASIC	£ 2.75
Users Guide to North Star BASIC	£ 10.00
A Practical Introduction to PASCAL	£ 3.95
Microsoft BASIC	£ 5.50

## FOR THE 6502

### See Magazines and Subscriptions!

Best of Micro, Vol 1	£ 5.50	<i>See Osborne Books!</i>
Best of Micro, Vol 2	£ 5.50	
Programming the 6502 (Zacs)	£ 7.95	
Programming the 6502 (Foster)	£ 6.75	
6502 Applications	£ 7.95	
6502 Software Gourmet Guide and Cookbook	£ 6.95	

## FOR THE 8080

### See Osborne Books!

8080 Programmers Pocket Guide	£ 1.95
8080 Hex Code Card	£ 1.95
8080 Octal Code Card	£ 1.95
8080 Software Gourmet Guide & Cookbook	£ 6.95
8080/8085 Software Design	£ 6.75
8080 Standard Monitor	£ 9.95
8080 Standard Assembler	£ 9.95
8080 Standard Editor	£ 9.95
8080 Special Package: Monitor, Editor, Assembler	£ 20.00
BASEX: A Simple Language and Compiler for the 8080	£ 5.50

## FOR FUN

SARGON - A Chess Game (for the Z80)	£ 9.50
BASIC Computer Games	£ 5.00
More BASIC Computer Games	£ 5.50
What to do After you Hit Return	£ 8.95
8080 Galaxy Game	£ 6.95
SUPER-WUMPUS - A game in 6800 Assembler Code & BASIC	£ 4.25
Computer Music Book	£ 6.75
Computer Range (A board game)	£ 6.95
Artist and Computer	£ 3.95
Games, Tricks and Puzzles for a Hand Calculator	£ 2.49
Introduction to TRS-80 Graphics	£ 5.75
Take My Computer Please . . . (Fiction)	£ 3.25
Introduction to Low Resolution Graphis	£ 5.50

## FOR THE NOVICE

### See Magazines and Subscriptions!

Your Home Computer	£ 5.95	<i>See Osborne Books!</i>
Introduction to Personal and Business Computing	£ 4.95	
Getting involved with Your Own Computer	£ 4.75	
How to Profit from Your Personal Computer	£ 5.50	
Microcomputer Potpourri	£ 2.40	
Hobby Computers are Here	£ 3.95	
New Hobby Computers	£ 3.95	
Understanding Microcomputers and Small Computer Systems	£ 6.75	
Understanding Microcomputers and Small Computer Systems and Audio Cassette	£ 8.75	
Getting Down to Business With Your Microcomputer	£ 5.50	

## MAGAZINE BACK ISSUES

Micro 6502 Journal	£ 1.50
Personal Computing	£ 1.95
Interface Age	£ 2.95
ROM	£ 1.95
Dr. Dobbs Journal	£ 1.95
Computer Music Journal	£ 3.75
Peoples Computers (now called Recreational Computing)	£ 1.95
BYTE	£ 2.95
Creative Computing	£ 1.95
Calculators and Computers	£ 1.95
Kilobaud	p.o.a.
Compute - for the 6502	£ 1.95
68' Micro	£ 1.95
Magazine Storage Box (Holds 12)	£ 1.25
80' Microcomputing	£ 2.25

## MAGAZINE SUBSCRIPTIONS (all processed within 3 weeks)

Micro Journal (12 issues)	£ 12.50
68 Micro (12 issues)	£ 17.50
Personal Computing (12 issues)	£ 17.00
Interface Age (12 issues)	£ 25.00
Dr. Dobbs Journal (10 issues)	£ 13.50
Computer Music Journal (4 issues)	£ 11.00
Recreational Computing (6 issues)	£ 8.50
BYTE (12 issues)	£ 24.50
Creative Computing (12 issues)	£ 16.50
Kilobaud Microcomputing (12 issues)	£ 21.00
Compute for the 6502 (6 issues)	£ 10.50
80' Microcomputing (12 issues)	£ 17.50

	Software & Manual	Manual only	Software & Manual	Manual only
<b>BYROM SOFTWARE</b>				
BSTAM - Utility to link one microcomputer to another also using BSTAM	£ 70.00/	5		
<b>COMPUTERS PLUS</b>				
<b>FMS-80 (File Management System)</b>				
Demo Pack (includes manual & disc)	£ 35.00			
Complete System	£395.00/25			
<b>COMPUTER SERVICES</b>				
Bidirectional driver for Diablo Hytype printers for use on CPM & CDOS systems	£ 65.00/10			
<b>CP/M USER LIBRARY</b>				
33 Volumes on 8" disc	£ 4.00			
33 Volumes on 5" disc	£ 8.00			
<b>CREATIVE COMPUTING</b>				
<b>For CP/M</b>				
CS-9001 BASIC Computer Games disc 1	£ 12.00			
CS-9002 BASJC Computer Games disc 2	£ 12.00			
CS-9000 Both discs purchased together	£ 20.00			
<b>CREATIVE SOLUTIONS</b>				
Multi-FORTH	£ 65.00/20			
<b>DIGITAL RESEARCH (Most formats now available)</b>				
MPM 1.1	£175.00/18			
CP/M 1.4	£ 65.00/18			
CP/M 2.2	£ 90.00/18			
SID	£ 45.00/12			
ZSID	£ 55.00/12			
MAC	£ 55.00/15			
TEX	£ 45.00/12			
DESPOOL	£ 30.00/ 5			
PL/1	TBA			
<b>INFORMATION UNLIMITED</b>				
<b>WHATSIT (Database Management System)</b>				
on North Star	£ 59.00			
on CP/M	£ 75.00			
on APPLE 2:48k (requires int Basic)	£ 72.00			
on APPLE 2:32k (requires int Basic)	£ 59.00			
on ITT 2020 (see Apple)				
<b>GUNN</b>				
Utilities for Cromemco CDOS	£ 65.00/10			
<b>KLH SYSTEMS</b>				
Spooler for CPM systems	£ 65.00/ 5			
<b>L.P. ENTERPRISES</b>				
Diablo driver runs 110 to 9600 baud with autoloader for CP/M or CDOS	£ 30.00/ 5			
OMNIX - UNIX like multiuser, multitasking operating system for Z80 i.e. IMS, Cromemco, Horizon	£150.00/30			
Yearly maintenance on OMNIX	£ 50.00			
<b>MICAH INC</b>				
<b>CP/M for CDOS Users:</b>				
Program to Expand CP/M system to be compatible with Cromemco CDOS software	£ 59.00/ 5			
<b>ORDER INFORMATION:</b>				
Software prices reflect distribution on 8" single density discs. If a format is requested which requires additional discs a surcharge of £4.00 per additional disc will be added.				
Please add VAT and £1.50 for first class postage, packing and insurance.				
If required, DATAPOST D service is available for an extra charge of £6.00.				
All software on this Advertisement is available from stock and a 24-hour return service is thereby offered on all prepaid orders.				
When ordering CP/M software please specify the format you require otherwise software will be dispatched on a 8" single density disc.				
<b>BONUS DISCOUNTS</b>				
a) For the purchase of 3 or more books and paying by cheque, P.O. or cash with the order, give yourself a 10% DISCOUNT.				
b) For the purchase of 3 or more magazine back issues and paying by cheque, P.O. or cash with the order, give yourself a 10% DISCOUNT.				
<b>Disc Utilities:</b>				
Pack one for CDOS users includes: Fast disc copy, Track test, Disc test, Compare files and others				
Pack two for CP/M users includes same as pack one				
Pack three for Cromemco users includes same as pack one and spool & print				
<b>MICROSOFT INC</b>				
BASIC-80	£175.00/17			
BASIC Compiler	£195.00/17			
FORTRAN-80	£220.00/17			
COBOL-80	£355.00/17			
EDIT-80	£ 45.00/17			
MACRO-80	£ 80.00/11			
<b>MICHAEL SHRAYER INC</b>				
<b>Electric Pencil Word Processor</b>				
SSII for tty etc.	£100.00			
DSII for Diablo	£105.00			
TRS-80 Cassette/disc	£ 50.00			
<b>MICROFOCUS LTD</b>				
CIS COBOL version 4.2	£425.00/25			
FORMS 2	£100.00/10			
<b>MICROPRO INC</b>				
WORD-MASTER 1.7	£ 70.00/20			
TEX-WRITER 2.6	£ 35.00/15			
WORD-STAR 1.00	£240.00/25			
SUPER-SORT: version 1	£120.00/20			
version 2	£100.00/20			
version 3	£ 75.00/20			
<b>NORTHSHARE</b>				
Multi-user system for Horizon Users	£ 24.00/ 5			
<b>SOFTWARE SYSTEMS (Compiler systems)</b>				
CBASIC v2.05	£ 65.00/15			
<b>SOFTWARE WORKS</b>				
<b>Northstar Format Only</b>				
Inventory-1 (Stock Control)	£ 50.00/10			
Inventory-2 with order entry, invoicing	£130.00/15			
Mailroom	£ 50.00/15			
Housekeeper (Utilities, sorts)	£ 35.00/10			
Preventative Maintenance	£ 75.00/15			
Housekeeper-2 (Coming soon)	TBA			
<b>STRUCTURED SYSTEMS All converted to UK standard</b>				
Sales Ledger	£275.00/15			
Purchase Ledger	£275.00/15			
Nominal Ledger	£325.00/15			
Stock Control	£275.00/15			
Letterlight	£ 95.00/10			
Analyst (File management Reporting System)	£115.00/10			
NAD (Name & Address selection system)	£ 50.00/10			
QSORT	£ 50.00/10			
<b>TINY-C ASSOCIATES</b>				
Tiny-C language for 8080, 8085, Z80 systems	£ 50.00/35			

c) For the purchase of 2 or more software packages and paying by cheque, P.O. or cash, with the order, give yourself a 10% DISCOUNT.

For more information on any of these items, please phone, write or visit. (We are open during office hours).

All publications are published in the U.S.A. and are stocked in Britain by L.P. Enterprises. Prepaid orders are despatched by return of post, or advice concerning.

#### HOW TO ORDER:

Send cash, postal order, cheque card number to L.P. Enterprises, Room 8, Cambridge House, Cambridge Road, Barking, Essex IG11 8NT. All payment must be in Sterling and drawn against a U.K. bank.

**Please note:** If you wish to pay by Diners Club credit card, we must have your signature. For any payment by credit card, we need the expiry date of the card and the address that the credit card company knows (although we can send the goods to an alternative address).

For the purchase of software, please add VAT and £1.50 for First Class postage, packing and insurance.

Due to fluctuations of the dollar, prices are subject to change without notice.

**TRADE ENQUIRIES WELCOME**

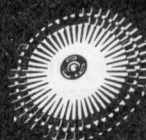
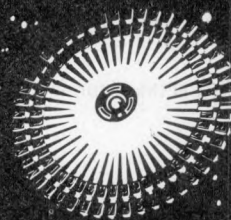
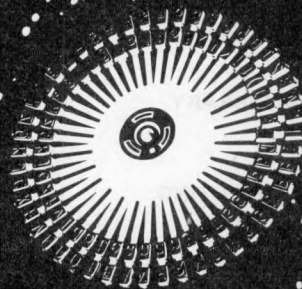
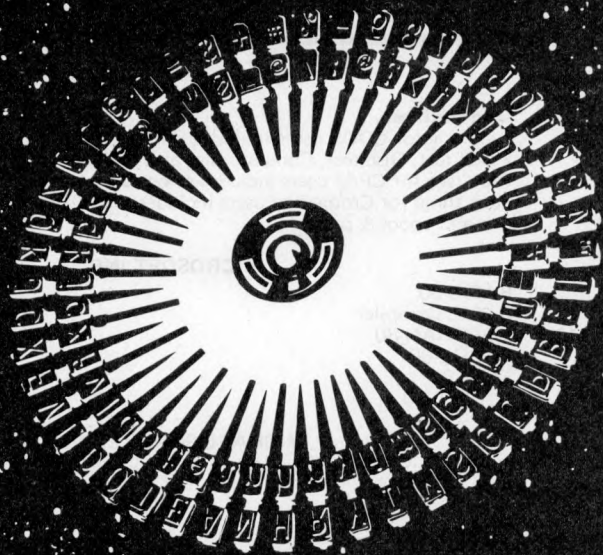

**small systems  
presents**

# **PET COMPATIBLE DAISY WHEEL PRINTER**

**S.S.E. RICOH R.P.40**

- Printing Speed - 40 C.P.S.
- Character-set - 96 characters, metal faced printwheel
- Choice of typefaces
- Line width - 136 characters (10 characters per inch)
- Line width - 163 characters (12 characters per inch)
- Form width - 16"
- Integral PET IEEE-488 Addressable Interface (Disc compatible)
- 240v 50Hz
- Micro-Processor controlled
- Reputation for high reliability
- Options:-
  - Pin Feed Platen
  - Acoustic cover
  - Form Tractor
  - RS232 C Interface, Centronics Interface

**Complete word processing systems - Commodore PET,  
Software and RP40 Printer also available.**

**HIGH QUALITY PRINTING AT LOW COST £1590.00 inc. PET INTERFACE**

 **Small  
Systems  
Engineering  
Limited**

62 New Cavendish Street · London W1M 7LD Telephone: 01 637 0777 Telex: 8813085 (Abacus)

# Thinking Computers?



## Then come to the number one micro-computer centre

If you're wondering if a micro-computer can help you, we are here to advise you. At Lion House—London's leading centre for micro-computers—you'll find:

- \* Experts who'll explain the equipment in a way you can easily understand, showing how and where it applies to *your* work.
- \* Demonstration areas where you can get immediate experience of using micro-computers yourself.
- \* Probably the biggest range of software in the UK.
- \* Programmes can be tailored for your particular commercial needs by our In-House Analysts and Programmers.
- \* Total service—including the availability of full maintenance after you've bought an installation.
- \* Leasing and H.P. facilities immediately available.
- \* A computer book section with publications that give you new insight into the world of micro-computers.

**How will micro-computers help you?** In thousands of ways—only a few can be mentioned here...

MICRO-COMPUTERS FOR BUSINESS



**For business and professional,** the versatility of compact micro-computers means that all the benefits of big computers are made available to all at low cost. The businessman can now computerise his accountancy, his stock control, his records and much more—cutting his overheads and improving his efficiency.

**For the home,** micro-computers have innumerable uses and considerable value too—sometimes in unexpected ways.

MICRO-COMPUTERS FOR THE HOME



Budgeting... investments... controlling heating or security... storing information on things like recipes... designing complex and fascinating games... education...

**Come and see.** We invite you to visit us and investigate the possibilities and the potential. If you're too far away, phone or write and we'll send you more information.

**You need a micro-computer.** We can supply it.



## LION MICRO-COMPUTERS

SMALL COMPUTERS—TO MAKE YOUR BUSINESS BIGGER

Lion Computer Shops Ltd, Lion House, 227 Tottenham Court Road, London W1 (First Floor). Telephone: 01-637 1601.

Telex: 28394 Lion G.

Open 9 to 6, Monday to Saturday (Thursday to 7).



# Britain's first comp

**A complete personal computer for a third of the price of a bare board.**

**Also available ready assembled for £99<sup>95</sup>**

## The Sinclair ZX80.

Until now, building your own computer could easily cost around £300 – and still leave you with only a bare board for your trouble.

The Sinclair ZX80 changes all that. For just £79.95 you get *everything* you need to build a personal computer at home...PCB, with IC sockets for all ICs; case; leads for direct connection to your own cassette recorder and black and white or colour television; everything!

And yet the ZX80 really is a complete, powerful, full-facility computer, matching or surpassing other personal computers on the market at several times the price. The ZX80 is programmed in BASIC, and you could use it to do quite literally anything from playing chess to running a power station.

The ZX80 is pleasantly straightforward to assemble, using a fine-tipped soldering iron. Once assembled, it immediately proves what a good job you've done. Connect it to your TV set... link it to an appropriate power source\*... and you're ready to go.

### Your ZX80 kit contains...

- Printed circuit board, with IC sockets for all ICs.
- Complete components set, including all ICs – all manufactured by selected world-leading suppliers.
- New rugged Sinclair keyboard, touch-sensitive, wipe-clean.
- Ready-moulded case.
- Leads and plugs for connection to domestic TV and cassette recorder. (Programs can be SAVED and LOADED on to any portable cassette recorder.)
- FREE course in BASIC programming and user manual.

### Optional extras

- Mains adaptor of 600 mA at 9 V DC nominal unregulated (available separately – see coupon).
- Additional memory expansion boards allowing up to 16K bytes RAM. (Extra RAM chips also available – see coupon.)

\*Use a 600 mA at 9 V DC nominal unregulated mains adaptor. Available from Sinclair if desired (see coupon).

### Two unique and valuable components of the Sinclair ZX80.

The Sinclair ZX80 is not just another personal computer. Quite apart from its exceptionally low price, the ZX80 has two uniquely advanced components: the Sinclair BASIC interpreter; and the Sinclair teach-yourself BASIC manual.

**The unique Sinclair BASIC interpreter...** offers remarkable programming advantages:

- Unique 'one-touch' key word entry: the ZX80 eliminates a great deal of tiresome typing. Key words (RUN, PRINT, LIST, etc.) have their own single-key entry.
- Unique syntax check. Only lines with correct syntax are accepted into programs. A cursor identifies errors immediately. This prevents entry of long and complicated programs with faults only discovered when you try to run them.
- Excellent string-handling capability – takes up to 26 string variables of any length. All strings can undergo all relational tests (e.g. comparison). The ZX80 also has string input-to request a line of text when necessary. Strings do *not* need to be dimensioned.
- Up to 26 single dimension arrays.
- FOR/NEXT loops nested up to 26.
- Variable names of any length.
- BASIC language also handles full Boolean arithmetic, conditional expressions, etc.
- Exceptionally powerful edit facilities, allows modification of existing program lines.
- Randomise function, useful for games and secret codes, as well as more serious applications.
- Timer under program control.
- PEEK and POKE enable entry of machine code instructions, USR causes jump to a user's machine language sub-routine.

- High-resolution graphics with 22 standard graphic symbols.
- All characters printable in reverse under program control.
- Lines of unlimited length.

**... and the Sinclair teach-yourself BASIC manual.**

If the features of the Sinclair interpreter listed alongside mean little to you – don't worry. They're all explained in the specially-written 128-page book *free* with every kit! The book makes learning easy, exciting and enjoyable, and represents a complete course in BASIC programming – from first principles to complex programs. (Available separately – purchase price refunded if you buy a ZX80 later.) A hardware manual is also included with every kit or built machine.

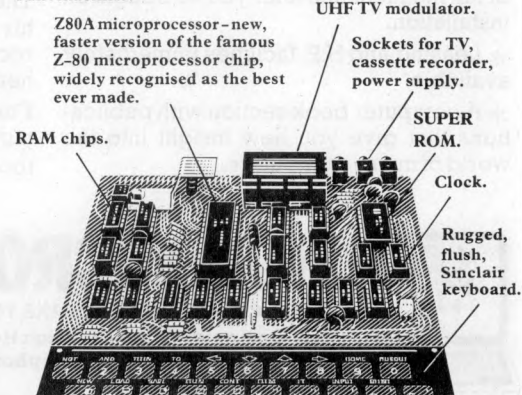

# ete computer kit.



**£79<sup>95</sup>**

**Including VAT.  
Including post and  
packing.  
Including all leads  
and components.**



**fewer chips,  
compact design,  
volume production –  
more power per pound!**

The ZX80 owes its remarkable low price to its remarkable design: the whole system is packed on to fewer, newer, more powerful and advanced LSI chips. A single SUPER ROM, for instance, contains the BASIC interpreter, the character set, operating system, and monitor. And the ZX80's 1K byte RAM is roughly equivalent to 4K bytes in a conventional computer – typically storing 100 lines of BASIC. (Key words occupy only a single byte.)

The display shows 32 characters by 24 lines. And Benchmark tests show that the ZX80 is faster than all other personal computers.

No other personal computer offers this unique combination of high capability and low price.

**The Sinclair ZX80. Kit: £79.95. Assembled: £99.95. Complete!**

The ZX80 kit costs a mere £79.95. Can't wait to have a ZX80 up and running? No problem! It's also available, ready assembled, for only £99.95.

Demand for the ZX80 is very high: use the coupon to order today for the earliest possible delivery. All orders will be despatched in strict rotation. We'll acknowledge each order by return, and tell you exactly when your ZX80 will be delivered. If you choose not to wait, you can cancel your order immediately, and your money will be refunded at once. Again, of course, you have a refund option for 14 days after your computer is despatched. We want you to be satisfied beyond all doubt – and we have no doubt that you will be.

**sinclair  
ZX80**

**Science of Cambridge Ltd**  
5 Kings Parade, Cambridge, Cambs., CB2 1SN.  
Tel: 0223 311488.

## Order Form

To: Science of Cambridge Ltd, 6 Kings Parade, Cambridge, Cambs., CB2 1SN.  
Remember: all prices shown include VAT, postage and packing. No hidden extras.

Please send me:

Quantity	Item	Item price £	Total £
	Sinclair ZX80 Personal Computer kit(s). Price includes ZX80 BASIC manual, excludes mains adaptor.	79.95	
	Ready-assembled Sinclair ZX80 Personal Computer(s). Price includes ZX80 BASIC manual, excludes mains adaptor.	99.95	
	Mains Adaptor(s) (600 mA at 9 V DC nominal unregulated).	8.95	
	Memory Expansion Board(s) (each one takes up to 3K bytes).	12.00	
	RAM Memory chips – standard 1K bytes capacity.	16.00	
	Sinclair ZX80 Manual(s) (manual free with every ZX80 kit or ready-made computer).	5.00	
		<b>TOTAL</b>	£

NB. Your Sinclair ZX80 may qualify as a business expense.

I enclose a cheque/postal order payable to Science of Cambridge Ltd for £

Please print

Name: Mr/Mrs/Miss

Address

# Computer Communications

## STACK COMPUTERS ANNOUNCE

KEYPAK<sup>®</sup>      **£45** plus VAT  
REMOTE PROGRAMMING AID  
FOR PET COMPUTERS



**Stack Computers** have developed packages for the old ROM and NEW ROM PETS to enable them to be programmed from external devices.

**Once KEYPAK is running Paper Tape Reader:**— a listing of a PET basic program can be read in by a reader directly into program area and run without any user contact with the PET.

**Transfer Programmes:**— a PET or any other microcomputer outputting a PET acceptable basic

structure can send its programme to the PET running **KEYPAK**.

**Send Programmes by 'phone** using an acoustic coupler or modem a PET running **KEYPAK** can receive programmes via the GPO Telephone System.

**Telephone Communication and Editing.** Ring your colleague and under **KEYPAK** have him edit **your** program on **your** PET screen or show you the correct lines.

**KEYPAK** is a PET compatible programme supplied on cassette

- \* Remote **stop key** operation is implemented
- \* Remote **clear screen** is implemented
- \* Handles quotes mode

**KEYPAK** does not handle cursor or screen controls in quotes mode during programme run.

Suitable interfaces and acoustic couplers are available from stock.

# STACK COMPUTER SERVICES

290/298 Derby Road, Bootle, Liverpool 20.  
051-933 5511

The new  
powerful  
personal  
computer  
from  
Sweden...



... now looking  
for powerful  
retailers  
to be appointed  
for many areas  
in UK

Now available from  
UK stocks

The microcomputer which out-  
sells all others in Scandinavia.

Write: Dator Ltd. / Fox Oak / Seven Hills Road / Walton-on-Thames / Surrey kt 124 dg

## Apple or PET? West London's specialists are also in the West End.\*

### apple®

APPLE II EUROPLUS 16K	£695.00
DISC DRIVE WITH CONTROLLER	£349.00
DISC DRIVE WITHOUT CONTROLLER	£299.00
16K ADD ON MEMORY	£ 69.00
HITACHI 9" BLACK & WHITE MONITOR	£127.00
EUROCOLOUR CARD	£ 69.00
PASCAL LANGUAGE CARD	£296.00
ALF MUSIC SYNTHESISER CARD	£215.00
TCM 100 SILENT 40 COLUMN PRINTER	£243.00
PAPER TIGER PRINTER	£585.00
TCM INTERFACE FOR PET OR APPLE	£ 49.00

### PET®

PET 8K WITH INTEGRAL CASSETTE	£475.00
NEW PET 8K WITH LARGE KEYBOARD	£495.00
PET 3016 16K COMPUTER	£675.00
PET 3032 32K COMPUTER	£795.00
PET 3040 DUAL DRIVE FLOPPY DISK	£795.00
PET 3022 TRACTOR PRINTER	£525.00
PET 2023 FRICTION PRINTER	£475.00
PET C2N TAPE DECK	£55.00
24K EXPANSION MEMORY	£320.00
COMPUTHINK 800K DISK DRIVE	£1145.00
TELETYPE 43 PRINTER	FROM £860.00
QUME SPRINT DAISYWHEEL	FROM £1800.00

FROM

**adda**

FROM

**adda**

Adda Computers, 17-19 The Broadway (between W. H. Smith and Burtons), Ealing, London W.5. Tel. 01-579 5845  
\*New West End address: Abbott House, 1-2 Hanover Street, London W1R 9WB. Tel: 01-408 1611

# MICROTAN 65

£69  
plus VAT

## The Microcomputer that thinks it's a Mini

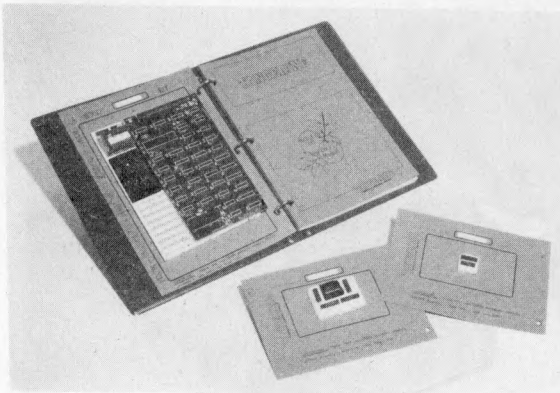

*The MICROTAN kit has won widespread acclaim for it's super presentation.*

High quality, plated thru' hole printed circuit board, solder resist and component legends. Full set of I.C. sockets. 64 way D.I.N. edge connector. 6502 microprocessor. 1K monitor TANBUG. 1K RAM for user programme, stack and display memory. VDU alphanumeric display. Intelligent keyboard socket. A4 MICROTAN 65 system file binder. 136 page, bound, A4 size users hardware/software manual with constructional details and sample programmes. Logic and discrete components to fully expand MICROTAN 65.

### TANEX

from £43.00 plus VAT

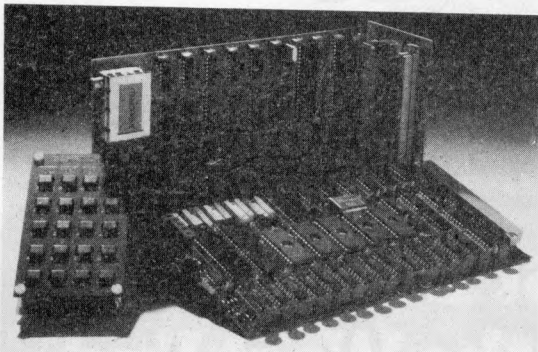

Fully expanded TANEX offers; 7K RAM, 6K ROM, 8K MICROSOFT BASIC, 32 parallel I/O lines, two TTL serial I/O ports, a third serial I/O port with RS232 20mA, full modem control and 16 programmable baud rates, four 16 bit counter timers, cassette interface, data bus buffering and memory mapping.

Ready built the mini-mother board has two 64 way female connectors, a 4 way power supply connector and a reset switch on board. It is used to connect MICROTAN to TANEX, and will fit inside the mini system rack. £8.64 plus VAT.

### Full System Rack

from £49.00 plus VAT

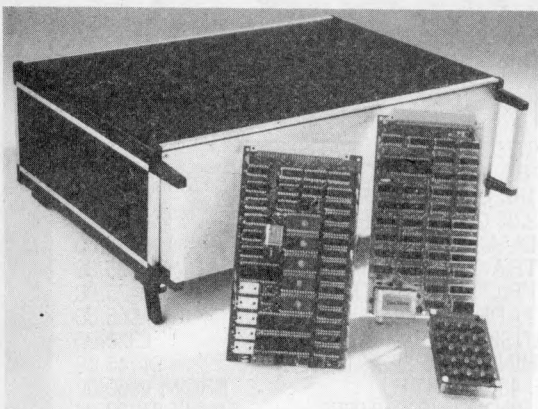

For the man that has everything! 19 inch wide system rack which accepts MICROTAN 65, TANEX, TANRAM, SEVEN FURTHER EXPANSION BOARDS, TANDOS AND THE SYSTEM POWER SUPPLY.

Available in many formats e.g. Individual module front panels, full width hinged front panel, back panel with or without connectors, etc.

We have produced a mini-rack which accepts MICROTAN 65 and TANEX, it has an integral power supply, just plug it into the mains and away you go! Finished in Black/Tangerine/Brushed aluminium, it gives your mini-system the professional finish.

£34.75 plus VAT

### Full ASCII keyboard

£49.00 plus VAT

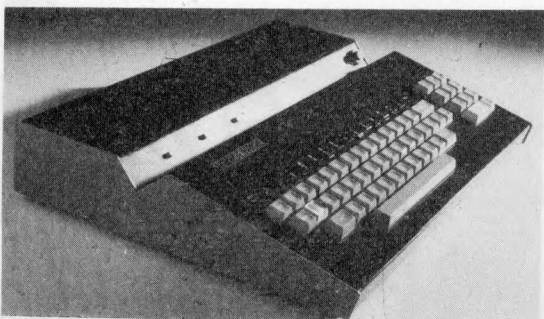

The ASCII keyboard includes a numeric keypad and ribbon cable connector. Available only as fully built and tested.

Cabinet available at £21.21 plus VAT.

**TANGERINE**  
COMPUTER SYSTEMS LIMITED

Extract from Mini  
Review in ETI

April 1980

- An excellent kit
- The concept of TANBUG is excellent
- Rock steady VDU
- The extremely reasonable cost has not been achieved by skimping on design
- A gem of a product
- An excellent introduction to 6502 based systems

- A 6502 based microcomputer.
- Superb 1K monitor TANBUG.
- Expansion boards to make a full system.
- Fully socketed
- 1K RAM for user programme, stack and display memory
- 136 page software/hardware users manual, with example programmes and A4 size!
- Intelligent keyboard socket, accepts 20 key keypad or full ASCII keyboard
- Full alphanumeric video display on an un-modified domestic TV - makes programming much easier
- Optional lower case pack £9.48 + vat
- Optional chunky graphics pack £6.52 + vat

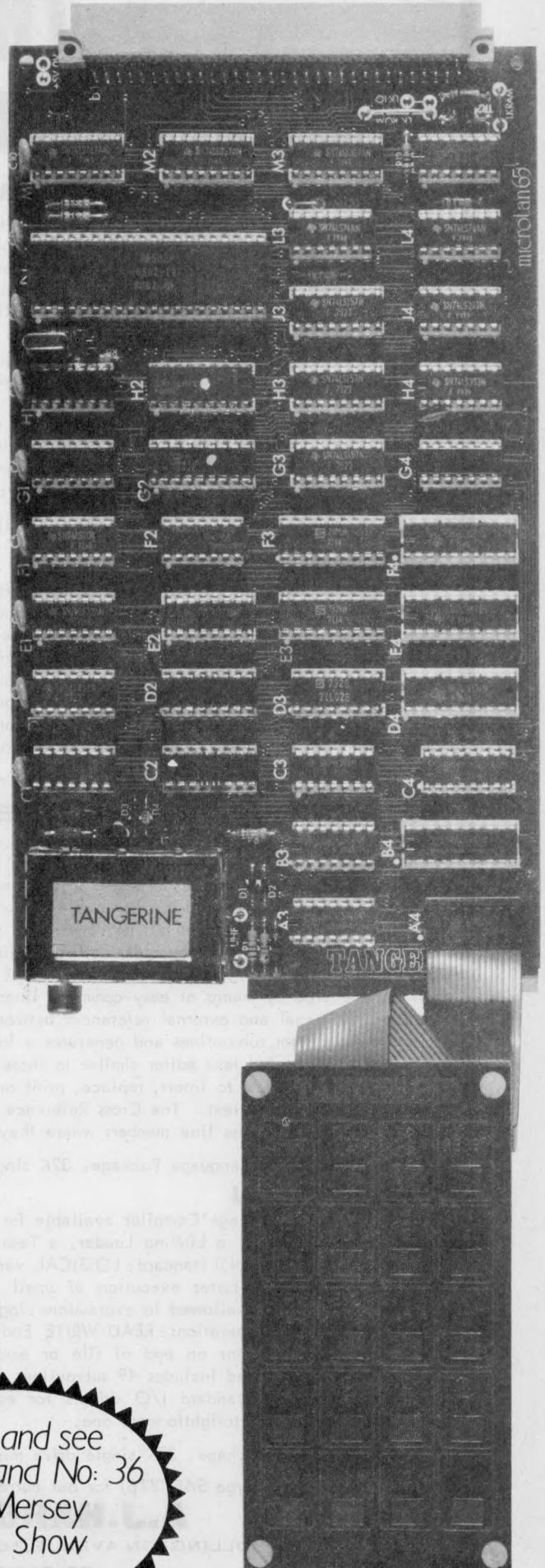

BROCHURE AVAILABLE  
ON REQUEST, 12p stamp



TANGERINE COMPUTER SYSTEMS LTD.,  
FOREHILL, ELY, CAMBS. Tel: (0353) 3633

NAME  
ADDRESS

Come and see  
us on stand No: 36  
at the Mersey  
Micro Show

# INNOVATIVE

# TRS-80 SOFTWARE

## FROM THE PROFESSIONALS

### EDITOR/ASSEMBLER PLUS

Now get every feature of Tandy's Editor Assembler and T-Bug all in one package. PLUS - many "big computer" features to simplify your programming, editing and debugging. Its no longer necessary to waste time creating both source and object tapes - Assembler Plus assembles directly into memory. Macros are supported, simply define a Macro and any frequently used sequencies are automatically assembled. Assembler Plus also supports Conditional Assembly with 2 new pseudo ops, which enable assembly if a condition is true. There are 7 new expressions available, together with an automatic ORG, improved symbol print out and a Quash command to give you more storage space for general text editing. And that is all just on the Assembly side! The Editor is improved with extra commands like Substitute, Move, Copy and Extend for moving entire blocks and repeating them anywhere in the file, and for searching and substituting occurrences in old text for new text. A Range command is available for both Edit and Find enabling you to operate on a single line or a range of lines. Included in the package is a debugger called Z-Bug which includes all of the features of Tandy's T-Bug and features single step execution, direct execution in command mode and symbolic references, plus up to 8 breakpoints, rather than the single one in T-Bug. Editor/Assembler Plus is written by the original author and comes with an 80 page Manual - best of all it costs the same as Tandy's Editor/Assembler alone!

Editor/Assembler Plus for 16K Level II. Cassette based.....£21.70 + VAT = £24.95 50p P & P

### ADVENTURE

The original Adventure was written for a main frame computer and was called Adventureland. Since then there have been many derivatives. The best are written in machine code like the Scott Adams series (for which label we happen to be the sole importers!) but good as they are, they have had to be shortened to fit into 16K. This Microsoft Adventure is the original uncut main frame version, for the first time available for a microcomputer. Once you enter the Colossal Cave, your journey takes you through a labyrinth of caves containing active volcanoes, green snakes, sulfur lakes, killer dwarves, trolls, five foot oysters and many many more surprises before you can collect the 25 Treasures and be a Grand Master! All the while directing your journey with commands and questions to the computer in English. Over 400 messages and descriptions are combined in an endless number of ways in the program vocabulary. Almost literally mind blowing!

Adventure. 32K single drive minimum. Disk based .....£19.50 + VAT = £22.43 50p P & P

### ASSEMBLY LANGUAGE PACKAGE

A Complete Assembly Language package for the user who requires the ultimate in programming aids. This package consists of a Macro Assembler, a Linking Loader, a Text Editor and a Cross Reference Facility. The Macro Assembler accepts Z-80 opcodes and supports a complete Intel standard macro facility including IRP, IRPC, Repeat, local variables and ExitM. The code is assembled in relocatable modules which offer the advantages of easier coding, faster testing, debugging and modifying. An expanded set of conditional pseudo ops allows testing of assembly pass, symbol definition and parameters to macros. Other assembler features include comment blocks, octal or hex listings, titles and subtitles, variable input radix (base 2 to 16) and a complete set of listing controls. The Linking Loader provides a number of loader capabilities executed by means of easy command lines and switches. Any number of programs may be loaded in user specified locations. Internal and external references between modules are resolved automatically. The Loader also performs library searches for system subroutines and generates a load map of memory showing the locations. The Text Editor is a random access line orientated text editor similar to those used on the IBM 360 and PDP-10 computers. The Editor's speed and simplicity make it easy to insert, replace, print or delete lines; edit individual lines; renumber lines in a file and to find or substitute specified text. The Cross Reference Facility provides a convenient alphabetical list of all program variable names, together with the line numbers where they are referenced and defined.

Assembly Language Package. 32K single drive minimum.....£65.00 + VAT = £74.75 50p P & P

### FORTRAN

The best Fortran Language Compiler available for the TRS-80 - a standard ANSI Fortran from Microsoft. The package includes the Compiler, a Linking Loader, a Text Editor and a Fortran Runtime Library. The Compiler has a number of enhancements to the ANSI standard: LOGICAL variables which can be used as integer quantities, +127 to -128; LOGICAL DO loops for tighter, faster execution of small valued integer loops; mixed mode arithmetic; hexadecimal constants; Literals and Holleriths allowed in expressions; logical operations on integer data AND..OR..NOT..XOR can be used for 8 or 16 bit Boolean operations; READ/WRITE End of File or Error Condition transfer, that is, control may be transferred to a specified statement on end of file or error encounter; Encode/Decode for Format operations to memory. The standard library supplied includes 49 subroutines, together with routines for 32 bit and 64 bit floating point functions. Users may write non-standard I/O drivers for each Logical Unit Number - making the task of interfacing non standard devices to Fortran, a straightforward one.

Fortran Package. 32K single drive minimum .....£65.00 + VAT = £74.75 50p P & P

Send large SAE (27p) for our current Catalogue of TRS-80 Software. Add £1.45 for a binder.

## A.J.HARDING (MOLIMERX)

28 COLLINGTON AVENUE, BEXHILL-ON-SEA, E.SUSSEX. TEL: (0424) 220391

TELEX 86736 SOTEX G FOR A. J. HARDING



# MICRO MARKET

ALL YOUR FAVOURITE SYSTEMS AT PRICES YOU CAN AFFORD

WE OFFER A WIDE RANGE OF PERSONAL, PROFESSIONAL AND BUSINESS SYSTEMS, AND PERIPHERALS AT DISCOUNT WAREHOUSE PRICES, BUT WITH A SUPPORT SERVICE MORE COMPREHENSIVE AND EFFICIENT THAN FULL PRICE STORES. ALL MACHINES CARRY OUR EXTENDED NO QUIETLE WARRENTY, AND 'MICRO MAINTENANCE' OFFERS YOU COMPETATIVE MAINTENANCE AGREEMENTS OR REPAIR SERVICES ON ALL EQUIPMENT AFTER THE WARRENTY PERIOD. OUR IN-HOUSE SOFTWARE DIVISION IS ALWAYS AVAILABLE TO OFFER ADVICE AND SOLUTIONS TO YOUR SOFTWARE PROBLEMS, AS ARE THE STAFF OF 'MICRO MAINTENANCE' TO HELP WITH YOUR HARDWARE AND PERIPHERAL ATTACHMENT DIFFICULTIES.

## SJL 8000

WE ARE NOW DISTRIBUTORS FOR THE SJL 8000 BUSINESS MANAGEMENT SYSTEM. SJL HAS BROUGHT TO THE MICRO COMPUTER INDUSTRY UNVALUABLE EXPERIENCE GAINED FROM DESIGNING AND IMPLEMENTING SYSTEMS ON LARGE MAINFRAME COMPUTERS.

- \* DESIGN CONCEPT ELIMINATES OPERATING SYSTEM, FILES, AND USER PROGRAMS, ENSURING EASE OF USE BY EXISTING STAFF. CALL IN FOR DEMONSTRATION

#### EXTRACTS FROM OUR PRICE LIST

##### COMPUTERS

- \* COMPUCOLOR II 16K RAM with internal Floppy Disc, Extended Basic, Assembler, Text Editor Sampler Disc, Formatter, and 10 part basic tutorial From £1095.00
- \* EXIDY SORCEROR 32K ROM Basic, dual cassette interface, RS232, fully expandable From £699.00
- \* ALTOS 4MHz Z80 32K RAM, 1 megabyte 8 inch dual density Floppy Discs, RS232 x 2, Parallel Port. Full software range available including CP/M, Cobol, Business Basic, Fortran, Pascal, Microsoft Extended Basic From £2750.00

##### VDU'S

- \* CIFER 2600 series - high quality displays with detachable 62 or 102 key keyboard From £650.00
- \* PENTLAND VDU terminals - excellent value for money From £430.00

##### PRINTERS

- \* PAPER TIGER 132 char. RS233/parallel switchable interface, up to 275 lines/minute, tractor feed From £525.00
- \* ANADEX DP 8000 serial/parallel switchable interface, 120 CP's bi-directional, tractor feed From £499.00

##### SUPPLIES

Full range of top quality discs, cassettes, paper etc. always available

THE SJL SYSTEM IS PRICE FROM £8500.00 AND INCLUDES:-

- \* HARDWARE AND SOFTWARE COMPLETE IN SYSTEM DESK
- \* FULL SUPPORT BEFORE, DURING AND AFTER INSTALLATION
- \* SYSTEM TAILORED TO YOUR UNIQUE REQUIREMENTS
- \* DATA BASE CONCEPT ENSURES TOTAL INTEGRATION OF APPLICATIONS

PHONE, CALL OR WRITE FOR COMPLETE PRICE LIST AND DEMONSTRATIONS  
TEL: 01-751 6695 TWX: 8954428 138 CHALMERS WAY, NORTH FELTHAM TRADING  
ESTATE, FELTHAM, MIDD.

## MICRO MAINTENANCE

NOW THE MAINTENANCE AND REPAIR SERVICE YOU HAVE BEEN WAITING FOR. WE HAVE EXPANDED OUR EXISTING LARGE MAINFRAME ENGINEERING OPERATION TO INCLUDE MOST MAJOR MAKES OF PERSONAL, PROFESSIONAL AND BUSINESS COMPUTER SYSTEMS. THIS MEANS YOU CAN NOW OBTAIN THE SPEEDY AND EFFICIENT SERVICE DEMANDED THROUGHOUT DATA PROCESSING BY LARGE INDUSTRIAL MAINFRAME USERS:

MAINTENANCE CONTRACTS ARE AVAILABLE ON INDIVIDUAL ITEMS OR ON COMPLETE SYSTEMS. BECAUSE OF OUR LARGE RESOURCES BOTH IN TEST EQUIPMENT AND MICRO ENGINEERING SKILLS, THOSE NOT REQUIRING A MAINTENANCE CONTRACT WILL FIND THEIR REPAIRS ARE CARRIED OUT WITH MINIMUM DELAY AND EXPENSE. BOTH REPAIR AND MAINTENANCE SERVICES ARE OFFERED ON SITE OR DELIVERED TO ENGINEERING CENTRE BASIS. TRADE ENQUIRIES WELCOME.

PHONE, CALL OR WRITE FOR COMPLETE PRICE LIST AND DEMONSTRATIONS  
TEL: 01-751 6695 TWX: 8954428 138 CHALMERS WAY, NORTH FELTHAM TRADING  
ESTATE, FELTHAM, MIDD.

'MICRO MARKET AND MICRO MAINTENANCE ARE PART OF SUN COMPUTING SERVICES LTD'

# apple<sup>®</sup> III USERS

## 8" DISK DRIVES 1 MEGABYTE ON-LINE

Available either as:

- |                             |                       |
|-----------------------------|-----------------------|
| <b>1. COMPLETE SYSTEM</b>   | <b>£1800 + V.A.T.</b> |
| <b>2. ½ MEGABYTE SYSTEM</b> | <b>£1200 + V.A.T.</b> |
| <b>3. CONTROLLER ONLY</b>   | <b>£285 + V.A.T.</b>  |

**FARMPLAN / SVA**  
**Netherton**  
**Ross-on-Wye**  
**Herefordshire**

**Tel: 0989 4321**

# VECTOR GRAPHIC COMPLETE SYSTEMS



Micro-computers for research, laboratory work, word processing, business systems, Schools, Colleges, Universities and Industry. At Almarc, when you buy Vector Graphic Micro-computers, you get Almarc's experience of over 200 systems installed throughout the U.K. and their back-up of full service facilities carried out by experienced staff. Plus an ever growing list of compatible software including:

Pascal, Fortran, Cobol, APL, Algol, C Basic Compiler, etc.

#### **Vector MZ Spec**

- ★ 56K Bank Selectable Ram.
- ★ 3 Serial Ports, 2 Parallel Ports.
- ★ Twin Disc Drives, 630K Capacity.
- ★ 280 CPU, with Fast 4MHZ Clock.
- ★ Prom Programmer (2708).
- ★ Interrupt Handling on I/O Board.
- ★ 18 slot Motherboard.

#### **Vector System B**

- ★ Vector Mindless Terminal.
- ★ Flashwriter II Video Board (24 × 80).
- ★ MDOS + CP/M2 Operating System.
- Plus Microsoft Version, 5 basic options.
- Plus many S100 Bus add-ons, such as Extra Memory, A/D-D/A Boards, High Resolution Graphic, etc.

We will be pleased to demonstrate any of the Vector Graphic Systems, please contact:

**ALMARC**  
**DATA SYSTEMS LTD**

906 Woodborough Road, Nottingham. Telephone: (0602) 625036

Specialists in Vector Graphic Equipment.

# which computer?



## which software?

**Fully Integrated Ledger System** £855  
Gives management information i.e. aged accounts on individual clients, sales analysis. Trial balance. Profit and loss and Balance sheet included.

**Invoicing** £140  
Either stand-alone — or can form part of our General Ledger System.

**Cash Flow/Bank Forecast** £80  
Automatically updates all data following each alteration of an item. Gives Column and line totals. Saves a lot of boring work when a Company operates with more than one bank account.

**Payroll II** £375  
Accepts all tax codes. Gives departmental analysis. It's user configurable and tax rates are user changeable. Operator can change names of items on payslips.

**New Word Processing/Data Base** £120  
Screen-based editor, powerful global search editing facilities, formatting facilities, address data base facilities and possibility to join sections of text, old and new, for the final printout. FAST AND EASY TO USE.

The above programs work either on Apple II floppy system or a version for 10Mb Corvus hard disc drive is available.

### Complete computer system with above, under £5,000

including installation, training and 1 year warranty.

#### Financial Analysis with VisiCalc £95.00

VisiCalc combines the convenience and familiarity of a pocket calculator with the powerful memory and electronic screen capabilities of the computer and can do calculations of sales projections, income taxes, financial ratios, your personal budget, engineering calculations, cost estimates, in fact, anything normally done with a calculator, pencil and paper. Recalculation makes VisiCalc a powerful planning and forecasting tool. Not only can you effortlessly correct mistakes and omissions, you can also examine various alternatives, and above all it does not require any previous knowledge of computers and programming.

TRADE ENQUIRIES WELCOMED

### Stationery Support

**Listing paper and labels**  
Please phone for details or send for comprehensive catalogue.

**Binders**  
Special sizes to fit those non-standard computer listing paper sizes.

**BASF Diskettes**  
Best quality at reasonable prices.

**Bespoke Stationery**  
Ring for advice on customised stationery or consult our catalogue — no quantity too small.



**Service is our business**  
We are as near as your telephone, an extensive range of standard items always in stock.

BARCLAYCARD

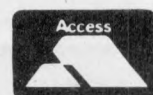

Vlasak Electronics Ltd., Thames Building, Dedmere Road, Marlow, Bucks.  
Tel: Marlow 74789

# MEET THE FAMILY



## ... THERE MUST BE ONE HERE FOR YOU

The Exidy family is a sophisticated range of products designed to meet the ever increasing variety of computing needs, including home and business uses, educational and laboratory applications, industrial process control etc.

The Exidy range has been designed with built-in growth capacity to take the risk factor out of computer investment. The Sorcerer Computer now has a memory expansion capability from 8K up to 48K within its own cabinet, enabling the system to grow with your needs plus the ability to add many additional plug-in facilities such as disk drives and pre-programmed ROM PAC's.

The standard configuration includes a 63 key typewriter-style keyboard and a 16 key numeric pad. Remote control for dual cassettes. Serial RS232 and parallel interfaces, Z80 processor, 4K resident operating system, 8K Microsoft BASIC in separate plug-in ROM PAC cartridge, 64 character x 30 line display, 128 upper/lower case ASCII character set and 128 user defined graphic symbols, operators manual, introduction to basic programming, connecting leads. All Exidy equipment is backed up by a 12 month warranty covering both parts and labour.

The Word Processing ROM PAC features auto wraparound, dynamic cursor control, variable line length, global search and replace, holding buffer for re-arrangement of text, right justification, line width and line to line spacing, underlining or boldfacing, text merging and a macro-facility permitting tasks such as formletter typing, multiple column printing of automatic forms entry.

### Now contact your nearest dealer:

#### The NORTH

T.W. COMPUTERS, 293 London Road, Hazelgrove, Stockport. 061 4568187  
BASIC COMPUTING, Oakville, Oakworth Road, Keighley, W. Yorkshire. 0535 65094  
E. S. MICROCOMPUTERS, 7 Berkeley Precinct, Eccleshall Road, Sheffield S11 8PN. 0742 668767  
GLYSTHYDON LTD., Nook Farm, Rake Lane, Werton, Preston, Lancs. 0772 633138  
MICRODIGITAL, 25 Brunswick Street, Liverpool L2 0BJ. 051 227 2535  
MICROPUTE, 7 Westbourne Grove, Manchester M20 8JA. 061 445 8588  
MAGNUM CONSULTANTS, 57 Fairburn Drive, Garforth, Leeds. 0532 867897

#### MIDLANDS

M & R SYSTEMS, 20 Norwich Road, Wisbech, Cambs. 0945 5900  
MIDLAND MICROCOMPUTERS, 1 Cherry Wood Drive, Aspley, Nottingham. 0602 298 281  
GRIFFIN & GEORGE Birmingham, Manchester, London, Eastkilbride 01-997 3344

#### LONDON and the SOUTH EAST

C.C.S. MICROSALLES, 7 The Arcade, Letchworth, Herts. 046 26 73301  
MICROBITS, 34b London Road, Blackwater, Camberley, Surrey. 0276 34044  
SLOUGH MICROSHOP, 120 High Street, Slough, Berks. 0753 22855  
HOME & BUSINESS COMPUTERS, 445 High Street, Manor Park, London E12. 01-472 5107  
E. M. G., 30 Heathfield Road, Croydon, Surrey CR0 1E4. 01 688 0088  
G. P. W. ELECTRONICS, 146a London Road, North End, Portsmouth, Hants. PO2 9DJ. 0705 693341  
INFORMEX LTD., 8-12 Lee High Road London SE13. 01-318 4213  
N.I.C., 61 Broad Lane, Tottenham N15. 01-808 0377  
TVJ MICROCOMPUTERS, 165 London Road, Camberley, Surrey CU15 3JS. 0276 62506

#### WALES and the WEST

ELECTROPRINT, 5 Kingsdown Parade, Bristol BS6 5UD 0272 292375  
TRYFAN COMPUTERS, 3 Swifts Buildings, High Street, Bangor, Gwynedd LL57 1UW. 0248 52042  
TVJ MICROCOMPUTERS, 48 Gloucester Road., Bristol 0272 422061

Or send coupon for further information to:

#### SOLE DISTRIBUTORS

Geoff Wilkinson  
LIVEPORT DATA PRODUCTS  
The Ivory Works, St. Ives, Cornwall.  
0736-798157

PLEASE SEND DETAILS OF THE EXIDY RANGE

NAME \_\_\_\_\_

ADDRESS \_\_\_\_\_

\_\_\_\_\_

\_\_\_\_\_

\_\_\_\_\_

\_\_\_\_\_

\_\_\_\_\_

# GREAT NORTHERN SOLVE THE SOFTWARE PUZZLE



If you are puzzled by the lack of good software for micro computers - then puzzle no longer! Great Northern Computer Services are distributing first class packages for CP/M based and Apple micro computers.

There are complete packages for:

- Stock Control for retailers for Apple or CP/M Systems.
- Integrated Accounting System - Sales, Purchase and Nominal Ledger for CP/M systems.
- Professional Client Billing - complete invoice and sales ledger system for a professional practice.
- Statistics for Apple.
- Data Base Management for Apple or CP/M systems.

If you want to write your own then use MAGSAM multi-index routines within your Basic Programmes. Whatever your needs, stop puzzling - contact your dealer or.....

**GREAT NORTHERN** Computer Services Limited

116, Low Lane, Horsforth, Leeds, LS18 5PX. Telephone: [0532]589980. Telex: 556276 FOR GT. NORTHERN.

## RICOH RP-1600.

£1250

Richo high-speed daisy wheel, heavy duty commercial printer gives a high-quality printout, coupled with low noise level necessary for office environment. Nationwide service by UDS. Service under 90 day warranty is provided at your premises.

124 char: upper/lower case. - 60 chars./sec print speed - 10/12 chars: per inch giving 136 or 163 columns. - 15 inch wide friction platen. - forward/reverse paper feed for graphics. - Top of the form and host of other features. - Centronics type parallel interface as standard.

Options: serial interface £60  
- PET interface £75  
APPLE interface £75 -  
TRS-80 interface £45.

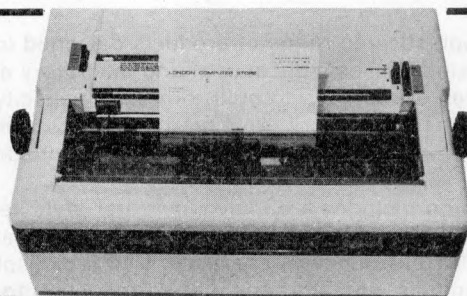

## SUPERBRAIN £1875

COMPLETE COMPUTER  
TWIN Z 80-A 4MHZ. - 2 DOUBLE DENSITY DISC DRIVES. - 64K RAM. - HIGH RESOLUTION 12 INCH CRT. 80 x 24 LINES. - UPPER/LOWER CASE. - 2 RS232 PRINTER PORTS. - CPM OPERATING SYSTEM. - WORD PROCESSING & ACCOUNTS PACKAGES AVAILABLE.



## EPSON TX-80 £395

DOT-MATRIX PRINTER WITH PET GRAPHICS PRINTS 80 COLUMNS ON PLAIN PAPER AT 90 CHARACTERS/SECOND. ADJUSTABLE TRACTOR. - UPPER/LOWER CASE. - DOUBLE WIDTH PRINTING. - MICRO CONTROLLED. - SELF TEST. - HEAVY DUTY PRINT HEAD USING JEWELL BEARINGS FOR LONG LIFE. - CENTRONICS PARALLEL INTERFACE. - MADE BY SHINSHU SEIKI AN AFFILIATE OF SEIKO WATCH CO OF JAPAN. OPTIONS: PET INTERFACE WITH CABLE £50. APPLE INTERFACE WITH CABLE £60.

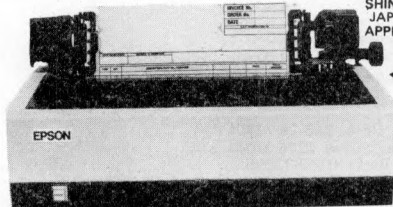

## OKI MICROLIN 80

THE QUIETEST DOT MATRIX PRINTER AVAILABLE. VERY HIGH PRINT QUALITY. TAKES ALL THREE, LETTER HEADS (SINGLE SHEETS), OR FANFOLD, PAPER OR PAPER ROLLS. 40, 80 OR 132 CHARACTERS PER LINE SOFTWARE SELECTABLE. 100% DUTY CYCLE. YOU CAN USE DAY IN AND DAY OUT. VERY COMPACT. NO MAINTENANCE NECESSARY. CENTRONICS PARALLEL INTERFACE STANDARD. INTERFACES FOR RICOH, ANADIX AND OKI PET NON-ADDRESSABLE £40.00, ADDRESSABLE £75.00, APPLE £75.00, SERIAL (RS232) £75.00.

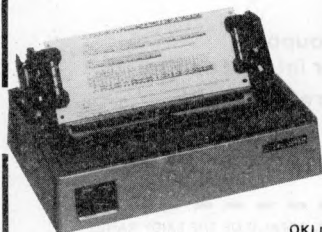

Prices quoted above do not include VAT. Phone or call for further details or demonstrations.

## LONDON COMPUTER STORE

43 GRAFTON WAY, OFF TOTTENHAM COURT ROAD, LONDON W.1  
TEL: 01-388 5721 OPENING HRS: 11-7 MON-FRI, 12-4 SATS.

# DATRON of SHEFFIELD

## NASCOM SYSTEM 80

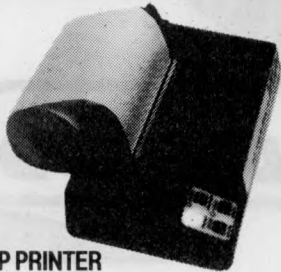

IMP PRINTER  
£325 + VAT



SYSTEM 80  
Case & Card Frame  
£85 + VAT

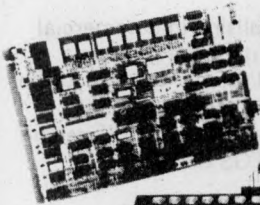

Nascom 2 (Kit) £225 + VAT  
Memory Boards

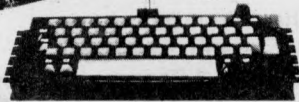

16 K £110  
32K £165  
48K £225  
+VAT

### + Z80 Books

Z80 Programming For Logic Design	Osborne	£6.30
Practical Micro. Programming With Z80	Weller	£19.55
Z80 Microcomputer Handbook	W. Barden	£6.95
Z80 Microprocessor Programming & Interfacing Vol. 1	Nichols & Rony	£7.75
Z80 Programming & Interfacing Vol. 2.	Nichols & Rony	£8.50
Z80 Assembly Language Programming	Osborne	£6.95
Z80 Instant Programs	J. Hopton	£7.50
Z80 Instant Programs - Cassette of above		£10.00
Mostek Z80 Microcomputer Software Programming Guide		£6.00
Z80 Assembly Language Programming	Leventhal	£6.95

### + Basic Books

The Basic Handbook	David A. Lien	£11.50
The Little Book of Basic Style	Nevison	£5.25
Basic/Basic	Donald M. Munro	£2.00
Basic/Basic	J. Coan	£6.50
Advanced Basic	J. Coan	£6.00
Outline Programming with Basic	Gottfried	£3.70
Problem Solving & Structured Programming in Basic	Koffman & Friedman	£8.95
Illustrating Basic	Donald Alcock	£2.50
Some Common Basic Programs	Osborne	£6.45
Some Common Basic Programs (Pet Cassette)		£7.95
32 Basic Programs for the Pet	Rugg & Fieldman	£9.75
Basic Primer	Waite & Pardee	£6.95
A Guide to Basic Programming	Spencer	£8.85
A Guide to PL/M Programming	McCracken	£7.95

### + Basic Course PROGRAMMING IN BASIC

An intensive week-end course  
28-29 June 1980 Hallam Tower Hotel, Sheffield.  
19-20 July 1980 £125 inclusive

## INTEGER PASCAL FROM DATRON

T2/B-BUG/T4/NASSYS Compatible.  
For this 12K Compiler we recommend a 32K ram Machine. The compiler produces Z80 machine code and supports.

Procedures and Functions, BEGIN-END, IF-THEN-ELSE, CASE-OF-ELSE-END, WHILE-DO, REPEAT-UNTIL-, FOR-TO/DOWNTO-DO-, CALL- (Call assembler routine), READ/WRITE (Character, hexadecimal and decimal integer I/O is allowed WRITE also allows string output). MEM(-) (An array allowing access to memory, the equivalent of PEEK/POKE), Arrays allowed, Programme fully recursive, Integers ± 32767.

Each statement fully documented, and a complete set of syntax diagrams provided. Also a sample programme is provided.

Cassette & Documentation £35  
Plus V.A.T.  
Documentation alone £2.50.

### + Pascal Books

Introduction to Pascal	Welsh & Eider	£6.95
Structured Programming & Problem Solving with Pascal	Richard Kieburz	£8.40
Primer on Pascal	Conway et al	£7.10
Programming in Pascal	Grogono	£6.75
Pascal An Introduction to Methodical Programming	Findlay & Watt	£4.95
Micro Problem Solving - PASCAL	Bowles	£6.95

## + CROMEMCO, SHARP, APPLE, ITT, PET, ITHACA



Please supply:—

### NASCOM

Imp at	£325	<input type="checkbox"/>	Pascal Tape	£35	<input type="checkbox"/>
System 80 Case	£85	<input type="checkbox"/>	for monitor-T2		<input type="checkbox"/>
Nascom 2	£225	<input type="checkbox"/>	T4		<input type="checkbox"/>
16 K Memory Board	£110	<input type="checkbox"/>	B Bug		<input type="checkbox"/>
32K	£165	<input type="checkbox"/>	Nas Sys		<input type="checkbox"/>
48K	£225	<input type="checkbox"/>	Documentation	£2.50	<input type="checkbox"/>
3 Amp Power Supply	£29.50	<input type="checkbox"/>	Basic Course Details		<input type="checkbox"/>

Books \_\_\_\_\_

I enclose :- £ \_\_\_\_\_

Cheque/Postal Order No. \_\_\_\_\_

Barclaycard/Access No. \_\_\_\_\_

Name \_\_\_\_\_

Address \_\_\_\_\_

DATRON MICRO CENTRE, Latham House, 243 London Rd  
Sheffield S2 4NF. Tel:0742 585490 Telex: 547151







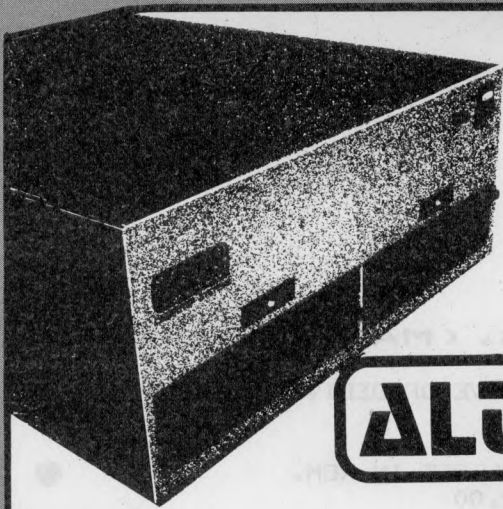

**ALTOS**

SHORTLY TO ARRIVE ON ALTOS  
EXCLUSIVE TO B&B  
PRESTEL.

**B&B [Computers] Limited**

The Consultants for the North West

SUITE 1

124 NEWPORT ST, BOLTON  
Tel 26644

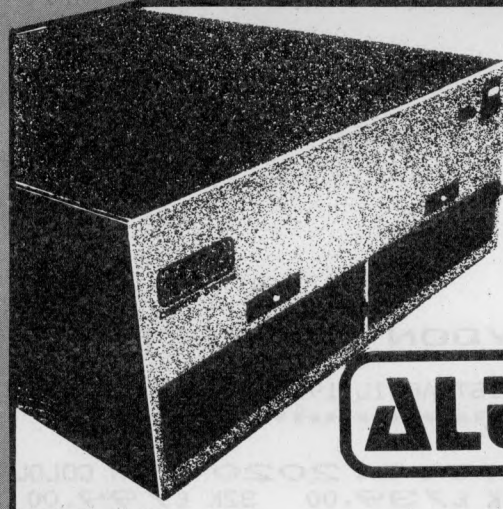

**ALTOS**

For ALTOS systems in the West Midlands Region  
contact:

**CLE.COM**

CLE.COM Ltd., 8 Stanley Road, Kings Heath  
BIRMINGHAM 14.

(TEL. 021-444 3618 or 021-472 8233)

Specialists in the provision of COMPLETE  
systems:

Technical Advice, Hardware, Software  
Development, Installation and Training.

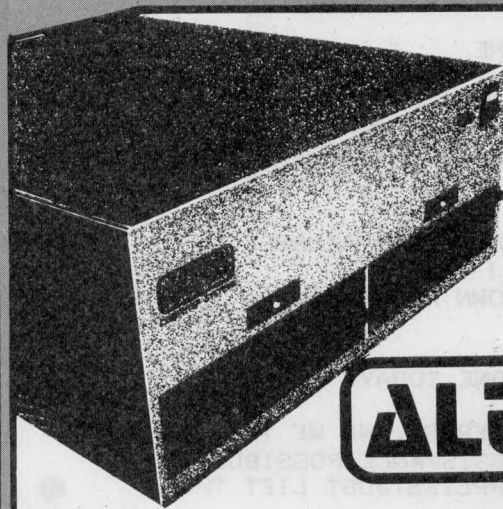

**ALTOS**

What other system offers you so much for  
a capital investment of £3000.

Wendmore offer brokers an easy to operate and  
inexpensive micro-computer system called *Offload*.

*Offload* produces the  
following:

- Storage of client information.
- Financial and statistical analyses.
- Debtor controls and profit accounts for easy insurers reconciliation.

- Production of renewal notices.
- A ability to select particular categories for direct mailing.
- The facility for automatic letter writing.

What other system offers you  
so much for a capital  
investment of £3000.

**offload**  
— the system designed  
to grow with you.



— the company that  
brought you MOQUOTE.

For further information  
about the 'offload'  
system please write to:  
Jeremy Bensted,  
The Sales Director,  
Wendmore  
Management Services  
Limited.

Salisbury Buildings,  
180 Bridge Road,  
Salisbury Green,  
Hampshire, SO3 7EH  
Tel: Locks Heath  
(04895) 6318/9/0  
Telex: 47146



**ALTOS**

FOR ALTOS 800 SYSTEMS IN THE SOUTH-WEST  
CONTACT BOB CHEDD AT VALIDATA

**VALIDATA**

FOR ALTOS 800 SYSTEMS IN THE SOUTH-WEST  
CONTACT BOB CHEDD AT VALIDATA  
26 HIGH STREET, MELKSHAM, WILTSHIRE  
(0225) 705 957

**THEYDON COMPUTER SERVICES. (MAIL ORDER).**

PRICE LIST APRIL 1980

ALL PRICES EXCLUSIVE OF DELIVERY & V.A.T.

\*\*\*\*\*

**I.T.T. 2020 WITH COLOUR CARD AND PALSOFIT IN ROM.**  
16K £739.00 32K £799.00 48K £859.00

I.T.T. 5.25 INCH DISK DRIVES :-  
CONTROLLER CARD £49.00 DISK DRIVE £299.00  
PRINTER CARD (PARALLEL) £79.00  
MEMORY UPGRADE (16K) FOR I.T.T. 2020 £60.00

**ANADEX DP8000 PRINTER £449.00**

ALSO NEW ANADEX APPLSIDER AND DP-9500.

11.5 BY 8.5 PAPER 4000 SHEETS £18.00

5.25 INCH MINI FLOPPIES (BOX OF TEN) £19.50

ALL CONSUMABLES AVAILABLE !!!

TRAINING GIVEN. COURSES FROM IDIOT LEVEL UPWARDS !  
**SOFTWARE WRITTEN OR AVAILABLE EX-STOCK**  
**ALL ENQUIRIES WELCOME**

\*\*\*\*\*  
\*  
\* WE RECOMMEND THE **BRITISH MADE** ITT 2020 MICROCOMPUTER \*  
\* \*  
\* BECAUSE WE HONESTLY FEEL THAT IT REPRESENTS THE \*  
\* \*  
\* BEST VALUE FOR MONEY CURRENTLY AVAILABLE. \*  
\* \*  
\*\*\*\*\*

FULL SUPPORT WITH ALL SERVICING AND "HANDS ON" COURSES AVAILABLE  
**SOFTWARE ASSISTANCE !!!**  
BEFORE PURCHASE. LET US SHOW YOU HOW TO WRITE YOUR OWN PROGRAMS....

ALL MAJOR CREDIT CARDS ACCEPTED. DON'T DELAY, PHONE TODAY.

WE APPRECIATE THAT NOT EVERYONE SPEAKS COMPUTERESE AND WE TRY TO  
GIVE NEWCOMERS TO THE MICRO-CHIP ERA EVERY ASSISTANCE POSSIBLE.  
FOR ADVICE AND DETAILS OF OUR COURSES AND SUPPLIES, JUST LIFT THE  
TELEPHONE AND DIAL :-

**THEYDON BOIS (ESSEX) 4321**

ONLY FIVE MINUTES FROM THE LONDON UNDERGROUND (CENTRAL LINE)

**WARNING FROM THEYDON COMPUTER SERVICES.**  
DEALING WITH OTHER COMPANIES CAN DAMAGE YOUR PURSE.....

"Micro mania hits London—staggering success—the sort of frenzy usually seen at January sales." Datalink (16/7/79)



# The Big One

See you at The Wembley Conference Centre  
**22-24 July, 1980**

Last year's Show broke all records and made headline news in many newspapers. The 1980 Show with its exhibition, international conference and one-day seminars, adds up to the most significant microcomputer event ever held.

Join the top names in the business and reserve your space now—and remember exhibitors who have also booked for the Mersey Micro Show are entitled to a 10% discount on both events!

Seminars held on the first two days will inform the business man of the many ways micros can be used as a commercial aid, both in the office and the home. The seminar on the third day will be devoted to education applications.

In addition, a two-day international conference will examine the state of the art in microelectronics with distinguished speakers from the UK and overseas.

Return this coupon or call Jane McBarnet at Online Conferences Ltd.,  
Argyle House, Northwood Hills HA6 1TS.  
Telephone: Northwood (09274) 28211

*onTime*

Please send 1980 Microcomputer Show exhibitor details  
 Please send Mersey Micro Show details

Name \_\_\_\_\_  
Address \_\_\_\_\_  
Tel. No. \_\_\_\_\_



## Consumer Division

Texas Instruments' consumer products incorporate the latest micro-electronics technology for which our name has become a by-word.

Pioneers in electronic calculators, digital watches and learning aids, Texas Instruments' position as market leader was established with winners such as the TI-30 student calculator and 59 programmable calculators. This leadership is maintained by the continuous introduction of innovative ideas. Consumer products such as Speak and Spell, the speaking Language Translator; Starbust - the world's first analogue display LCD watch; and now the Home Computer.

# Home Computer Marketing

## c £7000 + car

Texas Instruments are developing a new concept in personal computing and are building a dynamic, consumer-oriented marketing team in Bedford.

An opportunity now exists for a technical contributor to this team. He or she must be familiar with technical aspects of personal computing hardware, but should already be thinking about the applications of this new technology to self-tuition, entertainment and home management.

The job includes aspects of market research, promotions, product evaluation and marketing planning. This assignment offers a unique opportunity for a self-motivated individual who wants to join one of industry's most innovative organisations and give micros to the world.

The ideal candidate will probably be under 30, with HNC or above and knowledge of

microprocessor technology. Above all, he or she will be able to demonstrate a creative flair which can be harnessed to this exciting new market place.

The position is based at our UK Headquarters in Bedford, easily accessible, with reasonably priced housing in an attractive part of England. Comprehensive relocation assistance will be given where appropriate.

Starting salary is negotiable c £7000 p.a., depending on age and experience plus car, profit-sharing, free medical and life assurance schemes, contributory pension plan and extensive sports/social facilities.

In the first instance, please write with full details to: Ann Stevens, Texas Instruments Limited, Manton Lane, Bedford, or telephone her for an application form on Bedford (0234) 67466.



## TEXAS INSTRUMENTS LIMITED

*... where people and technology meet*

# IF

..... you want the best service  
you need professional advice  
years of experience impress you  
you are trying to find the best computer equipment  
as well as the finest software .....

# MICROSOLVE

is the Company to contact

MICROSOLVE COMPUTER SERVICES LTD

3rd Floor (rear),  
MIDDLESEX HOUSE,  
29-45 High Street,  
EDGWARE,  
Middlesex.  
(exit 4 M1/20 mins. West End).  
(prices ex. VAT)

01-951 0218/9/0

We cover a full range of equipment including the APPLE II (from £695/16K); the MICROSTAR multi-user system (from £4,950) and the powerful ALPHA MICRO which will run 1 to 22 terminals - the most cost effective system available today.

WE OFFER A COMPLETE SERVICE which encompasses advice, systems design, sale and installation of computer and peripherals, as well as tailor-made software, where necessary. There are fully documented ACCOUNTING and WORD PROCESSING PACKAGES etc., for Accountants, Solicitors, Manufacturers, Retailers, Medical Practitioners in fact all business applications.

ALSO in stock are PRINTERS, VDUs, CONTINUOUS STATIONERY, DISKETTES, DISK BOXES, all from the best names in the computer world - TEXAS, LEAR SEIGLER, TALLY, QUME, PAPER TIGER etc.

So if you either wish to buy a computer to program yourself or take advantage of our service TELEPHONE NOW FOR AN APPOINTMENT.

# MICROSOLVE MICROSOLVE

# OUR SYSTEMS CAN GROW ON YOU

When you buy one of our low price microcomputer development systems you not only get a fully burnt-in and tested system designed and manufactured to industrial standards. You also get access to an ever-increasing range of software tools. And if you require a VDU or printer now or later, there is a selection of these and other peripherals from which to choose. So your system can grow and grow.

Our systems start to grow on you at £1450. This buys you a 32KB system with dual 5¼ inch double density floppy drives. At £1675 you can have a 48KB system or for £2495 one with the extra memory storage provided by dual 8 inch double density floppy drives. All the systems are based on the powerful Z80 microprocessor and S100 bus structure and can provide memory management. Cartridge disc drives are available providing up to 40MB of storage.

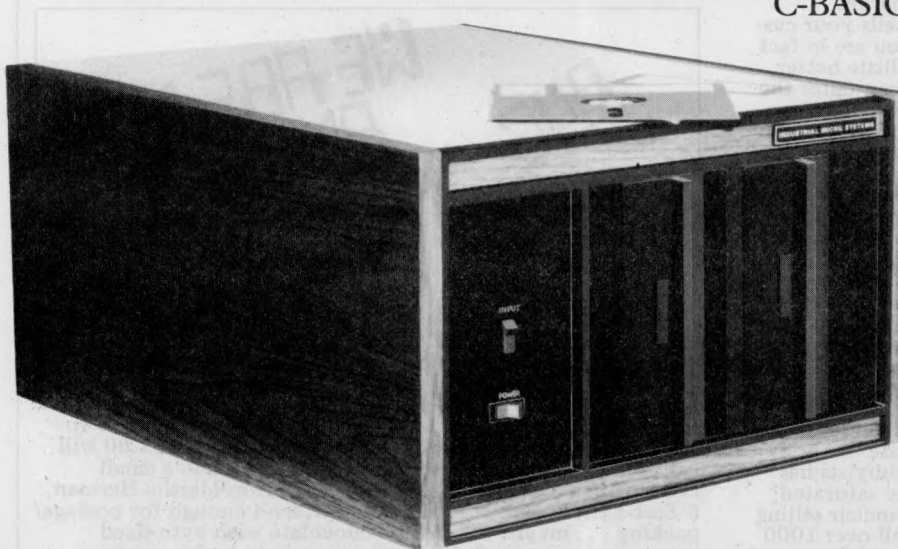

The prices include an operating system and language, in this case CP/M and C-BASIC, to

give a typical system cost. But with slight cost adjustment the software options are:

## Operating Systems

- CP/M • PASCAL • CAP MICROCOBOL BOS
- Multi-User, Multi-Tasking Operating Systems

## Languages

- C-BASIC COMPILER • M-BASIC • FORTRAN-80
- COBOL-80 • PASCAL • CIS-COBOL

There is also a word and text processing system available that is ideal for report writing.

You simply take your pick from the software options. Or visit our London showroom and see the systems demonstrated.

SYSTEMS 32KB + Dual **£1450**  
WITH CP/M AND 5¼ inch Floppies:

48KB + Dual **£1675**  
5¼ inch Floppies:

48KB + Dual **£2495**  
8 inch Floppies:

Prices exclude VAT.  
Nationwide maintenance facilities available.

# EQUINOX

**COMPUTER SYSTEMS LTD.**

Kleman House, 16 Anning Street,  
New Inn Yard, London EC2A 3HB  
Tel: 01-739 2387/9 & 01-729 4460

In addition to his normal run through the general news, this month Guy Kewney presents a special Stateside Supplement.

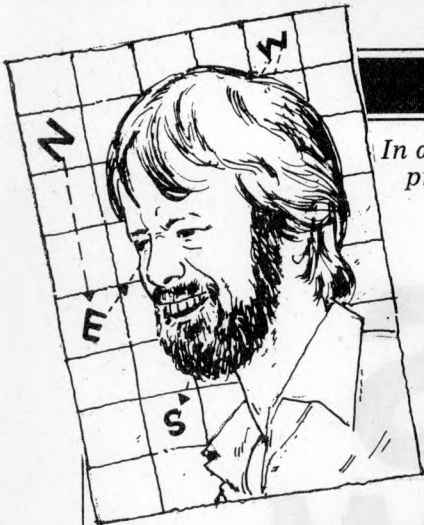

## The ups and the downs

Many firms have gone bust in the micro business both in the UK and in America — including famous ones such as Byte Shop and less famous ones such as Sphere. The question of why they went under is important. To Clive Sinclair, the answer is clearly “competition”. He is very nervous about the market lead he has established with his ZX80 £100 computer, and will not say anything about how the inside works.

To people with less at stake, the reason that companies like Processor Technology (American maker of the Sol computer) died is simple: bad management, and an apparently mindless determination to destroy themselves. As far as I have been able to find out, nobody with micro-processors to sell has been unable to sell them. More, even those without micro-processors to sell, have been able to get money in advance, with which to design them.

Where most of the companies that have gone wrong, went wrong, was in trying to move “up market” and in trying to supply “business machines”. The new micro men have all arrived in the computer business by mistake, and it isn’t surprising that they should be tempted by the “up market” argument. They weren’t around for the Small Business Crash of six or so years ago.

At that time, the advances of technology which made the minicomputer possible, had led to the VRC — the visible record computer. Its strong point was that it was cheap, and that it was a very basic do-nothing machine. That was in about 1968; and around then, the idea that these things were “really” computers began to tease the minds of their makers.

If the machine is “really” a computer, reasoned the buyers, they could do all the things on the machine that big computer owners could do on their machines. It took a while for this attitude to feed back to the

computer makers . . . to Phillips, Olivetti, Kienzle, Triumph Adler, and similar office computer makers. But when it did, the result was: disaster.

In theory, a machine which does accounts under control of software can, indeed, do anything else. In practice, the cost of getting it to do something else is prohibitive. Very roughly, the cost of an item of software, to a commercial enterprise producing it by paying clerks, is £10,000. The cost of marketing it, and supporting it, is estimated as between another £10,000 and three to four times that figure.

The office minicomputer companies found that their salesmen were promising to supply programs to do anything from stock control to planning of salesman’s rounds, for an additional fee of around £3000 “or more”. The “or more” naturally turned out to be anything up to £20,000 — on a computer costing under £10,000.

Is all this starting to sound familiar?

The simple fact is that unless a man writes his own software in his own time, software costs that sort of money. To sell a £30,000 package for £300, you have to sell 100 identical packages. Moving “up market” immediately tells your customers that you are in fact going to do a little better, and that you can tailor the software to their requirements; this usually costs much more than either side expects.

The logic usually advanced to justify a move “up market” is: “We’ve saturated the hobbyist market, and have to cater to the small business, which is more profitable anyway; so we’ve packaged the system and put the price up.”

What has actually happened is often a lot simpler. The product has gone out of date. If the market for hobbyists has indeed become saturated, why is Clive Sinclair selling at a rate of well over 1000 systems a month? Because he has gone up market? At £100

including tax? I doubt it.

All this is about as long an introduction as even I can be expected to write, to front the news that Nascom has packaged its Nascom 2. From the tone of the introduction, readers will gather that the packaging and “moving upmarket” doesn’t impress me. The only thing about the new-look Nascom that does impress me is the new memory board with 48 Kbytes of memory chipperly — and a paging system.

Look at Nascom from historical experience: when the first machine was announced, the choice was between the Motorola D2, the Kim 1, American systems retailing at a couple of thousand pounds, or the first rumours of the PET (to sell at £1000 at today’s prices). The Nascom was the first cheap system that you could build with a real typewriter keyboard, a real video output, and a whole 2 Kbytes of memory. By contrast, the competition had 16 grotty keys, had to be programmed in hex, and could output only hex numbers on six calculator-type display characters, from a mere 256 bytes of store.

Technology has not got stuck since then, and if Nascom truly wants to sell the way it did in the early days, a £500 system (using a central processor that looked reasonable when it

was originally announced but won’t be available till nearly a year later) is not going to steal any thunder from Clive Sinclair. Well if Nascom did it once, why not again? The answer, if you want my opinion, is that Nascom isn’t in the business of stealing thunder, but of cushioning our ears. It doesn’t want to upstage the Nascom 1 too much.

There is the subsidiary problem; that the money which should have been transforming the Nascom 2 into the Nascom 3 (the way the Apple I was transformed, utterly, into the Apple II) has been kept off stage in the wings. Nascom boss John Marshall has arranged about £1 million worth of finance, jointly from the NRDC and the City (Grove-wood Securities, in North London geographically, but in the City nonetheless) . . . he’s not used a penny of it. Grove-wood tells me that he has until June to make up his mind about whether he wants it. John Marshall himself tells me he has plans and hints that they involve other sources of finance, and asks for secrecy while he wheels and deals. He won’t want my advice, but here it is: he is almost a genius at buying semiconductor parts, and producing products that are much cheaper than anyone else could arrange. He should stick to his genius.

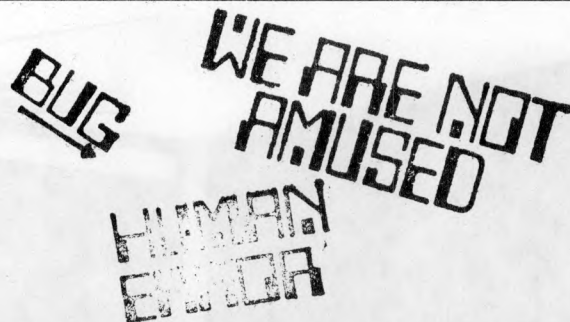

The ultimate comeback to a computer-printed income tax demand or overdue and overestimated gas bill is, of course, to get your own computer to add its own comments, and return it. While waiting for the price of printers that can do this to come down to your budget level, a mere \$11.00 will get you these stamps — plus a red stamp pad and a small carrying bag. Get them from New York firm Martha Herman, 5 East 17th Street, NY, NY 10003; send enough for postage/packing . . . maybe \$2. It’ll be chocolate with byte-sized prices next; we computeers are becoming a truly consumer market.

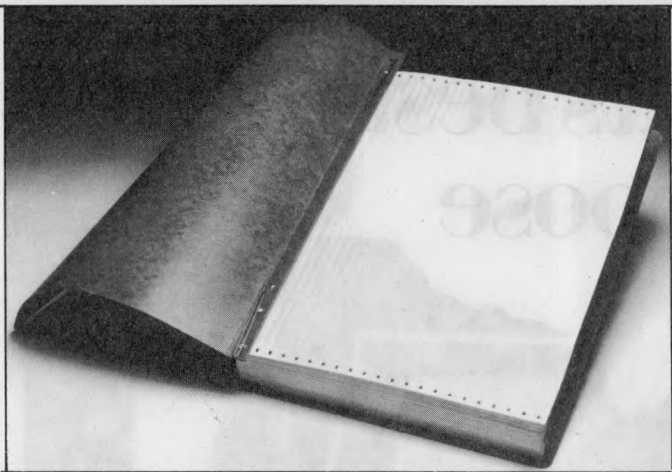

Three different sizes of computer print-out can be filed in the Cavadex binder. For those who think printouts are only for the big computer rooms that can afford line printers turning out words at 300 lines a minute, here is a little thought. Call round to one of these places, and get as much used, scrap paper as they have left after teachers, children and other paper hoarders have had their cut — and use the back. Cave is in Northampton on 0604 48125.

## Acorn's mighty Atom

At last a new computer! A genuinely new personal machine is to be launched by the Cambridge firm Acorn, in May, at about £125 kit or £150 built. It's called the Atom.

The machine incorporates that fundamental necessity for a cheap system . . . it's on a single board. It includes a BASIC which Acorn people say is three to five times faster than Apple Integer BASIC, and has the unique feature of including an assembler in the interpreter.

Normally, a BASIC interpreter is the program that a computer runs all the time; even when it appears to be running your own program it's actually doing nothing of the sort. The interpreter program is handling your BASIC instruction list data. The output from the data is what the BASIC expected, but the BASIC is not what does it.

In the case of Atom BASIC data supplied includes standard 6502 mnemonics. When the interpreter finds and recognises this data, it actually runs it, rather than calculating output from it.

Acorn directors, Herman Hauser and Chris Curry explain the ingenious nature of this BASIC by pointing at the writer, Roger Wilson. He happens to have a 6502 assembler in his head, and can at any stage in the program, apparently recall what is in the various registers, stack pointers, and status flags; he can do amazing short cuts.

As an example, the diskette operating system is a routine that is run by the machine every time data comes in from the diskette. The data interrupts the machine, which responds by

running this routine. Nobody else has found a routine quick enough to run in this way: Acorn's diskette operating system therefore runs at least three times faster than anyone else's.

At the back of the Atom, there will be a 64-way connector that is exactly the same as the one on the bottom of today's £70 Acorn two-card system. There will also be outputs to cassette tape, TV colour, and to other Atoms.

The "other Atom connection" is a daring innovation, and looks very like an idea first proposed by Chris Moller, an engineer at Modular Technology (the minimodem makers) two years ago. Each Atom can have a receiver/transmitter (not wireless, wired) with its own station code; this is done with what's known as a universal asynchronous receiver transmitter . . . or UART. Any Atom can transmit the station code of any other Atom in the circle of connected computers, and the UARTs of all remaining machines in the circle immediately set themselves to a "do not transmit" position until the other two have finished talking. The conversation runs at 9600 baud. The Acorn people see this as a classroom technique first; the teacher can take over any of the pupils' machines and see what's going on — and they can print messages on the screen.

The machine looks, to me, like a slightly more polished version of what Clive Sinclair has produced in the ZX80; it has a proper typewriter keyboard, and as things stand right now, the video offers a few extras in sophistication. The price is proportionately higher, but still in an acceptable bracket to make it credible as a higher priced alternative for buyers in a

hurry, or people with differing tastes.

Acorn will announce firm prices at the official launch, which may not come until June.

## Z80 on the line

By the end of this year, the Sinclair ZX80 will have a Prestel circuit and a diskette both at prices "in keeping with the price of the machine", as Uncle Clive put it. This means that the machine will be able to talk to other ZX80s down the phone line.

The alterations that will make the ZX80 a Prestel machine are slight, points out Sinclair. It offers 32 characters on a TV screen now: it only has to offer eight more to be Prestel compatible. The changes will involve a completely new read-only memory chip, since that contains the BASIC interpreter, the operating system, and the video character generator. The ROM was going to be changed anyway: a new, enhanced (floating point arithmetic) BASIC with all the trigonometric and logarithmic functions currently omitted, will be with us some time soon.

The Prestel attachment is still in fact in Uncle Clive's eye. However, he has had this twinkle undimmed since he first conceived the machine. "I would have mentioned it at the launch, only nobody asked me about it," he told me.

The modem that talks to the central Prestel computers, he hopes will work by acoustic coupling. The idea is that a plug-in socket for the normal sort of Prestel modem would cost too much compared to the cost of his coupler. "Definitely the main objective is to get the

machines able to communicate," he added, "so it won't be a standard Prestel modem with slow transmit and different (fast) receive, which can't talk to itself."

The diskette drive will happen this year, but only "if we can get the price down to a comparable level with the machine." That means well under £200 he agreed, but wouldn't say if it also meant well under £150. Tantalisingly, he also refused to confirm that it would be a five-inch minifloppy.

## Paging Nascom

About the cleverest idea to emerge from the Nascom stable so far this year is a deeply buried technical specification in a paragraph dealing with details of the new 48 Kbyte memory board. It's the fact that "four of these boards can be plugged into a system simultaneously."

Normally, plugging four 48 Kbyte boards into a system using the Zilog/Mostek Z80 chip would be a waste of three of them. The machine has 16 wires with which to address memory, and the maximum memory that can give is 64 Kbytes (65,536 memory locations, in strictly accurate point of fact, that number being the possible permutations of 16 dots and dashes, or 2 to the power 16). Nascom has done its trick by "paging". An output instruction addressed to port FF of the Zilog cpu chip sets any one of the boards to read, and any of the boards to write. They can be the same board, but they don't have to be.

According to technical director David Wadham: "I use the paging system to keep a protected copy of my software in memory when doing development work."

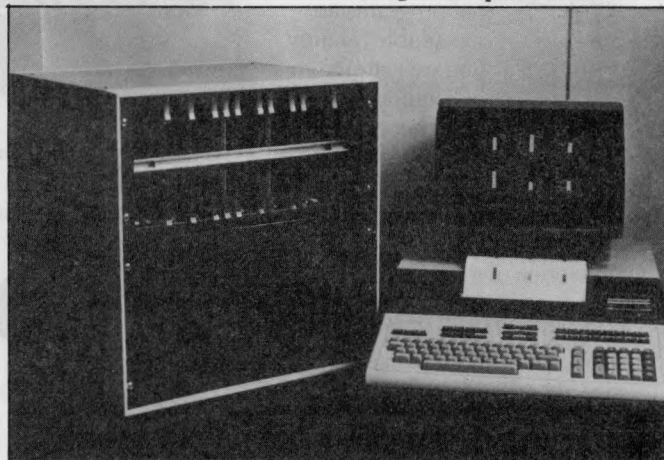

A neat solution to some of the problems involved in expanding a micro that monitors a factory is this one from Burr-Brown: each input/output card has its own memory on the board. The IOS 2000 10z also keeps the software needed to run the I/O cards on them, so that the system is always the right size for the number of lines being controlled. 0923 33837.

# “If you want what’s best for your PET, choose Commodore software”

Kit Spencer  
General Manager  
of Commodore Systems  
360 Euston Road  
London NW13BL



The Commodore PET is Britain’s best selling micro-computer, with over 18,000 already installed in a wide range of fields, including Education, Business, Science and Industry.

This has led to a tremendous demand for high quality software.

And Commodore has met this demand by producing a first class range of programs, now available from the nationwide network of Commodore Dealers.

Commodore’s support also includes training courses, a Users’ Newsletter and Official Approval for compatible products of other manufacturers who reach agreed standards.

## COMMODORE PETPACKS

Over 50 Petpacks of programs are available (mainly on cassette) from Commodore Dealers.

These cover such popular titles as Strathclyde Tutorial, Statistics pack 1, Assembler Development System, Stock Market Trends and the Treasure Trove Collection of game packs. Plus the new Arcade Supergame Series including “INVADERS” – quick to learn but difficult to master and already a No 1 favourite. Prices range from £5-£50.

## TRAINING COURSES AND SEMINARS

PET systems are simple to use and any normal advice or assistance

you may need can be obtained from Commodore Dealers.

On the other hand, for rapid training on a basic or advanced level, you will certainly be interested in Commodore’s intensive 2- and 3-day residential courses. We also run one day general appreciation seminars.

## PET USERS’ NEWSLETTER

This is Commodore’s official method of sharing new information and ideas between the many thousands of PET users. The newsletter is published regularly and for an annual subscription of £10 you can start receiving copies now.

Look out for this sign. It tells you that compatible products of other manufacturers have met with our standards of approval.

**BUSINESS SOFTWARE PROGRAMS ON DISK**  
Commodore’s Floppy Disk Unit and high-speed Printer, combine with PET to form a complete system (ideal for running a business) for under £2,500.  
Commodore also produce a range of business software application packages on disk. They were created by leading experts specifically for the PET business system. Here is our current range:—

**NEW COMACCOUNTS PROGRAM — £650 + VAT**  
This puts complete financial control at your fingertips, with immediate access to current and trial balances. It is an integrated accounting system with up to 650 Sales Accounts, 650 Purchase Accounts and 400 Nominal Accounts.

**NEW computerised diary**  
**COMPLANNER £50 + VAT**  
Business Information — COMBIS £150 + VAT  
Stock Control — COMSTOCK £150 + VAT  
Word Processor — COMWORDPRO II + III £75 + VAT & £150 + VAT  
Payroll — £150 + VAT



(Tick the appropriate boxes)

To: Commodore Information Centre, 360 Euston Road, London NW13BL 01-388 5702

I am a PET owner  Please put me in touch with my nearest dealer   
Please send me details of: Commodore PET Software   
Training Courses & Seminars  I would like to receive the Users’ Newsletter and enclose £10 annual subscription

Name \_\_\_\_\_  
Address \_\_\_\_\_  
Tel. No. \_\_\_\_\_



**commodore**  
We made small computers big business.

You make the copy by executing the copy instruction, LDIR (check that) from each byte to itself. But you set one board to read, and a different one to write, so you end up with one board copied to the other. Then you set the original board to write-protect, and you can't corrupt it."

Paging systems are as simple as that — plus the associated simple chip on each memory board which decides what page that board actually is. But the snag with paging is that without modification, programs written for one system of paging will not run on another. The modification may look trivial at code level . . . but compilers and assemblers don't work at code level. They have to decide at the time they write code whether it will fit on the page, or whether it's time to turn over — and loading programs have to make the same decision.

The result is that any paging system tends to stay around for ever, providing it catches on in the first place. As Nascom's ex-marketing man Kerr Borland said, this one offers almost the same capacity as a floppy disc, at about the same price. It could well catch on.

## Ingersoll dangles carrot

Prices for the Atari 400 and 800 video computers have been set by Ingersoll — provisionally. The 400, with 16 Kbytes of memory, is expected to cost £395 (including tax) and the 800, £695.

My immediate reaction is

that Apple dealer Microsense has already arrived at a price level where these machines pose little threat to the Apple. Ingersoll, the importer of Atari (remember that picture of two video games players dressed in basket ball gear) seems to think so too. The company has decided to recruit its existing users as salesmen.

The deal is: if you are a member of the Atari Owners Club and introduce a new member (subject to a dealer's proof of purchase) you get a free set of Atari keyboard controllers, worth £19. The controllers, which look like pocket calculators on leads, are used for certain Atari games. But that's the video computer, not the 800. To make one take the 800 more seriously, Ingersoll has announced a price of £500 for the Atari printer, and £525 for the disc drive. Don't get too excited before July, however, because nothing will be available generally before then. More details from Ingersoll on 01-226 1200.

## Pet collection

A free catalogue of ACT Petsoft PET goodies: that is how Julian Allason describes the Pet Collection. There are 16 pages, covering programs from Personal Software, Programma International, Understanding (Petplan business simulator), Hipposoft and, of course, Petsoft. All are said to be available through the 220 PET dealers. Copies from 021-455 8585.

## Yes or no?

Should you be using a computer? Ask yourself this question, together with a few



Typing at a video is a great way to enter errors into a computer, especially if the output is appearing line by line on a printer somewhere else. This is an idea from Data Dynamics; the video on this Zip KDP terminal slides from side to side, above the printer/keyboard, and can be swivelled about to cut out reflections, or accommodate people who type with their heads on one side (a lot do). I'd tell you the cost, only DD is, as usual, unaccountably coy about mentioning money . . . try 01-848 9781.

other likeminded sceptics, at a seminar costing £28 on Thursday June 17. It's a "practical seminar" organized by the London Chamber of Commerce and Industry (members get a £6 discount) from 2.15 pm to 5.15 at the LCCI premises in 69 Cannon Street EC4N 5AB. Queries on 01-248 4444 and talk to Ann Measures.

than as a visual stimulus.

And if you didn't know about it, you've just missed the chance to see Telidon at the Viewdata 80 exhibition which ran from March 26-28 at Wembley Conference Centre. I'd have told you sooner, but the Canadian High Commission (bless their Maple leaf socks) didn't announce it until Feb 21, and a fat lot of good that is to us monthly journals.

## Original is not the greatest

Where the Americans today pay the penalty for their cleverness in being first to use colour television — theirs is crude, sensitive to transmission troubles, and most unlife-like even down cable TV lines — we are likely to find the boot on the other foot when it comes to Prestel.

So say the Canadian view-data people who offer a system called Telidon. It's hard to disagree: Telidon generates images using basic geometric shapes which can be positioned all over the screen. By contrast, Prestel (and the French system, Antiope) think the screen is really a sheet of paper, and type blobs starting from the top left corner, line by line. Putting a convincing picture on Prestel is an art more satisfying as a pure intellectual challenge

## Gassing on oil

The application of process control computers in oil and gas industries will be discussed by the British Computer Society specialist group on process control on April 23 and 24 at the Waldorf Hotel, London. Speakers are from Ferranti, Kent, Honeywell and Shell, as well as British Gas and British National Oil. Details from Deborah Hart 01-637 1471. Prices from £60 for BCS students to £115 for non BCS members.

## Translator transformation

The translation machine I got so excited about a couple of issues back — the Lexicon — is now officially the Nixdorf. It has the Filing System module that is supposed to

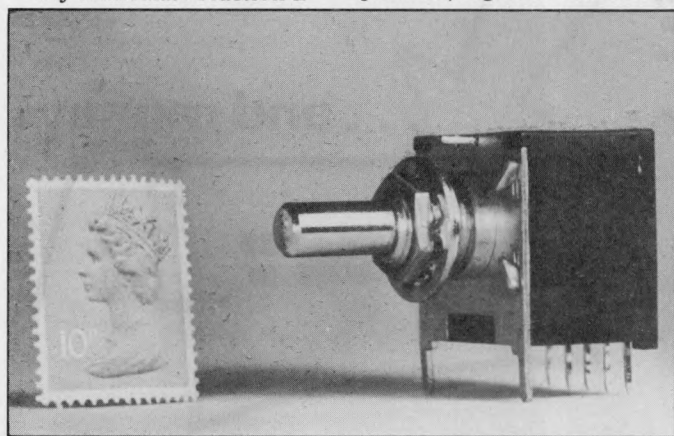

The most daunting thing about the majority of domestic systems is their insistence that the user know exactly what the computer thinks is going on. Turn the power on, and the system says "?" without any clue given as to what on earth you are expected to do. My favourite way of solving the problem involves a set of different firmware programs; the user sets a switch on the panel to "expert" through "quite bright" down to "idiot" (and ending with "journalist") and the machine treats him accordingly. This switch will give you ten such options: your monitor/program can read it and see what decimal number (coded in binary) appears across its four contacts — and act accordingly (when set to Journalist, it can phone up the Thought Police, for instance). Impetron, the maker, is on 0403 50111.

# The New DDP Video Monitor . . .

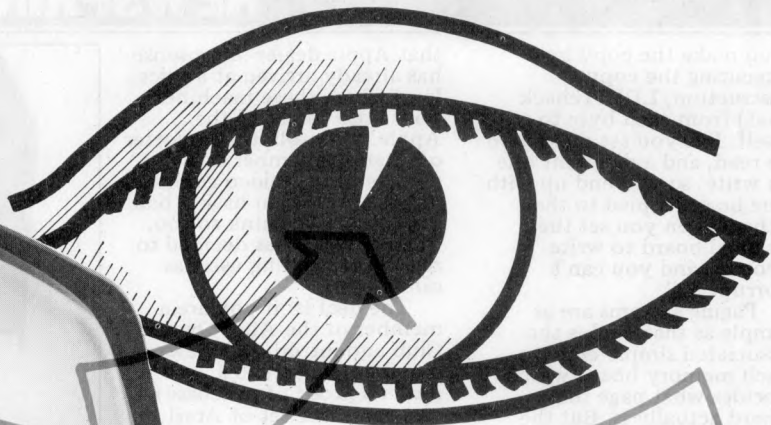

. . . that's  
scientifically  
proven . . .

. . . to save  
operational error . . .

At last, from DDP, here's the video monitor that eyes and ears all over Britain have been waiting for. Eyes, because as alternatives to black and white tubes, green and revolutionary new orange tubes are optionally available. Ears, because now you're going to enjoy the sound of silence – from your service engineer.

But to take first things first, we mention a few colourful facts. After Scandinavian scientists had proved how close-range human vision could benefit from working with orange light, orange tubes quickly replaced green as standard for most Scandinavian videos. A few years behind, we in Britain still belong to the Green Screen Club – but as indifferent members when it comes to monitors. With DDP's new monitor, however, you can experience Scandinavian sophistication. And all the difference it makes to operating profits when allowance is made for operator fatigue.

Inside our monitor you'll discover its second big advantage. More easily overlooked, but just as important to long-term operating profitability is the unique modular circuitry. The resin-block circuits will outperform conventional systems and delight engineers when, aeons into the future, servicing is eventually required. And the cost? Bearing in mind the big 12 inch screen, you'll be amazed at our recommended retail price of £140 (ex. VAT). Generous DDP volume discounts are equally astonishing, but most surprising of all is how quickly we can deliver. To find this out, though, you'll need to make a phone call . . .

. . . and, therefore,  
your time . . .

. . . and money.



**DDP Video Monitor Orderline: (0268) 727563**



**Distributed Data Processing Ltd.**

Essex House, Cherrydown, Basildon, Essex SS16 5AQ

turn it into a genuine personal computer system, and the price is £85 on 30 days delivery, according to PhoneAids, a distributor. The company will sell through two offices: one at Brackley, Northants in premises quite noticeably similar to those of Portable Microsystems, and with the aid of one Heather Ayres, of the same surname as Mike at Portable — ah, probably coincidence. Also at Southampton. Phone 0280 704761 for Heather, or 0703 771400 for Andy White.

## LSI gobusiness

Four micro-based systems under £10,000 have been launched by LSI Computers aimed at the businessman. Smallest is the M-One Model I at £6000 with twin floppies, screen and printer: biggest is the £10,000 Model V with faster printer, two terminals, faster processor and bigger floppies. Software announced includes a bill of materials processor, an inventory management package, and a modular account packate — Bomp, Imp and Map. Details: 0344 54471.

## 8080 lives

A reminder that the Intel 8080 is far from dead: a microtutor called Microtutor, made by Northwich company Limrose, has been bought by the Post Office and the Navy. Actually the Navy ordered 48 and the PO 36 — in two lots of 18. The Microtutor has been around a while: it was one of the machines on show ready-built at the very first Build Your Own Computer Show (run by Online four years ago) where such things as the RML 380Z were nests of wire-wrap, and the Bear software was all kapok stuffing. Limrose is on 0606 41696, and all the other people who make things called Microtutor needn't bother ringing me up unless theirs pre-dates the RCA Cosmac microtutor.

## On the button

This week's prize in the "at the touch of a button" award goes to one of our own consultants, Stephen Castell. He used the phrase in the announcement that BBCData was getting involved in the Prestel International market trial.

You needn't feel guilty at never having heard of BBC Data — because it's new. It's the trade name under which the BBC is sending "a unique and integrated database covering World Business and Trade Personalities and Events, to Prestel's international service".

As a man who has used

Prestel, and occasionally even discovered that the information he could not find was definitely not in the system — rather than merely disguised under some other heading — I feel that the Rest of The World should be disabused of the notion that the information, (which "a typical overseas businessman will be able to see on his TV screen,") is available at the touch of a button.

It was I who, when Computing Consultant of New Scientist — a mantle which passed, after I was fired, to our own Malcolm Peltu (*Shame! Ed.*) — sat down one evening and touched buttons until the system eventually asked me to "Enter Password". It was I who, wondering what it did if you entered the wrong password, touched a few buttons at random. It was, therefore, I, who at the touch of a button, rendered the entire New Scientist database inaccessible to New Scientist staff by creating a password which not even I knew. That is the only thing I've ever done on Prestel at the "touch of a button" . . . all else took blood and tears and sweat and persistence.

## Lisp for the big questions

The words "Artificial Intelligence" are equated in too many minds with some vague picture of a lunatic scientist trying to create a Computer That Lives.

A man called Aaron Sloman describes the actual benefits of artificial intelligence much more accurately. In a grotesque

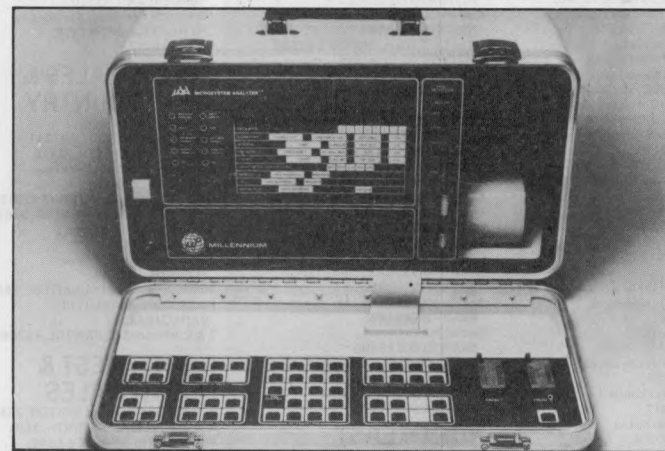

One of these test devices would be a comforting thing to see in the back room of the place you buy your system. It is a Millenium microsystem analyser — now revealed to be the machine which National Semiconductor refers to (internally) as an ICAT . . . that is, in-circuit automatic testing. It combines the "signature analysis" test system developed by Hewlett Packard as a very good fault pinpointing aid for systems that are nearly working correctly, with the in-circuit emulation (ICE) system that exercises components on a board that is definitely not working. It's available through Microsystem Services, and anyone bright enough to use one is bright enough to sort out your system in minutes. With luck. 0494 41661.



Cut-price Hazeltine video terminals: Electronic Brokers offers "as new" standard models at £425, and editing versions at £695. Details on 01-837 7781.

summary of his superb book "The computer revolution in philosophy" it could be said that Sloman has found a real use for both philosophy and artificial intelligence by observing how well they solve the limitations of each. In particular, he accuses philosophy of building theories without the barest models of Mind to test them on. By testing concepts of Mind in artificial intelligence one can quickly find out if it is possible to create a set of rules that express the concepts: and from that, whether the rules (simulated on a computer) actually produce "behaviour" that parallels observable intelligent behaviour.

All this is by way of saying that the language Lisp, used by artificial intelligence researchers, is eventually going to be the sort of tool that enables someone to define "sense of humour" accurately, and freeing philosophers from protesting that, sure, they're concerned with the problems of real life — like, what do we mean by

"real" and what is an empirical definition of "life"? (with acknowledgements to The Hitch Hiker's Guide to the Galaxy). And Lisp is now available from Microsoft, together with another product written by the Soft Warehouse, for micros. The package is called muLisp (microlisp) and costs \$200, to run under CP/M. The other package is a maths package, muMath at \$250.

The muLisp package "offers all of Lisp's unique programming features," says Microsoft: "including 83 Lisp functions, flexible program control structures, and infinite precision integer arithmetic in any desired radix from base 2 (binary) to base 36." Dealers, contact Microsoft on (206) 455 8080 in the USA.

## Business guide update

A guide to some 900 different computer systems is available for £24 from ECC Publications: it's the Guide to Small Business Systems, and it covers machines from £100 £1000 up. Last year's edition had 250 systems fewer and sold well, according to Cathy Lane at ECC. It's designed "primarily for the businessman with little or no computing knowledge." Details from Cathy on 01-359 7481.

## File it

The Intelligent Filing System advances further into our midst: Compssoft has enhanced DMS, its information storage and retrieval system, to run on a 32 Kbyte PET. It will organise up to 5,000 items on one diskette and manipulate them for even the least sophisticated user, says Compssoft: for details please phone Guildford (0483) 39665.

## Courses

A wide range of four-day courses on micros has been announced by ICS Publishing.

# Your Commodore PET System

The Commodore PET is Britain's best selling microcomputer and the most popular choice in every field:-

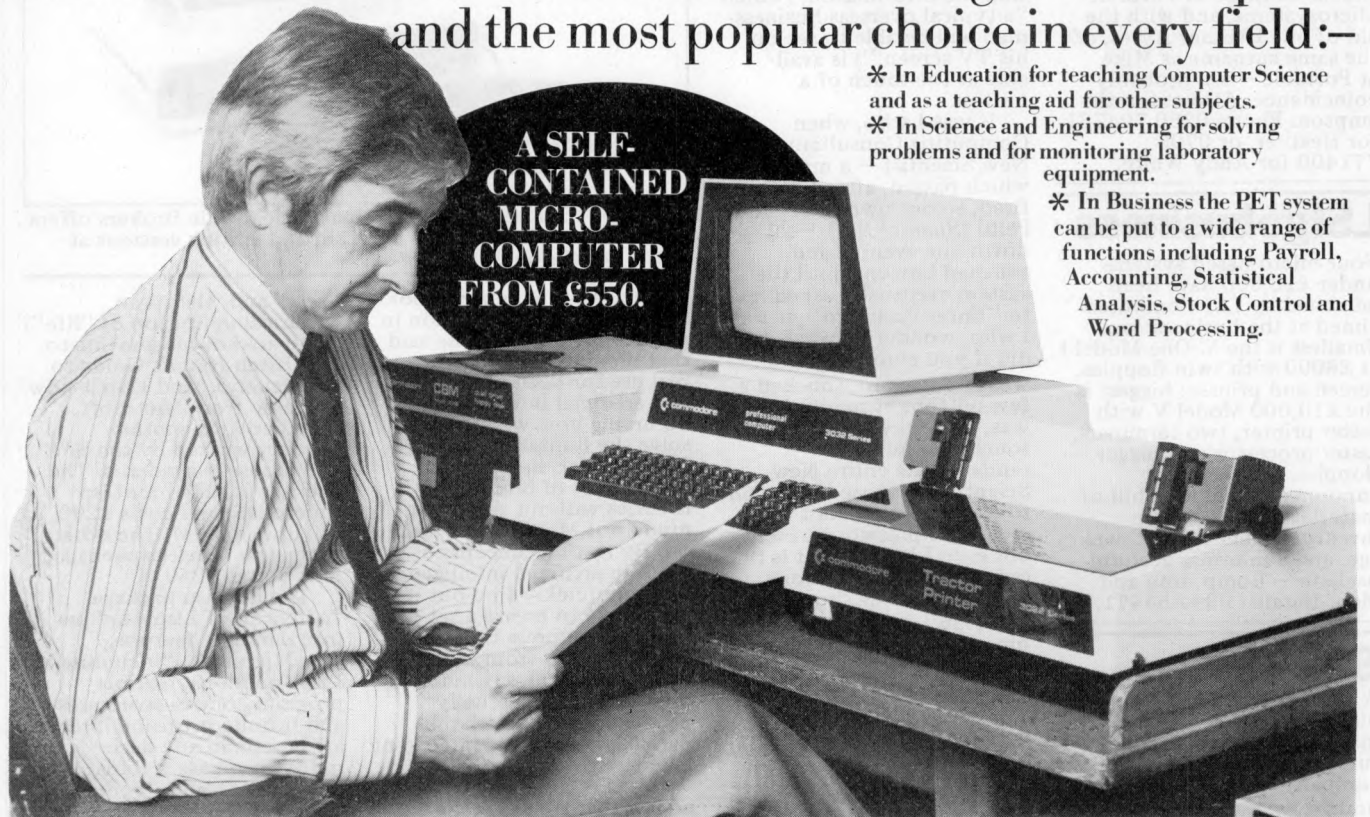

\* In Education for teaching Computer Science and as a teaching aid for other subjects.

\* In Science and Engineering for solving problems and for monitoring laboratory equipment.

\* In Business the PET system can be put to a wide range of functions including Payroll, Accounting, Statistical Analysis, Stock Control and Word Processing.

Not least of its attractions is the price of a PET - from £550 for a self contained unit, to under £2,500 for the complete system including Floppy Disk Unit and high-speed Printer. Ask your nearest Commodore dealer below for details about Commodore hardware, software and training courses.

## Our Dealer\* Network

### LONDON

Capital Computer Systems,  
W1. 637 5551  
ACE (by Top TV Ltd), SW1. 730 1795  
Micro Computer Centre,  
SW14. 876 6609  
Logic Box Ltd, SW1. 222 1122  
Sumlock Bondain Ltd, EC1. 250 0505  
Da Vinci Computers Ltd,  
NW4. 202 9630  
L & J Computers, NW9. 204 7525  
Adda Computers, W1 408 1611  
CSS Business Equipment Ltd,  
E8. 254 9293  
Advanced Management, EC2. 638 9319  
Metyclean Ltd, SW1. 828 2511  
Microcomputation,  
Southgate. 882 5104  
T.L.C. World Trading Ltd, WC2. 839 3894

### HOME COUNTIES

Orchard Electronics Ltd,  
OXON. 0491 35529  
D. L. Chittenden Ltd, CHESHAM, 4441  
J. R. Ward Computers Ltd,  
MILTON KEYNES, 562850  
Dataview Ltd, COLCHESTER, 78811  
South East Computers Ltd,  
HASTINGS, 426844  
Symtec Systems Ltd,  
SOUTHAMPTON, 38868  
Alphascan Ltd, BANBURY, 75606  
Super-vision, SOUTHAMPTON, 774023  
Millhouse Designs Ltd,  
ALTON, (042) 050374  
Micro Facilities Ltd, MIDDX. 979 4546  
DDM, BRENTWOOD, 230480  
Stuart R. Dean Ltd, SOUTHEND, 62707  
Alpha Business Systems,  
HERTFORD, 57423  
HSV Microcomputers,  
BASINGSTOKE, 62444  
HSV Microcomputers,  
SOUTHAMPTON, 22131  
RUF Computers (UK),  
BURGESS HILL, 45211  
Wego Computers Ltd,  
CATERHAM, 49235

T. & V. Johnson, CAMBERLEY, 62506  
T. & V. Johnson, OXFORD, 721461  
Petalact Electronic Services Ltd,  
WOKING, 23637/21776  
Business Electronics,  
SOUTHAMPTON, 738248  
Amplicon Micro Systems Ltd,  
BRIGHTON, 562163  
Bromwall Data Services Ltd,  
HATFIELD, 60980/64840  
MMS Computer Systems,  
BEDFORD, 40601  
Isher-Woods, LUTON, 416202  
Sumlock Bondain, NORWICH, 26259  
CSE (Computers), READING, 61492  
Oxford Computer Systems,  
WOODSTOCK, 811976

### MIDLANDS & STH. HUMBERSIDE

Taylor Wilson Systems Ltd,  
KNOWLE, 6192  
Betos (Systems) Ltd,  
NOTTINGHAM, 48106  
Holbrook Business Systems,  
DERBY, 368088  
Lowe Electronics Limited,  
MATLOCK, 2817  
Davidson-Richards Ltd,  
DERBY, 366803/4  
Arden Data Processing,  
LEICESTER, 22255  
Tekdata Ltd, STOKE-ON-TRENT, 813631  
C.S.M. Computer Systems,  
BIRMINGHAM, 360 6264

Business & Leisure Microcomputers,  
KENILWORTH, 512127  
Caddis Computer Systems Ltd,  
HINCKLEY, 613544  
Allen Computers, GRIMSBY, 40568  
CPS (Data Systems) Ltd,  
BIRMINGHAM, 707 3866  
Camden Electronics,  
BIRMINGHAM, 773 8240  
Cliffstock (Computer Systems) Ltd,  
WOLVERHAMPTON, 24221

### YORKSHIRE & NTH. HUMBERSIDE

Microprocessor Services,  
HULL, 0482 23146  
Microware Computers, HULL, 562107  
Computer Workshop, LEEDS, 788466  
Hallam Computer Systems Ltd,  
SHEFFIELD, 663125  
Ackroyd Typewriters Ltd,  
BRADFORD, 31835  
Datron Micro Centre,  
SHEFFIELD, 585490  
Yorkshire Electronics Service Ltd,  
MORLEY, 522181  
Sheffield Computer Centre,  
SHEFFIELD, 53519  
NORTH EAST  
Dyson Instruments, DURHAM, 66937  
Currie & Maughan,  
GATESHEAD, 774540  
Wards Office Supplies,  
GATESHEAD, 605915

Tripont Associated Systems,  
SUNDERLAND, 73310  
Newcastle Computer Services,  
NEWCASTLE UPON TYNE,  
(0632) 615325

### SOUTH WALES & WEST COUNTRY

Computer and Design,  
BROADSTONE, 0202 697341  
A. C. Systems, EXETER, 71718  
Computer Supplies (Swansea),  
SWANSEA, 290047  
Sigma Systems Ltd, CARDIFF, 21515  
Devon Computers, PAIGNTON, 526303  
Bristol Computer Centre,  
BRISTOL, 23430  
J. A. D. Integrated Services,  
PLYMOUTH, 62616  
Sumlock Tabdown Ltd, BRISTOL, 26685  
Radac Computational Ltd,  
BATH, 318483  
T. & V. Johnson Ltd, BRISTOL, 422061

### NORTH WEST & NORTH WALES

B. & B. Computers Ltd, BOLTON, 26644  
Megapalm Ltd, CARNFORTH, 3801  
Tharstern Ltd, BURNLEY, 38481  
Fyde Business Machines Ltd,  
PRESTON, 731901  
Preston Computer Centre,  
PRESTON, 57684  
RPL Microsystems, DOUGLAS, 4247/8

### LIVERPOOL

Microdigital, LIVERPOOL, 227 2535  
Rockliff Brothers Ltd,  
LIVERPOOL, 521 5830

### MANCHESTER

Cytek (UK) Ltd,  
MANCHESTER, 832 7604  
Executive Reprographic Ltd,  
MANCHESTER, 228 1637  
Sumlock Manchester Ltd,  
DEANSGATE, (0618) 834 4233  
Computer Workshop,  
MANCHESTER, 832 2269  
Professional Computer Services Ltd,  
OLDHAM 061 624 4085  
D. Kipping Ltd, SALFORD, 834 6367  
Catlands Computers Ltd,  
WILMSLOW 527166

### SCOTLAND

Microcentre, EDINBURGH, 225 2022  
Thistle Computers, KIRKWALL, 3140  
McAllister Business Equipment,  
EDINBURGH, 336 2402

### IRELAND

Softch Ltd, DUBLIN, 784739  
Medical and Scientific,  
LISBURN, 77533

\*This is a list of dealers participating in associated advertising and not a full list.

# commodore

We made small computers big business.

Commodore Information Centre, 360 Euston Road, NW1 3BL. 01-388 5702

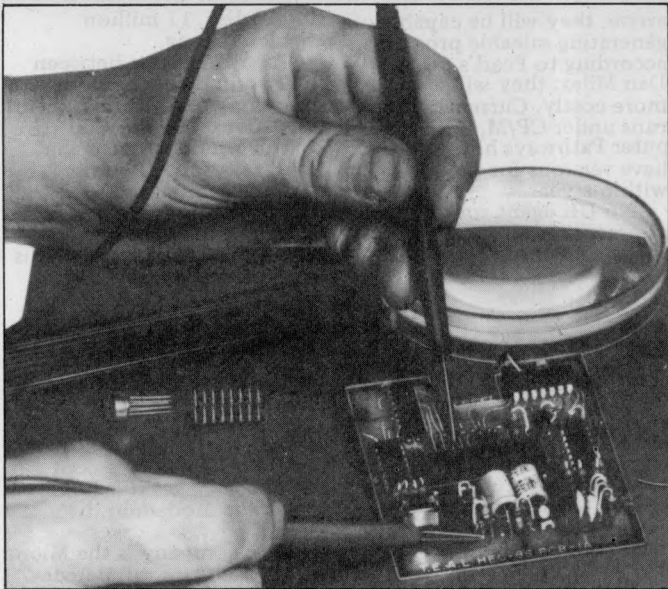

The important object in this picture is the background: it's a non-slip mat. The idea is that one hand holds the soldering iron, the second holds the component and the solder, and instead of the tiny board immediately tobogganing off the bench, it stays put. Impressively the "coefficient of friction" quoted by the maker, Cobonic, is close to 12; by comparison, the quoted figure for steel to rubber is  $\frac{1}{2}$ . It will work on the wall, they say. Details on 01-767 6780.

Subjects range from Hands-on micro trouble-shooting to Voice input and output for computers, and the program starts from April 4, with seminars in London and Amsterdam. Details from ICS UK at Leatherhead (03723) 79211.

## Ongoing

I quite like Prime — a mini-computer-making company that will obviously go far. The company's reputation is not being enhanced, however by its persistence in sending information to PCW care of a man who stopped being its editor last August, to an address which we haven't use used for even longer. Other doozies, please copy.

## Centronics News from

A £555 printer from Centronics is marketed by Rair, aimed at the micro user. It's the Model 730 mini-printer. Details on 01-836 4663 for anybody who can't get the X-Data Oki 80.

## Who's who

One of the most visible men in the UK computing world is the director of the National Computing Centre — a job that can steal as much lime-light as that of the secretary of the Computing Services Association. When the CSA lost Alan Benjamin, it did take care (by employing Doug Eyeions) to ensure that everybody knew there was a new man in the job. The NCC, by replacing David Firnberg with David Fairbairn, has been rather less

careful — especially as Fairbairn, like Firnberg, is ex-ICL. Now all together: who is NCC Director? No, not Benjamin Fairberg, try again . . .

## Database Primer-free

A free primer on database, attempting to explain it both to users and prospective users, has been launched by the Lafayette producer of micro database systems, MDBS, mentioned in our last issue. The primer runs to 54 pages, and is free as long as stocks last from MDBS Inc, PO Box 248, Lafayette, Indiana 47902.

## Curry sauce

The arrival of the washing machine chain, Curry's, into computers is planned for April 8th. Derek Moon has announced that they will carry PET and ITT 2020 for the business he calls "traffic", with the Sord and National Panasonic computers supplying the business end. Stores will be opening in Birmingham, Nottingham, Bristol, and New Malden in South London.

## As you were

In the March edition of "Newsprint" I referred to "a lawsuit" which supposedly existed between Nascom and Mine of Information. In fact, although "sabres were rattled" towards the end of last year, up to this moment no direct legal moves have been made. I will of course keep you informed of any future developments.

## The source of the trouble

In theory at least, the Post Office's Prestel system of publishing information on TV screens could have a chance in America as its biggest competitor is now widely tipped to go under. The competitor is The Source, a network of information providers that's connected to home users via two existing networks — called Tymnet and Telenet.

Normally, these two networks are used by people who need to retrieve information from very large scientific databases. . . chemical, legal, all the way through to current affairs. And normally, these people are company librarians, who have considerable skill in chasing down the information they want, and who have practised the virtuoso performance of entering passwords and signing on, many many times.

The idea of using Tymnet and Telenet to carry the information was a good one, in that they already existed and were in good working order. By comparison, when the Post Office set up Prestel, the salesman who sold them the first GEC 4000 computer ended up earning more (in commission on that and subsequent sales) than his corporate boss, Sir Arnold Weinstock; you get some idea of the money that was needed to set it up.

What the idea had going for it there was countered, technically, by the fact that first, you can't call up Tymnet and Telenet on your television, and second, there is a lot more to it than just pressing a button and finding a page index.

It's quite true that the Prestel page number system can be infuriatingly slow and tedious for the sophisticated user who longs for short cuts in the search for the elusive bit of information. And it's also true that in the UK, the television sets are in short supply, and the information available is still not all that comprehensive (although I did find out, in flying over here, that Pan Am puts its standby ticket status on a Prestel page. It said: "NIL", but never mind).

However on The Source, the routine of signing on is a bit like casting a magic spell. One full stop wrong, and the genie escapes out of the bottle and eats the terminal. Computer store owners have to sell subscriptions to The Source, and they describe it as a hard sell. They say they get a once-off payment of \$100 for every subscriber signed up, that they have to keep stocks of the sign-up kit, and that confused subscribers keep coming back to try to work out what they are doing wrong. Perhaps, all

this might matter less if the company had not run into financial trouble.

No official word has been released yet from Telecomputing Corporation of America, which runs The Source; but it has written a pleading letter to its creditors, asking for time to pay its debts. The theme of the letter is disturbing to its recipients. It doesn't say, jauntily: "We may be short of cash, but we're signing up a thousand users a day, and while this costs us a thousand times a hundred dollars, now, revenues of at least \$5 per month and \$15 per hour connect. . ." and so on. Instead it says that, of course, if they really want to insist, then creditors can get some money by forcing TCA into bankruptcy under Chapter 11. . . after which assets will be frozen until the company is wound up, and then they'll only get a level of repayment to be decided by the authorities; gloom and doom is the name of the game.

Dealers tell me to interpret this as meaning The Source will be closed down in three months or less. They also speak highly of the deal offered by competing service Micronet, which promises dealers 25% of all revenues generated by any of their subscribers, for ever.

Whatever happens (and the situation has not been helped by the fact that, since former TCA boss William von Meister left the company, a great many more debts have been discovered) it would be a tragedy if the idea failed. What The Source offered (that Prestel is still dreaming of) is instant communication with any other user, plus actual data processing power to boost the micro user's system.

## Apple change of heart

The heart of the Apple II computer has been transplanted — an astonishing bit of surgery that has drastically changed its character. The standard Apple II computer uses the 6502 micro and therefore cannot run any of the software available to users of systems with Z80 or 8080 micros (which have the standard CP/M operating system). This gap in the Apple's abilities has prompted one of the two best-known suppliers of computer control software — Microsoft — to produce a card which gives the Apple II a Z80 processor.

This unexpected grafting allows the Apple II to run the piece of software produced by the other best-known systems software company — Digital Research — that is, the CP/M operating system. The cost of the new processor board and two diskettes (with the CP/M

software) is \$349.

Microsoft executives at the West Coast Faire promise that the package will be available by May. . . good news from their point of view as the card will be a way to sell more copies of disc BASIC. Microsoft BASIC, included in the package price, "has all the features not found in Apple-soft, plus exclusive new features added to take advantage of the Apple II's special capabilities".

And adding the Z80 soft-card doesn't stop the Apple being an Apple. "It allows you to use either the 6502 or the Z80 processor — whichever is needed to run a particular program", says Microsoft: "and switching between the two processors is as easy as typing in a particular command. All the features that you love about your Apple stay intact".

The only caveat is that programs and data generated on the Apple in CP/M are not transferable to the normal Apple. It's either one, or the other. . . never both.

## Pearls for the swine

The newcomer to computing quickly finds that he can either buy programs or write them — and that writing programs is exactly the sort of

job (tedious, repetitive, nit-picking and long) that he thought the computer was going to save him from.

The obvious step of getting the computer to write the programs for you has now been achieved by many. Not all are successful, not all are cheap, but usually it's easier for the complete beginner to write in high level languages and get the computer to write the machine code.

The concept is moving further: an example was released at the Faire in the form of PEARL levels 1 and 2 which actually write the high level language instructions.

Where Pearl (Producing Error-free Automatic Rapid Logic) differs from other systems is in its \$90 listing.

The level 1 cannot cope with difficult subtleties of computing such as multiplication and division, but it can, and does (according to Computer Pathways Unlimited) write useable personal programs.

It can do data validation — something human programmers often neglect — operator messages, and data editing. It can generate reports, and control input and output.

Level 2 is for business applications; it has an indexing function which it can build into your programs. And when levels 3 and 4

arrive, they will be capable of generating saleable programs, according to Pearl's creator, Dan Miles: they will also be more costly. Currently Pearl runs under CP/M, but Computer Pathways hopes to have versions for the PET within a year.

No UK agent was booked at press time: hopefuls should contact CPU on (503) 363 8929.

## Disc deals

Users of the Apple II who think they need to store 10 million characters inside the machine can buy the well-known Corvus hard disc from Tim Keen. Keen has the import exclusive on the device — which uses a mechanism made by disc company IMI in America.

However, Keen doesn't have the exclusive on the IMI drive; that has been sold to, not Corvus, but Lobo of Goleta California. At the Faire, I saw an Englishman setting up a deal to import the Lobo product.

The differences between the two devices, technically, is not large. Where the Corvus drive is electronically disguised as 20 floppy discs, the Lobo drive is configured (that means disguised) as one drive, which the Apple II operating system will think is a normal

floppy disc, 11 million characters long.

The differences between the two in price could be something else. Trade price of the Corvus drive here is around \$3500 whereas the Lobo sells for \$500 less. The Englishman (he has requested anonymity until the deal is clinched) hopes to reflect the buying price in his UK selling price.

## Tandy to Tandy

Any Tandy computer in America can talk to any other TRS-80 via a \$250 telephone modem that plugs into the processor. . . and the company that makes it is hoping to sell the modem in the UK.

That company is the Micro Peripheral Corp. of Mercer Island, Washington 98040, and the story they tell is that the device will need very little adaptation to be used on UK phone lines.

What is needed, however, is for somebody to get the specification approved by the Post Office for connection to Buzby's knitting. That somebody should contact Don Stoner about the device — called The Connection — on (206) 454 3303.

*Guy Kewney is Technology Editor of Computing.*

# New from Newnes Technical Books

Write Your Own Programs  
with

## Introduction to Microcomputer Programming

Peter C. Sanderson

Package programs can be expensive and are often unsuitable for your needs.

This practical guide tells you all you have to know to write your own programs.

Describes BASIC, including common variants and assembly languages of microcomputer systems commonly available.

Covers the four assembly languages of the microprocessors that form the basis of most systems — Intel 8080, Motorola 6800, MCS 6502 and Zilog Z-80.

Includes practical hints on program testing development and a glossary of terms.

1980

144 pages

£3.75

US \$8.50

**Newnes Technical Books**  
Borough Green, Sevenoaks, Kent TN15 8PH

Butterworths has companies in Australia, New Zealand, Canada, South Africa and the USA, where local prices apply.

# COMMUNICATION

PCW welcomes correspondence from its readers. Be as brief and concise as possible and please add "not for publication" if your comments/questions are to be kept private.

Address letters to: "Communications", Personal Computer World, 14 Rathbone Place, London W1P 1DE.

## Software datasheets

Nothing makes me so wild as to hear computer hobbyists being told that any program that more or less works is a good one.

Bad programming, whether perpetrated by professionals or amateurs, is an abomination that pollutes the mental processes of anyone, including those who actually wrote it, who might later want to use and modify it.

Hobbyists do not have to use machine code programming of anything but the highest quality.

Any software takes time to develop and test into something the originator can use. Just a little extra time could turn it into something that could be shared and improved by others, so that everyone finishes up with a set of first class software products.

I would like, through PCW, to get a group of people writing Z80 general purpose subroutines, to define standards, for criticism and improvement by others. Those submitting the original routines could choose whether their offerings were anonymous or signed.

Final, improved, versions of the most useful routines would then form a collection of Software Datasheets. Magazine, book and EPROM publishing rights of the Software Datasheets would belong to the magazine but the right to use and list them, as part of applications software, would belong to anyone.

I would edit and check that contributions worked and conformed to standard and even supply routines, if necessary, for the first few months, to get the project off the ground.

To illustrate the standards I have in mind, I list Rules and Documentation standards for the routines, together with an example. I would try to improve on the presentation of these, perhaps PCW readers could help with this.

The ideas of the Z80 routines could, of course, be worked in 6502, 6800 and other machine codes as well. A useful set of BASIC general purpose routines might also be worth developing.

Rules and Documentation for Software Datasheets for Z80 general purpose subrou-

tines. (Developed from the paper "Microcomputer Software Design" by Thomas P. Hughes, Dwight H. Sawin III and David R. Hadden Jr. of the U. S. Army Electronics Command.)

### RULES

1. Registers not being used to convey data into or out of the routine will, if used by the routine, be saved on entry to and restored before exit from the routine.

2. It is assumed that the general routines library will always be in memory (possibly ROM) so that routines may call other general routines.

3. RAM addresses, outside the general routines' library, will never be explicitly specified in routines. References to RAM may be made through the contents of registers, which the caller supplies as pointers or as address parameters immediately following the call in the main routine.

4. Registers HL, DE, IX and IY will be used as pointers to RAM.

5. Registers B and BC will be used to pass single and double byte counts.

6. To avoid having areas of RAM that need to be defined by the user, the stack may be used for local RAM.

7. Data may be supplied to a subroutine as parameters immediately following the call in the main routine.

8. The alternate register set will not be used by routines, to leave it available for processing interrupts.

9. Routines that call no other routines are classed as level 0 and all others as level 1.

### DOCUMENTATION

1. The first part of the documentation, marked ":", contains a brief textual description of the routine.

2. The second part, marked ":", contains a technical description developed after a format used by Nicoud: - Line 1 gives the name and level of the routine. Line 2 gives a one-line description.

Section 3 gives the main actions carried out by the routine.

Section 4 specifies flags, registers, parameters, stack or other areas assumed to have meaningful values when the routine is called.

Section 5 specifies flags, registers and other areas containing results when the routine returns.

Section 6 gives the registers

disturbed by use of the routine.

Section 7 gives the maximum number of bytes that could be added to the stack, including growth from the routine calling other routines.

Section 8 gives the memory size of the routine.

Section 9 lists any monitor or general purpose routines on which the routine depends.

= DL1S — One second delay at 2MHz

:/ "DL1S" — Level 0

:/ To use 2000000 time states, inclusive of call, without other effect.

:/ ACTION: ( SP-2 ) ← L

( SP-1 ) ← H

H ← ( SP+1 )

L ← ( SP )

repeated 42,551 times

:/ INPUT: None

:/ OUTPUT: None

:/ REGs USED: None

:/ STACK USE: 6

:/ LENGTH: 19

:/ SUBr DEPENDENCIES: None

:/ INTERFACES: None

:/ 8080 COMPATIBLE?: No

DL1S

PUSH AF	; save flags	F5
PUSH BC	; & registers	C5
LD BC,42551	; set loop counter	01 37 A6
PUSH HL	; main	E5
POP HL	; delay	E1
DEC BC	; decrement counter	0B
LD A,C	; set zero flag only if both	79
OR B	; bytes of BC are zero	B0
JR NZ,-5	; jump if not zero to loop	20 F9
PUSH HL	; make up	E5
POP HL	; delay to	E1
NOP	; 1,999,983	00
NOP	; time states	00
POP BC	; restore registers	C1
POP AF	; and flags	F1
RET	; return	C9

A very interesting letter. I agree with Alan's sentiments and would like to help him move this idea forward. The magazine welcomes all ideas, proposals and modifications from interested readers; some we'll publish and all will be passed to Alan. Please

Section 10 gives any I/O interfaces and peripherals needed.

Section 11 states whether or not the object code is 8080 compatible.

3. The third part is a complete listing of the routine, with assembler mnemonics, comments and object code.

Alan Tootill, Enfield, Middlesex.

write stating your area of interest and likely involvement, marking your envelope "standards". If you do not wish your letter to be printed please write "not to be published" on it. I look forward to hearing from you — Ed.

## Suffering systems

For the past three months I have read the software reviews by Mike Rose with increasing frustration and annoyance. These really are the worst sort of review to publish in an influential magazine such as yours and are guaranteed to confuse and even mislead any potential purchaser.

Here are my specific complaints:

1. By reviewing only a small proportion of the available packages it leaves the potential buyer no better off as he does not know if there is a better system available which was not reviewed.

Can you imagine Which only reviewing 6 brands of washing machine and leaving the rest to the imagination? No way.

By not being reviewed there is a stigma attached to other software, which is unfortunate since in all cases the best available software has not been reviewed. 2. The reviews themselves are not sufficiently thorough. Many of the important aspects of the packages are completely ignored whilst trivial information is provided. As an example, the one on stock recording packages ignored the important subject of response times to an enquiry. There is a world of difference between the best (about 3 seconds

# Packaged Information Processing Systems

We offer a variety of turnkey systems based on APPLE II and MICRO STAR.

It is our endeavour to give a complete service from problem determination through to the supply of computer based solutions. We will solve the problem either with a tailor made suit of programs, or a ready written package from another famous software house.

We can also supply three excellent DEVELOPMENT SYSTEMS, namely NASCOM, ACORN and NORTH STAR HORIZON



Phone for further details or...

Come along and see all of the above equipment, plus a wide range of peripherals, which are now on display in our new offices and showroom.

AT

15 Sandhill, Quayside, Newcastle Upon Tyne  
Tel: 0632 614939



# POWERFUL MICROS AT THE RIGHT PRICE

- Multi-User ● Multi-Tasking
- Multi-Language ● Hard Disc Storage ● Word Processing
- Priced from under £5000

Languages supported include – Basic, Cobol, Fortran.  
OEM, Educational and Dealer enquiries invited

## EQUINOX

COMPUTER SYSTEMS LIMITED  
Kleeman House, 16 Anning Street  
New Inn Yard, London EC2A 3HB  
Tel: 01-739 2387 & 01-729 4460

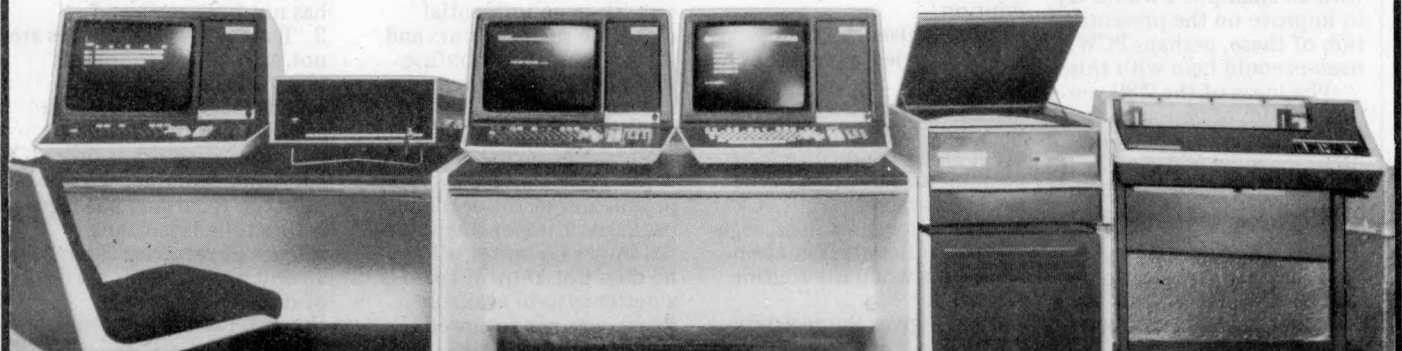

with 1500 items) and the worst (30 seconds or more). In this same review the author listed as a desirable point a facility to link assemblies to components — a facility that has nothing to do with the majority of stock recording applications and is most difficult to achieve within the restraints of a microprocessor system.

3. Such items as system capacity do not seem to be consistent. Some systems are quoted on a per diskette basis, while others are for a maximum configuration of four discs.

All in all, a poor series, especially as Mike Rose advertises himself in your magazine as an expert in the field. The general impression given is one of a quick half hour read of the manuals rather than a thorough try-out of the working systems. Perhaps you should try again with a somewhat larger budget!

Mike Collier, West Yorkshire  
 Thank you for your interesting letter. You have actually highlighted the need for us to restate our objectives from time to time — if not every month. I see you have only been reading this feature for three months; you will therefore not realise that our intention is purely to examine documentation made available to us by software package suppliers and to report on the various claims made. Bearing this in mind I shall now take your points one by one.

1. The Stock Control feature was the first review in the series, following the introduction in the previous issue. We underestimated the time it would take for suppliers to respond to our questionnaires and requests for documentation. We were also surprised by the generally low response. We are about to repeat the sequence, starting with Stock Control, so this will give those companies that missed us first time around another chance (dealers, please contact us for inclusion). We cannot hope to review every package on the market because a) we haven't the time and b) even if we did, we wouldn't have enough space in the magazine.

2. At no time did we ever intend to set up dummy systems and test the programs themselves; our intention is simply to save the reader a bit of "leg work" by getting hold of the information that would be made available to him anyway, analysing it and producing a comparative

report. The series has the added benefit of outlining the sort of things a buyer might need to consider when purchasing a package.

Any in-depth reviews will be occasional and based on a real-life user's experience of his chosen package. (Users please note — if you are soon to implement a standard package and don't mind being put "under the microscope", then why not contact us and we shall be pleased to consider you as a case study.)

As far as the comment regarding sub-assemblies etc was concerned, I think Mike said something along the lines of "If we do manufacture then we probably want details of the relationships between parts, sub-assemblies and assemblies". Note: "If we do manufacture..."; in fact, none of the packages considered this requirement and, provided that you are not a manufacturer looking for these facilities, then there is no problem.

I suppose that we could have quoted response times as claimed by the brochures but these do rather depend on the chosen test circumstances, which in a selling brochure are likely to be "loaded" at the very least.

3. This information is based on that provided by the supplier.

I trust that these replies have helped clarify the situation regarding "Systems"—Ed.

## Praise indeed

Under no circumstances must you do anything which would alter "Bookfare"! Malcolm Peltu is the only technical book reviewer (that I know of) who does not treat his readers as a bunch of mindless jerks waiting for the Sirius Cybernetics Corporation to employ them.

Clive Jackson, Tewkesbury, Gloucester

## Look Sharp

I have recently acquired a Sharp MZ-80K Personal Computer with 22K User RAM after a close evaluation of its competitors (the PET Apple, Sorcerer, etc.) on performance and price. I can only say that I am entirely satisfied with the capabilities of the machine. I would be grateful if you could publish my intention to form a London and South East Sharp MZ-80K User Group in your magazine to enable all members to exchange ideas, software, etc. Interested

parties should write to me or telephone during the evenings on Hornchurch (STD 04024) 42905. Affiliation of the Group to other User Groups will be considered at a later stage, depending on the response from members.

Do you know if Sharp Corporation have any plans for establishing a Software Bank along the same lines used by the American producers? If not, this may be a profitable venture for your magazine!

Joe Seet, 16 Elmhurst Drive, Hornchurch, Essex, RM11 1PE.

Sharp have looked at this problem and have appointed HB Computers to manage this task. HB Computers have confirmed that the marketing exercise is well under way with 25 programs already available and more arriving daily. Catalogues are available on request. HB Computers welcome high quality software for inclusion in the catalogue. Royalty terms are negotiable. All enquiries to Johnnie Johnson 0536-83922 /520910 — Ed.

## School games

At our school, we are forming a program library for all the computer users. We need to find a source of cheap programs. It was suggested that I write to you for help. If you would please write a list of programs you have included in earlier issues, with the issue number and the length of the program in Kilobytes, I would be very grateful. We have only a PET microcomputer. When you send us this list, we will be able to send off for some of the back issues of the programs. Thank you very much.

R. J. Lewis, Winchester

Sorry, we can't help with the sizes but you'll find that the programs have been listed in our Back Issues advertisements — Ed.

## Program power

It has been apparent for some time that there has been a lack of software available for Nascom 1 & 2. We are certain that a substantial number of near-professional standard programs have been written, but knowledge of these probably remains with the author or his local Nascom club. Not least amongst the reasons will be the variety of monitors which have been available at one time or

another.

To remedy this situation, "Program Power" has been set up to act as a form of program exchange. We will undertake to make programs available nationally to owners of Nascoms, at a price which will enable us to pay reasonable royalties to the authors. We hope this will generate the enthusiasm to finish off those brilliant ideas which are almost saleable programs and perhaps generate a few more original thoughts. We shall be concentrating on 8K BASIC and machine code programs.

In this respect if there are any authors out there, of BASIC programs written for TRS 80, PET or other micros who could provide listings for conversion to Nascom, we would love to hear from them.

Nascom have produced some terrific hardware and we would like to see an equally terrific and complementary software base established.

R. G. Simpson, "Program Power", 5 Wensley Rd, Leeds LS7 2LX

## Right and wrong

Congratulations on publishing Macronoia, the best example of program documentation I have met in any magazine, British or American. May it soon become the accepted standard, for any and every non-trivial program or short routine, to:

- Explain the model and give a flowchart of it.
- Explain how to "play" or use the program.
- List the equations (algorithms).
- List and identify all variables.
- Identify the computer on which the program was developed.
- Generalise the BASIC, to work on most machines.
- Modularise the program, with adequate REMarks.
- Show a program flowchart.

A good piece of work like this whets the appetite for more and if you want to do even better may I suggest reproducing results of a typical run?

You probably know about the errors. I hope you will be able to publish the corrections promptly before too many readers lose interest in the original.

Peter Reynolds, Tunbridge Wells, Kent

Thanks for the comments, Peter, we certainly endorse them. The errors were corrected in Blunders last month and this month — Ed.

**BENCH  
TEST**

# TI99/4 HOME COMPUTER

*The long awaited launch of the TI99/4 marks the beginning of a "new wave" of personal computers aimed at the home. Like most electronic consumer goods, it's well made, well packaged and would hardly look out of place in the living room alongside the family hi-fi.*

by David Tebbutt

## Introduction

The 99/4 had been designed for domestic use and it makes absolutely no pretence of being a business computer. I suspect, however, that a businessman would find it useful provided that he can set sensible limits on his expectations.

The machine comprises a single unit which can be connected to the domestic television (more on this in a moment) and a normal audio cassette player. It even has a lead for connecting to the hi-fi system for those with a yearning for computer music in full stereo. Unfortunately, there is one drawback to this approach — you need a television which can accept American NTSC colour signals. (In the UK we use the PAL system, which is quite incompatible). This is not the end of the story, however, because you can buy dual standard televisions which accept both types of signal. In view of this difficulty, Texas are packaging their home computer with a variety of televisions at prices ranging from £750 for the 99/4 plus black and white monitor (or a modification to a suitable existing set), to £1300 for the 99/4 and a really swish dual standard, colour set with remote controls and viewdata options.

Should you prefer your viewing and computing to be kept separate then you would need to buy some sort of television anyway, so the point may become somewhat irrelevant. Therefore, enough said, except perhaps to add that, although TI engineers are working on the problem it will be some time yet before the machine itself comes suitably modified.

The 99/4 has a slot which accepts "Solid State Software Command Modules" i.e. preprogrammed ROMs. A wide variety were supplied with the review machine, the favourites being the

games and Beginning Grammar.

As well as running programs from the command modules, it's possible, too, to write your own in TI BASIC and to save them on cassette.

There's one other feature — a rather curious one which I have never seen implemented elsewhere. It's called an equation calculator and it does just that. The user keys in details of a calculation just as he would write it algebraically, assigning letters or names to all the variables. (The equation is shown on the screen while each variable is given a value.) Once they've all been entered, a press of a button and the equation is evaluated. In this way the exercise can be repeated with different values, but without any need to rekey the equation. It's halfway between employing the BASIC in direct mode and actually running a program . . . and much simpler to use than a programmable calculator.

All in all, the 99/4 is elegant looking, well made, easy to set up and simple to use. The major drawback, in my view, remains its inability to plug straight into a PAL television.

## Hardware

In this section I shall consider each of the hardware elements separately, starting with the CPU and working outwards to the keyboard, screen, sound unit, and cassette.

As the name would suggest, the 99/4 is built around Texas' 16 bit processor — the 9900. Thus it has far greater inherent mathematical precision than the more common 8 bit micros. In fact its display shows an apparent 10 digit decimal precision whereas the internal precision is between 13 and 14 digits, depending on the value. One would expect the machine to perform well on benchmark programs, but partly because of the extra effort needed to

maintain this level of precision and partly because of the speed of the interpreter, the test results were nothing to write home about. Exactly 26K of ROM looks after the BASIC and the operating system, while 16K of RAM is available to the user. "Only 16K eh?", I hear you say. Yes, despite the 9900 being a 16 bit machine and therefore capable of addressing much more memory, TI are offering 16K — no more, no less. My feeling is that later they may just decide to provide some add on memory, but I shouldn't let this form part of your decision to buy — just in case I'm proved wrong.

I only managed to make the system go wrong once and that was as a result of a poor cassette recording (probably caused by the overwriting of something else). The effect was to make the system ignore the end of file record, thus loading rubbish at the end of a program. The fun began when I tried to list or run the program — it would get to this bit and then dive off in a loop, throwing up spurious patterns all over the screen. I must stress that this only happened once and I mention the fault not because it was terribly important but rather it was something out of the ordinary. With this one exception the system was completely idiot proof.

The keyboard (comprising 40 slightly dished keys) has a very nice feel to it; it's small and laid out in the normal qwerty format. Having allocated letters and numbers the remaining 4 keys are used for space, shift, enter and full stop. There is also a space bar but everything else has to be found using the shift key. This can be very irritating, especially with common things like mathematical symbols and punctuation

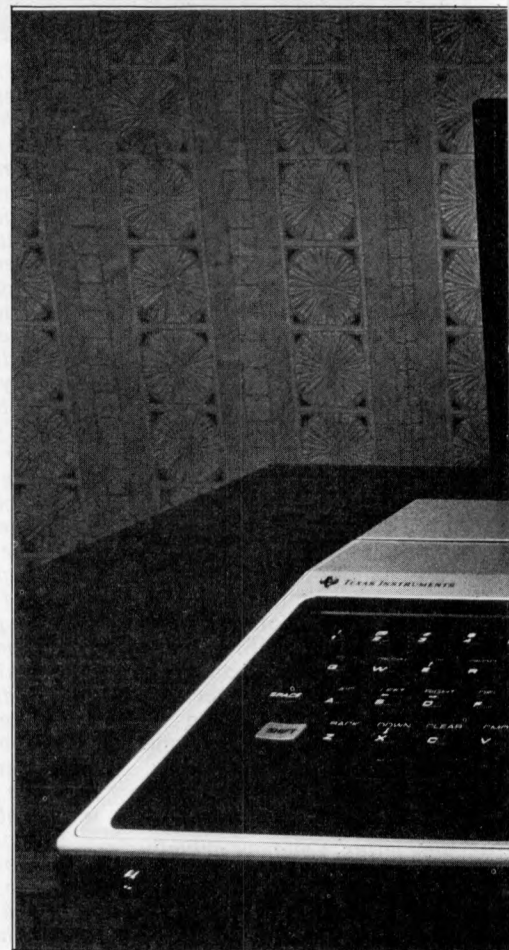

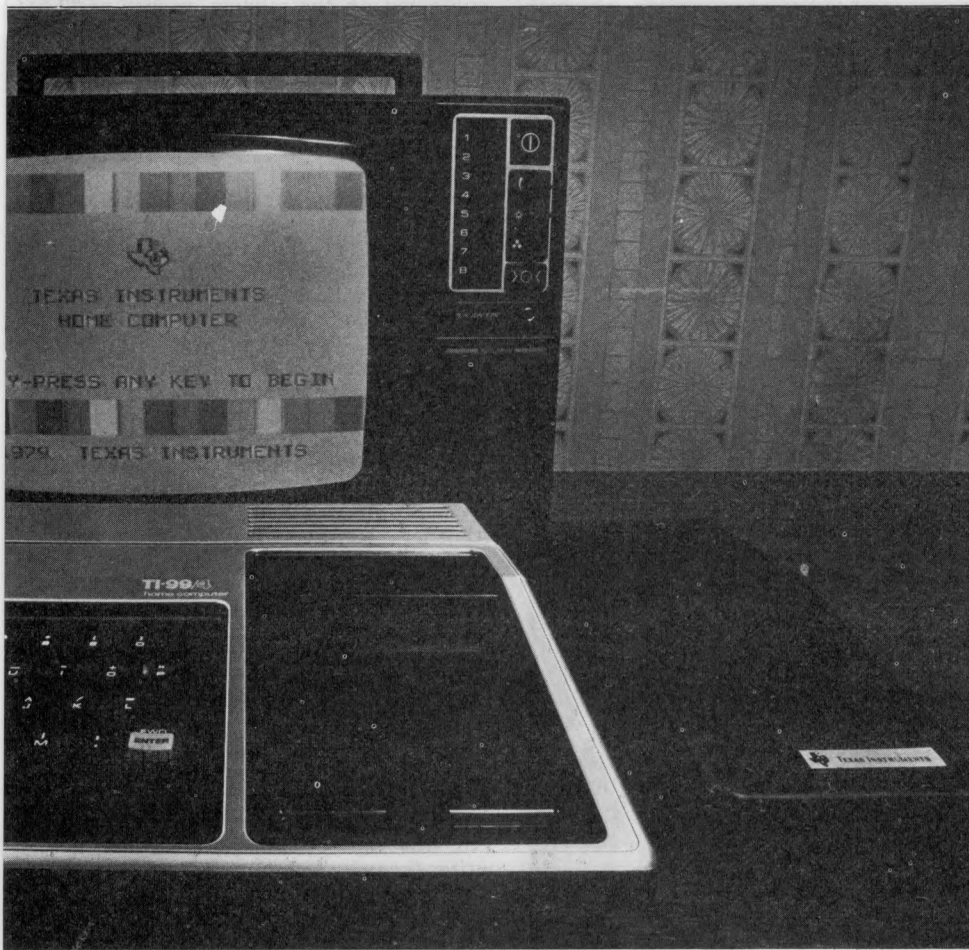

The TI 99/4 connected to a Skantic dual standard television. The TI power supply is to the right.

marks. The keyboard is provided with a useful overlay which indicates the use of various keys when in EDIT mode. Other overlays are supplied with some of the command modules to show which functions are assigned to which keys.

The screen comprises 24 lines of 32 characters each of which can have a foreground colour and a background colour. The screen itself may be any one of 16 different colours as may be the character foreground squares, it's simply a case of defining the same foreground and background colours for a character.

By now you may have realised that high resolution graphics are not provided on this machine, although it is possible to redefine the pattern of each of the 128 characters. In this way it would be feasible to improve the resolution — although that's something you'll have to work out for yourself. Each character comprises an 8 x 8 matrix which may be redefined by using a 16 character hexadecimal string. For character graphics this is a great approach because it means you'll be able to produce just about any shape you're ever likely to need.

The TI manuals suggest that you ignore the first and last two characters of every line on the grounds that, on a poorly adjusted television, they could get lost. This was no problem on the machine I had but it's nice to note that Texas have taken their own advice, with all their displays fitting in positions 3 to 30.

The only other point worth making is that the connecting lead between computer and screen is mighty short. I

found continued proximity to the screen a bit too dazzling and would strongly recommend getting an extension or persuading TI to provide something longer.

The 99/4 has a built in loudspeaker which drives you round the bend after a while (although I'll admit the kids didn't seem to mind it at all. In fact one of the games got played for hours, simply because they loved the jingles that went with it — we seem to lose something in the process of growing up). The machine can play three part music plus one part noise and it's possible to vary duration, frequency and volume, thus giving a very wide range of effects. The top end of the frequency range is reputedly 44733Hz (great for sending the dog up the wall) but my machine could only get up to 14911Hz. This may have been limitations in the internal amplifier and speaker, but I'm not sure; I didn't fancy connecting the system to my hi-fi to find out. Braver men than me (at TI) have tried and said there are no problems — I believe them.

Another useful thing about the internal speaker is that you can hear the cassette loading and, because you have a manual volume control, it doesn't shatter your eardrums. The system and command module software is also designed to make the machine "peep" at you when it requires an action, or when it doesn't like something you've done. If you are a particularly selfless individual there's an earphone socket at the front of the machine that will enable you to compute in complete privacy.

The cassette connection, comprises a

9 pin plug at one end and five jackplugs at the other, enabling you to connect two cassette recorders — one for reading and writing and the other for writing only. Occasionally, as on my Panasonic machine, the motor control jack polarity is the wrong way round. This is easy enough to solve although I didn't bother . . . I just kept switching the recorder on and off. You may have some difficulty setting the playback volume correctly but once cracked you will have no further problems.

TI recommend that any recorder used with this machine should have the following features: volume control; tone control; microphone jack; remote jack; earphone or external speaker jack and a digital tape counter to help you find your recorded programs or data. TI are currently evaluating all the cassette recorders commonly available in the UK to see which ones perform best with the 99/4. No doubt in due course they will make their conclusions known to their dealers.

Just one or two more hardware related comments to go. First, I haven't yet mentioned sprites, yes — sprites. These are used in the command modules but cannot be employed by the BASIC programmer. They are the images that move around the screen . . . things like targets and gunsights. The clever bit is that the 99/4 will detect a coincidence, thus increasing the realism of certain types of game. It's a shame that the BASIC doesn't allow access to these as it's probably one of the most useful features in games programs.

Another thing I noticed was a vibration on the metal part of the computer whenever the television was plugged in. This was presumably a fault with the television although I couldn't locate the problem (TI are now getting it fixed). And there are a couple of sockets that I haven't yet mentioned — one is for the attachment of joysticks and the other for a speech synthesis unit, an RS232 interface (for two devices), a disc controller and a print controller. None of these extras are available at present but they are on the way (see Expansion). Each of these plug in modules carries the 41 way edge connector so they can be piggy backed on to each other.

The only other thing is that the manuals are full of dire warnings about touching the machine and causing static problems. In fact, they advise you to always touch something metallic before using the 99/4. Those with children will know there is no chance of enforcing this rule. I didn't remember and nor did the man from TI. I suspect it's a case of excessive caution, although I think that you should steer well clear of edge connectors and suchlike, just to be on the safe side.

## System software

Invisible — that was my first thought when I came to write this section of the benchtest. Of course, it's not invisible at all, the system software is there to help you key in, test and run programs. Apart from that I suppose you could say it's invisible. When keying a program you are first of all struck by the fact that the syntax checking is pretty strict. You must flank reserved words with



spaces or operators, for example. My own view is that this is a jolly good discipline, making your program much more intelligible than, say, some of the PET programs I have seen. The editing is a joy — key EDIT followed by the first line to be edited and from then on any adjacent lines to be edited will be presented when you hit the cursor down or up keys. Insertion and deletion as well as cursor right and left are all provided making it very quick and straightforward to use.

Before a program actually runs, the code is checked through and the system reports any errors it might find. This always happens when you type RUN. Should you encounter persistent problems then there are two facilities to make your debugging easier. The first is the BREAK function which allows the program to stop running at the lines at which you have set breakpoints. Provided you do not amend any variable values, the CONTINUE command will resume the running of the program. Secondly, you have the TRACE facility which lists the line numbers being executed in a program. This is particularly helpful when your program is looping and you can't see why. Indeed it was when tracing one of my programs that I felt the need for a printer; easier to browse through a listing than trying to debug from a moving display. I'd like it if TI were to offer a printer option on this particular facility.

The final points on system

software relate to the user friendliness aspects of the machine. It's very helpful in that it always gives full instructions to the operator, issuing messages like "REWIND CASSETTE CS1 THEN PRESS ENTER"; it will then issue another message telling you what to do next — all jolly good stuff. Another nice touch — although to the experienced user quite superfluous — is that when a program terminates, the message \*\*DONE\*\* appears, followed by the usual operator prompt. It's superfluous because a) we have the prompt and b) the screen has a natty way of changing colour according to whether or not a program is running — light green when running and cyan when not. Finally, you will notice that after about ten minutes of non use the screen goes blank. Don't be alarmed; this is quite intentional and hitting any key will bring the display back again.

## ROM Software

"Solid State Software" is supplied in a brightly coloured card box containing the Command Module itself, an instruction booklet and, when appropriate, a keyboard overlay. The command module comprises a single pcb carrying from one to five ROM chips (depending on the complexity of the package) all contained in a black plastic cartridge about the size of an 8 channel cassette which slides into the front of the 99/4. Once inserted you have the option of any of the packages

contained on the module, as well as TI BASIC and the equation calculator. The children loved them, for a while at least, especially the moving colour graphics and the Stylophone-like tunes.

Some of the packages were very good, in particular the games and grammar packs. The pre school learning package seems a bit confusing — it uses lower case letters (quite rightly) but the keyboard is exclusively upper case. It may be that there should have been a suitable keyboard overlay supplied, in which case this is an unfair criticism. Another package insisted that I press the key marked BKWD when the overlay had BACK written on it. Attention must be paid to this sort of detail when dealing with the home consumer; however obvious to the experienced DP person, it can be very confusing to the beginner. Another package offered was the previously mentioned Keep Fit, in which little graphic people show you how to do an exercise; the machine plans a sequence and talks you through. I'm sure that this sort of thing goes down a treat in the USA but I wonder if it will catch on over here?

Our very own David Levy has written a chess program for the TI 99/4, although it will be a while yet before the ROMs are produced. I suspect that this is going to be quite something, and I'm not saying that just because he writes for us!

Finally the sprites again. They are used in several of the games and their size can be from one to four characters in each direction; they move around the screen quite freely, without any sign of jerkiness. It's possible to move them vertically, horizontally or diagonally using (refer to a keyboard) the WERSDZXC keys. I'm sure this is done just to make you covet joysticks!

## TIBASIC

The BASIC seemed fairly normal although Texas prefer to use some of their own command names rather than the more familiar ones. Extra instruction sets are included to handle colour, graphics and sound as well as a fairly comprehensive set of file handling instructions. GCHAR is the equivalent of the more familiar PEEK except that it only works on the screen memory — you can't ferret around inside the other parts of memory. KEY is a touch more than the equivalent of a GET instruction, in that it returns the value 1 if a new key is pressed, -1 if the same key is pressed again and 0 if no key is pressed.

The BASIC can handle string constants up to 112 characters long, although these can be concatenated to the string limit of 255 characters. Variable names can be up to 15 characters in length and every character counts, giving an enormous number of possibilities. Numeric variables may carry the same name as string variables, the difference being that the string variable name is terminated with the conventional \$. A number of string functions are offered, most of them familiar to BASIC aficionados but one or two are unusual. The functions are: ASC, CHR\$, LEN, POS, SEG\$, STR\$, and VAL. POS will find the position within a string of any specified sub-

## Basic

ABS	ASC	ATN	BREAK
BYE	CALL CHAR	CALL CLEAR	CALL COLOR
CALL GCHAR	CALL HCHAR	CALL JOYST	CALL KEY
CALL SCREEN	CALL SOUND	CALL VCHAR	CHR\$
CLOSE(DELETE)	CONTINUE	COS	DATA
DEF	DELETE	DIM	DISPLAY
EDIT	END	EOF	EXP
FOR..TO..STEP	GOSUB	GOTO	IF..THEN..ELSE
INPUT(REC)	INT	LEN	LET
LIST	LOG	NEW	NEXT
NUMBER	OLD	ON..GOSUB	ON..GOTO
OPEN			
OPTION BASE	POS	PRINT(REC)	RANDOMIZE
READ	REM	RESEQUENCE	RESTORE
RETURN	RND	RUN	SAVE
SEG\$	SGN	SIN	SQR
STOP	STR\$	TAB	TAN
TRACE	UNBREAK	UNTRACE	VAL

string and SEG\$ is our old friend MID\$ in disguise.

Alphabetic or numeric arrays are available, each up to 3 dimensions. You also have the option of defining the base of the array as 0 or 1, thus avoiding great confusion.

Several graphics commands are available enabling you to colour the screen, the individual characters and their own backgrounds. You could, for example, have a cyan screen with a black letter on a red background while the letter next door could be green on a yellow background (ugh!). Two instructions exist to enable you to repeat a character horizontally or vertically. Two nested loops containing these instructions would produce a rectangle of the chosen character.

The characters from 96 to 159 are undefined... you may create whatever characters you like using these codes. You may also redefine characters in the range 32 to 95, replacing the conventional character with one of your own choosing. If you were to redefine 32 (space) for example and then issue a CALL CLEAR instruction, the screen will be covered in your chosen character instead of spaces.

TI BASIC has commands to handle files on cassette and disc. They comprise OPEN, CLOSE, INPUT, PRINT, RESTORE and EOF. Files can be held sequentially or randomly on disc, with fixed or variable length (sequential only) records. The information may be stored in internal or display format, that is to say packed or ASCII. Files can be opened in input, output, update or append modes — thus minimising the risk of data corruption. EOF reports the logical or physical end of file when reading from disc while RESTORE puts the record pointer back to the beginning of the file.

All in all a pretty comprehensive BASIC although the graphics potential is restricted through the lack of plotting facilities.

## Documentation

A lot of thought has gone into the documentation for this machine. Three books are provided — Read This First (quick steps to get you set up and started now), the Beginners BASIC manual and the Users Reference Guide; each is ideal for its respective audience. A BASIC reference card is also supplied which is simply a memory jogger containing the syntax for each of the BASIC commands, together with lists

of things like frequencies associated with the C Major scale and a hex to decimal conversion table. Each cartridge comes with its own explanatory booklet. There's not much one can say when presented with documentation such as this except that it is very good.

## Potential use

By now, the aim should be quite clear... the TI 99/4 is intended for the home where it can be used to educate, play games or handle tasks like household accounts. I've no doubt that some people working from home will slip in the odd business application, but this will not be the prime reason for purchase. The fact that you can learn to program in BASIC on this machine means that the possibilities for use are, as always, only limited by the users' imagination.

## Expansion

Lots of things are planned although none of them are available as yet. In the order that they are likely to appear, the add ons are speech synthesis, RS232, joysticks, printer and discs. The printer will be 32 columns, thermal and therefore almost silent. Up to 3 disc drives may be attached each being single sided, single density, 5" and 90K Byte capacity. The speech synthesis will be user programmable (if you're clever) and contain vast numbers of words and phrases already programmed in; according to TI it will be "much better than our Speak 'n Spell". All I can say to that is "Thank goodness"!

The RS232 interface means that all sorts of non TI devices may be hooked

### TECHNICAL DATA

CPU:	9900, 16 bit, 3.58MHz
Memory:	16K user RAM, 26K ROM
Keyboard:	40 keys
Screen:	32 x 24, NTSC
Cassette:	Audio
Bus:	Unknown
Ports:	TI's own, RS232 on the way
Language:	TI BASIC

### Benchmark Timings (in seconds)

BM1	2.9
BM2	8.8
BM3	22.8
BM4	24.5
BM5	26.1
BM6	61.6
BM7	84.4
BM8	38.2

up, not forgetting the acoustic modems which are to become increasingly important in this game (just ask David Hebditch). Prestel is being considered although there are no firm plans for it to be introduced. The problem here centres around the fact that Prestel demands 24 lines of 40 characters and a 240 x 240 resolution graphic capability — the 99/4 has 24 lines of 32 characters and no high resolution graphics facility as such. Don't write it off though, because internally the 99/4 can work in compressed character mode which (surprise, surprise) offers 40 characters per line.

## Conclusion

This machine, very smartly packaged in silver and black, will look good in your home and will undoubtedly provide hours of pleasure. It has a good BASIC and high precision mathematics. Its drawbacks are that it needs a special, or modified, television and, surprising for a "gamey" type of machine, lacks high resolution graphics facilities. The add ons will undoubtedly make this a very attractive machine, especially with a speech synthesis that's likely to be ahead of anything seen so far. It comes rather expensive to my mind, at £655 plus the cost of the special TV or modification, but on the other hand, it certainly has a lot to offer. The question is, are people in the UK yet ready to spend this sort of money on a home computer?

## Prices

TI-99/4	with B/W monitor	£750
TI-99/4	with modification to existing set	£750
TI-99/4	with 14" dual standard colour TV	under £1000
TI-99/4	with 20 or 26" colour set, remote controls etc	£1300
Command Modules		£14.95-£44.95
Speech module (due April)		under £90
RS232 interface "		under £150
Joysticks (due May)		under £30
Printer (due May)		under £270
Discs (due July)		n/a

## At a glance

<b>FIRST IMPRESSIONS</b>	
Looks	*****
Setting up	****
Ease of use	****
<b>SOFTWARE AND LANGUAGES</b>	
BASIC	****
System software	***
Home and education packages	**
<b>PERFORMANCE</b>	
Processor	**
Cassette Interface	***
<b>EXPANDABILITY</b>	
Memory	n/a
Cassettes	**
Discs	coming
Speech synthesis	coming
Printer	coming
<b>COMPATIBILITY</b>	
Hardware	n/a
Software	**
<b>DOCUMENTATION</b>	
	****
<b>VALUE FOR MONEY</b>	
	**

*****	excellent
****	v. good
***	good
**	fair
*	poor

# ALTOS ACS 8000-2

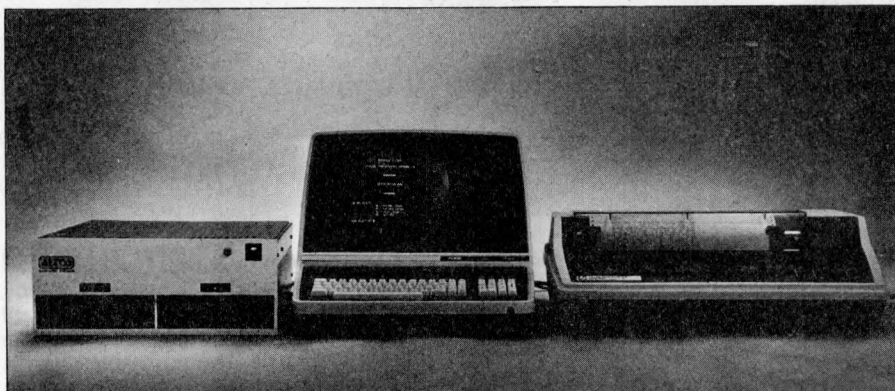

*As designers develop methods for putting more and more circuits onto a single chip so the computer designers develop complete systems with fewer and fewer components. The American manufacturer ALTOS has taken advantage of the situation to produce a range of single board computers with the power of bus based systems. The British company Logitek have put together a turnkey business system, based on the ALTOS range of computers, complete with accountancy packages and a word processor. Sue Eisenbach reports. . .*

## Hardware

The Altos ACS 8000-2 computer is a Z80 disc based computer that comes in a box 7" high by 18" deep by 17" wide. The box normally sits in a specially designed desk, but because I live in a flat (and not a computer showroom — which may come as a surprise to some of my closer friends!), Logitek thoughtfully supplied the review machine without its "office" housing. The lid comes off the box by the removal of six screws, revealing the single board computer on the right side and one of the disc drives and its related circuitry on the left. By unscrewing the single board computer the second disc drive plus circuitry becomes accessible. The CPU is a Z80A running at 4 MHz and the 64K of RAM is dynamic. A 1K ROM containing CP/M bootstrap and monitor with the usual set of commands is also on the board.

The ACS 8000 range of computers uses a Z80-SIO and two times Z80-PIO for communications. Each of these controls two ports. The first serial port is used by the console while on the review machine the second was linked to a printer (it can be used for a modem instead). One PIO is used to control disc operations while the other is connected to an external parallel connector and may be used for a printer, EPROM programmer or any other parallel device.

The disc drives are controlled by a 1771-1 floppy disc formatter/controller which is able to cope with both single and double density discs. For double density the formatting is as follows:

Track	Density	Sectors Per Track	Bytes Per Track
0-1	Single	26	3328
2-76	Double	48	6144

So, when formatted, each disc holds 450K. The disc drives are Shugart's SA800 and are mounted horizontally, but with their controlling circuitry on top. In other words, the discs are positioned with their front facing down.

In addition to the configuration I had, the literature reports that a Z80-DMA controller and an AM9511 Arithmetic Processor (for floating point trigonometric and other mathematical functions) are available as options. An EPROM programmer is listed in the table of contents of the Altos system manual although the manual itself reveals that this feature has yet to become available.

The review machine came with an Adds Regent 25 VDU and a Texas 810 printer. The VDU keys, which have an extremely firm feel, require a lighter touch than I am used to. There are 76 of them and that includes a separate numeric/cursor pad. The layout is good and includes both shift and case keys so that upper case typing does not require shifting to get to the numbers. There's no repeat key but the "repeat" function occurs when a key is held down longer than usual. The printer (with single printhead which produces a nine by seven dot matrix) is bidirectional at the rate of 150 characters per second. The one I had for review had options for compressed print (so that 132 columns can fit on an A4 piece of paper) and compressed lines (8 to the inch rather than 6). Both peripherals seemed robust.

## System software

The review machine came with both CP/M 1.4 and CP/M 2.0. The major enhancement which CP/M 2.0 has over 1.4 is the ability to deal with up to sixteen logical drives each containing up to eight megabytes — its directories can hold 512 names. Random access facilities have been improved over previous versions: CONTROL H now backspaces properly and Delete or Rubout can be altered to send ^H There are four differences between 1.4 and 2.0 at CCP level. DIR lists four elements per line (in MBASIC format) while a USER command allows the maintenance of up to 16 different logical areas in a directory. ERA now only deletes the current

user's files while SAVE no longer alters the memory image and STAT and PIP have been extended. STAT VAL gives a summary of the available status commands, STST DSK produces a drive characteristics table for all currently active drives and STAT USR produces a list of user numbers which have files on the currently addressed disc.

Any file can be made Read Only (R/O) or a system file — e.g. PIP — and system files won't feature in a DIR listing, but will appear under STAT. PIP has three new functions: Gn for setting a file from user n's area, W for writing over R/O files and R for reading system files. ED now standardly verifies lines and to disable this a "-V" command is needed. There's a new utility, XSUB, which allows the SUBMIT facility to include line input to programs as well as to the CCP.

CP/M 2.0 is upwardly compatible with 1.4 but only downwardly compatible if none of the new features are used.

Most of the Altos utilities supplied with the review machine (and these come supplied with any Altos 8000 computer regardless of the choice of CP/M version) dealt with the density of the discs. The Altos utilities are:

SINGLE X — sets drive X to single density.  
 DOUBLE X — sets drive X to double density.  
 REFORM — allows the formatting of discs in IBM or ISIS single density or Altos double density.  
 SETUP — for changing the bootstrap loader with reference to disc density and printer baud rate.  
 COPY — for copying a single density disc.  
 DCOPY — for copying a double density disc.  
 PROMMR — not available yet, but for programming 2708's and 2716's.  
 DTEST — tests disc drives.  
 MTS — tests memory.

Like most CP/M software, the Altos

utilities are supplied in single density format; the user requiring double density operation must transfer into Altos double density. This is a sensible arrangement since it allows the user to purchase any CP/M software and also to transfer to and from non-Altos CP/M systems. Unfortunately, I was unable to succeed in producing double density discs under single density CP/M 2.0 (although I had no difficulty using the same utilities under CP/M 1.4). Using two discs of different densities was not quite as straightforward as I would have liked. When the system is bootstrapped it takes on the density of the disc from which the bootstrap occurs. If the second drive is to be of the other density then a SINGLE B (or DOUBLE B) will allow access. However, there's no command which enables the user to find out the density of a particular disc. I feel that the system should take care of changes in disc density automatically, or there should at least be some command that will allow a human check to be made. All I could think of doing was using STAT and counting the Kbytes, or taking a chance on which density it was — thereby risking a disc read error (BDOS error) and having to re-boot the system.

## Languages

The Microsoft BASIC is release 5.1 and has a few features not found in release 5.0 — in particular:

RANDOMIZE now prompts with "Random Number Seed (-32768 to 32767)"

INKEY\$ returns either a one character string (from the terminal) or a null string if nothing has been typed in. No characters are echoed. (similar to PET's GET\$).

VAL now strips leading blanks, tabs and linefeeds.

VARPTR(#<file number>) for random access files returns the address FIELD buffer instead of the disc I/O buffer.

The other languages provided were CBASIC, Fortran 80 and Cobol 80.

## Applications software

The Logitek Business System comes with a full range of application software; Wordstar is provided for word-processing. The rest of the business packages come from Interface Software Ltd (which is half owned by Logitek). They have anglicized (and improved) the Peachtree business packages which hailed originally from Retail Sciences of Atlanta, Georgia.

I had never seen Wordstar before and I must say that I was impressed. It's easy to use (menus at the top of the screen eliminate the need to turn to a manual) and extremely powerful; it was fun watching lines justify themselves before my eyes. By following the menus it's a simple matter to insert and delete individual words, re-arrange lines, re-format whole pages, insert external files into the middle of the text and of course output the file on the printer. In theory editing and printing can occur at the same time (using different files). . . in practice, without the DMA chip, keyboard input must be so

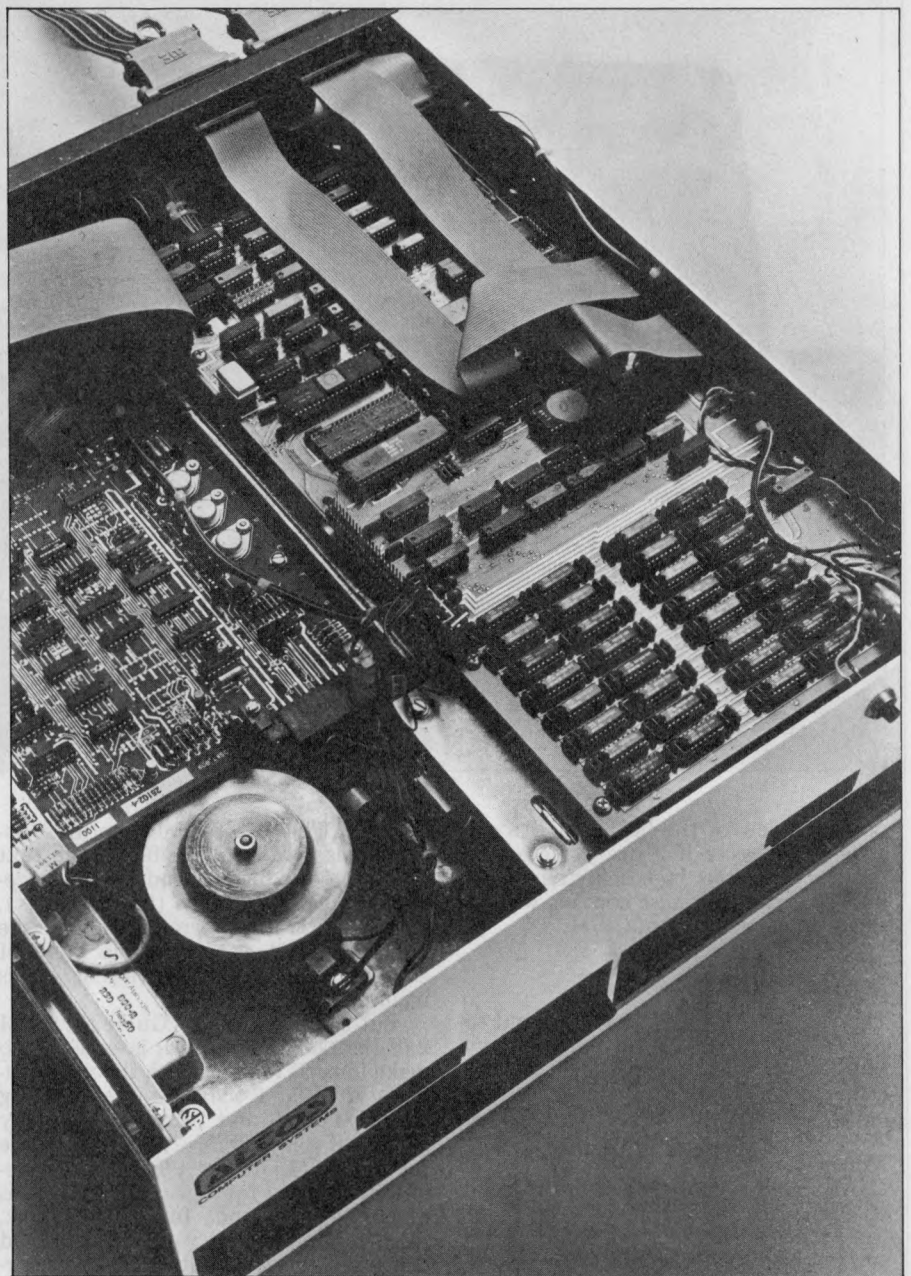

The processor/disc unit with its lid removed showing the single board computer to the right and one of the drives visible on the left.

slow (to avoid losing the odd character or command input during a disc swap) as to make it worth letting the printer have the processor to itself. My other criticism, as a touch typist, is that all cursor controls involve the CONTROL key and one of the left-hand keys, which must be depressed simultaneously. In the interests of balanced action, it would be more comfortable if the right-hand keys were used in conjunction with the CONTROL key.

The Interface Software packages that were provided with the review machine included Inventory Management, Mailing Address System, Nominal Ledger, Sales Ledger and Purchase Ledger. The payroll package was not available at the time of the review. All the software was written in Microsoft BASIC 5 and although the version that I had was in interpreted BASIC, there are plans for the next release to be compiled. The programs are all menu driven and well laid out on the screen (they don't scroll up but rather come down from the top of the screen).

Interface Software Ltd. provided an automatic demonstration of the ledger packages which took its input from a

file rather than the terminal. When I ran the packages manually there was obvious confirmation that data input was being vetted; anything unacceptable caused a "beep" and a request for another input. During disc transfers the user is asked to wait. If a user has the full set of accounting packages, during month end processing, ledger information can be transferred to the Nominal Ledger Transaction File for an integrated ledger system.

To give some idea of the level of sophistication of the packages in general, the following is the list of programs in the Sales Ledger package:

Set today's date; Customer file maintenance; Enter transaction; Delete transaction; Open credit reconciliation; Invoice report generation; Statement report generation; Aging report; Transaction report; Customer account report; End of period processing; Query customer activity; Verify file structure; System initialisation; Create demonstration data files.

The one criticism I have of the packages is that disc maintenance must be done through the operating system. From the

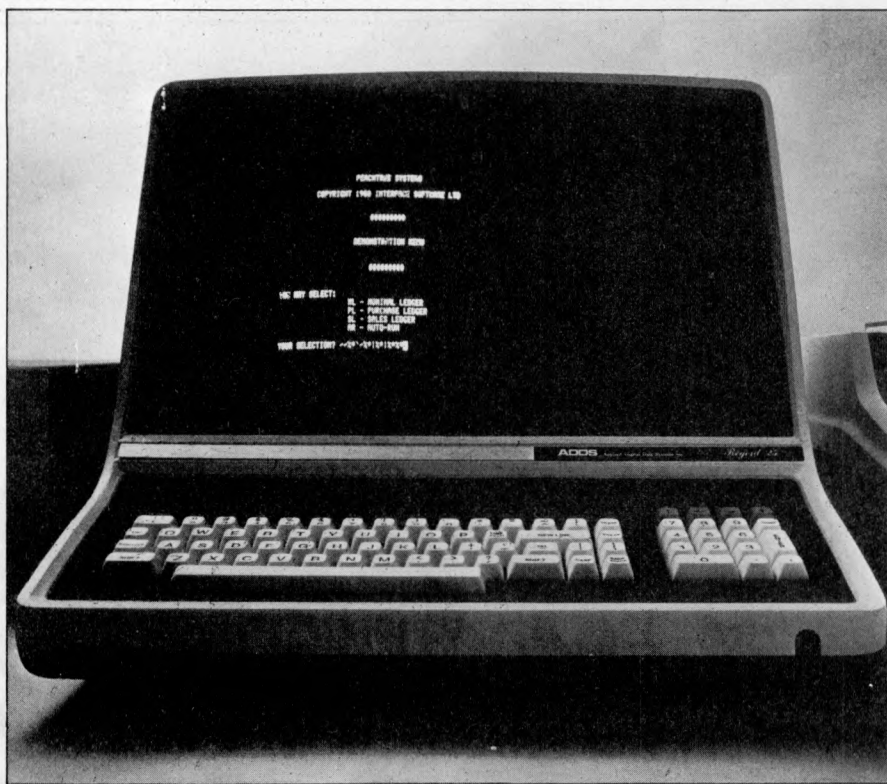

point of view of the beginner, it would have been easier if a disc maintenance option had been included, thus allowing formatting and disc copying without the need to be aware of CP/M.

## Potential

The Altos ACS 8000-2 has been put together to appeal to the businessman. Logitek say that their desk consists of a leather-topped table, plus separate cabinet fitting neatly underneath (which can be used to house additional floppy or Winchester drives).

Although potential business users are at liberty to build up their own suites from the available range of CP/M system and applications programs, they are unlikely to do so since the Interface Software packages, together with Wordstar, form as complete and comprehensive a collection as most could require. Interface Software discs can be set up to boot directly into the package — thus avoiding the more complicated “manual” initiation via the system software.

Looking at the machine from an educational vantage point, there are advantages and disadvantages. It feels solid and having CP/M for its operating system allows the widest range of system software. Also the optional floating point processor must make it a good bet for a micro number cruncher. However, the lack of graphics cannot be inexpensively overcome — there's no bus into which to slot a graphics board and a full graphics terminal would be necessary to provide such a facility. Also the lack of a bus structure would prevent some educationists from customising their hardware, although the latest Altos glossy does describe a prototype board.

## Documentation

Since the hardware and software come from several sources, the documentation

is varied. The ACS 8000 Operating Manual is reasonably accessible — the text within it is coherent and there's a detailed table of contents (but no index). The pages are numbered, although the numbers don't appear in the table of contents; a full set of circuit diagrams is included.

But there's no User's Guide for CP/M 2.0. Instead, the operator is expected to make himself familiar with the main features of CP/M 1.4 via the corresponding User's Manual, and then “transfer” by means of the “CP/M 2.0 User's Guide for CP/M 1.4 Owners”. This is extremely inconvenient for new users and not as helpful as it sounds for ex 1.4 users, since two manuals have to be accessed and cross referenced in order to understand the system. I hope that Digital Research are planning a CP/M 2.0 User's Guide.

The manual for BASIC 80 version 5.1 has not shown any signs of improvement over the 5.0 manual — in fact if anything it's got worse as there are now two pages of 5.1 additions at the front of a 5.0 manual.

However, I was impressed with Interface Software Ltd.'s manuals for application software. These don't ask the user to become familiarised with system manuals as they contain step by step details for using any necessary system utilities. As well as eliminating the need to go about finding information from other manuals, the application software manuals contain descriptions of the systems, equipment requirements and capacities, detailed instructions for using the programs and sample runs using test data supplied with the software. The tables of contents are paginated and detailed.

I have to admit that I found it easier to use Wordstar's menus than to go by their comprehensive manual. For most practical purposes the information contained in these menus is sufficiently detailed for the user to achieve any required effect.

## Expansion

The minimum system comes with 32K but this can be upgraded to 64K with the plugging in of a few chips. (The review machine arrived as a 48K version but was expanded to 64K in a matter of minutes). Also, as previously mentioned, the machine's desk has room for extra drives — adding them should be straightforward. There are sockets on the board for the DMA controller and the arithmetic chip.

To expand the system from a single to a multiuser, the one board computer must be replaced with another (double size) board. According to the literature, the largest system (ACS 8000-6, with DMA as standard) can handle up to four users and two printers. This can run under either M/PM or AMEX, Altos' own operating system which can still run CP/M programs. A fully expanded four user system can have 208K RAM on board — AMEX takes 16K and each user gets 48K.

## Logitek business systems

All Logitek Business Systems come complete with an Adds Regent 25 VDU, Texas 810 Matrix printer and all the business and software listed above — as well as CP/M and BASIC.

## Prices

Logitek sells a wide range of computers and business systems based on the Altos range of computers. Below is a representative sample of their range. Altos CPU with single floppy capacity

1/2 Mbyte	
32K	£2398
48K	£2569
64K	£2713

Altos CPU with twin floppies capacity

1 Mbyte	
32K	£3083
48K	£3240
64K	£3398

Additional Disc and Tape Drives

Single capacity 1/2 Mbyte	£1028
Twin capacity 1 Mbyte	£1370
Winchester 14.5 Mbyte	£2450
Winchester 29 Mbyte	£3250
Tape backup 17.5 Mbyte	£2400

Peripherals

Texas 810 with options	£1650
NEC Spinwriter	£2195
Adds Regent 25	£ 675

System Software

CP/M + Altos Utilities	£ 85
AMEX (Altos Multiuser executive)	£150
BASIC 80 Interpreter	£215
BASIC 80 Compiler	£215
CBASIC	£ 85
Fortran 80	£245
Cobol 80	£375
UCSD Pascal	£125
Z80 Macro Assembler	£ 85

Business Software

Nominal Ledger	£295
Purchase Ledger	£295
Sales Ledger	£245
Mailing List	£295
Stock Control	£395
Payroll (forthcoming)	£295
Word Processor	£255

Single User Systems	
F1-48K Altos CPU with 1 Mbyte floppies	£ 8900
F2 — as above but 64K	£ 9060
H1 — System F2 + 14.5 Mbyte hard disc	£12,135
H2 — As H1 but 29 Mbyte hard disc	£12,960

Multi User Systems	
MU2-112K with 1 Mbyte floppies and 14.5 Mbyte hard disc plus another terminal	£13,795
MU2A — as MU2 but 29 Mbyte hard disc	£14,615
MU4 — 208K with 1 Mbyte floppies and 14.5 Mbyte hard disc plus three more terminals	£16,065
MU4A-As MU4 but 29 Mbyte hard discs	£16,885

The Logitek Business System prices include installation and hence are more expensive than the component parts.

#### BENCHMARKS

BM1	1.4 secs.
BM2	4.3 "
BM3	11.3 "
BM4	11.3 "
BM5	12.0 "
BM6	21.2 "
BM7	34.9 "
BM8	2.7 "
DISC TESTS:	
D1	0.9 secs.
D2	6.3 "
D3	33.5 "
D4	6.3 "
D5	31.9 "

## Conclusion

As well as examining the software provided and running the disc and benchmarks, the review machine underwent extensive use as a word processor. Both this article and Chapter 9 of *The Complete Pascal* were typed (and subsequently revised) using Wordstar. I soon came to trust the reliability of the system.

Since the Altos range of computers are single board systems, any potential user is locked into Altos hardware. Fortunately, the Altos single user system runs CP/M while the multiuser systems run operating systems that are upward compatible with CP/M. And even though potential users are not tied into one supplier for software, Logitek have made every effort to hold customers by selling at reasonable prices a range of business software tailored to the Altos range of hardware.

#### TECHNICAL DATA

CPU	Z80A 4MHz
Memory	32K to 64K dynamic RAM
Keyboard	Adds Regent 25
Screen	
Cassette	N/A
Disc Drives	2 drives, 8" double density single sided
Printer	Texas 810
Bus	N/A
Ports	2 serial, 2 parallel
System Software	CP/M and Altos utilities, UCSD Pascal
Languages	BASIC 80, CBASIC, UCSD Pascal, Fortran 80 Cobol 80, 8080 Assembler

#### AT A GLANCE

FIRST IMPRESSIONS	
Looks	***
Setting Up	****
Ease of Use	****
HIGH LEVEL LANGUAGES	
BASIC	****
Cobol	**
Fortran	***
Pascal	**
System Software	****
PACKAGES	
Business	****
Education	**
Home	***
PERFORMANCE	
Processor	****
Cassette	N/A
Disc	***
Peripherals	***
EXPANSION	
Memory	***
Cassettes	N/A
Discs	****
Bus	N/A
COMPATIBILITY	
Hardware	**
Software	****
DOCUMENTATION	
	***
VALUE FOR MONEY	
	**** excellent
	**** very good
	*** good
	** fair
	* poor

# BENCHMARKS ROUND-UP

*Here follows all the timings for all the machines tested since the September 1979 issue. For the sake of completeness, others have been included that date back to the days of "the old regime". Timings from this month's Benchtests do NOT appear in the list.*

Machine	BM1	BM2	BM3	BM4	BM5	BM6	BM7	BM8
ABC 80	1.1	2.3	11.1	12.1	12.6	17.7	23.9	13.6
ACT 800	.9	4.6	8.5	9.4	10.1	14.9	23.4	5.6
Apple II	1.3	8.5	16.0	17.8	19.1	28.6	44.8	10.7
Challenger C2 4P	1.4	7.8	15.0	16.5	17.8	27.0	39.5	7.5
Challenger C3 S1								
CP/M	2.3	7.9	21.0	21.0	22.5	37.5	59.6	9.9
65D	1.7	13.1	21.6	23.7	29.2	39.6	58.3	17.6
CompuColor II	2.0	10.9	22.4	23.9	25.7	38.7	55.2	10.2
Cromemco System Three								
Short reals	1.7	4.6	14.9	17.8	19.4	30.2	41.9	22.9
long reals	1.9	5.7	16.4	19.7	21.3	32.4	44.1	22.9
Heath WH89								
EBHB	4.1	17.0	35.0	38.8	44.0	75.8	113.0	11.0
MBASIC	2.5	9.2	25.8	26.0	27.0	46.6	73.2	13.0
Micromation Z Plus								
Interpreter	1.4	4.4	11.2	11.3	11.5	21.2	34.9	3.9
Compiler	.6	.5	3.6	1.8	1.8	4.7	13.5	4.9
Panasonic JD 700	2.8	9.1	24.6	24.7	26.2	43.9	69.7	11.8
PET	1.7	9.9	18.4	20.4	21.0	32.5	50.9	12.3
Sharp MZ-80K	1.4	9.4	16.3	22.5	25.4	36.8	51.1	10.2
Sinclair ZX80	1.5	4.7	9.2	8.9	12.7	25.9	39.2	—
Sorcerer	1.8	10.0	20.7	22.2	24.3	37.6	53.7	9.6
TRS 80 Level I	2.5	18.0	34.5	39.0	45.0	67.0	109.0	—
TRS 80 Level II	2.7	11.6	28.0	28.5	31.3	51.9	81.0	11.7
Video Genie	2.7	11.6	28.0	28.5	31.3	51.9	81.0	11.7

## Superboard II - OHIO - Challenger 4P

At these prices why waste time and money on unauthorised kit copies?



New 50 Hz version  
- No Flicker

**NOW  
£159.95**

610 Expansion Board 8k RAM  
**ONLY £159.95 + VAT**  
IP CD3P Minifloppy Disc, Cased, PSU,  
2 copies of DOS - **ONLY £289 + VAT**  
Set of 4k RAM (Superboard users only)  
**ONLY £28 + VAT**  
Plastic Case - Beige **ONLY £26 + VAT**  
Challenger IP - Metal Cased, Superboard,  
PSU modulator - **ONLY £208 + VAT**  
Discs & Cassettes available

PAL COLOUR AND SOUND

A major breakthrough  
in price/performance  
for personal/  
business educational

micro's  
- Single RF O/P  
provides both  
sound & vision  
to colour TV.  
(Colour sets  
only).

\*8k Microsoft 8k User RAM \*16 colours,  
32 rows x 64 cols. \*Programmable tone  
generator and DAC \*Joystick and keyboard  
interface.

Challenger 4P - 8k Basic in ROM 8k RAM  
expandable to 32k - **ONLY £475 + VAT**  
Challenger 4P MF - Same as 4P but with Mini-  
floppy 24k RAM, expandable to 48k -  
**ONLY £1095 + VAT**  
Complete range of accessories available

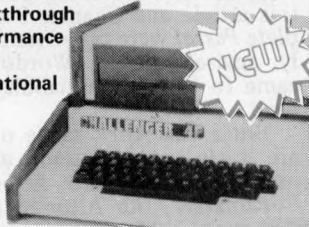

## ZT Driving Computer

Add a new dimension to your car with cost effective fuel management.

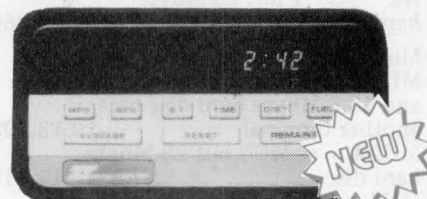

\*MPH Instant \*MPH average \*Gals. used  
since fillup \*Miles to empty \*Elapsed time  
\*Time to empty \*Time on trip \*Miles on trip

Accuracy: Time ± 30 secs/month  
Speed ± 0.5 mph Instant  
± 0.005mph Average  
Fuel used ± 3%

Takes about 2hrs to fit **ONLY £77.50 +VAT**

## TRS80 LEVEL 2 16K



**ONLY £399  
+ VAT**

Keyboard, computer, power supply, UHF  
modulator and all cables to plug into your  
own TV set and cassette recorder and go!  
16K of user RAM for decent size programmes  
and data, sophisticated level II microsoft  
basic. Fully converted to UK standard.



## Super Print 800

80 COLUMN HIGH PERFORMANCE  
IMPACT PRINTER

The ideal companion for PET, Apple,  
TRS80, Exidy, Superboard, Compukit  
and most Micro's

Rugged metal enclosure makes it ideal for  
home computing, small business systems, data logging etc.

\*96 character ASC II Standard  
\*Auxilliary User Defined Character Set  
\*Accepts 8 1/2" max. paper - pressure feed  
9 1/2" max. paper - tractor feed  
\*Tractor & Fast Paper Feed /Graphics(modelST)

OPTION:-

\*2k Terminal Buffer

Just look at these standard features:

\*RS-232, 20mA, IEEE 488 and Centronics I/O  
\*16 Baud Rates to 19,200  
\*60 Lines per minute - Bidirectional  
\*5 print densities 72,80,96,120 or 132 Chr/Line  
\*Self Test Switch

Standard Feed-Model 800  
**ONLY £329 +VAT**

Tractor & High Speed-Model 800ST  
**ONLY £389 +VAT**

## NEC Spinwriter



- for the  
professional  
word processing  
system

**£1699 + VAT**

NEC's high quality printer uses a print "thimble" that  
has less diam.and inertia than a daisy wheel.Giving a  
quieter, faster more reliable printer than can cope  
with plotting and printing(128 ASC II chs.) with up  
to 5 copies,friction or tractor fed.The ribbon and  
thimble can be changed in seconds. 55 chs.per sec.  
bidirectional printing with red/black,bold,subscript,  
proportional spacing, tabbing, and much much more.

GP MODEL 14

## Eprom Eraser

**ONLY £78  
+ VAT**

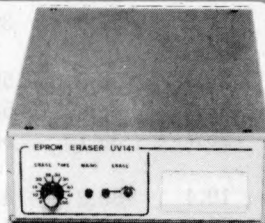

\*14 Eprom capacity \*Unit safety interlocked  
to prevent accidental exposure \*Erase time  
(Model UV141) adjustable 5 to 50 minutes in  
5 minute steps \*Fast erase times typically 20  
mins for 2708 Eprom \*UV source output at  
2537 Angstroms

## SOFTY

### INTELLIGENT EPROM PROGRAMMER

Built or in Kit form  
Connects directly  
to TV. Develop,  
Copy, Burn,  
Verify 2708,  
2716 and with  
modification 2516.

Softy is a versatile product and each application will  
be different by definition. When Softy is connected  
via a serial (RS 232) or parallel link with any small  
computer capable of supporting an assembler a  
simple and capable Product Development System  
is formed. For product developments with less than  
2k of firmware Softy may be the only development  
tool you will need.

\*Fast cassette interface-over 2000 baud equiv.  
\*Ideal Training Aid-useful control computer  
\*Equivalent dev. systems cost over £500+

**ONLY £120 + VAT Built & Tested  
£100+VAT Kit. £20+VAT BuiltPowerSupply**



## Atari VCS System

Most popular top range micro-video game



Current carts. include:- Air-Sea  
Battle, Space War, Outlaw, Video  
Olympics, Breakout, Basketball,  
Surround, Blackjack, Basic Maths,  
Hunt & Score, Miniature Golf,  
Skydiver, Street Racer, Chess,  
Backgammon and many more.

Cartridges mostly - **£13 + VAT**  
Chess (8 levels) - **£39 + VAT**  
Backgammon - **£30 + VAT**  
Superman - **£20.80 + VAT**  
Indy 500 - **£30 + VAT**

Coming Soon - BASIC Computing, Space  
Invaders plus many more!

Buy a VCS, introduce a friend to buy one  
and get a Keyboard FREE worth **£19**  
(limited Ingersol Offer)

Atari VCS NOW **ONLY £113 + VAT**  
+ your first cart. - **£6.90 + VAT (worth £13)**

# Mighty Micro

In association with Watford Electronics

Please add VAT at 15%. Carriage extra, will advise at time of order. Official orders  
welcome. Product details on request. Trade and export enquiries welcome.

**33 CARDIFF ROAD, WATFORD, HERTS. WD1 8ED**

Tel: (0923) 38923 (Sales) or 40588/9 Open 9 am to 5.30 pm Mon.-Sat.  
Close to Watford Football Ground. Nearest Station - B.R. Watford.

BUY IN CONFIDENCE - In the event that we are unable to deliver your goods within 7 days,we  
do not bank your remittance until such time as we have the goods to despatch. If on receipt of  
your order the goods do not meet with your satisfaction, return within 7 days for full refund.



**BENCH  
TEST**

# HP-85

*Hewlett Packard are much renowned for their high quality electronic equipment, with a range that stretches from television waveform monitors through pocket calculators to computers. The HP 85 (or Capricorn) is their long awaited entry into the small computer market and has many "plus" features — and some surprising omissions. Has it been worth the wait?*

by Guy Kewney

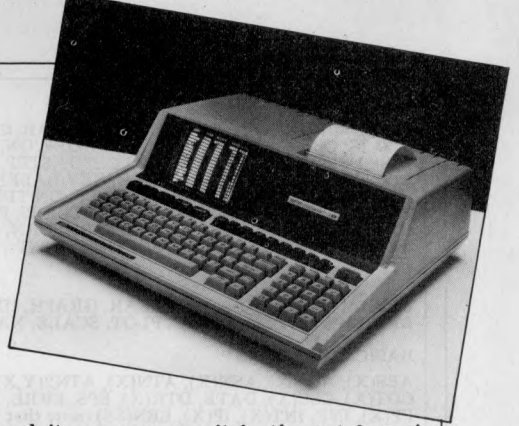

## Hardware

As is to be expected from HP, the machine is superbly engineered and similar in design concept to the PET. The processor, power supply, keyboard, screen, loudspeaker, tape drive and printer are contained in a unit about the same size as an Apple; although reasonably light in weight HP's excellent carrying case would be a worthwhile investment.

The CRT screen is a minuscule 5" with a paltry 32 characters per line and 20 lines to the screen. The CRT uses its own dedicated memory and can store up to four screenfuls that "roll-away" out of sight at the top of the screen but can easily "roll-back" at the touch of a key. However, the limit of 32 characters is rather low and this must give rise to serious misgivings as to the machine's business potential. In addition to these four screens, there's an additional graphics screen that is comparable to the Apple Hi-Res graphics. Actually it's 255 horizontal dots by 191 vertical dots thus giving the same apparent resolution in both axes.

Several commands are available to manipulate the dots, such as DRAW 40,30 which draws a line from wherever the "spot" happens to be to point 40 on the X-axis and point 30 on the Y-axis. These points are referenced to the edges of the screen and if your chosen points are off the screen then tough luck as it will attempt to draw a line there anyway. The absolute movement of the DRAW instruction is affected by the dimensions set by the SCALE statement that effectively tells the computer what scale you are using on the screen, be it 40 points in each direction or 40,000. DRAW 40,30 will have more effect with a coarse SCALE such as 40 by 40 than with a finer scale of 40,000. A similar command is IDRAW but this draws relative to the last plotted point on the screen. For example, 130,-40 will add 30 to the last plotted point's X co-ordinate and subtract 40 from the Y co-ordinate. It then draws a line from where the last point is to these newly calculated co-ordinates. MOVE and IMOVE are identical to DRAW and IDRAW except that the "pen" moves to the new specified location but without drawing a line behind it.

BPLOT enables you to draw pictures but the actual operation, like the Apple SHAPE table, is a bit awkward and cumbersome. Care has to be exercised when BPLOTTING lest the BPLOT data "interferes" with existing screen data to produce a meaningless scribble. Mixed text and graphics is possible with the LABEL command. The snag is that, while you can put messages onto the graphics screen by

saying LABEL "WHAT KIND OF PARAMETER IS THAT?" getting them off again requires care. If you know exactly where the PEN was when the LABEL started, you can go there again, reverse the PEN and reLABEL and it will vanish. If you know approximately where the LABEL was and it was near the bottom of the screen, you can specify a detailed GCLEAR from a certain Y level down and clear only that much of the screen. GCLEAR, by itself, will clear the graphics screen but I couldn't find an easy way to clear the text screens under program control. A nice feature is the ability to dump the entire contents of the screen — both text and graphics — to the 32 character thermal printer under the action of the COPY key. LDIR is a beautiful command that defines in what direction the label will be printed and also re-orientates the attitude of the letters — straight up will print

Comparison with the Apple graphics is inevitable and both have their good and bad points. The HP 85 has total lack of direct cursor control under program command. With the Apple you can type a list of prompts down the left-hand side of the screen — move the text window to the middle of the screen and clear the remaining half ready to accept data from the keyboard. Not so with HP85 — it will take blood, sweat and possibly even tears to program it to reach a similar result. Most graphic routines that I have seen get round this problem by re-writing the screen everytime — just like a VDU on the end of a bit of wire — which in a 32K BASIC is a bit of a drop-off.

Eventually, the HP85 will come with a disc based operating system but currently there is a very good tape operating system driving the 3M mini cartridge. This features fast and slow tape movement under program control and a sliding tab that prevents accidental erasure. It's much more efficient than the humble cassette in locating and loading data and makes the PET tape system look even more pathetic. Data files are either sequential or random in access and to avoid unnecessary tape movement, the last 22 items from the catalogue are kept in RAM for immediate access — which is good. The loading routine will look for the first available space on the tape big enough to take the program. . . a very economical system. The 98 series of HP machines uses an identical drive but the two tape formats are different. However, a man from HP said that "a binary program is available to convert between the two". Another strong point of the tape system is its security checking. For example, it's possible to protect a program to the level that an unauthorised user cannot

load it, or even see it in the catalogue! The weak point of the tape system is in the error protection — it's too good. One example that one would love to ignore is the tape flaw detection. This involves a light which shines onto the tape. If a piece of brown oxide flakes off, the tape becomes transparent and the computer thinks that it has reached the end of the tape — and stops the drive. I wrote fifteen programs, but in the process of amendment, damaged, number two. Thereafter, all thirteen programs that followed were lost forever. It was small consolation to hear the HP man explain that a bit of black ink on the backing would solve the problem!

The keyboard is excellent and supplies the full ASCII set and also a comprehensive numeric pad. There are other single function keys such as RUN, PAUSE, LOAD, COPY, TEST, STORE, CLEAR and GRAPH although the idiot that put the SCRATCH key where it is needs burying in a deep hole. . . it's very easy to accidentally SCRATCH instead of ENDLINE (Carriage Return to you) and hence erase that program that you spent two hours typing in. Another part of the keyboard that deserves special mention is the idea of programmable or user-defined keys. Under the screen are keys that can be made to control the user's program without the necessity to hit return everytime. At the bottom of the screen, the program can display the labels, like "THINKS" bubbles, that it has assigned to each key — such as STOP, YES, NO etc. This simplifies operation for the unsophisticated user no end. In conjunction with the editing keys, the cursor forms a very powerful on-screen editor that features both character and line editing; however, there's the drawback that the cursor deletes any underscoring of letters as it progresses along the line.

The HP85 is built around Hewlett Packard's own custom built chip set and includes an 8 bit CPU, dynamic RAM and I/O controller. As a consequence, the chip count on the CPU board is reduced considerably to only 16 ICs! The disadvantage with this is that no-one outside HP knows the instruction set and no programming is available in either machine code or assembler — which is a potential disaster particularly if you want to write some very tightly controlled timing loops for some outside peripheral. True, there is a real time clock with a resolution in mSecs but in practical terms, the unknown and variable time delays introduced by the other BASIC program statements tend to make this clock perhaps not quite as useful as it otherwise might be. I feel this lack of any machine code programming to be a serious oversight on the part of HP.

## BASIC INSTRUCTIONS

Statements: ASSIGN, BEEP, CHAIN, CLEAR, COM, CRT IS, CREATE, DATA, DEFAULT OFF/ON, DEF FN, DEG, DIM, DISP, DISP USING, END, FN END, FOR, .TO, .STEP, .NEXT, GOSUB, GOTO, GRAD, IF, .THEN, .ELSE, IMAGE, INPUT, INTEGER, KEY LABEL, LET, LOAD BIN, NORMAL, OFF/ON ERROR, . . . GOTO, or GOSUB, OFF KEY/ON KEY, ON TIMER, . . . GOTO or GOSUB, OPTION BASE, PAUSE, PRINT, PRINT USING, PRINTER IS, PURGE, RAD, RANDOMIZE, READ, REAL, REM, RENAME, RESTORE, RETURN, SHORT, STOP, STORE BIN, TRACE, TRACE ALL, TRACE VAR, SETTIME, WAIT

## GRAPHICS STATEMENTS

ALPHA, B PLOT, DRAW, GCLEAR, GRAPH, IDRAW, I MOVE, LABEL, LDIR, MOVE, PEN, PENUP, PLOT, SCALE, X AXIS, Y AXIS.

## BASIC FUNCTIONS

ABS(X), ACS(X), ASN(X), ATN(X), ATN2(Y,X), CEIL(X), CHR\$(X), COS(X), COT(X), CSC(X), DATE, DTR(X), EPS, ERR1, ERRN, EXP(X), FLOOR(X), FP(X), INF, INT(X), IP(X), LEN\$(S) (note that it is S\$), LGT(X), LOG(X), MAX(X,Y), MIN(X,Y), NUM(S\$), PI, POS(S1\$,S2\$), RMD(X,Y), RND, RTD(X), SEC(X), SGN(X), SQR(X), SIN(X), TAB(N), TAN(X), TIME, UPC\$(S\$), VAL(S\$), VAL\$(X).

## HP85 SYSTEM COMMANDS

Non programmable:  
AUTO, CONT, DELETE, INIT, LOAD, REN, RUN, SCRATCH, STORE, UNSECURE.  
All except REN and UNSECURE are single key commands.

Programmable:  
CAT, COPY, CTAPE, ERASETAPE, FLIP, LIST, PLIST, PRINT ALL, REWIND, SECURE. Only COPY, LIST/PLIST and REWIND are single keystrokes.

## Software

The BASIC comes in a 32K ROM with floating point, 12 digit precision and is claimed to "meet and exceed the ANSI standard". Let's get one thing straight, the ANSI standard is not a competition but an attempt to standardise on available BASIC commands and thus save you and me a lot of time laboriously rewriting programs from one machine to another. So any claim to "exceed" the standard is so much hot air. Nevertheless, as can be seen from the list of statements, the BASIC is very comprehensive and has many features not normally found in personal computers. All the software is upwardly compatible in that HP say, providing statements are limited to one per line, then the more advanced 98 series will be able

to understand about 95% of the HP 85's BASIC repertoire. Notice however, the surprising omission of PEEK, POKE, USR and CALL — all confirmation of the lack of machine code support. As can be seen from the Benchmarks, the HP85 is respectably fast if not the fastest.

Firmware support is achieved by making the bottom 8K of the BASIC ROM "transparent" and user firmware packages up to 8K in size can be accessed at this location instead — the idea being, I guess, for HP to issue a stream of plug-in packages.

Another aspect of HP BASIC is that it's very friendly while the program is being entered and the comparison with other micro's in terms of writing and editing programs is astonishing. If, for example, you try to enter a faulty BASIC statement, the old statement with the same number is not deleted thereby giving you the chance to correct your mistakes or leave the old line alone.

Comprehensive error checking and reporting is another good feature although one annoying error was overflow. Try loading a long program (there's one supplied with the HP85 called COMPZR which plays tunes, using the BEEP instruction. It will load a data file called MUSIC and thereafter, if not carefully handled, will play over 600 notes from Rossini's William Tell overture with heartrending accuracy and total lack of sensitivity). Unfortunately, the William Tell notes seem to take up all available memory because, when I attempted to change a section of the tune, I got the OVF message — overflow of memory. Once the machine signals OVF the only thing that can be done to start the program again is RESET. However, you can't clear the OVF problem by pressing RESET! The program will run until you try to delete the overflowing data when the OVF will be signalled again. Presumably the system software looks down the data block for an "end of block" code which doesn't exist because it was never entered, or so it seems. The same thing happens again if you try to write a new block of data over the old block. I hardly need to point out that this problem could easily be solved by a simple POKE instruction but . . . you have to SCRATCH, LOAD the program and LOAD the data and hope that this time the problem solves itself. It can be a time consuming procedure.

## TECHNICAL DATA

CPU:	Hewlett Packard custom-designed chip, in NMOS
Memory:	16K bytes standard; add-on 16 Kbyte modules planned.
Keyboard:	IBM typewriter standard, plus programmable function keys, plus numeric calculator pad, plus system function keys.
Screen:	Five-inch, with 32 characters per line, 20 lines per screen
Tape:	Cassette-width, cartridge drive integral, 195 Kbytes per cartridge, 29-second rewind, 650 bytes/second transfer rate, 60inches/second search, error-correcting
Printer:	Integral thermal printer, identical character set as screen, same size — permits totally accurate screen copies of print and graphics. Speed: two lines per second.
Bus:	Will support the HP-IB eventually.
Peripherals:	To be announced; will attach to HB-1B or other interfaces.
System software:	Tape operating system with high security options to prevent accidental or deliberate access to important data.
Language:	Only BASIC, with sophisticated graphics extensions, no Peek or Poke.
Power supply:	UK standard, safe, inaccessible, integral.
Cooling:	Convection

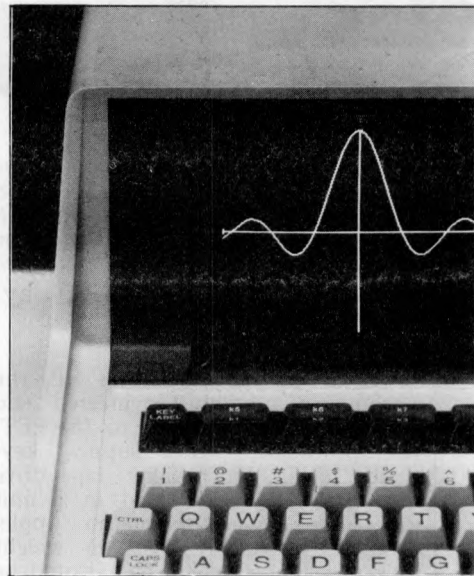

Pass the magnifying glass — the 5" "micro" screen plus user defined keys.



## Documentation

The biggest thing going for the HP85 is the manual. The quality will come as no surprise to anybody who has ever bought an HP calculator before. Any reference to keys is accompanied by a clear diagram of the key to assist recognition and when any output is derived, then that output as produced by the machine is printed; there are no discrepancies, or at least very few. The manual is also the best "Teach Yourself BASIC" book that I have ever met although it needs the machine to make it work.

## Expansion

Theoretically, it should be possible to design one's own interface boards but in practice this will be difficult with



Have case will travel — HP's neat extra that makes carrying that little bit easier.

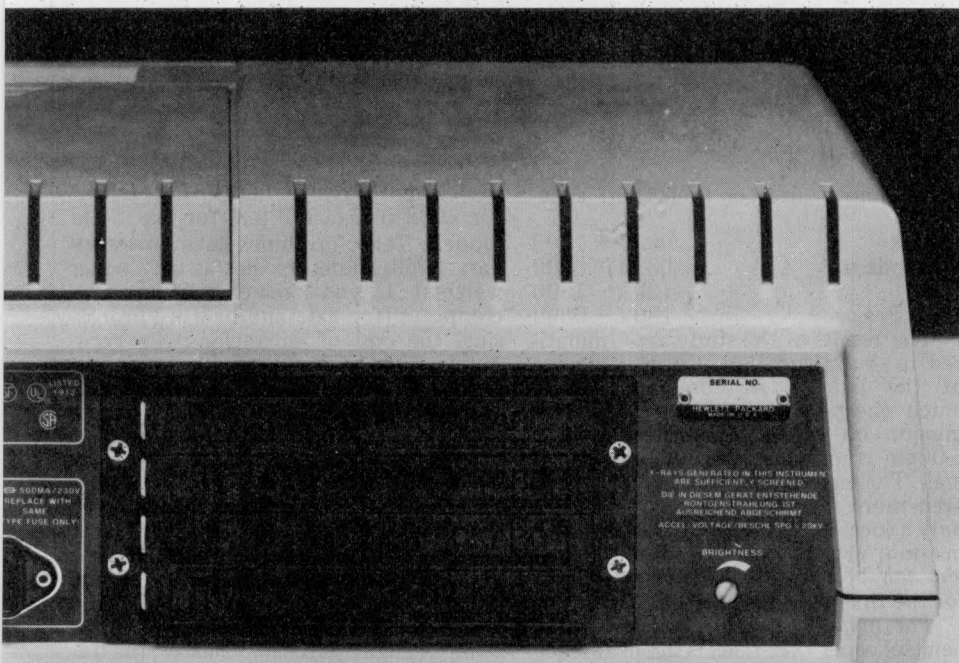

HP's no-nonsense back panel — showing the four expansion sockets.

the HP85 as little information regarding the exact nature of the hardware is available. This means relying just about exclusively on HP for any add-on boards, of which there are four promised for June. They are an IEEE-488 or HP-IB, ASCII parallel, RS232 serial and BCD board and all will come presumably with appropriate software in ROM. It just seems a bit crazy that HP didn't include the HP-IB as a standard fitting from the outset — after all, they invented it! All of these boards plug into four expansion sockets at the rear of the machine.

The standard machine comes, perhaps surprisingly, with only 16K of RAM of which 14.5K is available to the user. This RAM can be expanded by plugging a further 16K in to one of the rear sockets. The big question mark, how-

ever, is the lack of hardware information — would you send your car back to the factory to have the oil changed because the bonnet was welded shut?

## Potential

HP sees the 85 as being aimed at "the scientific, technical and professional user" who is prepared to pay a price premium for good mathematical and graphic features; clearly the HP85 meets these objectives, albeit at an excessively high price. The business user would do better looking elsewhere at a machine that had been designed with him in mind — that screen really is tiny.

## Conclusion

The HP85 cannot be compared sensibly with most classes of personal computer

... its market is so completely different. It has been designed specifically for one area — the scientific — and in that particular sphere it excels. Nonetheless, there are annoying gaps in the manufacturer's understanding of the market, perhaps reflecting the fact that the HP85 comes from the calculator side of HP. The most irritating of these gaps is the absence of any access to machine code instructions and the most puzzling, the omission of the Hewlett Packard Interface Bus. If more attention had been paid to this and perhaps the needs of the business user — say a larger screen and an RS232 socket at the rear for a printer — then the HP85 could be described as an excellent all-rounder. In the final analysis, the machine is overpriced for the hardware content but almost redeems itself by producing superb documentation that is virtually 100% error free.

*PCW acknowledges the assistance given by Mike Dennis in producing the final draft of this Benchtest.*

### PRICES (excluding VAT)

Basic System	£1950
Additional 16K RAM	£ 237
Applications packages	£ 57

### HP85 Benchmarks (in seconds)

1	1.8
2	3.8
3	16.3
4	16.5
5	17.7
6	30.0
7	44.8
8	12.7

## At a glance

### FIRST IMPRESSIONS

Looks	*****
Setting up	*****
Ease of use	*****

### HIGH LEVEL LANGUAGES

BASIC	***
Graphics BASIC	*****
System software	*****

### PACKAGES

Games	*****
Mathematics	*****
Business	**

### PERFORMANCE

Processor	*****
Tape	*****
Diskette	to come
Printer	*****
Video	***

### EXPANDABILITY

Memory	to come
Diskette	to come
HB-IB	to come
Printer	possibly to come
Other interfaces	to come

### COMPATIBILITY

Hardware	*
Software	**

### DOCUMENTATION

System	*****
Processor	*
Software	*****(!)

### VALUE FOR MONEY

*****	excellent
****	v. good
***	good
**	fair
*	poor

# POWERING~UP THE POST

*With the concept of electronic mail rapidly approaching popular fruition it's timely that David Hebditch should have turned momentarily from his endless discussions with the Post Office to produce this two part costing evaluation on "the state of the art".*

## PART 1: ECONOMICS ANDEMBRYONICS

For many companies wishing to transmit messages between their own various locations, the use of the dial-up telephone system could yield big savings over both the Post and Telex. For example, a 3000 character inter-office memo could be sent long-distance over the telephone for as little as 6p compared with 12p by first-class post and 57p by telex. Both the speed and the accuracy of transmission are also significantly improved, especially when compared with the mail.

In performing these calculations, these are the assumptions made:

1. A message of 3000 characters (or about 600 words). This is probably longer than the average but does tend to favour the postal service where the charge is fixed (up to a certain number of characters — which cannot easily be calculated because it depends upon the weight of the paper you use)!
2. That the call made would be a long-distance one. Again, this biases the study in favour of the post (which is distance-independent) and against the telephone and telex networks (which have distance-structured tariffs).
3. I've made two calculations for telex. The first assumes that the message be entered directly on the keyboard by the operator at a sustained rate of 3 ch/s. In the second case, I assume the message to be prepunched into paper tape and then transmitted at the full line rate of 6.6 ch/s.
4. The calculations for transmission between microcomputers on the public

telephone network were performed three times, once for each tariff time-band:

— Peak	0900 — 1300
— Standard	0800 — 0900 1300 — 1800
— off Peak	1800 — 0800

The results of the study are summarized in the table below. Clearly, the use of the public telephone network is much cheaper than telex. Also, transmission on the speech network after 6.00pm is much cheaper than first class mail. The scale of the difference becomes even more marked if one assumes that only a local call is required for the transmission; in this case, the message costs *one half of a penny* compared with 12p for the first class post!

The major reason for the telephone being cheaper than telex is the difference in speed; 30 ch/s compared with 6.6 ch/s respectively. Also, Telex doesn't have a low off-peak rate.

But what are the other costs involved?

A telex machine with paper tape facilities currently rents from the Post Office for £592 p.a. (£632 p.a. for a console model). Telex machines have no secondary applications (except as ugly paper weights). If you already own a micro-computer (for data and/or word processing) the cost of enhancing it for communication purposes may well be minuscule. Many machines (e.g. the Rair Black Box, the Cromemco range and the North Star Horizon) all come equipped with spare V-Series (RS-232) ports as standard. On other machines, the cost of a serial communications adaptor might range from between £50 and £200.

A modem is then required to convert between digital and analogue signalling. These range in price from £75 p.a. to £250 outright purchase. Clearly, the use of the public telephone network for outside business hours message transmission is only going to take-off if calls can be originated and received automatically.

Comparison of Transmission Costs

	Transmit Time (secs)	Rate	Cost per message	Transmit Time (mins)	Cost per message	
First Class Post	—	—	—	12 hrs (?)	12p	POST
Telex @ 3 ch/s	1,000	2.5p per 20s	125p	17 mins	125p	TELEX
Telex @ 6.6 ch/s	455	2.5p	57p	8 mins	57p	
Micro @ Peak	100	3.5p per 10s	35p	2 mins	35p	MICROS VIA PUBLIC TELEPHONE NETWORK
Micro @ Standard	100	3.5p per 15s	24p	2 mins	24p	
Micro @ Off-peak	100	3.5p per 60s	6p	2 mins	6p	

## PART 2: WHICH MODEM?

Modems must be the most boring pieces of equipment in the marketplace (unless you are another modem, I suppose). We use the telephone network for data transmission because it's there; we have no choice about it. But digital signals are not suitable for transmission on telephone lines and have to be converted to an analogue form within the speech frequency band carried by the Post Office. Obviously, at the receiving end, the signals need to be converted back to digital form. All this is the job of the *modem* (short for modulator-demodulator).

The functionality of modems is very limited; they work one bit at a time in each direction and know nothing about things called "characters". This review of available modems is purposely restricted to those devices which are most applicable to the home and small business environments. In other words, they are cheap and simple to use. I've also limited the list to those modems with which either I or my associates have had some practical experience. Having said that, if I'm doing any company an injustice by not including them in the list, if they'd care to write in I'll give them a mention in the upcoming "Network Notes" column.

First of all, what does one look for in a modem? The following notes correspond to the columns in the comparison table.

1. Modems can be directly connected to the telephone line (via a junction-box or jack plug) or, alternatively, they can transmit and receive signals via a telephone handset.
2. The UK Post Office will not "assume" transmission on the public telephone network at speeds greater than 200 bit/s. In spite of that, 300 bit/s seems to have worked reliably enough for some years. You can get 1200 bit/s modems but they are more expensive (as you would expect). Acoustically coupled modems which work at 1200 bit/s have also been around for a while, but the reliability of these is questionable. I would certainly have to use one for a sustained period before being convinced of their practicability.
3. Most of the modems and couplers included in the list are designed for use at 300 bit/s (CCITT V21 Specification). This is a full duplex arrangement (simultaneous both way transmission). Transmission takes place on different carrier frequencies for each direction... a "calling modem" sends on Channel 1 and receives on Channel 2. Clearly, the connected modem cannot do the same — it must receive on Channel 1 and transmit on Channel 2. Three techniques are employed to achieve this:
  - a) The modem is constructed to receive on Channel 1 only.
  - b) The modem can be switched (manually) to transmit or receive on Channel 1.
  - c) The modem normally transmits on Channel 1 but will switch to Channel 2 if it hears a carrier frequency on Channel 1 (the Post Office Modem does this).

For home and business applications, there seems to be a clear need for the ability to switch between channels to

become standard.

4. The Post Office has chosen (until recently) to exercise its monopoly privilege over the provision of units that will automatically dial calls on the public telephone network. The Post Office device for dialling calls under computer control is called a "DEC 1". It's bigger than a PET and is reputed to have valves and cogs inside. There's no reason at all why auto-dial cannot be built into every modem (just as it is in the Prestel 1200/75 modem).

5. Auto-answer is usually incorporated in modems but these have to be hard-wired, thus restricting the choice.

6. On the hard-wired modems, it's sometimes possible to get simple loop test facilities. I've found these to be invaluable in development work, but they are also recommended for operational working for times when you need to isolate a fault.

Most of the modems in the comparison table are, unfortunately, acoustic couplers. The majority do a fine job but the coupler is an expedient solution to the requirement to transmit on the public network. Originally, couplers were designed for use in situations where the terminal was itinerant. I would suggest that today, only a small minority of couplers are employed in such applications. They are popular now because they provide a handy way of getting started in data communications — one that doesn't involve the Post Office.

Over the past ten years or so, I've regularly used a variety of acoustic couplers. Mostly I've stayed with the Anderson-Jacobson ADC212 in its fine polished wooden case and the less-elegant but more compact Minimodem 3001C. The latter is made by Modular Technology and resembles a tank landing craft in Post Office red (if you can imagine that).

If you have a reasonably quiet office you should be all right. But I've found that in acoustically and electrically noisy environments (especially exhibitions) such couplers can become totally unusable. That, however, is the exception; under normal circumstances there should be no problems. Unquestionably though, you should use a hardwired modem whenever possible. At the present time there are only two suppliers

who can meet this requirement... the Post Office and Modular Technology.

For many years the Post Office only offered 300 bit/s working on the public network with its Modem No. 2. You cannot purchase these — they rent for £130 per annum. A more recent alternative is the Modem 13; it's provided as an integral unit and forms the base of a regular telephone set. Costing £75 per annum, it's powered from the telephone line itself but will only transmit on Channel 1 — which is an obvious limitation. I've used both these modems extensively and have had no trouble from the point of view of reliability. I've also used Modular Technology's Minimodem 3C and 3A (the C standing for a call modem and the A for the answer model). These cost £225 and £250 respectively but that's a one time purchase price. Again the equipment is very reliable... indeed I cannot remember ever having a fault on Modular Technology equipment.

One advantage of using the Mini-modem unit is that each device includes a display of the various interface lead levels. This is a very encouraging facility because it enables you to see exactly when the device is transmitting and receiving or has lost carrier — or whatever the problem might be. The modems also include local and remote test facilities which enable you to carry out various simple routines for locating possible faults in your link up. The 3C and 3A modems also include a Quality Indicator lamp which is a useful facility when working on the variable public network. The Post Office modems do not include such facilities.

The major disadvantage with the Minimodems is that, at present, there is no facility to switch one model between call and answer functions; by the time you are reading this, however, Modular Technology should have announced a completely new range of acoustic couplers and hard wired modems. These are as yet un-named (as you will see from the entries in the comparison chart) but they carry a very impressive specification. For example, they are both switchable between call and answer operation and in addition to the usual standard V-Series interface,



"It's not very encouraging I'm afraid Mr Nisbett  
I fed your symptoms into the computer and it died"

they also offer a 20 MA interface and din type connectors for the attachment of cassette tape units. The hardwired modem includes an auto-answer facility (as does the present 3A) and an optional auto-dial capability.

In view of what I said earlier, the auto dial arrangement can only be used on inhouse PABX networks or in countries where the telecommunications

authority is a little less paranoid than ours about such attachments. For an estimated price of around £300 it would seem to be an excellent modem for domestic and small business purposes. Modular Technology will continue to sell their low cost (£160) calling coupler.

The other suppliers on the list, namely Peripheral Hardware Ltd., K&N Electronics and Transdata Ltd., all supply

high quality and reliable modems although my personal experience of these is not as extensive as it has been with the other units mentioned above. I certainly look forward to an opportunity of trying out a Peripheral Hardware Sendata 1080 acoustic coupler which works at 1200 bit/s. If I manage to get my hands on it I'll report the results in Network Notes.

Supplier/Product	Hardwired (HW) Acoustic (AC)	Speed (Bit/s)	Call	Answer	C/A Switch	Auto Dial	Auto Answer	Test	Price	Notes
Anderson-Jacobson ADC 211	AC	300	✓	x	x	x	x	x	£193	Includes complete enclosure for handset
ADC 212	AC	300	✓	x	x	x	x	£255		
K & N Electronics Ltd AC 3500M	AC	300	✓	x	x	x	x	£212		
Modular Technology Minimodem Range										Includes V-Series 20 mA & Cassette Interfaces
3001C	AC	300	✓	x	x	x	x	x	£160	
3001A	AC	300	x	✓	x	x	x	x	£160	
3C	HW	300	✓	x	x	x	x	✓	£225	
3A	HW	300	x	✓	x	x	✓	✓	£250	
New Range (1) (2)	AC HW	300 300	✓ ✓	✓ ✓	✓ ✓	x ✓	✓ ✓	✓ ✓	c.£220 c.£300	
Peripheral Hardware Ltd Sendata 1080	AC	1200 (+ 75 return channels)	✓	✓	x	x	x	x	£345	Includes complete enclosure for handset
Post Office Modem 13	HW	300	✓	x	x	x	x	x	£75pa	Rental only
Modem 2	HW	300	✓	✓	✓	✓ (extra)	✓	x	£130pa	
Transdata Ltd Acoustic Modem 307	AC	300	✓	x	x	x	x	x	£185	



## NewBear Books



### NEW BOOKS

The S100 and other Micro-buses . . . . .	Poe . . . . .	£ 5.05
Software development . . . . .	Jones . . . . .	£13.95
Computers and Commonsense . . . . .	Hunt . . . . .	£ 3.95
Architecture of Small Computer Systems	Lippiatt . . . . .	£ 4.50
Principles of Data Base Management . . . . .	Martin . . . . .	£12.50
Cobol for Beginners . . . . .	Worth . . . . .	£ 7.75
16-bit Microprocessor Architecture . . . . .	Dolhoff . . . . .	£16.20
6502 Assembly Lang. Programming . . . . .	Osbourne . . . . .	£ 6.95
Introductory Experiments with Digital Electronics and 8080A Book 1 . . . . .	Rony . . . . .	£ 8.40
Book 2 . . . . .	Rony . . . . .	£ 8.40
Microcomputers for Business Applications	Barden . . . . .	£ 5.80
Handbook of Microprocessors, Microcomputers and Minicomputers . . . . .	Lenk . . . . .	£11.65
Introduction to Microprocessors . . . . .	Levanthal . . . . .	£ 8.95
The VNR Concise Encyclopedia of Mathematics . . . . .	Gellert . . . . .	£15.35

### COOKBOOKS

Active Filter Cookbook . . . . .	Lancaster . . . . .	£10.45
CMOS Cookbook . . . . .	Lancaster . . . . .	£ 6.95
IC OP AMP Cookbook . . . . .	Jung . . . . .	£ 9.50
IC Timer Cookbook . . . . .	Jung . . . . .	£ 7.50
T.V. Typewriter Cookbook . . . . .	Lancaster . . . . .	£ 7.50
TTL Cookbook . . . . .	Lancaster . . . . .	£ 6.95
The Cheap Video Cookbook . . . . .	Lancaster . . . . .	£ 4.30
IC Converter Cookbook . . . . .	Jung . . . . .	£ 8.40

### INTRODUCTORY BOOKS

The Mighty Micromite . . . . .	Evans . . . . .	£ 5.75
Intro. to Personal & Business Computing	Zaks . . . . .	£ 4.95
A Dictionary of Microcomputing . . . . .	Burton . . . . .	£10.00

### Z80 BOOKS

Z80 Programming for Logic Design . . . . .	Osbourne . . . . .	£ 5.95
Z80 Technical Manual . . . . .	Zilog . . . . .	£ 4.00
Z80 P10 Technical Manual . . . . .	Zilog . . . . .	£ 3.25
Z80 Programming Manual . . . . .	Zilog . . . . .	£ 4.50
Z80 Microcomputer Handbook . . . . .	Barden . . . . .	£ 6.95
Practical Microcomputer Programming Z80	Weller . . . . .	£19.55
Z80 Instruction Handbook . . . . .	Scelbi . . . . .	£ 3.25
Z80 Assembly Language Programming . . . . .	Osbourne . . . . .	£ 6.95
Introduction to TRS 80 Graphics . . . . .	Inman . . . . .	£ 5.75
Z8001/Z8002 Product Specification . . . . .	Zilog . . . . .	£ 3.75
Z8000 CPU Instruction Set . . . . .	Zilog . . . . .	£11.50
Z80 Instant Programs (book) for Nascom	Hopton . . . . .	£ 7.50
Z80 Instant Programs (cassette) for Nascom	Hopton . . . . .	£10.00
Z80 Microprocessor Programming and Interfacing Book 1 . . . . .		£ 7.75
Book 2 . . . . .		£ 8.50
Z80 Assembly Language Programming . . . . .	Osbourne . . . . .	£ 6.95

### BASIC

The Basic Primer . . . . .	Waite . . . . .	£ 5.80
The Basic Handbook . . . . .	Lien . . . . .	£11.00

### SOFTWARE TAPES FOR PET & TRS 80

Applications Program . . . . .	Educational Program
Game Program . . . . .	Mathematics Program
Graphics Display & Misc. Program . . . . .	

All at **£6.65 each.**

**Terms:** OFFICIAL ORDERS (min. £10.00). ACCESS & BARCLAYCARD WELCOME.  
SEND FOR COMPLETE BOOK LIST. ALL PRICES INCLUDE POSTAGE & PACKING.

**MAIL ORDER:** 40 Bartholomew Street, Newbury, Berks. Tel: 0635 30505

**MANCHESTER:** 220-222 Stockport Road, Cheadle Heath, Stockport. Tel: 061 491 2290

**BIRMINGHAM:** 1st Floor Offices, Tivoli Centre, Coventry Road, Birmingham. Tel: 021 707 7170

# VIEWDATA AND THE INFORMATION AGE

## PART 2:~THEORY INTO PRACTICE

by Dr. Adrian Stokes

*Last month I described the background to viewdata and Teletext and included instruction on the basic mechanics of how to use them. Here, in part two, I'll be considering tasks to which they can be put — with particular reference to the use of microcomputers as videotex receivers (and vice versa). I'll be looking too at possible future uses for such systems.*

Although I've described how to find your way around the viewdatabase, the mechanical ability to meander around a fairly large database doesn't imply any ability for finding useful information.

The basic structure of the viewdatabase is a tree and can only be searched with a simple search strategy, compared to the complex strategies allowed in most information retrieval systems. For example, to find an Italian restaurant in North London in a conventional information retrieval system would require a search of the type:

FIND (RESTAURANT) AND (ITALIAN) AND (NORTH LONDON) whereas, in a viewdata system, no connectives are allowed and the user has to choose the search path carefully. In the above case, a reasonable choice is:

Entertainment = > Eating Out = > Italian Restaurant = > North London.

It might, however, have been just as reasonable to start the search by geography, looking for entertainment in North London, and then deciding what type of entertainment was required. Therefore, the Information Provider should ideally include multiple routes to the same data.

Given that this has been done (and it leads to significant problems if cross-linkages are required to other IP's data), to what tasks can viewdata be put?

The different usages can be divided into four major areas — residential, public, business and specialised. Viewdata was always intended to be aimed at the general public rather than at business users and the Post Office are predicting that, within three years, the ratio of domestic to business receivers will be about five to one (with a projected total, in 1983, of three million sets). In this market, one major role of viewdata will be as a first line of reference. Even though the viewdatabases are reasonably large, there is no way in which they can be extended to hold even a small fraction of the information which might be required. For example, a user who wanted to find out about microcomputers would probably be able to get a list of (most of) the micros available at present and might even be able to get some details of configurations available; but he'd almost certainly not be able to get hold of

machine code listings, purely because of the amount of data involved.

This is one type of data likely to be available. A second is transient information, again provided that the volume of data is not too high. For example, railway timetables are noticeably subject to change at frequent intervals and printed timetables can easily be made incorrect; these could be stored on viewdata and updated as regularly as needed.

If data changes even more rapidly — take share prices for example — viewdata is perhaps not the ideal medium. This is where Teletext is more attractive since not only can its data be changed within seconds, but also the revised version is automatically disseminated to customers whereas, with viewdata, the updated frames have to be called for.

The fact that viewdata can be used as the first line of reference implies that the user might want access to the full reference; so one obvious place to have a viewdata terminal would be in a library or other public place. And there is likely to be a growing market for "coin-in-the-slot" viewdata terminals; already there has been a six-month experiment with half a dozen such facilities (made by Cherry Leisure).

The third area for viewdata is in business applications. In the case of large companies, there's likely to be relatively small use of viewdata since they'll quite probably have their own dedicated systems — although they might use viewdata for communicating with either the general public (advertising), with distributors or with other companies. However, in the case of small businesses, viewdata might provide the ideal solution for maintaining information since the investment is very much lower than for a dedicated system and can be increased in small steps. Also, the information can be accessed from remote locations if required.

Finally, there are specialised uses of the system. Teletext was originally proposed as a means of sub-titling television programmes for deaf people but there are now many other ways in which viewdata and Teletext can be used to help the disabled. Indeed for the deaf, viewdata has been adapted so that they may communicate via the telephone — using the system's interactive capabil-

ities. The screen is divided in two, half being dedicated to each customer with the centre line being used for system messages. Also, a nice touch, each user's typing comes out in a different colour. Of course, there would be no need to go through viewdata at all, except for the fact that the send and receive channels of the modems operate at different speeds. Obviously ordinary keypads cannot be used — one needs the full alphanumeric range (as used by the IPs for editing frames).

Viewdata can also be very helpful to physically disabled people. One simple use is to be able to order (and pay for) goods without leaving home. But another, perhaps more important use, is the provision of generally helpful information and there is an experiment in progress at the moment to provide a Prestel database on the problems of disability.

There are in fact lots of other specialised uses, many of which are only just beginning to be realised as a result of the research that's going on now in this area.

### Telesoftware

A viewdata adaptor consists of, among other things, a processor and memory — so does a computer! In fact, if the processor wasn't too restricted in what it can do and if there were more memory, then the viewdata adaptor would make for quite a respectable microcomputer with, of course, its own (usually colour) display. In addition, it has communications capabilities.

This is the basis of telesoftware, the idea that the hardware at the user's end can be enhanced, thus providing him with a micro as well as a viewdata receiver. From there, an obvious step is to keep most of the software on the viewdatabase (since there is no reason why the data on the viewdatabase need be textual) and retrieve it when needed. Similarly, programs can be kept on Teletext and loaded as required.

Of course, there are problems. First, what language should be used? There are a number of common languages around and although one obvious solution might be to use machine code, there are enough different processors about to make this impractical, parti-

cularly for Teletext where storage is limited. Perhaps the best idea is to use a standard language such as ANSI Minimal BASIC which, though not particularly efficient, should work on most machines.

In addition, what programs should be retained? On Teletext, due to the limited storage (although the problem is not quite as bad as I have implied in this case), it's likely that the programs to be stored would be standard ones, e.g. a calculator simulator, a mortgage calculation etc. On the other hand, not only could viewdata hold a large library of programs (possibly in different machine codes), it could, because of its interactive nature, allow the user to write his own programs.

One problem that arises with proprietary software is the question of cost. The most that can be charged for a frame on Prestel is 50p and, for his money, the user can keep a copy of the program forever. In order to overcome this, some work has been done in the field of self-destructive programs so that you can rent a program, only for it to become inaccessible either after a fixed period of time or a certain number of uses.

In this section, I have implied that Telesoftware is not on the market yet and, to some extent, this is so in that it's not generally available. However, the IBA has been conducting regular experiments in this area and one software company, CAP Microsoft, has been carrying out texts with the implementation of MicroCOBOL via Telesoftware.

Of course, to make significant use of Telesoftware, the receiver ought to be enhanced by means of a printer — and backing store, such as cassette tape or discs. Once these are available, not only will the receiver run Telesoftware, its use as a viewdata set will be greatly enhanced.

## Intelligent terminals

The first "enhanced viewdata receivers" were, in fact, micros which interfaced between the receiver and the line. There are now quite a few of these on the market and, forgetting those which can be used as stand-alone viewdata systems (such as GEC's), the prices vary from about £1500 up to nearly £10,000. In the lower price range are such machines as the Telemachus TM-1, the TECS (Technalogs Expandable Computer System) and the Jasmin Electronics machine. At these prices, the storage is obviously limited and consists of RAM with no backing storage (although this can be added). At the upper end of the market, the Telemachus TM-3 is based on a PDP-11/03 with twin 8" floppy discs — obviously an extremely powerful system.

Although these machines can be used as stand-alone micros, their intended use (and what the customer is paying for) is as an intelligent viewdata terminal, enabling pages to be obtained from a viewdata base and stored locally (or created locally), edited as required (with far more facilities than the minimal ones provided by the Post Office on Prestel) and then transmitted to the viewdata base. The number of frames which can be held locally vary from about three up to 200 per disc for the TM-3.

## Home computers as viewdata terminals

What of the user who already has a micro and wants to use it as an intelligent viewdata terminal? Already, coming onto the market there are packages that enable micros to be modified for this purpose. For example, "Appletel" was recently announced in PCW (Feb 80). This is a package which converts an Apple II into an intelligent editing terminal, allowing storage of up to 60 frames per disc. At present, the display is only monochrome and a separate Post Office Datel 600 modem is required; future developments, however, include an integral modem with autodialler and a colour display.

Further packages for other machines are coming onto the market, especially for S-100 bus machines and there will be regular updates to this article on this topic. In fact, if any reader has experience of any such packages, I'd be pleased to hear from them.

## The future

It's obvious that there is a significant future for viewdata and Teletext, even if perhaps not quite what was envisaged ten years ago. Such ideas as transmitting daily newspapers via these systems are technically feasible but impractical at present when one considers the volume of data involved. However, use of viewdata for "electronic mail" has far-reaching implications including the whole question of the Post Office monopoly.

The PO has already relaxed its monopoly significantly because of Prestel (for

example, by allowing television sets with integral modems to be connected to the telephone system) and further changes are inevitable. Also, there are problems over the Post Office's role as a common carrier. Already, for reasons of demand, it has had to suspend this role — it hasn't been able to give Prestel facilities to everyone who has asked.

A further problem which has raised considerable interest recently is that of frame content on Prestel. The ones in question described various pornography shops in Soho (and were called, most appropriately, "Rupert Streetwalker"). They were removed after complaints from an MP (and replaced by frames telling you how to complain if you were offended by material on Prestel). The Post Office has no more responsibility (nor control) over content than it does over the content of mail but this could lead to some interesting situations.

The introduction of "new" technology raises many new questions. For example, there was much discussion last year over the VAT rate for the information content of frames. When the Finance Act 1972 excluded books etc. from VAT, viewdata was not considered and hence not mentioned; eventually Customs and Excise agreed that the information content should be zero rated.

Viewdata is an area where there is bound to be considerable growth over the foreseeable future, particularly when coupled with home micros and, although it may not so far have lived up to all its expectations, during the next five years or so we should increasingly be able to witness the impact of this Information Age.



# ACORN ATOM



The elegant injection moulded plastic case houses a full size professional keyboard and a hardware/software combination of extraordinary power and versatility; in the minimum price configuration the kit of parts provided allows BASIC and ASSEMBLER, graphics and sound output, direct cassette and T.V. interface and much more. Sockets and connectors allow for expansion *within* the case to allow features normally associated with computers costing ten times as much.

Every kit is sent with assembly instructions and a beginners guide to Atom BASIC, ASSEMBLER and operating system.

The basic unit in kit form costs £120 plus VAT and postage, total £143.00. Prices and details of ready built units and accessories on request. Delivery in beginning of May.



**ACORN  
COMPUTER**

Acorn Computer Ltd.,  
4a Market Hill,  
Cambridge, CB2 3NJ  
Tel. (0223) 312772

- Fast 32-bit Integer BASIC
- Floating point math routines (10 digit)
- Mnemonic Assembler
- Cassette load and save
- 16 letter file names
- Graphics Plot, Draw and Move
- Screen editor
- Timer function
- Many extended BASIC features
  
- 192 Graphics characters
- 5 Graphics modes
- High resolution (256 x 192)
- Internal speaker
- Printer output
- UHF output
- Monitor output
- Colour output
- Communication loop
- Cassette I/O
- 24 User I/O lines
- Internal socket for any Acorn card
- Acorn bus output

# ALTOS

## In essence, the best in integrated circuit technology

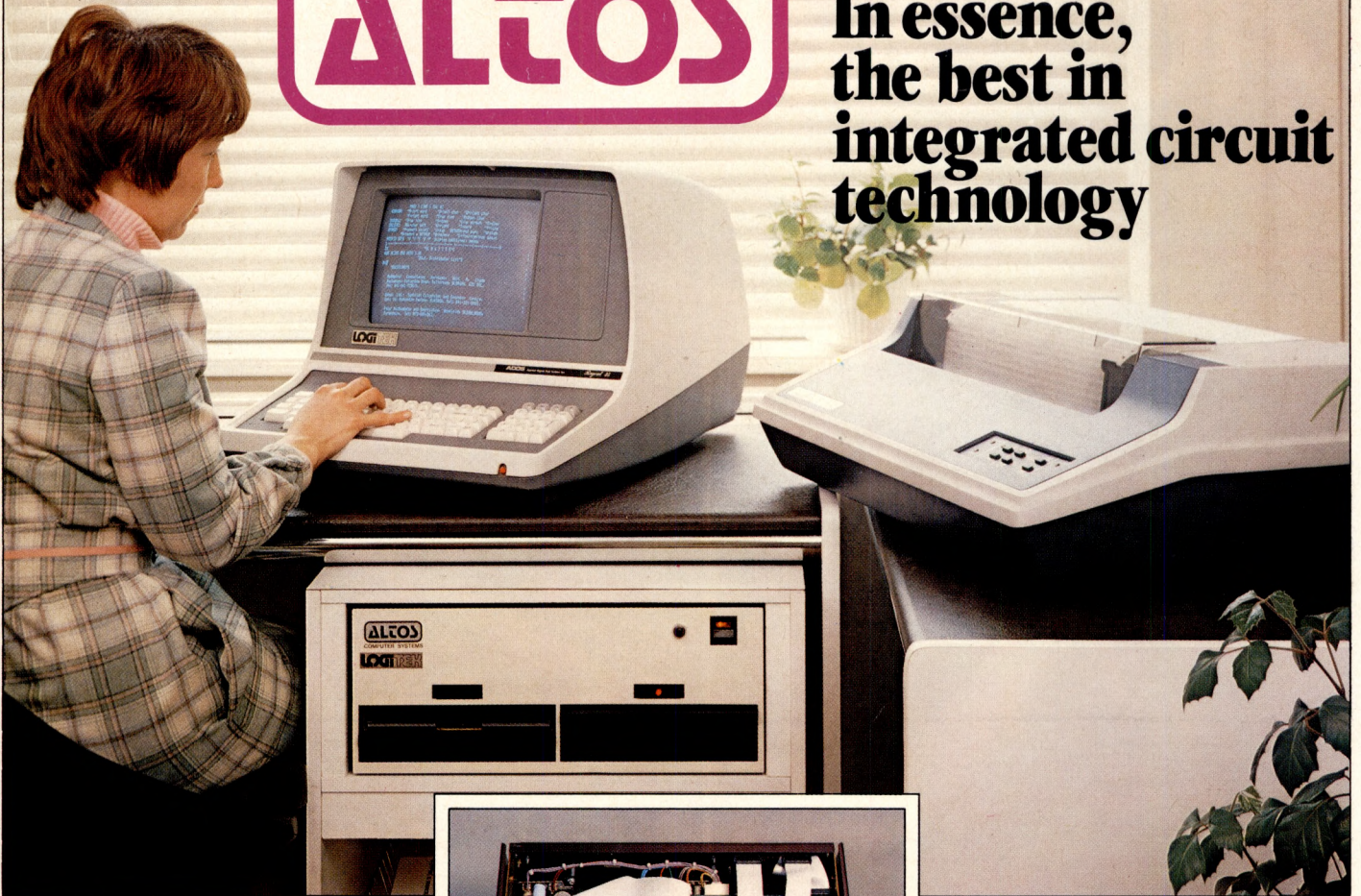

The ALTOS ACS 8000 range of business/scientific micro computers creates a new standard in quality and reliability in high technology micro computers.

### High Technology

**Floppy Disk System** The ACS 8000 single board Z80 floppy disk based micro computer utilises the ultra reliable Shugart 8 inch, IBM compatible, disc drives, double density — single sided, and providing 1 M. byte of data storage. Featuring the ultimate in high technology hardware: a fast 4 MHz.Z80CPU, 65 kilobytes of 16 K dynamic RAM, 1 kilobyte of 2708 EPROM, an AMD 9511 floating point processor (OPTIONAL) a Western Digital floppy disc controller, a Z80 direct memory access (OPTIONAL), Z80 parallel and serial I/O (two serial RS232 ports, 1 parallel port) and a Z80 CTC Programmable Counter/Timer (real time clock). In essence, the best in integrated circuit technology.

### Hard Disk/Multi User Systems

The Winchester hard disk/multi user systems are now available supporting up to 4 simultaneous users and providing a maximum of 58 Megabytes of hard disk data storage.

The systems are truly flexible and allow expansion of the ALTOS floppy disk system to keep pace with the users requirements.

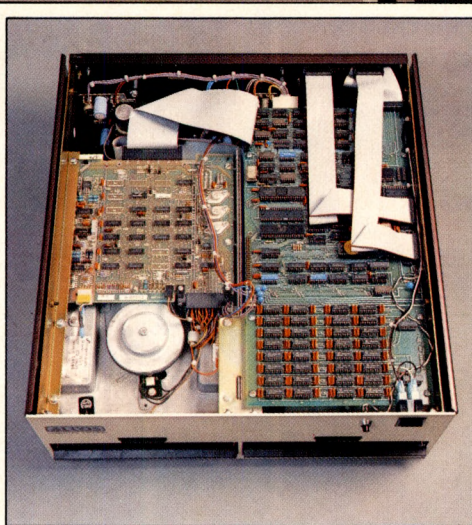

Still single board, features include  
\* a high speed I/O section with up to six serial ports and one 8 bit Parallel port  
\* up to 208K of on board RAM.  
\* High speed (4 MHz.) D.M.A. control as standard.

Yes, mini power and at micro cost too.

### Built-in Reliability

The ACS 8000 range are true single board micro computers making them extremely reliable and maintainable. All electronics are socketed for quick replacement. Complete diagnostic utility software for drives and memory is provided.

The board and Shugart floppy disk drives are easily accessible and can be removed in less than ten minutes.

### Quality Software

Unlimited versatility. The ACS 8000 range support the widely accepted CP/M and MP/M operating systems plus basic (Microsoft and CBasic), Cobol, Pascal, and Fortran IV. All available now.

Logitek in conjunction with its own microsoftware house, Interface Software Ltd. of Camberley are able to supply a wide range of proven 'off the shelf' business software including general accounting, word processing, stock control, mailing list etc.

There are already over 1000 micro computer installations using this software. A track record which we consider speaks for itself. Why 're-invent the wheel' when there is standard software of this quality available now?

### After Sales Support

Logitek are supported by DDT Maintenance Ltd. who provide a nationwide field maintenance service for ALTOS products and offer the option of maintenance contracts.

### Availability

Logitek carry deep shelf stocks of ALTOS hardware and compatible peripherals.

If you are a dealer who may be interested in promoting ALTOS and/or Interface Software by joining the fast growing network of approved suppliers, contact Logitek.

We can offer you something rather special now.

# LOGITEK

LOGITEK, E.I.C. Electronics Ltd. All enquiries to: Portland St. Chorley, Lancs. Tel: 02572 66803  
also at: 30 Kelvin Ave., Hillington Industrial Estate, Glasgow G52 4LH.

Logitek are now the exclusive distributors of Altos Computer Products for the U.K. & Eire.

**See page 76 for complete list of approved dealers.**

# COMPUTER ANSWERS

Each month Sheridan Williams and his panel of consultants answer readers questions. Topics may be hardware — from kits to mainframes, or software — from differential equations and statistics to file handling or sorting; the choice is yours. Send your questions direct to Sheridan Williams at 35 St Julians Road, St. Albans Herts.

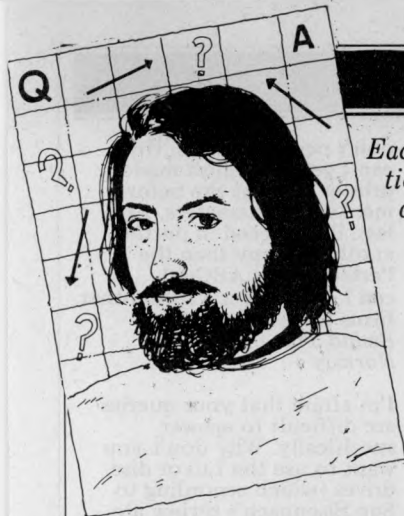

## Growing pains

I am considering buying discs for my Commodore PET. I have been told that there are alternatives to the PET discs... are they worth considering and if so, why?  
*B. Abbott, Nottingham*

It's very unusual to find someone asking this sort of question; in my experience most people would just go out and buy PET discs for their system. Why on earth people are prepared to spend hundreds of pounds without seeking advice I don't know.

One of the important considerations in choosing a suitable disc system is its ease of use, by that I mean its operating system. I find the PET disc system a pain to operate and simple everyday tasks like a disc directory are far more difficult to obtain than they should be. I think the main reason for the difficulty is that the PET disc thinks it is a "printer".

One of the best alternatives to the PET disc is the Computhink disc; it comes with its own operating system which supports a very comprehensive set of commands. These commands allow direct access files which although possible on the PET discs, are incredibly tedious to implement. The Computhink discs are available in two forms: 200K per disc (single sided), and 400K per disc (double sided)... thus with the two drives you can have 800K on line!

Many people consider that double sided tend to be unreliable, mainly because of the heads banging together as they access the disc; the Computhink discs have the heads slightly offset and seem no less reliable than single sided disc drives. The PET disc drives are available only in a 170K version — which is single sided. Prices compare quite favourably too; around £810 for PET discs and cable; and £895 for single density Computhink discs; remember though that you get 15% greater capacity on the Computhink for an extra cost of only 10%. The double sided 400K Computhink discs will cost around £1150. Neither disc system uses any of the main store on a 32K

PET so there are no worries there.

The only advantage that I can see for the PET discs is that they are "intelligent", which is to say they have their own processor on board. In plain English this means that the PET discs can be getting on with one job while the PET itself is tackling another. The next point worth considering when buying discs is the availability of software. It seems that my approval of the Computhink discs is backed up by Petsoft who can supply most of their software on both systems. Before anyone asks, I have used both systems and am totally unconnected with Computhink; I'm just making recommendations based on my personal experience. The Computhink disc operating system is not perfect by any means, but it's far easier to use than the PET system.  
*S.W.*

## Printing to a price

Can you recommend a good, cheap printer for our school's Research Machines 380Z. Our budget won't extend much past £500 so this makes a Teletype 33 out of the question.  
*D. Thomas, Bath*

The Teletype 33 does have a keyboard, paper tape reader and punch — all very useful for preparing programs and data off-line. They can be obtained in a refurbished condition, but as you say, they are still outside your budget.

One of the best value-for-money printers on the market must be the Anadex; it's a fairly fast (110 c.p.s.), bi-directional matrix printer and can be used on the 380Z with only a single modification (you have to connect the busy signal from the printer to the 380Z... a very simple thing to do). The Anadex has both serial and parallel inputs and can be used very easily and with little trouble on virtually any micro. It supports 110-9600 baud input, together with others that control double sized characters and form feed. Amazingly enough, I've seen many people using the Anadex who have not yet found out that it can print double sized characters. You need to send the ASCII character 14 to switch on the double sized facility, and ASCII character 15 to switch it off. Example on the 380Z:

LPRINT CHR\$(14); 'Large';  
CHR\$(15); 'Chars'

Printing ASCII code 12 will activate a form-feed.

The ANADEX is compact, fast, robust, versatile, and cheap, and I can certainly recommend it.  
*S.W.*

## Call for CAL

Can you give me any information on existing CAL packages, including where they may be obtained. Ideally I'd like to know what is available and what machines they run on.  
*J.H. Ruston, Wimbledon*

As a computer is a general purpose tool, we need to tailor it to suit individual requirements. If the computer is to assist learning in a particular subject area there should be good, well tested packages available. This whole subject comes under the term "Computer Assisted Learning" (CAL).

At present it's difficult to provide a single CAL package for any topic because there is too large a variety of hardware and systems software on which to run it (different versions of BASIC for example). There are dozens of micros and mainframes, each one with its own sub varieties. A package designed to run on the old 8K PET might not run on a larger PET that makes frequent use of PEEK and POKE. If we try and use a standard subset of BASIC we are up against the problem that we cannot use graphics, files and machine code routines — all of which make the package more impressive and useful. For this reason, and the fact that there is not much profit to be made, the availability of CAL material is severely limited.

I suggest that you keep in touch with material available by reading PCW, "Computer Education" (from North Staffordshire Polytechnic, Blackheath Lane, Stafford, ST18 0AD), "Educational Computing" (30-31 Islington Green, London N1 8BJ) and by joining MUSE (Oundle School Oundle, Peterborough, PE8 4AQ).

Find out if your local education area has a policy towards computers in schools and colleges. If it has then it should have developed some CAL material of its own; in the Hertfordshire area for example there is the Advisory Unit for Computer Based Education. There ought to be equivalent organisations in all areas —

but there aren't, which is an absolute disgrace.

Material currently available can be obtained from Edward Arnold Ltd, Woodlands Park Avenue, Woodlands Park, Maidenhead, Berks SL6 5BS; information about what they supply can be obtained from the Educational Computing Section, Chelsea College, Pulton Place, London SW6 5PR. These two work in collaboration and can supply BASIC programs on paper tape or, in some cases, cassette for the 380Z, in the subject areas of Biology, Physics, Economics, Chemistry, and Geography.

Other bodies that may be able to help are Council for Educational Technology, 3 Devonshire Street, London W1N 2BA. Petsoft have one or two educational programs for the PET. Qwertysoft 20 Worcester Road, Newton Hall, Durham, have several programs written by teachers for the PET and TRS 80. There is the Central Program Exchange at Wolverhampton Polytechnic which has BASIC programs available and MUSE have a fairly good library for the SWTP and 380Z micros. For those using the 380Z there are programs available from F. Donovan 35 St Julians Road, St Albans, Herts AL1 2AZ (an address that may not be too unfamiliar with some of you).

Finally, I am always interested to hear of any material available from any source and in any language; I'll keep you posted of anything good that comes my way.  
*S.W.*

## PET to printer problems

Some time ago my school purchased a PET, and through the good offices of a local company we acquired two printers. The first was an 8B CREED, the second a terminal printer with keyboard, tape reader and punch facilities. Our problem is to know how to connect these printers to our machine.  
*A. Mawdsley, Manchester*

Your terminal printer probably has an RS232 or "current loop" interface. These use a seven bit ASCII code, sent serially along a pair of wires, sandwiched between parity, start and stop bits. In an RS232 interface each bit is expressed by a positive or a negative voltage; in a current loop interface, by a current or no current.

The PET IEEE 488 port is an eight bit parallel one, so the data must be converted to a serial format, and to the voltage or current level that is compatible with the terminal. Most interfaces use a UART (Universal Asynchronous Receiver Transmitter) chip and they are readily available from most Commodore dealers at around £89 for a uni-directional and £149 for a bi-directional interface.

With a paper tape reader/punch and keyboard a bi-directional one would be useful. The CREED teleprinter is a bit more tricky. This uses a 5-bit Murray code which again is serial, although not an ASCII code. The data from the PET must be converted to the right format, either by hardware (expensive) or by software in the computer (fiddly). Don't forget either that the teleprinter will have to be switched between letter and figure modes. If you browse through copies of PCW you will find a number of companies who specialise in producing interfaces for the PET. They may be able to supply one to suit your needs.

If any readers have made an interface for the CREED and can let me know, I will gladly pass on the information.

*M. Wratten*  
(Mr Maudsley may well find it interesting to read "Hard copy at a soft price" p.77 this month — Ed.).

## The forgotten interface

I am the owner of a Kompukit UK101 (6502 cpu) and a TI 58 calculator. Please could you inform me if it would be possible to interface the two, allowing extensive number-crunching on the computer with intrinsic functions of the calculator — and if so, how?

*M. Buckley, Norwich.*

I found your question particularly interesting, not least because it brings to the fore the idea of the "Systems Approach". This is one of the main foundations of professional computing, yet so far it has rarely been mentioned in personal computer magazines. As you may know, professional computer staff tend to work within one of three groups of activity: operators, programmers or systems analysts. The task of the latter is to consider each problem in its entirety, and decide the best approach to take . . . which may not involve computers at all!

Just as many recent articles have (rightly I think) exhorted us "not to rush into coding" when writing a program, so the "Systems Approach" would advise us "not to rush to use a

computer" when first considering how to tackle a problem. Perhaps it's because systems analysts are not so directly computing orientated that this topic has received little attention in personal computing circles. More likely, however, it's that having to combine the tasks of programming and operating — and in our leisure hours at that — is quite enough, and there isn't time to consider the Systems Approach. (Not to be confused with "operating systems"!)

Supposing we take the Systems Approach to the problem of interfacing your UK101 & TI-58? We may well be surprised to find that this quickly yields an easy, cheap and reliable solution. There is a near perfect interface available and at no cost whatsoever . . . yourself! Write your program so that when "number-crunching" is needed the screen displays "NOW CRUNCH THIS" (or some similar message) the nature of the operation, and the numbers in question. This should be followed by an INPUT statement so that the answer can be entered back to the computer via the keyboard. Key the numbers and operation into the TI-58; key the answer back into the UK101 . . . and proceed!

Now, I know this is not the answer you had in mind — or were hoping for — but I do think that the Systems approach should more often be borne in mind.

In fact electrically interfacing the UK101 to the TI-58 is far from easy, for the calculator is not designed to accept an electrical input. Therefore you would either have to build an electro-mechanical device to enable the computer to literally press the keys of the calculator, or else remove the keyboard of your TI-58 to make an electrical connection to the Texas chip. Neither approach is beyond the hobbyist who is really skilled in electronic construction and measurement.

If you would like to know more about the possibility of connecting your UK101 directly to the calculator chip, then you will find the article "Sinclairly Yours" in the February 1979 issue of PCW very helpful. This describes interfacing a Sinclair Cambridge Programmable calculator to an MPU, and as well as discussing techniques, it also explains how to overcome some of the other problems that are likely to arise — such as incompatibility between the supply voltages for the computer and the calculator. I don't know of anyone who has taken the other approach of constructing an electro-mechanical "key-presser", but I'd be delighted to hear from any reader who has tried to build something of the sort.

(Then of course you still have the problem of reading the calculator display! — Ed).

## Holding on

On the ITT 2020 a single character can be fetched from the keyboard as soon as a key is depressed — either by means of the GET statement, or by PEEKing the keyboard buffer. The character so obtained remains in the keyboard buffer until another key is depressed. Is there any way of detecting the lifting of the finger from a key? This would have applications in interactive programs such as one for an electronic organ.  
*D.C. Leedham, Enfield, Middlesex.*

I'm afraid not. Most keyboards generate a strobe pulse once when any key is pressed and it is the edge of the strobe pulse that is used by any following circuitry. The ITT 2020 is no exception. What you require is a constant output while the key is pressed and that is only feasible with a custom built keyboard.

*M. Dennis*

## Cursor damage?

I am considering the purchase of a NASCOM1 and wonder whether the VDU's cursor would damage a television screen.

*G.M. Taylor, Leeds*

It's undoubtedly true that the high intensity of the characters on a VDU screen can cause deterioration of the phosphor on a cathode ray tube, as witnessed by the screens of industrial terminals which have seen heavy use. However, for domestic purposes where you will be using the computer on and off and not continuously there should be little problem. It's advisable you keep the contrast and brightness to the minimum visible display, and blank the screen when not in use. Other than that I wouldn't worry.

*M. Wratten*

## Adding to the ABC-80

I really have problems. My ABC-80 is working so well that I would like to put on floppies, printer etc. What should I do if I don't want the Pertec floppy which Luxor sell, or the Centronics printer either? You see I don't understand about interfaces. How is the IEEE 488 and RS232 bus? Can I just buy a Shugart or Macro and put it on?

Also the last three letters of the Norwegian alphabet

don't occur in yours. How can I get an English made printer to print the before mentioned characters. And last, if I succeed in putting another floppy than the Pertec on my ABC-80, can I use software from other firms than Luxor?  
*Eivind Trana, Bergen, Norway*

I'm afraid that your queries are difficult to answer specifically. Why don't you want to use the Luxor disc drives (which according to Sue Eisenbach's review are BASF not Pertec)? My advice is to stick to the Luxor drive unless you are prepared for an awful lot of extra work at ALL levels of hardware and software. As far as the printer is concerned I would suggest that you approach some printer manufacturers directly in Norway. Alternatively, maybe an IBM Selectric could be fitted with the appropriate golfball.  
*M. Dennis*

## Students choice

Because I'm a student I'll have to buy a kit micro-computer very soon. Which one shall I buy? Shall it be an S-100 bus system with a little bit from this and a little part from that or should I stick to kits like the Nascom. Also can I upgrade a Nascom 1 to a Nascom 2?

*Reidar Otto Johnsen, Tromsdalen, Norway*

S-100 is fine for ready-to-run business systems and a lot of computer shops plug them hard — purely and simply because they are complete and well made. However, they are expensive for the enthusiast and a single-board computer would be much cheaper than an equivalent S-100 system.

Which single-board computer? Well, if you want to program with equal ease in machine code and BASIC then without a shadow of a doubt buy a Nascom 2. If you only want to program in BASIC then the other two may be suitable. You should be aware that the Nascom 2 does have a few more BASIC commands available but only you can decide whether they are worth the extra cost or not.

Don't forget that you have to add the cost of a power supply for the Nascom (approx. £30) and you can't upgrade a Nascom 1 to a Nascom 2.

*M. Dennis*

## Brain-racking

I am fully aware of the vast selection of personal computers available. I am now in a position to purchase

# COMPUTER ANSWERS

one for myself and can probably afford as much as the top end of the range of PETs or the new Sharp MZ80K. I have been racking my brain about the right choice; to add to the confusion, having read a lot about Superboards as well I find it difficult to see the advantage of, say, a PET over a Superboard — providing you own a TV as I do. Will it be wise to pay £750 when £250 will buy something as good and probably more expandable?

S.W. Hepburn, Bisley, Surrey

Your question is difficult to answer as you don't state exactly what you expect of your computer. If by expandability you mean a large range of ready-made "add-ons" that are currently available, then none of the computers that you mention fall into this category. You should look instead at either the Apple or ITT 2020 which are about the same price as the top-end PET.

The single board computers such as the Ohio, Compuquit UK101 and the Nascoms are, at the moment, limited in their upward growth. There is simply no well-defined path to follow. The long promised additions seldom seem to materialise. As you can afford £750 then I suggest that you take a closer look at the

Apple/ITT2020; buy one with only 16K and get the extra memory as and when you require it — it simply plugs in. Try, too, to treat yourself to a floppy disc as soon as possible. I don't think that you will regret the decision. Remember, make 1980 the year of the Apple!!

M. Dennis

## 380Z Basic access

How do I access the keyboard directly in BASIC on a Research Machines 380Z? What I require is a function similar to the Commodore PET's GET command where the keyboard is scanned and the character returned (or a zero if no key is depressed). The INPUT statement is no good to me because I require truly interactive routines such as reaction times.

Anon.

This is a common question so I'm answering it here for the benefit of all 380Z users. As most users will know, the 380Z is available in two machine types — the C4100 and the C100. It doesn't matter which version of BASIC you are using and neither does it matter how much store is available. The subroutine below will store

in CH the ASCII code of the key pressed and CH will be zero if no key is pressed.

```
1000 CH=PEEK(K9)AND127
1010 IF CH=0 THEN 1040
1020 POKE P9,195
1030 IF CH=26 THEN STOP
(CHR$(26) is CONTROL Z)
```

This subroutine could be used as follows:

```
10 K9=4092: P9=16403: REM
C4100
```

```
20 K9=64508: P9=65301:
REM C100
(Delete 20 or 30 as appropriate)
30 PRINT "PRESS ANY KEY"
40 GOSUB 1000: IF CH=0
THEN 40
50 PRINT "YOU HAVE
PRESSED"; CHR$(CH)
60 GOTO 30
```

I have many programs available that use this technique, and those interested are welcome to write directly to me. S.W.



"I thought we'd be the last people to be replaced by the silicon chip."

Honeysett

## PET' MACHINE LANGUAGE GUIDE

PET'  
MACHINE  
LANGUAGE  
GUIDE



Contents include sections on:

- Input and output routines.
- Fixed point, floating point, and Ascii number conversion.
- Clocks and timers.
- Built-in arithmetic functions.
- Programming hints and suggestions.
- Many sample programs.

If you are interested in or are already into machine language programming on the PET, then this invaluable guide is for you. More than 30 of the PET's built-in routines are fully detailed so that the reader can immediately put them to good use.

Available for \$7.95 + \$2.00 postage and handling. Payment is in U.S. dollars or charged to your Barclaycard or Eurocard — include card number and expiration date. Quantity discounts are available.

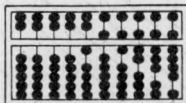

**ABACUS SOFTWARE**  
P. O. Box 7211  
Grand Rapids, Michigan 49510

## SHARP Computer

A personal computer that opens the world of programming to your own fresh ideas!

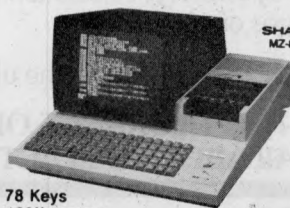

SHARP  
MZ-80K

**CRT Display**

This unit is equipped with a 25 cm (10") monochrome CRT for up to 1,000 letters (40 letters x 25 lines). Processing results can be displayed on the CRT and it is possible to program and edit (addition, deletion, etc.) while watching the operation for confirmation.

**A Technical Masterpiece**

A personal computer that makes full use of the multi-functions of an 8-bit microcomputer (Z-80), this model is certainly one of the most advanced anywhere. It employs BASIC language, a feature which provides easy programming even to those totally unfamiliar with computer operation.

**78 Keys**

ASCII standard  
Alphabet (capital and small letters)  
Graphic symbols

**Built-In Clock**

Clock circuit, time is displayed according to program.

### SHARP MZ80K SOFTWARE

BREAKOUT	£5.00	SUPER SIMON	£5.00
MASTERMIND	£5.00	MIZ-MAZE	£8.00
SHAPE MATCH	£5.00	GRAPHICS/MUSIC	£5.00
LUNAR LANDER	£5.00	BOMBER	£5.00
SNAKES & LADDERS	£5.00	FIREBALLS	£5.00
		DONKEY DERBY	£5.00

## HB COMPUTERS LTD

22 NEWLAND STREET, KETTERING, NORTHANTS.

Tel. (0536) 83922 & 520910 Telex 341297

# THE ADVANCED ACT DISK UNIT

## It turns your Pet into a business system



### Supports a wealth of Business Systems

#### Sales Ledger/Purchase Ledger

Powerful packages integrated to Nominal Ledger and Analysis.

#### Nominal Ledger

Up to 2,500 active postings a month; on-screen enquiries; month-end trial balance.

#### Analysis Package

Sales performance by territory; calculation of commissions; analysis of purchases.

#### Stock Control

Parameter driven; on-line enquiries; comprehensive range of reports.

#### Invoicing

Parameter driven; invoices tailored to user requirements; automatic typing.

#### Pagemate™ Database

Sophisticated report generating package; for work in progress, direct mail etc.

**Wordcraft™** Simply the ultimate word processor for the PET.

**+ A FULL RANGE OF PETSOFT PROGRAMS.**  
**ALL AVAILABLE FROM ACT'S PET BUSINESS COLLECTION.**

### Advanced Disk Hardware

- 1 Ultra fast-loads and auto verifies a 32K program in 5 seconds from a cold start.
- 2 Up to 800 Kbytes on-line— dual density double sided.
- 3 Powerful Disk Operating System— 9 additional commands and 7 extra disk instructions to the PET's own Basic.
- 4 Compatible with 16K and 32K new ROM PETS.
- 5 Random and sequential file access and support.

6 Comprehensive manual and utility disk.

7 Languages—Microsoft Basic, 6502 Assembler, Forth, Fifth, Pilot and Cesil.

**400 Kbyte  
Disk Unit £895.**

**800 Kbyte  
Disk Unit  
£1,145.**

PET is the trademark of Commodore. Prices exclude VAT and are correct at time of going to press.



**ACT (COMPUTERS) LTD.**  
 Radclyffe House, 66-68 Hagley Road,  
 Edgbaston, Birmingham B16 8PF.  
 Tel: 021-455-8686. Telex: 339396

**ACT  
TOTAL  
COMPUTING**

**ACT (COMPUTERS) LTD.** Radclyffe House, 66-68 Hagley Road, Edgbaston,  
 Birmingham B16 8PF. Tel: 021-455-8686. Telex: 339396.

**Please rush me details of:**  The PET business system collection.  The advanced ACT disk unit.  
 The Petsoft catalogue.

Name: \_\_\_\_\_  
 Company: \_\_\_\_\_  
 Address: \_\_\_\_\_  
 Tel. No.: \_\_\_\_\_

# THE 5th WEST COAST COMPUTER FAIRE



San Francisco boasts many attractions — Golden Gate bridge, Fisherman's Wharf, Chinatown and the cable cars to name but a few. Last weekend, however, the biggest attraction for 20,000 computer buffs was the Fifth West Coast Computer Faire. David Tebbutt reports from the show.

San Francisco, that delightful city at the top end of "Silicon Gulch" was chosen as the location for the Fifth West Coast Computer Faire. It's an event that has the reputation of being something of an enthusiast's show, packed to the gills with computer freaks and full of pioneering spirit. It has the distinction of being the place where many very successful products and companies achieve their first public showing; it's also highly likely that it's the place where quite a few of them appear in public for the last time!

The show is staged by Jim Warren, an ex-roller skating instructor. To be fair to Jim, he's also very knowledgeable about computers; he was once editor of *Dr Dobb's Journal* and currently he's working on a sort of Ceefax/Oracle of the radio waves, a project that's due to be announced later this year. He was to be seen frequently (and fleetingly) buzzing in and out of the stands on his skates.

Over 200 companies filled the two halls and, in addition, there was a full, three stream conference programme. People who should know told me that this year's effort placed less emphasis on hardware and far more on end user products — a trend which is happening all over the place as the hobbyists find themselves diluted by business, education and home users. Around 20,000 people attended and the overall impression I gained was that it was lively, interesting and worthwhile.

## Conference capers

I managed to attend a few of the sessions and of those the best was undoubtedly that given by Hal Chamberlin of MTU; he was describing the various ways of producing computer music. He's an unassuming young man with shoulder length hair, the sort you might meet in any programming department. But unlike such programmers, Hal is something of a world authority on the digital representation of music. He gave a fascinating lecture with demonstrations which convinced me that we are only at the very beginning of the development of the computer's potential as a music machine. Hal's own very successful company, which he runs with David Cox, produces the hardware and software necessary to make the finest music ever heard on a micro — more about their products later in the report.

Another memorable talk was given by Don Perry Dunlap, who chose as his topic "Is Electronic Technology Making Mankind An Endangered Species?". With a title like that, you'd perhaps expect the hall to be full — but then maybe people knew what was coming.

The hall was plunged into darkness . . . a carousel projector was checked . . . the cassette player was checked . . . and the show began. At first there was just spooky

music. This turned into the "2001" theme and then, reaching the climax of the first crescendo, Don Perry Dunlap squeezed the remote control of the carousel projector. A blinding rectangle of white light appeared on the screen! He pressed it again — another white rectangle. The music continued. Don Perry Dunlap pressed, and pressed, and pressed but all to no avail. The slides had, presumably, been mounted on the "wrong" side of the projector . . . The music died and so, slowly, did Don Perry Dunlap. More in hope than expectation he continued to squeeze the remote control until, finally, he realised the game was up — modern technology had pulled the rug from under him. The lights came on and everyone waited expectantly, wondering how he would continue. Up to then he had had our sympathy, but not for long. He proceeded to read his speech — jokes and all — from a copy of the conference proceedings. Being near the door I sneaked out.

The whole world seemed to turn up to see Adam Osborne present his white elephant awards (despite the name these are a genuine attempt to grant recognition to significant achievements). Unfortunately, I find Mr. Osborne's style irritating; there is something very dictatorial in his manner, but then he usually has something sensible to say. He gave one award jointly to Zilog and Intel for their 8002 and 8089 products and the other

to the writers of the Visicalc program. He noted that the latter award was in recognition of "the beauty of design and timeliness of the product". There's nothing wrong with what Adam says, except maybe his tendency to repeat the same old jokes; what jars is the way he says it.

So what, I hear you ask, is a white elephant award? Well, it's a North Star board containing a suitably inscribed brass plate plus a chip mounted for each recipient; each chip is, in turn, surmounted by a microscopic white elephant. Before leaving the presentation I asked a pretty young delegate why she had attended the session. She replied: "I didn't understand a word of what he said but, wow, that voice!" (Rumour has it that the young lady in question was subsequently invited to go yachting by the man himself).

And, while on the subject of sailing with Adam Osborne, I simply have to tell you the misfortune that struck our very own Guy Kewney just a day or two before the show. Seeking the pleasures of the sea, the two of them (having decided that it would be a good idea to use the engine for pottering around San Francisco Bay) carefully stowed the sails, upped anchor and motored off. After a while it became apparent that the yacht wasn't making too much progress — in fact it was proceeding at approximately walking pace even on full throttle. Guy held on to the rudder while Adam went

## Stories from the Show

below to investigate and, not knowing quite where to go, our "newshound" steered into the middle of the bay. Eventually Adam re-emerged with the news that the gears (or something) had stripped and that they would have to unstow the carefully stowed sails; the job done, Guy was again given the tiller while Adam went below to fix a drink. This time Guy headed in the general direction of the harbour entrance and just as he was starting to feel apprehensive about getting back again, Adam reappeared to take over the helm. A few deft course adjustments later they were stranded on a mud-bank! And technology wasn't finished yet!

Adam, attempting to catch the harbourmaster's ear via the radio waves, managed to re-integrate an important Lutton on the radio; thus the two of them were reduced to frantic waving at passing boats. It's all true. . . it must be, Guy told me.

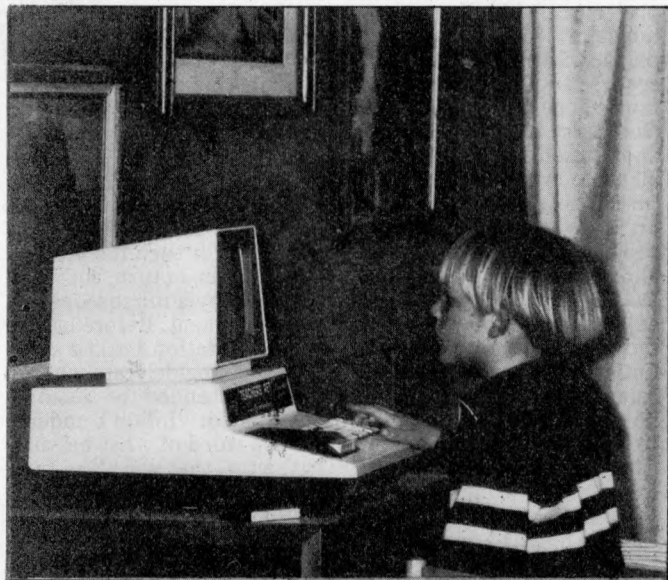

The inhabitants of Menlo Park have the good fortune to count Ramon Zamora and Bob Albrecht among their neighbours. Ramon and Bob, with help from their friends, have set up a project called "Computertown USA!". It's an attempt to introduce the community, mainly the kids, to the joys of computing. The picture shown here was taken in the Menlo Park library where a number of PETs and a TRS-80 have been installed, at no charge. Children spend an hour or so being taught how to use the machines and once they can prove themselves able they are given a badge that proclaims "my computer likes me". This gives them the authority to attend the library at any time and also qualifies them to help other children less able than themselves. They are not allowed to ask the librarians for help, only the organisers of Computertown USA! — or other children. Although all of the programs used are games, they are educational ones and they give the children a grasp of fairly advanced mathematics — for example, the complex problems involved when manoeuvring in deep space. More about this enterprising idea in a future issue of PCW — probably via an *Interrupt* from America.

Ipex International Inc. presented the answer to every editor's prayer — an attachment which can convert the common-or-garden Selectric typewriter into a computer printer. It doesn't alter the appearance of the typewriter because it fits neatly inside, into existing screw holes. It comprises a solenoid assembly (which pulls the appropriate bail bars depending on the letter required), a control unit which can contain the power supply as well as being able to decode the computer's ASCII into the ball select code and, for the S100 user, a card which fits directly into your computer. If you choose the S100 option then the control unit comes minus the power supply. By the way, yes, it does work on the UK power supply. In the USA this ESCON SELECTRIC Interface System costs from \$495. Those interested should contact 16140, Valerio Street, Van Nuys, CA 91405, USA.

Another very interesting product was one made by Nestar . . . called the Cluster-shared microcomputer system. Using this system it's

possible to have up to 65 Apple computers working together in a network. All machines have access to central storage — up to 33 Mbytes of it — thus enabling each machine to work by itself or with others, sharing the same files and communicating. A system was running at the show on which one screen displayed a list of names for whom messages were held in the central system. Anyone seeing their name on the list could walk up to another terminal on the Clusterbus, type in their name (as spelt on the list) and have one or more memos displayed to them. Guy Kewney and I made frequent and good use of this system. Contact Nestar Systems Inc., 430, Sherman Avenue, Palo Alto, CA 94306 for further information. (Any buyers . . . please contact me for a possible future PCW case study).

I talked to a college professor from Canada about Computer Aided Instruction and he told me a true story about his own experience in Vancouver. The day came when some of his colleagues decided to evaluate these new-fangled computer things as teaching aids. Well, what do you think the demonstration packages were designed to teach? Wait for it . . . the use of slide rules and logarithms! It's so awful it's hardly even funny.

Gary Kildall, the man who brought us CP/M and MP/M, is launching PL/1 worldwide on April 15th. I took a picture of him so that you'd all know what he looks like — unfortunately the gremlins got at it and it didn't come out; sorry Gary.

Infoworld is a great bi-weekly newspaper for the micro-computing community. Published in the heart of Silicon Valley, its writers are really in touch with things as they happen. The cost is \$35 per year (\$18 per half year) airmail. Write to Infoworld, 530 Lytton Avenue, Palo Alto, CA 94301. (By the way, it used to be called the *Intelligent Machines Journal*). The publisher is John Craig — the same John Craig that used to edit *Creative Computing*. If there are any dealers out there who'd be interested in selling this or any other magazine from the USA I suggest they contact me at PCW for pointing in the right direction.

Back to Hal Chamberlin and MTU. Professionally thorough and a company to watch, they are reputed to produce the best documen-

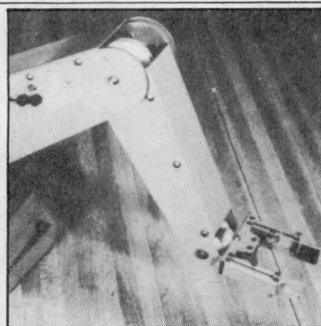

Another exciting product was the Minimover-5. . . a five-jointed, computer controlled arm. It can handle weights up to 8 ounces (even when fully extended), operates within a sphere of 17.5" radius and travels at between 2 and 6 inches per second, depending on the weight being carried. The jaws open to a maximum of 3 inches with a squeezing pressure of between 0 and 3lbs. I saw the arm being driven by a TRS-80, for which a package exists. It will cost around \$1700 plus freight, \$30 for the software and \$19 for a reference and application manual. Contact: Microbot, 1259 El Camino Real, Suite 200, Menlo Park, CA 94025.

tation in the business. They specialise in 6502 products — things like AIM, KIM and SYM floppy disc controllers, visible memory for the PET (with light pen facility) and the excellent four voice sound system mentioned earlier. One day this firm will produce a music compiler to save all the tedious coding of waveform tables and the like. All you'll need to do is feed in the music, dictate the instrument definition and away it will go to compile your music for you. IJJ in Marlborough are their UK agents.



Eric Bakalinsky dreamt up the well-known phrase or saying "Dr. Dobb's Journal of Computer Calisthenics and Orthodontia". He describes himself as an "Interior designer and willing co-pilot for flights of fancy". He also pressed us to publish his phone number, (415) DAFODIL, where he awaits calls from "beautiful women who'd like to join him for chocolate moussee".

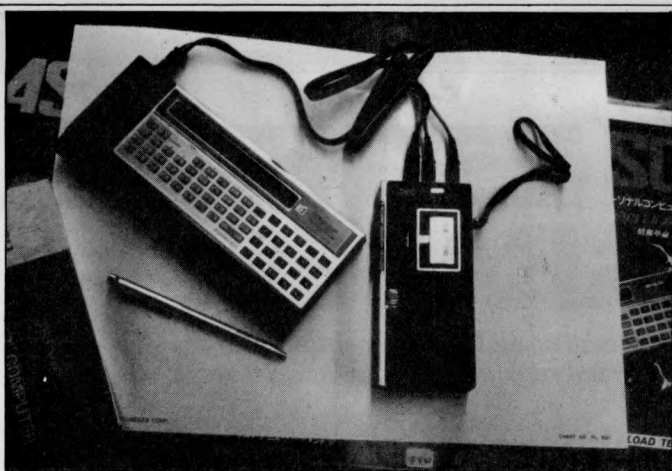

Sharp has produced a hand-held computer which can be programmed in BASIC and here's a picture to prove it. The machine fits into a cradle which in turn connects to a miniature cassette recorder. In America it retails for around \$300 for the 400 byte version or around \$450 for the 1424 byte version. Amazing! What's more, Sharp UK are actively considering marketing it in Britain.

The stringy floppy was as much in evidence as it was at the Las Vegas show. Next month we'll be bringing you a user's report. . . in the meantime those interested could write to Exatron, 3555, Ryder Street, Santa Clara, CA 95051. For those who don't know, a stringy floppy is a cassette drive which powers a continuous loop cassette (of tape length between 5 and 75 feet). The tape is pulled from the centre of a capstan which revolves as the tape is unwound; at the same time the other end of the tape is rewound on to the outside of the same reel. It's used as a mass storage device and far outstrips the performance of a normal cassette drive both, in terms of speed and also because it's possible to access data randomly, without any need to rewind the tape. Maximum tape capacity is 2.88 million a flux change is one bit — you work it out from there, but don't forget the control bits). It's fast, cutting program loading time down from minutes to seconds (e.g. 4K in 6 secs).

Ken Cohn collects Apple programs the way some people collect matchbox labels. He's got over 3600, some of which he's never tried. Is this a record? He belongs to ADAMII (standing for Arizona Desert Apple Menagerie) — what else can I say?

I have to report that Suzanne Rodriguez — editor of Dr Dobbs Journal — is lovely. I took some pictures of her, too, but they didn't come out either — sorry fellas!

Something no enthusiast should be without — A Periodical Guide for Compu-

terists. It lists articles, book reviews, letters and editorials by subject from all the popular computer, radio and electronics magazines — including PCW, of course. The 1979 issue will cost \$5.95 surface (\$7.15 air) while 1976, 77 and 78 cost \$5.00 surface (\$6.00 air). Write to E Berg Publications, 622 East Third, Kimbell, NE 69145 for further information.

John Craig and Hal Chamberlin both reckon that PCW has got a head start over other foreign computer publications in that it's written in a language that they can understand. Such taste and discrimination!

The Atari graphics are super but the word is we may have to wait until the end of the year before the international version is ready — and that means us folks.

Another lovely lady was manning the Syntauri music exhibit. She had a piano type keyboard interfaced to the Apple — through which she was playing some pretty good music. She was able to fiddle around with various parameters at the Apple keyboard thus varying the nature of the notes produced. The sound was nowhere near as good as Hal's but that keyboard interface was so tempting. For further information contact Ellen Lapham, Vaille Associates, 3506, Waverley Street, Palo Alto, CA 94306.

One thing is pretty clear to me and that is that there's as much opportunity in software for us here in the UK as for anyone else. The Canadian chap I talked about earlier had unravelled the innards of the SYM and had been able to define a lot of new BASIC instructions —

making the language really powerful. He hawked his ideas around the show and ended up with a company accepting his ideas and giving him a new machine to enable him to develop them still further. That could have been one of us. I'm sure software is the one area where we can really show the world that Britain is a good match for anyone. Another example is the man who computerised the Luscher colour test. He was running one of the most popular stands at the show, giving personality evaluations based on colour preferences. Another man I bumped into has already proved how good we are. His company, Microfocus, has set up an office in Santa Clara to sell its products in the USA. Their CIS Cobol is the only micro-computer Cobol to have been certified by the US government. Among the big deals they have pulled off are one from Intel and another from Texas Instruments. The company is Microfocus of 58, Acacia Rd., St. John's Wood, London, NW8 6AG. Three cheers for them — if you've got something on the boil that you'd like to show at the next Computer Faire, it will be held on the 3rd — 5th April 1981. Address all enquiries to Computer Faire, 333 Swett Road, Woodside, CA 94062. Don't try to go there, as I did, because all you'll find is one of those American letter boxes on a stick. The building is being constructed. If you want to phone them the number is (415) 851 7075.

Here's a very quick round of the various magazines that caught my eye. (Remember, dealers, if you want to sell them, liaise with me and I may be able to help). *Compute* magazine specialises in the 6502 — uses, products, packages etc. PET,

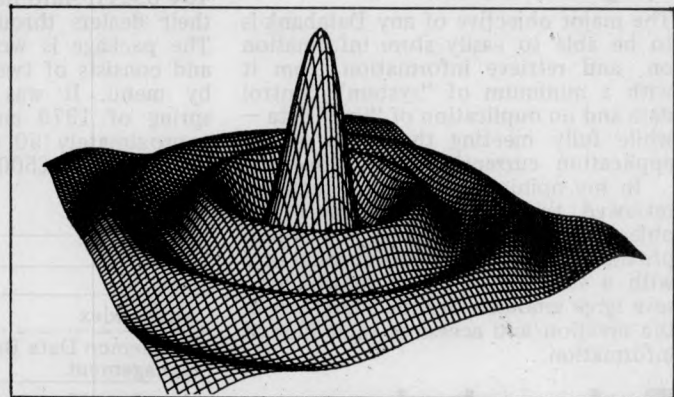

How about this for a bit of plotting? The machine that did it can handle paper 8½" wide by up to 11" long and plot in an area of 8" by 10". In America it costs from \$755 (for Apple II) plus the cost of the software package at \$60. It can be hooked up to a TRS-80 or an S100 system and packs of 4 pens cost \$7.50. Contact Strobe Inc., 897-5A Independence Avenue, Mountain View, CA 94043.

Atari, Apple and single boards all catered for. \$22.50 in US funds drawn on a US bank to Compute, PO Box 5119, Greensboro, NC 27403. 104 pages — good and glossy.

Interested in robots? *Robotics Age*, issued 4 times yearly, is aimed at professional, student and hobbyist. Send \$15 or \$16(air) per annum to Robotics Publishing Corporation, 3410 Marquart, Suite 203, Houston, Texas 77027.

There's a non profit program exchange and they publish 9 times per annum. Get your Apple group to contact them at A.P.P.L.E, 517 11th Avenue E., Seattle, WA 98102. In the USA the one time Apple-cation (ugh!) fee is \$25 and the 1980 sub is \$15.

Dr. "Lux" Luxenberg is the man who runs *SYM-Physis*, the SYM 1 user's group bi-monthly publication. It looks good to me, full of hard information to the equivalent of 20 pages of single spaced typing. As "Lux" says in his introduction ". . . that's a lot of software and documentation for the money". They are quite independent of Synertek. Send a cheque for \$12.50, payable in US Dollars to SYM Users' Group, PO Box 315, Chico, CA 95927.

Finally, my favourite quote from the show. A company mentioned earlier (and who shall remain nameless) tell me that they are being extremely cautious — they want to hold their growth down to 400% this year!

# INFORMATION RETRIEVAL AND DATABASES

*Mike Knight of Mike Rose Micros sifts through all available documentation to present this month's selected report.*

If you were to ask the "man in the street" what his impressions of a computer were, his response would probably be prejudiced by the films he had seen or the TV programs which he watched regularly. How many times has Dr Who been saved by K9? Could Blake really triumph over the Federation without ORAC or ZEN? Even Wonder Woman uses the services of a computer which can instantly tap into any other. Almost daily on our screens, instant responses are given to large numbers of world savers by friendly computers who can call upon enormous banks of data. Of course, a businessman with a micro-computer is not normally expected to save the world. He may, however, wish to run his company more efficiently and to do this he certainly needs to be able to tap the information available within it.

Over the past few months I have reviewed a large number of packages covering most of the functions normally found in any business i.e. Stock Control, Sales Ledger, Purchase Ledger, Payroll and Word Processing. In some cases, particularly in accounting, linkages are provided between the packages. But almost without exception these linkages simply mean that a user of the system can move from one business function to another without resubmitting the basic data entered into the first. In this month's "Systems" I am, therefore, going to look at packages which may enable the businessman to use his computer, not just as a workhorse within the various functions of his company, but as a databank of information which he may call upon as needed.

## Objectives

The major objective of any Databank is to be able to easily store information on, and retrieve information from it with a minimum of "system" control data and no duplication of "live" data — while fully meeting the needs of the application currently being processed.

In my opinion none of the packages reviewed this month fully meet this objective; almost all, however, would provide the business or professional user with a very useful tool with which to save large amounts of time and effort in the creation and access of their files of information.

## Tasks and volumes

I am not going to compare each of the packages this month since there are no common objectives. I'll give instead some indication of the facilities available within each package, in the evaluation section.

## Evaluations

### ANALYST

This package, written by Structured Systems Group Inc. of California, USA, is marketed in this country by Terodec (Microsystems) Ltd of Yateley, Hants (0252 874790). The package is designed to run on any Z80 or 8080 using CP/M with 48K, one disc, printer (80 column min) and a VDU, amounting in all to approximately £3000. Costing £180 it consists of four program segments linked by a menu, written in CBASIC. The manual supplied is reasonably comprehensive but little thought seems to have been given to the small number of examples presented.

The major illustration is of an attorney at law which, even if the American wordage is understood, is not likely (apart from the legal profession) to fill most small business users with confidence. However, even if the illustrations are comprehended, I have some doubts whether the jargon, used extensively throughout, would be. If this communication problem could be overcome I'm sure that the package would be useful to many small businesses. Bought together with the minimum hardware, an installation service is provided for £150; training is provided at £75 per day and maintenance support costs 14% of the retail cost per annum.

The functions available in this package are: define a data file, create or modify a data file, define a report, print a report. Data may be selected by use of up to ten range or match conditions.

### AUTO INDEX

Written by CAP-CPP of London (01-404 0911), Auto Index is available from their dealers throughout the country. The package is written in MicroCobol and consists of twelve programs linked by menu. It was introduced in the spring of 1979 and there are so far approximately 50 users. The list price from CAP is £500 but there may be

some variation in amounts charged by various dealers. The minimum hardware required is a 64K disc system with a 132 ch printer costing between £5000 and £6000.

A user manual is supplied but it's not for the beginner. Firstly, jargon is used throughout, with no accompanying definitions; secondly, although many examples are used the language is, to say the least, unusual. This is a great pity because, if the manual were rewritten in English with the first time business user in mind, it would enhance what I am sure is a fine product. In fact, the sales literature supplied is very good and will undoubtedly attract many small businessmen.

Back up for the package varies according to the dealer who supplies it, but all of them are supported by CAP. The package allows for the following functions; defining the database, building and updating the database, enquiries, maintaining the database and loading/unloading the database. Records are defined as key, attribute or text data and selection from the database can be made from all of the key and attribute portions of the record.

### CROMEMCO DATA BASE MANAGEMENT

This package was written by Cromemco Inc. of California, USA and is available from Computerland in Manchester (061 236 4737) or any of the Cromemco dealers around the country. The package costs £59 and the minimum hardware required is a 64K dual drive Cromemco System 2 costing £2095. First introduced in 1978, the package is written in 16K extended BASIC and consists of approximately 12 programs which are linked, invisible to the user, by a menu.

A user manual is supplied which has obviously been written with the first time user in mind. All jargon where used is explained in laymans terms and each operation is illustrated with examples.

### COSTS

Package	Software	Min Hardware	Total
Analyst	£180	£3000	£3180
Auto Index	£500(+)	£5000(+)	£5500(+)
Cromemco Data Base Management	£59	£2095	£2154
Data Base Management	£32.50	£500	£532.50
DMS	£170	£1800	£1970
Locate	varies	£3000	
Petaid	£45-300	£605-1495	£650-1795
Pagemate	£325	£1495	£1820
Protext	£38.50	£1200	£1238.50

Support during and after installation varies from dealer to dealer but in most cases if the package was supplied together with the hardware, it would be installed and maintained on the same basis, ie. three months warranty and 12% of the total purchase price per annum thereafter. Training on the package would normally be provided free in the dealer's showroom.

The operations available in this package are as follows: create a new database, examine a system layout, enter new data, create sort files, display change and delete records, enquiry, modify the master, change master file and drive assignment and print mailing lists. Selection is done by simple matching criteria.

## DATABASE MANAGEMENT

This product was written by Hubert S Howe and is available from A J Harding (Molimerx) Bexhill-on-Sea, Sussex (0424 220391) or any of their country-wide dealers. It's designed to run on a 16K TRS 80 with cassette, costing approximately £500. A disc version is also available for a 48K TRS-80. The package costs £32.50 and if necessary can be customised. A user manual is supplied which gives a simple overview both of the system and of databases in general. A full telephone backup service is provided during installation although no actual training is available.

Maintenance arrangements depend on the dealer concerned but if necessary the program listing could be supplied. The commands available in the package are as follows: add records to the file, change records, delete records, find an item, justified or format printing, list the file on the VDU, print the file, sort the file, total the items in any numeric field and write the file to cassette or disc. Selection is done by single field matching.

## DMS

Written by Compssoft Ltd. of Guildford, Surrey (0483 39665) DMS is available direct from them or from any of their dealers throughout the south of England. The package consists of two programs written in Microsoft BASIC which are never co-resident but are complementary. The package was introduced in July 1979 and to date has about 46 users.

The minimum configuration is a 32K PET with dual disc drives, costing £1800; the package itself costs £170 for the full version or £95 for each of two smaller versions which are available. The documentation supplied is excellent, a first time user would not only understand but would enjoy reading the first section. If he's daring he might go past the warning issued when the technical section is entered and even there he could probably get well stuck in before realising his mistake. As my secretary said on reading it: "Thank goodness some microcomputer people are real humans!" (You may not have realised that I have three heads and am coloured green.)

As regards support, any bugs found are corrected free of charge together

with any enhancements made to the package. The system is split into three main sections, namely creation of file description, creation and update of individual records and selection and reporting of stored information. Selection is done by matching to preset constants or by any logical comparison of fields or partial fields.

## LOCATE

This system was written by Loveden Computer Services Ltd of Grantham, Lincs (0476 72000) and is available directly from them. The package is written in BASIC and costs vary since it all depends on the amount of personalisation required. It's designed to run on a minimum 24K plus disc configuration although 32K is preferred; the cost of the minimum hardware is approximately £3000. Part of the customisation service is the provision of personalised operating instructions and if necessary that would include telephone backup and training. The facilities available within the package are access, display, change, create and print.

## PETAID

Stage One Computers of Bournemouth (0202 23570) wrote this package and it's available direct from them or from any one of their countrywide dealers. It can be supplied in five different versions, namely sequential tape, sequential disc, random disc, sequential/random disc and indexed sequential disc — costing £45, £130, £180, £220, £300 and £250 respectively — together with an associated utility Extract & Sort costing £75.

The prime use of the package is as a formatted access file management system which will allow the user to create, maintain, examine, and print random access files on PET floppy discs. The package is supplied with a user manual which tends to concentrate on system operation although it does illustrate the instructions with simple examples. The system is designed for the user with no programming experience, yet no attempt has been made to introduce the package in simple English. Computer jargon is used extensively throughout the introduction and while my experience leads me to believe the package would be beneficial to many business users, I have some doubts as to whether they would appreciate it from the description given. However, since there are 300 users of the system, presumably they either went straight to the operating sections relying on a previous demonstration for an overview, or were already knowledgeable about computers.

The minimum hardware required for the package is an 8K PET with two tape drives costing £605 for the tape version and £1495 for the 16K minimum dual disc configuration. Training is offered at £75 per day and maintenance, including updates, costs £100 per annum for written answers to queries submitted on special report forms.

The facilities available within the package are as follows: create a new screen format or file, create a new file

with an existing format, insert amend delete and display records, search and display selected records, and search and print selected records. Selection is done by matching a field or part of a field using any logical function.

## PAGEMATE

A product written by Computhink, California, USA and available from ACT Petsoft Ltd., Newbury, Berks (0635 201131) and Birmingham (021 455 8686) or from any of their Computhink dealers (approximately 150) throughout the country.

The package consists of six programs linked by menu and it costs £325. A manual is supplied which explains the organisation and access to the database; it doesn't, however, give the first time user enough help in creating anything other than the simplest of databases. Petsoft seem to have recognised this since they organise regular courses on the use of the package. With training I believe most businessmen would find it very useful.

The options available are editing, sorting, copying, statistics, listing and diskcopy. Selection criteria are by matching field(s) using any normal logical function.

## PROTEXT

Nigel Dibben wrote this one and it's available from A J Harding (Molimerx), Bexhill-on-Sea, Sussex (0424 220391) or any of their countrywide dealers. It's written in BASIC and costs £38.50. The minimum hardware is a 32K TRS 80 with disc backing store costing approximately £1200. It comes supplied with a manual which is definitely not for the faint hearted. To be fair, A J Harding does warn that the package is not intended for the beginner. A great pity this because the facilities available look just what a small businessman might need and I'm sure that eventually both the software and the manual will be modified for "normal" humans. In the meantime perhaps business users might consider this package when they are fully acquainted with both the machine and programming — until then, be warned.

An installation backup service is provided and maintenance support thereafter depends on the dealer concerned. The facilities available in this package are creation/amendment of datafile structure, creation/amendment of data file, display, print and include, print and exclude. The selection is done by field, partial field or floating field matching using any normal logical criteria.

## Postscript

One other package which I have not had a chance to review is Visicalc, available from Microsense Computers Ltd. Hemel Hempstead (0442 41191). This runs on a 32K Apple armed with at least one Disc II drive. Among the functions available are sum values in list, minimum value in list, maximum value in list and average value in list.

# CHECKOUT

by John Moore

## MICRODATA UV8 EPROM ERASER

*Microdata Computers Ltd is a recently formed company based in Hayes, Middlesex, and the UV8 eraser is their first product on the market. Already a good seller I decided to take a look at it to see what you get for your money.*

The UV8 sells for £97 plus VAT, can erase up to 14 EPROMS at a time, and does so in the surprisingly short time of 8 minutes. The secret lies in driving the UV tube from a high frequency (16 kHz) inverter instead of directly from the 50 Hz mains. This keeps the tube, an 11¼ inch Sylvania germicidal type, continuously ignited instead of letting it flicker at 100 Hz because of the re-ignition every time the mains voltage passes through zero. The result is a much higher intensity than you would normally expect. Microdata tell me they have consulted the tube manufacturers and they confirm there will be no reduction in tube life running it like this. In fact, as the heater is not used, the tube could well last longer than when conventionally driven.

My own home built eraser uses a tube of twice the wattage and takes typically at least 10 minutes to erase a 2708. The UV8 is claimed to take 4 to 7 minutes, and my first tests on a Motorola 2708 showed that complete erasure of all 1024 locations could be achieved in 2 minutes 35 seconds when positioned at the centre of the tube, or 4 minutes 20 seconds at one end. These

times are undoubtedly fast by any standards. They also confirm my findings with my own eraser that the output of UV tubes varies considerably along the length. When four National Semiconductor ICs were tried they took rather longer, between 3½ and 9 minutes. However these were quite old ICs that may have become "sticky": incidentally did you know that some PROMs can go like this if they have been cycled many times? I once had a 2708 that even after two or three dozen consecutive programming runs (with no erasure in between) still had about 3 bits stuck high. I tried the standard cure of baking in an oven for 40 minutes at 400 deg F (the same as for bread!) and this worked wonders. It may be possible that ageing can lengthen the erasure time as well. If a situation like this should arise it's catered for by a switch on the eraser that doubles the exposure time to 16 minutes.

Although the erasure time of the UV8 is internally preset to a nominal 8 minutes, the model under test actually ran for anything from 9 minutes 44 seconds when cold to 8 minutes 34 seconds when hot. This variation arises

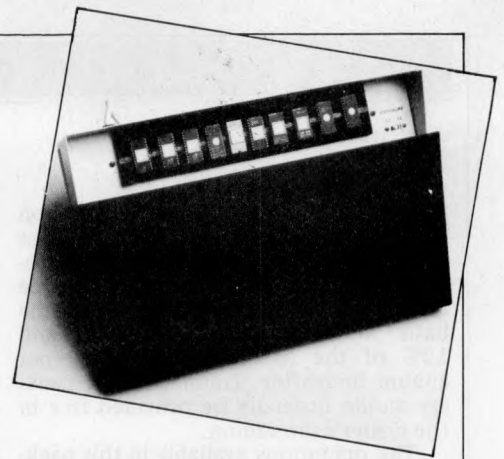

because the timing is derived by division from an RC oscillator that uses ordinary standard temperature sensitive components; however the variation is not usually critical. In any event there is a 100k pot in the circuit which could no doubt be adjusted if necessary to bring the time down a bit.

The case and lid of the eraser are made of good thick aluminium and are very nicely finished. The whole device occupies a bench space of only 7 by 14 inches. There's 4½ feet of 3 core mains lead which is fused at 1 amp and properly earthed inside the case. Surprisingly the exposed live line inside the box passes within only 3/16 inch of the chassis at one point. This is not good practice, but everything seems secure in this area so it doesn't appear dangerous.

When power is applied the circuit automatically resets to prevent the UV light coming on. The PROMs are insert-

*Cont. on Page 128*

# ALTOS

## IN ESSENCE THE BEST IN INTEGRATED CIRCUIT TECHNOLOGY

### Approved Dealers

#### SCOTLAND

**Aethotrol Consultancy Services**, Unit 4, Clyde Workshops, Fullarton Road, Tollcross, GLASGOW. G32 8YL. Tel: 041-641-7758/9.

**Robox Ltd.**, Scottish Calculator and Computer Centre, Unit 14, Audenston Centre, GLASGOW. Tel: 041-221-5401.

**Peter MacNaughton and Associates**, Annfield, GLENALMOND, Perthshire. Tel: 073-888-267.

#### NORTH EAST AND YORKSHIRE

**Shermac Computers Ltd.**, Victoria Industrial Estate, HEBBURN, Tyne and Wear. Tel: 0632-837405.

**Monitor (Data Processing) Ltd.**, Prospect Chambers, 4, Prospect Crescent, HARROGATE, N. Yorks. Tel: 0423-60670.

**Metrodata** Sutcliffe House, 49, Barrack Road, LEEDS 7. Tel: 0532-623788.

**Derwent Electronics Ltd.**, 120, Holgate Road, CITY OF YORK. Tel: 0904-53990.

**Sheffield Computer Centre**, 225, Abbeydale Road, SHEFFIELD, S7 1FJ. Tel: 0742-53519.

#### NORTH WEST

**Computer Business Systems**, 36, Clifton Street, LYTAM, Lancs. Tel: 0253-730033.

**Minicom Business Machines**, Brook Mill, Wrea Green, KIRKHAM, Preston, Lancs. Tel: Kirkham 686617.

**B. & B. Computers Ltd** 24, Newport Street, BOLTON, Greater Manchester. Tel: Bolton 26644.

#### MIDLANDS

**East Midlands Computer Services**, 12, Astle Court, Plains Estate, Arnold, NOTTINGHAM, NG5 6RU. Tel: 0602-267079.

**Evans Jackson**, 92, Monks Road, LINCOLN, LN2 5PG. Tel: 0522-30371.

**Microspecific**, 91, Braunston Road, OAKHAM, Rutland, Leicester, LE15 6LE. Tel: 0572-2528.

**Saba Computer Systems Ltd.**, Scala House, Holloway Circus, Queensway, BIRMINGHAM B1 1EQ. Tel: 021-643-2021.

**CLE-COM**, 8, Stanley Road, King's Heath, BIRMINGHAM. Tel: 021-444-3618 or 021-472-8233.

#### SOUTH WEST

**Validata Services**, 26, High Street, MELKSHAM, Wilts. Tel: 0225-705957.

**Opco Ltd.**, Coln House, Mawley Road, Quenington, CIRENCESTER, Glos. Tel: 0285-75225.

#### BEDFORD

**Starwest Computer Services**, 7 Thurlstone Close, Devon Park, BEDFORD. Tel: 0234-57135.

#### SOUTH EAST INCL. LONDON

**Boyd Microsystems Ltd.**, 4, Ivinghoe Road, BUSHEY HEATH, Herts. Tel: 01-950-0303.

**Computer Systems Analysis**, Ravenscroft, Bulstrode Way, GERRARDS CROSS, Bucks. Tel: 02813-85389.

**Silicon Chip**, 302, High Street, SLOUGH, Berks. Tel: 0753-70639.

**Micro-Market**, 138, Chalmers Way, North Feltham Trading Estate, FELTHAM, Middlesex. Tel: 01-979-9824.

**Systematika**, 36, Montpelier Grove, LONDON NW5. Tel: 01-485-3634.

**Logic Box Ltd.**, 31, Palmer Street, LONDON SW1. Tel: 01-222-1122.

**Profac Computer Services Ltd.**, 100, Park Street, CAMBERLEY, Surrey. Tel: 0276-25247.

**Kewill Systems Ltd.**, 4, Drynham Park, Otlands Chase, WEYBRIDGE, Surrey. Tel: 09322-22448.

#### EAST ANGLIA

**Proloc Computer Services Ltd.**, Fair Close, BECCLES, Suffolk. Tel: 0502-714038.

#### SOUTH

**Software Development Services**, 11, St. Cross Road, WINCHESTER, Hants. Tel: 0962-68956.

**Wendmore Management Services Ltd.**, 180, Bridge Road, Sarisbury Green, SOUTHAMPTON, Hants. Tel: 04895-6318.

#### CHANNEL ISLANDS

**Jersey European Airways**, States Airport, JERSEY, Channel Islands. Tel: 0534-44171.

# LOGITEK

Portland Street, Chorley, Lancs. Tel: Chorley 66803  
also at. 30 Kelvin Avenue, Hillington Industrial Estate, Glasgow G52 4LH  
The exclusive distributors of Altos Computer Products.  
See colour advertisement on Page 66

# HARD COPY ATA SOFT PRICE

One of the most trying tasks in this world is programming a micro-computer while having no facilities for hard copy. Apart from the problem of not being able to print computer art (?), listings or program output cannot be produced and you have no record at all of what was done during the day. In this article, Tim Steele shows the practicalities of "making" a cheap output printer from a "common or garden" teleprinter.

If you know the "right" shops the transformation could cost you as little as £10; a more realistic figure, however, would be £20 - £50. This compares extremely favourably with the so-called "quick" or "screen" printers available and, to my mind, produces better output. As an added bonus, certain machines provide the facility to punch input (programs, etc.) into paper tape off-line while your computer is thinking about something else, and then to run the corrected and (you hope) error-free paper tape into the micro.

Teleprinters come in all shapes and sizes, and you can buy anything from a machine that would sink the Titanic to a small, lightweight, civilised machine not much larger than an electric typewriter. Beware of scrap machines: if you see any rust, blackening or corrosion, steer well clear! If you're thinking of buying one second-hand, try and get it plugged in - at least see if the motor runs - or failing that, turn the governor (the black drum with white stripes on it) in the direction of the white arrow only. If there is any binding or jamming, don't buy it. If you turn the governor the other way, you will lock the thing solid, and possibly break it. Be careful when transporting the machine, it may be heavy, but it's also delicate! Fig. 1 shows some of the more common models available and their prices; they are all made by Creed.

You can also buy a paper tape reader, the Creed 6S6 or 6S6/M for £5 - £10. The suffix /M means that a solenoid is fitted for remote control of tape start and stop. The reader is electrically identical to the keyboard contacts. (See later.)

Most machines are coded with the standard teleprinter code, but some use a special computer code because they were used as computer terminals. It doesn't matter greatly which type of machine you use; the computer-coded variety are easier to write software drivers for, but the teleprinter-coded machines are to be preferred for their compatibility with standard 5-track punched tapes and the Amateur Radio teleprinter transmissions (if that's a field that interests you).

Once bought, commissioning the teleprinter will of course take a little

Machine	Tape Reader	Tape Punch	Price	Fig. 1
7B		X	£5 - £25	
7E		X	£5 - £30	
54		X	£5 - £30	
75	X	X	£30 - £100	
444	XX	XX	£50 - £150	
X = Available Option XX = Installed always				
Meaning of Suffixes				
/RP - Includes tape punch /RO - No Key Board				

time, and it pays to plan everything before you start. If you want to be really thorough, buy the Teleprinter Handbook (from the Radio Society of Great Britain, 35 Doughty Street, London) and clean and adjust the machine in accordance with the instructions. This is not essential, and if you fully understand the technical gobbledegook they use you are well on the way to becoming a teleprinter repairman anyway.

The teleprinter works by using the movements of a solenoid (known as the

magnet) to set up five two-state latches; these determine which character is to be printed. The magnet has two positions - "mark" and "space". To move the solenoid lever from side to side, a current is passed through it one way for "mark" and the other way for "space". To ensure the magnet moves quickly enough, a high voltage (80V) is used and resistors are placed in series to limit the current to 20 mA. The keyboard is an SPDT switch which produces the character when a key is pressed. A typical character is shown in Fig. 4.

It can be seen from this that the character consists of a start pulse, five character elements that are mark or space, and a stop pulse 1½ units long. The extra length is to give the mechanism time to come to rest. After this, the next character can begin. Since the maximum number of characters is 32, a shift key has to

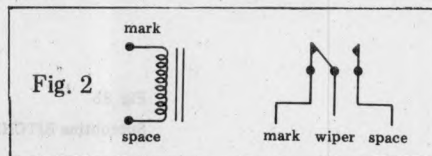

Fig. 2

MACHINE	Magnet Keyboard					"J" Bell	Comments
	m	w	m	wiper	s		
7B	5	3	6	7	8	4 Earth	Prints one character behind
7E	7	9	1	2	3	31 32	
54	7	9	1	2	3	10 11	
75	J	G	Obtain wiring diagram from Creed.			K L	Keyboard wiring complex
444	9	32	13	2	3	27 31	Tape reader M - 1 wiper - 12 S - 3

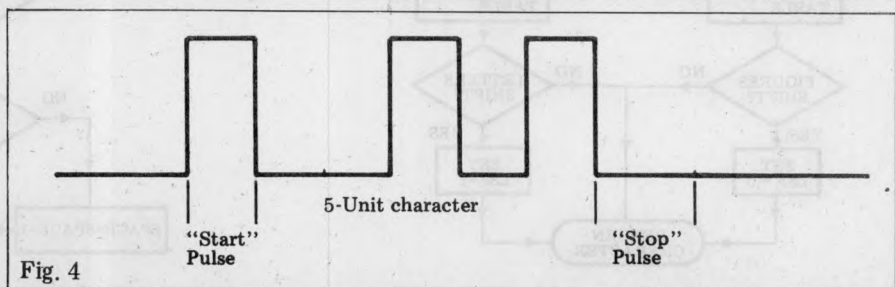
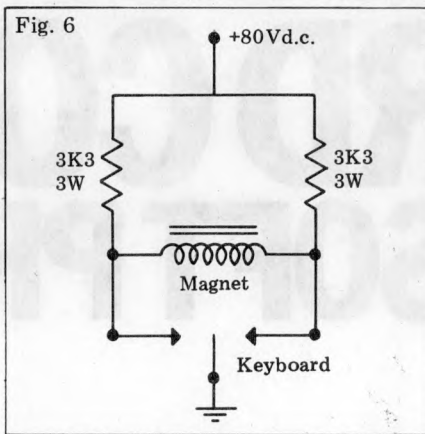

Fig. 4

CODE	Fig. 5	
	Letters	Figures
MMSSS	A	—*
MSSMM	B	?
SMMMS	C	:
MSSMS	D	WRU?
MSSSS	E	3
MSMMS	F	%*
SMSMM	G	@*
SSMSM	H	£*
SMMSS	I	8
MMSMS	J	BELL*
MMMS	K	(
SMSSM	L	)
SSMMM	M	.
SSMMS	N	,
SSSMM	O	9
SMMSM	P	0
MMMSM	Q	1
SMSMS	R	4
MSMSS	S	,
SSSSM	T	5
MMMSS	U	7
SMMM	V	=
MMSSMM	W	2
MSMMM	X	/
MSMSM	Y	6
MSSSM	Z	+
SSSS	CAR RET	CAR RET
MSSMM	FIGS	FIGS
MMMMM	LTRS	LTRS
SMSSS	LINE FEED	LINE FEED
SSMSS	SPACE	SPACE
SSSSS	ALL SPACE	ALL SPACE



be used to determine whether "letter" or "figures" shift is selected. Once having sent "letters" or "figures", the machine stays in that shift until another shift character is sent — a little practice will make this clear. The complete code is reproduced in Fig. 5.

So, assuming that you have the machine in your workshop and you have checked it turns over freely, connect the mains to the motor. If the teleprinter makes a noise like a machine-gun, find the solenoid arm (RHS of machine at front) and push it to its other position. The sound is perfectly normal and does not indicate any damage being done. If it makes loud screaming noises, or goes off bang, blame whoever you bought it from! Now try waggling the solenoid lever from side to side — the machine should print gibberish (assuming you have put paper in). If this test does not work, refer to the Teleprinter Handbook or your scrap merchant. Now press

a key (if the machine has a "HERE IS" key, press that instead) and check that the machine makes buzzing noises.

Having done this, you will probably want to see if it types properly. To do this, hook up the circuit of Fig. 5. If you wish to adjust the speed of the machine, find the black drum on the end of the motor (if the machine has one) and adjust the screw on the rim (first switch the machine off and on again afterwards) until a piece of white paper or tape stuck across a diameter of the disc appears stationary in neon light. Then turn the screw 7½ turns in the "—" direction. This sets the teleprinter up for 45.45 Baud.

All that is left now is to interface the machine to your micro. To type into the micro from the keyboard, the circuit shown in Fig. 7 will suffice. This will send the input high for "mark" and low for "space". Fig. 8 is a flow diagram of a suitable keyboard input routine. Outputting to the printer is slightly harder; I suggest using the circuit of Fig. 9 for this — although other circuits will do as well. Fig. 10 provides a flow diagram of a suitable output routine.

Having wired up your teleprinter,

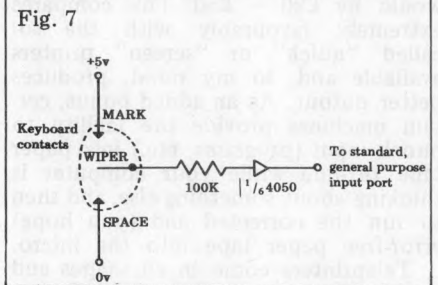

Fig 8a

Subroutine INCH

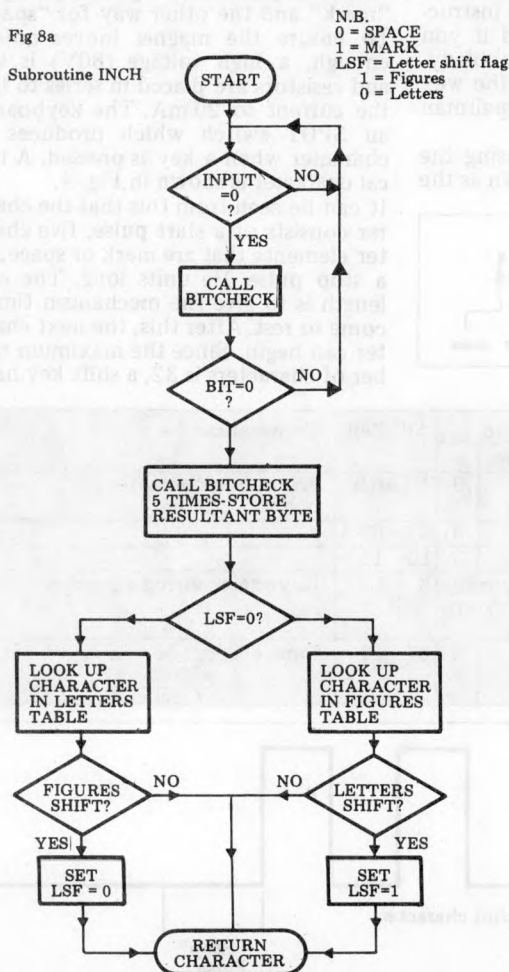

Fig. 8b

Subroutine BITCHECK

N.B.  
K<sub>0</sub> depends on your micro's speed

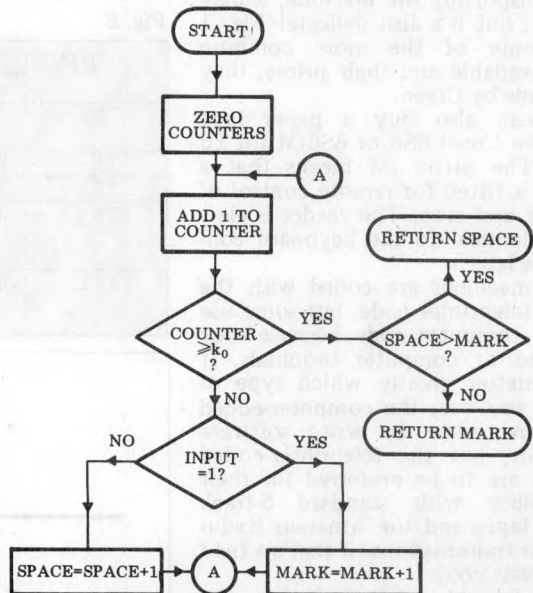
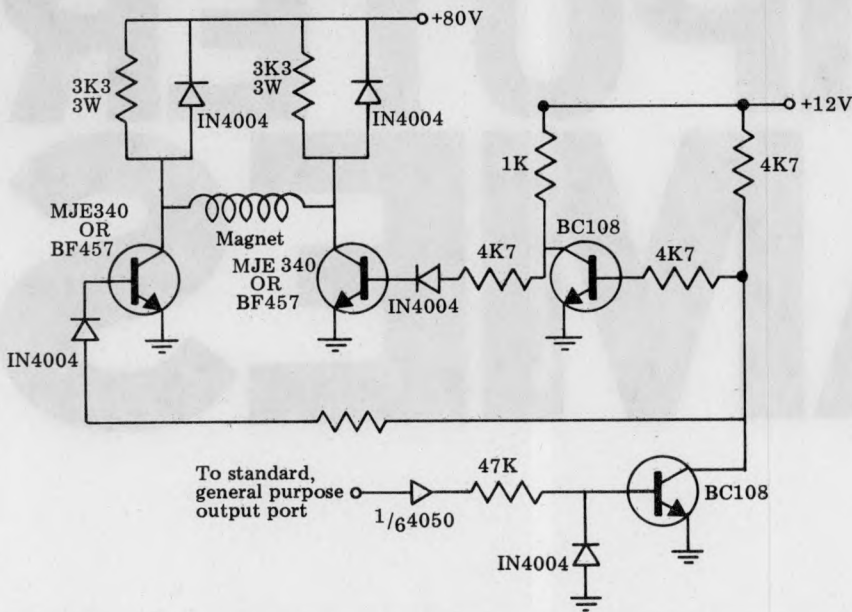

Fig. 9



you are ready to start writing programs. The first thing you may want to do is produce listings on the printer. You can do this using the same LIST routine as your monitor software by shifting the routine somewhere else in memory, correcting the branches and substituting the OUTCH routine for its own.

When you use INCH to input from the keyboard, try to bear these points in mind:-

1 Don't leave it longer than 30 milliseconds before calling INCH again or you may lose characters.

2 Don't forget to call OUTCH after inputting a character so that the character is echoed back to the printer.

Also, you might like to write your input routine so that on pressing "CAR RET" the user gets "CAR RET", "LINE FEED", "(" - (as a prompt).

Fig. 10a

Subroutine OUTCH

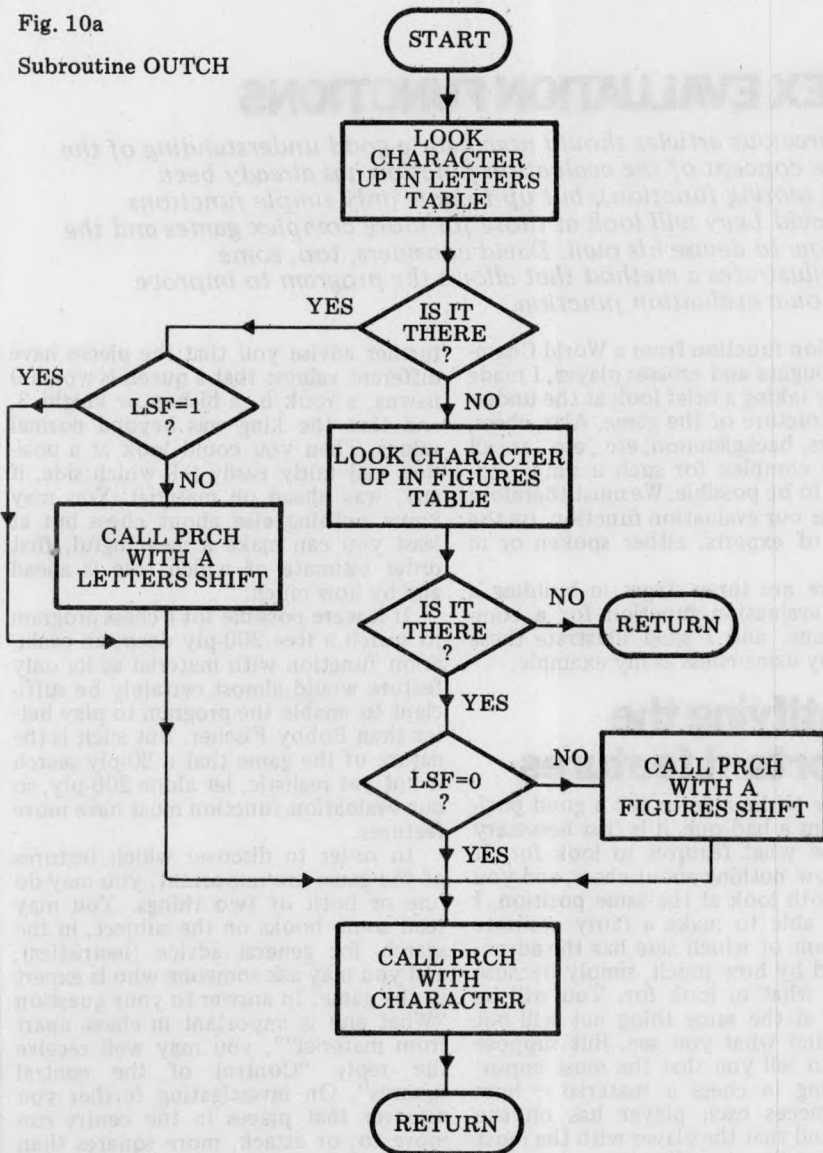
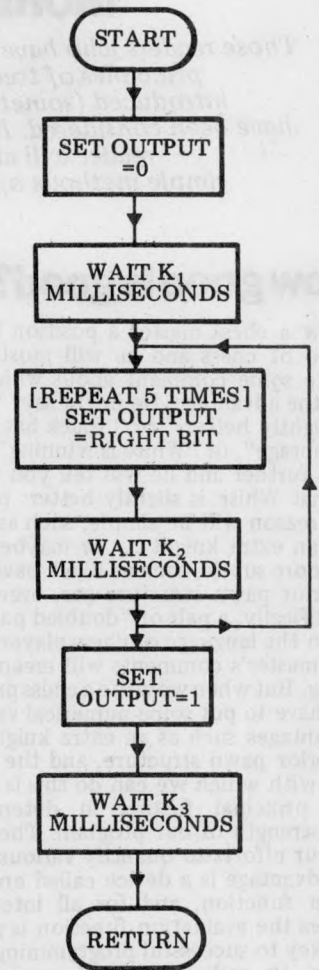
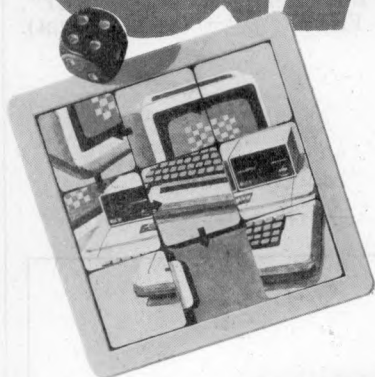

Fig. 10b

Subroutine PRCH



# COMPUTER GAMES



## MORE COMPLEX EVALUATION FUNCTIONS

*Those readers who have followed the previous articles should now have a good understanding of the principles of tree searching. The concept of the evaluation function has already been introduced (sometimes called the scoring function), but up to now only simple functions have been considered. In this article David Levy will look at those for more complex games and the reader will also be shown how to devise his own. David considers, too, some simple methods of learning, and illustrates a method that allows the program to improve its own evaluation function.*

### How good is good?

Show a chess master a position from a game of chess and he will most likely make some comment about which side has the advantage. He might say: "White is slightly better," or "Black has a clear advantage", or "White is winning". Press him further and he will tell you why it is that White is slightly better: perhaps the reason will be simple, such as White has an extra knight . . . or maybe it will be more subtle, such as Black having the inferior pawn structure (or, even more specifically, a pair of "doubled pawns").

In the language of chess players all of the master's comments will mean something. But when we write a chess program we have to put some numerical value on advantages such as an extra knight or a superior pawn structure, and the accuracy with which we can do this is one of the principal factors in determining the strength of our program. The result of our efforts to quantify various forms of advantage is a device called an evaluation function, and for all interesting games the evaluation function is part of the key to successful programming.

In an earlier article I suggested a simple evaluation function for noughts and crosses, the justification for which lies in the fact that only rows, columns or diagonals with moves by one player only (and not his opponent) are of any real interest. Once a row has one move by each player, that row is of no further use to either of them. I did not get this

evaluation function from a World Champion noughts and crosses player, I made it up by taking a brief look at the underlying structure of the game. Alas, chess, checkers, backgammon, etc., etc., are all far too complex for such a simple approach to be possible. We must therefore rely, for our evaluation function, on the advice of experts, either spoken or in books.

There are three stages in building a useful evaluation function for a complex game, and I shall illustrate these stages by using chess as my example.

### Identifying the important features

In order to be able to tell a good position from a bad one, it is first necessary to know what features to look for. If you know nothing about chess, and you and I both look at the same position, I will be able to make a fairly accurate assessment of which side has the advantage and by how much, simply because I know what to look for. You will be looking at the same thing but will not understand what you see. But suppose I were to tell you that the most important thing in chess is material — how many pieces each player has on the board, and that the player with the most pieces usually wins. Then you can count the pieces, and if White has 16 pieces but Black has only 8 you will hazard a guess that White is doing quite well, and in general you will be correct. I could

further advise you that the pieces have different values: that a queen is worth 9 pawns, a rook 5, a bishop or knight 3, and that the king was beyond normal values. Then you could look at a position and fairly easily tell which side, if any, was ahead on material. You may know nothing else about chess but at least you can make a meaningful, first order estimate of which side is ahead and by how much.

If it were possible for a chess program to search a tree 200-ply deep, an evaluation function with material as its only feature would almost certainly be sufficient to enable the program to play better than Bobby Fischer. But such is the nature of the game that a 20-ply search is not yet realistic, let alone 200-ply, so our evaluation function must have more features.

In order to discover which features of the game are important, you may do one or both of two things. You may read some books on the subject, in the search for general advice (heuristics), and you may ask someone who is expert in the game. In answer to your question "What else is important in chess, apart from material?", you may well receive the reply "Control of the central squares". On investigating further you discover that pieces in the centre can move to, or attack, more squares than pieces on an edge or in a corner. And pieces that attack central squares may eventually be able to move to a central square, so attacking central squares is a useful thing to do.

Further questioning, and/or reading, will reveal that if your pieces are getting in each other's way they will not be able to do very much, whereas if they have plenty of scope to move they will be more likely to help you improve your position; thus it is important for your pieces to have as many moves as possible.

Everyone knows that the king is the most important piece in chess, so obviously one should look after one's own king. Expert advice will tell you to keep it away from the centre of the board until the final stage of the game has been reached; castle during the opening stage so as to put your king nearer a corner, where it will be safer than on its original square; and don't rashly advance the pawns in front of it once you have castled. You can learn all this from any decent book on the game.

A fifth feature, whose importance is often underestimated is pawn-structure. Good chess players know that "isolated pawns", that is pawns which do not have any supporting pawns on adjacent columns, are weak, because if the opponent attacks them they can only be defended with something more valuable than a pawn, and it is always best to use your less valuable pieces for defence. Also, it is usually a disadvantage to have "doubled" pawns, i.e. two of your own pawns, one in front of the other, since they will not be able to defend each other and the front one will block its colleague's path.

To summarise this stage of function building: Read some good books on the game and try to get advice from a strong player. You need to know which features in a position are important, and you need to understand why they are important so that you can measure roughly how much of each feature is present in a position.

## Quantifying the features

I have already explained how to measure the material situation in a chess position. The scale of values: queen=9, rook=5, bishop=knight=3, pawn=1 is a very useful guide. Some programmers find that giving the bishop a value between 3 and 3½ leads to a more accurate assessment, but it is useful to work with integer values since integer arithmetic is faster than floating point. So if you do decide to use non-integer values, scale everything up so that the final calculations are all integer.

These values of 9, 5, 3 and 1 are known to work well, though there is no logical explanation as to why they are better than some other set of values. It has simply been shown, throughout the modern history of chess, that a knight is worth roughly three pawns, but that a player with four pawns is better off than a player with a knight, while the man with only two pawns will probably lose to the man with the knight.

Features other than material are not so easy to quantify. This is probably because the material count is something that can be performed quickly by anyone who can add, while a count of (say) the number of squares that your pieces attack is not an easy matter for a human player to accomplish when thinking ahead. Because human players do not use any method of quantifying centre

control, mobility, etc., when playing games against each other, there exists no well-tested set of values for these features. We must therefore devise our own.

In an earlier article I gave a simple evaluation function for solving the 8-puzzle. Since the object of the exercise is to move tiles from their present location to some target location, it seems logical to measure the merit of a configuration by summing the straight line distances that the tiles need to be moved before they will all be on target. Similarly, for any feature in any other game, we look for a logical explanation of why that feature is important, and this will often lead us to a possible method of quantifying the feature. In chess, as we have discovered, control of central squares is important because from the centre of the board a piece exerts more influence (i.e. it attacks more squares) than it does from an edge or corner square. So to determine the relative values of the squares, from the point of view of centre control, we should, perhaps, count how many moves can be made by each piece, on each square, when the remainder of the board is empty. Of course the remainder of the board is never empty, and sometimes it is very cluttered, but this approach does have a logical foundation and provides us with a first order measure of central square values. A detailed discussion of this method can be found in Jack Good's paper, to which I refer in the bibliography.

Let us assume that we decide to assign square values as follows: each of the four central squares counts 4, those next nearest the centre count 3, the next group 2 and those on the edge of the

1	1	1	1	1	1	1	1
1	2	2	2	2	2	2	1
1	2	3	3	3	3	2	1
1	2	3	4	4	3	2	1
1	2	3	4	4	3	2	1
1	2	3	3	3	3	2	1
1	2	2	2	2	2	2	1
1	1	1	1	1	1	1	1

board count 1. We might then count the total centre control for a player by summing the square values on which his pieces stand, or by summing the values of all the squares that his pieces attack. This may sound like a rather ad hoc statement, but the quantification of features is something of a trial and error process. Since you are a computer programmer you must have a logical mind, so apply some logic to the feature in question and you will come up with a quantification that will serve as a useful model.

How easy or difficult it is to quantify a feature varies enormously. To take some more examples from chess: mobility (the freedom of movement of the pieces) may be measured simply by counting how many moves each player has at his disposal. In fact mobility is

the second most important feature in chess, and if you plot (White's mobility - Black's mobility) throughout a master game, you will almost certainly discover that whoever wins the game has a lead in mobility throughout much of its duration. The two key elements of pawn-structure, isolated pawns and doubled pawns, are also easy to measure - we can simply count them.

But what about king safety? This is not so easy because there are so many aspects of the position to take into consideration. The king is usually safest when it hides behind a few of its own pawns, but when these pawns advance they offer considerably less protection. A king is normally much safer near a corner of the board, but not if the opponent has many of his pieces trained on that particular corner. It is usually advisable to castle early in chess, to put the king into safety, but if queens are exchanged during the first few moves it may be better to leave the king nearer the centre, since it will be relatively safe during the middle-game and better placed for the end-game. With so many factors to take into consideration, the quantification of a feature such as king safety can be rather prone to error, but some attempt to do so is essential, so don't be put off if you encounter difficulties of this sort.

## Weighting the features

Having decided which features to include in your evaluation function, and worked out a suitable method of quantifying each of them, you must then decide which of them are the most important, and assign some numerical weighting to each, to indicate its importance relative to the other features.

Let us suppose that we are writing a chess program and that we have decided to employ only two features in our evaluation function, material and mobility. We quantify material using the scale of values given above (9,5,3,3,1) and we measure mobility by counting how many moves each side can make from a given position. Let us denote the material difference (program's material - opponent's material) by  $M_a$ , and the mobility difference (program's mobility - opponent's mobility) by  $M_o$ . If we were to compute a score for a chess position simply by adding  $M_a$  and  $M_o$ , the result would be unrealistic. The reason for this is that one unit of material (in our case one pawn) is not of equal value to one unit of mobility (a move). A pawn is more valuable than a move (other things being equal) and so we must weight the material feature accordingly, multiplying  $M_a$  by some numerical weighting  $W_{M_a}$ . If we set  $W_{M_a}$  at 3, we are telling the program that one pawn is equivalent to three extra moves, so if it sees an opportunity to increase its mobility scores by 4, the program would be willing to sacrifice a pawn to do so.

The best method of arriving at a good set of weightings for an evaluation function is to start with values that seem to be in the right range, and then improve these values in the light of the program's performance. With our two featured chess function, if we were to play a number of games we would almost certainly discover that with  $W_{M_a}$  set at

# Shopping List

Super software from the world's leading microsoftware supplier.

	Software with Manual	Manual Alone
<b>DIGITAL RESEARCH</b>		
<input type="checkbox"/> CP/M* FDOS	— Diskette Operating System complete with Text Editor, Assembler, Debugger, File Manager and system utilities. Available for wide variety of disk system including North Star, Helios II, Micropolis, ICOM (all systems) and Altair. Supports computers such as Sorcerer, Horizon, Cromemco, Ohio Scientific, RAIIR Black Box, Research Machines, Dynabyte, etc.	£75/£15
<input type="checkbox"/> CP/M version 2	(not all formats available immediately)	£95/£15
<input type="checkbox"/> MP/M		£195/£25
<input type="checkbox"/> MAC	— 8080 Macro Assembler. Full Intel macro definitions. Pseudo Ops include RPC, IRP, REPT, TITLE, PAGE, and MACLIB. Z-80 library included. Produces Intel absolute hex output plus symbols file for use by SID (see below)	£55/£10
<input type="checkbox"/> SID	— 8080 symbolic debugger. Full trace, pass count and break-point program testing system with back-trace and histogram utilities. When used with MAC, provides full symbolic display of memory labels and equated values	£45/£10
<input type="checkbox"/> ZSID	Includes Z80 mnemonics, requires Z80 CPU	£50/£10
<input type="checkbox"/> TEX	— Text formatter to create paginated, page-numbered and justified copy from source text files, directable to disk or printer	£45/£10
<input type="checkbox"/> DESPOOL	— Program to permit simultaneous printing of data from disk while user executes another program from the console	£30/£1
<b>MICROSOFT</b>		
<input type="checkbox"/> BASIC-80	— Disk Extended BASIC Interpreter Version 5, ANSI compatible with long variable names, WHILE/WEND, chaining, variable length file records	£155/£15
<input type="checkbox"/> BASIC Compiler	— Language compatible with Version 5 Microsoft interpreter and 3-10 times faster execution. Produces standard Microsoft relocatable binary output. Includes Macro-80. Also linkable to FORTRAN-80 or COBOL-80 code modules	£195/£15
<input type="checkbox"/> FORTRAN-80	— ANSI '66 (except for COMPLEX) plus many extensions. Includes relocatable object compiler, linking loader, library with manager. Also includes MACRO-80 (see below)	£205/£15
<input type="checkbox"/> COBOL-80	— ANSI '74 Relocatable object output. Format same as FORTRAN-80 and MACRO-80 modules. Complete ISAM. Interactive ACCEPT DISPLAY, COPY, EXTEND	£325/£15
<input type="checkbox"/> MACRO-80	— 8080/Z80 Macro Assembler. Intel and Zilog mnemonics supported. Relocatable linkable output. Loader, Library Manager and Cross Reference List utilities included	£75/£10
<input type="checkbox"/> XMACRO-86	— 8086 cross assembler. All Macro and utility features of MACRO-80 package. Mnemonics slightly modified from Intel ASM86. Compatibility data sheet available	£155/£15
<input type="checkbox"/> EDIT-80	— Very fast random access text editor for text with or without line numbers. Global and intra-line commands supported. File compare utility included	£45/£10
<b>EIDOS SYSTEMS</b>		
<input type="checkbox"/> KISS	— Keystroke Sequential Search. Offers complete Multi-Keyed Index Sequential and Direct Access file management. Includes built-in utility functions for 16 or 32 bit arithmetic, string/integer conversion and string compare. Delivered as a relocatable linkable module in Microsoft format for use with FORTRAN-80 or COBOL-80 etc	£190/£15
<input type="checkbox"/> KBASIC	— Microsoft Disk Extended BASIC with all KISS facilities, integrated by implementation of nine additional commands in language. Package includes KISS REL as described above, and a sample mail list program	£295/£25
	To licensed users of Microsoft BASIC-80 (IM BASIC)	£215/£25
<b>MICROPRO</b>		
<input type="checkbox"/> SUPER SORT 1	— Sort, merge, extract utility as absolute executable program or linkable module in Microsoft format. Sorts fixed or variable records with data in binary, BCD, Packed Decimal, EBCDIC, ASCII, floating, fixed point, exponential, field justified, etc. etc. Even variable number of fields per record!	£125/£15
<input type="checkbox"/> SUPER SORT II	— Above available as absolute program only	£105/£15
<input type="checkbox"/> SUPER SORT III	— As II without SELECT/EXCLUDE	£75/£15
<input type="checkbox"/> WORD MASTER Text Editor	— In one mode has super set of CP/M's ED commands including global searching and replacing, forward and backwards in file. In video-mode, provides full screen editor for users with serial addressable-cursor terminal	£75/£15
<input type="checkbox"/> WORD STAR	— Menu driven visual word processing system for use with standard terminals. Text formatting performed on screen. Facilities for text paginate, page number, justify, center, underscore and PRINT. Edit facilities include global search and replace, read/write to other text files, block move, etc. Requires CRT terminal with addressable cursor positioning	£255/£15
<input type="checkbox"/> WORD STAR/MAIL MERGE	— above with option for production mailing of personal documents with mail list from Datastar or NAD	£315/£15
<input type="checkbox"/> DATASTAR	— Professional forms control entry and display system for key-to-disk data capture. Menu driven with built-in learning aids. Input field verification by length, mask, attribute (i.e. uppercase, lowercase, numeric, auto dup., etc.). Built-in arithmetic capabilities using keyboard constants and derived values. Visual feedback for ease of forms design. Files compatible with all CP/M/MP/M supported languages. Requires 32K CP/M	£195/£25
<b>GRAFFCOM</b>		
<input type="checkbox"/> PAYROLL	— Designed in conjunction with the spec for PAYE routines by HMI Taxes. Processes up to 250 employees on weekly or monthly basis. Can handle cash, cheque or bank transfer payments plus total tracking of all year to date figures. Prints emp master, payroll log, payslips and bank giro. Requires CBASIC-2	£475/£15
<input type="checkbox"/> COMPANY SALES	— Performs sales accounting function. Controls payments of invoices and prints sales ledger and aged debtors report. Suitable for any accounting period. Comprehensive VAT control and analysis of all sales invoices. Requires CBASIC-2	£425/£15
<input type="checkbox"/> COMPANY PURCHASES	— Performs purchase accounting function. Controls invoices, credit & debit notes. Prints purchase ledger, aged creditors report and payment advices. Comprehensive VAT control and analysis of all purchases. Interfaces with the ADD system. Requires CBASIC-2	£425/£15
<input type="checkbox"/> GENERAL ACCOUNTING	— Produces Nominal Ledger, Trial Balance, P/L and Balance Sheet. Define your own coding system. Interactive data entry plus optional data capture from Company Sales and Company Purchases. Requires CBASIC-2	£375/£15
<input type="checkbox"/> STOCK CONTROL	— Maintains stock records, monitors stock levels to ensure optimum stock holding. Details include stock desc., product code, unit, unit price, quantity on hand or order/minimum. Stock analysis reports can be weekly, monthly, quarterly etc. Interfaces with Order Entry Invoicing system. Requires CBASIC-2	£325/£15
<input type="checkbox"/> ORDER ENTRY & INVOICING	— Performs order entry and invoicing function. Handles invoices for services and consumable items, part orders and part trends for user-defined period. Interfaces with Stock Control, ADD and Company Sales systems. Requires CBASIC-2	£325/£15
<input type="checkbox"/> ADD	— Complete control of all your names & addresses including suppliers, clients, enquiries etc. Assign your own coding system and select all output via the report generator. Will print anything from mailing labels to directories. Requires CBASIC-2	£225/£12
<input type="checkbox"/> COMPLETE ACCOUNTING PACKAGE	— Combined Company Sales, Company Purchases, General Accounting, and ADD systems	£950/£45
<input type="checkbox"/> SALES ORDER PROCESSING PACKAGE	— Combined Stock Control, Order Entry and Invoicing and ADD systems	£550/£30
<b>STRUCTURED SYSTEMS GROUP</b>		
<input type="checkbox"/> ANALYST	— Customised data entry and reporting system. User specifies up to 75 data items per record. Interactive data entry, retrieval and update facility makes information management easy. Sophisticated report generator provides customised reports using selected records with multiple level breakpoints for summarisation. Requires CBASIC-2, 24 x 80 CRT, printer and 48K system	£125/£10
<input type="checkbox"/> LETTERIGHT	— Program to create edit and type letters or other documents. Has facilities to enter, display, delete and move text, with good video screen presentation. Designed to integrate with NAD for form letter mailings. Requires CBASIC-2	£105/£15
<input type="checkbox"/> NAD Name and Address selection system	— interactive mail list creation and maintenance program with output as full reports with reference data or restricted information for mail labels. Transfer system for extraction and transfer of selected records to create new files. Requires CBASIC-2	£45/£12
<input type="checkbox"/> QSORT	— Fast sort/merge program for files with fixed record length, variable field length information. Up to five ascending or descending keys. Full back-up of input files created. Parameter file created optionally with interactive program which requires CBASIC-2. Parameter file may be generated with CP/M assembler utility	£50/£12
<b>SOFTWARE SYSTEMS</b>		
<input type="checkbox"/> CBASIC-2	— Disk Extended BASIC — Non-interactive BASIC with pseudo-code compiler and runtime interpreter. Supports full file control, chaining, integer and extended precision variables etc.	£75/£10
<b>MICRO FOCUS</b>		
<input type="checkbox"/> STANDARD CIS COBOL	— ANSI '74 COBOL standard compiler fully validated by U.S. Navy tests to ANSI level 1. Supports many features to level 2 including dynamic loading of COBOL modules and a full ISAM file facility. Also, program segmentation, interactive debug and powerful interactive extensions to support protected and unprotected CRT screen formatting from COBOL programs used with any dumb terminal	£400/£25
<input type="checkbox"/> FORMS 2	— CRT screen editor. Automatically creates a query and update program of indexed files using CRT protected and unprotected screen formats. Output is COBOL data descriptions for copying into CIS COBOL programs. No programming experience needed. Output program directly compiled by CIS COBOL (standard)	£100/£12
<b>OTHER</b>		
<input type="checkbox"/> HDBS	— Hierarchical Data Base System. CODASYL orientated with FILES, SETS, RECORDS and ITEMS which are all user defined. ADD, DELETE, UPDATE, SEARCH, and TRAVERSE commands supported. SET or FILE is sorted, FIFO, LIFO, next to prior. One to many set relationship supported. Read/Write protection at the FILE level. Support FILES which extend over multiple floppy or hard disk devices.	

Software for most popular 8080/Z80 computer disk systems including  
**NORTH STAR HORIZON, VECTOR MZ, OHIO SCIENTIFIC,  
 CROMEMCO, PROCESSOR TECHNOLOGY, RAI BLACK BOX,  
 DYNABYTE, SD SYSTEMS, RESEARCH MACHINES, ALTAIR,  
 EXIDY SORCERER, IMSAI, HEATH, and 8" IBM formats**

- Software with Manual / Manual Alone
- MDBS** - Micro Data Base System. Full network data base with all features of HDBS plus multi-level Read/Write protection for FILE, SET, RECORD and ITEM. Compact representation of one to one SET relationships. Supports multiple owner and multiple record types within SETs. HDBS files are fully compatible.
  - MDBS-DRS** - MDBS with Dynamic Restructuring System option which allows altering MDBS data bases when new ITEMS, RECORDS, or SETs are needed without changing existing data.  
 HDBS-Z80 version ..... £135/£25  
 MDBS-Z80 version ..... £395/£25  
 MDBS-DRS-Z80 version ..... £455/£25  
 8080 Version available at £45 extra  
 Z80 version requires 20K RAM. 8080 version requires 24K RAM. (Memory requirements are additional to CP/M and application program.)  
 When ordering HDBS or MDBS please specify if the version required is for 1) Microsoft L80 i.e. FORTRAN-80, COBOL-80, BASIC COMPILER, 2) MBASIC 4, XX, or 3) BASIC-80 5.0.
  - PASCAL/M** - Compiler generates P code from extended language implementation of standard PASCAL. Supports overlay structure through additional procedure and the SEGMENT procedure type. Provides convenient string handling capability with the added variable type STRING. Untyped files allow memory image I/O. Requires 56K CP/M ..... £195/£20
  - PASCAL/Z** - Z80 native code PASCAL compiler. Produces optimised portable reentrant code. All interfacing to CP/M is through the support library. The package includes compiler companion macro assembler and source for the library. Requires 56K and Z80 CPU. Version 2 includes all of Jensen/Wirth except variant records ..... £155/£15  
 Version 3 Upgrade with variant records and strings expected 2/80 ..... £205/£15
  - PASCAL/MT** - Subset of standard PASCAL. Generates ROMable 8080 machine code. Symbolic debugger included. Supports interrupt procedures, CP/M file I/O and assembly language interface. Real variables can be BCD, software floating point, or AMD 9511 hardware floating point. Version 3 includes Sets, Enumeration and Record data types. Manual explains BASIC to PASCAL conversion. Source for the run time package requires MAC (See under Digital Research). Requires 32K ..... £135/£20
  - TINY C** - interactive interpretive system for teaching structured programming techniques. Manual includes full source listings ..... £45/£30
  - BDS C COMPILER** - Supports most major features of language, including Structures, Arrays, Pointers, recursive function evaluation, linkable with library to 8080 binary output. Lacks data initialization, long & float type and static & register class specifiers. Documentation includes "C" Programming Language book by Kernighan & Ritchie ..... £60/£10
  - WHITESMITHS' C COMPILER** - The ultimate in systems software tools. Produces faster code than Pascal with more extensive facilities. Conforms to the full UNIX Version 7 C language, described by Kernighan and Ritchie, and makes available over 75 functions for performing I/O, string manipulation and storage allocation. Compiler output in A-Natural source. Supplied with A-Natural. Requires 60K CP/M ..... £325/£20
  - POLYVUE/80** - Full screen editor for any CRT with XY cursor positioning. Includes vertical and horizontal scrolling, interactive search and replace, automatic text wrap around for word processing, operations for manipulating blocks of text, and comprehensive 70 page manual ..... £70/£12
  - POLYTEXT/80** - Text formatter for word processing applications. Justifies and paginates source text files. Will generate form letters with custom fields and conditional processing. Support for Daisy Wheel printers includes variable pitch justification and motion optimization ..... £45/£10
  - ALGOL 60 Compiler** - Powerful block-structured language featuring economical run time dynamic allocation of memory. Very compact (24K total RAM) system implementing almost all Algol 60 report features plus many powerful extensions including string handling, direct disk address I/O etc. Requires Z80 CPU ..... £110/£12
  - Z80 Development Package** - Consists of (1) disk file line editor, with global inter and intra-line facilities; (2) Z80 relocating assembler, Zilog Mostek mnemonics, conditional assembly and cross reference table capabilities; (3) linking loader producing absolute Intel hex disk file for CP/M LOAD, DDT or SID facilities ..... £50/£12
  - ZDT** - Z80 Debugger to trace, break and examine registers with standard Zilog/Mostek mnemonic disassembly displays. Facilities similar to DDT £20 when ordered with Z80 Development Package ..... £30/£7
  - DISTEL** - Disk based disassembler to Intel 8080 or TDL/Xitan Z80 source code, listing and cross reference files. Intel or TDL/Xitan pseudo ops optional. Runs on 8080 ..... £35/£7
  - DISILOG** - As Distel to Zilog Mostek mnemonic files. Runs on Z80 only ..... £35/£7
  - TEXTWRITER III** - Text formatter to justify and paginate letters and other documents. Special features include insertion of text during execution from other disk files or colisole, permitting recipe documents to be created from linked fragments on other files. Has facilities for sorted index, table of contents and footnote insertion. Ideal for contracts manuals, etc. .... £75/£3

- Software with Manual / Manual Alone
- POSTMASTER** - A comprehensive package for mail list maintenance that is completely menu driven. Features included keyed record extraction and label production. A form letter program is included which produces neat letters on single sheet or continuous forms. Compatible with NAD files. Requires CBASIC 2 ..... £85/£10
  - XASM-68** - Non-macro cross assembler with nested conditionals and full range of macro operations. Assembles from standard Motorola MC6800 mnemonics to intel hex ..... £115/£15
  - XASM-65** - As XASM-68 for Intel Technology MCS-6500 series mnemonics ..... £115/£15
  - WHATSI7?** - Interactive data-base system using associative tags to retrieve information by subject. Hashing and random access used for fast response. Requires CBASIC ..... £70/£15
  - XYBASIC Interactive Process Control BASIC** - Full disk BASIC features plus unique commands to handle bytes, rotate and shift, and to test and set bits. Available in integer, Extended and ROMable versions.  
 Integer Disk or Integer ROMable ..... £165/£15  
 Extended Disk or Extended ROMable ..... £215/£15
  - SMAL/80 Structured Macro Assembly Language** - Package of powerful general purpose text macro processor and SMAL structured language compiler. SMAL is an assembler language with IF-THEN-ELSE, LOOP-REPEAT-WHILE, DO-END, BEGIN-END constructs ..... £40/£10
  - SELECTOR III-C2** - Data Base Processor to create and maintain multi Key data bases. Prints formatted, sorted reports with numerical summaries or mailing labels. Comes with sample applications including Sales Activity, Inventory, Payables, Receivables, Check Register, and Client/Patient Appointments, etc. Requires CBASIC Version 2. Supplied in source code ..... £185/£12
  - CPM/374X Utility Package** - has full range of functions to create or re-name an IBM 3741 volume, display directory information and edit the data set contents. Provides full file transfer facilities between 3741 volume data sets and CP/M files ..... £125/£7
  - BASIC UTILITY DISK** - Consists of (1) CRUNCH-14 Compacting utility to reduce the size and increase the speed of programs in Microsoft Basic and TRS-80 Basic. (2) DPFUN - Double precision subroutines for computing nineteen transcendental functions including square root, natural log, log base 10, sin, arc sin, hyperbolic sin, hyperbolic arc sin, etc. Furnished in source on diskette and documentation ..... £30/£10
  - THE STRING BIT** - Fortran character string handling.  
 (M) Routines to find, fill, pack, move, separate, concatenate and compare character strings. This package completely eliminates the problems associated with character string handling in FORTRAN. Supplied with source ..... £30/£10
  - BSTAM** - Utility to link one computer to another also equipped with BSTAM. Allows file transfers at full data speed (no conversion to hex), with CRC block control check for very reliable error detection and automatic retry. We use it! It's great! Full wildcard expansions to send \*.COM, etc. 9600 baud with wire, 300 baud with phone connection. Both ends need one. Standard and M versions can talk to one another ..... £75/£5

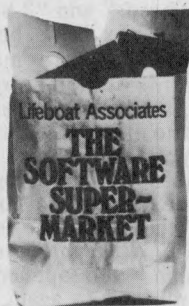

Orders must specify disk type and format, e.g. North Star-Horizon single density.

Add VAT to orders for software (not manuals alone) Add 50p per item postage and packing (minimum £1)

All orders must be prepaid (except COD or credit card) Make cheques POs etc payable to Lifeboat Associates.

Manual costs are deductible from subsequent software purchase

**Lifeboat Associates**  
 32 Neal Street  
 London WC2H 9PS  
 01-379 7931

(M) Modified version available for use with CP/M as implemented on Heath and TRS-80 Model 1 computers.

(L) User license agreement for this product must be signed and returned to Lifeboat Associates before shipment may be made.

\*CP/M is a trademark of Digital Research  
 \*\*Z80 is a trademark of Zilog Inc.

The Software Supermarket is a trademark of Lifeboat Associates.  
 EFFECTIVE MARCH 1980

3, the program would not be sufficiently careful about its own pieces, and that as WMa was increased to 5 or 6 the program's performance would also improve. The task becomes more difficult and more time consuming when using a multi-feature function. I would recommend building up your function slowly, starting with two features and getting their weightings adjusted satisfactorily, then adding a third feature and adjusting its weighting while keeping the other two constant, then add your fourth feature, and then add new ones in descending order of importance. As you add each new feature you should carry out some experiments, if you have sufficient memory, by playing the new version of the program against the previous one. You may discover that the addition of a particular feature, while giving a more accurate position assessment, results in such an increase in computation that the program can search only a much smaller tree and the end result is weaker play.

## Making your program learn

You will have gathered from the previous paragraph that it is often a very time consuming and difficult matter to reach an optimal set of weightings for your evaluation function. One way to help overcome this is to make the program learn from its experience and improve its own evaluation function!

A simple example is the case of our two featured chess function:

$$WMA \times Ma + Mo$$

We could modify our program so that it was able to play against itself, using two different values of WMa in each of the two "versions" of the program. If we start out in total ignorance, we could make WMa=1 in version 1, and WMa=100 in version 2. We then set the program to play a large number of games against itself, in half of which version 1 would be White and in the other half it would be Black. At the end of the series we would discover that version 1 had lost almost all, if not all, of the games. (I have already explained that one pawn is worth much more than one move.) We then set WMa to be 2 in version 1 (or we could reduce WMa in version 2) and keep the other value constant. After another series of games we would find that version 1 still lost very heavily, but possibly not quite so heavily as in the first series. If WMa was kept at 100 in version 2, we would discover that as the value of WMa reached 3 in version 1, version 1 would start to win a few games; when it reached 4 or 5 its results would improve considerably, and by the time WMa was 6 it would possibly be outscoring the version with WMa=100, because although material is more important than mobility there are situations in which the sacrifice of a pawn or two can advantageously increase a player's mobility, and WMa=100 will never recognise those situations.

This process of adjusting the weighting in accordance with the program's results can, of course, be fully automated, so you could switch on at night, go to sleep for a week, and when you woke up your program would be play-

ing like a Grandmaster. But with more than two features in the evaluation function this type of learning process can be difficult to operate — the self-learning reaches a local peak in the n-dimensional surface representing the various possible weightings and their results (n is the number of features), and it becomes difficult to climb out of the local peak in the search for a global peak. A method of overcoming this problem was discovered by Arthur Samuel, author of a famous draughts (checkers) program, but more about that in a moment. First I would like to describe a simple method of learning called "Boxes", which can be applied to equally simple games with surprisingly effective results.

## Boxes

Boxes is a method of decision taking that allows for a certain amount of program learning. A task (such as making the best move in a game) is split up into a number of sub-tasks (such as making a move in a particular game position) and a box is assigned to each sub-task. Inside the box is the information that is used by the program to guide its decision, and this information can be updated in the light of the program's experience.

Boxes was originally tested on the game of noughts and crosses. Donald Michie has calculated that there are 288 essentially different positions with which the player moving first may at some time be confronted. To each of these 288 positions is assigned one box (matchboxes were used) and inside each box there are a number of beads. The beads each have a number on them, the numbers indicating vacant elements in the noughts and crosses array (i.e. places in which the box "program" can make its next move). If one box corresponds to a situation in which elements 1, 2 and 3 are vacant, then that box will start out life with an equal number of "1 beads", "2 beads" and "3 beads".

When this box is opened (i.e. when the "program" has to make a move from the configuration corresponding to that box), a bead is drawn out at random, and the move is made according to the number on that bead. The bead is then replaced but the "program" makes a note of the fact that this box was used, and that the bead chosen was (say) numbered 2. When the game is over, the boxes which were opened during the game are referred to again. If the "program" won the game, then each box used during the game has one bead added to it, the number on the new bead corresponding to the move made from that box. If the game was a draw the contents of the box remain unchanged, but if the game was lost then one bead is removed from each box in order to reduce the probability that the same move will be played again should that situation ever arise in a future game.

The interested reader is referred to the paper (1968) by Michie and Chambers, which is mentioned in the bibliography. The authors describe how the boxes method, with some modification, learned so well that it could win at noughts and crosses between 75% and 87% of the time when it had played a series of 1,000 games against a program which played first in every game and always moved at random. Of course

methods such as this are far too simple to be able to cope with games of the complexity of chess or bridge, but it is interesting to see how effective a learning mechanism it can be in a simple environment.

## Samuel's draughts program

Probably the most famous game playing program up to the late 1960s was the draughts (checkers) program written by Arthur Samuel of IBM. I shall be discussing Samuel's work in some detail in a future article so here I shall restrict myself to a description of two methods of learning which the program employed.

The simpler of the two methods is called rote learning. Each time the program conducts a tree search from a position (the root of the tree), it provides an evaluation of this position based on the results of the look-ahead search. This evaluation is therefore more accurate than the evaluation which would be achieved by applying the evaluation function directly to the root position. Thus the evaluation of the root position is stored, together with the position itself, and when the program next encounters the same position, but as a terminal node, instead of applying the evaluation function to the terminal node it looks up the stored evaluation. The process is relatively fast, since the positions can be hash coded and stored in such a way as to make retrieval easy; it results in more accurate play because the evaluation taken from the store is more reliable than a superficial evaluation. The obvious disadvantage of this method, from the micro-user's point of view, is the large memory required to make effective use of the rote learning process. (By the time that the program reached the peak of its playing ability, quite a high proportion of all reasonable draughts positions were in its store, and the program played at or near championship level).

A more generalised approach to learning was Samuel's method for the self-modification of the weightings in the evaluation function. Samuel used the argument that if an evaluation function was ideal, the score obtained by applying the function directly to a position would be the same as the score obtained as a result of a look-ahead search from that position. The fact that the two scores are often different was employed in the following way.

Let us assume that our evaluation function has three features, A, B and C, and that the features are weighted with WA, WB, and WC respectively, so that the whole function is expressed as:

$$(A \times WA) + (B \times WB) + (C \times WC) = \text{score}$$

where A, B and C are the quantities present of each feature. We shall denote the backed-up score for a root position by  $S_b$ , and the score which was backed-up to that same position during the previous tree search (two ply ago) as  $S_p$ . Note that if the tree search is normally n-ply, the score  $S_b$  will be the result of an n-ply search, whereas the score  $S_p$ , although arrived at during an n-ply search, is only the result of a search to depth n-2.  $S_b$  is therefore a

more reliable score than  $S_p$ .

Samuel computed, for each such pair of values, the difference, which he called delta. If  $S_b - S_p$  (i.e. delta) was positive, then he argued that  $S_p$  was in error and terms in the evaluation function which contributed positively should have been given more weight, while features which contributed negatively should have been given less weight. Whenever delta was negative he used the converse argument that features which contributed negatively should have been given more weight, and those which contributed positively should have been weighted less.

Samuel kept note of the correlation existing between the signs of the individual feature contributions (i.e. the signs of A, B and C) and the sign of delta, and he updated these correlation coefficients after every move of a game. He then selected the feature with the largest correlation coefficient (other than material advantage, which is always the most important feature), and he set the weighting for this feature at a prescribed maximum value, with the weightings of the other features adjusted in accordance with their correlation coefficients. In fact Samuel set all the weightings to be integer powers of 2, so that if the ratio of two correlation coefficients lay between  $n$  and  $n+1$  then the ratio of their feature weightings would be  $2^n$ . (If a correlation calculation gave rise to a negative sign, the sign associated with the weighting itself would be reversed.)

The obvious advantage of Samuel's generalized learning method is that it can be implemented on a microcomputer with little difficulty, because it is

not necessary to store an enormous number of board positions. When your program makes a move from the root of the tree, you need only store all the 2-ply positions in the relevant part of the tree together with their backed-up scores. (In chess this would normally be in the region of 36 positions, in checkers probably less than 10). A problem arises when the alpha-beta algorithm prunes off the branch actually selected by the program's opponent, since the relevant 2-ply position will not have been stored, but it is reasonable to argue that this will only happen when the opponent makes a mistake (or a move which the program thinks is a mistake), so such instances could be ignored. More accurately, if the program's opponent makes an unexpected move, before computing its reply move the program could first re-examine the relevant part of the tree from the previous root position, searching along the path represented by the opponent's move. This refinement would permit the program to take into consideration the  $S_b$  and  $S_p$  comparison for positions which, in the first instance, had been pruned away.

### Task for the month

Write a noughts and crosses program, using an evaluation function in which the features are:

- $c_3$ : The number of cross' "3-rows" (i.e. the number of rows containing 3 crosses).
- $c_2$ : The number of cross' 2-rows (2 crosses and an empty space).
- $c_1$ : The number of cross' 1-rows (1

cross and two empty spaces).  $n_3$ ,  $n_2$  and  $n_1$ : Corresponding features for noughts.

Your program should perform a 3-ply exhaustive search (without alpha-beta pruning) and the evaluation function should start with all weightings equal. Modify your exhaustive search noughts and crosses program ("Task of the Month" in article 3) so that it can act as a sparring partner for the present program, and set the two programs playing each other. After every move of every game, the 3-ply search program should modify its weightings using Samuel's method. After each game, print out (or display, if you have no printer) the result of the game and the new weightings in the evaluation function. Observe how the 3-ply program improves its performance.

### Bibliography

Chambers, R.A., and Michie, D: *BOXES: an experiment in adaptive control*. Machine Intelligence 2 (Ed. Dale, E. and Michie, D.), Oliver & Boyd, 1968, pp. 137-152.

Good, I.J.: *A five-year plan for automatic chess*. Machine Intelligence 2 (ed. Dale E. and Michie, D.), Oliver & Boyd, 1968, pp. 89-118.

Samuel, A.L.: *Some Studies in Machine Learning Using the Game of Checkers*. I.B.M. Journal of Research and Development, vol. 3, 1959, pp. 211-229. (reprinted, with minor additions and corrections, in *Computers and Thought*, edited by Feigenbaum and Feldman, McGraw-Hill, 1963).

## CALCULATOR CORNER EXTRA

# PUTTING SOME THOUGHT INTO CALCULATORS

"Noughts and Crosses" is not one of the world's more intellectually demanding games to play; to program a computer to play it is more challenging, but it's now so thoroughly worked out that David Levy, in his excellent series on games, sets "noughts and crosses" programs as homework exercises for the reader!

So why, you'll be asking, are we publishing a noughts and crosses program? This example, written by Peter Brooks (a medical researcher from Oxford), is interesting for three reasons. 1. It's written for a programmable calculator (the increasingly popular Casio FX502P) and despite using less than 256 bytes and 18 memories, it nevertheless plays an "intelligent" game. This must surely make it one of the most compact strategic games programs around.

2. The programs structure will repay study, as it makes ingenious use of data-packing, indirect addressing and subroutine calling to achieve its brevity. It shouldn't be too hard to translate into other calculator dialects, or into machine code/assembler for Mk 14, Acorn and the like, or to incorporate it into a more sophisticated game program (3D for instance).

3. The way the program has been docu-

mented is exemplary. Would that all the programs we receive, whether in BASIC or whatever, were as comprehensively explained as this one.

### Movescoring

The opponent's moves are given a weighted value of 4 against the calculator's move value of 1. Because of the method used by the program of testing for a calculator win (it checks to see if the move made was in response to a match with a comparison value for a possible win line — i.e., a line in which one position is empty, and the other

two positions are held by the calculator — rather than making the move and then searching again to find out whether a winning line has been made), the opponent's move value is low enough to prevent a line of two opponent's moves and one empty position adding up to a two-digit number, but large enough to enable a distinction between lines with only one position occupied (by the opponent) and lines with two positions occupied (both by the calculator). The full list of values given by different line positions can be found in the table below.

It can be seen from the above that the only positions worth considering are

Occupied by Calculator	Occupied by Opponent	Total line Value
0	0	0
0	1	4
0	2	8
0	3	12 (this position not tested for)
1	0	1
2	0	2
3	0	3 (this position not tested for)
1	1	5
2	1	6 (this position not tested for)
1	2	9 (this position not tested for)

those in which the calculator already has one or two moves; those in which the opponent has one or two moves; those in which neither player has any moves; and those in which both players have one move each, leaving one position empty. After some trial and error, the preferable (or one of the preferable) sequences to test was discovered to be 2, 8, 4, 1, 5, 0 (with the possibility of interchanging the last two numbers). Originally it appeared that a good rule of thumb for the strategy sequence was 2, 8, 1, 4, 5, 0, but more often than not the calculator forced a win upon the opponent (i.e., if all the opponents did was to block calculator winning lines, and not attempt to create their own winning lines, they would win because the sequence of moves made by the calculator would result in the creation of opponent winning lines by default. If you don't believe me, try the exchanging 1 and 4 in the instruction ".28415 Min .1 Min .F" in the program, and playing a few games).

The strategy therefore is to search for the following:

- 2 : winning line for calculator — move to win
- 8 : winning line for opponent — move to block
- 4 : one move made by opponent — move to disrupt possible opponent strategy.
- 1 : one move made by calculator — move to create possible winning line
- 5 : two out of three positions occupied by opponent and calculator — move into position left
- 0 : empty line — move into centre position of the line.

In tactics terms, the priority is: Win/Block/Disrupt/Possible win/Complete

disrupted line/Begin line. The number is entered as a fraction in the program because fewer steps are required to extract the values one at a time from the sequence; e.g.,  $.28415 \times 10 = 2.8415$ ; the fractional part is already in the correct position for storing back in the working memory, and the integer part is easily separated from the whole number and stored in the comparison memory ready for testing.

## Move making

Once a subroutine returns and the total score for the particular line matches the value tested for, the program jumps to a section that determines which position the calculator will move into according to a rule of thumb.

The rule is to move into the centre position of the line if unoccupied, and to the end positions (whichever is unoccupied) if occupied. Again the positions are stored as a fraction to enable easy operation to extract the moves in the right sequence.

The decision as to which line to search first (i.e., 1-2-3, 4-5-6, 7-8-9, etc) was purely arbitrary; the only drawback is that because the program only searches until the number returned by the subroutine matches the strategy value, other possible matches are not searched for, so the calculator will, quite frequently, ignore positions which are, tactically, highly advantageous to it. That will apply especially to positions where one move can create two winning lines — the opponent can only block one of them, and so the calculator would automatically win. This might perhaps give the opponent a better game; certainly it's not difficult to draw. But it also opens up possibilities for ex-

perimentation with the program for those seeing the effect of different strategies (which might help underline some of the points in David Levy's series on Computer Games). Juggling with the section on subroutine calling could conceivably remove redundant searching; the only limit to the experiments would be the user's imagination.

The subroutines are called, incidentally, in reverse numerical order; that is, P8 first — the reason for this is, again, that fewer steps are involved.

## Symbols used in the program listing

After seeing the difficulties experienced by the magazine over correct printing of certain symbols in listings, I have attempted to avoid, wherever possible, the use of symbols which could be misinterpreted. I have therefore chosen to use standard computer symbols in two cases: the asterisk "\*" in place of the multiplication sign (to avoid confusion with X), and the oblique "/" in place of the division sign (to avoid confusion with the minus sign). I could not think of a viable alternative to the decimal point (except perhaps dp or D, but that could still lead to problems) so it has been left in the lap of the gods (!). I have also included all INV second function statements for clarity if not brevity.

## Input-output protocol: Summary

1. Initialise: press PO
2. If Opponent is to move first go to (3) Otherwise calculator moves first: press EXE, move displays
3. Key move using layout of numbers 1 — 9 on keypad: press EXE; calculator's response appears after about 9 seconds
4. Further opponent's moves entered as in (3)
5. If calculator wins, flashes winning move alternating with '2'
6. If game drawn, last move made is flashed, alternating with '9'
7. Sequence of moves made in a game may be recalled (before re-initialisation) using MR .4
8. Attempted entry of illegal moves will cause opponent to lose the chance to move, the sequence record will show that the opponent attempted to cheat, and the calculator takes the move instead.
9. Display format:

M.123456789ON

where M = calculator's move; 123456789 = board positions, with '1' for calculator's position, '2' for opponent's; N = number of moves made so far.

10. While the HLT status indicator is visible, a game is in progress, and moves may be entered whenever the display settles.

## Input-output protocol

1. To start a game press PO. The HLT status indicator will appear, and the display will show zero.
2. Decide whether the calculator or the opponent is to move first. If the opponent is to move first, go to (3). If the

CASIO fx502P : NOUGHTS AND CROSSES PROGRAM : OUTLINE FLOWCHART

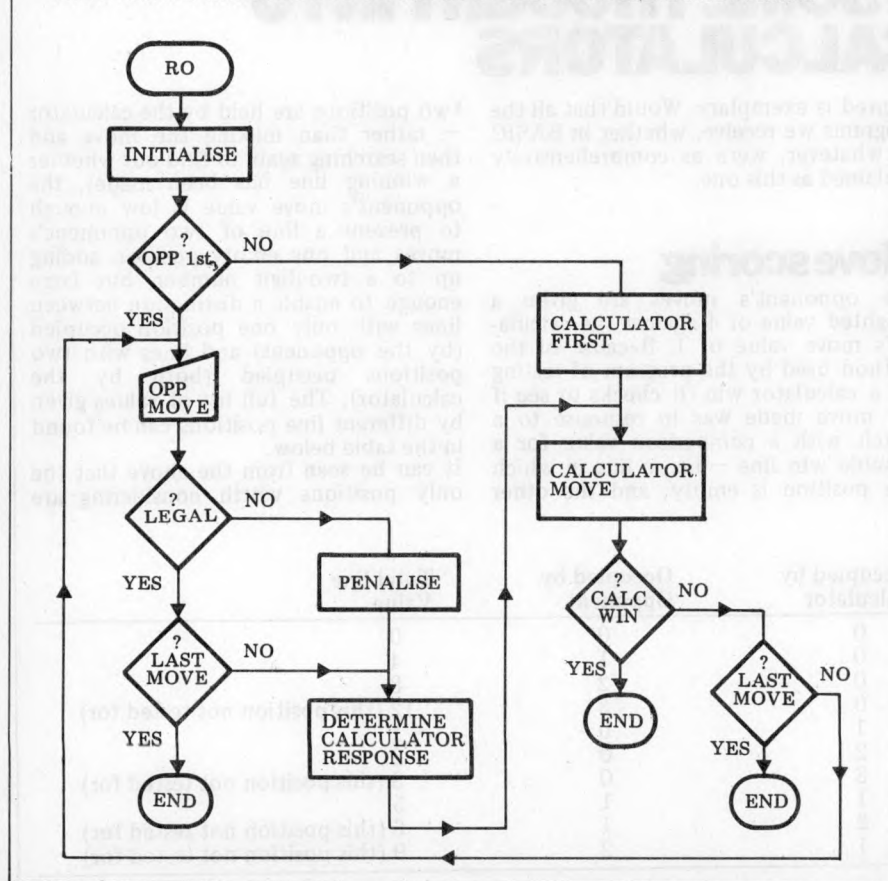

calculator is to move first, press EXE and the display will show the first move thus:

5.000010000<sup>0 1</sup>

where 5 is the move position .000010000 is the entire board position, numbered 1 to 9, giving '0' for empty box, '1' for

the calculator's move, and '2' for the opponent's move, and the exponent shows the number of moves made so far.

3. The opponent must decide on his/her move within 15 minutes (!), otherwise the calculator will automatically switch off, preventing further moves

in the game in progress, and a new game will have to be initiated.

Use the numeric keypad to enter the move, with the noughts and crosses board corresponding to the same layout of the keypad (i.e. to move into the top left hand box, key '7', etc).

Cont. on P. 127

PROGRAM MEMORY : TITLE AND LABEL ALLOCATIONS

P0 Main program  
 — initialisation  
 — calculator's random first move generation  
 — test for entry of opponent's move  
 Label 0 Execution of calculator's move  
 — update move counter  
 — update board positions  
 — update move sequence record  
 — refresh game strategy in working memory  
 — check for calculator's win  
 — check for end of game  
 — display current move, current board, current move count  
 Label 1 Opponent's response  
 — take absolute integer of opponent's entered move  
 — test for illegal entry; penalise if illegal, update move sequence record, and give move to calculator  
 Label 2 — if move legal, accept and execute opponent's move  
 — update move counter  
 — update board positions  
 — update move sequence record  
 Label 3 — check for end of game  
 Label 4 — initialise search for calculator's response  
 Label 5 — indirectly call subroutines P1 to P8 until condition satisfied  
 Label 6 — recall move sequence stored by last subroutine called. Find the empty position and begin response.  
 Label 7 — initialise end of game loop: prepare current move, board positions, and move count; put into Y — register. Recall reason for end of game and put into X — register.  
 Label 8 End of game loop  
 — exchange X with Y register, prepare display format, pause to display, loop to beginning of label 8  
 Label 9 Penalty for attempting to cheat  
 — set current move memory to zero and update move sequence record. This will cause a zero to be included as an indication that the opponent attempted to cheat (except for an illegal move on the opponent taking the first move in a game) without affecting the board or current move count

PROGRAM MEMORY : TITLE AND LABEL ALLOCATIONS

P1 Subroutine for bottom row total  
 P2 Subroutine for middle row total  
 P3 Subroutine for top row total  
 P4 Subroutine for left column total  
 P5 Subroutine for centre column total  
 P6 Subroutine for right column total  
 P7 Subroutine for first diagonal total  
 P8 Subroutine for second diagonal total  
 P9 Subroutine for move sequence record

DATA MEMORY ALLOCATIONS

Memory	Content
0	Move position; Subroutine call; Indirect operations
1	Board position: bottom left
2	Board position: bottom centre
3	Board position: bottom right
4	Board position: middle left
5	Board position: middle centre
6	Board position: middle right
7	Board position: top left
8	Board position: top centre
9	Board position: top right
.0	Move sequence from subroutine
.1	Game strategy: refresher memory
.2	Current board positions ready for display
.3	Ongoing move counter
.4	Ongoing move sequence record
.5	10 (a constant)
.6	Unused
.7	Unused
.8	Unused
.9	Unused
F	Comparison memory for game strategy, wins, endgame
.F	Game strategy: working memory

CASIO fx502P : LISTING AND RATIONALE FOR NOUGHTS AND CROSSES PROGRAM

P0 INV MAC Clear all memories  
 10 Min .5 Store constant  
 .28415 Min .1 Min .F Store game strategy  
 INV RAN# Generate pseudo-random number  
 \*9 Min F Multiply by 9 (store 9)  
 + 1 = INV INT Add 1, take integer part  
 Min 0 Store in move memory. This is the calculator's first random move, ready to begin a fresh game  
 AC HLT Clear display and stop  
 INV x = 0 Was there an input?  
 GO TO 0 No. The calculator is to move first  
 GO TO 1 Yes. The opponent is to move first  
 LBL 0 1 INV IND Min 0 Calculator's move. Store 1 for calculator in memory 0  
 M+ .3 Increment move counter by 1  
 MR 0 Recall move position  
 INV 10<sup>x</sup> Take antilog  
 INV 1/x Take reciprocal  
 M+ .2 Add to board contents memory  
 GSB P9 Store move in sequence record  
 MR .1 Min .F Refresh game strategy working memory  
 2 INV x = F Was the condition before the calculator's move a check for calculator's win?  
 GO TO 7 Yes, and the winning move was made. Go to end of game loop  
 9 Min F Store end of game (draw) check value  
 MR .3 INV x ≥ F Was it the last possible move?

GO TO 7 Yes. Go to end of game loop  
 INV 10<sup>x</sup> No. Take antilog of move count  
 \*(MR 0 + MR .2) = Multiply by (move made plus current board position)  
 INV RND 0 Prepare to display to zero decimal place  
 HLT Stop and display move made, current board positions, and current move count  
 LBL 1 INV ABS INV INT Opponent's move; take absolute integer of move value  
 INV x = 0 Was move entry zero?  
 GO TO 9 Yes. Illegal move. Penalise opponent  
 Min 0 — MR .5 = Store move, and subtract 10  
 INV x ≥ 0 Is remainder equal to or greater than zero? (i.e., the move value is 10 or greater)  
 GO TO 9 Yes. Illegal move. Penalise opponent  
 INV IND MR 0 Recall contents of memory addressed by memory 0  
 INV x = 0 Are contents zero?  
 GO TO 2 Yes. Move permitted. Go to opponent's move label  
 GO TO 9 No. Illegal move. Penalise opponent  
 LBL 2 4 INV IND Min 0 Opponent's move. Store 4 for opponent in memory addressed by memory 0  
 1 M+ .3 Increment move counter by 1  
 MR 0 Recall move position  
 INV 10<sup>x</sup> / 2 = Take integer (antilog of move divided by 2)  
 INV 1/x Take reciprocal  
 M+ .2 Add to board contents memory  
 GSB P9 Store move in sequence record  
 LBL 3 MR .3 INV x ≥ F Recall move counter (9 is still stored in F) and check for last possible move  
 GO TO 7 Yes, it was the last possible move. Go to end of game loop  
 LBL 4 MR .F No, it wasn't the last possible move. Recall game strategy  
 \* MR .5 — INV INT Multiply by 10 and take integer  
 Min F Store integer in F  
 = Min .F Subtract integer from (10 times strategy) and store remaining strategy back in .F  
 8 Min 0 Set memory 0 to 8 ready for subroutine calls  
 LBL 5 INV IND GSB 0 = Call subroutines addressed by memory 0  
 INV x = F Does value returned match contents of memory F?  
 GO TO 6 Yes. Row/column/diagonal in which calculator's move is to be made has been found. Go to label for deciding which position is to be used  
 INV DSS No. Decrement memory 0. Is value in 0 zero?  
 GO TO 5 No. Go to beginning of label to try next subroutine  
 GO TO 4 Yes. Go to label 4 and try next value in game strategy  
 LBL 6 MR .0 Recall the row/column/diagonal sequence stored by the subroutine which caused a jump to this label  
 \* MR .5 — INV INT Multiply by 10 and take integer  
 Min 0 Store integer in memory 0  
 = Min .0 Subtract integer from (10 times move sequence) and store remainder of sequence back in memory .0  
 INV IND MR 0 Recall contents of memory addressed by memory 0  
 INV x = 0 Are contents zero?  
 GO TO 0 Yes. Go to label 0 to make calculator's move  
 GO TO 6 No. try next in move sequence  
 LBL 7 MR .3 End of game loop. Recall move counter  
 INV 10<sup>x</sup> Take antilog  
 \*(MR 0 + MR .2) = Multiply by (move made plus current board position)  
 INV x+y Put result in Y register  
 MR F Recall contents of memory F (contains the value whose matching caused the jump to this label)  
 LBL 8 INV x+y Exchange contents of X and Y registers  
 INV RND 0 Prepare to display contents of X register to zero decimal place  
 INV PAUSE Pause to display  
 GO TO 8 Go to display contents of Y register  
 LBL 9 0 Min 0 Prepare to penalise opponent for attempting illegal move. Store zero in move memory  
 GSB P9 Add zero to move sequence record to show that opponent cheated  
 GO TO 4 Award move to calculator  
 P1 .213 Min .0 Store .213 in memory .0; this is the move sequence for the bottom row which will determine which moves the calculator looks at first if the move is to occur in this row. All such sequences give priority to the centre position, followed by the end positions, for each row/column/diagonal  
 MR 1 + MR 2 + MR 3 Total value of all moves in the bottom row. The other subroutines follow the same pattern  
 P2 .546 Min .0  
 MR 4 + MR 5 + MR 6  
 P3 .879 Min .0  
 MR 7 + MR 8 + MR 9  
 P4 .417 Min .0  
 MR 1 + MR 4 + MR 7  
 P5 .528 Min .0  
 MR 2 + MR 5 + MR 8  
 P6 .639 Min .0  
 MR 3 + MR 6 + MR 9  
 P7 .519 Min .0  
 MR 1 + MR 5 + MR 9  
 P8 .537 Min .0  
 MR 3 + MR 5 + MR 7  
 P9 MR .4 Recall move sequence made so far  
 \* MR .5 + MR 0 = Multiply by 10 and add value from memory 0  
 Min .4 Store updated sequence in memory .4

# WAVE~MAKING ON A NASCOM 1

*Don Finlay of the City University describes a synthesis program which adds fundamental and six harmonics — for use in acoustics demonstrations or in music.*

## Fourier analysis...

In principle, any repetitive waveform may be analysed into an infinite series of sinewaves. For instance, a square-wave contains a fundamental, a third harmonic which is one third as large as the fundamental, a fifth harmonic one fifth as large, and so on through all the odd harmonics up to infinity, as given by the expression

$$f(x) = \frac{4}{\pi} \left( \sin x + \frac{\sin 3x}{3} + \frac{\sin 5x}{5} + \dots \right)$$

where  $x = \omega t$ , an angle which increases constantly with time  $t$ .

The mathematical process for determining the magnitudes and relative phases of the components of any given waveform is generally referred to as Fourier analysis. As with so many mathematical operations, computers are now used to speed the process and display a graph showing harmonic amplitude with frequency. Microprocessors can be used, with algorithms based on the Fast Fourier Transform<sup>(1)</sup> although they are limited in accuracy and speed. Dedicated instruments in the form of spectrum analysers are more efficient at dealing with continuously varying signals, but are very expensive.

## ...and synthesis

A process which is generally easier is the inverse of analysis, i.e. synthesis. If we know what harmonic content we need in a given waveform, we can synthesise that waveform by generating and adding together these harmonics. This was the principle of the Hammond organ from its introduction, some 50 years ago: a series of mechanically driven "tone-wheels" provided all the frequencies needed for the notes of the scale and their harmonics. Nowadays, sinewaves for synthesis are usually generated electronically, including digitally.

This program enables the owner of a Nascom 1, with a small amount of added memory, to generate a 256-byte waveform table using 2nd, 3rd, 4th, 5th, 6th and 8th harmonics of a sine-wave fundamental. The 7th is not used because it is "discordant". The sine-wave table is assumed to be already entered into memory, in 2's complement form, in locations 1000H to 10FFH, and the new waveform table is calculated and entered automatically into locations OE00H to OEFFH. From the latter

locations, samples can be taken to play a tune, as I described in December 1979 (2).

## The method

Data for the harmonic weightings are entered into locations 1100H to 1106H. These are the relative amplitudes of the required fundamental and six harmonics, in ascending order. The principle of the program is that the first 8-bit sample in the sinewave table is multiplied by the 8-bit weighting of the fundamental, and the 16-bit result stored in locations 110FH and 1110H. Next, a sample one place further on in the table is multiplied by the 2nd harmonic weighting and the result added to the previously stored result. For the  $n$ th harmonic, the weighting is multiplied by a sample  $n$  places further on in the sine table, and added in. Finally, the sum of all these products is taken from the store and divided by the total weights, so that the result fits within 8 bits again, forming the first new sample. This is repeated, with appropriate pointer increments, for each of the 256 samples required.

It would be possible for the sum to exceed 16 bits if too large a sum of weights were used; for this reason, the total of the weights must not exceed FFH. If the operator disobeys this, an error message is displayed and the program does not run.

Pointers are needed for the new sample (location 1107H) and for the fundamental and each harmonic (1108H to 110EH). The sum of the weights is stored in 1111H, and the 256 samples to be calculated are counted by decrementing from an initial zero stored in 1112H. The pointers must be initialised; if all are initialised to zero, then the resulting waveform consists of sinewaves all starting from zero. If any pointer is set to 40H, then a 90° phase shift is

introduced, giving a cosine wave; 80H gives phase inversion and COH gives 270° phase shift. Any phase angle can be allowed for, within the 256-bit resolution for a full cycle.

Execution starts at 1113H. The seven weights are first added and the result tested for excess, as indicated by the labels in the program listing. At label FT8, the pointer for the fundamental, which corresponds to a rank of pipes whose largest is 8 ft long, is loaded into register HL and the corresponding sample is fetched from the address now pointed to by HL and loaded into the E register. The weighting for this sample is fetched from 1100H and loaded into register C. Subroutine MULT is then called; this multiplies the weight and the sample and adds them into temporary store 110FH, 1110H, which is initially set to zero. Since the sample may be 2's complement negative and is stored as an 8-bit number, it's tested and if necessary converted to 16-bit negative by putting FFH into the D register, which holds the more significant byte, with the less significant in E. Normal multiplication to a 16-bit result can then take place.

Similar procedure is followed for the harmonics. Labels FT4, FT2 and FT1 refer to octave-related harmonics in imaginary 4 ft, 2 ft and 1 ft pipes. NASARD indicates the 3rd harmonic, TIERCE the 5th, and LARIGO the 6th; these names come from the builders of pipe (and electronic) organs.

At the end of the FT1 section, the sum of all the harmonic products for one new sample is in store and must be divided by the sum of the weights. Again the number may be negative, so a test is made at label SIGN and if the MSB is high then a jump is made to COMP. This routine complements before and after calling an ordinary subroutine DIV which does long division.

TABLE 1

	HARMONIC							
	Fund.	2nd	3rd	4th	5th	6th	8th	
1100H	8	8	0	0	0	0	0	(0)
1108H	0	40H	0	0	0	0	0	(0)
1110H	(0)	(0)	(0)					

*Locations of weights and phases which must be entered before running a program. Initial values shown are for a waveform with only fundamental and 2nd harmonic, with the second harmonic phase-shifted by 90°. Terms in brackets are pointers and temporary stores which are always pre-set to zero.*

## Running the program

To make use of the program, it's loaded, together with the sine table, into locations 1000H to 1243H. The sine table is at 1000H to 10FFH; weights, pointers, temporary store and count at 1100H to 1112H; and the program from 1113H to 1243H. Decisions must be made about the weights and phases required. Table 1 makes it easy to keep track of the requirements; it's arranged so that weights and corresponding angles are in columns. As an example, a simple waveform with equal fundamental and 2nd harmonic amplitudes but with the phase of the 2nd harmonic shifted 90° is entered. Executing from 1113H causes the new waveform table to be calculated and entered in about a second (there are 256 sequences each of which includes seven multiplications, seven 16-bit additions and a division).

To see the waveform, a simple program can be devised to output all samples in page 0E consecutively and continuously to a digital to analogue converter, and thence to an oscilloscope. The accompanying photographs were taken using such a program, and the example quoted appears in No. 7.

Alternatively, the waveform can be used in my tune-playing programme<sup>(2)</sup>. To use this program, a further execution from EF79H is needed. However, I found it necessary to shift the frequency and duration data from the area of memory just below 1000H, as the stack operations always corrupted the top of this. This is simply achieved by changing the contents of memory location 0DA0H from 0F to 12, and copying the data, 1E bytes, from a starting address 0FCBH to 12CBH.

Sources of information for waveform synthesis include mathematic texts dealing with Fourier; *The Dictionary of Hammond Organ Stops* by Stephens Irwin (Chappell & Co, 1968); and various numbers of *Computer Music Journal*<sup>(3)</sup> (available from LP Enterprises, 313 Kingston Road, Ilford, Essex IG1 1PJ). The Hammond book gives a series of numbers for each voice, representing the amplitude of each harmonic, but these are weighted to give roughly equal increase in loudness for each increment of the setting 0 to 8, i.e. they are logarithmic. A way of interpreting them in this program would be to regard each of the Hammond numbers as a power of  $\sqrt{2}$ , giving a 3dB increase at each step, or double the amplitude for each 2 steps. Hence the numbers would be converted as follows:

Hammond	Program weight
1	2
2	3
3	4
4	6
5	8
6	11 = OBH
7	16 = 10H
8	22 = 16H

Many pieces of music arranged for electronic organ have a similar numbering system to the Hammond, and these conversions could be used on them.

The *Computer Music Journal* articles emphasise how inadequate is this synthesis in imitating musical instruments, since each harmonic grows and decays at its own individual rate, and may also

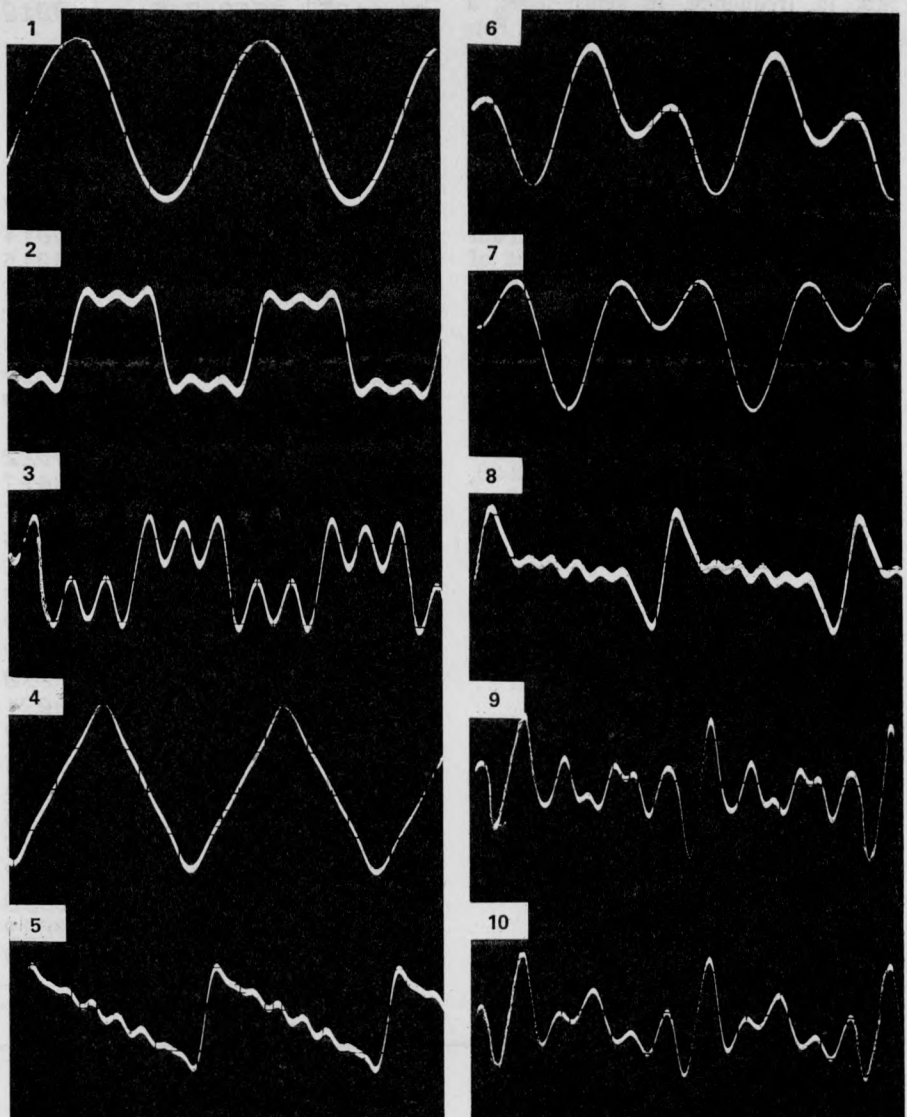

Some demonstration waveforms, obtained by pre-setting the harmonic weighting factors and phases as shown. All other locations between 1100H and 1112H are pre-set to zero. Executing from 1113H enters the waveform table into page 0E, using samples already stored in page 10. A further, simple pro-

gramme is used to step through page 0E continuously, and output each step to a digital-to-analogue converter. The two flutes can be used to demonstrate the similarity of sound, although the phase of the second harmonic is shifted 90° in the second one. The oboe phase shift was inserted in error!

Address	WEIGHTS							PHASE
	1100	1101	1102	1103	1104	1105	1106	1108 to 110E
1. Sinewave	Any	0	0	0	0	0	0	All 0
2. Squarewave	F	0	5	0	3	0	0	All 0
3. Clarinet	7	0	3	0	5	0	0	All 0
4. Triangle	DD	0	19	0	9	0	0	(110A) ← 80H
5. Ramp	50	28	1B	14	10	0D	0A	All 0
6. Flute	8	8	0	0	0	0	0	All 0
7. Flute	8	8	0	0	0	0	0	(1109) ← 40H
8. Trumpet	C	C	C	9	4	3	3	All 0
9. String	1	3	1	7	5	2	2	All 0
10. Oboe	4	3	5	4	6	1	0	(1109) ← 40H

• 0000'	0001	ORG 1113H	•
• 1113 0607	0002 WGT5	LD B, 7	•
• 1115 210011	0003	LD HL, 1100H	•
• 1118 7D	0004	LD A, L	•
• 1119 86	0005 SUM	ADD A, (HL)	•
• 111A 3808	0006	JR C, EXCESS	•
• 111C 2C	0007	INC L	•
• 111D 10FA	0008	DJNZ SUM	•
• 111F 321111	0009	LD (1111H), A	•
• 1122 1821	0010	JR FT8	•
• 1124 EF	0011 EXCESS	RST 28H	•

vary in frequency. In synthesisers, a limited provision is made for this. Perhaps it could be the next step in the development of Nascom-based sound — although some of the waveforms I have generated are not bad imitations of steady, organ-like tones.

#### References

1. William D. Stanley and Steven J Peterson: "Fast Fourier Transforms on Your Home Computer" (The Byte Book of Computer Music, pp.97-103, Byte Publications Inc. 1979).
2. Don Finlay: "Words and Music by Nascom" (Personal Computer World, Dec. 1979 pp.61-65).
3. James A. Moorer and John Grey: "Lexicon of Analysed Tones" (Computer Music Journal Vol.1 No.2 pp.39-45, violin tones; Vol.1 No.3 pp.12-29, clarinet and oboe tones; Vol.2 No.2 pp 23-31, trumpet tones).

*Acknowledgements are due to The City University, as before, for equipment and finance; and to Stan Butler for his invaluable help in photographing the waveforms.*

Program continues on P.124

1125	45584345	0012	DEFM 'EXCESS
	53532057		WEIGHTS;
	45494748		RE-ASSIGN
	54533B20		
	52452D41		
	53534947		
	CE		
113E	00	0013	DEFB 0
113F	CD4002	0014	CALL 0240H
1142	C38602	0015	JP 0286H
1145	3A0811	0016 FT8	LD A, (1108H)
1148	6F	0017	LD L, A
1149	2610	0018	LD H, 10H
114B	5E	0019	LD E, (HL)
114C	2C	0020	INC L
114D	7D	0021	LD A, L
114E	320811	0022	LD (1108H), A
1151	3A0011	0023	LD A, (1100H)
1154	4F	0024	LD C, A
1155	CD0212	0025	CALL MULT
1158	3A0911	0026 FT4	LD A, (1109H)
115B	6F	0027	LD L, A
115C	2610	0028	LD H, 10H
115E	5E	0029	LD E, (HL)
115F	2C	0030	INC L
1160	2C	0031	INC L
1161	7D	0032	LD A, L
1162	320911	0033	LD (1109H), A
1165	3A0111	0034	LD A, (1101H)
1168	4F	0035	LD C, A
1169	CD0212	0036	CALL MULT
116C	3A0A11	0037 NASARD	LD A, (110AH)
116F	6F	0038	LD L, A
1170	2610	0039	LD H, 10H
1172	5E	0040	LD E, (HL)

# M I C R O C O N T R O L

 **apple** SALES SERVICE

Official Dealers — Apple II — Microstar — Compucorp

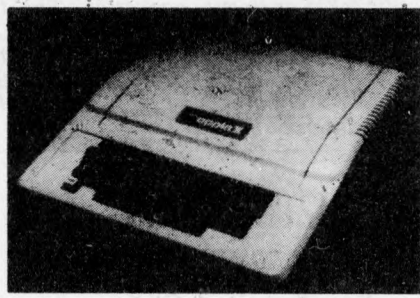

**LEASING FACILITIES AND FINANCE AVAILABLE**  
RING FOR QUOTE

**SPECIAL INTERFACES**  
We can design and produce special interface systems at reasonable cost

**COMING SHORTLY**  
COLOUR FOR PET TRS80

**PART EXCHANGE**  
We offer generous P.X allowances, ring for quote  
All prices exclude VAT

224, EDGWARE ROAD  
LONDON W2 1DN  
TEL (01) 402 8842

PRICE LISTS	
APPLE II 108K VIDEO OUTPUT	750 00
HIGH-SPEED SERIAL CARD	110 00
CLOCK CARD	140 00
LIGHT PEN	165 00
VOICE RECOGNITION CARD	127 00
LOWER CASE GENERATOR	40 00
EPROM BURNER & SOCKET ADAPTOR	95 00
PROTOTYPING BOARD	20 00
FAL CARD	72 00
B/W MODULATOR	20 00
PROGRAMMERS AID NO.1	29 00
APPLE II MODULATOR OUTPUT	770 00
DISK DRIVE WITH CONTROLLER	300 00
DISK DRIVE	355 00
DOS 3.2 MANUAL & DISKETTE	18 00
APPLE PASCAL	295 00
AUTO-START ROM	40 00
GAMES PADDLES	17 90
SUPER TALKER	190 00
APPLE II INTEGER BASIC MANUAL	3 95
APPLESOFT BASIC MANUAL	5 75
8002 PROGRAMMING MANUAL	8 80
APPLE II PLUS COLOUR (PAL)	819 00
8002 HARDWARE MANUAL	8 80
BLANK CASSETTE (C15)	0 85
MICROPRODUCTS PARALLEL PORT	40 00
8" FLOPPY DISK SYSTEM (112 MB)	2760 00
DISK BASED ASSEMBLER	30 00
VINYL CARRYING CASE	25 00
MICROCHESS 2.0 CHESS DISC	18 00
16K ADD-ON MEMORY	95 00
INTEGER FIRMWARE CARD	110 00
PARALLEL PRINTER CARD	110 00
COMMUNICATIONS CARD	132 00
APPLE II REFERENCE MANUAL	5 75
BASF FLOPPY DISKETTE	3 80
CENTRONICS 770 PRINTER	880 00
CENTRONICS PRINTER CARD	132 00
HITACHI 8" B/W MONITOR	132 00
TRENDCOM 100 PRINTER	23 00
TRENDCOM PAPER (80 FT)	4 25
TC 3 TRENDCOM 100 I/F	48 00

## APPLE PASCAL TM

This Hardware/Software package provides a very powerful tool for the serious user. High speed hires "Turtle" graphics, fast editor, Compiler, Relocatable Assembler, Excellent System Utilities, Superb documentation £289.

**NEW!**

**DIGITAL COLOUR CARD**  
Apple II or IIT 2020  
Mixed Colour Text!!!

Complete software control allows 15 fully-saturated colours in Graphics and Text modes. Simple plug-in system. Existing Software Compatible Designed and Manufactured by us  
Complete System. £148.00  
Monitor Mod Kit £27.00

**12-BIT RESOLUTION**  
**A/D Conversion**

Our new A/D cards offer high 12-bit resolution with a fast conversion time, 4 inputs on board expandable to 8.

Max. Sensitivity 10 uV F.S.D.  
Demonstration Software Supplied.

Turn your apple to a fast analogue data acquisition system X, Y plotter etc.

12-Bit System £174.  
8-Bit System £116.

# PET PRINTER PEP-UP

*"When I got the new CBM 3022 printer for the PET I found its speed and clarity of print to be a tremendous help in program development. However it wasn't long before I also discovered the printer to be not fully compatible with the PET character set." J. C. Moore continues...*

If you have tried using the POKE 59468, 14 statement in your programs to allow the use of mixed lower case, upper case and graphics on the screen, you will have found the printer failing to respond. Instead it prints lower case as upper case and upper case as graphics. This, of course, turns listings and printouts into gobbledegook.

The solution is either to rewrite all your existing programs or (and this is the point of the article) to use one of the programs given here to rewrite them automatically. Listing 1 was the first attempt (written in BASIC). Load it first, list it on the screen (it has been made as compact as possible for this purpose), load your own program, and then re-enter the unshift program directly off the screen using the screen editor. Finally, type "RUN 35000" to execute it. To show how things are progressing it will display each line number of your program as it processes it. When tried on a test program of about 700 lines it took 18 minutes to do the job which, although relatively slow, is quite painless!

To achieve a faster result use the assembly language version in Listing 2. This is loaded into the second cassette buffer area of memory. It doesn't display line numbers, it processes the 700 line test program in less than one second

(a salutary reminder of the slowness of interpreters).

As the PET has no means of saving binary programs, use the BASIC loader version of the assembly language program given in Listing 3. Load it first, execute it and it will then be available by typing "SYS 826" anytime until you switch the power off.

Both the BASIC and the binary versions work by scanning the program text

and removing the shift bit (bit 7) from all characters enclosed between string quotes which represent letters of the alphabet. Graphics obtained from the other keys are untouched as they still print correctly on the printer. The only exceptions to the latter rule are the 4 characters ),->,↑ and : (Hex 29, 5F, 7F, 3A) which produce two different graphic characters each — did you know about these? As they are not documented or marked on the keyboard it was decided to ignore them. If you particularly wish to cater for them, you must add the four individual tests to either program.

Finally, having unshifted your program, it only remains to remove any POKE 59468, 14 statements and it will run successfully on both the screen and the printer.

```

Listing 1
70 REM ** THIS PROGRAM WILL UNSHIFT ANY LETTERS BETWEEN STRING QUOTES IN
90 REM ** YOUR PROGRAM. ENTER THIS ONE FIRST, RUN IT, THEN LOAD YOUR
90 REM ** OWN PROGRAM. TYPE SYS 826 TO EXECUTE.
100 DATA162,15,169,2,133,15,169,4,133,16,161,0,208,1,96,230
101 DATA15,208,2,230,16,230,15,208,2,230,16,230,15,208,2,230,16,161,0,208
102 DATA15,230,15,208,2,230,16,230,15,208,2,230,16,76,68,3,201,34,208,227,230
103 DATA15,208,2,230,16,161,0,240,227,201,34,240,213,201,193,144,8,201,219,176
104 DATA4,41,127,129,0,76,114,3
110 FORI=826TO910
120 READJ:POKEI,J:NEXTI
130 END
READY.
    
```

```

Listing 2
033A A2 0F          LDX# POINTERLOW
033C A9 02          LDA#02
033E 85 0F          STA POINTERLOW
0340 A9 04          LDA#04
0342 85 10          STA POINTER HI
0344 A1 00          $3 LDAA(00,X) high byte of link address
0346 D0 01          BNE$4
0348 00             BRK exit
0349 E6 0F          $4 INC POINTERLOW
034B D0 02          BNE $8
    
```

Cont. on Page 128

## REAL-TIME SPECTRUM ANALYZER £340

You can now buy, for about one-sixth the price of current products, a third-octave spectrum analyzer with more features and capabilities than were previously available at any price. What's the catch? If you don't already own a Commodore PET computer (or, soon, a Radio Shack TRS-80 or Apple), you'll have to get one. This will raise the price to somewhat under one-half the price of competing products, but of course you'll also have a COMPUTER!

The THS 224 REAL-TIME FREQUENCY ANALYZER comprises a single circuit board which installs inside the PET. This board contains a set of 31 third-octave filters (20 Hz to 20 kHz), detectors, an analog-to-digital converter, a 1K Read Only Memory containing machine language routines which allows the PET processor to interface with the Analyzer, and the peripheral circuitry necessary to transfer analog data into the PET memory. The simplest BASIC program required to turn the PET into an analyzer is only three statements long! Much longer programs can be written to allow complete user interaction with the analyzer, including many new forms of statistical signal processing, curve weighting, voice recognition etc.



**PETS 8k from £495**

PET IS A TRADEMARK OF COMMODORE BUSINESS SYSTEMS

## EXPANSION MEMORY

with space for eprom

**Price break-through**

**24k £280**

**32k £325**

**All items can be seen and demonstrated at our London showroom. Orders accepted by mail, phone or in person.**

Prices exclude VAT. Send or phone for further details and brochure.

Access, Barclaycard, and Trustcard accepted.



UK Distributors

**Feldon Audio Ltd.,**

126 Great Portland Street, London W.1. Tel: 01-580 4314. Telex: London 28668

# THE COMPLETE PASCAL

BY SUE EISENBACH AND CHRIS SADLER

## CHAPTER 9: ADVANCED PROGRAMMING TECHNIQUES

*In this chapter the PASCAL implementation of a number of powerful programming tools is discussed. The use of these techniques can affect a programmer's style as profoundly as the "structured" control and data structures met earlier in this series.*

### Introduction

As programmers become more experienced the pressures imposed on them while engaged in program writing begin to resolve themselves. Some of these pressures emerge from the run-time environment where particular restrictions as to memory usage or execution time may require the overall programming strategy to be considerably modified. These pressures are often alleviated by hardware enhancements — like adding more memory or by the availability of such software tools as optimizing compilers which reduce the effort required by the programmer to meet the run-time specifications of the program.

Other, more numerous, pressures exist at what might be described as "write-time". These may be imposed by the nature of the problem itself, by the algorithm which enables its solution, or by the syntax of the language in which the program is being written. In this series we have discussed the top-down design approach and shown how it can help the programmer to make a complex problem more manageable. Likewise, the constructs of structured programming can help the programmer to express the solution (i.e. the program) simply and effectively. Finally, we have described how programming languages have evolved to allow these programming philosophies to be formulated in a natural and concise manner, thus reducing these pressures.

Hardware improvements, software tools, sophisticated design techniques and a sympathetic language all contribute towards easing the programmer's load. But programming is still a tricky business that requires planning, concentration and skill and, inevitably, experienced programmers will learn to develop ploys to cut down coding, speed up some forms of manipulation or generally take further action to reduce both the write-time and run-time pressures. In this chapter we discuss a small but popular sample of these techniques — recursion, dynamic data structures and variable field records — and show how PASCAL deals with these. The chief problem, however, is not so much how the language realizes the required constructs, as how the underlying logic can be formulated to take advantage of the elegance or efficiency offered by the indicated technique. Like any skilled accomplishment, these methods will

take practice and perseverance and many programmers may (legitimately) decide, after investigation, not to bother. Others may find them familiar or at least interesting. Either way, they complete the major features of PASCAL as a programming language.

### Recursive programming

Recursion, or recursive programming is a concept to conjure with. To some it represents the peak of "intellectual" programming while to others it seems like a logical trick or an ineffectual waste of time. The truth must lie between these points of view since, while some desirable or even necessary outcomes are only possible by means of recursive methods, for most applications the result could often have been achieved with less effort and with greater machine efficiency by means of an iterative method. At the same time, however, a language which incorporates the facility to perform recursive algorithms offers an opportunity to produce elegant and concise code which, once the general principles are grasped, is usually more readable than the iterative alternative.

Consider the problem of searching a character string (called SENTENCE, say) for the first occurrence of some particular character (say "space"). Let us say that it will be convenient to write this as a function which returns an integer value equal to the position of the first space in the string, if one exists,

and equal to zero if no space exists in the string. The call

```
I := FIRSTSPACE (SENTENCE)
```

will initiate the iterative version of the function (Box 1, lines 1 to 11). Tactically the function must search the character positions one-by-one, keeping count of the number of characters inspected and keeping a lookout for the end of the string. The REPEAT-UNTIL construct controls the search, moving from character to character until something happens (i.e. until one of the UNTIL conditions in line 7 is met).

In the second example, (the recursive case, lines 13 to 23), control of the search is handled in a subtly different way. The call

```
I := FINDSPACE (SENTENCE, 1)
```

initiates this version, the constant '1' indicating that the search is to start at the first character position. First note that lines 15 and 18 are testing for the same conditions stipulated in line 7 and that the resulting assignments correspond (i.e. line 9 and 22; line 10 and 20). The search however, is controlled by means of the recursive function call in line 19 which has the effect of restarting FINDSPACE but with a modified starting character position HERE + 1 (=2 in the first case).

In an elementary example such as this the similarities between the iterative and recursive techniques are much more evident than the differences. Nevertheless it should be possible to discern the major features of the recursive approach. Firstly, a recursive procedure "calls

```

1: FUNCTION FIRSTSPACE (SENTENCE : STRING) : INTEGER ;
2: VAR J : INTEGER ;
3: BEGIN
4:   J := 0 ;
5:   REPEAT
6:     J := J+1
7:   UNTIL (SENTENCE[J] = ' ') OR (J = LENGTH(SENTENCE)) ;
8:   IF J = LENGTH(SENTENCE)
9:   THEN FIRSTSPACE := 0
10:  ELSE FIRSTSPACE := J
11: END ; (FIRSTSPACE)
12: ...
13: FUNCTION FINDSPACE (SENTENCE:STRING; HERE:INTEGER) : INTEGER ;
14: BEGIN
15:   IF HERE < LENGTH(SENTENCE)
16:   THEN
17:     BEGIN
18:       IF SENTENCE[HERE] <> ' '
19:       THEN FINDSPACE := FINDSPACE(SENTENCE, HERE+1)
20:       ELSE FINDSPACE := HERE
21:     END
22:   ELSE FINDSPACE := 0
23: END ; (FINDSPACE)

```

①

```

1:PROGRAM ANAGRAM ;
2:VAR I, LENGTH : INTEGER ;
3:  LETTER, NEWWORD : ARRAY [1..10] OF CHAR ;
4:  USED : ARRAY [1..10] OF BOOLEAN ;
5:PROCEDURE PERMUTE (COUNTDOWN : INTEGER) ;
6:VAR J : INTEGER ;
7:BEGIN
8:  IF COUNTDOWN = 0
9:  THEN
10:   BEGIN
11:    WRITELN ;
12:    FOR I := LENGTH DOWNT0 1 DO
13:     WRITE (NEWWORD[I])
14:   END
15:  ELSE
16:   BEGIN
17:    FOR J := 1 TO LENGTH DO
18:     BEGIN
19:      IF NOT USED[J]
20:      THEN
21:       BEGIN
22:        USED[J] := TRUE ;
23:        NEWWORD[COUNTDOWN] := LETTER[J] ;
24:        PERMUTE (COUNTDOWN - 1) ;
25:        USED[J] := FALSE
26:       END
27:     END
28:   END
29:END ; (PERMUTE)
30:BEGIN (MAIN PROGRAM)
31:  WRITE ('Please type in your word --->') ;
32:  READLN ;
33:  I := 0 ;
34:  REPEAT
35:   I := I + 1 ;
36:   USED[I] := FALSE ;
37:   READ (LETTER[I])
38:  UNTIL (I=10) OR EOLN ;
39:  LENGTH := I ;
40:  PERMUTE (LENGTH)
41:END.

```

②

recursive task which would be very messy if tackled with iterative techniques. The idea is to print out every permutation of the letters of a particular input word ( $\leq 10$  characters). In the main program (lines 30 - 40) the word is read in and its length calculated. In line 40 the recursive procedure PERMUTE is called. This procedure produces all the permutations before it exits.

The algorithm hinges on the Boolean array USED[ ] which keeps track of which letters have already been used in the current permutation - the letters being held in LETTER[ ] in their original order. The array NEWWORD[ ] is used to accumulate the re-ordered letters one-by-one and the re-ordering is achieved by recursively calling PERMUTE (line 24) until every letter has been used (COUNTDOWN = 0) at which point the escape clause (lines 9-14) is invoked, printing out the current word and exiting. Control then shifts back one level and one element of USED is de-allocated (line 25) and so on until a new permutation can be formed. How far back control must go will depend on the combined states of USED, J and COUNTDOWN but when all the letters have been shuffled around to the original word, control returns to the main program.

Take the unlikely situation where a procedure is required to call a second procedure which in turn calls the first procedure. Since a procedure can only be called if it is on at most the same level or nested in the calling procedure, the problem here arises as to which procedure to declare first. The remedy lies in the PASCAL facility to make a "dummy" procedure declaration called a *forward reference*. The format of a forward reference is as shown in Box 3.

This ploy provides the compiler with enough information (i.e. the parameter list) to set up that part of the stack frame which deals with communicating beyond the scope of the procedure whilst FORWARD tells the compiler to pick up the rest of the procedure when it is next declared. Although the example is somewhat artificial, the necessity of the forward reference can be seen by considering the reaction of the compiler if the forward reference were omitted.

Exercise: Desk-run PERMUTE on your favourite four letter word. Keep track of NEWWORD, USED, J and COUNTDOWN, especially COUNTDOWN which provides a measure of the depth to which PERMUTE has been called.

```

PROCEDURE TRYAGAIN (parameter list); FORWARD ;
(*No "body" follows as this is the forward reference*)
PROCEDURE TRY (parameter list);
BEGIN
  IF NOSUCCESS
  THEN TRYAGAIN(parameters)
END ;

PROCEDURE TRYAGAIN ; (*No parameter list!*)
BEGIN (*Body of TRYAGAIN*)
  - (*Some code deals with NOSUCCESS*)
  -
  TRY(parameters)
END ;

BEGIN (*Main Program*)
  TRY(parameters)
END .

```

③

itself" - (line 19). Programmers often experience a "Russian dolls" feeling when they first encounter this aspect of recursion, the implication being that an infinite sequence of nested procedure calls will ensue. Secondly, however, a recursive procedure always contains an escape clause - so there is a "mole" inside the innermost Russian doll. In FINDSPACE this consists of the different paths indicated by the conditionals on lines 15 and 18. Since these are of exactly the same nature as the loop-terminating conditions in FIRSTSPACE (line 7), the recursion is no more likely to "go infinite" than the loop (although careless programming can always bring this about).

Thirdly, compared with iteration, recursion tends not to produce code which executes particularly efficiently. Every procedure call implies another stack frame and set of local variables loaded onto the stack. This tends to eat up memory and also to slow down the program execution somewhat. On the other hand, recursion can be highly effective at write-time, producing concise, readable code which expresses the underlying algorithm clearly and elegantly. Proponents of recursion claim that recursive algorithms are more

"natural" than their alternatives and certainly many mathematical relations may implicitly be expressed in recursive terms. Finally, once a programmer becomes accustomed to thinking along these lines, a recursive procedure is probably more "top-down" than its iterative equivalent in the sense that it usually requires less detailed analysis to realize a precise solution.

At run-time, the recursive mechanism depends heavily on the stack-oriented procedure call, as described in Chapter 7, to control the different levels of recurrence and to ensure the proper returns. Of course the depth of nesting possible depends on how much memory is available for the stack to grow into. Some innocent-looking mathematical recursive algorithms can nest to a fantastic depth very rapidly so that the program runs out of memory and crashes. Languages whose compilers are not so dependent on the stack, especially in the context of its procedure-calling mechanism, do not offer recursive facilities although the determined programmer can usually get away with building his own "software stack" to control the nesting depth and returns.

Program ANAGRAM in Box 2 is an example of a slightly more complex

## Dynamic data structures

At any point in a program the data which is being processed is normally held, either internally or externally, in one of the predefined data structures. Internally, the record is used to associate complex and varied data items together while an array offers the ability to contain a number of similar data items simultaneously and manipulate them at random. In a typical data processing application therefore, the most flexible arrangement is probably an array of records since the bulk of the processing is likely to be concerned with

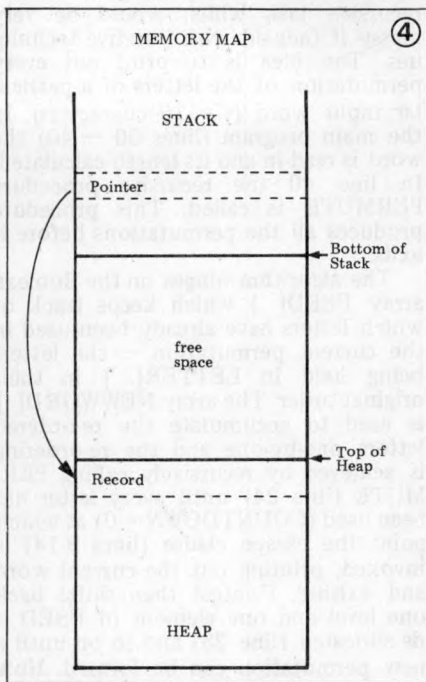

manipulating matching fields within a group of the records.

This is not as flexible as it might be however. One problem is that the precise number of records needed in memory at run-time is not necessarily known when the program is written and will in any case vary from one run to the next. The programmer must therefore declare the array as large as the maximum number of records likely to be required even though at least some of this space will be wasted on most runs. For this reason, the array is known as a *static* structure. PASCAL is often criticized for not providing for *dynamic* (i.e. run-time) allocation of array space. In fact PASCAL does provide a dynamic data type via the *pointer type*. Instead of some particular variable (say a record) being embedded in the stack, as with other declarations, the *pointer type* declaration enables a *pointer* variable to be placed in the stack, associating (or *binding*) that pointer to the required data type (i.e. the record). When the record is created (dynamically) the memory locations will be allocated in a region of memory known as the *heap*, and the starting address of the record will be placed in the pointer variable on the stack. The heap is usually located at the bottom of memory while the stack is located at the top. As the program proceeds, the stack and heap grow towards one another, the former as a result of successive procedure calls and secondary processing; the latter as a result of the creation of new dynamic records — see Box 4. If the stack and the heap touch, the program has run out of memory.

The pointer type is declared as follows:

```
TYPE MARKERS = ^DATATYPE
```

where MARKERS is the name of the pointer type and DATATYPE is the name of the data type — which need not be a record — to be dynamically allocated. The statement

```
VAR POINTER1, POINTER2,  
DUMMY : MARKERS
```

then *binds* the variable names POINTER1 etc. to the data type DATATYPE.

To initialise a pointer variable on the stack, a value NIL is assigned. This is a reserved word indicating that no address in the heap is being pointed to.

A variable of type DATATYPE may then be created by executing the statement

```
NEW (POINTER1)
```

at which time the memory locations in the heap will be allocated and their starting address will be placed in POINTER1. Note that the variable has no name of its own and can only be referred to by means of POINTER1 as follows:

```
POINTER1^.REFNUMBER := 301
```

assuming that DATATYPE is a record type and that an integer field REFNUMBER has been declared.

In this way, a series of records may be built up in the heap, each of which has its own pointer on the stack through which it may be referenced. If extra pointers have been declared (e.g. DUMMY) then one such record may have more than one pointer pointing to it. So

```
DUMMY := POINTER1
```

implies that DUMMY<sup>^</sup> and POINTER1 refer to the same record on the heap. A record can be de-allocated by

```
POINTER2 := NIL
```

which means that the record will become inaccessible even though the space on the heap will stay occupied. The business of clearing up the de-

allocated regions of the heap is known as "garbage collection" and is handled so differently, if at all, on the different systems, that we won't discuss it here.

The advantage of this scheme is that different records of the same type can easily be amended, enhanced or sorted into a different order. In a static array a record is accessed by its position in the array (e.g. NUMBER[3] will refer to the third element of an array NUMBER [1..N]) and if the elements must be re-ordered, or one element eliminated say, a considerable amount of manipulation is required. A dynamic "array", on the other hand, can be created by defining an array of pointers and re-ordered simply by redirecting the pointers. Likewise, one record could be deleted by setting its pointer to NIL without disturbing the other elements at all.

A really powerful application can be brought about by declaring one of the fields *within* the dynamic record as a *pointer type*. By this means, one record in the heap can be set up to reference another record simply by assigning its pointer to the relevant field in the first record. In this way, a *linked list* of records can be built up, consisting of a set of records whose structure (i.e. order) is defined implicitly by the sequence of pointer fields rather than explicitly by some static format arbitrarily declared at compile-time. The last element of the linked list must always have its pointer field set to NIL and the first element (and only the first) will be referenced by a pointer in

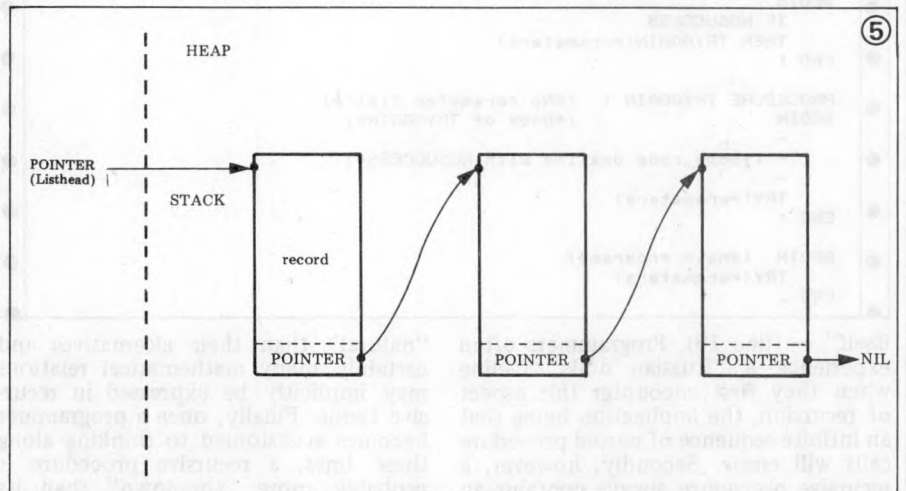

⑥

```

1: PROGRAM ESTATE ;
2: TYPE DATE = RECORD
3:   DAY : 1..31 ;
4:   MONTH : 1..12 ;
5:   YEAR : INTEGER
6: END ; (DATE)
7: NAME = PACKED ARRAY [1..20] OF CHAR ;
8: OCCUPATION = (VACANT, FILLED) ;
9: POINTER = ^FLAT ;
10: FAMILY = RECORD
11:   SURNAME : NAME ;
12:   SIZE : 1..20
13: END ; (FAMILY)
14: FLAT = RECORD
15:   NUMBER : INTEGER ;
16:   ROOMS : 1..10 ;
17:   NEXT : POINTER ;
18:   CASE STATUS : OCCUPATION OF
19:     VACANT : (LASTDATE : DATE) ;
20:     FILLED : (TENANTS : FAMILY)
21:   END ; (FLAT)
22:
23: VAR FIRSTFILLED, FIRSTFREE, LINK : POINTER ;
24: CHOICE : INTEGER ;
25: NEWDATE : DATE ;
26:
27: PROCEDURE STREARDLN (VAR N : NAME) ;
28: VAR I, J : INTEGER ;
29: BEGIN

```

Box 6 Cont. on P. 130

the stack. Thus one pointer in the stack, sometimes called the *listhead*, grants access to the entire structure of records in the heap — see Box 5.

Instead of continuing with a description of the data-handling capabilities offered by linked lists, we prefer to illustrate these capabilities by means of the sample program ESTATE in Box 6. The purpose of this program is to assist a housing estate manager to keep track of the tenants in a block of flats. Initially, the flats are created as a linked list

of records, called FLAT, in the heap. (FLAT is an example of a variant field record which will be fully discussed in the next section.) As flats are allocated to different people, the relevant fields in FLAT are updated, and as families move out the vacant flats are returned to the pool. Thus two linked lists will be maintained — one consists of the empty flats, beginning with the one that has been vacant longest; the second containing the occupied flats in alphabetic order of the tenants surnames.

Individual flats will be transferred between these two as the occasion  
Cont. on Page 128

## Look up table

**Computer Jargon**  
Compile-time / Static  
Run-time / Dynamic  
Recursion  
Forward Reference  
Pointer  
Heap  
Binding  
Linked List  
Listhead  
Garbage Collection  
Variant Field Record  
Tag Field

**Pascal Words**  
FORWARD  
NEW  
NIL  
ORD

### UCSD Exceptions

There is rudimentary garbage collection within the heap by means of standard procedures MARK and RELEASE — see UCSD User Manual.

### Exercises:

1. Desk-run ANAGRAM
2. Write procedures to handle communication between linked lists and disc files.
3. Amend ESTATE to fit families into correctly-sized flats.

### ACKNOWLEDGEMENTS:

1. LOGITEK — for loan of ALTOS 8000-2 with word-processing facilities.
2. TRANSAM — for CP/M version of TCL PASCAL system.

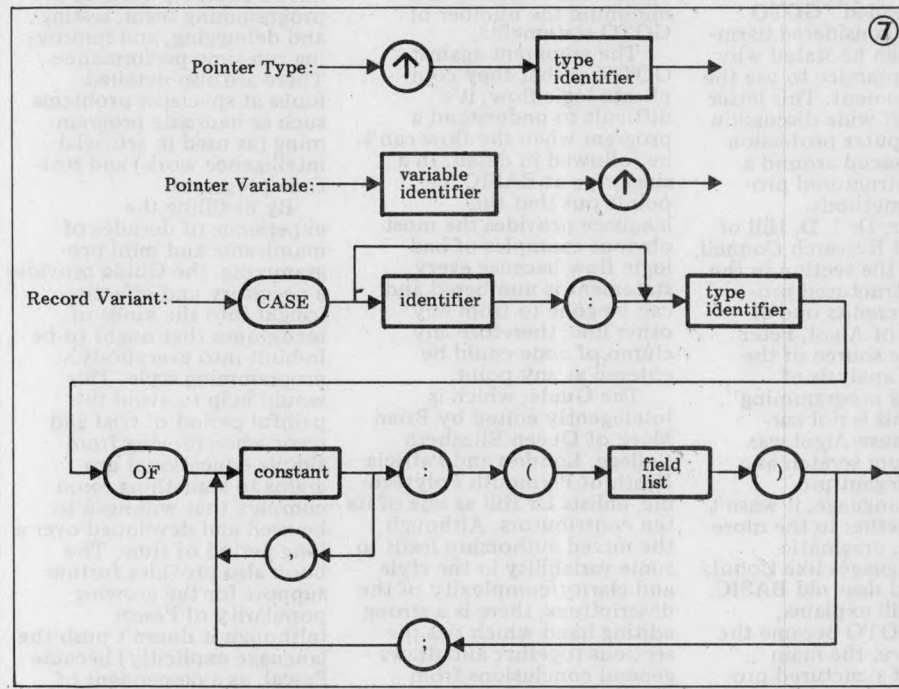

# SAVE £££'s ON TOP QUALITY FULLY GUARANTEED SECOND USER EQUIPMENT



### NEW ASCII KEYBOARDS

TTL compatible, ROM-encoded Full 128 ASCII character set Range of spares and accessories Prices from **£45.00** Send for full leaflet/price list.

### HAZELTINE H1000 VDU

12 lines by 80 character display. Upper case ASCII 110/300 baud (higher speeds optional). RS 232 Interface NOW ONLY **£225.00** (mail order total £280.00)

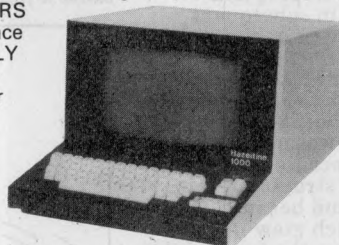

### NEWSHUGART FLOPPYDISC DRIVES

SA 400 Minifloppy 110/220 KB capacity Power + 5VDC + 12VDC **£195.00** (mail order total £234.00)



SA 800 8in. floppy 40/800 KB capacity + 24VDC + 5VDC — 5VDC **£395.00** (mail order total £468.00)

### BALL MIRATEL MONITOR

9in. Diagonal TV monitor complete with high and low voltage power supplies and attractive moulded plastic case with ample space for keyboard. Requires separate horizontal and vertical sync. input. **£95.00** (mail order total £123.00)



### TELETYPE ASR 33

10 cps, upper case ASCII 74-column friction feed platen Paper Tape Punch & reader Choice of Interface (20 mA or RS232) **£650.00** (pedestal £30 extra) (Acoustic cover-£25 extra)



### EMI 15/3A TV MONITOR

15in. Diagonal TV Monitor complete with high and low voltage power supplies. Accepts composite or separate video input. Dimensions 12in.H x 18 3/4 W x 16 1/2 D. Wt. 22kg. BRAND NEW SURPLUS. **£100.00** (mail order total £138.00)

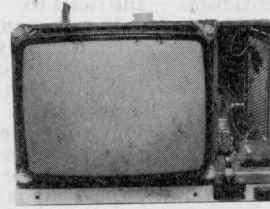

## Electronic Brokers

49/53 Pancras Road London NW1 2QB Tel: 01-837 7781. Telex 298694

All items are refurbished second-user equipment unless otherwise stated. All prices subject to VAT.

A copy of our trading conditions can be supplied on request.

Good programming practice and robots are the diverse subjects that appear under the Malcolm Peltu microscope this month.



## So what if it works!

At an international conference in 1977, one of the most respected of computer scientists, Professor Edsger Dijkstra (sic) made a violent attack on hobbyist programmers in general and the BASIC language in particular. At the same conference, a pioneer of data communications techniques, Paul Barran, opined that the standard of hobbyist programming often betters that of so-called professional programmers.

Although these comments seemed to be contradictory, Dr A.N. Walker of Nottingham University pointed out, in a letter to *Computer Weekly*, that both observations could be true: amateur programmers may be awful but professional ones are even worse. As if this kind of onslaught on their technical abilities was not enough, professional programmers and systems analysts are increasingly being criticised for failing to take organisational and human factors into sufficient account when designing systems.

Two new books make a significant and positive contribution to the debate about programming and systems practice.

*The Guide to Good Programming Practice* goes to the heart of Professor Dijkstra's criticisms — the need to understand and implement techniques which not only produce programs that work but that are also of a high standard in terms of bug-counts, simplicity of understanding and ease of maintenance. *The Human Side of Information Processing* is a collection of papers which shift the focus of computer systems design from purely technical issues to include wider sociological and psychological factors.

Professor Dijkstra's most popular claim to public fame is that he originated the move towards the software development techniques now known as structured programming.

In 1968 he wrote a letter to the journal of the ACM (the American equivalent of the British Computer Society) headed "GOTO statements considered harmful" in which he stated why it was bad practice to use the GOTO statement. This letter triggered off wide discussion in the computer profession which coalesced around a variety of structured programming methods.

However, Dr I. D. Hill of the Medical Research Council, who wrote the section in the Guide on structured programming, credits one of the fathers of Algol, Peter Naur, as the source of the first public analysis of "GOTO-less programming", in 1963. This is not surprising because Algol was designed from scratch as a clear and elegant programming language; it wasn't scraped together in the more cobbled-up, pragmatic style of languages like Cobol, Fortran and dear old BASIC.

As Dr Hill explains, although GOTO became the *cause célèbre*, the main objective of structured programming and good programming practice in general is not directed towards eliminating or promoting any particular instructions or languages. The objective is to produce programs which are as simple and logically lucid as possible, eliminating any clever-clever trick programming, and structuring in such a modular and clearly documented way as to assist in developing and testing and in subsequent maintenance or enhancement.

Professor Dijkstra was "appalled" by the programs he read in the US hobbyist mags (PCW was not around at the time) because they broke the rules of structured programming and because BASIC, which grew in popularity on the back of the personal computer boom, is generally regarded as a poor language for writing elegant code and for handling complex data structures. The hobbyists had put back programming by 25 years, he bitterly commented.

Dr Hill lists seven basic principles of good programming, starting with the avoidance of any tricks... never use a complicated method where a simple one will do, is a piece of advice which applies to any language. But some of the other points he makes would be difficult or impossible to carry out fully in BASIC — for example using meaningful names for variables (i.e. more than just A or A1), employ-

ing the IF-THEN-ELSE statement which is available in languages like Algol and Pascal, and reducing to a minimum the number of GOTO statements.

The argument against GOTOs is that they complicate logic flow; it's difficult to understand a program when the flow can't be followed in detail. In a sideswipe at BASIC, he points out that this language provides the most obvious examples of bad logic flow because every statement is numbered and can be gone to from any other line; therefore any clump of code could be entered at any point.

The Guide, which is intelligently edited by Brian Meek of Queen Elizabeth College, London and Patricia Heath of Plymouth Polytechnic, enlists Dr Hill as one of its ten contributors. Although the mixed authorship leads to some variability in the style and clarity/complexity of the descriptions, there is a strong editing hand which ties the sections together and draws general conclusions from detailed examples of particular languages (Algol and Fortran are used most frequently). The editors even point out that the sequence they chose to present the subjects is not necessarily the best one and they provide pointers to other sequences which a reader might prefer to follow.

In addition to structured programming, the Guide takes a practical and common

sense approach to such subjects as program documentation, choosing a language (if you have a choice), working in a programming team, testing and debugging, and improving run-time performance. There are also detailed looks at specialist problems such as heuristic programming (as used in artificial intelligence work) and real-time programs.

By distilling the experience of decades of mainframe and mini programming, the Guide provides a necessary and effective insight into the kinds of techniques that ought to be in-built into everybody's programming style. This would help to avoid the painful period of trial and error when moving from simple educational programs to something more complex that will need to be used and developed over a long period of time. The book also provides further support for the growing popularity of Pascal (although it doesn't push the language explicitly) because Pascal, as a descendant of Algol, falls more in line with the suggested good programming methods than BASIC.

*The Human Side of Information Processing* is the proceedings of a conference held in Copenhagen in 1978 and lacks the cohesiveness of a strongly directed book like the good programming guide. However, a sound theme does emerge from the papers, as summarised by its

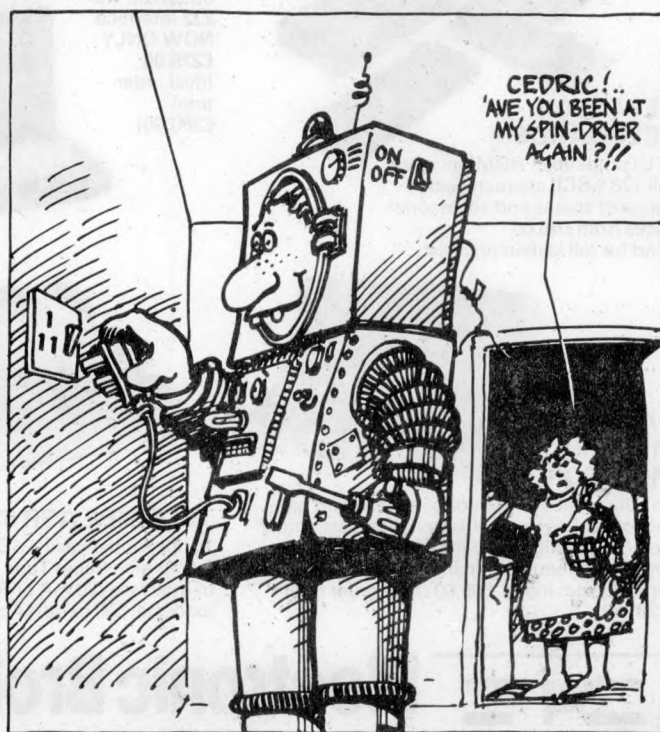

Chris Welch

## BOOKFARE

editor, Niels Bjorn-Anderson of the Copenhagen Business School: "For too long the design of information systems has been treated as a technical problem only. Some benefits have certainly been achieved but the major benefits with this technology lie in the broader perspective."

That broader perspective, according to the book, includes factors as varied as the politics of organisational change, using computers to design more humane working environments, user participation in systems design, the impact of computers on the working class (sic) and the future of systems designers. Inevitably, as a book based on papers given at an international conference, it's heavy going in some parts, particularly as there are some obvious translation boobs. There are also some ghastly poems by the editor at the start of each paper, which rhyme words like Lancashire and bank-cashier (for an article written by Enid Mumford from Manchester on an experiment in systems design at a bank.)

The human factor is being given growing priority in the design of computer systems and the book provides much food for thought. For the professional computer person, a challenging picture is painted with new social responsibilities thrust on to the already pressurised analysts and programmers. And Per Grøholt of the Norwegian Standard Telephone and Cable company goes as far as to suggest that "most so-called 'professionals' in systems design will disappear during the 1980s although a few will remain and become real professionals, i.e. hardware/software experts with an academic background." He believes that computer users will eventually become their own systems designers, taking into account their organisational needs and the wider social and human context.

The user as designer is, of course, a trend that was initiated in the personal computer world, which is one reason why personal computers, with colour TVs, graphics, synthesisers, et al, are so much more "user friendly" than their opposites in the traditional computer business. But if the "amateurs" do inherit the computing earth, I hope that they first read and assimilate the valuable advice offered in these two books.

### Oyrobot

One of my first robot loves recently made a guest appearance on Wonder Woman. He is called Robby and sci-fi buffs will know

that he first appeared in *Forbidden Planet* in 1956. Since then Robby and robots have come a long way.

Now teenagers like Tod Loofbourrow not only build their own computer-controlled robots that can "see" and "hear", they also write DIY books on how to do it. But although Loofbourrow's robot, called Mike and based on a KIM-1, may be very clever, it doesn't have the twirly ears, flashing eyes and chubby arms of Robby.

Anyone interested in a DIY robot will find *How To Build A Computer-Controlled Robot* a good starting point, although some of the US-oriented details are inappropriate to the UK and, anyway, new products have come on to the market since it was published last year that will enhance any Mike look-alikes. Each step in the construction is described in full, from building the metal frame to fitting voice recognition equipment.

But for those who, like me, still enjoy fantasising about human robots, like Wonder Woman herself, a magazine called *CineMagic* presents a superb alternative DIY robot called ON/OFF, the Wonder Robot! ON/OFF (I wonder if he has any relations with four-letter Christian names) is motivated by human power and the jargon in the detailed guide includes references to rubber gloves and tin-can couplings.

Having twinned a serious book like Loofbourrow's with all this cine-freaking, I will now, Houdini-like, escape from this review with a neat punchline that draws the threads together: Did you know that the name of the forbidden planet on which Robby first appeared was, would you believe, Altair (a name which was of course assigned to the first of the personal computers). Another strange stream of unconsciousness is generated by the thought that the human in *Forbidden Planet* was called Dr Morbius, which reminds me of a Mobius Strip... and Strip makes me think of Wonder... oh well!

Featured in Bookfare this month were:  
*Guide To Good Programming Practice* edited by Brian Meek and Patricia Heath (Ellis Horwood/John Wiley, £10.50);  
*Computer Programming in Basic* by Ian Williamson, Rodney Dale and Tim Eiloart (Cambridge Learning Enterprises, Rivermill Lodge, St Ives, £7.50 for four volumes);  
*How to Build a Computer-controlled Robot* by Tod Loofbourrow (Hayden/Butterworth, £4.80);  
*CineMagic*, (75p, obtained from *Dark They Were And Golden Eyed*, London);

## TOMORROW TODAY

at  
**Birmingham Computer Centre**

Commodore official distributors

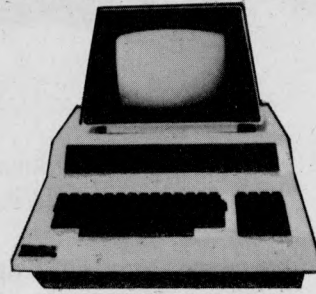

**3016, 3032, 3008 PETs**  
 The reliable value for money system with after sales support, instruction and training facilities and a wide range of programmes.



**3040 DUAL DRIVE FLOPPY DISC**  
 The latest in disc technology. Low cost with reliable data transfer.

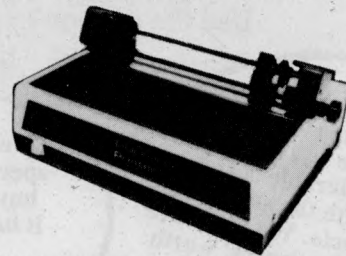

**3022 PROFESSIONAL PRINTER**  
 The high specification printer. Prints all PET characters onto paper and accepts labels, printed forms, cheques etc.

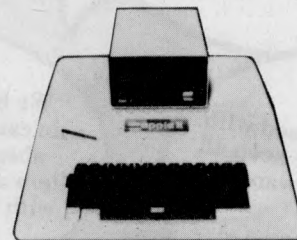

Apple authorised distributors  
 The sophisticated quality system with a reputation for advanced design and innovation.

**Camden Electronics, First Floor,  
 462 Coventry Road, Small Heath,  
 Birmingham B10 0UG.  
 Telephone 021 773 8240  
 Open Mon.-Sat. 9.30-6.00 p.m.**

A MEMBER OF THE COMPUTER RETAILERS ASSOCIATION

"This exhibition is the one and only national rallying point for the home enthusiast."  
R. Warren, Amateur Computer Club

# The 3rd Personal Computer World Show

"The quality of the visitors has been excellent. We have had a very successful show."  
Ted Russell, Tandy Corporation

This year the microcomputing industry is being inundated with offers to promote its products and services at a plethora of U.K. Exhibitions.

The 3rd Personal Computer World Show will be held at the Cunard Hotel, Hammersmith, London on September 4, 5 & 6 this year.

Is it going to be "just another show"?

We don't think so. And without wishing to appear immodest we thought potential visitors and exhibitors would like to study some of the comments made about last year's enormously successful show.

The 3rd Personal Computer World Show is going to be the biggest and most ambitious show to date, offering a state-of-the-art showcase for a whole range of micro and mini systems and software.

We believe that this year's event will establish the Personal Computer World Show as the U.K.'s most important annual exhibition in the small computer marketplace. Whether as an exhibitor or a visitor . . . we want you to *be* there.

Use the coupon opposite for further information or to apply for tickets from the organisers.

"At this rate (11.30am on 2nd day) we will cover our very considerable costs at the show with the sale of our minor products. We also have at least three months' worth of follow up work on orders from the business sector."  
Michael Dean, Managing Director,  
Katanna Management Services

"We have met a complete spectrum of the potential buyers of our products. It has been a marvellous show for us."

David Taylor, Managing Director,  
Heath (Zenith)

"The interest of the overseas trade visitors has been absolutely outstanding."  
Peter Oldershaw, General Manager,  
ACT Petsoft

"We are very pleased with the show. We have seen all of the people we wanted to see."

Graham Clifton,  
Transam Components

"We have taken about £4,000 in cash and enquiries worth about £40,000 on just one item alone. We are delighted with the quality of visitor."

Marketing Manager,  
Keen Computers

"This show has done more for the image of the Society than any other we have participated in."

Martin Carrington,  
Technical Information Officer,  
British Computer Society

"A fine exhibition for the businessman to see a completely different way of meeting his needs."

Philip Virgo, Secretary of the  
Parliamentary Computer Forum

"At 11 o'clock on the first day of the Show we had done enough business to pay for the stand. Everything else was pure profit."

Colin Stanley, Director,  
HB Computers

"On the strength of this show, we will certainly exhibit next year."

Clifford Shilling, Managing Director,  
C.S. Microcomputers

"The layout and planning of the exhibition was perfect for this type of show."

Chris Mead, Sales & Marketing  
Director, CIS Ltd

If the coupons on your copy of this magazine have already been used, write directly to Timothy Collins,  
Montbuild Ltd., 11 Manchester Square, London W1M 5AB.

Can your business, research project or teaching laboratory be made more efficient? Yes. Today's users demand complete, high performance micro computer systems. Expandable to meet future needs and with software capable of immediate application.

The North Star Horizon is the answer. A cleverly balanced configuration: Z80A processor with 12 slot S100 chassis, one parallel and two serial interface ports. Now with double or quad capacity too.

The compact design gives you value for money and economy of space. The Horizon will not break your bank or your desk top.

Quick delivery and nationwide service are only part of the attraction. Add to this the wealth of software available, including the well known CP/M, and you can see why the Horizon has already sold in thousands.

The reason for its success is simple.

The North Star Horizon reflects your needs.



For technical specification and details of your nearest dealer contact Britain's leading North Star Supplier.

 **comart**

PO Box 2, St. Neots, Cambridgeshire.  
Tel: (0480) 215005. Telex: 32514.  
COMART G.

**North Star Horizon  
reflects a new age in computing**

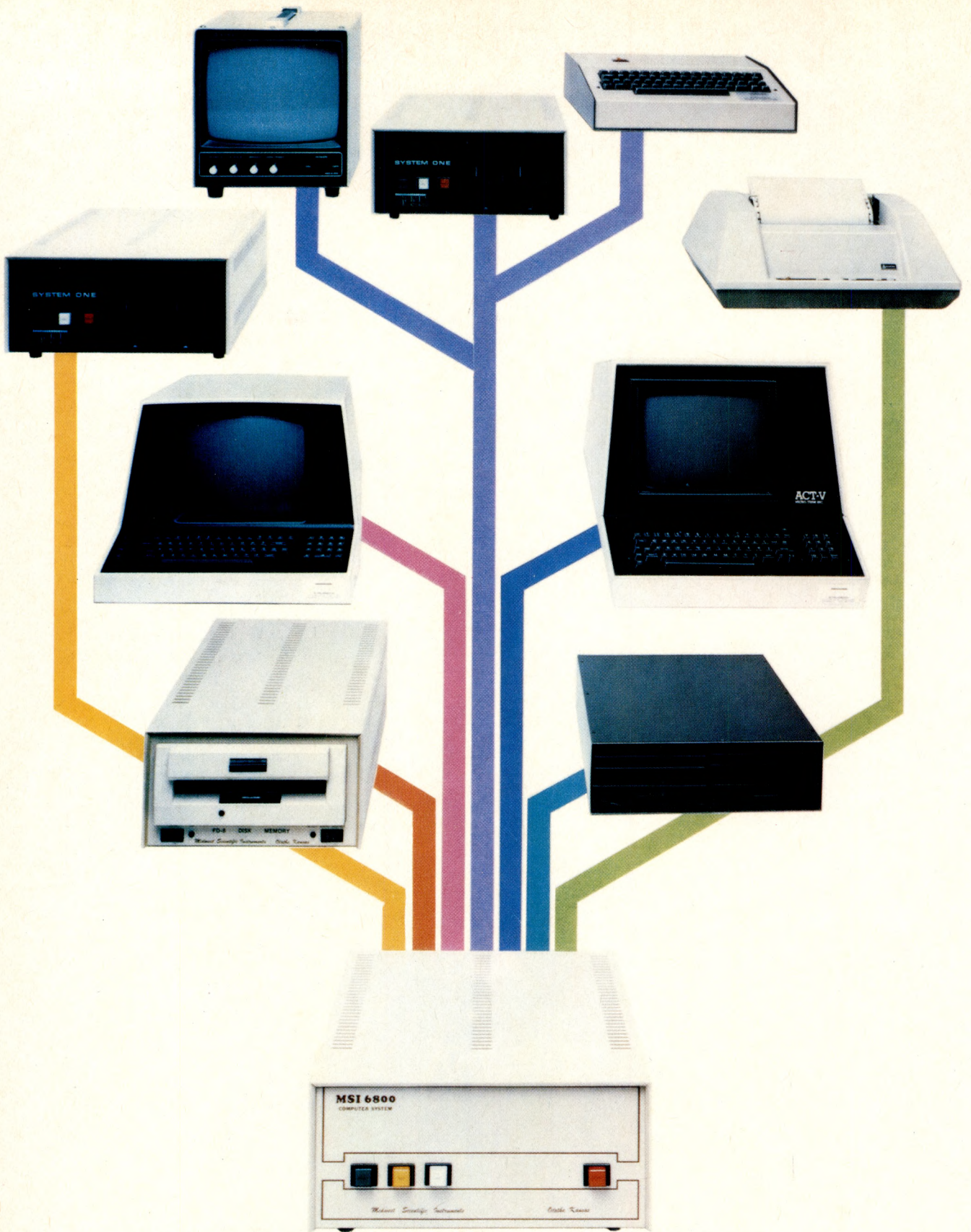

**MSI 6800: At the root of every good system.**

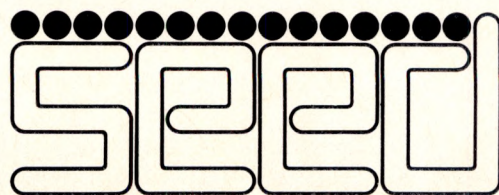

Strumech Engineering Electronic Developments Limited  
Portland House, Coppice Side, Brownhills, Walsall, West Midlands. Telephone (279) 4321

# RANDOM WRITINGS RESUMED

By Michael James

In *Random Writings* (PCW Vol. 1, No. 10) I consider what a random number is and go on to examine methods of generation. Now, picking up the threads, I move on to deal with some of the uses to which random numbers can be put. Most of the time the text will steer clear of explaining the theoretical foundations of the results; rather I'll just state the useful conclusions. (The more advanced reader might like to consult "further reading" listed at the end). For compactness, the BASIC function RND will be used in all the examples. However, if any of these methods are used for purposes other than game playing, then a good congruential generator should be used (such as the one included in the previous article).

## Making things happen

(with a fixed probability)

The most elementary act in any simulation or game is making something happen with a known probability. This is easy given a random number generator supplying uniformly distributed numbers between zero and one. First recall that the words "uniformly distributed between zero and one" mean that any number between zero and one is as likely to be produced as any other. Suppose we want an event to happen with a probability of 0.75. If we write:

```
IF RND < .75 THEN "event happens"
```

in a program, then the event will occur 75 percent of the time. The reason is not difficult to see. Simply ask yourself what proportion of the time the random number will fall below 0.75 if it is equally likely to fall anywhere between zero and one. The answer is about three-quarters, ie. 0.75 of the time. In fact the general principle is just as easy to understand:

The probability of a uniformly distributed random number falling in any part of the line between zero and one is equal to the length of that part (see Fig.1).

Thus in general if we want an event to occur with a probability .P then we use:

```
IF RND < .P THEN "event happens"
```

Fig. 1

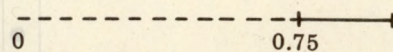

## Many happenings

The above method is simple and OK for producing any number of events happening with various probabilities so long as the events are required to be independent. For example, a program for the tossing of two (fair) coins would be:

```
10 IF RND < .5 THEN 40
20 PRINT "COIN ONE = TAILS"
30 GOTO 50
40 PRINT "COIN ONE = HEADS"
```

```
50 IF RND < .5 THEN 80
60 PRINT "COIN TWO = TAILS"
70 GOTO 10
80 PRINT "COIN TWO = HEADS"
90 GOTO 10
```

However, when a number of dependent events must occur with specified probabilities this simple method will not work. If we were trying to simulate a dice, then only one of the numbers between 1 and 6 must be produced each time and each with the probability 1/6th. To solve this problem we must resort to our general principle. If each digit 1,2,3,4,5,6 is assigned a piece of a line 1/6th of the total length and, if we say that when the random number falls in a number's sixth this number has "come up", we have a dice. For example, we could divide the line up as in Fig.2. If RND falls in the interval 3/6 to 4/6 say, then we have thrown a 4, etc. This satisfies our requirement that only one number is produced at a time and, as the length of each piece of line is one-sixth (and hence is the probability of RND falling there), we have a fair dice.

Fig. 2

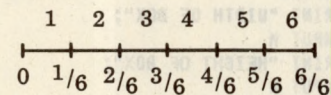

A BASIC dice program can now be written. Instead of simply testing, using IF statements, whether RND falls in any given interval, we can use a trick to speed things up. If RND lies in the interval  $n/6$  to  $(n+1)/6$  then  $RND*6$  lies in the interval  $n$  to  $n+1$  and  $INT(RND*6)$  equals  $n$ . Thus  $INT(RND*6)$  is either 0,1,2,3,4 or 5 with equal probability one-sixth. In general, to produce random integers from  $m$  to  $n$  with equal probability, the statement:

```
10 R = INT(RND*(N-M+1)) + M
```

can be used. For example, a dice would use  $R = INT(RND*6) + 1$ . In the same way, to produce random numbers uniformly distributed from  $a$  to  $b$ :

```
10 R = RND*(b-a) + a
```

can be used.

## Various distributions

(and un-equal probabilities)

Using the fact that the probability of an event occurring is equal to the length of the part of the line we associate with it, we can see how to make events occur with unequal probabilities. For example a three-sided dice with the probability 0.5 of being 1, 0.25 of being 2 and 0.25 of being 3 can be simulated by dividing the line as shown in Fig. 3. In a BASIC program we would generate a random number and test if it was in the interval 0 to 0.5, 0.5 to 0.75 or 0.75 to 1. In fact this can be done in a simpler way. By asking if RND is less than 0.5 and then if less than 0.75, we can decide which interval it is in. If it is less than 0.5 it is in 1. If not and it's less than 0.75 it's in 2, and if it is not less than 0.75 then it must be in interval 3.

This simple observation gives us a routine way of obtaining any unequal probabilities. Given a set of probabilities  $p_1, p_2, p_3, \dots, p_n$ , form the set of numbers  $p_1, p_1 + p_2, p_1 + p_2 + p_3, \dots, p_1 + p_2 + p_3 + \dots + p_n$ . Generate a random number. If RND is less than  $p_1$  then event one happens. If not, and it is less than  $p_1 + p_2$ , then event two happens and so on. (See Fig.5, subroutine 7000.)

## Continuous events

Until this point we have been considering a finite collection of separate events. It is possible that we could want to generate a set of random numbers distributed over some range with something other than a uniform probability. This is, in general, a very difficult thing to do. It is possible to give a few methods for the commoner distributions without going into too much theory and a collected list will prove useful to the more advanced or ambitious programmer. (If you don't recognise the distributions named below then it is unlikely that you would even want to use them, so skip to the next section.)

Fig. 3

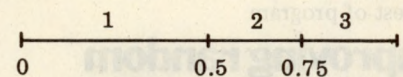

### 1. THE NORMAL DISTRIBUTION

As this is a very important distribution two methods are given.

#### CENTRAL LIMIT THEOREM

```
10 F = SQR(3/N)
```

```
20 Z = 0
```

```
30 FOR I = 1 TO N
```

```
40 Z = Z + RND
```

```
50 NEXT I
```

```
60 Z = F * (2*Z - N)
```

Z is normal with a mean of zero and a standard deviation of one. N should be chosen between 20 and 50, the accuracy of the approximation improving with larger N.

#### BOX-MULLER METHOD

```
10 Z = SQR(-2*LOG(RND)) * COS(3.145*RND)
```

Z is normal with a mean of zero and a standard deviation of one.

### 2. THE CHI-SQUARED DISTRIBUTION

```
10 X = -2 * LOG(RND)
```

X has a chi-squared distribution with

two degrees of freedom.

```
10 U = 1
20 FOR I = 1 TO D
30 U = U * RND
40 NEXT I
50 X = -2 * LOG(U)
```

X has a chi-squared distribution with 2D degrees of freedom. To generate intermediate degrees of freedom use

$$10 Z = X + Y * Y$$

where X is chi-squared with 2D degrees of freedom, Y is normal (mean = 0, S.D. = 1) and Z is chi-squared with 2D + 1 degrees of freedom.

### 3. THE EXPONENTIAL DISTRIBUTION

```
10 X = -(1/L) * LOG(RND)
X is distributed as 1 - exp(-LX).
```

### 4. THE LOGISTIC DISTRIBUTION

```
10 U = RND
20 X = A - B * LOG((1 - U)/U)
X is distributed as 1 + exp(-(X - A)/B).
```

### 5. THE GAMMA DISTRIBUTION

```
10 U = 1
20 FOR I = 1 TO K
30 U = U * RND
40 NEXT I
50 X = -(1/L) * LOG(U)
```

X is distributed as

$$\frac{L}{\Gamma(K)} (\lambda X)^{K-1} \exp(-LX)$$

These distributions are the ones most often found in simulations. Others may be obtained from the reference.

I have ignored one very important distribution — the Poisson. The reason is that, unlike the others, the Poisson is concerned with the non-negative integers and is more complicated. The following program gives values of  $K(=0,1,2,\dots)$  distributed as  $(\exp(-L))L^K/K!$ .

```
10 U = 0
20 K = 0
30 U = U - (1/L) * LOG(RND)
40 IF U > 1 THEN 70
50 K = K + 1
60 GOTO 30
70 rest of program
```

## Improving random number generators

Any random number generator can be improved by shuffling. A typical shuffling algorithm is:

1. Fill an array of size N with random numbers.
2. Generate an integer random number R in the range 1 to N (see earlier) and swap the contents of the first array element with the Rth.
3. Repeat (2) for each of the array elements until all have been swapped.
4. Use the N random numbers in the array as the next N in the sequence. A subroutine for shuffling in BASIC is:

```
10 DIM A(N)
5000 FOR I = 1 TO N
5010 A(I) = RND
5020 NEXT I
5030 FOR I = 1 TO N
5040 T = A(I)
5050 R = INT(RND * N) + 1
5060 A(I) = A(R)
5070 A(R) = T
5080 NEXT I
5090 RETURN
```

```
● 0001 LINE= 200
● 0005 REM DIFFUSION SIMULATION
● 0010 DIM B(4),P(4)
● 0015 REM INPUT BOX SIZE N BY M AND APERTURE SIZE A
● 0025 REM AND PROBABILITIES
● 0030 GOSUB 1500
● 0035 REM CLEAR AND INITIALISE VDU
● 0040 GOSUB 1000
● 0045 REM MOVE TO ABOUT THE CENTRE OF THE SCREEN
● 0050 FOR I=1 TO 5
● 0060 PRINT
● 0070 NEXT I
● 0105 REM DRAW BOX
● 0110 PRINT TAB(10);
● 0120 R=INT((M-A)/2)
● 0130 GOSUB 2000
● 0140 FOR I=1 TO A
● 0150 PRINT " ";
● 0160 NEXT I
● 0170 R=M-R-A+1
● 0180 GOSUB 2000
● 0190 PRINT
● 0200 FOR I=1 TO N
● 0210 PRINT TAB(10);"*";TAB(10+M);"*"
● 0220 NEXT I
● 0230 R=M+1
● 0240 PRINT TAB(10);
● 0250 GOSUB 2000
● 0260 GOSUB 3000
● 0270 GOSUB 5000
● 0280 GOSUB 5000
● 0290 X=M
● 0300 Y=N
● 0315 REM SET BOUNDARY FLAGS
● 0320 GOSUB 9000
● 0330 T=0
● 0585 REM START DIFFUSION
● 0595 REM GET DIRECTION
● 0600 GOSUB 7000
● 0610 FOR J=1 TO Z
● 0615 REM IF ON A BOUNDARY THEN REFLECT DIRECTION IF NECESSARY
● 0620 GOSUB 8000
● 0625 REM MOVE CURSOR
● 0630 ON D GOSUB 3000,6000,4000,5000
● 0640 IF Y<1 THEN GOTO 700
● 0645 REM SET BOUNDARY FLAGS
● 0650 GOSUB 9000
● 0660 T=T+1
● 0670 NEXT J
● 0680 GOTO 600
● 0700 IF E=1 THEN GOTO 600
● 0710 GOSUB 3000
● 0720 Y=Y-1
● 0730 X=-11
● 0740 E=1
● 0750 PRINT "ESCAPE !!! AFTER ";T;" TIME UNITS"
● 0760 GOTO 600
● 0999 END
● 1000 PRINT CHR$(30);CHR$(19);CHR$(12);
● 1010 RETURN
● 1500 PRINT "WIDTH OF BOX";
● 1510 INPUT M
● 1520 PRINT "HEIGHT OF BOX";
● 1530 INPUT N
● 1540 PRINT "SIZE OF HOLE";
● 1550 INPUT A
● 1560 FOR I=1 TO 3
● 1570 PRINT "PROBABILITY OF MOVING IN DIRECTION ";I;
● 1580 INPUT P(I)
● 1590 IF I=1 THEN 1650
● 1600 P(I)=P(I-1)+P(I)
● 1650 NEXT I
● 1660 P(4)=1
● 1670 IF 1-P(3)<0 THEN GOTO 1560
● 1680 RETURN
● 2000 REM SUBROUTINE TO PLOT R *'S IN A LINE
● 2010 FOR I=1 TO R
● 2020 PRINT "*";
● 2030 NEXT I
● 2040 RETURN
● 2905 REM SUBROUTINES 3000,4000,5000,6000 MOVE THE CURSOR
● 2915 REM UP,DOWN,LEFT AND RIGHT AND ADJUST THE
● 2925 REM X Y COORDINATES
● 3000 PRINT CHR$(1);
● 3010 Y=Y-1
```



There are many ways of shuffling and the general rule seems to be that the more you shuffle the better the random numbers! Of course the trouble is that shuffling takes time and if you need a lot of random numbers it's probably better to work on the quality of your generator. Even so shuffling can make a very poor generator very good — if in doubt, shuffle!

## More than one dimension

Using a random number generator which gives uniformly distributed numbers in the range zero to one to generate coordinates of a point in say two dimensions has its problems. Most people would agree that  $X = \text{RND}_1$ ,  $Y = \text{RND}_2$  would give a pair of numbers which could be interpreted as a point in the unit square (see Fig.4) which was uniformly distributed. That is, every point is as likely to be produced as every other. Unfortunately, and surprisingly, this is *not* so.

Fig. 4

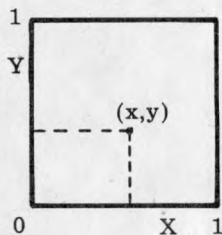

If a random number is generated by any of the usual methods then X, Y will not be uniform over the unit square! There will be regions where *no* points fall. These regions usually take the form of strips and may be clearly seen if random points are plotted on a graphics display device. How important this is depends, as always, on the application. For game playing it can usually be ignored. The point is — do not always expect *pseudo*-random numbers to behave like *truly* random numbers. The solution to the problem seems to be to use *two different* pseudo-random number generators or to use shuffling to produce two separately shuffled streams of numbers.

## An example

Finally we come to a simple example. The program listed in Fig.5 simulates, not very seriously it must be admitted, a gas molecule in a box! The molecule collides with other invisible molecules and the walls of the box until it find a hole (of variable size) in the top of the box. Thus the process bears a passing resemblance to diffusion of gas through a hole.

The program actually demonstrates another technique as well as simulation. By using the cursor of a VDU to represent the gas molecule and the cursor up, down, left and right commands to move it, we can produce a moving graphics display. This technique is sometimes known as pseudographics.

The program begins by asking for the size of the box, the size of the hole and the probability of the molecule moving in the various directions shown in Fig.6. The next major part of the program (45 — 250) draws the box on the screen using asterisks. This part

```

● 3020 RETURN
● 4000 PRINT CHR$(2);
● 4010 Y=Y+1
● 4020 RETURN
● 5000 PRINT CHR$(4);
● 5010 X=X-1
● 5020 RETURN
● 6000 PRINT CHR$(9);
● 6010 X=X+1
● 6020 RETURN
● 7000 Z=INT(RND*M/2)+1
● 7010 Q=RND
● 7020 I=1
● 7030 IF P(I)>=Q THEN 7400
● 7040 I=I+1
● 7050 GOTO 7030
● 7400 D=I
● 7410 RETURN
● 7415 REM SUBROUTINE TO REFLECT DIRECTION IF NECESSARY
● 8000 IF B(D)=0 THEN RETURN
● 8010 D=D+2-INT((D+1)/4)*4
● 8020 RETURN
● 8095 REM SUBROUTINE 900 SETS BOUNDARY FLAGS B(I)=1 MEANS "ON BOUNDARY I"
● 9000 FOR I=1 TO 4
● 9010 B(I)=0
● 9020 NEXT I
● 9030 IF X=M THEN B(2)=1
● 9040 IF X=1 THEN B(4)=1
● 9050 IF Y=1 THEN B(1)=1
● 9060 IF Y=N THEN B(3)=1
● 9070 IF B(1)<>1 THEN RETURN
● 9080 IF X<INT((M-A)/2) THEN RETURN
● 9090 IF X>INT((M+A)/2) THEN RETURN
● 9100 B(1)=0
● 9200 RETURN

```

is fairly straightforward and produces the box shown in Fig.7, leaving the cursor in the bottom right-hand corner.

Fig. 6

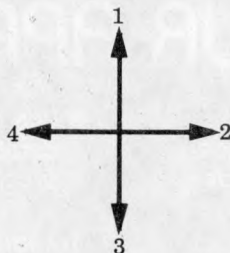

At this point we reach a VDU specific part of the program. Subroutines 3000 to 6000 move the cursor in directions 1 to 4. The control characters which will move the cursor of your own VDU in each direction must be found and substituted in the PRINT CHR\$(code) statements.

If you don't know your VDU's cursor control characters, try

```

10 FOR I = 1 TO 128
20 PRINT I, CHR$( I)
30 FOR J = 1 TO 200
40 NEXT J
50 NEXT I

```

As the program runs each ASCII character will be sent to the VDU — watch for the ones that move the cursor! If the cursor does not move in all the required directions then you cannot use pseudographics on your VDU. (If your VDU has a page and a scroll mode try again in page mode.) Subroutine 1000 must also be adjusted to initialise, i.e. clear, the screen and home up your VDU.

The part of the program that actually simulates the diffusion is 600 to 760. A call to subroutine 7000 gives a random value of Z between 1 and  $(M/2 + 1)$  as the distance that the molecule will travel before a collision (unless it hits

a wall of course) and a random value of D equal to 1,2,3 or 4 as the direction of motion. Examination of subroutine 7000 will reveal two of the methods we have been discussing. Lines 610 to 670 move the cursor Z places in direction D. After each move, subroutine 9000 is called to discover whether the cursor is on a boundary and, if so, which. Notice that it could be more than one and that the hole does not count as part of boundary one. Subroutine 5000 checks to see whether the next step would take the cursor across the boundary and if so the direction of movement is reversed. The only other function is telling when the molecule passes through the hole and this is achieved by line 640. On leaving the box, the number of moves made is printed as a final result.

The program is not a particularly good simulation of a gas molecule, but it is fun to watch and provides an ideal starting point for a more ambitious program. Even so, the relationship between aperture size and time to escape can be investigated as, say, a classroom exercise. Interesting extensions of the program might include adding more directions and a more realistic distribution (the exponential — see sections on continuous distributions) of times between collisions.

## Reference

J.M. Hammersley and D.C. Handscombe, *Monte Carlo Methods*, Methuen

## Further reading

Yu. A. Schneider (Ed.), *The Monte Carlo Method*, Pergamon Press, 1966.  
R. B. Coates and A. Parkin, *Computer Models in the Social Sciences*, Edward Arnold, 1977.

Fig. 7

RUN  
 WIDTH OF BOX? 40  
 HEIGHT OF BOX? 10  
 SIZE OF HOLE? 10  
 PROBABILITY OF MOVING IN DIRECTION 1 ? .25  
 PROBABILITY OF MOVING IN DIRECTION 2 ? .25  
 PROBABILITY OF MOVING IN DIRECTION 3 ? .25

```

Side 4
*****
* 00 *
* * *
* * *
* * *
Side 3 * * Side 1
* * *
* * *
* * *
* * *
* * *
* * *
*****
Side 2
READY
#
  
```

# BIG SOFTWARE VALUE FOR THE SMALL BUSINESS

High quality, simple to use business programs for PETS from the Microtrend portfolio.

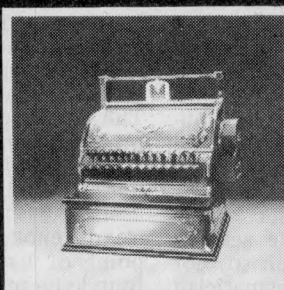

## BUSINESS MONEY MANAGER

Business Money Manager and the PET together enable small businessmen and professional people to benefit from financial control procedures previously available only on large, expensive computers:

- Specify target income and expenditure
- Employ our classifications or use your own
- Enter transactions month by month
- Summarise individual months or the year to date
- Shows actual performance against budget
- Income and expenditure analysed in Cash Book format for bank account reconciliation
- Cash flow situation is highlighted
- If you have a printer any detail or summary pages may be listed.

**AN ESSENTIAL TOOL FOR THE MODERN BUSINESSMAN**

**TAPE £29.95** incl. VAT

These packages run on 16K or 32K PETS (printer support available on 32K version only)

## TRENDSTOCK 1

A practical and easy to use recording system for businesses with a large number of small unit non-invoiced sales. Typical users are retail shops, pubs, general outlets and small distributors:

- Maintenance of sales/usage records of stock items
- Collation of sales/usage statistics
- Cost/Sales value and VAT content
- Free format entry of basic data, deliveries, stock items and adjustments
- Correlates calculated sales/usage values with any independently maintained figure (e.g. total takings; this allows immediate identification of shortages and surpluses)
- Reports low stock levels
- Permits variety in the units employed (e.g. cases delivered, bottles held in stock, measures sold)
- Maintains sales margins for individual lines, by classification and for total sales
- If you have a printer any detail or summary page may be listed.

**TAPE £29.95** incl. VAT

For our 24 hour telephone ordering service call 0423 711878, or complete the coupon:

Name \_\_\_\_\_  
 Address \_\_\_\_\_  
 \_\_\_\_\_ (tick)  
 Please send me Trendstock/1 at £29.95   
 Business M/M at £29.95   
 Please send me your product catalogue   
 Total £ \_\_\_\_\_ Signature \_\_\_\_\_  
   CHEQUE  (tick)  
 Credit Card No. \_\_\_\_\_

Send to: **Microtrend Ltd.**,  
 P.O.Box 51, Pateley Bridge,  
 PCW Harrogate, North Yorkshire HG3 5DP

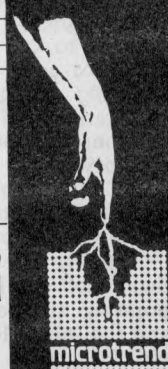

# Personal Computer World

## SUBSCRIPTIONS

Just over 2 years ago PCW became the first magazine in Europe to deal exclusively with the home and business use of Personal Computers. It has been an unqualified success. The current subscription list stands at well over 3,000, with a staggering 70% renewal rate! PCW reader loyalty is already a byword in the publishing business. We aim to keep it that way. So if you are having difficulty in obtaining PCW at your newsagent, why not take out a subscription and have the magazine mailed to you direct?

UK Subscriptions: £8.00  
 USA Subscriptions: £22.00 (airmail)  
 Europe Subscriptions: £13.00 (airmail)  
 Elsewhere: £25.00 (airmail)

Please send me the next 12 issues of PCW

NAME \_\_\_\_\_

ADDRESS \_\_\_\_\_

*(Block capitals please)*

I enclose cheque/P.O. for £ \_\_\_\_\_ made payable to SportsScene Publishers Ltd.  
 Send coupon to PCW (Subscriptions), 14 Rathbone Place, London W1P 1DE. Allow at least 14 days for processing.

## CALCULATOR CORNER

*This month Dick Pountain has handed over to reader N. Horwood who relates his experience of using the TI59 with printer for accountancy; the moral being that the calculator can often provide a cost effective alternative to the micro if you make a realistic analysis of the data requirements of your application.*

# NEW COURSES FOR TEXAN HORSES

I was in two minds when I bought the TI59 some two or three years ago, knowing nothing about programming, but having been involved in a user capacity in industry. Initially I tried to develop programs without the printer, but, except for very short and uncomplicated programs, I found editing and debugging extremely frustrating and time consuming. It wasn't long before I was forced to buy the print cradle which transformed the whole activity of program development. Even so, not being a recently trained mathematician but merely a middle aged Engineer, it took several months of all my spare time to become reasonably fluent in the Texas dialect. I have nothing but praise for the great assistance, patiently given to me by the TI people at Bedford, usually with me on the phone in yards of paper tape, having forgotten to read the excellent manual properly!

Once having gained confidence both in my ability to write useful programs and in the reliability of the machine mechanically and electronically, it occurred to me that here was a very powerful device. Admittedly the storage capacity for bulk data was limited, but the logic and arithmetic capacity was of a very high order. I experimented with some simple applications in industrial costing and accountancy and found that by choosing the type of program structure which gave user prompting on the printer (which doubled as result annotation and dealt with the general form of the data processing so that a program was as flexible as possible — thus minimising the need to change magnetic cards for slightly altered requirements) it was possible to use this machine in a commercial context.

There are drawbacks. For example the 20 column printout is a little narrow for traditional layout, and while the printing rate of about two lines per second free running is acceptable, the data transfer rate round logic loops and into the four print registers is slow, and complex programs can be frustrating. There are ways of speeding up loops by using direct addressing, but this is only to be recommended after you are certain that no further changes will be required to the program and where there is plenty of spare space. Another trick is to use any spare data registers for print code instruction storage, thus releasing program space for logic instructions. There's no doubt that commercial type programs use enormous memory space for text, but in spite of these limitations I have been able to apply this machine to a wide variety of office and factory applications.

One of the first of these was my own (self-employed) accounts, incorporating all the requirements for VAT and the Inland Revenue, apportionments etc. Of course the program had to be

cleared by the local VAT office, but, believe it or not, they were most helpful. Leading on from this I developed programs for the most used Retailers VAT special schemes, also cleared by the local friendly VAT man for general use. The ability of this machine to provide printed prompts in this type of application is invaluable since the routine is not in daily use, and although the users crib sheet sets out the procedure clearly enough, it's not the same as the point of use prompt. In fact I have found the printed prompt/title easier to use and less strain than most VDUs. It also provides the permanent record of the transaction. Okay, it's long and narrow, but it can easily be folded concertina-wise, and for less than £300 complete (including VAT) it must be good value.

I am not an accountant, although for my sins I have much to do with that fraternity. One of the mysteries associated with the running of any business is the manipulation of the simple figures derived from the purchase and sale of various items or services. The end result has to be a set of accounts. One of the beauties of the "59" is that data as well as program steps can be stored on magnetic cards. This means that data can be input and processed and stored in RAM and then transferred to magnetic card, just like tape or disc. The data may then be saved for future addition or modification. This is possible due to the four way split of the data banks, with each bank independent of the others.

Admittedly relatively small volumes of data can be stored at a time, but even so there is enough to allow a full set of analysed company accounts. The technique is to print and annotate automatically every cash book entry, giving a clear audit trail and hard copy of the input. This can be organised to segregate Capital and Revenue and Dr and Cr in batches of register locations. Program No. 1 carries out the trial balance with full annotation; with the data still intact a second program is overlaid from another magnetic card to produce the Profit and Loss A/C in more or less standard format, and yet another program is overlaid on this data to give the Balance sheet. For presentation purposes a matching set of descriptive headings may be preserved on another magnetic card to suit the user's needs. The whole set can be put together and Xeroxed for filing etc. It looks almost traditional!

One of the side benefits of the wider use of the TI59 has been the development of some "utility" programs which might be of general use. One is what I have called "Auto-Folio". This enables any value to be keyed in, along with its destination register number. Upon entry the value

is loaded into that register and summed to what is already there, the value printed together with, on the same line and at the far right of the tape, the register, or folio number. This provides a much more compact listing than the Trace mode which prints everything twice, once before the destination and function code and again after.

The memory capacity allows up to 99 registers to be so addressed, 01 to 99. At the end of a batch of entries a listing routine prints an annotated statement of every register and clears all registers ready for a new batch. It takes about three seconds including printing for each entry to be completed. About the right tempo for the small keyboard and for the type of data analysis commonly required in say a Work Study office or laboratory. This program is shown in detail as it gives the encoding of numerical characters for loading into the No.4 print register. The Nop statements are left in the program in case it is required to speed up the action slightly by converting to direct addressing without having to change the program location numbers.

Another useful method of auto-routing data is to incorporate within a number a two digit code, or a series of two digit codes which may be decoded after splitting out of the original number. The example shown uses standard Op. codes, and can split a number of the form abcdefgh into four pairs, i.e. ab; cd; ef; gh, stored in four data registers ready for use as indirect addresses. There is a more complicated approach available, using the pseudo-Op. code HIR. This utilises the eight "pending result" registers, not normally available to the user except by inference when using nested parentheses. The great advantage in using them in the Code Splitter and similar programs is that precious data registers are not sacrificed in the splitting up process, and may be utilised for the safe storage of working data. However, be warned! There are many pitfalls in using these pseudo-ops., which is probably why they have not been included in the standard manual; however, used with care they increase the capability of this great little machine even further.

Another word of warning. If this machine, or similar magnetic card readers, are to be used more generally in industry, commerce, and schools (as their price level warrants) care must also be taken to ensure that the card reading mechanisms of different machines which have to share families of magnetic cards are matched. I have occasionally needed to adjust the card feed speed of a satellite machine to match the one which originally wrote the program on to the card. This is not

Continued on P. 127

# DR. PLAYGOOD

FOR  
PET, APPLE, TRS-80

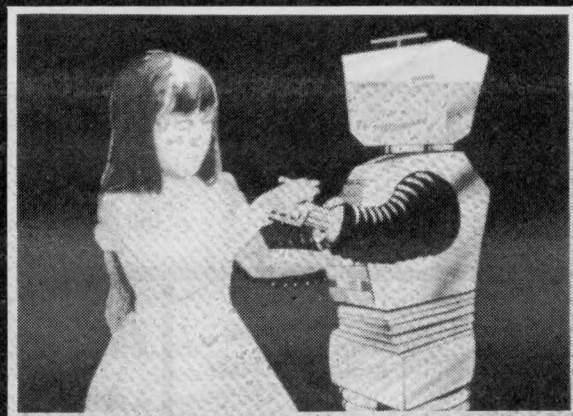

Introduced by Tom O'Ton, Microtrend's friendly robot, this imaginative and entertaining implementation of four traditional games is ideal for 4-8 year olds. Full use is made of sound and graphics capabilities and success is liberally rewarded by the friendly animated robot.

Package includes:

- OXO Noughts and Crosses – win the best of five games and receive a stunning trophy of gold!
- Hunt the HURKLE using the keyboard (or game controls) but watch out for those sneaky snappers!
- Keep death off micros with our constructive version of hangman – WORDS!
- GUESS numbers or letters, the nearer you get, the more fun things become. Designed to improve recognition of numbers, letters and words.

**FOUR SUPER PROGRAMS FOR ONLY £9.95** (incl. VAT)

**OTHER ENTERTAINING SOFTWARE INCLUDES:**

<b>PET 8K</b>		
HURKLE v SNAPPER	FOUR PROGRAMS	£9.95
GAMBLER'S WORLD/1	FOUR PROGRAMS	£9.95
BRAINTASERS/2	THREE PROGRAMS	£9.95
<b>APPLE II 16K</b>		
BRAINTASERS/1	FOUR PROGRAMS	£9.95
<b>TRS-80 LEVEL II 16K</b>		
REVERSI (OTHELLO)		£9.95
GAMBLERS WORLD/2	FOUR PROGRAMS	£9.95

For our 24 hour telephone ordering service call 0423 711878, or complete the coupon:

Name \_\_\_\_\_  
Address \_\_\_\_\_  
\_\_\_\_\_

Please send me \_\_\_\_\_ At £ \_\_\_\_\_  
for the \_\_\_\_\_ system.

Please send me your product catalogue  (tick)

Total £ \_\_\_\_\_ Signature \_\_\_\_\_

CHEQUE  (tick)

Credit Card No. \_\_\_\_\_

Send to: Microtrend Ltd.,  
P.O. Box 51, Pateley Bridge,  
PCW Harrogate, North Yorkshire HG3 5DP



Code Splitter	Sample Output	063	76	LBL
000	76 LBL	123456.78	064	24 CE
001	11 A	12.	065	82 HIR
002	99 PRT	34.	066	03 03
003	42 STD	56.	067	07 7
004	04 04	78.	068	32 XIT
005	59 INT		069	82 HIR
006	48 EXC	4.05	070	13 13
007	04 04	0.	071	77 GE
008	22 INV	0.	072	25 CLR
009	59 INT	4.	073	68 NOP
010	65 x	5.	074	85 +
011	01 1		075	01 1
012	00 0	AUTO FOLIO	076	95 =
013	00 0		077	87 IFF
014	95 =	000	078	01 01
015	48 EXC	001	079	23 LNX
016	04 04	002	080	68 NOP
017	55 +	003	081	82 HIR
018	01 1	004	082	02 02
019	00 0	005	083	61 GTD
020	00 0	006	084	34 FX
021	95 =	007	085	68 NOP
022	42 STD	008	086	76 LBL
023	03 03	009	087	12 B
024	59 INT	010	088	98 ADV
025	48 EXC	011	089	98 ADV
026	03 03	012	090	01 1
027	22 INV	013	091	22 INV
028	59 INT	014	092	90 LST
029	65 x	015	093	98 ADV
030	01 1	016	094	98 ADV
031	00 0	017	095	98 ADV
032	00 0	018	096	47 CMS
033	95 =	019	097	91 R/S
034	48 EXC	020	098	00 0
035	03 03	021		
036	55 +	022		
037	01 1	023		
038	00 0	024		
039	00 0	025		
040	95 =	026		
041	42 STD	027		
042	02 02	028		
043	22 INV	029		
044	59 INT	030		
045	65 x	031		
046	01 1	032		
047	00 0	033		
048	00 0	034		
049	95 =	035		
050	48 EXC	036		
051	02 02	037		
052	59 INT	038		
053	42 STD	039		
054	01 01	040		
055	99 PRT	041		
056	43 RCL	042		
057	02 02	043		
058	99 PRT	044		
059	43 RCL	045		
060	03 03	046		
061	99 PRT	047		
062	43 RCL	048		
063	04 04	049		
064	99 PRT	050		
065	98 ADV	051		
066	98 ADV	052		
067	98 ADV	053		
068	91 R/S	054		
069	00 0	055		
		056		
		057		
		058		
		059		
		060		
		061		
		062		

Press A to enter data.

Press B to list and clear

Personal demonstrations available at all times in our new showrooms at 30 Lake Street. Also a large range of personal computers, books and magazines. Barclaycard and leasing facilities available.



**CompUtopia**  
LIMITED

30 Lake Street, Leighton Buzzard, Bedfordshire  
Tel: (0525) 376600 24 hour Answering Service

**EPSON**

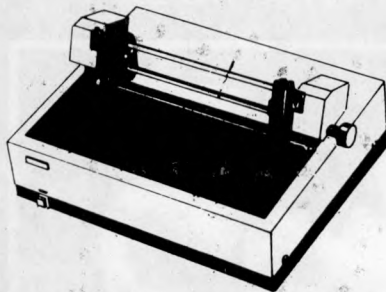

The TX-80 offers

- 96 Ascii char. set and Pet graphics
- 80 col., 150/125 char/sec
- Condensed line, Enhanced print
- 5 x 7 dot matrix, 6 x 7 dot matrix for graphics

**£445**  
(+ VAT)

Our prices are incredibly low, starting at £445 + VAT but including postage and packing.

The TX-80 is supplied with a parallel interface as standard, but interface boards and cables for Pet, Apple, TRS 80, IEEE 488, and Serial are available at £45 each.

see **BENCHTEST** in this issue

TI 99/4

This TI Home computer helps take the guesswork out of problem solving, whilst also providing a "fun" way of education and giving stimulating entertainment for everyone. The TI 99/4 has all the features you have been waiting for ..... only £995\* complete with 14" colour TV with NTSC/PAL video input — or if sold separately TI console £665 and NTSC/PAL £375\*.

Call CompUtopia for comprehensive price list. \* Incl. VAT

**ACORN** —for the discerning hobbyist

A complete range of single boards and accessories available

Acorn Controller . . . . .	£ 35
Micro Computer . . . . .	£ 65
Assembled Microcomputer. . . . .	£ 79
Memory . . . . .	£ 95
Memory Assembled . . . . .	£100
V.D.U. . . . .	£ 88
V.D.U. Assembled . . . . .	£ 98

(All prices exclude VAT)

**THE VIDEO GENIE SYSTEM EG 3003**



At last, value for money in microcomputers.

**£425 incl VAT**

- \*16k User RAM plus 12k Microsoft BASIC in ROM
- \*Fully TRS 80 level II software compatible
- \*Huge range of software already available
- \*Self contained, cassette, PSU & UHF modulator
- \*Simply plugs into video monitor or UHF TV
- \*Full expansion capability for disks & printer

# FARMLAN COMPUTER SYSTEMS

**HARDWARE**

16k I.T.T. 2020 Microcomputer	£650
16k R.A.M. Upgrade kit	£60
Disk Drive and controller	£350
Parallel Printer Interface card	£95
Anadex Printer	£525
Numeric Key Pad	£75
Music Composer	£120

**STATIONARY**

5¼ Verbatim Disks	£2.50 each
Box Printer Paper	£13.60 per box
Other stationary available upon request	

ALL MACHINERY EXCEPT PRINTER (3 MONTHS) GUARANTEED FOR 12 MONTHS

**IMPORTANT** We now have available — controller cards for 8" Drives I.B.M. compatible, suitable for Apple/I.T.T. Price on application

**ORDERING INFORMATION:**

Delivery/Insurance extra. All prices exclude V.A.T. @ 15% Price list correct at time of publishing, subject to change without notice.

FRAMPLAN, NETHERTON, ROSS-ON-WYE, HEREFORDSHIRE:  
Tel: Ross 4321

**SOFTWARE**

Agricultural Package	£2565
Desk Top Management (Financial analysis)	£125
Visi-Calc (Problem Solving)	£95
Rent Master	£250
Word Processor	£125
Payroll	£200
Data Base	£125
Quotation System	£350
Games & Utility Disks Vols.1-6	£20 each
Documentation Utility Disk	£50

Offices also at Melton Mowbray, Northallerton, Aberdeen



## SOMEBODY'S GOING TO BE SORRY

Your business is not exactly the same as any other and neither are its problems. Any solutions are probably unique and must be tailored exactly for you.

You know your business better than anyone else and any system designed should use your knowledge. The micro-computer specialist should show you how to use the computer to meet your business requirements.

You should be able to get the micro-computer which best suits your business. It should be chosen after your requirements are specified.

You and your staff have a right to know all about YOUR system, including helping to program it if you want to. Training is your right — not an additional service.

If microcomputers cannot satisfy your business needs, you want to know — you don't want false promises.

**67 Nova Road, Croydon, Surrey CR0 2TN.  
Telephone: 01-688 6013**

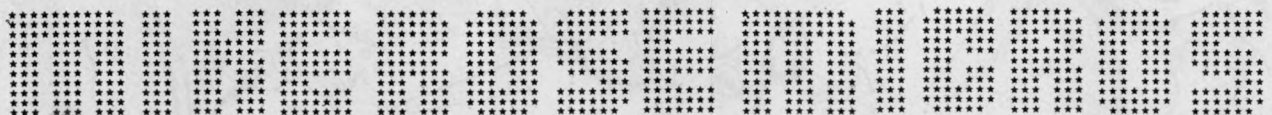

# INTERRUPT

From one of our regular contributors, a slightly jaundiced look at how governments attempt to reach their infinitely wise decisions; plus, a warning from Ted Cluff, Secretary-General of the IDPM, on the danger to companies of allowing the uncontrolled acquisition of micros.

## Too much monkey business

Here is an idea to while away the dark hours before World War III (if it hasn't already begun by the time this is published).

The object of the game is simple and is well-known to those who drift around the corridors of power. Starting with a hot-potato-issue like "What is to be done about Britain's industrial decline?"

each player aims to spend as much time as possible studying the issues to produce answers that are as self-evident as possible but which get the maximum amount of mashed media coverage. I call it the Infinite Wise Monkey game based on that well-known theory that an infinite number of monkeys banging away at an infinite number of typewriters for an infinite time will produce all the works of Shakespeare, Tom Sharpe and Saatchi and Saatchi. Make those monkeys wise and you have commissions galore.

In true modern socio-psychopseudary style, Wise Monkeys is a role playing game — of the "imagine you are king for a day, so how many palaces can you build with a Lego Kit" ilk.

Each player in Wise Monkey chooses a role. Those of a civil service bent can select an obscure sounding but pronouncable acronym, say ACARD, and then suggest it stands for something as modern but uncontroversial as Advisory Council for Applied Research and Development. Such players are represented by a Prime Minister's Ear — to which they have access via Cabinet Office connections. They are also supplied with special Working Party cards which they can shuffle about to create confusion amongst onlookers. These players start with the media handicap of complete facelessness.

More ego-tripping players can take the role of the Big Name in the Big Name Commission, as in the Longford Commission on porno or the Finniston Commission on engineers. These players start off with extra media "high personal profile cards", although they can be trumped by the political "change of government" joker which invalidates all their results if there is new government installed by the time the report is made — or if the new government was elected on a manifesto totally opposed to your conclusions (as in a recent Labour-initiated study of the National Health Service). On the other hand, this political joker can turn to your Big Name advantage if, as with Sir Monty Finniston's commission on engineers, the incoming government decides to take the glory for the last lot's initiative.

Although Wise Monkeys is a game for a large, if not an infinite number of players, some exclusivity must be maintained to separate the know-alls

and think-we-knows from the honest don't-knows. So, in addition to playing at Government Working Party or Big Name Commission, those taking part can become Consultants and Pundits. Being a Pundit is a bit like being a banker at Monopoly — you are the focus of attention, your power over pretend (or pretentious) resources gives you status, and you can become involved with the activities of all the other players — the unscrupulous can pocket fortunes under false pretences.

Points in Wise Monkey are awarded for time taken to investigate, study, research and think about the subject, and its resultant media coverage, etc. But the crucial point which must be reached by each player eventually is the Magic Answer to complete that well known phrase "The reason for Britain's decline is . . . ."

An exciting feature of the game is that ratings vary with time. For example, during the early part of 1979, top points were given for those best sellers "failure to adapt to the micro-electronics revolution" and "too much government interference". However, in the 1980s, with the public still awash with the media Chip Crap, that culminated in the Chip joining Neasden, Talbot and Situations amongst Private Eye's Galaxy of Cliches, any reference to microelectronics in the Magic Answer now leads to the award of two-yawn backsteps while an answer on the lines of "Government's failure to direct/stimulate . . ." could result in a swift budget cutback and an "Do Not Pass Go, Do Not Collect Your Department of Industry £2,000 Consultancy". And as the "too much government" thesis begins to wear threadbare, you get more points by blaming "the people" for failing to swallow their nasty medicine.

For advanced students of Wise Monkeys, the (real) ACARD and Finniston reports provide some interesting insights into shrewd game plays. Way back in early 1978, Jim Callaghan thrust the mantle of glory on to ACARD (which then — as now — was little known). He set up three ACARD working parties; one looked at the industrial and business impact of semiconductors; another at innovation in small businesses and the third at the social impact of technology.

Since then, the Working Party cards have been played with sheer mastery.



Illustration by Conny Jude

The semiconductor study, rudely stimulated by the Horizon Chips film, seemed to break all the rules of Wise Monkeys — it took months not years to do the study and was acted upon immediately, with the setting up of various Department of Industry micro awareness and support schemes backed by millions of pounds.

The once eagerly awaited small business innovation report was silently slipped out by the social impact study, after running the whole gamut of rumours about arguments, suppression, delays because the chairman broke a leg, etc. It received many points for the time it was dragged out, eventually appearing so late in the day that everyone had forgotten about it.

The Finniston report, however, achieved even dizzier heights of successful play. It managed to take a couple of years to discover the same thing that has been found out by other studies in the last 100 years — that British society, led by the Oxbridge/Public School intellectual ethos has failed to give engineers/technologists the status and pay they deserve. The Finniston Commission scored heavily for producing a weighty document to support its self-evident thesis.

There was also a nice end-game ploy. For months (it seemed like years) before the report was published in January, details of the main conclusions were published in the press — for example in New Scientist. Yet when Sir Keith Joseph was interviewed on the day of official publication, he accepted the “urgency” of acting on it but said he had not had a chance to study it yet and needed time for more consultations before announcing a response. Doesn't he read the press, or get his minions to read it for him? And why wait for yet more consultations after such a thorough study? Answers to these questions get no points at all.

Wise Monkeys, like most games, can be ruined by spoil-sports. They point out that the Wise Monkeys, like the Emperor, have no clothes to cover their nakedness and they suggest that one reasonably intelligent, unbiased person, given a month of quiet research, could come up with similar conclusions. And a particularly intelligent person, with experience of the subject and imagination could

reach a Magic Answer that was perceptive and original enough to have practical meaning. In 1977, for example, Iann Barron at a conference organised by a British Computer Society group and Computer Weekly gave a paper which succinctly analysed the impact of Information Technology and laid out a clear national strategy to deal with it; given the will, the power and the insight, Barron's plan could have been put to effective use in helping Britain get ahead in Information Technology.

The infinite Monkeys thesis, says the spoil-sport, forgets or obscures the simplicity of one person at one typewriter producing works of originality and value. And as American comedian Bob Newhart pointed out on one of his records, when somebody watching one of the infinite monkeys banging away at a keyboard eventually finds something of interest, his report might go along the lines of . . . “Hey, we've really got something with this monkey . . . he's typing . . . TO BE . . . yeh . . . OR NOT . . . go on boy . . . TO BE, THAT IS THE KRIPST\*\*DT . . .”

*Malcolm Peltu*

Presumably no one believes anything is going to happen.

I am on record as being opposed to the marketing of micros as small business systems with very low cost software which cannot possibly be supported and hardly ever has the back-up needed to cater for the inevitable changes in business requirements resulting from growth or legislation. Every day brings more evidence that this warning is necessary if small businesses are not to be jeopardised by their unjustified faith in the efficacy of a system acquired at a much lower price than that charged by houses equipped with the resources to provide the necessary back-up.

There is, however, yet another key area where micros are being oversold — although not necessarily by the vendors. I refer to companies who already have centralised dp installations, some of which have problems of understaffing, or other causes of user dissatisfaction. The view is now widespread that users can achieve Nirvana merely by sneaking a micro in the backdoor without consulting the dp manager; superficially this may even be true.

*Continued on Page 125*

## A question of boundaries

To keep one's feet on the ground whilst measuring one's ability to reach up to new levels — that is the problem. Such a surfeit of superlatives has been used in the popular press about micros, lay people can almost be forgiven for believing that problems fly out of the window having merely made a decision to acquire one. The first myth we have to dissipate is that a microcomputer can organise data input by a disorganised person.

I don't know whether it's the micro vendors or the press who are the more to blame for the misconceptions surrounding the new technology's undoubted benefits, but perhaps the message is getting through. One week before the Department of Employment produced a report saying that “micros will cause fewer job losses than feared” a one-day seminar I had hoped to attend on the social implication of micros was cancelled due to lack of support.

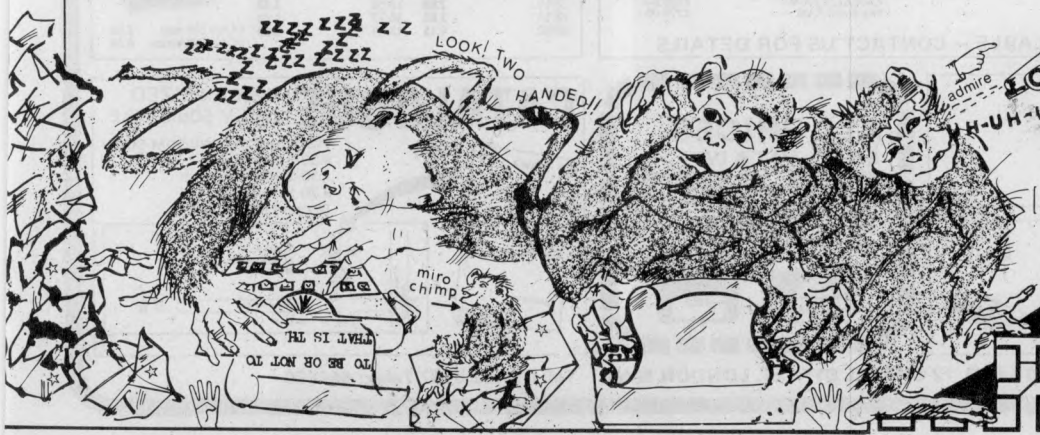

# TRANSAM

## COMPONENTS AND SYSTEMS FROM TRANSAM COMPUTERS

•CP/M  
•BASIC  
•PASCAL

**TRITON IS IMPRESSIVE!**  
PRACTICAL COMPUTING REVIEW DEC. 79.

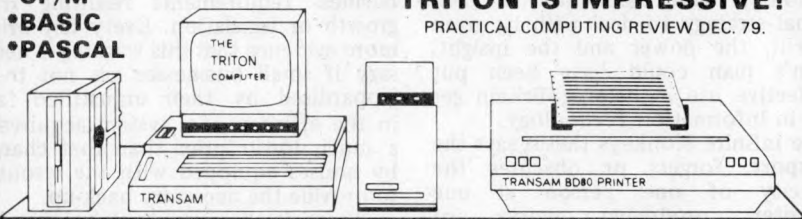

### TRITON COMPUTER SYSTEM.

Designed for ease of construction and flexibility. Kits come complete and all components and software are available separately. UK designed and supported. Fully documented hardware and software and a totally flexible approach to system building. Powerful and easy to use system monitors - a range of languages available. Firmware is Eprom based and upgrading from one level to the next is easy.

- L5.2 with 1.5k monitor 2.5k basic £294.00
- L7.2 with 2k mon 8k extended basic £409.00
- L8.2 4k ed/mon 20k res pascal £611.00
- L9.2 CP/M disc based system P.A.O.
- 8k ram card kit (21141) £97.00
- 8k eprom cars (EXCL 8 x 2708) £31.00
- Motherboard expansion 8 slot £50.00
- Trap-res asm/edit etc (8 x 2708) £80.00
- Transam BD80 bi-dir printer £595.00
- TVM 10 video monitor 9" £79.00
- Eprom prog (2708) kit £29.50

SEND FOR OUR CATALOGUE FOR FULL DETAILS OF TRITON FEATURES!

### CP/M AVAILABLE NOW FOR TRITON

Disc operating system complete with text editor, assembler, debugger, system utilities and complete file management. Makes Triton fully CP/M compatible and able to run CP/M based software. Triton will support up to four 5 1/2" or 8" drives single or double density full CP/M software user group facilities available. SAE for details.  
CP/M Disk + manuals (6) £75.00

### DISK DRIVES & POWER SUPPLIES

<b>SHUGART</b>	SA400 5 1/2" drive	£205.00
	SA800 8" drive	£380.00
	Power one quality power supplies	
	CP249 1 x 5 1/2" PSU	£33.00
	CP323 2 x 5 1/2" PSU	£60.00
	CP205 1 x 8" PSU	£56.00
	CP206 2 x 8" PSU	£76.00

### TCL PASCAL CP/M compatible

A standard Pascal compiler available on a resident (20k) Eprom based configuration\* or available to run under CP/M on 8" disc plus documentation. CP/M version £120.00 \*P.O.A.  
TCL Pascal Manual and Specification £6.50

### DIL PLUG SOCKETS & SWITCHES

W/WRAP SKTS	DIL SKTS	DIL PLUGS	DIL SWITCHES
8DIL 0.20	8DIL 0.17	14DIL 0.60	4DIL 1.20
14DIL 0.35	14DIL 0.15	18DIL 0.65	7DIL 1.75
18DIL 0.42	16DIL 0.17	SCOTCHFLEX	8DIL 1.80
18DIL 0.80	18DIL 0.24	14DIL 1.30	16w ZIF* 4.95
24DIL 0.52	20DIL 0.27	18DIL 1.50	24w ZIF* 6.20
28DIL 0.74	24DIL 0.30	24DIL 2.80	
40DIL 0.95	28DIL 0.38		
	48DIL 0.50		

ZERO INSERTION FORCE

### FULL RANGE OF MICRO SUPPORT CHIPS - IN STOCK

SUPPORT				RAMS									
SN74LS00N	22	SN74LS54N	21	SN74LS138N	95	SN74LS195AN	85	SN74LS325N	2.55	8212	2.20	2101	2.32
SN74LS01N	22	SN74LS55N	21	SN74LS139N	95	SN74LS196N	1.20	SN74LS326N	2.55	8216	2.80	2102L4	1.20
SN74LS02N	26	SN74LS63N	1.50	SN74LS145N	1.20	SN74LS197N	1.20	SN74LS327N	2.55	8224	2.80	2111	2.32
SN74LS03N	26	SN74LS73N	35	SN74LS148N	1.75	SN74LS221N	1.25	SN74LS352N	1.35	8228	4.20	2112	2.46
SN74LS04N	26	SN74LS74N	40	SN74LS151N	85	SN74LS240N	2.20	SN74LS353N	1.50	8253 (F8)	10.00	2117	2.46
SN74LS05N	26	SN74LS75N	48	SN74LS153N	80	SN74LS241N	1.90	SN74LS365N	85	8228	4.20	6810	4.00
SN74LS08N	20	SN74LS76N	35	SN74LS154N	1.80	SN74LS242N	1.90	SN74LS366N	85	8T26A	1.75	8154	11.50
SN74LS09N	22	SN74LS78N	35	SN74LS156N	1.25	SN74LS243N	1.95	SN74LS367N	85	8T28	1.90	2114L-450	5.50
SN74LS10N	18	SN74LS83AN	1.15	SN74LS156N	1.25	SN74LS244N	2.10	SN74LS368N	85	6522	8.75	2114L-250	7.60
SN74LS11N	26	SN74LS85N	1.10	SN74LS157N	80	SN74LS245N	3.80	SN74LS373N	1.75	8251	5.00	74C920	11.00
SN74LS12N	25	SN74LS86N	40	SN74LS158N	99	SN74LS247N	1.25	SN74LS374N	1.70	8253	11.00	74C921	11.00
SN74LS13N	25	SN74LS89N	40	SN74LS160N	1.15	SN74LS248N	1.95	SN74LS375N	1.75	8255	5.50	74C929	11.00
SN74LS14N	89	SN74LS91N	99	SN74LS161N	1.15	SN74LS249N	1.30	SN74LS377N	1.75	8257	£11.00	40J27	5.00
SN74LS15N	25	SN74LS92N	90	SN74LS162N	1.15	SN74LS251N	1.45	SN74LS378N	1.32	8259	12.50	4044	7.00
SN74LS20N	20	SN74LS93BN	65	SN74LS163N	90	SN74LS253N	1.25	SN74LS379N	1.40	8155	12.50	4045	7.00
SN74LS21N	26	SN74LS95AN	1.20	SN74LS164N	1.50	SN74LS257N	1.40	SN74LS381N	3.85	6402	5.00	4060	7.00
SN74LS22N	26	SN74LS96N	1.75	SN74LS165N	1.70	SN74LS258N	95	SN74LS386N	57	6821P	4.50	2107	7.80
SN74LS26N	29	SN74LS107N	39	SN74LS166N	1.75	SN74LS259N	1.45	SN74LS390N	1.88	6850P	4.80	4116 (58 for 818)	20.00
SN74LS27N	35	SN74LS109N	39	SN74LS168N	1.85	SN74LS260N	39	SN74LS393N	1.25	6852P	5.50	4118	20.00
SN74LS28N	35	SN74LS112N	39	SN74LS169N	1.95	SN74LS261N	3.50	SN74LS395N	1.80	AY5.2376	11.50	28P10	8.00
SN74LS30N	25	SN74LS113N	44	SN74LS170N	2.50	SN74LS266N	39	SN74LS396N	1.70	MC14411	12.00	280CTC	8.50
SN74LS32N	27	SN74LS114N	44	SN74LS171N	2.20	SN74LS273N	1.85	SN74LS398N	2.75	M51709	12.43	280AP10	9.00
SN74LS33N	39	SN74LS122N	79	SN74LS174N	1.15	SN74LS279N	79	SN74LS399N	1.80	M57160	10.00	280ACTC	9.50
SN74LS37N	29	SN74LS123N	90	SN74LS175N	1.05	SN74LS280N	1.75	SN74LS424N	4.50	M57161	10.00	EPROMCS	
SN74LS38N	29	SN74LS124N	40	SN74LS181N	2.75	SN74LS283N	1.80	SN74LS445N	1.25	1M56011	5.00	1702	5.00
SN74LS40N	25	SN74LS125N	85	SN74LS190N	1.75	SN74LS290N	1.80	SN74LS447N	1.25	81LS95	1.80	5204	5.00
SN74LS42N	79	SN74LS126N	85	SN74LS191N	1.75	SN74LS293N	1.80	SN74LS490N	1.95	81LS96	1.80	1708	8.00
SN74LS47N	95	SN74LS132N	75	SN74LS192N	1.45	SN74LS295AN	2.20	SN74LS496N	95	81LS97	1.80	2516	25.00
SN74LS48N	95	SN74LS133N	39	SN74LS193N	1.75	SN74LS298N	2.20	SN74LS496N	95	81LS98	1.80	2532	50.00
SN74LS49N	1.09	SN74LS136N	40	SN74LS194AN	1.89	SN74LS324N	1.80	SN74LS567N	2.70				

### DPS.1 MAINFRAME - PASCAL SYSTEM

S100 to IEEE spec



Send 50p for our ITHACA catalogue



### ITHACA

PASCAL/Z build your own Pascal Micro Development system. IEEE-S100 bus system using DPS1 main-frame. Supports K2, ASSEMBLE/Z and PASCAL/Z on 8" disc

Complete system: £2,910.00

### S100 BOARDS

8k Static RAM board (450ns)	£99.00
8k Static RAM board (250ns)	£119.00
Z80 cpu board (2MHz)	£105.00
Z80 cpu board (4MHz)	£123.00
2708/2716 EPROM board	£57.00
Prototype board (bare board)	£15.00
Video display board (64 x 16, 128U/L Ascii)	£108.75
Disc controller board	£131.25
K2 disc operating system	£45.00
ASSEMBLE/Z Macro Assm	£37.50
PASCAL/Z compiler	£205.00
PASCAL/Z CP/M	£235.00
16k Static RAM	£275.00

DOUBLE DENSITY CP/M NOW AVAILABLE - CONTACT US FOR DETAILS

### VISIT OUR SHOWROOM

WE ALSO STOCK: a comprehensive range of books and magazines, VERO products including S100 and Eurocard and Wire Wrap equipment, Weller soldering equipment, Ribbon Cables, tools, tapes, diskettes, connectors and OK Tool range.

Systems continuously on display in our showroom.

CRYSTALS	4MHz	2.10	F8 (3850)	9.50	
100k	3.00	4.43M	1.00	8080A	8.33
200k	3.70	5MHz	2.70	6809	24.00
1MHz	3.60	6MHz	2.70	Z80	8.00
1000k	3.50	7MHz	2.70	Z80A	15.00
1843k	3.00	7.168M	2.50	8085A	12.95
2MHz	1.50	8MHz	2.70	8502	8.00
2457k	3.05	10MHz	2.70	SCMP11	10.00
3276k	2.70	10.7M	2.70	6802	13.95

### ALL PRICES

Exclude VAT & P/P  
VAT 15% P. & P. 40p on small orders.  
For larger items please Tel.  
Telephone credit card orders accepted subject to £5 min.  
RAPID MAIL ORDER SERVICE



### MULTIWAY CONNECTORS

INSULATION PIERCING	35/70	4.80	
20 way plug	2.30	36/72	4.74
25 way plug	3.70	40/80	5.00
34 way plug	2.30	43/86	5.50
50 way plug	4.60	50/100	5.80
20 way skt	3.40		
25 way skt	4.00		
34 way skt	6.00		
30 way skt	6.00		
EDGE CONN PCB			
GOLD 156 PITCH			
22/44	3.20	22/44	3.85
25/50	3.60	28/56	3.30
28/56	3.90	36/72	3.30
30/60	4.15	43/86	4.60
			64 way DIN male 2.50
			64 way DIN female 4.50

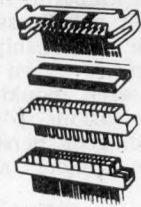

### CATALOGUE NEW A4 SIZED ONLY 50p & SAE



VISIT OUR SHOWROOM SOON  
9.30-5.30 Mon-Fri  
1.30-2.30 closed lunch  
9.30-5.00 Sat  
Thursday half day 1.30

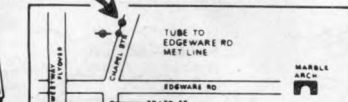

TRANSAM COMPONENTS LTD, 12 CHAPEL STREET, LONDON NW1

Tel: 01-402 8137 Telex: 444898

# YOUNG COMPUTER WORLD

*There's a new name at the top of the page this month. For personal reasons John Coll has decided to stand down (although, happily, he has promised his continued part-time support); stepping into his shoes we welcome Derrick Daines.*

## Thanks

Those of us who know John Coll are aware of the tremendous pioneering work he has put in over the years to lift computer education off the ground in all sorts of ways. Thousands of youngsters were first introduced to the computer by John and Charles Sweeten, and many of them have grown up to join the computer industry. There must be quite a number of successful young business men in computing today who owe a lot to John's inspiration. He is quite a guy to follow and I just hope that I will be able to do nearly as well. In taking over from him, I must say that I find it a comfort to know that he is only as far away as the nearest telephone. Thanks, John — and keep taking the tablets!

## Installations

Once I had agreed to join YCW (and the editor had taken his foot off my neck), one of the things that he gave me to look at was the report from Mr. Hemmings about the mother-and-daughter computer system they've got running in Sandbach High School. It looks a great idea to me and neatly solves several problems at once. Look out for a report next month.

The installation is a real step up with the added advantage that there's little necessity for hardware uniformity. In theory at least, any micro could talk to any other, with software taking care of translation problems. This thought brings in its train a whole lot of other questions that I would like your views on. For instance, given a certain amount of cash to spend on school computing — and Heaven knows, there's little of it — would it be better to have three or four identical microcomputers, the same number of different kinds of computer, or one large machine? With recent new hardware and price reductions, more and more schools will be in the happy position of making this sort of decision; I'd like to hear, not only from young readers, but also their teachers, many of whom will be trying to make up their minds on this very point.

## Competition

Would you like a badge or tee-shirt that tells those in the know that you're a computer freak? I'm sure that many would. Well, here's your chance. I'm after designs for a YCW logo and I'll give book tokens for the best. The winning design will appear monthly at the top of this page and we'll get somebody to make us a supply of metal badges for sale at cost — hopefully tee-shirts, too. Just think, your design could be the one that everybody's wearing!

I don't much mind what you put in your design, but it should convey something of what it's all about — computing — and, of course, it must look good. Don't worry too much if your artwork is poor — we've got some tame artists on the staff who can tidy it up. Oh, and

since metal badges are usually circular, I suppose your logo design ought to be circular, too. Get doodling — I'll close the competition in a couple of months.

## Him-um-her

You'll probably notice in my writing that I tend to assume my readers to be "hims", whereas they could just as well be "hers". It's YOUR fault, girls; you don't write in! Are there any girls out there? I want to hear from you, too! I know girls ARE interested in computing — I see them in their hundreds, tapping away at consoles all round the country — but they never get in touch. Now that's a pity because I just don't believe that good ideas spring only from boys' minds; girls are just as clever. Perhaps they'll prove it in our competition.

## Programs

Keep 'em rolling in! We'll give book tokens for all small programs published in connection with this page and super ones will qualify for publication at normal rates — which can't be bad. Of course, we don't undertake to publish all those that we receive, but we'll do our best.

An example of this policy at work is this month's teleprinter/printer conversion article by Tim Steele. Tim is only

16 and a pupil at Solihull School. He originally submitted his article to this page, but it's so good that it deserves a wider audience; so it gets "the treatment" and Tim gets a fat cheque. Well done, Tim!

Another program deserving of a wider audience was sent in by D.J. Danziger of Manchester Grammar School. This is a BASIC renumber package running to five pages — representing an awful lot of work by its author. We're having it re-written in the more common Microsoft BASIC so that more of you will be able to use it when it's published.

### PROGRAMS RECEIVED

SNAP — by Paul Bowden of Truro (11)

BASE CONVERSION — by Jonathan Roberts of Ilford (15)

WORD PROCESSOR — by Tony Hailes of Camberley (15)

EQUATION PROGRAM, GAMBLING — by Mark Taylor of Leeds (15)

MAZE GAME — by A Stirges of Wolverhampton (15)

ALIEN INVADERS — by T Carter of London (17)

NUMBER GUESSING, MEMORY CLEARER — by Richard Powell of Coventry (13)

Thanks a bunch to all of you! Take a look at the program listings to see which the editor has managed to get in this issue!

### SIMPLE WORD PROCESSOR — by Tony Hailes

```
10 CLEAR4500
11 PRINTTAB(10);"SIMPLE WORD PROCESSOR"
12 PRINT
15 DIMA$(100)
16 FORA=1 TO5:READA1:NEXT
17 FORA=0 TO14
19 READA1
20 POKEA,A1
21 NEXTA
25 DATA76,80,65,70,67
27 DATA245,253,126,61,246,128,253,119,69,211,254,241,195,18,224
45 PRINT"TYPE IN YOUR TEXT, EACH LINE STARTING WITH A ";CHR$(34)
;"
46 PRINT"AT THE END OF EACH LINE, PRESS RETURN."
47 PRINT"WHEN YOU HAVE FINISHED, TYPE [END]."
```

Program Cont. on Page 126

# Personal Computer

World

## FEATURE INDEX

Index to current volume, up to, and including, last month. (Previous volumes were indexed in March and April 1980 issues).

Hardware Projects		Sound to colour	
280 Homebrew	3-1	conversion	3-3
Selective PROM copier	3-3	American report	3-3
TV to Monitor		Simple approach to	
conversion	3-3	programming	3-3
MK-14 Expansion	3-4	Communication aid for	
Benchtest Evaluations		disabled	3-4
Luxor ABC 80	3-1	Imphex — intelligent	
WH 89	3-2	game PET	3-4
ACT System 800	3-2	House of Commons	
Panasonic JD 700U	3-3	report	3-4
Sinclair ZX-80	3-4	Package evaluations (systems)	
Challenger C2 4P	3-4	Sales Ledger	3-1
Series		Purchase Ledger	3-2
PASCAL	3-1,2,3,4	Payroll	3-3
David Levy's		Word Processing	3-4
games	3-1,2,3,4	Indexes	
On the line	3-1,2,3	Back Issues 1-1 to 2-4	3-2,3
Viewdata	3-4	Back Issues 2-5 to 2-8	3-4
Fact Sheets (Fax)		Programs	
6800 opcodes	3-1	BASIC Star Wars	3-1
6502 opcodes	3-2	PET Alien Attack	3-1
Personal Opinion (Interrupt)		Revas (conclusion) Reverse	
The end of work? Lord		assembler for Z80	3-1
Avebury	3-1	Planet name generator	
Protest against technological		— 6800	3-1
determinism	3-3	Naming Nascom files	3-2
Who needs the CRA?	3-4	380Z Pictures	3-2
Schools computing —		Fuel tank calculations —	
David Firnberg	3-4	PET	3-2
Evaluations (Checkout)		PET large numeral	
Video Genie	3-2	generator	3-2
Vector Graphic		PET tank battle	3-2
Flashwriter II	3-2	BASIC string handling	
Apple II Symtec light pen	3-3	routines	3-2
Calculator Corner		MK-14 scrolled messages	3-3
TI 58/9 Pseudo opcodes	3-1	6800 Keyword retrieval	
Casio Fx 502P Brag	3-1	system	3-3
Casio Fx 501/2P Master		PET Kaleidoscope	3-3
Pack	3-2	Efficient character storage	
TI 58/9 Economics		Z80 Assembler	3-3
Simulations. . . . .	3-2	UK101 Dodgems	3-4
Programming efficiency	3-3	TRS-80 Fox and hounds	3-4
Casio random number		MZ 80K Sine wave	
generator	3-3	addition	3-4
HP 41C review	3-4		
Special Features			
Computer Retailers'			
Association	3-1		
Christopher Evans tribute	3-1		
Show chess results	3-1		
The British Computer			
Society	3-2		
Astrology — case study	3-2		
IEEE-488 bus explained	3-2		
Economic simulation	3-3		

PLEASE NOTE THAT THE FOLLOWING  
ISSUES ARE  
SOLD OUT

VOLUME 1 Nos. 4, 5, 6, 7, 9, 11, 12

VOLUME 2 Nos. 5, 6

ALL OTHER ISSUES MAY BE  
ORDERED USING THIS FORM. →

# Personal Computer

World

## BACK NUMBERS

THINK OF THE FUTURE-LOOK BACKWARDS!

PCW has long been regarded as by far the most authoritative journal in its field.

Every issue published has contained a wealth of detailed technical information on all aspects of the rapidly growing Personal Computer Market.

Demand for our limited stock of back numbers has also become something of a rapid growth industry! Consequently, early back numbers of PCW are going to be increasingly difficult to get hold of, so make absolutely certain of getting yours by checking the coupon at the foot of the page.

Volume 1 No. 1 May 1978  
Nascom 1/77-68: The Mighty  
Micromite/A charity system

Volume 2 No. 4 August 1979  
The North Star Horizon/High  
Speed Cassette Interface for  
the SWTP 6800/Garage Acco-  
unting program/Apple Medi-  
cal Application.

Volume 1 No. 2 June 1978  
Research Machines 380Z/  
Computer in the classroom/  
The Europa Bus.

Volume 2 No. 7 November  
1979 PCW Show issue/6800  
Bug/Hard disc security/  
Detecting literary forgeries/  
Benchtest — the Challenger  
C3

Volume 1 No. 3 July 1978  
Buzzwords — A to Z of  
computer terms/Pattern re-  
cognition/Micro music

Volume 2 No. 8 December  
1979 Micro-controlled toys/  
'NASCOM — words and  
music/Systems — stock con-  
trol/Benchtest — the Micro-  
mation Z-Plus.

Volume 1 No. 8 December  
1978 Computers and Art/3-D  
Noughts and Crosses/Mickie  
— the interviewing micro.

Volume 3 No. 1 January 1980  
CRA aims/Benchtest ABC 80  
/Homebrew Z80/Computer  
Games — Series

Volume 1 No. 10 February  
1979 Review — the Attache/  
Word on word processing/  
Micro assembler for the  
6800/Sinclair to MPU inter-  
face/Draw pictures, written  
in Tandy Level II

Volume 3 No. 2 February  
1980 Benchtests — ACT 800,  
WH89/Micro Astrology/  
Checkout — Video Genie/  
IEEE-488 analysed.

Volume 2 No. 1 May 1979  
Small computers for small  
organisations/Sorcerer graph-  
ics/Chess Programming Hints/  
Parkinsons Revas.

Volume 3 No. 3 March 1980  
Benchtest — Panasonic JD-  
700U/Checkout — Symtec  
Light Pen/Introduction to  
programming/TV to Monitor  
Conversion.

Volume 2 No. 2 June 1979  
MSI 6800/Witbit — disassem-  
ble your programs/The Multi-  
lingual Machine/Polytechnical  
Processing.

Volume 3 No. 4 April 1980  
Benchtests: Sinclair ZX80  
and Challenger C2-4P/View-  
data — Part 1/Mk-14 Expan-  
sion/Word Processing  
Packages/

Volume 2 No. 3 July 1979  
Vision link: Interfacing and  
Software for the Superscamp  
VDU/Pet Preening/Extended  
cursor graphics for the TRS-  
80.

Any one issue 95p; Any two issues £1.75; Any three  
issues £2.50; Any four issues £3.00. All additional issues  
@ 50p each. Binders @ £2.95. All prices include post and  
packing. Cheque or P.O. payable to (PCW) SportsScene Pub-  
lishers Ltd., 14 Rathbone Place, London W1P 1DE. Please  
allow up to 3 weeks for delivery and don't forget to state  
clearly your name and full address with your order.  
Please send me the following copies of PCW. I enclose a  
cheque/P.O. for £

Volume 1	Volume 2	Volume 3
1 2 3 8 10	1 2 3 4 7 8	1 2 3 4
<input type="checkbox"/> <input type="checkbox"/> <input type="checkbox"/> <input type="checkbox"/> <input type="checkbox"/>	<input type="checkbox"/> <input type="checkbox"/> <input type="checkbox"/> <input type="checkbox"/> <input type="checkbox"/> <input type="checkbox"/> <input type="checkbox"/>	<input type="checkbox"/> <input type="checkbox"/> <input type="checkbox"/> <input type="checkbox"/>

Name \_\_\_\_\_

Address \_\_\_\_\_

\*Tick appropriate boxes

# THE BYTE SHOP & COMPUTERLAND

Still the biggest 6 in the country

## London

48 Tottenham Court Road  
London W185 4TD  
Tel. 01-636 0647

## Birmingham

94-96 Hurst Street  
Birmingham B5 4TD  
Tel. 021-622 7149 Telex. 336186

## Nottingham

92a Upper Parliament Street  
Nottingham NG1 6LF  
Tel. 0602 40576 Telex. 377389

## Ilford

426/428 Cranbrook Road,  
Gants Hill,  
Ilford, Essex IG2 6HW  
Tel. 01-554 2177

## Manchester

11 Gateway House  
Piccadilly Station Approach  
Manchester  
Tel. 061-236 4737 Telex. 666168

## Glasgow

Magnet House  
Waterloo Street  
Glasgow  
Tel. 041-221 7409 Telex. 779263

Your six main computer centres, stocked up with new equipment for 1980. Complete systems carefully chosen for their reliability and availability. Plus the widest range of software for business, education and industry. For expert advice on which system suits you best call into one of the Big Six.



6 &

# Introducing the PET COLLECTION



... A suite of powerful business programs at a budget price – from ACT Petsoft, the professional software specialists!

## **ACT SALES LEDGER £120**

**Commodore Disk £95 Cassette version**

Full facilities for the maintenance of the Sales Ledger, the preparation of a list of outstanding balances and printing of statements. All data including new customer details, invoices, credits, cash and transfers are entered under step by step guidance on the display screen. Printed results include Audit List, Aged Debtors List, Control Account and Statement.

For 32K PETs

Both Sales Ledger and Purchase Ledger are ...



## **ACT PURCHASE LEDGER £120**

**Commodore Disk £95 Cassette version**

Full facilities for maintenance of the Purchase Ledger, the preparation of a list of outstanding balances and printing of remittance advices. The system produces the following printed results: Audit List, Aged Creditors List, Control Accounts, Purchase Ledger Record, Remittance Advice, Cheques and Payment List. For 32K PETs

## **PLUS 3 INVOICING WITH STOCK £75**

A powerful, easy-to-use system for the CompuThink Disk, handling 1200 or 2400 stock items per diskette.

## **PLUS 4 PAYROLL 200 £50**

For up to 200 employees, on disk or cassette.

## **PLUS 5 WORDCRAFT £325**

The ultimate PET Word Processor, now on CompuThink Disk.

... and over 200 more business programs, games and programming aids in the NEW **PETSOFT CATALOGUE**.

DEBTORS CONTROL LIST				DATE	PAGE
				30 JUN 79	1
				CREDIT	REPORT
				LIMIT	
				500	
				TOTAL BALANCE	
				296.18	
				OUTSTANDING	
STATEMENT					
HAMILTON STEEL LTD					
45 GOODSON STREET					
BIRMINGHAM B15 4HN					
UNITED MANUFACTURING CO LTD					
120 STOCKYARD ROAD					
WESTINGTON					
STAFFS ST13 4JK					
DATE	REFERENCE	TRANS	DEBIT	CREDIT	
MAR 79	B/F		1565.40		
APR 79	B/F		836.45		
MAY 79	B/F		1941.64		
				366.09	
				1017.50	
	1014	INV			
	1096	CH			
	1096	INV			
			1096.23		
				1565.40	
				1565.40	

To: ACT PETSOFT  
Radclyffe House,  
66-68 Hagley Road,  
Edgbaston, Birmingham  
B16 8PF. Tel: 021-455 8585  
Telex: 339396

Please rush me information on ...  1  2  3  4   
 5 also the NEW **PETSOFT CATALOGUE**

My Name is \_\_\_\_\_  
I live at \_\_\_\_\_

Tel. No. \_\_\_\_\_

# ACT Petsoft

Britain's most up-to-date and comprehensive guide to the selection of microcomputer equipment, compiled for PCW by Richard Olney of Heuristic Consultants.

Machine (Price from)	Main Distributor/s (No. of Dealers)	Hardware	Software	Miscellaneous (Documentation)
ABC 80 (£790)	CCS Microsales; 01-444 7739 (TBA)	16-40K RAM; Z80A: C: 12", 16x40 b&w VDU: 4680 bus: IEEE 488: RS232 port: option — dual 5 1/4" F/D (160K, own DOS), £895	DOS: BASIC:	Graphics loudspeaker with 128 effects: Viewdata compatible: (S)
Act System 800 (£3950)	ACT: 021-455 8585 (50)	48K RAM; 6502: dual 5 1/4" F/D (800K): 12", 30x64 VDU: 1 S/P: 1 P/P	MDOS: BASIC: A: PL/M: Fifth	Fully IBM compatible K/B: high resolution graphics: available with dual 8" F/D (2.4MB), £4950: (E)
Alpha Micro (£8,200)	Alpha Micro (UK) Ltd 01-250 1616 (TBA)	64K-16M RAM: 16 bit: dual 8" F/D (2.4MB): 6 S/P: modular	multi-user O/S: BASIC: M/A: Pascal: U	Expands to 1200 MB, 32 terminal systems: (E)
Altos ACS 8000 (£3,398)	Logitek: 02572 66803 (TBA)	64K RAM; Z80: 1K ROM: dual 8" F/D (1MB): 2 RS232: 1 P/P	CP/M: BASIC: Fortran: Cobol: Pascal: M/A	(S&H)
Apple II (£695)	Microsense: 0442 41191 (190)	16-48K RAM; 6502Z: 81/O slots: option — single 5 1/4" F/D (116K) £349	O/S: BASIC: Pascal: games:	280x192 high res graphics: integer BASIC in 6K ROM (S)
Athena 8285 (£7955)	Butel-Comco Ltd: 0703 39890 (TBA)	64K RAM; 8085A: dual 5 1/4" F/D (644K): 12", 25x80 VDU: 150 cps printer: RS232C port: options — dual 8" F/D (2MB)	AMOS: T/E: BASIC: Cobol: Fortran: Pascal: APL: M/A	Extended ASCII K/B with numeric pad: graphics: many fully integral configurations possible: (S)
Atom (£120)	Acorn: 0223 312772 (N/A)	2-11K RAM; 6502: Full keyboard: C int: T.V. int: 20 I/O lines: 1 P/P	BASIC in 8K ROM: A: Cass OS	High resolution graphics on bigger model: colour monitor O/P: loudspeaker (B)
Attache (£7,000)	R.H.Thorpe Ltd: 0276 29492. R.J.Spiers Ltd: 0603 416573 (TBA)	48K RAM; 8080: dual 8" F/D (616K): 9", 16x64 b&w VDU: 180 cps printer	ExBASIC: Fortran	(S)
Billings BC-12FD (£4,295)	Mitech: 04862 23131 (TBA)	64K RAM; Z80A: dual 5" F/D (640K): 12", 24x80 b&w VDU	DOS: BASIC: Fortran: Cobol: A	8" F/D (2MB) to replace 5", £6,000: additional dual 8" F/D, £2,750 (S)
Canon BX-1 (£3,850)	Canon Business Machines (UK) Ltd: 01-680 7700	64K RAM; 6800: Single 5 1/4" F/D (65K): 12", 25x80 VDU: 5xV24 ports: options — single 5 1/4" F/D (65K), £1,500	DOS: ExBASIC: A:	Also supplied with integral thermal printer instead of VDU: (S&H)
CBS Mk 2&3 (£5900;£8648)	Compelec: 01-636 1392 (N/A)	64K RAM; Z80: dual 8" F/D (1MB): 12", 24x80 VDU: 132 col, 30 cps printer: 2 S/P: 1 P/P	CP/M: BASIC	Mk. 2 with 2MB F/D, £5,900. Can upgrade to Mk.3 — £8,150 (11MB H/D and 4 more S/Ps): Desk mounted: Up to 44MB H/D possible, £4,529 extra: multi user system with 208K RAM, £10,648: (S&H)
Challenger 1P & C2 (1P, £238; C2, £404)	CTS: 0706 79332; MBM: 01-980 3993; Mutek: 0225 743289; Millbank Computing: 01-549 7262; U-Micro-computers: 0606 853390; Byte Shop: 01-518 1414	4-32K RAM; 6502: C int: RS232 port:	O/S: BASIC: A: ExBASIC	D/A conv: col capability: 8K microsoft BASIC in ROM: option — dual 5 1/4" F/D (160K), £550: for C2, dual 8" F/D (1.15MB) and 20MB H/D: runs OSI business software on 8" F/D. (S)
Challenger C3 (£2,334)	As above	32-56K RAM; 6502, 6800, Z80: dual 8" F/D (1.15MB): 2-16 S/P	OS65U: BASIC: CP/M: Fortran: Cobol	Also C3B & C3P H/D modules: 74MB for about £10,000: (S&H)
Comma VO3 (£4,200)	Comma: 0277 811131: (N/A)	32K RAM; LSI 11: dual 8" F/D (512K): 4 serial DLU11S ports: modular	RT11 O/S (£750): BASIC: Cobol: Fortran	Many configurations possible: (H)
Compucolor II (£998)	Abacus: 01-580 8841: (6)	8-32K RAM; 8086: 13", 32x64 8-colour VDU: single 5 1/4" F/D (51K): RS232 port	ExBASIC (ROM): A	16K module, £1,078: 34K, £1,209: maintenance and programming manual available: (I)
Compucorp 625 (£6,000)	Compucorp: 01-952 7860: (17)	60K RAM; Z80: dual 5 1/4" F/D (700K): 9", 16x80 b&w VDU: 40 cps printer: 1 RS232 port	A: BASIC: U	Also 655 model with 320K F/D capability and 12", 20x80 VDU — £4,345 (B)
Comp Workshop System 1 (£1,600)	Comp Workshop: 01-491 7507 (N/A)	32K RAM; dual 5 1/4" F/D (170K): 9", 16x64 b&w VDU: modular	A: BASIC: Fortran: Flex: Pascal: Pilot	This is an example configuration from a fully compatible modular range: (E)
Cromemco System 2, System Z2H, System 3 (£1,995/£4,998/£3,293)	Comart: 0480 215005; Datron: 0742 585490; Microcentre: 031 225 2022 (20)	64K RAM; Z80: dual 5 1/4" F/D (346K) Sys 2 and Z2H... dual 8" F/D (1.24MB) Sys. 3: S/P: P/P	CDOS: BASIC: Cobol: Fortran; Multi-user BASIC: A:	All systems expandable to multi-user (2-7 users), £3,455 £6,400: 11 and 22MB options: also dual 8" F/D (996K) on Sys. 2 and 3: (E)
DAI (£998 48K version)	Data Applications (UK): 0285 2588 (TBA)	12-48K RAM; 8080: C int: 24x60 VDU int: RS232 port: Over 20 industrial ints: 2 C ints	BASIC (ROM): U (ROM)	Up to 255x335 resolution graphics: 3 notes and noise generator: PAL output to TV: games paddle
Diablo 3000 (£9450)	Business Computers Ltd: 01-207 3344 (TBA)	32K RAM; 8085: dual 8" F/D (1.2MB): 12", 24 x 80 b&w VDU: 45cps printer	DOS: DACL: A: U:	Selection of business packages supplied in price: (S)
Digital Microsystem DSC-2 (£5,395)	Modata: 0892 39591 (TBA)	64K RAM; Z80: dual 8" F/D (2.28MB): 4 RS232 ports: EIA port	CP/M: BASIC-E: CBASIC: Cobol Fortran: Pascal	Up to 6 additional F/D units possible: (H)
Durango F-85 (£8,250)	Comp Ancillaries: 07843 6455 (12)	64K RAM; 8085: dual 5 1/4" F/D (1MB): 9", 16x64 green VDU: 132 col 165 cps printer: N/P	O/S: DBASIC	Takes up to 5 work stations: fully integrated system: options — additional dual 5 1/4" F/D (1MB) and 12 MB H/D: (S)
Dynabyte DB8/1 (£1,500)	Dynabyte UK/Europe Ltd: 0723 65559 (6)	32-64K RAM; Z80: S100 bus: 2 RS232 ports: 1 P/P	CP/M: BASIC: Cobol: Pascal	Expands to multi-user system: option — dual 8" F/D (1MB), £2,000: also DB8/2 with dual 5 1/4" F/D (400K), £3,000 (E)
Equinox 200 (£7,500)	Equinox: 01-739 2387 (N/A)	64-256K RAM; Z80: 10MB H/D: 1 S/P: 1 P/P	CP/M: CBASIC: cobol: Fortran:	Multi-user MVT/FAMOS available in place of CP/M: (S/H)

List of Abbreviations

A Assembler	F/D Floppy disc	M/A Macro assembler	S/P Serial port
B BASIC	G/C Graphics card	N/A Not available	T/E Text editor
C Cassette	H Hardware	N/P Numeric pad	TBA To be announced
E Extensive	H/D Hard disc	O/S Operating system	U Utility
	I Introductory	P/P Parallel port	
	Int Interface	S Software	

Please note: Software items listed in *italic* are not included in the basic price of the equipment. All prices are *exclusive* of VAT.

Machine (Price from)	Main Distributor/s (No. of Dealers)	Hardware	Software	Miscellaneous (Documentation)
Euroc (£7,995)	Eurocalc Ltd: 01-405 3113 (TBA)	64K RAM: 8080A: dual 8" F/D (1MB): 15", 25x80 b&w VDU: 132 col 140cps printer	CP/M: CBASIC: A: U:	A year's maintenance and station- ery supply inc: (S)
Executive Minicom- puter	Binatone 01-903 5211	See Video Genie		
Exid Sorcerer (£650)	Liveport Data Products 0736 798157 (27)	8-32K RAM: Z80: RS232: 1 P/P: S100 connector: 30 x 64 VDU I/O	O/S: ExBASIC (ROM): Editor: A: CP/M: Algol: Fortran	High res graphics capability: 16K version, £760: 32K £859: 48K, £960: option — dual 5 1/4" F/D (630K), £1,200: User program- mable character set: (I)
HP 85 (£2,240)	Hewlett Packard Ltd: 0734 784774 (16)	16-32K RAM: C.P.U.: 5" 16x32 b&w VDU: C (200K): 64 cps printer: RS232 port: 4 P/P	BASIC:	Full dot matrix graphics: N/P: compact portable unit: (S)
IMS 5000 (£1,935)	Equinox: 01-739 2387 (20)	32-64K RAM: Z80: dual 5 1/4" F/D (320K)	CP/M: CBASIC: Cobol: Fortran:	3 drives option: (S&H)
IMS 8000 (£3,515)	As above	64-256K RAM: Z80: dual 8" F/D (1MB)	CP/M: CBASIC: Cobol: Fortran: MicroCOBOL	Multi-user MVT/FAMOS available in place of CP/M: (S&H)
IMSAI VDP 42 (£3,900)	Computermarket: 0603 615089 (TBA)	32-64K RAM: 8085: dual 5 1/4" F/D (400K): 9", 24x80 b&w VDU: 1 S/P: 1 P/P	IMDOS (CP/M comp): A: ExBASIC: U: CBASIC: Cobol: Fortran	Supports 8 additional F/D drives: also available, VDP 44 with F/D (780K), £4,400: (H)
IMSAI VDP 80 (£6,200)	As above	32-64K RAM: 8085: dual 8" F/D (1.2MB): 12", 24x80 b&w VDU: 1 S/P: 1 P/P	IMDOS: A: ExBASIC: U: CBASIC: Cobol: Fortran	(H)
ITT 2020 (£867)	ITT: 0268 3040 (15)	16-48K RAM: 6502	Monitor: A: ExBASIC: Dis A:	360x192 high res graphics: Ex- BASIC in 6K ROM: options — single 5 1/4" F/D (116K), £425; 16K RAM, £110; RS232 port, £96: 32K system, £931: 48K sys- tem, £995: (B)
LSI M-One (£5995)	LSI Computers: 04862 23411	8K RAM: 8080: dual 8" F/D (1.2MB): 12", 24 x 80 b&w VDU	FMOS: A	A choice of standard business pack- age included in price: (S)
LSI M-One Model 5 (£9900)	As above	16K RAM: 8080: dual 8" F/D (2.4MB): 2x12", 24x80 VDU's: 120cps bidirectional printer	FMOS: A	One of the VDU's is for inquiry only: (S)
LX-500 (£3,500)	Logabax Ltd: 01 965 0061 (13)	32K RAM: Z80: dual 5 1/4" F/D (180K): 12" 25x80 b&w VDU: 100cps printer	DOS: BASIC: A	Other printers available: (S)
Megamicro (£6,080)	Bytronics: 0252 726814 (5)	256K: 8080A: dual 8" F/D (1MB): 12", 20x80 b&w VDU: 120cps printer: 2 S/P: 2 P/P	CP/M: U	(H&B)
Microstar 45 Plus (£4800)	Microsense: 0442 41191 (30)	64K RAM: 8085: dual 8" F/D (1.2MB): 3 S/P: RS232 port	STARDOS: CP/M: BASIC: Cobol: Fortran	(E)
MSI 6800 (£1,203)	Strumech: 05433 4321 (5)	16K RAM: 6800: C: 9", 16x64 b&w VDU: 1 S/P	BASIC: Mini A: U	Up to 8 serial or parallel ints possible: (S&H)
MSI 6800 System 1 (£2,175)	As above	32K RAM: 6800: dual 5 1/4" F/D (160K): 9" 16x24 b&w VDU: 1 RS232 port	DOS: BASIC: U: A: Fortran	As above: option — dual 8" F/D (624K), £1,640: (S&H)
MSI 6800 System 2 (£7,500)	As above	56K RAM: 6800: single 8" F/D (312K): 10MB H/D: RS232 port: 9", 16x64 b&w VDU	DOS: BASIC: Multi- user BASIC: A	Rack mounted: options — dual 8" F/D (624K), £1,640; 10MB H/D, £4,250: (S&H)
MSI System 7 (£5,200)	As above	56K RAM: 6800: dual 5 1/4" F/D (640K): 9", 16x24 VDU: 1 P/P	DOS: BASIC: A	Choice of FDOS, SDOS or Flex: also option — 10MB H/D: (H&S)
Nanocomputer (£420)	Midwich: Waltham Cross 29310 (TBA)	4K RAM: 2K ROM: Z80: C int: 8 digit LED: K/B: RS232 port: 4 P/P	Machine language: BASIC: A: T/E:	Designed for hardware educa- tion: expandable to 64K RAM system with F/D: (E)
North Star Horizon (48K, £4,650)	Comart: 0480 215005; Comma: 0277 811131; Equinox: 01-739 2387 (20)	24-56K RAM: Z80A: dual 5 1/4" F/D (360K): 15", 24x80 b&w VDU: 150 cps printer: 2 1 P/P	DOS: BASIC: CP/M Cobol: Fortran: Pascal	(E)
Oxford Mini- computer	Binatone 01-903 5211	See Video Genie		
Panasonic JD740U; JD840U (£4550, £5500)	Teletronix: 01-262 3121 (10)	56K RAM: 8085A: 2-4K PROM: dual 5 1/4" F/D (570K) JD740U: dual 8" F/D (2MB) JD840U: 12", 24 x 80 b&g VDU: 3xRS232 ports.	CP/M: BASIC: Microcobol	Also available — JD700U with 140K disc capacity, £4175; JD800U with 1/2 MB disc, £4750
Pascal Microengine (£2,080)	Pronto: 01-599 3041 (TBA)	64K RAM: MCP 1600: 2 RS232 ports: 2P/P: options — dual 5 1/4", F/D (1MB), £1550: dual 8" F/D (2MB), £1950	BASIC: Pascal	CPU has user written word set:
Periflex 630/48; 1024/64 (£2500; £3300)	Sintrom: 0734 85464 (5)	48K RAM, 630/48: 64K RAM; 1024/64: Z80: dual 5 1/4" F/D (630K), 630/48: dual 8" F/D (1MB), 1024/64: 2xRS232 ports: 1 P/P: Options — dual 5 1/4" F/D (630K) £859; dual 8" F/D (1MB) £1025	CP/M: BASIC: Fortran: Cobol: A	One day installation training on site included in price (S&H)
PET 8K,16K & 32K (£550, £675 & £795)	Commodore: 01-388 5702 (150)	8-32K RAM: 6502: C: 9" ~ 25x40 VDU: IEEE488 port	O/S: BASIC: A: Forth Pilot:	BASIC in 8K ROM: options — dual 5 1/4" F/D (353K), £795; same, but (800K), £995, plus, with the 2001-8, £30 for the disc operating ROM: (I)
Powerhouse 2 (£1,175)	Powerhouse Micros: 0422 48422 (TBA)	32-64K RAM: Z80A: 5", 27x96 b&w VDU: 1 P/P: RS232 port	FDOS: BOS: BASIC: ExBASIC: (14K EPROM), £260	Graphics card available, £190: option — dual 5 1/4" F/D (700K): (I)
Rair Black Box (£2,300)	Rair: 01-836 4663 (N/A)	32-64K RAM: 8085: dual 5 1/4", F/D (160K): 2 RS232 ports	CP/M: BASIC: Cobol: Fortran: M/A	16K RAM expansion, £250; dual 5 1/4" F/D (520K), £1,000: (H)
Research Machines 380-Z (£1,048)	Research Machines: 0865 49791 (N/A)	16-56K RAM: Z80A: C: RS232 port:	Tiny BASIC: graphics: A: ExBASIC: CBASIC: Cobol: For- tran: Algol: CP/M: U:	Designed for education: high res graphics being developed: options — dual 5 1/4" F/D (168K), £895 and dual 8" F/D (1MB), £1,695: 56K version, £1,654: (S)
SDS 100 (£4,290)	Airamco: 0294 57755 (11)	64K RAM: Z80: dual 8" F/D (1MB): 12", 24x80 VDU: S100 bus: RS232 port: N/P: 1 P/P	CP/M: A: ExBASIC: Cobol: Fortran	Facility for 8K PROM: (E)

Whether you're a software engineer looking for the best hardware — an educationalist requiring versatility and the ultimate in reliability — or an OEM demanding flexibility, the finest documentation available, and 'realistic' margins — Zenith Data Systems is your automatic choice.

**Z89 Series Microcomputer.**

This highly advanced Microcomputer is the star of the Zenith range.

Specification includes: Floppy disc storage. 48K RAM. 'Intelligent' video terminal.

Two Z80 Microprocessors. Choice of operating systems including CPM.

Standardised communication, RS 232. Prices from £1570

**Z11A Series 16-bit computer.**

Based on the powerful new KD11-HA CPU (LSI — 11/2) it offers you the speed and versatility of a minicomputer at

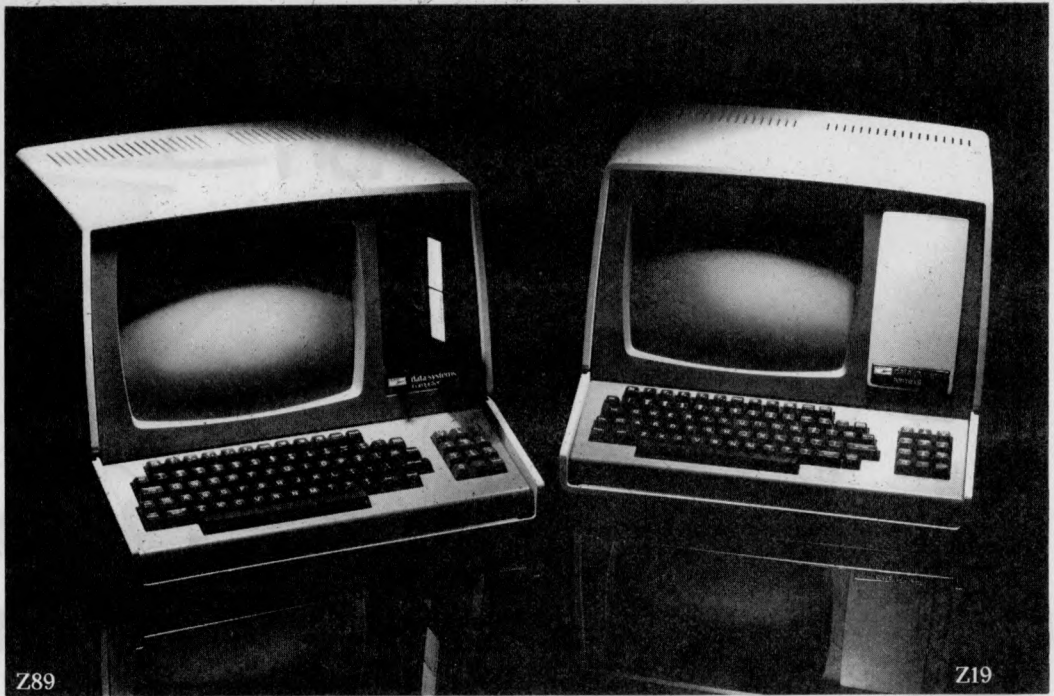

Z89

Z19

# The Professionals

a microcomputer price. With memory\* to 32K words (64K Bytes). Seven additional I/O positions. PDP 11/03 compatible.

Systems from £4335. \*Memory boards available from £562 per 16K.

**WH14 Serial Printer.**

Microprocessor based electronics makes it capable of a wide variety of uses in most computing applications.

It features 5 x 7 dot matrix. Impact print. Operator/software selectable line width — 132, 96 and 80 characters per line. And sprocket paper feed with adjustable spacing. Price. £510

**Z19 'Intelligent' Video Terminal.**

Z80 based, it is capable of a multitude of high-speed functions. It has an easy-to-read, high resolution CRT. Heavy duty keyboard. 128 characters. Addressable cursor, relative and direct. Versatile edit functions. And E.I.A. RS 232/c at 110 to 9600 baud. Price. £735



Z11A

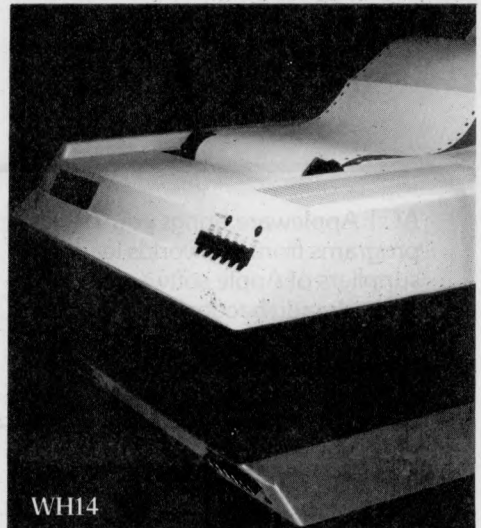

WH14

**Zenith data systems**



THE ULTIMATE IN MICROCOMPUTERS

If you'd like more information about any, or all of the Zenith Data Systems range, just contact us at Zenith Data Systems Division, Heath Electronics (U.K.) Limited, Dept PCW 5, Bristol Road, Gloucester GL2 6EE. Telephone (0452) 29451. All prices are exclusive of VAT and delivery charges. Generous OEM discounts available.

AT LAST!

# Appleware

The best of  
British and American  
**APPLE  
SOFTWARE**

ACT Appleware brings you 70 classic programs from the worlds leading suppliers of Apple software. Many have already become best sellers in America. So send today for a free copy of the most exciting Apple software catalogue ever. We promise

to keep you on the mailing list.

*Appleware is backed by the resources of the ACT Group, Britains leading computing company. Contributing software houses include Programma International, Personal Software, Automated Simulations, Speakeasy Software and P.D.I.*

Disk programs include:

Applepie Text Editor £30  
Alien Invaders £8  
Apple Database £23.50  
Talking Disk (Speech Synthesis) £14.95  
Apple FORTH £39.95  
Assembler/Editor (in machine code) £45

Try them at your Apple Dealer. Also available by mail order direct from ACT Appleware.



Send a free catalogue to

Name .....

Address .....

Post code .....

I have an  Apple II  ITT2020  
 No Apple

# Appleware

Radclyffe House, 66/68 Hagley Road, Edgbaston, Birmingham B16 8PF  
Telephone 021-455 8585 Telex 339396

# IN STORE

**DIRECT ACCESS**

Machine (Price from)	Main Distributor/s (No. of Dealers)	Hardware	Software	Miscellaneous (Documentation)
S.E.E.D. System One (£2,175)	Strumech: 05433 4321 (4)	32-56K RAM: 6800: dual 5 1/4" F/D (160K): 9", 16x24 b&w VDU: RS232 port	DOS; BASIC: U; Fortran: Cobol: M/A	Up to 8 I/O ports: max of 4 F/D drives: option — dual 8" F/D (624K): (E)
Semel 1 (£2,900)	Strutt Electrical: 0822 5439 (N/A)	16-64K RAM: Z80: single 8" F/D (250K): 12", 24x80 b&w VDU: RS232 port	BASIC: Cobol: Fortran	Supports up to 8 drives option — single 8" F/D (250K), £500: (I)
Sharp MZ-80K (£520)	Sharp Electronics (UK) Ltd: 061 205 7321 (22)	6-34K RAM: Z80: C: 10", 24x40 b&w VDU	BASIC: A:	Graphics: loudspeaker: BASIC in 14K RAM: 34K machine, £740: (B)
Sinclair ZX80 (100) (£100)	Science of Cambridge: 0223 311488 (N/A)	1-16K RAM: 780-1: C int: T.V. int: full K/B: 44 pin expansion port	4K BASIC in ROM	CPU is NEC 3.25 MHz version of Z80A: available as kit, £80: mains adaptor £9: (S)
Sirocco (£3,900)	Elvingate Computers: 069 245189 (TBA)	64K RAM: Z80: dual 5 1/4" F/D (940K): 12", 24x80 VDU: RS232 port	CP/M: CBASIC: Cobol: MBASIC: Fortran	Direct memory addressing: memory mapped VDU: free standing keyboard: option — 10MB H/D
Smoke Signal Chieftain 1 (£3,050)	Windrush Micro Designs 069 245189 (TBA)	32-64K RAM: 6800: dual 5 1/4" F/D (160K): 12", 24x80 VDU: 112 cps printer: RS232C port	DOS: BASIC: DBASIC: RBASIC: A: Fortran: U	Also Chieftain 3 with dual 8" F/D (1MB), £3,950 (E)
Solitaire WP & BS200 (£6,750 & £7,950)	Solitaire KPG: 01-995 3573 (TBA)	64K RAM: 8085: 14" VDU (with own CPU): 45 cps printer: CPU port: dual 5 1/4" F/D (700K) with "WP", and dual 8" F/D (960K) with "BS200"	DOS: BASIC (optional on the "WP")	All Solitaire systems are compatible: graphics on 11x13 dot matrix: (S)
Solitaire/HBS100 (£9,500)	As above	64K RAM: 8085: 10MB H/D: 14" VDU (with own CPU): 200 cps printer: CPU port	DOS: BASIC	Up to 8 interface terminals can be used: also HBS200 with 20-80 MB of H/D: HBS100 limit is 40MB: (S)
Sord M100 ACE (£2,650)	Midas Computer Services Ltd: 0903 814523	48K RAM: Z80: single 5 1/4" F/D (143K): 12" 24x64 col VDU RS232 port	O/S: BASIC	With colour graphics: 8K ROM: option — single 5 1/4" F/D, £300: (I)
Sord M223 (£3,500)	As above	64K RAM: Z80: single 5 1/4" F/D (350K): 12" 24x80 b&w VDU: S100 bus: RS232 port	O/S: BASIC	Other configs possible: extra F/D, £450: (I)
Superbrain (£1,995)	Icarus: 0632 29593 (TBA)	64K RAM: 2xZ80: dual 5 1/4" F/D (320K): 12", 25x80 b&w VDU: S100 bus: RS232: TRS80 port	CP/M: A: BASIC: Cobol: Fortran: APL Pascal	Limited graphics: mainframe int available: options — dual 5 1/4" F/D (320K): dual 8" F/D (2.4MB): 8-120 MB H/D: (S&H)
Tandberg EC10 (£5,000)	Tandberg: 0532 35111: (N/A)	50K RAM: 8080A: single 8" F/D (250K): 12", 25x80 b&w VDU: RS232 port	ExBASIC (24K): Multi-user BASIC: A: U: Cobol	(S&H)
Tandy TRS 80 Level 1 (£380)	Tandy: 021 556 6101 (200)	4-16K RAM: Z80: C: 12", 16x64 b&w VDU	BASIC: A:	BASIC in 4K ROM: upgradable to level 2: (I)
Tandy TRS 80 Level II (£515)	As above	4-48K RAM: Z80: C: 12", 16x64 b&w VDU: RS232 int: 1 P/P	BASIC: M/A: Fortran	16K machine includes N/P: 4-16K upgrade, £120 (£85 without pad): max config, £1,005: option single 5 1/4" F/D (78K), £478 (max of 4): (I)
Tandy TRS80 Model 2 (£2290)	As above	32-64K RAM: Z80A single 8" F/D (500K) 12", 24x80 VDU: 2S/P 1P/P	DOS: BASIC	Keyboard has numeric pad: 64K version, £2250: (S)
TECS (£1,600)	Technalogs: 051 724 2695 (TBA)	16-56K RAM: 6800: 8K PROM: RS232 port: C int	BASIC: T.DOS: Prestel: Monitor:	256 ch graphics: Prestel compatible: plugs into standard TV: option — dual 5 1/4" F/D (320K), £800: (S&H)
TEI 208 (£3,841)	Abacus: 01-580 8811 (5)	32-60K RAM: 8080/8085: dual 5 1/4" F/D (320K): 9", 24x80 green VDU: 3 S/P: 3 P/P	CP/M: BASIC: Cobol: Fortran: Pascal: Algol	(S&H)
TEI 212 (£4,886)	As above	32-60K RAM: 8080/8085: dual 8" F/D (1MB): 15", 24x80 green VDU: 3 S/P: 3 P/P	CP/M: BASIC: Cobol: Fortran: Pascal: Algol	(S&H)
Terodec DPS 64/1-4 (£3,014)	Terodec (Micro-systems) Ltd: 0344 51160: (TBA)	64K RAM: Z80: dual 8" F/D (1MB): 12", 24x80 b&w VDU: 2 S/P: 3 P/P	CP/M: BASIC: Cobol: CBASIC: Fortran: Algol: Pascal	TMZ 80, enhanced model in integral work station, £5,495 (with 4MB F/D): DPS 64 with 2MB F/D is £3,319: options — dual 8" F/D (1MB), £1,150: dual 8" F/D (2MB), £1,455: (S&H)
Vector Graphics MZ (£2,595)	Almarc: 0602 625035: Sintrom Microshop: 0734 85464: Metrotech 0895 57780: (5)	56K RAM: Z80: dual 5 1/4" F/D (630K): 3 S/P: 2 P/P	DOS: BASIC: A: CP/M2: Algol: CBASIC: Cobol: Fortran: Pascal	Includes PROM burner: also System B with graphics and N/P, £3,195: (E)
Video Genie EG 3003 (£378)	Lowe Electronics: 0629 2817: Binatone: 01-903 5211 (N/A)	16K RAM: Z80: 500 bps C: 32x64 TV int: extra C int: 1 P/P	BASIC: M/A: Fortran	BASIC in 12K ROM: graphics available: F/D under development: Binatone call their 16K model "Executive Minicomputer" and a 4K version, "Oxford Minicomputer" — prices TBA: (I)
Zenith WH-11A (£4,359)	Heath Ltd 0452 29451 and 01-636 7349 (N/A)	LSI 11: 16-32K RAM: 25x80 VDU: S/P: P/P	O/S: BASIC: Fortran: A: U:	PDP 11 compatible: option — dual 8" F/D (512K): (S&H)
Zenith Z89 (£1,490)	As above	16-48K RAM: Z80: single 5 1/4" F/D (102K): 12", 25x80 b&g VDU: RS232	BASIC: A: H.DOS: CP/M: MBASIC: CBASIC: Fortran	3 drives option: (I)
Zentec (£5,700)	Zigal Dynamics Ltd: 02405 75681 (1)	32-64K RAM: 2x8080: dual 5 1/4" F/D (512K): 15", 25x80 b&w VDU: RS232 port	O/S: A: U: BASIC: Micro Cobol	User programmable character set: option — dual 8" F/D (1MB): (S)
Zilog MCZ 1/05 (portable): MCZ 1/20A (£4200, £4800)	Micropower: 0256 54121: Memec: 084421 5471 (N/A)	64K RAM: Z80: dual 8" F/D (600K): RS232 port: MCZ 1/20 A only... 1P/P: option — 10MB H/D, £7100	RIO: O/S: Cobol: BASIC: Fortran: Pascal 1/05... M/A: U 1/20A... PLZ: U	Available desk top or rack mounted: Debug in 3K PROM: 1/20A runs multi-user Cobol and has up to 5 terminals and 40MB possible: (S&H)
Z Plus (£4,000)	Rostronics: 01-874 3665 (TBA)	32-64K RAM: Z80: dual 8" F/D (1MB): 2 S/P: 2 P/P	CP/M: A: U: BASIC: Cobol: Fortran: Pascal	(S&H)

**List of Abbreviations**

A Assembler	F/D Floppy disc	M/A Macro assembler	S/P Serial port
B BASIC	G/C Graphics card	N/A Not available	T/E Text editor
C Cassette	H Hardware	N/P Numeric pad	TBA To be announced
E Extensive	H/D Hard disc	O/S Operating system	U Utility
	I Introductory	P/P Parallel port	
	Int Interface	S Software	

Please note: Software items listed in *italic* are not included in the basic price of the equipment. All prices are *exclusive* of VAT.

**DIRECT  
ACCESS**

# IN STORE SINGLE BOARDS

Machine (Price from)	Main Distributor/s (No. of Dealers)	Hardware	Software/ Firmware	Miscellaneous (Documentation)
Acorn (£65)	Acorn: 0223 312772 (N/A)	1.1/8K RAM; 6502; EPROM socket; Hex K/B; C int: 8 digit LED display; up to 16 ports; options — Eurocard 64 way connector; VDU card: Full K/B card	½K monitor: <i>BASIC</i>	Kit: programmable address linking; on board 5V regulator; available assembled, £79 (S&H)
Aim 65C (£265)	Pelco: 0273 722155 (4)	1-4K RAM; 6502; 12K ROM; full K/B; 20 char LED display; 20 char thermal printer; Cx2: RS232 port.	A: Dis A: T/E: 8K monitor in ROM	Available as S100 system with A or BASIC in ROM (£480) from Portable Micros (0280 702017); they also have briefcase version (£750) (E)
Cromemco SC (£260)	Comart: 0480 215005 (17)	1K RAM; Z80A; 8K EPROM sockets; RS232 port; 3 P/P; option — S100 bus.	Monitor and control <i>BASIC</i> in EPROM	5 program interval timers; can put own BASIC programs in EPROM (E)
ELF II (£114)	Newtronics: 01-348 3325	1/4K RAM; RCA 1802; Hex K/B; 2 digit LED; TV int; C int; RS232 port; options — 4K RAM, £69; full K/B; VDU card	1K monitor; A: Dis A: T/E: <i>BASIC</i> : 244	TTY, n-line decoders; low resolution graphics (high resolution available) kit (H)
Explorer (£295)	Newtronics: 01-739 1582 (15)	4K RAM; 8085; Hex K/B; RS232 port; S100 bus; C int; options — 6 slot S100 £32; 8K EPROM sockets £50.	2K monitor: <i>CP/M</i> : <i>BASIC</i>	Programmable 14 bit counter: kit (S&H)
H8 (£262)	Heath: 0452 29451 (TBA)	4K RAM; 8080A; Octal K/B; 6 digit LED; speaker; options — single 5¼" F/D (102K), £399; 16K RAM, £314; C int, £72	1K monitor: <i>BASIC</i> in RAM: <i>FORTRAN</i> : T/E: A: U:	Kit (S&H)
Hewart 6800S (£299)	Hewart: 0625 22030 (N/A)	16K RAM; 6800; full K/B; VDU int; 2xC int; 1 S/P; 2 P/P; option — 16K RAM, £90	1K monitor: A: T/E	Can be upgraded with 6809 (H)
Hewart 6800 MkIII (£152)	As above	1K RAM; 6800; VDU board; options — single 5¼" F/D (75K), £350; PROM programmer, £32; calculator board, £32	1K monitor	(H)
Mk 14 (£39.95)	Science of Cambridge: 0223 311488 (N/A)	8060; 1/4-2K RAM; Hex K/B; 7 char LED; options — VDU int (32x16 with graphics), £29; C int, £6; PROM prog, £10, 2K memory expansion, £15	Machine code	Designed for control applications rather than high level computing expansion (H)
Microtan 65 (£69)	Tangerine: 0353 3633	1K RAM; 6502; 16x32 T.V. int; options — TANEX board, 7K RAM, 6K ROM, 8K BASIC; 3S/P	1K TANBUG monitor: <i>BASIC</i>	Optional 64x64 pixel graphics:(E)
Nascom 1 (£165)	Nascom: 02405 75155 (20)	4K RAM; Z80; full K/B; TV int; 2 P/P; 1 S/P	2K monitor: <i>BBASIC</i> ; <i>tiny BASIC</i> : A: T/E: U	Now available as Nascom 2 with 8K RAM and 8K microsoft BASIC in ROM, £295
77/68 (£90)	Newbear: 0635 30505 (N/A)	4K RAM; 6800; LED; C int; VDU int.	1K Monitor: <i>BASIC</i> : VDU	Expandable to racked Nascom compatible system: (B)
SBC 100 (£135)	Airamco: 0294 57755 (11)	1K RAM; Z80; 8K ROM; S100 1 S/P; 1 P/P; option — voltage regulator	1K monitor: <i>DOS</i> in ROM	Kit: available assembled, £196 (E)
Superboard (£188)	MBM: 01-981 3993 (N/A)	4-8K RAM; 6502; 10K ROM; full K/B; VDU int; C int; options — RS232; single 5¼" F/D (100K), £316; 8K RAM, £188	<i>BASIC</i> in 8K ROM:	Available with 32K RAM and single 5¼" F/D, £867 (S&H)
SYM-1 (£160)	Newbear: 0635 30505 (N/A)	1-4K RAM; 6502; bps C int; VDU int; 2x6522 ports; option — TV int.	4K monitor: <i>BASIC</i> : A	Can be expanded to 64K RAM (S&H)
Triton 4.1 (£286)	Transam: 01-402 8137 (N/A)	2K RAM; 8080; 3K ROM; full K/B; 16x64 VDU or TV int; C 1 S/P; option — 2K RAM, £30	1K monitor: 2K <i>BASIC</i> : U	64 character graphics: 8 levels interrupt: kit (S&H)
Triton 5.1 (£294)	As above	2K RAM; 1K VDU RAM; 8080; C int: T.V. int	1½K monitor: 2½K <i>BASIC</i> : A: Dis A: 8K <i>BASIC</i> : <i>Pascal</i>	Graphics facility: disc interface running CP/M, about £200: (S&H)
Tuscan (£170)	As above	8K RAM; 8K ROM; Z80; 6xS100 slots; RS232 int: T.V. int: C int	8K monitor: or 8K <i>BASIC</i>	DD disc controller, £195: graphics: (S&H)
UK 101 (£219)	Computer Shop: 01-440 7033	4K RAM; 6502; full K/B; 16x48 VDU or TV int; C int; RS232 port; option — 4K RAM, £49	1K monitor: 8K <i>BASIC</i> : Dis A: U	Graphics: will run Superboard software (S&H)

## TRANSACTION FILE

The classified service that's FREE to readers (but not companies, please). Advertisements 50 words maximum to: PCW Transaction File, 14 Rathbone Place, London W1P 1DE.

### For sale

**PET 2001-8K**... good condition, little used, 5 months old — £495 ono. Contact C H Towns, 57 Woodend Walk, Armadale, West Lothian, EH48 3QN

**Teletype ASR 35**... ASCII code, good condition, some manuals. Will haggle around £250. Phone Welwyn Garden (07073) 23742.

**MK 14**... with latest monitor, extra RAM, cassette interface, single step addition and improved K/B — £40. Phone Ashby-de-la-Zouch 6231.

**PET - 8K**... new ROMs, big keyboard, cassette, green screen, lots of pages, £400. Phone Biggin Hill 71742 (eves).

**Casio FX502P**... programming calculator (see PCW Sept '79)

with FA-1 data storage adaptor. Plus "Master Pack" software pack package, manual (with over 100 programs) and many games — £75. Phone South Benfleet 52147.

**Superboard II**... power supply, modulator and Cottis Blandford tape interface connected, all fully working — £200. Ring A. Forster on 0323 30742 (Sussex).

**TRS 80 Level II**... 16K, plugs into own TV and cassette, hardly used. Offers to Ely 721508

**MK.14**... extra RAM, cassette interface, new keyboard, revised monitor, single step. Extension board with all data, control, address and I/O lines available. Extensive SC/MP documentation and PSU — £50. Phone Robin Lewis on Bristol 30124.

**Challenger C2.4P model 2**... one month old, 8K Microsoft BASIC; 8K RAM; RS232 port; D/A converter; audio output to speaker; 3-32 lines by 64 ch display; 53-key keyboard with full auto repeat; can be expanded to disc system. Software are games and BASIC renumber — £395 ono. Phone 01-560 8806 (Tony Chow) — anytime.

**PET 2001**... with Expandamem to 32K; nearest offer to silly price of £550 will secure. Phone Henry Barnett on 01-843 1288 (day), 01 01-954 5588 (eve).

**Nascom 1**... PSU, buffer board, T2 monitor and CCSOFT Level A Tiny BASIC. Includes all documentation, fully functional — £125 ono. Also non-functional 8K memory board with 8K BASIC ROM (RAM chips believed damaged by static) — only £25.

Phone Mark Burgis on 01-567 2024 (West London), eves.

**TRS 80 Level 1&2 (switchable)**... plus some software including chess and T-Bug — £450. Phone 061-320 8512.

**Triton Motherboard**... with 5 out of 8 sockets — £45. **Printer Mechanism**... impact dot matrix, 2 steppers, no logic — £50. **Star Devices**... touch keyboard — £25. **TV Monitor**... 12" in strong chassis — £50. **Elektor TV Oscilloscope**... needs attention, hence £120. Ring David Pearce on Biggin Hill 73585.

**TRS 80 Level II**... 16K with video and cassette deck. Plus editor, assembler, RSM 2D monitor, T Bug, Renumber, Starwars and other games. Phone Al on Andover 61486.

UK101... cased, some extra RAM and programs, modified cassette — £315. Phone 061-643 2343.

ITT 2020... 48K version with floppy disc drive and controller card. Also included — colour modulator for TV and printer controller card. Total rig, £1300. Phone (0385) 61765.

Expandoram... S.D. Sales RAM memory board, 32K, for S100 bus; assembled & tested — £120 inc. p&p. Phone Portsmouth 67865.

Tandy TRS 80 Level II... 32K, comprising VDU, DOS 2.2 plus; 2x disc drive; tractor feed line printer; quick printer and many extras. Will separate: £2750 ono. Phone 021-558 2468. (6-9pm)

Nascom 1... PSU and T2 monitor with all documentation and some games tapes. Best offer secures or exchange for audio equipment. Phone Watford 48096 anytime.

Texas Silent 700... keyboard, send/receive printer terminal,

RS232 interface and acoustic coupler. Complete with case and 110 V transformer. Brand new — £650. Phone 01-427 8634 (after 7pm)

MK.14... built and working, full fully socketed, revised monitor and decoding, RAM I/O, extra RAM, tape interface, click switch, keyboard in case with PSU, manual and 2 SC/MP guides — £60. Phone Ken on Southend (0702) 335380 (eves).

PET 2001-8K... fitted upgrade ROM, hobby use only. With manuals and many programs (tutorials, utilities and games) — £425. Phone Blackpool (0253) 869108 evenings/weekends.

MK.14... with VDU, 5 Amp 5 Volt PSU, revised monitor, single step, RAM I/O, click keyboard, 32x16 VDU (has own 1K of RAM). Also full documentation, useful programs — bargain at £65! What's the catch? Buyer must collect from Kensington. Phone 01-937 8632

PET Bargain... 32K business PET with 2040 dual floppy disc. 8 months old and little used — £1200 ono. Phone Gerrards Cross (02813) 83095.

Compukit 4K... onto bigger things! Fully assembled and working — £190 (including assembler/editor). Also Kim... hardly used, with power supply and First Book of Kim — £89. Phone 01-866 3326 (evenings/weekends).

PET 2001-8K... with 24K memory expansion and Compu-think disc drive. Also second cassette unit, external keyboard, TIS Workbooks and a vast selection of software and tapes — £1600 ono for the complete system. Phone Brighton 202918 (office hours) or Storrington 2663 (evenings/weekends).

TRS 80... 48K, expansion interface, including Level III and Mon 3 with games galore. As new, cost £1000, now asking £700 ono (cash preferably).

Contact I. Wilkinson, 234 Union Road, Oswaldtwistle, Lancashire BB5 3JB.

## Wanted

National Charity would welcome the donation of a microprocessor and/or printer. We can collect. Cancer Prevention Research Trust, 36 Roehampton Vale, London SW15.

September and/or October issues of PCW. Must be in good condition. Phone 01-848 0020 or 01-868 4411 and ask for George.

PET system... if you're selling all or part of your system (PET, discs and/or printer) contact Mr Andrews on 01-520 2230.

## DIARY DATA

London, England	All Electronic Show. All Electronic Show, 34-36 High Street, Saffron Walden, Essex. Tel: 0799 22612	Apr 29 - May 1
Liverpool, England	Mersey Micro Show. Online Conferences Ltd., Cleveland Road, Uxbridge UB8 2DD. Tel: 0895 39262	April 30 - May 2
Brussels, Belgium	Compec Europe Exhibition. Iliffe Promotions Ltd., Dorset House, Stamford Street, London SE1 9LU. Tel: 01-261 8000.	May 6 - May 8
Manchester, England	Business Efficiency & Office Equipment Exhibition, Gwen Shillaber Design, 81 Whiteladies Rd., Clifton, Bristol BS8 2NT. Tel: 0272 312850	May 13 - May 15
Anaheim, USA	National Computer Conference and Exhibition (NCC). 210 Summit Ave., Montvale, NJ 07645	May 19 - May 22
Dallas, USA	Int. Telecommunications Exbn — INTELCOM. Horizon House — Microsol Inc., 25 Victoria Street, London SW1H OEX. Tel: 01-222 0466	May 19 - May 23
London, England	International Word Processing Exhibition and Conference. Business Equipment Trade Association, 109 Kingsway, London WC2B 6PU. Tel: 01-405 6233	May 20 - May 23
Dublin, Ireland	International Computing Exhibition — COMPUTEX. SDL Exhibitions Ltd., 68 Fitzwilliam Square, Dublin 2, Ireland. Tel: Dublin 763871	June 17 — June 19
Geneva, Switzerland	International Microcomputers, Minicomputers, Microprocessors & Data-communications Exhibition — IMMM/DATACOMM. Kiver Communications S.A., 171/185 Ewell Road, Surbiton, Surrey. Tel: 01-390 0281	June 17 — June 19

## FAX

**DIRECT ACCESS**

LSB SC/MP MNEMONICS ARRANGED BY OPCODE

MSB	0	1	2	3	4	5	6	7	8	9	A	B	C	D	E	F
0	HALT	XAE	CCL	SCL	DINT	IEN	CSA	CAS	NOP							
1													SR	SRL	RR	RRL
2																
3	XPAL*				XPAH*								XPPC*			
4	LDE															
5	ANE								ORE							
6	XRE								DAE							
7	ADE								CAE							
8																DLY DISP
9	JMP DISP*				JP DISP*				JZ DISP*				JNZ DISP*			
A									ILD DISP*							
B									DLD DISP*							
C	LD DISP				LDI DATA				ST DISP							
D	AND DISP				ANI DATA				OR DISP				ORI DATA			
E	XOR DISP				XRI DATA				DAD DISP				DAI DATA			
F	ADD DISP				ADI DATA				CAD DISP				CAI DATA			

▲ Bits 0-2 auto index flag and pointer register

\* Bits 0 and 1 = pointer register

# MICROMART

## NASCOM Z-2 4K EDITOR-ASSEMBLER

Professional package equivalent to IBM large Systems Package specially written for Nascom-2 and includes many powerful features

- \* Full screen edit fully utilises Nas-2 cursor control.
- \* File scrolling feature.
- \* Multi-tabbing facilities allows compressed files saving RAM.
- \* No wasteful line numbering to remember.
- \* Powerful string search/replace facilities.
- \* Named files saved/restored to cassette using NAS-SYS routines.
- \* High speed VDU output puts listings, etc. straight to VDU memory.
- \* High speed assembler supports all pseudo-ops/arithmetic operators.
- \* Output to printer tape or VDU, with many listing options.
- \* Repeat key feature

Supplied on cassette with user manual for only £14.00 inc. VAT.

Mail orders to DPSS Dept. S1, 14 Vale Rd, Claygate, Esher, Surrey.

### SPEED — VERSATILITY — ECONOMY



Designed originally for logic wiring applications, it is now accepted and used extensively throughout industry, education and research. ROADRUNNER is used by hobbyists, students, technicians, designers and engineers, to carry out work on —

\* P.C.B. REPAIRS \* ANALOGUE BREADBOARDING \* SIMPLE LOGIC WIRING \* COMPLEX INTERCONNECTING OF MICROS AND MEMORIES.

EURO INTROKIT £15.73. PROJECT INTROKIT £8.80. PENCIL WITH LOADED BOBBIN £2.44. WIRE DISTRIBUTION STRIPS: GLUE FIX 20pin 6" LONG £2.80. ADHESIVE £0.30 TUBE. PRESS FIX 20pin 2" LONG £2.82. SINGLE EUROCARD. HIGH DENSITY 3 PLANE (36 x 16 PIN DILS) £4.50. DOUBLE EUROCARD. WITH CAPACITY OF 84 x 16 PIN DILS £7.25. PROJECT CARD HIGH DENSITY 5-SIDED 20 x 14 PIN DILS £2.85. BOBBING: BLUE 4pin £2.12 GREEN 4pin £2.12 PINK 4pin £2.12 GOLD 4pin £2.12. 1 OF EACH COL £2.20. TINNED COPPER WIRE 4pin £2.12. RECOMMENDED SOLDERING IRON FOR ROADRUNNER HOBBYIST £4.80.

Please add 40p for p & p + 15% VAT to all orders.

FOR FURTHER INFORMATION ON ROADRUNNER PRODUCTS  
SEND LARGE S.A.E. TO:—  
T.J. BRINE ASSOCIATES  
56B, HIGH STREET, HASLEMERE, SURREY.

IN ADDITION TO ROADRUNNER WE PROVIDE A SPECIALIST MICRO-PROCESSOR PRODUCT DEVELOPMENT SERVICE.  
PLEASE PHONE 0428-53850 FOR MORE DETAILS.

"SUCKER" the unique game of chance which simulates artificial intelligence. Basic listing for all machines: £5

25 programmes for Sinclair ZX80: £20  
For enquiries or orders:

UMC (PCW)  
Manor House, Rathlin Island,  
County ANTRIM  
Tel: 02657 71220

### COURSES

1. Micro computer programming
2. Basic programming
3. Micro appreciation for industry

All courses with 'hands on' experience to be held in:  
London, Bristol, Manchester,  
Birmingham, Leeds.

### LIMITED NUMBERS:

Write early for a date to:  
NDP Ltd, Microsystems Div,  
69 Northampton Road,  
Rushden, Northants.

### Wave-Making on a NASCOM I cont. from p.90

• 1173	2C	0041	INC L
• 1174	2C	0042	INC L
• 1175	2C	0043	INC L
• 1176	7D	0044	LD A, L
• 1177	320A11	0045	LD (110AH), A
• 117A	3A0211	0046	LD A, (1102H)
• 117D	4F	0047	LD C, A
• 117E	CD0212	0048	CALL MULT
• 1181	3A0B11	0049	LD A, (110BH)
• 1184	6F	0050	LD L, A
• 1185	2610	0051	LD H, 10H
• 1187	5E	0052	LD E, (HL)
• 1188	3E04	0053	LD A, 04'
• 118A	85	0054	ADD A, L
• 118B	320B11	0055	LD (110BH), A
• 118E	3A0311	0056	LD A, (1103H)
• 1191	4F	0057	LD C, A
• 1192	CD0212	0058	CALL MULT
• 1195	3A0C11	0059	LD A, (110CH)
• 1198	6F	0060	LD L, A
• 1199	2610	0061	LD H, 10H
• 119B	5E	0062	LD E, (HL)
• 119C	3E05	0063	LD A, 05
• 119E	85	0064	ADD A, L
• 119F	320C11	0065	LD (110CH), A
• 11A2	3A0411	0066	LD A, (1104H)
• 11A5	4F	0067	LD C, A
• 11A6	CD0212	0068	CALL MULT
• 11A9	3A0D11	0069	LD A, (110DH)
• 11AC	6F	0070	LD L, A
• 11AD	2610	0071	LD H, 10H
• 11AF	5E	0072	LD E, (HL)
• 11B0	3E06	0073	LD A, 06
• 11B2	85	0074	ADD A, L
• 11B3	320D11	0075	LD (110DH), A
• 11B6	3A0511	0076	LD A, (1105H)
• 11B9	4F	0077	LD C, A
• 11BA	CD0212	0078	CALL MULT
• 11BD	3A0E11	0079	LD A, (110EH)
• 11C0	6F	0080	LD L, A
• 11C1	2610	0081	LD H, 10H
• 11C3	5E	0082	LD E, (HL)
• 11C4	3E08	0083	LD A, 08
• 11C6	85	0084	ADD A, L
• 11C7	320E11	0085	LD (110EH), A
• 11CA	3A0611	0086	LD A, (1106H)
• 11CD	4F	0087	LD C, A
• 11CE	CD0212	0088	CALL MULT
• 11D1	CB7C	0089	BIT 7, H
• 11D3	201D	0090	JR NZ, COMP
• 11D5	CD2012	0091	CALL DIY
• 11D8	260E	0092	LD H, 0EH
• 11DA	3A0711	0093	LD A, (1107H)
• 11DD	6F	0094	LD L, A
• 11DE	79	0095	LD A, C
• 11DF	77	0096	LD (HL), A
• 11E0	2C	0097	INC L
• 11E1	7D	0098	LD A, L
• 11E2	320711	0099	LD (1107H), A
• 11E5	3A1211	0100	LD A, (1112H)
• 11E8	3D	0101	DEC A
• 11E9	321211	0102	LD (1112H), A
• 11EC	C24511	0103	JP NZ, FT8
• 11EF	C38602	0104	JP 0286H
• 11F2	7D	0105	LD A, L
• 11F3	2F	0106	CPL
• 11F4	6F	0107	LD L, A
• 11F5	7C	0108	LD A, H
• 11F6	2F	0109	CPL
• 11F7	67	0110	LD H, A
• 11F8	23	0111	INC HL
• 11F9	CD2012	0112	CALL DIY

• 11FC 79	0113		LD A, C	•
• 11FD 2F	0114		CPL	•
• 11FE 3C	0115		INC A	•
• 11FF 4F	0116		LD C, A	•
• 1200 18D6	0117		JR STNS	•
• 1202 0608	0118	MULT	LD B, 00	•
• 1204 210000	0119		LD HL, 00	•
• 1207 1600	0120		LD D, 00	•
• 1209 CB7B	0121		BIT 7, E	•
• 120B 2802	0122		JR Z, SHIFT	•
• 120D 16FF	0123		LD D, 0FFH	•
• 120F 29	0124	SHIFT	ADD HL, HL	•
• 1210 CB21	0125		SLA C	•
• 1212 3001	0126		JR NC, DEC	•
• 1214 19	0127		ADD HL, DE	•
• 1215 10F8	0128	DEC	DJNZ SHIFT	•
• 1217 ED5B0F11	0129		LD DE, (110FH)	•
• 121B 19	0130		ADD HL, DE	•
• 121C 220F11	0131		LD (110FH), HL	•
• 121F C9	0132		RET	•
• 1220 010008	0133	DIV	LD BC, 0800H	•
• 1223 59	0134		LD E, C	•
• 1224 3A1111	0135		LD A, (1111H)	•
• 1227 57	0136		LD D, A	•
• 1228 A7	0137	MOVE	AND A	•
• 1229 CB1A	0138		RR D	•
• 122B CB1B	0139		RR E	•
• 122D E5	0140		PUSH HL	•
• 122E A7	0141		AND A	•
• 122F ED52	0142		SBC HL, DE	•
• 1231 3003	0143		JR NC, NXT	•
• 1233 E1	0144		POP HL	•
• 1234 1802	0145		JR FLAG	•
• 1236 DDE1	0146	NXT	POP IX	•
• 1238 3F	0147	FLAG	CCF	•
• 1239 CB11	0148		RL C	•
• 123B 10EB	0149		DJNZ MOVE	•
• 123D 210000	0150		LD HL, 00	•
• 1240 220F11	0151		LD (110FH), HL	•
• 1243 C9	0152		RET	•

### Interrupt cont. from p.111

However what lies below the surface is of longer term importance. If one user can get away with it, doing his own programming in BASIC perhaps, there's nothing to stop another trying and yet another . . . all from the same company. And with at least 164 different micros on the market the chances of several users in one company all acquiring different and probably incompatible units and then writing programs in different versions of BASIC are high.

What are the chances of them being able to communicate with each other either by wire or on disc? Ah, you will say, why should they want to? My reply is that, as the number of user operated micros increases, so the chances of requiring interchange of data or programs will probably be squared. But not only will incompatible equipment tend to preclude this, so will the lack of any standards or disciplines to which the users should conform.

The problem really is that personal computing assumes expertise in several areas that a user may not have, because it goes against the concept of area specialisation; that's why we have accountants, salesmen, lawyers, etc. It's a false assumption to say that a specialist in one area may also become an efficient computer programmer. At best, their computing function will be

secondary to their main job.

I recently heard of a top man planning to replace his central dp installation with 1,000 micros (if true, a nice order for someone). But personal computing is contrary to the principles of functional management. A group of individual department managers would be replacing the dp manager in deciding on which applications are to be most cost/effective, construction of files, the documentation of the systems. Instead of increasing the overall efficiency of the organisation, there will tend to be increased empire building and departmental isolation. It would become increasingly difficult for one department to know what another was doing, to co-ordinate efforts and to control costs.

It's a fallacy to believe it is possible to demolish a centrally managed structure and replace it completely by a distributed structure that has no management. It's also a fallacy to believe that with multi-users, the dp skills of the professionals will be unnecessary. It's a question of recognising the boundaries of what is possible.

Edward G Cluff, Secretary-General,  
Institute of Data Processing Management

## MICROMART

86 High Street, Bletchingley,  
Redhill, Surrey RH1 4PA.  
Tel: Godstone (0883) 843221  
The used COMPUTER specialists

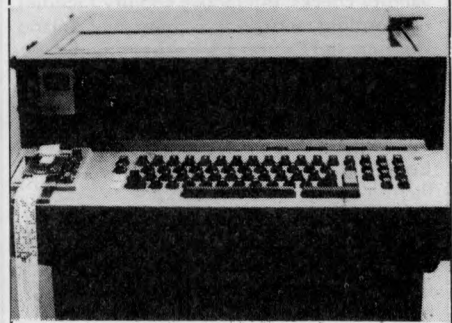

APPLE II MICROCOMPUTER SYSTEM with 32K bytes, single floppy disc drive, colour board, 9in B/W monitor, CENTRONICS 101A 165 cps printer £150.00  
TELETYPE model ASR 33. Fully refurbished machines always from stock £350.00  
TELETYPE Model KSR 33. Various options available at £150.00  
TELETYPE Model KSR 33. Printing terminal RS232 and 20 mA version available. £150.00.  
DATA DYNAMICS Model ASR 390 terminal. RS232 interface. Under 500 hours on clock. £425.00.  
OLIVETTI Model 318 terminal with RS232 interface and reader/punch. ASCII coded with high quality upper case printout. Free stand and accessories. £130.00  
OLIVETTI Model 328. As above but refurbished and with excellent quality upper/lower case. With stand and RS232 interface. £250.00.  
ITEL Model 1051 Terminal. With golfball typewriter, tape reader/punch and RS232 interface. NEW LOW PRICE £375.00  
ITEL Model 941. Similar, but WITHOUT interface. £250.00.  
G. E. TERMIPRINTER 30cps Terminal featuring RS232 interface £325.00  
TEXAS Silent 700 Terminal £350.00  
DIABLO HyType daisy-wheel printer with serial interface and paper tractors £650.00  
IBM Model 735 Selectric I/C (Golfball) typewriter £195.00  
QDHNER accounting machine incorporating BRAND NEW correspondence coded IBM Selectric 72 typewriter. £175.00  
CDC VDU with RS232 interface, printer output 12x80 display £145.00



RECORDING DESIGNS Ltd. Model MTD 10510 7-track NRZI Tape Drive. BRAND NEW in original box with accessories etc. £450.00  
PERTEC Model 6640-9-25 9-track P. E. tape drive £495.00  
CALCOMP T80 exchangeable disc drive of 80 megabyte capacity. In ex-demo condition (current list price £4,000). £975.00  
DIABLO Model 31 high density (2.5 mbyte) cartridge disc drives now available. These are directly compatible with the DIGITAL RK15 and will cable directly to most RK11 type controllers for PDP/LSI 11. Fixed and removable both available at £495.00 and £650.00 respectively.  
VERMONT Model 1004-S Memory Drum £75.00  
UNIT DATA INCREMENTAL MAGTAPE RECORDER/REPRODUCER, £50.00  
TERNA Matrix printer ASCII code. 132 column. 120 cps £275.00  
PRINTEC Model 100 LINE PRINTER. 100 cps. Parallel TTL interface and ASCII code £195.00.  
CENTRONICS Model 101A printer. With standard and serial interface 165cps operation £650.00  
ICL 8K x 12 MOS memory cards. BRAND NEW £35.00.  
GNT 50 cps compact desk top tape punch £75.00  
MOTOROLA 80 col. card reader with RS232 interface £150.00  
TREND HSR 500 optical paper tape reader £225.00  
TREND PTS paper tape reader/punch in self-contained box £375.00  
LSI 11/2 processor boards, BRAND NEW and dated 79/80 £395.00

\* All equipment may be viewed at our premises, but by appointment please.

\* VAT and carriage extra all items.

# MICROMART

## APPLE & ITT 2020 BUSINESS SOFTWARE

Professionally written packages now available with comprehensive manuals, built-in validity checks, interactive enquiry facilities, user options, satisfying accountancy, Inland Revenue and Customs & Excise requirements. On diskette under DOS 3.2 in Applesoft with SPACE utility. Not adaptations. Written for Apple System. Support all printer interfaces. Sales, Purchases and General Ledgers £295-00 each. Manual only £3. Payroll £375. Manual only £4. General Ledger supports Incomplete Records, Job Costing, Branch and Consolidated Accounts, etc. General Ledger Applications Manual £10. Prices exclusive of V.A.T. From our shop or your nearest stockist.

## COMPUTECH SYSTEMS

168, Finchley Road, London NW3,  
Tel: 01-794 0202

### 6250 BAUD FOR NASCOM 1

This ultra-fast cassette interface board will provide reliable data storage and recall at up to 6250 BAUD on most standard cassette recorders.

e.g. 1K of data loaded in less than 1½ seconds.

The modifications required are minor and full documentation is supplied with each board which comes built, tested and guaranteed.

For immediate delivery send £15.95 + 35p P&P to:-

J. C Hunter  
65 Portland Street, TROON  
Ayrshire, Scotland  
or phone 0292 311513

Also a competitively priced EPROM programming service is provided where we can supply the EPROM's programmed to your listings or programme your own EPROM's on a 24 hour turn round basis. Please write or telephone for details.

# Take Advantage of Us in Leighton Buzzard

For as little as £3.50 an hour you can use our Alpha Micro computer.

For a small additional cost we can provide a complete service for applications such as -

Accounting  
Word Processing  
Mailing Lists, Estate Agency.

For around £10,000 you can install your own Alpha Micro which can be expanded to support a number of terminals and printers and almost unlimited data storage.

Contact John Bennett  
Wing Systems Ltd.  
46 High Street  
Leighton Buzzard, Beds.  
Telephone 0525 370200

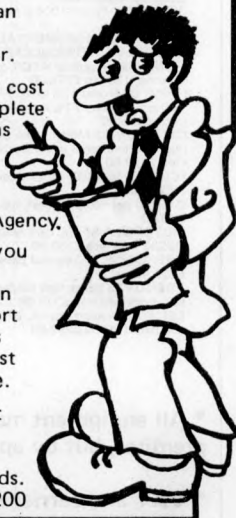

## YCW cont. from p.113

```

255 IFA<>0 THEN290
256 RESTORE
260 FORA1=1 TO5
270 READA2
275 IFASC(A$)=A2 THEN279
277 NEXTA1
278 GOTO180
279 ONA1GOTO100,500,50,750,820
280 IFA=0 THEN240
290 IFA>N THENN=A
292 IFA<0 THEN690
295 IF INT(A)<>A THEN630
300 PRINTA-1;CHR$(34);A$(A-1)
310 INPUT " ";A$(A)
330 PRINTA+1;CHR$(34);A$(A+1)
340 GOTO240
500 POKEB142,0
510 A1=PEEK(B144)
520 A2=PEEK(B145)
530 POKEB144,0
540 POKEB145,0
550 NULL4
555 PRINT;PRINT;PRINT;PRINT
560 FORA=1TON
570 PRINTA$(A)
580 NEXTA
590 POKEB144,A1
600 POKEB145,A2
610 NULL0
620 END
630 FOR I=INTO(INT(A)+1) STEP-1
640 A$(I+1)=A$(I)
650 NEXT
660 N=N+1
670 A=INT(A)+1
680 GOTO300
690 A=ABS(A) Delete line A.
700 FOR I=A+1TON
710 A$(I-1)=A$(I)
720 NEXT
730 N=N-1
740 GOTO240
750 INPUT"ENTER SEARCH STRING: ";B$
760 B=LEN(B$)
770 FORI=1TON
780 GOSUB1000
782 IFC$="" THEN800
784 PRINTI;C$;PRINTI;
785 IFT=1 THEN795
786 FORJ=1TOT-1
788 PRINT " ";
790 NEXTJ
795 PRINT "t"
800 NEXTI
810 GOTO240
820 INPUT"ENTER LINE NUMBER";I
830 INPUT"ENTER OLD TEXT";B$
835 B=LEN(B$)
840 GOSUB1000
850 IFC$<>"" THEN885
860 PRINTI;A$(I)
870 PRINT"ERROR - TEXT NOT FOUND"
880 GOTO240
885 INPUT"ENTER NEW TEXT";C$
887 C=LEN(C$)
888 A$=A$(I)
890 A$(I)=MID$(A$,1,T-1)+C$
892 IFT-1+B>ATHEN900
895 A$(I)=A$(I)+MID$(A$,T+B,A-B-T+1)
900 PRINTI;A$(I)
910 GOTO240
1000 C$=""
1010 A=LEN(A$(I))
1020 FORT=1TOA-B+1
1030 IFMID$(A$(I),T,B)<>B$ THEN1060
1040 C$=A$(I)
1080 GOTO1070
1060 NEXTT
1070 RETURN
READY
    
```

(program for an 8K Exidy Sorcerer)

## SNAP-FOR A NASCOM 2

```

10 CLS
20 PRINT TAB(20); "SNAP"
30 POKE 3200,25311
40 POKE 3202,312
50 POKE 3204,18351
60 POKE 3206,10927
70 POKE 3208,-8179
80 POKE 3210,233
90 POKE 4100,3200
100 LET A=INT(RND(1)*13)+1
110 LET B=INT(RND(1)*13)+1
    
```

```

● 120 LET X=INT(A/4)+1 : IF X>4 THEN 100
130 LET Y=INT(B/4)+1 : IF Y>4 THEN 110
● 140 FOR H= 1 TO 13
150 IF A>H THEN 170
● 160 PRINT CHR$(X+187);
170 NEXT H : PRINT
180 FOR H= 1 TO 13
● 190 IF B>H THEN 200
195 PRINT CHR$(Y+187);
200 NEXT H : PRINT
● 210 IF A=B THEN 300
220 FOR A=1 TO 100: NEXT A:S=S+1
225 IF S+G+L>52 THEN 500
● 230 GOTO 10
300 FOR A= 1 TO 180
● 310 LET X=USR(0): IF X<>0 THEN 330
320 NEXT A
● 330 IF A>60 THEN 400
340 FOR A=1 TO 100
● 350 PRINT "YOUR SNAP"
360 NEXT A
● 370 G = G+1
380 GOTO 10
390 PRINT
● 400 FOR A=1 TO 100
410 PRINT "MY SNAP"
420 NEXT A
● 430 L=L+1
440 GOTO 10
500 PRINT "FINAL SCORE"
● 510 PRINT "YOURS";G;"MINE";L

```

#### Calculator Corner cont. from p.107

too difficult when you know how, but it should not be necessary. Texas Instruments please note.

In spite of the minor problems, and no machine is perfect, I hope that I have been able to demonstrate the extra scope available with the application of some imagination to the use of these inexpensive but powerful calculators.

#### Postscript

Mr Horwood has expressed his willingness to answer any further enquiries about these applications. You can write to him at: 11 Melville Hall, Holly Road, Edgbaston, Birmingham B16 9NJ (and not to PCW please!).

Here, to stop you all pestering me, is the answer to the problem which Rolf Howarth set in his TI59 Pseudo Op codes article:-

It is possible to examine the internal routines which perform the P/R, decimal/sexagesimal and statistic operations by keying in the following:

```

10 Op 17 (6 Op 17 for the TI58)
99 ST0 00
Pgm 01 A
CLR D.MS

```

#### Noughts and Crosses cont. from p.87

Key the move, and press EXE. Moves need not necessarily be positive integers, as the program will correct the negative, integer + fraction moves, taking the integer part only, but all moves must lie on the interval (1,9); attempts to enter either moves outside this range, or moves which have already been made, will cause the opponent to be penalised by having the move denied, and the calculator will be given the option to move.

The calculator will display its move as above, together with the current board positions and move count.

4. If the calculator wins, the HLT status indicator will disappear, and the winning move, together with the updated

board position and move count, will flash alternately with '2' in the same format. No further moves can be made. If either player's move completes the board, that move, together with the updated board and move count, will flash alternately with '9'.

The routines start at the following steps:

Op 12	000
Op 15	047
Op 14	058
x	067
Op 11	084
INV x	107
Op 13	149
Σ+	192
INV Σ+	213
INV P/R	250
P/R	284
D.MS	303
INV D.MS	341

board position and move count, will flash alternately with '2' in the same format. No further moves can be made. If either player's move completes the board, that move, together with the updated board and move count, will flash alternately with '9'.

To stop the flashing, press HLT (not AC, as this only stops the flashing temporarily); (if you are impatient to play another game, don't bother pressing HLT, just press PO); and if you want to review the moves made by both players during the game, press MR .4; a zero in the number indicates an attempted illegal move by the opponent (except when the illegal move was attempted on the opponent's first move in a game where the opponent moves first — not

## MICROMART

### WANTED

**Freelance Micro Programmers**  
Can you program in either  
Cobol, Basic, Pascal,  
machine code?

Do you have a microcomputer?  
Would you like to be paid  
for programming?

Do you have a programming  
requirement?

Send for information to:  
NDP Ltd,  
MICROSYSTEMS DIV  
69 Northampton Road,  
Rushden, Northants.

## TANDY SOFTWARE

Our best seller at the  
Personal Computer World Show

### STAR TREK

Now vastly improved with many  
extra facilities — it's the best!

**£12 post free**

Full catalogue of guaranteed quality  
Level II 4K 16K software on request

### Kansas

Unit 3, Sutton Springs Wood,  
Chesterfield. Tel: (0246) 850357

Phone anytime — Return post service.

## APPLE and PET SYSTEMS in DUBLIN

\* Come and try these fine computers  
in our showrooms

### Sensible Software for Apple

\* Sales, Creditors Ledgers; Financial  
Modelling

\* Educational systems in Maths,  
Physics, Geography, Commerce.

## SOFTTECH

SOFTECH Ltd., 51 Lr Camden St.,  
Dublin 2, Ireland. Phone Dublin 784739

## Vets for Pets

Anita Electronic Services (London) Ltd.  
are specialists in the repair and service of  
Commodore Pets.

We offer a fast on-site service, or alternatively repairs can be carried out at our workshops should you wish to bring in your Pet.

Pet maintenance contracts are available at very competitive prices. Trade inquiries welcomed.

For further information, tel or write to:

John Meade  
Anita Electronic Services  
15 Clerkenwell Close, London EC1  
01-253 2444

We also specialise in the repair of all makes of office equipment.

# MICROMART

## DATA + =

Business Systems  
Supplied and programmed to your  
requirements  
Buy or Lease

\*\*\*  
CENTRONICS 730  
NOW IN STOCK  
£525 +VAT

DATAPLUS, 67 BRIDGE STREET  
MANCHESTER, M3 3BQ

Tel: 061-832 3265

A division of  
Norman Green (Photo) Ltd

## µHex EPROM PROGRAMMERS

**426** 2508/2708/2758/2516/2716  
Dual and Single supply Eproms. £95

**416** 2704/2708/2716 Dual only. £65

**480** 2704/2708 Kit £35. Built £40.

All programmers require only standard  
power supplies.  
The 426 & 416 are cased and have push-  
button selection.

Program any length block into the Eprom.  
Software included. Range covers 280,  
8080, 6800 and 6500. State machine.

**PIO, PIA INTERFACE MODULES**  
Available for 280/8080 and 6800/6500.

Prices include carriage. Please add VAT  
SAE for further product information.

### MICROHEX COMPUTERS

2 STUDLEY RISE, TROWBRIDGE, WILTS.

### The Logical Solution...

...TO YOUR INDIVIDUAL BUSINESS PROBLEMS:-

a made-to-measure software system,

specially designed to meet your needs.

Talk over the possibilities with



Ron Meldon on

Waterlooville (07014) 53775.

37 Purbrook Gardens, Purbrook,  
Portsmouth PO7 5LB.

To advertise in  
**MICROMART**  
Please ring Jacquie Hancock  
on 01-631 1682

as daft as it sounds). For example, a  
game played to a draw might yield a  
sequence thus:

635419827

if the calculator moved first, its move  
sequence would be the 1st, 3rd, 5th,  
etc., numbers: i.e., 6,5,1,8,7. If the  
opponent attempts to cheat, the  
sequence might look like this:

63504

In the above example, the opponent  
attempted an illegal move at the fourth  
move in the game (i.e., his second move),  
whereupon the calculator took immedi-  
ate advantage, and won. Note that if  
the opponent takes the option to move  
first, and then enters an illegal move,  
the calculator will discard its original  
random move, and determine a first  
move based on its game strategy. For  
most games this is unlikely to occur,  
but when it does, the calculator always  
takes the centre position (5) which for-  
ces a draw.

5. The program does not possess the

facility to check for an opponent win  
(the move time would increase) and it  
has remained unbeaten to date. I have  
learned that it is unwise to tell a pros-  
pective opponent that they cannot pos-  
sibly win; either they give up immedi-  
ately, or they go to the other extreme  
and spend hours trying to prove you  
wrong. It is therefore highly embarras-  
sing when they find the only flaw in  
the program that allows them to win  
(and they never let you forget it!). So  
this program is not unbeatable, only  
unbeaten. If anyone CAN beat it, I'd  
be interested in the move sequence  
(naturally).

For users of other calculators or com-  
puters the following notes may be  
useful:

Min n = Enter Memory n (STOn)  
MR n = Recall Memory n (RCLn)  
INV is merely a SHIFT (2nd Function)  
instruction and may be ignored.  
GSB = GOSUB  
RNDn = Round off to n digits

### Pet Printer Pep-Up cont. from p.91

034D	E6	10		INC	POINTER HI
034F	E6	0F	\$8	INC	POINTERLOW
0351	D0	02		BNE	\$9
0353	E6	10		INC	POINTER HI
0355	E6	0F	\$9	INC	POINTERLOW
0357	D0	02		BNE	\$10
0359	E6	10		INC	POINTER HI
035B	A1	00	\$10	LDA	(00,X) get byte
035D	D0	0F		BNE	\$1 end of line?
035F	E6	0F	\$6	INC	POINTERLOW
0361	D0	02		BNE	\$11
0363	E6	10		INC	POINTER HI
0365	E6	0F	\$11	INC	POINTERLOW
0367	D0	02		BNE	\$12
0369	E6	10		INC	POINTER HI
036B	4C	44	03 \$12	JMP	\$3
036E	C9	22	\$1	CMP	£X'22' opening quote?
0370	D0	E3		BNE	\$9
0372	E6	0F	\$7	INC	POINTERLOW
0374	D0	02		BNE	\$5
0376	E6	10		INC	POINTER HI
0378	A1	00	\$5	LDA	(00,X) get next byte
037A	F0	E3		BEQ	\$6 end of line?
037C	C9	22		CMP£X'22' closing quote?	
037E	F0	D5		BEQ	\$9
0380	C9	C1		CMP£X'C1'	
0382	90	08		BCC	\$12
0384	C9	DB		CMP£X'DB'	
0386	B0	04		BCS	\$12
0388	29	7F		AND	£X'7F' remove shift bit
038A	81	00		STA	(00,X)
038C	4C	72	03 \$12	JMP	\$7

### Listing 3

```

35000 I=1027:REM UNSHIFT PROGRAM
35010 F=1:A=256*PEEK(I+1)+PEEK(I):IFA>34999THENPRINT PRINT"FINISHED":END
35020 PRINTA:I=I+1
35030 I=I+1:X=PEEK(I):IFX=0THENI=I+3:GOTO35010
35040 IFX=34THENF=-1*F:GOTO35030
35050 IFF=1THEN35030
35060 IFX>192ANDX<219THENX=X-128:POKEI,X
35070 GOTO35030
READY.
```

Thanks to Microflow Path-  
finder Limited of Farnborough  
for kindly loaning the neces-  
sary equipment.

### Checkout cont. from p.76

ed, legs down, into a layer of antistatic  
foam, and timing is initiated by closing  
the lid. At the end of the 8 minutes (or  
so) the light switches off and a beeper  
sounds with a pleasant but insistent  
note to attract attention.

The box is well sealed against escape  
of UV light. I examined it in a dark  
room with the light operating and could  
detect only a very faint leakage, right at

the back. There is thus no risk of in-  
advertently exposing the eyes to UV  
light.

Overall then my conclusion is that  
the UV8 is well made, good value at the  
price, and very efficient at its job. It  
would certainly be a good buy for any  
industrial user of EPROMs and even  
some hobbyists could find it a worth-  
while investment.

### Pascal cont. from p.95

arises.

The first thing to notice in program  
ESTATE is the declaration of the

pointer type POINTER (line 9) and the  
declaration of the pointer variables  
FIRSTFILLED etc. as type POINTER  
in line 23. The record FLAT is declared

in lines 14 to 21 and line 17 declares the field NEXT as a field of type POINTER. It is this mechanism which allows the linked list to be formed since the address of the next flat will be stored in NEXT.

In order to make the program both interactive and complete, the main program offers the user a MENU of different options (lines 50 - 55) including: INITIALISE - which "commissions" the block to start with.

MOVEIN and MOVEOUT - which manipulate the flats between the two linked lists.

FREEFLATS and TENANTLIST - which offer the user the opportunity of listing the vacant or occupied flats at any time.

Procedure INITIALISE (lines 67 - 87) constructs the entire linked list once the number of flats is known (line 71). First, two listhead pointers are initialised (72 and 73) and a record of type FLAT is created in line 76. Then the relevant data are assigned to the fields of the variable LINK^(77 - 85). Note the two pointer assignments on lines 79 and 84. NEXT is the pointer field within the record so that the first time through, NEXT is set to NIL and this record will always be the last record in the list. In line 84, the pointer to this record (LINK) is assigned to FIRST-FREE so that when the next record is created, this value can be placed into its NEXT field (line 79 again). The second record is thus linked to the first.

Procedure MOVEIN is designed to allow a predefined number of flats to be allocated to families. In order to do this a second linked list is formed although no new FLAT records will be created. Instead, some of the links in the current vacant list will be broken and new ones forged to build up a list of occupied flats. Procedure FIND-FLAT tests for the first vacant flat and, if one is there, passes its pointer address to the pointer NEXTFLAT so that when the next procedure, FILLFLAT, needs the flat record it has merely to reference NEXTFLAT^ (line 140). FILLFLAT however also has the tricky job of linking the new flat into the list of occupied flats so that the tenants' names are in alphabetical order. This is done in SETPOINTERS with the help of the Boolean function BEFORE (106 - 117) which returns the value TRUE provided that the first string passed to it (N1) comes before the second (N2), taken alphabetically. BEFORE is a recursive function (line 116) which recalls itself as long as there are still unvisited characters left in the string (tested for in lines 108 and 110) and as long as corresponding characters in the two strings (referenced by the integer P) are identical (checked in lines 112 and 114). Note the use of the PASCAL standard function ORD which maps its argument (which must be a character) onto a set of integers, one for each character in the character set. The letters of the alphabet form part of this character set so that two letters can be compared as in line 112 and alphabetically ordered by placing the lower one first. (i.e. A<B<...<Z).

SETPOINTERS itself is an example of the ease with which a linked list can be used. Line 121 (and 128) ensures that the search loop will run until the end of the list is reached if necessary.

Line 130 drives the search through the list by redirecting the search pointer (LINK) to the record indicated by the current record's pointer field. Once the correct place in the list has been found, control moves to the final sequence of SETPOINTERS (133 - 137), where the new flat is detached from the list of vacant flats, its link pointer being assigned the address of the next record up the list while its address is passed to the pointer field of the last record down the list (or the listhead pointer if necessary). Procedure MOVEOUT performs the opposite process, searching out specified occupied flats and removing them from the list (EVICTIFHERE) and ensuring that the flat that has been vacant longest will be the first to be filled (TIDYUP). Further use is made of recursion in EVICTIFHERE and TIDYUP, demonstrating how concisely a linked list may be traversed (lines 181 and 194). In comparison the procedures FREEFLATS and TENANTLIST access the same lists but iteratively. Note how EVICTIFHERE deletes a record, pin-pointing the flat to be cleared in line 178 and excluding it from the list by linking its immediate neighbours together in line 179.

Exercises: (1) No-one would use a program like this because as soon as the machine is switched off all the data would be lost. Write procedures to dump both lists onto disc files at the end of each day and to build up a new heap from the same disc files when the system is booted up next morning.

(2) Modify FINDFLAT so that it finds the first vacant flat in the list with sufficient rooms to provide at least one room per person.

## Variant field records

It is a frequent occurrence that the data one wishes to associate together in one record will not fit conveniently into any fixed record format. For these occasions PASCAL provides a means of building variants into the record declaration so that a portion of the record can contain alternative (and different) formats depending on the nature of the items in the fixed part of the record.

An example of this feature appears in the program in Box 6. The information required in the record of a vacant flat (e.g. date last occupied) is quite different from the information needed for an occupied flat (name of tenants and size of family). Consequently, in the record declaration of FLAT (lines 14 - 21) the first few fields are common to both types of flat but at line 18 some sort of split has to be made. This is done by means of a CASE statement which must enumerate the different possibilities open at this point.

The format for such a variant field declaration is as follows:

```
CASE tag field : type OF
  const1 : (fields of const1) ;
  const2 : (fields of const2) ;
  -
  -
```

Note that there is no "END" reserved word to close off the case statement. The tag field is a variable (common to all records) which acts as a selector, picking out the appropriate variant format. In ESTATE the tag field is STATUS (line 18) which can be either VACANT (implying a variant field

# MICROMART

## PETS!

Pets - new for old, part exchange your faithful Pet for a new model.

We stock Commodore or Computhink discs, PET printers and teletypes etc.

We also buy used Pets and peripherals for cash.

## HORIZONS!

32K static memory (the best) 2 double density discs (2 serial and 1 parallel port) from £1999

## HIRE!

PET 8K £4.75 per day  
PET 32K £6.95 per day  
Teletype 43 £6.00 per day  
HORIZON P.O.A.

## HIGH QUALITY CASSETTES!

C15 41p C30 55p including VAT  
Post 20p

Orders over £4.00 free postage  
Contact

Richard Mortimore or Chris Phelps

at  
MICRO - FACILITIES  
01-979 4546/941 1197

Software for 8/16/32K PETS

## TEXT AND ADDRESS PROCESSOR (TAP)

Allows creation and editing of TEXT and SECONDARY files to operate in three modes:

-WORD PROCESSOR (Text file)  
-WORD PROCESSOR with inserts from secondary file (letters etc)

-REPORT GENERATOR (Sec. file) using text file to format prints.

User sets secondary file content:

Stock Lists	Inventories
Spare Lists	Personnel
Exam Questions	Pupil Records

and, of course, name and address.

Features conditional selection of secondary file entries!

Business: 2040 disc-based	£40
Personnel: tape-based	£20
Documentation only	£6

Configuration details please.

T.I.-59 Software incl. address labeller.  
S.A.E. for list.

## HARTFORD SOFTWARE

9 Massey Avenue, Hartford,  
Cheshire CW8 1RF.

## MICROTYPE STAK-PAK

CASSETTE STORAGE SYSTEM FOR EASY PROGRAM FILING.



- Each drawer section takes 2 cassettes.
- Drawers lock together vertically.
- Each twin pack comes with 2 C10 digital cassettes.
- Each 'pak' is complete with index cards, cassette and drawer labels.

FIVE TWIN PAKS (10 CASSETTES)  
FOR £6.60 INC. VAT & P&P.

Send cheques or Postal Orders to:  
MICROTYPE, PO Box 104,  
HEMEL HEMPSTEAD,  
HERTS HP2 7QZ.

# MICROMART

## SURPLUS EQUIPMENT MUST GO

Heath WH14 Printer, built and tested 360.00  
Teletype ASR 33 (with tape read and punch) recently refurbished £300.00  
S.S.M. 104 S100 2 serial/4 parallel 20ma + RS232, built and tested 90.00  
S.S.M. S100 Extender Board 8.00  
Exidy Sourcerer 32K + S100 850.00  
Expansion Box o.n.o  
Sinclair Mk14 Boxed with P.S.U and decent keyboard 30.00  
Vero S100 W.W. bare board 8.00  
Newbury Labs professional 80 x 21 VDU 110/300 Baud, RS232 180.00  
TASA ASCII Touch  
Keyboard uc/lc 32.00

Attention Micropolis Mod II owners  
Phone for details of Users Club.

Phone 0670 822790/733125

WHAT "Turns a board into a real computer"?

### MICROCASE!

We make cases for micros.  
Stylistically designed.  
Beautifully made.  
Room for extensions + PSU.

### SUPERBOARD COMPUTKIT NASCOM 2 or UNCUT FOR OEM USE

From your dealer or write to:

**MICROCASE**  
Simple Software Ltd  
15 Havelock Road  
Brighton BN1 6GL.

+ SOFTWARE FOR SUPERBOARD +

### SMALL TURNKEY SYSTEMS

Applications specialists with  
CROMEMCO/CENTRONICS/CIFER  
systems in:

Financial Planning  
Budgeting  
Schedule Order Handling  
Invoicing  
Ledgers  
Information Index

TANDY/CENTRONICS in  
Builders Commercial Systems  
in BASIC — source available

Expandable to:  
— Multi-user systems  
— 10 Mb Hard discs

We aim to solve YOUR problems.

Supply : Support : Service

Contact: Alan Perry  
01-272 3530 or 01-263 1951

### APPLE II : ITT 2020 RELOCATED INTEGER

A large number of programs written for the Apple II in Integer Basic will not run on ITT, Palsort or Apple II Plus machines without an Integer Basic Card.

The problem can now be overcome using RELOCATED INTEGER, a revised software version of Integer Basic which will accept all Integer programs.

Relocated Integer remains co-resident in memory with both disc and cassette system and also makes available the Mini-Assembler facility.

Cassette Version £12 Disc Version £14  
Specify whether 32K or 48K system.

D.J. BOLTON, THE OLD SCHOOL HOUSE,  
1 BRANCH ROAD, PARK STREET, ST.  
ALBANS. TELEPHONE (0727) 72917.

named LASTDATE) or FILLED (implying TENANTS).

When a record is assigned (e.g. lines 140 — 143), as soon as STATUS is defined, the required variant field is selected and can itself be subsequently assigned. If STATUS is altered (lines 189 — 192) the new variant is automatically switched in and overwrites

the previous data. Note that a record type may only contain one set of variant fields (i.e. one CASE statement) although record types (with their own variant fields) may be nested within the variations. Box 7 contains the syntax diagrams for both pointer types and record field variants.

Pascal Box 6 cont. from p.94

```
30: READLN ;
31: I := 0 ;
32: REPEAT
33:   I := I + 1 ;
34:   READ(NCII)
35: UNTIL EOLN OR (I=20) ;
36: FOR J := I+1 TO 20 DO
37:   'NCJJ := '
38:END ; (STREADLN)
39:FUNCTION LENGTH(N : NAME) : INTEGER ;
40:VAR I : INTEGER ;
41:BEGIN
42:   I := 20 ;
43:   WHILE (I>0) AND (NCII=' ') DO
44:     I := I - 1 ;
45:   LENGTH := I
46:END ; (LENGTH)
47:
48:PROCEDURE MENU ;
49:BEGIN
50:   WRITELN('0. EXIT FROM THIS PROGRAM.') ;
51:   WRITELN('1. SET UP A NEW ESTATE.') ;
52:   WRITELN('2. MOVE NEW TENANTS IN.') ;
53:   WRITELN('3. MOVE TENANTS OUT.') ;
54:   WRITELN('4. SEE FREE FLATS.') ;
55:   WRITELN('5. SEE LIST OF TENANTS.')
56:END ; (MENU)
57:PROCEDURE GETDATE ;
58:BEGIN
59:   WITH NEWDATE DO
60:   BEGIN
61:     WRITE('DAY--->') ; READ(DAY) ;
62:     WRITE('MONTH--->') ; READ(MONTH) ;
63:     WRITE('YEAR--->') ; READ(YEAR)
64:   END
65:END ; (GETDATE)
66:
67:PROCEDURE INITIALISE ;
68:VAR NUM, I : INTEGER ;
69:BEGIN
70:   GETDATE ;
71:   WRITE('NUMBER OF FLATS--->') ; READ (NUM) ;
72:   FIRSTFILLED := NIL ;
73:   FIRSTFREE := NIL ;
74:   FOR I := 1 TO NUM DO
75:     BEGIN
76:       NEW(LINK) ;
77:       WITH LINK^ DO
78:         BEGIN
79:           NEXT := FIRSTFREE ;
80:           WRITE('FLAT NUMBER--->') ; READ(NUMBER) ;
81:           WRITE('NUMBER OF ROOMS--->') ; READ(ROOMS) ;
82:           STATUS := VACANT ;
83:           LASTDATE := NEWDATE ;
84:           FIRSTFREE := LINK
85:         END
86:       EN
87:     END ; (INITIALISE)
88:PROCEDURE MOVEIN ;
89:VAR I, NUM : INTEGER ;
90:   FOUND : BOOLEAN ;
91:   NEXTFAMILY : FAMILY ;
92:   NEXTFLAT, PREVIOUSLINK : POINTER ;
93:PROCEDURE FINDFLAT ;
94:BEGIN
95:   IF FIRSTFREE = NIL
96:     THEN FOUND := FALSE
97:   ELSE
98:     BEGIN
99:       FOUND := TRUE ;
100:      NEXTFLAT := FIRSTFREE
101:    END
102:END ;
103:PROCEDURE FILLFLAT ;
104:PROCEDURE SETPOINTERS ;
105:VAR CONTINUE : BOOLEAN ;
106:FUNCTION BEFORE(N1, N2 : NAME ; P:INTEGER) : BOOLEAN ;
107:BEGIN
108:   IF P = LENGTH(N2)
109:     THEN BEFORE := FALSE
110:   ELSE IF P = LENGTH(N1)
111:     THEN BEFORE := TRUE
112:   ELSE IF ORD(N2[P]) < ORD(N1[P])
113:     THEN BEFORE := FALSE
114:   ELSE IF ORD(N1[P]) < ORD(N2[P])
115:     THEN BEFORE := TRUE
116:   ELSE BEFORE := BEFORE(N1, N2, P+1
117:END ; (BEFORE)
118:BEGIN (SETPOINTERS)
119:   LINK := FIRSTFILLED ;
120:   PREVIOUSLINK := FIRSTFILLED ;
```

# MICROMART

**TRS80 or PET**  
**16K 'THE ANTIQUE GAME'**  
A realistic instructional business simulation including auctions, realistic pricing from £50 to £5,000. Stolen property. Thousands of different items to buy and sell. Interesting characters to deal with. One to four players.

Price £15 inclusive  
(VAT, post and packing.)  
from

**Island Software**  
132 Ashleydown Road, Bristol 7.  
Telephone enquiries to:  
0272 513121

## WESTFARTHING COMPUTERS

Thinking about a computer?  
Get independent  
professional advice  
Also **PERSONAL CLIENT SERVICE**  
for potential home users.

Phone Helston (03265) 4098  
for brochure.

Please note: we do not sell computers or  
accept commissions on sales.

## MICROCOMPUTER CONSULTANTS

### SOFTWARE FOR THE NEW ROM PETS

#### COMMAND KEY

A 300 byte machine-code routine that turns the shift key into a command key when used outside quotes. Single key entry of BASIC words. Squeeze complex IF & DEF's onto one line. Logical layout with template provided. Also gives optional repeating keys and a one-key monitor call.  
£3.50

#### LIBRARIAN

Keeps a commented catalogue with fast-forward location of all subsequent programs on a tape. New programs of any length can be added at any time. Not a tutorial - ready to run.  
£4.50

#### PALETTE

Four fast machine-code subroutines in one program to fit in the second cassette buffer. Set or clear a quarter pixel, instant screen reverse, block transfer and screen wash.  
£3.50

Mail order only. Send or phone for free list.

#### MYCROFT

262 Francis Chichester Way, London SW11 5HY,  
Tel: 01-720 0991

# TOPMARK Computers

dedicated to

## APPLE II

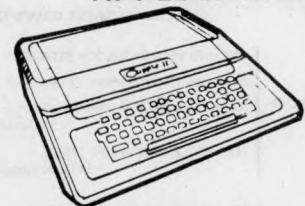

Simply the best!

Full details from Tom Piercy on  
Huntingdon (0480) 212563

```
121: CONTINUE := LINK <> NIL ;
122: WHILE CONTINUE DO
123: BEGIN
124: IF BEFORE(NEXTFAMILY.SURNAME, LINK^.TENANTS.SURNAME, 1)
125: THEN CONTINUE := FALSE
126: ELSE
127: BEGIN
128: CONTINUE := LINK <> NIL ;
129: PREVIOUSLINK := LINK ;
130: LINK := LINK^.NEXT
131: END
132: END ;
133: FIRSTFREE := NEXTFLAT^.NEXT ; (TAKE FLAT OFF FREE LIST)
134: NEXTFLAT^.NEXT := LINK ; (LINK NEW FLAT INTO OCCUPIED LIST)
135: IF (FIRSTFILLED = NIL) OR (PREVIOUSLINK=LINK)
136: THEN FIRSTFILLED := NEXTFLAT
137: ELSE PREVIOUSLINK^.NEXT := NEXTFLAT
138:END ; (SETPOINTERS)
139:BEGIN (FILLFLAT)
140: WITH NEXTFLAT^ DO
141: BEGIN
142: STATUS := FILLED ;
143: TENANTS := NEXTFAMILY ;
144: SETPOINTERS
145: END
146:END ; (FILLFLAT)
147:BEGIN (MOVEIN)
148: WRITE('HOW MANY NEW TENANTS--->') ;
149: READ (NUM) ;
150: FOR I := 1 TO NUM DO
151: BEGIN
152: WITH NEXTFAMILY DO
153: BEGIN
154: WRITE('SURNAME--->') ; STREADLN(SURNAME) ;
155: WRITE('SIZE--->') ; READ(SIZE) ;
156: FINDFLAT ;
157: IF FOUND
158: THEN FILLFLAT
159: ELSE WRITELN('CAN'T BE DONE.')
160: END
161: END
162:END ; (MOVEIN)
163:PROCEDURE MOVEOUT ;
164:VAR LASTNAME : NAME ;
165: FOUND : BOOLEAN ;
166: I, NUM : INTEGER ;
167: EMPTYFLAT : POINTER ;
168:PROCEDURE EVICTIF THERE ( VAR EMPTYFLAT, LINK:POINTER ) ;
169:BEGIN
170: FOUND := TRUE ;
171: IF LINK = NIL
172: THEN FOUND := FALSE
173: ELSE
174: BEGIN
175: IF LINK^.TENANTS.SURNAME = LASTNAME
176: THEN
177: BEGIN
178: EMPTYFLAT := LINK ;
179: LINK := LINK^.NEXT
180: END
181: ELSE EVICTIF THERE (EMPTYFLAT, LINK^.NEXT)
182: END
183:END ; (EVICTIF THERE)
184:PROCEDURE TIDYUP (VAR LINK : POINTER ; EMPTYFLAT :POINTER) ;
185:BEGIN
186: IF LINK = NIL
187: THEN
188: BEGIN
189: LINK := EMPTYFLAT ;
190: LINK^.NEXT := NIL ;
191: LINK^.STATUS := VACANT ;
192: LINK^.LASTDATE := NEWDATE
193: END
194: ELSE TIDYUP (LINK^.NEXT, EMPTYFLAT)
195:END ; (TIDYUP)
196:BEGIN (MOVOUT)
197: GETDATE ;
198: WRITE ('HOW MANY FAMILIES ARE LEAVING-->') ;
199: READ (NUM) ;
200: FOR I := 1 TO NUM DO
201: BEGIN
202: WRITE ('WHAT IS THE SURNAME OF THE LEAVING FAMILY-->') ;
203: STREADLN(LASTNAME) ;
204: EVICTIF THERE(EMPTYFLAT, FIRSTFILLED) ;
205: IF FOUND
206: THEN TIDYUP (FIRSTFREE, EMPTYFLAT)
207: ELSE WRITELN (LASTNAME, ' DON'T LIVE HERE.')
208: END
209:END ; (MOVEOUT)
210:
211:PROCEDURE FREEFLATS ;
212:BEGIN
213: WRITELN ('FLAT NUMBER ROOMS') ;
214: LINK := FIRSTFREE ;
215: WHILE LINK <> NIL DO
216: BEGIN
217: WRITELN(LINK^.NUMBER, LINK^.ROOMS) ;
218: LINK := LINK^.NEXT
219: END
220:END ; (FREEFLATS)
221:PROCEDURE TENANTLIST ;
222:BEGIN
223: WRITELN('NAME FLAT NUMBER') ;
```

# MICROMART

## A COMPILER FOR TRS-80® BASIC

Southern Software ACCELERATOR speeds execution of BASIC programs by compiling the common statements to Z80 machine-code.

- Develop and debug normally.
- Compile for production work.

Properly-structured, error-free level 2 programs only. £19.95

SOUTHERN SOFTWARE, PO Box 39  
Eastleigh Hants. SO5 5WQ

50 HZ  
SUPER BOARD  
NOW FROM ONLY

# £159.95

Plus P&P & VAT

Includes 8K BASIC, 4K RAM  
KEYBOARD etc  
FITTED MODULATOR EXTRA

CTS 1 Higher Calderbrook,  
Littleborough, Lancs, OL15 9NL  
Tel: Littleborough (0706) 79332  
anytime



## UPERSOFT

— WE TRY HARDER

All the extras for your machine in our latest catalogue. Racial-Zonal C12 cassettes (10 for £3.95); Verbatim 5 1/4 in. diskettes

(10 for £25), 8in single density (10 for £32) or double-density (10 for £39); PET parallel interface £39 or £65 with decoding; ribbons, paper etc. etc. PLUS nearly 40 great PET programs at £1-£12. Post free but add 15% VAT to all prices.

SUPERSOFT 28 Burwood Avenue, Pinner, Middx.

\*\*\*\*\* STOP PRESS \*\*\*\*\*

PET GAMES PACK: 17 GREAT GAMES FOR JUST £25

\*\*\*\*\*

## Modata

30 ST. JOHNS ROAD  
TUNBRIDGE WELLS  
KENT

Telephone: Tunbridge Wells (0892) 41555

DIGITAL MICROSYSTEMS  
LOW COST BUSINESS COMPUTERS

DSC-2

ONE to 29 MEGABYTES DISK STORAGE  
64 Kbytes of Main Memory - STANDARD  
Digital Research CP/M operating system -  
STANDARD  
TEXT PROCESSING BASIC COBOL  
FORTRAN available

HEX-29

32 to 96 MEGABYTES DISK STORAGE  
32 USER & 16 TASK capability STANDARD  
Reentrant ASSEMBLER & BASIC STANDARD  
Floppy disk based development system  
available

MODATA still need DEALERS in parts of U.K. and IRELAND

```

224: LINK := FIRSTFILLED ;
225: WHILE LINK <> NIL DO
226: BEGIN
227:   WRITELN (LINK^.TENANTS.SURNAME, LINK^.NUMBER) ;
228:   LINK := LINK^.NEXT
229: END
230: END ; (TENANTLIST)
231:
232: BEGIN (MAIN PROGRAM)
233:   REPEAT
234:     MENU ;
235:     WRITE('YOUR CHOICE-->'); READ(CHOICE) ;
236:     WRITELN ; WRITELN ; WRITELN ;
237:     IF (CHOICE>5) OR (CHOICE<0) THEN CHOICE := 0 ;
238:     CASE CHOICE OF
239:       0 : WRITELN('GOOD BYE') ;
240:       1 : INITIALISE ;
241:       2 : MOVEIN ;
242:       3 : MOVEOUT ;
243:       4 : FREEFLATS ;
244:       5 : TENANTLIST
245:     END ; (CASE)
246:     WRITELN ; WRITELN ; WRITELN
247:   UNTIL CHOICE = 0
248: END.
    
```

## PROGRAMS

### PET Backgammon

by J. Aughton

We figured that as "Programs" is somewhat short this month we would give you a real treat.

This program is one of the best that we have ever received at PCW; it will more than repay the effort involved in keying it in.

You will notice a POKE in line 9010.

This is because the original program used lower case letters in the "instructions" section. As you probably know this produces gibberish on the PET printer. We've left the POKE there in case you decide to restore the instructions to their former glory.

```

30 REM*****
40 REM*   BACKGAMMON   *
50 REM*
60 REM*   BY J. AUGHTON   *
70 REM*****
80 W(1)=-300:W(2)=500:W(3)=100
90 W(4)=-300:W(5)=-500:W(6)=-1200
100 W(7)=70:W(8)=700:REM HEIGHTS
110 DIMA$(6),A%(25),P%(12),Q%(12)
120 U$="TTTTTT":D$="XXXXXXXXXXXX"
130 DEFN(X)=INT(X/RND(7)+1)
140 A$(1)="3  XXXXX  XXXXX  "
150 A$(2)="3  XXXXX  XXXXX  "
160 A$(3)="3  XXXXX  XXXXX  "
170 A$(4)="3  XXXXX  XXXXX  "
180 A$(5)="3  XXXXX  XXXXX  "
190 A$(6)="3  XXXXX  XXXXX  "
200 Z$="":GOTO9000
500 REM INITIALISE
510 F=0:BH=0:BP=0:NH=15:NP=15
520 RESTORE:FORI=1TO12:READA%(I)
530 A%(25-I)=-A%(I):NEXT
540 DATA2,0,0,0,0,-5,0,-3,0,0,0,5
550 PRINT"PRESS SPACE TO START ";
560 PRINT"IN THE USUAL WAY
570 GETA$:IFA$<" THEN570
575 POKE59468,12
580 PRINT"XXXXXXXXXX  PET YOU
585 PRINT"SI PLAY  - YOU PLAY 0
590 GOSUB4000:IFP=0THEN590
600 GOSUB5600:GOSUB5600:GOSUB6000
610 GOSUB5000:F=1:FM=1:IFP>0THEN2000
620 GOTO1040
1000 REM HUMAN MOVE
1010 GOSUB5500
1020 PRINT"PRESS SPACE TO ROLL DICE
1030 GETA$:IFA$<" THEN1030
1040 GOSUB4000:K=0:M=2:IFP=0THENM=4
1050 FM=0:GOSUB5500:GOSUB1510
1060 PRINT"YOUR MOVE WITH THE";P;"? ";
1070 GETA$:IFA$=" THEN1070
1080 N=ASC(A$)-64
1090 IFN>26ORN<1THEN1050
1100 PRINTA$:IFN=25THEN1330
    
```

# PROGRAMS

```

● 1105 IFN=26THEN1370
1110 IFBH=0THEN1140
1120 GOSUB5500:PRINT"YOU'RE ON THE BAR
● 1130 GOSUB5600:GOTO1050
1140 REM
● 1150 IFAX(N)>0THEN1180
1160 GOSUB5500:PRINT"NOTHING THERE !
1170 GOTO1130
● 1180 IFN+P<25THEN1220
1190 IFHI=NHTHENF=0:GOTO1410
● 1200 GOSUB5500:PRINT"OFF THE BOARD !
1210 GOTO1130
● 1220 IFAX(N+P)>-2THEN1250
1230 GOSUB5500:PRINT"SORRY IT'S BLOCKED
1240 GOTO1130
● 1250 AX(N)=AX(N)-1:GOSUB5000:N=N+P
1260 IFAX(N)>-1THEN1290
● 1270 AX(N)=0:BP=BP+1:GOSUB5500
1280 PRINT"OUCH !-YOU GOT ME
1290 AX(N)=AX(N)+1:M=M-1:GOSUB5000
● 1300 P=0:IFM>0THEN1050
1310 GOTO2000
● 1330 IFBHTHEN1350
1340 GOTO1160
1350 IFAX(P)<-1THEN1230
● 1360 N=0:BH=BH-1:GOTO1250
1370 IFK=0THEN1400
● 1380 GOSUB5500:PRINT"YOU'RE STUCK(?)
1390 GOSUB5600:GOTO2000
1400 K=P:P=0:Q=K:GOTO1050
● 1410 IFN+P>25THEN1460
1420 NH=NH-1:IFNHTHEN1450
1430 GOSUB5500:PRINT"YOU WIN
● 1440 GOSUB5600:GOTO7000
1450 AX(N)=AX(N)-1:N=0:GOTO1290
● 1460 FORI=19TON-1
1470 IFAX(I)<=0THEN1500
● 1480 GOSUB5500:PRINT"YOU CAN'T-YOU ";
1490 PRINT"CAN MOVE AT ";CHR$(I+64):GOTO1130
1500 NEXT:GOTO1420
● 1510 HI=0:FORI=19TO24
1520 IFAX(I)>0THENHI=HI+AX(I)
● 1530 NEXT:RETURN
2000 REM PET MOVE
● 2010 K=0:GOSUB5500:PRINT"IT'S MY MOVE
2020 GOSUB4000:M=2:IFP=0THENM=4
● 2030 FM=0:IFBP>0THEN2240
2040 PI=0:FORI=1TO6
● 2050 IFAX(I)<0THENPI=PI-AX(I)
2060 NEXT:IFPI=NPTHENF=0:GOTO2320
● 2070 GOSUB4500:GOSUB3000
2080 IFQM>0THEN2210
● 2090 IFPM>0THENN=P(X):GOTO2120
2100 GOSUB5500:PRINT"I CAN'T MOVE
● 2110 GOSUB5600:GOTO1000
2120 GOSUB5500:PRINT"WITH THE";P;
● 2130 PRINT"I'LL MOVE ";CHR$(64+N)
2140 AX(N)=AX(N)+1:GOSUB5000:N=N-P
● 2150 IFAX(N)<1THEN2180
2160 AX(N)=0:BH=BH+1:GOSUB5500
● 2170 PRINT"TAKE THAT !
2180 AX(N)=AX(N)-1:M=M-1:GOSUB5000
● 2190 K=1:P=0:IFM>0THEN2030
2200 GOTO1000
● 2210 IFPM=0THEN2230
2220 IFPM<0THENN=P(X):GOTO2120
2230 N=Q(Y):K=P:P=0:Q=K:GOTO2120
● 2240 IFAX(25-Q)<2THEN2280
2250 IFAX(25-P)<2THEN2270
● 2260 GOTO2100
2270 N=25:BP=BP-1:GOTO2120
● 2280 IFAX(25-P)<2THEN2300
2290 K=P:P=0:Q=K:GOTO2270
● 2300 GOSUB4500:IFQM<PMTHEN2290
2310 GOTO2270
● 2320 IFAX(P)>=0THEN2390
2330 GOSUB5500:PRINT"I WILL BEAR ";
● 2340 PRINT"OFF WITH THE";P
2350 NP=NP-1:IFNPTHEN2380
● 2360 GOSUB5500:PRINT"I WIN
2370 GOSUB5600:GOTO8000
● 2380 N=P:AX(N)=AX(N)+2:GOTO2180
2390 FORI=6TO1STEP-1
● 2400 IFAX(I)<0ANDI>PTHEN2070
2410 IFAX(I)<0THEN2430
● 2420 NEXT
2430 GOSUB5500:PRINT"I CAN BEAR OFF ";
● 2440 PRINTCHR$(64+I);" WITH THE";P
2450 P=I:GOTO2350
● 3000 REM INTELLIGENT MOVES
3003 IFKTHEN3010
● 3005 GOSUB5500:PRINT"LET ME THINK..
3010 IFPM=0THEN3170
● 3020 IFHI=NHTHEN3500
3030 E=-9999:FORI=1TOPM:H=0

```

# MICROMART

Horizon Business Systems  
Incomplete Records, Sales,  
Purchase, Nominal Ledger,  
Letter Writers, Stock Control,  
etc.

We write packaged or bespoke  
software for  
North Star Horizon  
**MICOSYS LIMITED**  
58 High Street, Prescott,  
Merseyside L34 6HQ.  
Tel: 051 426 7271  
Computer bureau service now available.

## PASCAL SUBSET FOR NASCOMS

The first PASCAL subset for cassette-based systems

- produces Z-80 object code directly: no P-codes
- occupies only 4k RAM
- all major PASCAL statements, integer arithmetic,
- WRITE(LN) (formatted), READ(LN), INCH, (D)PEEK, (D)POKE, USER, RANDOM, HALT
- fully recursive procedures

## 12K BASIC FOR NASCOMS

All the features of a Microsoft BASIC plus:

- 12 digit precision
- PRINT USING, list variables, O/P to printer
- Multi-line recursive user functions
- IF... THEN... ELSE, logical operators
- Renumber, auto line numbering
- line editor, + lots more.

Above run under a new monitor, NASMON, suitable for N1 and N2 systems with memory board.

### PRICES:

NASMON monitor supplied in	
3 EPROMS:	£30
PASCAL supplied on tape:	£35
BAS 12K supplied on tape:	£30
NASMON, PASCAL, BAS12K:	£85

Available Soon: Extended PASCAL (special terms will be available for owners of initial version), Assembler, Disassembler.

### Contact:

HISOFT, 27 AVENUE DU BUDE,  
1211 GENEVA 20, SWITZERLAND.

**TRS-80** HIGH PERFORMANCE MODULE

Increase the speed and power of your  
**TANDY TRS-80 Level II**  
by

**50% TO 100%**

EFFICIENT INTERNAL MODIFICATION

Send SAE for full details to  
CENTRAL BUSINESS ASSOCIATES  
P O Box 14  
EPSOM, Surrey.

KIT: £30  
Excl. VAT FITTED: £55

PERSONAL COMPUTER WORLD  
APOLOGISES TO FARMPLAN  
FOR THE TYPOGRAPHICAL  
ERRORS IN THEIR AD ON PAGE 20  
OF OUR MARCH ISSUE.



## PROGRAMS

```

7050 IFA#="Y"THEN500
7060 END
8000 REM PET WINS
8010 PRINT"NOW !!-I WON !!
8020 PRINT"I REALLY ENJOYED THAT !
8030 GOTO7030
9000 REM INSTRUCTIONS
9010 POKE59468,14:PRINT"Q";TAB(13);
9020 PRINT"BACKGAMMON
9030 PRINT" I PLAY ALL THE USUAL"RU";
9040 PRINT"LES , WHICH YOU SHOULD K";
9050 PRINT"NOW BEFORE YOU PLAY ME.
9060 PRINT" FROM NOW ON THE ONLY ";
9070 PRINT"KEYS YOU NEED TO PRESS ";
9080 PRINT" ARE AS FOLLOWS.
9090 PRINT" A-X TO MOVE FROM A POINT"
9100 PRINT" Y TO RETURN FROM THE BAR"
9110 PRINT" Z TO PLAY THE DICE IN REVERSE ORDER"
9120 PRINT"SPACE AS INDICATED"
9130 PRINT" IF YOU PRESS Z TWICE YOU";
9140 PRINT" WILL SURRENDER YOUR MOVE.";
9150 PRINT"REMEMBER THAT YOU MUST ";
9160 PRINT"USE ALL OF YOUR MOVE IF TH";
9170 PRINT"IS IS POSSIBLE. I WILL TRU";
9180 PRINT"ST YOU IN THIS (AFTER A";
9190 PRINT"LL YOU HAVE TO TRUST ME";
9200 PRINT"-WHO ROLLS THE DICE?)
9210 GOTO500
READY.
    
```

## LEISURE LINES

With J. J. Clessa

An excellent response to the cube problem — 127 entries were received (including one from Norway), not to mention a further 25 late entries for the previous palindromic square puzzle (sorry chaps, the prize had gone). Of the 127 entries, 102 plumped for green, 19 for yellow and 6 for blue.

I wish I could say the answer was red, but the statistical evidence is too strong — GREEN is the correct solution.

The problem is not too difficult to solve by trial and error (since the number of possibilities is small), if you realise that, of the five colours: 1) if a colour is present on two faces, then obviously the other four colours can only be on one face each, and b) when a colour is only present on one face, then successive views showing this colour must, of course, be of the same cube face.

One reader, by the way, said it took him 30 seconds to solve, whereas the Irish crossword took him 15 minutes... sorry to hear that, Patrick!

Anyway, the winning entry (as picked by our biased random number generator) comes from a lady (at last!). Congratulations to Miss V. Mason of Cobham, Surrey... your book token is on its way.

### QUICKIE

A train leaves Edinburgh at 8.00am and travels to London at 60mph. At 9.00am another train leaves London

and travels towards Glasgow at 90mph. Which train is nearest to London when they pass each other (*I don't believe it — Ed*).

### PRIZE PUZZLE

A turkey farmer has 100 cages ranged in the form of a continuous circle around the perimeter of his farm. The cages are numbered clockwise sequentially from 1 to 100, with cage number 100 completing the circle and immediately adjacent to cage number 1. In each cage is a turkey.

The farmer decides to kill one turkey only per month, and in order to make his monthly selection, he counts clockwise N birds from the cage of last month's victim (N being the number of days in that month) to obtain his current month's turkey dinner.

Assuming his first bird comes from cage number 31 in January 1980, a) which will be the last bird to be eaten, and b) which bird will be Xmas dinner in 1985?

Note that the count is made on BIRDS, not on cages.

Answers please on a *postcard* to Puzzle No. 9, Personal Computer World, 14 Rathbone Place, London W1P 1DE. All solutions must arrive by May 12th latest.

### PRIZE OF THE MONTH

Winging its way towards the lucky winner will be a pack of ten, C-90 blank tape cassettes.

## BLUDNERS

March 1980. Page 80: Macronoia needs a bit more tweaking. Line 875 should read (J-1) not (J - I) and line 1680 should read INT(P1(J)\*1000)/10 at the end of the line.

March 1980: Page 107: Mark Franklin's Ds were misread as 2s, accordingly 0F36

now reads CD01 and 0F4D reads C8DA.

April 1980. Page 73: Imphex lost a line immediately above Figure 2. It reads: "computer is limited to 26 single-letter". Now you know why you should feel cuckolded.

## MICROMART

### MICROSALES, MICROHIRE, MICROLEASE.

Micros bought, sold or exchanged

Moving to new premises in Wood Green Shopping Precinct We are also dealers in the best in micros. See Promglow Ltd (Icarus) also in Practical Computing for details on Intertec Superbrain.

Sales & Lease:  
APPLE, Intertec Superbrain, Horizon, Sorcerer, TRS80, PET, Disk drives, printers.

Hire:  
Some less than £12 per week. No delivery or collection charge in London. All systems sold complete or in parts and there is no charge for VAT.

Bargains:  
Three complete TRS80II 11s + 32K + disk drive + 800 £'s worth of software free for only £1000.

Two Sorcerer 32K £600  
Two ITT2020 32K £600  
Complete Horizon with disk drive £1250.  
PET 8K with software £400  
NASCOM I for £100.  
Expansion \$100 available.  
Challenger system

Phone for what you would like.  
01-368 9002 Monday to Sunday  
(evenings more convenient).

PROMGLOW LTD

## CARDIFF MICRO CENTRE

PETs  
+  
SHARP MZ-80s  
+  
HEWLETT PACKARD  
+  
COMPUTER BOOKS

## SIGMA SYSTEMS

54 Park Place  
Cardiff 21515/34869

EAST ANGLIAN MICRO ENTHUSIASTS SEE US FIRST!

EASICOMP 'COMPANION'-Superboard, smart case, 8KRAM, BASIC & manuals, UK spec, 1yr gtee £280  
SUPERBOARD 4KRAM, BASIC, manuals, UK spec £155  
MICROCASES red/black or ivory/brown £28  
PSU KIT for S'bd etc £15. MODULATORS £4.50  
4KRAM 2114 £34. Range of components in stock  
DATA CASSETTES C12+case 55p or 10 for £4.80  
REGULATORS various V/A eg 5V 3A £2.50 (KIT)  
SOFTWARE for Superboard, PET, Nascom, Research Machines-1st class new programs £1.50-£3.50  
WANTED-Software for Superboard, PET, Nascom send tape/listing for approval must be good original material. Highest commission rates S.A.E. details / lists. Enquiries welcome Callers any time (By appointment). Prices include post(discout to callers) BUT NOT VAT so please add 15% VAT to total. All ex-stock

Easicomp Ltd. 0603-416352/  
407923  
57 Parana Court, Sprowston, Norwich.

**Introducing  
MAIL ORDER  
from Intex**

**A NEW  
SERVICE  
FOR YOU!**

**MAIL ORDER DEPARTMENT  
CASH WITH ORDER ONLY**

PET		DEMAGNETISERS	
2001-8	£ 495.00	Curved Head (Mains)	4.00
3016	675.00	Cassette (Battery)	12.00
3032	795.00		
C2N Cassette Deck	55.00	WORKBOOKS	
IEEE to IEEE Lead	25.00	TIS WORKBOOKS (NO VAT)	
PET to IEEE Lead	20.00	Set of 6	18.00
3040 Disk	795.00		
Computhink 400K for		CONNECTORS	
8K via exp/PET	825.00	PET USER/IEEE PORT	1.25
For 16/32K	895.00	PET 2nd CASS PORT	.95
800K Unit	1145.00	Covers for USER/IEEE	
24K Expandapet	320.00	PORT Connector	2.50
		D52 RS232 Connectors	
INTERFACES		Male/Female	3.25
Small sys, Serial C	120.00	Covers	2.50
Serial B Bi-Dir	175.00		
TNW2000 Bi-Dir	165.00	KIM	
All IEEE/RS232		KIM 1	99.95
PETSET 1 A/D	166.00	KIM 3B	99.95
Stockists of PETSOF &		KIM 4	69.95
COMMODORE SOFTWARE			
		NASCOM	
PAPER		Nascom 1 (kit)	125.00
TCM100 Roll	2.50	Nascom 1 (Built)	140.00
Anadex/PET 80 Col	15.00	Nascom 2 (Kit)	295.00
Teletype 132 Col	25.00	Power Supply (kit)	29.50
PR-40 Roll	1.00		
CASSETTES		SEND FOR OUR FULL SOFTWARE & MAIL ORDER PRICE LIST -	
C12 Cass Highgrade Per 10 in library cases	4.00	DUST COVERS	
		PET (All models)	£5.75
DISKETTES		PET 3040	£3.50
PET 3040 per 10	25.00	COMPUTHINK DISK	3.00
APPLE " "	25.00	T/T 43 PRINTER	5.75
C/THINK D/D Per 10	35.00	Anadex DP8000 Printer	3.50

**ALL PRICES ARE EX. VAT.  
PLEASE ADD 50p p&p ON SMALL ITEMS £2.50  
ON LARGER ITEMS**

**ALL GOODS DESPATCHED BY RETURN OF  
POST OR YOU WILL BE NOTIFIED OF ANY  
DELAY & OFFERED AN ALTERNATIVE OR THE  
RETURN OF YOUR MONEY**



**Don't delay  
SEND  
NOW!**



Name .....

Address ..... Phone .....

Item No.....

INTEX DATALOG LIMITED EAGLESCLIFFE INDUSTRIAL ESTATE, EAGLESCLIFFE, STOCKTON ON  
TEES, CLEVELAND TS 16 0PN, ENGLAND, TELEPHONE: EAGLESCLIFFE 781193 (STD Code 0642),  
CABLES INTEXRAD, STOCKTON ON TEES, TELEX 58252.

**Intex**

**You've heard about it  
Read about it — HERE IT IS**

**AVAILABLE EX-STOCK  
COMPLETE KIT AS PER  
MANUFACTURER'S SPECIFICATION**  
With provision for 8K on board expansion. Excludes 4118 x8\*

**INCLUDES FREE 16K EXPANSION**  
VALUE £140 includes ALL parts with every kit

**NASCOM-2  
ON DEMONSTRATION NOW**

**£295 + 15% WITH  
VAT FREE**  
16K EXPANSION WORTH £140

**SCOOP OFFER  
ONLY 500 KITS AVAILABLE  
AT THIS PRICE**

AVAILABLE ONLY FROM US ON THE COUPON BELOW

**OPTIONAL EXTRAS  
3 AMP POWER  
SUPPLY VAT 15%  
£29.50 Post £1.50  
For NASCOM-2**

**8 OFF 4118\*  
For NASCOM-2  
Purchasers  
£80 Early  
Delivery**

**RS232 COMPATIBLE  
80 COLUMN PRINTER** brand new **OUR PRICE**  
List price £550 If sent by carrier £5 extra **£325 + VAT**  
15%

**FULL MANUFACTURER'S WARRANTY — DON'T DELAY. ORDER TODAY**

Please send me my **NASCOM-2 KIT** with the **FREE 16K EXPANSION**  
for **£295 + VAT**.

I enclose remittance

to cover

Name & Address

Also in stock **NASCOM-1 • ELF • TRS80** as previously advertised



**HENRY'S**

Computer Kit Division  
404 Edgware Road, London, W2, England  
01-402 6822



**MICROCHIPS AT MICRO**

**PRICES**

**CMOS SALE**  
4011B brand new, factory  
prime from HITACHI  
Your choice (while stocks  
last) only 24p  
25 — 89 22p  
100 + 19p  
5000 pcs. in stock!

**MEMORIES**

2102 LHPC Low power 0.99  
High performance 250NS  
2114 Low power 300NS 2.95  
4118 250NS 18.95  
4315-45L 4K CMOS  
SRAM Low power  
450NS 12.95  
4116 300NS 3.50  
4116 200NS 3.75

**EAROM**

ER3400 4K 650NS 15.95

**EPROMS**

1702A 3.95  
2708 450 NS 4.50  
2716 Single 5V  
(INTEL TYPE) 13.95

**UARTS**

AY-5-1013A 2.98  
AY-3-1015D 3.98  
IM6402IPL 3.98

**CHARACTER  
GENERATOR**

RO-3-2517 4.50

**KEYBOARD  
ENCODER**

AY-5-2376 7.95

**FLOPPY DISK  
CONTROLLER**

FD1771 B-01 Single  
Density IBM Compa-  
tible 19.95  
FD1791 B-01 Dual  
Density IBM Compa-  
tible 39.95

**SHIFT  
REGISTERS**

3341PC FIFO 700KHz 4.95  
3341APC FiFo 1MHz 5.50  
3342PC 64 bit shift  
register 4.95  
**OTHER**  
MC14412 VL 7.97

**NEW SYSTEMS**

Z8001 16 Bit CPU with segmented address space to 8 Megabytes £125.00  
Z8002 16 Bit CPU with non segmented address space to 64K bytes £95.00  
Z8000DM A single board micro computer that interfaces directly to any Zilog micro system. It contains a Z8002 CPU, 16K words of Dynamic RAM, a dual channel serial I/O port, 32 parallel I/O lines and a wire wrap user area £1099.00  
WD9000B The Pascal Micro engine chip set. The set of 5 chips including the 16 bit CPU which will directly execute Pascal generated P code (UCSD P-machine instruction set — Revision 2.0). The only CPU in the market designed to directly execute a high level language at speeds five times faster than most typical computer systems. £199.00  
WD0090A Single board micro computer containing WD9000 chip set, 64K drive bytes and single sided 8 inch disk £1,495.00

75451 50p  
74491/2 75p  
8T26 1.75  
8T28 1.75  
8T95 1.75  
8T97 1.75

**SUPPORT DEVICES**

6520 4.95  
6522 7.95  
6532 8.95  
6551 10.95  
6810 3.75  
6820 4.25  
6821 4.25  
6850 4.25  
6852 4.25  
8212 2.00  
8216 2.00  
8224 2.75  
8228 3.95  
8251 4.95  
8253 10.50  
8255 4.75  
8257 10.50  
8259 11.95  
MC14412VL 7.97

**NEW GI COMPUTER  
SOUND CHIP**

CPUS  
6402 7.95  
6504 7.95  
6505 7.95  
6800 6.95  
6802 9.95  
8080A 4.75  
8085A 10.95  
Z80 7.95  
Z80A 9.95  
Z8001 125.00  
Z8002 95.00  
WD9000 199.00

**INTERFACE ICs**

DM8123 1.25  
75150 1.25  
75154 1.25  
75182 1.95  
75322 2.50  
75324 3.25  
75325 3.25  
75361 2.50  
75363 3.50  
75365 2.95

**NEW GI COMPUTER  
SOUND CHIP**

AY-3-8510 As featured in July BYTE. Fantastically powerful sound & music generator. Perfect for use with any 8 bit microprocessor. Contains 3 tone channels, noise generator, 3 channels of amplitude controls, 16 bit envelope period control, 2 parallel I/O, 3 D/A converters plus much more. All in 40 pin DIP. Super easy to interface to the S-100 or other Buses. ONLY £8.25 + VAT. Add £2.25 for 64 page data manual

**ORDERING INFOR-**

**MATION:** Postage free on orders over £10 otherwise add 25p. Add 15% VAT to total.  
**MICROBYTE**  
Unit 9-10 1st floor,  
Block E, 38 Mount  
Pleasant, London  
WC1X 0AP  
Tel: 01-278 7369  
Telex: 8953084

**MICROBYTE  
MICROBYTE**

# Buy here at discount prices!

**Save money-**

☆ Full after-sales service in our own workshops

☆ One year guarantee on all machines

Leasing available to companies

## Up to 1-6Mb for PET!

and 'on-line' with the Computhink Disc System

\* Allows powerful business programmes using 16 Extra BASIC commands. \* Easy to connect and use - plugs directly into 16/32K PETs, detailed manual supplied. \* Simple startup (no difficult procedures to remember) as Disc Op. System in ROM. \* Ready to run - useful programmes supplied free; full set of professionally written business packages available - Sales and Purchase Ledger, Stock Control, Payroll etc., \* Real-Time processing, Engineering and Commercial boundaries overcome with full language support - Business BASIC, Assembler, FORTRAN, COBOL, PASCAL, FORTH, FIFTH, PLM, PILOT & CESIL.

24K Memory expansion with dual disc for old ROM 8K PET £275 for new ROM 8K PET £320

Basic 400K dual disc system

only **£840**

800K £1,095  
1.6 Mb £2,190

Credit terms available

## Get into print this easy way!

**Fast! Immaculate! Silent!**



**Anadex DP 8000 dot-matrix printer**

\* Speedy 112 ch/s bidir. \* Fits A4 page - up to 80 cols. \* Up to 4 copies. \* Precision form-filling with sprocket feed. \* Special headings using double-width chars. \* Modern paper format to match A4 filing systems. \* Other paper sizes with adj. sprocket. \* Full punctuation, U/L case, £ sign, 96-ch. set. \* Reliable - strongly built, 100 M.ch. head.

**Knock down price!**

**£499**

Interfaces -  
Pet £45 Ohios £10  
TRS-80 £40 Sorcerer £8  
Apple £45

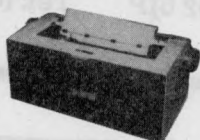

**IBM golfball printer ideal for word-processing**

\* Forget expensive Spin-Wheel printers - the Golfball produces equal quality at up to 15 ch. per sec. \* Match various typewriter styles with IBM interchangeable heads. \* Completely reliable - each machine rebuilt by IBM trained engineers and fully guaranteed. \* Precision form-filling possible with 15 in. pin-feed platen.

**Limited supply!**

**£595**

Interfaces -  
Pet £45 Ohios £10  
TRS-80 £35 Sorcerer £8  
Apple £45

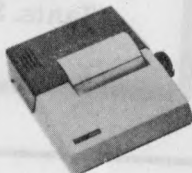

**TCM 100 Thermal Printer**

\* Stop disturbing others with noisy printout! \* Neat, clear, 96-ch. set, U/L case & symbols. \* Matches Pet/Apple line lengths. \* Fast, 40 ch/s bidir. \* Reliable - robust - only two driven parts. \* Plug in and go, built in PSU, detailed manual. \* Thermal paper 4 1/2 in wide x 80 ft, less expensive than electro-sensitive paper.

**A snip!**

**£249**

Interfaces -  
Pet £45 Ohios £10  
TRS-80 £40 Sorcerer £8  
Apple £45

While stocks last

## The only 16k complete computer for under £400

Keyboard computer, power supply, UHF modulator and all cables to plug into your own TV set and cassette recorder and go!! 16K of user RAM for decent size programmes and data, sophisticated level II Microsoft BASIC. Complete with level I and level II programming manuals. What more could you ask?

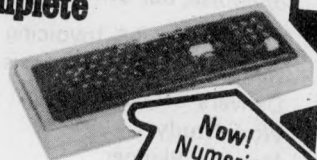

TRS-80

Now! Numeric keypad included

**£381<sup>74</sup>**

Expansion interface £199.09  
4K level I computer £251.30

This must be today's best buy!

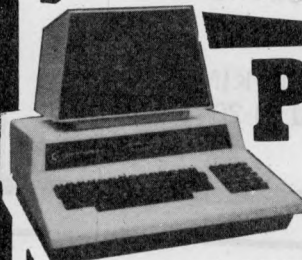

**PET 2001-8N**  
(8K RAM  
New large keyboard)

**£469**

2001 - 16N (16K RAM and new large keyboard) £590  
2001 - 32N (32K RAM and new large keyboard) £690

External cassette deck, suitable for all Pets £75  
CBM dual drive mini floppy £745  
Tractor feed printer with Pet graphics £499  
Pet high-res. graphics 200 x 320 £259

## You can afford to start computing now! - with the Ohio CI-P

As imported, fully tested, complete with 4K RAM, but unconverted to UK std. (conversion instructions supplied).

**£199**

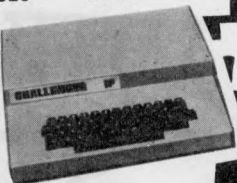

Add £24 for converted model. Extra 4K RAM £39.

\* Powerful programming possible - 6502 processor, fast 8K Microsoft floating-point BASIC (easy to learn). Superior utilities, 53 key key-board, giving upper and lower case, user-definable keys, gaming and graphics chs. Ultra-fast and powerful machine code from keyboard.

\* No intricate soldering or metal work. Computer supplied assembled in ready-made case. \* Reasonable sized programmes in 4K RAM. \* Expandable to 24K RAM in case. drives discs, printer; available items include Assembler/Editor and Extended Monitor. \* Programme interchangeability/reliability - Kansas City tape interface. \* Save programmes on own cassette recorder - all cables supplied.

- at a lower price than equivalent kits!

# COMPUTERAMA

LTD.

TANDY DEALER

AMERICAN EXPRESS

9000 TRAVELCARD VISA

AMERICAN EXPRESS

master charge

BARCLAYCARD VISA

Please add £10 Securicord delivery on computers etc plus 15% VAT on all prices

Your dealer for Bath, Bristol and S.W.

**Tel: Bath (0225) 28819**

We stock components, test instruments, tools etc.

Computerama Ltd.

Harpers Kensington

Showrooms

London Rd. Bath, Avon

Credit card orders accepted by telephone for immediate despatch.

Loads of software - ask for list!

# L&J COMPUTERS



KEEN & COMPETITIVE!

WE ARE SPECIALISTS.  
'PET' SPECIALISTS.  
HARDWARE & SOFTWARE.

WE HAVE EXCELLENT  
STOCKS OF BOTH



*Inc. a full range of Commodores and Petsoft; and, of course, our own, such as:*

Stock Control & Invoicing	£ 60
Random Entry & Analysis	£ 40
Delivery Services	£220
Work Study	£150
Monthly Planner	£ 7
etc. etc. (SAE for descriptive leaflet)	

*We will also write programs for you that you are unable to do or get written.*

**YOU ARE WELCOME TO TRY, BROWSE & PURCHASE AT OUR PREMISES... TRY US!**

ORDERS TAKEN BY POST OR PHONE: ACCESS-BARCLAYCARD-VISA

3 CRUNDALE AVENUE, KINGSBURY  
LONDON NW9 9PJ 01-204 7525

## Happy Memories

4116	200ns	£4-50	4116	150ns	£5-50
2114	200ns	£4-75	2114	450ns	£4-25
2708	450ns	£4-95	2716	5 volt	£16-95
21L02	450ns	85p	21L02	250ns	£1-25

VERBATIM mini discs soft sectored -- with FREE library case £19-95 per ten

## SALE

We're moving shortly to new premises and don't want to carry much. Bargains from Sat. 26th April

All prices include VAT. 30p postage on orders below £10. Access & Barclaycard. All orders to:  
Dept. PCW

19 Bevois Valley Road, Southampton,  
Hants. SO2 0JP Tel: (0703) 39267

# IN-HOUSE VIEW DATA SYSTEM

Full specification colour viewdata system, compatible with Ceefax, Prestel etc. Implemented on Cromenco, North Star or an existing S100 machine. Uses unmodified tv. Single or multi-user, up to 11,000 frames stored. Intelligent 'soft-key' frame-editing. Modem/autodialler will allow interface to Prestel, the Post Office Viewdata system, or other distant viewdata bank.

Prices from £800 to £15,000

## hi-tech electronics

1 Richmond Gardens, Highfield Southampton SO2 1RY  
Telephone (0703) 555072

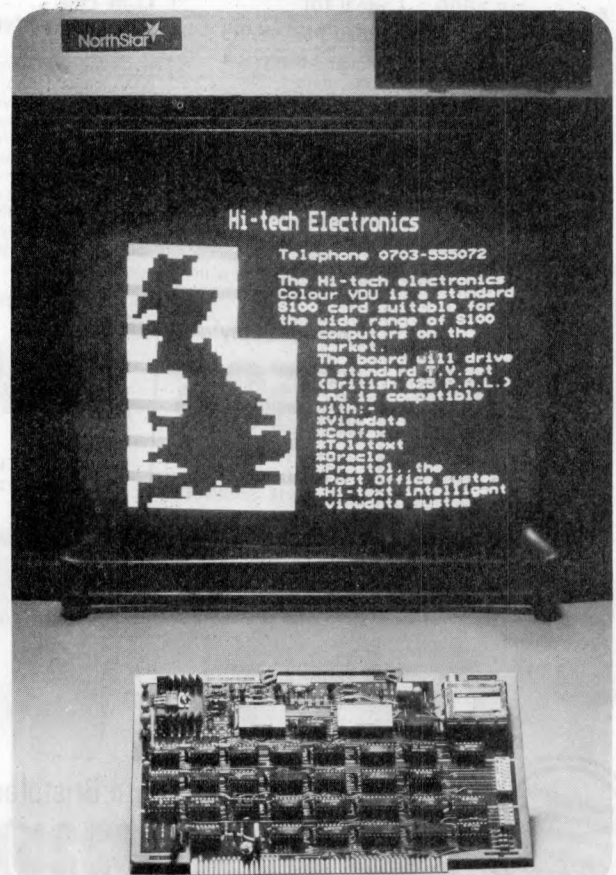



13-19 MILFORD STREET, SWINDON  
WILTSHIRE SN1 1DW  
Tel: (0793) 42615 Telex: 449703

Make more time available  
Enhance your quality of life  
Improve your business

COMPUTER SALES • HARDWARE • SOFTWARE • CONSULTANCY • MEDIA • STATIONERY ETC

\*\*\*\*\*  
\* We will consider purchase of second-hand \*  
\* equipment: \*  
\* \*  
\* **TRS 80** \*  
\* **ITT 2020** \*  
\* **APPLE** \*  
\* **COMMODORE PET** \*  
\* **CROMENCO etc.** \*  
\* \*  
\* Good allowance given for part-exchange \*  
\* against the **64K Twin Z80 Superbrain** \*  
\* \*  
\*\*\*\*\*

**PROGRAMS**

for: **TRS 80, APPLE, ITT 2020, PET, COMPUTHINK, SUPERBRAIN.**

Business complete package including sales, purchase, nominal, stock, invoicing etc. Also plenty of games.

**SUPERBRAIN £2,300**

64K + DUAL DISK DRIVES  
Keyboard and Numeric Keypad  
Fortran, Cobol, MBasic, Wordstar, etc., available.

**CONSULTANCY**

Please write or telephone if you require advice on BEGINNING or EXPANDING your computer installation. Software programs customised to your requirements.

**REPRESENTATIVES** required in various areas — please contact us for full details.

**OUR BUSINESS EXISTS ON IMPROVING YOUR BUSINESS.**

We are continually adding new products to our range and would be pleased to receive your enquiries. ● Quantity Discounts available.

	ex. VAT	inc. VAT
<b>TRS 80</b>		
16K Level 2 (c/w K/bd, VDU, T/Rec)	500.00	575.
0K Interface (to add printer & disk drives)	195.66	225.
16K Upgrade kits (for k/bd or interface)	65.22	75.
Disk Drives, single (125K)	260.88	300
Disk Drives, dual (250K)	456.53	525.
Disk Drives, cable 2 & 4 way from	21.74	25.

**ITT 2020**

16K (c/w K/bd & Palsoft ROM)	695.65	800.
16K Upgrade kits	65.22	75.
Disk Drive, single with cable	347.83	400.
Printer Interface	108.70	125.

**COMMODORE PET**

2001-32N (New keyboard & 32K)	782.61	900.
2040 Dual Disk Drive 343K	782.61	900.
3022 Printer with graphics	608.70	700.
Printer cables, each	26.09	30.
Computhink Drive 400/800K		POA

**MEDIA LIST**

5¼" Verbatim	from (Qty 5)	10.43	12.
5¼" Verbatim	from (Qty 10)	17.39	20.
5¼" Dysan	from (Qty 10)	26.09	30.
8½" 3M	from (Qty 10)	30.44	35.
Blank 5¼" & 8½" Diskettes, Soft/Hard Sected, Formatted/Unformatted. We have diskettes to suit many systems. When ordering please quote: SYSTEM MANUFACTURER, MODEL, MEDIA TYPE, AND DISK SIZE. Available in smaller or larger quantities.			

**STATIONERY** Listing Paper, Continuous Forms, Labels.

Listing paper 11" x 8½", 11" x 9½", 11" x 12", boxed 2,000 incl. VAT ..... £10  
Labels 2¼" x 1¾", white, fanfold, £5 per 1000 ..... 12,000 incl. VAT ..... £40

Post/Packing/Insurance extra. Delivery by Registered Post, Securicor, etc. Price List correct at time of going to Press, subject to change without notice. E & O.E. Standard Warranties apply. All stocks subject to availability.

**Your enquiries assist us in forward purchasing.**

Please send Full Details & Price Lists		My requirements are for		Requirements	Description	inc. VAT
HOME <input type="checkbox"/>	HOBBIES <input type="checkbox"/>	STUDENT <input type="checkbox"/>	BUSINESS <input type="checkbox"/>	Microcomputer	.....	
Name	.....			Upgrade Kit	.....	
Street	.....			Interface	.....	
Town	.....			Disk Drive	.....	
County	.....			Printer	.....	
Post Code	.....			Cable/Interface	.....	
Telephone	.....			Cluster System	.....	
Name of Co	.....			Colour TV	.....	
Position	.....			Media	.....	
PO/Chq No	.....			Stationery	.....	
Mail order: Cheque/Bankers' Draft/Cash/Barclaycard/Access etc. — allow 28 days for delivery.				Stationery	.....	
				Software	.....	
				Post/Pkg/Ins	(please tel. for cost.....)	
						TOTAL: _____

# PETALECT

ELECTRONIC  
SERVICING LTD.



Petact authorised distributors for central Southern England for the full range of Computhink disc systems (dealer enquiries welcome)

Computhink Old ROM 400K	£795.00
" New ROM 400K	£895.00
" New ROM 800K	£1145.00
All + VAT	

Large Keyboard PETS in stock 32K PET £795 + VAT 16K PET Ask for delivery on 16 2040 Disc System and C.B.M Printers. Large Extension Keyboard for the PET £89.50 + VAT.

Stockists for Petact Business Systems (Sales accounting, purchase invoicing, payroll, Stock Control, Nominal Ledger and management information.

A wide range of Printers available i.e. Teletype 43, Anadex C.B.M, Printerm

**COMPUTER BOOKS** — for professionals, hobbyists, businessmen and newcomers.

**ACCESS, BARCLAYCARD**

If you require any more information or demonstration regarding the PET 2001/8 or any associated equipment, programs, etc., please contact:

Mr. P.J.A. Watts or Mr. D.W. Randall at:

**PETALECT ELECTRONIC SERVICES LTD**

33/35 Portugal Road  
Woking  
Surrey

Tel: Woking 69032/68497

Shop at:  
**PETALECT**

Chertsey Road  
Woking  
Surrey

Tel: Woking 21776/23637



## Micro-Computer Centre for the MIDLANDS

Nascom and Commodore Specialists

A full range of micro computers and peripherals are available, whether buying or browsing we can give helpful and friendly advice.

**Commodore Business Systems** are suitable for the professional office, the small business or the sole trader. We will be pleased to give advice and a demonstration.

**Nascom 2 systems** can be fully built and tested to order. We are sole distributors for the **Micro Type case** for Nascom 1 and 2, also stockists of the **William Stuart colour graphics** and full range of 'add-ons'.



**Business & Leisure Micro Computers**

16 The Square, Kenilworth, Warwickshire CV8 1EB.

Tel: (0926) 512127

## LITTLE GENIUS

If you find self-instruction manuals difficult to follow, then meet our Little Genius.

Little Genius floppy diskettes are the fastest, easiest way to master your micro.

Little Genius will save you time and effort, teaching you to exploit all your micro's facilities.

Courses now available:

1. Applesoft basic
2. Advanced Applesoft
3. Using your Apple

4. Pet basic
5. Advanced Petbasic

6. Palsoft basic
7. Advanced Palsoft
8. Using your 2020



For further information ask your local dealer or contact:

Peter Brown at Suite 504, Albany House,  
324 Regent Street, London W1R 5AA.  
Telephone 01-580 6361.

# OFF THE SHELF AVAILABILITY FROM COMPUTER CENTRE

## KIT PACKAGES

### KIT

Best priced CP/MZ80 Micro in UK. Add power and terminal. Minifloppy 16KB Z80, CTC, serial + parallel I/O, S100 board, connectors, manuals, CP/M. Free basic and Algol. Full two drive case illustrated. Power supply. £149.00

**£800**

### DI KIT

CP/M disc operating system, 16K bytes, Z80, serial and parallel I/O, motherboard, connectors and cables.

**£911**

Full power supply kit. £77.00

## THE MEGABOX

### MEGABOX - S

8" single sided drives plus Power Supply in an attractive box to two megabytes. Attractive 3 U case with cooling fans switch.

**£913**

### MEGABOX - D

8" double sided drives plus Power Supply in an attractive box.

**£1090.00p**

## 8 INCH DRIVE

### HUGART COMPATIBLE

Single/dual density. Disc drive assembled and guaranteed.

**£350**

Double sided. Price £450

## MINI FLOPPY

Single/dual density hard or soft sector, used on TRS80, North Star etc. Assembled and guaranteed.

**£175**

## TRS 80 EXPANSION

### SC DRIVE

8" disc drive + power supply in attractive case.

**£199**

## PRICE LIST

### OEM PACKAGED SYSTEMS

OEM	ASSEMBLY
OEM1. Z80, 32KB, 1SER, 1PAR. 2 x 1/4 MEG Disks	1970.00
OEM2. Z80, 48KB, 1SER, 1PAR. 2 x 1/2 MEG Disks	2270.00
OEM3. 4MHz, 64KB, 2SER, 1PAR. 2 x 1 MEG Disks	3570.00

### DISC DRIVES

SA400 mini floppy disc drive	175.00
DRI 7100 8 inch drive (single sided)	350.00
DRI 7200 8 inch drive (double sided)	450.00

### VDU'S

Pentland (full spec)	590.00
----------------------	--------

### PRINTERS

DRI 6320 (140 cps Max) 132 chts, Tractor Feed	1500.00
ANADEX 8000	499.00

### SOFTWARE

CP/M operating system + 6 manuals + basic E	70.00
Library index (33 volumes available)	2.80
Library copies on 8 inch media	4.40
Library copies on 8 inch media (10 or more)	3.40
Microsoft BASIC	193.00
Microsoft FORTRAN	267.00
Micro focus compact COBOL	376.00
Micro focus forms	75.00
UCSD PASCAL	193.00
Microsoft BASIC compiler	211.00
WORDSTAR	193.00

### MPU

	KIT	ASSEMBLY
CB2 Z80A 1EEE S100	112.00	136.00
IDS Z80A CPU BOARD		115.00
SBC 100 Z80 + serial + parallel	155.00	197.00
SBC 200	182.00	242.00

### DISC CONTROLLERS

Tarbell single density	132.00	188.00
Tarbell double density	188.00	244.00
Versafloppy 1 single density	135.00	190.00
Versafloppy 2 double density	184.00	241.00
Nat Mux double density		215.00
Tarbell Cassette Interface		104.00

### MEMORY

8K bytes Econoram 2 (4MHz) static ram	84.00	100.00
16K bytes Econoram 4 (4MHz) static ram	145.00	178.00
24K bytes static	214.00	259.00
32K bytes static ram	302.00	349.00
Expandoram 2 (Dynamic) 64K population	663.00	713.00
Expandoram 1 (Dynamic) 64K population	366.00	416.00

### I/O

2SIO (2 serial full hand shaking uarts)	105.00	136.00
IO4 2 serial/parallel	86.00	129.00

### SPECIAL BOARDS

VDB-8024 (80 chts x 24 lines) video	194.00	263.00
PB1 2716/2708 eprom programmer	78.00	122.00
Memtech 3MHz floating point board		280.00
Prototype board		16.60
2708 prom board (ex proms)	52.00	63.00
VB1 16/32x64 video	78.00	107.00
MT3 11 slot motherboard		21.00
S100 extender + logic probe		31.20

Dealer, Educational and Quantity Discount Available.

## OEM RANGE



FROM UNDER  
**£2000**

- Up to 2 Megabytes of floppy disc storage
- High speed Z80 micro
- Up to 64K bytes fast ram storage
- High level operating system (supports Cobol, Fortran, APL, Basic, Pascal, Wordstar)
- 2 drive minimum system under £2000

Available off the shelf in an attractive case, the Computer Centre OEM 2 provides a powerful main frame computer.

System builders are free to add peripherals to suit the final applications. The operating system provided with the OEM's is a powerful upward compatible extension to CP/M and will support up to 128 mega byte disc storage.

A 10 mega byte fixed disc is already planned and should be available as an extra during 1980.

Another remarkable extension to the OEM range is the availability of the multi terminal operating system. But with hardware costs as low as the OEM, the market for sharing the system is likely to be small!!!

**OEM's are invited to write or call for details**

## NEW PRODUCTS

Now available from stock, new plug in card/cards to enable Tandy owners to run CP/M and/or two 8" disc drives.

**Full range of power supplies, Firmware, Connectors and IC's**

All advertised items generally in stock. Cash with order ensures same day despatch. Add 2% postage and 15% VAT to advertised prices. I enclose cheque for £

Send:  Catalogue (please tick)

Name .....

Address .....

Send .....

# COMPUTER CENTRE

THE DISCOUNT COMPUTER STORE

9 De la Beche Street, Swansea, SA1 3EX. Tel: 0792 460023 Telex: 48638

# aculab Ltd

## > ACULAB 735, a fully self-contained interface for IBM 735 output golfball typewriters

The ACULAB 735P INTERFACE is a self-contained controller for IBM I/O typewriters and printers. The 735P accepts standard 7-bit parallel ASCII data and provides all of the handshake protocol, code conversion and solenoid voltages to run the printer at full speed using any correspondence or ASCII golfball to produce letter quality printing at 15 chars/sec ... £155.00 + VAT

The TRS-1 PARALLEL PORT DECODER plugs into the bus connector on the TRS-80 keyboard and decodes the port used by the ELECTRIC PENCIL and the LPRINT and LLIST commands in TRS-80 BASIC. ... £55.00 + VAT

The IEEE TO PARALLEL PORT CONVERTER plugs onto the PET IEEE bus connector and converts it into a parallel printer port. It also converts PET's unique version of ASCII to standard ASCII and provides a switch to give UC/LC compatibility with the new PET ... £45.00 + VAT

The ADDRESSABLE IEEE PARALLEL PORT DECODER has all of the features of the converter but may be set to answer to any of the available addresses on the PET IEEE bus and so be used along with the PET disc or any other bus compatible devices ... £66.00 + VAT

These last three devices are all fitted with 2 metres of heavyweight cable and a metal shrouded Centronics compatible connector.

**aculab** Ltd.

24 Heath Road,  
Leighton Buzzard, Beds.  
LU7 8AB

For further information  
Telephone. 0525-371393.

# DISCOUNT PETS

NEW 8K PET £445 with large keyboard, 16K £540, 32K £640, Dual Floppy £670, Programmer's Toolkit £45, Printer £400.  
BASE 2 PRINTER £350 compatible with PET 3 Interfaces: IEEE, RS232, Centronics parallel, 3 Character fonts—one down-loadable, programmable horizontal & vertical densities, stepping motor, tractor feed, contiguous plotting.

TEXAS TI 99/4 £800 with 13" colour monitor. The most advanced home computer.

AIM 65K SYSTEM £400, cased, powered and with optional assembler and BASIC. Also memories & motherboards for AIM 65/KIM by Seawell. Disk system (2 x 5" drives) with DOS £800.  
S-100 SYSTEM £1000 based on North Star with single disk drive, Z-80, 2 ports, 32K memory, completely assembled and tested. Runs all North Star software. Dual Disk version £1200.

NORTH STAR HORIZON II £1400

SOROC IQ 120 VDU £550

S-100 BOARDS assembled and tested only. 16K fully static 2MHz memory with bank select, optional wait states, write protect etc. £150. 4MHz £200. Jade 4MHz A-80 CPU £140.

SD PROM-100 EPROM programmer £140. 2 serial & 1 parallel I/O card £120.

SOFTWARE

COMPLETE ACCOUNTS PACKAGE FOR NORTH STAR £520 e.g. BOUGHT & SALES LEDGERS, VAT, AUDIT TRAIL, PAYROLL for NORTH STAR on two disks £56. (also for PET, Listing only £50.

SUPER BLAKE 7 game for PET on disk £23, for Challenger 8" disk £15, PET cassette £20, listing only £10, self-learning noughts and crosses (NS, PET, OSI) £13 disks, £11 cassette.

Send for list or call:

# INTELLIGENT ARTEFACTS LTD

CAMBRIDGE ROAD, ORWELL  
ROYSTON, HERTS.  
Telephone: Arrington 689

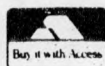

## The complete range of computer systems under one roof

### Commodore System



# HB COMPUTERS LTD

22 NEWLAND STREET, KETTERING NORTHANTS.

Tel. (0536) 83922 & 520910 Telex 341297

New

Produced and widely used in England and U.S.A.

# COMPLETE BUSINESS PACKAGE

INCLUDES EVERYTHING FROM INVENTORY TO SALES SUMMARY  
PROMPTS USER AND VALIDATES ENTRIES. MENU DRIVEN  
BUS VER 3.00 TO VER 9.00 PET AND CP/M

APPROXIMATELY 60-100 ENTRIES/INPUTS REQUIRE 2-4 HOURS WEEKLY AND ENTIRE BUSINESS IS UNDER CONTROL

- \* PROGRAMS ARE INTEGRATED.....
- 01==ENTER NAMES & ADDRESSES.....
- 02==ENTER/PRINT INVOICES.....
- 03==ENTER PURCHASES.....
- 04==ENTER A'C RECEIVABLES.....
- 05==ENTER A'C PAYABLES.....
- 06==ENTER/UPDATE INVENTORY.....
- 07=ENTER/UPDATE ORDERS.....
- 08==ENTER/UPDATE BANKS.....
- 09==EXAMINE/REPORT SALES LEDGER...
- 10==EXAMINE/REPORT PURCHASE LEDGER
- 11==MONITOR INCOMPLETE RECORDS....
- 12==EXAMINE PRODUCT SALES.....

- SELECT FUNCTION BY NUMBER.....
- 13==PRINT CUSTOMERS STATEMENTS
- 14==PRINT SUPPLIER STATEMENTS.
- 15==PRINT AGENT STATEMENTS....
- 16==PRINT TAX STATEMENTS.....
- 17=GENERAL HELP.....
- 18=ALTER VOCABULARIES.....
- 19=PRINT YEAR AUDIT.....
- 20=PRINT PROFIT/LOSS A'C.....
- 21=ENDMONTH MAINTAINANCE.....
- 22=PRINT CASHFLOW FORECAST....
- 23=ENTER PAYROLL NO RELEASE...
- 24=EXIT SYSTEM.....

.....ENTER WHICH ONE ?

DATABASE MANAGEMENT INCLUDES  
\*\*\* FILE CREATE/DELETE/SEARCH. \*\*\* RECORD CREATE/DELETE/SEARCH/4 OPTION PRINT. \*\*\* RECORD SORT ANY FIELD ALPHA OR NUMERIC. \*\*\* INDEX SEARCH OR GENERAL SCAN/PRINT IN ANY FIELD (EG TOWN OR NAME). \*\*\* 4 ARITHMETIC FUNCTIONS TO USE AS CALCULATOR ON LAST 4 FIELDS.\*\*\* AUTO CHECK TO PREVENT DOUBLE ENTRY TO FILE MANAGEMENT SYSTEM, DYNAMICALLY ALLOCATING INFORMATION TO MINIMISE DISK SPACE CONSUMPTION

VERY FLEXIBLE.EASY TO USE

G.W.COMPUTERS U.K. ARE THE PRODUCERS OF THIS BEAUTIFUL PACKAGE

VER 3.00 (EXC PROG 19,20,22,23)=475.00, VER 4.00 INCLUDES AUTO STOCK-UPDATE=575.00, VER 5.00 INCLUDES AUTO BANK UPDATE=675.00, VER 6.00 IN CORE=775.00, VER 7.00 (INC 19,20,22,23)NOT YET RELEASED=875.00, VER 8.00 RANDOM ACCESS=900.00, VER 9.00 TRANSLATEABLE=975.00. +++EACH LEVEL OVERRIDES LOWER ONE

WE EXPORT TO ALL COUNTRIES CALLERS ONLY BY APPOINTMENT CONTACT TONY WINTER UN 01.636.8210  
89 BEDFORD COURT MANSIONS, BEDFORD AVENUE, LONDON W.C.1.

NOTE!!! ALL VERSIONS, ESPECIALLY 9.00 USE BROAD FINANCIAL PRINCIPLES AND 9.00 IS ONE 16K CORE PROGRAM RELEASING BOTH DISK DRIVES FOR DATA STORAGE, AS WELL AS BEING TRANSLATEABLE INTO ANY FOREIGN LANGUAGE

**IMPORTANT**

We also sell the Hardware to do the above tasks so you can do the complete purchase at one source.

OFFER A GENERAL FILE DATABASE MANAGEMENT SYSTEM (VALUE 100 POUNDS) PLUS 1 YEARS SOFTWARE SUPPORT (VALUE 50 POUNDS) FREE WITH A TOTAL SYSTEM PURCHASE

PET + PET + PET + PET + PET + PET	
=====	
CBM 32K 3032	795.00
CBM 3040 FLOPPY DISKS	795.00
CBM 3022 PRINTER	525.00
CBM CABLES FOR ABOVE	45.00
CARTON PAPER AND 10 DISKS	57.00

SUPERBRAIN + SUPERBRAIN	
=====	
TWIN Z80CPU TWIN D'D/DRIVES	
64K RAM AND CRT VIDED	1950.00
OPTIONAL S100 BUS ADAPTER	250.00
ADD-ON 11 MEGABYTE DISK	P.O.A.

PRINTERS + PRINTERS + PRINTERS	
=====	
PAPER TIGER 195CPS	575.00
TELETYPE 43KSR 30CPS	875.00
DEC-LA34 TRACTOR 30CPS	875.00
NEC-SPINWRITER	1650.00
QUME SPINWRITER SPRINTS	1950.00

SPECIALS + SPECIALS + SPECIALS	
=====	
INS 48K TWIN D'D/DRIVES	1750.00
N'STAR QUAD DRIVES .7 MEG	2150.00
INTERTUBE III TERMINALS	495.00
COMPUTHINK 800K DRIVES	895.00
CORDLESS TELEPHONES IN/OUT	195.00
TELEPHONE ANSWER MACHINE	230.00
CORDLESS PHONE IN/ONLY	80.00

SOFTWARE + SOFTWARE + SOFTWARE	
=====	
CBM CONMACCOUNTS	650.00
CBM COMPAY	150.00
CBM COMBIS/CONSTOCK	150.00
CBM WORDPRO II	75.00
CBM WORDPRO III	150.00
BUS VER 3.00	475.00
BUS VER 4.00 STK OR BNK	575.00
BUS VER 9.00 R'ACCESS	975.00
CPH W'STAR TX/PROCESSOR	250.00
CPH WORD-MASTER TX'ED	75.00
CPH MBASIC 80	150.00
CPH COBOL 80	320.00
CPH PASCAL Z	150.00
CPH FORTRAN 80	200.00
CPH ED'ASM'ETC S'BRAIN	FREE..
CPH PASCAL-M	250.00
CPH BYSTAM	75.00
CPH SUPERSORT	120.00
CPH BASIC COMPILER	190.00
CPH DESPOOL	30.00
CPH BYSTAM INS'N-STAR	75.00
CPH TEXTWRITER	75.00
CPH POSTHATER	75.00
CPH SELECTOR 3	180.00
CPH CBASIC INS	75.00
CPH MACRO 80	75.00

WARRANTY + WARRANTY + WARRANTY  
=====

90 DAY FREE REPLACEMENT

+++++ SPECIAL INSTITUTION AND UNIVERSITY DISCOUNTS +++++  
STOCK AND COMING ROUND. (BARCLAYCARD WELCOME OTHERWISE CHEQUE WITH ORDER)  
CONTACT TONY WINTER 01.636.8210  
89 BEDFORD CT MANS, BEDFORD AVE W.C.1.

**STOP PRESS**  
Tony Winter (B.A.Lit; B.A. Phil) will give a day's seminar on the business package, at the Polytechnic of Central London (short course unit).  
35 Marylebone Road, London NW1  
Contact M Jordan for information: 01-486 5811

# Q-COM SALE

## ELECTRONICS

PET PERIPHERAL SPECIALISTS

### PLESSEY MEMORIES 32K WORDS

PETITE (add on) £270  
INPET (mounted inside) £240

### I EEE-488 SERIAL OUTPUT INTERFACE

BOXED WITH POWER SUPPLY £ 65

### TERMINALS:-

DECWRITER LA34 £795  
TELETYPE 43 £785  
TVI-912 VDU £595

TERMS:- ALL EQUIPMENT EX-STOCK  
CASH WITH ORDER PLEASE -  
VAT EXTRA. 3 MONTHS' WARRANTY.  
TERMINAL DELIVERY £15 EXTRA.  
FULL BACK UP SERVICE AVAILABLE

TELEPHONE 021-643-3540

Q-COM ELECTRONICS LTD.,  
5TH FLOOR, ST. MARTINS HOUSE  
10 BULL RING, BIRMINGHAM B5 5DT

**INTERACTIVE**  
Data Systems

**Interactive Data System**

14 Buckman Close · Greenleys · Milton Keynes · MK1  
Telephone (0608)

DATA PROCESSING SYSTEMS — INDUSTRIAL CONTROL SYS  
Sales — Design — Menu

### THE BRITISH S100.

At last you can buy a range of S100 boards manufactured to the highest standards in the U.K., compatible with the new I.E.E.E. S100 specification and competitive in price with anything the Americans can throw at us.

**Z80 CPU.** A basic 4MHz CPU board with all the logic and buffers required to drive the S100 bus.

Kit £84 A & T £105

**SBMC** A 4MHz Z80 single board microcomputer featuring 2 RS232 ports (or 20mA) with full handshaking, 1K of scratchpad memory, up to 16K of EPROM and a 4 channel counter/timer/vector interrupt.

Kit £178 A & T £235

**16K SRAM** This is a 16K static memory board utilising the industry standard 2114 memory chip.

Kit £174 A & T £198

**FDC** Any combination of 8" and 5", single or double sided floppy disk drives can be handled in single or double density with this board.

Kit £216 A & T £255

**TERM 40** Active termination board for reduction of crosstalk and ringing in the bus.

Kit £25 A & T £32-50

Information now available on the following:-

**PCI** Process Control Interface, 8 channels relay isolated output, 8 channels opto-isolated input, 8 bit TTL I/O, 4 x 8 bit D/A, 4 x 8, bit A/D.

**IOC** 2 channel serial I/O, 2 channel parallel I/O.

**12 bit** 16 channels 12 bit D/A, 16 channel 12 bit

**Analogue** A/D.

Details from the Distributors:-  
**MENDIP COMPUTERS**  
57 Bath Road, Wells, Somerset, BA5 3HS.  
Telephone: (0749) 75249

**INTERTRONIX**  
83 West Street, Farnham, Surrey GU9 7EN.  
Telephone: (0252) 722011

## BRITISH S100 BOARDS

(Manufactured in the United Kingdom by  
INTERACTIVE DATA SYSTEMS)

<b>Z80 CPU</b>	Basic 4MHZ CPU board	Kit: £ 84 A&T £105
<b>SBC 40</b>	4MHZ, Z80 board, 1K RAM, up to 16K EPROM, 2 SERIAL PORTS, 4 channel Counter/Timer & 4 Vector Interrupts	Kit £178 A&T £235
<b>16K SRAM</b>	4MHZ Static RAM	Kit £174 A&T £198
<b>FDC</b>	Double/Single density, Double/Single sided Floppy Disc Controller, up to 4 drives	Kit £216 A&T £255

### £15 OFF ABOVE PRICES for

Cash orders received before 10th June 1980		
<b>CHIPS</b>	2114, 200 ns, low power	£ 4.75
	2716, Single supply	£19.95
	Z80A, 4MHZ CPU	£11.20
	2708	£ 6.65
	4116	£ 5.95

**OTHERS** I/O, TERM, A/D, KEYBOARDS, DRIVES, MAINFRAMES, PERIPHERALS, MOTHER BOARDS, SOFTWARE etc.

Please ask for full details of our range.

### COMING SHORTLY

By the time this advert appears, we expect to have full details of a new VDU board AND,

**PCI 10** Process Control Interface, 8 independent relay outputs, 8 opto-isolated inputs, 8 bit TTL input channel, 8 bit TTL output channel, multichannel analogue I/O.

**MENDIP COMPUTERS**  
57 BATH ROAD  
WELLS, SOMERSET  
BA5 3HS

p&p, 50p under £15.00  
Add 15% VAT to all prices  
Mail Order only  
Telephone 0749 75249

## COMPUTERS FOR HOME BUSINESS EDUCATION

WIDE RANGE OF  
ELECTRONIC GAMES

**Exidy Sorcerer**  
16K - £860 32K - £918 48K - £976  
S100 Expansion Box 6-slot - £276.00  
Micropolis Dual Disc Drive - £1,380.00  
NEC Spinwriter (receive only) - £2185

**Z-89 ALL-IN-ONE COMPUTER**  
The new all-in-one computer from Zenith is the most versatile micro-computer available today.  
• 'Intelligent' video terminal • two Z80 microprocessors • floppy disc storage system • expandable to 48K RAM  
Easy to programme. Simple to operate. It is capable of a multitude of high-speed functions and speaks the language of today's most popular software. Price from £1805



### The most advanced microcomputer yet.

**WH 14 SERIAL PRINTER**  
With a compact table top configuration, the WH 14 is designed for a broad variety of uses in any computing environment.  
Price £596.50

**video 100**

12" BLACK & WHITE LOW COST VIDEO MONITOR

£90.00

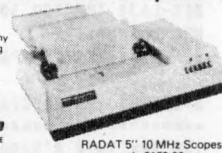

**RADAT 5" 10 MHz Scopes**

only £169.00

SELECTION OF SOFTWARE GAMES & BUSINESS

5 1/4" FLOPPY DISK for TRS 80 Type

**FD50A**

Single Drive 1287 50

Dual Drive £506.00

Integral Power Supply



**TRS80 LEVEL 2 16K**

ONLY £440 KBD ONLY EXPANSION BOX 32K £340.00

Large range of computers etc. books. Send for List

SAE with all enquiries - All prices inclusive.

SUPPLIERS TO BUSINESS, EDUCATION & HEALTH AUTHORITIES



**N.I.C.**

61 Broad Lane, Tottenham, London N15.  
01-808 0377



# SOUTHEAST ENGLAND'S ELECTRONICS CENTRE

## OLIVETTI TE318

ONLY  
**£130**  
+ CARR  
+ VAT

The cheapest way to I/O to your computer, 80 column high quality printer, friction feed, serial SCII in and out, RS232, feather light keyboard, and inbuilt 8 bit paper tape punch and reader. Applied in good condition with interface data and accessories but untested, unguaranteed. What more could you ask for.

\* Paper tape 75p per roll + pp 40p.  
**HURRY WHILE STOCKS LAST.**

**RACAL C10 "Supergrade" cassettes.**  
66p each, 10 for £5.45

## VENTEK WORD PROCESSOR VDU TERMINALS

Still a few available. The VDU with the GREEN screen. Made by the VENTEK Co. with the following spec: 12" monitor, 24 lines x 80 characters, upper and lower case with descenders, 85 + keyboard, auto repeat, ASCII, RS232 interface, adjustable baud rates, full cursor control, edit function, character(s) flash etc., etc. Latest technology used, mostly 74LS with dynamic RAMs.

Supplied in 2 grades  
Grade 1 Complete tested and working £275.00 + VAT  
Grade 2 Condition as seen or described £225.00 + VAT  
Carriage Extra  
Although Grade 1 sold tested and working no guarantee offered. Anyone with circuits/manuals please contact us.

**HY GRADE SMOOTHING CAPS**  
MULLARD - PLESSEY - MALLORY - SPRAGUE  
1500mf 100v 60p\* 3300mf 40v 50p  
3300mf 63v 70p\* 1mf 600v MYLAR 28p  
10,000mf 15v £1+ 22,000mf 16v £1.10+  
100mf 250v 45p 2100mf 200v £2.50+  
\*Ex equipment tested +P.P. 40p

## SEMICONDUCTOR 'GRAB BAGS'

Amazing value mixed semiconductors, include transistors, digital, linear I.C.'s, triacs, diodes, bridge recs. etc. All devices guaranteed brand new, full spec. with manufacturers markings, fully guaranteed.  
50 + BAG £2.95 100 + BAGS £5.15

## MUFFIN FANS

Keep your equipment Cool and Reliable with our tested ex-equipment "Muffin Fans" almost silent running and easily mounted. Available in two voltages. 110 V.A.C. £5.05 + pp 65p DR 240v A.C. £6.15 + pp 65p DIMENSIONS 4 1/2" x 4 1/2" x 1 1/2"

**ELECTRONIC COMPONENTS & EQUIPMENT**  
**66% DISCOUNT**

Due to our massive bulk purchasing programme which enables us to bring you the best possible bargains, we have thousands of I.C.'s Transistors, Relays, Cap's, P.C.B.'s, Sub-assemblies, Switches, etc. etc. surplus to our requirements. Because we don't have sufficient stocks of any one item to include in our ads., we are packing all these items into the "BARGAIN PARCEL OF A LIFETIME". Thousands of components at giveaway prices! Guaranteed to be worth at least 3 times what you pay plus we always include something from our ads. for unbeatable value!! Sold by weight

7lb £ 5.25 + pp £1.25 14lb £ 7.95 + pp £1.80  
28lb £13.75 + pp £2.25 56lb £22.00 + pp £4.75

## ISOLATED 240v 4 AMP & 10 AMP SOLID STATE RELAYS

Interface your MPU etc, with the outside world made by the famous "Astralux" Co. They consist of a miniature plastic module with mounting holes containing a reed relay for isolation, choke and triac. 12-20 volts D.C. at a few milliamps enable on/off control of A.C. loads up to 10 amp! The 10 amp version should be mounted on a heatsink. 100's of uses including power control, lighting, etc. etc.  
Dimensions: 4 amp, 1 1/2" x 1" x 2 1/2". 10 amp, 1 1/2" x 1 1/2" x 1".  
4 amp £1.45 10 amp £2.10 complete with circuit

## IBM SELECTRIC I/O GOLFBALL TYPEWRITERS

Ideal for word processor applications, will accept a host of different typefaces for all correspondence uses. Supplied in good working order. After seeing the printer only version advertised at over £900.00 we must be mad asking only £295.00 + carr. & VAT. Why pay a fortune? Even if your computer fails you still have a first class typewriter at your disposal!

ACULAB interface unit for PET, TRS80, SORCERER £165.00 + VAT.

## OPTO SMASH!

TIL 302/MAN 7 7 segment LED readout common anode direct drive (via resistors) from 7447 £1.10 each  
TIL 119/OC72 Darlington opto isolator 3 for £1.00  
TIL305 0.3" x 5 matrix LED alphanumeric readouts £3.75 each.  
PHOTO TRANSISTOR Fairchild FPT-100 NPN silicon 30v 25ma. 4 for £1.00

## DISPLAY I.C. AND TRANSISTOR BARGAINS NEVER CHEAPER

All I.C.'s and Transistors by well known manufacturers and fully guaranteed. No fall outs. Comprehensive data on I.C.'s 15p per type.  
2N4351 N channel MOS FET.  
2N4352 P channel MOS FET.

60p each £1.00 per pair.  
HIGH VOLTAGE NPN POWER SWITCHING transistors BVcbo 600v BVceo 500v BVBebo 15v 1c 5 amps Pc 125 watts HFE 60 typ ft 2.5 mhz ideal invertors, etc. TO3 £1.60 each 4 for £5.40.  
BF258 NPN 250v @ 200ma 45p each 3 for £1.08.

I.R. BSB01 2.5 amp 100v bridge rec. P.C. mount long leads 35p each 4 for £1.08.

IN4998 4 amp 100v P.C. mount diodes long leads 14p each 10 for £1.10.  
LM309K + 5v 1.2 amp regulator £1.10 each 6 for £5.35.

2N1671B unijunction 450mw 30v 48p each 3 for £1.00.  
IN4004 SD4 1 amp 400v diodes 7p each 18 for £1.00.  
I.R. 12 amp BRIDGE RECS. 400 volt £1.25 each.

POWER DARLINGTON SCOOP!  
MJ1000 NPN 60v 90w 8 amps TO3 95p each  
2N6385 NPN 80v 100w 10 amps TO3 £1.25 each  
MJ4030 NPN 60v 150w 16 amps TO3 £2.25 each

DECADE 0-9 THUMBWHEEL SWITCHES. Stackable, gold plated contacts, dim. 33 x 43 x 8 mm. 90p each, 10 for £5.50.

Miniature Continental Series 12VDC 4c/o plug in relays £1.30 each.

Greenpar 50Ω BNC Chass. socket single hole fixing 65p  
C90 Audio Cassettes screw type construction 45p each 3 for £1.00.

Bulbs 24v 14 watt white frosted S.B.C. 8 for £1.00.  
Bulbs 12v 100 watt clear, base similar S.B.C. 45p each.  
S.B.C. Bulb Holders All steel cad. plated panel mount easily fixed via nut and round hole, ideal disco displays, scoreboards, etc. 4 for £1.10.

VMOS VMPI Siliconix TO3 power FET 0-60v, DC-200 mhz will drive direct from CMOS etc, £1.50 each, full date 30p.

Heavy Duty Flat Insulated Earth 100-200 amp braided tinned copper in heavy clear PVC sheath 50p per metre. £6 for 15 metres + PP £1 per 15 metres.

BULGIN miniature 6 way male chassis mount socket and matching free plug 60p each, 2 for £1.10.

Red L.E.D.'s full spec. 0.2" 14p each, 10 for £1.25.  
Red L.E.D.'s 0.125" 10p each 10 for 80p)

Dynamic Stick Mics 600Ω with built in on/off switch complete with lead and min. jack plug £1.15 each, 10 for £11.00.

TO5 HEATSINKS "Thermaloy" black anodised press on aluminium finned type 18p each, 8 for £1.00.

## BURROUGHS SELF SCAN DISPLAYS

A masterpiece of electronic engineering. This unit could be described as a miniature VDU. Module consists of an 18 digit display area, mounting bezel, on board character generator and decoder driver circuitry, all measuring only 8.5" x 2.25" x 1.34". By inputting a 6 bit ASCII T.T.L. code 18 GIANT 0.4" full alpha numeric characters may be displayed simultaneously, addition of external logic enables the unit to scroll along just like a newscaster. Internal 64 character repertoire, or external inputs for special characters are provided. Power requirements +5v, -12, and 250v.

Supplied brand new, complete with data **£55.00** + £1.25pp.

## BARGAINS GALORE!

In our walk round Warehouse  
NOW open Monday to Saturday 9.30-5.30



Dept. P.C.W. 64-66 Melfort Rd., Thornton Heath, Surrey. MAIL ORDER INFORMATION  
Telephone: 01-689 7702

Unless otherwise stated all prices inclusive of VAT. Cash with order. Minimum order value £2.00. Prices and Postage quoted for UK only. Where post and packing not indicated please add 40p per order. Bona Fide account orders minimum £10.00. Export and trade enquiries welcome. Orders despatched same day where possible. Access and Barclaycard Visa welcome.

In stock now test equipment, microprocessors, teletypes, transformers, power supplies, scopes, sig. gen's, motors, peripheral equipment, I.C.'s, tools, components, variacs, keyboards, transistors, microswitches, V.D.U.'s sub-assemblies + thousands of other stock lines. Just a mere fraction of our vast range, is displayed below: 100's of bargains for callers.

## SUPER 77 KEY KEYBOARD KIT

We've done it again! We've purchased a large quantity of CP CLARE top quality keyboard reed switches plus full QWERTY keytop sets and thrown in a PCB to enable you to customise the keys just as YOU want them, just add and wire an encoder chip and you can arrange ASCII, BAUDOT, anything! Adding up to a quality keyboard which would normally cost around £100.00. Supplied with layout and assembly info at only £26.99 + £1.50pp.

## HOW TO GET HERE

Victoria, London Bridge or Holborn Viaduct to Thornton Heath. 1 minute from Thornton Heath Station.

## POWER SUPPLY UNITS

5 VOLT 2.5/8 AMP TTL Made for TTL this compact ex computer systems unit features a 10 amp transformer. DC outputs of 5 volts @ 2.5 amps and 7.5 volts @ 5 amps are available. The 5v output is fully regulated and smoothed with electronic current limiting. May be easily moded for 5 volts @ 7.8 amps. Sold complete with circuit, believed working but untested. £8.25 + £1.60pp.

5 VOLT 5 AMP An extremely compact unit measuring only 125 x 175 x 83 mm, almost fully enclosed with terminal type connections. Features such as adjustable volts and current limit make it ideal for an MPU system. Sold as new. £14.99 + £1.60pp.

"+" & "-" 12-15v @ 250 ma. ITT Powercard. Measuring only 140 x 80 x 40 mm, this precision totally enclosed PSU should meet all your memory and negative rail requirements. Individual pots allow independent adjustment of both the plus and minus supply rails. Supplied BRAND NEW with circuit and edge connector at only £12.75 + £1.00pp.

## KEYBOARDS

★ 76 KEY ASCII CASED ★

At last a coded 75 key cased ASCII keyboard at the right price. Housed in an attractive light grey case, this unit was originally made for ICL for use in airport reservation systems so only the BEST parts were used. It has everything, we think, to meet your most exacting requirements, numeric keypad, upper and lower case, cursor controls, single 5 volt rail, serial and parallel data outputs, plus eight LEDs mounted on the case. Supplied with circuits, believed brand new, but may have minor scratches on cases.

Only **£43.50** + £1.60pp

## ★ LOW PRICE CHASSIS ★

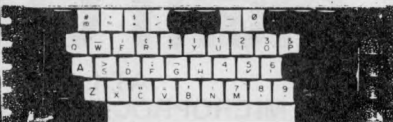

A special bulk purchase enables us to offer the above keyboard at a lowest ever price. 49 coded keys encoded into a direct TTL compatible 7 bit output. Features such as delayed strobe, 5 volt D.C. single rail operation and rollover protection make this an absolute must for the MPU constructor! Supplied complete with connection diagram and edge connector, at a secondhand

"no time to test" **£20.00** + P.P. £1.60

price of CASED  
SUPER CASED VERSION Same as above spec. but housed in attractive two tone moulded, free standing case. Unit also includes an all TTL parallel to serial converter (no details) etc.

**£27.50** + P.P. £1.85

## TOROIDAL TRANSFORMERS

HP 240v pri. sec. 2 x 30v @ 4 amps 2 x 18v @ 1 amp £11.00 + p.p. £1.95 dimensions 4 1/2" x 2 1/2"  
PR 240v pri. sec. 15 0 15 @ 2 amps dimensions 3 1/2" x 2 1/2" £4.95 + p.p. 99p  
TM 240v/110v pri. sec. 15 0 15 8vA dimensions 2 1/2" x 1" £1.95 + p.p. 30p  
All voltages measured off load.

## HIGH EFFICIENCY SMITHS RADIAL BLOWERS

Are your hot parts sweltering? Then keep them cool with our high efficiency radial snail type blowers. Made by Smiths, designed for continuous use in expensive electronic equipment very powerful and quiet, gives massive air flow to prolong component life and reliability. Easily mounted, air aperture 2 1/2" x 3". Ideal linears etc.  
Please state 240v or 110v operation. 50hz only.

BRAND NEW  
**£4.55**  
P.P. £1.60

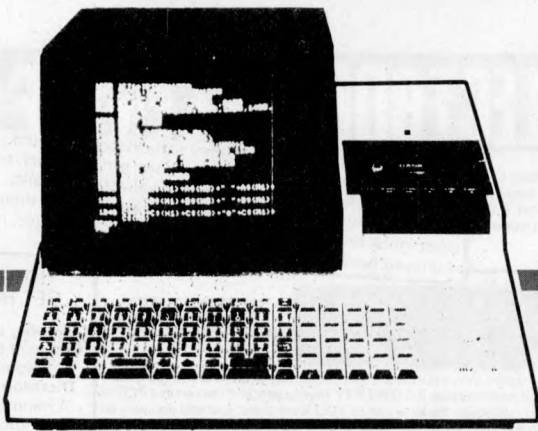

# SHARP MZ80K

THE FIRST  
DESKTOP  
COMPUTER  
TO STRIKE  
THE

FULL RANGE OF SHARP GAMES  
ON CASSETTE NOW AVAILABLE

## RIGHT CHORD!

AT LAST!  
THE MICROPROCESSOR THAT BRINGS  
SOUND TO YOUR PROGRAMME.  
COME AND LISTEN TO THE DIFFERENCE

AT  
COMPUTERIST  
SOUTH EAST ESSEX FIRST COMPUTER  
SHOWROOM AND BOOKSHOP

642 London Road,  
Westcliffe-on-Sea, Essex  
Telephone Southend 335298  
and

Dair Electronics  
Your North Essex  
Computer Centre  
33 High Street, Halstead  
Essex. Telephone 2533

**NOW AVAILABLE  
FROM**

**THE COMPUTERIST**

**&  
DAIR  
ELECTRONICS**

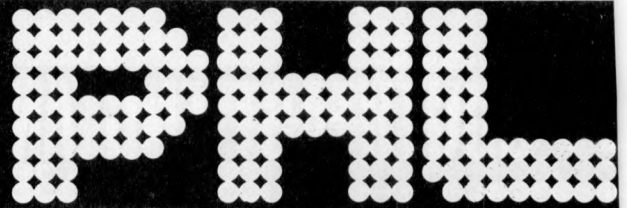

...when you need a dependable supplier, an authorised distributor with a comprehensive range of products at keen prices, backed by large stocks for fast delivery, with full after-sales support. We promise you a rapid response.

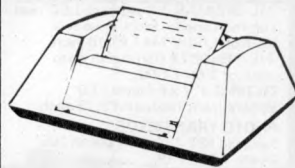

### ANADEX DP8000

Exceptional value and high reliability. 84 lines per minute, 112 cps. Parallel and serial interfaces as standard. 96 ASCII set, 9 x 7 font. Variable tractor. Forms handling facilities. 1K buffer store. Options include 2K extra store IEEE interface.

from only **£516**



### LEAR SIEGLER ADM-3A

The most popular visual display in the world. 1920 character screen capacity. Cursor addressing. Dual interfacing. Auxiliary port. Wide range of speed and word formats. Options include Tektronix 4010 compatible graphics.

from only **£570**



### LEAR SIEGLER ADM-31

Low cost VDU with two page display and full editing features. Dual interface, 50-9600 baud data rates. Upper/lower case character set. Cursor addressing, editing, protected fields, dual intensity. Optional polling and addressing, printer port.

from only **£795**



### LEAR SIEGLER ADM-42

Semi-intelligent VDU with up to 8 pages of display. Full editing features, blinking, blanking, cursor addressing, format transmission, protected fields, dual intensity, separate function keys, status display. Optional alternative character set, programmable function keys, synchronous interface, line drawing set.

from only **£1049**



### TYPEWRITER TERMINAL

Two machines for the price of one. Typewriter style friction feed for single documents, letters etc. Pin feed for continuous business stationery. Electric typewriter keyboard layout and touch. Left and right hand margin setting. Crisp, high quality printout.

from only **£825**

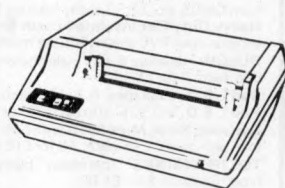

### TEXAS 810

Compact 150 cps 132 column printer. Optimised bi-directional printing. Adjustable tractor feeds, 3 - 15 inches. 9 x 7 dot matrix. RS232 interface. Forms control options. Other serial and parallel interface options. Compressed print option.

from only **£1392**

### LOW COST GRAPHICS TERMINAL

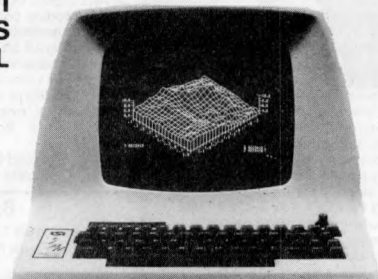

**£1295**

A low cost Tektronix 4010 software compatible option means that we can offer the well-known Lear-Siegler ADM 3A with powerful graphics capability. A Z-80A microprocessor and RAM sufficient to provide a 512 x 250 dot grid and automatic scaling from a 1024 x 780 dot grid enable point plotting, vector drawing and alphanumeric character display. Call today for a demonstration or more details.

### PERIPHERAL HARDWARE LIMITED

Armfield Close West Molesey Surrey Telex 922175

**SOUTH**  
01-941 4806

**NORTH**  
Harrogate 501263/4

**IRELAND**  
Dublin 952316



# SIRTON PRODUCTS

76 Godstone Road, Kenley, Surrey (nr. Croydon).  
Tel: (01) 668 0761/2

Professional versatile computer system with comprehensive front panel facilities and 20-slot motherboard. Units have substantial power supply etc. and come with 2 or 4 MHz Z80 CPU. BUS conforms to the IEEE S100 standard.

DPS.1 from £695

Available with K2 operating systems & PASCAL/Z. Companion Disc Drive Enclosure for on-line storage for 250K Bytes to 2 M Bytes.

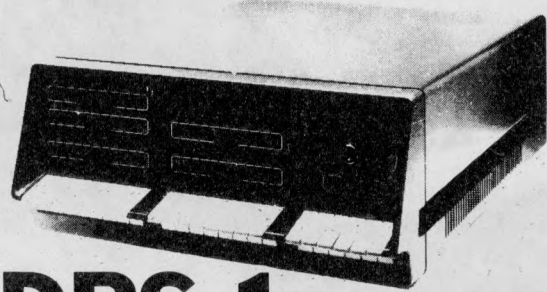

## DPS.1

### MIDAS S.100 SYSTEMS

Substantial Mainframe to house your S100 system, with optional 5" or 8" disc drives. Special systems built to your requirements from Z80 CPU and other S100 boards held in stock

Mainframes from £239

MIDAS 1 : Z80 System from £680

MIDAS 2 : Z80 Disc System from £1259

MIDAS 3 : Z80 Disc System 8" from £1595

DOUBLE DENSITY recording available on MIDAS giving up to 2M BYTES of on-line storage. Software for MIDAS includes CP/M, FORTRAN, COBOL, PASCAL and several BASICS including XYBASIC for control applicaitons.

## MIDAS

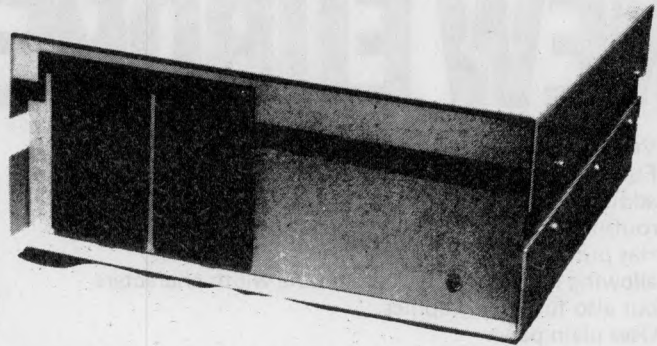

**Board Kits** — All available as built & tested boards

Z80 Starter kit, featuring on-board Key-board, 2K Monitor, 1K RAM, 2x8 bit I/O Ports, Prom Programmer etc. etc.	£188.00
ITHACA MPU-80 A/T	£235.00
Z80 CPU, 2MHz, 1K RAM, up to 8K EPROM, S/P I/O Port, four-channel counter timer — SBC100	£159.00
Z80 CPU, as above but 4MHz SBC200	£177.00
Z80 CPU Board, 4 MHz, A/T jump-on-Reset	£116.00
8080 CPU Board, jump-on-reset	£92.00
8K RAM Board, low power 450 n Sec (21L02)	£79.00
16K RAM Board, low power 250 n Sec Static A/T	£195.00
32K RAM Board, extended addressing, Static	£343.00
Memory Manager, allows memory expansion addressing to 16M Bytes — IEEE spec	£39.00
Dynamic RAM Board, 2 MHz, 16-64K	£129.00
Dynamic RAM Board, 4 MHz, 16-64k, A/T	from £167.00
2708 EPROM (16k) Board	£60.00
2708/2716 EPROM Board, Prog	£90.00
2 Textool Sockets	£110.00
PROM 100 Programmer Board	£110.00
I/O Board, 2S/2P, with DIP switch selection	£100.00
I/O Board, 2S/4P, provision 4K RAM/4K ROM	£135.00
I/O Board, 2S/4P, with interrupts A/T	£235.00
Analogue I/O Board, 8 ch	£295.00
8/10 Bit A/T	£295.00
Analogue I/O Board, 2 ch 12 bit A/D, 2 ch D/A	£287.00
Video Interface, 16 lines, 32 or 64 ch/line (60 frames)	£93.00
Video Interface, 16 lines, 64 ch/line (I/O Port driven)	£99.00

Video Interface, IEEE spec, 80 ch by 24 1, memory mapped up to 256 ch, 50Hz,	£230.00
Video Display, 24 1, 80 ch/1, keyboard interface, 2K RAM, special characters available etc	£198.00
Video Interface, 16 lines, 64 characters (50 frames)	£104.00
High Density Graphics from Vector, inc	£333.00
8K RAM Board A/T	£180.00
Real Time Clock Board from Mountain Hardware A/T	£34.00
Motherboard (8 slot with active terminators)	£43.00
Motherboard (13 slot with 4 edge connectors)	£29.00
Extender Board with logic probe for voltage level impulses	

<b>FLOPPY DISCS</b>	
Disc Controller, 5" or 8"	£139.00
Double density controller A/T	£280.00

<b>Software</b>	
CP/M on 8" or 5"	£75.00
CP/M 2	£100.00
C-BASIC 2	£75.00
Microsoft BASIC V.5	£155.00
XYBASIC Extended	£215.00
Microsoft FORTRAN 80	£205.00
Microsoft COBOL 80	£325.00
PASCAL/Z CP/M Version	£165.00
PASCAL (UCSD)	£150.00
MAC Macro-Assembler 8080 with Z80 Library	£55.00
Z80 Ass, Linker & Editor	£56.00
ZS1D Trace & Debug Tool	£50.00
Diszilog Disassembler	£35.00
Wordstar Text Editor	£255.00
Supersort	£125.00

WRITE OR PHONE FOR CATALOGUE

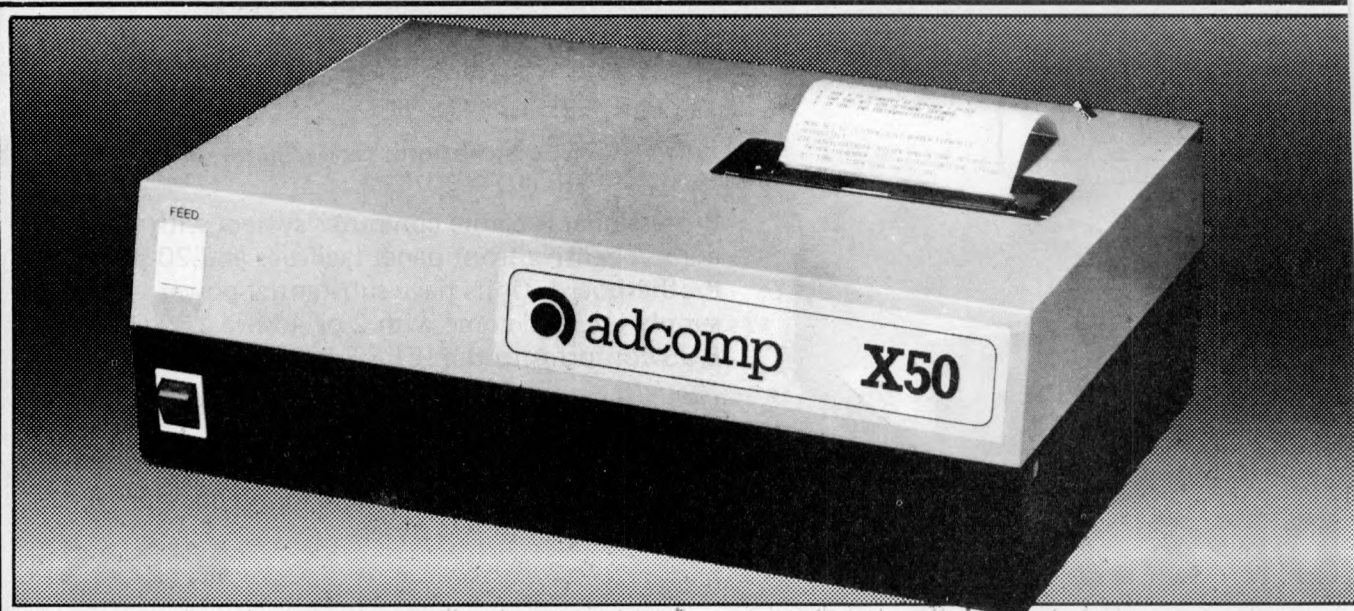

# NEW EUROPEAN PRINTER

- \* Versatile matrix printer with no hidden extras.
- \* Fully compatible with all main computers — no additional hardware needed; PET handshake routine, RS232 and V24 all standard features.
- \* Has primary and secondary addressing capability allowing not only single and double width characters but also full PET graphics.
- \* Uses plain paper

- \* Choice of blue or black ribbon

80 column bi-directional £590 + VAT  
 52 column bi-directional £490 + VAT

Journal printers etc. also available. For further details write to UK distributors:

Barnes Consultants, 36 Eaton Court, Boxgrove Ave., Guildford, Surrey  
 Tel: Guildford 60982

## GATE MICROSYSTEMS LIMITED

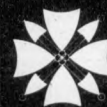

### Scotland's Complete Microcomputer Service

now supply and support:

#### HARDWARE:

Apple II Systems and Peripherals  
 Commodore Business Systems  
 A wide range of VDUs, printers, etc.

#### SOFTWARE:

Incomplete Records Accounting  
 Sales Ledger  
 Purchase Ledger  
 Nominal Ledger  
 Stock Control  
 Payroll  
 Word Processing  
 Database

Software can be tailored to your requirements or written completely to your specifications.

Our service is comprehensive, ranging from advice on system selection through installation and implementation, to operator training and comprehensive Hardware and Software maintenance.

You don't have to take our word for it.

Call us and arrange a demonstration. GATE MICROSYSTEMS LTD.,  
 THE NETHERGATE CENTRE,  
 66 NETHERGATE,  
 DUNDEE.  
 TEL: (0382) 28194.



# NewBear Components



### MICROCOMPUTING I.C.'s

Z8001	£142.50
MC6800	£ 6.75
MC6802	£ 8.50
MC6821	£ 4.63
MC6850	£ 4.99
MC6810AP	£ 3.61
MC6840	£ 12.72
MC8602P	£ 2.88
MC14536P	£ 3.69
MC3459	£ 2.43
Z80 CPU 2.5MHz	£ 8.99
Z80 P10 2.5MHz	£ 7.99
Z80 CTC 2.5MHz	£ 7.99
Z80 SIO	£ 25.57
Z80A CPU 4MHz	£ 13.99
Z80A P10 4MHz	£ 10.00
Z80A CTC 4MHz	£ 10.00
SC/MP 11	£ 8.88
(INS 8060N)	
INS 8154N	£ 8.18
8080A	£ 5.50
6502	£ 9.90
6522	£ 7.30
6532	£ 12.76
6545	£ 16.66
6551	£ 10.79

### MEMORIES

2708	£ 6.99
4116 (16K Dynamic)	£ 6.99
2716 (INTEL)	£21.50

## SHARP MZ 80K at NEWBEAR

### EXERCISER COMPATABLE PRODUCTS

9600 MPU Module	Ass	£330.00
9601 Motherboard (16 slot)		£128.65
9603 Motherboard (8 slot)		£73.60
9602 Card Cage (Kit)		£55.00
9610 Prototyping Board	N/A	
9616 32K EPROM/ROM Module		£191.00
9620 16 port parallel I/O (with 8 PIA's)		£215.00
9620 16 port parallel I/O (with 2 PIA's)		£185.00
9622 Combination Serial/Parallel I/O Module		£250.00
9612 Buffered Utility Prototyping Board	T.B.A.	
9627 8 16K Ram Module (470ns 8K bytes)		£235.00
9627 16K RAM module (470ns 16K bytes)		£360.00
9627A 16K RAM Module (300ns 16K bytes)		£410.00
9630 Card Extender		£45.00
9640 Multiple Programmable Timer		£269.40
9640 Multiple Programmable Timer (Part populated)		£205.00
9650 8 port Duplex serial I/O (with 8 x 6850's)		£240.50
9650-2 8 port Duplex serial I/O (with 2 x 6850's)		£207.00
96702 Relay Contact Module		£275.00
9690 Card Puller		£9.95
96102 32/32 I/O Module		£222.00

### a 6800/6809 MICRO SYSTEM

## 77-68 Prices Slashed!

Bearbag 1	77-68 CPU KIT	£35.00
Bearbag 5	77-68 4K RAM KIT	£55.00
Bearbag 6	77-68 MON 1 KIT	£37.50
Bearbag 12	77-68 V.D.U. KIT	£42.50
Bearbag 13	77-68 MON 2 KIT	£47.50
Bearbag 16	77-68 EPROM BOARD KIT	£21.50
Bearbag 17	77-68 PIO BOARD KIT	£40.00
Bearbag 23	77-68 32K DYNARAM KIT	£75.50
Bearbag 18	CASSETTE INTERFACE	£12.50

**STOP PRESS! ☆☆☆**

6809 & FLOPPY DISC CONTROLLER BOARDS  
NOW AVAILABLE - SEND/PHONE FOR DETAILS.

### KEYBOARDS

Boxed 76 Key, High quality ex-Avionic computer keyboards £38.00 + £1.00 p&p + VAT  
Send/Phone for details.

### TANDON TM100

5¼ Double sided disk drive £250.00  
SHUGART SA400  
5¼" single sided disk drive £189.00

### VISIT OUR NEW BOOKSHOP ☆☆☆☆☆

1st FLOOR OFFICES, TIVOLI CENTRE,  
COVENTRY ROAD, BIRMINGHAM. Tel: 021 707 7170

## ACORN

6502 BASED MICRO KIT	£65.00
8K RAM KIT	£95.00
MAINS ADAPTOR	£ 5.00
V.D.U. KIT	£88.00

**NEWBEAR SYSTEMS FOR APPLE II,  
HORIZON AND SHARP.**

**TERMS. Official orders (min £10.00), Access and Barclaycard welcome. p&p 50p, PLEASE ADD 15% VAT. SEND FOR BOOK list and hardware catalogue.**

**CALLERS AND MAIL ORDER:** 40 Bartholomew Street, Newbury, Berks. Tel: 0635 30505

**CALLERS ONLY:** 220-222 Stockport Road, Cheadle Heath, Stockport. Tel: 061 491 2290

a division of Newbear Computing Store Ltd.

WE'RE THE NEWEST AND MOST UP-TO-DATE COMPUTER CONSULTANTS AND SUPPLIERS. WE'RE SPECIALISTS IN HARDWARE, SOFTWARE AND CONSULTANCY.

# JUST LOOK AT THESE PRICES !!

SOFTWARE  
SALES LEDGER  
PURCHASE LEDGER  
INVOICING  
(FOR COMPUTHINK)

£350 EACH  
INCLUDING  
TRAINING  
COURSE

STOCK CONTROL  
WORD PROCESSOR  
ASSORTED GAMES AND  
INSTRUCTION COURSES

PRICES  
ON  
REQUEST

AND AVAILABLE ALMOST IMMEDIATELY:

77 TRACK 5¼" DISC DRIVE      INCLUDING  
8"      "      "      DOS

TRAINING COURSES FOR ITT,  
COMMODORE – BOOK NOW!

MEDIA 5¼" from £22 for 10  
8" from £37 for 10

MAIL ORDER:  
PLEASE ALLOW 21/28  
DAYS FOR DELIVERY.  
P&P EXTRA AT COST

<b>HARDWARE</b>	
SHARP MZ-80K	From £575
ITT 2020 (APPLE)	£750
DISC DRIVE	£370
COMMODORE PET 32K	£795
COMMODORE DISC DRIVE	£795
3022 PRINTER	£700
COMPUTHINK DRIVE 400K	£955
800K	£1245
VIDOGENIE 16K	£395
TEAC DISKDRIVES SINGLE	£275
DUAL	£499
ANADEX DP8000	£499

ALL OUR PRICES INCLUDE  
VAT AND THE BEST SERVICE  
BACK-UP AVAILABLE

NAME \_\_\_\_\_ ADDRESS \_\_\_\_\_ TEL: \_\_\_\_\_  
PLEASE SUPPLY: \_\_\_\_\_ I ENCLOSE POICHEQUE £ \_\_\_\_\_  
COMPUTER CONSULTANTS,  
64 Parkfield Road., Rugby,  
Warwickshire  
Tel: (0788) 72596

## Philips Mini-Digital Cassette Recorder.

### CASSETTE RECORDER

The Mini-Digital Cassette Recorder (Mini-DCR) can operate in the following modes: Idle, Read, Write, Backspace and Rewind. Complementing the quality and reliability of the Mini-Digital Cassette Recorder are Philips mini-cassettes certified for digital data recording applications. These mini-cassettes use tape which is certified for freedom from drop-outs. Mini-cassettes have been widely used for program loading in Philips office computers during the last four years, and over half a million are already in service. Low cost, low power consumption and compact size of the Mini-Digital Cassette Recorders mean they are ideal for program loading and updating applications as well as providing a highly convenient data capture facility.

Ample capacity for program loading and data interchange is provided by the 128 k byte capacity, and the high data transfer rate of 6000 bits/sec allows quick reading and writing of programs and data.

PRICES INCLUDING MANUAL  
MINI D.C.R.      £95 ea. + VAT  
INTERFACE      £37.50 ea. + VAT  
INCLUDE £2.25 FOR CARRIAGE ETC.

Manual available separately price £10.00. Refundable on receipt of order.

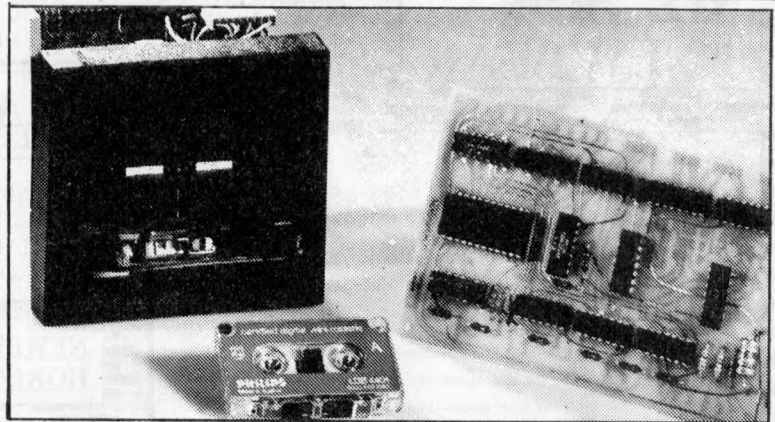

### INTERFACE BOARD

This compact interface board was designed specifically for the purpose of interfacing the Philips Mini DCR to a Micro-computer. Power consumption is very low, enabling it to be powered from the micro-computer that it is serving. Flexibility of the system was held as paramount, address decoding can be changed simply by moving links

By using subroutines held in the micro-computer to control the system the user can make his controlling program to suit his own particular needs and can be as simple or as complicated as necessary.

**CURRAH**

COMPUTER  
COMPONENTS

79 Crowland Rd. Hartlepool Cleveland.  
TS 24 2JN. Phone 0429 / 871900



# XITAN SYSTEMS

\*LOOK AT THESE  
NEW PRICES\*

## CROMEMCO SYSTEM 3

£4,412.00 for this system with vdu.

The ideal business system. System includes a full 64K fast RAM, dual full-size floppies (Persci 277), RS232 interface/20mamp loop for console device, parallel printer port (Centronics/Anadex compatible), 21 slots for expansion, Lear Siesler 24 lines or 80 chars vdu, and ... CROMEMCO's CDOS operating system with their 14 digit BCD extended disk Basic — ideal for those accurate large numbers required by successful businesses. CDOS is CP/M functionally equivalent, with many extra facilities. Optional extras from Xitan include Fortran, Cobol, Text Formatting, Z-80 macro-relocating assembler and DBMS at £59.00 each. CIS interactive screen handling Cobol at £425.00 (recommended to serious business users), Cromemco S100 boards, CP/M (we are an authorised oem distributor of Digital Research's CP/M) for the System 3, Wordmaster, Wordstar, Supersort, and CPM374X utilities.



COMING SOON! ... Full 7-terminal multi-user operating system from Cromemco for System 3 users. Up to 48K per user, all running independently. This operating system has to be seen to be believed. It will run any of the Cromemco provided and supported software packages, in any combination. Features include partition rescue facilities, allocating more memory to users, real-time clock for time/date stamping of jobs and disk queueing techniques. Buy your System 3 now, expand later as you need it.

## S100 BRITISH COLOUR BOARD

We are proud to offer the first BRITISH S100 Colour board. Manufactured by a local Southampton company — Hi-tech, we can thoroughly recommend this product. Features include true PAL colour generation for high-definition on your television or colour monitor, 15+ colours and black/white with 6 additional grey scales, 24 lines with 40 characters per line, with standard character set plus 44 numbers and symbols, and 64 computer selected graphics symbols. Symbols include fractions and the £ symbol. Plotting is available at 80 x 72 resolution. Single or double-height characters, with flashing on an on/off duty cycle of 3-1. The board is memory mapped on any 2K boundary, with its I/O port set at any of the 256 available on the S100 bus. Just plug into your S100 system and colour television and go! Driver software and documentation provided. Price £295.00ex vat cash with order. Please specify if for television or 75 ohm monitor.



ON DEMO NOW! The Cromemco Z2-H. For only £5,380.00 set the reliability and quality of Cromemco, coupled with the capacity of the new IMI 11 megabyte hard disk drive. This is incredible value for money. Specification includes transfer rates of up to 10 times faster than the fastest standard floppy disk, DMA controller for up to 7 hard disk units, and the new extended CDOS operating system. Systems available in three configurations: — A) The Z2-H complete integral system, 64K RAM, Z80A cpu, two double-sided mini-floppies, RS232 console port, parallel printer port, power supplies, cables, case and 12-slot S100 motherboard (7 slots free). B) Additional hard disk subsystem for existing system 2 or system 3 users consisting of one hard disk, DMA controller, power supply, case and cable. C) As unit B but with two hard disks. Prices: Unit A) £5,380.00  
B) £4,330.00  
C) £7,420.00

Xitan Systems also supplies and stocks vdus, printers, NORTH STAR HORIZON computers, Commodore Business Machines PETs, S100 boards, and books. We are here to demonstrate the range of quality microcomputer systems available for use today. Ring up for an appointment now! You'll not be disappointed. We have Osborne's Sales Ledger and Payable Ledger in source form for use on Cromemco System 3 with CBASIC2, and we can offer a customising service on these programs. Additional software includes Microsoft Basic Interpreter and Compilers, Cbasic, Macro80, and CP/M for the North Star Horizon.

**Xitan Systems Ltd., 23 Cumberland Place, Southampton SO1 2BB.**

**Tel: (0703) 38740**

**Hours Tue-Sat 9.30 am to 5.30 pm**



**CRYSTAL ELECTRONICS  
CC ELECTRONICS**

## XTAL Basic 2.2 NOW ON SHARP MZ80K

All of the features of SHARP BASIC and more. Occupies 5K less memory, thus effectively increasing memory size for programs.

MZ80K 20K RAM £520+VAT  
(with XTAL BASIC leaves 11K for programs)  
XTAL BASIC for SHARP £40+VAT

**Coming Soon—PETSOF\* programs in XTAL BASIC format for SHARP & NASCOM—  
Prices as PETSOF list+20%.**

NASCOM 1 & 2 owners—XTAL BASIC 2.2 £35+VAT  
NEW EPROM version £100+VAT  
(please state monitor used)  
EPROM version runs in EOOOH-FFFFH.

### APPLE II PLUS OWNERS

APPLE INTEGER BASIC on disc for 32K or 48K APPLE.  
Now you can run nearly all of your programs—  
£20+VAT

\* PETSOF is a trademark of ACT PETSOF LTD.

Members of Computer Retailers Association & Apple Dealers Association

Shop open 0930-1730 except Wed. & Sun.

40 Magdalene Road, Torquay, Devon, England. Tel: 0803 22699

Access and Barclaycard welcome.



COMPUTERS  
AND  
COMPONENTS



# Your key. To MICROCOMPUTERS

This coupon will bring you details of our new complete home computer course.

You will learn all the basic principles of computer technology and receive full instruction on computer functions and programming. Tuition is carried out at your own pace on your own home computer and is supervised by our qualified computer staff.

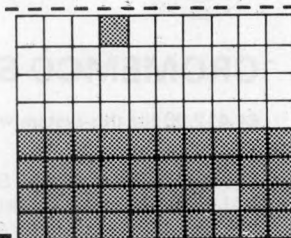

**FREE  
BROCHURES**



Send today for a brochure on this exciting new course.



**TUTORCOURSES**  
HOME COMPUTERS

Please rush me details of your HOME COMPUTER COURSE

Name

Address

Block Caps. Plea

Post now, without obligation to:

**British National Radi  
& Electronics School**

P.O.Box 156, Jersey, Channel Isles

PCS

**PET, THINK  
COMPUTER  
& ANADEX  
HOME COUNTIES**

New Keyboard Pets & Peripherals

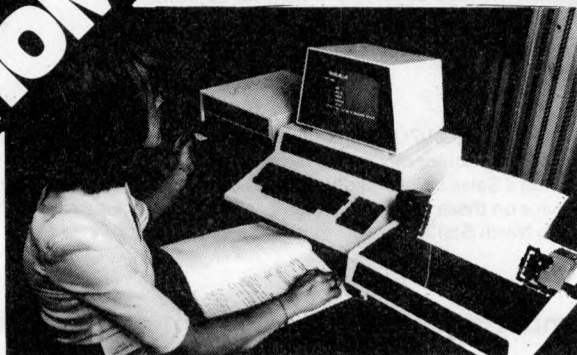

Comprehensive demonstration facilities available (by appointment)

\*Also call us for your component requirements \*

### SALE OF THE CENTURY

With every order received in the next week for 16K or 32K Pet, a Petsoft Programmers Toolkit (RRP £55) yours for only £5.00.

Specialise in supplying the business user.  
Software available:

#### BUSINESS PROGRAMS

Sales Ledger  
Purchase Ledger  
Nominal Ledger  
Payroll

#### ACCOUNTANTS & AUDITORS

Incomplete Records

#### PLUS

Other Software  
Guidance given to: Go It Alone, DIY,  
Teach Yourself Customers.

DISKS, TAPES, AND  
PRINTER PAPER AVAILABLE

(Ask for Barry Blyth FCCA or Dave Trueman)

Orchard Electronics Ltd

21 St Martins Street

Wallingford

Oxon OX10 0DE

Tel: (0491) 35529



# 'EPROMPT' ERASER

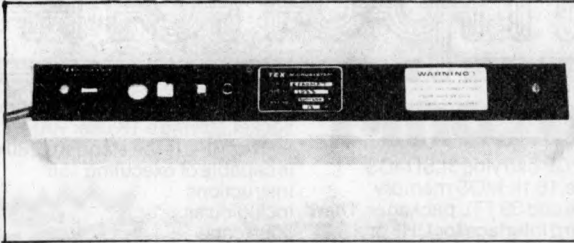

- \* SCRUBS UP TO 32 CHIPS IN 15 MINS ON 200-250v A.C. \*
- \* CONTINUOUS 253.7nm BEAM. SAFE & SIMPLE. GUARANTEED \*
- \* **£39** C.W.O. **£40** NETT 30 DAYS: ALL INCLUSIVE ! \*

+ NEW PRODUCTS +

## TEX 90 8K 16-BIT MICROCOMPUTER £99

TMS9980. 'TEXBUG' MONITOR. RAM. TIMER. V24 I/O. MANUALS

## TEX100 IEEE S100 BUS & POWER UNITS: PAIR £95

RUNS Z80A+64K DRAM+V24 I/O+DISC I/O+2 MINIFLOPPIES:  
'EXPANDBUS' 4-SLOT EXPANDABLE MOTHER/EXTENDER £39  
COMPACT POWER: +9v8a. +16v6a. -16v1a. FROM 240v A.C. £59

## TELE-TEX SMART V24 T.V. TYPEWRITER FROM £99

16x64. 256 CHAR. PROGRAMMABLE SOUND&DEVICE CONTROLS

TRADE ENQUIRIES INVITED FOR SUBSTANTIAL DISCOUNTS.  
WE ALSO NEED PARTNERS FOR PRODUCTION INVESTMENT.

ALL ORDERS AND ENQUIRIES POST-FREE TO:

## TEX MICROSYSTEMS LTD.

FREEPOST. ST. ALBANS. HERTS. AL1 1BR

OR PHONE ST. ALBANS 64077 OUTSIDE WORKING HOURS

# BITS & P.C.s

COMPUTER PRODUCTS

## Nascom specialists Add-ons System 80 Complete technical and Order with confidence Mail order

CONTROL AND HEX. KEY PADS FOR NASCOM 1 or 2  
DUAL MONITOR BOARD  
PORT PROBE  
NAS-CHESS with graphic options NASCOM 1 or 2  
NASCOM 1 GRAPHICS SYSTEM  
LARGE S.A.E. FOR DETAILS PLEASE  
DEMONSTRATIONS BY APPOINTMENT



18 Rye Garth, Wetherby,  
West Yorkshire LS22 4UL



## 0937 63744

# £39.50\*

## Professional ASCII Keyboards



MODEL KB 756

FULLY ASSEMBLED & TESTED  
CASE AVAILABLE

Accessories Available include:-

Edge Connector	KB15P	£1.95*
Numeric Key Pad	KB710	£7.50*
Plastic Case (Black)	KB701	£12.75*
DC to DC Converter	DC512	£5.00*

\* U.K. Orders add 15% VAT on Order total.

FULL DATA SHEET ON REQUEST

## Citadel Products Limited.

Dept. PCW 50 High Street, Edgware,  
Middlesex HA8 7EP. Telephone 01-951 1848

## CARTER KEYBOARDS

# LET US MIND YOUR OWN BUSINESS

We offer systems for the smaller business user based on microprocessors by Apple and Microstar and supported by extensive software for a wide variety of applications. We also supply daisywheel printers by Qume, matrix printers by Texas, and a variety of video screens. We sell or lease equipment and guarantee our installations in the field. AND we offer in situ service support via our own engineers.

If you have specific requirements for individual items of hardware, come and discuss it with us.

We're Access Data Communications... your flexible friends.

Access Data Communications Ltd.,  
228 High Street,  
Uxbridge, Middx.  
Tel: 0895 30831/59205

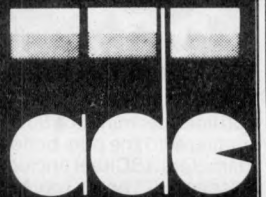

# What will you do with a 2-year old programmer when he reaches 16?

Any microcomputer is a major investment for an educational establishment. Many potential users feel that a BASIC only computer is ample for their needs. That may be fine today, but with computer education starting so early you may in a surprisingly short time find you want more than current implementations of BASIC.

The 380Z is a computer that can grow to match your needs.

In the design of the 380Z our target user is the graduate research scientist. This ensures that the expandability and versatility needed tomorrow has been provided for in the computer you buy now.



## Might you want to add disc storage in the next few years?

*If you do:*

Given good hardware, software availability completely determines the flexibility and usefulness of your system. There is absolutely no question that a Z80 based micro-computer which uses the industry-standard CP/M\* disk operating system has several times more software on the market available to it than non CP/M computers.

Today you can purchase a mature CP/M BASIC, FORTRAN, COBOL or Text Processor for the 380Z. Soon there will be CP/M Pascal and Database Management systems.

CP/M software is several years ahead of software available for non CP/M family machines.

*If you don't:*

Remember that professionals writing packages for your cassette system will themselves often use a disk 380Z, and the power of their tools will influence what they produce.

For many people a disk machine is too expensive—but at least the 380Z

approach will allow your students to advance.

380Z BASIC is not frozen in ROM. An enhanced BASIC could be loaded in mid 1980 and a BASIC with structured features sometime later.

On the 380Z the memory used by a BASIC interpreter can also be used for other software.

## Does our research-oriented design pay off in classroom hardware?

Our scientific graphics was produced for the professional user. Interest in it for classroom use has been surprising.

The 380Z has the best graphics now available on a microcomputer,

allowing multiple resolutions, multiple paging, fading and accurate control over colour. All these features help bring excitement to efforts in computer assisted learning.

Our standard machine comes with low resolution graphics and support for this from BASIC allows you to plot a point directly with a plot command—useful for training and teaching.

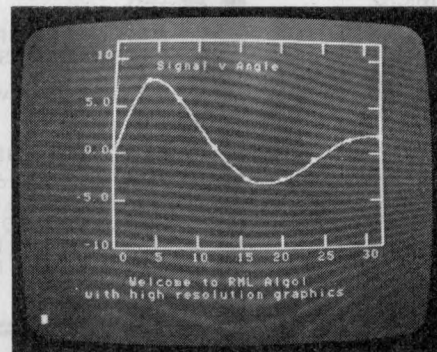

It is worth remembering too that neither our low resolution graphics nor our optional scientific (high resolution) graphics has any limiting effect on your memory usage, and in both you can



freely mix upper and lower case text and diagrams.

Mains noise can cause system crashes which result in loss of programs and data. All current 380Zs include a mains filter which significantly reduces the chances of this happening.

## Don't buy a 380Z on patriotic grounds.

Please only buy it if you would have bought it anyway. But remember, because it is designed and manufactured here you are bound to have better access to us for influence and help than if we were on the other side of an ocean.

Prices range from a 16K cassette 380Z @ £897 to a 56K Dual Full Floppy Disk 380Z @ £3322.

## LOWER COSTS

Three things have happened which make it easier to buy a 380Z.

ONE: From 1st November 1979 most prices have been reduced.

TWO: Schools and some colleges can now get a 5% discount on computer orders.

THREE: A new Local Authority quantity discount scheme has been introduced to make it easier for more users to benefit from quantity purchasing.

Please contact the Sales Office for details.

## RESEARCH MACHINES

RESEARCH MACHINES Ltd,  
P.O. Box 75, Mill Street, Oxford, England.  
Telephone: Oxford (0865) 49791/2/3.  
Please send for full sales information.  
Prices do not include shipping costs or VAT @15%.

\*Trademark, Digital Research.



Small  
Systems  
Engineering  
Limited

### IEEE-488/PET INTERFACES

**Type B** £186  
Bidirectional serial interface is fully addressable and can have split BAUD rates

**Type C** £120  
Serial interface - output only  
PET disk, compatible, RS232 C Handshake (Printer Busy), switch selectable Baud rates, Listen Address link selectable.

**Type CS** £132  
Serial interface output only with switchable character sets to match the new PET's lower case Screen mode, otherwise as Type C.

All interfaces are crystal controlled

**Type G.P.I. A.P.** £249  
Micro-based, bidirectional with buffering. The General Purpose Interface allows free use of PET's INPUT # statement without hangup problems. Software changeable BAUD rates optional features include: Second Serial I.O. Port, 20 mA Loop I.O.

**Addressable parallel (disc compatible) for Centronics, Anadex etc.** £106

**Non addressable parallel** £45

**TV/Video monitor interface** £35

**Real Time Audio Spectrum Analyser for Commodore PET Microcomputer**  
32 Channels 1/3 Octave Filters, 1K ROM ROUTINES on board for analysis and graphical display. USR Functions for linkage to PET basic operating system £450

### PET MEMORY EXPANSION BOARDS INTERNALLY MOUNTED

24K £328  
32K £432

### S100 BOARDS

**Dynamic Memory Boards**  
IEEE-S100 Specification Timing  
Transparent on Board Refresh  
4Mhz Z80 Operation with no wait states.  
Fully tested and Burned In  
Bank Select versions available -  
North Star, Cromemco and Alpha Micro  
I.O. Port Bank select  
Bank Size to 64K in 16K increments

Size	Standard	Bank Select
64K	£449	£595
48K	£398	£539
32K	£346	£483

**P&T IEEE-488 Interface**  
Provides S100 computers with IEEE-488 Controller, Listener, Talker, Capability £350

All prices exclude VAT  
P&P £5.00 (includes Securicor Express Delivery)

62 New Cavendish Street · London W1M 7LD  
Telephone: 01-637 0777 Telex: 8813085 (Abacus)

# Explorer/85

## Professional Computer Kit

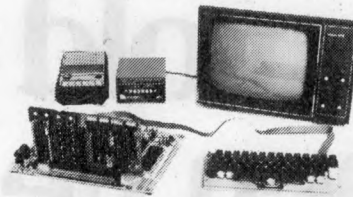

AT  
**£295** + VAT

**FLEXIBILITY:** Real flexibility at LAST  
The EXPLORER/85 features the Intel 8085 cpu  
100% compatible with all 8080A and 8085 software. Runs at 3MHz.  
Mother Board (Level A) with 2 S-100 pads expandable to 6 (Level C)

**MEMORY**  
2K Monitor ROM  
4K WORKSPACE/USER RAM  
1K Video RAM  
8K Microsoft BASIC in ROM

**WITH ONBOARD S-100 EXPANSION**

**INTERFACES**  
STANDALONE FULL ASC11 Keyboard Terminal, 32/64 characters  
RS-232/20Ma Loop. 4, 8bit: 1, 6 bit I/O ports, programmable 14 bit binary counter/timer. Direct interface for any S-100 Board.  
FULL Buffering decoding for S-100 Bus pads, wait state generator for slow memory. Each stage has separate 5v 1A regulator for improved isolation and freedom from cross talk. P.S.U. requirements: 8v 6.3v.  
Runs with North Star controller and Floppies/CPM: EXPLORER/85 expandable to meet your own requirements with easy to obtain S-100 peripherals. EXPLORER/85 can be purchased in individual levels, kit form or wired and tested OR as a package deal as above.

BASE - 2 PRINTER, 80 character unidirectional . . . . . £450  
Hitachi Monitor 9" . . . . . £127

### 16k Dynamic RAM Kit

Expandable to 64K on one S-100 board in 16K increments, designed NO wait state operation utilizing the most advanced RAM controller.  
16K RAM Kit . . . . . £139  
16K RAM Expansion Kits each . . . . . £89.50

### NOW: - EXPLORER/85 with NORTH STAR FLOPPY DISCS

32K . . . . . £599  
48K . . . . . £698  
56K . . . . . £787

North Star Double Density Disc System, 3-drive controller and a Single 5 1/4" Drive with regulator, 180K byte . . . £500

Twin Drive System . . . . . £600

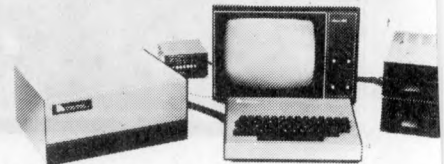

### PETS CENTRE

LATEST PET's WITH LARGE KEYBOARD

8K £475 \*RRP £795  
16K £575 +VAT for 32K  
32K £675

BASE 2 PRINTER £450  
PROGRAMMERS TOOLKIT, £45

Full range of software available.



### SEND SAE FOR COMPREHENSIVE BROCHURE

Please add VAT to all prices. Please make cheques and postal orders payable to NEWTRONICS or phone your order quoting BARCLAYCARD, ACCESS number.  
We are now open for demonstrations and Sales, Monday-Saturday 9.30am. 6.30pm. Near Highgate Underground, on main A1 into London



**Newtronics**



255 ARCHWAY ROAD, LONDON N. 6

TEL: 01-348 3325

# Can small computers be more than toys?

You've looked at them all. Most of the small systems are great for playing games... and very little else. And most of the larger systems are designed to run the manufacturer's standard 'applications packages'... which is fine if you don't mind rebuilding the whole of your business to suit. It's true: most small computers are just expensive toys whose limited flexibility and expansion is soon outgrown.

When you want to move on to *real* computing, the right choice is *Ohio Scientific*.

## Real flexibility...

... at a realistic price! Even the smallest Superboard has a realistic 4K of RAM in which to use its Microsoft BASIC; the smallest Challenger 2 has two spare slots in its case for easy expansion; while the Challenger 3 series can be supplied as standard with a 74-Mb hard disc — probably more on-line memory than all the other 'large' micro-computers put together!

Mutek offer three Ohio Scientific ranges:

C1/Superboard from £175

Challenger 2 from £349

Challenger 3 from £2600 (complete system)

C1 is a single-board 'starter' system, complete with keyboard, video display and Microsoft BASIC; it can be expanded to run mini-floppies and most OSI-bus expansion boards.

C2 systems start with a versatile two-board computer; expansion can include the full hard-disc and input-output capacity of the C3 series.

C3 is the big one! A unique triple-processor CPU and easy expansion up to 300MB hard-disc memory on-line; almost unlimited input/output; can control a sixteen-terminal multi-processing network.

Detailed technical reports for these ranges are available on request.

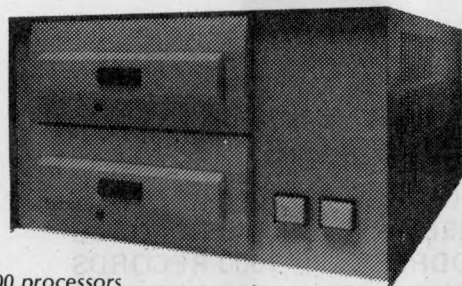

### C3-OEM

6502, Z-80, 6800 processors

32K RAM, twin 8" discs, 4 spare slots for expansion

Ohio Scientific computers use a simple but versatile 'bus' structure that allows real flexibility and easy expansion. Sensible-sized boards make specialist systems simple to design and implement compared to the complexity and cost of comparable S-100 systems.

For example:

CM6 — 48K dynamic RAM — £265

CA-12 — 96-line parallel I/O (six 6821 PIAs) — £95

MU-116 — multi-function real-time clock, with 6821 PIA and 8-channel relay driver — £95

C2-based 16K 'engineer' system with CA-12 — £595

Ohio Scientific computers are backed by sensible software: OS-65D development package for the 6502 is standard with all disc systems (assembler package on cassette for smaller systems — £20); while OS-DMS Database Management software gives practical database handling for business and other uses, and is compatible with all Ohio Scientific disc systems, floppy or hard-disc.

## a superior Superboard...

Mutek offer a variety of options on the C1/Superboard series. The standard system is fast and flexible, runs its 6502 processor at 1MHz, and has a nominal 32×32 display which is limited in practice, for technical reasons, to about 25×25. The Superboard is the unmounted version; the C1 is a cased Superboard complete with power supply.

Standard Superboard — £175

Standard C1 — £220

2MHz conversion — add £5.00

This doubles the speed of operation. The standard BASIC is faster than most; this makes it *really* fast — more than three times the speed of Tandy's TRS-80®, for example.

True 32×32 display option — add £20

This alters the video circuitry to allow the full 1K of screen memory to be displayed on a standard TV set.

2K display option — add £25

Recommended for special work only, as it is driven by a software 'patch' (supplied on cassette). Gives an effective 50×30 display.

All this is backed by the best range of Superboard software available — British and American — and sensibly priced, mostly from £3 to £8. Software catalogue available.

## a programmable printer...

Mutek offer the new *BASE-2 matrix printer*. At first glance it looks a typical medium-duty matrix printer. But there's a lot more to it than anything in its field — a truly flexible printer to match the flexibility of Ohio Scientific computers.

- Four interfaces built-in as standard: IEEE-488, Centronics parallel, RS-232 (software-selected baud rate), 20 ma.
- bidirectional print at 125 characters per second.
- two 96-character sets in ROM (includes APL); space for two more sets in ROM; user-programmable set in RAM; dot-plotting mode — all as standard.
- five software-selectable character widths plus double-width characters.
- form, tabs, line-length, line-space all software selectable.
- uses plain paper up to 8½" width.
- friction and adjustable tractor feed *both* fitted as standard

An amazing specification for an even more amazing price: *Base-2 matrix printer* — only £395

## and full technical support

Our prices are some of the lowest around, but that doesn't imply poor technical support!

We give a full after-sales service that includes much more than 'standard'. As well as the usual service facilities we can offer technical advice on both hardware and software aspects of Ohio Scientific computers and their applications, and can also undertake technical development — hardware and software — for most types of specialist application.

All prices quoted exclude VAT.

# Mutek — real computing...for less than you expect

Mutek — the independent OSI specialists — Quarry Hill, Box, Wilts. Telephone: Bath (0225) 743289

## 'Ever heard of COMAL?

COMAL is an extended and structured form of BASIC with constructions such as:  
REPEAT-UNTIL WHILE-ENDWHILE  
IF-THEN-ELSE CASE-ENDCASE  
and including built-in file system, named procedures and many other features.

Ever heard of a 100% modular multi-user system running two high-level languages (COMAL and PASCAL) at the same time?

Starting at £1995 + VAT for a single-user, ready to run system including the micro with on 5¼" disc drive, VDU, 32K bytes of RAM and COMAL real-time interpreter.

Expanding to an 8-user system with up to 80 Megabytes of cartridge disc storage — and capable of running COMAL, Pascal and Assembler at the same time under what must be the most sophisticated operating system on the market.

Phone (01) 727 6668  
for more information on the  
SPC/1 microcomputer system  
from  
digital data electronics ltd



# WE'RE IN THE NORTH WEST! ARE YOU?

## BUSINESS SYSTEMS FOR PROFESSIONAL PEOPLE

All our systems cover the major problem areas encountered running your business, i.e. Ledgers, Payroll, Stock Control, Word Processing, Personnel Records etc.

**1. For the smaller business.**  
Commodore Pet based system from **£2,500**

**2. For the more ambitious enterprise.**  
Rostronics Z-Plus from **£3,950**

**3. For the more demanding user.**  
ACT 800 from **£3,950**

We are available for consultation, feasibility studies and general overviews, etc. We also provide sensible, user orientated service contracts.

For more extensive details of our services and many more products not listed—write to or telephone

**IAN KENDRICK on 051-236 5778.**

We are approved ACT and STAGE ONE Dealers.



**North Western Systems (Microcomputers) Limited**  
6a Lombard Chambers, Ormond Street, Liverpool 3.

# E.G.A.

Software available for your Apple II with one disc drive only

### TIME — COSTS — INVOICING

DISC ONE	JOB BOOK	1000 RECORDS
DISC TWO	TIME SHEET	1000 RECORDS
DISC THREE	CLIENTS ADDRESS	1000 RECORDS
DISC FOUR	INVOICING	200 RECORDS

SAMPLE PRINTOUTS AND DESCRIPTIONS SENT ON REQUEST. DISCS CAN BE USED SEPARATELY OR TOGETHER. PROGRAMS ARE FULLY INTERACTIVE AND SORTS IN ALL FIELDS ON DEFINED KEYS ON ALL FILES.

**ALL DISCS £200.00 EACH**

**DESIGNERS AID**

ALLOWS 200 PREDEFINED OBJECTS TO BE TAKEN FROM DISC IN THREE DIMENSIONS AND PLACED IN A DEFINED ROOM. DISPLAYS AND PRINTS FIVE DRAWINGS. LISTS NAMES OF OBJECTS AND THEIR POSITIONS ON THE DRAWINGS. SAMPLE PRINTOUTS AND DESCRIPTIONS SENT ON REQUEST.

This program is for an **APPLE II** with one disc drive and plotter  
**£500.00 EACH**

ALL ENQUIRIES TO: — **ENGINEERING GRAPHIC APPLICATIONS LIMITED.**  
52 SUTHERLAND SQUARE LONDON S.E.17 3EL.  
TEL No. 01-670 6293



**OPTELCO** 26 ALBANY ROAD RAYLEIGH ESSEX  
 RAYLEIGH (0268) 774089 (12am-8pm)  
*(Personal callers by appointment only)*

\*\*\*\*\*  
**PETS 'N BITS:** NEW 8K £450 : 16K £625 : 32K £715  
 COMPUTHINK 400K £755 : 800K £995  
**CASSETTE DRIVE** with Audio Monitor & Tape Counter ! £55  
 'GREEN SCREEN' or 'BLUE SCREEN' £5.50 (also for MZ80k)  
 4K - 8K CONVERSIONS £79 : 8K - 32K from £210

**APPLE & ITT:** 16K EUROAPPLE £649 : 2020 COLOUR 16K £699  
 16K UPGRADE £68 : DISK DRIVES £339 : CONTROLLER CARD £48

**COMPUCOLOR:** FULL COLOUR BUILT IN MONITOR & DISK DRIVE  
 16K USER RAM £998

**ACT:** 808 £3950\*  
 824 £4950\* **VIDEO GENIE:** SPECIAL INTRODUCTORY PRICE  
 16K RAM 12K ROM £349

**SHARP** MZ80K ALL MODELS AT LIST PRICE BUT ONLY (EQUIVALENT)  
 HALF RATE V.A.T. !

**PRINTERS:** ANADEX £560 : LA34 £939 : EPSON TX-80 £495  
 PR40 (With PET interface) £215 others available

**ODDS & ENDS:** VERBATIM (PET/APPLE) DISKS £23 PER TEN  
 CURVED HEAD DEMAGNETISER £4 : CASSETTE CLEANING KIT £1.50  
 Both above HALF PRICE with any new computer purchased !  
**PETSOFT:** GEMSOFT: LANDSLER: DATABANK programs TAX + CARR. FREE  
 TELETEXT CONVERTOR (with remote) INSTANT CEEFAX/ORACLE £199.95

\*\*\*\*\*  
**CURRENT SECONDHAND BARGAINS:-**  
 EX-DEMO 32K (UPGRADE) PET £600 : 8K PET (OLD ROM) £425  
 C2-4P DISK (IMMACULATE) 24K £825 WITH MONITOR (LIST APP. £1200)  
 EX-DEMO ELF II - IMMACULATE, HEAPS OF EXTRAS, FULLY BUILT &  
 TESTED FOR LESS THAN KIT PRICE ! £325  
 OLIVETTI TE300 TELETYPE WITH P/P T PUNCH. UNKNOWN COND. £55

\*\*\*\*\*  
**MOST MAKES SOLD/BOUGHT/EXCHANGED/CONSTRUCTED**  
**WANTED-YOUR OLD 'PETS' (EVEN DECEASED PETS FOR VIVISECTION !)**  
 \*TELETEXT CONVERTOR FREE WITH ACT 808/824 + PRINTER

ALL PRICES EXCLUDE V.A.T. & CARRIAGE (EXCEPT WHERE  
 STATED OTHERWISE). CARRIAGE CHARGED AT COST.

# BIRMINGHAM Computer Centre

HIGH SPEED **NEW** MATRIX  
 PRINTER  
 NOW WITH PET GRAPHICS

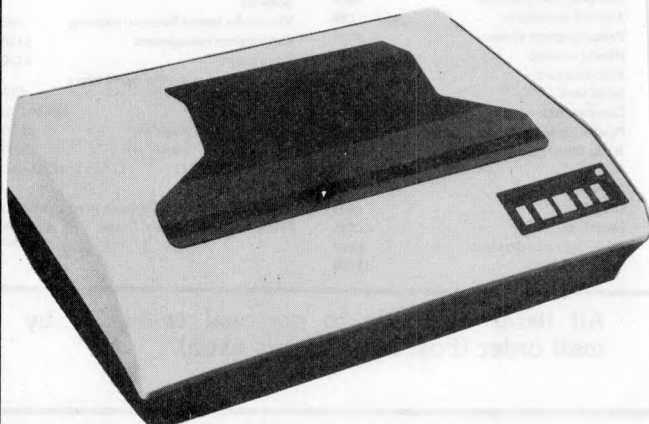

Full ASC II 96 Character Set plus Graphics  
 plus 750CH Buffer 2K.  
 Extra Buffer available  
 UNI - or Bi-Directional  
 IEEE or Parallel Interface Plugs  
 direct into PET.  
 No Interface needed  
 £525

COMMODORE 3022 PRINTER

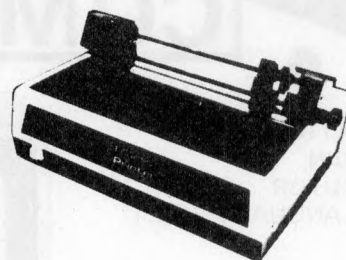

★ **NEW LOW PRICE** ★  
 Tractor Feed - Genuine C.B.M.

Camden Electronics  
 First Floor  
 462 Coventry Road  
 Small Heath, Birmingham B10 0UG  
 Phone: 021-773 8240

Due to expansion we are pleased to announce the  
 opening of our new Computer Shop in Edgware.



Call in and see these systems:-

Word Processing. Stock Control/Invoicing.  
 Incomplete Records. Purchase Accounting. Information  
 retrieval Payroll. Games. Programming Tutorials and  
 many others. If you don't see what you want we will  
 probably be able to get it for you.

We specialise in this system.

Pet prices start from £495.00

We also stock the QUME Sprint 5 Daisy Wheel printer  
 for the best quality word processing. Also call us for  
 the latest second hand equipment supplies.

Open Mon-Sat  
 9 - 5.30

Easy parking at rear of shop.  
 Entrance Whitchurch Lane



Davinci Computer Shop  
 65 High Street  
 Edgware  
 Tel. 952 0526



# Now Available

Orders being taken by Sole Distributors.

## B&B [Computers] Limited

The Consultants for the North West

SUITE 1.  
124 NEWPORT STREET, BOLTON. TELEPHONE: 26644.



VIEWDATA  
ACCESS  
VIA PHONE  
NETWORK

AERIAL INPUT TO T.V.

UHF T.V.  
AERIAL

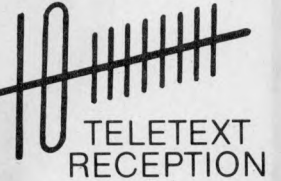
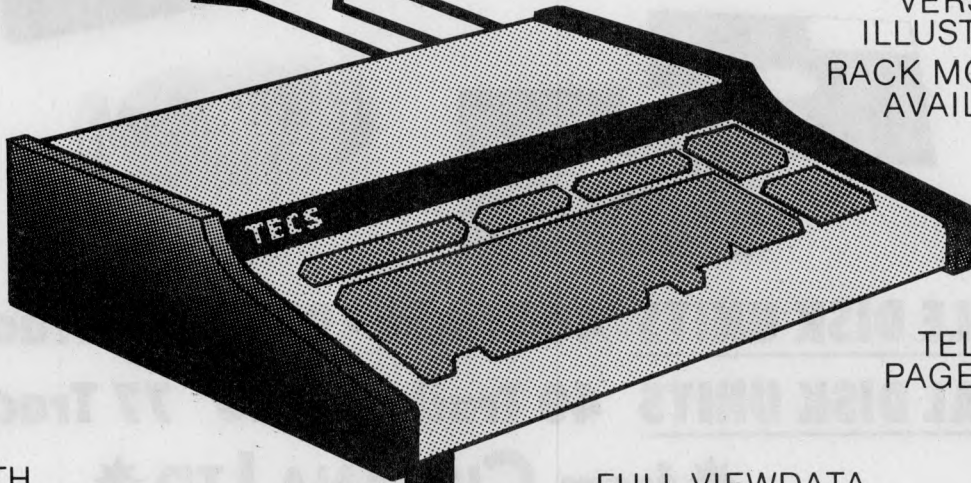

TABLE TOP  
VERSION  
ILLUSTRATED  
RACK MOUNTING  
AVAILABLE



TELETEXT  
PAGE SELECT

EXPAND WITH  
RAM/PROM UP TO 64K

FULL VIEWDATA  
EDITING KEYBOARD

HARD  
COPY

DISC  
DRIVE

MAINFRAME  
COMPUTER  
E.G. PDPII  
INTERFACE

CASSETTE  
I/O

TELETEXT  
LINE INSERTER

PERIPHERAL  
I/O

FULLY EXPANDABLE BUS STRUCTURE

THE SYSTEM IS FULLY EXPANDABLE VIA THE TECS BUS STRUCTURE UP TO 64K; WILL SUPPORT ALL STANDARD PERIPHERALS.

Send for further details to above address.

Dealer enquiries invited.

# Floppy Disk Systems AT LOW COST

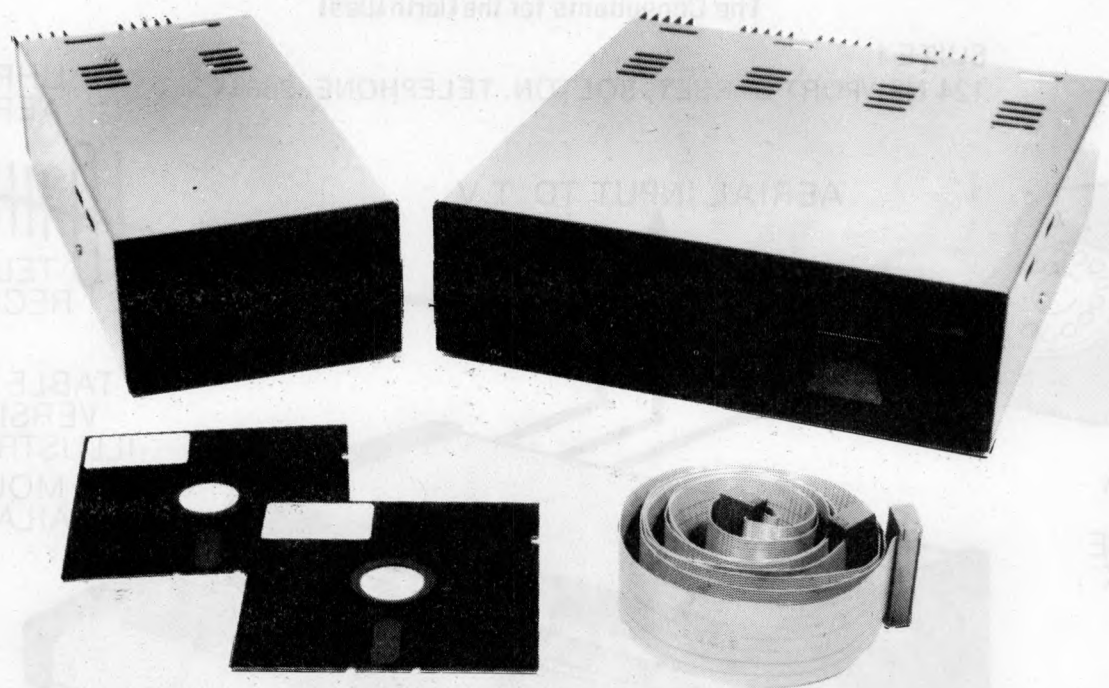

**SINGLE DISK UNITS 40 Tracks • £250 77 Tracks • £345**

**DUAL DISK UNITS 40 Tracks • £440 77 Tracks • £645**

**★ from CUMANA LTD ★**

*The high quality and very reliable TEAC 40 track FD-50A and 77 track FD-50C 5 1/4 inch Mini Floppy Disk Drives packaged in single Disk and Dual Disk configurations with integral mains power supply unit.*

- \* Both FD-50A and FD-50C are Shugart SA400 interface compatible.
- \* FD-50A has 40 tracks giving 125K Bytes unformatted capacity.
- \* FD-50C has 77 tracks giving 240K Bytes unformatted capacity.
- \* Both models can be used in double density recording mode.
- \* Daisy Chain up to 4 drives on your computer system.
- \* Directly compatible with TRS 80, SWTP, Heathkit, Superbrain, Video Genie, etc. etc.
- \* Japanese quality and reliability.
- \* 220-240v 50 HZ mains power unit.
- \* Warranty and service back up from Cumana.

\* \* \* \* \*

DEALER ENQUIRIES WELCOMED

*Please add VAT to all prices. Delivery at cost will be advised at time of order.*

Cheques payable to: CUMANA LTD.,  
35 WALNUT TREE CLOSE,  
GUILDFORD, SURREY. GU1 4UN  
TEL: (0483) 503121  
TELEX: 859680 (INPUT G)

**AVAILABLE SOON**  
ADD-ON DISKS FOR APPLE II AND IIT 2020  
**£259**

# ADVERTISERS INDEX

Access Data	69	Currah	150	Leicester Computers	159	Petsoft	116
Communications	154	Comp Shop	164,IBC	Lifeboat Associates	82,83	PHL	146
Com Computers	65	Datron	27	Lion Microcomputers	13	PIPS	46
Conlab	142	Davinci	160	Little Genius	140	Q-Com Electronics	144
CT	70	Digital Data Electronics	158	Liveport Data Products	25	Research Machines	155
Imarc Data Systems	23	Direct Data Marketing	8	Logitek	66,76	Rostronics	8
Appleware	120	D.D.P.	40	London Computer Store	26	Science of Cambridge	14,15
Barnes Consultants	148	Display Electronics	145	LP Enterprises	10,11	Sintrom Microshop	6
IB&B	161	E.G.A.	158	Mendip	144	Sirton Products	147
Bits and Pc's	154	Electronic Brokers	95	Microcentre	IFC	Slough Microshop	163
BNR & ES	152	Ensign	139	Microcircuit	136	Small Systems	12,156
Business & Leisure		Equinox	35/46	Microcontrol	90	Softwarehouse	7
Microcomputers	140	Farmplan	22,108	Microdata	159	Stack	3,16
Butterworths	44	Feldon Audio	91	Microdigital	9	Strumech (SEED)	100
Camden Electronics	97,160	Gata Microsystems	148	Microsolve	34	Sun	21
Carter Keyboards	154	Great Northern	26	Microtrend	103,105,107	Tandy	4,5
Comart	99,115	GW Computers	143	Mighty Micro	56	Tangerine	18,19
Commodore	38,42	Happy Memories	138	Mike Rose Micros	109	Teq Data	17
Computerama	137	A J Harding (Molimerx)	20	Mutek	157	Tex	154
Computer Centre	141	Heath	119	Newbear	62,149	Texas Instruments	34
Computer Consultancy	150	Henry's	136	Newtroniks	156	Theydon Computer	32
Computerist/Dair	146	HB Computers	69,142	NIC	144	Transam	112
Computermania	159	Hitech Electronics	138	North West	158	TVJ Microcomputers	2
Computopia	108	Intelligent Artefacts	142	On-line Conferences	33	Vlasak	24
CRA	163	Interactive Data	144	Optelco	160	Xitan	151
Crystal Electronics	152	Interface Components	153	Orchard	152	PCW would like to apologise to	
Cumana	162	Intex Datalog	136	Petalect	140	SIRTON PRODUCTS for the mistake	
		L&J Computers	138	Personal Computers	OBC	we made in their telephone	
						number last issue. This should	
						have been 01-668 0761	

SUPPORT MEMBERS OF THE COMPUTER RETAILERS ASSOCIATION...



THEY WILL SUPPORT YOU.

For further details on the associations aims, membership, code of conduct etc.

Please contact: Mrs H. Gibbons, C.R.A., Owles Hall, Buntingford, Hertfordshire. (0763) 71209.

## MICROCOMPUTER SHOPPING MADE SIMPLE

The Slough Microshop is the Thames Valley Specialist in microcomputer systems — for business, professional or personal use.

Our services include:

- \* TAILORMADE OR PACKAGED SOFTWARE
- \* COMPLETE HARDWARE MAINTENANCE SERVICE
- \* FULL DEMONSTRATION EQUIPMENT

We are the officially approved stockist for  
**COMMODORE PET**  
**EXIDY SORCERER**  
**NORTH STAR HORIZON**  
**APPLE II**  
**IMS 5000/8000**  
**EQUINOX 300**

Ask for a demonstration. Phone or call into the Slough Microshop showroom — where microcomputer shopping is made simple.

## THE SLOUGH MICROSHOP

120 High Street Slough Berkshire  
 Telephone: Slough 72470 or 22855

8MHz Super Quality Modulators	£4.90
6MHz Standard Modulators	£2.90
C12 Computer Grade Cassettes 10 for	£4.00
Super Multi-rail P.S.U. +5 -5 +12v	£29.50
ETI Breakout Game - Chip and PCB	£9.90
S100 Expansion Motherboard for Nascom I	£39.00
Anadex Printer Paper - 2000 sheets	£25.00
Floppy Disks 5¼" Hard & Soft Sector	£3.50
Floppy Disk Library Case 5¼"	£3.50
Eprom Boards	£63.00
8K Static Ram Boards - S100	£110.00
Cartridges for Grandstand	£11.99
George Risk Ascii Keyboard	£39.00
Cartridges for Atari - Full Range in Stock	£13.90
Interface PET IEEE - Centronics Parallel Not decoded	£49.00
Decoded	£77.00
Interface to Centronics parallel for TRS80	£75.00
Verocases for Nascom 1 & 2 etc.	£22.50
Keyboard Cases	£9.90
Electric Pencil for TRS80	£29.00

**SPECIAL SCOOP**

**GET YOURSELF A PRINTER FOR YOUR PET AND SAVE A FORTUNE**

only **£399 + VAT**

Full Pet Graphics including cables. Ready to go.

**EX-STOCK.**



**HITACHI PROFESSIONAL MONITORS**

9" - **£129**  
12" - **£199**

- **Reliability** Solid state circuitry using an IC and silicon transistors ensures high reliability.
- **500 lines horizontal resolution** Horizontal resolution in excess of 500 lines is achieved in picture center.
- **Stable picture** Even played back pictures of VTR can be displayed without jittering.
- **Looping video input** Video input can be looped through with built-in termination switch.
- **External sync operation** (available as option for U and C types)
- **Compact construction** Two monitors are mountable side by side in a standard 19-inch rack.

**A PROFESSIONAL WORD PROCESSING SYSTEM AND IT'S A COMPUTER AS WELL.**

**ALL FOR ONLY £3250 + VAT**  
including Word Pro and Cables.

**£790 + VAT**

**PET 32K** - This is the standard 32K Pet from Commodore. Reverse video and graphics allow the WordPro Package to give simple clear and easy to read displays.

**2040 Disk Drives** Twin disk drives allow large high speed storage for your letters, or paragraphs. Plugs in the back of the PET.

**NEC Spinwriter** NEC's high quality printer uses a print "thimble" that has less diameter and inertia than a daisy wheel, giving a quieter, faster, more reliable printer that can cope with plotting and printing (128 ASCII characters) with up to five copies, friction or tractor fed. The ribbon and thimble can be changed in seconds.

55 characters per second bidirectional printing - with red/black, bold, subscript, superscript, proportional spacing, tabbing, and much, much more.

**WordPro II** The heart of the system - consists of a ROM and diskette. The ROM is inserted into a space socket inside the Pet. One of the most versatile Word Processing Packages around.

**£1750 + VAT**  
RRP £2200

**All items sold separately.**

only **£356 + VAT**



**TRS80 LEVEL 2 16K**

Fully converted to UK T.V. Standard. Comes complete with easy to follow manuals. UK Power Supply - Cassette Leads - Sample tapes. Special box to enable you to plug into your own TV. Recommended for first time-buyers. Just plug in and go.

Full Range of Software Available  
Model with numeric key pad £389 + VAT  
4K Level I - machine only £251 + VAT

**NEW REDUCED PRICES**

8K **£449** + VAT  
16K **£549** + VAT  
32K **£649** + VAT



**RRP £795 for 32K**

**The PEDIGREE PETS**

Very popular for home & business use. 8K Microsoft Basic in ROM. 8K Pet 32K & 16K with new improved keyboard. All with green screen.

Extra cassette deck **£55** Full range of software available

32K **£690 + VAT**  
48K **£790 + VAT**



**RRP £859 for 32K**

**EXIDY SORCERER**

For Personal or Business Use.  
32K or 48K memory. 8K Microsoft Basic in ROM. Dual Cassette I/O, RS232 I/O. Parallel I/O (Centronics). Expansion available through optional extra S100 Motherboard. 69 Key keyboard including 16 key numeric pad.

**S100 EXPANSION - £199**

**NASCOM IMP PLAIN PAPER PRINTER**

**£325 NEW**

Fully built and housed in a stylish enclosure for just **£325 plus VAT**. Interfaces with all micro computers.

**The Nascom IMP (Impact Matrix Printer) features are listed below:**

- 60 lines per minute.
- 80 characters per line.
- Bi-directional printing.
- 10 line print buffer.
- Automatic CR/LF.
- 96 character ASCII set (including upper/lower case, \$, #, £).
- Accepts 8½" paper (pressure feed).
- Accepts 9½" paper (tractor feed).
- Tractor/pressure feed.
- Baud rate from 110 to 9600.
- External signal for optional synchronisation of baud rate.
- Serial RS232 interface with parallel option available soon.

only **£295 + VAT**

**TRS80 EXPANSION INTERFACE**

Expand your TRS80 by 32K. 32K Memory on board. Centronics parallel port. Disk controller card. Real time clock. Requires Level II Basic. Interface for 2 cassette decks, complete with power supply.



**RRP £540**

only **£4 + VAT**

**ANAD DP800**

Super Quality - Low cost printer. Tractor Feed with ASCII character set. Accepts RS232C at band rates between 100 and 9600 and Parallel Bit data. Attaches either directly or through interfaces to Pet, TRS80, Sorcerer, Nascom, Komputik etc.



**video 101**

12" BLACK & WHITE LOW COST VIDEO MONITOR

RRP **£79**

only **£69 + VAT**

- Ideal for home, personal and business computer systems
- 12" diagonal video monitor
- Composite video input
- Compatible with many computer systems
- Solid-state circuitry for a stable & still picture
- Video bandwidth - 12MHz + 3dB
- Input impedance - 75 Ohms
- Resolution - 650 lines Minimum
- Central 80% of CRT; 550 Lines Minimum beyond center



**NASCOM-2 MICRO-COMPUTER**

only **£295 + VAT**



**Your choice of freebies with every Nascom 2 purchased from us**

**either FREE POWER SUPPLY OR FREE GRAPHICS ROM OR FREE VERO CASE TO TAKE NASCOM 2**

**Microprocessors** Z80A. 8 bit CPU. This will run at 4MHz but is selectable between 1/2/4 MHz. This CPU has now been generally accepted as the most powerful, 8 bit processor on the market.

**INTERFACE**

**Keyboard** New expanded 57 key Licon solid state keyboard especially built for Nascom. Uses standard Nascom, monitor controlled, decoding.

**T.V.** The tv peak to peak video signal can drive a monitor directly and is also fed to the on-board modulator to drive the domestic T.V.

**I.O.** On-board UART (Int.6402) which provides serial handling for the on-board cassette interface or the RS232/20mA teletype interface.

The cassette interface is Kansas City standard at either 300 or 1200 baud. This is a link option on the NASCOM-2.

The RS232 and 20mA loop connector will interface directly into any standard teletype.

The input and output sides of the UART are independently switchable between any of the options - i.e. it is possible to house input on the cassette and output on the printer.

**PIO** There is also a totally uncommitted Parallel I/O (MK3881) giving 16, programmable, I/O lines. These are addressable as 2 x 8 bit ports with complete handshaking controls.

**Documentation** Full construction article is provided for those who buy a kit and an extensive software manual is provided for the monitor and Basic.

**Basic** The Nascom 2 contains a full 8K Microsoft Basic in one ROM chip with additional features like DEEK, DOKE, SET, RESET for simple programming.

With free 16K RAM board.

# COMPUKIT UK101

## EUROPE'S FASTEST SELLING ONE BOARD COMPUTER



- ★ 6502 based system — best value for money on the market.
- ★ Powerful 8K Basic — Fastest around
- ★ Full Qwerty Keyboard
- ★ 4K RAM Expandable to 8K on board.
- ★ Power supply and RF Modulator on board.
- ★ No Extras needed — Plug-in and go.
- ★ Kansas City Tape Interface on board.
- ★ Free Sampler Tape including powerful Disassembler and Monitor with each Kit.
- ★ If you want to learn about Micros, but didn't know which machine to buy then **this is the machine for you.**

Build, Understand and Program your own Computer for only a small outlay.

KIT ONLY **£199** + VAT  
NO EXTRAS NEEDED

AVAILABLE READY ASSEMBLED & TESTED  
READY TO GO FOR **£249** + VAT

Specialty designed case for CompuKit in orange/black. With room for accessories. **£29.50** + VAT

6502 Assembler/Editor for CompuKit **£14.90** + VAT

The **CompuKit UK101** comes in kit form with all the parts necessary to be up and working, supplied. No extras are needed. After plugging in just press the reset keys and the whole world of computing is at your fingertips. Should you wish to work in the machine code of the 6502 then just press the M key and the machine will be ready to execute your commands and programs. By pressing the C key the world of Basic is open to you.

This machine is ideal to the computing student or Maths student, ideal to teach your children arithmetic, and is also great fun to use.

Because of the enormous volume of users of this kit we are able to offer a **new reduced price of £199** + VAT

**NEW MONITOR FOR COMPUKIT UK101** • In 2K Eprom 2716  
• Allows screen editing • Saves data on tape  
• Flashing cursor • Text scrolls down **£22.00** + VAT

## THE NEW TRS80 SURPRISE — MODEL II

**Fast and expandable!**

Model II operates at twice TRS-80's high speed.

In addition to either 32 or 64 thousand characters (bytes) of internal Random Access Memory, one built-in 8" floppy disk stores an additional one-half million bytes, including the Disk Operating System. And you can easily expand up to a four-disk system for up to two-million bytes of storage.

Model II features upper and lower case letters. Its built-in 12" high-resolution video monitor displays 24 lines of 80 normal characters. The professional 76-key keyboard (with "calculator" keypad) includes advanced functions such as Control, Escape, Caps, Hold, Repeat. The keyboard is detachable and moveable for convenient data entry.

You get the enhanced Level III version of TRS-80's already-famous Level II BASIC language and "TRSDOS" operating system, automatically loaded in memory when you "power up." (About 24K of RAM is used by this software.)

Each time you power up, Model II thoroughly tests itself to insure proper operation. Your chosen program can appear immediately, without any intermediate steps or questions to answer.

### Versatility ... plug-in expandability

Built-in input/output capabilities include two RS-232C channels, and one Centronics parallel port. Future expansion is provided for through four plug-in slots for optional PC boards.

64K 1-Disk Model II **£2250.00** + VAT

### 1 DISK EXPANSION Room for 3

500K per Drive gives total of 1.5M Byte — 1 Drive plus Cabinet **£799** + VAT

Just Plug In

**WE ARE NOW EX-STOCK**

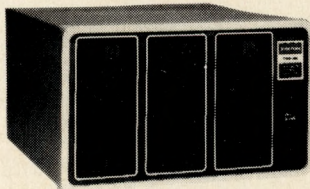

### Why do people buy more from COMPSHOP than anywhere else?

- ★ **LARGER STOCKS** — we hardly ever run out
  - ★ **GOOD SERVICE** — we give extended warranties on all our products.
  - ★ **EXCELLENT REPAIR SERVICE** — Through Computare we repair and maintain most makes of personal computers.
- LAST YEAR WE SUPPLIED TO THE PUBLIC — LARGE & SMALL**  
16,000 Television Games & 7,000 Computer Systems

### NEW TV GAME BREAK OUT

Has got to be one of the world's greatest TV games. You really get hooked. As featured in ETI. Has also 4 other pinball games and lots of options. Good kit for up-grading old amusement games.

**MINI KIT** — PCB, sound & vision modulator, memory chip and de-code chip. Very simple to construct **£14.90** + VAT  
**OR PCB £2.90 MAIN LSI £8.50** Both plus VAT

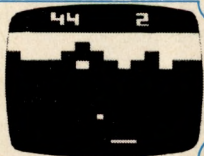

### THE ATARI VIDEO COMPUTER SYSTEM

**£99.00** + VAT

Atari's Video Computer System now offers more than 1300 different game variations and options in twenty great Game Program™ cartridges!

Have fun while you sharpen your mental and physical coordination. You can play rousing, challenging, sophisticated video games, the games that made Atari famous.

You'll have thrill after thrill, whether you're in the thick of a dogfight, screeching around a racetrack, or dodging asteroids in an alien galaxy. With crisp bright colour (on colour TV) and incredible, true-to-life sound effects. With special circuits to protect your TV.

**Cartridges now available** All at **£13.90** each + VAT

Basic Maths, Airsea Battle, Black Jack, Breakout, Surround, Spacewar, Video Olympics, Outlaw, Basketball, Hunt & Score\*, Space War, Sky Diver, Air Sea Battle Codebreaker\*, Miniature Golf.

Extra Paddle Controllers  
— **£14.90** + VAT

\*Keyboard Controllers  
— **£16.90** + VAT



"Europe's Largest Discount Personal Computer Store"

Please add VAT to all prices — Delivery at cost, will be advised at time of purchase. Please make cheques and postal orders payable to COMPSHOP LTD., or phone your order quoting BARCLAYCARD, ACCESS, DINERS CLUB or AMERICAN EXPRESS number. CREDIT FACILITIES ARRANGED — send S.A.E. for application form.

**14 Station Road, New Barnet, Hertfordshire, EN5 1QW** Telex: 298755 TELCOM G  
Telephone: 01-441 2922 (Sales) 01-449 6596

**OPEN - 10 am - 7 pm — Monday to Saturday**  
Close to New Barnet BR Station — Moorgate Line.

★ **NOW IN IRELAND** at: 80 Marlborough St., Dublin 1. Tel: Dublin 749933

**COMP COMPUTER COMPONENTS**

(Part of the Compshop Ltd. Group)



# "My best Apple programs are on long-term deposit in the City... it pays rather well!"

We brought the first five Apples into the U.K. in November '77, with every penny we had. In November '79, we find several thousand throughout the country.

*THANK YOU* Apple owners.

Now we'd like to help you re-coup your investment by cataloguing and supporting the best Apple programs in the U.K. The Apple Software Bank is more like an old penny bank than a major clearing bank, but we know you'll help it grow. Telephone Stephen Derrick on 01-626-8121 to discuss your investment.

**ATTENTION ALL** Estate Agents, Employment Agencies, Yacht Brokers, Antique Dealers and Motor Traders. Find out about *FINDER SOFTWARE!*

## **SOME BLUE CHIPS**

**TESKIM.** This ROM will simulate the Tektronix 4010 family of graphics terminals. It's rather good!

**UPPER LOWER CASE ADAPTOR** A chip for the chap considering word processing.

## **NEW ISSUES**

We are continually trying to bring the latest add-ons for your Apples. Please phone for the latest product information and data sheets.

## **NEW PRODUCTS**

**8" SHUGART DISKS** giving 1.2 Megabytes A twin drive (with room for a third.) disk system with controller and software, give tremendous commercial possibilities. £2350 Excl. V.A.T.

**WORD PROCESSOR.** Ask about our Apple II Plus word processor package. Complete System with Diablo 1650 Daisy-Wheel Printer. £4250 Excl. V.A.T.

**PERSONAL COMPUTER PRINTERS.** Sensational 40 & 80 Character printer (graphics options) from £243 Excl. V.A.T. Interfaces for Apple, Pet & TRS 80. High quality silent printers. It's your choice!

**A/D BOARD** At last we have either an 8 bit or 12 bit A/D card for Apple. Excellent spec from £125 Excl. V.A.T.

**APPLE PASCAL** £296



# Personal Computers Limited

194-200 Bishopsgate, London EC2M 4NR.

Let us advise you about *COLOUR DISPLAY* on your Apple. Contact Technical Services

