

Personal Computer

PET
ADD-ON
STRIKES CHORDS

Centre £2.20 (US \$2.95) (UK £1.10) (DM 2.00) FL 4.00
SP 34.00 (US 44.00) (UK 9.30) (DM 18.20) FR 2.00

World January 1981 60p

EUROPE'S LEADING MICRO MAGAZINE



THE BLAND LEADING THE BLIND?
Secrets of business computer buying

The best computers PLUS the best service

At MicroCentre, we're concentrating our resources on what we genuinely believe are the very best computers available today. . . . Cromemco computers, naturally. This way we can offer you the best deal possible.

What we don't do

What we don't do is spread our expertise thinly amongst umpteen different systems, or try to stock every S100 product on the market. We don't claim to offer "impartial" advice on the best buy. And we don't sell from price lists or catalogues.

The MicroCentre approach

Some micro-computer suppliers work like that, but we don't. Because we realise that when you're buying a computer you want more than the "brochures and boxes" approach. You want to see computers running; to try them out with different software products; to study the documentation; above all, you want expert answers to your most searching questions.

Cromemco specialists

That's why we've specialised in Cromemco systems. Not simply because we think Cromemco systems are the best serious computers available at the price.



MicroCentre's Cromemco demonstration room, with the full range of Cromemco computers, peripherals, operating systems and software products on permanent exhibition. Why not pay us a visit? We're only an hour's Shuttle flight from Heathrow!



Cromemco Model Z-2H hard disc computer. 10 megabyte hard disc, 2 floppy discs, Z-80 computer and 64K memory. MicroCentre price £5,326.

But because by doing so we can dedicate our time, energy and resources to giving you the highest standard of Cromemco support possible.

demonstration; expect the full range of Cromemco peripherals; single-user and multi-user systems; and interactive graphics.

Demonstrations

So when you visit MicroCentre expect to find Cromemco systems on permanent

Software

Expect a choice of operating systems and compilers to evaluate; expect complete documentation; and expect the largest collection of Cromemco systems software in the UK.

Expertise

Expect to find in-depth professional expertise at MicroCentre, the kind that is only acquired by installing Cromemco systems all over Britain. Expect a thorough appreciation of how Cromemco systems can be applied . . . in business, scientific research, industrial engineering, medicine and education.

Support

Expect to get frank, accurate answers to your questions at MicroCentre. Above all, once you've bought a Cromemco system from us, expect to get a very high standard of technical support with your hardware enhancements and continuing software needs.

At MicroCentre, simply expect the best.

For  **Cromemco... call the experts**

**NOW IN SPACIOUS
NEW SHOWROOMS**

Tel. 031-556 7354

Micro Centre

**STILL IN
CENTRAL EDINBURGH**

Complete Micro Systems Ltd., 30 Dundas Street, Edinburgh EH3 6JN

CONTENTS

Volume 4 No 1 January 1981

Founder
Angelo Zgorelec

Editor
David Tebbutt

Deputy Editor
Peter Rodwell

Sub Editor
Jon Wall

Art Director
Paul Carpenter

Art Assistant
Shelley Gray

Editorial Office
14 Rathbone Place
London W1P 1DE
01-637 7991

Advertisement Director
Stephen England
01-636 4461

**Assistant Advertisement
Manager**
Patrick Dolan
01-636 4463

Advertisement Executive
Jacquie Hancock
01-631 1682

Production Manager
Dick Pountain

Typesetter
Jane Hammell

Published by SportsScene
Publishers (PCW) Ltd., 14
Rathbone Place, London
W1P 1DE, England. Tel:
01-637 7991/2/3. Telex:
8954139 A/B 'Bunch' G
London

Copyright notice
Personal Computer World is
published by SportsScene
Publishers (PCW) Ltd. © 1980

Felden Productions. No
material may be reproduced
in whole or part without
written consent from the
copyright holders.

Printed by Riverside Press
Whitstable

40 NEWSPRINT: Guy
Kewney reports on
the latest micro happen-
ings.

**48 WEST COAST
FAIRE: GOTO**
California next Spring
with PCW.

49 CTUK! NEWS:
Yes, Computer-
Town UK! is happen-
ing — we bring you the
latest developments.

**50 COMMUNICA-
TIONS:** Our readers
in their own write.

53 BENCHTEST:
Lyn Antill builds
and tests the Transam
Tuscan.

58 PRINTERS: We
update last August's
printer survey.

**65 JOANNE LOVES
MAVIS:** How
micros have helped one
little girl overcome her
handicap.

**69 SECRETS OF
SYSTEMS ANALY-
SIS:** Lyn Antill continues
her series with tips on
handling salesmen.

71 COMPETITION:
Win £100 in a
'help the handicapped'
essay comp.

73 BOOKFARE:
Malcolm Peltu has
something for everyone
this month.

**77 GET ON THE
RIGHT TRACK:**
Real-time control using
trains as an example.

**81 GATEWAYS TO
LOGIC:** Derrick
Daines continues his
series on teaching micro-
computing.



Cover Illustration Colin Hadley

**85 YOUNG COMPU-
TER WORLD:**
Especially for our
younger readers.

**86 COMPUTER
ANSWERS:** Your
problems answered by
Sheridan Williams and
his team.

**89 COMPUTER
GAMES:** David
Levy takes an in-
depth peek at poker.

94 FACE TO FACE:
Continuing his
series on the man/
machine interface,
David Hebditch looks at
finite state automata.

97 PRINTERFACING:
Hook a printer to
your micro, with Peter
Faff.

**105 GET WELL
SOON:** How to
recover from a data tape
disaster.

109 PET QUARTET:
Don Finlay gets
his PET to 'sing'.

113 MICRO CHESS:
With our resident
chess expert Kevin
O'Connell.

**115 MULTI-USER
SYSTEMS:** Sue
Eisenbach and Dr Adrian
Stokes start a new series.

**116 CALCULATOR
CORNER:** Some
handy routines for
Casios.

121 PCW SUB SET:
Alan Tootill
brings you more useful
assembler sub-routines.

**124 FEATURE
INDEX:** The
complete listing for
1980.

**125 NEWCOMERS
START HERE:**
A quick intro for those
new to the micro scene.

**126 DIRECT
ACCESS:** with
PACKAGES, DIARY
DATA, TRANSACTION
FILE, and USER
GROUPS.

136 PROGRAMS:
Our readers'
latest listings.

**146 LEISURE
LINES:** More
brainbursters from
J J Clessa.

183 CHIP CHAT:
Europe's leading
microgossip page.

Coming shortly models 82 & 83

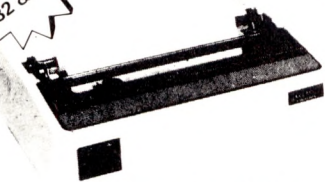

Oki Microline 80

THE WORKHORSE MICRO PRINTER
- Small, light, quiet matrix printer.

- * 40, 80, or 132 cols. * 6 or 8 lines per inch
- * 96 ASCII + 64 graphics character set with Centronics compatible interface * 9x7 matrix
- * 80 chs. per sec. * 200 x 10⁶ head warranty
- * No duty cycle limitation * Double width characters * Friction and Pin Feed * Rugged business use - metal chassis - two motors

Now ONLY £349 + VAT RS232 option available

Compukit UK101 DISC DRIVES

with up to 32k RAM exp



free games disc

* 9 Digit extended Basic
* Plugs straight into 8k Compukit requires no hardware mods. (5v.5A required for 610)
610 Expansion (8k) ONLY £159 + VAT
Disc Drive with DOS ONLY £285 + VAT

EXATRON Stringy Floppy

COMBINES ECONOMY OF CASSETTE WITH SPEED & RELIABILITY OF DISC

16k loads in approx. 24 secs. - Wafers to 75ft (48k approx.)



PET ONLY	TRS 80 ONLY	APPLE ONLY
£199 + VAT	£188 + VAT	£199 + VAT

Stringy Floppy with 10 Wafers (Tapes) BUS EX. 2 for 1. Machine Lang. Monitor

Base 2 MODEL 800MST

80 COLUMN HIGH PERFORMANCE IMPACT PRINTER - suitable for most Micros.

JUST LOOK AT THESE STANDARD FEATURES:-



- * RS-232, 20mA, IEEE 488 and Centronics I/O
- * 15 Baud rates to 9,600 * 100 Chrs. per second - Bidirectional * 6 print densities 60, 72, 80, 96, 120 or 132 Chr/line * Self test switch * 96 Chrs. ASC II Standard * Auxilliary User Defined Ch. set * Tractor and fast paper feed/graphics
- * 2k Buffer * Accepts 8 1/2" max. paper pressure feed and 9 1/2" max. paper tractor feed.

Now ONLY
800 MST £295 + VAT
850 MST £375 + VAT

Model 850 - utilises Fifo, 125cps.

Anacom 150

150 CPS, 15" carriage dot matrix printer



£699 + VAT

- * 150 chs per sec * 9 x 9 dot matrix
- * 10 chs per inch horizontal * 6 or 8 chs vertical * 136 columns, 13.6" line length * 94 ASCII chs
- * Upper and lower case with decs. * Logic seeking * Centronics and/or RS232

NEVER KNOWINGLY UNDERSOLD
WE WILL MATCH OR BEAT ANY PRICE CURRENTLY ADVERTISED FOR THESE PRODUCTS

excel Discs



10 x 5 1/4" ONLY £18.50 + VAT

WITH HUB RING

+ FREE LIBRARY CASE

Epson MX 80 - COMPLETE RANGE OF INTERFACES TANDY, SHARPE, PET, APPLE, etc.

- * 9x9 dot matrix * Logic Seeking * Bi-directional
- * 96 ASCII Characters * 64 Graphics and 8 International Characters * Centronics I/P with optional RS232 and IEEE 488 * Four print densities 40, 80, 66 or 132 columns * Multiple type fonts * Self Test * Self Diagnostics
- * Buzzer for end of paper and bell code error

Now ONLY £359 + VAT

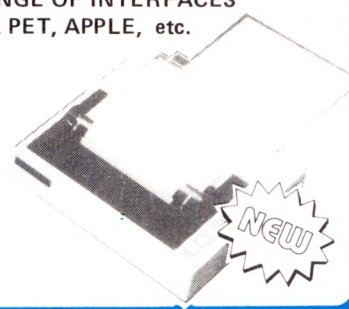

NEC Spinwriter



- for the professional word processing system

£1390 + VAT

Model 5510 - RS232, Model 5530 Centronics 8bit par. NEC's high quality printer uses a print "thimble" that has less diam. and inertia than a daisy wheel. Giving a quieter, faster more reliable printer that can cope with plotting and printing (128ASC II chs.) with up to 5 copies, friction or tractor fed. 55Chrs/sec.

Dip 81 FULL 80 COLUMN IMPACT PRINTER



100 characters per second, bidirectional, low profile, ideal for hobby or educational. at ONLY £249 + VAT

Ohio Superboard III & Challenger 1P Series 2



- the no fuss start to Micro's.

* Ready Built 8k Microsoft in ROM, 6 digit floating point basic plus full features. 4kRAM - expandable to 32k.

SUPERBOARD III (24x24 format)	£159 + VAT
or switchable to 48 x 12	
POWER SUPPLY 5v, 3A	£27 + VAT
CASE	£29 + VAT
CHALLENGER 1P Series 2	£219 + VAT
(Superboard is used in Challenger)	

Micro Peripherals

(MITRECREST LIMITED)

formerly Mighty Micro

FULL SERVICE BACKUP - FULL DETAILS ON REQUEST INCLUDING PRINTOUT
Please add VAT @ 15%. Carriage extra, will advise at time of order. Official orders welcome

61 NEW MARKET SQUARE, BASINGSTOKE, HAMPSHIRE

Telephone: Basingstoke (0256) 56468 and 56417 (4 lines)

Buy in confidence. If on receipt of your order the goods do not meet with your satisfaction, return within 7 days for full refund. Credit facilities arranged.

DISCOUNTS: Attractive quantity discounts for OEM, Educational & Dealers also in association with O.S.I. Computers, Esher, Surrey. Telephone: 0372 62071



COMPUTECH for

COMPUTECH for **ITT**

Well proven software for business applications on the
ITT 2020 and Apple microcomputers.

Prices excluding V.A.T. for cash with order, F.O.B. London NW3

PAYROLL	(300+ Employees, 100 Departments, hourly, weekly, monthly. Very powerful but easy to use).	£375
SALES LEDGER	(500+ Accounts, 100 Departments).	£295
PURCHASES LEDGER	(500+ Accounts, 100 Departments).	£295
GENERAL (OR NOMINAL) LEDGER	(1000 Accounts, 100 Analyses, multi-purpose package). Job costing etc.	£295
UTILITIES DISK 1	(Diskette patch, slot to slot copy, zap etc).	£20
APPLEWRITER	(Word Processing, see below for U/L case).	£42
VISICALC	(Financial Modelling, Costing, Analysis).	£95
CAI	(Converts Apple pictures for ITT display).	£10

Over 500 packages in use, fully supported by us.

AND NOW HARDWARE!

LOWER & UPPER CASE CHARACTER GENERATOR £50
Replaces character generator to display upper and lower case characters on screen, includes patches to work with Applewriter, supplies the missing link! Specify Apple or ITT.

COMPUTECH DIPLOMAT H/S SERIAL INTERFACE £80
This card has been designed and built to the same professional standards that have resulted in the success of our software. The DIPLOMAT observes the proper "handshaking" protocol so that you can drive fast printers and send and receive data from other peripherals at high speeds without loss of data. Switch (& software) selectable baud rates to 19200 and many other options. Plug compatible with 'terminal' or 'modem' wired peripherals. Guaranteed.

MICROLINE M80 PRINTER £425
This neat, reliable machine prints at 10 characters per inch, 80 characters on an 8 inch line, or 40 expanded characters, or 132 very readable characters, upper and lower case and graphics, 9 x 7 dot matrix, 6 or 8 lines per inch. Parallel interface is standard, serial optional. Both friction and sprocket feed are standard, tractor optional. We can also supply the parallel interface card for Apple System computers for £80 and a driver to enable both text and graphics to be used. Optional custom colour matching for Apple or ITT. Optional character sets. *Trade supplied at very generous discounts for modest quantities.*

THE FABULOUS MICROMUX 8000 from £800
This is a brand new product, an asynchronous serial multiplexor with up to 16 ports, any one of which may communicate with any other independently, like a 'telephone exchange' for data! Built in test function. Firmware may be customised for special applications. Available in multiples of 4 ports up to 16.

COMPUTECH SYSTEMS

168, Finchley Road, London NW3 6HP. Tel: 01-794 0202

AGENTS THROUGHOUT THE UK AND OVERSEAS

From Motor...

The way things are developing leaves little doubt: while the motor was in every sense the driving force in the first half of the present century, the second half will clearly belong to the dator. The nearer the good old motor, as an additional source of power in our daily lives, gets to the limits of its capabilities, the more the new dator will be called upon to keep things moving. Less motorization – more datorization.

The history of the motor and the development of the dator are strikingly similar. Available in its early days only to a selected few, the motor is nowadays indispensable to almost everybody. Once the engineers and the businessmen had realized its tremendous potential, things began to move – literally – much faster and very soon almost everyone had his own car, his own private means of transport, for bu-

ness and pleasure alike. The 1980s will be for the dator what the 1920s were for the motor. But with one little difference: the “luxury” of a professional, reliable high-performance data processing machine is in fact something we can all afford now. For business or private use. Even people who, technically speaking, haven’t a clue will find it almost impossible to go seriously wrong with a modern dator.

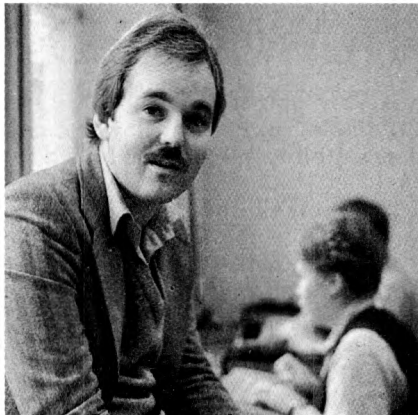
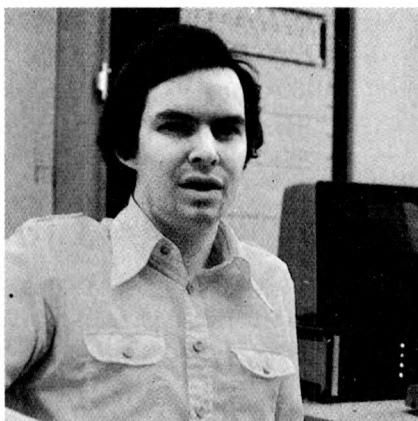

G.L. runs a small company specializing in exclusive equipment and fittings for boats:

“The ABC80 is my dator for costing and checking materials, invoicing, work planning and word processing. I can now do my invoicing 8–10 times faster. Suddenly I’ve got enough time again and don’t have to rely anymore on my old rule-of-thumb calculations. And my wife does our word processing on the dator as well.”

H.W. is an executive in an international food manufacturing group:

“The ABC80 is my dator for developing programmes for the central computer. At last I can do my programming in peace and quiet – and the company saves up to 30% into the bargain, because I no longer need to work on-line.”

P.A. is production manager in a medium-size factory making effervescent tablets:

“The ABC80 is my monitoring and control dator. You can’t imagine the problems even a missing tube-cap used to cause on our packaging line in the old days. Now, with uniform production throughput, we’re not only saving time and money – we’ve also built up a great working atmosphere among our personnel.”

C.W. is a teacher in a perfectly ordinary school in a small town:

“The ABC80 is our dator for teaching and learning. Every student learns in five lessons how to write his own programme, get rid of his computer complexes and is far better prepared for almost any career.”

P.A. is an engineer in a laboratory investigating air conditioning systems:

“The ABC80 is my dator for calculating fan performance. Waiting for days for data from our central computer department is a thing of the past for me. If I’ve got an idea – or a customer comes up with one suddenly on the phone – I can get cracking on my dator right away. That’s what I call service.”

H.E. has three children and is a dyed-in-the-wool private user:

“The ABC80 is my home dator. Before I got it I hadn’t the faintest idea about computers. Now I know that there’s nothing magic about them. And I’ve discovered that you can do no end of useful things with them – quite apart from the fun we all have with the dator almost every day.”

...to Dator*

So much for these six satisfied users selected from the total of ABC 80 dator pioneers which now exceeds 15,000. Now let's see what the ABC 80 dator engineers at Luxor – Sweden's leading manufacturer of sophisticated electronic equipment, have to offer:

The screen: 12" with built-in sound generation and graphics/View data-compatible/Real-time clock.

The keyboard: High quality com-

ponents/National typewriter standards with umlauts/Special shift key for letters and bounce-free function up to 30 characters per second.

The microprocessor: Built into the keyboard/Z80A with 16K Basic Interpreter and 16K user storage/Basic version also has interfaces for parallel, V24 and cassette connections.

The cassette tape unit: Double-frequency encoding with transmis-

sion rate of 700 baud/Start and stop program controls/Fast forward and reverse/Counter.

The main options: User storage can be extended up to 32K/Diskette storage up to 2x1MBytes/Daisy-wheel printer with standardized interfaces/Separate numerical keyboard/Plotter/Digitizer/Video and colour TV adaptor/UART/IEEE adaptor/AD and DA converters/Relay matching.

*Swedish for computer



ABC 80 – The professional microcomputer from Luxor in its basic version: display unit, keyboard and cassette tape unit.

The comprehensive Basic Interpreter is ideal for convenient writing of sophisticated programs. The following standard applications are available: book-keeping / invoicing / stock control / salaries and wages / word processing / address register / data bank administration. Other programming languages are possible.

datormark



Datormark Ltd
Seven Hills Road
Walton-on-Thames
Surrey KT12 4DG / England

W M
Wilfried Maier / Markenentwicklung



Please complete in block capitals and mail to:

Datormark Ltd / Fox Oak / Seven Hills Road / Walton-on-Thames / Surrey KT12 4DG / England



My special interest is:

Name:

Address:

Company:

Town / Post code:

Position:

Telephone:

Please send me literature on the ABC80.

Please let me know my local ABC80 dealer.

Enquiries from dealers invited.

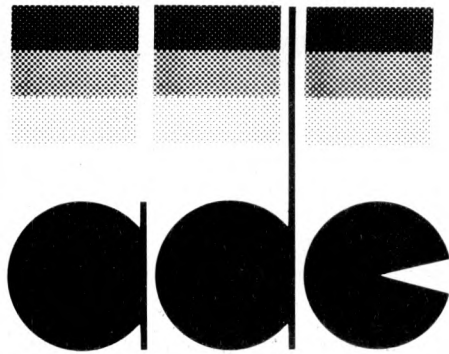

The Peripherals Supplier for the Thinking Man!

We are the peripherals suppliers who do more than just supply.
We get you going . . . and keep you going – with expert maintenance
and service back-up on the machines that we supply.

We sell: Low cost 80 col/100cps and 132 col/150cps matrix printers
High quality Qume Sprint 5 daisywheel impact printers
An impressive new family of VDU's - three models to suit
all requirements.

We are appointed distributors for peripherals we sell and provide full engineering back-up.
We sell end user and OEM. And we stock a wide range of supplies and accessories.

So, before you buy, make sure you've got details from ADC.
Because you may find you'd prefer to rent . . . and we do that, too!
Contacting us won't cost you a thing - and we've a great deal to offer.

access data communications ltd.

Access Data Communications Ltd.,
228, High Street, Uxbridge, Middlesex.

Telephone: Uxbridge (0895) 30831 or 59205.

VISICALC™

VISICALC AND A PERSONAL COMPUTER DO TO THE CALCULATOR, PAPER AND PEN WHAT WORD PROCESSING HAS DONE TO THE TYPEWRITER AND PAPER. REVOLUTIONIZE IT.



Take virtually any problem you would explore using calculator, pen, and paper, working in rows and columns. Apply VisiCalc and you'll see why every reviewer of this product has said the same thing: VisiCalc is the most useful, most important program yet developed.

With VisiCalc, you work with an electronic worksheet of up to 63 columns and 264 rows. At the juncture of any column and row you can type in words or numbers. To put VisiCalc to work, you first create any format or form you need by typing in words — just like writing column headings across the top of a piece of paper and items down the left side. Then, where you want the worksheet to perform a calculation, you type a formula. VisiCalc automatically performs all arithmetic functions, net present value, and transcendental functions. Instantly — and we mean instantly — VisiCalc displays the results. And if you change any of the numerical data, the electronic worksheet instantly displays a new result. Automatically. You can play "what if" as often as you wish to solve thousands of different problems. When finished, you can get a hard copy of all the information on your worksheet from your computer printer.

Absolutely no programming is necessary. VisiCalc does all the work. Now, isn't THAT magic?

ANYONE WHO WORKS WITH NUMBERS USES VISICALC:

Managers and Management consultants: plan budgets, compare actual results to budgeted forecasts, and modify projections faster than ever before. VisiCalc is the most powerful and easy-to-use projection tool ever developed.

Financial Analysts: quickly determine rate-of-return under varying assumptions using the built in net present value functions. VisiCalc will also compute financial ratios, and project tax consequences.

Accountants: develop financial statements and "pro formas", making changes and comparisons easily with VisiCalc's ultimate "what if" recalculation feature.

Tax Accountants: compute the tax effects of many alternatives, and print out all the different scenarios for client discussion and documentation.

Engineers and Scientists: appreciate VisiCalc's transcendental functions, scientific notation, and features like eleven-digit precision in numeric calculations.

Marketing Managers: find VisiCalc is the answer to every forecasting and budgeting need. They refine assumptions-commission rates, sales costs, advertising expenditures, leads, sales closing percentage - and watch the effect on the bottom line.

For Apple II

£69.50

+ VAT

For PET

£99

+ VAT

CCA DATA MANAGEMENT SYSTEM™

The CCA/DMS stores and retrieves information. It is very simple to learn and use, and at the same time provides real data processing capabilities for you and your APPLE II.

You can computerize most, if not all of your record keeping. DMS will give you control over any type of information which lends itself to "row and column" storage, retrieval and analysis.

If you are familiar with the concept of a computer "data base" the power and flexibility of the DMS will amaze you. If you are not familiar with "data base" operation, don't worry. It is logical and

CCA/DMS FEATURES:

- Fields may be alphanumeric, numeric, integer, floating point, or fixed decimal with commas.
- Fields may be COMPUTED FIELDS.
- Fields may be alphanumeric, numeric, integer, floating point, or fixed decimal with commas.
- Fields may be COMPUTED FIELDS. DMS will compute any field within a record, using constants or other fields in the same record. Functions include add, subtract, multiply, divide and raise exponential powers.
- Records are easily located, using the scan feature. Scan for records with a field over, below, or between a range of values.
- Records are easily added and updated. DMS "prompts" you with questions.

simple. You'll find it easy to store the system, sort, update and print all kinds of files. Files for your mailing list, accounts receivable or payable, customer list, expense reporting, budget analysis, or any report you need. The 130 page manual has full instructions plus samples for a mailing list and inventory application.

For Apple II

£46.50

+ VAT

A MUST FOR EVERY APPLE II IN BUSINESS

- Multi-diskette capabilities for larger files-up to 85,000 characters per file!
- Sort the records into almost any order, using up to 10 fields as "keys". So you can sort for customer numbers; within zip code, for instance.
- Delete records, "compact" files, and backup files on data diskettes easily.
- Print reports with records in any order.
- Select fields to be printed.
- Print mailing labels.
- Numeric totals and subtotals can be specified when a value in an unrelated field in the same record changes. For example, sort, subtotal, and print according to department, or month, or customer number, or model number.

DESKTOP PLAN — A Programming Language for Analysis

Desktop plan is the software tool that makes it practical to develop your own customized. . . .

- | | |
|----------------------------|-------------------------------|
| Strategic plan analysis | Profit & loss projections |
| Budget planning system | Manpower requirement planning |
| Capital budget planning | Salary/labor cost planning |
| Cashflow planning | Balance sheet projections |
| Product pricing analysis | Financial report preparation |
| Job development estimating | Make/buy analysis |
| Job cost estimating | Sales forecasting |

... WITHOUT PROGRAMMING AT A LOW ONE-TIME COST!

£46.50

+ VAT

FORTRAN FOR YOUR APPLE



£110

+ VAT

FORTRAN is a powerful programming language, especially suitable for work in mathematics, engineering and the sciences. Apple FORTRAN, usable with the Apple Language System, is the ANSI Standard Subset of the recently-defined FORTRAN 77 standard, in several areas. Apple FORTRAN contains enhanced features and capabilities.

Apple is providing FORTRAN for use by technical professionals and educators who are both familiar with the FORTRAN language and are using packages written in FORTRAN. Because FORTRAN is a well-established language, large libraries of FORTRAN programs are already in existence, particularly for engineering and scientific applications. Apple FORTRAN provides the sophisticated FORTRAN user with the capability to develop new and modify existing FORTRAN programs on an Apple. Apple does not recommend FORTRAN for the individual new to programming.

There are two minor differences between the ANSI Standard Subset FORTRAN 77 and Apple FORTRAN. They are:

- Subprogram names cannot be passed as parameters
- INTEGER and REAL data types have different storage requirements—two bytes for INTEGER, four bytes for REAL

Apple FORTRAN is written in Pascal and produces P-code which runs in the Apple Pascal Operating System

Diskettes: 16 sector format

To use Apple FORTRAN, you will need:

- Apple II or Apple II Plus, each with the Apple Language System.
- Apple Disk II drive with controller*
- video monitor or television

*While a single drive system is adequate for very small programs, two drives are strongly recommended for ease of operation and more serious program development

Apple FORTRAN...

- offers enhanced features and capabilities because it supports the newest computer industry standard, ANSI X3.9-1978.
- provides a comprehensive software design environment including an editor, linker, file handler, assembler, Apple Pascal compiler, and system library, operating in the Apple Language System.
- eliminates the need to recompile or reassemble existing code files when incorporating them into FORTRAN programs, compiled P-code and assembled machine code can be combined with a FORTRAN P-code file through the Apple Language System's linker facilities.
- allows you to take full advantage of Apple's Hires graphics capabilities by interfacing to graphics routines in the system library.
- gives programmers access to large libraries of material, since FORTRAN is a familiar, well-established language.
- provides access to special Apple features, such as sound generation and control paddles, through its system library routines.
- permits you to combine several source files in a single compilation through compiler directives in the source code.

First, Some Words About FORTRAN 77

FORTRAN 77 contains significant additions and enhancements to the previous 1966 standard. For example, mixed-mode arithmetic expressions are allowed. Structured programming is supported through expanded IF statement constructs: Logical IF, Block IF, ELSE IF, ELSE, and END IF. Statements provide a vastly improved method of clearly and accurately specifying the flow of program control. CHARACTER data type replaces Hollerith, alphanumeric data can be represented as strings rather than array elements.

Some Specifics About Apple FORTRAN

- Apple FORTRAN is the ANSI Standard Subset FORTRAN 77. It also supports enhancements and facilities from the full FORTRAN 77 language. In particular:
 - Subscript expressions may include array elements and function calls
 - DO statement limits may be defined by expressions, rather than just single variables
 - I/O units may be specified by expressions, rather than just constants or simple variables
 - The I/O list of a WRITE statement may include expressions
- All combinations of FORMATTED/UNFORMATTED and SEQUENTIAL/DIRECT files are allowed, with the following restrictions:
 - BACKSPACE is supported only for files connected to the blocked devices, it is not supported for UNFORMATTED SEQUENTIAL files.
 - DIRECT files must be connected to blocked devices

Apple FORTRAN contains a number of enhancements beyond the full FORTRAN 77 specifications. In particular:

- Compiler directives may be included in the source code. For instance, the \$INCLUDE directive allows you to insert previously-developed code into your program without having to repeat the code. This is useful, for example, when you are writing many subroutines which use the same COMMON block. You can write the COMMON block just once, and \$INCLUDE it in every subroutine
- An additional parameter to the OPEN statement allows you to specify whether the file is blocked or unblocked



APPLE II PLUS

When Stephen Jobs and Steven Wosniak launched their first APPLE II, they were far from realising the worldwide success this microcomputer would have. Nearly anything can be done with the APPLE II. Whether it be business, science, leisure or art, your APPLE II can handle it all. (We've even seen an APPLE preparing coffee lately!)

It's full expansion capabilities enable you for example to connect your APPLE II to 4 disks, 2 printers, one tape cassette recorder, and one optical pen still leaving you room for 4 other connections. Therefore your APPLE will never become out of date and will always be able to adapt to new techniques, however versatile or varied the they may be.

Two types of computers are now available:

— APPLE II: this system is supplied with INTEGER BASIC, high resolution graphics routines, mini-assembler, disassembler and system control firmware in ROM. Demo programs and manuals are oriented around INTEGER BASIC.

— APPLE II PLUS: this system is supplied with APPLESOFT extended BASIC (including high resolution graphics routines), disassembler and new auto-start system control firmware in ROM. Demo programs and manuals are oriented around APPLESOFT extended BASIC.

Integer Basic or Applesoft Basic are available as plug-in card options for 110. — each.

Both APPLEs are based on the 6502 microprocessor, they include: sockets for up to 48K RAM, 8 peripherals board connectors, speaker, two hand controllers, cassette interface, colour graphics hardware, I/O connectors and typewriter style ASC II keyboard.



APPLE 16K: **£595** + VAT

16K ADD: **£49** + VAT

PRINTERS

Centronics 730 **£ 390** + VAT

Centronics 737 **£ 490** + VAT

Axiom IMP 2 **£ 530** + VAT

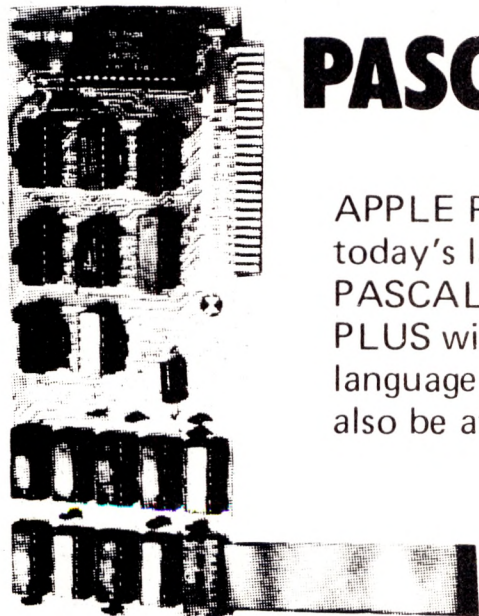

PASCAL LANGUAGE CARD

APPLE PASCAL offers extended features employing today's latest high-level structure programming language. PASCAL operates in a 48 K APPLE II or APPLE II PLUS with one to six disk drives and the APPLE language system. An external 80 column terminal can also be attached.

£230 + VAT

PET 2001 - 2008 - 3016 - 3040 **3022 - 8050 - 8032**

This family of Basic systems compares quite favorably with mini and large computer systems. These systems are highly competitive in maintaining financial records, storing records, controlling appliances, typewriting, sales analysis, and inventory control. PET systems are just what the small business user needs. It may also be scaled down to the users particular needs. Their applications are endless. PETs are popular not only in business but also at home. They have a self-contained monitor. The PET is concisely built with its numeric key pad key board.

8K, 16K, 32K memory

Full expansion capabilities for cassette, disks and printer.



PET 2001 - £389 + VAT

PET 2001 This microcomputer has the small keyboard and the Integral tape deck. Also comes with 8K Byte memory.

£389 + VAT

PET 2008 A popular micro-computer build with a green self-contained monitor with new large keyboard. Comes with 8K Byte memory:

£425 + VAT

PET 3016 This model has also the new improved large keyboard and Integral screen. It has 16K Byte memory.

£540 + VAT

PET 3032 £595 + VAT

PET 3040 Dual Drive Disk System: Built for the PET micros, it allows you rapid access to both programs and data. 343K user storage.

£595 + VAT

PET 3022 PRINTER (tractor feed): Prints on multiple copy paper all the PET characters, letters, numbers, and PET graphics,

£399 + VAT

ALSO AVAILABLE: PET 8050: £850 + VAT. PET 8032: £850 + VAT

PET 3040 Disk Systems

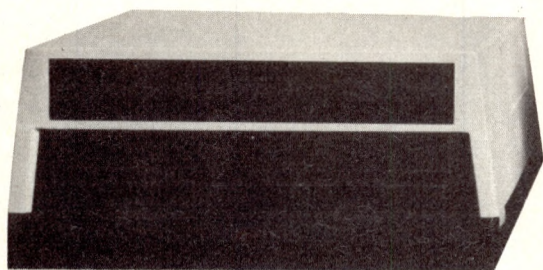

£650 + VAT

PET 3022 Printer (Tractor Feed)



£399 + VAT.

IF NOT SATISFIED MONEY WILL BE REFUNDED

If within 30 days you are not entirely satisfied with your purchase, send it back to us and money will be refunded.



CP/M FOR YOUR APPLE !!

The Microsoft Z80 Softcard

- A LITTLE STROKE OF GENIUS FOR YOUR APPLE II.

£172

+ VAT

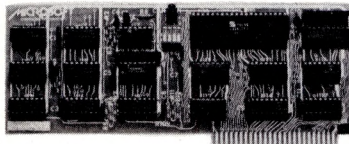

TRANSFERRING STANDARD CP/M APPLICATION PACKAGES TO APPLE CP/M

Literally thousands of CP/M based applications can be easily transferred to run on the Apple. It is simply a matter of converting programs from standard 5" and 8" CP/M disk format into CP/M disk format. This is done by transferring CP/M files from a CP/M machine to the Apple via a serial I/O port. You'll need an Apple High Speed Serial interface or an Apple Communications interface; a connecting cable; and, of course, a CP/M machine from which to transfer. Utilities that make this process easy are supplied with the Z-80 SoftCard.

USING PERIPHERAL WITH THE Z-80 SOFTCARD

A Z-80 SoftCard system will run with all standard Apple peripheral I/O cards and most independent peripherals including any printer that is supported by Apple printer interface cards. Since CP/M provides the same I/O environment as Apple Pascal, a good rule of thumb is that the SoftCard will interface with any peripheral that currently works with Apple Pascal.

The Z-80 SoftCard will support up to six disk drives, 24 x 80 column video cards such as the Videx and Sup-R-Term are supported as are most popular 80 column terminals such as those from Hazeltine and Soroc.

In addition, user I/O drivers can be easily added to CP/M.

WHY CP/M?

Next to the SoftCard itself, CP/M is the most important key to allowing a wide variety of Z-80 software to run on the Apple including version 2.2 of the CP/M operating system in the SoftCard package.

More software choices for the user. You have your choice of many sophisticated system, word processing, accounting, business and professional software packages when you have CP/M.

Unlike standard Apple DOS, CP/M supports many languages in addition to BASIC. These include FORTRAN, COBOL, BASIC Compiler.

And CP/M has many conveniences not found in Apple DOS. Such as easy interface to machine language programs; faster disk I/O simple file transfer; and wild card file-naming conventions that allow you to refer to multiple files with one name.

Included as standard with CP/M 2.2 is a complete set of system utilities that give you complete control of the CP/M operating environment. These include PIP, a general purpose file transfer utility and STAT, a program that lets you keep track of important system information such as disk space and file size. SUBMIT and XSUB allow you to execute batch processing jobs. And a powerful text editor, assembler, and sophisticated assembly language debugger, are also included.

The Z-80 SoftCard is not an emulator. It is an actual Z-80 chip plus interfacing circuitry on a circuit board that plugs directly into any of the slots on your Apple (except slot 0).

The Z-80 does not replace your 6502; it adds to it. You use Z-80 mode when you want to run Z-80 software. Switching back and forth is simple.

When you are in Z-80 mode, the Z-80 assumes all the processing tasks, but the 6502 continues to handle I/O. Thus, you can still use most Apple peripherals when you are in Z-80 mode.

MEMORY REQUIREMENTS

To run the Z-80 SoftCard requires a disk-based Apple II or disk-based Apple II Plus computer with at least 48K RAM memory. If used with a Language Card, 12K additional RAM can be utilized.

Whether you have a 48K system or a 60K system with Language Card, 4K of RAM is required to handle the Apple screen and CP/M sector read and write routines.

CP/M occupies 7K of RAM, 2K of which can be used by other programs, such as BASIC. The standard versions of Microsoft BASIC, which supports all Applesoft extensions except high-resolution graphics, requires slightly more than 24K RAM. So BASIC and CP/M together occupy just over 29K RAM.

The version of BASIC that supports high-resolution graphics is somewhat large because 8K of screen memory is necessary for high-resolution graphics. It occupies just over 33K, making a total of slightly more than 38K for both CP/M and the high-resolution version of BASIC.

BEYOND MICROSOFT BASIC

Microsoft 5.0 BASIC is provided with the Z-80 SoftCard. Microsoft FORTRAN, COBOL, BASIC Compiler, and Assembly Language Development System will be available and sold separately to Z-80 SoftCard users.

Just imagine the power of your Apple Computer when it has one of the following:

Microsoft FORTRAN-80. Comparable to the FORTRAN compilers used on large mainframes and mini-computers. Microsoft's FORTRAN-80 brings the world's most popular science and engineering programming language to the Apple. Compilation is very fast (up to several hundred statements per minute) and less than 25K bytes of memory are needed to compile most programs. All of ANSI FORTRAN X3.9-1966 is included except the COMPLEX data type. Therefore, you may take advantage of

the many application programs already written in FORTRAN:

Microsoft COBOL-80. The most widely used language for business applications, COBOL is excellent for inventory, personnel, payroll, order entry, accounting and forecasting applications. Powerful use of disk files, CRT screen handling, easy-to-use syntax and readable programs give programmers the tools they need to meet the rising challenge of data processing. Microsoft's COBOL-80 is an ANSI standard COBOL with many enhancements.

Z-80 SOFTCARD PRODUCT SPECIFICATIONS £25

The Hardware: Processor: 8080 Clock Rate: 2.5 MHz Addressing Options: 16-bit addressing Memory Mapping: 16-bit addressing Power Consumption: 1.5 watts Size: 5.25" x 7.5" x 1.5" Selecting Z-80 Mode: Push button Installation: Plug into any slot Compatibility: IBM PC compatible CP/M Operating System: Version 2.2 CP/M Programs: 1000	Microsoft BASIC ANSI Standard Memory Exclusive 5.0 Features Approach Features Features added to BASIC 5.0 for SoftCard version Computer Compatibility: IBM PC Utilities Optional Download: Access programs for the Apple II Plus 13.5 Sector Disk Conversion Utility Apple DOS to CP/M Copy
--	---

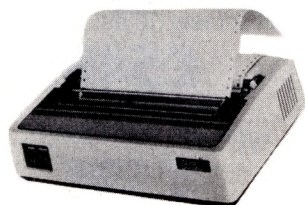

OKI MICRO LINE 80

FOR APPLE II
OKIu80 + Parallel interface
+ Graphics **£475**
(see below)

Parallel printer interface
for APPLE:
£110.00
(wire included) **£99**

- 40, 80, 132 columns (compressed and doubled characters)
- 80 characters per second
- 96 characters ASCII and semi-graphic 7 x 9
- 6 or 8 lines an inch
- Original + 2 copies
- End of copy detector
- Parallel interface

£349.50

+ VAT

OPTIONS: - Adjustable tractor **£90**
- Serial Interface RS232c/v 24 : **£80**

HARD COPY HIRES PAGES FOR OKI MICROLINE 80 AND APPLE

This was obtained with the Minimic Computer Hard copy, Microline 80 and APPLE with disk

£ 50 + VAT
Hardware & Software



All items guaranteed 12 months. Some items not ex-stock
All orders will be acknowledged, if delay unacceptable, orders may be cancelled and money will be refunded.

Mail order only - All prices include postage in U.K. - VAT not included and are correct at time of going to press.

NAME Tel
ADDRESS

QUANTITY	ITEM	ITEM PRICE	TOTALS

I enclose cheque/P.O. for £.....
made payable to: **MINIMIC COMPUTERS**
Third Floor
Airwork House
35 Piccadilly
LONDON W1V 9PB

SUB-TOTAL
+15% VAT
TOTAL

**WHEN CUSTOMERS
COME BACK -
THE REASONS ARE
SIMPLE:-**

- * *High quality*
- * *Low prices*
- * *Speedy service*
- * *Reliability*

BUSINESS 



Try our programs
today - you
will be suprised!

GAMES 

REMEMBER:-

**DATABANK
DEVELOPS
SOFTWARE**

LET US WRITE
SOME FOR
YOU!



0509 217671

BUSINESS - PACK

- WORD PROCESSOR
- PAYROLL
- BANK ACCOUNT
- STOCK CONTROL
- MAILER/LETTER
- CASH REGISTER
- SALESMAN
- LIBRARY INDEX

COMPLETE PACK (inc. DISKS, DOCUMENTATION & POSTAGE):

APPLE II / ITT 2020 (disk) ONLY: **£99**

HARDWARE

- * ITT 2020 48K
- * PRINTER
- * DISK DRIVES
- * COLOUR MONITOR
- * FULL SOFTWARE

Complete system: **£3000**

TRY IT!

**PHONE FOR A
DEMONSTRATION
NOW**

BUSYLINK

★ A fully integrated business system for:
• INVOICING
• WORD PROCESSING
• ADDRESSING
inc. Disk, Documentation & post.
APPLE II & ITT 2020
£250

NEW NEW

- SUPER STOCK CONTROL £70
- DOUBLE ENTRY LEDGER £70
- INVOICER £50
- FILING CABINET £50
- YEAR PLANNER PRINTER £30

APPLE II & ITT 2020

Prices include: DISK, POSTAGE & DOCUMENTATION

SPECIALS

THE VERY POPULAR:-

★ MAILER/LETTER & **£50**

★ Word processor inc. Disk, postage. **£40**

APPLE II & ITT 2020

★ **INCREDIBLE PRICES! ORDER NOW.** ★

OR MORE DETAILS FROM:-



DATABANK



66, Queens Road, Loughborough, Leic.
Tel. 0509 217671

PETSSETTE

20 PET PROGRAMS **£20**

- PAYROLL
- MAILING LIST
- BANK ACCOUNT
- LIBRARY INDEX
- STOCK CONTROL
- CASH REGISTER
- LUNAR LANDER
- SNOOKER
- ASTRONOMY
- STARTREK
- JET FLIGHT
- HANGMAN
- SPACE ATTACK
- KLINGON
- LOST IN SPACE
- STANDARD LETTER
- SPACE DOGFIGHT
- NOUGHT & CROSSES
- SALES LEDGER
- LUNAR INVADERS

All for **£20**
inc. Cassette & postage

PETMERGE

NOW YOU CAN SAVE LOTS OF TIME BY JOINING USEFUL GOSUBS TOGETHER - USING YOUR CBM DISK, AND OUR LONG AWAITED MERGER PROGRAM.

ONLY **£40** inc. DISK, INSTRUCTIONS & POSTAGE 

GAMES-PACK

- Snooker
- Crossword
- Noughts & crosses
- Space dogfight
- Startrek
- Phaser
- Jet flight
- Spaceship
- Klingon

£20 (inc. disk & postage)

APPLE II - ITT 

SCI-PACK

- STATISTICS
- GRAPH PLOT **£20**
- ASTRONOMY

APPLE II & ITT 2020
Prices include: DISK & POST

✳ **SAVE MONEY WITH** ✳

DATABANK

Cheque with order for our 'by-return' mail service.

Your computer? MORE DETAILS

Apple II ITT2020 [disc]

Name _____

Address _____

Postcode _____



SOFTWARE DIRECT FROM WRITERS
QUALITY AT THE RIGHT PRICE!

GW Computers Ltd

89 Bedford Court Mansions, Bedford Avenue, London W.C. 1.
call only by appointment

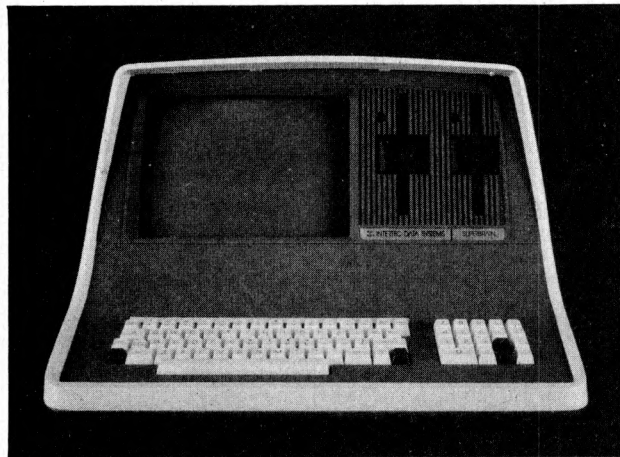

SUPERBRAIN™

Intelligent Video Terminal Systems

350K or 700K of Disk Storage
SuperBrain's CP/M operating system boasts an overwhelming amount of available software in BASIC, FORTRAN, COBOL, and APL. Whatever your application . . . General Ledger, Accounts Receivable, Payroll, Inventory or Word Processing, SuperBrain is tops in its class. And the SuperBrain QD boasts the same powerful performance but also features a double-sided drive system to render more than 700K bytes of disk storage and a full 64K of RAM. All standard!

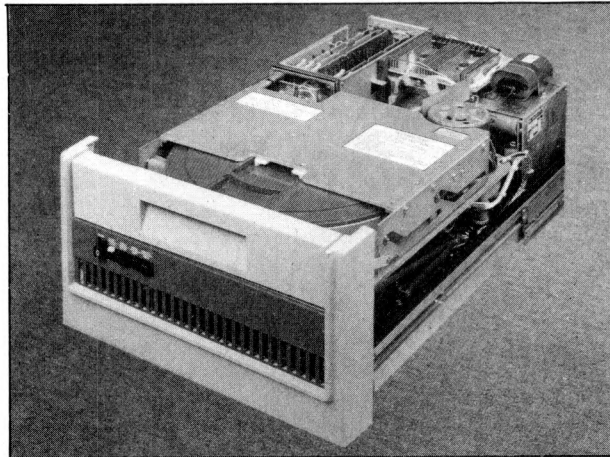

COMPUSTAR™

MULTI-USER TERMINAL SYSTEM

CompuStar user stations can be configured in a countless number of ways. A series of three intelligent-type terminals are offered. Each is a perfect cosmetic and electrical match to the system. The CompuStar 10-a 32K programmable RAM-based terminal (expandable to 64K) is just right if your requirement is a data entry or inquiry/response application. And, if your terminal heads are more sophisticated, select either our CompuStar 20 or CompuStar 40 as user stations. Both units offer dual disk storage in addition to the disk system in the CompuStar. The Model 20 features 32K of RAM (expandable to 64K) and 350K of disk storage. The Model 40 comes equipped with 64K of RAM and over 700K of disk storage. But, most importantly, no matter what your investment in hardware, the possibility of obsolescence or incompatibility is completely eliminated since user stations can be configured in any fashion you like - whenever you want - at amazingly low cost!

DISK STORAGE

Options for the Superbrain and CompuStar Video Terminal

"Backup" for the 20 megabyte Century Data drive is provided via the dual disk system housed in the CompuStar or the SuperBrain. The Control Data CMD Drive features a removable, front-in-separable top loading cartridge of 16 megabyte capacity plus a fixed disk capacity of either 16 or 80 megabytes.

Each drive is shipped equipped with an EIA standard 19" rack mounting system and heavy duty chassis slide mechanisms to permit easy accessibility for fast and efficient servicing.

**** WIDELY USED IN UK AND USA ****
**** TESTED AND PROVEN ****
**** POWER AT YOUR FINGERTIPS ****
**** JUST COMPARE THIS LIST ****

*** SALES COMMENT ***

No other program in the world combines these features in one. Many other programs, less integrated, do not provide even some of those features to be found on our 'bus'.

- 1 = Total integration of sales, purchase 'nominal' stock addresses etc
- 2 = Full random access enables retrieval of any record in a second
- 3 = Flexibles prompts enables word change even to foreign language.
- 4 = Files may be named and set to drive default, maximising storage.
- 5 = Easy to use, menu driven, no serious need of manual.
- 6 = Tested and debugged in many installations world wide.
- 7 = Priced less than the acquisition of a library of programs.
- 8 = The program is ***totally *** in core, maximising disk space.
- 9 = Core program means that disks may be interchanged during use.
- 10 = Core program means your main drive is ***free *** for data
- 11 = Numerous reports may be generated (eg: sale ledgers up to 30).
- 12 = Invoice produces immediate stock update + double journey entry.
- 13 = Reference on invoices enable cost centre build-up on ledgers.
- 14 = Stock valuations and re-order reports easily generated.
- 15 = Bank balance and reports plus standard mailing facilities.
- 16 = Customer statements and invoices printed on plain paper.

As prices vary from dealer to dealer we append for your guidance, some details of the justification in our prices being higher than the cash/carry concept of trade.

A standard Superbrain 64K ★ 320K Disk at 1795.00 includes the following values not normally expected at the lower price.

- 1) Equipment is burned and tested for a minimum 48 hours
- 2) Delivery in U.K. is free of charge
- 3) All goods & software are stocked on immediate delivery
- 4) 6 month main unit, 12 month memory guarantee
- 5) 24/48 hour mailing of any spare module free within warranty
- 6) Same service as 5) outside warranty for ad hoc charge
- 7) 10 free Diskettes (28.50)
- 8) 10% of hardware value in free software (1795.00)
- 9) Positive before ★★ and ★★ after sales service

If the transaction includes a printer and the business programs then the following are also added:

- 10) All cabling between printer and Superbrain free (25.00)
- 11) Ribbon and thimble free (eg: Spinwriter 4.75 + 9.75)
- 12) Extra 10 Diskettes free (28.50)
- 13) Additional free software based on 10% of printer value
- 14) Free training session plus all necessary follow up
- 15) Box printer paper (28.50)

A typical deal could look like this:

Superbrain	1795.00
NEC Spinwriter	1695.00
	3490.00

BUS Program 775.00 plus Basic 150.00 (less 349.00) = 576.00
Total Purchase Price 4066 plus V.A.T.

The total value of free items on this deal was in excess of 500 pounds in virtue of incidental items as well as extended warranty and software.

Do consider your purchase on the basis of some of the things you may be likely to need after your equipment purchase, and may either fail to obtain because the dealer has no stock or has lost interest in you, or because you aimed at the short term gain in price and are then compelled to pay heavily for small needs afterwards.

Also at: Gamma Data Systems, Dollard House, Wellington Quay,
Dublin 2. Tel Dublin 711877

***** MAIN MENU DISPLAY *****

**New! Produced in U.K. and widely used in England and the U.S.A.
Complete Business Package**

**INCLUDES EVERYTHING FROM INVENTORY TO SALES SUMMARY
PROMPTS USER AND VALIDATES ENTRIES. MENU DRIVEN**

PET AND CP/M SUPERBRAIN, TRS80 ii, N'STAR, IMS5000.
APPROXIMATELY 60-100 ENTRIES/INPUTS REQUIRE 2-4 HOURS WEEKLY
AND ENTIRE BUSINESS IS UNDER CONTROL

* PROGRAMS ARE INTEGRATED .. SELECT FUNCTION BY NUMBER .. .

- | | |
|-------------------------------|--------------------------------|
| 01=*ENTER NAMES AND ADDRESSES | 13=*PRINT CUSTOMERS STATEMENTS |
| 02=*ENTER/PRINT INVOICES | 14=*PRINT SUPPLIER STATEMENTS |
| 03=*ENTER A'C RECEIVABLES | 15=*PRINT AGENT STATEMENTS |
| 04=* ENTER PURCHASES | 16=*PRINT TAX STATEMENTS |
| 05=*ENTER A'C PAYABLES | 17=LETTER TEXT AREA |
| 06=*ENTER/UPDATE INVENTORY | 18=ALTER VOCABULARIES |
| 07=*ENTER/UPDATE ORDERS | 19=PRINT YEAR AUDIT |
| 08=*ENTER/UPDATE BANKS | 20=PRINT PROFIT/LOSS A'C |
| 09=*REPORT SALES LEDGER | 21=OPEN AREA |
| 10=*REPORT PURCHASE LEDGER | 22=PRINT CASHFLOW FORECAST |
| 11=*INCOMPLETE RECORDS | 23=ENTER PAYROLL (NO RELEASE) |
| 12=*USER DBMS AREA | 24=DISK SWAP/EXIT |

..... ENTER WHICH ONE?

DATABASE MANAGEMENT INCLUDES

*** FILE OR RECORD CREATE/DELETE/AMEND/SEARCH/PRINT 4 WAYS *** INFORMATION RETRIEVAL ON ANY KEY RECORD OR PART THEREOF *** AUTOMATIC CHECK TO PREVENT DOUBLE ENTRY TO FILE SYSTEM *** DYNAMIC ALLOCATION OF INFORMATION CONSERVING DISK SPACE.

VERY FLEXIBLE. EASY TO USE.

G.W. COMPUTERS LTD. UK ARE THE PRODUCERS OF THIS BEAUTIFUL PACKAGE. *AUTHOR* TONY WINTER (B.A.LIT; B.A.HON.PHIL).

PET VER 3.00 LOW LEVEL INTEGRATION = 475.00. PET VER 4.00 INCLUDES AUTO STOCK-UPDATE = 575.00. PET VER 5.00 INCLUDES AUTO BANK UPDATE = £675.00. CPM VER 6.00 IN CORE, TRANSLATABLE PLUS DBMS = 775.00. CPM VER 7.00 AUTO STOCK-UPDATE = 875.00. CPM VER 8.00 AUTO BANK UPDATE = 975.00. CPM VER 9.00 INCLUDES OPTIONS 19, 20, 22, 23 (LATER RELEASE). +++ EACH LEVEL AUGMENTS LOWER ONE.

WE EXPORT TO ALL COUNTRIES CALLERS ONLY BY APPOINTMENT

CONTACT TONY WINTER ON 01-636 8210

89 BEDFORD COURT MANSIONS, BEDFORD AVENUE, LONDON W.C.1.

**NOTE!!! LEVEL 9.00 TOTALLY IN CORE PROGRAM LEAVES MASTER DRIVE FREE
(SAVING OF 200 POUNDS HARDWARE).**

IMPORTANT!!! No computer hardware is ever of value without software, so we provide you with a starting set of programs ** free **** at 10% of hardware purchased. A Superbrain and NEC Spinwriter could give you up to 400 pounds of programs. See [] .**

PET + PET + PET + PET + SOFTWARE + SOFTWARE + SUPERBRAIN + SUPERBRAIN

CBM 3032 32K	595.00	BUS VER 3.00	PET	475.00	SUPERBRAIN 320K	1795.00
CBM 3040 DISKS	595.00	BUS VER 4.00	PET	575.00	TWIN Z80 64K+CRT
CBM 3022 PRINTER	425.00	BUS VER 5.00	PET	675.00	+2 D'D-D'S DRIVE
CBM 8032 32K	875.00	BUS VER 6.00	CP/M	775.00	SUPERBRAIN 800K	2195.00
CBM 8050 1MEG DISKS	875.00	BUS VER 7.00	CP/M	875.00	TWIN Z80 64K+CRT
CBM EPSON PRINTER	395.00	BUS VER 8.00	CP/M	1000.00	+2 D'D-D'S DRIVE
CBM MULTI USER	650.00	BUS VER 9.00	CP/M	1075.00	SUPERBRAIN 2MEG	2795.00
CBM 3032 + EPSON +		CBM WORDPRO II		75.00	COMPUSTAR 10	1595.00
CBM 3040 + BUS V3	2215.00	CBM WORDPRO III		150.00	COMPUSTAR 15	1495.00
PRINTERS + PRINTERS +		CPM* WORD-STAR		195.00	COMPUSTAR 20	2295.00
DIABLO 630 40CPS	1595.00	CPM* MBASIC 80		150.00	COMPUSTAR 30	2495.00
DOLPHIN BD80 125CPS	495.00	CPM* COBOL 80		320.00	COMPUSTAR 40	2795.00
NEC 5510 PRINTER	1695.00	CPM* PASCAL MT		150.00	INTERTUBE III	495.00
MICROLINE 80 120CPS	475.00	CPM* FORTRAN 80		200.00	EMULATOR	495.00
TELETYPE 43SR 30CPS	875.00	CPM* DATASTAR		175.00	10 MEG H'DISK	2950.00
DEC-LA34 TRACT 30CP	875.00	CPM* PASCAL-M		250.00	16 MEG (8'8)	3950.00
NEC-5530 PRINTER	1595.00	CPM* BYSTAM S'BRAIN		75.00	96 MEG (4DISK)	7950.00
QUME DAISY SPRINTS	1950.00	CPM* SUPERSORT		120.00	(ADDRESS'MAILER)	95.00
TEXAS 810 150CPS	1390.00	CPM* BASIC COMPILER		190.00	(STOCK CONTROL)	95.00
SPECIALS + SPECIALS +		CPM* DESPOOL		30.00	(DBMS DATABASE)	195.00
N'STAR QUAD .7 MEG	1500.00	CPM* BYSTAM IMS'N-STAR		75.00	IEEE TO PARALLEL	55.00
IMS 5000 48K D'D	1200.00	CPM* TEXTWRITER		75.00	IEEE'RS232 BI'DI	195.00
COMPUTHINK * 800K *	795.00	CPM* POSTMASTER		75.00	IEEE TO RS232	75.00
2 WAY CRDLESS PHONE	135.00	CPM* SELECTOR 3		180.00	S'HAND SWTP TERM	100.00
TELEPHONE ANSWER	230.00	CPM* CBASIC		75.00	WARRANTY	
SHUGART SA400 5" DR	135.00	CPM* MACRO 80		75.00	6 MONTH FULL REPAIR	***
		CPM* W'STAR M'MERGE		245.00		
		BUS MANUAL *****		9.00		
		SUPERBRAIN 320K		1695.00		
		TWIN Z80 32K+CRT			
		+2 D'D-S'S DRIVE			

+++++++ SPECIAL INSTITUTION AND UNIVERSITY DISCOUNTS ++++++
MOST ITEMS IN STOCK. (ACCESS 'AMEXCO' BCLYCARD OTHERWISE CHEQUE WITH ORDER)
CONTACT TONY WINTER 01-636 8210
89 BEDFORD CT MANS, BEDFORD AVE W.C.1.

**Comart Approved
Cromemco Dealers**

Belfast

O & M Systems
95 Dublin Road
Contact: Richard Owens

Birmingham

Byteshop Computerland Ltd
94/96 Hurst St, B5 4TD
Contact: Jim Attfield
Tel: 021 622 7149
Telex: 336186 BYTE G

Cambridge

Cambridge Computer Stores
1 Emmanuel St, CB1 1NE
Contact: Claude Cowan
Tel: 0223 68155

Cornwall

Benchmark Computer
Systems Ltd
Tremena Manor
Tremena Road
St Austell, PL25 5GG
Contact: John Fisher
Tel: 0726 610000

Dublin

Lendac Data Systems Ltd
8 Dawson St
Contact: Danny McNally
Tel: 0001 372052

Glasgow

Byteshop Computerland Ltd
Magnet House
61 Waterloo St, G2 7BP
Contact: Gordon Coventry
Tel: 041 221 7409
Telex: 779263 BYTE GW G

Leeds

Holdene Ltd
Manchester Unity House
11/12 Rampart Road
Woodhouse St
Contact: Jim Jackson
Tel: 0532 459459
Telex: 556319 HOLDEN G

London

Byteshop Computerland Ltd
48 Tottenham Court Road,
W1R5 4TD
Contact: John Braga
Tel: 01 636 0647

Digitus

9 Macklin Street
Covent Garden WC2
Contact: Alan Wood
Tel: 01 405 6761

Manchester

Byteshop Computerland Ltd
11 Gateway House
Piccadilly Station Approach
Contact: Peter King
Tel: 061 236 4737
Telex: 666186 COMMAN G

NSC Computers

29 Hanging Ditch
Contact: Adam Wiseberg
Tel: 061 832 2269

Newbury

Newbear Computing Store
40 Bartholomew St
Contact: Tim Moore
Tel: 0635 30505
Telex: 848507 HJOLPN

Nottingham

Byteshop Computerland Ltd
92A Upper Parliament St,
NG1 6LF
Contact: David Clarke
Tel: 0602 40576
Telex: 377389 BYTENOG

Sheffield

Hallam Computer Systems
451 Eccleshall Road, S11 9PN
Contact: Stuart Pulford
Tel: 0742 663125

Southampton

Xitan Systems
23 Cumberland Place,
SO1 2BB
Contact: Geoff Lynch
Tel: 0703 38740

Sudbury

Eurotec Consultants
Holbrook Hall
Little Waldingford
Contact: Dr Klimowicz
Tel: 0206 262319
Telex: 987248

Warwicks

Business & Leisure
Microcomputers
16 The Square
Kenilworth
Contact: David Searle
Tel: 0926 512127

**Comart Microcomputer
dealers are located
strategically throughout the
country to give support,
guidance and assistance. In
the event of difficulty contact
Comart direct.**

 **Cromemco**



Flexibility + Versatility

System Flexibility

Cromemco give you the high performance, reliable computer power you need now, with the in-built capability for future expansion and adaption as demands and requirements change.

The choice is wide. Cromemco's S-100 bus construction provides for expandable memory capability and the widest choice and future options in peripheral support.

Now there is the exciting range of Cromemco High Resolution Colour Graphics Systems.

Applicational Versatility

Cromemco's CDOS Operating System supports proven, well documented Software for Business, Industry, Science, Research and Education; COBOL, RPG II, Macro Assembler, 16K and 32 BASIC, FORTRAN IV, LISP, RATFOR, Word Processing and Data Base, are all included in the range.

Now, there is the new CDOS compatible, Cromix Multi-user Multitasking Operating System which opens up new avenues in application and performance for Cromemco System Users.

The U.K. Leaders in Microcomputer Development, Application and Support.

comart

PO Box 2, St Neots, HUNTINGDON, Cambs
Tel: (0480) 215005 Telex: 32514 Comart G.

KGB MICROS LIMITED

THE PROFESSIONAL ORGANISATION OFFERING
HARDWARE AND SOFTWARE PLUS FULL CLIENT SUPPORT
WHO WISH TO MAKE YOUR BUSINESS OUR BUSINESS

SUPERBRAIN™

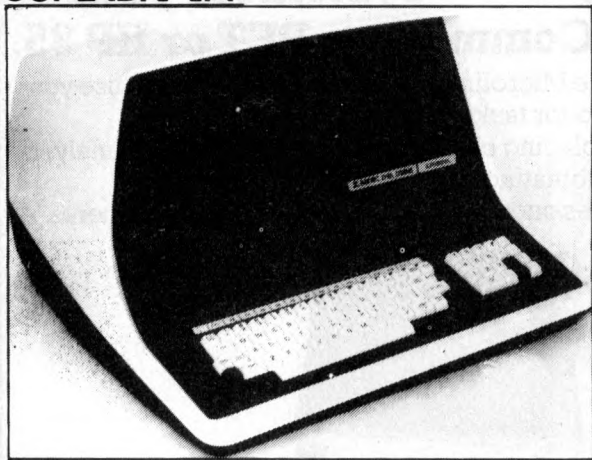

THE MICRO COMPUTER THAT HAS
THE BEST PRICE/PERFORMANCE
RATIO.

£1495 (64K RAM)

MICROLINE 80

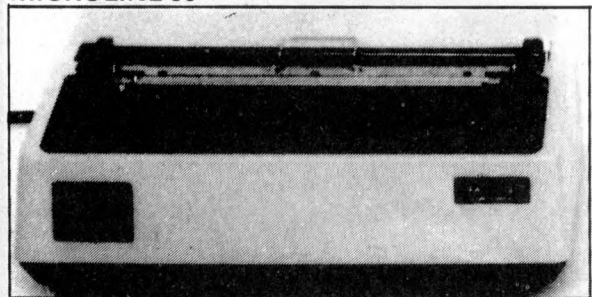

THE EFFICIENT BUSINESS SYSTEM
SUPERBRAIN

+
MICROLINE 80 PRINTER

£1795

INDIVIDUAL PRICE £500.00

DIABLO 630

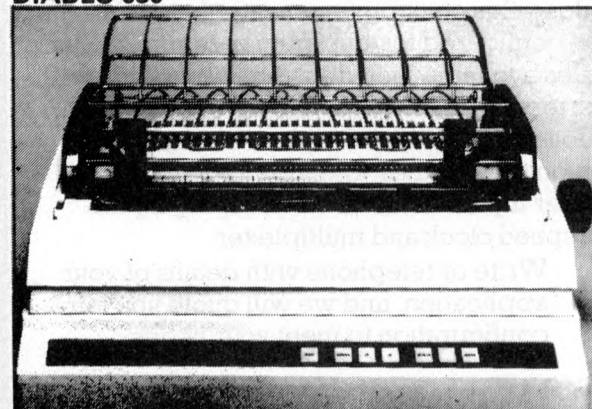

THE COMPLETE WORD PROCESSING
SYSTEM

SUPERBRAIN + DIABLO 630 PRINTER
THE PROVEN 'WORD STAR' PACKAGE

£2995

INDIVIDUAL PRICE £1675.00

SOFTWARE SUPPORT

- * KGB offer a wide range of standard software — FORTRAN, COBOL, BASIC, PASCAL.
- * KGB will customise our software packages to meet your unique requirements — Invoicing £95, Sales Ledger £235, Purchase Ledger £235, Nominal Ledger £235, Payroll £335.
- * KGB will design and implement software to suit your business needs.

**KGB Micros Ltd., 88 High Street, Slough, Berkshire.
Tel: Slough 38581/38319**

Superbrain is the registered trademark of Intertec Data Systems. Prices exc. VAT.

VERBATIM MAGNETIC MEDIA



THE BEST THAT MONEY CAN BUY.

VERBATIM — the world's finest and best known range of magnetic data storage products — includes Floppy Discs, Mini-Floppies, Cassettes, Mini-Cassettes, cartridges and cards. All are 100% tested during manufacture, all are *certified* error free. We stock all types, including all varieties of the popular 5 1/4 -inch floppy discs.

If you are a dealer:

Start stocking VERBATIM products — your customers will appreciate a better quality product at better prices. Call BFI Electronics for a comprehensive catalogue, dealer price list, and details of display material and retail packaging.

If you are a user:

Your system is only as good as its data storage — so don't be content with inferior products. Insist on VERBATIM by name, as indeed do some of the biggest names in the computer business!

BFI Electronics Limited
516 Walton Road,
West Molesey,
Surrey KT8 0QF
Tel: 01-941 4066
Telex: 261395

MICROLINK MICROLINK MICROLINK

The flexible interfacing system for your Commodore PET or HP 85.

The Microlink interface makes it easy to use your micro for tasks such as:

- * Replacing chart recordings by computer analysis
- * Automating experiments
- * Adding data processing capability to monitoring instruments.



The MICROLINK interface consists of a mainframe incorporating a power supply, an IEEE 488 interface and a cabinet holding up to 10 modules — this construction means that an interface can be configured to your precise requirements. Modules available include: * Analogue to digital converters * Digital to analogue converters * Analogue X-Y plotter driver * Analogue input conditioning modules * Relay outputs * BCD character inputs * Signal conditioning inputs * High speed clock and multiplexer.

Write or telephone with details of your application, and we will quote you for a configuration to meet your needs.

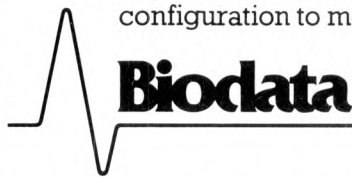

Biodata Ltd., 6 Lower Ormond St.,
Manchester M1 5QF.
Telephone:
061-236 1283.

MICROLINK MICROLINK MICROLINK

The best in data base management for your micro-computer

Get the most out of your micro-computer. Use our advanced and progressive data management system.

HDBS is an extended hierarchal data base system offering

- fixed length records
- file-level read/write protection
- one-to-many set relationships

MDBS is a full network data base system offered as an upgrade from HDBS... or it may be ideal as your initial system. **Unique and versatile**, it adds these features:

- full network CODASYL-oriented data structures
- variable length records
- multiple levels of read/write protection
- one-to-one, many-to-one, and many-to-many sets
- non-redundancy of data, easy updating
- occurrences of a record type may own other occurrences of the same type
- a single set may have multiple owner and member record types

MDBS-DRS. As an add-on to MDBS, the DRS system offers extraordinary flexibility in data base restructuring to meet new needs.

- Item, record, and set types can be added, deleted, or renamed in an existing data base as well as other data base characteristics. You can redesign the data base after it is already on-line!

MDBS-RTL. As an add-on to MDBS, the RTL (Recovery Transaction Logging) logs all data base transactions, so that in the event of a system failure, the data base can be recovered with minimal loss of information.

- The recovery processor permits selective reloading of the data base from the transaction file. Users can log messages, indicate complex transaction sequences, and effect selective control over the recovery process.

MDBS-QRS. An interactive Report-Writer/Query-System for HDBS/MDBS data bases. Features...

- may be customized for non-technical users
- complex retrieval conditions may be specified
- detailed reports can be quickly generated
- wildcard and "match-one" string specifications included

HDBS and MDBS Packages Include:

- DDL data definition language analyzer/editor
- 260-page users manual
- DMS data management routines callable from host language
- Sample application program and DDL files
- Relocator to re-org all routines
- System specific manual for bringing up our software

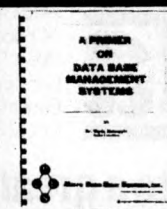

Coming soon: Multi-User Versions of MDBS, and a Z8000 Version.

54-page "primer" on data base systems for micro-computers - only £5.00 per copy.

NEW!

NEW!

Both HDBS and MDBS Systems...

- Run under...
 - CP/M with Microsoft BASICs, FORTRAN or COBOL; InterSystem PASCAL/Z; Sorcim PASCAL/M; Micro Focus CIS COBOL; Digital Research PL/1
 - MVT/FAMOS with BASIC
 - OASIS with BASIC
 - TRSDOS and NEWDOS (Models I and II) with Disk BASIC
 - North Star DOS with North Star BASIC
 - Apple DOS and Applesoft BASIC
 - Machine Language Interface available on all above systems.
- Up to 254 record-types definable in the data base; each record-type may contain up to 255 item-types; each item-type may be up to 9,999 bytes in length.
- Names of data items, records, sets, and files are wholly user definable.
- Commands to add, delete, update, search, and traverse the data base.
- Straightforward use of ISAM-like structures.
- Records can be maintained in several sorted orders.
- Written in machine language for maximum execution efficiency and minimal memory usage.
- Independent of types and sizes of disk drives. Support data base spread over several disk drives (max.8); disks may be mini- or full-sized floppies or hard disks.
- Available versions: Z80 (requires approx. 18K), 6502 (approx. 26K), 8080 (approx. 22K). Total memory requirement must allow for buffer areas.
- 8086 version available. (Call or write for details and prices.)

Ordering and pricing information:

(applicable to Z80, 8080 and 6502 versions):

HDBS	£235.00	When ordering, specify intended use with ...
MDBS	600.00	
DRS	150.00	
RTL	150.00	
QRS	300.00	
HDBS upgrade to MDBS	440.00	
MDBS with DRS, RTL and QRS	950.00	
HDBS/MDBS Manual	30.00	
DRS Manual	5.00	
RTL Manual	5.00	
QRS Manual	5.00	
System Specific Manuals each	5.00	

Within a given operating system, add £240 for each additional language selected.

1. North Star DOS and BASIC
2. CP/M - Microsoft BASIC 4.XX
3. CP/M - Microsoft BASIC 5.XX
4. CP/M - Microsoft BASIC Compiler or FORTRAN-80
5. CP/M - Microsoft COBOL-80
6. CP/M - InterSystem PASCAL/Z
7. CP/M - Sorcim PASCAL/M
8. CP/M - Digital Research PL/1
9. CP/M - Micro Focus CIS COBOL
10. TRSDOS/NEWDOS and TRS Disk BASIC (Models I and II)
11. Apple DOS and Applesoft BASIC
12. MVT/FAMOS and BASIC
13. OASIS and OASIS BASIC
14. Machine Language Programs (Specify operating system)

Finally, our software may cost a little more... but it's worth a lot more in quality and versatility.

Micro Data Base Systems from

SYSTEMS PLUS LTD.,
19c Glengormley Park, Newtownabbey BT36 7RE.
Tel: Glengormly 42117.

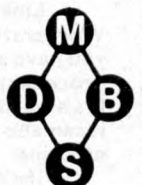

Get the latest on PET...



Dial 01-579 5845.

Adda make it their business to get in first on all that's best and new in PET hardware and software...and in finding out how to make the latest advances work more profitably for you.

All the advice, assistance and arrangement of demonstrations you could ask for are there for the taking. And that's just for starters. Long term Adda look after your future requirements with software, full engineering support and maintenance contracts that can include machine loan.

In addition to the 16k PET 3016 and 32k PET 3032, Adda offer you the new 32k PET 8032—with 80 columns, 12-inch screen and a keyboard that really gets down to business. Recent advances make possible some exciting applications for these mighty micros.

Link the 32k PET up to the Wordcraft word processing program and you have a very sophisticated word processing system for less than £4000. It's a word processor and more—because it can also be used as a small business machine.

The Wordcraft program comes on a mini floppy disc ready for use on a Commodore 3040 diskette drive. The whole system gives you word processing to standards achieved by expensive

purpose-built machines; and you can use a large selection of output printers including dot matrix, golfball and daisy wheel. So much for words—now for some action: phone 01-579 5845.

If you're looking for mainframe access, the Communicator 1 mainframe-PET link enables file transfer to be made in both directions... with a PET Communicator system configured with either dual floppy disc or cassette tape drive and a printer.

Files transferred from mainframe to PET can be manipulated locally and data transfer monitored on the PET screen. It's a fast way of cutting costs on bureau time share—and it also doubles up as a fast normal terminal. The Communicator 1 mainframe-PET link paves the way to big cost savings. Your first step is digital input to 01-579 5845.

More cost savings can be realised when you link up three to eight PETs to one Commodore disc drive and a printer using Mupet (Multi-User PET)—and you don't have to make any program changes. As a Mupet dealer, Adda can put you fully in the picture. Just phone 01-579 5845 for a demonstration of Mupet being put through its paces.



adda

Adda Computers
14 Broadway
West Ealing
London W13 0SR
Entrance in
Kirchen Road

we add up to a great deal.

GAMBIET '80

The World's No.1
Microcomputer Chess Program
by Wim Rens

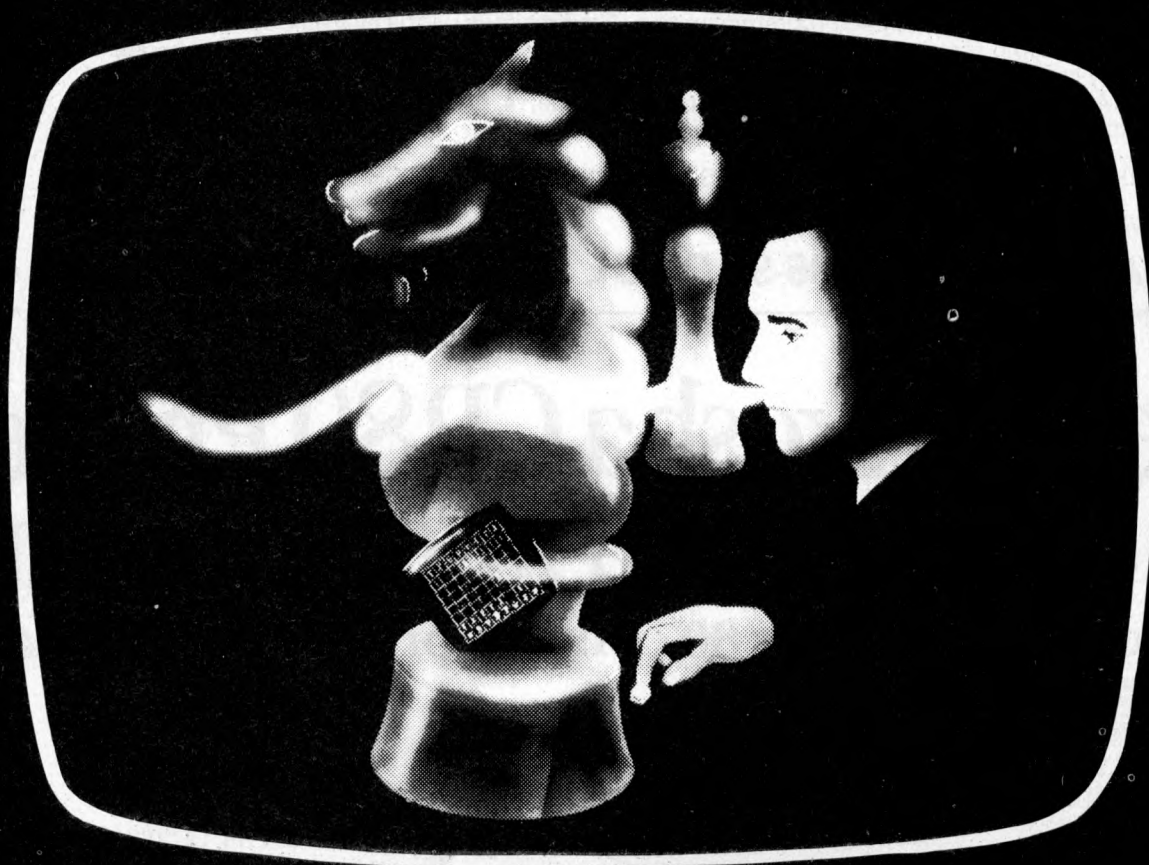

Gambiet 80 was the most successful commercially available Chess Program at the official World Microcomputer Chess Championship in London, September 1980.

FACILITIES INCLUDE:

- * 6 levels of play from speed chess to tournament level
- * Graphic board display
- * Chess Clock
- * Game record in standard notation on the screen and optionally on a printer
- * Board set up for solution of chess problems
- * 'Take-back' facility
- * Continual display of moves being evaluated by the program
- * Mate anticipation



The fastest serious program for the TRS-80 or Video Genie

Name _____

Address _____

Please send me:
Gambiet/80 on tape for the TRS-80. £19.95

Total £ _____ Signature _____

  CHEQUE (tick)

Credit Card No.

Send to: **Microtrend Ltd.**,
P.O. Box 51, Pateley Bridge,
Harrogate, North Yorkshire HG3 5DP



PCW

CHRISTMAS OFFER FROM SHARPSOFT

HARDWARE

SHARP MZ80K 20K Model	£445.00
SHARP MZ80K 36K Model	£495.00
SHARP MZ80K 48K Model	£545.00
sharp mz80P3 Printer	£515.00
SHARP MZ80FD Dual Drive Floppy Disk	£755.00
SHARP MZ I/O Interface Unit	£95.00
SHARP PC1211 Pocket Computer	£95.00
SHARP CE121 Cassette Interface for PC1211	£15.00
SHARP RD610 Cassette Player	£20.00

SOFTWARE

Full range of software for the MZ80K available including

System software:	Search & replace
Assembly code (Sharp)	Variable table utility
Machine code (Sharp)	Business software:
Zen Assembler	Payroll
Xtal basic (R)	Purchase & Sales Ledger
CP/M(R)	Mailing list
	Stock control
Utilities:	Costing Package
Ardensoft toolkit	Simple Word Processor
Renumber & tape copy	and a large selection on
Machine code dump	games etc.

SHARPSOFT — USER NOTES is the name of a new publication giving all the latest news of the SHARP MZ80K products, software and programming tips. The first issue will be available early January 1981.

Send a 20p stamp for our SHARPSOFT hardware/software catalogue and a subscription/registration form for your copy of the SHARPSOFT — USER NOTES.

PURCHASE A MZ80K from us and get a games tape, 4 blank Sharpsoft Cassettes and one year's free subscription to the SHARPSOFT — USER NOTES.

ALL SHARPSOFT — HARDWARE PRICES INCLUDE VAT. DESPATCH & TRANSIT INSURANCE.

SEND TO:

SHARPSOFT LTD 86-90 PAUL STREET, LONDON EC2A 4NE.

New Seikosha GP 80 Printer for educational and home use.

Smallest, plain paper 80 column printer on the market.

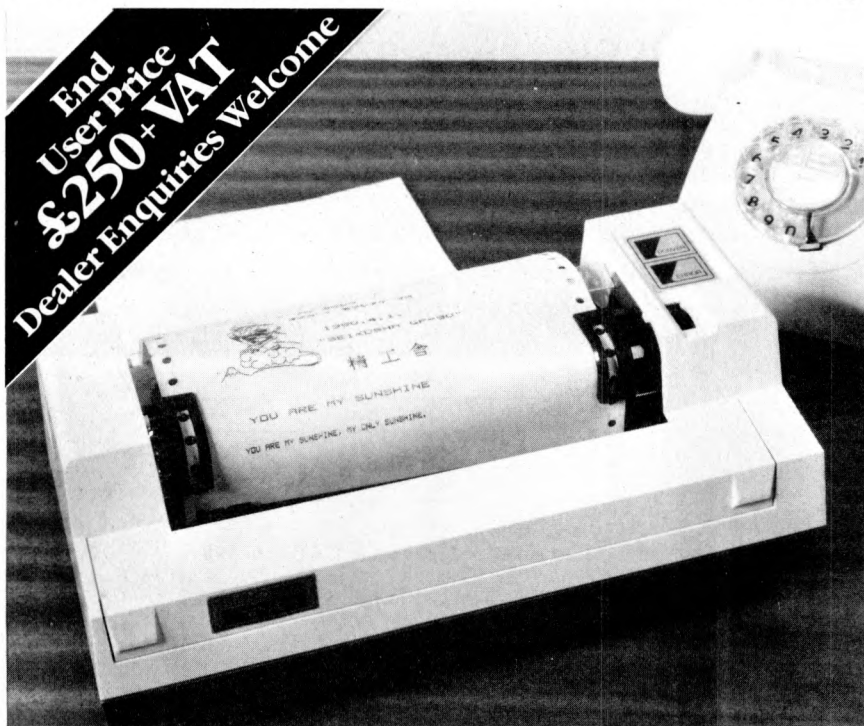

Features:

- Plain paper
- 80 column width
- 30 cps
- Full ASCII character set
- Graphics facility
- 5 × 7 dot matrix
- Double width characters
- Pin feed
- Centronics interface standard

Other Interfaces and cables available:

IEEE/488, PET, TANDY, APPLE, RS/232C.

Ring Sheila Maycroft at DRG Business Machines for your nearest dealer.
13/14 Lynx Crescent, Winterstoke Rd.,
Weston-super-Mare, Avon B24 9DN.
Tel: (0934) 416392

(DRG) A Dickinson Robinson Group Company.

our best advert

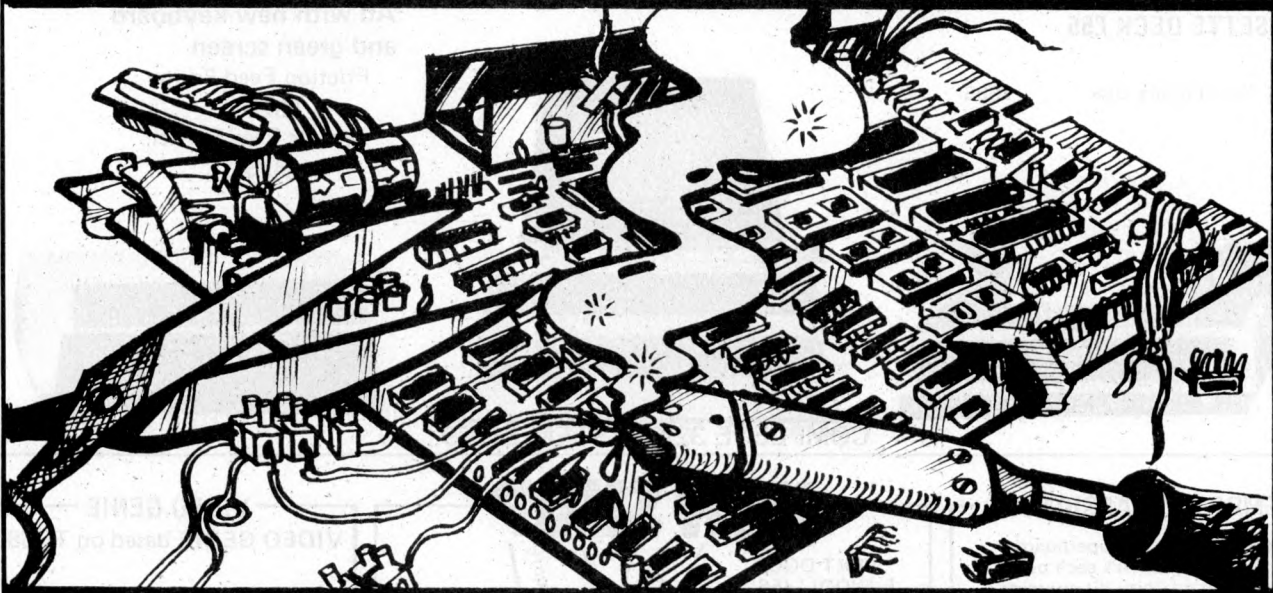

**is our competition...
ask their customers!**
**FOR TRULY COMPETENT SKILLED
SERVICE AND SUPPORT, SPECIALIST
DEVICES AND DEPENDABLE ADVICE ON
ALL YOUR MICROCOMPUTER
REQUIREMENTS**

FOR MORE INFORMATION CUT OUT THIS COUPON

I am interested in particular aspects of microcomputing
please send me details as new products appear.

Subjects of interest

Pet

Industrial

Educational

Consumables

Apple

Commercial

Service Contracts

Name _____

Address _____

Please send to **STACK COMPUTER SERVICES LTD**
290-298 Derby Road, Bootle, Liverpool 20.
Telephone 051-933 5511 for all your enquiries.



CHROMASONIC electronics

48 JUNCTION ROAD, ARCHWAY, LONDON N19 5RD 50 yds from Archway Station & 9 bus routes
 TELEPHONE 01-883 3705 01-883 2289

YOUR SOUNDEST CONNECTION IN THE WORLD OF COMPONENTS AND COMPUTERS

8N 8K RAM £399
 16N 16K RAM £499
 32N 32K RAM £599
 CASSETTE DECK £55

PETS & SYSTEMS

NEW 32K with 80 col Screen £825
 Twin Disk Drive 950K £895

All with new keyboard
 and green screen

Friction Feed Printer £375
 Tractor Feed Printer £425

343K Twin Floppy Disk £695

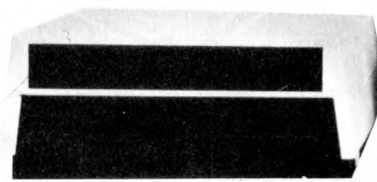

COMPLETE 32K SYSTEM £1789

MEMORY EXPANSION KIT

Suitable for UK101, Superboard expansion using 2114's each board has 16K ram capacity kit contains:

- ★ On board power supply
- ★ 4K Eprom expansion
- ★ Fully buffered for easy expansion via 40 pin socket
- ★ 8K kit £ 89.95
- ★ 16K kit £122.95
- ★ Printed Circuit Board £ 29.95
- ★ 40 pin-40 pin header plug £ 8.50

NEW SHOP

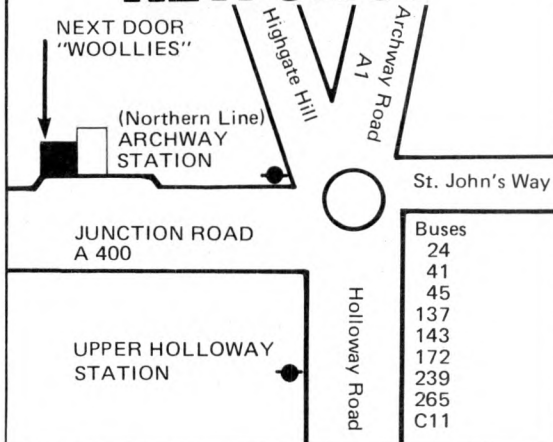

VIDEO GENIE

VIDEO GENIE based on TRS80



Utilises Z80, 12k level II Basic, Integral Cassette Deck, UHF O/P. 16k RAM

all TRS80 features £289

CASES

Available for U.K. 101, Superboard Nascom Appx. DIM. 17" x 15" 435 x 384 mm

PRICE £24.50

Post & Packing £1.50

UK101 P.P.I.

BUILT & TESTED. INTERFACES TX80 PRINTER DIRECT, CAN BE PROGRAMMED TO OPERATE RELAYS, MOTORS, VARIOUS OTHER PERIPHERALS "CENTRONICS COMPATIBLE PLUGS INTO IC SOCKET. RED BINARY DISPLAY FULLY DOCUMENTED.

£29.95

UK101

£179 IN KIT FORM
 £229 READY BUILT & TESTED
 £255 COMPLETE IN CASE

4K EXPANSION (8 x 2114) NOW ONLY £18.00

- No extras required
- ★ Free sampler tape
 - ★ Full Qwerty keyboard
 - ★ 8K basic
 - ★ Ram expandable to 8K on board (4K inc)
 - ★ Kansas City tape interface

★ NEW MONITOR ALLOWS FULL EDITING & CURSOR CONTROL

£22.00



PRINTERS

EPSON TX-80
 £349

Dot-matrix printer with Pet graphics interface: Centronics parallel, options: PET, Apple and aerial.

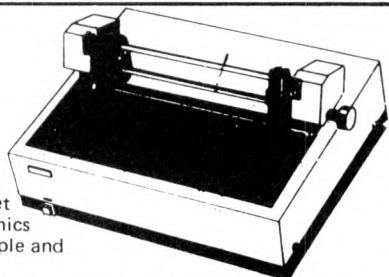

PLEASE ADD VAT 15% TO ALL PRICES. POSTAGE ON COMPUTERS, PRINTERS & CASSETTE DECKS CHARGED AT COST. ALL OTHER ITEMS P&P 30p. PLACE YOUR ORDER USING YOUR ACCESS OR BARCLAYCARD (Min. Tel. order £5.00). TRADE & EXPORT ENQUIRIES WELCOME, CREDIT FACILITIES ARRANGED.



NEW SHOP & SHOWROOM NOW OPEN

TELEPHONE
01-263 9493/01-263 9495

UK101 SOUND

SOUND GENERATOR
AND COMBINED
PARALLEL IN/OUT
PORT KIT
CONTAINING P.G.B.,
RY-3-8910, 6520 PIA,
FULLY DOCUMENTED
AND DEMO TAPE.

£29.95

AY-3-8910

£8.50

UK 101 SOFTWARE

SPACE INVADERS	6.50
REAL TIME CLOCK	5.00
CHEQUERS	3.00
OTHELLO	4.00
GAME PACK I	5.00
GAME PACK II	5.00
GAME PACK III	5.00
SCREEN MONITOR	4.00
ASSEMBLER EDITOR	14.90
10xC12 BLANK TAPES	4.00

CPUS

Z80 2.5 MEG	7.95
Z80A 4 MEG	9.95
6502	6.95
6800	6.50
8080	4.75
9900	25.95

SUPPORT CHIPS

Z80 CTC	5.95
Z80A CTC	6.95
Z80A PIO	5.95
Z80A PIO	6.95
6520	3.95
6522	6.85
6532	8.50
6821	4.25
6850	3.60
6852	4.35
8212	1.95
8216	1.95
8224	2.75
8228	3.75
8251	4.95
8253	9.75
8255	4.50
TMS9901	13.16
TMS9902	11.18
TMS9904 (74LS362)	4.21

MEMORY

D. RAMS	£	p
4027	2.75	
4050 (350NS)	2.35	
4060 (300NS)	2.39	
4116	3.95	

S. RAMS	£	p
2102A	1.30	
2102A2	1.69	
2112A	2.75	
2114/4045	2.75	
4035	1.07	
4044-5257	6.93	
6810	3.50	

BULK PURCHASE

8x2114	18.00
8x4116	27.50
16x2114	34.00

EPROMS

2708	4.25
2716 (5v)	6.95
2532	29.95

ROM

2513 (UC)	5.95
-----------	------

I.C. SOCKETS

	DLL	W/W
8 pin	.09	.25
14 pin	.11	.35
16 pin	.12	.42
18 pin	.16	.50
20 pin	.20	.62
22 pin	.22	.65
24 pin	.24	.70
28 pin	.30	.80
36 pin	—	.99
40 pin	.40	1.10

BUFFERS

81LS95	1.25
81LS96	1.25
81LS97	1.25
81LS98	1.25
SN74365	.52
SN74366	.52
SN74367	.52
SN74368	.52
BT26	1.50
8T28	1.50
8T95	1.50
8T96	1.50
8T97	1.50
8T98	1.50

BAUD RATE GENS

MC14411	8.75
MM5307	8.75

UARTS

AY-5-1013	3.95
AY-3-1015	4.75
MM5303	4.75
TMS6011	3.55

SEND S.A.E. FOR COMPLETE
PRICE LIST OR PHONE 01-263 9493

TRS-80 SOFTWARE



In the beginning there was . . .
ADVENTURE

but now comes . . .

DUNJONQUEST!

FANTASY . . .

Does the glory road beckon? Would you sail with Sinbad, revisit Middle Earth, see the hurtling moons of Barsoom? Then the **DUNJONQUEST** microcomputer games are for you!

. . . ROLE PLAYING . . .

Take the part of a stalwart adventurer — bargain with a tight-fisted innkeeper for the weapons of yore — go in quest of hoarded riches, hidden secrets and forgotten lore.

. . . ADVENTURE!!!

Within the ruined shrine lie not only rich sacrifices to the dread insect god but also the valued possessions of other adventurers who never returned from . . . **The Temple of Asphai!**

- First in the **DUNJONQUEST** series
- Hours of solitary excitement — you alone against all the perils the computer can summon!
- Each game as short as you like — or as long as you survive!
- Four levels — Over 200 rooms and passages
- Explore where you dare — fight or flee when you must!

DUNJONQUEST is role playing, graphic, real-time 'adventure', where your alter-ego's survival depends not only on you finding the right way, but also on his own intelligence, intuition, ego, physical strength, constitution, and dexterity. You can have a character created for you or create your own. You can bargain with the innkeeper for the type of weapons, armour you need to survive. **DUNJONQUEST** is that good that we offer a 10 day money-back guarantee if you're not satisfied, what could be fairer than that.

The Temple of Asphai comes with 56 page **BOOK OF LORE** describing the Monsters, Treasures, Magic Items, and over 200 rooms and passages along with the Traps that infest the nether regions of Asphai.

GUARANTEE — If you don't like **The Temple of Asphai** then return within 10 days for a complete refund

£12.95 LII, 16k, Cassette — **£14.95** LII, 32k, Disk, TRSDOS
(including VAT, P. & P.)

ALGRAY

ALGRAY House, 33 Bradbury Street, Barnsley,
South Yorkshire Tel: Barnsley (0226) 83199

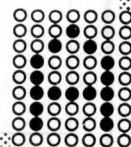

ANGLIA COMPUTER CENTRE

MICROCOMPUTERS FOR BUSINESS,
EDUCATION AND HOME

FOR ALL YOUR BUSINESS, EDUCATION & LEISURE
COMPUTER REQUIREMENTS!!!

APPLE II & III

TRS-80

SHARP

NORTH STAR

HORIZON

TANGERINE

U.K. 101

NASCOM

VIDEO GENIE

+PRINTERS AND

OTHER PERIPHERALS

BOOKS**

SOFTWARE*

MAGAZINES**

STATIONERY***

BUSINESS +

INDUSTRIAL

CONTROL

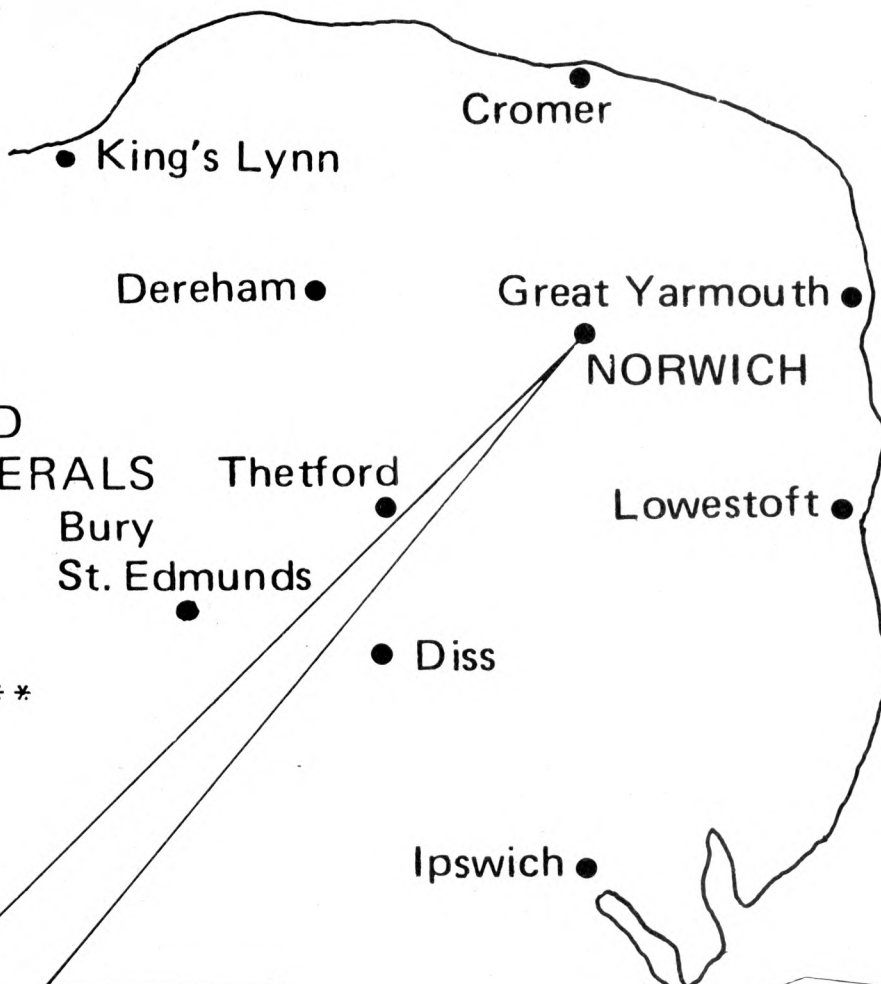

WE ARE HERE!!!

88 St. Benedict's Street

NORWICH NR2 4AB

Tel. (0603) 29652

24hr. Answering Service.

Open on Sundays

during Dec.

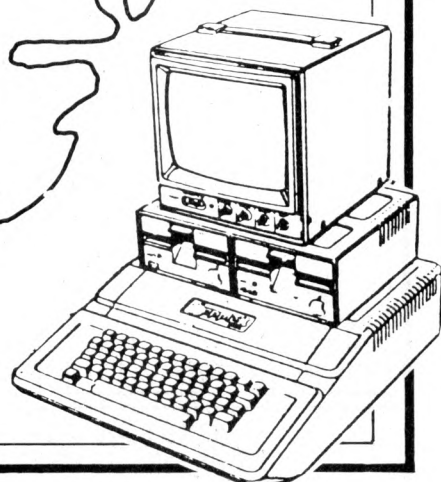

TVJ

MICROCOMPUTERS ETC

For Hardware, Software, Peripherals, Consultancy and Competitive Prices.

Registered business name



PET 2001



from **£425**

commodore authorised dealers

TRS 80



from **£365**

From Radio Shack Corp.

APPLE II

from **£695**



apple authorised dealers

SORCEROR

from **£730**

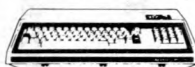

authorised dealers

ADVANCED SYSTEMS



BASIC SYSTEMS	
PET 3016 (16K RAM and large keyboard) *	£550.00
PET 3032 (32K RAM and large keyboard) *	£695.00
IEEE/RS232 Serial Interface 'A' Output only	£106.00
IEEE/RS232 Serial Interface 'B' Input/Output	£186.00
Programmers Toolkit - 10 powerful new commands for your Pet - plug in ROM chip 8K and 16/32K resp	£75/£55
PET 2001-8 (PET with 8K memory + integral cassette)	* £425.00
PET 3008 (8K) with large keyboard *	* £450.00
PET C2N External Cassette Deck	£53.00
ACCESSORIES	
IEEE-448/Centronics type parallel Interface	£35.00
IEEE to Pet Cable	£19.00
IEEE to IEEE cable	£24.00
PETSET 1 16 Channel AD Converter c.w. all interfacing requirements	* £166.00

BASIC SYSTEMS	
TRS 80, 4K Level I consisting of Keyboard with 4K memory, Video Unit, Cassette Drive and 240v power supply unit	£365.00
TRS 80, 4K Level II (as above with Level II Basic)	£425.00
TVJ 232 serial interface Centronics Parallel Printer Interface (direct to keyboard)	£40.00
TRS 80, Voice Synthesizer	£345.00
TRS Voxbox - speech recognition system	£135.00
Stringy Floppy drive (complete with manual & wafers)	£180.00
TRS 80, 16K Level II (as above with 16K memory)	£499.00
TRS 80, Expansion Interface with 16K RAM	£275.00
TRS 80, Expansion Interface with 32K RAM	£360.00
ACCESSORIES	
Radio Shack Phone Modem	£160.00
UHF Modulators (encased with leads for 625 lines)	£20.00
RAM upgrade (4-16K, 16-32K, 32-48K) supplied and fitted at our premises (Kit £80.00)	£85.00
TRS80 CPU 2 speed mod.	

BASIC SYSTEM	
Apple II Plus computer - APPLESOFT extended basic in ROM - (16K RAM) - video output	£695
ACCESSORIES	
Apple black and white modulator for domestic TV	£14.00
Eurocolor card - provides colour on domestic TV	£79.00
Parallel Printer Interface Card	£104.00
High Speed Serial (RS232C) Interface Card	£113.00
Communications Card	£132
Centronics Card	£132
Integer Basic Firmware Card	£116.00
PASCAL language system - includes language card to provide user with PASCAL, PALSOFT & INTEGER BASIC	£299.00
Real time clock/calendar card - 1/1000 sec to 388 days with interrupt, software controllable	£128.00
Speechlab - provides voice control for the Apple	£160
Supertalker - adds human speech output!	£136.00
ALF Music Synthesizer Card	£180.00
A1-02 Data Acquisition Card	£180.00
Graphics Tablet	£462.00
AC Line Controller	£270.00
RAM Upgrade (16-32K, 32-48K)	£69.00
Hobby Prototype Card	£20.00
Romplus - u, l/c, mixed text/graphics	£105.00

BASIC SYSTEMS			
Sorcerer (inc. UHF Modulator) Special low prices on limited stock.			
16K RAM	£590.00	32K RAM	£650.00
		48K RAM	£695.00
ACCESSORIES			
Exidy Video Disk Unit (High Resolution monitor with Integral 630K Dual Drive)		Exidy S100 Unit	£240.00
		Exidy Video Monitor	£240.00
	£1,590.00	CP/M on Disk	£145.00

ADVANCED SYSTEMS	
TRS 80 Model II with integral 8" floppy disk drive and up to 64K RAM. Expandable up to 3 Megabytes Disk Storage (Available for demonstration - by appointment only). From	£2,300
SUPERPETS SYSTEM - CBM8032 Computer with 30 col. screen	£895
CBM8050 - Dual Disk Drive giving 950K User Storage	£895

PET BUSINESS SYSTEM	
comprising	
CBM 3032 Micro computer, CBM 3040 Dual Disk Drive, CBM 3022 Tractor Feed Printer and all cables	£1799.00

Special Offers!

DISKS	
PET CBM 3040 (dual drive) 343K User storage *	£695.00
Computhink (dual drive) 400K storage	£895.00
Computhink (dual drive) 800K storage	£1145.00
TRS80 Shugart drive	£299
Micropolis drive	£299
Percom FD200 drive 110v	£275
Micropolis Dual Drive (394K storage)	£995.00
Corvus Hard Disk (11mb)	£3500.00
APPLE	
Apple Drive - 116K storage 1st drive	£349.00
Apple Drive - 116K storage 2nd drive	£299.00
Corvus Hard Disk (11mb)	£3500.00
SORCEROR	
Exidy - 315K Storage	£630
Exidy Dual drive (630K storage)	£1195.00
Corvus Hard Disk (11mb)	£3500.00

PRINTERS	
PET CBM 3022 (80 col with PET graphics - tractor feed) *	* £425.00
TRS80	
TRS 80 Screen Printer (text - graphics) (110v)	£345.00
New Radio Shack Micro Printer	£245.00
GENERAL	
Teletype 43 KSR Serial (pin or pinch feed, 132 cols)	£825.00
PASCAL Binder Printers - truly professional printers for microcomputers - high speed (up to 280 cps), upper/lower case	P.O.A
OKI - parallel/serial (pin or pinch feed, 40, 80, 132 cols selectable)	£499.00
Centronics 779 parallel (tractor feed, 132 cols)	£825.00
DOLPHIN BD60P tractor printer (125 cps bi-directional, 40, 80 columns - optional 132; w/l case & graphics). Available with Serial, parallel or IEEE interface	£925.00
Centronics Micro Printer (20, 40, 80 cols selectable)	£395.00
Heath WH 14 serial (80, 96, 132 cols	
QUME daisy wheel printers	P.O.A
TCM100/MICROHUSH Thermal Printer (40 cols) inc. interface for PET/APPLE	£266.00
SILENT PRINTER for APPLE... allows printing of high res. graphics	£349

ETC.	
Diskettes 5 1/4" (blank) boxed (min order 10) each	from £3
C12 Cassettes (min order 10) each	£0.35p
Ansaback phonemate telephone answering machine, voice operated twin cassette	£190.00
Pace EZ-PHONE - Cordless Telephone	£225.00
Hitachi Video Monitors 9"/12" resp.	£127/£187
BOOKS - Large range of microcomputer related books and magazines	
STATIONERY	
Listing Paper - most common sizes	
Ribbons for MOT Printers	
PROGRAMMABLE CALCULATORS, TEXAS INSTRUMENTS, Business Programmable	
Calculators - complete range. Send for list + prices. (We are authorised TI dealers)	

IF YOU DON'T SEE IT - ASK IF WE HAVE IT

SOFTWARE	
PET PETSOF authorised dealers - over 160 programmes on cassette and disk. Send for catalogue	
74 Common BASIC Programs on one tape	£15.00
PETACT Business Software - Sales and Purchase Ledger, Invoicing, etc.	P.O.A
CBM DISK-BASED BUSINESS SOFTWARE	
COMWORDPRO II/COMWORDPRO IV powerful word processor, low/high level resp.	£75/150.00
COMSTOCK - STOCK CONTROL - gives complete stock report	£150.00
COMBIS - BUSINESS INFORMATION SYSTEM - Storage & Retrieval of all types of company records	£150.00
COM ACCOUNTS - Full Financial Business Accounting System incl: Sales, Purchase, Nominal Ledgers	£650.00
COMPAY - Handles hourly, weekly or monthly paid employees	£150.00
COMPLANNER - Personal information tool for the busy executive (We are authorised CBM Business Software Dealers) Send for List.	£50.00
GD 1001 - Assembler Development System	£75.00
GD 010 - Lisp Interpretive Language (Artificial intelligence)	£138
GD 1000 - PASCAL Language for PET	
BRISTOL SOFTWARE FACTORY S/W dealers - TRADER, ITEM, MONITOR, etc. - Send for details.	
TRS 80	
COMAC III SUITE - computerised accounting for TRS 80 (TVJ SOFTWARE)	£75.00
STOCK CONTROL - complete inventory control - recorder level - P.O's etc	£115.00
CP/M	£95.00
CBASIC	£75.00
FORTTRAN includes compiler, relocatable assembler text editor and linking loader	£95.00
PASCAL - tomorrow's programming language today	£195.00
ELECTRIC PENCIL - powerful word processor allows full cursor movement, insert/delete, string search block movement, adjustable line length, justification on cassette	£39
ELECTRIC PENCIL as above - disk version	£95.00
LOWER CASE MOD KIT ONLY/FITTED for Electric Pencil	£8.00/£28.00
DATA MANAGEMENT/REPORT GENERATOR - easily formats disk files, allows entry, edit, delete and list of records and retrieves data for display or calculation on screen or printer	£150.00
RSM-2D DISK MONITOR - powerful system manipulates disk data, has Z-80 break routine	£25.00
ST80D communications software	£60.00
NEWDOS - TRSDOS with corrections and enhancements	£25.00
NEWDOS + - as above but with further facilities - KBFIX, Renum, Screen to printer in one step, DOS commands from BASIC, Level II in II, Superzap, Disassemble, load and save faster, list variables	£49.00
LIBRARY 100 - an assortment of 100 programs	£39.00
SARGON CHESS - 16K Level II - the 1979 Champ Version I	£14.00

APPLE	
CASHIER - Retail Store Management System	£195
U-DRAW II - High Resolution graphics editor. Create a figure then rotate, expand, contract etc and store on disk	£27.00
LISP - programming language suitable for research in artificial intelligence	£30.00
3-MILE ISLAND - Complex disk based game simulating nuclear reactor	£27.50
VISCALC - Instant Visual Calculation - provides a powerful planning and forecasting tool	£52.00
APPLE WORD PROCESSOR - Complete text editing, storage and retrieval of text (disk based)	£42.00
LITTLE GENIUS - Comprehensive disk based Apple Soft Tutorial	£35.00
ACT Appeware and MUSE authorised software dealers - Many programs on cassette and disk. Send for list.	
SORCEROR many programs available - send for list.	
Word Processor Rompac	£120
Development Pac	£70.00

* 5% DISCOUNT ALLOWED FOR EDUCATIONAL ESTABLISHMENTS



T&V JOHNSON (MICROCOMPUTERS ETC) LTD

Member of the TV Johnson Group of Companies

Camberley (Head Office)
Johnson House,
75/79 Park Street,
Camberley, Surrey, GU15 3XE.
☎ (0276) 20446

Oxford
148 Cowley Road, Oxford
OX4 1JY.
☎ (0865) 721461

Bristol
48 Gloucester Road, Bristol
BS7 8BH
☎ (0272) 422061

Hours of business
Mon-Fri 9.30 - 5.30
Sat 9.00 - 12.30

+ Ansaback evens and w/ends.
Telex 858893



Directors: Dr. R.V. King BA, MIEE
S.G. Johnson, BSc. (Hons.)
T.S. Johnson, ABIA, ACMB, FBSC, MBIM
A.S. Barton ACII, ABIBA, CdiPAF.
PRICES EXCLUDE VAT, FREIGHT & HANDLING SEND OR PHONE FOR PRICE LIST & BROCHURES (All prices correct at time of compilation)

Call in and buy a better business

at

CREAM

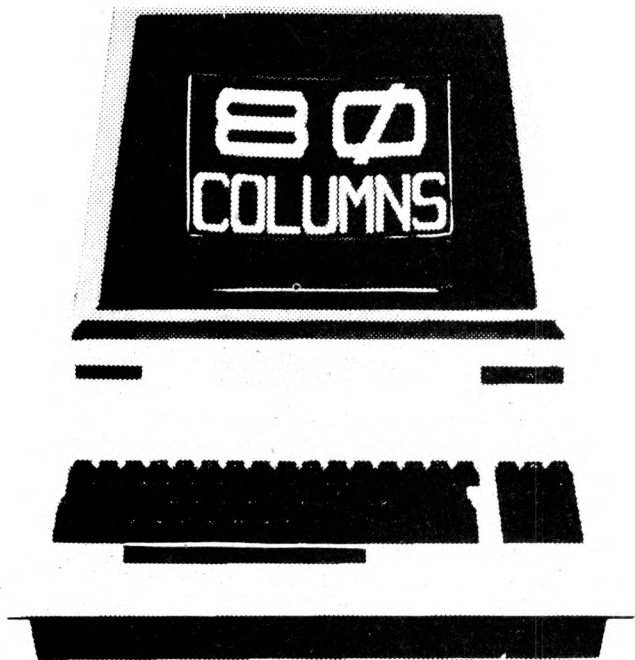

Commodore 8000 series business computers

CREAM ARE THE COMPLETE COMPUTER SHOP
CLIENTS WHO BUY FROM OUR LARGE MODERN SHOP, 3 MINS FROM HARROW-ON-THE-HILL TUBE STN.
TAKE FULL ADVANTAGE OF OUR PROFESSIONAL DEMONSTRATIONS, ADVICE, PROMPT DELIVERY AND
FULL ENGINEERING SUPPORT.

WE CARRY NOT ONLY A COMPREHENSIVE RANGE OF HARDWARE BUT ALSO POWERFUL
BUSINESS PROGRAMS FOR MOST APPLICATIONS i.e. WORD PROCESSING, PAYROLL, STOCK CONTROL,
RECORD KEEPING INVOICING ETC, OUR OWN TOP QUALITY ACCOUNTING CONTROLLER PROGRAMS,
WRITTEN BY OUR OWN SOFTWARE HOUSE OFFER BUSINESSES MAINFRAME/MINICOMPUTER QUALITY
AT MICROCOMPUTER PRICES.

A TYPICAL BUSINESS SYSTEM FROM CREAM CONSISTING OF COMPUTER, DISK DRIVES PRINTER
AND SOFTWARE CAN RANGE FROM AS LITTLE AS £2200 + VAT – A PRICE MOST BUSINESSES CAN
EASILY JUSTIFY.

**BUYING FROM CREAM MAKES GOOD BUSINESS SENSE
BUYING FROM CREAM IS GOOD NEWS FOR HOBBYISTS TOO.**

OUR DISCOUNT PRICES MEANS YOU CAN AFFORD MORE THAN YOU INITIALLY THOUGHT POSSIBLE.

i.e.

APPLE II 16K EUROPLUS
COMPUTER £590
16K MEMORY UPGRADES £50
PET COMPUTER 8K SMALL
KEYBOARD £389
LARGE KEYBOARD £410
16K LARGE KEYBOARD £500
32K LARGE KEYBOARD £610
ALL + V.A.T.

SHARP PC 1211

NEW
HAND HELD
COMPUTER –
1K RAM BASIC
LANGUAGE.
ALPHA-
NUMERIC
KEYBOARD
24 CHARACTER DISPLAY
£79.95.

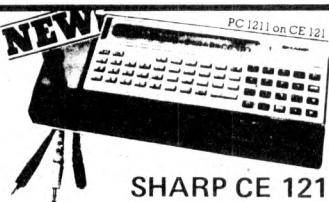

SHARP CE 121

TAPE INTERFACE
£12.95.

ADD 15% V.A.T.

ALL MACHINES GUARANTEED 12 MONTHS

FOR BUSINESS, HOME,
EDUCATION, RESEARCH &
LEISURE – IT PAYS TO BUY
FROM CREAM.
DISKS, CASSETTES, BOOKS, &
ACCESSORIES ARE ALL
READILY AVAILABLE.

CREAM COMPUTER SHOP
380 STATION ROAD, HARROW, MIDDX, HA1 2DE.
01-863 0833/4
TUESDAY TO SATURDAY – 10 AM – 6 PM
ACCESS, BARCLAYCARD AND MAIL ORDERS WELCOMED

London Computer Centre Limited

60 CHARACTERS PER SECOND THE FASTEST DAISY WHEEL PRINTER.

FAST, heavy duty commercial DAISY WHEEL printer, with high quality printout, coupled with low noise necessary for office environment. Nationwide service by NEXOS. 90 day warranty provided at your premises.

124 char: upper/lower case. * 10/12 chars: per inch giving 126 or 163 columns. * 15 inch wide frintion platen. */reverse Top of the form, BOLDING, underline, and host of other features. * Centronics type parallel interface as standard options: serial interface 60 * PET interface 65 * APPLE interface 75.

RICOH RP 1600

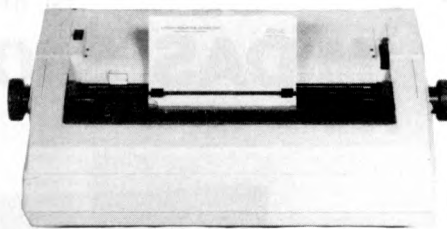

NEW LOW PRICE £1095 SHEET FEEDER OPTIONAL EXTRA £550.

- ← TRS 80 Model 1 & 11
- ← SUPERBRAIN
- ← APPLE
- ← PET
- ← HORIZON Etc

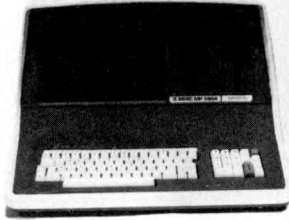

NEW SUPER BRAIN DUAL DENSITY £1595 QUAD DENSITY £1995

Now with CP/M 2.2 & increased disc storage. Twin Z80-A 1MHZ * 2 disc drives, dual density 320 K quad density 700 K storage * 64K ram * High resolution 12 inch CRT. 80 x 24 lines upper/lower case * 2 RS-232 printer ports * CPM 2.2 operating system * M basic, Cobol, Fortran, Pascal, Word processing & accounts packages available Dealer enquiries invited.



TRS-80 MODEL II

State of the art second generation computer. Over 10,000 already sold in USA, 8 slot bus ensures expansion of hard discs & other peripherals., 76 Key professional keyboard, self test on power up, TRSDOS & Level III basic standard. CP/M available as option. making a wide range of accounting, educational, scientific & word processing packages instantly usable. Nationwide service through 180 Tandy stores & computer centres.

NOW WITH CP/M 2.24 £1999



NEW TRS-80 MODEL 1 48K SYSTEM WITH DUAL DISC DRIVES

NEW LOW PRICE £1095
WITH DESK AND EPSON
PRINTER £1495

New greenscreen VDU, with rock steady display. Redesigned 32K expansion intrface with trouble free disc operation, two 40 track teac disc drives, complete with cables. Tridata sales, purchase, invoicing, payroll packages available.

OKI MICROLINE 80/132. THE QUIET PRINTER YOU CAN LIVE WITH

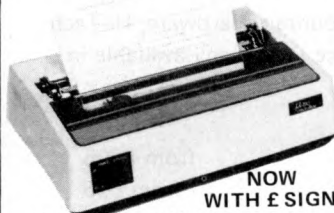

NOW
WITH £ SIGN

The quietest Dot Matrix available. 40, 80 or 132 cols per line * excellent print quality * 3 way paper handling: letterheads, fanfold, or paper rolls * graphics * ideal for software written for large 132 col printers * continuous rating printing day in and day out * centronics parallel standard. Options: Rs-232, PET, Apple. Dealer enquiries invited.

NEW LOW PRICE £399

MX80

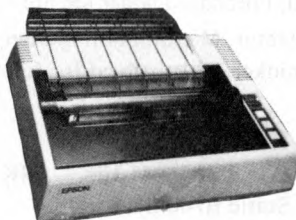

TRS-80 Graphics * Prints 48, 66, 80 and 132 columns with true decoders at 90 cps * logic seeking, bidirectional 9 x 9 point head * upper and lower case * forms handling: Top of form, horizontal and vertical tabs * Centronics parallel interface standard * optional extras: serial, PET and Apple interfaces

Also Available
TX80 £325 (Not Illus)

737



80 CPS + double spacing and mono spacing 10 and 16.7 CPI * nx9 proportional spacing, 3 way paper handling * 96 character set * Expanded print * Right margin justification * Underlining * Bidirectional * Pound sign conronics parallel and serial interfaces standard * optional extras: PET & Apple interfaces.

NEW MAXI ANADEX WITH GRAPHICS £895



Takes up to 13.5 inch wide paper * Upper/lower case with decoders * £ sign * 132 or 175 chrs/line with double width printing * Fast 150 CPS bi-directional logic seeking printing * Heavy duty print head giving 650 million chrs print life * serial, Parallel and Current Loop interfaces built in * Host of other features found on printers costing twice as much.

Also Available
DP8000 £425 (Not Illus)
DP 9501 £995 (Same as 9500 Illus)

CPM SOFTWARE

Word Star	250.00
Word star mail merge	315.00
Magic Wand	250.00
Data Star	195.00
T/Maker	175.00
Report Writer (VisiCalc)	90.00
Accounts Packages	from 295.00
Payroll	from 295.00

Various other packages available — ask for details.

SOFTWARE FOR TRS-80

Electric Pencil (disc)	60.00
Electric Pencil (cassette)	35.00
Scripsit (disc)	75.00

Scripsit (cassette)	60.00
Mail Merge for Pencil/Scripsit	45.00
VAT Aid Programme	45.00

MISCELLANEOUS

Floppy discs (Box of 10) including library case. Xcel Silver 5" single sided double density For Pet, Apple, TRS-80 & Superbrain	25.00
Xcel Gold 5" double sided double density	
For Superbrain Memorex 8" Single Sided double density	30.00
Qume Daisy Wheels	35.00
Qume Daisy Wheels	5.00
Ricoh RP 1600	15.00
Paper, Ribbons, etc.	POA

LOW COST WORD PROCESSOR I

Based on TRS-80 level 2 16K cassette recorder, electric pencil software, upper/lower case mod, printer interface and OKI Dot Matrix printer. Complete ready to go £895 free mailing list program.

WORD PROCESSOR II

Same as above but with 48K, 2 disc drives and ricoh daisy wheel printer £2195

WORD PROCESSOR III

Based on Superbrain computer shown above. With Ricoh printer & "Magic Wand" the ultimate in word processing. Letters automatically formatted with addresses fetched from separate file. Complete system £2950. Invoicing, stockcontrol, sales ledger, purchase ledger, payroll available for above computers from £250 per package.

LONDON COMPUTER CENTRE LIMITED 43 GRAFTON WAY, OFF TOTTENHAM COURT ROAD, LONDON W1
TEL: 01-388 5721 OPENING HRS: 11-7 MON-FRI, 12-4 SATS.

MICRO SYS LTD, 58 HIGH STREET,
PRESTCOTT, MERSEYSIDE TEL: 051 426 7271

NORTHERN DEALERS

HORIZON SOFTWARE LTD, REGENT HOUSE
16 WEST WALK, LEICESTER LE1 7NG. TEL 0533 556550



NOW WITH MP/M

SIRTON COMPUTERS

76 Godstone Road, Kenley (Nr Croydon)
Surrey CR2 5AA
Tel: 01-668 0761/2

MIDAS S100 SYSTEMS

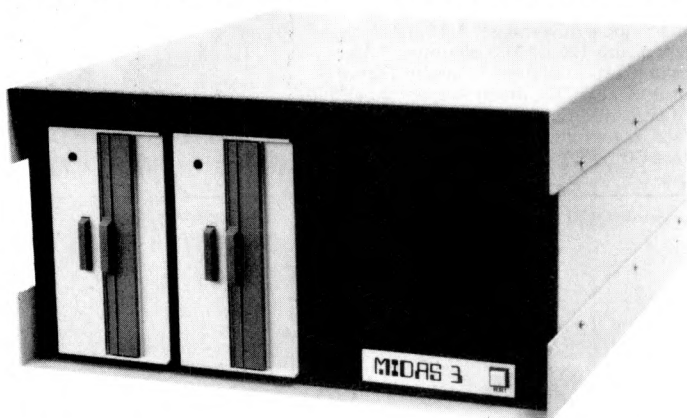

- MIDAS 1 : From £750**
- MIDAS 2 : From £1580**
- MIDAS 3 : From £2150**
- MIDAS 4 : From £5900**

ITHACA-DPS 1 : From £1075

- Our versatile Z80 Microcomputers are available as standard units or custom configured to your exact specification from a comprehensive range of stocked S100 boards.
- Disc storage capacity of the MIDAS 3 can be 2M Bytes, expandable to over 20M Bytes with a Winchester Hard Disc Unit in our MIDAS 4 range.
- MIDAS runs CP/M and MP/M is also available. Other Software includes M-BASIC, C-BASIC, FORTRAN, COBOL, CIS-COBOL, PASCAL and Word Processing.
- **A MIDAS 3, with 64K RAM and 2M Bytes storage on two 8" drives with two Serial I/O Ports and CP/M 2 only £2835**
Multi-User System (four users) – MIDAS 3 with four 48K blocks of RAM, 1 MByte disc storage on two 8" drives and four Serial I/O Ports, and CP/M 2 + MP/M – **£3850.**
- Printers, VDUs and other peripherals stocked to give complete package systems at keen prices.
- Business Packages include Accounts, Stock Control, Purchase Ledger etc etc.

Boards stocked from Ithaca, Godbout, SSM, S D Systems, Vector, Micromation Mullen, Mountain Hardware, Hi-Tech, Video Vector, Pickles & Trout, Central Data, Cromemco, Thinker Toys – Send for full Price List (many available in kit form).

PROCESSOR

Z80 Starter Kit	£188
SBC100	£208
SBC200	£237
Z80 CPU's4 MHz	from £130

EPROM

2708 EPROM (16K)	£60
2708/2716 Programmers from	£134

VIDEO

16 lines, 32/64 ch	from £104
24 Lines, 84 ch	from £265

DISC CONTROLLERS

Versafloppy S/D	£198
Doubler D/D	£280

SOFTWARE

CP/M 1 & 2, MP/M, PL/1, C-BASIC 2, M-BASIC V5, XYBASIC, FORTRAN 80, COBOL 80, CIS-COBAL, PASCAL/Z, PASCAL (UCSD), PASCAL M/T, Forth, MAC, ZSID, Disassembler, Wordstar, Datastar, Magic Wand, Wordmaster, Supersort etc etc.

MAINFRAMES

We are the sole UK Distributor for Integrand Mainframes and Disc Enclosures, available in nine models including Desk Top and Rack Mounting, with or without provision for Disc Drives. All units totally enclosed, painted on all external surfaces and complete with power supply etc.

RAM

Dynamic RAM 16K – 64K	from £205
Static RAM 8K – 64K	from £95
Memory Manager	£52

I/O

2S/4P prov 4K RAM/4K ROM	£169
2S/2P or 2S/4P or 3P/1S or 4S/2P	from £135
Analogue 8 or 12 bit	from £287
Optically isolated I/O	£114
IEEE 488 Interface	£350

MISCELLANEOUS

Real Time Clock	£180
High Dens Graph/8K RAM	£333
Hi-Tech Colour	£295
Motherboards – various from	£34
Extender Board/logic probe	£39
Maths Board AMD 9511	£330

WRITE OR PHONE FOR CATALOGUE PRICES EXCLUSIVE OF VAT

APPLE® II DISK DRIVES

DUAL DISK UNIT

£498

DISK CONTROLLER CARD

£ 49

- * Two Disks in one Cabinet
- * Has its own Power Supply Unit
- * Connects to standard Apple Disk Controller Card
- * Runs all Apple Software including Pascal
- * Japanese quality and reliability



APPLE DEALERS:- Write or phone direct to Cumana and specifications plus dealer discounts will be mailed to you.

TRS-80® DISK DRIVES

DUAL DISK UNIT

2 x 40 Track Drives
2 x 80 Track Drives

£440
£645

SINGLE DISK UNIT

1 x 40 Track Drive
1 x 80 Track Drive

£236
£345

TRS 80 DISK CABLES

2 Drive Cable
4 Drive Cable

£20
£32.50

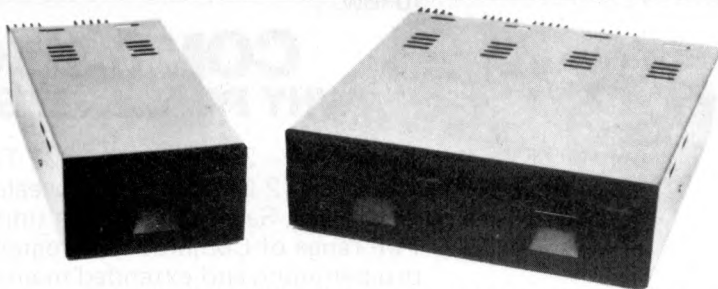

TRS-80 DEALERS:- Write or phone direct to Cumana and specifications plus dealer discounts will be mailed to you.

EDUCATIONAL & QUANTITY DISCOUNTS

VERY GENEROUS EDUCATIONAL AND QUANTITY PURCHASE DISCOUNTS ARE NOW AVAILABLE ON CUMANA TRS 80 DISK DRIVES. OUR DEALERS WILL BE HAPPY TO SUPPLY PRICE QUOTATIONS

Call your nearest dealer for a demonstration:

RADIO SHACK LTD.,
188, Broadhurst Gardens,
London NW6
Tel: 01-624-7174

COMPSHOP LTD., 14, Station
Road, New Barnet, Herts.
Tel: 01-441-2922

COMPSHOP LTD.,
311, Edgware Road,
London W2. Tel: 01-262-0387

MICRO-CONTROL LTD.,
224, Edgware Road,
London W2. Tel: 01-402-8842

**LONDON COMPUTER
CENTRE**, 43 Grafton Way,
London W1. Tel: 01-388-5721

**TRANSAM COMPONENTS
LTD.**, 59-61, Theobalds Road,
London WC1
Tel: 01-405-5240

N.I.C. 61, Broad Lane,
Tottenham, London N15
Tel: 01-808-0377

**KATANNA MANAGEMENT
SERVICES**, 22, Roughtons,
Galleywood, Chelmsford,
Tel: 0245-76127

I.C. ELECTRONICS,
Flagstones, Stede Quarter,
Biddenden, Kent.
Tel: 0580-291816

**CAMBRIDGE COMPUTER
STORE**, 1, Emmanuel Street,
Cambridge. Tel: 0223-65334

**PORTABLE MICRO-
SYSTEMS**, 18, Market Place,
Brackley, Northants
Tel: 0280-702017

COMPUTERAMA LTD.,
5, Cleveland Place East,
London Road, Bath.
Tel: 0225-333232

ENSIGN, 13-19, Milford
Street, Swindon, Wilts.
Tel: 0793-42615

SEVET TRADING, 14, St.
Paul's Street, Bristol 2
Tel: 0272-697757

PARWEST LTD., 58, Market
Place, Chippenham.
Tel: 0249-2131

**HEWART MICRO-
ELECTRONICS**, 95, Blakelaw
Road, Macclesfield.
Tel: 0625-22030

HARDEN MICROSYSTEMS,
28-30, Back Lord Street,
Blackpool. Tel: 0253-27590

MICRO CHIP SHOP,
197, Waterloo Road, Blackpool.
Tel: 0253-403122

MICRO CHIP SHOP,
190, Lord Street, Fleetwood,
Lancs. Tel: 03917-79511

EWL COMPUTERS LTD.,
8, Royal Crescent, Glasgow.
Tel: 041-332-7642

**NORTH WEST COMPUTER
CONSULTANTS LTD.**,
241, Market Street, HYDE,
Cheshire
Tel: 061-366-8624

ZERO ONE ELECTRONICS,
36, Oaklands Avenue,
THORNTON HEATH,
Surrey
Tel: 01-689-7924

P & J EQUIPMENT LTD.,
3 Bridge Street,
GUILDFORD
Tel: 0483-504801

CUMANA LTD 35 Walnut Tree Close, Guildford, Surrey, GU1 4UN.
Telephone: (0483) 503121. Telex: 859680 (Input G).

*Please add VAT to all prices.
Delivery at cost will be advised
at time of order.*



COMPLETE COMPUTER SYSTEMS



BUY — FROM CCS Microsales

SOFTWARE FOR APPLE/PET

NOW you can WRITE PROGRAMS FAST for the Apple II/PET. Using our modular data handling approach, many tasks are reduced to your calculations — plus simple calls to our routines to handle all the disk input/output — screen editing and input of data — report production.

At a cost of £40 for the main 4 modules (Define DESCRIPTION — READ file DESCRIPTION — FETCH — STORE) its going to pay for itself very quickly. Also available are: AMEND — MOVE — MOVE COMPUTED — PRINTER (PRINTER requires MOVE and MOVE COMPUTED).

ALL 8 MODULES for £64 — with more modules to follow.

COMMODORE WHY PAY MORE? SAVE £200

3032 PET — 3040 Disc — 3022 Tractor Printer — c2N Cassette — 2 Cables — Pet Revealed. Our price £1722 (ex. VAT). Save £50 on most units.

Full range of Commodore programs available plus programming and extended maintenance.

APPLE

- The Apple is great in a business environment, with our commercial systems software.
- An Apple based Word Processing System is available for only £1990, including software.
- File management/database systems available.
- For the technically minded there are CCS boards, including Arithmetic Processor, ROM, IEEE interface, Synchronous and Asynchronous Serial Interface, and an A-D converter.

* 18 months guarantee included

HIRE — FROM CCS Microhire

- The leading microcomputer hire company.
- Available are: Apple, PET, Exidy Socerer, Seed System One/ MSI 6800, NASCOM/MICROS, and the Tandy TRS 80.
- Peripherals also available, and software!
- New monthly rates — £79 to £99 per month (8K to 48K).

CCS Microsales

and

CCS Microhire

WE HAVE RELOCATED! Visit or contact us at our new showroom

7 The Arcade
Letchworth
Herts

Tel No. (04626)-73301
Telex 261507 (Ref 3244)

Pascal is born.

Micro Computer Connections announce the arrival of the "Pascal Utility Package." This brand new package available to Apple II users and has been developed to help those users with some experience in BASIC to become acquainted with USCD PASCAL.

Four procedural units are provided, in a format easily adaptable to any application. They simplify input/output formatting, allow access and/or change in the disc directory from a Pascal program, perform integer... string... real conversions, and support files of variable-length records.

Five useful sample programs have been incorporated on the disc. They are a set of simple PASCAL demos with listings on BASIC equivalents, a routine to view disc files in ASCII or HEX code, a text formater for simple word processing, a program to maintain a variable-length data file for the international traveller.

There is also our "Birthday Surprise" to celebrate the arrival of this unique program which is offered for immediate release only through Micro Computer Connections at the special introductory price of £40.

For details see reply coupon below.

MICRO COMPUTER CONNECTIONS LTD.
41 High Street, Egham, Surrey TW20 9DS. Tel. (0784) 37433/4.

All your answers at the touch of a button.

Micro Computer Connections Ltd., 41 High Street, Egham, Surrey TW20 9DS.
Complete coupon and send together with your remittance for £40.00 p&p included, made payable to MICRO COMPUTER CONNECTIONS LTD.
Within 28 days of receipt you will receive the new MCC Pascal Program complete with instructions. (Credit Card facility available.)

NAME _____
COMPANY _____
POSITION _____
ADDRESS _____

I enclose my cheque/PO for £ _____



OTHER

or debit my Access/Diners/Barclaycard/credit card No.

--	--	--	--	--	--	--	--	--	--	--	--	--	--	--	--	--	--	--	--

DATRON of SHEFFIELD

for Cromemco the ultimate name in micros

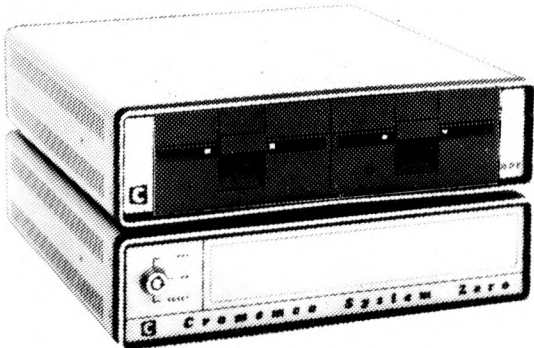

Cromemco new System Zero/D

Complete Systems supplied for Business, Research, Education and Industry

Wide range of languages, 16K and 32K Basic, Rationalized Fortran and Fortran IV, Lisp, RPG etc. Operating systems — Cromemco CDOS, CP/M Compatible or Cromix for Multi-User

Write or 'phone for free advice and catalogue or call in for demonstration.

Demonstrations. 9am-5pm Monday-Saturday.

DATRON import direct from Cromemco
DATRON supply and support nationally
DATRON stock Cromemco Micros, Cards & Software.

DATRON prices:

Unit	RAM	ROM	Disc	
System Zero/D	64K	4K	2 x 390K	£2,524
System 2	64K	4K	2 x 390K	£2,095
System 3	64K	4K	2 x 1.2M	£3,746
Hard Disc Z2-H	64K	4K	10M + 2 x 390K	£5,373
Z2H Colour Graphics	64K	4K	10M + 2 x 390K	£7,800*

Prices include Interfaces for VDU, dot matrix and letter quality printers, documentation and systems familiarization.

* also includes 13" RGB Monitor and 2 x 48K graphic memory cards.



BOOKS from DATRON

all books in stock at press date

Your First Computer	R. Zaks	£5.95
The BASIC Handbook	David Lien	£11.00
Learning Level II	David Lien	£11.00
Illustrating BASIC	Donald Alcock	£3.25
Basic BASIC	Donald M. Munro	£2.40
The Little Book of BASIC Style	Nevison	£5.75
Some Common Basic Programs	Osborne	£7.95
Some Common Basic Programs CBM/PET		£8.95
32 BASIC Programs for the PET	Rugg & Feldman	£9.75
BASIC Cookbook	K. Tracton	£3.95
BASIC for Beginners	B.M.J. Kavanagh	£3.25
A guide to BASIC Programming	Spencer	£8.85
A Guide to PL/M Programming	McCracken	£7.95
PASCAL An Intro to Methodical Prog.	Findlay & Watt	£4.95
Introduction to PASCAL	Welsh & Eider	£6.95
Programming in PASCAL	Grogone	£6.95
Primer on PASCAL	Conway et al	£7.10
Struct. Prog. & Problem Solving with PASCAL	Kiebertz	£8.40
Problem Solving using PASCAL	Bowles	£7.95
An Introduction to Programming and Problem Solving with Pascal	Schneider	£5.20
PASCAL Programming	L. Atkinson	£6.95
COBOL for Business Applications	Philippakis	£10.25
Learning COBOL Fast	de Rossi	£6.45
FORTTRAN Techniques	A. Colin Day	£2.95
FORTTRAN Fundamentals	J. Staingraber	£3.45
Problem Solving & Struct. Prog. in FORTRAN	Friedman & Koffman	£9.95
An Intro to Prog. & Applications with FORTRAN	Hull & Day	£8.45
Z80 Micro Handbook	W. Barden	£6.95
Z80 Programming for Logic Design	Osborne	£6.30
Z80 Micro. Prog. & Interfacing Bk. 1	Nichols & Rony	£7.75
Z80 Micro. Prog. & Interfacing Bk. 2	Nichols & Rony	£8.50
Z80 Assembly Language Prog.	Leventhal	£8.15
Z80 Programming for Logic Design	Osborne	£6.30
Programming the Z80	Zaks	£9.75
Mostek Z80 Micro Software Programming Guide		£6.00
6502 Assembly Language Prog.	Leventhal	£8.25
6502 Applications Book	Sybox	£8.95
Programming the 6502	Zaks	£8.75

Programming a Micro (6502)	Foster	£7.25
PET Work Books Vol. 1-7 (excl. 3)		£15.00
PET Work Book Vol 3 (Graphics)		£3.00
The Best of Micro. Vol 1		£5.50
Vol 2		£6.50
The PET Revealed		£10.00
Library of PET Subroutines		£10.00
Peanut Butter & Jelly Guide to Micros.	Willis	£6.35
A Career in Computing	Penney	£4.25
Philips Guide to Bus. Computers & the Electronic Office	Enticknap	£3.00
The S-100 Bus. Handbook	D. Bursky	£9.15
The CP/M Handbook	R. Zaks	£8.95
Using CP/M	Fernandez, Ashley	£5.95
Computer Games	Nahigian & Hughes	£8.40
6502 Games	R. Zaks	£8.95
Basic Computer Games	Creative Computing	£5.50
More Basic Computer Games	Creative Computing	£5.50
Game Playing with BASIC	Spencer	£5.50
How to Build a Computer Controlled Robot	Loofbourrow	£5.95
1976 US Comp. Chess Championships	Levy	£5.00
TV Typewriter Cookbook	Lancaster	£7.50
TTL Cookbook	Lancaster	£7.15
CMOS Cookbook	Lancaster	£7.50
Home Computers - Beginners Glossary & Guide	Miller & Sippl	£4.75
Home Computers Vol. 1 Hardware	Didday	£5.20
Home Computers Vol. 2 Hardware	Didday	£4.60

P&P free U.K. Overseas add £1

Phone in your Access/
Barclaycard No
0742 585490
or complete this
order form

Send s.a.e. for full list. Prices correct at going to press. Add 12p insurance on books if required.

Please supply

I enclose - £
Cheque/Postal Order No
Barclaycard/Access No
Name
Address

DATRON MICRO CENTRE
DATRON INTERFORM LTD

2 Abbeydale Road, Sheffield S7 1FD.
Telephone 0742-585490. Telex 547151.

**WE HAVE ALL THE NEW ATARI®
VIDEO GAME PROGRAM™
CARTRIDGES.**

ATARI £86 + VAT

SILICA SHOP

TELEPHONE FOR FREE BROCHURES 01-301 1111

ELECTRONIC GAMES

ATARI



SPECIAL PRICE
£86 + VAT

INTELLIVISION MATTEL



£173.87 + VAT

Available August 1980
This is the most advanced TV
game in the world.
Expandable
next year into a full
microcomputer.
COLOUR CATALOGUE
AVAILABLE WITH
DETAILS ON ALL THE
CARTRIDGES

CHESS COMPUTERS



Send for further details.

NEW RANGE
AVAILABLE
AUGUST 1980
We specialise in
computer chess
machines & stock
over 13 different
models from
£20 to £300

TELETEXT



RADOFIN
TELETEXT
Add on Adaptor

£173 + VAT

BRIDGE

COMPUTER



- ★ Plays 1/2/3 or 4 Hands
- ★ Problem Mode
- ★ Audio Feedback
- ★ Instant Response
- ★ Auto scorekeeping

BACKGAMMON

COMPUTERS



From £38 to £108. Send for further details.

OMAR 1
OMAR 2
CHALLENGER
GAMMONMASTER

SPACE INVADERS

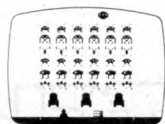

HAND HELDS + CARTRIDGES
ATARI - ACETRONIC
PRINZTRONIC
RADOFIN - DATABASE etc.
We keep a full range!
Send for cartridge lists stating which
machine you own.

DRAUGHTS

COMPUTER

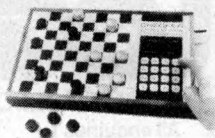

- ★ Solves Problems
Rejects illegal moves
- 2 level machine
£43 + VAT
- 4 level machine
£77.78 + VAT

LEISURE

- ★ CHEAP TV GAMES
- ★ TELEPHONE ANSWERING MACHINES
- ★ AUTO DIALERS
- ★ CALCULATORS
- ★ DIGITAL WATCHES
- ★ PRESTEL
- ★ HAND HELD GAMES

24 TUNE
DOOR
BELL
£13.65
+ VAT



FREE CATALOGUE

For a free copy
of our 32 page
catalogue, send
a 12p stamp to
Silica Shop Ltd
or Telephone
01-301 1111

MAIL ORDER SERVICE - Free postage & Packing

TELEPHONE & MAIL ORDERS - accepted on:
Access ★ Barclaycard ★ American Express ★ Diners Club

CALLERS WELCOME - at our shop in Welling - Demonstrations daily
Open from 9am-5pm Mon-Sat (9am-1pm Wed)

GUARANTEE - Full 12 months + After Sales Support!

We have comprehensive brochures on all products. Please let us know what you are interested in and we will send you detailed brochures AND our own
32 page catalogue covering most games on the market.

SILICA SHOP

SILICA SHOP
1/4 The Mews, Hatherley Rd.,
Sidcup, Kent
Tel: 01-301 1111

ALTOS

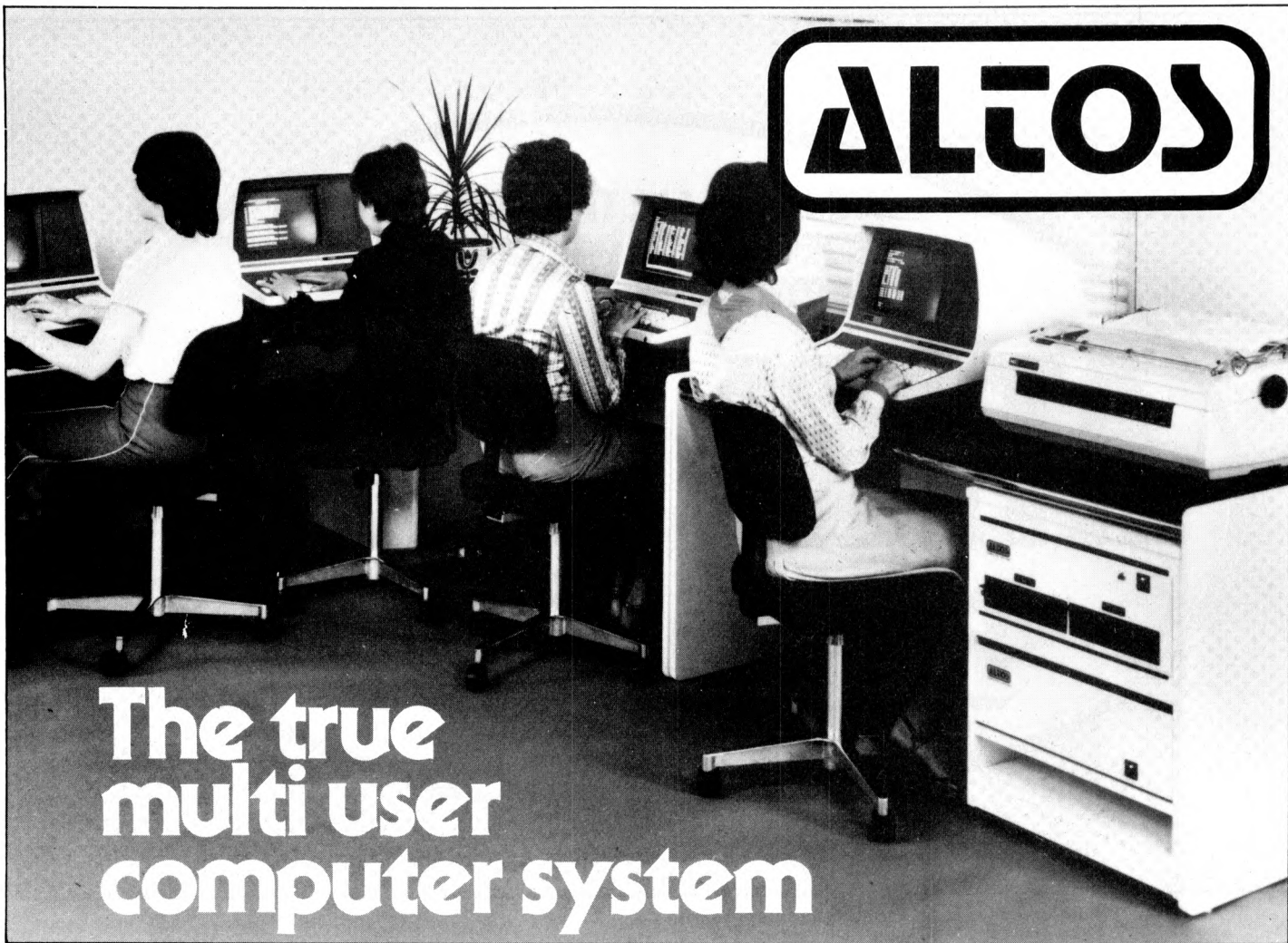

The true multi user computer system

The ALTOS ACS 8000 range of business/scientific micro computers creates a new standard in quality and reliability in high technology micro computers.

Hard Disk/Multi User Systems

The Winchester hard disk/multi user systems are now available supporting up to 4 simultaneous users and providing a maximum of 58 Megabytes of hard disk data storage.

The systems are truly flexible and allow expansion of the ALTOS floppy disk system to keep pace with the users requirements.

- Still single board, features include
- a high speed I/O section with up to six serial ports and one 8 bit Parallel port
 - up to 208K of on board R.A.M.
 - High speed (4 MHz.) D.M.A. control as standard.

Yes, mini power and at micro cost too.

Hard Disk Security Back-up

The 17.5 Megabyte funnel tape unit permits selective dumping from the Winchester at a rate of 1 Megabyte per minute.

Built-in Reliability

The ACS 8000 range are true single board micro computers making them extremely reliable and maintainable. All electronics are socketed for quick replacement. Complete diagnostic utility software for drives and memory is provided.

The board and Shugart floppy disk drives are easily accessible and can be removed in less than ten minutes.

Quality Software

Unlimited versatility. The ACS 8000 range support the widely accepted CP/M and MP/M operating systems plus basic (Microsoft and CBasic), Cobol, Pascal, and Fortran IV. All available now.

Logitek in conjunction with its own microsoftware house, Interface Software Ltd. of Camberley are able to supply a wide range of proven 'off-the-shelf' business software including general accounting, word processing, stock control, mailing list etc.

There are already over 1000 micro computer installations using this software. A track record which we consider speaks for itself. Why 're-invent the wheel' when there is standard software of this quality available now?

Communication Software

Two new custom software packages are now available for the Altos Computer System operating with CP/M to enable it to communicate with remote machines over ordinary telephone lines. ASYNC is an asynchronous package that operates with almost any remote machine. SYNCH is a synchronous package for use with the IBM 3780 protocols.

Custom Graphics & Scientific Software

A full graphics and scientific package is now available for use for the Altos with FPP.

GRAFLIB is a custom Altos software package containing a complete range of FORTRAN—callable graphics subroutines. It is designed with DRE RG—512 board, or a Tektronix 4000 series graphics terminal. Several multi-colour X-Y plotters are supported allowing hard copy in addition to screen graphics.

After Sales Support

Logitek are supported by DDT Maintenance Ltd. who provide a nationwide field maintenance service for Altos products and offer the option of maintenance contracts.

Availability

Logitek carry deep shelf stocks of Altos hardware and compatible peripherals.

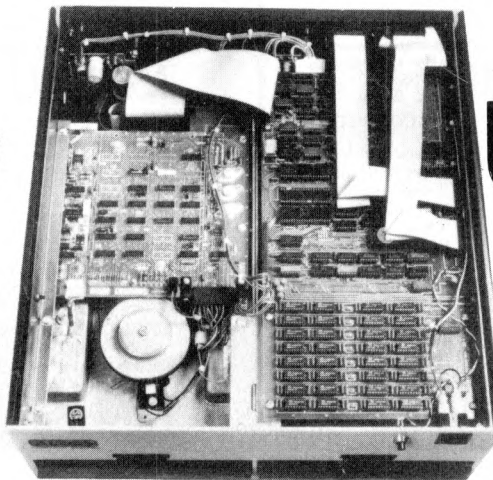

LOGITEK

LOGITEK, E.I.C. Electronics Ltd.

All enquiries to

8-10 Fazakerley St., Chorley,
Lancs. Tel: 02572 67615/70206

also at

30 Kelvin Ave.,
Hillington Industrial Estate,
Glasgow G52 4LH

Logitek are now the exclusive distributors of
Altos Computer Products for the U.K. and Eire

TOMORROW TODAY at Birmingham Computer Centre

Commodore official distributors

New
low
price

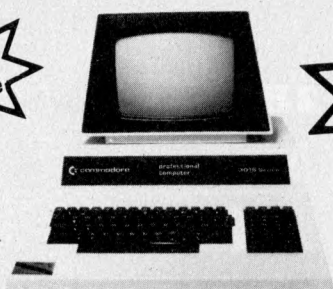

8032
£825

3016, 3032, 3008 PETs

The reliable value for money system with after sales support, instruction and training facilities and a wide range of programmes.

New
low
price



48K
Disk
drive with
controller
£1,044
+ VAT

Apple authorised distributors

The sophisticated quality system with a reputation for advanced design and innovation.

SHARP
Z80K

New
low
price



20K
£380

The incredible computer system. Now available ex-stock including the new dual drive duple sided floppy disk.

THE ULTIMATE IN DAISYWHEEL PRINTERS
RICOH RP 1600

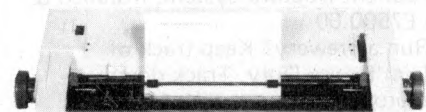

New
low
price

THE BEST WORD PROCESSOR
PRINTER AVAILABLE
DEALER ENQUIRIES WELCOME

UNBEATABLE
VALUE

Camden Electronics, First Floor,
462 Coventry Road, Small Heath,
Birmingham B10 0UG.
Telephone 021 773 8240

Open Mon.-Sat. 9.30-6.00 p.m.

A MEMBER OF THE COMPUTER RETAILERS ASSOCIATION

Z19.



The Intelligent terminal.

The Z19 'intelligent' Video Terminal, from Zenith Data Systems, is ideal for a wide variety of high-speed data handling tasks.

Compatible for use with EIA RS-232 or 20mA current loop, it has all the capabilities and features you'd expect from a top-of-the-line peripheral.

- Z80 Microprocessor based electronics
- Special deflection system for sharp resolution
- Full editing functions, plus user-definable keys
- Reverse video by character
- 24 lines of 80 characters plus 25th user status line
- 5 x 7 Dot matrix (upper case)
- 5 x 9 Dot matrix (lower case)
- 128 characters (95 ASC11 and 33 Graphic)
- ANSI and DEC VT 52 compatible

And there's one feature of the Z19 you wouldn't expect. The price. Just £735, exclusive of VAT and delivery charges.

Generous OEM discounts are available.

**Zenith
data
systems**



For full details about the Z19, complete this coupon and return it to:

Zenith Data Systems Division, Heath Electronics (UK) Ltd.,
Dept. (PCW 11), Bristol Road, Gloucester, GL2 6EE.

Name _____

Company _____

Address _____

Z19

XITAN SYSTEMS LTD

The South's CROMEMCO experts

Need a Hard Disk System with FAST RELIABLE Backup?

Xitan now have the answer with the Z-2H plus DC300 Tape cartridge BACKUP system (S100 controller, drive, psu & software).

The Cartridge BACKUP system is available separately for existing Z-2H users (13.4 Megabyte capacity – 1 Megabyte per 5 minutes).

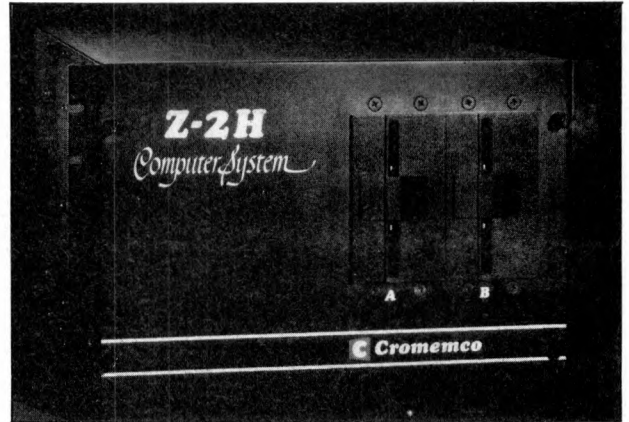

Utilities/Software for CROMEMCO Systems.

Tired of XFER – Use FCOPY or DFCOPY. Single sided 8" copy in 54 seconds, Double sided 8" copy in 104 seconds, £50.00 ea. Need to build Assembler libraries – try LIBR at £50.00.

CP/M 2.2 and MP/M 1.1 available for System 3 and Z-2H systems.

EASYFORM. For creation/editing of forms on the 3102 VDU with structured Basic. Forms useable from Cobol, Fortran etc. £160.00.

BUSINESS SOFTWARE

CROMEMCO systems – a complete Business system based on the system 3 from CAP-CPP. Phone for an appointment to see it running.

For the smaller customer, we have an integrated Sales, Purchase and Nominal system for the North Star Horizon.

Nothing fancy – but installed and running for over 7 months. IT WORKS!

WHATIF! Cash Flow, Accounts budgetting utility. Just released. Incredible value at £95.00.

Also available an Incomplete Records system for the Horizon.

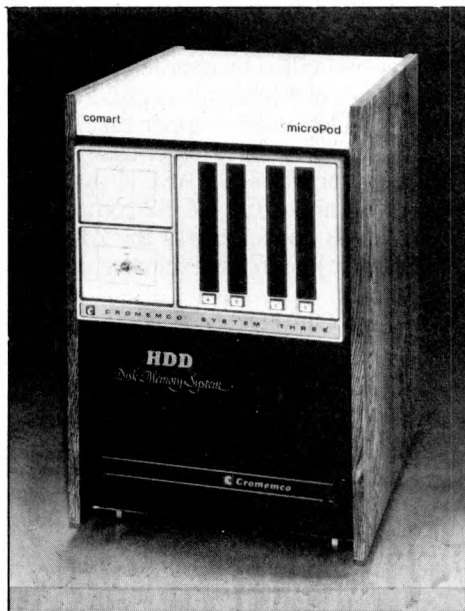

SPECIALS.

Real Time Clock -- S100 – 100 microseconds up to 99,999 days £155.00. Hi-Tech S100 PAL colour card, 24 x 40 Prestel format £295.00. Video Vector Fastlib £495.00. Dual Tandon Double/sided 40 track mini-floppy sybsytsem £625.00.

INTEGRATED SPECIALIST SYSTEMS.

MEDIDATA 32,000 patient Doctors' system. Installed & running. Prices from £7500.00.

RETURNED ALE. Run a brewery? Keep track of returned ale and reclaim Excise Duty. Track down production & storage problems. Copes with 10,000 + barrels. Prices from £8500.00.

Xitan Systems also supplies and stocks vdus, printers, NORTH STAR HORIZON computers, Commodore Business Machines PETs, S100 boards, and books. We are here to demonstrate the range of quality microcomputer systems available for use today. Ring up for an appointment now! You'll not be disappointed. We have Osborne's Sales Ledger and Payable Ledger in source form for use on Cromemco System 3 with CBASIC2, and we can offer a customising service on these programs. Additional software includes Microsoft Basic Interpreter and Compilers, Cbasic, Macro80, and CP/M for the North Star Horizon.

Xitan Systems Ltd., 23 Cumberland Place, Southampton SO1 2BB.

Tel: (0703) 38740

Hours Tue-Sat 9.30 am to 5.30 pm

TEMPLEMAN SOFTWARE LIMITED

25-26 Greenhill Street, Stratford Upon Avon
Warwickshire CV37 8LR
Telephone: Stratford Upon Avon (0789) 66237

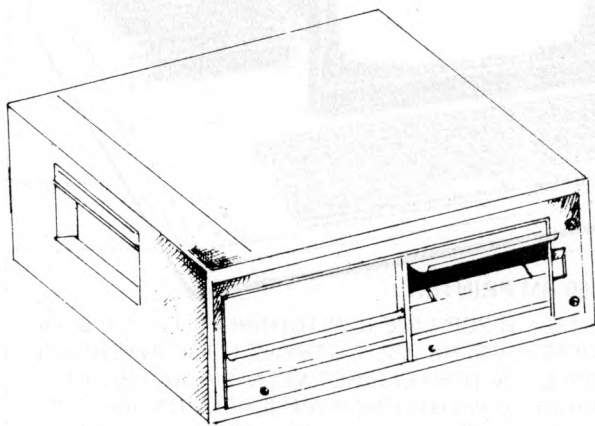

**8" DOUBLE SIDED, SINGLE
DENSITY FLOPPY DISC DRIVE.**

***THEY HOLD FIVE TIMES AS
MUCH INFORMATION AS 5"
DRIVES, I.E. ONE MILLION
CHARACTERS.**

***TWO VERSIONS OF DOS ARE
SUPPLIED; MAXIDOS AND
NORMALDOS.**

***PASCAL IS AVAILABLE.**

***ITT SILVER OR APPLE CREAM
CASING.**

***R.R.P. £1550 (exc. VAT).**

***DEALER ENQUIRIES WELCOME.**

**SOFTWARE IS OUR MIDDLE
NAME**

Z89.



Altogether a better computer.

All the power and built-in peripherals for business and educational computing in one compact, desk top unit.

The Z89 Series Microcomputer.

Designed and built to the highest specification, the Z89 combines reliability and efficiency with ease of operation. And is backed, of course, by our excellent after sales service.

Features include:

- Z80 CPU
- Built-in floppy Disc with optional dual external drives
- Built-in Z19 VDU
- Up to 65K RAM
- Three serial RS-232 I/O
- Operating systems C/PM & H.DOS.
- Languages: M-Basic, C-Basic, Fortran, Pascal, etc.

And with generous OEM discounts available you can see why the Z89 is a better computer.



Zenith data systems

For full details about the Z89, complete this coupon and return it to:

Zenith Data Systems Division, Heath Electronics (UK) Ltd.,
Dept. (PCW 11), Bristol Road, Gloucester, GL2 6EE.

Name _____

Company _____

Address _____

Z89

NewBear

Computing Store Ltd

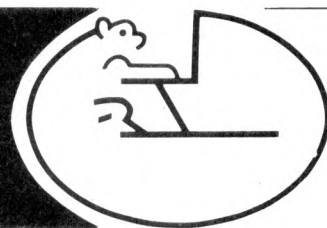

MZ-80K

NBMZ80K MONITOR LISTING	£15.00
NBMZ80K BASIC LISTING	£30.00
NBMZ80K ZEN EDITOR/ASSEMBLER TAPE & MANUAL	£19.50
MZ80K MACHINE CODE TAPE & MANUAL ...	£22.50
MZ80K ASSEMBLY LANGUAGE TAPE & MANUAL	£45.00
NBMZ80K V24/RS232 PRINTER INTERFACE ..	£49.50

DISKS & PRINTER NOW AVAILABLE
A COMPLETE BUSINESS SYSTEM FOR
LESS THAN £2000.

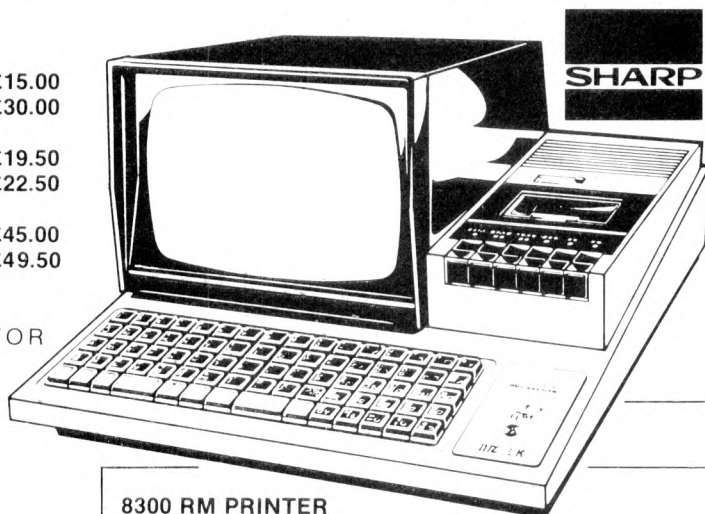

MICROCOMPUTING I.C.'S

MC6800	£6.75
MC6802	£10.50
MC6809	£17.75
MC6810AP	£3.61
MC6821	£4.63
MC6840	£10.50
MC6850	£4.99
MC6852	£4.75
MC8062P	2.88
MC14536P	£2.50
MC3459	£2.43
Z8001	£142.50
Z80 CPU 2.5 Mhz	£8.99
Z80 CTC 2.5 Mhz	£7.99
Z80 P10 2.5 Mhz	£7.99
Z80 S10	£25.57
Z80A CPU 4 Mhz	£10.50
Z80A P10 4 Mhz	£10.00
Z80A CTC 4 Mhz	£10.00
SC MP 11 (INS806ON)	£11.30
INS8154N	£8.18
6502	£8.99
6522 VIA	£8.14
6532	£9.75
6545 CRT CONTROLLER	£18.50
6551 ACIA	£9.99
8080A	£5.50
8224	£2.95
8228	£3.00
DM 8835N	£1.35
8212	£2.25
8216	£2.50

**NEW
LOW
PRICES!**



NORTH STAR ★ HORIZON

8300 RM PRINTER

80/132 CH PER LINE (SWITCHABLE); 125 C.P.S; 2K BUFFER; V24 RS 232/ CURRENT LOOP INTERFACE; SPEED SWITCHABLE BETWEEN 110.9600 BAUD; VARIABLE WIDTH CHAR AVAILABLE UNDER SOFTWARE CONTROL; SPROCKET FEED; 4 x 9 DOT MATRIC; PAPER WIDTH 4.5" TO 9.5"

PRICE £499.00

SPECTRONICS U.V. EPROM — ERASING LAMPS

PE 14 ERASES UP TO 6 CHIPS, TAKES APPROX. 19 MINS	£45.00
PE 14T ERASES UP TO 6 CHIPS, TAKES APPROX. 19 MINS	£59.95
PE 24T ERASES UP TO 9 CHIPS, TAKES APPROX. 15 MINS	£87.00
PR 12ST ERASES UP TO 16 CHIPS, TAKES APPROX. 7 MINS	£186.24
PR 320T ERASES UP TO 36 CHIPS, TAKES APPROX 7 MINS	£302.00

U.V. EPROM ERASING CABINET

PC 1100 ERASES UP TO 72 CHIPS, TAKES APPROX. 7 MINS	£693.00
PC 2200 ERASES UP TO 144 CHIPS, TAKES APPROX. 7 MINS	£1142.00
PC 3300 ERASES UP TO 216 CHIPS, TAKES APPROX. 7 MINS	£1595.00
PC 4400 ERASES UP TO 288 CHIPS, TAKES APPROX. 7 MINS	£2047.00

SPECTACULAR

19th — 30th JANUARY
MINI BARGAINS & SPECIAL
OFFERS AT ALL BRANCHES

JANUARY SALE

Send for details of New Sharp add ons.

NewBear

for the widest selection of computing books

NEW BOOK LIST

MEMORIES

4116 (16K DYNAMIC)	£4.50
2716 (INTEL + 5V TYPE) - ..	£12.50
2708	£4.50

**GET A SHARP DEAL
FROM NEWBEAR**

SEND FOR OUR
FREE CATALOGUE

NEWBEAR COMPUTING STORE LTD, (HEAD OFFICE) 40 BARTHOLOMEW STREET, NEWBURY, BERKS
TELEX 848507 NCS (MAIL ORDER) TEL. (0635) 30505
FIRST FLOOR OFFICES, TIVOLI CENTRE, COVENTRY ROAD, BIRMINGHAM. TEL. 021 707 7170
220-222 STOCKPORT ROAD, CHEADLE HEATH, STOCKPORT. TEL. 061-4912290

PLEASE ADD V.A.T. TO ALL PRICES.



CompUtopia
LIMITED

30 Lake Street, Leighton Buzzard, Bedfordshire
Tel: (0525) 376600 24 hour Answering Service

APPLE II

authorised dealers
from
£695
+
VAT

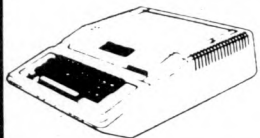

- * Choice of 16K, 32K, 48K user RAM
- * Huge range of software already available.
- * Simply plugs into video monitor or UHF TV.
- * High resolution graphics (5400 point array)
- * Eight Accessory expansion slots for disks, printer etc.

commodore

authorised dealers

- * Choice of 8K, 16K, 32K user RAM
- * Huge range of software already available
- * Self-contained monitor
- * Numeric keypad on keyboard.
- * Full expansion capability for cassette, disks and printer.



from
£445
+ VAT

PET 2001

- * 16k User RAM plus 12k Microsoft BASIC in ROM
- * Fully TRS 80 level II software compatible
- * Huge range of software already available
- * Self contained, cassette, PSU & UHF modulator
- * Simply plugs into video monitor or UHF TV
- * Full expansion capability for disks & printer

THE VIDEO GENIE SYSTEM EG 3003

£330 + VAT



PERIPHERALS

PRINTERS

Texas Instruments Omni 810 Printer £1450.00

Paper Tiger Printer with Graphics £ 598.00

MONITORS
VM 129 Hitachi 12" B&W Video Monitor £ 187.00

VM910 9" B&W Video Monitor £ 127.00

£395 + VAT complete with interface for APPLE, PET or VIDEO GENIE

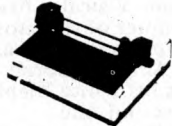

THE MICROSOFT Z80 SOFTCARD OPENS UP IN HORIZONS FOR YOUR APPLE II

Plug the new Microsoft Z80 SoftCard into your APPLE II and start using *all* of the system and application software written for Z80 based computers.

Included with the board is the versatile CP/M; the most widely used microcomputer operating system, and Microsoft's 5.0 BASIC, the most powerful version to date of Microsoft's famous BASIC Interpreter. £199+VAT Dealer enquiries welcome.

WATCH YOUR APPLE GROW TO TWICE ITS SIZE!!

Add a twin 8" disk and give yourself up to 1.6 million characters of storage on line. £1280+VAT Dealer enquiries welcome.

Illustrating Basic	Alcock	3.25
Basic Handbook	Lien	11.00
Computer Programs that Work	Lee/Beech/Lee	3.95
Basic Computer Games	Ahl	4.25
More Computer Games	Ahl	4.25
C207 Microprocessor Interfacing Techniques	Lesea/Zaks	9.50
6502 Assembly Language Programming	Leventhal	7.95
C202 Programming the 6502	Zaks	7.95
G402 6502 Games Book	Zaks	8.20
The Pet Revealed	Hampshire	10.00
Z80 Assembly Language Programming	Leventhal	7.95
Z80 Microcomputer Handbook	Barden	6.80
Introduction to Microcomputers Vol 0	Osborne	5.00
Introduction to Microcomputers Vol 1	Osborne	7.50
The Personal Computer Book	Bradbeer	5.30

Please phone or write for complete book list and prices. Prices include P & P within the U.K.

Please send cheque or P.O., or if phoning your order, state Barclaycard number.

WH14.

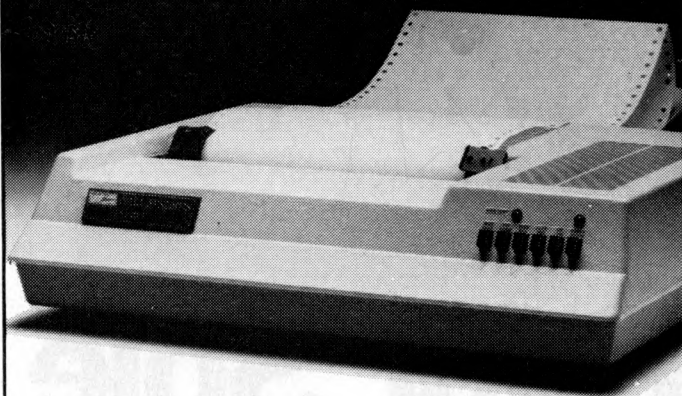

First in line.

If you're looking for an above average line printer at a lower than average price then the WH14 from Zenith Data Systems is your first choice.

Microprocessor controlled, this compact tabletop unit can be used with most computers through a standard serial interface. It provides hard-copy output of your programmes as you execute them, plus handy copies of address lines, lists and other programming data for educational or business applications.

Features include:

- 5 x 7 Dot matrix printing
- Clear easy-to-read images
- Upper and lower case characters
- Operator/software selectable line width: 132, 96 and 80 characters per line.
- Sprocket paper feed with adjustable spacing
- Stepper motor feeds allows 6 or 8 lines per inch vertical.
- Form feed operator/computer control
- Microprocessor based electronics

And at £510, exclusive of VAT and delivery charges, the WH14 puts economy first in line too.

Generous OEM discounts are available.



Zenith data systems

For full details of the WH14, complete this coupon and return it to:

Zenith Data Systems Division, Heath Electronics (UK) Ltd., Dept. (PCW11), Bristol Road, Gloucester, GL2 6EE.

Name _____

Company _____

Address _____

WH14

Guy Kewney, Editor of Datalink, brings his usual enjoyable assortment of news, rumours and gossip from the microworld.



Poor Sole

Just give me one good reason why you or I should prefer to buy our computer from the Sole Distributor? The obvious reason (that nobody else supplies it) is not acceptable because that is true of nothing — not even IBM restricts itself to selling through its own outlets these days.

The question arises because of a curious telex, which arrived on the PCW news desk just after the expiry of Compec, the country's largest computer show. The telex came from Nottingham micro man Tim Keen. It was not so much a statement, more a contradiction. It read: **CONTRARY TO A RECENT PRESS RELEASE ONYX SYSTEMS INC HAVE NOT APPOINTED A EUROPEAN DISTRIBUTOR. VERIFICATION CAN BE OBTAINED FROM THE PRESIDENT DOUG BROYLE, TELEPHONE USA =) (@- -//). 408 946 6330. KEEN COMPUTERS LTD HAVE BEEN APPOINTED DISTRIBUTOR FOR ONYX FOR UK**

What had happened was that at Compec, a company called Graham Dorian Software Systems had announced that it was the sole UK distributor. This sort of thing doesn't happen often. Normally such squabbles are carried out in gentlemanly seclusion, not with enthusiastic letters to the press.

Tim Keen is not a man to let such matters pass unnoticed just because of gentlemanly traditions. If there's a fight, he tends to want to win — if you don't want blood on the carpet, move the carpet. Carpets accordingly began to be moved. Doug Broyle was telephoned, as per instructions — and he was said to be engaged. His marketing chief at Onyx Systems explained: 'One of our distributors has been a little overenthusiastic.'

What had happened (I think) was this. Once there was a bright bunch of technologists and visionaries who set up a firm called IMI. It made the world's first big capacity storage disk which was physically small enough to fit into the same box as a normal floppy disk storage unit — the mini Winchester 'hard' disk. Then it sat down in the American stock market and tore itself to pieces in a battle for control of itself.

Bits came down everywhere. Sorry, pieces, not bits. Some of the technologists left and started up other companies, some came back, and some attracted the same financiers in both cases.

One such shard was a company called Corvus, and another was a company called Onyx. Corvus was clever enough to take the IMI drive and market it to people who already had that very popular microcomputer, the Apple II. It came to Britain through the agency of — Tim Keen. He became sole UK distributor.

Onyx was equally clever. It bought the enormously powerful microprocessor chip, the Zilog Z8000 and designed a computer around it (see story below). And because big micros need big storage to make them work, Onyx included the IMI drive in the box.

Corvus liked the micro enough to buy a large quantity, for resale to shops. Onyx didn't like the idea of working with shops, so it sold through four such 'original equipment manufacturers', (so called because they supply *somebody else's* original equipment. Got it?)

One of them is an American firm, Graham Dorian. I think it, too, includes some of the shrapnel from the IMI explosion, but I can't be sure. Both Corvus and Graham Dorian, and the agents of both, are entitled to call themselves distributors of Onyx in Great Britain. Okay?

The story doesn't end there. Two more UK-based firms, currently supplying original equipment made by Texas Instruments, are going to add Onyx to their ranges. If they, too, call themselves 'sole distributor' — I'm blessed if I can see the point. If I buy something, I want to know that somewhere, there is another firm who can put it right, if my source goes bust. I won't buy from a sole source. Am I alone?

The bigger they come ...

The best news for users of the TRS-80 is that Visicalc is going to be runnable on that machine. Visicalc is not really a program as such — it is a piece of software that eliminates the need to write some programs.

Two fascinating little details about Visicalc: first, it was the winner of the most prized US micro award earlier this year (Adam Osborne awarded it his White Elephant trophy); second, the orthodox data processing business doesn't believe it exists.

When I first found that Visicalc didn't exist, I was a bit surprised. Storekeepers in the USA say that more

people have bought Apple II micros just to run Visicalc than for any other reason. Mike Gurr, a veteran of that most orthodox of data processing offices, the one inside British Oxygen Corporation, now sells Apples and Visicalc and swears that no user of Visicalc has ever been unhappy with it.

When Mike was recently (November) asked to speak about small systems, angry orthodox data processors rose to their feet at the seminar, and called him a cowboy. Why? Because he was selling a program and was not 'supporting' it — that is a phrase meaning 'going round to the customer once a month, drinking coffee from his vending machine and soothing him about the number of times the software failed in the previous four weeks.'

Mike Gurr protested that Visicalc, since it didn't fail, didn't need 'support'. He wasn't actually called a liar by the dinosaurs, but ...

The next occasion on which I found that Visicalc did not exist was inside a big oil company. A programmer for the big central computer found one of the company executives using an Apple II.

'What are you running on it — Star Trek?' he asked. The user described Visicalc. 'Can



Next time some idiot tells you that micros are only toys, show him this pic. The huge black box on the right is a Solartron 1170 frequency response analyser. The most effective device which Solartron (a big company, subsidiary of Schlumberger, which owns Fairchild) could find to process the data generated by this device was an Apple II. Solartron sells the Apple as part of the data management system.

you produce something like Visicalc on our big central computer?' asked the user and the programmer foolishly said he would try. For his pains he was told by his boss, the data processing manager, that first, Apple II computers were not authorised by the DP department, so there were none in the company (there were over 30); second, Visicalc was a dream, and no such program could be written; and third, if it could be written, it would not fit on a tin-pot video games machine like an Apple II. Finally, his promotion to the Chicago office was cancelled for disloyalty. You think I'm kidding, don't you?

By the way, the seller of Visicalc for the TRS-80 is A J Harding. I can't resist this. Harding has also 'in conjunction with ACT (Petsoft), been appointed sole TRS-80 distributors in the UK for Personal Software of the US.' Contact the joint sole distributor on (0424) 2230391. But try not to take the mickey — he's a good supplier.

Unique Unix

Over the next two years or so plausible salesmen will start to make more and more mileage out of the fact that they can offer a '16-bit multi-user' business system.

The question to ask them is not 'what is 16-bit?' but, 'is the operating system Unix compatible?'

The latest system to hit the headlines, the Onyx is. Another system with a claim to be considered is the South West Technical Products machine, the 6809, which has an operating system called Uniflex. And Ithaca is working on a version of its own operating system (for the Z8000 chip) which will do the same.

Now, why should you care?

On a simple level, you will have noticed, even if this is the first computing magazine you have ever picked up, that the number of references to CP/M indicates clearly that it is important.

It is important because so many people use it, so that not having it looks suspiciously like ignorance. It is also important because it allows the user of one CP/M machine to run programs written for another machine.

The question is: how?

Programs do not spend all their time calculating and computing, despite popular myth. Most computer programs spend all their time either waiting for input or looking for a pattern of numbers and letters (such as David Tebbutt, or Bumper Harris, or ticket no 345/4567.98) in one block of mass storage, and then arranging it in another block

of storage (either a mass store like disk, or an output store like a piece of paper.)

The business of finding one of those patterns in a disk, or in a tape, or merely in a block of memory, is shockingly tedious and detailed. The computer has to move the reading head of the disk to the index, to find where it wants to look. It has to wait for the index to spin past it. It then has to find the track of the disk where the item it wants actually is. It then has to move the head and wait until it has got there. It then has to read the track, and wait until the start of the right record comes past. It then has to read off the disk into the right part of the computer's own internal memory. Then it finds that that was not the right part of the disk, and starts all over again . . .

Oddly enough, this is exactly what most of an operating system does. It does it in its own sweet way, and it does it reliably and simply. All the programmer needs to know is the right operating system call, and the system does it all for him.

Give the operating system the call belonging to another operating system and, if you're lucky, nothing will happen.

Unix is an operating system, designed by Bell Labs for the very good reason that Bell liked using mini-computers made by Digital Equipment, but didn't go a bundle on its operating systems. Bell, being rather bigger than Digital, decided to make its own — and by all accounts, did a better job than most.

The operating system Bell made attracted many admirers and imitators. Some, like Onyx, actually got a licence from Bell to produce a version of Unix itself (Onyx calls its version Onix, and sells Onix systems with Onix on them to Bell itself).

The point is that the Digital Equipment mini-computer, the PDP/11, in all its versions, is a 16-bit machine. It gets information from memory and storage in chunks of 16 binary digits at a time. CP/M gets its chunks in 8-bit 'bytes' and is therefore no earthly use on a 16-bit machine. It may be possible to make CP/M look like Unix, in the same way as it may be possible to make two bicycles look like a car (you strap two side by side, bolt the handlebars to a steering wheel, and cover it with a car body) but the resulting contraption has none of the advantages of either CP/M nor Unix, and most of the disadvantages of being neither.

If someone tries to flog you a 16-bit system because it has a 'better' operating system than Unix, believe him by all means. But avoid it unless it is Unix compatible.



Anyone who has ever taken a heavy tape recorder all the way back to Tottenham Court Road or the local equivalent for a repair, only to find that the cable connecting it to the amp was broken internally, will suddenly understand why engineers need special equipment to test the 25-wire cables that connect computers to printers. This one costs £165 and tests each wire in turn, showing which are broken, which are connected to others, which are connected to the wrong pin of the plug, and so on. Details on 01-941 3604.

And incidentally, if anyone tries to sell you an operating system on the grounds that it is multi-user, be pleased, but also asked for assurances that it is also multi-processor. But that, as Kipling said, is another story.

Sharp competition

If anything is going to worry Commodore over the next year, it is going to be Sharp. The Commodore is currently top seller in this country and the new range of machines with big screens has been neatly priced, and quickly available (see 'Egg On Face' elsewhere in 'Newsprint').

However the PET, for all its virtues, is not a Japanese computer. It is an American machine, with some models made in Europe. And neither the European nor the American electronics factory has quite got the hang of making kits the way the Japanese have — that is, they aren't as reliable.

Now that Sharp has got its MZ 80K fitted out with the necessary extras (printer and disk storage) to turn it into a proper system rather than a desk-top novelty, its reputation for working as soon as a plug is fitted and

distributors to take it up by dozens.

In the words of Bruce Everiss, outspoken boss of Microdigital (a Lasky subsidiary), 'There have been batches of PETs where six out of ten have needed attention before they could be sold. Of all the Sharps I've sold, maybe two have needed attention — and I've sold many more Sharps than PETs!'

Sharp's answer to the new PET, however, looks as if it needs a bit extra. Like the new PET, it displays a row of 80 characters across every line on the video screen. Like the PET, it comes with the option of a big disk store. And like the PET, it includes a workmanlike printer. However, the new Sharp PC3200, despite 64K and a snazzy keyboard, still looks a bit pricey. The disk is not as big as the much-slandered Commodore 8050 drive. And if the price is attributable to the printer, then the printer should be a lot nicer, as printers these days are good and cheap. At £3000, the PC3200 needs that bit extra — maybe reliability will do it? On the other hand, maybe Commodore has made the 8030 PET more reliable? Watch this space.

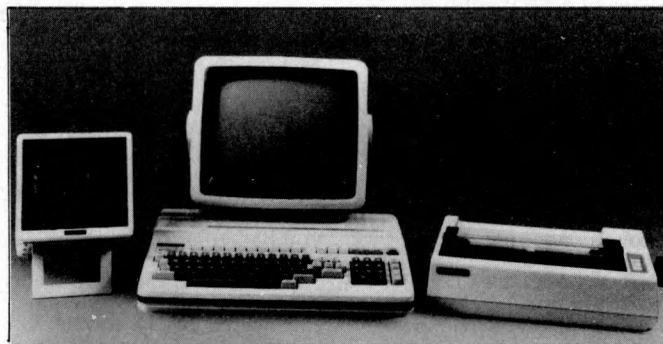

Sharp's new PC3200 system

Egg on the face

Considering how beastly I was to Kit Spencer of Commodore in this column two months ago, he was astonishingly polite when he phoned.

I knew what he was going to say. 'You're going to tell me that the new disk drive, the 8050, was available roughly a week after I wrote my piece saying it was late,' I told Kit.

He was, and he did: 'We were late on the printer,' he said, in anguished tones, 'and ever since, people have been expecting us to be late on everthing.' True. 'We just can't win. If we announce it well in advance, we're pre-selling. If we keep it secret until it's available, nobody believes we've got it.' True. 'Well, at least I hope we'll talk to each other a bit more in future,' he ended. I hope so too. Still, not too much harm done, because at the time of writing, orders still outstripped available disk drives by quite a bit. By the time you read this, the backlog might be cleared a bit and you may be able to get one.

Burning chips

Beginners in the computer field often ask shyly: exactly what is the use of read-only memory — how do you get something in them to read? The answer, of course, is that they are no good at all without some means of getting program or data in. And normally, this costs money, either through a company which offers a programming service or through the purchase of a programming machine.

One supplier of such chips, Celdis in Reading, has decided to leap to the aid of people with neither service nor programmer to hand. Celdis is supplying all PROMs with free programs in them. You, naturally, supply the program and Celdis engineers load them. This offer is available on all orders, no matter how large or small, promised Dave Watson at Celdis. He may see something of a boost in memory sales. Details on 0734 582211.

Charity chess

PCW's computer games expert, David Levy, recently raised £2000 for the Bourne-mouth Symphony Orchestra by playing 30 chess games simultaneously.

The BSO receives only enough state funding to support ten of its members, a situation which Levy describes as 'tragic'. He made the exception to his 'no exhibition matches' rule because of his love of classical

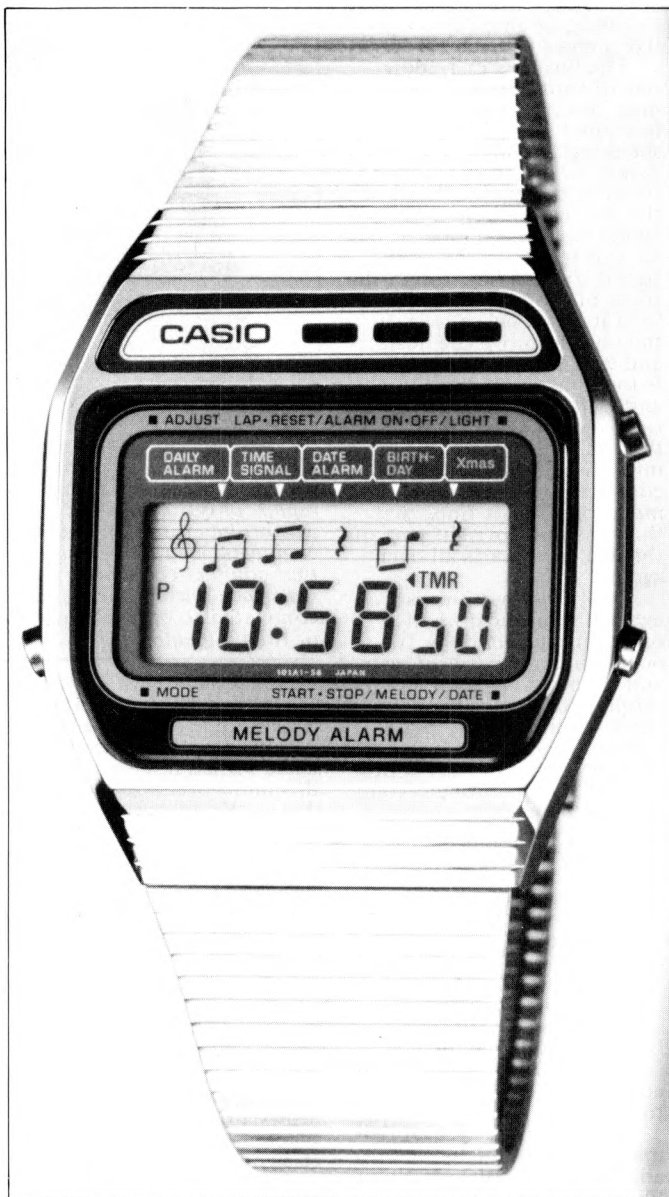

'Yer Honour, I wuz driving wiv doo care an' attention, when suddenly, I wuz distracted from my scrutiny of the M4 by the enchantin' chimes of that well-known ditty, "Oh Danny Boy", rendered in 'eart-breakin' syncopation by me Casio M12 musical alarm watch, which my wife 'ad programmed in on account of it was St Patrick's Day. Transfixed by the magical appearance of the notes on the LCD five-line musical stave (which appears on the front of the watch display, yer Honour) I would still have been competent to continue proceeding along the highway but for the unfortunate occurrence of the rhythmic response from me foot, what began tapping all involuntary on the brake pedal, causing loss of road adhesion. . .'

music. Of the 30 games, he won 24, drew two and lost four.

Chatty chips

Until now, getting a computer to talk was a job that left you little choice. Either you bought a standard Texas Instruments speech chip, or you had a hard time, or it cost you plenty.

A 'considerable advance' is a new General Instruments chip which gives a choice between lots of low quality chatter, or fewer beautifully-

pronounced words.

It gives a maximum number of 3825 'sequences' of synthesised speech, says General Instruments (these sequences are normally words or phrases) and the quality 'is normally significantly better than telephone voice quality' — it approaches that obtainable on Radio One.

The snag is that you have to connect it to a computer board yourself, or use General Instruments' own PIC micro — ah, you don't have one? No, me neither, and I don't know where you'll find it. Ask GI on 01-439 1891.

Name change

When Oxford Computing dreamed up a writing pad which entered data directly into a computer, the name Datapad suggested itself. Unfortunately, somebody failed to discover that the same name had suggested itself rather earlier to a company called Quest. I hope that somebody enjoys the hot water. Meanwhile, Oxford Computing has renamed its OCL Datapad as the OCL Saker. Less obvious what it does, perhaps. Still, at least it is just as obvious as before that Oxford Computing is in Reading, on (0734) 587138.

Local S/W support

When someone tells you that you need 'support' for a product, you know one thing: it doesn't work. In the case of computer programs, this is only forgivable if the program was written for you and you alone. Nobody can catch all the faults in a piece of software all by himself. So it is a very sensible idea of a group of software writers to get together to arrange mutual support (sounds disgusting) for the 'tailored' products. The idea is that a small producer of programs joins the league and when a customer living more than 50 miles away wants a copy of his software, he doesn't supply it himself but gets his local colleague operator to supply it.

Tailored software, by the way, is software which is cut from a basic pattern on a design of cloth which can fit everybody. The local supplier just puts in the details needed for the local application.

According to one of the founders of the new Software Producers Association, Peter Wills, 'The range of computers covered by the association is wide and currently there are programs available for most general business applications. There are also systems available for the more specialised areas such as agriculture, garages, engineers, auctioneers and market research agencies, to name but a few.'

The Association aims to 'set very high standards' and is prepared to back them up by offering a money back guarantee on all products. Mind you, I can think of a lot of suppliers who would draw the line well before they got that far. And I have to admit that there are many doubts as to whether tailored software, however well supported, is really worth the extra money it costs, by comparison with off-the-shelf stuff which



PROGRAMMED FOR FUN

The Sharp MZ-80K personal computer can handle serious business as well as the next microcomputer. But it can also be programmed for fun.

This masterpiece of low-cost, easy-to-use, micro-processor technology takes over where TV games end, becoming a sophisticated source of endless hours of family entertainment. And for youngsters, of course, it has added educational value, providing a very useful introduction to the computerised world in which they will live and work.

A comprehensive catalogue of fascinating computer games is now available for use with the MZ-80K: races, battles, quiz games, exploration, showjumping, space adventures; trials of skill and concentration, pitting players against each other or against the computer. Exciting, entertaining, educational, and with such variety of appeal that the incentive to play is never dulled.

The versatile tabletop MZ-80K – and the whole range of cassette-based games – is marketed by HB Computers Ltd, Sharp's appointed software supplier for the UK. Ring or write NOW for an MZ-80K demonstration and/or your free copy of the HB catalogue of computer programmes.

SHARP MZ-80K Personal Computer with built-in cassette drive unit ONLY £380

COMPUTER GAMES
Cassette-based for use with MZ-80K £5 to £12 (see catalogue)

From the leading SHARP micro-computer supplier

HB COMPUTERS LTD
22 Newland Street,
Kettering,
Northamptonshire
Telephone
0536 520910



HB COMPUTERS



often comes at under £100.

Details from Peter Wills on 0272 312079, or David West on 061-832 6792. Wills works for Mercator Management Consultants in Bristol and West for Chess Consultants in Manchester.

Telesoftware

It may turn out to be easier to 'tune in' to a program for your computer than to pick out a tape, load it and start it up, especially if you don't have the right tape to hand.

The matter is, at least, being investigated. The project is a huge collaboration of various people starting with the BBC and working out. The man at the centre, who wants to hear from anybody else with ideas on the subject, is Mr L Mapp, research fellow at Brighton Polytechnic. The way Mr Mapp describes the project, it could be the first real use for those brief pages of news that the BBC and ITA broadcast in their teletext services, Ceefax and Oracle (apart from putting subtitles on films for the benefit of the deaf). Instead of getting lines of print, the receiver would get a computer program, complete with instructions to the computer on how to load and run it.

Mr Mapp thinks it will help teachers. 'Currently,' he tells me, 'using a micro-computer to assist in teaching requires a good knowledge of computer programming — finding a suitable program, transferring it to a computer's memory and then

checking its reliability, is often a daunting task.'

What isn't clear yet is whether we are going to get a new microcomputer out of all this. The Beeb is known to be planning a 'teach yourself micros' machine and this project is based on ten prototype 'receivers' — that is, television sets with micro-computing abilities, made by Mullard.

Three years ago, this would have been a splendid way of launching a British microcomputer. Now it may be too late, and I predict the project will either switch to a standard existing micro — the Newbrain? — as the basis for its existence, or will go the way of the Open University computer.

I hope it survives. Just think of what the BBC and ITV could do for program distribution! And if they did it properly, just think of what that would do for compatibility standards. Details from Mr Mapp on 0273 606622.

C/P Net launched

Telling somebody who has just pushed the budget to the limit to get a microsystem that, 'you should have asked yourself which network it uses,' may be regarded as unnecessary provocation. If you can't really afford one, why bother about the cost of a whole lot joined together? And to these people, the announcement of CP/Net will appear to be so much

irrelevant hot air.

The object of launching this network is not to allow each computer caught in it to send messages to another. It is to save money. It works in the same way as sharing a taxi saves money — you have to have four or five people all together, going the same way — but it works.

CP/Net comes from Digital Research and is now officially here as the ultimate version of CP/M.

CP/M gave the user storage capacity on disks. MP/M gave two or more users on the same computer their own slice of that computer.

CP/Net gives every computer user his own slice of disk storage, printers, modems or any other expensive, seldom-used luxury. Details are available from the European agent, Vector International, at Research Park, B-303 Leuven in Belgium, tel 32 016 20 24 96.

But like present CP/M versions, CP/Net will only work on 8080/8085/Z80-based micros. If you want a network for a PET, contact Kobra, whose MU-PET system has been sold to 60 network users in the two months after it was launched. Mu-Pet allows up to eight PETs to share one or more Commodore disk drives and any compatible printer. When somebody configures a big (hard) disk to look like a PET disk, then Mu-Pet will look wonderful, because the big disk will cost much less per byte than floppies. Details on 01-579 5845. For Apple users, see last month's item on Nestar and contact Colin Crook or Ian Powers on 0895 59831.

Cobol for Apples

The fact that a company like Micro Focus has produced a Cobol compiler for the Apple II is not an invitation to its 150,000-odd owners to learn how to write programs in Cobol. It is a concession to reality.

Reality is the fact that Cobol is an old language, not very good at performing the tasks that today's micros are best at. It is at least as awful (in purist terms) as the Basic all we micro owners use and five times as hard to find faults in programs written in it, and ten times as hard to correct them. Okay, so that's just opinion — but it's a common one.

The reason it is important is simple: most of the world's professional full-time software writers know how to write in Cobol and in nothing else.

Their employers, seeing 150,000 Apples rolling around, would like to start producing programs to run on them — and all their current programs are written in Cobol.

Micro Focus produced the

first Cobol compiler for the Intel 8080 some time ago but that micro is not the chip inside the Apple. To get the Micro Focus onto the Apple, they had to wait for Microsoft, who launched a little plug-in unit called the Z80 softcard, which actually puts a new microprocessor into the Apple — a micro on which Micro Focus's Cobol will run. So, for that matter, will Microsoft's Cobol — but the word so far is that Micro Focus (a British company) has a rather better Cobol than Microsoft's. Talk to Micro Focus on 01-722 8843.

Microwriter-based WP system

Typoists tend to make mistakes. Users of the ultra-clever six-finger typing keyboard (see our December review) tend to make mistakes too and it's sensible to get a computer to sort them out.

A system for connecting the Microwriter to a computer has been developed by South West Technical Products. The computer concerned is the SWTPC machine, and the software which handles the connecting is a word processor called Autotext. This goes further than just handling the input from the Microwriter, they say; it also allows it to be used as part of a flexible filing and word processing business system. For instance, names and addresses may be handled in combination with text, to produce personalised overdue account letters and other correspondence where a different amount of money can be inserted into the text of each individual letter. Details on 01-491 7507

Zilog seeks compatibility

'We want to ensure that all software for the Zilog Z8000 micro, whether written by Zilog, independent vendors or others, is transportable and compatible,' said a top Zilog man in the UK recently.

This sort of statement about any other micro, if made by the proprietor, would be dismissible with some colourful metaphor about breaking wind in a gale, but with the Z8000 there are two good reasons for taking Zilog seriously.

First, all the software theories on which the original designers of Zilog's programming languages based their chip designs have been fully catered for in the Z8000. It was Charlie Bass's theory that all Zilog languages should link to each

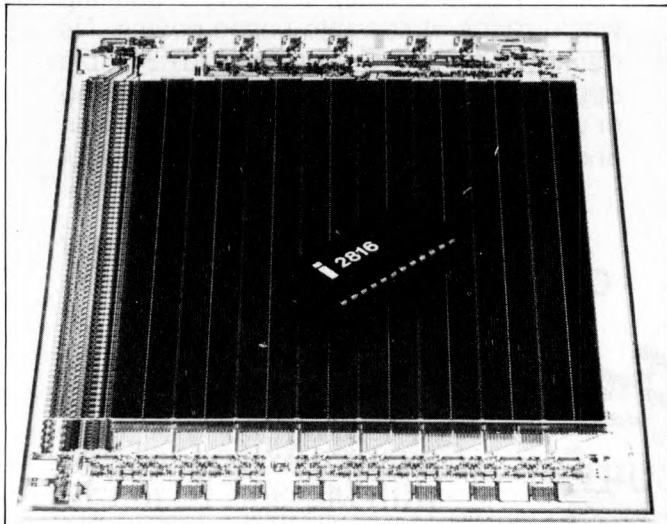

This is a picture of a hell of a lot of very special transistors. They are Intel's new electrically erasable permanent memory, the closest step so far to a memory chip that retains its memory when the power fails but functions normally. Putting data into this new 16 kbit chip (2 kbytes) takes absolute ages — a 21 volt pulse is needed for 10 milliseconds. A computer that had to store data at that speed would never get anything done, so clearly that side has a long way to go. But at least it is no longer necessary to pull the chip out of the computer and bake it under ultra-violet light to get rid of the data when it isn't wanted. Instead, it takes 20 milliseconds to erase eight bits with another electrical pulse.

YOU DON'T NEED A MAGIC WAND TO SAVE £7,000 ON A MINICOMPUTER AND GAIN DATABASE FLEXIBILITY.

JUST A MIRACLE.



When 2-8 Apple micros share up to 40Mb of Corvus hard disc capacity through a Constellation host multiplexer, you get a Miracle – no less. A Miracle is the answer to the bottlenecks that can happen with a mini-network. And more. A Miracle can outperform a mini-network and save you money all along the line.

Stack up a 4-Apple/Miracle system against a mini system with 4 passive terminals and you've hit on an intelligent way of saving yourself £7,000.

So much for the sizzle. But what about the hard facts?

THE HEART OF THE SYSTEM

At the heart of the Miracle is the Constellation host multiplexer. This allows 2-8 host micros to share high-speed access to one common Corvus disc drive. The micros are connected in star configuration and each of their interfaces uses the standard Corvus bus. And with the Constellation at the centre of things all the micros in the network are active.

There's also room for expansion to a multi-level network: as many as eight host multiplexers can be linked together which, in turn, allows up to

64 micros to share the disc. A user can implement Miracle using 2-8 micros and later upgrade with no penalty in cost or software effort.

HARD DISC STORAGE

The big thing about the Corvus hard disc drive is that it can normally be accessed twenty times faster than floppies. In real terms this means 2-3 minutes for sorting a complex file instead of 15-20 minutes.

Corvus is a fixed disc 10Mb storage device which has a closed-loop filtered-air system to provide enhanced reliability in a contamination-free environment. The disc controller, based on the Z-80 processor with 16k of RAM, provides the intelligence for the system without the costs and overheads of a dedicated central computer; and the ROM-resident software is interfaced to both BASIC and the new Apple PASCAL operating systems. You can use as many as four Corvus disc drives in a Miracle system to give a total capacity of 40Mb.

BACK-UP TRANSFER

When it comes to back-up transfer you've no problems with a Miracle: the unique Mirror

system, which is included as standard, dumps up to 300Mb on to video tape at 1Mb per minute.

All this is just the beginning of the Miracle – because its multiplexer opens up no end of possibilities for sharing peripherals and communicating with other Apples in the system. 3-4 devices can be connected to each Apple in the system: for example a printer, an interface for graph plotter and digitiser, a light pen, a graphics terminal or a pair of floppy discs.

A MIRACLE FOR EVERYONE

So much for the Apple-oriented Miracle. But what if you're not an Apple user? The good news is that a Miracle system can be built with other micros: S100 computers, TRS80, and Commodore in any mixture you like.

In short, a Miracle can happen in all shapes and sizes. Send for our brochure and we'll show you how.

Keen Computers

5b the Poultry, Nottingham NG1 2HW
tel: 0602 583254. telex: 37297 (keenco)

28 Lower Addiscombe Road,
Croydon CR0 6AA. tel: 01-680 4646.



Keen Computers' extensive range of products and services gives you hard and soft options: we supply Apple, North Star, Commodore and Sharp computers. For details of one of the most extensive ranges of special applications software, peripherals and a host of exciting add-on goodies that will really let you take the lid off computing, send for the new KEENSTAR catalogue.

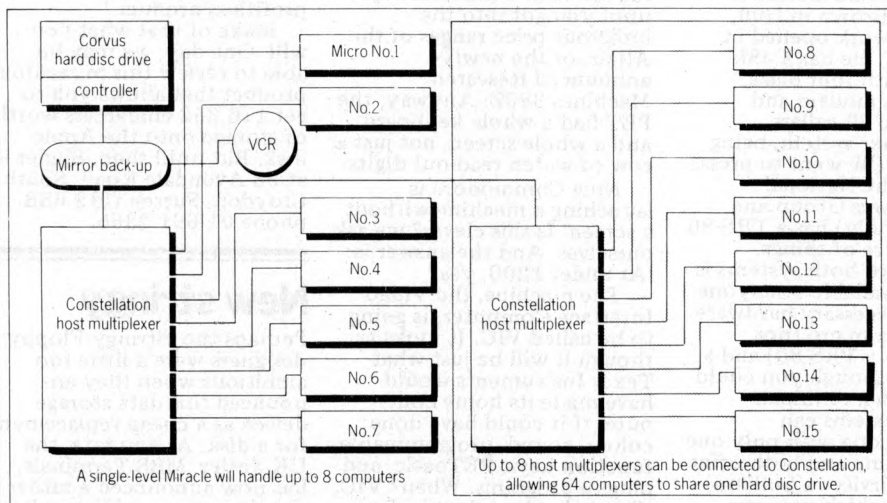

other through the operating system so that sections of Basic code could link to sections of machine level direct code in ROM and to sections of code called up, say, from disk.

These theories apply (rather less fruitfully) to the Z80, which was not Zilog's ideal machine but merely their way of getting into the market; that is, it was more than half a copy of the Intel 8080 (and still is). More to the point, everybody who uses the Z80 has gone too far down many paths of their own choosing to pay much attention to Zilog's theories.

On the big Z8000, it may not be too late for Zilog to influence us all. And the bold bid which Zilog has made is to establish 'calling conventions' for programmers. These are designed to enable Z8000 programs written in any language to call Z8000 programs written in any other language, just as Bass dreamed when he designed PL/Z (a language).

The standards specify practices. That makes them very hard to impose on users, who tend to blunder into these things and work out what their customs and practices were later, looking back. They specify how one language should pass parameters to another language, how the registers should be used, and how Zilog itself has done these things in the software it has written so far.

Now the important thing about this is that, naturally, we humble home programmers are hardly ever going to bother our heads about how we pass parameters or handle registers. But the people who write the languages we will one day use do. Compiler writers get very worked up about register usage and any successful establishment of good habits now could be enormously useful to Basic Bangers in three years' time.

If Microsoft and Personal Software and Microdatabase Systems and all the other software kings pay attention, of course.

Details from Phil Pitman on Maidenhead (0628) 36131.

In the lab

The criticism levelled at the first Commodore PETs and the feeling in some quarters that such toys should not be allowed to taint a scientific environment did not seem to herald an auspicious future for these machines in the scientific laboratory. The situation was not helped by the suspicion among some managers that the main reason their junior personnel requested such things was to play 'Star Trek' during tea breaks — and beyond.

Despite such obstacles, however, the PET and similar machines have now

found a place in the scientific laboratory and are increasingly mentioned in research papers. Research into certain aspects of nuclear magnetic resonance spectroscopy being carried out by L E Erickson of the National Research Council in Ottawa requires a magnetic field of specific strength and direction. Such a field can be provided by using three pairs of coils mutually at right angles and a recent paper describes the use of a Commodore PET to control the set up. After the field strength and direction required have been input by the experimenter, the PET performs the necessary mathematical transformations and uses the data to control the power supplies of the three pairs of coils. A feature of the program is that it compensates automatically for the earth's magnetic field.

The interface uses 12-bit digital to analogue converters and data is transferred to the power supply interface by a 20-byte serial, bit parallel transfer. Odd-numbered bytes are for synchronisation of the transfer and even-numbered bytes are components of address and data. The program is written in Basic and the entire transfer takes 0.3 seconds. The author notes that this would be much faster if machine language programming were used to control the timing.

Geoff Turner

Nets working

Personal computer networks are at last appearing in Britain. Networks have been booming in the States for 18 months or more and are a well-established feature of the micro scene over there. By the time you read this, Britain will have two, one in Hull and one in Milton Keynes.

First off the mark was Frederick Brown in Hull, whose network opened in September. He has a 48k TRS-80 with four disks, linked to a modem and available to all callers.

The other system, being set up as PCW went to press, is run by the National TRS-80 Users Group and also (naturally) has a TRS-80 at the centre of things.

Access to both systems is free and available to anyone with the necessary hardware. You need a micro (not necessarily a TRS-80) and a modem, although you could get by with a terminal.

Both systems can presently cope with only one user at a time and both offer a similar service: a bulletin board, on which you can leave messages — either personal to and accessible by one other user or 'global' — and a library of programs

which you can download and execute/save on your own machine. The programs are in Microsoft Basic for maximum machine independence and at the time of writing Frederick had a dozen on his system.

Use of these networks naturally depends on the availability of low-cost modems, which have to be approved by British Telecom — no easy (or cheap) matter. Hopefully, now that two networks are running, the demand for cheap modems will increase and we'll see some on the market.

Frederick reports that he has half a dozen regular users who live locally, a couple in Scotland and others in France and Holland. He also gets the occasional trans-Atlantic link-up from personal computer users in the States!

The Hull service is available on Tuesdays and Thursdays, 7-10pm and at weekends from 12 noon to 10pm. For further details ring Frederick on Hull (0482) 859169 — but not during the network's operating hours or you'll get an earful of modem carrier.

For details of the TRS-80 User Group Service, contact Brian Pain on (0908) 566660 (office hours).

CBM announces new micro

The nicest thing about the PET, when it was first announced, was the keyboard. After that, the video screen.

That may be a bit hard to swallow today, but four years ago, when the first prototype appeared in Europe, there simply was no other machine available with a keyboard that had an alphabet on it. The Motorola D2 kit, with 16 keys, was seen as the only serious rival for the Kim 1 (also 16 keys) until you got into the ludicrous price ranges of the Altair, or the newly-announced Research Machines 380Z. Anyway, the PET had a whole keyboard and a whole screen, not just a row of watch read-out digits.

Now Commodore is launching a machine without a screen. Is this clever? we ask ourselves. And the answer is: 'At under £200, yes.'

The machine, the Video Interface Computer, is going to be called VIC. It looks as though it will be just what Texas Instruments would have made its home computer if it could have done: colour, sound, programmable function keys, PETbasic, and plug-in programs. When? VIC, 'first being launched in Japan, is intended to be marketed in the UK towards the middle of 1981,' says Commodore. I can't wait.

Cheapo DB

At £23 it must be the cheapest-ever database system. By the definitions enclosed with the announcements, it can't be all that bad to use. And nobody will stock it.

'Our dealers have advised us that they consider a retail price of £150 would be more appropriate, in relation to similar products,' claims the aggrieved company which produced it, Spider Software. It's the Apple dealers who are causing the problem, say Nick Spicer and Dick Williams at Spider. Well, they don't say so specifically but their utility database runs on an Apple, so it must be.

The dealers have a point. As Spider observes, 'a full demonstration of the database's capabilities may take as long as half an hour, resulting in a relatively low profit to the retailer, and in the possible loss of more lucrative sales.'

One can't help feeling that some compromise solution must be possible but Spider absolutely refuses to raise the price. 'Much as we are in business to make a profit, this program uses standard routines which we have developed for bespoke business software,' the Spider pair say intransigently. 'And as such, we consider that D/DATABASE is essentially a loss-leader and an advertisement for our services. Naturally we appreciate the dealers' point of view. . .'

They won't raise the price 'artificially' because 'we cannot justify a higher price and this would defeat the whole object of the exercise.'

And here's the bit that hurts: they won't take a full page advertisement explaining the reason for the low price and showing what a marvellous product it is, because they can't afford £300 to launch 'an almost profitless product.'

Make of that what you will. One day, we may be able to review this miraculous product that allows you to get 116,352 characters worth of storage onto the Apple disk. But until then, Spider is at 98 Avondale Road, South Croydon, Surrey CR2 6SB, phone 01-661 2365.

New stringy

Perhaps the 'Stringy Floppy' designers were a little too ambitious when they announced this data storage device as a cheap replacement for a disk. At any rate, the UK dealer, MBS Terminals, has now announced a rather simpler version of the endless-loop tape, a version which connects through an RS232 interface. Details on Byfleet (09323) 49511.

Apple Price List

Product Code	Description	Price (£)	Product Code	Description	Price (£)
A2S1016P	HARDWARE APPLE 16K VIDEO OUTPUT ONLY	695.00	A2L001A	DOCUMENTATION APPLE II REFERENCE MANUAL	11.00
A2M0003	DISC DRIVE WITHOUT CONTROLLER	299.00	A2L0002	6502 HARDWARE MANUAL	9.00
A2M0004	DISC DRIVE WITH CONTROLLER	349.00	A2L0003	6502 SOFTWARE MANUAL	9.00
A2M0016	16K ADD ON RAM	69.00	A2L0005	APPLE II BASIC PROGRAM MANUAL	6.00
			A2L0006	APPLE II REFERENCE MANUAL	6.00
			A2L0012	DOS 3.2 MANUAL	6.00
			A2L0018	APPLE II BASIC TUTORIAL MANUAL	6.00
A2B0001	CARDS & ACCESSORIES PROTOTYPE/HOBBY CARD	15.00			
A2B0002	PARALLEL PRINTER INTERFACE CARD	104.00			
A2B0003	COMMUNICATIONS CARD	130.00			
A2B0005	HIGH SPEED SERIAL INTERFACE CARD	113.00	A2D0000	GENERAL ACCESSORIES (10) BLANK APPLE DISCETTES	32.40
A2B0006	PASCAL LANGUAGE SYSTEM	299.00	A2M0009	VINYL CARRYING CASE	16.00
A2B0007	CENTRONICS CARD	130.00	AD/LB	MINI DISC LIBRARY BOX	2.64
A2B0009	APPLESOFT FIRMWARE CARD	116.00	MD5172	DISCOFLEX FILING CASE - MINI	12.64
A2B0010	INTEGER CARD	116.00	APP1	APPLE DESK TWO TIER	145.00
MHP-X003	MOUNTAIN HARDWARE CLOCK/CALENDAR CARD	168.00	APP2	PRINTER TABLE	92.00
MHP-X006	MOUNTAIN HARDWARE SUPERTALKER	179.55	APPLETEL	APPLETEL SYSTEM	595.00
MHP-X007	MOUNTAIN HARDWARE ROM PLUS BOARD	127.89	DIST/APP	DUSTCOVER FOR APPLE II	9.95
MHP-X015	MOUNTAIN HARDWARE ROMWRITER	106.05	E2B013	APPLEJUICE RESERVE POWER SUPPLY	157.00
A2B0017	EUROCOLOUR CARD	113.00			
E2B101	APPLE BLACK & WHITE MODULATOR	14.00			
A1-02	A1-02 DATA ACQUISITION CARD	192.00	A2M0034	PRINTERS & ACCESSORIES SILENTYPE 80 COLUMN GRAPHICS PRINTER	349.00
10-5-16	ALF MUSIC SYNTHESIZER CARD	103.00	A2C0001	10 ROLLS OF THERMAL PAPER FOR SILENTYPE PRINTER	28.00
10-5-17	ALF TIMING MODE INPUT BOARD	14.00	CENT 737	CENTRONICS 737 PRINTER C/W ADAPTOR	450.00
13-3-2	ALF ALBUM MUSIC DISKETTE NUMBER ONE	12.00	TIGER/G	PAPER TIGER PRINTER WITH GRAPHICS OPTION	598.00
13-3-4	ALF ALBUM MUSIC DISKETTE NUMBER TWO	12.00	TIGER /C	CONNECTOR CABLE FOR TIGER PRINTER	9.00
13-5-5	ALF ALBUM MUSIC DISKETTE CHRISTMAS	12.00	TIGER/D	GRAPHICS SOFTWARE FOR TIGER PRINTER	20.00
H/SP/LAB	HEURISTICS SPEECH LAB	122.00	TIGER/P	TIGER PAPER 2,000 SHEETS 11" x 9.5" 1 PART	31.43
A2M0019	PROGRAMMERS AID 1	27.00	T1810	TEXAS OMNI 810 PRINTER	1450.00
A2M0027	AUTO START ROM PACK	38.00	LP5	PAPER 2000 SHEETS 11" x 15" S/PART	14.06
A2M0029	GRAPHICS TABLET	462.00	LP9	PAPER 3000 SHEETS 8" x 12" S/PART	14.85
H/CON 70	HEURISTICS CONTROLLER 70	57.00			
H/SP/LINK	HEURISTICS SPEECHLINK 2000	168.00			
E2B108	IEEE INTERFACE	212.00			
			VM129	VIDEO MONITORS 12" BLACK AND WHITE VIDEO MONITOR	189.00
A2D0005	SOFTWARE CONTRIBUTED SOFTWARE VOLS 3-5	60.00	VM910	9" BLACK AND WHITE VIDEO MONITOR	127.00
A2D0006	CONTRIBUTED SOFTWARE VOLS 1-2	27.00	VM906	9" HIGH RESOLUTION BLACK AND WHITE VIDEO MONITOR	148.00
A2D0009	MICROCHESS 2.0 CHESS DISK	15.00	VM/C	CABLE FOR VIDEO MONITOR	9.00
A2D0010	DISC UTILITY PACK	15.00			
A2D0012	APPLE BUSINESS CONTROLLER PROGRAM	340.00			
A2D0013	APPLE POST PROGRAM	27.00			
A2D0018	APPLE BOWLING DISCETTE	9.00			
A2D0025	APPLE CASHIER PROGRAM	194.00			
A2D0026	APPLE WORD PROCESSING PROGRAM	42.00			
A2T0013	MICROCHESS 2.0 CHESS CASSETTE	15.00			
E2D001	VISICALC DISC & BOOK COMPLETE	125.00			

Prices exclusive of carriage and VAT and are correct at time of going to press. Available from Apple Dealers all over the UK - for your nearest please contact Microsense Computers.

Dealer/OEM enquiries welcome.

microsense computers limited

Finway Road, Hemel Hempstead, Herts HP2 7PS
Tel (0442) 48151 and 41191
Telex: 825554 DATEFF G



SOLE UK DISTRIBUTOR

apple computer

® Apple is a trade mark of Apple Computer Inc., Cupertino, C.A., USA



APPLE COMPUTER SYSTEMS APPLE COMPUTER SYSTEMS APPLE
COMPUTERS MICROSENSE COMPUTERS MICROSENSE COMPUTERS

COMPUTER FAIRE

A Conference & Exposition

on

Intelligent Machines

for

Home, Business, & Industry

Personal
Computer
World

Spring in San Francisco from £440

Enjoy a two-centre holiday in sunny California, 1 – 9 April, 1981
just in time for the 6th West Coast Computer Faire.

Lounge on Santa Monica beach, visit the first ever computer store or maybe even take a peek at Hollywood. Follow this with a few days in San Francisco visiting the Computer Faire and possibly pop down El Camino Real to Silicon Valley.

All this, and much more can be yours if you take advantage of Meridian Tours' special offer to PCW readers, details of which are now being finalised.

Three holidays are planned, each of which ensures that you are in San Francisco for the duration of the Faire, which must be the biggest micro-dedicated show in the world. The first holiday comprises one night in Los Angeles at the first-class Sheraton Miramar at Santa Monica Beach followed by six nights in San Francisco at the Civic Centre Holiday Inn, just round the corner from the Faire. The second holiday provides the chance to spend three nights in Los Angeles and four in San Francisco while the third allows you to 'do your own thing' for a week following one of the above holidays, simply returning to base for the journey home.

The holiday price includes all flights, hotel accommodation, supervised transfers between airports and hotels, entrance to the Faire, a copy of the conference proceedings and compulsory insurance.

The cost does not include transport to and from Gatwick, meals abroad or additional accommodation for those wishing to stay an extra week.

Car hire can be arranged at special rates by Meridian before departure and special excursions may be booked with their local representatives while abroad.

Having said all that, this promises to become quite an event in the PCW year; it's bound to be fun — even for those who aren't too interested in computers. They can make the most of San Francisco with its Golden Gate Bridge, cable cars, Chinatown, Fisherman's Wharf — not to mention a more recent phenomenon, lobby watching in the Hyatt Regency.

For further information and a booking form write to West Coast Trip, PCW, 14 Rathbone Place, London W1P 1DE.

This holiday is being organised by Meridian Tours Midlands Ltd who are bonded tour operators
(Air Tour Operator's Licence No. 700B)





NEWS

ComputerTown UK is a nationwide network of voluntary computer literary centres.

CTUK! Sutton-in-Ashfield is up and running. Its first night attracted between 80 and 150 people

By any account it's a wonderful start — congratulations to you all.

Eleven computers were made available — five Atoms, two Sinclairs, a UK 101, a 6800, an Apple and a Sharp — and people of all ages and from all walks of life came along to join in the fun. The pre-launch publicity was a bit haphazard — a poster in the library put up the previous day, a (very) brief mention on Radio Trent and, probably most successfully, word of mouth.

With a dab of Superglue and a couple of strong brackets the Sutton organisers have installed an Atom in the library, permanently available for anyone on the list of 'authorised' users. Training sessions are being run by a pair of 15-year-olds Chris Holloway and Darren Flint.

Phil Stone, a director of local firm, Intercom, brought along the office Apple and drew a large audience by running 'Lemonade Stand' and with demonstrations of his stock system.

Shortly after the event we were sent clippings from four local papers plus a note from the librarian:

'The suggestion of staging a ComputerTown UK! publicity evening, plus the feature of having a computer permanently on show in Sutton-in-Ashfield library, sounded very attractive — we like to think of the library as a progressive establishment and are always anxious to encourage events and unusual activities which will bring people through our doors. It would also help to change the rather dowdy image that libraries seem to project. It was obvious that an event like this would have the greatest appeal to teenagers who, as far as libraries are concerned, are the most difficult group to recruit as users.

'Thursday was chosen, as our least busy evening, for the main computer demonstration and the machines were set up in a public area just inside the main doors. This proved an immense draw and the area was hectically busy all evening. I would have reservations about staging anything on this scale again in a public area, since it could have easily detracted

from our main purpose — book supply. To move it to a non-public area would, I suppose, have ruined the object of the exercise, which is to bring computers to the general public.

'The Atom which is now permanently available within the library has had heavy usage, particularly at lunch-time and during the evening, with youngsters who are qualified to operate it demonstrating it to, and training, others. The library staff have very little involvement other than in giving a tape and a manual to people whose names are listed as "approved" users. Having watched this exercise with some interest, there do appear to me to be some slight drawbacks — some of the approved users are using the machine for purely selfish reasons and make no attempt to train others. Also, some are hogging the machine and not allowing others a chance to try their skills. On the whole, however, the experiment has been a great success and I am very pleased that the library has taken part in it.'

So there we have it — the librarian's story. I'm sure that it would help to show this issue of CTUK! News to any librarian thinking of giving support to CTUK! The problems mentioned — those of hogging machines and not helping others — should be fairly easy to overcome — in Menlo Park library they maintain a log of machine use. In busy periods people sign on for half-hour slots and for that half hour they can do what they like with the machine but at the end of the time they *must* hand over to the next person on the list. Up to two additional people can sign on for the same slot if they want to watch or maybe they do some sort of deal with the person who booked as prime user. Often people would rather watch others fooling around than miss out completely. 'Validation' sessions, as they are called in America, take place at set times and comprise an hour of formal teaching. In this way, the body of approved users keeps growing (and the pressure for machine time).

A number of lessons have been learned at Sutton. The ones not mentioned so far are:

— On an introductory evening, restrict the number of programs being run to one per machine. This is your only hope of getting a newcomer off the machine because, if you keep changing the programs,

(s)he'll be there all night.

— Don't start off as big as Sutton.

— Knock up a booklist for the librarian. If the books are available this will draw in new readers like nobody's business.

— When training people, make sure that is the trainee and not the trainer who is actually at the keyboard.

There is a definite need for some 'this is a computer and this is how it works' type of software — any offers?

Now for the rest of the news. We've had several letters from people interested in starting local ComputerTowns, including some from those in the business who feel that they'd like to make machines and premises available to the project. The first is from Mike Baker who is setting up an Ealing ComputerTown. He has already hooked the interest of his borough librarian and is to see him in a day or two — unfortunately we will have gone to press before we hear how Mike got on.

The next letter comes from the Ohio Scientific UK User Group. Tom Graves writes to say that he plans to use the Wordsmith premises (they print the OSI newsletter among other things) and, with support from Mutek's Dave Graham and Steve Hanlan from Beaver Systems, they will be starting their CTUK! in Street, Somerset. They tell us that the local Currys manager has also shown interest and said that he would try to enthuse Currys' Bristol computer department. Already Tom has a C2, a C3 and one, or possibly two C1 systems. At the moment the main requirement is for volunteers because they won't be able to start running the project until mid-January. Anyone interested, regardless of machine loyalty, please contact Tom on Street (0458) 45359.

Edward Teague expects to open CTUK! Romiley soon. His phone number is 061-430 7255

P J Colmer wants to start a CTUK! in the Salisbury area. He is a fifth-form student and at the moment doesn't have a computer. He and his friends are willing to put in the effort in Salisbury — is there anyone out there who'd like to join in? All letters direct to 'Ivanho', Woodgreen, Fordingbridge, Hampshire, or telephone Breamore 551.

Euan Fyfe writes from Chiswick to offer his services. We have put him on to

Malcolm and Jo who are also in Chiswick. We look forward to hearing things from you soon.

Mr Jefferson of Piercebridge, Darlington already makes his PET available to children at his remedial teaching school but in the Christmas holidays he plans to try it out on the village children as well. We suspect you may have just started a Piercebridge ComputerTown, Mr Jefferson. Anyone interested write to 19 The Green, Piercebridge.

COMICS sounds like a ready-made ComputerTown. In fact in Newcastle they are in the process of setting up a computer literacy charity called 'Interface'. Anyone in Tyneside who'd like to join in please contact Pete Rowan, 10 Lambton Road, Newcastle Newcastle-upon-Tyne, NE2 4RX.

Robert Clifford is anxious to start a group in the South Benfleet area. We've put him onto the SE Essex computer club but anyone else interested should write to Robert at 52 Woodham Road, South Benfleet, Essex, SS7 5DG.

Andy Fenner is an enthusiastic newcomer to computing. He'd like to help with a ComputerTown in the Ilford area. Anyone out there thinking of starting a ComputerTown should contact Andy at 47 Kingsley Road, Berkingside, Ilford, Essex.

Martin Kennelly reckons the ComputerTown idea is 'the greatest' and he's getting cracking on a group in the Allestree, Derby area. He's about to buy a Tandy and he reckons the local church will make room for him. Anyone wanting to join in the fun should contact Martin on Derby (0332) 550408 or write to 18 Welwyn Avenue, Allestree, Derby, DE3 2JQ.

Our thanks to all those people mentioned who seem so keen to make CTUK! a reality.

Finally some good news from ComputerTown, USA! which has been awarded a grant from the National Science Foundation — \$224,000... DOI please note!

And that about wraps up the news for this month. Keep writing in with details of your local CTUK! activities and don't forget — we aim to cover the country with ComputerTowns so we still need several thousand more volunteers. Write to ComputerTown UK! 14 Rathbone Place, London W1P 1DE. Please *don't* phone the PCW offices because we run CTUK! in our spare time.

COMMUNICATIONS

PCW welcomes correspondence from its readers but we must warn that it tends to be one way! Please be as brief as possible and add "not for publication" if your letter is to be kept private. Please note that we are unable to give advice about the purchase of computers or other hardware/software — these questions must be addressed to Sheridan Williams (see 'Computer Answers' page). Address letters to: 'Communications', Personal Computer World, 14 Rathbone Place, London W1P 1DE.

Interesting ideas

While I enjoy reading the reviews of the more elaborate equipment coming on the market, I should like to see Benchtest reviews or some such thing on the popular machines that have been around for a bit. Prices, the competition and your style of review have all changed so how about doing the Apple, PET, TRS-80, etc, again? I should also like to see an in-depth appraisal of the stringy floppy type of storage system compared to disk units, some of which now seem to be available for not much more than the floppy tape systems.
Peter Tootill, Liverpool

Thanks for your suggestions. You'll be pleased to hear that we've already started work on the first one — Ed.

Wanted-programmers

The letter from Terry Rigby (November 1980) on the MZ-80K he won last year, contained the remark, 'I wonder how many people like me have a computer but don't have a real application.' As head of a university department I have the opposite problem; ie, a fair number of problems which would benefit from the use of computers but neither the time nor the money to do so.

For example, in our department we have a number of small computers (Olivetti, Apple, Nascom, Sharp) and access to the university mainframe computer (Vax) but are hard pressed for time to develop (a) special input/output devices for these, and (b) programs both to run these devices and for other purposes.

If it is indeed correct that there is a pool of skilled builders/programmers of computers in this country, I would like to suggest that we (and others like us) would be most happy to cooperate

with them to find a use for this talent. Would you, or one of your readers, like to organise this?

Prof J F Lamb, Head of Department of Physiology & Pharmacology, St Andrews University, Fife.

Anyone interested write direct to Professor Lamb at the above address — Ed.

Bouquets and brickbats

Thanks for an interesting publication. I appreciate particularly:

Your impressive array of specialists. Your publication is one of very few (in my experience) which appears to seek out an expert to cover each separate topic — right from assembler level programming to 'Chip Chat' with all the meaty coverage of hardware and software in between.

The appearance of 'Transaction File' indicates to me a real interest in the reader. Most publications concentrate on projecting their advertisers' and potential advertisers' images to 'best' effect and, while I can understand that this is, to most people, 'good' business sense, I find that your clear wish to provide a useful and informative publication shows through on every page. This more than any other single feature makes PCW my favourite computer publication.

I hope you will continue to publish 'Computer Answers' or its equivalent. It is most useful in helping me keep abreast of the real state of the technology, ie the truth behind the glossy advertisements. Not just the Skeleton in the cupboard, but the frequent pleasant surprises which some products reveal through Sheridan's page. I'm also pleased to see his insistence on finding experts to answer readers' queries.

One comment I have on some micros — why is it that some manufacturers bow to the convention of 'Qwerty' configuration keyboards and then promptly make it almost unusable by non-standard

key positioning? I will be the first to applaud the introduction of a faster keyboard layout but until then let's have the proper 'Qwerty' layout with standard key-spacing and inclination.
Michael Bews, Liverpool

Mjdfk llkdirhcci h fjhfn jh jhd qoypid! — Ed

New technology

You will be glad to hear that PCW is not the only perpetrator of Bludners. Ms London recently headed its recruitment section thus:

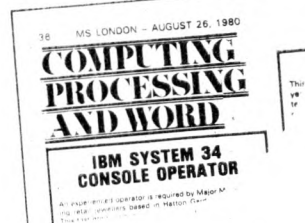

T J Grant, Bushey Heath, Herts

ACC lives

I would like to apologise to Mr Bendall (November PCW) on behalf of the ACC for the lack of communication with my predecessors. The ACC is alive and kicking, having awakened from a somewhat dormant period. I would also like to answer the queries he raised in his letter, point by point:

1. Firstly, I would like to thank him for his various articles for *Accumulator*, the newsletter, none of which have reached the current editor (Derek Fordred). If he would care to send any future articles to either Derek or myself I will endeavour to ensure that they are acknowledged/published;
2. The ACC year 79/80 was extended to cover the period to September 80 and hence to include issue 6 of the newsletter. The current year 80/81 started 1 October 80 and ends on 30 September 81. The current rate of subscription is £3.50 per volume; however this is to be increased to £4.50 per volume of *Accumulator*

(subject to ratification at the EGM, 15 December, Conway Hall). Further details of membership and membership forms are available from the membership secretary Jim MacDonald (send an SAE please);

3. Last year's membership actually exceeded 1500;
4. The AGM was duly notified to the members in the last issue (issue 6) of *Accumulator*, and was held on 9 October 80;
5. The new executive committee is: Chairman, Peter Whittle; Gen Secretary, Phil Warn; Treasurer, Alan Secker; Membership Sec, Jim MacDonald (1 Carlton Court, Studley Grange Rd, London W7 2LU); Newsletter Editor, Derek Fordred (72 Mill Rd, Hawley, Dartford, Kent);
6. The 80/81 editions of *Accumulator* will be published in November, January, March, May, July and September.

The ACC does not charge an excess for overseas members (however, as you can well appreciate, even surface postage is considerably more expensive to destinations outside the UK).
Peter Whittle, Chairman, ACC

Microwriter reply

As you have undoubtedly learned to expect, no matter how favourably you treat an inventor's brainchild, his parental expectation for unstinted praise always exceeds the objective evaluator's supply of favourable adjectives. With this in mind, may I first thank you for nice things you have written about the Microwriter and then comment on some of the slight negatives.

First — not terribly important — the 'Memory Full' does not crash the machine, even in this software version, although you correctly point out that our updated program, which is on line and should be available very soon, will improve this routine and practically every other limitation you mention. For your present information, however, when you fill the memory and are so informed

by the display, you can come back to the text point simply by pressing 'Control-H'.

But I most regret your comments on pricing of the Microwriter and comparison to the Tandy price. Yes, your point about mass production is true but notwithstanding, the omission in your logic of your comparison is the fact that we provide our customers with much higher-priced CMOS components, which make the Microwriter fully portable.

I emphasize the point on price because there is nothing quite like the term 'over-priced' to chase away potential customers — and that's the basis of our survival, isn't it?

Cy Endfield, Microwriter Ltd

Quickie reply

If the version of Basic on the Ohio Superboard is similar to that of the CBM then here's an answer to the 'Ohio Quickie' in October's PCW.

PEEK(S)=49 is a logical expression which delivers true (-1) or false (0). Thus V=PEEK(S)=49 means V=(PEEK(S)=49). This is quite obvious on the Algol-type languages which use := for assignment and = for relations.

U P Cheah, Walsall

Time-sharing hobbyist

I have read PCW ever since the first issue, and have always found the articles excellent. However, I have one complaint. You have never given a thought to the computer enthusiasts like myself. I do not own a micro. Quite honestly I cannot ever see a time when I will own one. I have instead for many years bought time from various time-sharing systems — in some instances the organisation whom I had asked about buying time has allowed me free access to their system, albeit limited to certain times of the day and usually all day Sunday, which for an enthusiast like myself is ideal. I must admit that my user number has usually had a low priority code attached to it and I have usually been limited to 100 pages of memory but it gives me all the power I can use.

Surely there are others like myself who have had the 'good fortune' not to have been caught up in the micro-revolution but are still

involved in computing as a hobby. I would appreciate any contact with kindred spirits.

One minor difficulty caused in part by the home computer is the sudden and dramatic increase in the cost of second-user terminals. Not many years ago it was possible to pick up terminals for £50-100. Now the similar equipment is on sale for £300-400.

P H Charlton, Hull, North Humberside

101 clear-up

The following subroutine may be of interest to any UK101 owners who, like myself, have been looking for an easy way of clearing the screen (ie, without entering a whole string of numbers in DATA statements):

```
1000 POKE 129,255:POKE
130,211
1010 POKE 131,255:POKE
130,211
1020 A$="sixteen spaces"
1030 A$=A$+A$+A$+A$+
A$+A$+A$+A$+A$+
A$+A$
1040 RETURN
Vince Early, Orpington
```

Buying blues

There is no doubt that the small computers currently available on the UK market represent good value for money. It is a pity that the selling of such advanced technology has more in common with the 19th than the 20th century.

As a prospective purchaser of a small computer, I have been, as they say, investigating the market. Mail order has caused several acquaintances near heart attacks and big telephone bills; terms like 'rip-off' and 'swindle' have been used. Many firms launch advertising campaigns long before they are in a position to deliver; one hears of power supplies (rather essential!) being three months in the coming when the computer (and its guarantee) arrive within a week or two. And why, in this area of digital devices, cannot your advertisers add VAT, postage and packing, and all those little extras that are needed to run the machine? £150 announces one — actually nearer £200 is needed to obtain the machine.

I decided to avoid these problems by attempting to buy a machine in a shop and set off for the Edgware Road. I needn't have bothered. Not

only is almost everything-out of stock but little interest is shown in the customer. In one shop I observed a gentleman performing prodigious feats on a small machine for at least ten minutes before fortuitously discovering he was a sales assistant. No one asked whether I wanted anything and I left without the slightest notice being taken of my presence. Curiously enough they did have a small machine I might have been interested in, but no matter. By comparison, buying hi-fi in the Tottenham Court Road is a positive pleasure.

Colleagues in the business advise me to wait a while — or forever?

Professor J C Marsden,
Tunbridge Wells, Kent

Anti-LIST

While writing a program for a small local firm I was asked to write a program which couldn't be listed — only RUN. At the time I was using an Ohio Superboard and I found that an amendment to the pointers used by the LIST routine did the trick. The first line points to the address of the next line and so on. So, by zeroising this first pointer, only line one will be listed. The program will still work since these pointers are not used when the program is run.

As the lowest line number on a Superboard is 0, I suggest that you put a REM statement in at this position. A POKE 769,0 will zeroise the pointer, while POKE 769,7 will restore it.

Users of other machines should be able to use this method — it's simply a case of finding out where programs are stored in memory and studying the first few bytes for the pointer.
B Mistry, Bradford

Those with PETs may get some useful tips from the 'Get Well Soon' article later in this issue — Ed.

Squire's squawk

Poor old Commodore. No fewer than four separate digs at them in your November issue.

There has been much cause for criticism in the past but the interesting point is that the company has been making huge efforts to remedy these problems.

Printout's postbag provides a pretty good barometer of Commodore's performance. The number of letters of complaint received during the last couple of months has declined sharply. These days even their documentation is readable.

Credit where credit is due might encourage some of the other manufacturers to put their houses in order.
Julian Allason, Printout

That's funny. Kit Spencer rang us to say almost the same thing — Ed.

A Toady trick

I fear that Trevor Lusty may have been paid more than his due for his program in your November issue; he has used the old PET programmer's trick of increasing the printer line feed length to make a program look longer. Compared with another PET program in the same issue, Mr Lusty's is 1½ times the length. Well, I suppose that will teach you to dig at his native publication with almost unsolvable anagrams.
David Boreham, Fife

Sharp crash

Regarding R L Tucker's query (PCW Nov '80) about why his MZ-80K occasionally crashes when LIMIT MAX is used, Sharp's reply seems a trifle coy.

There is, in fact, a bug in Sharp's cassette Basic Interpreter. When the internal clock is set using the TI\$ function part of memory used by the LIMIT MAX command is overwritten. So this is a likely problem on any cassette-based MZ-80K.

How to overcome it? Surely Sharp didn't suggest GOTO 1200, which the Monitor will simply ignore. The instruction is GOTO \$1200. A misprint perhaps? In any event, a 'cold Hart' is 'cold comfort' to anyone wishing to reset maximum memory while retaining an existing program. My suggestion to R L Tucker and other others experiencing this problem is to forget about MAX, determine the top of memory value for your particular configuration and use that value with the LIMIT command instead. For a 24k RAM machine the value is 28672 (4k monitor + 24k RAM = 28k or 28672 bytes) and in this case the command is LIMIT 28672.

It works for me everytime.
E W Hare, Haslemere

25 Ways to use **VISICALC Software** on CBM/PET or Apple

1. A Birmingham sales rep. uses VisiCalc to do his sales reports, sales summaries and expense accounts.
2. A farmer in Wiltshire compares budgeted and actual expenditure, analyzes transactions and solves numerous other business problems.
3. A Louisiana shipyard manager does inventory pricing, cost estimating, and stability and tonnage calculations.
4. A City financial analyst, who computes and prints trust fund reports for his clients, says, "VisiCalc is paying for itself over and over again. An excellent money maker."
5. A California real estate and financial planner automated much of his work with VisiCalc's powerful features. For example, he has created an array of 13 certificates of deposit with varying base amounts, term periods, and interest rates, with associated calculations for required "break-even" terms and interest rates when current date and available money market rates are entered. Penalties for early withdrawal are applied and gain/loss shown if proceeds reinvested. Daily compounding of interest is provided for.
6. A ceramic tile manufacturer has "new applications all the time," including costing model, budget preparation, ceramic empirical formula calculations and financial analysis. Says, "VisiCalc is dynamite."
7. The financial director of a Newcastle company does his budgeting and planning.
8. A professional translator using VisiCalc for cost/profitability comparisons, budgeting and income tax, says VisiCalc is the "best microcomputer application program I've ever seen."
9. A chemical research scientist keeps weekly budget planning, tax records (income and deductions), medical expenses and personal inventory.
10. An Australian manufacturing firm manager's uses include factory production reports, labour costing, calculation of recent price increases, and "a race horse selection program that is yet only moderately successful."
11. A Swiss retail food store manager uses VisiCalc for profit centre calculations, enabling him to know the net profit of every store on a monthly basis with the input of only three reference numbers.
12. A life insurance agent, who already prepares client proposals combining insurance and other investments and quotations on small group plans, says, "I can't wait until I really learn how to use VisiCalc - it's outstanding."
13. A Norwich company secretary appreciates VisiCalc's "ease of use" while doing corporate budgeting, sales forecasts, production forecasts, financial report analysis and ratios, and construction cost analysis.
14. A London management consultant's uses include analysing key financial ratios and balance of business planning and modelling business performance, and management training.
15. An electrical engineer does his business plans, balance sheets, cash flow analysis and sales forecasts. Says he likes VisiCalc's "protection from errors and mistakes."
16. An Oregon medical laboratory director does his workload calculations and space forecasting.
17. A New York finance manager does balance sheet forecasting and keeps a five-year income statement.
18. A Surrey teacher likes the built-in formula calculations when doing statistical research, charts, football statistics, classroom marking and home budget projections.
19. An anesthesiologist calculates gas flows on anesthesia equipment, plus a running record of income tax, pending orders and computer hardware and software expenditures.
20. An executive of a major management consultancy explains how they had used an expensive time-sharing service which tied up a programmer/analyst to create and run the models, so there was always someone between their needs and the final results. "We attempted to duplicate what we had at the service bureau and surprised ourselves that we could do it easily and without specialised programming skills. Now we have evolved far more sophisticated forecasting and modelling tools that go well beyond anything we originally envisaged. These analyses are used by us on behalf of our clients or prospective clients and they help us get more business."
21. A Manchester optician took the hand calculations out of his budgets and sales projections.
22. A senior financial analyst does his balance sheet financial analysis (ratios, rates, yields, etc.) and financial modelling such as profit plans.
23. The president of a New York retail business is using VisiCalc to figure out how he can pay for his personal computer. (He should talk to the guy mentioned in number 4!)
24. The co-owner of a Nuneaton restaurant calculates food costs, bar costs and total operation cost projections.
25. A Massachusetts student is crunching numbers at Harvard Business School with VisiCalc....straight to the head of the class.

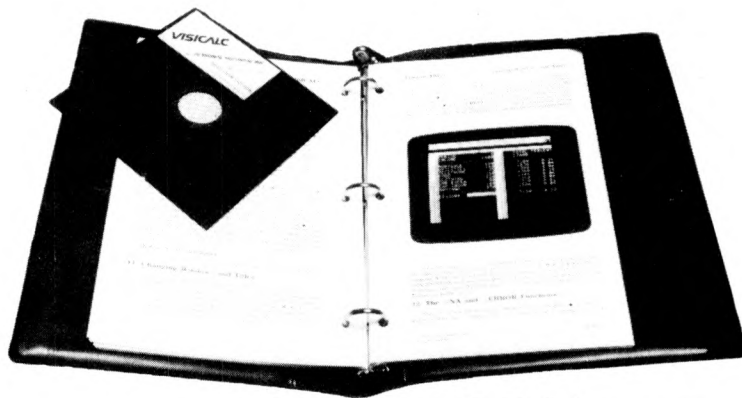

£125+VAT

VisiCalc is the award winning program from Personal Software. It handles mathematical and financial forecasting — and solves just about any problem that can be represented in tabular form. Try it at your nearest PET or Apple dealer or send for your copy direct from:

ACT MICROSOFT

Radclyffe House, 66/68 Hagley Road, Edgbaston,
Birmingham B16 8PF. Tel. 021-455-8585
Telex 339396

PET is the trademark of Commodore Systems. Apple is the trademark of Apple Computers.

- Rush me free details of VisiCalc
 I enclose £125 + VAT for PET/Apple VisiCalc

Name:

Address:

.....

..... Postcode:

Credit card holders may order by telephoning 021-455 8585



**BENCH
TEST**

TRANSAM TUSCAN



Lyn Antill builds and tests an all-British system.

The idea of the Tuscan is stunning — you start off with a kit costing less than £200 and keep building it up until you have a full size 64k, twin disk, S100, CP/M machine. The improvements can cost as little or as much as you want to pay at any one time — from £10 or less for a couple of extra RAM chips to £350 for a disk controller and one drive. The finished machine has a very professional appearance and the specification looks good, too. You can stop off at several

different stages in the building process and have considerable choice as to the eventual configuration.

Transam developed the idea after evaluation of its previous computer kit — the Triton — which is a multi-board system. One of the novel features of the Tuscan is that the 8k Basic system is accommodated on one board, which also holds slots for up to five additional S100 boards, all of which will fit into the one case. The 8k Basic board holds four Basic ROMs,

8k of user RAM, the processing logic and the video logic.

You can, in fact, have a smaller system than the 8k Basic, because Tuscan will work on a 2k Monitor ROM (called Mitsi) with 1k of RAM. This is suitable for such applications as process control. You don't even need to buy a keyboard if you can borrow a terminal to plug into the board while you're programming it. Several colleagues of mine have made the kits to control laboratory equipment; unfortunately none of them has, to my knowledge, succeeded in designing the interface to the equipment, so I can't yet comment on the Tuscan in this role.

A route up from the Basic, or a more expensive alternative to it, is the 32k resident Pascal system. This is another novel idea and the Pascal looks very good. (Transam wrote the TCL Pascal for the PET.) Program storage could still be on cassette. Programming teachers dream of the day when Pascal takes over from today's Basic; perhaps the Tuscan is a further step in realising that dream.

If you don't want resident Pascal, you can just go the whole way to a disk system, possibly starting off with just one disk while you save up for the other. To do this you need at least 32k of memory, a disk controller and one or two disk drives. The cabinet has room for two 5¼in disk drives, or a separate drive is available for twin 8in disks. Printer connections are provided, and if you want a graphics terminal this can be arranged with an appropriate memory-mapped video control card.

Building the minimum system

The assembled and tested version only costs an extra £40, so don't bother reading this section unless you relish the prospect of soldering (and much head-scratching when things don't work first time).

To place my comments in context, I must point out that I had never held a soldering iron before, let alone used one on a computer, nor did I know anything about electronics or microcomputer hardware or logic. My object in building the kit was partly educational — as a teacher of computer studies, I wanted to know what went on inside a computer and this seemed a good way of finding out. It also seemed like a cheap way of getting a computer for myself. I knew I could never go out and write a cheque for £1500, which was the absolute minimum for the sort of system I wanted, but this way I could buy a bit at a time.

Sue Eisenbach had seen the Tuscan kits while they were still in the design stage and thought that they would form a suitable basis for a 'Build your own Micro' course — which she duly

set up. So it was that a mixed group of scientists gathered together in the physics lab and got to work, with advice from two electronics experts. Transam said that the kits took six hours to build, so we doubled that, allowed a bit extra for tea-breaks and interruptions and a bit more for sorting out mistakes, and set aside three days for the course. This was a mistake. We spent the whole three days soldering, working out what all those little things that looked like sweets were and whether we had all the right ones, squabbling about who'd pinched whose soldering iron, and muttering darkly about incomprehensible manuals.

We should have all taken home a copy of the Hardware Manual the week before so that we could have worked out in advance what it was that we were supposed to be doing and what equipment we might need.

Working on the board was great fun but we all found the power supply downright frustrating. I would certainly recommend buying that ready-made as the saving is minimal. We didn't really know which gauge of wire to use. If we'd been able to do our sums, we should have been able to work it out but it would have been nice to be told. A fourth day was spent fiddling around, going back to Transam for extra pieces of ribbon cable, etc, checking each other's work, and moving the bits we'd soldered into the wrong holes! Even at the end of this time several people hadn't completed their power supplies or connected things like keyboards.

Then came the agony! It was time to try the boards out. There are two problems in dealing with a board as large as this: several people found it awkward to handle and were concerned lest they crack it and lose all their money's worth, or at least that components put in earlier would take too much of a battering as later ones were dealt with. (The manual does indicate what order to do things in.) The other problem occurred to us as we queued up to use the one monitor — you can't check the work as you go along! From some there were cries of ecstasy as the welcome Mitsi message appeared, while others groaned as a strange tartan pattern came up. (This is an initialisation error caused by things like setting the Power On Jump switch or the System switch incorrectly.) I kept quiet, as my board showed no signs of life whatsoever.

The manual gives no real clues as to where to start looking for faults. It's a case of looking at all 101 sockets and the components slotted into them for bent pins and faulty soldering, for ICs inserted the wrong way round and for any items that might have been misplaced. Another week of careful checking went by before it was decided that four of the boards had faults on them, one of which turned out to be a bent pin after all. Transam admitted it had had faults with the first batch of boards but was able to put ours right within a week. (And that was before it knew I was doing the Benchtest, just in case you're suspicious!)

The housing for the Tuscan (and the Triton) is expensive at £85. Our

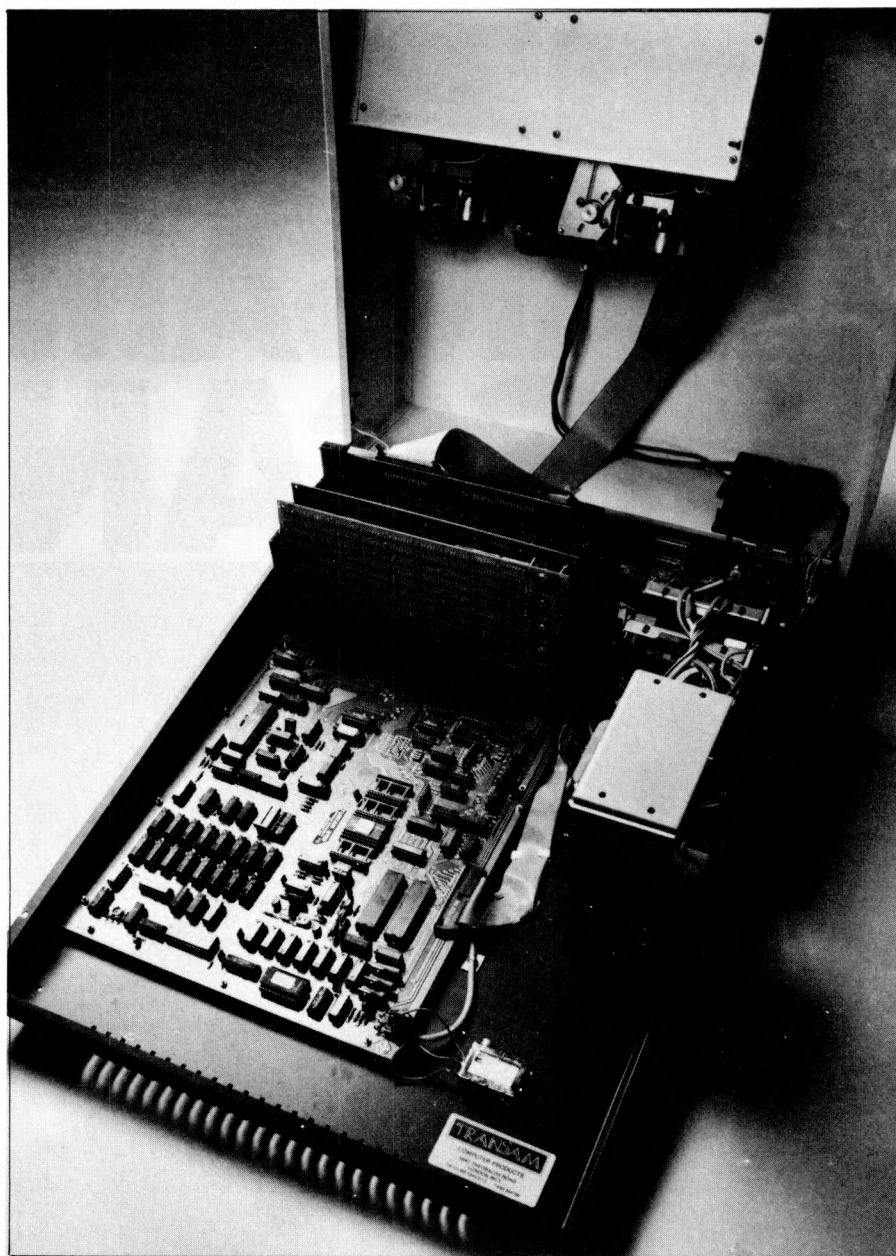

Tuscan's case hinges open neatly to show the motherboard with its five S100 slots

engineers were convinced that the board and power supply could probably be fitted into a much cheaper home-made box by anyone with access to metal-working or plastics moulding facilities. But they admitted that the size, strength and shape required for holding the keyboard and disks as well, and for supporting the TV or monitor screen, could not easily be provided for less. And, anyway, it is handsome.

Fitting the board into the case ought to be straightforward, but the documentation completely overlooks the fact that some of us don't even know what a dipole switch is, or how to connect coaxial cable or the wires to the tape-recorder. The guys at Transam were always very helpful answering my questions. Perhaps when enough other people have asked such questions, they will put all the answers into an expanded manual.

Another thing to bear in mind when assembling a kit is that you have to specify every single thing you want to buy, down to the last nut and bolt. This probably means that you will be making several visits to Transam for the bits you've forgotten, or having a

long chat with the salesmen about what you're going to need for the application you have in mind. Also, nuts and bolts and sockets and wires may not be expensive in themselves but they do tend to add up, and so does VAT at 15 percent.

Hardware

As well as my own system, with 8k and resident Basic, Transam provided a system with twin 5¼in disks. It also markets a Centronics printer in matching trim.

The Tuscan is based on an 18 by 11in single board. The case provided by Transam is 24in deep by 18in wide by 8in high. It is metal with a white, textured finish and has a good, solid feel to it. It is quite big and heavy; too deep, in fact, to sit comfortably on my desk.

The CPU is a Z80A which will run at 2 MHz or 4 MHz. Most of the machines are currently being set up to run at 2 MHz because the faster 2516 EPROMs are difficult to obtain. A complete system at 4 MHz would only cost about £100 more. The board can hold up to 8k of ROM and 8k of RAM. A total of 64k memory can be ac-

commodated, with the top 8k being ROM and the rest RAM. Static or dynamic RAM cards can be added to make up the 48k extra.

The video logic on the board gives a screen size of 16 lines of 64 characters. This is not memory-mapped, although there is a line buffer. The EPROM character generator provides 128 characters including upper and lower case letters and 32 'blobby' graphics characters. This can be re-programmed to give a user-defined character set. Output is to a monitor or, via a UHF modulator, to a domestic TV set. The clarity of the characters left something to be desired on my 6in portable TV but they were fine on Transam's 9in monitor. The onboard video works at 1200 chs/second. There is a 'wrap around' effect on the screen which you are warned about in the manual. This is normally only encountered when the cursor is flashing at the extreme left of the screen and results in a flashing point at the extreme right.

Transam is working on a system with output to a colour monitor. Other I/O facilities are: RS232 serial in/out switch selectable up to 4.8 kbaud; 8-bit parallel input port; 8-bit parallel output port; software and hardware selection of I/O devices; eight levels of vectored interrupts; and spare uncommitted ports for user definition.

The disk drives are Shugart SA400 or SA800 compatible, using IBM format soft-sectored single or double density disks. Up to four disk drives may be used which can be either 5 $\frac{1}{4}$ in or 8in or any combination.

Two keyboards are available to fit into the case, one of which has a numeric keyboard and cursor keys. The smaller, 56-key keyboard, which is only anchored at its four corners, bends a bit as you strike the keys, although I understand that there is a standard cradle that can be fitted to support it if it is likely to get too much of a pounding. The 71-key board is perfectly trim. My own machine — and another new one I tried out — developed keyboard faults as it warmed up. Characters appeared on the screen when the keys had not been touched, or failed to appear when the key was struck. This may have been caused by key sticking, or, as Transam suggests, be due to a faulty batch of keyboards from the suppliers. I have seen several different machines in use which had perfectly adequate keyboards, including the Benchtest machine which took a good hammering, so the problem is obviously not inherent.

If you are going to use a machine with resident Basic or Pascal, then you will need a cassette on which to store programs. Transam doesn't supply a specific cassette player to go with their systems, or even any of the wires, although they will give advice on buying and interfacing a cassette player of your own. They are hoping to make use of stringy floppies in the near future.

Software

There is an 8k Basic available in ROM, a 10k disk Basic, a 32k resident Pascal (with the first 8k in ROM) and a disk

Pascal. These are all TCL's own software. Once you have built the full CP/M system, then you should be able to take your pick of all the CP/M software, although Transam hasn't got anything running yet. (Some CP/M programs rely on memory mapping, which isn't available with the on-board video but requires a separate video card.)

Basic

The 10k disk Basic is intended to be a superset of the 8k resident Basic with additional commands for handling disk files.

I was a bit surprised when the INPUT statement on the resident Basic jumped up to the top left-hand corner of the screen each time and over-wrote whatever was there, including its own '?' prompt. I forgot to ask Transam whether this was intended, but it had me worried until I realised that it should be preceded by CLS which clears the screen. This doesn't happen on the disk Basic. Spacing of input and output can be done quite nicely with TAB and SPC, and the '?' prompt can be replaced with one of your own choosing for any INPUT statement, making for a sensible dialogue with the user.

The Basic is fairly standard with a good range of mathematical functions. It has a precision of 6 $\frac{1}{2}$ digits, allowing for rounding of the last digit. There are no matrix manipulations per se, although multidimensional arrays (up to 256 dimensions!) are permitted, always provided there is enough memory. I ran out of space using three dimensions with anything larger than DIM M(9,9,9), and DIM M(4,4,4,4) was the largest four-dimensional array I could manage, but I was only using a 32k system. To use string arrays of more than 50 characters, it is necessary to CLEAR space for it early on in the program.

Long names are permitted for variables, although only the first two characters are treated as significant. Upper and lower case letters are interchangeable in variables and in commands. Tuscan has a neat way of storing the Basic without any spaces and putting them back in again when it lists the program. This is done to save storage space without reducing program readability. The manual gives a long list of ways to avoid wasting space, including that particular trick which is anathema to teachers of programming — avoiding REM statements. Unless you are programming entirely for your own amusement, when lost time and faulty programs cost nothing, then it is cheaper to buy more memory than to waste time struggling through a long program with no REMs.

Good string handling instructions are provided: you can pick any number of characters from the beginning, middle or end of a string, or find out whether a particular smaller string is present within it. A SWAP statement swaps the contents of one variable with another, or one string with another. This is very handy when sorting.

I ran into two problems with the file handling, both of which Transam's programmer was able to sort out for me. The first one was that I got a

DATA ERROR when I tried to read records which contained both strings and variables. This was resolved by putting a ',' between each data item as it was written to the record, just as one would when typing several items on the screen at once. As a writer of commercial programs I was delighted to see ROPEN, RGET and RPUT to open a file for random access, get records from it and write records to it, eg, RGET 1,15,A\$ will get the 15th record on the file on channel 1 and place it in A\$. Unfortunately, a copying error in my disk caused it to hang on ROPEN. The master disk in Transam's workshops did this perfectly but I wasn't able to try out the random files as well as I would have liked — file handling is central to most of my programs.

One very nice feature of TCL Basic is the amount of work that can be done in command mode. DIR is available from Basic, files can be opened and closed, and you can use it in calculator mode, eg, PRINT (274/47.5 + 43*0.75) will work out the answer and print it on the screen. It is also possible to CALL one program from another. This enables one to create libraries of useful routines.

Pascal

Unfortunately I didn't get a chance to use the Pascal, but the description in the manual of the facilities it offers looks very promising and TCL Pascal certainly enjoys a good reputation.

Packages

There aren't any yet, although Wordmaster and Wordstar are being worked on and others are in the pipeline.

Documentation

The hardware manual is critical for anyone building their own system. It has been written by and for people who know what they are doing. The level at which the explanations should be pitched is obviously difficult to determine — if it sounds too easy you'll skip what you ought to be reading and if it's not easy enough you'll get lost.

I had expected to find the instructions for making the board to be the most difficult but in fact they were the clearest. Perhaps the writer was aware that this was likely to provide the greatest difficulty and had taken extra care. The instructions for the power supply were sketchier but this didn't concern the physicists in our group, who worked straight from the wiring diagram: although I was able to understand what they were

Benchmark timings:

These are for the slower 2 MHz version of Tuscan rather than the 4 MHz, which should have given correspondingly better results. (All timings in seconds.)

BM1	2.3
BM2	13
BM3	26
BM4	27
BM5	32
BM6	48
BM7	68
BM8	6

Almarc + Vector Graphic

The complete partnership
in Micro computers

System 2800.

- * S-100 bus.
- * Switch-selectable asynchronous baud rates between 110 and 9600 bits/second.
- * Vector-3 console chassis with 12-inch CRT (18" W x 12 1/2" H x 21" D).
- * Capacitance Keyboard 6 slot motherboard, and power supply.
- * Z-80 based single board computer with 1 serial port, 3 8 BIT parallel ports, 3 PROM slots, and

- 1K RAM. Flashwriter II. Video board, 64K dynamic memory board and disc controller. DUALSTOR enclosure with two 8-inch double density disc drives, total disc storage capacity 2.4 m bytes.
- * Version 4 extended systems monitor on PROM, Vector CP/M 2.2, SCOPE. Screen Oriented Program Editor, full screen dynamic simulating debugger, ZSM Z-80 assembler, Microsoft BASIC-80 Release 5.

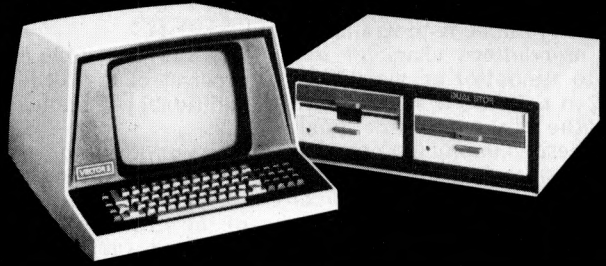

System 3030.

- * Vector-3 console chassis with 12-inch CRT (18" W x 12 1/2" H x 21" D), capacitance keyboard, 6-slot S100 motherboard, and power supply.
- * ZCB Z-80 based single board computer with 1 serial port, 3 parallel ports, 3 PROM slots, and 1K RAM. Flashwriter II Video board, 64K dynamic memory board, floppy disc controller board, Winchester disc interface board, Megastor enclosure with 8-inch Winchester 3-platter hard disc drive, and

- 2 Micropolis Mod II quad density mini-floppy disc drives.
- * Capacity Hard Disc 32 M bytes.
- * 2 5 1/4" MICROP DISC DRIVES giving 630 Kbytes, Storage Capacity.
- * Version 4 extended systems monitor on PROM, Vector CP/M 2.2, SCOPE. Screen Oriented Program Editor, full screen dynamic simulating debugger, ZSM Z-80 assembler, Microsoft BASIC-80 Release 5.



System 'B'

- * 64K Bank Selectable Ram (56K available to user).
- * 3 Serial Ports, 2 Parallel Ports.
- * Twin Disc Drives, 630K Capacity.
- * Z-80 CPU, with Fast 4MHZ Clock.
- * Interrupt Handling on I/O Board.

- * 18 Slot Motherboard.
- * Vector Mindless Terminal.
- * Flashwriter II Video Board (24 x 80).
- * CP/M 2.2 Operating System.
- Plus Microsoft Version 5 BASIC, SCOPE. Screen Oriented Program Editor, Full screen dynamic simulating debugger, ZSM Z-80 Assembler.

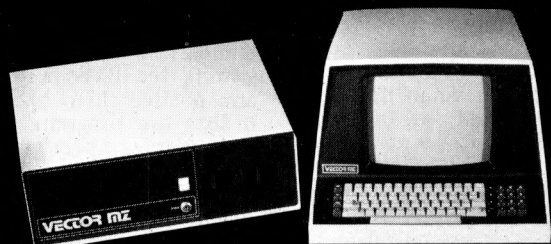

At Almarc Data Systems, when you buy Vector Graphic Micro-Computers, you are assured of Almarc's experience of over 430 systems installed throughout the U.K. — plus their back-up of full service facilities carried out by experienced staff.

Almarc are Specialists in Vector Graphic equipment which includes Micro-Computers for research, laboratory work, word

processing, business systems, schools, colleges, universities and industry. Plus an ever growing list of compatible software including Pascal, Fortran, Cobol, APL, Algol, Basic Compiler and others.

We will be pleased to demonstrate how Almarc + Vector Graphic Systems equates to The Complete Partnership in Micro-Computers.

ALMARC
DATA SYSTEMS LTD

906 Woodborough Road, Nottingham NG3 5QS.
Tel: (0602) 625035

doing, I would never have had the confidence to do it that way myself. The instructions for the UHF modulator appear to be wrong — at least the way I read them, which I did several times until the salesman suggested I try it the other way round. The keyboard connections were easy to follow but I despair of ever connecting my tape recorder (it's probably one of those things

which is easy when you know how — but I don't). The user-definable ports are left entirely to your own imagination. Of course they could be used in a great variety of ways but it would help if the manual gave you some idea of the sort of information that could be fed down them and what the machine could be expected to do with it, what instructions could be used to interpret it, etc.

The 'How it Works' section is for experts only. How many users are really likely to know the significance of such a pin being high or low? Many will, but there will also be many who won't but would like some enlightenment on the subject.

The only documentation I can compare this with is Heathkit, who charges considerably more for its manuals (and its kits, come to that) but which are very much more detailed and much easier for the non-expert to follow. Perhaps Transam should investigate the market for such an 'Idiot's Guide'.

I shouldn't have had any difficulty with the Assembler language section — for five years of my life I wrote all my programs in Assembler and converted them myself into hex — but I didn't actually get any Assembler programs going. Those of my colleagues using the minimum Tuscan for process control are going to need a much fuller guide to Assembler programming than this. My first Assembler manual for a system little bigger than this occupied

a complete volume and told you everything you needed to know about every instruction.

Resident Basic is described in the general software manual and there is a separate volume for disk Basic. These are on a par with most people's Basic manuals, ie, they are brief and presuppose a knowledge of the language, meaning I can never find the instruction I'm looking for. I am not complaining about this manual in particular but about micro manuals in general. They always look as though they were put together in a hurry (which they probably were) but never seem to get tidied up even after the first rush of new products has settled down a bit.

The Pascal manual is a pleasing exception, written as an introduction to the language as well as a manual and providing plenty of examples of the instructions as used in programs. I suppose Transam worked on the assumption that most people will already be familiar with the hardware and with Basic but that most will be coming fresh to Pascal and will therefore need more help.

Potential use

This machine is aimed at anyone who wants to start small and work up. The 8k Basic system is roughly comparable in price and performance with the 8k PET but lacks its compactness and the convenience of the built-in screen and cassette. The twin disk system is again broadly comparable in price and performance with, say, the Superbrain, but again lacks the built-in screen. Where the Tuscan scores is on its versatility — starting with something almost at the bottom end of the market and going up almost to the top. I wonder when Transam is going to bring out a multi-user Tuscan?

I would imagine that three separate types would be interested in the kits — electronics wizards who just like building things, engineers and scientists who want to control laboratory equipment and people with limited finances and great expectations. Prominent in this last group would seem to me to be school teachers. They are likely to have access to equipment such as voltmeters and would benefit, as I did, from the knowledge of computers gained by making one. However, I do feel that such people would need more help from the documentation.

TCL Pascal is something of a pace-maker. Will the micro user be jolted out of his Basic mentality? The resident Pascal system could be just the thing to do this. Certainly there are many of us who believe that good, reliable, portable packages will not really be achieved, at least not at the right price and in the right quantity, until they can be written in Pascal. Basic is too muddily and one version differs too much from another.

Prices

The best thing about Tuscan prices is that they keep going down — in last summer's price list, 48k of dynamic RAM was £398 and now it is £285! A remarkable reduction by any

At a glance

FIRST IMPRESSIONS	
Looks	*****
Setting up	*****
Ease of use	*****
LANGUAGES	
System Software	****
Basic	****
Packages	N/A
PERFORMANCE	
Processor	***
Cassette	not reviewed
Disk	****
COMPATABILITY	
Hardware	***
Software	***
DOCUMENTATION	

VALUE FOR MONEY	

***** excellent, **** V. good, *** good, ** fair, * poor.

8k Resident Basic has the following commands and functions:

PRINT	TO	STEP	TAB	DEF
CLS	OR	AND	-	END
DATA	XOR	+	@	GOSUB
EDIT	*	/	ASC	INPUT
FOR	<	=	CHR\$	LIST
GET	FN	PI	HEX\$	LET
IF	SPC(COS	LEN	OUT
LINE	ATN	FRE	RND	RUN
NEXT	EXP	INT	SQR	REM
ON	INP	PEEK	VAL	STOP
RETURN	LOG	SIN	MID\$	SCR
READ	SGN	TAN	>	WIDTH
SWAP	STR\$	RIGHT\$	<=	ELSE
TRACE	LEFT\$	STRING\$	>=	
NOT	INSTR	AUTO	>	
CALL	THEN	LPRINT	<>	
DUMP	VDU	LOAD	RESTORE	
ERASE	CLEAR	OFF	RANDOMISE	
GOTO	DIM	POKE	SAVE	

The following additional commands are in the disk Basic

GET #	CLOSE
INPUT #	RENAME
LINE INPUT #	RGET
PRINT #	ROPEN
CREATE	RPUT
OPEN	DELETE

TECHNICAL SPECIFICATION

CPU:	Z80A 2 MHz or 4 MHz
Memory:	1k — 64k RAM 2k or 8k ROM (for Monitor or Basic)
Keyboard:	Full Qwerty 56ch or 71chs with numeric pad and cursor keys.
Screen:	Monitor or TV through UHF modulator 64chs x 16 lines with on-board video
Cassette:	Supply your own, and your own connecting wires.
Disk Drives:	Up to 4, any combination of 5¼in and 8in single or double density.
Printer:	Dolphin BD80, Centronics 730 or 737 (with proportional spacing)
Ports:	RS232 serial and parallel. modem I/O. User definable.
System S/W:	2k MITSU in ROM for minimum system. Built into resident Basic and Pascal. 2k TUBS — ROM for running CP/M disk.
Languages:	Assembler, Basic and Pascal

GOTO page 134

PRINTERS UPDATES

This is an update (not a replacement) of the printer survey we published in last August's *PCW*. Since that time, a number of new machines have appeared and we've included as many of these which a) have come to our notice and b) we've been able to get details of.

One encouraging trend is that prices seem to be dropping all the time, particularly at the lower end of the market, which is good news for the home/small business user.

For a while now we've been moaning about the disproportionately high cost of printers compared to that of mechanical typewriters (which contain several hundred expensive-to-make moving parts). At last, though, prices are beginning to reflect the relative simplicity of some printers — Centronics, for example, has just dropped the prices of its 730 and 737 models (see August) to £375 and £425 respectively.

Daisywheel printers are also getting cheaper. The Ricoh RP1600, for example, is now available from at least one shop for £900 retail, compared to its £1300+ price tag of mid-1980. And if you're prepared to sacrifice speed, you can get even cheaper daisywheels but be warned — the 17 characters per second printing speed of these low-cost machines can seem painfully slow if you're doing a lot of printing!

Finally, a new market is beginning to appear in the form of 'intelligent' electronic typewriters with computer interfaces. These can be used off-line as a normal typewriter or on-line as a letter-quality printer or even as a terminal.

PRINTERS UPDATES

Access Data
Communications
(0895) 30831

Adler Business
Systems
01-686 8344

Model		ADC 1251	ADC 2401	P80	P360	P250
Print mechanism type		DM	DM	DM	DW	DM
Line or character		Both	CR	CR	CR	CR
Speed cps	Max	125	240	80	17	250
	Min					
Lines/min	Max	70		60		120
	Min					
Characters/line	80					
	132					
	other		136	120	198	
Characters/inch	horizontal	10	10	10/12	10	10/12/15
Lines/inch	vertical	6	6	6	6	6/8
Proportional spacing						
Bidirectional printing						
Justification						
Multiple copies				3	5	4
Ballistic head						
Matrix format		7x9	7 or 9x9			9x7
Change print size						
Change type font						
No. in character set		96	96	96	100	96
Headlife (million chrs)		100	200	100		300
Descenders			on 9x9			
Underlining						
Ribbon life (million chrs)	normal	0.5	1.6	2		2
	carbon					
Mobius loop type?						
Graphics						
Bidirectional movement						
Pin feed						
Tractors						
Dual tractor						
Paper widths	Min	2½	4			
	Max	10½	15½	9½	15.5	
Friction feed						
Sheet feeder						
Paper cutter						
Serial interface						
Max baud rate		19,200	19,200	9600		19,200
Buffer	Opt.	2.8k				2
	Fixed	750	10k	256		0.5k
Parallel interface						
Parallel transfer rate (ch/sec)						
Self-test						
VFU						
Switchable forms length						
Punched tape						
8 Channel cartridge						
Electronic + No. channels						
Paper-out sensor						
Measurement in inches	width			16.3	20	24
	depth			10	13	17.7
	height			6	5.5	8.27
Approx weight (lbs)				15	26	50
Cost		£560	£1350	£450	£650	£1300

Key:
 DM Dot Matrix PH Print Head
 DW Daisy Wheel P Pressure Sensitive
 DR Drum E Electro Sensitive
 SW Spin Wheel TH Thermal
 GB Golf Ball * Half Space Facility
 CM Comb ■ Optional
 CH Chain □ Standard

PRINTERS UPDATE

	Anderson Jacobson Slough 25172			Dataplus 0245 30030	DRG (0934) 415 398	Diablo (04862) 71337	Epson 01-422 5612		
Model	AJ880	AJ860	AJ832	TX-80 Grafrax	Star- writer	Citizen 5700/5800	630	MX-80	
Print mechanism type	DM	DM	DW	DM	DW	DM	DW	DM	
Line or character	CR	CR	CR	CR	CR	L	CR	L	
Speed cps	Max	40	120	30	150	25	120/180	40	80
	Min	30	30	15				32	
Lines/min	Max				70				105
	Min								46
Characters/line	80								
	132								
	other	218		158		224	198 @ 15cpi		
Characters/inch	horizontal	10-16.5	10	10/12	10	10/12	10/12/16.5	10/12/15	10-16.5
Lines/inch	vertical	2-12	6	6	6/8	6/8	6/8		8-72
Proportional spacing									
Bidirectional printing									
Justification									
Multiple copies		5		5	4	4			
Ballistic head									
Matrix format		7x5			7x5, 7x7		9x9		9x9
Change print size									
Change type font									
No. in character set		96	128	96	96	96	96	128	96
Headlife (million chrs)				2	50				100
Descenders									
Underlining									
Ribbon life (million chrs)	normal			0.5	2			3	3
	carbon			0.1				0.235	
Mobius loop type?									
Graphics									
Bidirectional movement									
Pin feed									
Tractors									
Dual tractor									
Paper widths	Min	2.5	2.7	2		5			4
	Max	14.5	14.5	15	10	15	17	16.5	10
Friction feed									
Sheet feeder									
Paper cutter									
Serial interface									
Max baud rate		9600	1200	300	9600			9600	9600
Buffer	Opt.	700		2000				2k	
	Fixed		350	256		256		768	Line
Parallel interface									
Parallel transfer rate (ch/sec)					9600				
Self-test									
VFU									
Switchable forms length									
Punched tape									
8 Channel cartridge									
Electronic + No. channels						TOF			
Paper-out sensor									
Measurement in inches	width	22	23.5	23	12.5	24	24.8	22.5	14.7
	depth	16.4	10.5	23	15.5	14	15.7	18.25	12
	height	6.5	21.5	34	5	8	8.1	8.25	4.2
Approx weight (lbs)		22	43	90*	20	40	50	60	12
Cost		£699-899	to £2045	£2350	£295	£1185	£1295-1495	£1675	£425

Key:
 DM Dot Matrix
 DW Daisy Wheel
 DR Drum
 SW Spin Wheel
 GB Golf Ball
 CM Comb
 CH Chain

PH Print Head
 P Pressure Sensitive
 E Electro Sensitive
 TH Thermal
 * Half Space Facility

Optional
 Standard

*inc stand
 Grafrax option £40
 Any int. other than Centronics £40

PRINTERS UPDATES

Facit
(0634) 401721

General
Electric
01-702
4100

Mannesman Tally
0734 580141

Model	4520-21	IPS 5000/80	4525	IPS 5000/132	4526	Terminet 2030	M80 MC	MT1602
Print mechanism type	DM	DM	DM	DM	DM	DM	DM	DM
Line or character	CR	CR	CR	CR	CR	CR	CR	CR
Speed cps	Max 100	125	150	125	150	60	200	160
	Min					10	140	
Lines/min	Max 60							
	Min							
Characters/line	80						@ 10cpi	
	132						@ 16cpi	
	other							
Characters/inch	horizontal 12	10	10	10	10	10/13.2/16.5	10-16.5	10
Lines/inch	vertical 6	6/8	6/8	6/8	6/8	2-12	6/8	6/8
Proportional spacing								
Bidirectional printing								
Justification								
Multiple copies							6	6
Ballistic head								
Matrix format	9x7	9x9	9x9	9x9	9x9	9x7	7x7,9x7,9x9	
Change print size								
Change type font								
No. in character set	108	96	96	96	96	128	128	96/192
Headlife (million chrs)	100	200	200	200	200		100	200
Descenders								
Underlining								
Ribbon life (million chrs)	normal 6	10	10	10	10	3	5	2
	carbon							
Mobius loop type?								
Graphics								
Bidirectional movement								
Pin feed								
Tractors								
Dual tractor								
Paper widths	Min 8.6	3	3	3	3	2	4.5	4
	Max	11.5	11.5	15	15	15	8.5	15
Friction feed								
Sheet feeder								
Paper cutter								
Serial interface								
Max baud rate	9600	9600	9600	9600	9600	1200	9600	9600
Buffer	Opt. 712	2k	2k			4k	1k	
	Fixed			2k	2k	516		655
Parallel interface								
Parallel transfer rate (ch/sec)								100k
Self-test								
VFU								
Switchable forms length								
Punched tape								
8 Channel cartridge								
Electronic + No. channels								
Paper-out sensor								
Measurement in inches	width 14.6	18.3	18.3	24	24	22	22	25
	depth 6	14	14	14	14	18.5	18.5	19.7
	height 15.6	7	7	7	7	5.5	8.7	8.7
Approx weight (lbs)	21	30	30	35	35	22	48	66
Cost	£583	£774	£938	£910	£1052	n/a	n/a	n/a

Key:
 DM Dot Matrix PH Print Head
 DW Daisy Wheel P Pressure Sensitive
 DR Drum E Electro Sensitive
 SW Spin Wheel TH Thermal
 GB Golf Ball * Half Space Facility
 CM Comb Optional
 CH Chain Standard

PRINTERS UPDATE

Mannes-
man Tally
0734
580141

Pertec
(0734) 582115

Qume
(0734)
584646

Roxburgh
079 73 3777

Model	TZ200 Q	P80	P360	P250	Sprint 3/45	8480C-FF	8480C-TF
Print mechanism type	DM	DM	DW	DM	DW	DM	DM
Line or character	L	CR	CR	CR	CR	CR	CR
Speed cps		80		250		100	100
Max							
Min			17		45		
Lines/min				100			
Max	200						
Min	125	52					
Characters/line	80						
132							
other		120 opt	158/198	158/198			
Characters/inch horizontal	10	10	10/12/15	10/12/15	10/12	10	10
Lines/inch vertical	6/8	6	6	6/8	6/8	6/8/12	6/8/12
Proportional spacing							
Bidirectional printing							
Justification							
Multiple copies	6	4	6	6		2	2
Ballistic head							
Matrix format	7x8,7x10 5x7,5x9	7x9		7x9		9x7	9x7
Change print size							
Change type font						PROM	PROM
No. in character set	96	96	100	96	96	224	224
Headlife (million chrs)		100	50	100	20	100	100
Descenders							
Underlining							
Ribbon life (million chrs)	normal carbon	12	2	3.5	2	0.2	2
Mobius loop type?							
Graphics							
Bidirectional movement							
Pin feed							
Tractors							
Dual tractor							
Paper widths	Min						2.5
Max	4	10	15.5	15.75	15	10	10
Friction feed							
Sheet feeder							
Paper cutter						T e a r b a r	
Serial interface							
Max baud rate	9600	9600		19,200		4800	4800
Buffer	Opt.			2k			
Fixed	1k	256	1k	512		80	80
Parallel interface							
Parallel transfer rate (ch/sec)	100k						
Self-test							
VFU							
Switchable forms length							
Punched tape							
8 Channel cartridge							
Electronic + No. channels							
Paper-out sensor							
Measurement in inches	width	28	16.3	21	24	22.5	
depth	24.5	10.2	13	18	13.5		
height	11	6	5.5	8.3	7		
Approx weight (lbs)	110	16	29	55	28	19	21
Cost	n/a	£478	£666	£1311	\$1900	£253	£280

Key:
DM Dot Matrix
DW Daisy Wheel
DR Drum
SW Spin Wheel
GB Golf Ball
CM Comb
CH Chain
PH Print Head
P Pressure Sensitive
E Electro Sensitive
TH Thermal
* Half Space Facility
Optional
Standard

Both available in
March 1981

In the microcomputer jungle The Sharp MZ-80 system now with



Since its introduction, the Sharp MZ-80 system has proved to be one of the most versatile systems in the micro jungle, for commerce, industry and enthusiasts alike.

Now the MZ-80 Computer system has even more versatility thanks to CP/M[™], giving greater adaptability to face the future. After all look what happened to the Dinosaur.



The MZ-80 system is made up of the MZ-80K computer with the powerful Z-80 microprocessor. MZ-80FD Floppy Disc storage unit, now with CP/M[™] for even greater versatility. MZ-80P3 dot printer producing ultra Sharp print out copy.

CP/M[™] is a Trade Mark of Digital Research Ltd and was developed by Crystal Electronics, Torquay.

survival depends on adaptability. CP/M has even greater versatility.



Your Sharp Microcomputer Dealers

AVON
BCG SHOP EQUIPMENT LTD - BRISTOL -
TEL: 0272 425338
DECIMAL BUSINESS M/CS LTD - BRISTOL -
TEL: 0272 294591
BEDFORDSHIRE
ISHERWOODS (H.B. COMPUTERS) LTD -
LUTON - TEL: 0582 416202

BERKSHIRE
BCG SHOP EQUIPMENT LTD - READING - TEL: 0734 54015
NEWBEAR COMPUTING STORE LTD - NEWBURY -
TEL: 0635 30505
BUCKINGHAMSHIRE
INTERFACE COMPONENTS LTD - AMERSHAM -
TEL: 02403 22307
CHESHIRE
CASH REGISTER SERVICES - CHESTER - TEL: 0244 317549
FLETCHER WORTHINGTON LTD - HALE - TEL: 061-928 8928
NEWBEAR COMPUTING STORE LTD - HEADLE HEATH,
STOCKPORT - TEL: 061-491 2290

CLEVELAND
HUNTING COMPUTER SERVICES LTD - STOCKTON -
TEL: 0642 613021

DEVON
BCG SHOP EQUIPMENT LTD - PAIGNTON - TEL: 0803 557711
CRYSTAL ELECTRONICS LTD - TORQUAY - TEL: 0803 22699
PETER SCOTT (EXETER) LTD - EXETER - TEL: EXETER 73309

DORSET
SOUTH COAST BUSINESS M/CS - FERNDOWN, DORSET -
TEL: 0202 893040

ESSEX
PROROLE LTD - WESTCLIFFE ON SEA - TEL: 0702 335298

GLOUCESTER
GLOUCESTERSHIRE SHOP EQUIPMENT LTD -
GLOUCESTER - TEL: 0452 36012

LANCASHIRE
B & B (COMPUTERS) LTD - BOLTON - TEL: 0204 26644
MICRODIGITAL LTD - LIVERPOOL - TEL: 051-227 2535
SUMMITA ELECTRONICS LTD - PRESTON - TEL: 0772 55065
SUMLOCK SOFTWARE LTD - MANCHESTER -
TEL: 061-228 3502

LEICESTERSHIRE
ARDEN DATA PROCESSING - LEICESTER - TEL: 0533 22255
GILBERT COMPUTERS - LUBENHAM - TEL: 0858 65894
LINCOLNSHIRE
HOWES ELECT. & AUTOM. SERVS. WASHINGTON -
TEL: LINCOLN 32379

LONDON
C.S.S. BUSINESS EQUIPT LTD - LONDON - E8 -
TEL: 01-836 1176

CENTRAL CALCULATORS LTD - LONDON - EC2 -
TEL: 01-729 5588
DIGITAL DESIGN & DEVELOPMENT - LONDON - W1 -
TEL: 01-387 7388
EURO-CALC LTD - LONDON E.C.2 - TEL: 01-729 4555
EURO-CALC LTD - LONDON W.1 - TEL: 01-636 5560
EURO-CALC LTD - LONDON W.C.1 - TEL: 01-405 3113
JAXREST LTD - LONDON EC1 - TEL: 01-403 1801
LION COMPUTER SHOPS LTD - LONDON W.1 -
TEL: 01-637 1601
PERSONAL COMPUTERS LTD - LONDON - TEL: 01-626 8121
SCOPE - LONDON EC2M4HX - TEL: 01-247 8506
SUMLOCK BONDAIN LTD - LONDON EC1R 0AA -
TEL: 01-253 2447
VIDEO SERVICES (BROMLEY) - TEL: 01-460 8833
CREAM COMPUTER SHOP - HARROW - TEL: 01-380 0833

NORFOLK
SUMLOCK BONDAIN (EAST ANGLIA) LTD - NORWICH -
TEL: 0934 742184

NORTHAMPTONSHIRE
HB COMPUTERS LTD - KETTERING - TEL: 0536 83922

NOTTINGHAMSHIRE
KEEN COMPUTERS - NOTTINGHAM - TEL: 0602 583254
MANSFIELD BUSINESS M/CS LTD - MANSFIELD -
TEL: 0623 26610

OXEN
MODES SCIENTIFIC CONSULTANCY - OXFORD -
TEL: 0865 45172

SALOP
COMPUTER CORNER - SHREWSBURY - TEL: 0743 55166

SOMERSET
NORSETT OFFICE SUPPLIES LTD - CHEDDAR -
TEL: 0934 742184

SUFFOLK
MICROTEK - IPSWICH - TEL: 0473 50152

SURREY
PETALLECT ELECTRONIC SERVICES
WOKING - TEL: 04862 69032
R.B.M. DATA SERVICES
CROYDON - TEL: 01-684 1134
BARNES CONSULTANTS - GUILDFORD
SARADAN ELECTRONICS SERVICES -
WALLINGTON - TEL: 01 669 9483

T & V JOHNSON (MICROCOMPUTERS) - CAMBERLEY -
TEL: 0276 20446

SUSSEX
M & H OFFICE EQUIPMENT - BRIGHTON -
TEL: 0273 697231

TYNE & WEAR
P.M.S. LTD - SUNDERLAND - TEL: 0783 480009

WALES
CITY RADIO - CARDIFF - TEL: 0222 28169
SIGMA SYSTEMS LTD - CARDIFF - TEL: 0222 21515

WEST MIDLANDS
CAMDEN ELECTRONICS - SMALL HEATH (BIRMINGHAM) -
TEL: 021-773 8240
E.B.S. LTD - BIRMINGHAM - TEL: 021-233 3045
JAXREST LTD - BIRMINGHAM - TEL: 021-328 4908
NEWBEAR COMPUTING STORE LTD - BIRMINGHAM -
TEL: 021-707 7170
POINTCRAFT - BIRMINGHAM - TEL: 021-233 2325

YORKSHIRE
DATRON INTERFORM LTD - SHEFFIELD - TEL: 0742 585490
BITS & P.C.'S - WETHERBY, W YORKSHIRE - TEL: 0937 63744

SCOTLAND
A & G KNIGHT - ABERDEEN - TEL: 0224 630526
BUSINESS & ELECTRONIC M/CS - EDINBURGH -
TEL: 031-226 5454
FORTRONIC LTD - DUNFERMLINE - TEL: 0383 823121
STRATHAND LTD - GLASGOW - TEL: 041-552 6731

NORTHERN IRELAND
O & M SYSTEMS - BELFAST 49440

EIRE
TOMORROWS WORLD LTD - DUBLIN 2 -
TEL: 00001 776861

ISLE OF MAN
DELTA SYSTEMS LTD - DOUGLAS - TEL: 0624 4586

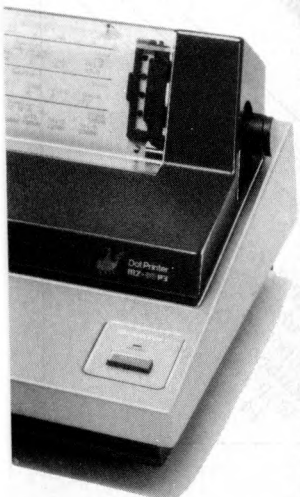

COMPUTER APPLICATIONS

Find out today what a Sharp Microcomputer will do for you.

Personal Computer

BINDERS KEEPERS LOSERS WEEPERS

Half the people you meet today are not preoccupied with pollution, perversion or persecution. It's worse than that — they've lost a copy or two of PCW and don't know where to find replacements.

So keep *your* copies of PCW in a beautiful bright yellow binder. £2.95 worth of smart security.

Just check the coupon at the foot of the page.

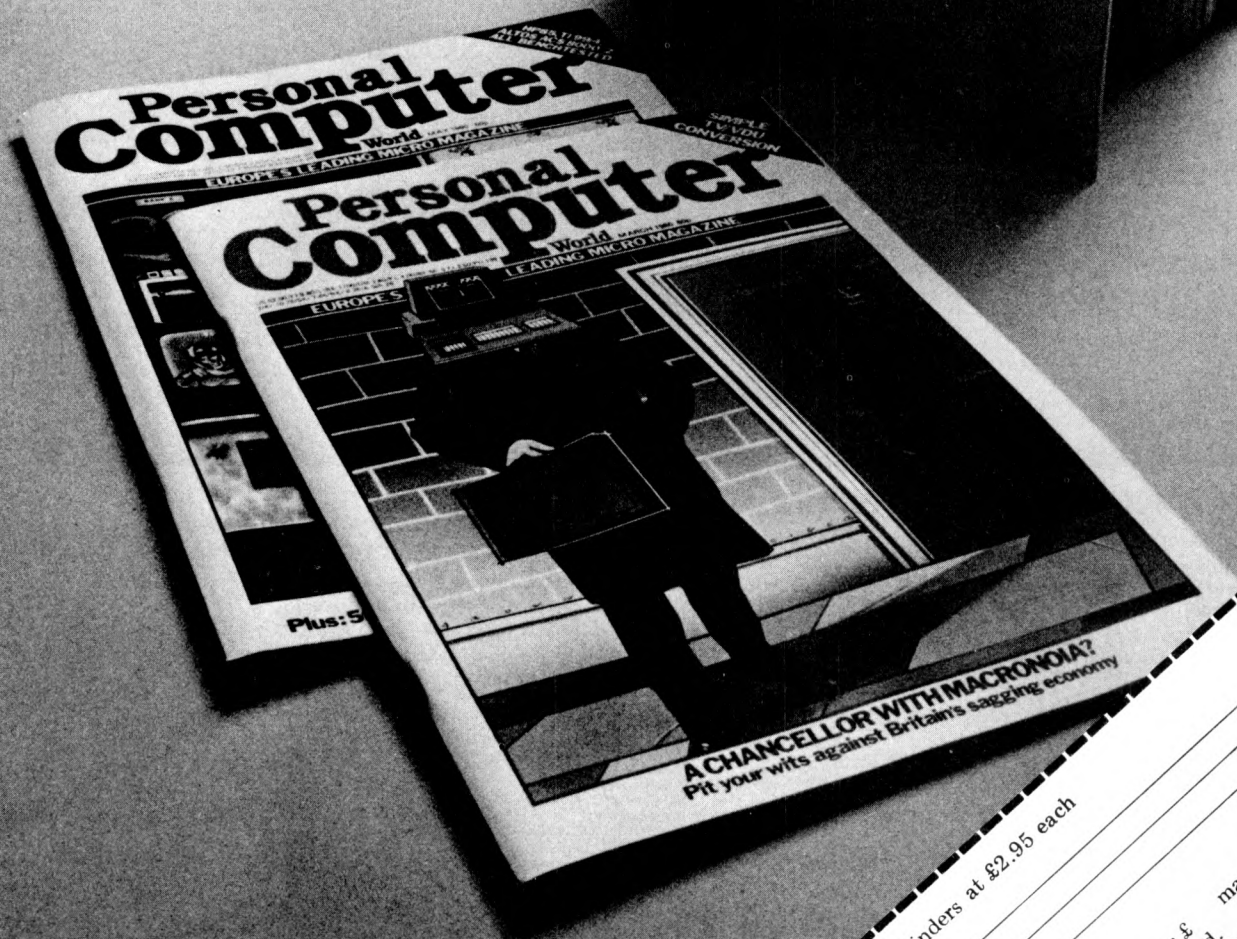
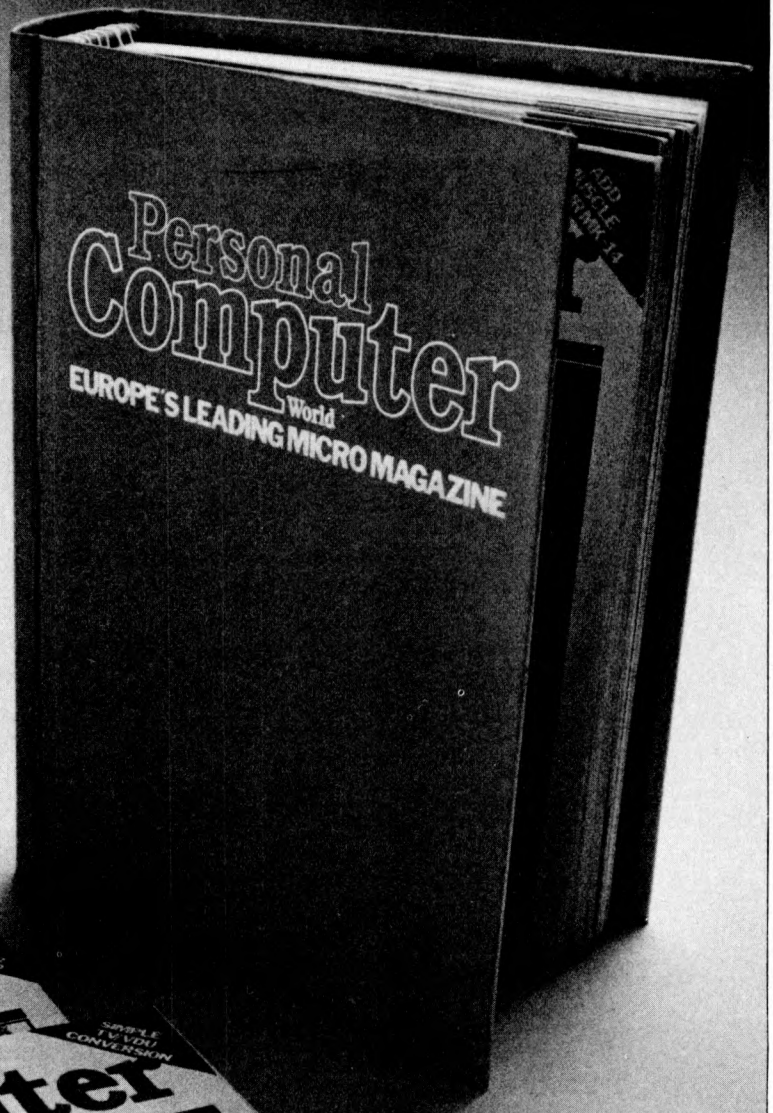

Please send me — PCW Binders at £2.95 each

NAME _____
ADDRESS _____

(Block capitals please)

I enclose cheque/P.O. for £ _____ made payable to
Sportscene Publishers Ltd.
Send coupon to PCW (Binders),
14 Rathbone Place, London
W1P 1DE. Allow at least
14 days for processing.

Joanne loves MAVIS



One of the nicest applications of microelectronics is to the problems of the handicapped. For the first time in history the blind can 'see', the deaf can 'hear' and the mute can 'speak'. Here is one example of such an aid.

Julia Howlett reports.

Joanne is five years old and a severe spastic — she's unable to speak or make controlled movements, which poses many problems for a bright youngster, both at school and at play. Until February this year Joanne's main means of communication was by eye movement, pointing at symbols, which she manages very successfully and at great speed. She was also at that time just learning to use a switch-operated typewriter called POSSUM. The input to a POSSUM can be varied according to the type of disability and in Joanne's case, I think, she was using two buttons in the beginning.

Since February, Joanne has been the proud user of another device, called MAVIS (Microcomputer-based Audio/Visual Information System). This is a specially-designed personal computer, developed at the National Physical Laboratory in conjunction with Loughborough University, under the guidance of the late Dr Chris Evans, and funded by BP. Trials so far have been very successful and all the prototypes currently under test have been built to full production specification. Joanne is one of those taking part in these field trials.

MAVIS was designed to enable the development of handicapped children through both formal education and through play. Until recently Joanne has used the system mainly for play, manipulating colours on the attached TV screen and making tunes with the built-in music function. As her skills develop, she'll be able to have a go at drawing and take part in computer games with the rest of her family.

Joanne's formal schooling began in

autumn 1980 and to prepare for this her teachers were given instruction in the system's use. MAVIS enables her to achieve a greater degree of independent communication than was ever possible using the eye-pointing method. Joanne manipulates a switch rather like a windscreen wiper to select from coloured symbols displayed on the TV screen and for the first time in her life she finds that she can scribble and 'turn' the pages of a book. This sort of activity is very encouraging for Joanne and gives her the motivation to explore the system further. Who knows — there's no reason why MAVIS shouldn't be used to send electronic signals to any device capable of acting on them. Remote control of moving toys seems like an ideal application for a child like this. The possibilities are clearly endless.

One of the good things about MAVIS is that it doesn't need a computer specialist hovering around. Mums and dads, teachers and kids are all able to use it with very little training. At the same time there's no reason why someone who's interested shouldn't write their own programs, thus widening the potential still further. Standard offerings are word processing, games, music facilities, environmental remote control, switch control and wordstore typing packages. Since parents and teachers are not always willing or able to prepare software packages, the aim is to give the user maximum independence by providing these prewritten packages. The system is easily portable (thank goodness for micros!), providing the maximum continuity between Joanne's home and school environments. In effect this is Jo's electronic exercise

book and is both simple and enjoyable to operate.

Another MAVIS system has been installed at Banstead Place assessment centre, which caters for several disabled school leavers who are experiencing difficulties in going on to further education or employment. Banstead uses the system for a variety of purposes including assessment, in which the screen equivalent of a form can be filled in by students who would be unable to do this in any other way without help. It is used in teaching both literacy and numeracy as well as specific topics such as the Highway Code. Since television has been the main source of out of school entertainment, the arrival of MAVIS has been something of a welcome relief since it offers the opportunity to play games and really communicate with each other.

Results coming in from these trials are being used to influence future MAVIS developments and will be of great benefit when planning the use of computers for the disabled. These devices will become a fundamental part of the lives of disabled people around the world, being used at home, at work and in their recreational activities. And Jo, with her parents, is a pioneer in these new techniques. Watching her progress will reveal vital information in the struggle of all disabled people to achieve independence and minimise their frustration.

If you know of an area in which microelectronics could be used to help the disabled, turn to page 71 for details of an essay competition in which you could win £100.

Comart Approved Dealers

Belfast
O & M Systems
95 Dublin Road
Tel: 0232 49440

Birmingham
Byteshop Computerland Ltd
94/96 Hurst St, B5 4TD
Tel: 021 622 7149

Cambridge
Cambridge Computer Stores
1 Emmanuel St, CB1 1NE
Tel: 0223 68155

Cornwall
Benchmark Computer
Systems Ltd
Tremena Manor
Tremena Road
St Austell, PL25 5GG
Tel: 0726 610000

Dublin
Lendac Data Systems Ltd
8 Dawson St
Tel: 0001 372052

Glasgow
Byteshop Computerland Ltd
Magnet House
61 Waterloo St, G2 7BP
Tel: 041 221 7409

Leeds
Holdene Ltd
Manchester Unity House
11/12 Rampart Road
Woodhouse St
Tel: 0532 459459

London
Byteshop Computerland Ltd
48 Tottenham Court Road,
W185 4TD
Tel: 01 636 0647

Digitus
9 Macklin Street
Covent Garden WC2
Tel: 01 405 6761

Jarrogate
67 Tulsemere Road,
West Norwood,
London SE17
Tel: 01-670 3674

Manchester
Byteshop Computerland Ltd
11 Gateway House
Piccadilly Station Approach
Tel: 061 236 4737

NSC Computers
29 Hanging Ditch
Tel: 061 832 2269

Newbury
Newbear Computing Store
40 Bartholomew St
Tel: 0635 30505

Nottingham
Byteshop Computerland Ltd
92A Upper Parliament St,
NG1 6LF
Tel: 0602 40576

Sheffield
Hallam Computer Systems
451 Eccleshall Road, S11 9PN
Tel: 0742 663125

Southampton
Xitan Systems
23 Cumberland Place,
SO1 2BB
Tel: 0703 38740

Sudbury
Eurotec Consultants
Holbrook Hall
Little Walingford
Tel: 0206 262319

Warwicks
Business & Leisure
Microcomputers
16 The Square
Kenilworth
Tel: 0926 512127

Watford
Lux Computer Services
108 The Parade
High Street
Watford WD11 2AW
Tel: 0923 29513

Comart Microcomputer dealers are located strategically throughout the country to give support, guidance and assistance. In the event of difficulty contact Comart direct.

comart communicator

The clean simplicity outside...

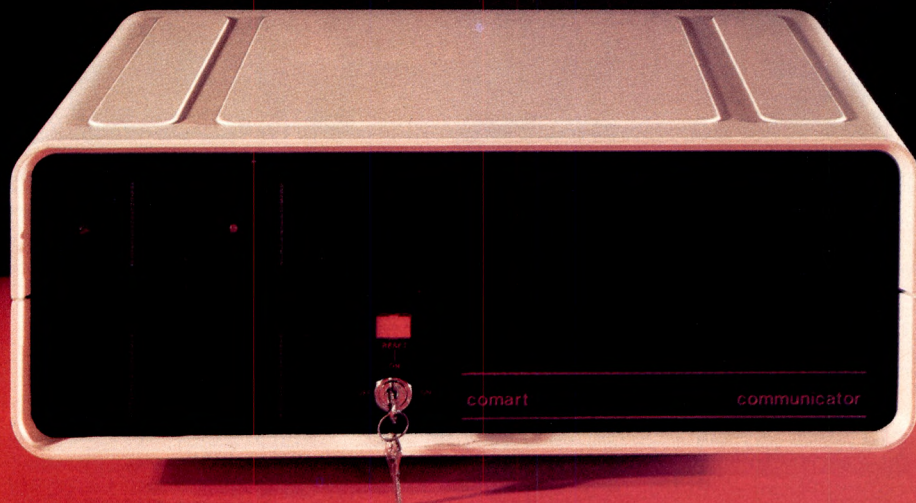

...conceals the pedigree inside.

Comart's CP 100 Communicator is the new British designed, British made Microcomputer from Comart. It is the result of a carefully conceived development programme. It exploits Comart's first hand experience of the British computer market, and their growing strength as a manufacturer.

CP100 is the first of a new generation of flexible, expandable micros specifically developed to suit British operating conditions and communication requirements.

The clean lines outside, conceal the power within; its S-100 bus means wide ranging peripheral support, and simple after sales care. And, that's not all. Communicator is built to keep your future options open. It's ready for Prestel, asynchronous, and synchronous operation. It has expandable memory capability and yet it's price competitive as a stand-alone system with its CP/M™ operating system, and support software.

Find out more about Communicator today.

The U.K. Leaders in Microcomputer
Development, Application and Support.

comart

St Neots HUNTINGDON Cambs PE19 2AF
Tel (0480) 215005 Telex: 32514 Comart G.

Unique in concept—the home computer that grows as you do!

The Acorn Atom

£120

plus VAT and p&p

Special features include

- * FULL SIZED KEYBOARD
- * ASSEMBLER AND BASIC
- * TOP QUALITY MOULDED CASE
- * HIGH RESOLUTION COLOUR GRAPHICS*

* optional



Also available ready-built
£150
plus VAT and p&p

● The picture shows mixed graphics and characters in three colours

The Acorn Atom is a definitive personal computer. Simple to build, simple to operate. A powerful, full facility computer with all the features you would expect. Just connect the assembled computer to any domestic TV and power source and you are ready to begin. (Power requirement: 8V at 800mA). There is an ATOM power unit available – see the coupon below.

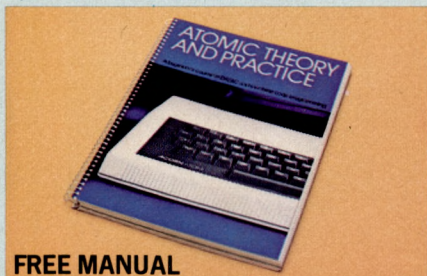

FREE MANUAL

Free with every ATOM, kit or built, is a computer manual. The first section explains and teaches you BASIC, the language that most personal computers and the ATOM operate in. The instructions are simple and learning quickly becomes a pleasure. You'll soon be writing your own programs. The second section is a reference

manual giving a full description of the ATOM's facilities and how to use them. Both sections are fully illustrated with example programs.

The standard ATOM includes:

HARDWARE

- Full-sized QWERTY keyboard
- 6502 Microprocessor
- Rugged injection-moulded case
- 2K RAM
- 8K HYPER-ROM
- 23 integrated circuits and sockets
- Audio cassette interface
- UHF TV output
- Full assembly instructions

SOFTWARE

- 32-bit arithmetic ($\pm 2,000,000,000$)
- High speed execution
- 43 standard/extended BASIC commands
- Variable length strings (up to 256 characters)
- String manipulation functions
- 27 x 32 bit integer variables
- 27 additional arrays
- Random number function
- PUT and GET byte
- WAIT command for timing
- DO-UNTIL construction
- Logical operators (AND, OR, EX-OR)
- Link to machine – code routines
- PLOT commands, DRAW and MOVE

The ATOM modular concept

The ATOM has been designed to grow with you. As you build confidence and knowledge you can add more components. For instance the next stage might be to increase the ROM and RAM on the basic ATOM from 8K + 2K to 12K + 12K respectively. This will give you a direct printer drive, floating point mathematics, scientific and trigonometric functions, high resolution graphics.

From there you can expand indefinitely. Acorn have produced an enormous range of compatible PCB's which can be added to your original computer. For instance:

- A module to give red, green and blue colour signals
 - Teletext VDU card (for Prestel and Ceefax information)
 - An in-board connector for a communications loop interface – any number of ATOMs may be linked to each other – or to a master system with mass storage/hard copy facility
 - Floppy disk controller card.
- For details of these and other additions write to the address below.



ACORN COMPUTER 4a Market Hill, CAMBRIDGE CB2 3NJ

Your ACORN ATOM may qualify as a business expense. To order complete the coupon below and post to Acorn Computer for delivery within 28 days. Return as received within 14 days for full money refund if not completely satisfied. **All components are guaranteed with full service/repair facility available.**

Please send me the following items:

Quantity	Item	Item price inc. VAT+p&p	TOTALS
	ATOM KIT – 8K ROM + 2K RAM (MIN)	@ £140.00	
	ATOM ASSEMBLED – 8K ROM + 2K RAM (MIN)	@ £174.50	
	ATOM KIT – 12K ROM + 12K RAM (MAX)	@ £255.00	
	ATOM ASSEMBLED – 12K ROM + 12K RAM (MAX)	@ £289.50	
	1K RAM SETS	@ £11.22	
	4K FLOATING POINT ROM (inc in 12K Version)	@ £23.30	
	PRINTER DRIVE 6522 VIA	@ £10.35	
	(inc in 12K version) LS244 Buffer	@ £3.17	
	MAINS POWER SUPPLY (1.3 amps)	@ £10.20	
	TOTAL		

To: Acorn Computer Ltd., 4a Market Hill, CAMBRIDGE CB2 3NJ

I enclose cheque/postal order for £ _____

Please debit my Access/Barclaycard No. _____

Signature _____

Name (Please print) _____

Address _____

Telephone No. _____

Registered No: 1403810. VAT No: 215 400 220

PCW/1/81



We've made it....

A 315K Disk Unit to Plug Directly Into Your Sorcerer for only £599.00 Complete



Coloured and styled to match your existing Exidy equipment this disk unit comes complete with its own internal power supply, connecting cable, software and full documentation—just plug it directly into the 50 way edge connector on your Sorcerer. Expansion is possible for up to three add on drives allowing a maximum on-line capacity of over 1 Megabyte. The single master drive will give you 315,000 bytes of formatted storage per disk.

Features include:

- ★ CP/M Operating System
- ★ Microsoft Extended Basic
- ★ Z-80 Assembler
- ★ Full Documentation
- ★ 315K Formatted Storage
- ★ Up to Three Add-On Drives
- ★ Micropolis Drive Mechanism
- ★ Complete and Ready to Run

★ ASK YOUR DEALER FOR A DEMONSTRATION

Contact Geoff Wilkinson
for further information.
Telephone: (0736) 798157

LIVEPORT
DATA PRODUCTS

The Ivory Works, St. Ives, Cornwall TR26 2HF
Telephone: (0736) 798157

Please send me further details of the FDM 180 DISK UNIT

Name _____

Address _____

Tel No. _____

SECRETS OF SYSTEMS ANALYSIS

PART 5: CHOOSING A MACHINE

So far in her series about installing a microcomputer in a business, Lyn Antill has described the lengthy but very necessary decision-making processes which you should go through before even looking at actual computers. This month, Lyn discusses the next decision-making stage — finding the computer which best suits your application.

As I pointed out at the end of the previous article, you cannot isolate the choice of the machine from the choice of the software that operates on it. The two are complementary — only the complete computer system can solve your problems. Having said this, however, I shall be dealing with the two separately, partly for reasons of space but partly also because the micro and the software may be coming from different sources.

Background material

Now, it goes without saying that you've been reading all the *PCW* Benchtests and if you've succeeded in digesting all that material then you probably feel like a walking encyclopaedia on the subject of microcomputer hardware. Or do you? Perhaps you actually feel more confused than ever. The very fact that a Benchtest tries to answer everybody's questions makes it less likely that it will give a full answer to the questions you are asking. It's possible that you don't agree with all the answers. Even if the reviewer likes the documentation, for example, it doesn't necessarily mean that you will. Again, reviews are written soon after the machines make their first appearance and there are often teething troubles which are later ironed out, giving the impression that the machine is less reliable than it turns out to be in practice.

Reviews of machines won't tell you what you should buy but they do have several useful functions:

- they introduce you to what's on the market;
- they highlight some of the good and bad features;
- they give an indication of the sorts of questions that should be asked;
- they contain factual information about the machines and the suppliers.

Other people's machines

There's nothing quite like seeing a thing working to decide whether or not you like it. Of course, with a micro we come back to the problem of distinguishing between what is specific to the machine

and what to the program, but some things can be clearly distinguished. If you don't like certain messages that appear on the screen, then that is the fault of the program, as it is when calculations are not done to your liking, or files kept quite as you want them. Other features are obviously those of the machine — the amount of noise it makes, its size, portability, robustness and physical appearance.

For other features, the causes may not be so obvious. A program may appear to be slow and for this there is a variety of possible causes — a slow machine, inefficient programming, inefficient language (Basic programs are slower than programs in compiled languages, such as Cobol), slow VDU, or it may just be that the program is doing lots of things you didn't know about. (The converse is true of many demonstration programs which are doing very little that is not immediately apparent on the screen, thus appearing very quick and efficient.) Many machines come with the screen built-in and so you are stuck with what's offered, but others can be attached to a variety of terminals — in which case, don't judge the quality of the micro by the VDU, and vice versa.

Another thing that can only be assessed on a working machine is the keyboard and anyone who spends a lot of time at a keyboard is very fussy about the feel of the keys and their layout. For example, some of the terminals at the Polytechnic where I work have the 'Break' button very close to the 'Return' and students are continually disconnecting themselves because their finger slipped. Silly things like this can lead to great irritation and time-wasting.

Good features on a keyboard, like function keys and cursor control, are only good if your program uses them. CAP-CPP, for example, writes for a very wide range of machines, so its programs ignore features such as these as it cannot rely on any particular machine having them, or using them in the same way. The same is true of many bought programs. So don't be carried away by the salesman's raptures — ask to see how you yourself will be able to make use of any special features and decide if that

usefulness is worth the extra price. If the keyboard will be used by someone else (eg your secretary), then let him/her make the decision.

If someone else likes — or dislikes — their machine, this does not oblige you to agree with them. For instance, at the Polytechnic we've recently bought some Ithacas and we have all been struck by the same feature — the row of switches and flashing lights. The computer scientists were ecstatic, and I was horrified. Now I don't want to say that the Ithaca is either good or bad, merely that different people look for different things and that the sort of non-computer business people I work with do not usually want to be reminded that the nice little black box that does the accounts is actually a *computer*.

Micro shops

The marvellous thing about micros, as opposed to any other sort of computer, is that you can just go into a shop and look at them. So make sure you do just that! Have a good look, chat to the salesman, collect all the free sales literature you can. You can only make a good choice if you know what is available and who you like to deal with.

There are two extremes of reaction to avoid. Either the thought of having to computerise is so awful, or you are so shy, that you can't face the thought of having to go through the door more than once and, afraid to ask too many questions, you take the first system that appears to do the job. Or else you are so enthralled by the first system you see that you never ask whether there is anything else that can do the job better or cheaper. Just remember that it is your money you are parting with, for the hardware *and* the software, and even more for the time it takes to get your own work set up and running on the new machine. Your time and effort won't appear on any bill but it could be the greatest cost of all.

In London we have a wealth of micro shops — no doubt this is true of other large cities — but not everyone is so fortunate. At the *PCW* show I met a businessman from the Channel Islands who was sure he would be buying a PET simply because they were the only machines offered on his island. It was

only a short flight to the Apple dealer but if the computer went wrong at the start of a foggy spell his business would grind to a halt because the serviceman would not be able to fly over. Still, if he only knew what other shops were offering he would be able to keep his PET dealer up to the mark and would know what he could reasonably expect of him in terms of delivery, support, etc.

Talking to salesmen

We all know the caricature of the salesman — fast talking, only interested in taking your cash, telling you all the good things you didn't want to know and ignoring all the bad things you did, or trying to bulldoze you into buying something you don't know you want. Sue Eisenbach tells the story of a time she went to collect a machine for a Benchtest and was having a very interesting conversation with the guy in the shop when she happened to mention that she wanted to buy some equipment. Instantly he went into 'sales mode', stopped talking to her as an intelligent human being and went into his standard patter, even forgetting to mention that the machine he was offering her wasn't even working properly!

Of course, not all salesmen are like this. I know some who are super — really trying to find out their customers' needs and provide the best equipment, advice and support. These are the ones who stay in business.

But even the best salesman cannot meet your requirements if he doesn't understand them, which is why you should have armed yourself with your list of user requirements, constraints and ideas for potential solutions. Explain these as concisely as you can, using a 'top down' approach — eg, 'Hello, I'm thinking of buying a computer system.' Well, you *might* have wanted to buy some blank cassettes or to complain about something.

'I run a motor accessories shop which employs two assistants,' tells him that you want a business system rather than a computer game, and also the size of business he's catering for — you don't want a Sinclair, nor something with four terminals.

'I'm having trouble with stock control: we try to record every item that is sold so that we know what to reorder but often find items have been missed off the reorder list so that we are out of stock' — now he knows that you want a stock control system not a payroll, giving him an opening for discussing the way in which the system he offers could solve your problem.

If he says, 'I have the very thing here,' he probably hasn't — he still hasn't got enough information to go on. But even if he *does* say this, you have your list of volumes of transactions, information to be stored, reports to be produced, etc, so that you can ask intelligent questions about the system he is demonstrating.

'How many separate stock items can this record? What analysis of figures can it provide at the end of the day, month, etc?' As you go through the factual questions you will get some of the answers you need. You will also get clues to follow up — supplementary questions, things you weren't sure about, things you didn't like.

If he does go into 'sales mode' and starts reciting that well-rehearsed patter, what should you do about it? That rather depends on how naturally polite you are. Many people find it rather difficult to butt in, preferring to accord a speaker the courtesy of listening to the end, even if he is not telling quite what they wanted to hear. Others are sharp enough to be able to interrupt and get an immediate response, but most of us are likely to feel out-talked.

Perhaps one way of coping with this situation is to listen (after all, there is usually quite a lot of information put into the patter) and to make a mental list of all the things he is *not* telling you. We all do this to TV adverts: 'Most cats prefer. . . ' 'Prefer it to what?' we ask ourselves. Use this technique on the salesman. One can then politely enquire 'What about. . .?', giving him the chance either to fill in the gap in his patter, or to admit that perhaps the system left something to be desired in that respect, and offer some alternative.

Ideally, you want to see a demonstration of the program on the very machine you are being offered, but this is rarely possible. Only a limited number of demonstration machines can be set up in the shop and they will only have small data files. You will have to decide how different machines will fulfil your requirements. There's no easy way of doing this but be a little sceptical of bland assurances and try to make sure that your screen really will be brighter, your disks faster, your print clearer, or whatever.

What can a salesman tell you about a machine?

My technically-minded friends will probably answer 'Not very much!', because they are only thinking about technical information. There will be technical questions to be answered — like 'Can this micro be interfaced with that VDU?' — and a technical expert or a manual will have to be consulted, but there are very important questions that only the salesman can answer:

— 'How much does it cost?' (including all the extras you will need to run the programs you had in mind).

— 'What is the delivery time?' — the time it's actually going to take, rather than the one they quote on the adverts. 'By the time you read this it will be in your shops,' usually implies that the advertiser thinks printing magazines is a very much slower business than it really is. Even when he points to a micro on the shelf, make sure that all the extras are there, too.

— 'What sort of guarantee do you offer?'

— 'What about maintenance contracts?'

— 'Will your engineers install the machine for me and, if so, will there be a charge for this?'

Talking to engineers

This can be very difficult for the businessman — you don't know what questions to ask and, even if you do, you don't know what to make of the answers. My main problem has been that the engineer is primarily interested

in theory rather than practice. For example, if a businessman asks: 'Can this printer be used on that micro?' he actually means 'Is there a standard connector and do you have it in stock?' whereas the engineer is answering the question 'Could it be done?' and not thinking too much about whether he could find the time to work out the connection and wait for the required parts to be delivered.

The only real advice I can give (apart from continuing to increase your own technical knowledge by reading *PCW*) is to decide what questions you really want to have answered and to stick at it until you get answers.

'What is the mean time between failures of this product?' (ie, how long, on average, does this work before going wrong?). In fact, this is a difficult question to answer because so many of the products being sold are new on the market and there has not been time to gather such statistics.

'How long does it take to repair the most common faults on this product?' (including the time it takes the engineer to get there and to obtain spare parts if necessary).

'Is there a standard connection between the micro and this printer (VDU, disk drive, etc)?'

'Have you actually got this configuration working somewhere?'

The practical problems that arise when setting up a microcomputer system are frequently trivial and irritating and can be very time-consuming both in engineer hours and in working hours lost on the micro. If your engineer already has this configuration working in a few other places, you know that he should be able to get yours up, too. This may well influence your choice of machine, if the advantage for you of having the thing up and running quickly outweighs the advantage of the updated version that your engineer hasn't tried yet (but is dying to have a chance to). If you are in this situation you may decide to be sceptical about his enthusiasm for the new product.

Don't let him blind you with science, but if he can put across technicalities in words you can understand, then listen.

The choice

This will depend on a lot of factors, including things like software, which we haven't discussed yet. It is not a choice that can be hurried because there is so much more involved than in buying, say, a car. A computer system is a composite of several pieces of hardware — and some software. The thing to do is make a list of all the possibilities, remembering to write down all the bits required for each one. This will serve as a checklist to make sure that nothing has been forgotten (there always seem to be more extras than you bargained for), to enable you to work out the cost of each option and to list its advantages and disadvantages.

You may find that one system stands out as the only real possibility but often there's not all that much to choose between them. In that case, don't agonise over which is the *best* one; go for the one you fancy, but not until you have read next month's article on Choosing Programs!

COMPETITION

Modern microcomputer technology has many applications, but one where it has so far had little impact is in reducing the problems of disability.

To mark the designation by the United Nations of 1981 as "The International Year of Disabled People", *PCW*, in conjunction with the IYDP Technology Working Group, is holding a competition for the best article on the subject:

"The application of micro-computer technology to the problems of disability".

There must be many possible applications for microtechnology in the fields of physical and sensory disabilities — remember, these include handicaps such as deafness, blindness, diabetes and epilepsy, as well as the more obvious physical impediments.

£100

We are offering a prize of £100 for the best article of around 2,500 words, which can be either theoretical or a description of an actual application (with photographs, if possible), and which we will print in *PCW* later in the year.

Entries will be judged by *PCW*'s Editor, David Tebbutt, and Adrian V Stokes, Chairman of the IYDP Technology Working Group. A third judge will be announced soon.

Please send your entry to IYDP Competition, 14 Rathbone Place, London W1P 1DE, to arrive not later than 30 April 1981, enclosing a suitable SAE if you would like it returned.

Personal Computer World



International Year of
Disabled People

FRUSTRATED S100 USERS CAN NOW GIVE THEIR FLOPPIES A SLIGHTLY BETTER MEMORY.

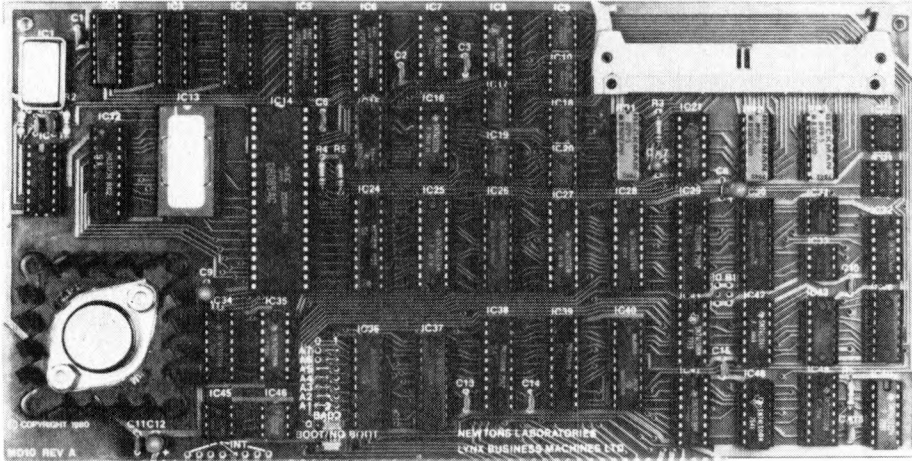

MD10 CONTROLLER FEATURES

- * Designed and made in England
- * IEEE S100 bus standard
- * On-board 8085 CPU and RAM
- * On-board bootstrap PROM
- * Controls up to 4 10Mb disc drives
- * On-board error checking
- * Fully tested and burnt in
- * Low power consumption
- * Supports many types of disc drive
- * Complete documentation and software
- * 3 month warranty

WOULD YOU BELIEVE 40 MEGABYTES?

MD10 is our new low cost cartridge disc controller. It completely eliminates the storage and back-up problems associated with floppy discs. It interfaces S100 micro computers with industry standard 10 Megabyte (5Mb fixed, 5Mb cartridge) disc drives.

By daisy chaining up to 4 disc drives you can have no less than 40 Megabytes of fast, on-line storage

NO MORE BACKUP PROBLEMS

The limited storage capacity of floppy discs was recently solved with the introduction of the "Winchester-type" disc drive. But this introduced a new problem... backup...! The MD10 cartridge disc controller interfaces with 10 Megabyte capacity disc drives which combine a 5Mb fixed disc and a 5Mb industry standard (IBM-5540 type) removable cartridge disc. Each disc is individually addressed and accessed. This means that all important programs and data files can be kept on the fixed disc and, when required, copy the whole disc onto the cartridge for security or backup purposes.

MD10, THE INTELLIGENT... LOW COST... CARTRIDGE DISC CONTROLLER

The MD10 contains an on-board 8085 processor, 1024 Bytes of random access memory and a bootstrap PROM which, depending on the operating system used, will enable any S100 micro computer to boot from the hard disc rather than from the floppy. Data is transferred at a rate of 2.5 million bits per second between the controller and the drive.

The controller accepts, interrupts and performs CRC error checking. Bus compatible, the S100 transfers 8-bit data between the CPU and the controller and serial data between the controller and the disc drive(s).

The 8085 CPU on the controller takes care of the data transfers between the S100 bus and the on-board RAM. The on-board 8085 allows normal processing to continue in between data transfers to and from the MD10 controller and disc drive. This is especially important for multi-user systems.

NEWTONS Laboratories now supply ex-stock complete subsystems consisting of the controller and 10Mb AMPEX disc drive for £3995 (1-off end-user) including a rewritten BIOS for CP/M 2.2. The controller board alone costs £600 (1-off end-user). The disc drive alone costs £3395 (1-off end-user). Manual only £10. OEM and quantity discounts are available. Dealer and export enquiries (not USA) are invited.

MD10 S100 CARTRIDGE DISC CONTROLLER

FOR BROCHURE

Name _____

Title _____

Company _____

Address _____

Postcode _____

Telephone _____

ORDERS FOR MANUALS MUST BE PREPAID

NEWTONS 111-113 Wandsworth High Street,
LABORATORIES London SW18 4JB. Tel: 01-874 6511
Telex: 21768 (NEWTON G)

'Something for everyone' is this month's motto as Malcolm Peltu reviews a bumper book bundle.



Business before people

This month's Bookfare follows the computer industry's traditional equivalent of putting the cart before the horse. Books about the *business* come first and get more prominence than a book about the needs of computer users.

I have decided to adopt this approach because I feel the number of books under review about the business of computing (six) require enough space to do them justice (or injustice). I also feel that PCW readers might perceive that books about choosing one's first computer or applications are more important than ones concerned with the psychological and sociological aspects of human/computer interaction. In the short term they are probably right, just as hobby freaks are right to take umbrage with my recent attacks on Basic.

I hope, however, that the long-term human and strategic aspects of computer development will eventually be given their due priority, after which disclaimer, here goes with a look at the six latest pillars of business computing wisdom.

A good place to start is with the facts. And there is one clear fact about the use of small computers in business — there is a lot of money involved. In probably the best in-depth study of the current state of micro-business affairs in the UK, *Microcomputer Systems in Business*, edited by Derek Pedder for BIS Pedder Associates, provides a valuable insight into the product, market and usage trends of small systems in the UK. One startling statistic summarises the microcomputer boom: in 1976 there were 274 systems installed in the UK, valued at less than £15,000; at the end of 1979 there were 44,510, which, according to other Pedder statistics, is over 50 percent more than the total number of installed computers over £15,000. By 1984, Pedder estimates there will be almost 400,000 microcomputers in the UK at an average growth rate of about 55 percent in the installed base.

In 1977 there were only 18 different types of computer under £15,000 installed in the UK; by 1979 there were at least 137, with the variety of options continuing to grow at a rapid rate. As Pedder comments, 'If user choice has so far been a complex (or hit and miss!) task, it is likely to become even more so in the future.'

With the value of the 1979

installed base something like £115 million, and likely sales in the next few years averaging at least £200 million, it is hardly surprising that new manufacturers and systems suppliers are being attracted like piranha fish to a crowded swimming pool.

Although microcomputers have been nourished by the domestic and hobbyist user, the target of systems suppliers is moving to business applications. According to the Pedder report, at the end of 1979 about 38 percent of installed microcomputers (17,000 systems) were used primarily for domestic and personal tasks. By 1984, however, Pedder expects that only about 6 percent (25,000 systems) will be in the domestic/hobby category (the survey does not include education as a separate category).

Even given that new cheap packaged systems like the Sinclair ZX80 are giving a fresh boost to the home computer market, it is clear that suppliers will be placing increasing emphasis on the lucrative business market, particularly in manufacturing industry where the number of microcomputers in use is expected to grow from 4000 (9 percent) in 1979 to 150,000 (38 percent) in 1984, and in professional and scientific services, where over 87,000 new systems are expected to be sold.

These figures, like Pedder's book, are of prime interest to the computer suppliers, as an aid to their strategic planning. But their message is also of significance to all micro-computer users because they indicate the kind of marketing and systems development environment in which they will have to pick their way to find an appropriate business tool.

Pedder places the user point of view in context by identifying the suddenness of the business micro revolution: '1979 was the year the microcomputer market caught fire,' he points out. In addition to technological advances, an important catalyst was a growing awareness among potential users; the resultant fire is now spreading so rapidly that it is in danger of getting out of control. Manufacturers are having difficulty in satisfying the explosive demand at a time when skilled computing expertise is very thin on the ground.

The rate of market growth and shortage of experienced software staff mean, according to Pedder, that the widespread use of packaged application software is 'the only means by which the projected 1984 installation

figures can be achieved; neither investment nor programming manpower is available to achieve this degree of market penetration with bespoke applications for every user.'

Yet, he observes, improvements are needed in the reliability and convenience of packages if software does not prove to be a dampener on users and suppliers. He also points out that the micro market has 'spawned a variety of middlemen between the hardware or software originator and the ultimate user' and that business strategies of manufacturers are in a constant state of flux.

All this leaves the potential purchaser 'with a very difficult set of decisions to take' in selecting a system, with increasing importance being given to applications software.

This is the cue to introduce two extremely useful and practical books aimed at facilitating the 'very difficult set of decisions' when selecting a system. *Buying A Business Computer* by Michael J L Turner covers the whole spectrum of choosing a new computer system, particularly if you are on your first trip into the computer minefield. *Choosing Programs for Microcomputers* by John Lane focuses on how to select applications programs for microcomputers and is based on a survey conducted by the National Computing Centre.

Both books adopt a 'checklist' approach to guiding the reader. As its foreword states, Lane's book 'is not a panacea, nor will it tell you which is the best system. However, if followed, it will prompt you into asking questions, of yourself and your supplier, that will lead you into making a wise choice.' This is substantially true and could also be applied to Turner's book, although it should be pointed out that the necessarily generalised nature of the advice in such books means that a great deal of the 'wisdom' — or lack of it — rests on the user's astuteness in applying general guidelines to particular requirements.

Turner's book is aptly subtitled 'a systematic plan for computerisation', as it emphasises the importance of creating and implementing a coherent systems strategy, beginning with defining business objects and ending with the live switchover to the computer service.

Turner provides a great deal of commonsense advice, based on practical experience of helping users to become computerised. For example, he warns against building up

expectations that a computer which successfully handles one task, say purchase ledger, will automatically deliver other benefits of automation that may have been touted by salesmen.

Reducing administration costs, he says, may be the main reason for considering computerisation but it is 'rarely achieved'. A computer, however, is likely to help stabilise administration costs over a long-term period even if the workload increases.

He also warns that for some small businesses, the need for standardisation imposed by computers may be unacceptable. Smaller companies, he says, often benefit from the fact that they can cater for the idiosyncratic requirements of each customer. Turner advises, 'When you investigate the feasibility of a computer system, all these individual requirements have to be identified; a conscious decision must be taken as to whether the business can stand the degree of standardisation that will be required by the computer and what the cost of handling exceptions will be.'

In addition to generalised — but pertinent — advice like this, Turner also follows the process of computerisation step-by-step, punctuated by checklists, detailed examples of types of systems and procedures (such as a specimen invitation to tender) — all expressed in clear, basic English.

The main fault — and this is an almost universal failing of computing and systems people — is that Turner gives insufficient priority to the human factor, both in the systems design process and in the operation of the system. 'The general effects of a computer system on a company's staff are fairly well understood,' he states. But this is simply untrue.

As will be discussed later in the review of *Human Interactions With Computers* the human, sociological and organisational impact of computerisation is poorly understood. The impact on job design, staff satisfaction and motivation, industrial relations, etc. are only beginning to become accepted as an intrinsic and vital part of computerisation, although it is well known that many computers fail through lack of attention to the human factor.

Turner provides much good, sensible guidance on the systems side of computerisation — the problems and the opportunities, the costs and potential benefits. But he says little about human factors, such as the



best form of interactive dialogue and screen formatting from the human psychological point of view, machine ergonomics, and industrial relations consequences.

John Lane's *Choosing Programs for Microcomputers* is also essentially a book about evaluating systems characteristics, with little about the human factors in the software. Nevertheless, it is valuable and useful and a good complement to Turner's. In the third quarter of 1979, the National Computing Centre sent about 900 questionnaires to potential suppliers of applications software for microcomputers; about 100 companies replied.

The results of this survey confirm those of Derek Pedder's. About 600 different software products were identified, covering 80 types of application — from accounting to bakery administration. Many of the suppliers were newly-formed companies and 55 percent of the suppliers had employed staffs of less than five. Coupled with the fact that over 60 percent of the companies supplying software are in the South East of England, Lane points out that the level of support provided for applications packages could be very small. This, coupled with the price that the user is willing to pay for it should therefore be a significant part of the evaluation.

Despite the apparent overwhelming predominance of Basic as the hobbyist micro language and the relatively short time that Cobol has been available on micros, almost 30 percent of the packages are written in Cobol and under 50 percent in Basic. In addition to presenting the results of the survey and a list of suppliers, Lane also offers guidelines on how to use and get the best from applications packages, detailed examples of typical basic business packages (including guidelines on different capabilities that can be expected from differently priced systems), and an easy-to-read introduction to the basic concepts of microcomputers. As in any book that attempts to provide detailed advice to particular suppliers, including examples of costs, it is inevitable that the information can quickly become out-of-date and is likely to be incomplete even at the time of compiling, given the rapidly changing state of the market. This should be borne in mind when reading and using this book.

An interesting finding, which once again emphasises the significance of software over hardware, is that there was little correlation between

the prices charged for software and the value of the hardware on which they run. Although for the hardware costing less than £5000 it was true that the cheapest software was available (generally under £500), for hardware in the £5000 to £10,000 range, software was evenly spread over the £500 to £3000 band.

Lane concluded with some invaluable advice, such as: 'Approach software with caution, assuming the worst; there are good packages around, but you cannot judge on price alone, you have to probe a lot deeper. Keep in mind what you really want the computer for before you set your mind on a particular make or model; in other words, approach selection with your own needs upmost in your mind.'

If you are a practising accountant, you will have a clear idea of what you want from a computer. The question is really whether a computer would do you any good at all; if you are an accountant and think it will, then the *Guide to Systems for Practising Accountants* would be a reasonable starting point. It provides general background to the types of computer service available (bureau, in-house, use of consultants, etc). The major part of the guide is an analysis of 70 suppliers who claim they have suitable systems (covering the whole spectrum of computing, not just microcomputers). With the proviso that this analysis could also become out-of-date, the *Guide* is a worthwhile investment if a decision has been made to use a computing service.

Successful Software for Small Computers by Graham Beech is also of benefit to a specialist market — programmers with a scientific bent — although it could have been a much more important book with wider interest had the author developed his idea in a less restrictive form.

Beech says the original motivation for the book was to answer a typical problem of students he has taught: 'I can write Basic but I cannot design programs.' Within one book he hoped to bring together a description of general programming techniques with examples of Basic programming for a particular subject, emphasising reliable design techniques.

Its value, however, is limited because the examples have a strong mathematical and scientific flavour and therefore do not appeal to people frightened by equations. The important program design techniques discussed are related to a specific

Algol-like language called a Program Description Language (PDL), rather than to elucidating these ideas via more generalised insights. Having shown how a well-designed program can be written in PDL, Beech translates the PDL into Microsoft Basic, where it becomes easy to be bogged down in the trees of PDL and Basic translation without seeing the woods of good programming techniques.

A chapter in the book *Human Interaction With Computers* by Michael Jackson (see below), offers a much better insight into the overview of programming techniques, although Beech's book will be useful to some Basic programmers.

Although its cover and title claims that *Your First Computer* by Rodney Zaks is a 'guide to business and personal computing', I can find little in it of value to a business user and I feel the novice hobbyist could also find a more satisfactory introduction. Zaks adopts the traditional hardware, bits, bytes and circuits approach to describing the nature of microcomputers. I criticised the Turner and Lane books earlier in this review because they did not emphasise the human aspects of systems enough. But at least they are written in plain language and focus on business systems.

After an initial chapter of waffle about the shape of society in the future using the wonders of microcomputing power, Zaks immediately becomes involved in talking about how to plug the micro in and get the system going. We are over a third of the way into the book before business applications are introduced, where the des-

criptions are heavily-oriented to program code.

If the book is used by people developing business software, its lack of discussion of good programming techniques and software engineering will create many problems. I cannot see any businessman really wanting to write an accounts package, say, based on the flimsy advice in this book; and I cannot see many hobbyist being interested in the business applications described.

And now to what I regard as the most important book of all.

Behavioural problems

'Computers have a potential flexibility that makes them seem infinitely adaptable to different tasks. And yet this adaptability is more projected than real. Getting a computer to do what you want is exceedingly difficult.'

With these words, Hugh Smith and Thomas Green encapsulate the dilemma posed by computing power. The generalised flexibility that is at the core of that power also poses major problems to the people who have to design and use computers for specific tasks. Michael Jackson (he of structured programming rather than soul-singing fame) poses the same problem from the point of view of a programmer writing a complex software system: 'The programmer, unlike the mechanical engineer, is free to weld any part of a program to any other part or, indeed, to mix up the parts in any desired way. It need not be considered that this part is made of steel, that from glass and a



I programmed it to do everything I could do. Finally my wife ran off with it.



third from plastic. Nor does the stuff of programs provide any constraints, such as the strength of materials or a required power-weight ratio. Any program, however poorly conceived, can be made to work by ad hoc patches.

'Since the structural form of the program,' Jackson continues, 'is largely invisible to its buyers and users it is horribly easy — and tempting — to allow the quality of design to sink to a standard that would not pass muster for a moment in a motor car or bridge.'

Smith and Green are the editors of *Human Interactions With Computers*, which brings together experts from many disciplines — sociology, psychology, business administration and computing — to show how much (and how little) progress has been made 'to narrow the gap between the computer and the user, to produce packages that the user wants in ways that the user can grasp.'

Jackson provides a notable contribution to the section in the book on programming research. He explains why existing programming languages are inadequate for producing well-engineered software because they fail to distinguish between the problem being solved and the particular coding used to get one machine to solve the problem.

At the user end of the spectrum, Hugh Smith himself provides an excellent chapter on human-computer communications. Like most current writings on this subject, Smith's major contribution (and of the whole book) is to highlight those areas which should be given more attention by researchers and systems designers. He also exposes the lack of real research to provide good answers to the problems raised.

Technological and economic objectives, Smith says, are more easily set and carried through than social ones. 'Consequently social studies of the effects of technology tend to resemble a post mortem, ie, a search for cause and effects which can seldom be used to benefit the patient.' Until better social studies are available, he suggests, it is still worthwhile to spend 'more time thinking how we might build humans into systems rather than designing them out in pursuit of technical advances.'

The topics covered by Smith and other contributors indicate the scope and importance of the social and human requirements. These range from global questions, like how people perceive computers and the impacts of

computer-based automation on employment levels, to systems design tasks, such as appropriate response times and assessing the merits of different forms of information retrieval dialogue.

Then there are the human aspects in specific applications systems such as medical decision making, architecture, education and decision making and in the more detailed systems development aspects, such as programming.

In some areas, Smith admits that there is very little research, such as in how well systems meet 'end user' expectations (the end user, of course, is the real user, ie, the typist, manager booking clerk who actually uses the system to carry out a real world task). This is extraordinary, given that the end user should be the raison d'être of systems design.

Niels Bjorn Andersen and Leif Bloch Rasmussen from Denmark believe that increased industrial democracy will help to raise the computer expert's 'level of consciousness' about the aspects of systems design over and above the technical/economic issue. They say, 'The traditional expert strategy for systems design, with or without a hostage from the user department, is not going to work in the long run.'

Mike Fitter and Max Sime raise the crucial issue of what happens to the decision-making process when people rely on interpreting computer processing routines, such as air traffic control, production management — or even starting (or preventing) the Third World War.

The dependence on computers for decision-making should become a shared process between man and machine, they say. But in order to achieve this, it will be necessary to ensure that the complex computer system can explain its own behaviour and 'rationale' for reaching a conclusion in a way that can be understood by the person in terms of human perceptions of reasoning. This requires a great deal of more work both in understanding human reasoning and psychology as well as developing better forms of computer 'reasoning' and man-computer dialogue.

Applied psychology also has an important role to play in improving programming languages and methodology, according to Thomas Green. For example, he says that any psychologist knows that 'slips of the pen are hard to find, just like misprints on the page.' He goes on: 'I hope that this "discovery" seems banal to you and provokes

the thought "Well I don't need a psychologist to tell me that!" But the designers of Fortran overlooked it.'

A mistake in Fortran could still make 'sense' to the compiler, although not the sense you wanted, he points out. A widely used statistical package (SPSS) demands that certain control records start in column 16: 'God knows how much expensive time has been wasted by this unnecessary whimsy, left over from punched cards and the Fortran input/output structures,' Green comments.

Every person involved in designing, using, selling or selecting a computer should read *Human Interactions With Computers*. Much of it might be irrelevant to the particular computing concerns facing the reader immediately. It raises far more questions than it supplies answers. Some of the contributions are wootly and some are esoteric.

But together, the contributors demonstrate that, although the technological computer revolution has begun, we are still stumbling in the dark in our attempts to tackle the most important

task of getting the computer to do what we want it to do, where the 'we' encompasses any role that human beings can adopt in relation to using computers or being affected by a computer system.

This month's Bookfare reviewed:

- Human Interaction With Computers*, Hugh Smith and Thomas Green, editors (Academic Press, £6.40)
- Microcomputer Systems In Business* edited by Derek Pedder (Gower Press, £25.00)
- Choosing Programs for Microcomputers*, John Lane (National Computing Centre, £8.00)
- Buying a Business Computer*, Michael J L Turner (The First Computer Handbook, Whitney on Wye, Hereford, £9.75)
- Your First Computer*, Rodney Zaks (Sybex, £5.95)
- Successful Software for Small Computers* by Graham Beech (Sigma Technical Press, £5.50)
- Systems for Practising Accountants* edited by Barry Knight (Computer Guides Ltd, 30-31 Islington Green, London N1, £24.00)

BUTEL-COMCO

RP1600 Daisywheel Printer

60cps!

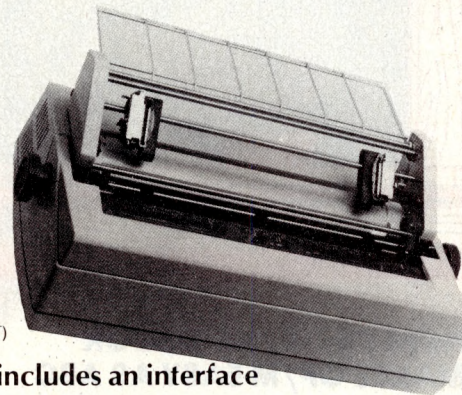

List Price:
£1450
(excluding VAT)

- Price includes an interface
- Interfaces available are
Serial V24/IEEE/Centronics/Qume/Hytype
- Trade/OEM discounts available

Write or call for further information

Butel-Comco Limited
50 Oxford Street,
Southampton,
England SO1 1DL
Telephone 0703 39890
Telex 47523

BUTEL
Technology for business

I am interested in purchasing the RP1600 for connection to

Name

Company

Address

Telephone

the ABC's of CP/M®



NEW! CP/M HANDBOOK MAKES CP/M EASY AS ABC

CP/M—the industry standard in operating systems: now Sybex makes it easy as ABC with a new step-by-step guide: THE CP/M® HANDBOOK (with MP/M™).

Gain a clear understanding of CP/M's basic operation, learn how to use the editor and assembler, then explore all versions of CP/M, including CDOS and multi-user MP/M.

Numerous sample programs, practical operating hints and handy reference tables make the CP/M HANDBOOK a must for anyone—from beginner to experienced programmer.

For sophisticated editing or simple copying, the new CP/M HANDBOOK gives you a hand—and makes CP/M easy as ABC.

By Rodney Zaks, 250 pp., Ref. C300,

CP/M® and MP/M™ are trademarks of Digital Research

Get your copy of the CP/M Handbook from your local Computer store or Bookshop. In case of difficulty, send cheque/ P.O. for £8.95 + 70p post & packing to the SYBEX UK Distributor.

**The
Computer
Bookshop**



**Temple House,
43/48 New Street,
Birmingham B2 4LH**

Please send me a copy of the CP/M Handbook.

I enclose Cheque/P.O. for £9.65

Name

Address

.....

.....

PCW

GET ON THE RIGHT TRACK

In the first of two articles, Jeff Barton describes how he built a micro-controlled train layout as part of his research into real time control applications.

The control of a model railway layout is one of the more 'attractive' applications for a microprocessor. One of the final year projects for my Joint Honours Degree in Computing and Electronics at Durham University has been to design, construct and program such a system. Besides its obvious attraction as an intelligent toy, the control of a train set layout is a very complex Real Time Control System (RTCS). These two articles will summarise the RTCS developed at Durham and illustrate the techniques used for automatic route generation and execution with built-in collision avoidance.

This system differs from the commercial ones on offer in that the track is controlled rather than the trains. The commercial systems require some sort of 'loco module' in each engine and superimpose the coding signals sent out by the microprocessor controller on top of the power to the track. There is only one continuous length of track and, although the power is always applied to it, an engine only responds when addressed by the microprocessor.

The system at Durham reverses this situation and locos on the layout need no modification at all. The track is split up into short, isolated lengths or sections and each section is individually controlled by the microprocessor. The section driver circuitry is designed so as to produce a TTL-compatible signal to indicate when a train is drawing power from a section. It is also possible for this signal to generate an interrupt which, as will be seen later, is an extensively-used facility.

The computing system is provided by an MSI 6800 microprocessor system (uPS) which controls the 10ft x 5ft track layout via the Train Layout Interface (TLI). An overall view of the system architecture is shown in Figure 1 and a plan view of the layout in Figure 2. There are 19 sets of points and 41 totally isolated sections of track, although only 32 are so far implemented. Each point can be switched to either direction and each section is capable of driving an engine at one of 16 speed settings in either direction under program control. The system software allows the simultaneous control of multiple trains on the layout.

Hardware

The TLI provides the necessary decoding and conversion of signals between the TTL logic levels of the uPS and those required by the layout. This is performed by eight boards. Six of these are 'module boards', each providing the necessary logic and driver circuitry to control a group of eight

sections of track. The 'decoder board' performs all the buffering and decoding of control signals prior to their connection to the backplane. The 'points board' supplies the logic and driver circuitry to enable any of the sets of points on the layout to be switched to either direction. The TLI is controlled via just one 6821 PIA so the interface to processor connection comprises 16 data, four control lines and an earth. These signals are decoded by the various boards and drive the layout via two 100-core cables.

Operation

Every action which can occur on the layout is totally under the control of the operator via the console. On each program run, train movement is not possible until an explicit command is entered. The user is provided with 26 different possible command functions to enable the layout to be operated either under manual control or automatically. It is possible to display status reports on the console at any time to inform the user about any desired system parameter.

The software displays a descriptive prompt each time that input is required from the user. This means that even a first-time user can control the layout within a short length of time at the console.

The program makes the system appear to be 'intelligent'. It is possible to place a train anywhere on the layout and after instructing the program of its location, together with a variable length list of sections to pass through, the program generates a route. This route is capable of driving the train through all the specified sections (and any that interconnect them), switching points as required, until the train reaches its destination. The actual execution of this route may occur at any time after it has been created and the positions of other trains on the layout need not be the same at the time of execution as that at route creation.

The routes operate on a localised basis; this means that each runs as a separate task within the system and allocates, uses and frees sections and points as it needs them. If two trains are about to collide on the layout, the program detects this and prevents it.

When taken to the general case with a lot of routes executing concurrently, this localised method is probably the most satisfactory way of operating the system. However, the solutions for escaping from deadlocks have not yet been implemented due to lack of time. Deadlocks and the 'master task' method will be discussed later.

Automatic route generation and execution

It is obviously necessary for the program to be able to determine how the sections of track are interconnected so it can calculate how to get from A to B. This information is contained in three tables, called 'postab', 'points' and 'slips'. Each table comprises a list of pointers to the beginning of each of the variable length data entries. Sample entries for these tables are given in Tables 1, 2 and 3.

postab	fdb	sec00p
	fdb	sec01p
	:	
	fdb	sec31p
sec00p	fdb	1,1
sec01p	fdb	1,2
sec02p	fdb	0
	fdb	3,3,3,3,3,3,3,3
	fdb	3,3,3,3,3,3,3,3
	fdb	3,3,3,3,3,3,3,3
	fdb	24,24,24,24,24,24,
	fdb	24,3
sec03p	fdb	0
	fdb	4,4,4,15,15,15,15,15
	fdb	15,15,4,4,4,15,15,15
	fdb	15,15,15,4,4,4,4,4
	:	
	:	

Table 1

points	fdb	psec00
	fdb	psec01
	:	
	fdb	psec31
psec00	fdb	29,\$11,0
	fdb	8,\$11,1
	fdb	-1
psec01	fdb	0,\$12,0
	fdb	11,\$12,1
	fdb	-1
psec02	fdb	24,\$13,0
	fdb	3,\$13,1
	fdb	-1
	:	
psec06	fdb	-2
psec07	fdb	-1
	:	
	:	

Table 2

slips	fdb	slip06
	fdb	slip09
	fdb	slip11
	fdb	slip15
slip06	fdb	5,18,\$17,0
	fdb	18,5,\$17,0
	fdb	5,7,\$17,1
	fdb	7,5,\$17,1
	fdb	17,7,\$17,0

Continued over

```

fcb 7,17,$17,0
fcb 17,18,$17,1
fcb 18,17,$17,1
fcb -1
:
:

```

Table 3

The 'postab' table is used by the route specification command to discover the next section in the route which will eventually take the train to its destination. There is one entry per section and this is of one of two types — 'brief' or 'long'. It can easily be seen that to travel from section 01 (see Figure 2) to any other section in an anticlockwise direction (referred to as the 'positive' direction), the train must always pass through section 02 next. Therefore the entry for section 01 in 'postab' is of type 'brief'. On the other hand, the entry for section 02 is of the 'long' type since, when travelling in a positive direction, the train could enter section 03 or 24, depending on the setting of point 13. This method of storing data enables easy calculation of the route by simply walking through the table. For example, if the user enters '0' and '26' as the start and end sections respectively, the program first accesses the entry for section 01. This is of 'brief' type, so the program stores the one and only next section, 02, and then looks in 'postab' at the entry for section 02. By using section 26 as an index within this entry it finds that to travel from 02 to 26 requires passing through section 24 next. This process is continued until it arrives at its destination — in this case the route is 01, 02, 24, 25, 26. Although not yet implemented, to travel in the negative direction simply requires using 'negtab' instead; this will, of

course, be different since section 01 now has two possible next sections... and so on.

Once the list of consecutive sections has been completed, the points settings which are required to create this desired route must be calculated. Two further tables, 'points' and 'slips', contain the necessary information for this purpose. A point is simple and has possible either one entry and two exit paths, or two entry and exit path, depending on the train's direction. If a train arrives at a point switched incorrectly, no serious damage occurs as the points are spring-loaded to account for this. However, it is obviously desirable to simulate the real life case whenever possible and so the point is always switched to the correct path. A slip is slightly more complex, with two entry and two exit paths. There are four slips on the layout, at sections 06, 09, 11 and 15. Each is operated by a single, bi-directional point motor and can be considered to direct a train into the 'opposite' or 'adjacent' section, depending on their setting. If slip 06 (point 17) is set to 'opposite', a train entering it from section 05 will depart on section 18 and a train from section 17 will depart on section 07. In the 'adjacent' setting, trains from sections 05 and 17 will depart on sections 07 and 18 respectively. If a route passes through a slip section, it is necessary to treat it as a special case requiring further processing.

The list of consecutive sections is now considered to be a series of pairs of source and destination sections. Each pair in turn is applied to the 'points' table to determine if a point must be switched in order to travel from the source to the destination section within

each pair. Using the route calculated above to travel from section 01 to 26, the pairs 01+02, 02+24, 24+25 and 25+26 are considered. Each section has a corresponding entry within the 'points' table. Section 01 is first considered as the source and 02 as the destination section by examining the entry in 'points' for section 01. Although this entry tells how to get to sections 00 or 11 by switching point 12, it has no information on how to get to section 02. Section 02 is then considered as the source and 01 as the destination and the process is repeated by examining the entry for section 02. Since this entry contains no information on which point to switch to get to section 01 from section 02, it can be safely assumed that no point switching is necessary to travel between sections 01 and 02. Therefore the next pair in the list, 02+24, is considered. The entry for section 02 this time says that to travel to section 24 from 02 requires point 13 to be switched to a direction '0'. The program stores this information and interchanges source and destination and looks again in 'points' for section 24 to section 02 information (the case of section 08 to section 00 illustrates the need for this usually redundant test). This procedure is continued for every pair in the list until all the point-switching information for the route has been compiled.

A value of '-2' for a section entry in 'points' indicates that the section is a slip and so requires further processing. In this case the triplet of source, slip and destination sections is extracted from the list. The table 'slips' is then used to determine the switching information.

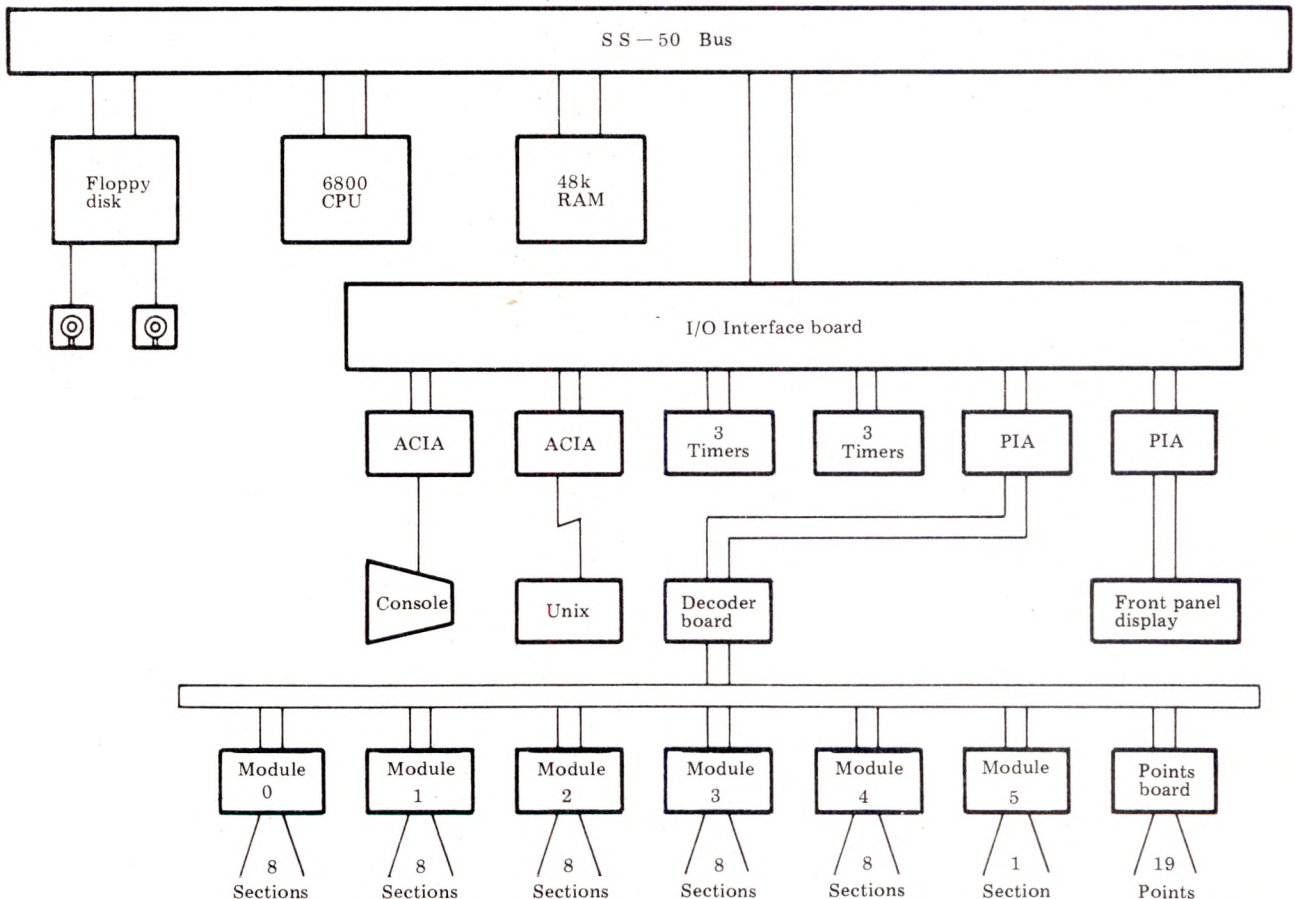

Fig 1 System architecture

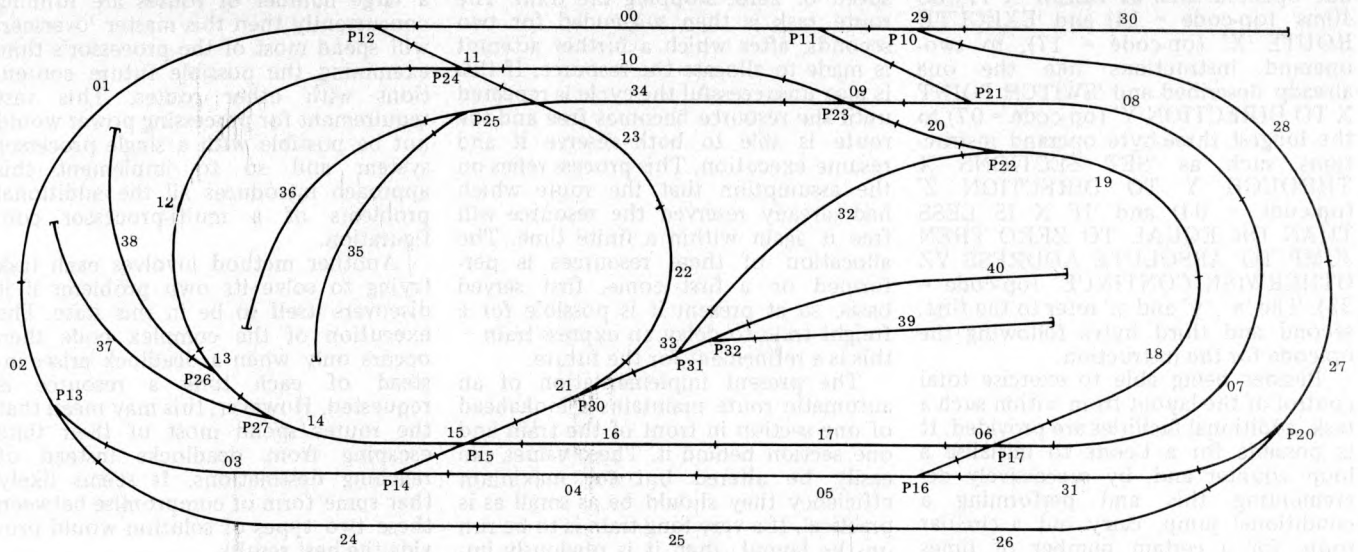

Fig 2 The train layout

START →	01	section number
	00	direction
	09	speed setting
ACTTOP →	02	next resource
	00	to free
	09	
	-13	point 13
	00	direction
	00	null value
ACTMID →	24	section currently
	00	powering train
	09	speed setting
	25	
	00	
ACTBOT →	26	next resource
	00	to allocate
	09	
	-1	end of route flag

Table 4

The final result of this processing is a data structure (as shown in Table 4) containing all the necessary information for the route to be executed. Each section or point entry in this table is of 3 bytes in length, with the first byte being the number of the resource itself. In order to distinguish between the two types of resource, the point addresses are stored as two's complement values. The second byte is the direction to which the resource is to be set, and the third byte is either the sections speed setting or, in the case of a point entry, a null value.

The most important piece of information when executing a route is the number of that route assigned to it at creation time. This is used by the sub-routines as an index into the many tables of pointers and essential data so that all of these routines are shareable between routes.

As a train progresses through its route, the program maintains three tables, 'acttop', 'actmid' and 'actbot', each with an entry corresponding to the route which is an address pointer into the data structure created for that route. When the command is given to begin executing the route, all three pointers are initialised to the start of the data structure. Each time the next required resource is successfully allocated and set up (either powered up with interrupt capability enabled or switched), the 'actbot' pointer is moved down the structure by one entry (ie three bytes).

When the train enters a new section the 'actmid' pointer is moved to the next section entry further down the structure and when a resource is freed by the route after it has been used, the 'acttop' pointer is similarly moved. These three pointers are therefore used to keep track of the active subsection of the route within the larger confines of the data structure.

The use of two further tables, this time containing data values, called 'ahead' and 'behind', enable the number of reserved resources in front of, and behind, the engine to be recorded. Again, these tables contain one entry per route. Both counters are initialised to zero when the route is first begun and they both have maximum values which are determined by program constants. The 'ahead' counter is incremented each time the next section in the route is allocated successfully — the allocation of a point resource does not affect the counter. When it reaches its maximum value of 'maxfor' the program moves from allocating new resources to freeing used resources.

When the 'actmid' pointer is updated to point to the next section through which the train is to pass, the 'ahead' counter is decremented and the 'behind' counter is incremented. Unless the 'behind' counter is less than or equal to 'minbak' the 'acttop' pointer is updated and the resource at which it pointed in the data structure is freed. The freeing of a section resource decrements this counter but freeing a point resource does not affect it. These counters therefore ensure that 'maxfor' sections in front of and 'minbak' sections behind, together with the section currently powering the train, are held in a 'locked' state by the route. At present both of these constants have the value '1' and so a total of three sections (maximum) are activated by the route at any one time during its execution.

The end of a route's data structure is indicated by a value of -1 for the resource entry. On reaching the end of the route, the train is stopped and all resources held by the route are freed again. A resource entry of -2 indicates that the route is to be operated continuously and so as each of the three pointers 'actbot', 'actmid' and 'acttop' reach this value they are reset to the top of the data structure again. This route

would continue until either it or the program is aborted.

Besides executing the automatically generated routes as described already, it is also possible to run multiple trains on manually-produced routes. With patience, this allows the compilation of very complex 'demonstration calibre' routes. The system software treats each executing route as a task, running a program within the system. By the use of scheduling, it is possible to achieve multi-tasking and so multiple train routes may be operated concurrently in real time.

Perhaps the easiest way of considering the methods employed would be to regard the system as emulating a 'pseudo micro-programmable machine'. To avoid too much confusion, let us call the program that a task runs a 'task code program' or 't-code' rather than a program. A t-code can be any number of 'high level' instructions in length and each of these instructions is performed by a routine of 'low level' (6800) instructions. An example of a 'high level' instruction is, "SET SECTION 10 TO A SPEED SETTING OF 5" which would appear in t-code as three bytes: 01, 10, 05. The first byte, 01, is the op-code for this 'high level' instruction and the second and third bytes are the necessary operands to set section 10 to a speed 5. When the 'pseudo program counter' for the task reaches this instruction, the op-code (01) is used as an index into a jump table containing the start addresses of the 6800 subroutines which carry out the instructions. For this particular instruction the routine obviously requires two operands — a section number and a speed setting. It therefore accesses the two bytes following the op-code by using the 'program counter' and then updates the current route's entry in the 'program counter' table so that it contains the address of the next 'high level' instruction. Then, after updating the speed tables to modify the speed for the desired section, it returns to decode the next high level instruction as determined by the pseudo program counter.

There are currently 27 different 'high level' instructions which a route task can execute. They vary in length from the single byte instructions such as 'NO-OPERATION' (op-code = 00) and 'UPDATE STATUS ON CONSOLE' (op-code = 11) to instructions requiring

one operand such as 'SLEEP X TIMES 40ms' (op-code = 14) and 'EXECUTE ROUTE X' (op-code = 17), to two-operand instructions like the one already described and 'SWITCH POINT X TO DIRECTION Y' (op-code = 07) to the longest three-byte operand instructions such as 'SET SECTIONS X THROUGH Y TO DIRECTION Z' (op-code = 04) and 'IF X IS LESS THAN OR EQUAL TO ZERO THEN JUMP TO ABSOLUTE ADDRESS YZ OTHERWISE CONTINUE' (op-code = 25). The 'x', 'y' and 'z' refer to the first, second and third bytes following the op-code for the instruction.

Besides being able to exercise total control of the layout from within such a task, additional facilities are provided. It is possible for a t-code to initialise a loop counter and, by successively decrementing this and performing a conditional jump, carry out a circular route for a certain number of times before continuing with a different part of the route. Absolute unconditional jumps are also provided for. One of the third-year projects for next year is to write a high level language and compiler for controlling routes.

Collision avoidance

The task of detecting that two trains are about to collide is performed by the routines concerned with the allocation of resources to a route. Whenever a train needs a point to be switched, or a section to be powered on, in order to continue its travel, an attempt is made to reserve that resource in the systems tables. If the resource is free it will be allocated to the route and the train allowed to continue. If the resource has already been reserved by another route then to proceed would result in a collision. The section currently powering the train which made the unsuccessful reservation attempt is therefore set to a

speed of zero, stopping the train. The route task is then suspended for two seconds, after which a further attempt is made to allocate the resource. If this is also unsuccessful the cycle is repeated until the resource becomes free and the route is able to both reserve it and resume execution. This process relies on the assumption that the route which had already reserved the resource will free it again within a finite time. The allocation of these resources is performed on a first come, first served basis, so at present it is possible for a freight train to delay an express train — this is a refinement for the future.

The present implementation of an automatic route maintains a lookahead of one section in front of the train and one section behind it. These values can easily be altered but for maximum efficiency they should be as small as is practical. If a very long train is to be run on the layout, then it is obviously important to ensure that sufficient sections are kept reserved behind the engine to prevent another train hitting the last few trucks. However, if the train causes 'locks' to be placed on sections it does not need, other trains will be unnecessarily delayed and the likelihood of a deadlock occurring is greatly increased.

If there are sufficient trains on the layout to form a 'nose to tail' queue with each route waiting for a resource to be freed by another, it will not be possible for any of the routes to continue. This is a 'deadlock', to which there are many solutions. One of the more desirable ones is to prevent them happening in the first place. This could be done by some sort of 'master task' being responsible for ensuring that a resource is only given to a route if that route can successfully terminate within a finite time. This method entails checking that the rest of the route to be executed will be free when required. If

a large number of routes are running concurrently then this master 'overseer' will spend most of the processor's time examining the possible future contentions with other routes. This vast requirement for processing power would not be possible with a single processor system and so to implement this approach introduces all the additional problems of a multi-processor configuration.

Another method involves each task trying to solve its own problems if it discovers itself to be in this state. The execution of the complex code then occurs only when a deadlock arises instead of each time a resource is requested. However, this may mean that the routes spend most of their time escaping from deadlocks instead of reaching destinations. It seems likely that some form of compromise between these two types of solution would provide the best results.

The ability to determine the existence of such a deadlock is by no means easy to implement and the methods of escaping from it more difficult still. Reversing into sidings or backing over points together with dynamic re-routing of the train are some of the obvious possible methods yet these introduce further complications. If a route tries to solve a deadlock by reversing and thereby causes another deadlock, how is this one to be solved? It is obviously impossible for the route to escape from this situation by itself, but does it signal this to the other routes and let them try to provide the answer? Or does it call for the temporary execution of a master task as described above? At present there are no facilities for any form of inter-communication between tasks and each executes in a totally isolated environment. The need for signalling between concurrent tasks is an essential requirement and is under investigation.

Next month Jeff will look at how the system handles scheduling and routing.

BACK NUMBERS

PLEASE NOTE THAT THE FOLLOWING ISSUES ARE SOLD OUT

VOLUME 1 Nos. 4, 5, 6, 9, 10, 11, 12

VOLUME 2 Nos. 5, 6, 8

VOLUME 3 Nos. 1, 2, 3, 4.

ALL OTHER ISSUES MAY BE ORDERED USING THIS FORM.

Volume 1 No. 1 May 1978
Nascom 1/77-68: The Mighty Micromite/A charity system

Volume 1 No. 2 June 1978
Research Machines 380Z/Computer in the classroom/The Europa Bus.

Volume 1 No. 3 July 1978
Buzzwords — A to Z of computer terms/Pattern recognition/Micro music

Volume 1 No. 8 December 1978
Computers and Art/3-D Noughts and Crosses/Mickie — the interviewing micro.

Volume 2 No. 1 May 1979
Small computers for small organisations/Sorcerer graphics/Chess Programming Hints/Parkinsons Revas.

Volume 2 No. 2 June 1979
MSI 6800/Witbit — disassemble your programs/The Multilingual Machine/Polytechnical Processing.

Volume 2 No. 3 July 1979
Vision link: Interfacing and Software for the Superscamp VDU/Pet Preening/Extended cursor graphics for the TRS-80.

Volume 2 No. 4 August 1979
The North Star Horizon/High Speed Cassette Interface for the SWTP 6800/Garage Accounting program/Apple Medical Application.

Volume 2 No. 7 November 1979
PCW Show issue/6800 Bug/Hard disc security/Detecting literary forgeries/Benchtest — the Challenger C3

Any one issue 95p; Any two issues £1.75; Any three issues £2.50; Any four issues £3.00. All additional issues @ 50p each. Binders @ £2.95. All prices include post and packing. Cheque or P.O. payable to (PCW) SportsScene Publishers Ltd., 14 Rathbone Place, London W1P 1DE. Please allow up to 3 weeks for delivery and don't forget to state clearly your name and full address with your order. Please send me the following copies of PCW. I enclose a cheque/P.O. for £

Volume 1					Volume 2				
1	2	3	7	8	1	2	3	4	7
<input type="checkbox"/>	<input type="checkbox"/>	<input type="checkbox"/>	<input type="checkbox"/>	<input type="checkbox"/>	<input type="checkbox"/>	<input type="checkbox"/>	<input type="checkbox"/>	<input type="checkbox"/>	<input type="checkbox"/>

Volume 3						
5	6	7	8	9	10	11
<input type="checkbox"/>	<input type="checkbox"/>	<input type="checkbox"/>	<input type="checkbox"/>	<input type="checkbox"/>	<input type="checkbox"/>	<input type="checkbox"/>

Name _____

Address _____

*Tick appropriate boxes

GATEWAYS TO LOGIC

CHAPTER 6: THE MICROPROCESSOR

Derrick Daines continues his series on teaching microcomputing to others

We have reached the point where a computer can shunt data about automatically, like a toy engine shunting trucks. What is now needed is knowledge of how the data gets there in the first place, how it is brought out and, by no means least, why these processes are so vital for our future. But first we need a long cool look at the microprocessor.

Looking at the microprocessor from the outside reveals nothing. We see an integrated circuit with a lot of pins sticking out of it — nothing more. However, concealed within that black, uninteresting package is every device that we have so far learned about, and more. Again, we must be selective. A lot of the stuff that is in there is not necessary for our students to learn about unless they wish to specialise, so here I will confine myself to the essentials.

To begin with, it contains those good old favourites, the A and B registers. These are the registers upon which arithmetic functions are performed — in binary, of course. There is an Arithmetic Unit, which does the actual adding and subtracting, and the Control Register recently met. Other registers will be mentioned as the need arises. In addition to these short-term memories and gating circuits, there are also masses of gates needed to shunt data about and the multiplexing or decoding circuits which determine which gates are to be opened and which closed. Some micros also contain their own clock and clock counter, while others require an external clock. All require an external crystal for accuracy, since this item is very bulky.

By anyone's standards, that's a whole lot of goodies to be packed into one small container and it is one of the miracles of modern technology that this has been done. We have already introduced our pupils to the enormous feat of miniaturisation, but it does no harm to stress it.

In our discussion of the Control Register, we simply stated that the next instruction is fetched from memory but of course this cannot be fetched from anywhere. The instructions must be in sequence or chaos results. In fact any part of the computer memory can be used to store data or instructions and frequently the two terms are interchangeable, so a Program Counter is required to keep track of where the next instruction is to be fetched from. Unless it receives instructions to the contrary, the Program Counter is notched up '1' after each operation, so that consecutive instructions are nor-

mally at consecutive addresses. The special instructions applicable to the Program Counter are of course the JUMP instructions met already. The Program Counter is otherwise just a register like the others.

The Index Register is also inside the micro and is one of those gadgets that once you have it, you wonder how on earth you managed without it. Normally it is incremented by 1 every time that we do an operation such as multiple addition, which makes it easy for the computer to multiply or divide. Like the Program Counter, the Index Register is directly accessible and may be loaded with any number at any time.

The Condition Code Register tells us indirectly of the state of various registers, such as if they are negative or overflowing, etc. This is of interest mainly to the programmer in his development of the program, so I do not intend to refer to it again. Interested readers are referred to the literature applicable to their particular micro. General readers may note that it is there, and then forget it.

Similarly for the Stack Pointer — another special-purpose register within the micro. Briefly, it points to the address at the top of a stack of data and is chiefly used when the computer

jumps to execute sub-routines; that is, frequently used portions of program.

Instruction codes

A little reminder here would do no harm. The salient facts of computer operation are that, by transferring a word of binary bits from memory to the Control Register, the circuitry decodes them as instructions to open this gate and that. This causes one instruction in the program to be carried out.

Table 1 gives a carefully-selected number of hexadecimal codes. Again, there is no need for the general reader to remember all this stuff — particularly as each micro has its own instruction codes — and just grasping the main idea is sufficient. The instructions given are for the Motorola 6800 micro and also given are mnemonics for each instruction, which will be mentioned again shortly.

To follow what happens, let us take a simplified view of one or two instructions. The LD(A) instruction (86 in hex) is read by humans as 'Load accumulator A'. The micro also takes this as meaning, 'with whatever number is immediately following.' Therefore a complete hex instruction might be 86 00 (load A with zero) or 86 8E (load A with hex 8E).

Hex Instructions (for 6800 Microprocessor)

Hex	Mnemonic	Instruction
1B	ADA	Add Accumulator B to Accumulator A
89	ADC(A)	Add to Accumulator A whatever is coming next. Carry if Nec.
8B	ADD(A)	— Ditto, but do not carry
24	BCC	Branch if carry clear
25	BCS	Branch if carry set
27	BEQ	Branch if equal (result of previous test)
2C	BGE	Branch if greater than or equal to zero
2F	BLE	Branch if less than or equal to zero
2B	BMI	Branch if minus
26	BNE	Branch if not equal
20	BRA	Branch always
8D	BSR	Branch to sub-routine
0C	CLC	Clear carry
4F	CLA(A)	Clear accumulator A
81	CMP(A)	Compare accumulator A with the following number.
5A	DEC(B)	Decrement accumulator B by one.
5C	INC(B)	Increment accumulator B by one.
7E	JMP	Jump to the address following.
86	LDA(A)	Load accumulator A with the number following.
01	NOP	No operation
39	RTS	Return from sub-routine.
10	SBA	Subtract accumulators.
82	SBC(A)	Subtract from accumulator A, the following number.
97	STA(A)	Store accumulator A at the following address.
3F	SWI	Software interrupt — halt.
16	TBA	Transfer contents of accumulator A to accumulator B
17	TAB	Transfer from A to B

Table 1 A selection of instruction codes. Note that the full instruction set for the 6800 microprocessor is very nearly 200 different instructions, covering almost every conceivable requirement.

When the instruction is encountered, it is stored in the micro's Control Register, thereby opening the appropriate gates and at the same time signalling the micro to wait for the next binary word which, as the gates are ready open to receive it, is shunted into Accumulator A.

At this point, pupils might wonder how the computer knows the difference between the 86 (instruction) and 8E (data). The short answer is that it knows by the context. Once it had received the 86, it waited for the data to follow.

Sometimes it does not need to wait. For example, instruction 16 (binary 0001 0110) tells the micro to transfer the contents of Register A to Register B (thereby erasing any previous contents of B, incidentally). Now once the micro has opened the appropriate gates and counted eight pulses, the job is done and the next instruction is fetched.

Similarly, some instructions are three words long. For example, CE tells the computer to load the following numbers into the Index Register, which is long enough to hold two hex words. Therefore a complete instruction might be CE A04A, which means, 'Load the Index Register with the value A04A.' Inherent in the instruction CE is a code that instructs the micro to expect two words.

As to the question, 'Does the micro ever get things mixed up?' — ah ha! Therein lies a tale! The short answer is that no, the micro never gets things mixed up but the programmer does. For example, if he wanted the program to jump to where it would read 86 8E (load A with 8E), but made a tiny mistake so that the program missed the 86 and fetched the 8E instead, the micro would understand that as, 'Load the Stack Pointer with the next two hex words.' It doesn't take much imagination to see that in these circumstances the program would go wrong, with the micro reading data as instructions and vice-versa. This process is known as 'bombing' and usually results in the entire stack of memory being loaded with rubbish. This is perhaps the major reason why people fight shy of machine code, as the hexadecimal method is called.

In Table 2, I illustrate a short program in machine code, suitable for the Motorola 6800 micro. It presumes a keyboard input and a VDU output (see later for explanation of these terms) and as the earlier program for the cardboard computer did, simply multiplies any input number by four. The product appears on the VDU and is in hex.

If the reader does not have access to a computer, please don't worry. As I have said, it is not my intention to instruct on how to program and as long as the reader can see points of similarity between Table 2 and Figure 10 of Chapter 3, that is all that matters. The following notes will help to explain the program and illustrate some points of interest.

The first column of Table 2 lists the memory locations in which the instructions are stored. Note that they are in hex. The program contains one, two and three-word instructions and the memory list must take account of this, since of course only one word may be stored in each memory.

The second column lists the hex instructions. (Remember that two hex

Sample Program

0100	CE 0000	LDX	Load index register with zero
0103	BD E1AC	BSR	Fetch number from keyboard, into Accumulator A
0106	16	TAB	Copy it in Accumulator B
0107	08	INX	Increment Index register by 1.
0108	1B	ADA	Add contents of B to A
0109	8C 0004	CPX	Compare Index with value 4
010C	26 FA	BNE	Branch if not equal.
010E	BD E1D1	BSR	Print out value of accumulator A
0111	3F	SWI	Stop.

Table 2

symbols make one word.) In the case of hex instructions that are more than one word long, the actual data stored is given after a space. Thus in the first few memories the following are stored:

Memory	Hex	Binary
0100	CE	1100 1110
0101	00	0000 0000
0102	00	0000 0000
0103	BD	1011 1101
0104	E1	1110 0001
0105	AC	1010 1100
0106	16	0001 0110

and so on.

The third column contains the mnemonic and, on the right of that, are comments for the use of the programmer and anyone who reads the program. Even the most experienced programmers use this area a lot as it helps enormously to come back to a program later. I usually make a habit of including arrows for the same reason.

The reader will understand most instructions quite readily. The BD or jump to sub-routine instructions cause the micro to jump and execute special short routines held in memory addresses E1AC and E1D1. These are provided by the manufacturer in a special dedicated chip called a Read Only Memory (ROM) for the obvious reason that the micro can read memory contents but cannot alter them by sending in new data. I shall have more to say about these devices later. The first sub-routine halts everything until an input is received from the keyboard; the second causes a printout of the contents of Accumulator A.

The BNE instruction (Branch if Not Equal) may, however, cause some furrowed brows. If we're jumping back seven instructions, why the FA? The answer lies in a clever little provision by the manufacturer of the micro. Following a Branch instruction, data from 1 to 7F is read as a FORWARD jump while from 80 to FF is read as a BACKWARD jump, counting down.

Finally, the 3F instruction is vital. Without it, the micro would read whatever else happened to be in that memory location and would execute it. The chump doesn't know when it's finished, you see. Inevitably the whole thing would 'bomb'.

For a variety of reasons I have a personal preference for machine code programming over any other computer language. I find it precise, economical, and altogether highly satisfying. I use it whenever I can. Of course other people will have their preferences, too, but I stress my own here to encourage those who may be put off by apparent dif-

iculties and talk of programs 'bombing'. Firstly, the difficulties are more apparent than real and like most difficulties tend to disappear when one gets down to the job. Secondly, even if the program does 'bomb', nothing has been damaged. All that has happened is that the memories are loaded with rubbish — that and nothing else. One simply reloads the program.

Under the age of 11, no programming of any kind should be attempted by even the brightest children and one should not expect machine code programming to be attempted by anyone under 13 or 14, but the broad outlines can be learned by children in the middle school. That is to say, they should be aware of the hex coding of instructions and have a general idea of how these instructions are carried out by the micro.

Compilers

It very soon occurred to some bright folks that there was no reason why the computer should not be used to write programs — that is to say, treating an objective program like any other form of data to be worked on. With memory stores running into thousands, it seemed that some could be put aside to form a sort of look-up table so that the human user could input the mnemonics of Table 1 and get in return the machine code applicable. It proved to be very easy of realisation. From there it wasn't very difficult to having the computer write out the entire program in machine code from the sorted list of mnemonics provided by the user. The stumbling-block of JUMP instructions was hurdled by the simple expedient of applying a unique code word at every point to which a jump was made as well as from which a jump was made. Thus all that the program did was run through the objective program twice — the first time assembling all the hex instructions and the next time counting the length of jumps. When the program was finished it could either be printed out for use elsewhere or on another occasion, or be transferred to memory ready for immediate use.

Notice very carefully that the second (objective) program was produced as a complete program in its own right. Once it had been compiled, the original compiling program was no longer needed.

Interpreters

The essential point to grasp about an interpreter computer language is that it is working all the time. As the name

10	LET X = 4
20	INPUT Y
30	PRINT X * Y
40	END

Table 3 Sample Basic program

```

30 PRINT X * Y
10 LET X = 4
40 END
20 INPUT Y

```

Table 4 Runs exactly as program in Table 3

suggests, the interpreter stands between the machine and the human operator, constantly translating inputs and outputs from one to the other. Such a computer language is termed 'high-level' and there are many such available today. Fortran was the first on the scene, but there are also Cobol, Basic, Lisp, Pascal, Pilot and many others, some of which are applicable to one manufacturer's product only. Every language has its own vocabulary and syntax and is like learning any other language such as Latin or French. (One would be perfectly entitled to put on forms, 'Languages spoken - Computer'.)

Of all the widely-used high-level languages at the present time, Basic is the easiest to learn since it uses a number of well-understood English words and phrases such as RUN, STOP, GOTO and so on. Because of this, Basic is a firm favourite among those learning programming for the first time. Every manufacturer of home computers offers it - some in several versions, with more and more facilities on offer.

The great advantage of interpretive programs is that they relieve the human operator of the necessity to keep track of data. No longer is there any need to tell the computer to put this data in that register or take this data out of any particular memory - the program does that automatically, while the human operator can concentrate on the overall strategy. If we want two numbers multiplied, we say so. The interpreter does the rest.

It should be clear that an interpreter is a highly-specialised machine code program in which a programmer has already done all the hard work. His program decodes our English inputs into hex instructions. It is his program that keeps track of all the registers, memories and what-have-you. His program keeps notes of where everything is.

Compare Table 3 with Table 2. The two programs do exactly the same job of multiplying by four any number that is put in, and printing out the answer, but how much easier it is to understand the Basic program of Table 3! How much quicker to program it!

Before we go on to compare the two programs in a little more detail, a few notes should be made for the benefit of readers who are new to it all.

Each line in Basic must have a statement number. I have given them the numbers 10, 20, 30 etc, but they may be any numbers at all, up to 9999. When the program is run (by typing RUN, incidentally), the Basic interpreter executes the statements in numerical order. If the program of Table 4 was entered, it would be executed exactly as Table 3. The advantage is that extra statements can be inserted at any time without the necessity of retyping the whole program.

The statement LET X = 4 causes the interpreter to pick a memory location of its own choosing, load it with the value 4 (translated into binary) and label the memory 'X'. The label is stored in a special section so that whenever the program encounters the variable 'X', it goes first to the memory store to find where it has put the value it has labelled.

The same applies to the next statement, except that an INPUT statement causes the program to wait for a value to be input from the keyboard, exactly as the BDEIAC instruction of Table 2. The value is then dealt with as before.

Line 30 is self-explanatory, but notice that an asterisk is used for the multiply sign, to prevent confusion with an X. As for line 40, some versions of Basic don't even need to be told to stop. When no more instructions are available, they stop of their own accord. Other

versions insist upon it and won't run until a STOP or END statement is inserted.

The operator types the program exactly as per Table 3 (or 4) and then types RUN. The result is exactly as in the previous program examples - a question-mark for a prompt and when a number is typed in, the computer prints out four times the number.

At first sight, Basic might appear to be quicker and simpler and use less memory, but this is simply not so. The very simplest Basic takes up nearly 3000 memory stores by itself, while a good working version will use 8000. The very best versions occupy no less than 16000 memory stores, but these are very sophisticated versions indeed, with some very advanced features not likely to be needed by many people, although with the plummeting cost of memory, today's luxuries become tomorrow's necessities. More and more manufacturers are offering Basic as a plug-in extra, with a subsequent saving in memory anyway. As an indication, most home computers are provided with an initial memory store of 4000-8000 and these can be easily added to.

A much more important difference between machine code and Basic is speed of operations. Basic can take up to 1000 times the operating time of machine code for the same function. The reason why is not hard to find. The complete program of Table 3 is loaded into memory almost as it is - each symbol translated into binary. While running, the Basic program must access each memory - maybe thousands - to find the next statement to be obeyed. Then it must bring out all memories pertaining to that statement, decode them, sort out the data part(s) from the instruction part(s) and go through thousands of similar operations before it can obey the instruction.

Figure 1 might help to make the situation clearer. The micro itself works in binary. The running Basic interpreter works in hex, while the user's program is superimposed on Basic and utilises English and decimal arithmetic. Every single letter, symbol and number of each instruction must be translated step by step all the way down to binary, worked on and then re-translated all the way up. The achievement is astonishing, especially when one considers that for 99 percent of the time the user is unaware of any delay whatsoever because the peripheral devices are not as fast as the interpreter.

Nevertheless, there are times when one is rudely aware of how slow the interpreter can be. The writer has more than one Basic program that is so slow that one has time to drink a cup of tea while waiting for a response. There is no doubt that if speed is required, machine code provides it. One would expect some improvement in the speed of interpreters in the future, but even without it there would always be considerable scope for Basic. For one thing, it is excellent at number work and for another, it is supreme as a learning tool.

On balance, it is my conviction that in the world of tomorrow the greatest impact will come from machine codes and their derivatives, the language of the microprocessor. The reasons for this conviction will I hope become clear later in this series.

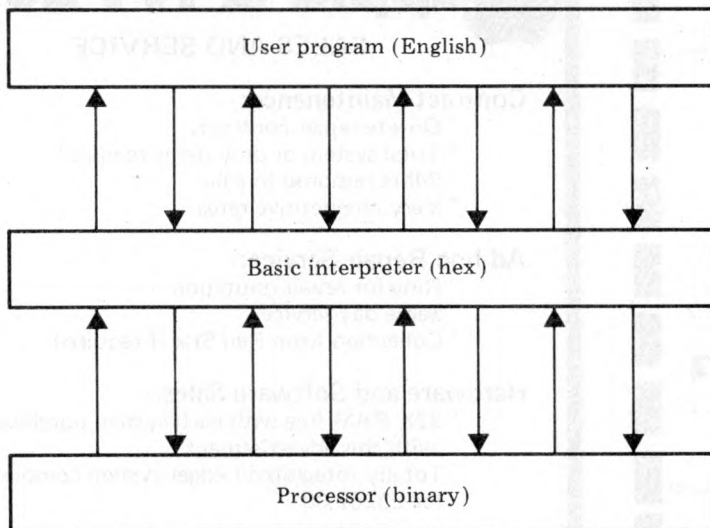
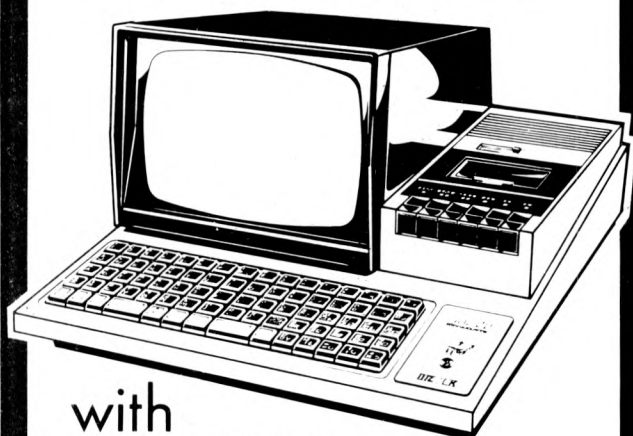

Fig 1

SHARP MZ-80K



with
48K RAM

£460 + VAT.

*includes delivery within Mainland U.K.

*includes 12 months guarantee.

*tested before despatch

*bona fide official orders welcome

Prices.	Nett	VAT	Total
MZ 80k Computer 48k RAM	460.00	69.00	529.00
MZ 80I/O Interface unit	82.00	12.30	94.30
MZ 80 FD Dual Disk Drive	650.00	97.50	747.50
MZ 80 P3 Printer	430.00	64.50	494.50
CP/M Operating System	200.00	30.00	230.00
PC 1211 Pocket Computer	82.00	12.30	94.30
CE 121 Cassette Interface	12.00	1.80	13.80

ledger and stock control available free with full system purchases.

I enclose cheque/P.O. for: _____

Access: 5224

Barclaycard 4929

Name _____

Address: _____

Post Code _____

Goods required _____

24 Hour - 7 Day ANSAPHONE SERVICE on 051-236 0707



25 BRUNSWICK STREET,
LIVERPOOL L2 0PJ.
Tel. 051-227 2535/6/7



Mail Orders to:
MICRODIGITAL LIMITED
FREEPOST (No stamp required)
Liverpool L2 2AB.

MICRODIGITAL



**CRYSTAL ELECTRONICS
CC ELECTRONICS**

THE SKY'S THE LIMIT FOR YOUR SHARP MZ80K with SHARP CP/M 2.21 (XTAL)

CP/M is the trade mark of Digital Research

**This sophisticated interactive program
development system will give your home computer
BUSINESS/INDUSTRIAL potential.**

Basic CP/M facilities include:

- Dynamic file management
- General purpose editor
- Fast assembler
- Advanced debugging utility

YOUR SHARP CP/M 2.21 (XTAL) PACKAGE INCLUDES

- Hardware modification (if fitted by a SHARP dealer does NOT break the guarantee)
- SHARP CP/M 2.21 (latest version) on disc
- XTAL Monitor and Operating system
- 7 Digital Research manuals
- CP/M Handbook (by RODNAY ZAKS)
- 12 months guarantee and up-dates

**IF YOU ARE A SHARP MZ80K OWNER, CP/M 2.21 (XTAL)
IS A MUST FROM £200.00**

Ask your SHARP dealer for further details or contact
CRYSTAL ELECTRONICS

**CP/M SOFTWARE HOUSES - XTAL CAN HELP YOU
ESTABLISH YOUR SOFTWARE ON THE SHARP**

Members of Computer Retailers Association & Apple Dealers Association

Shop open 0930-1730 except Saturday & Sunday

40 Magdalene Road, Torquay, Devon, England. Tel: 0803 22699

Telex 42507 XTAL G

Access and Barclaycard welcome.



COMPUTERS
AND
COMPONENTS



FERGUSSON COMPUTER SERVICES

For All Your

 **apple & ITT 2020**
SALES AND SERVICE

Contract Maintenance:-

- * On-site repair contracts
- * Total system or only items required
- * 24hrs response to calls
- * Very competitive rates

Ad-hoc Repair Service:-

- * Ring for repair quotation
- * Same day service
- * Collection from Red Star if required

Hardware and Software Sales:-

- * 32K RAM free with each system purchased with this advertisement
- * Totally Integrated Ledger system complete for £3262.00

For further information ring
Byfleet (09323) 45330

Fergusson Computer Services

"Sharberry", Maitland Close, West Byfleet, Surrey

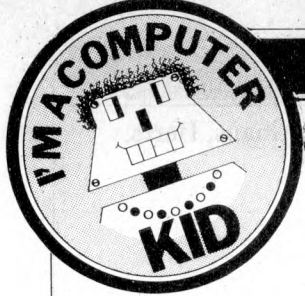

Kit comments

I was informed recently that a computer kit is 'easy — just like Airfix.' The young man expressing this view had never assembled a computer kit before, so it was really quite arrogant of him. As might be expected, he had cause to regret his rash words when his assembled computer refused to oblige with a screen prompt and he was forced to seek help.

In a way, he was right — a kit is a kit and if you follow instructions the thing should go together quite well. The trouble is that not only is there a constructional element to the task but an electronic element, too. Now, given great care, some skill and a little luck, the assembled kit should work perfectly as soon as it's switched on, so why do so many constructors need help?

I regard kit construction as a task involving the correct solution of a multitude of puzzles. Components need to be correctly identified, for example, and manufacturers of electronic components don't help with their frequently confusing markings. Then there's the need for neat soldering. Just the tiniest solder splash can prevent a computer from working, or even destroy expensive ICs. A solder splash can also provide puzzling symptoms of malfunction, sometimes intermittent, which are the worst faults to locate.

Manufacturers of kits may not thank me, but I also have to point out that assembly instructions are usually inadequate and often misleading. I cannot criticise too freely, however, because I know from experience how difficult it is to write instructions that are clear and yet concise. Then again, the writer of the instructions must start assuming knowledge on the part of the constructor, otherwise he would have to begin by telling you how to plug a soldering iron into the mains and switch on! (Even then, I suppose that someone would complain that it didn't explain what a soldering iron was and why wasn't one provided with the kit?)

Then there's that difficult-to-quantify commodity — experience. The experienced constructor will have a multitude of little dodges to help him in his task, wrinkles that no-one is going to bother to write down because, individually, they are trivial

but which together are labour-saving and usually successful. They are the stuff of experience and, as tyros in a card game find out, experience doesn't come cheaply.

I told the story of my young friend to a chap even older than I and he sighed heavily. 'Ah, the arrogance of the young!' he said, shaking his head. I don't think there's much difference between arrogance and confidence — and I'm in good company: Winston Churchill once said, 'I am confident; you are arrogant; he is pig-headed.' Without the confidence to try, I am sure that many tasks would never even be attempted, let alone brought to successful conclusion. An old saying has it: 'He didn't know that it couldn't be done — so the fool just went out and did it.' He must have been young.

So — if you fancy constructing a computer kit, go right ahead. As I said, with great care, some skill and a little luck, you'll succeed. Notice, however, that I mentioned only a little luck and a lot of care. The job must be approached with respect — it is most definitely *not* 'just like an Airfix kit'!

Teachers' PET

Teachers and administrators with a PET computer will be interested in the Schools Administration System offered by the Mellor Computer Consultancy, 125 Longhurst Lane, Mellor, Stockport. Using student records as a database, the system produces lists of all kinds, standard letters, labels and figures for the DES Form 7. It also produces the analysis of exam results, option pools for the Secondary Third Year and even substitution lists for absent staff.

It looks good to me. Apparently the work was commissioned by Manchester LEA, and Mellor will be pleased to send you details or give demonstrations.

Queueing

If you have ever helped out in a shop or in any place where the public come and go, you will have noticed that you are 'run off your feet' at one time and then, suddenly, things go quiet. That's just how it is here. After the last few months, with programs and letters dropping on my mat by every post, suddenly there there's a breathless hush!

Unless I've said something to upset every youngster who reads YCW — it must simply be the fickle finger of random events. It does mean, however, that I cannot include a 'Programs Received' section this month, 'cause there ain't none! (Bang goes my chance of making a take-over bid for PCW!)

Like the shopkeeper scurrying to serve everyone as quickly as possible, I have made it a Golden Rule to clear my desk every month and this has meant that only the very best programs received in any month have been published. Now I find myself without a single one! So I think that for the future I'll hang on to those 'second division' programs a little longer, just in case. In fact, a sort of queue.

So, all you budding genii, we still want those programs and letters. Long programs are good; so are rehashes of old games, but short programs and new applications are better!

Helping the blind

Talking of new applications, one lady approached me at the PCW Show with a request for help. She is a teacher of

backward children who also suffer from sight defects — tunnel vision, partial blindness and so on — and she wanted to know how the micro-computer could help. Of course, I was able to tell her about speech synthesisers and the like, but it occurs to me that somewhere in the great Out There there'll be somebody with more ideas.

How about it? Get your thinking caps on and let us — and her — know about your bright notions. You'll be doing a lot of very unfortunate kids a lot of good. You may like to submit your suggestions to the 'Year of the Handicapped' competition — see elsewhere in this issue.

Arcade games

Another lady teacher raised a point that worries a lot of people. Is the arcade-type of computer game a 'good thing' or a 'bad thing'? She was definitely 'agin 'em,' as are (I think) most teachers. Me — I'm not so sure. I have a sneaky feeling that kids who get hooked on arcade-type games are very soon going to want to alter them and start writing their own — and then they're into programming.

The amusement arcade itself is another matter — very often unsavoury and unwashed characters hang about these places and the prices charged are, in my view, extortionate. But the game itself, on a home, club or school computer — why not? I would like your views on this matter. Do the arcade-type games do anything at all other than exercise manipulation skills?

It's a topic for a discussion that could get quite hot!

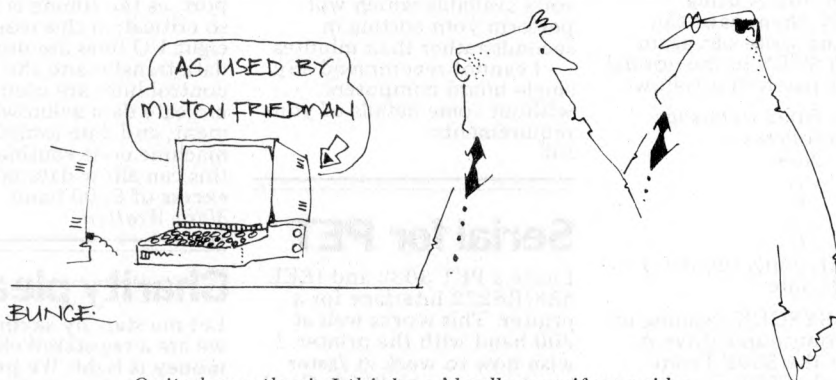

Quite honestly sir I think we'd sell more if we said, "As used by J.R."

COMPUTER ANSWERS

Send your queries to: Sheridan Williams, 35 St Julians Road, St Albans, Herts.



RML disks

I have a problem writing programs for the RML 380Z that are totally portable. How do I instruct CP/M that when I want to access disk drive C, I really mean drive C?

B Spinburg, Leominster.

I think I had better explain your question in more detail for those who are confused. CP/M accesses disk drives as A, B, C, D, etc, not 1, 2, 3, 4, etc. Research Machines chose to label its disks as follows: left drive/left side = A; left drive/right = C; right drive/left side = B; right drive drive/right = D.

The reason is to maintain compatibility with all versions of its single and double-sided drives and those with either one or two drives. It could have been made more simple, in my view, by making the whole of drive one accessible as a single drive, in a similar manner to CP/M on the North Star Horizon.

I had the following answer given to me by RML who replied very promptly indeed:

'With the newer versions of our EPROM monitor, COS 3.4 and later, there is a relatively simple patch. A table at address 40 defines the characteristics of drives A to C. Thus to make all references to drive B refer to drive C, you need merely make the contents of address 41 the same as address 42.

With earlier COS versions it is necessary to patch the basic I/O system (BIOS) of CP/M. CP/M should be read into memory from the system tracks of disk A using SYSGEN, then make the patch, and write out again using SYSGEN in the normal way. See patch that follows:

Patch to BIOS to change drives as follows:

Old	New
A	A
B	C
C	A
D	C

NB: RML 380Z CP/M 1.4 and 1.4B only.

1. Run SYSGEN, reading in CP/M from source drive A.
2. Enter the 380Z Front Panel with CTRL F and make the following changes. Note that "xx" will vary. Use old

value from 1F9C at address 1F99.

Addr	Old	New
1E99	15	1C
1E9C	19	15
1EEA	19	15
1F95	0E	79
1F96	00	87
1F97	18	32
1F98	05	FA
1F99	79	xx
1F9A	32	C9
1F9B	FA	00
1F9C	xx	0E
1F9D	C9	00

3. Type K and carry on with SYSGEN.'

SW

Collecting garbage

Which computers besides the PET exhibit the garbage collection problem? I wish to sort 100 strings in less than one minute; is that reasonable and, if so, how? Can you recommend any single board computers?

Len Wood, Bourne End, Bucks.

The problem of garbage collection is not caused by the machine or by the language Basic but by the particular version of Basic. Normally garbage collection is meant to aid the programmer, not hinder him but the problem comes to a head when sorting. As far as I remember, all versions of Basic that I have used on different machines have this problem and your solution lies in one of the methods outlined in a previous 'Answer': compare the strings for order, but swap pointers, not the actual strings. A better solution is to buy one of the many machine code sorts available which will perform your sorting in seconds rather than minutes.

I cannot recommend any single board computers without some details of your requirements.

SW

Serial for PET

I have a PET 3032 and IEEE 488/RS232 interface for a printer. This works well at 300 baud with the printer. I wish now to work at faster baud rates, up to 9600. Can I write a machine code program using the 'user

port' as an RS232 serial port? I need a program that will accept serial data at up to 9600 baud and place it somewhere in memory so that I can look at it in Basic.

Graham Smit, Warmond, The Netherlands

Although it is possible to write a routine which will make one of the data lines available on the user port act as a serial transmitter, it is not really practical for high baud rates; it is difficult to provide an accurate timing pulse because the PET has to service the keyboard, run programs, etc.

It would be better to adjust the interface to run at a higher speed. This can normally be done by changing a switch setting, or by twiddling a potentiometer inside. At high baud rates it is important that the computer knows whether the receiving device is capable of accepting data. This is normally done by providing another wire, which the terminal sets to a negative voltage when it is incapable of receiving data. If this is not provided, but the terminal is capable of sending data to the computer, then the same procedure can be carried out in software. Failing this, the data must be sent in packets which the terminal can handle. If the PET is receiving data, it will be necessary to write a machine code routine to accept the data and place it directly in memory, as Basic is not fast enough. It will be necessary to reset the Basic top of memory pointers to reserve a section of store as a character buffer. In this case the software method of handshaking would be the best.

The user port can more readily be used as a parallel port, as the timing is not so critical; in this case the eight I/O lines are used for data transfer and the two control lines are used to indicate data acknowledgement, and data available. A machine code routine to do this can allow data rates in excess of 9600 baud.

Mark Wratten

Charity plea

Let me start by saying that we are a registered charity, so money is tight. We provide industrial therapy for all Birmingham and much of the West Midlands. Our need is to

provide regular surveys giving us and our clients better insight to the operation of the unit, to obtain a general view of our turnover and the success rate of our placings outside, along with current trends. We have no experience at all of computing, and no contacts whatsoever. We need a very elementary machine with the logic of a simpleton. Would the Sinclair ZX80 be of any use?

R M Heney, BITA, Birmingham

Mr Heney provided a fairly comprehensive description of the required data structure but only minimal description of what routines he requires. He is in obvious need of a systems analyst who can help them determine what he really wants. He obviously knows what he wants, but will have to be shown how to specify his requirements in detail.

All that I can say at this stage, Mr Heney, is that the ZX80 is not at all suitable for your purpose and that you do not require an elementary machine.

If anyone in the area is prepared to advise BITA, I will forward their letter. I would have thought that they should approach a local computer club as a first step, but am not convinced that they should try and get all the work done for free. Are all their requirements performed free by other trades? By asking for free program analysis they may find that they are lumbered with a very poor makeshift program which actually costs them more in extra work. Anyway, good luck to them in their search.

SW

Tuscan tips

I am looking for an inexpensive single-board computer with flexible expansion possibilities, which will permit data capture in the laboratory, as well as some analysis. Have you any views on the Transam Tuscan in this context?

A Sharp, Tayport, Fife

The Transam Tuscan is most unusual in being a single-board micro-computer designed to the new S100 standard. The important feature of S100 is that the computer is designed

to take slot-in expansion card cards, all made to the same standard bus design, so that (in theory at least, and usually in practice) an S100 card from any manufacturer can be used in any S100 machine.

This obviously makes the Tuscan potentially attractive for your application — whatever I/O or processing facility you need, just plug in the right card! With so many suppliers, there's almost bound to be a source for what you need, whether it's A to D, D to A, a disk controller, extra memory, floating point arithmetic, etc. Of course, the cost can soon mount up with all those cards... although the Tuscan can only (!) take five extra cards at one time.

Another advantage of the Tuscan for your needs is that, being based on the Z80, it can be used with the CP/M disk operating system. This will then allow you to pick and choose your software from a wide range of sources. You can obtain a variety of different assemblers, and interpreters or compilers for many high-level languages... Basic, Pascal, APL, Fortran, even Micro-Cobol.

However, when comparing prices you should bear in mind that the advertised starting price of £195 is just for the basic board, and does not include such essentials as a keyboard, UHF modulator, etc. You may well prefer to attach a standard VDU with its own keyboard, rather than add these features separately.

The micro-computers which seem to have become the most used for your type of application are the PET, and the Hewlett-Packard HP85. While the PET would be not dissimilar in price to a Tuscan plus keyboard and screen, the HP85 at nearly £2000 is in another price bracket. It might also be worth looking at the type of system you could put together using Microtan 65 and Tanex, with associated racks and cards.

P L McIlmoyle

Cassette subs

Can you suggest a subroutine to provide cassette data file statements for the Nascom 2 similar to the INPUT # -1 and PRINT # -1 on the TRS-80? As well as this, a method of switching the cassette on and off under program control would be welcome bonus.

A Hetherington, Cleckheaton

Much as we would like to help, neither PCW nor I are philanthropic institutes, for this task is not so simple! To write, debug and validate machine code sub-routines of this sort would

almost certainly cost several hundred pounds at least!

Enough of the bad news. The good news is that it's already been done, in effect. As you may know, there are a number of Basic interpreters commercially available for the Nascoms. At least one of these (XTAL Basic from Crystal Electronics) has the ability to CSAVE and CLOAD data in arrays. Indeed, this same facility is available in Nascom's own 8k Basic, designed specifically for the Nascom 2. However, while this feature is available when running with the T-4 or NAS SYS monitors, it is not available with the ROM or EPROM versions of Nascom 8k Basic running with the T-2 Monitor.

P L McIlmoyle

Dates disgust

I was really disgusted at September's 'Computer Answers' in which some moron called Sheridan Williams has used my Gregorian to Julian algorithm without acknowledgement. It doesn't work; when implemented properly it does. It should be valid from 1/1/190 1/1/1900 to infinity not just to year 2400. You shouldn't use real arithmetic and neither should you use Basic which is not suitable for describing algorithms or any other purpose. As anyone who has used structured programming can tell you it is easy to understand several short routines than one long one. Using integer arithmetic is much faster also.

R J Baker, London

I want to answer this letter, as it gives me the opportunity to answer others who enquire whether they should go for Pascal or Basic. The above is just a precis of a very long letter from someone who felt that they had a grievance, and I have sent a detailed reply to him personally even though he didn't send an SAE and despite his abusive turn of phrase.

Each time you boil a kettle, do you credit the people who discovered how to boil it before you? The Gregorian to Julian problem is nearly as trivial, especially as I have seen 10-year-olds work out their own algorithms. The algorithm used was my own discovery. Why would anyone who wants such an algorithm require one that works outside the range 1901-2399 especially when used for business purposes? Also, why worry whether the answer takes 0.02s or 0.01s to run — it is being performed once only, therefore time and accumulation of errors are insignificant. Running cine films at 300 frames per second is quicker than 25

fps but for ordinary viewing is pointless.

I agree that Pascal is a better language but so is a Rolls-Royce compared with a Mini (or should I say Metro). The point is that you need a larger system to run Pascal than you do Basic. The magazine would not sell well if we ignored all those ZX80/Acorn Atom/PET/etc owners. ZX80 owners are usually very short of memory (sorry, their machines are!) and an algorithm such as mine is essential to reduce the amount of coding. If they were to use your program they would have used a large chunk of their precious memory. I assume that you are the proud user of a disk-based system and perhaps have forgotten the more lowly users. I do agree that, generally, a well-structured program is easier to read, but remember that there are libraries of sub-routines that have been compiled and tested and which don't have to be decyphered before they can be used.

Finally there is an error in the routine, not mine but PCW's; the two sets of signs should read \mp not \pm .

SW

Small machines, big question

I would like to buy a computer for around £200 including VAT with the aim of eventually being able to do the following: 1, learn to program from the manual provided; 2, use floating point arithmetic and trigonometric functions; 3, play games with fast-moving graphics; 4, play the computer at chess; 5, write teaching programs, including text, for my children; 6, program in machine code; 7, use a computer-driven speaker; 8, not have to change my initial machine for a more powerful one later.

Could you comment on this list in relation to the Sinclair ZX80, the UK101, the Ohio Superboard, the Acorn Atom and any others that could be considered?

Could you also comment on the differences between the Superboard and the UK101, the difference between a single board, and a computer proper, and whether programs in Basic taken from a book of programs could be used in any machine with Basic.

I R Walker, Ilkeston

Taking your points in the same order:

1. Excellent as some manuals may be, (and leaving much to be desired, as others do), it's hard to beat a good book if you want to learn to

program. Personally, I like *Illustrating Basic* by D Alcock. Ideally, go on a course, get a friend to teach you, or join the local computer club, where you'll get 'hands-on' experience; 2. The original version of ZX80 Basic provides neither floating point nor trig functions. These will be available in the future for the ZX80 and are available for all the other three machines; 3. I haven't come across chess programs for any of the machines you mention, but that's not to say that they may not be around, or become so later. I wouldn't suggest writing your own, unless you are expert in both chess and computers! 5. Yes, all four machines will let you write teaching programs, using text. You might well find yourself wanting to add extra memory if you go in for a lot of text; 6. Machine code programming is possible on all of these computers, although the ZX80 is limited to PEEK and POKE; 7. The Acorn Atom is the only one of the machines you list which has an in-built loudspeaker; interfacing the others would need some skill in electronics, at the least; 8. If you want to avoid having to change your computer by expanding it to take more memory, disks, a printer, etc, then the Acorn Atom is designed for just that. An expansion system for the Ohio Superboard and the UK101 has just been announced by Zen Computers while such facilities for the Sinclair ZX80 are still in the future;

The Superboard and the UK101 are very similar, the most obvious differences are the number of characters per line on the screen (25 for the 'standard' Superboard, 48 for the UK101), and the price. The Superboard is only available made up, and in this form is cheaper than the UK101. However, the UK101 in kit form is cheaper.

Single board computers are indeed 'computers proper'. It's just that they are rather small computers! By definition all the components are located on a single printed circuit board, and this is usually sold without a case, though cases are becoming available for many of them.

If you take programs in Basic from books or magazines, you will very often have to alter them to suit the particular 'dialect' of Basic used by your machine. This is especially true of input/output and file statements. If the programs use PEEK or POKE statements you will have to alter the addresses to match your machine's memory map.

P L McIlmoyle

Discover the full professional power of Hewlett-Packard's personal computer.

Now you can extend the HP-85's power simply by plugging in high-performance printers, plotters and flexible disc systems.

Power where you need it.

The HP-85 puts professional problem-solving power wherever you need it. There's a video display with high resolution and editing capability. A whisper-quiet thermal printer for hard copies of display graphics and alphanumerics. A magnetic tape unit with up to 217 K of storage per cartridge. And a complete keyboard, including eight keys you can define yourself. Powerful, easy-to-use features, thanks to HP's extended BASIC programming language.

Decide the peripherals you need.

HP's Interface Bus (HP-IB/IEEE-488) lets you add up to 14 peripherals or instruments. No need to write special operating programs—HP's peripheral ROMs do it for you.

New HP enhancement ROMs and modules give you access to 80 K bytes of operating system, without significantly reducing user memory. The HP 2631B printer means high-speed, high-quality printing. And the HP 7225 Graphics Plotter gives you high-resolution, publication-quality graphics on paper or film.

For extra memory storage, use the HP 82900 series of 5¼" flexible disc drives. Each drive gives you about 270 K bytes of formatted storage on double-sided, double-density discs. The operating system is in the Mass Storage ROM, leaving the HP-85 main memory free.

Behind the HP-85 computing system is the strength of Hewlett-Packard. Continuous commitment to quality. One-source service and support.



For more details or a demonstration, contact your nearest HP Dealer shown below.



**HEWLETT
PACKARD**

Contact your nearest dealer for a demonstration. **Aberdeen** Tyseal Typewriter Services, Tel: 29019; **Belfast** Cardiac Services, Tel: 625566; **Birmingham** Anglo American Computing, Tel: Colleshill 65396; Taylor Wilson Systems, Tel: Knowle 6192; **Bournemouth** South Coast Business Machines, Tel: Wimborne 893040; **Brighton** Office Machinery Engineering, Tel: 689682; **Bristol** Decimal Business Machines, Tel: 294591; **Cambridge** Cambridge Computer Store, Tel: 65334; **Chelmsford** Automatic & Electronic Calculators, Tel: 69529; **Dublin** Abacus Systems, Tel: 711966; **Edinburgh** Business & Electronic Machines, Tel: 226 4294; Holdene, Tel: 668 2727; **Glasgow** Robox, Tel: 221 5401; **Leeds** Holdene, Tel: 459459; **Leicester** Sumlock Services, Tel: 29673; **Liverpool** Rockliff Brothers, Tel: 521 5830; **London** Automatic & Electronic Calculators, Tel: 247 1886; Euro Calc, Tels: 739 6484, 636 8161, 405 3113; Sumlock-Bondain, Tels: 250 0505, 626 0487; The Xerox Store, Tel: 629 0694; **Manchester** Automated Business Equipment, Tel: 432 0708; Holdene, Tel: Wilmslow 529486; **Newcastle** Thos Hill Group, Tel: 739261; **Newport** Micromedia Systems Ltd, Tel: 59276; **Reading** CSE Computers, Tel: 61492; Sintrom Electronics, Tel: 85464; **Royston (Herts)** Electroplan, Tel: 41171; **Southampton** South Coast Business Machines, Tel: 22958; **Sunderland** Thos Hill Group, Tel: 42447; **Tunbridge Wells** DJ Herriott, Tel: 22443/4; **Wallingford** Midas Advisory Services, Tel: 36773; **Watford** Automatic & Electronic Calculators, Tel: 31571; **Woking** Petallect Electronic Services Ltd, Tel: 69032; **Worthing** Office Machinery Engineering, Tel: 207292; **Channel Islands:** (Guernsey) Professional Business Systems, Tel: 26011, (Jersey) Professional Business Systems, Tel: 75611.



POKER

David Levy peeks at poker.

For some reason which I fail to understand, poker is one of the most widely misrepresented games ever invented. Most people who do not know how to play poker consider it a game of luck, in which the person who gets dealt the best cards wins. I have even heard highly intelligent people refer to poker as a 'base, gambling game'. And there are those who associate poker with the card sharps of the 19th century Mississippi steamboats and assume that every poker player is some sort of low life. These opinions could not be further from the truth and, in my opinion, there is no less skill in poker than in chess or bridge.

The game of poker that became famous during the days of the Wild West is now known as five-card draw and is still popular. But there is another family of poker games which require even greater skill and which are much more interesting to play: these go under the generic name of stud poker. This month, I shall describe in some detail how a stud poker program might be written and next month I shall write about the older form of the game — draw poker.

Five-card stud

Briefly, each player is dealt one card face down and one card face up, and may look at his own down card. A round of betting takes place, and all those who put in the necessary amount of money on this round will stay in the game and receive a second face up card (the others drop out of the hand). After receiving the second up card, the players indulge in another round of betting and, once again, those who put in the necessary remain for a further round, while the others drop out. The third up card is followed by another round of betting, and then comes the fourth and final card up and the fourth and final round of betting. When the last round of betting is over, those remaining in the hand turn over their one down card, and the player with the best five cards wins the money. In order to determine whose cards are the best, the following ranking applies to the hands:

Straight flush: This is the best type of hand to have, and most regular poker players will only have such a hand a few times in their life. A straight flush is five cards of the same suit which are in an unbroken sequence, for example the 6 7 8 9 and 10 of hearts.

Four of a kind: As its name suggests, this type of hand has four cards of the same denomination.

Full house: Three cards of one denomination and two of another, for example three 6s and two aces.

Flush: All five cards of the same suit but not in an unbroken sequence.

Straight: All five cards in an unbroken sequence, though not all of the same suit.

Three of a kind: Three of the cards are of one denomination, the other two are not of the same denomination as each other.

Two pairs: For example two aces and two 7s — the fifth card is of no importance unless two players have the same two pairs, in which case the fifth card breaks the tie.

One pair: Aces is the highest pair, then kings, queens, and so on down to 2s. **High card:** If a player has none of the above hands, then his holding is valued in accordance with the highest denomination card in his hand (ace is high) and then if two players have the same high card their second highest cards are compared and so on.

So much for the procedure and the ranking of the hands. Various betting options exist in most forms of poker, the most common ones being:

Bet: At the start of a round of betting, one player is first to speak. There are various methods for deciding who is first to speak and in stud poker it is usually the player with the highest face up cards. He has two options, he may bet or he may 'check'. If he wishes to add to the money in the pot, the player bets, by putting into the pot any amount of money that is in accordance with the house rules. We shall assume that we are playing 'pot limit', which means that the size of the bet may be anything from one unit up to the total amount of money already in the pot. So if the pot stands at £10 and we are playing in £1 units the first person to speak may, if he wishes to bet, put in any amount from £1 to £10.

Check: If the person whose turn it is to speak does not wish to bet and no-one else has put money in on that round of betting, he may say 'check', which means that he does not wish to put money in at this stage but he may decide to do so when it is next his turn. If, at any time in a round of betting, all the players check in succession, then the round of betting is over.

Call: Once someone has put some money into the pot during a round of betting, the next player must put in at least the same amount if he wishes to remain in the game. Putting in the same amount as the others is known as calling. When all the players have put money into a particular betting round, that round may only end when all of the players bar one have called — at that point everyone has put in the same amount.

Raise: Is it possible to put in more than the previous bettor and this is known as raising. If the first player puts in £1 and the second player wants to put in an extra £1, he will say something like 'your £1 raise £1', and put £2 into the pot. Once there has been a raise it is necessary for all the players after the last raiser to call the bet before the round is at an end, so that everyone will have contributed the same amount to the pot. The maximum that can be raised is the amount in the pot before the raise takes place. So if the pot stands at £1, and the player bets £1, making the pot £2, the second player can put in the £1 to meet the bet and then raise £3 (the current size of the pot).

Pass: Sometimes known as 'fold'. This is what happens when a player decides that he no longer wishes to take part in this particular hand — he turns his cards face down and relinquishes all claim to the money. Beginners often think that passing is cowardly but in fact more hands are passed by good players than by bad ones.

Some basic principles

Two essential principles should be followed in a game of stud poker. On card two and card three (ie when you have a total of two or three cards, including the down card), you should *never* put money into the pot unless your cards so far, including the down card, can beat every hand that you can see on the table. The reason for this is obvious enough — if your up cards are a 6 and an 8 of different suits, and your down card is a 2, and if your opponent is showing a 5 and a 9 of different suits, you should not be putting money into the pot because you are beaten 'on the table' and your opponent has a hidden card which may well go nicely with the others. Many beginners make the mistake of assuming, in a situation such as this one, that they have just as much chance of 'hitting a pair' (ie getting another 2, 6 or 8 on the fourth or fifth card) as their opponent and so it is almost an even money shot if they stay in the pot. But this is false accounting. Firstly, your opponent may already have a pair — his down card might be another 5 or a 9. In this case he will

INNOVATIVE

TRS-80 SOFTWARE

FROM THE PROFESSIONALS



**Animation
Animation
Animation**

Animate is a machine language program representing an entirely new breakthrough in the use of graphics on the TRS-80 or Video Genie microcomputers. As Walt Disney and others found to their profit some years ago, if you draw a number of separate pictures slightly different to each other, and then display them consecutively sufficiently fast, a moving picture is produced. This is precisely what Animate does. Pictures are built up as a sequence of frames, each one being as small or as large as you wish and composed using an easily used graphics cursor. The entire graphics content of a frame can be shifted in any direction so as to move objects without the need to redraw them in each new position. As each new frame is completed it is automatically stored in memory and given a number, so that it may be recalled and edited at will. The timing of the projection of each frame is definable up to a maximum of 100 seconds. When the picture is completed it may be viewed and edited as you wish. When the final picture is complete it may be stored on cassette as a SYSTEM program. Thereafter it may be loaded and accessed either by Animate or by any Basic program. Thus the same picture may be used in any number of different Basic programs, if you wish. Animate is available at present only on cassette for Level II or Genie machines of 16K and up. A disk version will be available shortly. A comprehensive manual is included.

£14.95

Plus VAT and 75p P & P = £17.94.

Send large SAE (38p) for our current Catalogue of TRS-80 software. Add £1.85 for a binder.



A.J.HARDING (MOLIMERX)

MOLIMERX LTD.

28 COLLINGTON AVENUE, BEXHILL-ON-SEA, E. SUSSEX.

TEL: (0424) 220391

TELEX 86736 SOTEX G



certainly beat you if you do not draw a pair; he may beat you even if you do draw a pair because his pair of 9s or 5s may be higher than your eventual pair; and if he does not yet have a pair and you both draw a pair, he has better chances than you because his cards at the moment are higher than yours, so it will be odds on that his pair will be higher than yours. The only way that you can win is if he does not make a pair and you do, but then your pair may be 'open' (ie both cards face up) in which case he will not put any money into the pot on card five. If you don't believe me, try it for yourself.

The second golden rule is that when betting on card four, don't put money into the pot unless you have 'equity', that is to say, unless the ratio of the money already in the pot to the money you are now putting in is no less than the odds against you having a winning hand when the last card is dealt.

A simple example will explain this principle. Suppose that you hold the 2, 3, 4 and 8 of hearts (the 2 is the down card) and that your opponent is showing the 5 of clubs, the 5 of diamonds and the 10 of spades. The pot stands at £10 and your opponent bets £10. What should you do? In order to win the hand, and to be sure that you are winning the hand, you need to hit a fifth heart to make a flush. Then, unless your opponent already has three of a kind or two pairs, and makes a full house on the last card, you must hold the winning hand. And if he does have a chance of making a full house you will see it from his fifth card, so there will be no danger of your betting too heavily on the fifth round.

Since you need to hit a heart to win and you have already seen four hearts (the ones in your hand), you know that of the 45 unseen cards remaining (the 44 in the deck and the one down card in your opponent's hand) there are nine hearts. The odds against your hitting a heart are therefore (44-9):9, or 35:9 (almost 4 to 1). But your equity, or investment odds, are only 2:1, because there is £20 currently in the pot and you must put in £10 to stay in. In making this calculation it is important to remember that the money in the pot does not belong to you in any way, even though you put some of it in there — the money belongs to the pot until someone wins it. It is also important to remember that you cannot usually count on winning any more money on the fifth round of betting, because your opponent will not be obliged to put in any more money, but there will be some occasions when it is reasonable to assume that your opponent will put money in the pot after the fifth card.

It is precisely because of this concept of equity that it is vital to make a good-sized bet when you are in the lead, because otherwise you are making it cheap or free for your opponent to stay in the pot, and then he may hit better cards than you do later on in which case he will 'steal' the pot. In the above situation, for example, if your opponent bets only £1 instead of £10, he is playing like a sucker. You call his £1 bet and now you have 11:1 money odds while the odds against hitting a winning card are only about 4:1. If your opponent plays like that often enough, in the hope of 'sucking you in' to the pot

when you really should be out of it, he will be sorry to see his financial empire crumbling as you get better cards than him one hand out of five.

These two golden rules provide the basis for solid play in a game of five-card stud. Of course like most rules of thumb, there will be occasions when they should be broken, but it takes a good player to recognise these situations and, until you or your program is a regular winner, you should play it safe. There is one exception, and that is concerned with bluffing, about which I have written a little in the past. To play good poker it is essential to bluff occasionally, but the good player will judge when to bluff by taking careful note of his opponents' styles of play and their mannerisms. I shall write more on the subject of bluffing next month, when we will be looking at draw poker, so for our stud poker program let us assume, for the time being, that there will be no bluffing. I shall give an algorithm for programming stud poker but its parameters are subject to variation at the reader's discretion. In order to illustrate the algorithm, I shall describe one hand of stud poker in some detail and for the sake of simplicity I shall assume that the program is playing against only one opponent — you may extend the principles of the algorithm to a higher number of players and I would recommend five or six as being the right number for a personal computer program.

The algorithm in action

Our stud poker algorithm is based on a system for estimating the probability that our opponent's down card is of a certain denomination. These probabilities are adjusted in the light of information obtained from his play, or more precisely, from the way that he bets during the hand. Other factors, such as bluffing and poor play by the opponent, could also be included in such an algorithm but for the purpose of this example I shall keep things as simple as possible. The reader ought to have little difficulty in generalising from this example, to produce a routine that implements the algorithm successfully.

Let us suppose that when the cards are dealt the program receives the Ace of clubs as the down card, and the 9 of hearts as the up card. The opponent has the 8 of diamonds as his up card.
PROGRAM: (A C) 9 H
OPPONENT: (??) 8 D

Before the betting begins, we can already make certain probability estimates about our opponent's down card. We have seen one ace, one 8 and one 9, and there are 49 unseen cards at this stage in the proceedings. Of these 49 cards three are aces, three are 8s and three are 9s and there are four of every other denomination. So without any more information to go on, we can estimate the probabilities of the opponent's down card being an ace as 3/49, of its being a king as 4/49, a queen 4/49, and so on, giving us Table 1.

The program has the highest face up holding (9 is higher than 8), so it opens the betting. There is an 'ante' of £1 in the pot, so the program bets £1 and the opponent decides to call, putting in £1

DENOMINATION	PROBABILITY
Ace	0.061
King	0.082
Queen	0.082
Jack	0.082
10	0.082
9	0.061
8	0.061
7	0.082
6	0.082
5	0.082
4	0.082
3	0.082
2	0.082

Table 1 Probabilities for opponent's down card before first round of betting (correct to three decimal places)

to make the total amount of money in the pot £3. From the fact that our opponent called, it is reasonable to make two deductions: (a) he almost certainly has a down card which can beat a 9, otherwise he was very foolish to call the bet; (b) he may have another 8, giving him a pair of 8s but if he did have a pair of 8s he might well have raised the bet, so he is probably less likely to have another 8 than to have a 10, J, Q, K or A. (This deduction can be made into a learning mechanism, so that after playing a long session against the same opponent, the program could estimate the number of hands in which the opponent had not raised with a pair on card two.)

We must now apply some formula to adjust the old probabilities in the light of the new information received. This must be done in some way that weighs the importance of the old information relative to the new. Since the information that we had prior to the first round of betting was all *a priori* information, whereas we now have some *a posteriori* information, I would give the new information something like four times as much weight as the older information. Furthermore, I would suggest that we assume it to be twice as likely that the opponent's hole card was an A, K, Q, J or 10 than another 8. So from the assumptions made on the basis of the one called bet we can estimate the probabilities of the various denominations being the opponent's down card as in Table 2.

These fractions come from the fact that we wish to estimate the probability that he holds an Ace, King, Queen, Jack or 10 as being twice as much as the probability of his holding an 8, and we must have all the probabilities adding up to 1. We estimate the probabilities of his holding a 9, 7, 6, 5, 4, 3 or 2 as being zero, on the assumption that he is not playing badly, though as I mentioned before, this presumption can be varied by the program itself.

We must now combine the old and new probabilities in accordance with their weightings (new:old = 4:1), and so the new measure for the opponent holding an Ace as his down card is given by:

$$(0.061 \times 1) + (0.182 \times 4) = 0.789$$

The measure for the King is given by:

$$(0.082 \times 1) + (0.182 \times 4) = 0.810$$

The Queen, Jack and 10 have the same old estimates and the same new estimates as the King, so their revised measures are all given by:

$$(0.082 \times 1) + (0.182 \times 4) = 0.810$$

The measure for the 9 is given by:

$$(0.061 \times 1) + (0 \times 4) = 0.061$$

Exatron Stringy Floppy

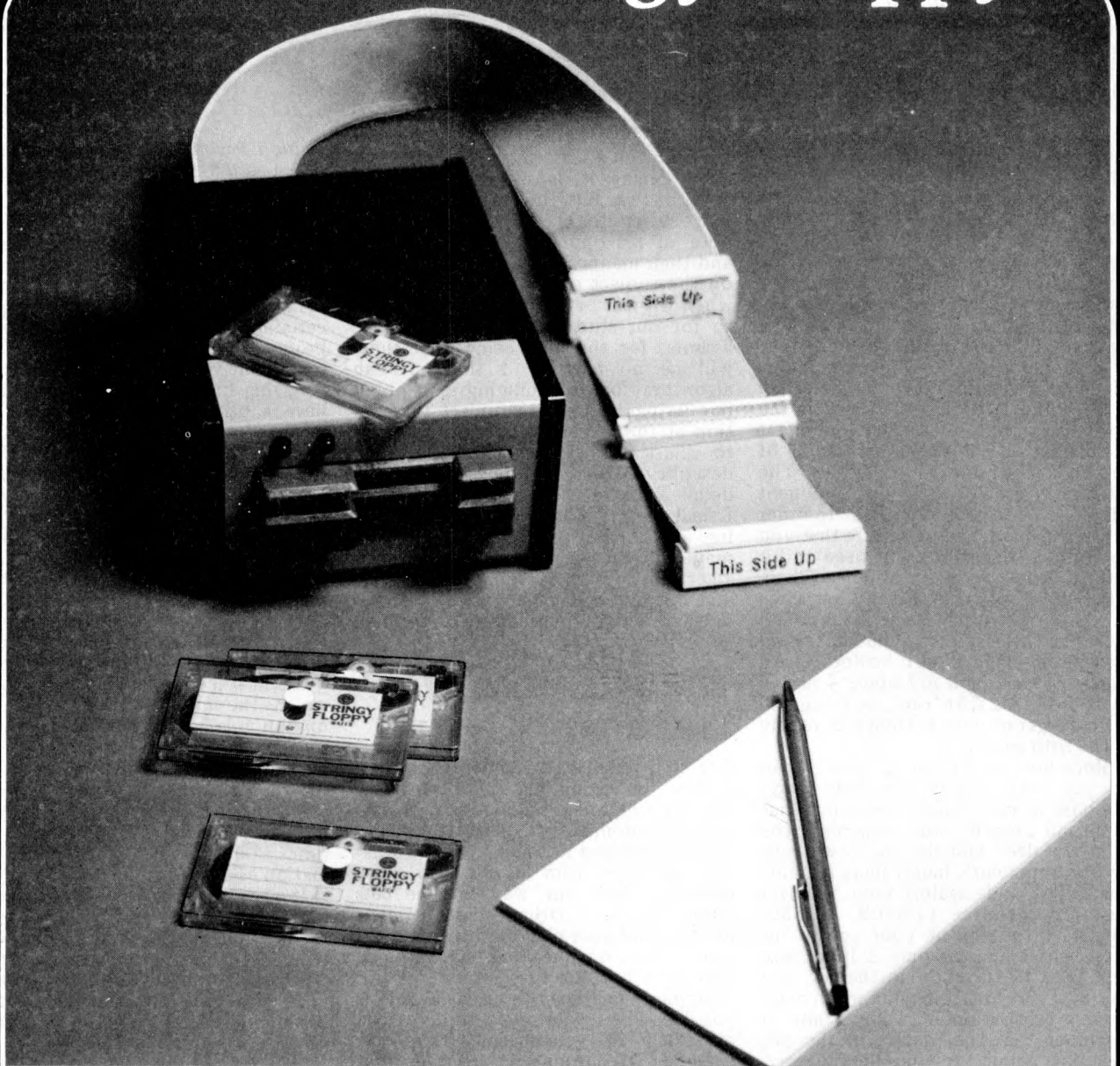

Dealer enquiries invited

The starting point for Professional quality Digital Data Storage System

MBS Terminals

MBS Terminals Ltd., Aldwych House, Madeira Road, West Byfleet, Surrey KT14 6BA Telephone: Byfleet (093 23) 53151 & 49618

Suppliers of Computer Peripherals

Ace	King	Queen	Jack	10	9	8	7	6	5	4	3	2
2/11	2/11	2/11	2/11	2/11	0	1/11	0	0	0	0	0	0

(2/11 = 0.182; 1/11 = 0.091)

Table 2

The measure for the 8 is given by:
 $(0.061 \times 1) + (0.091 \times 4) = 0.425$

And the measures for the 7, 6, 5, 4, 3 and 2 are all given by:

$(0.082 \times 1) + (0 \times 4) = 0.082$

Finally, to arrive at the new probability estimates for all the denominations, we need to normalise these figures so that the total probability adds up to 1. So we sum the above measures:
 $0.789 + (4 \times 0.810) + 0.061 + 0.425 + (6 \times 0.082) = 5.007$

and divide each of them by 5.007 to arrive at the new probability estimates (Table 3).

DENOMINATION	PROBABILITY
Ace	0.789/5.007 = 0.158
King	0.810/5.007 = 0.162
Queen	0.162
Jack	0.162
10	0.162
9	0.061/5.007 = 0.012
8	0.425/5.007 = 0.085
7	0.082/5.007 = 0.016
6	0.016
5	0.016
4	0.016
3	0.016
2	0.016

Table 3 Probabilities for opponent's down card after the first round of betting.

The first round of betting is now over, and the dealer gives each of the players one more card. The program receives the 7 of spades while its opponent gets the 10 of clubs, so the situation on the table now looks like this:

PROGRAM: (A C) 9 H, 7 S

OPPONENT: (??) 8 D, 10 C

and there is £3 in the pot. The opponent is now 'high', ie he has the highest cards showing on the table, since 10, 8 is better than 9, 7, and so it is the opponent to open the betting on this round. He may check, or he may bet anything from £1 to £3. Let us assume that he bets the maximum of £3.

The first thing that the program must do is to determine whether or not, on the basis of the probability estimates that it had before this £3 bet, the opponent is likely to have the winning hand and if so, by what margin of probability. In order to be winning at this stage, the opponent must hold, as his down card, an Ace, an 8 or a 10. An ace would give him A, 10, 8 against A, 9, 7, while a 10 or an 8 as the down card would give him a pair. From Table 3 the program can determine that the probability of its opponent's down card being an A, 8 or 10 is:

$0.158 + 0.085 + 0.162 = 0.405$

So the probability that he does not hold the winning hand is $1 - 0.405 = 0.595$, and the odds against the program having the winning hand are 0.405:0.595, or 1:1.47. If the program calls the £3 bet, since the pot now stands at £6 the program will be getting 2:1 money odds, so the program definitely has enough equity to call the bet because 2:1 is better than 0.68:1. From this

calculation the program may determine that it is safe to call the bet. The algorithm ought to have some randomly-based adjustment in its calculations to determine when to raise rather than call — possibly this might be a probability function whose input parameters are the actual odds against the opponent having the better hand, and some measure of how the opponent sees the situation. It is clearly better for the program, when raising the pot, to have its strength hidden in the down card if it wants the opponent to stay in the hand, while it is better to have all its strength on the table (with the 'threat' of more strength in the down card) if it is trying to bluff its opponent out of the pot.

Having made the above calculations, the program has determined that it is safe to call the £3 bet but since the odds against the opponent having the best hand at this stage are only 1.47:1, it would be a little imprudent to raise at this stage. What the odds should be is not an easy question to answer but I would recommend not raising unless the odds are at least 2:1. (In fact I would recommend an over-riding heuristic, under which the program would never raise when the opponent could have a cast iron cinch, as here, if he has another 10, the opponent knows for sure that he is winning.)

The program therefore calls the £3, making the total in the pot £9 and the dealer gives out another card to each player; this time the program gets the 6 of diamonds and its opponent the Jack of spades, so the situation on the table is now this:

PROGRAM: (A C) 9 H, 7 S, 6 D

OPPONENT: (??) 8 D, 10 C, J S

and there is £9 in the pot. The opponent is still high, since J, 10, 8 is a better holding than 9, 7, 6, but the program's hidden Ace is still an important card, because unless the opponent already has a pair or an Ace, the program is still winning. The situation has now been made even more complicated because the latest cards to be dealt give each player, in theory at least, the chance for a straight if the fifth card is exactly right. For example, if the opponent's hole card is a 9, 7 or Q, he can make a straight on card five by hitting a 7 or Q (if he holds a 9), or a 9 (if he already holds a 7 or Q).

The opponent's betting situation has improved somewhat since his highest face up card is better than the program's highest face up card, the opponent's second highest up card is better than the program's, and so is his third highest up card. So the opponent happily tosses in £9 with a smile on his face that the poor microcomputer cannot see. What should the program do now? Answer: stay calm and calculate the odds. In order to be winning at this stage, the program's opponent must hold an Ace, 8, 10 or J as his hole card. The probability of this, from Table 3, is:

$0.158 + 0.085 + 0.162 + 0.162 = 0.567$

This means that the program probably doesn't hold the winning hand at the moment, but the odds against it holding the winning hand are only 0.567:0.433, or 1.31:1, whereas if it calls the £9 bet it is getting 2:1 money odds, since the £9 bet has made the pot up to a total of £18. Therefore, the program should still call this bet, even though the odds indicate that at this stage it is probably not holding the best cards. So the program calls the bet, the pot stands at £27, and the fifth and final card is dealt. The program gets an Ace while its opponent gets another Jack, so the players have the following cards showing:

PROGRAM: (A C) 9 H, 7 S, 6 D, A D

OPPONENT: (??) 8 D, 10 C, J S, J H

and there is £27 in the pot. The human opponent now feels very smug, with a pair of Jacks showing, and says, 'I suppose I ought to bet something — here is £20.'

The principles apply here, just as they did on the previous rounds of betting, except for the fact that this is the final round, after which whoever has the best cards will take the money. The program calculates that to beat it the opponent must have a Jack (for three Jacks) or a 10 or 8 in the hole (for two pairs). The probability estimates indicate that the total probability of the opponent having the winning hand is:

$0.162 + 0.162 + 0.085 = 0.409$

therefore the odds against the program are 0.409: (1-0.409) = 0.692:1, well below the money odds, so there is every reason to call the final bet.

Refinements to the algorithm

There are various ways in which the reader might care to modify this algorithm. To begin with, there is the fact that when, for example, the opponent hit a 10 at card three, the program knew that its original, *a priori* estimate of the probabilities wasn't accurate because the 10 of clubs was actually still in the deck. At that point it could have recalculated the original *a priori* probabilities in the light of the news that the 10 of clubs and 7 of spades were still in the deck after card two and this would have the effect of making the calculations of the probability estimates more accurate from card three onwards.

Another useful idea is to modify the probabilities all the way through the hand on the basis of the opponent's betting. If the opponent shows strength (ie raises when he could call, or bets when he could check) the program could assume that it was more likely that he held a good card, and adjust the probabilities for the good cards upwards by (say) 10 percent, normalising the others as necessary. If the opponent showed weakness by checking when he might have been expected to bet, then the probabilities for the good cards could be adjusted downwards by 10 per cent.

Bluffing plays an extremely important part in poker, so it would be as well to assume that on a certain percentage of occasions the opponent will bluff, and then adjust this percentage over a

GOTO page 133

FINITE STATE AUTOMATA

David Hebditch discusses a method of designing man-machine interactions.

A 'finite state automaton' may be formally defined as '... a machine that
1. recognises its current state from a narrowly-defined set of states;
2. scans input, character by character, and classifies it according to a narrowly defined set of classes;
3. takes an action and alters its state, based upon the current state and the class of the current input character, (see reference).

Finite state automata (FSA) are extremely useful devices for the formal specification of free-format input messages and to date, they have mostly been employed in language processors. A simple and consistent extension can be employed to convert the specification into a computer program. Where free-format input is not being used, FSAs can be employed to specify the checking to be carried out on 'complex' input fields such as dates, self-checking numbers, structured codes and so on.

A particular benefit of the technique is the ease with which programs may be subsequently modified to incorporate changes in the input format. Furthermore, the technique imposes a standard structure on such programs which further aids their maintainability.

FSAs are defined using circles for *states* and arrows for the *transitions* between them. An example is shown in Figure 1.

Figure 2 shows a simplified state diagram for the input of a date in the format DD/MM/YY (eg 16/6/80).

States are usually numbered sequentially and in Figure 2, State 1 is concerned with 'days' and scans the input, character-by-character, accumulating a numeric item. Slash (/) causes the FSA to move to State 2, which scans the 'month' and the FSA stays in this state while it continues to receive characters 0 through 9. Slash (/) causes a transition to State 3, which accepts numeric characters for the 'year' until any other character causes the FSA to terminate.

Any state diagram may be rewritten in the form of a matrix. This is done by showing the *states* as columns, *input classes* as rows and the *transitions* as 'next state' entries in the matrix itself. There are three states (1, 2 and 3) and '0' can be used to indicate an exit from the automaton. The three input classes are 0-9, '/' and 'other'. So the state matrix for our simple date routine is as below:

Input classes \ States	1	2	3
0-9	1	2	3
/	2	3	0
other	0	0	0

Interpretation is simple; if the FSA is in State 1 and a '3' is entered then the automaton remains in State 2. If a '/' is entered while in State 2, a transition

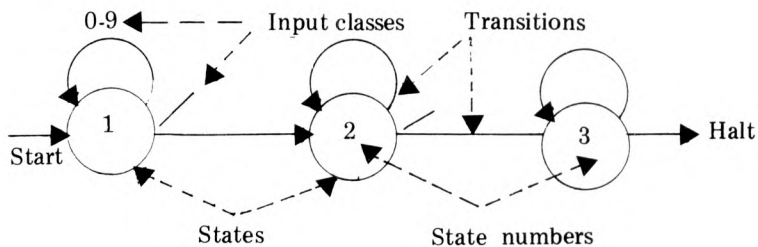

Fig 1

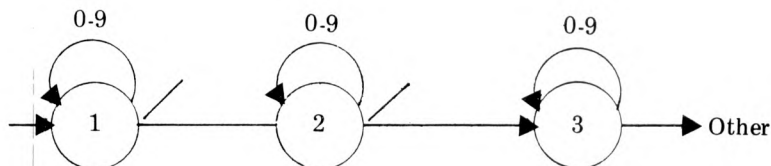

Fig 2

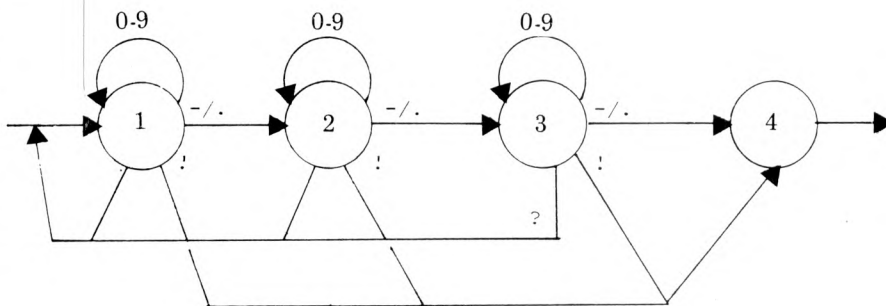

Fig 3

takes place to State 3.

Of course, this routine is oversimplified. The state diagram shown in Figure 3 is more comprehensive. Try to interpret it before reading further.

A number of 'improvements' have been made. These are:

- 1 Hyphen (-) and point (.) are now acceptable alternatives to slash (/) as delimiters.
 - 2 If at any time the user presses '?' the input so far is cancelled and he can start the date again.
 - 3 Similarly, if the user presses '!' the FSA goes to the 'end' routine. This enables the program to complete the date from the contents of the last date entered. For example, if the user types the date 16-6-80 and subsequently enters 18! the program will transform this to 18-6-80.
- Using '!' alone will 'Dupe' the whole date.

Translating Figure 3 into a state matrix produces:

Input classes \ States	1	2	3
0-9	1	2	3
-/.	2	3	4
? (or other)	0	0	0
!	4	4	4

The matrix shows how the entry of any other character causes the date to reset. If this is not the desired approach 'other' characters could be included in a different class (eg 0-9).

The *state matrix* merely indicates the logical flow of the Finite State Automaton. No actual processing is taking place. To define the checking and manipulations of the input we make use of an *action matrix*.

Note: Actions always take place before transitions. The actions which may be required in our date example will include:

- concatenating one numeric digit with the previous one;
- storing a complete input number as a 'day';
- storing an input number as a 'month';
- storing an input number as a 'year';
- checking the complete date.

The action matrix for the date example is shown below, along with a list of the actions to be taken. (It is assumed that initialisation has taken place).

Input classes \ States	1	2	3
0-9	A	A	A
-/.	B	C	D
? (other)	E	E	E
!	F	F	F

FACE TO FACE

Actions:

- A Concatenate digit
eg N = N * 10 + digit
 - B Store number as 'day'
eg D = N : N = 0
 - C Store number as 'month'
eg M = N : N = 0
 - D Store number as 'year'
eg Y = N : N = 0
 - E Reset all items
eg N = 0 : D = 0 : M = 0 : Y = 0
 - F Duplicate as necessary
eg IF D = 0 THEN D = OD
IF M = 0 THEN M = OM
IF Y = 0 THEN Y = OY
- Check for errors (see below).
If no errors save date eg OD = D:
OM = M : OY = Y
Exit date routine.

For the time being, the error checking has been omitted.

Clearly, it is not practical to continue to treat the logical structure of the FSA and the associated processing separately. Combining the state-flow and action-together makes the processing of the FSA much clearer. Given that the action must always take place before the state-transition makes the merging of the matrices simple. A combined matrix for the date routine is shown below:

Input classes	States					
	1		2		3	
	A	NS	A	NS	A	NS
0-9	A	1	A	2	A	3
-/.	B	2	C	3	D	4
? (other)	E	0	E	0	E	0
!	F	4	F	4	F	4

A = Action
NS = Next State

Error handling

The same matrix concept may be employed to specify the occurrence of error conditions in an FSA. The type of error which may occur includes:

- day number not in the range 1 through 31;
- day number too large for month
eg > 28, > 29 or > 30;
- month number not in the range 1 through 12.

Some conditions (eg input character not in an acceptable class) may be handled in the state matrix (eg by returning to the beginning of the input sequence).

A possible error matrix for our date routine may be as below:

Input classes	States		
	1	2	3
0-9	0	0	0
-/.	1	2-3	4
? (other)	0	0	0
!	5	5	5

Errors:

- 0 No error message but Action
 - 1 Day < 1 or > 31
 - 2 Month < or > 12
 - 3 Day > 28, > 29 or > 30 for certain months:
- eg
D > 28 and M = 2
AND Y MOD 4 ≠ 0
D > 29 and M = 2
AND Y MOD 4 = 0
D > 30 and

(M = 4 or M = 6 or M = 9 or M = 11)
4 LEN (Y) > 2 AND NOT END-OF-STRING
5 NO PREVIOUS DATE ENTERED
(ie OD = 0 or OM = 0 OR OY = 0)
but Action F exits date routine.

The error handling can be further incorporated with the earlier combined matrix as follows:

Input classes	States								
	1		2		3				
	A	NS	A	NS	A	NS			
0-9	A	1	0	A	2	0	A	3	0
-/.	B	2	1	C	3	2-3	D	4	4
? (other)	E	0	0	E	0	0	E	0	0
!	F	4	5	F	4	5	F	4	5

The number of states, input classes, actions, conditions and errors will obviously vary according to the complexity of the item being processed.

The programming of finite state automata is relatively easy and can be performed in high level languages so long as they support the following functions:

- two-dimensional matrices and
- ON ... GO TO ... or
ON ... GOSUB ... or
PERFORM ... DEPENDING ON ...

functions.
The following example shows how the date processing routine can be programmed in MBASIC.

This material is based on a paper presented by T A Dimock of Cornell University at a conference 'Pragmatic Programming and Sensible Software' held in London in 1978.

```

1000 REM *** DATE CHECKING SUBROUTINE ***
1010 REM (C)1980 DAVID BERTHOUD.
1020 REM
1030 REM *****
1040 REM
1050 REM DEMONSTRATES THE USE OF...
1060 REM ...FINITE STATE AUTOMATA
1070 REM ----- IN THE CHECKING
1080 REM OF FREE FORMAT ITEMS OR MESSAGES FROM
1090 REM INTERACTIVE DIALOGUES.
1100 REM
1110 REM *****
1120 REM
1130 REM USE OF VARIABLES AND VARIABLE-NAMES.
1140 REM -----
1150 REM
1160 REM DT$: Contains the input date.
1170 REM RT: Contains the return code.
1180 REM RT=0 - No error.
1190 REM RT=1 - Error found (message in E$).
1200 REM E$: Contains the error message.
1210 REM D$: Contains the day.
1220 REM M$: Contains the month.
1230 REM Y$: Contains the year.
1240 REM MA: Contains the master array
1250 REM - four states by
1260 REM - four input classes by
1270 REM - action / next state entry.
1280 REM PD$: Contains previous day.
1290 REM PM$: Contains previous month.
1300 REM PY$: Contains previous year.
1310 REM NY$: Contains current number (as string).
1320 REM NY: Contains current number (as value).
1330 REM C$: Contains current character.
1340 REM
1350 REM
1352 IF NW=1 THEN 2000 : REM ROUTINE ALREADY SET UP
1354 NW=1 : REM NO SET UP NEXT TIME
1355 REM
1360 REM *****
1370 REM
138 REM DIMENSION ARRAY AND SET UP VARIABLES
1390 REM -----
1400 REM
1410 RT=0 : REM Return code for no error
1420 PD$="": REM Previous day.
1430 PM$="XX": REM Previous month.
1440 PY$="XX": REM Previous year.
1450 REM
1460 OPTION BASE 1: REM Set first array element number to one.
1470 REM
1480 DIM MA(4,4,2) : REM master array: format is
1485 REM
1490 REM MA(STATE,CLASS,ACTION-NEXT)
1500 REM -----
1510 REM
1520 REM The next routine sets up the master array.
1530 REM
1540 FOR STATE=1 TO 3
1550 FOR CLASS=1 TO 4
1560 FOR ACTION-NEXT=1 TO 2
1570 READ MA(STATE,CLASS,ACTION-NEXT)
1580 NEXT ACTION-NEXT
1590 NEXT CLASS
1600 NEXT STATE
1610 REM
1620 GOTO 1690 : REM GO PAST THE DATA STATEMENTS.
1630 REM
1640 REM DATA STATEMENTS FOR THE MASTER ARRAY
1650 DATA 1,1,2,3,0,0,4 : REM STATE 1, CLASSES 1-4
1660 DATA 1,2,3,3,5,0,6,4 : REM STATE 2, CLASSES 1-4
1670 DATA 1,3,4,1,5,0,6,1 : REM STATE 3, CLASSES 1-4
1680 REM
1690 REM SET UP INPUT CLASS STRINGS.
1700 REM
1710 DIM INCLASS$(4)
1720 REM
1730 INCLASS$(1)="0123456789" : REM INPUT CLASS 1
1740 INCLASS$(2)="-./." : REM INPUT CLASS 2
1750 INCLASS$(3)="?" : REM INPUT CLASS 3 (+OTHER)
1760 INCLASS$(4)="!" : REM INPUT CLASS 4 (+END)
1770 REM
1780 GOTO 2000 : REM GOTO START ROUTINE
2000 REM *****
2010 REM
2020 REM MAIN ROUTINE TO PROCESS DATE USING FSA.
2030 REM -----
2040 REM
2050 STATE=1 : REM Start with STATE ONE.

```

GOTO page 135

A Word Processor, Report Writer, Mailing System, Data Base Manager, and a Computer all for £1995*

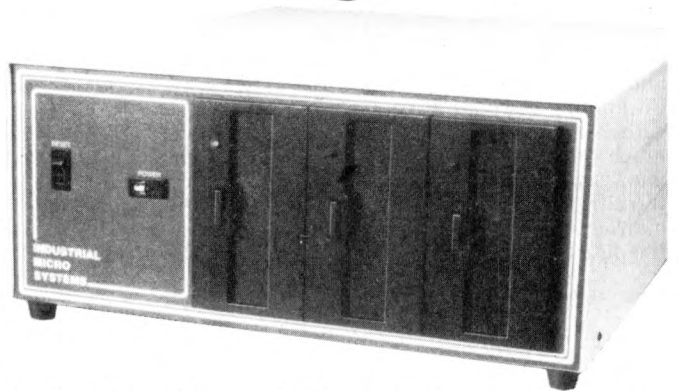

Yes, we are offering all this with our SERIES 5000 5" floppy-disc system for the incredibly low price of £1995.*

Not only do you get a powerful Z-80A system on the S-100 bus built to high quality standards by Industrial Microsystems, one of the longest and best-established companies in the microcomputer industry, and supported by Equinox, specialists in microcomputers and multi-user systems.



You also get the popular CP/M Operating System (from Digital Research), a 12-slot bus for easy expansion, a Z-80A CPU for powerful performance, 2 serial and one parallel interfaces, 64KB of dynamic RAM with in-built error detection capability,

and dual 5" double-density drives with the option of a third drive (or quad capacity drives in place of double-density) in the same cabinet. Additionally, there is the Turbocharger option providing both enhanced disc capacity, disc performance and diagnostics. And if even greater storage is required we can supply 8" floppy drives and cartridge disc drives.

A powerful system for the computer-user and system developer – and one with eventual access to OS/2000, the Industrial Microsystems networking system.

And for the office or business user we are including as standard a powerful Word-Processing package (Wordstar), a Mailing and Letterwriting package (Mail-Merge) and the Datastar Data Base Manager. All these packages are widely accepted and professionally written by Micropro International.

Being CP/M based, the system with suitable configuration will also run the business software developed by (for instance) Graffcom, Peachtree, Paxton, etc.

It will also run a wide range of languages – Basic, Cobol, Fortran, Pascal, APL, Algol, C.Lisp, and Forth and will support a wide range of add-on S-100 devices, such as floating point processors, Prestel interfaces, speech synthesisers, digitisers and plotters, etc.

And just to make certain that you get full use out of your system, nationwide field service support is available at a modest extra cost.

*add VAT and the terminal and printer of your choice at the costs shown.

Series 5000 with 64KB Dynamic RAM, dual 5" double density drives, CP/M Operating System, Wordstar, Mail-Merge and Datastar £1995

The same system with quad drives in place of the double density drives £2230

Add-on double density drive £290

Add-on quad drive £405

Peripherals:
Televideo 912C VDU £595

Elbit 1920X VDU with Wordstar keyboard £895

OKI Microline 80 printer £595

Texas 810 150cps printer £1450

NEC Spinwriter RO Word processing printer £1850

All prices exclude VAT, carriage, training and installation and are subject to our standard terms and conditions.

OEM dealer and educational enquiries welcome.

EQUINOX
COMPUTER SYSTEMS LIMITED

Kleeman House, 16 Anning Street,
New Inn Yard, London EC2A 3HB
Tel: 01-739 2387/9 & 01-729 4460

PRINTER INTERFACING

Peter Faff continues his series on low-cost printers and how to connect them to your micro.

This month I will continue by looking at examples of matrix printers that are readily available. Each month I will try to give examples of printers that use all three technologies to give you as much choice as possible. Each article will contain a description of the mechanical operation of the printer, details of the printer timing signals and ways in which the printer could be interfaced to a control circuit or micro.

These articles are intended to be used as design guidelines by persons with a reasonable amount of knowledge of, and experience with, digital circuitry. Beginners will find that full constructional projects for working matrix printer units have been published in the well-known electronic hobby magazines over the last few years.

TI Thermal printers

Texas Instruments manufactures two types of thermal printer mechanism — the EPN 9112 12-character printer and the EPN 9120 20-character printer. Both are available from Marshalls and cost approximately £38.00 and £52.00 respectively. The mechanical construction of both units is similar and very simple. The paper feed is carried out by a large-diameter rubber roller which is driven via a gear chain by a stepping motor. The ceramic print head is clipped into a holder and is held against the roller by spring pressure. The print head itself consists of a parallel array of heating elements which are multiplexed into groups of five — see Figure 1, which also shows the electrical connections to the printers. The print heads are fabricated on a ceramic substrate using beam-lead technology. Each element has a diode connected in series to eliminate problems when the elements are multiplexed. The elements should run from a supply of about 14 V and they require a pulse width of about 10 ms; the peak current drawn by a cold element is about 200-300 mA, falling to 50-100 mA as it warms up. Figure 2 shows a suggested drive circuit that can be used with both units. The five-element connections should be taken to 14 V to heat an element, and at the same time a digit connection should be grounded to enable a particular digit. To use the minimum amount of power, the elements should be enabled one at a time while the digits are strobed sequentially, although if a faster print rate is required then a number of digits could be grounded while a particular element is energised; this way several dots can be printed at the same time, at the cost of increased power consumption. The connection to the EPN 9112 is by a flexible 18-way printed circuit connector while the EPN 9120 uses a 25-way wire connector (see Figure 3). In both cases,

the motor requires a supply of approx 17 V; the two windings should be energised in turn to rotate the motor by one step and a circuit to achieve this is given in Figure 4.

The Texas Instruments thermal printers are reasonably simple to use. For an interface and control circuit, the basic units required are as follows: (i) a RAM array to hold one line of character data, ie, 12 or 20 6-bit words; (ii) a character generator ROM that outputs data in 5-bit rows. This ROM should allow the data for one character to be output row by row; (iii) element drive, digit select and drive and motor control circuits, and, finally; (iv) hard-wired control logic or a suitable program to control all the above units. Figure 5 is a block diagram of a suggested system.

Figure 5 shows a 5 x 7 character cell; a typical ROM will contain 64 such character cells which can be selected by a 6-bit address bus while a further 3-bit address line allows the user to select one of seven rows of five bits. The line of data to be printed is stored in the RAM array. When

printing starts, the control logic uses a 3-4 bit address line to select the digit to be printed, the RAM outputs the 6-bit digit data to the character generator ROM and at the same time the control logic selects the first row to be printed. When the row has been printed, the control logic selects the next digit and the data for the next character is fed to the ROM. This is repeated for 12 or 20 digits. After a full line of 5-bit rows has been printed, the control logic selects the next row stored in the character generator and again steps through the 12/20 digits. After seven rows have been printed the cycle is completed and a new line of data can be entered into the RAM. After each full row of dots has been printed, the motor should be incremented by one step; in this way a line of characters is printed sequentially in groups of five dots. If you do not like the idea of building a circuit to do all this then you can, of course, write a suitable program but you will still require a character generator ROM and the interface circuits to drive the printer.

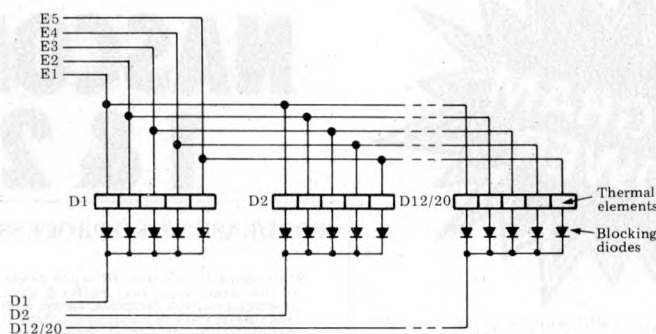

Fig 1 Electrical configuration of EPN 9112 and EPN 9120 print heads.

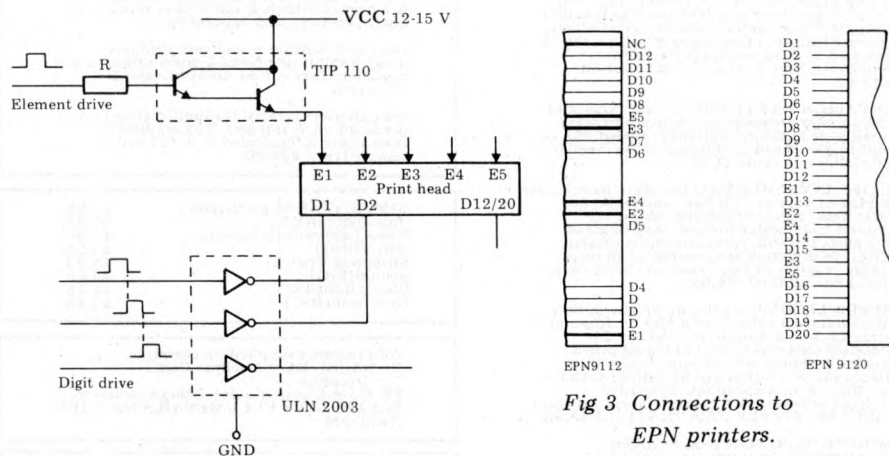

Fig 2 Suggested drive circuit.

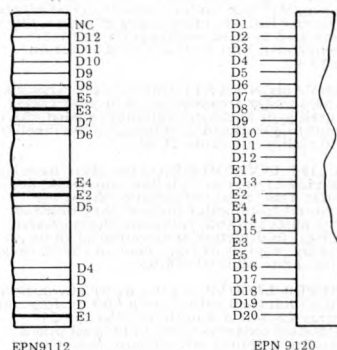

Fig 3 Connections to EPN printers.



L&J COMPUTERS

3 CRUNDALE AVENUE, KINGSBURY NW9 9PJ 01-204 7525

THE "PET" SPECIALISTS



BUY A PET FOR CHRISTMAS!
at advantageous prices

AVAILABLE FROM STOCK

Pet 8K (large keys) £420 *
Pet 16K £499 *
Pet 32K £630 *

Ext. cassette decks (+ counter) £55 *
8032 (80 col. screen: new keyboard)

SUPERPETS NOW EX-STOCK!

Printers	Disc Drives	Sundries
PAT 3023	PET 3040	Tool kits: library cases
PET 3022	Compu 400K	Disks: C12 cassettes
Centronic 779	Compu 800K	Paper (roll & tractor feed)
Spinwriter	Interfaces	Labels: Dust covers

**TRY US!
YOU WILL NOT BE
DISAPPOINTED**

SOFTWARE

As well as a full range of Petsoft and Commodore Software, we have some highly reliable "Home-Brewed" programs available.

STOCK CONTROL & INVOICING £60
(Handles up to 500 items - 32k) (80 on 16K). Stock depleted on invoicing, search etc. Cassette, disk (& colour print option).

CASH BOOK £90
Enter daily/weekly amounts printout and totals, weekly monthly analysis, totals and balances.

MACHINE HIRE Typewriter & Plant Hire £420

STOCK TAKING Cuts out all the hard work £230

OUTSIDE SERVICES (For Mini-Cabs etc.) £220

Sae for free software booklet

SPECIALISTS IN:

Commodore Business Programs: Superpay;
Bristol Trader, Item & Monitor: Word Processing

**SPECIALISED SOFTWARE APPLICATIONS
UNDERTAKEN. RING FOR DETAILS**

2 FOR JUST OVER THE PRICE OF 1!

We now have limited stock of new cassette decks with a built-in counter soundbox for PETS!
At ONLY £65*
Orders dealt with in strict rotation.

The "MUPETS" are HERE!

3 to 8 PETS only need 1 DISK DRIVE . . .

Daily demonstrations: Ring for details.



**COMPLETE SYSTEMS
FROM £1700!!**

**THE ESTIMATES WE SUPPLY & INSTALL ARE COMPLETE
ESTIMATES GIVEN FREE WITH NO HIDDEN EXTRAS:
FULL BACK-UP: GUARANTEED EXPERTISE.**

* PRICES DO NOT INCLUDE VAT

**PERSONAL SHOPPERS WELCOME
Phone & Mail Orders accepted.**

**ALL GOODS SENT SAME DAY WHEREVER POSSIBLE
LARGE S.A.E. FOR LISTS ETC.**

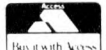

Buy it with Access



NASCOM 1 & 2

WORDEASE-WORD PROCESSOR (MC)

Professionally written 4K word processor:— 14 line window on text buffer & extensive on-screen editing facilities. Insert & delete characters, lines & paragraphs. Text manipulation—copy from one section of text to another, or read in additional material from tape to any point in the text. FIND & REPLACE facility.

Exceptional formatting capability:— commands embedded in text allow complete flexibility e.g. variable tab position, indent, line length & page length. Use of up to 10 'MACROS' permits automatic inclusion of headings, footings & other 'text repeats', & also automatic page numbering.

Output to printer — can vary character delay, inhibit line feeds & force upper case if required. Text can be saved on tape & recovered.

An extensive manual is supplied (itself prepared on WordEase). The method of formatting is illustrated in detail with a sample text. £25.00

SUPER STARTREK(B/16K)	£9.95
Spacefighter(B/G)	£7.95
Alien Labyrinth(B/G/16K)	£7.95
Driver(B/G)	£6.95
Sheepdog Trial(B)	£5.95
Slalom(B/G)	£5.95
Biorhythm(B/G)	£4.45
Labyrinth(B/G)	£5.45

All programs supplied on cassettes.
B= BASIC, MC = Machine Code.
G = Graphics.
8K RAM required unless otherwise stated.
PLEASE GIVE FULL DETAILS OF YOUR NASCOM

**NASCOM 1 — Cottis Blandford Cassette Interface for N2 format, reliability & fast load. £16.30 or £13.30 with program order.

MUSIC BOX

Now you can make music with NASCOM. Easy to follow program allows you to key in old favourites or have fun composing your own tunes. 7 octave range with staccato option, 9 tempos. Set note duration or tap in rhythm as required. Comprehensive editing. Delete, insert or amend notes. Single-step forwards & backwards through tune. Add new lines within declared array size. The program includes tape generating & play-back routines & is supplied with 2 demonstration melodies & instructions for connecting your Nascom to an amplifier/speaker such as our unit below. Min.16K required — please state T4 or Nas-sys/2 or 4 MHz/with or without graphics. **Only £13.95**

MUSICAL BREAK-OUT/ (MC/G)

You have 8 chances to hit all the bricks out of a moving wall. The object is to keep the ball in play. As in squash, the angle of bounce is not always predictable. Good reflexes required. If fitted with an amplifier/speaker, different notes are produced on hitting the various bricks. **£6.95**

COWBOY SHOOT-OUT(MC/G)

Full feature Cowboy Shooting game for 2 players. Two versions played alternately — firstly, shoot your opponent across 'Main Street' avoiding the moving Chuck Wagons and then through a wall which has to be demolished first. Complete with sound of shots & musical accompaniment when fitted to an amplifier/speaker. **£6.95**

AUDIO INTERFACE BOARD & SPEAKER

Compact & ready assembled, suitable for use with "Music Box" & other 'sound effects' programs. 3 simple connections. Complete with instructions on programming for sounds £9.75.

Please add 45p/order P & P.
V.A.T. of 15% payable after 14/1/81.
Sae for FULL CATALOGUE to
PROGRAM POWER
5, Wensley Road,
Leeds LS7 2LX.

Telephone (0532)683186.

LUNAR LANDER SUPREME(32K/B/G)— classic spacecraft landing simulation. Short, medium & long-range scans show planet surface in varying detail. Continuously updated STATUS REPORT gives vertical, horizontal & relative velocity, altitude, fuel level, G factor & surface scan for suitable landing site. 8 skill selections. Brilliant graphics £13.95

STARTREK II(32K/B/G)—enthralling, real-time version from our Invasion Earth author, using M/C code sub-routines to great effect. Special features include larger galaxy, shielded homing warheads (fired by Klingons), time slots & non stop action. £13.95

INVASION EARTH (MC/G)—fast version of the popular arcade game. 4 invader types/intelligent homing, exploding, angled, direct, multiple warhead & radio-jamming missiles. 40 skill levels. Only £9.95

CLIFF INVASION(B/G)—the aliens have landed in droves. You have one remaining laser base. Your only chance—shoot the ground from under them as they descend the cliffs towards you. Landslides created. Errors in direction & elevation of shots are costly. 3 levels of skill. Like all aliens, they breed like rabbits! £8.95

SUPER LIFE(MC/G)—the BEST!—Evolution of a biological colony with 100 by 125 cell array (2/3 or 3/4 options). Use the 21 standard patterns or set individual pixels. Rotate & reflect any pattern. Select from 10 speeds. Evolution can be halted, patterns modified & new speed set. Extensive instructions—overlay technique keeps program within 8K. SIMPLY FASCINATING! £8.95

MINI-TOOLBOX(MC)—aid to BASIC programming. Features are:— REPEAT KEY, AUTO line numbering, Decimal to HEX & HEX to Decimal conversions, RECOVER (from CLOAD error) & Multiple USER(X) routines. Resides in spare memory from OC80HEX. £7.95

Olivetti series-parallel thermal printers

This is probably the most common thermal printer in existence. It can be found in various guises in the majority of thermal printing calculators, and is also available as a new unit, type PE 1800, from Datac Ltd for approx £38. To save wear and tear on my typing finger I will refer to the Olivetti series — parallel printer as the OSPP from now on.

The OSPP is a compact 20-column matrix printer that is mechanically very simple and reliable. The character field is divided up into 20 columns of five dots each by an internal timing disc and so the unit is not suitable for continuous graphics. The print head comprises ten thermal elements and each element prints two characters — see Figure 7.

As you can see from Figure 7, each element covers two characters and during each print cycle a total of 100 dots can be printed by each element. A print cycle starts and finishes with the print head at the extreme right of its travel. This point is indicated by the timing signal STLN. When the motor is operated, a cam causes the print head to oscillate across the paper. The print head begins to move from right to left and the strobe disc generates dot timing signals DT1 and DT2 which can be simply connected together. After ten DT signals have been produced, the mechanism causes the paper to space up by one dot line and the print head reverses direction to move from left to right generating

a further ten DT signals. After these ten DT signals, the print head is back in the start position and another STLN signal is generated. The cycle can be continued as above to cover another two dot lines until the next STLN signal. After five STLN signals, a complete field of 100 dots will have been covered and the print cycle should be stopped by turning off the motor.

The timing signals are generated by a rotating disc and wiping contact arrangement within the printer and Figure 8 gives the full relationship between the DT1, DT2 and STLN signals and the dots that go to form a character. When the motor is running at the correct voltage the pulse widths should be approximately as shown.

From Figure 8 it can be seen that the two dot signal lines DT1 and DT2 carry alternate pulses. These pulses indicate when the print element is in the correct position to print a dot. In practice, the DT1 and DT2 signals should be connected together to give a pulse train that consists of discrete groups of five pulses. This pulse train should be debounced by a monostable with a pulse-width of approx 1.5 ms; the resultant signal can then be fed to the control logic to determine the sequence that dots should be printed to build up a character. It can also be used to enable the high current drivers for the individual heating elements.

The signal STLN occurs after every 20 DT signals and indicates that the print head is in the home position. STLN should be debounced by a 2 ms monostable and the resultant signal is used by the control logic to stop the

printer at the correct point in the print cycle. From Figure 8 you will see that it takes 100 ms to print two dot lines and it will thus take approx half a second to print an entire line of characters and line space ready for the next line of print.

The printer comes with a 17-way flexible PCB connector. Figure 9 shows how this is wired. The OSPP comes in several versions, with or without a paper release lever. The mounting arrangements (feet) can differ and there are several motor voltages but this should cause little trouble since the important characteristics are all the same.

The supply rail for the elements is approx 20 V and to heat an element it must be connected to ground; a current limiting resistor of approx 47 ohms should be used in series with each element and the drive signal should be gated by the DT1 + DT2 signal to give a current pulse of about 1.5 ms. To get a good print it may be necessary to alter the values of the current limiting resistors. The drivers could be darlington's or VMOS FETs — the choice is left to you.

The motor will operate from a supply of about 6 V and the motor control circuit should contain an electronic braking circuit to ensure that the printer inertia does not cause the motor to coast on past its home position. The easiest way to brake the motor is to short the two terminals together when the supply is removed; this allows the motor's back emf to bring the motor to a swift halt. Again the finer details of the circuit are left

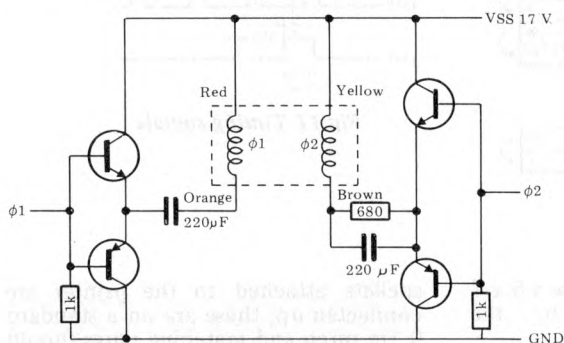

Fig 4 Suggested drive circuit and timing for stepping motor.

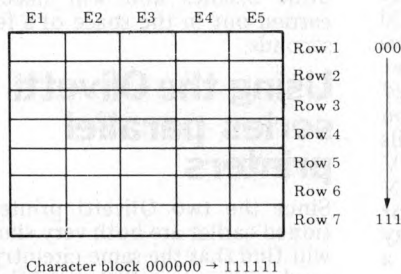

Fig 6

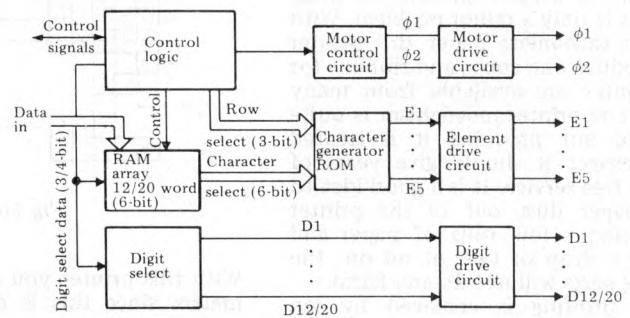

Fig 5 Block diagram of suggested control circuit for TI thermal printer units.

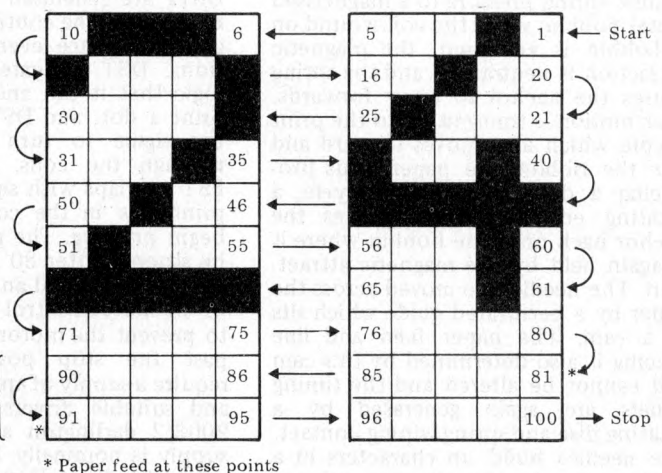

Fig 7 Print area covered by each print element.

to the constructor.

The element drivers and the motor control circuits are quite straightforward but the difficult bit is the rest of the control logic that decides when to print a dot to build up each character. To keep the control logic simple you should let your micro do most of the hard work of selecting which dot to print. To print a line of characters it is necessary to turn on or off each of the ten element drivers in sequence. Referring to Figure 7, you can see that one element prints two characters. The characters are printed line by line alternately and the direction of motion reverses after each line; somehow you must generate a serial bit stream corresponding to the numbered dots in Figure 3. Since there are ten elements, the process must be repeated ten times during an interval of approx 3 ms between DT signals. The element drivers should be controlled by a 10-bit latch. The control logic must set or reset each bit in turn, depending on whether or not a dot is to be printed. The outputs of the latch are enabled by the DT1+DT2 signal to print the dots at the same time.

This impact printer mechanism is very similar to the Olivetti thermal printer mentioned earlier. It is a compact 20-column matrix printer and again it is available new (as type PU 1100) from Datac Ltd for approx £59 or it can probably be found living in an Olivetti printing calculator (Logus series). Mechanically, the unit bears little resemblance to its thermal brother but the print is built up in the same way and the timing signals are similar. Since this is an impact printer it generates a certain amount of noise but this is only a minor problem. With two-ply carbonless paper this printer can produce one copy, and ribbons for the printer are available from many shops. The printer mechanism is quite complex but provided it is treated with respect it should give years of trouble-free service. It is a good idea to blow paper dust out of the printer after using a few rolls of paper and putting a drop or two of oil on the rotating parts will not do any harm.

The printing is achieved by ten metal needles which rest in guides under a removable cover. Each needle is coupled to an anchor that moves backwards and forwards, and is held against spring pressure to a magnetised metal bobbin; when the coil wound on a bobbin is energised, the magnetic attraction is neutralised and the spring causes the anchor to move forwards. This motion is transmitted to the print needle which also moves forward and hits the ribbon and paper, thus producing a dot. Later in the cycle, a rotating eccentric shaft pushes the anchor back onto the bobbin where it is again held by the magnetic attraction. The needles are moved across the paper by a perforated guide which sits in a cam. The paper feed and line spacing is also determined by this cam and cannot be altered and the timing signals are again generated by a rotating disc and spring wiping contact. The needles build up characters in a similar way to the thermal printer; Figure 10 shows the dots within two character cells that each needle covers.

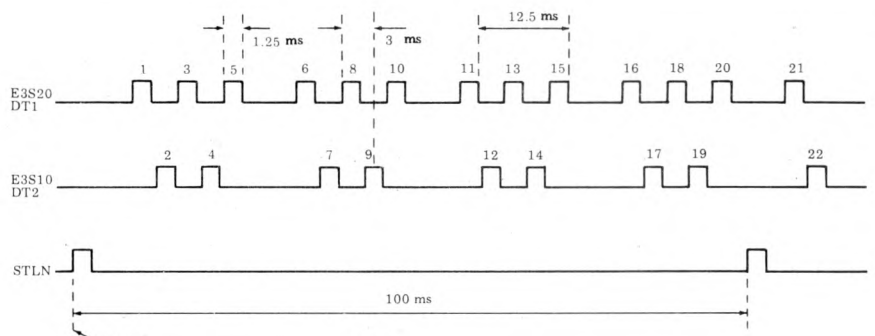

Fig 8

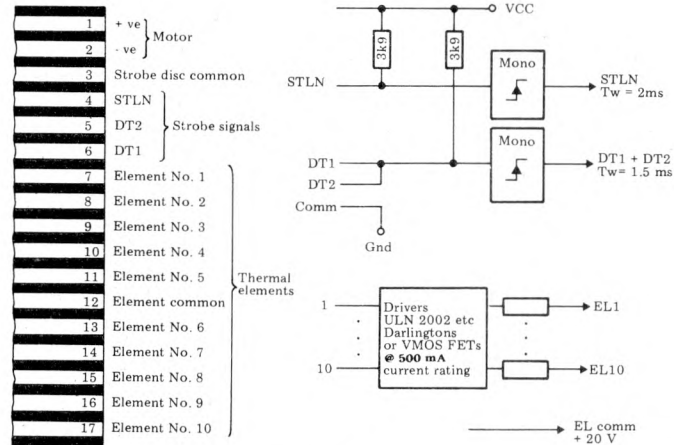

Fig 9

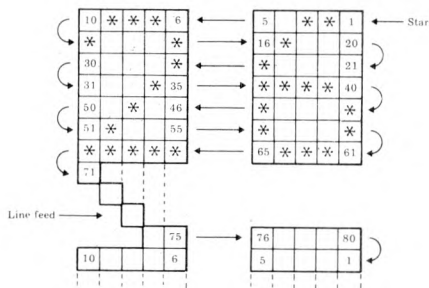

Fig 10

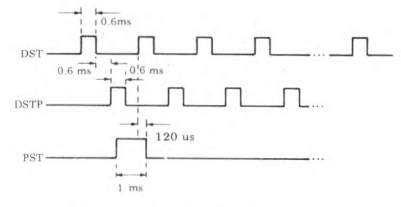

Fig 11 Timing signals

With this printer you must use a 5 x 7 matrix since this is defined by the main control cam.

The timing signals generated by this printer are shown in Figure 11. There are three timing signals: DST and DSTP are generated 20 times for each rotation of the control cam and PST is generated once every four cam rotations. DST indicates to the control logic that it can energise the coils to print a dot, and DSTP that follows is the signal to turn off the current through the coils. When the signal PST overlaps with signal DST then the printer is in the correct position to begin printing. The print cycle should be stopped after 80 DSTP signals have been received and an electronic brake in the motor control circuit is required to prevent the motor from coasting on past the stop position. The coils require a supply of approximately 38 V and suitable drivers would be VLN 2003/2 darlington arrays. The motor supply is nominally 18 V but this may need to be adjusted to obtain a printing speed of 1.7 lines per second.

Figure 12 shows how the two

sockets attached to the printer are connected up; these are on a standard 0.1in pitch and matching plugs should be easy to find.

The circuitry required to work this printer would be similar to that required for the thermal version. A 10-bit latch would be used to control the state of the ten coils, the signals DST and DSTP turn the coils on and off, and the signal DSTP must also be used by the control logic to determine which particular dot out of two 5 x 7 arrays is to be printed. This processing must be carried out for each of the ten print needles and will need to be carried out in the space of a few milliseconds.

Using the Olivetti series parallel printers

Since the two Olivetti printers mentioned earlier are both very similar you will find that the same circuitry can be used with only a little modification to operate both units. Before you start

Now available on Earth



THE SHARP MZ-80 COMPUTER SYSTEM

The Sharp MZ-80 System is a new approach to computer applications and their efficient use. Our aim is to make computers relatively simple and therefore better

understood and better used by those they are designed to serve. Take a look at the Sharp range - it will change the way you think about computers.

BCG Computer Systems Ltd
The Promenade
20 Gloucester Road
Bristol BS7 8AE
0272 425338/41979

The Computerist
642 London Road
Westcliff on Sea
Essex
0702 335298

Crystal Electronics Ltd
40 Magdelene Road
Torquay
Devon
0803 22699

Datron Micro Centre
2 Abbeydale Road
Highfield
Sheffield
0742 585490

Digital Design & Development
Duchess House
18-19 Warren Street
London W1P 5DB
01-387 7388

Electronic Business Systems Ltd
54 Clement Street
Birmingham B1 2SW
021-233 3045

Euro-Calc Ltd
Euroc House
128/132 Curtain Road
London EC2
01-405 3223

Gilbert Computers
Old Hall Lane
Lubenham
Leics
0858 65894

HB Computers
22 Newland Street
Kettering
Northants
0536 83922

Howes Elect.
Microcomputer Centre
Newton Street
Lincs
0522 32379/791088

Newbear Computing
40 Bartholomew Street
Newbury
Berks
0635 30505

Norset Office Supplies Ltd
Myrtle House
Bath Street
Cheddar
Somerset
0934 742184

Personal Computers Ltd
194-200 Bishopsgate
London
EC2M 4NR
01-626 8121

PMS (Print Marketing) Ltd
82 Sea Road
Sunderland
Tyne & Wear
0783 480009

Scope
Stone House
Houndsditch Entrance
128/140 Bishopsgate
London EC2m 4HX
01-247 8506

Sigma Systems Ltd
54 Park Place
Cardiff
S. Wales
0222 21515

South Coast Business Machines Ltd
South Coast House
Wimborne Road
Ferndown
Dorset
0202 893040

Sumlock Bondain Ltd
263-9 City Road
London EC1V 1JX
01-250 0505

Sumlock Bondain (East Anglia) Ltd
32 Prince of Wales Road
Norwich NR1 1LG
0603 26259

Tomorrow's World Ltd
Grafton Arcade
Dublin 2
Dublin 776861

This is a list of dealers participating in associated advertising and not a full list.



COMPUTER APPLICATIONS

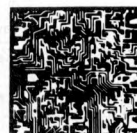

Business Systems, Audio, Video, Calculators, Cash Registers, Copiers, Microwave Ovens.

work it is a good idea to experiment with the printer so that you become familiar with its operation. Try to design a simple circuit that will make the printer print a solid five by seven array and then stop. This circuit can later be incorporated in the control logic.

As mentioned previously, each printer has ten printing elements which must be energised in parallel. The best way to achieve this is to use a 10-bit latch so that you can load the state of each element into the latch as it is determined by the control logic. When all ten bits have been loaded, a separate input can be used to enable all the outputs when the next dot-number signal is received.

Since each print element covers two character fields you will need to determine which character the element is over at any one time. You will also need to keep track of which row is being printed and also which particular dot in that row is being printed. All this can be done with an arrangement of counters and logic or a suitable program by using the timing signals that are generated. After a dot signal has been received you should be able to determine which particular dot in the character field is to be printed.

At the start of the print cycle all the counters should be reset. To find the row number you should use a counter that is incremented after every ten dot signals. An up/down programmable counter that counts from one to five will give you the dot number with the aid of a bit of extra logic to control the resetting and the count direction of the counter. From START, the count sequence will be: START -5-4-3-2-1-5-4-3-2-1-1-2-3-4-5-1-2-3-4-5- (repeat from START). To determine which character (left or right) is being printed is a little more difficult but again a counter and some simple logic should suffice.

A 20-character memory is required to store the line to be printed and a 6- or 7-bit RAM should do for this. The micro will load the line to be printed into this RAM and the control logic will read this data out as the print cycle progresses. The next major stage is the character generator; this will probably be a ROM and it must output data in groups of five bits that correspond to the slices down a 5 x 7 character cell.

A six-bit address from the line storage RAM is used to select the particular character 'page' in the ROM and a 3-bit address from the row counter will select the correct row out of the seven in each 'page'; a further circuit, controlled by the dot counter will then select the correct bit out of the five that appear at the ROM outputs. Finally this bit must be loaded into the 10-bit latch in the correct position for the digit to be printed.

Before anything can be printed, a digit counter must cycle through ten

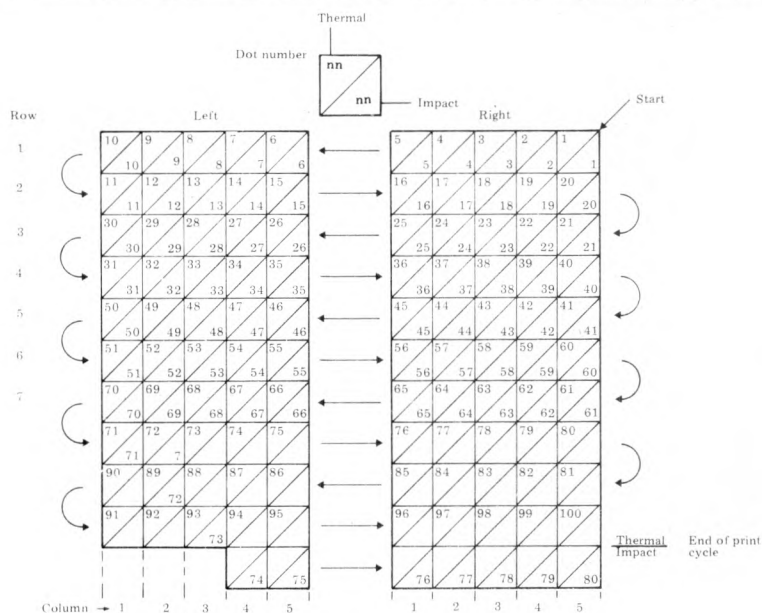

Fig 13 Character cells covered by print element.

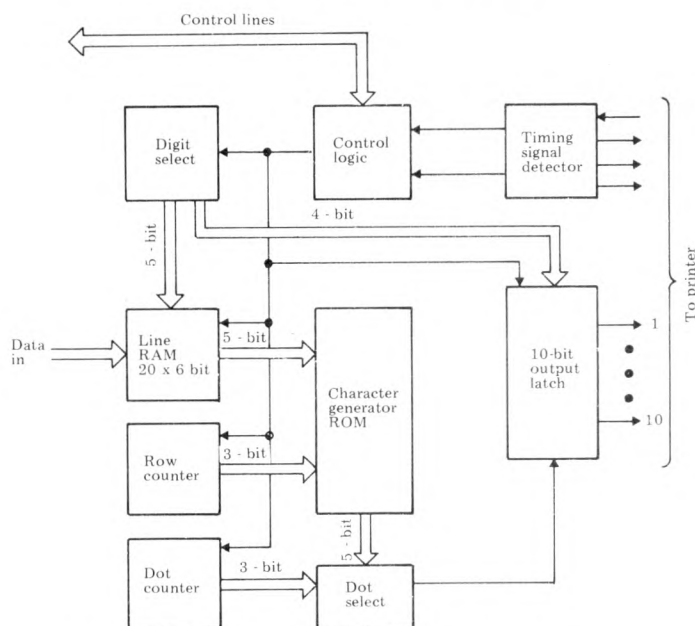

Fig 14 Block diagram of suggested control system.

of the 20 digits stored in the line RAM. Every alternate character should be read out to the character generator and a single bit will be loaded into the 10-bit latch as outlined above. This is repeated until each bit in the latch has been filled and a line of dots can be printed.

It is now only necessary to design a suitable control circuit that ensures that the operations explained above are carried out in the correct sequence to produce a coherent line of print. Figure 13 shows how the individual dots in the character field are numbered for both printers. It also shows the row and column numbers and the direction of movement of the print element. Figure 14 shows a block diagram of the system outlined above but please bear in mind that this is given only as a guide and you will have to take your brain out of neutral while you design this system. Depending on how ambitious you feel, you might end up with a system that is self-contained and only needs to be

loaded with 20 characters and told to print, or you could reduce the hardware down to the basic interface circuits needed and concentrate your attentions on developing a program that will carry out all the processing. This latter approach is probably cheaper but since I am a hardware freak I will leave the software approach alone.

Olympia NMP 20 printer mechanism

The Olympia is a low cost 20-column printer that uses metallised paper. The unit is very compact and comes with a hinged lid that also serves as a paper roll holder. You might be able to get hold of a secondhand Olympia CPM12 or CPM12/1 calculator within which you should find an NMP20 mechanism lurking. If you use a calculator unit you will have to remove the interface board and add the missing components to be able to use the full 20-column width; this should be fairly

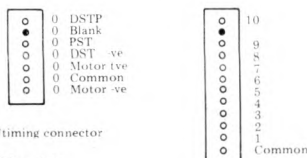

Fig 12.

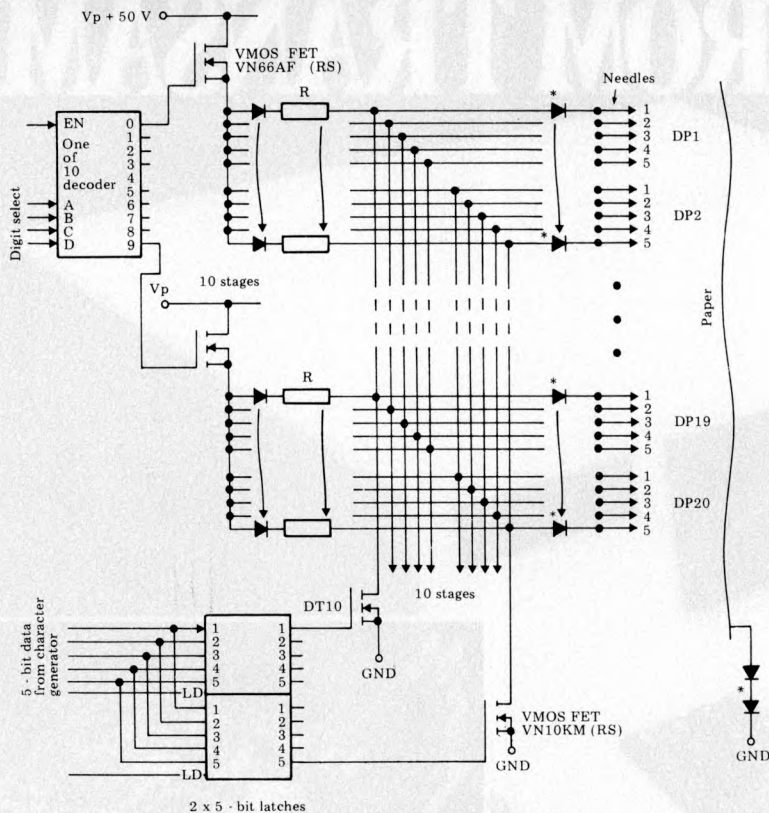

Fig 15 Suggested circuit of multiplexed interface board for NMP 20.

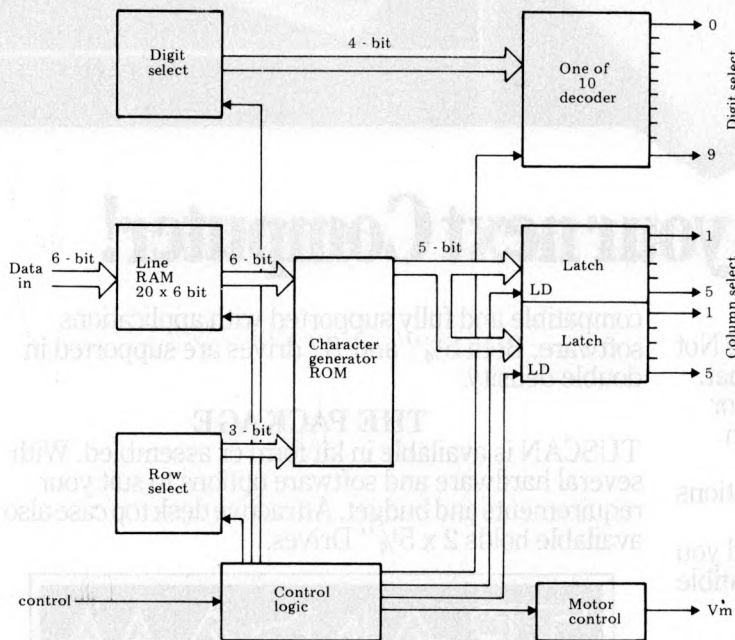

Fig 16 Block diagram of suggested control system for NMP20

feed roller. In operation, the printer generates no timing signals and the size of the print can be varied over a wide range by simply adjusting the speed of the paper feed.

The printing is carried out by a parallel array of 100 sprung metal fingers or needles. These are moulded into a small unit that screws onto the frame and plugs into the interface board underneath. The needles are arranged as 20 groups of five needles each. There are several ways that this unit could be used. Firstly, you could buy the unit with the interface board or you could design your own interface board to save money. The idea of the interface board is to reduce the number of connections going to the printer and this is done by connecting the needles into ten groups of ten needles which can be multiplexed in the normal fashion. The alternative is to dispense with the interface board altogether and operate each needle individually. This method will enable you to achieve a very high printing speed but it does mean a lot of wires need to be used for interconnections; also, the power consumption could be quite high.

Figure 15 shows a suggested circuit for an interface and multiplexing board. This is similar in concept to the board that comes fitted to the NMP20 but it uses VMOS FETs instead of bipolar devices and as such should be more reliable, I have not yet tried this circuit but it should work. (If not than a little experimentation is in order — let me know if you try it.) Basically this circuit divides the needles into ten groups of ten; the needles are commoned together and connected to the FETs DT1 to DT10. These FETs are switched by the two 5-bit latches which store the parallel data output from the character generator ROM. The individual groups of ten needles are connected in series with a blocking diode and a current limiting resistor and can be sequentially connected to V_p by high current FETs. These are controlled by the one of ten decoder. The paper is connected to ground by a roller in the paper feed. The diodes in the return line raise the potential of the paper roll slightly above ground.

In use, the character generator would load two sets of row data into the 5-bit latches, the one of ten decoder would select a digit group and the outputs would be activated. This would allow current to flow to one group of ten needles. The PD between the needles and the roll is approx 50 V and so the resultant arc would cause a dot to appear on the metal surface. To prevent a needle from printing a dot, the relevant common line must be grounded via DT1-DT10, which are controlled by the latch. When a common line is grounded, it presents a preferential path to the current and so no arcing occurs at the needle tip. The one of ten decoder and the five-bit latches should be CMOS devices operating at 15 V to provide sufficient drive voltage for the VMOS FET switches.

Figure 16 shows a suggested block diagram for the remainder of the circuit. This is fairly straightforward

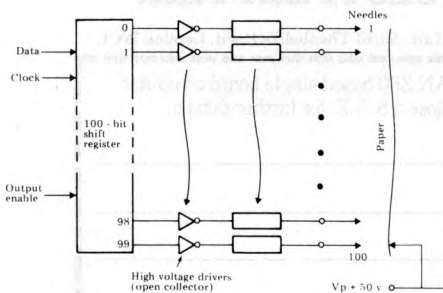

Fig 17 Suggested circuit using a shift register for parallel operation.

straightforward if you copy the existing circuitry. Alternatively you can buy the unit new, in which case you should contact Dataplus Ltd. The printer comes in two versions. The cheaper of the two at approx £35 comprises the basic mechanism without the interface board. This interface board reduces the number of connections required from over 100 to 23; the circuit is quite complex and expensive to construct, so the printer with interface board will set you back about £90.

The printer mechanism itself is very simple and robust and the only moving part apart from the hinged lid is a small DC motor that drives the paper

'TUSCAN' FROM TRANSAM



Take a step up to your next Computer!

THE CONCEPT

How many ways are there to build an S100 system? Not many, and all expensive. TUSCAN changes all that.

Five S100 boards on one single board—just for starters. Plus five extra slots for future expansion.

What a combination! Z80 and S100 with the TRANSAM total package of system and applications software.

How do we do it? Our prices start at £195 and you can build up in easy stages to a fully CP/M compatible disc based system. Something to think about!

THE HARDWARE

The first Z80 single board computer with integral S100 expansion. British designed to the new IEEE (8 BIT) S100 specification, the TUSCAN offers total system flexibility. A flexibility available now.

The board holds the equivalent of a Z80 cpu card, 8k ram, 8k rom video and I/O cards with 5 spare S100 expansion slots and offers a price/performance ratio which is hard to beat.

Just compare our price with a commercial S100 ten slot motherboard with this specification.

THE SOFTWARE

TUSCAN offers the user the choice of system monitor, editor, resident 8k basic, resident Pascal compiler or full CP/M disk operating system. All options are upwards

compatible and fully supported with applications software. Both 5¼" and 8" drives are supported in double density.

THE PACKAGE

TUSCAN is available in kit form or assembled. With several hardware and software options to suit your requirements and budget. Attractive desk top case also available holds 2 x 5¼" Drives.

TRANSAM

NOBODY DOES IT BETTER!

Send to Transam Components Ltd., 59/61 Theobald's Road, London WC1.

I am interested in the TUSCAN Z80 based single board computer with S100 expansion and enclose a S.A.E. for further details.

Name _____

Address _____

Telephone _____

TRANSAM COMPONENTS LTD., 59/61 THEOBALD'S ROAD, LONDON WC1. TEL: 01-405 5240/2113

GET WELL SOON

A TAPE RECOVERY SYSTEM

Ever pressed 'record' by mistake and started to overwrite your only copy of a much-loved program?
Alan Shelley explains how to cure this and other tape-related ills.

The program to end all programs is complete. You worked well into the small hours to finish it, could hardly sleep for thinking about it and finally when you did, strings of graphics characters switched themselves on and off in splendid arrays, and that neat new maths function that really clinched things munched its way through byte after byte in a multi-coloured field of data statements. Next morning you've come down bleary-eyed, intent on reliving the glory of this thing you've created. You switch on, check the cassette is rewound, slip it into place, type LOAD and start the cassette player. The message 'SEARCHING FOR ULTPROG' displays itself and you wait happily...

That's funny, it's never taken this long to find it before; you check the tape is going round, then — horror! The record button is down and there is no second copy... Who hasn't pressed 'record' by mistake and realised too late when hours of work have been lost? Well all is not lost, there are ways to rescue what's left. This article explains how to do it on the Commodore PET and it may well be possible to develop similar methods for other micros.

First, let's consider how a Basic program is held in memory. Each program line consists of a line number, followed by the statement(s) comprising the line itself, then a zero byte which marks the end of the line. In front of each line number are two 'link bytes' which contain the address of the first of two bytes in front of the next line number. At the end of the program, instead of an address, two more zero bytes are found. This pair of zero bytes with the zero at the end of the last line form a group of three zero bytes at the end of the program. The link byte before the first line of the program is preceded by a zero byte; this is at memory location 1024 (hex 0400). See diagram 1.

By means of the link bytes, the operating system can skip through the program examining line numbers without having to go through every statement; this is used in executing GOSUB and GOTO statements, for example.

When a program is saved on tape, the PET operating system gets the start address of the program (this is usually 1025 [hex 0401] and is held in two bytes at locations 40 and 41 [0028 and 0029 hex][122 and 123 for old ROMs hex 007A and 007C]) and the end address, which obviously varies according to the length of the program. These two addresses plus the program name form the header which is preceded by a timing tone. The program itself follows, and is also preceded by a timing tone. Both the header details and the program are recorded twice and

in each case the two copies are separated by a short 'bleep' of the timing tone. This is known as a 'redundant recording' method and is used in the interests of reliability.

When the program is loaded into memory from tape, the first thing encountered is the timing tone which enables the operating system to adjust itself to the tape speed. This is another reliability feature, by virtue of which the system tolerates a variation of running speed from machine to machine. The next thing encountered on the tape is the program name, followed by the start and end addresses. If the program name matches the one required, these addresses are stored in memory for reference. Starting at the location indicated by the first address — usually 1025 (hex 0401) — the program is loaded into memory (RAM) byte by byte. As each byte is loaded, a checksum bit is calculated and, if this does not agree with the checksum bit on tape, an error count is incremented and the location is noted. If errors have been noted after the first copy of the program has been read, the system starts at the beginning of the program in memory and compares the error locations with the second tape copy. Whenever a correct byte (tested by the checksum bit) occurs on the second copy, this is substituted for the faulty byte in memory and the error count is decremented. If uncorrected errors still exist at the end of the second pass, the message 'LOAD ERROR' is displayed on the screen. If no errors have occurred on the first pass, the program in memory is complete and the system simply scans to the end of the second copy.

Now, with a program tape which has lost its header and possibly part of the program, the first problem is that of giving the computer something to find, since it cannot switch straight into loading a program totally unprepared. It

cannot manage without at least a small part of the timing tone and it needs the start and end addresses of the program. In order to recover a damaged program, a way has to be found to provide this information and the obvious way is to use the header of another program. First, wind the damaged recording to a position just before the start of the un-erased portion (this can easily be found with the help of an audio cassette player or by pressing 'play' on the PET cassette deck and holding down the '<' key on the keyboard; if there is a recording present, the '<' sign will be printed repeatedly on the screen). Having positioned the damaged tape correctly in readiness, place another tape in the cassette deck, preferably with a program known to be longer than the corrupted one. (If a shorter one were used, part of the wanted program would be lost because, when the end address obtained from the program header is reached, the computer stops loading information. The way round this is to make up a 'dummy header' with addresses that will cover any length of program. This will be dealt with later.)

The method now is to enter 'LOAD' and start the cassette deck in the normal way. However, as soon as the message 'FOUND PROGRAM' appears, press the cassette stop button but do not touch the computer. Remove the dummy tape and substitute the corrupted tape, then start the cassette deck again and the computer will continue to read the tape, apparently blissfully unaware that anything untoward has taken place. At the end of the read one of four things will happen:

1. The message READY appears and the recovered program will list normally (success!);
2. The message READY appears but the program will not list;
3. The message ?LOAD ERROR appears and the program will not list;
4. The system 'hangs' — either of the

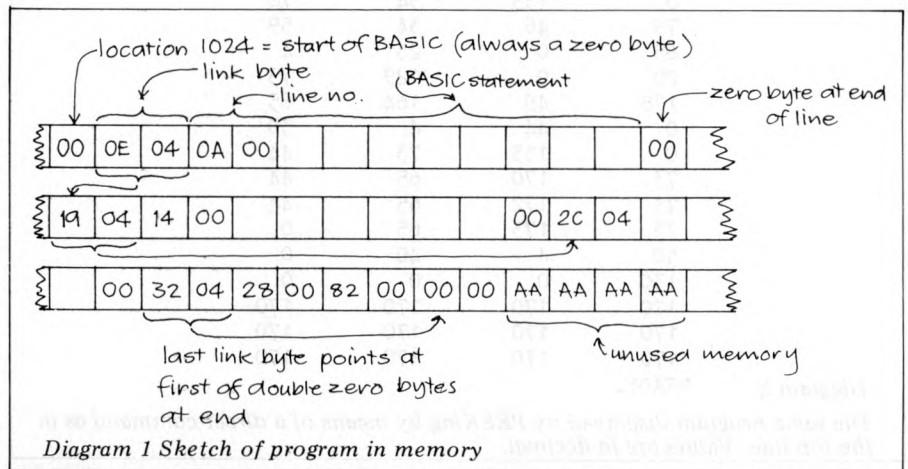

above messages may be displayed but the cursor does not reappear.

If the program is complete, ie, it has lost no more than part of the header, then No 1 will probably happen and the program should also run. It is possible, however, for No 1 to occur with an incomplete program so it is worth checking this before running it, although nothing worse than an undefined statement error is likely to occur. If the first program copy has been corrupted, there is about a 10% chance of 1, 2 or 3 happening and a 90% chance of No 4. If the system hangs, unless you know how to 'uncrash', you have no alternative but to switch off and start again. Since uncrashing is such a useful procedure, especially when working with machine code, a separate paragraph will be devoted to it later.

Now if either of alternatives 2 or 3 have occurred, it is necessary to do some machine code adjustments which can be time-consuming, and to have either the tape Monitor or new ROMs with the resident Monitor, or to devise a routine using PEEKs and POKEs. The object is to discover whether or not anything has been loaded and, if so, whether it is the required program or

just garbage. In order to be able to determine this, it is a good idea to familiarise oneself with the appearance of a program in memory before attempting the rescue operation. This may be achieved as follows: first load or key in a short program — say about ten lines or so — written for the purpose if necessary. What it does is unimportant, since we only want to look at it in code. Having keyed in the program, enter the command SYS 1024. This will cause the contents of the various registers to be displayed, which will look like the first two lines of diagram 2, although the actual values may vary.

The contents of memory can be displayed by typing 'M', followed by the start and end addresses (in hex) of the section of memory required to be examined. Thus M 0400 0480 (the spaces are necessary), followed by return, will display the first 128 bytes of memory where the program resides and will include the whole of your program if it is short enough. Compare this with diagram 2 and you will be able to identify the various parts of the program. Note that the link bytes preceding each line of the program actually point to the start of the next line. A method

using PEEKs is described later and this avoids the need to enter the Monitor.

Now, to get back to what may have been loaded from the corrupted tape. Enter SYS 1024 then display the first 128 bytes of memory as described above and examine them to see if they conform to the pattern of a program. If not, then the whole recovery procedure will have to be repeated, but if they do then the link bytes should be examined. Since the program would not list, the link bytes must point to the wrong addresses and the reason for this is that the program has been loaded into the wrong place in memory. This can be remedied in one of two ways: either by changing the link bytes to point to the correct addresses, or by moving the program up or down in memory into the correct position. Both are laborious procedures to carry out manually, but there is no need to do this because entering SYS 50242 (50234 for old ROMs) calls the subroutine which puts in the correct link bytes throughout the program. Any garbage there might be at the beginning of the program is left and when the program is saved again, this will be saved along with it, unless it is deleted first. This is possible to do because it will always have a spurious line number associated with it, which happens because the operating system takes whatever happens to be in locations 1027 and 1028, where it expects to find a line number, and interprets it as such.

When using this SYS 50242 (50234 old ROMs), the system will hang if, for any reason, the three zero bytes at the end of the program are missing and, if this happens, the only thing to be done is to insert them at the end of the saved material by the use of the Monitor (or PEEKs and POKEs), after uncrashing the system of course. (Uncrashing does not cause the contents of memory to be lost.)

This process of program recovery is usually a lengthy business because the failure rate is so high. So, when repeatedly doing this exercise it is worth clearing the whole of memory each time by switching the computer off and on again, so that anything that is subsequently loaded is easily distinguishable from the AAs which fill virgin memory. Actually, it is better to use SYS 64721 (64824 old ROMs) which will clear the whole of RAM from 1024 upwards and will reset the pointers without the need to switch off. This will leave a machine code program in the second cassette buffer intact.

One word of caution here. It is wise, having rescued a program from a partially-erased tape, to save it before doing anything else because if it happens to be incomplete in some aspect, or has picked up some incorrect bytes, it is quite possible to hang the system merely by trying to edit it. In fact, even the SAVE could be tricky, so first enter the command CLR which will reset any pointers which have been disturbed.

The use of a dummy header was mentioned earlier; since the purpose of this is to prevent the object program being truncated by having the end address too low, it is necessary to put a fairly high address into the pointer to the start of variables. This is done by POKeing into the pointer an address

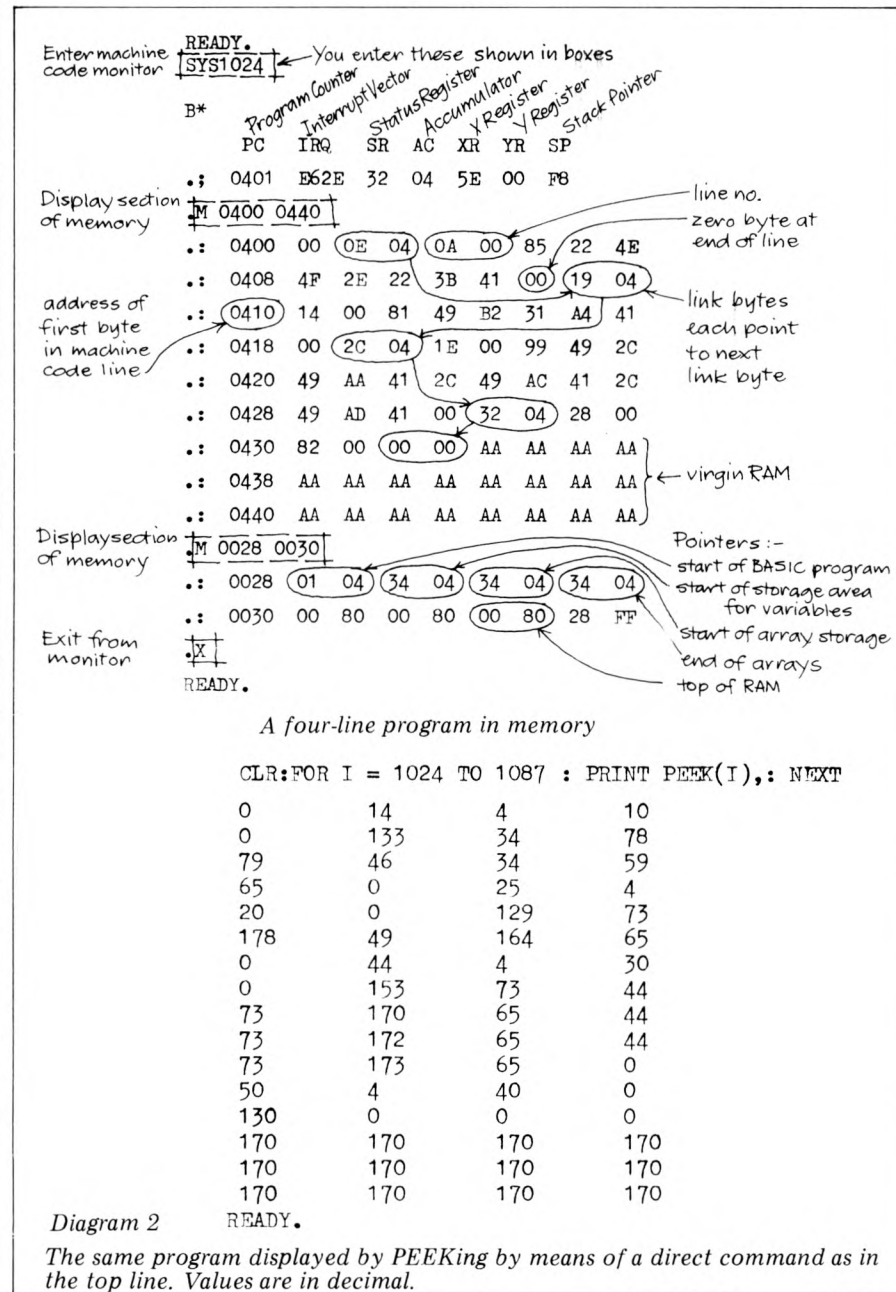

which is near the top of the memory. The pointer is held at addresses 42 and 43 in the new ROMs, so the command POKE 43, PEEK(53)-4 (old ROMs A=PEEK(134):POKE 124, A-4) will set the end of Basic 1024 bytes below the top of memory, since location 53 is the high byte of the top of memory address. Then enter SAVE "DUMMY HEADER" and press play and record on the cassette player. Let it run for about 20 seconds then press RUN/STOP and switch off the cassette. As we only want the header, there is no point in leaving it to record the whole of memory.

After using the dummy header in a rescue operation it is necessary to set the end of Basic pointer to the end of the rescued program otherwise it will not SAVE properly. There is no need to do this if No 1 occurred, since it will have been done automatically by the operating system. The method is somewhat laborious as it involves searching through memory for the three zero bytes at the end of the program as follows: enter SYS 1024 followed by M 0400 8000. This will cause the contents of the whole of RAM to be displayed on the screen. It will, of course, scroll up at a rate of knots but slowing it by pressing the RVS key should enable you to pick out the three zero bytes as they go by. If memory was cleared by switching off before making the recovery, the program will be followed by clear memory which will be displayed as a large block of AA bytes and will be easily recognisable. If necessary, displaying 128 bytes at a time will make the job easier but obviously longer. Having found those three zero bytes, determine the address of the first byte following them - a simple matter, since the address of the first byte of each line is displayed at the beginning of the line. Let's assume the one in question is 0434, as in diagram 2. Now, still in the monitor, enter M 0028 0030 and two lines of memory will be displayed which contain the pointers vital to the operating system. Cursor up to the third byte on line 0028, change it to 34 (or whatever is applicable) and the next one to 04 (or otherwise as applicable), and then press return. The rescued program can now be saved again before doing anything else, apart from checking the three zero bytes at the end.

To examine the contents of memory by means of PEEKs instead of entering the machine code Monitor, the following routine should be entered as direct commands:

```
CLR : POKE 43, PEEK (53)-1 :
      POKE 42,0 (RETURN)
FOR 1 = 1024 TO 32768 : PRINT 1 ;
      PEEK (1) : WAIT 59410, 4, 4 :
      NEXT (RETURN)
```

(For old ROMs the first line should be amended to:

```
CLR : A=PEEK(134):POKE 124,A-1 :
      POKE 123, 0 (RETURN))
```

This will display the contents of RAM from the start of Basic upwards and it will consist of each address followed by its contents. The WAIT has been included to make it more convenient in use since the routine will only run while the space bar is depressed. To stop the program, press the space bar and the RUN/STOP key simultaneously. The WAIT may not work on old ROMs so, if this is the case, it should be omitted

and you will be able to slow the operation down by using the RVS key. The POKE at the beginning is necessary to set the variable storage area high up the memory, in order to prevent the routine from corrupting any of the rescued program data. When running the routine, the thing to watch for is the three consecutive zeros or, if these are not present, a succession of 170s which correspond to the AAs of virgin memory. If the three zeros are absent, they should be POKED in place of the first three 170s. Having found or entered the three zeros, the address of the location following them should be determined as above and the following additional direct command should be entered:

```
1 = (here put the required address) :
      POKE 43, 1/256: POKE 42, 1-
      INT(1/256)
(For old ROMs change 43 to 124 and
42 to 123 as before)
```

Following this, SYS 50242 (50234 old ROMs) can be entered as above and the program can be listed and saved.

The foregoing method is the only hope of recovering what remains if the 'middle marker' has been lost, but is little more than academic if this is still intact.

A reliable method of recovering a damaged program, provided erasure has not gone beyond the middle marker, is to use the PET's own operating system to load it by calling the relevant sub-routines. This has to be done in machine code and a Basic loader for an appropriate program on new ROMs only is given. The machine code program

resides in the second cassette buffer and is run by our old friend SYS 826 which produces the normal message PRESS PLAY ON TAPE 1.

Before pressing play it is necessary to position the object tape as already described. When play is pressed a quickly-changing series of characters in the top right corner of the screen indicates that there is something on the tape and a tell-tale single character in the top left corner indicates what has been found, as follows:

```
A - there is a signal present on the tape
@ - the timing tone is present
* - loading is taking place
```

Loading is complete either when the quickly-changing series stops and becomes a single stationary character (which could be anything), or when the cassette stops and the screen displays READY. In the former case, you should press the RUN/STOP key and enter SYS 883; in both cases switch off the cassette player and enter CLR. If the CLR is not done, strange results will occur when running programs, since zero page locations are altered by the routines.

If the * doesn't appear, loading has not taken place and this is almost certainly because the program has been erased beyond the middle-marker. The only possibility for recovery is the direct method described earlier.

The reason for two possible results after loading has occurred successfully is that one of two conditions exists. First, the program has been erased

GOTO page 133

```

1 REM BASIC LOADER FOR RECOVER
2 REM M.D.SHELLEY, OCTOBER 1980
3 FOR I = 826 TO 969
4 READ A
5 POKE I, A
6 NEXT
7 DATA 160,0,132,201,132,157
8 DATA 132,206,132,203,132,171
9 DATA 132,192,132,193,132,178
10 DATA 132,194,200,132,44,132
11 DATA 212,132,199,132,251,160
12 DATA 4, 132,200,132,252,160
13 DATA 128,132,202,32,18,248
14 DATA 120,238,17,232,169,132
15 DATA 133,144,169,3,133,145
16 DATA 32,158,248,32,66,196
17 DATA 24,165,31,105,2,133
18 DATA 42,165,32,105,0,133
19 DATA 43,96,174,73,232,160
20 DATA 255,152,237,72,232,236
21 DATA 73,232,208,242,134,204
22 DATA 170,165,191,141,39,128
23 DATA 165,44,141,0,128,48
24 DATA 18,240,19,165,171,240
25 DATA 2,198,44,169,8,133
26 DATA 183,165,191,16,2,132
27 DATA 191,76,66,249,165,178
28 DATA 240,13,165,208,208,9
29 DATA 56,165,221,9,128,133
30 DATA 221,198,44,76,66,249
```

G geveke
electronics

New MODEL 630

LETTER QUALITY PRINTING AT REALISTIC PRICES

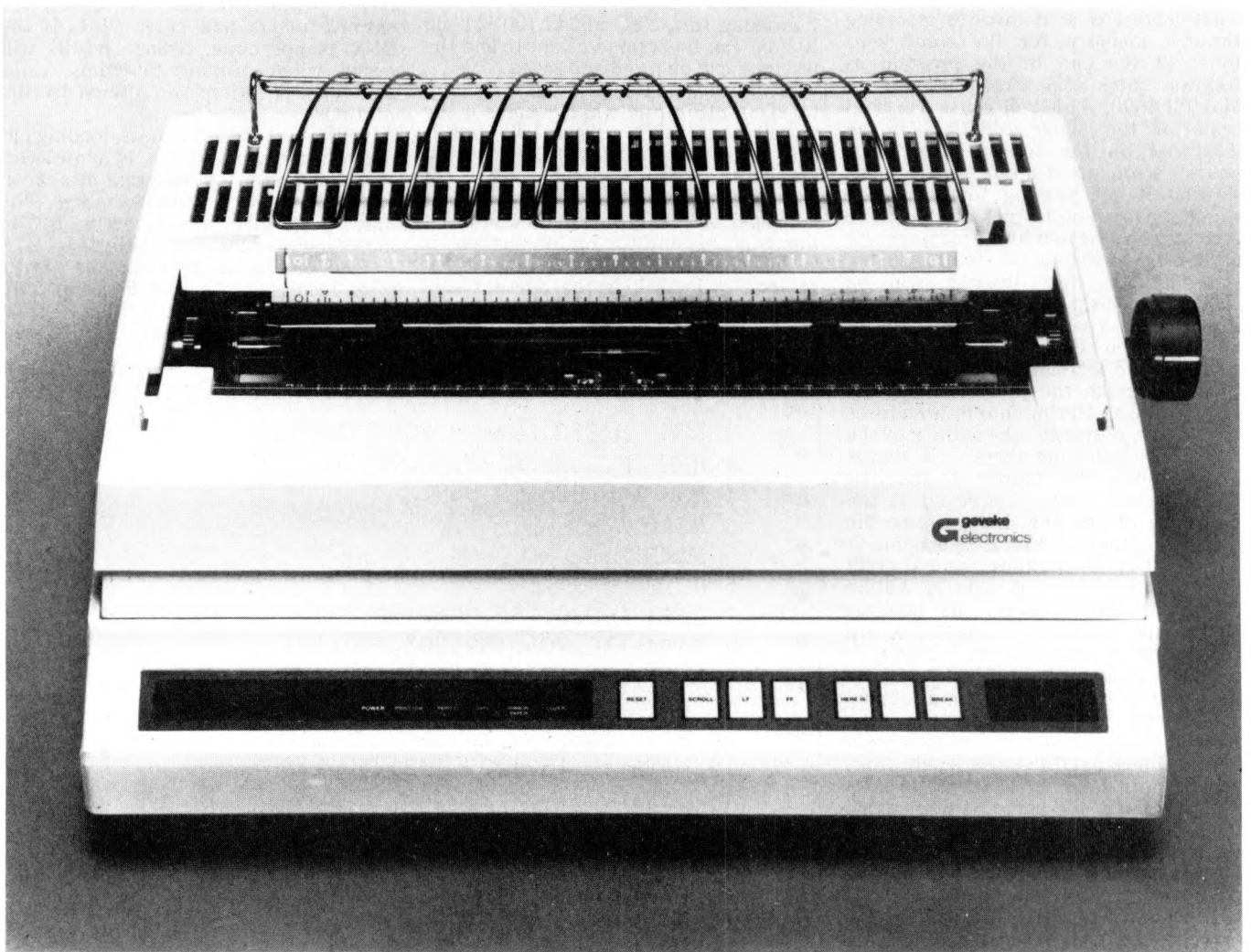

- Interchangeable Metal/Plastic Print Wheels
- Automatic Bi-directional Printing
- Word Processing Options
- Diablo Quality and Reliability
- Paper Handling Accessories

FOR INNOVATIVE DISTRIBUTION TO OEMs

Call us.. Geveke Electronics Ltd. RMC House. Vale Farm Rd. Woking.. 04862 71337

position, used as terminators. The first example supplied on cassette is for '76 Trombones', and occupies memory from 1000H to 1844H. It gives almost exactly three minutes of music, in an amusing and elaborate arrangement. Secondly, there is 'The Entertainer', occupying 1000H to 179FH and running for 3½ minutes. The user can study the codings for both, by examining the PET memory in machine code mode.

Sequencing

In addition to the song table, a set of instructions must also be provided which specifies tempo, waveforms and sequences of song table to be followed. This starts at location 0F00H, and can again be studied on the screen.

There are in all eight different instructions, all starting with FF.

FF 00 NN sets the number of voices to be used, where NN is a code for each number 1 to 4. This instruction enables the song table to be interpreted as sets of two bytes, for a solo voice, up to five bytes for four parts.

FF 01 0B 0C 0D 0E is the usual instruction to use the four waveform tables stored in pages 0B, 0C, 0D and 0E. If fewer than four voices have been selected by the FF 00 instruction, it is still necessary to specify four here because the PLAY routine is unaltered and steps through four waveform sample additions regardless, maintaining its timing loop. So any unused voices are directed to a 'silent' page which has preferably all zeros but can be just an unused page of memory full of 24s or AAs. I found, however, that if I set up only one active voice and had three pages all with AAs for the silent ones, something went terribly wrong with the waveform; examination on a CRO showed a very large pulse superimposed on it. Clearly, something had caused an overflow in the waveform calculations. It didn't occur with only two pages of AAs. The advice to use zeros, given in the software booklet, is good.

FF 02 NN sets the tempo, according to a table of values which in execution are multiplied by the duration values in the song table, in two count-down loops controlling the length of an event. A whole piece, or any sections of it, can be speeded or slowed by this instruction, without altering the pitch.

FF 03 PP is followed by sets of three bytes defining harmonics in amplitude and phase, which set up a chosen waveform in page PP. No limit is quoted for these, but the memory allocated indicates a maximum of 18 harmonics — far more than in drawbar organs, for instance, and more than will be heard for notes above about 200 Hz since the filter will eliminate them. A word of warning is necessary: a waveform must not contain any harmonic which exceeds the frequency of half the sample rate (ie, harmonics are limited to frequencies below 4385 Hz). If it does, then 'aliasing' or 'foldover' will be heard; this is the generation of a sort of mirror image frequency, which is lower than 4385 Hz by the amount by which it was intended to be higher. The resulting note sounds random, as it is not harmonically related to the fundamental. For example, if we take a 440 Hz as a fundamental, we can use up to nine harmonics but the tenth will alias,

The filter cannot prevent this, as the waveform is already distorted before reaching it. As the software book says, it may be necessary to use a different waveform table for higher notes.

The software book doesn't give any guidance on good waveforms to choose and, although the monitor and sample programs supplied on cassette sound quite good, there is no indication how these were calculated. Looking up the sequencer for the sample tunes, by displaying the block of memory starting at 0F00H, doesn't help because the FF 03 instruction is not used in either of them; the tables were evidently pre-calculated. I soon found a few pleasant sounding ones, though, with some trial and error.

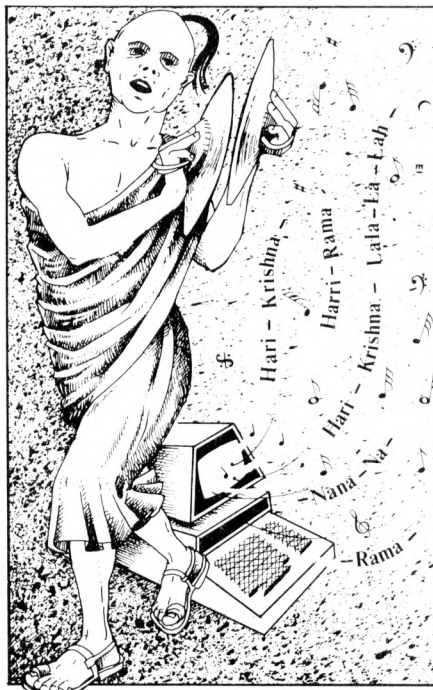

FF 04 PP DD sets up a rectangular waveform in page PP, with duty cycle DD and maximum amplitude determined by a byte in address 00BFH, loaded by the FF 06 instruction. This is not a Fourier approximation, but a block of bytes at the maximum specified amplitude, followed by zeros, in the appropriate page. The recommended highest note to be used with this waveform is middle C, 'to avoid significant alias distortion'. I would dispute that this is the true reason. There are indeed unpleasant sounds with this waveform, but surely the real reason is that the waveform table is nearly always being scanned unevenly, to get the right frequency. If we outputted every sample in the table at absolutely regular intervals, we would have a perfect rectangular waveform with an infinite number of harmonics, and no aliasing.

FF 05 PP creates a silent waveform in page PP.

FF 06 AM sets the waveform amplitude by putting the byte AM into location 00BFH, for use in waveform calculations. Usually this is set to 3F, so that when four waveforms are added, the maximum amplitude cannot exceed FF. If you try using only a single voice, however, you find the quality is greatly improved by increasing this to FE; this is increasing the resolution of the waveform from six bits to about eight bits, improving the signal-to-noise ratio by 12 dB. For some reason the system won't accept FF as a maximum here;

when I tried it the waveform came out with a maximum of only 7F. The instruction is normally used before the FF 03 waveform instruction, so is out of logical order.

FF 07 HH LL is an instruction to jump to a subroutine starting at HH,LL, which can return to the sequencer if terminated with RTS (6502 mnemonic for return from subroutine — object code 60). No suggestions are made for the use of this; you could, perhaps, print a message or text or words of a song on the VDU.

FF FF indicates the end of the sequence, causing the program to return to BASIC control.

Also in the sequencer section of instructions are sets of 2-byte addresses, each of which is the starting address of a section of song data. Any of these pairs which doesn't start with FF is recognised as an address rather than an instruction. The program follows the sequencer instructions in order, so addresses may be repeated if sections are to be repeated.

A sequencer example in the software book uses the instructions FF 00 to FF 04, mixed in with some addresses. Care is needed in examining this, as there is an FF representing an amplitude within the FF 03 instruction sequence — FF doesn't always indicate an instruction. It would have been better if laid out as one instruction per line, as in an assembly listing, rather than in the tabulated block with eight bytes per line. The small section of song table coding printed as an example is shown in lines of five bytes, which is better. Further study can be made by looking at the memory blocks allocated to song table and sequencer, for the two demonstration songs. If you are new to the PET, as I was, it also helps to make you familiar with manipulation of its machine code data. However, the sequence blocks in these two programs are even simpler than those in the booklet, although longer.

That tune again

My first attempt at writing a new program was to code my old tune 'Gaudeamus Igitur' (cries of 'Not



that again' resound in the lab when I demonstrate it to another victim — must code another one soon) into a four-part arrangement for male voice quartet, as I happened to have a good version by Leslie Woodgate. The first effort was too smooth, as I hadn't allowed for breaks between repeated notes. Second one was very pleasing, and reminiscent of barber-shop singing, although with organ-like tones. I used the demonstration cassette's waveforms before experimenting with my own, and these were evidently well chosen for my limited range of notes.

Experimenting with your own waveforms rapidly leads to trouble. Because it is possible to use so many harmonics in the Fourier synthesis program, you naturally try looking up a table of harmonics from (eg) *Computer Music Journal* and synthesising a flute, oboe, trumpet or violin from this. It is very good mental exercise, as the quoted harmonic levels are in dB, whereas the amplitudes needed for this program are linear and in hex. You have to remember that each 6 dB reduction is a ration of 2:1, so that for instance a seventh harmonic which is 12 dB down from the fundamental is one quarter the amplitude. Not only this, but you must remember that the sum of all the harmonic amplitudes must not exceed 255 decimal, or the table overflows. But you want the sum to be near 255 for good resolution. If you overlook this, the synthesis does not work, or produces a faulty wavetable. I would have preferred to have an error message displayed here, as it is very easy to slip up. Eventually I devised a sequence of operations necessary:

1. Decide the fundamental frequency of the highest note to be played. It is useful to mark frequencies against notes in the table in the software booklet, an aid which the authors should have included.
2. Divide this frequency into 4385. The integer result gives the highest harmonic permissible.
3. Convert harmonic amplitudes for the required instrument from dB into ratios relative to the lowest amplitude. At this stage, use decimal; let the lowest amplitude be 8 for four harmonics; 4 for eight harmonics; or 2 if 16 harmonics are to be used.
4. Add all these relative amplitudes. If the sum exceeds 255, reduce them all by the same ratio until they do not.
5. Convert relative amplitudes into hex.
6. Enter into the FF 03 instruction.

I followed this procedure in translating a 'Cornocean' sound for notes up to a 440 Hz. Only nine harmonics are possible, and the amplitudes I arrived at were, in hex, 3A 35 20 1D 1A OF OE 07 04. The waveform was entered into page OB and I wrote a program to play out a complete scale covering the six octaves allowed for in the software. The results were better than expected in that several notes above 440 Hz sounded reasonable — possibly because the aliasing frequencies were high enough to be trapped by the filter. The sound was reedy to some extent, but the brightness was limited by the 3.5 kHz upper limit, of course.

Up but not down

Transposition is something all musicians require from time to time. I wondered

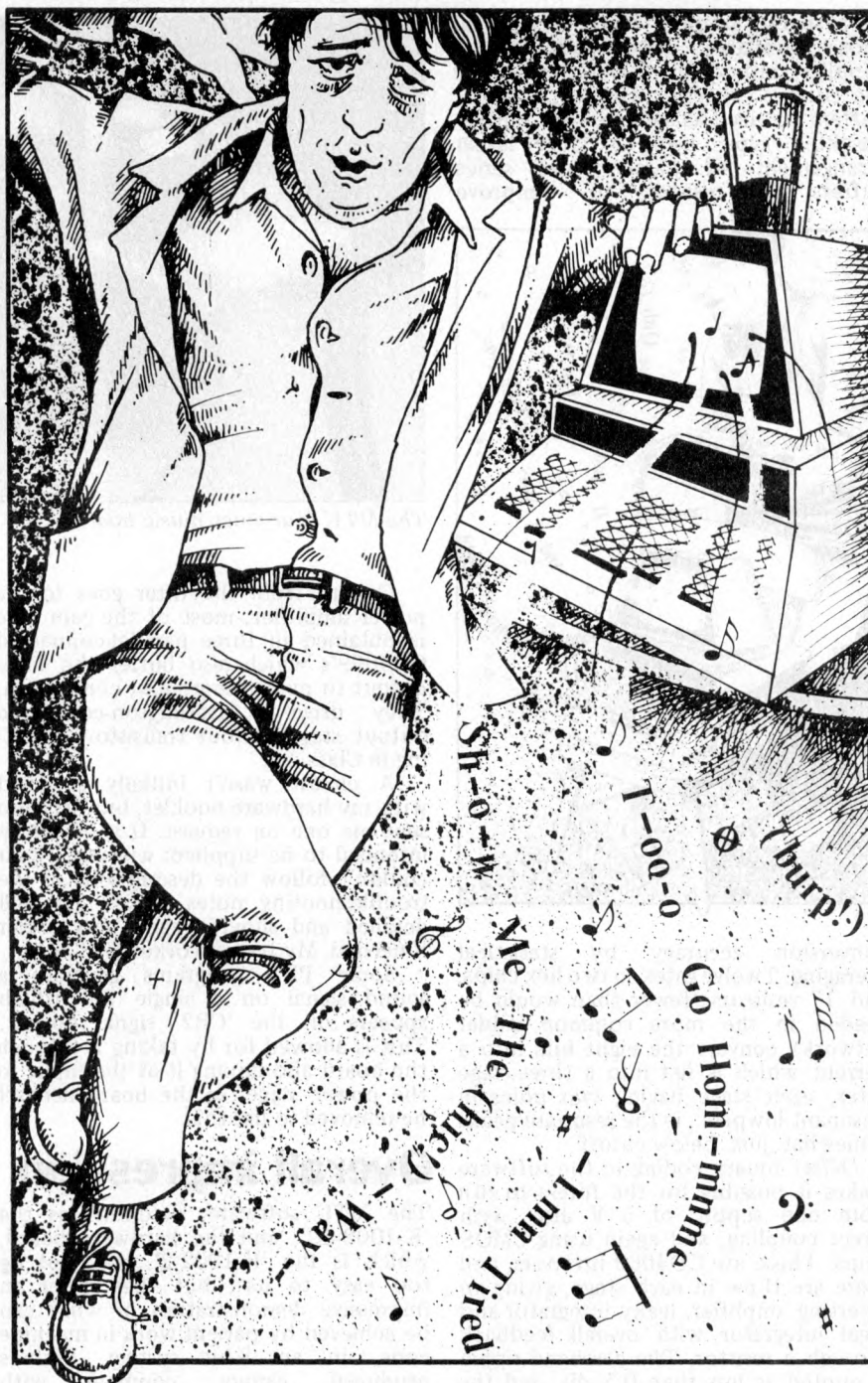

how my male voice quartet would sound if I transposed all voices up an octave. This ought to be easy; rather than re-write all the note codes, I could re-voice the four parts with new waveform tables containing no fundamental pitch and only even harmonics (since all the harmonics of a note which is transposed up an octave must be doubled in order). As far as the waveform table is concerned, the page would now contain two complete cycles of the new waveform.

I put in second, fourth and sixth harmonics and found this worked quite successfully, turning my barber-shop into a close harmony 'female' voice sound. It would also be possible, of course, to transpose only some of the voices this way.

Transposition by only a semi-tone or two is not possible, however, with the monitor supplied. One would have to re-write the song table, in the absence of a program to offset the note codes. And I can't see how to transpose down an octave — you can't make a double-

length wavetable.

Hardware

In principle, this is very simple, but some unusual and clever techniques have been adopted to enable the 8-bit binary output signal to drive a loudspeaker using only the 5 volt rail. It consists of three sections: a digital-to-analogue converter (DAC); a sharp cutoff lowpass filter; and a power amplifier. The cassette connection is brought through the board, so the cassette deck is plugged onto the back of the board which is in turn plugged into the back of the PET, employing the two ports designated 'user' and 'second cassette'. A phono socket can drive a loudspeaker, delivering 300 mW into 8 ohms or 500 mW into 4 ohms (not MW as in the brochure — why are some technical people so careless over units?) and the current drain is less than 50 mA quiescent, or 300 mA at full power, squarewave drive.

The DAC does not take the easy way

of a special purpose chip, because all those available need split power supplies, either for themselves or for the current converter. Instead, CD4050 buffers are used as switches in a binary-weighted type, using a fairly lavish arrangement of parallel and series buffers and resistors to improve



conversion accuracy by statistical averaging. Twelve gates, in two hex chips, and 17 resistors (fewer than would be needed in the more common ladder network) convert the eight bits into a current which is fed into a three-stage filter, each stage having two poles in 'resonant lowpass', ie the response peaks somewhat, just below cutoff.

Offset binary coding in the software makes it possible for the filters to run from one supply of 5 V also, with direct coupling, and again using CMOS chips. These are CD4069 inverters, and there are three in each stage, giving an inverting amplifier, leaky integrator and ideal integrator with overall feedback through a resistor. The passband ripple is quoted as less than 0.5 dB, and the cutoff slope gives 30 dB attenuation at 1.35 times the cutoff frequency of 3.5 kHz.

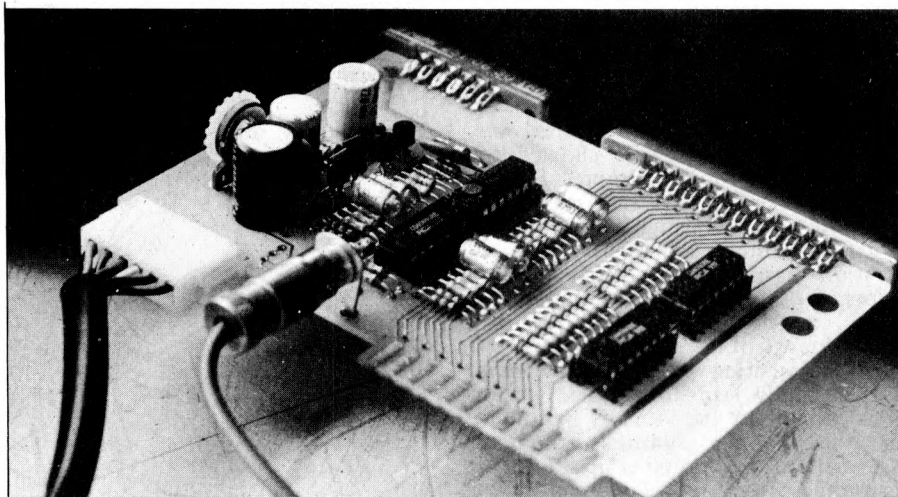

The MTU four-voice music board.

Output from the filter goes to the power amplifier; most of the gain here is obtained in three parallel-connected CD4069's which also buffer the filter output to power amp input connection. They drive a Darlington-connected output stage of four transistors, working in Class AB.

A circuit wasn't initially supplied with my hardware booklet, but IJJ soon sent me one on request. It is evidently intended to be supplied; without it you couldn't follow the descriptions or the troubleshooting notes, which are well detailed and should enable easy repair if needed. My board worked first time.

Some PET programs generate a sound signal on a single line which appears on the 'CB2' signal output. This is allowed for by taking it through the board and mixing it at the input to the power stage, so the board needn't be removed to use this.

Overall impression

The MTU software, described as the 'K-1002-3C', and the hardware board, which is the 'K-1002-2', may not be too easy to use, but they offer an impressive demonstration of what can be achieved by patient work in machine code, in an 8-bit system. Sounds produced cannot compete with electronic music produced by large computers or even by analogue synthesizers, but have value in demonstration or

teaching work, or possibly in composition. Defects of digital synthesis are shown up, in the form of noise generated by limited resolution, and the limitation of waveform synthesis at constant amplitude, regardless of frequency, shows up in weak sounds coming from the loudspeaker at low note frequencies. There is also the limitation to 3.5 kHz maximum in the output. However, if songs are coded with each voice given an appropriate amplitude for a limited range of notes, a good balance can be achieved. For the price, the system is good value to any teacher or experimenter interested in music.

Things to come

It is possible to get away from the organ-like sounds that I have been describing by making much more use of large memories. MTU has now produced an 'Instrument Synthesis Software Package' which does just this, enabling you to get harpsichord, wah-wah, chiming and a whole range of more interesting sounds, still using up to four-part harmony. I will be reporting on this shortly.

Acknowledgements: To The City University Microprocessor Laboratory, for use of a PET 3032; and to Ted Willett, University Photographer, for the picture.

Secondhand Terminals Stock Clearance

ITEL Model 1051
IBM SELECTRIC (Golfball) typewriter with
optical tape reader and tape punch in

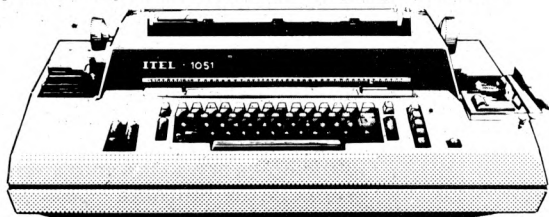

compact desk-top unit with RS232 serial interface. EBCDIC coded. Reduced from £375 to £295.

Also available a *limited number only* of machines untested, except for typewriter operation, at £195.

- *DI/AN Model 9030 Desk-top terminal similar to DECwriter LA36. Upper/lower case matrix printer, up to 300 Baud. Features switchable Baud rate, parity, keyboard and duplex options. Reduced from £225. **£190**
- *DATA DYNAMICS Model KSR 33 Teletype with keyboard and printer for 110 Baud operation. RS232 interface. In excellent condition. Reduced from £175. **£150**
- *DATA DYNAMICS Models ASR 33 and ASR 390 terminals with paper tape reader/punch also available from **£195**

VAT and carriage extra on all items

COMPUTER APPRECIATION 86 High Street, Bletchingley, Redhill, Surrey.
 RH1 4PA Godstone (0883) 843221

MICROCHESS

By our chess expert, Kevin O'Connell

The 11th ACM (Association for Computing Machinery) tournament, held in Nashville, Tennessee (October 26-28), was a triumph for Ken Thompson and Joe Condon of Bell Telephone Labs. Their program, running on a PDP 11/70 with some special chess hardware, made a clean score to win this event just one month after Belle took the world title in Linz.

This achievement establishes a new record. In 1977, Chess 4.6 won the world title but could only share first place in the ACM tournament.

Since 1970 the ACM has been won by Chess 2.0, Chess 3.5, Chess 3.6, Chess 4.0, Ribbit, Chess 4.4, Chess 4.5, Chess 4.6 and Duchess (tie), Belle, Chess 4.9 (with Belle equal second).

This year was certainly the year of the micro, with Bebe (special chess hardware), Challenger (stand alone unit) and Mychess (Cromemco) all doing respectably, as you can see from the table of results.

The following game was described by David Levy, controller of the ACM tournament, as 'one of the most exciting games in the history of this event.' Played in the last round, it decided the tournament.

White: CHESS CHALLENGER
Black: BELLE

1 e2-e4 e7-e5
2 Ng1-f3 Nb8-c6
3 Bf1-b5 a7-a6
4 Bb5-a4 Ng8-f6
5 0-0 (Ke1-g1) Nf6xe4

It just so happens that I am the author of the only book in English about this lively opening variation.

6 d2-d4 b7-b5
7 Ba4-b3 d7-d5
8 d4xe5 Bc8-e6
9 c2-c3 Bf8-c5

So far according to the book.

10 Bc1-e3?

This move is not given house room in my book. It allows Black to saddle its opponent with doubled, isolated pawns, 10 Nb1-d2 or 10 Bb3-c2 would be normal and good.

10 ... Bc5xe3
11 f2xe3 Ra8-b8
12 Nb1-d2 Ne4-c5

Threatening a knight fork of the pawns on e5 and b2.

13 Qd1-e1 Nc5-d3
14 Qe1-g3 0-0 (Ke8-g8)
15 Ra1-b1?!

A strong human would have played 15 Bb3-c2, when Black would almost certainly have played 15... Nd3xb2, allowing the combination 16 Bc2xh7+ Kg8-h8 (16... Kg8xh7 17 Nf3-g5+ Kh7-g8 18 Qg3-h4 Rf8-e8 19 Qh4-h7+ Kg8-f8 20 Ng5xf7 Be6xf7 - take my word for it that White also wins after the even more complicated Qd8-d7 - 21 Rf1xf7+ Kf8xf7 22 Ra1-f1+ Qd8-f6 - or 22... Kf7-e6 23 Qh7-f5+ Ke6-e7 24 Qf5-f7 mate - 23 e5xf6 and White wins) 17 Nf3-g5 (threatening Qg3-h4) 17... g7-g6 18 Ng5xe6 f7xe6 19 Bh7xg6 and White is a pawn up with a very strong attack. Though it would be expecting rather a lot from any program to see all that.

15 ... Qd8-e7?

Results

	R1	R2	R3	R4	Total	Place in World Ch.
1 BELLE	W6	W5	W2	W4	4	1
2 CHAOS	W8	W9	L1	W5	3	2
3 BEBE	D4	W6	L5	W9	2½	6=
4 CHESS CHALLENGER	D3	W8	W9	L1	2½	18
5 CRAY BLITZ	W7	L1	W3	L2	2	-
6 MYCHESS	L1	L3	W7	W10	2	12=
7 CUBE 2.0	L5	W10	L6	D8	1½	-
8 OSTRICH	L2	14	W10	D7	1½	12=
9 AWIT	W10	L2	L4	L3	1	6=
10 CLASH	L9	L7	L8	L6	0	-

Better 15... b5-b4

16 Bb3-c2 Qe7-c5

White cannot now capture on d3 because of Qc5xe3+ (that is what BELLE was planning on), but White has something better.

17 Nf3-g5! Nc6xe5

18 Ng5xh7! Rf8-d8

If 18... Kg8xh7?? 19 Qg3xe5 and the knight on d3 is lost.

19 Nh7-f6+ Kg8-f8

White should now be aiming for Nd2-b3, gaining time, by attacking the black queen, to put his knight on the excellent square d4.

20 Bc2xd3 Ne5xd3

21 Nf6-h5 g7-g6

22 Nh5-f6 Be6-f5?

This move soon lands Black in trouble.

22... b5-b4 was a good alternative.

23 Qg3-g5 b5-b4

24 Nf6-h7+ Kf8-e8

25 Nh7-f6+ Ke8-f8

26 Nd2-b3

At last.

26 ... Qc5-c4

27 Nf6-h7+

But now White really should have followed up with 27 Nb3-d4! (or 28 Nb3-d4! or even 29 Nb3-d4). If then 27... Qc4xa2, 28 Nd4-c6 wins: Black has to play Kf8-g7 (otherwise Qg5-h6 is mate) then 29 Nc6xd8 and if 29... Rb8xd8 30 Nf6-h5+ followed by Qg5xd8. If Black does not take the a-pawn then he must deal with the threat of 28 Rf1xf5 (28... g6xf5 29 Nd4xf5 and mate follows).

27 ... Kf8-e8

28 c3xb4 Rb8xb4

29 Nh7-f6+ Ke8-f8

30 Nf6-g4?

It would have been better to try for the draw with a series of knight checks. Guess what other move is also available!

30 ... Rd8-d6

31 Ng4-h6 Qc4-e4!

An important move - centralising the most powerful piece, helping to defend the king-side and pressuring g2.

32 Rf1xf5?!

An interesting exchange sacrifice that just fails. White should have played 32 Nh6xf5 g6xf5 33 Qg5xf5 Qe4xe3+ 34 Kg1-h1 with the result that his only weakness (the e-pawn) would have disappeared.

32 ... g6xf5

33 Qg5-g8+ Kf8-e7

34 Qg8xf7+ Ke7-d8

35 Nh6xf5 Rd6-c6

36 h2-h4

36 Nb3-d4 (that move again) was very much stronger and would have considerably improved White's otherwise slim attacking chances.

36 ... Rc6-c2!

37 Qf7-f8+ Kd8-d7

38 Qf8-f7+ Kd7-c8

39 Qf7-g6 Kc8-b7

40 Nb3-a5+ Kb7-a8!!

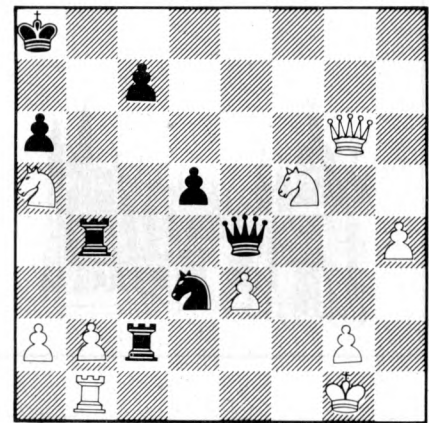

A very deep move. Black gives up a pawn (with check) to get some time (time can sometimes be at least as important as material, but programs are rarely able to follow such subtle changes in values). White will find its queen on the wrong side of the board and the time it takes to get it back to the king-side is enough to transfer the initiative to Black and enable the latter to launch the decisive phase of the attack.

41 Qg6xa6+ Ka8-b8

42 Qa6-g6 Nd3-e5!

Mate on g2 was prevented but this is a real blow, threatening the queen as well as Rc2xg2+ (discovering an attack from the black queen against the rook on b1).

43 Qg6-g8+ Kb8-a7

44 Rb1-f1 Rb4xb2

Threatening mate in two.

45 Kg1-h1 Rc2xg2

White's next few moves would be called 'spite checks' in a game between humans here they are 'horizon checks'.

46 Na5-c6+ Ne5xc6

47 Qg8-a8+ Ka7xa8

48 a2-a4 Ka8-b8?

What is this nonsense? Fortunately for BELLE the bug scuttles back into the woodwork after a few moves.

49 a4-a5 Kb8-a8?

50 a5-a6 Ka8-a7?

51 h4-h5 Ka7-b6?

52 a6-a7 Rg2-g1+

53 Kh1xg1 Qe4-g2 mate

And with that, our resident expert O'Connell was whisked to the local intensive care unit in a severe state of nervous excitement. Massive doses of librium are reportedly taking effect.

15 good reasons for visiting Cambridge

1. Sharp Pocket Computer
2. TRS-80 Model I & II
3. Apple II & III
4. CBM (PET) 3000
5. North-Star Horizon
6. Cromemco
7. Hewlett-Packard HP-85
8. Acorn Atom
9. UK-101
10. X-Y Plotters
11. Qume
12. Farm Systems
13. Word Processing
14. Computer Books

With a uniquely comprehensive selection like this — all generally on demonstration and available from stock with full support by our team of computer professionals — you'll have the ideal chance of finding precisely the right system for your application.

Looking for a microcomputer? — then visit us at:

Cambridge Computer Store

1 Emmanuel Street Cambridge CB1 1NE
Telephone: (0223) 65334/68155



BYTESHOP COMPUTERLAND

your specialist Computerstore.

Commodore Business System



Well-proven systems for the serious user. Our computer stores are staffed by business experts, backed by first class maintenance support.

The Commodore is a complete computerized business system, ideal for first time users. Based on the world famous PET computer, it is easy to use and extremely cost-effective. The system includes large capacity disks

and an excellent quality printer thus bringing many applications within the reach of the small business.

Find out why the Commodore Business System is so popular — call in to any of our shops for advice and a demonstration of this and other systems.

London

48 Tottenham Court Road
London W185 4TD
Tel. 01-636 0647

Nottingham

92a Upper Parliament Street
Nottingham NG1 6LF
Tel. 0602 40576 Telex. 377389

Manchester

11 Gateway House
Piccadilly Station Approach
Manchester
Tel. 061-236 4737 Telex. 666168

Birmingham

94-96 Hurst Street
Birmingham B5 4TD
Tel. 021-622 7149 Telex. 336186

Glasgow

Magnet House
Waterloo Street
Glasgow Tel. 041-221 7409
Telex. 779263

BYTESHOP
COMPUTERLAND
— your specialist Computerstore.

Until quite recently, multi-user systems had been very much a mainframe phenomenon. Now, however, a number of micro systems are appearing with these capabilities, a trend which should rapidly increase with the recent announcement of CP/Net.

As many PCW readers may be unfamiliar with the way in which multi-user systems originated, developed and currently operate, we'll begin this series with a look at their history. Next month we will talk about the various implementation approaches and then, in the rest of the series, we'll examine different systems in the marketplace.

The past

All early mainframes were single user; only one person could run a program at one time and, in fact, only one program could be run at one time. This was a quite acceptable state of affairs since cycle times were very slow and operator interventions took only a low percentage of the total time. The user had control over the computer and could interact with and oversee his program while it was executing, although not in today's interactive sense (unless one regards the system waiting for the user to feed more data cards in as 'interactive').

The next few years brought the substantial reduction of cycle times and a new mode of operation was necessary if computers were not to remain idle waiting for human action. Batch processing was introduced to solve this problem. Several jobs were grouped together to form a single batch. A monitor program, sitting in memory, to which control was returned at the completion of a program run, processed the batch. Operator actions were not required during the processing of individual programs.

Unfortunately, as processors became faster, this type of batch processing could not keep the processor busy and the mechanical I/O devices of the time could not be speeded up enough. The next development was to use magnetic tape for I/O. Input could be transferred from cards to tape and output from tape to cards, under the control of a slow, cheap processor. With this kind of arrangement the (expensive) CPU was only idle during data transfer to and from magnetic tape — a much more efficient use of its time.

In a batch processing system the user cannot control his program while it is in the machine and so the monitor had to be capable of coping with any program errors that might occur. For instance, a program might go into an infinite loop (or worse, an infinite loop while outputting to magnetic tape). Although looping might be detected by a conscientious operator watching the console lights, it was better to get the monitor to handle it automatically.

The clock interrupt was developed to force regular entry into the monitor and time limits were imposed on user programs. The Interrupt mechanism generates a call to the monitor in response to some external event in such a way that the original program can be resumed as if nothing happened. Interrupts have many other uses besides time limitation and their development was a significant step in computer design.

MULTI-USER SYSTEMS

Sue Eisenbach and Dr Adrian Stokes begin their new series devoted to multi-user microsystems with an historical summary of the subject.

Another problem area concerned the accidental destruction of the monitor program or work areas by errors in a user's program. (This fault is frequently not catered for in today's micros.) If this happened, an operator had to restart the machine to continue processing the batch. The program interrupt solves this problem, too. Extra hardware was included in the processor to check the legality of each attempt to write into a memory location and a violation interrupt is generated when an illegal access is attempted.

The program interrupt mechanism also allowed peripheral devices to be used more efficiently. A program can pass a line of output to the monitor which can be transferred, one character at a time, to magnetic tape (or later to disk) using a program interrupt for each character. While data is being transferred, the user program can be processed. The converse would apply to data input. This overlapping of computation with I/O (generally not available on micros) allowed the return to a single machine architecture since computation and I/O could be handled simultaneously by a single processor. Disks allowed more efficient systems to be produced as there's no tape winding time and disks can buffer I/O from several devices at one time.

The next software development was the common file store using magnetic disks. The user or the system software could deposit files on the disks to be kept for safe keeping by the operating system, as the now rather large monitor program came to be known.

The availability of interrupts allowed multi-programming operating systems to be produced. A number of programs could share the system resources, particularly the CPU. These almost always worked such that a program ran until it had to wait for something, usually data to be read or output, then the next ran and so forth, possibly with some priority system to allow more important programs to obtain a larger share of system resources. One of the most complex multi-programming systems is IBM's OS/MVT (Operating System/Multi-programming with a Variable number of Tasks) which, unlike many of its predecessors, didn't allocate fixed memory regions but allowed memory to be re-allocated dynamically. Needless to say, a fairly high proportion of CPU time is concerned with such resource allocation and other functions of the operating system.

Finally, the development of a public file system led to multi-access systems where the user (and there can be as many as 300 users on some systems) sits at an interactive terminal and is able to

control his program. To be more specific, this means that the user may interact with his running program, either to input data in response to prompts or to interrupt its execution. This is achieved using a technique known as 'time sharing' whereby each user is allocated a period of time, often the same for each user but sometimes altered to implement a priority system. The users are allocated the CPU on some pre-determined basis (often 'round robin') and run during their time slice or until an interrupt occurs (usually input or output). Most multi-access systems are also multi-programmed.

So, on mainframes a vast amount of development was required before the user finally regained control over the processor while executing his program. However, in contrast to the first computers, a relatively low proportion of CPU time is spent actually processing users' programs. Rather, the processor spends a fair proportion of its time executing the operating system (for example, dealing with resource allocation).

Micro systems

Nearly all microcomputer systems are single-user interactive systems for several reasons. The first is that such systems are relatively simple to implement. Secondly, micros have limited resources in terms of memory, CPU power and I/O ports. A typical system might have Z80 CPU, 16k RAM and two I/O ports, a configuration which is scarcely sufficient to support multiple users.

By expanding the system configuration to, say, 64k (usually the maximum possible) and adding extra I/O ports, it is possible to obtain a system which will support a few users but is heavily restricted by CPU power. Of course, it is necessary to modify (enlarge) the operating system to cope with more than one user. Such systems are available on the market but are only satisfactory for a limited number of applications. In order to implement a multi-user system with wider appeal, other techniques must be adopted.

Looking at the components of a micro system, it's clear that the part which runs out of steam first is, luckily, one of the cheapest — the CPU. This points the way to a real multi-user system: give each user his own CPU and a bit of memory and share the expensive components, such as disks (the approach used by CP/Net in fact). In fact, as the number of users increases, larger disks (eg 8in hard disks) become attractive since they are very

GOTO page 133

CALCULATOR CORNER

Compiled by Dick Pountain

CASIO I/O ROUTINES

The Casio fx501/502p was the first programmable calculator to provide tape rather than magnetic cards as its bulk storage medium, although now, of course, it has been joined by the Sharp PC1211 and its Tandy clone.

The Sharp possesses two features which make data and program saving far more flexible than on the Casio. Firstly, the recorder may be stopped and started under program control via the Remote socket and secondly, since the Sharp uses Basic, it is possible to save and load selected data memories without overwriting (ie, obliterating) the contents of other registers. This is performed by the PRINT# and INPUT# commands with a named data memory, eg INPUT# DATA 1 : A(3) loads tape file DATA 1 into memory register A(3). In addition the Sharp can load and run consecutive program files under program control using the CHAIN command.

On the Casio, the data SAVE dumps the contents of all M registers to tape and data LOAD loads all M registers, overwriting their previous contents. The contents of the X, Y and L registers are not dumped and are overwritten on loading and so lost.

Reader Vernon Mantle has produced routines using the non-standard INV EXE instruction which allow saving and loading of the X register without loss of M register data and also independent saving and loading of the F register.

INV EXE is not mentioned in the Casio manual but it can be programmed and has the op code FF-E6. Files saved under program control with INV EXE always have the file number 00. Vernon has also submitted two short programs which write a succession of data and read the same, under program control, without the loss of M register data. These demonstration routines could easily be modified to perform arithmetical operations on an unlimited chain of data, the practical limit being time, since the saving and loading is rather slow.

Vernon's modified I/O routines are as follows:

SAVE X (writes the contents of the X register to tape under program control).
Coding: INV SAVE INV EXE

This routine will write a block of data onto tape. The block label will be F 000. The block will contain the contents of the X register at the time of execution. All other registers will be unaffected.

SAVE M (writes the contents of all current M registers to tape under program control).
Coding: INV SAVE EXE

This routine will write the M registers' contents to tape, setting the X, Y and L registers to zero but leaving the M registers unaltered. The block label will

be F000.

LOAD X (loads data from tape into the X register under program control).

Coding: INV LOAD INV EXE INV PAUSE

This will read the next block of data on the tape regardless of the block label. If the block was created by SAVE X, the saved X register will be loaded back into the calculator's X register. If the block was created by SAVE M, the saved F register will be loaded into the X register. Executing this routine will not affect the Y, L or M registers.
LOAD M (loads data from tape into the M registers under program control).

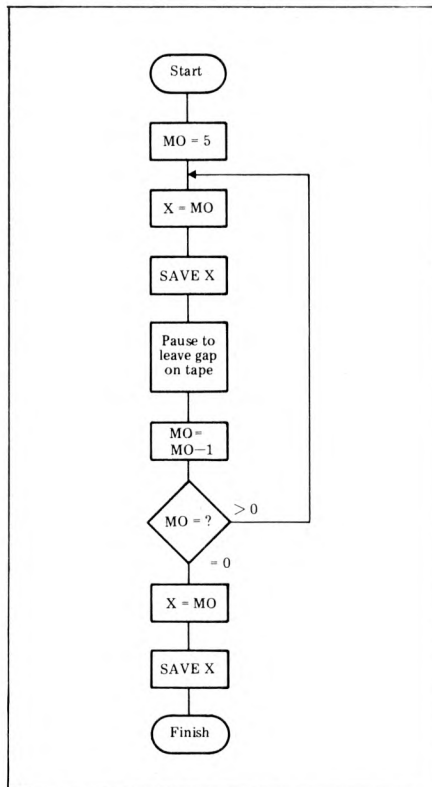

Operation

- 1 Enter program statements
- 2 Connect calculator to cassette recorder
- 3 Set recorder to record, start tape running.
- 4 Press PO to write data blocks to tape.

Coding

PO 5 MIN 0

LBL 0

MR 0
INV SAVE INV EXE (SAVE X)
INV PAUSE INV PAUSE
INV DSZ GOTO 0

MR 0
INV SAVE INV EXE (SAVE X)

Fig 1 Program to write six blocks of data to tape using SAVE X.

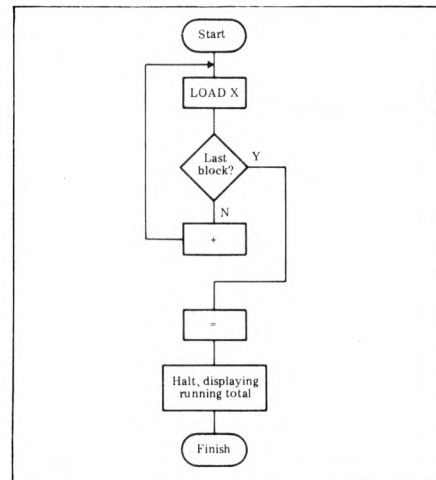

Operation

- 1 Enter program statements
- 2 Connect calc to cassette recorder
- 3 Play tape recorded by previous program.
- 4 Press P1 to read tape and accumulate running total.

Coding

P1

LBLO

INV LOAD INV EXE INV PAUSE
(LOAD X)
INV X = 0 GOTO 1
+ GOTO 0
LBL 1
=

Fig 2 Program to read six blocks of data saved by program in Figure 1, keep running total and display it when last block read in, using only X and Y registers.

Coding: INV LOAD EXE INV PAUSE

This will read the next data block on tape, regardless of block label. If the block was created by SAVE X, it contains only one saved register and this will be loaded into the calculator's F register, leaving the other M registers unaltered. If the block was created by SAVE M, all the calculator's M registers will be overwritten with data from the tape. Executing LOAD M will always set the X, Y and L registers to zero.

I suspect that this is not the end of this subject. I shall certainly be experimenting with Casio I/O routines; one valuable objective would be to find a way of saving/loading selected M registers (if possible) and also selected program memories. I shall also try to produce and report to you a useful calculating routine using SAVE X to write to tape in order to store more than 20 results. Any results of other readers' researches will be gratefully received.

Make your micro

POWERFUL



Get the most out of your microcomputer with Graham-Dorian Business software.

At any given time, your hardware is only as useful as the software you run in it. Our programs let you realise the full potential of your hardware.

Graham-Dorian provides highly detailed and well documented programs. All pretested on the job. Each so comprehensive that it takes little time to learn to run a program — even for someone who's never operated a computer before.

Graham-Dorian programs are on-line now working for us and others around the world. They are ready to go to work immediately or to be tailored for your more specific needs. Each package contains a software program in BAS and INT film form plus a user's manual and hard copy SOURCE LISTING.

Programs are compatible with most major computers using CP/M disk operating systems, and come in standard 8" or on various mini-floppy disks.

Graham-Dorian stand behind dealers with technical advice.

Yes, there's a world of difference in business software. Graham-Dorian has more per-package capabilities and more packages (with new ones added every few months).

Distributors for Micropro:- Wordstar, Datastar & Mailmerge. CP/M for Tandy Model I & II

†GDSS are appointing UK Dealers and European Distributors. Enquiries and applications invited.

*CBASIC-2 is a trade mark (copyright 1980) of Compiler Systems, Inc. GDSS are the European Distributor for CBASIC-2.

The Graham-Dorian line now includes these packages:

- Nominal Ledger
- Purchase Ledger
- Sales Ledger
- Job Costing
- Order Entry & Invoicing
- Payroll
- Manufacturing Inventory
- Manufacturing Job Costing
- Wholesaler Inventory
- Retailer Inventory
- Cash Register
- Apartment
- Surveying
- Dental

CBASIC-2*

Ask your dealer for a demonstration soon.



Graham-Dorian Software Systems

A division of Graham-Dorian Enterprises
& Terodec (Micro Systems) Ltd.
Unit 58, Suttons Park Avenue, Earley
Reading, Berks RG6 1AZ
Tel (0734) 664345/6 GDSS

Why the Sinclair ZX80 is Britain's best selling

Built: £99.95

Including VAT, post and packing, free course in computing, free mains adaptor.

Kit: £79.95

Including VAT, post and packing, free course in computing.

This is the ZX80. A really powerful, full-facility computer, matching or surpassing other personal computers at several times the price. 'Personal Computer World' gave it 5 stars for 'excellent value'. Benchmark tests say it's faster than all previous personal computers.

Programmed in BASIC—the world's most popular language—the ZX80 is suitable for beginners and experts alike. And response from enthusiasts has been tremendous—over 20,000 ZX80s have been sold so far!

Powerful ROM and BASIC interpreter

The 4K BASIC ROM offers remarkable programming advantages:

- * Unique 'one-touch' key word entry: the ZX80 eliminates a great deal of tiresome typing. Key words (RUN, PRINT, LIST, etc.) have their own single-key entry.
- * Unique syntax check. A cursor identifies errors immediately.
- * Excellent string-handling capability—takes up to 26 string variables of any length. All strings can undergo all relational tests (e.g. comparison).
- * Up to 26 single dimension arrays.
- * FOR/NEXT loops nested up to 26.
- * Variable names of any length.
- * BASIC language also handles full Boolean arithmetic, conditional expressions, etc.
- * Randomise function, useful for games and secret codes, as well as more serious applications.
- * Timer under program control.
- * PEEK and POKE enable entry of machine code instructions.
- * High-resolution graphics.
- * Lines of unlimited length.

Unique RAM

The ZX80's 1K-BYTE RAM is the equivalent of up to 4K BYTES in a conventional computer—typically storing 100 lines of BASIC.

No other personal computer offers this unique combination of high capability and low price.

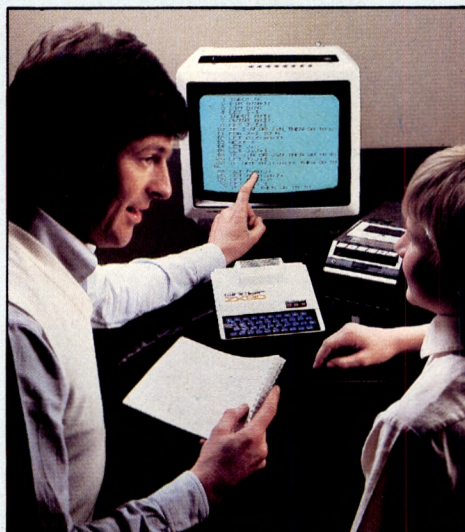

The ZX80 as a family learning aid. Children of 10 years and upwards are quick to understand the principles of computing—and enjoy their personal computer.

The Sinclair teach-yourself BASIC manual

If the specifications of the Sinclair ZX80 mean little to you—don't worry. They're all explained in the specially-written 128-page book (free with every ZX80). The book makes learning easy, exciting and enjoyable, and represents a complete course in BASIC programming—from first principles to complex programs.

Kit or built—it's up to you

In kit form, the ZX80 is pleasantly easy to assemble, using a fine-tipped soldering iron. And you may already have a suitable mains adaptor—600 mA at 9V DC nominal unregulated. If not, see the coupon.

Both kit and built versions come complete with all necessary leads to connect to your TV (colour or black and white) and cassette recorder. Plug in and you're ready to go. (Built versions come with mains adaptor.)

personal computer.

Now available for the ZX80... New 16K-BYTE RAM pack



Massive add-on memory. Only £49.95.

The new 16K-BYTE RAM pack is a complete module designed to provide you – and your Sinclair ZX80 – with massive add-on memory. You can use it for those really long and complex programs – or as a personal database. (Yet it can cost as little as half the price of competitive add-on memory for other computers.)

For example, you could write an interactive or 'conversational' program to show people what your ZX80 can do. With 16K-BYTES of RAM, they could be talking to your computer for hours!

Or you can store a mass of data – perhaps in a fairly simple program – such as a name and address list, or a telephone directory.

And by linking a number of separate programs together into one giant, but modular, program, you can achieve the same effect as loading several programs at once.

We're also confident that it won't be long before you can buy cassette-based software using the full 16K-BYTE RAM. So keep an eye on the personal computer magazines – and brush up your chess perhaps!

The RAM pack simply plugs into the existing expansion port on the rear of the ZX80. No wires, no soldering. It's a matter of seconds and you don't need another power supply. You can only add one RAM pack to your ZX80 – but with 16K-BYTES who could want more!

How to order

Demand for the ZX80 exceeds all other personal computers put together! So use the coupon to order today for the earliest possible delivery. All orders will be despatched in strict rotation. We'll acknowledge each order by return, and tell you exactly when your ZX80 will be delivered. If you choose not to wait, you can cancel your order immediately, and your money will be refunded at once. Again, of course, you may return your ZX80 as received within 14 days for a full refund. We want you to be satisfied beyond all doubt – and we have no doubt that you will be.

To: Science of Cambridge, FREEPOST 7, Cambridge CB2 1YY.

Remember: all prices shown include VAT, postage and packing. No hidden extras. Please send me:

Qty	Item	Code	Item price £	Total £
	Sinclair ZX80 Personal Computer kit(s). Price includes ZX80 BASIC manual, excludes mains adaptor.	02	79.95	
	Ready-assembled Sinclair ZX80 Personal Computer(s). Price includes ZX80 BASIC manual and mains adaptor.	01	99.95	
	Mains Adaptor(s) (600 mA at 9V DC nominal unregulated).	03	8.95	
	16K-BYTE RAM pack(s).	18	49.95	
	Sinclair ZX80 Manual(s). (Free manual with every ZX80 kit or ready-made computer.)	06	5.00	

NB. Your Sinclair ZX80 may qualify as a business expense.

TOTAL: £

I enclose a cheque/postal order payable to Science of Cambridge Ltd for £ _____
Please print

Name: Mr/Mrs/Miss _____

Address _____

FREEPOST – no stamp needed.

PCW/1

sinclair ZX80

Science of Cambridge Ltd.

6 Kings Parade, Cambridge, Cambs.,
CB2 1SN. Tel: 0223 311488.

megastor and apple

the perfect couple

1 Megabyte on  line for £1970

Plug-in compatible with Apple standard 5¼" disk drives.

Runs on Apple DOS. Includes SVA Disk 2+2 Controller Card.



Dealer enquiries
welcomed.

Apple is a trade mark of
Apple Computer Inc.
Disk 2+2 is a trade mark
of Sorrento Valley Associates.

VLASAK ELECTRONICS Ltd, Thames Building, Dedmere Road, Marlow, Bucks, SL7 1PB.
Telephone: Marlow (STD code 06284) 74789. Telex: 847008 Vlasak G

PCW SUBSET

Continuing PCW's unique series aimed at the serious programmer working in assembler language, Alan Tootill brings more examples of work sent in by readers.

We seem to be addicted to relative calling. October's datasheet RLTV, to implement a relative call, has drawn the best response we have had from readers to date.

Mark Restorick, from Oldham, put his finger on a flaw in RLTV. The fourth instruction, ADD HL,SP, could change the state of the flags register, which has not been saved. He gave the solution to move the PUSH AF from 14th to third instruction and make the instruction which now follows, LD HL,+6, instead of +4. Mark also proposed a version of the routine one byte shorter but taking eight more T-states to execute.

Paul Jenner of Southampton sent the code in Figure 1, which we will call RLTVB. It shortens October's RLTV from 27 bytes and 199 T-states to 24 bytes and 188 T-states.

```
PUSH HL      ; save
PUSH DE      ; registers.
PUSH AF
LD HL,+6     ; point to return
ADD HL,SP    ; address on stack.
LD E,(HL)    ; get original
INC HL       ; return address
LD D,(HL)    ; in DE.
LD A,(DE)    ; displacement in A.
INC DE       ; increment
LD (HL),D    ; return address
DEC HL       ; and return it
LD (HL),E    ; to the stack.
LD, L,A      ; put displacement
RLA          ; in HL
SBC A,A      ; properly
LD H,A       ; signed.
ADD HL,DE    ; add to return.
POP AF       ; restore
POP DE       ; registers.
EX (SP),HL   ; put new return on
RET          ; stack & jump to it.
```

Figure 1

RLTV transformed

If this series wasn't about showing that routines made public will inevitably be improved, I would kick myself for not having seen this better way of ordering things. Take note all you who keep your software secret and tatty.

In fact, Paul doesn't use this code. He has written interruptable RCAL (relative call) and SCAL (indexed subroutine call) routines for his Nascom, using the 10H and 18H restart locations and a common subroutine, GETPRM, to get the parameter in A and the return address in DE. His SCAL routine needs a table of routine addresses and the address of this table is given at locations STAB and STAB+1, as in the Nascom monitor.

For those of you who still like this system, particularly if you have restart locations still uncommitted, this is how

Datasheet

```
; = SFIFO, WFIFO, RFIFO — first-in-first-out buffer suite
;/ CLASS: 2
;/ TIME CRITICAL? : No
;/ DESCRIPTION: SFIFO sets up an empty buffer at (IX).
;/              WFIFO writes a byte to the buffer.
;/              RFIFO reads a byte from the buffer.
;/ ACTION: sets up a buffer of given length in memory with buffer
;/          variables stored below (IX) to (IX-8);
;/          writes a byte to the next place in the recirculating
;/          buffer, which puts its first byte after initialisation
;/          at (IX+1) and in subsequent cycles from (IX);
;/          reads the first byte to have been written and not yet
;/          read from the buffer.
;/ SUBR DEPENDENCE: local within the Datasheet.
;/ INPUT: IX holds the base address of the buffer for all entries.
;/        DE holds the maximum size of the buffer for entry to SFIFO.
;/        C holds the byte to be written for entry to WFIFO.
;/ OUTPUT: from all entries:
;/          (IX-1) holds the most significant byte of the displacement
;/          of the last byte read.
;/          (IX-2) holds the least significant byte of the displacement
;/          of the last byte read.
;/          (IX-3) holds the most significant byte of the displacement
;/          of the last byte written.
;/          (IX-4) holds the least significant byte of the displacement
;/          of the last byte written.
;/          (IX-5) holds the most significant byte of the count
;/          of bytes written but not yet read.
;/          (IX-6) holds the least significant byte of the count
;/          of bytes written but not yet read.
;/          (IX-7) holds the most significant byte of the maximum
;/          buffer length.
;/          (IX-8) holds the least significant byte of the maximum
;/          buffer length.
;/          from WFIFO:
;/          the byte from C has been placed in the buffer unless full.
;/          if the buffer is full, the carry is set.
;/          from RFIFO:
;/          if the buffer is empty, the carry is set and A = 00H,
;/          otherwise the byte read is in A.
;/ REGs USED:   by SFIFO: AF, DE, IX.
;/              by WFIFO: AF, C, IX.
;/              by RFIFO: AF, IX.
;/ STACK USE: 8
;/ LENGTH: 121
;/ PROCESSOR: Z80
LSTRH EQU -1
LSTRL EQU -2
LSTWH EQU -3
LSTWL EQU -4
BCNTH EQU -5
BCNTL EQU -6
MAXBH EQU -7
MAXBL EQU -8
SFIFO: PUSH HL      ; SAVE HL          E5
        LD A,+6     ;                   3E 06
        PUSH IX     ; get buffer base   DD  E5
        POP HL      ; pointer in HL.   E1
FZ1:    DEC HL      ;                   2B
        LD (HL),+0  ; zeroise          36 00
        DEC A       ; displacements    3D
        JR NZ,FZ1   ; & byte count.    20  FA
```

THE LOWDOWN ON PET!



My name is Julian Allason and I publish a magazine called **PRINTOUT**. It is exclusively about the CBM/PET.

I first saw the PET in America three years ago. It was made of wood then. I was so impressed that I came right back and opened a software house publishing PET programs.*

Then a little over a year ago I started **PRINTOUT**. There was a need for an independent magazine that could conduct really thorough evaluations of the flood of new hardware and software products, and report the latest PET developments in detail. Since then **PRINTOUT** has tested scores of programs and peripherals, and broken the major PET news stories.

We recruited the world's top PET experts to explain the intricacies of the system, to answer your questions and give advice. These days **PRINTOUT** probably publishes more useful PET information than the other magazines put together. Take a look at the contents of the last issue and you will see what I mean.

There are a whole bundle of changes around the corner that are going to affect every single CBM/PET owner. An example. The complexities of Commodore's new BASIC 4.0 and DOS chips are already causing mind bending problems. Add in the increasing number of plug-in ROM chips and the situation's really complicated. **PRINTOUT** is there to save you headaches, and money too!

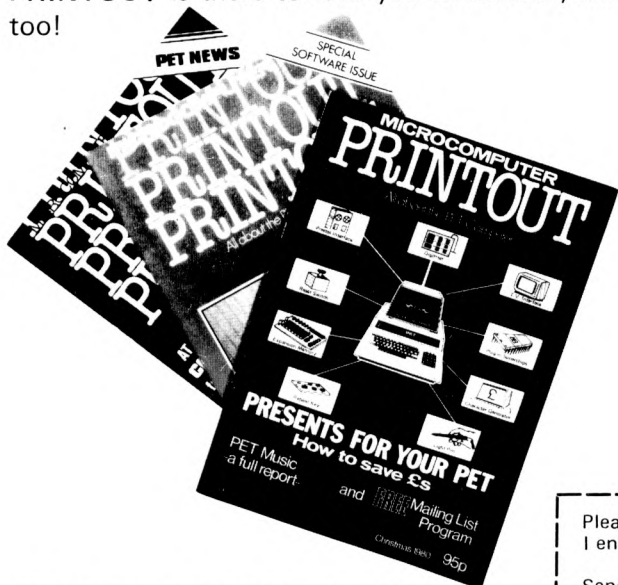

We didn't set out to be an encyclopaedia, but there's no doubt that is what **PRINTOUT** is on the way to becoming — a single reliable source of unbiased information about the PET system. And fun to boot!

I don't think you can afford to be without **PRINTOUT**. So try a copy for yourself. Or better still, subscribe now!

*Petsoft, since acquired by ACT.

PRINTOUT

PO Box 48,
Newbury, Berkshire RG16 OBD.
Telephone 0635-201131

Please enter my subscription to Volume 2 (1981):
I enclose £9.50 UK £11 Eire £14.50 overseas

Send the full set of Vol. 1 I enclose £9.50 UK £11 Eire £14.50 Overseas

Rush me the latest issue. I enclose 95p UK & Eire £1.25 Overseas airmail

My name is:

My address is:

..... Postcode:

PRINTOUT is independent of Commodore whose trademark PET is.

```

it goes:
RCAL:  PUSH HL
        PUSH AF
        PUSH DE
        CALL GETPRM
        JR RCAL2
SCAL:  PUSH HL
        PUSH AF
        PUSH DE
        CALL GETPRM
        JR SCAL2
        .
        .
RCAL2: LD L,A
        RLA
        SBC A,A
        LD H,A
        ADD HL,DE
RCAL3: POP DE
        POP AF
        EX (SP),HL
        RET
        .
        .
SCAL2: LD E,A
        LD D,00H
        LD HL,(STAB)
        ADD HL,DE
        ADD HL,DE
        LD E,(HL)
        INC HL
        LD D,(HL)
        EX DE,HL
        JR RCAL3
GETPRM: LD HL,+8
        ADD HL,SP
        LD E,(HL)
        INC HL
        LD D,(HL)
        LD A,(DE)
        INC DE
        LD (HL),D
        DEC HL
        LD (HL),E
        RET

```

RLTV run riot

Geoff Barker, who lives near Oxford, asks, 'Why limit calls to the plus 7FH-minus 80H displacement of the relative jumps? Surely an opportunity now exists to go anywhere!' It does indeed, if you don't mind a two instead of a one-byte parameter in the main code, every time the routine is used.

Geoff also thinks that the displacement ought to be from the first byte of the CALL RLTV, to make it similar in operation to the relative jump. That depends on what you are used to. If you write in machine code, you will be used to giving displacements from the first byte of the instruction following the relative jump and will want a routine that handles such displacements for relative calls. If you supply displacements, rather than labels, to an assembler, you will probably be used to giving displacements from the first byte of the relative jump instruction and will be more at home with a relative call routine that handles displacements of this kind. Geoff's code, which we will call RLTVW, is for two-byte displacements taken from the first byte of the CALL RLTVW instruction — see Figure 2.

```

EX (SP),HL ; update return
INC HL    ; address and
INC HL    ; return it
EX (SP),HL ; to stack.
PUSH HL   ; save

```

```

        DEC HL ;
        LD (HL),D ; set
        DEC HL ; maximum
        LD (HL),E ; buffer length
        POP HL ; restore HL.
        RET ; return.
WFIFO: PUSH DE ; save
        PUSH HL ; registers.
        LD E,(IX+BCNTL) ; get byte
        LD D,(IX+BCNTH) ; count in DE.
        INC DE ; update count.
        CALL CPMAX ; if buffer full
        JR C,INFL ; jump out else
        LD (IX+BCNTL),E ; restore new
        LD (IX+BCNTH),D ; byte count.
        LD E,(IX+LSTWL) ; get disp of
        LD D,(IX+LSTWH) ; last byte written.
        CALL RCIRC ; get next disp &
        ; put abs addr to HL.
        LD (IX+LSTWL),E ; restore
        LD (IX+LSTWH),D ; new displacement.
        OR A ; unset carry.
        LD (HL),C ; write byte.
INF1:  POP HL ; restore
        POP DE ; registers.
        RET ;
RFIFO: PUSH DE ; save DE.
        LD E,(IX+BCNTL) ; get byte
        LD D,(IX+BCNTH) ; count in DE.
        LD A,D ; set carry
        OR E ; and jump
        SCF ; out if
        JR Z,OUF1 ; count zero.
        PUSH HL ; save HL.
        DEC DE ; reduce count.
        LD (IX+BCNTL),E ; restore
        LD (IX+BCNTH),D ; new count.
        LD E,(IX+LSTRL) ; get disp of
        LD D,(IX+LSTRH) ; last byte read.
        CALL RCIRC ; get next disp &
        ; put abs addr to HL.
        LD (IX+LSTRL),E ; restore
        LD (IX+LSTRH),D ; new displacement.
        LD A,(HL) ; get byte.
        OR A ; clear carry.
        POP HL ;
        POP DE ;
        RET ;
OUF1:  INC DE ; next displacement.
        CALL CPMAX ; check buffer.
        JR NZ,RC1 ; jump if not limit.
        EX DE,HL ; else recircle.
RC1:   PUSH IX ; get buffer base
        POP HL ; pointer in HL.
        ADD HL,DE ; add displacement.
        RET ;
CPMAX: LD L,(IX+MAXBL) ; get maximum
        LD H,(IX+MAXBH) ; length to HL.
        OR A ; clear carry.
        SBC HL,DE ; subtract disp.
        RET ;
        DEC HL ; correct to
        DEC HL ; first byte
        DEC HL ; of CALL.
        POP AF ; restore
        POP DE ; registers.
        EX (SP),HL ; put new return on
        RET ; stack & jump to it.

```

Figure 2

To alter RLTVW to handle displacements from the first byte of the instruction following the displacement,

```

PUSH DE ; registers.
PUSH AF ;
LD HL,+6 ; point to updated
ADD HL,SP ; return address on stack.
LD E,(HL) ; get displacement
INC HL ; address + 2
LD D,(HL) ; in DE
EX DE,HL ; and HL.
DEC HL ; disp addr + 1.
LD D,(HL) ; get
DEC HL ; displacement
LD E,(HL) ; in DE and
ADD HL,DE ; add to ret addr.

```

GOTO page 133

Personal Computer

World

COMPLETE FEATURE INDEX FOR 1980

Hardware Projects

Z80 Homebrew	3-1
Selective PROM copier	3-3
TV to Monitor conversion	3-3
MK-14 Expansion	3-4
Teleprinter conversion	3-5
Adding a Z80 to a 6800 system	3-7
VCR to PET interface	3-8
MK14 large LEDs	3-9
Sound Advice	3-10
Int IMP printer to TRS-80'	3-11

Benchtest

Luxor ABC 80	3-1
WH 89	3-2
ACT System 800	3-2
Panasonic JD 700 U	3-3
Sinclair ZX-80	3-4
Challenger C2 4P	3-4
Texas Ti 99/4	3-5
Altos ACS 8000-2	3-5
Hewlett Packard HP-85	3-5
Benchmark Timings summary	3-5
TRS-80 Model II	3-6
Sintrom Periflex 630/48	3-6
Acorn Atom	3-7
DDE SPC/1	3-7
Super Brain	3-8
BASF 7120	3-9
CBM 8032	3-9
DAI Personal Computer	3-10
Atari 400 & 800	3-10
Benchmarks explained	3-10
SBS-8000	3-11
Raannd SP1/ Pascal Microengine	3-12

Series

PASCAL	3-1, 2, 3, 4, 5
David Levy's games	3-1,2,3, 4,5,6,7,8,9,10, 11,12
On the line	3-1, 2, 3
Viewdata	3-4, 5, 6
Pascal Part 10 — Concluded	3-6
IEEE interface — Part 2	3-6
Chess	3-7,8,9,10,11,12
Gateways to logic	3-7,8,9, 10,11,12
Face to face	3-7,8,9,10, 11,12
Network Notes	3-7, 9
Secrets of systems analysis	3-9,10,11,12
PCW sub set	3-9,10,11,12
Printerfacing	3-12

Fact Sheets

6800 opcodes	3-1
6502 opcodes	3-2

Personal Opinion

The end of work? Lord Avebury	3-1
Protest against technological determinism	3-3
Who needs the CRA?3-4	3-4
Schools computing — David Firnberg	3-4
Stating the obvious	3-5
Micros in big businesses	3-5
Animistics — a look at 'friendly' computers	3-7
Computer/Information technology & the law	3-8

Evaluations (Checkout)

Video Genie	3-2
Vector Graphic Flashwriter II	3-2
Apple II Symtec light pen	3-3
Microdata UV8 EPROM eraser	3-5
Softy intelligent EPROM programmer	3-5
Exatron stirngy floppy 380Z High	3-6
Resolution Graphics ROMPLUS+ for Apple II	3-8
Hi-Tech VDU board	3-9
Microwriter	3-12
Micro-based toys	3-12

Calculator Corner

TI 58/9 Pseudo opcodes	3-1
Casio Fx 502P Brag	3-1
Casio Fx 501/2P Master Pack	3-2
TI 58/9 Economics Simulations.	3-2
Programming efficiency	3-3
Casio random number generator	3-3
HP 41C review	3-4
Artificial Intelligence Accounts on TI-59	3-5
Data Packing Sharp PC1211 evaluation	3-7
Pentathlon program	3-8
Aid for the blind	3-9
Godel, Escher, Bach	3-10
Casio Quirks & Data Packing	3-11
PC1211 Speed up	3-12

Special Features

Computer Retailers' Association	3-1
Christopher Evans tribute	3-1
Show chess results	3-1

The British Computer Society	3-2
Astrology — case study	3-2
IEEE-488 bus explained	3-2
Economic simulation	3-3
Modern evaluations	3-5
5th West Coast Faire report	3-5
Wave Synthesis on Nascom 1	3-5
Overcoming PET printer problems	3-5
Random numbers	3-5
Sound to colour conversion	3-3
American report	3-3
Simple approach to programming	3-3
Communication aid for disabled	3-4
Imphex — intelligent game PET	3-4
House of Commons report	3-4, 9
Interrupt handling	3-6
Case Study — CompuColor installation	3-6
Poem	3-6
Power supplies explained	3-6
Power supply design	3-6
Program structuring in Basic	3-6
Sandbach school system	3-6
M68000 preview	3-7
Case Study — Apple Installation	3-7
3 - D Plotting	3-7
Cassette files	3-8
Printer survey	3-8
Basic Basic	3-9
Worl Micromcomputer Chess Championship	3-9
Portable Basic	3-9
Parkinson's Pep-up	3-10
Bare Bones of Robotics	3-10
Helping the Handicapped	3-10
Another Dimension	3-10
Computertown UK	3-11
Apple/ITT colour graphics	3-11
Reader Survey	3-11
Forecasting	3-11
PCW Show round-up	3-11
Pascal Benchmarks	3-12
Computer Art	3-12
ComputerTown UK!	3-12
Football Pools program	3-12
CRAM random access circa 1960	3-12

Package evaluations

Sales Ledger	3-1,8
Purchase Ledger	3-2
Payroll	3-3
Word Processing	3-4
Information retrieval & databases	3-5
Integrated accounts packages	3-6
Stock Control	3-7

Programs

BASIC Star Wars	3-1
PET Alien Attack	3-1
Revas (conclusion) REverse assembler for Z80	3-1
Planet name generator 6800	3-1
MK-14 scrolled messages	3-3
6800 Keyword retrieval system	3-3
PET Kaleidoscope	3-3
Efficient character storage Z80 Assembler	3-3
UK101 Dodgems	3-4
TRS-80 Fox and hounds	3-4
MZ 80K Sine wave addition	3-4
PET Backgammon	3-5
UK101 Nedge	3-6
PET Horse race	3-6
BASIC Renumber	3-6
Naming Nascom files	3-2
380Z Pictures	3-2
Fuel tank calculations — PET	3-2
PET large numeral generator	3-2
PET tank battle	3-2
BASIC string handling routines	3-2
UK101 Dogfight	3-6
MK 14 Frequency counter	3-6
North Star Maths test	3-6
PET Sweeper	3-6
PET Delete/Renumber	3-6
PET Cat and Mouse	3-7
UK 101 Graph Plotter	3=7
UK 101 Black Box	3-7
TRS-80 Graphics	3-7
PET Robot Nim	3-7
PET Golf	3-7
PET Nightmare Park	3-8
PET Dots & boxes	3-9
PET Bloobers	3-9
PET Demolition	3-9
Apple Showpiece	3-9
PEEK & POKE for Apple Pascal	3-9
PET Giant Slalom	3-9
Speed & Acceleration	3-9
PET Racer	3-10
PET Fighter Pilot	3-10
UK101 Graphics	3-10
Apple Plotting	3-10
UK101 Gunfight	3-10
PET Algebraic evaluation	3-10
ZX80 Breakout	3-10
PET Ski	3-11
MZ-80K Bouncing ball	3-11
Superboard/UK101 Bug bypass	3-11
PET Replace	3-11
TRS-80 Tarot	3-12
PET Cat & Mouse	3-12
PET Rebound	3-12
MZ-80K Alligator Swamp	3-12
PET Connect	3-12
UK 101 Minefield	3-12
PET Simon	3-12

NEWCOMERS-START HERE

This is our unique quick-reference guide, reprinted every month to help our readers pick their way through the most important pieces of (necessary) jargon found in PCW. While it's in no way totally comprehensive, we trust you'll find it a useful introduction. Happy microcomputing!

Welcome to the confusing world of the microcomputer. First of all, don't be fooled; there's nothing complicated about this business, it's just that we're surrounded by an immense amount of necessary jargon. Imagine if we had to continually say 'numbering system with a radix of 16 in which the letters A to F represent the values ten to 15' when instead we can simply say 'hex'. No doubt soon many of the words and phrases we are about to explain will eventually fall into common English usage. Until that time, *PCW* will be publishing this guide — every month.

We'll start by considering a microcomputer's functions and then examine the physical components necessary to implement these functions.

The microcomputer is capable of receiving information, processing it, storing the results or sending them somewhere else. All this information is called *data* and it comprises numbers, letters and special symbols which can be read by humans. Although the data are (yes, it's plural) accepted and output by the computer in 'human' form, inside it's a different story — they must be held in the form of an electronic code. This code is called *binary* — a system of numbering which uses only 0s and 1s. Thus in most micros each character, number or symbol is represented by eight binary digits or *bits* as they are called, ranging from 00000000 to 11111111.

To simplify communication between computers, several standard coding systems exist, the most common being *ASCII* (American Standard Code for Information Interchange). As an example of this standard, the number five is represented as 00110101 — complicated for humans, but easy for the computer! This collection of eight bits is called a *byte* and computer freaks who spend a lot of time messing around with bits and bytes use a half-way human representation called *hex*. The hex equivalent of a byte is obtained by giving each half a single character code (0–9, A–F): 0=0000, 1=0001, 2=0010, 3=0011, 4=0100, 5=0101, E=1110 and F=1111. Our example of 5 is therefore 35 in hex. This makes it easier for humans to handle complicated collections of 0s and 1s. The machine detects these 0s and 1s by recognising different voltage levels.

The computer processes data by reshuffling, performing arithmetic on, or by

comparing them with other data. It's the latter function that gives a computer its apparent 'intelligence' — the ability to make decisions and to act upon them. It has to be given a set of rules in order to do this and, once again, these rules are stored in *memory* as bytes. The rules are called *programs* and while they can be input in binary or hex (*machine code* programming), the usual method is to have a special program which translates English or near-English into machine code. This speeds programming considerably; the nearer the *programming language* is to English, the faster the programming time. On the other hand, program execution speed tends to be slower.

The most common microcomputer language is *Basic*. Program instructions are typed in at the keyboard, to be coded and stored in the computer's memory. To run such a program the computer uses an *interpreter* which picks up each English-type *instruction*, translates it into machine code and then feeds it into the *processor* for execution. It has to do this each time the same instruction has to be executed.

Two strange words you will hear in connection with *Basic* are *PEEK* and *POKE*. They give the programmer access to the memory of the machine. It's possible to read (*PEEK*) the contents of a byte in the computer and to modify a byte (*POKE*).

Moving on to *hardware*, this means the physical components of a computer system as opposed to *software* — the programs needed to make the system work.

At the heart of a microcomputer system is the central processing unit (*CPU*), a single microprocessor chip with supporting devices such as *buffers*, which 'amplify' the *CPU*'s signals for use by other components in the system. The packaged chips are either soldered directly to a printed circuit board (*PCB*) or are mounted in sockets.

In some microcomputers, the entire system is mounted on a single, large, *PCB*; in others a *bus system* is used comprising a long *PCB* holding a number of interconnected sockets. Plugged into these are several smaller *PCBs*, each with a specific function — for instance, one card would hold the *CPU* and its support chips. The most widely-used bus system is called the *S100*.

The *CPU* needs memory in which to keep programs and data. Microcomputers generally have two types of

memory, *RAM* (Random Access Memory) and *ROM* (Read Only Memory). The *CPU* can read information stored in *RAM* — and also put information into *RAM*. Two types of *RAM* exist — *static* and *dynamic*; all you really need know is that *dynamic RAM* uses less power and is less expensive than *static*, but it requires additional, complex, circuitry to make it work. Both types of *RAM* lose their contents when power is switched off, whereas *ROM* retains its contents permanently. Not surprisingly, manufacturers often store interpreters and the like in *ROM*. The *CPU* can only read the *ROM*'s contents and cannot alter them in any way. You can buy special *ROMs* called *PROMs* (Programmable *ROMs*) and *EPROMs* (Erasable *PROMs*) which can be programmed using a special device; *EPROMs* can be erased using ultra-violet light.

Because *RAM* loses its contents when power is switched off, *cassettes* and *floppy disks* are used to save programs and data for later use. Audio-type tape recorders are often used by converting data to a series of audio tones and recording them; later the computer can listen to these same tones and re-convert them into data. Various methods are used for this, so a cassette recorded by one make of computer won't necessarily work on another make. It takes a long time to record and play back information and it's difficult to locate one specific item among a whole mass of information on a cassette; therefore, to overcome these problems, floppy disks are used on more sophisticated systems.

A floppy disk is made of thin plastic, coated with a magnetic recording surface rather like that used on tape. The disk, in its protective envelope, is placed in a disk drive which rotates it and moves a *read/write head* across the disk's surface. The disk is divided into concentric rings called *tracks*, each of which is in turn subdivided into *sectors*. Using a program called a *disk operating system*, the computer keeps track of exactly where information is on the disk and it can get to any item of data by moving the head to the appropriate track and then waiting for the right sector to come round. Two methods are used to tell the computer where on a track each sector starts: *soft sectoring* where special signals are recorded on the surface and

hard sectoring where holes are punched through the disk around the central hole, one per sector.

Half-way between cassettes and disks is the *stringy floppy* — a miniature continuous loop tape cartridge, faster than a cassette but cheaper than a disk system. *Hard disk* systems are also available for microcomputers; they store more information than floppy disks, are more reliable and information can be transferred to and from them much more quickly.

You, the user, must be able to communicate with the computer and the generally accepted minimum for this is the visual display unit (*VDU*), which looks like a TV screen with a typewriter-style *keyboard*; sometimes these are built into the system, sometimes they're separate. If you want a written record (*hard copy*) of the computer's output, you'll need a *printer*.

The computer can send out and receive information in two forms — *parallel* and *serial*. Parallel input/output (*I/O*) requires a series of wires to connect the computer to another device, such as a printer, and it sends out data a byte at a time, with a separate wire carrying each bit. Serial *I/O* involves sending data one bit at a time along a single piece of wire, with extra bits added to tell the receiving device when a byte is about to start and when it has finished. The speed that data is transmitted is referred to as the *baud rate* and, very roughly, the baud rate divided by ten equals the number of bytes being sent per second.

To ensure that both receiver and transmitter link up without any electrical horrors, standards exist for serial interfaces; the most common is *RS232* (or *V24*) while, for parallel interfaces to printers, the *Centronics* standard is popular.

Finally, a *modem* connects a computer, via a serial interface, to the telephone system allowing two computers with modems to exchange information. A modem must be wired into the telephone system and you need British Telecom's permission; instead you could use an *acoustic coupler*, which has two obscene-looking rubber cups into which the handset fits, and which has no electrical connection with the phone system — British Telecom isn't so uppity about the use of these.



PACKAGES

This package guide appears bimonthly alternating with our In Store hardware guide.

	ARDEN DATA PROCESSING 0533 22255		B+B COMPUTERS LTD 0204 26644		BEAM BUSINESS CENTRE 01-636 1392		BENCHMARK COMPUTER SYSTEMS 0726 61000	
	PET	Apple	PET/CBM	Altos (CP/M MP /M)	PCC 2000 Simpelec Triton 3	PET	Apple	North Star Horizon
Stock Control/Recording	15	P.O.R.	300	300	350			450
Sales Ledger		300			350			250
Purchase Ledger		300			350			250
General Ledger/NL		300			350			250
Integrated Accts			300	300				950
Word Processing		75						
Mailing List		300	75	75				
Invoicing			25-50					100
Database Management/ Information Retrieval		150	75					250
Payroll		P.O.R.						350
Incomplete Records								
Personnel Records								
Estate Agent		850			350			
Time/Cost Recording			300		350			250
Job Costing								
Mail Shot					450			
Credit Control								
Cash Flow								
Production Analysis			300					
			Disk Operating System 150			Standard PET + Apple Packages		

BENCHMARK COMPUTER SYSTEMS 0726 61000	BRISTOL SOFTWARE FACTORY 0272 23430	CAP-CPP MICRO PROD- UCTS LTD 01-404 0911	COMMODORE 01-388 5702	COMP- SOFT 0483 39665	COMPUTASTORE LTD 061-832 4761
--	--	---	--------------------------	--------------------------------	-------------------------------------

	Cromemco	PET		PET/CBM	8000 Series	PET	Vector	PET
Stock Control/Recording	450	300		150				
Sales Ledger	250	300	800	200	250		400	
Purchase Ledger	250	300		200	250		400	
General Ledger/NL	250		1000	200			400	
Integrated Accts	950			(50)	P.O.R.		1000	
Word Processing				75/150	250		400	325
Mailing List								
Invoicing	100		400					
Database Management/ Information Retrieval	250		P.O.R.	50/150	P.O.R.	170		
Payroll	350		P.O.R.	150	250			200/350
Incomplete Records								
Personnel Records								
Estate Agent								
Time/Cost Recording	250							
Job Costing								
Mail Shot								
Credit Control		650						
Cash Flow								
Production Analysis								
	Revolving Credit 400+			Assembler Dev 50				
	Hire Pur- chase 400+			LISP 75				
	Leasing 400+			Pascal 120				

PACKAGES

**DIRECT
ACCESS**

COMPUT-A-CROP
01-499 6987

COMPUTECH
01-794 0202

DATA BANK 0509 217671

	CP/M	Apple II	ITT 2020	PET	ITT 2020	Apple II
Stock Control/Recording	500-1500			10	10	10
Sales Ledger	500	295	295			
Purchase Ledger	500	295	295			
General Ledger/NL	500	295	295			
Integrated Accts	1500					
Word Processing	150-260			40	40	40
Mailing List	50-150			50	50	50
Invoicing	150-350					
Database Management/ Information Retrieval	150-750					
Payroll	495	375	375	10	10	10
Incomplete Records						
Personnel Records	450					
Estate Agent	750					
Time/Cost Recording						
Job Costing	700					
Mail Shot	200-360					
Credit Control						
Cash Flow						
Production Analysis	700					
Property Management 450-1000		Utilities 20	Utilities 20	Bank Account 10	Bank Account 10	Bank Account 10
Company Secretary 450				Salesman 10	Salesman 10	Salesman 10
Legal Precedents 1100				Cash Register 10	Cash Register 10	Cash Register 10

N.B. Discounts on multiple sales

GRAFFCOM SYSTEMS LTD
01-734 8862

GRAMA (WINTER) LTD
01-636 8210

GREAT NORTHERN
0532 450667

A J HARDING
0424 220391

HARTFORD SOFTWARE
0606 76265

	CP/M	PET/CBM	8080/Z-80	Apple	TRS 80	PET
Stock Control/Recording	350	150	275	150	200	
Sales Ledger	450		275		225	
Purchase Ledger	450		275		225	
General Ledger/NL	400		275		225	
Integrated Accts	1100	650	995			
Word Processing	400	75/150			15	85/65/40/20
Mailing List	250				25/38/55	45
Invoicing					25	
Database Management/ Information Retrieval		150			32.50	
Payroll	500	150	275		200	
Incomplete Records					40	
Personnel Records						85
Estate Agent						
Time/Cost Recording	400					
Job Costing						
Mail Shot						
Credit Control						
Cash Flow						
Production Analysis						
Equipment Lease/Rent/HP 400			Job Order Control 275	Video message 200	VAT Register 15	Lotteries 45
Financial Modelling 400			Prof Appts. groups 275	Statistics 150		Membership Accting 85
Order entry/invoicing 350			Prof Appts individ. 220			T.A.P. Business System 125
			Prof Client. Billing 330			

H.B COMPUTERS 0536 83922	HIPPOSOFT 0332 23127	INTEREUROPE SOFTWARE DESIGN 0734-786644	INTEX DATALOG LTD 0642 781193	T V JOHNSON 0276 62506
--------------------------------	-------------------------	--	--	---------------------------

	CBM	PET	ACT 800	MCZ Zilog	PET	PET/CBM
Stock Control/Recording	35/25				195	150
Sales Ledger	350					P.O.R.
Purchase Ledger	350					P.O.R.
General Ledger/NL	200					
Integrated Accts						650
Word Processing	35	375	375	500+		75/150
Mailing List	35					
Invoicing						P.O.R.
Database Management/ Information Retrieval		225	225			150
Payroll	10				50/195	150
Incomplete Records						
Personnel Records				500+		
Estate Agent	30					
Time/Cost Recording						
Job Costing						
Mail Shot				200		
Credit Control						
Cash Flow						
Production Analysis						
Utility set 78				Screen Generator 75+		Petsoft programs 160
VAT				Conference		
Master 25				Organiser 500+		
Bureau de Change 8				Budgeting		
Price				Package 500+		
Lister 12						

TV JOHNSON 0276 62506	KATANNA MANAGEMENT SERVICES 0245 76127	KAT-ANNA (cont'd)	KEEN COMPUTERS 0602 583254	LIFEBOAT ASSOCIATES 01-836 4663
--------------------------	---	----------------------	----------------------------------	---------------------------------------

	TRS 80	Apple II	TRS 80I	CP/M	Apple	CP/M	8080/Z80
Stock Control/Recording	115		200	500	P.O.R.	325	325
Sales Ledger			225	500	300	425	425
Purchase Ledger			225	500	300	425	425
General Ledger/NL			325	500	300	375	375
Integrated Accts	75					950	950
Word Processing	45/95	75	70	500	75		
Mailing List					300		
Invoicing			75	500		325	325
Database Management/ Information Retrieval	150				150		
Payroll			218	500	P.O.R.	475	475
Incomplete Records					P.O.R.		
Personnel Records							
Estate Agent					850		
Time/Cost Recording							
Job Costing							
Mail Shot							
Credit Control							
Cash Flow							
Production Analysis							
			Individual designed programs 100 up			Order processing 550	

PACKAGES

**DIRECT
ACCESS**

	LIVEPORT (EXIDY SORCERER FIRMWARE) 0736 798157	LUDHOUSE (COMPUTING) LTD 01-679 4321	MICRO COMPUTER APPLICATIONS LTD 0734 470425	PADMEDE COMPUTER SERVICES 025671 2434		
	Sorcerer	CP/M	Tandy Model I	Tandy Model II	Apple II	ITT 2020
Stock Control/Recording			30-50	300	300	300
Sales Ledger		500	90	90	300	300
Purchase Ledger		500	90	90	300	300
General Ledger/NL		500	90	90		
Integrated Accts			350*	350*	450	450
Word Processing			50/75	175-240		
Mailing List			40	75		
Invoicing			90	90	300	300
Database Management/ Information Retrieval			25-80			
Payroll	250	450	249			
Incomplete Records			40			
Personnel Records						
Estate Agent						
Time/Cost Recording			P.O.R.	P.O.R.	300	300
Job Costing			P.O.R.	P.O.R.	300	300
Mail Shot				75		
Credit Control						
Cash Flow		250				
Production Analysis						
	+ range of Life- boat progs.	S/L, P/L + Stock con- trol, 1000 Contract costing, 2000		CP/M & utilities 150 CBasic 70		* includes invoicing

	PERSONAL COMPUTERS LTD 01-626 8121	ACT/PETSOFT 021-454 5348	ROCKLIFF 051-521 5830	SMG MICRO COMPUTERS 0474 55813	
	Apple II	MZ-80K	PET	PET/ Computhink	PET*/8032
Stock Control/Recording	35/98	150	12/25/350	250	395
Sales Ledger	295		95/350		395
Purchase Ledger	295		95/120/350		395
General Ledger/NL	295				
Integrated Accts	340	150			
Word Processing	150-300		25/325		
Mailing List	40		15		75/150
Invoicing	125		350		in stock control
Database Management/ Information Retrieval	98		325		
Payroll	200		50/25/195		
Incomplete Records	125				
Personnel Records	98				
Estate Agent	175		25		
Time/Cost Recording	125				
Job Costing	125				
Mail Shot	225				
Credit Control	98				
Cash Flow	75		8		
Production Analysis	75				
	Pad to plotter system 250		VAT 17.50		Vet Package P.O.R. Solicitor's package 750 Planning/ maintenance 595 Warehousing P.O.R.
	Statistics 100-195 Program- ming Aids 40				*Computhink Disks

DIRECT ACCESS

PACKAGES

THE SOFTWAREHOUSE
01-637 2108

STAGE ONE SOFTWARE
0202-23570

SYSTEMATICS INTER-NATIONAL
0268 284601

SUMLOCK BONDAIN LTD
01-250 0505

TRIDATA MICROS LTD
021-622 1754

	Apple	TRS-80	Commodore/Computhink	Apple II/ITT 2020	Apple	TRS 80I	TRS 80II
Stock Control/Recording	80	48	100/250	500	P.O.R.	200	375
Sales Ledger			P.O.R.	250P	300	225	375
Purchase Ledger			P.O.R.	250P	300	225	375
General Ledger/NL			P.O.R.	250P	300	225/325	425
Integrated Accts			P.O.R.				
Word Processing	60	30/60/90	120	180/95	75		
Mailing List	50-150	50-150	100	100	300		125
Invoicing	295		P.O.R.			75	
Database Management/Information Retrieval	60-140	60	45-250	100	150		
Payroll	200			250P	P.O.R.	218	375
Incomplete Records	250		750				
Personnel Records							
Estate Agent			250	750	850		
Time/Cost Recording			P.O.R.				
Job Costing	450						
Mail Shot	14		125				
Credit Control							
Cash Flow							
Production Analysis							
Solicitor's complete record	45		Petaid report generator 125	Text File Librarian 125			
Investment accounting	Portfolio 20		PR/Advertising Package 1000	Financial Planning 250			
Postal Advertising Response Package	350		Bonds/Pension Quotations 100	Office Admin 100			
			Printers Job Control 250				
			Bank Accounts 100				
			Appointment Planner 100				

Key: POR Price on request
() Program used to link accounts packages.
P = program written in Pascal

VLASAK ELECTRONICS LTD
062-84 74789

Apple II

Stock Control/Recording	285
Sales Ledger	315
Purchase Ledger	315
General Ledger/NL	225
Integrated Accts	855
Word Processing	120
Mailing List	
Invoicing	140
Database Management/Information Retrieval	
Payroll	375
Incomplete Records	
Personnel Records	
Estate Agent	
Time/Cost Recording	
Job Costing	
Mail Shot	
Credit Control	
Cash Flow	80
Production Analysis	
Letter writer	80

Personal Computer World

PACKAGES

PCW's 'Packages' section is produced bi-monthly, alternating with our 'In Store' hardware guide. As it is obviously impossible to include every package currently available for every machine, we have confined coverage to business packages which are available and supported at national level and which have been in use for at least six months in a minimum of five sites.

Producers of packages which fall within these constraints should send details or updates (formatted as printed in this section) to: Packages, PCW, 14 Rathbone Place, London W1P 1DE.

DIRECT ACCESS

TRANSACTION FILE

The classified service that's free to non-commercial readers. Advertisements (50 words max) to:
PCW Transaction File, 14 Rathbone Place, London W1P 1DE.

For sale

Cromemco... Z2 with a 4 MHz Z80A, 4FDC disk controller, 64k RAM, 21-slot motherboard, twin 8" disks, only 6 months old. Unforeseen financial crisis forces sale with full doc, £2600. Tel 051-228 0144.

Chess Challenger 7... still in new cond, mains adaptor, £80 ono. A Samet, 8 Elm Park Ave, London N15 6AT. Tel 01-800 9257 after 7.

T158... prog calc, well used but in working order with charger, manuals etc, £25. Alastair Mutch, Tel Aberdeen (0224) 573378 (6-9pm).

Computhink... 400k twin disk unit for PET, £750. PET 3022 printer with cable, £395. Both as new cond. Tel Rugeley (08894) 2052.

Olivetti TE300... printer terminal with 110 baud RS232 int, paper tape punch & reader (reader needs attn), with stand, cables, some 8 1/2" paper & copy of manual. Will demo, asking £225. Tel Watford 34560 after 5 weekdays, anytime weekends.

Apple II Plus... 48k, one disk drive & controller, all extras inc modulator, many progs, 2 months old, £1050 (list £1400 for hardware only). Also Z80 softcard, £195. 3 months old Centronics 730, £450. Tel 01-450 5049.

TRS-80 Level II... 16k, VDU, cassette, covers, tapes, learning Basic, stats package & Basic books £450 ono. Tel Botley (Hants) 5714 after 5.

ZX80... assembled, inc PSU and all leads & manuals, £75. Tel 061-432 2247 eves.

TRS-80 Level I... 4k inc VDU, cass recorder, PSU, game progs, instruction tapes & manuals, 6 months old, offers around £300. Tel Blackpool (0253) 36646 eves or mornings (shift worker) or all weekend.

Nascom 1... with buffer board, mother board, PSU, NasSys, 8k RAM, new case, £150. Also Nascom 1 16k, two Basics (one tape, one EPROM), PSU, all Verocase with 12" monitor, printer & software, £450 ono, may split. Tel Chris Rose, Tiverton 57657 day, 57886 night.

Superboard... 8k RAM, PSU, modulator & case (not fitted), offers around £215. Tel Southend-on-Sea 204901 after 7.30.

TRS-80 Level II... 32k plus cassette, manual, video or TV adaptor, tapes, £450. Tel 01-828 7822 ext 463 day.

PET 32k... (expanded from 8k), large keyboard, green screen, toolkit, reset switch, cover, progs & doc inc PET Revealed, only 3 months old, £650 ono. Also monitor & 4k exp for UK101, £15 & £25 resp. Tel 01-543 1890 after 5.

Bits & PCs... Toolkit for Nascom £30; Sale due to floppy upgrade. Tel 01-550 8965.

ZX80... one month old with exp board for up to 3k & PSU. Checked by Science of Cambridge. Switchable video. Reason for sale — upgrading. Accept £80 ono. Tel Orpington 70601.

UK101... 8k, assembler, case, new & old monitor, extended monitor in ROM, disassembly of all monitors, £250 ono or swap for Nascom 1 why? Tel A Crofts, Warwick (0926) 53868 eve, 44111 day.

Used VDU... in good working order, £100. Tel Sue, 01-794 8419 after 8pm.

Acorn... System One, working with Acorn PSU & programs, £65 inc postage. A Johnson, 5 Johnsburn Rd, Balerno, Edinburgh EH14 7DN.

Sorcerer... 32k Cognivox voice synthesiser/speech recogniser/music & sound effects producer, full manuals (technical & software) & £80 worth of software on cassette (mainly games), £700. Write D Mok, 33 St Cross Rd, Winchester, Hants SO23 9JA.

PET 2001... 8k old ROMs, calc keyboard, new cassette head just fitted, £325 buyer collects. To view & test tel 01-582 7766.

Bargain... 2111-2 RAMs (unused) half price, £2 (32 chips); unused KB756 ASCII keyboard, £35; Superboard PIA int- £15; light pen, £8; must sell, sold Superboard, B Mistry, 75 St Margarets Rd, Bradford, W Yorks.

Apple Z80... card as new, never used, with CP/M, Microsoft Basic 5.0, £180. Tel 01-450 5049.

T159 & T158... both exc cond, boxed with all manuals, cards, & stats lib module. Offers, tel Dr D Boxer, 0382 23181 ext 583 or 0382 825090.

Casio FX502P... plus FAXI cass int, with instruction and application manuals & cassette, Masterpac application book, new cass, total val over £120, as new cond for £75, or exch 6502-based m/c code dev board — Kiml, Syml etc. Greenload, tel Skipton (0756) 60811.

Triton... L7.2 (2MHz), 8k ext Basic, motherboard, full on-board RAM, manuals, games tapes, cased, working, offers. 27 Beaumont Ave, Sudbury, Middx or tel Rob, 01-450 8911 ext 337/324 office hours.

UK101... 8k RAM, new monitor, 600/300 baud cassette, 1/2 MHz RS232 int, cased, all skcits fitted (video, TV, etc), £450. Tel Harlow (0279) 415335.

PET 2001... 8k, new keyboard & ROMs, green screen, Basic course on cass, beginner's manual, some games, plenty of magazines, quick sale, £400 ono. P Griffin, 6 Florence St, Chuckery, Walsall WS1 2LG.

Nascom 1... T4, NasSys, full doc, £100. Hewart 6800, full kb, 1k monitor, VDU & cass, ideal starter, £60. Tel Steve, 01-370 8458 day, Wokingham 785470 eves.

Used... working system, processor, keyboard, 35 cps printer (190 car wide, platten/sprocket feed), mag card handler, 50 cps paper tape reader/punch, manuals, mag cards, paper, complete, £450 ono. Tel Locks Heath (04895) 3818.

PET... 8k, old ROM, Expandamem, Toolkit, £500. Computhink disk drive, 400k, £600; extension keyboard, £50. Buy it all & you get 250 free progs. Tel 01-948 2847/01-894 7149.

Microtan 65... built by Tangerine, keypad, graphics, l/case, mini-motherboard, MPSI PSU, manual, some simple software, £125 ono — no split. Farnfill, 55 Meadowfield, Gosforth, Cumbria, tel Gosforth (09405) 345 after 6.

PET 32k... plus Computhink 400k, little used, immac cond, Petalect maintained, dust cover, disks, PET literature, £1000 ono. Tel 079-78 416.

Olivetti... TE300 printer with Bailey bi-dir int (for PET), paper tape read/write, full keyboard, instr manual, unused since recent service, offers around £300. Ken Hall, 4 St Paul's Court, Kettering, tel 0536 515136.

ZX80... as new, Sinc built, with leads & book, £70. Tel Ipswich 210028.

Merlin... electronic toy with Mastermind, Noughts & Crosses, Blackjack, Magic Square, Echo & Music Machine. Uses LED display with sound, in good cond, £20 ono. Tel Paul Myatt, Hitchin (0462) 4085 eves & w/ends.

UK101... assembled & cased, 8k RAM on board plus spare 6k RAM, extended monitor & games on tape, cassette, tapes, 5 Basic books, £225. Tel Porthcawl (065671) 6138.

PE VDU... board, assembled, £20; Proto-board 6 breadboard, unused, still boxed, £8. Geoff Kitt, tel 0204 694265.

T159... prog calc, PC100C printer, 37 spare prog cards, spare rolls paper, PFX59 club cat & newsletters, pristine cond, best offer. Andrew Taylor, 01-444 5104, or write 23 Park Hall Rd, London N2 9PT.

8k PET... brand new, large keyboard, new ROMs, fitted metal screen eliminating 'wobble', £420, buyer collects. Tel Whitchurch (Hants) 2602 after 6 or any time w/ends.

Nascom II... plus 16k RAM on 48k board, PSU in kit, unwanted gift, £330. Dr V Tam, 80 Streathbourne Rd, London SW17 tel 01-736 1212 ext 6338.

T158C... brand new, a T158 but with non-volatile memory, stores progs indefinitely, standard module & manuals, cost £90, accept £74, buyer collects. Tel Whitchurch (Hants) 2602 after 6.

Printer... Centronics 101 dot matrix, parallel/RS232 int, working, £100 ono; Nolton 1602A modems, 1800-19200 baud, synch with multidrop facility, built in word checker, V24, also line filter units, tech h/book, £150 ono for pair. Milgo 4400 modems, 4800 baud, with field kits, V24, £35 each, £60 pair. Tel Horsham (0403) 69835.

Apple II + 48k... with plenty of software. 12 Harold Ave, Blackpool, tel 692261/67091.

Sorcerer... word proc pac, £90; development pac, £60, as new with doc. Tel 01-979 4370.

Sharp MZ-80K... as new, 48k RAM, inc dis/assembler, debugger, monitor, Basic listing, programming & games books, software (games etc worth over £200), home used, only two months old, worth £1000, accept £750 ono. Tel 0604 37402 after 7 or w/ends.

IMP printer... recent purchase, need faster one so IMP must go for £260. 12 Harold Ave, Blackpool, tel 692261.

Nascom 16k... DRAM board type A, built, working on Nascom 1, full doc etc, £135. With 32k RAM, £170 ono. Also Stuart colour graphics board, built but unused, full doc, £35 ono. Tel Oxford (0865) 725495 after 6.30 eves & w/ends.

UK101... assembler tape, manual, hints on use, cost £17, sell £10; Space Invaders in UK101 m/c code, cost £5.75, sell £3. Tel Dave, 031-664 2144 eves.

PDP8/S... with std int & hi-speed reader int, cables, h/books, PSU, working, needs ASR/KSR, £150 ono. Reed SW keyboard, qwerty, ASCII, new, £35 ono. Part finished 'Champ' as PE, with articles, £60. Jack, tel 0705 596058.

Games computer... Signetics 2650 proc, UHF output to TV, 8 colour graphics, mult resolution to 227 x 252, sound via speaker & AY8910, cass int with named files, monitor in ROM, lots of software, manual, also full spec Textext decoder, UHF output & remote keypad, sensible offers please, tel 0925 811191 eves & w/ends.

MK14... + I/O chip, cost £56 new 6 months ago, unused, needs slight attn, most chips skc'd, offers around £45? Also alarm bell, siren, keyswitches, all unused, offers? Tel Leamington Spa (0926) 38678 after 6 weekdays.

ZX80... Sinc built, hardly used, manual, TV & tape leads, book of Basic comp games, £70 inc p&p. Tel Canvey Island 69902.

Printing terminal... Friden Flexowriter incorporating 11" max width printer, keyboard, 8-level punch & reader, 2nd unit for spares, 110 V AC supply, not ASCII hence only £50. Tel 0254 22314 eves & w/ends.

Casio FX502P... prog sci calc. Systema C3800 sci calc. Sell sep or together, tel Michael, 01-949 0120 after 6.

Data 100... S-1200 matrix printer, 120 cps, 192 char set, 136 col (15") width, Centronics par int, line buffer, etc. Hardly used (owner needs APL char set), £650 with manual. Tel Liverpool 051-924 2581 eves.

UK101... 8k Microsoft Basic, 8k RAM, cased + all leads, various cassettes inc ext monitor & dis-assembler, m/c code book, extra 2x8 bit par int using 6522 VIA, £250. Tel Colchester 61193.

32k PET... big keyboard, green screen, cass, software, little used, boxed, £350 ono. Tel Bob Marshall, 01-659 4748 eves.

Apple II + 48k... disk drive, software inc w/proc, Chess, etc, only 6 months old, as new, £950 ono. Tel (04203) 5273 eves.

77/68... Mon 2 PCB with TBug, £45; 3 off 77/68 4k RAM PCB, socketted, exc memories, £15 each; VDU board, £40; 5 V 30 amp Kingshill PSU, £30; Mon 1 PCB + skc'ts & bootstrap ROM only £12; 5 V Vero rack with 12 wire wrap edge connectors, £25; cass int, £10. Tel 099 386 698.

UK101... 8k RAM, built, cased, tested, bought mid-March '80, all leads supplied, no hidden snags, mags, games & utility progs, £275 ono. H Wynn, 89 Ossulton Way, E Finchley, London N2 0JS, tel 01-883 1983.

ZX80... + exp board & add'n 1k RAM, PSU, manuals, cables, listings for graphics, music, misc games, cost new £120, sell at £70. Tel Leatherhead (03723) 76256 after 5 or any time w/ends.

PET 2001-8... (8k with int cass & small keyboard), 30 progs inc Microchess, Space Invaders, Star Trek, Wartet, etc, as new £395. 5 PET manuals & assorted pile PET mags, £17.50.

Space Invaders... & about 50 other PET games, bought in error, all work on 8k except 2, with case & card, cost over £20, accept £5 inc postage. Tel Graeme, Woodbridge (03943) 3267.

Apple II 48k... 2 disk drives & ctrlr, Applesoft in ROM, UHF o/p, games paddles, many games inc Space Invaders, £1100. Tel Norwich 810675.

Atari... video computer with 2 games carts, £75 in perfect working order. Tel 01-381 5312.

TRS-80 L2 32k... with VDU, exp int, cass, one disk drive, software (Sargon, Adventure, Assembler, TBUG) & manuals, retails for £1300, sell for £950 ono. TISR52 prog calc, £50 ono. Dave Goodwin, 1 Clopton Green, Clopton, Suffolk IP13 6QL.

Sharp MZ-80K... full 48k RAM, Xtal Basic, assembler, monitor, Basic listing, 9 months warranty, hardly used, inc games & cassettes, £625 for quick sale. Tel Oxford (0865) 880362.

ZX80... inc leads, mains adaptor & manual, £70 ono. Tel 031-663 5937.

TRS-80 L4 16k... + lots of software, 4 months old, would like PET (large keyboard, new ROMs). Tel Maidenhead 39393 eves.

HP19C. . . . prog sci calc with printer, 98 step memory, 29 addressable storage registers, mains charger, h/books & spare printer paper, £85. Tel Rickmansworth 76067.

Acorn System 1. . . . with extra RAM & I/O, two books, good cond with all doc, price £78 or offer. Tel Roger Shingler, 021-353 0753 after 6.

Teleguipment. . . . S61 scope, single beam, 5 MHz, large 10 cm screen, £100 (or trade-why?). Tel Peter, 01-637 8882, office hours.

TRS80. . . . RS232C int, unused, with cable & manual, £65. TRS80 cassettes with d/precision routine & 7 games, £25. Whole lot for £83. Tel Bosco, 01-546 2044, Mo Mon-Thurs after 6.

PET. . . . new 16k large keyboard with cassette plus extensive games s/ware, as new, £600 ono. Tel 0274 670114 eves.

Printer mechanism. . . . 40 col LRC 7040 dot matrix with motor mains transformer & capacitor, £40. Tel Wolverhampton 763617 eves.

Acorn. . . . System 1 with VDU card & modulator, doc, 2 books inc 6502 Applications Book, built & tested, cost £190, accept £110. Tel 0532 681588.

Nascom 2. . . . 32k user RAM, graphics in video terminal toroidal txfrmr, doc & tapes, first reasonable offer secures. Tel (0234) 43843 eves or w/ends.

Triton. . . . L7.2 monitor & 8k Basic in EPROMs, 19k RAM, S100 disk interface, RS232, video or TV, fast VDU EPROM & cass rec, £500 ono. SA800 disk drive & manuals, £225. Tel Stoke-on-Trent (0782) 314053 eves.

ZX80. . . . 2k RAM, PSU & leads, 5 good progs on C12 cassettes, book of progs, £110 ono. Tel Andrew, Peterborough (0733) 44342.

Acorn Atom. . . . 8k Basic, 2k RAM, with case, prof built & tested, all leads & op manuals, ideal for beginner, fully expandable, ex cond, £155. Tel Leicester (0533) 730653 after 6.

Wanted

MK14. . . . revised monitor, socketed, extra RAM, RAM I/O, working. Willing to pay £30-£35. Tel Martin, 01-393 1054 eves.

Tangerine. . . . Microtan 65, ASCII keyboard preferred, Tanex exp considered. Tel George Rees, Swansea (0792) 61753.

16k Apple II+. . . . with Applesoft in ROM, price subject to cond. Tel Chorleywood 3042.

Details. . . . of software used successfully for RTTY & CW on a UK101. Ward, 44 Northgate, Barnsley, S Yorks.

PCW. . . . Vol 1 no 5. Tel Peter Tootill, 051-220 9733 or 051-922 7260 ext 250.

Apple II+. . . . or ITT2020, 16k, must be in good cond, for exch with 32k Sorcerer with voice synthesiser/recogniser, music production, lots of software & manuals. Write D Mok, 33 St Cross Rd, Winchester, Hants SO23 9JA.

PCW. . . . vol 1 nos 4, 5, 6, 7, 9, 10, 11, 12, vol 2, nos 5, 6, 8 (in good cond). Contact Aron Felix Gurski, Kvernevikstemma 18, N-5084 Tertnes, Norway.

DIARY DATA

Birmingham, England	(Edgbaston Cricket Ground) Electronic Business Equip. Exbn — BIZTRONIC. Contact: Groundrule Ltd, 061-928 0406	27 — 29 Jan
Bahrain	Middle East Electronic Comms. Show & Conf — MECOM. Contact: Arabian Exbn. Management, 49-50 Calthorpe Rd., Edgbaston, Birmingham. 021-454 4416	2 — 5 Feb
Eindhoven, Holland	Int. Microelectronics Sub. Systems Trade Fair — Microelectronica. Contact: Golden Gate Exbns Inc, PO Box 428, Los Altos, CA94022, USA	4 — 6 Feb
Bilbao, Spain	Electrical & Electronic Equip Exbn — ELA Contact ECL Ltd, 01-486 1951.	2 — 8 Mar
London, England	(Wembley Conf C) Microsystems '81 Exbn. Contact: IPC Exbns Ltd, 01-837 3636	11 — 13 Mar
Glasgow, Scotland	(Albany Hotel) Computermarket. Contact: Couchmead Ltd., 42 Gt Windmill Street, London W1. 01-437 4187	17 — 19 Mar
Malmö, Sweden	Computer Exbn — DATAKRAFT. Contact: ECL Ltd, 01-486 1951	23 — 27 Mar
Manchester, England	(New Cent. Hotel) Computermarket. Contact: Couchmead Ltd., 01-437 4187	24 — 26 Mar

USER GROUPS INDEX

Here are the details of additions and changes recently notified. If we have failed to include YOUR group (or have published incorrect information) either here or in the complete listing, then please address changes/additions to: PCW (User Groups Index), 14 Rathbone Place, London W1P 1DE. Finally, the next complete listing will appear in our February issue.

NATIONAL

UCSD p-System User Society. Will hold its first AGM on 30-31 Jan at the Dragonara Hotel Bristol. Registration fee £10. Membership is £25 pa. Contact: Malcolm Harper, Programming Research Group, 45 Banbury Rd., Oxford OX2 6PE, tel 0865 58086

TRS-80 Level 1 User Group. For all users of Level 1. Quarterly newsletter containing software (which is also available on cassettes). Annual sub £3 (newsletter) or £7 (newsletter & cassette). Contact (with SAE): N Rushton, 123 Roughwood Drive, Northwood, Kirkby, Merseyside L33 9UG.

British Apple Systems User Group. For Apple II and IIT 2020 users. Meets first Tues eve and third Sun afternoons each month at The Old School, Branch Rd, Park Street, St Albans (on A5 about 2 miles south of city

centre). Contact: John Sharp, Garston (09273) 75093 or David Bolton, Park Street (0727) 72917.

TRS-80 Users Group. The group is about to launch a computerised bulletin-board system. Members with appropriate h/ware and s/ware will be able to access a central system outside working hours to leave/receive messages and download programs from the Group's software library. Users of other systems will also be able to use the bulletin board. Contact: Brian Pain, National TRS-80 Users Group, 40A High Street, Stony Stratford, Milton Keynes, tel (0908) 566 660 (office), 564271 (home).

MIDLANDS

Birmingham Computer Club. To be formed shortly, catering for all micro users. Fortnightly meetings planned but venue not yet fixed. Contact: Dr M Bayliss, 021-743 7197.

TRS-80 Independent User Group. Recently formed in Birmingham. Contact Mike Bayliss, 021-743 7197.

LONDON

TRS-80 Users' Group London Branch, recently formed and meets 2nd Friday each month, 6pm, at 292 Caledonian Rd, London N1. Contact: J Wellsman, 01-607 0157.

Compucolor User Group, London area. Has contacts with both US and Canadian Compucolor user groups. Contact: Bill Donkin, 19 Harwood Ave, Bromley, Kent BR1 3DX.

380Z User Group, North London Branch. Includes Herts, Cambs, Oxon. Contact: Sheridan Williams, 35 St Julian's Rd, St. Albans, Herts AL1 2AZ.

NOTTINGHAMSHIRE

Ashfield Computer Club. Meets 1st & 3rd Thurs each month at Carsic Junior School, membership £3 pa. Contact Deric Ellerby, tel 0380 753576 or Derrick Daines, tel 0380 870841.

SUSSEX

A PET group is being formed on the Sussex/Surrey border, presently centered on Crawley & Horsham. Aims to meet monthly & produce a monthly newsletter. Contact: Richard Dyer, 33 Parham Rd, Ifield, Crawley RH11 0ET.

YORKSHIRE

Anyone interested in forming a micro group in the Doncaster area, contact Mr P Flinders, tel Doncaster 784954 or Doncaster 868 379, 6-9pm.

GET WELL SOON

A TAPE RECOVERY SYSTEM

Continued from page 107

beyond the header and part of the first copy of the program has been lost. In this case the cassette will not stop, the load will not have been verified and the link bytes will not have been corrected. Hence the need to SYS 883, which calls the routine to put in the link bytes and the pointer to the end of Basic. Second, only the header has been lost and part of the timing tone remains. In this case, the load will have been verified, the link bytes corrected and the end pointer entered automatically.

The program can now be listed and run, but before doing so it is obviously prudent to save it again and to check for any obvious errors, if only the second copy was intact.

One last comment: on trying to list the program only a single line may be displayed, consisting of a strangely high line number, a program name then garbage or spaces followed by a few lines of plus signs. This occurs because the recover program is picking up the header of the target program (which has not been completely erased) or the header of the following program on the tape. This should be checked with an audio cassette-player. If the former happens, make sure you position the target tape just before the end of any

timing tone. If there are two timing tones present, the header is complete and the tape should load normally but sometimes, on poor quality tapes, it does not work so it is worth trying a recovery by positioning the tape on the second tone. If the name is that of the program following the target, this is almost certainly due to the erasure having gone beyond the middle marker and the only possible means of recovery is the sledgehammer way.

The uncrash routine is as follows and is suitable only for new ROMs; it is known as 'the hairpin method' and I believe it comes from Jim Butterfield. First, connect pin 5 of the parallel user port to ground — pin 1 on the cassette port is handy for this — then briefly connect pin 22 (Reset line) on the memory expansion connector to ground. This causes the PET to jump to the diagnostic routine in the Monitor and the registers are displayed on the screen. Now enter X, to get out of Monitor, and then CLR to reset the pointers. Finally, disconnect pin 5 from ground. This is not a cure for all ills, crashwise, since some will only respond to switching off.

PLEASE NOTE it is definitely not recommended to go poking about with all sorts of bits of wire so only proper connectors should be used and no responsibility can be accepted if anything untoward should happen while you are using this routine.

number of hands in the playing session. The program can then allow for the possibility of the opponent bluffing when making its calculations, possibly by calling a suitable proportion of slightly adverse equity situations.

More players

If you want to get the most fun out of a poker program, I would suggest that you write one for six players, five hands being played by the program and one by the user. You can use similar probability estimates, although the actual calculations will be more complex and you will find the game with more players is more stimulating than the two-handed game.

together. The largest hurdle to overcome in order to produce a reasonable multi-user system is not the cost of the hardware but the design and development of the more complex system software required to control the hardware.

Many companies are now looking at the question of providing multi-user micro systems and, in the next article, we will describe how these are being implemented and attempt to provide criteria for evaluating these systems.

either conditional or unconditional relative calls are needed, an unconditional jump, following the CALL, could be used to skip the two-byte displacement thus:

```
CALL (opt cond), RLTVC
JR SKIP
DEFW nn nn ; disp
```

SKIP: .

The coding for RLTVC, which wouldn't need to adjust the original return address, could be as in Figure 3.

ELCOMP Books

- Care and Feeding of the Commodore PET**
Eight chapters exploring PET hardware. Includes repair and interfacing information. Programming tricks and schematics.
Order No. 150 \$11.00
- 8K Microsoft BASIC Reference Manual**
Authoritative reference manual for the original Microsoft 4K and 8K BASIC developed for Altair and later computers including PET, TRS-80, and OSI OS/1 owners please take note!
Order No. 151 \$9.95
- Expansion Handbook for 6502 and 6802**
(S 44 Card Manual) Describes all of the 4.5 x 6.5 44 pin S 44 cards incl RAM, ROM, dig I/O, MUX/A to D, EPROM Prog, etc. With schematics and funct descriptions. A must for every KIM, SYM and AIM owner.
Order No. 152 \$9.95
- Microcomputer Application Notes**
Reprint of Intel's most important application notes, including 2708, 8085, 8255, 8251 chips. Very necessary for the hardware buff.
Order No. 153 \$9.95
- Complex Sound Generation**
New, revised applications manual for the Texas Instruments SN 76477 Complex Sound Generator. Circuit board available (\$8.95)
Order No. 154 \$6.95
- Small Business Programs**
Complete programs for the business user. Mailing List, Inventory, Invoice Writing and much more. Introduction into Business Applications. Many listings.
Order No. 156 \$14.90
- The First Book of Ohio Scientific, Vol. I**
Contains an introduction to personal computers and describes the Ohio Scientific Line. Contains explanatory diagrams, block, hook up, expansion, tricks, hints and many interesting listings. Hardware and software information not previously available in one compact source. 192 pages.
Order No. 157 \$7.95
- The First Book of Ohio Scientific, Vol. II**
Vol. II contains very valuable information about Ohio Scientific microcomputer systems. Introduction to OS 650 and OS 65 U, networking and distributed processing, systems specifications, business applications, hard and software hints and tips.
Order No. 158 \$7.95
- Mailing List Program for Challenger C1/C2 8K**
Order No. 2004 - Personal Version \$9.95
Order No. 2005 - Business Version \$9.95
- Ohio Scientific Expansion Information**
Conversion of CIP (Cassette) to 52x26 display. Detailed step by step instructions for doubling the CIP speed and display size!
Order No. 1105 \$12.00
- Important Software for CBM 16K/32K**
Most powerful Editor/Assembler for Commodore CBM 16/32K on cassette. Very fast—Editor divides screen into 3 parts. Scrolling text window. 24 direct commands, 19 serial commands, status and error messages. Assembler can be started directly from the editor or from the TIM monitor. Translates in three passes. If an error is encountered, automatic return to the editor. Cassette with DEMO
Order No. 3276 \$69.00
- ATTENTION APPLE USERS**
Same as above for Apple II or Apple II plus
Order No. 3500 \$89.00
- MONJANA/1 makes Machine Language Programming easy!**
In every Commodore CBM there is a spare ROM socket waiting for its MONJANA/1. The new MONJANA/1 Machine Language Monitor in ROM offers more user guidance and debugging aids than any other monitor available today. It is indispensable for anyone intending to take full advantage of the computers features. Trace, link disassemble, dump, relocate, line assemble and much more. Every command function has demand printout option. Price includes extensive manual.
Order No. 2001 \$98.00
- JANA-Monitor on cassette for the PET**
Similar to MONJANA/1 very powerful
Order No. 2002 \$29.00

ELCOMP PUBLISHING Inc.
3873-L Schaefer Ave., Chino CA 91710 (714) 591-3130

Please send me the books/software indicated below

I enclose \$_____ send postpaid

Send COD (\$5 extra)

Charge my Visa Mastercharge

Acct No _____

Expir date _____ signature _____

Book No _____ Book No _____ Software No _____

1 Year subscription to ELCOMP Newsletter \$9.80

Name _____ Phone _____

Address _____

City _____ State _____ Zip _____

CA add 6% sales tax. We also accept Eurocheck. All orders outside USA must add 15% shipping.



Continued from page 91

MULTI-USER SYSTEMS

Continued from page 115

much cheaper than floppy disks on a 'per bit' basis their only problem in small systems is that they generally cost more than the rest of the system put

PCW SUBSET

Continued from page 123

INC HL twice, instead of decrementing it three times, before restoring the registers.

To alter Paul's RLTVB to handle one-byte displacements from the first byte of the CALL RLTVB, you can insert the instruction SUB +4, following the LDA,(DE), and restrict the displacement to the range -124 to +127. Geoff goes on to suggest that if

MICROMART

LISTING PAPER

PERSONAL COMPUTER

11x8½ £4.55 per 500

Add 15% VAT + p/p & Ins. £1.75

LABELS one across web

3½ x 1 7/16 £4.95 per 500

Add 15% VAT + p/p & Ins. £1.75

LEO BUSINESS SYSTEMS

4 The Heights

Market Harborough

Leicestershire LE16 8BQ

THE ZX80 MAGIC BOOK

£4.75

For machines with 1-3K RAM. New edition 3 contains 20 plus programs including one which allows you to make music with your ZX80, and games such as Moon Lander, Hammurabi, Othello, Hexpaw and Animals. Also sections on How it Works, Plotting, Using USB, Converting other BASICS, and Hardware Notes including circuits for static and dynamic memory extension and I/O.

TIMEDATA Ltd. 57 Swallowdale,
Basildon, Essex

TANGERINE SOFTWARE

GAMES (all m/c code)

LIFE—In 4k graphics cells! (3k).

PONTOON—Your cards dealt graphically (4)

Os & Xs—A self learning version (at least 4k)

HANGMAN—With graphics (4k)

All 4 on cassette for £4.95

3K INTEGER BASIC

Hav'nt forked out for Microsoft's yet?

Try mine—resides in first 4k RAM.

Includes editor (full line editing) & graphics.

User program resides in 1000 to 1FFF.

Interpreter, inc language spec, and demonstration maze drawing program — on cassette £4.95.

ALL ABOVE ON ONE CASSETTE £8.50.

Send order to — M. Blainy

1 Spencer Close Gloucester.

SUPAPACK ALPHA: £4.95

(Kamikaze Alien, Duckshoot, Digital Clock, Docker & Safebreak.)

SUPAPACK BETA: £4.95

(Cavemaster, Star-blinder, Juggler, Bishop Berkely & Whirlpool).

SUPAPACK GAMMA: £4.95

(Liar, Centenary Test, Traffic Jam, Cold Turkey & Passive Resistance)

SUPAPACK DELTA: £4.95

(Aztec, Mind Control, Wild Eddy, Prison Break & Ned Kelly).

Please make cheque/P.O. payable to:

SYNTAX SOFTWARE

Dept PCW,

96 Collinwood Gardens, Ilford, Essex.

EPROMPT ERASER



- CLEARS UP TO 32 CHIPS IN 30 MINS ON 200-250V A.C.
- CONTINUOUS 253.7mM BEAM. SAFE & SIMPLE. GUARANTEED.
- **£39 C.W.O. £40 C.O.D.** * P&P+VAT INCLUSIVE! *

TRADE ENQUIRIES INVITED FOR SUBSTANTIAL DISCOUNTS
ALL ORDERS AND ENQUIRIES POST-FREE TO:

TEX MICROSYSTEMS LTD.

FREEPOST, ST. ALBANS, HERTS. AL1 1BR
TRING 4797/ST. ALBANS 64077 ANYTIME

PUSH HL ; save
PUSH DE ; registers.
PUSH AF
LD HL,+6 ; point to return
ADD HL,SP ; address on stack.
LD E,(HL) ; get return
INC HL ; address in
LD D,(HL) ; DE
EX DE,HL ; and HL.
INC HL ; point ret addr
INC HL ; past JR to disp.
LD E,(HL) ; load
INC HL ; displacement
LD D,(HL) ; in DE
ADD HL,DE ; add disp to
; ret addr + 3.
LD DE,—6 ; adjust to 1st byte
ADD HL,DE ; of CALL RLTVC.
POP AF ; restore
POP DE ; registers.
EX (SP),HL ; put new return on
RET ; stack & jump to it.

Figure 3

To alter RLTVC to handle displacements from the first byte of the instruction following the displacement, replace instructions LD DE,—6 and

ADD HL,DE with INC HL.

This just about exhausts the possibilities of relative calling. I leave you to select and complete the Datasheet(s) that will best suit your system.

Buffers

For something new, we are again indebted to Jim Chance of Birmingham. He sends the collection of first-in-first-out buffer handling routines, which is the subject of our Datasheet this month. The collection is treated as one item with three entries, as there are so many features common to each part.

It is re-entrant and only one copy is needed for any number of buffers in a program. Designed for maximum general application, the coding may not be the shortest but is the kind really worth having in a library.

If you have a pet subroutine which would make a Datasheet then *send it in!* We welcome subroutines in any micro assembler language, not just Z80. Send it to: Alan Tootill, Sub Set, PCW, 14 Rathbone Place, London W1P 1DE.

PRINTERFACING

Continued from page 103

when compared with the system required by the Olivetti printers. The control logic must decide which row is to be printed; it then cycles through all 20 characters stored in the RAM and loads the output into the correct latch. After two digits, the digit select decoder is enabled and the resultant current pulse prints two digits. The control logic then steps to the next two digits and the process is repeated. After ten steps, the next row is selected and the logic again cycles through the line RAM to print the next line of dots. A similar circuit could be used with the commercial interface circuit but some modification will probably be required.

Figure 17 suggests how the interface board can be dispensed with by driving each needle directly. In this case the roll is at Vp potential and to print a dot, the driver connected to a particular needle is switched low and the resultant current flow to ground vaporises the metal film. A 100-bit shift register holds the data for each

driver and the enable input ensures that all the drivers are operated at the same time. The five-bit data from the character generator is clocked into the shift register in a serial format and each digit is sequentially read out of the line RAM and into the character generator. The row selection is performed as in the other circuit. Again this circuit is untested but it should work, and anyway a little experimentation is good for the soul.

Anyway, that's it for this month. I hope that you have found this article interesting and informative. If you start to build a system and require more assistance then please drop me a line at the PCW office and I will do my best to help. Next month I will again look at several different printer mechanisms.

Suppliers of units mentioned in this article are:

Datac Ltd, Tudor Road, Broadheath, Altrincham, Cheshire, WA14 5TN
Tel: 061-941 2361/2.

Data-Plus Ltd, 39/49 Roman Road, Cheltenham, Gloucestershire GL51 8QQ
Tel: (0242) 30030.

Marshalls, Kingsgate House, Kingsgate Place, London NW6 4TA
Tel: 01-624 0805

TRANSAM TUSCAN

Continued from page 57

standards! The 5¼in disk drives are quoted at £195 but I gather that these are going down to nearer £150.

Board, power supply and 56 ch keyboard £334
8k Basic + 8k RAM £102 extra
Case £85
8k Basic version assembled in case £621
Dynamic RAM expansion to 56k. £285

Twin 5¼in disk system, total cost £1481
BD80P printer £525
CP/M and manuals. £75

Conclusion

Perhaps one is never totally objective about anything for which one has paid good money. At several times during the building I wondered why I hadn't just gone out and bought an Apple, and then I groaned again when the prices of the Superbrains suddenly dropped. However, the excitement of getting that first Basic program working on the machine I had built myself could not have been matched by anything on a machine I'd brought home in a box. The confidence of working

on the Benchtest disk system has persuaded me to take mine in for an upgrade.

The thing I like best about Transam is that it is a British firm doing its own designs and marketing its own product. It really cares about its computers, and its customers, come to that. Dealing

with the supplier of an imported machine is just not the same as dealing with the makers themselves. It is especially nice to hear Transam staff talking about their plans for the future, knowing that the development work is being done just down the road and not somewhere in California.

Face to Face continued from page 95

```

206 REM
2070 REM LOOP THROUGH INPUT DATE PROCESSING
2080 REM     EACH CHARACTER.
2090 REM
2100 FOR X = 1 TO LEN(DT*)
2110   C$=MID$(DT*,X,1) :REM EXTRACT A CHARACTER
2120 REM
2130 REM DETERMINE INPUT CLASS
2140 REM
2150   FOR Y = 1 TO 4
2160     IF INSTR(INCLAS$(Y),C$) > 0 THEN CLASS=Y:GOTO 3000
2170   NEXT Y
2180 CLASS=3 :REM MUST BE 'OTHER', SO CLASS IS 3
2190 GOTO 3000:REM GO TO PROCESS CHARACTER
2200 REM
3000 REM *****
3010 REM
3020 REM ROUTINE TO PROCESS THE CHARACTER.
3030 REM
3040   ON MA(STATE,CLASS,1) GOSUB 5000,6000,7000,8000,9000,10000
3050 REM
3060 REM DETERMINE THE NEXT STATE
3070 REM
3080   STATE = MA(STATE,CLASS,2)
3090   IF STATE = 0 THEN UT$="":RT=1:G$ = "TRY AGAIN."
3100   IF STATE = 0 THEN GOSUB 9000:RETURN:REM EXIT DATE ROUTINE
3110   IF RT = 1 THEN RETURN
3120 REM
3130 REM LOOP BACK FOR NEXT CHARACTER
3140 REM
3150 NEXT X
3160 REM
3170 REM ALL CHARACTERS OF DATE SCANNED
3175 IF STATE(>)3 THEN STATE =0:GOTO 3090
3180 GOSUB 3000 : REM ACTION FOR YEAR
3200 REM
3210 GOTO 10000
3220 REM
5000 REM *****
5010 REM
5020 REM ACTION 1.
5030 REM
5040 REM CONCATENATE DIGIT.
5050 REM
5060   N = VAL(N$)
5070   C = VAL(C$) :REM NUMERIC VALUE OF C$
5080   N = (N * 10) + C :REM CONCAT DIGIT
5090   N$ = STR$(N)
5100 REM
5110 RETURN
5120 REM
6000 REM *****
6010 REM
6020 REM ACTION 2.
6030 REM
6040 REM STORE NUMBER AS 'DAY'.
6050 REM
6060   D$ = N$ :REM DAY
6070   N$ = "" :REM CLEAR NUMBER
6080   N = 0 :REM ZERO NUMBER
6090 REM
6100 RETURN
6110 REM
7000 REM *****
7010 REM
7020 REM ACTION 3.
7030 REM
7040 REM STORE NUMBER AS 'MONTH'.
7050 REM
7060   M$ = N$ :REM MONTH
7070   N$ = "" :REM CLEAR NUMBER
7080   N = 0 :REM ZERO NUMBER
7090 REM
7100 RETURN
7110 REM
8000 REM *****
8010 REM
8020 REM ACTION 4.
8030 REM
8040 REM STORE NUMBER AS 'YEAR'.
8050 REM
8060   Y$ = N$ :REM YEAR
8070   N$ = "" :REM CLEAR NUMBER
8080   N = 0 :REM ZERO NUMBER
8090 REM
8100 RETURN
8110 REM
9000 REM *****
9010 REM
9020 REM ACTION 5.
9030 REM
9040 REM RESET ALL ITEMS.
9050 REM
9060   N$ = "" : N = 0 : REM RESET NUMBER
9070   D$ = "" : REM RESET DAY
9080   M$ = "" : REM RESET MONTH
9090   Y$ = "" : REM RESET YEAR
9100 REM
9110 RETURN
9120 REM
10000 REM *****
10010 REM
10020 REM ACTION 6.
10030 REM
10040 REM CHECK COMPLETE DATE.
10050 REM
10060 REM FIRST CHECK FOR DUPLICATE FUNCTION.
10070 REM
10080   IF D$ = "" THEN D$ = PD$
10090   IF M$ = "" THEN M$ = PM$

```

Change your
Superboard
or UK101
into a
real machine

Two add-ons
from Mutek

CEGMON

The new monitor for all OSI and UK101 systems, with the *right* range of features!

- ★ Twin-cursor screen editor ★
- ★ Improved keyboard routine ★
- ★ New screen-handler ★
with fully programmable protected areas,
screen and 'window'-clear, cursor controls
- ★ New machine-code monitor ★
with load/save, tabular display,
'modify' entry for text and hexadecimal,
breakpoint handler, block move,
and much more
- ★ Disc bootstrap ★
- ★ Full compatibility ★

Complete with full manual and card
price **£29.50**

**48x32 VIDEO
CONVERSION**

Converts Superboard, C1 or UK101 display to 32 lines of 48 characters. Also converts system clock to 2MHz — halves program run times! Compatible with CEGMON monitor Available as Mutek upgrade or kit

Superboard/C1: upgrade **£40**, kit **£40**
UK101: upgrade **£34**, kit **£16**

All prices quoted exclude VAT
MUTEK Quarry Hill, Box, Wilts
Tel: Bath (0225) 743289

MICROMART

Software for TRS80®

see how they run!

Another Cheap Advertising Gimmick From Southern



SEND JUST £1.00 for a cassette of THREE BLIND MICE, a ridiculous new game from SOUTHERN. You have to dodge the mice while trying to cut off their tails.

The tape contains two copies of the game:
1) In source BASIC See how slowly it runs!
2) The same program compiled by ACCEL2, Southern's new compiler for Disk BASIC. See how Fast it runs!

Compare the two versions, and then think what ACCEL or ACCEL 2 could do for your BASIC programs.

ACCEL Compiler for Level 2 BASIC £19.95
ACCEL2 Compiler for Disk BASIC £39.95

SOUTHERN SOFTWARE, P.O. Box 39
Eastleigh, Hants. SO5 5WQ

PET COMPUTERS Southampton

New 4000 series PET's now available (identical to 3000 series but with SUPERPET operating system) For a limited period at the following prices 400 8N £405, 4032N £620, C2N Printer £395

2001-8S Small Keyboard PET £395

TENSAI Cassette Deck with counter, CB2 sound £70

TOOLKIT £45 or £35 with computer

We also HIRE Commodore equipment by the week 8K £23, 16K £26, 32K £30, includes manuals, tutorials, games (Invaders, Microchess) & Cassette Floppy Disk Unit £30, Printer £30

Some new and ex-hire 3000 PET's available e.g. 32K £565 16K £475 Matching beige dustcovers for all models E4 Software (Commodore, Petsoft), books and many other PET related items stocked. All prices exclude VAT
Official Commodore Dealer

SUPER-VISION

13, St. James Road, Shirley, Southampton
Telephone (0703) 774023 After hours (0703) 554488

Softcentre

OVER 100 PROGRAMS FOR CBM/PET

Send 12p stamp for free catalogue or 50p stamps for catalogue + free program...worth £3!

Part Exchange your unwanted (Brand Label) Programs.

Top Royalties for your own original top quality programs - send cassette. (Sharp & TRS80/V. Genie also wanted).

VIDEO GENIE £330 SHARP (48K) £499

EPSON TX-80B £365 FRICTION/TRACTOR

RADOFIN TELETEXT CONVERTOR ONLY £187.50!

PETMASTER SUPERCHIP £45 TOOLKIT (IN.R.) £39

VERBATIM MD525-01 DISKS (PET/ITT/CIT/INK) £22/10

PET SOUND BOX £14.50 10x C-12 CASSETTES £3.60

COMPUTHERK D/D: 400K £825 800K £999

PET CASSETTE (PANTAL)

WITH AUDIO MONITOR & COUNTER £55

MOST MICROS BOUGHT, SOLD, REPAIRED

26 ALBANY ROAD
RAYLEIGH ESSEX

Callers strictly by appointment
(0268-774089) NOON - 8pm Mon-Sat

ALL PRICES EXCLUSIVE OF V.A.T. & CARRIAGE

OPTELCO

```
10100 IF Y# = "" THEN Y# = PY#
10110 REM
10120 REM NOW CHECK FOR ERRORS.
10130 REM
10140 D = VAL(D$) : M = VAL(M$) : Y = VAL(Y$)
10150 REM
10160 IF D=0 THEN E$="DAY CANNOT BE 0":RT=1:RETURN
10170 IF D>31 THEN E$="DAY CANNOT BE MORE THAN 31":RT=1:RETURN
10180 IF M=0 THEN E$="MONTH CANNOT BE ZERO":RT=1:RETURN
10190 IF M>12 THEN E$="MONTH CANNOT BE MORE THAN 12":RT=1:RETURN
10200 IF M=4 AND D>30 THEN E$="APRIL HAS ONLY 30 DAYS":RT=1:RETURN
10210 IF M=6 AND D>30 THEN E$="JUNE HAS ONLY 30 DAYS":RT=1:RETURN
10220 IF M=7 AND D>30 THEN E$="JULY HAS ONLY 30 DAYS":RT=1:RETURN
10230 IF M=11 AND D>30 THEN E$="NOV HAS ONLY 30 DAYS":RT=1:RETURN
10240 IF M < 0 THEN GOTO 10300
10250 IF Y MOD 4 = 0 AND D<30 THEN GOTO 10300
10260 IF Y MOD 4 < 0 AND D<29 THEN GOTO 10300
10270 E$="TOO MANY DAYS FOR FEB":RT=1:RETURN
10280 REM
10290 REM
10300 REM DATE IS VALID
10310 REM
10320 REM GAVE FOR USE AS PREVIOUS DATE
10330 REM
10340 PD# = 0#
10350 FM# = M#
10360 PY# = Y#
10370 REM
10380 RT=0
10390 GOSUB 9000 : REM RESET ALL ITEMS
10400 RETURN
10410 REM
```

PROGRAMS

TRS-80 Target Practice

by Gordon Mills

```
1 '*****
2 'COPYRIGHT - GORDON MILLS (1980).
3 '*****
5 DIMA(31)
7 ONERRORGOTO280
10 CLS
15 SH=15:ST=15
20 PRINTCHR$(23)
30 PRINT@268,"TARGET PRACTICE"
40 FOR TD=1 TO 1000:NEXT
50 CLS:PRINT:PRINT"THIS IS A GAME FOR TWO PLAYERS -"
51 PRINT:PRINTTAB(6)"THE OBJECT OF THE GAME IS TO DESTROY AS MANY TARGETS"
53 PRINTTAB(7)"AS POSSIBLE WITH YOUR FIFTEEN SHOTS. THE PLAYER ON"
55 PRINTTAB(7)"THE LEFT USES THE LETTER 'Z' AND THE PLAYER ON THE"
57 PRINTTAB(6)"RIGHT THE '/' TO FIRE THE MISSILE. THE SPEED OF THE"
58 PRINTTAB(6)"MISSILE LAUNCHER MAY BE VARIED BETWEEN FAST AND SLOW."
60 PRINT:INPUT" ENTER THE NAME OF THE FIRST PLAYER":A$
70 PRINT:INPUT" ENTER THE NAME OF THE SECOND PLAYER":B$
80 PRINT:PRINT"ENTER SPEED (<1 FAST - 10 SLOW)"
90 PRINT:PRINTA$:PRINT" ":INPUTA
92 IF A<1 OR A>10 THEN 90
95 PRINT:PRINTB$:PRINT" ":INPUTB
97 IF B<1 OR B>10 THEN 95
100 CLS
105 DATA 1, 2, 3, 4, 5, 6, 7, 8, 9, 10, 11, 12, 13, 14, 15, 16, 17, 18, 19, 20,
21, 22, 23, 24, 25, 26, 27, 28, 29, 30, 31
106 FOR L=1 TO 31:READ A(L):NEXT L
110 FOR Z=1 TO 10
120 M=RND(31)
130 IF A(M)=0 THEN 120
140 IF M=31 THEN M=10
145 IF M<2 THEN M=2
150 N=M+32
155 IF M+Z*64=0 THEN M=10+Z
160 PRINT@M+Z*64,"#"
170 PRINT@N+Z*64,"*"
175 A(M)=0
180 NEXT Z
200 Y=43
210 FOR X=0 TO 127
220 SET(X, Y)
230 NEXT X
233 PRINT@960, A$:
235 PRINT@995, B$:
240 X=63
250 FOR Y=3 TO 42
260 SET(X, Y)
270 NEXT Y
```

PROGRAMS

```

280 CT=CT+1:IF CT=150 THEN 800
282 IF SH=0 THEN 310
285 FOR X=1 TO 60
290 Y=42
300 SET(X,Y)
303 FOR TD=1 TO A:NEXTTD
304 RESET(X,Y)
305 G$=INKEY$:IF G$="" THEN 308
306 IF G$="Z" THEN GOSUB 460:GOTO 310
308 NEXT X
310 IF ST=0 THEN 280
315 FOR X=65 TO 127
320 Y=42
330 SET(X,Y)
333 FOR TD=1 TO B:NEXTTD
334 RESET(X,Y)
335 H$=INKEY$:IF H$="" THEN 338
336 IF H$="/" THEN GOSUB 660:GOTO 280
338 NEXT X
340 GOTO 280
460 PRINT@974,"                ";:SH=SH-1:PRINT@974,SH" SHOTS LEFT";
470 FOR Y=41 TO 3 STEP -2
490 SET(X,Y)
500 FOR W= 1 TO 5
510 NEXT W
520 RESET (X,Y)
530 NEXT Y
535 RETURN
660 PRINT@1007,"                ";:ST=ST-1:PRINT@1007,ST" SHOTS LEFT";
680 FOR Y=41 TO 3 STEP -2
690 SET(X,Y)
700 FOR W=1 TO 5
710 NEXT W
720 RESET(X,Y)
730 NEXT Y
735 RETURN
750 GOTO 280
800 CLS:PRINT:PRINTTAB(10)"DO YOU WANT TO PLAY AGAIN (Y/N)";:INPUTQ$
810 IF Q$="Y" THEN RUN
820 IF Q$="N" THEN 800
830 CLS:PRINT:PRINTTAB(20)"THANK YOU FOR PLAYING"
840 FOR TD=1 TO 1000:NEXT
    
```

TRS-80 Four in a row

by Spiesoft

This program displays an 8 x 8 grid in a row wins. Sadly the program and two players take turns dropping 'chips' into it. First player to get four doesn't tell you though.

```

1150 'FOUR-IN-A-ROW'
60 'AN ORIGINAL PROGRAM BY SPIESOFT'
70 CLS:INPUT"THE FIRST PLAYER'S NAME";W$
80 INPUT"THE SECOND PLAYER'S NAME";B$
90 CLS:FORY=15TO47STEP4:FORSX=28TO108:
SET(X,Y):NEXTX:NEXTY
100 FOR X=28TO110STEP10:FORY=15TO47:
SET(X,Y):NEXTY:NEXTX
110 PRINT@272,"1 2 3 4
5 6 7 8";
120 PRINT@448,"PLAYER 1 :";
130 PRINT@512,"- ";W$;" -";
140 PRINT@576,"PLAYER 2 :";
150 Q=1:PRINT@640,"- ";B$;" -";
160 Z1=0:PRINT@0,"PLAYER":Q:INPUTA
170 IFA(0)THEN160
175 IFA(8)THEN 160
180 IFA=1THENVV=34
190 IFA=2THENVV=44
200 IFA=3THENVV=54
210 IFA=4THENVV=64
220 IFA=5THENVV=74
230 IFA=6THENVV=84
240 IFA=7THENVV=94
250 IFA=8THENVV=104
260 CC=44
270 IFPOINT(VV-1,CC)THEN280ELSE310
280 Z1=Z1+4:CC=CC-4
    
```

MICROMART

µHex EPROM PROGRAMMERS

426 2508/2708/2758/2516/2716
Dual and Single supply Eproms, £95

416 2704/2708/2716 Dual only.£65

480 2704/2708 Kit £35. Built £40.

All programmers require only standard power supplies. The 426 & 416 are cased and have push-button selection.

Program any length block into the Eprom. Software included. Range covers 280, 8080, 6800 and 6500. State machine.

PIO, PIA INTERFACE MODULES

Available for 280/8080 and 6800/6500.

Prices include carriage. Please add VAT SAE for further product information.

MICROHEX COMPUTERS

UNION STREET, TROWBRIDGE, WILTS.

CONFUSED?

DO YOU FIND IT ALL TOO COMPLICATED? ARE THERE TOO MANY TECHNICAL TERMS? WE DON'T JUST SELL MICROS. WE LIVE AND WORK WITH THEM, WE TEACH ALL OUR CUSTOMERS TO USE THEM. BUY A MICRO FROM US AND GET AS MUCH HELP AS YOU NEED!

MICROTEK

PHONE CHRIS ROBINSON ON
IPSWICH (0473) 50152

ZX80 SPECIALS

SPACE INTRUDERS: Zap the intruders as they attempt to land — a simplified version of the famous computer game. £4.00.
BREAKOUT: Try to knock all bricks out of the wall before your final ball is lost. £4.00.
MOVIES: 7x8 character pictures displayed in rapid rotation — gives animation effect (2K or more for best results), £3.00. The three above are continuous motion programs with no loss of T.V. Sync.
ACTIVE DISPLAY MKII: A routine that lets you decide how long a display should hold before your program continues, a keyboard scanning routine (keys 0 to 9) and a Hexadecimal loader are included. Write your games using active display features. £5.00 (MKII free for previous active display purchasers — Send S.A.E. and MKI Listing). Inclusive prices for listing & details, or send S.A.E. for list of all ZX80 Specials.

K. Macdonald, 26 Spiers Close, Knowle, Solihull, B93 9ES.

MINE OF INFORMATION LTD

1 FRANCIS AVENUE,
ST ALBANS AL3 6BL
ENGLAND

Phone: 0727 52801
Telex: 925 859

MICROCOMPUTER CONSULTANCY & BOOK SELLERS

BIG EARS

SPEECH
INPUT
FOR
YOUR
COMPUTER!

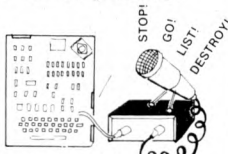

BIG EARS opens the door to direct man-machine communication. The system comprises analogue frequency separation filters, preamps and signal conversion, together with a quality microphone and extensive software.

Words, in any language, are stored as "voice-prints" by simply repeating them a few times in "learn" mode. Using keyword selection techniques, large vocabularies can be constructed.

Use BIG EARS as a front end for any application: data enquiry, robot control, starwars — the possibilities are unlimited...

BUILT, TESTED & GUARANTEED £45

PRICE INCLUDES POSTAGE & PACKING. PLEASE ADD VAT AT 15%
PLEASE STATE COMPUTER, UK101, SUPERBOARD, NACCOM2.
Also available: PET, TRS80, ETC.

COLOUR MODULATOR

- R G B inputs, PAL/UFH output
- Unlimited colour combinations
- TTL etc interface details supplied
- 1000's already in use!

KIT: only £12 Built & Tested: only £18

— please add VAT at 15% to all prices
— Barclay/Access orders accepted by telephone

**WILLIAM
STUART
SYSTEMS Ltd**

Dover House, Bilenicay Road,
Herongate, Brentwood,
Essex CM13 3SD
Telephone: Brentwood (0277) 810244

CUT TYPING COSTS

WORDPRO 3/4 TURN PETS INTO
WORD PROCESSORS
NOSENT LTD

1-DAY COURSES & MANUALS
TURN TYPISTS INTO
WORDPRO EXPERTS

Details from Tom Nosworthy
Nosent Ltd, Tel 094787, 232 Brackengarth,
Lealholm WHITBY YO21 2AE

OUR PETMAN SHORTHAND

DISK SPEEDS TYPING

READABLE MANUALS SELL PRODUCTS
CAN WE WRITE YOURS?

PET CHIPS

PETMASTER SUPERCHIP £45
PIC-CHIP £45
PROGRAMMER'S TOOLKIT £29
MIKRO ASSEMBLER £50

Write for full details of these plug-in PET add-ons which fit in the spare ROM sockets of a large keyboard machine. If your PET has a calculator keyboard you'll need an extension board (£13) which will accommodate any two of the chips.

BASIC 4.0 versions are available to fit the 4000 and 8000 series models — write for information and prices.

We also sell programs on cassette and disk (£2.50 extra) — there are over a 100 to choose from including BLOCK RENUMBER (£12), DISK APPEND (£15), HALLS OF DEATH (£14), ALIEN ATTACK (£10), and WIZARD'S LAIR (£10). And MAKRO ASSEMBLER at £50 offers an opportunity for machine code programmers to really flex their mnemonics.

Why not phone for our free catalogue!
Add 15% VAT to all prices. Post Free.

SUPERSOFT

28 Burwood Avenue,
Eastcote, Pinner, Middlesex

Telephone: 01-866 3326



PROGRAMS

```

290 IFCC=12THEN350ELSE300
300 GOTO270
310 FORXX=0TO2STEP0:FORA1=29TO38STEP2:
    SET(A1+(10*(A-1)),44-Z1+XX):NEXTA1:NEXTXX
320 IFQ=2THENQ=1ELSEQ=2
330 GOTO160
340 END
350 PRINT@95,"THAT ROW IS ALREADY OCCUPIED":
    FORX3=1TO500:NEXTX3:GOTO160
    
```

PET Maze chase

by Steve Clark

The rest of this month's programs are all for the PET. This isn't a secret plot to promote Commodore's products, it's simply that we receive an enormous number of programs for this machine. Inevitably, by the time the 'bad' are weeded out, we end up looking like a Commodore benevolent society. How about it all you users of

other machines? — send in your good programs. After all we do pay and we don't mind what the program is as long as it's in Basic, original, bug free and interesting.

All listings are courtesy of Steve Clark and done on a printer borrowed from Cream Computers.

```

10 PRINT"OBTAIN 12"MAZE CHASE" PRINTTAB(12)
15 FORT=1TO500:NEXT
20 T="NIN THIS GAME TWO DRIVERS HURTLEROUND A" GOSUB5000
30 T=" MAZE AT TOP SPEED." GOSUB5000
35 FORT=1TO500:NEXT
40 PRINT T="REACH HINS TO SCORE POINTS BY RUNNING" GOSUB5000
50 T=" DOWN OBJECTS IN HIS PATH AND BY SHOOTING" GOSUB5000
60 T="MISSILES AT HIS OPPONENT." GOSUB5000
65 FORT=1TO500:NEXT
70 PRINT T="ANDYOU SCORE POINTS AS FOLLOWS:" GOSUB5000
75 FORT=1TO500:NEXT
80 PRINT T="N = 10 POINTS" GOSUB5000
90 PRINT T=" = 50 POINTS" GOSUB5000
95 FORT=1TO500:NEXT
100 PRINT T="DESTROYING OPPONENT SCORES 1000" GOSUB5000
105 FORT=1TO1000:NEXT
110 PRINT T="NIN HIT ANY KEY TO CONTINUE" GOSUB5000:POKE158,0:WAIT158,1
115 POKE158,0
120 T="CONTROLS ARE AS FOLLOWS:" PRINT:GOSUB5000:FORT=1TO500:NEXT
130 PRINT T="NIN PLAYER #1 PLAYER #2" GOSUB5000
140 PRINT PRINT" W S "
150 PRINT"
160 PRINT" A-D 4-6"
170 PRINT"
180 PRINT" X 2 "
185 FORT=1TO1000:NEXT
190 PRINT T="NIN HIT 'S' AND '5' RESPECTIVELY TO FIRE." GOSUB5000
200 PRINT T="NIN THE COMPUTER MAY PLACE EXTRA WALLS IN THE WAY SOMETIMES."
205 GOSUB5000:FORT=1TO500:NEXT
210 PRINT T="THESE WALLS LOOK LIKE THIS: '8' AND THEYCAN BE DESTROYED."
215 GOSUB5000
220 PRINT T="NIN HIT ANY KEY TO START" GOSUB5000:POKE158,0
230 GETO:IFQ="":THEN230
240 PRINT T="THAT'S ALL YOU HAVE THREE MINUTES, STARTING" GOSUB5000
250 FORT=1TO1000:NEXT:PRINT" NOW"
260 FORT=1TO1000:NEXT:GOSUB1000
490 POKE158,0
500 IFT="000500"THEN6000
510 GETO:IFQ="":THEN620
520 IFVAL(Q)00THEN580
530 IFQ="W"THEND1=1
540 IFQ="A"THEND1=2
550 IFQ="D"THEND1=3
560 IFQ="X"THEND1=4
565 IFQ="S"ANDM1=32767THENM3=D1:M1=A:Y=32
570 GOTO620
580 IFQ="8"THEND2=1
590 IFQ="4"THEND2=2
600 IFQ="6"THEND2=3
610 IFQ="2"THEND2=4
615 IFQ="5"ANDM2=32767THENM4=D2:M2=B:L=32
620 X=INT(RND(1)*10):IFX=0THENX=INT(RND(1)*800+32888):XX=PEEK(X):GOTO7000
625 X=INT(RND(1)*1000+32767):IFPEEK(X)=32THENPOKEX,46
627 X=INT(RND(1)*1000+32767):IFPEEK(X)=32THENPOKEX,58
630 OND1GOTO640,650,660,670
640 Z=-40:GOTO680
650 Z=-1:GOTO680
660 Z=1:GOTO680
670 Z=40
680 X=PEEK(A+Z)
690 IFX=32THEN730
700 IFX=46THEN$1=$1+10:GOTO730
710 IFX=58THEN$1=$1+50:GOTO730
720 POKER,90:GOTO740
730 POKER,32:R=A+Z:POKER,90
740 OND2GOTO750,760,770,780
750 Z=-40:GOTO790
760 Z=-1:GOTO790
770 Z=1:GOTO790
780 Z=40
790 X=PEEK(B+Z)
800 IFX=32THEN840
810 IFX=46THEN$2=$2+10:GOTO840
820 IFX=58THEN$2=$2+50:GOTO840
830 POKER,35:GOTO850
840 POKER,32:R=B+Z:POKER,35
850 IFM1<>32767THEN3000
860 IFM2<>32767THEN3500
870 GOSUB2000
880 GOTO500
1000 REM***SET UP BOARD***
1010 PRINT"Z":FORT=32768TO32847:POKET,160:NEXT
1020 FORT=32768TO33728STEP40:POKET,160:NEXT
1030 FORT=32807TO33767STEP40:POKET,160:NEXT
    
```

PROGRAMS

```

1040 FORT=33728T033767:POKET,160:NEXT
1050 FORT=32931T033131STEP40:POKET,160:NEXT
1060 POKE32932,160:POKE32933,160:POKE32972,160:POKE32973,160
1070 FORT=1T04:POKE32989+T,160:POKE32949+T,160:NEXT
1080 FORT=32994T033314STEP40:POKET,160:NEXT
1090 FORT=33304T033314:POKET,160:NEXT
1100 POKE32943,160:POKE33042,160:POKE33122,160
1110 FORT=32996T033196STEP40:POKET,160:POKET+4,160:NEXT
1120 FORT=1T04:POKE32956+T,160:POKE32996+T,160:NEXT
1130 FORT=1T04:POKE33383+T,160:POKE33423+T,160:POKE33460+T,160:POKE33500+T,160
1140 NEXT:FORT=33506T033511:POKET,160:NEXT
1150 FORT=1T05:POKE33388+T,160:POKE33428+T,160:POKE33586+T,160:POKE33626+T,160
1160 FORT=1T05:POKE33388+T,160:POKE33428+T,160:POKE33586+T,160:POKE33626+T,160
1165 NEXT
1170 FORT=33393T033593STEP40:POKET,160:POKET+1,160:NEXT:POKE33592,160
1180 FORT=33279T033639STEP40:POKET,160:NEXT
1190 FORT=33204T033484STEP40:POKET,160:NEXT
1200 FORT=33479T033484:POKET,160:POKET+160,160:NEXT
1210 FORT=33520T033606STEP40:POKET,160:POKET+1,160:NEXT
1220 POKE33280,160:POKE33202,160:POKE33203,160
1230 FORT=1T020:POKE33052+T,160
1240 IFT:GRNDT:17THENPOKE33012+T,160
1250 IFT:12RNDT:17THENPOKE32972+T,160
1260 IFT:14RNDT:17THENPOKE32932+T,160
1270 IFT:2THENPOKE33092+T,160:POKE33132+T,160
1280 IFT:7THENPOKE33212+T,160
1290 NEXT
1300 POKE33112,160:POKE33152,160:POKE33192,160
1305 POKE33094,160:POKE33134,160
1310 FORT=32937T032941:POKET,160:NEXT
1320 FORT=32975T032977:POKET,160:NEXT
1330 FORT=33454T033459:POKET,160:POKET+40,160:NEXT
1340 FORT=33572T033575:POKET,160:POKET+40,160:NEXT
1350 POKE33534,160:POKE33535,160
1360 FORT=33282T033402STEP40:POKET,160:NEXT
1370 POKE33951,160:POKE33481,160
1380 FORT=33136T033150:POKET,160:NEXT
1390 FORT=33293T033502:POKET,160:NEXT
1400 FORT=33177T033257STEP40:POKET,160:POKET+1,160:NEXT
1410 POKE33041,160:POKE33342,160:POKE33381,160:POKE33382,160
1420 FORT=33577T033585:POKET,160:NEXT
1430 POKE33625,160:POKE33617,160
1440 FORT=33078T033198STEP40:POKET,160:NEXT
1450 FORT=0T04:POKE33211+T,160:POKE33211+40*T,160:NEXT
1460 FORT=33372T033379:POKET,160:NEXT
1470 FORT=33276T033636STEP40:POKET,160:POKET+1,160:NEXT
1480 FORT=32849T032886:POKET,160:POKET+840,160:NEXT
1490 FORT=32849T033689STEP40:POKET,160:POKET+37,160:NEXT
1500 FORT=33450T033650STEP40:POKET,160:NEXT
1510 FORT=33659T033663:POKET,160:NEXT
1520 POKE33451,160:POKE33452,160:POKE33491,160:POKE33492,160
1530 POKE33673,160:POKE33674,160:POKE33564,160:POKE33565,160
1540 POKE32895,160:POKE32905,160:POKE32915,160:POKE33565,160
1550 FORT=32964T033124STEP40:POKET,160:NEXT:POKE32962,160:POKE32963,160
1560 POKE32889,90:POKE32926,35
1565 POKE33563,160
1567 FORT=33166T033171:POKET,32:NEXT
1568 FORT=33526T033531:POKET,32:NEXT
1570 FORT=1T0100
1580 X=INT(RND(1)*1000+32768):IFPEEK(X)◇32THEN1580
1590 POKE X,46:NEXT
1600 FORT=1T050
1610 X=INT(RND(1)*1000+32768):IFPEEK(X)◇32THEN1610
1620 POKE X,58:NEXT
1621 FORT=1T010
1622 X=INT(RND(1)*800+32888):IFPEEK(X)◇32ANDPEEK(X)◇160THEN1622
1623 POKE X,102:NEXT
1630 REM***INITIALIZE***
1640 S1=0:S2=0:A=32889:B=32926:M1=32767:M2=M1:T1#="000000":GOSUB2000:RETURN
2000 REM***INFORMATION***
2010 PRINT "SCORE 1:"S1TAB(25)"TIME:"MID$(T1#,4,1),"RIGHT$(T1#,2)"■"
2020 PRINT "SCORE 2:"S2"■"
2025 IFT1#="000300"THEN6000
2030 RETURN
3000 FORT=1T02
3010 ONMSGOT03020,3030,3040,3050
3020 Z=-40:P=93:GOT03060
3030 Z=-1:P=64:GOT03060
3040 Z=1:P=64:GOT03060
3050 Z=40:P=93
3060 X=PEEK(M1+Z)
3070 IFX=102THENPOKEM1,Y:POKEM1+Z,42:FORTT=1T0250:NEXT:POKEM1+Z,32:M1=32767:GOT
0860
3080 IFX=160THENPOKEM1,Y:M1=32767:GOT0860
3090 IFX=35THEN3110
3100 POKEM1,Y:M1=M1+Z:POKEM1,P:Y=X:NEXT:GOT0860
3110 POKEM1,Y:POKEM1+Z,42:FORTT=1T0250:NEXT:POKEM1+Z,32
3115 B=INT(RND(1)*1000+32768):IFPEEK(B)◇32THEN3115
3116 POKE B,35
3120 M1=32767:S1=S1+1000:GOT0860
3500 FORT=1T02
3510 ONM4GOT03520,3530,3540,3550
3520 Z=-40:P=93:GOT03560
3530 Z=-1:P=64:GOT03560
3540 Z=1:P=64:GOT03560
3550 Z=40:P=93
3560 X=PEEK(M2+Z)
3570 IFX=102THENPOKEM2,L:POKEM2+Z,42:FORTT=1T0250:NEXT:POKEM2+Z,32:M2=32767:GOT
0870
3580 IFX=160THENPOKEM2,L:M2=32767:GOT0870
3590 IFX=90THEN3610
3600 POKEM2,L:M2=M2+Z:POKEM2,P:L=X:NEXT:GOT0870
3610 POKEM2,L:POKEM2+Z,42:FORTT=1T0250:NEXT:POKEM2+Z,32
3615 A=INT(RND(1)*1000+32768):IFPEEK(A)◇32THEN3615
3616 POKE A,90
3620 M2=32767:S2=S2+1000:GOT0870
4999 END
5000 REM***SLOW WRITER***
5010 FORW=1TOLEN(T1):PRINTMID$(T1#,W,1):FORV=1T025:NEXTV,W:RETURN
6000 IFS1>HSTHENHS=S1:HS#="HIGH SCORE BY PLAYER #1:"
6010 IFS2>HSTHENHS=S2:HS#="HIGH SCORE BY PLAYER #2:"
6020 PRINT T#="NO TIME UP":GOSUB5000
6022 IFS1>S2THEN#="WINNER PLAYER #1 WINS":PRINT:P1=P1+1:GOSUB5000:GOT0600
6024 IFS2>S1THEN#="WINNER PLAYER #2 WINS":PRINT:P2=P2+1:GOSUB5000:GOT0600
6025 GD=GD+1:PRINT T#="NO GAME DRAWN":GOSUB5000
6030 PRINT T#="NO GAME DRAWN":GOSUB5000
6035 PRINT T#="NO GAME DRAWN":GOSUB5000
6036 PRINT T#="NO GAME TO PLAYER #1":GOSUB5000
6037 PRINT T#="NO GAME TO PLAYER #2":GOSUB5000
6040 FORT=1T05500:NEXT:PRINT T#="DO YOU WANT ANOTHER GAME":GOSUB5000
6045 POKE158,0
6050 INPUTO#IFLEFT$(O#,1)="Y"THEN240
6060 END
7000 IFX=320RND=160THENPOKEX,102:GOT0625
7010 GOT0625

```

MICROMART

6800

A selection from our latest catalogue:-

Printed Circuit Boards for 6800/6809 systems

1. MPS Serial Interface	£6.60
2. MPL/A Parallel Interface	£6.60
3. MPB/2 SS50 Motherboard	£24.20
4. MPA/2 6800 CPU	£11.00
5. MPA/2 6800 CPU assembled	£75.00

Tape Software for 6800 Systems

1. CST014 TSC Editor	£22.00
2. CST015 TSC Assembler	£22.00
3. CST016 TSC Text Processor	£22.00
4. CST017 TSC Relocator	£16.50

Prices include postage. Add VAT @ 15.00%

COMPUSENSE LTD., P.O. BOX 169,
LONDON N13 4HT - Tel. 01-882 0681

MORRISTON COMPUTER CENTRE
46 CROWN ST
MORRISTON
Tel: 795817 SWANSEA

SHARP MZ80 VIDEO
PC1211 GENIE

In our CHRISTMAS catalogue for the

ZX80

MASTERMIND* KALA* MORTGAGE
MORSE BATTLESHIPS TARGET
HANGMAN SPIDER TRIANGLES*
MATHS TEST* DIAR REGRESSION

plus many more

*Coupon worth £2.00 with these

programmes, one only per order.

*£2.75, all others £3.75

Hints and Tips for the ZX80 £3.50

Hewson Consultants 7 Grahame Close

Blewbury Oxon OX11 9QE

0235 850075

Which Way?

• If you're lost in the Micro Maze and don't know which way to turn... turn to us

• For impartial advice from an independent consultant... consult us

• For bespoke software designed to meet your needs... you need us

m meldon micro services

37 Purbrook Gardens
Purbrook, Portsmouth
(Waterlooville) S3775J

BASIC PROGRAMS FOR THE PET

for problems in structural analysis & vibration from **£20**

Dr. C.T.F. Ross
6 Hurstville Drive, Waterlooville,
Portsmouth, Hants. PO7 7NB

MICROMART

To advertise in
MICROMART
Please ring Jacquie Hancock
on 01-631 1682

ZX80 SOFTWARE

Pontoon, Guess the Number, Battleships,
Slot machine (1 & 11) Maths Quiz,
Maze (1 & 11)
All on one cassette £6.50
for 1K Memory.

Send cheque or P.O. made out to
P. Branswell to:
BRAMWELL ENTERPRISES
87 ANDERSON CRESCENT, GREAT
BARR, BIRMINGHAM B43 7ST.

UK 101 & SUPERBOARD * SOFTWARE

The top ten from the guy who wrote "LE PASSE-TEMPS"
1. GALACTIC HITCHHIKER (8K) An Adventure, all in Machine Code, A beauty!
2. STARTREK (8K) The old favourite but no scrolling! All the info, on display all the time.
3. SUPERTREK (8K) A graphics version. Sail boldly, through the universe, zapping moving Klingons in real time.
4. PIRANHA* A fun, real time graphics game.
5. BREAKOUT* A smashing version with machine-code to move the paddle.
6. STUD POKER (8K) You against the mean machine.
7. LUNAR LANDER A real challenge. You won't get down in less than 3 hours.
8. STOCKMARKET (8K) A realistic simulation for would-be millionaires.
9. LE PASSE-TEMPS* You need this one, if you haven't already got it.
10. HANGMAN* Excellent graphics (P.E. said so!).
Others available include a BASIC TUTOR @ £10. (comprises 8x4K programs) and lots more games. Note that these are ORIGINAL PROGRAMS, NOT 101 VERSIONS OF PRINT!
PRICES: 8K £4, 4K £2 all inclusive from Mr. A. Knight,
28, Simonside Walk, Ormesby, Cleveland.
Phone (0642) 321266

TRS-80, NASCOM, OTHER Z80 SYSTEMS

BS232C SERIAL INTERFACE — crystal controlled, baud rates up to 19200, bi-directional, full handshake, etc. Suitable for connecting to modern, serial printer (4 additional signals available; CSR, DSR, CD, RI), other computers. Port addresses selectable, TRS-80, Expansion interface NOT required. Complete kit £68, including cable and plug for keyboard unit and upper/lower case video modification details.

PRINTER INTERFACE BOARD — run the Nascom Micro Imp printer from the TRS-80 (Expansion Interface not necessary). Handshake capability, run up to 9600 baud. The cheapest dot matrix, plain paper 80 col, printer for the TRS-80. Interface board ready built £30, including cable and plug for keyboard unit and upper/lower case video mod details.

LOGIC PROBE — build yourself a really good logic probe. Complete kit £12.

For further details of the above, send a large stamped addressed envelope to:

SCALE ENGINEERING,
6 GOSS BARTON, NAILSEA,
AVON BS19 2XD

N.B. Prices include VAT & postage

PROGRAMS

PET Convoy

by Jeff Aughton

Here's a challenging game in which the edge of the screen the game terminates. It gets progressively more difficult to play as your skills increase.

```

10 REM CONVOY BY J.AUGHTON
15 GOSUB1000
20 N=3 U=.058 V=.04 P=.180
30 DIMM(13),S(9)
40 B=0 E=10 H=0 K=0 R=0 L=33733
60 RESTORE FORI=0T013:READM(I):NEXT
70 REM DRW
80 PRINT"Q":FORI=1T019:PRINT"Q "
90 NEXT:PRINT"Q "
100 PRINTTAB(29)"Q "
110 PRINTTAB(31)"Q "
120 PRINTTAB(33)"Q "
130 PRINTTAB(35)"Q "
140 PRINTTAB(37)"Q "
150 PRINT"Q "
160 PRINT"Q "
170 PRINT"Q "
180 PRINT"Q "
190 PRINT"Q "
200 PRINT"Q "
210 PRINT"Q + Q"
230 FORI=32807T033767STEP40
240 POKE1,96:NEXT
250 FORI=7T033:POKE1,I,96:NEXT
260 FORI=1TON:READM(S(I))%+32888
270 POKES(I),113:NEXT:SB=TI
280 PRINT"SHIPS HITS":H:" ELEVATION":
290 PRINT"Q":E:" BEARING":B:"II "
300 K=K+1:IFKONTHEK=1
320 M=PEEK(151)
330 E=E-(ED10)*M+(EC85)*M+50
340 B=B-(B-5)*M+42+(BC90)*M+41
360 IF(M<34)ORRTHEN420
370 POKES9409,52:FORI=1T07
375 TS=200*SIN(E*P):NEXT
380 POKES9409,60:T=TI
390 R=23*SIN(2*E*P)
400 N=INT(1,2*R*SIN(B*P)+.5)
410 Y=INT(0*R*COS(B*P)+.5)
420 IFRAND(TID+TS)THEN600
430 D=(RND(1)*SU-40*(RND(1)*CV)
440 M=S(K)+D:IFPEEK(M)=96THEN920
450 IFPEEK(M)<32THEN280
460 POKES(K),32:S(K)=M
500 POKES(K),113:GOTO280
600 REM SHELL LANDS
610 R=0 N=3:Q=L+X-40*Y
620 IFPEEK(Q)=113THENM=10
630 FORI=1T05:POKE0,182-I:GOSUB960
640 POKEO,32:GOSUB960:NEXT
650 FORI=-3T03:T(I+3)=PEEK(Q+I)
660 POKEO+I,M(I+4):NEXT
670 IFW=3THEN720
690 FORI=1TON:IF(S(I)<0)THENNEXT
700 S(I)=S(I):N=N-1:H=H+1:T(I)=43
720 FORI=1T0500:NEXT
730 FORI=-3T03:POKE0+I,T(I+3)
740 NEXT:IFNTHEN280
800 REM ALL DESTROYED
810 T=INT((TI-SB)/60)+POKE525,0
815 PRINT"SHIPS GAME OVER **
820 PRINT"BYOU DESTROYED":H:"SHIPS
830 PRINT"BYOUR TIME WAS":T:"SECS
840 IFKTHEN880
850 PRINT"BECAUSE OF YOUR MISERABLE":
860 PRINT" FAILURE YOU MUST TYPE ":
865 PRINT"RUN IF YOU WANT TO PLAY ":
870 PRINT"AGAIN":END
880 PRINT"PRESS SPACE FOR A HARDER GAME
890 GETA:IFA#0:" THEN890
900 IFA=9THENH=8:U=2*U:V=2*V
910 N=H+1:GOTO40
920 POKES(K),32:FORI=0T09:POKEM,241
930 PRINT"SHIPS SHIP ESCAPES! **
940 GOSUB960:POKEM,113:GOSUB960:NEXT
950 K=0:GOTO810
960 FORI=0T070:NEXT:RETURN
970 DATA 147,144,140,129,147,136,161
980 DATA 160,130,143,143,141,161,160
990 DATA 2,7,43,129,50,83,166,89,125
1000 PRINT"Q CONVOY OF SHIPS IS SAI":
1020 PRINT"LING S-E AND YOUHAVE TO ":
1030 PRINT"DESTROY THEM ALL USING TH":
1040 PRINT"E GUNN (+) IN THE BOTTOM":
1050 PRINT" CORNER OF THE SCREEN,":
1060 PRINT" ELEVATION IS MEASURED I":
1070 PRINT"N DEGREES (10-85)FROM TH":
1080 PRINT"E HORIZONTAL TO INCREASE ":
1090 PRINT"PRESS 0 TO DECREASE PR":
1100 PRINT"ESS 3 MAXIMUM RANGE OCC":
1110 PRINT"URS WHEN ELEVATION=45 DEG,":
1120 PRINT" BEARING IS MEASURED IN":
1130 PRINT" DEGREES FROM -5 NTHROUG":
1140 PRINT"H 0 (NORTH) TO 90 (EAST).":

```

PROGRAMS

```

1150 PRINT"INCREASE XBY PRESSING 35";
1160 PRINT".DECREASE BY PRESSING 34.";
1170 PRINT"UNTO FIRE (AND START THE ";
1180 PRINT"GAME) PRESS 35.";
1190 GETA$:IFA#<>"5"THEN1190
1200 RETURN
    
```

PET Wire

by Paul Makin

This game simulates the said show ringing a bell. Only one tiny piece of game in which you have to pass a the wire is on view in front of the metal ring along a bent wire without ring, so swift reactions are needed.

```

2 REM**WIRE-BY PAUL MAKIN**
3 DIMB(100):GOSUB600
5 FORD=1TO18:PRINT" ":NEXTD
10 N=33183:M=33183
60 POKEM,64:M=M+1:GOTO80
80 FORZ=1TO100:IFZ>5THEN105
90 B(Z)=1:IFZ=1THEN200
102 GOTO110
105 GOSUB400
107 O=O+B(Z)
108 IFINT((O-32767)/40)<(O-32767)/40AND0<32807AND0<33600THEN110
109 O=O-B(Z):GOTO105
110 IFB(Z)=B(Z-1)THEN200
120 IFB(Z-1)=1ANDB(Z)=40THENPOKEM,110:M=M+40:GOTO230
130 IFB(Z-1)=1ANDB(Z)=40THENPOKEM,125:M=M+40:GOTO230
140 IFB(Z-1)=1ANDB(Z)=40THENPOKEM,112:M=M+40:GOTO230
150 IFB(Z-1)=1ANDB(Z)=40THENPOKEM,109:M=M+40:GOTO230
160 IFB(Z-1)=40ANDB(Z)=1THENPOKEM,109:M=M+1:GOTO230
170 IFB(Z-1)=40ANDB(Z)=1THENPOKEM,125:M=M+1:GOTO230
180 IFB(Z-1)=40ANDB(Z)=1THENPOKEM,112:M=M+1:GOTO230
190 IFB(Z-1)=40ANDB(Z)=1THENPOKEM,110:M=M+1:GOTO230
200 IFB(Z)=1THENPOKEM,64:M=M+1:GOTO230
205 IFB(Z)=1THENPOKEM,64:M=M+1:GOTO230
210 IFB(Z)=40THENPOKEM,93:M=M+40:GOTO230
215 IFB(Z)=40THENPOKEM,93:M=M+40
230 IFZ=2THEN260
240 A#="6":POKEM,42:M=M+1:GOTO335
260 POKEM,42
270 GETB$:IFB#=""THEN300
280 A#="6"
300 IFA#="8"THENM=N-40:P#="8":GOTO335
310 IFA#="6"THENM=N+1:P#="6":GOTO335
320 IFA#="2"THENM=N+40:P#="2":GOTO335
330 IFA#="4"THENM=N-1:P#="4":GOTO335
332 A#="P":GOTO300
335 IFPEEK(N)=32ORPEEK(N)=42THEN350
337 FORW=1TO100*Y:NEXTW:NEXTZ
340 PRINT"TIME UP":GOTO1050
350 PRINT"MISSED":GOSUB1000
351 FORW=1TO300:NEXTW:PRINT"ANOTHER GAME?":POKE158,0
352 GETQ$:IFQ#=""THEN352
353 IFQ#<>"Y"THENEND
354 GOSUB710:GOTO5
360 PRINT"HELL DONE"-END
400 C=INT(5*AND(1))
410 ONCGOTO420,430,440,450
420 B(Z)=1:IFB(Z-1)=1THEN400
425 GOTO460
430 B(Z)=1:IFB(Z-1)=1THEN400
435 GOTO460
440 B(Z)=40:IFB(Z-1)=40THEN400
445 GOTO460
450 B(Z)=40:IFB(Z-1)=40THEN400
460 O=M+5:RETURN
600 PRINT"O":TAB(16):"WIRE"
610 PRINT"MIN THIS GAME, YOU MUST FOLLOW":
620 PRINT" A WIRE, WHICH WILL ONLY APPEAR":
630 PRINT" ONE SQUARE AHEAD OF YOU, THE *":
640 PRINT" MOVE IN THE USUAL WAY, I.E.":
650 PRINT"*****UP"
660 PRINT"*****RIGHT"
670 PRINT"*****DOWN, AND"
680 PRINT"*****LEFT"
681 PRINT"IT IS ONLY NECESSARY TO PRESS A KEY TO CHANGE DIRECTION-NOT EVERY MO
VE.":
682 PRINT"TO DO WELL AT WIRE, I WOULD ADVISE YOU TO ":
684 PRINT"ROCK BETWEEN THE KEYS AS THE WIRE ADVANCES.":
686 PRINT"YOUR FIRST TRY....":
690 PRINT"PRESS ANY KEY TO START"
700 GETR$:IFR#=""THEN700
710 PRINT"SET ABILITY(1-5, AMAZING-POOR)":
720 GETW$:IFW#=""THEN720
730 Y=VAL(W#):IFY<1ORY>5THEN710
740 PRINT"O" WIRE " "
900 RETURN
1000 PRINT"SCORE=":(INT(Z/101*1000)/10:"%"):
1010 IFZ>20THEN1020
1015 PRINT"-USELESS!":RETURN
1020 IFZ>80THEN1030
1025 PRINT"-ACCEPTABLE":RETURN
1035 PRINT"-NEAR PERFECT!":RETURN
1050 PRINT"SCORE=100%-EXCELLENT!":GOTO351
    
```

MICROMART

topmark

computers

NEW! NEW! NEW!



APPLE FORTRAN
(Needs language card)

Send only £120 + VAT £18 (Fortran only)
or £419 + VAT £62.85 (complete
system, includes Pascal and language card)

NEW! NEW! NEW!

NEW! DOS 3.3 - much improved
capacity £40 + VAT £6.

NEW! Eurocolour card - vastly
superior to previous versions £113 + VAT
£16.95

Official Government and Educational
orders accepted.

Contact Tom Piercy at
Topmark Computers, 77 Wilkinson Close,
Eaton Socon, St Neots, Cambs. PE19 3HJ
Huntingdon (0480) 212563

SPECIALS FOR PET

PROGRAMMER'S TOOLKIT	£39
LIGHT PEN (+ SOFTWARE)	£25
WORD PROCESSOR (M/CODE)	£35
MUSIC SYSTEM COMPLETE	£37
ADVENTURES 1 & 2 £ 7	

(ALL & VAT BUT INCL. POSTAGE)
Send for details - state model.



MICROCASE "turns a board
into a real computer"

NASCOM 1 & 2

SUPERKIT

COMPUKIT

ALSO UNCUT KEYBOARD MODEL

Direct from us or from your
dealer - but make sure you see a
GENUINE MICROCASE!
About £30

Simple Software Ltd

15 HAVELOCK ROAD
BRIGHTON SUSSEX



MINIMAL COST ZX80 SOFTWARE

1k to 4k programs 50p or £1
also newsletter and technical support.

Membership:- £6.00 U.K.
£10.00 Overseas

Send stamped addressed envelope/

International Reply Coupon

for further details to:

DAVID BLAGDEN

ZX80 Users Club P.O. Box 159,

Kingston upon Thames, Surrey KT2 5UQ

PROGRAMS

```

1120 PRINT"####PHASE# SCORE# HI-SCORE#"
1130 PRINT"MSFC(30)HS"
1140 RETURN
1150 LK=2:FORZL=1T0750:NEXT SYS826
1170 PRINT"####"
1180 GC=GC+1:IFGC=3THENRETURN
1190 IFGC=1THENSYS826:POKEN,214:FORU=1T0100:NEXT SYS826:POKE32845,214
1200 IFGC=2THENSYS826:POKEN,214:FORU=1T0100:NEXT SYS826:POKE32925,214
1210 RETURN
1230 IFSC2>HSTHENHS=SC2
1232 SYS826:POKEN,214
1235 FORU=1T05000:NEXT SYS826:RESTORE:TT=0:GOTO10
1240 RETURN
1260 FORN=826T0863:READA:POKEN,A:NEXT
1270 DATA169,128,133,95,169,0,133,94,162,4,160,0,177,94,201,128,48,6,56,233
1280 DATA128,76,85,3,24,105,128,145,94,200,208,236,230,95,202,208,231,96
1290 RETURN
1300 REM
1310 PRINT"ON"
1360 PRINT"##### >>>> ANDROID ATTACK <<<<<"
1390 PRINT:PRINT
1400 PRINT"BY P.L.FAROUHAR."
1410 PRINT:PRINT
1490 FORI=1T0100:NEXT
1500 PRINT"#####";TT=TT+1
1510 PRINTPT#;PS#;PL#;TT=TT+1:IFTT=37THEN1530
1520 FORU=1T050:NEXT:GOTO1510
1530 PRINTPT#;PS#;PS#;"#####"
1540 SYS826:FORU=1T0300:NEXT
1550 REMFORU=1T0100:SYS826:NEXT SYS826
1560 PRINT"#####DO YOU WANT INSTRUCTIONS?"
1570 GETY#;IFY#=""THEN1570
1580 IFY#<"Y"THEN90
1590 IFY#="Y"THENPRINT"##### ANDROID ATTACK#"
1600 PRINT"#####
1610 PRINT" \ = /#####"
1620 PRINT"#####THIS LITTLE BOY HAS HIS"
1630 PRINT"#####LIFE THREATENED BY SOME"
1640 PRINT"#####MEAN AND NASTY ANDROIDS."
1650 PRINT"#####THEY WANT TO CAPTURE HIM"
1660 PRINT"#####SO THAT HIS FATHER WILL"
1670 PRINT"#####GIVE THEM THE SECRETS OF"
1680 PRINT"#####HIS COUNTRY'S LASER GUNS"
1690 FORU=1T05000:NEXT
1700 POKE32972,251:POKE33051,87
1710 PRINT"#####PLEASE#####HELP#####"
1720 PRINT"#####PRESS ANY KEY#"
1730 GETY#;IFY#=""THEN1730
1740 PRINT"#####YOU ARE IN CHARGE OF THE"
1750 PRINT"#####LASER GUNS AND THE"
1760 PRINT"#####ANDROIDS HAVE STARTED"
1770 PRINT"#####ATTACKING."
1780 PRINT"#####"
1790 PRINT"#####THREE ANDROID PLANES"
1800 PRINT"#####HAVE TO GET PAST YOUR"
1810 PRINT"#####LASER BEFORE THEY CAN"
1820 PRINT"#####CAPTURE THE LITTLE BOY."
1830 POKE32972,236:POKE33050,74:POKE33051,64:POKE33052,75
1840 PRINT"#####PRESS ANY KEY#"
1850 GETY#;IFY#=""THEN1850
1860 PRINT"#####"
1870 PRINT"#####YOUR CONTROLS ARE :-"
1880 PRINT"#####8# MOVES THE LASER UP"
1890 PRINT"#####F# FIRES THE LASER"
1900 PRINT"#####2# MOVES THE LASER DOWN"
1910 REMPRINT"#####"
1920 PRINT"#####THE SOONER YOU HIT THE"
1930 PRINT"#####ANDROID, THE HIGHER YOUR"
1940 PRINT"#####SCORE."
1950 PRINT"#####"
1960 GETY#;IFY#=""THEN1960
1970 PRINT"#####"
1980 PRINT"#####THE DEFENCE TRACKS BECOME"
1990 PRINT"#####DAMAGED AS TIME GOES ON."
2000 REMPRINT"#####"
2010 PRINT"#####THE FATE OF THE LITTLE"
2020 PRINT"#####BOY IS IN YOUR HANDS."
2030 PRINT"#####GOOD LUCK!"
2040 PRINT"#####"
2050 PRINT"#####"
2060 GETY#;IFY#=""THEN2060
2070 GOTO90
2080 PRINT"ON" COPYRIGHT:P.L.FAROUHAR."
2090 PRINT" 20TH OCTOBER 1980"
2100 PRINT"ON" PROGRAM:ANDROID ATTACK"
2110 PRINT"ON" ALL RIGHTS RESERVED."
2040 FORI=1T01000:NEXT
2050 RETURN

```

PET Anagram

by Jeff Aughton

An anagram is displayed which you have to guess within ten seconds. A visual indication of the time passing creates an alarming sense of panic. Constants M and N represent the word

count and number of words given before totalling. Increase the number of words by tacking them on to the DATA statements.

```

120 REM ANAGRAM BY J.AUGHTON
130 M=60:N=10
140 DIM A(20),B(20),A$(20)
150 DEF FNR(X)=INT(X*RNDRND(TI)+1)
160 PRINT"#####ANAGRAM"
170 PRINT"#####I WILL PRINT AN ANAGRAM:"
180 PRINT"#####WHICH YOU HAVE TO UNSCRA:"
190 PRINT"#####MBLE WITHIN 10 SECONDS.ONC:"
200 PRINT"#####E YOU HAVE TYPED A LETTER:"

```

MICROMART

CARDIFF MICRO CENTRE

PETs & SUPERPETs

+

SHARP MZ-80s

+

HEWLETT PACKARD

+

COMPUTER BOOKS

SIGMA SYSTEMS

54 Park Place

Cardiff 21515/34869

APPLE & ITT 2020 BUSINESS SOFTWARE

Professionally written packages now available with comprehensive manuals, built-in validity checks, interactive enquiry facilities, user options, satisfying accountancy, Inland Revenue and Customs & Excise requirements. On diskette under DOS 3.2 in Applesoft with SPACE utility. Not adaptations. Written for Apple System. Support all printer interfaces. Sales, Purchases and General Ledgers £295.00 each. Manual only £3. Payroll £375. Manual only £4. General Ledger supports Incomplete Records, Job Costing, Branch and Consolidated Accounts, etc. General Ledger Applications Manual £10. Prices exclusive of V.A.T. From our shop or your nearest stockist.

COMPUTECH SYSTEMS

168 Finchley Road, London NW3,
Tel: 01-794 0202

VETS FOR PETS

Anita Electronic Services (London) Ltd. are specialists in the repair and service of Commodore Pets.

We offer a fast on-site service, or alternatively repairs can be carried out at our workshops should you wish to bring in your Pet.

Pet maintenance contracts are available at very competitive prices. Trade inquiries welcomed.

For further information, tel or write to:

John Meade
Anita Electronic Services
15 Clerkenwell Close, London EC1
01-253 2444

We also specialise in the repair of all makes of office equipment.

6250 BAUD for NASCOM 1

This ultra-fast cassette interface board will provide reliable data storage and recall at up to 6250 BAUD on most standard cassette recorders.
e.g. 1K of data loaded in less than 1½ seconds.

The modifications required are minor and full documentation is supplied with each board which comes built, tested and guaranteed.

For immediate delivery send £15.95 + 35p P&P to:-

J. C. Hunter
65 Portland Street, TROON
Ayrshire, Scotland
or phone 0292 311513

Also a competitively priced EPROM programming service is provided where we can supply the EPROM's programmed to your listings or programme your own EPROM's on a 24 hour turn round basis. Please write or telephone for details.

OSI/UK User Group

Support for

OHIO SCIENTIFIC

the independent user group
for all users of Ohio Scientific
small computers (Superboard to C3)
and UK101

professionally-produced
A5-format bi-monthly Newsletter
development and documentation
programming and planning aids
and much more!

£10.00

for six-issue membership/subscription

contact: *George Chkiantz*
12 Bennerley Road, London SW11 6DS

GAMES FOR THE SUPERBOARD II

SPACE INVADERS — 8 skill levels, invisible invaders, zig-zagging bombs and more. 8K **£5.00**

BREAKOUT — A very addictive ball game, 12 levels of difficulty and 4 demonstrations models. 4K **£4.00**

AIR ATTACK — Destroy the skyscrapers or you will crash. 4K **£2.50**

GUN TURRET — 4 aliens fly around you; shoot them but beware of the deadly flying saucer. 4K **£2.50**

ASTEROID DODGER — Try to catch the alien but don't hit an asteroid. 4K **£3.00**

SURROUND — A very fast-moving game of skill for 2 players. 4K **£3.00**

Computator kits, 8 St Vincent Drive, St Albans, Herts.
All prices include P & P

STOKE on TRENT

for
TUSCAN
and
TANGERINE
and
VIDEO GENIE
and
BOOKS

MICRO-PRINT Ltd.,
59, Church Street, Stoke on Trent.
(0782) 48348. Barclaycard and Access

CHEAP PETS

32K **£575**
8K **£355**
Disk Drive **£575**
Tractor Printer **£355**

TELE:— 09277-65056 (HERTS.)

PROGRAMS

```

210 PRINT "I WON'T LET YOU DEL-ETE I";
220 PRINT "T AND INCORRECT OR OVERTIM";
230 PRINT "E WORDS WILL BE CHARGED ";
240 PRINT "AT THE FULL 10 SECOND NR";
250 PRINT "ATE - SO WATCH IT !!!";
260 PRINT "AFTER";N;"WORDS I WILL";
270 PRINT " PRINT YOUR SCORE. ";
280 PRINT TAB(10) "PRESS SPACE TO PLAY";
290 GETA$:IFA$<>" THEN290
300 P=33687:S=0:O=0:C=0:W=0:G=0
310 PRINT "XXXXXXXXXXXXXXXXXXXXXXXXXXXX";
320 PRINT "
330 PRINT "0 1 2 3 4 5 6 7 8 9";
340 PRINT "HERE IS YOUR WORD:-";
350 PRINT " ";TAB(14);
360 REM FIND WORD
370 RESTORE R=FNR(M)
380 FOR I=1 TO R:READ W$:NEXT
390 REM ANAGRAM IT
400 L=LEN(W$):FOR I=1 TO L:A(I)=I:NEXT
410 FOR I=L TO 1 STEP -1:R=FNR(I)
420 B(I)=A(R):A(R)=A(I):NEXT
430 IF B(1)=1 THEN B(1)=B(2):B(2)=1
440 FOR I=1 TO L
450 PRINT MID$(W$,B(I),1):NEXT:PRINT
460 REM INPUT ROUTINE
470 PRINT "YOUR GUESS ? ";
480 J=1:K=0:G$="":POKE 525,0
490 A=TI
500 IF TI-A>15 THEN 550
510 GETA$(J):IFA$(J)="" THEN 500
520 G$=G$+A$(J):PRINTA$(J);
530 IF J=L THEN 700
540 J=J+1:GOTO 500
550 K=K+1:POKEP+K,226:IF K<40 THEN 490
560 O=O+1:PRINT:PRINT "OVERTIME!!";
580 REM CHECK WORD
590 T=10:PRINT "-THE WORD IS ";W$
600 S=S+T:PRINT "YOUR SCORE IS:-";
610 PRINTO:"CORRECT ";W;"WRONG ";
620 PRINTO:"OVERTIME"
630 FOR J=1 TO 2000:NEXT
640 G=O+1:IF G<N THEN 310
650 PRINT "AFTER";N;"WORDS YOUR ";
660 PRINT "AVERAGE TIME IS";
670 PRINT (INT(10*S/N+.5))/10
680 POKE 525,0:PRINT "AGAIN (Y/N)?";
685 GETG$:IF G$="N" THEN END
690 IF G$="Y" THEN PRINT " ":GOTO 280
695 GOTO 685
700 PRINT " ":IF G$=W$ THEN 720
710 W=W+1:PRINT "WRONG !!!":GOTO 590
720 C=C+1:T=K/4:PRINT "CORRECT !!!";
730 PRINT "YOU GOT IT IN";T;"SECONDS";
740 GOTO 680
800 DATA ADULT, BATTLE, CASTLE, DENTIST
810 DATA EQUATE, FRIEND, GUITAR, HOUSE
820 DATA INSIDE, JAMBOREE, KIMONO, LEGAL
830 DATA MIGHT, NOBODY, ORACLE, PICTURE
840 DATA QUEST, RUBBER, STRENGTH, TORNADO
850 DATA URCHIN, VIVID, WITNESS, YEAST
860 DATA ZEALOT, ANAGRAM, BRIGHT, CHEESE
870 DATA DEPICT, ENDURE, FRIGHTEN, GHOST
880 DATA HUDDLE, ISLAND, JOUST, KITTEN
890 DATA LEATHER, MATADOR, NOISE, OBVIOUS
900 DATA PREVIEW, QUIETLY, RIBBON, STRAIN
910 DATA TERRIFY, UNUSUAL, VIOLENT, WHALE
920 DATA YOUTH, ZENITH, ATTIC, CUSTOM
930 DATA FEATHER, INTEREST, LICHEN, NURSE
940 DATA PASSIVE, RANCID, TREMBLE, WONDER
    
```

PET Obstacle Course

by I Platt

This game gets you to drive along a moving road littered with obstacles. Your success is dictated by the time elapsed before a collision.

10 REM
15 REM

PROGRAMS

```

20 REM *****
25 REM **
30 REM ** OBSTACLE COURSE **
35 REM ** IN PET BASIC--BY I.PLATT **
40 REM ** MARCH 1980 **
45 REM **
50 REM ** NOTE - OLD ROM PETS **
55 REM ** CHANGE PEEKS IN LINES **
60 REM ** 570,580,700,710 TO 515 **
65 REM ** AND ADJUST VALUES TO SUIT**
70 REM **
75 REM *****
110 REM
115 REM ***** INSTRUCTIONS *****
120 POKE59468,14
130 PRINT" "
140 PRINT " "
150 PRINT"DU ARE DRIVING A CAR ALONG AN"
160 PRINT"ENDLESS TRACK. THE TRACK IS FILLED WITH"
170 PRINT"OBSTACLES WHICH YOU HAVE TO TRY TO"
180 PRINT"AVOID. IF, HOWEVER, YOU HAPPEN TO CRASH"
190 PRINT"INTO SUCH AN OBSTACLE, THEN THAT, I'M"
200 PRINT"AFRAID, IS THE END OF THE GAME. YOU'RE"
210 PRINT"TIME WILL BE DISPLAYED AND SHOULD YOU"
220 PRINT"WISH TO PLAY AGAIN, YOU MAY, PROVIDED"
230 PRINT"WE THINK YOU HAVE DISPLAYED AN ADEQUATE"
240 PRINT"ABILITY"
250 PRINT"PRESS ANY KEY TO CONTINUE"
260 A$="" : GETA$ : IFA$="" THEN260
270 POKE59468,12 : PRINT" " CONTROLS"
280 PRINT " "
290 PRINT" " /4'----- LEFT"
300 PRINT" " /6'----- RIGHT"
310 PRINT" " HIT ANY KEY TO START"
320 GETA$ : IFA$="" THEN320
325 REM ***** PRINT UP INITIAL TRACK **
330 PRINT" "
340 FORI=1TO24:PRINT " "
350 DATA" "
360 DATA" "
370 DATA" "
380 DATA" "
390 DATA" "
400 DATA" "
410 DATA" "
420 DATA" "
430 FORI=1TO8:READA$(I):NEXTI
440 K=32828:TIME$="000000"
450 POKEK,251:POKEK+1,236
455 REM ***** PRINT LINE OF TRACK *****
460 M=9
480 N=INT(RND(1)*2)*4-2
490 FORO=1TO2
500 M=M+N:IFM>20ORM<1THENM=M-N
510 I=INT(RND(1)*8)+1
520 FORJ=1TO2
530 PRINTTAB(M)A$(I)
540 IFPEEK(K+40)=102ORPEEK(K+41)=102THENK=K+40:GOTO650
550 IFPEEK(K)=127ORPEEK(K+1)=127THENK=K+40:GOTO650
560 POKEK,251:POKEK+1,236
565 REM ***** ACCEPT CONTROL *****
570 IFPEEK(151)=41THEND=1:GOTO600
580 IFPEEK(151)=42THEND=-1:GOTO600
590 NEXTJ:NEXTO:GOTO480
595 REM ***** MOVE CAR *****
600 IFPEEK(K+D)=102ORPEEK(K-40+D)=102THENK=K+D:GOTO650
610 IFPEEK(K+1+D)=102ORPEEK(K-39+D)=102THENK=K-D:GOTO650
620 IFPEEK(K+D)=127ORPEEK(K+1+D)=127THENK=K-D
630 POKEK,32:POKEK+1,32:POKEK-40,32:POKEK-39,32:
K=K+D:POKEK,251:POKEK+1,236
640 POKEK-40,251:POKEK-39,236:NEXTJ:NEXTO:GOTO480
645 REM ***** PRINT OUT *****
650 POKEK-40,251:POKEK-39,236:FORX=1TO500:NEXTX
660 PRINT:PRINT" "
670 PRINT"TIME$:PRINTMID$(TIME$,3,2):" MINS":
";RIGHT$(TIME$,2):" SECONDS
680 PRINT"HIT ANY KEY FOR ANOTHER GO SPACE BAR TOFINISH"
690 FORX=1TO10:GETA$:NEXTX
700 IFPEEK(151)=255THEN700
710 IFPEEK(151)=6THEN730
720 GETA$:RESTORE:GOTO270
730 FORX=1TO10:GETA$:NEXTX:PRINT"DOHAVE A NICE DAY":END

```

MICROMART

Bring new life to your NASCOM

We offer a new 3K monitor, NASMON, for both NASCOM 1 and NASCOM 2 systems which gives you more power and flexibility than ever before:

- text editor built in.
- 'front panel' display of registers, flags etc. this *must* be seen.
- blocked, buffered tape routines.
- powerful low-level 'search' and single step commands.
- a total of 34 commands available through the keyboard.

PASCAL IN UNDER 6 K.

NASPAS runs under NASMON or NAS-SYS and offers:

- all major PASCAL statements.
- INTEGER, CHAR, BOOLEAN and Enumerated TYPES.
- fully recursive Procedures and Functions with value parameters.
- many pre-defined functions e.g. SUCC, PRED, (D)PEEK, (D)POKE etc.

AT LAST, A 12K BASIC

Running under NASMON, this extended BASIC gives you all the features of an 8K BASIC plus:

- 11 significant figure arithmetic.
- IF ... THEN ... ELSE.
- PRINT USING.
- Multi-line, recursive functions calls (using DEF).
- line or screen editing.
- excellent printer support.
- Renumber and Automatic line numbering.
- and ... more!

PRICES

NASMON	(in 3 EPROMS)	£25
BAS12K	(on tape)	£25
NASPAS	(on tape under NASMON)	£25
NASPAS	(on tape under NASSYS)	£30

BUY NASMON NOW and get a FREE Chess program - NASCHK.

New 3 K Assembler £25 on tape
£25 in EPROM.

HISOFT 60 Hallam Moor,
LIDEN, SWINDON, Wiltshire.

SCHOOL LEAVER

A vacancy exists for a school leaver with an interest in microcomputers. For temporary work. Would suit someone going up to University in October 1981.

Please apply in writing to:
Imprint Editions, 16 Milton Avenue
London N6

DEMONSTRATION EQUIPMENT FOR SALE AT BARGAIN PRICES

Apple, Sharp, Heath. Send for price list.

DELTA SYSTEMS LTD.,
32 Finch Road, Douglas, Isle of Man.

MICROMART

BUG-BYTE SOFTWARE

MAIL ORDER ONLY
ALL PRICES INCLUSIVE.

ZX80

WIDE RANGE OF LOW COST ZX80 SOFTWARE ON C12 CASSETTE. ONLY £3 PER CASSETTE.

- ZX80 PROGRAMMING COURSE-book&cassette of progs.£7.50
- No1) Moon-landing; Reaction test; Codebreaker; Hangman; Intercept.
- No2) Bio-rhythms; Solitaire; Battleships; Dice.
- No4) Sine&cosine; Simultaneous equns; Averages; Simple differentiation; Area of a circle.
- No5) Guess & gamble; Number-sort; Treasure hunt; Fruit machine.

MANY MORE AVAILABLE - SEND TWO 12p STAMPS FOR FULL CATALOGUE

ATOM

SOFTWARE ON C12 CASSETTE:- ATOM BREAKOUT(4K) ONLY £4

CASSETTE OF 4 2K PROGRAMS-£5 PINBALL(6K)-£6

The following 4K programs are £3 each:- HORSE-RACE; PONTOON; ALIEN DESTROY; MINEFIELD; BATTLESHPIS; BIO-RHYTHMS.

COMING SOON: ATOM INVADERS available from mid-December-uses graphics mode 4 ORDER NOW @ £12.00

NASCOM2

SOFTWARE ON C12 CASSETTE

NASCOM BREAKOUT; TENNIS; FOOTBALL; SQUASH all M/C using Nas-sys & graphics £3 each. FRUIT MACHINE £4

BUG-BYTE: 251, HENLEY ROAD, COVENTRY CV2 1BX.

SHARP MZ-80K software

SUPERB CASSETTE BASED PROGRAMS INCLUDING

- £5 **MANIAC** - Nerve-racking real-time game. Drive like a maniac! Run over stray animals! Try not to crash. Compulsive and exhausting!! 9 skills, 9 speeds. Highest speeds terrifying!
- £5 **MOONLANDER** - Real-time lunar lander. 5 skill levels. Superlative graphics/sound.
- £4 **COMPOSER** - Play tunes via the keyboard. See the notes you play. Replay your compositions. Print music strings for future use.
- £4 **BANK ACCOUNT** - Input your regular income/outgoings. See your cash flow over the next year in monthly statements.
- £4 **FOX AND GEESE** - Superb graphics. Outwit the computer's fox with your geese - but watch out - he's very Sharp!!
- £5 **DUST COVERS** - Tailored specially for the MZ-80K. A must for every Sharp user.

* Complex program (requires minimum 10K available RAM)
Cash with order. All prices include P&P. Catalogues available.

HIGHLIGHT SOFTWARE

76 St. Cyrus Road, Colchester CO4 4LR
Telephone (0206) 64437

OLD ROM SUPERPETS

Add the PETMASTER SUPERCHIP to your old Rom 8k Pet and you will have many of the advanced features of the new 8032 Superpet! Auto-repeat, screen manipulation, plus lots more for only £45. If have Toolkit fitted then you can plug the Superchip into the spare socket - otherwise you'll need to buy an extension board (£13). Or else why not consider the

TOOLKIT PACKAGE

Buy the Superchip and Toolkit for just £75 including extension board - you could have paid £75 for the Toolkit alone until very recently!

Our catalogue of PET programs and supplies has programs for all models, including the latest 8032 and 4032 - and it's absolutely free to PET owners.

Add 15% VAT to all prices. Post free.

SUPERSOFT

28 Burwood Avenue,
Eastcote, Pinner, Middlesex

Telephone: 01-866 3326



LEISURE LINES

We had a very good response to Puzzle 14 - over 200 entries, in fact. Many offered five possible solutions corresponding to the ways in which the £2 could be exactly spent on the stated denominations of stamps.

But the real test was to use the information given in a logical way so as to eliminate all but the correct solution, which was:

- 4 x 12p stamps
- 6 x 14p stamps and
- 4 x 17p stamps.

One of our correspondents said the problem was impossible since 14p stamps don't exist! Well, I hope he has been watching the papers lately and noticed the new postal charges coming soon - don't say that PCW didn't give you The Warning!

Anyway, the randomly-chosen winner was Mr Peter Cowley of Wrexham. Congratulations, Mr Cowley - a book token will be on its way to you just as soon as we can wake up the Editor.

Quickie

Here's a simple multiplication problem in which each letter represents a different digit:

$$\begin{array}{r} \text{IF X} \\ \text{AT} \\ \hline \text{FIAT} \end{array}$$

As usual, no answers required, so no prizes.

Prize puzzle

Here's an old problem which should set a few micros and calculators whirring. Every four years in the village of Poorihana in Burma, the rice-piling ceremony takes place at the appointed hour on the given feast day.

When the ceremony begins, one grain of rice is placed in a chosen spot outside the witch-doctor's hut. Exactly one hour later, two grains are added; after a further hour, three more grains are added and so on - every hour, one more grain is added to the pile than was added at the previous hour.

The ceremony continues non-stop until there are exactly enough grains to give each of the 23 poorest villagers a meal consisting of a quantity of rice grains that is a perfect square - each villager receives exactly the same.

Assuming that the ceremony ends before the next one begins, what is the number of rice grains that each of the 23 villagers receives?

Answers on a postcard, please, to Puzzle No 17, PCW, 14 Rathbone Place, London W1P 1DE, to arrive no later than 31 January.

Submitting programs to PCW

Our programs section thrives on contributions from you, the readers. In particular we're looking for original ideas (no more Nim, decimal-hex conversions, Masterminds, digital clocks, etc please!) and we're not just interested in games - if you've a handy business/scientific/educational program then we'd be interested to hear from you.

Once you've written and thoroughly debugged your program, send it to us on cassette or disk with, if possible, a

clear printout made with a new ribbon on plain (not lined) paper. Write a covering letter stating briefly what the program is, *exactly* which machine it's for (ie old/new ROM PET, or TRS-80 Level I or II) and how much memory it requires. On a separate sheet list any special instructions which aren't included in the program and write your name and address on each piece of paper you send us as well as on the cassette/disk. If you'd like your cassette/disk returned then enclose a suitable SAE.

Send your programs to: PCW Programs, Personal Computer World, 14 Rathbone Place, London W1P 1DE.

NEED A SUBSCRIPTION?

See card insert inside front and back covers.



"HURRY - THERE'S A NEWSAGENT IN ABERDEEN THAT STILL HAS ONE COPY LEFT OF THE LATEST ISSUE OF PCW!"

WEST MIDLANDS

**If you want a computer
for business use
consult the experts!**

PAYROLL
STOCK CONTROL
PURCHASE/SALES
STOCK/INVOICING
INSURANCE BROKERS
VISICALC
WORD PROCESSING
MAILING LIST
etc.



 **apple II** SALES AND LEASING

LEASE AN APPLE II 48K SYSTEM INCL.
TWIN DISK DRIVES, MONITOR AND PRINTER
From £11.50 per week!

MICRO BUSINESS CENTRE LTD.

Castle Bridge House, Lichfield Road
Wednesfield, Wolverhampton
Tel: 0902 725687 for Sales and Service

Master Your Micro FAST with...

Little Genius floppy diskette based courses will teach you, how to use your system and how to realise the full potential of the "Mighty Micro". These fully interactive computer lessons will guide you quickly to a high level of understanding and confidence in your ability to make the most of your microcomputer system.

Courses now available:

- Applesoft BASIC
- Advanced
- Applesoft BASIC
- Using your Apple
- Palsoft BASIC
- Advanced Palsoft BASIC
- Using your 2020
- PET BASIC
- Advanced PET BASIC



Little Genius

Each course, comprising a floppy diskette, and starting instructions, costs only £40.00 plus VAT.

SPECIAL "3 in one" OFFER for 3 courses covering the same system only £99.00 plus VAT.

Little Genius courses are available from most computer retail outlets, or direct mail order form:

LITTLE GENIUS

Suite 504, Albany House, 324 Regent Street, London W1R 5AA.
Telephone: 01-580 6361

HIRE

TAKE HOME A MICROCOMPUTER OVER XMAS

HIRE FROM	BARGAIN Inc. VAT	NEW Ex. VAT
£20 ... PET	£340	
£28 ... EURO & APPLE II 32K		£610
£25 ... TRS80	£280	
... ITT2020 48K	£600	
£18 ... SOCCERER 32K	£400	
£68 ... SUPERBRAIN 64K		£1450
£60 ... HORIZON 56K	£900	

SALES or LEASE or EXCHANGE

APPLE II Guaranteed EUROPLUS.

Price 32K £610 + V.A.T. Lots of exciting software, all types of cards: Asteroids in space, Zork Adventure, Rainbow software, hire text graphics space invaders. Z80 Card/CPM/COBOL, PASCAL, FORTRAL, ALL NEW

SUPERBRAIN 64K £1450 + VAT
HIGH LEVEL LANGUAGES
AVAILABLE

PROMGLOW Ltd

01-368 9002 + EVENING
12 DENE ROAD
LONDON, N.11.

New, low prices on memories!!!

Compare our prices before you buy elsewhere! All devices are brand new, factory prime, full spec. and fully guaranteed!

MEMORIES			
	1+	50+	100+
2114 L 450NS	225p	200p	175p
2114 L 300 NS	250p	225p	195p
4116 150 NS	375p	350p	325p
4116 200 NS Ceramic	250p	225p	195p
6514 (TC 5514P) 1k x 4			
CMOS RAM 450 NS	550p	525p	495p

EPROMS			
2708 450 NS	395p	375p	350p
2716 Single 5V 450 NS	595p	550p	495p
2532 Single 5V 450 NS	1995p	1695p	1495p

LINEARS			
ICL 7106 CPL	575p	525p	475p
LCD 106 3 1/2 -digit			
LCD Display	575p	525p	475p
NE 555P	18p	17p	16p
723	33p	30p	28p

All prices exclude p&p and VAT. Please refer to 'Ordering Information' before ordering.

DON'T DELAY - BUY TODAY - SUCH LOW PRICES DON'T LAST FOR EVER!!!

NEW 6809 S-100 SINGLE-BOARD COMPUTER

- * Meets IEEE S-100 Standard!
- * Uses Motorola's Powerful MC6809 CPU!
- * 4K, 8K, 16K ROM!
- * 2K RAM!
- * ACIA, PIA, 8080 Simulated I/O!
- * RS - 232 Handshake!
- * Selectable BAUD Rates!
- * Manual includes: 11" x 7" Schematic, Parts List, User Notes, Software Listings and MORE!

Bareboard only, £49! (plus £1 p&p)
CPU (6809) £24.50!
ADSMON; Monitor (2716) £25!

COMPLETE BOARD ASSEMBLED AND TESTED, £250!
(plus £2 p&p)

NEW ASTEROIDS IN SPACE!!!

EXCITING, ENTERTAINING SOFTWARE FOR THE APPLE II and APPLE II PLUS!!

If you liked 'Invaders' you'll love ASTEROIDS IN SPACE by Bruce Wallace! Your spaceship is travelling in the middle of a shower of asteroids. Blast the asteroids with lasers, but beware - BIG ASTEROIDS FRAGMENT INTO SMALL ASTEROIDS! The Apple game paddles allow you to rotate your spaceship, fire its laser gun, and give it thrust to propel it through endless space. From time to time, too, you'll encounter an alien spaceship whose mission is to DESTROY YOU so you'd better destroy it first! High resolution graphics and sound effects add to the arcade-like excitement this program generates. RUNS ON ANY APPLE II WITH AT LEAST 32K AND ONE DISK DRIVE!

ON DISKETTE ONLY **£14.95**

NEW! SUPER MUSIC MACHINE KIT!

AT LAST - an affordable kit that can be PROGRAMMED TO PLAY ANY SONG OR GROUP OF SONGS! Instead of a nightmare of numerous ICs and special expensive Bipolar ROMs, the SUPER MUSIC MACHINE uses a SPECIAL MASK PROGRAMMED COMPUTER CHIP, one CMOS gate and the most popular erasable EPROM, the 2708/2716 series. BASIC KIT includes drilled, plated and screened PC board and ALL components except the EPROM and 12V transformer. The basic kit will play short renditions of 25 tunes through its 7 WATT AMPLIFIER SECTION. Add an optional ROM and any tune programmed will be played. If you have the equipment to program 2708 EPROMs, we supply full information on programming your own music!

FEATURES:

- * Basic kit contains 25 short tunes in the main IC!
- * Will address external ROM for up to 1,000 MORE NOTES per ROM! (ROM is not included)
- * Operates on 12V AC or 12V DC @ 500mA. (Using unit on 12V DC and with optional ROM requires 9V bias battery, not included).
- * 7 watts of audio power will drive 8 or 16 ohm speakers or horn speakers (not included).
- * DIP switches not included.
- * 'NEXT TUNE' provision steps sequentially through all tunes.
- * Tune address can be wire jumper selected or board is designed to take DIP switches.
- * PITCH, VOLUME and TEMPO are all adjustable.
- * SPECIAL 'CHIME' SEQUENCES can be activated regardless of tune address to provide for multiple doorbell applications.
- * All tunes consist of electronic musical notes played one at a time. There are no chords or harmony sound to the music.
- * STEP-BY-STEP ASSEMBLY INSTRUCTIONS provided.
- * Large number of PREPROGRAMMED ROMS with popular and classical tunes readily available. Send SAE for list and prices.

ONLY £16.95 for basic kit (plus p&p 80p)

MICROCHIPS AT MICRO PRICES!

INTERFACE	SUPPORT DEVICES	BIPOLAR RAMS
LINEAR	6520	27LS00
MC1488	495p	93419DC
MC1489	6522	995p
DM8123	6532	1125p
75150	6551	
75154	6810	
75182	6820	
75322	6821	
75324	6845	
75325	6852	
75361	8212	
75365	8214	
75491 2	8216	
8T26	8224	
8T28	8228	
8T95	8251	
8T97	8253	
	8255	
	8257	
	8259	
DISPLAYS	MC 144 12VL	797p
FND500	Z80 P10	595p
FND510	Z80 CTC	595p
FND567	Z80A P10	695p
DL704	Z80A CTC	695p
DL707	Z80 DMA	1995p
MV57164	Z80A DMA	2495p
	Z80 S10 1	2995p
	Z80 S10 0	3495p
	Z80 S10 1	2995p
	Z80 S10 1	3495p
	Z80 S10 2	2995p
	Z80 S10 2	3495p
CPU'S		
6502	695p	
6504	750p	
6505	750p	
6800	645p	
6802	925p	
6809	2450p	
8080A	425p	
8085A	1095p	
Z80	700p	
Z80A	900p	
Z8001	12500p	
X8002	9500p	
KEYBOARD ENCODER		
AY 5 2376	795p	
EPROMS		
1702A	450p	
2708 450 NS	425p	
2716 5V 450 NS	995p	
2532 32K 450 NS	2995p	
4315 (4k x 1) CMOS	2564 64K (8K x 8)	£120
RAM 450 NS	450NS 28-pin	
6514 (1k x 4) CMOS		
RAM 450 NS	CHARACTER GENERATOR	
	RO-3 2513 UC	450p
UARTS		
AY 5 1013A	325p	
AY 3 1015D	398p	
IM6402 IPL	425p	
BIPOLAR PROMS		
All are identical and equivalent types - we reserve the right to substitute any make.		
256 bit (32 x 8) 16-pin tri-state		
MB7051/27S09/7603/5600/6331/74S288/82S123		395p
256 bit (32 x 8) 16-pin open collector		
MB7056/27S08/7602/5600/6330/74S188/82S23		395p
1K (256 x 4) 16-pin tri-state		
MB7052/74S287/TBP14S10/93427/82S129/7611/6301		395p
1K (256 x 4) 16-pin open collector		
MB7057/74S387/TBP14SA10/93417/82S126/7610/6300		395p
2K (512 x 4) 16-pin tri-state		
MB7053/93446/82S131/7621/6306		495p
2K (512 x 4) 16-pin open collector		
MB7058/93436/82S10/7620/6305		495p
4K (1024 x 4) 18-pin tri-state		
MB7122/74S476/93453/82S137/7643/6353/27S33/3625/5626		995p
DEVELOPMENT MODULE		
Z8000 DM	1099p	

THE NEW GI COMPUTER SOUND CHIP

The amazing AY-3-8910 is a fantastically powerful sound and music generator, perfect for use with any 8-bit micro processor. Contains 3 tone channels, noise generator, 3 channels of amplitude controls, 16-bit envelope period control, 2 parallel I/O, 3D/A converters plus much more. All in 40 pin DIP. Super easy to interface to the S-100 or other Busses. ONLY £8.50 + VAT, including FREE reprint of BYTE '79 article! Also, add £2.25 for 60 page data manual. Perhaps the next famous composer will not direct a 150 piece orchestra but, rather, a trio of micro computers controlling a bank of AY-3-8910s. BYTE July '79

NEW! SPECIAL OFFER!

4K CMOS RAM (1K x 4) 450 NS
ONLY £5.50
The TIC 5514P from Toshiba. CMOS equivalent of the 2114!
* Lower Power Dissipation
10pW /BIT (TYP.) at 3.0V (STANDBY)
10uW /BIT (TYP.) at 5.0V (OPERATING)
* Data Retention Voltage 2V to 5.5V
* Single 5V Power Supply
* 18 PIN Plastic Package
* Full Static Operation
* Three State Output
* Input Output TTL Compatible
* Fast Access Time 450NS.

Toshiba's TC5514P (industry type 6514) is a full static read write memory organised as 1024 words by 4 bits using CMOS technology. Ultra low power dissipation means it can be used as battery-operated portable memory system and also as a non-volatile memory with battery back-up. Operates from a single 5V power supply with static operation, hence no refresh periods and a much simplified power supply circuit design. Three state outputs simplify memory expansion for minimum data retention voltage is 2V, the battery back-up system needs only simple circuit. Toshiba's original C2MOS technology also means wide operating and noise margins. The TC 5514P is moulded in a dual-in-line 18 pin plastic package 0.3 inch in width.

Ordering information. Unless otherwise stated, for orders under £50 add 50p p&p. Add 15% VAT to total (no VAT on books). All devices are brand new, factory prime and full spec. and subject to prior sales and availability. Prices subject to change without notice. Minimum telephone order using ACCESS is £10. If ordering by post with ACCESS, include name, address and card no. written clearly. Please allow 4/6 weeks delivery on books.

MICRO BYTE

Dept. PC5
Unit 9/10, 1st Floor, E Block,
38 Mount Pleasant,
London WC1X 0AP.
Tel: 01-278 7369
Telex: 895 3084

SAMS BOOKS AT LOWEST PRICES

COMPUTER BOOKS

Microcomputer Primer (2nd Edition)	NEW £7.17
Microcomputers for Business Applications	£5.37
The Howard W. Sams Crash Course in Microcomputers	NEW £10.50
Fundamentals of Digital Computers (2nd Edition)	£5.97
Getting Acquainted with Microcomputers	£5.37
How to Buy & Use Minicomputers & Microcomputers	£5.97
Computer Graphics Primer	NEW £7.77
TEA - An 8080 8085 Co-Resident Editor Assembler	NEW £5.37
6502 Software Design (Book 1)	£5.70
(Book 2)	£5.97
BASIC Programming Primer	£5.37
DEBUG - An 8080 Interpretive Debugger	£3.75
How to Program Microcomputers	£5.37
Computer Dictionary (3rd Edition)	NEW £7.17
Boolean Algebra for Computer Logic	£3.95
Computers & Programming Guide to Scientists & Engineers (3rd Edition)	NEW £9.57
Microcomputer Interfacing with the 8255 PPI Chip	£5.37
Programming & Interfacing the 6502, with Experiments	NEW £7.17
TRS 80 Interfacing	NEW £5.37
Z 80 Microcomputer Design Projects	NEW £7.77
Z 80 Microprocessor Programming & Interfacing Books 1 and 2	
(Book 1)	£6.97
(Book 2)	£7.77
Interfacing and Scientific Data Communications Experiments	£3.95
Introductory Experiments in Digital Electronics and 8080A	
Microcomputer Programming and Interfacing	
(Book 1)	£7.77
(Book 2)	£7.77
Microcomputer Analog Converter Software and Hardware	
Interfacing	£5.70
The 8080A Bugbook - Microcomputer Interfacing and Programming	£6.30
The S 100 and Other Micro Buses	£3.95
The Cheap Video Cookbook	£3.75
TV Typewriter Cookbook	£5.97
Using the 6800 Microprocessor	£4.77
Z 80 Microcomputer Handbook	£5.37
8085 Microcomputer Design	NEW £5.97
COOKBOOKS	
TTL Cookbook	£5.70
Active Filter Cookbook	£8.97
TV Typewriter Cookbook	£5.97
CMOS Cookbook	£6.97
The Cheap Video Cookbook	£3.75
IC Converter Cookbook	£8.37
IC Op-Amp Cookbook (2nd Edition)	£8.97

INTERFACE YOUR PET TO THE OUTSIDE WORLD

WITH OUR
**MULTI-PURPOSE IEEE/488 BUS, TALKER/LISTENER
 BOARD 32 I/P:32 O/P PLUS RS 232**

Applications include:-

EDUCATION/EXPERIMENT – allows Pet basic to drive L.E.D.s, switches, relays, etc.

A.T.E. (Automatic Test Equipment) – allows interface to equipment such as D.V.M.s, timers, counters, printers, etc.

Double height Eurocard (9" x 6") micro-computer board: requires 5V (1A) supply – (± 12V - RS 232 only)

BOARD PRICE: £149.50 : P.S.U./Pet harness available.

For info. contact F. Holmes **M/H/G** Leeds 589495 Ext. 294

TRIDATA COMPLETE BUSINESS SOFTWARE PACKAGES

- | | |
|-------------------|-----------------------|
| * SALES INVOICING | for use on |
| * SALES LEDGER | * TANDY TRS 80 |
| * PURCHASE LEDGER | * TANDY TRS 80 Mk. II |
| * NOMINAL LEDGER | * SHARP MZ-80K |
| * PAYROLL | * PET AND SUPERPET |
| * STOCK CONTROL | * APPLE |

Our business packages are supplied with master diskettes, detailed operating manuals and training procedures. For small businesses and traders with up to 700 employees, 9,999 customers and 9,999 suppliers, our proven programs written by experienced DP professionals provide fast, simple control, with built in security routines for prevention of unauthorised use, abuse or mishandling. Over 550 Tridata business systems are now in use.

TRIDATA WARRANTY

Every Tridata program has a written 12 month warranty and can be automatically updated to conform to any legislation that may alter your accounting procedures.

**SEND THE COUPON TODAY
 OR TELEPHONE
 021-622 6085**

Tridata

TRIDATA MICROS LTD., Smithfield House, Digbeth, Birmingham

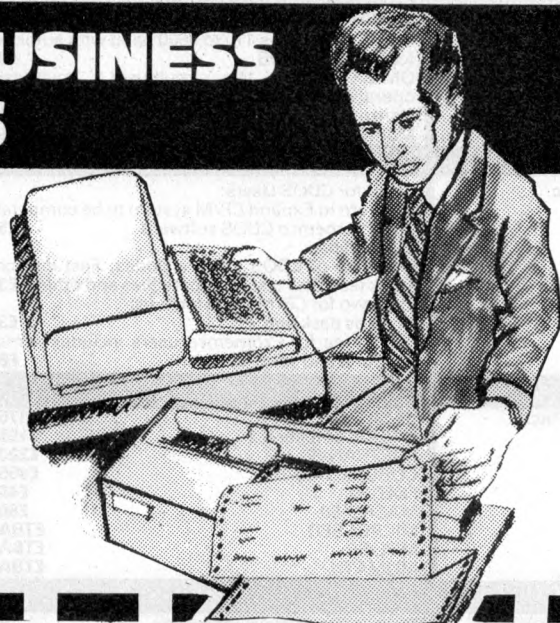

Send me details of the Tridata Business Software Systems. I am interested in

PURCHASE LEDGER	For TANDY TRS 80
SALES LEDGER	TANDY TRS 80 Mk. II
PAYROLL	SHARP MZ-80K
NOMINAL LEDGER	PET
SALES INVOICING	SUPERPET
STOCK CONTROL	APPLE

Name _____
 Company _____
 Address _____

TRIDATA MICROS LTD., Smithfield House, Digbeth, Birmingham B5 6BS

SOFTWARE

Software & Manual/Manual Only

Byrom Software	BSTAM—Utility to link one microcomputer to another also using BSTAM £70/5
Computer Plus	FMS 80 (File Management System) Demo Pack (includes manual and disc) Complete System £35 £395/25
Computer Services	Bidirectional driver for Diablo Hytype printers for use on CPM & CDOS systems £65/10
CP/M User Library	42 Volumes on 8" disc £4 42 Volumes on 5" disc £8

Creative Computing	For CP/M CS-9001 BASIC Games 1 £12 CS-9002 BASIC Games 2 £12 CS-9000 BASIC Games 1 and 2 £22 CS-9003 ADVENTURE I.O. £12 CS-9004 BILINGUAL Original Adventure £12 CS-9005 BASIC Games 3 £12 CS-9006 BASIC Games 4 £12 CS-9007 BASIC Games 3 and 4 £22 CS-9008 BASIC Games 1, 2, 3 and 4 £40
---------------------------	---

Digital Research	(Most formats now available) MPM 1.1 £175/18 CP/M 1.4 £65/18 CP/M 2.2 £90/18 SID £45/12 ZSID £55/12 MAC £55/12 TEX £45/12 DESPOOL £30/5 PL/1 £POA/25
-------------------------	---

Information Unlimited	WHATSIT (Database Management System) on North Star £59 on CP/M £75 on APPLE 2:48k (requires int Basic) £72 On APPLE 2:32k (requires int Basic) £59 on ITT 2020 (see Apple)
------------------------------	--

KLH Systems	Spooler for CPM systems £65/5
--------------------	-------------------------------

L.P. Enterprises	Diablo driver runs 110 to 9600 baud with autoloader for CP/M or CDOS £30/5 OMNIX—UNIX like multiuser, multitasking operating system for Z80 i.e. IMS, Cromemco, Horizon £250/30 Multiforth £65/20
-------------------------	---

MICAH Inc.	CP/M for CDOS Users: Program to Expand CP/M system to be compatible with Cromemco CDOS software £59/5 Disc Utilities: Pack one of CDOS users includes: Fast disc copy, Track test, Disc test, Compare files and others £30/5 Pack two for CP/M users includes same as pack one £30/5 Pack three for Cromemco users includes same as pack one and spool and print £65/5
-------------------	---

Microsoft Inc.	BASIC-80 £175/17 BASIC Compiler 5.2 £195/17 FORTRAN-80 £220/17 COBOL-80 4.0 £355/17 EDIT-80 £45/11 MACRO-80 £80/11 MICROSEED £TBA/20 MULISP £TBA/20 MUMATH £TBA/20
-----------------------	--

Michael Shroyer Inc.	Electric Pencil Word Processor £100 SSII for tty etc £100 DSII for Diablo £105 TRS-80 Cassette/disc £50
-----------------------------	--

Microfocus Ltd.	CIS COBOL version 4.2 £425/25 FORMS 2 £100/10
------------------------	--

Micropro Inc.	WORD-MASTER 1.7 £70/20 TEX-WRITER 2.6 £35/15 WORD-STAR 2.1 £240/25 SUPER-SORT: Version 1 £120/20 Version 2 £100/20 Version 3 £75/20 WORD-STAR with MAIL-MERGE 2.1 £310/35 MAIL-MERGE 2.1 £70/10 DATASTAR 1.07 £165/20
----------------------	---

MT Microsystems	Pascal MT £125/12
------------------------	-------------------

Northshare	Multi-user system for Horizon Users 5.1 £40/5
-------------------	---

Software & Manual/Manual Only

Osborne & Associates	Accounts Payable & Accounts Receivable (disc only) £50 General Ledger (disc only) £50 Payroll with Cost Accounting (disc only) £50
---------------------------------	--

Compiler Systems	CBASIC v2.06 £65/15
-------------------------	---------------------

Structured Systems all Converted to UK Standard	Sales Ledger £275/15 Purchase Ledger £275/15 Nominal Ledger £325/15 Stock Control £275/15 Letterright £95/10 Analyst (File management Reporting System) £115/10 NAD (Name and Address selection system) £50/10 OSORT £50/10
--	--

TDL Software (Technical Design Labs)	Business Basic £80 ZTEL (Text Editing Lang.) £35 MACRO II (Z80 Macro Assembler) £35 LINKER £35 DEBUG II (for 8080/Z80) £45
---	--

Tiny-C Associates	Tiny-C language for 8080, 8085, Z80 systems £50/35
--------------------------	--

Supersoft Inc.	DIAGNOSTICS 1 £35/5 TERM £65/5
-----------------------	-----------------------------------

Software Works	Northstar Format only Inventory-1 (Stock Control) £50/10 Inventory-2 with order entry, invoicing £130/15 Mailroom £50/15 Housekeeper (Utilities, sorts) £35/10 Preventative Maintenance £75/15 Housekeeper-2 (Coming Soon) £TBA
-----------------------	---

ORDER INFORMATION

Software prices reflect distribution on 8" single density discs. If a format is requested which requires additional discs a surcharge of £4 per additional disc will be added.

Please add VAT and £2.50 for first class postage, packing and insurance.

If required, DATAPOST D service is available for an extra charge of £7.50.

All software on this Advertisement is available from stock and a 24-hour return service is thereby offered on all prepaid orders. When ordering CP/M software please specify the format you require otherwise software will be dispatched on an 8" single density disc.

For more information on any of these items, please phone, write or visit. (We are open during office hours).

OEM terms available

MAIL ORDER TELEPHONE ORDER VISIT

Send Cash, Cheque, Credit Card No., Postal Order, IMO to L.P. Enterprises, Room PCW, 8 Cambridge House, Cambridge Road, Barking, Essex IG11 8NT.

All Payment must be in sterling and drawn against a UK bank. Subscriptions are processed to start with the next current issue, after the date of order.

These details are all current as of August 1980.

Prices are subject to change without notice, due to fluctuation in the dollar rate.

Trade Enquiries welcome. Bulk Purchasers welcome.

ComServe

COMPUTER SHOP PRESENTS

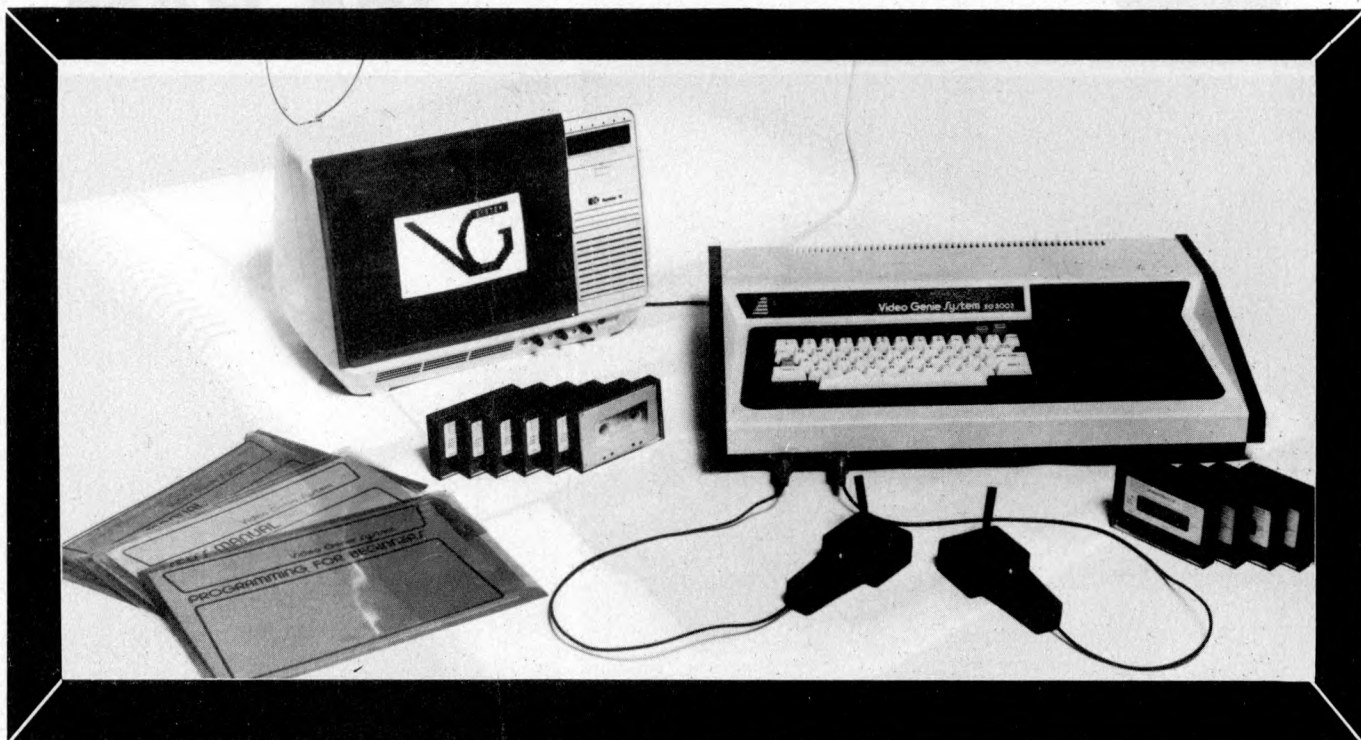

THE ELEGANT, EXPANDABLE

video genie system

£364 inc VAT. Postage. Requires T.V. or monitor – £70 if bought with Genie

Comprises standard 16K computer. 3 manuals. Demonstration tape. Lead for additional cassette player. Lead for monitor.

- FREE** Standard cover. Head cleaning/demagnetising tape.
- FREE** Programs: Games. Utilities. Subroutines.
- FREE** Standard soundkit if wanted
- FREE** Comserve joysticks if wanted
- FREE** Coloured plastic folders for manuals or screen overlays.

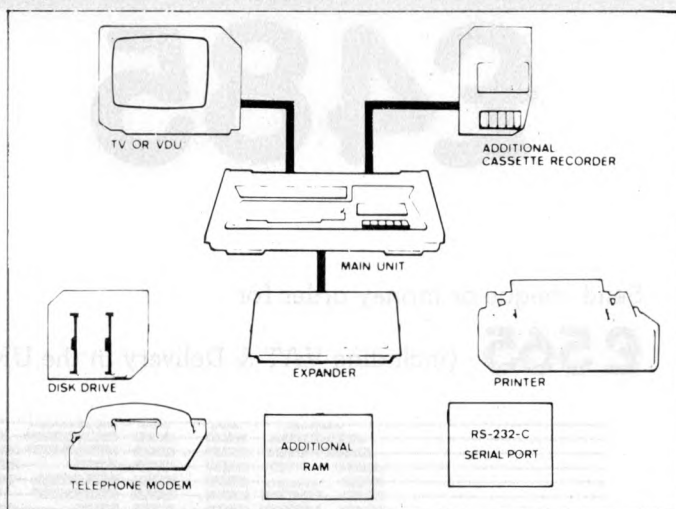

CWO to

ComServe

98 TAVISTOCK STREET,
BEDFORD, BEDFORDSHIRE
TELEPHONE (0234) 216749

We supply various printers.

We will supply S100 expansion box, colour boards, disk drive, fast tape drives, RS232 interfaces as available.

We supply some '80, Genie and CP/M programs at 20% discount. We buy some secondhand programs (in manufacturers' original pack and with original documentation only)

S.A.E. for further information. Items and prices are as at time of going to press and are subject to alteration.

apple®][PLUS 16K RAM

© Apple is a trade mark of Apple Computer Inc., Cupertino, CA. USA.



£485

Send cheque or money order for

£565 (including VAT & Delivery in the UK) to:

Trade Enquiries
Welcome

GUESTAL LIMITED

Refuge House, 2-4 Henry Street, Bath, BA1 1JT.

Telephone: 0225-65379

Please allow 28 days for delivery

Price-bombing is fun...

...especially if you're the buyer!

We've bombed the prices of peripherals again...about £120 off the price of a popular terminal and printer, and a really low price on a brand-new heavy-duty printer for the commercial market.



TVI 912C/920C terminal

- ◁ A fully intelligent terminal at an intelligent price. A very complete specification includes 24×80 display with dual intensity, blinking, reversed, underline and protected fields; 96 ASCII upper and lower case character set; separate numeric keypad; auto-repeat on all keys; full tabbing facilities and addressable cursor for forms work; single key edit-functions (on 920C version only); serial printer port.

Runs in full- or half-duplex from 75 to 9600 baud.

TVI 920C (as shown here) £550

TVI 912C £475

Anacom 150 printer

A fast and practical printer for commercial use — printing up to four copies as well as the original. 150 characters per second, bidirectional printing, full upper and lower case character set with true descenders on a 9×9 matrix, and programmable double-width characters. Adjustable tractor feed, for up to 15" wide paper; 6 or 8 lines per inch, 10 columns per inch character spacing. Programmable top-of-form and skip controls, 11" standard form length. Parallel or serial (RS232) interfaces.

Anacom 150 £699



now only **£349**

Microline 80 matrix printer

- ◁ Lightweight but heavy-duty, the now well-known Microline at our unbeatable price of **£349**. Full upper and lower case ASCII character set, plus 64 pixel-type graphics characters. Standard, double-width and condensed character sizes; six- and eight-lines-per-inch line-spacing. 80 characters per second print speed. New-style print head is lighter, quieter and more reliable than conventional counterparts. Pin-feed and friction feed for up to 9" paper as standard; adjustable tractor feed option. Roll-holder for paper roll as standard. Parallel interface as standard; serial interface (RS232 or 20ma) option.

London and South East:
Northamber Ltd
Great Oak House
Esher, Surrey.
Tel: 0372 62071

Midlands and South West:
Mutek
Quarry Hill
Box, Wilts.
Tel: Bath (0225) 743289

All prices quoted exclude VAT.



COMPUTER WAREHOUSE

NOW OPEN
MONDAY-SATURDAY
9.30-5.30

In stock now test equipment, microprocessors, teletypes, transformers, power supplies, scopes, sig. gen's, motors, peripheral equipment, I.C.'s, tools, components, variacs, keyboards, transistors, microswitches, V.D.U.'s sub-assemblies + thousands of other stock lines. Just a mere fraction of our vast range, is displayed below: 100's of bargains for callers.

2716 EPROM 5v Rail . . . £10.25
2716 EPROM 3 Rail £8.50
2708 EPROM £4.95

4116 16k x 1 200ns . . . 8 for £27.50
2114L-31k x 4 300ns . . . 8 for £22.50
2102L-31k x 1 650ns . . . 8 for £5.50

TELETYPE ASR33 I/O TERMINALS

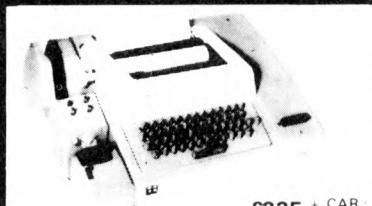

£235 + CAR + VAT

Fully fledged industry standard ASR33 data terminal. Many features including: ASCII keyboard and printer for data I/O, auto data detect circuitry, RS232 serial interface, 110 baud, 8 bit paper tape punch and reader for off line data preparation and ridiculously cheap and reliable data storage. Supplied in good condition and in working order. Options: Floor stand **£12.50 + VAT**
Sound proof enclosure **£25.00 + VAT**

ICL TERMIPRINTER 300 BAUD TERMINALS



£325 + CAR + VAT

Made under licence from the world famous GE Co. The ICL Termiprinter is a small attractive unit with so many features it is impossible to list them in the space available! Brief spec. as follows: RS232 serial interface, switchable baud rates 110, 150, 300, (30 cps), upper and lower case correspondence type face, standard paper, almost silent running, form feed, electronic tab settings, suited for word processor applications plus many more features. Supplied in good condition and in working order. Limited quantity.

SCOOP PURCHASE 9" VIDEO MONITORS

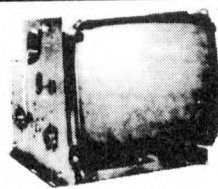

ONLY £57.50 + VAT

Made by the famous MOTOROLA CO. The 9" video monitor type XM226 16 is a self contained unit featuring a quoted bandwidth of 10Hz to 10MHz with 800 lines resolution at the screen centre. The printed circuit board and power transistors are both plug-in for ease of servicing. All controls are easily accessible from the rear. By connection of any 75Ω composite video signal and 12v D.C. you have a professional monitor to do any MPU/CCTV system proud! Supplied **BRAND NEW** complete with circuits at only **£57.50 + VAT**
Specialist carriage and insurance **£7.50 + VAT**.

EX STOCK SOFTY

SOFTWARE DEVELOPMENT SYSTEM, INVALUABLE TOOL FOR DESIGNERS, HOBBYISTS ETC.

Enables "open heart surgery" on 2708, 2716, etc. Blows, Copies, Reads EPROMS or emulates EPROM/RAM IN-SITU whilst displaying contents off ROM/RAM on a domestic TV receiver. A host of other features.

Write or phone for more details.

£115 + VAT & CARR
PSU £20 + VAT

You'll never regret buying a SOFTY!

EQUIPMENT CASES



GIVE YOUR M.P.U. A HOME ONLY £9.95 + 1.85 pp

Superb professional fully enclosed, made for the G.P.O. to the highest standard, offered at a fraction of their original cost they feature aluminium sides, hinged removable front panel, which can be secured by 2 screws to prevent prying fingers. All are finished in two tone G.P.O. grey and although believed brand new may have minor scuff marks/scratches due to bad storage. Dimensions 16" D x 6 1/2" H x 14 1/4" W

MAKE YOUR COMPUTER TALK!!! VIA OUR EX-GPO MODEM UNITS

Well, not exactly talk, but communicate over a standard dial up G.P.O. line with any other modem. The modem unit 2A is housed in an attractive fibre glass case measuring only 15 w x 13 d x 5 h, inside are the electronics and mains power supply which enable serial duplex data communication between terminal/computer etc. at any speed up to and in excess of 250 baud (300 at a push). Made to the most stringent, exacting specification for the G.P.O. These units feature Modular plug in P.C.B.'s, internal test points. Standard tone frequencies, Configurable to terminal or computer end. Auto unatended answer, RS232/V24 interface on standard 25 way 'D' socket, etc. etc., supplied complete with diags., at a fraction of their original cost only **£55.00 + £4.50 CARR**

NOTE: Units believed working, but untested, unguaranteed. Per mission may be required for connection to G.P.O. lines.

SEMICONDUCTOR 'GRAB BAGS'

Amazing value mixed semiconductors, include transistors, digital, linear I.C.'s, triacs, diodes, bridge recs etc. All devices guaranteed brand new, full spec. with manufacturers markings, fully guaranteed.
50 + BAG **£2.95** 100 + BAGS **£5.15**

MUFFIN FANS

Keep your equipment Cool and Reliable with our tested ex-equipment "Muffin Fans" almost silent running and easily mounted. Available in two voltages 110 V.A.C. **£5.05 + pp** 90p DR 240v A.C. **£6.15 + pp** 90p DIMENSIONS 4 1/2" x 4 1/2" x 1 1/2"

ELECTRONIC COMPONENTS & EQUIPMENT

66% DISCOUNT

Due to our massive bulk purchasing programme which enables us to bring you the best possible bargains, we have thousands of I.C.'s, Transistors, Relays, Cap's., P.C.B.'s, Sub-assemblies, Switches, etc. etc. surplus to our requirements. Because we don't have sufficient stocks of any one item to include in our ads., we are packing all these items into the "BARGAIN PARCEL OF A LIFETIME!" Thousands of components at giveaway prices! Guaranteed to be worth at least 3 times what you pay plus we always include something from our ads. for unbeatable value!! Sold by weight

2.5kls £ 4.75 + pp £1.25 **5kls £ 6.75 + pp £1.80**
10kls £11.75 + pp £2.25 **20kls £19.99 + pp £4.75**

LED DIGITAL ALARM CLOCK MODULE

★ 12 HOUR ★ 50/60 HZ ★ LARGE DISPLAY ★ 100's OF USES
The same module, NATIONAL MA1012, used in most alarm clock/radios on the market today, the only difference is our price! GIANT 1/2" LED characters give extremely clear viewing and readability. All electronics are self-contained on a P.C.B. measuring only 3" x 1 1/4". By addition of a few switches and 5/16 volts A.C. you have a multi-function alarm clock at a mere fraction of cost. Dozens of functions include snooze timer, am-pm, alarm set, power fail indicators, flashing seconds cursor, modulated alarm output, dimmer control, etc. etc. Supplied brand new with full data at only **£5.25**
suitable transformer for mains operation **£1.75**



Save Over £1200!! Logabax DZM180 High Speed Matrix Printers

This must be one of our greatest bulk saving deals this year. This fabulous printer is listed at over £1800 and judging by the quality workmanship we are not surprised. The Logabax DZM180 Matrix printer, capable of printing up to 132 characters per line on any size (via variable tractor unit) sprocket fed fanfold paper. A precision matrix head utilising ruby bearings gives exceptionally clear uniform legible characters via standard ribbon. Many other features include internal buffer, for high throughput, in excess of 180 characters per second, software controllable form and tab functions, standard TTL parallel interface, etc. etc. Supplied brand new and boxed at only

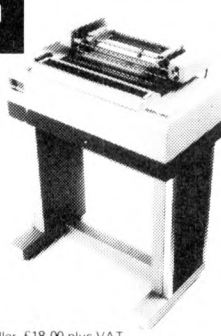

£599.00 plus VAT*
Optional extras:
Floor stand (as picture) **£30.00** plus VAT Paper handler **£18.00** plus VAT
*Carriage - please enquire for specific quote.

THE "MULTIVOLT" MULTI RAIL P.S.U.

This has got to be the power supply to end all your M.P.U./LAB supply requirements. Recently made by the famous "WIER" Co Ltd to the highest professional specifications. With an original cost of over £200 the supply features every possible form of protection, full regulation, over voltage and current limit and just look at these outputs; it may have been made to your specifications!
+ 5 V at 12 Amps + 30 V at 2 Amps + 5 V at 4.5 Amps
+ 5 V at 4 Amps - 12 V at 2.5 Amps + 12 V at 2.5 Amps
- 9 V at 1 Amp

you agree! then order now whilst stocks last.
Supplied **BRAND NEW** at only complete with diagrams **£59.99** CARR & INSUR **£6.75**

BRAND NEW 8" FLOPPY DISK DRIVES

DRI 7100 . . . £245 + carr + VAT
DRI 7200 . . . £300 + carr + VAT

5v D.C. POWER SUPPLIES

Following the recent "SELL OUT" demand for our 5v 3 amp P.S.U. we have managed to secure a large quantity of ex-computer systems P.S.U.'s with the following spec.: 240 or 110v A.C. input. Outputs of 5v @ 3.4 amps, 7.2v @ 3 amps and 6.5v @ 1 amp. The 5v and 7.2v outputs are fully regulated and adjustable with variable current limiting on the 5v supply. Unit is self contained on a P.C.B. measuring only 12" x 5" x 3". The 7.2v output is ideal for feeding "on board" regulators or a further 3 amp LM323K regulator to give an effective 5v @ 7 amp supply. Supplied complete with circuit at only **£10.95 + £1.75 pp**. Believed working but untested, unguaranteed.

KEYBOARDS

★ LOW PRICE CHASSIS ★



A special bulk purchase enables us to offer the above keyboard at a lowest ever price. 49 coded keys encoded into a direct TTL compatible 7 bit output. Features such as delayed strobe, 5 volt DC single rail operation and rollover protection make this an absolute must for the MPU constructor! Supplied complete with connection diagram and edge connector, at a secondhand

"no time to test" **£20.00 + P.P. £1.60**
price of only

SUPER CASED VERSION Same as above spec. but housed in attractive two tone moulded, free standing case. Unit also includes an all TTL parallel to serial converter (no details) etc.

£27.50 + P.P. £1.85

TOROIDAL TRANSFORMERS

PR 240v pri sec 15 0 15 @ 2 amps dimensions 3" x 2 1/2" **£4.95 + pp 99p**
TM 240v 110v pri sec 15 0 15 8VA dimensions 2 1/2" x 1" **£1.95 + pp 30p**
All voltages measured off load.

Plugs, Sockets & Connectors Cannon 'D' Range

Ways	Plug	Socket
9	£1.03	£1.26
15	£1.17	£2.01
25	£1.72	£2.58
37	£2.35	£4.14
50	£2.90	£5.46

25 way ex-equip. plug or socket **£1.25**
- Edge connectors, gold plated

0.1 DS	40 way	£2.45
0.1 DS	85 way	£3.99
0.15 DS	56 way	£3.25
0.156DS	36 way	£2.00

All connectors easily cut to size
1000's of other connectors ex stock

ELECTRONICS

Dept. E.T.I. 64-66 Melfort Rd., Thornton Heath, Croydon, Surrey. Tel: 01-689 7702 or 01-689 6800

MAIL ORDER INFORMATION

Unless otherwise stated all prices inclusive of V.A.T. Cash with order. Minimum order value £2.00. Prices and Postage quoted for UK only. Where post and packing not indicated please add 50p per order. Bona Fida account orders minimum £10.00. Export and trade enquiries welcome. Orders despatched same day where possible. Access and Barclaycard Visa welcome.

INDEPENDENT COMPUTER ENGINEERING LTD

CROMEMCO Systems & Software

SYSTEM ZERO – the latest low cost computer from Cromemco

CP/M 2.2 for Cromemco systems **£95**

64K S100 Memory Boards **£350**

10 Megabyte Cartridge Disk
(5 Megabyte fixed 5 removable)
and controller for the S100 Bus

£3,950 including installation
(London area)

We supply computer solutions to business problems

- * Software packages
- * Hardware maintenance
- * Hardware configuration and design

We also have an "Aladdin's Cave" of computer spares, power supplies, boards, chips, etc, etc.

For further details and information, please contact:

Independent Computer Engineering Limited,
16/18 Littleton Road, Ashford, Middlesex.
Tel: 07842 47171/2
Telex: 8952042 (DPCUST G)

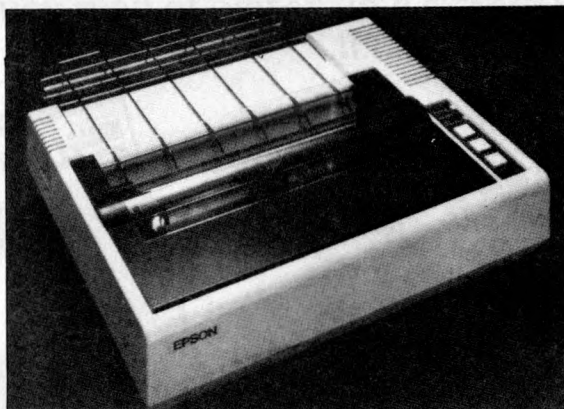

EPSON – MX80 DOT MATRIX PRINTER

The printer you have been waiting for

- * 9x9 matrix (true descenders in lower case)
- * 80cps bidirectional printing with logical seeking print head (maximises throughput)
- * 96 ASCII character set, plus 64 graphics incorporating 4 switch selectable European language options.
- * Programmable forms handling
- * 12 different print modes, up to 132 characters per line
- * Operator controls and indicators, including self test feature.
- * **£395** – with standard parallel interface (interface options – RS232, Pet, TRS80, MZ80 Apple).

ALL PRICES EXCLUDE VAT

SPIDER SOFTWARE

CUSTOMISED SOFTWARE

Apple II/ITT 2020 software written to your own specifications. Many of our packages already in use. The largest user of postal services in the world uses a Spider Software bespoke mailing-list. Firm quotations given on receipt of program requirements. Please write or phone for details.

PACKAGED SOFTWARE

Write or phone for a copy of our free catalogue of Apple/ITT software. Includes:

D/DATABASE

D/DATABASE uses advanced programming techniques and unique data storage and retrieval routines. A special high-speed disc I/O controls the data held on disc, searching and evaluating information at many times the rate achieved by the standard DOS's random access capabilities. Every possible byte on a disc is available for data storage on a DDA formatted disc – that means a full 116,352 characters on every disc. D/DATABASE is not operated using limiting numbered indexes. All 'Conversation' with the system is in the form of logical statements, similar to BASIC statements.

10 databases per disc maximum – 909 useable files per disc.
128 characters maximum record size – 9 character field names.
9 user named fields per record, 27 characters maximum per field within limit of total record size – 16 character index files.
D/DATABASE is very user-friendly.

Introductory offer:- £22.95 including 1 data-disc.
Basic and machine-code. Requires minimum 32K.

MYSTERY HOUSE

In this hi-res adventure you are transported to the front yard of an old Victorian house. Your friends are being murdered one by one and you must find out why and who the killer is. Over 100 hi-res pictures and an extensive vocabulary of over 300 words. £24.95 on disc only. Machine-code. Requires 48K.

THE WIZARD AND THE PRINCESS

Fantastic hi-res adventure with hundreds of pictures in 21 different colours. Rescue the princess from the wizard after crossing the hazardous desert. The graphics in this game have to be seen to be believed.

£29.95 on disc only. Machine code. Requires 48K. + 100 other games, business, science and utilities packages.
Ten 5¼" blank diskettes. Guaranteed 100% error free. £23.95
16K memory upgrade for Apple/ITT. Guaranteed 3 months.
Only £4.95

Prices are inclusive but please add 50p p&p for orders under £30.00 totally.

SPIDER SOFTWARE

98 AVONDALE ROAD, CROYDON, SURREY
Tel: 01-661 2365

Our High Speed, 136 column Printer



MEANS BUSINESS

ONLY
£699
+ VAT

(Inc Serial or Parallel interface, please specify)

The ANACOM 150 CPS printer that prints its 9 x 9 dot matrix bi-directional whilst logic seeking the quickest way to print the next line, it has an 136 column format, but accepts tractor feed paper of any width, vertical format is programmable as are double width characters. Interfacing is accomplished by use of a personality board with parallel or series interface. Its modular construction combines rugged quality with convenient serviceability. It is fully warranted with a comprehensive service facility available for continued customer protection.

FEATURES: *150 chs per sec. *Bi-directional printing, logic seeking *Paper width 3" to 15" *9 x 9 Dot Matrix *Upper and lower case with descenders *Double width chs *10 chs per in - horizontal *6 or 8 lines per inch - vertical *Adjustable tractors *Original and 4 copies *Extended life head *Paper out sensor

NORTHAMBER LTD

GREAT OAK HOUSE, ESHER, SURREY. KT10 9BR

Phone: ESHER (0372) 62071 & 01-786 2072

Full details on request. Prices exclude VAT & delivery

**The Sinclair ZX80 is innovative and powerful.
Now there's a magazine to help you get
the most out of it.**

Get in sync



SYNC magazine is different from other personal computing magazines. Not just different because it is about a unique computer, the Sinclair ZX80 (and kit version, the MicroAce). But different because of the creative and innovative philosophy of the editors.

A Fascinating Computer

The ZX80 doesn't have memory mapped video. Thus the screen goes blank when a key is pressed. To some reviewers this is a disadvantage. To our editors this is a challenge. One suggested that games could be written to take advantage of the screen blanking. For example, how about a game where characters and graphic symbols move around the screen while it is blanked? The object would be to crack the secret code governing the movements. Voila! A new game like Mastermind or Black Box uniquely for the ZX80.

We made some interesting discoveries soon after setting up the machine. For instance, the CHR\$ function is not limited to a value between 0 and 255, but cycles repeatedly through the code. CHR\$(9) and CHR\$(265) will produce identical values. In other words, CHR\$ operates in a MOD 256 fashion. We found that the "=" sign can be used several times on a single line, allowing the logical evaluation of variables. In the Sinclair, LET X=Y=Z=W is a valid expression.

Or consider the TL\$ function which strips a string of its initial character. At first, we wondered what practical value it had. Then someone suggested it would be perfect for removing the dollar sign from numerical inputs.

Breakthroughs? Hardly. But indicative of the hints and kinds you'll find in every issue of SYNC. We intend to take the Sinclair to its limits and then push beyond, finding new tricks and tips, new applications, new ways to do what couldn't be done before. SYNC functions

on many levels, with tutorials for the beginner and concepts that will keep the pros coming back for more. We'll show you how to duplicate commands available in other Basics. And, perhaps, how to do things that can't be done on other machines.

Many computer applications require that data be sorted. But did you realize there are over ten fundamentally different sorting algorithms? Many people settle for a simple bubble sort perhaps because it's described in so many programming manuals or because they've seen it in another program. However, sort routines such as heapsort or Shell-Metzner are over 100 times as fast as a bubble sort and may actually use less memory. Sure, 1K of memory isn't a lot to work with, but it can be stretched much further by using innovative, clever coding. You'll find this type of help in SYNC.

Lots of Games and Applications

Applications and software are the meat of SYNC. We recognize that along with useful, pragmatic applications, like financial analysis and graphing, you'll want games that are fun and challenging. In the charter issue of SYNC you'll find several games. Acey Ducey is a card game in which the dealer (the computer) deals two cards face up. You then have an option to bet depending upon whether you feel the next card dealt will have a value between the first two.

In Hurdle, another game in the charter issue, you have to find a happy little Hurdle who is hiding on a 10 X 10 grid. In response to your guesses, the Hurdle sends out a clue telling you in which direction to look next.

One of the most ancient forms of arithmetical puzzle is called a "boomerang." The oldest recorded example is that set down by Nicomachus in his *Arithmetica* around 100 A.D. You'll find a computer version of this puzzle in SYNC.

Hard-Hitting, Objective Evaluations

By selecting the ZX80 or MicroAce as your personal computer you've shown that you are an astute buyer looking for good performance, an innovative design and economical price. However, selecting software will not be easy. That's where SYNC comes in. SYNC evaluates software packages and other peripherals and doesn't just publish manufacturer descriptions. We put each package through its paces and give you an in-depth, objective report of its strengths and weaknesses.

SYNC is a Creative Computing publication. Creative Computing is the number 1 magazine of software and applications with nearly 100,000 circulation. The two most popular computer games books in the world, *Basic Computer Games* and *More Basic Computer Games* (combined sales over 500,000) are published by Creative Computing. Creative Computing Software manufactures over 150 software packages for six different personal computers.

Creative Computing, founded in 1974 by David Ahl, is a well-established firm committed to the future of personal computing. We expect the Sinclair ZX80 to be a highly successful computer and correspondingly, SYNC to be a respected and successful magazine.

Order SYNC Today

Right now we need all the help we can get. First of all, we'd like you to subscribe to SYNC. Subscriptions are posted by air directly from America and cost just £10 for one year (6 issues), £18 for two years (12 issues) or, if you really want to beat inflation, £25 for three years (18 issues). SYNC is available only by subscription; it is not on newsstands. We guarantee your satisfaction or we will refund the unfulfilled portion of your subscription.

Needless to say, we can't fill up all the pages without your help. So send in your programs, articles, hints and tips. Remember, illustrations and screen photos make a piece much more interesting. Send in your reviews of peripherals and software too—but be warned: reviews must be in-depth and objective. We want you to respect what you read on the pages of SYNC so be honest and forthright in the material you send us. Of course we pay for contributions—just don't expect to retire on it.

The exploration has begun. Join us.

The magazine for Sinclair ZX80 users
SYNC

27 Andrew Close
Stoke Golding
Nuneaton CV13 6EL, England

A * C * E

Advanced

Computer Equipment

95 MEADOW LANE LEEDS II

TEL: 0532 446960

Ricoh RP1600

ULTIMATE IN DAISYWHEEL PRINTERS



£1050 EX STOCK

Know your ZX80

WITH LINSAC PRODUCTS FOR THE SINCLAIR ZX80 LITERATURE

'THE ZX80) COMPANION' Second Edition. A complete guide to the ZX80 with chapters on operating, ZX80 BASIC, hardware, the Monitor (incl. moving display routine) and programs. Price £10.00 (add £4.95 for a cassette of ten programs from the book).

'THE ZX80 MONITOR LISTING'. A full assembly language listing with annotations. Price £10.00

SOFTWARE

All the following packs come on single C12 cassettes with run instructions, price £10.00

GAMES PACK 1 — Three Towers, Number Guessing, Mastermind, Sketcher, Hurdle, Nim and Symbol Simon.

GAMES PACK 2 — Nine Lives, The Maze Game, Plain Sailing, Noughts & Crosses, Chinese Puzzle, Tower of Hanoi, Battleships.

GAMES PACK 3 — (for 2 — 4K) Fruit Machine, Four-in-a-Line, Zombies.

EDUCATION PACK 1 — Maths Drill, Dot Recognition, Musical Notes, Spelling Quiz, Day Finder.

EDUCATION PACK 2 — Graph Plotter, Prime Factors, Number Bases, Bar Charts, Statistics.

UTILITY PACK 1 — Memory Display, Hex Code Monitor, Renummer, Memory Search.

All packs except GP3 run on 1K ZX80s, and all prices include postage. Send cheques to:

LINSAC 68 Barker Road, Linthorpe, Middlesbrough, Co. Cleveland TS5 5ES.

SOFTY Software Development System AND EPROM PROGRAMMER **EX-STOCK**

SOFTY is intended for the development of programs which will eventually become software residing in ROM and forming part of a microsystem. During the development stage of a microsystem, SOFTY will be connected in place of the firmware ROM via a ribbon cable, terminated in a 24 pin DIL plug. Data may be entered into the SOFTY RAM via the **serial port, parallel port, direct memory access, or the keypad**, and manipulated using the **assembler key-functions**. When the program has been entered, and the internal microprocessor can be 'turned off', and the external microsystem and its resident microprocessor allowed to access and run the program in SOFTY's RAM and/or programming socket. In this way, modification can be made until the required program is complete — the **contents of the RAM being clearly visible as a 'page' on TV or monitor**. 4 pages are available, 2 of the Data RAM and 2 of the programming socket.

In the end, when the program is complete and working, the DIL plus is removed and replaced by an EPROM device programmed by SOFTY. **SOFTY is able to program the 2704/2708/2716 family** which have 3 voltage rails — To help in the process of program development SOFTY has various assembler key-functions, which include — **block shift without overwriting, block store, cursor control, match byte and displacement calculations** (for jumps etc). A **high speed cassette interface** is also provided for storing working programs and useful subroutines.

SOFTY kit of parts: (including zero insertion force socket for EPROM programmer) Price £100 + VAT (postage paid). SOFTY built & tested — £120 + VAT (postage paid). Built SOFTY power supply — £20 + VAT (postage paid). Write or telephone for full details.

NEW

SOFTY CONVERSION CARD — **EX-STOCK**
Enables SOFTY to program the single rail EPROMs 2508, 2758, 2516, (INTEL 2716), 2532.
Selection of device type and 1K block are by 4 way pcb slide switches. Programming socket is zero insertion force. Supplied ready built & tested with Dip jumper for connection to SOFTY, £40 + VAT (postage paid).

NEW

SOFTY PRINTER CARD — **EX-STOCK**
• 40 column electrosensitive printer • 5 x 7 dot matrix
• software selection of characters per line (1 to 16 bytes)
• push button printing of EPROM/RAM/Intercursor contents
• Connects to SOFTY card edge • Well documented • Supplied ready built & tested, including power supply, edge connector & paper roll for £145 + VAT (post paid), Spare paper rolls (28-30 metres/roll) — £6.96 + VAT

EX-STOCK EPROMS

	1-9	10-24	25-49	50up
2708 (450ns)	£4.00	£3.80	£3.60	£3.35
2716 (450ns)	£6.95	£6.50	£5.95	£5.40

Single rail
Deduct a further 5% for cash with order on these low EPROM prices.

Add VAT at 15%. Postage paid.

MODEL 14 EPROM ERASERS **EX-STOCK**

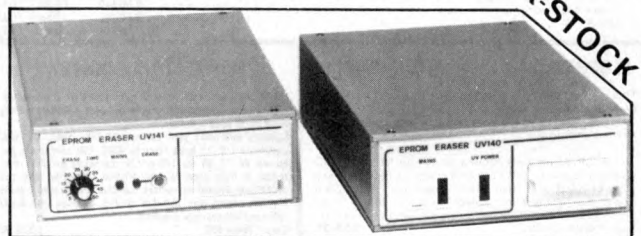

MODEL UV 141 EPROM ERASER
• Fast erase times (typically 20 minutes for 2708 EPROM)
• 14 EPROM capacity
• Built-in 5 to 20 minute timer to cater for all EPROMs
• Safety interlocked to prevent eye and skin damage
• Convenient slide-tray loading of devices
• 'MAINS' and 'ERASE' indicators
• Rugged construction
Priced at only £78 + VAT post paid

MODEL UV 140 EPROM ERASER
Similar to Model UV141 but without timer
Low price at only £61.50 + VAT post paid
WRITE OR TELEPHONE FOR FULL DETAILS OR SEND CHEQUES OFFICIAL COMPANY ORDERS TO:

GP Industrial Electronics Limited

Unit 6, Burke Road, Totnes Industrial Estate,
Totnes, Devon. Tel. Totnes (0803) 863360 Sales, 863380 Technical.
TRADE AND EXPORT ENQUIRIES WELCOME

Greenbank

Greenbank Electronics
(Dept WIE) 92 New Chester Road, New Ferry
Wirral, Merseyside L62 5AG
(Tel: 051-648 2391)



TERMS, VAT, C.W.O. Cheques etc payable to Greenbank Electronics and Express.
Add VAT to all prices at 15% except where stated otherwise. Post etc: (UK 35p
+ 5p VAT = 40p) per order. Export: NO VAT but add 35p (Eire), 75p (Europe) and
£2.50 elsewhere. Access: Barclaycard, Visa, telephoned orders accepted.
Polys, universities, gov't depts, etc can telephone their orders for immediate
despatch on account.



QUARTZ

32.768KHz	£3.23
(Watch)	£3.23
60 KHz	£9.95
100.0 KHz	£3.62
200.0 KHz	£3.92
204.8 KHz	£3.92
282.144 KHz	£3.92
307.2 KHz	£3.92
312.5 KHz	£3.92
455.0 KHz	£4.95
1.000 MHz	£3.62
1.008 MHz	£3.92
1.330 MHz	£3.92
1.6 MHz	£4.25
1.8 MHz	£4.25
1.8432 MHz	£3.62
2.000 MHz	£3.62
2.097152 MHz	£3.23
2.4576 MHz	£3.62
2.500 MHz	£3.92
2.56250 MHz	£3.62
3.000 MHz	£3.62
3.2768 MHz	£3.23
3.579545 MHz	£1.95
4.508 MHz	£3.23
5.000 MHz	£3.62
4.93619 MHz	£1.25
4.800 MHz	£3.23
4.9152 MHz	£3.23
5.000 MHz	£3.23
5.0688 MHz	£3.23
5.120 MHz	£3.23
5.185 MHz	£3.23
6.000 MHz	£3.23
6.144 MHz	£3.23
6.400 MHz	£3.23
6.55360 MHz	£3.23
7.000 MHz	£3.23
7.168 MHz	£3.23
7.680 MHz	£3.23
7.86432 MHz	£3.23
8.000 MHz	£3.23
8.08333 MHz	£3.23
8.388608 MHz	£3.23
8.867231 MHz	£3.23
9.375 MHz	£3.92
9.800 MHz	£3.92
10.000 MHz	£3.23
10.245 MHz	£3.23
10.700 MHz	£3.23
10.92 MHz	£3.23
11.000 MHz	£3.23
12.000 MHz	£3.92
14.0 MHz	£3.92
14.81818 MHz	£3.23
16.000 MHz	£3.92
18.000 MHz	£3.23
18.432 MHz	£3.23
20.000 MHz	£3.62
20.134 MHz	£3.23
24.0 MHz	£3.92
26.690 MHz	£3.23
27.0 MHz	£3.92
27.145 MHz	£2.10
27.648 MHz	£3.92
38.6666 MHz	£3.23
48.000 MHz	£3.23
100.000 MHz	£3.23
116.000 MHz	£3.23

UV 140, UV ERASER

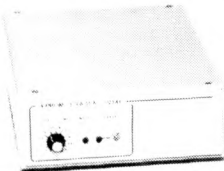

Two easy to use units designed for both the professional and amateur UV-prom user

Features

- Can erase up to 14 proms
- Special short wave ultraviolet tube
- Erase time variable between 5 and 50 minutes in 5 minute steps (preventing over exposure which may shorten prom life)
- Sliding tray carries proms on conductive foam
- Safety interlock switch prevents the timing circuit from operating and switching on the tube with the tray open
- Mains On and Tube On indicators
- Smart textured case
- Complete instructions supplied

Supplied complete with mains plug and flex

Model UV141. Price £77.70

Also available without timer as

Model UV140. Price £61.20

TEX MICROSYSTEMS "EPROMPT" UV ERASER



A low cost alternative to the above erasers (UV 140/141) claimed by the manufacturer to erase up to 32 chips in 15-30 mins. This is the cheapest eraser we have seen. The unit has no timer, power switch or safety interlock switch. The user places up to 32 chips into loose conducting foam in the erasure tray (16 along the base, 8 on each side). The chips are held in place by the UV tube which sits in the tray. (Unlike the UV 140/141, no special precautions have been taken to prevent the seepage of UV light, but the manufacturers state that "Incident light from this device is quite safe at distances above 12 inches.")

(Dimensions - 325 x 64 x 38mm)

EPROMPT ERASER Price £33

MODULAR COMPUTER SYSTEM CARDS

A range of International (114 x 203mm) size cards which may be purchased individually as desired, or to build up a complete system. Further details available on request. All boards are epoxy glass with gold plated edge plug

VDU A, B, G (set of 3)	£27.20
SC, MP, P, SC, MP CPU	£9.40
MPA 7 Buffered SC, MP CPU	£9.40
MZB 3 Z80-CPU	£9.40
MXA 1 2K of 2102	£9.40
MXA 3 8K of 2114	£9.40
MXD 2 16K of 4116	£9.40
PRM 2 4K of 5204	£9.40
PRM 8 8K of 2708	£9.40
RRM 14 8K of 2516 + 6K of 2114	TBA
SIO 2 RS-232 (two)	£9.40
TPA 2 Tape Interface	£9.40
IP 2 Input Port	£9.40
DCR 6 Keyboard Input	£8.90
OP 3 Output Port	£9.40
PP 2 PROM Programmer	£9.40
PSU A4 Power Supply	£8.90
PSU B 5V Power Supply	£5.50
PSU C 2.5V Power Supply	£5.50
13 slot backboard, can be used with most of the above boards. 1.3" x 4.1"	£11.50
ISBUS-1.1	£11.50

CMOS

These cut prices for Amateurs Users and Export. Note: Industrial users - quantity prices available. Mostly Motorola, RCA

4000 18p	4042 80p	4095 £1.97	4410 £8.55	4531 £1.45
4001 25p	4043 90p	4096 £1.97	4411 £10.72	4532 £1.30
4002 25p	4044 90p	4097 £5.98	4412VPP £14.93	4534 £5.60
4006 95p	4045 £2.63	4098 £1.92	4415V £5.24	4536 £3.69
4007 18p	4046 £1.10	4099 £2.00	4422 £5.66	4537L £26.10
4008 80p	4047 £1.71	4100 £1.92	4433 £12.30	4538 £1.20
4009 40p	4048 77p	4101 £1.69	4435V £5.40	4539 97p
4010 50p	4049 45p	4102 £3.67	4450 £3.81	4541 £1.19
4011 25p	4050 49p	4103 £3.67	4451 £3.81	4543 £1.80
4012 18p	4051 80p	4104 £1.85	4461 £3.93	4549 £4.38
4013 50p	4052 80p	4105 £1.85	4462 £4.41	4552 £14.85
4014 84p	4053 80p	4106 92p	4490FP £4.20	4553 £4.50
4015 84p	4054 £2.18	4107 £1.28	4490PP £3.14	4554 £1.38
4016 45p	4055 £2.55	4108 £1.54	4495 £6.54	4555 £7.00
4017 80p	4056 £2.55	4109 £1.28	4501 29p	4556 72p
4018 85p	4059 £9.23	4110 £3.00	4502 £1.20	4557 £3.86
4019 45p	4060 £2.10	4111 £1.77	4503 70p	4558 £1.25
4020 99p	4062 £10.00	4160 £1.54	4505 £5.71	4559 £4.38
4021 £1.10	4063 £1.90	4161 £1.54	4506 50p	4560 £2.50
4022 £1.00	4066 55p	4162 £1.54	4507 55p	4561 81p
4023 27p	4067 £7.21	4163 £1.54	4508 £2.90	4562 £5.60
4024 78p	4068 27p	4174 £1.54	4510 99p	4566 £1.59
4025 27p	4069 27p	4181 £5.03	4511 £1.50	4568 £2.38
4026 £3.25	4070 30p	4182 £1.90	4512 80p	4569 £2.50
4027 50p	4071 25p	4192 £2.41	4514 £2.65	4572 40p
4028 84p	4072 25p	4193 £2.41	4515 £3.00	4580 £4.77
4029 99p	4073 25p	4194 £3.27	4516 £1.10	4581 £2.62
4030 74p	4075 25p	4202 £7.54	4517 £4.46	4582 £1.14
4031 £4.31	4076 £1.07	4207 £2.31	4518 £1.00	4583 90p
4032 £1.31	4077 29p	4160 98p	4519 80p	4584 90p
4033 £2.63	4078 29p	4161 98p	4520 £1.00	4585 £1.27
4034 £2.00	4081 27p	4162 98p	4521 £1.67	4586 £2.44
4035 £1.10	4082 27p	4163 98p	4522 £1.11	4598 £2.98
4037 £1.99	4085 £1.35	4174 90p	4526 £1.08	4599 £6.95
4038 £1.20	4086 £1.35	4175 £1.15	4527 £1.50	4700 £1.75
4039 £2.78	4089 £2.91	4194 £1.16	4528 £1.20	
4040 £1.00	4093 80p	4408 £9.37	4529 £1.30	
4041 £1.59	4094 80p	4409 £9.37	4530 70p	

74C

74C00 28p	74C76 57p	74C163 £1.15	74C903 57p	74C925 £5.01
74C02 28p	74C83 £1.34	74C164 £1.08	74C904 57p	74C926 £5.01
74C04 28p	74C85 £1.34	74C165 £1.08	74C905 57p	74C927 £5.01
74C08 28p	74C86 67p	74C173 93p	74C906 57p	74C928 £5.01
74C10 28p	74C89 £4.62	74C174 93p	74C907 57p	74C929 £5.01
74C12 28p	74C90 89p	74C175 93p	74C908 £1.00	74C930 £17.90
74C16 28p	74C93 89p	74C192 £1.15	74C909 £1.69	
74C18 28p	74C95 £1.08	74C193 £1.15	74C910 £7.45	80C95 85p
74C20 28p	74C107 £1.27	74C195 £1.08	74C911 £7.39	80C96 92p
74C24 28p	74C120 £3.81	74C200 £7.46	74C912 £7.39	80C97 85p
74C30 28p	74C151 £2.55	74C221 £1.41	74C913 £1.46	80C98 92p
74C32 28p	74C154 £3.81	74C245 £2.98	74C915 £1.15	80C99 £6.20
74C42 95p	74C157 £2.29	74C273 £1.79	74C918 £1.10	88C29 £2.90
74C48 £1.43	74C160 £1.49	74C374 £1.79	74C921 £1.07	88C30 £2.90
74C73 57p	74C161 £1.15	74C901 57p	74C922 £3.78	
74C74 59p	74C162 £1.15	74C902 79p	74C923 £3.86	

74LS

74LS00 14p	74LS51 30p	74LS151 96p	74LS244 £1.70	74LS374 £1.95
74LS01 14p	74LS53 45p	74LS152 76p	74LS245 £3.50	74LS375 £1.60
74LS02 16p	74LS54 41p	74LS153 96p	74LS247 £1.90	74LS377 £2.12
74LS03 16p	74LS76 40p	74LS155 96p	74LS248 £1.90	74LS378 £1.84
74LS04 16p	74LS78 40p	74LS156 96p	74LS249 £1.90	74LS379 £2.15
74LS05 20p	74LS83 £1.15	74LS157 76p	74LS251 £1.34	74LS384 86p
74LS08 22p	74LS85 £1.18	74LS161 98p	74LS253 £1.42	74LS386 86p
74LS09 22p	74LS86 43p	74LS162 98p	74LS258 £1.46	74LS393 £2.30
74LS10 20p	74LS89 60p	74LS163 £1.38	74LS259 £1.60	74LS395 £2.18
74LS11 22p	74LS91 £1.04	74LS164 £1.14	74LS266 52p	74LS398 £2.76
74LS12 23p	74LS92 89p	74LS165 75p	74LS273 £2.44	74LS399 £2.30
74LS13 38p	74LS93 89p	74LS166 £2.26	74LS275 £2.50	74LS445 £1.50
74LS14 75p	74LS95 £1.16	74LS170 £2.86	74LS279 66p	74LS447 £1.44
74LS15 30p	74LS96 £1.16	74LS173 £1.95	74LS283 £1.92	74LS490 £1.80
74LS20 20p	74LS107 44p	74LS174 £1.00	74LS290 £1.28	74LS568 £1.82
74LS21 22p	74LS109 55p	74LS175 £1.10	74LS293 £1.28	74LS569 £1.82
74LS26 48p	74LS112 55p	74LS181 £3.98	74LS295 £1.85	74LS670 £2.48
74LS27 28p	74LS113 50p	74LS183 £2.98	74LS298 £1.68	
74LS28 48p	74LS114 50p	74LS190 £1.40	74LS324 £2.40	
74LS30 22p	74LS122 70p	74LS191 £1.40	74LS325 £2.90	
74LS32 27p	74LS123 70p	74LS192 £1.30	74LS326 £2.94	
74LS33 39p	74LS124 £1.80	74LS193 £1.30	74LS327 £2.86	
74LS37 39p	74LS125 60p	74LS194 £1.66	74LS347 £1.48	
74LS38 39p	74LS126 60p	74LS195 £1.36	74LS348 £1.86	
74LS40 28p	74LS132 95p	74LS196 £1.00	74LS352 £2.28	
74LS42 98p	74LS136 65p	74LS197 £1.40	74LS353 £2.28	
74LS47 90p	74LS138 85p	74LS221 96p	74LS365 65p	
74LS48 £1.20	74LS139 85p	74LS240 £2.36	74LS366 65p	
74LS49 £1.20	74LS145 £1.08	74LS241 £2.32	74LS367 65p	
74LS51 24p	74LS147 £1.70	74LS242 £2.32	74LS368 66p	
74LS54 28p	74LS148 £1.73	74LS243 £2.32	74LS373 £1.80	

FLOPPY DISK CONTROLLER BOARD

This is used in conjunction with a Kemtron Z80 board to interface to two single density 5.25" floppy disks. It is not available as a bare board, but only built and tested, less circuit diagram

£165.00

To run CP/M on the system a serial interface (e.g. SIO board) to some sort of VDU or terminal is required, and 32K of RAM (e.g. two MXD2 boards). The MZB-3 board has facilities for power on jump, and a boot prom to load the CP/M operating system from the disk. Boot PROM (2708) £19.95 CP/M (8.6 disk) £95.00

DOT MATRIX PRINTER

This is about the same price as for example the Nascom Imp, but has many features only previously found in models costing hundreds of pounds more. Standard interfaces (not extras): RS-232, 20mA, IEE 488, Centronics I/O. 15 baud rates to 9600. 100 characters per second. 64, 72, 80, 96, 120 or 132 characters per line, rear, bottom or front paper loading, friction or tractor feed, can accept user defined characters, can also print graphics under program control, has self-test facility. Supplied with mains cable and full operator's manual. Base 2 Model 800 £325.00

DAISYWHEEL PRINTER

High quality printer for use with word processing packages running under CP/M. 45 characters per second RS-232 interface. Check stock position before ordering. Qume Sprint 5 Model 45-RO £1495.00

EUROCARD 19" CARD FRAME

Kit of 2 end plates + angles. 2 front and 2 rear tie bars, 4 guide location strips £27.47

Card guides (pack of 10) £1.40
Eurocard Plug (64 way DIN 41612) £2.22
Eurocard Socket (64 way DIN 41612) £3.39
Connector mounting strips (pair) £3.12
Case conversion kit £18.86
(for fit into separate 3U 19" D-type cr.) £28.17

MICROPROCESSORS

Z80 CPU (2.5MHz)	£5.95
Z80 CPU (2MHz)	£3.95
Z80 P10 (2MHz)	£3.95
[Add £1 for the 4MHz version of any of the above 3 chips.]	
6800 MPU	£5.95
6801 MPU	£9.95
6809	£19.95
6810 (128 x 8 RAM)	£3.25
68A10 (128 x 8 RAM)	£3.75
68C02 6821 PIA	£22.30
68A50 AIC	£4.85
MC6880	£2.64
SC/MP H RAM I/O	£10
INS B154 RAM I/O	£9.40
CMOS COSMAC CPD 1802ZE	£6.50
COSMAC CPD 1802E	£10.85
CDP 1864	£7.25
STATICS (Mostly 450ns)	
2102-1K x 1	£1.20
2111-256 x 4	£2.25
2112-256 x 4	£2.25
2114-4096-1K x 4	£2.25
8 x 2114	£17.84
2114L-1K	

NEW THE TUSCAN S100

A Z80 based S100 Computer System.

TUSCAN main board. The heart of the system with Z80, video, Ram, Rom, and I/O plus five S100 slots for expansion.

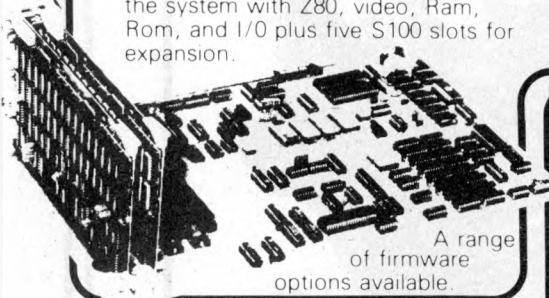

A range of firmware options available.

Available in Kit Form or Assembled. All components available separately.

Houses two 5 1/4" drives for a compact business system

Professional case will house the complete system

Two keyboard options

Hinged lid for easy access.

Stylish finish ideal for office or home.

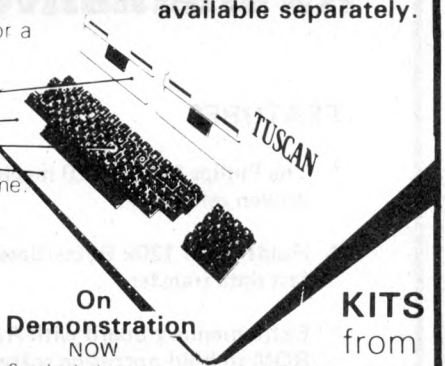

On Demonstration NOW

KITS from

Complete business system 48K with two 5" drives £1481

£235 + VAT delivery Ex-Stock

NASCOM-2

MICRO-KIT COMPUTER WITH IMPROVED 16k B RAM Board

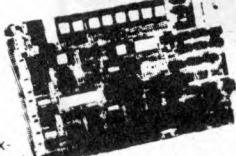

Ex-stock

only £335 + VAT

Full after sales service

POWER SUPPLY £29.50

Firmware & MOS ICs Software

Zeap Assembler (4, 1Kx8 EPROMS) £50

Nas Pen text editor (2, 1Kx8 EPROMS) £30

Expansion boards (in kit form)

48K RAM £210

32K RAM £175.00

16K RAM £140

EPROM CARD (NASCOM compatible) KIT. Suitable for 16 x 2708 or 16 x 2716 or mixed 1 x NASCOM 8k BASIC ROM £55.00. BASIC programmers aid. Self locating tape £14.95.

NASCOM-1

12" x 8" PCB carrying 5LSI MOS packages, 16 1K MOS memory packages and 33 TTL packages. There is on-board interface for UHF or unmodulated video and cassette or teletype. The 4K memory block is assigned to the operating system and video display leaving a 1K user RAM. The MPU is the standard Z80 which is capable of executing 158 instructions including all 8080 code.

Nascom-1 Kit Price **£125** Plus VAT
+ P&P £1.50

Built price £140 + VAT.

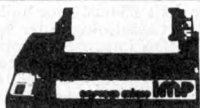

PLAIN PAPER £325 PRINTER

Fully built and housed in a stylish enclosure for just £325 plus VAT.

INTERFACES WITH ALL MICRO COMPUTERS

The Nascom IMP (Impact Matrix Printer) features are 60 lines per minute. 80 characters per line. ● Bi-directional printing. ● 10 line print buffer. ● Automatic CR/LF. 96 character ASCII set (including upper/lower case, \$, £). ● Accepts 8 1/2" paper (pressure feed). ● Accepts 9 1/2" paper (tractor feed). ● Tractor/pressure feed. Baud rate from 110 to 9600. ● External signal for optional synchronisation of baud rate. **IDEAL FOR WORD PROCESSING**

NASCOM PRODUCT LIST + VAT

I/O board kit less I/O chips	45.00
UART + BAUD rate generator + crystal for I/O board	16.00
Econographics kit for additional 128 characters (N1 only)	30.00
Bits & Pcs toolkit	£28.00
Bits & Pcs Chess	£35.00
Nascom 19" rack mounting card frame for N1 and N2	32.50
Nas-DA disassembler 3 EPROM for Nas-sys	37.50
MK36271 8K BASIC in 1K x 8 ROM	
Naspen VS in 2 EPROM	30.00
Nas-sys monitor in 2 EPROM	25.00
4 Games Tape	£8.50
Nasbug T4 2 x EPROM	25.00
Tiny Basic 2 x EPROM	25.00
Super Tiny Basic 3 x EPROM	37.50
Super Tiny Basic upgrade 1 x EPROM	12.50
Tape Software	
ZEAP 2 tape and documentation for Nas-sys	30.00
8K BASIC tape and documentation for N1	15.00

THE HENELEC DISK SYSTEM

FOR NASCOM and any other Z80 8080 Microcomputer with an uncommitted P10

DISKS

- The Henelec controller card plugs direct into a Z80 P10 and controls up to 3 double-sided mini-floppy drives giving a maximum 480K system.
 - General Purpose FDC control software for simple DOS or for CPM.
 - Simple DOS software for NASCOM 1/2 under NAS-SYS
 - OR ROM CB10S for CPM on NASCOM 1.2 incorporating the major NAS SYS features. Maximum 60K CPM system.
 - New MD.prom supplied for N2 CPM
- TWO SYSTEMS**
- SIM-DOS "Floppy Tape Recorder" with 1 drive PSU firmware, etc. Double sided £380 plus VAT
 - CPM System with 1 drive, double sided PSU firmware, etc. £450 plus VAT
 - Additional Drives with PSU £205 plus VAT



COMPUTER KEYBOARDS

APPLE COMPUTER KEYBOARD

52 Key 7 Bit ASCII coded Positive Strobe + 5V - 12V. Size 13x4 1/4". Sturdy Construction Sloping Keys. Black/White print. Made in USA for Apple Inc. Brand New £35 incl VAT. Post £2.50 Individually packed in ANTI-STATIC FOAM

71 KEY ASCII KEYBOARD INCLUDING NUMERIC KEYPAD. £49.00 plus £7.36 VAT TOTAL £56.36. Uses gold crosspoint keys. Includes keypad and ribbon cable. Only available as fully assembled and tested



CARTER 57 key ASCII keyboard. Conventional key board. 128 ASCII characters including control keys. Parallel output with strobe. Shift lock. + 5 V and -12 V DC. 12" x 5.5" x 1.5". Black keys with white legends. **39.34 + VAT.**

FERRANTI - "SIZE 14 x 6 x 3" SLOPING FRONT" 55 Key ASCII Coded in steel case. Complete with Plug and Cable with circuit to convert to T.T.L. levels.

In good condition at only **£19.95 + VAT.** P/P £2.50

CENTRONICS QUICK PRINTER

Model P1
List Price
£459
incl VAT

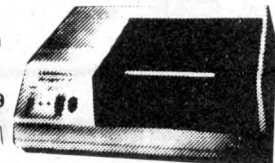

OUR PRICE incl VAT

EXCLUSIVE TO HENRY'S 50% OFF MAKER'S PRICE £195

for: Software selectable 20, 40 and 80 column using 120mm aluminium-ised paper. 1 roll supplied. 150 lines per minute. **NASCOM** Centronics parallel data interface for Nascom, Tandy, etc. 240 volt mains input. ASCII character set Paper feed, and on/off select switches 'BELL' signal Weight 10lbs Size: 13" x 10 1/2" x 4 1/2"

MONITORS New and Reconditioned FROM £35

Microtan 65 kit	£69.00	Tanex assembled	53.00
Microtan 65 assembled	79.00	Tanex (expanded)kit	106.50
Lower case option	9.48	Tanex (expanded)assmbld	116.50
Graphics option	6.52	Serial I/O option	12.87
20 way keypad	10.00	Tanram kit	34.00
Full ASCII keyboard	49.00	Tanram assembled	44.00
Tanex kit	43.00	Tanram (expanded)assbld	190.00

SEND FOR COMPLETE COMPUTER BROCHURE FREEPOST TO ADDRESS BELOW

MEMORIES Discounts 10% for 4, 15% for 8, 20% for 16

MK 3880 (NZ80)	7.50		
MK 3880-N4 (Z80A)	7.95	2708	5.00
MK 4116 16K x 1 dy RAM	4.50	2716	12.50
MK 4027 4K x 1 dy RAM	2.25	IM6402 UART	4.50
2102 1K x 1 static RAM	1.00	2114 1K x 4 static RAM	2.95
4118 1K x 8 static RAM	12.75	8080A	5.25

ADD VAT 15% TO YOUR ORDER EXCEPT WHERE STATED



TANGERINE LONDON STOCKISTS

MPS1 power supply	23.00
Mini Mother board	10.00
Mini Rack	43.00

10K extended Microsoft in ROM £39.00

10K extended Microsoft in EPROM 49.00

HENRY'S

Computer Kit Division

404 Edgware Road, London, W2, England I.E.D. 01-402 6822

Official Export & Educational Orders Welcome Our telex: 262284 Mono Ref. 1400 Transonics

Mini-Digital Cassette Recorder

An alternative to disc for program & data storage

FEATURES

- * The Philips MDCR 220 mechanism of proven reliability
- * Holds up to 120k Bytes/Cassette with fast data transfer
- * Extra memory board with RAM and ROM to hold operating software
- * Will read & write (in blocks from 256 bytes to 60k Bytes), backspace & search for end of data on tape
- * Compatible with 6502 based systems ie PET, AIM65, OHIO, KIM, COMPUKIT ETC.

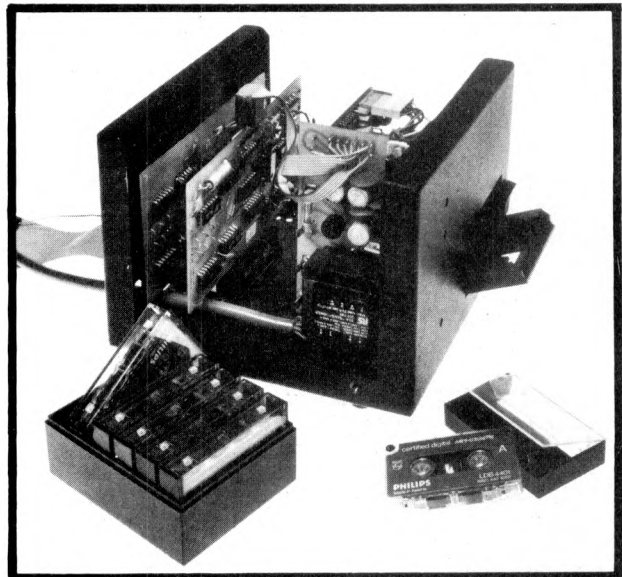

PRICES (INCLUDING MANUAL)	
MINI RECORDER MECHANISM	£95.00
INTERFACING BOARD (TYPEA)	£42.50
MEMORY BOARD (WITH ROMS FOR 6502)	£55.00
CASSETTES (BOX OF 6)	£15.90
MANUALS (SEPARATE)	£10.00
CARRIAGE	£2.25
PRICES EXCLUSIVE OF VAT @ 15%	

CURRAH

COMPUTER COMPONENTS

Unit 7 Hartlepool Workshops, Sandgate Industrial Est.
Hartlepool, Cleveland Tel. 0429 72996

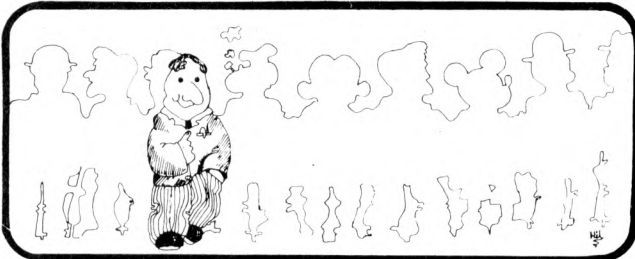

You stand out in a crowd

Your business is not exactly the same as any other and neither are its problems. Any solutions are probably unique and must be tailored exactly for you.

You know your business better than anyone else and any system designed should use your knowledge. The micro-computer specialist should show you how to use the computer to meet your business requirements.

You should be able to get the micro-computer which best suits your business. It should be chosen after your requirements are specified.

You and your staff have a right to know all about YOUR system, including helping to program it if you want to. Training is your right – not an additional service.

If microcomputers cannot satisfy your business needs, you want to know – you don't want false promises.

67 Nova Road, Croydon, Surrey CR0 2TN.
Telephone: 01-688 6013

THE NEW SE MICRO

OHIO SCIENTIFIC SUPERBOARDS WITH 32 x 32 DISPLAYS

Announcing the new 50Hz guard band models with 1.5MHz clocks giving 50% more speed, a full 32 x 32 display and a multi-speed tape interface.
BLACK AND WHITE £159 + 15% post free.
COLOUR VERSION £225 + 15% VAT.

THE UNIQUE SPECIAL OFFER YOU CANNOT RESIST

If bought with Superboard these items are at the reduced prices shown first. Also sold separately at the bracketed prices. Add 15% VAT. Guard band kit £0(£8). Modulator and power supply kit £1 (£25). 4K extra ram £20 (£24). Display expansion kit approx 30 lines x 54 characters £15(£20). Case £23(£26). Colour conversion board kit £35(£45) or built £65 (£65). Cassette-recorder £14(£16). CEGMON improved monitor rom poa. Extended monitor (tape) £20(£20). Assembler/Editor £25 (£25). Word processor £10(£10).

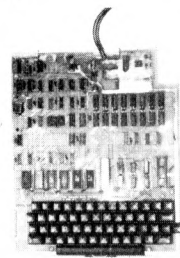

PRINTERS

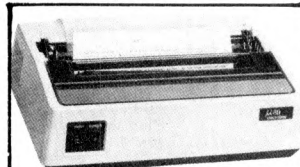

The best value in matrix printers and a fantastic cheapo offer to boot. OKI Microline 80 (Illustrated) £359 +15% BASE 2 800B (New improved version of the 800MST) £359+15%. BASE 2 850 Model price by secret quotation only. Anacom 150 £699+15%. Buy any of the above and we will supply an interface kit and word processor program for Superboard for only £1.

CHEAPO EXPANSION OFFER
Buy a 610 expansion board with 8k ram on board and space for another 16K for £159 + 15% and get a free 5V 2A power kit and any extra ram you want for £3-50/K + 15%. Buy a minifloppy +case+power supply+2 copies dos for £275 + 15% with the 610 and we will do the extra ram for £2/K + 15% (up to 16K).

THE NEW OHIO SERIES 2 CHALLENGER C1P

Program selectable 24 x 24 or 12 x 48 displays. Sound, music and voice output. 8K ram expandable to 32K. 8K basic. We dare not publish our cheap price for fear of being gunned down in the street by desperate rivals. Send a highly opaque sae for a stunning quote from the masters of cheapo and freebie trading. We also stock the C1PMF Series 2 disc version. Again, secret quotations only.

SWANLEY ELECTRONICS
Dept. PCW, 32 Goldsel Rd., Swanley, Kent BR8 8EZ

Telephone Swanley 64851. Please add 40p postage. Prices include VAT unless stated. Lists 27p post free. Overseas customers deduct 13%. Official credit orders welcome.

HEWLETT PACKARD

HP85

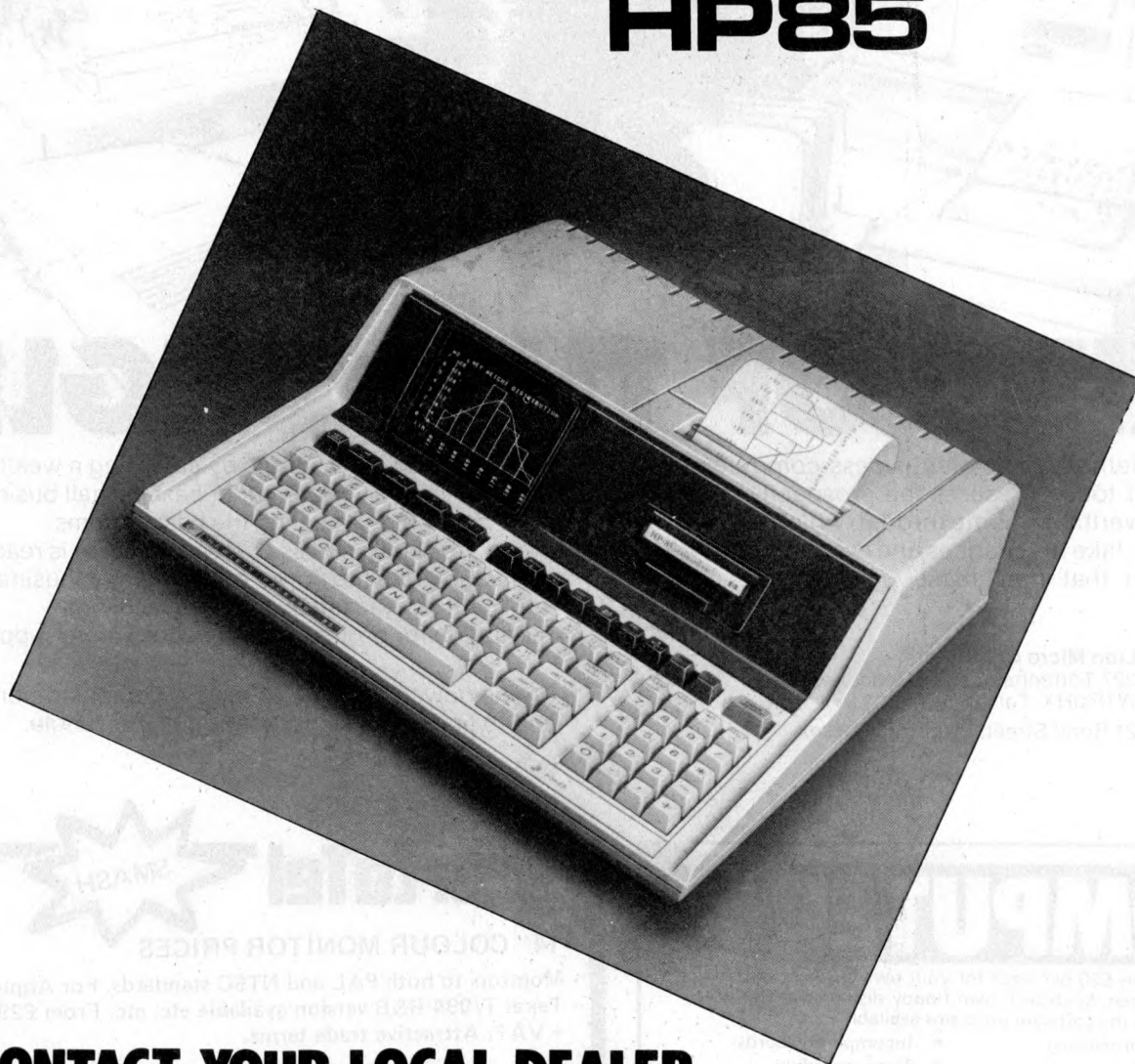

CONTACT YOUR LOCAL DEALER

Anglo-American Computing
9 Coventry Road
Coleshill
Warks
0675 65396

Automated Business Equipment
Mersey House
Heaton Mersey Industrial Estate
Battersea Road
Heaton Mersey
Stockport
Manchester (061 432) 0708

Cambridge Computer Store
1 Emmanuel Street
Cambridge CB1 1NE
0223 65334/68155

Cardiac Services
95a Finachy Road
Belfast BT10 DBY
Belfast 625566

Central Southern Calculators
12 Wokingham Road
Reading
Berks
Reading (0734) 61492

DBM Systems & Software
58 Victoria Street
Bristol BS1 6DE
0272 214093/4

D J Herriott Ltd
42 Camden Road
Tunbridge Wells
Kent TN1 1EE
(0892) 22443

Holdene Ltd
10 Blenheim Terrace
Leeds
Leeds (0532) 459459

Office Machinery Engineering
73 London Road
Brighton
E. Sussex
Brighton (0273) 689682

Petalect Ltd
32, Chertsey Road,
Woking,
Surrey,
04862 217766/63901

Robox Limited
Unit 4
Anderston Shopping Centre
Glasgow
Glasgow (041 221) 5401

Sumlock Bondain Ltd
15 Clerkenwell Close
London EC1
01-250 0505

Sumlock Services
Epic House
Charles Street
Leicester
Leicester (0533) 29673

This advertisement is organised by Personal Computer World and sponsored by the above Hewlett-Packard dealers. It is not a full list of all HP dealers, but only of those participating in this advertisement.



KING OF THE JUNGLE

The plethora of small business computers on the market today presents the prospective purchaser with a veritable jungle through which he has to hack a path, take his chances and eventually choose the system that may make or break his company.

Lion has tamed this jungle by amassing a wealth of experience in microcomputer based small business systems, and by selecting the best systems available. Our Business Systems Division is ready to demonstrate the power of the micro in business applications, backed by Lion's established reputation for professionalism and system support.



Lion Micro Computers
227 Tottenham Court Road, London
W1P 0HX Tel: 01-580 7383
21 Bond Street, Brighton, Sussex.



Phone now to arrange a personal demonstration and to find out why Lion is King of the Jungle.

COMPUTERS

From as little as £20 per week for your own business system with video screen, keyboard, twin floppy disk unit and printer. Choose any of the software programs available i.e.:

- ★ Word processing
- ★ Payroll
- ★ Invoicing
- ★ Stock control
- ★ Book-keeping
- ★ Incomplete records
- ★ Time recording
- ★ Information retrieval
- ★ Cash flow
- ★ Projection analysis

And when you've finished your easy days work we've got a few games for you to relax to including Space Invaders. We have first hand experience in dealing with businesses and can offer you expert advice in setting up your very first system. We can also offer installation, training and maintenance contracts.

NOW IS THE TIME

EXTRAS & OPTIONS

Floppy disks
Continuous Stationery
Dustcovers
Automatic sheet feeder
Tractor feed
Daisy wheels
Printer ribbons

Special desk work station

Lockable disk boxes
Pencilpots
Sound boxes

HARDWARE

CBM 3032 Computer
CBM 3040 Floppy
CBM 3022 Printer

Call into the

CBM 8032 Computer (new model)

CBM 8050 Floppy (New model)

Qume Springs Daisy Wheel Printer

SERVICES

Installation
Training
Maintenance
After Sales Service

DA VINCI COMPUTER SHOP
65 High St., Edgware, Middx.

Tel. 952 0526

Open Mon-Fri. 9.5.30. Sat 9.30-5.00
or send for details



PLEASE SEND ME DETAILS:

Name
Company Position
Address
Tel. No.
I am interested in

PortaTel

SMASH

14" COLOUR MONITOR PRICES

Monitors to both PAL and NTSC standards. For Apple/Texas T/994 R&B version available etc. etc. From £299 + VAT. Attractive trade terms.



OFF AIR
PAL &
NTSC 14"
MONITOR

SKANTIC 3781 14" CTV

Display of American
Standard Video
TEXAS TI 99/4
home computer etc.

£299 plus VAT

FULLY GUARANTEED
PAL VIDEO AND LARGER SIZES AVAILABLE

PortaTel Conversions Limited

25 SUNBURY CROSS CENTRE
SUNBURY ON THAMES MIDDX
TEL. No. SUNBURY (09327) 88972

VIDEO MODIFICATION SPECIALISTS

ACCESS & BARCLAYCARD WELCOME

interface components



MICRO MART

ICs
EPROMs 2708 £6.50 each
EPROMs 2716 £11.50 each

MEMORIES
21L02 £0.80 each
4027 £1.50 each
4116 £3.95 each
2114 £3.00 each

Z80 DEVICES
MK3880 £9.50 each
MK3881 (P10) £6.25 each
MK3882 (CTC) £6.25 each

VOLTAGE REGULATORS
7805 80p each
7812 80p each
7815 80p each
7824 80p each
7905 65p each
7912 65p each
7915 65p each
7918 65p each
7924 65p each
Add VAT and 30p P&P to all orders

SHARP'S DESK-TOP BRAIN. MZ-80K FROM £480

Plus VAT
An amazing Z-80 controlled personal computer supplied with 78-key ASCII keyboard; 14K extended BASIC; VDU (40 characters x 25 lines); fast cassette facility; 4K monitor ROM; 80 x 50HR Graphics; and a choice of 20K, 32K or 48K of internal random access memory.

A 50-pin universal BUS connector allows the addition of printer, floppy discs, etc. There is also a built-in 3-octave music function.

20K System £480 + VAT
32K System £529 + VAT
MZ80FD (twin floppies with 208K) £780 + VAT
MZ80P3 Printer £517 + VAT
MZ80 I/O Interface £99 + VAT

Stock control & Sales/Purchase ledger software now available.

NASCOM-2

MEMORY ● 8K Microsoft BASIC ● 2K NAS-SYS 1 monitor ● 1K Video RAM ● 1K Workspace/User RAM ● On-board 8 sockets provided for memory expansion using standard 24-pin devices: 2708 EPROMs and MK4118 static RAM. MICROPROCESSOR ● Z80A which will run at 4MHz but is selectable between 2/4 MHz. HARDWARE ● Industrial standard 12" x 8" PCB, through hole plated, masked and screen printed. All bus lines are fully buffered on-board. INTERFACES ● Licon 57 key solid state keyboard (included) ● Monitor/domestic TV interface ● Kansas City cassette interface (300/1200 baud) or RS232/20mA teletype interface.

The Nascom 2 kit is supplied complete with construction article and extensive software manual for the monitor and BASIC.

EXPANSION OPTIONS

● MK4118 £10 + VAT each
16K RAM B Board £140 + VAT
32K RAM B Board £170 + VAT
48K RAM B Board £200 + VAT

£345
Built & tested incl. 16K Ram A. - VAT - £2.00 P&P

£295
- VAT (Kit)

NASCOM IMP PLAIN PAPER PRINTER

The Nascom IMP (Impact Matrix Printer) features:

- 60 lines per minute ● 80 characters per line ● Bi-directional printing ● 10 line print buffer ● Automatic CR/LF ● 96 characters ASCII set (includes upper/lower case, \$, £) ● Accepts 8½" paper (pressure feed)
- Accepts 9½" paper (tractor feed)
- Tractor/pressure feed ● Baud rate from 110 to 9600 ● External signal for optional synchronisation of baud rate
- Serial RS232 interface
- Ribbon cartridge £6.60 + VAT + 50p P&P
- 2000 sheets Fan Fold paper £18.00 + VAT + £2.50 P&P

Nascom Imp
£325
Plus VAT + £2.75 P&P

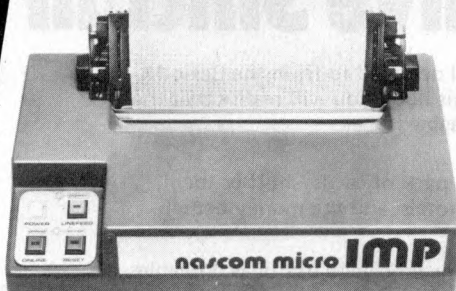

NASCOM-1

12" x 8" PCB carrying 5LSI MOS packages, 16 1K MOS memory packages and 33 TTL packages. There is on-board interface for UHF or unmodulated video and cassette or teletype. The 4K memory block is assigned to the operating system and video display leaving a 1K user RAM. The MPU is the standard Z80 which is capable of executing 158 instructions including all 8080 code. Built price £140 + VAT.

Nascom-1 Kit Price
£100 Plus
- P&P £1.50

NASCOM FIRMWARE IN EPROM

NASPEN £30.00 + VAT + 35p P&P
ZEAP 2 £50.00 + VAT + 50p P&P
NAS-SYS 1 £25.00 + VAT + 35p P&P
NAS-DIS £37.50 + VAT + 35p P&P
NAS-DEBUG £15.00 + VAT + 35p P&P
NAS-SYS 3 £40.00 + VAT + 35p P&P

NASCOM HARDWARE

Motherboard £5.50 + VAT + 50p P&P
Mini Motherboard £2.90 + VAT + 50p P&P
3 amp PSU £32.50 + VAT + £1.50 P&P
VERO DIP board £12.50 + VAT + 50p P&P
FRAME £32.50 + VAT + £2.00 P&P
8 Amp PSU Built £140.00 + VAT + £2.75 P&P
I/O Board £45.00 + VAT + £1.00 P&P
Buffer Board £32.50 + VAT + 50p P&P

NASCOM SOFTWARE ON TAPE

8K BASIC £15.00 + VAT + 50p P&P
ZEAP 2 £30.00 + VAT + 50p P&P

Microtype
Model 3 Case £24.50 + VAT + £1.50 P&P

NEW POCKET COMPUTER FOR UNDER £100 + VAT. SHARP PC-1211

It's true! A real computer that employs the BASIC programming language and fits into a pocket!

The PC-1211 measures only 175mm wide by 70mm deep by 15mm high and weighs a mere 170g (less than 6 ounces) yet look at its features! Up to 1424 program steps, 80 character input line with full editing features, 18 user definable keys, 24 character alpha-numeric LCD display and built-in tone function are included.

An optional cassette interface is available for loading or dumping programs or data. The PC-1211 is battery operated, has an auto power off function, and maintains all programs and data in its memory even after the power has been turned off.

£91.26
Plus VAT - P&P £1.00
(cassette interface £13.00 plus VAT + P&P 50p)

NASBUS EPROM BOARD

Expands Nascoms 1 & 2 with up to 32K of Eprom. Accepts 2708s or 2716s. Also 24 pin socket for 8K ROM. Wait-state fitted for N2 users. Board can also support Nascom Page Mode Scheme.

£55 (Built & tested) Plus £1.00 P&P
+ VAT (Kit)

£70 (Built & tested) Plus £1.00 P&P
+ VAT

Prices correct at time of going to press.

INTERFACE COMPONENTS LTD.
OAKFIELD CORNER, SYCAMORE ROAD, AMERSHAM, BUCKS HP6 6SU
TELEPHONE: 02403 22307. TELEX 837788

**ELECTRONIC BROKERS LTD
VDU PRICES**

SHATTERED

£199



HAZELTINE 1000
The low, low priced teletypewriter — compatible video display terminal with 12" screen (12 x 80) 64 ASCII alphanumeric and symbols. Full/Half Duplex. RS-232

£299

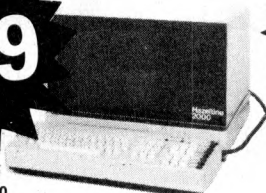

HAZELTINE 2000
The world's largest-selling teletypewriter — compatible video display terminal. Features include: 12" screen (74 x 27) 64 alphanumeric and symbols. 32 ASCII control codes. Switch-selectable transmission rates to 9600 baud. Three switch-selectable operating modes full-duplex, half-duplex or batch. Direct cursor addressability. Dual-intensity video. Tabulation. Powerful editing capability. Remote keyboard. Selective or automatic roll-up. RS-232

£399



MODULAR ONE BASIC
Now with Upper & Lower Case 12" screen (24 x 80). XY cursor addressing, 64 ASCII alphanumeric & symbols. Dual intensity detachable keyboard. Choice of 8 transmission rates up to 9600 baud. RS232. Range of options including printer port (£70.00).
MODULAR ONE EDIT
All the above plus full edit capability, tabulation, 8 special function keys + many other features. £695.00.
POLLING MODELS also available — P.O.A.

ALL EQUIPMENT RECONDITIONED UNLESS OTHERWISE STATED

NEW! NEW! NEW! GP80 GRAPHICS PRINTER

80 column 30 cps matrix printer with full upper/lower case ASCII character set PLUS GRAPHICS FACILITY. Adjustable tractor feed. Standard Centronics parallel interface ONLY **£249.00**
Optional interfaces available for RS232, IEEE, Pet, Tandy and Apple.

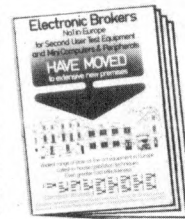

NEW CATALOGUE JUST OUT. Send for your FREE copy now.

WE HAVE MOVED — TO EXTENSIVE NEW PREMISES



Electronic Brokers Ltd., 61/65 Kings Cross Road, London WC1X 9LN. Tel:01-278 3461. Telex 298694

ZX80

'THIS BOOK IS EXCELLENT' — Clive Sinclair

This unique book contains 30 programs all designed to fit in the Basic 1k version of the SINCLAIR ZX-80!! With this book you will realise that the ZX-80 is more powerful than you ever imagined!

112 pages packed with solid information!

BLACKJACK — actually contains a full pack of cards, shuffles them, keeps track of the dealer and players card totals, and the money bet, all within 1k.

MEMORY LEFT — an incredible routine especially useful as it enables you to know exactly how much memory is left, even during the running of a program. This also illustrates USR routines.

DR. ZX-80 — A conversational program with the computer as analyst which uses an ingenious method of storage.

GOMOKU — the computer challenges you to this complex Japanese game, Incredibly this program including display of the 7 x 7 board fits into 1k — it only does so because it uses the display as memory!

Other programs included are HORSE RACE, LUNAR LANDER (with moving spaceship), NOUGHTS AND CROSSES, NIM, SIMPLE SIMON, HANGMAN, LIFE, MASTERMIND, PINCH and seventeen others.

As well as the programs, the book illustrates programming techniques you can use in your own programs — space compression, PEEKs and POKEs, USRs and so on.



£6.95 (plus 50P p&p)

available by mail order only

Please send me copies of 30 programs for the Sinclair ZX-80 1k

NAME

ADDRESS

MELBOURNE HOUSE PUBLISHERS

Orders to: 131 Trafalgar Road, London SE10
Correspondence: Glebe Cottage, Glebe House, Station Road, Cheddington, Leighton Buzzard, Bedfordshire.

Please enclose cheque or P.O., for £7.45 per copy. Orders outside the UK £7.95

NORTH STAR BUSINESS SYSTEM

WORD-PROCESSING
STOCK CONTROL
INVOICING
SALES & PURCHASE LEDGER
ETC. ETC.

FREE
CP/M &
WORDSTAR

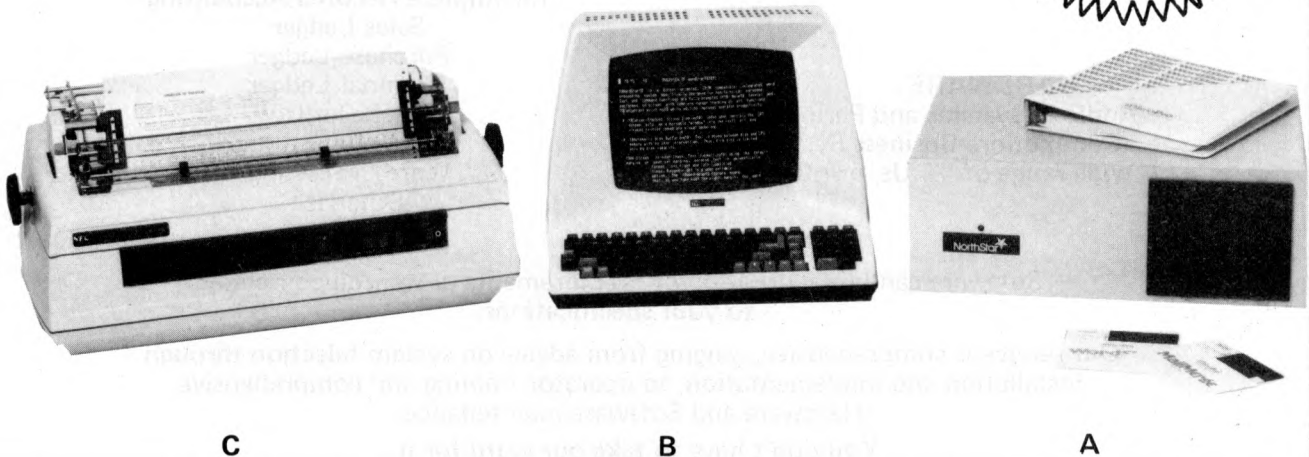

C

B

A

**EX-STOCK PROVEN RELIABILITY
1 YEAR GUARANTEE**

SAMPLE RECOMMENDED SYSTEM (AS ABOVE):—

A	Horizon Computer (64K Ram 2 D/D Drives)	£2080.00
B	TVI-912C VDU, numerous features	£595.00
C	NEC RO Spinwriter (RS232) + tractors	£1775.00
	COMPLETE SYSTEM PRICE (Includes cables)	£4450.00
	ABOVE SYSTEM WITH DOUBLE-SIDED DRIVES	£4730.00

FREE !! WORDSTAR plus CP/M with above system.

INVENTORY Package — With Sales & Purchase Management System	£295.00
KDS Development System for North Star BASIC	£50.00
KDS Disk Despooler — North Star DOS despooler	£50.00
CP/M V2.2 — supports double-sided drives	£95.00
WORDSTAR V2.1 — Superb word processing package	£235.00
MAIL-MERGE — Adds form letter generation to WORDSTAR	£75.00
DATASTAR — CP/M compatible Database Management System	£195.00
North Star UCSD PASCAL-D/Q System	£105.00
Microsoft BASIC interpreter V5.1	£155.00
Microsoft BASIC compiler V5.1	£195.00
Microsoft FORTRAN-80	£205.00
Econoram IIa — 8K Static Memory	£100.00
Econoram XX — 32K Static Memory with bank switching	£355.00
DMB-6400 — 64K Dynamic RAM with bank switching	£545.00
Godbout Interfacer 1 — 2 full RS232 serial I/O card	£135.00
Switchboard — 2 Serial, 4 parallel I/O card	£155.00
OKI Microline-80 Printer — Lightweight, 80 cps, Graphics	£425.00
Paper Tiger Printer — 2K buffer, full graphics, form-feed	£595.00
Anadex DP9500 Printer — Fast, bi-directional, logic-seeking	£895.00
Morrow 26Mb Hard Disk Sys. + Timeshaver CP/M-North Star DOS	£3495.00
Morrow 26Mb Hard Disk — Add on hard disk	£2495.00

PLEASE WRITE OR PHONE FOR LATEST PRODUCT CATALOGUE

PHONE US OR CONTACT
YOUR NEAREST DEALER

- CODAS LTD**
Pontypridd Wales Tel: 0443-406450
- CONQUEST COMPUTER SALES LTD**
Benfleet Essex Tel: 03745-59861
- DIGITAL DEVICES LTD**
Southborough Kent Tel: 0892-37977/9
- FYLDE MICROCOMPUTER SERVICES**
Blackpool Lancs. Tel: 0253-692954
- THE HARDWARE SOFTWARE CO.**
London NW3 Tel: 01-722 6436
- HOTEL MICROSYSTEMS LTD**
Middlesex Tel: 01-890 9696
- JAD INTEGRATED SERVICES**
Plymouth Devon Tel: 0752-626164
- KBS COMPUTER SERVICES**
Liverpool Tel: 051-236 8333
- KBS COMPUTER SERVICES**
Cardiff Wales Tel: 0222-394313
- KBS COMPUTER SERVICES**
Coventry Warwicks. Tel: 0203-27266
- LOVEDEN COMPUTER SERVICES LTD**
Grantham Lincs. Tel: 0476-72000
- MICRO FACILITIES LTD**
Hampton Hill Middx. Tel: 01-979 4546
- MICROSYS LTD**
Prescot Merseyside Tel: 051-426 7271
- MICROTECH COMPUTER SERVICES**
Liverpool Tel: 051-236 2208/9
- SAPPHIRE SYSTEMS**
Billericay Essex Tel: 02774-57743
- SPOT COMPUTER SYSTEMS LTD**
Doncaster Yorks Tel: 0302 50833
- S. SYSTEMS**
Crawley Sussex Tel: 0293-515201
- STAG TERMINALS LTD**
Teddington Middx. Tel: 01-943 0777
- SUMLOCK-BONDAIN LTD**
London EC1 Tel: 01-250 0505
- VIDEO VECTOR DYNAMICS LTD**
Glasgow Scotland Tel: 041-226 3481/2

INTERAM

UK Distributor:
INTERAM Computer Systems Ltd.
59 Moreton Street,
Victoria, London SW1V 2NY
Tel: 01-834 0261/2733
Telex: 925859



Scotland's Complete Microcomputer Service

now supply and support:

HARDWARE:
 Apple II Systems and Peripherals
 Commodore Business Systems
 A wide range of VDUs, printers, etc.

SOFTWARE:
 Incomplete Records Accounting
 Sales Ledger
 Purchase Ledger
 Nominal Ledger
 Stock Control
 Payroll
 Word Processing
 Database

Software can be tailored to your requirements or written completely to your specifications.

Our service is comprehensive, ranging from advice on system selection through installation and implementation, to operator training and comprehensive Hardware and Software maintenance.

You don't have to take our word for it.
 Call us and arrange a demonstration.

Gate Microsystems Limited

THE NETHERGATE CENTRE, 66 NETHERGATE,
 DUNDEE. TEL: (0382) 28194.

Wego Computers Ltd

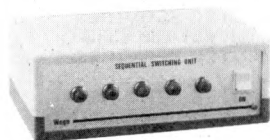

Wego Sequential Switching Unit

Allows up to 5 devices to be connected to the mains, and with one switching operation power up and down all the devices, in the correct sequence.

 CBM approved
 £75.00 + VAT



Numeric Key Pad for the Apple.

A 13 digit Key pad (0-9, -, ., ENTER) to run in parallel with the numeric section of the APPLE Keyboard. Supplied with connecting cable, plugs and sockets.

£89.50 + VAT

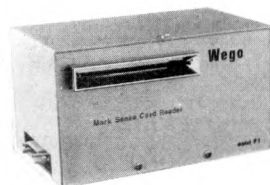

Mark Sense Card Reader

"A pencil, a card, and this low-cost reader. . . it's the new, fast way to enter data into your microcomputer." Versions available able to communicate with PET, APPLE, TRS-80, or any S100 or RS232 bus. Ideal for business and education applications.

 CBM approved
 Prices from £620 + VAT

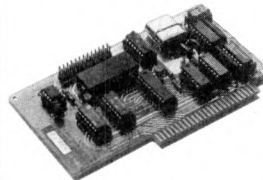

California Computer Systems Cards for the Apple.

Synch Serial Card	£119.97+VAT
Asynch Serial Card	£106.37+VAT
Parallel Card	£ 79.97+VAT
Arithmetic Proc. Unit	£265.97+VAT
Programmable Timer	£106.37+VAT
IEEE GPIB	£199.50+VAT
A/D Converter	£ 99.72+VAT
ROM/PROM Module	£ 70.89+VAT
Clock Card	£ 83.33+VAT
Centronics Card	£ 79.97+VAT

 Sole UK Distributors

Available from your local dealers, or direct from Wego Computers Ltd., 22A, High Street, Caterham, Surrey CR3 5UA. Tel: (0883) 49235 Telex: 933660

Authorised COMMODORE & APPLE Dealers

SUMLOCK BONDAIN makes the decisions easier..



Discover the full professional power of Hewlett Packard's personal computer.

The portable, stand-alone HP-85 personal computer was only the beginning of a total system. By itself, the HP-85 lets you put professional problem-solving power wherever you need it. Because all its features are built into a single unit weighing less than 10 kgs.

And now you can extend the HP-85's power to match your increasing professional requirements. Simply plug in HP's new high-performance printers, plotters and flexible disc systems. In fact, you can add up to 14 peripherals or instruments. It's up to you.

It's your personal computer system. You decide which HP peripherals you need.

Add the HP 2631B printer for high-speed, high-quality printing - with choice of line spacing, character width and density. Add the HP 7225 Graphics Plotter for high-resolution, publication-quality graphics on A4-size paper or film. Add memory with the HP 82900 series of flexible disc drives, each 5¼" disc providing up to 270K bytes of formatted storage. And HP's new enhancement ROMs and modules let you expand to 80K bytes of operating system, without reducing user memory.

See the HP-85 and its new peripherals in action. Getting your hands on so much professional computing power was never so easy.



It costs less from the calculator specialists. Advanced calculators to solve your professional problems.

...with our latest range of advanced calculators to solve your professional problems.

HP-32E Advanced statistical and scientific calculator All functions of the 31E plus hyperbolics and their inverses. Full set of 2 variable statistics - means, standard deviations, linear regressions, Fixed, scientific or engineering display modes. 15 addressable storage registers.

£38.76



NEW

HP-34C Advanced programmable scientific calculator Indirect addressing. Controlled memory varying between 210 program lines and 70 data registers. Innovative SOLVE and INTEGRATE functions. With Continuous Memory to retain data and programs even when switched off.

£79.50



£406.88

HP-67/HP-97 Magnetic card programmable calculators

Pre-recorded application packs covering maths, statistics, electrical engineering, business and finance. 20 data storage registers. 224 merged program lines with up to 3 keystrokes per line.

HP-97 is a desk-top model with integrated thermal printer. £196.87

NEW

HP-38C Programmable financial calculator

Direct solution of rate of return and NPV in discounted cash flow calculations. Interest rates, yields, payments, number of payments etc. Applications in securities trading, leasing, loans and savings. Calendar functions. Programmable facility for individual solutions. With Continuous Memory to retain data and programs even when switched off.

HP-38E Lower cost version of HP-38C without Continuous Memory. £79.50
HP 38E £66.45

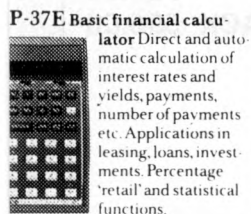

P-37E Basic financial calculator Direct and automatic calculation of interest rates and yields, payments, number of payments etc. Applications in leasing, loans, investments. Percentage 'retail' and statistical functions.

£41.78

No hidden extras. Every Hewlett-Packard calculator comes complete with: soft, zip-up lined case; owner's and application manuals (plus additional applications book where appropriate); factory-fitted rechargeable cells and recharger (apart from the 41C); two rolls of thermal paper on printing machines. Beyond the standard package, we've a wide range of optional accessories and our comprehensive software support, which gives you a choice of applications pacs to really extend your range of ability.



NEW

HP-41C HP's unique expandable calculating system Advanced 130-function programmable calculator. Full alphanumeric liquid crystal display. Up to 319 registers for data or programs. Add-on extras include Magnetic Card Reader and Printer.

HP41C £168.04
HP82104A £122.76
HP82143A £219.89



NEW

HP-33C Programmable scientific calculator 49 lines of program memory. 3 levels of subroutines. 8 addressable storage registers. Integer, fraction and absolute value of a number. With Continuous Memory to retain data and programs even when switched off.

HP-33E Lower cost version of HP-33C without Continuous Memory. HP33C £59.50
HP33E £49.83

Come to the Hewlett Packard open days at our new premises in City Road, December 2nd and 3rd. Come and hands-on test any of our superb range of products.

SUMLOCK BONDAIN LTD.

Head office: 263-269 City Road, London EC1V 1JX
and at Cannon Street Station, London EC4
Tel. 01-250 0505 Telex 299844

If you need advice, ask for it — WE CAN GIVE IT!
Barclaycard/ Access, official orders accepted by phone

All prices include postage, packing & VAT

aculab

floppy tape,

The tape that behaves like a disc,
For TRS-80 LEVEL II and Video Genie.

Connects directly to TRS-80 Level 2 Keyboard. Operating and file handling software in ROM. 8 commands add 12 powerful functions to Level 2 BASIC. No buttons, switches or volume controls. Full control of all functions from Keyboard or program. Daisy chain multiple drives. Certified digital tape in endless loop cartridges. Reads and writes in FM format at 9000 Baud. Soft sectored with parity and checksum error detection for highly reliable operation—just like discs. Maintains directory with up to 32 files on each tape, tapes may be write-protected. Supports Basic and machine-language program files, memory image and random access data files. 12 character filespecs—: "FILENAME/EXT:d" (d is drive no. 0-7). Automatic keyboard debounce. Full manual with programming examples and useful file-handling routines.

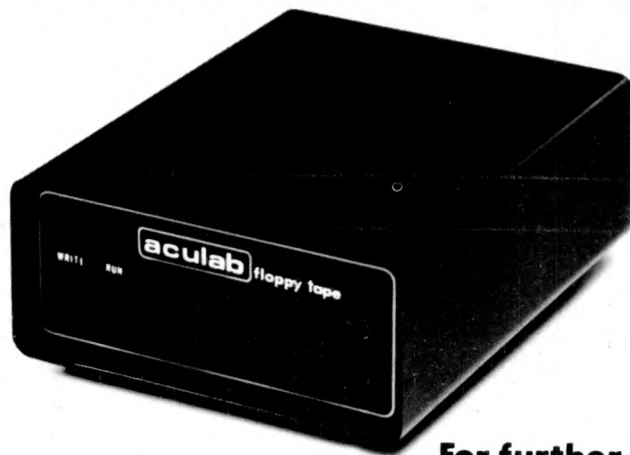

COMMANDS (usually followed with a filespec and possible parameter list).

@SAVE, @LOAD, @RUN —for BASIC programs, machine language programs and memory image files. **@GET, @PUT** —moves a 256-byte record between a random access file and BASIC's data buffer. **@KILL** —removes a file from the directory and releases tape sectors for immediate re-use. **@LIST** —displays file directory along with sector allocation and free sectors. **@NEW** —formats tape and creates a blank directory.

Master drive with PSU, Manual and a selection of tapes.

For TRS-80 £169-00, for Video Genie £174-00.

Slave drives £125-00. (add £2-00 p.p. + vat).

(Export orders pp charged at cost)

For further information,
Telephone
0525 371393

aculab Ltd.
24 Heath Road,
Leighton Buzzard,
Beds. LU7 8AB

AD 2000 IS HERE!

SMG Microcomputers

SOFTWARE



39 Windmill St., Gravesend, Kent.

TEL: 0474-55813

Open 9-5.30

AD2000 STOCK CONTROL	395.00
AD2001 SALES LEDGER	395.00
AD2002 PUR. LEDGER	395.00
AD2003 MAILIST 1	75.00
AD2004 MAILIST 4	150.00
AD2010 SOLICITORS PACK	750.00
AD2011 PLANNING/MAINT PACK	595.00

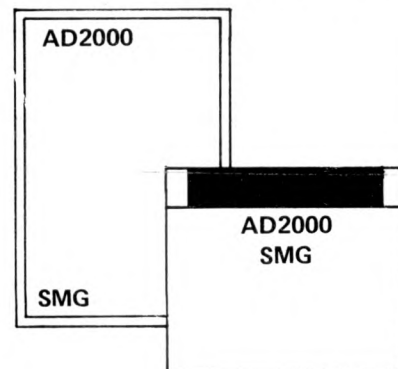
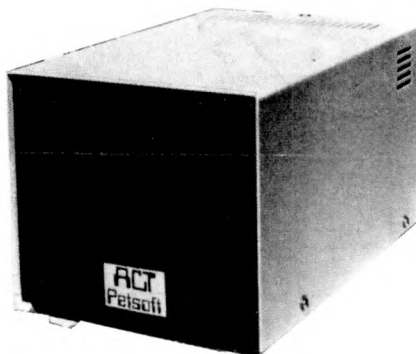

DEALER ENQUIRIES WELCOME *****

COMING SHORTLY:— VETS PACKAGE, INCOMPLETE RECORDS & WAREHOUSE PACKAGE

A GREAT DEAL FROM 6 NASCOM DEALERS

and guaranteed after-sales service

BUILT FLOPPY DISC SYSTEM FOR NASCOM 1/2 FROM £395+VAT

It's here at last. A floppy disc system and CP/M. **CP/M SYSTEM.**

The disc unit comes fully assembled complete with one or two 5 $\frac{1}{4}$ " drives (FD250 double sided, single density) giving 160K per drive, controller card, power supply, interconnects from Nascom 1 or 2 to the FDC card and a second interconnect from the FDC card to two

drives, CP/M 1.4 on diskette plus manual, a BIOS EPROM and new N2MD PROM. All in a stylish enclosure.

Nascom 2 Single drive system . £450 + Vat
 Nascom 2 Double drive system £640 + Vat
 Nascom 1 Single drive system . £460 + Vat
 Nascom 1 Double drive system £650 + Vat
 Additional FD250 drives £205 + Vat

D-DOS SYSTEM

The disc unit is also available without CP/M to enable existing Nas-Sys software to be used. Simple read, write routines are supplied in EPROM. The unit plugs straight into the Nascom PIO.

Single drive system £395 + VAT
 (please state which Nascom the unit is for)

Certain parts of the CP/M and D-DOS disc systems are available in kit form. Details available on request.

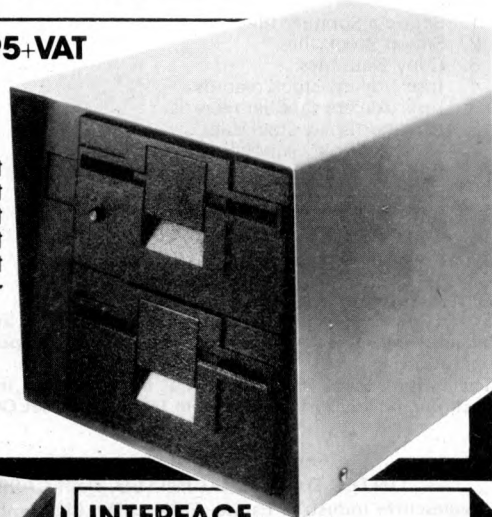

ENCLOSURE FOR N2 + 5

The Kenilworth case is a professional case designed specifically for the Nascom 2 and up to five additional 8" x 8" cards. It has hardwood side panels and a plastic coated steel base and cover. A fully cut back panel will accept a fan, UHF and video connectors and up to 8 D-type connectors. The basic case accepts the N2 board, PSU and keyboard. Optional support kits are available for 2 and 5 card expansion.

Kenilworth case £49.50 + Vat
 2-card support kit £7.50 + Vat • 5-card support kit £19.50 + Vat

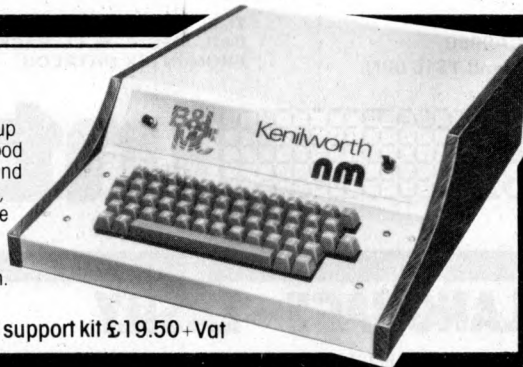

INTERFACE ENHANCING UNIT

The Castle Interface is a built and tested add-on unit which lifts the Nascom 2 into the class of the fully professional computer. It mutes spurious output from cassette recorder switching, adds motor control facilities, automatically switches output between cassette and printer, simplifies 2400 baud cassette operating, and provides true RS232 handshake.

Castle Interface Unit .. £17.50 + Vat

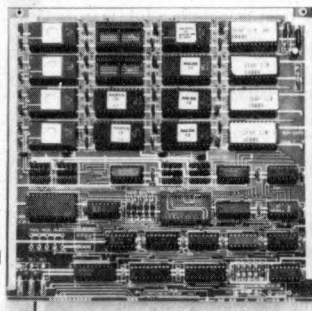

EPROM EXPANSION

The Nasbus compatible EPROM board accepts up to 16,2708 or 2716 EPROMs. It has a separate socket for the MK36271 8K BASIC ROM for the benefit of Nascom-1 users. And for Nascom-2 users, a wait state for slower EPROMs. The board also supports the Nascom Page Mode Scheme.

EPROM Board (kit) £55 + Vat
 EPROM Board (built & tested) £70 + Vat

A-D CONVERTER

For really interesting and useful interactions with the 'outside world' the Milham analogue to digital converter is a must. This 8-bit converter is multiplexed between four channels - all software selectable. Sampling rate is 4KHz. Sensitivity is adjustable.

Typical applications include temperature measurement, voice analysis, joystick tracking and voltage measurement. It is supplied built and tested with extensive software and easy connection to the Nascom PIO.

Milham A-D Converter (built and tested) £49.50 + Vat

PROGRAMMER'S AID.

For Nascom ROM BASIC running under Nas-Sys. Supplied in 2x2708 EPROMs. Features include: auto line numbering; intelligent renumbering; program appending; line deletion; hexadecimal conversion; recompression of reserved words; auto repeat; and printer handshake routines. Price £28 + Vat.

DUAL MONITOR BOARD. A piggy-back board that allows N1 users to switch rapidly between two separate operating systems. Price (kit): £6.50 - Vat.

BASIC PROGRAMMER'S AID.

Supplied on tape for N1/2 running Nas-Sys and Nascom ROM BASIC. Features include auto line number, full cross-reference listing, delete lines, find, compacting command, plus a comprehensive line re-numbering facility. Price: £13 - Vat.

PROM-PROG MKII.

2708 (multi-rail) and 2716 (single-rail) EPROM programmer kit controlled by N1/2 PIO. Supplied with comprehensive software for use with Nas-Sys. Price: £25.95 - Vat.

NASCOM-2 Microcomputer Kit £225 + Vat
 NASCOM-1 Microcomputer Kit £125 + Vat
 Built & tested £140 + Vat
 IMP Printer. Built & tested £325 + Vat

All prices are correct at time of going to press.

All the products are available while stocks last from the Nascom dealers below. (Mail order enquirers should telephone for delivery dates and post and packing costs.) Access & Barclaycard welcome.

BITS & PC'S
 4 Westgate, Wetherby, W. Yorks.
 Tel: (0937) 23744

BUSINESS & LEISURE MICROCOMPUTERS
 16 The Square, Kenilworth, Warks.
 Tel: (0926) 512127.

ELECTROVALUE LTD.
 680 Burnage Lane, Burnage,
 Manchester M19 1NA.
 Tel: (061) 432 4945.

28 St Judes, Englefield Green,
 Egham, Surrey TW20 0HB.
 Tel: (0784) 33603. Tlx: 264475.

TARGET ELECTRONICS
 16 Cherry Lane, Bristol BS1 3NG.
 Tel: (0272) 421196

INTERFACE COMPONENTS LTD.
 Oakfield Corner, Sycamore Road,
 Amersham, Bucks.
 Tel: (02403) 22307. Tlx: 837788.

HENRY'S RADIO
 404 Edgware Road, London W2.
 Tel: (01) 402 6822.
 Tlx: 262284 (quote ref: 1400)

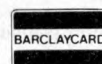

Intex DATALOG LTD COMPUTERS

MICROPAY-200

STOCK CONTROL 3750

Stock Control 3750 is a complete stock control system designed and written to meet the needs of a small business.

It will accommodate up to 3747 stock items and runs on a COMMODORE PET microcomputer interfaced to a printer and COMPU/THINK disk drives.

The System incorporates programs to:

1. Set up a Supplier file.
2. Set up Stock files.
3. Copy Data files.
4. Insert/delete stock records.
5. Insert/delete supplier records.
6. Update/display stock file.
7. Update/display supplier file.
8. Print stock list.
9. Print supplier list.
10. Print reorder report.
11. Print stock movement report.
12. Print stock valuation report.

And perform other useful routines.

Stock Control 3750 is fully protected from misuse and can easily be used by someone with no knowledge of computers or their operation.

The System costs 195.00 + V.A.T. and this price includes a full back-up and advisory service from INTEX DATALOG.

For full specification write to:-

INTEX DATALOG LIMITED, Dept CA0980

Eaglescliffe Industrial Estate, Eaglescliffe, Cleveland TS16 0PN.

Micropay-200 is a complete payroll System designed to run on a COMMODORE 32K PET microcomputer, interfaced to dual floppy disk drives and a printer.

The System provides:

1. Weekly/monthly payslips
2. Summary page of all payments and deductions that month
3. Summary page of all payments and deductions for the tax year to date
4. Weekly/monthly cash analysis slip for all cash payments made
5. Monthly summary of all payments and deductions
6. Year end summary of all payments and deductions

The System copes with:

1. Up to 200 current employees, plus end of the year details of up to a further 400 ex-employees who have left during the year.
2. Suffix L,H,P,V and T cumulative and Week 1 Codes
3. Prefix D and prefix F, BR and NT codes
4. All necessary alterations concerned with changes in income tax rates, band widths and personal allowances.
5. National Insurance Contributions at rates A, B and C for non-contracted out employees and at rates D and E for contracted out employees.
6. All necessary alterations concerned with changes in N.I. contribution rates and earnings limits.
7. Up to 5 user-definable wage rates for each employee, plus the normal hourly rate.
8. Holiday pay — including a check on the amount of holiday taken in the year
9. Up to a total of 5 user-definable additions/deductions to the before after tax pay
10. Changing an employee from one N.I. rate to another and backdating such a change
11. Job costing and analysis

THE SYSTEM COSTS 195.00 + VAT AND THIS PRICE INCLUDES A FULL BACK-UP AND ADVISORY SERVICE FROM INTEX DATALOG.

Intex

GET INTO MACHINE LANGUAGE — EASILY

UNLEASH THE ENORMOUS ADVANTAGE OF MACHINE LANGUAGE PROGRAMMING ON YOUR TANDY TRS-80 OR VIDEO GENIE WITH THE HELP OF KANSAS.

The Kansas Editor, Assembler & Debugger is the program to get you into machine language programming, for not only does it include a full feature editor assembler, but a complete debugger as well — two in one, in fact.

Altogether it contains 22 different commands, which are available at all times and simply entered as Input.

In addition to the commands you have the option of outputting to either the video, cassette or a printer.

Edit commands include Enter, which allows the continuous entry of text anywhere in the file; Zap to erase lines; New to replace a line with a new one. All with line numbers automatically displayed as a guide.

The assembler accepts source statements in the Z80 language, each line divided into fields, including comments which are of course ignored. These include the label, operator and operands, which are all very extensive.

Symbols can be used instead of values, or by using the pseudo operand your own value can be assigned to a symbol. There are many commands for this, all giving a very easy usage of this assembler, whether source or object.

The commands for the assembler include Size, Sort, Assemble, Kill, Top, Bottom, Up, Down, Print, Find.

Error messages are generated if an error is found by the assembler, with the line displayed and the command loop re-entered.

The assembled program can be listed on the video or onto the printer and both the source and object files can be saved onto cassette and read back into memory.

The program is line orientated, and so always maintains a pointer to the current line, with the pointer movable by various commands.

The various debugger commands allow a great deal of control and are very extensive, including Copy, Goto, Modify, Fill, Examine and Check.

User input can be edited and parameters can be either decimal, hexadecimal or octal.

We believe this to be the best program of its kind on the market, not only for its extensive features but for its ease of operation and especially for its price. . .

£19.50. Return first class post service. Barclaycard or Trustcard accepted.

GRAPHICS ASSEMBLER £8.50

Assemble graphics in your Basic program in super-fast machine language — and by simple Basic statements!

That's what you can do with the Graphics Assembler.

This remarkable program will allow you to take a single line of any Basic program and pack it with machine language graphics and control commands.

The program itself being in Basic means it can easily be incorporated in any of your Basic programs to give extended graphics capability without having to load the two separately.

And of course, all kinds of animation of the graphics created can be obtained, using the normal Basic routines.

All that is needed in a Basic program is a 'dummy' line, to take the characters in a string.

As each character is inserted the actual graphic block is shown on the screen.

Just think what you can do with your program with various lines containing this facility.

Unlock the entire graphics potential of your Tandy TRS-80 or Video Genie, and see what your computer is really capable of.

FREE
'Master and Editor
Assembler' By Laurie
Shields starts you off
from square one.

This program will run perfectly on the Video Genie as it does not utilise the right arrow key

Kansas

Kansas City Systems, Unit 3, Sutton Springs Wood, Chesterfield, Derbys. Tel 0246 850357

MAGTRONICS

74LS SERIES

74LS00	.18				
74LS01	.18	74LS114	.35	74LS242	1.90
74LS02	.18	74LS122	.70	74LS243	1.90
74LS03	.18	74LS123	.75	74LS244	2.10
74LS04	.22	74LS124	1.40	74LS245	2.50
74LS05	.22	74LS125	.40	74LS247	1.20
74LS08	.20	74LS126	.40	74LS248	1.80
74LS09	.22	74LS132	.65	74LS249	1.25
74LS10	.18	74LS133	.40	74LS251	1.10
74LS11	.22	74LS136	.40	74LS253	1.10
74LS12	.22	74LS138	.70	74LS257	1.10
74LS13	.40	74LS139	.70	74LS258	0.95
74LS14	.70	74LS145	1.10	74LS259	1.65
74LS15	.22	74LS148	1.70	74LS260	.30
74LS20	.20	74LS151	.85	74LS261	3.50
74LS21	.22	74LS153	.55	74LS266	.40
74LS22	.22	74LS154	1.40	74LS273	1.75
74LS26	.22	74LS155	.75	74LS279	.65
74LS27	.22	74LS156	.75	74LS280	1.75
74LS28	.22	74LS157	.60	74LS283	1.00
74LS30	.20	74LS158	.65	74LS290	0.95
74LS32	.26	74LS160	1.10	74LS293	0.95
74LS33	.28	74LS161	.80	74LS295A	1.45
74LS37	.26	74LS162	1.10	74LS298	1.40
74LS38	.26	74LS163	.80	74LS324	1.80
74LS40	.22	74LS164	1.10	74LS325	2.55
74LS42	.65	74LS165	.80	74LS326	2.55
74LS47	.85	74LS166	1.70	74LS327	2.55
74LS48	.85	74LS168	1.70	74LS352	1.35
74LS49	1.00	74LS169	1.70	74LS353	1.35
74LS54	.20	74LS170	1.70	74LS365	.60
74LS55	.20	74LS173	1.10	74LS366	.60
74LS63	1.50	74LS174	.95	74LS367	.60
74LS73	.35	74LS175	.95	74LS368	.60
74LS74	.35	74LS181	2.75	74LS373	1.75
74LS75	.42	74LS190	1.20	74LS374	1.75
74LS76	.35	74LS191	1.20	74LS375	.75
74LS78	.35	74LS192	1.10	74LS377	1.75
74LS83A	.85	74LS193	1.10	74LS378	1.30
74LS85	1.00	74LS194A	1.00	74LS379	1.40
74LS 86	.35	74LS195A	.90	74LS381	3.65
74LS90	.58	74LS196	.95	74LS386	.60
74LS91	.99	74LS196	.95	74LS390	1.75
74LS92	.90	74LS197	.95	74LS393	1.50
74LS93A	.65	74LS424	4.50	74LS395	1.80
74LS95A	1.00	74LS445	1.25	74LS396	1.70
74LS96	1.25	74LS447	1.25	74LS398	2.70
74LS107	.35	74LS490	1.95	74LS399	1.60
74LS109	.35	74LS221	1.20	74LS668	1.95
74LS112	.35	74LS240	2.10	74LS669	.95
74LS113	.40	74LS241	1.90	74LS670	.95

DISKETTES

UNCONDITIONAL GUARANTEE

5.25"	MINI-DISKETTES	SINGLE SIDED
	1 SECTOR	PER 10 £24.00
	(SOFT)	
5.25"	MINI-DISKETTE	SINGLE SIDED
	10 SECTOR	PER 10 £24.00
5.25"	MINI-DISKETTE	SINGLE SIDED
	16 SECTOR	PER 10 £24.00
8"	SINGLE SIDED	SINGLE DENSITY
	26 SECTOR	PER 10 £25.80
8"	SINGLE SIDED	DOUBLE DENSITY
	26 SECTOR	PER 10 £32.00
8"	DOUBLE SIDED	SINGLE DENSITY
	26 SECTOR	PER 10 £38.20
8"	DOUBLE SIDED	DOUBLE DENSITY
	26 SECTOR	PER 10 £40.00

MEMORIES

C.P.U.s

SUPPORT DEVICES

C.MOS.

TRANSISTORS

DIODES

ALL STOCKED

PHONE FOR

QUOTATION

All orders under £50 add 50 p P&P. Add 15% VAT to total.

Many other types of hard and soft sector diskettes available. Phone for quotation.

Magnetic cards, data cartridges, digital cassettes are also stocked.

Official orders from schools, colleges, universities and Govt. Bodies accepted.

E. PROMS	MEMORIES	C PUS.	SOCKETS
1702A	2114L	400p 6502	800p L.P.
2708	2114L-2	500p 6800	700p 8 PIN
2716(+5v)	2114L-3	500p 6802	1200p 14 PIN
2532(+5v)	4116L-2	500p 8080A	450p 16 PIN
	6810	350p 8085A	1100p 24 PIN
			9p
			10p
			11p
			22p

OHIO SCIENTIFIC

Bits and Pieces

Title	C1-P	C4-P	UK101	£	Title	C1-P	C4-P	UK101	£	Title	C1-P	C4-P	UK101	£
Galactic Warfare	BS428	BS446	BS456	7.00	Packer	ATS209	ATS209	ATS209	6.50	Awari	ATS225	ATS225	ATS325	4.00
Draughts	BS429	BS447	BS457	5.50	Chess	ATS240	ATS210	—	10.00	Bomber	ATS226	ATS226	ATS326	4.00
3D-Tic-Tac-Toe	BS430	BS448	BS458	6.50	Starfighter	ATS211	ATS211	ATS311	4.00	Slashball	ATS227	ATS227	ATS327	4.50
Super Fruit Machine	BS427	BS445	BS455	6.00	Ten Tank Blitz	ATS212	ATS212	ATS312	5.50	Math Practice	ATS229	ATS229	ATS329	3.50
Renumber BASIC	BS405	BS405	BS406	5.00	Battlefleet	ATS213	ATS213	ATS313	4.00	Cannoneers	ATS233	ATS233	ATS333	4.00
Checksum Save	BS407	BS407	BS407	5.00	Tank for Two	ATS214	ATS214	ATS314	4.00	Race Course	ATS236	ATS236	ATS336	4.00
Super Battleships	BS463	BS464	BS465	6.00	Robotank	ATS215	ATS215	ATS315	4.00	Air-Sea Battle	ATS238	ATS238	ATS338	4.00
Alien Invaders	ATS200	ATS200	ATS300	4.00	Breakthru	ATS216	ATS216	ATS316	4.00	Othello	BS100	BS100	BS100	5.00
Backgammon	ATS201	ATS201	ATS301	6.50	Reflex	ATS217	ATS217	ATS317	4.00	Labyrinth	BS603	—	—	5.00
Time Trek	ATS202	ATS202	ATS302	5.50	Concentration	ATS218	ATS218	ATS318	4.00	Silverstone	—	BS604	—	4.00
Variable Table	ATS205	ATS205	ATS305	4.00	Seawolfe	ATS221	ATS221	ATS321	4.00	U-Boat	ATS275	ATS275	ATS375	4.00
Search	ATS206	ATS206	ATS306	4.00	Killerbot	ATS222	ATS222	ATS322	4.00	Towers of Hanoi	BS101	—	—	5.00
Disassembler	ATS207	ATS207	ATS307	5.00	Fighter Pilot	ATS223	ATS223	ATS323	4.00	Shepherding	BS102	—	—	4.00
Poker Maker	ATS208	ATS208	ATS308	4.00	Lunar Lander	ATS224	ATS224	ATS324	4.00	Minefield	BS103	—	—	4.00

Stop Press! Programmable Character Generator board for all Ohio Scientific systems. Available from early January — phone for details!

LIFE

The ultimate implementation

Board size — 128x128

Speed — less than 1 1/2 secs/generation

Full cursor and board scan

Load and dump on cassette

Full documentation

Price: £10.00

FIRMWARE

CEGMON Monitor

The best thing for OSI systems since OSI itself!

New editor...new screen handler

New keyboard handler

New m/c monitor with full range of facilities

Available for Superboard/C1-P, C1-E, C1-U, C2, C4, UK101

£29.50 with 20-page booklet

HARDWARE

Standard display (25x25)

Superboard II, 4K **159.95**

Challenger 1P, 8K **245.00**

Display upgrade to 48x32 **40.00**

With 48x32 display, 2MHz speed

Superboard II-E, 4K **199.95**

Challenger 1P-E, 8K **285.00**

610 Expander board, 8K **159.95**

610 Expander board, 24K **250.00**

Single mini-floppy drive **289.00**

Base-2 matrix printer **375.00**

AIDS

Workpads

BASIC, machine-code, video memory-map, variables, etc. 100-sheet pads **£2.30**

Laminated cards as pads, plus 6502 opcodes, number conversions, ASCII, new Challenger graphics set. Cards **£0.80** each

We also stock books!

All prices quoted exclude VAT

OHIO SCIENTIFIC SYSTEMS

Norlett House, Dormer Road, Thame, Oxon OX9 3UC
Telephone (24hrs): Thame (084421) 5020

Enter the Computer Age video genie system

12K MICROSOFT BASIC
16K RAM, UHF MODULATOR
INTERNAL CASSETTE
SECOND CASSETTE INTERFACE

**£330
PLUS VAT**



80 COLUMNS
70 LINES PER MINUTE
GRAPHICS CHARACTERS
INTERFACES TO MOST MACHINES

**£395
PLUS VAT**

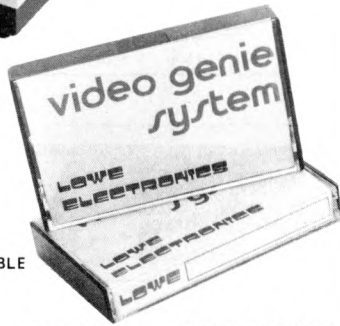
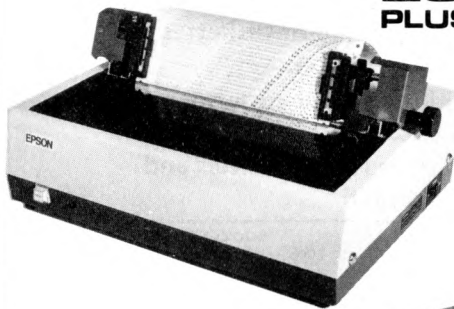

100's OF PROGRAMS AVAILABLE
TRS-80 LEVEL II SOFTWARE COMPATIBLE

Dealer List

3 Line Computing ABC Supplies	Hull 445496 Levenshulme 061-431-9265 Shipleigh 585333	East Midlands Computer Services Emprise Ltd G B Organs & TV	Nottingham 267079 Colchester 865773 St Saviour Jersey 26788
Advance TV Services	Stoke on Trent 616929	Gemsoft Kansas City Systems	Woking 22881 Chesterfield 850357
Allen TV Services	Huddersfield 20774	Kays Electronics Leisurronics Marton Micro- computer Services	Chesterfield 31696 Blackpool 27091 Northampton 890661 Melton Mowbray 812888 Stoke on Trent 541743
Amateur Radio Shop	Peterboro' 49577	Matrix Computer Systems	Beckenham 01-658 7508/7551
Anglia Computer Centre	Leicester 222 55	Midland Micro- computers	Nottingham 298281
Arden Data Processing	Littlehampton 22461	Microdigital Mighty Micro Mighty Micro	Liverpool 227-2535 Basingstoke 56417 Burnley 32209/ 53629
Beaver Computers	Blandford 53737	Morrison Computer Centre	Swansea 795817
Blandford Computers	Middlesborough 242017	MRS Communications	Cardiff 616396/7
Briers Bookshop	Watford 40698	Optelco	Rayleigh 774089
Buss Stop	Newport Pagnell 610625	C Owens	Peterlee 865871
Cambridge Micro- computers	Cambridge 314666	Q Tek Systems	Stevenage 65385
Catronics	Wallington 01-669 6700/1	Radio Shack Ltd	London NW6 01-624 7174
Cavern Electronics	Milton Keynes 314925	Rebvale Computers	Garboldisham 316
Computer Business Systems	Lytham 730033	SMG Micro- computers	Gravesend 55813
Computer and Chips	St Andrews 72569	SMG Micro- Tryfan Computers	Gravesend 55813 Bangor 52042
Computarama	Bath 333232	University Radio Stores	Nottingham 45466
Computopia	Leighton Buzzard 376600	Ward Electronics	Birmingham 021- 554-0708
D B Micro- computers	Limerick 42733	Watford Electronics	Watford 405888/ 37774
Derwent Radio	Scarborough 65996		
Eiron Computers	Dublin 808575/ 805045		
Eley Electronics	Dublin 808575/ 805045		
Eley Electronics	Leicester 871522		

LOWE ELECTRONICS

BENTLEY BRIDGE
CHESTERFIELD RD
MATLOCK
DERBYSHIRE DE4 4LE

Trade Enquiries Welcome



**CRYSTAL ELECTRONICS
CC ELECTRONICS**

SHARP MZ80K

**For the latest competitive
PRICE**

Contact us

Before you accept discounts elsewhere.

GIVE US A TRY

**CRYSTAL ELECTRONICS is the home of XTAL BASIC
ACCLAIMED BY MANY**

We KNOW the SHARP computers, we BACK the SHARP computers
What we give FREE is worth more than money.

**MZ80K owners — are you XTAL followers?
NO! Then please read on.**

XTAL BASIC (SHARP)

Takes 5K less memory, has all the features of SHARP BASIC
PLUS Multi dim strings, error trapping, logical operators,
machine code monitor, more flexible peripheral handling,
improved screen control, increased list control, auto run, If..
then.. else — and it doesn't stop there — it grows. You can
extend the commands and functions at will — 10K, 12K, 16K,
BASIC?

SHARP to XTAL BASIC conversion program is included.
£40 plus VAT (Disc version on its way)

**DESIGNERS OF MICROCOMPUTER SYSTEMS + XTAL BASIC
IS WORTH CONSIDERING ON COST ALONE.**

Members of Computer Retailers Association & Apple Dealers Association

Shop open 0930-1730 except Saturday & Sunday

40 Magdalene Road, Torquay, Devon, England. Tel: 0803 22699

Telex 42507 XTAL G

Access and Barclaycard welcome.



COMPUTERS
AND
COMPONENTS



**YOU NEED
SOUND EFFECTS**

FOR PET, SUPERBOARD, UK101, NASCOM.

- * COMPLEX EFFECTS AND MUSIC
- * USES INCREDIBLE AY-3-8910
- * COMPLETELY BUILT, SIMPLY PLUGS IN
- * BASIC OR MACHINE CODE
- * BUILT IN AMP & SPEAKER + STEREO
- * INCLUDES 2 8 BIT I/O PORTS
- * COMATIBLE WITH OTHER EXPANSIONS
- * FREE DEMO PROGRAM + INSTRUCTIONS

£43
+ VAT
EX STOCK

Send for free information leaflets.

NB: 8T28 buffers (Superboard/UK101) next 6502 @ £3.00
per pair if required

SOON AVAILABLE!! EPROM Programmer for Superboard/UK101.

Peripheral board 24 I/O lines for
relay driving etc., etc.

SUPERBOARD II 50Hz → £159 + VAT

610 EXPANSION £159 + VAT
CD3P FLOPPY DISC £285 + VAT
BASE 2 800MST PRINTER £359 + VAT

SOFTWARE FOR PET, SUPERBOARD, UK101, NASCOM.
EXAMPLES 4116-300ns 8 for £22.50

57 PARANA COURT
SPROWSTON
NORWICH
NR7 8BH
0508 46484

Easicomp

Can you afford to be less than excellent?

Whether you're in high vacuum technology, space research, brewing, computers or commerce, if you've got something to control, we've got something with which to control it.

Our top quality range of British designed and manufactured S100 products from INTERACTIVE DATA SYSTEMS are already used in all the above fields and others by many of the country's leading industries and universities etc.

They all chose IDS equipment for excellent reasons, i.e.: EXCELLENT SPECIFICATIONS,

EXCELLENT DESIGN,
EXCELLENT QUALITY,
EXCELLENT PRICES.



'High Vacuum Technology by SCANWEL Ltd, Bala, Gwynedd'

APPLY NOW FOR YOUR COPY OF OUR FREE CATALOGUE.

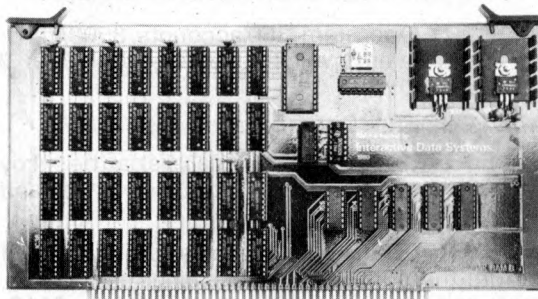

BRITISH S100 by INTERACTIVE DATA SYSTEMS

The MENDIP range includes:-

IDS SBMC	4MHz Z80A Single Board Micro Computer, 1K RAM, sockets for up to 32K EPROM, 2 Serial Ports, 4 channel CTC etc.	EA&T * 235.00
IDS 16K SRAM	16K bytes Static RAM board (2114).	198.00
IDS 8K SRAM	8K bytes memory board.	114.00
IDS DFDC	Double/single density, double/single sided diskette controller.	198.00
IDS PCI 10	A mixture of input and output channels of various types to monitor and control external circuitry.	223.00
IDS Z80 CPU	A basic 4MHz Z80A processor board.	105.00
IDS TERM 40	Active Termination Board.	32.50
IDS SARACEN SERIES	A range of "ready-to-go" systems based on IDS components. (VDU and Printer extra)	from 1925.70 to 2676.45

* We also sell KIT versions, however we strongly recommend A&T (Assembled & Tested) equipment to all except very experienced constructors with adequate test equipment. Please add VAT to all prices (standard rate 15%)

Mendip Computers...

57 BATH ROAD, WELLS, SOMERSET, BA5 3HS. TEL: WELLS (0749) 75249

MAIL ORDER ONLY.

Erase Eproms in 8 minutes for under £100

£97 delivered in U.K.
+ V.A.T.

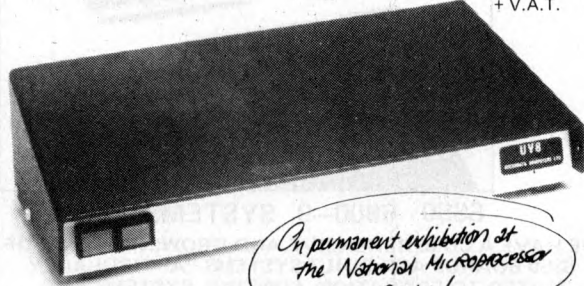

*On permanent exhibition at
the National Microprocessor
Centre!*

The high speed, high capacity model UV8 sets new performance and price standards.

- Cuts typical erasure times by a factor of 5
- 8 MINUTE SOLID STATE TIMER
- Capacity up to 14 EPROMS
- 2708 type erased in 4 to 7 minutes
- High intensity 254 NM UV source
- Safety interlock automatically starts timing sequence
- Audio tone signals erasure cycle complete
- Internal switch to extend erase time.

MICRODATA Computers Ltd, Belvedere Works, Bilton Way, Pump Lane Industrial Estate, Hayes Middlesex.

Telephone (01) 848 9871 (6 lines) Telex 934110

Happy Memories

4116	200ns	£2.95	2114	200ns	£3.45
2114	450ns	£2.95	2716	5V	£7.95
2708	450ns	£4.75			

Memorex soft-sectored mini-discs with free plastic library case £19.95 per 10.

Low profile I.C. sockets:

Pins:	8	14	16	18	20	22	24	28	40
Pence:	10	11	12	16	17	19	21	28	37

Euroconnectors:

64/96 Male (right angled) £2.39 64/96 Female £3.52

RS232 connectors (solder):

Male 25 way: £1.86 Female 25 way: £2.13

Hoods: 66p

ALL PRICES VAT INCLUSIVE

Please add 30p postage to orders under £10.

Government + Educational orders welcome
£10 minimum

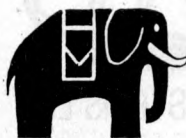

Happy Memories
Gladestry
Kington
Herefordshire
HR5 3NY

Tel: (054 422) 618

BARCLAYCARD



MAP SOFTWARE FAST MAIL

SALES LEDGER – Open item, 350 accounts, 3500 transactions, includes sales invoicing, requires 64K and 2 floppy drives – **£300**

PURCHASE LEDGER – Ditto (no invoicing) – **£300**

NOMINAL LEDGER – 250 heads of analysis can be set by the user, 2500 transactions, P & L, Balance Sheet and Trading Account – **£300**

ACCOUNTS PRODUCTION – Allows production of accounts from the nominal, after allowing for accruals, prepayments and up to 20 closing stock values – **£110**

STOCK RECORDING – In – Out balance system, receipts, orders, costings, below re-order levels, etc. – **£250**

INCOMPLETE RECORDS – Designed for the professional accountant for production of accounts from Vouchers, Statements, Private Entry Documents etc. – **£550**

As above including word processing for customisation of clients accounts – **£900**

NEWSBOY – An aid for Newsagents, keeps records of newsrounds, customer accounts etc. – **£425**

JOB COSTING – Creation, Post Purchases, Invoices, Labour, Stock, Delivery Notes, Status and Profitability – **£550**

MAP HARDWARE

DOLPHIN BD 80 PRINTER – Full feature, serial or parallel interface (state which please) – **£425 + cable**

TEXAS OMNI 810 – Printer, very reliable, good for heavy duty utilisation, full 132 character width – **£1450 + cable**

ANADEX 9500 – Superb fast matrix printer with lots of features including 132 column, character etc., serial interface – **£895 + cable**

We also supply SUPERBRAIN & DYNABYTE Computers, Desks, Stands, Work-Stations, Stationery, Media etc., etc.

Please rush me the following SOFTWARE / HARDWARE:—

Name _____

Address _____

Please make cheques payable to MAP as address below. Please allow 7 days for delivery. Hardware orders add £15 packing/delivery.



BELGRAVE ESTATE
HONEYWELL LANE
OLDHAM, MANCHESTER
Tel: 061-633 3804/5

COMPUTER SYSTEMS LTD.

small enough to CARE – large enough to COPE

IBM SELECTRIC GOLFBALL PRINTERS AND INPUT, OUTPUT 735 TYPEWRITERS

PRINTERS FROM	£195.00
735 TYPEWRITERS FROM	£245.00
WIRING AND COMMISSION	
TO SUIT ACULAB INTERFACE	£48.00
ACULAB INTERFACES EX STOCK	£155.00

ALSO AVAILABLE

IBM 71, 72, 82 typewriters.
Full workshop facilities for rebuilds and servicing.
Keyboard ASCID-ASCII, 10-12 pitch, language conversions undertaken.

11", 13", 15" platen lengths, split platens pin feed platens. Operational keylever repeats fitted on request.

Full IBM range of 10-12* pitch heads including language, symbol and metric.

Language keybuttons blue or grey

WE BUY SELL OR EXCHANGE ALL IBM SELECTRIC TYPEWRITER MODELS

For further details phone Stuart Kirby or Louis Baker Prices excl VAT @ 15% carriage & packing, callers by appt only please



Saul Lodge, Saul, Gloucester GL2 7JE
Tel: 0452 740 612

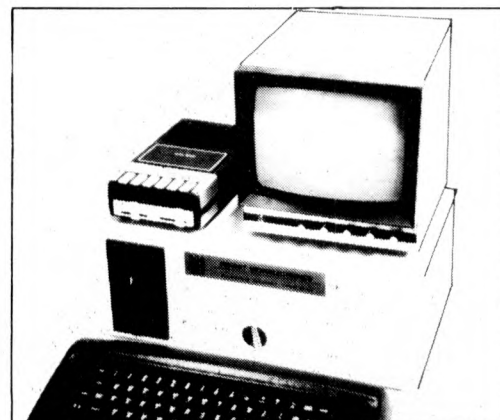

SS50 6800-9 SYSTEMS

WE HAVE A COMPREHENSIVE AND GROWING RANGE OF SS50 BOARDS AND BUILT SYSTEMS PARTICULARLY SUITED TO EDUCATION, CONTROL SYSTEMS AND SOFTWARE DEVELOPMENT.

AVAILABLE: Processor Card **£80**, Memory Mapped VDU with U/L Case and Graphics **£80**, 16-32K RAM Card **£130**, Interface Card with Timer and Real Time Clock, Disc Card, Extra Thick Mother Board.

As an example of a built system, the illustration shows Trainer 2, a single disc teaching unit with cassette, TV, keyboard and interface + switchbox to give a compact teaching station for machine control using basic or assemble. Price **£1130.00**

WE ARE OFFICIAL APPLE DEALERS.

16K Apple now only **£695** All prices exclude VAT

HEWART MICROELECTRONICS

95 Blakelow Road, Macclesfield, Cheshire
Tel: 0625 22030

3D

Digital Design and Development

18/19 Warren Street · London W1P 5DB Tel: 01 387 7388

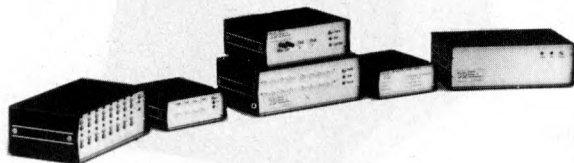

CBM PET SHARP MZ-80K
Specialist Suppliers of
Complete Systems for
Industrial and Laboratory
Monitoring and Control.

Please note our new address.
Callers welcomed for demonstration
and/or discussion.

SHARP MZ-80K INTERFACES

- Parallel Printer Interface £110
- Serial Printer Interface £150
- Bi-Directional Serial Interface £210
- 16-Channel A/D Converter Unit £280
- Fast Data Acquisition System –
40,000 readings/sec. 4 analog channels
IN and 4 channels OUT. P.O.A.

PET INTERFACES

IEEE-488 Compatible Units

- 16 Channel 8-Bit A/D Converter £300
- 8 Channel 8-Bit D/A Converter £350
- 8 Channel 12-Bit A/D Converter £600
- 12-Bit D/A Converter P.O.A.
- X-Y Analog Plotter Interface £200
- Digital Data Input Unit, 64 Bits £400
- Digital Data Output Unit, 64 Bits £350
- 16 Channel Relay Unit £350

Also....

- USER Port Converter A/D plus D/A £200
- Fast Data Acquisition System
40,000 readings per sec. 4 A/D + 4 D/A P.O.A.

All units boxed complete with IEEE-488 address internally selectable, with integral power supply, cables, switch, fuse, indicators and illustrative BASIC software.



TERMS: All prices EX-VAT. P&P extra.
Cheques should be made payable to
3D Digital Design & Development.
All goods supplied under 90 days warranty.
CUSTOM DESIGN UNDERTAKEN

The video genie system only needs a plug



£380 inc. VAT

- 16K RAM + 12K
Microsoft BASIC in ROM
- TRS-80 Level II compatible ● Ideal for Business, Education
+ Leisure ● Integral Cassette + TV Output
- Customized Business Packages available
- Expansion to Disks + Printer

MATRIX COMPUTER SYSTEMS LIMITED

325, Upper Elmers End Road, Beckenham, Kent. Telephone 01-658 7508/7551

Colour —
at Black-and-White Prices

DYAD Developments

Dealer Inquiries Welcomed
prices excl. VAT

COMPUCOLOR II

The Priory — Great Milton — Oxon — OX9 7PB — Tel (08446) 729

NEW! in the
Intecolor 8000 Series
Desktop Computers

- * 13" COLOUR MONITOR for COLOUR GRAPHICS etc
- * Built in MINIFLOPPY DRIVE 51.2K per side
- * Impressive EXTENDED BASIC on 16K ROM
- * HIGH RESOLUTION GRAPHICS 128x128
- * RS232C port simplifies PRINTER or MODEM atch.



GAMES

- Formatted Twin Pack
- Sampler
- Othello
- Chess
- Star Trip
- Blackjack
- Cubic Tic Tac Toe
- Sharks
- Air Raid
- Star Trader
- Swarms
- Bounce
- Shoot
- Lunar Lander
- Solitaire
- Maze Master

INTECOLOR 8063

- CP/M™ Compatible System, 19" Color Data Display with 590K byte Dual 8" Floppy Disk Drive, CP/M Operating System Sof-Disk and Documentation, Microsoft® BASIC, Computer Manual and 32K User RAM.

£2895.00 excl VAT

£2995.00 excl VAT

Intecolor 8964 features 19" display, CP/M operating system and 1182K byte storage capacity.

Color Communicates Better



CP/M Compatible Desktop Computers

These Intecolor desktops are designed to give small businesses the advantages of both color graphics and an abundant selection of readily-available software. There are CP/M programs for virtually any business application, which minimizes the need for specially-prepared software.

Intecolor CP/M compatible desktops are available in the 13" contemporary case (model 8363), 19" contemporary case (model 8963) and 19" standard case (model 8063).

CP/M Operating System

The CP/M operating system is the latest version of CP/M, and is stored on Sof-Disk.™ When loaded, it allows the user to run any CP/M program without modification, whether it's in BASIC, COBOL, FORTRAN IV or any other programming language.

Languages

A Sof-Disk containing ISC's color version of Microsoft® Business BASIC is also included. It provides 19 commands, 29 program statements, 15 input statements, 26 arithmetic functions, 15 string functions, and 9 input/output functions. In addition, Microsoft COBOL and FORTRAN IV are available as options.

Memory and Mass Storage

CP/M compatible desktops are equipped with 32K of user RAM (expandable to 48K), and 8K of ROM. Two disk drives are available: the 591K dual 8" floppy disk drives and the 1182K double-headed drive.

The Color Advantage

Research studies chronicled in such professional publications as the *Journal of Applied Psychology* and the *Journal of Experimental Psychology* * as well as extensive on-the-job experience have proven repeatedly that *colour displays convey information more quickly and more effectively* than any other visual method. Color-coded displays lead to easier data recognition, thus minimizing search time and permitting faster operator response. Color dramatically reduces operator fatigue and can cut costly error by as much as 80%.

MODEL	RAM	PRICE
MODEL 3	8K	£995.00
MODEL 4	16K	£1078.00
MODEL 5	32K	£1198.00
CCN 101	KEYBOARD	£80.00
CCN 117	KEYBOARD	£120.00
MODEL 9	"TUTOR", 25"	£1580.00
COMPUCOLOR "EXECUTIVE"	MODEL	TBA

All systems include an Instruction Manual, Programming Manual, Sampler softdisc Demo programs and six months free subscription of Colorcuc Users Newsletter.

COMPUCOLOR 11

SYSTEMS/UTILITY	
ASSEMBLER (16K)	£15.00
TEXT EDITOR (16K)	£15.00
PERSONAL DATA BASE (16K)	£25.00
MONITOR (16K)	£12.50
SCREEN EDITOR (16K, 117KYBD)	£20.00
FORMATTER	£20.00
DEBUGGER (16K)	£20.00
PILOT (16K)	£30.00
FORTRAN (32K)	£40.00
ALGAE (32K)	£25.00

EDUCATIONAL	
BASIC LANGUAGE VOL. 1	£15.00
MATH TUTOR	£12.50
HANGMAN	£12.50
ENGINEERING	
STATISTICS 1 (16K)	£15.00
STATISTICS 2 (16K)	£20.00
STATISTICS 3 (16K)	£20.00

MISCELLANEOUS HARDWARE	
RS232 ADAPTOR CABLE	£25.00
LOWER CASE CHARACTERS	£85.00
ADD-ON RAM, 16K	£195.00
ADD-ON PROM BOARD	£45.00
SOUNDWARE	£30.00
KEYBOARD UPGRADE 72-101	£95.00
KEYBOARD UPGRADE 72-117	£135.00
KEYBOARD UPGRADE 101-117	£55.00
MAINTENANCE MANUAL	£25.00

Basic Computing

MICROLINE-80 PRINTER £385 + VAT
— small, quiet, reliable — and now, cheap!

DAISY WHEEL PRINTERS FROM £1200+ VAT
for PET, Tandy, Apple, Sorcerer etc.

TOOLKIT FOR SORCERER
Extends Exidy BASIC to give full screen editing, user programmable function keys, auto line numbering, renumber, link programmes together + many other features. Price includes membership of Sorcerer Programme Exchange Club. £30 + VAT + 50p p&p (= £35).

SORCERER PROGRAMMES
Send SAE for list.

CP/M
Full range of software available on 8" discs, eg. WORDSTAR/MAIL MERGE for £300 + VAT.

BUSINESS SYSTEMS
We specialise in business systems, single or multi-user, at competitive prices. Hard discs available now up to 64 Mbytes. Basic system: 64k, dual 8" diskettes, terminal, S-100, CP/M — £3,100 + VAT.
We offer a personal service to our business customers, and are only able to do that within a 75 mile radius of Bradford.

Basic Computing, 25 Bradford Road,
Keighley, W. Yorkshire.
Tel (0535) 63145

FREE — ADVICE/DEMO/COFFEE

PET NEW KEYBOARD	from £399.00 + £59.85 VAT	£458.85
COMPUKIT UK101 KIT	£179.00 + £26.85 VAT	£205.85
UK 101 BUILT	£249.00 + £37.35 VAT	£286.35
SUPERBOARD II	£156.52 + £23.48 VAT	£180.00
STYLISH CASE—UK101/BOARD	£ 29.39 + £ 4.41 VAT	£ 33.80
TRS80 16K LEVEL II	£356.00 + £53.40 VAT	£409.40
5% DISC DRIVE for TRS80	£236.00 + £39.40 VAT	£271.40
H 14 LINE PRINTER KIT	£356.00 + £53.48 VAT	£410.00
BUILT	£510.00 + £76.50 VAT	£586.50
EXIDY SORCERER 16/32/48	from £749.00+£112.35 VAT	£861.35
VIDEO GENIE SYSTEM 16K	£320.00 + £48.00 VAT	£368.00

COMPUTER BOOKS · CASSETTES · DISKS · PAPER

SOFTWARE

2 New TRS 80 Adventures	
Vampires Castle	£7.50
Cratermass	£7.50
TRS 80	
Save the City	£6.00
Mastermind	£5.00
Space Attack	£6.00
O X O	£5.00
One Arm Bandit	£7.00
Graphic Aid	£5.50
SHARP	
Sheepdog Trials	£7.00
Invaders	£8.00
Submarine	£7.00
Graph Plotter	£6.00
UK 101	
Renumber	£4.00
Graphic Finder	£4.00
O X O	£4.00
Pontoon	£4.50

COMING SOON TRS 80 MODEL III



- * Stylish Desk-Top Unit
- * Upper & Lower Case
- * 1500 Baud Cassette
- * Model III Basic
- * Software compatible with Model I
- * Supports D.D. Disks

We are now accepting orders

16K Model III

£649 inc.

S.a.e. Enquiries. Please allow up to 21 days for delivery. All prices inc. of VAT.



N.I.C.



Day 01-808 0377 — Eve 01-889 9736
(Unit 1), 61 Broad Lane, Tottenham, London N.15.

PET' MACHINE LANGUAGE GUIDE

PET'
MACHINE
LANGUAGE
GUIDE



By ABACUS SOFTWARE

Contents include sections on:

- Input and output routines.
- Fixed point, floating point, and Ascii number conversion.
- Clocks and timers.
- Built-in arithmetic functions.
- Programming hints and suggestions.
- Many sample programs.

If you are interested in or are already into machine language programming on the PET, then this invaluable guide is for you. More than 30 of the PET's built-in routines are fully detailed so that the reader can immediately put them to good use.

Available for \$7.95 + \$2.00 postage and handling. Payment is in U.S. dollars or charged to your Barclaycard or Eurocard — include card number and expiration date. Quantity discounts are available.

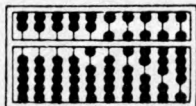

ABACUS SOFTWARE
P.O. Box 7211
Grand Rapids, Michigan 49510

PET and APPLE II Users

P A S C A L

ABACUS Software makes available its version of TINY PASCAL for the users of two of the most popular personal computers.

TINY PASCAL is a subset of the standard PASCAL as defined by Jensen and Wirth. It includes the structured programming features: IF-THEN-ELSE, REPEAT-UNTIL, FOR TO/DOWN TO-DO, WHILE-DO, CASE-OF-ELSE, FUNC and PROC. Now you can learn the language that is slated to become the successor to BASIC.

TINY PASCAL is a complete package that allows you to create, compile and execute programs written in the PASCAL language. You can save source and object code on diskette or cassette (PET version only). Comprehensive user's manual included. The manual can be examined for \$12 (refundable with software order).

VERSIONS AVAILABLE:

PET 16K/32K New ROMS cassette	\$50
PET 16K/32K New ROMS diskette	\$45
Apple II 32K/48K Applesoft ROM w/DOS	\$45
Apple II 48K Applesoft RAM w/DOS	\$45
TINY PASCAL User's Manual	\$12
6502 P-Code Interpreter Listing	\$30

Price includes airmail postage. All orders must be prepaid in U.S. dollars or Barclaycard or Eurocard — include card number and expiration date.

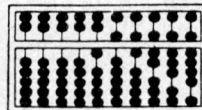

ABACUS SOFTWARE
P.O. Box 7211
Grand Rapids, Michigan 49510
U.S.A.

Research Resources Ltd

UNIX on a MICRO

- * The new standard DEC/PDP operating system is now available on 6809 micros.
- * UNIFLEX is a MULTI-USER/MULTI-TASKING system for up to 12 users.
- * RRL provide the complete system with from 128k to 768k RAM.
- * 2.5 Megabyte floppy disk drives and .16 Megabyte fixed disks.
- * Full range of VDU's, terminals, printers, interfaces etc.

SWTP and GIMIX 6809 computers

- * RRL specialises in the EDUCATIONAL and SCIENTIFIC applications.
- * Small systems from 32k with 5" disk drives upwards.
- * PASCAL, FORTRAN, PILOT, BASIC Compiler, LAB-BASIC, Statistical Analysis etc.
- * D-A, A-D converters and special interfaces to solve your problem.

RESEARCH RESOURCES LTD, P.O. Box 160
Welwyn Garden City, Herts. England
Tel: (07073) 26633

Memories

2114-300ns	1k x 4 SRAM	2.25
4116-200ns	16k x 1 DRAM	2.61
2708-450ns	1k x 8 EPROM	3.60
2516-450ns	2k x 8 EPROM	7.92
2716-450ns	2k x 8 EPROM	7.92
2532-450ns	4k x 8 EPROM	23.40

Please add 50 pence for postage and VAT.
Send SAE for price list.

STRUTT LTD

3c, BARLEY MARKET STREET,
TAVISTOCK,
DEVON, England, PL19 0JF.
Tel: TAVISTOCK (0822) 5439/5548
Telex: 45263

CASH AND CARRY SUPERDEALS

SUPERBRAIN 64K £1499
QUAD DENSITY SUPERBRAIN £1950
NEC SPINWRITER £1599

CROMENCO – (All hardware and software in stock for immediate delivery)

WORDSTAR £245
MAILMERGE £ 75
WORDSTAR & MAILMERGE £300
DATA STAR £175

DEALERS: BEST DISCOUNTS

Telephone 01-840 1926

Westwood Computers

117 TENNANT STREET, FIVE WAYS,
BIRMINGHAM

In our new showrooms
and training centre you can see
the complete

Z Plus micro computer systems
with word processing, accounts packages,
stock control etc.

We're offering practical courses in
programming – BASIC, PASCAL and
COBOL, The Electronic Office, Computer
Accounting, Newcomers Guide to the
Computer World, and of course we have
one of the most extensive ranges of
computer books and services in the city.
Browsers welcome.



AUTHORISED APPLE DEALER

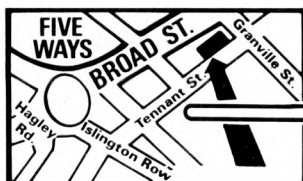

021 632 5824
On the street parking
always available.

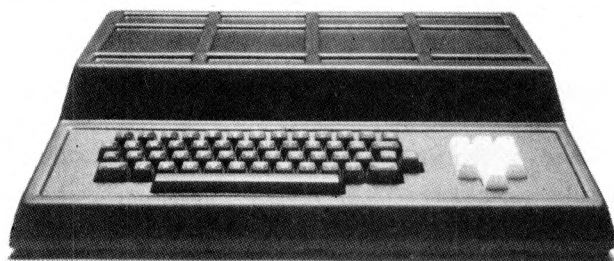

MICROTYPE MODEL 3 CASE

Ready cut for SUPERBOARD/UK 101, NASCOM 2
and blank for HOMEBREWS

Produced in black ABS Plastic, complete with fixings and instructions,
space for PSU, expansion, force feed fan, numeric pad and
additional keys.

£24-50 + p&p + VAT

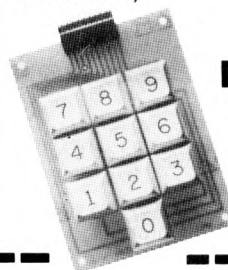

NPS1 NUMERIC PAD

for SUPERBOARD/UK101 only

A 0-9 numeric pad in kit form, complete with
switches, caps, PCB, plug and socket, cable and
full instructions.

£11-95 + p&p + VAT

- Please send me a Model 3 case at £29.90 inc.
My micro is
- Please send me a NPS1 numeric pad for my Superboard/
UK101 at £14.32 inc.
- Please send me your full literature. I enclose SAE.
(Please enclose your name and address with cheque or P/O)



MICROTYPE

PO BOX 104 HEMEL HEMPSTEAD HP2 7QZ

S100

Do You Have All These Facilities On Your S100 System, With Just Two Boards?

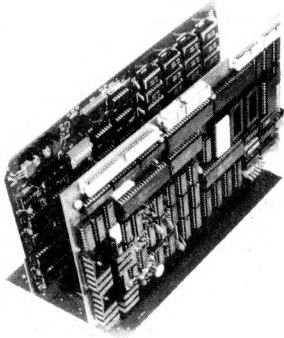

1. Z80A CPU-2 or 4MHz Operation.
2. Z80A CTC — 4 Channels.
3. Z80A S10—2 RS—232.
4. Z80A P10.
5. Disk controller; Takes up to 4 disk drives, single or double density operation.
6. 64k Bytes of memory.
7. EPROM Programmer.
8. Real time clock.
9. Software:
Standard 2k Monitor.
CP/M Cold Start Loader.
CP/M BIOS (1.4)

Prices:
FDC-1 Board £495.50
Expandoram £327.56
Mother Board £42.00
All prices exclude VAT.

SEMEL

MICROCOMPUTER - HARDWARE - SOFTWARE

3c, BARLEY MARKET ST., TAVISTOCK, DEVON.
PL19 OJF.
Tel. TAVISTOCK (0822) 5247. Telex: 45263

ASSEMBLER PROGRAMMERS

WE HAVE CAREER OPENINGS FOR PROGRAMMERS WITH EXPERIENCE IN MICRO/MINI ASSEMBLER/MACHINE LANGUAGE. WE ARE A LARGE COMPANY LOCATED IN CENTRAL LONDON AND ACTIVELY ENGAGED IN DEVELOPING STATE OF THE ART OPERATING SYSTEMS AND COMMUNICATIONS SOFTWARE FOR MINI COMPUTERS.

THESE POSITIONS WILL SUIT YOUNG AND HIGH CALIBRE PROGRAMMERS WHO HAVE AN INTEREST IN GETTING STARTED IN REAL TIME AND COMMUNICATIONS SOFTWARE DEVELOPMENT.

PLEASE CALL P. MURRAY ON
01-487 5881 FOR DETAILS

BITS & P.C.s

COMPUTER PRODUCTS LTD

The North's Leading Nascom Specialist

NEW PRODUCTS FOR NASCOM

PROGRAMMABLE CHARACTER GENERATOR FOR NASCOM 2

Gives 64 Programmable characters 8,192 Programmable dots. Free demonstration software. Ask for details.

DISCS:

Single drive £380.00
Double drive with CPM & EBASIC £640.00

Ask for details. Professionally designed for your NASCOM.

KENILWORTH CASE:

A high quality case made from stelvete coated steel and solid mahogany £49.50
Mounting kit for two cards £7.50
Mounting kit for five cards £19.50

SARGON CHESS PACK:

This pack includes the book and a tape with Sargon prepared to run under NAS-SYS. Also included is a special graphics rom and a PCB giving your NASCOM the ability to switch between two graphics ROMs, your original and the chess ROM.
All the above for only £35.00

INTERFACE EPROM BOARD:

Provides sockets for both 2708 and 2716 EPROMs (up to 16 EPROMs) and also provides a fully decoded socket for the NASCOM 8K BASIC ROM. This board is produced to full NASBUS specification and can be used in "page mode" together with the new NASCOM RAM B. Wait states may be generated on board to allow a NASCOM 1 to run at 4MHz in BASIC.
The complete kit at only £55.00

CASTLE INTERFACE:

Gives the following features: Auto tape drive * Auto cassette muting * Auto serial printer muting * 2400/1200/300 BAUD cassette. This interface built and tested complete with documentation at only £17.50

ASTEK 10" B/W MONITOR:

A professional cased 10-inch Monitor giving superb resolution, only £99.50

ANALOGUE TO DIGITAL CONVERTER:

This unit gives 4 channels with an Input Range of 0 to 120mV up to 0 to 24V. Conversion time (average) 0.5 mSec. Supplied built and tested at only £49.50

DUAL MONITOR:

This kit allows switching between two monitors on a NASCOM 1 e.g. T4 and NAS-SYS £6.50

PORT PROBE:

A very useful device for testing and evaluating ports and peripheral software with improved documentation £17.50

HEX AND CONTROL KEY PADS:

Our popular range of add-on keyboards for the NASCOM micros.
HEX for NASCOM 2 £34.00
HEX & CONTROL KEYS for NASCOM 1 £40.50

CASSETTE MACHINE:

Will reliably record data at 2400bd and above, manufactured by SHARP £25.50

PROGRAMMERS' AID:

In 2 2708 EPROM gives the NASCOM rom BASIC many extra commands: AUTO, RENU, DELE, DUMP, FIND, HEX, APND, HELP. . . etc. £28.00

BITS & P.C.s GAMES TAPE 1:

Good value, ten excellent games £8.00

PRINTERS:

We have a good range of printers, all of which will work on the NASCOM, RICOH, EPSON, IMP, QUME ANADEx.

BOOKS:

Full range including INMC mags.

MEDIA:

Paper, diskettes, ribbons, leaderless cassettes, VDU tables etc.

MEMORIES:

4116, 4027, 2708, 2716.

BUILT SYSTEMS REPAIRS MAIL ORDER and ADVICE are our SPECIALITY.

BITS & P.C.s Computer Products Ltd.
4 Westgate, Wetherby, West Yorkshire.

Tel: 0937 63744.

SAE for details: prices exclude VAT and postage and package.



INTELLIGENT ARTEFACTS LTD

East Anglia's Leading Micro Specialists

We are looking for new applications for microprocessors and are prepared to write software for your application FREE of CHARGE as a development project.

We can provide software for Desktop microcomputers such as the Superbrain and the North Star Horizon; if you feel the efficiency of your business will be increased using one of the machines then please contact us at the address given below.

Intelligent Artefacts is a subsidiary of Sands-Whiteley R & D, government listed microprocessor applications consultants, we have on our staff Applications Engineers experienced in business administration and a wide variety of manufacturing processes. We already supply programs for parts listing, PAYE, Job costing and General Ledger, on low cost hardware, giving all our products 1 year free support.

INTELLIGENT ARTEFACTS LTD Cambridge Road, Orwell, Royston, Herts.
Technical Services Department. Telephone ARRINGTON (022020) 689



TRS-80 OWNERS!



MODEL II

CPM 2.2X	£165.00
CBasic 2 (CP/M)	£80.00
Postmaster (CP/M)	£85.00
Supersort III (CP/M)	£80.00
RSM II	£35.00
T/Maker (CP/M)	£175.00
DSM II	£87.50
GSF II	£30.00
Development System	£70.00
Utility Package	£87.50
Basic X-ref Utility	£30.00
Hard Disk Operating Sys.	£250.00
WORD PROCESSORS	
Electric Pencil II (CP/M)	£200.00
Electric Pencil II TRSDOS	£225.00
Magic Wand (CP/M)	£230.00
Wordstar (CP/M)	£275.00
BUSINESS SYSTEMS	
Osbourne & Associates Programmes in CBasic	
Accounts Rec & Payable	£150.00
General Ledger	£150.00
In TRSDOS	
Accounts Rec & Payable	£200.00
General Ledger	£200.00
CP/M USERS GROUP	
23 Volumes	Each £12.00

ALL PRICES INCLUDE VAT AT 15%, PACKING & RETURN POSTAGE TO U.K. ADDRESSES. PRICES TO OVERSEAS ADDRESSES INCLUDE RETURN AIRMAIL. SEND 50p FOR DESCRIPTIVE CATALOGUE.



MICROCOMPUTER APPLICATIONS
11 RIVERSIDE COURT,
CAVERSHAM,
READING RG4 8AL,
ENGLAND.
TEL: (0734) 470425

MODEL I

DISK

LEVEL II CASSETTE GAMES		UTILITIES		DISK	
Adventures:-		Inventory Control	£11.00	A.P.L. 80*	£30.00
Adventureland*	£9.50	Pork Barrel	£6.50	Accounts Receivable II	£40.00
Pirates Cove*	£9.50	Pre School Games	£6.50	Advanced Personal	£15.50
Mission Impossible*	£9.50	PR Dogfight	£6.50	Auto Disk Directory	£9.50
The Count*	£9.50	Robots	£4.50	C.C.A. Data Management	£52.50
Voodoo Castle*	£9.50	Round The Horn	£6.50	Compress It	£15.00
Strange Odyssey*	£9.50	Safari	£6.50	Data Base III	£30.00
Mystery Fun House*	£9.50	Santa Paravia	£6.50	DCV-1	£8.50
Pyramid of Doom*	£9.50	Sargon II*	£18.50	Dynamic Data Base	£22.50
Ghost Town*	£9.50	Space Battles	£9.50	Electric Pencil*	£30.00
Adventure Sampler*	£6.50	Star Trek III.5	£9.50	File Manager 80	£40.00
Air Raid*	£8.50	Taipan	£6.50	Forth* (Incl. Primer)	£45.00
Air Traffic Control	£6.50	Time Trek*	£9.50	General Ledger II	£40.00
Alien Invaders	£8.50	Ting Tong*	£6.50	Inventory 'S'	£50.00
Android NIM	£9.50	Trek '80	£6.50	KVP Extender*	£16.00
Backgammon	£6.50	Trolls Gold	£4.50	Level I in Level II*	£16.00
Balloon Race	£6.50	Tycoon	£5.50	Mailist IV	£45.00
Barriade*	£8.50	Warfare I	£5.50	Newdos Plus*	£47.50
Baseball	£6.50	X-Wing Fighter II	£6.50	Newdos 80*	£87.50
Battleship	£7.50			Payroll (Tridata)	£249.00
Bee Wary	£9.50	APL-80*	£9.50	Print Spooler*	£16.50
Bingo	£4.50	Accounts REC II	£13.50	Roots	£14.50
Bowling (Ten Pin)	£6.50	Appointment Log	£6.50	RSM 2D Monitor*	£16.00
Bridge Challenger	£9.50	Astronomy II	£7.50	Simplify-It	£15.00
Challenge	£6.50	Basic IP*	£11.50	SCRIPSIT*	£65.00
Cribbage	£6.50	Basic Toolkit*	£11.50	SUPERSCRIPT*	£17.50
Dogstar	£6.50	Biorythms	£4.50	ST-80D* Terminal	£45.00
End Zone II	£6.50	Calendar Functions	£7.50	ST-80 III* Terminal	£85.00
Fastgammon*	£12.00	Copsys	£9.50	Visicalc*	£65.00
Galactic Blockade	£6.50	Data Base II	£17.50		
Galactic Empire	£9.50	Debug*	£12.50	Taranto & Associates Conversion of Osbourne & Associates Business Programmes	
Galactic Revolution	£9.50	Dosort*	£23.00	Accounts Payable	£90.00
Galactic Trader	£9.50	Electric Pencil*	£50.00	Cash Journal (for G/L)	£40.00
Game of Life*	£6.50	Electronics Asst.	£6.50	Invoicing	£90.00
Gammon Challenger*	£9.50	EMU 6502	£16.00	Accounts Receivable	£90.00
Gangster	£5.50	ESP Tester	£4.50	General Ledger	£90.00
Hangman	£4.50	File Handling	£7.50	Complete Co-ordinated System with Manuals	£350.00
I Ching	£6.50	Finance I	£7.50		
Invaders from Space*	£9.50	Finance II	£7.50		
Kamikaze	£6.50	Forth (Incl. Primer)	£37.50		
Kreigspiel II	£9.50	Fourier Transforms	£7.50		
Lost Dutchmans Gold	£6.50	Graph Builder	£9.50		
Mastermind II*	£5.50	G.S.F.*	£17.50		
Mean Checkers*	£6.50	General Accounting	£8.50		
Noughts & Crosses	£4.50	Ham Radio	£6.50		
Othello III	£6.50	Histogram/Scattergram	£6.50		
Pentominoes	£6.50	Home Finance	£6.50		
		Infinite Basic*	£31.00		
		Infinite Business*	£18.50		
		Inst. Calculator	£7.50		
		Inventory 'S'	£16.00		
		IQ Builder (Vocab)	£9.50		
		IQ Builder (Spelling)	£10.00		
		IQ Builder (Stories)	£9.50		
		IQ Builder (Pre School)	£9.50		
		IQ Builder (Numbers)	£9.50		
		IRV*	£16.50		
		Keyboard 80*	£7.50		
		KVP*	£9.50		
		Level III Basic*	£30.00		
		Linear Programming	£7.50		
		Magic Paper Calculator	£9.50		
		Math Drill	£5.00		
		Math Library I	£8.50		
		Math Library II	£8.50		
		Medump*	£8.50		
		Microtext Editor	£6.50		
		Minicrossword	£9.50		
		Mortgage Calculator	£5.00		
		Multi-Choice	£26.00		
		Pascal*	£11.50		
		Penmod*	£6.50		
		Personal Finance	£6.50		
		Personal X-REF	£9.50		
		Pilot 2.2*	£9.50		
		Pre Flight	£11.00		
		Renumber*	£6.50		
		Remodel-Preload*	£23.00		
		RPN Calculator	£6.50		
		RSM 2 Monitor*	£15.50		
		Statistics	£6.50		
		S.T.A.D.	£16.00		
		Star Finder	£7.50		
		Super Simon	£6.50		
		Super T-legs*	£6.50		
		T-Step*	£7.50		
		System Copy*	£8.50		
		Timser	£9.50		
		T-Short*	£6.50		
		T-Short**	£12.50		
		Tarot Cards	£6.50		
		Teachers Assistant I	£9.50		
		Teachers Assistant II	£9.50		
		Tiny Comp*	£12.50		
		TRS-80 Opera	£6.50		
		Typing Tutor	£11.50		
		X-ref	£9.50		
		Yybar	£9.50		
		76 Basic Programs	£23.00		
		Manual for Above	£7.00		
		Library 100	£40.00		

*Denotes Machine Language
TRS-80 Trademark of Tandy Corp.
CP/M Trademark of Digital Res.
C-Basic Trademark of Compuser Systems.

The 4th Personal Computer World Show

Cunard Hotel Hammersmith 10-12 September 1981

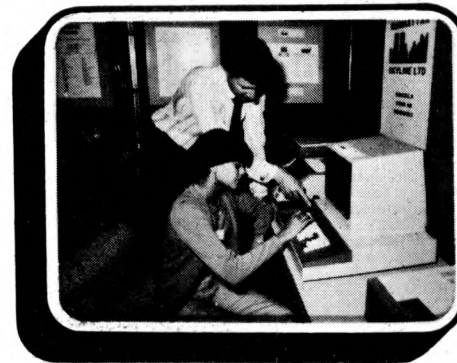
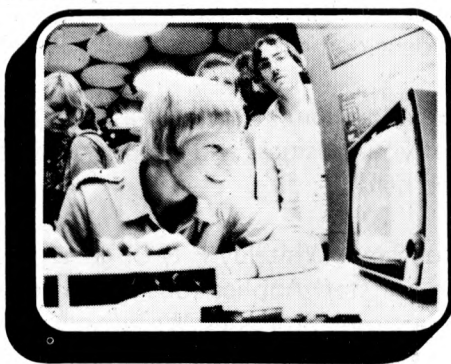

The Show which brings your market direct to you . . .

The Personal Computer World Show is the only exhibition exclusively for the small computer industry. It is your opportunity to meet, face-to-face, potential buyers who visit the Show specifically to see demonstrations and discuss the application of your products.

This is the Show where buyers come to buy ... not just look.

To discuss how the 4th Personal Computer World Show could form the focus of your 1981 promotional calendar contact Timothy Collins on 01-486 1951 or write to him at Montbuild Ltd, 11 Manchester Square, London W1.

ADVERTISERS INDEX

Abacus	177	Davinci Comp	162	L P Enterprises	150	Newtons Laboratories	72
Access Data	6	Digital Design & Development	175	Leicester Comp Centre	179	Northamber	155
Acorn Computers	67	Display Electronics	154	Linsac	157	Petsoft	52
Aculab	168	Dyad	176	Lion House	164	Plus Business Systems	15
Adda	18	Easi Comp	172	Little Genius	147	Portatel	162
Algray	23	Electronics Brokers	162	Liveport Data Products	68	Program Power	98
Almarc Data Systems	56	Equinox	96	Logitek	34	Promglow	147
Anglia Computer Centre	24	Ferguson Computers	84	London Computer Store	27	Printout	122
BFI Electronics	16	G P Industrial	157	Low Electronics	172	Research Resources	177
BASIC	176	Gate Microsystems	166	M.B.S. Terminals	92	S M G Microcomps	168
Beaver Systems	171	Geveke	108	Magtronics	171	Science of Cambridge	118,119
Biodata	16	Graham Dorian	117	Map Computer Systems	174	Sharp	62,63
Bits & Pieces	180	Grama Winter (G.W.)	12,13	Matrix Computer Systems	175	Sharp Co-op	101
Byte Shop	112	Greenbank Electronics	158	Melbourne House Publishers	164	Sharp Soft	20
Butel	74	Guestel	152	Mendip Ccomputers	173	Silica Shop	33
CCS Microhire	30	H.B. Computers	43	Microbusiness Centre	147	Sirton	28
Cambridge Computer Store	112	Happy Memories	173	Microbyte	148	Sperry Univac	180
Camden Electronics	35,179,157	A J Harding	90	Microcentre	IFC	Spider Software	155
Chromasonic	22,23	Heath	35,37,39	Microcomputer Connections	31	Stack	21
Comart	14,66	Henry's	159	Microdata Computers	173	St. Commercial Systems	178
Comp Shop	184,IBC	Hewart	174	Microdigital	84	Strutt	177/180
Computer Appreciation	95	Microelectronics	88	Microputer Applications	181	Sumlock Bondain	167
Computer Bookshop	76	Hewlett Packard	161	Micro Sense	47	Systems Plus	17
Computopia	39	Hewlett Packard Co-op	155	Microtrend	19	Swanley Electronics	160
Comserve	151	Independent Computer Engineering	181	Mighty Micro	2	T V J Micro Computers	25
Cream Microcomputer Shop	26	Intelligent Artefacts	165	Mike Rose Micros	160	Templeman Software	37
Creative Computing	156	Interam Computer Systems	163,169	Minimie	7,8,9,10	Terodec	3
Crystal	84,172	Interface	170	Music Hire	149	Transam	104
Cumana	29	Intex Datalog	45	Mutek	153	Tri-Data	149
Currah	160	Keen	170	NIC	176	Vlasak	120
DRG Business Machines	20	Kansas City	174	Nascom Dealers Guide	165	Wego	166
Data Bank	11	Keytronics	98	Newbear Computing	38	Westwood Computers	178
Datormark	4,5	L & J Computers				Xitan Systems	36
Datron Microcentre	32						



A certain company is rumoured to have produced a disk-based program which can copy the Visicalc system 'for security purposes'. Does Personal Software know about this, we ask ourselves... At the Electronica show in Munich recently an enterprising exhibitor kindly distributed his brochures in the Gents' thunderboxes (and in the ladies, too, for all we know). We presume they were left there to be read... Last year Canon produced a micro with a printer and a single-line display, saying that VDUs were bad for the eyes. Now, we notice, Canon micros are sporting VDUs... Personal Computer Ltd's Compec stand was bristling

with lovely ladies but the biggest attraction was a velvet-clad Mike Sterland, complete with revolting — no, *revolving* — bow tie... Would you believe that Atari's international marketing man Fred Mitchell and PCW's Editor share a common background in — wait for it — the cardboard box industry?!... 'The Money Programme' (on t'telly) said recently that Uncle Clive Sinclair made £500,000 net profit in the first six months of 1980. Hmmm... Our humble thanks to reader J J Sandford for sending in his Reader Survey. Why are we thanking him? Because he sent it in a year late, that's why... Henry Budgett (he of

Toady fame) is now known in the trade as 'Shoestring'. Apalling pun apart, he does bear an uncanny resemblance to said character and the West Country detective is alleged to have once worked in the computer industry. Surely Henry isn't moonlighting as an actor — is he? ... Roger Derry, if you're out there please get in touch — we've lost your address and we owe you some money... Supersoft's Peter Calver has a PET name for partner Pearl Wellard. Pearl has threatened the Editor with all sorts of dire horrors if he reveals that it's Pearl*****. (A prize for the first correct entry)... Nice to see 'Bumper' Harris back

in the country. Isn't it time you wrote another article for us, 'Bumper'?... PCW has made it to the dizzy heights of the *Silicon Gulch Gazette* with a report on our West Coast Fair jolly. What? You don't know about it?! GOTO page 48 immediately... Deputy Editor Rodwell trotted along to the dungeons of the Cafe Royal recently to participate in a Commodore party. He'd been expecting a roasting from Kit Spencer (see recent 'Chip Chat' and 'Newsprints') but the nearest he got was a flood of candle grease down his lapel and Kit asking him to pass the sugar... Finally, a happy New Year to all of you from all of us at PCW!

NEW REDUCED PRICES

8K **£399**
16K **£499**
32K **£599**
RRP £795 for 32K



EXTENDED WARRANTY BY COMPUKARE

The PEDIGREE PETS Very popular for home & business use 8K Microsoft Basic in ROM 8K Pet 32K & 16K with new improved keyboard. All with green screen. Cassette Deck **£55** extra. Full range of software available. Interface PET IEEE — Centronics Parallel. Not decoded **£49.00** + VAT Decoded **£77.00** + VAT

NOW IN STOCK
SUPER 80 COLUMN PET
only **£825** + VAT

SPECIAL SCOOP GET YOURSELF A PRINTER FOR YOUR PET AND SAVE A FORTUNE

only **£299** + VAT

Interface Cards **£49**

Full Pet Graphics including cables. Ready to go. **EX-STOCK.**

Interfaces with APPLE, PET, EXIDY, TRS80, COMPUKIT and NASCOM.

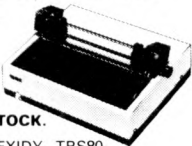

EXTENDED WARRANTY BY COMPUKARE

NASCOM 2 DISC DRIVES

Add a powerful, double density, mini floppy disc to your Nascom system.

- Disc Controller Card (includes Nasbus 6 S100 interface)
- Will control 4 Drives.
- CPM operating system.
- Extended Disc Basic Compiler.
- Power supply included

One Disc System — **£499** + VAT
Additional Disc Unit — **£299** + VAT

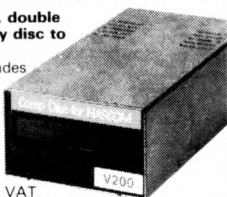

NASCOM 2 GAMES TAPE

featuring Space Invaders and Android Nim, Re-numbering program and other goodies!

£7.50 + VAT

NEC SPINWRITER

only **£1490** + VAT



NEC's high quality printer uses a print "thimble" that has less diameter and inertia than a daisy wheel, giving a quieter, faster, more reliable printer that can cope with plotting and printing (128 ASCII characters) with up to five copies, friction or tractor fed. The ribbon and thimble can be changed in seconds. 55 characters per second bidirectional printing — with red/black, bold, subscript, superscript, proportional spacing, tabbing, and much, much more.

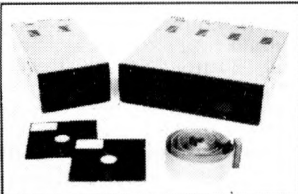

TEAC DISK DRIVES

- TEAC FD-50A has 40 tracks giving 125K Bytes unformatted single density capacity.
- The FD-50A can be used in double density recording mode.
- The FD-50A is Shugart SA400 interface compatible.
- Directly compatible with Tandy TRS80 expansion interface.
- Also interfaces with Video Genie, SWTP, Heathkit, North Star Horizon, Superbrain, Nascom, etc., etc.
- Address selection for Daisy chaining up to 4 Disks.
- Disks plus power supply housed in an attractive grey case.

Single Disk Drive **£225** + VAT Double Disk Drive **£389** + VAT

COMP POCKET COMPUTER GREATEST BREAKTHROUGH YET

£99.90 + VAT



COMPUTER POWER THAT ONCE FILLED A ROOM CAN NOW BE CARRIED IN YOUR POCKET!

- Programs in BASIC • "QWERTY" Alphabetic Keyboard • 1.9K Random Access Memory • Long Battery Life.

Computer power that once filled a room can now be carried in your pocket! It's easy to load with ready-to-run software from cassette tape (interface and recorder optional) or program it yourself in easy-to-learn BASIC. 24-character liquid crystal readout displays one line at a time. Special feature is advanced non-volatile memory allows you to power on and off without losing the contents of memory. Note: Memory must be transferred to tape before changing batteries. Automatic statement compaction squeezes every ounce of memory space. Features power-off retention of programs and data. Powerful resident BASIC language includes multiple statements, math functions, editing, strings, arrays and much more. Multiple program loading capability subject to RAM availability. Carrying case and batteries included.

Program	Each	Program	Each
Real Estate	£13.95	Games 1	£8.95
Civil Engineering	£13.95	Business Statistics	£10.95
Aviation	£13.95	Business Financial	£10.95
Math Drill	£8.95	Personal Financial	£10.95

EXTENDED WARRANTY BY COMPUKARE

EXATRON STRINGY FLOPPY FOR TRS80

(Expansion interface not needed)

only **£169** + VAT



High Speed storage medium that is cheap and reliable. Includes 20 wafers - M/C monitor - BUS EXPN cable. **£169**

COMMERCIAL • EXPANDABLE • COMPLETE TRS 80 • MODEL II

This new unit from the world's most successful micro company is now available immediately with software. The basic unit comes complete with 64 thousand characters (bytes) of Memory. The built in 8" Floppy disc adds another 1/2 million extra characters including the disc operating system. More disc expansion is now available.

The Model II is a complete unit with a full keyboard including a numeric pad and 12" screen which gives 24 lines of 80 characters. The computer is supplied with both the disc operating system and the Level III Basic.

A full self test routine is written into the power up procedure to eliminate incorrect operation. Both serial and parallel expansion sockets are standard. A printer is a plug-in operation. Both hardware and software necessary to talk to a mainframe are included. Terminal usage is very possible. With the addition of CPM2 you can operate with COBOL, FORTRAN, MBASIC, CBASIC in which languages are many other applications packages i.e. accounting, payroll stock etc.

64K 1-Disk Model II **£1995.00** + VAT
RRP £2250.00

EXTENDED WARRANTY BY COMPUKARE
COMING SOON
26 megabyte
Hard Disc
multi-user
DOS

WE USE THIS MACHINE IN OUR BUSINESS

1 DISK EXPANSION Room for 3

500K per Drive gives total of 1.5M Byte — 1 Drive plus Cabinet **£799** + VAT

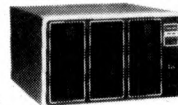

CP/M2	£95.00	C BASIC	£75.00	FORTRAN	£220.00
CIS COBOL	£400.00	M BASIC	£155.00	WORDSTAR	£255.00

EPROM 2716 **£12.50** + VAT

EXTENDED WARRANTY BY COMPUKARE

only **£325** + VAT



TRS80 LEVEL 2 16K

Fully converted to UK T.V. Standard. Comes complete with easy to follow manuals. UK Power Supply — Cassette Leads — Sample tapes. Special box to enable you to plug into your own TV. Recommended for first time buyers. Just plug in and go. Full Range of Software Available.

Interface to Centronics Parallel for TRS80 **£75.00** + VAT

only **£295** + VAT

Expand your TRS80 by 32K. 32K Memory on board. Centronics parallel port. Disk controller card. Real time clock. Requires Level II Basic. Interface for 2 cassette decks. complete with power supply.

TRS80 EXPANSION INTERFACE



YOU NEED NEVER MISS AN IMPORTANT CALL AGAIN TWO CORDLESS TELEPHONE SYSTEMS — DIRECT FROM USA

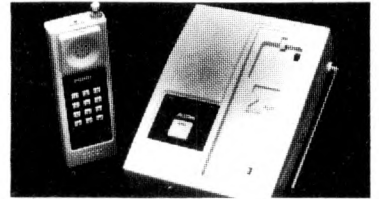

THE ALCOM only **£147** + VAT

Base station connects to your telephone line. Remote handset clips to your belt and gives you push-button dialling — Bleeps when call arriving — Nicad rechargeable batteries. Charger in base unit.

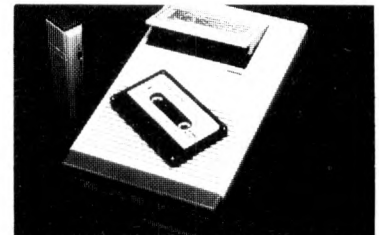

LOW COST TELEPHONE ANSWERING MACHINE only **£99.95** + VAT

Microprocessor controlled answering machine. Plug into your phone line. Records any phone call messages. Remote bleeper enables you to listen to your messages from anywhere in the world. Uses standard cassettes. Comes complete with mains adaptor, microphone, remote bleeper, base unit, cassette with 30 sample pre-recorded messages.

THE VIDEO GENIE SYSTEM

EG3000 Series

16K **£289** + VAT



WITH 16K user RAM plus extended 12K Microsoft BASIC in ROM • Fully TRS-80 Level II software compatible • Huge range of software already available • Self contained, PSU, UHF modulator, and cassette • Simply plugs into video monitor or UHF TV • Full expansion to disks and printer • Absolutely complete — just fit into mains plug.

COMING SOON

THE MARTELL TV GAME

BUY IT FIRST! WEAN YOUR PRICES EARLY! YOUR CUSTOMERS

RRP £540 only **£399** + VAT
ANADEX DP8000

Super Quality — Low cost printer. Tractor Feed with full 96 ASCII character set. Accepts RS232C at band rates between 100 and 9600 and Parallel Bit data. Attaches either directly or through interfaces to Pet, Apple, TRS80, Sorcerer, Nascom, CompuKit etc.

EXTENDED WARRANTY BY COMPUKARE

THE NEW ANADEX DP9501
A PROFESSIONAL PRINTER

- Bi-directional printing
- Up to 220 chars/line with 4 print densities
- 500 char buffer
- RS232C and Centronics Parallel interface built in
- Full software control of matrix needles allowing graphics capability
- 200 chars/sec • Adjustable width tractor feed.

All this for only **£895** + VAT.

EXTENDED WARRANTY BY COMPUKARE

THE ATARI VIDEO COMPUTER GAMES SYSTEM **£83.00** + VAT

Atari's Video Computer System now offers more than 1300 different game variations and options in twenty Game Program™ cartridges!

Most Cartridges only **£13.90** + VAT. Prices may vary with special editions Basic Maths, Airsea Battle, Black Jack, Breakout, Surround, Spacewar, Video Olympics, Outlaw, Basketball, Hunt & Score*, Space War, Sky Diver, Air Sea Battle, Codebreaker*, Miniature Golf.

Extra Paddle Controllers — **£14.90** + VAT. *Keyboard Controllers — **£16.90** + VAT

SPACE INVADERS NOW IN STOCK £25

EXTENDED WARRANTY BY COMPUKARE

NEW TV GAME BREAK OUT

Has got to be one of the world's greatest TV games. You really get hooked. As featured in ETI. Has also 4 other pinball games and lots of options. Good kit for up-grading old amusement games.

MINI KIT — PCB, sound & vision modulator, memory chip and de-code chip. Very simple to construct. **£14.90** + VAT
OR PCB £2.90 MAIN LSI £8.50 Both plus VAT

EXTENDED WARRANTY BY COMPUKARE

WE ARE NOW STOCKING THE APPLE II EUROPLUS AT REDUCED PRICES

16K **£599**
 32K **£649**
 48K **£659** + VAT

Getting Started APPLE II is faster, smaller, and more powerful than its predecessors. And it's more fun to use too because of built-in features like:

- BASIC — The Language that Makes Programming Fun.
- High-Resolution Graphics (in a 54,000-Point Array) for Finely-Detailed Displays.
- Sound Capability that Brings Programs to Life.
- Hand Controls for Games and Other Human-Input Applications.
- Internal Memory Capacity of 48K Bytes of RAM, 12K Bytes of ROM; for Big-System Performance in a Small Package.
- Eight Accessory Expansion Slots to let the System Grow With Your Needs.

You don't need to be an expert to enjoy APPLE II. It is a complete, ready-to-run computer. Just connect it to a video display and start using programs (or writing your own) the first day. You'll find that its tutorial manuals help you make it your own personal problem solver.

EUROPE'S FASTEST SELLING ONE BOARD COMPUTER

COMPUKIT UK101

★ 6502 based system — best value for money on the market. ★ Powerful 8K Basic — Fastest around ★ Full Qwerty Keyboard ★ 4K RAM Expandable to 8K on board. ★ Power supply and RF Modulator on board. ★ No Extras needed — Plug-in and go. ★ Kansas City Tape Interface on board. ★ Free Sampler Tape including powerful Disassembler and Monitor with each Kit. ★ If you want to learn about Micros, but didn't know which machine to buy then **this is the machine for you.**

40 pin Expansion Jumper Cable for CompuKit expansion **£8.50** + VAT

Build, Understand and Program your own Computer for only a small outlay. **KIT ONLY £179** + VAT **NO EXTRAS NEEDED**

Available ready assembled, tested & ready to go **£229** + VAT

NEW MONITOR FOR COMPUKIT UK101

- In 2K Eprom 2716
- Allows screen editing
- Saves data on tape
- Flashing cursor
- Text scrolls down

£22.00 + VAT

FOR THE COMPUKIT

Assembler/Editor	£14.90
Screen Editor Tape	£5.90

All Prices exclusive VAT

Game Packs

1. Four Games	£5.00	Super Space Invaders (8K)	£6.50
2. Four Games	£5.00	Space Invaders	£5.00
3. Three Games 8K only	£5.00	Chequers	£3.00
		Real Time Clock	£3.00
		Case for CompuKit	£29.50

HITACHI PROFESSIONAL MONITORS

9" — ~~£129~~ **£99.95**
 12" — ~~£199~~ **£149**

- **Reliability** Solid state circuitry using an IC and silicon transistors ensures high reliability.
- **500 lines horizontal resolution** Horizontal resolution in excess of 500 lines is achieved in picture center.
- **Stable picture** Even played back pictures of VTR can be displayed without jittering.
- **Looping video input** Video input can be looped through with built-in termination switch.
- **External sync operation** (available as option for U and C types)
- **Compact construction** Two monitors are mountable side by side in a standard 19-inch rack.

EXTENDED WARRANTY BY COMPUKARE

ENGLISH COLOUR TV/ AMERICAN NTSC COLOUR MONITOR

Suitable for Apple, Atari and Texas 99/4 **£295** + VAT

8MHz Super Quality Modulators	£4.90
6MHz Standard Modulators	£2.90
C12 Computer Grade Cassettes	10 for £4.00
Anadex Printer Paper — 2000 sheets	£25.00
Floppy Discs 5 1/4" Hard and Soft Sector	£3.50
Floppy Disc Library Case 5 1/4"	£3.50
Verocases for Nascom 1 & 2 etc.	£24.90
Keyboard Cases	£9.90

MEMORY UPGRADES

16K (8 x 4116) **£29.90** + VAT
 4K CompuKit (8 x 2114) **£29.90** + VAT

SPECIAL OFFER

We will part exchange your Sinclair ZX80 for any of our products.

Refurbished ZX80's—fully guaranteed **£69.90** + VAT (Supply dependant upon stocks).

EXTENDED WARRANTY BY COMPUKARE

MEMORY UPGRADES

We have one of the largest collections of Computer Books under one roof, along with racks of software for the PET and TRS80. **Come and see for yourself.**

NOW OPEN

OUR NEW SHOWROOM & SALES CENTRE AT
 311 Edgware Road,
 London W2.
 Telephone: 01-441 2922

SPECIAL—ONCE IN A LIFETIME OFFER!

RRP £740 + VAT

16K **£399**
 32K **£449**
 48K **£499** + VAT

EXIDY SORCERER

For Personal or Business Use.
 32K or 48K memory. 8K Microsoft Basic in ROM. Dual Cassette I/O, RS232 I/O, Parallel I/O (Centronics). Expansion available through optional extra S100 Motherboard. 69 Key keyboard including 16 key numeric pad.

EXTENDED WARRANTY BY COMPUKARE

COMP SHOP

"Europes Largest Discount Personal Computer Stores"

Please add VAT to all prices — including delivery. Please make cheques and postal orders payable to **COMP SHOP LTD.**, or phone your order quoting **BARCLAYCARD, ACCESS, DINERS CLUB** or **AMERICAN EXPRESS** number. **CREDIT FACILITIES ARRANGED** — send S.A.E. for application form.

MAIL ORDER AND SHOP:
 14 Station Road, New Barnet, Hertfordshire, EN5 1QW (Close to New Barnet BR Station — Moorgate Line).
 Telephone: 01-441 2922 (Sales) 01-449 6596 Telex: 298755 TELCOM G

NEW WEST END SHOWROOM:
 311 Edgware Road, London W2. Telephone: 01-262 0387

OPEN — 10am - 7pm — Monday to Saturday

- ★ **IRELAND:** 80 Marlborough Street, Dublin 1. Telephone: Dublin 749933
- ★ **COMP SHOP USA,** 1348 East Edinger, Santa Ana, California, Zip Code 92705. Telephone: 0101 714 5472526

BARCLAYCARD VISA **AMERICAN EXPRESS** **DINERS CLUB INTERNATIONAL**

COMP COMPUTER COMPONENTS (Part of the Compshop Ltd. Group)

We are now entering our fourth financial year of dealing solely in the personal computer market — in fact, we started it! Over this period Personal Computers Limited have formed a group of graduate specialists who will help you in the fields of word processing, financial planning, statistics, economic modelling, forecasting, accounting systems, foreign exchange, banking and oil exploration. We also do rather well with computer graphics and highly recommend the graphics tablets and our plotter for Apple.

We can also offer two excellent items of software — Format 40 and Visicalc — at a combined price of ONLY £189, and the Super Sound Generator for only £90! (excl. V.A.T.)



8" Disk Drive (above left)

Our 8" disks are still as popular as ever — 2 drives give you 1.2MB with all the reliable security of Shugart Technology. Easily interfaced to Apple, uses the same D.O.S.

A.I.O. Serial and Parallel Card (above centre)

Three handshake lines (R.T.S., C.T.S. and D.C.D.). Firmware for serial interfaces on board, software for parallel printer available, 2 bi directional 8 bit parallel ports, plus 4 additional interrupt and hand shaking lines.

Light Pen (above right)

A much sought after product which we introduced to the U.K.

80 Character Card (below left)

... opens up the real commercial world for all Apple owners.

Paper Tiger (Below centre)

132 character line, plus graphics, 8 character sizes, ordinary paper, multiple copy, upper and lower case 96 character, parallel/serial, form control.

Centronics 730 (Below right)

A substantial, robust printer from a major manufacturer. 3 way paper handling system, 100 character per second. Special low cost including interface. 96 characters.



Items pictured

Sharp MZ — 80K

A new generation of personal computer, self contained, versatile and starting at only £570 (excl. VAT). Explore the Zilog Z80 now the easy way. Disks and printer available shortly.

Numeric Keypad

... with 8 function keys is a must in all financial applications.

TCM 100 & TCM 200

... both now have graphics as well as their own power supply, essential with this type of printer.

Qume Sprint 5

The quality word processing printer. Clean, clear executive reports the way you want them. Can print up to 5760 points per square inch — or even print in 2 colours.

This is what we do..

and we do it rather well!



Personal Computers Limited
194-200 Bishopsgate, London EC2M 4NR. Tel. 01 626 8121

For further information, please complete this coupon and post to:
Personal Computers Limited, 194-200 Bishopsgate, London EC2M 4NR.

NAME _____
ADDRESS _____

*** Now here details for
APPLE
III**