

Personal Computer

WIN A DAI COMPUTER!

Canada \$2.25/US \$2.00/FF8.80/Lire 1700/DM 3.80/FL 4.00/BFr 64/Dkr 17.00/Skr 9.30/Nkr 10.50

World February 1981 60p

EUROPE'S LEADING MICRO MAGAZINE

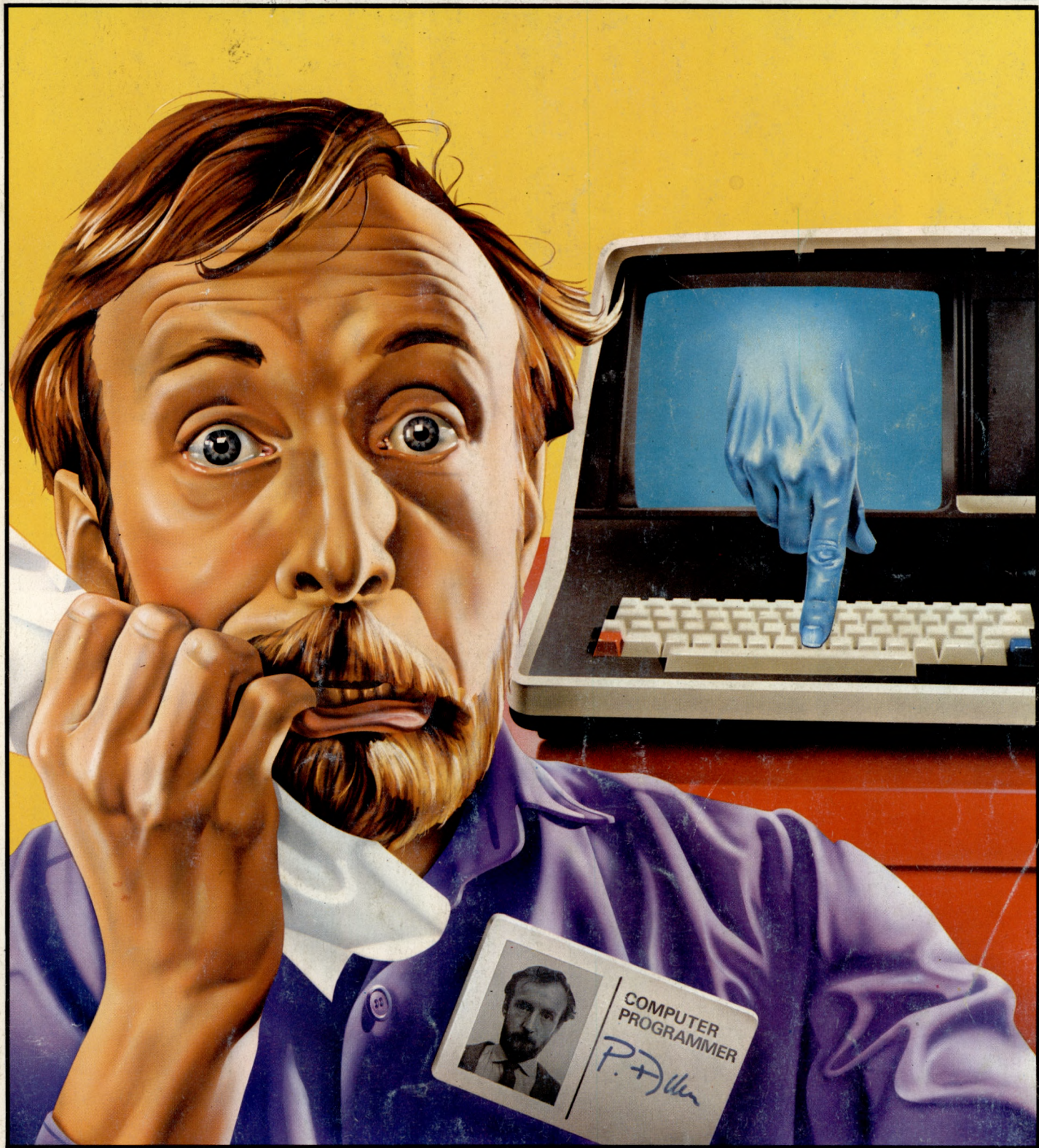

PCW WORLD EXCLUSIVE!
At last - the end of programming?

MicroCentre introduce

High Resolution Graphics

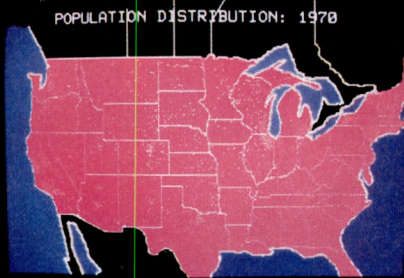

Demographic Display



Management information

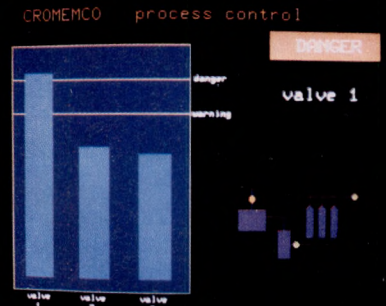

Control system display

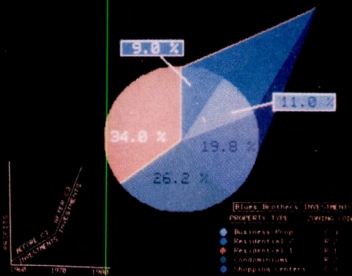

3-D display with angled labels

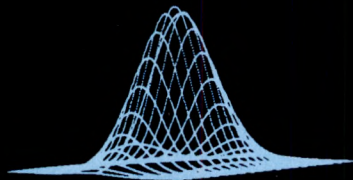

3-D plots

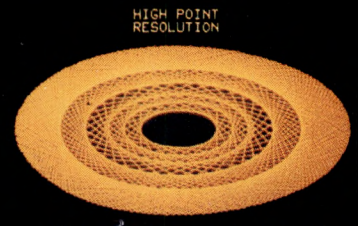

High-resolution display with alphanumerics

Up to 16 colours can be displayed simultaneously, from a choice of 4069. Areas can be filled with colour, windows created, graphs plotted, etc—all under control of simple Basic, Fortran or Assembler functions.

At the heart of any Cromemco graphics system is Cromemco's "SDI" board, the most versatile video interface in the microcomputer industry today. The Cromemco SDI is designed to meet the challenge of professional and industrial environments where uncompromising performance, reliability, and continued compatibility are essential. With its high point resolution, colour map selection, dual page windowing function, automatic fill mode, and NTSC or PAL broadcast compatibility, the most demanding requirements for a video interface can be met. The SDI provides a choice of 4096 individual colours and up to 754 by 482 point resolution. Its different modes of operation include bit or nybble mapped displays with varying levels of resolution, and window effects requiring as little as 12k data storage.

RGB-13 Colour Monitor

The Cromemco RGB-13 Colour Monitor has been specially designed for optimum colour graphics performance when used with Cromemco's SDI video interface. It includes a fine-pitch 13" CRT with a high-precision electron gun, internal magnetic shielding, and implosion protection band. The monitor combines alphanumeric character generation with colour graphics and

high resolution, to give an overall performance vastly more superior than conventional colour TVs or CRT terminals.

Graphics Software

Cromemco's graphics software package provides an interface to Fortran IV, Ratfor, Macro Assembler, 16K Extended Basic and 32K Structured Basic. It is written for ease of use and takes full advantage of the RGB-13 monitor's special graphics facilities. Thus it is efficient, flexible and extremely fast. The package contains routines to change the colour map, scale the display area, draw dots, lines and circles, display text, and fill areas with colour. Screen addressing can be by absolute or relative co-ordinates.

Model Z2H/GS Graphics System

The Z2H/GS is a special configuration of the Z-2H Hard Disk computer which includes full graphics capability and software. Yet at under £8,000 it's a fraction of the cost of comparable systems. It is ideal for applications in medical imaging, computer-aided instruction, pattern recognition, and the television industry.

The Z2H/GS includes a Z-80A processor, 64k of RAM memory, integral 11 megabyte hard disk, RGB-13 colour monitor, 2 floppy disks, printer interface, RS-232 serial interface, and graphics software package.

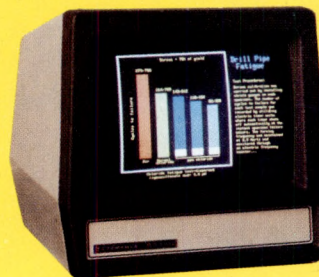

The high-performance Z2H/GS colour graphics system includes a Z-2H hard disk computer, RGB-13 colour monitor, and comprehensive graphics software package—all for under £8,000!

For  **Cromemco... call the experts**

MicroCentre
Tel: 031-556 7354

LEADING UK DISTRIBUTORS

Complete Micro Systems Ltd.,
30 Dundas Street
Edinburgh EH3 6JN

CONTENTS

Volume 4 No 2 February 1981

Founder
Angelo Zgorelec

Editor
David Tebbutt

Deputy Editor
Peter Rodwell

Sub Editor
Jon Wall

Art Director
Paul Carpenter

Art Editor
Shelley Gray

Editorial Office
14 Rathbone Place
London W1P 1DE
01-637 7991

Advertisement Director
Stephen England
01-636 4461

Assistant Advertisement
Manager
Patrick Dolan
01-636 4463

Advertisement Executive
Jacquie Hancock
01-631 1682

Production Manager
Dick Pountain

Typesetter
Jane Hamnell

Published by SportsScene
Publishers (PCW) Ltd., 14
Rathbone Place, London
W1P 1DE, England. Tel:
01-637 7991/2/3. Telex:
8954139 A/B 'Bunch' G
London

Copyright notice
Personal Computer World is
published by SportsScene Pub-
lishers (PCW) Ltd. © 1980
Felden Productions. No
material may be reproduced
in whole or part without
written consent from the
copyright holders.

Printed by Riverside Press
Whitstable

38 NEWSPRINT: The latest micro news from Guy Kewney.

47 CTUK! NEWS: ComputerTown is spreading fast!

48 WEST COAST FAIRE: GOTO California this Spring with PCW.

49 YANKEE DOODLES: The American viewpoint, from Tom Williams.

52 COMMUNICATIONS: Where you have your say.

54 BENCHTEST: The Vector Graphics VIP, tested by Stephen Withers.

58 PATTERNS: Starting a new series, from Alan Sutcliffe.

62 PRINTERFACING: Peter Faff gives hook-up details of more low-cost printers.

69 COMPETITION: Win a DAI personal computer in our 'help the handicapped' essay comp.

70 COMPUTER GAMES: David Levy continues his in-depth peek at poker.

76 THE LAST ONE: David Tebbutt reports on the program which writes programs.

80 COMPUTER ANSWERS: Sheridan Williams and his team answer your queries.

85 BOOKFARE: Malcolm Peltu reviews books on the political implications of micros.



Cover illustration Paul Allen

89 PUNTER'S PET: Alan Green shows you how to beat the bookie at his own game.

91 CALCULATOR CORNER: Dick Pountain brings more Casio Quirks.

93 SECRETS OF SYSTEMS ANALYSIS: Lyn Antill continues her series aimed at bridging the micro 'knowledge gap'.

99 GATEWAYS TO LOGIC: Derrick Daines pauses in his series to consider systems.

100 SURVEY WINNERS: Did you win an MZ-80K or a year's PCW sub?

102 GET ON THE RIGHT TRACK: Concluding our look at real-time control, using trains as an example.

106 YOUNG COMPUTER WORLD: Especially for our younger readers.

107 FEATURE INDEX/BACK ISSUES: Find out what you've missed and buy it!

109 MULTI-USER SYSTEMS: Sue Eisenbach and Adrian V

Stokes continue their series on big micros.

113 ZX80 PRINTER: Add a printer to your Sinclair!

123 NEWCOMERS START HERE: A quick intro for those new to the micro scene.

124 DIRECT ACCESS: with in IN STORE, TRANSACTION FILE, the full USER GROUPS INDEX, DIARY DATA and — new — NETWORK NEWS.

134 PCW SUB SET: Alan Tootill presents more handy assembler language sub-routines.

137 LEISURE LINES LINES: J J Clessa poses more puzzlers.

137 PROGRAMS: Our readers' latest listings.

148 BLUDNERS: We confess all!

183 CHIP CHAT: Europe's leading microgossip page!

Sorry! No 'Face to Face' this month.

megastor and apple

the perfect couple

1 Megabyte on  line for £1970

Plug-in compatible with Apple standard 5¼" disk drives.
Runs on Apple DOS. Includes SVA Disk 2+2 Controller Card.

Dealer enquiries
welcomed.

Apple is a trade mark of
Apple Computer Inc.
Disk 2+2 is a trade mark
of Sorrento Valley Associates.



VLASAK ELECTRONICS Ltd, Thames Building, Dedmere Road, Marlow, Bucks, SL7 1PB.
Telephone: Marlow (STD code 06284) 74789. Telex: 847008 Vlasak G

Speed up your PET programming with The BASIC Programmer's Toolkit™, now only £30.00.

Don't waste valuable programming time if there's an easier way to go. Here it is: The BASIC Programmer's Toolkit, created by Palo Alto ICs, a division of Nestar. The Toolkit is a set of super programming aids designed to enhance the writing, debugging and enhancing of BASIC programs for your PET.

The BASIC Programmer's Toolkit has two kilobytes of ROM firmware on a single chip. This extra ROM store lets you avoid loading tapes or giving up valuable RAM storage. It plugs into a socket inside your PET system, or is mounted on a circuit board attached on the side of your PET, depending on which model you own.

There are basically two versions of PET. To determine which Toolkit you need, just turn on your PET. If you see ***COMMODORE BASIC*** your PET uses the TK-80P Toolkit. If you see ###COMMODORE BASIC###, your PET uses the TK-160 Toolkit. Other versions of the BASIC Programmer's Toolkit are available for PET systems that have been upgraded with additional memory.

PET™ is a trademark of Commodore Business Machines, Inc. The BASIC Programmer's Toolkit™ is a trademark of Palo Alto ICs, a division of Nestar Systems, Inc.

How Toolkit makes your programming easier:

FIND locates and displays the BASIC program lines that contain a specified string, variable or keyword. If you were to type *FIND A\$,100-500*, your PET's screen would display all lines between line numbers 100 and 500 that contain *A\$*.

RENUMBER renumbers the entire program currently in your PET.

You can instantly change all line numbers and all references to those numbers. For instance, to start the line numbers with 500 instead of 100, just use *RENUMBER 500*.

HELP is used when your program stops due to an error. Type *HELP*, and the line on which the error occurs will be shown. The erroneous portion of the line will be indicated in reverse video on the screen.

These simple commands, and the other seven listed on the screen, take the drudgery out of program development work. And for a very low cost. The BASIC Programmer's Toolkit costs as little as £30.00 or at most, £45.00.

Get the BASIC Programmer's Toolkit and find out how quick and easy program development can be. See your local PET dealer today.

Increase your PET's IQ for £30

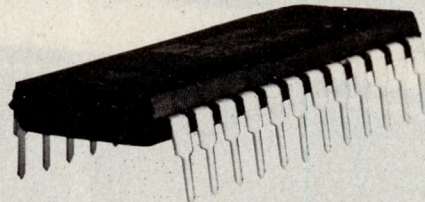

Now available - the TK-4.0 for the new 4000-8000 PET

PALO ALTO ICs
A Division of Nestar Systems, Incorporated

The Toolkit is fully assembled. It is not a kit and requires no special tools to install.

Contact your nearest Commodore dealer for the 'new deal' Toolkit

Now made available at super low prices in Europe by Zynar Ltd., Nestar's European business partner

ZYNAR 122/3 HIGH STREET · UXBRIDGE · MIDDX Telephone: Uxbridge (0895) 59831

The b



TRS-80 Model I
 from £379
 4K Level I
 £559
 16K Level II
 (illustrated).

£559.00*
 (16K Level II)

TRS 80 Model I Microcomputer Here's the push button brain, the entertainer, the tutor, the timesaver. Fun for the children, a helper for the businessman and the teacher, a catalogue for the housewife, an analyser for the investor and an informer for the salesman. Run Maths, English, Chess, Draughts and video game programmes for educational fun. Easy to learn and operate — you can even write your own programmes. Suddenly you have a ready and reliable source of brainpower — put it to work immediately.



£289.00*

£439.00*

TRS 80 Model I C.P.U.'s Complete and ready to run from your TV monitor. Just plug in and start computing. The lowest priced 4 K level I CPU contains 4096 bytes of user memory and can be expanded to 16K within the keyboard unit. The 16K level II CPU is a more powerful and flexible version using an additional 12K ROM. Level II also incorporates a calculator style numeric keypad for faster data entry.

rains.



S-80 Model II Microcomputer A bigger, more powerful brother to Model I. Designed for more data storage and versatility. Like Model I is completely modular allowing easy, plug-in expansion. It's available memory will allow maximum use of future languages.

S-80 COMPUTER CENTRES NOW OPEN AT—
Birmingham—Edgbaston Shopping Precinct, Hagley Road.
Barnsley—214, Forster Square.
Bristol—Colston Centre, Colston Avenue.
London—1-2, Seacoal Lane, Ludgate Hill, EC4.
111, Kingsway, WC2.
Manchester—30, Market Place, Deansgate.

FULL COMPUTER FACILITIES AVAILABLE AT—
Leeds—72, Merrion Centre.
Liverpool—168, Market Way, St. Johns Centre.
Wednesbury—Bilston Road.
Wimbledon—124-126, The Broadway, London, SW19

*All prices include VAT.

IT'S POSSIBLE, ONLY AT Tandy
Better Equipment. Lower Prices. No Middlemen!

Small computers with big-system performance from **Ohio Scientific**.

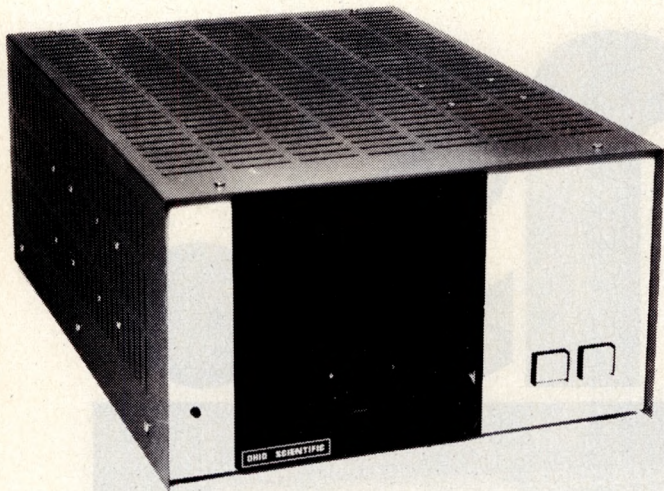

Proven business systems from the desk-mounted C2-OEM to the massive multi-user C3-B with networking capability — currently the world's most powerful micro-

computer. A full range of eight-inch disc formats to choose from. With a choice of three hard-disc capacities as standard.

With a software-selectable choice of processor — 6502, Z80 and 6800. With a choice of operating system — CP/M®, for example, or multi-user, multi-tasking OS-65U. With a range of languages available — BASIC, Pascal, Fortran, Cobol, APL, Forth. Also purpose-built for data-base management.

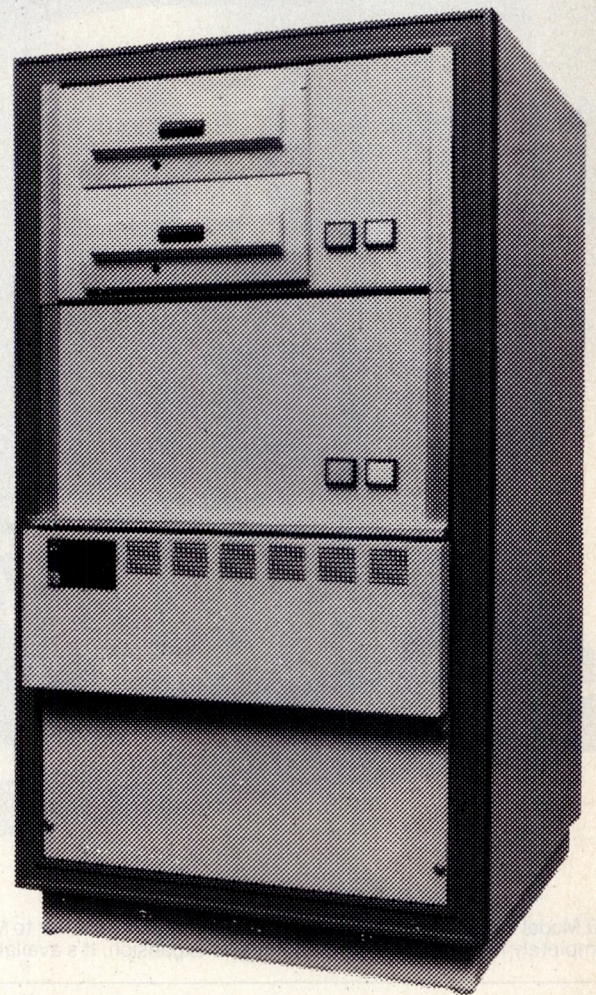

The right range of systems, with the right range of facilities. And at the right kind of price.

Mutek — the **OHIO SCIENTIFIC** specialist
Mutek, Quarry Hill, Box, Wilts. Telephone: Bath (0225) 743289

VISICALC™

VISICALC AND A PERSONAL COMPUTER DO TO THE CALCULATOR, PAPER AND PEN WHAT WORD PROCESSING HAS DONE TO THE TYPEWRITER AND PAPER. REVOLUTIONIZE IT.

Take virtually any problem you would explore using calculator, pen, and paper, working in rows and columns. Apply VisiCalc and you'll see why every reviewer of this product has said the same thing: VisiCalc is the most useful, most important program yet developed.



With VisiCalc, you work with an electronic worksheet of up to 63 columns and 264 rows. At the juncture of any column and row you can type in words or numbers. To put VisiCalc to work, you first create any format or form you need by typing in words — just like writing column headings across the top of a piece of paper and items down the left side. Then, where you want the worksheet to perform a calculation, you type a formula. VisiCalc automatically performs all arithmetic functions, net present value, and transcendental functions. Instantly — and we mean instantly — VisiCalc displays the results. And if you change any of the numerical data, the electronic worksheet instantly displays a new result. Automatically. You can play "what if" as often as you wish to solve thousands of different problems. When finished, you can get a hard copy of all the information on your worksheet from your computer printer.

Absolutely no programming is necessary. VisiCalc does all the work. Now, isn't THAT magic?

ANYONE WHO WORKS WITH NUMBERS USES VISICALC:

Managers and Management consultants: plan budgets, compare actual results to budgeted forecasts, and modify projections faster than ever before. VisiCalc is the most powerful and easy-to-use projection tool ever developed.

Financial Analysts: quickly determine rate-of-return under varying assumptions using the built in net present value functions. VisiCalc will also compute financial ratios, and project tax consequences.

Accountants: develop financial statements and "pro formas", making changes and comparisons easily with VisiCalc's ultimate "what if" recalculation feature.

Tax Accountants: compute the tax effects of many alternatives, and print out all the different scenarios for client discussion and documentation.

Engineers and Scientists: appreciate VisiCalc's transcendental functions, scientific notation, and features like eleven-digit precision in numeric calculations.

Marketing Managers: find VisiCalc is the answer to every forecasting and budgeting need. They refine assumptions-commission rates, sales costs, advertising expenditures, leads, sales closing percentage — and watch the effect on the bottom line.

For Apple II

£69.50

+ VAT

For PET

£99

+ VAT

CCA DATA MANAGEMENT SYSTEM™

The CCA/DMS stores and retrieves information. It is very simple to learn and use, and at the same time provides real data processing capabilities for you and your APPLE II.

You can computerize most, if not all of your record keeping. DMS will give you control over any type of information which lends itself to "row and column" storage, retrieval and analysis.

If you are familiar with the concept of a computer "data base" the power and flexibility of the DMS will amaze you. If you are not familiar with "data base" operation, don't worry. It is logical and

simple. You'll find it easy to store the system, sort, update and print all kinds of files. Files for your mailing list, accounts receivable or payable, customer list, expense reporting, budget analysis, or any report you need. The 130 page manual has full instructions plus samples for a mailing list and inventory application.

For Apple II

£46.50

+ VAT

CCA/DMS FEATURES:

- Fields may be alphanumeric, numeric, integer, floating point, or fixed decimal with commas.
- Fields may be COMPUTED FIELDS.
- Fields may be alphanumeric, numeric, integer, floating point, or fixed decimal with commas.
- Fields may be COMPUTED FIELDS. DMS will compute any field within a record, using constants or other fields in the same record. Functions include add, subtract, multiply, divide and raise exponential powers.
- Records are easily located, using the scan feature. Scan for records with a field over, below, or between a range of values.
- Records are easily added and updated. DMS "prompts" you with questions.

- Multi-diskette capabilities for larger files-up to 85,000 characters per file!
- Sort the records into almost any order, using up to 10 fields as "keys". So you can sort for customer numbers; within zip code, for instance.
- Delete records, "compact" files, and backup files on data diskettes easily.
- Print reports with records in any order.
- Select fields to be printed.
- Print mailing labels.
- Numeric totals and subtotals can be specified when a value in an unrelated field in the same record changes. For example, sort, subtotal, and print according to department, or month, or customer number, or model number.

A MUST FOR EVERY APPLE II IN BUSINESS

DESKTOP PLAN — A Programming Language for Analysis

Desktop plan is the software tool that makes it practical to develop your own customized. . . .

- | | |
|----------------------------|-------------------------------|
| Strategic plan analysis | Profit & loss projections |
| Budget planning system | Manpower requirement planning |
| Capital budget planning | Salary/labor cost planning |
| Cashflow planning | Balance sheet projections |
| Product pricing analysis | Financial report preparation |
| Job development estimating | Make/buy analysis |
| Job cost estimating | Sales forecasting |

. . . WITHOUT PROGRAMMING AT A LOW ONE-TIME COST !

£46.50

+ VAT

FORTRAN FOR YOUR APPLE



£110

+ VAT

FORTRAN is a powerful programming language, especially suitable for work in mathematics, engineering and the sciences. Apple FORTRAN, usable with the Apple Language System, is the ANSI Standard Subset of the recently-defined FORTRAN 77 standard; in several areas, Apple FORTRAN contains enhanced features and capabilities.

Apple is providing FORTRAN for use by technical professionals and educators who are both familiar with the FORTRAN language and are using packages written in FORTRAN. Because FORTRAN is a well-established language, large libraries of FORTRAN programs are already in existence, particularly for engineering and scientific applications. Apple FORTRAN provides the sophisticated FORTRAN user with the capability to develop new and modify existing FORTRAN programs on an Apple. Apple does not recommend FORTRAN for the individual new to programming.

There are two minor differences between the ANSI Standard Subset FORTRAN 77 and Apple FORTRAN. They are:

- Subprogram names cannot be passed as parameters
- INTEGER and REAL data types have different storage requirements—two bytes for INTEGER, four bytes for REAL

Apple FORTRAN is written in Pascal and produces P-code which runs in the Apple Pascal Operating System

Diskettes: 16 sector format

To use Apple FORTRAN, you will need:

- Apple II or Apple II Plus, each with the Apple Language System.
- Apple Disk II drive with controller*
- video monitor or television

*While a single drive system is adequate for very small programs, two drives are strongly recommended for ease of operation and more serious program development

Apple FORTRAN...

- offers enhanced features and capabilities because it supports the newest computer industry standard, ANSI X3.9-1978...
- provides a comprehensive software design environment including an editor, linker, file handler, assembler, Apple Pascal compiler, and system library, operating in the Apple Language System...
- eliminates the need to recompile or reassemble existing code files when incorporating them into FORTRAN programs; compiled P-code and assembled machine code can be combined with a FORTRAN P-code file through the Apple Language System's linker facilities...
- allows you to take full advantage of Apple's Hires graphics capabilities by interfacing to graphics routines in the system library...
- gives programmers access to large libraries of material, since FORTRAN is a familiar, well-established language...
- provides access to special Apple features, such as sound generation and control paddles, through its system library routines...
- permits you to combine several source files in a single compilation through compiler directives in the source code.

First, Some Words About FORTRAN 77

FORTRAN 77 contains significant additions and enhancements to the previous 1966 standard. For example, mixed-mode arithmetic expressions are allowed. Structured programming is supported through expanded IF statement constructs: Logical IF, Block IF, ELSE IF, ELSE, and END IF statements provide a vastly improved method of clearly and accurately specifying the flow of program control. CHARACTER data type replaces Hollerith; alphanumeric data can be represented as strings rather than array elements.

Some Specifics About Apple FORTRAN

- Apple FORTRAN is the ANSI Standard Subset FORTRAN 77. It also supports enhancements and facilities from the full FORTRAN 77 language. In particular:
 - Subscript expressions may include array elements and function calls.
 - DO statement limits may be defined by expressions, rather than just single variables.
 - I/O units may be specified by expressions, rather than just constants or simple variables.
 - The I/O list of a WRITE statement may include expressions.

- All combinations of FORMATTED/UNFORMATTED and SEQUENTIAL/DIRECT files are allowed, with the following restrictions:
 - BACKSPACE is supported only for files connected to the blocked devices; it is not supported for UNFORMATTED SEQUENTIAL files; — DIRECT files must be connected to block devices

Apple FORTRAN contains a number of enhancements beyond the full FORTRAN 77 specifications. In particular:

- Compiler directives may be included in the source code. For instance, the \$INCLUDE directive allows you to insert previously-developed code into your program without having to repeat the code. This is useful, for example, when you are writing many subroutines which use the same COMMON block. You can write the COMMON block just once, and \$INCLUDE it in every subroutine.
- An additional parameter to the OPEN statement allows you to specify whether the file is blocked or unblocked



apple II^{MT}

APPLE II PLUS

When Stephen Jobs and Steven Wosniak launched their first APPLE II, they were far from realising the worldwide success this microcomputer would have. Nearly anything can be done with the APPLE II. Whether it be business, science, leisure or art, your APPLE II can handle it all. (We've even seen an APPLE preparing coffee lately!)

It's full expansion capabilities enable you for example to connect your APPLE II to 4 disks, 2 printers, one tape cassette recorder, and one optical pen still leaving you room for 4 other connections. Therefore your APPLE will never become out of date and will always be able to adapt to new techniques, however versatile or varied the they may be.

Two types of computers are now available:

— APPLE II: this system is supplied with INTEGER BASIC, high resolution graphics routines, mini-assembler, disassembler and system control firmware in ROM. Demo programs and manuals are oriented around INTEGER BASIC.

— APPLE II PLUS: this system is supplied with APPLESOFT extended BASIC (including high resolution graphics routines), disassembler and new auto-start system control firmware in ROM. Demo programs and manuals are oriented around APPLESOFT extended BASIC.

Integer Basic or Applesoft Basic are available as plug-in card options for 110. — each.

Both APPLEs are based on the 6502 microprocessor, they include: sockets for up to 48K RAM, 8 peripherals board connectors, speaker, two hand controllers, cassette interface, colour graphics hardware, I/O connectors and typewriter style ASC II keyboard.



APPLE 16K: **£595** + VAT

16K ADD: **£49** + VAT

PRINTERS

Centronics 730 **£ 390** + VAT

Centronics 737 **£ 490** + VAT

Axiom IMP 2 **£ 530** + VAT



PASCAL LANGUAGE CARD

Pascal

APPLE PASCAL, incorporating UCSD PASCAL,™ offers extended features in a complete, interactive package employing today's most sophisticated structured programming language. It provides advanced capabilities that boost performance and cut development time for large business, scientific, and educational programs.

The software package provides a powerful set of tools for the serious programmer:

Relocatable assembler

Permits relocatable assembly language routines to be generated and linked to PASCAL programs.

Filer

General purposer program for manipulating all system disk files.

System utilities

- DESK CALCULATOR — performs basic calculations
- PARAMETER — allows examination and modification of system operating environment.

PASCAL operates in a 48K APPLE II or II Plus with one to six disk drivers and the APPLE Language System. An external 80-column terminal can be attached. The package includes: • Language Card • 5 diskettes including • Integer BASIC • Applesoft Extended BASIC • PASCAL System • JC puller • 3 PASCAL manuals • 3 BASIC Language manuals • Installation & Operation manual

£230 + VAT



CP/M FOR YOUR APPLE !!

The Microsoft Z80 Softcard

— A LITTLE STROKE OF GENIUS FOR YOUR APPLE II.

£172

+ VAT

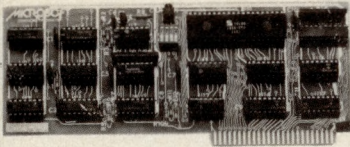

TRANSFERRING STANDARD CP/M APPLICATION PACKAGES TO APPLE CP/M

Literally thousands of CP/M based applications can be easily transferred to run on the Apple. It is simply a matter of converting programs from standard 5" and 8" CP/M disk format into CP/M disk format. This is done by transferring CP/M files from a CP/M machine to the Apple via a serial I/O port. You'll need an Apple High Speed Serial interface or an Apple Communications interface; a connecting cable; and, of course, a CP/M machine from which to transfer. Utilities that make this process easy are supplied with the Z-80 SoftCard.

USING PERIPHERAL WITH THE Z-80 SOFTCARD

A Z-80 SoftCard system will run with all standard Apple peripheral I/O cards and most independent peripherals including any printer that is supported by Apple printer interface cards. Since CP/M provides the same I/O environment as Apple Pascal, a good rule of thumb is that the SoftCard will interface with any peripheral that currently works with Apple Pascal.

The Z-80 SoftCard will support up to six disk drives, 24 x 80 column video cards such as the Videx and Sup-R-Term are supported as are most popular 80 column terminals such as those from Hazeltine and Soroc.

In addition, user I/O drivers can be easily added to CP/M.

WHY CP/M?

Next to the SoftCard itself, CP/M is the most important key to allowing a wide variety of Z-80 software to run on the Apple including version 2.2 of the CP/M operating system in the SoftCard package.

More software choices for the user. You have your choice of many sophisticated system, word processing, accounting, business and professional software packages when you have CP/M.

Unlike standard Apple DOS, CP/M supports many languages in addition to BASIC. These include FORTRAN, COBOL, BASIC Compiler.

And CP/M has many conveniences not found in Apple DOS. Such as easy interface to machine language programs; faster disk I/O simple file transfer; and wild card file-naming conventions that allow you to refer to multiple files with one name.

Included as standard with CP/M 2.2 is a complete set of system utilities that give you complete control of the CP/M operating environment. These include PIP, a general purpose file transfer utility and STAT, a program that lets you keep track of important system information such as disk space and file size. SUBMIT and XSUB allow you to execute batch processing jobs. And a powerful text editor, assembler, and sophisticated assembly language debugger, are also included.

The Z-80 SoftCard is not an emulator. It is an actual Z-80 chip plus interfacing circuitry on a circuit board that plugs directly into any of the slots on your Apple (except slot 0).

The Z-80 does not replace your 6502; it adds to it. You use Z-80 mode when you want to run Z-80 software. Switching back and forth is simple.

When you are in Z-80 mode, the Z-80 assumes all the processing tasks, but the 6502 continues to handle I/O. Thus, you can still use most Apple peripherals when you are in Z-80 mode.

MEMORY REQUIREMENTS

To run the Z-80 SoftCard requires a disk-based Apple II or disk-based Apple II Plus computer with at least 48K RAM memory. If used with a Language Card, 12K additional RAM can be utilized.

Whether you have a 48K system or a 60K system with Language Card, 4K of RAM is required to handle the Apple screen and CP/M sector read and write routines.

CP/M occupies 7K of RAM, 2K of which can be used by other programs, such as BASIC. The standard versions of Microsoft BASIC, which supports all Applesoft extensions except high-resolution graphics, requires slightly more than 24K RAM. So BASIC and CP/M together occupy just over 29K RAM.

The version of BASIC that supports high-resolution graphics is somewhat large because 8K of screen memory is necessary for high-resolution graphics. It occupies just over 33K, making a total of slightly more than 38K for both CP/M and the high-resolution version of BASIC.

BEYOND MICROSOFT BASIC

Microsoft 5.0 BASIC is provided with the Z-80 SoftCard. Microsoft FORTRAN, COBOL, BASIC Compiler, and Assembly Language Development System will be available and sold separately to Z-80 SoftCard users.

Just imagine the power of your Apple Computer when it has one of the following:

Microsoft FORTRAN-80. Comparable to the FORTRAN compilers used on large mainframes and mini-computers, Microsoft's FORTRAN-80 brings the world's most popular science and engineering programming language to the Apple. Compilation is very fast (up to several hundred statements per minute) and less than 25K bytes of memory are needed to compile most programs. All of ANSI FORTRAN X3.9-1966 is included except the COMPLEX data type. Therefore, you may take advantage of

the many application programs already written in FORTRAN:

Microsoft COBOL-80. The most widely used language for business applications, COBOL is excellent for inventory, personnel, payroll, order entry, accounting and forecasting applications. Powerful use of disk files, CRT screen handling, easy-to-use syntax and readable programs give programmers the tools they need to meet the rising challenge of data processing. Microsoft's COBOL-80 is an ANSI standard COBOL with many enhancements.

Z-80 SOFTCARD PRODUCT SPECIFICATIONS £25

The Z-80 SoftCard is a plug-in processor card for the Apple II. The SoftCard package includes the CP/M operating system and Microsoft 5.0 BASIC.

Hardware:
Processor: Intel 80C86
Clock Rate: Variable (up to 10 MHz)
Addressing Capabilities: 16-bit addressing
Memory Mapping: 16-bit addressing
Power Consumption: Average 200 mA
Size: 160mm x 160mm x 1.5mm
Operating Modes: 8086, 8088, 8080
Installation: Plug-in to slot 0
Compatibility: IBM PC compatible
CP/M Operating System: Version 2.2
Microsoft 5.0 BASIC: Version 5.0
Apple II Disk Controller: Version 1.0
Apple II Disk II: Version 1.0
Apple II Disk III: Version 1.0
Apple II Disk IV: Version 1.0
Apple II Disk V: Version 1.0
Apple II Disk VI: Version 1.0
Apple II Disk VII: Version 1.0
Apple II Disk VIII: Version 1.0
Apple II Disk IX: Version 1.0
Apple II Disk X: Version 1.0
Apple II Disk XI: Version 1.0
Apple II Disk XII: Version 1.0
Apple II Disk XIII: Version 1.0
Apple II Disk XIV: Version 1.0
Apple II Disk XV: Version 1.0
Apple II Disk XVI: Version 1.0
Apple II Disk XVII: Version 1.0
Apple II Disk XVIII: Version 1.0
Apple II Disk XIX: Version 1.0
Apple II Disk XX: Version 1.0
Apple II Disk XXI: Version 1.0
Apple II Disk XXII: Version 1.0
Apple II Disk XXIII: Version 1.0
Apple II Disk XXIV: Version 1.0
Apple II Disk XXV: Version 1.0
Apple II Disk XXVI: Version 1.0
Apple II Disk XXVII: Version 1.0
Apple II Disk XXVIII: Version 1.0
Apple II Disk XXIX: Version 1.0
Apple II Disk XXX: Version 1.0

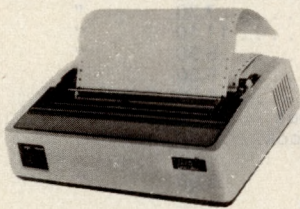

OKi MICRO LINE 80

FOR APPLE II
 OKi u80 + Parallel interface
 + Graphics
 (see below) **£475**

Parallel printer interface
 for APPLE:
£110.00
 (wire included) **£99**

- 40, 80, 132 columns (compressed and doubled characters)
- 80 characters per second
- 96 characters ASCII and semi-graphic 7 x 9
- 6 or 8 lines an inch
- Original + 2 copies
- End of copy detector
- Parallel interface

£349.50

+ VAT

OPTIONS: — Adjustable tractor **£90**
 — Serial Interface RS232c/v 24 : **£80**

HARD COPY HIRES PAGES FOR OKI MICROLINE 80 AND APPLE

This was obtained with the Minimic Computer Hard copy, Microline 80 and APPLE with disk

£ 50 + VAT
 Hardware & Software

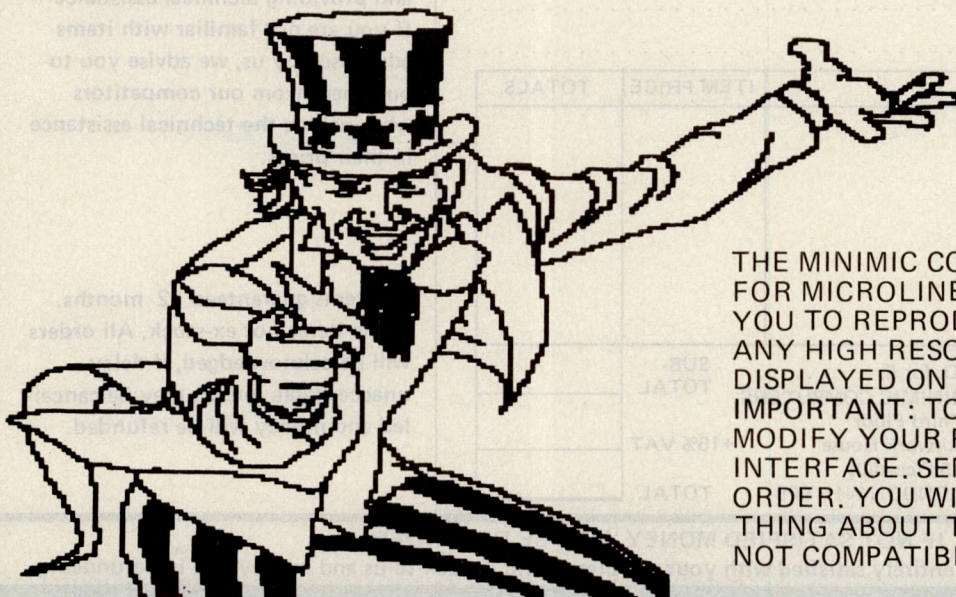

THE MINIMIC COMPUTERS HARD COPY FOR MICROLINE 80 AND APPLE ENABLES YOU TO REPRODUCE ON THE PRINTER ANY HIGH RESOLUTION GRAPHICS DISPLAYED ON THE MONITOR. IMPORTANT: TO DO SO WE NEED TO MODIFY YOUR PARALLEL PRINTER INTERFACE. SEND IT TO US WITH YOUR ORDER. YOU WILL RECEIVE THE WHOLE THING ABOUT TWO WEEKS LATER. NOT COMPATIBLE WITH PASCAL.

MINIMIC COMPUTERS Ltd

PET 2001 - 2008 - 3016 - 3040 3022 - 8050 - 8032

This family of Basic systems compares quite favorably with mini and large computer systems. These systems are highly competitive in maintaining financial records, storing records, controlling appliances, typewriting, sales analysis, and inventory control. PET systems are just what the small business user needs. It may also be scaled down to the users particular needs. Their applications

are endless. PETs are popular not only in business but also at home. They have a self-contained monitor. The PET is concisely built with its numeric key pad keyboard. 8K, 16K, 32K memory. Full expansion capabilities for cassette, disks and printer.

- PET 2001** This microcomputer has the small keyboard and the Integral tape deck. Also comes with 8K Byte memory. **£389 + VAT**
- PET 2008** A popular micro-computer build with a green self-contained monitor with new large keyboard. Comes with 8K Byte memory: **£425 + VAT**
- PET 3016** This model has also the new improved large keyboard and Integral screen. It has 16K Byte memory. **£540 + VAT**
- PET 3032 **£595 + VAT**
- PET 3040** Dual Drive Disk System: Built for the PET micros, it allows you rapid access to both programs and data. 343K user storage. **£595 + VAT**
- PET 3022** PRINTER (tractor feed): Prints on multiple copy paper all the PET characters, letters, numbers, and PET graphics, **£399 + VAT**

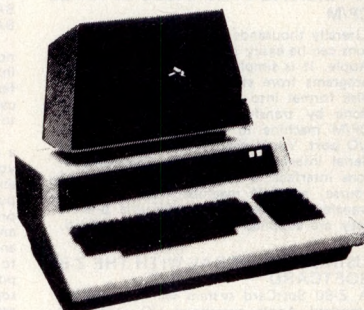

PET 2001 - £389 + VAT

ALSO AVAILABLE: PET 8050: £850 + VAT. PET 8032: £850 + VAT

BOOKS

Microprocessors	5.90	ZAKS	More Basic Computer Games	5.50	"
Microprocessors interfacing technique	8.90	"	Computer Coin Games	2.90	"
Programming the Z80	8.30	"	Problems for Computer Solutions.	3.80	"
Programming the Z8000	8.30	"	Computers in Mathematics.	11.85	"
6502 Application book.	7.10	"	6800 Software Guide and Cookbook.	6.30	Scelbi
6502 Game book	7.10	"	8080 Software Guide and Cookbook.	6.30	"
Your first computer	4.15	"	Understanding Microcomputers.	5.50	"
CP/M Handbook	10.80	"	Standard 8080 Editor	7.30	"
Introduction to Personal and			8080 Standard Assembler	11.10	"
Business computing	4.35	"	Standard 8080 Monitor	5.50	"
6800 Programming for logic design	5.70	Osborn	808 Galaxy Game.	5.50	"
The best of creative computing (Vol 1)	6.70	Creative Comp.	Calculating with Basic	4.50	"
The best of creative computing (Vol 2)	6.70	"	Z80 Software Guide and Cookbook	8.20	"
Best of byte	8.20	"	6502 Software Guide and Cookbook.	6.30	"
Basic Computer Game	5.50	"	Introduction to Low Resolution		
Colossal Computer Cartoon Book.	3.85	"	Graphics	5.55	"
Be a Computer Literate	2.95	"	6502 Software Gourmet Guide &		
			Cookbook	6.30	
			Programming the 6502	7.00	Zans
			6502 Applications	7.40	

Mail order only — All prices include postage in U.K. — VAT not included and are correct at time of going to press.

NAME Tel.

COMPANY

ADDRESS

QUANTITY	ITEM	ITEM PRICE	TOTALS

I enclose cheque/P.O. for £. SUB-TOTAL

made payable to: MINIMIC COMPUTERS Third Floor +15% VAT

Airwork House 35 Piccadilly LONDON W1V 9PB TOTAL

Mail order only. Sorry, we can't do everything: selling at low cost and providing technical assistance — If you are not familiar with items advertised by us, we advise you to buy them from our competitors who include the technical assistance in their prices.

All items guaranteed 12 months. Some items not ex-stock. All orders will be acknowledged, if delay unacceptable, orders may be cancelled and money will be refunded.

IF NOT SATISFIED MONEY WILL BE REFUNDED

If within 30 days you are not entirely satisfied with your purchase, send it back to us and money will be refunded.

CASTLE ELECTRONICS MICRO COMPUTER CENTRE

Now out of twelve years' experience in electronics and communication comes the South Coast's own Computer Centre. Choose from our wide range of micro-computers and support material. Ideally suited to the hobbyist about to enter the fascinating world of computers. Personal callers or mail order welcome.

TANGERINE

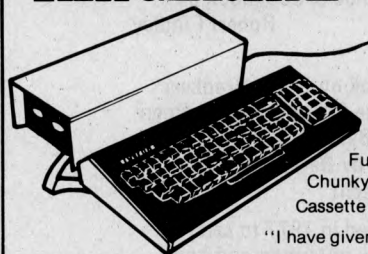

microtan 65 £69

Microtan 65 is the most advanced, most powerful, most expandable microcomputer available — it also happens to be the most cost effective.

6502 Microprocessor 1K Tanbug 1K User RAM Full TV Display **£79** (ready-built). 20-way KEYPAD—**£10**. TANEX—**£43**
1K 16 parallel 1/0 lines. Cassette Interface—1 serial 1/0 line. 2 x 16 BIT counter timers OPTIONS 7K. RAM total—32 parallel 1/0 lines. 4 x 16 BIT counter timers—RS232. 20MA current loop.
10K MICROSOFT BASIC—**£49**
System Rack—**£49** in black/tangerine in brushed aluminium.
Full Ascii Keyboard with numeric pad—**£60.85**. Cabinet available—**£20**. Lower Case option—**£9.48**.
Chunky Graphics Pack—**£6.52**. Tanram Full Memory Expansion to 40K—**£119.00**. Mini Motherboard—**£10.00**.
Cassette with counter—**£21.70**.

"I have given TANGERINE five bonus points for getting just about everything right"—E.T.I. Mag., May 1980.

COMMODORE PET



Everything has been said about PET—Britain's number one selling microcomputer. A full range of accessories and software, (both games and business), is held in stock.

8K Inbuilt Cassette—**£399**,
8K Large Keyboard—**£425**
16K Large Keyboard—**£499**
External Cassette—**£55**
Dual Disc Drive—**£695**
Tractor Printer—**£425**



£399

CASSETTE SOFTWARE: Strathclyde Basic Course, Basic Basic Course, Invaders, Treasure Trove of Games 1 to 10 (10 selections of games), Basic Maths, Algebra, Statistical Packs and lots more!



£599

The Apple II+ is more powerful than its predecessors with built-in sound and high resolution graphics, which make it ideal for scientific and games applications.

16K—**£599**
32K—**£649**, 48K—**£659**, Epsom printer—**£349**, cassette with counter—**£21.70**.
Disc-drive without controller—**£299**
Disc drive with controller—**£349**, 16K add-on—**£69**. CARDS: Prototype/hobby card—**£15**, parallel printer interface card—**£104**, communications card—**£130**, high speed serial interface card—**£113**, Pascal language system—**£299**.

NASCOM

NASCOM 1 — **£125** (Kitform)
NASCOM 1 — **£140** (Ready-built)
NASCOM 2 — **£225**
IMP PRINTER — **£325**

VIDEO GENIE

Fully TRS80 compatible — **£299**

SHARP MZ80

£449

SINCLAIR ZX80 taken in part-exchange for all Micros.

Atari Video Computer Game

Atari **£83** Standard cartridges **£13.90**
Every cartridge held and latest Space Invaders, Night Driver, Adventure, Hangman, etc.
Chess Challenger Sensory—**£110**, Chess Challenger 7-level—**£75**, Chess Challenger 10-level (voice)—**£180**. Galaxy Invaders—**£17.50**.
Amtron Electronic Kits Ex-Kit electronic Kits

BUSINESS SOFTWARE SALE

PETACT Purchase Ledger (Disc.)	£75.00
PETACT Sales Ledger (Disc.)	£75.00
Commodore Word Processor III (Disc)	£75.00
Commodore Stock Control (Disc)	£75.00
Commodore Sales/Purchase/Nominal Ledger...	£500

Further details of business software available on request

BOOKS (No V.A.T.)

Basic Computer Game—**£5.50**, Instant Basic—**£7.20**, Pet Revealed—**£10.00**, Library of Pet Subroutines—**£10.00**, Your First Computer—**£5.95**, Guide to Basic Programming—**£8.85**. Basic Basic—**£6.50**. Advanced Basic—**£6.00**. Basic Programming Z80—**£8.95**, 6520 Applications Book—**£7.95** and lots more. Send for full list of microcomputer and electronic books.

PET SCIENTIFIC & INDUSTRIAL APPLICATIONS

16-channel A/D converter	£300
16-channel Relay Unit	£350
8-channel D/A Converter	£350

MEMORIES & MEDIA

2114	£3.00	2708	£5.00	Cassettes 10 for	£5.00
4116	£3.00	2716	£6.90	Floppy Discs 10 for	£25.00
				Listing paper 2,000 sheets for	£15.00

MATTEL 3D TV Game due JAN.

CB rigs now available

ATARI Computer due MARCH

ALL PRICES—ADD 15% VAT. DELIVERY: POSTAGE/PACKING WILL BE NOTIFIED BARCLAYCARD AND ACCESS ORDERS TAKEN BY PHONE

CASTLE ELECTRONICS

7 CASTLE ST., HASTINGS, EAST SUSSEX TN34 3DY
Shop hours 09.00 to 17.30 Mondays to Saturdays

Telephone: Hastings (0424) 437875
Personal callers welcome

'Far superior to the text we formerly supplied' say Commodore

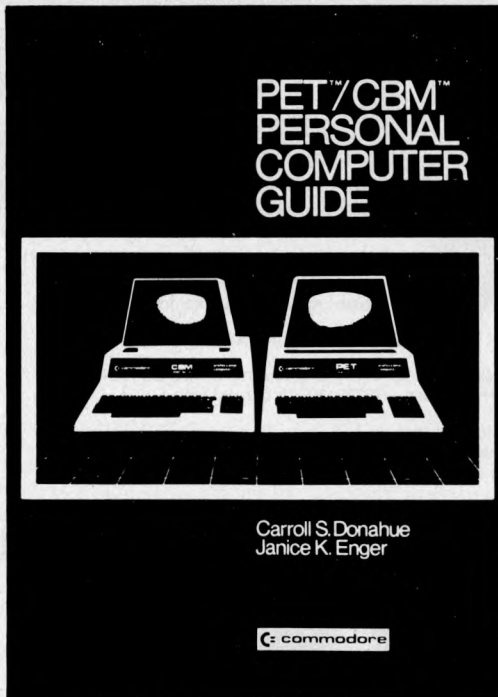

BOOKS FOR THE PET/CBM

- 7.90 Some common Basic Programs (Pet/CBM) by Poole & Borchers
- 9.20 Pet/CBM Personal Computer Guide by Donahue & Enger
- 9.50 Pet & the IEEE-488 Bus by Fisher & Jensen
- 10.00 The Pet Revealed (2e) by Nick Hampshire
- 10.00 Library of Pet Subroutines by Nick Hampshire
- 10.50 32 Basic Programs for the Pet by Rugg & Feldman

MACHINE CODE PROGRAMMING

- 7.50 6502 Software Design by Leo Scanlon
- 8.20 C202 Programming the 6502 (2e) by Rodney Zaks
- 8.90 6502 Assembly Language Programming by Lance Leventhal
- 8.90 6502 Software Gourmet Guide & Cookbook by Robert Findley

OTHER USEFUL BOOKS

- 5.30 The Personal Computer Book by Robin Bradbeer
- 5.40 Microcomputers & the Three R's by Christine Doerr
- 5.90 Basic Computer Games by David Ahl
- 5.90 More Basic Computer Games by David Ahl
- 7.20 Microsoft Basic by Ken Knecht

Mine of Information Ltd was formed in 1977 to carry on the general business of consultancy, publishers and booksellers — the field of specialisation is microcomputing.

Today Mol is one of Britain's foremost microcomputer booksellers. The emphasis is on quality. Books are selected by an experienced computer consultant on the basis of accuracy, relevance and value for money.

Prices include P+P in UK.

Orders to: Mol (PTB) 1 Francis Avenue · St Albans · Herts AL3 6BL · England · Phone 0727 52801 · Telex 925859

For overseas delivery add 10% (surface mail) or 20% (air mail)

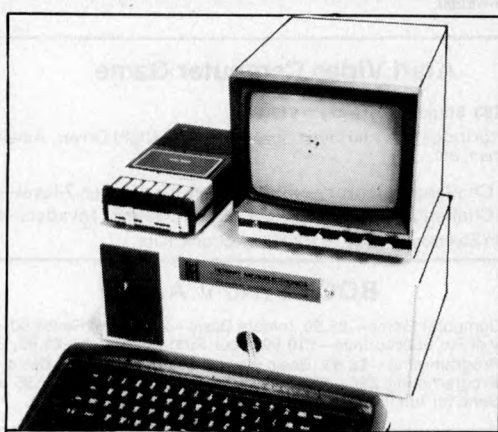

SS50 6800-9 SYSTEMS

WE HAVE A COMPREHENSIVE AND GROWING RANGE OF SS50 BOARDS AND BUILT SYSTEMS PARTICULARLY SUITED TO EDUCATION, CONTROL SYSTEMS AND SOFTWARE DEVELOPMENT.

AVAILABLE: Processor Card £80, Memory Mapped VDU with U/L Case and Graphics £80, 16-32K RAM Card £130, Interface Card with Timer and Real Time Clock, Disc Card, Extra Thick Mother Board.

As an example of a built system, the illustration shows Trainer 2, a single disc teaching unit with cassette, TV, keyboard and interface + switchbox to give a compact teaching station for machine control using basic or assemble. Price £1130.00

WE ARE OFFICIAL APPLE DEALERS.

16K Apple now only £695 All prices exclude VAT

HEWART MICROELECTRONICS

95 Blakelow Road, Macclesfield, Cheshire
Tel: 0625 22030

SHARP MZ-80K software

DUST COVERS £5

Tailored specially for the MZ-80K. A must for every Sharp user.



SUPERB CASSETTE-BASED PROGRAMS INCLUDING:



MANIAC

£5 **MANIAC** — Nerve-racking real time game. Drive like a maniac. Run over stray animals! Try not to crash. Compulsive and exhausting. 9 skills, 9 speeds. Highest speeds terrifying!



MOONLANDER

£5 **MOONLANDER** — Real time lunar lander. 5 skill levels. Superlative graphics/sound. Complex program (requires 10K user RAM).



BIORHYTHM

£4 **BIORHYTHM** — Feeling run down? Worried? Depressed? Want to know why? It's probably your biorhythms! Plot your physical, emotional, intellectual cycles with this excellent program. Find when you'll be your best. Unrivalled excuse-maker when things go wrong!



COMPOSER

£4 **HANOI** — Cunning Chinese logic required to build a tower. Fiendish clever!

£4 **COMPOSER** — Play tunes via the keyboard. See the notes you play. Replay your compositions. Print music strings for future use.

£5 **CHASE** — Try to steal the diamonds. But watch out!! The police are chasing you with their dogs — remorselessly and in real time all over the screen! Dynamic graphics. 9 theft levels. A real challenge.

Cash with order. All prices inclusive of P&P etc. Catalogues available.

"These programs are of a very high standard indeed, with excellent graphics" — MZ-80K S.E. User Group Newsletter.

"I enjoyed your programs so much I am back for more" — Satisfied, Swansea.

HIGHLIGHT SOFTWARE

76 St. Cyrus Road, Colchester CO4 4LR
Telephone (0206) 64437

THE INTELLIGENT PLOTTER....

.... at a sensible price

£850-00



**THE DIGI-PLOT
A3 SIZE INTELLIGENT
PLOTTER WX4671**

The new Watanabe 'Digi-plot' intelligent X-Y plotter has many features you would expect to find on a plotter costing at least £1000 more, a built in character generator eliminates the need for the user to program graphic elements or alphanumeric characters. The characters can be upper or lower case, any of 16 sizes and rotated to four orientations, other functions include axes and broken line drawing.

The interface is Parallel 7-bit ASC11. With RS232 and 1EEE offered as options.

AS SOLE U.K. IMPORTERS WE OFFER AN EXCELLENT AFTER SALES SERVICE.

SPECIFICATIONS

Plotting area	: 360mm x 260mm
Maximum plotting speed	: 50mm/sec (axially)
Programmable step size	: 0.1mm (internal interpolation in 0.05mm steps)
Distance accuracy	: Within 1%
Repetition accuracy	: Within 0.3mm
Pen type	: Hard fiber-tip (max. weight 7g)
Power supply	: 100, 110, 120, 200, 220, 230, 240 VAC ±10% (50/60Hz)
Power consumption	: 70 VA max.
Operating temperature	: 5°C ~ 35°C
Relative humidity	: 35% ~ 75%
Recording paper	: Max. size 420mm x 300mm (A3 size)
External dimensions	: 600 (W) x 520 (D) x 95 (H)mm
Weight	: Approx. 13kg

**ENVIRONMENTAL EQUIPMENTS (NORTHERN) & TD
'ENVIRON HOUSE' 64 WELSH ROW, NANTWICH, CHESHIRE CW5 5ES
HEAD OFFICE TEL (0270) 65115. SOUTHERN RECORDER SALES (0342) 311225**

GW Computers Ltd

89 Bedford Court Mansions, Bedford Avenue, London W.C.1.
call only by appointment

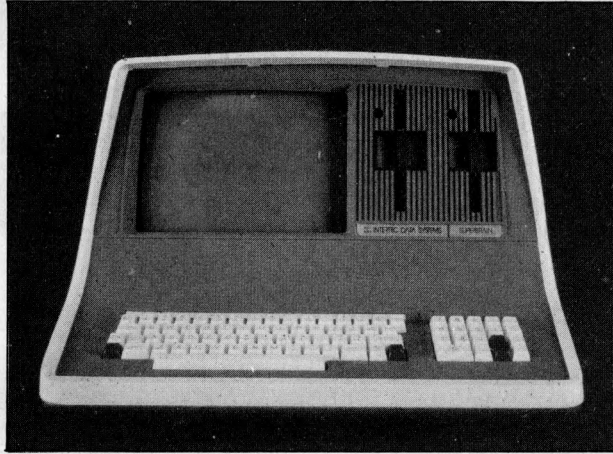

SUPERBRAIN™

Intelligent Video Terminal Systems

350K or 700K of Disk Storage
SuperBrain's CP/M operating system boasts an overwhelming amount of available software in BASIC, FORTRAN, COBOL, and APL. Whatever your application . . . General Ledger, Accounts Receivable, Payroll, Inventory or Word Processing, SuperBrain is tops in its class. And the SuperBrain QD boasts the same powerful performance but also features a double-sided drive system to render more than 700K bytes of disk storage and a full 64K of RAM. All standard!

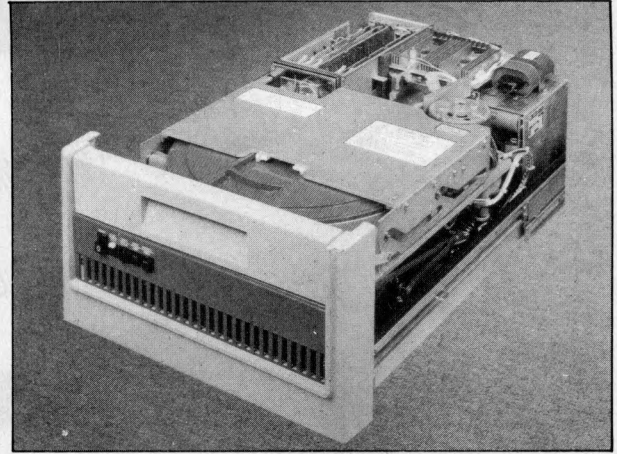

COMPUSTAR™

MULTI-USER TERMINAL SYSTEM

CompuStar user stations can be configured in a countless number of ways. A series of three intelligent-type terminals are offered. Each is a perfect cosmetic and electrical match to the system. The CompuStar 10-a 32K programmable RAM-based terminal (expandable to 64K) is just right if your requirement is a data entry or inquiry/response application. And, if your terminal heads are more sophisticated, select either our CompuStar 20 or CompuStar 40 as user stations. Both units offer dual disk storage in addition to the disk system in the CompuStar. The Model 20 features 32K of RAM (expandable to 64K) and 350K of disk storage. The Model 40 comes equipped with 64K of RAM and over 700K of disk storage. But, most importantly, no matter what your investment in hardware, the possibility of obsolescence or incompatibility is completely eliminated since user stations can be configured in any fashion you like — whenever you want — at amazingly low cost!

DISK STORAGE

Options for the Superbrain and CompuStar Video Terminal

"Backup" for the 20 megabyte Century Data drive is provided via the dual disk system housed in the CompuStar or the SuperBrain. The Control Data CMD Drive features a removable, front-in-sertable top loading cartridge of 16 megabyte capacity plus a fixed disk capacity of either 16 or 80 megabytes.

Each drive is shipped equipped with an EIA standard 19" rack mounting system and heavy duty chassis slide mechanisms to permit easy accessibility for fast and efficient servicing.

**** WIDELY USED IN UK AND USA ****
**** TESTED AND PROVEN ****
**** POWER AT YOUR FINGERTIPS ****
**** JUST COMPARE THIS LIST ****

*** SALES COMMENT ***

No other program in the world combines these features in one. Many other programs, less integrated, do not provide even some of those features to be found on our 'bus'.

- 1 = Total integration of sales: purchase 'nominal' stock 'addresses' etc
- 2 = Full random access enables retrieval of any record in a second
- 3 = Flexible prompts enables word change even to foreign language.
- 4 = Files may be named and set to drive default, maximising storage.
- 5 = Easy to use, menu driven, no serious need of manual.
- 6 = Tested and debugged in many installations world wide.
- 7 = Priced less than the acquisition of a library of programs.
- 8 = The program is ***totally ***in core, maximising disk space.
- 9 = Core program means that disks may be interchanged during use.
- 10 = Core program means your main drive is ***free ***for data
- 11 = Numerous reports may be generated (eg: sale ledgers up to 30).
- 12 = Invoice produces immediate stock update + double journey entry.
- 13 = Reference on invoices enable cost centre build-up on ledgers.
- 14 = Stock valuations and re-order reports easily generated.
- 15 = Bank balance and reports plus standard mailing facilities.
- 16 = Customer statements and invoices printed on plain paper.

As prices vary from dealer to dealer we append for your guidance, some details of the justification in our prices being higher than the cash/carry concept of trade.

A standard Superbrain 64K *320K Disk at 1795.00 includes the following values not normally expected at the lower price.

- 1) Equipment is burned and tested for a minimum 48 hours
- 2) Delivery in U.K. is free of charge
- 3) All goods & software are stocked on immediate delivery
- 4) 6 month main unit, 12 month memory guarantee
- 5) 24/48 hour mailing of any spare module free within warranty
- 6) Same service as 5) outside warranty for ad hoc charge
- 7) 10 free Diskettes (28.50)
- 8) 10% of hardware value in free software (1795.00)
- 9) Positive before **and **after sales service

If the transaction includes a printer and the business programs then the following are also added:

- 10) All cabling between printer and Superbrain free (25.00)
- 11) Ribbon and thimble free (eg: Spinwriter 4.75 + 9.75)
- 12) Extra 10 Diskettes free (28.50)
- 13) Additional free software based on 10% of printer value
- 14) Free training session plus all necessary follow up
- 15) Box printer paper (28.50)

A typical deal could look like this:

Superbrain	1795.00
NEC Spinwriter	1695.00
	3490.00

BUS Program 775.00 plus Basic 150.00 (less 349.00) = 576.00
Total Purchase Price 4066 plus V.A.T.

The total value of free items on this deal was in excess of 500 pounds in virtue of incidental items as well as extended warranty and software.

Do consider your purchase on the basis of some of the things you may be likely to need after your equipment purchase, and may either fail to obtain because the dealer has no stock or has lost interest in you, or because you aimed at the short term gain in price and are then compelled to pay heavily for small needs afterwards.

GRAMA WINTER, 89 BEDFORD COURT MANSIONS, BEDFORD AVE.,
LONDON WC1. TEL NO. 636 8210/631 4818

***** MAIN MENU DISPLAY *****

**New! Produced in U.K. and widely used in England and the U.S.A.
Complete Business Package**

**INCLUDES EVERYTHING FROM INVENTORY TO SALES SUMMARY
PROMPTS USER AND VALIDATES ENTRIES. MENU DRIVEN**

PET AND CP/M SUPERBRAIN, TRS80 II, N'STAR, IMS5000.
APPROXIMATELY 60-100 ENTRIES/INPUTS REQUIRE 2-4 HOURS WEEKLY
AND ENTIRE BUSINESS IS UNDER CONTROL

* PROGRAMS ARE INTEGRATED .. SELECT FUNCTION BY NUMBER ...

- | | |
|-------------------------------|--------------------------------|
| 01=*ENTER NAMES AND ADDRESSES | 13=*PRINT CUSTOMERS STATEMENTS |
| 02=*ENTER/PRINT INVOICES | 14=*PRINT SUPPLIER STATEMENTS |
| 03=*ENTER A'C RECEIVABLES | 15=*PRINT AGENT STATEMENTS |
| 04=* ENTER PURCHASES | 16=*PRINT TAX STATEMENTS |
| 05=*ENTER A'C PAYABLES | 17= LETTER TEXT AREA |
| 06=*ENTER'UPDATE INVENTORY | 18=ALTER VOCABULARIES |
| 07=*ENTER'UPDATE ORDERS | 19=PRINT YEAR AUDIT |
| 08=*ENTER'UPDATE BANKS | 20=PRINT PROFIT'LOSS A'C |
| 09=*REPORT SALES LEDGER | 21=OPEN AREA |
| 10=*REPORT PURCHASE LEDGER | 22=PRINT CASHFLOW FORECAST |
| 11=*INCOMPLETE RECORDS | 23=ENTER PAYROLL (NO RELEASE) |
| 12=*USER DBMS AREA | 24=DISK SWAP'EXIT |

..... ENTER WHICH ONE?

DATABASE MANAGEMENT INCLUDES

*** FILE OR RECORD CREATE'DELETE'AMEND'SEARCH'PRINT 4 WAYS *** INFORMATION RETRIEVAL ON ANY KEY RECORD OR PART THEREOF *** AUTOMATIC CHECK TO PREVENT DOUBLE ENTRY TO FILE SYSTEM *** DYNAMIC ALLOCATION OF INFORMATION CONSERVING DISK SPACE.

VERY FLEXIBLE. EASY TO USE.

G.W. COMPUTERS LTD. UK ARE THE PRODUCERS OF THIS BEAUTIFUL PACKAGE. *AUTHOR* TONY WINTER (B.A.LIT; B.A.HON.PHIL).

PET VER 3.00 LOW LEVEL INTEGRATION = 475.00. PET VER 4.00 INCLUDES AUTO STOCK-UPDATE = 575.00. PET VER 5.00 INCLUDES AUTO BANK UPDATE = £675.00. CPM VER 6.00 IN CORE, TRANSLATABLE PLUS DBMS = 775.00. CPM VER 7.00 AUTO STOCK-UPDATE = 875.00. CPM VER 8.00 AUTO BANK UPDATE = 975.00. CPM VER 9.00 INCLUDES OPTIONS 19, 20, 22, 23 (LATER RELEASE). ++ EACH LEVEL AUGMENTS LOWER ONE.

**WE EXPORT TO ALL COUNTRIES CALLERS ONLY BY APPOINTMENT
CONTACT TONY WINTER ON 01-636 8210
89 BEDFORD COURT MANSIONS, BEDFORD AVENUE, LONDON W.C.1.**

**NOTE!!! LEVEL 9.00 TOTALLY IN CORE PROGRAM LEAVES MASTER DRIVE FREE
(SAVING OF 200 POUNDS HARDWARE).**

IMPORTANT!!! No computer hardware is ever of value without software, so we provide you with a starting set of programs ** free **** at 10% of hardware purchased. A Superbrain and NEC Spinwriter could give you up to 400 pounds of programs. See [] .**

PET + PET + PET + PET + SOFTWARE + SOFTWARE + SUPERBRAIN + SUPERBRAIN

CBM 3032 32K	595.00	BUS VER 3.00	PET	475.00	SUPERBRAIN 320K	1795.00
CBM 3040 DISKS	595.00	BUS VER 4.00	PET	575.00	TWIN Z80 64K+CRT
CBM 3022 PRINTER	425.00	BUS VER 5.00	PET	675.00	+2 D'D-D'S DRIVE
CBM 8032 32K	875.00	BUS VER 6.00	CP'M	775.00	SUPERBRAIN 800K	2195.00
CBM 8050 1MEG DISKS	875.00	BUS VER 7.00	CP'M	875.00	TWIN Z80 64K+CRT
CBM EPSON PRINTER	395.00	BUS VER 8.00	CP'M	1000.00	+2 D'D-D'S DRIVE
CBM MULTI USER	650.00	BUS VER 9.00	CP'M	1075.00	SUPERBRAIN 2MEG	2795.00
CBM 3032 + EPSON +		CBM WORDPRO II		75.00	COMPUSTAR 10	1595.00
CBM 3040 + BUS V3	2215.00	CBM WORDPRO III		150.00	COMPUSTAR 15	1495.00
PRINTERS + PRINTERS +		CPM* WORD-STAR		195.00	COMPUSTAR 20	2295.00
DIABLO 830 40CPS	1595.00	CPM* MBASIC 80		150.00	COMPUSTAR 30	2495.00
DOLPHIN BD80 125CPS	495.00	CPM* COBOL 80		320.00	COMPUSTAR 40	2795.00
NEC 5510 PRINTER	1695.00	CPM* PASCAL MT		150.00	INTERTUBE III	495.00
MICROLINE 80 120CPS	475.00	CPM* FORTRAN 80		200.00	EMULATOR	495.00
TELETYPE 43SR 30CPS	875.00	CPM* DATASTAR		175.00	10 MEG H'DISK	2950.00
DEC-LA34 TRACT 30CP	875.00	CPM* PASCAL-M		250.00	16 MEG (8'8)	3950.00
NEC-5530 PRINTER	1595.00	CPM* BYSTAM S'BRAIN		75.00	96 MEG (4DISK)	7950.00
QUME DAISY SPRINTS	1950.00	CPM* SUPERSORT		120.00	(ADDRESS'MAILER)	95.00
TEXAS 810 150CPS	1390.00	CPM* BASIC COMPILER		190.00	(STOCK CONTROL)	95.00
SPECIALS + SPECIALS +		CPM* DESPOOL		30.00	(DBMS DATABASE)	195.00
N'STAR QUAD .7 MEG	1500.00	CPM* BYSTAM IMS'N-STAR		75.00	IEEE TO PARALLEL	55.00
IMS 5000 48K D'D	1200.00	CPM* TEXTWRITER		75.00	IEEE'RS232 BI'DI	195.00
COMPUTHINK * 800K *	795.00	CPM* POSTMASTER		75.00	IEEE TO RS232	75.00
2 WAY CRDLESS PHONE	135.00	CPM* SELECTOR 3		180.00	S'HAND SWTP TERM	100.00
TELEPHONE ANSWER	230.00	CPM* CBASIC		75.00	WARRANTY	
SHUGART SA400 5" DR	135.00	CPM* MACRO 80		75.00	6 MONTH FULL REPAIR	***
		CPM* W'STAR M'MERGE		245.00		
		BUS MANUAL *****		9.00		
		SUPERBRAIN 320K		1695.00		
		TWIN Z80 32K+CRT			
		+2 D'D-S'S DRIVE			

+++++++ SPECIAL INSTITUTION AND UNIVERSITY DISCOUNTS +++++++

**MOST ITEMS IN STOCK. (ACCESS 'AMEXCO' BCLYCARD OTHERWISE CHEQUE WITH ORDER)
CONTACT TONY WINTER 01-636 8210/01-631 4818
89 BEDFORD CT MANS, BEDFORD AVE W.C.1.**

INNOVATIVE

TRS-80 SOFTWARE

FROM THE PROFESSIONALS

INSTANT SORT/SEARCH DATABASE

Everything in electronics takes a finite time, consequently nothing can be instantaneous. However a database that will search 500 records and sort the names into alphabetical order in 1½ seconds, that will go on to do the same thing with 1,000 names in only 2½ seconds, is fast. If you add that ability to search 500 or 1,000 records for a specific range of names or ages or sexes or whatever, in such a small amount of time that it is not worth timing it, then the program deserves to be described as instantaneous. Especially as these times are attained on a standard Level II TRS-80.

These results are achieved, obviously, by some very clever machine language coding. This however is not enough. After all GSF from Racet will sort 1,000 arrays in about 11 seconds and that is indeed a clever program. No, in order to achieve the results required from this program it is necessary to change one's entire overview of database.

There are many databases available for the TRS-80 now. All of them have been designed to store as much data as possible, as easily as possible. Not as an afterthought, but nor as a prime design requirement, they have also incorporated as fast a sort as was practicable. This program was designed from the outset to achieve unbelievably fast sort and search times. Indeed we do not recommend this database for application in which fast searching or sorting is not a prime requirement. And what are the applications? It's a hackneyed phrase to say that they are limited only by the user's imagination, but that's about it. Let's take an example. Suppose you are running a marriage or data bureau. An ordinary database will file all the names and addresses away together with the necessary information as to sex, age and so on and with some you would be able to sort the list, so that only people with similar characteristics were eventually obtained. With this database you could, for instance, file the name, sex, age, category of hobby, category of chief interest, vital statistics and other data so that at the touch of a button you could instantaneously display on the screen all women of a certain age with certain vital statistics, living in a certain area. You could also display men with similar (excluding the vital statistics!) data that fall into similar categories. And all of this almost instantaneously. Not everybody runs a marriage bureau, but other applications are not hard to think of. Estate agents can file details of property away so that they can instantaneously obtain data on houses in a certain area or of a certain size. Doctors can reach information as to patients with similar diseases, ages or whatever immediately. In the home, a record library can be stored and every record by a certain composer written in a certain year can be accessed without delay. The list of applications is endless. For any use where it is important to extract information within a certain range or it is important to sort information, this database will find a use.

The prime commands and features of this program are as follows:

Datafile creation	Sort/Search
1. Create a file.	1. Sort up or down.
2. Add a record.	2. Page forward or backward.
3. Delete a record.	3. Select a range for search.
4. Display a record.	4. Select or exclude a category.
5. Tape a file.	5. Select or exclude on initial letter.
6. Amend a record.	6. Resort records in a sort.
7. Display the file data.	7. New sort all records.
8. Load a tape.	8. Extended sort.
	9. Arithmetic.
	10. Display file data.
	11. Load a tape.
	12. Printout sorted data.

The data is displayed in columnar form and the data may be alphabetical, alphanumeric, integer or decimal. The number of columns is from 2 to 10 and the records may contain a maximum 44 - 60 characters depending upon the number of columns used. Columns may be of any width within the screen capacity but integer or decimal columns more than five and six characters wide respectively will not have the option of searching within a range.

The program consists of two parts. The first is used for entering the data and the second for the sort or search. The second part overlays the first when it is loaded so only 4K of memory is used by the entire program. The remainder of your memory space is available for data. The amount of data that can be contained will of course depend upon the amount of memory available, but as a rough guide a 16K user will be able to manipulate at one time 250 records of 39 characters each or 514 records of 17 characters each. As a further rough guide on sorting speed, the time to sort 1,000 records on fields of random strings of random length, or of random number between 1 and 99,999, averages under 2½ seconds.

Numeric columns either integer or decimal may be arithmetically manipulated almost instantaneously. A total may be cast or an average taken for any numeric column up to five digits. This is so fast that when adding 1,000 numbers totalling over 50 million, only a slight hesitation can be noticed before the total is given.

In summary therefore this program is ideal for any application concerning the manipulation of information whether it be business, personal or hobby which can be comfortably displayed as one record per line upon the screen and in respect of which it is required that super fast searches or sorts be carried out. The program is supplied on cassette. At this time it is not compatible with disk systems. A disk version is in the course of preparation. The cassette includes a set of data randomly generated which can be fed into part 2 of the program to demonstrate the fantastically fast sort and search features.

Tape for 16K TRS-80 or video genie£19.50

All prices exclusive of VAT which should be added at the prevailing rate. Postage and packing including VAT 75p regardless of the number of programs ordered.

Send large SAE (44p) for our current Catalogue of TRS-80 software. Add £1.85 for a binder.



A.J.HARDING (MOLIMERX)

MOLIMERX LTD.

28 COLLINGTON AVENUE, BEXHILL-ON-SEA, E.SUSSEX.

TEL: (0424) 220391

TELEX 86736 SOTEX G



INNOVATIVE

TRS-80 SOFTWARE

FROM THE PROFESSIONALS

SUPERSCRIPT

SuperScript is a series of machine language programs which will permanently customise Tandy's Scripsit to a user's own requirements, particularly as to his printer. It also adds a number of enhancements to the original Scripsit program. The program includes a number of features which we do not have space to list here, but the three principal ones are that the user can now access the Disk Directory from within SuperScript, listing all files and the number of free granules on the diskette. Files can be killed from within SuperScript so as to make extra space to fit in a large text file. The third and perhaps the most important enhancement is to permit almost any printer to be used with Scripsit. It includes eight driver routines for both serial and parallel printers and these include utilities to enable the user to sculpture a customised serial or parallel driver to his own particular requirements. If your printer will backspace then underlining and slashed zeroes are options. Dedicated drivers in the package are for Diablo parallel and serial, NEC5330 parallel and serial and two general purpose drivers.

Disk for minimum single drive 32K machines£19.50

DUEL-N-DROIDS

A "second generation" Android Nim. Leo Christopherson has done it again! Two androids battle it out before your eyes with laser swords! There are two forms of play. In the first the player controls one android and the computer the other. The player must achieve a certain rank of skill as a swordsman to enable the android to go on to fight a tournament. The player's android is controlled by four keys and the higher the rank that the player can attain the better the chance that his android will beat the computer when it enters the tournament. Tournaments are of two types. In one, the player's android is pitted against an equally ranked android controlled by the computer. In the other the player's android fights against androids controlled by the computer of random ranking. Android Nim by Christopherson created something of a revolution in microcomputer games and Duel-N-Droids follows on in this same tradition. Excellent sound is provided in the program.

Tape version 16K TRS-80 or video genie£9.50, Disk version 32K one drive£12.50

BASKETBALL

Another highly graphically orientated machine language action game with sound. Each game lasts four minutes and either two players take part or one player plays the computer. The graphics are based on a three dimensional depiction of a basketball court on which there are two players. One is controlled by each human player if two are playing, or when a human player plays against the computer the home player is controlled by the computer. The appeal of the game is its realism. The court player may be controlled in one of four directions, may dribble and shoot for the basket. The player who scores the most baskets in the four minutes of play wins the game.

Tape version 16K TRS-80 or video genie£9.50, Disk version 32K one drive£12.50

QUAD

Quad is three dimensional noughts and crosses. As its name implies, it is played on a cube of four layers each with four ranks. Like noughts and crosses the aim of the game is to get crosses or noughts in a line either horizontally, vertically or diagonally. The cube is depicted graphically on the VDU and either two players may take part or a single player may play the computer. Four levels of difficulty are provided and a time clock is also included for each move. A particularly important feature of the game is that the cube on which the game is played may be rotated so that the player can see it from a different angle. A number of commands are provided including setting up previous positions, backing up to a previous position, progressing to the next position, reversal of order of play and switching of opponents. This is a complex game of strategy in which the player will need all of his skills.

Tape version 16K TRS-80 or video genie£9.50, Disk version 32K one drive£12.50

CODE BREAKER

Code Breaker is a logic game with sound effects. It is not necessary to describe this program in great detail because it is essentially a computer adaptation of the well known logic game Mastermind. The object of the game is to determine with as few moves as possible the colours and positions of four secret code pegs. For each move the colour and position of four pegs is chosen and the response of the computer is with a black, white or pink peg in respect of each position of the player's peg. These three colours have different meanings and from their positioning it is possible to logically deduce the position of the hidden pegs. The program features sound effects and a graphic layout of the code pegs.

Tape for 16K TRS-80 or video genie£6.50

All prices exclusive of VAT which should be added at the prevailing rate. Postage and packing including VAT 75p regardless of the number of programs ordered.

Send large SAE (44p) for our current Catalogue of TRS-80 software. Add £1.85 for a binder.



A.J.HARDING (MOLIMERX)

MOLIMERX LTD.

28 COLLINGTON AVENUE, BEXHILL-ON-SEA, E.SUSSEX.

TEL: (0424) 220391

TELEX 86736 SOTEX G



AIM 65 PLUS EVERYTHING!

THAT'S CUBIT

EVERYTHING
ROCKWELL

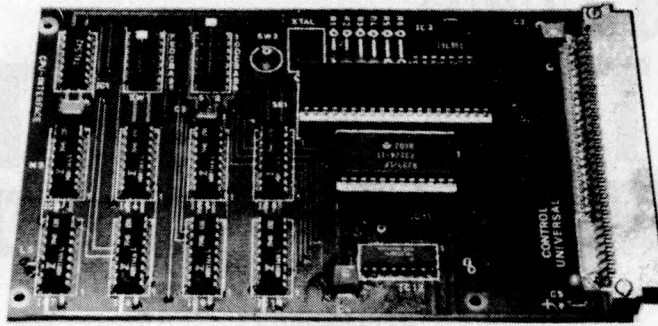

EVERYTHING
ACORN

FOR £75

- * AIM 65
- * BASIC
- * Assembler
- * FORTH
- * PL-65
- * 19" rack industrial version

Unplug the 6502, plug in Cubit, replace the 6502 – it's that simple.

- * ADDS 4K RAM to give AIM 8K total
- * ADDS 4K EPROM socket
- * ADDS an additional VIA to give a total of 32 i/o lines
- * ADDS an interface to all Acorn Eurocards
- * Can be used as a stand-alone computer
- * Disc operating system valid for all Rockwell and Acorn software.

- * 8K RAM, 8K EPROM memory card
- * PROM programmer
- * 16K memory card, CMOS RAM/EPROM
- * Colour VDU card
- * Floppy disk controller
- * 1 or 2 disk drives
- * 19" rack mounting
- * Accounting system
- * Word processor
- * Atom

all Rockwell, Acorn and Cubit products available from:

CONTROL UNIVERSAL LTD,
11-15 Bush House, Bush Fair, Harlow, Essex. tel Harlow (0279) 31604

Have we got a program for you!

EXCELLENT QUALITY PROGRAMS CHOSEN FOR THEIR SUPERB GRAPHICS AND SMOOTH ACTION

Apple TRS 80 Video Genie ZX80

ATTACK
FORCE
WITH SOUND!

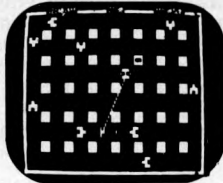

Dodge the alien Ramships and fire missiles to destroy them before they get you. The alien Flagship uses his deadly laser bolt to transform a Ramship into another Flagship or into your ship's double. Look out!! Destroy your double and you could destroy yourself.

TRS 80 Level 1 or 11.16K Tape £10
Hours of exciting fun.

NEW
ASTEROID
NOVA

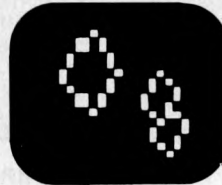

For the first time the amazingly popular ASTEROIDS pub game is now available for your microcomputer. Huge asteroids have invaded the galaxy. Your mission is to destroy them and the alien saucers before they destroy you. But beware, big asteroids break up into smaller ones.

TRS80 Levels 1 & 11.16K
Tape £10
Video Genie 16K Tape £10
Apple 11 or 11+32K Disk £15

GALAXY
INVASION
WITH SOUND



The newest and most exciting invaders type game yet! Cruel and crafty aliens attack Earth. You are the sole defender. As you fire your laser at the aliens they swoop down and bomb you. Exciting use of graphics! Must be seen.

TRS 80 Level 1 or 11.16K
Tape £10
Video Genie 16K Tape £10

Stop press
JUST ARRIVED -
VISICALC for TRS 80
32K DISK ONLY
£75

SEE OUR COMPLETE
RANGE
SEND STAMPED ADDRESSED
ENVELOPE FOR FREE
CATALOGUE

THE ESSENTIAL SOFTWARE COMPANY
(Viscounti Ltd.)
47 Brunswick Centre, London WC1N 1AF

I have a microcomputer
 Please send me your software catalogue. I
enclose a stamped self addressed envelope.
 Please send me
I enclose a cheque/postal order for £
(plus 50p post & packing)

Signature
Name
Address
Postcode

The Dodo was one of the few interfacing problems we couldn't help with..



.... but we can almost certainly solve yours

Microcomputer interfacing often seems more like an art than a science... a bewildering array of 'standards', conventions and communications protocols assuming of course, that your chosen problem actually meets one of the standards and is not a 'significant subset' of the standard (i.e.: does not actually conform!) Stack-Apple has the widest range of Apple peripheral interfaces available, but more importantly we have the technical back-up to go with them. e.g.

Apple and Communications

Apple to Apple, Micro, Mini or Mainframe asynchronous or synchronous RS 232 A-E with full handshaking.

Apple and the Analogue World

8, 10 and now 12 bit A/D with fast conversion time. 8, 10 bit D/A. Our own design, 0-5V, screw terminal output.

Apple and Instrumentation

I-EEE 488 - Full implementation Parallel B.C.D. or TTL I/O

Apples and Control

Low power relay switching on a single card. Mains switching with settable defaults and safety options.

STOP PRESS

Stack Apple now have the answer to low-cost, reliable mass storage on Apple - 5 megabyte capacity, built-in back-up, at an unbelievably low price - please call for details.

PLEASE ADD OUR NAME TO YOUR MAILING LIST

Please send the coupon to **STACK-APPLE 290/298 DERBY ROAD, BOOTLE, LIVERPOOL.** Telephone: 051-933 5511.

Name _____
 Address _____

 Telephone _____



New Seikosha GP 80 Printer for educational and home use.

Smallest, plain paper 80 column printer on the market.

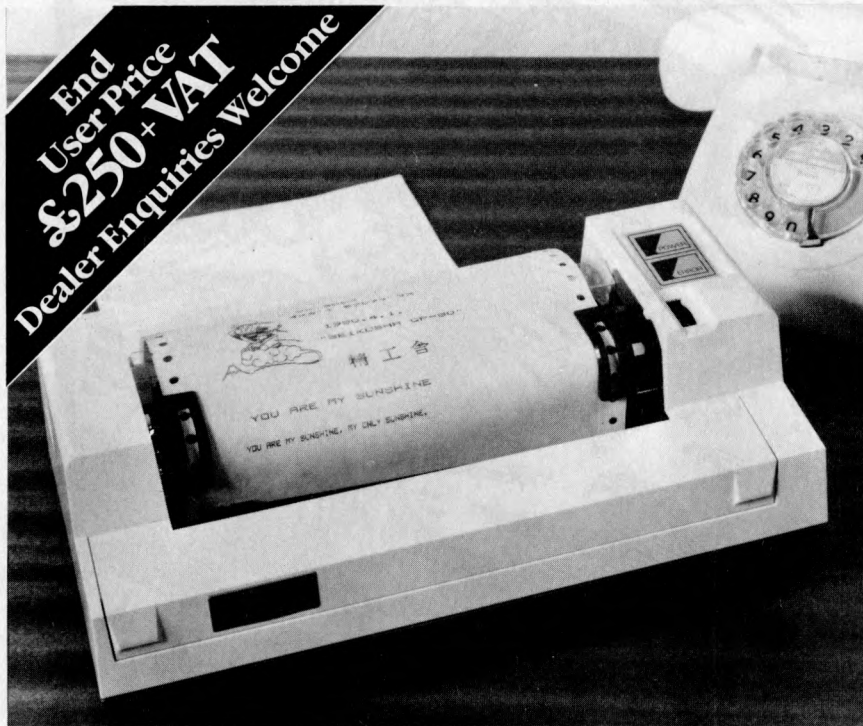

Features:

Plain paper
80 column width
30 cps
Full ASCII character set
Graphics facility
5 × 7 dot matrix
Double width characters
Pin feed
Centronics interface standard

Other Interfaces and cables available:

IEEE/488, PET, TANDY,
APPLE, RS/232C.

Ring Sheila Maycroft at DRG Business
Machines for your nearest dealer.
13/14 Lynx Crescent, Winterstoke Rd.,
Weston-super-Mare, Avon B24 9DN.
Tel: (0934) 416392

(DRG) A Dickinson Robinson Group Company.

cut throat discounts?

... not at Dataview

— our customers prefer our service

- Client requirements carefully analysed.
- Full in-depth demonstrations of complete systems.
- Delivery, installation and training always available.
- Complete engineering service backed by comprehensive spare parts & loan machines.
- All "off the shelf" business programs tested and supported, by us.
- Specially prepared 'bespoke' programs our speciality.

Remember!

for Commodore
Business Systems
in East Anglia

Dataview in business to keep you
in business

Dataview Limited, Church Street, Colchester, Essex
Tel: 0206-78811/63377 Telex 987562

Osborne & Byte Books from McGraw-Hill

We don't expect you to buy something you've never seen — that's why Osborne and Byte books are now on show at your local bookshop.

You know Osborne and Byte Books are the most up-to-date, authoritative, and innovative source of information you can find, but did you know they were available through your local bookshop? Some of the latest and most popular titles are detailed below — but don't ring, write, or fill in forms, just go to your local bookshop and make your own selection!

Osborne

PET and the IEEE 488 BUS (GPIB) Eugene Fisher, C.W. Jensen ISBN: 0 931988-31-4	236pp	£10.00
The CRT Controller Handbook Gerry Kane ISBN: 0 931988-45-4		£3.95
Z8000 Assembly Language Programming Adam Osborne ISBN: 0 931988-36-5	500pp	£7.95
The 8090 1/0 Processor Handbook Adam Osborne ISBN: 0 931988-39-X	150pp	£3.95
Some Common Basic Programs PET/CBM Edition Lon Poole, Mary Borchers, Carroll Donahue ISBN: 0 931988-40-3	200pp	£7.95
The 8086 Book Russel Rector, George Alexy ISBN: 0 931988-29-2	550pp	£10.00
8080A/8085 Assembly Language Programming Lance A. Leventhal ISBN: 0 931988-10-1	500pp	£7.95
6800 Assembly Language Programming Lance A. Leventhal ISBN: 0 931988-12-8	500pp	£7.95
Z80 Assembly Language Programming Lance A. Leventhal ISBN: 0 931988-21-7	500pp	£7.95
6502 Assembly Language Programming ISBN: 0 931988-27-6	500pp	£7.95
PET/CBM Personal Computer Guide 2/e Carroll Donahue ISBN: 0 931988-55-1	430pp	£10.00

Byte

Bar Code Loader Ken Budnick ISBN: 0 07 008856-X	32pp	£1.25
Ciarcia's Circuit Cellar Steve Ciarcia ISBN: 0 07 010960-5	128pp	£5.25
Super-Wumpus Jack Emmerichs ISBN: 0 07 019342-8	79pp	£3.95
6800 Tracer: An aid to 6800 Program Debugging Robert J. Grappel, Jack E. Hemenway ISBN: 0 07 024121-X	24pp	£3.95
Link 68: An M6 800 Linking Loader Robert D. Grappel, Jack E. Hemenway ISBN: 0 07 024120-1		£5.25
Programming Techniques: Volume 1 Program Design Blaise Liffick ISBN: 0 07 037825-8	104pp	£3.95
Programming Techniques: Volume 2 Simulation Blaise Liffick ISBN: 0 07 037826-6	126pp	£3.95
Programming Techniques: Volume 3 Numbers in Theory and Practice Blaise Liffick ISBN: 0 07 037827-4	186pp	£5.95
The Byte Book of Computer Music Christopher P. Morgan ISBN: 0 07 043097-7	144pp	£6.25
BASEX: A Simple Language and Compiler for 8080 Systems Paul Warme ISBN: 0 07 068290-9	100pp	£5.25

All prices are approximate, and subject to alteration without notice.

McGraw-Hill Book Co., (UK) Ltd., Shoppenhangers Road, Maidenhead, Berkshire SL6 2QL. Tel: 0628 23431.



A NEW YEAR OFFER FROM SHARPSOFT

HARDWARE

SHARP MZ80K 20K Model	£445.00
SHARP MZ80K 36K Model	£495.00
SHARP MZ80K 48K Model	£545.00
SHARP MZ80P3 PRINTER.	£448.50
SHARP MZ80FD Dual Drive Floppy Disk	£667.00
SHARP MZ I/O Interface Unit.	£95.00
SHARP PC1211 Pocket Computer	£95.00
SHARP CE121 Cassette Interface for PC1211	£15.00
SHARP RD610 Cassette Player	£20.00

SOFTWARE

Full range of software for the MZ80K available including

System software:	Search & replace
Assembly code (Sharp)	Variable table utility
Machine code (Sharp)	Business software:
Zen Assembler	Payroll
Xtal basic (®)	Purchase & Sales Ledger
CP/M(®)	Mailing list
	Stock control
Utilities:	Costing Package
Ardensoft toolkit	Simple Word Processor
Renumber & tape copy	and a large selection on
Machine code dump	games etc.

SHARPSOFT — USER NOTES is the name of a new publication giving all the latest news of the SHARP MZ80K products, software and programming tips. The first issue will be available early January 1981.

Send a 20p stamp for our SHARPSOFT hardware/software catalogue and a subscription/registration form for your copy of the SHARPSOFT — USER NOTES.

PURCHASE A MZ80K from us and get a games tape, 4 blank Sharpsoft Cassettes and one year's free subscription to the SHARPSOFT — USER NOTES.

ALL SHARPSOFT — HARDWARE PRICES INCLUDE VAT. DESPATCH & TRANSIT INSURANCE.

SEND TO:

SHARPSOFT LTD 86-90 PAUL STREET, LONDON EC2A 4NE.

MicroStyle

9 St. Peters Terrace,
Lower Bristol Rd.
Bath, BA2 3BT.
Telex: 44371 (KEMP-G)

COMPUTERS

PET 8K	£415
PET 16K	£525
PET 32K	£650
PET 8032	£895
OHIO CI-P	£220
OHIO CI-E	£255
SUPERBOARD	£160
SUPERBOARD 'E'	£195
VIDEO GENIE	£330
SHARP MZ80K	£480
APPLE II	£695

SUPERBRAIN

SuperBrain's CP/M operating system boasts an overwhelming amount of available software in BASIC, FORTRAN, COBOL, and APL. Whatever your application. . . General Ledger, Accounts Receivable, Payroll, Inventory or Word Processing, SuperBrain is tops in its class.

320K £1850 700K £2400
1.5Mb £2750

DISC DRIVES

COMPU/THINK

400K	£795
800K	£995

COMMODORE

CBM 30/40	£695
-----------	------

THE BEST IN THE WEST ARE THE FIRST IN THE WEST
TO OFFER THE

PETAL FOR PET

THE NEXOS RP1600 'PETAL' DAISY WHEEL PRINTER

The Fastest Daisy Wheel with these features at the price!

- *Integral IEEE
- *True £ Sign
- *Addressable
- *Switches for Single & 1 1/2 line spacing
- *10/12/15 c.p.i.
- *Reverse upper & lower case
- *Self Test
- *Rated speed of 60 cps
- *Optional Tractor Feed
- *Optional Serial I/F

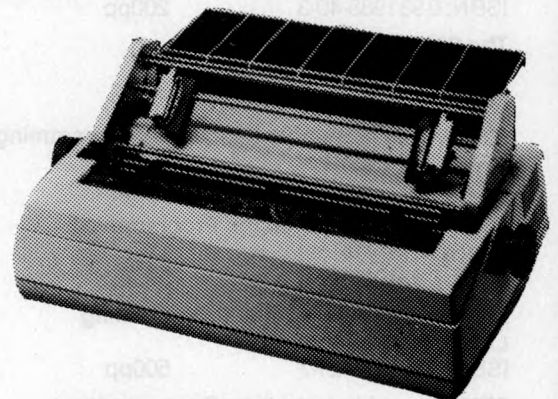

£1195

Serial I/F	£65
Tractor Feed	£175
Single Sheet Feeder	£695
Acoustic Cover	£60

ACULAB FLOPPY TAPE

The ideal graduation from Cassettes for all TRS.80 and Video Genie owners

TRS.80 Version £165: Video Genie £174

PRINTERS

EPSON TX80B (inc. I/F & cable)	£359
EPSON MX80	£425
ANADEX DP8000	£495
ANADEX DP9500	£895
ANADEX DP9501	£995
PAPER TIGER	£585
MICROLINE 80	£359
IBM GOLFBALL	£595
CENTRONICS 737	£425
NEXOS PETAL	£1195

VIDEO MONITORS

10" BLACK & WHITE	£85
10" GREEN SCREEN	£95

PLEASE ADD
.15% VAT
ON ALL PRICES

TEL: BATH (0225) 334659
AF TER HOURS (0761) 33283

**WE HAVE ALL THE NEW ATARI®
VIDEO GAME PROGRAM™
CARTRIDGES.**

ATARI £86 + VAT

SILICA SHOP

TELEPHONE FOR FREE BROCHURES 01-301 1111

ELECTRONIC GAMES

ATARI



SPECIAL PRICE
£86 + VAT

INTELLIVISION MATTEL



£173.87 + VAT

Available August 1980
This is the most advanced TV
game in the world.
Expandable
next year into a full
microcomputer.
COLOUR CATALOGUE
AVAILABLE WITH
DETAILS ON ALL THE
CARTRIDGES

CHESS



Send for further details.

COMPUTERS

NEW RANGE
AVAILABLE
AUGUST 1980
We specialise in
computer chess
machines & stock
over 13 different
models from
£20 to £300

TELETEXT



RADOFIN
TELETEXT
Add on Adaptor

£173 + VAT

BRIDGE

COMPUTER

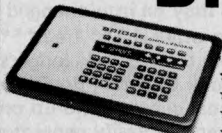

- ★ Plays 1/2/3 or 4 Hands
- ★ Problem Mode
- ★ Audio Feedback
- ★ Instant Response
- ★ Auto scorekeeping

BACKGAMMON

COMPUTERS

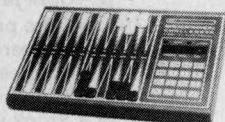

OMAR 1
OMAR 2
CHALLENGER
GAMMONMASTER

From £38 to £108. Send for further details.

SPACE INVADERS



HAND HELDS + CARTRIDGES
ATARI - ACETRONIC
PRINZTRONIC
RADOFIN - DATABASE etc.

We keep a full range!
Send for cartridge lists stating which
machine you own.

DRAUGHTS

COMPUTER

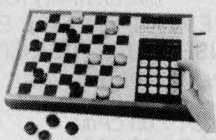

- ★ Solves Problems
- ★ Rejects illegal moves
- 2 level machine
£43 + VAT
- 4 level machine
£77.78 + VAT

LEISURE

- ★ CHEAP TV GAMES
- ★ TELEPHONE ANSWERING MACHINES
- ★ AUTO DIALERS
- ★ CALCULATORS
- ★ DIGITAL WATCHES
- ★ PRESTEL
- ★ HAND HELD GAMES

24 TUNE DOOR BELL

£13.65
+ VAT



FREE CATALOGUE

For a free copy
of our 32 page
catalogue, send
a 12p stamp to
Silica Shop Ltd
or Telephone
01-301 1111

MAIL ORDER SERVICE - Free postage & Packing

TELEPHONE & MAIL ORDERS - accepted on:

Access ★ Barclaycard ★ American Express ★ Diners Club

CALLERS WELCOME - at our shop in Welling - Demonstrations daily

Open from 9am-5pm Mon-Sat (9am-1pm Wed)

GUARANTEE - Full 12 months + After Sales Support!

We have comprehensive brochures on all products. Please let us know what you are interested in and we will send you detailed brochures AND our own 32 page catalogue covering most games on the market.

SILICA SHOP

SILICA SHOP

1/4 The Mews, Hatherley Rd.,

Sidcup, Kent

Tel: 01-301 1111

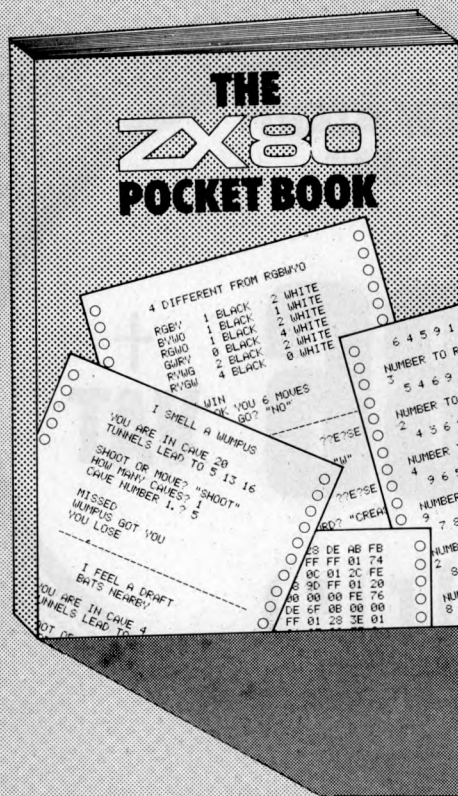

THE ZX80 POCKET BOOK

6 NEW PROGRAMS

- Mastermind
 - Reverse
 - Space-Docking
 - Wumpus
 - Hangman
 - Share Valuation
- plus many others

PLUS HINTS AND TIPS ON

- Program Writing
- Graphics
- Cassette Use
- Program Efficiency

PLUS REFERENCE SECTIONS ON

- Basic
- ZX80 Op Codes
- Error Codes

92 Pages

£4.95

Including Postage & VAT

Mail Order
only please

PHIPPS ASSOCIATES 3, DOWNS AVENUE, EPSOM, SURREY. KT18 5HQ
or Telephone Epsom (03727) 21215 Quoting your Access Card Ref.



*** COMPLETE BUSINESS PACKAGES ***

WIDELY USED IN UK AND USA

DEMONSTRATED IN THE NORTH BY THE EXCLUSIVE NORTHERN DISTRIBUTOR

Freshfield Computer Services

MAIN MENU DISPLAY

- * PROGRAMS ARE INTEGRATED ...
- SELECT FUNCTION BY NUMBER
- 01= *ENTER NAMES AND ADDRESSES
- 02= *ENTER/PRINT INVOICES
- 03= *ENTER A'C RECEIVABLES
- 04= * ENTER PURCHASES
- 05= *ENTER A'C PAYABLES
- 06= *ENTER/UPDATE INVENTORY
- 07= *ENTER/UPDATE ORDERS
- 08= *ENTER/UPDATE BANKS
- 09= *REPORT SALES LEDGER
- 10= *REPORT PURCHASE LEDGER
- 11= *INCOMPLETE RECORDS
- 12= *USER DBMS AREA
- 13= *PRINT CUSTOMERS STATEMENTS
- 14= *PRINT SUPPLIER STATEMENTS
- 15= *PRINT AGENT STATEMENTS
- 16= *PRINT TAX STATEMENTS
- 17= LETTER TEXT AREA
- 18= ALTER VOCABULARIES
- 19= PRINT YEAR AUDIT
- 20= PRINT PROFIT/LOSS A'C
- 21= OPEN AREA
- 22= PRINT CASHFLOW FORECAST
- 23= ENTER PAYROLL (NO RELEASE)
- 24= DISK SWAP/EXIT

No other program in the world combines these feature in one. Many other programs, less integrated, do not provide even some of those features to be found on our 'bus'.

- 1 = Total integration of sales 'purchase 'nominal 'stock 'addresses etc
- 2 = Full random access enables retrieval of any record in a second
- 3 = Flexibles prompts enables word change even to foreign language.
- 4 = Files may be named and set to drive default, maximising storage.
- 5 = Easy to use, menu driven, no serious need of manual.
- 6 = Tested and debugged in many installations world wide.
- 7 = Priced less than the acquisition of a library of programs.
- 8 = The program is *** totally *** in core, maximising disk space.
- 9 = Core program means that disks may be interchanged during use.
- 10 = Core program means your main drive is *** free *** for data
- 11 = Numerous reports may be generated (eg: sale ledgers up to 30).
- 12 = Invoice produces immediate stock update + double journal entry.
- 13 = Reference on invoices enable cost centre build-up on ledgers.
- 14 = Stock valuations and re-order reports easily generated.
- 15 = Bank balance and reports plus standard mailing facilities.
- 16 = Customer statements and invoices printed on plain paper

DATABASE MANAGEMENT INCLUDES

*** FILE OR RECORD CREATE'DELETE'AMEND'SEARCH'PRINT 4 WAYS *** INFORMATION RETRIEVAL ON ANY KEY RECORD OR PART THEREOF *** AUTOMATIC CHECK TO PREVENT DOUBLE ENTRY TO FILE SYSTEM *** DYNAMIC ALLOCATION OF INFORMATION CONSERVING DISK SPACE.

VERY FLEXIBLE, EASY TO USE

SUPERBRAIN + SUPERBRAIN + SUPERBRAIN	
SUPERBRAIN 320K	1695.00
SUPERBRAIN 800K	2195.00
PRINTERS + PRINTERS + PRINTERS + PRINT	
NEC-5530PRINTER	1595.00
MICROLINE 80 120CPS	475.00

SOFTWARE + SOFTWARE + SOFTWARE	
BUS VER 6.00 CP/M	775.00
BUS VER 7.00 CP/M	875.00
BUS VER 8.00 CP/M	975.00
BUS VER 9.00 CP/M	1075.00
plus	
WORD-STAR MBASIC 80 SUPERSORT etc	
(Also GDSS micropay, stock control etc)	

CONTACT DAVID MAWDSLEY ON FORMBY (07048) 79186
RIPLEY HOUSE, 56 FRESHFIELD ROAD, FORMBY, MERSEYSIDE L37 3HW

Order out of Chaos

The International Microcomputer Software Directory

At last! Your Software needs answered by one single comprehensive source.
Essential for everyone concerned with microcomputers

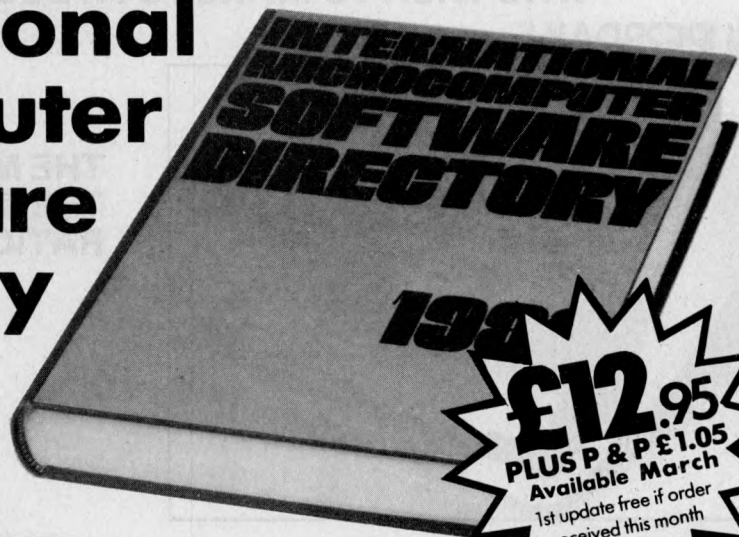

The Directory

The International Microcomputer Software Directory has three sections:

1 Lists software according to specific subjects organised within seven major categories, Commerce, Education, Home, Industry, Professions, Sciences, Systems. Within the categories programs are listed with: • Name • A unique ISPN (international standard program number) • A short description • Systems with which it is compatible (machine and operating system) • Software house • Price.

2 Lists in ISPN order (thus in Software House order) the programs with a full description of: • Features • Special requirements • Method of distribution.

3 Lists by machine (make and model), then within general categories and subjects the names and ISPNs of compatible programs.

Appendices include details of compatibility between machines and operating systems, plus a glossary of computer terms. Also included is a special consumers' guide to buying software.

Comprehensive

Every effort has been made to obtain full details from every reliable supplier of microcomputer software.

International

With offices in Britain, America, and Hong Kong, we are well placed to keep in touch with developments in these major centres. We also employ a team of translators to obtain up-to-date information from software centres throughout the world.

Independent

The publishers have no affiliation with any of the software houses whose programs are listed in the directory.

Easily-accessed

The clear cross-referencing system outlined above enables the reader to select programs by specific applications, operating systems, and price.

Up-to-date

Information is stored immediately it becomes available in a large computer database which generates fully indexed and cross-referenced camera ready copy. Thus we are able to include software made available immediately prior to publication.

INTERNATIONAL
MICROCOMPUTER
SOFTWARE
DIRECTORY

PET

£5.85p plus P & P 0.85p

INTERNATIONAL
MICROCOMPUTER
SOFTWARE
DIRECTORY

APPLE

INTERNATIONAL
MICROCOMPUTER
SOFTWARE
DIRECTORY

CP/M

INTERNATIONAL
MICROCOMPUTER
SOFTWARE
DIRECTORY

TRS 80

Also Available

The International Microcomputer Software Directory Supplements

Available for individual machines or operating systems the Supplements contain listings of software compatible only with particular machines or operating systems. Supplements are organised as in the first two sections of the Directory section above.

Please send me _____ copies of the International Microcomputer Software Directory,
and/or _____ copies of Software Directory Supplements, state which _____

Name (Block letters Please) _____

Address _____

OR phone your order through now
(24 hr. service) giving your credit card
number, and address 01-348 3998

Imprint Software

16 Milton Avenue,
Highgate, London N6.

KGB MICROS LIMITED

THE PROFESSIONAL ORGANISATION OFFERING
HARDWARE AND SOFTWARE PLUS FULL CLIENT SUPPORT
WHO WISH TO MAKE YOUR BUSINESS OUR BUSINESS

SUPERBRAIN

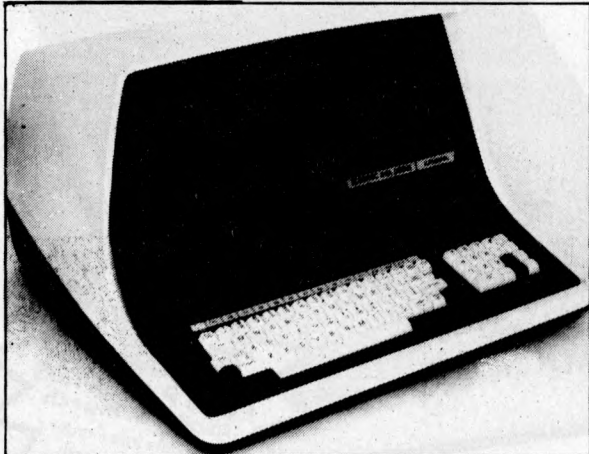

THE MICRO COMPUTER THAT HAS
THE BEST PRICE/PERFORMANCE
RATIO.

£1495 (64K RAM)

MICROLINE 80

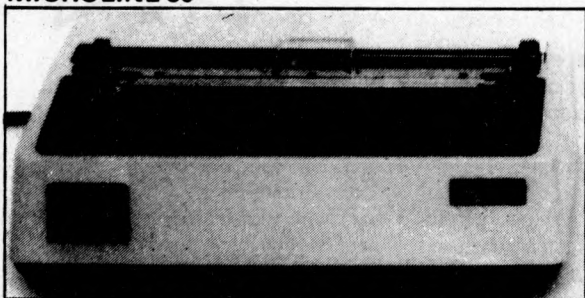

THE EFFICIENT BUSINESS SYSTEM
SUPERBRAIN

+
MICROLINE 80 PRINTER

£1795

INDIVIDUAL PRICE £500.00

DIABLO 630



THE COMPLETE WORD PROCESSING
SYSTEM
SUPERBRAIN

+
DIABLO 630 PRINTER

+
THE PROVEN 'WORD STAR' PACKAGE

£2995

INDIVIDUAL PRICE £1675.00

SOFTWARE SUPPORT

- * KGB offer a wide range of standard software — FORTRAN, COBOL, BASIC, PASCAL.
- * KGB will customise our software packages to meet your unique requirements — Invoicing £95, Sales Ledger £235, Purchase Ledger £235, Nominal Ledger £235, Payroll £335.
- * KGB will design and implement software to suit your business needs.

KGB Micros Ltd., 88 High Street, Slough, Berkshire.
Tel: Slough 38581/38319

Superbrain is the registered trademark of Intertec Data Systems. Prices exc. VAT.

interface components

NASCOM SYSTEMS & PERIPHERALS

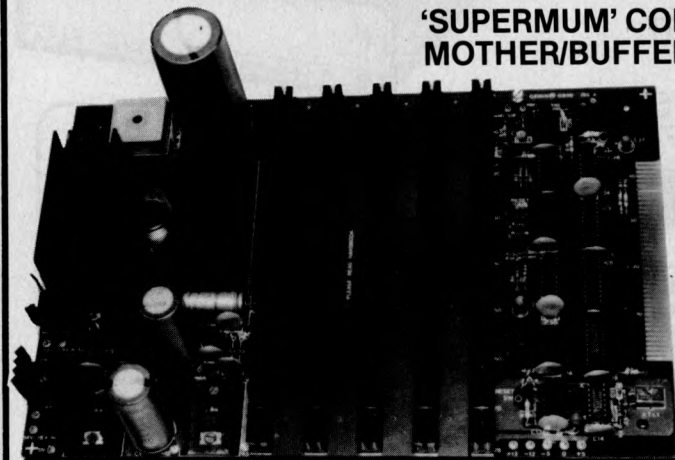

'SUPERMUM' COMBINED MOTHER/BUFFER/PSU BOARD

A 12 x 8 piggy-back board for the Nascom 1, it contains a five-slot motherboard, quality 5A power supply and reliable buffering with reset jump. The board facilitates easy floppy disk expansion.

£85
+ £2.50 P&P + VAT

SHARP PC-1211 POCKET COMPUTER

The PC-1211 uses BASIC and has up to 1424 program steps. 80 character input line with full editing facilities, 18 user definable keys, 24 character alpha-numeric LCD display. Optional cassette interface is available. PC-1211 is battery-operated, has auto power off function and maintains all programs and data in its memory even after the power has been turned off.

Cassette interface
£13 + VAT

£86.92
+ £1 P&P + VAT

CENTRONICS MICRO PRINTERS

High performance — Low cost
737—£425 + £3 P&P + VAT

737 Dot Matrix Printer runs at 80cps (proportional) or 50cps (monospaced) giving text processing quality print. This new printer is capable of printing subscripts and superscripts.

730—£375 + £3 P&P + VAT

730 Dot Matrix Printer can print 10cpl or 16.5cpl at 100cps and 165cps respectively.

Both printers have 3-way paper handling and parallel interface as standard. RS 232/V24 serial interface is optional.

Fanfold paper (2000 sheets) £18 + £2.50 P&P + VAT



MICRO MART

Voltage Regulators

T0220 1 amp
+ 5, + 12, + 15, + 24V . 80p + VAT
- 5, - 12, - 15, - 24V . 65p + VAT

T03

1A + 5V LM309K 50p + VAT
3A + 5V LM323K £3.50 + VAT
5A ± 5V 78H05 £5.50 + VAT

ICs
EPROMs 2708. £4.50 + VAT
EPROMs 2716. £7.50 + VAT
Memories
21L02 £0.80 + VAT
4027 £0.70 + VAT
4116 £2.50 + VAT
4118 £7.50 + VAT
2114 £3.00 + VAT
Z80 Devices (4MHz 'A' version)
MK3880 £8.00 + VAT
MK3881(PIO) £5.00 + VAT
MK3882(CTC) £5.00 + VAT

Also extensive range of standard and LS TTL, CMOS and linear ICs, plus other semiconductors, in stock. Send for list.

Unless stated otherwise add 50p P&P to all orders. Prices correct at time of going to press. *New Interface catalogue now available on request. Access and Barclaycard accepted.

FLOPPY DISC SYSTEM

Built and tested stand alone unit with 1/2 drives for both Nascom 1 & 2.

Single drive CP/M (160K) £450 + £4 P&P + VAT
Double drive CP/M (320K) £640 + £4 P&P + VAT
Single drive D-DOS system £395 + £4 P&P + VAT (enables existing NAS-Sys software to be used)
Spare drive £205 + £2 P&P + VAT
Verbatim Diskettes £3.75 + VAT each
10 for £32 + VAT

Nascom 1 owners: Add £10 + VAT to prices above for Reset Jump Kit

NASCOM 1 kit £125 + £1.50 P&P + VAT
NASCOM 1 built £140 + £1.50 P&P + VAT

SPECIAL INTERFACE OFFER
NASCOM 2 WITH 16K RAM BOARD
BUILT £345. KIT £295 (+ £2 P&P + VAT)

NASCOM IMP PLAIN PAPER
PRINTER £325 + £2.75 P&P + VAT

RAM BOARDS—SPECIAL PRICES

16K RAM £90 + £1 P&P + VAT
32K RAM £110 + £1 P&P + VAT
48K RAM £130 + £1 P&P + VAT
64K RAM £150 + £1 P&P + VAT

SOFTWARE ON TAPE

BASIC Programmers Aid £13 + VAT
8K BASIC £15 + VAT ZEP 2 £30 + VAT

SHARP MZ-80K + Peripherals

Bi-Directional Serial Board £99.50 + VAT
MZ80FD (twin floppies 208K) £675 + £5 P&P + VAT
MZ80P3 Printer £425 + £5 P&P + VAT
MZ80 I/O Interface £99 + £2 P&P + VAT
CP/M 2.2 £200 + VAT

Stock Control, Sales/Purchase Ledger and other business software and games in stock. Full list available on request.

SPECIAL INTERFACE OFFER
48K MZ-80K System **£460**
+ £10 carriage + VAT

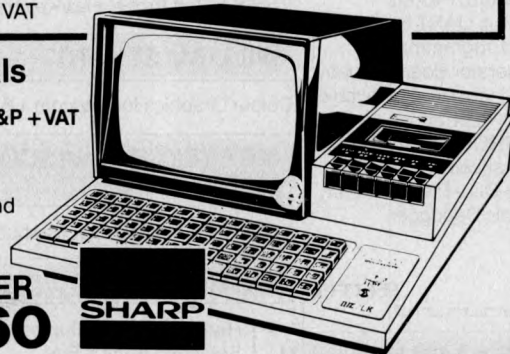

SHARP

SHARP

SHARP

INTERFACE COMPONENTS LTD.

OAKFIELD CORNER, SYCAMORE ROAD, AMERSHAM, BUCKS HP6 6SU

TELEPHONE: 02403 22307. TELEX 837788

Datron of Sheffield for Cromemco

— the ultimate name in micros

- * Datron import
- * Datron supply
- * Datron stock

DIRECT FROM
CROMEMCO
AND SUPPORT
NATIONALLY
CROMEMCO SYSTEMS,
CARDS & SOFTWARE



Datron Prices				
Unit	RAM	ROM	Disc	
System Zero/D	64K	4K	2 x 390K	£2,450
System 2	64K	4K	2 x 390K	£2,526
System 3	64K	4K	2 x 1.2M	£4,050
Hard Disc Z2-H	64K	4K	10M + 2 x 390K	£5,373
Z2H Colour Graphics	64K	4K	10M + 2 x 390K	£7,800†

Prices include Interfaces for VDU, dot matrix and letter quality printers, documentation and systems familiarization.

† also includes 13" RGB Monitor and 2 x 48K graphic memory cards.

Complete Systems supplied for Business, Research, Education and Industry



Wide range of languages, 16K and 32K Basic, Cobol, Rational Fortran and Fortran IV, Lisp, RPG etc. Operating systems — Cromemco CDOS, CP/M Compatible or Cromix for Multi-User

Write or 'phone for free advice and catalogue or call in for a demonstration.

DEMONSTRATIONS 9am-5pm MONDAY-SATURDAY

DATRON MICRO CENTRE
DATRON INTERFORM LTD

2 Abbeydale Road, Sheffield S7 1FD.
Telephone 0742-585490 / 585400.
Telex 547151.



Some new introductions by the Midlands Computer Centre...

We celebrate our first birthday with news of new introductions available from the Micro Computer Centre.

NEW HORIZON NEW CROMEMCO

In addition to Nascom and Commodore micro computers

PERIPHERALS

(Excluding printers)
Sharp Cassette Decks. Crofton 10" Cased Monitors.

PRINTERS

Nexos Ricoh RP 1600 Daisy Wheel Printer. Diablo Daisy Wheel Printer. Nascom Micro Imp. Dot Matrix Plain Paper Printer. Centronics Dot Matrix. Anadex Dot Matrix. Newbury Laboratories Dot Matrix Impact Printer.

ADD-ONS FOR NASCOM

Input/Output Board. PIO Kit. Counter Timer Kit. UART Kit. (Colour Board Programmable Character Generator Board. Floppy Disc System (Single Drive) available in September). Nas-Pen Text editor. ZEAP 2.0 in EPROM or on Tape. Nas-Sys 3 Enhanced version of Nas-Sys 1. Nas-Dis - Disassembler. Debug - Dynamic Debugger.

BITs & PCs

Tool Kit. Port Probe. Hex Key Pad.

WILLIAM STUART

Colour Graphics for Nascom 1 & 2.

MERSEYSIDE NASCOM USER GROUP

ROM/EPROM Board for Nasbus.

EXTRAS

Henry's EPROM Burner. Antex Soldering Irons & Bits.

SOFTWARE

Northstar. CAP-CPP. Cromemco. Petsoft. Supersoft. Nascom Games.

BOOKS

Very full range of books on 6502, Z80, Languages, Interfacing, Introductory books and games and General Programs.

MAGAZINES

Personal Computer World. Computing Today. Practical Computing. Educational Computing. Liverpool Software Gazette. Printout.

ASK ABOUT THE KENILWORTH CASE

The "Kenilworth" Case. Microtype Case. Veroframe.

BUSINESS & LEISURE MICROCOMPUTERS

Castle Interface.

Business & Leisure Micro Computers

16 The Square, Kenilworth, Warwickshire CV8 1EB. Tel: (0926) 512127

Microcomputers on a mini budget

Businessmen and professional people alike can rid themselves of day-to-day problems and increased workload with a microcomputer.

Just a few tasks a microcomputer could be organising for your company, division or department:-

- Accountants
- Estate Agents
- Retailers
- Insurance Brokers
- Doctors
- Dentists
- Solicitors
- Architects
- Engineers
- Chemists
- Farmers
- Bankers
- Teachers

to name but a few

- Sales Ledger
- Purchase Ledger
- Nominal Ledger
- Sales Forecasting
- Stock Control
- Job Costing
- Estimating
- Payroll
- Word Processing

(automatic compilation, editing and production of repetitive letters and documents).

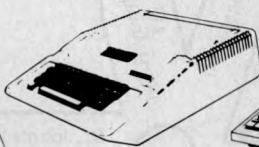

	PET	APPLE II	SHARP	SUPERBRAIN	TANDY II
SYSTEM A Basic computer including screen & keyboard	£399	£775	£450	—	—
SYSTEM B As 'A', plus floppy disk drive(s) and matrix printer for small business user.	£1700	£1655	£1750	£2200	£2450
SYSTEM C As 'B', but quality printer for word processing as well.	£2700	£2050	£2250	£2600	£2850
SYSTEM D As 'C', plus hard disk for up to 10,000,000 bytes on line.	—	£5550	—	—	£4800

*Prices exclude VAT

Johnson microcomputers

A member of the T. V. Johnson Group

Johnson House, 75-79 Park Street,
Camberley Surrey. Telephone 0276 20446
48 Gloucester Road, Bristol. Telephone 0272 422061
148 Cowley Road, Oxford. Telephone 0865 721461

CHROMASONIC electronics

48 JUNCTION ROAD, ARCHWAY, LONDON N19 5RD 100 yds from Archway Station & 9 bus routes
TELEPHONE 01- 263 9493 01-263 9495

YOUR SOUNDEST CONNECTION IN THE WORLD OF COMPONENTS AND COMPUTERS

8N 8K RAM
16N 16K RAM
32N 32K RAM
CASSETTE DECK
343K TWIN FLOPPY DISK

PETS & SYSTEMS

NEW 32k with 80 col screen
Twin Disk Drive 950K

All with new keyboard
and green screen
Friction Feed Printer
Tractor Feed Printer

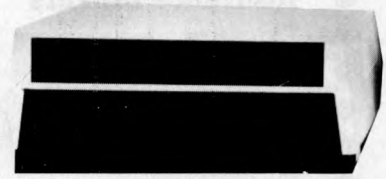

COMPLETE 32K SYSTEM
APPROVED COMMODORE DEALER



MEMORY EXPANSION KIT

Suitable for UK101, Super-board expansion using 2114s each board has 16K ram capacity kit contains:

- ▶ On board power supply
- ▶ 4K Eprom expansion
- ▶ Fully buffered for easy expansion via 40 pin socket
- ▶ 8K kit £89.95
- ▶ 16K kit £122.95
- ▶ Printed Circuit Board £29.95
- ▶ 40 pin-40 pin header plug £8.50

NEW SHOP

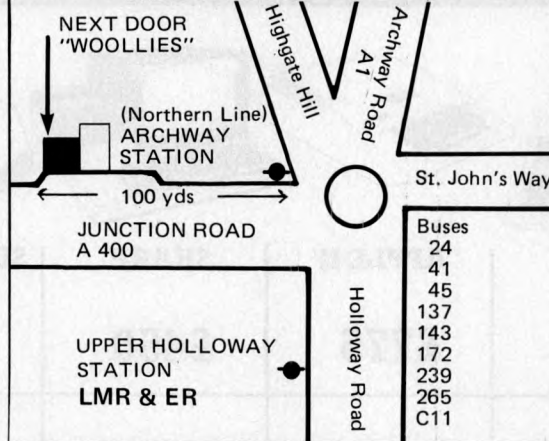

VIDEO GENIE

VIDEO GENIE based on TRS80



Utilises Z80, 12k level II Basic, Integral Cassette Deck, UHF O/P, 16k RAM

all TRS80 features £289

CASES

Available for U.K. 101, Superboard Nascom Appx. DIM. 17" x 15" 435 x 384 mm

PRICE £24.50

Post & Packing £1.50

UK101 P.P.I.

BUILT & TESTED. INTERFACES TX80 PRINTER DIRECT, CAN BE PROGRAMMED TO OPERATE RELAYS, MOTORS, VARIOUS OTHER PERIPHERALS "CENTRONICS COMPATIBLE PLUGS INTO IC SOCKET. RED BINARY DISPLAY FULLY DOCUMENTED.

£29.95

UK101

£179 IN KIT FORM

£229 READY BUILT & TESTED

£255 COMPLETE IN CASE

4K EXPANSION (8 x 2114) NOW ONLY £18.00

No extras required

- ★ Free sampler tape
- ★ Full Qwerty keyboard
- ★ 8K basic
- ★ Ram expandable to 8K on board (4K inc)
- ★ Kansas City tape interface

★ NEW MONITOR ALLOWS FULL EDITING & CURSOR CONTROL

£22.00



PRINTERS

EPSON TX-80

£349

Dot-matrix printer with Pet graphics interface: Centronics parallel, options: PET, Apple and compatible

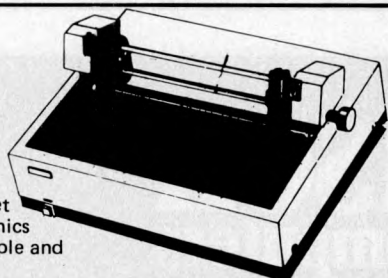

PLEASE ADD VAT 15% TO ALL PRICES. POSTAGE ON COMPUTERS, PRINTERS & CASSETTE DECKS CHARGED AT COST. ALL OTHER ITEMS P&P 30p. PLACE YOUR ORDER USING YOUR ACCESS OR BARCLAYCARD (Min. Tel. order £5.00). TRADE & EXPORT ENQUIRIES WELCOME, CREDIT FACILITIES ARRANGED.



NEW SHOP & SHOWROOM NOW OPEN

TELEPHONE
01-263 9493/01-263 9495

UK101 SOUND

SOUND GENERATOR AND COMBINED PARALLEL IN/OUT PORT KIT CONTAINING P.C.B., AY-3-8910, 6520 PIA, FULLY DOCUMENTED AND DEMO TAPE.

£29.95

AY-3-8910 £8.50

UK 101 SOFTWARE

SPACE INVADERS	6.50
REAL TIME CLOCK	3.00
CHEQUERS	3.00
OTHELLO	4.00
GAME PACK I	5.00
GAME PACK II	5.00
GAME PACK III	5.00
SCREEN MONITOR	4.00
ASSEMBLER EDITOR	14.90
10x12 BLANK TAPES	4.00

CPUS

Z80 2.5 MEG	7.95
Z80A 4 MEG	9.95
6502	6.95
6800	6.50
8080	4.75
9900	25.95

SUPPORT CHIPS

Z80 CTC	5.95
Z80A CTC	6.95
Z80A PIO	5.95
Z80A PIO 6520	6.95
6522	3.95
6532	6.85
6821	8.50
6850	4.25
6852	3.60
6852	4.35
8212	1.95
8216	1.95
8224	2.75
8228	3.75
8251	4.95
8253	9.75
8255	4.50
TMS9901	13.16
TMS9902	11.18
TMS9904 (74LS362)	4.21

MEMORY

D. RAMS	£ p
4027	2.75
4050 (350NS)	2.35
4060 (300NS)	2.39
4116	3.95
S. RAMS	
2102A	1.30
2102A2	1.69
2112A	2.75
2114/4045	2.75
4035	1.07
4044-5257	6.93
6810	3.50
BULK PURCHASE	
8x2114	18.00
8x4116	27.50
16x2114	34.00

EPROMS

2708	4.25
2716 (5v)	6.95
2532	29.95

ROM

2513 (UC)	5.95
-----------	------

I.C. SOCKETS

	DLL	W/W
8 pin	.09	.25
14 pin	.11	.35
16 pin	.12	.42
18 pin	.16	.50
20 pin	.20	.62
22 pin	.22	.65
24 pin	.24	.70
28 pin	.30	.80
36 pin	-	.99
40 pin	.40	1.10

BUFFERS

81LS95	1.25
81LS96	1.25
81LS97	1.25
81LS98	1.25
SN74365	.52
SN74366	.52
SN74367	.52
SN74368	.52
BT26	1.50
8T28	1.50
8T95	1.50
8T96	1.50
8T97	1.50
8T98	1.50

BAUD RATE GENs

MC14411	8.75
MM5307	8.75

UARTS

AY-5-1013	3.95
AY-3-1015	4.75
MM5303	4.75
TMS6011	3.55

SEND S.A.E. FOR COMPLETE PRICE LIST OR PHONE 01-263 9493

Enter the Computer Age video genie system

12K MICROSOFT BASIC
16K RAM, UHF MODULATOR
INTERNAL CASSETTE
SECOND CASSETTE INTERFACE

£330 PLUS VAT



80 COLUMNS
70 LINES PER MINUTE
GRAPHICS CHARACTERS
INTERFACES TO MOST MACHINES

£395 PLUS VAT

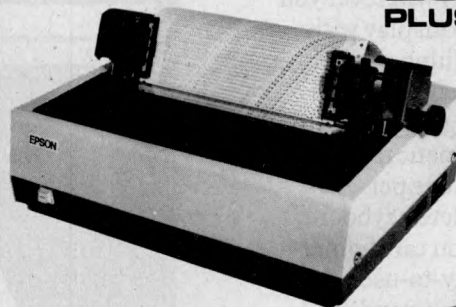

100's OF PROGRAMS AVAILABLE
TRS-80 LEVEL II SOFTWARE COMPATIBLE

Dealer List

3 Line Computing	Hull 445496	East Midlands	Nottingham 267079
ABC Supplies	Levenshulme	Computer Services	
	061-431-9265	Emprise Ltd	Colchester 865773
	ShIPLEY 585333	G B Organs & TV	St Saviour Jersey 26788
Advance TV		Gemssoft	Woking 22881
Services		Kansas City	Chesterfield 850357
Allen TV Services	Stoke on Trent 616929	Systems	
Amateur Radio	Huddersfield 20774	Kays Electronics	Chesterfield 31696
Shop		Leisurronics	Blackpool 27091
Anglia Computer	Norwich 29652	Marton Micro-	Northampton
Centre		computer Services	890661
Arden Data	Peterboro' 49577	Melton Mowbray	812888
Processing	Leicester 222 55	Stoke on Trent	541743
Beaver Computers	Littlehampton 22461	Beckenham 01-658	7508/7551
Blandford	Blandford 53737	Nottingham 298281	
Computers		Matrix Computer	
Briers Bookshop	Middlesborough 242017	Systems	
Buss Stop	Watford 40698	Midland Micro-	
	Newport Pagnell 610625	computers	
	Cambridge 314666	Microdigital	Liverpool 227-2535
Cambridge Micro-		Mighty Micro	Basingstoke 56417
computers		Mighty Micro	Burnley 32209/53629
Catronics	Wallington 01-669 6700/1	Morrison Computer	Swansea 795817
		Centre	
Cavern Electronics	Milton Keynes 314925	MRS	Cardiff 616396/7
	Lytham 730033	Communications	
Computer Business		Optelco	Rayleigh 774089
Systems		C Owens	Peterlee 865871
Computer and	St Andrews 72569	Q Tek Systems	Stevenage 65385
Chips		Radio Shack Ltd	London NW6 01-624 7174
Computerama	Bath 333232	Rebvale Computers	Garboldisham 316
Computopia	Leighton Buzzard 376600	SMG Micro-	Gravesend 55813
	Limerick 42733	computers	
D B Micro-		SMG Micro-	Gravesend 55813
computers		Tryfan Computers	Bangor 52042
Derwent Radio	Scarborough 65996	University Radio	Nottingham 45466
Eiron Computers	Dublin 808575/805045	Stores	
	Dublin 808575/805045	Ward Electronics	Birmingham 021-554-0708
Eley Electronics	Leicester 871522	Watford Electronics	Watford 405888/37774

LOWE ELECTRONICS

BENTLEY BRIDGE
CHESTERFIELD R3
MATLOCK
DERBYSHIRE DE4 3LE

Trade Enquiries Welcome



Discover the full professional power of Hewlett-Packard's personal computer.

Now you can extend the HP-85's power simply by plugging in high-performance printers, plotters and flexible disc systems.

Power where you need it.

The HP-85 puts professional problem-solving power wherever you need it. There's a video display with high resolution and editing capability. A whisper-quiet thermal printer for hard copies of display graphics and alphanumerics. A magnetic tape unit with up to 217 K of storage per cartridge. And a complete keyboard, including eight keys you can define yourself. Powerful, easy-to-use features, thanks to HP's extended BASIC programming language.

Decide the peripherals you need.

HP's Interface Bus (HP-IB/IEEE-488) lets you add up to 14 peripherals or instruments. No need to write special operating programs—HP's peripheral ROMs do it for you.

New HP enhancement ROMs and modules give you access to 80 K bytes of operating system, without significantly reducing user memory. The HP 2631B printer means high-speed, high-quality printing. And the HP 7225 Graphics Plotter gives you high-resolution, publication-quality graphics on paper or film.

For extra memory storage, use the HP 82900 series of 5¼" flexible disc drives. Each drive gives you about 270 K bytes of formatted storage on double-sided, double-density discs. The operating system is in the Mass Storage ROM, leaving the HP-85 main memory free.

Behind the HP-85 computing system is the strength of Hewlett-Packard. Continuous commitment to quality. One-source service and support.



For more details or a demonstration, contact your nearest HP Dealer shown below.



**HEWLETT
PACKARD**

Contact your nearest dealer for a demonstration. **Aberdeen** Tyseal Typewriter Services, Tel: 29019; **Belfast** Cardiac Services, Tel: 625566; **Birmingham** Anglo American Computing, Tel: 65396; **Bristol** Decimal Business Machines, Tel: 294591; **Cambridge** Cambridge Computer Store, Tel: 65334; **Chelmsford** Automatic & Electronic Calculators, Tel: 69529; **Dublin** Abacus Systems, Tel: 711966; **Edinburgh** Business & Electronic Machines, Tel: 226 4294; **Holdene**, Tel: 668 2727; **Glasgow** Robox, Tel: 221 5401; **Leeds** Holdene, Tel: 459459; **Leicester** Sumlock Services, Tel: 29673; **Liverpool** Rockliff Brothers, Tel: 521 5830; **London** Automatic & Electronic Calculators, Tel: 247 1886; **Bournemouth** South Coast Business Machines, Tel: Wimborne 893040; **Brighton** Office Machinery Engineering, Tel: 689682; **Manchester** Automated Business Equipment, Tel: 432 0708; **Reading** CSE Computers, Tel: 61492; **Sintrom** Electronics, Tel: 85464; **Royston (Herts)** Electroplan, Tel: 41171; **Southampton** South Coast Business Machines, Tel: 22958; **Sunderland** Thos Hill Group, Tel: 42447; **Tunbridge Wells** DJ Herriott, Tel: 22443/4; **Wallingford** Midas Advisory Services, Tel: 36773; **Watford** Automatic & Electronic Calculators, Tel: 31571; **Woking** Petalect Electronic Services Ltd, Tel: 69032; **Worthing** Office Machinery Engineering, Tel: 207292; **Channel Islands**: (Guernsey) Professional Business Systems, Tel: 26011, (Jersey) Professional Business Systems, Tel: 75611.



NOW WITH MP/M

SIRTON COMPUTERS

76 Godstone Road, Kenley (Nr Croydon)
Surrey CR2 5AA
Tel: 01-668 0761/2

MIDAS S100 SYSTEMS

MIDAS 1 : From £750

MIDAS 2 : From £1580

MIDAS 3 : From £2150

MIDAS 4 : From £5900

ITHACA-DPS 1 : From £1075

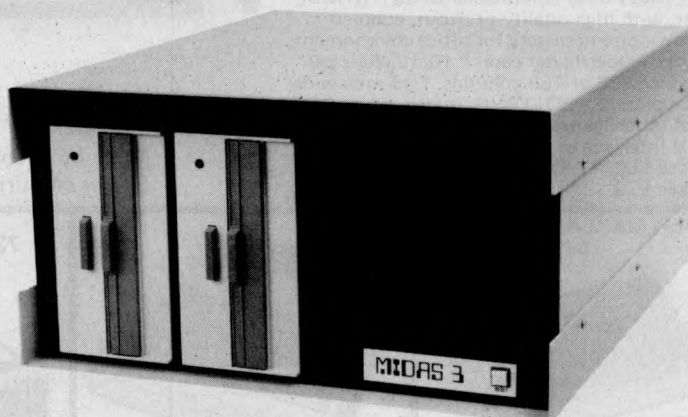

- Our versatile Z80 Microcomputers are available as standard units or custom configured to your exact specification from a comprehensive range of stocked S100 boards.
- Disc storage capacity of the MIDAS 3 can be 2M Bytes, expandable to over 20M Bytes with a Winchester Hard Disc Unit in our MIDAS 4 range.
- MIDAS runs CP/M and MP/M is also available. Other Software includes M-BASIC, C-BASIC, FORTRAN, COBOL, CIS-COBOL, PASCAL and Word Processing.
- **A MIDAS 3, with 64K RAM and 2M Bytes storage on two 8" drives with two Serial I/O Ports and CP/M 2 only £2835**
Multi-User System (four users) – MIDAS 3 with four 48K blocks of RAM, 1 MByte disc storage on two 8" drives and four Serial I/O Ports, and CP/M 2 + MP/M – £3850.
- Printers, VDUs and other peripherals stocked to give complete package systems at keen prices.
- Business Packages include Accounts, Stock Control, Purchase Ledger etc etc.

Boards stocked from Ithaca, Godbout, SSM, S D Systems, Vector, Micromation Mullen, Mountain Hardware, Hi-Tech, Video Vector, Pickles & Trout, Central Data, Cromemco, Thinker Toys – Send for full Price List (many available in kit form).

PROCESSOR

Z80 Starter Kit	£188
SBC100	£208
SBC200	£237
Z80 CPU's 4 MHz	from £130

EPROM

2708 EPROM (16K)	£60
2708/2716 Programmers from	£134

VIDEO

16 lines, 32/64 ch	from £104
24 Lines, 84 ch	from £265

DISC CONTROLLERS

Versafloppy S/D	£198
Doubler D/D	£280

SOFTWARE

CP/M 1 & 2, MP/M, PL/1, C-BASIC 2, M-BASIC V5, XYBASIC, FORTRAN 80, COBOL 80, CIS-COBAL, PASCAL/Z, PASCAL (UCSD), PASCAL M/T, Forth, MAC, ZSID, Disassembler, Wordstar, Datastar, Magic Wand, Wordmaster, Supersort etc etc.

MAINFRAMES

We are the sole UK Distributor for Integrand Mainframes and Disc Enclosures, available in nine models including Desk Top and Rack Mounting, with or without provision for Disc Drives. All units totally enclosed, painted on all external surfaces and complete with power supply etc.

RAM

Dynamic RAM 16K – 64K	from £205
Static RAM 8K – 64K	from £95
Memory Manager	£52

I/O

2S/4P prov 4K RAM/4K ROM	£169
2S/2P or 2S/4P or 3P/1S or 4S/2P	from £135
Analogue 8 or 12 bit	from £287
Optically isolated I/O	£114
IEEE 488 Interface	£350

MISCELLANEOUS

Real Time Clock	£180
High Dens Graph/8K RAM	£333
Hi-Tech Colour	£295
Motherboards – various from	£34
Extender Board/logic probe	£39
Maths Board AMD 9511	£330

WRITE OR PHONE FOR CATALOGUE PRICES EXCLUSIVE OF VAT

LONDON COMPUTER CENTRE

NEW! — IMPROVED! Additional Facilities —

RP 1600

NEW LOW PRICE £1095

60 CHARACTERS PER SECOND
THE FASTEST DAISY WHEEL PRINTER.
FAST, heavy duty commercial DAISY WHEEL printer, with high quality printout, coupled with low noise necessary for office environment. 124 char: upper/lower case. * 10/12 chars per inch giving 126 or 163 columns. * 15 inch wide friction platen. * BOLDING, underline, and host of other features. * Centronics type parallel interface as standard options: serial interface £60. * PET interface £65. * APPLE interface £75.

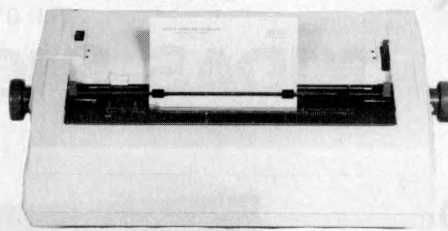

Made by Ricoh in Japan
Dealer enquiries invited

- * Built in proportional spacing
- * Look-ahead logic
- * On-off switch

- ← TRS 80 Model 1 & 11
 - ← SUPERBRAIN
 - ← APPLE
 - ← PET
 - ← HORIZON Etc
- TRACTOR FEED OIE £175
SHEET FEEDER
OPTIONAL EXTRA £550.

NEW MAXI ANADEX WITH GRAPHICS £895



Takes up to 13.5 inch wide paper * Upper/lower case with decenders * £ sign * 132 or 175 chrs/line with double width printing * Fast 150 CPS bi-directional logic seeking printing * Heavy duty print head giving 650 million chrs print life * serial, Parallel and Current Loop interfaces built in * Host of other features found on printers costing twice as much.

Also Available
DP8000 £425 (Not Illus)
DP 9501 £995 (Same as 9500 Illus)

MX80



TRS-80 Graphics * Prints 48, 66, 80 and 132 columns with true decenders at 90 cps * logic seeking, bidirectional 9 x 9 point head * upper and lower case * forms handling: Top of form, horizontal and vertical tabs * Centronics parallel interface standard * optional extras: serial, PET and Apple interfaces

Also Available
TX80 £325 (Not Illus)

737



80 CPS + double spacing and mono spacing 10 and 16.7 CPI * nx9 proportional spacing, 3 way paper handling * 96 character set * Expanded print * Right margin justification * Underlining * Bidirectional * Pound sign * centronics parallel and serial interfaces standard * optional extras: PET & Apple interfaces.

OKI MICROLINE 80/132. THE QUIET PRINTER YOU CAN LIVE WITH



The quietest Dot Matrix available. 40, 80 or 132 cols per line * excellent print quality * 3 way paper handling: letterheads, fanfold, or paper rolls * graphics * ideal for software written for large 132 col printers * continuous rating printing day in and day out * centronics parallel standard. Options: Rs-232, PET, Apple.

NOW WITH £ SIGN
NEW LOW PRICE £350
DEALER ENQUIRIES INVITED.



TRS-80 MODEL II

State of the art second generation computer. Over 10,000 already sold in USA, 8 slot bus ensures expansion of hard discs & other peripherals., 76 Key professional keyboard, self test on power up, TRSDOS & Level III basic standard. CP/M available as option, making a wide range of accounting, educational, scientific & word processing packages instantly usable. Nationwide service through 180 Tandy stores & computer centres.

NOW WITH CP/M 2.24 £1999

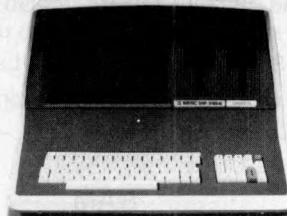

NEW SUPER BRAIN DUAL DENSITY £1595 QUAD DENSITY £1995

Now with CP/M 2.2 & increased disc storage. Twin Z80-A MHz * 2 disc drives, dual density 320 K quad density 700 K storage * 64K Ram * High resolution 12 inch CRT. 80 x 24 lines upper/lower case * 2 RS-232 printer ports * CPM 2.2 operating system * M basic, COBOL, FORTRAN, Pascal, Word processing & accounts packages available
DEALER ENQUIRIES INVITED.

NEW TRS-80 MODEL 1 48K SYSTEM WITH DUAL DISC DRIVES



New greenscreen VDU, with rock steady display. Redesigned 32K expansion intrface with trouble free disc operation, two 40 track teac disc drives, complete with cables. Tridata sales, purchase, invoicing, payroll packages available.

NEW LOW PRICE £1095
WITH DESK AND EPSON
PRINTER £1495

CPM SOFTWARE

Word Star	250.00
Word star mail merge	315.00
Magic Wand	250.00
Data Star	195.00
T/Maker	175.00
Report Writer (VisiCalc)	90.00
Accounts Packages	from 295.00
Payroll	from 295.00

Various other packages available — ask for details.

SOFTWARE FOR TRS-80

Electric Pencil (disc)	60.00
Electric Pencil (cassette)	35.00
Scripsit (disc)	75.00

Scripsit (cassette)	60.00
Mail Merge for Pencil/Scripsit	45.00
VAT Aid Programme	45.00

MISCELLANEOUS

Floppy discs (Box of 10) including library case. Xcel Silver 5" single sided double density For Pet, Apple, TRS-80 & Superbrain	25.00
Xcel Gold 5" double sided double density	
For Superbrain Memorex 8" Single Sided double density	30.00
Qume Daisy Wheels	35.00
Ricoh RP 1600	5.00
Paper, Ribbons, etc.	15.00
	POA

LOW COST WORD PROCESSOR I

Based on TRS-80 level 2 16K cassette recorder, electric pencil software, upper/lower case mod, printer interface and OKI Dot Matrix printer. Complete ready to go £895 free mailing list program.

WORD PROCESSOR II

Same as above but with 48K, 2 disc drives and ricoh daisy wheel printer £2195

WORD PROCESSOR III

Based on Superbrain computer shown above. With Ricoh printer & "Magic Wand" the ultimate in word processing. Letters automatically formatted with addresses fetched from separate file. Complete system £2950. Invoicing, stockcontrol, sales ledger, purchase ledger, payroll available for above computers from £250 per package.

43 GRAFTON WAY, LONDON W1P 5LA (Opposite Maples)
Tel: 388 6991/2 OPENING HOURS: 11-7 MON-FRI 12-4 SAT
24 hour answer phone: 01-388 5721

TOMORROW TODAY

at
Birmingham Computer Centre

Commodore official distributors

New
low
price



8032
£825

3016, 3032, 3008 PETs
The reliable value for money system
with after sales support, instruction
and training facilities and a wide
range of programmes.

New
low
price



48K
Disk
drive with
controller
£1,044
+ VAT

Apple authorised distributors
The sophisticated quality system with
a reputation for advanced design and

innovation.
SHARP
Z80K

New
low
price



20K
£380

The incredible computer system.
Now available ex-stock including the
new dual drive duple sided
floppy disk.

THE ULTIMATE IN DAISYWHEEL PRINTERS
RICOH RP 1600

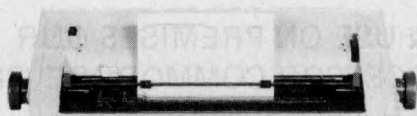

New
low
price

THE BEST WORD PROCESSOR
PRINTER AVAILABLE
DEALER ENQUIRIES WELCOME

UNBEATABLE
VALUE

**Camden Electronics, First Floor,
462 Coventry Road, Small Heath,
Birmingham B10 0UG.
Telephone 021 773 8240**

Open Mon.-Sat. 9.30-6.00 p.m.

A MEMBER OF THE COMPUTER RETAILERS ASSOCIATION

Almarc would like you to meet their new VIP

P.T.O.



Scotland's Complete Microcomputer Service

now supply and support:

HARDWARE:

Apple II Systems and Peripherals
Commodore Business Systems
A wide range of VDUs, printers, etc.

SOFTWARE:

Incomplete Records Accounting
Sales Ledger
Purchase Ledger
Nominal Ledger
Stock Control
Payroll
Word Processing
Database

Software can be tailored to your requirements or written completely to your specifications.

Our service is comprehensive, ranging from advice on system selection through installation and implementation, to operator training and comprehensive Hardware and Software maintenance.

You don't have to take our word for it.
Call us and arrange a demonstration.

Gate Microsystems Limited

THE NETHERGATE CENTRE, 66 NETHERGATE,
DUNDEE. TEL: (0382) 28194.

CBM now down £300 +

NEW 4000 Series with 2.1 DOS and 4.0 BASIC

SUPER NEW DEAL £1699 ex. VAT.

For all this :

4032 Computer + 4040 Disc + 3022 tractor
printer + 2 Cables + c2N cassette + PET

Revealed.

* Commodore price for 3000 Series +2.1
DOS and 4.0 Basic equivalent to above was
£2001 ex. VAT.

Hurry! The PET is gone

GET ONE WHILST YOU CAN!

2008 (Old Keyboard) £365.00

3016N £485.00

(money with order price ex. VAT)

Our prices are lower than many unofficial
sources but we ARE OFFICIAL DEALERS

CCS MICROHIRE

16K Microcomputer £89/month — 32/48K £99

2 — Discs £89/month

CCS MICROHIRE/MICROSALES

7 The Arcade
Letchworth
Herts

Telephone (04626) 73301

RENT-A-WORKSHOP

864 High Road, N. Finchley, London N12

Telephone: 01-445 0033

NEW! NEW! NEW!

COME & USE ON PREMISES OUR
MICRO-PROCESSOR COMMODORE 'PET'
WITH NEC SPINWRITER

PROGRAMMES

'WORDCRAFT' FOR WORD PROCESSES
& AUTOMATIC MAILING

'COMBIS' FOR DATA PROCESSING

'PAYROLL' ETC ETC

HIRE CHARGES

£6.50 PER HOUR

APPOINTMENTS BOOKABLE

commodore
PET PACK
software
DIRECT FROM
audiogenic

(WE MANUFACTURE THEM)

The Commodore range of Petpack Software is big and getting bigger! At the moment there are over 60 Petpacks and new programs are being added all the time. Here at Audiogenic we hold stocks of every Petpack and GD series disc, ready for immediate despatch.

For the Businessman we have programs for Stock Control, Filing, Accounts, Payroll, a very powerful Word Processor, and more!
 For Educational applications we have programs to aid in the tuition of Languages, Physics, Maths, English, Pet Programming, Statistics, etc.
 For the Scientist or Engineer we have programs on Mechanics of Materials, Harmonic Analysis, Circuit Design, Drawing Load and Die Design, Statistical Analysis, Geometry and Algebra, to mention but a few. Then for the Programmer, there is a selection of Programming Aids on cassette and disc. And, of course, there are the Games Petpacks! Fun for all the Family! There are at present 12 cassettes in the Treasure Trove series, with over 40 different games in all. The Arcade series has 6 games which will be familiar to those of you who frequent pubs, clubs or amusement arcades. The games are PET versions of those popular pastimes like the addictive 'Space Invaders' or the universe-encompassing 3D Startrek.

Get our catalogue for the exciting details.

We also supply for your PET

CONNECTICUT MICRO

A range of analog to digital conversion equipment with up to 16 inputs for the collection of information. Temperature probes and software provided, all at prices starting at around £90.00. Also a range of IEEE to RS232 converters which are addressable and uni- or bi-directional. Prices start at £65.00

A B COMPUTERS VISIBLE MUSIC MONITOR

This unit is absolutely phenomenal. It actually displays music (staves, notes, signature etc.) on the screen and plays it at the same time. It will handle 4 part harmonies and you can add or delete notes with simple keyboard commands. It's a sort of musical word processor. Ideal for computer music freaks, whether rock, classical or budding "Stockhausens". Comes complete with notes, 8 bit D/A converter and some beautiful pieces of music inc. Maple Leaf Rag and some Bach. Excellent value at £39.50 inc. VAT plus 25p P+P.

PROMINICO X-DOS

This little ROM makes all the difference to using disks, as it gives a range of commands like MENU, which displays the disc directory in the form of pages. It does not lose the program currently resident in the PET, and does away with initialisation. It also incorporates a screen dump to printer, disk copy and scratch routines. See our catalogue for further details.

JCL EPROM BURNERS

An essential device for programmers wishing to incorporate their programs into ROMs. Comes complete with software. Another nice little number from this company is the TURNKEY ROM set, which is suited to business software writers and users. It will load from disk a program as soon as you power up - also features a "BULLET PROOF" input routine. See our catalogue for the details of this versatile little beauty.

BOOKS

Over 15 titles from

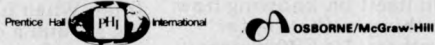

SIGMA, MOE and COMPUTABITS. All the titles have been selected with the PET user in mind, and the range includes books on PASCAL, GRAPHICS, PROGRAMS, IEEE BUS, CIRCUITS, HARDWARE, etc. Don't forget the PET/CBM Personal Computer Guide at £9.25 plus £1.00 p+p.

BASIC 4 and DOS 2 CONVERSION

BASIC 4 gives your new ROM PET all the commands of the new 80 column PETs. DOS 2 goes in your disk drive and is necessary when using BASIC 4 or may be used on its own to get rid of initialisations every time you use a disk. Both sets are priced at £43.70 inc. VAT + 50p P+P each.

ACCESSORIES

SOUND BOARDS, DISKS, CASSETTES, ROMS, DISK HOLDERS, PETSET (GETS YOU OUT OF CRASH), DEMAGNETISER, RIBBONS see catalogue for full details.

Now 22 issues of this superb magazine.

All back copies available £3.50 each plus 25p post + package.



**P.O. Box 88 Reading, Berkshire,
 Tel: (0734) 595269 24 Hour.**

**Almarc would like you to
 meet the
 Vector Graphic
 VIP**



High performance at an astonishingly low price. Compare this specification:

- *The Vector 3 terminal, with 6 slot industry standard S100 bus.
- *Z80 Processor.
- *56K of user RAM.
- *1 serial RS232 port, 3 8-bit parallel ports.
- *80 x 24 characters video display with 8 x 10 character matrix.
- *Typewriter style keyboard with a separate numeric key pad and capacitance keys.
- *Unistor disc drive module giving 315 Kbytes of storage capacity.
- PLUS** CP/M2, Microsoft BASIC 80, SCOPE (text editor) and RAID (simulator debugger).
- PLUS** Almarc's 12 month warranty.

Almarc are Specialists in Vector Graphic equipment which includes Micro-Computers for research, laboratory work, word processing, business systems, schools, colleges, universities and industry. Plus an ever growing list of compatible software including Pascal, Fortran, Cobol, APL, Algol, Basic Compiler and others.

We will be pleased to demonstrate how Almarc + Vector Graphic Systems equates to The Complete Partnership in Micro-Computers.

ALMARC
DATA SYSTEMS LTD
 906 Woodborough Road, Nottingham NG3 5QS.
 Telephone: (0602) 625035

Guy Kewney, editor of Datalink, reports on the latest happenings in the micro world.



Give us a ring

Take a class of 30 children and buy them a nice computer — say a PET or Apple or Tandy or Acorn or Nascom — and what have you achieved? You have absolutely fascinated one child for one period, that's what.

All the rest are bored solid after the first ten minutes, waiting for their turn at the keyboard. And for most of the time they are waiting, child number one is stolidly entering phrases like "50 GOTO 60" and going back to change that to "50 GOTO 30" ten minutes later. The only way to run a class of computer students is to give them at least one machine between three (assuming you're not a university which can afford one each). I know — I've been in classes like that.

Even at the cost of the Acorn, £150 ready built, we are talking about an absolute minimum of £1500 before we buy our monitors and cassette recorders. If we want disks and PETs, we're up to the £5000 level for the machines and the same again for data storage.

It is when you look into the costs of disk storage on this scale that you see why Acorn has agonised so long about its Econet, which connects a lot of Atoms together and allows them to share a single disk and a single printer.

The idea isn't unique to Acorn — a net of Apples has been built by Zynar (under licence from the inventor, Nestar in California) and 'local area networks' are on the minds of all good

designers today.

What makes the Econet so interesting is the low cost of each keyboard. Assuming ten Atoms in the classroom and assuming that video displays have been found at around £50 each (old tellies will do), then the network and a disk brings the cost to about £300 per 'work-station'. In the classroom, once the network starts working, it looks even better. The program for the day can be loaded once — by the teacher — into every machine simultaneously, from disk (compare that with loading from tape, moving from one machine to the next — it would take the whole period to load the same program into ten machines). And if something goes wrong, any machine can watch what is going on on the screen of any other and can intervene if necessary.

Mind you, this last feature is in serious need of some modification. As things stand, if you know the network number of somebody else's machine, it is a simple matter to say *REMOTE 220 and to stop whatever that machine is doing, turning it instantly into a duplicate of your own. How to lose friends and editors — I did it to the Editor of PCW at the demonstration and he pretended to laugh.

Acorn is, according to Herman Hauser and Chris Curry, entirely aware of the need for market trials before the system is finally released. The company is installing an

Econet itself, 'to save having to buy a second printer,' and another pre-production network is going into a local school near Cambridge.

It was an interesting demonstration but unfortunately it gave David Johnson-Davies the chance to buttonhole me and show me that the Acorn Atom can, in fact, draw pictures without covering the screen in snow: 'noise-free graphics', as he calls it, can be done.

He also glowered disapprovingly at me when I suggested that the floating point add-on should not give 3²⁷ as 26.99999999... but as 27. 'You feel it should be rounded up from the binary?' he asked me loftily. Well, yes. Any pocket calculator can do it, so why not the Atom?

The captain does a U-turn

It isn't right to gloat, so please restrict yourself to a smallish, rather wry smile at the news that Zilog has decided to 'provide systems with the popular CP/M operating system', as their announcement stiffly puts it. It's a bit like the BBC must have sounded when it finally caved in and launched Radio One.

Zilog makes micro-processors and has always prided itself on knowing how to do things rather better than others. Its Z80 processor, for instance, was designed to do all the things that Intel's 8080 could do — and quite a few more — and faster. And, naturally, it has an operating system, for getting information off disks and back on again, which is much better than CP/M — at least, Zilog thinks so. 'By implementing CP/M on their systems,' says the announcement, 'Zilog are offering micro users a unique choice — in RIO, a highly professional operating system, superb for development work, and in CP/M, a widely known operating system for which a vast amount of high level languages and applications software is available.'

Quite so: one notices how CP/M is not described as 'professional', nor does Zilog

dwell on the vast amount of languages available on RIO and one is pleased that it has at last seen the light; perhaps one tries not to recall how scornful Zilog has been of us 'hobbyists' in the past.

That is not to say that Zilog CP/M (at £150) doesn't still have a few things in it designed to make sure that, while CP/M users may join Zilog because it is there, at least Zilog RIO users will not be seduced away.

It is the extras that do it. 'As might be expected,' says the company, 'Zilog CP/M has some unique features.' This means that if you use the real-time clock, or the interrupt driven control, or BIOS source containing drivers for several printers and try to switch to someone else's CP/M, you will find that they are incompatible. Not to worry; at £3200 for a 64 kbyte system including video, twin full-size disks and operating software (both RIO and CP/M) Zilog is at last offering an MCZ system that is actually cheaper than some only moderately overpriced 'hobbyist' systems. Now, will Intel ever unbend? Zilog is in Maidenhead on 0628 36131.

Monopoly magic

I have a friend (! — Ed), a small elf called Marvin, who is a Level II magic user and thief. When he is not wandering around a dungeon with a couple of priests, footpads and armed heroes, he is a computer consultant called Richard, an expert on view-data.

One of his dreams is to be able to play the fantasy game (in which he is Marvin) called Dungeons and Dragons, on a computer, without having to tolerate the low level of wit which seems to be the best the computer can aim for, by comparison with the human Dungeon Master who designs and manipulates the eerie caverns where Marvin and his friends search for buried treasure.

Naturally, Richard rather thinks viewdata might provide the answer. 'I'd like to have several users all connected to each other, and the dungeon would be created somehow by their wanderings



around, and what they were doing would feed back to each other — I'm sure it could be done.'

Not, however, unless the terminals are a lot more intelligent than the average viewdata TV set. This restriction to the use of Prestel applies to more dignified matters than playing fantasy games — which is why the announcement of a private viewdata system from GEC has been such a disappointment.

A private viewdata system is merely a system of giving everybody a terminal that can get data out of a central computer, with all the disadvantages of Prestel. That is, the terminals are dumb, unable to talk to each other and slow to receive data. Since GEC is the company which supplies the Prestel system to British Telecom, it was widely hoped that there would be rather more signs of awareness inside GEC that times have advanced since it supplied its first 400 series computer to Sam Fedida, inventor of Prestel.

The problem of getting individual Prestel sets to talk to each other remains insoluble. British Telecom says it is possible under a 'closed user group' where all the machines use the Prestel computer as a sort of telephone exchange. This is the only way BT will allow it and it isn't accepting any more closed groups (for finance reasons).

The result is that The Source and Micronet in America, supposedly miles behind our glorious Prestel, offers any micro user hooked up to the vastly better service of two information networks (Tymnet and Telenet) with enormous, instantly-updated news and information services, plus the ability to send messages to each other, while micro users in this country have to try getting an expensive PO modem to talk to each other and cannot use it to talk to Prestel.

There is an old saying that guinea pigs never profit from the experiments performed on them, and this applies to the British and Prestel. We are the victims of being first.

And there is another old saying about people who insist you use their service but won't provide it (whether this is modems or closed user groups doesn't matter) for their own reasons; 'dive or get off the springboard'.

BBC programs

Can the BBC possibly put together a TV programme which shows how to program? Can the BBC also launch the book of the program? Can the Beeb also release the machine of the book? Can it publish the language of the machine of the book? And can it sell the whole concept to the American broadcasting stations? And, in view of this month's cover story, is it worth it in the first place? It takes a bit of believing, especially since the current plan is to use the Newbury Newbrain as the machine and to launch the programme in the middle of 1981 (this year).

First, the Newbrain is a nice machine. . . but it isn't available. The first orders are now trickling through but dealers won't promise delivery for machines ordered in November until March. Quite when the situation is expected to improve isn't clear, either, because one of the most reliable signs I know that a machine is in short supply (as opposed to no supply at all) is that the company can spare a couple of dozen for journalists to play with. And if the programme works *at all*, it will be seen by a couple of hundred thousand people, all keen, and of whom I would confidently predict 20,000 as a minimum who would like one to follow the series with. From experience in America, where a series on programming was tried recently, these figures could easily be wildly low, and more like four million viewers will watch, with as many as a third of them wanting a machine before the broadcasts start. I like Newbury but subsidiaries of the National Enterprise Board are notoriously difficult to get moving fast these days and I just don't believe it.



To clean computer products — switches, disks, tapes and so on, you need the right equipment and you also need to know how to use it. Illustrated is an approved solvent for cleaning tape drives; other products are detailed in catalogues from Automation Facilities of Blakes Road, Wargrave, Berks, tel 073 522 3012.

Then there is the problem of getting the language. Apparently the BBC is divided into more than two camps (sic) on how the programme should go — some favour the Newbury as standard, others want a special-purpose machine and both of these camps want their own language — something called ABC, not Basic. I don't know what to say.

All right, I do. You're a bunch of absolute Gonzos, you lot in the Beeb. If you use a standard language you won't stand a chance in hell of getting all the software you need up and running by the time broadcasts start. Oh, yes, running at first, maybe, but just press the wrong key at the wrong moment and watch it crash, leaving half your class with a jammed system, needing a RESET and a complete software reload. If you have a new language on top of this, you won't know where the bugs are because debugging a language is the work of years, not months, and interfacing an operating system to it is another long task.

And here's the daftest thing of all. The BBC has, on every television, a nice little system for loading programs. All that is needed is a Ceefax decoder and some instruction like LOAD Page 287, and the students can start RUNNING. So the Beeb isn't doing it. . .

Ups and downs

At the time of writing, it still wasn't clear whether Nascom had gone down the tubes again. From the receiver, the news was clear-cut — there were 'contractual irregularities' and the deal was off. From Peter Matthews there were off-the-record non-comments indica-

ting optimism. Unfortunately these were contradicted by his own remarks to friends, subsequently reported to me, that he didn't rate his chances. And nobody was saying what the problem was.

Nascom is still up for grabs then — though, by the time you read this, it may be all over. Demand for the computers stays high — talk to the dealers who could sell as many as they could get. And there were stocks of parts to build them, say my sources, so really, isn't it about time this farce ended?

PET struggle

Prediction: the Computer Retailers' Association will set up a department specialising in the Commodore PET. If it doesn't, PET dealers will set up a PET Dealers' Association anyway.

According to dealers, the new Commodore terms and conditions don't please them at all. In outline, they cover the time a dealer has to pay for stock he orders, and at what point Commodore ceases to be responsible for them. These are always subjects for dispute between supplier and dealer and the line has to be drawn somewhere — apparently the dealers feel it has moved too close to their side of the desk.

It's hard to avoid the feeling that there isn't much the dealers can do about it. Their idea is to form a strong lobby and to tackle what they see as Commodore's successful 'divide and rule' policy of the past. But unless they are prepared to shift from PET to another machine that sells as well, in the end they are stuck with the deal that Commodore offers.

Whether it affects the end



Shop moves: we proudly show the 16th-century premises in Sheen of the Micro Computer Centre. The address is 28 Sheen Lane, London SW14, the phone number 01-878 7044. You can not only buy computers here — you can hire them.

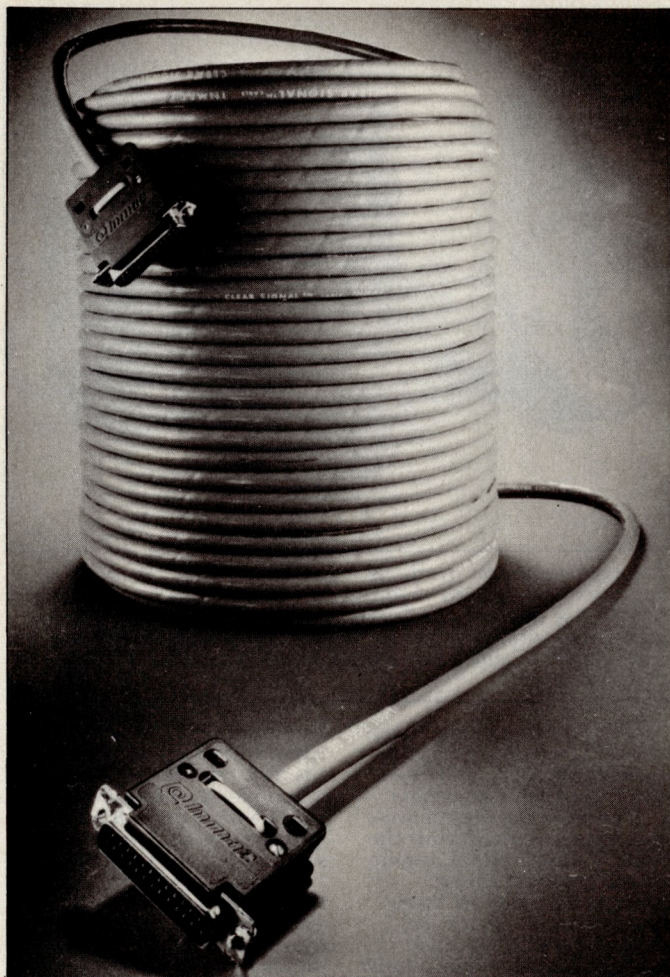

If you have sometimes wondered why large companies who can afford big computers still go to the bother of buying micros, then this wire may tell you something. It can be up to 200ft long and all it does is connect a video display to a computer. Now, if you have to go to the trouble of laying one of these cables through the corridors to get connected to the central computer and if you think what it must cost (the maker is rather coy about this), you start to see why stand-alone micros look better and better.

customer one way or another remains to be seen. If the Commodore three-month warranty really has to stand up against a year's warranty from Apple dealer (sorry, subsidiary?) Microsense, then dealers will either have to match the Apple terms at their own expense, or put up with some customer drift. With Apple prices floating down all the time, the cost of putting a matching warranty could put the PET into a less competitive position, think some Apple dealers.

We'll see. In the meantime, look for a nice little squabble over whether the Commodore Retailers' Association will or will not be under the control of the Computer Retailers' Association. . .

Shy micro...

Everybody seems to have his or her own theory about why Bruce Everiss, incorrigible boss of Lasky's Microdigital chain of micro stores, has declared that he 'will not put the Acorn Atom in the next catalogue'.

Some cynically claim it is because the margins that Acorn gives dealers are too small for Brucie. It may be and it may not be, but it is worth noting that he manages some very keen prices on the Video Genie, the Oriental imitation of the TRS-80 (now down to £260 plus VAT). And he claims that he is well ahead of the competition by offering a two-year warranty on parts and service for the Sharp MZ-80K, which may be no indication of margins, since the machine is notoriously fault-free. It might cost him nothing to do that and I have no way of knowing.

The reason Bruce himself gives is a little surprising — that he can't get enough machines. Acorn itself is reassuring on this point — it recently told *PCW* readers that deliveries would be up with demand before Christmas and Chris Curry also reports that production is starting in a Hong Kong subcontractor, boosting his output somewhat. The figure he quotes is 'around 2000 per month'.

Bruce says this is timid of Acorn (from timid Acorns, what do grow?) and that the company could sell twice that number if it made them. 'I'm a retailer,' he added trenchantly, 'and it's no good having something in the catalogue if I can't send the stuff to people when they order.'

The moral would be: don't order from anybody who doesn't have a machine in the catalogue and complain loudly if you don't get delivery as promised.

Thanks Meyer

Journalists watch each other carefully, but readers tend not to know who writes for which paper, or who thinks what. So although all of us in the Press world know what happened to the first Editor of this magazine, Meyer Solomon, most of you readers can confidently be said to be unaware of his new venture, two magazines called respectively *Computer Age* and *Business Computing*.

Now the point about these papers is that they are competitors of *Personal Computer World*, Meyer Solomon moved on when *PCW* was taken over by its current publishers and might be expected not to hold us all in an over-warm regard.

In the light of that, you will understand that I felt rather humbled recently when a printers' gremlin got into my office and displaced an entire month's supply of press releases from the industry — and Meyer Solomon, hearing of the disaster, stepped forward and volunteered his services, lending me a copy of any press release that I needed.

He took the attitude that, since we all got the same releases, it wasn't fair to allow one paper to struggle through an issue ignorant of the announcements that had been made. This may be true, but it is a generous-minded gesture to act on the principle, and one which many journalists would have dodged.

Peelings...

Price cuts are always welcome in the hardware side of this business so it is probable that it will puzzle some readers if a substantial price cut gets ignored. The price cut on the Microstar, however, is going to get no more mention than this: the old price of £4800 for a single density disk drive version has been cut to £4385, while a double density version comes down from £5600 to £4895.

At these prices, the market isn't going to get worked up about a cut, because it obviously isn't the low, low price that sells the Microstar, even if Data Efficiency says that: 'There is no other small

business system with as many operating advantages and performance features at such a low price.'

No, what is interesting is the name Data Efficiency. When Data Efficiency first moved into micros, it bought out the late John Miller Kirkpatrick and used the title of his newly published book *Microsense* as its operating name. Under this name it sold Microstar and Apple.

As I write, Apple in America has finally put its stock onto the exchange and, naturally, not even the managing director of Apple's stockbrokers can get his hands on a share. So much for bluster by various large US corporations that they would 'take over' when the stock appeared.

One thing which Apple said it would do (and later denied having said) when the stock came up on the open market, was set up more overseas operating subsidiaries. One of these, it said, would be Microsense. By the time you read this, an announcement may even have been made, and Microsense may have officially become Apple UK. Certainly, the fact that Microsense no longer handles Microstar is (at least) a pointer. And what difference will it make to users? Maybe not a lot but let's piously put our hands together and say: 'we hope it will be a Good Thing.' It may even be.

CP/M business S/W

If the operating system CP/M from Digital Research is a large field, there are several strong plants growing in it — additions, extensions, developments. One of these, available for some time now, is Graffcom Systems' business operating software ISBS-F which piles a whole series of business programs on top of CP/M, using floppy disks as the main storage medium.

Now this has been improved in its turn. The new package, ISBS-W, is still an 'integrated small business software' but it uses Winchester (big) disks, instead of floppies. That's it. Details on 01-840 3090.

Paper chase

It has been said that Technalogs is a company which could sell a lot more of its viewdata computers if it could make them, which it could if it had the production and finance resources.

One thing the company may not be short of any more is production facilities. Indeed, if the supply of paper available to this Liverpool bunch of whizzkids is anything to go by, their cup runs over like mad — I have six

Outstanding value. Superb support.



Commodore produce Britain's number one microcomputer. But we don't stop there. We also insist on providing comprehensive support throughout our national dealer network.

Our dealers can examine your needs and demonstrate which hardware and software will suit you best. Their trained engineers are always at hand and a 24-hour field maintenance service is available.

Ask your local dealer to tell you more about the following Commodore Services.

The Commodore PET
The Commodore PET computer range covers everything from the self-contained unit at under £500 to complete business systems at under £2,500.

Commodore Business Software and Petpacks
Our software range covers hundreds of applications. Business software includes Sales and Purchase Ledgers, Accounting, Stock Control, Payroll, Word Processing and more. In addition over 50 Petpacks are available covering such titles as Strathclyde Basic Tutorial, Assembler Development System, Statistics, plus our Treasure Trove and Arcade series of games.

Commodore Approved Products
Compatible products of other manufacturers with Commodore's mark of approval are also available.

Commodore Courses
Commodore offer a range of residential training courses and one day seminars. An excellent start. And when you have installed your system the PET User's Club Newsletter can keep you informed of new ideas and latest developments.

LONDON AREA

Advanced Management Systems, EC2. 01-638 9319
Centralex - London Ltd, SE13. 01-318 4213
Computer Sales & Software Centre Ltd, ILFORD, 01-554 3344
Cream Microcomputer Shop, HARROW, 01-863 0833
Da Vinci Computer Shop, EDGWARE, 01-952 0526
Henderson Bennett, SE25. 01-654 5609
Home and Business Computers, E12. 01-472 5107
L & J Computers, NW9. 01-204 7525
Logic Box Ltd, SW1. 01-222 1122
Merchant Systems Limited, EC4. 01-353 1464
Micro Computer Centre, SW14. 01-878 3206
Sumlock Bondain Ltd, EC1. 01-250 0505
Sumlock Bondain Ltd, EC4. 01-626 0487

HOME COUNTIES

Millhouse Designs Ltd, ALTON, 84517
HSV Microcomputers, BASINGSTOKE, 62444
MMS Ltd, BEDFORD, 40601
Amplicon Micro Systems Ltd, BRIGHTON, 562163
T & V Johnson (Microcomputers Etc) Ltd, CAMBERLEY, 20446
Wego Computers Ltd, CATERHAM, 49235
Dataview Ltd, COLCHESTER, 78811
Amplicon Micro Systems Ltd, CRAWLEY, 26493
S. M. G. Microcomputers, GRAVESEND, 55813
South East Computers Ltd, HASTINGS, 426844
Bromwall Data Services Ltd, HATFIELD, 60980
Alpha Business Systems, HERTFORD, 57423
Commonsense Business Systems Ltd, HIGH WYCOMBE, 40116
Kingsley Computers Ltd, HIGH WYCOMBE, 27342
Brent Computer Systems, KINGS LANGLEY, 65056
Computopia Ltd, LEIGHTON BUZZARD, 376600
South East Computers Ltd, MAIDSTONE, 681263
J. R. Ward Computers Ltd, MILTON KEYNES, 562850
Sumlock Bondain (East Anglia) Ltd, NORWICH, 26259
T & V Johnson (Microcomputers Etc) Ltd, OXFORD, 721461
C. S. E. (Computers), READING, 61492
Slough Microshop, SLOUGH, 72470

Business Electronics, SOUTHAMPTON, 738348
H. S. V. Microcomputers, SOUTHAMPTON, 22131
Super-Vision, SOUTHAMPTON, 774023
Syntex Systems Ltd, SOUTHAMPTON, 38868
Stuart R Dean Ltd, SOUTHEND-ON-SEA, 62707
The Computer Room, TUNBRIDGE WELLS, 41645
Orchard Computer Services, WALLINGFORD, 35529
Photo Acoustics Ltd, WATFORD, 40698
Microchips, WINCHESTER, 68055
P. P. M. Ltd, WOKING, (04867) 80111
Oxford Computer Systems, WOODSTOCK, 812838

MIDLANDS & S. HUMBERSIDE

C B S Consultants, BIRMINGHAM, 772 8181
Marchant Business Systems Ltd, BIRMINGHAM, 706 8232
Micro Associates, BIRMINGHAM, 328 4574
Peach Data Services Ltd, BURTON-ON-TRENT, 44968
Jondane Associates Ltd, COVENTRY, 664400
Davidson-Richards Ltd, DERBY, 366803
Allen Computers, GRIMSBY, 40568
Caddis Computer Systems Ltd, HINCKLEY, 613544
Machsize Ltd, LEAMINGTON SPA, 312542
Arden Data Processing, LEICESTER, 22255
Roger Clark Business Systems Ltd, LEICESTER, 20455
Lowe Electronics, MATLOCK, 2817
A J R Office Equipment Services Ltd, NOTTINGHAM, 206647
Betos (Systems) Ltd, NOTTINGHAM, 48108

PEG Associates (Computer Systems) Ltd, RUGBY, 65756
Walters Computer Systems Ltd, STOURBRIDGE, 70811
Systems Micros, TELFORD, 460214

YORK & N. HUMBERSIDE

Microprocessor Services, HULL, 23146
Holdene Ltd, LEEDS, 459459
South Midlands Communications Ltd, LEEDS, 782326
Yorkshire Electronics Services Ltd, MORLEY, 522181
Computer Centre (Sheffield) Ltd, SHEFFIELD, 53519
Hallam Computer Systems Ltd, SHEFFIELD, 663125
Holbrook Business Systems, SHEFFIELD, 484466

NORTH EAST

Dyson Instruments, DURHAM, 66937
Currie & Maughan, GATESHEAD, 774540
Elfton Ltd, HARTLEPOOL, 61770
Fiddes Marketing Ltd, NEWCASTLE, 815157
Intex Datalog Ltd, STOCKTON-ON-TEES, 781193

S. WALES & W. COUNTRY

Radan Computational Ltd, BATH, 318483
C. S. S. (Bristol) Ltd, BRISTOL, 779452
T & V Johnson (Microcomputers Etc) Ltd, BRISTOL, 422061
Sigma Systems, CARDIFF, 34869
Reeves Computers Ltd, CARMARTHEN, 32441
A. C. Systems, EXETER, 71718

Milequip Ltd, GLOUCESTER, 411010
Micro Media Systems, NEWPORT, 59276
J. M. Computer Services Ltd, NEWQUAY, 2863
A. C. Systems, PLYMOUTH, 260861
J. A. D. Integrated Services, PLYMOUTH, 62616
Business Electronics, SOUTHAMPTON, 738248
Computer Supplies (Swansea), SWANSEA, 290047

N. WEST & N. WALES

B + B (Computers) Ltd, BOLTON, 26644
Tharstern Ltd, BURNLEY, 38481
Megapalm Ltd, CARNFORTH, 3801
Catlands Information Systems Ltd, CHESTER, 46377
Catlands Information Systems Ltd, WILMSLOW, 527166

LIVERPOOL

Aughton Microsystems Ltd, LIVERPOOL, 548 7788
Stack Computer Services Ltd, LIVERPOOL, 933 5511

MANCHESTER AREA

Byte Shop Computerland, MANCHESTER, 236 4737
Cytek (U.K.) Ltd, MANCHESTER, 872 4682
Professional Computer Services Ltd, OLDHAM, 061-624 4065

SCOTLAND

Gate Microsystems Ltd, DUNDEE, 28194
Holdene Microsystems Ltd, EDINBURGH, 668 2727
Gate Microsystems Ltd, GLASGOW, 221 9372
Robox Ltd, Glasgow, 221 5401

To: Commodore Information Centre,
360 Euston Road, London W1 3BL. 01-388 5702

Please send me further information about the Commodore PET, .

Name _____

Position _____

Address _____

Intended application _____

Do you own a PET? YES NO

commodore

01PC1

This list covers dealers participating in our advertising.

Press Releases in front of me, each one paragraph long, each on its own sheet of paper, one of these even being upside down.

The source of all this wealth appears to be both orders and support. One sheet of paper reads: 'Technalogs has been given formal backing by the National Enterprise Board; the company manufactures viewdata and Prestel Bulk Update Offline intelligent editing terminals and viewdata adaptors.' Another announcement informs us that the printer will now print out Prestel text and graphics in any size and format. Yet another breaks the news that you can attach a hard disk to the 6800-based computer, making it usable as a multi-user terminal. A mystifying fourth paragraph says that Technalogs has been given a contract to supply hardware, which it won in competition with British Telecom. And before ending up with a list of 'information providers' who use TECS, there is a little paragraph saying that VNU, a Dutch publisher, has awarded a contract for viewdata editing and bulk update systems to Technalogs.

Much more relevant to those of us who want to be information receivers, rather than providers, is Technalogs' list of hardware, the BEE, which can convert any home micro into a Prestel receiver. At the time I spoke to the company, the planned price was a deterrent, likely to be higher than the computer itself in many cases, but by all means contact them in Manchester on 061-793 5293 and ask for details, because the plan must be due for modification.

Sord quest

After the Americans, it is the turn of the Japanese personal computer makers to go to Ireland.

Sord is setting up a £2.9

million factory which will make its range of personal and business machines, mainly for export to European markets. It brings the number of planned Japanese-generated Irish jobs to something like 4000, from nine operating subsidiaries of Japanese companies, says the Irish Development Authority.

Oh Oh Ohio!

Commiseration Corner would be the best title for the OSI/UK user group newsletter. Its readers and contributors are united only in their contempt for the supplier of the hardware and software they are stuck with — not because they don't like what they get for the money but they all wish it worked!

Interesting to see the group's reaction, then, to the announcement of Ohio Scientific's new machine, the C1 Series II.

'We don't exactly think it will improve OSI's market position — quite the opposite. It has all the hallmarks of a badly thrown together hodge — a nasty plastic case, a profusion of little add-on and stick-on boards to fix one thing or another; the serial and parallel ports, colour and sound, while there in principle, are not there in fact, for they aren't actually implemented; the keyboard and garbage collector are as scatterbrained as ever,' writes a reviewer who spotted the machine at the recent Compec exhibition.

'The colour memory starts at D400H instead of E000H for no apparent reason which makes a 2k screen memory very much more difficult to implement and the much-vaunted 12 x 48 screen format can only run with a software patch, which in any case overwrites the few locations that its still absurdly limited machine-code monitor uses. Documentation is marginally improved but still diabolical



Long ago, some computer expert decided to glue several copies of the same form together, so that the top copy and the bottom copies all had the words in the right boxes. Then he fed it into a computer printer, bottom first, and, as they all went round the roller, they all came unstuck. That's why Mannesman Tally has adjusted this printer to print upside-down. The result, say engineers, is perfect printing when the form goes in upside-down too. Details on 0734 580141.

— most of it was for the disk system which wasn't even at the show.'

You would never guess how much these characters enjoy playing with their systems from this sort of thing, would you? Oh, yes, they do, because they actually recommend that you rush out and buy the old Superboard now, before the new £100-extra version replaces it.

Would-be members contact Tom Graves, 19a West End, Street, Somerset BA16 0LQ. He's setting up a ComputerTown UK site down there, by the way.

processor'). It is the fact that the company is very expert on what it calls 'communications systems'.

To a large extent, communications on the Cx500 are good because of the multiprocessor basis. In their own technical phrasing, 'This multiprocessor structure permits additional processing modules to be added, which are dedicated to managing particular tasks, or controlling specific peripheral devices.'

The basic Cx500 uses a Z80 micro with CP/M as the disk operating system — a combination so common as to be self-recommending, because it allows software from other machines to be transferred. Which means you don't have to write it from scratch.

Transdata uses a system of plugging in extra processors whenever a new process is needed, as mentioned above; one of the most important things about the way this is done is the fact that the extra processors are plugged directly into the system bus — that is, they control the main computer's memory as if it were their own.

Where this scores is when you want to add a new peripheral — you want to read data from a disk instead of a tape, or you want to drive a different printer — without telling the operating system that you have changed. A peripheral processor (programmed by Transdata) can

Peripherals processed

There are many customers of microsystems to whom price is not everything. Some of these can be dismissed as merely ignorant — others have priorities above mere cost. It is easy to look at the Transdata range of Cx500 microsystems and say that for £3500, a system with two 8in floppy disks is overpriced — but there are obvious compensations, because many of the customers of the range do know what they want. And one of these customers is British Telecom.

The point that impresses on the Cx500 is not the one that the company makes most song and dance about (the fact that it is a 'multi-

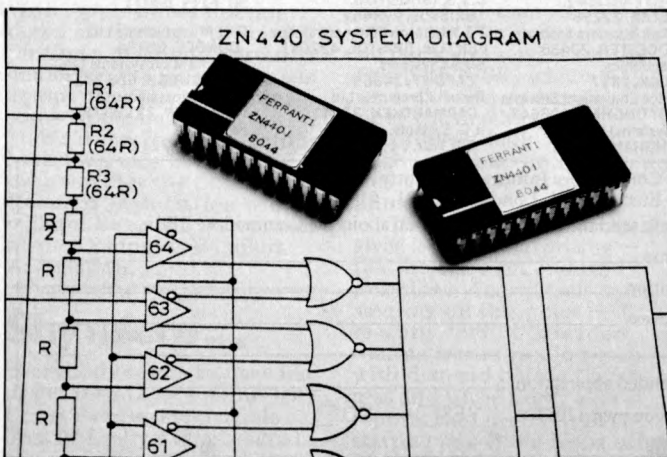

Normally chips to turn analogue vibrations into digital pulses with values work slowly. This new six-bit A/D chip from Ferranti will run up to 18 mega-samples per second. Details on 061-442 6060.

our best advert

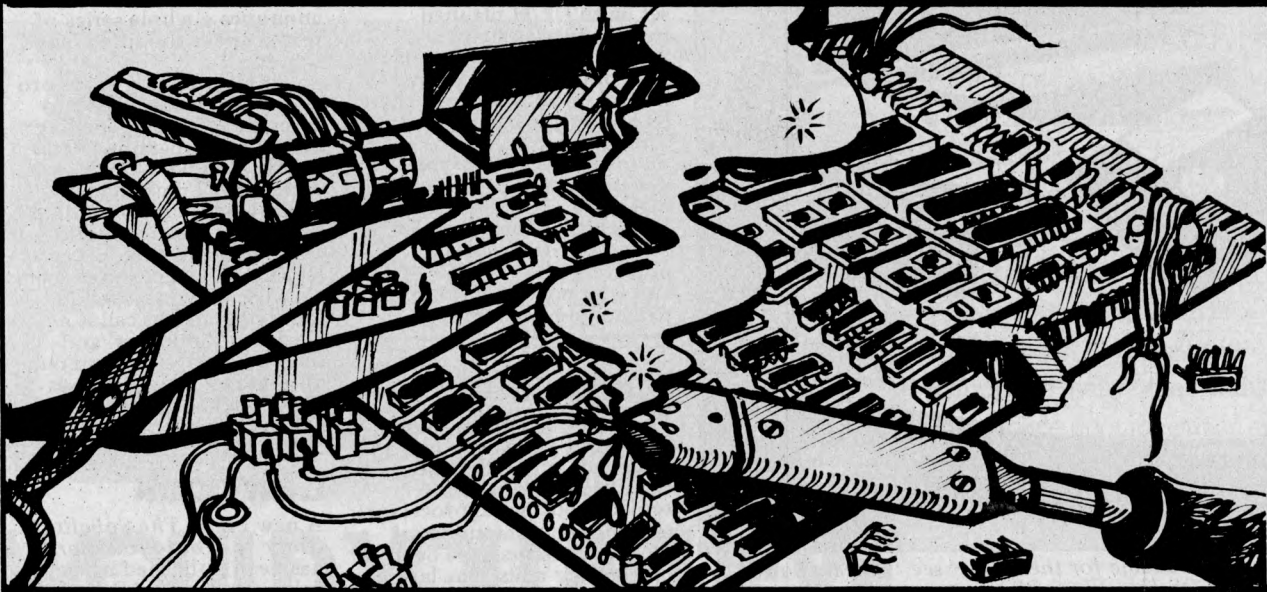

**is our competition...
ask their customers!**
**FOR TRULY COMPETENT SKILLED
SERVICE AND SUPPORT, SPECIALIST
DEVICES AND DEPENDABLE ADVICE ON
ALL YOUR MICROCOMPUTER
REQUIREMENTS**

FOR MORE INFORMATION CUT OUT THIS COUPON

I am interested in particular aspects of microcomputing
please send me details as new products appear.

Subjects of interest

Pet

Industrial

Educational

Consumables

Apple

Commercial

Service Contracts

Name _____

Address _____

Please send to **STACK COMPUTER SERVICES LTD**
290-298 Derby Road, Bootle, Liverpool 20.
Telephone 051-933 5511 for all your enquiries.



COMPUTECH for

COMPUTECH for

Well proven software for business applications on the
ITT 2020 and Apple microcomputers.

Prices excluding V.A.T. for cash with order, F.O.B. London NW3

PAYROLL	(300+ Employees, 100 Departments, hourly, weekly, monthly. Very powerful but easy to use).	£375
SALES LEDGER	(500+ Accounts, 100 Departments).	£295
PURCHASES LEDGER	(500+ Accounts, 100 Departments).	£295
GENERAL (OR NOMINAL) LEDGER	(1000 Accounts, 100 Analyses, multi-purpose package). Job costing etc.	£295
UTILITIES DISK 1	(Diskette patch, slot to slot copy, zap etc).	£20
APPLEWRITER	(Word Processing, see below for U/L case).	£42
VISICALC	(Financial Modelling, Costing, Analysis).	£95
CAI	(Converts Apple pictures for ITT display).	£10

Over 500 packages in use, fully supported by us.

AND NOW HARDWARE!

LOWER & UPPER CASE CHARACTER GENERATOR £50
Replaces character generator to display upper and lower case characters on screen, includes patches to work with Applewriter, supplies the missing link! Specify Apple or ITT.

COMPUTECH DIPLOMAT H/S SERIAL INTERFACE £80
This card has been designed and built to the same professional standards that have resulted in the success of our software. The DIPLOMAT observes the proper "handshaking" protocol so that you can drive fast printers and send and receive data from other peripherals at high speeds without loss of data. Switch (& software) selectable baud rates to 19200 and many other options. Plug compatible with 'terminal' or 'modem' wired peripherals. Guaranteed.

MICROLINE M80 PRINTER £425
This neat, reliable machine prints at 10 characters per inch, 80 characters on an 8 inch line, or 40 expanded characters, or 132 very readable characters, upper and lower case and graphics, 9 x 7 dot matrix, 6 or 8 lines per inch. Parallel interface is standard, serial optional. Both friction and sprocket feed are standard, tractor optional. We can also supply the parallel interface card for Apple System computers for £80 and a driver to enable both text and graphics to be used. Optional custom colour matching for Apple or ITT. Optional character sets. *Trade supplied at very generous discounts for modest quantities.*

THE FABULOUS MICROMUX 8000 from £800
This is a brand new product, an asynchronous serial multiplexor with up to 16 ports, any one of which may communicate with any other independently, like a 'telephone exchange' for data! Built in test function. Firmware may be customised for special applications. Available in multiples of 4 ports up to 16.

COMPUTECH SYSTEMS

168, Finchley Road, London NW3 6HP. Tel: 01-794 0202

AGENTS THROUGHOUT THE UK AND OVERSEAS



NEWS

ComputerTown UK! is a nationwide network of voluntary literacy centres.

Twenty one! That's the number of districts that are now seriously interested in ComputerTown. Not bad in the six weeks since the first announcement is it? Of the 21, two are already in operation — Eastcote and Sutton-in-Ashfield. Eastcote, being a very small library, could only cope with two machines on the first night. Both were PETs — one on loan from Supersoft, the other brought along by one of the helpers. Incidentally, our thanks to Cream Computer Shop for fixing a nasty little hardware bug just before the big day. Eastcote was kept pleasantly busy all evening, purely on the strength of a poster in the library plus a bit of 'passing trade'. No doubt, next time, word of mouth will be responsible for a significant increase in traffic — we'll see.

Sutton's second ComputerTown evening was an altogether calmer affair than its first night when around 100 people turned up. The second evening kept three machines (two Atoms and a 6800) nicely busy. The librarian is probably breathing an immense sigh of relief — see last month's letter from him. The Atom, which Sutton have permanently glued to a library table, has been kept busy almost continuously, so for those with the space (and the money) this seems like a good way of spreading the word during your absence.

Space is tight so let's swiftly move on to the many letters received this month. Edward Teague, who is working on a ComputerTown Romiley, writes to tell us we should have included the Sharp MZ-80K in the list of machines suggested as being good for ComputerTown. True, true. Vernon Gifford of the ACC and Croydon Computer Club is planning a ComputerTown Croydon — all interested write to him at 111 Selhurst Road, London, SE25 6LH, preferably enclosing a first class SAE. John Nicholson writes from Old Forge Workshops, Sparrows Green, Wadhurst, Sussex TN5 6SL — he'd love to meet any other ComputerTown enthusiasts in his neck of the woods (Tunbridge Wells). John has a fairly grown-up Vector MZ which he's using to voice pipe organs in his workshop. He can be contacted on 089288 3715. Mal Part writes from Witham in Essex to wish ComputerTown all the best and to offer his services together with his PET. Anyone in Mal's locality who'd like to join in should contact him on 0376 511806 after 7pm weekdays, or anytime weekends. Alternatively write to him at 35 Town End Field, Witham, Essex CM8 1EU.

Up now to Scotland, whence John Wilson writes on behalf of the Scottish Amateur Computer Society (SACS) who are already heavily into computer

literacy. They plan to run courses for adults and children — slightly more formal than ComputerTown but, no doubt, just as friendly. Anyone interested should contact John at 21 Rowantree Grove, Currie, Midlothian (that's near Edinburgh).

Julian Allason writes from his secret Berkshire hideout to offer all the help he can. He got off to a flying start by persuading his friends at Commodore and Petsoft to donate a few programs to ComputerTown, Eastcote — thanks Julian and thanks Commodore and Petsoft. As a result of this favouritism we realised that we ought to find out what the score is for all those other ComputerTowns. Commodore told us that it has some 200 programs in the public domain — ie anyone can copy them — so we'll bring you more news of that next month. In the meantime, raid your own tape libraries and try and scrounge from your local dealers. All donations will be publicised through our monthly ComputerTown News page. Julian will also be promoting the project through the pages of his illustrious organ, *Printout*.

A 'name and address given' letter from Newcastle upon Tyne bodes well for a group up there. Unfortunately we can't say any more than that at the moment because the person concerned must clear the idea with his peers before making a commitment. Anyone in that area interested should write c/o ComputerTown, 14 Rathbone Place, London W1P 1DE. Gwent Computer club are taking CT seriously — they can be contacted at 10 Park Square, Newport, Gwent.

Roger Farrell of Sydney, Australia dropped by to pick up some ComputerTown bumf. He went off highly enthused, so we can maybe expect to hear from ComputerTown, Collaroy, Sydney, Australia. (9 Hendy Avenue, if anyone wants to contact him).

Andrew Hinchley is setting up some kind of computer literacy project in Hackney which may even become a ComputerTown. Anyone interested contact Andrew on 01-405 8400. Peter Faff, of 'Printerfacing' fame, would like to help out in his home town of Hitchin in Hertfordshire. Anyone else in the area might like to contact him at 22 Common Road, Stotfold, Hitchin, Herts, SG5 4BX. Telephone 0462 732432.

Meyer Solomon wrote us a nice letter. He will be including something on the project in his magazine, *Computer Age*.

Wimbledon CT is being set up by Tandy's David Payne. Anyone in that area should contact David at 87 Kirkstall Road, Streatham Hill, London SW2. Writing will be best since he's hardly ever there.

Martin Kennelly writes again from Derby to say that the pace is hotting up there. He's brought his own TRS-80 and is now working on somewhere to hold his CT evenings. Anyone interested should contact Martin on 0332 550408 or write to 18 Welwyn Avenue, Allestree, Derby DE3 2JQ.

A visit to Commodore resulted in their offering to publicise ComputerTown through their trade and education newsletters. It also resulted in some very nice PET posters showing what all the bits are and listing its various capabilities. Sounds boring but looks lovely.

Peter Lambert of the National Computing Centre (NCC) is going to talk to David Fairbairn, NCC's director, about ComputerTown. We look forward to hearing from him again. Michael Lyne writes from Lincoln to say that the Lincolnshire Microprocessor Society will be discussing the project. Let's hope this leads to a ComputerTown, Lincoln. Anyone interested should contact Michael at Far End, Far Lane, Coleby, Lincoln LN5 0AH or telephone Lincoln 810468. P D Street, who runs a boys' club and has access to a TRS-80, is interested in getting a ComputerTown going in Atworth, Melksham, Wiltshire. Anyone in the area can contact him at 49A Bath Road, Ilminster (see the cover story) may soon be boasting its own ComputerTown. David James is very keen on the idea. He can be contacted on 04605 3011. Gareth Williams writes from North Tidworth, Hants. He is well qualified to run a ComputerTown but the only problem is that he hasn't got a machine! Anyone else in his area should contact him at 36 Cherry Tree Avenue, North Tidworth, Hants.

Finally, we had a visit from Tom Graves, who is setting up a ComputerTown in Street, Somerset. He tells us that the only night he can run his project is the night the fish and chip shop across the road is closed. He just dreads the thought of all those greasy fingers on his keyboards!

Well, thanks to all of you — it really looks as if ComputerTown is going to work. Remember, we need centres all over the country so if you're more than a few miles from your nearest centre why not set up one of your own? Further information can be obtained from ComputerTown, c/o 14 Rathbone Place, London W1P 1DE — remember to include an SAE for a reply. Please *don't phone us* as this is a spare-time project. Finally, please write and tell us your news. There are too many people setting up projects for us to be able to contact them regularly so the communication must be from the centres to us and then out again via PCW.

COMPUTER FAIRE

A Conference & Exposition

on

Intelligent Machines

for

Home, Business, & Industry

Personal Computer World

Spring in San Francisco from £440

Enjoy a two-centre holiday in sunny California, 1 – 9 April, 1981
just in time for the 6th West Coast Computer Faire.

Lounge on Santa Monica beach, visit the first ever computer store or maybe even take a peek at Hollywood. Follow this with a few days in San Francisco visiting the Computer Faire and possibly pop down El Camino Real to Silicon Valley.

All this, and much more can be yours if you take advantage of Meridian Tours' special offer to PCW readers, details of which are now being finalised.

Three holidays are planned, each of which ensures that you are in San Francisco for the duration of the Faire, which must be the biggest micro-dedicated show in the world. The first holiday comprises one night in Los Angeles at the first-class Sheraton Miramar at Santa Monica Beach followed by six nights in San Francisco at the Civic Centre Holiday Inn, just round the corner from the Faire. The second holiday provides the chance to spend three nights in Los Angeles and four in San Francisco while the third allows you to 'do your own thing' for a week following one of the above holidays, simply returning to base for the journey home.

The holiday price includes all flights, hotel accommodation, supervised transfers between airports and hotels, entrance to the Faire, a copy of the conference proceedings and compulsory insurance. The cost does not include transport to and from Gatwick, meals abroad or additional accommodation for those wishing to stay an extra week.

Car hire can be arranged at special rates by Meridian before departure and special excursions may be booked with their local representatives while abroad.

Having said all that, this promises to become quite an event in the PCW year; it's bound to be fun — even for those who aren't too interested in computers. They can make the most of San Francisco with its Golden Gate Bridge, cable cars, Chinatown, Fisherman's Wharf — not to mention a more recent phenomenon, lobby watching in the Hyatt Regency.

For further information and a booking form write to West Coast Trip, PCW, 14 Rathbone Place, London W1P 1DE.

This holiday is being organised by Meridian Tours Midlands Ltd who are bonded tour operators
(Air Tour Operator's Licence No. 700B)





YANKEE DOODLES

Tom Williams in California reports the latest news and rumours from Silicon Valley.

Connoisseurs of Adventure games will be delighted at the new delicacy being served up by Personal Software: Zork has come to microcomputers. Zork is a product of MIT's Computer Science Lab and was originally written by David Lebling, Marc Blank, and Bruce Daniels for a DEC PDP-10. The fact that even a significant subset of Zork has been made available for 32k Apple IIs and TRS-80s is a tribute to programming skill, because Zork is one of the richest computer fantasy games.

The command structure of Zork consists of 'actions' and up to two 'objects'. Thus, ATTACK TROLL WITH MACE would be a typical command. The feature of Zork that sets it apart from similar computer fantasy games, like the classic Adventure, is the richness of its text and the variety of interesting possibilities it presents to the player. The interesting thing about Adventure-type games is that once you've figured out one (no mean task if the game is any good) the variety offered by another is irresistible — this from a confirmed Adventure addict.

Rumours

At the high end of the trade (for those thinking about trading in their Rolls-Royces) there are rumours coming out of Hewlett-Packard's Colorado stronghold that the company is working on a desktop computer that will run a high-level processor chip similar in concept to the type being developed by Intel. Sources say that benchmark tests on the 32-bit machine have turned out faster than an IBM 370/158. Now the limiting factor on computer power for a desktop machine appears to be the amount of power that can be drawn from a common wall outlet without requiring special wiring. That may sound far-fetched in a remote laboratory today but we all know where these things lead.

Great things are happening in graphics: more resolution, better speed and lower cost. One of the more interesting gadgets is an adaptation of what was once a very sophisticated \$100 graphics system to a very sophisticated graphics and imaging peripheral. Digital Graphic Systems of Palo Alto, Cali-

fornia, has combined its CAT-100 system with a Z80 processor and firmware and a parallel interface to create a peripheral that will not only display high resolution graphics (in the top model, up to 512 x 256 x 8 pixels in any of 16 million hues) but will also instantly digitise a TV frame with the use of the 'frame grabber' feature. The picture data can then be manipulated, animation created and output to a display or to a video recorder. Bob Flexer, inventor of the CAT-100, has pulled picture data from the Voyager Jupiter mission directly from a TV set and stored it on disk to demonstrate the system. The new peripheral is available for most computers with parallel I/O and the firmware graphics commands can be called by the host. DGS is planning to introduce a separate disk controller option, so image data can be instantly stored without going over the host interface.

'What has been happening with Heathkit?' The answer, it turns out, is 'Quite a lot.' Since the leader in electronic kits was purchased by Zenith, the consumer electronics giant, there have been developments in the computer line that are definitely aimed at the small business market. The star of that development has been the Z-80 based H-89 stand alone computer. The H-8, the machine that got Heath started in the computer business, seemed all but forgotten.

The hobbyist market, although tiny compared to the business world, is nonetheless very real and has been largely abandoned. Heath has apparently recognised an opportunity to serve its traditional clientele via the H-8. One avenue has been to introduce a number of interesting board-level products, and the other is to make available source listing of system software. . . something that is a closely-guarded secret in other companies.

Getting back to the earlier remark about graphics, Heath has introduced a new graphics board which uses the Texas Instruments 9918 video display processor, which has a basic resolution of 192 x 256 pixels. The 9918 also works with an overlay technique that can store four independent sets of images that can be alternated instantaneously.

Patterns up to 16 pixels square can be defined and stored, and 16 colours are available.

Portability

THE UCSD Pascal system is becoming the software choice for a growing number of corporations who are waking up to find that microcomputers have invaded their operations almost without the awareness of upper management. They are now such an important part of day-to-day work that they are definitely here to stay. The problem management now has is to try to get some economy out of a default situation.

The main problems are involved with portability of software — the need to transfer programs between often quite incompatible machines. The UCSD System (so called because it now supports Fortran in addition to Pascal) is the only software system for micros so far which addresses the problem by creating an in-between code, pseudocode, which is independent of any processor's instruction set. Pseudocode can thus be interpreted and run by any machine to which the pseudocode has been adapted.

In large organisations, some order is at last being achieved in transporting programs among individual machines, many of which were initially purchased by the employees themselves as an aid to doing their jobs. Now, the micros have become entrenched and an ever-increasing number of department heads are seeing the wisdom of providing their people with the proper tools.

The next step will be local networking or the use of clustered systems. At present, this is only being done with compatible machines, as with the Apples used with Nestar's Cluster/One or the 8086-based machines used in the new clustered system introduced by Convergent Technologies of Santa Clara, California. The Convergent system is still a step farther along the road. It communicates with its own machines over a high-speed proprietary bus and communicates with a Shared Resources Processor (SRP) that handles disk access and peripheral usage for the various workstations. In addition, there is also a

Multibus card cage to allow customisation of the system by plugging in any of a huge variety of Multibus circuit boards now available. Convergent Technologies is developing a Multibus-based card that will allow the system, in addition to communicating over its own bus, to access the Ethernet system being jointly-developed by Intel, DEC, and Xerox.

So much for the automated office. If anyone has any doubts that the totally automated factory will soon be a reality, then they need only look into Hewlett-Packard. HP is actively developing a line of small computers with wide I/O bandwidths and real-time interrupt-driven operating systems with the express intention of making possible computer control of individual machines on the factory floor. But beyond that, HP sees the need for these machines to provide data to higher level computers which can then provide it for data bases used by management. The 'management' computer will have to be able to analyse the data provided, download the appropriate programs to the 'worker' computers, and the whole network will have to be controlled by 'switchboard operator' computers, or I/O intensive, real-time network controllers.

Such a system is possible today, although software, financing and overcoming entrenched ideas are still problems. But there is every reason to believe that forward-looking American companies will make the move towards more total automation as the economic situation worsens and the threat from Japan increases.

Leaders in the electronics industry have already recognised the fact that automation increases the productivity and, interestingly enough, the quality of the manufacturing process. Thus, the economic rationale for such moves already exists. What will follow will be to a great extent a social problem as we witness for the first time in history an increase of both real wealth and of unemployment. Should be interesting — think I'll hang around to watch.

PCW welcomes correspondence from its readers but we must warn that it tends to be one way! Please be as brief as possible and add "not for publication" if your letter is to be kept private. Please note that we are unable to give advice about the purchase of computers or other hardware/software — these questions must be addressed to Sheridan Williams (see 'Computer Answers' page). Address letters to: 'Communications', Personal Computer World, 14 Rathbone Place, London W1P 1DE.

Commodore complains

I appreciate that journalism is sometimes about 'creating' stories and that, as the leading UK microcomputer company, Commodore is often fair game for a dig! However, the November issue of *PCW* was factually incorrect both about Commodore and myself in two areas.

The first incorrect statement was in an article by Guy Kewney which stated he did not believe the official announcement by Commodore and myself about the 8050. Guy stated 'that at the time of writing 90 days plus ten have elapsed since the last time I spoke to Kit.' He went on to say 'I have to report no evidence of the promised 90 day delivery on the 8050.' My statement was made when we announced the 8050 at the PET Show (June 13/14) and that we anticipated commencing delivery in 90 days. My records show that we did start delivery in the third week of September which was 90 days from the PET Show and nearly 60 days before I received my copy of *PCW* stating that there was no evidence of deliveries! We had been delivering continuously during the period since September.

The second incorrect statement was on the 'Computer Answers' page where Mike Dennis stated Commodore is also unhappy about other manufacturers supplying add-ons such as the Computhink disk drive and is trying to make this sort of thing as difficult as possible. The reverse is true. We have an official scheme for encouraging reputable software houses and other companies who develop add-on products for the PET. Indeed all enquiries we receive from the public are sent a catalogue of Commodore 'Approved Products'. These products are not manufactured by ourselves. This naturally does not mean we will approve everything as we are trying to establish meaningful standards.

With many approved product companies we are working closely and in some cases have released pre-production equipment for development work to ensure maximum support to users as possible. You will probably

have noted that coincidentally with the release of our 8050 drive we were able to release some excellent software products.

Whilst I appreciate that the microcomputer world is still a young and growing industry, it does seem to be full of sometimes unfounded remarks and gossip. During the three years since launching the PET microcomputer we have made some mistakes as happens in any new business area. However I believe we have always managed to offer excellent value for money, continually tried to improve standards and have the best supported microcomputer in the market place. If this was not true it is unlikely the public would have continued to support our products and PET would not have been such a success. Is it not time we stopped looking backwards to the first few months of the microcomputer industry. We should view the situation as it stands today and try to set standards we would like to see for tomorrow. I believe this should apply to journalism as well as in manufacturing.

I wish your usually excellent magazine every continued success in the future. I also hope you will be a little more careful in checking your facts before condemning people — with the authority of a leading magazine such as yours should go responsibly.

I would be grateful if you would point these facts out to your readers.
Kit Spencer, Commodore, Slough

What you say is true, Kit. We perhaps make the mistake of looking at the world from the reader's point of view. We understand that although disk drive deliveries were started in September, these were for demonstrations only. Deliveries to actual users didn't start until some weeks later. We take your point about add-ons — you do indeed support some.

Our advice to PCW readers is to talk to local suppliers about true delivery situations. Commodore clearly cannot make guarantees about end-user deliveries when they are only responsible for deliveries to dealers — Ed.

Pools polish

Following publication of my article on football pools

forecasting I have done some further work myself and have had discussions with one or two colleagues. The result is that there are a few additional or modified lines which will make the program more effective and, indeed, correct a theoretical error in one of the calculations. These are listed below.

Further to this, I suggested in the article possible ways in which the program may be squeezed into an 8k machine. It seems in the event that my suggestions were inadequate. For this I apologise to any of your readers who have spent time trying to squeeze this particular quart into their own pint pot. My only other suggestion, which I have not tried, is that the program be made into three separate ones, one to create and file the initial leagues, another to update the leagues with new results, and a third which simply reads the leagues from files and makes the forecast. Whether this approach would handle all leagues or one at a time I leave to the programming ingenuity of your readers.
A L Green, Norwich

Benchtest update

My colleagues and I were pleased with the very fair review of our Microengine-based machine, the Raannd SP1, in the December issue. I am also pleased to announce the changes to the pre-production prototype employed in the review to produce the current production model.

The production version of the Raannd SP1 has the following additional features:

full numeric keypad, full cursor pad plus 8 special function keys, fully-screened monitor thereby erasing the line interference with the display, an etched screen, thereby obviating the filter, in white P4 or green P31 phosphors. In addition, later revisions of the software, with Vers IV Pascal (full concurrency) software in February or March.
Dr. Gordon Rankine, Raannd Systems Ltd, Livingston Scotland

Pascal benchmarks

Thank you for sending the correspondence received concerning our 'Pascal Benchmarking' article. Before you send any more, please publish this! We have discovered (and so have your readers) that one of the programs appears to have been wrongly transcribed. This is PROGRAM MATHS which should read:

```
program maths;
var k:integer;
    x,y:real;
begin
  writeln('s');
  for k:= to 1000 do
  begin
    x:=sin(k);
    y:=exp(x);
  end;
  writeln('e')
end.
```

Most of your correspondents felt (rightly) that exp(10000) was a bit heavy going for a micro.

We would like to respond to all the points raised and tabulate all the results given

```
117 DIMQA(130),QH(130)
10010 IFEN=1THENRETURN
11291 TX=TH(HT):TH(HT)=XT*(Q1-QH(HT))+(XS*TX):QH(HT)=Q1
11296 TX=TA(AT):TA(AT)=XT*(Q2-QA(AT))+(XS*TX):QA(AT)=Q2
11660 X1=PP(J):X2=HR(J):X3=HG(J):X4=AR(J):X5=AG(J):
      X6=FA(J):X7=FA(J):X8=TH(J)
11670 X9=TA(J):X10=N*(J):Y1=QH(J):Y2=(QA(J))
11740 TH(J)=TH(J+1):TH(J+1)=X8
11745 TA(J)=TA(J+1):TA(J+1)=X9
11746 QH(J)=QH(J+1):QH(J+1)=Y1
11747 QA(J)=QA(J+1):QA(J+1)=Y2
13111 PRINT#1,QH(I)
13112 PRINT#1,QA(I)
14010 IFEN=1THENRETURN
14111 INPUT#1,QH(I)
14112 INPUT#1,QA(I)
```

Mods to the pools program — see 'Pools polish'

in a future article but in the meantime may we thank PCW's readers for all their timings.
Chris Sadler, London

Atari query

Having read the Benchmark of the Atari 400 and 800 computers, I am considering buying one of them. I would like to have details of these machines, how much they cost and when they will be sold in the UK, but I have been unable to find an address to write to.
R Shenton, Stratford-Upon-Avon

Write to Ingersoll Electronics, 202 New North Road, London N1 7BL — Ed.

ZX80 memory

Further to your correspondence about memory left in the Sinclair ZX80 during programming, I'm afraid that the latest suggestion — to PEEK 16400, etc — is not much better than the earlier suggestion. The problem is that this doesn't take into account the number of bytes which will be used by the display as soon as the program is run, since the display file contains nothing but 25 end of line codes, unless and until there is something actually on the screen. Obviously, the usable memory left is governed by what is eventually to be needed for display purposes once the program is completed and run. Thus, one can only estimate according to the likely extent of screen usage at its maximum extent during the RUN. Also, it is not quite true to say that 17408 is 'near enough' the top, since it is very likely that 40 bytes will be used for the stack. 17375 would be a better estimate. While it doesn't particularly matter which of the system variables are PEEKed, between 16392 and 16400, I would point out that they all, in themselves, use quite a few precious bytes, at least if incorporated into the program.

I offer a discovery I happened to make recently.

If one keys in:
1 PRINT USR (47)
this will show the address of the end of the Variables. A figure, if desired, of the count of bytes, can then be obtained if the above is amended to:
1 PRINT 17375 — USR (47)
From this, of course, must be subtracted an estimate of the number of bytes required eventually for display.
Michael Kirkland, Prescot, Merseyside.

Stamp scheme

In answer to your reader Neil Stokes' query about computing philatelists — I am one such! I use an Apple II with disk drive (courtesy of the school in which I work) to store want lists of stamps needed, in files, by country. These I then update and send to my correspondents around the world.

I am also working, in the planning stage, on a catalogue program to update the value of my collections and to diagnose the areas showing the greatest appreciation, etc. I would be very grateful to hear of anybody else working in similar, or other, philatelic fields.

Any listings on paper or, if Applesoft, on diskette please.

John Oldfield, Calle Galatxo 29, Capdella, Mallorca, Spain.

Apple omissions

I wonder if you would make it clear to your readers that Apple computers offered by this company are in fact genuine Apple II Plus machines covered by the standard 90 day warranty. The omission of the Apple Logo in December's PCW was a production error.

Allen Timpany, Guestel Ltd., Bath.

Glad to set the record straight Mr Timpany — Ed.

Sharp words

I am writing to you about a recent letter in PCW concerning the LIMIT MAX command on the Sharp MZ-80K.

The solution you suggested although it works, cannot be used in a program as the LIMIT command may be used. Since only the LIMIT MAX is affected, it is possible to use the ordinary LIMIT followed by an address:

Machine size	Command
20k	LIMIT 24576
24k	LIMIT 28672
36k	LIMIT 40960
48k	LIMIT 53248

In each case the address is one more than the highest memory location. You said that some MZ-80Ks produce this problem but in fact it is common to all machines running SP5025 Basic if the command is used after the clock has been accessed in Basic. This is because Sharp has left only eight bytes for the time storage and a carriage return overwrites the location where the upper

RAM address is stored.

With reference to the letter about AND and OR on the Sharp, it should be noted that a combination of both AND and OR cannot be directly replaced with * and plus. Statements like X = (5 AND 7) are also not easily simulated.
Duncan Booth, Aberdeen

ZX80 fix

Your readers might be interested in:

The solution to your problems with LOADING and SAVEing programs from/to a cassette tape recorder using the Sinclair ZX80.

I recently bought a ZX80, and had great difficulty with the cassette interface. I know that I am not alone experiencing that. The solution is:

1. Use a small pre-amplifier between the ZX80 and the cassette tape recorder. (see later). You use this, when SAVEing.

2. Use only best quality cassette tape. (I recommend Afga Super Ferro Dynamic Low Noise.)

About the pre-amplifier: this is a small battery-operated two-transistor version, which I bought in kit form for around £3 at the local electronic kit-shop. (At: Josti Electronic, Vangedevej 116, DK2820 Gentofte, Denmark.) The name of the kit was: Line-amplifier AF45.

The kit named above makes all the difference between unreliable and reliable use of the cassette interface with the ZX80. PS: Thanks for a really good magazine.
Hasse Taube, Copenhagen, Denmark.

Ohio challenge

In your 'Computer Answers' of November 1980, I think P McIlmoyle, replying to D N Hardwick of Stourbridge, should have mentioned OSI equipment.

By comparison with the £500 quoted for the PET, and £420 for the Tandy, £350 spend on an Ohio machine could provide 8k of

memory, colour, 50 percent extra screen display with the potential for just as much expansion, and if initial economy was most important, a completely functional machine can be bought for less than £200 still with the expansion potential.
Roger Beaumont, Keighley, Yorks

PET POKEs

Many of your readers will be acquainted with the Commodore PET 'Space Invaders' program and many of them are probably left-handed. I myself am one of these unfortunates; I too wish that the controls of the program were the same way round as the real thing.

I have disassembled the program and can reveal that the appropriate modifications are as follows:

POKE 1428,252
POKE 1430,253
POKE 1442,254
POKE 1938,8
POKE 5434,65
POKE 5462,68
POKE 5491,74
POKE 5945,253
POKE 5953,254
POKE 5964,247

These modifications only apply to the NEW ROM version of the program, though I suspect that they may work on the OLD ROM program as well. The new controls can be read in the instructions; they are A-Left, D-Right and J-Fire.

Anyone who knows how to record the corrected version onto a tape (for the sake of Commodore's profits I won't relate the method, but it is in the PET manual) might just as well correct the spelling mistake on the first screen by POKE 7736,15.

To make the changes, load the program using the LOAD command, type the POKE instructions and then type RUN. The whole program will then function as per normal, only the commands have been changed.

William Roberts, AC Systems, Exeter.

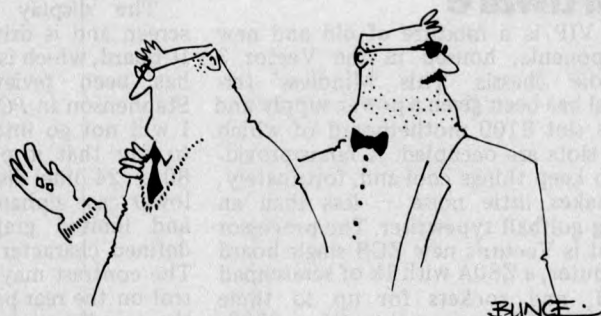

'Just a minute! How do I know there's 47 blue movies in each chip?'

**BENCH
TEST**

VECTOR GRAPHIC VIP



Stephen Withers examines Vector Graphic's new micro.

In the past, Vector Graphic micro-computers have been built around the 'mainframe' concept — a box containing an 18-slot motherboard, power supply and disk drives to which a terminal and other peripherals may be attached. The VIP is a departure from this tradition, as it is a computer within a VDU, an arrangement which is becoming increasingly popular.

Hardware

The VIP is a mixture of old and new components, housed in the Vector 3 console chassis. This 'Mindless' terminal has been given a power supply and a six slot S100 motherboard of which four slots are occupied. A fan is provided to keep things cool and, fortunately, it makes little noise — less than an idling golfball typewriter. The processor board is Vector's new ZCB single board computer, a Z80A with 1k of scratchpad RAM, and sockets for up to three EPROMs. These may be either 2708s or 2716s, selectable by jumpers. External input/output is handled by an 8251 IC driving an RS232 serial channel (this

may be converted to 20 mA current loop) and an 8255 which offers either three 8-bit parallel I/O ports, or two with handshaking lines. This means that most printers may be connected to the VIP, including those with a 'Centronics' style interface, although these will require some extra connectors and cabling within the VIP, as only the serial port is connected to a socket on the rear panel. Provision is made for three additional DB25 connectors.

The display has a non-reflective screen and is driven by the Flashwriter II board, which is impressively fast. This has been reviewed by Andrew M Stephenson in *PCW* (February 1980) so I will not go into any detail. Suffice it to say that it provides a very steady 80 x 24 line display, with upper and lower case alphanumeric, inverse video and limited graphics symbols. User-defined character sets may be installed. The contrast may be adjusted by a control on the rear panel, which also carries the on-off switch and a very small reset button.

A good keyboard is fitted to the machine. Although it was a fraction

light for my taste, I soon got used to it. In addition to the conventionally laid out main keyboard, there is a numeric pad and a cursor control cluster with all keys auto-repeating if held down. I was pleased to see indicator lights on the shift lock and caps lock keys.

The VIP is fitted with 64k of 4116 dynamic RAM chips on one board, although the top 8k is disabled to make room for the video and scratchpad RAM, and the 'Extended Systems Monitor', printer driver, and bootstrap PROMs. The second highest 8k may also be disabled independently of the top section. This seems a funny way of going on, even though it is cheaper than using a 58k plus an 8k board. However, I am not convinced that a 56k board would not be cheaper and it would also be useful in other systems, such as the North Star Horizon. As bank selection is supported, up to 192k (three banks of 64k) may be present in an expanded system. (Theoretically, eight banks could be used, but there are only two spare slots on the motherboard.)

The disk subsystem is another tried

and tested unit. The controller board itself is made under licence from Micropolis and takes care of a single 5¼in, 77 track, 315k Micropolis drive housed in a separate cabinet. This cabinet contains its own power supply, fed from a socket on the rear panel of the VIP. The cable between the controller and the disk drive is clamped to the cases to prevent accidental disconnection, although this does mean that the case must be opened to disconnect the drive prior to moving the system. The main failing in this area is that, while the read/write head lifts four seconds after an operation, the disk continues to rotate. It is only possible to stop it by dismounting the disk, a practice strongly encouraged by the manual. As this is essential for long disk life, why doesn't the controller turn the drive off?

Software

The Extended Systems Monitor is entered whenever the machine is switched on or reset. Depressing the 'B' key boots CP/M 2.2 from the disk drive. In addition to all the usual CP/M utilities, a number of programs are supplied by Vector. Perhaps the most useful is SCOPE, a screen-oriented editor which is a vast improvement over ED, although it is dependent on the Flashwriter. It allows the creation and editing of files with line lengths of up to 250 characters with pan-scrolling. The row and column number of the cursor's position is displayed at the top of the screen so you know where you are at all times. If you have never used a screen-oriented editor, you don't know what you are missing! The ability to see the results of the changes instantly makes editing a much easier task.

A Z80 assembler (ZSM) is provided which, however, doesn't use the standard Zilog mnemonics — 'extended' 8080 codes are used instead. What you think of this will largely depend on which instruction set you are used to. If you are happy with the 8080 you will be okay until you want to assemble someone else's Z80 source code (a booklet is provided with the ZSM equivalents to ease the problem) and you will be able to ignore the CP/M assembler. On the other hand, if you speak Zilog, you will probably end up paying for a 'proper' assembler from another supplier.

This problem with mnemonics extends to the other major addition. This is RAID, an acronym for RAPID Interactive Debugger. This may be used in two modes, either as a conventional debugger, or as a simulated processor. When the CPU is being simulated, the upper 18 lines of the display show exactly what is happening: the registers, the instructions most recently executed and those next in line (disassembled), the top 13 words on the stack, and the status of certain options available in RAID. The contents of 96 consecutive bytes of memory may also be displayed in either hex or ASCII. All the usual debugging functions are provided, such as breakpoints and examine or modify registers and memory locations.

A nice feature about RAID and SCOPE is that they both have a 'help' feature which displays the available commands and their meanings on the screen. This is often sufficient to avoid the need to refer to the manual.

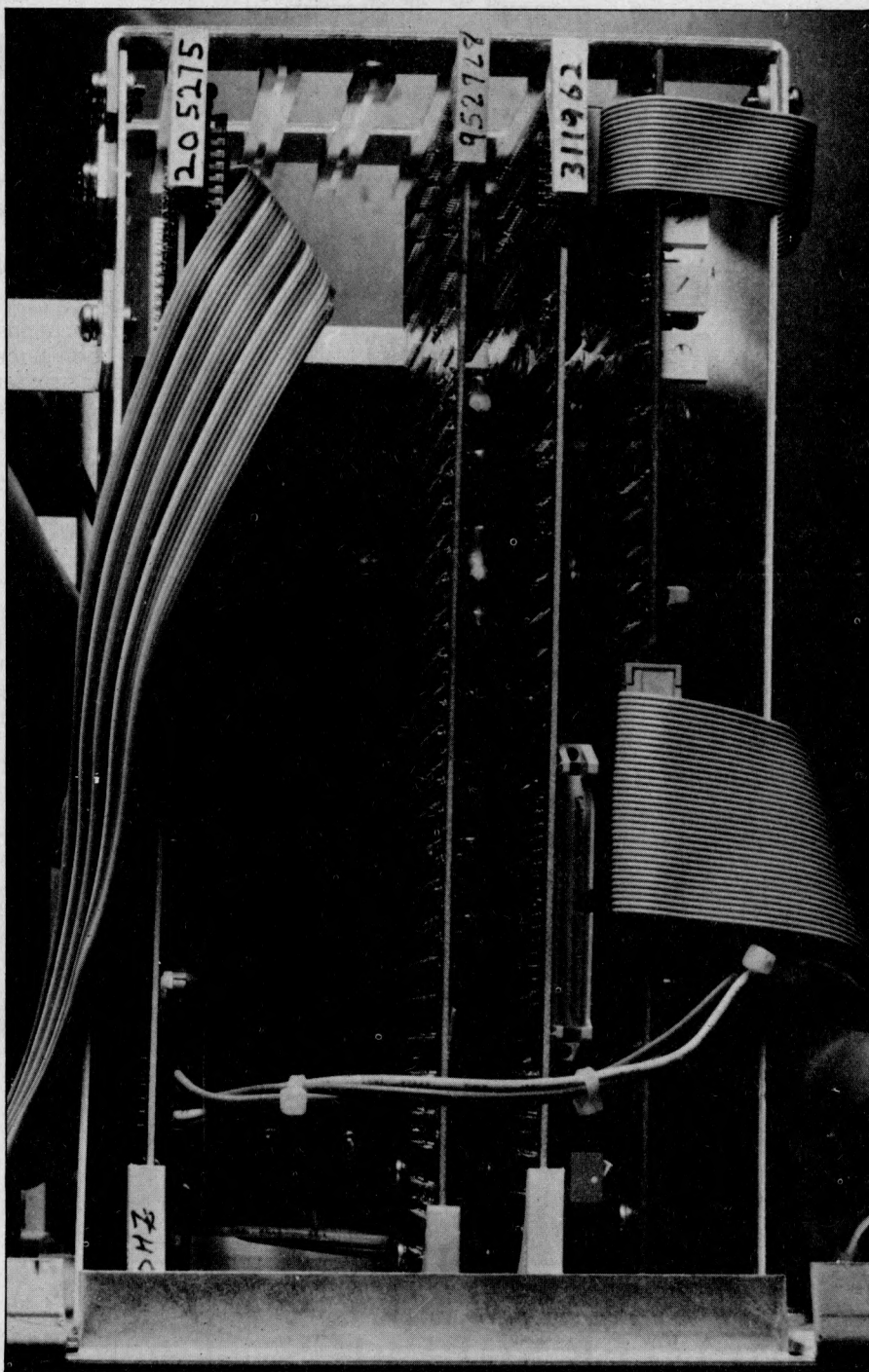

A close-up of the VIP's S100 rack.

Other utilities are provided for formatting disks, making backup copies (taking about four minutes with a single drive), testing memory and determining whether ROM, RAM, or no memory is present in each page. The final utility is a system configuration program. This allows the use of a number of different types of printer without having to go into the depths of the operating system (although the source code of the user area of the BIOS is supplied on disk) and makes it easy to set up a turnkey system which will automatically run a program when the system is booted. Also on the distribution disk is a program which gives a very effective demonstration of the capabilities of the Flashwriter board.

Version 5.1 of the well-known Microsoft interpreted Basic is the only high level language supplied with the system. Other languages available include Cobol, Pascal, and APL.

By the time this article appears,

Almarc expects the widely-praised Visicalc to be included in the standard package. A selection of applications software is also available at additional cost from Almarc. These include purchase, sales and nominal ledgers, stock control, and payroll. I was supplied with a copy of the payroll demonstration disk and it appears to be well-designed and easy to use. The programs are menu driven and it is easy to get back to an outer level if you accidentally enter the wrong command. As I once worked as a payroll clerk, I recognise that the program provides the required facilities in a usable format. I think the year-end analysis function would prove particularly useful, because, due to its otherwise time-consuming nature, this is a task which is not always given as a high priority as the Inland Revenue would like!

A final piece of software supplied with the review system was the Word Management System (WMS), a word

PortaTel

SMASH

14" COLOUR MONITOR PRICES

Monitors to both PAL and NTSC standards. For Apple/Texas T/994 R&B version available etc. etc. From £299 + VAT. Attractive trade terms.

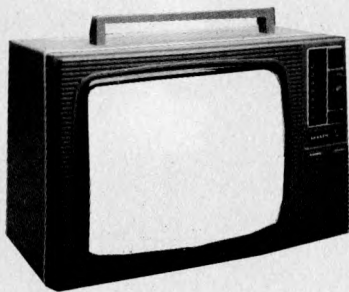

OFF AIR
PAL &
NTSC 14"
MONITOR

SKANTIC 3781 14" CTV

Display of American
Standard Video
TEXAS TI 99/4
home computer etc.

£299 plus VAT

FULLY GUARANTEED
PAL VIDEO AND LARGER SIZES AVAILABLE

PortaTel

Conversions Limited

25 SUNBURY CROSS CENTRE
SUNBURY ON THAMES MIDDX
TEL. No. SUNBURY (09327) 88972

VIDEO MODIFICATION SPECIALISTS

ACCESS & BARCLAYCARD WELCOME



ADVANCED MEDIA LTD.

WORD PROCESSING AND COMPUTER SUPPLIES

FLOPPY/FLEXIBLE DISCS STORAGE

DISC PACK/STORAGE MODULES

MAGNETIC TAPE CARTRIDGES

MAGNETIC TAPE PRINT WHEELS

DATA/WORD PROCESSING RIBBONS

FURNITURE LABELS

STATIONERY: SCREEN LISTING AND BESPOKE

To Place Orders or Obtain Further Information:

- | | |
|---------------------|---------------|
| 1) By Post: | 2) By 'Phone: |
| Advanced Media Ltd. | 01-751 2136 |
| Unit 'H', | |
| St. Anthony's Way, | 3) By Telex: |
| Feltham, | 8951031 |
| Middlesex. TW14 0NH | |

Communications is the name of the game

KINGSTON HAVE THE BEST TEAM

It's a whole new ball game in the field of micro-communications and Kingston, the specialists, have been in the game from the start. Kingston's experience allows them to provide low cost enhancements to make more use of your existing equipment. Introducing some of the Kingston Team.

THE NETKIT

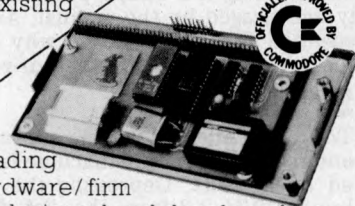

— our leading scorer. A hardware/firmware package designed and developed by Kingston to transform your Commodore PET into a more powerful yet controllable beast. Allowing high speed transfer of programs and data between a PET and any other RS232 device including MAIN FRAMES.

THE TNW 2000

and TNW 3000 — our international players. Fully addressable bi-directional IEEE 488/RS232 interfaces.



THE KEYNOTE

— our musical player. A hardware/software package which upgrades a PET into a first team player, giving a PET a repeat function on all keys, an automatic keyboard controlled reset, a key click and a music processor for the budding composer or for setting audio limits.



The KEY our low cost player. A hardware addition to the PET for the busy programmer who needs a repeat function on the number pad and cursor movement. These and many other devices for micro-computers enable the best performances from particular player to be achieved. Join the game, you are bound to be a winner with Kingston.

KINGSTON

Kingston Computers Limited, Electricity Buildings,
Filey, North Yorkshire YO14 9PJ U.K.
Telephone: 0723 514141 Telex: 52642

NAME

ADDRESS

processing program. As this is a useful function which utilises virtually all the hardware, I spent most of the time using it, including the preparation of this manuscript (my thanks to Almarc for the loan of a Qume Sprint 5 daisywheel printer). To see how a non-computer person would get on with the system, I turned the machine over to a secretary for a day. She was tremendously impressed and even after such a short period of use was wondering how to cope without it. My own feelings about the program are almost as favourable, although I prefer to use word-processors which display the text as it will be printed (WMS simply maintains an 80-column display with a ragged right edge and format controls shown by graphic characters). A useful facility not present in this program is the ability to edit one file while another is being printed. On the positive side, a minimum usable subset of the commands can be learnt in about 15 minutes, all the features found on daisywheel printers are supported and a mailing list module is included to allow the preparation of personalised form letters. These mailing lists may be sorted into alphabetical or numeric order and each entry may be allocated to any of 26 categories. WMS currently runs under MZOS (Vector's own operating system) but I am told that the next release of WMS will run under CP/M and will contain a number of significant enhancements.

Documentation

Two manuals are supplied, one each for hardware and software. Both are loose-leaf binders with index tabs dividing the various sections. Unfortunately, some sections of the hardware manual were

Memory map

FFFF	
FC00	RAM
FA00	EPROM
F900	spare EPROM
F800	EPROM
F000	Video RAM
EB00	spare EPROM
E000	EPROM
D600	BIOS
C800	BDOS
C000	CCP
0100	TPA
0	

Technical Data

CPU:	Z80A, 4 MHz
Memory:	64k dynamic RAM (56k usable), 2k video RAM, 1k scratch-pad RAM, 3.5k ROM
Keyboard:	Capacitance switched, 72 keys
Screen:	12in diagonal
Disk drive:	Single Micropolis 77 track, 5¼in, 315k capacity
Bus:	S100
Ports:	1 RS232, 3 8-bit parallel (or 2 parallel with handshaking)
System software:	CP/M 2.2
Languages:	Basic (others available at extra cost)
Dimensions:	13in high x 18in deep x 21in wide, weight 22lbs

lost or delayed in the post but those parts I did see were easy to understand, being written at three levels. The first explains what the unit (eg the RAM board) does, the second how to use it and the final part covers the theory of operation and includes circuit and schematic diagrams.

The software manual is based around the Digital Research CP/M manuals, with additions to describe the Vector software and modifications. Although these additions are arranged in a similar way to the Digital Research documents, they are less terse, making them easier to understand on the first reading. I found the general lack of indexes irritating, although the Basic manual has one. At least the WMS manual has a table of contents, although this is second-best to an index.

Expansion

Up to three additional drives may be daisy-chained onto the original but if this is inadequate for your needs, then either the Microstore subsystem giving two megabytes of storage on twin 8in double density drives can be added, or the 32 megabyte hard disk which will be available in the near future. Alternatively, complete systems in these configurations may be purchased. They are the System 2800 and the System 3030 respectively. Up to four hard disk drives can be connected to a single system.

As already mentioned, there are two spare S100 slots available for system expansion. One of the disk controllers mentioned above could be added, but any of the huge range of S100 cards could be installed. The availability of bank selected memory means that large (ie over 64k) programs may be run, although this tends to be tricky when using high level languages but I have heard that it is possible to modify the Microsoft link-loader to accommodate this feature.

The provision of serial and parallel

Benchmark timings (in seconds)

	Integer	Single Precision	Double Precision
BM1	1.0	1.0	—
BM2	3.0	3.8	4.9
BM3	10.9	10.9	39.1
BM4	10.7	10.7	39.9
BM5	11.6	11.6	40.5
BM6	18.2	20.5	49.5
BM7	27.1	32.7	61.1
BM8	3.4	3.4	3.4
DT1		1.2	
DT2		49.8	
DT3		58.5	
DT4		11.3	
DT5		17.6	

interface circuits on the standard VIP makes it possible to connect most peripherals to the system, although some extra cost is involved in making use of the parallel ports — about £35 for all the cables and connectors required to hook up a Centronics printer.

Potential

If fitted with a second disk drive, the VIP would be a useful business system due to the existence of commercial software written especially for the machine as well as the number of CP/M compatible programs. It is clear that this is the target market for this stylish machine, which looks perfectly at home in any office.

Whether or not it is suited for domestic use largely depends on your idea of 'home computing' — but something like the Apple II is more likely to fit the bill. Similarly, its usefulness in a laboratory or in schools is limited due to the restricted graphics and interfacing ability.

Conclusion

The VIP is a solid machine which performed perfectly throughout the test period. What it does, it does very well, but it does not offer any significant advantages over the competition. In particular, this computer cannot compete with similar machines on the basis of price. Consider the Superbrain, which costs about £500 less, or the TRS-80 Model II which is roughly the same price as the VIP but has an 8in disk drive giving more storage, three complete I/O ports (two serial, one parallel) and terminal-emulating software. The VIP's advantages are the flexibility and ease of expansion given by the S100 bus and CP/M, plus some very useful extra software, but the value of these depend on the purchaser's precise requirements.

Prices

VIP	£2125
Microstore	£1063
Hard disk subsystem	TBA

At a glance

For a variety of reasons we have decided to abandon our 'star' ratings in favour of a brief written summary — this will be done with all our Benchtests from now on.

The VIP has good looks and ease of use in its favour, although setting up was average.

The system software was good and the Basic excellent — other languages were not tested. The availability of CP/M means that a wide range of software is available to run on the system. Full versions of the packages available for the VIP were not tested, apart from the WMS word processor, which was good.

On the hardware side, the VIP has an S100 bus, which allows a great many products to be slotted in. Scope for memory and disk expansion is good.

Compared to some other machines, though, the VIP does not offer particularly good value for money.

PATTERNS

This month we introduce Alan Sutcliffe, a computer consultant who has a special interest in computer art and music. He was the founder of the Computer Arts Society and is currently a vice president of the British Computer Society. In this series, he discusses the use and generation of patterns and numbers in various applications. The series will be practical, with programming examples given at every opportunity and, inevitably, a certain amount of the underlying mathematics. If you should feel moved to join in and contribute to the series then write to Alan c/o PCW, 14 Rathbone Place, London W1P 1DE.

In this first article I explain how the Random function can be used to generate values with various kinds of distribution. After some general thoughts on randomness and structure, I go into the mathematical theory of applying functions to a random variable. The last part of the article gives an example program to illustrate the methods.

Patterns in randomness

There are all kinds of reasons for wanting to generate a pattern of numbers. It may be to compose a tune or synthesise a picture, it may be to make choices in a syntax tree for writing poems, or it may be to bet the initial positions of pieces in a game, or to provide values to drive a simulation, or it may be to try possible sets of values in the solution of a puzzle.

One of the most common ways to generate values is simply to call the system's own random number generator. This can produce interesting patterns. We are naturally pattern seeking and pattern recognising beings. Generate seven numbers at random and you no longer have randomness, you have a pattern. Any seven marks on a piece of paper make a pattern. On a cosmic scale, the stars in the sky are distributed more or less at random, excluding the Milky Way. Yet they are full of signs and symbols, gods and beasts, myths and meanings.

One set of seven stars is seen by different people as a dipper, a plough, a great bear. In Mongolia, it is known as the Seven Old Men, and it used to be invoked as the god of destiny. It seems that almost every culture recognises something in that random constellation.

However, straightforward random-

ness can become boring. The celestial display is enlivened by the bodies of the solar system and the clustering of stars in our own galaxy.

No computer system has a display than can rival the grandeur of the night sky. What we lack in splendour can be made up for by applying a bit of method.

Most natural objects — leaves, trees, rocks, waves, feathers, clouds — combine structure and randomness. It is the inter-lay between these two that we find attractive, the structure providing a theme and the randomness variations. It is useful to think of these properties of things in the real world when using a computer to make compositions, even though the result appears entirely abstract.

Applying a function

I shall assume that the Basic function RND provides values uniformly distributed in the range 0-1. Any number from 0 to 1 is just as likely to occur as any other. The next part of the article explains how other distributions can be got, such as one where values

near 0 are more likely to occur than values near 1. This is done by applying a function to the output from RND such as taking the square or the square root.

If you find the maths a bit daunting, I suggest you read the beginning of each section until it gets too steep and then step to the start of the next section. From a practical point of view the most important part of the article is the programs at the end, and to follow these a good place to start is the section headed Complex Distributions.

It is a simple matter to change the RND distribution:

$$X = \text{RND}(1) \\ Y = X * X$$

The function $Y = X^2$ has the useful property that when X lies in the range 0 to 1 so does Y . Clearly Y will have a distribution weighted towards the lower end of the range, since X^2 is less than X for the values in the range with which we are concerned.

It is not quite so simple, given a function, to determine the distribution it will produce. The rule is as follows: a. Take the inverse of the function, that is X expressed in terms of Y , and

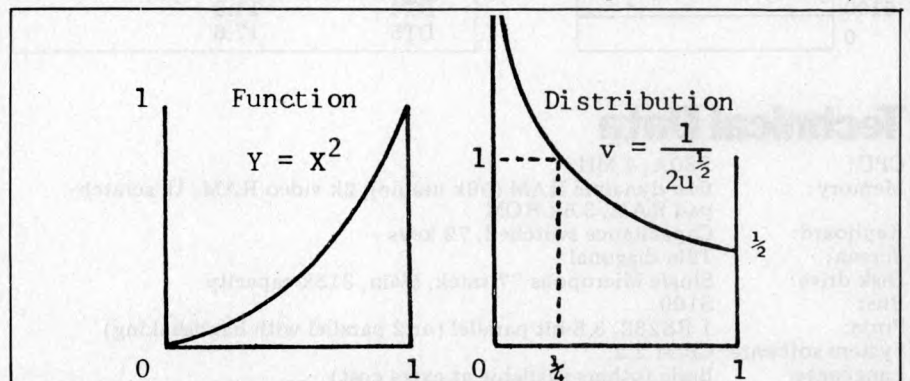

Fig 1 The relationship between a function and a distribution.

swap to new variable names u and v. This change in variable names is to avoid using the same variable for both the function and the distribution which might be confusing.

b. Differentiate this, dv/du , giving the distribution function.

A detailed demonstration of the correctness of this method given in the footnote at the end of this article.

An example will make the method clear:

Function $Y = X^2$

Inverse $X = Y^{1/2}$, rewritten $v = u^{1/2}$

Differentiate $D = \frac{dv}{du} = \frac{1}{2} u^{-1/2} = \frac{1}{2\sqrt{u}}$

The curve of

$$v = \frac{1}{2\sqrt{u}}$$

passes through the points $(1/4, 1)$ and $(1, 1/2)$ but at $x = 0$ it shoots off to infinity, as shown in Figure 1. At first this may seem puzzling — does it mean that an infinite number of the values of $X * X$ will be zero? Clearly not: it is the

```

100 DIMENSION C(10)
110 FOR K=1 TO 10
120 C(K) = 0
130 NEXT K
140 FOR I=1 TO 1000
150 J = RND(1)
160 J = J*J
170 FOR L=0.1 TO 1 STEP 0.1
180 K=10*L
190 IF J<=L THEN 220
200 NEXT L
210 GOTO 230
220 G(K)=C(K)+1
230 NEXT I
240 FOR K=1 TO 10
250 PRINT K,C(K)
260 NEXT K
270 FOR K=1 TO 10
280 MOVE K,0
290 DRAW K,C(K)
300 NEXT K

```

Program A

Ten bins for the distribution
Set the number in each bin to zero

Main loop to generate values
Generate a random number
Apply for function
Assign this value to its bin

Jump out if it is this bin

This point should never be reached
Add one to the bin count
Return for next value
Print the final bin totals

If there is a plotter draw the histogram: the values of K and C(K) may need scaling to fit the plotter

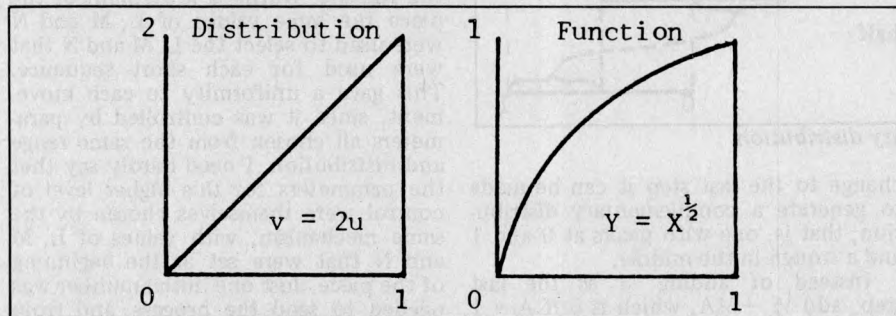

Fig 2 A distribution and the function that produces it.

area under the curve that is important and a curve that goes off to infinity can still have a finite area under it; as this one does. Indeed the area under the whole curve from 0 to 1 is unity, as it should be for any well-behaved distribution. This is equivalent to saying that the probability of a value lying in the range 0 to 1 is unity, that is, it is certain to do so.

The steps are then as follows:

- a) Integrate: $2udu = u^2 = v$
- b) Change variable names: $X = Y^2$ and invert the function: $Y = X^{1/2}$

The required function is thus the square root and all that is needed to produce a random variable in the range 0 to 1 with the distribution $v = 2u$ is $R = \text{SQR}(\text{RND}(1))$.

It is not always easy or even possible to differentiate or integrate a function, or to find the inverse of a function. You may not be able to carry out the process of getting from distribution to generating function, or its reverse, starting from a particular distribution or function that you may choose.

Numerical method

However, it is always possible to get a picture of the distribution that arises from a given function by using a numerical method. Just generate a large number of random values, apply the function to each one, determine the sub-range in the distribution that this value falls into and increase a counter for the total number of values falling into that sub-range. In this way a histogram of the distribution can be built up. Program A does the job for 1000 samples and ten sub-divisions of the range. It can easily be adapted to other cases.

Staying in range

All the functions considered so far have the convenient property that their values lie in range 0 to 1 when the original variable does. It is natural to want to exploit the other built-in functions of your system, such as LOG, EXP or SIN, to produce distributions. Take $Y = \text{EXP}(X)$ as an example:

For $X = 0$, $\text{EXP}(X) = 1$
For $X = 1$, $\text{EXP}(X) = e = 2.718...$
So, for the sake of uniformity, to reduce the new variable to the same range of 0 to 1, a little extra arithmetic is needed:
 $D = \text{EXP}(1) - 1$ (Set $e - 1$ at the start of the program)
 $R = \text{EXP}(\text{RND}(1))$
 $S = (R - 1) / D$ (Separated into two lines for the sake of clarity)
In mathematical terms the function is

$$Y = \frac{e^x - 1}{e - 1}$$

To derive the distribution corresponding to this, first obtain the inverse function $v = \log((e - 1)u + 1)$. Then differentiate this to give:

$$\frac{dv}{du} = \frac{e - 1}{(e - 1)u + 1}$$

To check that this has the required property of having unit area below the curve between 0 and 1, calculate the integral:

$$\int_0^1 \frac{e - 1}{(e - 1)u + 1} du = [\log((e - 1)u + 1)]_0^1$$

$$\log(e) - \log(1) = 1$$

The distribution is shown in Figure 3. You will see that it has a moderate bias towards zero, with numbers near 0 occurring about e times more frequently than those near 1.

For $u = 0$, $v = e - 1 = 1.72...$

For $u = 1/2$, $v = \frac{2e - 2}{e + 1} = 0.92...$

For $u = 1$, $v = \frac{e - 1}{e} = 0.63...$

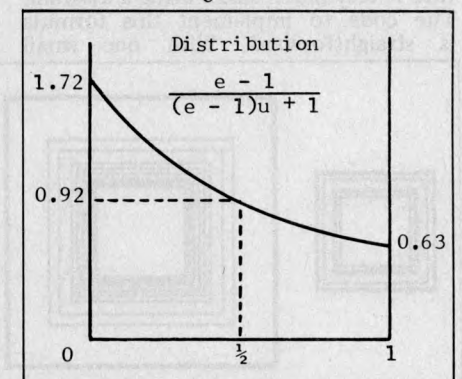

Fig 3 The distribution for the exponential function.

Function	Inverse	Distribution
X	u	1
X ²	u ^{1/2}	1/2 u ^{-1/2}
X ³	u ^{1/3}	1/3 u ^{-2/3}
X ⁿ	u ^{1/n}	1/n u ⁻ⁿ⁻¹
X ^{1/2}	u ²	2u
X	u ⁿ	n u ⁿ⁻¹

Table 1

Find the function

It is also possible to start with a distribution and derive the function that produces it. The process is the converse: a) Given $v = F(u)$ as the equation of the desired distribution, integrate this to give $G(u) = \int F(u) du$.

b) Change to new variables such that $X = G(Y)$. Note: this is again to avoid confusion! Then take the inverse of this function to give the one required: $Y = G^{-1}(X)$.

As an example of this procedure, suppose that the distribution wanted is a simple increasing one, a straight line passing through the origin: $v = Au$. To ensure that the area under this line between 0 and 1 is unity, A must take the value 2, making the function simply $v = 2u$, as shown in Figure 2.

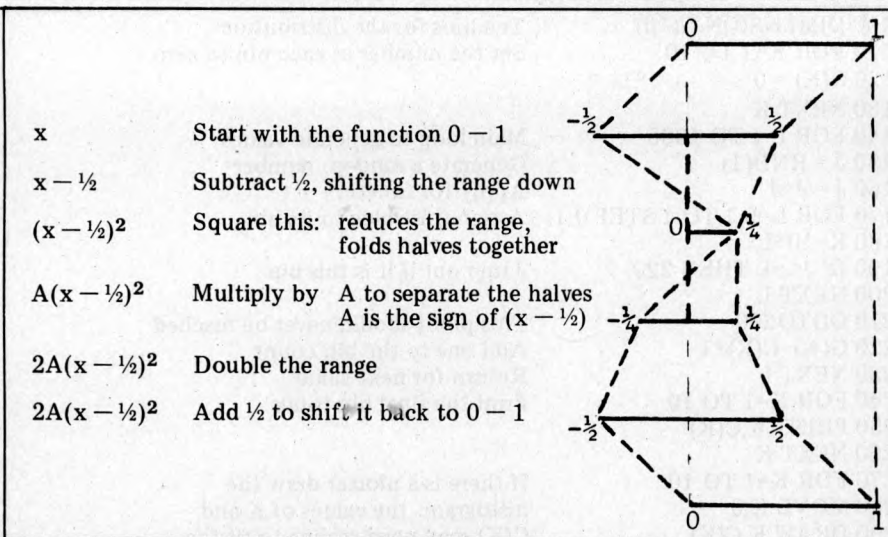

Fig 4 Using a diagram to construct a function

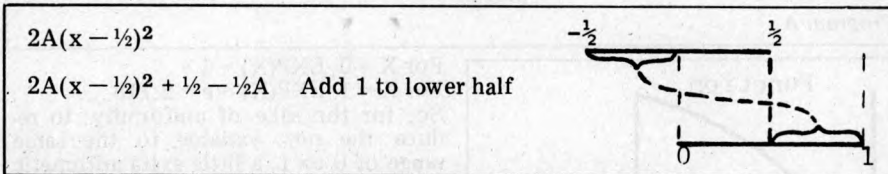

Fig 5 Alternative final step for complementary distribution

Complex distributions

So far all the distributions have been simply increasing or decreasing. There is one more method I have used to construct functions of a single random variable, which can be used for more complex cases. Suppose the exact shape of the distribution is not too important, only its general form. One with its peak in the middle and lowest points at the extremes is a good example — something like the normal curve of statistics but with its two tails cut off. I want to use simple algebraic expressions to keep computing time to a minimum, since this is a routine I shall want to use very often. I want to make use of the fact that the squares of a random number less than 1 are bunched towards zero, as seen in Figure 1. A diagram is used to keep track of the function and to ensure that it ends up in the right place. This is illustrated in Figure 4. In this particular case $A = \text{sign of } (x - 1/2)$ is used: $A = 1$ if $x - 1/2 > 0$
 $A = -1$ if $x - 1/2 < 0$.
It will be seen from the diagram that the function to use is
 $2A(x - 1/2)^2 + 1/2 =$
 $2Ax^2 - 2Ax + 1/2A + 1/2$.
Although it is possible to establish functions like this one by algebra alone, I find it very much easier using a diagram. The code to implement this formula is straightforward. With one small

change to the last step it can be made to generate a complementary distribution, that is, one with peaks at 0 and 1 and a trough in the middle.

Instead of adding $1/2$ as the last step, add $1/2 - 1/2A$, which is 0 if $A = 1$ and 1 if $A = -1$.

This has the effect of splitting the distribution in the middle and transposing the two halves, as shown in Figure 5. The function that results from this is thus:

$$2A(x - 1/2)^2 + 1/2 - 1/2A =$$

$$2Ax^2 - 2Ax + 1/2.$$

Building a system

That is enough for one month about individual functions. I hope to write later about some specific statistical distributions such as the normal and Poisson, and about some distributions depending on two random variables.

We have now looked at a miscellany of functions, and seen how to ensure that the resulting values lie in the range 0 to 1. In general a different range will be wanted, say L to M , and this is achieved by the simple Basic expression $R = L + (M - L) * R$.

To make a useful system a selection of functions can be put together in one program. A set of five makes a good start, and program (B) gives these distributions:

- $N = 1$ Uniform
- $N = 2$ Sloping up

- $N = 3$ Sloping down
- $N = 4$ Peak in the middle
- $N = 5$ Peaks at the ends

The program is entered with L and M set for the lower and upper limits of the range, and $N = 1$ to 5 for the distribution to be used. Distributions 2 and 3 use the square root function shown in Figure 2. To flip this from sloping up to sloping down all that is needed is to substitute $1 - R$ for R . Distributions 4 and 5 use the functions demonstrated in Figures 4 and 5.

I first used a scheme like this when I wrote a program to compose electronic music. Whenever a series of values was wanted, for the pitch, loudness, timing or tone colour of a note, for example, the routine was entered first to select three numbers for the range and distribution values, L , M and N . These values were then used to generate the numbers for a sequence of notes. The number of notes in the sequence had itself been chosen by another call to the routine. During a movement of the piece the same values of L , M and N were used to select the L , M and N that were used for each short sequence. This gave a uniformity to each movement, since it was controlled by parameters all chosen from the same range and distribution. I need hardly say that the parameters for this higher level of control were themselves chosen by the same mechanism, with values of L , M and N that were set at the beginning of the piece. Just one initial number was needed to seed the process, and from then on the whole thing generated a piece of the kind it had decided it should. The overall scheme was:

Choose L_0 M_0 and N_0 for the whole piece

Use these to choose L_1 M_1 and N_1 for each movement

Use these to choose L_2 M_2 and N_2 for each section

Use these to choose the individual notes in each section.

The program was written in Fortran and ran on an ICL 1905 in Putney. Its output was paper tape containing the values for all the individual notes. This was taken a few hundred yards across Putney Bridge to the electronic music studio of Peter Zinovieff, who had just installed a PDP-8 to control all his sound synthesis equipment.

Nowadays it would be called personal computing, but this was in 1967 and the term hadn't been coined. The piece won second prize in a contest at the 1968 IFIP Congress in Edinburgh. That was an occasion that led directly to the formation of the Computer Arts Society.

The program is too long to give here, even if I could find it in my filing

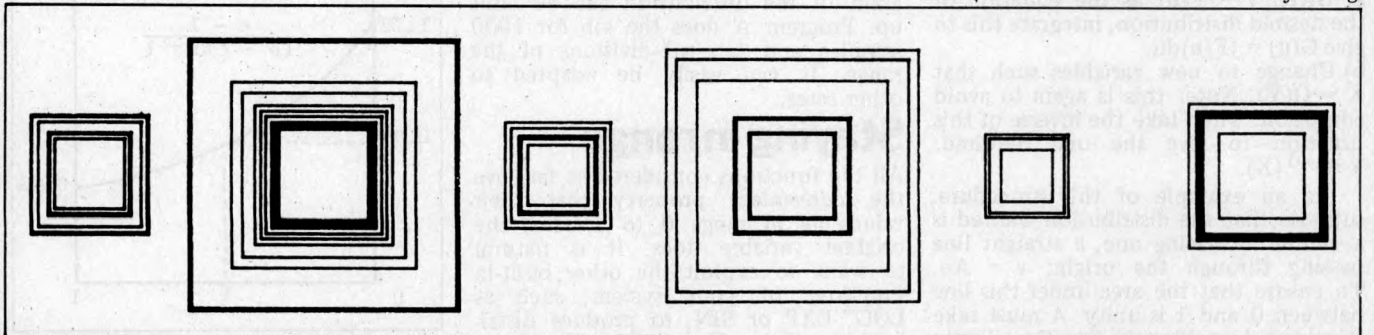

Fig 6 Sample output from Program C, structured randomness.

system — a cubic yard or two of piles of papers. Instead I have written a short graphics program (C) to illustrate the ideas. This draws six sets of concentric squares. For each set, values of L, M and N are chosen and then used to decide the number of squares in the set and the size of each one.

The output from a run of the program on a Tektronix 4051 is shown in Figure 6. The subroutine at 700 draws one square. The controlling values of L, M and N have given a mildly different appearance to each set of squares: more differentiated than if they had all been chosen with uniform randomness.

One useful bit of program (D) which I first used in the music project gives a series of values from a moving range. L1 and L2 denote the lower limits of the range at the start and end of the series, with M1 and M2 as the upper limits. Figure 7 shows the arrangement, with a set of eight points generated using N = 5, which was always my favourite distribution. C must be set with the number of points in the series before the subroutine is entered, together with values of L1, L2, M1, M2 and N.

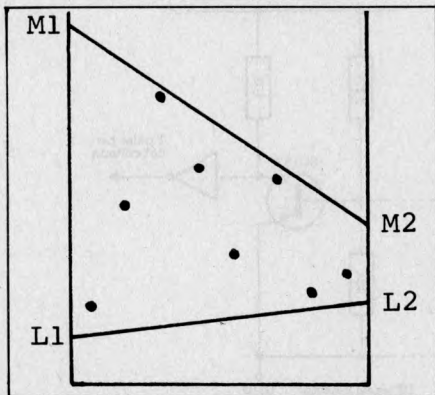

Fig 7 Values within a moving range

Footnote

Demonstration of the rule to derive a distribution from a function. Random numbers are generated in the range $0 \leq X \leq 1$ with uniform (equiprobable) distribution. The equation of this distri-

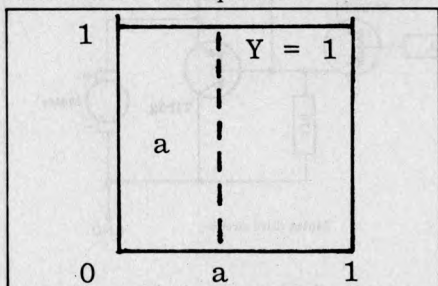

Fig 8 Uniform distribution of X.

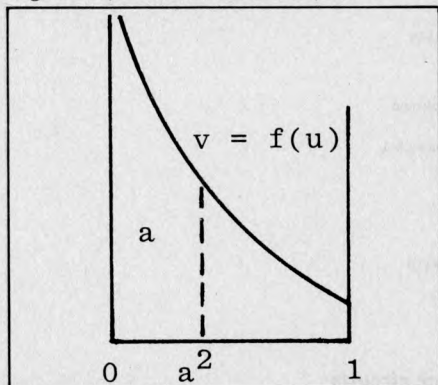

Fig 9 Distribution of X^2

tion is thus $Y = 1$, and the area under this line between 0 and 1 is unity. For a particular $X = a$, just a of the values of X will be less than a , as shown in figure 8. What is the distribution of X^2 ?

In the distribution of X^2 just a of the values of $M^2 X$ will be less than a^2 for each a . That is, the area under the curve of the distribution from 0 to a^2 will be a , as shown in Figure 9.

If $v = f(u)$ is the equation of this curve,

$$\text{then } \int_0^{a^2} f(u) du = a.$$

Substituting $b = a^2$ gives

$$\int_0^b f(u) du = b^{1/2}.$$

The next step is to find the function $f(u)$ which has the integral $b^{1/2}$ over the interval 0 to b . Since this is a definite

integral the constant terms cancel out.

Now —

$$\frac{d}{du} (u^{1/2}) = \frac{1}{2} u^{-1/2},$$

so that

$$\int_0^b \frac{1}{2} u^{-1/2} du = [u^{1/2}]_0^b = b^{1/2}.$$

Hence $v = f(u) = \frac{1}{2} u^{-1/2}$ is the required function, obtained simply by differentiating the inverse of the original function $F(X)$.

Switching between the variables X , Y and u , v may be a bit perplexing, though it is meant to avoid confusion. One set is for the function and the other for the distribution. Remember that a function is not changed by the names of the variables used to express it. $f(x) = x^2$ is the same function as $f(a) = a^2$.

```

790 REM
792 REM SUBROUTINE TO PRODUCE
794 REM 5 DIFFERENT RANDOM
796 REM DISTRIBUTIONS
800 R=RND(1)
810 IF N=1 THEN 930
820 IF N>3 THEN 870
830 R=SQR(R)
840 IF N=2 THEN 930
850 R=1-R
860 GO TO 930
870 A=1
880 IF R>0.5 THEN 900
890 A=-1
900 R=A*(2*R*(R-1)+0.5)+0.5
910 IF N=4 THEN 930
920 R=R-A/2
930 R=L+(M-L)*R
940 RETURN
Program B

```

Call random function
Jump for uniform distribution
Jump for N = 4 or 5
Take square root of R

Invert if N = 3
Jump to set range
Set sign of (R - 1/2)
Test
and reset
Compute function
Complete if N = 4
Adjust final term
Set range

```

90 REM PROGRAM TO DRAW SQUARES
95 REM USING RANDOM STRUCTURES
100 FOR Z=1 TO 6
110 L=1
120 M=6
130 N=1
140 GOSUB 800
150 I=INT(R)
160 GOSUB 800
170 J=INT(3*R)
180 GOSUB 800
190 N=INT(R)
200 L=I
210 M=I+J
220 GOSUB 800
230 J=INT(R)
240 FOR I=1 TO J
250 GOSUB 800
260 GOSUB 700
270 NEXT I
280 NEXT Z
290 STOP
700 S=R/2
710 MOVE @1:12*Z-3,12-S
720 RDRAW @1:R,0
730 RDRAW @1:0,R
740 RDRAW @1:-R,0
750 RDRAW @1:0,-R
760 RETURN
Program C

```

Draw 6 set of squares
Set limits to choose
new L, M, and N

Get new L

Get new M

Get new N

Copy L
and M
Choose no of squares

Loop for each square
Chooses square size
Draw 1 square

Set constant
Move to corner of square
Draw the square

```

390 REM SUBROUTINE TO PRODUCE
392 REM DISTRIBUTIONS WITH A
394 REM MOVING RANGE
400 J=L2-L1
410 K=M2-M1
420 FOR I=1 TO C
430 D=(I-0.5)/C
440 L=L1+J*D
450 M=M1+K*D
460 GOSUB 800
470 NEXT I
480 RETURN
Program D

```

Set range differences

Loop for C values
Calculate range for
this point

Choose value in range

PRINTER INTERFACING

Peter Faff continues his series on hooking low-cost printers to micros.

The first unit I will look at this month is the DP-822 impact printer mechanism, produced by Star in Japan and available through Roxburgh Printers Ltd for about £45. The unit uses standard 2¼ x 2¼in grade 'A' calculator paper and group 24 ribbons. The maximum printing field is 21 5 x 7 characters at two-and-a-half lines per second; the only power supply required is 12 V at approx 3 A and the unit is fairly small.

The print is built up column-by-column in a serial format by a seven-element print head. The head only prints while moving from left to right — during the return stroke, paper feed is accomplished. The print head is moved across the paper by a rotating shaft with a spiral groove cut into its surface — there are no belts or wires that can snap or slip. A 12 V DC motor provides the power for the print head traverse, the paper feed and the ribbon advance.

In use, the printer generates two timing signals. The first signal Print Active (PA) is generated by a magnet and reed switch. This switch is held closed during the entire print cycle and it should be used to determine when to start printing. When the reed is opened the motor should be turned off, or if another line is to be printed the motor should remain energised and the control logic must wait for the reed to close again before starting to print the next line of characters. The second signal, Dot Position (DP), is provided by a detector coil and rotating magnet. This provides a pulse for each column of dots during the print cycle. Since the printer can print 21 5 x 7 characters with a one-dot space between them, a total of 126 pulses will occur during each print cycle. Both of these signals will need to be further conditioned before they are of any use: the PA signal generated by the reed switch will need to be de-bounced and the DP signal, which is a 0.2 V p-p sine wave, will need to be amplified and clipped to provide a square wave pulse train — see Figure 1 for suggested circuits. This machine also has a paper feed solenoid and in order to feed the paper, the solenoid should be tripped and the motor drive will be transferred to the paper feed shaft; paper feed should occur during the print head return stroke. The motor control circuit should incorporate an electronic break to ensure that the motor comes to a quick stop when the motor drive is turned off. The final part of the printer is the needle head, comprising seven solenoids and needles in an easily-replaced housing. The solenoids have a resistance of 3.6 ohms each and they draw a peak current of 2.5 A from 12 V supply. The solenoids require a pulse with a width of 730 μ s to be energised — again Figure 1 gives suggested drive

circuits.

From Figure 1, you can see that the circuits are reasonably simple but, by all means, feel free to experiment. This printer prints characters column by column in a serial format (see Figure 2) and, because of this, the interface and control electronics that are required are reasonably simple. Figure 3 gives a suggested block diagram of the control circuit. The two major units are the character counter and the column counter. The character counter counts from

one to 21 and determines which character is to be printed. This counter is reset when the print cycle is started and is then incremented by the DP signals. After six DP pulses, the counter increments by one, thus keeping track of which character is to be printed. The second major unit is the column counter, which keeps track of which column is to be printed. This circuit again runs off the DP line and counts from one to five as it receives DP pulses. The sixth DP pulse resets the

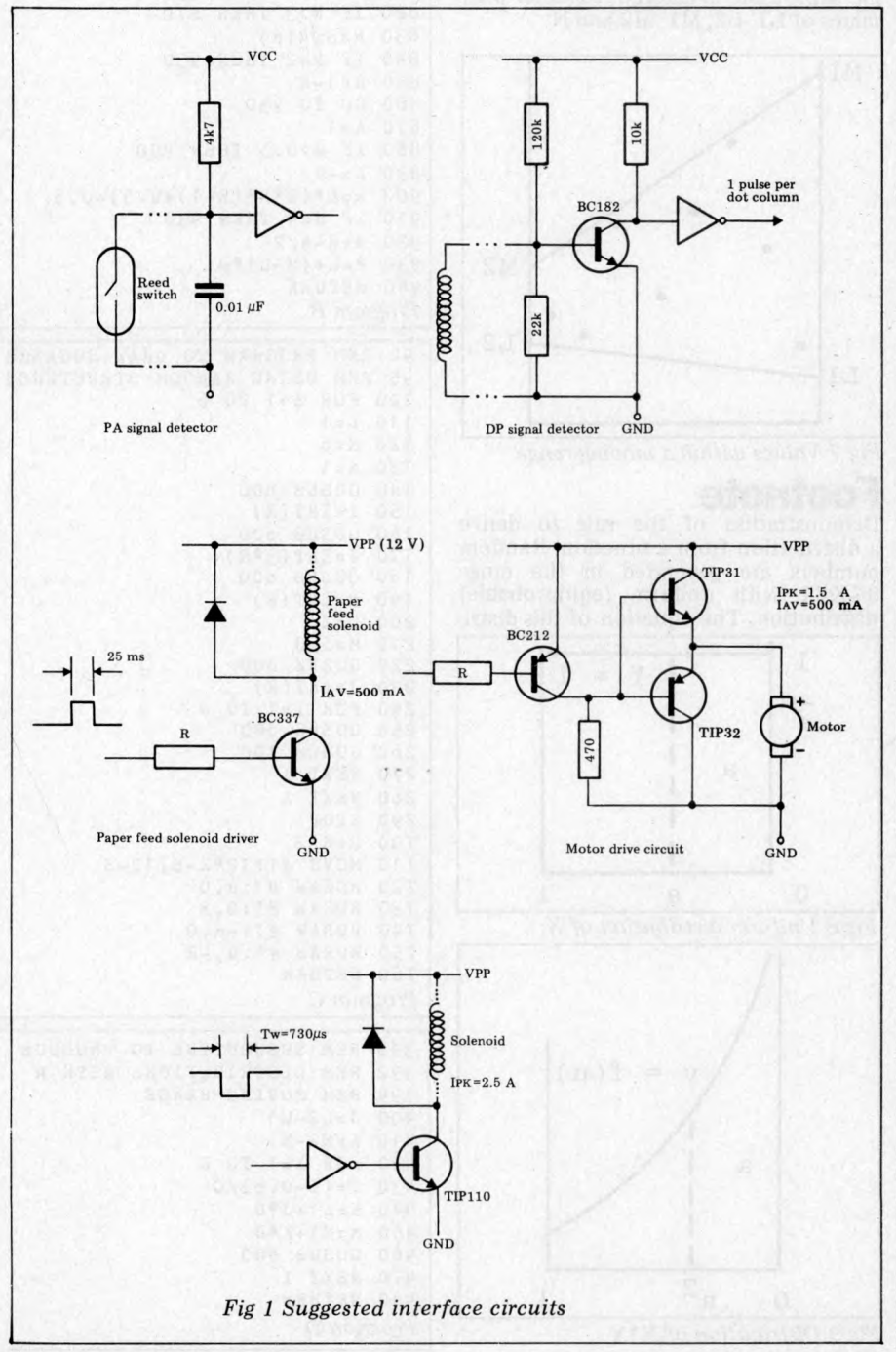

Fig 1 Suggested interface circuits

counter and, in this way, 5 columns are printed, followed by a one-dot gap and then another group of five columns.

The DP signals also feed a monostable that generates the 730 us pulse required by the print solenoids. The character generator should be of the type that stores 5 x 7 character cells as 5-7-bit columns. The particular character being printed is selected by a 5-bit address and a further 3-bit address selects one of the 7-bit columns to be output. When the print cycle is started, the first character is selected by the character counter and the data for the first column are output to the solenoid drivers. The data for the other columns have been printed; the character counter then selects the next digit stored in the line RAM and a further five columns are then sequentially printed. This continues until all 21 characters in the line have been printed, after which the cycle should be stopped.

National EUY series non-impact mechanisms

The National EUY series is a range of three basic types of printer. Each type is available in thermal or electro-discharge versions. All the printers use a serial print head that scans the paper printing characters column by column; printing only takes place in one direction. A choice of line widths is available, ranging from 15 to 80 characters per line between the three units. The mechanisms are all compact and consume little power. They should also be reasonably reliable because they are made by a reputable Japanese company. All the printers are available from Datac Ltd and the prices for the six basic units are:

EUY - 2E (285) Electro-discharge, 15 char	£25
EUY - 2T (295) Thermal, 15 char	£35
EUY - 10E (245 L/R) Electro-discharge, 32 char	£59
EUY - 10T (255 L/R) Thermal, 21 char	£89
EUY - 5E (265) Electro-discharge, 80 char	£119
EUY - 5T (275) Thermal, 80 char	£155

Since these printers use a serial print head, the control circuit required will be similar to that used by the DP-822 impact printer described elsewhere this month, although there will be some differences due to the different line widths used and also due to the different timing signals that are generated. Providing these factors are taken in to consideration, then the overall concept is similar and should pose no problems for the hardened constructor (think of driving a dot-matrix LED display).

The smallest printers in the series are the EUY 2E/2T. They are both 15 character per line printers, are physically quite small and they incorporate a roll holder in the printer frame. Connections to these units is by means of a 13-way flexible connector. These printers only generate one timing signal, produced by a rotating slotted disc and

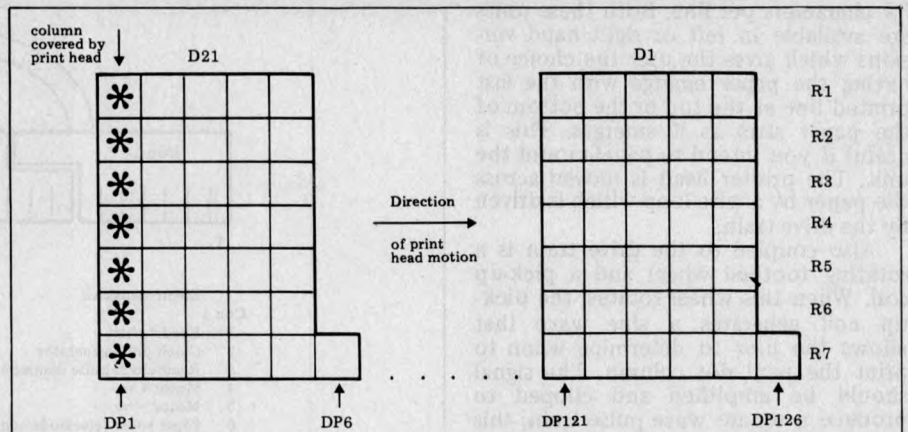

Fig 2

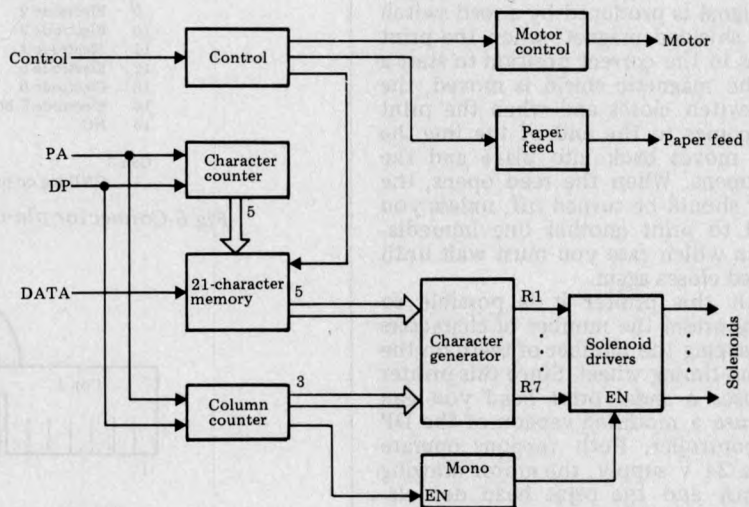

Fig 3 Block diagram of suggested control circuit

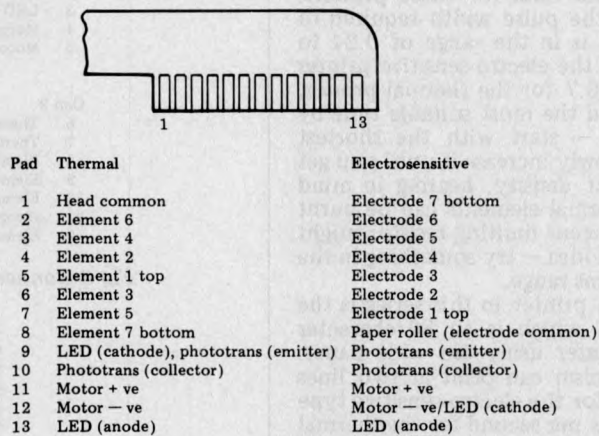

Fig 4 Pin-outs for FUY 3E/2T printers

a photo transistor/LED assembly. Also incorporated in this detector unit is a shutter, coupled to the drive train; when the print head is in the correct position to print a new line, the shutter moves out of the light path, thus allowing the photo transistor to produce a pulse train. Each pulse corresponds to a dot column position and when the print head reaches the end of the line the shutter again moves into the light path and stops the pulse train. To determine which character is to be printed, you must count these pulses and you

must remember to allow for a space between each character and the next. Both units have 5 V DC motors that require approximately 200mA. The print head on the electro-discharge printer requires a supply of 30 V at 50 mA per dot while the thermal print head requires 5 V at 270 mA per dot. Figure 4 gives the connector outline for these two units.

The next printer in this series is the EUY 10E/10T mechanism. This mechanism is slightly larger than the EUY 2E/2T series but it can print up to

32 characters per line. Both these units are available in left or right hand versions which gives the user the choice of having the paper emerge with the last printed line at the top or the bottom of the paper strip as it emerges. This is useful if you intend to panel-mount the unit. The printer head is moved across the paper by a wire loop which is driven by the drive train.

Also coupled to the drive train is a rotating toothed wheel and a pick-up coil. When this wheel rotates, the pick-up coil generates a sine wave that allows the user to determine when to print the next dot column. The signal should be amplified and clipped to produce a square wave pulse train; this should then be divided by two to produce the dot print signal. This mechanism also generates a second signal to indicate the start and finish of a line. This signal is produced by a reed switch and a shielded magnet; when the print head is in the correct position to start a line the magnetic shield is moved, the reed switch closes and when the print head comes to the end of the line the shield moves back into place and the reed opens. When the reed opens, the motor should be turned off, unless you intend to print another line immediately, in which case you must wait until the reed closes again.

With this printer it is possible to factory preset the number of characters by changing the number of teeth on the rotating timing wheel. Since this printer also uses a serial print head you can again use a modified version of the DP 822 controller. Both versions operate from a 24 V supply, the motor drawing 100 mA and the print head dot elements drawing 100 mA or 1A for the electro-sensitive and the thermal versions respectively. Figure 5 gives connector pin outs for these printers.

Finally, the pulse width required to print a dot is in the range of 0.24 to 0.48 ms for the electro-sensitive printer and 0.5 to 0.7 for the thermal printer. You can find the most suitable time by experiment — start with the shortest time and slowly increase it until you get a good print density, bearing in mind that the thermal elements can be burnt out, so a current limiting resistor might not be a bad idea — try something in the 15 to 40 ohms range.

The final printer in this series is the EUY 5E/5T which is an 80 character per line printer using 5in wide paper. This mechanism can print at two lines per second for the electro-sensitive type and 0.8 lines per second for the thermal type. Also, as with the EUY 10E/10T printers, the maximum number of characters per line can be factory preset by changing an internal timing wheel. These printers require a supply of 24 V, the motor draws 100 mA and the printing heads draw 100 mA per dot and 1 A per dot respectively for the electro-sensitive and the thermal types.

The photo detector LED requires a supply of 5 V at 30 mA. The pulse width required to print a dot is similar to that required by the EUY 10E/10T series and it should be adjusted in the same fashion to give a good print density. With the thermal heads you should attempt to keep the pulse width as small as possible, consistent with a legible print, in order to limit

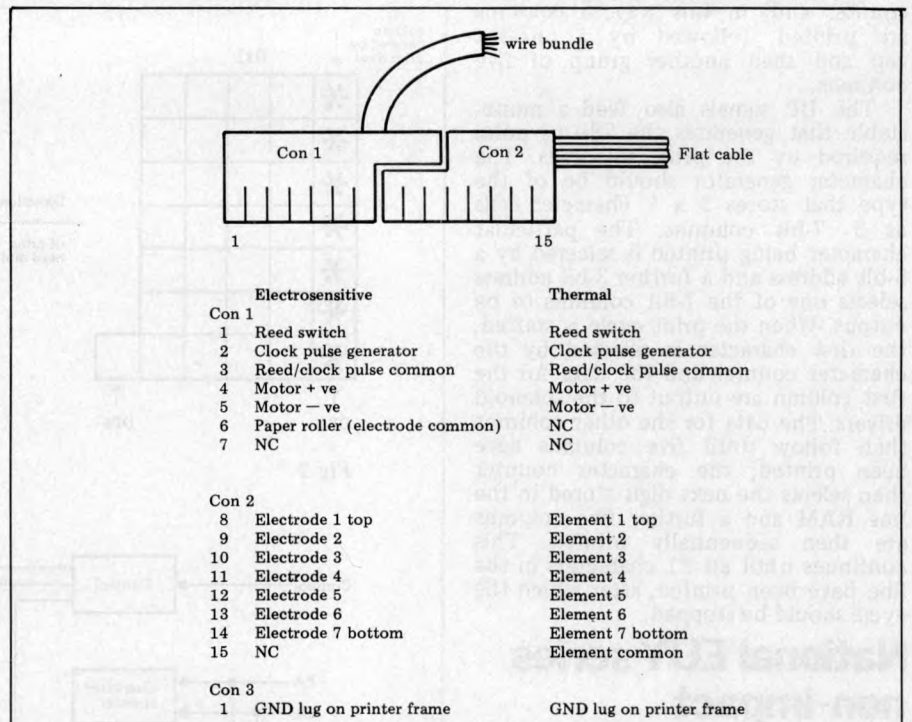

Fig 5 Connector pin-outs for EUY 10E/10T printers.

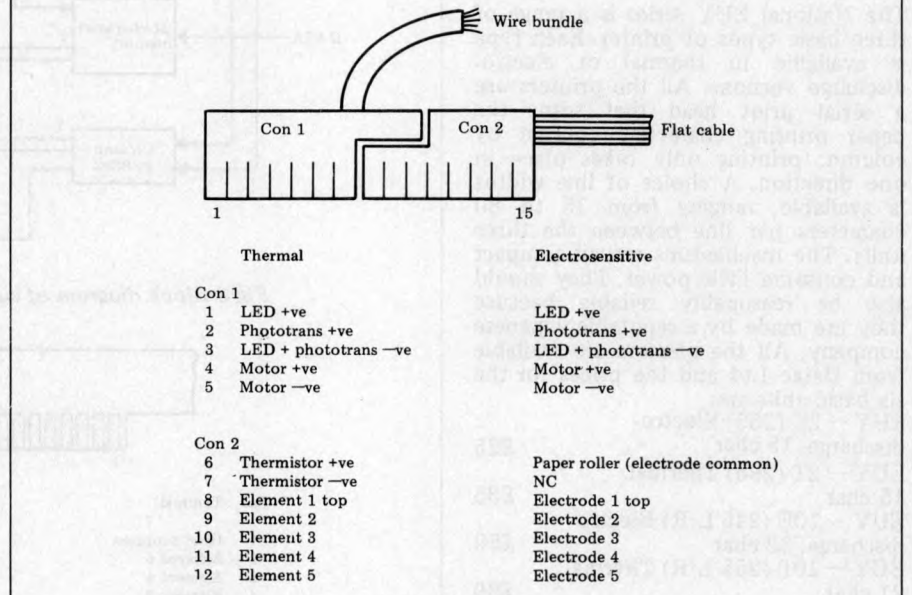

Fig 6 Connector pin-outs for EUY 5E/5T printers.

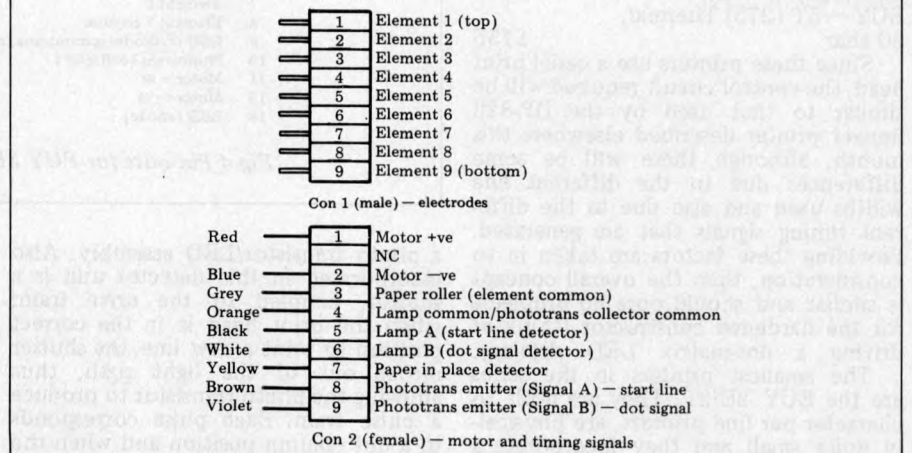
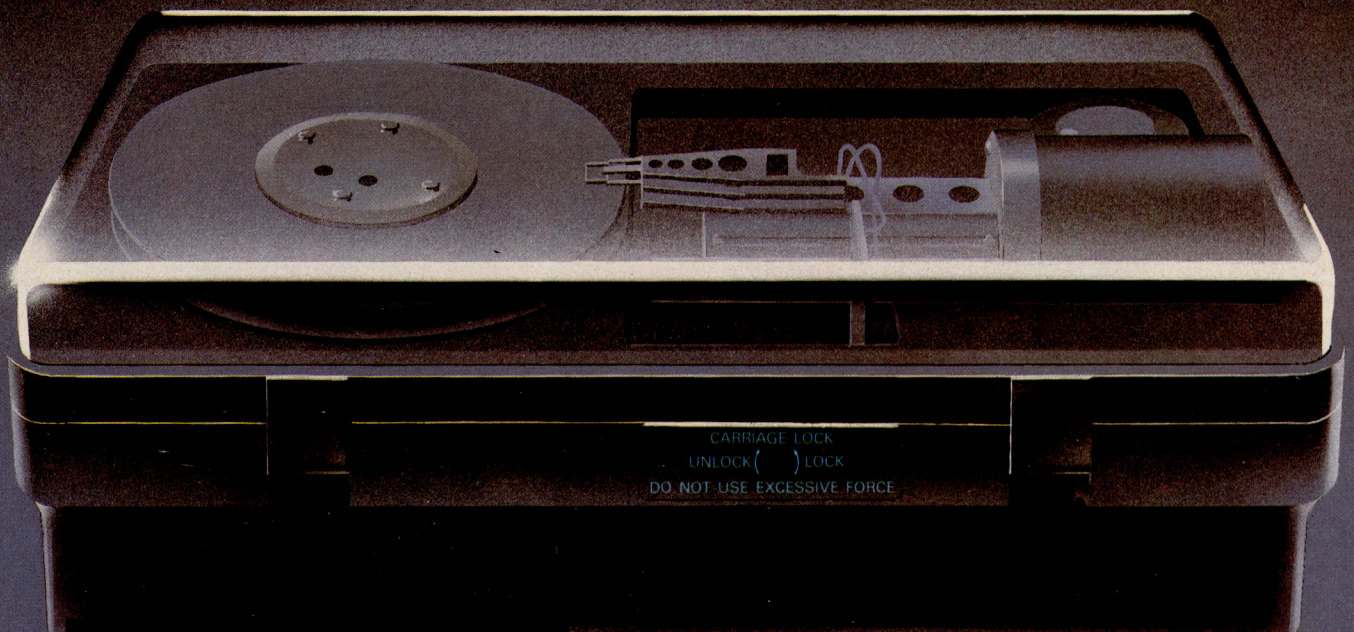

Fig 7 Pin-outs of DC4004A printer

power dissipation in the thermal element and increase its useful life. The thermal element also incorporates a

thermistor which could be used to control the pulse width applied to the

HARD. AND FAST.



Corvus/Constellation. A new concept in mass storage and shared data multiplexing for Apple, TRS-80, Pet, S100 and LSI-11.

Hard and fast—yet totally flexible. Corvus and Constellation provide a cost-effective means of substantially boosting microcomputer performance. They offer unlimited scope for accessing shared data via multiple terminals in scientific, educational, business and word processing applications.

Up to 72Mb of Corvus capacity

With 10Mb and 18Mb 8-inch Winchester hard disc drives, Corvus provides disc accessing speeds which are normally twenty times faster than with floppies. All the interfaces work with your existing software so there is no new disc operating system to learn.

Unique Corvus Mirror back-up transfer system

This interfaces the data signals on

the disc with a 100Mb capacity video tape system; and the entire contents of a 10Mb disc can be archived in about 15 minutes.

A microcomputer network with the Constellation shared data multiplexer

The Constellation enables you to link together from two to sixty-four computers—and for them to share high-speed access to the Corvus central memory. Like computers can communicate with each other in the network and their peripherals shared.

Total flexibility and cost-effectiveness

With Corvus and Constellation, you never have to buy more system than you need. You can use Corvus in a single-user system and upgrade later to a Constellation-

**CORVUS/CONSTELLATION
NOW INTERFACES WITH
SUPERBRAIN, ALPHA MICRO
AND ALTOS.**

linked multi-user network.

Make a hard and fast decision to find out more about Corvus and Constellation. For total flexibility.

**Keen
Computers**



5b the Poultry, Nottingham NG1 2HW
Tel: 0602 583254. Telex: 37297 (keenco)
Offices in London and San Francisco

ENQUIRIES FROM DEALERS, OEMs AND OVERSEAS ARE WELCOME

Comart Approved Dealers

Belfast

O & M Systems
95 Dublin Road
Tel: 0232 49440

Birmingham

Byteshop Computerland Ltd
94/96 Hurst St, B5 4TD
Tel: 021 622 7149

Cambridge

Cambridge Computer Stores
1 Emmanuel St, CB1 1NE
Tel: 0223 68155

Cornwall

Benchmark Computer
Systems Ltd
Tremena Manor
Tremena Road
St Austell, PL25 5GG
Tel: 0726 610000

Dublin

Lendac Data Systems Ltd
8 Dawson St
Tel: 0001 372052

Glasgow

Byteshop Computerland Ltd
Magnet House
61 Waterloo St, G2 7BP
Tel: 041 221 7409

Leeds

Holdene Ltd
Manchester Unity House
11/12 Rampart Road
Woodhouse St
Tel: 0532 459459

London

Byteshop Computerland Ltd
48 Tottenham Court Road,
W185 4TD
Tel: 01 636 0647

Digitus

9 Macklin Street
Covent Garden WC2
Tel: 01 405 6761

Jarrogate

67 Tulsemere Road,
West Norwood,
London SE17
Tel: 01-670 3674

Manchester

Byteshop Computerland Ltd
11 Gateway House
Piccadilly Station Approach
Tel: 061 236 4737

NSC Computers
29 Hanging Ditch
Tel: 061 832 2269

Newbury

Newbear Computing Store
40 Bartholomew St
Tel: 0635 30505

Nottingham

Byteshop Computerland Ltd
92A Upper Parliament St,
NG1 6LF
Tel: 0602 40576

Sheffield

Hallam Computer Systems
451 Eccleshall Road, S11 9PN
Tel: 0742 663125

Southampton

Xitan Systems
23 Cumberland Place,
SO1 2BB
Tel: 0703 38740

Sudbury

Eurotec Consultants
Holbrook Hall
Little Waldingford
Tel: 0206 262319

Warwicks

Business & Leisure
Microcomputers
16 The Square
Kenilworth
Tel: 0926 512127

Watford

Lux Computer Services
108 The Parade
High Street
Watford WD11 2AW
Tel: 0923 29513

Comart Microcomputer dealers are located strategically throughout the country to give support, guidance and assistance. In the event of difficulty contact Comart direct.

comart communicator

The clean simplicity outside...

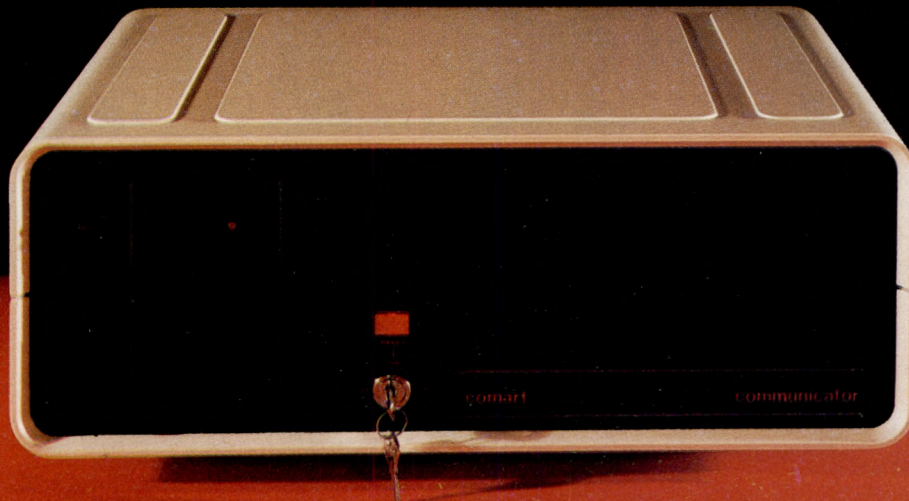

...conceals the pedigree inside.

Comart's CP100 Communicator is the new British designed, British made Microcomputer from Comart. It is the result of a carefully conceived development programme. It exploits Comart's first hand experience of the British computer market, and their growing strength as a manufacturer.

CP100 is the first of a new generation of flexible, expandable micros specifically developed to suit British operating conditions and communication requirements.

The clean lines outside, conceal the power within; its S-100 bus means wide ranging peripheral support, and simple after sales care. And, that's not all. Communicator is built to keep your future options open. It's ready for Prestel, asynchronous, and synchronous operation. It has expandable memory capability and yet it's price competitive as a stand-alone system with its CP/M™ operating system, and support software.

Find out more about Communicator today.

The U.K. Leaders in Microcomputer
Development, Application and Support.

comart

St Neots HUNTINGDON Cambs PE19 2AF
Tel (0480) 215005 Telex: 32514 Comart G.

Unique in concept—the home computer that grows as you do!

The Acorn Atom

£120

plus VAT and p&p

Special features include

- * FULL SIZED KEYBOARD
- * ASSEMBLER AND BASIC
- * TOP QUALITY MOULDED CASE
- * HIGH RESOLUTION COLOUR GRAPHICS*

* optional



Also available ready-built

£150

plus VAT and p&p

● The picture shows mixed graphics and characters in three colours

The Acorn Atom is a definitive personal computer. Simple to build, simple to operate. A powerful, full facility computer with all the features you would expect.

Just connect the assembled computer to any domestic TV and power source and you are ready to begin. (Power requirement: 8V at 800mA). There is an ATOM power unit available – see the coupon below.

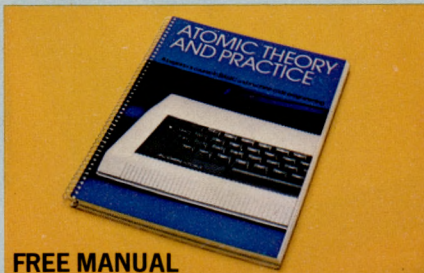

FREE MANUAL

Free with every ATOM, kit or built, is a computer manual. The first section explains and teaches you BASIC, the language that most personal computers and the ATOM operate in. The instructions are simple and learning quickly becomes a pleasure. You'll soon be writing your own programs. The second section is a reference

manual giving a full description of the ATOM's facilities and how to use them. Both sections are fully illustrated with example programs.

The standard ATOM includes:

HARDWARE

- Full-sized QWERTY keyboard
- 6502 Microprocessor
- Rugged injection-moulded case
- 2K RAM
- 8K HYPER-ROM
- 23 integrated circuits and sockets
- Audio cassette interface
- UHF TV output
- Full assembly instructions

SOFTWARE

- 32-bit arithmetic ($\pm 2,000,000,000$)
- High speed execution
- 43 standard/extended BASIC commands
- Variable length strings (up to 256 characters)
- String manipulation functions
- 27 x 32 bit integer variables
- 27 additional arrays
- Random number function
- PUT and GET byte
- WAIT command for timing
- DO-UNTIL construction
- Logical operators (AND, OR, EX-OR)
- Link to machine – code routines
- PLOT commands, DRAW and MOVE

The ATOM modular concept

The ATOM has been designed to grow with you. As you build confidence and knowledge you can add more components. For instance the next stage might be to increase the ROM and RAM on the basic ATOM from 8K + 2K to 12K + 12K respectively. This will give you a direct printer drive, floating point mathematics, scientific and trigonometric functions, high resolution graphics.

From there you can expand indefinitely. Acorn have produced an enormous range of compatible PCB's which can be added to your original computer. For instance:

- A module to give red, green and blue colour signals
 - Teletext VDU card (for Prestel and Ceefax information)
 - An in-board connector for a communications loop interface – any number of ATOMs may be linked to each other – or to a master system with mass storage/hard copy facility
 - Floppy disk controller card.
- For details of these and other additions write to the address below.



ACORN COMPUTER 4a Market Hill, CAMBRIDGE CB2 3NJ

Your ACORN ATOM may qualify as a business expense. To order complete the coupon below and post to Acorn Computer for delivery within 28 days. Return as received within 14 days for full money refund if not completely satisfied. **All components are guaranteed with full service/repair facility available.**

Please send me the following items:

Quantity	Item	Item price inc. VAT+p&p	TOTALS
	ATOM KIT – 8K ROM + 2K RAM (MIN)	@ £140.00	
	ATOM ASSEMBLED – 8K ROM + 2K RAM (MIN)	@ £174.50	
	ATOM KIT – 12K ROM + 12K RAM (MAX)	@ £255.00	
	ATOM ASSEMBLED – 12K ROM + 12K RAM (MAX)	@ £289.50	
	1K RAM SETS	@ £11.22	
	4K FLOATING POINT ROM (inc in 12K Version)	@ £23.30	
	PRINTER DRIVE	@ £10.35	
	6522 VIA	@ £3.17	
	(inc in 12K version) LS244 Buffer	@ £3.17	
	MAINS POWER SUPPLY (1.3 amps)	@ £10.20	
	TOTAL		

To: Acorn Computer Ltd., 4a Market Hill, CAMBRIDGE CB2 3NJ

I enclose cheque/postal order for £ _____

Please debit my Access/Barclaycard No. _____

Signature _____

Name (Please print) _____

Address _____

Telephone No. _____

Registered No: 1403810. VAT No: 215 400 220

PCW 2/81



The heart of a system...



Exidy's Sorcerer has stood the test of time and has proved to be one of the most complete and versatile machines available. Versatility and expandability were the principal aims of the original design and whilst other major suppliers have been continually changing models to try and compete, the Sorcerer range has remained ahead of its time

Whatever the application talk to the people who care and will help you get the best from your microcomputer, talk to the professionals—your Exidy Dealer. Consult your local supplier now or clip the coupon for further information about this outstanding machine.

LIVEPORT
DATA PRODUCTS

The Ivory Works, St. Ives, Cornwall TR26 2HF
Telephone: (0736) 798157

Please send details of the complete Exidy range and a dealer list.

Name

Address

Tel No.

PCW B

COMPETITION

Modern microcomputer technology has many applications, but one where it has so far had little impact is in reducing the problems of disability.

To mark the designation by the United Nations of 1981 as 'The International Year of Disabled People', *PCW*, in conjunction with the IYDP Technology Working Group, is holding a competition for the best article on the subject:

'The application of micro-computer technology to the problems of disability'.

There must be many possible applications for microtechnology in the fields of physical and sensory disabilities — remember, these include handicaps such as deafness, blindness, diabetes and epilepsy, as well as the more obvious physical impediments.

1st Prize

DAI PERSONAL COMPUTER

2nd Prize 3rd Prize

£100 £50

Articles of around 2500 words are invited, which can be either theoretical or a description of an actual application (with photographs, if possible), and which we will print in *PCW* later in the year. Entries will be judged by *PCW*'s Editor, David Tebbutt, Adrian V Stokes, Chairman of the IYDP Technology Working Group and Judith Hann, presenter of *Tomorrow's World* and science writer.

Please send your entry to IYDP Competition, 14 Rathbone Place, London W1P 1DE, to arrive not later than 30 April 1981, enclosing a suitable SAE if you would like it returned.

**Personal
Computer**
World



International Year of
Disabled People

Data Applications Ltd has kindly donated the first prize of a 48K personal computer worth £595. Plugging into the domestic TV, it provides sound, colour and high-resolution graphics. Sharp Electronics (UK) Ltd has kindly donated the third prize of £50.

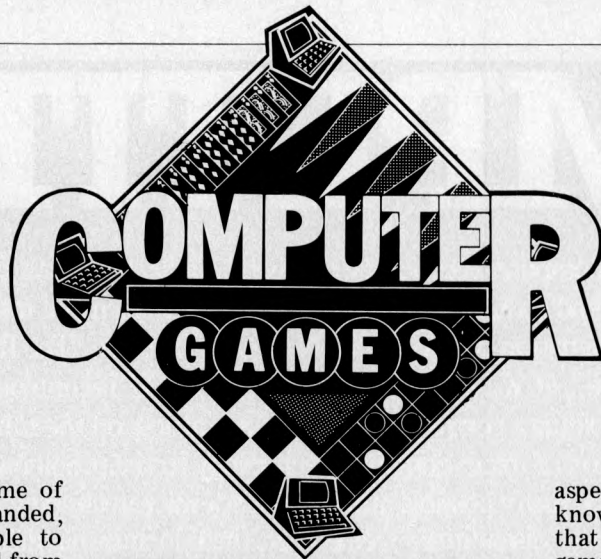

Last month we discussed the game of Stud Poker in a simplified, two-handed, form. We saw how it is possible to predict an opponent's hidden card from information gained during the betting and, from these predictions, we developed an algorithm for deciding whether or not to bet. This month we shall turn our attention to Draw Poker.

One major difference between last month's article and this is that, here, we shall consider a game for more than two players. Draw Poker for two would be extremely dull, and the ideal number is six or seven players. When writing your program I would suggest that you vary the number of players at your discretion. The principles that I am about to outline are applicable for any number of players.

The rules of the game

At the start of a hand, each player is dealt five cards face down, which he may look at. No-one else sees any of these cards. The player on the dealer's left usually opens the betting — there are various ways in which this is done; in some cases it is mandatory to bet, in other schools it is illegal to bet unless holding at least a pair of jacks. We shall assume that the first player may bet or check at will. (Incidentally, if you don't understand some of the terminology, obtain a copy of last month's PCW or, better still, place a subscription backdated to last month!)

The betting proceeds with each player having the option, when it is his turn to bet, of either dropping out of the pot ('passing' or 'folding') or putting in at least as much money as has been put in since he last bet ('calling' or 'raising'). When all of the active players have put the same amount of money into the pot, the first round of betting is over. The remaining players may then discard some of the cards in their hand and receive, in their place, an equal number of new cards from the unseen deck. This process, known as the draw, is conducted in a clockwise order starting on the dealer's left, so the dealer is the last player to draw new cards.

Once all the players have taken their turn to draw, a second round of betting takes place. When all remaining players have put the same amount of money into the pot, this second round is complete. The players all turn their cards over, and the one with the highest hand takes the pot. The order of importance of the hands is exactly the same as for five-card Stud (see last month's article).

DRAW POKER

David Levy continues his examination of poker.

The basis of the algorithm

At the start of a hand of Draw Poker, no-one *knows* anything about anyone else's cards, unlike Stud Poker in which at least one of the opponent's cards is visible from the outset. But by employing simple probabilities, it is possible to make certain estimates about the type of hand which a player is holding.

The probability of being dealt a straight flush is one in 64,974, or 0.0000153. The probability of being dealt the various other types of hand are shown in Table 1.

From this table we can determine the probability that an opponent has a certain type of holding after the cards are dealt, and it is an easy matter to work out the probability that the program holds better cards. For example, if the program holds a pair of Aces, the probability of a particular opponent having been dealt better cards is simply the sum of the probabilities of being dealt two pairs, three of a kind, straight, flush, full house, four of a kind and straight flush. If the program was dealt a full house — Aces and (say) twos — the probability that it was already beaten is the sum of the probabilities of the opponent being dealt four of a kind and a straight flush.

Thus, without any information gleaned from the betting or the other

aspects of play, the program already knows something about the probability that it is winning at this stage of the game.

To employ such probabilities with any real degree of accuracy throughout the game, we must introduce a greater degree of discrimination than that achieved by dividing all possible hands into the nine categories listed above. I am indebted to my friend Stewart Reuben, one of Britain's leading poker players, for the division into 109 categories. This list (Table 2) should be coded into your poker program in such a way as to assign a two-byte probability estimate to each holding for each player in the game (apart from the program itself, which of course knows what it is holding).

A few comments are required on this division into 109 types of holding:

- 1) Hand number five — four cards to an inside straight or a straight open at only one end: in a situation with 4, 5, 6, 8, J, by discarding the Jack it is possible to draw one card which will make a straight, provided that card is a 7. Similarly, when holding 8, J, Q, K, A, by discarding the 8 and drawing a 10 it is possible to make the straight. In each of these situations there is only one card denomination which will suffice to make the straight, whereas with a holding such as 2, 6, 7, 8, 9, it would be possible to discard the 2 and make a straight by drawing *either* a 5 or a 10. We must therefore distinguish between a situation in which either of two cards will bring joy to our hearts. The reason for this distinction is obvious — it is twice as easy to make a straight when any one of 8 cards will work, as it is when any one of four cards will do.
- 2) There are more Ace high flushes than there are flushes with any other card high (think about it if you don't believe me). So to have an Ace high flush in the making is much better than to have a chance of making just any old flush. Hence the distinction between hands 7 and 8.
- 3) When holding three kings it is useful

Four of a kind:	one in 4165 or 0.00024
Full House:	one in 694, or 0.00144
Flush:	one in 509, or 0.00196
Straight:	one in 255, or 0.00392
Three of a kind:	one in 47, or 0.02128
Two Pairs:	one in 21, or 0.04762
One Pair:	one in 2.37, or 0.42194
No pair (high card only):	one in 1.99, or 0.50251

Table 1 Probability of being dealt certain poker hands

Numerical designation of the various possible holdings in five cards:

No hand	1
Three cards to a flush	2
Three cards to a straight flush	3
Ace high	4
Four cards to a straight flush missing inside card or open only at one end (ie, only cards of one denomination will make the straight)	5
Four cards to an open ended straight	6
Four cards to a flush without an Ace	7
Four cards to a flush with an Ace	8
Four cards to a straight flush missing inside card	9
Four cards to straight flush including Ace low	10
Four cards to straight flush including Ace high	11
Four cards to an open ended straight flush	12
Pair of 2s	13
Pair of 3s	14
Pair of 4s	15
... etc	
Pair of Aces	25
Two Pairs 3s and 2s	26
Two Pairs, 4s high	27
Two Pairs, 5s high	28
... etc.	
Two Pairs, Aces high	37
Three 2s	38
Three 3s	39
Three 4s	40
... etc	
Three Kings with an Ace	50
Three Aces	51
Straight (A, 2, 3, 4, 5)	52
Straight (2, 3, 4, 5, 6)	53
Straight (3, 4, 5, 6, 7)	54
... etc	
Straight (10, J, Q, K, 1)	61
Flush (7 high)	62
Flush (8 high)	63
Flush (9 high)	64
... etc	
Flush (Ace high)	69
Flush (Ace, Q high)	70
Flush (Ace, K high)	71
Full House (2s)	72
Full House (3s)	73
Full House (4s)	74
... etc	
Full House (Ks)	83
Full House (Ks over A)	84
Full House (Aces)	85
Four 2s	86
Four 3s	87
Four 4s	88
... etc	
Four Ks with an Ace	98
Four Aces	99
Straight Flush 4 high	100
Straight Flush 6 high	101
Straight Flush 7 high	102
... etc	
Straight Flush A high	109

Table 2 The 109 types of hand

to have an Ace as one of the two remaining cards, as this substantially reduces the chance of an opponent having or drawing three aces. This explains the distinction between holdings 49 and 40, and for a similar reason we must distinguish between holdings 83 and 84, since it is very useful when holding a full house of Kings to know that one of the Aces is already denied your opponent, who therefore has much less chance of holding or drawing a full house of

Aces. Similarly, the distinction between hands 98 and 99.

Since we know the probability of a particular opponent being dealt a particular type of hand, we can calculate the probability of his holding any of the above 109 hands after the cards are first dealt. To do this accurately we would need to calculate exactly how many hands exist of each of the 109 types, and then divide this number by 2598960, which is the total number of possible hands in a 52 card deck with no wild cards.

The approximation that we shall use in this article is based on taking the probability of being dealt a particular category of hand (see table 1) and then dividing this by the number of types of hand within this category. Special calculations may be made for designations 1-12, but I doubt that this would improve the performance of the program, as any player holding a hand worse than 13 after the draw would (or should) certainly fold.

The probability of being dealt one pair is 0.42194. Since there are 13 possible pairs that one can have, the probability of being dealt a pair of 2s is $0.42194 \times 1/13$, or 0.0325.

The probability of being dealt a pair of 3s or a pair of anything else is also 0.0325, so we can assign to holdings 13 through 24 initial probability values of 0.0325. Up to now we have not used any approximation.

The probability of being dealt two pairs is 0.04762, but this total probability is not evenly split between two pairs (3 high), two pairs (4 high), . . . , two pairs (Ace high), because while there is only one way that a player can have two pairs 3s high (ie, two 3s and two 2s), there are two ways that he can have two pairs 3s high (ie, two 3s and two 3s, or two 4s and two 2s). It is easy to see that if you do not wish to follow my approximation, you can assign accurate probability estimates to holdings 26 through 37 by dividing the total probability of 0.04762 in the ratio 1:2:3:4:5: . . . :12. Alternatively, you can start with equal probability estimates for each type of hand, making all of them $0.04762 \times 1/12$, or 0.00397.

When this process has been completed, your program will have probability estimates for each of the 109 designations, these probabilities representing the likelihood that a player will be dealt a hand of this type in his first five cards.

These probabilities form the basis of our Draw Poker algorithm.

How the algorithm operates

Let us assume at the outset that there is no bluffing in our game. We can therefore deduce that when a player bets or raises he is indicating a strong hand, relative to some arbitrary point, and that if he checks or calls he is indicating a weak hand relative to that arbitrary point. As the betting proceeds, during the first round, players are repeatedly faced with a situation in which they must either fold, or put in more money knowing that other players have bet or raised. This point is very useful—a player who puts in money knowing that other players have indicated strength, must himself be indicating more strength than he would be indicating if

no-one else had yet bet. In other words, the arbitrary point has moved upwards. A player who raises during the betting when there have already been ten raises before him, must have a fairly strong hand: after all, the other players are raising each other, and with each raise there is an implicit 'I think that my cards are better than yours.' So, to be in the pot after a number of raises requires a strong hand.

When the cards are dealt, each player will have, on average, a hand whose designation lies somewhere just below 13. This is known from table 1, which indicates that there is a slightly less than 50 percent chance of being dealt a pair or better. So at the start of each hand the program should assign to each of his opponent's designation lists, a pointer which is set on 12 or 13 (12 if you want the program to be slightly optimistic, 13 if you wish it to be slightly conservative). As each player puts in money, the program should adjust the position of that player's pointer, to indicate what it thinks the player's *minimum* holding is. This process can be accomplished in the following way, though the reader may find it preferable to vary the size of jump made by the pointer, in accordance with how his program reacts.

When a player checks his pointer is not moved. If he calls or raises however, his pointer is moved up by: 5 percent x (number of designations between present and 109) x number of raises where number of raises indicates how many players have raised the pot since this particular player last put in money. If he himself is raising, this raise is included in the number of raises.

The following example should explain how the method works. We assume that there are five players, called A, B, C, D and E. Each of them has his pointer set initially at 12. A is the first to speak, since the player on his right (E) dealt.

A checks, pointer remains at 12;
 B bets, pointer moves up by $5\% \times (109 - 12) \times 1 = 4.85$, to 17 (rounded);
 C raises, pointer moves up by $5\% \times (109 - 12) \times 2 = 9.7$, to 22 (rounded);
 D calls, pointer moves up by $5\% \times (109 - 12) \times 2 = 9.7$, to 22 (rounded);
 E raises, pointer moves up by $5\% \times (109 - 12) \times 3 = 14.55$, to 27 (rounded);
 A calls, pointer moves up by $5\% \times (109 - 12) \times 3 = 14.55$, to 27 (rounded);
 B raises, pointer moves up by $5\% \times (109 - 17) \times 3 = 13.8$, to 31 (rounded);
 C calls, pointer moves up by $5\% \times (109 - 22) \times 2 = 8.7$, to 31 (rounded);
 D calls, pointer moves up by $5\% \times (109 - 22) \times 2 = 8.7$, to 31 (rounded);
 E calls, pointer moves up to $5\% \times (109 - 27) \times 1 = 4.1$, to 31 (rounded);
 A calls, pointer moves up to $5\% \times (109 - 27) \times 1 = 4.1$, to 31 (rounded).

Since the last four players have all called, the first round of betting is now at an end. The program has set the pointer for each of the players at 31, indicating that it expects each of them to have not less than two pairs, 8s high.

The next stage is to adjust the probabilities for all the hands of designation 31 through 109, so that they add up to one. The ratio of these probabilities is already known, it is simply the ratio of the initial probabilities as calculated from table 1 by dividing

THE CENTRONICS MODEL 737

Introducing the revolutionary Centronics Model 737, the first printer in its class capable of offering print quality suitable for text processing, plus the performance and application flexibility required for data processing.

The Model 737 is now demonstrating proportional spaced printing (using the exclusive Centronics Nx9 dot matrix) and providing right margin justification of the text. The 737 combines exceptional print quality, the flexibility to print on letterhead, fanfold, and roll paper, true underlining capability, and for the first time, the ability to print subscripts and superscripts.

letter quality — now only £349

The first low-cost matrix printer on which you have to look hard to see the dots! Three-way paper handling, proportional and two fixed spacings, print underlining, and a host of other useful features. Supplied with Centronics parallel interface as standard; RS232 serial interface £45 extra.

Its quality is unmatched — and so is our price!



TVI 920C terminal

A true intelligent terminal with a wide range of editing facilities and full range of function keys and numeric keypad. 912C version: as 920C, but less function keys.

920C	£550
912C	£475

Your dealers are:
London and South:
Northamber Limited,
Great Oak House,
Esher, Surrey
Tel: (0372) 62072

Midlands and South West:
Mutek,
Quarry Hill,
Box, Wilts
Tel: Bath (0225) 743289

All prices quoted exclude VAT

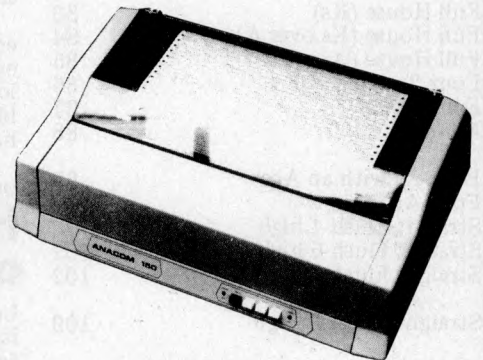

Anacom 150 printer

A fast, reliable, no-frills printer for commercial use — up to four copies at a time. Full upper and lower case, adjustable tractor feed, serial or parallel interface.

Anacom 150	£699
------------------	------



categories of hands into the 109 types of hand. The program merely adds up all the probabilities for hand designations 31 through 109, and then divides each of them by the total, to arrive at a new measure for each. This new measure will keep the probabilities in the same ratio as before, while ensuring that their sum is 1.

In fact this adjustment can be made during the betting process. As a player bets, calls or raises, his pointer is adjusted and the probability measures can also be adjusted in the manner described in the preceding paragraph. The program may then make its betting decisions based on up to date information about the estimated strength of each of its opponents' hands.

What happens during the draw

The program, if it is still in the pot after the first round of betting, must then make a decision as to how many cards to throw away in the hope of drawing a better hand. This decision is often obvious and unambiguous, for example holding four cards to a straight or a flush and a completely disconnected card, it will always throw the disconnected card and hope to make a straight or flush. On the other hand, when holding three of a kind, many players prefer to discard one card rather than two, since the reduced chance of making four of a kind is partly compensated for by the fact that a single discard disguises your hand (you might have four cards to a straight, four to a flush, four to a straight flush, or two pairs). Your program should have a set of rules telling it what to discard according to what designation holding it has. Where there is a choice of discard, it should choose at random between two possible discards to disguise its play and confuse the opposition.

A certain amount can be learned from the number of cards discarded by the opponent, and I would suggest adjusting the probabilities for players who discard certain numbers of cards. For example, a player discarding three cards must be assumed to be holding a pair. Make the probabilities for all other holdings zero, and adjust the pair probabilities so that they add up to one.

A player discarding one card can be assumed not to have a pair, so set all of his pair probabilities to zero and adjust the other probabilities accordingly. (If his pointer is already at 26 or higher you need take no action, since it is already assumed that he does not hold less than two pairs.)

A player who discards four or five cards (five is prohibited in some schools)

should be assumed to have designation 4 (if he discards four cards — assume that he has kept an Ace), or designation 1 (if he discards five cards).

A player who stands pat, ie, takes no cards at all, should be assumed to have at least designation 52, though when bluffing is added to your program you should allow for the 'no card bluff' in a certain proportion of hands, and assume a lower minimum designation.

Estimating how hands improve during the draw

All good books on poker give tables to show the odds against making various types of improvement to your hand during the draw. For example, Irwin Steig's *Poker for Fun and Profit*, teaches that when holding a pair and discarding three cards, the probability of making a full house is 0.0102, of making four of a kind 0.00278, of making three of a kind 0.1149, and of making two pairs 0.1587. We can use this information to adjust the probabilities still further.

Let us assume that, after the first round of betting, the pointers are all on 24 (a pair of kings). A player discards three cards, so we assume that he does indeed have a pair, and the designation probabilities are adjusted accordingly. We must then assume, after the draw, that the probabilities of his holding four of a kind, a full house, three of a kind and two pairs, are given by the above figures, and that the balance (0.7143) is the probability of his holding a pair after the draw. Having determined the probabilities for each of the feasible categories of hand, we can divide them up to indicate the probability of his holding each of the feasible types of hand (remember that some types, such as straights and flushes, are no longer feasible after the three card draw).

After the draw is over

The program now has at its disposal an updated list of probabilities and a pointer — all this for each player. The second round of betting now ensues and the pointers are adjusted as before, according to whether the player checks, bets, raises or calls. As the pointers move up and the probabilities are adjusted, so the program forms a changing picture of how its own hand compares to those of its opponents. If the program holds two pairs and there are four other players in the pot, all raising each other, the program will soon conclude that it is very probably beaten, and will fold. On the other hand, with a good full house, and only one other player raising, the program has more reason to be optimistic about its chances. How can this optimism be made into a betting strategy?

The program decides whether or not to remain in the pot in a similar manner to the method employed in Stud Poker. It calculates the probability that it holds the best cards, and compares this with the 'pot odds', the ratio of the amount of money that it must put in the pot: the amount of money already in the pot. If the odds against winning are less than the money odds, the program

should play. If the odds against winning are greater than the money odds, it should fold. To determine the odds against it winning, the program first identifies the designation of its own hand. It then adds up, for each player, the probabilities corresponding to all the hands of higher designation. This gives the probability that this particular player has a better hand than the program. If the probability that player A has better cards than the program is P_A , then the probability that the program has better cards than player A is $(1-P_A)$. The probability that the program holds the best hand of all is therefore:

$(1-P_A) \times (1-P_B) \times (1-P_C) \times \dots$ etc.

Bluffing

If nobody bluffed in poker, the game would immediately lose its appeal. A program could play super-accurate poker because it could calculate the odds much quicker and more accurately than its human adversaries. But bluff is an essential element of the game.

Your program may determine when to bluff by making a decision that it will do so in a certain proportion of situations in which its opponents all appear to have weakish hands, and the program has already shown strength by its first round betting and by drawing a small number of cards (two or less). What this proportion should be is very much up to the reader, and depends on what style of game he wishes his program to play. I would suggest that your program only bluffs when all of its opponents have a less than 0.1 chance of holding three of a kind or greater. Even 0.1 may be a little on the high side for a game with seven players (six plus the program), but it can be made a variable to be set at the user's discretion at the start of play.

An important part of the program will be a routine to estimate the proportion or occasions when the opponent is bluffing. This can only be done by examining the opponent's cards when the showdown takes place ie, all the money is in the pot and everyone turns over their cards). At this point the program can make certain deductions about whether the opponent may have over-represented his hand during the betting. For example, if a player turns out to have only a pair of 6s at the end of a hand, but has been betting in such a way as to make the program think that he had at least three of a kind, then either the player is very bad, or he has been bluffing. In either case we should allow the program to reduce the value that it places on information gained from that player's betting habits.

The program should keep track of the betting, and remember how each player bet until the hand is over. If the player turns out to have a worse hand than the program believed possible, the program should analyse how the player's pointer was adjusted, and count how many times the player bet, called or raised after this stage was reached. This number of 'illicit' bets will be called BADBETS, and the total number of bets made by a player during a hand will be called ALLBETS. For every hand that is played out to a stage where the program sees the player's cards, BADBETS and ALLBETS are counted

GOTO page 145



HAYDEN BOOKS

New Books from Hayden

LOGIC ANALYZERS FOR MICROPROCESSORS

by J. Kneen

Contains the most up-to-date information available on diagnostic test equipment for digital system troubleshooting. Describes the current second generation set of logic analyzers for bus analysis problems on a bus-by-bus basis, with inclusions of cross-bus event correlation and data trace for linked and nested loop algorithms. Also covers VLSI.

0810409534 approx. 128pp Feb'81 approx. £5.35 (paper)

PROGRAMMABLE POCKET CALCULATORS

by H. Mullish and S. Kochan

An in-depth examination of Programmable Pocket Calculators, pointing out their architecture, special features, and programming techniques. Calculators examined are: Novus Mathematician PR, Sinclair Scientific, HP-25, HP-25C, HP-55, HP-65, HP-67, HP-19C, HP-29C, HP-33E. Every program for each calculator covered is incorporated in schematic form showing precisely how to enter the program.

0810451751 approx. 244pp Feb'81 approx. £5.95 (paper)

MUSICAL APPLICATIONS OF MICROPROCESSORS

by H. Chamberlain

A comprehensive guide to all current electronic and computer music performance techniques as they apply to microprocessors. It features previously unpublished techniques that are practical with microprocessors. In non-mathematical language, signal processing techniques are presented and applied to the newer and more powerful 16-bit microprocessors. Numerous charts and graphs as well as some programs in BASIC are used to illustrate the concepts.

0810457539 approx. 688pp Feb'81 approx. £14.85

A CONSUMERS GUIDE TO PERSONAL COMPUTING AND MICROCOMPUTERS, 2nd Ed.

by S. Freiberger and P. Chew

This 2nd Edition up-dates the latest developments in micro-computer technology. A review of over one hundred microcomputer products from over sixty manufacturers.

081045116X approx. 208pp Feb'81 approx. £5.35

DIGITAL COMPUTER SIMULATION

by F.J. Maryanski

Provides methods for using digital computers to perform system simulation studies. After considering the general properties of systems that are significant in digital computer simulation, the text concentrates on the mechanism for the development of programs that simulate discrete systems. GPSS and Simscript are reviewed.

0810451182 approx. 304pp Feb'81 approx. £9.50

COMPONENTS FOR MICROCOMPUTER SYSTEM DESIGN

edited by D. Bursky

This edited compilation of articles from Electronic Design Magazine explores all the details of the latest microprocessors as well as some technology overviews that examine the various microprocessor areas. Covers several technological overviews, single-chip microcomputers, 8-bit and 16-bit processors, and the highest performance units — the bit slices.

0810409755 approx. 272pp Feb'81 approx. £7.15 (paper)

BASIC FORTRAN

by J.S. Coan

Using the same techniques applied to his outstandingly successful books; BASIC BASIC, and ADVANCED BASIC, the author's new book will enable novice programmers to write meaningful FORTRAN programs immediately. He has developed more readable programs by taking a step-by-step approach through the programming process. Beginning with short, complete programs, they are then developed into longer, more comprehensive ones. Over 80 program examples are included.

0810451689 approx. 192pp Feb'81 approx. £5.35 (paper)

WHAT TO DO WHEN YOU HIT RETURN

by the People's Computer Company

A collection of games and creative activities with the accent on leisure. In addition to game simulation, it will also serve as an educational tool exploring the many uses of the microcomputer. Includes number guessing games, word games, pattern games, and science fiction games.

0810454769 approx. 180pp Feb'81 approx. £8.90

BEAT THE ODDS:

Microcomputer Simulations of Casino Games

by H. Sagan

This useful programming guide provides realistic simulation of five popular casino games. Each of the five chapters has the same structure. Begins with a computer run, displaying the facets of the programs, followed by an explanation of the objectives and the physical execution of the game. All programs are written in BASIC and heavily REM'd for readability and conversion. Includes a comprehensive bibliography, and hints on the discrepancies between BASIC dialects.

0810451816 approx. 128pp Feb'81 approx. £4.75

BASIC STRUCTURED PROGRAMMING FORM

by G. Held

An indispensable worksheet that allows programs to be written in pencil before entering them into the computer. In an 11 x 8½ format, the worksheet contains 5 columns for line numbers and 67 columns for the statement, and enough room to write out 25 lines per worksheet. Contains 50 sheets per packet.

0810451719 Feb'81 approx. £1.75

Hayden Books available from all good Bookshops and Computer Stores —
or from John Wiley & Sons Ltd.

A complete list of all Hayden Books and Software is available on request.



Distributed by
John Wiley & Sons Limited
Baffins Lane · Chichester · Sussex PO19 1UD · England

AND SOFTWARE

Software from Hayden

HAYDEN EDUCATIONAL SOFTWARE

ENGINEERING MATHEMATICS 1

(Gilder)

Contains 8 programs for engineers such as: evaluation of a polynomial integration by Simpsons' rule, extended factorial calculations, etc.

08104 01301	PET	£8.90
08104 01303	TRS 80 Level II	£8.90
08104 01304	APPLE II	£8.90

MICROCOMPUTER AIDED DESIGN OF ACTIVE FILTERS

(Gilder)

Contains 8 programs that simplify the design of active filters and will calculate the component values needed for various band pass, low pass, and notch-type filters.

08104 01401	PET	£10.10
08104 01403	TRS 80 Level II	£10.10
08104 01404	APPLE II	£10.10
08104 01407	HEATHKIT	£10.10

HAYDEN FOR BUSINESS SOFTWARE

SUPER APPLE TM BASIC

(Lutus)

A structured BASIC that compiles into an optimized APPLESOFT or integer based program.

08104 05409	APPLE II Disk	£23.80
-------------	---------------	--------

APPLESOFT UTILITY PROGRAMS

(Gilder)

Contains 9 useful subroutines among them 3 different statement formatters: REM, PRINT, POKE writer.

08104 03504	APPLE II	£17.85
-------------	----------	--------

PROGRAMMING IN APPLE TM INTEGER BASIC: Self-Teaching Software

(Banks/Coan)

Teach yourself APPLE TM integer BASIC and control your own progress at all times with this programmed instruction format.

08104 05004	APPLE II	£17.85
08104 05009	APPLE II Disk	£23.80

APPLE ASSEMBLY LANGUAGE DEVELOPMENT SYSTEM: An Assembler/Editor/Formatter

(Lutus)

Write and modify your machine language programs quickly and easily. Features a cursor-based editor, global and local labels, and disk based macros which allow you to incorporate frequently used subroutines into any program.

08104 04609	APPLE II Disk	£23.80
-------------	---------------	--------

FINPLAN: A Financial Planning Program for Small Businesses

(Montgomery)

A financial planning model that allows you to enter data from a balance sheet into the program to make assumptions about future growth of business and to have the computer project results for up to a five-year period based on those assumptions.

08104 05103	TRS 80 Level II	£41.65
08104 05108	TRS 80 Level II Disk Version	£44.65

DATA MANAGER — A Data Base Management System and Mailing List

(Lutus)

Allows retrieval by specific names or category. Data retrieval within a half a second from up to 32,000 alpha numeric characters at a time. Total capacity 96,000 characters per diskette.

08104 04909	APPLE II Disk	£29.75
-------------	---------------	--------

HAYDEN SOFTWARE FOR ENTERTAINMENT

MICROSAIL

(Johnson)

A test of nautical skill against wind, tides and time.

08104 04401	PET	£7.10
-------------	-----	-------

MAYDAY

(Breitenbach)

A challenging airplane flight simulation, tests concentration, judgement and agility.

08104 02601	PET	£5.95
-------------	-----	-------

SARGON: A Computer Chess Program

(Spracklen)

The chess program that won first prize at the 1978 West Coast Computer Faire Chess Tournament. "An excellent buy for anyone who loves the game." Kilobaud.

08104 00603	TRS 80 Level II	£11.85
08104 00604	APPLE II	£11.85

BACKGAMMON

(Wazaney)

A classic game of skill and luck against a pre-programmed opponent.

08104 02501	PET	£6.55
08104 02503	TRS 80 Level II	£6.55

STARCLASH

(Walton)

Galactic Strategy for one or two players.

08104 05903	TRS 80 Level II	£7.70
-------------	-----------------	-------

SKETCHMODE

(Walton)

Create computer graphics, modify them, save them, and read them from tape. While the drawing is held in the memory, it can be reproduced on the screen, save it on tape, or translate it into a form that BASIC can use.

08104 03203	TRS 80 Level II	£7.15
-------------	-----------------	-------

APPLE is a trademark of Apple Computer Company Inc., and is not affiliated with Hayden Book Company Inc. V.A.T. is charged on all Software — Prices exclusive of V.A.T.

Hayden Software is available from your Computer Store —
or from John Wiley & Sons Ltd.

A complete list of all Hayden Books and Software is available on request.



Distributed by
John Wiley & Sons Limited
Baffins Lane · Chichester · Sussex PO19 1UD · England

CREDIT CARD SALES
AMERICAN EXPRESS · DINERS CLUB · ACCESS
BARCLAYCARD/VISA
Telephone:
JOHN WILSON
Chichester
(0243) 784531

THE LAST ONE

A casual phone conversation in early November sent David Tebbutt scurrying off to deepest Somerset where he discovered a program which could just become the last one ever written by a human being.

While the rest of the world has been developing a series of ever higher level languages, two men in Somerset, David James and Scotty Bambury, have quietly created a system which actually removes the need for program coding. Suddenly, programming languages seem a little irrelevant since this system will chomp out bug-free programs on receipt of a program design. Of course, in order that people understand the programs produced, they are listed in Basic, although there is no real reason why they shouldn't be produced in machine code, Cobol, Pascal, or whatever else takes your fancy.

The system not only produces bug-free code but it also does it jolly quickly — a matter of a few minutes once the design details have been keyed in. Since it keeps a record of the program design, this can be modified at any time and new programs generated on the spot. This means that, for the first time in his life, the user can change his mind or modify his system without it costing him an arm and a leg. For the first time, too, ordinary people can implement their ideas on a computer without having to worry about expensive 'experts' or the rigours of learning to program. Programmers on the other hand should find their jobs enriched, getting their intellectual satisfaction from program design and avoiding the tedium of coding and debugging.

This British system, christened 'The Last One'* has the potential to make the frustration and delays usually associated with software production things of the past.

It will, of course, challenge existing ideas and attitudes and, I suppose, the data processing industry could be about to receive a small dose of the medicine it has been dishing out to users for years. In other words, those in the DP industry who fail to adapt to the new approach may find themselves out of work. I believe, though, that this system, if made widely available, will lead to a massive expansion of the marketplace resulting in opportunities that will more than make up for any program coding jobs which may disappear.

The product

David James has created what I believe to be a unique product. Most people would describe The Last One as a program generator, but not in the limited sense of RPG, FILETAB or even PEARL. This system is fairly easy to learn and use and is totally free from acronyms, abbreviations and codes. All input to the system is in plain English; only the results are coded.

Figure 1 shows an outline structure of The Last One. At the highest level of operation, the user is invited to input broad design details — a note of the

* Trade Mark applied for

aims and objectives of the system, the number of files required and the number of programs in the suite. Anyone taking this 'system' option will then be led through a series of questions relating to the files and the programs and, on completion of the questioning, appropriate program code will be generated by The Last One. For those who prefer to build up their system at the keyboard, they can ignore the 'system' option and simply select other options as they need them. The 'create file' and 'create program' options are self-explanatory, while 'modify file' and 'modify program' mean just that — it is possible to amend any program or file details at any time. All necessary changes throughout the system will be taken care of automatically. The 'enquiry' option allows the user to interrogate the system in a number of ways. It is possible to look at file details — both layout and contents — and it is possible to study program details as well. For those who may be feeling a little lost within The Last One itself, there is a 'help' option which offers a guided tour to the various operations available.

'Nobody told us it couldn't be done so we went ahead and did it'

'Scotty' Bambury

File creation involves setting up the necessary descriptive information such as file size, name, password, number of fields per record plus the definition of things such as field names, sizes and type of contents. All pretty straightforward stuff — nothing very unfamiliar there.

Program creation is a little different. Having created the file definitions, and this must always be done first as with many conventional computer languages, the user is then invited to enter program design details. This is done in a way very similar to the way many programmers work, especially those who say 'I never use flowcharts'. Although called the flowchart entry part of the system, the layout is more like that piece of paper on which you jot down your first thoughts about a program. All the likely options are presented in menu form offering choices like 'Input from console' or 'set index to end of file' or 'unconditional branch to ...'. In this way, a program design is created with typical actions being provided for input, output and processing. One other facility within this flowchart section is to allow the user to name other programs which have already been defined. These are then built into the coding for the program being created.

A 'flowchart' might look something like the example in Figure 2. Here

we're opening two files — file 1 will have a field updated and file 2 will have transaction records added to it. Searching through the first file requires the index to be set to the start of file prior to each search. The user is required to input certain details through the console. In this example, we're assuming that each entry corresponds to a field in one of the files, the transaction file, therefore the labels can be 'borrowed' from this file and used as prompts on the screen. There are other ways of issuing prompts within The Last One if this isn't to your liking. The record in file 1 is accessed using a key, customer number perhaps, entered by the user. Calculations are performed — quantity times value and VAT calculation, perhaps. Then both files are updated. The cycle can be repeated until the user replies 'no' to the 'again' question, then the end of file is written to file 2 and the program terminated, usually by a call to another program.

Now, it's very clear from the above that there's a lot more to program writing than just putting in simple flowcharts like that. The point about The Last One is that once you've given it a structure to work to, it can then ask all the necessary questions to fill in the gaps in its information. It will be asking for details of the fields to be entered through the console, where to jump to, what key fields will be used to search the file and precisely what maths is involved.

Once the answers to these questions have been given, The Last One then gets on with generating program code. It produces two versions of each program — one following the precise structure laid down by the program designer, the other using its own knowledge of program structuring to optimise the code. It then benchtests each one, compares the results and churns the best one on to disk (or tape). Since PCW's visits, work has been done on a version which will give the user the option of choosing between speed and memory efficiency.

'..should be supported for ... its national importance'

Barclays Bank investigator

Program generation takes just a few minutes once the design details have been keyed into The Last One. Most of the programs I saw generated took around five or six minutes and they were absolutely bug free — a significant improvement over any programmer. Admittedly, the programs weren't vast — usually between 100 and 200 lines, but then The Last One is at present written in Basic so things could be hotted up phenomenally by the use of machine code. It's a funny thing, but

Who it's for

At the moment The Last One is clearly aimed at the system designer and the analyst/programmer. That's not to say that others won't use it, they most certainly will, it's just that that particular market can pick up the product and use it profitably within a couple of hours. Others less used to a structured approach to systems analysis and design will have to discipline their working methods a little — surely no bad thing. It will probably result in sounder systems designs anyway.

'If the computer is to be truly 'personal', adult and child users must be able to get it to perform useful activities without resorting to the services of an expert'

Robert M Gravina, Associate Professor of Mathematics, University of Lowell, Massachusetts.

One of the things which David and Scotty feel strongly about is documentation — David because he hates doing it and Scotty because he knows it's vital to the product's success. Accordingly, they plan two books, both of which will probably be written by an outsider who can make a first class job of them. Inevitably, the first book is an operating manual aimed at the experienced person and outlining the structure of The Last One and the options available at the various stages. This book will also contain a number of worked examples which will be particularly useful during the early stages of ownership. The other book will be an altogether grander affair which will be aimed at the inexperienced user — inexperienced in systems analysis and design, that is. This book will take such a person through all the stages necessary to take him from knowing nothing to being able to construct systems using The Last One. This book would almost certainly have much value in its own right, too, if readers ignore the fact that the final part will relate specifically to The Last One.

'It'll make computers available to many many more people'

'Scotty' Bambury

While no firm marketing decisions have yet been taken, it is looking almost certain that the product will be made available all over the world and will be marketed like any other standard package. There is some talk of registering

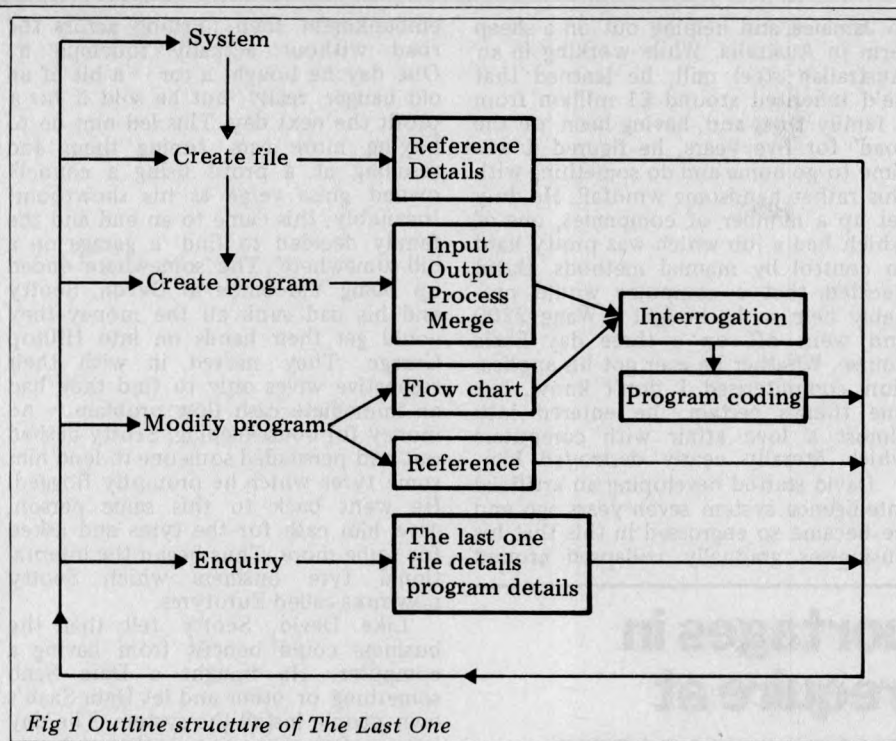

Fig 1 Outline structure of The Last One

- 1 Open files 1 - 2
- 2 Jump to end of file 2
- 3 Set Index to start of file 1
- 4 Console input using labels from file 2
- 5 Ask user 'Is this data correct'. If no jump
- 6 Search file 1 for data
- 7 Maths with files 1-2
- 8 Write to files 1-2
- 9 Ask user 'again'. If yes jump
- 10 Write 'end' to appended file number 2
- 11 Terminate program

Fig 2 A simple 'flowchart'

once you get used to programs being generated in six minutes you forget how amazing it is and start to get impatient!

The program can now be tested and the results analysed using the enquiry facility to look at the contents of files. If it doesn't work properly then it would be because of a logic fault somewhere in the design of your program or system. File design or program design can easily be modified and one of the nicest things about the whole system is that if a file layout is changed in any way, then all the programs affected by this change are themselves modified and regenerated. If a program is modified, the system will ask those questions necessary to complete its new design and then generate fresh code.

The design of The Last One allows it to be run on almost any computer from an HP 41C to, presumably, the biggest Cray. David does all his development work on an Ohio C3C with 96k memory, two terminals, a 23Mb hard Winchester disk — shortly to be upgraded to 74Mb — and twin 8in floppies for security purposes. He has had versions of The Last One running on Apple, Tandy, PET, Wang 2200, Sorcerer, HP 41C — 'admittedly a somewhat cut down version' said David — and one or two other machines to boot. At the moment, he is concentrating his efforts on getting the system running on a PET both disk- and tape-based, and under CP/M. Within a matter of

months the current version of the system should be available for all the popular machines. Of course, cassette and floppy based systems won't run quite as quickly as the Ohio system but even then, the speed will be many many times faster than hand coding.

'A lot of effort should be put into exporting it and showing the rest of the world that British can still be best'

Report from PCW to the DOI

Future developments of The Last One will make it more accessible to the user by removing the need to create program designs. Eventually, it is hoped that a user may simply be questioned about his needs and, once the system has a complete and logical picture of the requirements, it will itself define the files and design the programs. This is a little way way off because of the need to adapt it to run on the popular machines. There is also some talk about producing different versions of The Last One to suit the different types of user. For example, there may be an architect's version, one for the scientist, another for computer games, and so on.

users, thus entitling them to buy upgrades to the system as they become available, but no decision has been taken yet.

I am certain that when existing software houses see the product they will want to use it for their own systems development work. It will give them a measure of control over the programming function, previously such a difficult aspect to manage. The Last One is likely to result in a change of emphasis rather than in any revolution within the computer industry. Users who take the trouble to learn about The Last One will be able to implement their ideas without employing expensive experts. The likely consequence of this is that users will have a stab at computerising things that they would not have dreamt of previously. It won't matter if they

in Jamaica and helping out on a sheep farm in Australia. While working in an Australian steel mill, he learned that he'd inherited around £1 million from a family trust and, having been 'on the road' for five years, he figured it was time to go home and do something with this rather handsome windfall. He duly set up a number of companies, one of which had a job which was pretty hard to control by manual methods. David decided that a computer would probably help so he bought a Wang 2200 and went off on a three day Basic course. Whether he ever got his application computerised I don't know, but one thing's certain: he entered into almost a love affair with computers which literally nearly destroyed him.

David started developing an artificial intelligence system seven years ago and he became so engrossed in this that his businesses gradually collapsed around

embankment then hurtling across the road without actually touching it! One day he bought a car — a bit of an old banger, really, but he sold it for a profit the next day. This led him on to buying more cars, tuning them and reselling at a profit using a council-owned grass verge as his showroom! Inevitably, this came to an end and the family decided to find 'a garage on a hill somewhere'. The 'somewhere' ended up being Yarcombe in Devon. Scotty and his dad sunk all the money they could get their hands on into Hilltop Garage. They moved in with their respective wives only to find they had an immediate cash flow problem — no money for housekeeping! Scotty dashed out and persuaded someone to lend him some tyres which he promptly flogged. He went back to this same person, gave him cash for the tyres and asked for some more. Thus began the international tyre business which Scotty now runs called Eurotyres.

Like David, Scotty felt that the business could benefit from having a computer. He bought a Data Saab something or other and let Data Saab's own people install the system. The day came when he wanted the software changed and he was quoted such ridiculous prices and lead times that he started to reflect on the possibility of doing the job himself. One of his early ideas was to use the power of the computer to generate programs in response to the user defining his requirements. In fact, the more he thought about it, the dafter the DP industry seemed to be, sitting on all that power and not using it to help with their own jobs. Two days after deciding to write his own system, he read about David's downfall in *Computer Talk*. He realised immediately that David had already gone through this loop some five years previously so they arranged to meet.

The meeting took place at the Eurotyres office and Scotty's suspicions were confirmed — David had indeed constructed some program writing routines in

'Manpower shortages in England will require at least 500 new programmers per month until 1985 to keep pace with user demand'

David Butler at the Infotech 'State of the Art' review, 1980

make mistakes because it's no longer a time consuming and costly business to modify or rewrite the programs. If users know that The Last One exists and that they have a fair chance of being able to use it successfully, then they are more likely to take the plunge and buy themselves a computer. This will result in a tremendous market expansion — something that can't really happen without The Last One or something similar appearing on the scene.

If there is such a person as a program coder, and I have heard of one, then he is going to have to change his job — perhaps running The Last One on behalf of the analysts? The analyst/programmer should welcome this development because it means that he can spend more time on ideas and less on tedious coding and debugging. System designers should be overjoyed because it means they can implement their ideas in the way they want to without necessarily having to use the services of a programmer. One thing is certain: things are going to change, but the market expansion brought about by systems such as this will surely improve the employment prospects for data processing professionals rather than diminish them.

Background

The two principals in this story are somewhat unusual and it will help you understand how The Last One came into being if I explain. First of all, David James left school, Millfield, with just one 'O' level, in history, he thinks. Realising that this really wasn't quite good enough, he went back to school to take another two — maths and physics. Thus armed, he set off to see the world, ending up doing various strange jobs — such as being a film extra

him, leaving him bankrupt. All his computers — the Wang, an Apple, a Tandy and a PET — were taken away from him and, because of his previous wealth, he was pestered by television and newspaper reporters. Things got so bad for him that he tried to kill himself. He was rushed to hospital where he recovered, his mum bought him a Sorcerer and, once again, he was doing what he loved — working with the computer. He was still feeling despera-

'One of Scotty's early ideas was to use the power of the computer to generate programs in response to the user defining his requirements'

tely low when an article appeared in *Computer Talk* describing his rise and fall and mentioning the artificial intelligence system he was working on.

Before continuing with David's story I should introduce you to the other principal in this saga — 'Scotty' Bambury. Like David he'd left grammar school with a couple of 'O' levels and he'd also spent five of his early years 'bumming around', in his case on and around the Watford by-pass. Scotty was a motorbike freak and used to spend most of his time mending bikes at the roadside or performing daft stunts like driving up the by-pass

connection with his work on artificial intelligence. The two men hit it off together immediately and Scotty realised that he wouldn't have to learn to program after all — he could use David. Scotty formed a company immediately and took David under his wing, giving him computers, somewhere to work and, after a couple of months, somewhere to live as well. The company is now called DJ 'AI' Systems.

For the last 18 months David has worked exclusively on The Last One with Scotty keeping his feet on the ground whenever he tried to do some airy fairy stuff which wasn't strictly

relevant to their objectives. David tells me that meeting Scotty was nothing short of a miracle. He is con-

'We didn't know that we'd done anything clever until PCW told us'

'Scotty' Bambury

vinced that if they hadn't met, he would have taken another overdose but done it properly the second time. Instead, the pair of them have come up with a truly

remarkable product which removes software as a barrier to widespread use of computers. For the first time, the user can have the system he wants, when he wants it and one which is easy to change along with his changing requirements.

Conclusion

Because David James and Scotty Bambury have no real connection with the data processing industry, they have succeeded in creating a product which is quite unique. No doubt you will recognise the odd technique borrowed from here and another bit which reminds you of something you already know. But the fact is that they produced The Last One in almost complete isolation, concentrating on satisfying the needs of the user of such a system, rather than by studying things like language development. So it is that a

THE LAST ONE

system has been produced which not only makes it easy to create operational computer programs quickly, but also allows the user to change his mind without causing serious problems. In the past, a user was expected to agree to a computer system design without having any real idea of what the end product would be like in practice. He had to wait several months for the work to be done only to find that the results weren't quite what he wanted after all. Now, if the end results aren't quite right, the system can be changed at the drop of a hat.

'You've found the philosopher's stone'

PCW's first reaction

In Scotty's words: 'We now have the chance to put the computer industry right and get it running like a proper business.' And he's right. This development marks the end of the unwitting tyranny of the computer industry. Users will now be able to treat computers as tools rather than as parasites which is often the way they've been regarded in the past.

We should remember that this product is British and we should be feeling very proud of that fact. It is now up to those among us who have it in their power, to get The Last One through its final stages of development and on the world markets. Today Britain has a world lead — let's not kill it.

Finally, David and Scotty can't wait to get this product completed so that they can get to work on other projects. It is my view that, stunning as The Last One may be, you ain't seen nothing yet!

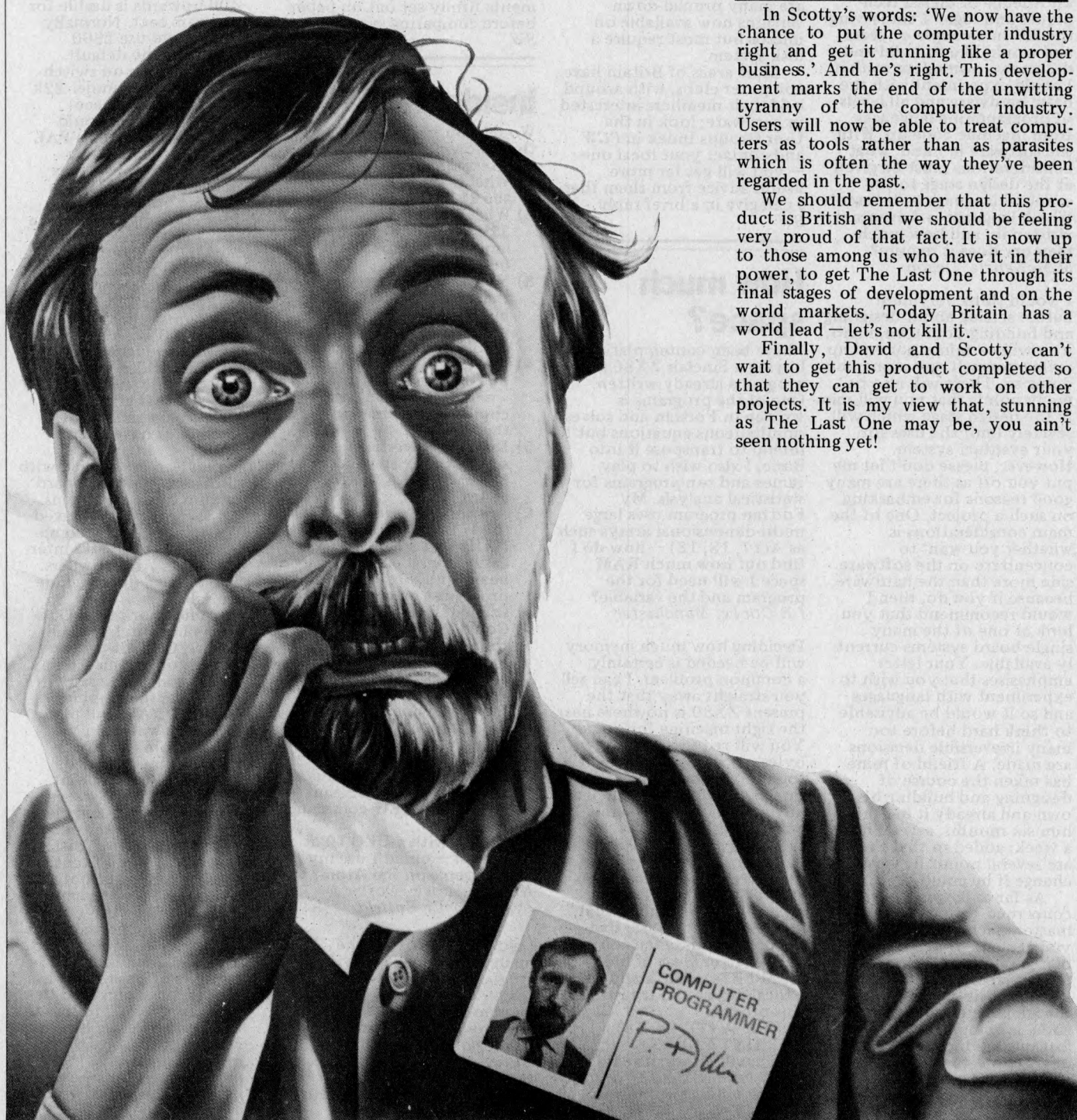



COMPUTER ANSWERS

Send your queries to: Sheridan Williams, 35 St Julians Road, St Albans, Herts.

Adventurous builder

I am an electronics technician with the RN and have a good knowledge of digital techniques and logic. I am leaving the RN in a couple of years and would like to build and design my own micro so that I could experiment with the basic hardware and all levels of programming languages from machine code up. With the software in mind, what considerations must be given at the design stage to the eventual language to be used? Which language is Adventure written in, and how much memory does it require?
M McKenzie, Devon

I would think very hard before setting about designing and building your own micro. You will certainly not end up saving yourself any money by doing so. There will also be many points that you will miss in the design stage which will severely limit the uses for your eventual system. However, please don't let me put you off as there are many good reasons for embarking on such a project. One of the main considerations is whether you want to concentrate on the software side more than the hardware, because if you do, then I would recommend that you look at one of the many single-board systems currently available. Your letter emphasises that you wish to experiment with languages and so it would be advisable to think hard before too many irreversible decisions are made. A friend of mine has taken the course of designing and building his own and already it has taken him six months, several hours a week; added to that there are several points he would change if he could.

As far as languages are concerned, you will have to master machine code, but you can ease this if an assembler is available. I would opt for a system that supports Forth as this language has all the advantages of machine code, is compact, runs very fast but has high-level type instructions to speed program writing. Make sure that the system that you choose has a

very good and comprehensive manual, as this will be of utmost importance to you.

Adventure source code is usually written in Fortran, and it was originally used on mainframe computers where 'main store' is unlimited compared to micros. For that reason, most versions call the file into main store and execute without recourse to files. This requires around 100k of main store (32 bits) as far as I can gather. There are many pruned-down versions now available on micros but most require a disk system.

Most areas of Britain have computer clubs, with around half their members interested in hardware; look in the User Groups Index in *PCW* and contact your local one — you will get far more useful advice from them than I can give in a brief reply.
SW

How much space?

I have been contemplating buying a Sinclair ZX80 to run programs already written. One of the programs is written in Fortran and solves simultaneous equations but I intend to transpose it into Basic. I also wish to play games and run programs for statistical analysis. My Fortran program uses large multi-dimensional arrays such as A(17, 18, 18) — how do I find out how much RAM space I will need for the program and the variable?
I R Cooke, Manchester

Deciding how much memory will be needed is certainly a common problem. I can tell you straight away that the present ZX80 is nowhere near the right machine for you. You will require around two bytes per integer and between four and eight bytes per floating point variable depending on the version of Basic being used. Your array requires around 8000 array elements and, at four bytes each, say, you will need 32k just for the array! There are a great many machines that have versions of Basic that support multi-dimension arrays (steer clear of old ROM PETs), take a trip to a local dealer and try running this program:

```
10 DIM A (17, 18, 18)
20 PRINT FRE (X)
which will either display 'OUT OF MEMORY' or print a value telling you how much
```

memory is left.

In order to ascertain how much memory is required for the program you can obtain a rough answer by assigning two bytes for each line number, one byte per keyword, one byte per extra symbol, two bytes per integer constant, four to eight bytes per fp constant and $n + 2$ bytes for an n -char string. Look at machines like Tandy, Video Genie, Sharp MZ-80K but get your requirements firmly set out on paper before comparing systems.
SW

Inside the Atom

Would you please answer the following questions on the Acorn Atom?

- 1) What is the access time of the 2114 static RAM chips?
- 2) What is the price of the 32k dynamic RAM board and the 8k static RAM board?
- 3) You say in your review that when the 32k RAM board is fitted, 9k is unseen. Is this only with a fully expanded machine?
- 4) What is necessary to output PAL colour signals, what is the resolution, choice of colours and the price?
- 5) Does the advertised power supply cover all versions ie 8 V at 800 mA to +5 V at 1.8 A?
- 6) Are the faults in the VDG (6847), ie 60 instead of 50 Hz and 32 x 16 display, easily upgradeable? I've heard of a 80 x 16 word processing card — would this aid the 60 Hz problem?
- 7) Could you state which of the following faults stated in your review have been corrected for production versions: video lead, faulty keyboard, engraved keys, cassette loading, index?
- 8) Could you state the graphics commands and tell me what they mean?
- 9) What is the NEW command for?
- 10) I work with a DEC 10 at school — could I use my programs on the Atom?
Krste Asanovic, Corby & Craig Zanelli, Enfield

I would send off for the manual *Atomic Theory and Practice* which is available from Acorn. This is a very good manual for the Atom and one worth buying for £8. Its author, David Johnson-Davies of Acorn Computers, very kindly provided most of the answers to the questions

above.

Here they are:

- 1) The RAM chips must have an access time of less than 500 ns;
- 2) The price of the 32k dynamic RAM board depends on the configuration but is around £195 to £205, excluding VAT. The 8k static RAM board costs £109 in kit form;
- 3) The 32k card can be fitted between addresses OH and 7FFFH and, of this, 400 upwards is usable for program text. Normally you would use 2900 upwards (the default configuration on switch-on) giving just under 22k of continuous space;
- 4) For colour you would need to fit an Atom PAL encoder board which costs £24.50 and plugs inside the Atom. There are two possible sets of four colours, selectable in software — green, yellow, blue, red and buff, cyan, magenta, orange;
- 5) The Atom power supply will power a fully expanded Atom, which requires 1.6 A at 8 V;
- 6) Acorn produces an 80 x 25 VDU which can be fitted inside the Atom case. Note that you will have to load a new VDU handler or have one in ROM;
- 7) Video lead is supplied with all Atoms. The keyboard seldom causes problems. All the keys are engraved. We do not get any complaints about cassette interface from Atom owners. The manual *does* include an index.
- 8) Graphics work with O, O at the bottom left-hand corner. CLEAR prepares screen for graphics in any one of nine modes. MOVE will move the graphics cursor. DRAW will plot a line anywhere on the screen from the cursor to the point specified. PLOT will plot a point anywhere on the screen.
- 9) The NEW command clears the memory of the current program. In fact it just moves the 'end of text' marker to the start of the text area. Programs may be recovered with 'OLD'
- 10) You will find considerable differences between DEC 10 Basic and other versions of Basic. This is a problem not confined to the Atom. Areas of major difference are the handling of strings and files. If you are a competent programmer, I can see no major problems for you,

COMPUTER ANSWERS

but your programs are unlikely to be directly transferable.

SW

Agro for HP

My section has a Hewlett Packard 9830B computer or 'desk-top calculator' and there is no prospect of renewing the system. I desperately need to compile and run Fortran programs or, at a pinch, Basic, in order to speed up some of the data processing work we do. Is there a Fortran for the 9830? *L W Huson, Ministry of Agriculture, Surrey*

Hewlett Packard tells me that none of its desk-top systems have Fortran. It's available on HP mini-computer systems and there is no chance of one being developed for the small machines.

I have thought about your problem and feel that the solution does not lie in a compiler of any sort. You see, for most data processing programs, the CPU is I/O bound; that means that however fast the CPU or compiler/interpreter works, it cannot work any faster than the rate at which data can be transferred between peripherals. This is a point often overlooked by those new to micros. Data processing usually involves a great deal of file handling and even if it doesn't, some of the work will be arithmetic, in which case all the floating point arithmetic is done at machine code speed anyway. The only chance of speeding up the program with a compiler is if the program does much of its processing using loops, in which a great deal of decision making is done. I have purposely oversimplified the whole task of data processing but, having tried compilers as a solution, I have not always been happy with the resulting increase in speed. I have often been able to make a similar improvements by redesigning my program and file structure/design. I expect that your problem would be solved with a direct access file but cannot tell without further details

SW

Whatsit mean?

I have a Tandy TRS-80, and want to type in the program 'Ski jump' on page 83 of the Nov issue. What is PRINT LIN/(2)? In fact, the / sign appears throughout the program. Can you also recommend a book which is full of TRS-80 programs? *H W Heppel, Lightwater, Surrey*

The / sign is a replacement for the S sign, and the LIN/(n) function prints n blank

lines; so replace line 70 with PRINT:PRINT. Yes, there is a book full of TRS-80 programs but I cannot recommend it because I haven't read it. It is called *32 Basic Programs for the TRS-80 (Level 2)* by Rugg & Feldman. It has 267 pages, and contains home/educational games, graphics mathematics and miscellaneous programs. There are at least nine other books with Basic programs in.

SW

New Roms for old

I own an 8k old ROM PET which I wish to upgrade to a new ROM version but cannot find any adverts offering this service. Can you tell me who provides this service? *C Petch, Leicester*

Virtually any dealer of PETs worth his salt will undertake the upgrade. It is only a matter of replacing a chip. Just phone around the dealers closest to you.

SW

Novel problem

I am a novelist and write around two novels a year (under different names). I am now getting fed up with scissors-and-paste revisions and the endless retyping of whole paragraphs because one or two words have changed. What I need to be able to do is produce good quality copies for publishers and also insert, delete, transpose and substitute text from single letters to whole paragraphs. Ideally I'd like to be able to move words around

using a light pen. I am restricted to the PET and Apple and would like your advice. *M Ross-MacDonald, Banagher, Co Offaly*

There are several points to consider here but basically there is no problem. Both the Apple and PET have word processors but in my view the 'Wordcraft' for the PET is superior. The PET also has a far better keyboard with a shift lock. The keyboard will be an immensely important consideration and should not be taken too lightly. You should go for the new 80-column screen PET, as this will make text far easier to view. There are versions for both the Computhink disks from Petsoft and also the PET disks from Dataview in Colchester; your dealer should have no problem obtaining either. If he does, then buy the hardware from him and order the software from another supplier by post.

I estimate that an average novel contains 800,000 characters; as the 2040 PET disks hold 170,000 characters and the 8050 PET disks hold 500,000, you will be able to work out easily how you will have to process your books. Several disks will be needed in order to hold backup copies of text (don't ignore or underestimate the importance of at least two copies plus the original disks).

SW

Pinta cure

I have a Sinclair ZX80 and when I enter about 47 lines, the cursor and the line I am entering both move up to the last line entered before I have pressed NEWLINE. Why? *John McRae, Strathclyde*

It appears that your ZX80 has a hardware fault which shows up when the machine overheats. ZX80s move in mysterious ways when they get hot. My own machine — before I moved the power supply away from the computer — often went into the SAVE mode when any key had been pressed after it had been running for a few hours. Try putting a frozen long-life milk carton on the ZX80, just to the left of the 'hump'. Absurd as this suggestion sounds, it is an easy, and non-technical (!) means of drawing heat away from the power supply. You may well find this stops your problem completely. Certainly my ZX80 no longer behaves oddly now that its heat is more adequately dissipated. If you're not into such extreme 'minimum technological support', you can rig up a big bolt, or tobacco can, as a heat sink. *Tim Hartnell, National ZX80 Users Club*

Foreign TV standards

Is it possible to connect computers like the Sinclair ZX80, Acorn Atom and New Brain with TV sets in places like France, West Germany, Brazil and the USA? If not, what modifications should be needed in the UHF modulators and/or video interfaces?

E D Zantotto, Sheffield

The easiest thing would be to take your own portable set with you! Television sets vary considerably to match local transmission characteristics. These can vary quite widely as to the number of

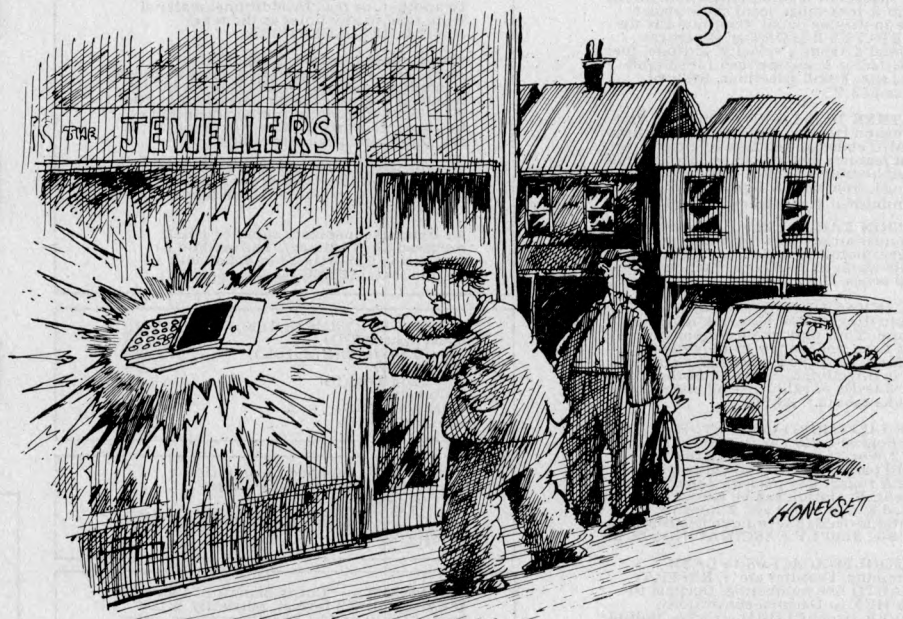

'Fred's really advanced — he uses a computer on all his robberies now.'

Applesoftware from Leicester Computer Centre

the correspondent

by R. Wagner

★ Now with mathematics routine ★

THE CORRESPONDENT is sure to be one of the most versatile programs in your library! It can be used as:

A Text Processor: Upper/lower case, 1-80 cols. (4-way scrolling). Text move/copy/insert/delete, tabbing, justify text, auto-centering and more!

A Database (with or without printer!) Extremely fast find routine and easy editing make it a natural for free-form data files. Create and fill out forms, access phone lists or index your magazines.

A Programming Utility: (printer or not). Examine, edit, transfer random or sequential text files. Create versatile exec. files. Even put bi-directional scrolling in your own programs!

Use the Correspondent to print-out your **Visicalc** formula. Apple disk £29.95 + VAT

DOS Tool Kit (3.3)

Programmers assistant gives you automatic line numbering, show control demonimators, Hi-Res character generator, define your own character set.

Animatrix — put characters anywhere on your Apple screen — useful for animation. 6502 Assembler/editor. Price on application

LCC UPDATE POLICY

Programs are constantly being improved — if you have an old one, you can exchange for the latest edition for only 20% of the current price — just send to us your original disc and remittance.

Apple-Doc

By Roger Wagner

An Aid to the Development and Documentation of Applesoft Programs

This 3 program set is a must to anyone writing or using programs in Applesoft! It not only provides valuable info. on each of your programs, but allows you to change any element throughout the listing almost as easily as you would change a single line!!

With Apple-Doc you can produce a list of every variable in your program and the lines each is used on, each line called by a GOTO, GOSUB, etc., in fact, every occurrence of (almost anything!) You can rename variables, change constants and referenced line numbers or do local or global replacement editing on your listing.

Apple-Doc is a must for the serious Applesoft programmer.

Diskette complete with full documentation £24.95 + VAT



Perspec, Rotate, View, Move to-3, View-from. Complete with comprehensive instructions

PASCAL—FORTRAN COMPATABLE An exciting new addition to your Pascal library — enables you to create 3D graphics, viewable from any angle and distance. As easy to use as Turtlegraphics. Procedures include Ortho, Min.16K required — please state T4 or Nas-sys/2 or 4 MHz/with or without graphics. £49.95 + VAT

Apple World is here. The fast 3D graphics package that runs on your Apple II plus. Zoom, pan, tilt and scale your own designs on the Apple screen, at only £24.95 + VAT

Plus a complete range of "off the shelf" programs for finance, commercial, scientific and education. Keep yourself up to date, send for our "Fact Sheets" giving full program details.

Now available Apple FORTRAN, Dos 3.3, Apple Plot

LEICESTER computer centre limited

67 Regent Road, Leicester LE1 6YF. Tel: 0533 556268



Sales and Service

Apple III! Send for details now

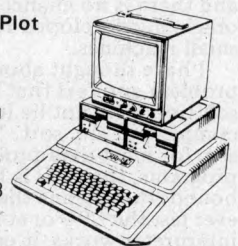

LUNAR LANDER SUPREME (16K/B/G)—classic spacecraft landing simulation. Short, medium & long-range scans show planet surface in varying detail. Continuously updated STATUS REPORT gives vertical, horizontal & relative velocity, altitude, fuel level, G factor & surface scan for suitable landing site. 8 skill selections. Brilliant graphics £13.95

STARTREK II(32K/B/G)—enthralling, real-time version from our Invasion Earth author, using M/C code sub-routines to great effect. Special features include larger galaxy, shielded homing warheads (fired by Klingons), time slots & non stop action. Save unfinished games on tape £13.95

INVASION EARTH (MC/G)—fast version of the popular arcade game. 4 invader types/intelligent homing, exploding, angled, direct, multiple warhead & radio-jamming missiles. 40 skill levels. Only £9.95

CLIFF INVASION(B/G)—the aliens have landed in droves. You have one remaining laser base. Your only chance—shoot the ground from under them as they descend the cliffs towards you. Landslides created. Errors in direction & elevation of shots are costly. 3 levels of skill. Like all aliens, they breed like rabbits! £8.95

SUPER LIFE(MC/G)—the BEST!—Evolution of a biological colony with 100 by 125 cell array (2/3 or 3/4 options). Use the 21 standard patterns or set individual pixels. Rotate & reflect any pattern. Select from 10 speeds. Evolution can be halted, patterns modified & new speed set. Extensive instructions—overlay technique keeps program within 8K, SIMPLY FASCINATING! £8.95

MINI-TOOLBOX(MC)—aid to BASIC programming. Features are:— REPEAT KEY, AUTO line numbering, Decimal to HEX & HEX to Decimal conversions, RECOVER (from CLOAD error) & Multiple USR(X) routines. Resides in spare memory from OC80HEX. £7.95

NASCOM 1 & 2

WORDEASE-WORD PROCESSOR (MC)

Professionally written 4K word processor:— 14 line window on text buffer & extensive on-screen editing facilities. Insert & delete characters, lines & paragraphs. Text manipulation—copy from one section of text to another, or read in additional material from tape to any point in the text. FIND & REPLACE facility.

Exceptional formatting capability:— commands embedded in text allow complete flexibility e.g. variable tab position, indent, line length & page length. Use of up to 10 'MACROS' permits automatic inclusion of headings, footings & other 'text repeats', & also automatic page numbering.

Output to printer — can vary character delay, inhibit line feeds & force upper case if required. Text can be saved on tape & recovered.

An extensive manual is supplied (itself prepared on Wordease). The method of formatting is illustrated in detail with a sample text. £25.00 (manual only £1)

SUPER STARTREK(B/16K)	£9.95
Spacefighter(B/G)	£7.95
Alien Labyrinth(B/G/16K)	£7.95
Driver(B/G)	£6.95
Sheepdog Trial(B)	£5.95
Slalom(B/G)	£5.95
Biorhythm(B/G)	£4.45
Labyrinth(B/G)	£5.45

All programs supplied on cassettes.
B= BASIC, MC = Machine Code.
G = Graphics.
8K RAM required unless otherwise stated.
PLEASE GIVE FULL DETAILS OF YOUR NASCOM

**NASCOM 1 — Cottis Blandford Cassette Interface for N2 format, reliability & fast load. £16.30 or £13.30 with program order.

MUSIC BOX

Now you can make music with NASCOM. Easy to follow program allows you to key in old favourites or have fun composing your own tunes. 7 octave range with staccato option, 9 tempos, Set note duration or tap in rhythm as required. Comprehensive editing. Delete, insert or amend notes. Single-step forwards & backwards through tune. Add new lines within declared array size. The program includes tape generating & play-back routines & is supplied with 2 demonstration melodies & instructions for connecting your Nascom to an amplifier/speaker such as our unit below. Min.16K required — please state T4 or Nas-sys/2 or 4 MHz/with or without graphics. Only £13.95

MUSICAL BREAK-OUT/ (MC/G)

You have 8 chances to hit all the bricks out of a moving wall. The object is to keep the ball in play. As in squash, the angle of bounce is not always predictable. Good reflexes required. If fitted with an amplifier/speaker, different notes are produced on hitting the various bricks. £6.95

COWBOY SHOOT-OUT(MC/G)

Full feature Cowboy Shooting game for 2 players. Two versions played alternately—firstly, shoot your opponent across 'Main Street' avoiding the moving Chuck Wagons and then through a wall which has to be demolished first. Complete with sound of shots & musical accompaniment when fitted to an amplifier/speaker. £6.95

AUDIO INTERFACE BOARD & SPEAKER

Compact & ready assembled, suitable for use with "Music Box" & other 'sound effects' programs. 3 simple connections. Complete with instructions on programming for sounds £9.75.

Please add 45p/order P & P. V.A.T. of 15% Sae for FULL CATALOGUE to PROGRAM POWER 5, Wensley Road, Leeds LS7 2LX.

Telephone (0532)683186.

lines, the supply frequency and the transmission band (VHF or UHF). This could certainly call for different modulators at the least.

In addition to the varying details mentioned above, at least three different colour transmission systems are in use — the French Secam, the German and British PAL and the US NTSC system — and there are often local variations on these. Brazil, for example, is one of several countries using a S25-line, 30 Hz fixed rate PAL system!

With all the variations in equipment listed, not to mention differing mains voltages, it would take a whole article, rather than the space here, to do justice to the modifications needed to adapt individual UHF modulators to each country. If you can't take your TV set with you, try buying the modulator in the country in question. Of course, you should have a demonstration that it will work with your computer before buying. Please also check that the local voltage will not damage your computer before you first plug it in.

P L McIlmoyle

Size diskussion

Could you advise on the pros and cons of full-size 8in floppy disks as compared with 5in mini-disks? I am thinking in terms of a typical 'small business' set-up, with two disk drives, costing in the region of £3000-£5000. Name and address supplied

The 8in floppy disks have been around for quite a bit longer and have come to be accepted as standard in main-frame and minicomputer circles. In those quarters, mini-disks are regarded usually as 'amateur' or 'for home computers'. Despite this, one of the leading makers of commercial word-processors — AES — Wordplex — have moved from twin 8in drives to twin mini drives as standard on one of their leading models. In brief, the 8in disks have going for them: — Older established and introduced by IBM; — Potentially greater storage capacity per disk (about 250k single-sided, single density, 500k double density, 1 to 1.2 Megabytes double density, double-sided); — Give a 'professional' image to the complete system.

The snags are: — A history of reliability problems with double-sided drives, although this is generally believed to have been largely overcome by the latest designs; — It is normal practice for 8in drives to rotate the whole time the system is switched on, rather than only when an access is made to them. This can lead to complaints

of noise from office staff (though they are quiet compared to printers!) and shortens disk life.

Points in favour of the mini-disks are: — The drives are small enough to build into VDU units; — Reasonable storage capacity (up to about 320 kbytes in the double density, double-sided format); — Established reliability even in the double-sided versions; — Lower cost of the drives; — Drives do not usually run continuously.

On the problem side, they have:

— Lower capacity;

— 'Toy computer' image.

Summing up, I have a suspicion that the 8in floppy disks will retreat before the onslaught of the 'Winchesters', while the mini-disks will gain greater acceptance in the commercial computing field, especially with the growth of 'distributed processing' and 'intelligent terminals'.

P L McIlmoyle

'Intelligent' ZX80

My ZX80 seems to think for itself. I was experimenting with a program to generate prime numbers and when LOADING it a day or two after first SAVEing it, I noticed a question mark in one line (LET S = 3? to TRIAL—1). Despite this, the program ran perfectly (was the ZX80 trying to help me?) but the question mark had vanished when I returned to the listing and there was no way I could get it back in. How come?

W Cartwright, Lostock, Bolton

It appears that you may have accidentally POKED a character code corresponding to a question mark into the listing. There is no way to directly enter a question mark in the position you found it without getting a syntax error. By the way, POKING these particular characters into the ZX80, and subsequently listing the program, is a dangerous practice which is likely to play such havoc with your machine that you have to disconnect the power before you are able to use it again.

Tim Hartnell, National ZX80 Users Club

Coming soon?

I have heard that Clive Sinclair is developing a printer for the ZX80. If this is so, when will it be on the market, and how much will it cost?

R Whiteley, Leeds

Uncle Clive is indeed developing a printer and withdrew the new 8k ROM in late

September, 1980, to re-program part of it to drive a printer. He is somewhat unforthcoming about the cost and proposed delivery date but my reading between the lines suggests availability in May/June and a price of around £85. However, these are only semi-educated guesses.

Tim Hartnell, National ZX80 Users Club

Display wanted

Where can I get a multi-character dot matrix display, as used in the Newbury New-Brain, Sharp PC-1211, etc, and what would it cost? *N Smith Milton Keynes*

Like many concerned with building prototype, one-off, or short-run electronic gear, my first reaction was to reach for that excellent catalogue produced by RS Components Ltd, (P O Box 427, 13-17 Epworth St, London EC2P 2HA). And there on page 109 of the latest (November) issue are devices which come close to being what you are looking for. Not quite, I'm afraid, as each unit is only one character wide and, as listed, displays only the hexadecimal characters of 0 through F, rather than the full range of alphanumeric characters, let alone the full ASCII set.

The first problem is easily overcome, by stacking them side-by-side (though, at £8.60 each, plus VAT, etc, you might not want to have too many!) The second problem is less simple, as it would mean by-passing the built-in decoder and display driver, to use your own control of the matrix. Check with RS Components before ordering to make sure you can do what you want to.

More complex display devices, very similar to the type you want are now on the market, but may not be available on a one-off basis. Try Perdix Components Ltd, Amber Controls Ltd or Epsom — the last-named has recently announced a series of alphanumeric LCD displays.

P L McIlmoyle

Stringy for Nascom

I have a 32k Nascom 1 system for which I'd like reliable, fast mass storage. The review of the 'stringy floppy' in PCW (June 1980) stated that this was available for a number of bus systems in addition to the TRS-80 compatible version advertised in this country. How could one of these be interfaced to a Nascom?

M Gibb, Glasgow

The Exatron 'Stringy Floppy' is certainly available from the

USA in versions suitable for a number of buses, notably the S100, the S50 bus and for the TRS-80. The problem with interfacing it to other computers is that, just like a floppy disk system, it needs a disk controller, implemented in hardware, to interface from the computer's control and data buses to the write head on the recorder. This controller has to code and format data, as well as directly controlling the drive(s).

In the case of the S100 and S50 buses, Exatron is providing the hardware to interface the controller to the bus control and data lines. In the case of the TRS-80, the situation is more complex.

To interface the Nascom to the Stringy Floppy you need either a special controller designed for the Nasbus, or else a Nasbus to S100 or S50 adaptor. With the number of Nascom extension modules currently on offer, I am surprised that I have not yet been able to track down such an adaptor.

So, for the moment, I can only suggest that, for 'fast, reliable mass storage for your Nascom, you consider one of the floppy disk systems on offer. They cost a lot more than a Stringy Floppy, but you should be able to get going sooner!

P L McIlmoyle

Printers and multi-users

I have in mind an application which requires a multi-user system as the volume of work grows. I also require a printer capable of printing normal characters at variable line spacing and pitch. Is there a printer available which can, under software control, jump from normal output of, say, eight char/in and eight lines/in to other densities? Which micros could it be interfaced with? Name and address supplied

There are several such printers available but two worth looking at are the larger Anadex and the Qume Sprint 5; their prices are £950 and £1800 respectively. The Qume is a daisywheel capable of superb quality print and *all* of the functions you request. It is rather slow, at 50-60 char/in, whereas the Anadex is capable of working bi-directionally at 150 char/in. Each of these printers will interface with virtually any machine so there is no problem there.

As far as multi-user systems are concerned, I would need to know far more in order to ascertain a suitable one for you. But PCW has just started a series on multi-user systems, so you should be able to glean some helpful hints from that.

SW

Seikosa GP80

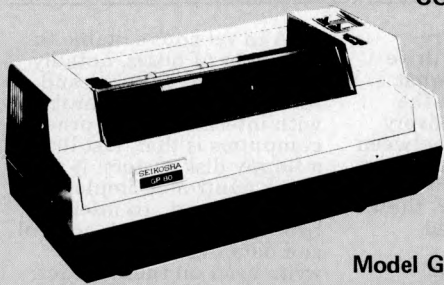

COMPLETE RANGE OF INTERFACES AVAILABLE

*One needle dot matrix *5x7 matrix
*128 Characters *ASCII *30 chs second
*80 chs or extended per line * 12 lines per inch *6 lines per inch (9 for graphics)
*5 lines per sec. (7.5 for graphics) *Pin Feed *Up to 8" plain paper *3 copies

Model GP80 ONLY £250 + VAT

NEW
80 COLUMN 32k **Pet**

ONLY £825 + VAT
Standard Large Keyboard
16k - £499 + VAT
32k - £559 + VAT



Very popular for home & business, using 8k Microsoft Basic in ROM. Both models are with new improved keyboard and all with green screen. Extra Cassette Deck £55 + VAT

Compukit UK101 DISC DRIVES

with up to 32k RAM expansion

free games disc



* 9 Digit extended Basic
* Plugs straight into 8k Compukit requires no hardware mods. (5v.5A required for 610)
610 Expansion (8k) ONLY £159 + VAT
Disc Drive with DOS ONLY £285 + VAT

Coming shortly
models
82 & 83

Oki Microline 80

THE WORKHORSE MICRO PRINTER
- Small, light, quiet matrix printer.

* 40, 80, or 132 cols. * 6 or 8 lines per inch
* 96 ASCII + 64 graphics character set with Centronics compatible interface * 9x7 matrix
* 80 chs. per sec. * 200 x 10⁶ head warranty
* No duty cycle limitation * Double width characters * Friction and Pin Feed * Rugged business use - metal chassis - two motors

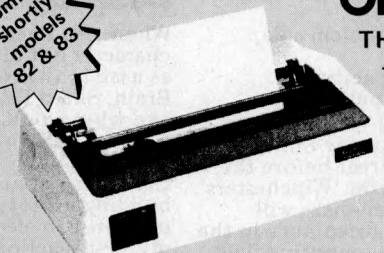

Now ONLY £349 + VAT RS232 option available

NEC Spinwriter

- for the professional word processing system

£1390 + VAT

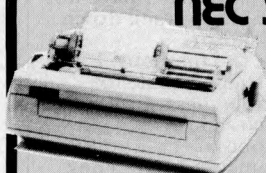

Model 5510 - RS232, Model 5530 Centronics 8 bit par. NEC's high quality printer uses a print "thimble" that has less diam. and inertia than a daisy wheel. (128 ASCII chrs.) *5 copies *Friction or Tractor fed *55 chrs. per second.

Epson MX 80 - COMPLETE RANGE OF INTERFACES TANDY, SHARP, PET, APPLE, etc.

* 9x9 dot matrix * Logic Seeking * Bi-directional
* 96 ASCII Characters * 64 Graphics and 8 International Characters * Centronics I/P with optional RS232 and IEEE 488 * Four print densities 40, 80, 66 or 132 columns * Multiple type fonts * Self Test * Self Diagnostics
* Buzzer for end of paper and bell code error

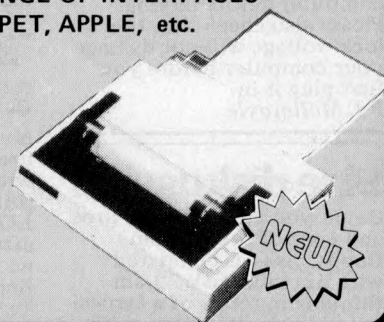

Now ONLY £359 + VAT

Dip 81 FULL 80 COLUMN IMPACT PRINTER

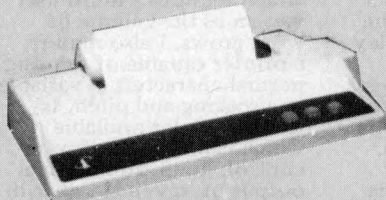

100 characters per second, bidirectional, low profile, ideal for hobby or educational. at ONLY £249 + VAT

Centronics 737

LETTER QUALITY PRINTER



* Dot Matrix: 7 x 9 * Paper Handling: 3 way
* Pitch: 5, 10 or 16 characters per inch
* Speed: 80 characters per second proportional / 50 characters per second monospaced
* Line Length: 40, 80 or 132 characters
* Standard Interface: Parallel

ONLY £349 + VAT

Base 2 MODEL 800 MST

80 col. High Performance Impact Printer - Suitable for most Micro's



Features include:
* RS232, 20mA, IEEE 488 & Centronics I/O * 15 Baud rates to 9600 * 100 chs per sec - bidirectional
Model 800 MST ONLY £295 + VAT

TVI Terminal

FULLY INTELLIGENT TERMINAL

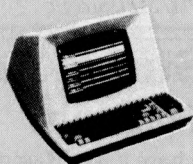

* 24 x 80 display with dual intensity, blinking, reversed, underline and protected fields * 96 ASCII characters (upper and lower case)
* Separate numeric keypad * Auto repeat

TVI 912C ONLY £475 + VAT

Anacom I50

150 CPS, 15" carriage dot matrix printer

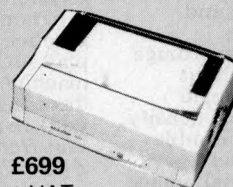

£699 + VAT

* 150 chs per sec * 9 x 9 dot matrix * 10 chs per inch horizontal * 6 or 8 chs vertical * 136 columns, 13.6" line length * 94 ASCII chs
* Upper and lower case with decs. * Logic seeking * Centronics and/or RS232

Micro Peripherals
(MITRECREST LIMITED)

FULL SERVICE BACKUP - FULL DETAILS ON REQUEST INCLUDING PRINTOUT
Please add VAT @ 15%. Carriage extra, will advise at time of order. Official orders welcome

61 NEW MARKET SQUARE, BASINGSTOKE, HAMPSHIRE
Telephone: Basingstoke (0256) 56468 and 56417 (4 lines)

Buy in confidence. If on receipt of your order the goods do not meet with your satisfaction, return within 7 days for full refund. Credit facilities arranged.

DISCOUNTS: Attractive quantity discounts for OEM, Educational & Dealers

also in association with O.S.I. COMPUTERS, ESHER, SURREY. Telephone: 0372 62071





Malcolm Peltu reviews several books which cover the social and political implications of micro technology.

Dialectic Siliconism

Technology is not neutral. It exists in a social, political, economic and industrial environment which shapes the direction in which technological power is channelled. Computing and micro-electronics have been offsprings of the Western capitalist world. Micros, in particular, flourished in the climate of entrepreneurial growth which was a feature of American society in the 1960s and early Seventies.

The environment in which this technology has expanded has been primarily directed towards increasing profits — profits of the manufacturers and suppliers of systems and productivity and profits of organisations using them. Valuable social gains, such as personal computing, education, health and other services have come more as a by-product than a central thrust.

Is such a pattern of development inevitable? Does the failure of communist countries to come anywhere near Western technology in this field prove that information technology is, by its very nature, a discovery and tool of the capitalist? Does the 'neutral' technologist and scientist have a responsibility for the way innovations are developed and used? Can capitalism cope with the employment consequences of micro-inspired automation — and can communist countries cope without the aid to industrial productivity brought by the micro?

Communist playwright Bertolt Brecht had no doubt about the duties of the individual scientists and technologist. In a new special report, the UK Conference of Socialist Economists (CSE) has no doubt that micro-electronics is a capitalist technology which is being ruthlessly used to oppress workers and break the power of unions. And a book on the Soviet use of computers leaves little doubt that the ideological attitude of a government can inhibit the development of an important technology.

The introduction of a dead Communist playwright into a review of books about computing may seem strange. But Brecht's *Life of Galileo*, which was revived last year at the National Theatre in London, is a magnificent and balanced analysis of the very modern contradictions of scientific and technological research — the optimistic desire to pursue knowledge for its own sake opposed to

the ever-lurking possibility that the end result may be socially divisive or physically disastrous.

When I saw *Galileo*, I was in the middle of reading *Microelectronics — Capitalist Technology And The Working Class* by the CSE Microelectronics Group, and *Computers and Economic Planning: the Soviet Experience* by Martin Cave. In my perception these three works became interwoven, with *Galileo* standing above the other two like a mocking Colossus.

Brecht shows how the Church in the 17th Century forced Galileo to recant his theories about the nature of the solar system (Earth going round Sun, not vice versa) because it went against current theological doctrine. Even more importantly, Galileo threatened the authority of the Church because he had popularised his scientific beliefs, leading to unrest among those who had previously been cowed by the Church's apparent omniscience.

After recanting, Galileo was placed under house arrest but still managed to complete the *Discorsi*, which became the foundation of much of modern physics, and which he had smuggled out of Florence. But, in the play, he tells a former pupil that perhaps it would have been better if he had stood firm and not recanted, even if it had meant that he could not have written the *Discorsi*:

'Had I stood firm the scientists could have developed something like the doctors' Hippocratic oath, a vow to use their knowledge exclusively for mankind's benefit. As things are, the best that can be hoped for is a race of inventive dwarfs who can be hired for any purpose,' he says, adding later, 'I handed my knowledge to those in power for them to use, fail to use, misuse — whatever best suited their objectives. I betrayed my profession. A man who does what I did cannot be tolerated in the ranks of science.'

Brecht strengthened Galileo's attack on the supposed primacy of the notion of 'pure' research for research's sake after the first atomic bomb was dropped on Hiroshima. In a draft foreword to *Life of Galileo*, Brecht commented: 'The formula $E=mc^2$ is conceived of as eternal, not tied to anything. Hence other people can do the tying: suddenly the city of Hiroshima became very short-lived. The scientists are claiming the *irresponsibility of machines*'

(my italics).

As the social consequence of microelectronics and computing begin to unfold, Brecht's message is as relevant today as it was in the 17th Century. Technology may be neutral in an abstract world; in the real world it is used primarily to benefit those who have most power and could be used negatively against those who have too little or no power at all.

The ringing irony of *Life of Galileo*, however, is that today's equivalent of the 17th Century Church's insistence on belief in those scientific theories which support the status quo is found at its worst in many countries governed by communist parties which claim to have scientific rationality as a major tenet of their belief — communist parties which Brecht himself supported. Martin Cave, in his book on Soviet computing, quotes a classic instance of dogma given higher priority than truth. In the early 1950s cybernetics was denounced in the Soviet Union as being a 'tool of the reactionary bourgeoisie and inimical to Marxism.'

This attitude was later altered and Cave says that it was even argued that the earlier denunciations of the science had unwittingly accepted a false view deliberately propagated by reactionary interests to conceal the true potential of cybernetics from Soviet scientists.

The approach of dogma first and the facts second unfortunately creeps into the CSE analysis of micro-electronics. Their theoretical stance is clear: capitalists are primarily concerned with making profits; micros help to cut labour costs and therefore increase profits, so they are used by capitalists to destroy jobs and break the power of unions. 'During depressions, capitalists are impelled to search for new forms of technology that can be used to restructure the economy. Above all, they have to be able to overcome their dependence on those sectors of the working class who have used their position in the economy to build sufficient strength to act as a bottleneck.'

This theory is a serious proposition and has evidence to support it. The main reason for introducing computing and micros is frequently 'to increase productivity' and 'to make more cost-effective use of resources.' In other words, to use fewer people to make more profits, more goods, more services. Some managers

do regard new technology as an opportunity to break the power of unions. I have frequently heard managers say (usually under the breath) that not only are micros cheap and efficient but 'they don't join unions and don't go on strike.' In many activities, computing and microelectronics are leading to deskilling of certain jobs as well as the eradication of others.

I was therefore looking forward to the CSE book to provide a new angle on the microelectronics saga; a critique on the existing environment; and an analysis of radical alternatives to the existing direction of technology. Unfortunately, it did none of these.

Firstly, there are too many places where the facts are shaped to fit the theory. Although it provides a reasonable summary of the employment impact of microelectronics in many activities, this adds very little to the many previous similar works on this topic. In common with other publications on this subject, its emphasis on microelectronics, rather than viewing information technology as a coherent entity, limits its field of vision. But perhaps my most serious disappointment was its conservatism (albeit left-wing conservatism). It seems to encourage negative resistance by workers but provides little vision of a positive alternative.

The CSE team does not seem to have heard of personal computing and has failed to even touch on the potential democratising affect of personal computing by taking computing power out of the exclusive control of big organisations. It does not look into the potential community benefits of computerised information services.

There is also no attempt to provide any kind of critique of the way computing has developed in non-capitalist countries and how it would be possible to build a society that balanced the community and social needs, with industrial and business aims and the push of technological change.

For a truly radical and alternative view of the positive application of technology, a better view is offered by the collective who publish *Undercurrents*, the 'magazine of radical alternatives and community technology.' This has the freewheeling style of the magazines like *Oz* and *International Times* in the Sixties. The use of computing for community rather than com-



mercial objectives is frequently analysed. Issue number 42 last year, for example, was devoted mainly to a blueprint for 'Protopia' in which 'convivial computing' played a major role. The magazine is well worth reading, at least occasionally, as it does provide a genuinely 'radical' approach to the application of technology.

The CSE group, however, seems to view microelectronics purely within the context of capitalist/worker struggle. In the industrial examples which they quote, such as in the automation of process control and manufacturing industries, there are genuine conflicts of this ilk. But the CSE determination to make its political point irrespective of the facts is illustrated at its worst in the chapter on software.

At first, I was impressed to see the prominence given to software. This is frequently underplayed in books about the social and employment consequences of microelectronics. It is also clear, from the references to operating systems, tele-processing monitors and software engineering, that the group understood the nature and scope of software. (The general technical level is reasonably good when it is left free from political distortions.) Yet it has chosen to portray software developments, such as the move to high level languages, as examples of management attempts to achieve a 'sustained initiative over labour'.

It correctly describes the evolution of the software process, through machine-coded programming in the early days to high level languages in the Sixties and towards more systematic software engineering methods for designing, building and testing software packages. But it does not explain the technical logic behind this evolution and the vital necessity to have structured methods of software engineering in order to create complex software products that will be reliable and easily maintained. Instead it interprets the movement as being initiated as a means of managers mounting 'an initiative against the labour force to capture control over the production process and push down the average wage of software workers.' It criticises program management techniques designed to eliminate errors through better and more open monitoring of program development as being motivated by a desire to 'drag the labour process of software production out into the open, out of the minds

and closed relations of one programmer to another.'

This it does not regard as a good thing, as an inevitable process if complex software systems are to be designed more efficiently and reliably. It regards it as a sinister attack by management on software workers, as a struggle, a battle, a fight between management and workers.

It opposes attempts to make software production a more open, well-monitored process, on the grounds that if the programmers are faced with the public availability of performance statistics on his or her programming ability, 'The programmer will then be at a disadvantage in project and careers reviews with management. The programmer can no longer appeal to a greater technical knowledge of software because the management will have documented proof of his or her errors of carelessness. *Once again a product of labour will be used to confront labour as management tries to gain mastery of the production process*' (my emphasis).

This passage highlights the central failure of their book. Blinded and blinkered by predetermined dogma and jargon, the group ends up taking up ridiculous, negative positions on issues where it could indeed make valid socialist criticisms.

Is the group really suggesting that sloppy, self-indulgent, undisciplined programmers are to be glorious Heroes of the Revolution? Why, when it accurately points out that software engineering techniques are so primitive that developing complex software is 'like having to make a saw every time you wanted to cut a piece of wood,' does it seem to oppose methods for improving software engineering? Does it regard engineering techniques that ensure bridges do not fall down are a blow against the extra work that would be obtained rebuilding bridges or as a major benefit to the users of bridges, just as it seems to perceive good software engineering techniques as being motivated more by antagonism to programmers than a desire to produce better software for users?

In its enthusiasm to turn everything into a binary good/evil, worker/manager context, it fails to make the solid case that it could about the deskilling and alienating process that professional programming could become in a structured programming environment, which has been created by a natural technological evolution. It should be discussing how programmer motivation and job satisfaction can be maintained in more disciplined software development — but that, of

course, would be regarded as typical of social democrat 'tinkering' with the system to maintain the status quo.

The section on software also displays ignorance — or deliberate suppression — of the growth of personal computing, which demonstrates how technology can lead to the potential for greater democratisation and less control by the existing power manipulators.

Without the development of high level languages, which the CSE group regards as a pro-capitalist development, there would have been no Basic and no personal computing movement. (High level languages were, of course, an inevitable, commonsense development.) Personal computing has taken computing power out of the exclusive hands of the powerful corporations and large public organisations and put it in the hands of ordinary people. While the CSE group directs its spleen at what it claims is the unwelcome but successful attempts of managers to turn software into the 'private property of the corporation' rather than the 'private property' of the professional programmers, a revolution has been happening under its noses. For the first time, there is genuinely private, personal software. Software developed for big machines and large organisations have never legitimately been the property of the individual programmer.

With a personal computer, you can now really do your own programming thing. Personal computing opens up opportunities for community information networks and community computing services; it offers individuals and organisations the power to challenge the computer models used by governments and companies to justify their decisions. None of the potentially-liberating applications of computing are even touched upon in the CSE book.

It also fails to attack systems like Prestel which are being directed towards large-scale information providers and business applications, rather than at being the basis of community networks. In fact, telecommunications is barely mentioned as such.

The CSE group also fails to tackle the question of whether the desire for improved productivity and the elimination of dull or dangerous work should be a valid aim in a 'socialist' or 'communist' society. For if it is, then it becomes a duty on all those who oppose the existing political system to show how the technology should be welcomed, in conjunction with associated social and economic changes (which is the attitude of the TUC and virtually every

British trade union).

Communist countries seem to have no doubt that their backwardness in computing and microelectronics is a disadvantage. If, as the CSE claims, microelectronics is intrinsically a capitalist technology, why are non-capitalist countries so keen to get their hands on it? And what is at fault in communist systems which has prevented research into such a vital modern technology, while allowing the Soviet Union to make great strides in the space race (itself a major stimulus to US micro-electronic developments)?

Martin Cave's book on the Soviet experience of using computers does not tackle broad questions like this. It is a description of the management and administrative uses of computing in the Soviet Union. Cave describes in great detail the programme which started in 1963 and began to peter out in the mid-Seventies which was aimed at improving the work 'on introducing computer technology and automated management systems in the economy.'

As is the Soviet way of doing things, this involved a grandiose central plan, run by a profusion of bureaucratic organisations. Cave concludes that 'one of the most conspicuous features of the whole history of the project has been the failure to meet deadlines.' In this and many other aspects — software problems, inadequate management understanding, poor communication between computer experts and managers, shortages of skilled staff, etc — there is a close correlation between experience in the Soviet Union and in the West.

The main difference is that in the Soviet Union, the national programme was the only real forum for computing development, as opposed to the diversity of experience in the West. The Soviet approach proved to be too cumbersome to keep pace with a rapidly-developing technology and failed to generate its own new technology and respond to the applications potential of the new technology.

This experience also proves the point thrust forcefully by the CSE group — that technology is not neutral. Computing in the Soviet Union is seen as a means of bolstering and extending the existing power structure. In the mid-1960s, the Soviet regime embarked upon experimenting with decentralisation of management. The inefficiencies of total centralisation had become obvious and the computerisation programme was perceived as a means of allowing some decentralisation while still keeping close central control over



activities.

Prime Minister Alexei Kosygin commented in 1971 that 'thanks to the advantages of the socialist economic system, which makes it possible to manage economic and social processes at the level of the country as a whole, the broad application of computer technology will help us to give our plans a stronger foundation and to make the optimal decision on them.' But Cave comments, 'This promise has not been realised. The opportunity to establish an automated planning and management system on a uniform basis throughout the entire economy has not yet been taken up.'

This failure by the central government computing system — being the only one of any substance — has led to the Soviet Union remaining an underdeveloped computing country.

Cave illustrates that the role of computing in the Soviet economy was just one facet of the political process — a process in which bureaucratic socialist centrism (to coin a phrase) was finding increasing difficulty in managing the economy and maintaining control of power.

The Soviet leadership wants to maintain its status quo while attempting experimental management forms that give more autonomy to local enterprises. As Cave says 'from the standpoint of the political leadership, the new system has the merit of retaining intact many of the valued elements of centralisation in the traditional Soviet planning and management system. Indeed, to the extent that computers permit the retention of these elements, they can be seen as a conservative influence in Soviet economic management.'

Twixt the 'devil' of capitalism and the deep red sea of communist authoritarianism, where does the scientist/technologist and the ordinary person stand? How should the millions of British unemployed and the fighting Polish trade unionists view new technology when it seems to be boosting authority rather than loosening the grip of the powerful?

I believe that microelectronics has greatly boosted the democratising potential of the technology and I would like to see a better analysis of radical alternative uses of technology, than that of CSE. But it is Brecht in *Life of Galileo* who summarises what seems to be the unfortunate reality.

Galileo says to a young disciple: 'Can we deny ourselves to the crowd and still

remain scientists? The movements of the heavenly bodies have become more comprehensible but the people are as far as ever from calculating the motives of their rulers. The battle for a measurable heaven has been won, thanks to doubt; but thanks to credulity the Roman housewife's battle for milk will be lost time and again.

'To what end are you working?' he continues. 'Presumably for the principle that science's sole aim must be to lighten the burden of human existence. If the scientists, brought to heel by self-interested rulers, limit themselves to piling up knowledge for knowledge's sake, then science will be crippled and your new machines will lead to nothing but new impositions.'

'You may, in due course, discover all that there is to discover and your progress will nonetheless be nothing but a progress away from mankind. The gap between you and it may one day become so wide that your cry of triumph at some new achievement will be echoed by a universal cry of horror.'

And as you, dear reader, beaver away at your Basic program or new accounting system, these words are worth recalling. Technology may be fun and it may be profitable but is it advancing the general welfare of mankind or reinforcing existing unjust and painful ways of life?

(The words from Galileo in this review are from a recently published translation by John Willett, which also includes notes on the play by Brecht; the latest National Theatre translation by Howard Brenton, in slightly more modern, muscular English, is available from the same publisher.)

From macro to micro

Most discussions about the employment impact of micros have been macro. They have discussed the macro-economics of national and international trends which are not of great benefit when trying to plan the real needs of a particular local area.

Tameside Metropolitan Borough Council in the North West is therefore to be congratulated on initiating a study in October 1978 to examine the impact of microelectronics technologies on Tameside industries in the next decade. The results of the study have now been published as a book, *The Effects of Microelectronics Technology on Employment Prospects*.

Although — or perhaps

because — it is concerned with local effects, this report provides a much better insight into the real employment implications of micros than the more global studies. It also shows the difficulty of predicting unemployment effects of a specific technology at a time when the overall economic climate is so poor.

For example, ICL manufacturing plants around Manchester fall under the Tameside area. The study team had estimated that the total amount of micro-inspired unemployment in the electrical and instrument engineering industry in Tameside (including ICL) would be about 260 jobs. Yet after the study was completed, one of the ICL factories was closed down, leading to a total of 800 staff being made redundant.

The approach of the report is to analyse, industry by industry, the likely impact of microelectronics directly on employment and also to estimate other indirect changes which may result as new technology generates changes in the nature and structure of industries throughout the world, including the way competitive effectiveness is gained or lost.

In a time of general economic growth, the overall conclusions would not be too depressing. The study team estimates that, in the 1980s, less than three percent of jobs in the area will be directly lost because of microelectronics, although they think that up to ten percent could go if there are extensive 'structural displacements' in industries as a result of technology.

This, however, has already been shown to be an underestimate by the way interest rates, exchange rates, cuts in public expenditure and the other shadows of recession have already increased unemployment through closures of factories like ICL's plant in the Tameside area.

In particular, their estimate of redundancies in public administration seem to be over-optimistic in the light of current developments.

The authors of the study admit: 'It is difficult to predict employment changes in the public sector. Local government and the health services are large employers in Tameside. Major cuts in their expenditure because of national government policy might necessitate the introduction of labour-saving technologies in, say, the office-work side of their activities.' It is clear that the intention of the Thatcher government is to cut public expenditure and, almost inevitably, employment levels in the public sector.

Despite these misgivings about the accuracy of the predictions, this study is well worth reading by anyone interested in the impact of micros on employment. It illustrates the importance of examining particular areas and industries in detail before jumping to any conclusion.

Indirectly — and in terms of employment levels at least — the study also makes a more trenchant political case against current government policies than the CSE book reviewed above. It shows that the potential seriousness of the position is so great that it cannot be left to free enterprise to sort out both the macro and micro employment difficulties. Some public intervention to encourage new industries, to provide adequate education and training and to alleviate the human suffering of unemployment are vital.

It also dispels the complacency generated by those optimists who argue that as many new jobs will be created by technology as those destroyed. This view is a smoke screen which covers the real suffering that even limited and localised unemployment can bring.

The authors of the Tameside report comment: 'If the complete microelectronics revolution should lead only to the closing of ten factories in the whole world and all those ten happened to be in Tameside then, even though globally the employment impact of microelectronics would be tiny, it would be little short of catastrophic for Tameside.'

The following were included in this month's Bookfare:

- Microelectronics — Capitalist Technology and the Working Class* by the CSE Microelectronics Group (Ultra Violet Enterprises, 25 Horsell Road, London N5, £2.95 paperback, £8.00 hardback)
- Life of Galileo* by Bertolt Brecht translated by John Willett (Eyre Methuen, £2.50)
- Computers and Economic Planning: the Soviet Experience* by Martin Cave (Cambridge University Press, £11.50)
- Undercurrents* magazine (published every two months from 27 Clerkenwell Close, London EC1R 0AT and available at some bookshops.)
- The Effects of Microelectronics Technologies on Employment Prospects — A Case Study of Tameside* by Kenneth Green, Rod Coombs and Keith Holroyd (Gower Press, £12.50)

**Comart Approved
Cromemco Dealers**

Belfast

O & M Systems
95 Dublin Road
Contact: Richard Owens

Birmingham

Byteshop Computerland Ltd
94/96 Hurst St. B5 4TD
Contact: Jim Attfield
Tel: 021 622 7149
Telex: 336186 BYTE G

Cambridge

Cambridge Computer Stores
1 Emmanuel St. CB1 1NE
Contact: Claude Cowan
Tel: 0223 68155

Cornwall

Benchmark Computer
Systems Ltd
Tremena Manor
Tremena Road
St Austell, PL25 5GG
Contact: John Fisher
Tel: 0726 610000

Dublin

Lendac Data Systems Ltd
8 Dawson St
Contact: Danny McNally
Tel: 0001 372052

Glasgow

Byteshop Computerland Ltd
Magnet House
61 Waterloo St. G2 7BP
Contact: Gordon Coventry
Tel: 041 221 7409
Telex: 779263 BYTE GW G

Leeds

Holdene Ltd
Manchester Unity House
11/12 Rampart Road
Woodhouse St
Contact: Jim Jackson
Tel: 0532 459459
Telex: 556319 HOLDEN G

London

Byteshop Computerland Ltd
48 Tottenham Court Road,
W185 4TD
Contact: John Braga
Tel: 01 636 0647

Digitus

9 Macklin Street
Covent Garden WC2
Contact: Alan Wood
Tel: 01 405 6761

Manchester

Byteshop Computerland Ltd
11 Gateway House
Piccadilly Station Approach
Contact: Peter King
Tel: 061 236 4737
Telex: 666186 COMMAN G

NSC Computers

29 Hanging Ditch
Contact: Adam Wiseberg
Tel: 061 832 2269

Newbury

Newbear Computing Store
40 Bartholomew St
Contact: Tim Moore
Tel: 0635 30505
Telex: 848507 HJOLPN

Nottingham

Byteshop Computerland Ltd
92A Upper Parliament St.
NG1 6LF
Contact: David Clarke
Tel: 0602 40576
Telex: 377389 BYTENOG

Sheffield

Hallam Computer Systems
451 Eccleshall Road, S11 9PN
Contact: Stuart Pulford
Tel: 0742 663125

Southampton

Xitan Systems
23 Cumberland Place,
SO1 2BB
Contact: Geoff Lynch
Tel: 0703 38740

Sudbury

Eurotec Consultants
Holbrook Hall
Little Walsingham
Contact: Dr Klimowicz
Tel: 0206 262319
Telex: 987248

Warwick

Business & Leisure
Microcomputers
16 The Square
Kenilworth
Contact: David Searle
Tel: 0926 512127

**Comart Microcomputer
dealers are located
strategically throughout the
country to give support,
guidance and assistance. In
the event of difficulty contact
Comart direct.**



Cromemco



Flexibility + Versatility

System Flexibility

Cromemco give you the high performance, reliable computer power you need now, with the in-built capability for future expansion and adaptation as demands and requirements change.

The choice is wide. Cromemco's S-100 bus construction provides for expandable memory capability and the widest choice and future options in peripheral support.

Now there is the exciting range of Cromemco High Resolution Colour Graphics Systems.

Applicational Versatility

Cromemco's CDOS Operating System supports proven, well documented Software for Business, Industry, Science, Research and Education; COBOL, RPG II, Macro Assembler, 16K and 32 BASIC, FORTRAN IV, LISP, RATFOR, Word Processing and Data Base, are all included in the range.

Now, there is the new CDOS compatible, Cromix Multi-user Multitasking Operating System which opens up new avenues in application and performance for Cromemco System Users.

The U.K. Leaders in Microcomputer
Development, Application and Support.

comart

PO Box 2, St Neots, HUNTINGDON, Cambs
Tel: (0480) 215005 Telex: 32514 Comart G.

PUNTER'S PET



Beat the bookie at his own game using this PET system
devised by Alan Green

Have you noticed every bookmaker you see wears a good suit and drives the latest limousine; at least it seems like that, doesn't it? Well, I can't guarantee the car and the suit but I can introduce you to the world of the bookie, show you why he makes money and why the punter loses and give you the chance to become the exclusive bookie on the PET racecourse.

Why the bookie wins

Imagine a horse race of five horses, all of which have an equal chance of winning. This means that each horse has one chance in five of victory or four chances of not winning. Hence there are four chances against the one of winning, or in the jargon of the bookie, it has odds of four to one against. If one horse was thought to have more chance of winning than the others then its odds would be less, say three to one or five to four (1¼ to one). A horse of lesser chance would have longer odds of perhaps eight to one or greater.

Returning to our original race of equally matched horses, each one is rated as having a 0.2 probability of winning and, if we add up the probabilities, they total 1.0, which is the probability of a certainty — namely one of them winning. On the assumption that the punters know no more than the bookies, it is reasonable to expect bets to be laid fairly equally on all five horses. If we assume that a total of £100 is bet, then that would be £20 on each horse. Whichever horse wins, the bookie will pay odds of four to one; he will pay out £80 plus the £20 stake returned — total £100. This means that £100 has been bet and £100 has been won and the bookie has made nothing. Bookies aren't like that: they want to make money. The way they achieve this is as follows:

If a horse has true odds of four to one, the bookie will quote something less, say three to one. This means that, where the true probability of winning is 0.2, the bookie tells you it is 0.25. Doing this to all the horses in the race means two things:

1. The sum of the probabilities is greater than 1.0 (1.25 in our example);

2. The bookie will pay out less than he takes in stakes (in our example he takes £100 but only pays out £80).

This is obviously highly satisfactory for the bookmaker and, consequently, he will always make sure that the probabilities associated with his quoted odds always add to more than 1.0. This is known as 'over-rounding' the book. If the book was under-rounded, the bookie would lose money on the race. They don't do it!

To calculate the bookies' expected percentage on any race you must do the following:

1. Convert the odds to probabilities — see Table 2;
2. Total the probabilities;
3. Calculate:

$$\% \text{ Take} = \frac{P-1}{P} \times 100$$

where P = the sum of probabilities.

The amount that the bookmaker can take varies in relation to the size of the race but 20 to 30 percent is reasonably typical; on very large races it can be much more.

In practice the bookie sets initial odds and, as bets are placed, he changes the odds to reflect the way the money is being laid. Horses attracting money

have their odds shortened (ie odds reduced but probability increased), while the less-favoured horses have their odds lengthened. Ultimately the odds reflect the opinions of the punters, not the form of the horses. To further prevent losses, on small races no place bets are allowed and on other races the amounts paid for place bets vary in relation to the number of runners.

The program

The program listed is not a game in the normal sense, although a number of people are invited to 'play' with you. The program enables you to run a complete race meeting acting as race organisers, bookmaker and information service. If you could encourage your friends to play real bets with real money, you would actually make a profit. Perhaps the friendliest thing to do would be to play with raffle tickets and monopoly money. The program follows a number of phases and each one is dealt with in detail below.

Racing options

This initial part of the program allows for the input of race details either from the keyboard or from the tape file. Any

Horse	Total Bets Placed
My Fair Lady	£60
Casanova	£80
Lucky Jim	£40
Pengler	£20
Blue Rum	£ 0
	£200

Proportion of horses with bets on them = 0.8

∴ Probability to be shared by horses carrying money is $0.9 + (0.8 \times 0.1) = 0.98$

Probability on unfancied horse = $\frac{0.10}{5} = 0.02$

Total probability = 1.0

	Basic Proby	Modified Proby (x 1.4)	Nearest Odds
My Fair Lady	$60/200 \times .98 = 0.294$	0.4116	11 - 8
Casanova	$80/200 \times .98 = 0.392$	0.5488	5 - 6
Lucky Jim	$40/200 \times .98 = 0.196$	0.2744	5 - 2
Pengler	$20/200 \times .98 = 0.098$	0.1372	6 - 1
Blue Rum	$= 0.020$	0.0280	33 - 1
	1.000	1.400	

∴ Bookmakers % = $\frac{0.4}{1.4} \times 100 = 28.6\%$

The basic probabilities are used in the program to generate proportionate random numbers to determine horse placings. The modified probabilities are used for all calculations involving bets laid and payouts made.

Table 1 Example of odds calculation.

race entered through the keyboard can be saved on tape. In this way complete race meetings can be copied in from the morning papers.

The only constraints are:

i. Number of horses must be between three and 12, and

ii. race cannot exceed 12 furlongs. If a reminder is needed on the settings of odds, the information is available.

Each horse's name (12 letters max.) is entered, together with its starting price. When all horses have been entered, the 'roundness' of the complete set of odds is checked and, if it is not to your (the bookie's) advantage, alterations are prompted. The race will only be accepted when the book is over-round.

Pre-race activities

When the race is accepted, a list of runners and odds is displayed, together with details of total cash staked on each horse. With this display, only three instructions are accepted: B, O or R. B indicates the laying of a bet; O allows the revision of odds, and R starts the running of the race. Up to 50 bets can be laid either as win only or each-way bets. The only exception to this is that in fields of fewer than six horses, it is not possible to lay each way bets — this is standard bookmaking practice. All bets are made in whole units to make display easier. The displayed odds are not changed unless deliberately requested.

Calculating the odds

As the odds are intended to reflect both the horses' chances of winning and what the punters think the chances are, the following calculation is made (lines 4000 - 4200):

i. The proportion of horses with bets on them is calculated: (BR/N);

ii. $90\% + ((BR/N) \times 10\%)$ of the chances of winning are allocated to all horses carrying money;

iii. $10\%/N$ is allocated to horses not carrying money. This, in effect, means that horses which are seen as rank outsiders do actually have a small chance of winning;

iv. The winning chances (probabilities) are divided among the money-bearing horses in proportion to money they are carrying;

v. The probabilities are increased by a factor of 1.40 in line 4025 to give the bookie his margin — this can be modified to suit;

vi. A matching search in arrays AA, BB and PR then give the odds to match the probability.

Sample calculations are shown in Table 1.

The race

The race is run over the designated distance with reports of the leading three horses at every furlong. The horses are selected at random but with a probability reflecting their odds. This is achieved by forming a cumulative probability list,

GOTO page 146

PROBABILITY WHEN ODDS AGAINST	ODDS	PROBABILITY WHEN ODDS ON
.500	EVENS	.500
.488	21 - 20	.512
.476	11 - 10	.524
.455	6 - 5	.545
.444	5 - 4	.556
.421	11 - 8	.579
.400	6 - 4	.600
.381	13 - 8	.619
.364	7 - 4	.636
.348	15 - 8	.652
.333	2 - 1	.667
.320	85 - 40	.680
.308	9 - 4	.692
.296	95 - 40	.704
.286	5 - 2	.714
.267	11 - 4	.733
.250	3 - 1	.750
.231	100 - 30	.769
.222	7 - 2	.778
.200	4 - 1	.800
.182	9 - 2	.818
.167	5 - 1	.833
.154	11 - 2	.846
.143	6 - 1	.857
.133	13 - 2	.867
.125	7 - 1	.875
.118	15 - 2	.882
.111	8 - 1	.889
.105	17 - 2	.895
.100	9 - 1	.900
.095	19 - 2	.905
.091	10 - 1	.909
.083	11 - 1	.917
.083	100 - 9	.917
.077	12 - 1	.923
.074	100 - 8	.926
.071	13 - 1	.929
.067	14 - 1	.933
.065	100 - 7	.935
.063	15 - 1	.937
.059	16 - 1	.941
.057	100 - 6	.943
.053	18 - 1	.947
.048	20 - 1	.952
.043	22 - 1	.957
.038	25 - 1	.962
.034	28 - 1	.966
.029	33 - 1	.971
.024	40 - 1	.976
.020	50 - 1	.980
.015	66 - 1	.985
.012	80 - 1	.988
.010	100 - 1	.990
.007	150 - 1	.993
.005	200 - 1	.995
.004	250 - 1	.996
.002	500 - 1	.998

Table 2 Odds and probabilities conversion table.

Horse	Basic ProbY.	Cumulative ProbY.
My Fair Lady	0.294	0.294
Casanova	0.392	0.686
Lucky Jim	0.196	0.882
Pengler	0.098	0.980
Blue Rum	0.020	1.000

Random Number	Horse	Position
.704	Lucky Jim	1st
.186	My Fair Lady	2nd
.815	Lucky Jim — repeat	ignore
.935	Pengler	3rd

Table 3

Compiled by Dick Pountain

MORE CASIO QUIRKS

At the end of my first article on this subject, I challenged readers to discover more about the operation of the non-numeric characters of the Casio 502 display. This challenge has been most convincingly answered by a Norwegian reader, Jonny Østensen of Oslo, to whom most of the following new revelations are due.

Many of you will have already guessed that these non-numeric characters are in some way connected with the hexadecimal notation used internally by the calculator. It would be expected that they would correspond to the hexadecimal digits 10 to 15 and that there would be six of them. A cursory count-up only reveals four: P, E, C and ⁰, but pause for reflection allows us to include the '—' (RUN) symbol. The sixth character is in fact a blank space, 'blank'.

Mr Østensen has discovered the following routine for isolating and individually displaying these symbols: 23 Min1 AC Inv Ind MRI Eng Inv Ind MRI =

The display now contains '—' and looks for all the world as if a program is running. This symbol represents hex 14, as will be seen if you add 0 to it: '—' + 0 = 14. The other five symbols may be produced by computation from this first one. As you produce each one, store it in the memory corresponding to its hex value, so: '—' Min 14 (.4).

13 - MR 14 = Min 15 produces the 'blank' (hex 15) and only a decimal point is left in the display. If you don't believe a 'blank' is really there, press +/-.

11 - MR 14 = gives E, which, since it is an error message, blocks the display register so that no further input is allowed until it is cleared. To get round this, we calculate its negative form, -E, which has no such effect, so: MR14 - 11 = Min 13.

C is treated in the same way, as it's also an error message; MR14 - 10 = Min 12 gives -C in M12.

Hex 11 is P but must be calculated as 10 - MR15 = Min 11, since 9 - MR14 = -5 as its answer.

Hex 10 is the ⁰ symbol but it cannot be calculated in the same way. Mr Østensen deserves a Nobel prize for uncovering this obscure route: 23 Min 1 AC 777 EXP 20 +/- ÷ Inv Ind MRI = Min 10.

You now have all six symbols stored in registers 10 through 15 and they be recalled at will. (E and C can be stored in positive form but will lock the display if recalled.)

Playing around with them results in an initial disappointment: there is no way I can find to concatenate them, either with each other or with digits from the keyboard. Moreover, most arithmetic operations cause them to 'collapse' back into decimal representation. However, certain classes of operation result in combinations of digits

Address	P	C	E	—	'blank'	1P	1C	1E	1—	1blank'
Register	L1	L2	L3	L4	L5	L6	L7	L8	L9	L10

Fig 1

and symbols. Try this: MR11 (12,13)+++++=... *ad nauseum*. Or: MR11 (12,13)+0+=..., or MR11 - 10 =. Perhaps some hopeless insomniac will produce a dictionary of possible combinations!

One particular group of combinations has a special significance, which will be seen later: 1⁰, 1P, 1C, 1E, 1— and 1 'blank'. This may be produced as follows:

[P] x = [1P]
 [P] += [1C]
 30 - [1P] = [1 'blank']
 30 - [1C] = [1—]
 [0] + [0] = [1⁰]

[] signifies a displayed symbol. Store these for future researches.

Mr Østensen discovered that ⁰ and 1⁰ are the indirect addresses for the F and IF (.F) registers, which are not normally indirectly addressable. So, Inv Ind Min 0 will load the F register if ⁰ is in M0. This, combined with last month's tip on loading the F register independently from tape, suggests possible unusual applications.

I found this quite exciting and began to wonder if any other symbols had such interpretations. They have; they address the L, or stack, registers L1 to L10, which are otherwise inaccessible to the user. The map is shown in Figure 1.

Data may be stored and recalled from these registers by using the above indirect addresses: 99 Inv Ind Min3 stores 99 in L3 if M3 contains -E. Any such data is erased, however, if the calculator uses that register for a pending operation. Surprisingly, if the L registers are filled up with pending operations (ten levels of parenthesis), these contents *cannot* be recalled indirectly, a zero always being returned. Indirect M+ or M- will modify the contents, however, and alter the result when the pending operations are executed.

Unlike the HIR operations on the TI59 (often mentioned in this column),

these extra ten registers represent a Pyrrhic victory, since ten registers are occupied in storing the indirect addresses!

Another unusual effect, due to Mr Østensen, is that a bizarre form of indirect jump to a subroutine may be made using the symbols as addresses. If ⁰ is placed in M0, on executing Inv Ind GSB0, a search is begun at the start of program memory and control is transferred to the first step at which the digit 0 is encountered, regardless of which program register it occurs in! In a similar fashion '—' will search for digit 1, C for digit 2 and E for 3. The other symbols have no such interpretation. By this means, an extra three subroutines could be created by entering a single subroutine at three different points:

Pn... 1... 2... 3...

If you have followed the story so far, once your brain stops hurting you will probably wonder what use any of this is. I wonder, too!

One certain use is that the 'blank' symbol provides a unique way of tally clearing the display (otherwise impossible), which is nice to have. Another use is for prompting and labelling results. It could be quite convenient in, say, an electronic engineering program, to label three results with a P, C, or E. This can be done as follows:

PO Min 0 AC HLT x10+20 - Inv Ind MRO =

If the 1 'blank', 1— and 1E symbols are now stored in M1, M2 and M3 then, by entering 1, 2 or 3 followed by a number, N, and EXE, the display will contain NP, NC or NE respectively; P, C and E are appended to the input N. This could be used as a subroutine to label results.

For more ambitious uses I'm going to rely on you, the reader. A small prize (a copy of *Godel, Escher, Bach*) will go to the best useful program (or subroutine) which uses any or all of these new insights. So get to it!



The New Paper Tiger 560 from T.E.

Performance at a price you won't believe.

The latest addition to the Paper Tiger family, the 560, is comparable in cost to many other matrix printers. But that's where the comparability ends.

Features like a unique nine-wire staggered head which gives a high quality image by literally filling in the gaps between the dots with one pass of the head and 132 column printing on full size paper, put it well ahead of it's rivals.

Other standard features include: a full upper and lower case 96 character set, six software selectable character sizes, parallel and RS 232 interfaces and XON/XOFF line protocol plus a host of print optimisation characteristics. Features which are often not even available as options on other printers.

If you're interested in a quality printer at a low price which is available ex stock, mail the coupon using our Freepost service



Teleprinter Equipment Limited —
the peripheral people

70-82 Akeman Street, Tring, Herts. HP23 6AJ. U.K.
Tel. Tring (0442 82) 4011/9 & 5551/9.
Telex: 82362 BATECO G.

PCW 92

Please send me details
of Paper Tiger 560

Name _____

Company _____

Address _____

Telephone _____

PCW 281

Video Genie

● New low price

Amazing Value – compatible with TRS80 16K level 2



Microdigital's new low price £280 + VAT includes free delivery within mainland U.K. and every machine is thoroughly tested by our engineering department before despatch.

The Video Genie is a complete computer system, requiring only connection to a domestic 625 line TV set to be fully operational; or if required a video monitor can be connected to provide the best quality display.

The system case contains the Central Processor Unit (CPU), 16,000 bytes RAM memory, the cassette system, a 12,000 byte operating system and BASIC interpreter in ROM, and a full size keyboard, in a stylish case, at a price that makes the Video Genie better value than some "kit" computers.

Applications

The Video Genie System has many uses in all spheres of life, the easy to use BASIC language means that programs are easily written for specific applications, and pre-recorded program tapes are available in great variety.

The system has great scope in the home, sophisticated games programs can introduce the computer age to all the family, who can then progress to writing their own programs in BASIC or even machine code. Software is continuously being developed to aid home budgeting and education.

In a school or college the machine can be used with a large screen TV to allow a whole class to be taught at once.

The powerful Extended BASIC interpreter makes the solution of complex scientific problems simple, and the graphics allow pictorial displays of results.

Cassette Unit

The Video Genie has an integral cassette system which can save information on standard tape cassettes. An interface is also provided to connect an external audio cassette unit for greater storage flexibility.

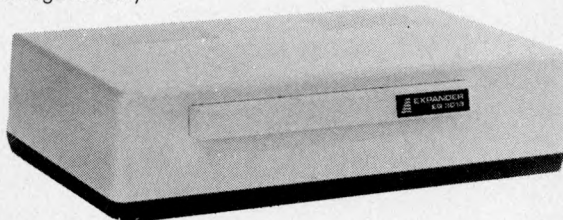

Expansion

The EG3013 EXPANDER (expansion unit)

is designed to upgrade your VIDEO GENIE SYSTEM, from a personal computer to a powerful microcomputer system, in the most flexible and inexpensive way. All resident interfaces are fully buffered to ensure reliability.

The Parallel Printer Interface will operate any printer, which has Centronics standard parallel interface, to provide hard copy printout.

2. Mass Storage and Fast Access

The Disk Controller Interface can handle up to 4 sets of mini-floppy disk drives (compatible types as Shugart SA-400 and Pertec FD-200).

- Storage options:
- i) Single side, single/double track density 35/40/77 tracks.
 - ii) Double side drives can also be used provided their side select signals are modified. If using double side, the Disk Interface can only handle 2 drives instead of 4.

Disk Operating System options: TRSDOS; NEWDOS; MICRODOS; VTOS.

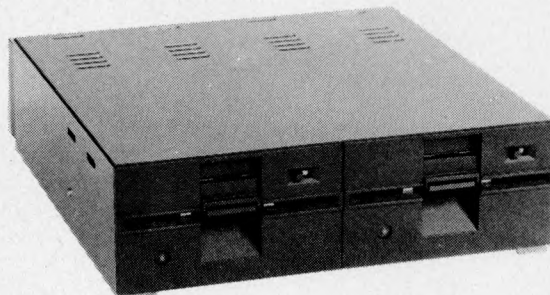

3. Communications

The RS-232-C Interface (optional) can be connected to telephone modem or other form of carrier to provide data communication capabilities. Besides communications, it can also be used to operate RS-232-C standard serial printers.

4. Memory Expansion

Memory capacity can be expanded from the basic 16K to 32K/48K by insertion of RAM CARD (not inclusive in the EG3013 EXPANDER package), into either one of the two remaining S-100 slots.

5. S-100 Bus Expansion

Optional S-100 Bus standard cards (such as controller cards) can be plugged into either one of the two remaining S-100 slots for further system expansion.

Prices	Nett	Vat	Total
Video Genie Computer	280.00	42.00	322.00
EG3013 Expander with RS232	215.00	32.25	247.25
EG3013 Expander without RS232	185.00	27.75	212.75
32K Memory Board S100	130.00	19.50	149.50
16K Memory Board S100	95.00	14.25	109.25
Single Disk Drive	215.00	32.25	247.25
Dual Disk Drive	410.00	61.50	471.50
2 Drive Cable	17.00	2.55	19.55
4 Drive Cable	32.00	4.80	36.80
Printer Cable	17.00	2.55	19.55
Centronics Parallel Interface for unexpanded Genie	33.00	4.95	37.95

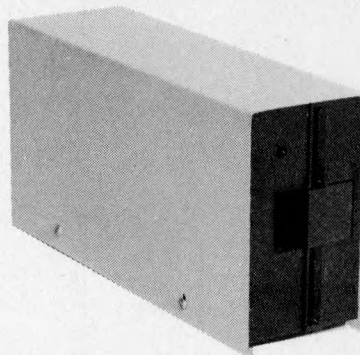

Mail Orders to:
MICRODIGITAL LIMITED
FREEPOST (No stamp required)
Liverpool L2 2AB.

Retail Premises at:
25 BRUNSWICK STREET,
LIVERPOOL L2 0PJ.
Tel:- 051-227 2535/6/7

free delivery within mainland U.K.
12 month guarantee
all equipment tested before despatch
bonafide official orders welcome.

● **New low price** **Sharp MZ80K**
The quality single unit computer with 48K RAM £460 + VAT

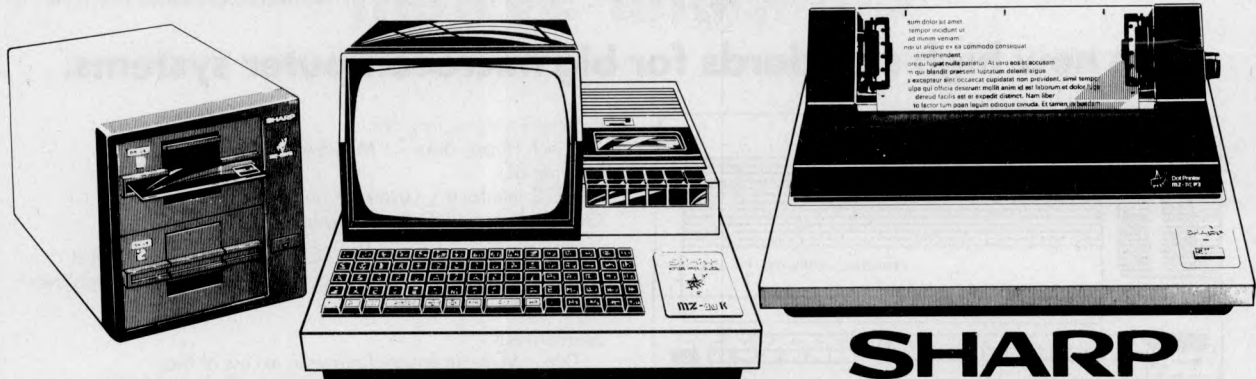

SHARP

Famed for its quality and reliability the MZ 80K is very competitively priced.
 Notable features of the basic unit are the built in 3 Octave Music Synthesiser and the high speed (1200 bps) of the cassette interface.
 Systems expansion is via an interface unit (MZ 80 I/O) into which are connected the printer, the dual disk drive, the second dual disk drive and the universal interface card.
 The basic unit comes with a 14K BASIC interpreter and the disk drives come with an enhanced disk version of this. Alternatively xtal BASIC can be used with the computer and the industry standard CP/M disk operating system is available for disk based systems.
 Ledgers and stock control software are available free when full systems are purchased.

Prices	Nett	Vat	Total
MZ 80K Computer 48K RAM	460.00	69.00	529.00
MZ 80 I/O Interface Unit	82.00	12.30	94.30
MZ 80 FD Dual Disk Drive	640.00	96.00	736.00
MZ 80 FDK Dual Add-on Drives	565.00	84.75	649.75
MZ 80 P3 Printer	415.00	62.25	477.25
MZ 80 I/O-1 Universal Interface Card	40.00	6.00	46.00
MZ 80 TU Assembler	36.00	5.40	41.40
MZ 80 T20C Machine Language	18.00	2.70	20.70
XTAL BASIC	40.00	6.00	46.00
CP/M Disk Operating System	200.00	30.00	230.00

Sharp Pocket Computer ● **New low price**
A Genuine advance in technology **£82 + VAT**



- Full QWERTY keyboard with numeric pad.
- Alphanumeric dot matrix liquid crystal display scrolls in all four directions.

- Features**
- 100 hours battery life using Alkaline manganese batteries.
 - Compact size 175 x 70 x 15mm and light weight 170g.

- Uses the BASIC programming language.
- Approximately 2K of user RAM.
- Program retained when computer turned off.
- Cassette interface (CE-121) available for storing programs and data – with file names.
- Built in beeper, with Beep function in BASIC.
- Supplied with a thick manual full of applications programs.

Our Low Prices	Nett	Vat	Total
PC1211 Pocket Computer	82.00	12.30	94.30
CE121 Cassette Interface	12.00	1.80	13.80



Mail Orders to:
MICRODIGITAL LIMITED
 FREEPOST (No stamp required)
 Liverpool L2 2AB

Retail Premises at:
25 BRUNSWICK STREET,
LIVERPOOL L2 0PJ
 Tel:- 051-227 2535/6/7

free delivery within mainland U.K.
 12 month guarantee
 all equipment tested before despatch
 bonafide official orders welcome.

4 Available
February,
1981

Sharp PC 3200 Desk Top Computer System

Microdigital Guarantee now extended to 2 years
on all Sharp and Apple hardware purchased after 1.1.81

Sets new high standards for big microcomputer systems.

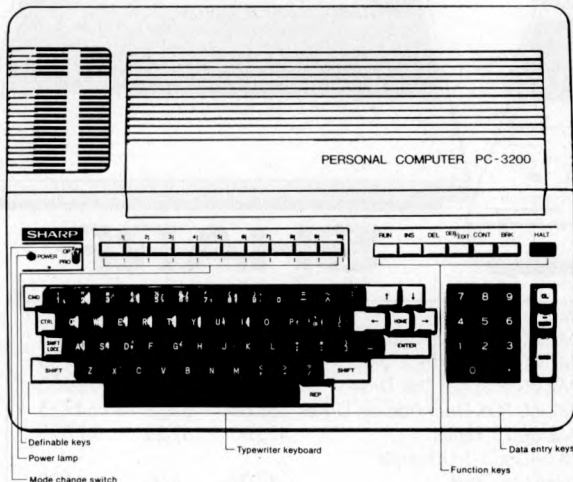

This is the machine all the others will have to beat with a fabulous list of features

RAM

64K - (expandable to 96K summer 1981).

ROM

32K (expandable up to 72K) including BASIC Interpreter.

Video Monitor

Green displays
80 chars x 25 lines) Selectable
40 chars x 25 lines)
Reverse video
Blinking video
Selected scrolling - Left, right, up and down
Pseudo line and matrix drawing function.
Graphic function = 160 x 50 dots.

Keyboard

Full ASCII format typewriter style
Numeric key pad
Cursor control keys
10 User definable keys
7 function keys
Repeat key.
96 character keyboard buffer.

Clock and Calendar

Built in Clock and Calendar with rechargeable battery back-up.

Printer

80/132 column dot matrix logic seeking bi-directional printer.
Double width print.
Upper & Lower case plus graphic characters.
Pin Feed.

Floppy Disks

Twin 5 1/4" disk unit giving total capacity of 568K.
Double sided - Double density.
Up to 8 drives can be connected
giving total capacity of 4.5 megabytes.

Future Enhancements

8 inch Floppy disks - 1 Megabyte capacity (available Summer 81)
RS 232C Interface - (available Summer 81)
General Purpose I/O Card - (available Autumn 81)

The BASIC supplied with the PC 3200 is one of the best yet available. The following is a list of some of the enhancements over other BASIC interpreters.

Statements

Dim - Multi-dimensional arrays in excess of two.
Print Using Call - Print formatted as specified in IMAGE Statement.
"Subprogram" - Call "SUBPROGRAM" with specified parameters.
DFK - Define the definable keys.
Keyin - Enables precise definition of input format for both
- numeric and string variables.
Move - Creates string variables of any length greater than 255.
- Also enables the copying of sections of program.
Search - Search for a variable or any array for a specified
- string and the string position is returned into a specified
- numeric variable.
Wait - Program execution is halted for a specified interval or
- until a specified time.
BL - Sets C.R.T. to blinking in specified area.
RV - Sets C.R.T. to reverse video in specified area.
Line - Draws ruled lines either horizontal or vertical according to
- specified parameters.
Scrol - Specified areas of the C.R.T. can be scrolled left, right,
- up or down.
Table - Forms a lattice on the C.R.T. using ruled lines or a
- specified character.
Merge - Merges two BASIC programs.
Aload - Causes the ALOADED Program to be loaded and RUN
- at power ON.
Debug - Machine code programming utility.

Commands

Auto - Auto line numbering.
Delete X, Y - Delete Program lines X - Y.
Edit X - Edit program line X.
Erase A (*) - Clear numeric array variable A.
List print - Print the whole program with page No. date & time,
- and "TITLE" being printed on each page.
Ren - Rename program.
TR - Trace the execution of the program.

Disk Statements

Statements allow both random and sequential data files to be handled.
Programs can be stored in either ASCII or binary format.
VSAVE/VLOAD - Stores/Loads the contents of the C.R.T. in a disk
- file.
VSAVE*/VLOAD* - Stores/Loads the ruled lines, reverse video
- and blinking state of C.R.T. in a disk file.

The PC 3200 is sold only as a complete system consisting of

- computer
- dual disk drive
- printer
- video monitor
- all plugs and leads

Price	Nett	Vat	Total
PC 3200 System	2995.00	449.25	3444.25

Place your order now to get one of the first machines in the U.K.

SHARP



Mail Orders to:
MICRODIGITAL LIMITED
FREEPOST (No stamp required)
Liverpool L2 2AB.

Retail Premises at:
25 BRUNSWICK STREET,
LIVERPOOL L2 0PJ.
Tel.: 051-227 2535/6/7

free delivery within mainland U.K.
12 month guarantee
all equipment tested before despatch
bonafide official orders welcome.

Printers

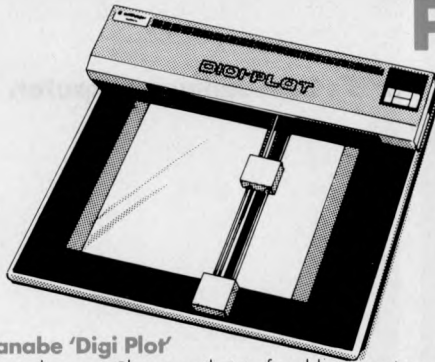

Watanabe 'Digi Plot'

Now a low cost Plotter easily interfaced to a micro computer. The DigiPlot incorporates all intelligent functions required for producing graphs and drawings. There are many uses for this Plotter ranging from design, research and development to administrative flowcharts and graphs. Control is via a 7-bit ASCII Parallel interface. This can be interfaced to nearly any microcomputer using set subroutines.

Price	Nett	Vat	Total
'Digi Plot'	895.00	134.25	1029.25

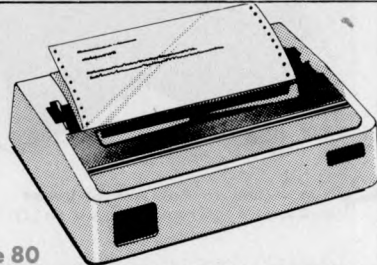

Microline 80

Now an old favorite, the MICROLINE has established itself on the market as one of the most reliable and versatile printers available. This quiet 5 x 7 dot matrix printer prints at 80cps and is capable of producing graphical output. It comes complete with 96 character set and centronics compatible interface. You can select from 40,80 and 132 characters per line in software. The 40 character output is double-size, 80 character is at 10 cpi, 132 character is at (16.5 cpi). Now at a new low price, exceptional value.

Price	Nett	Vat	Total
MICROLINE 80	395.00	59.25	454.25
Ribbons (available in blue, black, green, red and brown)	2.25	0.34	2.59

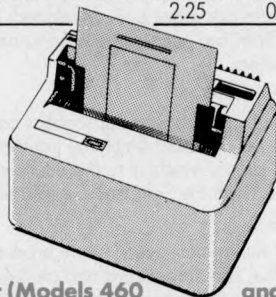

Paper Tiger (Models 460 and 560)

These are the latest models from the TIGER family. The 460 has higher speed (120 cps) and prints bi-directionally. There is a 96 character set which can be printed at 80,96 or 132 characters per line. The 9 x 9 dot matrix head has a life of 300 million characters and gives a very good print quality. RS232 and parallel interfaces are available. The 560 option is slightly quicker (120-160 cps) and is a full 132 column machine. It can accommodate 15 inch paper and has two print and speed modes. Naturally both these printers have full graphical capability.

Price	Nett	Vat	Total
Model 460	795.00	119.25	914.25
Model 560	995.00	149.25	1144.25
Paper (2000 sheets)	31.00	4.65	35.65

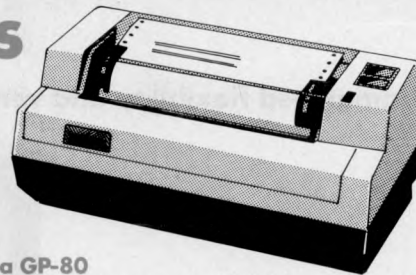

Seikosha GP-80

At last, an economic printer for the hobbyist. This must be the lowest-cost smallest impact graphic printer in the world. Graphics, normal (12 cpi) and double-width (6 cpi) characters can be printed on the same line. Pinfeed tractor is equipped as standard. The printer prints on plain paper and has a continuous self-inking ribbon. There is a wide range of optional interface boards available. A truly remarkable dot matrix printer, it prints at 30 cps using a 5 x 7 dot matrix. A parallel interface is standard.

Price	Nett	Vat	Total
GP-80	250.00	37.50	287.50
Interfaces:			
RS232c	50.00	7.50	57.50
IEEE 488 or APPLE II	30.00	4.50	34.50
PET	32.00	4.80	36.80
CABLES	25.00	3.75	28.75

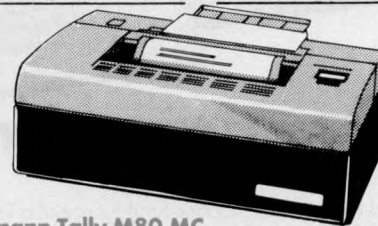

Mannesmann Tally M80 MC

The two keywords of this printer are reliability and long life. This is a true commercial printer which is ideal for long report generating or constant use. This 80 column device prints bi-directionally at 200 cps, and utilises a 7 x 7 dot matrix as standard. It comes complete with a parallel interface and a 96 character set. You can select from 10 characters per inch and 16.5 characters per inch, each mode has a double width option enabling you to highlight headlines etc.

Price	Nett	Vat	Total
M80 MC	1000.00	150.00	1150.00

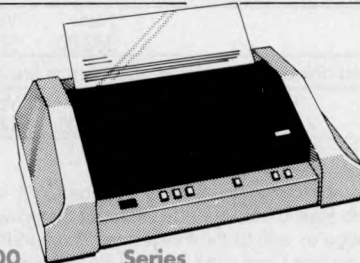

Anadex DP 9500 Series

The DP 9500 is designed for all printer applications. It comes complete with three ASCII compatible interfaces, a RS232c, an input that accepts 20/60 ma current drive mode and a centronics input. This is a truly amazing printer with a myriad of features. These features include a high density graphics mode (suitable for APPLE graphics printing), a 600 character buffer, 150-200 cps, programmable horizontal and vertical tabs, self test, 96 character set, normal, condensed and expanded print, the list seems endless. If you need a high speed, versatile printer, look no further.

Price	Nett	Vat	Total
DP 9500	895.00	134.25	1029.25
DP 9501	995.00	149.25	1144.25
New for 81			
Microline 82	550.00	82.50	632.50
Centronics 737	425.00	63.75	488.75



Mail Orders to:
MICRODIGITAL LIMITED
FREEPOST (No stamp required)
Liverpool L2 2AB.

Retail Premises at:
25 BRUNSWICK STREET,
LIVERPOOL L2 0PJ.
Tel:- 051-227 2535/6/7

free delivery within mainland U.K.
12 month guarantee
all equipment tested before despatch
bonafide official orders welcome.

Apple II

Unmatched flexibility and versatility from the world's best selling computer.



apple computer
Sales and Service

Microdigital Guarantee now extended to **2 years** on all Sharp and Apple hardware purchased after 1.1.81

Microdigital supply a 48k machine for the price of a 16k machine, we supply a Black and White modulator free and give free delivery and twelve month guarantee

Price	Nett	Vat	Total
Apple II Computer 48k	695.00	104.25	799.25

All Apples supplied by us are legitimately imported and are genuine 230V Europlus models.

Disk Subsystem

The latest DOS 3.3 16 sector disk drive with controller, which replaces the old model

Price	Nett	Vat	Total
	383.00	57.45	440.45

Second disk drive uses same controller as first drive.

Price	Nett	Vat	Total
	299.00	44.85	343.85

Language System

This package includes the Language Card, which allows APPLE users to take immediate advantage of the powerful PASCAL language as well as the Integer and Applesoft BASIC interpreters. The Language Card's 16K bytes of RAM memory electrically replace the ROM firmware built into each APPLE. Upon start-up this RAM memory is automatically loaded from disk with the user's choice of languages then electrically protected from change.

Price	Nett	Vat	Total
	299.00	44.85	343.85

Apple Fortran

Apple FORTRAN is "ANSI Standard Subset FORTRAN 77". These latest computer industry standards provide significant additions and enhancements over previous 66 standards (FORTRAN IV). An example of this is the expanded "IF" statements that have been added to traditional FORTRAN statements.

Apple FORTRAN operates in the Apple Pascal Language system offering the same comprehensive software development

environment provided to our Pascal programmers. The Editor, Linker, Filer and Assembler can all be used with the Apple FORTRAN compiler, which, like Pascal, produces 'P' code.

Price	Nett	Vat	Total
	120.00	18.00	138.00

MICROSOFT Z-80 Softcard

The Z-80 SoftCard is a plug-in peripheral card for the Apple II that actually contains a Z-80 microprocessor and allows the Apple to run software written for Z-80 based computers. Also included on diskette in the SoftCard package are the CP/M operating system and Microsoft BASIC, the two most significant microcomputer software packages ever developed. All of the features of the Z-80 SoftCard package add up to an incredible value for Apple II owners.

Thousands of Applications

Literally thousands of CP/M-based applications can be easily converted to run with the SoftCard simply by transferring CP/M files from your CP/M source machine to the Apple via a comm line. A utility is included with the SoftCard to facilitate this transfer.

Apple Compatibility

The SoftCard runs with almost every Apple product from the Apple II to Apple II Plus, Language Card and peripherals. Independent peripherals are supported too. A SoftCard software utility lets you transfer Apple DOS files onto a CP/M disk.

Easy Installation

The SoftCard plugs in to any of the Apple's peripheral slots. No hardware modification is required.

Requirements

Apple II or Apple II Plus

48K Memory*

1 Disk Drive

*When used in a 48K machine, 44K of memory is available.

When used with a Language Card, 56K is available.

Price	Nett	Vat	Total
	170.00	25.50	195.50



Mail Orders to:
MICRODIGITAL LIMITED
FREEPOST (No stamp required)
Liverpool L2 2AB

Retail Premises at:
25 BRUNSWICK STREET,
LIVERPOOL L2 0PJ
Tel:- 051-227 2535/6/7

free delivery within mainland U.K.
12 month guarantee
all equipment tested before despatch
bonafide official orders welcome.

Apple II

Microdigital Guarantee now extended to **2 years**
on all Sharp and Apple hardware purchased after 1.1.81

Unmatched flexibility and versatility from the world's best selling computer.

Cobol

CIS COBOL is a complete software system for compiling, testing, debugging, and executing standard COBOL programs.

It is called CIS COBOL because it is Compact, Interactive, and Standard.

Compact

Standard CIS COBOL runs on systems of 48K bytes and up.

Interactive

CIS COBOL has features specifically tailored to interactive applications — in which the operator communicates directly with the program via a CRT screen and keyboard. It also caters fully for interactive program development.

Standard

CIS COBOL conforms to the ANSI 1974 standard for COBOL, so that programs can be transferred to your system from other computers, or vice versa.

The two principal components of CIS COBOL are the CIS COBOL compiler and the CIS COBOL Run Time System.

Requires Z-80 SoftCard in a 48K system

Price	Nett	Vat	Total
	425.00	63.75	488.75

Forms - 2

Screen formatter/ Program generator

Price	Nett	Vat	Total
	100.00	15.00	115.00

Carrying Case

The Apple is truly portable and this padded vinyl, leather look case protects your Apple in transit and makes it easier to carry.

Price	Nett	Vat	Total
	16.00	2.40	18.40
Dustcover	9.95	1.49	11.44

Appletel

The Appletel package provides the means to bring the Apple II computer and the Prestel service together.

Price	Nett	Vat	Total
	595.00	89.25	684.25

Graphics Tablet

The Graphics Tablet is an image input device that allows the user to enter pictorial information directly (by sketching or tracing) from:

- maps and photographs
- architectural drawings
- logic diagrams and schematics
- fine art
- histograms

Tracing a shape on the tablet surface converts the image to digital values. This information is displayed on the video monitor and may be stored on disk for later processing by the Apple.

Price	Nett	Vat	Total
	462.00	69.30	531.30

DOS 3.3

Apple's new DOS, DOS 3.3, contains two significant improvements for the Apple owner. It creates a compatible environment so that the Apple owner can easily and efficiently use his Applesoft, Integer, and Pascal programmes on one set of hardware. The second benefit for the user is that the disk space available is increased 23%. Under the old operating system, approximately 103,000 bytes were available to user. With the new DOS, 126,976 bytes will be available for user programs.

Price	Nett	Vat	Total
	39.00	5.85	44.85

Silentye Printer

The Silentye allows printing of high resolution graphics at 60 dots per inch, at 40 upper/lower case characters per second and 80 characters per line. The Silentye eliminates the loading or writing of a programme to print a screen configuration, because you can dump any high-resolution screen directly to the printer.

Price	Nett	Vat	Total
	349.00	52.35	401.35
10 rolls thermal paper for Silentye	28.00	4.20	32.20
Dustcover for Silentye	9.95	1.49	11.44

Double Vision 80 Column Card

The adapter displays upper and lower case characters and is highly compatible with BASICS and PASCAL. In BASICS, PR# 0 does not switch off the card, a distinct advantage over some others. A 12" monitor is essential when displaying 80-Columns.

Price	Nett	Vat	Total
	162.00	24.30	186.30
Software to convert to Pascal	12.00	1.80	13.80

Alf Music Synthesiser

Three simultaneous voices
Interactive graphics music entry
Complete, ready to use
Stereo outputs
Pitch, envelope, and volume
Expandable to 6 or 9 voices.
No "music languages" to learn
Full piano range
No tuning required
Save and load songs

Price	Nett	Vat	Total
	95.00	14.25	109.25
Timing Mode Input Board	14.00	2.10	16.10
Alf Music Album 0 (Xmas)	12.00	1.80	13.80
Alf Music Album 1	12.00	1.80	13.80
Alf Music Album 2	12.00	1.80	13.80

Apple Cards

Parallel Printer Interface

The Parallel Printer Interface Cards are available to allow the use of parallel printers with your APPLE computer.

Price	Nett	Vat	Total
Parallel	104.00	15.60	119.60
Centronics	130.00	19.50	149.50

Communications Interface Card

The Communications Interface Card is available separately to allow you to connect your APPLE to modems, CRT terminals, and other devices employing a serial RS-232C interface. The card's built-in intelligence lets you control these devices easily, in BASIC.

Price	Nett	Vat	Total
	130.00	19.50	149.50

Eurocolour Card

Produces PAL colour signals to drive colour video monitor or with a Black & White modulator drives a colour T.V.

Price	Nett	Vat	Total
	113.00	16.95	129.95

Hobby/Prototyping Card

Create your own APPLE interface boards with this wire-wrap card. The 2 3/4" x 7", double-sided circuit board includes a hole pattern (on 100-mil centres) that accepts all conventional IC's and passive components. It plugs directly into any APPLE expansion

(Continued overleaf)



Mail Orders to:
MICRODIGITAL LIMITED
FREEPOST (No stamp required)
Liverpool L2 2AB.

Retail Premises at:
25 BRUNSWICK STREET,
LIVERPOOL L2 0PJ.
Tel.: 051-227 2535/6/7

free delivery within mainland UK
12 month guarantee
all equipment tested before despatch
bonafide official orders welcome.

Apple II

Microdigital Guarantee now extended to **2 years**
on all Sharp and Apple hardware purchased after 1.1.81

Unmatched flexibility and versatility from the world's best selling computer.

connector, and fits entirely within the computer case. Supplied with complete bus documentation to aid the interface designer.

Price	Nett	Vat	Total
	15.00	2.25	17.25

Serial Interface

The Serial Interface Card allows an APPLE computer to exchange data with computers, printers, and other devices in serial format (one bit at a time). It is intended for use (in place of the Communications Interface Card) in applications that:

- Use data rates other than 110 or 300 baud (10 or 30 char/sec)
- Involve serial printers that don't require "handshake".

Price	Nett	Vat	Total
	113.00	16.95	129.95

Heuristics

Speechlink Model H2000

A practical low-cost speech recognition peripheral for the Apple® computer that allows you actually to talk to your Apple-

- to enter data.
- to control programs and the disk.
- to control other equipment attached to the Apple.

The H2000 substitutes your voice for the keyboard. It enables you to think and control your computer at the same time, concentrating on the action - the video display, printer output, or external action under computer control.

Features

- Recognize 64 words or phrases of your choice on the Apple® computer.
- Link more than one set of 64 words to provide essentially unlimited vocabulary.
- Write your programs in BASIC (no assembly language coding required).
- Use it with Applesoft® Floating Point BASIC or Integer BASIC (Extendable to Pascal).
- Requires only 4K RAM to recognize 64 words or phrases.
- Run under Disk Operating System or Cassette Tape System.
- Small pre-trained vocabulary facilitates system use.
- Complete with microphone, manual, demonstration software, and one year warranty.

Price	Nett	Vat	Total
	168.00	25.20	193.20

Model 70 controller

Provides four relay contact-closure outputs on a card which plugs into an Apple® II peripheral slot and which is completely controlled by POKE statements in Apple® II BASIC. The unit is recommended for use with Heuristics™ SpeechLab® and SpeechLink™ voice data and control input cards for the Apple® II, but may be used with any Apple® in any application. More than one Model 70 may be used in an Apple®.

Price	Nett	Vat	Total
	57.00	8.55	65.55

Speechlab Voice Recognition Card

Allows the Apple to recognise a spoken vocabulary of up to 32 user-selected words. The computer can be programmed to perform any task desired upon recognition of a key word.

Price	Nett	Vat	Total
	122.00	18.30	140.30

Mountain

Clock/Calendar Card

Mountain Hardware, Inc.

This plug-in card provides a 388-day calendar and clock, with resolution to 1/1000 second. The clock is crystal controlled to yield .001% accuracy. A built-in rechargeable battery keeps the clock on time up to four days without system power, and external

batteries may be used for longer periods. Optional interrupt capability simplifies control applications. Supplied with complete operating instructions and rechargeable battery.

Price	Nett	Vat	Total
	168.00	25.20	193.20

ROM Plus card

ROMPLUS + provides six sockets to accept individually addressable 2K ROM's or EPROM's. Keyboard Filter a 2K ROM program, comes installed on the ROMPLUS + board and adds many useful features to your Apple, including:

- Upper and lower case letters. The only system that offers keyboard input and standard shift key operation.
- Multiple user-defined character sets.
- Coloured or inverse-coloured letters.
- Keyboard macros - two key-stroke, automatic typing of multiple, user-defined words or phrases. Including BASIC and DOS commands.
- Mixed text and graphics.
- Improved cursor control.
- STOP LIST and END LIST.

Price	Nett	Vat	Total
	105.00	15.75	120.75

Copyplus ROM

For use with ROM Plus Card.

Price	Nett	Vat	Total
	30.00	4.50	34.50

Supertalker

Give voice to your Apple

SuperTalker allows you to add the dimension of human speech output in your computer programs. Add voice to games. Program verbal prompting for the operator of your business system. Use verbal warnings under program control as an enunciator in commercial security or control rooms. Create educational programs that verbally coach the student.

The SuperTalker system

SuperTalker is a new peripheral system which allows the Apple II computer to output exceptionally high quality human speech through a loud-speaker under program control. Output may also be directed through any P.A. or stereo system. Initially, spoken words are digitized into RAM memory through the system microphone. Speech data in RAM may then be manipulated like any other stored data.

A complete package

The SuperTalker peripheral system consists of: The SuperTalker peripheral card which plugs into a peripheral slot on the Apple II; a microphone; a loudspeaker; easy-to-use operating software and documentation; plus, two ready-to-run SuperTalker programs.

Price	Nett	Vat	Total
	179.55	26.93	206.48

Romwriter

Hardware:

- Programs 2716 EPROMs—5V, 2K.
- Installs in any peripheral slot (except # 0).
- Zero insertion force socket. (ZIF). Mechanical lever opens up pin holders to drop in an EPROM.
- On-board Bat Handle switch for power off to ZIF Socket permits EPROM to be Installed/Removed without power-down of computer.
- On-board DIP switch provides:
 - Write Protect—provided to prevent accidental overwriting of EPROMs while RUNNING for RomWriter.
 - \$CFFF-Off-provided to suppress execution of this command (which shuts off all peripherals in the Apple system when executed) while programming or later while RUNNING.



Mail Orders to:
MICRODIGITAL LIMITED
FREEPOST (No stamp required)
Liverpool L2 2AB.

Retail Premises at:
25 BRUNSWICK STREET,
LIVERPOOL L2 0PJ.
Tel:- 051-227 2535/6/7

free delivery within mainland U.K.
12 month guarantee
all equipment tested before despatch
bonafide official orders welcome.

Microdigital Guarantee now extended to **2 years**
on all Sharp and Apple hardware purchased after 1.1.81

Apple II

Unmatched flexibility and versatility from the world's best selling computer.

- Programmed EPROMs can be RUN while residing on RomWriter board.
- Optimum voltage and current for trouble-free programming.
- Complete 2716 programmed in under 2 minutes (50 msec/byte).

Price	Nett	Vat	Total
	106.05	15.91	121.96

MusicSystem

This 16 voice digital synthesizer is said to set new standards for computer generated music. Its capabilities permit the creation of the sounds of real musical instruments utilizing the principle of additive synthesis. The generation of sounds is accomplished through fully programmable waveforms, envelopes, and amplitudes for each musical "voice". Provided with the hardware system is software for editing and playing of musical compositions. The Editor program permits graphical input of sheet music utilizing standard music notation. The Player program permits polyphonic performance of musical compositions. Stereo output is to users' stereo amplifier and speakers, or directly off card with stereo headphones.

MusicSystem generates the sound of any musical instrument — real or imagined — solo or sextet — rock or classical — at home or in the concert hall or classroom! MusicSystem permits virtuoso performance in computer generated music never possible before outside of research and development labs, and is a real breakthrough in low-cost music generation.

Price	Nett	Vat	Total
	312.00	46.80	358.80

California Computer Systems

Asynchronous Serial Interface

Price	Nett	Vat	Total
	106.00	15.90	121.90

Synchronous Serial Interface

Price	Nett	Vat	Total
	119.00	17.85	136.85

Parallel Card

Price	Nett	Vat	Total
	79.00	11.85	90.85

Arithmetic Processor Unit

Price	Nett	Vat	Total
	265.00	39.75	304.75

IEEE/GPIB Interface

Price	Nett	Vat	Total
	199.00	29.85	228.85

Programmable Timer

Price	Nett	Vat	Total
	106.00	15.90	121.90

A/D Converter

Price	Nett	Vat	Total
	99.00	14.85	113.85

ROM/PROM Module

Price	Nett	Vat	Total
	70.00	10.50	80.50

Centronics Card

Price	Nett	Vat	Total
	79.00	11.85	90.85

Clock Card

Price	Nett	Vat	Total
	83.00	12.45	95.45

Interactive Structures D109 Universal Digital Interface

Description

The D109 is a complete digital interface system on a single Apple II card. Plug it in and take control of 32 data lines, each one

usable by your software as an input or an output. Add a current driver and operate relays or light bulbs directly. Add an isolation card and you're set to operate in the most hostile of industrial environments.

Use the on-board timers to count events, generate precise square wave, or interrupt your program when it's time for lunch. Combine the timers to measure up to 17 years. Use them individually to measure microseconds.

Set the D109 to interrupt you for any of 14 different reasons. Use the control lines to shake hands with other equipment when you have data to exchange. If you have 8 bits but only one wire, serialize with the built-in shift registers.

The D109 is a powerful new member of the Applications (tm) Series. Plug it in and build a system that will surprise a few people.

Features

- 32 digital input or output lines.
- 4 programmable timers
- 2 shift registers.
- full interrupt capability.
- optional current drive and isolation.
- single Apple II card.

Price	Nett	Vat	Total
	213.00	31.95	244.95

A1 - 02 Analog Converter Card

What is the A1-02

The A1-02 is a single card system which allows Apple II* to look at analog, or non-digitized information. This means that the Apple can sample temperature, measure light level, or listen to sound, and use the result as an input to a program. Since most of the quantities of interest in controlling a home environment or an industrial process are analog quantities, this opens a very large set of new applications to the Apple user.

Analog Information

The A1-02 accepts information in the form of an analog voltage level in the range of 0 to 5.00 volts. Depending on the sensor used, this will correspond to a range of values such as 0°F to 212° or 5lbs. to 15lbs. of pressure.

Input Channels

The A1-02 provides 16 separate channels for input. One channel at a time is selected by the program, and the voltage present at the input when it is selected is the value returned to the program. There are no restrictions on the use of inputs: one may be selected repeatedly, all 16 may be selected in sequence, etc.

Price	Nett	Vat	Total
	192.00	28.80	220.80

AO - 03 Analog Output Board

General Description

- Up to 8 independent channels.
- Each channel digitally latched.
- Range and offset adjustable.
- Monotonic.
- Accurate to 1/2 LSB.

The AO-03 Analog Output system is a multi-channel interface between the Apple-II* microcomputer and the analog world. Using the AO-03 card, a BASIC or Assembly language program can, in a single operation, set or change an analog voltage level. Up to eight channels may be controlled, with the outputs being truly parallel, latched digitally on the AO-03. Resolution of the digital-to-analog conversion is 8 bits and the output will settle to within one-half LSB in 2 microseconds. The AO-03 is ideal for controlling light level, producing music, and deflecting CRT, Plotter or LASER graphics systems.

(Continued overleaf)



Mail Orders to:
MICRODIGITAL LIMITED
FREEPOST (No stamp required)
Liverpool L2 2AB.

Retail Premises at:
25 BRUNSWICK STREET,
LIVERPOOL L2 0PJ.
Tel.: 051-227 2535/6/7

free delivery within mainland U.K.
12 month guarantee
all equipment tested before despatch
bonafide official orders welcome.

Microdigital Guarantee now extended to **2 years**
on all Sharp and Apple hardware purchased after 1.1.81

Apple II

Unmatched flexibility and versatility from the world's best selling computer.

Analog Outputs

Each output channel of the AO-03 is buffered and short circuit protected. The output range of voltages correspond to the binary codes thru 255. Each channel is individually adjustable for range and zero adjust. A strap may be inserted to shift from the standard positive voltage range to a bipolar range. Space is also provided for addition of components to smooth the output transitions for the lower bandwidth applications.

Price	Nett	Vat	Total
4 Channel	180.00	27.00	207.00
8 Channel	281.00	42.15	323.15

Other Prices

Price	Nett	Vat	Total
Applesoft firmware card-for integer apples.	116.00	17.40	133.40
Integer Card - for applesoft apples	116.00	17.40	133.40
Programmers Aid I	27.00	4.05	31.05
Auto-Start ROM Pack.	38.00	5.70	43.70
Apple Juice			
Back up power supply.	157.00	23.55	180.55

Templeman dual 8" disk system.			
- 1M byte.	1550.00	232.50	1782.50
Apple Desk - Two Tier.	145.00	21.75	166.75
Apple Desk - Two Tier (Economy).	125.00	18.75	143.75
Printer Table.	92.00	13.80	105.80
Printer Table (Economy).	87.00	13.05	100.05
Single Tier Apple Desk.	48.00	7.20	55.20

Documentation

	No. VAT	£
Apple II Reference Manual		11.00
6502 Hardware Manual		9.00
6502 Software Manual		9.00
Apple II Basic Programming Manual		6.00
Applesoft II Reference Manual		6.00
DOS 3.2 Manual		6.00
Apple II Basic Tutorial Manual		6.00
Autostart ROM Manual		4.50

Apple Software

All supplied on disk, unless otherwise specified.
Where integer basic is required this can be either:

1. An integer Apple.
2. An Apple II + with integer card.
3. An Apple II + with relocated integer.
4. An Apple with language system.

Business Tools

CCA DATA MANAGEMENT (48K APPLE, Disk)

This system, developed by Personal Software, stores and retrieves information. It is very simple to learn and use, and at the same time provides real data processing capabilities for you and your Apple. Allows you to prepare and access files for your mailing list, customer lists, expense reporting, budget analysis or any report you need.

Price	Nett	Vat	Total
	75.00	11.25	86.25

DESK TOP PLANNER (48K APPLE, Disk)

A unique financial planning and forecasting system that is driven by a simple menu system. Allows you to create business models or sub-models and build up consolidated summaries if you have individual branches or cost centres. A best selling package available for the first time in the U.K.

Price	Nett	Vat	Total
	75.00	11.25	86.25

VISICALC (32K APPLE, Disk)

Visicalc provides an electronic worksheet of up to 63 columns and 254 rows. At the juncture of any column and row you can type in words or numbers. Where you want the worksheet to perform a calculation, you type the formula. Visicalc automatically performs all arithmetic functions and instantly displays all of the results. If you change any of the numerical data, the electronic worksheet instantly displays a new result - automatically. Anyone who works with numbers - managers, financial analysts, accountants, engineers and scientists - will find Visicalc essential for their personal computer. Voted program of the year in the U.S.A.

Price	Nett	Vat	Total
	125.00	18.75	143.75

Apple Plot

A useful addition to VisiCalc and Desktop/Plan systems which enables results to be plotted quickly and accurately. Multiple sets of data can be compared on the same report and displayed on the screen, in colour, or a hard copy generated for reports, files etc. Apple Plot can be used independent of Visicalc and Desktop/Plan.

Price	Nett	Vat	Total
	37.00	5.55	42.55

Apple Writer

Most probably the best word processing system available on a microcomputer for the price. Features include, fast easy cursor control, moving blocks of text, delete by character, word, and paragraph, search and replace, left right centre text justification.

Price	Nett	Vat	Total
	42.00	6.30	48.30

Estate Agents

Developed in conjunction with a leading firm of Chartered Surveyors and Estate Agents, the system is a cost-effective aid to residential property sales which quickly

matches the property and applicants vice versa.

Price	Nett	Vat	Total
	500.00	75.00	575.00

Mailing List

This system is a complete name, address and reference recording and management system for use in a wide variety of business operations. Up to 375 records can be held on each floppy disk. Features include add/amend/delete record, print records, print labels and various sort/selection facilities.

Price	Nett	Vat	Total
	70.00	10.50	80.50

Games and Simulations

INVASION ORION (32K APPLE, Disk)

A complete tactical science fiction war game that provides you with scenarios designed to allow players of different skills to find a challenging game of space warfare every time. Choose from three levels of play for the computer. You can allow the computer to play either side.

Price	Nett	Vat	Total
	18.00	2.70	20.70

MICROCHESS (16K APPLE, Disk)

Perhaps the most famous chess game of all Peter Jennings latest version written in machine code. It displays a graphic chess board and uses standard algebraic notation to describe the moves. You may set up special board situations and play them out against the computer "Should be well received at the low asking price" - Computing Today.

Price	Nett	Vat	Total
	15.00	2.25	17.25

STAR FLEET ORION (32K APPLE + INTEGER ROM CARD, Disk)

This program brings you the opportunity to fight space battles in your living room. 12 scenarios are provided in the game. These are of varying complexity with 2 to 15 spacecraft and playing times from 15 minutes to 6 hours. Starfleet Orion also includes a Rule Book, Battle Manual and Ship Control Sheets.

Price	Nett	Vat	Total
	18.00	2.70	20.70

TEMPLE OF APASHAI (48K APPLE, Disk)

This is a fantasy adventure, but goes far beyond any other fantasy adventure game you may have seen for microcomputers. There are over 200 rooms, chambers and passages and over 30 different kinds of monsters guard the many and varied treasures of Apschai. You'll spend hours or days wandering the ruins. "The Temple of Apschai is quite an experience. I am very pleased with it and rate it as one of my favourite PET programs." Len Lindsay - COMPUTE.

Price	Nett	Vat	Total
	22.95	3.44	26.39

APPLE INVADERS (48K + PADDLES)

An excellent representation of the famous arcade game "Alien Invaders." Very competitive game with remarkable hi resolution graphics and high scoring. Good luck!

Price	Nett	Vat	Total
	12.00	1.80	13.80



Mail Orders to:
MICRODIGITAL LIMITED
FREEPOST (No stamp required)
Liverpool L2 2AB.

Retail Premises at:
25 BRUNSWICK STREET,
LIVERPOOL L2 0PJ.
Tel.: 051-227 2535/6/7

free delivery within mainland U.K.
12 month guarantee
all equipment tested before dispatch
bonafide official orders welcome

Apple Software

STAR VOYAGER (32K + INTEGER ROM CARD + PADDLES)

A most challenging adventure in three parts. First destroy the evil emperor's city, Secondly dock with a military space station and finally defend yourself against space pirate ships. A three in one bargain.

Price	Nett	Vat	Total
	15.95	2.39	18.34

SUPER STARWARS (32K + INTEGER ROM CARD JOYSTICK OR PADDLES)

Very realistic galactic battle with "floating sights" adding a very high degree of professionalism to a most acclaimed computer battle game.

Price	Nett	Vat	Total
	11.25	1.69	12.94

CHECKER KING (16K APPLE, Disk)

Personal Software's Checker King lets you play against your computer at eight levels of difficulty. A unique feature allows you to store, in memory, up to three board situations and replay them. All moves on the draughts board are naturally checked for legality.

Price	Nett	Vat	Total
	17.50	2.63	20.13

DATESTONES OF RYN (48K APPLE, Disk)

A dastardly robber band led by the notorious rogue, Rex the Reavers, has stolen the precious Datestones. Your mission is to recover the Datestones before Rex and his cut-throats slip away. The Datestones of Ryn comes as a complete package, ready to play, including game program, 1200 Byte data file and 16 page manual.

Price	Nett	Vat	Total
	12.95	1.94	14.89

GAMMON GAMBLER (16K APPLE, Disk)

Become a Backgammon expert fast, Gammon Gambler provides ten levels of skill, from beginner to expert. The ideal way to learn or polish your game, because Gammon Gambler checks all of your moves for legality, lets you back up and correct your move, and optionally displays the number of points. Backgammon rules are included in the manual.

Price	Nett	Vat	Total
	15.00	2.25	17.25

Programming Aids

ASSEMBLER EDITOR (48K)

A two pass assembler which is a compatible subset of the Fortran cross assemblers available for 6500 series micros. This package incorporates the APPLEPIE text editor to facilitate preparation of source code for assembly. Machine instruction source statements provide mnemonics codes for all machine instructions in the 6500 series instruction set. File linkage facility allows simultaneous assembly of multiple source files.

Price	Nett	Vat	Total
	45.00	6.75	51.75

DISK MAGIC (48K + INTEGER ROMCARD)

An invaluable programmer's utility. Enables the user to read and write information at the sector level without the constraints of the normal disk operating system. Repair damaged files, "undelete" files, instant report of free space available.

Price	Nett	Vat	Total
	16.00	2.40	18.40

HI-RESOLUTION CHARACTER GENERATOR (48K + INTEGER ROMCARD)

The program gives unlimited potential for intricate designs; animation can be displayed with a faster speed compared to using normal routines. The memory used is half that of using the normal hires routines. Each character set is 96 characters and two sets can be accessed by the key board at one time - that is 192 accessible characters and even more can be used, allowing as many sets as your memory permits.

Price	Nett	Vat	Total
	16.50	2.48	18.98

APPLEFORTH (16K + INTEGER ROMCARD)

A fast, interactive, compact language originally developed by astronomers for the control of their instruments. Run time overhead of only 70-100% compared with around 1000% for Applesoft interpreter. Software development times are also much shorter than for Assembler programming. Appleforth runs stand-alone using the APPLE's onboard monitor for 1/0.

Price	Nett	Vat	Total
	39.95	5.99	45.94

LARGE CHARACTER (32K + INTEGER ROMCARD)

Uses low-res graphics to display a message of up to 33 pages long. Each page contains three lines of up to six letter/numbers in colour. Ideal for point of sale advertising and display.

Price	Nett	Vat	Total
	16.00	2.40	18.40

LISA (48K + INTEGER ROMCARD)

A powerful assembler. Symbolic and non-symbolic addressing modes, indexing and pseudo operation codes. A most essential tool.

Price	Nett	Vat	Total
	28.50	4.28	32.78

MASTER CATALOGUE (32K)

An alphanumeric sorting and filing program. It makes full use of the Ampersort routine as described in leading magazines, will enable the user to delete a file, add a volume, list file, sort by program name, sort by volume, find a program. Once you have more than one program diskette it is irresistible.

Price	Nett	Vat	Total
	14.00	2.10	16.10

SHAPE BUILDER (48K)

Brings hires graphics within reach of those unwilling to work with binary or hexadecimal. Gives full control over shape rotation and colour and is probably the best hires shaper available on the market.

Price	Nett	Vat	Total
	17.00	2.55	19.55

TINY PASCAL (32K)

This language is integer only unlike full Pascal. It is compatible with Integer Basic and APPLESOFT; all of these languages can reach in, manipulate, and write out to each other. Tiny Pascal includes very comprehensive documentation and programming examples. As favourably reviewed in BYTE magazine in America.

Price	Nett	Vat	Total
	40.00	6.00	46.00

LISP

The system consists of 6k bytes of machine code interpreter plus 4k bytes of initialised LISP workspace containing LISP utilities and constants. It is supplied on disc with a 44 page manual for a 16k or larger computer. Two demonstration programs are included. The system has been designed with ease of use in mind.

The fast compacting garbage collector automatically finds space for numbers, lists or character strings if there is any space at all remaining. This means that the programmer need never be concerned about the details of storage allocation. Supplied on Disk. Requires 32K System.

Price	Nett	Vat	Total
	58.00	8.70	66.70

Scientific

INDEX FILE (48K + INTEGER ROMCARD)

Provides facilities for new files, accessing data on existing files, recovering record details, adding records, deleting records and modifying records. Also contains text string search facility.

Price	Nett	Vat	Total
	16.00	2.40	18.40

FUNCTION PLOT (48K)

The program plots two dimensional functions using hi-resolution graphics. The functions can be simple or complicated and assists visualisation of types of co-ordinate systems. Plots rectangular or polar co-ordinates. Rectangular co-ordinates can be linear, logarithmic or semi logarithmic. Axes are clearly labelled and several examples are shown within the program.

Price	Nett	Vat	Total
	18.50	2.78	21.28

STATISTICS (24K)

A pack of six programs allowing the following statistical tests: Mean, Variance and Standard Deviation, Binomial, Normal Distribution Probability and Frequency, chi-Square-Distribution, chi-Square Test and T-Test. A practical business aid that is very simple to execute.

Price	Nett	Vat	Total
	19.95	2.99	22.94

Tutorials

STEP BY STEP (32K)

The famous basic tutorial for the APPLE. Comes complete with a sixty page manual. Ideally suited to the first time user and beginner. Its method of teaching will ensure that programming skills quickly become habit.

Price	Nett	Vat	Total
	25.00	3.75	28.75

Maths Sequences

A comprehensive software curriculum in mathematics for children aged 5-10. Topics covered range from simple arithmetic through to laws of arithmetic and negative numbers. Instruction is completely individualised based on each student's needs and abilities. The programs are success orientated and allow the student to work at his own pace towards set objectives. As well as all this each student's progress is monitored thus allowing the teacher to review the progress of all students in a matter of minutes.

Price	Nett	Vat	Total
	200.00	30.00	230.00

Other Software

Price	Nett	Vat	Total
Contributed Software 1-2	27.00	4.05	31.05
Contributed Software 3-5	60.00	9.00	69.00
Disc utility pack	15.00	2.25	17.25
Apple Post	27.00	4.05	31.05
Apple Bowling	9.00	1.35	10.35
Stellar Invaders	13.00	1.95	14.95
Apple Adventure	21.00	3.15	24.15
Checker King	15.00	2.25	17.25
Bridge Partner	14.00	2.10	16.10



Mail Orders to:
MICRODIGITAL LIMITED
FREEPOST (No stamp required)
Liverpool L2 2AB.

Retail Premises at:
25 BRUNSWICK STREET,
LIVERPOOL L2 0PJ.
Tel.: 051-227 2535/6/7

free delivery within mainland U.K.
12 month guarantee
all equipment tested before despatch
bonafide official orders welcome.

Books

We have been supplying a wide range of microcomputer books for over two years now and we are probably the largest supplier in the country. We stock for more titles than those listed in this brochure for browsers in our Liverpool shop. All prices include postage and packing and we welcome official orders from bona fide commercial educational and government organisations.

We hold enormous stocks so as to ensure a rapid turn around on your order.

SYBEX BOOKS

Introduction to Personal and Business Computing 4.90
by R. Zaks

A comprehensive yet simple introduction to the micro computer world for the potential user whether it be for home or business use.

Microprocessors - From Chips to Systems by R. Zaks 6.95
The basic text on micros for everyone with a technical or scientific background. This book teaches all the fundamentals of microprocessors step by step.

Microprocessor - Interfacing Techniques by R. Zaks 9.90
This comprehensive book introduces the basic interfacing concepts and techniques, then presents the implementation details from hardware to software.

Programming the 6502 by Rodney Zaks 7.90
This book is an educational text designed to teach programming, using the 6502. It does not require any prior programming knowledge, yet can be used to advantage by anyone wishing to familiarize himself with the 6502. An invaluable book for owners of the PET, Apple, Kim etc.

6502 Applications Book 7.90
This book presents practical applications techniques for the 6502 ranging from a complete home alarm system to an industrial control loop for temperature control. Also includes analog to digital conversion and simple peripherals from paper-tape reader to micro printer.

Programming the Z-80 8.90
Another in the highly successful Sybex Series by Rodney Zaks. This book combines the function of a teacher text, that Sybex do so well, with an extensive reference section. The book is much more than an introduction to the Assembly Language syntax of the Z-80.

Your First Computer by Rodney Zaks 5.90
A Basic introductory text on small computers. Clear, detailed explanations of what a computer system is, what it can do, how it works and how to select the various components and peripheral units. Comprehensive discussions on programming a computer, recent language developments (CP/M and PASCAL), the newest hardware and buying a system wisely. Includes in particular a detailed discussion of peripherals. Designed as a reference guide as well as an introduction to small computers.

The CP/M Handbook by Rodney Zaks 8.90
CP/M - the industry standard in operating systems. Now SYBEX makes CP/M as easy to use as ABC with this new step-by-step guide. This book teaches the reader to use the editor and assembler to create, copy and modify files. It offers a clear understanding of CP/M's basic operation, then explores all versions of CP/M, including CDOS and multi-user MP/M. A general overview, sample programs, practical operating hints and numerous handy reference tables, make the CP/M HANDBOOK a must for anyone using or considering CP/M - from input typists with no computer background to experienced applications programmers.

Programming the Z8000 by Richard Mateosian 7.90
This book describes, in detail, the architecture and function of the Z8000 and its family of support chips. It provides an introduction to machine language programming using the Z8000 and presents many sample Z8000 programs to illustrate programming techniques and design principles. It even shows how clear, well-organised programs can be written for complicated subjects like interrupt I/O programming and timesharing. It is intended for anyone interested in the Z8000; the electronic design engineer, the advanced programmer or the beginner. PDP-11 users should find it especially interesting since the step from a PDP-11 system to a Z8000 system is a relatively easy one.

OSBORNE BOOKS

Practical Basic Programs 9.90
Every program - and there are 40 programs in all - is presented with a verbal description, BASIC source listings, sample run, practice problems, and operating instructions. These short programs address management decision-making, financial, statistical, mathematical and scientific problems. It's a program recipe book, and you don't have to be a programmer to appreciate it.

Z-80 Assembly Language Programming 8.10
These books are assembly language primers in the "classical sense" - they treat assembly language as a means of programming a microcomputer system and are full of simple programming examples.

6502 Assembly Language Programming by Leventhal 8.20
Another fine manual in the Osborne Assembly Language series to join the best selling 8080, 6800 and Z-80 books.

PET and the IEEE 488 Bus (GPIB) by Fisher & Jenson 9.90
A book for instrument designers, scientists, programmers and hobbyists - which shows how you can have a low-cost versatile system that may be interfaced to any of hundreds of electronic instruments.

Introduction to Microcomputers by A. Osborne - Volume 0: The Beginners Book 5.90
If you know nothing about computers this is the book to begin with. It explains what computers are and describes their components.

Introduction to Microcomputers by A. Osborne - Volume 1: Basic Concepts 6.25

This book describes application techniques common to all microprocessors yet specific to none. All the basic hardware and software concepts are explained simply.

Introduction to Microcomputers - Osborne (September 1978 Edition) 14.90

Volume 2 - Some Real Microprocessors
This 9" x 7" loose leaf format book covers every major microprocessor on the market. 4 bit to 16 bit in detail and analyses more than 20 CPUs. Includes new sections on the most recent entries into the microprocessor market. Describes support devices for use with only one microprocessor.

Volume 3 - Some Real Support Devices - loose leaf 10.90
A companion volume to volume 2. This describes the micro support devices which can be used with more than one microprocessor - including system buses.

Some Common BASIC Programs 7.90
Includes 76 short programs covering financial, mathematical, statistical and general interest subjects, all of which have been tested.

Z-80 Programming for Logic Design 6.25
These books describe the implementation of sequential and combinational logic using assembly language. They describe the meeting ground of the programmer and the logic designer and are written for readers in both fields.

HOWARD SAMS BOOKS

Microcomputer Primer by M. Waite and M. Pardee 6.30
Written for the beginner in the computer field. All the basic concepts and characteristics of microcomputers are explored and explained.

Getting Acquainted with Micros by L. Frenzel 6.90
Learn about microcomputers in an effective low cost manner. The essential information contained in this book has been compiled especially for Engineers, Technicians and Scientists but is equally invaluable to the layman.

Computer and Programming Guide for Engineers by D. Spencer 9.10
Written specifically for the Engineer or Scientist, this book explains what a computer is, how it works and how it can be used to the best advantage. Details FORTRAN and BASIC programming.

TTL Cookbook by D. Lancaster 7.10
Discover what transistor-transistor logic is, how it works and how to use it. Discusses practical digital applications and teaches you how to build TTL systems that entertain test and train.

CMOS Cookbook by D. Lancaster 7.45
Your complete guide to the understanding and use of Complementary Metal-Oxide-Silicon integrated circuits. Gives usage rules, power supply design examples, applications, bread boarding and coverage of logic.

TV Typewriter Cookbook by D. Lancaster 7.20
A comprehensive guide to low cost television display of alpha-numeric and graphics data for microprocessor systems word processing, TV tiling and video games.

Cheap Video Cookbook by D. Lancaster 4.90
A complete guide to super low cost alphanumeric and graphic microprocessor based video displays - this book picks up where the TV Typewriter Cookbook ended.

How to Program Micros by W. Barden Jnr. 6.90
Explains assembly language programming of microcomputers based on the 8080, 6800 and 6502 microprocessors. Basic concepts, number systems and operations, computer operation and codes are examined.

Z-80 Microcomputer Handbook by W. Baden Jnr. 6.90
This book provides essential information on Z-80 technology and is organised into three sections: Hardware, software and microcomputers built around the Z-80.

Microcomputers for Business Applications by W. Barden Jnr. 7.10
This book will prove invaluable to a potential buyer of a business microcomputer system - helping him to select the best system for his particular needs. The micros discussed range from spin-offs of hobbyist computers to complete "turnkey" systems with customised software.

The S-100 and Other Micro Buses by Poe and Goodwin 5.10
This book is about buses and after acquainting the reader with bus basics moves on to detail the eleven most widely used bus systems.

BASIC Primer by Waite and Pardee 6.90
This book is exactly what it says it is - on top of this it also includes 7 appendices to help you optimise your code for speed or memory use. Finally at the back is a reference card which you will keep in your pocket during the rest of your BASIC programming career.

Z-80 Microprocessor Programming and Interfacing Volume 1 by Nichols and Rony 7.70
This book is the first of a two volume series on the Z-80. It covers programming at the assembly and machine language level for the Z-80. Book 2 will cover interfacing. The books are laboratory oriented texts. The strong emphasis is on learning through experiment. This book requires no background in computers.

Z-80 Programming and Interfacing Book 2 by Nichols and Rony 8.45
Address interfacing digital circuits with the Z-80 CPU, PIA and CTC chip and progresses on from Book 1 (Interfacing) assuming the reader is familiar with the topics covered in Book 1.

Industrial Process Control Systems by Patrick and Fardo 8.90
Process control procedures, system concepts, components, industrial applications and study questions in a logical text book.



Mail Orders to:
MICRODIGITAL LIMITED
FREEPOST (No stamp required)
Liverpool L2 2AB.

Retail Premises at:
25 BRUNSWICK STREET,
LIVERPOOL L2 0PJ.
Tel.: 051-227 2535/6/7

free delivery within mainland U.K.
12 month guarantee
all equipment tested before despatch
bonafide official orders welcome

Books

13

TRS-80 Interfacing by J.A. Titus 6.90
 Requiring a good understanding of Level II BASIC, this book describes the signals available in the TRS-80 computer and their applications to the control of external devices. Experiments in the construction and use of some typical interfaces are included.

The Howard W. Sams Crash Course in Microcomputers by L. E. Frenzel 10.60
 Written in a teach yourself format with study questions, this book provides a solid background in microcomputers quickly and effectively. All aspects from fundamentals and operating systems to programming and peripherals.

Computer Graphics Primer by M. Waite 8.90
 Instruction in the methods of producing drawings, plans, maps and schematics on a CRT. display. In 3 sections, 'Perspectives', 'Basic Concepts' and 'Graphics Programming'.

6502 Software Design by L. Scanlon 7.90
 Fundamentals of 6502 operation are explained and then extended to give a comprehensive coverage of 6502 use.

Z-80 Microcomputer Design Projects by W. Barden Jnr. 9.10
 A solid introduction to the Z-80 microcomputer and the EZ-80 chip. Simple construction of the EZ-80 microcomputer and several applications.

BUTTERWORTH BOOKS

Basic BASIC by J. Coan 6.45
 One of the most widely sold text books on BASIC. The book uses over 100 example problems to illustrate the essential techniques of the language.

Advanced BASIC by J. Coan 5.95
 Develops the readers expertise with BASIC through strings and files to graphing and more important mathematical functions.

FORTRAN Fundamentals - A Short Course by Jack Steingraber 3.40
 A fast and efficient guide to FORTRAN - providing an abbreviated means of learning the language. Sample problems and their solutions are included.

Programming for Microprocessors by Andrew Colin (hardback) 3.40
 This book has been written for those converting from other disciplines to the use of microprocessors. It is designed to allow fast progress to a useful working understanding of the application of microprocessors and includes sections on number representation.

Sargon: A Computer Chess Program by Dan and Kathe Spracklen 9.45
 Here is the computer chess program that won first place in the first chess tournament at the 1978 West Coast Computer Faire. It is written in Z-80 assembly language using the TDL macro assembler. It comes complete with block diagram and sample printouts.

The Systems Analyst by J. Atwood (Hardback) 7.45
 From the initial decisions whether or not to be use a computer for a specific problem, to the actual installations of the completed system, the book covers the strategies, skills and techniques needed. Written without complex maths it is a step by step guide for people developing systems for the business world.

How to build a Computer-Controlled Robot by Tod Loofbourrow 5.90
 Every step of the construction of "Mike" is explained with photographs and diagrams to direct you through the construction. The complete control programs for a robot are clearly written out. You may use the directions exactly as they are set forth in the book or as a basis for developing your own design. "Mike" can be built within the budget of the average hobbyist and the only technical requirement for building him is the ability to read and understand a circuit diagram.

How to Profit from your Personal Computer - Professional, Business and Home Applications by T. G. Lewis 5.45
 Written for business people and computer hobbyists contemplating business applications, it shows how to put your computer to work for you. It describes common business applications such as accounting, handling payroll, managing inventory, sorting mailing lists and many others.

FORTRAN with Style 4.70
 A little book to allow you to write professional and well laid out FORTRAN programs.

BASIC with Style 3.90
 This type of book is sorely needed by us all as we develop our understanding of BASIC, so that we may adopt some of the disciplines needed to make robust readable programs.

Game Playing with BASIC by D. Spencer 5.45
 A non technical book which includes an appreciation of the rules, structure and output for each example discussed.

Sixty Challenging Problems with BASIC Solution 5.90
 Contains 60 games, puzzles, mathematical, science and business problems for reinforcing computer programming skills in the BASIC language.

Problems for Computer Solution 5.10
 821 problems are arranged by topic ranging from mathematical disciplines to science and business.

CREATIVE COMPUTING BOOKS

Computers in Mathematics 10.90
A Sourcebook of ideas edited by David H. Ahl
 One section presents over 250 problems, puzzles and programming ideas, more than are found in most "problem collection" books. Pragmatic, ready to use, classroom tested ideas are presented for everything from the most basic introduction to binary numbers to advanced techniques like multiple regression analysis and differential equations. Every item discussed has a complete explanation including flowcharts, programs, and sample runs.
 The book includes many activities that don't require a computer. And if you're considering expanding your computer facilities, you'll find a section on how to select a computer complete with an invaluable microcomputer comparison chart.

Although much of the material has appeared in Creative Computing, many of those back issues are no longer available. Consequently this book meets the demand of making available that popular information.

BASIC Computer Games by David Ahl 5.45
 The first collection of games all in BASIC. Contains both a complete listing and a sample run of each game along with a descriptive write up.

More BASIC Computer Games by David Ahl 5.45
 This is the sequel to the best selling "BASIC Computer Games". 84 fascinating and entertaining games for solo or group play. All games are complete with a program listing in BASIC, a sample run and a description. Standard Microsoft BASIC is used throughout and the programs are simple to use with almost all microcomputers.

ADDISON - WESLEY BOOKS

Artificial Intelligence by Winston 13.75
 Artificial intelligence is concerned with extending the application of computers and gaining an understanding of the principles that make intelligence possible. This book designed for use in a course on artificial intelligence should prove invaluable to the newcomer to the topic as well as to the experienced as a reference text. Part one covers an introduction to the key ideas in the subject such as representation, symbolic constraint exploitation, search and control. Part two covers the LISP programming language and its use. The book is profusely illustrated.

Problem Solving and Structured Programming in BASIC by Koffman and Friedman 8.90
 The book reflects the view that good problem solving and programming habits should be introduced at an early stage. Three separate phases of the solution are used:-
 1) Specification of the algorithm using flow diagrams.
 2) Analysis of the problem.
 3) Implementation of the problem solution.

The Little Book of BASIC Style by Nevison 5.70
 Structure style and correctness and maintainability are the attributes of good programming - they are getting much attention as well they should. When one considers what we invest in programs their manageability and efficiency become very important. In this book these concepts are explained along with 19 rules and many examples in BASIC to help improve your programming style.

A Guide to BASIC Programming by Spencer 8.80
 A first course in BASIC for Scientists, Business people and Engineers. The book illustrates the application of the language with numerous examples which will be useful later in your BASIC programming career.

Introducing System Design by Squire 9.65
 This book assumes some knowledge of computers and from this builds a review of the techniques used in system design through data base, security of the system and top down design. An important book for the student of business use of computers.

Software Tools by Kemigan and Plauger 8.15
 This text is designed to emphasize Structured Programming and Top Down Design. It deals with filters, formatting, files, sorting, text patterns, editing and macro-processing.

BASIC and the Personal Computer by Dwyer & Critchfield 9.70
 The authors provide a detailed presentation of BASIC and extended BASIC. Included are many applications possible on any microcomputer. Readers are encouraged to think about personal computing in its widest sense, write programs and research new applications. A selection of projects appears at the end of each chapter. The book may be used as a self-study text or a course book.

Problem Solving and Structured Programming in FORTRAN by Friedman & Koffman 9.90
 This book is designed for a short first course in computer programming. This book introduces the techniques of structured programming at a very early stage. The authors emphasize three distinct phases of problem solving: 1) the analysis of problem 2) the specification of an algorithm and 3) the language implementation of the algorithm.

A Course in APL with Application by Grey 9.70
 This introductory text may be used by either the experienced computer user familiar with at least one general purpose language, or by the beginner with no previous programming experience. The presentation aims to show that APL is a refinement and enhancement of mathematics. Emphasis is placed on the use of APL as an ideal language for formulating and developing algorithms.

Programming in PASCAL by Grogono 6.90
 This introductory language manual is an excellent start to one of the fastest growing programming languages today. The book is arranged as a tutorial containing both examples and exercises to increase reader proficiency with the language. Besides a chapter on procedures and files there are sections on dynamic data structures such as trees and linked lists. These concepts are put to use in an example of bus service simulation.

Programming a Microcomputer (6502) by Foster 7.20
 This book will teach you how to program a microcomputer in machine language. Although designed specifically for the 6502 microprocessor used in the Kim 1, PET and the Apple. The basic principles involved apply to all computers.

The Computer - An Everyday Machine by Squire 8.40
 The text puts the data processing computer in perspective, introduces it as a tool that can be used and understood by anyone. The approach is to take a simple problem, analyse it and then solve it using a hypothetical language and a computer consisting of the simplest possible units. The book is an excellent introduction to the computer as used by large scale businesses. The author is a systems engineer with IBM Canada and provides her own interesting perspective. The book is widely used by business management students as their first introduction to computers.



Mail Orders to:
 MICRODIGITAL LIMITED
 FREEPOST (No stamp required)
 Liverpool L2 2AB.

Retail Premises at:
 25 BRUNSWICK STREET,
 LIVERPOOL L2 0PJ.
 Tel:- 051-227 2535/6/7

free delivery within mainland U.K.
 12 month guarantee
 all equipment tested before despatch
 bonafide official orders welcome.

Books

- The Art of Computer Programming Volume 1 – Fundamental Algorithms by Knuth** 9.90
This is the first book in this world wide best selling series and thought by many as the best books of their type available. Volume 1 begins with a thorough review of the mathematical techniques used, although it does not assume mathematics above high school level in the reader. It goes on to review assembly level programming and ends with a 200 page review of information structures. The book contains numerous exercises.
- The Art of Computer Programming Volume 2 – Semi-Numerical Algorithms by Knuth** 16.40
This book covers random numbers, random sequences, statistical tests, floating point arithmetic, multiple precision arithmetic, polynomials etc. This book offers a comprehensive interface between existing knowledge of computer programming and numerical analysis including a substantial amount of complexity and number theory statistics. It assumes 'A' level mathematics capability.
- The Art of Computer Programming Volume 3 – Searching and Sorting by Knuth** 20.40
This text is by far the most comprehensive survey of these computer techniques ever published. The material is presented such that the general principles are applicable to a wide range of problems. Some knowledge of computer techniques and elementary calculus is assumed.
- COBOL – An Introduction to Structured Logic and Design** 8.90
This introductory text stresses the logical development of solution to common business data processing.
- SIGMA BOOKS**
- Computer Programs that Work by Lee, Beech and Lee** 3.95
This book contains twenty four programs in BASIC in the areas of biology, mathematics, chemistry and physics and includes simulations of real-life situations and popular games.
- Z-80 Instant Programs (Nascom)** 7.50
These machine code routines can be entered in to a Z-80 system etc. and are applicable to even the smallest machines. The routines average 1000 instructions.
- COMPUSOFT BOOKS**
- Learning Level II BASIC by David Lien** 11.00
This is the second excellent book by Compusoft Publishing in California. No TRS-80 owner can afford to miss this one.
- The BASIC Handbook by David Lien** 11.00
This is a machine independent reference text for the BASIC on most personal computers. It also shows the syntax for the new ANSI standard BASIC. It is the only book of its kind in print at present.
- SCELBI BOOKS**
- Understanding Micros by N. Wadsworth** 7.90
If you are at all curious about small computers you must own this no-nonsense text which explains all the fundamental concepts behind the operation of virtually all microcomputers.
- Calculating with BASIC** 7.90
Here's a variety of programs in BASIC to help apply the language to practical problems. The book covers problems in finance, statistics, engineering, mathematics and electronics. Good descriptions and examples are provided with each program listing.
- PIMS Personal Information Management System** 7.45
This book is really a ready to use data base system in Microsoft BASIC with full instructions. An excellent starting point for your home applications.
- WELLER BOOKS**
- Practical Microcomputer Programming with the Z-80 by Weller** 19.50
18 chapters of solid accurate programming information. Debugging techniques, interrupt modes, array and table handling, number base conversation, floating point arithmetic, programmed input/output stackpointer usage. The book includes an editor assembler listing for Z-80 and 8080. If you return the coupon at the back of the book you receive either paper tape or TRS 80 cassette of the object code for the assembler.
- DILITHIUM BOOKS**
- Instant BASIC by G. Brown** 7.15
Here for the microcomputer enthusiast is finally a book to teach you BASIC which slowly introduces new ideas in a non-mathematical context. Interspersed with amusing graphics this book is fun to use.
- Beginning BASIC by P. Chirlian** 7.45
An introduction to BASIC for beginners written in response to the author's children's needs for a really basic BASIC.
- Starship Simulation by R. Garrett** 5.40
Simulation is the name of the game and it can be done on a small computer.
- 32 BASIC Programs for the PET Computer by Rugg & Feldman** 9.70
32 BASIC programs for the PET computer is precisely that. 32 fully documented programs that are ready-to-run on your Commodore PET 2001 computer. You also have the option of making a number of changes, as suggested, to these programs if you wish.
- Introduction to TRS-80 Graphics by D. Inman** 6.40
For some time now, graphic displays on microcomputers have been out of the reach of hobbyists because of their complexity and high cost. In this book the author will show you how, with a minimal knowledge of the BASIC computer language and your TRS-80 computer, you can create graphic displays that only a few years ago were the exclusive turf of the big computer owners. The book begins with the basics and works from line drawings through geometrics and right on up to moving figure animation and more advanced operations. A great handbook on computer graphics for microcomputer owners at all levels of experience.
- How to make money with your Microcomputer by Townsend & Miller** 5.70
The microcomputer system can be used as a "lever" to multiply your income and it is a tool of great power. It can do many jobs the individual cannot do at all, also process routine jobs in much less time than you could do them by hand. The possibilities only limited by your own creativity. This book will give a start with dozens of money making ideas.
- MICROSOFT (TM) BASIC by Knecht** 6.70
A tell it all book for TRS 80 users. It presents an introduction and tutorial on programming in MICROSOFT BASIC. The concepts presented are illustrated with examples that actually run. By starting with the simplest and most commonly used commands and then progressing onto the more complex instructions, the author illustrates how the more powerful versions of the BASIC language can save time and effort. Only an understanding of Computer fundamentals is required for the users of this book and the language is applicable to most small systems including the Apple and the PET.
- Peanut Butter and Jelly Guide to Computers by Jerry Willis** 6.15
This book is a welcome relief from the jungle of jargon and technical terms which seem to thrive like twitch grass in the garden of personal computing. It is a book rich with details you need to know and written in a style which is easy to understand. It is an important book for the beginner to be read first. It also has a wealth of information for the expert.
- MISCELLANEOUS**
- Best of Micro – Volume 1** 5.45
Micro is the best known and most widely read of the specialist journals dealing with the 6502 microprocessor as used in the PET, Apple, Aim, OSI, Computhink Minimax, etc. "Best of Micro" is a bound version of the first six issues.
- Best of Micro – Volume 2** 6.45
This is the bound version of the second six issues of Micro up to mid 1979.
- The Mighty Micro by Chris Evans** 5.75
This is the book written out of the well-known ITV series giving a more positive view perhaps than Adam Osborne's book.
- Illustrating Basic – a simple programming language by D. Alcock** 3.25
One of the best selling books on BASIC, its clear explanations, attention to details, style, wit and humour have won it widespread acclaim. . . "You don't have to be a computer scientist to read this book; it is for students meeting computers for the first time; for those in industry (particularly engineers) who never formally studied computing but who would like to write simple computer programs; for managers who do not want to write programs but would like to know more about a field in which they often have to take decisions; and for those who can already write in BASIC but seek a broader view of "portable" programming and an introduction to a few programmer's techniques like "state tables" and "list processing"
- OTHER TITLES**
- APL Implementation** 14.70
MICROPROCESSOR LEXICON 2.00
A - Z of Computer Games 5.30
Artificial Intelligence (TABS) 5.30
Basic Basic Programming 9.10
Basic Cookbook 3.90
Basic Comp Progs for the Home 6.45
Basic Comp Progs Science & English 6.45
Basic from the ground up 6.70
Basic Workbook 4.90
Beginning FORTRAN 7.90
Pascal for PET (TCL) 8.95
Computer Programming Handbook 7.20
Computer Technicians Handbook 7.20
Micros & the 3R's 5.90
Fortran With Style 4.70
Industrial Process Control Systems 8.90
Introduction to VLSI systems 10.90
Introduction to T-BUG 6.20
Modern Digital Communications 5.90
57 Practical Progs & Games 5.70
S-100 Bus Handbook 9.10
Some Common Basic Programs/PET 8.90
24 Tested Ready to Run Progs 4.70
TRS-80 Disc & Other Mysteries 11.90
TRS-80 Interfacing Book 1 6.90
Z80 Instant Programs 7.45
Z80 Instruction Handbook 3.05
Z80 Micro Design Projects 9.10
8086 Primer 6.45
Using FORTH 19.20
Programming and Interfacing the 6502 8.90
Pascal With Style 4.70
Robots on your doorstep 5.70
Basic Digital Electronics 3.90
PET Personal Computer Guide 10.45
Digital Interfacing with an Analog world 6.45
Introduction to Structured FORTRAN 9.20
Microcomputer Systems Principles featuring 6502/KIM 9.20
Microprocessor Systems Engineering 14.90
The ZX80 Pocket Book 4.95
Modern Guide to Digital Logic 5.70
Programming Microprocessors 4.90
6502 Cookbook 7.70
6502 Games 8.90



Mail Orders to:
MICRODIGITAL LIMITED
FREEPOST (No stamp required)
Liverpool L2 2AB.

Retail Premises at:
25 BRUNSWICK STREET,
LIVERPOOL L2 0PJ.
Tel:- 051-227 2535/6/7

free delivery within mainland U.K.
12 month guarantee
all equipment tested before despatch
bonafide official orders welcome.

LIVERPOOL SOFTWARE GAZETTE

15

The magazine for the microcomputer user. Authoritative articles on a wide range of software topics. Published bi-monthly.

Send a £9 cheque payable to Liverpool Software Gazette for 12 issues. State whether you wish to start with issue 1 2 3 4 5 6 7

Video Monitors

Microdigital can supply a wide range of video monitors, suitable for any situation.



Astec 10" Monitor

An economic monitor which provides a clear picture.

Price	Nett	Vat	Total
Astec	85.00	12.75	97.75

Hitachi 9" Monitor (VM910)

A standard monitor, very reliable.

Price	Nett	Vat	Total
	127.00	19.05	146.05

Hitachi Hi-Res 9" Monitor (VM906)

As above but with a finer tube giving clearer viewing.

Price	Nett	Vat	Total
	148.00	22.20	170.20

Hitachi 12" Monitor (VM129)

Excellent value for this superb Video monitor, a must for professional users. Extremely clear viewing.

Price	Nett	Vat	Total
	189.00	28.35	217.35

12" Green Screen Monitor (VM 12G)

An excellent clear green screen monitor, comes complete with 'anti-glare' shield.

Price	Nett	Vat	Total
	162.00	24.30	186.30

Colour monitors: Ring for prices and details.

Memory Chips ● New low price

We buy memory in enormous quantities, as a result we can afford to sell memory chips at really comprehensive prices. Any faulty chips should be returned to us within 12 months of purchase with proof of purchase for replacement by return of post.

4116 memory chips guaranteed to 200 nanosecond full cycle time. Suitable for Apple, TRS80, Nascom, Exidy Sorcerer, Sharp MZ80K etc.

Price	Nett	Vat	Total
8 x 4116 chips (16K bytes of memory)	18.00	2.70	20.70

25 x 4116 chips	48.00	7.20	55.20
100 x 4116 chips	160.00	24.00	184.00

2114 memory chips guaranteed to 300 nanoseconds full cycle time. Low power suitable for Superboard, Compukit, Atom, ZX 80 etc.

Price	Nett	Vat	Total
2 x 2114 chips (1K byte of memory)	4.00	0.60	4.60
25 x 2114 chips	46.00	6.90	52.90

Scotch 7440 Head Cleaning Diskettes

Keeping the heads free of debris means longer lasting heads, fewer diskette replacements and fewer engineer calls. The rotating cleaning fabric in the head cleaning diskettes alternately wipes the heads with the solution and dry surface, removing contamination from the read/write heads. In half a minute the heads are clean.

The cleaning diskettes can be used with either single or double headed diskette drives. The 7440 kit is for all 5 1/4" minidiskette drives. The kit contains one bottle of cleaning solution, one dispenser cap and two cleaning diskettes. Each cleaning diskette

can be used for approximately 15 cleanings.

Materials and solution are completely safe, being non-flammable, non-abrasive and will not harm metals, plastics or painted surfaces. Too little or too much cleaning solution will not affect the drive.

Price	Nett	Vat	Total
7440 kit	29.50	4.43	33.93

Cassettes

We are probably the largest supplier of microcomputer cassettes in the country and have them specially manufactured to our quality specification.

- C15 Agfa Tape
- Special Labels
- Cellophane wrapped
- Precision transport mechanism
- Leaderless
- Insert Cards
- Screw fixing case
- Proven performance

Prices	Nett	Vat	Total
one cassette	0.80	0.12	0.92
box of ten cassettes	5.20	0.78	5.98
fifty cassettes	25.00	3.75	28.75
one hundred cassettes	45.00	6.75	51.75

Guarantee

If within 12 months of purchase any of our cassettes does not give satisfactory performance send it back to Microdigital for replacement by return of post.

Disks

High performance Mini Floppy disks

- Anti static envelopes
- soft sectored
- single sided, single density
- free library cases (with 10 or more disks)

- labels and write protect tabs supplied

Prices	Nett	Vat	Total
one disk	3.00	0.45	3.45
ten disks	22.00	3.30	25.30
fifty disks	100.00	15.00	115.00
one hundred disks	180.00	27.00	207.00



Mail Orders to:
MICRODIGITAL LIMITED
FREEPOST (No stamp required)
Liverpool L2 2AB.

Retail Premises at:
25 BRUNSWICK STREET,
LIVERPOOL L2 0PJ.
Tel.: 051-227 2535/6/7

free delivery within mainland U.K.
12 month guarantee
all equipment tested before despatch
bonafide official orders welcome.

Microdigital Mail Order Form

Office Use only	Goods required	Price	
	1		
	2		
	3		
	4		
	5		
	6		
	7		
	8		
		Total	

If you require a stereoclub application form tick this box

Date: _____

Access: 5224

Barclaycard 4929

Expiry date: _____
Name _____

Address: _____

Post Code _____

Tel (day) _____ **PCW**

Lasky's Stereoclub

— the easy way to buy, from Microdigital.

For as little as £5 per month, you can join the Lasky's Stereoclub, which immediately entitles you to a credit limit of 24 times your monthly repayment, and enables you to buy **now** the microcomputer equipment that you've always wanted from Microdigital. Current Stereoclub interest rate is 2.5% monthly — equivalent to an APR of 34.5% (Rates may vary).

As a Stereoclub member we'll send you regular news and literature from Lasky's and Microdigital. Lasky's Stereoclub is probably the best thing that's happened to Microcomputers since the invention of the chip!

Microdigital Limited

Microdigital Limited is registered in England
Registered Number 319646437
Registered Office Chancel House, Neasden Lane, London NW10
Directors P.M. George, P. Klein, G.W. Ralph, A.J. Stirling, D.J. Sate.
Ultimate Holding Company:- Ladbroke Group Limited
VAT Number:- 240 1132 31

Terms and Conditions

In addition to cash we accept, Access, Barclaycard, Stereo Club and cheques covered by a bankers card.

Allow one week for personal cheques to clear.

VAT in this brochure has been calculated at the rate of 15% current at the time of writing. Please allow for any changes.

Postage and carriage is offered free of charge within the United Kingdom.

All products are covered by our 1 year warranty against failure due to faulty materials or workmanship.

Official orders over £10 are welcome, with normal 14 days credit extended to bona-fide commercial and government organisations.

All prices, specifications and terms are subject to change without notice at the discretion of the management.

The entire contents of this brochure are copyright Microdigital Limited 1981.

Microdigital 12 month Guarantee

Microdigital Ltd, (hereinafter called the 'company') warrants the products it sells against defects in material and workmanship for a period of one year from the date of purchase.

During the warranty period, the company will repair (or at its own option, replace) at no charge, components that prove defective. This is provided the product is returned, shipping prepaid, or by person, to 25 Brunswick Street, Liverpool 2, L2 0PJ, stating when it was bought and enclosing proof of purchase.

This warranty does not apply if, in the opinion of the company, the product has been damaged by accident, misuse, misapplication or, in the case of a kit, bad construction.

Ansaphone Service

24 Hour — 7 Day
Ansaphone Service
on 051-236 0707

Opening Hours

Shop — 9 till 5.30 Mon — Sat.
closed Bank Holidays.
Mail Order — 9 till 5 Mon — Fri.

Prices correct at
time of going to
press



Mail Orders to:
MICRODIGITAL LIMITED
FREEPOST (No stamp required)
Liverpool L2 2AB.

Retail Premises at:
25 BRUNSWICK STREET,
LIVERPOOL L2 0PJ.
Tel:- 051-227 2535/6/7

free delivery within mainland U.K.
12 month guarantee
all equipment tested before despatch
bonafide official orders welcome.

SECRETS OF SYSTEMS ANALYSIS

PART 6: CHOOSING A PACKAGE

It is difficult to believe that two years ago this article would have been about how to track down that elusive program that somebody, somewhere, had written for your machine. Nowadays, finding a package is all about sifting through the mass of what is available to find out which is the best one for you. Of course, you may still not find what you want but that is another story. Even if you decide not to buy any of the packages you see, you can still learn what you like and what you don't from them, and you will be in a better position to design a program of your own.

As I have said for the last two months, choosing a package cannot be divorced from choosing the machine to run it on. Many people buy an Apple, for example, because they want Visicalc. Others will buy Petsoft programs because they already have a PET. In these cases, half the decision has already been made and the options for the other half have been reduced accordingly.

Price range

I suppose one way of getting started on your search is to decide what end of the market you are interested in. It is convenient to divide software writers into three types. At the top end of the market are the established software houses, who are accustomed to providing mainframe software, and the manufacturers of office machinery who are now providing complete systems for office functions such as word-processing, accounting, stock-control and hotel reservations. They already have a good knowledge of their customers' requirements and they have been in business long enough to know what sort of problems lie in store for them if they provide machines or programs that do not come up to their customers' expectations!

At the bottom end of the market are the cowboys — people capable of writing Basic programs for their own purposes who think they can make themselves a good profit by selling them. You may well be lucky and find a program from such a source that serves your purposes, but you do have to make sure that it is crash-proof and that you know how to use it. There are also program-swapping arrangements among some groups, particularly in education and hobby computing.

In the middle price range, there are many software houses who write programs for micros. Some specialise in particular machines or particular programs (accounts programs, or language compilers), some are better than others and some who distribute programs bought in from different sources offer

Lyn Antill continues her series aimed at bridging the gulf between the would-be micro user and the microcomputer specialist.

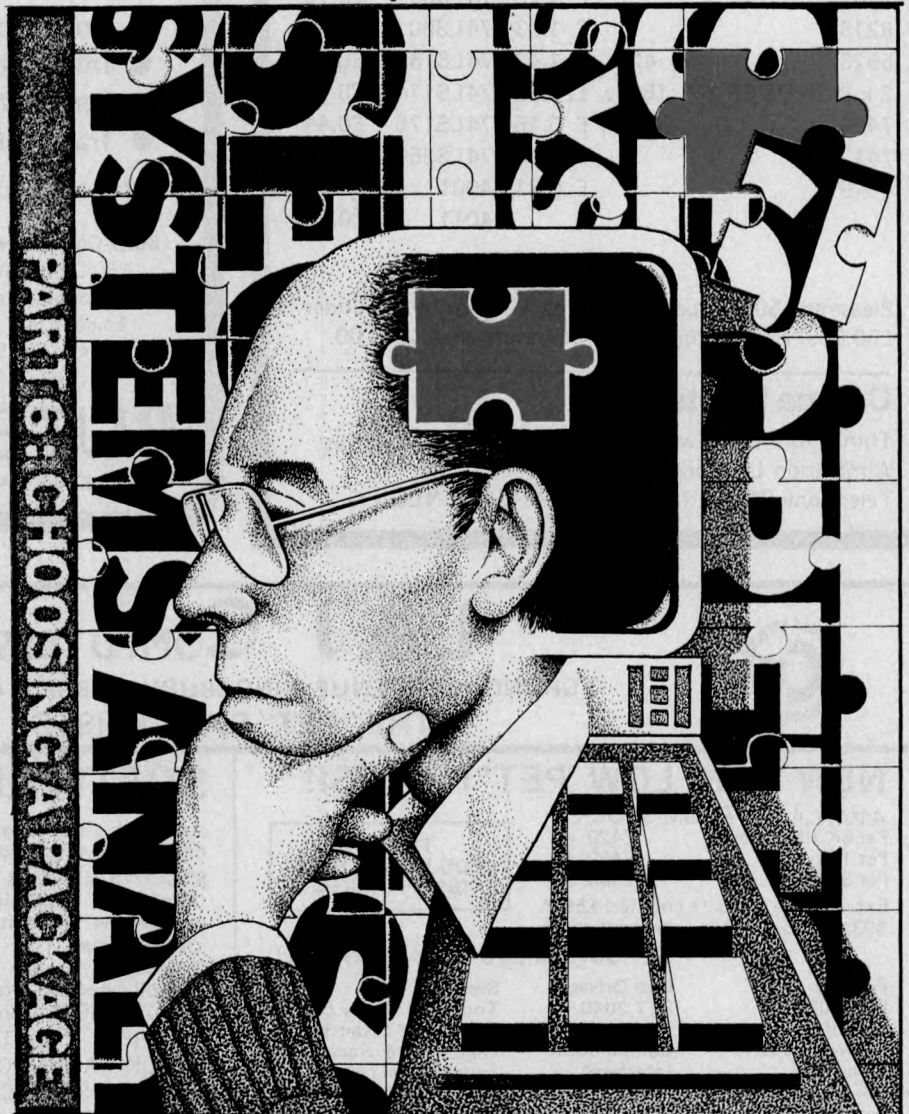

Illustration by Stuart Briers

products of variable quality. Between them, they have a pretty long list of programs, covering a wide range of machines and applications.

You probably already know if you are at the top end of the market, where reliability of the system and support from the manufacturer are high on your list of necessities. If you are a home user, looking anxiously at your bank balance, then you will know that if the program isn't cheap, you'll have to do without it. But even if you are quite sure what sort of supplier you're looking for, it is still worth thinking about the other options, just so that you can put your own choices — and the prices you're being quoted — into some sort of perspective. It helps in

your dealings with potential suppliers if you know what other companies are offering and what they are charging.

Complete business systems

Many established companies who have been supplying such things as typewriters, accounting machines, filing systems, closed circuit TV, etc, have taken up the challenge of the chip and entered into the micro market. Most of them have had the sense to build on what they are already good at and to provide complete systems (ie hardware and programs) to perform the jobs they know their existing customers want done. Most have also tried to integrate

Try us!

2732	450ns	£12.60		
2716	450ns	£ 4.50		
2708	450ns	£ 3.50		
2114	300ns	£ 2.46		
2114	450ns	£ 2.50		
16K DRAM	200ns	£ 2.50		
5101		£ 1.25	74LS09	£0.15
8216		£ 1.33	74LS90	£0.35
5623	40ns	£ 1.42	74LS163	£0.67
2 x 8 CMOS SRAM	150ns	£23.50	74LS174	£0.44
7404		£ 0.15	74LS175	£0.44
74175		£ 0.46	74LS257	£0.50
4049		£ 0.21	4001	£0.16
			4011	£0.16

Please add 50p for postage and packing for orders under £50.00. Prices include VAT. Minimum order £15.00.

Calona Limited

Third Floor Broadway House 112-134 The Broadway
Wimbledon London SW19 1RH
Telephone 01-543 1008 Telex 923416 CLNLDN G

BUTEL-COMCO

RP1600 Daisywheel Printer

60cps!

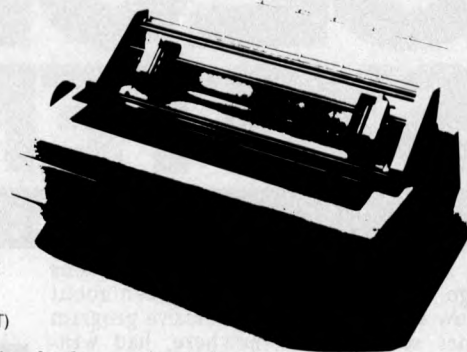

List Price:
£1450
(excluding VAT)

- Price includes an interface
- Interfaces available are
Serial V24/IEEE/Centronics/Qume/Hytype
- Trade/OEM discounts available

Write or call for further information

Butel-Comco Limited
50 Oxford Street,
Southampton,
England SO1 1DL
Telephone 0703 39890
Telex 47523

BUTEL
Technology for business

I am interested in purchasing the RP1600
for connection to

Name

Company

Address

Telephone



L&J COMPUTERS

3 CRUNDALE AVENUE, KINGSBURY NW9 9PJ 01-204 7525
THE "PET" SPECIALISTS



NEW LOW, LOW 'PET' PRICES!!

AVAILABLE FROM STOCK

Pet 8K (large keys)	£420 *
Pet 16K	£499 *
Pet 32K	£630 *

Ext. cassette decks (+ counter) £55 *
8032 (80 col. screen: new keyboard)

SUPERPETS NOW EX-STOCK!

Printers	Disc Drives	Sundries
PET 3023	PET 3040	Tool kits: library cases
PET 3022	Compu 400K	Disks: C12 cassettes
Centronic 779	Compu 800K	Paper (roll & tractor feed)
Spinwriter	Interfaces	Labels: Dust covers

Petmaster Superchips — upgrade your pet even more! £45

Toolkits — 3,000 series £30, 4,000 & 8,000 £35

The "MUPETs" are HERE!

3 to 8 PETs only need 1 DISK DRIVE

Daily demonstrations: Ring for details.



COMPLETE SYSTEMS
FROM £1700!!

THE ESTIMATES WE SUPPLY & INSTALL ARE COMPLETE
ESTIMATES GIVEN FREE WITH NO HIDDEN EXTRAS:
FULL BACK-UP: GUARANTEED EXPERTISE.

* PRICES DO NOT INCLUDE VAT

SOFTWARE

As well as a full range of Petsoft and Commodore Software, we have some highly reliable "Home-Brewed" programs available.

STOCK CONTROL & INVOICING £60
(Handles up to 500 items — 32k) (80 on 16K). Stock depleted on invoicing, search etc. Cassette, disk (& colour print option).

CASH BOOK £90
Enter daily/weekly amounts printout and totals, weekly monthly analysis, totals and balances.
(4032, & 8032 Versions £110 & £120).

MACHINE HIRE Typewriter & Plant Hire £420

STOCK TAKING Cuts out all the hard work £230

OUTSIDE SERVICES (For Mini-Cabs etc.) £220

Sae for free software booklet

SPECIALISTS IN:

Commodore Business Programs: Superpay;
Bristol Trader, Item & Monitor: Word Processing

SPECIALISED SOFTWARE APPLICATIONS
UNDERTAKEN. RING FOR DETAILS

2 FOR JUST OVER THE PRICE OF 1!

We now have limited stock of new cassette
decks with a built-in counter/soundbox
for PETS!

At ONLY £65*

Orders dealt with in strict rotation.

PERSONAL SHOPPERS WELCOME
Phone & Mail Orders accepted.

ALL GOODS SENT SAME DAY WHEREVER POSSIBLE
LARGE S.A.E. FOR LISTS ETC.



their new systems into the current office procedures. They are concerned, not so much to create something new and exciting ('gimmicky' is how some would see it), but to use the new technology to enable managers to run their businesses more efficiently.

If you were to look at the machines they are selling and the programs they have running on them, you would probably think that you could shop around and buy something to do the same sort of job for two-thirds the price. You might also feel that your alternative system was more versatile. But the complete business system is not the rip-off that this might imply because it offers features which the ordinary package does not:

- guaranteed compatibility between hardware and software (none of this business of getting the program reconfigured);
- a reputable supplier whose salesmen are used to dealing with your type of business;
- advice on security and backup procedures;
- help setting-up the system in the first place (always the most difficult job);
- compatibility between your existing system and the new one (if you stick with the same supplier).

If you are not sure whether this is the right approach for you, the first question to ask yourself is whether it is actually going to be worth your while paying the extra cost in order to get this additional service (having, of course, made sure that the supplier you had in mind actually provides that service). There are two halves to this question: how much more are you paying for how much additional support; and what do you stand to lose if you don't get that support? If your business would grind to a halt if the records were not kept for a couple of days, you can't afford a system which doesn't have a water-tight service guarantee.

People are surprisingly uncritical about the book-keeping system that has grown up with the business, so that, although the first reaction is, 'of course I must have up-to-date, accurate records!' it often turns out that they have managed perfectly well for years without either. So I challenge you to look at yourself for a day or so — how often do you look at the latest figures, and how critical would it be if you only had two-day-old figures to work on, along with your memory of what had been done since? Also, how much overtime would it take to get the books back up to date after the machine had been repaired? The converse of this is: if you have been managing with old figures, would you do better if your figures were better kept?

The complete business system is often referred to as a turnkey system, ie, you turn the key and the machine jumps straight into the built-in program.

Matching a package to a machine

If you are looking just for a program, then you've got two problems. One is that it is difficult to see what you're buying — floppy disks all look very much the same. The other problem is that you have to be sure that the program you're given will actually work

on your machine and this is a good place for us to start.

Certain programs are clearly designed to run on certain machines — Apple and PET programs, for example. The supplier will specify the minimum configuration needed to drive them, eg '32k SuperPET with twin 5¼in drives and a printer.' Most users are probably already aware that Apple, PET and Tandy each require their own software, at least until you have done something like put a CP/M card into the Apple. But I wonder if people know what sort of software is required for the Acorn, Atari, etc? If you're interested in buying one, you'll need to check up.

Other packages are available on a variety of machines. The great advantage of having a micro which runs the CP/M operating system is that you can run CP/M packages on it — but it is not always quite as simple as that. No machines are ever entirely standard and the programs often need to be reconfigured to take account of minor variations. Even the fact that the machine has quad density disk drives and the programs come on double density disks is enough to prevent them from being loaded directly. A programmer can usually get round some of these problems without too much difficulty, but a non-programming user could be in for a frustrating time.

The only way to make sure that the program you're looking at will work on the machine you had in mind is to get the technical specification of that machine written down and show it to one of the supplier's technical experts to see whether the program has been configured for that specification. Don't talk to the salesman (unless he's their technical expert as well) or the receptionist — they're trained to say 'yes' unless they are absolutely sure the answer's 'no'. And, anyway, they probably don't know what's likely to cause incompatibility problems between their program and your machine.

Does the program appear to do the job?

If you see a program called 'stock control', can you be sure of what it does? If you have goods coming in and going out you will have a very good idea of what you mean by 'stock control' but can you be sure that the writer of the program agrees with you? Alternatively, you may be looking for a package because your own stock is getting out of control, and you're not quite sure what to do about it. Will this program actually provide your solution? In point of fact, none of the 'stock control' systems I've yet seen on any micro lived up to that title. They were actually stock recording programs designed to provide the user with the information needed to do the controlling himself. For example, they can generate lists of items that are out of stock, or below the re-order quantity, but they don't actually create orders for the goods, or change the value of the re-order level for items whose level is, on the one hand, consistently too high, or which, on the other, are continually running.

So how do you find out what the program does? The ideal is to see it

running on some real data somewhere for a real user. For popular programs this may well be possible. Often, dealers have a demonstration version of the program with some sample files built-in. These can be useful for getting an idea of what the program does. At least they can help to weed out those programs which are obviously unsuitable. There are, however, two things which are very difficult to establish with sample data: how the program behaves with large data files and how good the security and backup procedures are. For example, I was testing a package of accounting programs and I wanted to inspect the day's end procedures. It was both pleasing and frustrating to find that I couldn't do this because the first job to be done at day's end was the taking of backup copies of the data and the program wouldn't continue until I had done this. I was pleased, because it showed a high level of security had been written into the program, but it meant I had to go out and buy a spare disk before I could finish the test! Any showroom test of a demonstration program is likely to be limited by such practical problems.

Even worse is the common situation of ordering programs from a catalogue. This is very unsatisfactory but it is one of the ways in which suppliers keep down their overheads and, consequently, their prices, so it does have some value. There is nothing lost if you speak to them on the telephone, and read all their sales literature. You will probably find that they say something like 'Program with manual: £295; Manual only: £10'. If you're interested, but not convinced enough to part with £295, it might be worth buying the manual. It could prove to be a waste of money but at least then it's a waste of not very much money. If, however, you like what's described in the manual and in the supplier's small print, you can buy the program (making sure you get credit for the cost of the manual!).

Program manuals

Obviously, these are a good guide to what the program does. But it's often difficult to follow a manual when you haven't got the program to try it out on and you may wonder whether it's you or the manual that is to blame when you can't make sense of something. If you're in any doubt, it's probably the manual. Only the largest companies employ technical writers and put any real effort into creating manuals for the genuine enlightenment of lay readers; smaller companies don't have that sort of money to spend. Even bearing in mind the financial constraints, however, some manuals leave a lot to be desired. A good manual gives a good impression of the product that it describes, and vice versa. Some good programs come with sloppy, skimpy or even inaccurate manuals and some otherwise reliable companies put out the odd bit of sloppy literature written in the rush to launch a new product. But if you don't like the manual, it does make you wonder about the program.

A manual is used for three purposes: — as a means of finding out in the first place what a program does; — for instruction on how to set up the data and run the program; — as a reference for looking up how to

A Word Processor, Report Writer, Mailing System, Data Base Manager, and a Computer all for £1995*

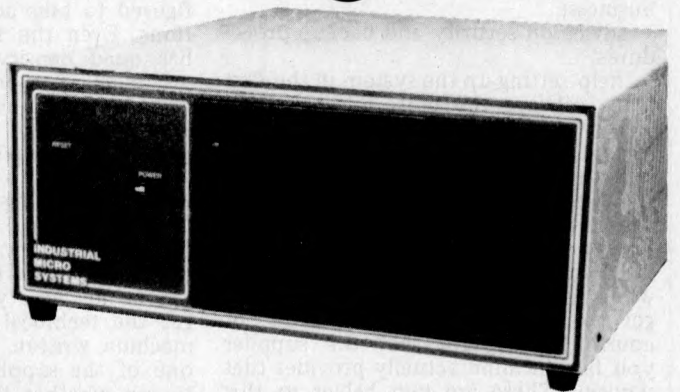

Yes, we are offering all this with our SERIES 5000 5" floppy-disc system for the incredibly low price of £1995.*

Not only do you get a powerful Z-80A system on the S-100 bus built to high quality standards by Industrial Microsystems, one of the longest and best-established companies in the microcomputer industry, and supported by Equinox, specialists in microcomputers and multi-user systems.

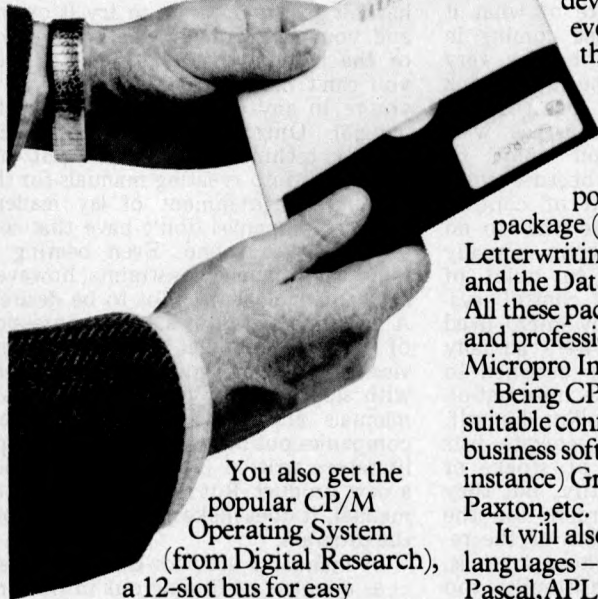

You also get the popular CP/M Operating System (from Digital Research), a 12-slot bus for easy expansion, a Z-80A CPU for powerful performance, 2 serial and one parallel interfaces, 64KB of dynamic RAM with in-built error detection capability,

and dual 5" double-density drives with the option of a third drive (or quad capacity drives in place of double-density) in the same cabinet. Additionally, there is the Turbocharger option providing both enhanced disc capacity, disc performance and diagnostics. And if even greater storage is required we can supply 8" floppy drives and cartridge disc drives.

A powerful system for the computer-user and system developer – and one with eventual access to OS/2000, the Industrial Microsystems networking system.

And for the office or business user we are including as standard a powerful Word-Processing package (Wordstar), a Mailing and Letterwriting package (Mail-Merge) and the Datastar Data Base Manager. All these packages are widely accepted and professionally written by Micropro International.

Being CP/M based, the system with suitable configuration will also run the business software developed by (for instance) Graffcom, Peachtree, Paxton, etc.

It will also run a wide range of languages – Basic, Cobol, Fortran, Pascal, APL, Algol, C. Lisp, and Forth and will support a wide range of add-on S-100 devices, such as floating point processors, Prestel interfaces, speech synthesisers, digitisers and plotters, etc.

And just to make certain that you get full use out of your system, nationwide field service support is available at a modest extra cost.

* add VAT and the terminal and printer of your choice at the costs shown.

Series 5000 with 64KB Dynamic RAM, dual 5" double density drives, CP/M Operating System, Wordstar, Mail-Merge and Datastar £1995

The same system with quad drives in place of the double density drives £2230

Add-on double density drive £290

Add-on quad drive £405

Peripherals:
Televideo 912C VDU £595
Elbit 1920X VDU with Wordstar keyboard £895
OKI Microline 80 printer £595
Texas 810 150cps printer £1450
NEC Spinwriter RO Word processing printer £1850

All prices exclude VAT, carriage, training and installation and are subject to our standard terms and conditions.

OEM dealer and educational enquiries welcome.

EQUINOX
COMPUTER SYSTEMS LIMITED

Kleeman House, 16 Anning Street,
 New Inn Yard, London EC2A 3HB
 Tel: 01-739 2387/9 & 01-729 4460

do the odd tricky bit.

A good — and therefore probably expensive — supplier will offer some help with the first and second of these, particularly the second. It takes quite a lot of confidence to commit your records to a computer. You may already have confidence in your ability to set up a computerised system but if you are wary, a comprehensible, comprehensive and reliable manual can be a great help — if you're the sort of person who gets on with manuals in the first place. Many people learn much better from practical demonstrations.

What matters when you are contemplating buying a package is whether you think you are going to be able to work from whatever you are being offered in the way of both practical training and manuals. If you don't think you can manage, then don't make the mistake of supposing that you can't get anything better. I've seen too many people driving themselves bananas trying to make sense of crummy manuals.

Is the program crash proof?

A few weeks ago, someone asked me during the course of a lecture, what it meant when I said a program had 'crashed'. Well, I learnt that term in 1964 when the pattern on the oscilloscope of my valve computer froze, indicating the memory location of the instruction it couldn't operate. For the benefit of those of you who have not had the sobering experience of a program crash, or who have not recognised it as such, let me explain the term.

A program crashes in much the same way as a car — it hits something it can't get through, so that it can go neither forwards nor backwards, by cancelling an invalid entry for example. The program is stuck trying to execute an impossible instruction but without any way of recognising the impossibility and stopping itself. The program may just freeze, or the operating system might abort the program, leaving the data in an unpredictable state. Obviously, you don't want a program that is likely to crash! 'Robust' is the word used to describe a program that is reasonably crash-proof. How do you find out whether a program is robust?

Once the initial testing is over and the program seems okay, a crash is most likely to occur in those areas where it is trying to handle an inherently tricky scenario — such as running out of space for storing the data, when the operator is trying to correct a mistake, or when the operator accidentally tries to do something the program wasn't expecting.

It's difficult for a programmer to get into the mind of an operator who has no idea of how the program works; programmers often underestimate the tangles that operators can get into, especially when trying to correct a mistake. It is these tricky situations which the inexperienced programmer takes least account of, not realising the extent to which the program will be abused over the course of a year's use. So, if you want to try out the quality of the program, do all the stupid things you can think of — typing punctuation marks instead of numbers, totalling out in the middle of an entry, entering an

invalid transaction and then trying to cancel it. If the program seems resistant to these attempts to sabotage it, then it is probably well-written in other ways.

The sort of program crash that occurs when files are full is much more difficult to test, because it takes time and effort to enter that much data. If you are really concerned about this, then you will have to go to the effort of setting up a full-scale test but you are unlikely to be able to do this until you have bought the program — or convinced the supplier that it is worth his while putting in the extra effort to get your custom.

However hard you try, there is no program that is going to be proof against all eventualities. You need to look at the small print to see what guarantee of service you are being offered for program errors.

User friendly

The ideal to which many computer theorists are working is the machine that understands English — so that you could just give it the morning's mail to read and have a friendly chat with it to find out what was going on. Voice-activated input, optical character reading and 'natural' query languages are all realities, albeit with considerable practical limitations. But there is a great deal that even the simplest micro program can achieve in the way of user-friendliness.

In particular, there are many ways in which a program can guide you through its own operations. All of these involve more coding (and hence more programmer time than is required for the straight processing) but they are of immense value to the novice or the casual user. Even the experienced key punch operator who appears never to look at the screen, still needs to be reminded occasionally of where she's up to.

A program may be menu-driven: at each stage you are invited to choose between several available options (including the option to drop out of that section of the program altogether and enter another). If the menus are well designed and the options self-explanatory, you can quickly learn to find your way around the program. This is often preferable to working through a manual. It is necessary for this type of program to keep some control over your selection of menus — just as the program I mentioned earlier wouldn't let me select 'CLOSE THE DAY'S BUSINESS' until after I'd selected 'MAKE BACKUP COPIES'.

A program can also guide the operator by means of 'dialogue', by displaying messages, instructions, prompts. Well-designed, these can be very helpful.

The advent of the memory-mapped screen has enabled the use of 'forms mode' input. During the whole of an input run, the screen is set up with protected fields which look like the headings and boxes on the form from which the operator is working. The cursor moves from one box to the next as each item is input. This is much quicker and easier for the operator to follow than is the use of prompts. If the program detects an error in the input, a warning message is displayed and the cursor returns to the box where

the error occurred and stays there until an acceptable input is received. The operator is also given the chance to change the entry in any of the boxes if s/he notices a mistake. If you are going to be doing a lot of data entry, or if individual transactions are likely to be complicated, then forms mode input is a great boon.

One marvellous idea that I have heard explained by a programmer working in the field of business micros is the use of graphics for output. I have not yet seen it used, but I think it has a great future. He gave an example of a hotel reservations system where the manager wanted to know how well bookings were going. The idea was to create a bar chart where times of unusually low bookings would be immediately visible. Very often, when looking at output, one is interested in trends or approximations rather than in exact figures and a graphical output is far more meaningful than a series of numbers.

Volumes of data

One of the first things a user must do is to discover the volume of data he wants to store and the number of transactions that may go through in one day. Can the program you're looking at cope? The formulae for working out how much storage capacity you've got are always fiddly. The supplier should be able to give you a rough figure to work to. If this appears to be a bit close to the mark, then you need to look at the program in more detail. If you are in any doubt, then you must consider whether your business is likely to expand in the next year or so. If you can barely cope now, then you won't be able to if you get 50 percent extra work.

The question of the speed at which work can be processed depends partly on your expertise in using the machine. You'll speed up as you get used to it but only up to a point. If you are aware of waiting for the machine when you are trying out the program, then you will always be spending time waiting for the machine, no matter how competent you become. This may not matter — you may have had to wait a great deal longer for a manual system to do the same thing. But if you are going to be putting a lot of work through, or if you're always going to be in a hurry for the results, then you must look for something faster.

Conclusion

I haven't talked very much about the task of deciding whether the program actually does the job you want — only you can recognise that. Instead, I have concentrated on helping you to find a package that does that job well, one that you will be able to learn easily, set up accurately, use reliably. Prices for programs vary enormously. You might get a simple calculation program for £20, or spend £2000 on a group of highly reliable, well-integrated programs to do all your accounts. Shopping around for a cheaper program, or patching up a shoddy one, may well cost more than buying an expensive one.

Next month I'll be looking at what to do if you can't find the program you want and decide to have one written.

Apple Price List

Product Code	Description	Price (£)	Product Code	Description	Price (£)
HARDWARE					
A2S1016P	APPLE 16K VIDEO OUTPUT ONLY	695.00	A2L001A	APPLE II REFERENCE MANUAL	11.00
A2M0003	DISC DRIVE WITHOUT CONTROLLER	299.00	A2L0002	6502 HARDWARE MANUAL	9.00
A2M0004	DISC DRIVE WITH CONTROLLER	349.00	A2L0003	6502 SOFTWARE MANUAL	9.00
A2M0016	16K ADD ON RAM	69.00	A2L0005	APPLE II BASIC PROGRAM MANUAL	6.00
CARDS & ACCESSORIES					
A2B0001	PROTOTYPE/HOBBY CARD	15.00	A2L0006	APPLE II REFERENCE MANUAL	6.00
A2B0002	PARALLEL PRINTER INTERFACE CARD	104.00	A2L0012	DOS 3.2 MANUAL	6.00
A2B0003	COMMUNICATIONS CARD	130.00	A2L0018	APPLE II BASIC TUTORIAL MANUAL	6.00
A2B0005	HIGH SPEED SERIAL INTERFACE CARD	113.00	GENERAL ACCESSORIES		
A2B0006	PASCAL LANGUAGE SYSTEM	299.00	A2D0000	(10) BLANK APPLE DISCETTES	32.40
A2B0007	CENTRONICS CARD	130.00	A2M0009	VINYL CARRYING CASE	16.00
A2B0009	APPLESOFT FIRMWARE CARD	116.00	AD/LB	MINI DISC LIBRARY BOX	2.64
A2B0010	INTEGER CARD	116.00	MD5172	DISCOFLEX FILING CASE - MINI	12.64
MHP-X003	MOUNTAIN HARDWARE CLOCK/CALENDAR CARD	168.00	APP1	APPLE DESK TWO TIER	145.00
MHP-X006	MOUNTAIN HARDWARE SUPERTALKER	179.55	APP2	PRINTER TABLE	92.00
MHP-X007	MOUNTAIN HARDWARE ROM PLUS BOARD	127.89	APPLETEL	APPLETEL SYSTEM	595.00
MHP-X015	MOUNTAIN HARDWARE ROMWRITER	106.05	DIST/APP	DUSTCOVER FOR APPLE II	9.95
A2B0017	EUROCOLOUR CARD	113.00	E2B013	APPLEJUICE RESERVE POWER SUPPLY	157.00
E2B101	APPLE BLACK & WHITE MODULATOR	14.00	PRINTERS & ACCESSORIES		
A1-02	A1-02 DATA ACQUISITION CARD	192.00	A2M0034	SILENTYPE 80 COLUMN GRAPHICS PRINTER	349.00
10-5-16	ALF MUSIC SYNTHESIZER CARD	103.00	A2C0001	10 ROLLS OF THERMAL PAPER FOR SILENTYPE PRINTER	28.00
10-5-17	ALF TIMING MODE INPUT BOARD	14.00	CENT 737	CENTRONICS 737 PRINTER C/W ADAPTOR	450.00
13-3-2	ALF ALBUM MUSIC DISKETTE NUMBER ONE	12.00	TIGER/G	PAPER TIGER PRINTER WITH GRAPHICS OPTION	598.00
13-3-4	ALF ALBUM MUSIC DISKETTE NUMBER TWO	12.00	TIGER /C	CONNECTOR CABLE FOR TIGER PRINTER	9.00
13-5-5	ALF ALBUM MUSIC DISKETTE CHRISTMAS	12.00	TIGER/D	GRAPHICS SOFTWARE FOR TIGER PRINTER	20.00
H/SP/LAB	HEURISTICS SPEECH LAB	122.00	TIGER/P	TIGER PAPER 2,000 SHEETS 11" x 9.5" 1 PART	31.43
A2M0019	PROGRAMMERS AID I	27.00	T1810	TEXAS OMNI 810 PRINTER	1450.00
A2M0027	AUTO START ROM PACK	38.00	LP5	PAPER 2000 SHEETS 11" x 15" S/PART	14.06
A2M0029	GRAPHICS TABLET	462.00	LP9	PAPER 3000 SHEETS 8" x 12" S/PART	14.85
H/CON 70	HEURISTICS CONTROLLER 70	57.00	VIDEO MONITORS		
H/SP/LINK	HEURISTICS SPEECHLINK 2000	168.00	VM129	12" BLACK AND WHITE VIDEO MONITOR	189.00
E2B108	IEEE INTERFACE	212.00	VM910	9" BLACK AND WHITE VIDEO MONITOR	127.00
SOFTWARE					
A2D0005	CONTRIBUTED SOFTWARE VOLS 3-5	60.00	VM906	9" HIGH RESOLUTION BLACK AND WHITE VIDEO MONITOR	148.00
A2D0006	CONTRIBUTED SOFTWARE VOLS 1-2	27.00	VM/C	CABLE FOR VIDEO MONITOR	9.00
A2D0009	MICROCHESS 2.0 CHESS DISK	15.00			
A2D0010	DISC UTILITY PACK	15.00			
A2D0012	APPLE BUSINESS CONTROLLER PROGRAM	340.00			
A2D0013	APPLE POST PROGRAM	27.00			
A2D0018	APPLE BOWLING DISCETTE	9.00			
A2D0025	APPLE CASHIER PROGRAM	194.00			
A2D0026	APPLE WORD PROCESSING PROGRAM	42.00			
A2T0013	MICROCHESS 2.0 CHESS CASSETTE	15.00			
E2D001	VISICALC DISC & BOOK COMPLETE	125.00			

Prices exclusive of carriage and VAT and are correct at time of going to press. Available from Apple Dealers all over the UK - for your nearest please contact Microsense Computers.
 Dealer/OEM enquiries welcome.

microsense computers limited

Finway Road, Hemel Hempstead, Herts HP2 7PS
 Tel (0442) 48151 and 41191
 Telex: 825554 DATEFF G

SOLE UK DISTRIBUTOR
 **apple computer**
 *Apple is a trade mark of Apple Computer Inc., Cupertino, C.A., USA



GATEWAYS TO LOGIC

CHAPTER 7: SYSTEMS-THE BROAD VIEW

Derrick Daines pauses in his series on teaching microcomputing to others to consider systems.

We began by considering the language and practice of logic. We have looked at the connection between decimal numbers, hexadecimal and binary, and we have seen how almost any information can be coded using binary techniques, and therefore handled by the computer. Latterly we have spent some time looking at how a computer works and how this ties much of our earlier work together. At this stage, our students should therefore have a good conceptual grasp of the computer, but unless other studies of, and work with, computers have proceeded in parallel, all their knowledge will be hypothetical, divorced from the real thing. At this point in the series it might be a good idea to step back a little and take a broader view.

Many people confuse the term 'computer' with 'computer system' and, using a sort of shorthand, all of us fall into the same trap which is very confusing for students. The plain truth is that a computer by itself can only sit there doing nothing — or apparently doing nothing. In fact, as long as a computer has power applied, the clocks are belting away and the machine is constantly doing the rounds of all its input points, looking for something to do — like our play in chapter 3, with the child in the middle looking for a message to carry. By itself, though, the computer is useless. It has no ears or eyes on the outside world and, knowing nothing, can do nothing.

When we talk about a 'computer' we are really talking about a 'computer system' — it only starts to make sense when other bits and pieces are added. These are called *peripherals* which are used for communicating with the outside world or storing vast quantities of information. Typical peripherals are keyboards, disk drives, printers and TV monitors.

The system installed

It should be apparent that our definition of a computer system as a computer connected to peripherals is too narrow. We need to take into account the whole environment of the computer and especially where it im-

pings upon the human being.

Breaking off for a moment, we may point out that *all* computer systems eventually lead back to the human. True, we may have a system working in isolation somewhere, perhaps collecting data from a desert pipeline, but eventually that data is accessed by a human being. No matter how complicated we make the system — perhaps by having a central computer controlling dozens of others — eventually all data paths lead to the human.

Now anyone who has suffered the installation of a computer at their place of work will tell you that developing a computerised system can be a most traumatic experience. Let's imagine that the owner of a garage wishes to computerise his operations. He decides to concentrate on billing because he finds great difficulty in keeping track of costs and the complications of VAT, not to mention customers who pay late, by instalments or not at all. It would not serve him in the slightest to buy the best computer that he could afford, plus lots of exotic peripherals. True, he has a computer system in the narrow definition of the term, but it is no good without dependable software (programs). And he must go through a long and careful investigation — called Systems Analysis — to ensure that the computer is put to use efficiently and effectively.

Teachers are urged to seek permission from local companies to allow them to take students into their computer room. Many will allow this, but others provide a viewing gallery. At first there might not seem to be much point — the computers are immobile and cased in seemingly sterile units — but with luck and a little prompting someone in the firm might be induced to talk about the wider system and show examples of inputs and outputs. From these, the necessary organisation may be deduced.

Myths and realities

Computer systems began by being exclusively the tool of mathematicians and cipher decoders. (See, for example, *Ultra Goes to War*, Ronald Lewin, Book Club Associates, 1978.) As a consequence, the computer gained

an aura all its own comprising three parts: (i) the computer was seen as being beyond the understanding of anyone with less than a Doctorate in higher mathematics; (ii) it was seen as being beyond the needs of anything less than a government agency or international company; and (iii) it was considered to be infallible. Every single one of these three parts of the computer's reputation was wholly undeserved and totally misleading.

So far in this series we have concentrated upon the first fallacy and it is to be hoped that we have given an insight into how computers work. Later, we shall devote time to a consideration of infallibility. What about need? Does our muddling garage owner really need a computer? Sooner or later, yes, he probably does.

The profession of book-keeper probably made its first appearance in ancient Sumeria and it arose out of a real need. The work-load and number of clerks rose steadily through the ages, more or less keeping in step with burgeoning populations, until the amount of data being dealt with assumed terrifying proportions. At least one SF writer postulated that man would, perforce, have to colonise the Moon and planets, simply to have somewhere to store books and files! (Simak, *Jackpot*, 1956.)

Information is truly the life-blood of the world today. For example, if a government is to make rational decisions about matters closely affecting its populace, then it needs information about that populace — and the more up-to-date the better. In the event, computing was forced upon us; a need far in excess of that of the Ancient Sumerians. In the early part of this century, for example, the US government was faced with another census before it had completed hand work on the previous one. A man called Hollerith invented a mechanical computer to do the work and founded a company to exploit the invention. Later, the company grew into what is now IBM.

As with governments, so with international companies. It is well known that General Motors of Detroit handles an annual budget far in excess of that of some countries. Could it seriously be

GATEWAYS TO LOGIC

imagined that in a competitive market they could make rational decisions without computers?

The pressures reach downward. Medium- and then smaller-sized companies realised that in order to compete and stay alive they had to make more and more efficient use of manpower, materials and capital.

If that seems a little too theoretical for you, let me recount two apparently disparate events. One day I watched on TV a program which showed the rising fortunes of a Japanese manufacturer making zip-fasteners in this country. In a few years he had taken over 60 per cent of the trade due to his high level of automation. Many small British manufacturers had been forced out of business.

The following day I read in an international trade journal that British computer experts of all kinds are widely regarded as the very best in the world. Apparently there is something — we know not what — in our attitudes and mentality that makes us that way. The only problem is, there are not enough experts to go round.

Disparate, unconnected events? I think not. The one shows up the problem in stark reality. The second shows us the solution.

It might be pointed out that there is a confusion of terms here and that computers and automation, although compatible, are nevertheless separate concepts. That is to say, automated factories can be computerised, but there is no necessity that they shall be so. The producers of the TV program did not make clear whether or not the zip manufacturer had computerised, by the way. The connection between computers and automation, however, is the microprocessor, which is a computer in miniature.

Now there might not seem to be any immediate connection between (say) the ability to play a good game of

Startrek and being able to design a microprocessor-controlled piece of machinery, so it may be worth spelling it out.

Because the microprocessor is a sort of computer in miniature, it has the same characteristics as a computer. That is to say, it is useless and uninteresting without peripherals. We cannot therefore train our pupils on the microprocessor directly, but may do so only when it is part of a system. As soon as we add switches or whatever to the micro, we have what is in effect a miniature computer. In fact, many thousands of home, hobby or training computer systems are in use which comprise very little else.

What you do with the system is up to you. You can use it as a word processor, play games, learn to write programs or study the workings of the microprocessor itself. No matter what you do with it, however, you are learning to live with the system. You are familiarising yourself with the broad characteristics of all such machinery. You are enriching your experience and extending your education.

The new Classics

We all want the very best education for ourselves and our children and it used to be said that the best education was a classical one — Latin and Greek — because they promoted logical thought. Not being a Classicist, I cannot judge, although I can see that this might well be so. However, one of the unspoken aims of this series is to show that the same is even more true of a computer education. Moreover, whereas a classical education is strictly limited in its practical applications, the uses of a computer-oriented education grow daily and its need, more and more urgent, both nationally and individually.

Universal education came about when it was realised that, in order to get the best out of the new machines of the first Industrial Revolution, a literate workforce was necessary. Instructions and notices had to be read, timesheets made out, and so on. At first, only a

section of the workforce was encouraged to read and write, but this was later extended to everyone and nobody doubts that this was right. A modern highly industrial nation *needs* a highly literate population.

We are in a parallel situation now. We need a computer-literate population. The muddling garage owner of our example will, in all probability, go out of business — he will certainly never become rich because too much of his billing is based upon 'guesstimates'. If his bill is too high he makes a disgruntled customer; if too low, it costs him hard cash. Either way, he loses.

If, on the other hand, the owner and his workers, customers, clerical staff, suppliers and all their wives were computer-literate, the owner would push his computerisation through despite teething problems and have an efficient, profitable organisation to show for it. It should be clear that computer-literacy does *not* mean that all the people mentioned should be able to operate the computer, and still less does it mean that they should be able to program one! What it *does* mean is that their education (post-school if necessary) should take the computer into account. Ideally, they would have had hands-on experience, but at the very least they should be familiar with the terminology and basic principles, with a friendly disposition towards the machine and not hostile to it, as many are at present.

Despite the work on ciphers, another fallacy grew up that a computer system was to be mainly used for manipulating numbers. Progress over the last few years seems to have knocked that well and truly on the head, but considerable work remains to be done in order to convince everyone that the computer and its concomitant systems will invade *all* aspects of our lives, generally to our benefit. The only way to do this is to (i) show the range and speed of peripheral devices, (ii) show how they can be assembled into an almost infinite variety of systems, and (iii) attempt to extrapolate into the future.

That is the purpose of the rest of this series.

PRINTER SURVEY PRIZEWINNERS

Winners of a year's free subscription to PCW



First prize... a Sharp MZ-80K

Simon Barson, Brockworth, Glos.	P V F Beardow, Twickenham, Middlesex.
J W Bloor, Basingstoke, Hants.	Nigel Howell, Warrington, Cheshire.
Robert Farman, Selby, N Yorks.	Nigel Pattinson, Derby.
Nigel Anderson, Scarborough, N Yorks.	B A Payne, Newbury, Berkshire.
Hugh E Williams, Basingstoke, Hants.	Mike Whitehead, Dundee.
Alexander Caldwell, Glasgow.	Peter Brinch, Denmark.
Michael J Rowley, Widnes, Cheshire.	Stephen Zara, Englefield Green, Surrey.
A Southern, Northallerton, N Yorks.	Rev E M Dowlen, Rhyl, Clwyd.
B J Maddock, Guildford, Surrey.	Mario Wolczko, Rochdale, Lancs.
J R Holdcroft, Kent.	Kenneth Spencer, Bath.
T J Tarpey, Colchester, Essex.	M Potok, Abingdon, Oxon.
R A Hutton, Aston, Herts.	D Hay, Harrogate, N Yorks.
Eric Hutchinson, Newcastle-on-Tyne,	and, finally, Larry Wood of Birmingham won the Sharp MZ-80K, more on this next month.

Now available on Earth



THE SHARP MZ-80 COMPUTER SYSTEM

The Sharp MZ-80 System is a new approach to computer applications and their efficient use. Our aim is to make computers relatively simple and therefore better

understood and better used by those they are designed to serve. Take a look at the Sharp range - it will change the way you think about computers.

BCG Computer Systems Ltd
The Promenade
20 Gloucester Road
Bristol BS7 8AE
0272 425338/41979

The Computerist
642 London Road
Westcliff on Sea
Essex
0702 335298

Crystal Electronics Ltd
40 Magdelene Road
Torquay
Devon
0803 22699

Datron Micro Centre
2 Abbeydale Road
Highfield
Sheffield
0742 585490

Digital Design & Development
Duchess House
18-19 Warren Street
London W1P 5DB
01-387 7388

Electronic Business Systems Ltd
54 Clement Street
Birmingham B1 2SW
021-233 3045

Euro-Calc Ltd
Euroc House
128/132 Curtain Road
London EC2
01-405 3223

Gilbert Computers
Old Hall Lane
Lubham
Leics
0858 65894

HB Computers
22 Newland Street
Kettering
Northants
0536 83922

Howes Elect.
Microcomputer Centre
Newton Street
Lincs
0522 32379/791088

Newbear Computing
40 Bartholomew Street
Newbury
Berks
0635 30505

Norset Office Supplies Ltd
Myrtle House
Bath Street
Cheddar
Somerset
0934 742184

Personal Computers Ltd
194-200 Bishopsgate
London
EC2M 4NR
01-626 8121

PMS (Print Marketing) Ltd
82 Sea Road
Sunderland
Tyne & Wear
0783 480009

Scope
Stone House
Houndsditch Entrance
128/140 Bishopsgate
London EC2m 4HX
01-247 8506

Sigma Systems Ltd
54 Park Place
Cardiff
S. Wales
0222 21515

South Coast Business Machines Ltd
South Coast House
Wimborne Road
Ferndown
Dorset
0202 893040

Sumlock Bondain Ltd
263-9 City Road
London EC1V 1JX
01-250 0505

Sumlock Bondain (East Anglia) Ltd
32 Prince of Wales Road
Norwich NR1 1LG
0603 26259

Tomorrow's World Ltd
Grafton Arcade
Dublin 2
Dublin 776861

This is a list of dealers participating in associated advertising and not a full list.

SHARP

**COMPUTER
APPLICATIONS**



Business Systems, Audio, Video, Calculators, Cash Registers, Copiers, Microwave Ovens.

GET ON THE RIGHT TRACK

Geoff Barton concludes his description of a real-time control experiment based on a model train layout.

Scheduling

The concepts of 'timesharing' or multi-tasking are well known to most computerists but the intimate details are more tricky. The method of scheduling the route tasks which run on this system is, hopefully, easier to follow than that used on larger systems since there is no need for 'pre-emptive swapping out' of tasks.

The one big assumption that is made for the system is: 'Each task will either suspend itself or complete within a finite time.' This requirement removes the need for the system to intervene and suspend a task before handing over the processor to a different one. Also, since each task executes a 'high level' instruction set there is no duplication of the large scale 'low level' routines, so enabling all the tasks to reside permanently in memory. This removes any swapping in and out of tasks onto backing store, since tasks do not require large amounts of memory space.

There are three means by which an executing task can give up the processor. When the train has reached its destination and has freed all the resources it was using, the route task has fulfilled its purpose and so is laid quietly to rest.

The other two methods only suspend the task temporarily and it will resume execution at a later time. The most common of these is when the engine pulling the train is known to be in one section and is expected to enter the next one on the route in the near future. Rather than hang around waiting for this event, the task is suspended until it occurs, thereby allowing the processor to be free for other tasks to use.

The third and final method is used when a collision is about to occur and so one of the trains is stopped to let the other get out of the way. Instead of complicating matters even more by getting the task which frees the resource required by the suspended task to restart that task, a programmable timer is used to suspend it for a period of two seconds. At the end of this delay the task is restarted and again tries to allocate the resource(s) it needs. If unsuccessful, this delay cycle is repeated until the first train has passed by and freed the necessary resource(s).

With reference to Figure 3 we will now discuss the program flow through the processor when it executes two route tasks concurrently. These routes have both been automatically generated by the system software. The operator has twice used the 'R' command and needed only to enter the start and destination section numbers for the routes to be calculated. The two routes

to be discussed are from section 04 to section 27 and from section 25 to section 00 (see Figure 2 last month). Please note that Figure 3 does not have a consistent time scale.

The processor spends most of its elapsed time in a 'wait for interrupt' state. This is to speed up the handling of interrupts which synchronise all of the events in the system. There are 16 different interrupt sources possible to the processor. The Console Command Processor (CCP) section of the program checks after each interrupt has occurred whether a character has been typed on the console. If the operator has typed the letter 'E' then the code which begins execution of a route task is run. The only parameter this command requires is the route number of the task to execute.

Since we know that within a finite length of time the task which is about to begin execution will be suspended, we place onto the system stack the necessary arguments to cause the

processor to resume execution of the CCP code. We then allow the task to 'run' its t-code program which allocates resources and controls the layout, so that the train begins moving to its destination. Eventually, the task will be unable to do any further processing until the train has entered the next section in its route — let us say this is section 26. The time at which this will occur depends on so many parameters, (length of section, speed of train, weight of coaches, type of engine, etc) that it is incalculable. It is therefore not possible to predict the event so the task is suspended until the train enters the new section and generates an interrupt to the processor. The task uses the 'reqint' subroutine to place a request for its resumption when this event occurs and is then suspended. Since it calls this routine by a 'jsr' instruction, the return address is saved on the stack. The 'reqint' routine removes this from the stack and saves it, together with the route number as a 3-byte entry in the

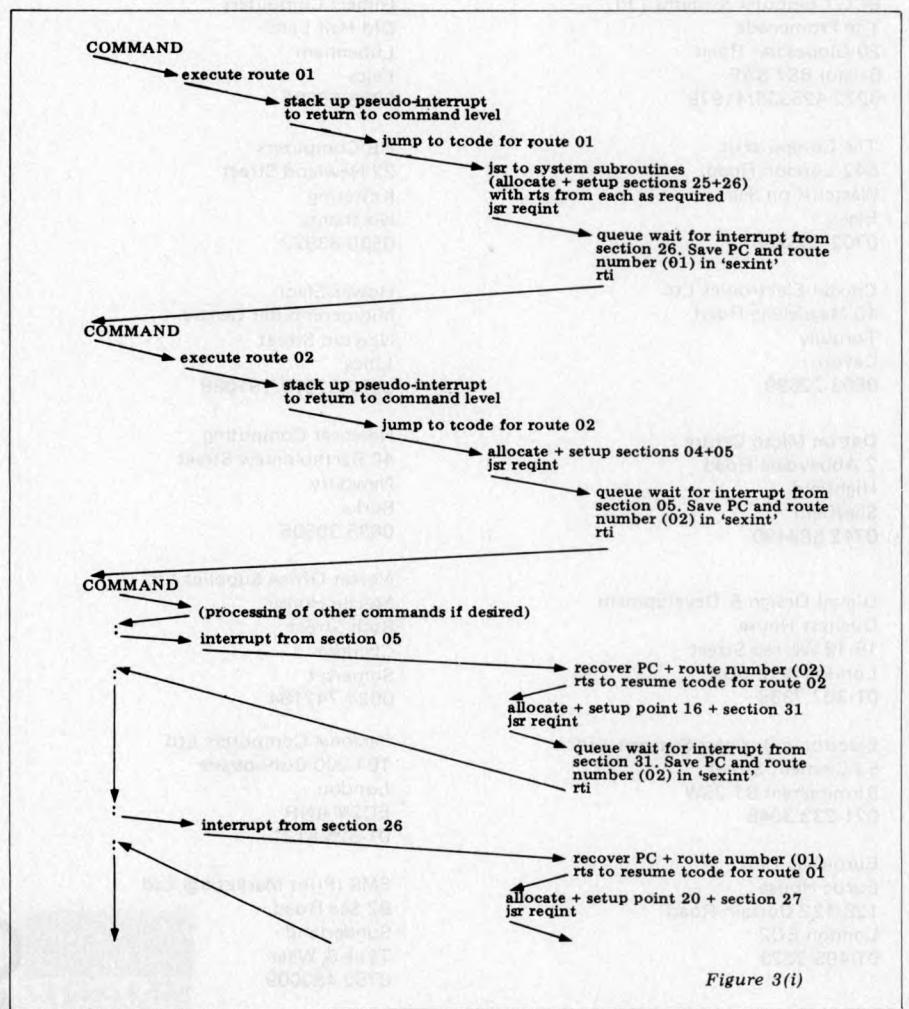

Figure 3(i)

'sexint' table. This table has an entry for each section on the layout and so when that section generates an interrupt, the task can be restarted since its route number and continue address are known.

It is obviously not possible for the processor to continue execution at the return address saved on the stack by the 'jsr' instruction, since this has now been removed. Therefore, the subroutine performs an 'rti' instruction instead. This causes the arguments placed there by the 'E' command to be unstacked and restored to the processor registers. The address placed into the program counter by this instruction just happens to be that of the Console Command Processor and so the program is now back at command input level. The only other register which needs to have a particular value is the condition code register, since it is vitally important that the interrupt mask is 'clear' so that IRQ-type interrupts are not ignored. It is now possible to obtain status reports about the layout, operate a train under manual control or even use the console as a terminal link to the PDP11/34 running UNIX further down the corridor. In fact, any of the operator command functions are possible.

The use of the 'E' command enables execution of another route task. Let us assume that the original task, which is now suspended, has a route number of '01' and we now execute route number '02' as well. An identical set of arguments is placed on the stack and the t-code for route 02 is executed. Having discovered that the train is in section 04, the task is suspended until it enters section 05. Again the 'reqint' subroutine saves the task return address and route number in the 'sexint' table but this time in the entry for section 05. The 'rti' instruction again returns the program to command input level. So, there are two tasks executing concurrently on the system, with the two trains they are controlling being driven around the layout, and the operator is again able to enter any of the 27 command functions made available to him/her by the CCP.

The train running on route 02 then enters section 05 and an interrupt is generated to inform the program of this event. The processor registers are saved on the stack and the interrupt service routine is entered. The source of the interrupt is identified and the return address obtained from section 05's entry in 'sexint' is placed on the stack. The route number (02) is also recovered from the table and the interrupt service routine performs the 'rts' instruction which resumes execution of the task at the instruction following the 'jsr reqint' call made earlier. The route task now allocates point 16 and section 31 and switches the former to drive the train through the latter. Since the 'behind' counter for this route is still less than or equal to 'minbak' because the route began in section 04, it is unable to free any resources as they are still in use. After enabling section 31 to generate an interrupt when the train reaches it, the task again calls 'reqint'. This routine saves the program counter value from the stack and the route number in 'sexint' but this time in the entry for section 31. It then performs the 'rti' instruction which, this time, is a 'proper' return from interrupt causing

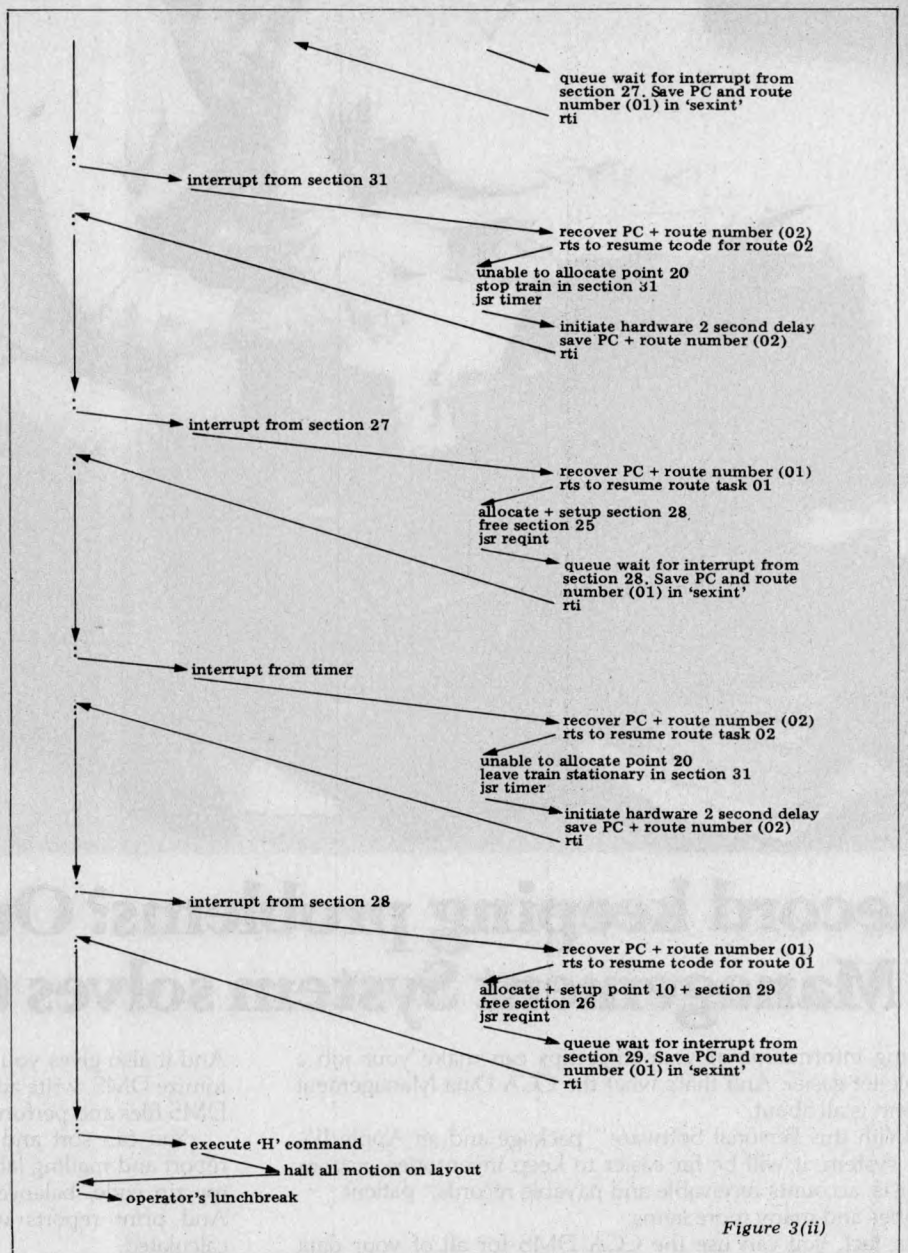

Figure 3(ii)

the processor to resume wherever it left off in the CCP.

Soon after this, the train controlled by route 01 enters section 26 and so this route task is restarted in a similar way. After allocating point 20 and section 27, they are set up to await the arrival of the train. The task is again suspended via a call to 'reqint' until the train reaches section 27.

From an outside - human - viewpoint it is clearly obvious that a collision is imminent but, as yet, the program is unaware of this approaching calamity. When the train on route 02 reaches section 31 the task is restarted in the way described above. The 'actbot' pointer into the data structure for this route informs the task that the next section it needs is point 20 and so it tries to allocate this point. However, the 'allpnt' routine discovers that this resource is not 'free', but has already been reserved by route 01 and so it returns an error signal to the task. Since it is unable to allocate this resource, the task is unable to continue with its route and so the train is stopped by setting the speed of section 31 to zero. The t-code then makes a call to the 'sleep' subroutine for a suspension of the task for two seconds. The 'sleep' routine

activates one of the programmable timers on the system to provide a hardware delay of two seconds. It then removes the return address of the t-code from the stack and saves it, together with the route number ready for the eventual interrupt from the timer. The 'sleep' subroutine performs the 'rti' instruction which causes the processor to continue at the instruction that would have been executed had the section not generated an interrupt (ie inside the CCP again).

Route 01 has its task restarted again when its train enters section 27. Section 28 is free so it is allocated and set up in preparation for the train's arrival. Since the 'actmid' pointer is incremented by one section entry in the data structure, due to the train entering a new section, the 'behind' counter is also incremented. This now has the value 2 and so, in order to keep this within its limit ('minbak' = 1), the resource pointed to by the 'acttop' pointer is freed. The 'behind' counter is only decremented when a section resource is freed and so, if a point resource is freed, the process does not affect the counter. Further resource(s) must therefore be freed until it is back within its limit. In this case, since there is no point between



Record keeping problems? Our CCA Data Management System solves them easily.

Having information at your fingertips can make your job a whole lot easier. And that's what the CCA Data Management System is all about.

With this Personal Software™ package and an Apple II™ disk system, it will be far easier to keep inventories, customer lists, accounts receivable and payable records, patient histories and many more items.

In fact, you can use the CCA DMS for all of your data management needs, rather than buying (expensive) or writing (time consuming) separate programs for each application. That's because DMS lets you create your own filing systems, adapting itself to the types of records you keep. You specify the number and names of each data field—without any programming.

With DMS keeping all of your records, you only have to learn how to use one system. That's easier, too. It's menu driven, with plenty of prompts to help you create files and add, update, scan, inspect, delete, sort, condense and print data. Our comprehensive 130-page step-by-step instruction manual even provides complete "how to" inventory and mailing list applications so you can start processing immediately.

DMS is a very powerful system, with more file and record storage capacity than other data base programs on the market.

ACT
Micro
Computer
Programs

PCW 104

And it also gives you greater data handling flexibility. To customize DMS, write add-on BASIC programs that read or write DMS files and perform any kind of processing you want.

You can sort and print your data in nearly any form of report and mailing label you want. Sort data by up to 10 fields for zip code, balance due, geographic location or whatever. And print reports with subtotals and totals automatically calculated.

Apple DMS has two additional features. Its ISAM search method helps you find any item on a diskette within 10 seconds. And its Data Interchange Format Program allows you to move DMS files into our Apple VisiCalc™ program—the "electronic worksheet"—for powerful, flexible calculating.

Ask your dealer to show you how easy computerized record keeping is. To locate the nearest dealer, contact

ACT (Microsoft) Limited

£75 + VAT



For free details plus the address of your nearest ACT dealer send us your name and address:

Name:

Address:

.....

.....

Postcode: Tel:

ACT Microsoft Ltd.,
5/6 Vicarage Road, Edgbaston,
Birmingham B15 3ES

Tel: 021-454 5341

Telex: 339346

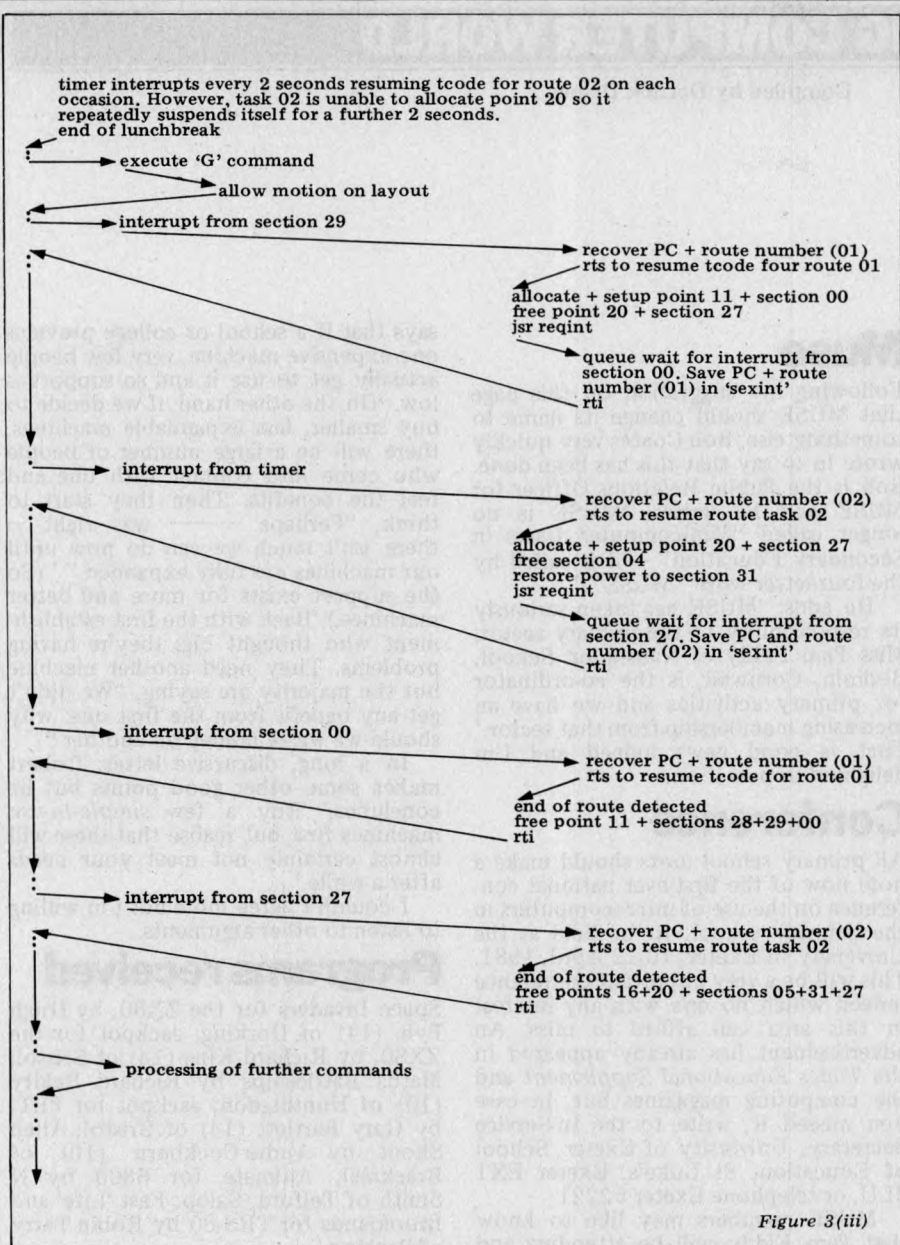

Figure 3(iii)

section 25 and 26, only section 25 is freed. The task is again suspended by a call to 'reqint' which saves the necessary resumption information in 'sexint' at the entry for section 28. The CPP code is again resumed.

After the hardware delay of two seconds has expired, the processor receives an interrupt from the programmable timer. The registers are therefore saved on the stack and the interrupt service routine for this device is run. This handler routine restacks the program counter and recovers the route number and then performs an 'rts' instruction. The task is thus restarted at the instruction following the 'jsr sleep' call made two seconds earlier. Point 20 is still busy and so the task again makes a call to 'sleep' for a further suspension of two seconds. The 'sleep' subroutine again executes the 'rti' return which effectively terminates the interrupt handler code and resumes again in the CCP.

Route 01 is resumed when the train enters section 28. Point 10 and section 29 are allocated to it and set up. It then frees section 26. Note that, because a section resource (26) is freed, the 'behind' counter is brought back to its limiting value. Point 20 is therefore

still allocated to the route. The task for route 01 is then suspended by a call to 'reqint' until the train enters section 29. The processor again returns to the CCP code to await any further commands from the operator.

If the 'H' command is entered at the console all motion on the layout is halted. This means that the train on route 01 will stop in section 28 and so be unable to enter 29. This will cause point 20 to remain in a locked state, and so each time the route 02 task is restarted, it will delay for a further two seconds. Let us assume that the operator goes for lunch and doesn't enter the 'G' (or Go) command until 2½ hours later to enable the layout motion to continue. The task for route 02 will have been trying every two seconds to allocate point 20 and been suspended again after each unsuccessful attempt. The task for route 01 is still suspended, since the train has not yet entered section 29. When the 'G' command is finally entered, the train in section 28 continues on its way again and enters section 29 shortly after.

The route 01 task is then resumed and it successfully allocated point 11 and section 00. These are set up to await the arrival of the train. The route

has now finished with point 20 and so it is freed. The 'behind' counter is not decremented by this action and so the next resource, section 27, is also freed. Unlocking this section resource returns it within its limit. The task is then suspended via a call to 'reqint' until the train enters section 00.

When the programmable timer generates an interrupt to indicate the completion of yet another two second delay, the route 02 task is once more resumed in its execution. This time point 20 is free, as is section 27, and so they are successfully allocated and set up. Section 04 is freed bringing the 'behind' counter back within its limit. The power to section 31 is finally restored and the train therefore starts moving again. The task is suspended via a call to 'reqint' to await the trains arrival in section 27.

Both routes are now in their final stages, since they finish in section 27 and 00. When the train enters section 00 the t-code for route 01 discovers that the next resource it is to allocate has the value of -1. This indicates that the route has been completed and so the allocated resources are all freed. Once the necessary housekeeping has been done by the t-code, it performs the 'rti' instruction which takes the processor execution back into the CCP. This action removes the task from the execution queue and so it is no longer active.

The train on route 02 now enters section 27, its final destination section. Therefore it is stopped and all the resources currently held by the route are freed before the task aborts by performing the 'rti' instruction. The status of the system is now back again at only a single task running, that task being the Console Command Processor code waiting to process further user input commands. The two trains which originally were in sections 04 and 25 have now moved to sections 27 and 00 respectively.

All of the resources used by the routes were allocated on a first come first served basis and then freed again after use. A situation in which a collision was obviously imminent arose but was recognised by the system and safely avoided.

Summary

Microprocessors can be used to make very powerful toys for grown-up boys. However, the system described here was developed as a piece of undergraduate teaching equipment with which to put into practice some of the theory taught in the course.

The ideas discussed here are currently in use but have been put over merely as hints and suggestions. I have tried to illustrate the methods involved in such a way as to provide the basic guidelines required to develop a Real Time Control System. The purpose of that system might be anything from a comprehensive home security system to a production line. The choice is yours...



Disillusioned

The young woman teacher was loud and fierce in her condemnation, her voice vibrant with contempt: 'Computers are a great big con trick!' she repeated over and over.

A month or two previously, her husband — also a teacher — had bought one of the latest generation of micro-computers and was playing with it happily, learning how to program it and put it to good use but, for her, computers were 'a great big con trick!'

The crux of her complaint was that to get the machine to do something involving an interrupt timer, it was necessary to purchase an extra chip. To be fair, she had previously been taken aback by the shortage of memory in the basic machine and her grumbles had not been too loud when they found that they needed another chip in order to do decimal arithmetic. But the interrupt timer — this was the last straw.

It is extremely difficult for newcomers to computing to find out what they're going to get for their money. Information from suppliers is mostly technical (for very good reasons) and meaningless to the tyro. His best course is to approach a knowledgeable friend but very often he doesn't know which questions to ask and assumptions are made on both sides.

My young friends are a case in point; they, of course, had never heard of an interrupt timer and, when they had approached me for advice, it had never crossed my mind that they would need one. So she had assumed that the computer would fulfil what she had in mind — and the disillusionment followed.

I can sympathise, too, with the suppliers. Not many users require an interrupt timer, an on-board real-time clock, colour graphics, relay drivers or what-have-you. So the designer makes a computer that conforms to the lowest common denominator — a basic machine to which the customers can add the facilities their needs require. Thus, in theory, all are satisfied and nobody pays for something they don't want.

In practice, things are not so easy. No supplier in his right mind advertises what his machine *doesn't* do and this leaves the door wide open for assumptions that lead to disillusionment and dissatisfaction.

There is no easy solution — indeed, one may not exist at all. One can only repeat the advice so often given — intending buyers should badger knowledgeable friends for information. Read and learn as much as you can before you buy — and then, if you're not 100 per cent sure, buy secondhand, or at the bottom end of the market. You can always trade it in later for something better.

Muse

Following my suggestion on this page that MUSE should change its name to something else, Bob Coates very quickly wrote in to say that this has been done. Bob is the Public Relations Officer for MUSE and he writes, 'MUSE is no longer called "Minicomputer Users in Secondary Education" — it is called by the four-letter word "MUSE"!'

He adds: 'MUSE has taken seriously its responsibility to the primary sector. Miss Pam Fiddy of Nanstallon School, Bodmin, Cornwall, is the co-ordinator for primary activities and we have an increasing membership from that sector.' That is good news indeed and I'm delighted to pass it on.

Conference

All primary school users should make a note now of the first-ever national conference on the use of microcomputers in the primary school, to be held at the University of Exeter, 10-12 April, 1981. This will be a very important conference indeed which no one with any interest in this area can afford to miss. An advertisement has already appeared in the *Times Educational Supplement* and the computing magazines but, in case you missed it, write to the In-Service Secretary, University of Exeter, School of Education, St Luke's, Exeter EX1 2LU, or telephone Exeter 52221.

MUSE members may like to know that Pam Fiddy will be attending and (ahem!) so will I!

Big versus many

Robert Pickering (17) of Middlesborough picked up the controversy about computer provision in school. He

says that if a school or college provides one expensive machine, very few people actually get to use it and so support is low. 'On the other hand, if we decide to buy smaller, less expandable machines, there will be a large number of people who come into contact with one and feel the benefits. Then they start to think, "Perhaps — was right — there isn't much we can do now until our machines are fully expanded." (So the support exists for more and better machines.) 'Back with the first establishment who thought big; they're having problems. They need another machine but the majority are saying, "We didn't get any benefit from the first one; why should we waste money on another?"'

In a long, discursive letter, Robert makes some other good points but he concludes, 'Buy a few *simple-to-use* machines first but realise that these will almost certainly not meet your needs after a while.'

I couldn't agree more but I'm willing to listen to other arguments.

Programs received

Space Invaders for the ZX80, by Hugh Pyle (14) of Dorking; Jackpot for the ZX80, by Richard King (14) of Bristol; Maths Battleships by Richard Baldry (10) of Huntingdon; Jackpot for PET, by Gary Bartlett (14) of Bristol; Alien Shoot, by Andre Cockburn (10) of Bracknell; Animate for 6800 by N Smith of Telford, Salop; Fast 'Life' and Brooklands for TRS-80 by Robin Terry of Barking.

It was nice to hear from Andre again, who is handicapped, but, as a 6800 user myself, I had the greatest fun with N Smith's contribution. That's one thing I really like about this job — I get to play with everybody's programs!

ZX80 Space Invaders by Hugh Pyle

```
10 DIM A(10)
20 PRINT,"* * SPACE INVADERS * *"
30 PRINT
40 PRINT "APPROX HOW MANY?"
50 INPUT F
60 FOR Y=1 TO 10
70 LET G=RND(10)
80 IF NOT G > F THEN LET A(Y)=1
90 NEXT Y
100 LET X=1
110 IF X > 18 THEN GOTO 400
120 FOR Y=1 TO X
130 PRINT
140 NEXT Y
150 POKE 16414,0
160 POKE 16415,0
```

GOTO page 144

Personal Computer

World

FEATURE INDEX

Index to current volume. (Previous volumes were indexed in March and April 1980 and January 1981.)

Benchtest

Transam Tuscan 4-1

Series

Secrets of Systems Analysis 4-1
Gateways to Logic 4-1
Computer Games Face to Face 4-1
Printer Interfacing 4-1
Microchess 4-1
Multi-user Systems 4-1
Sub Set 4-1

Evaluations

MTU PET Music Board 4-1

Calculator Corner

Casio Routines 4-1

Indexes

1980 Complete Volume 4-1

Special

Features

Printer Survey Update 4-1
MAVIS — Aid for Handicapped 4-1
Model Train Control System 4-1
Data Tape Recovery 4-1

Programs

TRS-80 Four in a Row 4-1
TRS-80 Target Practice 4-1
PET Convoy 4-1
PET Wire 4-1
PET Maze Chase 4-1
PET Android Attack 4-1
PET Anagram 4-1
PET Obstacle Course 4-1

BACK NUMBERS

PLEASE NOTE THAT THE FOLLOWING ISSUES ARE SOLD OUT
VOLUME 1 Nos. 4, 5, 6, 9, 10, 11, 12
VOLUME 2 Nos. 5, 6, 8
VOLUME 3 Nos. 1, 2, 3, 4
ALL OTHER ISSUES MAY BE ORDERED USING THIS FORM.

Volume 1 No. 1 May 1978
Mascom 1/77-68: The Mighty Micromite/A charity system

Volume 1 No. 2 June 1978
Research Machines 380Z/Computer in the classroom/The Europa Bus.

Volume 1 No. 3 July 1978
Buzzwords — A to Z of computer terms/Pattern recognition/Micro music

Volume 1 Number 7 Interfacing PET to X-Y Plotter/Structured Programming/Programming Decision Tables

Volume 1 No. 8 December 1978
Computers and Art/3-D Noughts and Crosses/Mickie — the interviewing micro.

Volume 2 No. 1 May 1979
Small computers for small organisations/Sorcerer graphics/Chess Programming Hints/Parkinsons Revas.

Volume 2 No. 2 June 1979
MSI 6800/Witbit — disassemble your programs/The Multilingual Machine/Polytechnical Processing.

Volume 2 No. 3 July 1979
Vision link: Interfacing and Software for the Superscamp

VDU/Pet Preening/Extended cursor graphics for the TRS-80.

Volume 2 No. 4 August 1979
The North Star Horizon/High Speed Cassette Interface for the SWTP 6800/Garage Accounting program/Apple Medical Application.

Volume 2 No. 7 November 1979
PCW Show issue/6800 Bug/Hard disk security/Detecting literary forgeries/Benchtest — the Challenger C3

Volume 3 Number 5 May 1980
Benchtests — TI 99/4, Altos ACS-8000-2, HP-85/West Coast Faire report.

Volume 3 Number 6 June 1980
Benchtests — TRS-80 Model II, Periflex 630/48/Stringy Floppy Checkout/CompuColor Case Study

Volume 3 Number 7 July 1980
Benchtests — Acorn Atom, DDE SPC-1/Animistics — Humanoid Micros/Sharp PC 1211 review

Volume 3 Number 8 August 1980
SuperBrain Benchtest/Printer Survey/ROMPLUS+ Checkout

Volume 3 Number 9 September 1980
Benchtests — BASF 7120, CBM 8032/Hi-Tech Colour Board Checkout/Portable Basic

Volume 3 Number 10 October 1980
Benchtests — DAI Personal Computer, Atari 400 and 800/Robotics/3D Graphics/Program 'Tuning'

Volume 3 Number 11 November 1980
Benchtest — SBS 8000/ComputerTown UK! — Community Computer Literacy Project/Apple Colour Graphics

Volume 3 Number 12 December 1980
Benchtest — Raannd SP1/Pascal Micro-Engine/Microwriter Checkout/Micro-based Toys Review

Any one issue 95p; Any two issues £1.75; Any three issues £2.50; Any four issues £3.00. All additional issues @ 50p each. Binders @ £2.95. All prices include post and packing. Cheque or P.O. payable to (PCW) SportsScene Publishers Ltd., 14 Rathbone Place, London W1P 1DE. Please allow up to 3 weeks for delivery and don't forget to state clearly your name and full address with your order. Please send me the following copies of PCW. I enclose a cheque/P.O. for £

Volume 1

1 2 3 7 8

Volume 2

1 2 3 4 7

Volume 3

5 6 7 8 9 10 11

Volume 4

1

Name _____

Address _____

*Tick appropriate boxes

...the new wealth is information. *NEWSWEEK*

SYBEX Brings You a Wealth of Books...

Your First Computer by Rodnay Zaks

A new edition of one of the most popular and widely acclaimed introductory books to computing and microcomputers. Includes a detailed guide for selecting basic hardware. "An excellent book for anyone new to computing." — *On Computing*. 280 pp., 150 illustr., 2nd Ed. £5.95

The CP/M Handbook (with MP/M) by Rodnay Zaks

CP/M — The industry standard in operating systems. The handbook goes step-by-step from basic commands through the editor and assembler to CDOS and multi-user MP/M. For everyone from input typists to applications programmers. 304 pp., 110 illustr. £8.50

Programming the 6502 by Rodnay Zaks

Written as a progressive course designed to test the reader at every step, this book covers the essentials of programming the 6502 from basic concepts to advanced data structures. "Thoroughly recommended." — *PET Gazette*. 392 pp., 200 illustr., 3rd Ed. £8.75

6502 Applications by Rodnay Zaks

This second book in the 6502 series presents real life applications techniques for any 6502 based microcomputer board. Programs range from home alarm systems to industrial applications including analog-digital conversion. The I/O book for the 6502. 288 pp., 200 illustr. £8.75

6502 Games by Rodnay Zaks

Third in the 6502 Series, this educational text shows how to program the complex algorithms for ten computer games, and how to use the 6502 addressing modes. All programs have been thoroughly tested. 250 pp., 150 illustr. £8.95

Microprocessors: From Chips to Systems by Rodnay Zaks

From the ground up: the components (ROM, RAM, MPU, UART, PIO), internal operation, comparative evaluation. Plus system interconnect, applications, interfacing, programming, system development and more. "Essential reading." — *Personal Computer World*. 420 pp., 200 illustr., 3rd Ed. £7.25



Microprocessor Interfacing Techniques by Austin Lesea, Rodnay Zaks

How to connect a microprocessor to the outside world. Covers the peripherals, from keyboard to CRT and floppy disk, I/O techniques, A/D conversion, standard buses and troubleshooting. "Clear and eminently readable." — *Interface Age*. 464 pp., 320 illustr., 3rd Ed. £9.95

Programming the Z-80 by Rodnay Zaks

Readable and informative, this book is both an introductory course on programming and a self-contained reference text offering a comprehensive description of the Z80 instruction set and a thorough account of its internal operations. 620 pp., 200 illustr., 2nd Ed. £9.75

Programming the Z8000 by Richard Mateosian

A comprehensive introduction to assembly level programming in the language of the Z8000. The detailed description of the Z8000 architecture and its family of support chips is indispensable for engineers, students and PDP-11 users. 320 pp., 133 illustr. £9.95

PLEASE SEND ME THESE BOOKS:

- YOUR FIRST COMPUTER £5.95
- THE CP/M HANDBOOK WITH MP/M £8.50
- PROGRAMMING THE 6502 £8.75
- 6502 APPLICATIONS £8.75
- 6502 GAMES £8.95
- MICROPROCESSORS FROM CHIPS TO SYSTEMS £7.25
- MICROPROCESSOR INTERFACING TECHNIQUES £9.95
- PROGRAMMING THE Z80 £9.75
- PROGRAMMING THE Z8000 £9.95

Available from your local Computer store, or in case of difficulty, from

**The
Computer
Bookshop**
Temple House,
43/48 New Street,
Birmingham B2 4LH



Name

Address

.....

Make Cheques/P.O.'s payable to:-
The Computer Bookshop

Total Amount Enclosed

Signature

Please send me your Free Book Review Leaflet.

MULTI-USER SYSTEMS

After last month's introduction, Sue Eisenbach and Adrian V Stokes continue this series with an in-depth look at multi-user micro systems.

In last month's issue we looked at the concept of multi-user systems in the context of mainframes and mini-computers. A typical such computer would have a very fast processor and a limited amount of fairly fast main memory whose purchase price would far outweigh all other costs, such as peripherals, operating expenses and so on. Every effort had to be made to extract maximum work from these two items, which gave rise to the operating system which controlled all the hardware and marshalled the queues of user jobs for optimum efficiency.

In a simple batch-processing system, jobs using the same system resources (usually a compiler) are 'batched' together so that, as soon as one is finished, the next one can be started with the minimum of delay. In general, however, a complex mix of jobs is queued together so that several jobs (or segments of jobs) exist in memory at once. The operating system gives different jobs access to the processor for periods which depend on an algorithm that can take into account such factors as the relative priority of the available jobs, the amount of I/O activity and so on. The essential difference is that the processing of one job may, before it is finished, be interrupted by the operating system to allow the processor to execute another job. Once the hardware for such interrupts was available, it became possible to dispense with 'batch processing' (although this is still a very efficient way of using computer resources) and interactive systems were developed where the terminals had the ability to issue interrupts, as could any other peripheral.

Microcomputers are now evolving from single-user towards multi-user configurations. Although similar in many respects to the evolution of mainframe systems, there are, nevertheless, a number of marked differences. For one, the prices of a microprocessor and a respectable chunk of semiconductor memory are now sufficiently low that it is unnecessary to go to a great deal of effort to optimise their usage. Instead, the upmarket peripherals (such as Winchester disks, fancy printers and graph plotters) are the resources which need to be shared. We shall see how the designers of multi-user micro systems have taken note of this by providing varying hardware configurations on one or more processors.

Nevertheless, the concept of fairly sharing out (electronically-connected)

facilities still involves an extension of the idea of an interrupt which can be initiated and acted upon by interconnected devices; our investigation of multi-user systems will take us as far as broadcast networks. Finally, we propose some Benchmarks which can be used to compare multi-access performance between different systems.

Classification of systems

Although virtually all multi-user systems operate by sharing expensive resources while duplicating cheap resources, this is achieved in a wide variety of ways.

To discuss these in a sensible order, it is useful to devise a classification scheme (or, as it is called in the best literature, a 'taxonomy') and a proposed scheme is shown in Figure 1.

Therefore, we can broadly divide multi-user systems into those which employ a single processor to service all the users and those for which a separate processor is associated with each user. In either case, there may be subsidiary processors — controlling the disk drives, VDU(s) or possibly a printer — but it is only the processor(s) which execute the user's own code with which we are concerned.

Single processor systems

The simplest example of a processor being required to do two jobs at once need not involve more than one user. This is called 'multi-tasking', where a processor divides its time between a normal interactive user (the 'foreground' job) and another program of lower priority (the 'background' job). One of the most common examples of this technique can be found in word-processing packages (such as Wordstar), where normal editing can occur on one file (at an admittedly slower pace) at the same time as a second file is being output to the printer.

A slightly more ambitious scheme is where a single processor is used but additional memory is provided, beyond the normal limit of the processor. Consider the Z80 — it has a 16-bit address range which means that it can cope with a maximum 64 kbytes of memory and this is too little to share between a number of users (as well as there being no mechanism for protect-

ing one user from another). However, memory is fairly cheap so it would be reasonable to buy, for example, 256 kbytes in a system, especially if it is possible to share this system between, say, four users. This is achieved by splitting the memory into 'banks', each of which can be the maximum addressable by the CPU (64k in this case), and assigning one bank to each user. The processor then uses 'time-slicing' whereby time is split (usually equally) between all the users into slots. During each time slot, the processor only 'sees' that user's bank of memory and so it seems that he has a dedicated Z80 processor, working at one-quarter of its speed. As a processor is idle most of the time, the degradation in performance is not likely to be nearly as dramatic as this suggests.

Several suppliers of single-user systems have bank-select multi-user systems which frequently can be obtained by expanding a single-user system (by adding memory, with the bank-select function, extra I/O ports for the additional terminals and modified software). In particular, Digital Research (which gave the world CP/M), has an operating system called MP/M, a multi-user upgrade of CP/M. Horizon also sells a bank-select upgrade for its system, as does Cromemco.

The third type of single-processor, multi-user system is that of a proper time-sharing system traditionally found on (and developed for) minicomputers and mainframes. Here, the operating system itself decides which jobs shall have which parts of memory and for how long. Jobs which are not currently active (although processing on them is not complete) are usually 'swapped-out' onto some form of backing storage such as a disk. It seems very unlikely that any 8-bit processor could cope satisfactorily with the traffic generated by such a busy operating system (nor would it have the spare capacity needed to service the operating system). However, some of the 16-bit designs (which are, effectively, mini-computers achieved with LSI technology) can be expected to offer these facilities on a scale of costs not far removed from those of a micro-computer.

Microsoft (of Basic-80, Forth-80, Cobol-80 and MxPascal fame) has signed a contract that will enable it to put a Unix (a very powerful time-sharing system originally developed at Bell Research Labs, running on PDP-11s) lookalike on the 8086, Z8000 and the

68000, Alpha Micro (and Equinox 300) has always had a time-sharing operating system available.

Multi-processor systems

The second major line of approach to multi-user systems is to provide each user with a processor and some, but not all, of the other facilities, which are provided on a shared basis.

These solutions are fairly new, first because users have only recently begun to hit the limitations of single user microprocessor systems, and, secondly, because microprocessors have dropped sufficiently in price to make it economically viable to design multiprocessor systems. The expensive parts of a micro system are the peripherals, which would certainly start with a hard disk system and may include any of a number of peripherals such as graphics terminals, plotters, digitisers and special printers, all of which are expensive.

The simplest example of this approach is to have one (master) micro-computer which is used to control traffic on a bus, into which is inserted a processor card for each user, with its own associated memory. Any I/O (including that to and from the user terminals) which occurs is dumped onto the bus and is picked up by the master processor which ensures that it (the I/O) goes to the correct destination. The snag is that, as the number of users rises, the traffic on the bus can become a bottleneck with a corresponding loss of response. Micromation has advertised that its Z system is of this design.

For a little more money it should be possible for one serial port to be associated with each user processor so that I/O to the terminal does not have to go onto the bus, which is then only used for disk transfers and more specialised I/O. This is the best of both worlds in that each user has a terminal, processor and memory — facilities which are awkward or inconvenient to share — and access to (say) 30 Mbytes of disk space or a flat-bed graph plotter when needed (with a little luck) which could never be afforded or justified on a single user's usage. From their press releases, it looks as if Intertec (of SuperBrain fame) and RML (380Z) are designing multi-processor systems using this type of 'star' configuration.

Finally, a new group of systems is appearing on the market in which costly or exotic peripherals may be shared, while, at the same time, participating machines in the network may communicate with each other independently of any central controller. Examples currently available are Nestar and Econet. Nestar allows up to 65 Apples to be connected with one of the machines acting as a server for a particular peripheral. In the Nestar system this 'server' machine would be dedicated to, say, file handling. The Econet system allows up to 255 Acorn Atoms to be connected to a network in a similar fashion to the Nestar system, except that the machine containing the 'server' program can be running another program at the same time and is interrupted while the appropriate service is performed. This system can be described as a 'broadcast network'.

The users are not usually connected by anything as sophisticated as a bus.

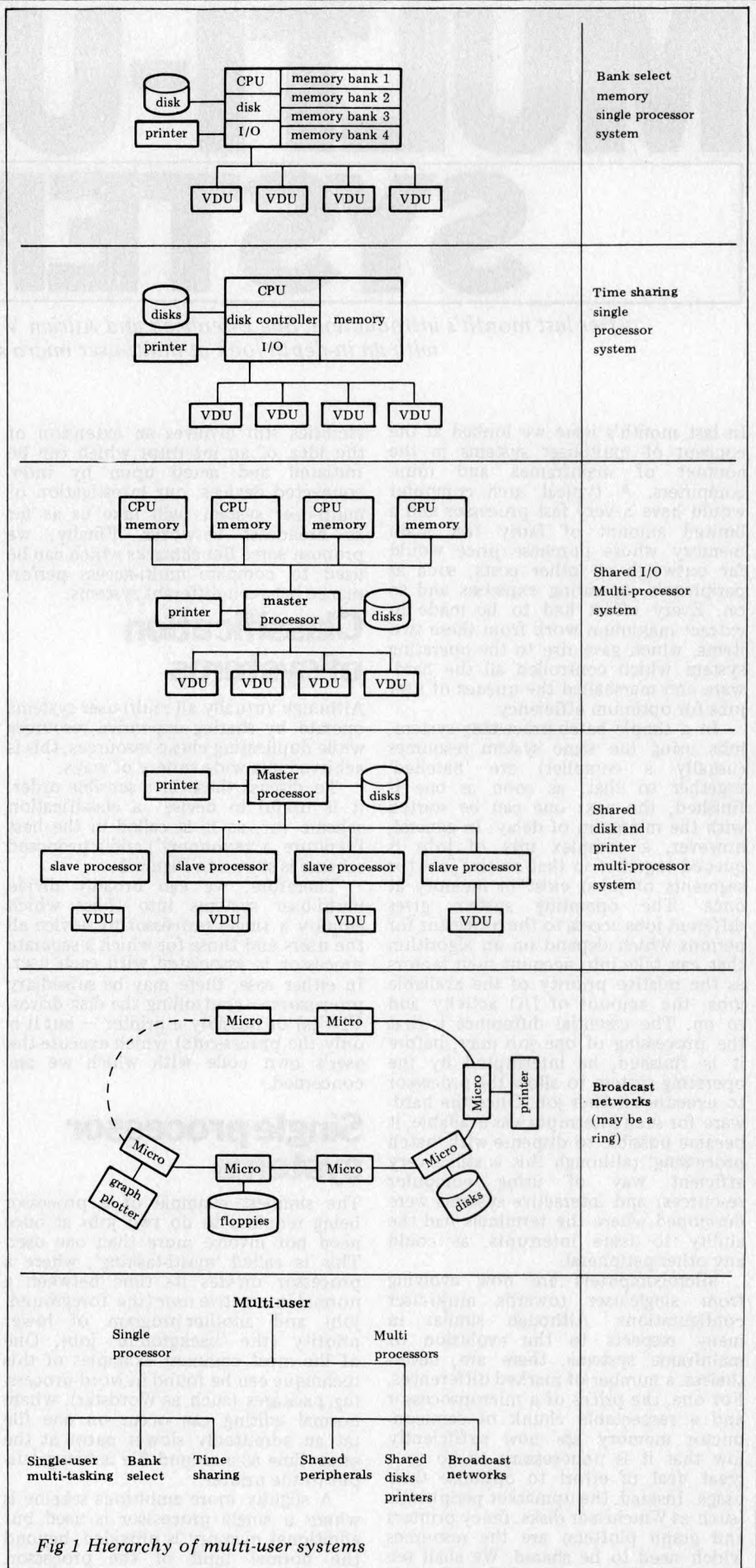

Fig 1 Hierarchy of multi-user systems

Instead, a parallel or even serial cable is used to connect the computers together. Complex networking protocols are required to ensure that data moves smoothly from point to point without

bottlenecks or interference. Such a system is very close in concept to the large-scale networks which have been developed to link mainframe computers together.

Benchmarks

On a single-user computer system, Benchmark programs are used to test the speed of a variety of commonly-performed operations. On a multi-user system, the user does not have access to the full resources of the computer. And so, even though it may be interesting to ascertain how fast a given machine can execute a program when only one user is on the system, this gives little indication of how the system will respond when it is fully used. What is interesting is the extent of degradation of performance caused by additional users on the system.

The level of degradation depends on the amount of stress a given task places on the shared resources of a system. We have decided to limit our tests to a maximum of four users on one machine. Looking at the multi-user systems available now, many seem to cater for this number. There are some systems (and these are primarily in the 'network' category), which will allow a far larger number (for example, 64) than two reviewers can borrow or test — a large number of monkeys would be helpful. More importantly, most trends as to how a given system is likely to deteriorate should be apparent by the time four users are on the system.

Each test will be run four times. The first time, the program will be run by one user, the second time by two, then by three and finally by four. For each run, every user will be timed independently in order to see how evenly the resources are spread.

The tests are designed specifically to test the processor, I/O and disk capabilities. They will be written in Basic unless a system does not have this language, in which case they will be translated into a language supported by the system. Fortunately, the language (and whether it is compiled or interpreted) is not important since the programs are designed to compare single and multi-user performances with each other, rather than with some absolute measure. Listings of the four tests in a pseudo-Basic are given.

The first program is intended to test the level of degradation to the response time of a processor-bound job. For this test, the Basic Benchmark 7 will be used as it contains a range of processor activities with minimal I/O and no traffic to and from the disks.

It is expected that a computer system based on a single processor would run (N+overheads) times as slow when N users are on the system, compared with timings for a single user. Not only does the processor have to execute the same job N times but it is also responsible for scheduling the jobs. On a bank-select, single processor system, this overhead should be minimal (it is usually performed mainly by hardware, with the processor having to merely save current registers, then execute a single instruction to change banks). On a time-shared system, where user programs are swapped to and from the disks, an operating system may need a significant amount of time for executing its routines.

It is on this test that multi-processor systems should score most favourably. There should be no noticeable deterioration as additional users are added to the

system.

The second test is designed to test the independence of I/O to the user's console. The printable character set is displayed on the screen 100 times. There is no input as this depends on the user's typing speed and, hence, is subject to wide variations. Confining the test to output only should not affect the validity of the test since it is difficult to think of a reasonable configuration where input and output are handled very differently.

For this task, the actual timing of a single user will be dependent on the speed of the VDU and so the relevant data will be the comparison of this time with that when two, three or four users are on the system. Systems which show a noticeable increase in time taken would not be suitable for I/O-bound tasks. This test should prove most interesting for multi-processor systems where I/O is controlled by a master processor.

The third test is designed to place stress on the disk filing system. A file (the same one for all of the users) is written to and read from 100 times. Before each access, the file is opened and after each access it is closed. It will be interesting to see how single-processor systems compare with multi-processor systems on this type of test. As most of the processing time is spent in disk transfers, there shouldn't be a great deal of difference between the two types of system. It will also be interesting to see how networks compare with the multi-processor systems.

Whereas test three opened and closed its file for every disk access (requiring access to the directory each time), the final test opens a file, writes 100 records, then closes the file; this is followed by an open, 100 reads and a close. This is a test of the system software rather than

the hardware. One of the problems of a multi-user operating system is that it has to cope with keeping files from being corrupted when two or more users wish to access them concurrently. On the simplest of systems, corruption of data will occur when two users write to the same record at the same time (MU-PET sales literature specifically warns potential customers of this difficulty). The easiest way to overcome this is to ensure that once a file has been opened on a disk by one user, no other user can write to that disk until the first user has closed his file (that is, protection at the disk level). This is a very drastic solution which certainly overcomes the problem but, for applications which make heavy use of the disk, is untenable. The second solution is to ensure that only one user at a time writes to a file but that other files on the same disk have unrestricted access (ie provide protection at the directory level). This is the system generally used in mainframes. It should be noted that anyone can read from a file which has been opened for writing, but the results are not guaranteed. The ideal solution would be to provide protection at the record level, but this is quite a complex method. However, this is a software problem and there shouldn't be any correlation between hardware configurations and response times.

Since writing the first article on multi-user systems, numerous such systems have been announced or have become available. We hope that we have described the different types of system in enough detail that potential users will be able to decide which type of system is appropriate for a given application. Over the next few months, we will Benchtest several of these systems, using the Benchmarks described here.

Multi-User Benchmarks

The Processor Test

```
-----  
PRINT "S"  
K = 0  
DIM M(5)  
500 K = K + 1  
A = K/2*3+4-5  
GOSUB 820  
FOR L = 1 TO 5  
M(L) = A  
NEXT L  
IF K < 1000 THEN 500  
PRINT "E"  
820 RETURN  
END
```

The Disk Access Test

```
-----  
PRINT "S"  
create file  
fill 128 byte record  
FOR I = 1 TO 100  
open file  
write record  
close file  
NEXT I  
FOR I = 1 TO 100  
open file  
read record  
close file  
NEXT I  
PRINT "E"  
END
```

The Disk Access Software Test

```
-----  
PRINT "S"  
create file  
fill 128 byte record  
open file  
FOR I = 1 TO 100  
write record  
NEXT I  
close file  
OPEN FILE  
FOR I = 1 TO 100  
read record  
NEXT I  
close file  
PRINT "E"  
END
```

The Input/Output Test

```
-----  
PRINT "S"  
FOR I = 1 TO 100  
FOR J = 32 TO 96  
PRINT CHR$(J) ;  
NEXT J  
PRINT  
NEXT I  
PRINT "E"  
END
```

INNOVATIVE

TRS-80 SOFTWARE

FROM THE PROFESSIONALS



**Animation
Animation
Animation**

Animate is a machine language program representing an entirely new breakthrough in the use of graphics on the TRS-80 or Video Genie microcomputers. As Walt Disney and others found to their profit some years ago, if you draw a number of separate pictures slightly different to each other, and then display them consecutively sufficiently fast, a moving picture is produced. This is precisely what Animate does. Pictures are built up as a sequence of frames, each one being as small or as large as you wish and composed using an easily used graphics cursor. The entire graphics content of a frame can be shifted in any direction so as to move objects without the need to redraw them in each new position. As each new frame is completed it is automatically stored in memory and given a number, so that it may be recalled and edited at will. The timing of the projection of each frame is definable up to a maximum of 100 seconds. When the picture is completed it may be viewed and edited as you wish. When the final picture is complete it may be stored on cassette as a SYSTEM program. Thereafter it may be loaded and accessed either by Animate or by any Basic program. Thus the same picture may be used in any number of different Basic programs, if you wish. Animate is available at present only on cassette for Level II or Genie machines of 16K and up. A disk version will be available shortly. A comprehensive manual is included.

£14.95

Plus VAT and 75p P & P = £17.94.

Send large SAE (38p) for our current Catalogue of TRS-80 software. Add £1.85 for a binder.



A.J.HARDING (MOLIMERX)

MOLIMERX LTD.

28 COLLINGTON AVENUE, BEXHILL-ON-SEA, E.SUSSEX.

TEL: (0424) 220391

TELEX 86736 SOTEX G



ZX80 PRINTER

To supplement Peter Faff's 'Printerfacing' series, Dr C J Ogle has sent this simple circuit to add a serial printer to the ZX80, something we know will be of immense interest to those ZX80 owners who can't wait for 'Uncle' Clive to produce an 'official' printer.

To operate a serial printer, you must first convert the data in 'byte' format inside the computer into a series of electrical potentials or currents representing a start bit, data bits in least significant to most significant bit order, a parity bit and one or more stop bits. The timing of these pulses depends on the baud rate used by the printer — see Figure 1.

In designing this interface for the ZX80, I considered two methods for this conversion:

1. Using a UART chip to convert the data presented to it on seven parallel data lines into the required serial format;

2. Using a machine code program in the ZX80 to perform the necessary conversions and output the data along one data line (D0).

Both methods have their advantages and disadvantages. If you use a UART, the data to be printed, after conversion to the appropriate ASCII format, need only be POKEd to the address at which the UART is located. While the character is being transmitted by the UART, the next character can be prepared for transmission. However, to weigh against these advantages is the need to provide the correct timing clock for the UART and also the interconnection of seven data lines.

The second method has the advantage that, while data is being transmitted, no other processing can be carried out but it has the advantage of simpler interconnections (only one data line is used) and the use of less sophisticated (and therefore cheaper) hardware. This second method has been developed into a working system for the ZX80 and is described here. It can be broken down into three distinct components:

1. Hardware interface to the printer;
2. Machine code program to provide timing and to output data to the printer;
3. Basic program to enter machine code program and to convert characters to ASCII format and send them to the m/c program for printing.

Hardware interface

The circuit for this is shown in Figure 2. It takes data in from data line D0 (edge connector A4 on the ZX80) and latches it, using the 7474 when AX is high and DE (device enable) is low. The source of the signals AX and DE will depend on whether the ZX80 has the Sinclair memory expansion pack or not.

With the expansion pack, DE can be obtained from pin 11 of the 74138 decoding chip on the expansion board. This can be brought out to pin B23 on the board as this pin is not connected in the computer; the track connecting the pin to ground will need cutting. If AX is connected to address line A0 (pin B7), then the printer is apparently

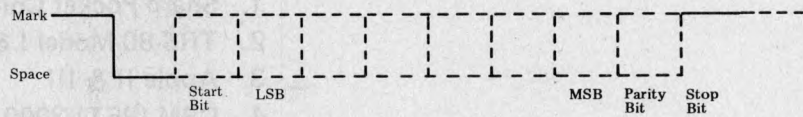

Fig 1 Serial data format. The duration of each bit is (1/baud rate) seconds.

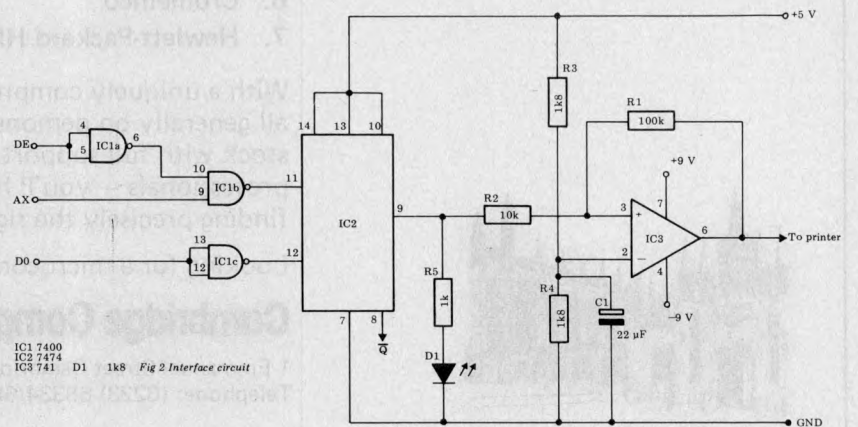

Fig 2 Interface circuit

located at all odd numbered addresses between 5001H and 53FFH.

If an unexpanded ZX80 is being used then DE can be WR (pin A17) and AX can be A12 (pin A14). In this case, the printer is located at 1000H to 1FFFH and at alternate blocks of 1000H upwards to FFFFH. My ZX80 has an expansion board and address 5001H (20480 decimal) has been used to access the printer.

The remainder of the circuit uses a 741 op amp to convert the 0 V (mark level) and +5 V (space level) from the 7474 to -9 V and +9 V required by the printer used. The LED — D1 — is used only as an indicator; it can be turned on by POKing 0 to the printer address (5001H or 1000H as above) and turned off by POKing 1 to that address.

The +9 V and -9 V supply for the

741 can be provided by two 9 V (PP3) batteries if an additional power supply is not available. Pin B1 provides +5 V and pins B4 and B5 are ground.

If your printer uses conventional +5 V and 0 V logic levels, then these are available from the Q output of the 7474. The provision of a 20 mA current loop would require some amplification of the 741 output and a 'beefier' power source than the two PP3s.

Machine code routine

This is quite short and is shown in Listing 1. The character to be printed — CHAR — is checked for parity and the parity bit is set if necessary. A start bit (00) is sent to the printer address and then a delay loop is

21 01 50	LD HL, 5001	; PRINTER ADDRESS
3E 00	LD A, CHAR	; LOAD CHARACTER
E6 7F	AND 7FH	; BIT 7=0
F5	PUSH AF	; SWAP FLAG REGISTER -
D1	POP DE	; INTO E
CB 53	BIT 2, E	; AND CHECK PARITY
20 02	JR NZ, PART	
F6 80	OR 80H	; SET PARITY BIT IF NECESSARY
37	SCF	; CARRY WILL BE STOP BIT
CB 17	RLA	
16 0A	LD D, 10	; BIT COUNTER
36 00	LD (HL), 00	; SEND START BIT
18 02	JR DELAY	
1F	RRA	; NEXT BIT INTO '0' POSITION
77	LD (HL), A	; AND SEND
0E 08	LD C, L1	; OUTER LOOP COUNTER
06 17	LD B, L2	; INNER LOOP COUNTER
10 FE	DJNZ LOOP2	
0D	DEC C	
20 F9	JR NZ, LOOP1	
15	DEC D	
20 F2	JR NZ, DATA	; GO FOR NEXT BIT
C9	RET	; RETURN IF DONE

Listing 1 Assembler language listing of printer subroutine

15 good reasons for visiting Cambridge

1. Sharp Pocket Computer
2. TRS-80 Model I & II
3. Apple II & III
4. CBM (PET) 3000
5. North-Star Horizon
6. Cromemco
7. Hewlett-Packard HP-85
8. Acorn Atom
9. UK-101
10. X-Y Plotters
11. Qume
12. Farm Systems
13. Word Processing
14. Computer Books

With a uniquely comprehensive selection like this — all generally on demonstration and available from stock with full support by our team of computer professionals — you'll have the ideal chance of finding precisely the right system for your application.

Looking for a microcomputer? — then visit us at:

Cambridge Computer Store

1 Emmanuel Street Cambridge CB1 1NE
Telephone: (0223) 65334/68155

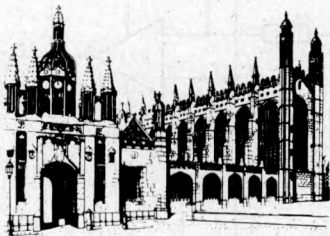

BYTE SHOP COMPUTERLAND

your specialist Computerstore.

Commodore Business System



Well-proven systems for the serious user. Our computer stores are staffed by business experts, backed by first class maintenance support.

The Commodore is a complete computerized business system, ideal for first time users. Based on the world famous PET computer, it is easy to use and extremely cost-effective. The system includes large capacity disks

and an excellent quality printer thus bringing many applications within the reach of the small business.

Find out why the Commodore Business System is so popular — call in to any of our shops for advice and a demonstration of this and other systems.

London

48 Tottenham Court Road
London W185 4TD
Tel. 01-636 0647

Nottingham

92a Upper Parliament Street
Nottingham NG1 6LF
Tel. 0602 40576 Telex. 377389

Manchester

11 Gateway House
Piccadilly Station Approach
Manchester
Tel. 061-236 4737 Telex. 666168

Birmingham

94-96 Hurst Street
Birmingham B5 4TD
Tel. 021-622 7149 Telex. 336186

Glasgow

Magnet House
Waterloo Street
Glasgow Tel. 041-221 7409
Telex. 779263

BYTE SHOP
COMPUTERLAND
— your specialist Computerstore.

entered, the length of which is determined by the values of L1 and L2. The character bits are then sent one at a time, starting with the least significant bit, the delay loop being entered between each bit. Finally a stop bit (01) is sent.

Basic program

The program in Listing 2 does what it claims — it prints its own listing — but it can also print anything (except graphic characters) which is PRINTed in a program.

It uses the machine code routine described above which is stored in array A(). This method of machine code storage has three main advantages: 1. Any code can be used (the suggestion has appeared elsewhere of using REM statements for M/C routines. This is not very satisfactory as some codes can make the system 'hang'); 2. The code is easily entered using INPUT statements and is retained when the program is SAVED; 3. The contents of the array relocate themselves when lines are added to or deleted from a program and cannot be overwritten by the display area.

The starting address of the variable storage area is held in memory locations 16392 and 16393 (VARS) and if the array A() is DIMed before any other variables are used then the elements of the array are stored in pairs of adjacent addresses from VARS+2 upwards. One point to note is that numerical variables are stored with their low byte first, eg 255 decimal is stored as FF00.

The numbers to be entered into array A() are given in Table 1. This is for 1200 baud and the values for other baud rates are given in Table 2. When the program is run, the values are typed in response to the prompt showing the array member being entered. A second array, B(), holds 18 members of a look-up table used to convert the non alpha-numeric characters into ASCII. Again the values of B() are given in Table 1 and are entered as for A().

At this point the program STOPS and it is as well to save it as, if any errors have been made in entering the machine code routine, the program may well crash. Having saved the program, it can be listed on the printer by entering GOTO 9900. The routine located

Contents of arrays A and B for 1200 baud rate, even parity.

A(0)	289	B(0)	32
A(1)	15952	B(1)	34
A(2)	-6646	B(2)	35
A(3)	-2689	B(3)	36
A(4)	-13359	B(4)	58
A(5)	8275	B(5)	63
A(6)	-2558	B(6)	40
A(7)	14208	B(7)	41
A(8)	6091	B(8)	45
A(9)	2582	B(9)	43
A(10)	54	B(10)	42
A(11)	536	B(11)	47
A(12)	30495	B(12)	61
A(13)	2062	B(13)	62
A(14)	5894	B(14)	60
A(15)	-496	B(15)	59
A(16)	8205	B(16)	44
A(17)	5625	B(17)	46
A(18)	-3552		
A(19)	201		
A(20)	0		

Table 1

Baud rate	L1	L2	A(13)	A(14)
110	88 (58H)	23 (17H)	22542	5894
150	64 (40H)	23 (17H)	16398	5894
200	48 (30H)	23 (17H)	12302	5894
300	32 (20H)	23 (17H)	8206	5894
600	16 (10H)	23 (17H)	4110	5894
1200	8 (08H)	23 (17H)	2062	5894
2400	4 (04H)	23 (17H)	1038	5894
9600	1 (01H)	21 (15H)	270	5382

Table 2

here gets the program line contents from its location in memory, converts the line number (held in binary form) into decimal and then PRINTs the line, character by character. Doing this automatically converts the tokens for PRINT, GOTO, REM, etc, into their full form. When the end of line character (76H — variable Q) is met, subroutine 30 is called. This routine first calculates the location of the start of array space (OUCH) and then the start of display space (S). The characters that have been sent for display by the print statements are then PEEKed one at a time and converted to ASCII format, letters and numbers being converted by the addition of 27 and 20 respectively to their code values. Other printable characters are given a value between 1 and 17 and these are converted to ASCII using array B(). Graphic characters are converted to ASCII 32 (space) from B(0).

The ASCII value is held in variable A which is transferred in subroutine 20 to the location CHAR in the machine code routine which is then called by the statement in line 24. The character is then printed.

Having printed the listing, the program again STOPS. The use of the program for general printing is shown by entering GOTO 1000.

In general, anything that is PRINTed in a program can be output to a printer

by using GOSUB 30 in a following statement. Note, however, that as it stands, the program will insert carriage returns and line feeds at the end of a printing call and not at the ends of display lines (this allows for full use of paper width). It recognises the end of display by two NEWLINE characters inserted at the beginning of subroutine 30 (PRINT in lines 34 and 36). At the end of the printing routine there is a clear screen statement which allows as many lines of subsequent printing as desired without the computer running out of display space.

Non-printable control characters such as Form Feed (ASCII 12) or TAB (ASCII 9) can be sent to the printer by LETing A= the desired value and GOSUBing to 20.

To use this program as a printing and listing part of another, it can be LOADED and the additional program entered between lines 200 and 9000 but note that the program so written will have to be run using a GOTO statement, as RUN will clear the arrays. Again the CLEAR statement cannot be used for the same reason but this is a small penalty to pay for this powerful printing facility.

If you are short of memory space, then after first running the program and filling the arrays, lines 100 to 160 can be erased without destroying the value of the variables created by them.

```

1 REM *** A PROGRAM TO PRINT ITS OWN LISTING
2 REM *** FOR THE ZX80
3 REM *** BY C.J. OGLE
4 REM *** IF ARRAYS HAVE BEEN FILLED
5 REM *** GOTO 9900 WILL LIST TO PRINTER
10 GO TO 100
20 REM CALL M/C ROUTINE TO OUTPUT TO PRINTER
22 POKE OUCH+4,A
24 LET X=USR(OUCH)
26 RETURN
30 REM GET CHARACTER FROM DISPLAY AND CONVERT TO ASCII
32 LET OUCH=PEEK(D-5)+256*PEEK(D-4)+2
34 PRINT
36 PRINT
38 LET S=256*PEEK(D)+PEEK(D-1)
40 LET S=S+1
42 LET CD=PEEK(S)
44 IF CD=0 AND PEEK(S+1)=0 THEN GO TO 64
46 IF CD=0 THEN GO TO 40
48 LET A=CD
50 IF A>1 THEN LET A=A-10
52 IF A>17 THEN LET A=A+30
54 IF A>57 THEN LET A=A+7
56 IF A<0 THEN LET A=0
58 IF A<18 THEN LET A=B(A)
60 GO SUB 20
62 GO TO 40
64 LET A=13
66 GO SUB 20
68 LET A=10
70 GO SUB 20
72 CLS
74 RETURN
100 DIM A(20)
105 DIM B(17)
110 FOR I=0 TO 20
115 PRINT "ENTER A(";I;")"
120 INPUT A(I)
122 CLS
125 NEXT I
130 FOR I=0 TO 17
135 PRINT "ENTER B(";I;")"
140 INPUT B(I)
142 CLS
145 NEXT I

```

GOTO page 144

Listing 2

GO SUB SAVE £'s!

SUBSCRIPTION ORDER FORM

I would like to subscribe to Personal Computer World for one year (12 issues)

My name _____ BLOCK CAPITALS PLEASE

My Company (if applicable) _____

My address _____

_____ This is my office home

This is a new subscription a renewal subscription

Date _____ signature _____

- U.K. £10.00
- Europe £17.00 (air mail)
- USA & Canada £22 (air mail)
- Rest of World £25 (air mail)
- I enclose my cheque, made payable to Personal Computer World, for £ _____
- Please invoice my company

Please send this entire order form, together with your remittance to Personal Computer World, Subscriptions Dept, 14 Rathbone Place, London W1P 1DE, England

For two inflationary years we have managed to keep the cover price of Personal Computer World down to 50p while continually increasing the number of editorial pages. But the ravages of inflation have finally caught up with us and our cover price is now 60p. However, for a short period only, you can subscribe at our 'old' rates and save £'s. Use this order form NOW to obtain a year's supply of PCW at the bargain price of £10.00 (inclusive of all postage) and sleep soundly at night, safe in the knowledge that your personal copy of PCW will come thudding through your letterbox every month.

Personal
Computer
World

Personal Computer World

BINDERS KEEPERS LOSERS WEEPERS

Half the people you meet today are not preoccupied with pollution, perversion or persecution. It's worse than that — they've lost a copy or two of PCW and don't know where to find replacements.

So keep *your* copies of PCW in a beautiful bright yellow binder. £2.95 worth of smart security.

Just check the coupon at the foot of the page.

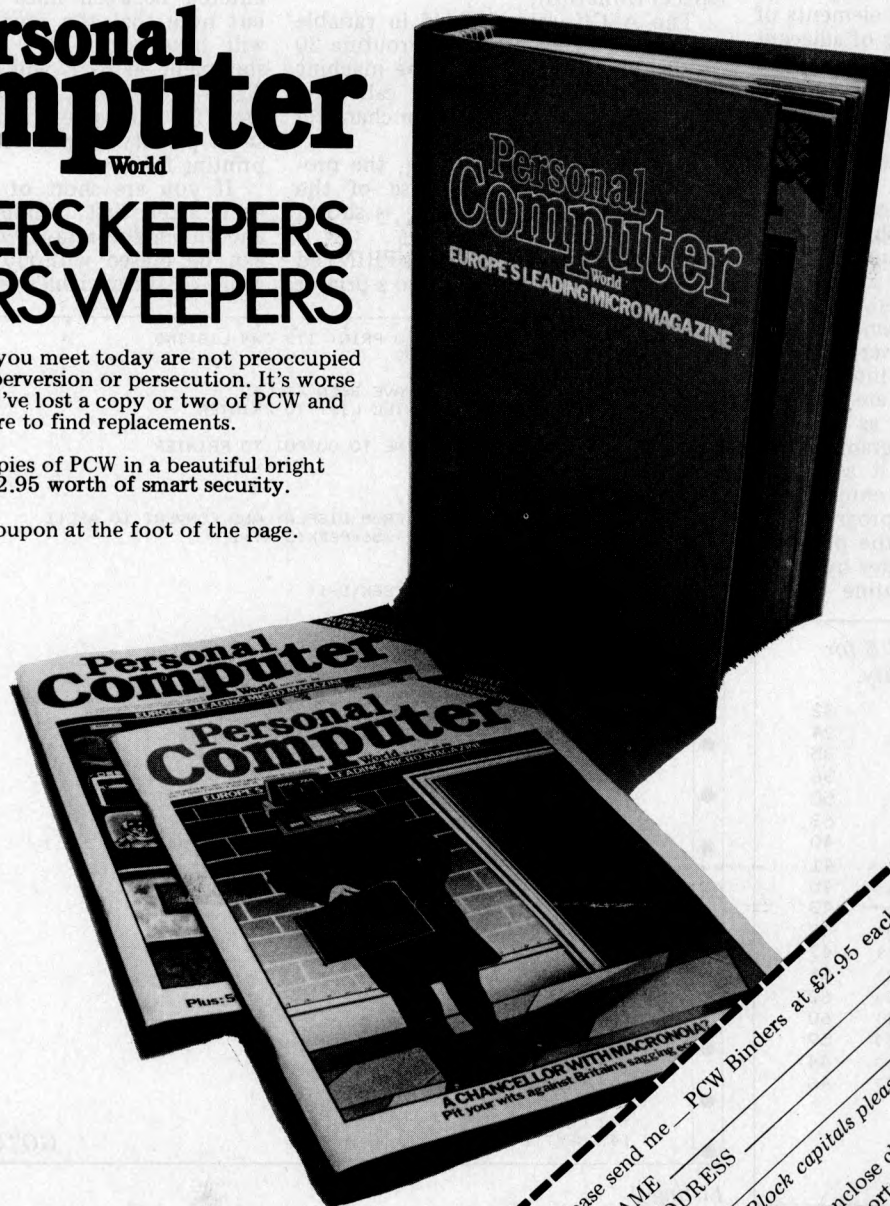

Please send me _____ PCW Binders at £2.95 each
NAME _____
ADDRESS _____
(Block capitals please)

I enclose cheque/P.O. for £ _____ made payable to
Sportscene Publishers Ltd.
Send coupon to PCW (Binders),
14 Rathbone Place, London
W1P 1DE. Allow at least
14 days for processing.

Make your micro

MIGHTY



Get the most out of your microcomputer with Graham-Dorian Business software.

At any given time, your hardware is only as useful as the software you run in it. Our programs let you realise the full potential of your hardware

Graham-Dorian provides highly detailed and well documented programs. All pretested on the job. Each so comprehensive that it takes little time to learn to run a program — even for someone who's never operated a computer before.

Graham-Dorian programs are on-line now working for us and others around the world. They are ready to go to work immediately or to be tailored for your more specific needs. Each package contains a software program in BAS and INT film form plus a user's manual and hard copy SOURCE LISTING.

Programs are compatible with most major computers using CP/M disk operating systems, and come in standard 8" or on various mini-floppy disks.

Graham-Dorian stand behind dealers with technical advice.

Yes, there's a world of difference in business software. Graham-Dorian has more per-package capabilities and more packages (with new ones added every few months).

Distributors for Micropro:- Wordstar, Datastar & Mailmerge. CP/M for Tandy Model I & II

†GDSS are appointing UK Dealers and European Distributors. Enquiries and applications invited.

*CBASIC-2 is a trade mark (copyright 1980) of Compiler Systems, Inc. GDSS are the European Distributor for CBASIC-2.

The Graham-Dorian line now includes these packages:

- Nominal Ledger
- Purchase Ledger
- Sales Ledger
- Job Costing
- Order Entry & Invoicing
- Payroll
- Manufacturing Inventory
- Manufacturing Job Costing
- Wholesaler Inventory
- Retailer Inventory
- Cash Register
- Apartment
- Surveying
- Dental

CBASIC-2*

Ask your dealer for a demonstration soon.



Graham-Dorian Software Systems

A division of Graham-Dorian Enterprises & Terodec (Micro Systems) Ltd.
Unit 58, Suttons Park Avenue, Earley
Reading, Berks RG6 1AZ
Tel (0734) 664345/6 GDSS

Why the Sinclair ZX80 is Britain's best selling

Built: £99.95

Including VAT, post and packing, free course in computing, free mains adaptor.

Kit: £79.95

Including VAT, post and packing, free course in computing.

This is the ZX80. A really powerful, full-facility computer, matching or surpassing other personal computers at several times the price. 'Personal Computer World' gave it 5 stars for 'excellent value'. Benchmark tests say it's faster than all previous personal computers.

Programmed in BASIC—the world's most popular language—the ZX80 is suitable for beginners and experts alike. And response from enthusiasts has been tremendous—over 20,000 ZX80s have been sold so far!

Powerful ROM and BASIC interpreter

The 4K BASIC

ROM offers remarkable programming advantages:

- * Unique 'one-touch' key word entry: the ZX80 eliminates a great deal of tiresome typing. Key words (RUN, PRINT, LIST, etc.) have their own single-key entry.
- * Unique syntax check. A cursor identifies errors immediately.
- * Excellent string-handling capability—takes up to 26 string variables of any length. All strings can undergo all relational tests (e.g. comparison).
- * Up to 26 single dimension arrays.
- * FOR/NEXT loops nested up to 26.
- * Variable names of any length.
- * BASIC language also handles full Boolean arithmetic, conditional expressions, etc.
- * Randomise function, useful for games and secret codes, as well as more serious applications.
- * Timer under program control.
- * PEEK and POKE enable entry of machine code instructions.
- * High-resolution graphics.
- * Lines of unlimited length.

Unique RAM

The ZX80's 1K-BYTE RAM is the equivalent of up to 4K BYTES in a conventional computer—typically storing 100 lines of BASIC.

No other personal computer offers this unique combination of high capability and low price.

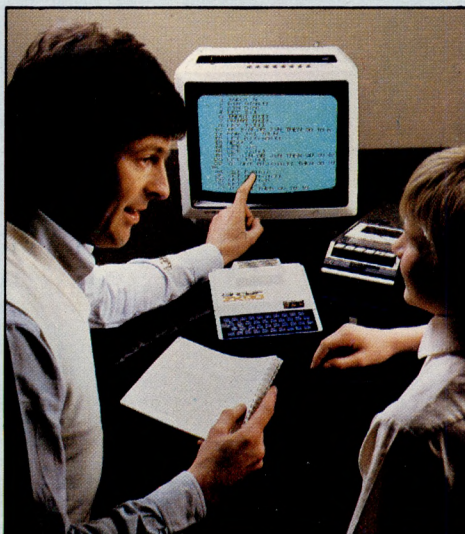

The ZX80 as a family learning aid. Children of 10 years and upwards are quick to understand the principles of computing—and enjoy their personal computer.

The Sinclair teach-yourself BASIC manual

If the specifications of the Sinclair ZX80 mean little to you—don't worry. They're all explained in the specially-written 128-page book (free with every ZX80). The book makes learning easy, exciting and enjoyable, and represents a complete course in BASIC programming—from first principles to complex programs.

Kit or built—it's up to you

In kit form, the ZX80 is pleasantly easy to assemble, using a fine-tipped soldering iron. And you may already have a suitable mains adaptor—600 mA at 9V DC nominal unregulated. If not, see the coupon.

Both kit and built versions come complete with all necessary leads to connect to your TV (colour or black and white) and cassette recorder. Plug in and you're ready to go. (Built versions come with mains adaptor.)

personal computer.

Now available for the ZX80... New 16K-BYTE RAM pack

Massive add-on memory. Only £49.95.

The new 16K-BYTE RAM pack is a complete module designed to provide you – and your Sinclair ZX80 – with massive add-on memory. You can use it for those really long and complex programs – or as a personal database. (Yet it can cost as little as half the price of competitive add-on memory for other computers.)

For example, you could write an interactive or 'conversational' program to show people what your ZX80 can do. With 16K-BYTES of RAM, they could be talking to your computer for hours!

Or you can store a mass of data – perhaps in a fairly simple program – such as a name and address list, or a telephone directory.

And by linking a number of separate programs together into one giant, but modular, program, you can achieve the same effect as loading several programs at once.

We're also confident that it won't be long before you can buy cassette-based software using the full 16K-BYTE RAM. So keep an eye on the personal computer magazines – and brush up your chess perhaps!

The RAM pack simply plugs into the existing expansion port on the rear of the ZX80. No wires, no soldering. It's a matter of seconds and you don't need another power supply. You can only add one RAM pack to your ZX80 – but with 16K-BYTES who could want more!

How to order

Demand for the ZX80 exceeds all other personal computers put together! So use the coupon to order today for the earliest possible delivery. All orders will be despatched in strict rotation. We'll acknowledge each order by return, and tell you exactly when your ZX80 will be delivered. If you choose not to wait, you can cancel your order immediately, and your money will be refunded at once. Again, of course, you may return your ZX80 as received within 14 days for a full refund. We want you to be satisfied beyond all doubt – and we have no doubt that you will be.

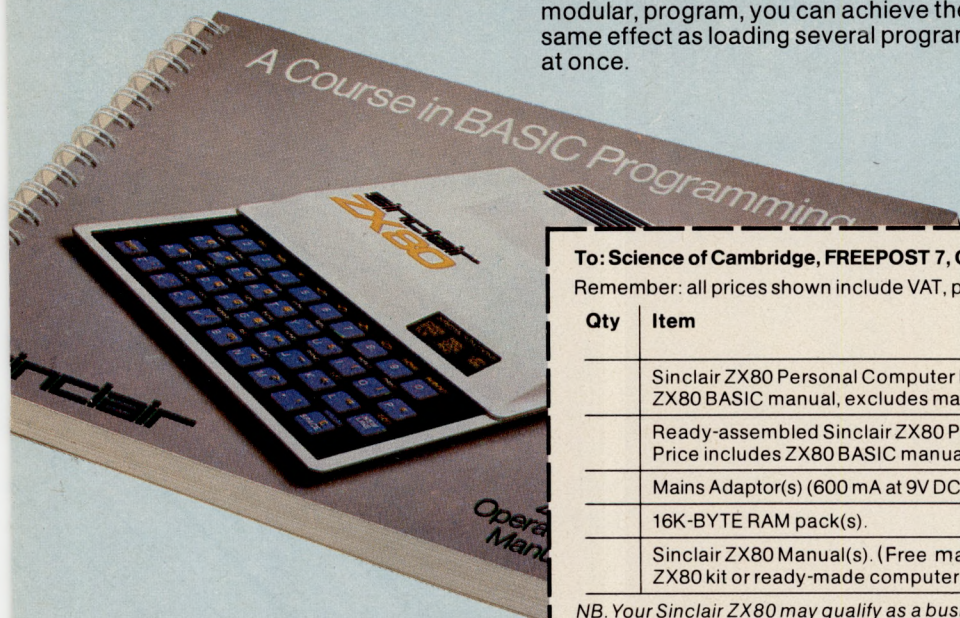

To: Science of Cambridge, FREEPOST 7, Cambridge CB2 1YY.

Remember: all prices shown include VAT, postage and packing. No hidden extras. Please send me:

Qty	Item	Code	Item price £	Total £
	Sinclair ZX80 Personal Computer kit(s). Price includes ZX80 BASIC manual, excludes mains adaptor.	02	79.95	
	Ready-assembled Sinclair ZX80 Personal Computer(s). Price includes ZX80 BASIC manual and mains adaptor.	01	99.95	
	Mains Adaptor(s) (600 mA at 9V DC nominal unregulated).	03	8.95	
	16K-BYTE RAM pack(s).	18	49.95	
	Sinclair ZX80 Manual(s). (Free manual with every ZX80 kit or ready-made computer.)	06	5.00	

NB. Your Sinclair ZX80 may qualify as a business expense.

TOTAL: £

I enclose a cheque/postal order payable to Science of Cambridge Ltd for £ _____
Please print

Name: Mr/Mrs/Miss _____

Address _____

FREEPOST – no stamp needed.

PCW02

sinclair ZX80

Science of Cambridge Ltd.

6 Kings Parade, Cambridge, Cambs.,
CB2 1SN. Tel: 0223 311488.

**Stop
press**
NOW ONLY £595 + VAT
BEAT THAT FOR VALUE

The DAI Personal Computer is Here

*** High Performance ***
*** High Value ***

48k RAM

£795

COLOUR

SOUND



Standard Features

- * 24k Resident High-Speed Basic
- * 16 Colour High-Resolution Graphics (255 × 335)
- * Scrolling Screen Editor
- * Sound Commands for Music Generation
- * Very High Speed Hardware Maths Option
- * Resident Monitor for Machine Language Programming
- * 3 Programmable Parallel Ports
- * Standard TV Interface via Aerial Socket
- * RS232 Serial Port and Dual Cassette Interfaces

Manufactured by:

DAI

THE
MICROCOMPUTER
ENGINEERING
COMPANY

Brussels, Belgium.

Available from:

Data Applications (UK) Ltd.

Personal Computer Division
16b Dyer Street
Cirencester
Gloucestershire
GL7 2PF

Tel: Cirencester
(0285) 61902

For further information please complete and post to:
Data Applications (UK) Ltd, 16b Dyer Street, Cirencester, Glos GL7 2PF

NAME.....

ADDRESS.....

MY INTEREST IS:.....

by Kevin O'Connell

MICRO BITES MAN!

For the first time in the history of chess, a computer will be taking part in an official international event intended primarily for humans. From 21 February to 1 March, Hong Kong will be playing host to the 3rd Asian Cities Team Championship. At least 26 teams, containing many chess masters, will be competing, including three each from Malaysia, Thailand, Indonesia, India and China, two each from Pakistan, Papua New Guinea and Japan and one each from Singapore, Brunei, Sri Lanka and Hong Kong.

The tournament will be partially sponsored by SciSys-W Ltd, which is one of the world's leading manufacturers of chess computers. This Hong Kong company will be entering a team of four of its own computers, called the Chess Champion Mark V, and chess experts are predicting that the computers will cause a number of surprises in the event.

If this competition is a great success, it is possible that the World Chess Federation (FIDE) might decide to allow computers to participate in the biennial World Team Championship.

The Chess Champion Mark V, as a warm-up for the Hong Kong event, played in the important annual tournament in Islington, London in December. I cannot show you any games from that event since it didn't start until a few days after the deadline for this article. Instead I offer you the following game, played last November, in which an earlier version of the program bit the hand that feeds it. For added interest, I include the notes written by the programmer immediately after the game (notes in italics are my additions).

White: Chess Champion Mark V

Black: Programmer

This game started off as a test of new features but quickly developed into a challenge I was not willing to give up.

1 d2-d4 d7-d5
2 Ng1-f3 c7-c5

I was willing to give up the pawn in the hope that it would try to hang on to it — which it did! Then I was supposed to prove that this was unwise. Trouble

was, I'd forgotten the details, except that one tries to undermine the c-pawn somehow with the a-pawn.

3 d4xc5 e7-e6
This is probably too early. Nb8-c6 would be better, or even a7-a5 first. Getting the pawn back with Qd8-a5+ would have defeated my object.

4 b2-b4 a7-a5
5 c2-c3 Nb8-a6
6 e2-e3

All my moves are bad and Chess Champion Mark V is proving it to me.

6 ... a5xb4

7 Bf1-b5+

I think Chess Champion Mark V played only two weak moves in this game and this was one.

7 ... Bc8-d7
8 Bb5xa6 b7xa6
9 c3xb4 Ng8-f6
10 0-0(e1-g1) Bf8-e7
11 Nb1-c3 0-0 (e8-g8)
12 Nf3-e5 Qd8-c7
13 Qd1-d4 Rf8-c8

I'm still hoping to undermine the c-pawn.

14 Bc1-d2 Bd7-e8

I had thought of bringing the knight to d7 to challenge the knight on e5 and also be able to play f7-f6.

15 a2-a4!

It's either now or never...

15 ... a6-a5
16 Nc3-b5 Be8xb5
17 a4xb5 a5xb4
18 Ra1xa8 Rc8xa8
19 Bd2xb4 Nf6-e8

Nf6-d7 is not so good now and I must do something quickly before these pawns get too far advanced. By this time I had given up hopes of winning.

20 b5-b6 Qc7-c8

Where else?

21 Rf1-c1

Interesting. I had expected Rf1-b1. This allows me to play Ne8-d6.

21 ... f7-f6
22 Ne5-f3 Ne8-d6

23 c5-c6
I expected this, of course, and thought I had a way out.

23 ... Ra8-a4

24 Qd4-g4?

This was the other weak move, though it turned out to be good in the long term. However, I thought I had won material with my next move.

24 ... Nd6-b7!
Yes?

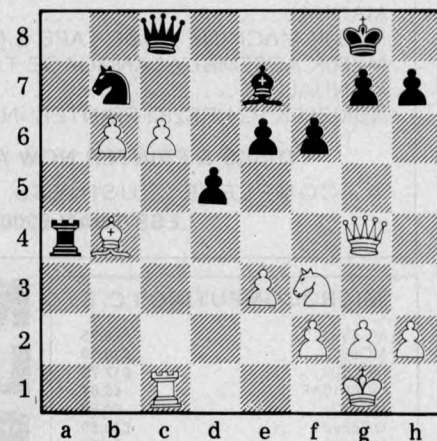

25 Nf3-e1!

No! Very good indeed. *The idea is that if 25 ... Be 7xb5 then 26 c6xb7! Qc8xb7 27 Qg4xe6+ and 28 Rc1-c8+.*

25 ... Nb7-a5

26 b6-b7!

Chess Champion Mark V now knows it can win material — at least a piece. In fact, it is impossible to avoid complete defeat now, so I resigned.

26 ... 1-0

Do you think that game is impressive? I do. The programmer's chess rating is about 1700 on the international scale, which means that he is in the select one percent or so of chess players who are (or were!) stronger than the best of the chess micros. It will certainly be interesting to see what happens in the Asian Cities Team Championship and I will keep you posted.

Writing for PCW

PCW welcomes approaches from would-be writers, even those who may never have appeared in print before. In this game it is often those with practical experience who have important things to say so we don't mind too much if their prose is less than perfect. Providing that submissions have a sensible structure and follow a logical sequence, we can take care of the polishing. Here are some tips:

If the article is already written, simply send it in, making sure that your name, address and 'phone number appear on both the article and the covering letter. If you have submitted the same work to other magazines you

should tell us — it would be embarrassing (to say the least) if the same article appeared in more than one.

If you have an idea for an article or a series, write us a letter outlining your ideas. A one or two page synopsis giving the proposed structure, sequence and content will give us a sound basis for discussion. Please give us a 'phone number if possible.

If you have nothing specific in mind but feel qualified to conduct case studies, benchtests or whatever then drop us a line saying what you'd like to do and why you think you're qualified to do it. We're not particularly looking for strings of academic qualifications —

experience carries just as much weight.

Dick Pountain is always on the lookout for interesting calculator features and we wouldn't mind seeing one or two readers getting on their soapboxes but remember: even articles such as this need a structure.

Reading PCW will give you a good idea of the style we prefer. You may notice that we try to avoid pomposity at one extreme and flippancy at the other (except in 'Chip Chat', that is).

Finally, have a look through back issue indexes and try not to re-invent any wheels. Oh, we almost forgot — PCW does pay for all published work.

NewBear

Computing Store Ltd

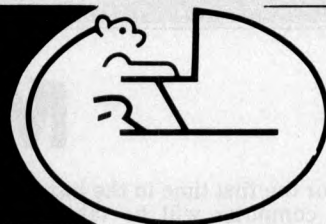

MZ-80K

NBMZ80K MONITOR LISTING	£15.00
NBMZ80K BASIC LISTING	£30.00
NBMZ80K ZEN EDITOR/ASSEMBLER TAPE & MANUAL	£19.50
MZ80K MACHINE CODE TAPE & MANUAL ...	£22.50
MZ80K ASSEMBLY LANGUAGE TAPE & MANUAL	£45.00
NBMZ80K V24/RS232 PRINTER INTERFACE ..	£49.50

DISKS & PRINTER NOW AVAILABLE

A COMPLETE BUSINESS SYSTEM FOR
LESS THAN £2000.

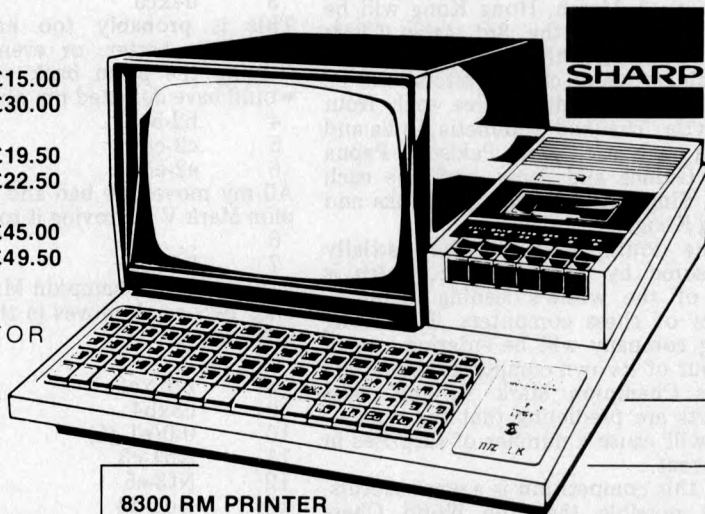

SHARP

MICROCOMPUTING I.C.'S

MC6800	£6.75
MC6802	£10.50
MC6809	£17.75
MC6810AP	£3.61
MC6821	£4.63
MC6840	£10.50
MC6850	£4.99
MC6852	£4.75
MC8062P	2.88
MC14536P	£2.50
MC3459	£2.43
Z8001	£142.50
Z80 CPU 2.5 Mhz	£8.99
Z80 CTC 2.5 Mhz	£7.99
Z80 P10 2.5 Mhz	£7.99
Z80 S10	£25.57
Z80A CPU 4 Mhz	£10.50
Z80A P10 4 Mhz	£10.00
Z80A CTC 4 Mhz	£10.00
SC/MP 11 (INS8060N)	£11.30
INS8154N	£8.18
6502	£8.99
6522 VIA	£8.14
6532	£9.75
6545 CRT CONTROLLER	£18.50
6551 ACIA	£9.99
8080A	£5.50
8224	£2.95
8228	£3.00
DM 8835N	£1.35
8212	£2.25
8216	£2.50

NEW LOW PRICES!



NORTH STAR ★ HORIZON

8300 RM PRINTER

80/132 CH PER LINE (SWITCHABLE); 125 C.P.S.: 2K BUFFER; V24 RS 232/ CURRENT LOOP INTERFACE; SPEED SWITCHABLE BETWEEN 110.9600 BAUD; VARIABLE WIDTH CHAR AVAILABLE UNDER SOFTWARE CONTROL; SPROCKET FEED; 4 x 9 DOT MATRIC; PAPER WIDTH 4.5" TO 9.5"

PRICE £499.00

SPECTRONICS U.V. EPROM — ERASING LAMPS

PE 14	ERASES UP TO 6 CHIPS, TAKES APPROX. 19 MINS.	£45.00
PE 14T	ERASES UP TO 6 CHIPS, TAKES APPROX. 19 MINS.	£59.95
PE 24T	ERASES UP TO 9 CHIPS, TAKES APPROX. 15 MINS.	£87.00
PR 12ST	ERASES UP TO 16 CHIPS, TAKES APPROX. 7 MINS.	£186.24
PR 320T	ERASES UP TO 36 CHIPS, TAKES APPROX. 7 MINS.	£302.00

U.V. EPROM ERASING CABINET

PC 1100	ERASES UP TO 72 CHIPS, TAKES APPROX. 7 MINS.	£693.00
PC 2200	ERASES UP TO 144 CHIPS, TAKES APPROX. 7 MINS.	£1142.00
PC 3300	ERASES UP TO 216 CHIPS, TAKES APPROX. 7 MINS.	£1595.00
PC 4400	ERASES UP TO 288 CHIPS, TAKES APPROX. 7 MINS.	£2047.00

SPECTACULAR

19th — 30th JANUARY
MINI BARGAINS & SPECIAL
OFFERS AT ALL BRANCHES

JANUARY SALE

Send for details of New Sharp add ons.

NewBear

for the widest selection of computing books

NEW BOOK LIST

MEMORIES

4116 (16K DYNAMIC)	£4.50
2716 (INTEL + 5V TYPE) - . . .	£12.50
2708	£4.50

NEWBEAR COMPUTING STORE LTD. (HEAD OFFICE) 40 BARTHOLOMEW STREET, NEWBURY, BERKS
TELEX 848507 NCS (MAIL ORDER) TEL. (0635) 30505
FIRST FLOOR OFFICES, TIVOLI CENTRE, COVENTRY ROAD, BIRMINGHAM. TEL. 021 707 7170
220-222 STOCKPORT ROAD, CHEADLE HEATH, STOCKPORT. TEL. 061-4912290

PLEASE ADD V.A.T. TO ALL PRICES.

GET A SHARP DEAL
FROM NEWBEAR
SEND FOR OUR
FREE CATALOGUE

NEWCOMERS-START HERE

This is our unique quick-reference guide, reprinted every month to help our readers pick their way through the most important pieces of (necessary) jargon found in PCW. While it's in no way totally comprehensive, we trust you'll find it a useful introduction. Happy microcomputing!

Welcome to the confusing world of the microcomputer. First of all, don't be fooled; there's nothing complicated about this business, it's just that we're surrounded by an immense amount of necessary jargon. Imagine if we had to continually say 'numbering system with a radix of 16 in which the letters A to F represent the values ten to 15' when instead we can simply say 'hex'. No doubt soon many of the words and phrases we are about to explain will eventually fall into common English usage. Until that time, *PCW* will be publishing this guide — every month.

We'll start by considering a microcomputer's functions and then examine the physical components necessary to implement these functions.

The microcomputer is capable of receiving information, processing it, storing the results or sending them somewhere else. All this information is called *data* and it comprises numbers, letters and special symbols which can be read by humans.

Although the data are (yes, it's plural) accepted and output by the computer in 'human' form, inside it's a different story — they must be held in the form of an electronic code. This code is called *binary* — a system of numbering which uses only 0s and 1s. Thus in most micros each character, number or symbol is represented by eight binary digits or *bits* as they are called, ranging from 00000000 to 11111111.

To simplify communication between computers, several standard coding systems exist, the most common being *ASCII* (American Standard Code for Information Interchange). As an example of this standard, the number five is represented as 00110101 — complicated for humans, but easy for the computer! This collection of eight bits is called a *byte* and computer freaks who spend a lot of time messing around with bits and bytes use a half-way human representation called *hex*. The hex equivalent of a byte is obtained by giving each half a single character code (0-9, A-F): 0=0000, 1=0001, 2=0010, 3=0011, 4=0100, 5=0101, E=1110 and F=1111. Our example of 5 is therefore 35 in hex. This makes it easier for humans to handle complicated collections of 0s and 1s. The machine detects these 0s and 1s by recognising different voltage levels.

The computer processes data by reshuffling, performing arithmetic on, or by

comparing them with other data. It's the latter function that gives a computer its apparent 'intelligence' — the ability to make decisions and to act upon them. It has to be given a set of rules in order to do this and, once again, these rules are stored in *memory* as bytes. The rules are called *programs* and while they can be input in binary or hex (*machine code* programming), the usual method is to have a special program which translates English or near-English into machine code. This speeds programming considerably; the nearer the *programming language* is to English, the faster the programming time. On the other hand, program execution speed tends to be slower.

The most common microcomputer language is *Basic*. Program instructions are typed in at the keyboard, to be coded and stored in the computer's memory. To run such a program the computer uses an *interpreter* which picks up each English-type *instruction*, translates it into machine code and then feeds it into the *processor* for execution. It has to do this each time the same instruction has to be executed.

Two strange words you will hear in connection with *Basic* are *PEEK* and *POKE*. They give the programmer access to the memory of the machine. It's possible to read (*PEEK*) the contents of a byte in the computer and to modify a byte (*POKE*).

Moving on to *hardware*, this means the physical components of a computer system as opposed to *software* — the programs needed to make the system work.

At the heart of a microcomputer system is the central processing unit (*CPU*), a single microprocessor chip with supporting devices such as *buffers*, which 'amplify' the CPU's signals for use by other components in the system. The packaged chips are either soldered directly to a printed circuit board (*PCB*) or are mounted in sockets.

In some microcomputers, the entire system is mounted on a single, large, PCB; in others a *bus system* is used, comprising a long PCB holding a number of interconnected sockets. Plugged into these are several smaller PCBs, each with a specific function — for instance, one card would hold the CPU and its support chips. The most widely-used bus system is called the *S100*.

The CPU needs memory in which to keep programs and data. Microcomputers generally have two types of

memory, *RAM* (Random Access Memory) and *ROM* (Read Only Memory). The CPU can read information stored in RAM — and also put information into RAM. Two types of RAM exist — *static* and *dynamic*; all you really need know is that dynamic RAM uses less power and is less expensive than static, but it requires additional, complex, circuitry to make it work. Both types of RAM lose their contents when power is switched off, whereas ROM retains its contents permanently. Not surprisingly, manufacturers often store interpreters and the like in ROM. The CPU can only read the ROM's contents and cannot alter them in any way. You can buy special ROMs called *PROMs* (Programmable ROMs) and *EPROMs* (Erasable PROMs) which can be programmed using a special device; EPROMs can be erased using ultra-violet light.

Because RAM loses its contents when power is switched off, *cassettes* and *floppy disks* are used to save programs and data for later use. Audio-type tape recorders are often used by converting data to a series of audio tones and recording them; later the computer can listen to these same tones and re-convert them into data. Various methods are used for this, so a cassette recorded by one make of computer won't necessarily work on another make. It takes a long time to record and play back information and it's difficult to locate one specific item among a whole mass of information on a cassette; therefore, to overcome these problems, floppy disks are used on more sophisticated systems.

A floppy disk is made of thin plastic, coated with a magnetic recording surface rather like that used on tape. The disk, in its protective envelope, is placed in a disk drive which rotates it and moves a *read/write head* across the disk's surface. The disk is divided into concentric rings called *tracks*, each of which is in turn subdivided into *sectors*. Using a program called a *disk operating system*, the computer keeps track of exactly where information is on the disk and it can get to any item of data by moving the head to the appropriate track and then waiting for the right sector to come round. Two methods are used to tell the computer where on a track each sector starts: *soft sectoring* where special signals are recorded on the surface and

hard sectoring where holes are punched through the disk around the central hole, one per sector.

Half-way between cassettes and disks is the *stringy floppy* — a miniature continuous loop tape cartridge, faster than a cassette but cheaper than a disk system. *Hard disk* systems are also available for microcomputers; they store more information than floppy disks, are more reliable and information can be transferred to and from them much more quickly.

You, the user, must be able to communicate with the computer and the generally accepted minimum for this is the visual display unit (*VDU*), which looks like a TV screen with a typewriter-style *keyboard*; sometimes these are built into the system, sometimes they're separate. If you want a written record (*hard copy*) of the computer's output, you'll need a *printer*.

The computer can send out and receive information in two forms — *parallel* and *serial*. Parallel input/output (*I/O*) requires a series of wires to connect the computer to another device, such as a printer, and it sends out data a byte at a time, with a separate wire carrying each bit. Serial I/O involves sending data one bit at a time along a single piece of wire, with extra bits added to tell the receiving device when a byte is about to start and when it has finished. The speed that data is transmitted is referred to as the *baud rate* and, very roughly, the baud rate divided by ten equals the number of bytes being sent per second.

To ensure that both receiver and transmitter link up without any electrical horrors, standards exist for serial interfaces; the most common is *RS232* (or *V24*) while, for parallel interfaces to printers, the *Centronics* standard is popular.

Finally, a *modem* connects a computer, via a serial interface, to the telephone system allowing two computers with modems to exchange information. A modem must be wired into the telephone system and you need British Telecom's permission; instead you could use an *acoustic coupler*, which has two obscene-looking rubber cups into which the handset fits, and which has no electrical connection with the phone system — British Telecom isn't so uppity about the use of these.

IN STORE

**DIRECT
ACCESS**

There are several interesting new entries this month, from the low-cost Atari, with its range of superb video games, to the up-market Onyx, a hard disk-based business system. Note that both of them use tape cartridges for removable memory. Other additions include the Sharp PC3200, the Tandberg TG 3450, and a new British machine, the Gemini 801. Icarus, main distributors of the Superbrain, have moved and their new phone number is 01-485 5574. Finally, C Itoh and Manhattan Skyline are, at time of press, completing arrangements for joint distribution of the SBS 8000. Send updates for 'In Store' to me, Dick Olney, at PCW, 14 Rathbone Place, London W1P 1 DE.

Machine (Price from)	Main Distributor/s (No. of Dealers)	Hardware	Software	Miscellaneous (Documentation)
ABC 80 (£738)	Datormark Ltd: 09322 44896	16-40k RAM; Z80A; C; 12", 16x40 b&w VDU; 4680 bus; IEEE 488; RS232 port.	DOS; Basic (16k ROM); <i>Fortran; Pascal; A; Multi user Basic.</i>	Colour video graphics with UHF output. Viewdata compatible. Loudspeaker. Numeric keypad. Options: dual 5 1/4" F/D (320k) £895; dual 8" F/D (2 Mb). BT 1/80. (I)
ACT System 800 (£3950)	ACT: 021-455 9898 (50)	48k RAM; 6502; dual 5 1/4" F/D (800k); 12", 30x64 VDU; 1 S/P; 1 P/P; Multi-screen int.	MDOS; Basic; A; <i>CBasic; PL/M; Forth; Fifth; Cesil; Pilot; Fortran.</i>	IBM compatible K/B. High resolution graphics. Available with dual 8" F/D (2.4 Mb) £4950 — 4.8 Mb maximum. BT 2/80 (E).
Alpha Micro (£5650)	Alpha Micro (UK) Ltd: 01-250 1616 (TBA)	64k — 1 Mb RAM; 16 bit; dual 8" F/D (2.4 Mb); 6 S/P.	Multi-user OS; Basic; M/A; Pascal; U.	Modular. Expands to 1200 Mb, 24 terminals or multiprocessor system. (E)
Altos ACS 8000 (£3398)	Logitek: 02572 66803 (33)	64k RAM; Z80; 1k EPROM; dual 8" F/D (1Mb); 2xRS232 ports; 1 P/P.	CP/M; <i>Basic; CBasic; Cobol; Pascal; Fortran.</i>	Expandable to 4-user system with 58Mb H/D. Maintenance contracts avail; BT 5/80 (S&H).
Apple II (£695)	Microsense: 0442 41191 (190)	16-48k RAM; 6502; 8 I/O slots.	O/S; <i>Basic; Pascal; Fortran.</i>	280x192 high resolution graphics; Integer Basic in 6k ROM; Option: single 5 1/4" F/D (116k) £349.
Atari 400 (£395-16k)	Ingersoll: 01-226 1200 (TBA)	8-16k RAM; 6502; C int; cartridge slot; 12 x 20 TV int; RS232C port; touchpad k/b; Opt: C £55.	OS (10k ROM); Basic (8k ROM).	High resolution colour graphics. 4-channel sound. Four games controller/light pen sockets. BT 10/80. (I/B)
Atari 800 (£695-16k)	As above.	8-48k RAM; 6502; C int; 4 x cartridge slots; 12 x 20 TV int; RS232C port. Opt: single 5 1/4" F/D (90k) £525; 16k RAM £145.	As above.	As above. Software & RAM on cartridge modules. Up to 4 disk drives. BT 10/80. (I/B)
Athena 8285 (£5694)	Butel-Comco Ltd: 0703 39890 (TBA)	64k RAM; 8085A; dual 5 1/4" F/D (644k); 12", 25x80 VDU; 150 cps printer; RS232 port.	AMOS; T/E; <i>Basic; Cobol; Fortran; Pascal; APL; M/A.</i>	Extended ASCII K/B with numeric pad; graphics. Options: dual 8" F/D (2Mb); up to 1200 Mb H/D
Atom (£120)	Acorn: 0223 312772 (N/A)	2-11k RAM; 6502; Full K/B; C int; TV int; 20 I/O lines; 1 P/P.	Basic in 8k ROM; A; Cass O/S.	High resolution graphics on bigger model; colour monitor O/P. Loudspeaker. Note also, systems based on Acorn SBC. BT 7/80 (B).
Attache System II (£8000)	Friargrove Systems Ltd: 01-572 3784 (10)	64k RAM; Z80; dual 8" F/D (1.2Mb); 12", 24x80 VDU; 180 cps printer.	Basic; <i>Fortran; Cobol.</i>	Upgradable to multiuser system with 34Mb H/D. Full range of business packages included software dealers TBA. (S)
BASF 7120 (£5155)	BASF: 01-388 4200 (TBA)	64k RAM; Z80A; 3 x 5 1/4" F/D (480k); 12", 24 x 80 VDU; RS232 port; P/P.	DOS; <i>Ex Basic; Cobol U.</i>	H/D available soon. Also 7110 with dual F/D £4275. Disk controller has own Z80A. BT 9/80. (I)
Billings BC-12 FD: (£3995)	Mitech: 04862 23131 (TBA)	64k RAM; Z80A; dual 5 1/4" F/D (640k); 12", 24x80 b&w (or b&g) VDU.	DOS; <i>Basic; Fortran; Cobol; A.</i>	With dual 8" F/D (2Mb) £5995. Additional dual 8" F/D £3000. (S)
C/09 (£3975)	SWTP Ltd: 01-491 7507 (16)	56k RAM; 6809; dual 8" F/D (2Mb); 8", 16x80 VDU; 1 S/P.	TSC FLEX; <i>Basic; Pascal; A; Dis A; T/E; U.</i>	VDU is intelligent. Option: 15Mb H/D £3575; with dual 5 1/4" F/D (350k) instead of 8", £3000. (H)
Canon BX-1 (£3850)	Canon Business Machines (UK) Ltd: 01-680 7700.	64k RAM; 6800; Single 5 1/4" F/D (65k); 12"; 25 x 80 VDU; 5 x V24 ports.	DOS; <i>Ex Basic; A.</i>	Also supplied with integral thermal printer instead of VDU. (S&H)
Challenger 1P & C4P (£220 & £395)	CTS: 0706 79332. Millbank Computing: 01-549 7262. Mutek: 0225 743289. U-Microcomputers: 0925 54117 (18)	4-32k RAM; 6502; C int; RS232 port. Options: dual 5 1/4" F/D (160k) £550; for C4P dual 8" F/D (1.15Mb) and 20MB H/D.	O/S; <i>Basic (8k ROM) Ex Basic; A.</i>	D/A conv; colour capability. Runs OSI business software on 8" F/D Plato educational software avail. soon. BT 4/80. (S)
Challenger 2 (£1500)	As above	48k RAM; 6502; dual 8" F/D (0.5Mb); RS232 port.	OS65U; <i>Ex Basic; A.</i>	Designed as low cost business system (S).
Challenger C3 (£2334)	As above	32-56k RAM; 6502; 6800; Z80; dual 8" F/D (1.15Mb); 2-16 S/P.	OS65U; <i>Basic; CP/M; Fortran; Cobol.</i>	Expandable to multi-user (8) system. Options: C3B & C3C H/D units. 74Mb for about £8500. (S&H).
Clenlo Conqueror System B (£1950)	Clenlo Computing Systems Ltd: 01-670 4202 (TBA)	64k RAM; Z80; dual 8" F/D (1Mb); 3 S/P; 2 P/P.	CP/M; <i>CBasic-2; Pearl 1; U.</i>	With four 8" F/D £2850. (S&H)
Clenlo Conqueror System D (£5150)	As above	64k RAM; single 8" F/D (500k); 10Mb H/D; 3 S/P; 2 P/P.	CP/M; <i>CBasic-2; Pearl 11; U.</i>	With 26Mb H/D and no F/D £5950.

List of Abbreviations

A Assembler	F/D Floppy disk	M/A Macro assembler	S/P Serial port
BT Bench Tested	G/C Graphics card	N/A Not available	T/E Text editor
C Cassette	H Hardware	N/P Numeric pad	TBA To be announced
E Extensive	H/D Hard disk	O/S Operating system	U Utility
	I Introductory	P/P Parallel port	
	Int Interface	S Software	

Please note: Software items listed in *italics* are not included in the basic price of the equipment. All prices are *exclusive* of VAT.

DIRECT ACCESS

IN STORE

Machine (Price from)	Main Distributor/s (No. of Dealers)	Hardware	Software	Miscellaneous (Documentation)
Compucolor II (£995)	Dyad Developments: 08446 729 (TBA)	8-32k RAM; 8080; 13" 32x64 8-colour VDU; single 5 1/4" F/D (51k); RS232 port.	DOS (ROM); Ex-Basic (ROM); A.	16k version £1078, 32k £1198. High resolution graphics. 6-month subscription to user magazine inclusive BT 9/79. (S)
Compucorp 625 (£6000)	Compucorp: 01-952 7860 (17)	48-60k RAM; Z80; dual 5 1/4" F/D (630k); 9", 16x80 VDU; 40 col printer; RS232 port, P/P.	Basic; A; <i>Fortran</i> ; <i>Pascal</i> ; U.	IEEE-488 Controller and S100 int. Many applications packages avail. (E)
Compucorp 655/665/675 (from £5895)	As above	60k RAM; Z80; Up to 4 x 5 1/4" F/D (160k-2.4Mb); 9", 20 x 80 or 12", 20 x 80 or 20", 60 x 80 VDU; 40-col printer; RS232 port.	As above	Prices incl installation and training. Opt: 10-20Mb H/D
Computermart 2000 DS (£1500)	Computermart: 0603 615089	32-256k RAM; 8085; dual 8" F/D (1-2Mb); S/P; P/P.	CP/M; <i>Cis Cobol</i> ; <i>Basic</i> ; <i>Fortran</i> .	Expandable to multi-user, multi-tasking, multi-processor 96Mb H/D system (around £15000).
Cromemco System 2, System 3, System Z2H. (£2100/£3730/£5340)	Datron: 0742 585490. Comart: 0480 215005. MicroCentre: 031 556 7354 (18)	64k RAM; Z80; dual 5 1/4" F/D (346k) on System 2 & Z2H; dual 8" F/D (1.2Mb) on Sys 3; 10Mb H/D on Z2H; S/P; P/P.	CDOS; <i>Basic</i> ; <i>Cobol</i> ; <i>Fortran</i> ; <i>RPG II</i> ; <i>Lisp</i> ; A; <i>W/P</i> ; <i>Multi-user Basic</i> .	All systems expandable to multi-user (max 7) £6408 Sys 2, £8304 Sys 3. Options: dual 8" F/D (996k); 11-22Mb H/D. BT 10/79 (E).
DAI (£998-48k)	Data Applications (UK): 0285 2588 (TBA)	12-48k RAM; 8080; C int; 24x 60 VDU int; RS232 port; over 20 industrial ints.	Basic (ROM); U.	Colour graphics up to 255x 335; 3 notes & noise generator; PAL O/P to TV; Paddle int; H maths option. (I). BT 10/80
Diablo 3000 (£8950)	Business Computers Ltd: 01-207 3344 (TBA)	32k RAM; 8085; dual 8" F/D (1.2Mb); 12", 24x80 b&w VDU; 45cps printer.	DOS; <i>Basic</i> ; <i>DACL</i> ; A; U.	Selection of business packages included (S).
Digital Micro-systems DSC-2 (£3525)	Modata: 0892 41555 (10)	64k RAM; Z80; dual 8" F/D (1.14Mb); 4xRS232 ports; EIA port.	CP/M; <i>Basic-E</i> ; <i>CBasic</i> ; <i>Cobol</i> ; <i>Fortran</i> ; <i>Pascal</i> .	14 or 28Mb H/D available or additional F/D units (H).
Digital Micro-systems DSC-4 (£6045)	As above	128k RAM; Z80A; single 8" F/D (500k); 11Mb H/D; 4x RS232 ports; 2 P/P.	CP/M; <i>Basic-E</i> ; <i>CBasic</i> ; <i>Cobol</i> ; <i>Fortran</i> ; <i>Pascal</i> .	Also DSC-3 with 64k RAM. Options: 128k RAM £1295; up to 4Mb F/D and 29Mb H/D. (H).
Durango F-85 (£7500)	Comp Ancillaries: 0784 36455 (12)	64k RAM; 8085; dual 5 1/4" F/D (1Mb); 9", 16x64 green VDU; 132 col 165 cps printer; N/P.	O/S; <i>DBasic</i> ; <i>CP/M</i> ; <i>CBasic</i> ; <i>Micro Cobol</i> .	Up to 5 work stations; fully integrated system. Options: additional dual 5 1/4" F/D (1Mb); 12-24Mb H/D. (S).
Dynabyte 5200-5900 £2300	Metrotech 0895-57780 (15)	64k RAM; Z80; S100 bus; 2 ser ports; 1 par port; any com of 5 1/4" F/D (1.2Mb) 9/27/45 Mb H/D, 32/64/96Mb Cart Module Disk.	CP/Net, <i>CBasic</i> , <i>MBasic</i> <i>Cobol</i> , <i>Fortran</i> , <i>Pascal</i> , <i>PL/1-80</i> .	All systems expandable to Multi-user and networking; CP/M inc in base price for F/D systems, MP/M for H/D systems.
Equinox 200 (£7500)	Equinox: 01-739 2387 (N/A)	64-512k RAM; Z80; 10Mb-1200Mb H/D; 6 x S/P; 1 P/P.	CP/M; <i>CBasic</i> ; <i>Cobol</i> ; <i>Fortran</i> .	Multi-user MVT/FAMOS available in place of CP/M. 16-bit version (Equinox 300) £10,000. (S&H).
Euroc (£7995)	Euroc: 01-729 4555 (TBA)	64k RAM; 8080A; dual 8" F/D (1Mb); 15", 25x80 b&w VDU; 132 col 140 cps printer.	CP/M; <i>CBasic</i> ; A; U.	Financial software available. Supply of stationary included.
Executive Mini-computer (£378)	Binatone Int: 01-903 5211 (N/A)	16k RAM; Z80; 500 bps C; 32x64 TV int; extra C int; 1 P/P.	Basic (12k ROM); <i>M/A</i> ; <i>Fortran</i> .	Graphics avail. F/D under development. Also 4k version called 'Oxford minicomputer'.
Exidy Sorcerer (£749)	Liveport Data Products: 0736 798157 (27)	16-48k RAM; Z80; RS232 port; 1 P/P; S100 connector; 30x64 VDU int.	O/S: <i>Basic (ROM)</i> ; <i>T/E</i> ; A; <i>CP/M</i> ; <i>Algol</i> ; <i>Fortran</i> ; <i>Basic</i> ; 80.	High resolution graphics capability; user programmable character set. 32k version £799; 48k £849. Option: single 5 1/4" F/D (315k) £600.
Gemini 801 (£1075)	Gemini: 02403 22307 (7).	64k RAM; Z80A; Single 5 1/4" F/D (315k); 25 x 80 VDU int; RS232 port. P/P.	CP/M; <i>Basic</i> ; <i>Cobol</i> ; <i>Fortran</i> ; <i>Pascal</i> ; A; <i>T/E</i> .	Up to two integral & two external F/D. Graphics. With no F/D and C int, £750. (S)
Haywood 3000 (£2022)	Haywood: 65 28301. (TBA)	48k RAM; Z80A; dual 5 1/4" F/D (800k); RS232 port; P/P. Opt: 15", 28 x 80 VDU £799.	CP/M; <i>Basic</i> ; <i>Cobol</i> ; <i>Fortran</i> ; <i>Pascal</i> ; <i>W/P</i> .	Also system 7000 with 48-65k RAM and 8" F/D (2.5Mb) £2999. (S)
HP 85 (£1830)	Hewlett Packard Ltd: 0734 784774 (16)	16-32k RAM; C.P.U.; 5", 16x32 VDU; C (200k); 64 cps printer; 4 P/P. Options: dual 5 1/4" F/D (540k) £1408; dual 8" F/D (2.4Mb) £3744.	Basic (ROM)	Full dot matrix graphics. Complete range of interfaces, peripherals and application packages avail. 16k RAM £222. (S).
IMS 5000 (£1500)	Equinox: 01-739 2387 (20)	16-56k RAM; Z80; dual 5 1/4" F/D (320k); 2 x S/P; 1 P/P.	CP/M; <i>CBasic</i> ; <i>Cobol</i> ; <i>Fortran</i> .	3 drives option: (S&H).
IMS 8000 (£2500)	As above	64-256k RAM; Z80; dual 8" F/D (1Mb); 2 x S/P; 1 P/P	CP/M; <i>CBasic</i> ; <i>Cobol</i> ; <i>Fortran</i> ; <i>MicroCobol</i> .	Multi-user MVT/FAMOS available in place of CP/M. (S&H).
ITT 2020 (£867)	ITT: 0268 3040 (15)	16-48k RAM; 6502	Monitor; A; ExBasic; Dis A.	360x192 high res graphics. Ex-Basic in 6k ROM: Options - single 5 1/4" F/D (116k), £425; 16k RAM, £110; RS232 port, £96; 32k system, £931; 48k system. £995. (B).
Ithaca DPS1 (£3995)	Ithaca: 01-341 2447 (10).	64k RAM; Z80; dual 8" F/D (1Mb); 2 x RS232 ports; 4 x P/P. Opt: H/D.	CP/M; <i>Basic</i> ; <i>Cobol</i> ; <i>Fortran</i> ; <i>Pascal</i> ; A; U.	Z8000 16-bit processor board avail. soon. IEEE/S100 (8 or 16 bit) compatible. (E)
LX-500 (£3500)	Logabax Ltd: 01-965 0061 (13)	32k RAM; Z80; dual 5 1/4" F/D (180k); 12" 25x80 b&w VDU; 100cps printer.	DOS; <i>Basic</i> ; A.	Other printers available. (S).

List of Abbreviations	F/D Floppy disk	M/A Macro assembler	S/P Serial port
A Assembler	G/C Graphics card	N/A Not available	T/E Text editor
BT Benchtested	H Hardware	N/P Numeric pad	TBA To be announced
C Cassette	H/D Hard disk	O/S Operating system	U Utility
E Extensive	I Introductory	P/P Parallel port	
	Int Interface	S Software	

Please note: Software items listed in *italics* are not included in the basic price of the equipment. All prices are *exclusive* of VAT.

IN STORE

DIRECT
ACCESS

Machine (Price from)	Main Distributor/s (No. of Dealers)	Hardware	Software	Miscellaneous (Documentation)
LSI M-One (£5995)	LSI Computers 04862 23411 (20)	8k RAM; 8080; dual 8" F/D (1.2Mb); 12", 24x80 b&w VDU.	FMOS; A.	Choice of standard business packages included in price. (S).
LSI M-One Model 5. (£9900)	As above	16k RAM; 8080; dual 8" F/D (2.4Mb); 2x12", 24x80 VDUs; 120 cps bidirectional printer.	FMOS; A.	One VDU is for inquiry only. (S).
Macro 1 & 2 (£3750 or £280 pm).	Micro APL Ltd. 01-834 2687 (TBA)	64k RAM; Z80; dual 8" F/D (1 Mb); 4xRS232 ports.	CP/M; APL; U; <i>Basic; Fortran; Cobol; Wordstar</i> Algol; Pascal; Forth.	Designed as timesharing replacement. (S).
Megamicro (£6080)	Bytronix: 0252 726814 (5)	56k RAM; Z80; dual 8" F/D (500k); 12", 20x80 green VDU; 180 cps printer; 2 S/P; 2 P/P.	CP/M; U; <i>Basic; A; M/A.</i>	Range of bus. packages now avail. from Ludhouse of Streatham. (H&B).
Micro Trainer 1 (£650)	Hewart: 0625 22030 (N/A).	16-32k RAM; 6800/6809; 10" 16 x 64 VDU; 2 x C int; Opt: dual 5 1/4" F/D (160k) £595; 8k RAM £17.	Basic; A; <i>Pascal; PL/M; W/P.</i>	SS50-based system. Graphics avail. Int card with real time clock £17. (I)
Mikro 1000 (£3950)	Airamec: 0294 57755 (TBA)	64k RAM; Z80; dual 8" F/D (1Mb); 12", 24x80 VDU; S100; RS232; 1 P/P.	CP/M; Basic; Cobol; Fortran.	Also word processor with 44 special function keys & NEC Spinwriter printer £4450. (S&H)
Microstar 45 Plus (£4800)	Data Efficiency Ltd: 0442 63561 (30)	64k RAM; 8085; dual 8" F/D (1.2Mb); 3 S/P; RS232 port.	Stardos; CP/M; Basic; Cobol; Fortran.	(E).
Microtan 65 (£69)	Tangerine: 0353 3633 (6)	1k RAM; 6502; TV-int; Exp up to 277k RAM.	1k TANBUG monitor; 2k A; disassembler, cassette firmware; 10k <i>Microsoft ExBasic.</i>	Options: bulk I/O modules, hi-def colour graphics, DOS, system racking, ASCII keyboard. (S&H)
Millbank Sys 10 (£2995)	Millbank: 01-788 1083 (6).	65k RAM; Z80; dual 5 1/4" F/D (700k); 12", 24 x 80 VDU; 2 x RS232 ports; RS449 port; P/P.	CP/M; <i>Basic; Cobol; Fortran; Pascal; PL1; W/P.</i>	One high level lang. included. 12-month warranty. Main-frame comm. package. H/D avail. soon. (S&H)
MS5001 (£8250)	BMG Ltd: 0793 37813 (N/A)	64k RAM; 8085; dual 8" F/D (1Mb); 12", 80x24 VDU; 160 cps printer; RS232.	CP/M; <i>Basic; Cobol; Fortran; MP/M.</i>	Price includes desk mounting and one computer. Hardware & software support. Leasing arrangements available. (E)
MSI 6816 (£1200)	Strumec: 05433 4321 (5)	16-56k RAM; 6800; 9" 16x64 b&w VDU; C int; 1 S/P; 1 P/P.	Basic; A.	Graphics & PROM programmer available. (S&H).
MSI System 7 (£3500)	As above	56k RAM; 6800; dual 5 1/4" F/D (160k); 9", 16x64 VDU; 1 S/P; 1 P/P.	FDOS; Basic; A; U.	As above. Multi-user O/S avail. Options: 10Mb H/D.
MSI System 12 (£8000)	As above	56-184k RAM; 6800; 10Mb H/D; 9", 16x24 VDU; 1 S/P; 1 P/P.	SDOS; Basic; CBasic; U.	As above. Business packages avail. (H & S).
Nanocomputer NBZ80S (£420)	Midwich: 0284 701321	4k RAM; 2k ROM; Z80; C int; 8 digit LED; Calc K/B; RS232 port; 2 P/P.	Machine language; <i>Basic; A; T/E.</i>	Designed for hardware education. Full training manuals included. Fully expandable. (E).
Newbrain MB £219	Newbury Labs. 021-707 7170, Newbear. 0635 30505 (N/A)	2-4k RAM; Z80A; Nat 420; 14x 16 VDU; 2x C int; TV int; V24 port. Option: C (50k) £60.	C Basic (16k ROM)	Graphics. Battery or mains. Mains only with 16k RAM £269. (low power battery version £299). (I).
North Star Horizon (£2230)	Comart: (7) 0480 215005. Comma: 0277 811131. Equinox: 01-739 2387 (20)	48-56k RAM; Z80A; dual 5 1/4" F/D (360k); 15", 24x80 VDU; 150cps printer; 2 S/P; 1 P/P.	DOS; Basic; CP/M; <i>Cobol; Fortran; Pascal.</i>	With 32k and single F/D £1495. Options: 18Mb H/D.
Onyx C8000 (£6850)	Onyx Dist Ltd: 0734 664345 (TBA)	64k RAM; Z80; 12Mb Cartridge; 10Mb H/D; RS232 port; P/P.	CP/M; <i>Basic; Cobol; Fortran; Pascal; W/P.</i>	C8001 with 128k RAM £8220. Multi-user version avail. using Oasis. (E)
Panasonic JD 800U, JD 840U (£4275, £4950)	Panasonic Business Equipment: 01-262 3121 (10 regional dist)	56k RAM; 8085A; 2-4k PROM; dual 8" F/D, JD800 U (500k), JD840U (2Mb); 12", 24x80 green VDU; 3xRS232 ports.	CP/M; Basic; <i>Micro-Cobol.</i>	Also available with 5 1/4" F/D; JD740U (570k) £4095. BT 3/80 (S).
Pascal Microengine (£2295)	Pronto Electronic Systems Ltd: 01-554 6222	64k RAM; MCP 1600; 2x RS232 ports; 2 P/P.	Pascal.	CPU instruction set is P-code; no interpreter needed. Available with dual 8" F/D (2Mb) £3900.
Periflex 630/64 (from £1995)	Sintrom: 0734 85464 (5)	64k RAM; Z80; dual 5 1/4" F/D (630k); 2xRS232 ports; 1 P/P.	CP/M; <i>Basic; Fortran; Cobol; A.</i>	One-day installation training on site included in price. Option: dual 5 1/4" F/D (630k) £859; dual 8 1/4" F/D (1Mb) £1025. BT 6/80 (S&H).
Periflex 1024/64 (from £2750)	As above	64k RAM; Z80; dual 8" F/D (1.2Mb); 2xRS232 ports; 1 P/P.	As above.	As above.
PET 8k, 16k, & 32k (£450, £550, £695)	Commodore: 01-388 5702 (150)	8-32k RAM; 6502; C; 9", 25x40 VDU; IEEE-488 port; Options: dual 5 1/4" F/D (353k) £695; same but (950k) £895.	O/S; Basic (in 8k ROM); <i>Forth; Pilot; Pascal.</i>	Disk controller for 8k version £30. New 8032 with 80-col screen (32k). BT 12/80. £895. (I).
Powerhouse 2 (£1125)	Powerhouse Micros: 0422 48422 (TBA)	32-64k RAM; Z80A; 5", 29x96 VDU; RS232 port; external bus.	4k Monitor; <i>FDOS; Basic; ExBasic (14k EPROM)</i>	VDU has flexible screen logic. Options: FDOS & Basic £210; graphics card £200. (H)
Powerhouse 3 (£2600)	As above	32-64k RAM; Z80A; dual 5 1/4" F/D (350k); 5", 29x96 VDU; RS232 port; external bus.	As above.	VDU as above. With 1.2Mb F/D £3500. ExBasic & FDOS in 14k EPOMs £300. (H)
Rair Black Box (£2250)	Rair: 01-836 4663 (N/A)	32-64k RAM; 8085; dual 5 1/4" F/D (260k); 2x RS232 ports.	CP/M; Basic; Cobol; Fortran; M/A.	16k RAM expansion £250 10Mb H/D £2500.

<p>List of Abbreviations</p> <p>A Assembler BT Benchtested C Cassette E Extensive</p>	<p>F/D Floppy disk G/C Graphics card H Hardware H/D Hard disk I Introductory Int Interface</p>	<p>M/A Macro assembler N/A Not available N/P Numeric pad O/S Operating system P/P Parallel port S Software</p>	<p>S/P Serial port T/E Text editor TBA To be announced U Utility</p>
---	--	--	--

Please note: Software items listed in *italics* are not included in the basic price of the equipment. All prices are *exclusive* of VAT.

Machine (Price from)	Main Distributor/s (No. of Dealers)	Hardware	Software	Miscellaneous (Documentation)
Research Machines 380Z (£1123)	Research Machines 0865 49791 (N/A)	16-56k RAM; Z80A; 2xC; RS232 port.	ExBasic; A; T/E; U; CP/M; Fortran; Cobol; Algol; Cesil.	Limited graphics. Many possible systems. With 48k RAM & dual 8" FD (1Mb) £3394.
S/09 (£5350)	SWTP Ltd: 01-491 7507 (16)	128k RAM; 6809; dual 8" F/D (2Mb); 8", 21x92 VDU; 2xS/P; 1 P/P.	TSC FLEX; Basic; Pascal; A; Dis A; T/E; U.	VDU is intelligent. Expands to 60Mb H/D multi-user system. Option: 15Mb H/D £3575. Maintenance contracts. (S&H)
SBS 8000 (£1449)	Manhattan Skyline Ltd: 08012 3442; C Itoh 01-353 6090 (TBA)	64k RAM; Z80A; 12", 16x64 VDU; 1 P/P; RS232 port (extra £133).	ExBasic (24k ROM); DOS.	Options: disk control card £237; dual 5 1/4" F/D (368k) £795; dual 8" F/D (2Mb) £1400. BT 11/80. (S)
SEED System 1 (£2000)	Strumech: 05433 4321 (4)	32-64k RAM; 6800; dual 5 1/4" F/D (160k); 9", 16x24 VDU; RS232 port.	DOS; Basic; U; Fortran; A; Pilot; Strubal; T/E.	Several F/D options. With 64k RAM & dual 8" F/D (1.2Mb) about £3000. (E).
Sharp MZ-80k (£480) (22)	Sharp electronics (UK) Ltd: 061-205 2333 (22)	6-34k RAM; Z80; C; 10", 24x40 VDU; Option: dual 5 1/4" F/D (280k) £780.	Basic (14k ROM); A.	Graphics; loudspeaker. 18k RAM version £529; 22k £549; 34k £599. BT 10/79 (B).
Sharp PC3200 (£2995)	As above	64k RAM; Z80A; dual 5 1/4" F/D (500k); C int; 12", 25 x 80 VDU; 70 lpm printer.	DOS; U; Basic.	CP/M may be avail. next year. Various expansion cards avail. (I&B)
Sinclair ZX80 (£100)	Science of Cambridge: 0223 311488 (N/A)	1-16k RAM; Z80A; C int; TV int; full K/B; 44-pin expansion port.	Basic (4k ROM).	Kit £80. Mains adaptor £9. (S).
Smoke Signal Chieftan (£1807)	Systems Implementation Ltd: 06924 5666 (TBA)	32-64k RAM; 6800/6809; dual 5 1/4" F/D (160k); 12", 24x80 VDU; RS232 port.	DOS; 68/FLEX; Basic; Fortran; Cobol; U.	With dual 8" F/D (2Mb) £2712. Designed as development system for industrial control. (H)
Solitaire WP & BS200 (£6750 & £8200)	Solitaire KPG: 01-995 3573 (TBA)	64k RAM; 8085; 14" VDU (with own CPU); 45 cps printer; CPU port; dual 5 1/4" F/D (700k); 8" F/D (1.02Mb) with BS200.	DOS; Basic.. dual	All solitaire systems are compatible; graphics on 11x13 dot matrix. (S).
Sord M100 (£795)	Midas Computer Services Ltd: 0903 814523 Exleigh Bus. Mach. 0736-66577. (8)	48k RAM; Z80; 8k ROM; 12", 24x64 green VDU; RS232 port; S100 bus; N/P.	O/S; Basic; A; Fortran; Pascal.	M100 ACE with single 5 1/4" F/D (143k) £1850. Up to 3 drives possible. Colour graphics avail. (I).
Sord M223 Mk II-VI (£3950)	As above	64k RAM; Z80; 8k ROM; single 5 1/4" F/D (350k); 12", 24x80 green VDU; RS232 ports; S100 bus; N/P.	O/S; ExBasic; CBasic; Multi-User Basic; Fortran; Pascal; Cobol.	Expandable to 4Mb F/D, 32Mb H/D, 5 screens, 2 printers, M243 with 192k RAM & dual 8" F/D £7000.
SPC/1 (£3770) (TBA)	Digital Data: 01-573 8854	64-1024k RAM; 8085A-2; dual 5 1/4" F/D (90k); 12", 24x80 VDU; 2xRS232 ports; Option: single 8" F/D (1Mb) £1090; 20Mb H/D £7000.	Mikados; Comal; Pascal; A.	With 32k RAM and single F/D (Comal only) £1995. Expandable to multi-user system (8 users). BT 7/80 (S).
Superbrain (£1995)	Icarus: 01-485 5574 (TBA)	64k RAM; 2xZ80; dual 5 1/4" F/D (320k); 12", 25x80 VDU; S100 bus; RS232 port.	CP/M; A; Basic; Cobol; Fortran; APL; Pascal.	Limited graphics. Mainframe int avail. Full range of application packages avail. Opt: dual 5 1/4" F/D (320k); dual 8" F/D (2.4Mb); 8-120Mb H/D. BT 8/80. (S&H).
System 80 (£1355-48k)	Nascom: 02405 75155 (32)	16-48k RAM; Z80A; dual 5 1/4" F/D (560k); TV int; RS232 port.	CP/M; Basic (8k ROM).	EPROM firmware avail. Colour graphics card £165. Many configurations possible. (S&H).
Tandberg EC10 (£4000)	Tandberg: 0532 774844 (N/A)	64k RAM; 8080A; single 8" F/D (250k); 12", 25x80 VDU; 7x RS232 ports; p/nter int.	CP/M; ExBasic (24k) Multi-user Basic; Pascal; Cobol; A; U;	Up to 7 terminals. Includes V28 comms port. (S & H).
Tandberg TG 3450 (£2200)	As above	64k RAM; 8085; single 5 1/4" F/D (77k); C int; 12", 24 x 80 VDU; RS232 port; P/P.	TDOS; Basic; Cobol; Fortran; Pascal.	TDOS is CP/M compatible. Opt: single 5 1/4" F/D (77k) £250 (up to four); dual 8" F/D (2Mb) £1800. (S&H)
Tandy TRS80 Level 1 (£335)	Tandy: 021 556 6101 (200)	4-16k RAM; Z80; C; 12", 16x64 VDU.	Basic (4k ROM); A.	Expandable to Level II. Many extras available. (I).
Tandy TRS80 Level II (£408)	As above	4-48k RAM; Z80; C; 12", 16x64 VDU; RS232 port; 1 P/P.	Basic (4k ROM); M/A; Fortran.	16k machine includes N/P. 4-16k upgrade £87. 48k system £620; Option: single 5 1/4" F/D (78k) £295, (subsequent £277, up to 4. BT 6/80 (I).
Tandy TRS80 Model 2 (£1999)	As above	32-64k RAM; Z80A; single 8" F/D (500k); 12", 24x80 VDU; 2 S/P; 1 P/P; N/P.	DOS; Basic.	64k version £2249. Expandable to four F/D drives, single drive expansion £799; three drive £1589.
TECS (£1200)	Technologies Computing Ltd: 061-793 5293 B&B Computers Ltd 0204 26644 (TBA)	4-56k RAM; 8k PROM; 6800/6809; 2xC; TV int; 2xRS232 ports; internal viewdata modem & printer port.	FLEX; Basic; Pascal; TDOS; A; T/E; Pilot; Fortran; Cobol.	Fully viewdata compatible. Options - dual 5 1/4" F/D (320k) £850; dual 8" F/D £120 £1200. (S&H).
Terodec DPS 64/1 (£3099)	Terodec (Micosystems) Ltd: 0734 664343 (8)	64k RAM; Z80; dual 8" F/D (1Mb); 12", 24x80 VDU; 2 S/P; 3 P/P. Options: dual 8" F/D (1Mb) £1150; with 2Mb £1455.	CP/M; Basic; Cobol; CBasic; Fortran; Algol; Pascal.	TMZ 80 enhanced model in integral workstation £5595 (with 4Mb F/D). DPS 64/2 with 2Mb F/D £3404. (S&H).
TI 99/4 (£750)	TI: 0234 67466 (TBA)	16k RAM; 26k ROM; 9900; 24x32 VDU; 2x C int; TV int; RS232 port.	OS; Basic.	Can run 16-colour TV screen. BT 5/80 (S).
Triton L8.2 (£611)	Transam: 01-405 5240 (N/A)	32k RAM; 8080; C int; 16x64 VDU int; 1 S/P; 1 P/P.	4k monitor; Pascal (20k ROM); CP/M; Pascal.	Graphics: 5 1/4" or 8" F/D are available; L7.2 with 2k monitor and Basic (no Pascal) £409. (S&H).

List of Abbreviations

A Assembler	F/D Floppy disk	M/A Macro assembler	S/P Serial port
BT Bench Tested	G/C Graphics card	N/A Not available	T/E Text editor
C Cassette	H Hardware	N/P Numeric pad	TBA To be announced
E Extensive	H/D Hard disk	O/S Operating system	U Utility
	I Introductory	P/P Parallel port	
	Int Interface	S Software	

Please note: Software items listed in *italics* are not included in the basic price of the equipment. All prices are *exclusive* of VAT.

IN STORE

DIRECT ACCESS

Machine (Price from)	Main Distributor/s (No. of Dealers)	Hardware	Software	Miscellaneous (Documentation)
UDS 3000 (£2300)	Kemitron: 0244 2187. (TBA)	64k RAM; Z80A; dual 8" F/D (500k); 2 x RS232 ports. Opt: with dual 8" F/D (2Mb) £2500.	CP/M; Basic; Cobol; Fortran; Pascal.	Full range of industrial support cards. Multi-user with H/D avail. soon. (E)
Vector MZ (£2595)	Almarc: 0602 62503 (3)	56k RAM; Z80A; dual 5 1/4" F/D (630k); 3 S/P; 2 P/P.	CP/M; Basic; Algol; Cobol; Pascal; Fortran; Coral; CBasic; A.	High resolution graphics. Also system B with video board & terminal £3195. (E).
Vector System 2800 (£4195)	As above	56k RAM; Z80A; dual 8" F/D (2.4Mb); 3 S/P; 2 P/P.	As above.	High-res graphics. Also System 3030 with 32Mb H/D and single 5 1/4" F/D £7500. (E)
Video Genie EG3003 (£330)	Lowe Electronics: 0629 2817 (N/A)	16k RAM; Z80; 500bps C; 32x64 TV int; extra C int; 1 P/P.	Basic (12k ROM); M/A; Fortran.	Graphics available.
WH8 (£352)	Heath 0452 29451 (N/A).	16-64k RAM; 8080A (or Z80); 4 S/P. Option: single 5 1/4" F/D (102k) £241.	OS; HDOS; CP/M; Fortran; Pascal; Basic	Kit. 3 drives max. Colour graphics avail. (S&H) BT 2/80.
Zentec (£4838)	Zygal Dynamics: 02405 75681 (TBA)	32-64k RAM; 2x8080; dual 5 1/4" F/D (256k); 15", 25x80 VDU; RS232 port.	O/S; A; U; Basic; Cis Cobol.	User programmable character set. Option: dual 8" F/D (1Mb). (S).
Zenith WH-11A (£2673)	Heath Ltd: 0452 29451 & 01-636 7349 (N/A)	LSI 11; 16-32k RAM; 25x80 VDU; S/P; P/P.	O/S; Basic; Fortran; A; U.	PDP 11-compat. Option: 2x8" F/D (1Mb). £1717 (S&H).
Zenith Z89 £1570-£1710	As above	16-48k RAM; Z80; single 5 1/4" F/D (102k); 12" 25x80 b&g VDU; RS232.	Basic; A; HDOS; CP/M; MBasic; CBasic; Fortran.	3 x 5 1/4" F/D possible. Options: dual 8" F/D (1Mb) £1717, 20Mb H/D.
Zilog MCZ 1/05 (portable): MCZ 1/20A (£3250)	Micropower: 0256 54121. Memec: 084421 5471 (N/A)	64k RAM; Z80; dual 8" F/D (600k); RS232 port; MCZ 1/20A only 1 P/P; Option: 10Mb H/D £7100	RIO; O/S; Cobol; Basic; Fortran; Pascal; M/A; U.	Available desk top or rack mounted. Debug in 3k PROM. 1/20A runs multi user Cobol, up to 5 terminals with 40Mb H/D. (S&H).
Z-Plus (£3950)	Rostronics Ltd: 01-874 1171 (16).	64k RAM; Z80; dual 8" F/D (1Mb); 4 S/P; 2 P/P.	CP/M; A; U; Basic; Cobol; Fortran; Pascal; APL; PL/1; Algol.	Available with 2Mb F/D. Option: 20Mb H/D £4000. BT 12/79 (S&H).

SINGLE BOARDS

Machine (Price from)	Main Distributor/s (No. of Dealers)	Hardware	Software/Firmware	Miscellaneous (Documentation)
Acorn System 1 (£65)	Acorn: 0223 312772 (10)	11/8k RAM; 6502; EPROM socket; Hex K/B; C int; 8-digit LED display; up to 16 ports. Options: Eurocard 64-way connector; VDU card; full K/B card.	1/4 monitor; Basic.	Kit. Programmable address linking. On-board 5 V regulator. Available assembled £79. Can be expanded to disk-based system. (S&H).
Aim 65C (£285)	Pelco: 0273 722155 (7)	1-4k RAM; 6502; 4-20k ROM; Full K/B; 2x C; 20 char LED; 20 char thermal printer; RS232 port.	A. Dis A; T/E; 8k monitor; Basic (8k ROM); PL65.	Power supplies and two types of case avail. Can be expanded to disk system. (E).
Biproc (£119)	B L Micros: 0494 443073. (TBA)	1k RAM; Z80; TV int; RS232 port. Opt: 4k RAM £8; K/B £30.	2k Monitor; A.	With 9980 instead of Z80 £155, as well as Z80 £180. Kit. (H)
Cromemco SC (£260)	Comart: 0480 215005 (17)	1k RAM; Z80A; 8k EPROM sockets; RS232 port; 3 P/P. Option: S100 bus.	Monitor; Basic.	5 program interval timers. Can put own Basic programs in EPROM. (E).
Elf II (£60)	Newtronics: 01-348 3325 (N/A)	1/4-64k RAM; RCA 1802; Hex K/B; 2-digit LED; TV int; C int; RS232. Options: Full K/B; VDU card.	1k monitor; A; Dis A; T/E; Elf-bug; Tiny Basic; Basic.	TTY, N-line decoders. Low resolution graphics (high res avail). Kits or built. (H).
Explorer (£82)	As above	4-64k RAM; 8085; Hex K/B; RS232 port; S100 bus; C int; 1k video RAM.	2k monitor; Basic; CP/M.	Supplied in kit or built. Full range of peripherals including F/D. (H).
Hewart 6800S (£299)	Hewart: 0625 22030 (N/A)	16k RAM; 6800; full K/B; VDU int; 2x C int; 1 S/P; 2 P/P; Option: 16k RAM £90.	1k monitor; A; T/E.	Can be upgraded with 6809. (H).
Hewart 6800 Mk III (£152)	As above	1k RAM; 6800; VDU board.	1k monitor.	Options: single 5 1/4" F/D (75k) £350; PROM programmer £32. (H).
Microtan 65 (£69)	Tangerine: 0353 3633 (6)	1k RAM; 6502; 16x32 TV int; Options: 64x64 Pixel graphics £6.50; 16k RAM £56.	1k monitor; Basic.	TANEX expansion kit with 7k RAM; 4k EPROM sockets; 10k Basic; 4 S/P; 32 P/P £145. (E).
Nascom 1 (£125)	Nascom: 02405 75155 (20)	4k RAM; Z80; Full K/B; TV int; 2 P/P; 1 S/P. Options: 16k RAM £140; single 5 1/4" F/D (250k) £240 (4 disk controller £127).	2k monitor; BBasic; Tiny Basic; A; T/E; U.	Kit. Built version £140. Also Nascom 2 with 8k Microsoft Basic in ROM £225 (no RAM). (S&H).
77/68 (£90)	Newbear: 0635 30505 (N/A)	4k RAM; 6800; LED; C int; VDU int.	1k monitor; Basic.	Expandable to 64k RAM with F/D. (B).
79/09 (£65)	As above	1k RAM; 6809; P/P; S/P.	2k Monitor.	Designed to upgrade 77/68. (H).
SBC 100 (£135)	Airamco: 0294 57755 (TBA)	1k RAM; Z80; 8k ROM; S100; 1 S/P; 1 P/P.	1k monitor; DOS in ROM.	Kit. Available assembled £196. (E).
Superboard (£188)	(as Challenger)	4-8k RAM; 6502; 10k ROM; full K/B; VDU int; C int.	Basic (8k ROM).	Options: RS232 port; single 5 1/4" F/D (100k) £316; 8k RAM £188. (S&H).

List of Abbreviations

F/D	Floppy disk	M/A	Macro assembler	S/P	Serial port
G/C	Graphics card	N/A	Not available	T/E	Text editor
H	Hardware	N/P	Numeric pad	TBA	To be announced
A	Assembler	O/S	Operating system	U	Utility
BT	Bench Tested	P/P	Parallel port		
C	Cassette	S	Software		
E	Extensive				
I	Introductory				
Int	Interface				

Please note: Software items listed in *italic* are not included in the basic price of the equipment. All prices are exclusive of VAT.

SINGLE BOARDS

Smoke Signal SCB 68 (£174)	Systems Implementation Ltd: 06924 5666 (TBA)	1k RAM; 6800/6809; 10-20k EPROM; 1 S/P.	2k monitor.	Many expansion boards available including F/D. (H)
SYM-1 (£160)	Newbear: 0635 30505 (N/A)	1-4k RAM; 6502; C int; VDU int; 2x6522 ports. Option: TV int.	4k monitor; Basic; A.	Expandable to 64k RAM with F/D. (B).
Triton L5.2 (£294)	Transam: 01-405 5240 (N/A).	1-3k RAM; 8080; 1k VDU RAM full K/B; 16x64 VDU or TV int; C int; 1 S/P.	1½k monitor; 2½k Basic.	64-char graphics. Disk int running CP/M about £200. (S&H).
Tuscan (£195)	As above	8k RAM; 8k ROM; Z80A; 5xS100 slots; RS232 port; TV int; C int; 1 P/P.	2k monitor; 8k Basic; CP/M; Pascal.	High res. graphics available. Can be expanded to F/D system. (S&H).
UK101 (£179)	Comp Shop: 01-441 2922 (4)	4k RAM; 6502; full K/B; 16x48 VDU or TV int; C int; RS232 port, Options: 4k RAM £29.	1k monitor; 8k Basic; Dis A; U.	Graphics. Will run Superboard software. New monitor EPROM with enhanced U £22. (S&H).
ZCB (£260)	Almarc: 0602 625035 (3)	1k RAM; Z80A; 3 PROM sockets; RS232 port; 3 P/P.	Will take any 2708/16/32 software.	S100 bus compatible. Expandable to full system. (E).

TRANSACTION FILE

The classified service that's free to non-commercial readers. Advertisements (50 words max) to: PCW Transaction File, 14 Rathbone Place, London W1P 1DE.

For sale

North Star . . . Horizon-based system, quad density, 48k, printer VDU, CAP-CP business s/ware (all ledgers & wage packages), unused, complete system £4,500 ono. Mr Kendrew, 461 Ongar Rd, Brentwood, Essex. Tel Coxtie Green 72386.

UK101 . . . 8k RAM, new monitor, 1 or 2 MHz switchable, RS232, data bus buffer, cased, boxed PSU, hour meter & s/ware, £300 or more. Tel Kez, Uxbridge 59309.

ZX80 . . . assembled with adaptor adaptor, all leads, Linsac ZX80 Companion, all s/ware, £80. Tel Mans (0623) 58553.

Video display card . . . (Thompson-CSF), cover to u/l case, + key board (George Risk), UHF mod, PSU. Just plug into TV for complete VDU with RS232 int. £85. Tel 01-790 0066 day, 01-431 0729 eve.

FullASCII . . . keyboard, brand new, common built in case with cable, connector & circuit diag, £65 ono. Tel 01-449 9035 (Barnet)

ZX80 . . . complete with leads, PSU & manual, virtually unused due to purchase of MZ-80K, £80 ono. Tel Dave Playfair, Rayleigh 743087.

PET 2001 . . . 8k, new ROM, central London, £370. Tel 01-834 8269 (eves), 01-213 4194 (day).

ZX80 . . . 3k RAM pack, £30 ono. Tel 0480 66038 eves.

TRS-80 L2 . . . 16k, green screen monitor, numeric keypad, £360 ono. Tandy Quick-Printer, £60 ono. Tel Worcester (0905) 51477.

UK101 . . . 8k RAM, cased, custom-built PSU, fully working, £230. Tel Mr Stobbs, Walsall 32511 day, 403353 eves.

ZX80 . . . Sinc built, PSU, leads, manual, as new, £70. Tel Ruislip 38204.

8k Basic . . . ROM for Nascom, £15. Tel Largs (0475) 674329.

Apple II . . . 16k, new and unused, manuals & maker's warranty, still in box, offers around £700. Tel Witcombe 3968.

Sharp PC1201 . . . prog calc, 128 steps, fully merged (same as fx501p), inc instr manual, app/ prog manual, recharger with rechargeable ails, 3 months new, £35. Tel 01-591 1478.

ZX80 . . . Sinc built, inc adaptor & leads, etc, £90 ono, or swap for Nascom 1, PSU & doc, cabs adjustment if nec. Tel Luton 595713.

MK14 . . . Issue 5, RAM/IO, extra opt RAM, SOC revised monitor, cass int, PSU, Manual, SC/MP Programming (Kimitron), extra doc, £45. VDU, £25. Tel 0642 316096 after 6.

HP41C . . . new, unwanted, DD390 Teletype, paper tape punch/reader, also Kim 1 with tape, PSU. Offers or swaps, tel Ware 870507, eves.

PET 8k . . . small keyboard, fitted Toolkit, Superchip, perspex green screen, soundbox, lots of s/ware, £350 ono. Tel 01-866 3326.

UK101 . . . 8k RAM, 8k ROM, cased, with all leads, ready to go, £270. Also Compshop's new monitor (ROM chip), £20, and some s/ware — will fit EPROM if req. Tel 01-363 5961 after 6.

Ohio Superboard II . . . only 4 months old, cased with 3 amp PSU, 3k RAM, little used, some games & s/ware tapes, £200 ono. Tel Clive Goodsell, Richmansworth 75617 after 7.

ZX80 . . . Sinc tested, new cond, all leads, PSU, manual & extra progs on cassette. The wife says it goes or she does! £67.50 inc postage. Tel Graham, Par 4515, Cornwall.

HP41C . . . with additional mem module, all standard manuals, case etc, £170 ono. Tel Peter Jost, 01-493 1235 ext 3767, office hours.

Olivetti TE300 . . . printer terminal, 110 baud, RS232 serial int, paper tape punch, tape reader (latter needs attention), stand, cables, some paper, manual, £225 ono. Tel Watford 34560 eves.

TI59/PC110C . . . as new, with blank mag cards, printer paper, full doc, all in perfect cond, offers around £210. Tel 01-736 3596 eves.

MZ-80K . . . 48k RAM, only 3 weeks old, inc 2 Basics on tape, manual, over 60 progs, hardly used, full warranty, £520 ono. Tel Bruce, 01-995 4965 after 5.

PET . . . high density graphics board/extra 8k memory. Complete MTU set-up, inc PET interface, card file, s/ware. Best offer over £150. Tel Canterbury 57995 after 6.

PET 32k . . . dust cover, 2 cass decks, Toolkit, £700. Tel Rayleigh, Essex, 774718.

48k Apple II+ . . . 6 months old, disk drive with controller, integer card, 9" b/w monitor, Visciale, 50+ games, case, £1350 (save £40 £400). Tel 092681 4282.

TI59C . . . brand new, with manuals & master module inc progs, retains progs indefinitely, buyer collects. Cost £90, accept £74. Tel Whitchurch (Hants) 2602 eves.

TI58 . . . prog calc with mains adaptor, manuals etc, good cond, £35. Tel 0482 861496.

TRS-80 L2 . . . monitor, exp int, 1 floppy disk drive, printer int, RS232 board, Newdos+, TRSDos 2.2, editor/assembler, cass rec, lots of s/ware, all manuals, soundbox, offers. 01-866 3326.

S100 memory boards . . . 2-off 8k Econoram II, working, as new, £60 each, £110 pair. Tel Camberley (0276) 61543 after 6.

Superboard . . . 8k RAM, PSU, modulator, case (not fitted), offers around £215. Tel Southend-on-Sea 204901 after 7.30.

MK14 . . . new monitor, max on-board RAM, RAM I/O chip, add-on no bounce keyboard, experimental I/O board & PSU, all manuals, book on SC/MP programming, £70 ono. Tel Derby (0332) 701964 after 6.

TRS-80 L2 16k . . . with modulator for TV, in as new cond, boxed, hardly used, £325. Tel A Bhatti, 01-574 5038 after 7.

TI59 . . . prog calc, print cradle, full doc, mag prog cards, programmer utilities listings, rechargeable batteries, listing function, graphics, s/ware check on h/ware, security lock, hardly used, £300. Apply: S Gillgrass, Dept of Psychology, Eleanor Rathbone Building, University of Liverpool, Liverpool.

Teletype 33 ASR . . . very good cond, recent overhaul, RS232 int, £350 ono. Tel Aldershot 314937.

Nas-sys 1 . . . monitor for Nascom 1/2, £10 or why? Tel Hitchin (0462) 56733.

ASR33 . . . Teletype with paper punch, good cond, £230 ono. Tel Steve Fitzgerald, 0865 52728.

Research Machines . . . 380Z, 48k, 80-col, 60 lpm X-data printer, 2 8" floppies, 2 cassettes, dual cassette controller, keyboard, VDU, extensive CP/M s/ware, exc cond, selling for financial reasons — offers. Tel Alyth (08283) 2787.

Horizon . . . computer, exc cond, complete with VDU, £1000. Tel C Baker, 0332 72569, eves.

PET 8k . . . £370. PET cassette m/c with built-in soundbox, £40. Tel High Wycombe 33164.

ZX80 . . . 1 month old, ass & full fully working, leads & Sinclair Basic manual, £80 inc UK postage postage. Tel Marlow 2389 eves.

PET 8k 2001 . . . old ROM, green screen, many progs (Microchess, Backgammon, Wartrek, Lem Lander), £360 ono. Also TI59 prog calc with manual, uses rechargeable batteries, £110 ono. Tel 01-407 4521 day, 02-01-398 0930 eves.

Centronics 701 . . . tractor printer with leads & lots of ribbons, £450. Tel Mr Ellis, 01-399 0207 (office), 01-549 3233 (home).

PET 32k . . . new ROM, green screen, Programmer's Toolkit & Superchip ROMs fitted (cost over £100) which add many new featu features & commands, also cass deck & some games/business s/ware, £650. Tel 0303 862967 (home).

PET2001-8k . . . small keyboard, plus usual s/ware, sound box, etc, £379; Epsom TX80 printer, as new, complete with IEEE488 int & cable, £365. Tel Kevin, 01-360 9576 (Enfield), eves.

ASR33 . . . printer with manuals, paper & tape, recently overhauled, £250 or will haggle/exchange for computer equipment — why? Tel Reg Broadberry, Bristol 56621 eves.

UK 101 . . . new monitor in ROM with orig instruction sheet, £16; assembler/editor, unused with manual, £10. Unneeded because I'm using disks. Write: J Rudge, Brendon Cottage, Riverside Drive, Esher, Surrey, tel Esher 66453.

PET 8k . . . old keyboard, with programmer's toolkit, serial & parallel ints, soundbox, all manuals, progs like chess, assembler, star wars, othello, etc (total 40), 2nd cass drive, £500. Tel Ashted (03722) 77570 w/ends only please.

Exchange . . . 1 Superboard II (8k) + s/ware & PSU + £180 for a PET (8k) + s/ware. Tel 061-225 4093 after 6.

Printer . . . Data Dynamics KSR 390, ASCII code, RS232, 110 baud, with keyboard, switch selectable simplex/duplex, 80-col, with stand, £135. Mr S Moss, 44 Premier Ave, Grays, Essex.

UK101 . . . just 3 months old, prof built, 4k RAM, PSU, 8k Microsoft Basic, new 2k monitor in 2716 EPROM allowing screen editing, flashing cursor, data saving on tape, etc, in large Microtype series 3 case, room for exp boards, fan etc, comes with full doc, sacrifice at £225. Tel 08444 4537.

Cash crisis . . . forces sale of 3 month old TMZ-80 micro comp with VDU, 4 8" floppy disks, built into work desk, 4 Mbytes total disk capacity, 64k RAM, with CP/M 1.4 & CP/M 2.2, MBasic interpreter, Cobol, Pascal, Fortran, £5,500. Tel 0793 31404.

ZX80 . . . assembled, brand new, unwanted gift, cost £100, accept £80. Tel 01-593 4235.

Centronics . . . 101A printer, 165 cps, 7x9 dot matrix, paper width to 15 3/8", with strong Centronics table, £630 ono. David Fox, 17 Mornington Ave, Wokingham, Berks, tel (0734) 734343.

Video Genie . . . 16k, little used, guaranteed, with some tapes, superb first computer, save over £100, yours for £300. Tel Collins, 0788 77177.

TRANSACTION FILE

Nascom 2... 16k DRAM board, PSU & full doc, ass & running @ 4 MHz, TV & cass rec inc, games tape, £350. Tel 051-339 4821.

ZX80... 1 month old, all leads, PSU, cass rec, manuals, some progs, ideal for beginner, £80 ono. Tel Cliff, 01-515 4595 (eves) or 01-980 9124 (day).

Casio FX502P... with FA1 cass int, prog library, instructions & original packing, good cond, owner gone micro, £85 ono or anyone willing to sway for N2 memory? Tel Camberley (0276) 63726 eves.

Two black and white... TVs (would make good monitors), dual trace scope, 200 electronics & computing journals, must sell, accept any offer around £100. Tel Ingrebourne 75432 after 5.

Superboard II... case, PSU, 4k, modulator, 50 Hz, as new, offers around £180. Write: D Jackson, Room M2-2 Darwin College, The University, Canterbury, Kent CT2 7NY.

Is there anyone... out there who's like to buy my Casio FX502P plus FA1, cass int, music adaptor & leads, manuals, prog library, demo cass & some original progs, for only £85 ono. Tel 0572 3643 w/ends.

Sorcerer 48k... 4 months old, seldom used, 8 months warranty to go, £505 ono, inc TV modulator. Tel 01-205 3521.

TI57... prog calc, complete with games, financial, conversion, phone call monitoring software, rechargeable batteries, mains unit, carrying case & intro to programming manual, £20. Tel 022 023 3718.

Compukit UK101... 8k RAM, comp with software & doc, only £240. Mr M Lancaster, 4 Hanover Place, London Rd, Bath, Avon.

TRS-80 L2 16k... complete with Trendcom printer, trolley stand, games, business progs, spare tapes, £495, or sell printer separately. Tel 051-526 7087.

HP29C... 9 months old; HP9835A, 64 kbyte memory, 15 months old; HP9866B thermal printer for parts — heads & 2 logic boards down; HP 16-biy I/O interface. Reasonable offers to 05805 2674.

CBM Assembler... package/chip £40; PET Revealed £5; CBM Soundbox, £10; floppies, inc games, 20 for £35; PET programming manual, £3; mags & newsletters. The lot for £80. Tel Jeremy, 01-954 6464, eves or w/ends.

Acorn System 1... assembled with PSU & manuals, good cond, £65 ono Tel Guildford 75809.

ZX80... factory built & in perfect order, comp with PSU & leads, £80. Tel South Benfleet 52147.

Sixteen... 4027 memory chips, 8k, suitable Nascom, etc, £10. Phone Dave, 0702 218662.

Nascom 2... 16k dyn RAM board, built & tested in prof aluminium cabinet with integ cass, fan, PSU & graphics ROM, £450 ono. Tel Scarborough (0723) 73178.

PET extras... Programmer's Toolkit (for old ROMs), PET workbooks 1-6 & The Pet Revealed, various games & blank tapes, £50 the lot. Tel Guiseley (0943) 78047 eves or w/ends.

Brand new... 8k PET, large Keyboard, new ROMs, in maker's box fitted with 'Mu-metal' screen eliminating screen wobble, £420, buyer collects. Tel Whitchurch (Hants) 2602 after 6 day weekdays, anytime w/ends.

Chalco... PTR CCT, £50; D43R scope handbook, £60; SA400 drive, little used, £150. Will haggle. Tel 047485 3585, w/ends.

Nascom 1... 32k, Vero frame, buffer, motherboard, W Stuart colour board, 3 amp PSU, power filter, Nas-sys, T4, Basic 10 books books, 10 programs £240. Tel Fareham 280829, 9-5.

DEC PDP-8/L... minicomputer, 4k core, ASR teletype with paper tape punch/reader, Teletype interface, software — Basic, Fortran, PAL III Assembler, Focal, binary and rim loaders, symbolic editor; the lot for £300. Phone Byfleet 44531.

Acorn Atom... fully assembled with all leads, 2k RAM, PSU 'Atomic' Manual, £120 ono. Mr L R Jackson, 97 Bracebridge Street, Nuneaton CV11 5PB.

TRS-80 Level 1 4k... with cassette, VDU and manuals, needed for a sixth form pupil at school. Tel Brownhills 4104 (Walsall, West Midlands).

TEC: full editing VDU, RS232 interface, etc, offers over £100. Also 1 other 'normal' VDU, lots of spares and manuals, offers over £50. Tel: Pete 01-998 7604.

PET 2001 8k... small keyboard, plus sound box, books, mags, cassette prog's on learning Basic and Invaders, Microchess plus ma many more; worth £150, all for £390 Tel: Terry, 01-534 1114.

TRS-80 Level 2... 16k, video monitor etc, as bought from Tandy, inc £200 of software and Aculab floppy tape drive, software inc edasm +; total cost: £959, nearest offer to £600 secures. Tel: 01-445 3281 (N. London).

Nascom... Veroframe, £20; Nascom 2 keyboard enclosure, £3; Nascom motherboard + 5 Nasbus edge connectors, £15; 8 x MK4118 static RAM, £70 or £10 each. Tel: Bedford (0234) 852942.

Expandoram II... S100 16k dynamic ram board, expands to 64k, £199. Contact: Mike Barbury, 17 Landeryon Gardens, Penzance, Cornwall (0736) 798157 after 7.

ZX80... including all leads and adaptor, ZX80 companion, 4 new cassettes for recording progs, £80. Tape with games on £4. Tel: Amersham 6635.

Why wait... 8 weeks for your ZX80. You can have my brand new, Sinclair-built ZX80 now for £90 (unwanted gift). Tel: 09323 44531.

HP-41C... and 2 memory module modules, complete with documentation and programs, sold as new, £215. Contact Fareham (0329) 280642 or 6 Blaven Walk, Fareham, Hants, after 6pm any evening.

PET Hi-Res... One only Micro Technology Unlimited K-1007-1 interface board, unused, converts any PET expansion port for use with MTU's externally-mounted K-1008P high-res graphics and other functions. Complete with instruction book: £30. F Chambers, Rock House, Ballycroy, Westport, Co. Mayo, Ireland.

Casio FX502P... plus FA1 cassette interface, brand new, still boxed, unwanted Christmas present, only £65 for both. Tel: 01-703 0424 after four weekdays.

6809... single board S100 processor with 1k RAM, 2k ROM with space for 10k 2400 baud guaranteed cassette interface, I/O, keyboard port, RS232 level shifters, with full documentation, £150. Tel: Aaron James, 01-959 4851.

Sorcerer 32k... Basic, word processing rompacs: Paper Tiger, graphics option: new LOBO 1.2Mb dual 8" Shugart drives, double density, single sided, case with fan, power supply: new JADE S100 disk controller, Z80A, Western FD179-01, CPM 2.21: TUM 10" monitor: will split, offers. Tel: 01-584 5000 ex 3081 day, 01-680 2284 evenings, ask for D J Bishop.

Tuscan... S100 computer, w/o disk drives, 8k RAM Basic/2k ROM monitor, on-board VDU, 771 keyboard, 5 months old, all manuals, £500 ono. Tel: Rob, 01-267 6447 after 6.

Low cost... 16k system, Nascom 1 with Nassys, 3A PSU hi-speed CUTS, Smart 1 32k RAM/buffer board with 16k installed, system needs repair, will split, best offer accepted. Write to 17 Greenwood Drive, Sheffield S9 4GY.

PET 16k... new rom, large keyboard, cassette and software including assembler, PET documentation, Comadore programming & hardware manuals and 6502 assembly language book, and PET revealed, £500 Tel: Yeovil 20596

ZX80... with PSU, perfect working order, Sinclair assembled, manual, leads, plus cassette carrying 15 games, £70. Tel: (Wellingborough) (0933) 224526. Gautrey, 1 Wilbye Grange, Wellingborough, Northants, NN83PS

Centronics 101... printer 165 cps, 132 col, manual, £450. SWTP CT64 terminal, matching monitor (also UHF modulator), manual, £300. Marconi Elliott Videodata 4000 Terminal — Ex/Rx ASCII or Baudot, offers? ASCII keyboard with 12 key control cluster, fine steel case, £30. May view working; deliver 50 miles Luton. Tel: 0525 220261.

UK101... 8k RAM, cased, assembler, disassembler, switchable 300/600 baud cassette interface, new monitor ROM, transformer inside case, heaps of software inc. 'Invaders', 'Programming the 6502', recorder thrown in, £300. Tel: Colin, 01-703 9742 eves.

Computhink... 800k disk drive, 2 months old, cost at current prices £1316, will sell for £800. Tel: Felix, 01-979 1328 eves or w/ends.

Superboard... 8k RAM, PSU, modulator and case (not fitted), offers around £215. Telephone Southend-on-Sea 204901 after 7.30.

Acorn System One... professionally assembled and tested, 6502 micro, with cassette interface, perfect condition, with full documentation, £75. Tel: Deal 62517 (eves).

TRS-80... Quick Printer II, 32 chars./line or double width. Users inexpensive aluminium paper, two rolls and cable included, as new £100. Tel: Rickman-sworth 76021 (eves only).

Wanted

Cheap printer... + int for Apple II (or just Apple compat printer). Tel Duncan, Canterbury 57995 after 6.

Exchange... my 1972 Triumph GTIII, 1 yrs MOT, zero rust, good all-round cond, value £1200, for micro set-up. Will swap or cash adjust either way but regret no kits. Tel John, Southend 40295 office hours only.

ZX80... either 1k or 16k, pref with 8k Basic ROM. Must be built & running with cass leads etc. Any stats packages also bought — good price paid. S. Gillgrass, c/o Dept of Psychology, Eleanor Rathbone Buildings, University of Liverpool, Liverpool.

CBM PET... or similar, any conc as long as it works (only limited funds available). Will collect within reasonable distance of Bournemouth. Tel John Woods, 0202 524060.

NETWORK NEWS

This month we introduce a new 'Direct Access' section. Personal computer networks have been springing up all over the States for 18 months or more and now we have two in Britain. As more networks appear — and as more facilities are added to existing networks — we'll report them in this section, which will appear monthly from now on.

Forum-80... operated by Frederick Brown, tel: Hull (0482) 859169. No access charge, open to any micro owner. Operating Tues & Thurs 1900-2200, Sat & Sun 1200-2200. Facilities: bulletin board, program library for downloading (all in Microsoft Basic).

National TRS-80 Users' Group... being set up at time of writing, will be available to all micro users, not just TRS-80 owners. Initially access charge will be a £10 sub, but as more join, this will be reduced and refunds made accordingly. Facilities: bulletin board & programs for downloading. Contact: Brian Pain, tel 0908 566660 (office).

USER GROUPS INDEX

As promised, here is a complete printout of our User Group Index. If we have failed to indicate YOUR group, then please address the relevant information to PCW (User Group Index), 14 Rathbone Place, London W1P 1DE. Notification of changes will also be appreciated. The next full listing will appear in PCW's May edition. In the meantime we shall of course continue to publish User Group Index update information — as and when it reaches us.

INTERNATIONAL

Tangerine Users Group (International). Recently formed for users of the Microtan 65, the TUG will act as a central information clearing house, including exchange of programs etc. Annual membership is £5.00. Details from TUG at 3/22 Donoughmore Road, Boscombe, Bournemouth, Dorset, UK.

USCD System User Society. Set up in San Diego in June for users of USCD Pascal, the society aims to establish a software library, promote regional and special interest group activities and liaise with USCD system distributor Softech on future development plans. Existing special interest groups include industrial application, word processing, real time, business applications and forward planning. UK contact: John Ash, Dicoll Data Systems Ltd., Bond Close, Kingsland Estate, Basingstoke, Hants RG24 0QB.

Microcomputer Users Club: recently established for program writing and exchange, emphasis on 6502/280 users. Contact c/o Synthetronics Microcomputers P.O. Box 151, 1322 Hoevik, Norway.

Group/380. Recently established for information interchange on microsystems equivalent to IBM 360/370 main frames. Group expects to see several desktop 370 systems available in next few years; services offered include newsletter on hardware & systems developments and read/write postal access to a computerised database listing relevant software from the large volume of existing 360/370 software which will eventually be of use to users of micro 360/370-equivalent systems. Annual sub: \$10 for individuals, \$25 for organisations. Contact: Mokurai Cheriin, PO Box 1131, Mount Shasta, CA96067, USA.

NATIONAL

Amateur Computer Club. National organisation with several local groups which hold their own meetings and talks. *Accumulator* newsletter issued bi-monthly; software libraries for 6800, Z80 & 6502 processors available. Contact: Jim MacDonald, 1 Carlton Court, Studley Grange Rd, London W7 2LU.

11s Users Group. A sort of help service only. No meetings no newsletter. Contact: Pete Harris, 119 Carpenter Way, Potters Bar, Herts, EN6 5QB. Tel: 0707 52091 or 01-248 8000 Ext. 7065.

The 6502 Users Club. Hoping soon to hold regional and national meetings, they offer "support, encouragement and fellowship". Contact: Walter Wallenborn, 21 Argyll Ave., Luton, Beds LU3 1EG.

77/68 Users Group. Quarterly Newsletter. Free membership for 1st year if you buy the 77/68 instruction manual, £1.50 thereafter. Contact: Newbury Computing Store, 40 Bartholomew St., Newbury, Berkshire.

9900 Users Group TIMUG. Contact: Chris Cadogan, 21 Thistle Downs, Northway Farm, Tewkesbury, Glos.

Amateur Computer Club — 2650 Library. No meetings, no newsletters, the library serves to act as a help point for disseminating 2650 related data on demand. Contact: Roger A. Munt, 51 Beechwood Drive, Feniscowles, Blackburn, Lancs BB2 5AT (0254 22341).

Minicomputer Users in Secondary Education (MUSE). MUSE is the national organisation for coordinating activity in schools, teacher training institutions, colleges of technology and so on. Meetings are held on both a regional and national basis. For full details on MUSE's range of activities, contact the Treasurer, R. Trigger, 48 Chadcote Way, Catshill, Bromsgrove, Worcestershire.

UK Intel MDS Users Group. Contact: Lewis Hard, 29 Chaucer Rd., Bedford.

Ithaca Audio S100 bus UK User Group. Contact: Dave Weater, 16 Etive Place, Cumbernauld, Glasgow O67 4JE. Phone 02867 36570.

MK14 Club. Bi-monthly magazine called "Complement and Add". Contact: Geoff Phillips, 8 Podsford Rd., London NW9 6HP.

Independent PET users Group. Contact: IPUG, 57 Clough Hall Road, Kidsgrove, Stoke-on-Trent, Staffs.

Research Machines Ltd. National User Group. Contact: M.D. Fischer, PO Box 75, Oxford, OX4 1EY, for a registration form.

UK Apple Users Group. Contact: (Keen Computers) 5 The Poultry, Nottingham. Tel: 0602 583254/5/6.

Central Program Exchange. Full membership (£25 Europe, £40 overseas) provides 30 free programs p.a. Small User Service (£10 Europe, £20 overseas) provides 10 free programs p.a. Contact: Mrs Judith Brown, The Polytechnic, Wilfruma St., Wolverhampton, WV1 1LY.

Cosmac Users Club (proposed). For people using the RCA 1802, Cosmac ELF, ELFII, Super ELF etc. Those interested contact James Cunningham at 7 Harrowden Court, Harrowden Road, Luton LU2 0SR (enclosed sae, please).

National TRS-80 Users' Group. Activities include a computerised bulletin board service (see 'Network News'). Contact: Brian Pain, National TRS-80 UG, 40A High St, Stony Stratford, Milton Keynes, tel (0908) 566660 (office), 564271 (home).

ZX80 Users Club. The group's aim is to create and share software which will fit within the machine's 1K RAM. Membership is free and first move will be to distribute a newsletter. Address to write is: 44-46 Earls Court Road, London W8 6EJ.

Ohio Scientific UK User Group. Independent of OSI, an important role will be the disentangling of poor documentation. There will be regular newsletters and membership is at present £5 per year. The group will initially be concerned with the practical aspects and applications of OSI systems — rather than with games. Contact Tom Graves at: 19a West End, Somerset, BA16 0LQ.

Medical Micro Users Group. Set up to enable medical micro users to locate programs already written in their field by other medics. Newsletters and meeting in the pipeline — contact P.J.V. Dixon, c/o MEDICOM, 1-2 Hanover Street, London W1.

UK Pet Users Club. Contact: Commodore Systems Division, 360 Euston Road, London NW1 3BL.

British TI Users' Club. A loose association of owners and users of Texas Instruments programmable calcs, the club exists for the purposes of information and program exchange (and is in no way sponsored by TI). The main activity is production of a (roughly) monthly newsletter and membership costs £5.50. Details from 2 Woodside Crescent, Clayton, Newcastle-under-Lyme, Staffs ST5 4BW.

ZX80 Users Club. Bi-monthly newsletter. Low cost software. Technical support. Subscription £6 (UK), £10 (overseas). Contact: D. Blagden, PO Box 159, Kingston upon Thames, Surrey, KT2 5UQ. (s.a.e. for further information).

COMP 80 Users Group. Monthly newsletter. Annual subscription £5. Contact: Philip L. Probetts, 50, Cromwell Road, Wimbledon, London, SW19 8LZ.

National Personal Computer Users Association. Full membership now costs £8.00, but you'll receive a free datasheet of special routines for the UK101/Suprboard on enrolment (routines include a fast Basic line renumberer only four lines long). For detail details send an SAE to: The Secretary, NPCUA, 11 Spratling Street, Manston, Ramsgate, Kent.

Powertran Users Club. Annual subscription £5.00, which includes a monthly newsletter. Contact Mr P L Probetts, 50 Cromwell Road, Wimbledon, London SW19 8LZ.

Acorn Atom User Group. Set up for interchange of software & hardware tips. Membership costs £4 p.a. inc. access to program library & free newsletter. Group supported by but independent of Acorn Computers. Contact: T G Meredith, "Sheerwater", Yealm View Rd, Newton Ferrers, S. Devon.

National T158/59 Club: bi-monthly newsletter, program exchange etc. Annual sub £5.50 or, if you include a program with your cheque then it's £3.50. Contact: R M Murphy, Dept. of Electronic Engineering, University College Swansea, S. Wales.

Sharp User Group: Sub £3. p.a., inc newsletter and free Space Invaders cassette for MZ-80K. Contact: Knights TV & Computers, 108 Rosemount Place, Aberdeen. Tel 0224 630526.

Sorcerer Program Exchange Club: Contact Colin Morle, 32 Watchyard Lane, Formby, Nr. Liverpool L37 3JU, Tel 070 48 72137.

TRS-80 Level 1 User Group. For all Level 1 users. Qtrly newsletter containing s/ware (also avail. on cassette), £3 p/a for newsletter, or £7 p/a for news & cassette. Contact (with SAE): N Rushton, 123 Roughwood Drive, Northwood, Kirkby, Merseyside L33 9UG.

CP/M Users' Group (UK). Annual sub £5. S/ware library, newsletter, 'help' service. Contact: 11 Sun St, Finsbury Sq, London EC2M 2ZD.

British Apple Systems User Group. For Apple II and ITT 2020 users. Meets 1st Tues eve & 3rd Sun afternoons monthly at The Old School, Branch Rd, Park St, St Albans (on A5 about 2 miles south of city centre). Contact: John Sharp, Garston (09273) 75093 or David Bolton, Park Street (0727) 72917.

Anyone interested in forming a Texas T199/4 Users' Club with a magazine and a software library, should contact Mr P Dicks, Data Processing Manager, Pershke Price Service Organisation Ltd, Dover House, 141 Morden Rd, Mitcham, Surrey CR4 4XB, tel. 01-648 709 7090.

Sharp PC-1211 Users' Club. Also open to TRS-80 Pocket Computer owners and anyone else with or without a computer. Membership costs £5 p/a which includes a newsletter containing programs etc. Contact: Jonathan Dakeyne, 281 Lidgett Lane, Leeds LS17 6PD.

SOUTH

Southern Users of PETs Association. Free membership, meet first Wed, each month, £1.50 for monthly newsletter. Contact: 42 Compton Road, Brighton BN1 5AN.

NORTHWEST

Manchester Computer Club (formerly the Amateur Computer Club (Northwest Group)). Meets 1st & 3rd Thursdays monthly at St Peter's Chaplaincy, Precinct Centre, Oxford Rd, Manchester. Contact: David Wade, 28 Hazel Rd, Altrincham, Cheshire WA14 1JL, tel: 061-941 2486.

TRS 80 — North West Group. Subscription £5. Newsletter £3 (for 6 issues). Meetings last Wednesday monthly (not Dec) at the Stag Hotel, Carswood, Wigan. Contact: Melvyn D. Franklin, 40 Cowlees, Westhoughton, Bolton, BL5 3EG. Tel: 0942 812843.

Northwest Computer Club. Fortnightly meetings, 25p attendance fee. No subscriptions. Contact: John Lightfoot, 135, Ashton Drive, Frodsham, Warrington, Cheshire, WA6 7PU. Tel: 0928-31519.

IRELAND

Computer Education Society of Ireland. A voluntary organisation that consists of a national body and an expanding number of local branches. Their brief is to monitor computer education in Ireland. *National CESI* (£3 p.a.) — Dairmuir McCarthy, 7 St. Kevin's Park, Kilmacud, Blackrock, Co. Dublin. *Cork branch* (£1 extra) — Michael Moynihan, Colaiste an Spioraid Naomh, Bishopstown, Cork. *Dublin branch* (£1.50 extra) — Jim Walsh, C.B.S. Naas, Co. Kildare. *Limerick branch* (£1 extra) — Sr. Lourda Keane, Convent F.C.J., Laurel Hill, Limerick. *Waterford branch* (£1 extra) — Mr. Hugh Dobbs, Newtown School, Waterford. *Kilkenny branch* (£1 extra) Sr. Helen Lenehan, Presentation Secondary School, Kilkenny.

WALES

Gwent Amateur Computer Club. Covering the Gwent and Cardiff areas, the club has its own computer room and technical library. Meetings are held once a week on Wednesdays at 10 Park Place, Newport. Contact Ian Hazell on 0633 277711 (office hours).

SCOTLAND

The Grampian Amateur Computer Society. They meet every 2nd Monday of the month at the Holiday Inn, Bucksburn, Aberdeen and there's a monthly newsletter. For more details, contact M. Basil, Orton Cottage, Burnside, Lumphpan, Kincardineshire, Grampian Region (033 983 784).

USER GROUPS INDEX

Central Scotland Computer Club. Meets first and third Thursdays each month at Falkirk College of Technology, Grangemouth Rd, Falkirk. Contact: J Lyon, 78 Slamannan Rd, Falkirk FK1 5NF, tel. 22430.

Crampian Amateur Computer Society. Meets second Monday monthly at local hotel, looking for own premises. Sub £4 p/a (£1 for junior members), monthly. About 50 members. Club owns an ICL 1902! Contact: Alan Hird, 20 Harcourt Rd, Aberdeen. Grampian, tel (0224) 33102.

AVON

Bristol Computing Club, £3.00 p.a. Meetings 3rd Wednesday, monthly. Contact: Leo Wallis, 6 Kilbirnie Rd., Bridge Farm Estate, Bristol, BS14 0HY. Tel: Bristol 832453.

Brunel Technical College Computing Club. The club divides into two sections... the "skilled" and the "not skilled". They share alternate Wednesdays at the College. Contact: S.W. Rabona at 18 Castle Road, Worle, Weston-Super-Mare, Avon, BS22 9JW (0934 513068).

Compukit User Club. Details, contact P. Crabb Esq., 21 Jones Close, Yatton, Avon (0934 834808).

BERKSHIRE

The Thames Valley Amateur Computer Club. Meetings are on the first Thursday of every month and from November on, that will be at "The Southcote", Southcote Lane, off the Bath Road, Reading, Berks. Starting time, 7.00pm. Contact: Brian Quarm (Camberley 22186) OR Brian Steer (Slough 20034).

BUCKS

Would any one interested in setting up an Apple Users Group in the Bucks/Berks area contact: Steve Proffitt, Tel: 01-759 5511 ext 7298 (day), or Marlow 73074 eves or w/ends.

CAMBRIDGESHIRE

Peterborough Computer Club. Recently formed, meets on first and third Mondays each month at Adult Education Centre, Brook Street, Peterborough. Contact: T Marchant, tel Peterborough 76681 after 6 weekdays, anytime weekends.

CLEVELAND

Cleveland Micro Computer Users Group. Adult Meetings 3rd Tuesday monthly, under 18s — 2nd Tuesday. Yearly subscription £2 (£18), £3 (£18-21), £5 (£21+). Journal. Contact: J. Telford, 13, Weston Crescent, Norton, Cleveland.

CORNWALL

Cornish Computing Club. Recently formed by members of the Cornish Amateur Club. Meets 7.30pm 3rd Monday monthly at the SWEB Social Club, Pool, on A30 between Redruth & Camborne. Contact: Richard Frost, Trearne, Alexandra Rd, Illogan, Redruth TR16 4EA.

Any one interested in forming a computer club in Cornwall catering mainly for PET, ZX80 and UK 101 computers should contact: M F Grove, 35 Causeway Head, Penzance, Cornwall.

DEVONSHIRE

Exeter and District Amateur Computer Club. General meetings 2nd Tuesday monthly, specialist meetings 3rd or 4th Tuesday. £5.00 p.a. Contact: Doug Bates, 3 Station Road, Pinhoe, Exeter, Devon.

Plymouth and District Amateur Computing Club. Subscription £5.00 p.a. Meetings last Wednesday monthly. Contact: Keith Gould, c/o JAD Ltd., 21 Market Ave., Plymouth 62616 or 2 Brook Rd., Ivybridge 2399.

DORSET

Bournemouth Area Computer Club. Meets monthly at the Kinson Community Centre. Contact: Peter Hills, 54 Runnymede Ave, Bournemouth, Dorset BH11 9SE, tel Northbourne 6547.

COUNTY DURHAM

Computer Club. Business & Word Processor section meets Fridays 7.30, Scientific & Recreational Saturdays 10.00. Contact: L. Boxell, 8 Vane Terrace, Darlington. Tel: 0325 67766.

Northeast PETS. Contact: Jim Cocallis, 20 Worcester Road, Newton Hall Estate, Durham. They meet the 2nd Monday of each month for software tuition and the 3rd Monday for hardware tuition (both in addition to normal activities). They start at 7.00pm and meet in the PET Lab, Newcastle Polytechnic, Ellison Building, Newcastle upon Tyne.

EAST ANGLIA

Anglia Computer User Group. Contact Jan Rejzl, 128 Templemere, Sprowston Road, Norwich NR3 4EQ.

EAST MIDLANDS

East Midlands TRS-80 Users' Group. For owners/would-be owners of TRS-80s or Video Genies. For free newsletter and further details contact: Mike Costello, 17 Langbank Avenue, Rise Park, Nottingham NG5 5BU.

ESSEX

TRS80 User Club (Chelmsford). Now part of the National TRS80 User Club. Contact: Michael Dean, 22 Roughtons, Galleywood, Chelmsford, Essex.

The Colchester Microprocessor Group. Meetings held at the University of Essex on the second and fourth Wednesdays of each month — 7.30 pm start. Membership is open to all, on payments of £5 annual sub (£1 for full-time students). Contact: the Information Centre at the University on the evening of the meeting.

Compukit User Club. Details, contact Adrian Waters, 117 Haynes Road, Hornchurch, Essex RM11 2HX (Hornchurch 40490).

Springfield Computer Club. Special interest in Sorcerer but beginners and others welcome. Meetings 1st Friday monthly. Contact: Stephen Cousins, 1, Aldeburgh Way, Springfield, Chelmsford, Essex CM1 5PB. Tel: 0245 50155.

South East Essex Computer Society. Meets monthly at the Southend-on-Sea College of Technology, has access to the college's micros, and is open to anyone over 14. Contact: R Knight, 128 Lt. Waking Road, Lt. Waking, Southend-on-Sea, Essex. Tel: Southend 218456.

GLOUCESTERSHIRE

Cheltenham Amateur Computer Club. Meetings, 4th Wednesday monthly, 7.30pm start. Contact: Mr. M. Pullin, 45 Merestones Drive, The Park, Cheltenham, GL50 2SU (Cheltenham 25617).

HAMPSHIRE

Southampton Amateur Computer Club. Meets 8 pm 2nd Wed each month (not July — Sept) at Medical Science Building, Bassett

Cres, East, Southampton. £3 pa. OAP, & students £2. Newsletter & special int. groups; 2 yrs old, 80 members soon setting up another club in Portsmouth area. Contact: P G Dorey, Dept Physiology, The University, Southampton SO9 3TU or Andy Low, Tel: (0703) 555 605 ext 34.

HERTFORDSHIRE

Harpden Microprocessor Group. They hold meetings every fortnight, cover a wide range of interests and attract members from the area around Luton. St. Albans and Welwyn. Contact: David James, 5 Ox Lane, Harpenden, Herts AL5 4HH (05827 5366).

ISLE OF WIGHT

IOW TRS-80 Users Club. Meets each Friday at 8 pm at 72 Union Street, Ryde. Contact: Mr M R Collins, 3 Alfofts Gardens, Ventnor, IOW.

KENT

MACRO (Medway Amateur Computer & Robotics Organisation). Meets monthly, sub £3, including a club newsletter; full-time students under 18 pay half-cost. The club now has 83 members. Contact: Panos Koumi, Southgate Computer Club, 33 Chandos Avenue, London N14.

North Kent Amateur Computer Club. Meetings, the second Tuesday of each month — usually at the Charles Darwin School, Jail Lane, Biggin Hill, Kent. The sub is £2.50 per annum (£1 for students). More members are needed. . . contact: Barry Biddles at 3 Acer Road, Biggin Hill, Kent (09594 71742).

LANCASHIRE

PET Users' in West Lancs. Meets monthly on third Thursday each month at Arnold School Blackpool. Contact: David Jowett, 197 Victoria Road East, Thornton, Blackpool FY5 3ST. tel Cleverleys 869108.

Merseyside Microcomputer Group. Several sub-groups including: 380Z User's Group (Alan Pope on 051-924 2470); Computer Education Society (Mr M. Trotter on 051-652 1596); SC/MP Special Interest Group (Bob Perrigo on 051-677 6716); PET Special Interest Group; 6800 and 77/68 Special Interest Group; Apple Special Interest Group. The Secretary is John Stout of the Dept. of Architecture, Liverpool Polytechnic, 53 Victoria Street, Liverpool L1 6EY (051-236 0598).

North Lancs User Group. Contact John Robinson, 12 Harold Ave., Blackpool, Lancashire.

Chorley Computer Club. PET-biased but owners of other (or no) computers welcome. Meets informally on alternate Tuesdays in a pub in Chorley. Contact: Rod Wilson, tel Chorley 71875 or Chris Hicks, tel Chorley 78376.

LEICESTERSHIRE

The Leicestershire Personal Computer Club. Meetings held the 2nd Monday in each month, at Leicester University and Loughborough University alternately. They start 7pm. Membership is £2 per annum (£1 for under 16s). Contact: Miss Jill Olorenshaw (Club Secretary) c/o Arden Data Processing, Municipal Buildings, Charles Street, Leicester (0533 22255) OR Mr Dick Foden (Club Chairman) at 11 Gadesbury Lane, Rearsby, Leicester.

LINCOLNSHIRE

Lincolnshire Microprocessor Society. Various meeting places. For up-to-date information, contact the Hon Sec, Mr Eric Booth, Senior Common Room, Bishop Grosseteste College, Newport, Lincoln.

LONDON

TRS-80 Users' Group London Branch. Recently formed and meet 2nd Friday each month 6pm, at 292 Caledonian Rd, London N1. Contact: J Wellsman, 01-607 0157.

Compucolor User Group, London area. Has contacts with both US and Canadian Compucolor user groups. Contact: Bill Donkin, 19 Harwood Ave, Bromley, Kent BR1 3DX.

380Z User Group, North London Branch. Includes Herts, Cambs, Oxon. Contact: Sheridan Williams, 35 St Julian's Rd, St. Albans, Herts AL1 2AZ.

West London Personal Computer Club. Meets first Tues, each month at Willesden Technical College. Also visits, special int. groups, demos, problem surgeries. Contact: Graham Brain, 81 Rydal Cres, Perivale Middx, Tel: 01-997 8986

Southgate Computer Club. The club recently held its AGM and adopted a formal constitution. Annual subscription will be £2.50 from January 1981, including a club newsletter; full-time students under 18 pay half-cost. The club now has 83 members. Contact: Panos Koumi, Southgate Computer Club, 33 Chandos Avenue, London N14.

East London Amateur Computer Club. Meetings 3rd Tuesday monthly. £2.50 p.a. (¼ price to school students). Contact: Dr. Graham Crisp, 45 Leadale Ave, Chingford, London E4 8AX. Tel: 01-520 6010.

The North London Hobby Computer Club. General meetings held on a Wednesday evening, once a month — specialised topics on three evenings each week. Location: The Polytechnic of North London. Contact: Robin Bradbeer (Chairman) at the Dept. of Electronic and Communications Engineering, Polytechnic of N. London, Holloway, N7 8DB (01-607 2789).

SELMIC (South East London Microcomputer Club). Meets fortnightly at Thames Polytechnic. Annual sub £5. Contact: Peter Phillips, 61 Craigerne Rd, London SE3, tel 01-853 5829.

Croydon micro/small computer group. Contact Vernon Gifford, 111 Selhurst Road, London SE25 6LH.

East London Amateur Computer Club. Meets 7-10pm on 2nd & 4th Tuesdays monthly at Harrow Green Library, Leytonstone, London E11. Contact: Fred Linge Linger, 01-554 3288.

LONDON & SOUTH EAST

Sharp MZ-80K User Group. Contact: Joe L.P. Seet, 16, Elmhurst Drive, Hornchurch, Essex, RM11 1PE. Tel: 04024 42905.

Sunbury Amateur Computer Club. Meets 1st Friday monthly whenever possible, 20p per meeting. Contact: S Taylor, 8 Priory Close, Sunbury-on-Thames TW16 5AB, tel Sunbury 86649.

MIDDLESEX

Sunbury Amateur Computer Club. Membership free. Contact Mr S N Taylor, 8 Priory Close, Sunbury on Thames, Middlesex, TW16 5AB. Tel: Sunbury 86649.

Harrow Computing Group. Meetings on alternate Wednesdays at 7pm in room G43 of Harrow College of Higher Education. They welcome anyone with an interest in computers — with or without a machine. Membership is free. For further information contact Bazyle Butcher, 16 St. Peter's Close, Bushey Heath, Herts WD2 3LG (01-950 7068).

USER GROUPS INDEX

IPUG setting up in Teddington. Interested? Contact: G. Squibb, 108, Teddington Park Road, Teddington, Middlesex.

MIDLANDS

Birmingham Computer Club. To be formed shortly, catering for all micro users. Fortnightly meetings planned but venue not yet fixed. Contact: Dr M Bayliss, 021-743 7197.

TRS-80 Independent User Group. Recently formed in Birmingham. Contact Mike Bayliss, 021-743 7197.

NORTHANTS

Anybody interested in forming a microcomputer users club in the Towcester (S. Northants) area, please contact R J Wellsted, 20 Hampton Court Close, Abbey Chase, Towcester, Tel: Towcester 51354 eves.

NOTTINGHAMSHIRE

Ashfield Computer Club. Meets 1st & 3rd Thurs each month at Carsic Junior School, membership £3 pa. Contact Deric Ellerby, tel 0380 75376 or Derrick Daines tel 0380 56198

OXFORDSHIRE

Oxfordshire Microcomputer Club. £5.00 p.a. Contact: S. C. Bird, 139 The Moors, Kidlington, Oxford OX5 2AF Tel: Kidlington (08675) 6703.

Microsoc the Oxford University micro group holds shared meetings with the Oxford Microcomputer Club. Contact: M. Bourla, St. John's College, Oxford.

SOUTH

IPUG South East Regional Group. Meets third Thursday each month, 7.30pm at Charles Darwin School, Jail Lane, Biggin Hill. Bi-monthly newsletter. Contact: W Cdr M Ryan, 164 Chesterfield Drive, Sevenoaks, Kent TN13 2EH, tel (0732) 53530.

SUFFOLK

Anyone interested in forming a Suffolk Computer Users' Club should contact Ian on Ipswich 831353 eves/weekends.

SURREY

Richmond Computer Club. Held the second Monday of each month at the Richmond Community Centre (20p per meeting), members have the use of a good range of equipment. Contact: Robert Forster, 18a The Barons, St. Margarets, Twickenham, Middx (01-892 1873).

Surrey Microprocessor Society. (SUMPS) Covering Surrey plus bits of South London and other adjacent counties. Anyone interested in joining, call Mike on 01-642 8362.

SUSSEX

A PET group is being formed on the Sussex/Surrey border, presently centered on Crawley & Horsham. Aims to meet monthly & produce a monthly newsletter. Contact: Richard Dyer, 33 Parham Rd, Ifield, Crawley RH11 0ET.

A Crawley computer club has recently been formed, open to anyone interested in personal computing, with or without computing facilities. The intention is to hold meetings weekly,

and publish a monthly or bi-monthly newsletter. Details, contact either Mr J. Fieldhouse, 18 Seaford Road, Broadfield, Crawley, West Sussex (Crawley 542509) — or — Mr J. M. Clarke, 31 Hyde Heath Court, Pound Hill, Crawley, West Sussex (Crawley 884207)

TYNE AND WEAR

Newcastle-upon-Tyne Personal Computer Society: meets first Tues each month in Room D103, Newcastle Polytechnic. Over 60 members sub £5.00. Several sub-groups inc. PET, TRS-80 and S100 (last one meets weekly). Contact Pete 0632 573905 or John on 0632 579887.

WARWICKSHIRE

ACC (Midland) Group. They meet every 3rd Saturday in room P109 at Lanchester College, Coventry . . . no sub, no magazine. Contact: Roy Diamond (Chairman), 27 Loweswater Road, Coventry, Warks (0203 454061).

WEST MIDLANDS

Research Machines 380Z. West Midlands User Group. Further details from: Peter Smith, Birmingham Educational Computing Centre, Camp Hill Teachers Centre, Stratford Road, Birmingham, B11 1AR. Tel: 021 772 6534.

West Midlands Amateur Computer Club. Meets the 2nd & 4th Tuesday of each month, usually at Elmfield School, Love Lane, Stourbridge, West Midlands. Annual sub is £3 (£2 if full time student). . . visitors welcomed without obligation. For more information contact John Tracey of 100 Booth Close, Kingswinford, West Mids (0384 70097).

Compukit User Club. Details, contact S.H. Grisvenor Esq., 11 Bernard Road, Oldbury, Warley, West Midlands (021-422 3298).

YORKSHIRE

Anyone interested in forming a micro group in the Doncaster area, contact Mr P Flinders, tel Doncaster 78954 or Doncaster 868 379, 6-9pm.

ShIPLEY College Computer Group (Sorcerer/6800). They meet Tuesdays (software) and Wednesdays (hardware/advanced) between 7.00 & 9.00 pm. Contact Paul Channell on ShIPLEY 595731.

West Yorkshire Microcomputer Group. Formed following an inaugural meeting on October 23rd, a varied diary of events has been drawn up. For details contact the Chairman, Phillip Clark, Care Computer Services, 15 Wellington Street, Leeds LS1 4DL (0532 450667) OR the Secretary, Keith Knaggs, Price Waterhouse & Co., Leeds (0532 448741).

South Yorkshire Personal Computing Group. Meetings are on the second Wednesday of each month in Room F135, St. Georges Building, Sheffield University. Experts and beginners welcomed alike, contact Paul Sanderson (Secretary), 8 Vernon Road, Totley, Sheffield S17 3QE (0742) 351895.

Penine & District Computer Club. Open at both 26 and 51 Mill Hey, Haworth, W. Yorks, each Sat & Sun 10am to 10pm. Systems, books, magazines, members' shop. Contact: club at w/ends on Haworth 43007 or chairman, Douglas Bryant, on Bradford 569660.

DIARY DATA

Bahrain	Middle East Electronic Comms. Show & Conf — MECOM. Contact: Arabian Exbn. Management, 49-50 Calthorpe Rd., Edgbaston, Birmingham. 021-454 4416	2 — 5 Feb
Eindhoven, Holland	Int. Microelectronics Sub. Systems Trade Fair — Microelectronica. Contact: Golden Gate Exbns Inc, PO Box 428, Los Altos, CA94022, USA	4 — 6 Feb
Bilbao, Spain	Electrical & Electronic Equip Exbn — ELA Contact ECL Ltd, 01-486 1951.	2 — 8 Mar
London, England	(Wembley Conf C) Microsystems '81 Exbn. Contact: IPC Exbns Ltd, 01-837 3636	11 — 13 Mar
Glasgow, Scotland	(Albany Hotel) Computermarket. Contact: Couchmead Ltd., 42 Gt Windmill Street, London W1. 01-437 4187	17 — 19 Mar
Malmo, Sweden	Computer Exbn — DATAKRAFT. Contact: ECL Ltd, 01-486 1951	23 — 27 Mar
Manchester, England	(New Cent. Hotel) Computermarket. Contact: Couchmead Ltd., 01-437 4187	24 — 26 Mar
Dublin, Eire	Int Computing Exbn — COMPUTEX. Contact: SDL Exbns Ltd, Dublin 763871	24-27 Mar
London, England	(Wembley Conf Centre) Numerical Control Equip Exbn & Conf. Contact: British Numerical Control Socy, 01-579 9411	30 Mar — 1 Apr
Birmingham, England	(Albany Hotel) Computermarket. Contact: Couchmead Ltd, 01-437 4187	31 Mar — 2 Apr
London, England	(West Centre Hotel) Peripherals '81 Exbn. Contact: IPC Exbns Ltd, 01-837 3636	1 — 3 Apr
London, England	(West Centre Hotel) Computermarket. Contact: Couchmead Ltd, 01-437 4187	7 — 9 Apr
Paris, France	Int Exbn of Electronic Components. Contact: French Trade Centre, 01-439 3964	7 — 11 Apr
Kenilworth, England	(Nat. Agric. Centre) Computer Numerical Control Equip, Machine & Services Exbn & Conf. Contact: Corinthian Exbns, 01-681 7055	12 — 14 Apr
London, England	(Grosvenor House) All Electronics Show. Contact: All Electronics Show, (0799) 22612	22 — 24 Apr

Two great products from Mutek

C1E

An enhanced version of the popular C1, with 32x48 display, sturdy metal case, double-speed (2MHz) operation

- ★ Ultra-fast BASIC ★
- ★ Built-in 53-key keyboard ★
- ★ Simple, practical, reliable ★

C1E — £255.00

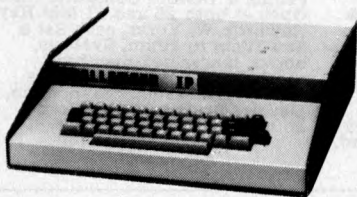

CEGMON

The new monitor for all OSI and UK101 systems, with the right range of features!

- ★ Twin-cursor screen editor ★
- ★ Improved keyboard routine ★

with fully programmable protected areas, screen and 'window'-clear, cursor controls

- ★ New screen-handler ★
- with load/save, tabular display, 'modify' entry for text and hexadecimal, breakpoint handler, block move, and much more

- ★ Disc bootstrap ★
- ★ Full compatibility ★

Complete with full manual and card for
only £29.50

All prices quoted exclude VAT

MUTEK Quarry Hill, Box, Wilts
Tel: Bath (0225) 743289

PCW SUBSET

Sub Set is not confined to Z80 routines; by sheer coincidence the original contributors were Z80 users, but contributions, documented as shown here, are most welcome from users of other processors. Send your subroutines to: PCW Sub Set, PCW, 14 Rathbone Place, London W1P 1DE

We are often told that any code that works is good code and here is your chance to judge the truth of this.

In the November issue, we asked for the shortest solution to HL = HL/2, when HL contains four BCD digits. There is a lot to be learned from the different ways you found of doing this. All of them work and leave any remainder in the carry flag.

Here is the longest solution, which does the job in 81 bytes and 331 — 361 T states:

```
HLFW: PUSH BC ; save
      PUSH DE ; registers.
      LD A,£0F ; get
      AND H ; all
      LD C,A ; four
      SRL H ; BCD
      SRL H ; digits
      SRL H ; from
      SRL H ; HL
      LD B,H ; into
      LD A,£0F ; registers
      AND L ; B
      LD E,A ;
      SRL L ; C
      SRL L ;
      SRL L ; D
      SRL L ; and
      LD D,L ; E.
      SRL B ; divide B by 2
      JR NC,HLF1 ; and if
      LD A,+10 ; there is
      ADD A,C ; carry add
      LD C,A ; 10 to C.
HLF1: SRL C ; divide C by 2
      JR NC,HLF2 ; and if
      LD A,+10 ; there is
      ADD A,D ; carry add
      LD D,A ; 10 to D.
HLF2: SRL D ; divide D by 2
      JR NC,HLF3 ; and if
      LD A,+10 ; there is
      ADD A,E ; carry add
      LD E,A ; 10 to E.
HLF3: SRL E ; divide E by 2.
      PUSH AF ; save any carry.
      SLA B ; move digit
      SLA B ; in B to
      SLA B ; most signfc
      SLA B ; end and
      LD A,B ; load into A.
      ADD A,C ; add digit from C
      LD H,A ; & store in H.
      SLA D ; move digit
      SLA D ; in D to
      SLA D ; most signfc
      SLA D ; end and
      LD A,D ; load into A.
      ADD A,E ; add digit from E
      LD L,A ; & store in L.
      POP AF ;
      POP DE ;
      POP BC ;
      RET ;
```

From A H Yates of Hemsworth comes this code, which does the same job in 34 bytes and introduces two different ways of adjusting for a carry from a previous digit:

```
HLFX: PUSH BC ; save registers.
      LD B,+0 ; zeroise B.
      BIT 0,H ; if will be cy
      JR Z,HLF4 ; from 2nd digit
      LD B,50H ; set B = 50H.
      HLF4: SRL H ; divide H by 2.
      BIT 3,H ; if carry
      JR Z,HLF5 ; from 1st digit
      LD A,H ; subtract
      SUB 3 ; 3 from
      LD H,A ; second digit.
      HLF5: SRL L ; divide L by 2.
      PUSH AF ; save flags
      BIT 3,L ; if carry
      LD A,L ; from 3rd digit
      JR Z,HLF6 ; subtract 3
      SUB 3 ; from 4th digit.
      HLF6: ADD A,B ; make any adjust
      LD L,A ; to 3rd digit.
      POP AF ;
      POP BC ;
      RET ;
```

Neil Imrie, from Bedford, sent a routine which, with two bytes added to make it strictly comparable to the other routines by returning the remainder in the carry flag, takes 29 bytes and 123—129 T states. Neil introduces yet another way of adjusting for a carry into the third digit:

```
HLFY: LD A,H ; 1st 2 digits/2.
      SRL A ; 2nd 2 digits/2.
      RR L ; with cy from A.
      PUSH AF ; save flags.
      BIT 3,A ; if carry from
      JR Z,HLF7 ; 1st digit take
      SUB 3 ; 3 from 2nd.
      HLF7: LD H,A ; store first
      LD A,L ; part result.
      BIT 7,A ; if carry from
      JR Z,HLF8 ; 2nd digit take
      SUB 30H ; 3 from 3rd.
      HLF8: BIT 3,A ; if carry from
      JR Z,HLF9 ; 3rd digit take
      SUB 3 ; 3 from 4th.
      HLF9: LD L,A ; store result.
      POP AF ;
      RET ;
```

Computer clubs

Neil is a member of the newly-formed Bedford Computer Club. It might be of interest to readers if other contributors will name any computer club which they belong to. It will show which clubs have members active in machine code programming and ready to share their efforts freely. I am a member of the Southgate Computer Club.

Its method is crystal clear and the easiest of all to follow.

Jan Beckman of Ashstead sent a routine in 29 bytes and 119-130 T states to match Neil's and starting:

```
HLFZ: ZOR A ; clear A & cy.
      RR H ; H/2. L/2 with
      RR L ; cy from H.
      PUSH AF ; save flags.
      BIT 3,H ; if carry
      JR Z,HLF7 ; from 1st
      DEC H ; digit
      DEC H ; reduce 2nd
      DEC H ; by 3.
      LD A,L ; continue as
                in HLFY
```

The Ultimate

By juggling with parts from these different routines, you might well come up with something better than any of them. But before you rush to send it in,

take a look at our first Datasheet this month, HLFHL, which, by an entirely different method, does the job in 21 bytes. This was sent by Dave Barrow who, like Mr Yates of HLFX, comes from Hemsworth.

Dave also sent the same three improvements to RLTV that we received from Paul Jenner and printed last month and Paul Bloomfield of Bryanston School got two of them.

I hate to disappoint any speed merchants by pointing out that HLFHL takes 960-978 T states to execute. It seems you can't have everything but we did ask for the shortest, not the fastest, solution.

I set out to shoot down the notion that any code that works is good code but perhaps, for some purpose, it is, when speed, brevity and clarity do not go together.

Datasheet

```
; = HLFHL - BCD digits in HL / 2.
;/ CLASS: 1
;/ TIME CRITICAL?: No
;/ DESCRIPTION: Divides by 2 four BCD digits in HL, setting the
;/ carry if there is a remainder
;/ ACTION: Reset carry flag initially
;/ [ If carry then: high nibble H ← high nibble H - 6.
;/ Rotate HL left through carry so that:
;/ bits 3210,L ← carry and bits 765,H ] 4 times.
;/ SUBr DEPENDENCE: None
;/ INTERFACES: None
;/ INPUT: HL contains four BCD digits
;/ OUTPUT: HL contains the four BCD digit result of the division
;/ by 2.
;/ Carry is set if HL was originally an odd number.
;/ REGs USED: A, HL and Flags
;/ STACK USE: 2
;/ LENGTH: 21
;/ TIME STATES: 960-978
;/ PROCESSOR: Z80
HLFHL: PUSH BC ; save BC C5
      LD B,A0H ; 2's complement of 60H 06 A0
      LD A,+4 ; digit counter 3E 04
      OR A ; clear carry B7
LOOP1: JR NC,JUMP ; skip if no adjust to make 30 01
      ADD HL,BC ; make into decimal carry 09
      LD C,+4 ; bit counter 0E 04
LOOP2: ADC HL,HL ; rotate HL left through ED 6A
      DEC C ; carry to bring next digit 0D
      JR NZ,LOOP2 ; into high nibble H 20 FB
      DEC A ; repeat until 3D
      JR NZ,LOOP1 ; finished 20 F3
      POP BC ; restore BC C1
      RET ; return C9
```

Some of you intentionally wandered from the point to offer routines of more general application. Roger Hargrave from Crawley sent this routine to divide by two the BCD digits in A and set the carry if there is a remainder:

```
HLFA PUSH DE ;
      RR A ; rotate right.
      PUSH AF ; save carry.
      BIT 3,A ; if carry from
      JR Z,HL11 ; 1st digit take
      SUB 3 ; 3 from 2nd.
HL11 BIT 7,A ; if previous
      JR Z,HL12 ; carry take
      SUB 30H ; 3 from 1st.
HL12 POP DE ; recover carry
      LD D,A ; and marry
      PUSH DE ; it to new
      POP AF ; result in A.
      POP DE ;
      RET ;
```

HL can then be divided by two, thus:

```
XOR A ; clear carry.
      LD A,H
      CALL HLFA
      LD H,A
      LD A,L
      CALL HLFA
      LD L,A
```

The advantage of this approach is that HLFA can be used to process any string of BCD bytes that can be loaded into A from any pointer (HL, DE, BC, IX+d, IY+d or NN).

Both Jim Chance of Birmingham and Jan Beckman of Ashstead (and HLFZ) sent the same code for our second Datasheet, HLFB, to divide a string of BCD digits at (HL) by two.

MICROMART

GOAL!

Goal! An exciting all action football match. Corners, free kicks, goal kicks, penalties. Super graphics. £5 Lord of the Dragons (16K) - fantasy adventure £7. Gomoku £4. Meteors £4. Stock Market £4. Supersub £3. Devil Weave £3. Penetrate £3. Hangman £3. All games are for PETS (8K unless stated otherwise.) Supplied on cassette from Bob Chappell, Newland Toft, South Green, Mattishall, Norfolk. NR20 3JY.

SUPERBOARD II

STILL the best value in Home Computers. Just compare the features:

- * 8K floating point BASIC in ROM
- * Full ASC11 keyboard
- * Standard cassette/TV interface
- * RS232 printer interface
- * 4K user RAM
- * Expandable to 32K and dual mini-floppy
- * Full range of OHIO Computers carried.

AVAILABLE NOW FROM:

C.T.S.
31/33 Church Street
Littleborough
Lancs OL15 8DA

PLEASE RING OR WRITE FOR LATEST PRICES.

TEL: LITTLEBOROUGH (0706) 74342 or 79332 ANYTIME

APPLE & ITT 2020 BUSINESS SOFTWARE

Professionally written packages now available with comprehensive manuals, built-in validity checks, interactive enquiry facilities, user options, satisfying accountancy, Inland Revenue and Customs & Excise requirements. On diskette under DOS 3.2 in Applesoft with SPACE utility. Not adaptations. Written for Apple System. Support all printer interfaces. Sales, Purchases and General Ledgers £295.00 each. Manual only £3. Payroll £375. Manual only £4. General Ledger supports Incomplete Records, Job Costing, Branch and Consolidated Accounts, etc. General Ledger Applications Manual £10. Prices exclusive of V.A.T. From our shop or your nearest stockist.

COMPUTECH SYSTEMS

168 Finchley Road, London NW3.
Tel: 01-794 0202

PET!

Contact PI-LOK Systems Ltd for all your software needs.

Send s.a.e. for list of currently available programs.

We also provide programming support for IBM370, IBM3790 and WANG2200.

313 Bury and Rochdale Old Road, Heywood, LANCs. O110 4GN.
Telephone 0706-69693 (Ansafone)

MICROMART

CARDIFF MICRO CENTRE

PETs & SUPERPETS

+

SHARP MZ-80s

+

HEWLETT PACKARD

+

COMPUTER BOOKS

SIGMA SYSTEMS

54 Park Place

Cardiff 21515/34869

Softcentre

OVER 100 PROGRAMS FOR CBM/PET
Send 14p stamp for free catalogue or
60p stamps for catalogue
+ free program... worth £'s!

Part exchange your unwanted (Brand Label)
Programs.

Top Royalties for your own original top
quality programs - send cassette.

(Sharp & TRS80/V, Genie also wanted).

VIDEO GENIE £330 SHARP (48k) £499

EPSON TX-808 £365

FRICITION/TRACTOR

RADOFIN. TELETEXT CONVERTOR
ONLY £169.95

PETMASTER SUPERCHIP £45 TOOLKIT
(N.R.) £30

VERBATIM MD525-01 DISKS (PET/ITT
C)THINK £22/10

PET SOUND BOX £14.50.

10xC-12 CASSETTES £3.60

COMPUTHINK D/D: 400K £825 800K
£995

PET CASSETTE (PANTAL)

WITH AUDIO MONITOR &

COUNTER £995

MOST MICROS BOUGHT, SOLD
REPAIRED

OPTELCO

26 ALBANY ROAD
RAYLEIGH ESSEX
Callers strictly by appointment
(0268-774089) NOON - 8pm Mon-Sat
ALL PRICES EXCLUSIVE
OF VAT & CARRIAGE

To advertise in
MICROMART

Please ring Jacquie Hancock
on 01-631 1682

PETKOM 1

16 BASIC commands for the new ROM PET

SHIFT UP/DOWN/LEFT/RIGHT -
screen shifted with or without wrap-
around

PLOT/DELETE/TEST - points in
double density (80x50) format.

CLEAR SCREEN-above/below cursor

REPEAT KEY - variable repeat

FILL SCREEN - with any character.

REVERSE SCREEN

£5 1580 bytes of machine code
in C12 cassette with printed
instruction sheet.

M. WIRT

12 ALLEYN CR. LONDON S.E.21

Datasheet

;= HLFB - BCD in (HL) / 2

;/ CLASS: 1

;/ TIME CRITICAL ? No

;/ DESCRIPTION: Divides by 2 a string of BCD digits at (HL)
setting the carry if there is a remainder

;/ ACTION: Get digit to A, add 10 if carry from last digit,
shift right. Rotate digits back to memory, repeat
for 2xC digits.

;/ SUBr DEPENDENCE: None

;/ INTERFACES: None

;/ INPUT: C bytes of BCD in (HL) which points to the most
significant byte

;/ OUTPUT: Input bytes divided by 2. HL points to the lowest
byte. BC=0=A.

;/ REGs USED: AF, BC and HL.

;/ STACK USE: None

;/ LENGTH: 19

;/ PROCESSOR: Z80

HLFB:	XOR	A	; clear A and carry	AF
BV1:	LD	B,+2	; 2 digits per byte	06 02
BV2:	RLD		; get most signif digit	ED 6F
	JR	NC,BV3	; 10 carried ?	30 02
	ADD	A,+10		C6 0A
BV3:	RRA			1F
	DJNZ	BV2	; loop for 2nd digit	10 F7
	RLD		; answer to memory	ED 6F
	DEC	C	; byte counter	0D
	RET	Z	; finished ?	C8
	INC	HL	; get next byte	23
	JR	BV1	; process it	18 EE

Putting it together

If you have a memory-mapped display and have kept all the Datasheets printed
in this series, try the code below.

```

● LINE1 EQU aaaa ; £090A on Nascom ●
● LINE2 EQU bbbb ; £098A on Nascom ●
● LINE3 EQU cccc ; £0A0A on Nascom ●
● ; Clear the screen ●
● LD B,+40 ; enter up to 40 ●
● LD C,"R ; ASCII chrs ●
● LD DE,LINE1+39 ; calculator ●
● CALL LSCN ; fashion. ●
● LD DE,LINE1+39 ; convert ●
● LD HL,LINE2+39 ; into BCD ●
● LD B,+40 ; on another ●
● CALL SNBF ; line. ●
● CALL DL1S ; delay 1 sec ●
● CALL DL1S ; twice ●
● INC HL ; divide ●
● LD C,+20 ; BCD ●
● CALL HLFB ; by 2. ●
● LD DE,LINE3 ; convert ●
● LD HL,LINE+20 ; divided ●
● LD B,+20 ; BCD back ●
● CALL BFSR ; to ASCII. ●
● Return to your monitor. ●

```

Remember that LSCN needs RLTV and
your own routine to get a character
from the keyboard into A. This is per-
haps not the most useful application
that has been devised but it does show
that we are getting to the point of
putting programs together from the
routines that have been printed.

There are now three things you can
do in this series:

- understand and improve the routines
that are printed;

- contribute your own original rou-
tines for others to have a go at;

- exercise your ingenuity in putting
routines together.

Cormac Duffin from Northern Ire-
land but now at Leicester University
has sent a shorter version (31 bytes)
of BFSR (the left justified version of
BFSR we printed in December). Cor-

mac's routine also saves AF and B
registers.

Mystery of OP codes

Dave Barrow is intrigued by the missing
instruction codes CB 30 to CB 37,
which shift left and increment B, C,
D, E, H, L, (HL) and A. Since they are
not in the CPU's specification, it is
assumed that they can not be relied on
to work in all circumstances. We would
be interested to know whether or not
they work on your Z80 machine and,
if so, what you can use them for.

Saving registers

Roger Hargrave, when playing with
graphics, needs to save and restore all

registers repeatedly and does so by calling:

```
PSHEM:  EX  (SP),HL ;HL to stack
        PUSH DE
        PUSH BC
        PUSH AF
        PUSH IX
        PUSH IY
        PUSH HL ;return addr to stack
        RET

and
POPEM:  POP  HL ;return addr to HL
        POP  IY
        POP  IX
        POP  AF
        POP  BC
        POP  DE
        EX  (SP),HL
        RET
```

PSHEM carries forward the values of all registers unchanged except for that of HL, which has been used to carry PSHEM's return address to the bottom of the stack. The problem is to carry forward from PSHEM the original values of all registers (including HL) and we want the shortest Class 1 solution.

Sub Set is not confined to Z80 routines; by sheer co-incidence the original contributors were Z80 users, but contributions, documented as shown here, are most welcome from users of other processors. Send your subroutines to : PCW Sub Set, PCW, 14 Rathbone Place, London W1P 1DE

LEISURE LINES

Well, Puzzle 15 doesn't seem to have been very difficult — only 50 of the 139 answers were incorrect and the randomly-chosen winner is Mrs Julia Todd of New Malden, Surrey. Congratulations, Mrs. Todd — your prize will soon be on its way to you.

The winning solution was:

Max: START-8-14-8-18-14-19-16-18-15-17-FINISH (166)

Min: START-2-2-3-3-7-11-2-2-1-1-8-FINISH (42)

Max difference = 124.

Quickie

As usual, no answers required and no prizes for these.

1. How many triangles are there in this figure?

2. One ninth is two less than a third of a half of X; what's X?

Prize puzzle

Messrs Baker, Cooper, Parson and Smith are a baker, a cooper, a parson and a

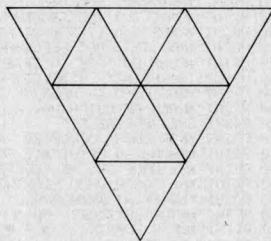

smith. However, no-one has the same name as his vocation. The cooper is not the namesake of Mr Smith's vocation; the baker is neither Mr Parson nor is he the namesake of Mr Baker's vocation. What is Mr Baker's vocation?

Answers on a postcard, please, to Puzzle No 18, PCW, 14 Rathbone Place, London W1P 1DE, to arrive no later than 28 February. The prize is the usual book token.

PROGRAMS

PET Greenfingers by Bob Chappell

Here is a 'vegetable planning' suite of programs.

The first program explains how to use the programs. The second gives sowing, planting and harvesting details for the 20 most common vegetables.

The third program enables you to plan your garden and record the details on tape. It can then be updated with amendments and harvesting details. POKE 59458,30 to restore screen printing to its normal mode.

```
100 REM**COPYRIGHT*BOB CHAPPELL*28/11/80**
110 POKES9468,14
120 POKES9458,62
130 L=1
140 PRINT"*****GREEN FINGERS INSTRUCTIONS."
150 PRINT"*****THERE ARE 2 PROGRAMS."CHR$(34)"VEG GUIDE"CHR$(34)" AND
160 PRINT"*****CHR$(34)"VEG PLAN"CHR$(34)".
170 PRINT"*****PROGRAM "CHR$(34)"VEG GUIDE"CHR$(34)" CONTAINS
180 PRINT"*****INFORMATION ON 20 OF THE MOST POPULAR
190 PRINT"*****VEGETABLES AND HAS 4 MAIN FACILITIES:-
200 PRINT"*****1. SEED INFORMATION.
210 PRINT"*****2. A SEED REQUIREMENT CALCULATOR.
220 PRINT"*****3. A ROW CALCULATOR.
230 PRINT"*****4. A MONTHLY CALENDAR.
240 GOSUB1180
250 PRINT"*****3. SEED INFORMATION.
260 PRINT"*****FOR ANY LISTED VEGETABLE, THE PROGRAM
270 PRINT"*****WILL GIVE:-
280 PRINT"*****1. THE AMOUNT OF SEED FOR A 30 FT ROW.
290 PRINT"*****2. THE AVERAGE YIELD FOR A 30 FT ROW.
300 PRINT"*****3. THE AVERAGE DURATION BETWEEN SOWING " PRINT" AND HARVESTING."
310 PRINT"*****4. SEED DEPTH. " PRINT"5. SPACING BETWEEN SEEDS.
320 PRINT"*****6. SPACING BETWEEN ROWS. " PRINT"7. SPACING BETWEEN TRANSPLANTS."
330 PRINT"*****8. RECOMMENDED SOWING DATES. " PRINT"9. RECOMMENDED PLANTING DATES.
340 GOSUB1180 PRINT"*****2. SEED CALCULATOR.
350 PRINT"*****WHEN BEING GIVEN THE NUMBER OF ROWS AND
360 PRINT"*****THEIR LENGTH, THE PROGRAM WILL LIST, FOR
370 PRINT"*****ANY VEGETABLE:-
380 PRINT"*****1. THE AMOUNT OF SEED REQUIRED.
390 PRINT"*****2. THE AVERAGE YIELD (PER ROW OR PLANT).
400 PRINT"*****FOR VEGETABLES THAT ARE PLANTED OUT, THE
410 PRINT"*****PROGRAM ALSO GIVES:-
420 PRINT"*****3. THE TOTAL NUMBER OF PLANTS NEEDED
430 PRINT"***** TO FILL THE GIVEN ROWS.
440 PRINT"*****4. THE TOTAL YIELD FROM THE PLANTS.
450 GOSUB1180 PRINT"*****3. ROW CALCULATOR.
460 PRINT"*****WHEN BEING GIVEN THE ROW LENGTH AND THE
470 PRINT"*****REQUIRED YIELD, THE PROGRAM WILL LIST,
```

MICROMART

GOOD THINGS FOR 6800 SYSTEM BUILDERS

1. P.C.B.'s, including component list & schematics:-
 CSH001 — SWTPC MOB/2 motherboard £24.20
 CSH002 — SWTPC MPA/2 CPU board £11.50
 CSH005 — SWTPC MPL/A parallel interface board £6.60
 CSH006 — SWTPC MPS serial interface board £6.60
 2. Assembled Boards.
 CSH003 — SWTPC MPA/2 CPU, SWTBUG, space for 8k Eprom £75.00
 CSH004 — SWTPC MPA CPU, MIKBUG £49.50
 3. Components.
 CSG020 — 6800 Chip set: M6800, M6821, M6850, M6810, & M6875 £16.50
 CSH021 — Molex connectors, 10 pin male, pack of 10 £2.50
 CSH022 — Molex connectors, 10 pin female, pack of 10 £3.00
 CSH030 — MOTOROLA 6800 PROGRAMMING MANUAL, VAT free. £6.60
 Prices include postage but add VAT at 15% when ordering
 COMPUSENSE LTD. P.O. BOX 169 LONDON N13 4HT Tel: 01-882 0681

JANUARY SPECIALS

SHUGART SA 801R
 8 inch disc drives £295
 ANADEX 9501
 Full graphics 2K Buffer £875

Postage and VAT extra

Call 0305 66913

T. A. Designs
 55 High West Street, Dorchester, Dorset

PET CHIPS

PETMASTER SUPERCHIP £45
 PIC-CHIP £45
 PROGRAMMER'S TOOLKIT £29
 MIKRO ASSEMBLER £50

Write for full details of these plug-in PET ad add-ons which fit in the spare ROM sockets of a large keyboard machine. If your PET has a calculator keyboard you'll need an extension board (£13) which will accommodate any two of the chips.

BASIC 4.0 versions are available to fit the 4000 and 8000 series models — write for information and prices.

We also sell programs on cassette and disk (£2.50 extra) — there are over a 100 to choose from including BLOCK RENUMBER (£12), DISK APPEND (£15), HALLS OF DEATH (£14), ALIEN ATTACK (£10), and WIZARD'S LAIR (£10). And MAKRO ASSEMBLER at £50 offers an opportunity for machine code programmers to really flex their mnemonics.

Why not phone for our free catalogue!
 Add 15% VAT to all prices. Post Free.

SUPERSOFT

28 Burwood Avenue,
 Eastcote, Pinner, Middlesex
 Telephone: 01-866 3326



THE ZX80 MAGIC BOOK

£4.75

For machines with 1-3K RAM. New edition 3 contains 20 plus programs including one which allows you to make music with your ZX80, and games such as Moon Lander, Hammurabi, Othello, Hexpawn and Animals. Also sections on How it Works, Plotting, Using USR, Converting other BASICs, and Hardware Notes including circuits for static and dynamic memory extension and I/O.

TIMEDATA Ltd. 57 Swallowdale,
 Basildon, Essex

UK 101 & SUPERBOARD * SOFTWARE

The top ten from the guy who wrote "LE PASSE-TEMPS".

1. GALACTIC HITCHHIKER (8K) An Adventure, all in Machine Code. A beauty!
 2. STARTREK (8K) The old favourite but no scrolling! All the info. on display all the time.
 3. SUPERTREK (8K) A graphics version. Sail boldly, through the universe, zapping moving Klingons in real time.
 4. PIRANHA* A fun, real time graphics game.
 5. BREAKOUT* A smashing version with machine-code to move the paddle.
 6. STUD POKER (8K) You against the mean machine.
 7. LUNAR LANDER A real challenge. You won't get down in less than 3 hours.
 8. STOCKMARKET (8K) A realistic simulation for would-be millionaires.
 9. LE PASSE-TEMPS* You need this one, if you haven't already got it.
 10. HANGMAN* Excellent graphics (P.E. said so!)
- Others available include a BASIC TUTOR @ £10. (comprises 8x4K programs) and lots more games. Note that these are ORIGINAL PROGRAMS, NOT 101 VERSIONS OF PRINT!
- PRICES: 8K £4, 4K £2 all inclusive from Mr. A. Knight,
28, Simonside Walk, Ormesby, Cleveland.
Phone (0642) 321266

OSI/UK User Group

Support for

OHIO SCIENTIFIC

the independent user group for all users of Ohio Scientific small computers (Superboard to C3) and UK101

professionally-produced
A5-format bi-monthly Newsletter
Issue 5 (Vol. 2 No. 1)
available now

development and documentation
programming and planning aids
and much more!

£10.00

for six-issue membership/subscription

contact: *George Chkiantz*

12 Bennerley Road, London SW11 6DS

Play KALA our best selling game for the ZX80

Now only *£2* on cassette with documentation

New SUPERKALA for the 2k machine—its almost, but not quite, unbeatable. Just *£3*

MASTERMIND MATHS-TEST

TRIANGLES £2 each

LUNAR LANDER SPACE DOCKING

STOPWATCH and CLOCK only £3.75

for all four.

Many more super programs in our catalogue.

C12 cassettes — only £2.75 for 5.

Hints and Tips for the ZX80 £3.50

Send see for catalogue or order *KALA* from Hewson Consultants 7 Grahams Close

Blewbury Oxon OX11 9QE

STOKE on TRENT

for
TUSCAN
and
TANGERINE
and
VIDEO GENIE
and
BOOKS

MICRO-PRINT Ltd.,

59, Church Street, Stoke on Trent.
(0782) 48348. Barclaycard and Access

PROGRAMS

```

480 PRINT"FOR ANY VEGETABLE:-
490 PRINT"01. THE NUMBER OF ROWS NEEDED.
500 PRINT"02. THE AMOUNT OF SEED NECESSARY.
510 PRINT"FOR TRANSPLANTS, THE PROGRAM WILL LIST:-
520 PRINT"03. THE TOTAL NUMBER OF PLANTS NEEDED.
530 PRINT"04. THE SPACING BETWEEN PLANTS." :GOSUB1180
540 PRINT" 04. THE MONTHLY CALENDAR.
550 PRINT"FOR ANY MONTH, THE PROGRAM WILL LIST ALL
560 PRINT"THE SOWINGS AND TRANSPLANTS THAT CAN BE
570 PRINT"CARRIED OUT IN THAT MONTH, TOGETHER WITH
580 PRINT"THE LATEST DATES BY WHICH SOWING AND
590 PRINT"PLANTING SHOULD HAVE BEEN COMPLETED." :GOSUB1180
600 PRINT"0 GENERAL NOTE.
610 PRINT"FOR ANY LISTING REQUIRED WHERE THE
620 PRINT"PROGRAM FINDS NOTHING TO REPORT" PRINT" (E.G. DECEMBER SOWINGS) )
630 PRINT"THE PROGRAM WILL MERELY PRINT A DOUBLE"
640 PRINT"LINE, LIKE SO:-" PRINT# PRINT#
650 PRINT"AND ASK YOU TO PRESS A KEY TO" PRINT"CONTINUE -- LIKE NOW!
660 GOSUB1180
670 PRINT"PROGRAM "CHR$(34)"VEG PLAN"CHR$(34)" COVERS
680 PRINT"THE SAME VEGETABLES, BUT ALLOWS YOU TO
690 PRINT"STORE YOUR INDIVIDUAL PLAN ON TAPE." PRINT"THE FACILITIES ARE:-
700 PRINT"01. READ IN A PREVIOUSLY RECORDED PLAN" PRINT" FROM CASSETTE.
710 PRINT"02. DISPLAY YOUR VEGETABLE PLAN.
720 PRINT"03. UPDATE THE PLAN." PRINT"04. RECORD THE LATEST PLAN ON CASSETTE.
730 GOSUB1180 PRINT" 01. READ IN A PLAN.
740 PRINT"YOU ARE PROMPTED TO LOAD THE APPROPRIATE
750 PRINT"TAPE PRIOR TO READING IN A PREVIOUSLY
760 PRINT"RECORDED PLAN."
770 PRINT"OBVIOUSLY, ON YOUR FIRST USE OF THE
780 PRINT"PROGRAM, YOU WILL NOT HAVE A PREVIOUS
790 PRINT"TAPE BUT THE PROGRAM ALLOWS YOU TO
800 PRINT"CREATE ONE FROM SCRATCH."
810 PRINT"AND IT IS NOT NECESSARY TO HAVE A RECORDED "
820 PRINT"PLAN ON TAPE IN ORDER TO USE THE PROGRAM
830 GOSUB1180 PRINT" 02. DISPLAY THE PLAN.
840 PRINT"THE PLAN IS MADE UP OF 100 GARDEN ROWS.
850 PRINT"REACH OF WHICH MAY HOLD INFORMATION ABOUT
860 PRINT"ONE VEGETABLE."
870 PRINT"FOR EACH OCCUPIED ROW, THE DISPLAY
880 PRINT"SHOWS:-" PRINT"01. ROW NUMBER." PRINT"02. LENGTH OF THE ROW.
890 PRINT"03. NAME OF THE VEGETABLE." PRINT"04. MONTH SOWN.
900 PRINT"05. MONTH WHEN PICKING IS EXPECTED." PRINT"06. THE EXPECTED YIELD.
910 GOSUB1180 PRINT"07. NORMALLY, THE YIELD IS SHOWN IN LBS.
920 PRINT"FOR LETTUCE, AN A H INDICATES 'HEADS.'" PRINT"08. LBS.
930 PRINT"FOR PLANTS, A S T INDICATES THE YIELD IN
940 PRINT"POUNDS FROM THE FINAL TRANSPLANTS." :GOSUB1180
950 PRINT" 03. UPDATE THE PLAN." PRINT"THE PROGRAM WILL ASK FOR:-
960 PRINT"01. THE ROW NUMBER (1-100)
970 PRINT"02. LENGTH OF THE ROW (IN MULTIPLES OF
980 PRINT" FIVE FEET, MAXIMUM LENGTH 9995.)
990 PRINT"03. THE VEGETABLE TO OCCUPY THAT ROW.
1000 PRINT"04. THE MONTH THE SEED WAS SOWN." :GOSUB1180
1010 PRINT"THE PROGRAM WILL GIVE YOU WARNING" PRINT"MESSAGES IF:-
1020 PRINT"01. YOU MAKE AN ENTRY TO A ROW WHICH IS
1030 PRINT" ALREADY OCCUPIED." PRINT"02. YOU ENTER A SOWING DATE THAT IS"
1040 PRINT"03. EARLIER OR LATER THAN THE RECOMMENDED" PRINT" LIMITS.
1050 GOSUB1180 PRINT" 04. RECORD THE PLAN ON CASSETTE.
1060 PRINT"THE FOURTH OPTION IS 'END OF RUN'
1070 PRINT"WHEN YOU SELECT THIS, THE PROGRAM WILL
1080 PRINT"ASK WHETHER YOU WISH TO WRITE AWAY YOUR
1090 PRINT"PLAN AND, IF SO, PROMPT YOU TO LOAD A
1100 PRINT"TAPE.
1110 PRINT"THE FINAL THING OPTION 4 DOES IS TO" PRINT"END THE RUN.
1120 GOSUB1180
1130 POKE59458,12
1140 PRINT"THOSE ARE ALL THE INSTRUCTIONS.
1150 PRINT"YOU WILL FIND THE PROGRAMS GIVE PLENTY
1160 PRINT"OF PROMPTS AT THE APPROPRIATE PLACES.
1170 PRINT" HAVE A BUMPER CROP!" POKE59458,30 END
1180 PRINT"
1190 PRINT"
1200 GET# IF#="" THEN1200
1210 PRINT"0" :RETURN
    
```

```

100 POKE59458,62
110 DIM#(20),S(20,10),M(12)
120 L#="" :G=32 :W=29
130 DEFFNAC(X)=INT(X*1012+.5)/1012
140 FORJ=1TO20 READ#(J) :FORK=0TO10 READS(J,K) :NEXT NEXT
150 FORJ=1TO10 READM(J) :NEXT
160 DATA000 BEAN,1.25,16,16,0.9,18,0,302,104,0,0
170 DATA001 BEAN,1.15,20,12,2,6,13,0,304,6,0,0
180 DATA002 BEAN,1.25,100,13,2,12,15,0,205,306,0,0
190 DATA003 BEAN,1.25,27,16,1,4,12,0,304,6,0,0
200 DATA004 BROCCOLI,1.25,1,5,40,1,5,0,9,24,4,105,5,6
210 DATA005 BRUSSELS SPROUTS,1.25,2,33,1,5,0,6,30,203,204,305,6
220 DATA006 CABBAGE,1.25,2,35,1,5,0,6,18,207,208,209,210
230 DATA007 CABBAGE,1.25,2,32,1,5,0,6,18,4,105,5,106
240 DATA008 CABBAGE,1.25,2,32,1,5,0,6,18,4,5,305,6
250 DATA009 AUTUMN CAULIFLOWER,1.25,1,5,21,1,5,0,6,24,4,5,305,6
260 DATA010 CAULIFLOWER,1.25,1,5,40,1,5,0,6,24,304,5,306,7
270 DATA011 BEETROOT,1.25,25,16,1,5,0,6,0,0,6,0,0
280 DATA012 LETTUCE,1,5,30,11,1,5,0,12,0,4,107,0,0
290 DATA013 SPRING ONION,1.25,2,15,1,5,0,12,0,3,208,0,0
300 DATA014 SPINACH,1.25,30,33,1,3,12,0,3,104,0,0
310 DATA015 PEA,1,5,30,14,2,6,36,0,303,106,0,0
320 DATA016 EARLY POTATO,5,55,13,5,12,24,0,104,204,0,0
330 DATA017 MAINCROP POTATO,5,55,22,5,15,30,0,204,304,0,0
340 DATATURNIP,1.25,30,10,1,5,0,18,0,104,206,0,0
350 DATASWED,1.25,30,22,1,5,0,18,0,5,6,0,0
360 DATAJAN,FEB,MARCH,APRIL,MAY,JUNE,JULY,AUG,SEPT,OCT,NOV,DEC
370 PRINT"0 0 OPTIONS 0"
380 PRINT"1. LIST SEEDS" :PRINT"2. CALC. SEEDS" :PRINT"3. CALC. ROWS"
390 PRINT"4. MONTHS" :PRINT"5. END OF RUN" :INPUT"OPTION":G
400 IF#<1OR#>5 THEN370
410 ON#0TO420,710,900,1090,1220
420 GOSUB440 :IF#=99 THEN370
430 GOTO480
440 PRINT"0 SEEDS" :FORJ=1TO20 :PRINTJ :TAB(4) :V#(J) :NEXT
450 INPUT" WHICH NUMBER (99 TO RETURN TO OPTIONS) ":V
460 IF#<1OR#>20AND#>99 THEN440
470 RETURN
480 PRINT" 0" :V#(V)
490 PRINT# :PRINT"SEED PER 30 FT ROW (<") :X#(V,0)
500 IF#<1 THENPRINT"02" :TAB(0) :X#(V,0) :GOTO530
510 IF#<2 THENX#-1 :PRINT"PRINT" :TAB(0) :X#(V,0) :GOTO530
520 PRINT" LBS" :TAB(0) :X#(V,0)
530 PRINT# :X#(V,1)
540 IF#<4AND#<12 THENPRINT"YIELD PER PLANT (LBS)" :TAB(0) :X#(V,0) :GOTO580
550 PRINT"YIELD PER 30 FT ROW (<") :IF#<13 THENPRINT"HEADS" :TAB(0) :X#(V,0) :GOTO570
560 PRINT" LBS" :
    
```

PROGRAMS

```

570 PRINTTAB(0);X
580 PRINTL$:PRINT"SOING-HARVESTING (WEEKS)"TAB(0)S(V,2)
590 PRINTL$:PRINT"SEED DEPTH (INS)"TAB(0)S(V,3):PRINTL$
600 PRINT"BEETWEEN SEEDS "
610 IFS(V,4)=0THENPRINTTAB(20)" SOW THINLY" GOT0630
620 PRINT"(INS)"TAB(0)S(V,4)
630 PRINTL$:PRINT"BEETWEEN ROWS (INS)"TAB(0)S(V,5):PRINTL$
640 IFS(V,5)=0THENPRINT650
650 PRINT"BEETWEEN TRANSPLANTS (INS)"TAB(0)S(V,6):PRINTL$
660 P=S(V,7):GOSUB1230:PRINT"SOW FROM "P#" TO " :P=S(V,8):GOSUB1230:PRINTP#
670 PRINTL$:IFV<50R0V11THEN700
680 P=S(V,9):GOSUB1230:PRINT"TRANSPLANT FROM "P#" TO "
690 P=S(V,10):GOSUB1230:PRINTP#:PRINTL$
700 PRINTL$:GOSUB1280:GOT0420
710 GOSUB440:IFV=99THEN370
720 PRINT"ROW LENGTH"
730 INPUT"MULTIPLES OF 5 FEET":F2
740 F1=INT(F2/5):IF2<F1*5THEN730
750 F=F2/30:INPUT"HOW MANY ROWS":R:IFR<0THEN750
760 Y=FNA(S(V,1)*F)*R
770 PRINT" "
780 PRINT"SEED REQUIRED ( ):N2=S(V,0)
790 IFX<1THEN:FNA((X2)*F)*R):PRINT"02)"TAB(W)*X GOT0620
800 IFX<2THEN:FNA((X2-1)*F)*R):PRINT"02)"TAB(W)*X GOT0620
810 PRINT"LB$":X=FNA((X2)*F)*R):PRINTTAB(W)*X
820 PRINT" AVERAGE YIELD PER PLANT (LBS)"TAB(W)*X GOT0890
830 IFV<50R0V11THENPRINT"HEADS)"TAB(W)*X GOT0890
840 X=FNA(S(V,1)):PRINT"PER PLANT (LBS)"TAB(W)*X
850 PRINT"LB$:PRINT"IF ROWS REFERS TO TRANSPLANTS THEN-
860 PRINT"TOTAL PLANTS":
870 X=FNA(INT((F*30*12)*R/S(V,6))):PRINTTAB(W)*X
880 PRINT" AVERAGE YIELD (LBS)":X=FNA(X*S(V,1)):PRINTTAB(W)*X
890 PRINT"LB$:PRINTL$:GOSUB1280:GOT0710
900 GOSUB440:IFV=99THEN370
910 PRINT"ROW LENGTH"
920 INPUT"MULTIPLES OF 5 FEET":F2
930 F1=INT(F2/5):IF2<F1*5THEN920
940 T="LB$":IFV=13THEN#="HEADS"
950 PRINT"HOW MANY "T$:INPUT P=INT(P):IFP<1THEN950
960 PRINT" "
970 PRINTL$:PRINT"TO PRODUCE"P:T# USING"2"FT ROWS"
970 PRINTL$:X=P/S(V,1):GOSUB1310:P=X:IFV<50R0V11THEN1010
980 X=P*S(V,6)/12:X=FNA(X/F2):IFX<1THEN#="
990 PRINT"TOTAL PLANTS NEEDED"TAB(24)*P:PRINT"NUMBER OF ROWS"TAB(24):
1000 GOSUB1310:PRINT"SPACE BETWEEN PLANTS"TAB(24)*S(V,6)"INS":GOT01060
1010 X=FNA(P*30/F2):IFX<1THEN#="
1020 PRINT"SEED NEEDED"TAB(24)*F:S=S(V,0)
1030 IFS(V,8)<1THEN#="02":GOT01060
1040 IFS(V,8)<2THEN#="PINTS":F=S(V,0)-1:GOT01060
1050 T="LB$":
1060 F=FNA(P*F):GOSUB1310:IFP<09THENF#=#09
1070 PRINTF:T#:PRINT"ROWS TO BE SOWN"TAB(24)*X
1080 PRINT"LB$:PRINTL$:GOSUB1280:GOT0900
1090 PRINT" ":FORJ=1TO12:PRINTJ:TAB(4)*M(J):NEXT
1100 INPUT"MONTH NO. (99 TO RETURN TO OPTIONS)":M
1110 M=INT(M):IFM<10R(MD12ANDM<99)THEN1090
1120 IFM=99THEN370
1130 INPUT"ROW OR TRANSPLANT (S/T)":A#
1140 IFA#="S"THENZ=7:Z1=8:A#=" SOWINGS":GOT01170
1150 IFA#="T"THENZ=9:Z1=10:A#=" TRANSPLANTS":GOT01170
1160 GOT01130
1170 PRINT" "
1180 P=S(J,Z):P1=INT(P/100):P=F-(P1*100)
1190 P2=S(J,Z1):P3=INT(P2/100):P1=P2-(P3*100):IFM=9FANDM<F1THEN1210
1200 NEXT:PRINTL$:GOSUB1280:GOT01090
1210 P=P2:GOSUB1230:PRINTM(J):TAB(26)*P#:GOT01200
1220 PRINT"END OF RUN"POKE59453,30:END
1230 P1=INT(P/100):IFP1=0THENP#="ALL " :P1=P:GOT01270
1240 IFP1=1THENP#="EARLY " :P1=P-100:GOT01270
1250 IFP1=2THENP#="MID " :P1=P-200:GOT01270
1260 P#="LATE " :P1=P-300
1270 P#P#M(P1):RETURN
1280 PRINT"PRESS SPACE TO CONTINUE"
1290 GETA#:IFA#=" "THEN1290
1300 RETURN
1310 A#STR$(X):FORK=1TOLEN(A#):IFMID$(A#,K,1)=" "THEN1330
1320 NEXT X=INT(VAL(A#)):RETURN
1330 IFA#MID$(A#,K+1,1)>4THENX=VAL(A#)+1:A#STR$(X)
1340 K=LEN(A#):GOT01320

```

```

100 REM*COPYRIGHT*BOB CHAPPELL*26/11/80*
110 DIM(100,1),K(100,1),S(20,3),V(20),M(12)
120 POKE59458,62
130 L#=""
140 FORJ=1TO20:READM(J):FORK=0TO3:READS(J,K):NEXT NEXT
150 FORJ=1TO12:READM(J):NEXT
160 DEFNAR(X)=INT(X*10+.5)/10
170 DEFNAR(X)=LEN(STR$(INT(X)))-(ABS(Z)-1)
180 DATARBON, BEAN, 16, 4, 4, 2
190 DATARF, BEAN, 20, 3, 6, 4
200 DATARUN, BEAN, 100, 3, 6, 5
210 DATAREETROOT, 27, 4, 6, 4
220 DATARF, BROCCOLI, 1, 5, 10, 5, 4
230 DATARF, SPROUTS, 2, 8, 4, 3
240 DATARF, CABBAGE, 2, 9, 8, 7
250 DATARF, CABBAGE, 2, 8, 5, 4
260 DATARF, CABBAGE, 2, 8, 5, 4
270 DATARF, CAULI, 1, 5, 5, 5, 4
280 DATARF, CAULI, 1, 5, 10, 5, 4
290 DATACARROT, 25, 4, 6, 3
300 DATALETTUCE, 30, 3, 7, 4
310 DATASPR, ONION, 9, 4, 8, 3
320 DATARHNSHIP, 30, 8, 4, 3
330 DATAPER, 30, 3, 6, 3
340 DATAR, POTATO, 55, 3, 4, 4
350 DATAR, POTATO, 55, 4, 4, 4
360 DATATURNIP, 30, 3, 8, 4
370 DATASWED, 30, 5, 6, 5
380 DATARF, FEB, MAR, APR, MAY, JUN, JULY, AUG, SEP, OCT, NOV, DEC
390 PRINT" "
400 PRINT" "
410 PRINT" "
420 A=INT(CA):IFA<10R4THEN390
430 ONA<GOT0440, 470, 690, 1020
440 PRINT"LOAD DATA TARE FOR READING":GOSUB1110:PRINT" "OPEN1,1
450 FORJ=1TO100:INPUT#1,G(J,0):INPUT#1,G(J,1):NEXT
460 FORJ=1TO100:INPUT#1,K(J,1):NEXT CLOSE1:GOT0390
470 X1=0:X=0:GOSUB660:FORJ=1TO100
480 IFG(J,0)=0THEN590
490 X1=X+1:X=X+1:IFX=10THENGOSUB1110:X=1:GOSUB660
500 Q=4:PRINTTAB(FNB(J)):J#":Q=9:PRINTTAB(FNB(G(J,0))):G(J,0)
510 PRINTTAB(11)*S(N(J,1)):TAB(23)*M(G(J,1)):TAB(28):
520 H=G(J,1)+S(N(J,1)):IFH<12THENH#="12
530 PRINTH#(H):Q=37
540 Z=N(G(J,1)):IFZ<4ANDZ<12THEN610
550 V=INT((G(J,0)/30)*S(Z,0)+.5):IFY<1THENY=1
560 PRINTTAB(FNB(V)):Y

```

MICROMART

OKI

MICROLINE 80

£359*

NORTHAMBER LTD
Great Oak House, Esher, Surrey
KT10 9BR Tel: 0372 62071
**plus VAT and delivery*

U.K.101 SOFTWARE "YOU'RE THE BOSS"

The Business Game that lets you control a Company and make all the decisions. Requires 8K.

£6.95 inclusive of VAT and p.& p.

PET SOFTWARE

We have a range of games and educational programmes on cassette. Write for a free list and see what we can offer you with a "by return service".

Appendek Ltd., 12 Cleeve Close, Astley Cross, Stourport-on-Severn, Worcs. DY13 0NY

topmark

computers

NEW! NEW! NEW!



APPLE FORTRAN
(Needs language card)

Send only £120 + VAT £18 (Fortran only) or £419 + VAT £62.85 (complete system, includes Pascal and language card)

NEW! NEW! NEW!

NEW! DOS 3.3 — much improved capacity £40 + VAT £6.

NEW! Eurocolour card — vastly superior to previous versions £113 + VAT £16.95

Official Government and Educational orders accepted.

Contact Tom Piercy at
Topmark Computers, 77 Wilkinson Close, Eaton Socon, St Neots, Cambs. PE19 3HJ
Huntingdon (0480) 212563

ZX80 MAIL ORDER SOFTWARE

Quality software at Realistic prices

Programs are packaged four per cassette and price includes all four programs, detailed instructions, loading hints, postage and packing.

GT1AA — 4 Games for 1 Kbyte ZX80 £5.00
Simon, Mindbender, Fruit Machine, Destroyer

GT1AD — 4 Games for 1 Kbyte ZX80 £5.00
Paper-Stone-Scissors, Calendar, Maxinum, Battleships

ET1AB — 4 Maths exercises for 1 £5.00
Kbyte ZX80 Arithmetic, Quadratics, Prime Factors, Profits

GT2AC — 4 Games for 2 Kbyte ZX80 £6.00
Hangman, TicTacToe, Reversi, Binary Squares

Cheque with order, or SAE for more details, to: ECONOSOFT, 4 The Loont, Winsford, Cheshire, CW7 1EU

MICROMART

SINCLAIR ZX80 SOFTWARE

HANGMAN	PONTOON
OTHELLO	LUNAR LAND
STARSHIP	AWARI
ADVENTURE	SOLITAIRE
HEXAPAWN	DRAUGHTS

Send a large sae for the
NEW CATALOGUE

CDS MICRO SYSTEMS
10 Westfield Close, Tickhill
Doncaster DN11 9LA
Mail Order Only

NASCOM GRAPHICS

VERY HIGH RESOLUTION FOR
NASCOM 2
380 x 220 individually addressable
points

FEATURES:

- * fully bit mapped from dynamic RAM
- * software controlled
- * software supplied for point-plot, line-draw, -block-shading and display control
- * mixed text and graphics
- * real time plotting from ASSEMBLER
- * real time plotting from BASIC with NAS-SYS-3
- * BASIC plot-then-display with other monitors
- * display size variable to suit memory available (approx 10k reqd for full screen)
- * professional double-sided PCB
- * built & fully tested with plug, socket and cable
- * full instructions for simple installation

Price including p&p . . . £55 + 15% VAT
L.J.NOBLE 6 Laleham Ave.
Mill Hill
London NW7 3HL

tel 01 959 0106

EIGHT INCHES OF PLEASURE

PROFESSIONAL 8"
IBM TYPE DISKETTES
Single Sided -

Single & Double Density Formats

£1.95 EACH Inclusive
+ 90p P&P per order

ANY QUANTITY (Cash with Order)

Fast Delivery	IT DATA SERVICE
Mail Order	43 PRAED STREET
(or call in!)	LONDON, W21NR

PROGRAMS

```

570 IFZ2=13THENPRINT"13H"
580 PRINT:PRINT#
590 NEXT:IFX1=8THENPRINT"NOEND RECORDS"
600 PRINT#1:GOSUB1110:GOTO390
610 IFZ2=6THENZ3=2.5:GOTO640
620 IFZ2>6ANDZ2<10THENZ3=1.5:GOTO640
630 Z3=2
640 V=INT((G(J,0)/Z3)*S(KZ2,0)+.5):IFV<1THENV=1
650 PRINTTAB(FNB(V)):V:"13H":GOTO680
660 PRINT"J" SROW SROW S TYPE OF "TAB(2)" DATE DATE S LBS. "
670 PRINT" NO. S LGTH S VEGETABLE "
680 PRINTTAB(23)"SSOWN"TAB(28)"SPICK"TAB(33)"WIELD":PRINT#1:RETURN
690 PRINT"J" SUPDATE":PRINT"XXXXXXXXXX"FOON NUMBER (1-100)
700 INPUT"XXXXXXXXXX"TYPE 999 TO RETURN TO OPTIONS:"N
710 M=INT(M):IFM=999THEN390
720 IFN<10RD100THEN690
730 IF(N,0)=0THEN780
740 PRINT"CAUTION:ROM"NM" HAS AN EXISTING ENTRY FOR"PRINT"MS"V(N,1))
750 INPUT"XXXX YOU WISH TO OVERWRITE IT (Y/N)":"A#
760 IFA#<"N"THEN690
770 IFA#<"Y"THEN750
780 PRINT"XXXXXXXXXX"ROW LENGTH "
790 INPUT"XXXXXXXXXX"MULTIPLES OF 5 FEET FROM 5-9995:"J
800 R1=INT(R/5):IFR1#5<ORTHE790
810 IFR>9995THEN790
820 PRINT"J":FORJ=1TO20:PRINTJ:TAB(5)V#(J):NEXT
830 INPUT"XXXXXXXXXX"WHICH NUMBER":"V
840 V=INT(V):IFV<10RV<20THEN820
850 PRINT"J":FORJ=1TO12:PRINTJ:TAB(5)V#(J):NEXT
860 INPUT"XXXXXXXXXX"WHICH MONTH":"M
870 M=INT(M):IFM<10RD12THEN850
880 IFM<S(V,2)THEN900
890 PRINT"CAUTION:LATEST DATE FOR SOWING IS "M$(S(V,2))":GOTO920
900 IFM<S(V,3)THEN950
910 PRINT"CAUTION:EARLIEST DATE FOR SOWING IS "M$(S(V,3))":GOTO920
920 PRINT"XXXX YOU WISH TO CONTINUE WITH "INPUT"XXXX THIS ENTRY (Y/N)":"A#
930 IFA#<"N"THEN920
940 IFA#<"Y"THEN920
950 PRINT"XXXXXXXXXX"TAB(11)H
960 PRINT"XXXXXXXXXX"TAB(11)H
970 PRINT"XXXXXXXXXX"ROW LENGTH"TAB(11)R"FEET"
980 PRINT"XXXXXXXXXX"VEGETABLE"TAB(12)V#(V)
990 PRINT"XXXXXXXXXX"TAB(12)M#(M)
1000 G(N,0)=R:G(N,1)=M:N(N,1)=V
1010 GOSUB1110:GOTO690
1020 PRINT"XXXX IS THERE ANY DATA TO BE WRITTEN"
1030 INPUT"XXXX TO TAPE (Y/N)":"A# IFA#<"N"THEN100
1040 IFA#<"Y"THEN1020
1050 PRINT"XXXX LOAD DATA TAPE FOR WRITING":GOSUB1110:PRINT"XX"
1060 POKE243,122:POKE244,2:OPEN1,1,2
1070 FORJ=1TO100:PRINT#1,G(J,0):GOSUB1140:PRINT#1,G(J,1):GOSUB1140:NEXT
1080 FORJ=1TO100:PRINT#1,N(J,1):GOSUB1140:NEXT
1090 CLOSE1
1100 PRINT"XXXXXXXXXX"END OF RUN"POKE59450,00:END
1110 PRINT"XXXX PRESS SPACE TO CONTINUE"
1120 GETAF:IFA#<" "THEN1120
1130 RETURN
1140 IFPEEK(625)<100THENRETURN
1150 POKE59411,53:T=TI
1160 IFTI-T<0THEN1150
1170 POKE59411,61:RETURN

```

ZX80 Bumper Bundle

by Rick Litherland

Here are three programs for the Sinclair ZX80. Perhaps the most interesting is a machine-code routine which flashes the contents of the display file onto the screen for a short time (like the PAUSE command on some programmable calculators) so that you can get animated graphics, etc. The other programs are a hex loader, which makes entering machine-code routines like the above a practical proposition, and a duck-shooting game which uses the pause routine to present a moving target.

Hex loader. This program allows entry of machine-code directly in hex, and also prevents the system from over-

writing your routine by creating a gap between the program and variable storage areas. Run the program, and each time an input string is requested, enter one byte of the routine in hex (using two digits - a leading zero counts). The starting address is given by the variable AD. Line 10 should be kept as the first line of the calling program. (Note: the starting address depends on the length of the calling program, so it's advisable to use relocatable code. Also, the array dimensioned in line 1 is a dummy which just opens up the space to be occupied by the routine.)

```

1 DIM A(d/2-1)
2 POKE 16392,PEEK(16394)-1
3 POKE 16393,PEEK(16395)+(PEEK(16394)=0)
10 LET AD=-d+PEEK(16392)+256*PEEK(16393)
20 FOR I=AD TO PEEK(16392)+256*PEEK(16393)-1
30 INPUT A$
40 PRINT A$;" ";
50 POKE I,16*(CODE(A$)-28)+CODE(TL$(A$))-28
60 NEXT I

```

d=decimal number of bytes in the machine-code program.

PROGRAMS

Hex print This BASIC program prints out the hex listing.

```

10 LET AD=-130 +PEEK(16392)+256*PEEK(16393)
20 PRINT CHR$(212);"PAUSE";CHR$(212);"ROUTINE."
30 PRINT
40 FOR I=AD TO AD+129
50 IF I-AD=8*((I-AD)/8) THEN LET B=USR(AD)
60 LET B=PEEK(I)
70 LET M=B/16
80 LET B=B-16*M
90 PRINT CHR$(M+28);CHR$(B+28);" ";
100 NEXT I
    
```

Pause routine. This hex routine causes a one second pause, during which time the results of any PRINT statements can be seen. Also, the top row of the keyboard (numerical keys) is scanned; if one of these is pressed, this value is returned; if none, or more than one, the value returned is -1. This is useful

for games needing quick reactions. The length of pause can be changed by POKE ing AD+21, where AD is the starting address:- this byte holds the number of frames to be displayed, so the maximum pause is about five seconds (256 frames).

```

0000 E5          PAUSE  PUSH HL
0001 2A 10 40    LD      HL,(4010H) ;end of display file
0004 ED 4B 24 40 LD      BC,(4024H) ;pos of next char
0008 04          INC     B
0009 AF          XOR     A
000A B9          CP      C
000B 3E 76       LD      A,76H      ;
000D 28 02       JR      Z,NEWLN   ;
000F 77          NEXT   LD      (HL),A ;fill out display file
0010 23          INC     HL ;with newline chars
0011 10 FC       NEWLN  DJNZ  NEXT ;
0013 11 FF 32    LD      DE,32FFH ;D is 'frame counter
0016 26 BF       FRAME  LD      H,BFH
0018 01 FE F7    LD      BC,F7FEH
001B ED 78       BANK   IN      A,(C) ;
001D F6 E0       OR      EOH ;
001F 6F          LD      L,A ;
0020 2F          CPL ;
0021 FE 01       CP      1 ;
0023 9F          SBC     A,A ;
0024 B4          OR      H ;scan top row and
0025 A5          AND     L ;store in E
0026 A3          AND     E ;
0027 5F          LD      E,A ;
0028 CB 00       RLC     B ;
002A CB 04       RLC     H ;
002C 38 ED       JR      C,BANK ;
002E 41          LD      B,C
002F ED 78       IN      A,(C)
0031 17          RLA
0032 17          RLA
0033 9F          SBC     A,A
0034 E6 18       AND     24
0036 C6 20       ADD     A,32
0038 32 23 40    LD      (4023H),A
003B D9          EXX
003C 06 2A       LD      B,42
003E 10 FE       DELAY1 DJNZ  DELAY1
0040 3E 0F       LD      A,0FH
0042 D3 FF       OUT     (FFH),A ;frame sync pulse
0044 3E EC       LD      A,ECH
0046 06 19       LD      B,25
0048 2A 0C 40    LD      HL,(400CH)
004B CB FC       SET     7,H
    
```

MICROMART

GAMER

SHARP MZ-80K (£499 + VAT for 48K)
 VIDEO GENIE (£399 + VAT for 16K)
 + INTELLIVISION + ACE TV GAMES
 + CHESS COMPUTERS
 + HAND-HELD ELECTRONIC GAMES
 + SF, FANTASY & WAR GAMES
 + ALL KINDS OF GAMES & PUZZLES

18 SYDNEY ST/TEL 698424
BRIGHTON

COMPUTERCLUB

FREE details of independent advice and experience as well as discounts on a wide range of computer hardware, software, supplies, etc.

Send large SAE to Dept PCW,
**COMPUTERCLUB, 42 Great Windmill
 Street, London W1V 7PA.**

BIAS POWER SUPPLIES FOR SYSTEM EXPANSION TO 64K

BIAS 1 for general micro use
 +5 @ 10 amps ±12v @ 2 amps
 -5 @ 1 amp **KIT £42.50**

BIAS 3 for S100 systems
 +8v @ 10amps
 ±18v @ 3.5amps **KIT £40.20**

Over Voltage Protection
 - optional B1 - £12;

HEAVY ALLOY CASE
 150 x 150 x 200
 includes switches, connectors,
 predrilled **£12**

Assembled & Guaranteed add £15

Mail order to:

ONUSTECH ENG LTD

474 CHISWICK HIGH RD
 LONDON W4
 01-995 0160

p&p £3.50
 Prices excluding VAT.

MINIMAL COST ZX80 SOFTWARE
 1k to 4k programs 50p or £1
 also newsletter and technical support.
 Membership:— £6.00 U.K.
 £10.00 Overseas

Send stamped addressed envelope/
 International Reply Coupon
 for further details to:
DAVID BLAGDEN
 ZX80 Users Club P.O. Box 159,
 Kingston upon Thames, Surrey KT2 5UQ

MICROMART

BIG EARS

SPEECH
INPUT
FOR
YOUR
COMPUTER!

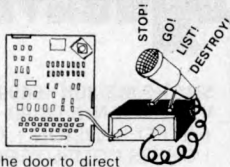

BIG EARS opens the door to direct man-machine communication. The system comprises analogue frequency separation filters, preamps and signal conversion, together with a quality microphone and extensive software. Words, in any language, are stored as "voice-prints" by simply repeating them a few times in "learn" mode. Using keyword selection techniques, large vocabularies can be constructed.

Use BIG EARS as a front end for any application: data enquiry, robot control, starwars — the possibilities are unlimited...

BUILT, TESTED & GUARANTEED ONLY £45!

PRICE INCLUDES POSTAGE & PACKING PLEASE ADD VAT AT 15%
PLEASE STATE COMPUTER: UK101, SUPERBOARD, NASCOM2,
PET, TRS80, ETC.

MICROGRAPHICS

Colour Conversion for
UK101/NASCOM 1 & 2/ Superboard.
(Modulator included)

KIT £45
BUILT £60

COLOUR MODULATOR

RGB in, PAL/UHF out

KIT £12
BUILT £18

Please add VAT at 15% to all prices
Barclay/Access orders accepted on telephone

**WILLIAM
STUART
SYSTEMS Ltd**

Dower House, Billericay Road, Essex CM13 3SD
Telephone: Brentwood (0277) 810244

VETS FOR PETS

Anita Electronic Services (London) Ltd. are specialists in the repair and service of Commodore Pets.

We offer a fast on-site service, or alternatively repairs can be carried out at our workshops should you wish to bring in your Pet.

Pet maintenance contracts are available at very competitive prices. Trade inquiries welcomed.

For further information, tel or write to:

John Meade
Anita Electronic Services
15 Clerkenwell Close, London EC1
01-253 2444

We also specialise in the repair of all makes of office equipment.

PET COMPUTERS Southampton

New 4000 series PET's now available (identical to 3000 series but with SUPERPET operating system) For a limited period at the following prices 400 8N £405, 4032N £620, C2N Printer £395

2001-85 Small Keyboard PET £395
TENSAT Cassette Deck with counter, CB2 sound £70

TOOLKIT £45 or £35 with computer
We also HIRE Commodore equipment by the week 8K £23, 16K £26, 32K £30, includes manuals, tutorials, games (Invaders, Microchess) & Cassette Floppy Disk Unit £30, Printer £30

Some new and ex-hire 3000 PET's available e.g. 32K £655
16K £475 Matching beige dustcovers for all models E4
Software (Commodore, Petsoft), books and many other PET related items stocked. All prices exclude VAT
Official Commodore Dealer

SUPER-VISION

13, St. James Road, Shirley, Southampton
Telephone (0703) 774023 After hours (0703) 554488

To advertise in
MICROMART
Please ring Jacquie Hancock
on 01-631 1682

PROGRAMS

```

004D CD AD 01      CALL 01ADH      ;
0050 3E F3         LD  A,F3H      ;
0052 04            INC  B          ;
0053 2B            DEC  HL         ;transmit one frame
0054 FD 35 23     DEC  (IY+23H)   ;
0057 18 00        JR   DELAY2    ;
0059 CD AD 01     DELAY2 CALL 01ADH  ;
005C 06 1D        LD   B,29      ;
005E 00            DELAY3 NOP      ;
005F 00            NOP          ;
0060 10 FC        DJNZ DELAY3  ;
0062 00            NOP          ;
0063 D9           EXX         ;
0064 15           DEC  D          ;
0065 20 AF        JR   NZ,FRAME ;
0067 7B           LD   A,E        ;
0068 1E 78        LD   E,TABLE-PAUSE ;
006A E1           POP  HL         ;
006B 19           ADD  HL,DE       ;TABLE to HL
006C 1E 0A        LD   E,10      ;
006E BE           NOTFND CP  (HL)   ;
006F 28 04        JR   Z,FOUND    ;
0071 23           INC  HL         ;
0072 1D           DEC  E          ;convert bit pattern
0073 20 F9        JR   NZ,NOTFND ;to digit or -1
0075 EB           FOUND EX  DE,HL   ;
0076 2B           DEC  HL         ;
0077 C9           RET          ;
0078 7D           TABLE DEFB 01111101B ;bit pattern for 9
0079 7B           DEFB 01111011B ; " 8
007A 77           DEFB 01110111B ; " 7
007B 6F           DEFB 01101111B ; " 6
007C AF           DEFB 10101111B ; " 5
007D B7           DEFB 10110111B ; " 4
007E BB           DEFB 10111011B ; " 3
007F BD           DEFB 10111101B ; " 2
0080 BE           DEFB 10111110B ; " 1
0081 7E           DEFB 01111110B ; " 0
    
```

Duck shoot. This uses the previous routine. A duck appears in one of six positions, and is shot by pressing the correct numerical key before it disappears again. You get ten shots; the more you hit, the faster the game gets. Note on keying in: the strings in lines 130 and 140 contain inverse characters, which have to be POKE'd there. If this is too much trouble, these lines can be replaced by:
 130 IF I=0 THEN PRINT CHR\$(6) ;
 CHR\$(130) ; CHR\$(133)
 140 IF I=1 THEN PRINT CHR\$(128) ;
 CHR\$(128)
 but you'll have to leave out the rules to avoid running out of RAM.

```

10 LET AD=-130+PEEK(16392)+256*PEEK(16393)
20 RANDOMISE
30 LET B=0
40 LET S=0
50 FOR G=1 TO 10
60 LET N=RND(6)
70 PRINT
80 PRINT
90 FOR I=0 TO 1
100 FOR J=1 TO N
110 PRINT " ";
120 NEXT J
130 IF I=0 THEN PRINT " "
140 IF I=1 THEN PRINT " "
150 NEXT I
160 PRINT
170 PRINT " ";
180 FOR J=1 TO 6
190 PRINT " ";
    
```

PROGRAMS

```

200 NEXT J
210 FOR I=1 TO 200-5*20
220 NEXT I
230 POKE AD+21,50-5*2
240 IF NOT N=USR(AD) THEN GOTO 410
250 CLS
260 PRINT
270 PRINT
280 PRINT
290 FOR J=1 TO N
300 PRINT "  ";
310 NEXT J
320 PRINT "AWK"
330 PRINT
340 PRINT "  ";
350 FOR J=1 TO 6
360 PRINT "D ";
370 NEXT J
380 POKE AD+21,15
390 LET I=USR(AD)
400 LET S=S+1
410 CLS
420 NEXT G
430 IF S>B THEN LET B=S
440 FOR I=1 TO 100
450 NEXT I
460 PRINT "YOU GOT ";S;" OUT OF 10"
470 PRINT "BEST SCORE: ";B
480 PRINT "DO YOU WANT ANOTHER GO? (Y OR N)"
490 INPUT A$
500 CLS
510 IF A$="Y" THEN GOTO 40
520 IF NOT A$="N" THEN GOTO 480
530 PRINT "BYE"
540 REM RULES
550 REM =====
560 REM
570 REM SHOOT THE DUCK BY
580 REM HITTING A KEY FROM
590 REM 1(LEFT) TO 6(RIGHT)

```

PET Brick stop

This follows our golden rules: shortness, originality and addiction. Try it — it's great fun.

```

5 REM *** BRICK-STOP ***
15 REM *** KJR JONES 7/12/80 ***
20 GOTO 230
30 PRINT "  PRESS ANY KEY TO START  "
40 GET A$: IF A$="" THEN 40
50 CLR: PRINT "T": P=33468: TI$="000000": R=PEEK(50003)
60 FOR X=33648 TO 33767: POKE X,102: NEXT
65 REM *** MOVE PLAYER ***
70 K=PEEK(547-381*R)
80 IF (K AND 4)<>4 THEN 120
90 IF K=5 AND P>33448 THEN POKE P+1,32: P=P-1
100 IF K=12 AND P<33486 THEN POKE P,32: P=P+1
110 POKE P,119: POKE P+1,119
115 REM *** MOVE BRICKS ***
120 B=B1: GOSUB 150: B1=B
130 B=B2: GOSUB 150: B2=B
140 GOTO 70
150 IF B=0 THEN B=INT(RND(TI)*40)+32768
160 IF PEEK(B+40)=160 AND B<33488 THEN 200
170 IF PEEK(B+40)=119 THEN POKE B,42: FOR X=1 TO 10:
NEXT: POKE B,32: B=0: RETURN
180 IF PEEK(B+40)=160 OR B>33607 THEN B=0: RETURN
190 POKE B,32: B=B+40: POKE B,160: RETURN
200 PRINT "XXXXXXXXXX";
210 PRINT " YOU SURVIVED FOR ";
60*VAL(MID$(TI$,3,2))+VAL(RIGHT$(TI$,2));" SECONDS."
220 FOR X=1 TO 100: GET A$: NEXT: GOTO 30
225 REM *** INSTRUCTIONS ***

```

MICROMART

MINE OF INFORMATION LTD

1 FRANCIS AVENUE,
ST ALBANS AL3 6BL
ENGLAND
Phone: 0727 52801
Telex: 925 859

MICROCOMPUTER CONSULTANCY & BOOK SELLERS

µHex EPROM PROGRAMMERS

426 2508/2708/2758/2516/2716
Dual and Single supply Eproms, £95

416 2704/2708/2716 Dual only. £65

480 2704/2708 Kit £35. Built £40.

All programmers require only standard power supplies. The 426 & 416 are cased and have push-button selection. Program any length block into the Eprom. Software included. Range covers 280, 8080, 6800 and 6500. State machine.

PIO, PIA INTERFACE MODULES

Available for 280/8080 and 6800/6500.

Prices include carriage. Please add VAT SAE for further product information.

MICROHEX COMPUTERS

UNION STREET, TROWBRIDGE, WILTS.

ZX80

National ZX80 Users Club

For details of membership and a copy of the latest club magazine, send SAE to Unit 3, 33 Woodthorpe Road, Ashford, Middlesex TW15 2RP

6250 BAUD for NASCOM 1

This ultra-fast cassette interface board will provide reliable data storage and recall at up to 6250 BAUD on most standard cassette recorders. e.g. 1K of data loaded in less than 1½ seconds.

The modifications required are minor and full documentation is supplied with each board which comes built, tested and guaranteed.

For immediate delivery send £15.95 + 35p P&P to:-

J. C Hunter
65 Portland Street, TROON
Ayrshire, Scotland
or phone 0292 311513

Also a competitively priced EPROM programming service is provided where we can supply the EPROM's programmed to your listings or programme your own EPROM's on a 24 hour turn round basis. Please write or telephone for details.

SPECIALS FOR PET

PROGRAMMER'S TOOLKIT £39
 LIGHT PEN (+ SOFTWARE) £25
 WORD PROCESSOR (M/CODE) £35
 MUSIC SYSTEM COMPLETE £37
 ADVENTURES 1 & 2 £ 7
 (ALL & VAT BUT INCL. POSTAGE)
 Send for details - state model.

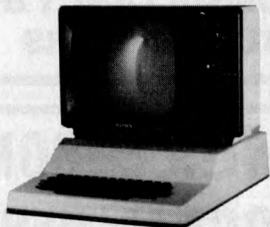

MICROCASE "turns a board
 into a real computer"

NASCOM 1 & 2
 COMPUKIT
 SUPERBOARD
 ALSO UNCUT KEYBOARD MODEL

Direct from us or from your
 dealer - but make sure you see a
 GENUINE MICROCASE!
 About £30

Simple Software Ltd

15 HAVELOCK ROAD
 BRIGHTON SUSSEX



ADP USED TELETYPE ASR 33's



V24 INTERFACES ARE STANDARD
 ALL UNITS CARRY 30 DAY
 RETURN-TO-DEPOT WARRANTY

£250 + VAT

(QUANTITY DISCOUNTS AVAILABLE)

Call or Write to Chris Turner
 ADP Network Services Ltd.
 179-193 Great Portland Street
 London W1. Tele: 01-637 1355

PART-TIME FROM HOME

PASCAL

MICRO PROGRAMMING
 SMALL BUSINESS
 APPLICATIONS
 TEL 01-989 0430

PROGRAMS

```

230 PRINT "    B R I C K - S T O P"
240 PRINT "YOU ARE THE / AT THE CENTRE OF THE"
250 PRINT "SCREEN. YOU CAN MOVE USING THE << AND"
260 PRINT ">> KEYS TO BLOCK THE PATHS OF BRICKS"
270 PRINT "WHICH ARE FALLING FROM THE SKY."
280 PRINT "BRICKS WHICH YOU DO NOT STOP ACCUMULATE;"
290 PRINT "IN A WALL AT THE BOTTOM OF THE SCREEN."
300 PRINT "WHEN THIS REACHES YOUR LEVEL, THE GAME"
310 PRINT "IS OVER."
320 PRINT "YOUR OBJECT IS SIMPLY TO STAY ALIVE FOR;"
330 PRINT "AS LONG AS POSSIBLE."
340 GOTO 30
    
```

ZX80 Printer listing continued from page 115

```

150 LET Q=118
155 LET D=16397
160 STOP
1000 REM PRINT OUT CONTENTS OF ARRAYS
1005 GO SUB 30
1010 LET A=12
1020 GO SUB 20
1030 PRINT "CONTENTS OF ARRAYS A AND B"
1040 GO SUB 30
1045 PRINT "BAUD RATE 1200-PARITY EVEN"
1046 GO SUB 30
1050 FOR I=0 TO 17
1060 PRINT "A(;"I;)",A(I),"B(;"I;)",B(I)
1070 GO SUB 30
1080 NEXT I
1090 FOR I=18 TO 20
1100 PRINT "A(;"I;)",A(I)
1110 GO SUB 30
1120 NEXT I
1130 STOP
9900 REM LISTING ROUTINE
9905 LET P=D+27
9910 IF PEEK(P)>39 THEN STOP
9915 LET LN=256*PEEK(P)+PEEK(P+1)
9920 PRINT LN;
9925 LET P=P+2
9930 LET CH=PEEK(P)
9935 LET P=P+1
9940 IF NOT CH=Q THEN GO TO 9955
9945 GO SUB 30
9950 GO TO 9910
9955 IF CH=1 THEN LET CH=212
9960 PRINT CHR*(CH);
9965 GO TO 9930
    
```

YCW listing continued from page 106

```

190 INPUT A$
200 LET B=(256*PEEK(16414)+PEEK(16414))/10
210 CLS
220 IF B > 10 THEN LET B=B-10
225 IF B > 20 THEN LET B=B-20
230 IF B > 30 THEN LET B=B-30
240 IF B > 40 THEN LET B=B-40
250 IF B > 50 THEN LET B=B-50
260 FOR Y=1 TO B-1
270 PRINT ".";
280 NEXT Y
290 PRINT "+"
300 LET A(B)=0
320 LET X=X+1
340 LET D=0
350 FOR Y=1 TO 10
360 IF A(Y)=0 THEN LET D=D+1
370 NEXT Y
380 IF D=10 THEN GOTO 440
340 GOTO 70
400 CLS
410 PRINT
420 PRINT,"INVADERS HAVE LANDED"
430 STOP
440 CLS
450 PRINT
460 PRINT,"ALL INVADERS KILLED"
470 PRINT,"IN ";X-1;" GOES"
480 STOP
    
```

DRAW POKER

Continued from page 73

and then added to variables called BADBETSTOTAL and ALLBETSTOTAL. The quotient BADBETSTOTAL/ALLBETSTOTAL is an indication of the extent to which that player bluffs, and is called the 'bluff factor' (BF).

When the program next comes to adjust the pointer for that player, it multiplies the calculated adjustment by (1-BF). This means that if the player is known to bluff all the time (ie BF=1), no inference about the strength of his hand will be made from his betting. But if he is known to bluff very rarely, BF will be low and the pointer adjustment will be very little changed from the calculated one.

To make the program more sophisticated it would be relatively easy to weight recent experience more than past experience when calculating the bluff factor. For example, BF could be calculated from the relation:

NEW BF := (0.9 x OLD BF) + (0.1 x latest hand BF)

This technique would have the effect of detecting recent changes in playing style by the opponent. A player who had bluffed little or never, but who suddenly changed his betting style and began to bluff at every opportunity, would get away with it for two or three hands at the most, but then the program would 'suspect' and BF would soar to nearly 1.

Making draw poker a many player game

You will almost certainly be playing against your program using a VDU of sort sort, or even a primitive LED for

output. It is not really practical under these circumstances for more than one human being to take part in the game at any one time, but you can make the program into an interesting recreation by having it play all the hands apart from your own. The program must not cheat, otherwise it will always win, and it can make its probability calculations from each player's 'seat' each time there is any action, either betting or drawing cards. Start each of the players off with the same amount of money, say £1 million, and play pot limit poker with £10 ante by the dealer. If you discover that the program is consistently too conservative for your liking, lower the 5 percent multiplicative factor. If the program plays too loosely, raise the 5 percent. If you wish to play in a poker game with players of varying styles, some loose some 'tight', have different factors for different players.

Bibliography

The following articles on Draw Poker should be considered more advanced reading for those interested in a more sophisticated approach. Findler, Nicholas V., Klein, Heinz, Gould W., Kowal A., and Menig J.: *Studies on Decision Making Using the game of Poker*. Proceedings of IFIP Congress 1971, Vol. 2.

Findler Nicholas V.: *Studies in Machine Cognition Using the Game of Poker*. Comm. ACM, Vol. 20, pp. 230-245 (1977).

Findler Nicholas V.: *Computer Poker*. Scientific American, Vol. 239, No. 1, July 1978, pp. 112-119.

It will also be essential for a poker programmer to find a book on the game which gives tables showing the odds against making certain improvements when drawing cards. The Steig book mentioned in the text is one such volume, but there are very many others.

PRINTERFACING

Continued from page 64

print head. This would mean that the print density remains constant as the ceramic substrate warms up. This printer generates a train of dot print pulses when the print head is in the correct start position in a similar fashion to the EUY 2E/2T series and a modified DP 822 control circuit would again suffice to drive this printer. Figure 6 gives the connector pin outs for these printers.

Hycom DC-4004A electro-sensitive printer

The DC 4004A is a compact mechanism that can print 48 or 36 characters per line on 120mm paper depending on whether you use a 5 x 7 or a 7 x 9 character matrix. The unit is manufactured across the pond by Hycom and it is available in this country through Seltek Ltd — the mechanism's cost is approximately £115. This printer is

somewhat more versatile than the other units that we have looked at because it has a nine-element print head which allows the user to build up characters that are far more legible than a standard 5 x 7 format.

The greatest benefit of a nine-element head will be found when printing lower case figures since you can now print descenders. This mechanism operates in a serial format, printing from left to right, and a modified version of the DP 822 control circuit explained earlier can be used to control the print head. The main advantage with serial printers is that they are very easy to control, unlike a parallel printer which is enough to make even a dedicated (masochistic?) hardware freak like myself reach for a bottle.

Anyway, this printer generates two timing signals, Signal A and Signal B. Both signals are generated by photo-transistors and shutters so there will be no problems caused by dirty contacts. Signal A becomes active when the print head reaches the left hand margin and is ready to start printing the line; when the photo transistor turns off, the motor should be stopped unless, of course, you wish to print another line, in which case you must wait for the

MICROMART

**MORRISTON
COMPUTER
CENTRE**

46 CROWN ST
MORRISTON
Tel: 795817 SWANSEA

SHARP MZ80 VIDEO
PC1211 GENIE

CONFUSED?

DO YOU FIND IT ALL TOO COMPLICATED? ARE THERE TOO MANY TECHNICAL TERMS? WE DON'T JUST SELL MICROS. WE LIVE AND WORK WITH THEM, WE TEACH ALL OUR CUSTOMERS TO USE THEM. BUY A MICRO FROM US AND GET AS MUCH HELP AS YOU NEED!

MICROTEK

PHONE CHRIS ROBINSON ON
IPSWICH (0473) 50152

A family of high level languages from RHA (Minisystems) Ltd.

ALGOL-60, the language from which PASCAL is derived. A mature implementation with comprehensive operating system and machine code interfaces.

SYSTEM-ALGOL, the subset of Algol-60 in which all the compilers are written. Compiled code is shorter, execution faster.

Z80 based CP/M systems including TRS80
RML Algol-60, includes the option of 32 bit integers instead of floating point. About 7 times faster than TRS80 level II BASIC, speed comparable with Micro-soft Fortran. Document £10, system £99+VAT. System-Algol £50+VAT, free leaflet.

PDP11 with RT-11, RSTS, RSX or IAS and PDP8 with OS/8 or stand alone

Complete package including both compilers in machine readable source form £250+VAT. Documents only £10.

The author of the compilers is available as a consultant.
83 Gidley Way, Horspath, Oxford OX9 1TQ
(08677) 3625

VIDEO GENIE

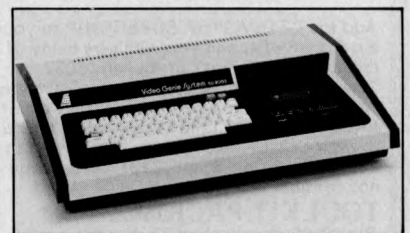

£344 VAT paid
Everything included
Fully tested and run, and with full
cassette modification

TOM CROSSLEY
B.Sc., M.I. Mech. E, Engineer
Sutton Springs Wood, Chesterfield,
S44 5XF
(0246) 850357 Ext. 10

MICROMART

Bring new life to your NASCOM

We offer a new 3K monitor, NASMON, for both NASCOM 1 and NASCOM 2 systems which gives you more power and flexibility than ever before:

- text editor built in.
- 'front panel' display of registers, flags etc. this *must* be seen.
- blocked, buffered tape routines.
- powerful low-level 'search' and single step commands.
- a total of 34 commands available through the keyboard.

PASCAL IN UNDER 6 K.

NASPAS runs under NASMON or NAS-SYS and offers:

- all major PASCAL statements.
- INTEGER, CHAR, BOOLEAN and Enumerated TYPES.
- fully recursive Procedures and Functions with value parameters.
- many pre-defined functions e.g. SUCC, PRED, (D)PEEK, (D)POKE etc.

AT LAST, A 12K BASIC

Running under NASMON, this extended BASIC gives you all the features of an 8K BASIC plus:

- 11 significant figure arithmetic.
- IF ... THEN ... ELSE.
- PRINT USING.
- Multi-line, recursive functions calls (using DEF).
- line or screen editing.
- excellent printer support.
- Renumber and Automatic line numbering.
- and ... more!

PRICES

NASMON	(in 3 EPROMS)	£25
BAS12K	(on tape)	£25
NASPAS	(on tape under NASMON)	£25
NASPAS	(on tape under NASSYS)	£30

BUY NASMON NOW and get a FREE Chess program - NASCHK.

New 3 K Assembler £25 on tape
£25 in EPROM.

HISOFT 60 Hallam Moor,
LIDEN, SWINDON, Wiltshire.

OLD ROM SUPERPETS

Add the PETMASTER SUPERCHIP to your old Rom 8k Pet and you will have many of the advanced features of the new 8032 Superpet! Auto-repeat, screen manipulation, plus lots more for only £45. If have Toolkit fitted then you can plug the Superchip into the spare socket - otherwise you'll need to buy an extension board (£13). Or else why not consider the

TOOLKIT PACKAGE

Buy the Superchip and Toolkit for just £75 including extension board - you could have paid £75 for the Toolkit alone until very recently!

Our catalogue of PET programs and supplies has programs for all models, including the latest 8032 and 4032 - and it's absolutely free to PET owners.

Add 15% VAT to all prices. Post free.

SUPERSOFT

28 Burwood Avenue,
Eastcote, Pinner, Middlesex
Telephone: 01-866 3326



signal to become active again. Signal B indicates when to print each dot column and is generated continuously so you must count the pulses to ensure that you do not run off the edge of the paper. With a two-dot space between characters, a full 5 x 7 line will last 336 pulses and a full 7 x 9 line will last 324 pulses. You could, of course, print a longer line by allowing only one dot space between characters but the resultant print might be difficult to read.

In order to form dots you must apply a 170 us pulse of -44 V to the electrodes via a current limiting resistor of approx 39 ohms. As with all printers of this type, the motor control circuit must include a dynamic break which short-circuits the motor windings when the motor is turned off, to ensure that the inertia of the printer mechanism does not carry it over into the next

line. The motor supply voltage is 12 V at approx 600 mA and the individual print elements draw approx 12 mA each from 43 volt. Finally, 60 mA each. The photo transistors should have emitter load resistors of approx 6k8 ohms although a little experiment may be required. See Figure 7.

Suppliers of units mentioned in this section:

National EUY series:

Datac Ltd, Tudor Road, Broadheath, Altrincham WA14 5TN, tel 061-941 2361/2.

Hycom DC - 4004A:

Seltek Ltd, The Old Pied Bull, High Street, Stanstead Abbots, Herts SG12 8AB, tel 0920-871094.

Star DP 822:

Roxburgh Printers Ltd, 22 Winchelsea Road, Rye, Sussex, tel: 07973 3777

PUNTER'S PET



After the race

When the race is over, the result is displayed together with the bookie's cash movements.

There is an option to re-run the race for fun without putting on any extra bets. This will demonstrate the randomness of the race in that, if the race were run enough times, the probabilities expressed in the odds would be realised. The favourite would win most times but outsiders would win occasionally.

Continued from page 90

generating a random number in the range 0 to 1 and scanning the list for a match, as in Table 3.

```

8 REM COPYRIGHT ALAN GREEN 1980
15 PRINT "DATA ARRAYS LOADING"
19 DIM T(50),M(50),MP(50),T*(50)
20 DIM A(12),B(12),A*(12),P(12),M(12)
25 DIM B*(12),O(12),R(37),C(37)
30 DIM A*(57),B*(57),P*(57)
50 FOR I=1 TO 57:READ A*(I),B*(I),P*(I):NEXT I
70 DATA 1,1,5,21,20,488,11,10,476,6,5,455,5,4,444,11,8,421,6,4,4
71 DATA 13,8,381,7,4,364,15,8,348,2,1,333,85,40,32,9,4,308,95,40,296
72 DATA 5,2,285,11,4,267,3,1,25,100,30,231,7,2,222,4,1,2,9,2,182
73 DATA 5,1,167,11,2,154,6,1,143,13,2,133,7,1,125,15,2,118,8,1,111
74 DATA 17,2,185,9,1,1,19,2,095,10,1,091,11,1,083,100,9,083,12,1,077
75 DATA 100,8,074,13,1,071,14,1,067,100,7,065,15,1,063,16,1,059,100,6,057
76 DATA 18,1,053,20,1,048,22,1,043,25,1,038,28,1,034,33,1,029,40,1,024
77 DATA 50,1,02,66,1,015,80,1,012,100,1,01
78 DATA 150,1,007,200,1,005,250,1,004,500,1,002
80 FOR I=1 TO 37:READ R*(I),C*(I):NEXT I
83 DATA 10,33,10,31,10,29,10,27,10,25,10,23,10,21,10,19,10,17,10,15,10,13,11,11
84 DATA 13,9,15,7,17,5,19,4,21,4,22,6,22,8,22,10,20,12,18,14,16,16,14,18,13,20
85 DATA 13,22,13,24,13,26,13,28,14,30,16,31,18,31,20,31,22,29,22,27,22,25,22,23
100 PRINT "GOSUB 24001:GOSUB 24002:GOSUB 24003:GOSUB 24002:GOSUB 24001
104 PRINT "UP TO 50 BETTING SLIPS CAN BE ISSUED "
105 PRINT "WELCOME TO THE MOST EFFICIENT AND THE"
106 PRINT "FAIREST RACECOURSE IN THE COUNTRY"
109 PRINT "YOU CAN SET THE OPENING ODDS FOR ALL "
110 PRINT "THE HORSES BUT EVENTUALLY THEY WILL"
111 PRINT "BE ADJUSTED TO REFLECT THE MONEY LAID":GOSUB 20232
114 GOT012000
116 PRINT "LIMITS: 12 HORSES 12 FURLONGS: INPUT "TITLE OF RACE":XY#
120 INPUT "NUMBER OF HORSES":N:IF N<2 AND N<13 THEN 124
122 PRINT "":GOT0120
124 GOSUB 21000
125 INPUT "LENGTH IN FURLONGS":F:IF F<13 AND F>0 THEN 150
135 PRINT "":GOT0125
150 PRINT "DO YOU NEED DETAILS ON SETTING ODDS?":GOSUB 20235
160 IF D#="N" THEN 200
165 IF D#="Y" THEN 180
170 PRINT "":GOT0150
180 GOSUB 17000
200 PRINT "HONEST AL TURF ACCOUNTANT":GOSUB 26000
220 PRINT "LIST OF RACE ENTRIES":Q(0)=0
225 PRINT "HORSE NAME OPENING ODDS"
230 PRINT "LAYER TAKER":GOSUB 14000
240 FOR I=1 TO N
245 PRINT "INPUT "A*(I)":IF LEN(A*(I))<13 THEN 259
252 PRINT "12 LETTER MAX DO AGAIN WHEN CLEAR":GOSUB 24100
255 PRINT "":GOSUB 24101:GOSUB 24101
258 PRINT "":GOT0245
259 PRINT "INPUT "B*(I)":IF LEN(B*(I))<13 THEN 270
270 PRINT "":GOSUB 24101:GOSUB 24101
280 INPUT "INPUT "C*(I)":IF LEN(C*(I))<13 THEN 290
290 PRINT "":GOSUB 24101:GOSUB 24101
295 PRINT "DO YOU WANT TO OPEN ODDS?":GOSUB 20235:IF D#="Y" THEN 310
302 PRINT "OK, DO AGAIN WHEN CLEARED":GOSUB 24100
305 PRINT "":GOSUB 24101:GOSUB 24101:PRINT "":GOT0245
310 P(I)=B*(I)/A*(I)+C*(I):Q(I)=Q(I-1)+P(I)
315 PRINT "NEXTI
400 IF Q(N)>1 THEN GOT0450
410 PRINT "A BOOK IS UNDER-ROUND...ADJUST ODDS " :GOSUB 13000:GOT0400
450 GOSUB 24101:PRINT "SAVE RACE ON TAPE ?":GOSUB 20235:IF D#="Y" THEN 12500
490 PRINT "
495 PRINT "ADJUST ODDS PLACE BET"
496 PRINT "RUN RACE ADJUST ODDS PLACE BET"
500 PRINT "HONEST AL TURF ACCOUNTANT":GOSUB 26000
504 PRINT "TOTAL BETS"
505 PRINT "HORSE ODDS TAKE BET"
510 FOR I=1 TO N:PRINT "TAB(4):A*(I):TAB(17):A*(I)-B*(I):TAB(26):M(I)
525 PRINT "TAB(32)":NEXT I
    
```

MICROMART

PET'S

PETS - We Sell Them

As authorised Commodore Dealers we stock and supply all PET Hardware, Computikh Discs, Oki Microine 80 Decwriter LA34, Texas 810, Qume Sprint 5 - all at competitive prices

PETS - We Buy Them

Part Exchange is very welcome, we also buy for cash.

PETS - We Hire Them

Our specialist hire service, with maintenance for all Commodore equipment.
 - Complete systems for evaluation
 - Multiple units for educational courses
 - Single units for individual use

From 1 day upwards, all units available. Delivery by arrangement, anywhere in UK.

PETS - Software

We are fully authorised BUSINESS SOFTWARE DEALERS for Commodore Software - COMPAY COMSTOCK, WORDPRO etc. Also PETSOF, BRISTOL SOFTWARE, LANDSLER PAYROLL & HOTEL SYSTEM.

PLUS for ACCOUNTANTS, the unique CSM INCOMPLETE RECORDS PACKAGE - this is the best available.

MAIL - ORDER

All Hardware and Software can be bought by Mail Order Delivery by Securicor, or Registered Post. Discounts for Cash & Carry or Mail-Order. Access accepted or by Leasing (subject to acceptance)

MICRO-FACILITIES LTD

129 High Street, Hampton Hill, Middlesex, TW12 1NJ 01-979 4546 or 01-941 1197



Microcomputers are coming — ride the wave! Learn to program with a new course written for the beginner. Learn BASIC- the language of the small computer and the most easy-to-learn computer language in widespread use. A self-instruction course which takes you from complete ignorance step-by-step to real proficiency with a unique style of graded hints. 60 illustrated lessons teach the five essentials of good programming: problem definition, flow-charting, coding the program, debugging, clear documentation. And you don't even need a computer!

PRICE £10.00 (inc. P&P)

Send cheque with order to Cambridge Learning Limited, Unit 79, Rivermill Site, FREEPOST, St. Ives, Huntingdon, Cambs. OR phone 0480-67446 with Access, Barclaycard, or other credit card details.

Cambridge Learning Limited

SUMMER SCHOOL In Personal Computing

covering

- *Programming (high and low level)
- *micro-architecture
- *input-output control
- *interfacing
- *practical sessions

July 1980 for two weeks residential

at University College of Wales, Aberstwyth

details from

PC Summer School,
 Sandmarsh, Queens Road,
 Aberstwyth, Dyfed, ST23 2HH
 Tel: 0970 617749

```

549 PRINT"
550 PRINT"
551 PRINT"
553 PRINT"
555 PRINT"
560 GETC$: IFC#="" THEN560
565 IFC#="B" THENGOSUB2000
570 IFC#="O" THENGOSUB4000
575 IFC#="R" THENGOTO10000
580 IFC#="B" THENGOTO500
585 IFC#="O" THENGOTO500
590 GOTO500
2000 IFT=50 THENRETURN
2002 T=T+1
2005 INPUT"*****" HORSE NUMBER " :H:IFH<N THEN2025
2015 PRINTTAB(20);" " :GOTO2005
2025 PRINT"*****" YOUR TICKET IS " :T:GOSUB25000:PRINT"*****"
2040 FORI=1TOH:PRINT" " :NEXTI
2051 FORK=1TO10:PRINTTAB(4):A#(H):ZZ=SQR(1111)
2054 PRINT" " :TAB(4):A#(H):ZZ=SQR(1111):PRINT" " :NEXTKK
2056 PRINT"*****" :TAB(34):" " :GOTO *****
2058 INPUT"*****" :MW(T):<0 THEN2056
2059 IFMW(T)>INT(MW(T)) THEN2056
2060 IFZ1=1 THEN2067
2061 PRINT"*****" :TAB(33):" " :GOTO *****
2063 INPUT"*****" :MP(T)
2064 IFMP(T)<0 THEN2061
2065 IFMP(T)=INT(MP(T)) THEN2067
2066 GOTO2061
2067 M(H)=M(H)+MW(T)+MP(T):MT=MT+MW(T)+MP(T):T#(T)=A#(H)
2070 IFBR(H)=1 THEN2080
2072 BR(H)=1:BR=BR+1
2080 X=1:RETURN
4000 GOSUB23000:PRINT"*****" CALCULATING ODDS " :Q(0)=0
4010 FORI=1TON:IFM(I)=0 THEN4024
4020 P(I)=(M(I)/MT)*(1.90+(1.10*BR/N)):GOTO4025
4024 P(I)=.10/N
4025 Q(I)=Q(I-1)+P(I):P(I)=P(I)*1.40:NEXTI
4050 SW=0:FORI=1TON:IFP(I)<.5 THEN4110
4090 P(I)=1-P(I):SW=1
4110 FORJ=1TO57:IFP(I)>PR(J) THEN4140
4120 NEXTJ
4140 IFSW=1 THEN4180
4150 A(I)=AA(J-1):B(I)=BB(J-1):GOTO4200
4180 A(I)=BB(J-1):B(I)=AA(J-1)
4200 SW=0:NEXTI:X=0:RETURN
10000 PRINT" " :IFBR=0 THEN500
10005 IFX=1 THENGOSUB4000
10006 GOSUB15000:SS=32768:PL=1+3*F
10009 POKESS+CO(PL)+(40*RO(PL)):209
10010 FORK=1TO10:PRINT"THEY'RE OFF":ZZ=SQR(111)
10012 PRINT" " :ZZ=SQR(111):NEXTKK
10020 FORFF=1TOF
10060 F#(1)="Y":F#(2)="Y":F#(3)="Z"
10070 FORHH=1TO3
10075 FORV=1TOBR*5:ZZ=SQR(V):NEXTV
10080 R=RND(1)
10100 FORJ=1TON:IFR<Q(J) THEN10120
10110 NEXTJ
10120 IFHH=1 THENX=J
10130 IFHH=2 THENY=J
10140 IFHH=3 THENZ=J
10150 F#(HH)=A#(J)
10160 IFF#(2)=F#(1) THEN10080
10170 IFF#(3)=F#(2) THEN10080
10180 IFF#(3)=F#(1) THEN10080
10182 POKESS+CO(PL)+(40*RO(PL)):160:PL=PL-1
10186 POKESS+CO(PL)+(40*RO(PL)):209:NEXTHH
10200 PRINT" " :GOSUB24102:PRINT" " :GOSUB24102
10210 PRINT" " :F#(1)
10220 PRINT" " :F#(2)
10230 PRINT" " :F#(3)
10240 NEXTFF
10270 PRINT" " :GOSUB24001:GOSUB26000
10300 PRINT"*****" RACE RESULTS:*****" :GOSUB24001
10320 PRINT"*****" HORSE ***** ODDS *****"
10340 PRINT"*****" FIRST ***** :TAB(10):F#(1):TAB(30):A(X)="-" :B(X)
10350 PRINT"*****" SECOND ***** :TAB(10):F#(2):TAB(30):A(Y)="-" :B(Y)
10360 PRINT"*****" THIRD ***** :TAB(10):F#(3):TAB(30):A(Z)="-" :B(Z)
10380 PRINT"*****" :GOSUB24001:GOSUB24001
10386 PRINT"*****" PRESS (SPACE) FOR PAYOUT DETAILS *****" :GOSUB20235:GOSUB20000
10390 PRINT"*****" :GOSUB24101:PRINT"*****" :GOSUB20235
10393 IFF#="" THEN10000
10394 IFF#<"N" THEN10390
10402 FORI=1TO12:M(I)=0:A#(I)=" " :BR(I)=0:NEXTI:MT=0:P=0:BR=0
10406 FORI=1TOT:T(I)=0:MW(I)=0:MP(I)=0:T#(I)=" " :NEXTI
10410 PRINT"*****" START A DIFFERENT RACE ? *****" :GOSUB20235
10421 IFF#="" THEN114
10424 IFF#<"N" THEN10410
10425 PRINT"*****" BYE AND THANKS.....HONEST AL *****" :END
12000 PRINT" "
12020 PRINT"*****" :GOSUB24001:PRINT"*****" RACING OPTIONS *****"
12050 GOSUB24004:PRINT"*****" 1 NEW RACE FROM KEYBOARD *****" :GOSUB24004
12070 PRINT"*****" 2 PREVIOUS RACE FROM FILE *****" :GOSUB24004:GOSUB24001
12090 T=0:PRINT"*****" OPTION ? *****" :GOSUB20235
12100 IFF#="1" THEN116
12110 IFF#="2" THEN12200
12130 GOTO12020
12200 PRINT"*****" FINDING RACE *****"
12210 OPEN1,1,0,"RACE"
12220 PRINT"*****" RACE LOADING *****"
12225 INPUT#1,XV#
12230 INPUT#1,N
12240 INPUT#1,F
12250 FORI=1TON
12260 INPUT#1,A#(I)
12270 INPUT#1,A(I)
12280 INPUT#1,B(I)
12290 NEXTI
12300 CLOSE1:GOSUB21000:GOTO490
12500 REM RACE SAVE
12505 PRINT"*****" OPENING RACE FILE *****"
12510 OPEN1,1,1,"RACE"
12520 PRINT"*****" FILE OPEN--FILING RACE *****"
12525 PRINT#1,XV#
12530 PRINT#1,N
12540 PRINT#1,F
12550 FORI=1TON
12560 PRINT#1,A#(I)
12570 PRINT#1,A(I)
12580 PRINT#1,B(I)
12590 NEXTI
12595 CLOSE1
12600 PRINT"*****" RACE FILED--FILE CLOSED *****" :GOSUB20232:GOTO490
    
```

PET EXPERTS

SUPERSOFT are specialists in programming aids — like SPEEDSORT (£12) which will sort 1000 strings in about 4 seconds! DISK APPEND adds a program on disk to one in memory — just like the Toolkit — for only £15. BLOCK RENUMBER (12) is an invaluable aid for the serious programmer and SCREENSAVE (£6) is equally essential for the artistic programmer. If you own a printer then J-K-L is a must, for it copies the screen to the printer every time the keys J, K, L are pressed! (£8)

There are games too in our free catalogue. HALLS OF DEATH (£14) was described as 'better than Apathi' — but why not judge for yourself. BLACK BOX (£6) and NIMBO (£7) challenge your logic, whilst at £10 ALIEN ATTACK and WIZARD'S LAIR require you to be nimble-fingered as well as quick-witted.

So now you know. We don't just market the SUPERCHIP — we have over one hundred tried and tested programs in our range. Write us today for your free catalogue! Add 15% VAT to all prices. Post free.

SUPERSOFT



28 Burwood Avenue,
Eastcote, Pinner, Middlesex
Telephone: 01-866 3326

**'THIS BOOK
IS EXCELLENT'**
— Clive Sinclair



SEE OUR AD ON PAGE 160

Second Hand

APPLE 48K £700
MASTER DISC 3.3 £380
CENTRONICS 799 £650

Phone Charles Kennard
Day Time 01-636 5560
After 8pm 01-883 0874

```

13000 Q(0)=0:Q(1)=0:PRINT"*****"
13015 FORI=1TON:F(I)=0
13017 PRINT"*****"
13020 INPUT"*****";A(I)
13025 PRINT"*****"
13030 INPUT"*****";B(I)
13035 PRINT"*****"
13040 PRINTF(I)=B(I)/(A(I)+B(I)):Q(I)=Q(I-1)+F(I):NEXTI
13050 PRINT"":RETURN
14000 PRINT"*****":GOSUB24001
14025 PRINT"ODDS EXAMPLE: THIS IS ODDS OF 4 TO 1"
14030 PRINT"PLAYER TAKER: TO ENTER TYPE 4:RETURN:"
14035 PRINT" 4 - 1 FOLLOWED BY 1:RETURN":GOSUB24001
14040 PRINT"*****":RETURN
15000 PRINT"*****";TAB(33);"FINISH"
15035 PRINT"
15036 PRINT"
15037 PRINT"
15038 PRINT"
15039 PRINT"
15040 PRINT"
15041 PRINT"
15042 PRINT"
15043 PRINT"
15044 PRINT"
15045 PRINT"
15046 PRINT"
15047 PRINT"
15048 PRINT"
15049 PRINT"
15050 PRINT"
15100 RETURN
17000 PRINT"
17001 POKES9468,14
17010 PRINT" TYPICAL ODDS ARE 4 TO 1. THIS MEANS"
17015 PRINT" THAT IF THE HORSE WINS, THE BOOKMAKER"
17020 PRINT" PAYS 4 POUNDS FOR EVERY 1 POUND STAKED"
17030 PRINT" IF A HORSE IS THOUGHT TO HAVE 1 CHANCE"
17035 PRINT" IN 5 OF WINNING THEN IT'S TRUE ODDS"
17040 PRINT" ARE 4 TO 1. HOWEVER, THE BOOKMAKER IS IN"
17045 PRINT" BUSINESS AND IS NOT INTERESTED IN "
17050 PRINT" FAIR BETS. CONSEQUENTLY HE WILL "
17055 PRINT" OFFER SHORTER ODDS OF SAY 3 TO 1"
17060 PRINT" ODDS OF 3-1 REPRESENT A PROBABILITY OF"
17065 PRINT" 0.25 THAT THE HORSE WILL WIN THE RACE."
17070 PRINT" OR THE BOOKMAKER TO MAKE MONEY, THE"
17075 PRINT" SUM OF ALL THE PROBABILITIES MUST BE"
17080 PRINT" GREATER THAN 1.00"
17085 PRINT" SUCH A BOOK IS CALLED
17095 PRINT" IF THE BOOK IS
17100 PRINT" THE BOOKMAKER WILL NOT MAKE A PROFIT"
17997 GOSUB20232:POKE59468,12:RETURN
20000 PRINT"":GOSUB24001:GOSUB26000:GOSUB24001:GOSUB24001
20026 PRINT"SLIP PAYS:SLIP PAYS:K=0:PO=0:VZ=0
20055 FORI=1TOT:W=0:WP=0:PA=0
20060 IFT(I)=F(1)THEN20140
20070 IFT(I)=F(2)THEN20120
20080 IFT(I)=F(3)THEN20110
20090 NEXTI:GOTO20210
20100 IFZ1=1THEN20200
20101 IFZ1=2THEN20200
20105 PA=INT(MP(I)*(1+(A(Z)/(Z*B(Z))))+.5):GOTO20160
20120 IFZ1=1THEN20200
20125 PA=INT(MP(I)*(1+(A(Y)/(Z*B(Y))))+.5):GOTO20160
20140 W=W(I)+(M(I)*A(X)/B(X))
20145 IFZ1=1THEN20155
20150 WP=MP(I)+(MP(I)*A(X)/(Z*B(X)))
20155 PA=INT((W+WP)*10+.5)/10
20160 PO=PO+PA:IFPA=0THEN20200
20180 K=K+1:IFK=4THENK=1:PRINT
20190 PRINTTAB(13*K-12);I:TAB(13*K-8);PA:
20195 VZ=1
20200 NEXTI
20205 IFVZ=1THEN20210
20206 PRINT"*****:NO WINNING BETS"
20210 PRINT"*****:STAKES:":NT:
20225 PRINTTAB(23);" PAYOUT:":PO
20232 PRINT"*****:PRESS (SPACE) BAR TO CONTINUE "
20235 GETD:IFD#=""THEN20235
20240 RETURN
21000 IFR:5THEN21030
21020 Z1=1:RETURN
21030 IFR:7THEN21050
21040 Z1=2:Z2=4:RETURN
21050 Z1=3:Z2=5:RETURN
22000 ONZ1GOTO22020,22030,22040
22020 PRINT" HORSES: PAY ON WIN BETS ONLY":RETURN
22030 PRINT" HORSES: PAY 1/4 ODDS FIRST 2 PLACES":RETURN
22040 PRINT" HORSES: PAY 1/5 ODDS FIRST 3 PLACES":RETURN
23000 PRINT"*****"
23002 FORKK=1TON:PRINTTAB(17);" " :NEXTKK
23005 RETURN
24001 PRINT"*****":RETURN
24002 PRINT"*****":RETURN
24003 PRINT"*****:HONEST AL:":RETURN
24004 PRINT"*****":RETURN
24012 PRINT"*****":RETURN
24100 FORDT=1TOD:Z2=SOR(DT):NEXTDT:RETURN
24101 PRINT"*****":RETURN
24102 PRINT"*****":RETURN
25000 PRINT"TTTT":TAB(26);"BET IN "
25015 PRINTTAB(26);"A WHOLE "
25020 PRINTTAB(26);"A UNITS " :RETURN
26000 PRINT"*****"
26001 PRINTTAB(19-INT((LEN(XY#)/2));XY#;
26002 PRINTTAB(34);"*****":RETURN
READY.

```

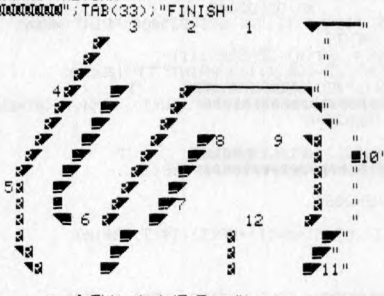

BLUDNERS

We've beaten you to it this month. Eagle-eyed readers may have noticed some 1s which appeared as 1s in January's 'Get Well Soon' article page 107. The errors are in the 17th and 18th lines from the bottom of the first column and the 20th to 22nd lines from the top of the second column.

Memories

2114-300ns	1k x 4 SRAM	2.25
4116-200ns	16k x 1 DRAM	2.61
2708-450ns	1k x 8 EPROM	3.60
2516-450ns	2k x 8 EPROM	7.20
2716-450ns	2k x 8 EPROM	7.20
2532-450ns	4k x 8 EPROM	18.00

Please add 50 pence for postage.
Send SAE for price list.
Prices not inclusive of VAT.

STRUTT LTD

3c, BARLEY MARKET STREET,
TAVISTOCK,
DEVON, England, PL19 0JF.

Tel: TAVISTOCK (0822) 5439/5548
Telex: 45263

IBM SELECTRIC GOLFBALL PRINTERS AND INPUT, OUTPUT 735 TYPEWRITERS

PRINTERS FROM	£195.00
735 TYPEWRITERS FROM	£245.00
WIRING AND COMMISSION	
TO SUIT ACULAB INTERFACE	£48.00
ACULAB INTERFACES EX STOCK	£155.00

ALSO AVAILABLE
IBM 71, 72, 82 typewriters.
Full workshop facilities for rebuilds and servicing.
Keyboard ASCID-ASCII, 10-12 pitch, language conversions undertaken.
11", 13", 15" platen lengths, split platens pin feed platens. Operational keylever repeats fitted on request.
Full IBM range of 10-12* pitch heads including language, symbol and metric.
Language keybuttons blue or grey

WE BUY SELL OR EXCHANGE ALL IBM
SELECTRIC TYPEWRITER MODELS

For further details phone Stuart Kirby or
Louis Baker Prices excl VAT @ 15% carriage &
packing, callers by appt only please

KEYTRONICS





Saul Lodge, Saul, Gloucester GL2 7JE
Tel: 0452 740 612

WEST MIDLANDS

If you want a computer
for business use
consult the experts!

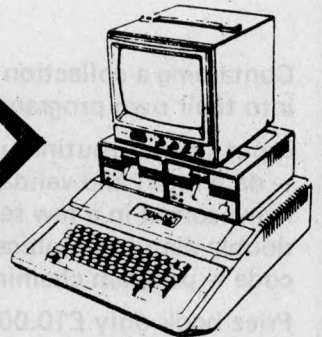
PAYROLL
STOCK CONTROL
PURCHASE/SALES
STOCK/INVOICING
INSURANCE BROKERS
VISICALC
WORD PROCESSING
MAILING LIST
etc.



 **apple II** SALES AND LEASING

LEASE AN APPLE II 48K SYSTEM INCL.
TWIN DISK DRIVES, MONITOR AND PRINTER
From £11.50 per week!

MICRO BUSINESS CENTRE LTD.

Castle Bridge House, Lichfield Road
Wednesfield, Wolverhampton
Tel: 0902 725687 for Sales and Service

2716

450ns SINGLE RAIL EPROMS
£3.95 EACH UP TO 100.
£2.95 1000
LARGER QUANTITIES POA.

EPROMS ERASED AND COPIED FROM
YOUR MASTERS WHILE-U-WAIT.

Erasing 45p Copying £4.00 per unit.
Various Video Game Conversions available from
£65.00 upwards.

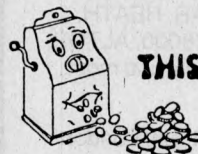

THIS COULD BE FUN (LEISURE) LTD.

307 NEW KINGS ROAD, LONDON SW6 4RF
01-736 5503

(PRICES EXCLUSIVE OF VAT)

Write better programs for your pet using **THE PET SUBROUTINE LIBRARY**



Containing a collection of useful subroutines, some in machine code, for readers to incorporate into their own programs.

Input/output routines incorporating error checking and validation – high density graphs and barplots – date input and validation – high speed machine code array sort (100 element array of any variable name sorted in a few seconds) – search routines – linked lists – utility programs – check digits – double density graphics – random access files – large sequential file sort – disk file access by machine code – program chaining and menus – disk file utilities and displays – plus many others.

Price book only £10.00 or

Book plus 3040 format diskette of all subroutines £20.00

THE PET REVEALED

Best selling reference book for the PET. Price £10.00

Cheques payable to Computabits Ltd

COMPUTABITS LTD,

P.O. BOX 13, YEOVIL, SOMERSET. Tel Yeovil 26522



INTEGRATED SMALL BUSINESS SOFTWARE ISBS

Professional Business Packages for Microcomputer systems include:

- **PAYROLL**
- **STOCK CONTROL**
- **ORDER ENTRY & INVOICING**
- **COMPANY SALES**
- **COMPANY PURCHASES**
- **GENERAL ACCOUNTING**
- **NAME & ADDRESS SYSTEM**

Available as individual modules or complete system to run on RAIK BLACK BOX, NORTHSTAR, HEATH, CROMEMCO, DYNABYTE, IMS 5000/8000, ALTOS, ALTAIR, SUPERBRAIN, MICROMATION and most other 8080 based systems.

Contact Lifeboat Associates, 32 Neal Street, London WC2 or your nearest dealer.

GRAFFBOM 52 SHAFTESBURY AVENUE
SYSTEMS GROUP LONDON W1 01-734 8862

MICRO- FACILITIES

127 HIGH STREET **01-979 4546**
HAMPTON HILL
MIDDLESEX **01-941 1197**

MIDDLESEX & S.W.LONDON

Approved Business Dealers for:

Commodore Computers & Business Packages
Apple II
North Star Horizon
IMS 5000/8000 Series

As fully authorised Dealers for the above equipment, and as experienced data processing professionals, we are the best people to help you.

Our complete package offers you:

Free initial discussion & advice
Systems Design & Programming
Software Packages
Supply & Installation of equipment
Leasing & Financing terms
Full Maintenance Contracts
Genuine After Sales Service

Contact us to discuss your problems and requirements, we offer you a lot more, but only charge the same. Our ability will give you peace of mind and confidence that the job will be done properly.

Pascal is born.

Micro Computer Connections announce the arrival of the "Pascal Utility Package." This brand new package available to Apple II users and has been developed to help those users with some experience in BASIC to become acquainted with USCD PASCAL.

Four procedural units are provided, in a format easily adaptable to any application. They simplify input/output formatting, allow access and/or change in the disc directory from a Pascal program, perform integer... string... real conversions, and support files of variable-length records.

Five useful sample programs have been incorporated on the disc. They are a set of simple PASCAL demos with listings on BASIC equivalents, a routine to view disc files in ASCII or HEX code, a text formater for simple word processing, a program to maintain a variable-length data file for the international traveller.

There is also our "Birthday Surprise" to celebrate the arrival of this unique program which is offered for immediate release only through Micro Computer Connections at the special introductory price of £40.

For details see reply coupon below.





MICRO COMPUTER CONNECTIONS LTD.
41 High Street, Egham, Surrey TW20 9DS. Tel. (0784) 37433/4.

All your answers at the touch of a button.

Micro Computer Connections Ltd., 41 High Street, Egham, Surrey TW20 9DS.
Complete coupon and send together with your remittance for £40.00 p&p included, made payable to MICRO COMPUTER CONNECTIONS LTD.
Within 28 days of receipt you will receive the new MCC Pascal Program complete with instructions. (Credit Card facility available.)

NAME _____
COMPANY _____
POSITION _____
ADDRESS _____

I enclose my cheque/PO for £ _____

 
 
 
 OTHER

or debit my Access/Diners/Barclaycard/credit card No.

--	--	--	--	--	--	--	--	--	--

NEW THE TUSCAN S100

A Z80 based S100 Computer System.

TUSCAN main board. The heart of the system with Z80, video, Ram, Rom, and I/O plus five S100 slots for expansion.

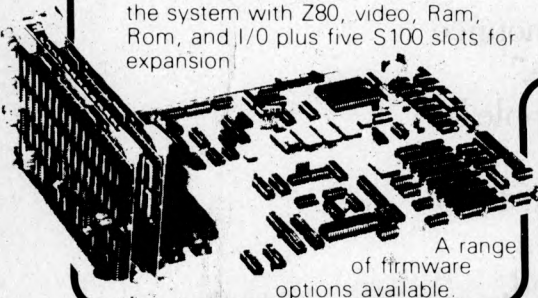

A range of firmware options available.

Available in Kit Form or Assembled. All components available separately.

Houses two 5 1/4" drives for a compact business system

Professional case will house the complete system

Two keyboard options

Hinged lid for easy access

Stylish finish ideal for office or home.



On Demonstration NOW

KITS from

Complete business system 48K with two 5" drives £1481

£235 + VAT delivery Ex-Stock

NASCOM-2

MICRO-KIT COMPUTER WITH IMPROVED 16k B RAM Board

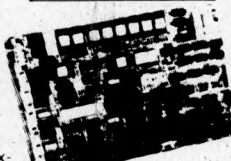

Ex-stock

only £335 + VAT

Full after sales service

POWER SUPPLY £29.50

Firmware & MOS ICs Software
Zeap Assembler (4, 1Kx8 EPROMS) £50
Nas Pen text editor (2, 1Kx8 EPROMS) £30
Expansion boards (in kit form)
48K RAM £210 ● 32K RAM £175.00
16K RAM £140

EPROM CARD (NASCOM compatible) KIT. Suitable for 16 x 2708 or 16 x 2716 or mixed 1 x NASCOM 8k BASIC ROM £56.00. BASIC programmers aid. Self locating tape £14.95.

NASCOM-1

12" x 8" PCB carrying 5LSI MOS packages, 16 1K MOS memory packages and 33 TTL packages. There is on-board interface for UHF or unmodulated video and cassette or teletype. The 4K memory block is assigned to the operating system and video display leaving a 1K user RAM. The MPU is the standard Z80 which is capable of executing 158 instructions including all 8080 code.
Built price £140 + VAT.

Nascom 1 Kit Price **£ 125** Plus VAT + P&P £1.50



PLAIN PAPER £325 PRINTER

Fully built and housed in a stylish enclosure for just £325 plus VAT.

INTERFACES WITH ALL MICRO COMPUTERS

The Nascom IMP (Impact Matrix Printer) features are 60 lines per minute. 80 characters per line.
● Bi-directional printing. ● 10 line print buffer.
● Automatic CR/LF. ● 96 character ASCII set (including upper/lower case, \$, £). ● Accepts 8 1/2" paper (pressure feed). ● Accepts 9 1/2" paper (tractor feed). ● Tractor/pressure feed. Baud rate from 110 to 9600. ● External signal for optional synchronisation of baud rate.
IDEAL FOR WORD PROCESSING

NASCOM PRODUCT LIST + VAT

- I/O board kit less I/O chips 45.00
- UART + BAUD rate generator + crystal for I/O board 16.00
- Electronic kit for additional 128 characters (N1 only) 30.00
- Bits & Pcs toolkit £28.00
- Bits & Pcs Chess £35.00
- Nascom 19" rack mounting card frame for N1 and N2 32.50
- Nas-DA disassembler 3 EPROM for Nas-sys 37.50
- MK36271 8K BASIC in K x 8 ROM 30.00
- Naspen VS in 2 EPROM 25.00
- Nas-sys monitor in 2 EPROM £8.50
- 4 Games Tape 25.00
- Nasbug T4 2 x EPROM 25.00
- Tiny Basic 2 x EPROM 25.00
- Super Tiny Basic 3 x EPROM 37.50
- Super Tiny Basic upgrade 1 x EPROM 12.50
- Tape Software
- ZEAP 2 tape and documentation for Nas-sys 30.00
- 8K BASIC tape and documentation for N1 15.00

THE HENELEC DISK SYSTEM FOR NASCOM and any other Z80 8080 Microcomputer with an uncommitted P10

DISKS



- The Henelec controller card plugs direct into a Z80 P10, and controls up to 3 double-sided mini-floppy drives giving a maximum 480K system.
- General Purpose FDC control software for simple DOS or for CPM.
- Simple DOS software for NASCOM 1/2 under NAS-SYS
- OR ROM CB10S for CPM on NASCOM 1/2 incorporating the major NAS SYS features. Maximum 60K CPM system.
- New MD prom supplied for N2/CPM
- TWO SYSTEMS**
- SIM-DOS "Floppy Tape Recorder" with 1 drive PSU firmware, etc. Double sided £380 plus VAT
- CPM System with 1 drive, double sided PSU firmware, etc. £450 plus VAT
- Additional Drives with PSU £205 plus VAT

COMPUTER KEYBOARDS

APPLE COMPUTER KEYBOARD

52 Key 7 Bit ASCII coded Positive Strobe +5V - 12V Size 13x4 1/4" Sturdy Construction Sloping Keys Black/White print. Made in USA for Apple Inc. **Brand New £36 incl VAT.** Post £2 50 Individually packed in ANTI STATIC FOAM

71 KEY ASCII KEYBOARD INCLUDING NUMERIC KEYPAD. £49.00 plus £7.36 VAT TOTAL £56.36. Uses gold crosspoint keys. Includes keypad and ribbon cable. Only available as fully assembled and tested.

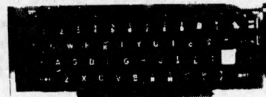

CARTER 57 key ASCII keyboard. Conventional key board. 128 ASCII characters including control keys. Parallel output with strobe. Shift lock + 5 V and -12 V DC. 12" x 5.5" x 1.5" Black keys with white legends. **39.34 + VAT.**

FERRANTI - "SIZE 14 x 6 x 3" SLOPING FRONT" 55 Key ASCII Coded in steel case. Complete with Plug and Cable with circuit to convert to T.T.L. levels.

In good condition at only **£19.95 + VAT, P/P £2 50**

CENTRONICS QUICK PRINTER

Model P1
List Price
£459
incl VAT

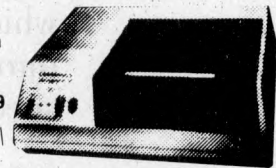

OUR PRICE incl VAT

EXCLUSIVE TO HENRY'S 50% OFF MAKER'S PRICE £195

for: Software selectable 20, 40 and 80 column using 120mm aluminium-ised paper. 1 roll supplied. 150 lines per minute.
NASCOM Centronics parallel data interface for Nascom, Tandy, etc.
240 volt mains input. ASCII character set Paper feed, and on/off select switches 'BELL' signal Weight 10lbs Size: 13" x 10 1/2" x 4 1/2"

MONITORS
New and Reconditioned FROM £35

Microtan 65 kit	£69.00	Tanex assembled	53.00
Microtan 65 assembled	79.00	Tanex (expanded)kit	106.50
Lower case option	9.48	Tanex (expanded)lassmbld	116.50
Graphics option	6.52	Serial I/O option	12.87
20 way keypad	10.00	Tanram kit	34.00
Full ASCII keyboard	49.00	Tanram assembled	44.00
Tanex kit	43.00	Tanram (expanded)lassbld	190.00

SEND FOR COMPLETE COMPUTER BROCHURE FREEPOST TO ADDRESS BELOW

MEMORIES Discounts 10% for 4, 15% for 8, 20% for 16	
MK 3880 (N280)	7.50
MK 3880 N4 (Z80A)	7.95
MK 4116 16K x 1 dy RAM	4.50
MK 4027 4K x 1 dy RAM	2.25
2102 1K x 1 static RAM	1.00
4118 1K x 8 static RAM	12.75
	2708
	2716
	IM6402 UART
	2114 1K x 4 static RAM
	8080A

ADD VAT 15% TO YOUR ORDER EXCEPT WHERE STATED

TANGERINE LONDON STOCKISTS

MPS1 power supply	23.00
Mini Mother board	10.00
Mini Rack	43.00

10K extended Microsoft in ROM £39.00

10K extended Microsoft in EPROM 49.00



HENRY'S

Computer Kit Division
404 Edgware Road, London, W2, England I.E.D.
01-402 6822

Official Export & Educational Orders Welcome
Our tele: 282284
Mono Ref. 1400 Transonics

APPLE® II DISK DRIVES

DUAL DISK UNIT

£498

DISK CONTROLLER CARD

£ 49

- * Two Disks in one Cabinet
- * Has its own Power Supply Unit
- * Connects to standard Apple Disk Controller Card
- * Runs all Apple Software including Pascal
- * Japanese quality and reliability

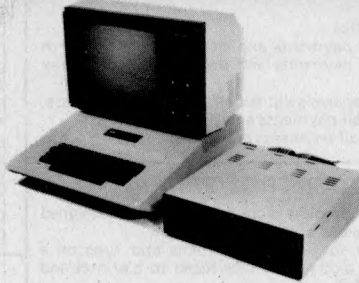

APPLE DEALERS:- Write or phone direct to Cumana and specifications plus dealer discounts will be mailed to you.

TRS-80® DISK DRIVES

DUAL DISK UNIT

2 x 40 Track Drives
2 x 80 Track Drives

£440
£645

SINGLE DISK UNIT

1 x 40 Track Drive
1 x 80 Track Drive

£236
£345

TRS 80 DISK CABLES

2 Drive Cable
4 Drive Cable

£20
£32.50

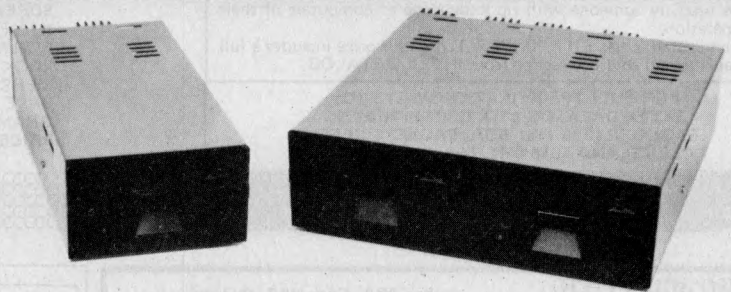

TRS-80 DEALERS:- Write or phone direct to Cumana and specifications plus dealer discounts will be mailed to you.

EDUCATIONAL & QUANTITY DISCOUNTS

VERY GENEROUS EDUCATIONAL AND QUANTITY PURCHASE DISCOUNTS ARE NOW AVAILABLE ON CUMANA TRS 80 DISK DRIVES. OUR DEALERS WILL BE HAPPY TO SUPPLY PRICE QUOTATIONS

Call your nearest dealer for a demonstration:

RADIO SHACK LTD.,
188, Broadhurst Gardens,
London NW6
Tel: 01-624-7174

COMPSHOP LTD., 14, Station
Road, New Barnet, Herts.
Tel: 01-441-2922

COMPSHOP LTD.,
311, Edgware Road,
London W2. Tel: 01-262-0387

MICRO-CONTROL LTD.,
224, Edgware Road,
London W2. Tel: 01-402-8842

**LONDON COMPUTER
CENTRE**, 43 Grafton Way,
London W1. Tel: 01-388-5721

**TRANSAM COMPONENTS
LTD.**, 59-61, Theobalds Road,
London WC1
Tel: 01-405-5240

N.I.C. 61, Broad Lane,
Tottenham, London N15
Tel: 01-808-0377

**KATANNA MANAGEMENT
SERVICES**, 22, Roughtons,
Galleywood, Chelmsford.
Tel: 0245-76127

I.C. ELECTRONICS,
Flagstones, Stede Quarter,
Biddenden, Kent.
Tel: 0580-291816

**CAMBRIDGE COMPUTER
STORE**, 1, Emmanuel Street,
Cambridge. Tel: 0223-65334

**PORTABLE MICRO-
SYSTEMS**, 18, Market Place,
Brackley, Northants
Tel: 0280-702017

COMPUTERAMA LTD.,
5, Cleveland Place East,
London Road, Bath.
Tel: 0225-333232

ENSIGN, 13-19, Milford
Street, Swindon, Wilts.
Tel: 0793-42615

SEVET TRADING, 14, St.
Paul's Street, Bristol 2
Tel: 0272-697757

PARWEST LTD., 58, Market
Place, Chippenham.
Tel: 0249-2131

**HEWART MICRO-
ELECTRONICS**, 95, Blakelow
Road, Macclesfield.
Tel: 0625-22030

HARDEN MICROSYSTEMS,
28-30, Back Lord Street,
Blackpool. Tel: 0253-27590

MICRO CHIP SHOP,
197, Waterloo Road, Blackpool.
Tel: 0253-403122

MICRO CHIP SHOP,
190, Lord Street, Fleetwood,
Lancs. Tel: 03917-79511

EWL COMPUTERS LTD.,
8, Royal Crescent, Glasgow.
Tel: 041-332-7642

**NORTH WEST COMPUTER
CONSULTANTS LTD.**,
241, Market Street, HYDE,
Cheshire
Tel: 061-366-8624

ZERO ONE ELECTRONICS,
36, Oaklands Avenue,
THORNTON HEATH,
Surrey
Tel: 01-689-7924

P & J EQUIPMENT LTD.,
3 Bridge Street,
GUILDFORD
Tel: 0483-504801

CUMANA LTD 35 Walnut Tree Close, Guildford, Surrey, GU1 4UN.
Telephone: (0483) 503121. Telex: 859680 (Input G).

*Please add VAT to all prices.
Delivery at cost will be advised
at time of order.*

Intex DATALOG LTD

COMPUTERS

MICROPAY-200

£195.00 + VAT

Micropay-200 is a complete payroll System designed to run on a COMMODORE 32K PET microcomputer, interfaced to dual floppy disk drives and a printer.

The System provides:

1. Weekly/monthly payslips
2. Summary page of all payments and deductions that month
3. Summary page of all payments and deductions for the tax year to date.
4. Weekly/monthly cash analysis slip for all cash payments made.
5. Monthly summary of all payments and deductions
6. Year end summary of all payments and deductions

STOCK CONTROL 3750

Stock Control 3750 is a complete stock control system designed and written to meet the needs of a small business. It will accommodate up to 3747 stock items and runs on a COMMODORE PET micro-computer interfaced to a printer and COMPU/THINK disk drives.

The System incorporates programs to:

1. Set up a Supplier file
 2. Set up Stock files
 3. Copy Data files
 4. Insert/delete stock records
 5. Insert/delete supplier records.
 6. Update/display stock file.
 7. Update/display supplier file.
 8. Print stock list.
 9. Print supplier list.
 10. Print reorder report.
 11. Print stock movement report.
 12. Print stock valuation report.
- And perform other useful routines.

Stock Control 3750 is fully protected from misuse and can easily be used by someone with no knowledge of computers or their operation.

The System costs £195.00 + V.A.T. and this price includes a full back-up and advisory service from INTEX DATALOG.

FOR FULL SPECIFICATION WRITE TO:
INTEX DATALOG LTD, DEPT PCW 0281
EAGLESCLIFFE IND. EST., EAGLESCLIFFE
CLEVELAND TS16 0PN. TEL: 0642 781193

MAIL ORDER SERVICE

BARCLAYCARD - ACCESS

INDEX	PRICE	TOTAL INC. VAT
***DUSTCOVERS		
PET - ALL MODELS	5.75	6.90
T/T43 PRINTER	5.75	6.90
ANADEX DP8000	3.50	4.35
CBM 3040 DISK	3.50	4.35
CBM 3022 PRINTER	3.99	4.80
COMPUTHINK DISK	3.00	3.75
ACOUSTIC COVER FOR		
CBM 3022 PRINTER	49.00	62.00
*** D/D DISKETTES IN FREE CASE		
BASF	35.00	40.83
ACCUTRAK	30.00	35.08
LIBRARY CASE	3.50	4.60
***BLANK CASSETTES		
C15 (PER 10)	4.00	5.75
C60 (PER 10)	6.00	8.05

*** CONNECTORS		
USER/EEE PORT	1.30	1.78
CASSETTE PORT	99	1.43
USERPORT COVER	2.50	3.16
MALE 'D' PLUGS	2.50	3.16
FEMALE 'D' SOCKETS	3.50	4.31
'D' CONNECTOR COVERS	2.50	3.16
***RIBBONS		
TELETYPE 43	7.72	9.17
ANADEX DP8000	2.75	3.45
ANADEX DP9500/1	15.00	18.40
CBM 3022	2.75	3.45
QUME (FABRIC)	4.25	5.18
QUME (CARBON M/S)	4.50	5.46
QUME (CARBON S/S)	5.00	6.04
DAISY WHEELS		
QUME SPRINT 5	6.50	7.76
***PROGRAMMERS TOOLKIT		
***SPECIAL OFFER		
OLD ROMS 8K	65.00	75.90
NEW ROMS 8K	65.00	75.90
NEW ROMS 8/16/32K	45.00	52.90

PROKIT 1

PROKIT 1 - PROGRAMMERS AID.

ADDS THAT TOUCH OF PROFESSIONALISM TO EVERY PROGRAM YOU WRITE.

NUMERIC INPUT ROUTINES - AUTOMATICALLY ADD LEADING AND TRAILING ZERO'S AND RESPOND ONLY TO MERIC KEYS AND DECIMAL POINT.

GENERAL INPUT ROUTINES - SET THE LENGTH OF FIELD REQUIRED. SPECIFY WHICH CHARACTERS YOU WANT PET TO RESPOND TO AND ALL OTHERS WILL BE IGNORED.

DATE INPUT ROUTINE - THE PROGRAM WILL NOT CONTINUE UNTIL YOU HAVE ENTERED A VALID DATE.

STRING SEARCH ROUTINE - FINDS A MATCHING SUBSTRING WITHIN A STRING ENABLES YOU TO USE ON GOTO WITH ANY CHARACTERS, NOT JUST NUMBERS.

SCREEN ROUTINES - CAN STORE SCREEN DISPLAYS IN MEMORY AND RETRIEVE THEM IN A FLASH - SUPER FOR MENUS AND GAMES!

PROKIT 1, DEFINITELY THE BEST THING FOR PROGRAMMERS SINCE THAT OTHER KIT! AVAILABLE ON DISK OR TAPE READY TO INCORPORATE IN YOUR OWN PROGRAMS'

PRICE £40.25 INC. VAT AND POSTAGE

Intex

OHIO SCIENTIFIC NEW SUPERBOARD 3

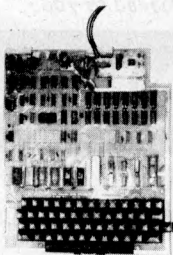

chrs £20. Case £27. Colour conversion board:-kit £45 or built £65. CEGMON improved monitor rom £29.50. Cassette recorder £16. 610 expansion board £159 (write for details of special offer). Assembler/editor £25. Word processor £10.

New Superboard 3 £159 + 15% VAT post free with free power supply and modulator kit. Kits for use with the old Superboard 2 (Add 15% VAT): -Guard band kit £8. 4K extra ram £16.95. Display expansion kit approx 30 lines x 54

SHARP COMPUTERS



Add 15% VAT to these prices. Sharp MZ80K Computer with Basic tape and a free tape of approx 50 programs:- 20K version £438. 48K version £486. MZ80 I/O £83. MZ80P3 £499. MZ80FD £772. PC1211 £83. CE121 £12.

PRINTERS

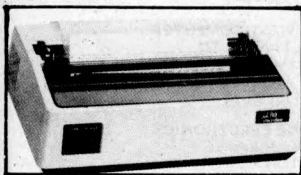

Buy any of the below and get a free interface kit and word processor program for UK101 or Superboard 2:- OKI Microline 80 (Illustrated) £349 + 15%. BASE 2 800MST £299 + 15%. Seikosha GP80 Printer p.o.a.

THE NEW OHIO SERIES 2 CHALLENGER C1P

Program selectable 24 x 24 or 12 x 48 displays. Sound, music and voice output. 8K ram expandable to 32K. 8K basic. Only £259 + 15%. We also stock the C1PMF series 2 which has all the above features plus a 90K mini-floppy disc and 20K ram expandable to 32K £689 + 15% VAT.

SWANLEY ELECTRONICS

Dept. PCW, 32 Goldsel Rd., Swanley, Kent BR8 8EZ

Telephone Swanley 64851. Please add 40p postage. Prices include VAT unless stated. Lists 27p post free. Overseas customers deduct 13%. Official credit orders welcome.

ANGLIA COMPUTER CENTRE

MICROCOMPUTERS FOR BUSINESS, EDUCATION AND HOME

FOR ALL YOUR BUSINESS, EDUCATION & LEISURE
COMPUTER REQUIREMENTS!!!

APPLE II
TRS-80
SHARP
NORTH STAR
HORIZON
TANGERINE
J.K. 101
NASCOM

+PRINTERS AND
OTHER PERIPHERALS
BOOKS**
SOFTWARE*
MAGAZINES**
STATIONERY***

BUSINESS+
INDUSTRIAL
CONTROL

WE ARE HERE!!!

**88 St. Benedict's Street
NORWICH NR2 4AB
Tel. (0603) 29652
24hr. Answering Service.**

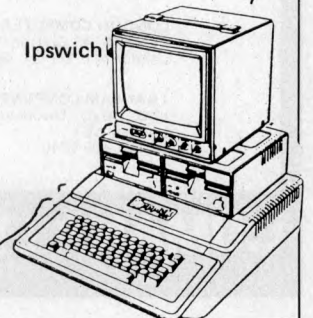
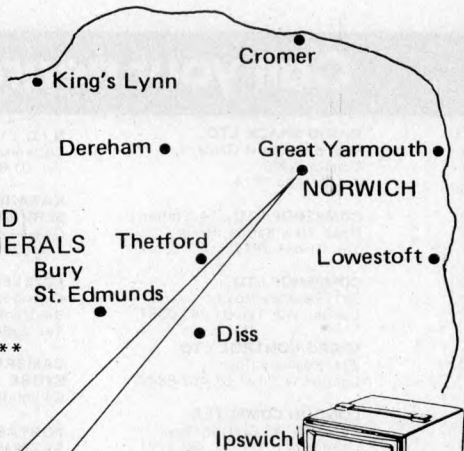

New Low, Low Prices On Memories

Compare our prices before you buy elsewhere! All devices are brand new, factory prime, full spec. and fully guaranteed!

STATIC RAMS

	1+	50+	100+
2114L 450 NS	195p	175p	160p
2114L 300 NS	250p	225p	195p
2114L 200 NS	275p	250p	225p
4118 250 NS 8K NEW!	£9.95	£8.95	£7.95
HM6116 16K (2K x 8)			
150 NS 24-pin NEW!	£26	£23.95	£19.95

DYNAMIC RAMS

4116 200 NS Ceramic	225p	195p	175p
4116 150 NS	375p	350p	325p
MB8264 64K (65K x 1)			
200 NS			
Single +5V supply, 16-pin NEW!	£40	£35	£30

CMOS RAMS

5101 1K (256 x 4)			
450 NS	350p	325p	295p
4315 4K (4K x 1)			
450 NS		995p	
TC5514P 4K (1K x 4)			
450 NS	550p	525p	495p
HM6116 16K (2K x 8)			
150 NS 24-pin NEW!	£26	£23.95	£19.95

EPROMS

2708 450 NS	375p	350p	325p
2716 Single 5V 450 NS	495p	450p	425p
2532 Single 5V 450 NS	1895p	1595p	1395p
2732 Intel-type 450 NS	1895p	1595p	1395p
2564 64K (8K x 8)			
450 NS 28-pin	£99	£95	£90

All prices exclude p&P and VAT. Please refer to 'Ordering Information' before ordering.

DON'T DELAY - BUY TODAY - SPECIAL OFFERS DON'T LAST FOR EVER!!!!

NEW 6809 S-100 SINGLE-BOARD COMPUTER

- * Meets IEEE S-100 Standard!
 - * Uses Motorola's Powerful MC6809 CPU!
 - * 4K, 8K, 16K ROM!
 - * 2K RAM!
 - * ACIA, PIA, 8080 Simulated I/O!
 - * RS - 232 Handshake!
 - * Selectable BAUD Rates!
 - * Manual includes: 11" x 7" Schematic, Parts List, User Notes, Software Listings and MORE!
 - * Bareboard only £49!!! (plus p&p£1)
 - * (CPU6809) £19!!!
 - * Adsmo Monitor (2716) £25!!!
- Complete board assembled & tested only £250!!! +£2 p&p

NEW EXCITING, ENTERTAINING SOFTWARE FOR THE APPLE II and APPLE II PLUS!!

ASTEROIDS IN SPACE!!!!

If you liked 'Invaders' you'll love ASTEROIDS IN SPACE by Bruce Wallace! Your spaceship is travelling in the middle of a shower of asteroids. Blast the asteroids with lasers, but beware - BIG ASTEROIDS FRAGMENT INTO SMALL ASTEROIDS! The Apple game paddles allow you to rotate your spaceship, fire its laser gun, and give it thrust to propel it through endless space. From time to time, too, you'll encounter an alien spaceship whose mission is to DESTROY YOU so you'd better destroy it first! High resolution graphics and sound effects add to the arcade-like excitement this program generates. RUNS ON ANY APPLE II WITH AT LEAST 32K AND ONE DISK DRIVE!

ON DISKETTE ONLY **£14.95**

AUTORANGING, AUTO UNIT DISPLAY, 3½-DIGIT LCD DMM for ONLY £39.95 incl. VAT!

The nationally advertised 6200, giving 200mA AC/DC current measurement; AC voltage to 750V (DC to 1000V); 100µA resolution and 0.1 Ohms - 2 Megohms. Accuracy is 0.8% and it displays mV, V and mA. You won't find a cheaper DMM with these features AND batteries, test leads, spare fuse and one year guarantee are INCLUDED in the low, low price of just

£39.95
incl. VAT

MICROCHIPS AT MICRO PRICES!

INTERFACE	SUPPORT DEVICES	FLOPPY DISK CONTROLLERS	
LINEAR	6520	FD1771 B-01 S/D Inverted Bus	2995p
MC1488	6522	FD1791 B-01 D/D Inverted Bus	3995p
MC1489	6532	FD1792 B-01 S/D Inverted Bus	3495p
DM8123	6551	FD1793 B-01 D/D True Bus	5495p
75150	6810	FD1794 B-01 S/D True Bus	3495p
75154	6820	FD1795 B D/D Inverted Bus, side select	5995p
75182	6821	FD1797 B D/D True Bus, side select	5995p
75322	6850		425p
75324	6852		425p
75325	8212		395p
75361	8214		450p
75365	8216		395p
75451	8224		395p
75491/2	8228		395p
8T26	8251		495p
8T28	8253		1125p
8T95	8255		495p
8T97	8257		1060p
	8259		1325p

DISPLAYS		
FND500	80p	MC 144 12V/L
FND510	80p	Z80 P10
FND567	125p	Z80 CTC
DL704	85p	Z80A P10
DL707	85p	Z80A CTC
MV57164	225p	Z80 DMA
		Z80A DMA
		Z80 S10/1
		Z80A S10/0
		Z80 S10/1
		Z80A S10/1
		Z80 S10/2
		Z80A S10/2

CPU'S		
6502	625p	
6504	795p	
6505	795p	
6800	695p	
6802	995p	
6809	£19	
8080A	525p	
8085A	1095p	
Z80	795p	
Z80A	995p	
Z8001	12500p	
X8002	9500p	
VD9000B	19900p	

KEYBOARD ENCODER	
AY 5-2376	795p

UARTS	
AY 5-1013A	325p
AY 3-1015D	398p
IM6402 IPL	325p

EPROMs		
2708 450 NS	375p	
2716 5V 450 NS	495p	
2532 32K 450 NS	1895p	
2732 Intel-type 450 NS	1895p	
2564 64K (8K x 8)	895p	
450 NS 28-pin NEW!	£99	

CHARACTER GENERATOR	
RO-3-2513 UC	450p

DEVELOPMENT MODULE	
Z8000 DM	1099p

MEMORIES			
STATIC RAMS			
2114L 450 NS		195p	
2114L 300 NS		250p	
2114L 200 NS		275p	
4118 250 NS 8K NEW!		£9.95	
HM6116 16K (2K x 8)			
150 NS 24-pin NEW!		£26	
DYNAMIC RAMS			
4116 200 NS Ceramic		225p	
4116 150 NS		375p	
MB8264 64K (65K x 1)			
200 NS Single +5V supply, 16-pin NEW!		£40	
CMOS RAMS			
5101 1K (256 x 4)			
450 NS		350p	
4315 4K (4K x 1)			
450 NS		995p	
TC5514P 4K (1K x 4)			
450 NS		550p	
HM6116 16K (2K x 8)			
150 NS 24-pin NEW!		£26	

Microbyte
Dept. PCW6,
Unit 9/10, 1st Floor, E Block,
38 Mount Pleasant, London WC1X 0AP.

Tel: 01-278 7369
Telex: 8953084



**MICRO
BYTE**
Dept. PC4

SAMS BOOKS AT LOWEST PRICES

COMPUTER BOOKS		
Microcomputer Primer (2nd Edition)		NEW £7 17
Microcomputers for Business Applications		£5 37
The Howard W. Sams Crash Course in Microcomputers		NEW £10 50
Fundamentals of Digital Computers (2nd Edition)		£5 97
Getting Acquainted with Microcomputers		£5 37
How to Buy & Use Minicomputers & Microcomputers		£5 97
Computer Graphics Primer		NEW £7 77
TEA: An 8080/8085 Co-Resident Editor Assembler		NEW £5 37
6502 Software Design (Book 1)		NEW £5 70
(Book 2)		£5 97
BASIC Programming Primer		£5 37
DEBUG: An 8080 Interpretive Debugger		£3 75
How to Program Microcomputers		£5 37
Computer Dictionary (3rd Edition)		NEW £7 17
Boolean Algebra for Computer Logic		£3 95
Computers & Programming Guide to Scientists & Engineers (3rd Edition)		NEW £9 57
Microcomputer Interfacing with the 8255 PPI Chip		£5 37
Programming & Interfacing the 6502, with Experiments		NEW £7 17
TRS-80 Interfacing		NEW £5 37
Z-80 Microcomputer Design Projects		NEW £7 77
Z-80 Microprocessor Programming & Interfacing - Books 1 and 2		
(Book 1)		£6 97
(Book 2)		£7 77
Interfacing and Scientific Data Communications Experiments		£3 95
Introductory Experiments in Digital Electronics and 8080A		
Microcomputer Programming and Interfacing		£7 77
(Book 1)		
(Book 2)		£7 77
Microcomputer - Analog Converter Software and Hardware		£5 70
Interfacing		
The 8080A Bugbook: Microcomputer Interfacing and Programming		£6 30
The S-100 and Other Micro Buses		£3 95
The Cheap Video Cookbook		£3 75
TV Typewriter Cookbook		£5 97
Using the 6800 Microprocessor		£4 77
Z-80 Microcomputer Handbook		£5 37
8085 Microcomputer Design		NEW £5 97
COOKBOOKS		
TTL Cookbook		£5 70
Active-Filter Cookbook		£8 97
TV Typewriter Cookbook		£5 97
CMOS Cookbook		£6 97
The Cheap Video Cookbook		£3 75
IC Converter Cookbook		£8 37
IC Op-Amp Cookbook (2nd Edition)		£8 97

Ordering information. Unless otherwise stated, for orders under £50 add 50p p&p. Add 15% VAT to total (no VAT on books). All devices are brand new, factory prime and full spec and subject to prior sales and availability. Prices subject to change without notice. Minimum telephone order using ACCESS is £10. If ordering by post with ACCESS, include name, address and card no. written clearly. Please allow 4/6 weeks delivery on books.

aculab

floppy tape,

The tape that behaves like a disc,
For TRS-80 LEVEL II and Video Genie.

Connects directly to TRS-80 Level 2 Keyboard. Operating and file handling software in ROM. 8 commands add 12 powerful functions to Level 2 BASIC. No buttons, switches or volume controls. Full control of all functions from Keyboard or program. Daisy chain multiple drives. Certified digital tape in endless loop cartridges. Reads and writes in FM format at 9000 Baud. Soft sectored with parity and checksum error detection for highly reliable operation—just like discs. Maintains directory with up to 32 files on each tape, tapes may be write-protected. Supports Basic and machine-language program files, memory image and random access data files. 12 character filespecs—: "FILENAME/EXT:d" (d is drive no. 0-7). Automatic keyboard debounce. Full manual with programming examples and useful file-handling routines.

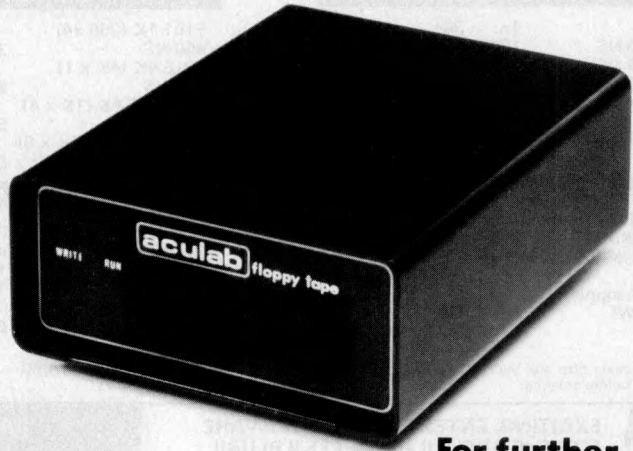

COMMANDS (usually followed with a filespec and possible parameter list).

@SAVE, @LOAD, @RUN —for BASIC programs, machine language programs and memory image files. **@GET, @PUT** —moves a 256-byte record between a random access file and BASIC's data buffer. **@KILL** —removes a file from the directory and releases tape sectors for immediate re-use. **@LIST** —displays file directory along with sector allocation and free sectors. **@NEW** —formats tape and creates a blank directory.

Master drive with PSU, Manual and a selection of tapes.

For TRS-80 £169-00, for Video Genie £174-00.

Slave drives £125-00. (add £2-00 p.p. + vat).

(Export orders pp charged at cost)

For further information,
Telephone
0525 371393

aculab Ltd.
24 Heath Road,
Leighton Buzzard,
Beds. LU7 8AB

74LS SERIES

74LS00	.18				
74LS01	.18	74LS114	.35	74LS242	1.90
74LS02	.18	74LS122	.70	74LS243	1.90
74LS03	.18	74LS123	.75	74LS244	2.10
74LS04	.22	74LS124	1.40	74LS245	2.50
74LS05	.22	74LS125	.40	74LS247	1.20
74LS08	.20	74LS126	.40	74LS248	1.80
74LS09	.22	74LS132	.65	74LS249	1.25
74LS10	.18	74LS133	.40	74LS251	1.10
74LS11	.22	74LS136	.40	74LS253	1.10
74LS12	.22	74LS138	.70	74LS257	1.10
74LS13	.40	74LS139	.70	74LS258	0.95
74LS14	.70	74LS145	1.10	74LS259	1.65
74LS15	.22	74LS148	1.70	74LS260	.30
74LS20	.20	74LS151	.85	74LS261	3.50
74LS21	.22	74LS153	.55	74LS266	.40
74LS22	.22	74LS154	1.40	74LS273	1.75
74LS26	.22	74LS155	.75	74LS279	.65
74LS27	.22	74LS156	.75	74LS280	1.75
74LS28	.22	74LS157	.60	74LS283	1.00
74LS30	.20	74LS158	.65	74LS290	0.95
74LS32	.26	74LS160	1.10	74LS293	0.95
74LS33	.28	74LS161	.80	74LS295A	1.45
74LS37	.26	74LS162	1.10	74LS298	1.40
74LS38	.26	74LS163	.80	74LS324	1.80
74LS40	.22	74LS164	1.10	74LS325	2.55
74LS42	.65	74LS165	.80	74LS326	2.55
74LS47	.85	74LS166	1.70	74LS327	2.55
74LS48	.85	74LS168	1.70	74LS352	1.35
74LS49	1.00	74LS169	1.70	74LS353	1.35
74LS54	.20	74LS170	1.70	74LS365	.60
74LS55	.20	74LS173	1.10	74LS366	.60
74LS63	1.50	74LS174	.95	74LS367	.60
74LS73	.35	74LS175	.95	74LS368	.60
74LS74	.35	74LS181	2.75	74LS373	1.75
74LS75	.42	74LS190	1.20	74LS374	1.75
74LS76	.35	74LS191	1.20	74LS375	.75
74LS78	.35	74LS192	1.10	74LS377	1.75
74LS83A	.85	74LS193	1.10	74LS378	1.30
74LS85	1.00	74LS194A	1.00	74LS379	1.40
74LS86	.35	74LS195A	.90	74LS381	3.65
74LS90	.58	74LS196	.95	74LS386	.60
74LS91	.99	74LS196	.95	74LS390	1.75
74LS92	.90	74LS197	.95	74LS393	1.50
74LS93A	.65	74LS424	4.50	74LS395	1.80
74LS95A	1.00	74LS445	1.25	74LS396	1.70
74LS96	1.25	74LS447	1.25	74LS398	2.70
74LS107	.35	74LS490	1.95	74LS399	1.60
74LS109	.35	74LS221	1.20	74LS668	1.95
74LS112	.35	74LS240	2.10	74LS669	.95
74LS113	.40	74LS241	1.90	74LS670	.95

MAGTRONICS

LTD.

MAGTRONICS LTD
3 GOLDHURST TERRACE
LONDON
N.W.6.
TELE. 01-624-9847

DISKETTES

UNCONDITIONAL GUARANTEE

5.25" MINI-DISKETTES	SINGLE SIDED	
1 SECTOR	PER 10	£20.00
(SOFT)		
5.25" MINI-DISKETTE	SINGLE SIDED	
10 SECTOR	PER 10	£20.00
5.25" MINI-DISKETTE	SINGLE SIDED	
16 SECTOR	PER 10	£20.00
8" SINGLE SIDED	SINGLE DENSITY	
26 SECTOR	PER 10	£20.00
8" SINGLE SIDED	DOUBLE DENSITY	
26 SECTOR	PER 10	£24.00
8" DOUBLE SIDED	SINGLE DENSITY	
26 SECTOR	PER 10	£30.00
8" DOUBLE SIDED	DOUBLE DENSITY	
26 SECTOR	PER 10	£30.00

All orders under £50 add 50 p P&P. Add 15% VAT to total.

Many other types of hard and soft sector diskettes available. Phone for quotation.

Magnetic cards, data cartridges, digital cassettes are also stocked.

Official orders from schools, colleges, universities and Govt. Bodies accepted.

E. PROMS	MEMORIES	C PUS.	SOCKETS
1702A	500p 2114L	400p 6502	800p L.P.
2708	450p 2114L-2	500p 6800	700p 8 PIN
2716(+5v)	900p 2114L-3	500p 6802	1200p 14 PIN
2532(+5v)	2700p 4116L-2	500p 8080A	450p 16 PIN
	6810	350p 8085A	1100p 24 PIN
			9p
			10p
			11p
			22p

SOFTWARE

Software & Manual/Manual Only

Byrom Software	BSTAM—Utility to link one microcomputer to another also using BSTAM £70/5
Computer Plus	FMS 80 (File Management System) Demo Pack (includes manual and disc) £35 Complete System £395/25
Computer Services	Bidirectional driver for Diablo Hytype printers for use on CPM & CDOS systems £65/10
CP/M User Library	42 Volumes on 8" disc £4 42 Volumes on 5" disc £8
Creative Computing	For CP/M CS-9001 BASIC Games 1 £12 CS-9002 BASIC Games 2 £12 CS-9000 BASIC Games 1 and 2 £22 CS-9003 ADVENTURE I.O. £12 CS-9004 BILINGUAL Original Adventure £12 CS-9005 BASIC Games 3 £12 CS-9006 BASIC Games 4 £12 CS-9007 BASIC Games 3 and 4 £22 CS-9008 BASIC Games 1, 2, 3 and 4 £40
Digital Research	(Most formats now available) MPM 1.1 £175/18 CP/M 1.4 £65/18 CP/M 2.2 £90/18 SID £45/12 ZSID £55/12 MAC £55/12 TEX £45/12 DESPPOOL £30/5 PL/1 £POA/25
Information Unlimited	WHATSIT (Database Management System) on North Star £59 on CP/M £75 on APPLE 2:48k (requires int Basic) £72 On APPLE 2:32k (requires int Basic) £59 on ITT 2020 (see Apple)
KLH Systems	Spooler for CPM systems £65/5
L.P. Enterprises	Diablo driver runs 110 to 9600 baud with autoloader for CP/M or CDOS £30/5 OMNIX—UNIX like multiuser, multitasking operating system for Z80 i.e. IMS, Cromemco, Horizon £250/30 Multiforth £65/20
MICAH Inc.	CP/M for CDOS Users: Program to Expand CP/M system to be compatible with Cromemco CDOS software £59/5 Disc Utilities: Pack one of CDOS users includes: Fast disc copy, Track test, Disc test, Compare files and others £30/5 Pack two for CP/M users includes same as pack one £30/5 Pack three for Cromemco users includes same as pack one and spool and print £65/5
Microsoft Inc.	BASIC-80 £175/17 BASIC Compiler 5.2 £195/17 FORTRAN-80 £220/17 COBOL-80 4.0 £355/17 EDIT-80 £45/11 MACRO-80 £80/11 MICROSEED £TBA/20 MULISP £TBA/20 MUMATH £TBA/20
Michael Shrayner Inc.	Electric Pencil Word Processor £100 SSII for tty etc £100 DSII for Diablo £105 TRS-80 Cassette/disc £50
Microfocus Ltd.	CIS COBOL version 4.2 £425/25 FORMS 2 £100/10
Micropro Inc.	WORD-MASTER 1.7 £70/20 TEX-WRITER 2.6 £35/15 WORD-STAR 2.1 £240/25 SUPER-SORT: Version 1 £120/20 Version 2 £100/20 Version 3 £75/20 WORD-STAR with MAIL-MERGE 2.1 £310/35 MAIL-MERGE 2.1 £70/10 DATASTAR 1.07 £165/20
MT Microsystems	Pascal MT £125/12
Northshare	Multi-user system for Horizon Users 5.1 £40/5

Software & Manual/Manual Only

Osborne & Associates	Accounts Payable & Accounts Receivable (disc only) £50 General Ledger (disc only) £50 Payroll with Cost Accounting (disc only) £50
Compiler Systems	CBASIC v2.06 £65/15
Structured Systems all Converted to UK Standard	Sales Ledger £275/15 Purchase Ledger £275/15 Nominal Ledger £325/15 Stock Control £275/15 Letterright £95/10 Analyst (File management Reporting System) £115/10 NAD (Name and Address selection system) £50/10 OSORT £50/10
TDL Software (Technical Design Labs)	Business Basic £80 ZTEL (Text Editing Lang.) £35 MACRO II (Z80 Macro Assembler) £35 LINKER £35 DEBUG II (for 8080/Z80) £45
Tiny-C Associates	Tiny-C language for 8080, 8085, Z80 systems £50/35
Supersoft Inc.	DIAGNOSTICS 1 £35/5 TERM £65/5
Software Works	Northstar Format only Inventory-1 (Stock Control) £50/10 Inventory-2 with order entry, invoicing £130/15 Mailroom £50/15 Housekeeper (Utilities, sorts) £35/10 Preventative Maintenance £75/15 Housekeeper-2 (Coming Soon) £TBA

ORDER INFORMATION

Software prices reflect distribution on 8" single density discs. If a format is requested which requires additional discs a surcharge of £4 per additional disc will be added.

Please add VAT and £2.50 for first class postage, packing and insurance.

If required, DATAPOST D service is available for an extra charge of £7.50.

All software on this Advertisement is available from stock and a 24-hour return service is thereby offered on all prepaid orders. When ordering CP/M software please specify the format you require otherwise software will be dispatched on an 8" single density disc.

For more information on any of these items, please phone, write or visit. (We are open during office hours).

OEM terms available

MAIL ORDER TELEPHONE ORDER VISIT

Send Cash, Cheque, Credit Card No., Postal Order, IMO to L.P. Enterprises, Room PCW, 8 Cambridge House, Cambridge Road, Barking, Essex IG11 8NT.

All Payment must be in sterling and drawn against a UK bank. Subscriptions are processed to start with the next current issue, after the date of order.

These details are all current as of August 1980.

Prices are subject to change without notice, due to fluctuation in the dollar rate.

Trade Enquiries welcome.

Bulk Purchasers welcome.

TEMPLEMAN SOFTWARE LIMITED

25-26 Greenhill Street, Stratford Upon Avon
Warwickshire CV37 8LR
Telephone: Stratford Upon Avon (0789) 66237

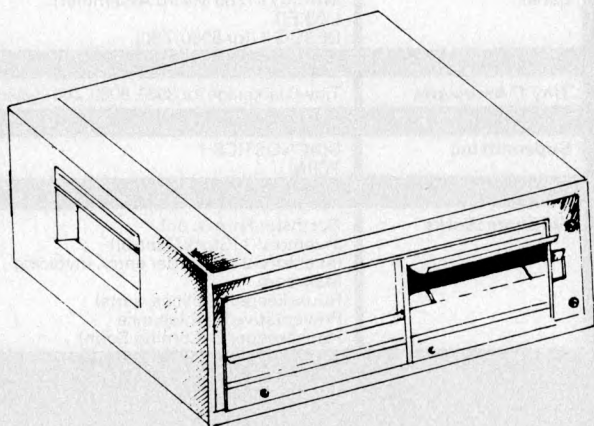

8" DOUBLE SIDED, SINGLE DENSITY FLOPPY DISC DRIVE.

*THEY HOLD FIVE TIMES AS MUCH INFORMATION AS 5" DRIVES, I.E. ONE MILLION CHARACTERS.

*TWO VERSIONS OF DOS ARE SUPPLIED; MAXIDOS AND NORMALDOS.

*PASCAL IS AVAILABLE.

*ITT SILVER OR APPLE CREAM CASING.

*R.R.P. £1550 (exc. VAT).

*DEALER ENQUIRIES WELCOME.

SOFTWARE IS OUR MIDDLE
NAME

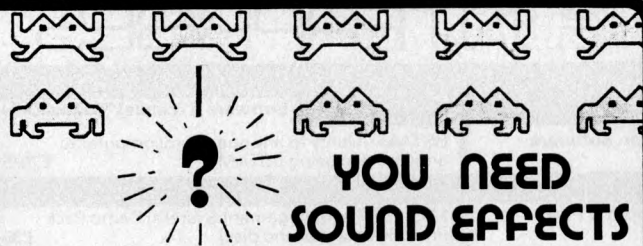

**YOU NEED
SOUND EFFECTS**

FOR PET, SUPERBOARD, UK101, NASCOM.

- * COMPLEX EFFECTS AND MUSIC
- * USES INCREDIBLE AY-3-8910
- * COMPLETELY BUILT, SIMPLY PLUGS IN
- * BASIC OR MACHINE CODE
- * BUILT IN AMP & SPEAKER + STEREO
- * INCLUDES 2 8 BIT I/O PORTS
- * COMATIBLE WITH OTHER EXPANSIONS
- * FREE DEMO PROGRAM + INSTRUCTIONS

£43
+ VAT
EX STOCK

Send for free information leaflets.

NB: 8T28 buffers (Superboard/UK101) next 6502 @ £3.00 per pair if required

SOON EPROM Programmer for Superboard/UK101.

AVAILABLE!! Peripheral board 24 I/O lines for relay driving etc., etc.

PHONE, WRITE FOR DETAILS.

SUPERBOARD II 50Hz → £159 + VAT

610 EXPANSION £159 + VAT
CD3P FLOPPY DISC £285 + VAT
BASE 2 800MST PRINTER £359 + VAT

**SPECIAL
OFFER**

2114L/300nF RAM 8 for £22
4116-300NS 8 FOR £22.50

Trade enquiries welcome. Send for extensive software list.

57 PARANA COURT
SPROWSTON
NORWICH
NR7 8BH



Easicomp

0508 46484

COMPUTERS

From as little as £20 per week for your own business system with video screen, keyboard, twin floppy disk unit and printer. Choose any of the software programs available i.e.:

- * Word processing
- * Payroll
- * Invoicing
- * Stock control
- * Book-keeping
- * Incomplete records
- * Time recording
- * Information retrieval
- * Cash flow
- * Projection analysis

And when you've finished your easy days work we've got a few games for you to relax to including Space Invaders.

We have first hand experience in dealing with businesses and can offer you expert advice in setting up your very first system.

We can also offer installation, training and maintenance contracts.

NOW IS THE TIME

EXTRAS & OPTIONS
Floppy disks
Continuous Stationery
Dustcovers
Automatic sheet feeder
Tractor feed
Daisy wheels
Printer ribbons

Special desk work station
Lockable disk boxes
Payslips
Sound boxes
HARDWARE
CBM 3032 Computer
CBM 3040 Floppy
CBM 3022 Printer

CBM 8032 Computer (new model)
CBM 8050 Floppy (New model)
Qume Springs Daisy Wheel Printer
SERVICES
Installation
Training
Maintenance
After Sales Service

Call into the

DA VINCI COMPUTER SHOP

65 High St., Edgware, Middx.

Tel. 952 0526

Open Mon-Fri. 9-5.30. Sat 9.30-5.00
or send for details



PLEASE SEND ME DETAILS:

Name
Company Position
Address
Tel. No.
I am interested in

Call in and buy a better business

at

CREAM

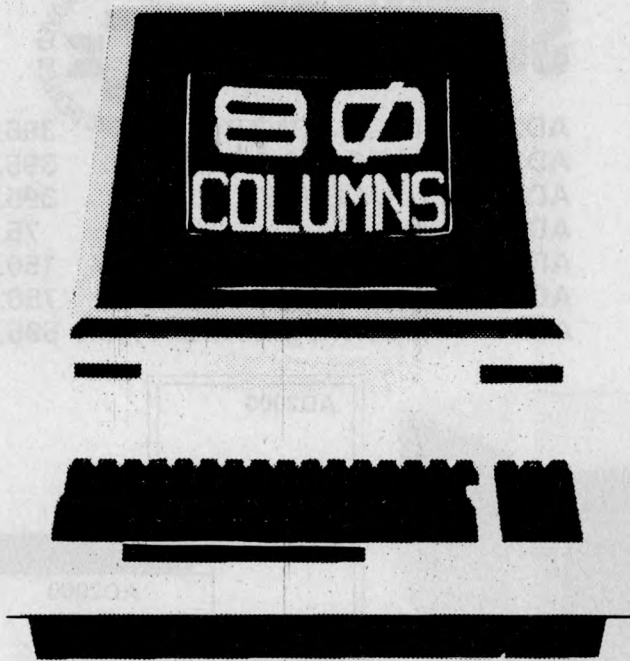

Commodore 8000 series business computers

CREAM ARE THE COMPLETE COMPUTER SHOP
CLIENTS WHO BUY FROM OUR LARGE MODERN SHOP, 3 MINS FROM HARROW-ON-THE-HILL TUBE STN.
TAKE FULL ADVANTAGE OF OUR PROFESSIONAL DEMONSTRATIONS, ADVICE, PROMPT DELIVERY AND
FULL ENGINEERING SUPPORT.

WE CARRY NOT ONLY A COMPREHENSIVE RANGE OF HARDWARE BUT ALSO POWERFUL
BUSINESS PROGRAMS FOR MOST APPLICATIONS i.e. WORD PROCESSING, PAYROLL, STOCK CONTROL,
RECORD KEEPING INVOICING ETC, OUR OWN TOP QUALITY ACCOUNTING CONTROLLER PROGRAMS,
WRITTEN BY OUR OWN SOFTWARE HOUSE OFFER BUSINESSES MAINFRAME/MINICOMPUTER QUALITY
AT MICROCOMPUTER PRICES.

A TYPICAL BUSINESS SYSTEM FROM CREAM CONSISTING OF COMPUTER, DISK DRIVES PRINTER
AND SOFTWARE CAN RANGE FROM AS LITTLE AS £2200 + VAT – A PRICE MOST BUSINESSES CAN
EASILY JUSTIFY.

BUYING FROM CREAM MAKES GOOD BUSINESS SENSE
BUYING FROM CREAM IS GOOD NEWS FOR HOBBYISTS TOO.

OUR DISCOUNT PRICES MEANS YOU CAN AFFORD MORE THAN YOU INITIALLY THOUGHT POSSIBLE.

i.e.

APPLE II 16K EUROPLUS
COMPUTER £590
16K MEMORY UPGRADES £50
PET COMPUTER 8K SMALL
KEYBOARD £389
LARGE KEYBOARD £410
16K LARGE KEYBOARD £500
32K LARGE KEYBOARD £610
ALL + V.A.T.

SHARP PC 1211

NEW
HAND HELD
COMPUTER –
1K RAM BASIC
LANGUAGE.
ALPHA-
NUMERIC
KEYBOARD
24 CHARACTER DISPLAY
£79.95.



SHARP CE 121
TAPE INTERFACE
£12.95.

ADD 15% V.A.T.

ALL MACHINES GUARANTEED 12 MONTHS

FOR BUSINESS, HOME,
EDUCATION, RESEARCH &
LEISURE – IT PAYS TO BUY
FROM CREAM.
DISKS, CASSETTES, BOOKS, &
ACCESSORIES ARE ALL
READILY AVAILABLE.

CREAM COMPUTER SHOP
380 STATION ROAD, HARROW, MIDDX, HA1 2DE.
01-863 0833/4
TUESDAY TO SATURDAY – 10 AM – 6 PM
ACCESS, BARCLAYCARD AND MAIL ORDERS WELCOMED

AD 2000 IS HERE!

SMG Microcomputers

SOFTWARE



39 Windmill St., Gravesend, Kent.

TEL: 0474-55813
Open 9-5.30

AD2000 STOCK CONTROL	395.00
AD2001 SALES LEDGER	395.00
AD2002 PUR. LEDGER	395.00
AD2003 MAILIST 1	75.00
AD2004 MAILIST 4	150.00
AD2010 SOLICITORS PACK	750.00
AD2011 PLANNING/MAINT PACK	595.00

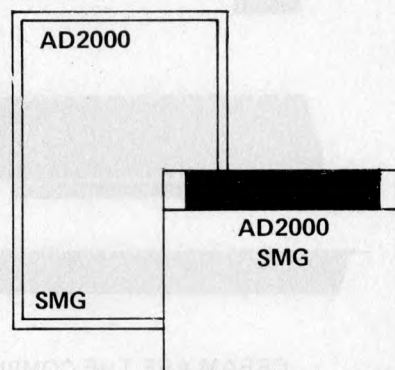
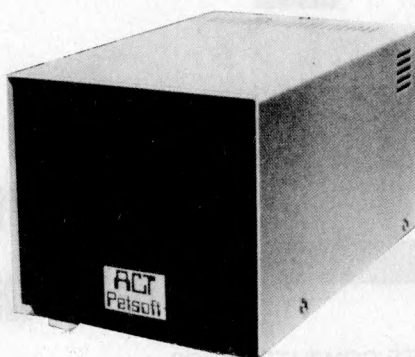

DEALER ENQUIRIES WELCOME *****

COMING SHORTLY: - VETS PACKAGE, INCOMPLETE RECORDS & WAREHOUSE PACKAGE



'THIS BOOK IS EXCELLENT'

- Clive Sinclair

This unique book contains 30 programs all designed to fit in the Basic 1k version of the SINCLAIR ZX-80!! With this book you will realise that the ZX-80 is more powerful than you ever imagined!

112 pages packed with solid information!

BLACKJACK - actually contains a full pack of cards, shuffles them, keeps track of the dealer and players card totals, and the money bet, all within 1k.

MEMORY LEFT - an incredible routine especially useful as it enables you to know exactly how much memory is left, even during the running of a program. This also illustrates USR routines.

DR. ZX-80 - A conversational program with the computer as analyst which uses an ingenious method of storage.

GOMOKU - the computer challenges you to this complex Japanese game, Incredibly this program including display of the 7 x 7 board fits into 1k - it only does so because it uses the display as memory!

Other programs included are HORSE RACE, LUNAR LANDER (with moving spaceship), NOUGHTS AND CROSSES, NIM, SIMPLE SIMON, HANGMAN, LIFE, MASTERMIND, PINCH and seventeen others.

As well as the programs, the book illustrates programming techniques you can use in your own programs - space compression, PEEKs and POKEs, USRs and so on.



£6.95 (plus 50P p&p)

available by mail order only

Please send me copies of 30 programs for the Sinclair ZX-80 1k

NAME

ADDRESS

MELBOURNE HOUSE PUBLISHERS

Orders to: 131 Trafalgar Road, London SE10
Correspondence: Glebe Cottage, Glebe House, Station Road, Cheddington, Leighton Buzzard, Bedfordshire.

Please enclose cheque or P.O. for £7.45 per copy. Orders outside the UK £7.95



COMPUTER WAREHOUSE

NOW OPEN
MONDAY-SATURDAY
9.30-5.30

In stock now test equipment, microprocessors, teletypes, transformers, power supplies, scopes, sig. gen's, motors, peripheral equipment, I.C.'s, tools, components, variacs, keyboards, transistors, microswitches, V.D.U.'s sub-assemblies + thousands of other stock lines. Just a mere fraction of our vast range, is displayed below: 100's of bargains for callers.

2716 EPROM 5v Rail . £10.25
2716 EPROM 3 Rail ... £8.50
2708 EPROM £4.95

4116 16k x 1 200ns .. 8 for £27.50
2114L-31k x 4 300ns .. 8 for £22.50
2102L-31k x 1 650ns ... 8 for £5.50

TELETYPE ASR33 I/O TERMINALS



£235 + CAR
+ VAT

Fully fledged industry standard ASR33 data terminal. Many features including: ASCII keyboard and printer for data I/O, auto data detect circuitry, RS232 serial interface, 110 baud, 8 bit paper tape punch and reader for off line data preparation and ridiculously cheap and reliable data storage. Supplied in good condition and in working order. Options: Floor stand £12.50 + VAT
Sound proof enclosure £25.00 + VAT

ICL TERMIPRINTER 300 BAUD TERMINALS



£325 + CAR
+ VAT

Made under licence from the world famous GE Co. The ICL Termiprinter is a small attractive unit with so many features it is impossible to list them in the space available! Brief spec. as follows; RS232 serial interface, switchable baud rates 110, 150, 300, (30 cps), upper and lower case correspondence type face, standard paper, almost silent running, form feed, electronic tab settings, suited for word processor applications plus many more features. Supplied in good condition and in working order. Limited quantity.

SCOOP PURCHASE 9" VIDEO MONITORS

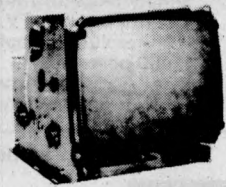

ONLY
£57.50 + VAT

Made by the famous MOTOROLA CO. The 9" video monitor type XM226-16 is a self contained unit featuring a quoted bandwidth of 10Hz to 10MHz with 800 lines resolution at the screen centre. The printed circuit board and power transistors are both plug-in for ease of servicing. All controls are easily accessible from the rear. By connection of any 75Ω composite video signal and 12v D.C. you have a professional monitor to do any MPU/CCTV system proud!
Supplied BRAND NEW complete with £57.50 + VAT
circuits at only
Specialist carriage and insurance £7.50 + VAT.

EX STOCK

SOFTY

SOFTWARE DEVELOPMENT SYSTEM, INVALUABLE TOOL FOR DESIGNERS, HOBBYISTS ETC.
Enables "open heart surgery" on 2708, 2716, etc. Blows, Copies, Reads EPROMS or emulates EPROM/ROM IN-SITU whilst displaying contents off ROM/RAM on a domestic TV receiver. A host of other features.
Write or phone for more details.
£115 + VAT & CARR
PSU £20 + VAT
You'll never regret buying a SOFTY!

EQUIPMENT CASES

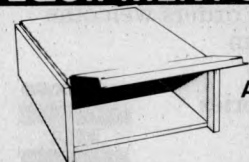

GIVE YOUR M.P.U. A HOME ONLY £9.95
+ 1.85 pp

Superb professional fully enclosed, made for the G.P.O. to the highest standard, offered at a fraction of their original cost they feature aluminium sides, hinged removable front panel, which can be secured by 2 screws to prevent prying fingers. All are finished in two tone G.P.O. grey and although believed brand new may have minor scuff marks/scratches due to bad storage. Dimensions 16" D x 6 1/2" H x 14 3/4" W

MAKE YOUR COMPUTER TALK!!! VIA OUR EX-GPO MODEM UNITS

Well, not exactly talk, but communicate over a standard dial-up G.P.O. line with any other modem. The modem unit 2A is housed in an attractive fibre glass case measuring only 15 w x 13 d x 5 h, inside are the electronics and mains power supply which enable serial duplex data communication between terminal/computer etc. at any speed up to and in excess of 750 baud (300 at a push). Made to the most stringent, exacting specification for the G.P.O. These units feature Modular plug in P.C.B.'s, internal test points, Standard tone frequencies, Configurable to terminal or computer end, Auto unattended answer, RS232/V24 interface on standard 25 way 'D' socket, etc., etc., supplied complete with diags., at a fraction of their original cost at only **£55.00** + £4.50 CARR.

NOTE: Units believed working, but untested, unguaranteed. Per mission may be required for connection to G.P.O. lines.

SEMICONDUCTOR 'GRAB BAGS'

Amazing value mixed semiconductors, include transistors, digital, linear I.C.'s, triacs, diodes, bridge recs. etc. etc. All devices guaranteed brand new, full spec. with manufacturers markings, fully guaranteed. 50 + BAG £2.95 100 + BAGS £5.15

MUFFIN FANS

Keep your equipment Cool and Reliable with our tested ex-equipment "Muffin Fans" almost silent running and easily mounted. Available in two voltages. 110 V.A.C. £5.05 + pp 90p DR 240v A.C. £6.15 + pp 90p DIMENSIONS 4 1/2" x 4 1/2" x 1 1/2"

ELECTRONIC COMPONENTS & EQUIPMENT

66%
DISCOUNT

Due to our massive bulk purchasing programme, which enables us to bring you the best possible bargains, we have thousands of I.C.'s, Transistors, Relays, Cap's., P.C.B.'s, Sub-assemblies, Switches, etc. etc. surplus to our requirements. Because we don't have sufficient stocks of any one item to include in our ads., we are packing all these items into the "BARGAIN PARCEL OF A LIFETIME" Thousands of components at giveaway prices! Guaranteed to be worth at least 3 times what you pay plus we always include something from our ads. for unbeatable value!! Sold by weight

2.5kls £ 4.75 + pp £1.25 5kls £ 6.75 + pp £1.80
10kls £11.75 + pp £2.25 20kls £19.99 + pp £4.75

LED DIGITAL ALARM CLOCK MODULE

★ 12 HOUR ★ 50/60 HZ ★ LARGE DISPLAY ★ 100's OF USES
The same module, NATIONAL MA1012, used in most alarm clock/radios on the market today, the only difference is our price! GIANT 1/2" LED characters give extremely clear viewing and readability. All electronics are self-contained on a P.C.B. measuring only 3 x 1 1/2". By addition of a few switches and 5/16 volts A.C. you have a multi-function alarm clock at a mere fraction of cost. Dozens of functions include snooze timer, am-pm, alarm set, power fail indicators, flashing seconds cursor, modulated alarm output, dimmer control, etc, etc. Supplied brand new with full data at only **£5.25**
suitable transformer for mains operation £1.75

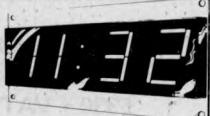

Save Over £1200!! Logabax DZM180 High Speed Matrix Printers

This must be one of our greatest bulk saving deals this year. This fabulous printer is listed at over £1800 and judging by the quality workmanship we are not surprised. The Logabax DZM180 Matrix printer, capable of printing up to 132 characters per line on any size (via variable tractor unit) sprocket fed, fanfold paper. A precision matrix head utilising ruby bearings gives exceptionally clear uniform legible characters via standard ribbon. Many other features include internal buffer, for high throughput, in excess of 180 characters per second, software controllable form and tab functions, standard TTL parallel interface, etc. etc.
Supplied brand new and boxed at only **£599.00** plus VAT +



Optional extras
Floor stand (as picture) £30.00 plus VAT Paper handler £18.00 plus VAT
*Carriage - please enquire for specific quote

THE "MULTIVOLT" MULTI RAIL P.S.U.

This has got to be the power supply to end all your M.P.U./LAB supply requirements. Recently made by the famous "WIET" Co Ltd to the highest professional specifications. With an original cost of over £200 the supply features every possible form of protection, full regulation, over voltage and current limit and just look at these outputs; it may have been made to your specifications!
+ 5V at 12 Amps + 30V at 2 Amps + 5V at 4.5 Amps
+ 5V at 4 Amps - 12V at 2.5 Amps + 12V at 2.5 Amps
- 9V at 1 Amp

you agree! then order now whilst stocks last.
Supplied BRAND NEW at only **£59.99** CARR & INSUR £6.75
complete with diagrams.

BRAND NEW 8" FLOPPY DISK DRIVES

DRI 7100 . £245 + carr + VAT
DRI 7200 . £300 + carr + VAT

5v D.C. POWER SUPPLIES

Following the recent "SELL OUT" demand for our 5v 3 amp P.S.U. we have managed to secure a large quantity of ex-computer systems P.S.U.'s with the following spec.; 240 or 110v A.C. input. Outputs of 5v @ 3-4 amps, 7.2v @ 3 amps and 6.5v @ 1 amp. The 5v and 7.2v outputs are fully regulated and adjustable with variable current limiting on the 5v supply. Unit is self contained on a P.C.B. measuring only 12" x 5" x 3". The 7.2v output is ideal for feeding "on board" regulators or a further 3 amp LM323K regulator to give an effective 5v @ 7 amp supply.
Supplied complete with circuit at only **£10.95 + £1.75 pp.** Believed working but untested, unguaranteed.

KEYBOARDS

★ LOW PRICE CHASSIS ★

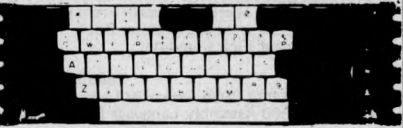

A special bulk purchase enables us to offer the above keyboard at a lowest ever price. 49 coded keys encoded into a direct TTL compatible 7 bit output. Features such as delayed strobe, 5 volt D.C. single rail operation and rollover protection make this an absolute must for the MPU constructor! Supplied complete with connection diagram and edge connector, at a secondhand **£20.00** + P.P. £1.60
"no time to test" price of only

SUPER CASED VERSION Same as above spec. but housed in attractive two tone moulded, free standing case. Unit also includes an all TTL parallel to serial converter (no details) etc.
£27.50 + P.P. £1.85

TOROIDAL TRANSFORMERS

PR 240v pri. sec. 15 0 15 @ 2 amps dimensions 3 1/2 x 2 1/2 £4.95 + p.p. 99p
TM 240v/110v pri. sec. 15 0 15 8vA dimensions 2 1/2 x 1 1/2 £1.95 + p.p. 30p
All voltages measured off load.

Plugs, Sockets & Connectors Cannon 'D' Range

Ways	Plug	Socket
9	£1.03	£1.26
15	£1.17	£2.01
25	£1.72	£2.58
37	£2.35	£4.14
50	£2.90	£5.46

25 way ex-equip. plug or socket £1.25
Edge connectors, gold plated -

0.1" DS	40 way	£2.45
0.1" DS	85 way	£3.99
0.15 DS	56 way	£3.25
0.156DS	36 way	£2.00

All connectors easily cut to size
1000's of other connectors ex stock



ELECTRONICS

Dept. PCW/64-66 Melfort Rd., Thornton Heath, Croydon, Surrey. Tel: 01-689 7702 or 01-689 6800
MAIL ORDER INFORMATION
Unless otherwise stated all prices inclusive of V.A.T. Cash with order. Minimum order value £2.00. Prices and Postage quoted for UK only. Where post and packing not indicated please add 50p per order. Bona Fida account orders minimum £10.00. Export and trade enquiries welcome. Orders despatched same day where possible. Access and Barclaycard Visa welcome.



CompUtopia LIMITED

30 Lake Street, Leighton Buzzard, Bedfordshire
Tel: (0525) 376600 24 hour Answering Service

APPLE II

authorised dealers
from
£695
+
VAT



- * Choice of 16K, 32K, 48K user RAM
- * Huge range of software already available.
- * Simply plugs into video monitor or UHF TV.
- * High resolution graphics (5400 point array)
- * Eight Accessory expansion slots for disks, printer etc.

commodore

authorised dealers

- * Choice of 8K, 16K, 32K user RAM
- * Huge range of software already available
- * Self-contained monitor
- * Numeric keypad on keyboard.
- * Full expansion capability for cassette, disks and printer.



from
£445
+ VAT

PET 2001

- * 16k User RAM plus 12k Microsoft BASIC in ROM
- * Fully TRS 80 level II software compatible
- * Huge range of software already available
- * Self contained, cassette, PSU & UHF modulator
- * Simply plugs into video monitor or UHF TV
- * Full expansion capability for disks & printer

THE VIDEO GENIE SYSTEM EG 3003

£330 + VAT



GENERAL READING

BKS0330 How to Profit from your Personal Computer	Lewis	£5.50
BKS0400 Introduction to Microcomputers Vol 0	Osborne	£5.00
BKS0410 Introduction to Microcomputers Vol 1	Osborne	£7.50
BKS0420 Your Home Computer	White	£6.20
BKS0430 Peanut Butter and Jelly Guide to Computers	Willis	£6.60
BKS0440 C201 Microprocessors—From Chips to Systems	Zaks	£6.95
BKS0445 The Personal Computer Book	Bradbeer	£5.30
BKS0450 Your First Computer	Zaks	£5.95

8080 AND 6880

BKS0270 8080A-8085 Assembly Language Programming	Leventhal	£7.95
BKS0280 6800 Assembly Language Programming	Leventhal	£7.95

Z80

BKS0290 Z80 Assembly Language Programming	Leventhal	£7.95
BKS0300 Z80 Microcomputer Handbook	Barden	£6.80
BKS0315 C280 Programming the Z80	Zaks	£8.95
BKS0320 CP/M Handbook	Zaks	£8.95

6502

BKS0170 6502 Assembly Language Programming	Leventhal	£7.95
BKS0180 C202 Programming the 6502	Zaks	£7.95
BKS0200 D302 6502 Applications Book	Zaks	£7.95
BKS0210 Programming a Microcomputer: 6502	Foster	£7.25
BKS0214 G402 6502 Games Book	Zaks	£8.20
BKS0216 The Pet Revealed	Hampshire	£10.00
BKS0218 The Pet and the IEEE 488 Bus	Fisher/Jensen	£8.95
BKS0219 The Pet Library of Sub Routines	Hampshire	£10.00

BASIC

BKS0010 Illustrating Basic	Alcock	£3.25
BKS0030 Little Book of Basic Style	Nevison	£5.40
BKS0045 Microsoft Basic	Knecht	£6.75
BKS0050 Basic Handbook	Lien	£11.00
BKS0060 Basic and the Personal Computer	Dwyer/Critchfield	£9.75
BKS0070 Computer Programs that work	Lee/Beech/Lee	£3.95
BKS0080 Basic Computer Games	Ahl	£4.25
BKS0090 More Computer Games	Ahl	£4.25
BKS0100 Some Common Basic Programs	Poole/Borchers	£7.90
BKS0130 Basic Programs for the Pet Computer	Rugg/Feldman	£9.50
BKS0135 32 Basic Programs for the TRS 80	Rugg/Feldman	£9.50

SYSTEMS DESIGN

BKS0140 Cheap Video Cookbook	Lancaster	£4.40
BKS0160 C207 Microprocessor Interfacing Techniques	Lesea/Zaks	£9.50

Please phone or write for complete book list and prices. Prices include P & P within the U.K.
Please send cheque or P.O., or if phoning your order, state Barclaycard number.

Happy Memories

4116	200ns	£2.95	2114	200ns	£3.25
2114	450ns	£2.55	2716	5V	£6.75
2708	450ns	£3.95			

Memorex soft-sectored mini-discs with free plastic library case £19.95 per 10.

Low profile I.C. sockets:

Pins:	8	14	16	18	20	22	24	28	40
Pence:	10	11	12	16	17	19	21	28	37

Euroconnectors:

64/96 Male (right angled) £2.39 64/96 Female £3.52

RS232 connectors (solder):

Male 25 way: £1.95 Female 25 way: £2.25

Hoods: 75p

ALL PRICES VAT INCLUSIVE

Please add 30p postage to orders under £10.
Government + Educational orders welcome
£10 minimum

Dept PCW

Happy Memories

Gladestry

Kington

Herefordshire

HR5 3NY

Tel: (054 422) 618



BARCLAYCARD



CRYSTAL ELECTRONICS CC ELECTRONICS

THE SKY'S THE LIMIT FOR YOUR SHARP MZ80K with SHARP CP/M 2.21 (XTAL)

CP/M is the trade mark of Digital Research.

**This sophisticated interactive program
development system will give your home computer
BUSINESS/INDUSTRIAL potential.**

Basic CP/M facilities include:

- Dynamic file management
- General purpose editor
- Hardware modification (if fitted by a SHARP dealer does NOT break the guarantee)
- SHARP CP/M 2.21 (latest version) on disc
- XTAL Monitor and Operating system
- 7 Digital Research manuals
- CP/M Handbook (by RODNAY ZAKS)
- 12 months guarantee and up-dates

**IF YOU ARE A SHARP MZ80K OWNER, CP/M 2.21 (XTAL)
IS A MUST FROM £200.00**

Ask your SHARP dealer for further details or contact
CRYSTAL ELECTRONICS
CP/M SOFTWARE HOUSES—XTAL CAN HELP YOU
ESTABLISH YOUR SOFTWARE ON THE SHARP

Members of Computer Retailers Association & Apple Dealers Association

Shop open 0930-1730 except Saturday & Sunday
40 Magdalene Road, Torquay, Devon, England. Tel: 0803 22699
Telex 42507 XTAL G

Access and Barclaycard welcome.

Greenbank

Greenbank Electronics
(Dept T1E) 92 New Chester Road, New Ferry
Wirral, Merseyside L62 5AG
(Tel: 051-645 2391)



TERMS, VAT, CWO. Cheques etc payable to Greenbank Electronics and crossed.
Add VAT at all prices at 15% except where stated otherwise. Post etc: UK 35p
+ 5p VAT = 40p per order. Export: NO VAT add 35p (Eire), 75p (Europe) and
£2.50 elsewhere. Access: Barclaycard, Visa, telephoned orders accepted.
(Polys. universities, gov. depts. etc can telephone their orders for immediate
despatch on account.)



UV 140, UV ERASER

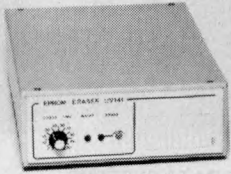

Two easy to use units designed for both the professional and amateur UV-prom user

- Features**
- Can erase up to 14 proms.
 - Special short wave ultraviolet tube.
 - Erase time variable between 5 and 50 minutes in 5 minute steps (preventing over exposure which may shorten prom life).
 - Sliding tray carries proms on conductive foam.
 - Safety interlock switch prevents the timing circuit from operating and switching on the tube with the tray open.
 - "Mains On" and "Tube On" indicators.
 - Smart textured case.
 - Complete instructions supplied.

Supplied complete with mains plug and flex

Model UV141. Price £77.70

Also available without timer as

Model UV140: Price £61.20

TEX MICROSYSTEMS "EPROMPT" UV ERASER



A low cost alternative to the above erasers (UV 140/141) claimed by the manufacturer to erase up to 32 chips in 15-30 mins. This is the cheapest eraser we have seen. The unit has no timer, power switch or safety interlock switch. The user places up to 32 chips into loose conducting foam in the erasure tray (16 along the base, 8 on each side). The chips are held in place by the UV tube which sits in the tray. (Unlike the UV 140/141, no special precautions have been taken to prevent the seepage of UV light, but the manufacturers state that "Incident light from this device is quite safe at distances above 12 inches")
(Dimensions - 325 x 64 x 38mm)

EPROMPT ERASER Price £33

MODULAR COMPUTER SYSTEM CARDS

A range of 'International' (114 x 203mm) size cards which may be purchased individually as desired, or to build up a complete system. Further details available on request. All boards are epoxy glass with gold plated edge plug.

VDU A, B, G (set of 3)	£27.20
SC/MP-P SC/MP CPU	£9.40
MPA-7 Buffered SC/MP CPU	£9.40
MZB-3 Z80-CPU	£9.40
MXA-1 2K of 2102	£9.40
MXA-3 8K of 2114	£9.40
MXD-2 16K of 4116	£9.40
PRM-2 4K of 5204	£9.40
PRM-8 8K of 2708	£9.40
RRM-14 8K of 2516 + 6K of 2114	£9.40
SIO-2 RS-232 (two)	£9.40
TPA-2 Tape Interface	£9.40
IP-2 Input Port	£9.40
DCR-6 Keyboard Input	£9.40
OP-3 Output Port	£9.40
PP-2 PROM Programmer	£9.40
PSU-A4 Power Supply	£9.90
PSU-B 5V Power Supply	£5.50
PSU-C 25V Power Supply	£5.50
13-slot backboard, can be used with most of the above boards. 13" x 4 1/2"	£11.50
ISBUS-1.1	

FLOPPY DISK CONTROLLER BOARD

This is used in conjunction with Kemitron Z80 boards to interface to twin single density 5 1/8" floppy disks. It is not available as a bare board, but only built and tested, less circuit diagram

£165.00

To run CP/M on the system a serial interface (e.g. SIO board) to some sort of VDU or terminal is required, and 32K of RAM (e.g. two MXD-2 boards). The MZB-3 board has facilities for 'power on jump' and a 'boot prom' to load the CP/M operating system from the disk Boot PROM (2708)

£19.95

T.V. MONITOR P.C.B. for OEM users

This is an assembled P.C.B. size 130 x 190mm, which you add to your own 12"/14" black and white C.R.T. (90 degree, 20mm dia. neck), to obtain a T.V. monitor at modest cost. (Regrettably we cannot supply the C.R.T. at present.)

Present controls, contrast, brightness, etc., are included, and the only inputs needed are 15 Volts ± 10% AC at 1.5 Amps and 1 Volt p-p composite video input.

Supplied with circuit diagram

KEYBOARD CASES

405 x 210mm. Panel size 380 x 180mm	£9.66
510 x 340mm. Panel size 430 x 115mm	£24.98

DOT MATRIX PRINTER

This is about the same price as for example the Necosim imp, but has many features only previously found in models costing hundreds of pounds more.
Standard interfaces (not 'extras') RS-232, 20mA, IEE 488, Centronics I/O, 15 baud rates to 9600, 100 characters per second, 64, 72, 80, 96, 120 or 132 characters per line, rear, bottom or front paper loading, friction or tractor feed, can accept user defined characters, can also print graphics under program control, has 'soft-test' facility. Supplied with mains cable and full operator's manual.
Base 2 Model 800

£325.00

DAISYWHEEL PRINTER

High quality printer for use with word processing packages running under CP/M. 45 characters per second RS-232 interface. (Check stock position before ordering.)

Qume Sprint 5 Model 45/RO

£1495.00

EUROCARD 19" CARD FRAME

Kit of 2 and plates + angles, 2 front and 2 rear tie bars, 4 guide location strips

Accessories

Card guides (pack of 10)	£1.40
Eurocard Plug (64 way DIN 41612)	£2.22
Eurocard Socket (64 way DIN 41612)	£3.32
Connector mounting strips (pair)	£3.32
Cass conversion kit	£18.86
(or fit into separate 3U 19" D-type cr)	£28.17

MICROPROCESSORS

Z80 CPU (2 1/2 MHz)	£5.95
Z80-CTC (2 1/2 MHz)	£3.95
Z80-10 (2 1/2 MHz)	£3.95
(Add £1 for the 4MHz version of any of the above 3 chips.)	

6800 MPU	£5.95
6802 MPU	£5.95
6809	£19.95
6810 (128 x 8 RAM)	£3.25
68A10 (128 x 8 RAM)	£3.75
6820, 6821 PA	£3.50
6845 ACDA	£22.30
NC5880	£2.64

SC/MP/H RAM I/O	£10
INS/814 RAM I/O	£9.40

COSMAC CP 1802CE	£6.50
COSMAC CDP 1802E	£10.85
COP 1864	£7.25

STATICS (Mostly 450ns)	
2102-1K x 1	£1.20
2111-256 x 4	£2.25
2112-256 x 4	£2.25
2114/4045-1K x 4	£2.25
8 x 2114	£17.84
2114-1K x 4	£5.58
4118-1K x 8	£9.95

811595/6/7/8	£1.40
1488 (RS232)	90p
75491 LED driver	50p
75492	92p
7N425	£3.95
8126/8128	£2.64
8174	48p

UV PROM ERASER	£61.20
UV141	£77.70
EPROMPT	£33.00

UV ERASABLES	
5204 (512 x 8)	£9.95
2708 1K x 8	£3.50
2716/2516 2K x 8 single 5v	
2532 4K x 8 (5v)	£5.95
2708/2516	£19.95

PROM WASHING SERVICE	50p ex. sh. prom
----------------------	------------------

CRT Controller: Uarts

AY-51013	£4.00
AY-51014	£4.70
AY-51015	£5.60
AY-51015	£5.60

CHAR. GEN. KEYBOARD ENCODER	
NK 2302	£15.29
RD-3-2513 (5v uppercase)	£6.00
DM 8678 CAB/B/F	£14.27
AY-5-2376	£9.75

FIRMWARE	
ZMON for Z80 (1 x 2708)	£14.95
2K TYP BASIC for Z80 (2 x 2708)	£19.95
4K NBL for SC/MP (4 x 2708)	£49.95
4K NBL-MM for SC/MP (4 x 2708)	£49.95
1K Various for SC/MP (1 x 2708)	£14.95

(Descriptive leaflet available on above Ref SW4, 5)	
1K Elektor Junior (1x2708)	£19.95
1K ELBUG (3x5204)	£35.00
ETIBUG 1 (1 x 5204)	£14.95
ETIBUG 2 (1 x 5204)	£14.95
SCM P/AB (1 x 5204)	£14.95

VOLTAGE REGULATORS	
7805	75p
7812	£1.08
7815	97p
7818	£1.08
78M05	£5.61

VOLTAGE CONVERTER MODULES	
Ideal for use in otherwise 5V only systems, to obtain +12V, -12V, or dual ± 12V power for ASCII keyboards, RS-232 interfaces, dynamic RAMs etc. All types have +5V input.	
Size of each module (excluding pins) 34 x 26 x 10mm.	
Type ADHP-12A10	£4.95
Type ADIN-12A10	£4.95
Type ADID-12A10	£4.95
± 12V dual output, 2 x (12-42mA)	£5.25

QUARTZ

32.768KHz (Watch)	£3.23
60 KHz	£9.95
100.0 KHz	£3.62
200.0 KHz	£3.92
204.8 KHz	£3.92
262.144 KHz	£3.92
307.2 KHz	£3.92
312.5 KHz	£3.92
455.0 KHz	£4.95
1.000 MHz	£3.92
1.000 MHz	£3.92
1.280 MHz	£3.92
1.6 MHz	£4.25
1.8 MHz	£4.25
1.8432 MHz	£3.62
2.000 MHz	£3.62
2.091152 MHz	£3.23
2.4575 MHz	£3.62
2.500 MHz	£3.62
2.56250 MHz	£3.62
3.000 MHz	£3.62
3.2768 MHz	£3.23
3.579545 MHz	£1.95
4.000 MHz	£2.90
4.032 MHz	£2.90
4.096 MHz	£3.23
4.194304 MHz	£3.23
4.433616 MHz	£1.25
4.608 MHz	£3.23
4.800 MHz	£3.23
4.9152 MHz	£3.23
5.000 MHz	£3.23
5.0688 MHz	£3.23
5.120 MHz	£3.23
5.185 MHz	£3.23
6.000 MHz	£3.23
6.144 MHz	£3.23
6.400 MHz	£3.23
6.55360 MHz	£3.23
7.000 MHz	£3.23
7.168 MHz	£3.23
7.680 MHz	£3.23
7.86432 MHz	£3.23
8.000 MHz	£3.23
8.08333 MHz	£3.62
8.38860 MHz	£3.23
8.867237 MHz	£3.23
9.375 MHz	£3.92
9.800 MHz	£3.92
10.000 MHz	£3.23
10.245 MHz	£3.23
10.700 MHz	£3.92
10.92 MHz	£3.92
11.000 MHz	£3.92
11.000 MHz	£3.92
12.000 MHz	£3.92
14.000 MHz	£3.92
14.31818 MHz	£3.23
16.000 MHz	£3.23
16.000 MHz	£3.23
18.432 MHz	£3.23
20.000 MHz	£3.62
20.134 MHz	£3.23
24.0 MHz	£3.92
26.690 MHz	£2.60
27.0 MHz	£3.23
27.145 MHz	£2.10
27.648 MHz	£3.92
38.6666 MHz	£3.23
48.000 MHz	£3.23
100.000 MHz	£3.23
116.000 MHz	£3.23

VEROBOARD

0.1" Pitch with copper strips	
2 1/2" x 1" (pack of 5)	74p
2 1/2" x 3"	53p
2 1/2" x 5"	62p
2 1/2" x 7"	£1.86
3 1/4" x 3"	62p
3 1/4" x 5"	69p
3 1/4" x 7"	£2.40
4 7/8" x 17 1/2"	£3.14
0.1" (plainboard)	
3 1/4" x 2 1/2"	38p
3 1/4" x 5"	59p
3 1/4" x 7"	£1.56
Terminal pin	£1.50/50.00
V-DIP board	£1.17
DIP breadboard	£2.91
Spot face cutter	93p
Pin insertion tool	£1.28

SOLDERCON PINS

100 500 1000 £3.95

DIL SOCKETS

8/14/16 pin	10p/12p/13p
18/20/22 pin	18p/20p/25p
24/28/40 pin	30p/40p/50p
24 pin Testlead lever type zero insertion force	£8.50

EDGE CONNECTORS

43 way, 0.1" pitch, wire wrap, pin/cutting slot pin 37
Single sided (1 x 42) £3.11
Double sided (2 x 42) £4.10

TIMER ICs

NE555/556 - 25p/49p

OP-AMPS

(All Mini dips)

CA 3102C	84p
CA 3140E	35p
UA 741 (Texas)	22p

LED DISPLAYS

DL-704E	99p
DL-727E/728E	£2.00
DL-747E/750E	£1.80
FWJ 500/560	£1.20

LIQUID CRYSTAL DISPLAY

4 x 0.5" Digis 40 pin DIL

£9.95

CLOCK CHIPS

AT-5-1224A	£2.60
NK 50253	£5.50
NK 50366	£6.50

SIX DECADE COUNTERS

NK 50395/6/7	£9.90
NK 50398/9	£7.50

SWITCH MODE PSUs



AC 5221S 5V/10A	£69.90
AC 9221S 5V/5A, 12V/1A - 12V/1A - 5V/0.1A	£86.80
AC 5421S 5V/20A	£99.20
AC 9421S 5V/10A, 12V/2A - 12V/2A - 5V/0.1A	£126.50

OPEN CARD SWITCH MODE PSU
FULLY ASSEMBLED P.C.B. CARD 197 x 108 x 52mm. Outputs +5V/6A, -5V/0.5A, +12V/1A, -12V/1A

Type AC9251

£79.80

Can you afford to be less than excellent?

Whether you're in high vacuum technology, space research, brewing, computers or commerce, if you've got something to control, we've got something with which to control it.

Our top quality range of British designed and manufactured S100 products from INTERACTIVE DATA SYSTEMS are already used in all the above fields and others by many of the country's leading industries and universities etc.

They all chose IDS equipment for excellent reasons, i.e.; EXCELLENT SPECIFICATIONS,

EXCELLENT DESIGN,
EXCELLENT QUALITY,
EXCELLENT PRICES.



'High Vacuum Technology by SCANWEL Ltd, Bala, Gwynedd'

APPLY NOW FOR YOUR COPY OF OUR FREE CATALOGUE.

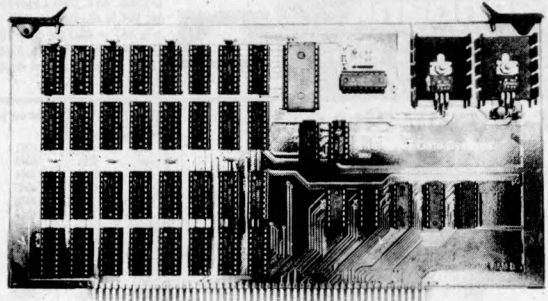

BRITISH S100 by INTERACTIVE DATA SYSTEMS

The MENDIP range includes:-

		£A&T *
IDS SBMC	4MHz Z80A Single Board Micro Computer, 1K RAM, sockets for up to 32K EPROM, 2 Serial Ports, 4 channel CTC etc.	235.00
IDS 16K SRAM	16K bytes Static RAM board (2114).	198.00
IDS 8K SRAM	8K bytes memory board.	114.00
IDS DFDC	Double/single density, double/single sided diskette controller.	198.00
IDS PCI 10	A mixture of input and output channels of various types to monitor and control external circuitry.	223.00
IDS Z80 CPU	A basic 4MHz Z80A processor board.	105.00
IDS TERM 40	Active Termination Board.	32.50
IDS SARACEN SERIES	A range of "ready-to-go" systems based on IDS components.	from 1925.70
	(VDU and Printer extra)	to 2676.45

* We also sell KIT versions, however we strongly recommend A&T (Assembled & Tested) equipment to all except very experienced constructors with adequate test equipment.

Please add VAT to all prices (standard rate 15%)

Mendip Computers...

57 BATH ROAD, WELLS, SOMERSET, BA5 3HS. TEL: WELLS (0749) 75249

MAIL ORDER ONLY.

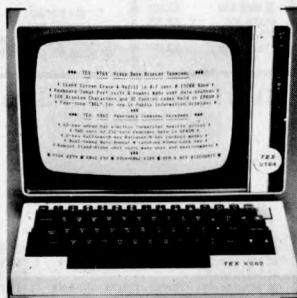

VIDEO DISPLAY UNIT
TEX VT64 - £299



UNIVERSAL KEYBOARD
TEX KB62 - £99



VT64 & KB62 - £389

- 16 x 64 FULL SCREEN REWRITE IN 0.5 SECONDS.
- 128 CHARACTER U/L SET + FULL CURSOR/SCREEN CONTROLS.
- FOUR-TONE 'BEL'. V24/20mA. 50-19200 BAUD.
- KEYBOARD INPUT PORT ACCEPTS & POWERS MOST TYPES.
- UPGRADEABLE TO 24 x 80 VT80 DURING 1981.
- KB62 HAS 464 x 8-BIT KEYCODES IN EPROM.
- 62 KEYS WITH DEDICATED CURSOR & USER FUNCTIONS.
- QUALITY 'FEEL'. ALPHA-LOCK. AUTO-REPEAT.
- QUAD-MODE ENCODING. 2/N-KEY ROLLOVER/LOCKOUT.
- LATCHED DATA. ± STROBE. CONTACTS OF USER KEY.
- KB16 SEPARATE ADD-ON NUMERIC PAD DURING 1981.

TEX EPROMPT ERASER - £39 inclusive

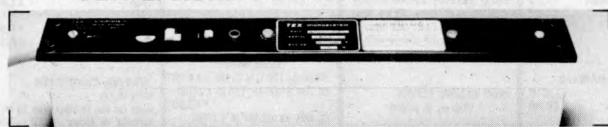

- SIMPLE 32-CHIP 1/2 HOUR PROCESS ON 200-250V A.C.
- TUBE RUNS COOL AT EXACT WAVELENGTH FOR EPROMS.
- 16-CHIP INTERLOCKED-DRAWER 'GT' MODEL £45 INCL.
- SOLID-STATE 30-MINUTE TIMER UNIT £15 INCL.

VT64/KB62 prices exclude shipping and value-added tax.
Terms C.W.O./C.O.D. or trade references for credit.

Trade enquiries invited for substantial discounts.
O.E.M. quantities available with custom trim.

All orders and enquiries post-free to:-

TEX MICROSYSTEMS LTD. FREEPOST
ST. ALBANS, HERTS. AL1 1BR HATFIELD 69909/ST. ALBANS 64077 (DAY/NIGHT)

FERGUSSON COMPUTER SERVICES

For All Your

apple & ITT 2020
SALES AND SERVICE

Contract Maintenance:-

- * On-site repair contracts
- * Total system or only items required
- * 24hrs response to calls
- * Very competitive rates

Ad-hoc Repair Service:-

- * Ring for repair quotation
- * Same day service
- * Collection from Red Star if required

Hardware and Software Sales:-

- * 32K RAM free with each system purchased with this advertisement
- * Totally Integrated Ledger system complete for £3262.00

For further information ring
Byfleet (09323) 45330

Fergusson Computer Services

"Sharberry", Maitland Close, West Byfleet, Surrey

**The Sinclair ZX80 is innovative and powerful.
Now there's a magazine to help you get
the most out of it.**

Get in sync



SYNC magazine is different from other personal computing magazines. Not just different because it is about a unique computer, the Sinclair ZX80 (and kit version, the MicroAce). But different because of the creative and innovative philosophy of the editors.

A Fascinating Computer

The ZX80 doesn't have memory mapped video. Thus the screen goes blank when a key is pressed. To some reviewers this is a disadvantage. To our editors this is a challenge. One suggested that games could be written to take advantage of the screen blanking. For example, how about a game where characters and graphic symbols move around the screen while it is blanked? The object would be to crack the secret code governing the movements. Voila! A new game like Mastermind or Black Box uniquely for the ZX80.

We made some interesting discoveries soon after setting up the machine. For instance, the CHR\$ function is not limited to a value between 0 and 255, but cycles repeatedly through the code. CHR\$(9) and CHR\$(265) will produce identical values. In other words, CHR\$ operates in a MOD 256 fashion. We found that the "=" sign can be used several times on a single line, allowing the logical evaluation of variables. In the Sinclair, LET X=Y=Z=W is a valid expression.

Or consider the TL\$ function which strips a string of its initial character. At first, we wondered what practical value it had. Then someone suggested it would be perfect for removing the dollar sign from numerical inputs.

Breakthroughs? Hardly. But indicative of the hints and kinds you'll find in every issue of SYNC. We intend to take the Sinclair to its limits and then push beyond, finding new tricks and tips, new applications, new ways to do what couldn't be done before. SYNC functions

on many levels, with tutorials for the beginner and concepts that will keep the pros coming back for more. We'll show you how to duplicate commands available in other Basics. And, perhaps, how to do things that can't be done on other machines.

Many computer applications require that data be sorted. But did you realize there are over ten fundamentally different sorting algorithms? Many people settle for a simple bubble sort perhaps because it's described in so many programming manuals or because they've seen it in another program. However, sort routines such as heapsort or Shell-Metzner are over 100 times as fast as a bubble sort and may actually use less memory. Sure, 1K of memory isn't a lot to work with, but it can be stretched much further by using innovative, clever coding. You'll find this type of help in SYNC.

Lots of Games and Applications

Applications and software are the meat of SYNC. We recognize that along with useful, pragmatic applications, like financial analysis and graphing, you'll want games that are fun and challenging. In the charter issue of SYNC you'll find several games. Acey Ducey is a card game in which the dealer (the computer) deals two cards face up. You then have an option to bet depending upon whether you feel the next card dealt will have a value between the first two.

In Hurkle, another game in the charter issue, you have to find a happy little Hurkle who is hiding on a 10 X 10 grid. In response to your guesses, the Hurkle sends out a clue telling you in which direction to look next.

One of the most ancient forms of arithmetical puzzle is called a "boomerang." The oldest recorded example is that set down by Nicomachus in his *Arithmetica* around 100 A.D. You'll find a computer version of this puzzle in SYNC.

Hard-Hitting, Objective Evaluations

By selecting the ZX80 or MicroAce as your personal computer you've shown that you are an astute buyer looking for good performance, an innovative design and economical price. However, selecting software will not be easy. That's where SYNC comes in. SYNC evaluates software packages and other peripherals and doesn't just publish manufacturer descriptions. We put each package through its paces and give you an in-depth, objective report of its strengths and weaknesses.

SYNC is a Creative Computing publication. **Creative Computing** is the number 1 magazine of software and applications with nearly 100,000 circulation. The two most popular computer games books in the world, *Basic Computer Games* and *More Basic Computer Games* (combined sales over 500,000) are published by Creative Computing. Creative Computing Software manufactures over 150 software packages for six different personal computers.

Creative Computing, founded in 1974 by David Ahl, is a well-established firm committed to the future of personal computing. We expect the Sinclair ZX80 to be a highly successful computer and correspondingly, SYNC to be a respected and successful magazine.

Order SYNC Today

Right now we need all the help we can get. First of all, we'd like you to subscribe to SYNC. Subscriptions are posted by air directly from America and cost just £10 for one year (6 issues), £18 for two years (12 issues) or, if you really want to beat inflation, £25 for three years (18 issues). SYNC is available only by subscription; it is not on newsstands. We guarantee your satisfaction or we will refund the unfulfilled portion of your subscription.

Needless to say, we can't fill up all the pages without your help. So send in your programs, articles, hints and tips. Remember, illustrations and screen photos make a piece much more interesting. Send in your reviews of peripherals and software too—but be warned: reviews must be in-depth and objective. We want you to respect what you read on the pages of SYNC so be honest and forthright in the material you send us. Of course we pay for contributions—just don't expect to retire on it.

The exploration has begun. Join us.

The magazine for Sinclair ZX80 users

SYNC

27 Andrew Close
Stoke Golding
Nuneaton CV13 6EL, England

MICROLINK MICROLINK MICROLINK

The flexible interfacing system for your Commodore PET or HP 85.

The Microlink interface makes it easy to use your micro for tasks such as:

- * Replacing chart recordings by computer analysis
- * Automating experiments * Adding data processing capability to monitoring instruments.



The MICROLINK interface consists of a mainframe incorporating a power supply, an IEEE 488 interface and a cabinet holding up to 10 modules – this construction means that an interface can be configured to your precise requirements. Modules available include: * Analogue to digital converters * Digital to analogue converters * Analogue X-Y plotter driver * Analogue input conditioning modules * Relay outputs * BCD character inputs * Signal conditioning inputs * High speed clock and multiplexer.

Write or telephone with details of your application, and we will quote you for a configuration to meet your needs.

Biodata

Biodata Ltd., 6 Lower Ormond St., Manchester M1 5QF.

Telephone: 061-236 1283.

MICROLINK MICROLINK MICROLINK

BITS & P.C.S.

COMPUTER PRODUCTS LTD

The North's Leading Nascom Specialist

NEW PRODUCTS FOR NASCOM

PROGRAMMABLE CHARACTER GENERATOR FOR NASCOM 2

Gives 64 Programmable characters 8,192 Programmable dots. Free demonstration software. Ask for details. £60.00

DISCS:
Single drive £380.00
Double drive with CPM & EBASIC £640.00
Ask for details, Professionally designed for your NASCOM.

KENILWORTH CASE:
A high quality case made from stelvete coated steel and solid mahogany £49.50
Mounting kit for two cards £7.50
Mounting kit for five cards £19.50

SARGON CHESS PACK:
This pack includes the book and a tape with Sargon prepared to run under NAS-SYS. Also included is a special graphics rom and a PCB giving your NASCOM the ability to switch between two graphics ROMs, your original and the chess ROM. All the above for only £35.00

INTERFACE EPROM BOARD:
Provides sockets for both 2708 and 2716 EPROMs (up to 16 EPROMs) and also provides a fully decoded socket for the NASCOM 8K BASIC ROM. This board is produced to full NASBUS specification and can be used in "page mode" together with the new NASCOM RAM B. Wait states may be generated on board to allow a NASCOM 1 to run at 4MHz in BASIC. The complete kit at only £55.00

CASTLE INTERFACE:
Gives the following features: Auto tape drive * Auto cassette muting * Auto serial printer muting * 2400/1200/300 BAUD cassette. This interface built and tested complete with documentation at only £17.50

ASTEC 10" B/W MONITOR:
A professional cased 10-inch Monitor giving superb resolution, only £99.50

ANALOGUE TO DIGITAL CONVERTER:
This unit gives 4 channels with an Input Range of 0 to 120mV up to 0 to 24V. Conversion time (average) 0.5 mSec. Supplied built and tested at only £49.50

DUAL MONITOR:
This kit allows switching between two monitors on a NASCOM 1 e.g. T4 and NAS-SYS £6.50

PORT PROBE:
A very useful device for testing and evaluating ports and peripheral software with improved documentation £17.50

HEX AND CONTROL KEY PADS:
Our popular range of add-on keyboards for the NASCOM micros. HEX for NASCOM 2 £34.00
HEX & CONTROL KEYS for NASCOM 1 £40.50

CASSETTE MACHINE:
Will reliably record data at 2400bd and above, manufactured by SHARP £25.50

PROGRAMMERS' AID:
In 2 2708 EPROM gives the NASCOM rom BASIC many extra commands: AUTO, RENU, DELE, DUMP, FIND, HEX, APND, HELP... etc. £28.00

BITS & P.C.s GAMES TAPE 1:
Good value, ten excellent games £8.00

PRINTERS:
We have a good range of printers, all of which will work on the NASCOM, RICOH, EPSON, IMP, QUME ANADIX.

BOOKS:
Full range including INMC mags.
MEDIA:
Paper, diskettes, ribbons, leaderless cassettes, VDU tables etc.

MEMORIES:
4116, 4027, 2708, 2716.

BUILT SYSTEMS REPAIRS MAIL ORDER and ADVICE are our SPECIALITY.

BITS & P.C.s Computer Products Ltd.
4 Westgate, Wetherby, West Yorkshire.
Tel: 0937 63744.

SAE for details: prices exclude VAT and postage and package.

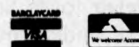

VIDEO VECTOR DYNAMICS

39 Hope St, Glasgow G2 6AE Tel. 041-226-3481/2

WE SELL SOLUTIONS. Have you discovered that your problems really begin after you've bought the hardware? Either you've bought the wrong hardware or no software exists to make it work properly. We specialise in providing total solutions to problems and professional after-sales support of hardware and software. We have the resources successfully to implement commercial, scientific and instrumentation/control projects.

COMMERCIAL Typical of our recent projects in this area was the connection of 12 remote stations to a central unit. This was achieved by using Commodore Pets as the remote stations allowing a degree of local processing linked via modems to a central S100 microcomputer with substantial disk storage capacity. This type of configuration is ideal where a limited amount of local accounting is required at each site but with a central collation of information on stock, payroll, etc.

SCIENTIFIC. Our scientific packages are currently in use by a number of major multi-national companies. Typical of these packages is our Chemical Graphics System used by pharmaceutical companies in drug design. This is designed to run on PDP-11 configuration using refreshed Graphics.

INSTRUMENTATION CONTROL. We can supply a complete range of hardware and software packages covering analog, digital and graphical input/output and logging using fast microprocessor-based systems.

COST. Due to our familiarity with a wide range of hardware we can supply systems either optimised for minimum price or maximum performance — you decide on the price/performance mix.

In addition to consultancy and turnkey packages we offer the following proprietary products.

FASTLIB. This package is based on the AMD 9511 arithmetic chip and is a complete hardware/software system. Use of FASTLIB is completely transparent to the user of Microsoft FORTRAN. The software is totally integrated with the FORTRAN compiler and simply by replacing the Microsoft-supplied library by FASTLIB existing programs can run 5-20 times faster without any modification. The hardware requires a single S100 slot. In addition to enhancing the speed of execution of the existing FORTRAN functions and operations, additional functions have been implemented — NINT, TAN, ASIN, ACOS, SINH, COSH, THAN, & RAN (a pseudo-random number generator).

GLIB. A graphics library enabling complex pictures to be produced from a series of simple subroutines calls such as: VECTOR (draws a line between any two (x,y) points); CIRCLE (draws a circle of any radius centered on any (x,y) point); TEXT (plots a 64-character ASCIIset); STEXT (plots Greek and Mathematical symbols); etc. Plots can be saved on or retrieved from disk by single subroutine calls. The standard package used the Vector Graphic High-Resolution Graphics board but the software can be configured for any graphics board or device. Microsoft FORTRAN, MACRO or BASIC is also required.

PRICE LIST

HARDWARE

North Star Horizon 64K, 2 Quad Capacity drives	£2360
TVI-912C VDU	£595
Anadex DP8000 Printer	£525
Anadex DP9500 Printer	£895
NEC Spinwriter daisywheel printer (RO)	£1775

SOFTWARE

All Digital Research, Microsoft, MicroPro etc software supplied — call for prices.

PACKAGES

FASTLIB/mSP9500	£495
GLIB	£500

SPECIAL OFFERS

Word processor —
64K, Quad capacity drives Horizon with TVI-912C and NEC Spinwriter complete with CP/M2 and MicroPro Wordstar

ONLY £4,750

* Mem Tech APU boards — limited numbers available going cheap.

* SD Starter kits

STOP PRESS: Our own 48K dynamic RAM board will be available soon at a price of £300. Full IEEE S-100, Z-80 refreshed, bank selectable, 200ns access time (equiv. to 5 MHz) — designed and manufactured in the U.K.

NEW.

Olympia Opus Daisy Wheel Printers, K.S.R. £998 ea.
RO. £836

ARRAY Processing from Silicon Glen on the West Coast of Scotland

VIDEO VECTOR DYNAMICS Ltd. announces what will be one of the most significant innovations in microcomputing during the 1980s — the VP-9500 vector processor. The VP-9500 is a British-designed and manufactured vector processor consisting of a two to 16 long vector of pipe-lined floating point processors with individual data stacks, optimised to operate on arrays of floating point numbers of up to 16,834 elements. The VP-9500 provides floating point processing at up to 200 times faster than ordinary 4 MHz Z-80A microcomputers and 20-30 times faster than a PDP-11/34. The benchmarks on which these figures are based may be obtained on request.

The VP-9500 is constructed on one (up to 8 elements) or two (9 to 16 elements) glass fibre PCBs with full solder masking and silk-screened component locations. The precision board lay-out was generated on a CAD facility and etching was performed for us by the U.K.'s leading PCB manufacturers. The VP-9500 has its own on-board crystal clock and DIP switches allow it to be placed anywhere in the I/O space of any S-100 microcomputer running at any clock speed.

Every VP-9500 comes complete with VPLIB, our library of Microsoft FORTRAN-callable array processing routines. Typical calls to VPLIB are CALL VSQRT (A, C, N) where the square roots of all of the N floating point numbers in array A are calculated and placed in array C; and CALL VMUL (A, B, C, N) where the N elements of array A are multiplied by the corresponding elements of array B and the results stored in array C. VPLIB contains over 100 such routines.

The VP-9500 is designed for those high-speed, computationally-intensive tasks such as real-time collection/processing of video data, finite element analysis, crystallography, molecular modelling, graphics, signal processing and large-scale scientific/engineering calculations which are beyond the capabilities of conventional micro and minicomputers.

All VP-9500s are field-upgradeable to the top-of-the-range VP-9500, an S-100 EPROM card containing complete diagnostic software, a scalar FORTRAN library FASTLIB which replaces Microsoft's FORLIB by calls to the VP-9500 in addition to providing extra FORTRAN functions (TAN, ASIN, ACOS, SINH, COSH, NINT & RAN), custom additions to VPLIB and full maintenance contracts.

And the cost? From approximately £1,600 for a VP-9500/2, through £3,400 for the VP-9500/8 and up to £5,800 for the top-of-the-range VP-9500/16. Complete microcomputer systems in our MVP range include the MVP-9500/16 based on a 64KB, hard disc, Z-80A microcomputer with VDU and software for around £11,000. This is £5,000 cheaper than PDP-11/34 system (20-30 times slower than MVP-9500/16).

INTELLIGENT ARTEFACTS LTD

DISK DEBUG PROGRAM

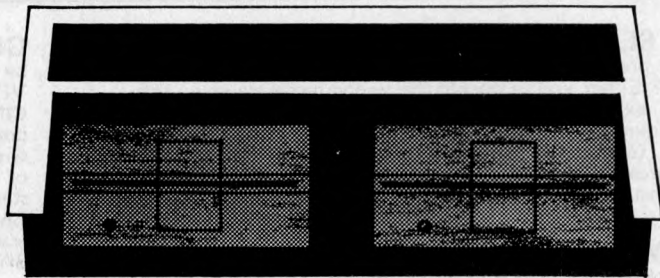

- * Debug your corrupted Pet disks with the Pet Disk Debug Program
- * Gain an insight into how the Pet Disk operating system works
- * See how programs are written onto disk
- * Even write programs straight onto the disk

* Join a main program and a subroutine together on the disk allowing the same subroutine to be loaded with more than one program.

DISK DEBUG..... £14.95

Documentation on its own £1.98

OR FREE:—

If you buy a Dual Drive Floppy from us at £5.75

Prices EX VAT

INTELLIGENT ARTEFACTS LTD. Cambridge Road Orwell Royston Herts
 Technical Services Department Telephone ARRINGTON (022020) 689

Master Your Micro FAST with...

Little Genius floppy diskette based courses will teach you, how to use your system and how to realise the full potential of the "Mighty Micro". These fully interactive computer lessons will guide you quickly to a high level of understanding and confidence in your ability to make the most of your microcomputer system.

Courses now available:

- Applesoft BASIC - Palsoft BASIC
- Advanced - Advanced Palsoft
- Applesoft BASIC BASIC
- Using your Apple - Using your 2020
- PET BASIC
- Advanced PET BASIC



Little Genius

Each course, comprising a floppy diskette, and starting instructions, costs only £40.00 plus VAT.

SPECIAL "3 in one" OFFER for 3 courses covering the same system only £99.00 plus VAT.

Little Genius courses are available from most computer retail outlets, or direct mail order from:

LITTLE GENIUS

Suite 504, Albany House, 324 Regent Street, London W1R 5AA.
 Telephone: 01-580 6361

Old tricks for new Pets...

COMMAND-0 is a FOUR KILOBYTE Rom for the 4000/8000 Basic 4 Pets with all the "Toolkit" commands RENUMBER (improved), AUTO, DUMP, DELETE, FIND (improved), HELP, TRACE (improved & includes STEP), and OFF - plus PRINT USING - plus four extra disk commands INITIALIZE, MERGE, EXECUTE, and SEND - plus extra editing commands SCROLL, MOVE, OUT, BEEP, and KILL - plus SET user-definable soft key, 190 characters - plus program scroll up and down - plus 8032 control characters on key. Ask for Model CO-80N for the 8032 or CO-40N for the 4016/4032. £50.00 plus Vat

New tricks for old Pets...

DISK-O-PRO is a FOUR KILOBYTE Rom that upgrades 2000/3000 Pets, but lets you keep all your old software - including Toolkit. As well as REPEAT KEYS and PRINT USING, you get all the Basic 4 disk commands CONCAT, DOPEN, DCLOSE, RECORD, HEADER, COLLECT, BACKUP, COPY, APPEND, DSAVE, DLOAD, CATALOG, RENAME, SCRATCH and DIRECTORY - plus extra disk commands INITIALIZE, MERGE, EXECUTE and SEND - plus extra editing commands SCROLL, MOVE, OUT, BEEP and KILL - plus SET user definable soft-key, 80 characters - plus program scroll-up and scroll-down. We recommend the 4040 disk or upgraded 3040 for full benefit of disk commands. Ask for Model DOP-16N for new Pets 2001-3032, and 2001-8 with retrofit Roms & TK160P Toolkit. £50.00 plus Vat, other models available.

PRONTO-PET hard/soft reset switch for the 3000/4000 Pets. We don't think you'll "crash" your Pet using our software, but if you do the Pronto-Pet will get you out! Also clears the Pet for the next job, without that nasty off/on power surge. £9.99 + Vat

and no tricks missed!

KRAM Keyed Random Access Method. Kid your Pet it's an IBM! VSAM disk handling for 3032/4032/8032 Pets with 3040/4040/8050 disks means you retrieve your data FAST, by NAME - no tracks, sectors or blocks to worry about. Over 2,500 users worldwide have joined the "Klub"! Now you can too, at the 1981 price, £75.00 plus Vat.

SPACEMAKER All our Rom products are compatible with each other, but should you want, say, Wordpro with Kram, or Disk-o-pro with Visicalc, then SPACEMAKER will allow both Roms to address one Rom socket, with just the flip of a switch, for £22.50 plus Vat.

We are sole UK distributors for all these fine products. If your CBN dealer is out of stock, they are available by mail from us, by cheque/Access/Barclaycard (UK post paid) or send for details.

Calco Software

Lakeside House Kingston Hill Surrey KT27QT Tel 01-546-7256

HEWLETT PACKARD

HP85

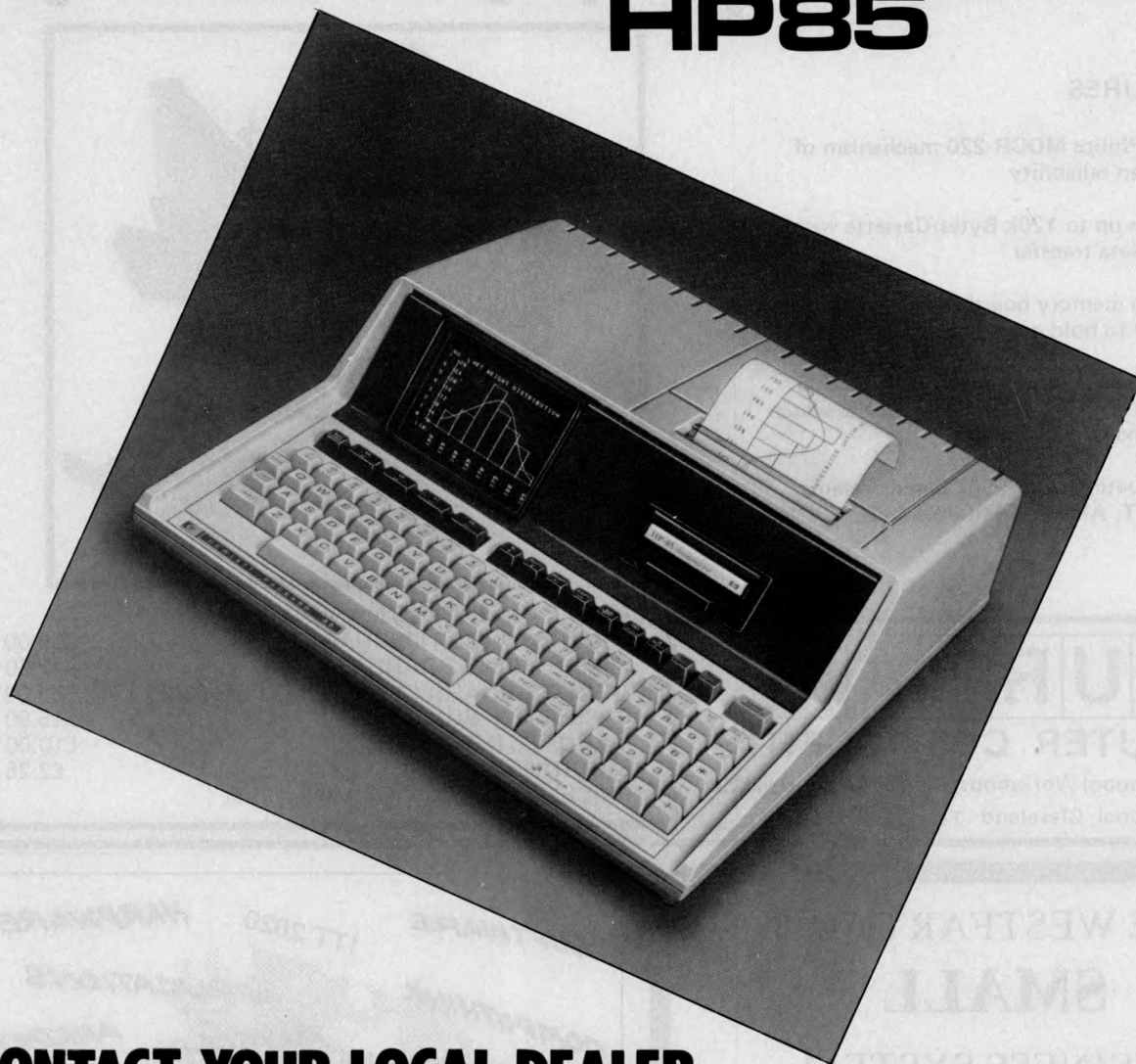

CONTACT YOUR LOCAL DEALER

Anglo-American Computing
9 Coventry Road
Coleshill
Warks
0675 65396

Automated Business Equipment
Mersey House
Heaton Mersey Industrial Estate
Battersea Road
Heaton Mersey
Stockport
Manchester (061 432) 0708

Cambridge Computer Store
1 Emmanuel Street
Cambridge CB1 1NE
0223 65334/68155

Cardiac Services
95a Finachy Road
Belfast BT10 DBY
Belfast 625566

Central Southern Calculators
12 Wokingham Road
Reading
Berks
Reading (0734) 61492

DBM Systems & Software
58 Victoria Street
Bristol BS1 6DE
0272 214093/4

D J Herriott Ltd
42 Camden Road
Tunbridge Wells
Kent TN1 1EE
(0892) 22443

Holdene Ltd
10 Blenheim Terrace
Leeds
Leeds (0532) 459459

Office Machinery Engineering
73 London Road
Brighton
E. Sussex
Brighton (0273) 689682

Petalect Ltd
32, Chertsey Road,
Woking,
Surrey,
04862 217766/63901

Robox Limited
Unit 4
Anderston Shopping Centre
Glasgow
Glasgow (041 221) 5401

Sumlock Bondain Ltd
15 Clerkenwell Close
London EC1
01-250 0505

Sumlock Services
Epic House
Charles Street
Leicester
Leicester (0533) 29673

This advertisement is organised by Personal Computer World and sponsored by the above Hewlett-Packard dealers. It is not a full list of all HP dealers, but only of those participating in this advertisement.

Mini-Digital Cassette Recorder

An alternative to disc for program & data storage

FEATURES

- * The Philips MDCR 220 mechanism of proven reliability
- * Holds up to 120k Bytes/Cassette with fast data transfer
- * Extra memory board with RAM and ROM to hold operating software
- * Will read & write (in blocks from 256 bytes to 60k Bytes), backspace & search for end of data on tape
- * Compatible with 6502 based systems ie PET, AIM65, OHIO, KIM, COMPUKIT ETC.

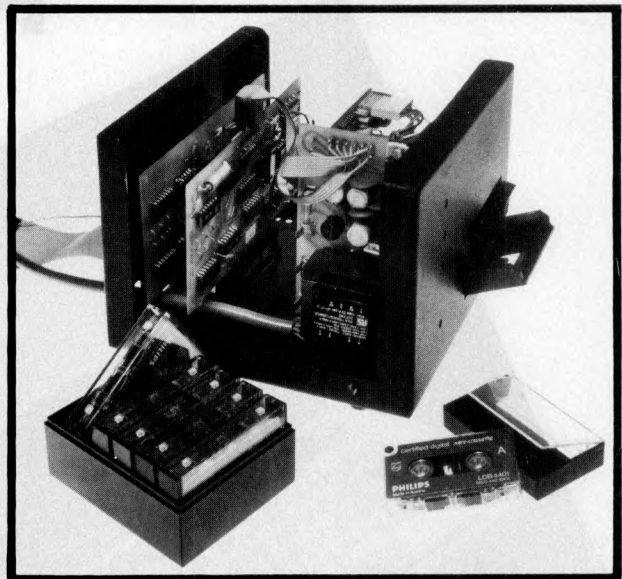

PRICES (INCLUDING MANUAL)

MINI RECORDER MECHANISM	£95.00
INTERFACING BOARD (TYPEA)	£42.50
MEMORY BOARD (WITH ROMS FOR 6502)	£55.00
CASSETTES (BOX OF 6)	£15.90
MANUALS (SEPARATE)	£10.00
CARRIAGE	£2.25
PRICES EXCLUSIVE OF VAT @ 15%	

CURRAH

COMPUTER COMPONENTS

Unit 7 Hartlepool Workshops, Sandgate Industrial Est.
Hartlepool, Cleveland Tel. 0429 72996

THE WESTFARTHING SMALL BUSINESS SYSTEM

for Apple/ITT 2020 micros

Designed from first principals for the family business, it will pay for itself by keeping the accounts in good order, saving management time on paperwork, and accountants fees.

FUNCTIONS: (in short, everything you need) invoicing (+ discounts, quotations, delivery notes) customer accounts and shop sales, bank and cash balances calculated weekly, sales and overheads (30 categories) totalled weekly, VAT return calculated (while you have lunch).

SPECIAL FEATURES FOR OWNER-MANAGERS: VAT-inclusive bills split automatically messages can be printed on invoices, automatic payment entry when customer pays on the spot, uses plain fan-fold paper, prints your heading, s/a customer address labels printed, User's Manual (50 pages) in clear, non-technical style. Designed to be user-modifiable.

Requires 48K RAM, Applesoft in ROM, 1 or 2 disc drives, printer. Program lives in core. Includes pages of program information, hundreds of REMs, disc map, etc.

Cost: £750 + VAT (£750 only to non-regd trader). For information, send £1 for 10 page description or £10 for User's Manual.

Westfarthing Computer Services Ltd, 21 Wendron St, Helston, Cornwall. Phone Helston [03265] 4098

SOFTWARE ITT 2020 HARDWARE
 COMPUTING APPLICATIONS
 SCOPIC PAYROLL ANADIX
 SPINWRITER Petsoft
 PALSOF
 CENTRONICS OLYMPIA
 DOLPHIN NETWORKS
 WORD PROCESSING LEDGERS

KING OF THE JUNGLE

Lion has tamed the microcomputer market by amassing a wealth of experience in micro-based small business systems, and by selecting the best systems available to market and support.

Lion's Business Systems Division is ready to demonstrate the power and flexibility of the micro in commercial applications, and is backed by Lion's established reputation for professionalism and support.

Phone now, at either location, to arrange a demonstration to show how micro's can help you, and why Lion is King of the Jungle.

Credit cards welcome and lease facilities available.

LION MICRO-COMPUTER SHOPS LTD.



At Lion House
227 Tottenham Court Road London W1P 0HX Tel: 01-580 7383
21 Bond Street Brighton Tel: (0273) 601838



A GREAT DEAL FROM 6 NASCOM DEALERS

and guaranteed after-sales service

BUILT FLOPPY DISC SYSTEM FOR NASCOM 1/2 FROM £395+VAT

It's here at last. A floppy disc system and CP/M. **CP/M SYSTEM.**

The disc unit comes fully assembled complete with one or two 5 1/4" drives (FD250 double sided, single density) giving 160K per drive, controller card, power supply, interconnects from Nascom 1 or 2 to the FDC card and a second interconnect from the FDC card to two

drives, CP/M 1.4 on diskette plus manual, a BIOS EPROM and new N2MD PROM. All in a stylish enclosure.

Nascom 2 Single drive system . £450 + Vat
 Nascom 2 Double drive system £640 + Vat
 Nascom 1 Single drive system . £460 + Vat
 Nascom 1 Double drive system £650 + Vat
 Additional FD250 drives £205 + Vat

D-DOS SYSTEM

The disc unit is also available without CP/M to enable existing Nas-Sys software to be used. Simple read, write routines are supplied in EPROM. The unit plugs straight into the Nascom PIO.

Single drive system £395 + VAT
 (please state which Nascom the unit is for)

Certain parts of the CP/M and D-DOS disc systems are available in kit form. Details available on request.

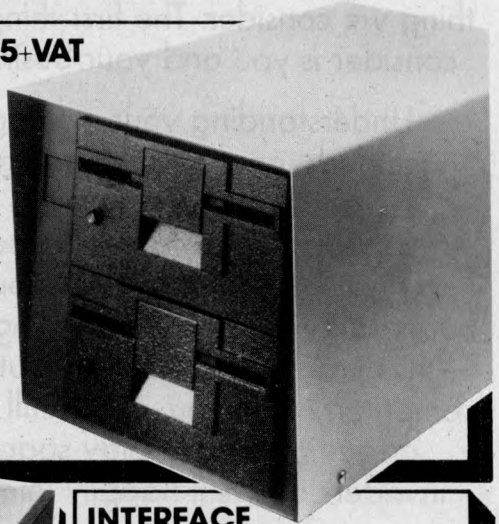

ENCLOSURE FOR N2 + 5

The Kenilworth case is a professional case designed specifically for the Nascom 2 and up to five additional 8" x 8" cards. It has hardwood side panels and a plastic coated steel base and cover. A fully cut back panel will accept a fan, UHF and video connectors and up to 8 D-type connectors. The basic case accepts the N2 board, PSU and keyboard. Optional support kits are available for 2 and 5 card expansion.

Kenilworth case £49.50 + Vat
 2-card support kit £7.50 + Vat • 5-card support kit £19.50 + Vat



INTERFACE ENHANCING UNIT

The Castle Interface is a built and tested add-on unit which lifts the Nascom 2 into the class of the fully professional computer. It mutes spurious output from cassette recorder switching, adds motor control facilities, automatically switches output between cassette and printer, simplifies 2400 baud cassette operating, and provides true RS232 handshake.

Castle Interface Unit .. £17.50 + Vat

EPROM EXPANSION

The Nasbus compatible EPROM board accepts up to 16 2708 or 2716 EPROMs. It has a separate socket for the MK36271 8K BASIC ROM for the benefit of Nascom-1 users. And for Nascom-2 users, a wait state for slower EPROMs. The board also supports the Nascom Page Mode Scheme.

EPROM Board (kit) £55 + Vat
 EPROM Board (built & tested) £70 + Vat

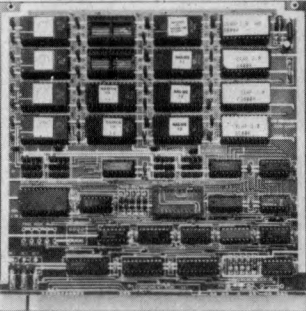

A-D CONVERTER

For really interesting and useful interactions with the 'outside world' the Milham analogue to digital converter is a must. This 8-bit converter is multiplexed between four channels - all software selectable. Sampling rate is 4KHz. Sensitivity is adjustable.

Typical applications include temperature measurement, voice analysis, joystick tracking and voltage measurement. It is supplied built and tested with extensive software and easy connection to the Nascom PIO.

Milham A-D Converter (built and tested) £49.50 + Vat

PROGRAMMER'S AID.

For Nascom ROM BASIC running under Nas-Sys. Supplied in 2x2708 EPROMs. Features include: auto line numbering; intelligent renumbering; program appending; line deletion; hexadecimal conversion; recompression of reserved words; auto repeat; and printer handshake routines. **Price £28 + Vat.**

DUAL MONITOR BOARD. A piggy-back board that allows N1 users to switch rapidly between two separate operating systems. **Price (kit): £6.50 + Vat.**

BASIC PROGRAMMER'S AID.

Supplied on tape for N1/2 running Nas-Sys and Nascom ROM BASIC. Features include auto line number, full cross-reference listing, delete lines, find, compacting command, plus a comprehensive line re-numbering facility. **Price: £13 + Vat.**

PROM-PROG MKII.

2708 (multi-rail) and 2716 (single-rail) EPROM programmer kit controlled by N1/2 PIO. Supplied with comprehensive software for use with Nas-Sys. **Price: £25.95 + Vat.**

- NASCOM-2 Microcomputer Kit £225 + Vat
- NASCOM-1 Microcomputer Kit £125 + Vat
- Built & tested £140 + Vat
- IMP Printer. Built & tested £325 + Vat

All prices are correct at time of going to press.

All the products are available while stocks last from the Nascom dealers below. (Mail order enquirers should telephone for delivery dates and post and packing costs.) Access & Barclaycard welcome.

BITS & PC'S
 4 Westgate, Wetherby, W. Yorks.
 Tel: (0937) 63744

BUSINESS & LEISURE MICROCOMPUTERS
 16 The Square, Kenilworth, Warks.
 Tel: (0926) 512127.

ELECTROVALUE LTD.
 680 Burnage Lane, Burnage,
 Manchester M19 1NA.
 Tel: (061) 432 4945.

28 St Judes, Englefield Green,
 Egham, Surrey TW20 0HB.
 Tel: (0784) 33603. Tlx: 264475.

TARGET ELECTRONICS
 16 Cherry Lane, Bristol BS1 3NG.
 Tel: (0272) 421196

INTERFACE COMPONENTS LTD.
 Oakfield Corner, Sycamore Road,
 Amersham, Bucks.
 Tel: (02403) 22307. Tlx: 837788.

HENRY'S RADIO
 404 Edgware Road, London W2.
 Tel: (01) 402 6822.
 Tlx: 262284 (quote ref: 1400)

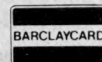
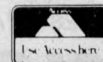

A computer is the last thing we'd sell you . . .

CompuSyst is a business consultancy with a wide knowledge of business systems so hardware is the very last thing we consider. The first thing we consider is you and your business.

Understanding your existing methods, analysing your exact requirements and then recommending a total approach which is appropriate for your business. Even if it means telling you that you're better off without a computer. Mind you, if you still insist on getting one to play space invaders on we'll happily join in.

CompuSyst

the computer consultancy for small businesses
Phone 01-602 1269 and ask for a consultant to visit you.



M&C BUSINESS SERVICES LTD

for **Tailor made
programs**

**Turnkey systems
and packages**

and



write or phone

M & C BUSINESS SERVICES LTD
122 HAVELOCK STREET,
KETTERING, NORTHANTS
0536- 510652

HIRE SALES, LEASE, or EXCHANGE

HIRE FROM	BARGAIN Inc. VAT	NEW Ex. VAT
£20PET	£340	
£28EURO & APPLE II 32K		£610
£25TRS80	£280	
.ITT2020 48K	£600	
£18SOCCERER 32K	£400	
£68SUPERBRAIN 64K		£1450
£60HORIZON 56K	£900	

APPLE II Guaranteed EUROPLUS. Price 32K £610+VAT
Lots of exciting software, all types of cards:
Asteroids in space, Zork Adventure, Rainbow software,
hire text graphics, space invaders. Z80 Card/CPM/COBOL,
PASCAL, FORTRAL,

ALL NEW
SUPERBRAIN 64K £1450 +VAT. HIGH LEVEL
LANGUAGES AVAILABLE

PROMGLOW Ltd

01-368 9002 + EVENING
12 DENE ROAD, LONDON N11

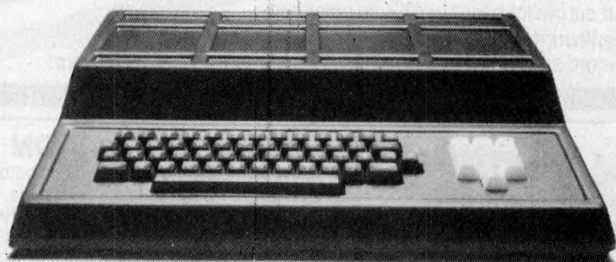

MICROTYPE MODEL 3 CASE

Ready cut for SUPERBOARD/UK 101, NASCOM 2
and blank for HOMEBREWS

Produced in black ABS Plastic, complete with fixings and instructions,
space for PSU, expansion, force feed fan, numeric pad and
additional keys.

£24-50 + p&p + VAT

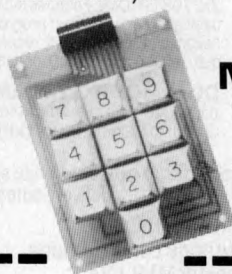

NPS1 NUMERIC PAD

for SUPERBOARD/UK101 only

A 0-9 numeric pad in kit form, complete with
switches, caps, PCB, plug and socket, cable and
full instructions.

£11-95 + p&p + VAT

- Please send me a Model 3 case at £29.90 inc.
My micro is
- Please send me a NPS1 numeric pad for my Superboard/
UK101 at £14.32 inc.
- Please send me your full literature. I enclose SAE.
(Please enclose your name and address with cheque or P/O)



MICROTYPE
PO BOX 104 HEMEL HEMPSTEAD HP2 7QZ

NORTH STAR BUSINESS SYSTEM

WORD-PROCESSING
STOCK CONTROL
INVOICING
SALES & PURCHASE LEDGER
ETC. ETC.

FREE
CP/M &
WORDSTAR

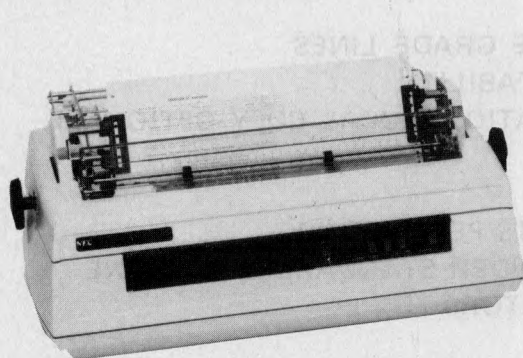

C

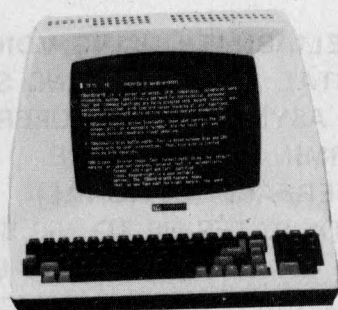

B

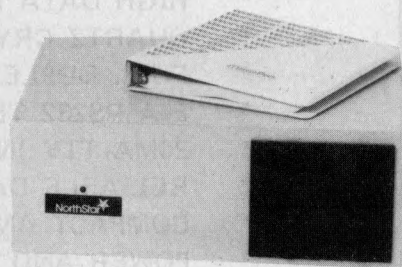

A

EX-STOCK

PROVEN RELIABILITY 1 YEAR GUARANTEE

SAMPLE RECOMMENDED SYSTEM (AS ABOVE):—

A	Horizon Computer (64K Ram 2 D/D Drives)	£2080.00
B	TVI-912C VDU, numerous features	£595.00
C	NEC RO Spinwriter (RS232) + tractors	£1775.00
	COMPLETE SYSTEM PRICE (Includes cables)	£4450.00
	ABOVE SYSTEM WITH DOUBLE-SIDED DRIVES	£4730.00
	FREE !! WORDSTAR plus CP/M with above system.	

INVENTORY Package — With Sales & Purchase Management System	£295.00
KDS Development System for North Star BASIC	£50.00
KDS Disk Despooler — North Star DOS despooler	£50.00
CP/M V2.2 — supports double-sided drives	£95.00
WORDSTAR V2.1 — Superb word processing package	£175.00
MAIL-MERGE — Adds form letter generation to WORDSTAR	£55.00
DATASTAR — CP/M compatible Database Management System	£145.00
North Star UCSD PASCAL-D/Q System	£105.00
Microsoft BASIC interpreter V5.1	£155.00
Microsoft BASIC compiler V5.1	£195.00
Microsoft FORTRAN-80	£205.00
Econoram IIa — 8K Static Memory	£100.00
Econoram XX — 32K Static Memory with bank switching	£355.00
DMB-6400 — 64K Dynamic RAM with bank switching	£495.00
Godbout Interfacer 1 — 2 full RS232 serial I/O card	£135.00
Switchboard — 2 Serial, 4 parallel I/O card	£155.00
OKI Microline-80 Printer — Lightweight, 80 cps, Graphics	£325.00
Paper Tiger Printer — 2K buffer, full graphics, form-feed	£595.00
Anadex DP9500 Printer — Fast, bi-directional, logic-seeking	£895.00
Morrow 26Mb Hard Disk Sys. + Timeshaver CP/M-North Star DOS	£3345.00
Morrow 26Mb Hard Disk — Add on hard disk	£2495.00

PLEASE WRITE OR PHONE FOR LATEST PRODUCT CATALOGUE

PHONE US OR CONTACT YOUR NEAREST DEALER

CODAS LTD
Pontypridd Wales Tel: 0443-406450

CONQUEST COMPUTER SALES LTD
Benfleet Essex Tel: 03745-59861

DIGITAL DEVICES LTD
Southborough Kent Tel: 0892-37977/9

FYLDE MICROCOMPUTER SERVICES
Blackpool Lancs. Tel: 0253-692954

THE HARDWARE SOFTWARE CO.
London NW3 Tel: 01-722 6436

HOTEL MICROSYSTEMS LTD
Middlesex Tel: 01-890 9696

JAD INTEGRATED SERVICES
Plymouth Devon Tel: 0752-626164

KBS COMPUTER SERVICES
Liverpool Tel: 051-236 8333

KBS COMPUTER SERVICES
Cardiff Wales Tel: 0222-394313

KBS COMPUTER SERVICES
Coventry Warwicks. Tel: 0203-27266

LOVEDEN COMPUTER SERVICES LTD
Grantham Lincs. Tel: 0476-72000

MICRO FACILITIES LTD
Hampton Hill Middx. Tel: 01-979 4546

MICROSYS LTD
Prescot Merseyside Tel: 051-426 7271

MICROTECH COMPUTER SERVICES
Liverpool Tel: 051-236 2208/9

SAPPHIRE SYSTEMS
Billericay Essex Tel: 02774-57743

SPOT COMPUTER SYSTEMS LTD
Doncaster Yorks Tel: 0302 50833

S. SYSTEMS
Crawley Sussex Tel: 0293-515201

STAG TERMINALS LTD
Teddington Middx. Tel: 01-943 0777

SUMLOCK-BONDAIN LTD
London EC1 Tel: 01-250 0505

VIDEO VECTOR DYNAMICS LTD
Glasgow Scotland Tel: 041-226 3481/2

INTERAM

UK Distributor:
INTERAM Computer Systems Ltd.
59 Moreton Street,
Victoria, London SW1V 2NY
Tel: 01-834 0261/2733
Telex: 925859

IF YOU WANT YOUR COMPUTER TO COMMUNICATE YOU NEED A MODTECH MODEM

THE MODTECH M103 IS AN ORIGINATE ONLY MODEM COMPATIBLE WITH ENGLISH (CCITT) STANDARDS, DIRECT CONNECTION FOR SUPERIOR DATA RELIABILITY NOT FOUND IN ACOUSTIC COUPLERS. THE M103 PROVIDES IMMUNITY FROM ROOM NOISE AND MECHANICAL VIBRATIONS WHICH ARE COMMON PROBLEMS WITH ACOUSTIC COUPLING.

- * HIGH DATA RELIABILITY USING VOICE GRADE LINES
- * QUARTZ CRYSTAL ACCURACY AND STABILITY
- * FULL DUPLEX ASYNCHRONOUS OPERATION (LOCAL COPY OPTIONAL)
- * EIA RS232 TERMINAL INTERFACE
- * 20MA TTY INTERFACE (OPTIONAL)
- * RELIABLE DATA RATES UP TO 450 BITS PER SECOND
- * COMPACT AND LIGHT WEIGHT FITS UNDER STANDARD TELEPHONE
- * POWER AND CARRIER DETECT INDICATORS
- * LINE CONNECT/DISCONNECT SWITCH
- * AUTO LINE DISCONNECT WITH LOSS OF CARRIER

M103 Originate only only £160.00 plus VAT

M103A Auto-answer only £225.00 plus VAT

AVAILABLE ONLY FROM :-

3-LINE computing

36 CLOUGH ROAD HULL HU5 1QL Telephone: (0482) 445496

DEALER ENQUIRIES WELCOME

Run North Star BASIC under CP/M

'Matchmaker' converts your North Star BASIC Programs and lets you run them under the universal CP/M operating system. There are lots of advantages in doing this: you'll have dynamic file allocation, automatic file creation and extension, and automatic re-use of deleted files, all under the control of the powerful instruction set of the North Star BASIC interpreter with its byte-access or random files, multiline functions, and extensive library of software. 32K memory is all you need. No relocation or modification of BASIC is necessary. Your existing North Star programs will run without modification!

The installation takes about 30 minutes and involves no disassembly or machine coding. Every powerful feature of both systems is maintained with this professional piece of software. The instructions are COMPLETE and very easy to follow.

Please rush me my copy of 'Matchmaker'
-price £65 including documentation.

Name _____

Address _____

Tel. _____

 digital devices ltd

134 London Road Southborough, Kent TN4 0PL
Tel: Tunbridge Wells (0892) 37977-9 or 39546-9

Note: CP/M and North Star are registered trademarks of Digital Research and North Star Computers, respectively.

MICROSYSTEMS '81

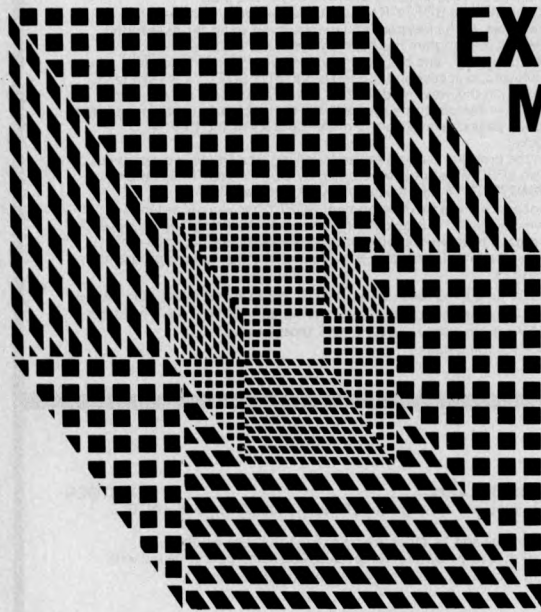

EXHIBITION & CONFERENCE

March 11-13, 09.30-18.00 daily

Wembley Conference Centre

Exhibition admission £1.00 A complete study of microprocessors in use.

Microsystems '81 consists of a wide ranging exhibition, together with a three day conference and three one-day microprocessor awareness courses. Together they comprise an invaluable opportunity for those interested in microprocessor applications and the latest developments in microelectronics technology.

Take advantage of this unique event to examine and discuss a comprehensive range of microprocessors, peripherals, memory products and personal computers together with the software which accompanies them.

For Conference details write to:
The Conference Administrator
IPC Conferences Ltd, Surrey House,
1 Throwley Way, Sutton,
Surrey SM1 4QQ

For *advance exhibition tickets at £1 each, write to:
Microsystems Tickets
IPC Exhibitions Ltd, Surrey House,
1 Throwley Way, Sutton,
Surrey SM1 4QQ

*Please note applications for tickets cannot be accepted after February 23, although tickets will be available at the door price £1. Cheques should be made payable in UK sterling to IPC Business Press Limited.

Floppy disc File



Easy reference filing system for your flexible computer discs, files 20 discs per binder. File sheets retain 4 discs, have reinforced binder edge and file reference tab. Leaves punched for 2 and 3 hole binders. Also available for 8" discs, files 10 discs per binder.

—Please state size when ordering

Binder complete with 5 leaves £4.95 + VAT

Pack of 5 leaves only £1.55 + VAT

BASF and Memorex mini discs £27 + VAT per box (10)

Clean your monitor screen with the revolutionary Quick Wipes, Anti-Static tissue. Removes dirt, dust and static in one wipe. £2.75 per can + VAT

LEICESTER
computer centre limited

109 QUEENS ROAD LEICESTER LE2 1TT Tel: 0533 709841

Acorn Atom SOFTWARE

ON HIGH QUALITY
C12 CASSETTE.

Note: figures refer to
TOTAL memory required.

Atom Invaders! 🐛🐛

GRAPHICS MODE 4
12K

A fantastic machine code program utilising the high-resolution graphics capability of the Atom and sound output. All the usual features. £12.00

ATOM BREAKOUT Another highly entertaining machine code program with sound output. Requires 4K memory. £4.00

PINBALL Fast-moving machine code game using graphics mode 2 and sound output, requiring 6K memory. Light up the targets and try to win a free ball, or beat the high-score. £6.00

The following 4K PROGRAMS are available at £3.00 EACH :- MINEFIELD; PONTOON; BIO-RHYTHMS; ALIEN DESTROY; BATTLESHIPS; HORSE-RACE.
2K PROGRAMS: Torpedo, Moon-landing, Hangman, Reaction test—all on 1 cassette @£5

Nascom-2

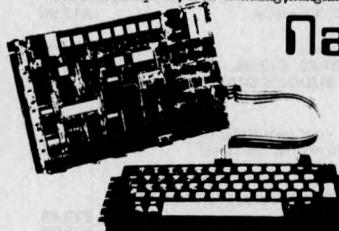

SOFTWARE ON CASSETTE

ALL PROGRAMS FIT IN 4K MEMORY,
AND USE NAS-SYS & GRAPHICS.

Football @ £3 Fruit Machine @ £3
Tennis @ £3 Squash @ £3
UFO @ £3 Lunar lander @ £3
Ski run @ £3 Pontoon @ £3
Nascom Breakout @ £3

XXXXXXXXXXXXXXXXXXXXXXXXXXXXXXXXXXXX

sinclair ZX80 SOFTWARE

XXXXXXXXXXXXXXXXXXXXXXXXXXXXXXXXXXXX
ZX80 PROGRAMMING COURSE
XXXXXXXXXXXXXXXXXXXXXXXXXXXXXXXXXXXX

This consists of a book and a cassette of programs, which together cover those aspects of ZX80 programming likely to cause difficulty. Many useful programming examples are included, dealing with PEEK & POKE, arrays, USR etc. Also includes sections on flowcharts, and the ZX80 microprocessor. ONLY £7.50.

OUR CASSETTES OF ZX80 PROGRAMS ARE STILL AVAILABLE FOR ONLY £3.00 EACH, e.g.:-
No.1 : Moon-landing; Reaction test; Codebreaker; Hangman; Intercept.
No.3 : Remcard; Bingo; Sequences; Letter-shuffle.
No.5 : Guess & gamble; Number-sort; Treasure hunt; Fruit machine.
No.6 : Secret codes; Horse race; Stopwatch
No.10: Graph-plotter; Summation; Histograms; Square roots.

EDUCATIONAL SOFTWARE FOR EXPANDED ZX80s now available. Send 2 x 12p stamps for complete catalogue.

ALL PRICES
INCLUSIVE.

BUG-BYTE

MAIL ORDER
ONLY.

251 HENLEY ROAD COVENTRY CV2 1BX



Pete & Pam Computers

Microcomputer hardware & software
Specialists in Applefare

HAVE YOU BEEN WATCHING OUR ADVERTISEMENTS?

If you have, you'll have noticed that one thing is common to all of them — FAIR prices. This month is no different. We bring you the latest Applefare at prices we hope you can afford.

ANDROMEDA

A 16K RAM EXPANSION CARD that saves the expense of a language system. Makes your APPLE into a 64K machine. **£110.95**

M & R ENTERPRISES

SUP-R-TERMINAL An 80 column by 24 line plug-in compatible board for APPLE II. 128 ASCII chrs. Upper and lower case — with descenders. Shift lock feature. Synchronous operation with APPLE. Incorporates PASCAL and BASIC control characters. **£195.00**

MICROSOFT

Z-80 SOFTCARD. A true Z80a microprocessor plug-in board to allow you to run CP/M software. Includes MICROSOFT'S BASIC 5.0. **£175.00**

FORTRAN for SOFTCARD. Has a strong advantage over APPLE Fortran. 4 to 6 times faster because it generates true machine code rather than "P" code. Featurewise, the two are essentially the same. **£99.95**

COBOL for SOFTCARD. The only COBOL available for APPLE. Ask for more information and our special SOFTCARD/COBOL deal. **£359.95**

BASIC COMPILER for SOFTCARD. Get fast program execution times without giving up BASIC. 3-10 times faster than interpreted BASIC. **£192.95**

OLYMPIC DECATHLON. Latest game from MICROSOFT. 10 events presented in extraordinary graphics. 1-8 players can play. **£15.95**

ADVENTURE. Yes, this is the original written for the PDPII, and played during many a lunch hour on expensive main frames! **£15.95**

TYPING TUTOR. Runs in INTEGER (incl. relocated) It works! **£8.95**

PERSONAL SOFTWARE

VISCALC. Yes, the one sold elsewhere for £95.00. Our price **£75.00**

CCA DATA MANAGEMENT. Our price just **£49.95.**

DESKTOP PLAN. Develop your own large business model. **£49.95**

HIGH TECHNOLOGY

INFORMATION MASTER. The latest data management system from High Tech. We use it for all our book-keeping up to trial balance and for our price lists. Can be user tailored for many uses. **£73.95**

DATA BASE MANAGEMENT SYSTEM. High Tech's original system. Not as many features as Info. Master, but is user oriented with lots of error trapping. **£49.95**

DATA MASTER A utility for use with both Info. master and D.B.M.S. allows you to re-define field types, transfer data from one system to another, using a wide set of parameters. We use this too. **£49.95**

CHEM. LAB SIMULATION #1. Uses Hires Graphics to simulate i) an acid-base titration experiment. ii) Determination of an unknown weak acid. iii) Determination of Avroardro's number. **£49.95**

CHEM. LAB. SIMULATION #2. Written in machine language for fast response time, uses colourful Lowres Graphics to simulate i) The Ideal Gas law. ii) The Kinetic-molecular theory. iii) The principles of entropy. **£49.95**

PERIPHERALS PLUS

VERSAWRITER. A low cost graphics tablet for APPLE **£124.95**

JOYSTICK. T.G. Products robust joystick — self centering. **£34.95**

COMPUTER STATION

PASCAL GRAPHICS DUMP PROGRAM for Paper tiger. 440G, 445G, 460G. **£22.95**

NEC Spinwriter and Anadex 9501. **£22.95**

ENHANCED GRAPHICS DUMP PROGRAM also available for above **£22.95**

VISILIST lists out the grid location and formulas of any Viscalc file. **£10.95**

MACRO SCREEN EDITOR Cursor oriented editing tool. **£19.95**

APPLEWRITER GRAPHICS. Links with Appewriter and any of the 28 character sets supplied in APPLE's "Dogs Tool Kit" to provide word processing with a difference! Tiger 440G, 445G, G Silentye. **£17.95**

CALIFORNIA PACIFIC GAMES

AKALABETH Latest Adventure type game. **£16.95**

TRILOGY £15.95. **TRANQUILITY BASE** £13.95.

HEAD-ON From Japan £13.95 **BILL BUDGE'S SPACE ALBUM** £20.95

CONTINENTAL SOFTWARE

LOS ANGELES MONOPOLY. Define your own street names or take a trip round the streets of L.A. Allows you to change the rules! **£15.95**

VARIOUS

DAN PAYMAR LOWER CASE ADAPTOR Produces upper and lower case **£29.95**

BASF 5.25 IN DISKS FOR APPLE. At a good price. **10 for £18.50**

CALIFORNIA COMPUTERS

CENTRONICS PARALLEL INTERFACE **£59.95**

PARALLEL INTERFACE **£59.95**

ASYNCHRONOUS SERIAL INTERFACE **£78.95**

SYNCHRONOUS SERIAL INTERFACE **£87.95**

ARITHMETIC PROCESSOR **£194.95**

DYNASOFT

DYNASOFT PASCAL. A portable p-code implementation of a Pascal subset specifically tailored for small scale micro systems. Will run on systems with only 16K of RAM. **Disk — £30.95 Cassette — £27.95**

PLEASE ADD 15% VAT TO YOUR ORDER

POSTAGE AND PACKING FREE

ASK FOR OUR FULL CATALOG

IF YOU KNOW WHAT YOU WANT AND DON'T WANT TO PAY

AN INFLATED PRICE

GIVE US A CALL — WE SELL ALL SORTS OF THINGS

FOR APPLE

TEL 01-677 2052 (24 HRS) 7 DAYS A WEEK

98 MOYSER ROAD LONDON SW16 6SH

POST OFFICE GIRO NO. 585 6450

SOFTY Software Development System AND EPROM PROGRAMMER

EX-STOCK

SOFTY is intended for the development of programs which will eventually become software residing in ROM and forming part of a microsystem. During the development stage of a microsystem, SOFTY will be connected in place of the firmware ROM via a ribbon cable, terminated in a 24 pin DIL plug.

Data may be entered into the SOFTY RAM via the **serial port, parallel port, direct memory access, or the keypad**, and manipulated using the **assembler key-functions**. When the program has been entered, and the internal microprocessor can be "turned off", and the external microsystem and it's resident microprocessor allowed to access and run the program in SOFTY's RAM and/or programming socket. In this way, modification can be made until the required program is complete — the **contents of the RAM being clearly visible as a 'page' on TV or monitor**. 4 pages are available, 2 of the Data RAM and 2 of the programming socket.

In the end, when the program is complete and working, the DIL plus is removed and replaced by an EPROM device programmed by SOFTY. **SOFTY is able to program the 2704/2708/2716 family** which have 3 voltage rails —

To help in the process of program development SOFTY has various assembler key-functions, which include — **block shift without overwriting, block store, cursor control, match byte and displacement calculations** (for jumps etc). **A high speed cassette interface** is also provided for storing working programs and useful subroutines.

SOFTY kit of parts: (including zero insertion force socket for EPROM programmer) Price £100 + VAT (postage paid). SOFTY built & tested — £120 + VAT (postage paid). Built SOFTY power supply — £20 + VAT (postage paid). Write or telephone for full details.

NEW

SOFTY CONVERSION CARD —

EX-STOCK

Enables SOFTY to program the single rail EPROMs 2508, 2758, 2516, (INTEL 2716), 2532.

Selection of device type and 1K block are by 4 way pcb slide switches.

Programming socket is zero insertion force. Supplied ready built & tested with Dip jumper for connection to SOFTY, £40 + VAT (postage paid).

NEW

SOFTY PRINTER CARD —

EX-STOCK

• 40 column electrosensitive printer • 5 x 7 dot matrix

• software selection of characters per line (1 to 16 bytes)

• push button printing of EPROM/RAM/Intercursor contents

• Connects to SOFTY card edge • Well documented • Supplied ready built &

tested, including power supply, edge connector & paper roll for £145 + VAT (post paid), Spare paper rolls (28-30 metres/roll) — £6.96 + VAT

EX-STOCK EPROMS

	1-9	10-24	25-49	50 up
2708 (450ns)	£3.90	£3.50	£3.10	£2.90
2716 (450ns)	£6.00	£5.50	£5.00	£4.50

Single rail

Deduct a further 5% for cash with order on these low EPROM prices.

Add VAT at 15%. Postage paid.

MODEL 14 EPROM ERASERS

EX-STOCK

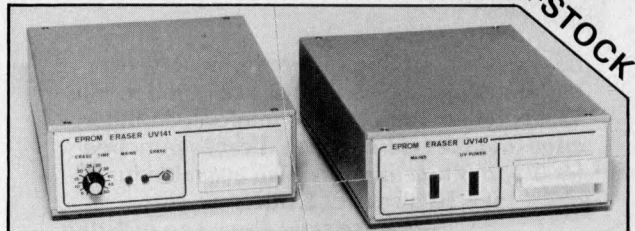

MODEL UV 141 EPROM ERASER

• Fast erase times (typically 20 minutes for 2708 EPROM)

• 14 EPROM capacity

• Built-in 5 to 20 minute timer to cater for all EPROMs

• Safety interlocked to prevent eye and skin damage

• Convenient slide-tray loading of devices

• 'MAINS' and 'ERASE' indicators

• Rugged construction

Priced at only £78 + VAT post paid

MODEL UV 140 EPROM ERASER

Similar to Model UV141 but without timer

Low price at only £61.50 + VAT post paid

WRITE OR TELEPHONE FOR FULL DETAILS OR SEND CHEQUES/OFFICIAL COMPANY ORDERS TO:

GP Industrial Electronics Limited

Unit 6, Burke Road, Totnes Industrial Estate,

Totnes, Devon. Tel. Totnes (0803) 863360 Sales, 863380 Technical.

Telex No. 42596

TRADE & EXPORT ENQUIRIES WELCOME

Apple II PLUS 16K RAM

® Apple is a trade mark of Apple Computer Inc., Cupertino, CA. USA.

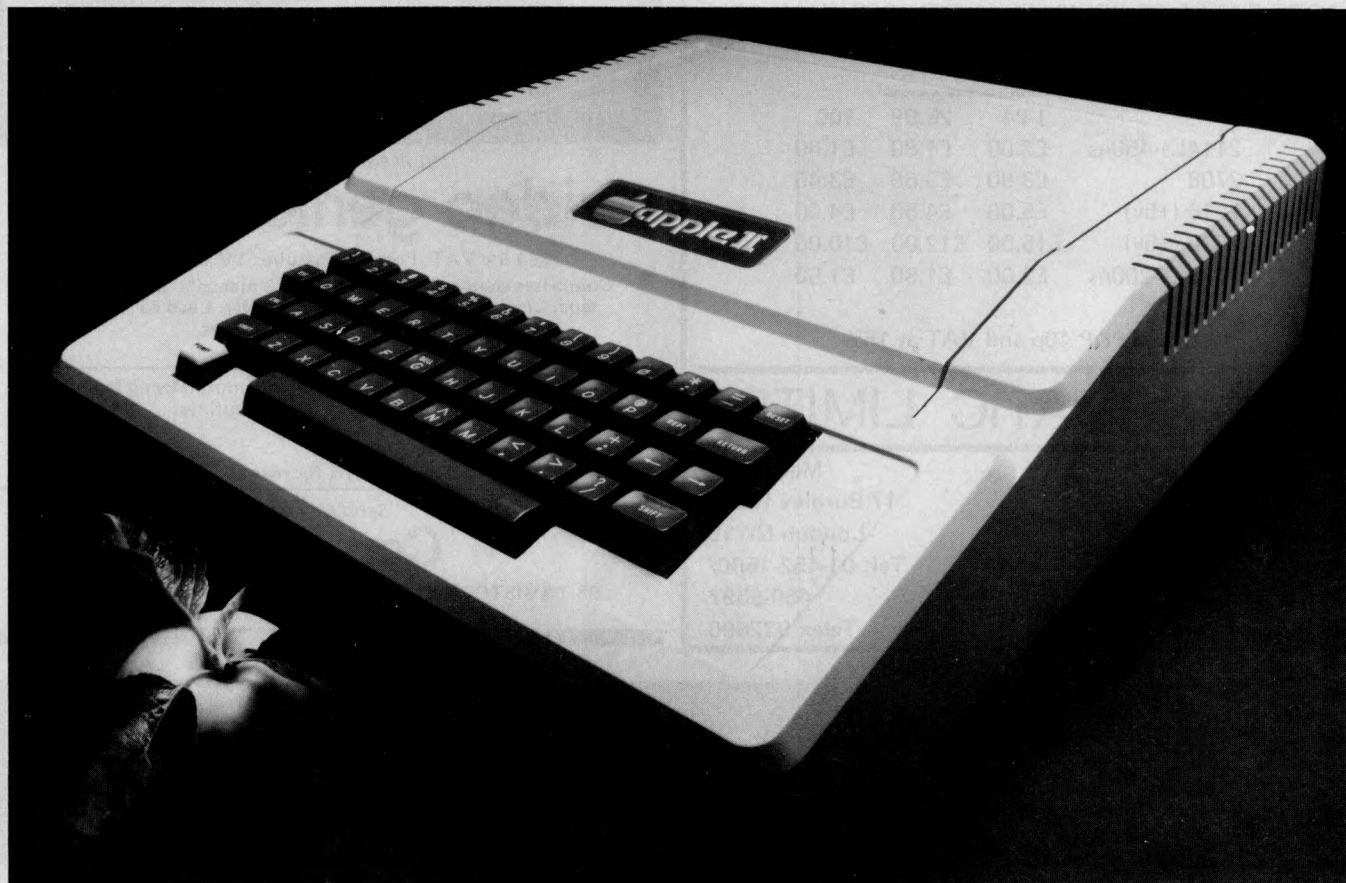

£485

"STOP PRESS: THIS PRICE WILL BE HELD UNTIL 13 FEBRUARY 1981. ORDERS RECEIVED AFTER THAT DATE WILL BE £550 PLUS DELIVERY IN THE UK AND VAT"

Send cheque or money order for

£565 (including VAT & Delivery in the UK) to:

Trade Enquiries
Welcome

GUESTEL LIMITED

Refuge House, 2-4 Henry Street, Bath, BA1 1JT.
Telephone: 0225-65379

Please allow 28 days for delivery

MICROS MEMORIES TTL's & INTERFACE DEVICES

Z80	£6.50	6800	£6.00	6502	£6.50
Z80A	£8.50	6802	£8.50	8080A	£4.50
8085A	£11.00	6809	£16.00	2650A	£16.00

LARGE RANGE OF PERIPHERAL DEVICES AVAILABLE.

SPECIAL OFFERS

	1-24	25-99	100
2114L-450ns	£2.00	£1.80	£1.60
2708	£3.90	£3.60	£3.40
2716 (+5v)	£5.00	£4.50	£4.00
2732 (+5v)	£15.00	£12.00	£10.00
4116L-200ns	£2.00	£1.80	£1.60

Please add P&P 40p and VAT at 15%

TECHNOMATIC LIMITED

Retail Shops:

17 Burnley Road,
London NW10

367 Edgware Rd., W2

Mail Order

17 Burnley Road,
London NW10

Tel: 01-452 1500/

450-6597

Telex 922800

ComServe

COMPUTER SHOP PRESENTS

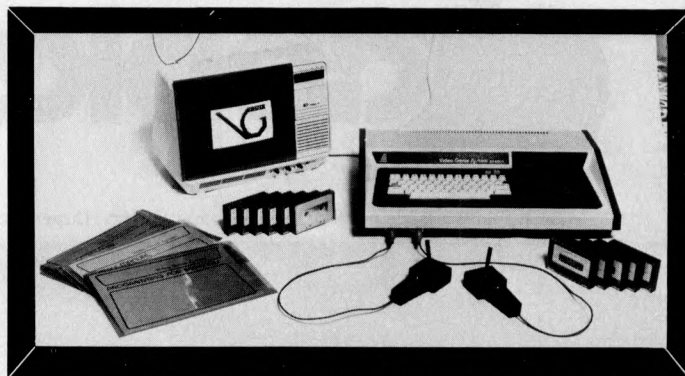

THE ELEGANT, EXPANDABLE

video genie system

£364 inc VAT. Postage. Requires TV or monitor.
Comprises standard 16K computer. 3 manuals. Demonstration
tape. Lead for additional cassette player. Lead for monitor.
Full support & accessories.

- FREE** Standard cover. Head cleaning/demagnetising tape.
- FREE** Programs: Games, Utilities, Subroutines.
- FREE** Standard soundkit
- FREE** Comserve joysticks
- FREE** Coloured plastic folders for manuals or screen overlays.

Send cheque to:

ComServe

98 TAVISTOCK STREET, BEDFORD, BEDFORDSHIRE.
TELEPHONE (0234) 216749

Know your ZX80

WITH LINSAC PRODUCTS FOR THE SINCLAIR ZX80 LITERATURE

'THE ZX80 COMPANION' Second Edition. A complete guide to the ZX80 with chapters on operating, ZX80 BASIC, hardware, the Monitor (incl. moving display routine) and programs. Price £10.00 (add £4.95 for a cassette of ten programs from the book).

'THE ZX80 MONITOR LISTING'. A full assembly language listing with annotations.

Price £10.00

SOFTWARE

All the following packs come on single C12 cassettes with run instructions, price £10.00.

GAMES PACK 1 – Three Towers, Number Guessing, Mastermind, Sketcher, Hurkle, Nim and Symbol Simon.

GAMES PACK 2 – Nine Lives, The Maze Game, Plain Sailing, Noughts & Crosses, Chinese Puzzle, Tower of Hanoi, Battleships.

GAMES PACK 3 – (for 2 – 4K) Fruit Machine, Four-in-a-Line, Zombies.

EDUCATION PACK 1 – Maths Drill, Dot Recognition, Musical Notes, Spelling Quiz, Day Finder.

EDUCATION PACK 2 – Graph Plotter, Prime Factors, Number Bases, Bar Charts, Statistics.

UTILITY PACK 1 – Memory Display, Hex Code Monitor, Renumber, Memory Search.

All packs except GP3 run on 1K ZX80s, and all prices include postage. Send cheques to:

LINSAC

68 Barker Road, Linthorpe,
Middlesbrough,
Co. Cleveland TS5 5ES.



Digital Design and Development

18/19 Warren Street · London W1P 5DB Tel: 01 387 7388

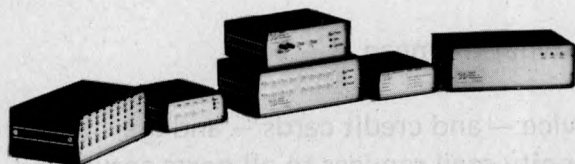

CBM PET SHARP MZ-80K Specialist Suppliers of Complete Systems for Industrial and Laboratory Monitoring and Control.

**Please note our new address.
Callers welcomed for demonstration
and/or discussion.**

SHARP MZ-80K INTERFACES

- Parallel Printer Interface £110
- Serial Printer Interface £150
- Bi-Directional Serial Interface £210
- 16-Channel A/D Converter Unit £280
- Fast Data Acquisition System –
40,000 readings/sec. 4 analog channels
IN and 4 channels OUT. P.O.A.

PET INTERFACES

IEEE-488 Compatible Units

- 16 Channel 8-Bit A/D Converter £300
 - 8 Channel 8-Bit D/A Converter £350
 - 8 Channel 12-Bit A/D Converter £600
 - 12-Bit D/A Converter P.O.A.
 - X-Y Analog Plotter Interface £200
 - Digital Data Input Unit, 64 Bits £400
 - Digital Data Output Unit, 64 Bits £350
 - 16 Channel Relay Unit £350
- Also....
- USER Port Converter A/D plus D/A £200
 - Fast Data Acquisition System
40,000 readings per sec. 4 A/D + 4 D/A P.O.A.

All units boxed complete with IEEE-488 address internally selectable, with integral power supply, cables, switch, fuse, indicators and illustrative BASIC software.



TERMS: All prices EX-VAT. P&P extra.
Cheques should be made payable to
3D Digital Design & Development.
All goods supplied under 90 days warranty.
CUSTOM DESIGN UNDERTAKEN

ADVANCED COMPUTER EQUIPMENT (LEEDS) LTD

95, MEADOW LANE, LEEDS, 11. Tel.0532 446960

New microcomputer store NOW OPEN

PRICES SHATTERED

COMMODORE PET

32K Professional keyboard green screen	£575
Dual disk drive 347k	£625
Cassete deck C2N	£ 50
Printer 3022 Matrix Tractor	£375

APPLE II PLUS

48K Auto start	£695
Disk with controller	£345
Disk without controller	£295
Hitachi 9" monitor B/W	£120

SHARP Z80

48K with 34K user RAM	£475
36K with 22K user RAM	£422
20K with 6K user RAM	£380
Disk drives, printers etc.	

SUPERBRAIN

64K with single density 320K disk	£1450
32K with single density 320K disk	£1395
64K with double density 700K disk	£2300
Operating system * MBASIC * COBOL * FORTRAN	

PRINTERS

BD80P – Hi-speed bi-directional with adjustable tractor feed 750 byte buffer. Fantastic offer £395.
IEEE * Parallel or RS232

SUNDRIES

Data tapes super quality (10)	£3.75
5¼" certified verbatim (10)	£27.00
Plain listing paper 2000 units	£12.50
Books * Games * Programs * galore	
Visicalc * Desktop planner special offer	

Please add VAT to all goods except books – cash & carry or 24-hour delivery – your choice.
All equipment is factory fresh and fully tested in our own workshops
Standard conditions of sale applies too all products.

Upgrade to Kansas

No matter what software you are using for your Video Genie or Tandy TRS-80, you will upgrade with Kansas programs.

Send for a copy of the Kansas Collection and see what we mean.

And remember we do a first-class return post service — and credit cards — and are situated right in the middle of the country, with fast inter-city mail services to all ports ensuring ultra-quick delivery.

Telephone after six if you want to take advantage of the cheap rate, leaving your name and address on tape for prompt despatch of your 'Collection'.

Kansas

Kansas City Systems, Unit 3, Sutton Springs Wood, Chesterfield, Derbys. Tel 0246 850357

OHIO..

..24 hours a day!

Yes that's right, we are at your service 24 hours a day offering a complete OHIO SCIENTIFIC service, giving technical information, advice on hardware expansion and satisfying your requirements in any of the following:

OSI SYSTEMS-including the popular SUPERBOARD II and CHALLENGER 4P as either cassette or disk based systems.

OSI SOFTWARE-cassette and disk based software covering a broad spectrum of uses. Some of the cassette based software can be run on the UK101.

BEAVER SOFTWARE-business, educational and entertainment software -professional programs with full listings and documentation. Also available for other programs especially the UK101.

BEAVER PROGRAMMING AIDS-including video workpads, BASIC workpads, machine code workpads, cassette index cards, labels and blank cassettes, all available for OSI UK101 and TRS-80.

In addition to the above, we also have available cases for the SUPERBOARD II (and others).

Demonstrations of all the systems and software available can be arranged in your own home or business premises (within a 50 mile radius of Oxford).

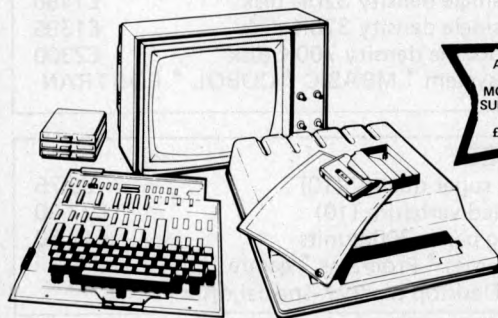

NOW AVAILABLE
NEW
MONITOR FOR
SUPERBOARD &
UK 101
£29.50 +VAT

BEAVER SYSTEMS 

Norlett House, Dormer Road, Thame, Oxon OX9 3UC
Telephone Thame (084421) 5020 (24hr)

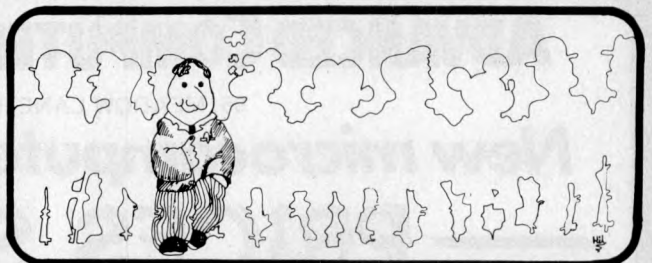

You stand out in a crowd

Your business is not exactly the same as any other and neither are its problems. Any solutions are probably unique and must be tailored exactly for you.

You know your business better than anyone else and any system designed should use your knowledge. The micro-computer specialist should show you how to use the computer to meet your business requirements.

You should be able to get the micro-computer which best suits your business. It should be chosen after your requirements are specified.

You and your staff have a right to know all about YOUR system, including helping to program it if you want to. Training is your right — not an additional service.

If microcomputers cannot satisfy your business needs, you want to know — you don't want false promises.

67 Nova Road, Croydon, Surrey CR0 2TN.
Telephone: 01-688 6013

MIKEROSE MICRODS

**Software People...
...have you the
Brilliance of Einstein
Creativity of Da Vinci
Diplomacy of Kissinger
Flexibility of Houdini
Humour of Groucho
Appearance of**

**If you cant match up
to the latter, we still
want to see you.**



Do you have a degree in **Mathematics** or **Computer Science** or a similar subject, do you have an indepth knowledge of software engineering gained within the **Process Control Industry**, the **Automotive Industry**, the **Communications Industry**, the **Aircraft Industry** or **Defence** or any other real time environment? Do you have experience of high level technical/scientific languages such as **CORAL**, **PASCAL**, **FORTTRAN**, **RTL** as well as **ASSEMBLER** level languages? Do you also have a familiarity with **DEC**, **GEC**, **SEL**, **DATA GENERAL**, **HEWLETT PACKARD** or any other micro hardware?

If you have experience in any of these areas then we can find you a more rewarding, more challenging and a more satisfying career in London or the Home Counties in 1981.

Don't you owe it to yourself and your family to explore the possibility by just picking up the telephone and ringing **Colin Maslen** on **St. Albans 68372** or **St. Albans 35113** or you can write to him at **Blue Arrow Executive Selection**, **2 Holywell Hill, St. Albans, Herts.**



**Blue Arrow
Executive Selection**

The 4th Personal Computer World Show

Cunard Hotel Hammersmith 10-12 September 1981

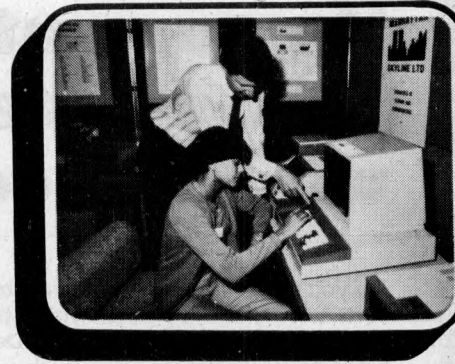
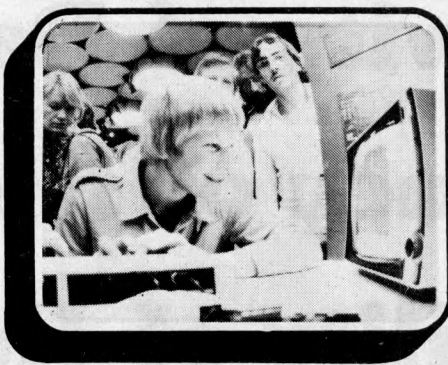

The Show which brings your market direct to you . . .

The Personal Computer World Show is the only exhibition exclusively for the small computer industry. It is your opportunity to meet, face-to-face, potential buyers who visit the Show specifically to see demonstrations and discuss the application of your products.

This is the Show where buyers come to buy ... not just look.

To discuss how the 4th Personal Computer World Show could form the focus of your 1981 promotional calendar contact Timothy Collins on 01-486 1951 or write to him at Montbuild Ltd, 11 Manchester Square, London W1.

ADVERTISERS INDEX

Acorn Computers	67	Machines	20	KGB	26	Newtons	45
Aculab	156	Data Applications		Kansas City	180	Newbear Computing	122
Advanced Media	56	International	120	Keen	65	Personal Computers	OBC
Almarc Data Systems,	35,37	Dataview	20	Keytronics	149	Pete & Pam Computers	176
Anglia Comp Centre	154	Datron Microcentre	28	Kingston Computers	56	Petsoft	104
Audiogenic	37	Davinci Comp	158	L & J Computers	94	Phipps	24
Beaver Systems	180	Digital Design & Development	179	L P Enterprises	157	Portatel	56
Biodata	166	Digital Devices	174	Leicester Comp Centre	82,175	Program Power	82
Bits & Pieces	166	Display Electronics	161	Linsac	178	Promglow	172
Blue Arrow	181	Easi Comp	158	Lion House	170	Rental Workshop	36
Bug Byte	175	Environmental		Little Genius	168	S M G Microcomps	160
Business & Leisure		Equipment	13	Liveport Data Products	68	Science of Cambridge	118,119
Microcomputers	28	Essential Software	18	London Computer Store	34	Sharp Soft	22
Butel	94	Equinox	96	Low Electronics	31	Sharp	50,51
Byte Shop	114	Ferguson Computers	164	M & C Business Services	172	Sharp Co-op	101
C C S Microhire	36	Freshfield Computers	24	Magtronics	156	Silica Shop	23
Calona	94	G P Industrial	176	McGraw Hill Book Co	21	Stack	19,43
Calco	168	Gate Microsystems	36	Melbourne House Publishers	160	Sirton	33
Cambridge Comp Store	114	Graffcom	150	Mendip Computers	164	Strutt	149
Camden Electronics	35,179	Graham Dorian	117	Microbyte	155	Swanley Electronics	154
Castle Electronics	11	Grama Winter (G W Ltd)	14,15	Microbusiness Centre	149	T V J Micro Computers	29
Chromasonic	30,31	Greenbank Electronics	163	Microcentre	150	Tandy	4,5
Comart	66,88	Guestel	177	Microfacilities	150	Technomatic	178
Commodore	41	A J Harding (Molimerx)	16,17	Micro Computer Connections	151	Tel Equipment	92
Compusyst	172	Happy Memories	162	Micro Sense Microsystems	81,175	Templeman Software	158
Computech	46	Henry's	152	Microstyle	22	Tex Microsystems	164
Comp Shop	184,IBC	Hewart Microelectronics	12	Microtype	172	This could be fun	149
Computerbits	150	Hewlett Packard	32	Mighty Micro	84	3-line Computing	174
Computer Bookshop	108	Hewlett Packard Co-op	169	Mike Rose Micros	180	Transam	112
Computopia	162	Highlight Software	12	Mine of Information	12	Wesfarthing Comps	170
Comerve	178	Inprint	25	Minimic	7,8,8,10	John Wiley	74,75
Control Universal	18	Intelligent Artefacts	168	Mutek	6,72	Video Vector	
Cream Microcomputer Shop	159	Interam Computer Systems	173	Nascom Dealers Guide	171	Dynamics	167
Creative Computing	165	Interface	27			Vlasak	2
Cumana	153	Intex Datalog	154			Zynar	3
Currah	170						
Crystal	162						
D R G Business							



Snippet picked up on a recent visit to Commodore — they own an LCD plant. Wonder how long it'll be before we see some interesting (book size?) LCD screens? . . . Apparently Berkshire taxi drivers read *PCW*. Every time Julian Allason gets into a taxi he is greeted with the words 'Hello squire!'. . . A certain finance manager from London E8, when asked in the reader survey, 'What else would you like to see in *PCW*', replied 'Sue Eisenbach in a wet T-shirt!' We tracked Sue down to a Christmas party where she confessed to being too drunk to think of a reply! . . . We wonder sometimes about the people who go in for our 'Leisure Lines' puzzles. In just one day we received four entries without the senders' names and addresses. . . A certain advertiser (sometimes) in Street, Somerset has taken to giving lectures on computing to a bunch of Druids. It helps them in their preparation of

homoeopathic medicines, apparently. It's a long way from witches' cauldrons. . . Our dear friend from *Toady* — Henry 'Shoestring' Budgett — has confessed that he is an actor, of sorts. From January he becomes Acting Editor. . . Read February's *Printout* for 1981's hottest panto review. In fact it's probably 1981's *only* panto review to date. . . Alistair Kelman of legal fame is apparently using conjuring tricks to explain program copyright problems to the judge. Rumour has it that Alistair trotted into court carrying two lovely red velvet bags — one small, the other large. Holding a postage stamp in one hand and brandishing an empty smaller bag in the other, Kelman dropped the stamp into the bag. Two seconds later he withdrew *two* stamps. He then repeated the trick with the larger bag and a floppy disk — two by the time he'd finished. 'And what,' so the story goes,

'would you think of the person who produced the bag, your honour?' said Kelman. We eagerly await developments. . . Commodore has withdrawn its tractor printer, apparently to get the ROM fixed. Other manufacturers can look forward to an upsurge in sales for a couple of months, then expect Commodore back with a vengeance. . . A heavy letter landed on the editorial desk this month. It was from

Markham and Markham of Chelsea, claiming to represent Brigadier 'Bumper' Harris. 'It is clear that your reports tend to ridicule our client'. . . etc, etc, drone, drone, The real 'Bumper' replies: 'Come off it, Inside Trader, you know darned well I was never a Brigadier'. . . Image digitisers and colour printers, Computer Art of Stockport sent us this lovely reply to our December cover, shown below.



YES IT IS ART

NEW REDUCED PRICES

8K **£399**
16K **£499**
32K **£599**

+ VAT

RRP £795 for 32K



The PEDIGREE PETS Very popular for home & business use 8K Microsoft Basic in ROM 8K Pet 32K & 16K with new improved keyboard. All with green screen.

Cassette Deck **£55** extra Full range of software available
Interface PET IEEE - Centronics Parallel
Decoded **£77.00** + VAT



We give a full one year's warranty on all our products.

SPECIAL SCOOP GET YOURSELF A PRINTER FOR YOUR PET AND SAVE A FORTUNE

only **£299** + VAT

Interface Cards **£49**

Full Pet Graphics including cables. Ready to go. **EX-STOCK.**

Interfaces with APPLE, PET, EXIDY, TRS80, COMPUKIT and NASCOM.

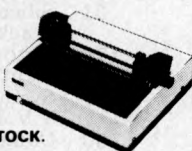

NASCOM 2 DISC DRIVES

Add a powerful, double density, mini floppy disc to your Nascom system.

- Disc Controller Card (includes Nasbus 6 S100 interface)
- Will control 4 Drives.
- CPM operating system.
- Extended Disc Basic Compiler.
- Power supply included

One Disc System - **£499** + VAT
Additional Disc Unit - **£299** + VAT

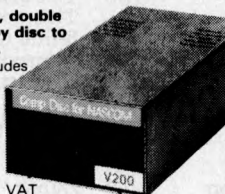

NASCOM 2 GAMES TAPE

featuring Space Invaders and Android Nim, Re-numbering program and other goodies!

£7.50 + VAT



NEC SPINWRITER

only **£1490**
+ VAT



NEC's high quality printer uses a print "thimble" that has less diameter and inertia than a daisy wheel, giving a quieter, faster, more reliable printer that can cope with plotting and printing (128 ASCII characters) with up to five copies, friction or tractor fed. The ribbon and thimble can be changed in seconds. 55 characters per second bidirectional printing - with red/black, bold, subscript, superscript, proportional spacing, tabbing, and much, much more.

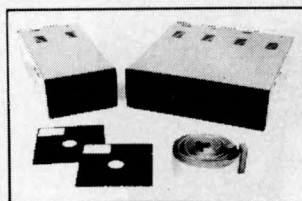

TEAC DISK DRIVES

- TEAC FD-50A has 40 tracks giving 125K Bytes unformatted single density capacity.
- The FD-50A can be used in double density recording mode.
- The FD-50A is Shugart SA400 interface compatible.
- Directly compatible with Tandy TRS80 expansion interface.
- Also interfaces with Video Genie, SWTP, Heathkit, North Star Horizon, Superbrain, Nascom, etc, etc.
- Address selection for Daisy chaining up to 4 Disks.
- Disks plus power supply housed in an attractive grey case.

Single Disk Drive **£225** + VAT Double Disk Drive **£389** + VAT

COMP POCKET COMPUTER GREATEST BREAKTHROUGH YET

£99.90
+ VAT

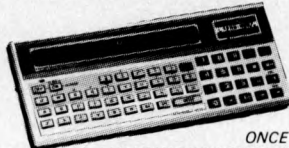

COMPUTER POWER THAT ONCE FILLED A ROOM CAN NOW BE CARRIED IN YOUR POCKET!

- Programs in BASIC • "QWERTY" Alphabetic Keyboard • 1.9K Random Access Memory • Long Battery Life.

Computer power that once filled a room can now be carried in your pocket! It's easy to load with ready-to-run software from cassette tape (interface and recorder optional) or program it yourself in easy-to-learn BASIC. 24-character liquid crystal readout displays one line at a time. Special feature is advanced non-volatile memory allows you to power on and off without losing the contents of memory. Note: Memory must be transferred to tape before changing batteries. Automatic statement compaction squeezes every ounce of memory space. Features power-off retention of programs and data. Powerful resident BASIC language includes multiple statements, math functions, editing, strings, arrays and much more. Multiple program loading capability subject to RAM availability. Carrying case and batteries included.

Program	Each	Program	Each
Real Estate	£13.95	Games 1	£8.95
Civil Engineering	£13.95	Business Statistics	£10.95
Aviation	£13.95	Business Financial	£10.95
Math Drill	£8.95	Personal Financial	£10.95



ACULAB FLOPPY TAPE

The tape that behaves like a disc, for TRS-80 LEVEL 2.

only **£169** + VAT

Connects directly to TRS-80 Level 2 Keyboard. Operating and file handling software in ROM. 8 commands add 12 powerful functions to Level 2 BASIC.

COMMERCIAL • EXPANDABLE • COMPLETE TRS 80 • MODEL II



COMING SOON
26 megabyte
Hard Disc
multi-user
DOS



WE USE THIS MACHINE IN OUR BUSINESS

1 DISK EXPANSION Room for 3

500K per Drive gives total of 1.5M Byte - 1 Drive plus Cabinet **£799** + VAT

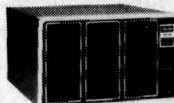

This new unit from the world's most successful micro company is now available immediately with software. The basic unit comes complete with 64 thousand characters (bytes) of Memory. The built in 8" Floppy disc adds another 1/2 million extra characters including the disc operating system. More disc expansion is now available.

The Model II is a complete unit with a full keyboard including a numeric pad and 12" screen which gives 24 lines of 80 characters. The computer is supplied with both the disc operating system and the Level III Basic.

A full self test routine is written into the power up procedure to eliminate incorrect operation. Both serial and parallel expansion sockets are standard. A printer is a plug-in operation. Both hardware and software necessary to talk to a mainframe are included. Terminal usage is very possible. With the addition of CPM2 you can operate with COBOL, FORTRAN, MBASIC, CBASIC in which languages are many other applications packages i.e. accounting, payroll stock etc.

64K 1-Disk Model II **£1995.00** + VAT
RRP £2250.00

CP/M2 **£95.00** C BASIC **£75.00** FORTRAN **£220.00**
CIS COBOL **£400.00** M BASIC **£155.00** WORDSTAR **£255.00**

EPROM 2716 **£12.50** + VAT

only **£325** + VAT



TRS80 LEVEL 2 16K

Fully converted to UK T.V. Standard. Comes complete with easy to follow manuals. UK Power Supply - Cassette Leads - Sample tapes. Special box to enable you to plug into your own TV. Recommended for first time buyers. Just plug in and go. Full Range of Software Available

Interface to Centronics Parallel for TRS80 **£75.00** + VAT

only **£295** + VAT
Expand your TRS80 by 32K
32K Memory on board
Centronics parallel port
Disk controller card. Real time clock. Requires Level II Basic. Interface for 2 cassette decks. complete with power supply.

TRS80 EXPANSION INTERFACE

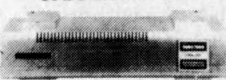

THE VIDEO GENIE SYSTEM

EG3000 Series



16K
£289
+ VAT



WITH 16K user RAM plus extended 12K Microsoft BASIC in ROM • Fully TRS-80 Level II software compatible • Huge range of software already available • Self contained, PSU, UHF modulator, and cassette • Simply plugs into video monitor or UHF TV • Full expansion to disks and printer • Absolutely complete - just fit into mains plug.

COMING SOON
THE MARTELL TV GAME

RRP
£540

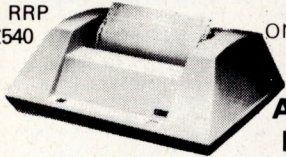

only
£399
+ VAT
**ANADEx
DP8000**

Super Quality — Low cost printer. Tractor Feed with full 96 ASCII character set. Accepts RS232C at band rates between 100 and 9600 and Parallel Bit data.

Attaches either directly or through interfaces to Pet, Apple, TRS80, Sorcerer, Nascom, CompuKit etc.

**THE NEW ANADEx
DP9501**

A PROFESSIONAL PRINTER



- Bi-directional printing
- Up to 220 chars/line with 4 print densities
- 500 char buffer
- RS232C and Centronics Parallel interface built in
- Full software control of matrix needles allowing graphics capability
- 200 chars/sec ● Adjustable width tractor feed.

All this for only **£895** + VAT.

**THE ATARI VIDEO COMPUTER
GAMES SYSTEM**



Atari's Video Computer System now offers more than 1300 different game variations and options in twenty Game Program™ cartridges!

Most Cartridges only £13.90 + VAT
Prices may vary with special editions Basic Maths, Airsea Battle, Black Jack, Breakout, Surround, Spacewar, Video Olympics, Outlaw, Basketball, Hunt & Score*, Space War, Sky Diver, Air Sea Battle, Codebreaker*, Miniature Golf.

Extra Paddle Controllers — **£14.90 + VAT** *Keyboard Controllers — **£16.90 + VAT**

SPACE INVADERS NOW IN STOCK £25

NEW TV GAME BREAK OUT

Has got to be one of the world's greatest TV games. You really get hooked. As featured in ETI. Has also 4 other pinball games and lots of options. Good kit for up-grading old amusement games.

MINI KIT — PCB, sound & vision modulator, memory chip and de-code chip. Very simple to construct. **£14.90 + VAT**
OR PCB £2.90 MAIN LSI £8.50 Both plus VAT



**WE ARE NOW STOCKING THE
APPLE II EUROPLUS AT
REDUCED PRICES**



16K £599
32K £649
48K £659 } + VAT

Getting Started APPLE II is faster, smaller, and more powerful than its predecessors. And it's more fun to use too because of built-in features like:

- BASIC — The Language that Makes Programming Fun.
- High-Resolution Graphics (in a 54,000-Point Array) for Finely-Detailed Displays.
- Sound Capability that Brings Programs to Life.
- Hand Controls for Games and Other Human-Input Applications.
- Internal Memory Capacity of 48K Bytes of RAM, 12K Bytes of ROM; for Big-System Performance in a Small Package.
- Eight Accessory Expansion Slots to let the System Grow With Your Needs.

You don't need to be an expert to enjoy APPLE II. It is a complete, ready-to-run computer. Just connect it to a video display and start using programs (or writing your own) the first day. You'll find that its tutorial manuals help you make it your own personal problem solver.

NOW OPEN

**OUR NEW
SHOWROOM &
SALES CENTRE AT**
311 Edgware Road,
London W2.
Telephone: 01-441 2922



"Europes Largest Discount
Personal Computer Stores"

Delivery is added at cost. Please make cheques and postal orders payable to **COMP SHOP LTD.**, or phone your order quoting **BARCLAYCARD, ACCESS, DINERS CLUB** or **AMERICAN EXPRESS** number.

MAIL ORDER AND SHOP:

14 Station Road, New Barnet, Hertfordshire, EN5 1QW (Close to New Barnet BR Station — Moorgate Line).
Telephone: 01-441 2922 (Sales) 01-449 6596 Telex: 298755 TELCOM G

NEW WEST END SHOWROOM:

311 Edgware Road, London W2. Telephone: 01-262 0387

OPEN — 10am - 7pm — Monday to Saturday

- ★ **IRELAND:** 80 Marlborough Street, Dublin 1. Telephone: Dublin 749933
- ★ **COMP SHOP USA,** 1348 East Edinger, Santa Ana, California, Zip Code 92705. Telephone: 0101 714 5472526

EUROPE'S FASTEST SELLING ONE BOARD COMPUTER
COMPUKIT UK101

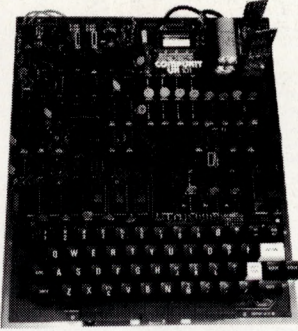

★ 6502 based system — best value for money on the market. ★ Powerful 8K Basic — Fastest around ★ Full Qwerty Keyboard ★ 4K RAM Expandable to 8K on board. ★ Power supply and RF Modulator on board. ★ No Extras needed — Plug-in and go. ★ Kansas City Tape Interface on board. ★ Free Sampler Tape including powerful Disassembler and Monitor with each Kit. ★ If you want to learn about Micros, but didn't know which machine to buy then **this is the machine for you.**

40 pin Expansion Jumper Cable for CompuKit expansion **£8.50 + VAT**

Build, Understand and Program your own Computer for only a small outlay.

KIT ONLY £179 + VAT
NO EXTRAS NEEDED

Available ready assembled, tested & ready to go **£229 + VAT**

NEW MONITOR FOR COMPUKIT UK101

● In 2K Eprom 2716 ● Allows screen editing ● Saves data on tape ● Flashing cursor ● Text scrolls down **£22.00 + VAT**

FOR THE COMPUKIT

Assembler/Editor	£14.90
Screen Editor Tape	£5.90

All Prices exclusive VAT

Game Packs

1. Four Games	£5.00
2. Four Games	£5.00
3. Three Games 8K only	£5.00

Super Space Invaders (8K)	£8.50
Space Invaders	£8.50
Chequers	£3.00
Real Time Clock	£3.00
Case for CompuKit	£29.50



**HITACHI
PROFESSIONAL
MONITORS**

9" — ~~£129~~ **£99.95**
12" — ~~£199~~ **£149**

- **Reliability** Solid state circuitry using an IC and silicon transistors ensures high reliability.
- **500 lines horizontal resolution** Horizontal resolution in excess of 500 lines is achieved in picture center.
- **Stable picture** Even played back pictures of VTR can be displayed without jittering.
- **Looping video input** Video input can be looped through with built-in termination switch.
- **External sync operation** (available as option for U and C types)
- **Compact construction** Two monitors are mountable side by side in a standard 19-inch rack.



**ENGLISH COLOUR TV/
AMERICAN NTSC
COLOUR MONITOR**

Suitable for Apple, Atari and Texas 99/4 **£295 + VAT**

8MHz Super Quality Modulators	£4.90
6MHz Standard Modulators	£2.90
C12 Computer Grade Cassettes	10 for £4.00
Anadex Printer Paper — 2000 sheets	£25.00
Floppy Discs 5 1/4" Hard and Soft Sector	£3.50
Floppy Disc Library Case 5 1/4"	£3.50
Verocases for Nascom 1 & 2 etc.	£24.90
Keyboard Cases	£9.90

MEMORY UPGRADES

16K (8 x 4116) **£29.90 + VAT**
4K CompuKit (8 x 2114) **£29.90 + VAT**

SPECIAL OFFER

We will part exchange your Sinclair ZX80 for any of our products.



Refurbished ZX80's—fully guaranteed **£69.90** + VAT
(Supply dependant upon stocks).

We have one of the largest collections of Computer Books under one roof, along with racks of software for the PET and TRS80.
Come and see for yourself.

APPLE DISC II

Disc with Controller **£349 + VAT**

Additional Drives **£299 + VAT**



- Powerful Disk Operating Software Supports up to 6 drives
- Name Access to Files for Ease of Use
- BASIC Program Chaining to Link Software Together
- Random or Sequential File Access to Simplify Programming
- Dynamic Disk Space Allocation for Efficient Storage
- Individual File Write-Protection Eliminates Accidental File Alterations
- Loads an 8K Byte Binary Image in 6.5 sec. (1.2 sec. in Pascal)
- Storage Capacity of 116 Kilobytes (143K Bytes with Pascal) on Standard 5 1/4" Diskettes
- Powered Directly From the APPLE (Up to 6 Drives) for Convenience and High Reliability
- Packaged in Heavy-Duty, Colour-Coordinated Steel Cabinet

**A SELECTION OF APPLE INTERFACES
ARE NOW AVAILABLE AT OUR NEW
SHOWROOM.**



COMP COMPUTER COMPONENTS
(Part of the Compshop Ltd. Group)



We are now entering our fourth financial year of dealing solely in the personal computer market — in fact, we started it! Over this period, Personal Computers Limited have formed a group of graduate specialists who will help you in the fields of word processing, financial planning, statistics, economic modelling, forecasting, accounting systems, foreign exchange, banking and oil exploration. We also do rather well with computer graphics and highly recommend the graphics tablets and our plotter for Apple.

We can also offer two excellent items of software — **Format 40** and **Visicalc** — at a combined price of **ONLY £189**, and the **Super Sound Generator** for only **£90!** (excl. V.A.T.)



8" Disk Drive (above left)

Our 8" disks are still as popular as ever — 2 drives give you 1.2MB with all the reliable security of Shugart Technology. Easily interfaced to Apple, uses the same D.O.S.



A.I.O. Serial and Parallel Card (above centre)

Three hand-shake lines (R.T.S., C.T.S. and D.C.D.). Firmware for serial interfaces on-board, software for parallel printer available, 2 bi-directional 8 bit parallel ports, plus 4 additional interrupt and hand-shaking lines.

Light Pen (above right)

A much sought after product which we introduced to the U.K.



80 Character Card (below left)

... opens up the real commercial world for all Apple owners.

Paper Tiger (Below centre)

132 character line, plus graphics, 8 character sizes, ordinary paper, multiple copy, upper and lower case 96 character, parallel/serial, form control.

Centronics 730 (Below right)

A substantial, robust printer from a major manufacturer. 3 way paper handling system, 100 character per second. Special low-cost including interface. 96 characters.



Items pictured

Sharp MZ — 80K

A new generation of personal computer, self contained, versatile and starting at only £570 (excl. VAT). Explore the Zilog Z80 now the easy way. Disks and printer available shortly.

Numeric Keypad

... with 8 function keys is a must in all financial applications.

TCM 100 & TCM 200

... both now have graphics as well as their own power supply, essential with this type of printer.

Qume Sprint 5

The quality word processing printer. Clean, clear executive reports the way you want them. Can print up to 5760 points per square inch — or even print in 2 colours.

This is what we do...

and we do it rather well!



Personal Computers Limited
194-200 Bishopsgate, London EC2M 4NR. Tel. 01 626 8121

For further information, please complete this coupon and post to:
Personal Computers Limited, 194-200 Bishopsgate, London EC2M 4NR

NAME _____
ADDRESS _____

* Now here details for **APPLE II**