

POPULAR  
**Computing**  
WEEKLY

6 May 1982 Vol 1 No 3

**30p**

**Hell Drivers  
on Vic-20**

**Seven pages of  
ZX81,  
Vic, and  
BBC programs**

**Win a Vic-20  
Super expander**

**First review  
of the new Sinclair**



# MORE FUN WITH YOUR ZX81!



## 16K RAM PACK

PUSH-ON PLUG-COMPATIBLE MEMORY

The addition of our fully-compatible, assembled, tested and guaranteed 16K Ram Pack means **more memory for better games and programs**

**ORDER YOURS TODAY FROM:**

CAPS LTD. Dept. E, 28 The Spain, Petersfield, Hants GU32 3LA

Please send me my Byg Byte 16K Ram Pack. I enclose cheque/postal order for £34.95 (includes VAT, Postage & Packing)

Name .....

Address .....

Dept. E

Allow 28 days for delivery

Fully **£34.95** inclusive

**From West London's  
mail order specialists:**

**ONLY  
£240**

incl. cassette deck

+ FREE GAME

+ FREE  
DELIVERY

# VIC-20

## SPECIAL OFFER

Order the superb VIC-20 and cassette deck at £240 (incl. VAT!) and get a FREE game ("Breakout" or "Stunt Cycle") worth £7.99 - and delivery is free, too!

We stock all VIC-20 software, peripherals, paddles, etc - including the full Stack and Arfon range.

The best microcomputers from leading makers (Apple, Commodore, etc) plus peripherals, printers, software, games, books - and all at low prices! Order today from the mail order specialists - send coupon with cheque (or phone your Barclaycard no). Delivery in 28 days or money-back option.

Please supply 1 VIC-20 & Cassette Deck & "Breakout" / "Stunt Cycle" (state which required)

NAME: \_\_\_\_\_

ADDRESS: \_\_\_\_\_

**TWICKENHAM  
COMPUTER CENTRE LTD**

72 Heath Rd Twickenham Middx TW1 4BW (01-892 7896/01-891 1612)

**From West London's  
mail order specialists:**

# Latest special offers:

48K Apple	£768
12" Green monitor	£115
12" Amber Phillips monitor	£135
Epsom printer	£399
Tantel adaptor	£230

**ALL PRICES INCLUDE VAT!**

**TWICKENHAM  
COMPUTER CENTRE LTD**

72 Heath Rd Twickenham Middx TW1 4BW (01-892 7896/01-891 1612)

# POPULAR Computing WEEKLY

## The Team

### Editor

Duncan Scot

### Production consultants

Myles Hewitt  
Eric Robbie

### Editorial Secretary

Fiona McCormick

### Advertisement Manager

David Lake [01-839 2846]

### Advertisement Executive

Peter Chandler [01-839 1881]

### Software Editor

Peter Gerrard [01-839 1855]

### Publishing Director

Nick Hampshire

*Popular Computing Weekly,*

Hobhouse Court,  
19 Whitcomb Street,  
London WC2 7HF

01-839 6835 and 01-839 1855

Published by Sunshine Publications Ltd,  
Hobhouse Court, 19 Whitcomb Street,  
London WC2 7HF

Typesetting, origination and printing by  
Chesham Press, Chesham, Bucks

Distributed by S M Distribution  
London SW9. 01-274 8611. Telex: 261643

© Sunshine Publications Ltd 1982

### Subscriptions

You can have *Popular Computing Weekly* sent to your home: the subscription rate is £19.95 per year, for addresses in the UK.

### How to submit articles

Articles which are submitted for publication should not be more than 1000 words long.

All submissions should be typed and a double space should be left between each line.

Programs should, whenever possible, be computer printed.

At present we cannot guarantee to return every submitted article, so please keep a copy.

### Accuracy

*Popular Computing Weekly* cannot accept any responsibility for any errors in programs we publish, although we will always try our best to make sure programs work.

## This Week



Cover illustration by Ian Craig

<b>News</b>	<b>5</b>
New Sinclair computer launched.	
<b>Club reports</b>	<b>7</b>
Mike Todd reports on the Association of London Computer Clubs' third fair.	
<b>Hell Drivers</b>	<b>8</b>
Dave Middleton presents a car racing game for the Vic-20	
<b>Review</b>	<b>10</b>
<b>EXCLUSIVE! The first full review of the new Sinclair.</b>	
<b>Open Forum</b>	<b>12</b>
Seven pages of programs.	
<b>Sound &amp; vision</b>	<b>19</b>
Sam Blythe continues his series on Vic-20 music.	
<b>Languages</b>	<b>20</b>
David Kingsbury continues his look at assembler languages.	
<b>Programming</b>	<b>21</b>
Simulating the DEF FN function on the ZX81.	
<b>Peek &amp; poke</b>	<b>23</b>
Your questions answered.	
<b>Competitions</b>	<b>25</b>
Win a Vic-20 Super Expander.	

## Editorial

A couple of years ago the BBC had a good idea. The corporation decided that it ought to do something about the personal computer revolution.

There was to be a series of computer literacy programmes and a specially designed BBC Microcomputer to accompany them.

So what went wrong?

The BBC took too long to decide on the design and manufacture of the computer and allowed too little time for problems to be ironed out.

This meant the computers were not sent out in time for the broadcast programmes.

The BBC also seriously underestimated the demand for the computer. Their guess was 12,000 units. In fact they will probably sell well over 50,000 this year.

The whole fiasco says far more about the BBC than it does about the personal computer market, booming year after year as eager entrepreneurs seize hold of a slice of the market.

Would that British industry, broadcasting, and Government were so unfettered by caution and timidity.

## Next Week



**Want to learn your innermost secrets? Play Mind Reader and you'll discover things you never even knew you knew.**

# ZX Users' Club

## JOIN YOUR USERS' GROUP — AND MAKE THE MOST OF YOUR MICROCOMPUTER

Join the National ZX80 and ZX81 Users' Club, by subscribing to the official monthly club magazine **INTERFACE**.

- ( ) Please send me the next 12 issues of **INTERFACE**, containing many programs for each machine in each issue, plus hints, tips, software, hardware and book reviews, plus special offers for members. I understand you will be able to help me with problems regarding my computer, and let me know of any local branches of the club in my area. I enclose **£9.50** (UK), **£12.50** (Europe) or **£16.00** (elsewhere).

### Please send me the following books:

- ( ) **GETTING ACQUAINTED WITH YOUR ZX81** — by Tim Hartnell — **£5.95**. This great ZX81 book contains over 80 programs in its 128 pages. Takes you from the first steps of programming your ZX81 to quite complex programs such as **WORD PROCESSOR**, **DRAUGHTS** and **LIFE**. You'll find a host of programs to get your ZX81 up and running with worthwhile programs, right from day one. Other programs include **SPACE BOY**, **ROLLER-BALL**, **CHEMIN DE FER**, **GRAFFITI**, **MICRO-MOUSE**, **POGO**, **TOWERS OF HANOI**, **BLOCKOUT**, **SALVADOR**, **BANDIT** and **DODGE CITY**.

As well as programs, there are sections to explain the use of **PLOT**, **UNPLOT**, **PRINT AT**, **MAKING THE MOST OF 1K**, **ARRAYS**, **WRITING PROGRAMS**, **BIO-RHYTHMS**, **ARCADE GAMES**, **RANDOM NUMBERS**, **PEEK AND POKE**, **HOW TO CONVERT PROGRAMS**, **USEFUL ADDRESSES**, **SPECIFICATIONS**, **THE NEW ROM**.

- ( ) **THE GATEWAY GUIDE TO THE ZX81 AND ZX80** — by Mark Charlton — **£6.45**. Explains ZX BASIC from first principles. 180 pages, more than 70 programs. Recommended by Creative Computing.
- ( ) **MASTERING MACHINE CODE ON YOUR ZX81 OR ZX80** — by Tony Baker — **£7.50**. Warmly welcomed by the computer press, this book has continued to attract praise, because it does exactly what it claims to do in the title.
- ( ) **49 EXPLOSIVE GAMES FOR THE ZX81 (and 29 for the ZX80)** — edited by Tim Hartnell — **£5.95**. Every game you need: **DRAUGHTS**, **GALACTIC INTRUDERS**, **STAR TREK**, **DEATH MAZE**, **4-IN-A-ROW** and an 8K **ADVENTURE**-type program **SMUGGLERS BOLD**.
- ( ) **34 AMAZING GAMES FOR THE 1K ZX81** — by Alastair Gourlay — **£4.95**. All programs dumped from the printer and guaranteed to run. This book is the key to making the most of 1K.
- ( ) **GETTING ACQUAINTED WITH YOUR VIC20** — by Tim Hartnell — **£6.95**. This book is the ideal one for first-time users of the VIC 20, with over 60 programs.
- ( ) **SYMPHONY FOR A MELANCHOLY COMPUTER** and other programs for the VIC20 — **£6.95**. A great collection of 24 great games — all dumped direct from the printer — for the VIC20.
- ( ) **GETTING ACQUAINTED WITH YOUR ACORN ATOM** — by Trevor Sharples and Tim Hartnell — **£7.95**.
- ( ) **39 TESTED PROGRAMS FOR THE ACORN ATOM (the best of INTERFACE)** — **£6.45**.
- ( ) **PASCAL FOR HUMAN BEINGS** — Jeremy Ruston — **£4.95**.

**INTERFACE**,  
44-46, Earls Court Road, Department PC, London W8 6EJ.

**Atom**  
**VIC**

Please send me the indicated items. I enclose £-----.

Name -----

Address -----

-----

## Vic gives specs for two

At the recent Hanover Fair Commodore were able to announce quite detailed specifications on their new range of microcomputers, including the Ultimac (now renamed the Vic-10), and the Vic-30.

The Vic-10 has an anticipated selling price of £100 and an expected launch date of September this year. Onboard RAM is just 2K, with no Basic to play with.

It is the sound and graphics capability which will attract most attention. The text screen area is 40 x 25 (much better than the original Vic), with a high resolution mode of 320 x 200 addressable pixels.

With the new 6566 chip creating true three-dimensional graphics becomes extremely simple.

Sound is controlled by the SID chip. This allows for three voices, each with a nine octave range. A programmable filter is also inbuilt for each voice. (Mike Oldfield, eat your heat out!)

Contrary to earlier rumours, the Vic-10 can interface to other peripherals. Most advantageous will be the cassette port.

### The first program programme begins

Radio WM has started a new regular radio programme on home computing. The first of the series was broadcast on Saturday, 24 April by the BBC local radio station, which covers the whole of the West Midlands area.

The programmes, brainchild of producer Tim Manning, are broadcast between 8.45 am and 9.00 am during the *Great! It's Saturday* morning slot.

Tim Manning believes it is the first time a radio station has offered a regular programme for home computer users. He plans to start at a very simple level, giving advice about how to choose a computer.

Future plans include finding a way of introducing people to programming and, at some stage, broadcasting Basic programs over the air.

The Vic-30 is essentially a 'big brother' to the other machine, having a Vic-20 style keyboard, but retaining the 40 x 25 character display on the screen.

You have 16K of RAM onboard, and also a full Basic

operating system. There is a serial interface port, memory expansion port, and a cassette interface port all built in.

Delivery is scheduled to commence in January of 1983, and the estimated retail price will be £250.



### Dynamic duo go Dutch in Prestel competition

Marco van Gent (*left*) and Ari Schot, both 16, have every reason to look pleased with themselves.

The two young Dutchmen from Leiden, Holland have just carried away the runners-up prizes in the Prestel competition to build a tele-software adaptor for the Sinclair ZX81.

Marco and Ari arrived in London on the Saturday before the contest with only a

£70 girocheque between them — which they couldn't cash. Prestel's Tony Sweet took pity on them and put them up until the post offices opened on Monday morning.

Marco and Ari will now be co-operating with co-winners of the contest, Lion Viewdata in the production of the tele-software adaptor. Lion will develop the hardware and the Dutchmen will do the software. Eventually Lion hope to offer an adaptor for other micros as well as the ZX81.

### They'll fit a ZX81 printer to anything

Own a Vic-20 but cannot afford a printer? Now you can buy a Sinclair ZX printer, for £59.95, and link it up to your Vic.

The interface is being sold by Microtanic Software and there are versions for the BBC Atom, Microtan and Aim-65 computers.

The Printerface costs £29.95 inclusive.

The address is on page 22.

## Sinclair Spectrum stuns BBC

The ZX Spectrum has arrived. Clive Sinclair announced the release of his new computer on the opening morning of the Computer Fair at Earls Court on Friday 23 April. (Did Sinclair know that it was St George's Day?)

The basic model comes with 16K of memory, full colour and sound, and costs £125. A full report on the announcements and the world's first hands-on review of the ZX Spectrum starts on page 10.

The reaction to the news of Sinclair's new computer was immediate. There is now strong speculation that Commodore will have to reduce the price of the Vic-20 to well under £100 with corresponding reductions on the prices of the peripherals.

Acorn has also dismissed Sinclair's suggestion that the ZX Spectrum will undermine the BBC Microcomputer. Speaking privately to *Popular Computing Weekly*, Acorn director Herman Hauser said that a new computer would be launched in the third quarter of this year — sometime between July and September.

The new Acorn computer will probably be called the Electron and cost between £120 and £150. There will be a 32K ROM and 32K of RAM and in effect the machine will be a miniaturised BBC Microcomputer with higher resolution graphics than those offered by the Spectrum.

● GOTO page 10!



The PC-1500 is a new handheld computer from Sharp, and is an enhanced and extended version of the PC-1211. The new computer has an optional 4-colour graphic printer/cassette interface, and is programmed in Basic. There is only 3.5K of internal memory, but this can be increased to 7.5K with a 4K module. It costs £169.95 and the cassette/printer interface is £149.95.

## MICRO GEN QUALITY PRODUCTS

### ZX81 A/D CONVERTER BOARD

This 4-channel analogue to digital converter, originally developed for joystick control, can be used for such applications as measurement of voltage, temperature, light intensity etc.

The board fits in between the RAM pack and the ZX81. (No skill is required to make this connection, and it actually improves the stability of the RAM pack.)

Price now only £18.50

### JOYSTICKS FOR THE ZX81, only £9.50 each

- ★ The most exciting add-on ever for the ZX81, free yourself of that dead, unresponsive keyboard.
  - ★ One or two joysticks may be connected via our A/D board.
  - ★ Turns your ZX81 into a true programmable games machine.
  - ★ Extends the capability of the ZX81, imagine the tremendous variety of games and applications that now become possible.
  - ★ Details supplied on how to use the joysticks in your own programs.
- Please note that you cannot connect conventional analogue joysticks directly to the digital input ports found on most I/O boards, an A/D converter such as ours is required.

A free copy of ZX AMAZE plus any one of the games listed below when ordering a Joystick and an A/D board.

#### Programs available

**ZX SPACE INVADERS** You've tried the rest, now try the BEST.

This program has many features including an ever increasing rate of play (they'll get you in the end).

only £3.95

**ZX BREAKOUT** Quite simply the best breakout on the market.

Features seven bat angles (you won't find this one easy).

now only £3.95

**ZX NEW YORK** A very addictive game.

Bomb and shoot your way out of trouble, otherwise you are doomed to crash. Generates a different pattern, for a different game each time you play. On the reverse of the cassette is ZX REFLEX, find out how fast you really are.

now only £3.95

**ZX CHESS** The original and still the best ★ Graphic display of chessboard ★ Six levels of play ★ Displays record of your moves and the computers ★ Board can be set up to any position ★ Has ability to change sides or level in mid-games ★ PLUS ★ CHESS CLOCK on reverse side, records time taken by each player ★ Resettable function ★ Single key entry.

now only £6.50

All our games are written in machine code, and can be used with joysticks or keyboard (except chess, keyboard only). Supplied on cassette with library case.

To allow you to prove to yourself that our products are second to none, MICRO GEN offers the following terms to our customers.

### 14 DAYS FREE APPROVAL ON ALL PRODUCTS

All money will be refunded if goods are returned in good condition within 14 days of despatch.

If you write a program which is exceptional, please submit it to us. We will offer a royalty if it is suitable. Cheques and PO's payable to MICRO GEN, Dep. P.1, 24 Agar Crescent, Bracknell, Berks.

## The ultimate in Useful Sharp MZ80A / Sharp MZ80K Software by Dale Hubbard

Fed up with boring games? Make your SHARP work for you!

All program cassettes based and written cleverly in Sharp standard Basic. All programs are "menu" operated and complete with demonstration files where appropriate. 48K memory required.

All prices include VAT and post and packing. Despatch by return.

#### DATABASE

The program that everyone needs. Facilities include sort, search, list, delete, change, totals, save file, line print if required, etc. etc. Can be used in place of any card index application. £19.95

#### RUBIK SOLVER

It's not our policy to offer games but we make an exception here for a program to solve the cube from ANY position. Shorthand notation makes learning the solution by heart possible for most active brains. £12.95

#### DECISION MAKER

A serious program that enables the computer to make a sound decision for you based on various criteria. If you want to buy a car, hi-fi, house, etc., or you don't know which woman to marry then you need this one. £5.95

#### STOCK CONTROL

All the necessary for keeping a small retail inventory. Routines include stock set-up, value totals, locations, minimum stock levels and many more including financial summary and line printer routines, please state machine type. £19.95

#### ACCOUNTS

A gem of a program, all for cassette, with the following features:

- Daily Journal
- Credit Sales
- Cash Sales
- Credit Purchases
- Purchases — other
- Sales Ledger
- Purchase Ledger
- Bank Account
- Year to Date Summary

A fully interactive program suitable for all businesses. Files can be saved and loaded and totals from one file carried forward to another on cassette. Particularly useful from a cash flow point of view, with an immediate accessibility to totals for debtors and creditors. Bank totally supported with entries for cheque numbers, credits and, of course, running balance. £19.95

Access cards accepted. Send cheque or PO or credit card number to:

#### GEMINI MARKETING LTD

Quay House, Quay Road, Newton Abbot, Devon TQ12 2BU.

OR telephone us with your credit card order on Newton Abbot (0626) 62869

Despatch by return

## MEMORY DEVICES FROM: GCC ELECTRONICS

Tel: 0223 210444

Telex: 817672

EPROMS		6500 Family		MEMORIES	
2708	200p	6502	415p	2114LP-2	90p
2716+5V	195p	6520	285p	2114-450	85p
2732	385p	6522	465p	4116-150	90p
2532	365p	6532	600p	4116-200	88p
2764	1200p	6545-1	900p	4516-2+5V	250p
				4164-200	455p
6800 Family		Z80 Family		6116-150	450p
6800	270p	CPU	315p	5516-250	635p
6802	350p	ACPU	350p		
6810	110p	CTC	270p	16K Memory pack	
6809	850p	ACTC	290p	for ZX81	
6850	135p	PIO	340p	Price incl. VAT	
6821	110p	APIO	350p	3600p	

We supply 74LS, 74TTLs, Diodes, Transistors. All components are guaranteed prime parts, from leading manufacturers.

Orders from Government, Educational and Overseas buyers welcome. Special prices for volume enquiries. Please add 50p post and packing plus VAT at 15%. Minimum order £10.00.

## GCC ELECTRONICS

18 CLAYGATE ROAD, CHERRY HINTON

CAMBRIDGE CB1 4JZ

TEL: 0223 210444

TELEX: 817672

# Club Reports

Is your club involved in any special projects? Use this page to tell the world about it.

## Thousands roll up for all the fun of the fair

*Mike Todd reports on the London computer clubs' annual exhibition.*

More than 5,000 computer enthusiasts turned up at the Polytechnic of North London for the Association of London Computer Clubs' third Computer Fair.

Two years ago, computer clubs in the London area decided they wanted their own exhibition catering for their own needs. At that time, most exhibitions were oriented towards the business user.

They also felt a need to start to co-ordinate the activities of the London clubs and to assist those wishing to start clubs in their area.

To that end, they got together and formed the Association of London Computer Clubs, and the group now numbers a dozen associated clubs, all of which hold regular meetings in London and neighbouring counties.

If you live in the London area and have a club which is not part of the ALCC, or would like to form a new club, get in touch with the ALCC secretary, Len Stuart, at 89 Mayfair Ave, Worcester Park, Surrey KT4 7SJ. If you've got Prestel, you'll find information on the activities of most of the ALCC groups on page 35748.

### Inter-computer communications

With data and inter-computer communication at the forefront of today's micro development, it is appropriate that the Amateur Computer Club, or ACC — not to be confused with the ALCC — should mount a seminar during the exhibition on the computer and the telephone.

About 40 people attended, and they were taken from the concept of Information Technology, through the interfaces and modems required for practical applications. They were also treated to a demonstration of British Telecom's Prestel service.

The seminar ended with a discussion of the use of the personal computer for 'bulletin board' applications, and of computerised mailboxes which will become widespread over the next year or so. With cheap modems becoming available, most microcompu-



*A wide range of interests were catered for at the London clubs' computer fair.*

ter owners should be able to take advantage of this aspect of information technology.

The Independent Commodore Product Users' Group (ICPUG) held a seminar of a slightly different kind. In one of the rooms (a bit of a slog from the main exhibition hall) they set up several Vics showing a range of games. During the course of the day, there were two programmers' clinics and a demonstration of Superscript which has to be the lowest cost, quality word processor available.

The groups that make up the ALCC were relegated to the bowels of the Poly where they showed off their software and hardware projects, while upstairs in the main theatre, 40 exhibitors showed their wares. These included national computer groups such as the ICPUG and the ACC, among them were the Sinclair User Group showing what they had to offer.

A number of dealers displayed their wares, and reported brisk sales of a wide range of devices including disks, disk drives, RAM chips and printers. With some of the discounts being offered, it was hardly surprising that their stands were busy.

By far the greatest crowds seemed to be the large numbers of small boys sitting at Vics, Ataris and Apples and playing just about every game imagin-

able! The BBC micro which certainly attracted a great deal of attention, but the greatest 'buzz' running through the fair must have been the rumours about the new Sinclair ZX82 — the Spectrum.

### Mice at the speed of sound

The heats of the Micro-Mouse competition were held in a crowded side room. For the uninitiated, this is a competition to find the robot mouse which can find its way fastest through a maze.

This task is not as easy as you might imagine, and there were only two competitors at the fair, although one of these, Alan Dibley, had three Mice running — Thezarus, Son of Thezarus, and T3.

With a ZX80 at the heart and a selection of model aircraft motors they unfortunately failed to beat Stirling Mouse entered by Nick Smith which was fastest in both attempts at the maze with a best time of 1'46".

**Write to Club Reports, Popular Computing Weekly, Hobhouse Court, 19 Whitcomb Street, London WC2 7HF, with details of successes you have had with your club, with ideas for helping clubs along and with any news of special meetings. We look forward to hearing from you.**

# Hell Driver

Race against time and trouble  
in this high-speed action game  
by Dave Middleton

SET THE controls for the heart of the road, as you assume command of a skimmer racing around the track. You have to get round the track in as short a time as possible, but you must be careful about trying to go too fast.

Your vehicle is equipped with four gears, and the scanner display keeps you constantly informed of which gear you are in, as well as showing you the speed at which you're travelling and the number of revs you're doing.

Keep a wary eye on your speed, and don't try and move away too fast. It is possible to over-rev your machine, and your engine can only handle so much. You will be warned if you are reaching danger point, and you'll have to very quickly take appropriate action to get out of trouble in time.

The track abounds with other obstacles to get past, so travelling at the right speed at the right time is vitally important. You have to keep a constant look out to avoid crashing.

## The Game

There are six keys you must use almost all the time. For accelerating

and braking, the keys A and B respectively do the trick. Changing gear is done by using the four function keys on the right of the Vic.

An examination of the program listing with this article will reveal how these remarkably undocumented keys can actually be used within a program. Lines 410 to 480 will do the trick for you.

The program works on the standard Vic, without any memory expansion required, and makes reasonable use of the Vic's built-in sound and colour capabilities.

Apart from the keys mentioned earlier, only one is required throughout the game, and that is simply pressing S to start the game rolling.

Then, quite simply, you have to get round the track in the shortest possible time, and try and avoid all the hazards mentioned earlier.

On the first few runs through that is quite a challenge, and you'll probably turn the sound down on your television as you begin to despair of ever completing the course.

The Vic plays an especially infuriating tune if (of more usually, when!) you encounter disaster.

In reproducing the listing here, we have adopted the usual convention of replacing the various graphic symbols that appear in the listings by more readable symbols, enclosed in square brackets.

Thus, when typing in the listings you just press the appropriate key. For those of you unfamiliar with this, below is listed all the symbols that are in this particular listing.

CLR	: Clear Screen
CD	: Cursor Down
CL	: Cursor Left
CR	: Cursor Right
RVS	: Reverse On
OFF	: Reverse Off
HOME	: Cursor Home
RED	: Control and Red together
BLK	: Control and Black together
CYN	: Control and Cyan together

Where you see something like 11CD, this signifies that you need to press the cursor down key eleven times. Similarly, where you see, say, CD,3CR this means that you need to press the cursor down key once, followed by three presses of the cursor right key.



```

90 DIM H1(14),B1(14),C1(14),GS(5),BS(10),NS(14)
95 X=7680+27 CO=38400+27 G=1 R=0 S=0
100 PRINT"[CLR]"
110 FOR Z=1 TO 14 READ A/B/C: A1(Z)=A B1(Z)=B:
    C1(Z)=C
120 FOR D=1 TO A: POKE(X,58): X=X+B: POKE(CO,2): CO=CO+B:
    NEXT D
130 X=X+C: CO=CO+C: NEXT Z
140 DATA 3,1,22, 3,23,-22, 3,1,22, 3,23,-1, 4,
    22,-1, 3,-1,-22, 3,-23,22
150 DATA 2,21,1,2,21,-22,2,-1,-22,4,-23,22,3,
    -1,-22,3,-23,2,4,-21,1
160 FOR Z=1 TO 5: READ GS(Z): NEXT
170 DATA 2,4,1,9,1,5,1,2,1
180 FOR Z=0 TO 9: READ BS(Z): NEXT
190 DATA 0,6,15,20,25,30,40,59,80,98
200 FOR Z=1 TO 14: READ NS(Z): NEXT
210 DATA 70,70,70,85,70,70,35,40,60,60,70,80,
    40,200
220 POKE36878,15
230 D=10
250 POKE X,81: POKE Y,58: Y=X: X=X+B2
300 X=7680+27 CO=38400+27 Y=X: S9=TI: B=0
305 FOR S0=100 TO 0 STEP-10: POKE36874,127+S0:
    FOR S5=1 TO 150: NEXT: NEXT: GOSUB890
310 A=3: GOSUB 860
320 FOR Z=1 TO 14
330 A2=A1(Z): B2=B1(Z): C2=C1(Z): M1=MS(Z)
340 D=15: GOSUB 890
350 IF Z<14 THEN PRINT"MAX SPEED AT BEND":M1
360 FOR DL=1 TO A2
370 D=16: GOSUB 890
380 PRINT"GEAR "G" REVS: "INT(R)"[CLR] [6CR]MPH:
    "INT(S)"[CLR] "
410 GET N#
420 IF N#="" AND NN=0 GOTO 500
430 IF N#="" AND NN=1 THEN NN=0: GOTO 490
435 N=ASC(N#)
440 IF N=133 AND G=2 THEN G=1
445 IF N=134 AND (G=1 OR G=3) THEN G=2
446 IF N=135 AND (G=2 OR G=4) THEN G=3
448 IF N=136 AND G=3 THEN G=4
460 IF N#="B" THEN GOSUB 770
470 IF N#="R" THEN GOSUB 830
480 NN=1: GOTO 410
490 GOSUB 860
500 IF S<2 THEN 590
510 IF R<2000 THEN 580
520 IF R<12000 THEN 560
530 IF R<14000 THEN 610
540 OV=OV+1: IF OV>2 THEN 610
550 D=17: GOSUB 890: PRINT"[RVS]WARNING[OFF] YOU HAVE 0
    VER-REVVED" S=S-S/4
555 FOR S5=1 TO 3: FORS0=1 TO 10: POKE36876,150:
    NEXT: POKE36876,200: NEXT
556 POKE36876,0
560 NL=1: IF S<200 THEN NL=INT((200-S)/8)
570 GOSUB 750: D=18: GOSUB 890: GOTO 630
580 D=17: GOSUB 890: PRINT"[RVS]YOU HAVE STALLED"
    GOTO600
590 D=17: GOSUB 890: PRINT"[RVS]YOU HAVE BRAKED TO A ST
    OP"
600 B=0: G=1: S=0: A=3: GOSUB 860: GOTO 560
610 D=17: GOSUB 890: PRINT"[CLR,11CD,RED]YOU HAVE BLOWN
    UP[BLK]"
615 POKE36877,129: FORS0=1 TO 150: POKE36874,128+RND(1)*
    30: NEXT
616 GOTO 667
630 NEXT DL
640 X=X+C2
650 IF S<M1 OR Z=14 THEN 690
660 IF S<(M1+M1/5) THEN 670
665 D=17: GOSUB 890: PRINT"[CLR,11CD,3CR,RED]YOU HAVE C
    RASHED![BLK]"
666 POKE36877,128: FORS0=1 TO 100: POKE36876,129+RND(1)*
    120: POKE36874,129+RND(1)*120: NEXT
667 POKE36877,0: POKE36876,0: POKE36874,0: POKE36878,
    0: END
670 D=17: GOSUB 890: PRINT"[CYN]YOU HAVE SKIDDED[BLK]"
675 FOR S0=R/150 TO (R/150)-30 STEP-3: POKE36874,
    S0+128: NEXT
680 S=S-S/3
690 NEXT Z
700 TS=(TI-S9)/60: TM=INT(TS/60)
710 TS=INT(TS-(TM*60))
720 D=17: GOSUB 890
725 POKE36874,0
730 PRINT"YOUR LAP TIME WAS:-[CD]" PRINTTM"MIN"TS"SECS
740 END
750 FOR L=0 TO NL: L1=SDR(NL): NEXT
760 RETURN
770 VV=1
800 B=B+VV: A=0
810 IF B>9 THEN B=9
820 RETURN
830 A=A+1: B=0: IF A>9 THEN A=9
850 RETURN
860 S=S+(A*3,2*GS(G))-BS(B)-S/20
870 R=S*GS(G)*61
880 POKE36874,129+R/150
890 PRINT"[HOME]"
900 IF D>16 THEN D=D-1: ML=1
910 FOR D1=1 TO D: PRINT: NEXT
920 IF ML=0 GOTO 940
930 ML=0: PRINT"
940 RETURN
970 END
1000 REM INSTRUCTIONS
1010 PRINT"[CLR]",CHR#(14)
1020 PRINT"YOUR SKIMMER IS VERY
1030 PRINT"EASY TO CONTROL -
1040 PRINT"[CD]GEARS ARE SELECTED BY
1050 PRINT"PRESSING THE FUNCTION
1060 PRINT"KEYS -
1070 PRINT"[CD] F1-FIRST F3-SECOND
1080 PRINT" F5-THIRD F7-FOURTH
1090 PRINT"[CD]TO ACCELERATE PRESS A
1100 PRINT"[CD]TO BRAKE PRESS B"
1110 PRINT"[CD] PRESS S TO START"
1120 GETA# IF A#<>"S" GOTO 1120
1130 PRINT"[CLR]"CHR#(14)
1140 RETURN

```

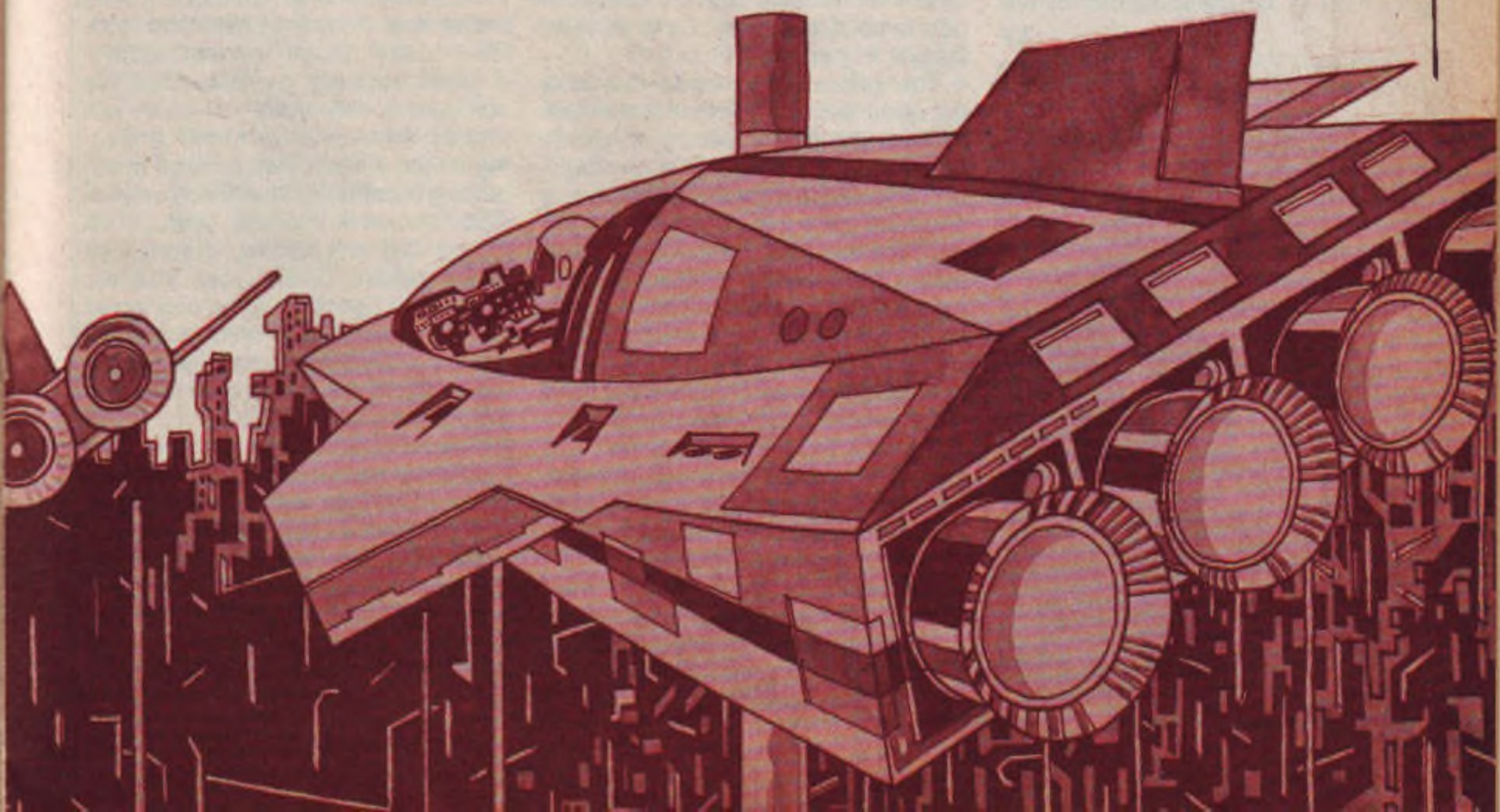

**EXCLUSIVE!**

# Review

## Sinclair strikes back at the BBC

*Nick Hampshire writes the first review of the new £125 ZX Spectrum.*



At a press conference at the Churchill Hotel on Friday, April 23, Clive Sinclair revealed to the waiting world his new microcomputer, the ZX Spectrum.

In comparing the Spectrum to another currently popular micro, the BBC micro model A, Clive Sinclair said: "It's obvious at a glance that the design of the Spectrum is more elegant. What may not be so obvious is that it also provides more power.

"The ZX Spectrum has more usable RAM, and higher maximum RAM. It offers twice as many colours on the screen at any one time, plus a colour brightness control. It also offers user definable graphics.

"It has a data transfer rate 25 per cent faster, supported by a VERIFY facility. And it employs a dialect of BASIC (Sinclair BASIC) already in use in over 400,000 computers worldwide. We believe the BBC makes the best TV programmes — and that Sinclair makes the world's best computers!"

The Spectrum comes with 16K of RAM on board the basic unit, expandable up to 48K. The keyboard is vaguely reminiscent of the early 8K PETs, but with the layout so designed that touch typing is possible: the keys have a nice responsive feel to them, rather than the original 'thump sensitive' keys. As was the case with earlier models each key has a number of functions available on it, including the now famous single key stroke entry for BASIC keywords.

The price of the basic unit is a remarkable £125. This will surely eat its way into the market being slowly established by the VIC and others, and since expansion to 48K costs only £60 more, you can start with the 16K version and end up with a 48K machine for only £185. There is a 48K version of the Spectrum available at a cost of £175: cheaper than a 3.5K VIC!

Features present on this machine that were not available on the ZX80 or ZX81 include full colour, sound and high resolution (a resolution of 256 × 192 is available to the user, at no extra cost). These three features will be examined in more detail later.

Availability of the machine is immediate. Sinclair is already geared up to producing 20,000 a month, but even this will probably not meet the anticipated huge demand. Also available



Top, shows use of PAPER command; below two 100K Microdrives, out later.

immediately is a printer, the original ZX printer that has been used for some time with the ZX81 is fully compatible.

There is a high degree of compatibility between the ZX81 and the Spectrum. Certainly users of one should have no difficulty in getting rapidly acquainted with the other. The only real problem is the 16K RAM pack for the ZX81, which should not be used under any circumstances, and software cassettes are untransferrable.

Other products announced at the conference are likely to cause an equally large upheaval in the computing industry when they emerge in the coming months. First of these was an RS232/network interface board, costing just £25, and coming out sometime in the autumn of this year. This will enable the Spectrum to be connected up to a whole host of printers, terminals and other computers. The operating systems for this are already designed into the ROM.

Clive diversified from the Spectrum briefly to announce a host of new software for the ZX81, with delivery commencing in May of this year.

Perhaps the biggest rabbit that Clive pulled out of his magician's hat was the ZX Microdrive. This is a very tiny disk drive, using two quarter-inch diskettes, with each diskette capable of holding up to 100K bytes, and a

# Review



The key spacing is just enough to allow for touch typing, although our reviewer found it hard going and some people might find the red on grey hard to read.

transfer rate of 16K bytes per second. You will be able to connect up to eight of these drives to the ZX Spectrum. Availability was announced as being 'later this year', so anticipate the first arrivals coming sometime in the late summer. The price: £50.

Ordinary cassette decks can also be used, as an alternative storage medium.

Ordinary screen resolution of  $32 \times 24$  is adequate for most business (and game!) uses, although this can be enlarged under software control to normal teletext standard.

At a total outlay of just £285 you have a 48K machine, with full colour, sound and high resolution, a disk drive giving you 100K of storage, and a printer. The RS232 interface for an extra £20 offers further possibilities.

## The hardware

The Spectrum is a smart, slimline machine in black plastic with grey keys, coloured legends and a bright flash of spectral colour across the bottom right corner. Width is 233mm, depth 144mm, and height 30mm. Inside the case is a compact printed circuit board containing a handful of discrete components and just 14 integrated circuits, the UHF modulator and a piezoelectric speaker. Of the 14 integrated circuits, eight are RAM memory chips.

The others include the 3.5MHz Z80A microprocessor, the 16K byte ROM (containing Basic and operating system software and the character generator) and lastly the special ULA chip made by Ferranti which allows all the complex colour display circuitry to be crammed into a single IC. Expansion sockets are included on the board allowing one to add an extra 32K of user memory on an internally mounted memory expansion board.

The Spectrum keyboard is a great advance on that of the ZX81. It is larger and the moving rubber keytops have a very pleasant touch and a light click feel on contact.

It is possible to make the key action more positive by giving it an audio feedback. This is done with a simple POKE — POKE 23609,255 — this produces a small beep every time a key is pressed. The keyboard has a standard typewriter layout and the keys are sufficiently widely spaced and large enough to allow touch typing, though the reviewer found this only just possible. There are 40 keys in total with both upper and lower case and a capitals lock feature. Like the ZX81 all the BASIC words are obtainable by pressing single keys, this is further enhanced by the addition of the graphics characters, the user definable by pressing single keys.

Like the ZX81 the Spectrum display

has 22 lines of 32 characters but here the similarity ends. Each pixel is memory mapped in a high resolution  $256 \times 192$  display. This uses a special 6144 byte display file located at the beginning of RAM memory, each bit of which maps directly into a pixel on the screen.

There are eight foreground and eight background colours, the data on which pair is chosen for a particular character cell being stored in the colour attribute RAM area. The colour file memory area is 769 bytes long and lies directly above the display file. To use the high resolution there are four new commands in Basic, they are:

PLOT  $x,y$  — plots a pixel at co-ordinates  $x,y$  on the  $256 \times 192$  point display area. A point can be removed by PLOT OVER (the same as UNPLOT on the ZX81).

DRAW  $x,y$  — draws a line from the last high-res point plotted using DRAW, PLOT or CIRCLE to the co-ordinates  $x,y$  on the screen. There is also a special form of DRAW which instead of drawing straight lines will draw curved lines and arcs. This has the syntax DRAW  $x,y,a$ . If  $a$  is positive the line curves left and if negative right;  $a$  is in radians so if  $a = \pi$  then a circle is drawn but if  $a = \pi/2$  then only a quarter circle is drawn.

CIRCLE  $x,y,a$  — draws a circle of radius  $a$  with centre at co-ordinates  $x,y$ .

Then there is the function POINT  $x,y$  which returns the pixel status at the specified co-ordinates.

These commands seem to be well thought out, easy to use and quite fast. The quality of the generated display is comparable the best currently available.

The circle command is excellent and produces a true circle properly adjusted for screen elongation — this is more than most other manufacturers can do. The draw command while very fast and obviously using a good algorithm is a bit difficult to use since the parameters are offsets of the previously plotted point rather than true screen co-ordinates.

This is definitely a colour machine and the quality of the colour display is excellent. There are eight colours, they are: black — blue — red —

*continued on page 18*

# Open Forum

OPEN FORUM is for you to publish your programs and ideas. It is important that you make sure your programs are bug-free before you send them in. We cannot test all of them.

As far as possible always send us a computer printed listing, made immediately after you have run the program.

Each program should include a description of what the program does, how to use it and how the program has been written.

Your contributions should be sent to Open Forum, *Popular Computing Weekly*, Hobhouse Court, 19 Whitcomb Street, London WC2H 7HF with a stamped addressed envelope.

We will pay £10 for each contribution published.

## 3-D Graphics

The following program will print high resolution graphics on your printer. By experimenting with line 120, you will be able to print a number of shapes based on the 'oval viewed from an angle'.

Enter line 1 as described; only enter spaces where space is written:

```
1 REM U INVERSE COLON RND.U INVERSE ? RND
INVERSE N "SPACE". TAN.
```

Before loading the program enter as a DIRECT command,

```
POKE 16389,124/NEW/
```

where / equals new line.

Line 2 tests to see if you have remembered to reserve some space in memory by doing this.

Because the program is calculating the position of up to 65000 odd loca-

## ZX81

tions it will take a long time — as much as 15 to 30 minutes depending on the formula. The best time to run this is when you're getting ready for bed, or about to have a meal, but it is fun!

## Ikebukuro

## Vic

You are in control of a little man running along the bottom of the screen, who is dodging a rain of arrows coming down from above. These get faster as the game progresses.

To protect you there are three bases, which diminish as the arrows wear them down. These can be replenished by getting to the right of the screen, picking up a bag of money and getting back alive: you gain points for each money bag you successfully

## 3-D Graphics by Barry Cornhill

```
2 IF PEEK 16389*256+PEEK 16389=31744 THEN GOTO 5
3 PRINT "MEMORY NOT RESERVED"
4 STOP
5 FOR I=0 TO 112
6 POKE 31744+I,PEEK (2161+I)
7 NEXT I
8 POKE 31100,63
9 POKE 31657,201
10 POKE 16517,35
11 POKE 16524,79
12 GIM RA(32,256)
13 FAST
14 LPRINT "3-D PLOTTING"
15 LET X1=120
16 LET X2=X1+2
17 LET Y1=120
18 LET Y2=32
19 FOR V=0 TO 127
20 LET W=X1+2
21 LET R=Y1
22 LET A=30R*(X2-X1)
23 FOR I=R TO A STEP 10
24 LET R=30R*(X4+1+1)/21
25 LET F=COS (10*R)*(1-R)*2
26 LET Y=1.5+R*Y2
27 IF Y<0 THEN GOTO 100
28 LET W=Y
29 LET Y=Y1+Y
30 LET X=X1+X
31 GOSUB 3900
32 LET W=X1+X
33 GOSUB 3900
34 NEXT I
35 GOTO 3900
36 IF X<0 OR X>256 OR Y<0 OR Y>255 THEN RETURN
37 LET C=1+INT (W/3)
38 LET R=256-INT Y
39 POKE 16526,CHR$(C,R)
40 POKE 16527,2+18*C-INT (W-1)
41 LET R$(C,R)=CHR$(USR 16514)
42 RETURN
43 FOR I=0 TO 246 STEP 6
44 FOR J=1 TO 32
45 FOR K=1 TO 3
46 POKE 32255+K+2*(J-1),CODE R$(J,K+1)
47 NEXT K
48 NEXT J
49 FOR H=0 TO 31
50 POKE 16444+H,H
51 NEXT H
52 LET HPRINT=USR 31744
53 NEXT I
```

## Magic Squares by David Lawrence

```
1 GOTO 4
2 SAVE "SQUARE"
3 STOP
4 LET X=CODE " "
5 LET Y=CODE " "
6 FOR I=X TO CODE "X"
7 LET H$(I)=0*(I)
8 NEXT I
9 LET A=CODE "2"
10 PRINT "NUMBER?"
11 INPUT D
12 LET B=D-A
13 FOR I=X TO CODE "X"*(B-Y)
14 LET H=VAL H$(I)+INT (B/Y)
15 LET H$(I)=STR# H
16 NEXT I
17 FOR I=X TO Y*(B-Y)+INT (B,Y)
18 LET H=VAL H$(I)+K
19 LET H$(I)=STR# H
20 NEXT I
21 CLS
22 FOR I=X TO CODE " "
23 FOR J=X TO Y
24 PRINT AT I+CODE " ",J+H$(I+Y+J)
25 NEXT J
26 NEXT I
27 24 17 22
28 25 22 18
29 20 21 26
30 19 30 29 22
31 FOR I=1 TO 16
32 INPUT H
33 LET H$(I)=STR$(H)
34 NEXT I
```

Graphics 1  
Graphics 4

Graphics 7  
Graphics 7

Displays magic  
square 400  
total 100

Testimony  
Input  
Output



# Open Forum

## Read and Data

ZX81

The lack of READ, DATA and RESTORE commands on the ZX81 can be very annoying, so machine code program mimics them.

Data can be string or numerical, and should be placed in REM statements, each line commencing in a comma, and with each item of data being separated by a comma. For example,

```
100 DATA 4,22,HARRY
```

would be replaced by

```
100 REM ,4,22,HARRY
```

There may be as many items of data in each line as you like, and lines of data can appear anywhere. Ordinary REM statements can be used, if the first character is not a comma.

Data can be read using the machine code routine starting at 16514, which reads the next article of data and puts it into A\$, and returns the length of the data. Line 4 in the program makes the variable READ equal to 16514, so USR READ can be used instead of USR 16514.

Here are some examples of READ statements.

```
50 READ D$
```

would be replaced by

```
LET D$=A$(TO USR READ)
```

and

```
70 READ N
```

would be replaced by

```
70 LET N=VAL A$(TO USR READ)
```

The machine code routine starting at 16601 can be used to set the data pointer to any part in the program. The line number to which the data pointer is set is contained in a RAND statement. For example,

```
130 RESTORE
```

would be replaced by

```
130 RAND I  
131 RAND USR RESTORE
```

and

```
170 RESTORE 200
```

would be replaced by

```
170 RAND 200  
171 RAND USR RESTORE
```

To enter the program, type the program as shown, and RUN it from line 10. Type in each number in the object code table. When you have finished, lines 10 to 40 may then be deleted, and the program can be saved on tape.

The number of characters to which A\$ is dimensioned in line 2 is the longest any item of data may be. You

```
1 REM 126 "X"/S  
2 DIM A$(50)  
3 LET RESTORE=16601  
4 LET READ=16514  
5 RAND I  
6 RAND USR RESTORE  
10 FOR I=16514 TO 16639  
20 INPUT N/  
30 POKE I,N  
40 NEXT I
```

Read and Data  
by Simon Lowe

may alter this if necessary. Do not alter line 1, or lines 3 to 6.

The program uses memory locations 16507 and 16508 to hold the data pointer. Any accompanying Basic program must not use the variable A\$, except for in READ statements. The machine code subroutines are in the REM statement in line 1.

### Object code table

42	123	64	126	254	26	40	39
35	62	117	60	190	40	66	35
35	35	35	126	43	43	254	234
40	7	94	35	86	35	25	24
232	35	35	35	126	43	43	43
254	26	32	238	35	35	35	237
91	16	64	19	19	19	19	19
19	1	0	0	35	62	26	190
40	11	198	92	190	40	6	126
18	19	3	24	239	34	123	64
201	43	1	255	255	24	246	33
1	0	237	91	50	64	34	50
64	33	124	64	35	126	35	70
186	40	9	48	11	35	78	35
70	9	24	240	120	187	56	245
43	43	34	123	64	201		

### Scrabble scorer

ZX81

The program is divided into four sections — picking the first player, setting up the display, keeping the score, and displaying a record.

Following the initialisation in lines 10 to 160, which will be explained later, the program asks for the names of the players. There may of course be two, three or four players, and counter P is used to record the number.

The maximum name that can be accommodated is eight letters, so Henrietta will have to accept an abbreviation. Array T is set up to hold the players' cumulative scores, while S holds the individual scores.

The program provides the option of

selecting the first player by the traditional method of turning up letters, or letting the computer choose. In the latter case, a pointer moves round the list of names, gradually slowing down until it comes to rest.

In order to get this name to the top of the list, the names of the players are copied across into array Q\$, starting with the first player.

The next stage, starting at line 800, displays the players' names as they are seated round the table, with the first player's name at the top.

We come not to the actual scoring. The program always indentifies the next player. The score may be input in a variety of ways. The most straightforward is of course a single figure, such as 24, but an expression such as 12\*2 would be equally acceptance.

There is no need to tot up the score, however, because the values of the individual letters are held in array W which was set up by lines 120 to 160. If a word is input, the appropriate score will be added.

Double and treble word scores are provided for by lines 1370 and 1430, which will multiply a word score by 2 or 3 if that figure is typed immediately after the word. Lines 1281 to 1289, which may be omitted, provide a timer.

Array X, set up by lines 30 to 110, contains the co-ordinates defining the positions at which the scores will be printed, which again allow for two players sitting 'north' and 'south'.

Note the spaces at the ends of lines 1520 and 1530. A nasty pitfall in ZX81 Basic is that if a short number is printed in the position previously occupied by a longer one, the final digits of the longer number are not cleared. For instance, if a score of 107 were entered, and then corrected by typing '-12', the result without the spaces would be not 95 but 957.

Finally, one of the players may want to check on the score in an earlier round. This is provided for by line 1300. If a score of 999 is input, this will cause a jump to line 4000, which prints out array S in the format of Figure 5. This would normally be used at the end of the game, so it is terminated by a STOP. Should you wish to continue, you would need to make a note of the players' cumulative scores and enter them again after restarting with RUN.

# Open Forum

```
1 REM SCRABBLE SCORER
2 REM COPYRIGHT T GOLDINGHAM 1982
10 FAST
20 DIM P$(4,9)
21 REM P$=NAMES OF PLAYERS
30 DIM X(4,2)
31 REM X=LOCATIONS TO PRINT TO TALS
40 LET X(1,1)=2
50 LET X(1,2)=15
60 LET X(2,1)=10
70 LET X(2,2)=24
80 LET X(3,1)=17
90 LET X(3,2)=15
100 LET X(4,1)=10
110 LET X(4,2)=4
120 DIM W(26)
121 REM W,Y$=VALUES OF LETTERS
130 LET Y$="1332142418513113A11114484A"
140 FOR J=1 TO 26
150 LET W(J)=CODE Y$(J)-28
160 NEXT J
170 SLOW
200 CLS
210 PRINT "WHOS PLAYING?"
220 FOR P=1 TO 4
221 REM P=NO. OF PLAYERS
230 INPUT Z$
240 IF Z$="" THEN GOTO 310
250 IF LEN Z$<9 THEN GOTO 280
260 PRINT AT 15,0;"NAME MUST NOT EXCEED 8 LETTERS"
270 GOTO 230
280 LET P$(P)=Z$
290 PRINT AT 5+2*P,5,P;". ";Z$
300 NEXT P
310 LET P=P-1
320 IF P<2 THEN GOTO 200
330 DIM T(P)
331 REM T=SUMULATIVE SCORES
340 DIM S(50,P)
341 REM S=INDIVIDUAL SCORES
350 PRINT AT 18,0;"TYPE NUMBER OF FIRST PLAYER,
OR ""R"" TO SELECT AT RANDOM"
360 INPUT Z$
370 IF Z$="R" THEN GOTO 430
375 IF Z$<>"R" AND (CODE Z$>37 OR CODE Z$<29) THEN GOTO 250
380 LET N=VAL Z$
381 REM N=NO. OF 1ST PLAYER
390 IF N>P THEN GOTO 250
400 CLS
410 PRINT AT 10,4;"FIRST TO PLAY IS ";P$(N)
420 GOTO 560
430 PRINT AT 0,0;"FIRST TO PLAY IS"
440 PRINT AT 18,0;"
450 LET I=1
460 LET N=INT (RND*P)+1
470 FOR J=1 TO 3
480 FOR K=1 TO P
490 PRINT AT 5+2*K,4;">"
500 IF I=2*P+N THEN GOTO 560
510 PAUSE 3*I
520 PRINT AT 5+2*K,4;" "
530 LET I=I+1
540 NEXT K
550 NEXT J
560 PAUSE 200
570 CLS
600 DIM Q$(P,9)
610 REM Q$=NAMES OF PLAYERS, 1ST PLAYER 1ST
620 LET C=1
621 REM C=COUNT OF ELEMENTS OF Q$
630 FOR K=N TO P
640 LET Q$(C)=P$(K)
650 LET C=C+1
660 NEXT K
```

## Scrabble Scorer by Tim Goldingham

```
670 FOR K=1 TO P-C+1
680 LET Q$(C)=P$(K)
690 LET C=C+1
700 NEXT K
800 FOR J=0 TO 25
810 PLOT 19+J,11
820 PLOT 19+J,36
830 PLOT 19,11,+J
840 PLOT 44,11+J
850 NEXT J
860 FOR J=4 TO 15
870 PRINT AT J,10;" "
871 REM (12 * GRAPHICS SHIFT/H)
880 NEXT J
900 PRINT AT 4,12;Q$(1,1);
910 FOR J=2 TO 9
920 IF Q$(1,J)= THEN GOTO 950
930 PRINT Q$(1,J);
940 NEXT J
950 IF P=2 THEN PRINT AT 15,12;Q$(2,1);
960 FOR J=1 TO 9
970 IF P=2 THEN FOR J=2 TO 9
980 IF 1$(2,J)=" " THEN GOTO 1020
990 IF P>2 THEN PRINT AT 6+J,23;Q$(2,J)
1000 IF P=2 THEN PRINT Q$(2,J);
1010 NEXT J
1020 IF P=2 THEN GOTO 1200
1030 PRINT AT 15,12;Q$(3,1);
1040 FOR J=2 TO 9
1050 IF Q$(3,J)=" " THEN GOTO 1080
1060 PRINT Q$(3,J);
1070 NEXT J
1080 IF P=3 THEN GOTO 1200
1090 FOR J=1 TO 9
1100 IF Q$(4,J)=" " THEN GOTO 1200
1100 PRINT AT 6,J,10;Q$(4,J)
1120 NEXT J
1200 LET A=1
1201 REM R=ROUND NO.
1210 FOR N=1 TO P
1220 LET D=1
1220 TEM C=COUNT OF PLAYERS
1230 PRINT AT 20,0;
1240 IF Q$(N,D)=" " THEN GOTO 1280
1250 PRINT Q$(N,D);
1260 LET D=D+1
1270 GOTO 1240
1280>PRINT "S SCORE? "
1281 REM RIMER (OPTIONAL):
1282 PRINT AT 20,24;" "
1283 LET T=10
1284 PAUSE 476
1285 IF INKEY$<>" " THEN GOTO 1290
1286 PRINT AT 20,24,J;" SECS"§
1287 LET T=T+10
1288 GOTO 1284
1289 REM END OF TIMER
1290 INPUT Z$
1300 IF Z$="999" THEN GOTO 4000
1305 IF Z$="" THEN GOTO 1290
1310 IF CODE Z$>37 THEN GOTO 1340
1320 LET Z=VAL Z$
1330 GOTO 1500
1340 LET SUM=0
1341 REM SUM=VALUE OF WORD
1350 FOR J=1 TO LEN Z$
1360 LET X=CODE Z$(J)
1370 IF X=30 OR X=31 THEN GOTO 1430
1375 IF X>31 AND X<38 THEN GOTO 1290
1380 IF X>31 AND X<38 THEN GOTO 1290
1390 LET SUM=SUM+U(X-37)
1400 NEXT J
1410 LET Z=SUM
1420 GOTO 1500
```

# Open Forum

**Morra**

**ZX81**

This absurd little game from America consists of two players each sticking one, two or three fingers out while at the same time guessing how many fingers their opponents will extend.

Guess right and your score is increased by the number of fingers on show from both players; guess wrong and you get nothing. The idea is to make a fool of yourself 12 times in this fashion and then declare a winner.

The accompanying program plays a mean game of Morra on a 1K ZX81, being based on a mathematical analysis of the game, no less. On each turn the computer invites you to guess how many bytes it will display (it could hardly be fingers, could it) and enter how many fingers you will show. Then — and it doesn't cheat — the computer declares its guess and the number of bytes.

That's about all there is to it, except to remind you that it is definitely cheating to analyse the ZX81's tactics when you are feeding in the program. As if you would.

Here are some program notes:

**Line 100.** CODE " " looks a great deal more wasteful than simply 0, which is all it represents. That is an illusion based on the fact that we are looking at a display of the program rather than at the program itself. In the real program, CODE takes only one byte and the whole term takes 4 bytes whereas 0 takes 7 bytes altogether. Literal numbers are inordinately expensive in 1K of memory — this program contains no literal numbers whatsoever and would not run if you changed all the CODE values to literal numbers, since there would be too little memory.

**Line 120.** This string and the subsequent loop set the frequency of the different moves and then shuffle the order of the moves.

**Line 130.** Graphics symbol is key '1' in graphics mode.

**Line 190.** Graphics '1'. This main loop requests moves and responds 12 times.

**Line 260.** Graphics '4'.

**Line 280.** Graphics '4'.

**Line 340.** Graphics 'S'. Note how logical conditions are attached to the print statements to provide three alternative outputs from one line.

**Morra**

*by David Lawrence*

```

100 LET C=CODE " "
110 LET H=C
120 LET A#="111112222333"
130 FOR I=CODE " " TO LEN A#
140 LET R=INT (RND*LEN A#+CODE " ")
150 LET T#=A#(I)
160 LET A#(I)=A#(R)
170 LET A#(R)=T#
180 NEXT I
190 FOR I=CODE " " TO CODE "#"
200 CLS
210 PRINT "YOUR GUESS ";
220 INPUT G
230 PRINT G, "NO. OF FINGERS:";
240 INPUT F
250 PRINT F, "*****"
260 PRINT "MY GUESS ", CODE " "-VAL A#(I), "NO. OF BYTES ";
    VAL A#(I)
270 IF G=VAL A#(I) THEN LET H=H+F+VAL A#(I)
280 IF CODE " "-VAL A#(I)=F THEN LET C=C+F+VAL A#(I)
290 PRINT "*****"
300 PRINT "MOVE="; I, "COMPUTER:"; C, "HUMAN:"; H
310 PRINT AT CODE "+", C; C; "NEWLINE"
320 INPUT O#
330 NEXT I
340 PRINT AT CODE " ", CODE "#", "I " AND C; "YOU " AND
    H; C; "NO-ONE " AND H=C; "WON"

```

**Twenty-one**

**BBC**

In this program, you and the BBC Microcomputer take it in turns to throw a six-sided die as many times as you like, trying to get a total of 21, or close to 21, without exceeding 21 ('busting').

This is a dice version of Blackjack, and the computer plays very well. You go first in every game, entering 1 to roll the die again, or 2 to stand, that is, to stay with the total of 21.

There are five rounds to a game and the winner, of course, is the player who wins the most out of the five rounds.

Line 20 sets the mode, and line 30 sends action to a procedure called 'initialise'. This short procedure (lines 70 to 100) sets the two variables which hold the scores — SI and SM — to zero.

From there, line 40 sends the computer's attention to the procedure called 'game\_\_count'. Note that procedure names can be more than one word in length, so long as the underline rule joins the words. The 'game\_\_count' procedure (lines 110 to 150) set up a loop which calls the procedure 'game' five times.

You can see from lines 120 and 140 that the BBC Microcomputer supports loop names which are whole words. In this case the word, as you can see, is 'count'. The procedure, 'game', which is called from within the procedure

'game\_\_count', runs from lines 160 to 330.

Line 190 is a delay loop, setting the variable T to the value held by the computer's internal clock, and then passing through a REPEAT/UNTIL loop until one second (TIME increments by one every fiftieth of a second) has passed.

Line 220 waits for the player's input, and line 230 rolls the die, and adds its value to the score (line 200) if the player has decided to keep rolling.

If not, the computer checks (line 240) to see if the player has exceeded 21 (and, if so, goes to the 'end\_\_of\_\_game' procedure). If the player has not busted, the computer acknowledges the total the human has decided to stick with (line 250) and proceeds to roll the die itself.

A three-second delay (line 280) comes before the computer announces the value it has rolled, and its total. Lines 300 to 320 check the computer's score, and compares it with the player's score, and decides whether or not to roll again.

The 'end\_\_of\_\_game' procedure (lines 340 to 380) looks at the two final totals, and decides which player has won. After five rounds have been played (counted, you'll recall, by the loop in the 'game\_\_count' procedure), action goes to the 'finale' procedure (lines 390 to 470) to find the winner of the five games.

# Open Forum

Twenty-one  
by Tim Hartnell

```
10 REM TWENTY ONE
20 MODE 7
30 PROCinitialise
40 PROCgame_count
50 PROCfinale
60 END
70 DEF PROCinitialise
80 SI=0
90 SM=0
100 ENDPROC
110 DEF PROCgame_count
120 FOR count=1 TO 5
130   PROCgame
140   NEXT count
150 ENDPROC
160 DEF PROCgame
170 E=0:F=0
180 PROCupdate
190 T=TIME:REPEAT UNTIL TIME-T>S0
200   IF E>0 PRINTCHR$(129);"TOTAL ";E
210   IF E=0 PRINTCHR$(131);"1 TO ROLL, 2 TO STAND""
220   A=GET
230   IFA=49 E=E+RND(6): GOTO190
240   IF E>21 PRINT CHR$(129);"YOU'VE BUSTED!!": PROCend_of_game:ENDPROC
250   PRINT'CHR$(133);"OK, YOU STAND ON ";E''
260   G=RND(6)
270   F=F+G
280   T=TIME:REPEAT UNTIL TIME-T>150
290   PRINT CHR$(128+G);"I rolled a ";G;", so my total is ";F
300   IF F=E PROCend_of_game:ENDPROC
310   IF F>18 OR F>E PROCend_of_game:ENDPROC
320   IF F<17 OR F<E AND E<22 THEN 260
330 ENDPROC
340 DEF PROCend_of_game
350 IF E=F AND E<22 PRINT'CHR$(129);"DEAD HEAT":SI=SI+1:SM=SM+1
360 IF E<>F AND (F>E AND F<22) OR E>21 PRINT'CHR$(129);"I WIN":SI=SI+1
370 IF E<>F AND F>21 OR(E>F AND E<22) PRINT'CHR$(133);"YOU WIN":SM=SM+1
380 ENDPROC
390 DEF PROCfinale
400 PRINT'CHR$(130);"FINAL SCORES:"
410 PRINT'CHR$(129);"YOU: ";SM,"ME: ";SI''
420 T=TIME:REPEAT UNTIL TIME-T>150
430 IF SI>SM PRINT"I ";
440 IF SM>SI PRINT"YOU ";
450 IFSI=SM PRINT"WE BOTH ";
460 PRINT CHR$(129);"WIN!"
470 ENDPROC
480 DEF PROCupdate
490 PRINT CHR$(132);"XXXXXXXXXXXXXXXXXXXXXXXXXXXXXXXXXXXXXXXXXXXXXXXXXXXX"
500 T=TIME:REPEAT UNTIL TIME-T>150
510 PRINT'CHR$(130);"ROUND ";count
520 PRINT'CHR$(134);"YOU ";SM,"ME ";SI''
530 ENDPROC
```

# Review

continued from page 11

purple — green — blue — yellow — white.

Any character location can have two colours, a foreground colour — this is the colour of the dots which make up a character — and a background colour. In Spectrum Basic the foreground colour is known as INK and the background as PAPER, the colour of either being specified by following the INK or PAPER command with a number from 1 to 8 which specifies the colour, or attributes as they are referred to in the manual.

The command BORDER will set the colour of the border around the screen display area. The command INVERSE can be used to display characters in reverse field — foreground colour becomes background colour and vice versa. OVER is an interesting command since it allows a character to be printed over the existing contents of that character square without obliterating it.

The brightness of the display in a particular character space may be changed by either the commands FLASH or BRIGHT. FLASH as its name implies causes the specified characters to flash between a very bright screen and a normal screen. BRIGHT enhances the specified characters by making them brighter than normal. There is also a colour function ATTR (line, column) which return the colours, both foreground and background of the specified character.

The Spectrum incorporates an in-built loudspeaker which can produce a sound with a frequency range of over 10 octaves. The sound can also be output to an amplifier via a jack socket at the rear. To generate a sound there is a special command in Basic called BEEP.

The BEEP command is followed by two variables. The first determines the frequency of the note and the second the duration. The quality of the produced sound is not marvellous but quite adequate for adding nice sound effects to games programs.

The Spectrum is broadly software compatible with the ZX81. ZX81 Basic is a subset of Spectrum Basic except for the following features. The FAST/SLOW commands have been abolished. The SCROLL command is



unnecessary since Spectrum automatically scrolls. UNPLOT has been replaced by PLOTOVER. The character codes used are the standard Ascii characters rather than the special ZX81 codes.

The memory map of the Spectrum is quite different to that of the ZX81 and the following are some of the salient features:

0	— 16383	ROM operating system and kernal
16384	— 32767	internal 16K of RAM
32768	— 65535	expansion RAM area
16384	— 22528	Display file 6144 bytes
22529	— 23296	colour attribute file
23297	— 23552	printer buffer
23553	— 23734	system variables
23735	—	microdrive maps, channel information etc then Basic program storage area

The cassette interface has been entirely changed from the ZX81 and tapes recorded on the ZX81 will not load on the Spectrum. The reason is that the tape data transfer rate has

been increased very considerably — up to 1500 baud. Verification and error trapping techniques have also been improved.

The RS232 network interface board will be very useful since besides allowing the user to construct local area networks with Spectrum computers and peripherals it will also enable the Spectrum to be connected to any of the myriad different computers and peripherals with RS232 interfaces. The potential here is enormous: large-scale networks via cheap modems; Spectrums as low-cost terminals to larger microcomputers or even mainframes.

The Microdrive disk drive is a sensation — the Japanese have been talking about it but Sinclair has done it. Capable of storing 100K on a 2.25 inch disk with a data transfer rate of 16K bytes per second — the average access time is less than 3.5 seconds, and all for a price tag of about £50. It will be available in the early autumn when we will give you a full review. The Basic commands required for the disk drive are included on the Spectrum so there is no need to upgrade your machine. The commands are: OPEN and CLOSE, MOVE, ERASE, CAT and FORMAT.

The documentation for the Spectrum is good and perfectly adequate for the average user. Sinclair has learnt a lot from the ZX81 manual which has been applied to the manuals. There are two for the Spectrum. There is a simple small 30-page introductory manual and a large 220-page main programmer's reference manual.

## Conclusion

This new computer from Sinclair clearly represents excellent value for money and will, no doubt, prove a great success.

The basic 16K version of the Spectrum costs £125. There is a 48K version at £175. Availability is immediate and Sinclair is geared up to produce 20,000 per month.

Sinclair also announced that later this year he would release a 100K ZX Microdrive using 2¼ inch disc, costing £50. Up to eight of these can be attached to the Spectrum. The Microdrive will be reviewed when it becomes available.

The RS232 interface costs £20.

# Sound & vision

## It's time to tune up your Vic to concert pitch

Last week I programmed the Commodore Vic-20 computer to play 'user friendly tunes'. This week I will make the tunes a little more user-friendly.

I don't really like the phrase 'user-friendly', but what I will do is make the program a little easier to use, especially if your main interest is in making music using established musical principles.

Before I describe how the program has been updated, I ought to warn the musical purist about the music creation facilities on the Vic-20.

Anyone who has an ear for music might notice that the notes generated by the Vic are not exactly pure; or, more to the point, are only approximations.

The nearer you reach the upper limits of the Vic's musical range, the more approximate these notes become. However, there is no need to be too pedantic.

The reason for this 'loss-of-tune' — if that is the right phrase — is that the Poke numbers given by Commodore for the Vic synthesiser are universal. The same Pokes that give the note of C in, say Japan, are also used to invoke C in the islands off the coast of Scotland. This would be fine, if all the Vics used the same clock speeds. Unfortunately because the world's power supplies are not all the same, the clocking speed of the world's Vics are not all the same.

### Getting the drift of a melody

That is why melodies played on the Vic often appear to drift in and out of tune. But we should be happy to live with these imperfections; after all, it is such imperfections that make most musical instruments sound so individual. Soon clever people will be standing in bars, listening to the juke boxes and saying 'Hey, listen to that funky Vic bass line!'

Last week's music program was fine — that is it worked OK, and it also produced some fairly interesting music. Would you believe I even managed to play some Bach on my Vic? It made a welcome change from all that Dépeche Mode stuff which is beginning to drive the neighbours up the wall.

There is however one minor problem with the program described last week — to enter notes you first have to look that note up in a table. I thought it would be a damn sight better to simply enter the

```
50 REM MUSIC LEVEL 2
60 PRINT"[CLR] INPUT NOTES AS LETTERS , TOPOCTAVE NOTES
  PRECEDED BY ↑"
100 REM
200 REM INITIALIZE
300 REM
400 V1=36874 : V2=36875 : V3=36876 : V4=36877 :
  V5=36878
500 REM SET VOLUME
600 POKE V5,7
700 REM
800 REM INPUT NOTES
900 REM KEY OF C
1000 REM
1100 DIM A(14),B$(14),S$(3)
1200 FOR I = 1 TO 14 :READ A(I) : READ B$(I):
  NEXT I
1300 DATA 195,C,201,D,207,E,209,F,215,G,219,A,
  223,B,225,↑C,228,↑D,231,↑E,232,↑F,236,↑G
1350 DATA 237,↑A,239,↑B
1400 REM
1500 REM INPUT USER DEFINED TUNE IN LETTER FORM
1600 REM
1700 PRINT:PRINT" HOW MANY NOTES " : INPUT N
1800 DIM NN(N,3)
1900 PRINT"[CLR,RVS] ENTER TUNE[OFF]":PRINT" VOICE1,
  VOICE2,VOICE3,[RVS]RETURN[OFF]"
2000 FOR I=1 TO N :FOR T=1TO3:INPUT S$(T): NEXT T
2100 FOR T=1 TO 3 : FOR J= 1 TO 14 :IF S$(T)=B$(J)
  THEN NN(I,T)=A(J)
2200 NEXT J:NEXT T
2300 PRINT"[CD]"
2900 NEXT I
3200 REM
3300 REM NOW PLAY TUNE
3400 REM
3500 FOR I=1 TO N
3600 POKE V1,NN(I,1):POKE V2,NN(I,2):POKE V3,
  NN(I,3)
3700 FOR J=1 TO 100 : NEXT J
3800 POKE V1,0:POKE V2,0 : POKE V3,0
3900 NEXT I
4000 PRINT "PLAY TUNE AGAIN":INPUT W$: IF W$="Y" THEN
  GOTO 3500
```

name of the required note straight away, and let the computer do the converting. After all that's what it's supposed to be good at.

Two problems arise in making the program easier to use — neither of them insurmountable. First, to use more than one octave — look the word up if you don't understand — there must be some way of telling the computer which octave is in use. I chose to precede a letter by the ↑ (up arrow) symbol to indicate the higher octave. Second, there is a little problem with the inputting routine.

In this week's program the line num-

bers have been changed a bit; I'm sorry about that, but it shouldn't be too confusing. One change that might catch you out is in lines 1100 and 1200 — note that DIM sizes and FOR values are now 14, rather than 15. The DATA statement in line 1350 is new, and line 1300 has been extended to list the names of the notes. Other changes are in the inputting routines, which are now more complicated, and the output routine which is now simpler. All these extra changes have been made at a cost of about eight notes off the maximum length of tune possible.

Sam Blythe

# Languages

## Up-to-date information is the key to control

David Kingsbury explains the importance of the process status register

The 6502 has a primitive set of jump instructions when compared to the Z80 microprocessor.

One important thing that you must understand in any microprocessor that you wish to program in assembly language is the processor status register (PSR). The PSR gives you information about the instruction that you executed most recently.

The 6502 PSR has seven bits that you can get at to control the microprocessor. Five of these bits reflect the outcome of the last operation and two (the Interrupt and Decimal flags) are used to force the 6502 to behave in a particular way.

The diagram shows the PSR. The example program using the BEQ instruction looked at the Zero bit of the PSR and altered the course of the program according to whether or not there was a 1 or a 0 in bit 1.

Now suppose you are writing a word processing program in which you need to increment (add one) or decrement (subtract one) from a counter that keeps track of how many letters you have typed. You will need to use a two byte counter because that can count up to 65535 where a single byte (8 bit) counter can only count up to 255.

You may need more than one counter in the program; for example, to keep track of the cursor when you are editing a document, to record the current end of text position.

If you place the counter bytes next to each other in Zero page memory then you need only one subroutine to increment any counter. Here it is.

REFERENCE = 60 (Memory location in Page Zero RAM)

	TXEND	TCURS	PCR	ECHO
LOW BYTE	60	62	64	66
HIGH BYTE	61	63	65	67

```

PHP
TXA
PHA
INC REFERENCE, X
BNE JIM
INX
INC REFERENCE, X
JIM
PLA
TAX
    
```



And to decrement one of the counters you could use this subroutine:

```

RTS
PHP
PHA
TXA
PHA
SEC
LDA REFERENCE, X
SBC #1
STA REFERENCE, X
BCS JAN
INX
    
```

```

JAN
DEC REFERENCE, X
PLA
TAX
PLA
PLP
RTS
    
```

If you load Register X with zero it will increment or decrement the counter labelled TXEND while if you load X with four before entering the subroutines PCR will be affected.

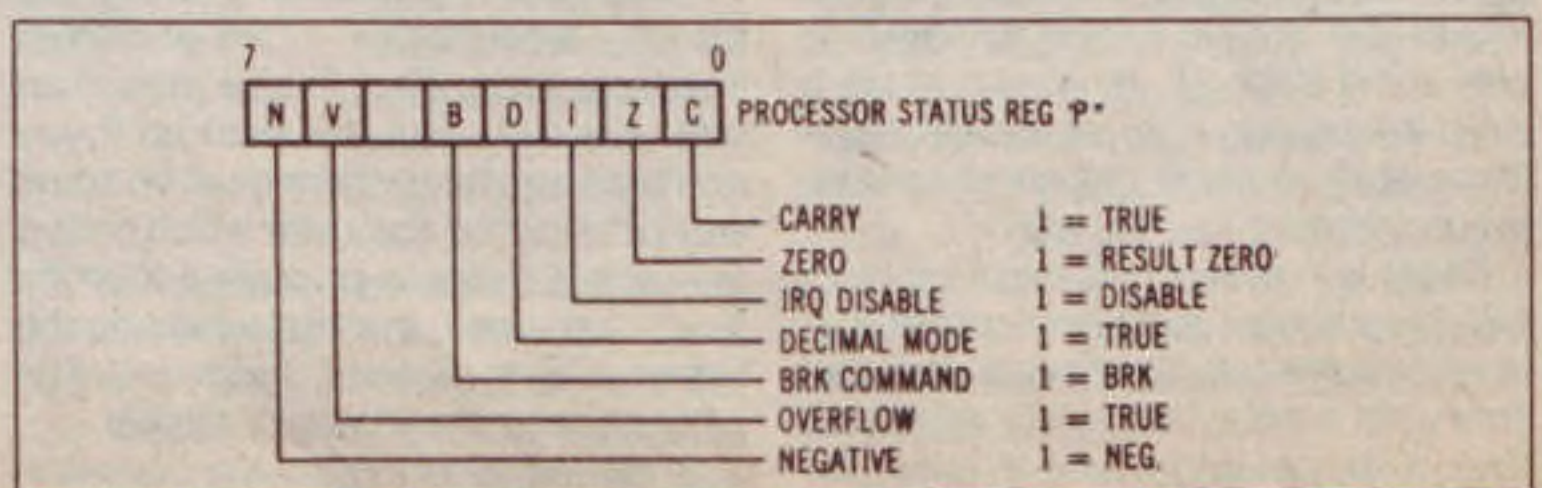

# Programming

## Increase the power of your Sinclair machine

*David Lawrence explains how to simulate the powerful DEF FN function on a ZX81.*

Non-ZX81 owners who own one or other of the more expensive micros often comment on the Sinclair machine's lack of the DEF FN function.

This is a powerful facility, available in many Basics, which allows the user to define a function once in the program, and from then on, rather than spell it out every time, the user can simply refer to it by a shorthand name.

For instance DEF FNA (X)=10\*X sets up a simple function which multiplies a variable by 10. On subsequent occasions in the program any variable can have the same operation performed on it; for example, LET Z=FNA (Y) would result in Z being set to 10 times Y.

Multiplying a number by 10 may not be a very impressive achievement, but the function defined could just as easily have been a formula 20 terms long, which could have resulted in considerable memory saving and ease of programming.

Even so, ZX81 owners should not despair, since the Sinclair micro's extraordinarily flexible VAL function can be made to perform most of the functions of DEF FN and some that exceed most other machines. The tiny program shown is a pointer to how this can be achieved.

The program is intentionally tiny, and in its present shape is of limited use because it shares the memory of an unexpanded 1K ZX81 with two string matrixes — A\$ (10,20) and B\$ (10,8) — leaving not a great deal of room for unnecessary frills.

### You can use long formulae

But the program is capable of processing data according to any one of 10 formulae up to 20 characters long, with up to 8 variables in each and with all the necessary variables being defined by the use of only one input line.

Needless to say, to design a 1K program with 10 lines of complex formulae, together with input lines for up to 8 different variables for each, would not be possible. It is achieved

```
10 CLS
20 PRINT "FORMULA:"
30 INPUT F1
40 PRINT A$(F1)
50 FOR I=CODE " " TO CODE "*"
60 IF B$(F1,I)="" THEN GOTO CODE " "
70 POKE 16677,CODE B$(F1,I)
80 POKE 16688,CODE B$(F1,I)
90 PRINT "DEFINE " B$(F1,I)
100 INPUT N
110 PRINT " " N
120 NEXT I
140 PRINT "ANSWER:" VAL A$(F1)
150 INPUT Q#
160 GOTO 10
```

```
FORMULA:2*V*V*SIN T*COS T/9.81
```

```
DEFINE V:1000
DEFINE T:1.2
ANSWER:66854.555
```

here by storing the formulae as strings in A\$.

Here, for example, are 5 formulae as stored in the array:

```
X=(1+R)**-N
PI=D/180
N=N*(N+1)**2/4
2*V*V*SIN T*COS T/9.81
SQR (U*U+2*F*S)
```

Parallel to these are the lists of necessary variables stored in B\$ 1-5:

```
XRN
D
N
VT
UFS
```

### A powerful calculator

The functions of the formulae are unimportant, they are shown purely for illustration. The important point is that, by Poking the variable name location in the input statement at line 100, the single loop at line 50 can read the appropriate line in B\$, obtain the necessary variable names and have them defined in what is, when lines which are not strictly necessary are removed, a space of 5 lines.

This would be true whether there were 10 formulae or 100 on an expanded ZX81 and, having obtained the values of the variables the formula can be assessed in a single line by the VAL function, as at line 140.

In the case of the particular program shown, the result is that a 1K ZX81 is turned into a powerful calculator for those who work with the same set of formulae a great deal, but have not previously been able to fit them into the unexpanded machine.

To set the program up, the formulae you wish to use must be entered in direct mode; eg, LET A\$(1)="X\*(1+R)\*\*-N", together with the list of variables required, in this case all that would be needed is LET B\$(1)="XRN". Once the formulae are entered, and there can be up to 10 using the 10,20 dimensions mentioned earlier for A\$ (more if your particular formulae are shorter) all the user has to do is to specify a number and the particular formula will be displayed, together with a series of requests to define the variables.

The program, however, is only one example of the power of the VAL function. Once stored in a string, your formulae can be called up at any time during the execution of the program. All that is necessary is that the variables be already defined then a simple LET A=VAL A\$(1) will execute whatever is stored in the first line of A\$, a real space saver if the same operation is to be performed several times.

The major limitation, as compared with the DEF FN of other Basics is that a formula can't be defined in terms of 10\*X, as in our first example, then made to work on Y instead but that limitation is easily overcome by simply operating on X and then setting Y=X, a small sacrifice in return for the ability to define far more than the 26 functions most Basics provide for.

### Program notes

**Line 30.** It is not usual to use a 2 character variable in a 1K program that is short on space but here it is important to have a variable name that will never be duplicated in any of the formulae.

**Line 50.** The 2 CODE values are simply to cut down on the number of literal numbers and, hence, on memory demands.

**Line 70.** If the character referred to in B\$ is 'A', line 100 becomes INPUT A.

**Line 80.** The same operation is performed on line 110.

**Line 140.** Hey presto! the result of the formula is displayed.

**Line 150.** This input is purely a device to leave the formula, variable values and answer on display until you press NEWLINE.

# MICROTANIC SOFTWARE

ADD A PRINTER TO YOUR 6502 SYSTEM FOR LESS THAN  
**£90**

Connect a  
**SINCLAIR ZX PRINTER**  
**(£59.95)**

to your 6502 COMPUTER with:

PRINTERFACE 1 for Microtan  
PRINTERFACE 2 for Micron/Tan rack  
PRINTERFACE 3 for ATOM/Acorn rack  
PRINTERFACE 4 for AIM-65/KIM/SYM  
PRINTERFACE 5 for BBC COMPUTER  
PRINTERFACE 6 for VIC 20

*Please ask for others*  
PRINTS UP TO 43 CHARACTERS/LINE  
OR 256-PIXEL GRAPHICS  
PRINTERFACE UNIT AND 600-byte  
PROGRAM LISTING: **£29.95** inc VAT

NOW AVAILABLE FOR  
MICROTAN 65  
ACORN ATOM  
BBC COMPUTER  
AIM 65/KIM/SYM  
VIC 20  
MICROTAN SYSTEM RACK

SEND CHEQUE/POSTAL ORDER PLUS 50p POST AND PACKING TO:

**MICROTANIC SOFTWARE**  
235 FRIERN ROAD, DULWICH, LONDON SE22  
or tel 01-693 7659  
PRICES INCLUDE VAT

## Croydon Micros

★★★ IN STOCK ★★★

**SHARP MZ80A**



**£477**

**ELECTRONIC  
MAGNIFICENCE**  
Personal  
Computer

Over **£50**-worth of FREE PROGRAMS including  
BASIC tutorial, 10 games, home finance, and  
GEMINI tape database

**01-689 4349**

★★ Now in our new premises ★★  
20-28 Whitehorse Road  
Croydon CR9 2NA

ALSO RC1500 Pocket Computer — **£145**

Prices exclude VAT FRONTREALM LTD (T/A)

## VIDEO SOFTWARE LTD

### NEW VIDEO-INDEX NEW

Q. How do you store 57,000  
characters in a 16K RAM?

A. Use VIDEO-INDEX.

Catalogue your cassettes, your record collection, references to magazine articles. Amazingly versatile. Capacity for 1,000 individual references each of which can generate 57 characters of text. Powerful search facilities once the index has been created.

#### How is it done?

The system cannot really fit 57,000 characters in a 16K RAM. It gives the illusion of doing so by eliminating duplicates. For instance in an index of articles in computer magazines about the ZX81 certain words occur time and again. VIDEO-INDEX detects these duplications and thereby conserves space.

#### What do you get?

1. A machine code master program which sits at the top of RAM. This is initially loaded like a BASIC program.
2. A demonstration index containing 1,000 references to articles about the ZX81 in the popular magazines.
3. A detailed instruction manual.

You may then proceed to create your own catalogues and indexes and save them on cassette. This program is fast, efficient and ingenious and is by far the best product we have introduced for the ZX81.

N.B. There isn't room for a commentary on this cassette so you'll have to read the manual. ZX81 or ZX80+BK ROM. ZX printer is useful but not essential. Price **£9.95**



STONE LANE,  
KINVER,  
STOURBRIDGE,  
WEST MIDLANDS,  
DY7 6EQ,  
ENGLAND.

**VIDEO**  
SOFTWARE LIMITED

TEL: Kinver 2462

Std. 038-483-2462

# Peek & poke

Peek your technical queries to Ian Beardsmore. He will poke back an answer.

## BUT WILL IT MAKE YOUR EYES HURT?

Ron Cryer of Grants Avenue, Bournemouth writes:

**Q** I have a BBC Micro-computer model A, and want to be able to use different coloured backgrounds and text, but find the explanations given for use of the VDU command far too complicated for me to understand. Will you tell me, in simple words, exactly how I can get, for example, a green background with red words.

**A** Just enter and run the following routine, and you'll soon learn how the different numbers produce different effects. Entering some higher numbers will produce some most peculiar results, as I'm sure you'll discover. Keep a notebook handy, and write down the combinations of A and B which produce the effects you most like.

```
10 REM **Determining colours**
20 REM **Model A BBC Micro**
30 MODE4
40 PRINT
50 INPUT"BACKGROUND NUMBER
  "A
60 INPUT"FOREGROUND NUMBER
  "B
70 VDU 19,3,B,0,0,0
80 VDU 19,0,A,0,0,0
90 GOTO 40
```

## TURN THAT CURSED THING OFF

H McWilliams of Conningham Road, London W12 writes:

**Q** I have been working with an Acorn Atom at school for some months now, trying to write interactive programs. I've managed some fairly primitive 'Space Invader' ones, and a 'Shoot the Target' game, but I find that although the computer runs quickly enough in Basic to produce a worthwhile game, the flickering cursor (which is very big in the standard text mode) is a nuisance. I can't find out how to turn the cursor off. I would be very grateful if you could explain this for me.

**A** It is fairly simple to turn the cursor off. All you need is a simple Poke command. Just enter, at the start of your program ?hashE1=0 and the cursor will disappear.

Pressing BREAK then OLD will get it back, as will ?hashE1=128. You can, in fact, make the cursor just about anything you want. Try Poking this address with other numbers and see what you come up with.

## THERE WILL NOW BE A SHORT DE . . . LAY

Matthew Buckie of Hyde Heath, Amersham writes:

**Q** I've noticed that some Basics, like the one available on the BBC Micro-computer, allow for an INKEY\$ with a specific built-in delay, so it waits for, say, half a second for a key entry, before continuing. Is there any way of providing a 'delayed INKEY\$' like this on the ZX81, as this would be very useful for me in a program I am writing.

**A** A simple routine should enable you to emulate the 'delayed INKEY\$' to some extent. You'll have to experiment to find out the most suitable value to check for in line 30 (where there is an 8 in the example).

```
5 LET S=1
10 LET AS=INKEY$S
20 LET S=S+1
30 IF S<6 AND INKEY$="" THEN
  GOTO 10
```

## DE FINEST FUNCTION YOU CAN FIND

Charles Vitrios of Roby, Merseyside writes:

**Q** I have a Sinclair ZX81 and I've noticed many programs in the computer magazines which I would like to run on my computer. However, they are not written in Sinclair Basic, and in many cases I don't know how to convert them.

As I am doing a computer science course at school, many of the programs I'm interested in are mathematical. One thing I come up against time and again is DEF FN and FN. How can I define and call functions on a ZX81? And what about the other commands when I don't even know what they're supposed to do? How can I convert them?

**A** DEF FN, to define a function, is available in many versions of Basic, but not on the ZX81. In some cases, assigning strings, and then using VAL can help you out of a spot, but this does not give you anything like a true FN call, which allows you to specify the argument of the function. The best way around the problem is to write out the function in full each time it is called in the program.

On the more general problem of converting from one Basic to another, there is a book which can be of great help. It is called *The Basic Handbook (An Encyclopedia of the Basic Computer Language)*, and is written by David Lien. Looking up an obscure command or statement in this book will give you many equivalents for it, and once you know what the Basic statement is meant to do, will make it fairly easy to work out an equivalent in ZX81 Basic.

## YOU TOO CAN HAVE A SUPER POWER . . .

Sally Francis of Woodlands Avenue, London W3 writes:

**Q** I have only 1K on my ZX81 and I am very frustrated by the tiny amount of memory available. Could you tell me some ways of saving memory, so I can get more program in? It is particularly difficult to edit lines when the memory is nearly full. Is there some way of doing it easily.

**A** There are a number of useful ideas for saving memory on the ZX81. For example, you can set a variable equal to the number one at the beginning of the program, and use it whenever you need to use one (like at the start of a FOR/NEXT loop). You can say LET A=PI/PI or LET A=SGN PI to set A to one. It is 'cheaper', in terms of the memory you use up, to then say LET B=A+A than it is to say LET B=2.

The VAL function is very useful. LET A=VAL A\$ where A\$="13245" is much more memory-efficient than saying LET A=13245. The codes of characters can also be

used if you want fairly low numbers. For example, LET A=CODE "inverse space" will set A=128, while saving you a few bytes in the process.

To edit on a ZX81 when the memory is nearly full, type in LIST n, where n is the line number you want to edit. Then press CLEAR, and when the screen goes clear, press the EDIT button, and the line you want will appear at the bottom of the screen where it can be edited.

## ER, EXCUSE ME IF I'M A BIT BASIC

Peter Overton of Little Stoke Road, Stoke Bishop writes:

**Q** You may think my questions are a little naive, but I find myself quite bamboozled when I read computer magazines. I do not yet have a computer, although I've been promised a ZX81 for my birthday, and have been buying various magazines to try and learn a bit about them. Could you tell me, in plain, simple language, the difference between ROM and RAM?

**A** Don't worry about asking what other people may think of as 'simple questions'. We all have to start somewhere, and the arcane language used by many computer users is not as difficult to master as it may appear to be the first time you hear it. ROM stands for Read Only Memory and RAM for Random Access Memory. The ROM part of the computer is all the things it knows permanently, things it does not forget when the power is turned off, like how to add numbers together, or how to produce a picture on the TV screen. By contrast, RAM is the temporary memory storage in which you can write your own programs. The computer forgets everything in RAM when the power is turned off.

Send your questions to Peek & poke, *Popular Computing Weekly*, Hobhouse Court, 19 Whitcomb Street, London WC2 7HF.

# Classified

Do you want to sell your computer and buy a bigger and better one?

Have you ever thought of trying to make some money out of selling tapes of your own programs?

Whatever it is you want to buy or sell why not use our classified pages? It has to be better than waiting for up to nine weeks to get into one of the old monthly magazines.

Not only that, but our rates are very reasonable.

For private individuals it only costs 20p per word, with a minimum of 10 words. We can make it so cheap because we charge companies using the classified columns 40p per word.

The classified pages can be used for semi-display advertising. The cost for this is £10 per single column centimetre, with a minimum charge of £30.

All copy for the classified pages must be pre-paid. Cheques/postal orders should be made out to *Popular Computing Weekly*, and your advertisement should arrive at least two weeks before the publication date.

For semi-display advertising please call David Lake on 01-839 2846.

For classified entries please fill in the form below and send it, with your cheque/postal order, to Classified Department, *Popular Computing Weekly*, Hobhouse Court, 19 Whitcomb Street, London WC2.

If you have any queries regarding classified advertising please call 01-839 1855.

**Please write your copy in bold capital letters on the lines below.**

## Here's my classified ad.

I make this ..... words, at ..... per word so I owe you £.....

Name .....

Address.....  
.....  
.....

Telephone .....

Please cut out and send this form to:  
Classified Department, *Popular Computing Weekly*, Hobhouse Court, 19 Whitcomb Street, London WC2

# Competitions

## 1 Here's how you can win Vic-20 Super Expander

Each week we plan to give away a valuable piece of hardware as a prize for the best program written by you, the readers, on a theme set by us.

The program must be no longer than 100 lines, and be suitable for the Vic 20, the ZX81, or the BBC Micro.

Your entry should be accompanied by an explanation of the function and use of the program and also of how you went about writing it.

The winner will be the reader who in the opinion of the Editor of *Popular Computing Weekly* has sent in the most original and inventive program.

In all cases his decision is final.

From time to time we will also publish programs which did not win the competition, but which we think will be interesting to other readers.

If that happens we will pay the usual rate for contributions to the magazine.

**This week's fantastic prize is a ZX81 16K RAM pack and the theme for the competition is: Moon Landing.**

Send your program to: The Editor, *Popular Computing Weekly*, 19 Whitcomb Street, London WC2.

Please mark your entry 'Hardware Competition 2' — and remember it must reach us by first post May 10, 1982.

## 2 Complete the crossword and win £10

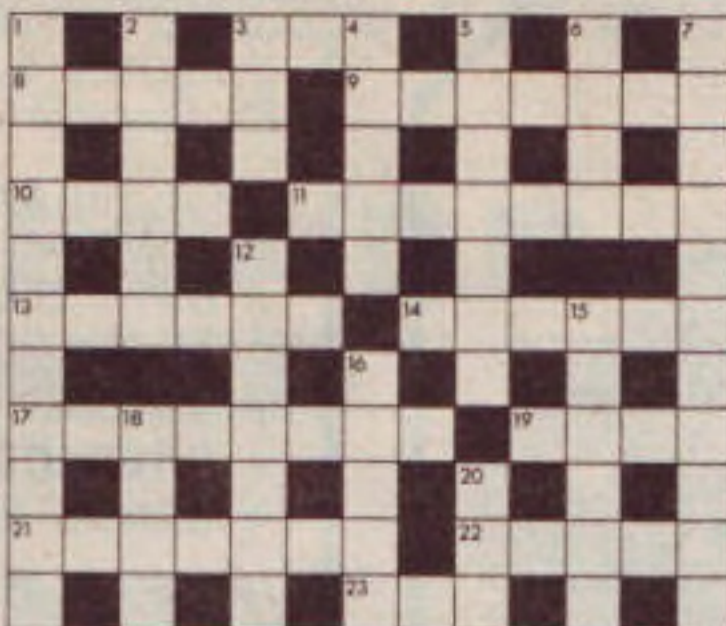

### ACROSS

- 8 Summer for micro-computer chip circuit (5)
- 9 False, poor, king without lock cleaner (7)
- 10 Cut basic integer operation (4)
- 11 US football field used for cooking (8)
- 13 Hide the sun-bed, do your hear? (3,3)
- 14 Interfacing method of the first couple in duty, pleasure and experience (6)
- 17 Right in the current neither to the north or south (8)
- 19 Analysts half passage (4)
- 21 Mixtures 'e put together all are genuine beer (4, 3)
- 22 Mini tube in France (5)
- 23 The edge of insolence (3)

### DOWN

- 1 Court call, as upsetting as 8As (11)
- 2 Not even love notes a strange rhyme (3,3)
- 3 Lament for leading cryptic clue (3)
- 4 Sorts of East Russian operators (5)
- 5 Audio interface 'eard before drink (7)
- 6 Support for the second standard (4)
- 7 Basic iteration during nearest circuit (3,4,4)
- 12 Not worth considering, for no short time, a student (7)
- 15 Stretch basically the number of bytes (6)
- 16 Jury rigged plane (5)
- 18 Stone circuit rising under another (4)
- 20 A representative current (3)

## 3 Solve the puzzle and win a gift voucher!

On a desert island were five castaways. They had collected a pile of coconuts which they agreed to divide into equal shares the following day.

That night the first man awoke, and, fearing that he might be cheated out of some of his coconuts, decided to take his share whilst the other men were asleep.

He went over to the pile of nuts, and divided them into five equal shares. There was one coconut left over, so he gave it to a passing monkey.

After hiding his share, he piled the remaining nuts back into one heap and went back to sleep.

Then the second man woke up; he too had the same idea. Like the first man, he too had one nut left over after dividing the pile of nuts into five. This, he too gave to the monkey. After hiding his share, he went back to sleep.

As the night progressed, the remaining three men, all carried out exactly the same procedure. The next morning they all woke and succeeded in dividing the remaining coconuts equally between them.

Can you discover (a) What is the smallest number of coconuts that were originally collected? (b) If, when making his final division, there was still one left over for the monkey, how many would there have been in the original pile?

Closing date for both the crossword and the puzzle is the Monday, three weeks after the cover date.

Please mark your envelope 'CROSSWORD' or 'PUZZLE'.

# CITIZEN PAIN

BY DAVID IRELAND and JAMES MACDONALD

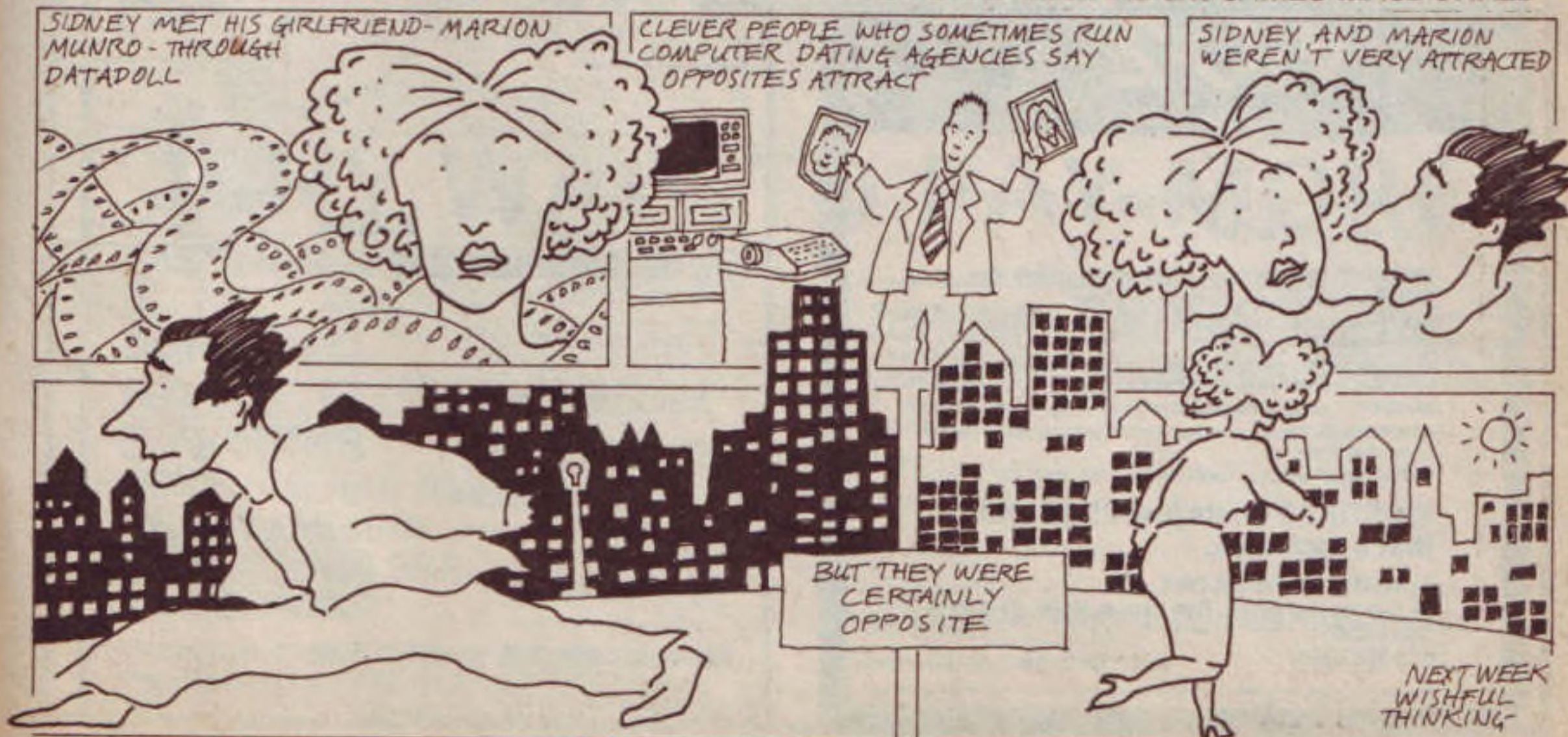

# RETAIL SHOP IN LEICESTER FOR ZX81

HARDWARE/SOFTWARE, BOOKS

KEYBOARDS, CASES, 16K AND 64K RAM PACKS,  
I/O PORTS, MONITORS AND MUCH MORE

FUN, BUSINESS, SERIOUS AND  
EDUCATIONAL SOFTWARE  
NEW SOFTWARE ALWAYS ARRIVING

WE WILL BE SURE TO STOCK  
PRODUCTS FOR ANY NEW SINCLAIR  
MICRO AS SOON AS AVAILABLE —  
KEEP AN EYE ON THE SHOP!

## MICROWARE

131 MELTON ROAD  
LEICESTER  
TEL: 681812

OPEN 9.30 am—  
5.30 pm  
CLOSED THURS

SEE US  
AT ZX FAIR  
MANCHESTER, MAY 29 & 30

## WELCOME SPECTRUM!

RD Laboratories are pleased to continue supplying Realtime Interface Modules for economic micro control and instrumentation — suitable for all ZX Computers. Including Clive Sinclair's brilliant new ZX Spectrum!

The RD 8100 Modules can be used in many applications:

- ★ DATA LOGGING
- ★ CONTROL
- ★ AUTOMATIC TESTING
- ★ INTERACTIVE GRAPHICS
- ★ GAMES AND LEISURE ACTIVITY

The RD 8100 Module range consists of Logic Input/Output Port; Analogue Input Port; Analogue Multiplexer/Amplifier; Analogue Output Port; Light Pen Module.

For full details of the RD 8100 System, please send a stamp and your address to Department P at RD Laboratories.

**R D Laboratories**  
5 Kennedy Road, Dane End, Ware,  
Herts SG12 0LU (0920) 84380



Full Colour  
and  
Superb Sound

**VIC-2** NEW  
SOFTWARE

Our latest VIC 20 package is **VICSOFT 7**  
and includes all of —

- BREAKOUT:** The noisiest and most colourful you've ever seen.
- SQUASH:** Will you make a tournament champion?
- DEATHRACE 2000:** Driving in a crazy road race you must run-over as many pedestrians as you can!!
- SOUNDS:** A sound effects synthesizer program. Everything from helicopters to birds of paradise — menu driven.
- MOROIDS:** Your astronaut must avoid the asteroids, very fast graphics!!
- MASTERMIND:** See if you can beat a microelectronic mind at this full colour brain teaser!
- WARLORDS:** Protect your castle from giant boulders!!

**VICSOFT 7 costs just £5.95 and  
that's inclusive.**

**CONTROL TECHNOLOGY**  
39 Gloucester Road, Gee Cross, Hyde, Cheshire  
SK14 5JG  
061-368 7558

08XZ

## JRS SOFTWARE

19 WAYSIDE AVENUE, WORTHING, SUSSEX, BN13 3JU  
TELEPHONE WORTHING 85891 (Evenings and Weekends only)

ZX81

**GAMES PACK** — Over 100 for your ZX81. Includes: **3-D Sports (16K/32K)** — Fast moving sports game with continuous play; **City Bank (16K/32K)** — Manage the building and bank your money; **Warp Wars (Basic & 16K/32K)** — A futuristic strategy game; **Snake (16K)** — A classic snake game; **Sweet Tooth (Basic & 16K/32K)** — A fast moving game for two players.

As reviewed in 'YOUR COMPUTER' March 1982

**16K RAM PACK**  
£35 (\$69.95)

WHY PAY  
MORE



Typos built, tested and guaranteed. No additional power supply required.

No wobble problems — fully compatible with printer etc. etc. (Please send large S.A.E. for a copy of 'YOUR COMPUTER' RAM pack review (March 1982) — Refunded when you purchase the RAM pack). Please allow 21 days for delivery.

**STOP PRESS**

NOW AVAILABLE — 64K RAM pack (64K available) £75 inclusive

**TOOLKIT** — An ESSENTIAL addition to your 16K RAM ZX81 for 256K RAM. Includes: **Line Generator** — and other graphics routines; **Search and replace** — changes any character of a program as you require; **Free space** — tells you how many free bytes you have left; **SPECIAL GRAPHICS ROUTINES** — **Hyper graphics mode** — graphics mode built on a ZX81 before; **Open** — instantly sets up as many empty lines as you require; **Fill** — used in conjunction with OPEN for your screen memory with your specified character; **Reverse** — changes each character on your screen to its mirror image; **TAPE ROUTINE** — provides a system WAIT (adjustable) until a signal is received in the cassette tape port; **Fill** — fills any number of lines you specify, starting at any line you specify, by your chosen character; **REVERSE** — converts all characters to their mirror image; **PRINT POSITION CONTROLS** — UP/DOWN/LEFT/RIGHT — after your next PRINT position in the screen indicated; **EDITPRINT** — moves next PRINT position to first blank line.

## NEW GRAPHICS TOOLKIT (Another masterpiece by PAUL HOLMES)

22 exciting MACHINE CODE routines that give you control over your screen as never before! (ZX81 - 16K RAM ONLY)

- DRAW UNDRAW** draws or deletes your own character shapes which is defined in a REM statement. You may define as many different shapes as you like and draw or undraw each at will at whatever screen position you choose.
- BACKGROUND ON/OFF** use this to without existing characters on your screen. When on new shapes will appear to slide behind and re-emerge from other shapes.
- BORDER UNBORDER** draws a border round the edges of your screen area. You can use to add a border. Your border is positioned when background is on.
- FILL** fills any number of lines you specify, starting at any line you specify, by your chosen character.
- REVERSE** converts all characters to their mirror image, similar to in FILL.
- PRINT POSITION CONTROLS** — UP/DOWN/LEFT/RIGHT — after your next PRINT position in the screen indicated.
- EDITPRINT** moves next PRINT position to first blank line.
- SCROLL** facilities — UPSCROLL/DOWNSCROLL/RIGHTSCROLL/LEFTSCROLL — Set the screen in the direction indicated.
- ONSCREEN/OFFSCREEN** turns your screen on or off.
- BACKGROUND ON/OFF** — Fill your screen by your specified character. When foreground is on existing information is unaffected and shapes will appear to pass in front of your background, without disturbing it.
- SEARCH AND REPLACE** will search the screen for every instance of the character you specify and replace it with your new character.
- SQUARE** draws a square or rectangle from your specified co-ordinates.

**ALL FOR ONLY £5.95 (\$11.90)** This includes a cassette with 2 copies of the program plus a comprehensive instruction booklet with examples.

NOTES: All prices are fully inclusive — send cheque or P.O. to JRS Software at above address. OVERSEAS CUSTOMERS: Payment may be made in Sterling (Money Order available at your bank) or U.S. (U.S.A. customers only). Prices quoted above are also export prices and include AIRMAIL postage.



# ZX80/1 PRICE WAR!

## ZX KEYBOARD FULLY CASED WITH REPEAT KEY

£37.95  
incV.A.T.



Fully cased keyboard £37.95  
Uncased keyboard £27.95  
Keyboard case £10.95

This is a highly professional keyboard using executive buttons as found on top Quality Computers. It has a Repeat key and comes complete in its own luxury case. This is a genuine professional keyboard and should not be confused with toy keyboards currently available on the market.

# 16K RAMPACK

## MASSIVE ADD ON MEMORY

ORDER WITH  
YOUR CREDIT  
CARD

£32.95  
incV.A.T.

# WHY WAIT TO PAY MORE

**FAST IMMEDIATE DELIVERY**

Post To  
Dept CW3  
**KAYDE ELECTRONIC  
SYSTEMS**  
48/49 Exmouth Road  
Great Yarmouth  
Norfolk NR30 3DP  
Tel 0493 57867

All products include VAT are fully built and tested and come with a complete Money Back Guarantee

PLEASE SEND ME..... RAM PACK/S £32.95 each  
PLEASE SEND ME..... CASED KEYBOARD/S £37.95 each  
PLEASE SEND ME..... UNCASD KEYBOARD/S £27.95 each  
PLEASE SEND ME..... KEYBOARD CASE/S £10.95 each

I enclose £.....

NAME .....

ADDRESS .....

.....

.....

Please add £1.50 P&P and make cheques payable to  
Kayde Electronic Systems.

BYTESHOP COMPUTERLAND



**VIC-20**

**See it here, buy it now**

**AT YOUR LOCAL  
BRANCH TODAY!**

**Birmingham** Byteshop Computerland 94/96 Hurst St, B5 4TD **Tel:** 021 622 7149 **London** Byteshop Computerland 324 Euston Road London W1 **Tel:** 01-387 0505 **Nottingham** Byteshop Computerland 92A Upper Parliament St NG1 6LF **Tel:** 0602 40576 **Manchester** Byteshop Computerland 11 Gateway House Piccadilly Station Approach **Tel:** 061 236 4737 **Glasgow** Byteshop Computerland Magnet House 61 Waterloo St, G2 7BP **Tel:** 041 221 7409

A member of the Comart Group of Companies.