

# Practical Computing

June 1982

Volume 5 Issue 6

**Natural language**

**Review:**  
**North Star Advantage**  
**Pearcom**  
**Hard-disc**  
**Superbrain**



**Tax accounting**  
**CP/M explained**  
**BBC programming**

**NEW  
MODEL**

**LOWER  
COST**



## **Cromemco System One**

**MicroCentre introduce Cromemco's new System One computer, available with an integral 5 megabyte Winchester hard disk, at a new low price.**

**The System One supports the full range of Cromemco interface cards, including high resolution colour graphics, and software packages. The choice of operating systems includes CDOS, CP/M and CROMIX—Cromemco's answer to Unix.**

**Call MicroCentre for  Cromemco**

**MicroCentre Ltd**  
(Complete Micro Systems)

● Circle No. 101

**Britain's independent  
Cromemco importer**

**30 Dundas Street  
Edinburgh EH3 6JN  
Tel: 031-556 7354**

# Practical Computing

Natural language

Review:  
North Star Advantage  
Pearcom  
Hard-disc  
Superbrain



Tax accounting  
CP/M explained  
BBC programming

Natural language — page 70

Editor

**Peter Laurie** 01-661 3500

Assistant Editor

**Bill Bennett**

Reporter

**Ian Stoble**

Production Editor

**John Liebmann**

Sub-editor

**Meirion Jones**

Prestel Editor

**Martin Hayman**

Editorial Secretary

**Julie Milligan**

Consultants **Nick Hampshire,**

**Chris Bidmead, Peter Wood**

Advertisement Manager

**Ian Carter** 01-661 3021

Assistant Advertisement

Manager

**Kenneth Walford** 01-661 3139

Advertisement Executives

**Fiona Howell** 01-661 3500

**Robert Payne** 01-661 3500

Midlands office:

**David Harvett** 021-356 4838

Northern office:

**Geoff Aikin** 061-872 8861

Publishing Director

**Chris Hipwell**

Published by IPC Electrical Electronic Press Ltd, Quadrant House, The Quadrant, Sutton, Surrey SM2 5AS. Tel: 01-661 3500. Telex/grams 892084 BIP-RESG.

Typeset and printed by Eden Fisher (Southend) Ltd, Southend-on-Sea. Distributed by IPC Business Press (Sales and Distribution) Ltd, Quadrant House, The Quadrant, Sutton, Surrey SM2 5AS.

Subscriptions: U.K. £10 per annum; Overseas £16 per annum; selling price in Eire subject to currency exchange fluctuations and VAT; airmail rates available on application to Subscription Manager, IPC Business Press (S & D) Ltd, Oakfield House, Perrymount Road, Haywards Heath, Sussex RH16 3DH. Tel: 0444 59188.

©IPC Business Press Ltd 1982  
ISSN 0141-5433

Would-be authors are welcome to send articles to the Editor but PC cannot undertake to return them. Payment is at £30 per published page. Submissions should be typed or computer-printed. Handwritten material is liable to delay and error. Every effort is made to check articles and listings but PC cannot guarantee that programs will run and can accept no responsibility for any errors.

# CONTENTS

- 41** Editorial / A question of band-width
- 43** Feedback / Input or Get?; 16-bit CP/M; Adventures
- 46** Printout / Sinclair ZX Spectrum; ICL markets micros; Pet terminal emulator
- 53** Printout extra / Bill Bennett reports on Seaview 82's ship-board tele-computing experiment
- 55** North Star Advantage / Mike Hughes takes a look at this versatile desk-top machine with a business graphics capability
- 58** Pearcom / We compare the Dutch-built Apple look-alike with the American original
- 61** Hard-disc Superbrain / The popular business micro can now be bought with a built-in hard disc — Peter Laurie investigates
- 62** MBasic / Continuing our re-evaluation of this important dialect, Chris Bidmead highlights Microsoft's new compile
- 69** Schools' software / Longman is venturing into educational software — can micros really be taking over from textbooks?
- 70** Famous first words / Computers learn to recognise natural language with Chris Naylor's program
- 74** Education / Chris Harrison's Cloze test program measures students' abilities in native and second languages
- 84** Applications / By the time British Leyland said it couldn't be done, Ivybridge Motors had already done it: Grahame Blackwell tells the tale of how one small business automated its stock list
- 86** Income Tax / Assess your annual liability with Elizabeth Acraman's program
- 90** CP/M explained / We reveal the mysteries of Digital Research's operating system and show how you can link it into your own programs
- 96** Crashing the System / Fiction by Chris Waugh
- 102** Ratmaze / Bob Merry explains how he programmed this underground Adventure game
- 109** Disc technology / The latest improvements to hard-disc reliability, by Dave Brodsky of Shugart
- 110** Art / Brian Reffin Smith's regular feature includes competition winners, and how one computer-graphics artist manages to stay sane
- 117** Ink-jet printers / John Lewell looks at the possibilities
- 119** BBC programming / BBC Basic's unusual features outlined by John Gordon and Tony Shaw
- 125** Roots / A subroutine for solving polynomial equations by Patrick Howden and Noel Kantaris
- 133** Machine code / Save memory space with this economical extension of 6502 assembler programming
- 139** Open file / A 16-page section of your programs, including ZX-80/81 Line-up; Z-80 Zodiac; 6502 Special; Pet Corner; Apple Pie; and Tandy Forum
- 163** Book Reviews
- 165** Puzzle
- 167** Expert systems / Boris Allan's sceptical view of computer-controlled Utopia
- 169** Printers buyers' guide
- 183** The War Machine / Eastern Front — a war game for Atari machines

Prestel page number 357

# WATFORD ELECTRONICS

33/35, CARDIFF ROAD, WATFORD, HERTS, ENGLAND

Tel Watford (0923) 40588. Telex: 8956095

ALL DEVICES FULL SPEC. AND FULLY GUARANTEED. TERMS OF BUSINESS: CASH/CHEQUE/P.O.S. (OR ACCESS) WITH ORDER. GOVERNMENT AND EDUCATIONAL INSTITUTIONS OFFICIAL ORDERS ACCEPTED. TRADE AND EXPORT INQUIRIES WELCOME. (P&P add 50p on all orders).

VAT ALL PRICES ARE EXCLUSIVE OF VAT. PLEASE ADD 15% TO THE TOTAL COST INCLUDING P&P. SHOP HOURS: 9.00am-6.00pm MONDAY TO SATURDAY. AMPLE FREE CAR PARKING SPACE AVAILABLE.

COMPUTER IC's	ULN2003	100	7481	120	74LS	LS253	40	74H	36
1702	299	7481	120	LS00	12	LS257	48	4067	399
1802CP	700	280CPU5	350	LS01	13	LS258	40	4067	399
2101-2	170	Z80CPU4M	385	LS02	14	LS259	85	4068	22
2112-2	250	Z80P10	290	LS03	14	LS261	195	4070	626
2114-L300n	87	Z80P10	320	LS04	15	LS266	25	4071	20
2114-200n	87	Z80CTC	200	LS05	15	LS273	290	4072	20
2147-3	425	Z80ACTC	325	LS06	15	LS279	88	4073	20
2532-450n	360	Z80DMA	10	LS08	15	LS280	2250	4075	20
2564	240	Z80DMA10	10	LS09	15	LS283	45	4076	60
2716-5V	215	Z80S10	123	LS10	15	LS290	57	4077	26
2732-450n	400	Z80S10	123	LS11	15	LS293	595	4078	26
2764	17	Z80DAART	440	LS12	15	LS295	215	4081	26
4027	400	Z80DAART	450	LS13	30	LS298	130	4082	21
4116-150n	95	ZN41HCE	190	LS14	48	LS299	420	4085	65
4116-200	80	ZN423E	138	LS15	15	LS300	157	4089	140
4418-250	400	ZN425E	345	LS20	15	LS302	175	4093	43
4164-200	620	ZN426E	300	LS21	15	LS320	270	4094	68
4354-3	795	ZN427E	400	LS22	15	LS323	270	4096	90
(CMOS)2114	325	ZN428E	478	LS26	15	LS423	200	4096	90
4816A-120n	290	ZN429E	210	LS27	15	LS323	270	4097	320
5101	270	ZN1034E	200	LS28	20	LS324	200	4098	80
4864-3	785	ZN1040E	675	LS30	18	LS325	320	4100	95
6167-150nS	450	74LS132	110	LS32	15	LS326	330	4161	99
6167-100nS	00	74LS138	180	LS33	16	LS327	315	4162	99
6502 CPU	600	74LS139	170	LS37	16	LS347	150	4162	99
6503	600	74LS188	210	LS38	16	LS348	190	4174	99
6504-250	550	74LS189	158	LS41	30	LS352	185	4175	105
6505	600	74LS194	320	LS42	35	LS353	186	4194	105
6521	150	74LS201	350	LS43	40	LS365	37	4408	790
6522 VIA	350	74LS202	390	LS44	60	LS366	37	4409	790
6530 RR10T	625	74LS211	1150	LS46	80	LS367	37	4410	725
6532 R10T	625	74LS212	1150	LS48	80	LS367	37	4411	695
6545 CRTC	10	74LS213	625	LS51	15	LS368	90	4412	417
6551 ACIA	650	74LS214	250	LS52	15	LS373	75	4415	480
6592 PC	320	74LS215	250	LS55	30	LS374	75	4419	280
6800	300	74LS216	625	LS56	150	LS375	48	4422	770
6802	400	74LS217	1150	LS57	25	LS377	90	4423	770
6803	850	74LS218	740	LS58	25	LS378	69	4435	850
6804	160	74LS219	740	LS59	25	LS379	65	4440	999
6805	670	74LS220	740	LS60	25	LS384	395	4450	850
6808	520	74LS221	740	LS61	25	LS385	378	4451	350
6809	895	74LS222	740	LS62	25	LS386	62	4450	675
6810	120	74LS223	740	LS63	25	LS387	60	4500	675
6821	125	74LS224	740	LS64	25	LS395	199	4501	28
6840	412	74LS225	740	LS65	25	LS445	140	4502	90
6843	12	74LS226	740	LS66	25	LS446	140	4503	50
6845	750	74LS227	740	LS67	25	LS471	620	4504	105
6847	850	74LS228	740	LS68	25	LS480	245	4504	105
6849	140	74LS229	740	LS69	25	LS481	135	4506	65
6852	255	74LS230	740	LS70	25	LS640	226	4507	40
6875	500	74LS231	740	LS71	25	LS641	225	4510	68
8080A	350	74LS232	740	LS72	25	LS642	225	4510	68
8085A	350	74LS233	740	LS73	25	LS668	175	4511	68
81LS95	90	74LS234	740	LS74	25	LS669	160	4512	75
81LS96	90	74LS235	740	LS75	25	LS670	550	4513	199
8123	125	74LS236	740	LS76	25	LS674	750	4514	195
8155	475	74LS237	740	LS77	25	LS674	750	4515	198
8202	225	74LS238	740	LS78	25	LS674	750	4517	415
8212	170	74LS239	740	LS79	25	LS674	750	4518	42
8214	425	74LS240	740	LS80	25	LS674	750	4519	29
8216	240	74LS241	740	LS81	25	LS674	750	4520	78
8226	250	74LS242	740	LS82	25	LS674	750	4521	200
8228	250	74LS243	740	LS83	25	LS674	750	4522	95
8251	320	74LS244	740	LS84	25	LS674	750	4523	115
8253	290	74LS245	740	LS85	25	LS674	750	4524	80
8255	290	74LS246	740	LS86	25	LS674	750	4525	90
8257	800	74LS247	740	LS87	25	LS674	750	4526	95
826A	699	74LS248	740	LS88	25	LS674	750	4527	115
8272	150	74LS249	740	LS89	25	LS674	750	4528	80
8278A	115	74LS250	740	LS90	25	LS674	750	4529	150
8T	7421	74LS251	740	LS91	25	LS674	750	4530	90
8T95N	99	74LS252	740	LS92	25	LS674	750	4531	130
8T97N	99	74LS253	740	LS93	25	LS674	750	4532	110
9364AP	550	74LS254	740	LS94	25	LS674	750	4533	500
AM26LS31C	125	74LS255	740	LS95	25	LS674	750	4534	295
AM26LS32A	125	74LS256	740	LS96	25	LS674	750	4535	115
AY-3-1015	360	74LS257	740	LS97	25	LS674	750	4536	115
AY-3-8910	600	74LS258	740	LS98	25	LS674	750	4537	135
AY-3-8912	625	74LS259	740	LS99	25	LS674	750	4538	150
AY-3-1013	300	74LS260	740	LS100	25	LS674	750	4539	175
AY-5-2376	600	74LS261	740	LS101	25	LS674	750	4540	460
FD1771	118	74LS262	740	LS102	25	LS674	750	4541	250
FD1791	28	74LS263	740	LS103	25	LS674	750	4542	99
FD1793	30	74LS264	740	LS104	25	LS674	750	4543	99
FD1795	30	74LS265	740	LS105	25	LS674	750	4544	99
FD1797	35	74LS266	740	LS106	25	LS674	750	4545	99
INS8154	110	74LS267	740	LS107	25	LS674	750	4546	99
IM6402	380	74LS268	740	LS108	25	LS674	750	4547	99
MC1488	55	74LS269	740	LS109	25	LS674	750	4548	99
MC1489	55	74LS270	740	LS110	25	LS674	750	4549	99
MC14411	695	74LS271	740	LS111	25	LS674	750	4550	99
MC14412	795	74LS272	740	LS112	25	LS674	750	4551	99
MC3447P	315	74LS273	740	LS113	25	LS674	750	4552	99
MM5280D	695	74LS274	740	LS114	25	LS674	750	4553	99
MM58174	825	74LS275	740	LS115	25	LS674	750	4554	99
MM740922	425	74LS276	740	LS116	25	LS674	750	4555	99
RO-3-2513L	700	74LS277	740	LS117	25	LS674	750	4556	99
RO-3-2513U	700	74LS278	740	LS118	25	LS674	750	4557	99
SFF96364E	800	74LS279	740	LS119	25	LS674	750	4558	99
TMS2716-3V	875	74LS280	740	LS120	25	LS674	750	4559	99
TMS6011	365	74LS281	740	LS121	25	LS674	750	4560	99

## WATFORD'S UNIVERSAL MICRO EXPANSION SYSTEM

Designed by Watford Electronics, this extremely versatile and economical Expansion System as published in E.T.I., starting from Dec. 1981 issue, offers a low cost flexible expansion system for ZX81, UK101, SUPERBOARD, ACORN ATOM, PET, TANGERINE, etc.

The Motherboard (interfaces with the computer) has capacity to accept up to five daughter cards and can be paralleled for even more daughter cards.

All PCBs are of computer grade finish and are supplied in kit form.

Just look at the Expansion possibilities.

**MOTHERBOARD** — Accepts up to five daughter cards. Full kit: **£36.50**

**SOUND CARD** — Utilising up to three AY-3-8910 sound chips (one supplied with the kit). Full kit: **£24.95**

**PIO CARD** — Using two 6520 PIO chips, this Board offers Centronics parallel printer driver, digital to analogue converter and a host of other output facilities. Full kit: **£19.95**

**PROM PROGRAMMER** — This simple but extremely useful card can flow 2716 single rail EPROMs. (2732) Full Kit: **£25.95**

**PROM CARD** — PCB cards for housing four 2716 or two 2732 EPROMs. (4 x 2716) Full Kit: **£11.95** (2 x 2732) Full Kit: **£11.75**

**RAM CARD** — 8K RAM card. Accepts 16 x 2114 RAMs. Board is supplied fully populated. Full Kit: **£28.50**

Soon available: **SPEECH CARD; HIGH RESOLUTION GRAPHICS CARD; DISC INTERFACE CARD; 32K DRAM CARD** (NB PCBs may be bought separately).

## SPECIAL OFFER

2114L-300n	87p	1+	25+
2114L-200n	87p		
2532	360p		
2716	215p		
2732	400p		
4116	75p		
4334-3	325p		
6116-150nS	450p		
6522	350p		
6520	150p		
6820	150p		

We stock thousands more items. It pays to visit us. We are situated behind the Watford Football Ground.

Just phone your order through, we do the rest

## EPSON MX Series PRINTERS

Now available from stock at very competitive prices.

- **MX80T** 10" Tractor Feed, 9x9 matrix, 80 column Speed 80 CPS bi-directional Centronics Interface, Baud rate 110-9600 (RS232) **£315**
- **MX80FT** Has Friction & Tractor feed plus all the MX80T's facilities. **£345**
- **MX80FT2** Has high resolution Graphics option plus all the MX80FT's facilities. **£390**

## VIDEO MONITOR 9" B&W. Fully cased. Professional quality. Fully guaranteed.

Only **£75**

## ACCESSORIES

- **TEX EPROM ERASER.** Erases up to 32 ICs in 15-30 min. **£33**
- **TEX EPROM ERAS**



# PET PRINTER GRAPHICS

by COMPUTACE LTD. PLUS North Star Horizon

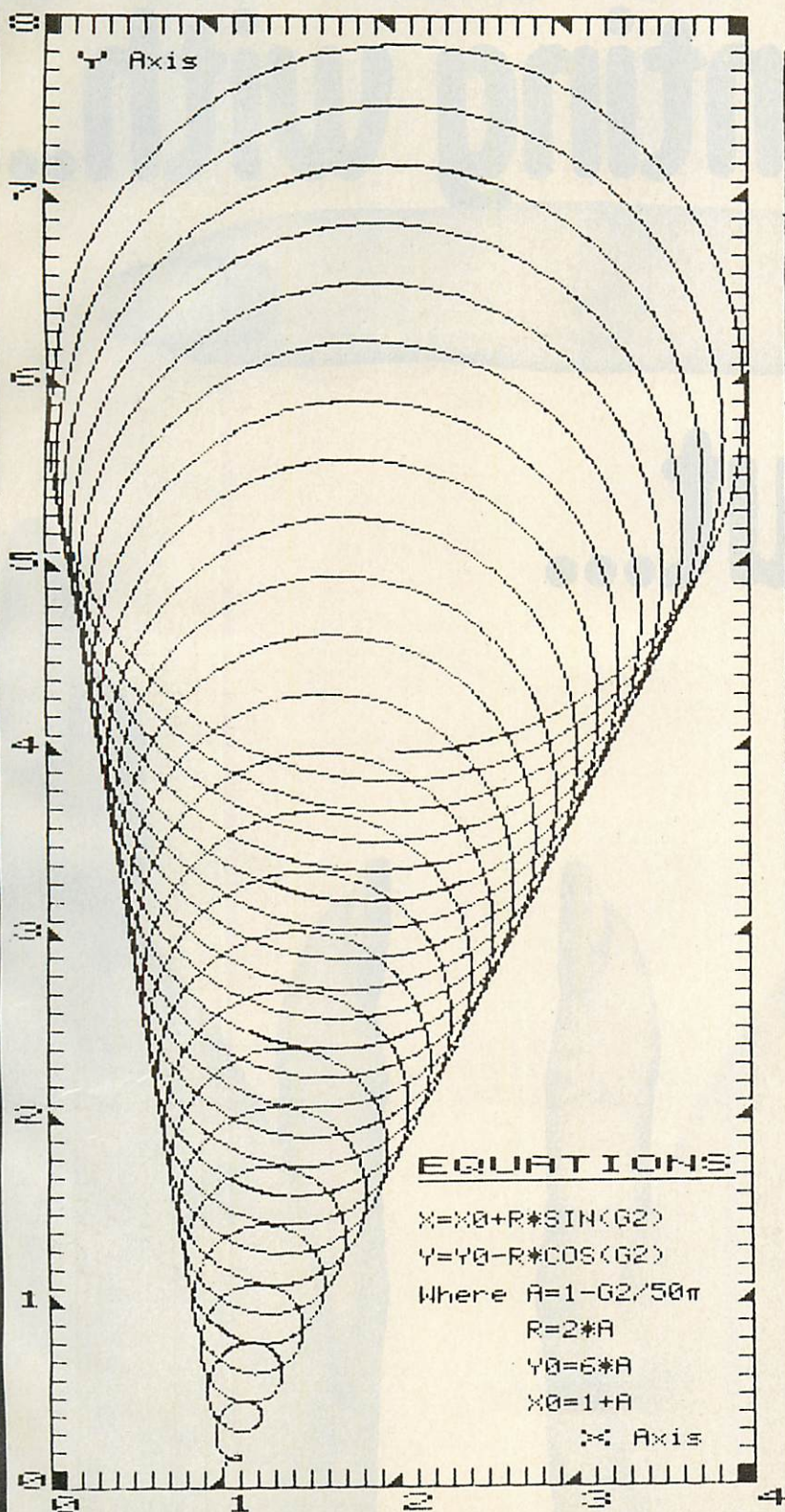

This graph is a typical example printed by AUTOGRAPH on a STANDARD COMMODORE 3022 or 4022 PRINTER. (Please specify when ordering) No disk drive or plotter required. Simple to use. Hard copy. Fully flexible graph dimensions and position on page. Automatic scale option. Variable background formats. Plots any X,Y function. Multiple graphs on same axes. Full Alphanumeric labelling for professional quality presentation:

**AUTOGRAPH** is supplied with extensive documentation. Send for Brochure.

**AUTOGRAPH 1** (16K, 32K only) Plots any function as illus. or in spaced dots. **£39.50 incl.**

**AUTOGRAPH 2** (16K, 32K only) As AutoGraph 1 but includes data point plot option with joining lines and marking circles. AutoGraphs 1 and 2 combined pack. **£49.50 incl.**

**CURVE FIT 1** (32 K only) Powerful Linear and Non-Linear Regression of any function to a least squares data fit. Complete with plot of regressed curve & data. **£55.50 incl.**

**CURVE FIT 0** As Curve Fit 1 plus Cubic Spline Fit, Integrals and Gradients throughout. **£65.50 incl.**

Send for Brochure and details of combined packs at reduced prices. Including: Epson Printers and Oxford Computer Systems Compiler.

COMPUTACE LTD., INFABCO GROUP, International Base, Greenwell Rd., East Tullos, ABERDEEN AB1 4AX  
TEL: (0224) 876622.

For fastest reply use:-  
COMPUTACE LTD.,  
PO BOX 50D  
NEW MALDEN, SURREY KT3 3BD

**Now you can do all  
accounting with...**



**without...**



# the filing, typing and

**Silicon Office** is the latest microcomputer software program from the Bristol Software Factory.

Designed specifically for use with the Commodore PET 8096, it'll help you run your office with the minimum amount of effort and maximum efficiency.

Think of it like three normal software packages in one, each separate package totally interactive with the other.

For around £4,500, you can have the complete electronic office, the solution to practically all your business problems. The price includes Commodore hardware, a high quality daisy wheel printer and Silicon Office software.

Silicon Office is made up from a flexible information management system which lets you create and maintain an extensive filing arrangement. Allowing you to search quickly through your records, making cross references between files in order to gain the facts you require.

A highly sophisticated word processing program allows you to generate letters, documents and reports. Letting secretaries get on with the more important tasks.

And a fully comprehensive calculator means you can handle all the number crunching you're ever likely to do in a business situation. Leaving the

accounts department to concentrate on more profitable things.

But that's not all by any means.

Silicon Office also has a special programmability feature which means you or your dealer can expand and tailor the Silicon Office program to your business.

When Silicon Office is used in an everyday business situation, certain command sequences are inevitably repeated. By writing short, very simple programs which are entered into the computer's memory, Silicon Office can perform the necessary tasks, automatically.

And last, but by no means least is an optional communications facility.

It doesn't take much imagination to see the potential of Silicon Office in virtually any line of business.

So to get a better grasp, send away for our brochure. It'll only cost you a stamp. And it could save you a fortune. Or talk to your local Commodore dealer who has all the facts at his fingertips.

You'll soon see how you're much better off with Silicon Office. Than without.

**commodore**  
COMPUTER



I can't wait to get my hands on a free copy of the Silicon Office brochure.

Name \_\_\_\_\_

Position \_\_\_\_\_

Company \_\_\_\_\_

Address \_\_\_\_\_

A/PC 2

I own a Commodore PET (Please tick box) YES  NO

BSF

Send to: Bristol Software Factory, PO Box 14, Horley, Surrey.

# SILICON OFFICE

● Circle No. 104

# NASCOM MEANS SOLUTIONS NASCOM MEANS PERFORMANCE

Nascom have come a long way since their acquisition by Lucas. With the knowledge of over 30,000 units already in the field you can buy with confidence from NASCOM.

#### PRODUCTS:

We have kits, built and tested boards, and our fully assembled and tested NASCOM 3 system with a full choice of configuration either cassette or disc based. Alternative operating systems include NAS DOS and CP/M.

#### SOFTWARE:

We have a team of programmers who are writing software and courseware especially for UK educational business and domestic users.

#### FREE ADVICE:

We have appointed experts to advise on the specialist use of micro computers in U.K. schools, homes or businesses.

#### BACK-UP:

We have a nationwide dealer network giving full sales back-up and after sales service. From our head office we have a service line to sort out any problems.

#### SYSTEM EXPANSION:

NASCOM machines are designed to grow with users. Easily and simply NASCOM systems can be expanded by adding extra modules to the basic system.



Learn more about NASCOM now. Complete the coupon for further information and a full list of dealers.

**LUCAS LOGIC LIMITED**  
NASCOM MICROCOMPUTERS DIVISION,  
Welton Road, Wedgcock Industrial Estate,  
Warwick CV34 5PZ, England.



Have you a NASCOM programme? If so send for an application form for inclusion in our programme book

Dealer Enquiries Welcome

**£1,548 + VAT**  
A typical system as shown consisting of a Nascom 3 (48K), dual disks, monitor, and printer is available from your dealer now.



## semicomps

NORTHERN LIMITED  
Semicomps Northern Ltd.  
East Bowmont Street,  
Kelso, Roxburghshire Tel (0573) 24366

## Eley Electronics

Eley Electronics, 100/104 Beatrice Road,  
(off Fosse Road North), Leicester. Tel: 0533 871522

## MID-SHIRE'S COMPUTER CENTRE

68 Nantwich Road, Crewe, Cheshire  
Tel: (0270) 211086

## MICROCOMPUTER SYSTEMS FOR HOME BUSINESS & SPECIAL APPLICATIONS

18, Station Road, Lower Parkstone,  
Poole, Dorset. BH14 8UB.  
Tel: Parkstone (0202) 746555



## MicroComms

Amateur radio, C.B. radio  
Electronics Computers

372-374 George Street Aberdeen  
Telephone: 0224 633385

## JPS

9 East Street, Colne,  
Nr. Huntingdon, Cambs.  
Tel: Ramsey (0487) 840710  
Contact Paul Jephcott



## SRS MICROSYSTEMS

161 Bramley Road, Oakwood,  
London N14  
Telephone: 01-363 8060

58 Battersea Rise,  
Clapham Junction  
London SW11 1HH  
Tel: 01-223 7730

## OFF Records

## SKYTRONICS LTD.

2 NORTH ROAD, THE PARK, NOTTINGHAM NG7 1AG  
TELEPHONE (0602) 45053

## authorized stockists



## In the heart of the Nascom country lies Business & Leisure

We specialise in tailoring  
systems to your specific  
requirements.

### Business & Leisure Micro Computers

16 The Square, Kenilworth, CV8 1EB.  
Tel: Kenilworth (0926) 512127



Stationstraat,  
6241 CL,  
Bunde (L),  
Netherlands.  
Tel: 043 641147

## CHRISALID for nascom

systems & software

tel 74569

13 High Street BERKHAMSTED

## OTHER NASCOM PRODUCTS

Kits from **£125 + VAT**  
Built from **£285 + VAT**  
Systems from **£399 + VAT**

## New Products

- ★ Micro-Ed—The Education Computer **£399 + VAT**
- ★ AVC—Advanced Video Controller with  
Colour Graphics and 80 x 24 Text **£155 + VAT**
- ★ M Basic—A compiled Basic  
for use under CP/M **£150 + VAT**
- ★ Monitor Display—12" Green Screen in  
Cream Metal Case **£120 + VAT**
- ★ Monitor Display—12" Green Screen in  
Cream Plastic Case **£99 + VAT**

To Lucas Logic Ltd., Nascom Microcomputers Division, Welton Road,  
Wedgcock Industrial Estate, Warwick CV34 5PZ, England

Please send:

Literature  Dealer List  Prog. Book Form

Name .....

Position .....

Establishment .....

Address .....

Tel. No. ....

PC 3

Lucas Logic

# MPI MICRO COMPUTER PRODUCTS

INTERNATIONAL LTD.

## SOFTWARE FOR CP/M COMPUTERS

Retailer and OEM terms available

	Software Manual & Manual Only		Software Manual & Manual Only		Software Manual & Manual Only
<b>BYROM SOFTWARE</b>			<b>MICRO-AP</b>		
BSTAM—Utility to link one micro-computer to another also using BSTAM	£95	£6	SELECTOR V	£275	£25
BSTMS—Utility to link a micro to a mini or mainframe	£95	£11	<b>MICROFOCUS</b>		
<b>CP/M USER LIBRARY</b>			CIS COBOL version 4.4	£425	£25
51 Volumes—Price per volume			FORMS 2 v11	£100	£10
8" disc (one volume per disc)	£5		<b>MICROLOGY</b>		
5" disc (one volume per 2 discs)	£10		FTNUMB (FORTRAN-80 RENUMBER & REFORMATTER)	£50	£5
Index	£2		<b>MICROPRO INC.</b>		
<b>DIGITAL RESEARCH</b>			WORD-MASTER 1.7A	£75	£22
CBASIC v 2.08	£65	£15	TEX-WRITER 2.6	£37	£17
MPM 1.1	£195	£20	WORDSTAR 3.0	£250	£38
MPM 2.0	£250	£30	MAIL MERGE 3.0 (requires Wordstar)	£75	£10
CP/M86	£160	£27	SPELLSTAR 1.0 (requires Wordstar)	£125	£10
CP/M 2.2	£95	£20	WORDSTAR TRAINING MANUAL	£18	
CP/NET	£120	£14	WORDSTAR CUSTOMIZATION NOTES	£50	
SID	£50	£14	SUPER-SORT 1.6:	£125	£22
ZSID	£55	£14	DATASORT 1.101	£175	£25
MAC	£60	£14	DATASORT CUSTOMIZATION NOTES	£50	
TEX	£50	£14	CALCSTAR	£150	£25
DESPPOOL	£33	£6	<b>APPLE VERSIONS</b>		
PL/1	£300	£27	WORDSTAR 3.0	£188	£38
BT-80	£140	£20	MAILMERGE 3.0 (requires Wordstar)	£63	£10
<b>FOX &amp; GELLER</b>			SPELLSTAR 1.0 (requires Wordstar)	£98	£10
QUICKSCREEN	£87	£12	DATASORT 1.101	£148	£25
<b>INFORMATION UNLIMITED</b>			SUPERSORT 1.6	£100	£22
WHATSIT (Database Management System)	£80		CALCSTAR	£98	£25
<b>KLH SYSTEMS</b>			<b>MICROSOFT INC.</b>		
Spooler for CPM systems v3.0	£70	£6	BASIC-80 5.21	£185	
<b>MPI LTD.</b>			BASIC Compiler 5.3	£205	
FORTH	£72		FORTRAN-80 3.43	£260	
PAYROLL	£500	£15	COBOL-80 4.01	£380	
SALES LEDGER	£200	£15	M/SORT 1.01	£75	
PURCHASE LEDGER	£200	£15	EDIT-80 2.02	£65	
NOMINAL LEDGER	£200	£15	MACRO-80 3.43	£105	
INCOMPLETE RECORDS	£1200	£20	MULISP 2.10	£105	
			MUMATH 2.10	£130	
<b>MT MICROSYSTEMS</b>			<b>MICROTECH EXPORTS</b>		
PASCAL MT- 5.5	£150	£25	REFORMATTER		
PASCAL MT- 5.5 with SPP	£265	£50	CPM ↔ IBM	£98	£17
Library Sources	£110		CPM ↔ DEC	£98	£17
Speed Programming Pkge. (Softbus)	£125	£25	<b>ORDER INFORMATION</b>		
<b>OSBORNE &amp; ASSOCIATES</b>			When ordering CP/M software please specify the format you require. All software items are subject to VAT. Manuals, when purchased separately, are not subject to VAT. Please add £4.00 for postage, packing and insurance on each item purchased. For overseas please add £6.50 per item. Most software in this advertisement is available from stock and a 72 hour return service is thereby offered on most prepaid orders. These details and prices are all current as of March 1982. Our prices reflect an exchange rate of U.S. \$2.00 to £1.00. Should the exchange rate vary by more than 5 cents, a surcharge may be added or a discount given. All payments must be in Sterling and drawn against a U.K. bank.		
ACCOUNTS PAYABLE & ACCOUNTS RECEIVABLE	£50	£15	MAIL ORDER TELEPHONE ORDER VISIT Send Cash, Cheque, Postal Order, IMO, Access or Barclaycard/Visa number to Microcomputer Products International Ltd., Room PC, 11 Cambridge House, Cambridge Road, Barking, Essex IG11 8NT.		
GENERAL LEDGER	£50	£15			
<b>PHOENIX SOFTWARE ASSOCIATES (For Z80 only)</b>					
PLINK—Disc to disc link loader	£72	£15			
PASM—Macro Assembler	£72	£15			
PEDIT—Line editor with Macros	£72	£15			
BUG—Very powerful debug	£72	£15			
PDEVELOP Package with all the above	£193	£33			
PLINK—2 Overlay Link Loader	£185	£15			
<b>STRUCTURED SYSTEMS (All converted to UK Standard)</b>					
SALES LEDGER	£350	£20			
PURCHASE LEDGER	£350	£20			
NOMINAL LEDGER	£350	£20			
STOCK CONTROL	£350	£20			
LETTERRIGHT	£95	£11			
ANALYST (File management Reporting System)	£125	£11			
NAD (Name and Address selection system)	£55	£11			
QSORT	£55	£11			
<b>SUPERSOFT INC.</b>					
DIAGNOSTICS 1	£45	£9			
TERM.	£72	£7			
<b>TDL SOFTWARE (Technical Design Labs)</b>					
BUSINESS BASIC	£80				
ZTEL (Text Editing Lang.)	£35				
LINKER	£35				

### NEW PRODUCTS

<b>DIGITAL RESEARCH</b>		
CB-80		TBA
XLT-86		TBA
<b>MAGIC CIRCLE SOFTWARE</b>		
CPMSIM		£120
<b>MICROPRO</b>		
INFOSTAR		TBA

### MEDIA AND FORMATS

Altos	A1	CPT 8000	A1	Intel MDS SD	A1	Nascom/Lucas	N1	SD Systems 5.25in	R3
APPLE CP/M-80 13 Sector	RG	Cromemco System 3	A1	Intertec Superbrain SSDD	RK	NCR 8140/9010	A1	SD Systems 8in	A1
APPLE CP/M-80 16 Sector	RR	Cromemco System 2 SD/SS	R6	Intertec Superbrain QD	RS	NNC-80	A1	Spacebyte	A1
Blackhawk Micropolis Mod II	Q2	Cromemco System 2 DD/SS	RX	ISC Intercol 8063/8360/8963	A1	NNC-80W	A1	Tarbell 8in	A1
California Computer Sys 8 in	A1	CSSN Backup	T1	ITT 3030 DSDD	R1	North Star Advantage	P2	TEI 8in	A1
CDS Versatile 4	A1	Datapoint 1550/2150	A1	Micromation	A1	North Star Horizon SSSD	P1	Televideo DSDD	S5
Columbia Data Products 8 in	A1	Delta Systems	A1	Micropolis Mod II	Q2	North Star Horizon SSDD	P2	Toshiba T200 DSDD	SF
Comart Communicator CP50	P2	Dynabyte DBB/4	A1	Morrow Discus	A1	North Star Horizon QD (MPI CP/M)P3	TRS-80 Modell · Shuffle-	board 8in	A1
Comart Communicator CP100	P2	Exidy Sorcerer · CP/M-80	Q2	Mostek	A1	North Star Horizon OD (Other CP/M)	P2	TRS-80 Modell II	A1
Comart Communicator CP200	P2	Exidy Sorcerer · Exidy CP/M-80 8"	A1	Multi-Tech 1	Q2	Nylac Micropolis Mod II	Q2	Vector MZ	Q2
Comart Communicator CP500	P2	EXO	A1	Multi-Tech 2	A1	Pertec PCC 2000	A1	Vector Systems 2800	A1
Compal-80	Q2	Heath H8 · H47	A1	Micromation	A1	Rade 1000 SSDD	RL	Vector System B	Q2
		Hewlett-Packard 125.8in	A1	Micropolis Mod II	A1	Rade 1000 DSDD	RM	Vector VIP	Q2
		ICOM 3712	A1	Morrow Discus	A1	Rair Black Box	RE	Xerox 820 5.25in	S6
		IMSAI VDP-80	A1	Mostek	R3	Research Machines 5.25in	RN	Xerox 820 8in	A1
		Industrial Microsystems 5000	RA	Nascom (Gemini Drives SSDD)	R7	Research Machines 8in	A1		
		Industrial Microsystems 8000	A1	Nascom (Gemini Drives DSDD)					

Full descriptive Catalogue: available £1 — deductible from first purchase

# 3 MORE GOOD REASONS TO RING 01 ~ 591 6511

## 1 CPMSIM CALLING ALL CDOS & CROMIX USERS THE SOFTWARE FAMINE IS OVER

At last the software famine is over. CPMSIM is a powerful simulator program for CDOS and CROMIX users. You can now savour the vast range of CP/M software that is available. This means you will no longer be starved of off-the-shelf software packages, you can indulge in the gourmet delight of your choice from our large range of CP/M programs.



## 2 APPLE

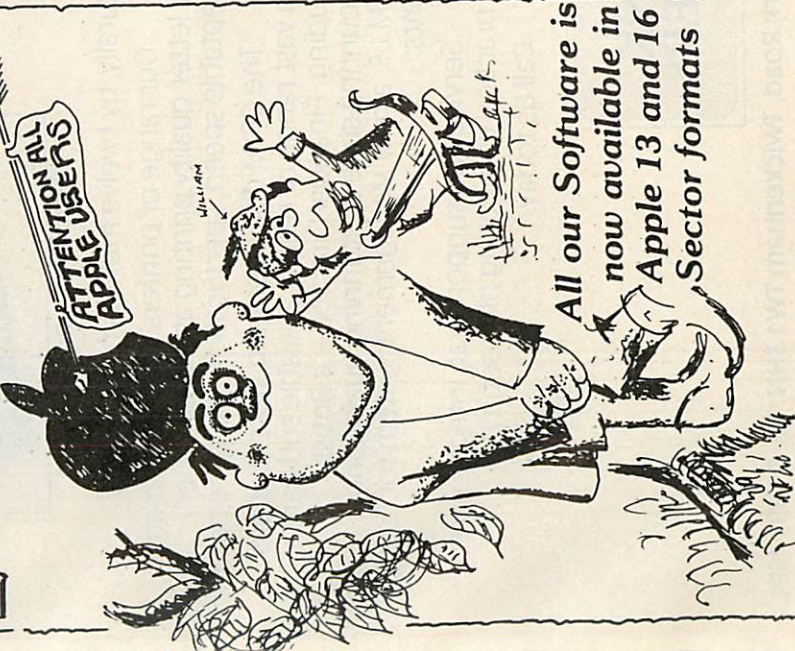

All our Software is now available in Apple 13 and 16 Sector formats

## 3 PAYROLL

Comprehensive Master File  
All Employees details stored on disc  
Six Pay Rates, standard payments/deductions and pension scales  
Employee Details screened for easy updating  
Leavers stored until Year End

### Manual Data Input for Payroll

Applicable for hourly paid employees working overtime etc.  
Screen displays standard payments and deductions per employee  
Cursor addressing used to input hours worked  
Variable payment input with description e.g. Sick £ 20.00  
Manual override for all standards screened  
Automatic calculation of Tax and N.I. for all rates and levels

Completed Payslip to NETT PAY screened for checking  
Tax Refunds flagged for operators acceptance or override  
Totals Updated only on acceptance of screened details

### Exceptions Payroll

Operated when paying weekly/salaried staff input only for employees with variances to standards  
Exceptions List printed for checking prior to payroll  
Automatic or Manual acceptance of payslips

### Print Routines

Employee Master File Details  
Comprehensive Payslips  
Coinage Analysis by Department, Credit Transfers and Cheques  
Summary of Totals and Cost Centre Analysis  
N.I. and Tax Payment Details  
P35 for Weekly Reconciliation  
Year End P60's prepared automatically  
Pro-Forms for all current employees



MAIL ORDER  
TELEPHONE  
CREDIT CARD  
ORDER  
★ VISIT ★

Trade Enquiries Welcome

# Practical Computing



Olivetti DM 5100 – Price: £900.00

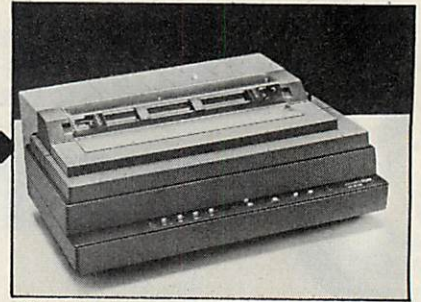

Olivetti DM80/180cps – Price: £1995.00

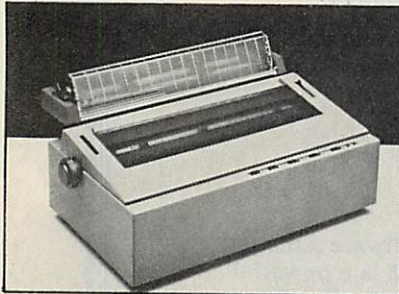

Olivetti DY211 – Price: Only £900.00!

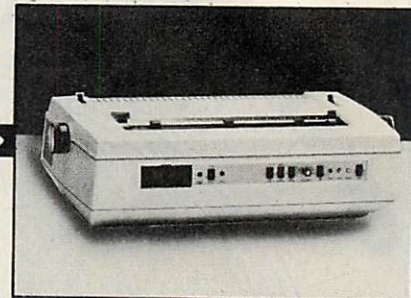
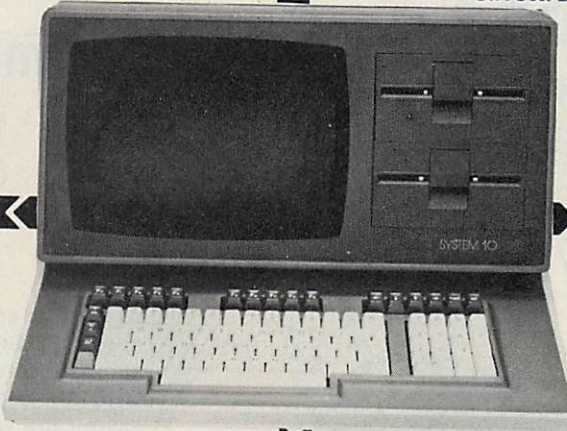

Qume Sprint 5 Range – Prices from: £1700.00

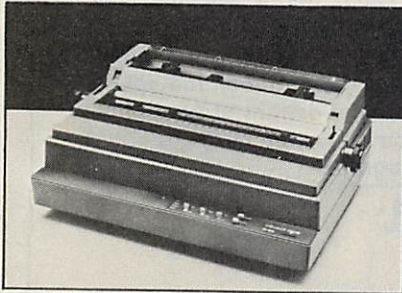

Olivetti DY311 – Price: £1050.00

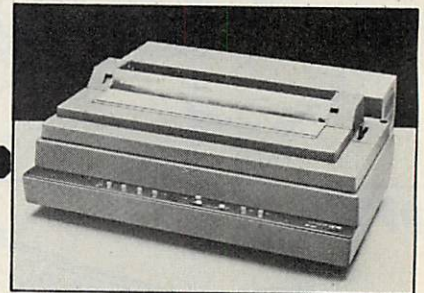

Olivetti DY811 – Price: £1995.00

Practical Computing is not only the name of a magazine. It is also a philosophy about which we feel strongly at Millbank Computers.

Practical computing solutions which meet the needs of the user is the basis on which we have built up our range of hardware, software and services.

We start with the **Millbank System 10** – the 'heavy duty' micro computer available exclusively from us and our appointed dealers. With 700K, 1.6 MB and hard disc options, the **Millbank System 10** is arguably the most reliable micro available in the UK – supported,

naturally, by twelve months full warranty.

Our range of printers covers dot matrix and letter quality printing at virtually every acceptable speed, specification and price point.

The CP/M disc operating system opens up a vast range of readily available software – including 'Financial Director' – a British Accounting suite of stunning quality and E.A.M.I.S. a new Management System for Estate Agents.

Service and support is an integral part of our practical computing philosophy.

Call us today.

**MILLBANK  
COMPUTERS**

Millbank Computers Limited, Millbank House, Amyand Park Road, Twickenham TW1 3HN. Tel: 01-891 4691.

# -and where to find it.

## BIRMINGHAM

Based in the heart of the professional area of Birmingham, **Midland Micro Ltd** provides a comprehensive computer service to users in the Midlands.

We supply everything from a single diskette to an advanced network or Mini-computer system using standard software and tailor-made packages.

Services provided by our experienced staff include consultancy, training, maintenance, and full after-sales service.

**Contact:** Ernest Willcox or Ian Willcox  
Midland Micro Ltd  
George House, George Road  
EDGBASTON, Birmingham B15 1PG  
Telephone: (021) 455 7431

## EXETER

**Teffont Business Systems** have specialised in 'word communication' equipment throughout south-west England for the past three years.

The computer division markets Micro and Mini computers. We put strong emphasis on well-proven business software, word-processing, telecommunication, and professional service/training by experienced engineering and training staff.

We also supply 'Europe's No. 1' range of facsimile machines and are Prestel dealers.

**Contact:** Stephen Taylor  
Teffont Business Systems Ltd  
48-49 High Street, EXETER EX4 3DJ  
Telephone: (0392) 30438/9

## LONDON (C)

**Forte Data Systems** offer a complete business computer service from feasibility study to implementation. We provide a wide range of evaluated business packages based on cost-effective solutions to user requirements, using customised software if necessary.

First-time users find our free consultation service an ideal starting point, existing users may be more interested in our main-frame and distributed data processing software development service.

**Contact:** Mr V. Sippy  
Forte Data Systems  
27 Rathbone Street, LONDON W1  
Telephone: (01) 637-0164

## CALNE, Wiltshire

Suppliers of accounting and related business software in particular, the **Financial Director** package incorporating bought and sales ledgers, cash book, nominal ledger, budgets and monthly management accounts.

Other software, eg. order entry, invoicing and stock control, tailored to individual user requirements.

**Microshade** provides a total sales and support service for the System 10.

**Contact:** Bryon Horton  
Microshade (Business Computers) Ltd  
Westhill House, 4 Market Hill  
CALNE, Wiltshire  
Telephone: (0249) 814879

## EPSOM, Surrey

The primary business of **Bryan Wright Ltd** is the production of programmes to meet specialised and individual needs, exclusively for the Millbank System 10 Micro-computer range.

Consultancy and advice to potential Micro-computer users.

Specifications, analysis and programming. A personal after-sales service for users' operational problems, for changing requirements in programming, and system upgrading.

Address labels and mailing-list service, with statistical analysis by areas or other criteria including delivery within a reasonable distance from Epsom.

**Contact:** Bryan Wright or Denis Wright  
Bryan Wright Ltd  
1st Floor, 57 South Street  
EPSOM, Surrey KT18 7PX  
Telephone: (78) 22653

## LONDON (N)

**B D Computer Systems** brings 'mainframe' levels of skills and professionalism to the Micro market. Our experience in selling and installing large computers now provides full operational systems solutions in the Micro market.

Our customers range from a small professional user to a large Government department.

We are ideally placed to serve all London and Home Counties organisations north of the Thames.

**Contact:** Hugh Benham,  
Susan Weitzkorn or Peter Hines  
B D Computer Systems  
2 Old Brewery Mews  
Hampstead High Street  
LONDON NW3 1PZ  
Telephone: (01) 435-4442

## CAMBRIDGE

The **Avery Computer Company** showroom caters specifically for the needs of local small businesses. A wide range of systems cover applications from financial modelling, forecasting, payroll etc. to large multi-user systems which can carry out all the functions of the electronic office.

We supply standard and customised software, special computer-aided learning courses and, above all, maintain close client liaison before and after installation.

**Contact:** Michael Avery or David Spry  
The Avery Computer Company  
13 The Mall, Bar Hill  
CAMBRIDGE CB3 8DZ  
Telephone: (0954) 80991

## MANCHESTER

**Calderbrook Technical Services (CTS)** moved successfully into the Micro computer business in the mid 1970s and now offer a wide range of products from personal to business systems, plus a vast software library.

CTS apply a very high level of technical and engineering skills to system design, installation, training and after sales service & maintenance.

**Contact:** Peter Fawthrop  
Calderbrook Technical Services  
31-33 Church Street  
LITTLEBOROUGH, Lancs OL15 8DA  
Telephone: 0706 74342/79332

## LONDON (S)

**Micro Automation Computing Ltd** was formed in 1979 with over fifty man years of computer experience to provide and support systems and software based on Micro and Mini technology.

Special emphasis is placed on real time systems for commercial, industrial and engineering applications. Services available include the supply of complete computer systems, tailored turnkey systems and packages, data base applications, specialised drivers for word-processing and colour graphics, and systems software for Micros.

**Contact:** David Shorter  
Micro Automation Computing Ltd  
207 Putney Bridge Road  
LONDON SW15 2NY  
Telephone: (01) 874 2535

## CHELTENHAM

'We won't blind you with science' is the basis of this locally owned company's services to businesses, institutions and individuals.

Partners have wide-ranging business and computer experience and have built up an impressive range of books, manuals, personal computers, business computers, standard software and consumables.

**Contact:** David Lewis,  
Robin Phelps or Don Price  
The Computer Shack  
14 Pittville Street  
CHELTENHAM, Gloucestershire  
Telephone: (0242) 584343

## SWANSEA

**Croeso Computer Services** is a well established Micro computer systems house specialising in turnkey systems for financial companies, bakeries, licenced trade stock-taking and petrol stations.

We design specialist software systems for individual requirements in business, industry and the professions. A wide range of computer equipment is available.

**Contact:** Simon Shellard or  
Michael Breach  
Croeso Computer Services  
516 Mumbles Road, MUMBLES  
Swansea, West Glamorgan  
Telephone: (0792) 61555/6

This is not a comprehensive list of Millbank dealers so if your area is not covered by any of the dealers listed here call us direct.

**Millbank Computers Limited**  
Millbank House Amyand Park Road  
TWICKENHAM TW1 3HN  
Telephone: 01-891 4691

# A GUIDE TO

# GOOD BRITISH SOFTWARE

LESSON NO 1

"WHAT IS DMS?"

DMS is Britain's best selling records management program for micro computers. You can think of DMS as a computerised super-efficient filing cabinet. Nearly 3000 companies, colleges, hospitals and other organisations use DMS to increase efficiency.

"WHAT MACHINES DOES IT RUN ON?"

It runs on all Commodore Machines, plus virtually any micro with an operating system known as CP/M or MP/M. This includes the ACT SIRIUS, The NEC PC 8000, the Rank Xerox 820 or 860, Superbrains, Apples with CP/M cards, the ICL Personal Computer, The Hair Black Box, the Sharp MZ 80B, the LSI M2 and M3, and the Caltext, and all machines with standard 8" disks.

"WHO USES IT?"

It's designed for use by managers, secretaries and clerical staff. They use it to make life easier by storing their personnel records, their student or patient records, their stock records, library lists, contract records, customer and client records, parts files, property and policy records, etc. etc.

"HOW DO I USE IT?"

All instructions are in everyday conversational English, so you need never have used a computer before. Just tell DMS what information you need to store, then type your information on to disk. Once they are on there you really start to reap the benefits. For instance DMS will find an individual records for you to check, amend or print, or it will find all those which meet various parameters handling batches of record faster than you could imagine possible. It can sort them into any order need — be it date order, numeric order, or alphabetic order. It can print lists, or transfer the information into your wordprocessor (eg Wordstar, Spellbinder, etc) to do selective mailing. (It even gives a little extra help by printing labels to match.) Or it can do some very clever calculations. Or print reports, to your own special layouts. Every facility is designed to save you time, remove those tedious clerical tasks and make your organisation more efficient. More than anything, DMS allows you to have all your information at your fingertips as soon as you want it.

"HOW MUCH DOES IT COST?"

Work on the Commodore version costing around £290, and the CP/M versions from £400. Staff can be trained on regular courses run at our training centre, both on DMS and Wordstar.

"WHAT ABOUT LESSON NO 2?"

Ring Compsoft Ltd, on Guildford (0483) 898545, or write or visit us at Hallams Court, Shamley Green, Nr Guildford, Surrey GU4 8QZ.



## MIDAS S100 SYSTEMS

**MIDAS 1: From £835**

**MIDAS 2: From £1,790**

**MIDAS 3: From £2,450**

**MIDAS 3HD: From £5,495**

**ITHACA-DPS 1: From £1,494**

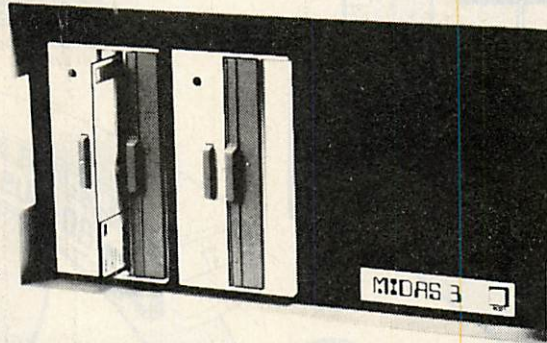

- Our versatile **Z80** Microcomputers are available as standard units or custom configured to your exact specification from a comprehensive range of stocked **S100** boards.
- Disc storage capacity of the **MIDAS 3** can be 2M Bytes, expandable to over 80M Bytes with a Winchester Hard Disc Unit in our **MIDAS 3HD** range.
- **MIDAS** runs **CP/M** and **MP/M**. Other Software includes **M-BASIC**, **C-BASIC**, **FORTRAN**, **COBOL**, **CIS-COBOL**, **PASCAL** and **Word Processing**.
- A **MIDAS 3D** with 64K RAM and 2M Bytes storage on two 8" drives with two Serial I/O Ports and **CP/M** only **£2985**.
- Printers, VDUs and other peripherals stocked to give complete package system at keen prices.

## BOARDS

We stock over 50 different S100 Boards all from quality manufacturers, such as Godbout, SSM, Micromation, Dual, Ithaca, Vector, S.D. Systems, Morrow, Pickles & Trout, etc.

### PROCESSOR

Z80 Starter Kit	£251
SBC 100	£215
8085/88 CPU	£190
Z80A CPU 4MHz (4 Types)	From £183
8086	(tba)

### EPROM

2716 EPROM (2 x 16K)	£95
2768/2716/2732 Programmer	From £143

### VIDEO BOARDS

24 x 80 I/O Drive	£298
24 x 80 Memory Mapped	£298

### DISK CONTROLLERS

Single Density 5" or 8"	From £285
Disc 1 D/D DMA	£282
Double D/D + Serial I/O	£336

### RAM

Static RAM 16-64K 24 Bit add.	From £175
Dynamic RAM 64K 8/16 Bit	£683
Memory Manager	£60

### I/O BOARDS

2s/2p or 4s/2p or 3p/1s etc	From £120
A/D & D/A 8 or 12 Bit	From £220
IEE 488 interface	£360

### MISCELLANEOUS

Real Time Clocks (2 Types)	From £120
Graphics 512 x 256	£416
Maths Board AMD 9511	£345
Extender Boards/Logic Probe	£45
Mother Boards 8-20 Way	From £32

### MAINFRAMES

We are the sole UK Distributor for Integrand Mainframes and Disc Enclosures, available in nine models including Desk Top and Rack Mounting, with or without provision for Disc Drives. All units totally enclosed, painted on all external surfaces and complete with power supply etc.

### SOFTWARE

CP/M 1 & 2, MP/M, PL/1, C-BASIC 2, M-BASIC V5, XYBASIC, FORTRAN 80, COBOL 80, CIS-COBOL, PRO-PASCAL, Forth, MAC, ZSID, Disassembler, Wordstar, Datastar, Magic Wand, Wordmaster, Supersoft etc etc.

Prices exclusive of VAT.

We are pleased to discuss your requirements and will advise you as to whether your needs can be met with one of our computers.

All of our systems are specials as they are configured to suit your specification, thus ensuring that you get what you want rather than what happens to be available.

Write or phone for a catalogue.

**Unit 14, 29 Willow Lane, Mitcham, Surrey**  
**Telephone: 01-640 6931/2/3**

# 80 BUS STATION

FARES		Hardware (Built & tested)	
GM813	£225	GM802	£140
GM814	£140	GM803	£65
GM815-1	£125	GM807	£40
GM815-2	£325	GM808*	£29.50
GM816	£550	GM809	£125
AM819	£125	GM810K	£69.50
AM820	£85	GM811	£175
GM821	£35	GM812	£140
GM824	£30	GM814	£140
GM825	£30	GM815	£140
GM826	£100	GM816	£140
GM827	£100	GM817	£140
GM828	£200	GM818	£140
		GM819	£140
		GM820	£140
		GM821	£140
		GM822	£140
		GM823	£140
		GM824	£140
		GM825	£140
		GM826	£140
		GM827	£140
		GM828	£140

## ROUTE

The Gemini Multiboard concept is the logical route to virtually any microcomputer system you care to name. Whether you require a business system, an educational system, a process control system or any other system, there is a combination of Multiboards to fulfil that function. This concept ensures maximum flexibility and minimal obsolescence. Maintenance and expansion is greatly enhanced by the modular board design. Multiboard is based on the 80-Bus structure, which is finding increasing acceptance among other British manufacturers; thus broadening the product base.

## SOFTWARE

- GM512 CP/M 2.2 for Multiboard
- GM517 Gem-Zap edit/csm tape
- GM518 Gem-Zap edit/csm disk
- GM519 Gem Pen editor
- GM520 text formatter tape
- GM521 Gem Pen editor
- GM522 text formatter EPROM
- GM523 text formatter disk

- GM813 280 CPU/64k RAM card
- EV814 IEEE488 card
- GM815-1 Single drive disk unit
- GM815-2 Double drive disk unit
- with PSU (700K)
- AM819 Speech board
- AM820 Light Pen
- GM821 ASCII keyboard
- GM824 Gem Dis dissembler
- GM825 Gem Dis dissembler
- GM826 Comal-80 tape
- GM827 Comal-80 disk
- GM828 APL disk

Utilising the powerful 4MHz 280A microprocessor the GM811 CPU card can be used as either a stand alone controller or as the heart of a complex microcomputer system. Four memory devices chosen. Input and output facilities include both programmable serial and parallel interfaces - RS232, 1200 baud CUTS cassette interface, 280A PIO, and an eight bit input port. In an expanded system the unique on-board RPI/M monitor allows the creation of cassette or EPROM based programs or files which are upwards compatible with a disk based CP/M system.

Similar to the popular GM813 CPU card, the new GM811 CPU card has 64k of dynamic RAM replacing the 'byte-wide' sockets. An extended addressing mode facilitates future memory expansion up to 2 megabytes! The RPI/M monitor retains full RPI/M - CP/M compatibility.

**START HERE OWNERS**

**GM 821 KEYBOARD**  
With a 59 key full QWERTY layout, this ASCII encoded keyboard includes cursor control keys, caps, lock, two key rollover and auto-repeat.

**GM 813 CPU/80K**

**GM 811 CPU**

**STOP & PICK UP ANY MULTIBOARDS ON YOUR WAY**

**GM 810**  
3 amp PSU with an 8-slot Motherboard

**GM 807**  
3 amp PSU for the smaller system

**CHEAPSKATE ROUTE**

**ESOTERIC ROUTE**

**SKY HIGH PRICES INC.**

**Gemini Multiboard**

**THE**

# LOGICAL ROUTE

**GM 812**  
-IVC



The GM812 Intelligent Video Controller card features an on board Z80A processor to provide independence of the host processor and the ability to redefine the functions and parameters of the display.

Normally used in an 80 x 25 mode the card contains a programmable character generator allowing three additional modes of operation - inverse characters, 160 x 75 block graphics, or user defined characters.

A keyboard socket allows buffered character input, and a light pen socket is provided for specialist applications. Being I/O mapped the card does not occupy any system memory space.

**GM 809**  
FDC

**GM 815**  
DRIVE UNIT



## GM 809 FDC

The GM809 floppy disk controller card can support up to four disk drives in either single or double density modes. The card uses the Western Digital 1797 controller and has variable write precompensation and phase locked loop data recovery circuitry.

## GM 815 Drive unit

The GM815 floppy disk housing contains one or two 5 1/4" double density, double sided Pertec FD 250 drives. This gives a storage capacity of 350K per drive. Power for the drives is provided by an integral supply unit.

**AUTO-EXCHANGE**  
All your RP/M software automatically transferred to CP/M



A CP/M 2.2 package is available with the GM 809 card and Pertec drives. On-screen editing auto single/double density selection and parallel or serial printers are supported. Running under CP/M is a wide range of utilities, application software and languages.

## FILL-UP WITH SOFTWARE

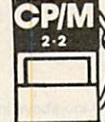

**GM 803**  
EPROM BOARD

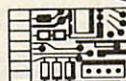

**PROTO-TYPING BOARDS**

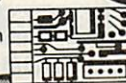

**GM 816**  
I/O BOARD

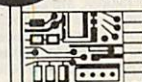

The Gemini I/O board provides a unique solution for interfacing to "the real world". The board contains 3 PIO's, a CTC and a real time clock with battery back up. "Daughter" boards may also be added and these include A-D, D-A, opto-coupling and serial interface boards.

**GM 808**  
EPROM PROGRAMMER



The GM808 EPROM programmer connects to the PIO on the CPU card and allows the user to program 2708 or 2716 type Eproms.

The GM802 RAM board provides a full 64K of dynamic memory. The 80 BUS RAMDIS signal is fully supported so that any EPROM in the system is given priority over the RAM, preventing any possibility of bus contention. Page Mode is also supported by the card which, with the appropriate software, allows up to four memory boards to be used in a system.

**GM 802**  
RAM

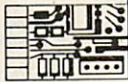

RP/M software is available on tape and includes Editor/Assembler; Text Editor/Formatter; Disassembler/Debugger; Pascal and Comal-80. These packages can also be run under CP/M.

The GM803 EProm Board will accept up to 16 2708 or 2716 EProm devices. This allows the addition of up to 32K of firmware to the system. The board supports the Page Mode system and consequently need not occupy any memory space when not in use.

A number of manufacturers are busy working on additional 80-BUS boards which will progressively increase the potential of your MultiBoard system.

80 BUS compatible prototyping boards are available from both Vero and Winchester Technology. These allow the user to easily add a card of their own design to the system.

**ONE WAY**

**MEN AT WORK**

**AM 819**  
SPEECH BOARD



The Arlon Microelectronics speech board utilises the National Semiconductor Digitaltalker chip set. This gives a vocabulary of over 140 words and sub sounds. Output is from an on-board speaker.

**AM 820**  
LIGHT PEN



This low cost light pen can be used with the GM812 IVC for many applications, including answer selection, editing, menu selection and movement of displayed data blocks.

**EV 814**  
IEEE 488



The EVC IEEE 488 Controller card has been designed to fully implement all IEEE 488 interface functions. This card gives the user a very versatile method of controlling any equipment fitted with a standard IEEE 488 or GPIB interface at minimal cost.

## GEMINI MULTIBOARDS - BUY THEM AT YOUR LOCAL MICROVALUE DEALER

All the products on these two pages are available while stocks last from the MicroValue dealers listed on right (Mail order enquires should telephone for delivery dates and post and packing costs.) Access and Barclaycard welcome.



**INTERFACE COMPONENTS LTD.**  
Oakfield Corner, Sycamore Road,  
Amersham, Bucks.  
Tel: (02403) 22307. Tlx: 837788.

**COMPUTER INTERFACING & EQUIPMENT LTD.,**  
The MICRO-SPARES Shop,  
19 Roseburn Terrace,  
Edinburgh EH12 5NG  
Tel: (031) 337 5611

**E. V. COMPUTING**  
700 Burnage Lane, Burnage,  
Manchester M19 1NA.  
Tel: (061) 431 4866.

**ELECTROVALUE LTD.**  
28 St Judes, Englefield Green,  
Egham, Surrey TW20 0HB.  
Tel: (0784) 33603. Tlx: 264475.

**SKYTRONICS,**  
2 North Road, The Park,  
Nottingham.  
Tel: (0602) 45053/45215

**TARGET ELECTRONICS**  
16 Cherry Lane, Bristol BS1 3NG.  
Tel: (0272) 421196.

**BITS & PC'S**  
4 Westgate, Wetherby,  
W. Yorks.  
Tel: (0937) 63774.

**HENRY'S RADIO**  
404 Edgware Road, London W2.  
Tel: (01) 402 6822.  
Tlx: 262284 (quote ref: 1400).

**LEEDS COMPUTER CENTRE,**  
62 The Balcony,  
Merion Centre, Leeds.  
Tel: (0532) 458877

● Circle No. 110

# CALL ONLY BY APPOINTMENT AT 55 BEDFORD COURT MANSION, BEDFORD AVENUE, LONDON W.C.1, TELEX 892031 TWC G

WARRANTY NOTE: WE HANDLE ALL REPAIRS OURSELVES.  
WARRANTY COVERS FREE REPLACEMENT EQUIPMENT IF DEFECTIVE IN FIRST THREE WEEKS.  
THEREAFTER UP TO 12 MONTHS THE COVER PROVIDES INSURANCE ON ALL SPARE PARTS AND LABOUR COSTS (EXCLUDING CARRIAGE).  
CALL OUT MAINTENANCE IS ALSO AVAILABLE AT 25.00 MINIMUM (LONDON) 50.00 MINIMUM ELSEWHERE IN U.K. PLUS MILEAGE.

OUR PRICE \*\*\*\*\* 595.00 \*\*\*\*\* VAT  
DBMS2 + SORTS + MAGIC WAND + MBASIC 80 + SUPER-CALC NORMALLY 1140 POUNDS  
EXTRA SPECIAL SUPERBRAIN PROGRAM MAIL ORDER OFFER OF THE 5 MAIN PROGRAMS

(NOT INC VAT)	OUR PRICE	(NOT INC VAT)	OUR PRICE
01 - SUPERBRAIN OR N/STAR 80	1950.00	01 - SUPERBRAIN OR N/STAR 80	1950.00
02 - NEC 6510 (OR SIMILAR)	475.00	02 - NEC 6510 (OR SIMILAR)	475.00
03 - CABLE ADAPTER	25.00	03 - CABLE ADAPTER	25.00
04 - 12 MONTH WARRANTY	235.00	04 - 12 MONTH WARRANTY	235.00
05 - DELIVERY IN U.K.	40.00	05 - DELIVERY IN U.K.	40.00
06 - TRAINING SESSION	50.00	06 - TRAINING SESSION	50.00
07 - CPM HANDBOOK	8.75	07 - CPM HANDBOOK	8.75
08 - 50 BASIC EXERCISES	8.75	08 - 50 BASIC EXERCISES	8.75
09 - BOX PAPER (2000 SHEETS)	20.00	09 - BOX PAPER (2000 SHEETS)	20.00
10 - DBMS2 (DATABASE)	575.00	10 - DBMS2 (DATABASE)	575.00
11 - MAGIC WAND	190.00	11 - MAGIC WAND	190.00
12 - MBASIC-80	150.00	12 - MBASIC-80	150.00
13 - SUPER CALC	150.00	13 - SUPER CALC	150.00
14 - 25 DYSAN D/SIDE DISKETTES	114.00	14 - 25 DYSAN D/SIDE DISKETTES	114.00
15 - DOS + AND DIAGNOSTICS	125.00	15 - DOS + AND DIAGNOSTICS	125.00
16 - MSCORT & DSORT	75.00	16 - MSCORT & DSORT	75.00
17 - RECOVER + AUTOLOAD	25.00	17 - RECOVER + AUTOLOAD	25.00
18 - INSTANT BASIC	9.00	18 - INSTANT BASIC	9.00
19 - 50 GAMES ON DISK	100.00	19 - 50 GAMES ON DISK	100.00
(NOT INC VAT)	4325.50	(NOT INC VAT)	4325.50
100.00		100.00	
9.00		9.00	
25.00		25.00	
75.00		75.00	
125.00		125.00	
150.00		150.00	
150.00		150.00	
150.00		150.00	
190.00		190.00	
575.00		575.00	
20.00		20.00	
8.75		8.75	
8.75		8.75	
50.00		50.00	
50.00		50.00	
410.00		410.00	
25.00		25.00	
1695.00		1695.00	
2395.00		2395.00	
NORMALLY		NORMALLY	
4950.00		4950.00	

## DATABASE MANAGEMENT + WORD-PROCESSING + MODELLING + DIY INTERPRETER + SERVICE \*\*\* ALL YOU NEED FROM A COMPUTER SYSTEM \*\*\*

G.W. COMPUTERS LTD, 01-636 8210 01-631 4818

ALL IN ONE PROGRAM FROM G.W. COMPUTERS, THE DBMS2 II.

Every word in the system, as well as the file architectures, print masks, and field attributes, is capable of alteration by you without programming expertise (but with some thought).

Individuals as well as for the total number of matches. In all some 60 bits of information relating to one record or a group of records on simply one permutation of the selection criterion, with a cross referencing facility as well.

Currently you can ask 5 types of questions 20 times for a single selection criterion, and then you can compute 10 mathematical relationships between the questions for the marital status, income, and frequency of illness in the past 2 years.

Find all patients who are currently at work and where treatment failed to effect a cure in under 6 days. When you find such persons then print a list showing their age, have more than 3 children, are currently at work and where treatment failed to effect a cure in under 6 days.

Find all patients who are currently at work and where treatment failed to effect a cure in under 6 days. When you find such persons then print a list showing their age, as the profit in either percent or round figures of that projected selling price.

You find such categories then print a report showing the description, cost price, quantity on hand, lead time for refills, what the selling price should be if raised by 12.3% as well 1000.00, the selling price higher than 2000.00; that are not in cartons bought from supplier 52, allocated more than 20, rated for tax at 15% and weigh less than 50 lbs. When you find such persons produce a printed list of them showing their names, telephone numbers, and what their salaries are as well as their salary if increased by 10% and show their availability for work. At the end of the list enumerate the total of such persons.

Find someone whose name begins with 'W', who is either in London or Birmingham, and available for work at a salary of less than 10,000.00; and is under 40 years of age, not married, or creditworthiness grade 1, with a car, prepared to travel, and who likes horses, does not mind the hours he works, is congenial and has good references. When you find such persons produce a printed list of them showing their names, telephone numbers, and what their salaries are as well as their salary if increased by 10% and show their availability for work. At the end of the list enumerate the total of such persons.

Find someone whose name begins with 'W', who is either in London or Birmingham, and available for work at a salary of less than 10,000.00; and is under 40 years of age, not married, or creditworthiness grade 1, with a car, prepared to travel, and who likes horses, does not mind the hours he works, is congenial and has good references. When you find such persons produce a printed list of them showing their names, telephone numbers, and what their salaries are as well as their salary if increased by 10% and show their availability for work. At the end of the list enumerate the total of such persons.

Within the appropriate frames of reference you could ask questions like the following:

The list is as endless as that which meets the requirements of your own imagination.

Within hours perform all the above in French or German.

Accounting  
Stock control  
Simulations  
Calc-type predictions  
Bureau services  
Answer what-if's  
Print reports  
Sort files

Budgeting  
Address mailing  
Time recording  
Hospital indexing  
General analysis  
Employee records  
Sort files

Letter writing  
Cashflow  
Accounting  
Stock control  
Simulations  
Calc-type predictions  
Bureau services  
Answer what-if's  
Print reports  
Sort files

DBMS2 is a record relational as well as a file relational database management tool that is capable of being at different times, many different things. The one core program can be set up to perform tasks normally associated with the following list.

## \*\*\* THE NEW DBMS (DATABASE) \*\*\*

G.W. COMPUTERS LTD, 01-636 8210 01-631 4818

Configured in any fashion you like - wherever you want.

Computer user stations can be configured in a countless number of ways. A series of three intelligent-type terminals are offered. Each is a perfect cosmetic and electrical match to the system. The Computer 10 - a 32k programmable RAM-based terminal (expandable to 64k) is just right if your requirements are more sophisticated. Select either our Computer 20 or Computer 40 as user stations. Both units offer dual disk storage in addition to the disk system in the Computer. The Model 20 features 32k of RAM (expandable to 64k) and 350k of disk storage. The Model 40 comes equipped with 64k of RAM and over 700k of disk storage. But, most importantly, no matter what your investment in hardware, the possibility of obsolescence or incompatibility is completely eliminated since user stations can be configured in any fashion you like - wherever you want.

Our New Computer 10 Megabyte Disk Storage System (called a DSS) features an 8 inch Winchester drive packaged in an attractive, compact desktop enclosure. Complete with disk, controller and power supply. Just plug it into the Z80 adaptor of your Superbrain and turn it on. It's so quiet, you'll hardly know it's there. But, you'll quickly be astounded with its awesome power and amazing speed. The secret behind our Computer DSS is its unique controller/multiplexor. It allows many terminals to "share" the resources of a single disk. So, not only can you use the DSS with your Superbrain, you can configure multiple user stations using our new series of Computer 10 terminals, called Video Processing Units of VPU STM.

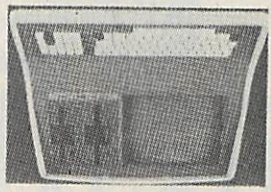
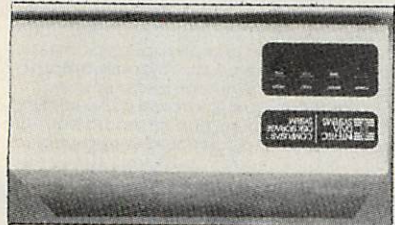

But the real beauty of the Computer is its "shared logic" design concept. Each user station contains its own distinct microprocessor and RAM. The result is lightning fast program execution. Even when all 16 users are on-line. Even when all are performing different tasks! A special multiplexor circuit in the Computer ties all external users together so that no single user ever need wait on another. An incredibly exciting concept!

A remarkable breakthrough in price/performance, the Computer boasts nearly 1 megabyte of on-line mini-disk storage (almost 2 megabytes on Computer II) and can be easily expanded to 20, 36 or 66 megabytes of hard-disk in just seconds. And since each user station can accommodate up to 64k or RAM, a total of over one million bytes can be incorporated into the system to tackle even your most difficult programming tasks.

CALL ONLY BY APPOINTMENT AT 55 BEDFORD COURT MANSIONS, BEDFORD AVENUE, LONDON WC1.

IF YOU WISH TO MAKE THE WARRANTY TO 1 YEAR THEN ADD 5% OF HARDWARE COST. OTHERWISE NO MAINTENANCE SCHEDULE. SIMPLY ADD-HOC CHARGES AFTER WARRANTY EXPIRATION. SAME QUALITY SERVICE. (SITE MAINTENANCE ON APPLICATION). MAIL ADDRESS: G. W. COMPUTERS LTD, 55 BEDFORD COURT MANSIONS, BEDFORD AVENUE, LONDON WC1. TELEX 892031 TWC G

Table with 3 columns: SYSTEM 1 (64K+750 K DISK, CRT AND GRAPHICS CP/M), SYSTEM 2 (64K+5.6 MEGABYTE CORVUS MICRO-WINCHMASTER & CRT IN 1 SUPERBRAIN UNIT), SYSTEM 3 (64K+1.5 MEG CRT AND TWIN 5" IN COMPUSTAR UNIT). Lists various hardware and software items with prices.

IMPORTANT!!! NO HARDWARE IS ANY VALUE WITHOUT THE SOFTWARE, AND OUR SOFTWARE IS UNEQUALLED. WE GIVE YOU A DISCOUNT TO SET YOU GOING. JUST DECIDE ON THE SYSTEM YOU INTEND PURCHASING, AND TAKE 10% OFF ITS VALUE. IF YOU WOULD HAVE TO PAY FOR THE SOFTWARE, YOU COULD GET THE SOFTWARE FREE WITH THE HARDWARE IF YOU CHOOSE THE BEST SYSTEM WE SELL.

G.W. COMPUTERS LTD, 01-631 4818

GRAMA (WINTER) LTD/G.W. COMPUTERS LTD. ARE THE PRODUCERS OF THIS PACKAGE WHICH IS UNEQUALLED FOR ITS LEVEL OF TOTAL INTEGRATION. LINGUISTIC FLEXIBILITY AND MAXIMISED DISK/MEMORY CONSERVATION.

\*\*\*\*\* SUPER - BUS \*\*\*\*\* A NEW HIGHER LEVEL OF THE ABOVE PACKAGE HAS BEEN REDUCED IN SIZE BY 50 PER CENT TO A SINGLE 15K BASIC PROGRAM, MAKING ALL FILE RETRIEVALS A MATTER OF NANoseconds. WORKS DBMS (DATABASE) HAS 01 = 02 = 04 = 06 = 07 = 08 = 17 = 18 = 21 = 24 = PRICE 475.00

- 01 = ADDRESS SECTION
02 = STOCK CONTROL
03 = A/C RECEIVABLES
04 = SALES LEDGER
05 = A/C PAYABLES
06 = PURCHASE LEDGERS
07 = BANK UPDATE
08 = USER DATABASE AREA
09 = INVOICE CREATION
10 = ORDER FILES
11 = 30/60/90 DAY AGE ANALYSIS
12 = ARITHMETIC SECTION
13 = PRINT CUSTOMER STATEMENTS
14 = PRINT SUPPLIER STATEMENTS
15 = PRINT AGENT STATEMENTS
16 = PRINT TAX STATEMENTS
17 = RUN SEPARATE PROGRAMS
18 = CHANGE VOCABULARY
19 = NOMINAL ANALYSIS
20 = AGED DEBTOR ANALYSIS
21 = DISK DIRECTORIES
22 = FILE MANAGEMENT
23 = SORTS
24 = DISK SWAP/EXIT SYSTEM
WHICH OPTION... (LEVEL 8.00 @ 875.00)

WIDELY USED IN U.K./FRANCE/U.S.A. AND ENGLISH SPEAKING COUNTRIES FOR ITS OVERALL FLEXIBILITY AS A COMPLETE BUSINESS PACKAGE INCLUDES INVENTORY, DATABASE MANAGEMENT, INVOICING, MAILING ADDRESSES, STATEMENTS, SALES/PURCHASE LEDGER WITH OR WITHOUT AUTO STOCK UPDATE AND DOUBLE ENTRY JOURNALS INCLUDING NOMINAL LEDGER; PLUS A/C RECEIVABLE AND PAYABLE MAKING AUTO BANK ENTRIES.

G.W. COMPUTERS LTD, 01-631 4818

Superbrain users get exceptional performance for just a fraction of what they'd expect to pay. Standard Superbrain features include: two double density mini-floppies with 350k bytes of disk storage, 32k of ram memory (expandable to 64k) with a high powered text editor, assembler, debugger and a disk formatter. And, with Superbrain's S-100 bus adaptor, you can add all the program power you will ever need... almost any type of S-100 compatible bus accessory. Superbrain's CP/M operating system boasts an overwhelming amount of available software in BASIC, FORTRAN, COBOL, and APL. Whatever your application... General Ledger, Accounts Receivable, Payroll, Inventory or Word Processing, Superbrain is tops in its class. And the Superbrain CD boasts the same powerful performance but also features a double-sided drive system to render more than 700k bytes of disk storage and a full 64k of RAM. All standard! Whatever model you choose, you'll appreciate the careful attention given to every engineering detail. A full ASCII keyboard with numeric pad and user-programmable function keys. A non-glare, specially focused, 12-inch CRT for sharp images everywhere on the screen. Twin Z-80 microprocessors to ensure efficient data transfer to auxiliary peripheral devices. Dual universal RS-232C communications ports for serial data transmission. And, a single board design to make servicing a snap!

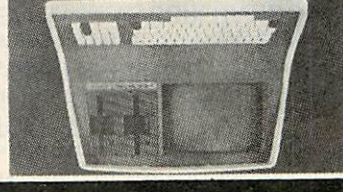
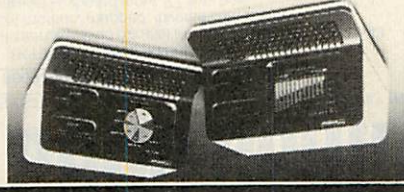

Integrated Desk Top Computer with 12 inch Bit-Mapped Graphics or Character Display, 64K RAM, 4 Mhz Z80A Two Quad Capacity Floppy Disk Drives. Selectric® Style 87 key keyboard, Business Graphics Software.

The North Star ADVANTAGE™ is an interactive integrated graphics computer supplying the single user with a balanced set of Business-Data, Word, or Scientific-Data processing capabilities along with both character and graphics output. ADVANTAGE is fully supported by North Star's wide range of System and Application Software. The ADVANTAGE contains a 4 Mhz Z80A CPU with 64k of 200 nsec Dynamic RAM (with parity) for program storage, a separate 20k 200 nsec RAM to drive the processor to control the keyboard and floppy disks. The display can be operated as a bit-mapped display, a 2kb bootstrap PROM and an auxiliary Intel 8035 micro-processor to control the keyboard and floppy disks. The display can be operated as a 1920 (24 lines by 80 characters) character display or as a bit-mapped display (240 x 640 pixels), where each pixel is controlled by one bit in the 20kb display RAM. The two integrated 5 1/4 inch floppy disks are double-sided, double-density providing storage of 360kb per drive for a total of 720kb. The n-key rollover Selectric style keyboard contains 49 standard typewriter keys, 9 symbol or control keys, a 14 key numeric/cursor control pad and 15 user programmable function keys.

# The '6809' centre

## RECOMMENDED SYSTEMS...

STIRLING '77-68', 6809 Based Kit System, on 8" x 8" PCB's. EX VAT INC VAT

6809 CPU BOARD: 1K RAM, 2K EPROM Socket (2716), RS-232 & TTL serial interface, 8 bit parallel I/O port, 77 way bus, video output, 8 bit parallel keyboard input, 77 way bus.	10.43	12.00
CASSETTE BOARD: Kansas City CUTS standard, TTL levels, 300-2400 baud operation, 3.5" x 4.5" board.	10.43	12.00
80 WAY EDGE CONNECTORS, one required per 8" board.	5.22	6.00
78 WAY BACKPLANE, to take edge connectors.	5.00	5.75
19" CARD FRAME, to hold backplane and boards.	7.83	9.00
SM-BUG: 2K Monitor EPROM, linking CPU with VDU & keyboard.	43.04	49.50
DESIGN NOTES: construction notes & diagrams for each board.	20.00	23.00
COMPLETE SYSTEM, CPU, VDU, CASSETTE.	0.87	1.00
	109.56	126.00

(Excluding Power Supply, TV/Monitor, Keyboard & Components)  
Full Range of 11 Boards Available, Including Disk Controller, Parallel Ports, Memory Boards, etc. Send for further details.

## FUJITSU, FROM JAPAN.

MICRO-8, 6809 PROCESSOR & KEYBOARD, Twin '6809' processors, 64K RAM, 48k Colour Graphics RAM, Cassette, RS-232, Parallel Printer and Analogue Interfaces, RGB Colour and B & W Video output, 40 x 20 or 80 x 24 Screen, 32k ROM Basic, Numeric and Cursor control pad, Function Keys, BMC RGB COLOUR MONITOR.	868.70	999.00
14" Screen, with TTL input levels, 8 pin connector supplied.	260.00	299.00
FUJITSU, DUAL 5 1/4" DRIVES, Single Density, Double Sided, with 656 Kbyte capacity.	1216.52	1399.00
Supplied complete with adaptor for Micro-8 COMPLETE SYSTEM, MICRO-8, MONITOR & DISKS.	2345.22	2597.00

## SOUTH WEST TECHNICAL PRODUCTS CORP - Superb Value from the USA.

SWTPC S/09-64K PROCESSOR, 6809 based CPU, with 64K RAM, expandable to 512K, with 2 Serial RS-232 & 1 Parallel Printer Port. Can be expanded to Multi-User system. Standard SS-50c bus.	1347.83	1550.00
SWTPC 8212 TERMINAL, 12" Intelligent Terminal, with full Keyboard & Cursor Pad, 82 x 20/24 Screen Format, Green Screen, Full Cursor Controls, RS-232 Serial & Parallel Printer Interfaces, Selectable Baud Rate.	860.87	990.00
SWTPC D-5, TWIN 5 1/4" DISK DRIVES, Single Density, Double Sided Drives, 740 Kbyte Capacity, Supplied with Flex9 Operating System for S/09-64K.	1129.57	1299.00
COMPLETE SYSTEM, PROCESSOR, TERMINAL & DISKS.	3338.27	3839.00

## SOFTWARE - 6800 & 6809 - on Cassette - 300 Baud, CUTS, S1 Format.

6800 Disassembler, with Move function.	10.00	11.50
6800 Text Editor, with Source Listing.	28.00	32.20
6800 Assembler, with Source Listing.	28.00	32.50
6800 Text Processor, with Source Listing.	28.00	32.50
6800 Relocator, with Source Listing.	16.09	18.50
6800 BK Basic Interpreter (V2.3).	15.22	17.50
6809 Text Editor, with Cassette Routines.	60.78	69.90
6809 Macro Assembler, Memory to Cassette.	60.78	69.90
6809 10.5K Basic Interpreter.	60.78	69.90

## FLEX9, 6809 Disk Software, on 5 1/4" or 8" Disks.

Configurable Flex, with Text Editor & Assembler Sort/Merge Package, with File Editing Facilities	120.00	138.00
Debug Package, a complete 6809 Simulator	58.26	67.00
Disk Utilities, Additional Commands for FLEX	58.26	67.00
Text Processor, for Text Formatting	46.96	54.00
Text Editor & 6800/6809 Macro Assembler	58.26	67.00
Disk & Memory Diagnostics, Further FLEX Commands	69.57	80.00
Extended Basic, Advanced Business Basic for 6809	52.17	60.00
Pascal, 6809 Machine Code Compiler	75.65	87.00
RMS, A Record Management System for 6809	145.22	167.00
Tabula Rasa, Financial Reporting Package	145.22	167.00
Stylograph, The Complete Word-Processing Package	120.00	138.00
Micro-Modeller, Now Available for FLEX9	173.04	199.00
	694.78	799.00

## SHARP MZ-80A

477.39 549.00  
Now in stock, the latest SHARP MZ-80A Personal Computer, 48K, Screen, Cassette & Sound.

## APPLE SYSTEMS

Full Range of APPLE II Systems in Stock, together with a wide range of Business and Leisure Software.

- Come and try any of our systems or make use of our mail order service.
- All prices include carriage charges within the mainland UK.
- All prices are correct at time of going to press and subject to availability.
- Send for our latest price list and catalogue covering our vast range.
- Further information is available on all the products listed, send for details.
- Store opening hours - 9.30 to 5.30 - Monday to Saturday - Access & Visa
- STIRLING MICROSYSTEMS LTD - THE '6809' HARDWARE & SOFTWARE STORE.

# STIRLING MICROSYSTEMS

241 Baker Street, London NW1 6XE. Telephone: 01-486 7671.

● Circle No. 112

# TEXAS INSTRUMENTS HOME COMPUTER STOCKISTS

**ABERDEEN** Dixons **ALTRINCHAM** Boots **ASHFORD** Rumbelows **BARNET** Rumbelows **BASILDON** Rumbelows **BASINGSTOKE** Boots **BATH** Boots, Microstyle **BEDFORD** Carlow Radio, Rumbelows, Boots, Comserve **BILLERICAY** Rumbelows **BIRKENHEAD** Dixons **BIRMINGHAM** Dixons, Comet, Hewards Home Stores, Boots **BLACKPOOL** Boots **BLETCHLEY** Rumbelows **BOREHAMWOOD** Rumbelows **BRADFORD** Ackroyd Typewriters **BRAINTREE** Rumbelows **BRENTWOOD** Rumbelows **BRIGHTON** Gamer, Boots **BRISTOL** Dixons **BROMLEY** Rumbelows, Boots **BROMYARD** Acoutape Sound **CAMBRIDGE** Rumbelows, Dixons, Heffers **CANTERBURY** Rumbelows, Dixons **CARDIFF** Boots, Dixons, Computer Business Systems **CARLISLE** Dixons **CHELMSFORD** Dixons, Rumbelows **CHESTER** Boots **CHINGFORD** Rumbelows **COLCHESTER** Rumbelows **CORBY** Computer Supermarket **CREWE** Midshires **CROYDON** Boots, Dixons, Allders **DARTFORD** Rumbelows **DERBY** Datron Microcentre, Boots **DORRIDGE** Taylor Wilson **DUNSTABLE** Rumbelows **EASTBOURNE** Rumbelows **EDINBURGH** Robox, Esco, Texas Instruments, Dixons, B.E.M. **ENFIELD** Rumbelows **EXETER** Peter Scott, Boots, Dixons **GLASGOW** Boots, Esco, Robox, Dixons **GT. YARMOUTH** Rumbelows **HANLEY** Boots **HARLOW** Rumbelows **HATFIELD** Rumbelows **HEMEL HEMPSTEAD** Rumbelows, Dixons **HITCHIN** Rumbelows **HODDESDON** Rumbelows **HULL** Radius Computers, Boots, Dixons, Peter Tutty **ILFORD** Boots **IPSWICH** Rumbelows **KINGSTON** Dixons **LEEDS** Dixons, Boots, Comet **LEICESTER** Dixons, Boots **LEIGHTON BUZZARD** Computopia **LETCHWORTH** Rumbelows **LINCOLN** Dixons **LIVERPOOL** Dixons, B.E.C. Computerworld **LONDON: Balham** Argos **Bow** Rumbelows **Brent Cross** Dixons, Boots **Camden Town** Rumbelows **City Road** Sumlock Bondain **Clerkenwell** Star Business Machines **Curtain Road** Eurocalc **Ealing** Adda Computers **EC1** Argos **Edmonton** Rumbelows **Finchley Road** Star Business Machines **Fulham** Mondial **Godge Street** Star Business Machines **Hackney** Rumbelows **Hammersmith** Dixons **Hendon** Futurtronic **Holborn** Dixons **Hounslow** Boots **Kensington High Street** Video Palace **Knightsbridge** Video Palace, Harrods **Loughton** Rumbelows **Marble Arch** Star Business Machines **Moorfield** Dixons **Moorgate** Star Business Machines **New Bond Street** Dixons **NW1** Mountandene **Oxford Street** Selfridges, H.M.V., Dixons **Regent Street** Star Business Machines **Tottenham Court Road** Landau, Eurocalc **Victoria Street** Army & Navy **Wandsworth** R.E.W. **Wood Green** Boots, Rumbelows **Woolwich** Rumbelows **LUTON** Dixons, Rumbelows **MAIDSTONE** Dixons, Boots, Rumbelows **MALDON** Rumbelows **MANCHESTER** Orbit, Boots, Dixons **MIDDLESBROUGH** Boots, Dixons **MILTON KEYNES** Rumbelows, Dixons **NEWBURY** Dixons **NEWCASTLE** Boots, Dixons **NORTHAMPTON** Dixons **NORWICH** Dixons, Rumbelows **NOTTINGHAM** Bestmoor, Dixons, Boots **ORPINGTON** Rumbelows **OXFORD** Science Studio **PETERBOROUGH** Boots **PLYMOUTH** J.A.D., Dixons **PORTSMOUTH** Boots, Dixons **POTTERS BAR** Rumbelows **PRESTON** Dixons **RAMSGATE** Dixons **RAYLEIGH** Rumbelows **READING** Dixons **RENFREW** Comet **ROMFORD** Rumbelows, Dixons **RUSHDEN** Computer Contact **SANDY** Electron Systems **SCARBOROUGH** Video + **SHEFFIELD** Datron Microcentre, Dixons, Video +, Wigfalls **SITTINGBOURNE** Rumbelows **SLOUGH** Boots, Texas Instruments **SOUTHAMPTON** Dixons, The Maths Box **SOUTHEND** Rumbelows, Dixons **ST. ALBANS** Rumbelows **STEVENAGE** Dixons, Rumbelows **STRATFORD** Rumbelows **SUDBURY** Rumbelows **SWANSEA** Dixons **TONBRIDGE** Rumbelows **WALTHAM CROSS** Rumbelows **WALTHAMSTOW** Rumbelows **WARE** Rumbelows **WARRINGTON** Boots **WATFORD** Computer Plus, Computer Centre, **WELWYN GARDEN CITY** Rumbelows **WETHERBY** Bits & Pieces **WOLVERHAMPTON** Dixons **WOODFORD** Rumbelows

# You can't get a Home Computer from Texas Instruments under 16 K RAM.



Make the right move into computing with the Home Computer from Texas Instruments. It gives you a large combined RAM/ROM capacity up to 110 K Byte and the ability to expand with a full range of peripherals and software. So as your knowledge of computers increases the TI Home Computer will grow with you.

Just compare the versatility of the TI Home Computer with its price—you'll find it real value for money that will prove to be a good long term investment.

The TI-99/4A is a sophisticated computer designed not only for the beginner with its ease of operation, but also for the professional with its vast computing power through a 16 bit microprocessor. And it simply plugs into an ordinary household TV set.



With its high resolution graphics with 32 characters over 24 lines in 16 colours (256 x 192 dots), 3 tones in five octaves plus noise, and BASIC as standard equipment and options such as other programming languages—UCSD-PASCAL, TI-LOGO and ASSEMBLER—and speech synthesis, you'll find that the TI 99/4A more than compares with the competition. Especially when the starting price is £340 or less. When you want to solve problems there are over 600 software programs available worldwide—including more than 40 on easy-to-use Solid State Software® Modules.

After all, from the inventors of the microprocessor, integrated circuit and microcomputer, it's only natural to expect high technology at a realistic price.



We'll help you do better.

**TEXAS INSTRUMENTS**

● Circle No. 113

21

# CHOOSING A COMPUTER MADE SIMPLE

**FOR  
BUSINESS**

Made simple...

**FOR WORD  
PROCESSING**

Made simple...

**FOR  
EDUCATION**

Made simple...

**ADVICE**

Made simple...

**SERVICE  
AND  
BACK-UP**

Made simple...

**IMPROVING  
ON PET**

Not so simple

**Choosing a computer is...** Choosing a computer is more than just choosing a computer. That is, it's a lot more than just hardware. Mind you, PET stacks up very well when it comes to the computer itself. Because at Commodore we've been involved with microcomputers for over 20 years - in fact, many other manufacturers pay us the compliment of using our microchip for their own computers.

**So, when you choose PET you know you have a microcomputer that everyone in the business admires and respects.**

**... choosing software...** Our software programs live up to the quality of our computer. The range, from both Commodore and specialist suppliers, covers everything from word processing, stock control and payroll to accounting and information processing. As well as specialist applications for education and the sciences.

For light relief, we've a pretty impressive range of games and other brain-teasing packages.

**... choosing value...** Our computers start at under £200 and go through to £8000 - which will buy you a business system. The extent of our range makes sure that you'll easily be able to choose the right computer for your individual needs.

**... choosing a dealer...** As you can see, you do get nationwide dealer back-up with Commodore.

What's more, many of our dealers have specific expertise - which means they can advise on anything from business systems to specialist technical applications. So, if your particular problem is of a highly specialised nature, it may be best to contact our Information Department direct. They will then recommend the dealers who understand - and who speak your kind of language.

**... choosing your computer...** It all adds up. By choosing a PET you can find out how you can benefit from our experience.



Send to: Commodore Information Services,  
675 Ajax Avenue, Slough, Berks. Tel: Slough 79292  
I'd like to know how Commodore could make choosing a  
computer simple for me.



Name \_\_\_\_\_ Position \_\_\_\_\_

Nature of Business \_\_\_\_\_

Company \_\_\_\_\_

Address \_\_\_\_\_

Tel. \_\_\_\_\_

20PR4

**COMMODORE PET**  
Quite simply, you benefit  
from our experience

Come and see us at the Third International  
Commodore Computer Show  
3rd-5th June, Cunard Hotel, Hammersmith

# Commodore Official Dealer List

- LONDON**  
 Adda W13 01-59 5945  
 Capital Computer Systems W1 01-636 3863  
 Logic Computer Systems SW1 01-636 3863  
 Micro Systems Ltd EC4 01-221 1235/92  
 Micro Computers Ltd EC4 01-583 6774  
 Micro Computers N14 01-882 5104  
 Micro Computer Centre SW14 01-878 7047  
 Sarnock-Bondan Ltd EC1 01-250 0905  
 Informer-London Ltd SE13 01-318 4217  
 CSS (Systems) Ltd E8 01-254 9293  
 Micro Computers Ltd NW3 01-431 3410  
 Data Base NW2 01-450 1388  
**SURREY & MIDDLESEX**  
 Double Moore Ltd Kingston-Luton-Thames 01-549 2121  
 Micro Systems Ltd Hampton Hill 01-979 4569/941 1197  
 PPM Ltd Woking 0467-80111  
 Datalec Computers Ltd Croydon 01-680 3581  
 Datalec Computers Ltd Woking 0462-25925  
 Datalec Computers Ltd Woking 0274-20446  
 Wepo Computers Ltd Caterham 0883-49235  
 Cream Computer Shop Harrow 01-863 0833  
 Da Vite Computer Shop Edgware 01-592 0526  
 L & J Computers Starnore 01-204 7252/206 0440  
**KENT, SUSSEX & HAMPSHIRE**  
 Amphion Micro Systems Brighton 0273-5621/63/60831  
 Business Electronics Southampton 0273-38248  
 HSY (Microcomputers) Ltd Hants 0256-6244/0703-331422  
 Millhouse Designs Ltd Alton 042-084517  
 The Computer Room Tonbridge 0732-355862  
 0966-5432  
**ESSEX**  
 Darnley Colchester 0206-865835  
 CSSC Ltd Ilford 01-554 3344  
 DCT 292979  
 Stuart & Dean Ltd Southend-on-Sea 0702-22707  
**BENKSHIRE, BUCKINGHAMSHIRE, OXFORDSHIRE & WILTSHIRE**  
 Commonwealth Business Systems Ltd High Wycombe 0944-4016  
 Oxford Computer Services Watlington 0491-35579  
 Wymark Micro-Computer Centre Salisbury 04254-77012  
 Alphacore Ltd Banbury 029575-8202  
 J R Ward Computers Ltd Milton Keynes 086-262580  
 The Computer Shop Oxford 0865-723872  
 Kingly Computers High Wycombe 0944-49719  
**HERTFORDSHIRE & BEDFORDSHIRE**  
 Alpha Business Systems Ware 020-68976  
 Business Data Services Old Hatfield 0707-60980/62925  
 Computer Plus Watford 0923-33927  
 HB Computers (Luton) Ltd Luton 0582-45466  
 Business Associates Watford 0923-40698/23006  
 MFS Ltd Bedford 0734-40601  
 Brien Computer Systems Rickmansworth 87-1306/70379  
**EAST MIDLANDS, SOUTH HUMBERSIDE & DEBYSHIRE**  
 Rogers (Business Systems) Ltd Leicester 0533-20455  
 Arden Data Processing Leicester 0533-22525  
 Baco Systems Ltd Nottingham 0602-48108  
 Caddis Computer Systems Ltd Hinckley 0455-61354  
**EAST ANGLIA, UNCLONSHIRE & NORTHAMPTONSHIRE**  
 Arden Data Processing Peterborough 0733-4767  
 HB Computers Ltd Kettering 0535-52910  
 Sarnock-Bondan Ltd Norwich 0603-26259/614302  
 Dataway Norwich 0603-616221  
**WEST MIDLANDS, STAFFORDSHIRE & WARWICKSHIRE**  
 James Watson Associates Birmingham 021-443 8033  
 Camden Electronics Ltd Birmingham 021-773 8240  
 Micro Associates Birmingham 021-773 8240  
 Tynard Systems Ltd Scourbridge 0565-6192  
 Walters Computer Systems Ltd Scourbridge 03843-70811  
 CBS Computers Ltd Birmingham 03843-70811  
 Peach Data Services Burton-on-Trent 021-772 8181  
 Computer Services Midlands Ltd Birmingham 021-382 4171  
 Business Equipment Rentals Ltd Rugby 0788-65756

Circle No. 114

# Don't spend more than £500 on a Local Area Network until you know about Clearway



Clearway brings the benefits of Local Area Networking to you at very low cost. So if you're thinking about a networking system be sure to find out more about Clearway.

**Mail the coupon now for full information**  
**I'm interested in Clearway - the low cost Networking System, please send me details.**

Developments Limited, Lynchford House, Lynchford Lane, Farnborough, Hampshire GU14 6JA  
 Telephone: Farnborough (0252) 546213  
 Telex: 858893 Fletel G

PC6.82

Name .....  
 Position .....  
 Address .....  
 Telephone .....

Send to: Real Time Developments Limited, Lynchford House, Lynchford Lane, Farnborough, Hampshire GU14 6JA

Circle No. 115

# "The best value for money on the small business systems market"

Which Computer? Magazine

## SUPERBRAIN

A smart, fully self-contained desk-top unit – that's the SUPERBRAIN microcomputer. It will operate as a complete business system, as a word processor (allied to a high quality printer) and as an intelligent terminal.

- 320K, 680K and 1.5 MB disc drives
- Wide range of standard packages
- Full graphics facility
- Nationwide dealer network
- Hard Discs available too – integral or separate

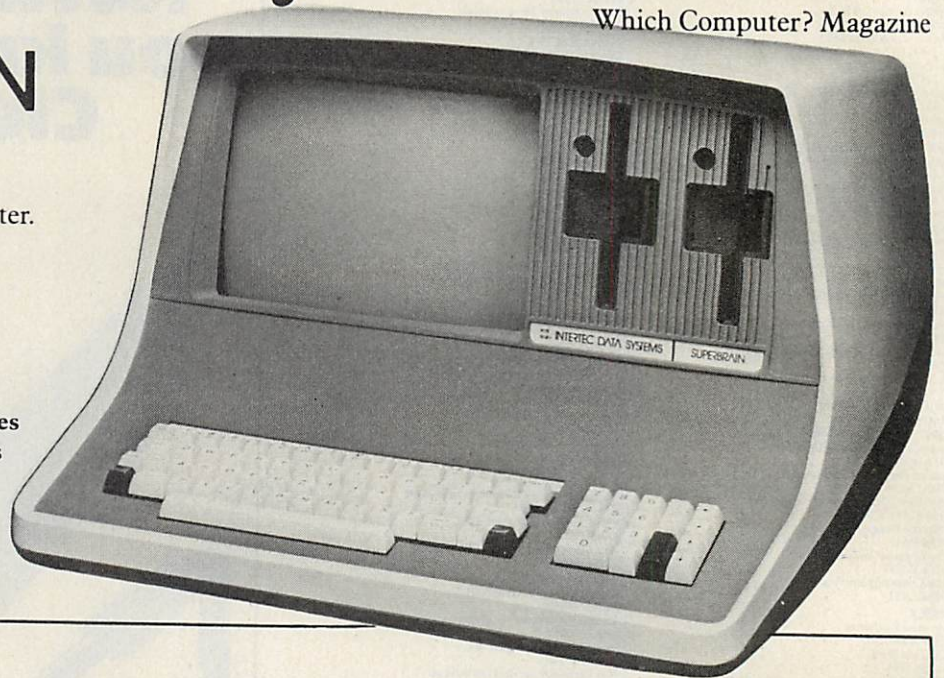

**SUPERBRAIN** is ideal for both first time buyers needing a general purpose machine, and for users wishing to upgrade from a personal microcomputer system. Its CP/M operating system will handle the most sophisticated programs. Twin Z80 microprocessors and an RS232 communications port make it easy to extend the system in the future.

### The Icarus dealer network

**ABRAXAS COMPUTER EMPLOYMENT**, 357 Euston Road, LONDON NW1 3AL. Tel: 01 388 2061

**A.P. LTD.**, Maple House, Mortlake Crescent, CHESTER CH3 5UR. Tel: 0244 46024

**BASIC BUSINESS SYSTEMS**, 61 Loughborough Road, WEST BRIDGEFORD, Nottingham. Tel: 0602 819713

**BUSINESS INFORMATION SYSTEMS**, 602 Triumph House, 189 Regent Street, LONDON. Tel: 01 437 1069

**BORDER COMPUTING LTD.**, Dog Kennel Lane, BUCKNELL, Shropshire. Tel: 054 74 368

**CAMBRIDGE MICRO COMPUTERS**, Cambridge Science Park, Milton Road, CAMBRIDGE. Tel: 0223 314666

**COMMONSENSE COMPUTING LTD.**, P.O. Box 7, BIDEFORD, Devon. Tel: 02372 4795

**COMPUTECH SYSTEMS**, 168 Finchley Road, LONDON, NW3 6HF. Tel: 01 794 0202

**CONQUEST COMPUTER SALES LTD.**, 92 London Road, BENFLEET, Essex. Tel: 03745 59861

**CULLOVILLE LTD.**, Thornfield, Woodhill Road, SANDON, Chelmsford, Essex. Tel: 024 541 3919

**DATA PROFILE**, Lawrence Road, Green Lane, HOUNSLOW, Middlesex. Tel: 01 572 6381

**DATA WARE**, 48 Eaton Drive, KINGSTON, Surrey KT2 7QX. Tel: 01 546 2984

**DAYTA**, 20b West Street, Wilton, SALISBURY, Wilts. Tel: 0722 74 3898

**DRAGON SYSTEMS LTD.**, 37 Walter Road, SWANSEA, W. Glam. Tel: 0792 749486

**DUPLEX COMMUNICATIONS**, 2 Leire Lane, Dunton Bassett, Lutterworth, LEICESTERSHIRE. Tel: 0455 209131

**EASIBEE COMPUTING LTD.**, 133/135 High Street, LONDON E6 1HZ. Tel: 01 471 4884

**ESCO COMPUTING LTD.**, 154 Cannongate, EDINBURGH. Tel: 031 557 3937

**ESCO COMPUTING LTD.**, 40a Gower Street, GLASGOW G51 1PH. Tel: 041 427 5497

**EFFICIENT BUSINESS SYSTEMS**, 9 Clarence Street, BELFAST 1, N. Ireland. Tel: 0232 647 538

**E.M.G. MICROS** 30 Heathfield Road, CROYDON, Surrey. Tel: 01 688 0088

**EMTEK COMPUTERS LTD.**, 102 Queen Street, NEWTON ABBOT, Devon. Tel: 0626 62389

**B. FITTON**, 97 Melbourn Road, ROYSTON, Herts. Tel: 0763 41949

**FOREST ROW COMPUTERS**, 53 Feshfield Bank, FOREST ROW, East Sussex. Tel: 034 282 4397

**G.T. OFFICE SYSTEMS**, 12 Clovelly Road, LONDON W5 SHE. Tel: 01 567 9959

**G.I.C.C.**, P.O. Box 519, Manama, Bahrain.

**JAEMMA LTD**, Unit 24, Lee Bank House, Holloway Head, Lee Bank, BIRMINGHAM. Tel: 021 643 1609

**JENNINGS COMPUTER SERVICES**, 55/57 Fagley Road, BRADFORD, W. Yorks. Tel: 0274 637867

**KENT BUSINESS SYSTEMS LTD.**, 85 High Street, Ramsgate, Kent. Tel: 0843 687816

**LONDON COMPUTER CENTRE**, 43 Grafton Way, LONDON W1. Tel: 01 388 5721

**M.G. ENTERPRISES**, 32 Rue Victor Hugo, 92800 Puteaux, France.

**MASS MICROS**, Wellson House, Brownfields, WELWYN GARDEN CITY, Herts. Tel: 96 31736

**MICROAGE LTD**, 53 Acton Road, LONG EATON, Nottinghamshire. Tel: 06076 64264

**MICROSERVE LTD.** 811 Kennedy Way, Pelham Road, IMMINGHAM. Tel: 0724 849 696

**MICROCARE COMPUTING LTD.**, 18 Hawarden Road, NEWPORT, Gwent. Tel: 0633 278040

**MICROCOMPUTER CONSULTANCY**, Lyngen, Oldhill Wood, Studham, DUNSTABLE, Beds.

**NASTAR COMPUTER SERVICES LTD**, Ashton Lodge, Abercrombie St., CHESTERFIELD. Tel: 0266 207048

**OMEGA ELECTRIC LTD.**, Flaxley Mill, Flaxley Road, MITCHELDEAN, Glos. Tel: 045 276 532

**PROTOCOL COMPUTER PRODUCTS**, 49 Beckenham Lane, Shortlands, BROMLEY, Kent.

**RANMOR COMPUTING LTD.**, Nelson House, 2 Nelson Mews, SOUTHBEND-ON-SEA. Tel: 0702 339262

**ROGIS SYSTEMS LTD**, Keepers Lodge, Frittenden, NR. CRANBROOK, Kent. Tel: 058 080 310

**S.D.M. COMPUTER SERVICES**, Broadway, BEBINGTON, Merseyside L63 5ND. Tel: 051 608 9365

**S.M.G. MICROS**, 39 Windmill Street, GRAVESEND, Kent. Tel: 0474 55813

**SAPPHIRE SYSTEMS**, 19-27 Kents Hill Road, BENFLEET, Essex. Tel: 03745 59756

**SISCO LTD**, 4 Moorfields, LONDON, EC2Y 9AA. Tel: 01 920 0315

**SORTFIELD LTD**, E. Floor, Milburn House, Dean Street, NEWCASTLE-UPON-TYNE. Tel: 0632 329593

**SPOT COMPUTER SYSTEMS LTD**, New Street, Kelham Street Indus. Estate, DONCASTER, S. Yorks. Tel: 0302 25159

**STAG TERMINALS LTD**, 30 Church Road, Teddington, Middlesex. Tel: 01 943 0777

**STUKELEY COMPUTER SERVICES**, Barnhill, STAMFORD, Lincs. Tel: 0780 4947

**TERMACRE LTD**, 126 Woodwarde Rd., LONDON SE22 8TU. Tel: 01 943 3037

**THAMES VALLEY COMPUTERS**, 10 Maple Close, MAIDENHEAD, Berks. Tel: 0628 23532

**TURNKEY COMPUTER TECHNIQUE**, 23 Calderglen Road, St. Leonards, EAST KILBRIDE. Tel: 03552 39466

**THE COMPUTER ROOM**, 87 High Street, TUNBRIDGE, Kent. Tel: 0732 355962

**WELSH BUSINESS SYSTEMS LTD**, 1 Windsor Chambers, Windsor Arcade, PENARTH. Tel: 0222 700059

**WORD PERFECT**, Old Town Hall, Box 148, READING, Berkshire. Tel: 0734 589068

For further details, or if you want to become a dealer yourself, contact:

# ICARUS

Computer Systems Ltd.

Icarus Computer Systems Ltd. Deane House 27 Greenwood Place London NW5 1NN Tel: 01-485 5574 Telex: 264209

● Circle No. 116

PRACTICAL COMPUTING June 1982

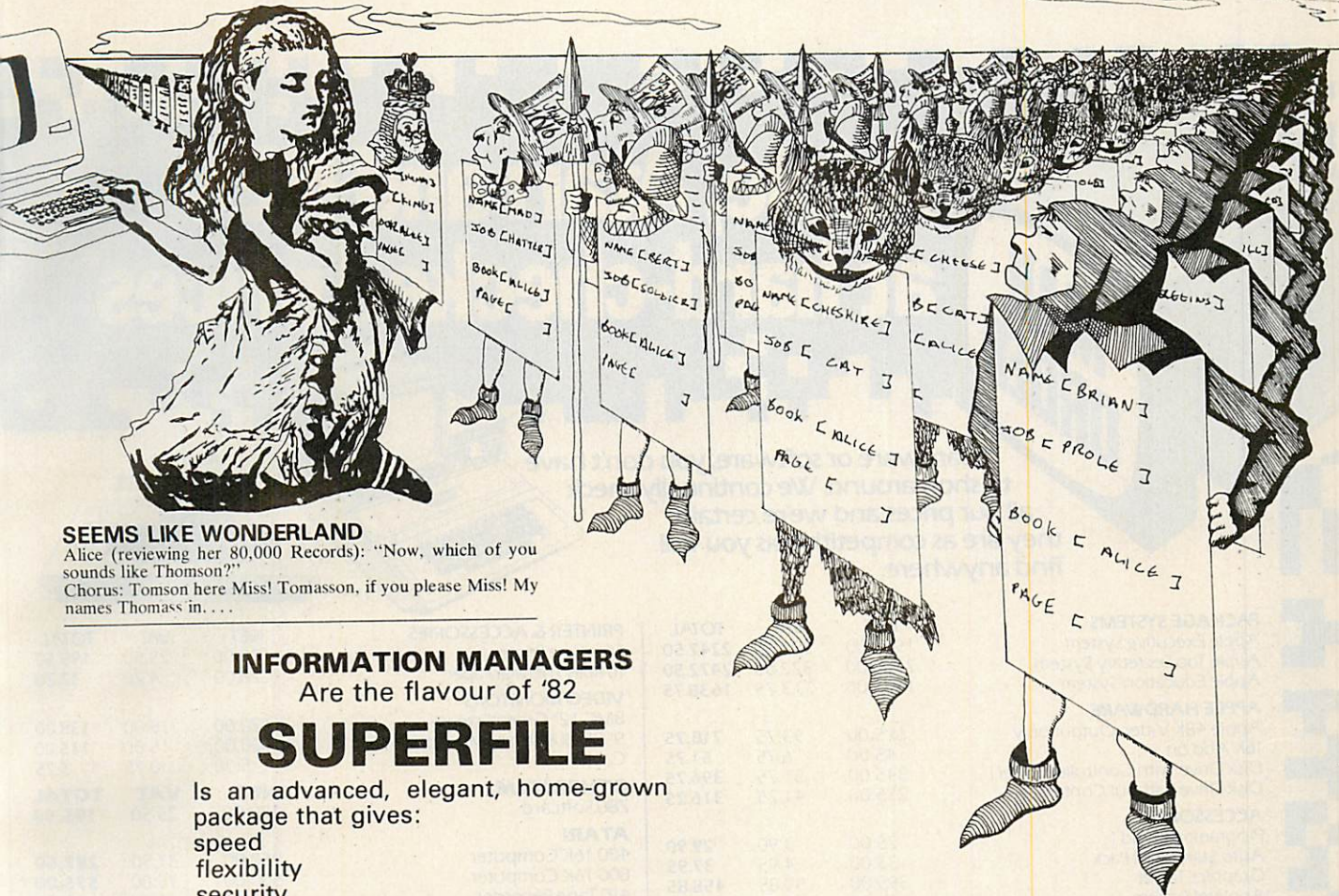

**SEEMS LIKE WONDERLAND**

Alice (reviewing her 80,000 Records): "Now, which of you sounds like Thomson?"  
 Chorus: Tomson here Miss! Tomasson, if you please Miss! My names Thomass in....

**INFORMATION MANAGERS**  
 Are the flavour of '82

**SUPERFILE**

Is an advanced, elegant, home-grown package that gives:

- speed
- flexibility
- security
- unique phonetic matching
- an interface to any CP/M language
- multi-user capability (the first in the world)

SUPERFILE is a 12K package in Z80 code for any CP/M machine — Xerox, Apple (with Z80 card), Osborne, Superbrain,; multi-user on Equinox under Turbodos, DC4 under MP/M etc.

Two advanced end-user packages are available: SUPERFORMS lets the non-specialist design, store and use screen Forms to enter information, retrieve it and do calculations. Half a dozen Forms — which take only an hour to set up — can do all a small company's book keeping. Tailored software at package prices! SUPERTAB for tabulated Reports, address labels, Mail Merge compatible files. (Ready June 1982)

*One-off prices:*

<b>SUPERFILE</b>	<b>£175</b>
<b>MULTI-USER</b>	<b>800</b>
<b>SUPERFORMS</b>	<b>75</b>
<b>SUPERTAB</b>	<b>75</b>
<b>DEMO DISK</b>	<b>20</b>
<b>MANUAL ALONE</b>	<b>10</b>

**Software dealers:**

**A BRITISH**  
 (and much better)  
**ALTERNATIVE**

Are you sick of having to say: "I'm very sorry — they're stuck at the airport" "I'm very sorry — we'll get on to California right away" "I'm very sorry — we'll ring you next week"

If you could do without:  
 Slow deliveries  
 Poor support  
 High prices  
 User-hostile software  
 Then you might try calling Southdata.

We can give you:  
 Immediate deliveries  
 Instant support  
 Low Prices  
 Terrific Discounts

Remember — the SUPERFILE package gives you Tailored Software at Package Prices.

**Southdata Ltd**

10 Barley Mow Passage, London W4 4PH  
 01-994 6477 Telex 8811418

● Circle No. 117



# Apple, Atari and NEC at hard-checked prices\*

\*Hardware or software, you don't have to shop around. We continually check all our prices and we're certain they are as competitive as you will find anywhere.



Apple VDU Disk Drives and Processor

Atari 800.

	NET	VAT	TOTAL
<b>PACKAGE SYSTEMS</b>			
Apple Executive System	1950.00	292.50	2242.50
Apple Top Secretary System	2150.00	322.00	2472.50
Apple Education System	1425.00	213.75	1638.75
<b>APPLE HARDWARE</b>			
Apple 48K Video Output only	625.00	93.75	718.75
16K Add on	45.00	6.75	51.75
Disk Drive with Controller (16 sec)	345.00	51.75	396.75
Disk Drive without Controller	275.00	41.25	316.25
<b>ACCESSORIES</b>			
Programmers Aid I	25.00	3.90	29.90
Auto Start ROM Pack	33.00	4.95	37.95
Graphics Tablet	399.00	59.85	458.85
Appletel System	525.00	78.75	603.75
TV Modulator	14.00	2.10	16.10
<b>INTERFACE CARDS</b>			
Prototype/Hobby Card	12.00	1.80	13.80
Parallel Printer Card	79.00	11.85	90.85
Communications Card	100.00	15.00	115.00
High Speed Serial Card	90.00	13.50	103.50
Centronics Card	100.00	15.00	115.00
Integer Card	90.00	13.50	103.50
Language Card	95.00	14.25	109.25
Controller Card	95.00	14.25	109.25
Eurocolour Card	65.00	9.75	74.75
IEEE - 48 Card	200.00	30.00	230.00
16K RAM Card (48K to 64K)	60.00	9.00	69.00
<b>SOFTWARE</b>			
Disk Utility Pack	12.00	1.80	13.80
Apple Post Program	27.00	4.05	31.05
The Shell Games	15.00	2.25	17.25
Elementary My Dear Apple	16.00	2.40	18.40
Apple Bowl Diskette	13.00	1.95	14.95
3.3 Operating System	34.00	5.10	39.10
DOS 3.3 Tool Kit	41.00	6.15	47.15
Apple Writer 1.1	34.00	5.10	39.10
Stellar Invader	13.00	1.95	14.95
Apple Plot	34.00	5.10	39.10
Apple Adventure	19.00	2.85	21.85
<b>APPLE DISTRIBUTED SOFTWARE</b>			
The Go Between (Centronics)	26.50	3.98	30.48
Micro Modeller	375.00	56.25	431.25
Visicalc 3.3	105.00	15.75	120.75
VisiFile	135.00	20.25	155.25
VisiPilot	95.00	14.25	109.25
VisiTrend/VisiPilot	135.00	20.25	155.25
VisiTerm	80.00	12.00	92.00
VisiDex	105.00	15.75	120.75
Desktop Plan II	105.00	15.75	120.75
<b>LANGUAGES</b>			
Pascal Language System	225.00	33.75	258.75
Apple Pilot	75.00	11.25	86.25
Apple Fortran	95.00	14.25	109.25
CIS Cobol with Forms -2	410.00	61.50	471.50

	NET	VAT	TOTAL
<b>PRINTER &amp; ACCESSORIES</b>			
Silentype Printer	170.00	25.50	195.50
10 Rolls Thermal Paper	28.00	4.20	32.20

	NET	VAT	TOTAL
<b>VIDEO MONITORS</b>			
BMC 12" Green Screen	120.00	18.00	138.00
9" Black & White Monitor	100.00	15.00	115.00
Cables	5.00	0.75	5.75

	NET	VAT	TOTAL
<b>OTHER ITEMS</b>			
Z80 Softcard	170.00	25.50	195.50

	NET	VAT	TOTAL
<b>ATARI</b>			
400 16K Computer	250.00	37.50	287.50
800 16K Computer	500.00	75.00	575.00
410 Tape Recorder	42.61	6.39	49.00
810 Disk Drive	260.00	39.00	299.00
822 Thermal Printer	200.00	30.00	230.00
825 80 Column Printer	400.00	60.00	460.00
850 RS 232 Interface	110.00	16.50	126.50
16K Ram Upgrade	52.13	7.82	59.95
Conversational French	28.26	4.24	32.50
Conversational German	28.26	4.24	32.50
Conversational Spanish	28.26	4.24	32.50
Conversational Italian	28.26	4.24	32.50
Assembler Editor Rom	30.39	4.56	34.95
Visicalc	105.00	15.75	120.75
Word Processor	78.22	11.73	89.95
<b>Video Computer System</b>	<b>69.56</b>	<b>10.43</b>	<b>79.99</b>

	NET	VAT	TOTAL
<b>NEW - N.E.C. PC 8000 SERIES</b>			
PC 8001 Keyboard	500.00	75.00	575.00
PC 8011 Expansion Unit	407.83	61.17	469.00
PC 8012 I/O Unit	346.96	52.04	399.00
PC 8023 Dot Matrix Printer	326.08	48.91	375.00
PC 8031 Floppy Disc Drive	543.48	81.52	625.00
PC 8041 12" Green or Amber Monitor	129.57	19.43	149.00
PC 8043 12" High Resolution CRT Colour Monitor	477.39	71.61	549.00

## HARDWARE GUARANTEE

All advertised products are guaranteed one year from date of purchase against defects in materials and workmanship. During the guarantee period, Metrotech will repair or replace, at no extra charge, components that prove defective - providing that the product is returned, shipping or postage prepaid, stating when bought and enclosing proof of purchase. This guarantee does not apply if, in the opinion of the Company, the product has been damaged by accident, misuse or misapplication.

## CONDITIONS OF BUSINESS.

We accept cheques or Access, Barclaycard, American Express and Diners Club Cards. All prices, specifications and terms are subject to change without notice at the discretion of the management. All offers subject to availability. Prices correct at time of going to press. E. & O.E. Hardware Post and packaging subject to confirmation.



If your business uses computers, the Willis Disk File is a new idea to save you time and money. Much more than just a storage box, it is a complete filing system for your flexible disks. It keeps them clean - avoiding the risk of errors from dust particles - and lengthens their useful life, as well as keeping them readily to hand.

Disks are stored in 10 sections, each with an ingenious lift mechanism enabling the disks to be fan-displayed five at a time using only the thumb and forefinger.

The file locks for security and prevents the use or removal by unauthorised personnel.

We're sure you'll find the Mini Disk File

# The new Willis Mini Disk File is now open for business. Only £35.

(plus VAT)

indispensable for your business and wonder how you ever did without it.

The Mini Disk File with its cream plastic base and tinted polycarbonate lid, is also a handsome modern piece of furniture with the

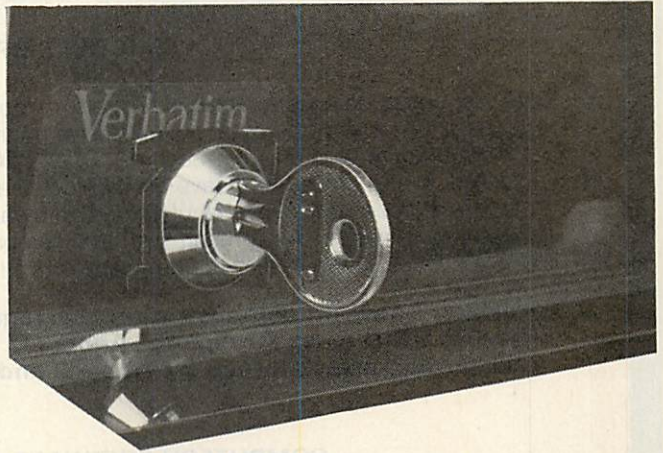

added advantage of being virtually unbreakable. The lid is detachable for easier access if required and, of course, the desk top neatness of the file makes it easily transportable.

Do away with old cardboard boxes and too large filing cabinets. Use the file specially developed after a careful analysis of business requirements by Willis, one of Britain's leading companies for computer supplies.

Order now or ask for further details. Just one of the exciting new items from the 1982 Willis Catalogue.

Mini-Disk Files are £35 each plus 15% VAT. Postage & Packing extra. Cash with order: carriage free.

To: Willis Computer Supplies Ltd, FREEPOST, PO Box 10, Southmill Road, Bishops Stortford Herts. CM23 1BR. Tel: Bishops Stortford (0279) 50649L

Please send.....(Qty) Mini Disk File(s). I enclose cheque/postal order made payable to Willis Computer Supplies for £.....(which includes .....p&p), or please debit my credit card.

ACCESS  BARCLAYCARD

Card No.....

Signature.....

Name.....

Address.....

Post Code.....

Please send catalogue and details only

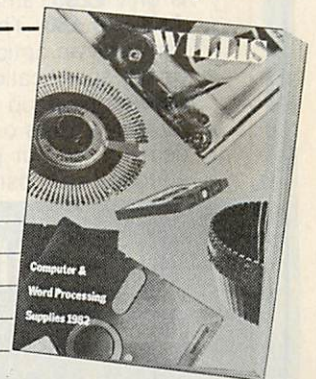

**WILLIS**

Computer Supplies

For people who know better.

PC 6/82

● Circle No. 122

# COMPUTECH for apple

## Authorised dealer, service centre and system consultancy

### SUCCESS BREEDS SUCCESS!

As authorised dealer and service centre for Apple computers we have acquired extensive experience of users' needs and the most cost effective means of satisfying them from the considerable resources of this popular and reliable machine. Over 1,000 of our financial accounting packages have been installed. In the process we have detected areas of special need and opportunities for enhancing these resources. Our own manufactured hardware and system software have been produced to meet these requirements. As a result we have compatible products for all configurations of Apple II and ITT 2020 installations - and the new Apple !!! !

<b>Apple !!! now on demonstration - systems from</b>	<b>£1,645</b>
<b>Pro-File 5 MB mass storage for Apple !!!</b>	<b>£2,256</b>
<b>Computech mass storage for Apple II and Apple !!!, up to 12 MB, from</b>	<b>£1,950</b>

### COMPUTECH SOFTWARE AND HARDWARE INCLUDES:

**Payroll** for 350 employees, 100 departments, all pay periods, printed payslips, approved year end documents, very quick and easy to use, **£375**. **Sales, Purchases** and **General Ledgers** **£295** each, detailed statements. **Job Costing** and **Group Consolidation** are amongst many and various applications of the **General Ledger** package, which supports values to totals of one thousand million accurate to a penny! Our **Utilities Disk** available like other packages in 13 sector or 16 sector format, is widely used for reliable, error checking, copying, including single drive, and the renowned **DPATCH** program beloved of programmers for **£20**. We have developed a **Terminal Utilities** package which enables Apple to Apple and Apple to mainframe communications with local processing and storage as well as Apple to host communications from the amazingly low price of **£130**. Our **Graphics Utilities** program for use with the **Microline** and **Epson** families of printers enable the plain paper production on low cost printers of high resolution screen pictures, graphs etc. - free with **Microlines** or **£30** separately. **Keyboard Driver** enables the use of our **Lower Case** adaptor with BASIC programs and **Appewriter Patches** supplied. **FREE** with our character generator package (total cost **£50**) is separately available on disk with documents for **£10**. At the same price **CAI** (convert Apple pictures for ITT) makes binary high resolution picture files display properly on the ITT 2020. We sell the famous **Visicalc** for **£111** and have delivered systems using it to do amazing things like production control, shipping accounts and stocks and shares valuations! The versatile **Appewriter** word-processing package at only **£39**, especially employed with our **Lower Case Character Generator** is widely used by people who cannot type to produce word-perfect copy! Experience with Apple systems has led to the design and manufacture of compatible products with enhanced features at very favourable prices to satisfy users' needs. These include the **Diplomat Serial Interface** which has handshaking capability and switchable options (**£80**), the **Diplomat Parallel Interface** which enables the direct use of text and graphics with the **Microline** and **Epson** printers and is a complete 'plug in and go' item with gold-plated edge-connector at **£80** and has optional direct connection for **Centronics 730/737** printers. Our new **Diplomat Communications Card** at **£95** is a sophisticated peripheral especially suitable for Apple to mainframe communications at high speeds in full duplex mode with switch selectable bit rates and other options. The **Lower Case** adaptor is available for Apples (revision 7 and earlier) as well as ITT 2020, complete with diskette software for **£50**. It offers true descenders on screen and the £ sign. We also have an **Optional Character Generator** for the ever popular **Microline M80** at **£15**. This provides £ sign and improved digits and lower case characters with USASCII special symbols. Our price for the **Microline M80**, with graphics, 40, 80 and 132 characters per line, friction, sprocket and teleprinter feed, is only **£295**, amazing for this small, quiet reliable 'look alike' printer. Tractor option is **£40** and **Serial Adaptor** **£80**. The **Microline M82**, bidirectional printer with both parallel and serial input is only **£345**, it can have an optional 2K buffer, while the **Microline M83** full width adjustable tractor 120 cps printer with similar specification is only **£595**. Then for all computer users there is the unique **Micromux** which from **£800** provides up to 16 ports for simultaneous independent serial asynchronous communications! Telephone for data sheets or to arrange a demonstration or for the address of our nearest dealer. Please hurry - the demand for our products has been such that some have been temporarily out of stock. We offer the effective low cost solutions you need. **Prices exclude V.A.T., carriage and packing.**

# COMPUTECH SYSTEMS

168, Finchley Road, London NW3 6HP. Tel: 01-794 0202

AGENTS THROUGHOUT THE UK AND OVERSEAS

"A leading computer company proves that if you've got something worth showing, it's good business sense to make an exhibition of yourself."

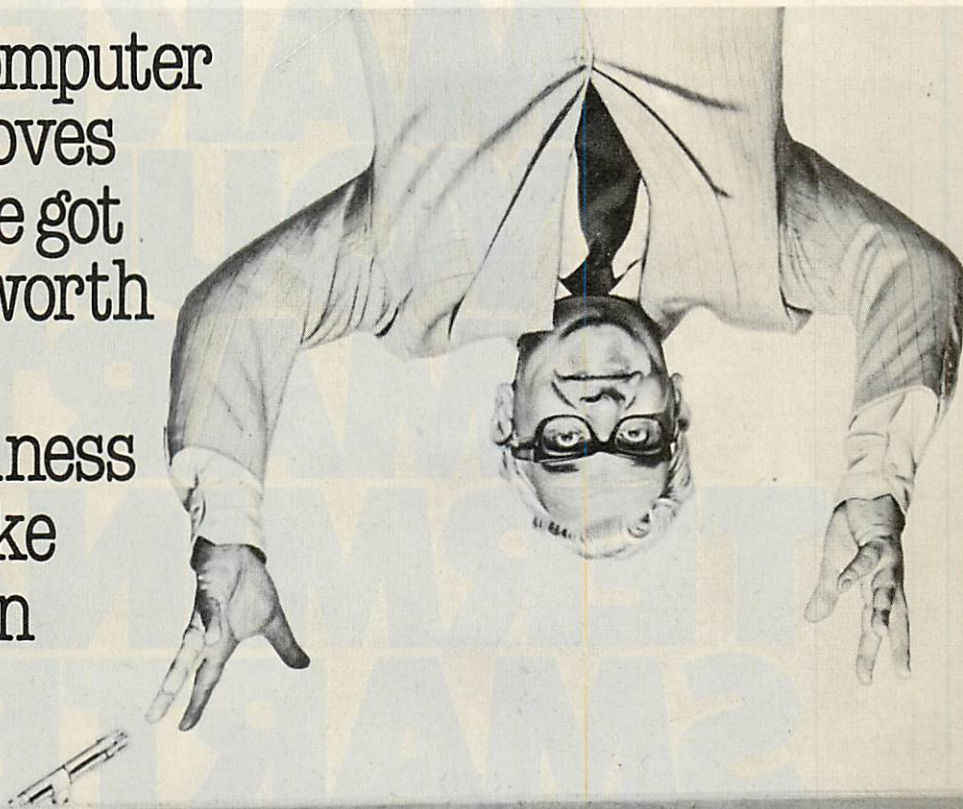

## THE THIRD INTERNATIONAL COMMODORE COMPUTER SHOW OPENS JUNE 3RD

The Commodore Show is one of the finest opportunities to see the best of today's micro-computer systems in action. A wide range that covers our home colour computer and our selection of sophisticated business systems as well as the latest in software and related products.

Also we'll demonstrate just how they can improve efficiency, whatever line of business you're in.

There'll be seminars on education, communications and a wide variety of business applications.

Guests include knowledgeable and interesting people like Jim Butterfield, who's the foremost authority on the PET and its capabilities.

All in all, it's the biggest and best Commodore Show yet, and definitely not to be missed.

See us at:

The Third International Commodore Computer Show, Cunard Hotel, Hammersmith, London.

Thursday June 3rd 12am - 6pm

Friday June 4th 10am - 6pm

Saturday June 5th 10am - 5pm



For further details ring

**SLOUGH (0753) 79292**

675 Ajax Ave, Slough, Berks.

**commodore**  
**COMPUTER**

**Quite simply, you benefit  
from our experience**

# MAKE YOUR SMART TERMINAL SMARTER.

*Automatic Date/Time Entry.* Simply install the SLC-1 Time Machine between your computer and terminal and it will automatically log the correct date and time of each transaction into your computer. The SLC-1 Time Machine will save you money, both in reduced operator time and the elimination of costly human errors.

The Time Machine contains a precision 24-hour clock and a 100-year self-correcting calendar that automatically adjust for leap years. Time and date functions include: hours, minutes, seconds, day, month and year.

But the SLC-1 is more than a clock. It constantly monitors the output from any computer and provides instant responses to a number of user-defined key

phrases. This makes it ideal for use with unattended process control or data acquisition systems. And since the Time Machine is a 6502 microprocessor system, it adds computing power to any terminal.

The Time Machine is easily installed without modification to your operating system. Both RS-232 and 20mA current loop serial link are provided. And because it's battery-supported, the time will always be correct, even after a power failure.

The single quantity price is only £550. Ten-digit display option, £80. For more information or literature on the SLC-1 Time Machine, contact John

Birkwood Assoc.,  
Wyvern House,  
49 Station Rd.,  
Billingshurst, West  
Sussex, RH14 9SE.  
Tel: (040381) 3813.

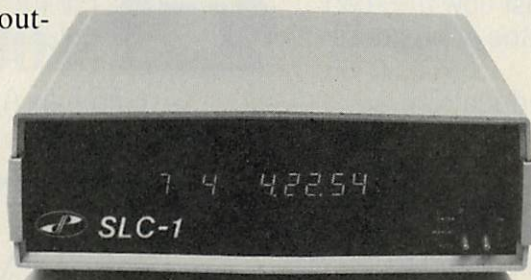

**GET INTO THE TIME MACHINE.  
DIGITAL PATHWAYS**

● Circle No. 125

# Word processing for the businessman of letters:

## £3135.

Like all Adler products, the Alpatronic is built to the highest technical standards. It is supported by a nationwide dealer network who are on hand just when you need them, whether it be for advice, assistance or technical service.

So if you want a word processor (with a free microcomputer) – Trust Adler.

Price exclusive of VAT.

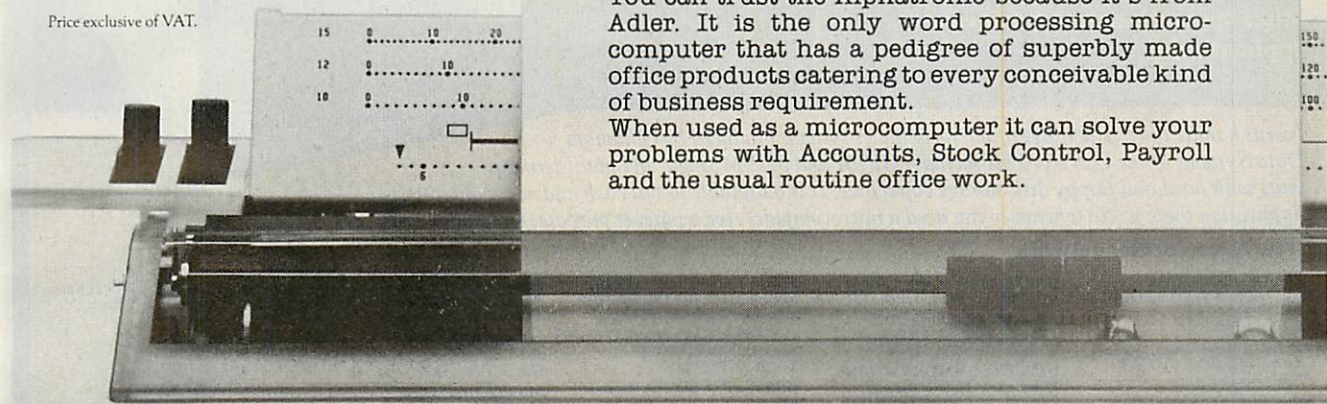

TRIUMPH ADLER (U.K.) LIMITED  
formerly: Adler Business Systems Ltd.,  
27, Goswell Road, London EC1M 7AJ  
Telephone: 01-250 1717. Telex: 857772

**TA** TRIUMPH ADLER

It's true – not only is the Alpatronic an impressive word processor but it is also a very versatile micro-computer.

It produces the kind of typing that keeps the fussiest of managing directors happy – thanks to the success proven daisy wheel printer.

You can trust the Alpatronic because it's from Adler. It is the only word processing micro-computer that has a pedigree of superbly made office products catering to every conceivable kind of business requirement.

When used as a microcomputer it can solve your problems with Accounts, Stock Control, Payroll and the usual routine office work.

ADLER

**TA** TRIUMPH ADLER

Triumph Adler (U.K.) Ltd.,  
27 Goswell Road, London EC1M 7AJ.  
Telephone: 01-250 1717.

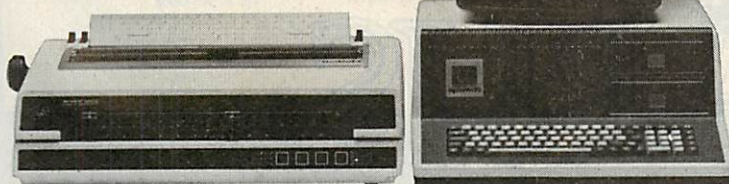

Please give me more information on the the Adler Alpatronic Microcomputer.

Name \_\_\_\_\_  
Company \_\_\_\_\_  
Address \_\_\_\_\_  
\_\_\_\_\_  
Telephone \_\_\_\_\_  
WP2

PC 6/82

## ANOTHER TRIUMPH FROM ADLER

● Circle No. 126

# COLUMBIA

## A complete range of microcomputers from 320K-80M

Single and multi-user upgradeable/expandable microcomputer systems from Columbia Data Systems offer the disk storage capacity that's exactly right for you. Single user machines to take 5¼" or 8" floppy disks giving 320K-2.4M capacity and multi-user machines with up to 80M on hard disk.

Up to 5 users can work simultaneously while sharing a single processing system. Ideal for word processing, general accounting or other special purpose business applications.

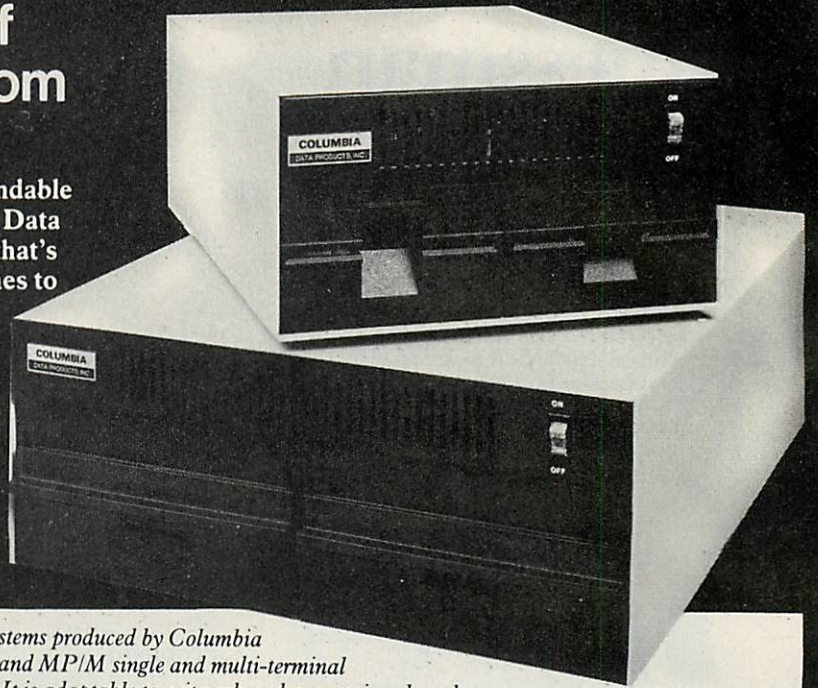

*Icarus handle the whole range of microcomputer systems produced by Columbia Data Systems of the U.S.A. This includes CP/M and MP/M single and multi-terminal units with hard and floppy disk storage capacities. It is adaptable to suit each and every micro-based application there is. So whenever you need a microcomputer, for whatever purpose, Columbia and Icarus have the answer.*

### The Icarus dealer network

**ABRAXAS COMPUTER EMPLOYMENT**, 357 Euston Road, LONDON NW1 3AL. Tel: 01 388 2061

**A.P. LTD.**, Maple House, Mortlake Crescent, CHESTER CH3 5UR. Tel: 0244 46024

**BASIC BUSINESS SYSTEMS**, 61 Loughborough Road, WEST BRIDGEFORD, Nottingham. Tel: 0602 819713

**BUSINESS INFORMATION SYSTEMS**, 602 Triumph House, 189 Regent Street, LONDON. Tel: 01 437 1069

**BORDER COMPUTING LTD.**, Dog Kennel Lane, BUCKNELL, Shropshire. Tel: 054 74 368

**CAMBRIDGE MICRO COMPUTERS**, Cambridge Science Park, Milton Road, CAMBRIDGE. Tel: 0223 314666

**COMMONSENSE COMPUTING LTD.**, P.O. Box 7, BIDEFORD, Devon. Tel: 02372 4795

**COMPUTECH SYSTEMS**, 168 Finchley Road, LONDON, NW3 6HF. Tel: 01 794 0202

**CONQUEST COMPUTER SALES LTD.**, 92 London Road, BENFLEET, Essex. Tel: 03745 59861

**CULLOVILLE LTD.**, Thornfield, Woodhill Road, SANDON, Chelmsford, Essex. Tel: 024 541 3919

**DATA PROFILE**, Lawrence Road, Green Lane, HOUNSLOW, Middlesex. Tel: 01 572 6381

**DATA WARE**, 48 Eaton Drive, KINGSTON, Surrey KT2 7QX. Tel: 01 546 2984

**DAYTA**, 20b West Street, Wilton, SALISBURY, Wilts. Tel: 0722 74 3898

**DRAGON SYSTEMS LTD.**, 37 Walter Road, SWANSEA, W. Glam. Tel: 0792 749486

**DUPLEX COMMUNICATIONS**, 2 Leire Lane, Dunton Bassett, Lutterworth, LEICESTERSHIRE. Tel: 0455 209131

**EASIBEE COMPUTING LTD.**, 133/135 High Street, LONDON E6 1HZ. Tel: 01 471 4884

**ESCO COMPUTING LTD.**, 154 Cannongate, EDINBURGH. Tel: 031 557 3937

**ESCO COMPUTING LTD.**, 40a Gower Street, GLASGOW G51 1PH. Tel: 041 427 5497

**EFFICIENT BUSINESS SYSTEMS**, 9 Clarence Street, BELFAST 1, N. Ireland. Tel: 0232 647 538

**E.M.G. MICROS** 30 Heathfield Road, CROYDON, Surrey. Tel: 01 688 0088

**EMTEK COMPUTERS LTD.**, 102 Queen Street, NEWTON ABBOT, Devon. Tel: 0626 62389

**B. FITTON**, 97 Melbourne Road, ROYSTON, Herts. Tel: 0763 41949

**FOREST ROW COMPUTERS**, 53 Feshfield Bank, FOREST ROW, East Sussex. Tel: 034 282 4397

**G.T. OFFICE SYSTEMS**, 12 Clovelly Road, LONDON W5 5HE. Tel: 01 567 9959

**G.I.C.C.**, P.O. Box 519, Manama, Bahrain.

**JAEMMA LTD**, Unit 24, Lee Bank House, Holloway Head, Lee Bank, BIRMINGHAM. Tel: 021 643 1609

**JENNINGS COMPUTER SERVICES**, 55/57 Fagley Road, BRADFORD, W. Yorks. Tel: 0274 637867

**KENT BUSINESS SYSTEMS LTD.**, 85 High Street, Ramsgate, Kent. Tel: 0843 687816

**LONDON COMPUTER CENTRE**, 43 Grafton Way, LONDON W1. Tel: 01 388 5721

**M.G. ENTERPRISES**, 32 Rue Victor Hugo, 92800 Puteaux, France.

**MASS MICROS**, Wellson House, Brownfields, WELWYN GARDEN CITY, Herts. Tel: 96 31736

**MICROAGE LTD.**, 53 Acton Road, LONG EATON, Nottinghamshire. Tel: 06076 64264

**MICROSERVE LTD.**, 811 Kennedy Way, Pelham Road, IMMINGHAM. Tel: 0724 849 696

**MICROCARE COMPUTING LTD.**, 18 Hawarden Road, NEWPORT, Gwent. Tel: 0633 278040

**MICROCOMPUTER CONSULTANCY**, Lyngen, Oldhill Wood, Studham, DUNSTABLE, Beds.

**NASTAR COMPUTER SERVICES LTD.**, Ashton Lodge, Abercrombie St., CHESTERFIELD. Tel: 0266 207048

**OMEGA ELECTRIC LTD.**, Flaxley Mill, Flaxley Road, MITCHELDEAN, Glos. Tel: 045 276 532

**PROTOCOL COMPUTER PRODUCTS**, 49 Beckenham Lane, Shortlands, BROMLEY, Kent.

**RANMOR COMPUTING LTD.**, Nelson House, 2 Nelson Mews, SOUTHBEND-ON-SEA. Tel: 0702 339262

**ROGIS SYSTEMS LTD.**, Keepers Lodge, Frittenden, NR. GRANBROOK, Kent. Tel: 058 080 310

**S.D.M. COMPUTER SERVICES**, Broadway, BEBINGTON, Merseyside L63 5ND. Tel: 051 608 9365

**S.M.G. MICROS**, 39 Windmill Street, GRAVESEND, Kent. Tel: 0474 55813

**SAPPHIRE SYSTEMS**, 19-27 Kents Hill Road, BENFLEET, Essex. Tel: 03745 59756

**SISCO LTD.**, 4 Moorfields, LONDON, EC2Y 9AA. Tel: 01 920 0315

**SORTFIELD LTD.**, E. Floor, Milburn House, Dean Street, NEWCASTLE-UPON-TYNE. Tel: 0632 329593

**SPOT COMPUTER SYSTEMS LTD.**, New Street, Kelham Street Indus. Estate, DONCASTER, S. Yorks. Tel: 0302 25159

**STAG TERMINALS LTD.**, 30 Church Road, Teddington, Middlesex. Tel: 01 943 0777

**STUKELEY COMPUTER SERVICES**, Barnhill, STAMFORD, Lincs. Tel: 0780 4947

**TERMACRE LTD.**, 126 Woodwarde Rd., LONDON SE22 8TU. Tel: 01 693 3037

**THAMES VALLEY COMPUTERS**, 10 Maple Close, MAIDENHEAD, Berks. Tel: 0628 23532

**TURNKEY COMPUTER TECHNIQUE**, 23 Calderglen Road, St. Leonards, EAST KILBRIDE. Tel: 03552 39466

**THE COMPUTER ROOM**, 87 High Street, TUNBRIDGE, Kent. Tel: 0732 355962

**WELSH BUSINESS SYSTEMS LTD.**, 1 Windsor Chambers, Windsor Arcade, PENARTH. Tel: 0222 70059

**WORD PERFECT**, Old Town Hall, Box 148, READING, Berkshire. Tel: 0734 589068

  
**ICARUS**  
 Computer Systems Ltd.

*For further details, or if you want to become a dealer yourself, contact:*

Icarus Computer Systems Ltd. Deane House 27 Greenwood Place London NW5 1NN Tel: 01-485 5574 Telex: 264209

● Circle No. 127

# Computer Supermarket

Big name hardware at cash-and-carry prices - and with service you'll find hard to match

## SHARP, COMMODORE, TEXAS, RICOH, ATARI and TANDATA EQUIPMENT

Fully tested before despatch, or collection complete with instruction manuals, tapes, and fitted with 13 amp plugs.

### COMMODORE EQUIPMENT

Model	User Ram	exc VAT	inc VAT
4016	12" 40 Col. 16K Mem	445.00	511.75
4032	12" 40 Col. 32K Mem	560.00	644.00
8032	12" 80 Col. 32K Mem	699.00	803.85
8096	12" 80 Col. 96K Mem	1040.00	1196.00
SUPERPET	Micromainframe	1300.00	1495.00
2031	121K Disk	350.00	402.50
4040	347K Disk	560.00	644.00
8050	1M Byte Disk	755.00	868.25
4022	Printer	350.00	402.50
8023	High Speed Printer	785.00	902.75
PET/IEEE	Cable	18.00	20.70
IEEE/IEEE	Cable	20.00	23.00
VIC 20	Personal Computer	173.90	199.99
VIC/C2N	Cassette	36.00	41.40
VIC 1011A	RS232 Int	28.50	32.78
VIC 1110	8K RAM Cartridge	36.00	41.40

VIC 1111	16K RAM Cartridge	60.00	69.00
VIC 1112	IEEE Int	44.00	50.60
VIC 1210	3K RAM Cartridge	25.00	28.75
VIC 1211M	3K RAM (Hi-Res) Cart	28.00	32.20
VIC 1212	Programmers Aid	28.00	32.20
VIC 1213	Machine Code Mon	28.00	32.20
VIC 1515	Matrix Printer	186.96	215.00
VIC 1540	Single Disk Drive	344.35	396.00
VIC Joystick		6.52	7.50
VIC Paddle (Pair)		11.00	12.65
VIC Expansion Unit (Arfon)		78.00	89.70
Lid for above expansion unit (Arfon)		6.95	7.99

### SHARP EQUIPMENT

MZ80A	48K Ram	434.78	499.99
MZ80B	64K Ram	950.00	1092.50
MZ80F1	Floppy Disc I/O Card	100.00	115.00
MZ80MDB	Master Diskette & Manual	31.00	35.65
MZ80F15	Cable	9.00	10.35
MZ80FD	Disc Drive	589.00	677.35
MZ80EU	Expansion Unit	50.00	57.50
MZ80P5	Matrix Printer	415.00	477.25

### RICOH

RP1600	Letter Qual. Printer IEEE	1200.00	1380.00
RP1600S	Letter Qual. Printer Cent.	1300.00	1495.00

### TEXAS EQUIPMENT

TI-99/4A	16K RAM	260.00	299.00
----------	---------	--------	--------

Full range of peripherals available

### ATARI EQUIPMENT

Atari 400	16K RAM Computer	260.00	299.00
Atari 800	16K RAM Computer	456.52	525.00

Full range of peripherals available

### TANDATA EQUIPMENT

Micro Tantel		152.17	175.00
Alpha Tantel		182.61	210.00

Full colour output. Connects to any TV. Full British Telecom approval. Requires British Telecom 96A jack-plug. Gives access to massive home computer base information from Mortgages to Theatres, Stocks to Holidays. Telephone us for further information on ease of installation.

Prices are valid only for the cover date month of this magazine

Credit Facilities Available. Ring or write for full details.

Special Price List Available for bonafide Government and Educational establishments.

All orders will be acknowledged by return of post.

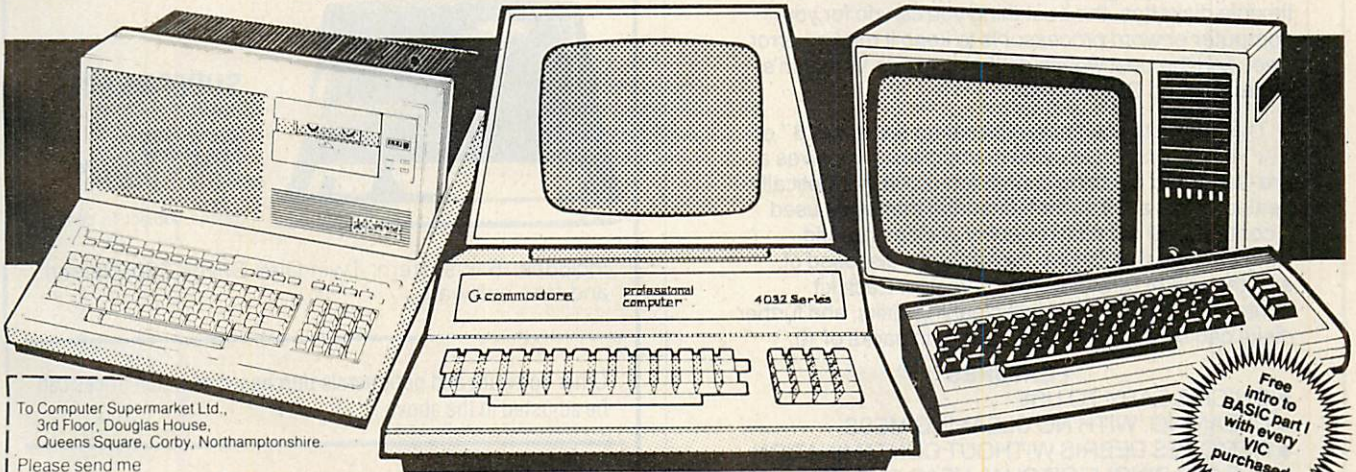

To Computer Supermarket Ltd.,  
3rd Floor, Douglas House,  
Queens Square, Corby, Northamptonshire.

Please send me

Model No.	Item	Price	Shipment	Total	Info only

I enclose my cheque for £  
Or debit my Access/Barclaycard/  
Diners Card/American Express No

(Cardholders may telephone orders to 05363 61587/8)

Signature \_\_\_\_\_

Name \_\_\_\_\_

Address \_\_\_\_\_

(BLOCK CAPITALS PLEASE)

Your remittance should be made payable to Computer Supermarket Reader's Account, and shall remain your money until the goods have been despatched to you at the address specified.

All goods offered are subject to Computer Supermarket conditions of sale, copies available on request. Reg. in England No. 2646589

Prestel subscribers may order through the Prestel service, Directory No. 400400.

Insured shipment arranged anywhere in UK for an additional £14.37 (inc. VAT). VIC, Atari and Texas shipped by insured post F.O.C.

Approved Distributor for Commodore, Sharp, Atari and Texas.

All goods sold with full manufacturer's warranty and subject to conditions of sale (available on request).

ALL MACHINES ARE FULL UK STANDARD.



### COMPUTER SUPERMARKET LTD

3rd Floor, Douglas House, Queens Square, Corby, Northamptonshire.  
Telephone 05363 61587/8 and 62571 Telex COMPSU 341543/4 Prestel No. 400400

# KEEP IT CLEAN!

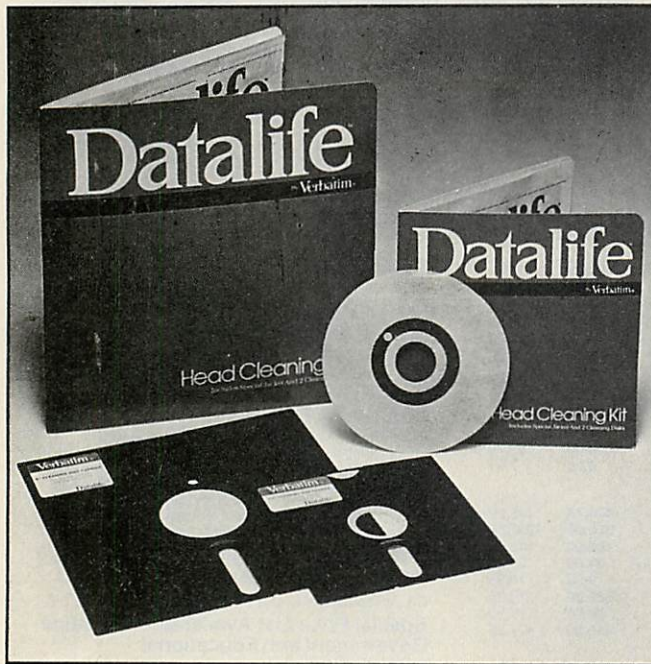

Next to keeping all your data on Verbatim **Datalife** flexible diskettes, the best thing you can do for your computer or word processor is to keep it running error free. And the best way to do that is to use Verbatim's **Datalife** head cleaning kit.

This consists of a flexible jacket (to suit either 8" or 5 1/4" single or double sided drives), which receives a pre-saturated cleaning disk. Each disk is hermetically sealed within a foil sachet, ensuring that when used it contains the optimum quantity of cleaning fluid. After use the disk can be conveniently disposed of, and the jacket re-stored for future use. Each kit contains one jacket and two cleaning disks, and further disks can be purchased separately in packs of 10.

#### FEATURES

- QUICK & EASY TO USE
- CLEANING, WITH NO CLEANING MESS
- REMOVES DEBRIS WITHOUT CONTAMINATION
- CLEANS SINGLE OR DUAL HEAD DRIVES
- PATENTED FEATURES
- ECONOMICAL
- RE-USABLE PRESSURE PAD PROTECT LABEL

**CALL THE Datalife™  
LINE NOW: 01-941-4066**

Scottish Distributor:  
Computer Supplies Co.,  
8/18 Union Street, Bo'ness,  
West Lothian, Scotland.  
Tel: 050-682-3393

BFI Electronics Ltd.,  
516 Walton Road,  
West Molesey,  
Surrey. KT8 0QF  
Tel: 01-941 4066  
Telex: 261395

● Circle No. 134

## FREE MICRO COMPUTER SOFTWARE

(with complete hardware system price)

OCSC Bookkeeping/Financial Accounting/Incomplete Records/OCSC Payroll and Wordstar/Mailmerge or Super Calc or Datastar/Supersort I or Invoicing and Sales ledger or Stock Control.

**ACT SIRIUS I** from **£2395** + printer cost + VAT includes 128k system, twin disk drives, 1.2 Megabytes, screen and free software.



### ADLER ALPATRONIC

from  
**£2095**  
+ printer cost + VAT  
(prices subject to change)

Includes: Alpatronic P2 with Twin Disk Drives 320, Screen & Free Software.

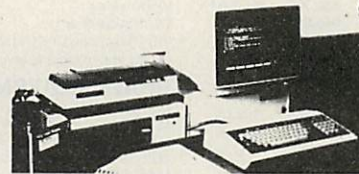

### NEC PC8000:

from  
**£1826**  
+ printer cost + VAT

Includes: 64k system, twin disk drives 320, Screen and free software.

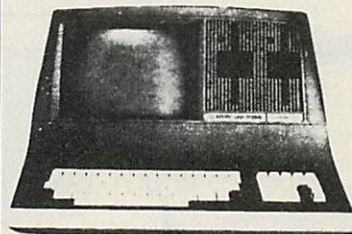

### SUPERBRAIN

from  
**£1630**  
+ printer cost + VAT

(prices subject to change)

Includes: 64k system, Twin Disk Drives 320, Screen and free software.

Other software and peripherals purchased of which prices can be adjusted in the above.

We were established in 1969 as a consultancy and software house, our consultants are well qualified and members of several professional institutes.

We undertake consultancy and contract work at a very reasonable fee and our systems can be tailored to meet your requirements at a nominal fee.

Other micro manufacturers, distributors and dealer enquiries are welcomed.

Also we are looking for distributors abroad and commission agents in the U.K. Please ring for details Watford 48580.

## OVERSEAS COMPUTER SYSTEMS CONSULTANTS

182a QUEENS ROAD, WATFORD, ENGLAND

CALLERS BY APPOINTMENT PLEASE

● Circle No. 135

# THINKING ABOUT BUYING A COMPUTER SYSTEM? TALK TO DATALECT FIRST!

## COMMODORE<sup>®</sup>

No. 1 best seller in the U.K. Tackles your bookkeeping, stock control and word processing. This system is reliable and superb value.



...because who else provides all this—at a price you can afford

We offer you a choice of these budget priced, easy to operate microcomputers. Starting in price from an amazing £200 for a computer, £1,500 for a complete system. All come with a versatile range of programs to meet today's modern business needs.

## APPLE<sup>®</sup>

One of the most versatile on the market. Expandability up to 48 kbytes of user memory, supported by a large range of programs and peripherals.



### Try one out for yourself

If you're not sure how a microcomputer can help, call in at our WOKING or CROYDON SHOWROOMS.

## HEWLETT<sup>®</sup> PACKARD

A portable (only 20 lbs) specialist computer with a fully integrated keyboard, display and printer.

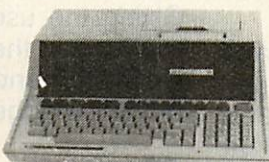

### Keeping you going

Fast reliable SERVICE if you're based in London and the South.

### Buying your system

Attractive terms, leasing and the best deals available in London and the South.

Remember, when you buy from Datalect you're getting 10 yrs EXPERTISE, SERVICE, ADVICE and TRAINING and the best after-sales care.

## ACT 800 series<sup>®</sup>

A large microcomputer system supported by an excellent range of programs. Expandable to multi-tasking up to 20 meg.



### SHOWROOMS:

CROYDON. 7, St. Georges Walk, Croydon, Surrey.  
Tel: 01-680 3581  
WOKING. 32, Chertsey Road, Woking, Surrey.  
Tel: 04862 63901

® Registered trademarks of Commodore, Apple Inc., Hewlett Packard, ACT.

**NOW IN STOCK! THE 16 BIT MICRO-SIRIUS 1**

# DATALECT COMPUTERS

Your computer company for London and the South

Please send me details and price list.

Name \_\_\_\_\_  
Company \_\_\_\_\_  
Position \_\_\_\_\_  
Address \_\_\_\_\_  
\_\_\_\_\_ Post Code \_\_\_\_\_

DATALECT Computers.  
Dept. PC, 33/35 Portugal Rd., Woking, Surrey GU21 5JF

● Circle No. 131

# HOW TO GET MORE FROM YOUR MICRO

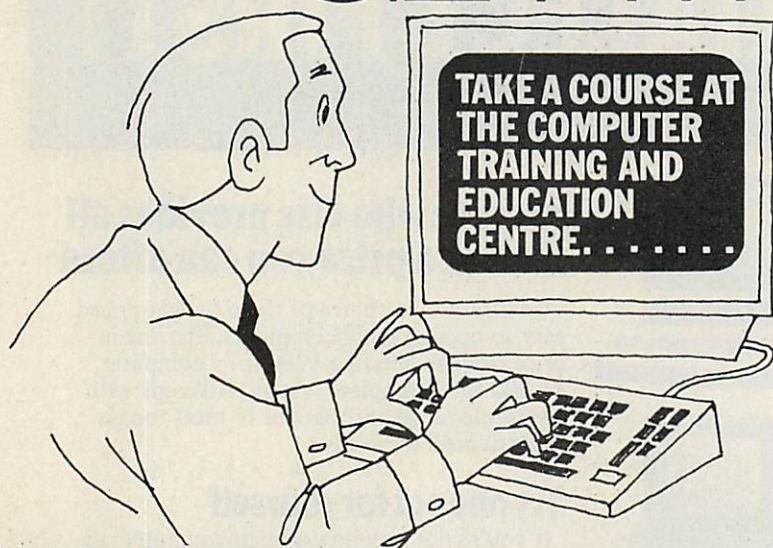

## CP/M\* (User level)

2 days

A practical course designed for those unfamiliar with CP/M, familiarising the new user with the operation of the typical hardware attached to a disc-based Z80 microprocessor system, and giving an understanding of the facilities available and of its management of disc files.

## Advanced CP/M

2 days

This course is designed for those who wish to modify the standard CP/M operating system and includes a detailed investigation of BIOS and its interaction with CCP and BDOS. Previous assembler experience is essential.

## Programming in BASIC

1 week

Giving a thorough understanding of the BASIC language and enabling the student to put this knowledge into practical use, facilitated by hands-on sessions and practical exercises.

## Programming in PASCAL

3 days

Giving an understanding of structured programming techniques as used in PASCAL and providing practical experience on a microcomputer.

## Wordstar† Wordprocessing

2 days

Giving the user an understanding of the facilities available in the Wordstar/Mailmerge Wordprocessing System and hands-on experience which enables this knowledge to be put to practical use.

**All courses are in London.** A wide range of hardware is available for practical work.

**Contact** The Courses Secretary, Computer Training & Education Centre Ltd, 102-108 Clerkenwell Road, London EC1. 01-251 4010/4019.

# CTEC

A professional organisation with first class training facilities in Central London.

\*CP/M is the T/M of Digital Research Corp.  
†Wordstar is the T/M of Micropro Corp.

Please send me further information on the course(s) about.....

Name.....

Position.....

Company.....

Address.....

Tel. No.....

PC6

# A question of band-width

THE ONLY successful economic activities in Britain nowadays seem to be telecoms and company liquidation — the impoverished talking to the broke. Out of that, in recent weeks, we received two pieces of news: one bad and one, possibly, very good.

The bad news, which so far is only a rumour, is that Prestel will fold its tents and steal quietly away into a less public line of business. Some of us can remember, three years ago, hearing about an early demonstration of Prestel to the Directors of IPC, the company that publishes *Practical Computing*. One of them was reported to have said, on being shown the electronic marvel: "It will never catch on". How we all laughed! How we all scorned this bone-headed example of big-business obscurantism! And how very right he was.

When Prestel was first mooted it was quite clearly a Good Thing. One could not exactly explain why it was a Good Thing without waving one's hands about, which is to say that its goodness was so deeply diffused throughout the whole structure of the invention that it did not, and could not, appear at any particular, graspable point. In retrospect, that hand-waving might be seen as a bad sign.

In competition with paper communication Prestel should allow a communication-hungry public to find out anything in very little time. If the 8.50 to Edinburgh is going to be 10 minutes late setting out this morning, the departure time in the Prestel timetable should say so. If there are 20 standby seats on the 1600 flight to San Francisco that should appear. If you want a 1932 Le Mans replica Bugatti, one old-lady owner, Prestel should lead you to her.

In practice it has not been like that. Because people do not rely on Prestel timetables you have no confidence that they are right. You tend to ring up to check, just as you always did. One of our contributors, who has spent three years intimately connected with the beast, confesses that he has only twice in that time used Prestel to find out information that he could have acquired no other way.

Prestel came into a world which had elaborate and effective ways of disseminating information, even if, as seen by the electronic whizz-kids, these methods were so archaic that they could not work. In practice, people knew how to use them and how much to trust them, and the channels of distribution had become woven over the course of time into a dense and satisfactory mat. There is, after all, no reason why you should automatically turn to the back page of *The Guardian* to see what yesterday's temperature was in New York, but some of us do.

A hundred years and more of newspaper publishing have arranged things so that this number is read in New York and transmitted to your breakfast table to arrive in just the place where you expect it. Dozens of people and millions of pounds worth of equipment must be involved, but no one gives it a second thought. How would you find out through Prestel?

Prestel offers a jungle that is very much like the game of Adventure. You have no idea what is hidden in those caves, how to find them and what they will do to you when you do. There is a horrible, groping-in-the-dark feel about using Prestel that compares very badly with printed information products. When you pick up *Practical Computing* you can see exactly what is there. You skim through, this way and that, and build up a picture of the issue in your mind. That ad looks interesting, I'll come back to it. Oh no, not that article again! Skip it.

The human mind has a need to comprehend, even if very vaguely, what it is dealing with. And it is a need Prestel does

not satisfy. You only learn about the database by examining it minutely, page by page. It keeps changing, so what you have learned does not persist. It is like the blind men feeling an elephant.

The same difficulty stymies many people when they try to get to grips with micros. You cannot see what is inside the thing. After some months of agonising experiment you learn to "see in the dark", to build up a picture of the internal structures by their actions. The only other job like it is that of the driver who often has to work in such muddy waters that a sense of sight is useless. You must learn to build up a picture of the surroundings by touch, just as though you were blind. Not many people are good at this, and fewer still enjoy having to do it.

The second supposed advantage of Prestel is that it does away with the wasteful and expensive process of cutting down trees, boiling them, marking them and trucking them round the country. It is a process that should not have to happen, but it does and it works fine. Anyone who plans to replace it has to offer very substantial advantages. Prestel does not.

What has been the drawback to Prestel? With hindsight — such a convenient position to pontificate from — it is a question of band-width. The human mind is built to process some 10Mbits of visual information each second; 0.5Mbits of sound, perhaps another 0.5Mbits of touch taste, temperature and internal sensations: a total of around 11Mbits each second. Without it the brain starves.

Unfortunately, all communications technology is narrow-band stuff. You can read about 200 words a minute, so a book has a bandwidth of 160 bits per second or about the same as Morse code. The telephone is limited to about 5Mbits per second, TV provides about 2Mbits per second and wide-screen 70mm. film about 6Mbits per second. You only have to compare the popularity of TV with books to see whether people at large prefer high bandwidth to narrow. Compare the number of people who write voluminous letters to those who send a colour photo.

It takes many years of education to train a person's mind to peer through the narrow-bandwidth keyholes. A minute fraction of the population has been taught properly to read: 98 percent of Americans cannot understand a sentence with more than 30 words, and there is no reason to think the British are any better. The progress of computing is a struggle to train people to compress their minds. The dedicated few may worry their heads about recursive languages and database management, but what the people like is pictures.

Having worked through this rather miserable preamble, we can now come to the good news: the Government's vigorous intention to rewire the country with optical fibre. No doubt there will be wrangles about standards and finance, but the upshot of it all will be long-distance personal information links capable of satisfying the brain's demand for bandwidth. When that can be fulfilled, you can expect the wired society to take off, because it will be capable of supplying what the mass market wants. We really will be able to have two-way mind travel. One would be surprised if this network did not make profound changes in the way people work, shop, go on holiday and go courting.

To go with broad-band data links we need cheap domestic computers, capable of powerful picture manipulation in real-time. In the light of this, the 64-bit micro with 1Mbit of RAM on a chip is not an esoteric engineering toy, but a consumer item that Woolworth's will want to stock before the end of the decade. □

# Now you can add 64K CP/M<sup>®</sup> to your Pet Commodore for only £497,- With the CP/M<sup>®</sup>Maker

It takes only five minutes and £ 497,- to raise your standard Commodore operating level by CP/M and add a hefty 64K RAM.

Not another tag-on box, this module actually plugs inside your present console. No new power supply, no soldering, no fiddling.

Whether you own the 3000, 4000 or 8000 series model you can still add CP/M versatility.

The CP/Maker gives you a massive 96K RAM at your disposal.

The Z80 microprocessor, incorporated in the CP/Maker will also enable you to use your 6502 as an intelligent I/O processor.

Look at all these other CP/Maker advantages:

- Compatible with all CP/M software such as wordstar.
- Compatible with all normal CBM software, including 69K Visicalc.
- The Z80 and 6502 work simultaneously.
- Languages include CB 80 (the fastest Basic compiler for micros), C-Basic, M-Basic, MT, Pascal, PL1, CISCobol, Fortran...
- Comes complete with CP/M 2.2 diskette and operating manual.

Enquire at:

Tamsys Ltd.

4 Park Str., Windsor, Berkshire SL41BG  
Tel. Winsor 56747, telex 849462 telfac

Micro Technology Ltd.

51/53 The Pentiles, Tunbridge Wells  
Kent, Tel. (0892) 32116, Telex 9541

for your local dealer

● Circle No. 133



\* £ 497,- is a recommended retail price.  
CP/M is a registered trade mark licensed  
from Digital Research Inc. U.S.A.

The  
CP/Maker  
a product  
from the exclusive  
European  
supplier of CP/M  
**vector**  
international  
Research Park B-3030 Leuven, Belgium  
Tel. 016/20.24.96 Telex: 26202 vector

**Our Feedback columns offer readers the opportunity of bringing their computing experience and problems to the attention of others, as well as to seek our advice or to make suggestions, which we are always happy to receive. Make sure you use Feedback—it is your chance to keep in touch.**

## Neat layout

MY PROGRAM Neat Layout, Pet Corner, February, contains an error in listing 1. Line 20 should read:

```
20 AL=LEN(A$):IFAL = <WCTHENAS =
AS+LEFT$(SP$,WC-AL+1):GOTO40
```

Bruce Humphries,  
Epsom,  
Surrey.

## 16-bit CP/M

I AM A KEEN ADVOCATE of the new 16-bit CP/M computers, believing this to offer sufficient advantages over the well-known eight-bit CP/M to be a serious alternative. However, the advertisement for the ACT Sirius in the March *Practical Computing* contains two statements which could seriously mislead:

- "It's launched with more software than anything before it."
- "And the ACT Sirius 1 can run any software written for CP/M — that means hundreds of specialised packages."

The CP/M Users' Group has received reports that the problem with 16-bit CP/M is the lack of software, and this is not surprising since CP/M-86 has not been available for long. This is not a reflection on either the performance of CP/M or the 16-bit computers, but simply that application software cannot be written until CP/M-86 computers become available to the software houses.

CP/M-86 is the implementation of CP/M for the Intel family of 16-bit processors known as the 8086 and 8088, which have a completely different machine-instruction set to the 8080 or Z-80 processors used by CP/M-80. Software written in 8080 instructions cannot be run without modification under CP/M-86. As the majority of CP/M software is written for the eight-bit CP/M, the claim that it is launched with more software cannot be substantiated. Indeed, there is currently little software written for CP/M-86, though I am sure this will change very shortly with the availability of 16-bit computers such as Sirius.

Perhaps these two statements appear in the advertisement because of a misunderstanding of the compatibility between the eight-bit 8080 and the 16-bit 8086. Software for the 8080 can run on the 8086, but the crucial factor is that the 8080 assembly-language operation code or mnemonics have to be converted into 8086 code. For each 8080 mnemonic there is an equivalent 8086 mnemonic or set of mnemonics.

Both Intel and Digital Research provide a conversion utility which will read

8080 assembly-language source code and produce an equivalent 8086 assembly-language source code. This code is then assembled using the 16-bit assembler. These converters make it simple for a software house to painlessly convert eight-bit software to 16-bit software, but there are two drawbacks:

- The program produced is likely to be larger.
- The program is likely to run slower on the 16-bit than the eight-bit.

A third limitation of the conversion is that the program space is limited to the eight-bit 64K. The space available for a user's Basic program can actually be less on the 16-bit than on the eight-bit, and can run slower on the 16-bit if the Basic interpreter is only a conversion from the eight-bit.

Any purchaser of 16-bit software should therefore ask if the software is a conversion of the eight-bit or whether it has been rewritten to make full use of the 16-bit features.

David Powys-Lybbe,  
CP/M Users Group (U.K.),  
London EC2.

## Patsy Pokes

PATSY, the Programmer Aptitude Testing System in the March issue turned out to be a real test after all. I have found errors in nine of the Poke statements, which should read.

Line			
10110	Poke 16639,	178	Poke 16640, 69
10210		61	73
10310		10	76
10410		130	79
10510		245	81
10610		109	84
10710		126	88
10810		47	92
10910		73	95

Ted Swann,  
Middle Assendon,  
Oxfordshire.

## Course programming

I READ with interest, and mounting amazement, Michael Smith's article on Programmer Aptitude Testing in the March issue of *Practical Computing*. The article sets out a method and program for testing the logical and analytical skills of an applicant for computer programming using what is effectively a binary-logic test.

It became apparent that the best score could be achieved by pressing the required buttons 4, 5 and 6 using simple combinational selection without any analysis of the problem at all. This will produce a working solution in a maxi-

imum of 7 steps, excluding the option of no switches pressed, for each of the night and day states. On average the solution will take only 3.5 steps. The possible combinations are as follows, using 1 to represent "pressed" and 0 to represent "unused":

Key	4	5	6
1 key	0	0	1
	0	1	0
	1	0	0
2 keys	0	1	1
	1	0	1
	1	1	0
3 keys	1	1	1

My amazement is that this rather simple and elegant application of binary counting was not obvious to either the programmer or any of the applicants. Does my solution qualify me for the Crude Programmer of the Year Award, or perhaps a free programming course from Michael Smith?

Brian Robinson,  
Lancaster.

## Road Racing

I AM SURE many readers must have noticed that Road Racing in March's Open File, Tandy Forum, does not work very well if entered as printed. The program is improved by changing the following lines:

```
160 PRINT @19,"SPEED (10-70 etc.
530 IF ZQ=3 THEN X=X-1:Y=Y-1
550 IF ZQ=8 THEN Y=Y+1
555 IF ZQ=9 THEN X=X-1:Y=Y+1
```

N S Grant,  
Heald Green,  
Cheadle.

## Input or Get?

I ENTIRELY AGREE with the April editorial, "Canned thoughts". One of the reasons why the concepts used in computing are all about computers, rather than the uses to which computers are put, is that people who make a living out of programming come to think that programming is a useful activity in itself, rather than a service to other people.

Even though programmers work with new technology they often hold the "We have always done it this way — therefore it cannot be done any other way" attitude to their work. It is reflected in the actual code written and one particularly infuriating custom is the way in which you have to press Return after you have entered data into the computer before it will stir itself into action. This dates back to the days when you had to use a teleprinter to get information in and out of a computer.

(continued on page 45)

# THE PRINTER YOU WANT IS HERE

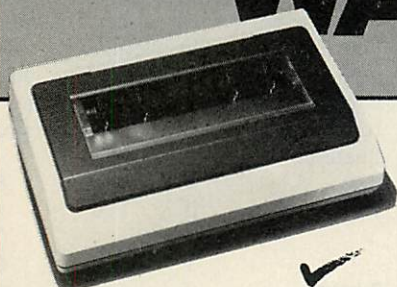

## PERTEC P80

\* Heavy duty matrix printer at a sensible price. \* 80cps.  
\* 80/120 character lines.  
\* Optional character sets, with true descenders. \* Centronics and RS232 serial interfaces.  
**£439 + VAT**

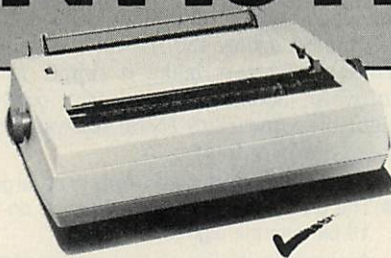

## RICOH RP 1600

\* Advanced daisywheel printer for word processing, mini and micro applications. \* 60cps.  
\* Intelligent option includes Qume/Diablo compatible commands and auto bidirectional operation.  
**£1395 + VAT**

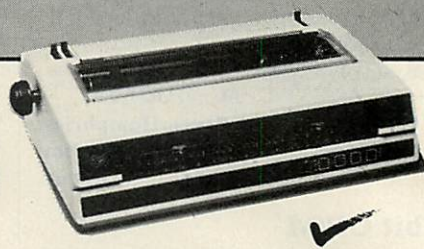

## TRIUMPH-ADLER STYLIST

\* Low cost daisywheel printer for most popular micros and minis. \* 14.5cps. \* Proportional spacing. \* Bidirectional / logic seeking. \* Range of type styles and languages.  
**£695 + VAT**

**Trade and OEM discounts available.**

Write or call for further information.

**Butel-Comco Limited**

Garrick Industrial Centre,

Garrick Road, London NW9 6AQ.

Telephone: 01-202 2277

# BUTEL

**Technology for business**

● Circle No. 129



TOWER  
OF  
LONDON

EROS

FENCHURCH  
STREET



WHITEHALL

NELSON'S  
COLUMN

## Visit London's new attraction (Entrance FREE)

Anita Business Systems has opened its new retail shop and we can now offer:-  
\* Commodore, Apple & Adler Micro Computers \* Associated Printers \* Disk Drives \* Full Software Support \* Demonstration Facilities \* Calculators \*

Typewriters \* Dictaphones \* Office Furniture \* Experienced service back up on all equipment \* Video Department

For all your business equipment requirements come to:-



# ANITA BUSINESS SYSTEMS

ANITA BUSINESS SYSTEMS

50 Fenchurch St., London EC3, and

15 Clerkenwell Close, London EC1.

Tel: 01-253 2444

● Circle No. 130

continued from page 43)

Programmers who write games do not use the Return key in this way. Would Space Invaders have caught on if you had to press Return to make your missiles fire? The standard reply to this is, "We need a non-QWERTY user interface".

Yet there are many Space Invaders games that use the standard computer keyboard. Programs can be written which do not require the user to press Return; the problem is that many programmers do not choose to write them.

It is particularly absurd when menu-driven programs require you to press Return after selecting each option. "Please press 1, 2, 3 or 4", says the computer. The new user cautiously presses 1; a 1 appears on the screen, but nothing else happens. After a long pause the user decides he has done something wrong, and that he is not clever enough to operate a computer. So he goes off to a computer expert, who often deals with this kind of query.

"It's quite simple", he says. "Although you pressed 1, it has not been entered into the computer". The user, who can see that the 1 is in the computer by looking through its glass screen starts to wonder why his common sense has failed

Who is wrong? Is it the user, or is it the programmer who used Input out of habit, when he could just as easily have used Get and avoided all the confusion?

J Read,  
Martock,  
Somerset.

● If the program never wanted more than single-digit inputs, then Get or its equivalents would be fine. But what about questions that like, "What is the most you would pay for a car?" which has to be able to accept from one to seven digits. The only way the computer can know that you mean £700 and do not intend to go on to £7,000 is if you press Return when you have finished. So why should menu options take effect immediately while prices, which are numbers just the same, do not? It seems reasonable to train the user to hit Return after every entry, rather than to discriminate in a way that may not be understood.

## Disc dialogue

I FOUND THAT QERA, in the January 1982 issue, would only work under special circumstances. The problem was traced to the fact that Num is not cleared at the start, so the program cannot tell reliably when it has reached the end of the list of "candidates for deletion".

The problem is easily corrected by inserting two lines after the first Push HL:

```
LD A,0
LD (NUM), A
```

When it runs correctly, this is a useful facility — many thanks to David Meeks,  
David Coates,  
Research Machines,  
Oxford.

## Apple SI card

WE HAVE recently purchased two Paper Tiger 445 printers for use with our Apple II systems. We are using the standard Apple serial interface card and have uncovered what appears to be a serious shortcoming in this card, at least as far as the use of the Paper Tiger is concerned, and possibly for other printers too.

The problem occurs when listing long programs. After a certain point the listings become garbled, with whole portions missing. It was clear that data was still being sent to the printer while its 2K buffer was full, and a temporary solution was to lower the baud rate from 1,200 to 300. On closer examination we discovered that the interface card has no provision for honouring the "buffer full" signal from the printer. The Data Terminal Ready line, pin 20, from the printer is set low when the buffer is full. The corresponding pin on the serial interface card is not connected and there appears to be no way of utilising the "buffer full" signal without making modifications to the card itself and the controlling software.

Have any other readers encountered this problem, and what solutions have they found?

P E Roberts,  
Halton College of Further Education,  
Widnes,  
Cheshire.

## Adventure history

HAVING RECENTLY invested my usual 80p in a copy of *Practical Computing*, I was pleasantly surprised to discover an article in the March issue on my favourite type of computer games, Adventures. Although the article by Dennis Ellis was good it appears to be lacking in a few aspects.

That Adventure games are based on Dungeons and Dragons is, of course, beyond doubt, although I would quibble with the general impression the article gives that Adventure is the more popular of the two. I have been playing Dungeons and Dragons for nigh on eight years, and it is played by more people more often. Those in a position to play both invariably prefer the person-moderated to the computer-moderated game.

Although most of the history in the article is correct, I would argue that Zork was a watered-down version of Dungeon. The Zork available on micros is, moreover, a watered-down version of a Zork running at MIT's artificial intelligence labs on a PDP-11. I used to play from time to time over the EPSS/ARPA nets, before British Telecom changed EPSS to PSS and started charging money.

The statement that there are no multi-player, Adventure-like games simply is not true. It may be true for micros, but for nearly four years the Essex University PDP-10 has been blessed with a

program called MUD — Multi-User Dungeon. MUD allows up to 36 players in it simultaneously, and was developed by the Essex University Computer Society.

The setting for MUD is The Land, which consists of about 330 areas called rooms, although many are above ground in a kind of mappable wilderness. Rooms can be chained together so that the environments between the MUDs remains consistent and the passage imperceptible — except that you can not yet take things with you or talk across the programs.

Not only did we frequently go to America via the satellite links for the odd game of Zork, but they came over in droves to play MUD. The vision of playing people in Australia is not all that strange: we regularly killed people from MIT, Stanford and UCLA.

Richard Bartle,  
Colchester  
Essex.

## Grandfather Clock

APPLE PIE in the March issue included R D Walker's Grandfather Clock. I think he must have been so excited with the result that he did not wait for an hour before writing in with his program: the program as published crashes when the clock tries to chime for the second time.

However, all is not lost if you insert the following lines:

```
8 GH = 19
5081 RESTORE
5082 FOR DT = 1 : READ WE : NEXT DT
```

Michael Trinder,  
Sunningdale,  
Berkshire.

## Tangled web

WE WERE PLEASED to be mentioned as suppliers of Apple software in the article on Adventures in the March issue of *Practical Computing*. We would like to remind readers, however, that our telephone number is 01-680 0267, and has been for some six months.

Dick Williams,  
Spider Software,  
Croydon,  
Surrey.

## Nascom Adventures

I READ WITH great interest the Adventure article in March 1982 *Practical Computing*. It is gratifying that microcomputer games are moving away from pub games like Space Invaders, towards games with a tendency towards artificial intelligence. However, the article does give the impression that very few Adventure games are available for the Nascom 1 and 2 range of computers. For several months now, we have been selling a very popular compact 16K version of the mainframe Adventure.

M J Evis,  
Syrtis Software,  
Bridgwater,  
Somerset. □

## Triple guide to software products

FOR EVERY PROFESSIONAL involved in computing, the International Directory of Software is a must. The book contains 1,360 pages packed with information about systems available in both Europe and the U.S. A total of 4,026 products are listed, more than half of which are appearing for the first time.

Data is indexed in three different ways. Once the relevant product has been identified, the user may discover such details as its date of origin, terms of purchase and operational mode.

The directory is not cheap — at £48 per copy plus postage it costs almost as much as some items of software contained within it; however, it will be of great use to dealers and computer department managers. For a copy of the directory contact Computing Publications Ltd, 430 Holdenhurst Road, Bournemouth, Dorset BH8 9AA. Telephone (0202) 302464. □

## Bureau link boosts Pets



THE COMMODORE PET computer can now be used as a terminal on-line to a mainframe computer bureau. The Pet requires the addition of a £900 terminal emulator, but is still cheaper than a dedicated terminal. Savings are particularly attractive to those users who already possess Pet computers, which retain their stand-alone computing power.

The new service has been established by the Midlands-based ACT. Managing director Tony Bryan said, "There are a lot of Pet users in the U.K. who may eventually find that the system is not powerful enough for all their processing needs. Instead of discarding the Pet, and buying a bigger system, they now have the option of linking into a bureau".

The bureau is based on an ICL mainframe, which can be accessed by the micro using either a telephone dial-up line or a leased line. Once on the system, a number of commercial accounting procedures become available on a batch or an interactive basis. The scheme represents a new low-level entry point into the world of commercial computing. For details of the ACT bureau service phone 021-454 8585. □

## T-Pert's way along the critical path

PERT IS a well-known technique used by planners to help arrange work in progress in such a way that wasted time is minimised. Also known as critical path analysis, the methods employed are well-suited to microcomputer

application. In the past there has been a lack of appropriate software, but this has now been changed with the introduction of T-Pert written by the Leatherhead-based software house, Thorncroft Manor Services.

Despite the fact that T-Pert has been written in Fortran it will run on any CP/M system with 64K of memory. Up to 750 activities can be time analysed and monitored simultaneously. The package is available to end-users at a recommended price of £465. The results of time analysis are printed out in bar-chart form and printouts are produced giving the permissible timings of activities.

Activities are defined by start and finish nodes, which are numbered. The duration of the activity is then given, and it is also possible to include a text description.

The most common usage of this type of software is in the construction industry where — to quote an obvious example — the roof cannot be put on a house until the walls are completed.

Because T-Pert is available on a microcomputer, work can be carried out on-site for more effective management.

For further information on T-Pert contact Thorncroft Manor Services. Telephone (0372) 376756. □

## Ricoh-based daisywheel to mimic Diablo

THE RICOH printer mechanism reviewed in the March issue of *Practical Computing* appears on the market in several guises. One widely advertised incarnation, the Ricoh RP-1600S, seems from the specifications to merit separate coverage.

The Cheshire firm of Micropute has beefed up the basic Ricoh carcass with a Z-80 processor board, incorporating a buffer that offers bi-directional printing facilities similar to the Flowriter. Unlike the Flowriter, which has chosen to be a Diablo look-alike, the Micropute "S" emulates the Spinwriter, thereby standardising its method of accessing the additional characters on the Ricoh wheel. □

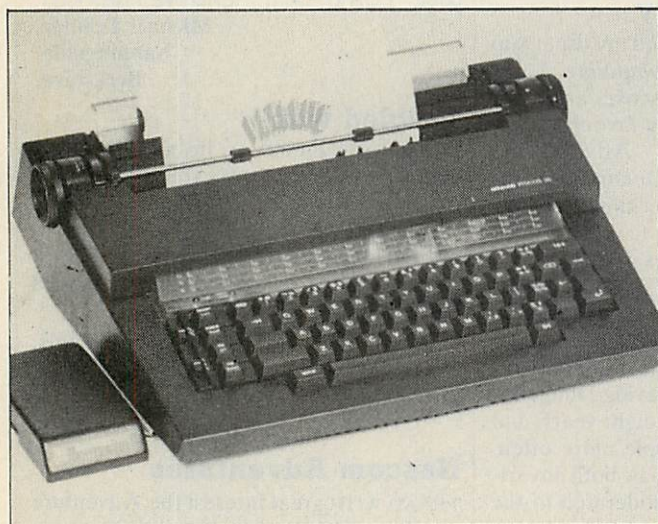

This T/Printer 35 is not only the lowest-priced read-only daisywheel printer on the market, but it is also an electronic typewriter off line. At £475 it is an ideal choice for smaller microcomputer users, who might need letter-quality printout from a word-processing package. The printer is based on the Olivetti Praxis 35 portable electronic typewriter and is comparable in price to many matrix printers. It has a lightweight ABS moulded carrying case, takes paper up to 12in. wide, uses the standard character wheels and can print 120wpm from a microcomputer. Special facilities include variable pitch and numerical fractions. Centronics parallel interface is standard, RS-232 costs extra. For further information contact Datarite Terminals, 144-146 High Road, Chadwell Heath, Essex RM6 6NT. Telephone 01-590 1155. □

## Matsushita's hot graphics

A VERSATILE 40-column bi-directional thermal printer, the Matsushita EUY-3T, is now available in the U.K.

Its graphics facility, which uses a nine-by-280 dot matrix, can be put to a wide range of uses, including microcomputer terminals, personal computers, instruments and point-of-sale terminals.

Contact GMT Products, Newport House, 22 Hartfield Road, London SW19 3TD. Telephone 01-947 7234. □

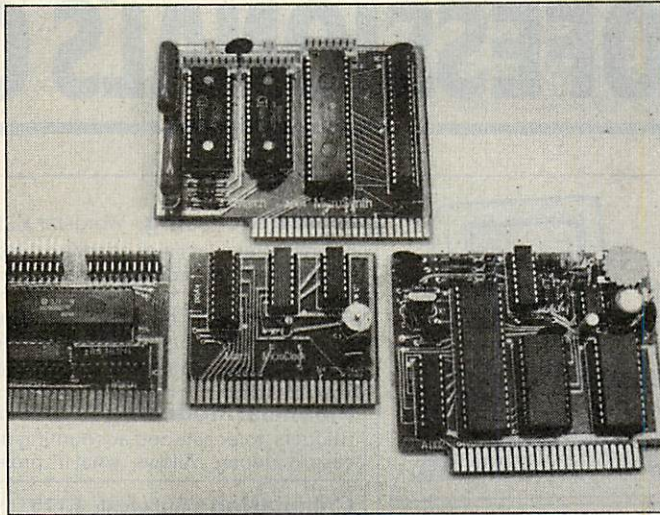

Marchcards are plug-in PCBs for the Apple II and Apple III micro-computers. Top of the line is Microsynth, a sound and music synthesiser card which uses the popular AY-3-8912 chip. Also included are Microtalker based on National Semiconductor's Digitaltalker, an eight-bit parallel input/output card called Microport, and the real-time Microclock. All come from March Communications, 14/16 Manchester Street, Liverpool L1 6ER. Telephone 051-236 2000. □

# Spectrum will carry the Sinclair colours

AMID A CRUSH of photographers to rival a Hollywood première the Sinclair ZX Spectrum was launched at the *Practical Computing/Your Computer Fair*. Nobody was quite clear whether the star was Clive Sinclair, or his new micro-computer — though the machine itself deserves to be a winner. A number of people in the microcomputer business are likely to be losing some sleep over their powerful new competitor.

As expected, the Spectrum is a colour machine, with eight available colours all of which may appear on the screen at the same time. It also includes a sound generator.

Attractive as these features are, the main selling point of the Spectrum will be that it is possible to buy a 16K micro-

computer for only £125. For those with a little more ready cash, a 48K version is available for £175. Memory expansion from the basic 16K machine to 48K will be available for around £60.

Like its precursor the ZX-81, the Spectrum comes in a smart little black box, measuring just 8.5in. by 5in. by 1in. There is a new 40-key ASCII keyboard, and the Sinclair Basic has been beefed up. The extra commands take control of the micro's colour facilities and operate Sinclair's new ZX Microdrives

ZX Microdrives are tiny tape-loop units that can hold up to 100K of program or data. Information is transferred from them at a rate of around 16K per second, filling the 48K Spectrum in three seconds. As yet, only the pro-

totypes have been built but full production is promised soon.

Up to eight Microdrives can be connected simultaneously to a ZX Spectrum. The quantity of on-line data which may be stored can be increased still further by using the Spectrum's networking capability.

Microcomputer networking is all the rage these days and Sinclair is no slouch when it comes to keeping up with current trends. The networking and RS-232 board is an optional extra, soon to be available at about £20.

The Spectrum contains a 16K implementation of the Sinclair dialect and program conversion to and from the older ZX Basic should be fairly easy. There are 13 new commands and the language can now accommodate multi-statement lines.

The new commands will be bound to delight Sinclair users. Beep will enable the Spectrum owner to enter the fertile pastures of computer music, with over 10 octaves of sound available through an internal speaker or via a jack socket. Ink, Paper, Bright, Flash, Over, and Inverse control the colours and brightness of the screen plotting. The Verify command enables the user to check stored data. The Border command controls the border colour, and Data is a long-awaited addition, providing the standard Basic Data control command together with



Read and Restore facilities.

The new machine comes with two manuals, one being an introduction for the newcomer to computing, the other a Basic manual. The ZX Spectrum will be available by mail order only from Sinclair Research, Freepost, Camberley, Surrey GU15 3BR. □

## Self-contained stock system

A COMPREHENSIVE stock-management system incorporating sales and order processing has been designed for the first-time computer user by Winchester-based Inchico Business Systems. The system can tackle stock recording, order entry, invoicing, purchasing and stocktake. It will build up a 12-month usage history and allows the user to view, amend or update purchase orders at any time.

Prices start from under £4,000. Contact Inchico Business Systems, Microcomputer Business Systems, 13 City Road, Winchester, Hampshire. Telephone (0962) 51930. □

Moving keys, not touch-sensitive pads, are used by the Spectrum.



# THE PROFESSIONAL'S CHOICE

## Act Sirius 1

16 Bit Stand Alone micro with superb features. 128K, 1.2MB Floppies. CPM86 as standard - £2395.

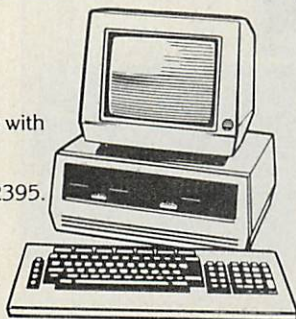

## Altos

Up to 4 terminals and 40MB of Winchester Disc. One of the biggest selling small business systems starting at £2350. 16 Bit system with 8 terminals available soon.

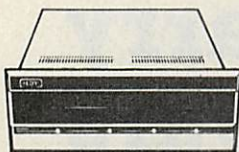

## OKI 1F800

Quality graphics micro with full colour screen and integral printer. 64K and Basic are standard - £4750. Wide range of peripherals available.



## LSIM3

High specification Stand Alone micro. CPM, 64K and up to 10MB of Winchester in one package. Very easy to use. Detachable keyboard. User programmable function keys. From £2250.

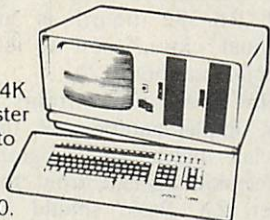

## Superbrain

Still a leader in 8 bit price performance. KGB having sold over 400 Superbrains has unbeatable experience on them. From £1875.



## Word Processing - Wordstar £250, Mailmerge £75.

Full on-screen facilities enabling the printing of standard letters and preparation of mail shots.



## Accounting - From £300 per module.

Integrated accounting systems with Invoicing, Sales, Purchase and Nominal Ledgers.



## Financial Modelling - Micromodeller £645.

Budgets, forecasts and accounting data become easy to prepare. Allows "what if" projections.



## Calculation - Supercalc £175.

Electronic worksheet for preparation of budgets and tables of data.



## Record Keeping - DMS £400.

Personnel, stock or any other records with quick retrieval, sorting and reporting.



## Sales Office Management - Sales Desk £300.

For the busy sales office to manage sales leads and marketing lists.



## Accounts - IRIS £750.

Incomplete records and time recording systems.



## Payroll - Graffcom £500.

Up to 500 employees both weekly and monthly paid. Automatic deduction for items like company pensions.



## Graphics - Price depends on application.

Full on-screen graphics both colour and black and white.



## Engineering - SPERT £450.

Suite of programmes for PERT analysis and civil engineering applications.



## Communications - Liberator £250.

Enables a micro-computer to act like a mainframe terminal and transfer data from Floppy disc to another computer.



## Languages - From £175.

Most major computer languages are available: Basic, Cobol, Fortran, Pascal and Assembler.



## Solicitors - Solace £1600.

Solicitors accounting, client accounting and time recording.



## Multi-terminals - MP/M and Oasis from £350.

Multi-user systems available.



# KGB

## MICROS LIMITED

14 Windsor Rd. Slough, Berks. Tel: Slough (0753) 38581/38319

# ICL advances into the microcomputer market

FOR SEVERAL MONTHS now there have been rumours that ICL is going into the microcomputer business in a big way. First came the news that the British computer giant was going to market the Rair Black Box range of microcomputers under an ICL label. Now the company's plans are brought into perspective its Trader Point scheme.

Trader Point is, as its name suggests, a marketing strategy. It is a bold venture, both from the point of view of ICL and the dealers who enter into agreements with it. Robb Wilmot, managing director of ICL, admits that the company did not know much about the microcomputer market, but is willing to learn.

It is this frank confession by Wilmot that points to the future of ICL — one that certainly looks much rosier than it did a year ago. Because ICL knows little about the micro market, it is prepared to lend its name and expertise to the

dealers who, in return, will sell the machines for ICL. Some dealers are expressing concern that they will be competing for sales against ICL salesmen. Others are worried that the lack of local licence agreements will usher in cut-throat selling, signifying the destruction of their businesses.

Despite these fears, the microcomputing industry should benefit by this new development — not least from the prestige bestowed by the famous ICL. Trader Point is not just concerned with selling the new ICL microcomputer, though the machine should make up the bulk of these sales. Other machines covered by the deal are the Wordskil 8800 range, which is a highly sophisticated word-processor based networking system, the system 25, and a very up-market graphics computer; known as Perq.

The ICL personal computer is expected to sell in very large quantities. According to the

sales team at ICL, the biggest buyers will be large international and national companies. The main competition is expected to be the IBM personal, which is not yet officially on sale in Europe.

For details about Trader Point or the ICL micro contact ICL at its World Headquarters, ICL House, London SW15 1SW. Telephone 01-788 7272. □

## HP-125 prices falling as hard disc arrives

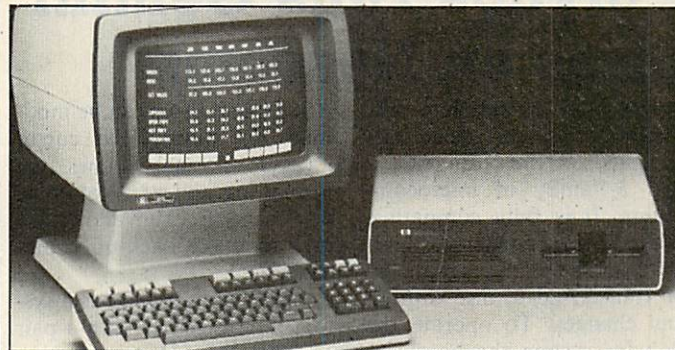

This is the world's smallest dot-matrix printer, the ultra-miniature model 150 from Epson (U.K.). The micro-dot printer has been designed to be used in pocket calculators, smaller computers and various other devices. The print head is of the impact dot-matrix type and can print a maximum of 96 dots per line or 16 columns of five-by-seven matrix characters, on 45mm. width paper. The speed of printing is approximately 1 line per second. Ribbons are provided in single-colour cassettes, either in purple or black. The printer uses a 4.5V power supply and the motor draws a current of 0.17A. The overall dimensions of the printer are: width 73.4 mm., depth 42.6mm., height 12.8mm., weight 60g. Further information is available from Epson (U.K.), Dorland House, 388 High Road, Wembley, Middlesex. Telephone 01-900 0466. □



## Another three for Apple III

ACCESS III is a data communications program, which Apple has introduced for its series III machine to transform it into a conversational terminal.

A Pascal Utilities Library and Script III, a text-editing package for Pascal text files, complete the trio. For further details contact Apple Computers (U.K.), Finway Road, Hemel Hempstead, Hertfordshire HP2 7PS. Telephone (0442) 48151. □

## Magic spells with CP/M

BRITISH SPELLGUARD is the first truly Anglicised spelling checker for CP/M machines. It will run alongside all the popular CP/M word-processing packages such as Wordstar, Magic Wand and Electric Pencil. The program is based on an American version which has sold over 3,000 copies in the U.S.

The program is available on either 8in. or 5.25in. floppy discs formatted for most popular microcomputers, and comes together with a 116-page instruction book. At a cost of £179 the program comes with a money-back guarantee. Spellguard is fast, being able to read 20 pages in under one minute, and has a dictionary of 20,000 words which may be expanded by the user. For details contact Vision Associates, 57 Woodham Lane, New Haw, Weybridge, Surrey. Telephone (0932) 55932. □

THE NEW HP-125 Model 30 is based on a 5.25in. Winchester hard-disc drive, coupled with a 5.25in. floppy in a dual-drive enclosure. Also included in the basic machine are two Z-80 microprocessors, 64K of RAM, 16K display memory, keyboard, and the display unit. The system is the third in the HP-125 range and costs £5,473.60.

Hewlett-Packard claims the new machine offers increased data reliability thanks to the Winchester discs which are sealed against attack from external agencies. A further advantage is the increased speed, and the final benefit is the massive increase in on-line storage.

To coincide with the introduction of the new HP-125 Model 30, Hewlett-Packard has reduced prices on the other models in the HP-125 range, which now starts at £3,238.84. Contact Literature Enquiry Section, Hewlett-Packard Limited, King Street Lane, Winnersh, Wokingham, Berkshire. Telephone (0734) 784774. □

# Daisywheel typewriter is Canon's new venture



## Polydos runs Gemini discs on Nascoms

POLYDOS IS a complete disc operating system specifically designed for the Nascom 1, 2 and 3 family of microcomputers. It is fully compatible with software written for Nas-Sys 1 or 3 so that programs can be transferred to disc without any changes. To operate the Polydos system the hardware must have a minimum of 48K RAM and either a Gemini GM-815 floppy-disc system with the GM-809 controller card or the GM-805 floppy-disc system.

Operating under Polydos the GM-815 disc system supports both double-sided, single-density and double-sided, double-density discs which yield 175K and 315K of storage per drive respectively. The GM-805 system supports the single-density format only. Discs in the single-density mode may be interchanged between the two drives.

Polydos includes a 4K extension to Basic, a disc-based editor and an assembler. All existing Basic programs will run without any modification. The disc assembler, called Polyzap, is claimed to be the most advanced assembler ever written for the Nascom microcomputers.

Three utility programs are supplied with Polydos; they are Superzap, Format and Backup. Superzap allows the editing of disc sectors; sectors are displayed in hex and

ASCII, and bytes can be modified by moving the cursor around. Format allows the formatting and verification of discs, and Backup allows the user to make back-up copies of discs.

Polydos is supplied as a system disc, together with a pair of EPROMs. Documentation is divided into five manuals, and the whole package costs £90 plus VAT. Polydos is available from Microvalue dealers. 

**This is a new all-British microcomputer, the MC Combo. Designed and built in the U.K. this CP/M-based business system is capable of conversing with mainframes. The basic machine comes with twin double-density, double-sided 5.25in. discs offering 400K of storage. The specifications include Z-80A processor, 64K RAM, 12K ROM including Z80 monitor, four serial RS-232 ports, a single Centronics bi-directional port and eight timers, four of which are user addressable. The**

**MC Combo is IBM compatible and there is an optional 6.9Mbyte hard-disc system costing £2,950. The basic system costs £1,088.**

**Contact Megabrain Computers, 2 Ganton Street, London W1. Telephone 01-734 9462. **

ALREADY RANKING among the world leaders in plain-paper copiers, Canon is preparing to tackle the market for electronic typewriters with its AP-500 and AP-400 machines, which are now available in the U.K. Each machine is controlled by a microprocessor which will help to eliminate chores like centring, column layout, and margin and tab setting.

The top of the range, the AP-500 retails for £1,425. Its special features include a 2K memory which can be expanded to a maximum of 32,000 characters in 10K steps.

The AP-400 costs around £840 and has a 500-character memory, and automatic selectors for pitch, line-space, punctuation, keyboard, impression control, carrier return and underlining. Both machines have a line-frame function for graph and chart construction, a daisywheel print mechanism and an output speed of 20 characters per second. For more information, contact Canon (U.K.), Waddon House, Stafford Road, Croydon, Surrey CR9 4DD. Telephone 01-680 7700. 

## Twin Z-80s and 64k RAM stars of Galaxy I

GEMINI MICROCOMPUTERS has introduced the Galaxy 1, a microcomputer built around Gemini's Multiboard system. The Galaxy 1 includes twin Z-80 microprocessors, 64K dynamic RAM, a detachable 59-key keyboard and two



double-density 5.25in. floppy-disc drives.

The Galaxy 1 provides a number of sophisticated video facilities. Full cursor-control functions give the user comprehensive on-screen editing capabilities.

Centronics and RS-232 interfaces permit the use of parallel and serial printers. A 1,200 baud Cuts cassette interface and a light-pen input are also included. The Galaxy 1 costs £1,450 plus VAT from Gemini Microcomputers, Oakfield Corner, Sycamore Road, Amersham, Buckinghamshire. Telephone (02403) 28321. 





# One Expander Card for apple leads to another....

In fact it leads to many others! Joining the amazing success of our PAL Encoder Card, these four new expander cards all featuring the unique 'Digitek Safety Tab' are ready to plug straight into your Apple Computer.

**Pal Colour Encoder Card £105** This amazing card with it's on-board modulator, displays exceptional colour graphics to your TV.

**16k Ramcard £91** Insert the card straight into slot 0, and increase the memory capability of your Apple without having to remove any memory chips.

**Z80 Expansion Card £110** Installing the Z80 into your Apple gives you two systems in one, which enables you to run the popular CP/M operating system.

**RS232 High Speed Serial Interface £72** The RS232 Interface Card incorporates 13 selectable Baud rates from 75 to 19,200.

**Print-master Interface £79** The ultimate parallel interface for Apple to all popular dot matrix printers.

The PRINT-MASTER accepts Apple protocols, 15+ software commands and has on-board graphics dump capability to all popular graphics printers. No need to load clumsy software routines - it's all at your fingertips on the PRINT-MASTER - choice of inverse printing, double size picture, 90° picture rotation, many word processor type text commands, plus many more.

Apple is the trademark of Apple Computers Inc. Digitek and Print-master are the trademarks of Digitek (International) Ltd.

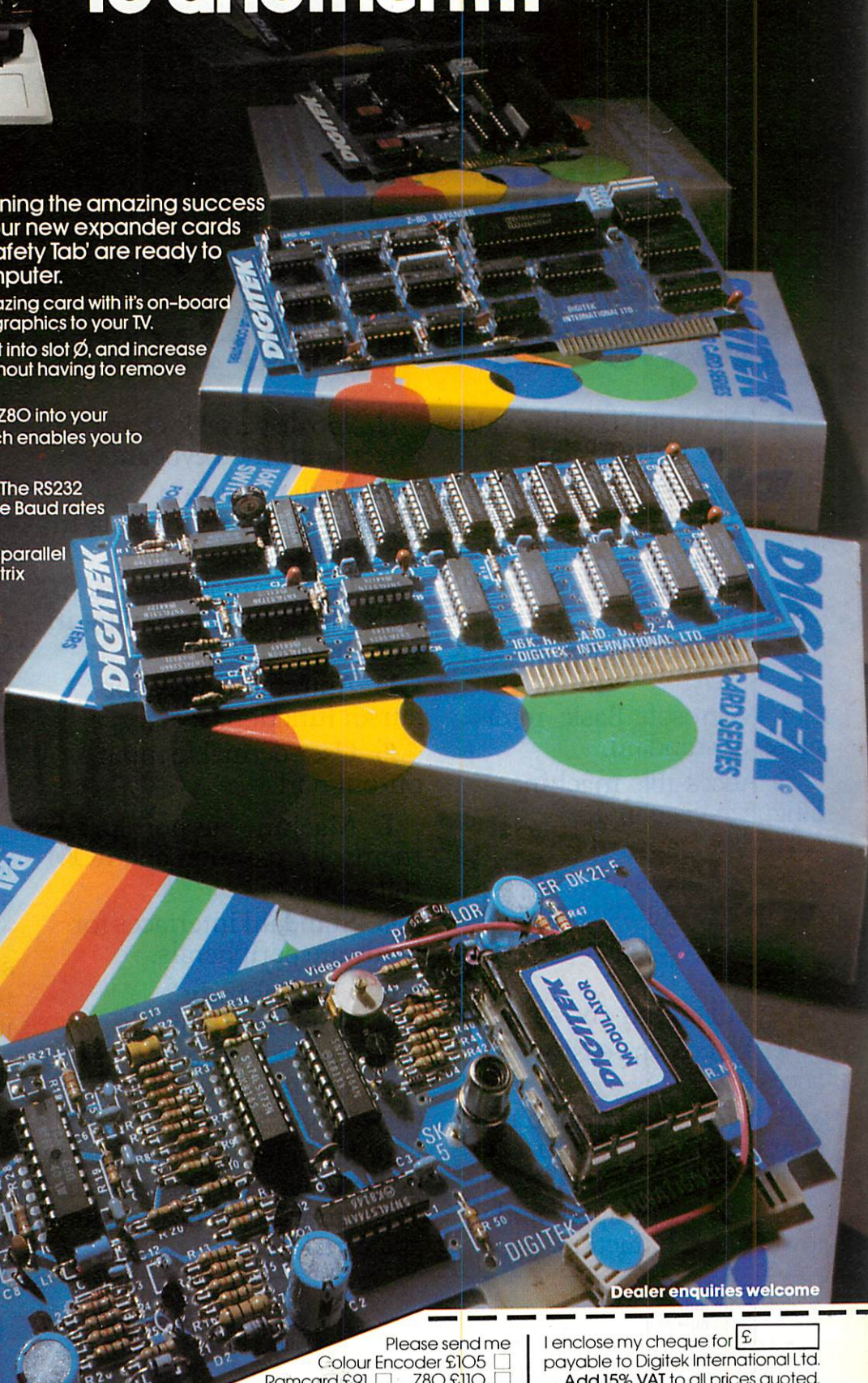

The people who are really into Apples.

# DIGITEK

● Circle No. 137 EXPANDER CARD SERIES

Please send me  
Colour Encoder £105   
Ramcard £91  Z80 £110   
RS232 £72  Print-master £79   
Further Information

I enclose my cheque for £   
payable to Digitek International Ltd.  
Add 15% VAT to all prices quoted.  
Post and packaging FREE.  
Telephone orders **0403 66550**

Name.....  
Address.....  
..... Post Code .....

My card.....  
.....  
Number is .....

DIGITEK (INTERNATIONAL) LTD. 37C WEST STREET, HORSHAM, WEST SUSSEX RH12 1PP.



PC 6

SEE VIC AT THE INTERNATIONAL  
COMMODORE COMPUTER SHOW,  
CUNARD HOTEL, HAMMERSMITH,  
3rd-5th JUNE.  
3rd June 12 noon-6pm. 4th June 10am-6pm.  
5th June 10am-5pm.



# “Give me one good reason why I should choose a VIC 20 home computer.”

1. VIC is outstanding value for money. No other colour home computer can give so much for under £200.
2. Total standard memory 25K made up of 20K ROM and 5K RAM.
3. Fully expandable to 27½K user RAM.
4. Microsoft Basic interpreter as standard.
5. Accessible machine language via plug-in cartridges.
6. Connects direct to monitor or standard television.
7. Full size typewriter style keyboard.
8. Full colour and sound.
9. All colours easily accessible.
10. 62 predefined graphic characters direct from the keyboard.
11. Full set of upper and lower case characters.
12. 256 displayable characters direct from the keyboard.
13. High resolution graphics capability via plug-in cartridges.
14. Programmable function keys can be used with plug-in cartridges.
15. Automatic repeat on cursor function keys.
16. User-definable input/output port.
17. Machine bus port for memory expansion and ROM software.
18. Standard interfaces for hardware peripherals.
19. VIC 20 is truly expandable into a highly sophisticated computer system with a comprehensive list of accessories (see panel below).
20. Full range of software for home, education, business and entertainment on disk, cassette and cartridge.
21. Books, manuals and learning aids from Teach Yourself Basic to the VIC programmers' reference guide (a must for advanced programmers).
22. Full support for VIC owners – their own magazine 'VIC Computing' as well as a national network of VIC user groups.
23. National dealer network providing full service and support to VIC owners.
24. Expertise and experience – Commodore are world leaders in microcomputer and silicon chip technology.
25. Commodore is the leading supplier of micro computers in the UK to business, schools, industry and the home.
26. VIC 20 is the best-selling colour home computer in the UK.

How many reasons was it you wanted?

#### Accessories include:

- Cassette tape unit.
- Single drive 5¼" floppy disk unit (170 K bytes capacity).
- 80-column dot matrix printer.
- 3K, 8K and 16K RAM expansion cartridges.
- Programming aid packs, machine code monitor cartridge, programmers' aid cartridge, high resolution graphics cartridge.
- Plug-in conversion box for a full 32K, 40-column x 24 lines VIC including Prestel compatibility.
- RS 232C communication cartridge.
- Memory expansion board.
- IEEE/488 interface cartridge.
- Joysticks, light pens, paddles and motor controllers.

**commodore**  
**VIC 20**  
The best home computer  
in the world.

# Prestel all at sea



Bill Bennet investigates a tele-computing experiment on board a North Sea ferry.

SEAVIEW 82 is one of the simplest, yet also among the most imaginative applications of the British Telecom Prestel system. Essentially it is a way in which shipboard Prestel sets can patch into the network. None of the technology involved is particularly novel, but as with all worthwhile feats of engineering it is the way that existing technologies are combined and applied that is important.

The prototype system is on board the Townsend Thoresen car ferry *Viking Voyager* which treks back and forth across the North Sea between Felixstowe and Zeebrugge. The link into shore-based Prestel is achieved by radio, as with normal ship-to-shore telephone network links, and the base-station radio receiver links into the telephone network.

The funding of the trial — which will cost in total £325,000 — is being met by a number of sources, with the lion's share of 70 percent coming from the Department of Industry. These funds are in addition to the costs met by CAP and Siemens who conducted all the earlier research and development. The money from the Department of Industry comes under the Information Technology Year budget.

## Ministerial optimism

The system was recently demonstrated by Under Secretary of State for Industry, John Wakeham, who commented that the project was very much in keeping with the spirit of IT Year. He also envisaged a future system where ships all over the world would be able to contact the Prestel network via communications satellites.

To send the digital signals associated

with Prestel, a special type of hardware is required which combines elements of digital and radio techniques. The nominal range of the ship-to-shore VHF radio is about 20 miles, though useful communication can still be achieved 24 miles out. Thanks to the international Gateways in Prestel it is possible to contact other countries' viewdata networks. Especially relevant in the North Sea and English Channel areas are the German and Finnish networks.

## Coastal relays

The Seaview system itself was invented by a team from the systems house CAP, which specialises in providing purpose-designed systems to clients' specifications, working in conjunction with a team from Liverpool Polytechnic and Siemens. The communications links for the Seaview system are provided by British Telecom. In all there are 11 manned and 19 unmanned VHF radiotelephone stations dotted around the coast of Britain, and more are on the way.

Ships normally operate a telephone service both for the benefit of the passengers and for the day-to-day business of running the vessel. For the purposes of the Seaview demonstration, at least one of the radio-telephone channels is occupied by the Prestel link.

One of the major partners in the Seaview venture is Townsend Thoresen, the ferry company that is actually using all the high-powered technology. Townsend Thoresen's Felixstowe operation thinks of itself as the technological vanguard of the fleet, and in Seaview it sees an opportunity to keep itself well at the fore of sea-borne information technology.

Why should a ship need Prestel? Of course it is a convenience to have a link to the Prestel service that can be used from a ship, but more to the point it establishes a communications link that will support digital computer signals.

Connecting the ship up to the Prestel system provides the sea-borne user with an interesting set of possibilities including access to distant databases through the Prestel Gateways. In this way for example, an on-board computer is able to patch in to the fleet's main base computer.

## Duty-frees

Cross-channel ferries make most of their profit from the duty-free shops and the on-board bars and catering, and it is replenishing these lucrative stocks that takes most of the time when the ferry is in port — clearly an unsatisfactory state of affairs for the ferry operators and the port authorities. Turn-round time can be reduced by the ship's computer contacting the stores computer in advance to ensure that the required supplies are waiting on the quayside.

A service which could make Seaview very popular with the ferry-using public is the facility to book hotel rooms at their destination while still on the boat. Motorists could be informed of traffic hold-ups well in advance of reaching them, and the general news and information services should prove useful to passengers on longer journeys. The expense of remaining on-line to the Prestel network can be cut considerably by saving the pages to tape or disc, and reviewing them later. This would be normal practice prior to leaving the limit of VHF transmissions. □



# Advantage of graphics



**With the Advantage, North Star has produced yet another desk-top micro with built-in discs: Mike Hughes found that it has something special to offer.**

THE NORTH STAR Advantage is a Z-80-driven integrated desk-top system comprising 64K of main memory, a 20K high-resolution monochrome display, a 2K bootstrap PROM, 87-position keyboard and twin double-sided 5.25in. hard-sectored disc drives. A second microprocessor, an 8035, is used within the system to provide keyboard and disc-drive control. It will support serial or parallel external printers via plug-in I/O boards, for which there are six slots inside the cabinet. There are currently two I/O-board options — one serial and one parallel.

## Keyboard

The keyboard contains three shift keys, designated Shift, Control and Command. Used in conjunction with the other keys, they generate up to 235 different codes. Through software, a "feedback" click can be made to sound whenever a key is depressed. The main keyboard contains an Alpha-lock key which, when active, is illuminated by an LED. Alpha-lock can be switched in and out either manually or through software. The numeric pad carries a similar Cursor-lock key which allows eight of the numeric keys to double as cursor-movement controls. Cursor-lock can be introduced either manually or via software. A further 15 keys, labelled F1 to F15, can be used for special user functions.

The display, when used in conventional character mode, displays 24 lines of 80 characters per line, with each character contained within an eight-by-10 matrix. The matrices for standard characters are contained within the 2K Boot PROM, and provide for proper descenders on lower-case letters. The PROM contains the character-driver routines which are accessible to the user, and allows matrices for special characters to be set up and addressed in RAM. Because of the high-resolution characteristics of the screen, characters do not have to be separated by fixed line intervals. It is possible, with custom-designed software and character pixel data, to display superscripts and subscripts, and even display sloping lines of characters. All this can be done by transporting data to the driver routine via the Z-80's registers. In graphics mode the 20K of display RAM allows every bit to be displayed giving a truly high-resolution display of 240 by 640 pixels.

The versatile video driver allows for reverse-field characters and stepwise or smooth scrolling. Other software permits the cursor to be extinguished, and there are routines which allow the screen to be blanked through software without affecting any writing in progress. A complex drawing can thus be entered with the screen blank, to be switched on subsequently to show the completed drawing.

The Boot PROM allows the system to be loaded from either of the two disc drives, which proved useful on the review system as it slowly developed an unwillingness to read through drive 1. This was probably a simple mechanical problem on an "as delivered" machine and would have been cleared up by an engineer's visit. This brought drive 2 into the limelight which, although a little inconvenient at times, allowed the system to operate satisfactorily. The transfer rate when taking back-up copies of discs appears to be rather slow. Comart confirms that this is so and puts it down to the disc drives being controlled via the firmware of the 8035, as opposed to a hardware control chip.

## Memory addressing

The internal "bleep" loudspeaker is driven either from a standard 500ms. bleep, generated by hardware and controlled by a monostable, or from a programmable frequency tone generated by switching a bit in an output register.

Extended memory addressing is used to keep control of up to 256K which is organised as 16 16K pages. The address bus is increased to 18 bits by using bits 14 and 15 to address four registers into which four data bits are loaded to define the pages that are currently required. The normal bits 0 to 13 then address the 16K within each of the selected pages. At any moment only four 16K pages can be current — for obvious reasons. Though this program is very powerful, it could cause a few programming headaches if put to a great deal of use, especially if maskable interrupts are used when the page they are on is mapped out of the system.

## Parity checks

The internal 64K of dynamic RAM occupies four of the 16 pages and is unusual in being nine bits wide. The extra bit is used as a parity bit for every memory location and is automatically checked by hardware. In the event of parity failure the hardware can flag it by issuing an interrupt which can be masked out, if desired, by a control register. The parity bit is always set during a write cycle; parity bits could be left in a random state after switching on, so it is essential that all memory locations are written to during initialisation.

The Advantage is well endowed with software control, making it an extremely versatile system. It means, however, that there is plenty to go wrong if the inexperienced start playing around with system software. Fortunately the average end-user need have no fear as the Advan-

*(continued on next page)*

(continued from previous page)

tage is supplied equipped with a choice of operating systems, neither of which requires intervention for most purposes. The CP/M supplied is up-graded to handle graphics and North Star's graphics operating system, GDOS; the review model was supplied with CP/M 2.2, a full complement of utilities and a handful of command programs introduced by North Star. The most significant of these are a Graphics Dynamic Debugging Tool, which is an upgraded form of DDT; a program for dumping the CP/M directory called DIRDUMP; and GMGRADD.COM which is a graphics subsystem extension to CP/M which is not normally resident in RAM but which can be linked to users' Com files.

Data passed to the graphics subsystem through the Z-80's registers allows four geometric routines to be invoked which respectively draw lines, ellipses, rectangles or polygons. Bounded areas can

optionally be filled in with 15 different types of shading, and the bounding perimeter can be deleted if required. Like the standard CP/M I/O call at 0005H, the graphics subsystem is accessed through a call to 000CH once the registers have been set up.

## Speedy Graphics

CP/M was used to run WordStar with Mailmerge and Spellstar which did all that could be expected of them. Great fun was had writing a few patched-up graphics routines in assembler, and linking them through the graphics subsystem. As long as the required tables of co-ordinates were properly set up, the graphics system made the rest of it very easy. The speed with which the most complex drawings are displayed is a sight to behold — it is not often you get the chance to play around so easily with complex high-resolution graphics in assembler.

MBasic was used to carry out a few groundwork checks on the Advantage and, in particular, some of the numerous software-controlled options. Many pages are taken up in the respective manuals describing the bit patterns of control and status registers. The system is organised in such a way that many of the options can be set up through the display output.

By expedient use of the Print CHR\$ statement, you are able to switch to reverse video, switch the keyboard "click" on and off, sound the "bleep", clear a line, clear the screen or clear to end of screen, turn on smooth scrolling at high or low speeds, switch the cursor on or off, or switch the display on or off. It is very disconcerting to switch off the screen by using the Print CHR\$(29) statement as the last in the program — you tend to draw a blank if you then try to find out what has gone wrong.

It is also possible to switch the display into Hybrid mode. It clears the top 20 character lines of the display and reserves this space for graphics, while the bottom four lines continue to be used as a scrolling text area for normal alphanumerics.

## Penalties exacted

Impressive as this wealth of options may be, there is a drawback in having so many control options accessed through the Character Out channel. This shows itself when you try to Type a non-printing file when in CP/M's command mode. Strange things may happen when a non-printing code is output: the screen can blank out, the video can reverse, bleeps sound, the keys start to click and, sometimes, you can find yourself "hybridised". Worse still, in a few cases the screen fills up with a pretty pattern and the system crashes. Perhaps it is a just punishment for being naughty, but North Star, through Comart, ought to sort out this problem.

Though the performance of the Advantage under Graphics CP/M is impressive, it is overshadowed by the spectacular things that can be done using North Star's own Graphics Basic which runs under Graphics DOS. It is a full-blown Basic interpreter with a host of special graphics-handling statements. An imaginary cursor can be positioned anywhere within the screen's area by means of the Move statement and, relative to that position, lines, circles, ellipses, rectangles, arcs of circles, "pie-slices" and chorded arcs of circles can be drawn with or without shading.

## A sad day

Its simplicity is demonstrated by this two-line program, which draws a near-perfect high-resolution circle of 50 pixels radius centred 100 pixels from the left of the screen and 80 pixels up from the bottom:

```
10 MOVE 100, 80
20 CIRCLE 50
```

Substituting

```
CIRCLE 50,29
```

in line 20 produces a solid circle, and

```
CIRCLE 50,32
```

produces a circular area of diagonal slash lines without an external perimeter line.

The Graphics Basic may not be as fast as doing the same thing in assembler, but it does make complex graphics programs possible even for the most mediocre of programmers. It was, indeed, a sad day when Comart asked for the machine to be returned.

## Conclusions

- The Advantage is a compact, highly-sophisticated piece of hardware with a multitude of versatile, software-controlled options.

- It is well supported with software through CP/M and North Star's Graphics DOS and, in particular, Graphics Basic. If WordStar were patched to make use of the 15 function keys instead of the usual control keys for the more commonly used word-processing operations, the Advantage would act as an easy-to-use office letter writer.

- It is housed in a strong cabinet that will easily stand up to a normal office environment. With 720K of disc storage within, it would form a significant small business system.

- Disc-to-disc transfer rates are slower than in other systems.

- The hardware and software documentation presented for review is weighty, well presented and easy to follow. It contains all the necessary facts, but if you wish to make use of the software-controlled options at a system level you will, nevertheless, need to read it very carefully indeed.

- The graphics-handling ability of the Advantage leaves very little to be desired of such a reasonably priced machine, but much of the credit for this goes to the graphics software. □

## Specifications

**Dimensions:** 480mm. deep, 510mm. wide, 315mm. high.

**Weight:** 19.5kg.

**Power requirements:** 230V/at 1A.

**Ambient operating temperature range:** 10°C to 40°C; cooling by integral fan.

**Central processor:** Z-80 operating at 4MHz plus 8035 microprocessor for keyboard and disc control

### Memory

**Main RAM:** 64K by nine-bit (eight bits plus parity)

**PROM:** 2K by eight-bit; contains Bootstrap

**Display RAM:** 20K by eight-bit

**Video display:** 11in. green phosphor screen

**Normal display:** 24 lines of 80 characters per line

**Character matrix:** five-by-seven character in eight-by-ten dot matrix

**Graphics display:** 240 pixels high by 640 pixels wide

**Keyboard:** 87 keys: 49 alphanumeric, Qwerty layout; 14-key numeric pad; 15 programmable function keys; nine control keys

**Disc drives:** twin 5.25in. double-sided hard sectored; 720K total capacity; 35 tracks per side; 10 hard sectors per track; 512 bytes per sector; 250 kilobits per second transfer rate; 5ms. access time, track to track

### Input/output

**Integral:** internal loudspeaker for bleep

**Extendable:** six slots for optional I/O boards within cabinet with provision for sockets to the outside world

### I/O boards

**Serial I/O:** RS-232 serial port; current loop option; 45baud to 19.2Kbaud, asynchronous; 2,400baud to 51Kbaud, synchronous

**Parallel I/O:** eight-bit data in and out, with three handshake lines

**Distributor:** Comart, St Neots, Cambridgeshire PE19 3JG. Telephone Huntingdon (0480) 215005

**Price:** £2,295 plus VAT



# ...now on the IBM Personal Computer.

TABS unique business software is a flexible package designed to maximise business efficiency and profitability.

TABS is also **modular**. Each IBM module may be run individually or together. Modules currently include System Generation, Sales Ledger, Purchase Ledger, Nominal Ledger, Stock Control and Payroll.

The system is **fully integrated** so that updated information on one module automatically updates information on a related module e.g. items entered on the Sales Ledger would deplete Stock Control.

Each module is **parameter driven** enabling end users to adapt each module to suit their unique accounting requirements.

The TABS system is **upgradeable**. It bridges the gap between micro and mini computers facilitating expansion from the single user system to the multi user system on SYSTIME and D.E.C.

Finally, TABS is **universal**. The modular system currently running on the IBM Personal Computer, PET, Apple and Superbrain will shortly be available on most CPM microcomputers.

We would, however, like to add a word of caution to the end user. Naturally a package as flexible as this is a sophisticated product and although simple to operate we strongly advise professional help either from your Dealer or from TABS during its installation.

● Circle No. 140

For more details about TABS software and hardware, please tick box(es) and return coupon to us. We are pleased to offer credit card facilities to our customers.

**Dealer enquiry**

Please send me details of your Dealer Plan

**User enquiry**

Please send me details about TABS accounting systems

Please send me the TABS User Manual £20 inc p&p

I enclose cheque/postal order for £ \_\_\_\_\_

Signature \_\_\_\_\_

Name \_\_\_\_\_

Address \_\_\_\_\_

Tel. No. \_\_\_\_\_

TABS Ltd. Sopers House, Chantry Way, Andover Hants. SP10 1LU  
Telephone: Andover (0264) 58933

PC IBM



Accounting Business Systems

**TABS**

**At first sight this European competitor to the Apple looks like an expensive choice but, as Simon Rushbrook Williams has found, it could be the economical alternative for some purposes.**

PEARCOM IS A NEW Dutch-built contender for the Apple sector of the market. Although the hardware is different, from the point of view of software it can be made to look identical to an Apple II.

The machine is supplied as a micro-computer frame with 32K of RAM and no software language at all. There are no PROMs on board, and no operating system or monitor programs. The review machine was already fitted with an Apple Autostart ROM set which is recommended by Pearcom. In this way the copyright of Apple software is not infringed.

Pushing the start button illuminates three coloured LEDs. A green glow confirms that power is being supplied, red that the main board has a clock running, and yellow that the keyboard is running, or at least has a pulse train on it. These seem an unnecessary gimmick. If there is a need for indicators of properly functioning boards, then they should be on the boards so they will be seen by a service engineer.

### Keyboard quirks

The manual praises the high quality of the reed-switch keyboard but the key-stroke is long, the keyboard is uneven and it feels cheap. Keyboards are personal things and I did not like this one. In addition to the normal keys there is a numeric keypad and seven function keys. Three are used for a special shift function and allow access to the ASCII characters normally forbidden on an Apple. The others are available as user keys.

To the right of the keyboard is a cover held by a screw. On the pictures in the manual and in the advertisements this holds a zero-insertion-force socket, presumably for a PROM programmer, but on my sample there was just a blank panel with ideas in the manual on what to do with it. It can be useful to have a customising area and this should tidy up some applications. It was unfortunate

that the blank panel was on the right of the machine as the main board was below it. If it had been on the left of the machine then the full depth of the case would have been available for circuits without danger of shorting out the board below.

There are four sockets on the side of the case. Two DIN plugs allow connec-

tion to cassette and one of them carries the sound output of the internal speaker so that you can record program output.

One video output is a modulated colour output to a PAL standard, together with a sound carrier, so a TV can give both colour and the output of internal speaker if required. The second output is for a black-and-white monitor.

To compensate for the lack of colour here, a true 16-level grey scale is supplied. This is a very fine feature compared to Apple outputs on a normal black-and-white which are often confusing if colours are used. If you wish to play sound from the TV only, then a volume control for the internal speaker is supplied on the board.

Inside the case there is plenty of space.

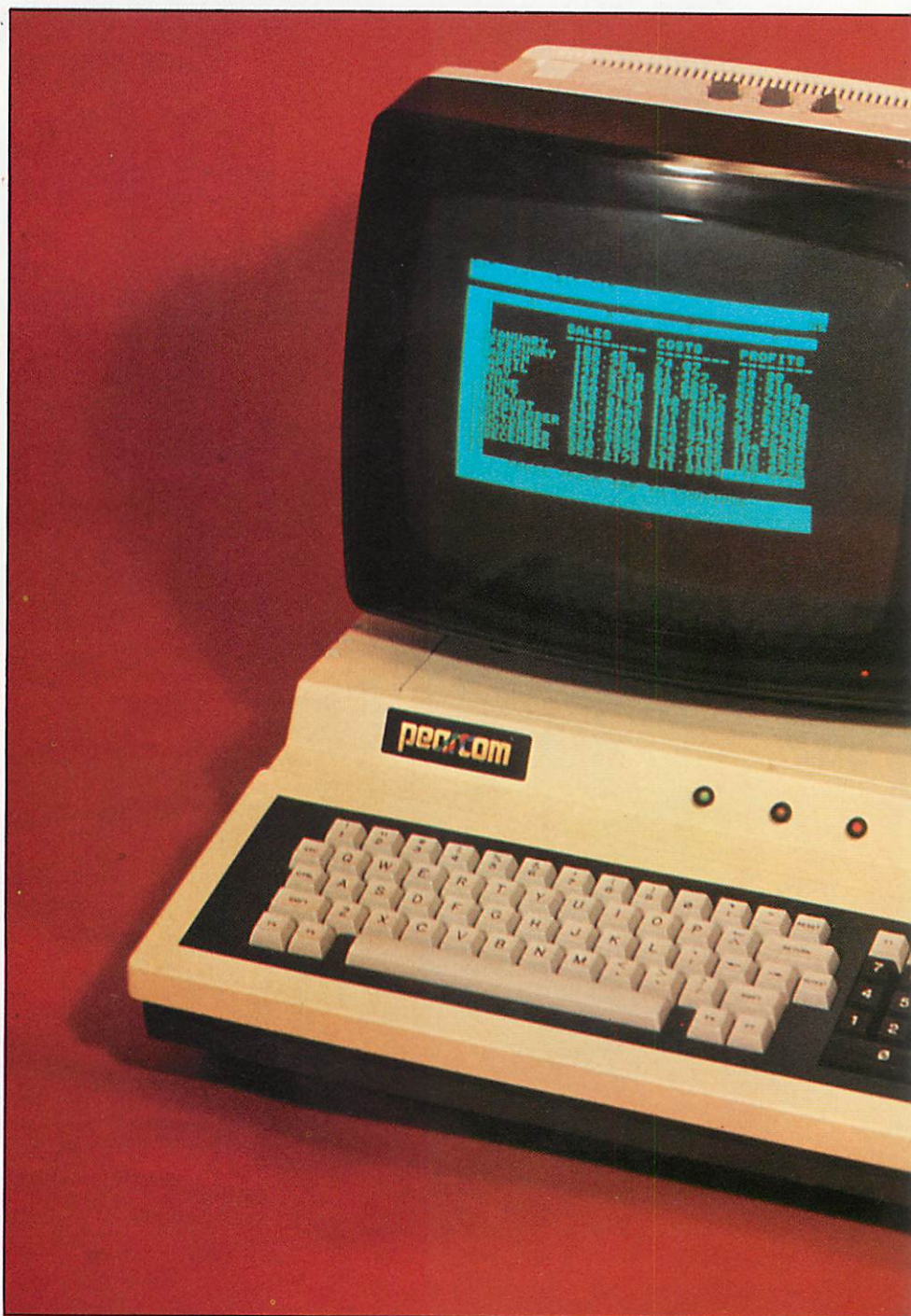

### Specifications

**Processor:** 6502, compatible with all Apple hardware and software

**Languages:** None supplied

**Monitor:** None supplied; UHF/PAL colour output

**Keyboard:** QWERTY, numeric keypad and seven function keys

**Memory:** 32K RAM, expandable to six 96K

**Expansion:** 14 I/O expansion slots; six ROM or EPROM sockets; bus compatible with Applesoft card

**Dimensions:** width 520mm., depth 490mm., height 130mm. (all approximate)

**Price:** £975

# PEARCOM



At the bottom is a large circuit board, with 14 I/O slots along the back which are identical to the seven slots to be found on the Apple. The usual games I/O socket is found near the centre right of the board.

The ROM sockets are selectable to be 2716 EPROM compatible or Applesoft ROM compatible by soldering a jumper pair together, so you could make your own system software.

There are plenty of sockets for 4116-type RAM. The basic Apple 48K of RAM is there, although to keep the price below the magic £1,000 figure only 32K is provided. The rest of the RAM sockets are for four extra pages of the top 16K of memory. Any page can be selected but only one can be active at any time.

The output on a black-and-white monitor was excellent and the grey scale improved many of the low-resolution graphics pictures with no harmful effects on the high-resolution output. The colour output to a TV was sharp and good. Pearcom has given four extra colours with the effect that Apple black 2 is now green, so some of my programs produced unexpected colours on a green background. Versawriter confused many colours; however, a few software patches should cure all, and new colours are always welcome.

All of the expansion cards worked without flaw. The Pearcom can work just like an Apple, but if that is all you want then the Pearcom is an expensive way to get it.

Pearcom's control comes from address -16288 or C060 hex, the cassette input port with bit 7 connected to the tape. However, Pearcom has made this a read-write port with bit 7 still as was, bit 6 not used and the lower six bits used to control all the Pearcom goodies.

Bits 5 and 4 control the character set displayed. Both upper and lower case, together with Greek and special symbols reside in the EPROM on the keyboard. What appears on the screen when a key is pressed depends on the value in these bits. If both bits are zero then the system looks Apple-like. If bit 4 is set, lower case is sent to the screen.

With the addition of a little software the keyboard allows proper shift operation. Bits 0, 1 and 3 control the extra RAM, which is configured usefully. If all three bits are zero then the system is Apple-like. However, the top 16K of RAM can be addressed using bits 0 and 1 to give one of four possible pages. So, for example, on a disc boot Dos will reside in the default page. If you now change bits 0 and 1, then Dos no longer occupies the top 10K and you have blank RAM. Obviously your software must handle these bits so that then the 0 page is selected when you want to use disc.

## Extra graphics pages

If bit 3 is set to logic 1, then the memory is changed to be page mapped in text, low-resolution graphics or high-resolution graphics, whichever is active. In other words, you now have page maps of your screen. As each screen already has two areas in Apple RAM, pages 1 and 2, you end up with 10 possible text or graphics pages available by changing a single address. Those programmers who already use HGR1 and HGR2 commands will see immediately the use of the extra eight pages. You can have 10 pictures all set up and switch between them in a few microseconds.

The last bit, bit 2, selects which seven of the 14 slots are active. All the DMA and interrupts are active all the time, and while I cannot see how to poll which slot is interrupted, I managed to get a clock running in an extension slot while the normal slots were active and still update software on an interrupt from the clock.

A nice feature of location C060 is that when read, it not only displays the cassette data, but also the current state of your control latches. This makes programs a little easier.

## Trial and error

The Pearcom comes with a file-like manual and an address to write to for a year's free update. The translation into English leaves much to be desired, and though a considerable amount of information is included it took a long time to find it. There are technical errors where 8 is printed as 3 or B. There are five pages on binary number systems but only one page on the screen mapping of the extra memory. I found the manual very confusing and often resolved what it meant only by trying out ideas on the machine. It is not for the beginner.

Suggestions for changing component values to increase repeat-key rate, and to solder jumpers on the board were dangerous. While it is often possible to improve or fine tune a board, it is not for a beginner, and unclear instructions in a manual could lead to warranty problems.

If you were to buy an Apple and expand the number of I/O slots, buy a colour card, an upper- and lower-case card and some memory expansion, together with a numeric keyboard, then you would have to lay out more than required if you were to buy a Pearcom, an Apple PROM set and some RAM. For those people who would require these systems extensions, or for a dedicated control unit, the Pearcom frame is ideal. For a user who intends to demonstrate Apple cards or for a research group with a number of I/O cards, the Pearcom could be the solution.

Some problems which present difficulties for an Apple can be solved instantly on the Pearcom. There is a place for the Pearcom in the market, but costing needs to be done carefully.

## Conclusions

- The system works just like an Apple and all software and peripherals should work.
- The documentation is poor but contains all necessary information if you are prepared to look for it.
- If you do not intend to use the extras, then the Pearcom is a more costly option than an Apple.

**Cash price**  
ONLY £595 + VAT  
BEAT THAT FOR VALUE

# The DAI Personal Computer is Here

**\*High Performance\***  
**\*High Value\***

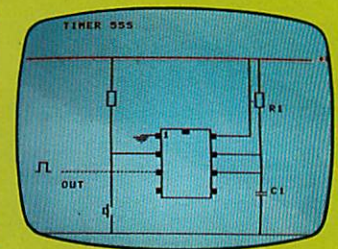
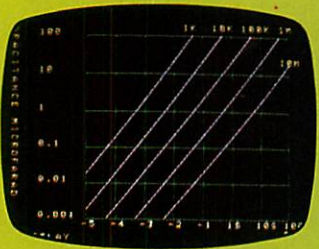
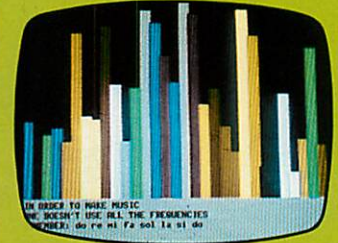
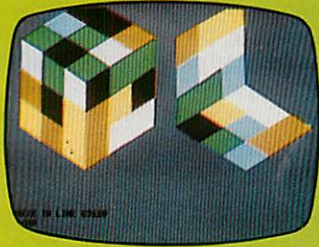

## Standard Features

- \* 24k Resident High-Speed Basic
- \* 16 Colour High-Resolution Graphics (255 × 335)
- \* Scrolling Screen Editor
- \* Sound Commands for Music Generation
- \* Very High Speed Hardware Maths Option
- \* Resident Monitor for Machine Language Programming
- \* 3 Programmable Parallel Ports
- \* Standard TV Interface via Aerial Socket
- \* RS232 Serial Port and Dual Cassette Interfaces

Manufactured by:

# DAI

THE  
MICROCOMPUTER  
ENGINEERING  
COMPANY  
Brussels, Belgium.

Available from:

## Data Applications (UK) Ltd.

Personal Computer Division  
16b Dyer Street  
Cirencester  
Gloucestershire  
GL7 2PF  
Tel: Cirencester  
(0285) 61902

For further information please complete and post to:  
Data Applications (UK) Ltd, 16b Dyer Street, Cirencester, Glos GL7 2PF

NAME \_\_\_\_\_

ADDRESS \_\_\_\_\_

MY INTEREST IS: \_\_\_\_\_

# Superbrain prepared for hard times ahead



**With a 6Mbyte hard disc in place of one of the mini-floppies, Encotel's modified Superbrain should give you memory to spare. Peter Laurie has been finding out more.**

THE ARRIVAL of hard discs in the same size boxes as 5.25in. floppy drives has produced a new kind of machine: the true desk-top information box. The first we have tried is a Superbrain conversion from Encotel of Croydon, using the Rodime system described in December's *Practical Computing*.

The 6Mbyte drive which replaces the second mini-floppy runs under CP/M 2.2. Although the outward manifestations of this change are slight — all you can see is a flat black surface in place of the disc door — the effect on performance is startling. Even more amazing, the thing worked as soon as we turned it on. This is by no means universally true with equipment we get for review.

When the machine is switched on, the helpful prompt appears:

Hit any key to boot off hard disc  
F to boot off floppy

On booting, a directory appears of the logged-in drive.

Although CP/M 2.2 will control up to 8Mbyte of disc, Encotel has chosen to split the 6Mbyte available into two 3Mbyte drives, A and B. If you boot off the floppy, they become E and F, while B, C and D are transferable drive names that make it easy to copy from one floppy to another in the single drive.

Size is the great asset of a hard disc, though even 6Mbyte — which needs six months' non-stop typing to fill up — disappears surprisingly fast. Speed is also impressive: accesses off the hard disc seemed to be about six times as fast as

those off the floppy. You can take standard CP/M software, transfer it to the hard disc and relax.

Unlike earlier hard-disc drives the Rodime is tough and quiet. You do not need to lock it before you move it and unlock it before you use it. The machine will stand being bumped about from car to desk. In use it is so quiet that you have to press your ear to the casing to detect head movement.

The only defect we found in the machine after a couple of weeks of energetic use was a very obvious bug — which is not connected with the hard disc — in the keyboard scanning routine. It would capture but fail to print about one key stroke in 10. This made many programs almost unworkable, but Encotel says that the problem is being remedied.

A hard disc takes a minute or so to run up to speed. If you boot too early, it may

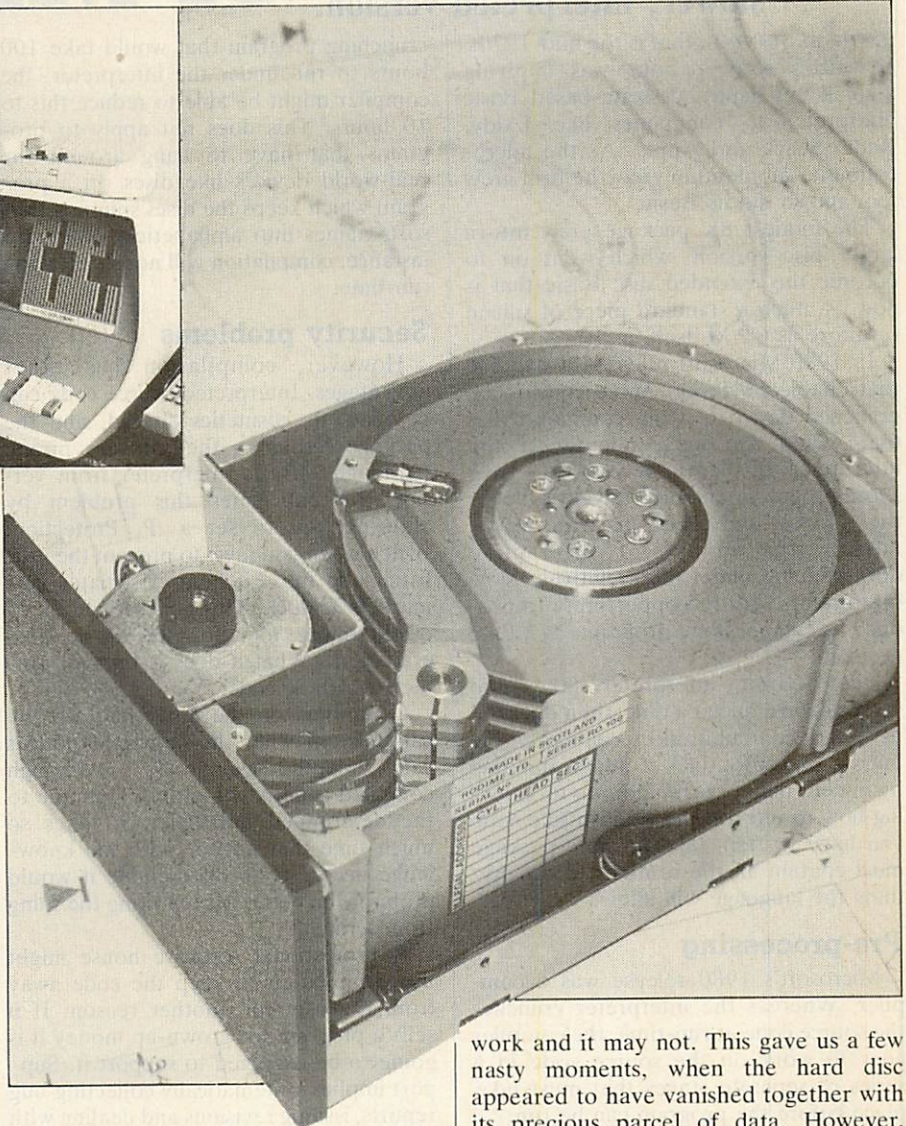

work and it may not. This gave us a few nasty moments, when the hard disc appeared to have vanished together with its precious parcel of data. However, switching off once again and waiting for a while before booting restored matters to a proper condition.

## Conclusions

- The Rodime installation in the Superbrain is neat and works well.
- It gives greatly increased storage and speed, and would make a very desirable personal computer. A 12Mbyte version is on the way, and on the horizon Rodime and other manufacturers are talking about 50 to 100Mbyte systems.
- We ran the machine for only a fortnight so we can say nothing about long-term reliability.
- Back-up is still a problem. However reliable a hard disc is, I would not be happy using it without some simple method of back-up. The prospect of shuffling a couple of dozen mini-floppies every evening does not appeal.

**Chris Bidmead found that the compiled variant of this powerful Basic dialect increases its speed and security while retaining the programming flexibility of the slower, interpreted version.**

# Compelling of MBasic's

IN THE BEGINNING, that is the mid-1970s, an Arizona software house was supplying a small but handy, cassette-based Basic interpreter to companies like Exidy, Radio Shack and Apple. As the micro-computer momentum grew the firm grew too, and so did its Basic.

The modest 8K package grew into a larger disc version, which went on to become the extended disc Basic that is now as much a standard piece of silicon furniture as CP/M itself.

In 1980 Microsoft released a package that enabled MBasic source code to be crunched down to .Com command files that would run independently of the interpreter. In theory, at least, this gave Basic programmers a big advantage over the Cobol and Fortran fraternities, namely the luxury of interactive development under the relatively slow interpreter, with the opportunity to produce fast stand-alone programs as a final product.

The MBasic interpreter takes the source code a line at a time, then does the necessary computation by calling the big bundle of subroutines it keeps standing by in core memory. In addition to knowing how to unravel the English-like code you have written, this run-time package must contain all the routines to do anything the language will allow.

## Pre-processing

Microsoft's 1980 release was a compiler. Whereas the interpreter crunches the source code at run-time, the compiler goes to work on the source code in a series of separate stages that must take place before the program can be run.

At first pass the compiler package produces relocatable code, so called because all its addresses are stored as relative rather than absolute quantities. This way the code postpones having to define where exactly in memory it will be placed before it is run.

In the second pass, when the proper computations are done on the addresses, the linker patches together this relocatable code with similarly structured standard routines borrowed from the MBasic standard library. The result is a single, coherent program.

Compiling and linking take time and trouble. The compiler is also expensive — somewhere around £200 on top of the cost of the interpreter — but its chief advantage is speed. In contrast to the purpose-built code the compiler produces, the interpreter is a time waster.

If you had some horrendous number-

crunching program that would take 100 hours to run under the interpreter, the compiler might be able to reduce this to 10 hours. This does not apply to programs that have to hang around for real-world devices like discs. In a program which keeps the discs spinning as it sorts names into alphabetical order, for instance, compilation will not shorten the run-time.

## Security problems

However, compilation has other advantages. Interpreted source code can be read, its cosmetics altered, and the package resold by the software pirate. Although MBasic interpreter from version 5.2 anticipates this problem by allowing you to set a /P, Protection, switch when you save, to prevent the user listing the file, Lifeboat Associates now markets Unlock. This is described as "a development tool for the Basic programmer". What it does is unravel protected MBasic code.

Compiling, on the other hand, really can prevent what the copyright notices call "unauthorised access". Although compiled code is not entirely immune to the determined unraveller, it takes so much time that anyone with the knowledge necessary to disassemble it would probably be better off rewriting the thing from scratch.

A professional software house might use compilation to keep the code away from the user for another reason. If it sells a program for grown-up money it is going to be expected to support it. Support implies systematically collecting bug reports, issuing revisions and dealing with the odd one-off mysterious crash. This process is hair-raising enough without the suspicion that users may be reporting faults on code they have tweaked in the privacy of their own workplaces. Electrical-goods manufacturers like to seal their products with the notice "No user-serviceable components beyond this point". Software houses are following their example.

## Simpler for users

Compilation has an advantage for the customer too. It is possible to configure an interpreted business system with CP/M's Submit facility so that the user simply types Run Accounts. Many modern CP/Ms now offer an autoboot feature that allows you to boot up directly into the program suite without having to enter anything at the keyboard. Comprehensive instructions would still have

to be given for loading the interpreter and the program separately if for any reason the turnkey version failed to work.

A compiled program presents a simpler face to the non-computing user. And even though the latest version of the compiler does require a few odd bits and bobs in addition to the Com file, these are more or less invisible to the user.

The MBasic interpreter takes up a lot of space in the machine, limiting the amount left available for the program itself. Because the compiler has an opportunity to digest the source code in chunks larger than single lines it is able to do a certain amount of optimising, and having "seen" the whole program before run time, it knows to leave out routines that are never going to be called.

## More compact

Well-designed compiling systems search a large library file and pick out only those routines that the programmer's code calls for. So although a run-time package of subroutines still has to be appended it is likely to be more compact than its interpreter counterpart.

Compilation lets you write bigger and more useful programs in the same space as simpler interpreted code. What happens if you are taking advantage of MBasic's unique facility to debug code prior to compilation, by running it interactively with the interpreter? How can you compile programs larger than the interpreter can handle?

The MBasic compiler has borrowed a trick from the up-and-coming Bell Labs language C. The compiler allows a %Include instruction that will pull in code from a defined file and process it exactly as if it were part of the current source file. Once you become reasonably proficient at manipulating the compiler and designing your code in modules, as the structuralists recommend, you can soak test your subroutines separately in interpreter mode and patch them all together at the moment of compilation.

The linking of .Rel files is a technique derived from Basic's predecessor, Fortran. Any .Rel file can also be produced from assembler code, and the facility for doing this — an assembler called Macro 80 (M80.COM) — is thrown in as part of the MBasic compiler package. By this means chunks of assembler code can be incorporated into your MBasic routines, providing an extremely powerful extension to the language.

Macro 80 is one of the most comprehensive 8080/Z-80 assemblers we

# rtues ompiler

know, but recent graduates from MBasic interpreter should not be deterred by the weight of the manual. Learning to write short bursts of assembler requires nothing more than patience and the ability to think like a chip — simple, pure thoughts that would not strain the understanding of your average eight-year-old. M80 is packed with facilities to make all this even simpler, but unfortunately they are rather complicated to explain.

## Call routines

As in the interpreter, external code can also be reached from Basic through the Call statement. For example,

```
CALL ZAP(A,B,C)
```

transfers execution to the memory address given by the variable Zap, with arguments A,B and C, all of which must have been assigned values earlier in the program. In the interpreter an absolute value will have to be assigned to Zap in a previous line, but the compiler expects Zap to be a global symbol set up by some other chunk offered up to the linker. So to compile a program that calls an absolute location such as a CP/M routine you will have to link in a small assembler patch along these lines:

```
PUBLIC ZAP      ;declare ZAP
                globally
ZAP: EQU       33423 ;the address of
                the code start
END
```

or of course the code you are calling could always be written directly in the assembler from the label Zap onwards. The USR facility can be made to do the same sort of job, but it is really only there to provide upward compatibility with the cassette-based 8K version, and is best avoided.

The linker, L80, is the same program supplied with Microsoft's other two main languages, Cobol-80 and Fortran-80, so it is possible in theory to write code in any of these languages and link it all together to form a single running program. In practice parameter passing tends to become difficult across languages, so you will probably stick to pure Basic, with the odd machine-code routine thrown in.

Your early attempts at compiling will be discouraging. You have written your program in the MBasic interpreter, and it works. To run it through the compiler the simple CP/M command level instruction

```
BASCOM = <yourprog>
```

will do the trick if you do not want to change any of the defaults.

Some options can be added to the command line such as

```
/O — use the original version of the library at
      Link time
/Z — write Z-80 code wherever possible
/D — include extra debugging and error handling
      code
```

Discs will whirr, and then a sinister line will appear on the screen saying:

```
37 Fatal Errors
```

or words to that effect. Even when you become proficient and manage to write programs the compiler does not balk at, the compiler will still close with:

```
0 Fatal Errors
```

reminding you that you only just got by with it that time.

The grudging approval of the compiler is no guarantee that you are home and dry with a runnable program. The linker has its own criteria to fulfil: in particular it has to find a subroutine in the library, unless you supply it, to match the name of every function your program is trying to evoke. Called globals, because unlike local names they are known and understood outside the parish of each individual chunk of code you are linking, these are the rivets that stick the whole thing together.

The linker will throw up the names of those that do not match. So when you get an incomprehensible screenful of

```
UNDECLARED GLOBALS
```

do not think your computer is just being insulting.

If you come to it from the Basic interpreter, the whole process will strike you as quite time-consuming.

On ordinary 8in. discs a compilation and a link of a moderately sized program may take 10 minutes while it creates the necessary symbol tables, writes them back to temporary files on the disc and updates them. With mini-floppies the process can take even longer, although one of the new mini-Winchester devices may trim the time to no more than a minute or so. To make any substantial program work you will probably have to go through the compilation/link process several times to iron out the bugs, at least until you get to know the compiler's little idiosyncrasies.

In principle the interpreter and the compiler are the same language, but in practice there are small but important differences. Obviously the compiler has nothing to do with the interpreter's Immediate mode, and the Edit command is out, along with Auto, New, Renum and Save. Another difference that should not raise an eyebrow is the compiler's refusal to deal with lines longer than 128 characters, whereas the interpreter can cope with 255. The compiler limitation refers to physical lines, and once you advance to the stage of writing long logical lines you will have learnt how to format them properly into short physical lines using the line-feed character.

Some versions of the interpreter are reputed to support constructs such as

```
400 FOR I = 1 TO 10
```

```
410 FOR J = 0 TO 5
```

```
....
```

```
450 NEXT I
```

```
460 NEXT J
```

which the compiler sensibly throws out, and a similar restriction applies to While-Wend. The careless rapture of jumping into the middle of both sorts of loops with a Goto, permitted in the interpreter, is also beneath the compiler's dignity. If you insist on writing code like this you will have to stick to the interpreter.

Arrays will have to be declared statically. If you have found it handy in the interpreter to be able to say

```
10 IF BIG THEN A = 20 ELSE A = 10
20 DIM BUFFER(A)
```

you will have to do some rewriting. The compiler has to set aside space in the .Rel file to accommodate the array, and cannot wait till run time to know the dimensions. For similar reasons Erase will no longer let you scrub out an array prior to redimensioning. The line containing the Dim statement must physically precede the use of the array; you cannot, as in the interpreter, tidily collect all your Dim statements into a subroutine at the end of the program.

Where the difference can become annoying is in the input/output routines. You may have discovered in the interpreter that an empty carriage return in response to a line like

```
20 INPUT A$
```

loads an empty string in A\$, i.e., puts A\$ = "". This is handy in a routine like menu selection, where you can offer a series of options

```
ENTER "A", "B", "C" OR "D"
```

or let the user fall back on a default by hitting carriage return.

## Still waiting

The compiled version of the code responds to a carriage return by waiting for the string it was promised. One way out is to abandon the use of Input altogether and employ Input\$(n) instead. If n is greater than 1 you and your program will probably be thrown by the fact that back-spaces entered by the user to correct mistakes in the input count as characters.

It is simpler to use Input\$(1) — some versions allow Inkey\$ — and write a small routine that catches back-spaces and unwanted control characters. An editing input routine like this would be worth considering as an assembler module, to be linked in as a .Rel file.

Writing larger and larger packages will eventually bring you up against a particularly infuriating feature of the package: a program that runs under the interpreter and has been compiled without errors may come unstuck with L80 because your .Rel files are bigger than the available memory.

The only way out of this is Plink, a

(continued on next page)

(continued from previous page)

providential package available from Lifeboat Associates. Plink can link files larger than memory by winding them on and off discs, so the size of the files it can deal with are limited only by the disc space at your disposal.

With the release of the new compiler it may not be necessary to write files this big. In MBasic it has always been particularly easy to Chain files, so that a complete business system can be built up out of a series of sections, each one a self-contained Basic program. This is the ideal way of structuring Basic programs.

Unfortunately the old version of the compiler lacked the facility, available in the interpreter, of passing values from program to program through variables designated as Common. The alternative method of communication between modules was by temporary data files, although the disc accesses that this implied necessarily slowed the program down.

## New version

The new version of the compiler takes a big step forward. An early code line will list the variables whose values are to appear identically in the Chained and Chainer programs:

```
100 COMMON A, WEEKSPAY, N,
EMPLOYEES()
```

and the job is done. The same statement must appear in all the programs that are supposed to be tapping into these values and the variables must be listed in the same order.

With a large program the designation may run to several program lines. In this case the burden of the clerical work can be lightened by making use of the %Include instruction. The Common statements can comprise a separate small file, called Comdef.Bas, or whatever. This file is then written into every file interested in the variables if each of them carries

```
??? %INCLUDE COMDEF.BAS
```

where ??? represents any line number that precedes the first executable statement.

The bad news about this new version of the compiler is its size. Instead of having the Basic .Rel file pick out only the subroutines it needs from the Bascom library, which takes quite a lot of time during the link run, Microsoft has bundled the more commonly used routines into a discrete run-time file called BRun.Com, which every compiled MBasic program will now have to pull into memory as its first act of office. BRun.Com is 16K in size. However short your program, it will always occupy at least that much memory.

Because Basic does not allow subroutines created by the user to be called by name, and because of the limitations in passing parameters to those routines, Basic compiler writers try to soften the

	Interpreter	New library	Old library
Compile	N/A	25s.	25s.
Link	N/A	1min. 20s.	1min. 55s.
Run time	46s.	20s.	20s.
Disc size	2K	2K	10K
Mem size	28K + D	16K + D	10K

Table 1. Performance of test program under interpreted and compiled MBasic.

rough edges of the language by offering more and more built-in statements and functions. BRun.Com is an admission that the inclusion of the Chain with Common facilities has made the Baslib library unmanageably large.

The idea of a separate run-time package is not new. CBasic has it, as do some of the Pascals, notably Pascal/M. But Bascom ingeniously does its best to make the extra file invisible to the user. Whereas the traditional CBasic user has to prefix a call to CRUN2 before the reference to the program he wants to run, the MBasic machinery is set to make the calling of the run-time package automatic when the program name is fed to CP/M's command line.

The only difficulty arises when the user program finds that BRun.Com is not on the expected disc. The location of BRun.Com has to be defined at link time, and the linker reads it from a small text file called BCLoad.

## Time saved

The invisible machinery is fine for substantial programs, especially for dealing with a series of programs that Chain each other. The bulk of the run-time package stays put and the application programs are overlaid in the memory area above it. The library does not have to be called in from disc each time a new program is brought in, and disc transfer time is saved.

Nonetheless the whole arrangement is rather cumbersome for the sort of short and sweet programs that Basic does best. For this reason Microsoft includes on the release disc a copy of the old version of the compiler library, now renamed Obslib.Rel. Obs does not stand for "obsolete", indeed the old library is still an important part of the development package. The code it creates takes less memory, and will run independently of any outside help. What it will not do is support Chain with Common.

To check the mechanism we took a short test program:

```
10 DEFINT K: DEFSNG B
20 PRINT "START"
30 FOR K = 1 TO 5000
40 B = K/K
50 BB = K*K
60 NEXT K
70 PRINT "STOP"
```

and put it through the mill in three different ways as shown in table 1. These timings are obviously hardware dependent, particularly as the compile and link figures include the time taken to pull the

systems files in off our rather slow Micro-polis 5.25in. discs. The third row gives genuine computation time, taken from the program's Start and Stop prompts, and you will see from this that compilation gives an improvement of 130 percent. Run timings are identical between the old and new libraries, but the improvement in link time, even for this small program, is very noticeable.

## Memory space

The disc-size row reflects the fact that typical mini-floppy implementations of CP/M try to improve disc speed by refusing to deal with memory transfers below a certain minimum, the block size. The actual size of the test program in memory under the interpreter is trivial, designated in the last row of the table as D. Most of memory in that case consists of the 28K of the interpreter.

Similar remarks apply to the program as compiled with the new library: the bulk is taken up by the 16K BRun package that must co-reside in memory. Notice that the total compiled size is larger under the new system; the 10K in the last row shows that the linker has selected only those routines associated with the test program.

As with all benchmark tests, the language comprises more than the two statements tested in this program so be cautious with the run-time figures. Change the program lines:

```
40 B = K*.5
50 BB = K*3
```

and you have a program that runs at 5 minutes 20 seconds whether you compile it or not.

## Conclusions

- The MBasic compiler package can be used without the interpreter, the programmer writing the source code as an ASCII file.

- Probably the best use of the compiler is in crunching down Basic programs developed under the interpreter. Used like this the whole MBasic5 package makes a very powerful program-development system.

- The new version of the compiler lets you create a complete suite of programs that pass values from one to the other. Very sophisticated business software can result, as there is now virtually no limit to the total size of the code.

- The bad news is that Basic is still Basic. It is worth repeating that a language should help you think about the problem, as well as code it. □

# STACKED WITH FEATURES

Each unit supports up to three users - each with 4MHz Z80A and 64K RAM

Virtually no limit on number of users; hard discs

Standard serial and parallel interfaces; CP/M-compatible operating system

Prices from **£1299**

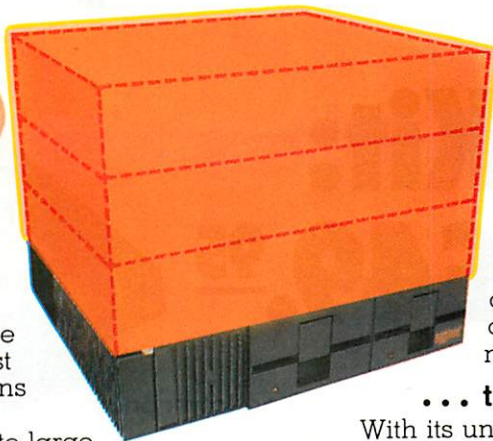

## The Ring and the Stack

The Sig/net concept - the simple interconnection of functional computing modules on the unique Sig/net Ring - achieves the widest variety of hardware configurations at the lowest possible cost. From single-user floppy drive systems to large multi-user configurations sharing hard discs and expensive printers, Sig/net can provide the right specification. And it can be expanded at low cost from a basic system to multi-user operation in which each user has a processor for full speed operation. There is virtually no limit to the hardware configurations possible.

The newly introduced 1000 Series has been designed especially for multi-user systems. One slim unit, serving up to three users, stacks on top of another. A twelve user system with over 800KB of internal memory and 16MB of hard disc requires only five units and measures just 420mm square and 450mm high!

All this advanced hardware is backed by an established dealer and distributor network to guarantee end user support and the CP/M-compatible operating system ensures the availability of the widest range of proven business software.

## For you to sell as a dealer..

Sig/net offers you advantages of advanced hardware, the backing of a professional distributor network and usual trade margins.

## ... to specify as a consultant ..

With its unrivalled expansion potential and flexibility at low cost, Sig/net enables you to tailor a system exactly to a client's needs and to add new facilities as required.

## ... to buy as a user ..

Sig/net offers a high specification at low cost, the potential for expansion with your business, the backing of a national dealer network for continued support and the widest range of business software. Compare it with other systems and see if they match up.

Post the coupon to Shelton Instruments Limited, 22-26 Copenhagen Street, London N1 0JD today or contact your nearest distributor for details.

**North** Micropute: contact Peter Casey 0625 612759  
**South and East** Interam: contact John Lagan 01-675 5325/6/7  
**South and West** Malvern Micro Systems: contact Ray Mansell 06845 68500  
**Scotland** Video Vector Dynamics: contact Chris Morrow 041-226 3481  
**Northern Ireland** ECL Group: contact Alan Richardson 0232 664737  
**Eire** ECL Group: contact Reg Vian 0001 767042

## MAKE THE RIGHT CONNECTION NOW

To: Shelton Instruments Limited, PC2  
 22-26 Copenhagen Street, London N1 0JD

I am interested in a Sig/net dealership   
 Please send me further details of Sig/net   
 Ask my nearest dealer to contact me

Name \_\_\_\_\_ Position \_\_\_\_\_

Company \_\_\_\_\_

Address \_\_\_\_\_

Tel: \_\_\_\_\_

Tel: 01-278 6273

**shelton sig|net**



# Sinclair ZX81 Personal Computer the heart of a system that grows with you.

1980 saw a genuine breakthrough – the Sinclair ZX80, world's first complete personal computer for under £100. Not surprisingly, over 50,000 were sold.

In March 1981, the Sinclair lead increased dramatically. For just £69.95 the Sinclair ZX81 offers even more advanced facilities at an even lower price. Initially, even we were surprised by the demand – over 50,000 in the first 3 months!

Today, the Sinclair ZX81 is the heart of a computer system. You can add 16-times more memory with the ZX RAM pack. The ZX Printer offers an unbeatable combination of performance and price. And the ZX Software library is growing every day.

## Lower price: higher capability

With the ZX81, it's still very simple to teach yourself computing, but the ZX81 packs even greater working capability than the ZX80.

It uses the same micro-processor, but incorporates a new, more powerful 8K BASIC ROM – the 'trained intelligence' of the computer. This chip works in decimals, handles logs and trig, allows you to plot graphs, and builds up animated displays.

And the ZX81 incorporates other operation refinements – the facility to load and save named programs on cassette, for example, and to drive the new ZX Printer.



**New BASIC manual**

Every ZX81 comes with a comprehensive, specially-written manual – a complete course in BASIC programming, from first principles to complex programs.

## Kit: £49.<sup>95</sup>

### Higher specification, lower price – how's it done?

Quite simply, by design. The ZX80 reduced the chips in a working computer from 40 or so, to 21. The ZX81 reduces the 21 to 4!

The secret lies in a totally new master chip. Designed by Sinclair and custom-built in Britain, this unique chip replaces 18 chips from the ZX80!

### New, improved specification

- Z80A micro-processor – new faster version of the famous Z80 chip, widely recognised as the best ever made.
- Unique 'one-touch' key word entry: the ZX81 eliminates a great deal of tiresome typing. Key words (RUN, LIST, PRINT, etc.) have their own single-key entry.
- Unique syntax-check and report codes identify programming errors immediately.
- Full range of mathematical and scientific functions accurate to eight decimal places.
- Graph-drawing and animated-display facilities.
- Multi-dimensional string and numerical arrays.
- Up to 26 FOR/NEXT loops.
- Randomise function – useful for games as well as serious applications.
- Cassette LOAD and SAVE with named programs.
- 1K-byte RAM expandable to 16K bytes with Sinclair RAM pack.
- Able to drive the new Sinclair printer.
- Advanced 4-chip design: micro-processor, ROM, RAM, plus master chip – unique, custom-built chip replacing 18 ZX80 chips.



## Built: £69.<sup>95</sup>

### Kit or built – it's up to you!

You'll be surprised how easy the ZX81 kit is to build: just four chips to assemble (plus, of course the other discrete components) – a few hours' work with a fine-tipped soldering iron. And you may already have a suitable mains adaptor – 700 mA at 9 V DC nominal unregulated (supplied with built version).

Kit and built versions come complete with all leads to connect to your TV (colour or black and white) and cassette recorder.



ter-



**Available now-  
the ZX Printer  
for only £59.<sup>95</sup>**

Designed exclusively for use with the ZX81 (and ZX80 with 8K BASIC ROM), the printer offers full alpha- numerics and highly sophisticated graphics.

A special feature is COPY, which prints out exactly what is on the whole TV screen without the need for further instructions.

At last you can have a hard copy of your program listings – particularly useful when writing or editing programs.

And of course you can print out your results for permanent records or sending to a friend.

Printing speed is 50 characters per second, with 32 characters per line and 9 lines per vertical inch.

The ZX Printer connects to the rear of your computer – using a stackable connector so you can plug in a RAM pack as well. A roll of paper (65 ft long x 4 in wide) is supplied, along with full instructions.

**How to order your ZX81**  
BY PHONE – Access, Barclaycard or Trustcard holders can call 01-200 0200 for personal attention 24 hours a day, every day.  
BY FREEPOST – use the no-stamp-needed coupon below. You can pay

by cheque, postal order, Access, Barclaycard or Trustcard.  
EITHER WAY – please allow up to 28 days for delivery. And there's a 14-day money-back option. We want you to be satisfied beyond doubt – and we have no doubt that you will be.

**16K-byte RAM pack for massive add-on memory.**

Designed as a complete module to fit your Sinclair ZX80 or ZX81, the RAM pack simply plugs into the existing expansion port at the rear of the computer to multiply your data/program storage by 16!

Use it for long and complex programs or as a personal database. Yet it costs as little as half the price of competitive additional memory.

With the RAM pack, you can also run some of the more sophisticated ZX Software – the Business & Household management systems for example.

To: Sinclair Research, FREEPOST, Camberley, Surrey, GU15 3BR.				Order
Qty	Item	Code	Item price £	Total £
	Sinclair ZX81 Personal Computer kit(s). Price includes ZX81 BASIC manual, excludes mains adaptor.	12	49.95	
	Ready-assembled Sinclair ZX81 Personal Computer(s). Price includes ZX81 BASIC manual and mains adaptor.	11	69.95	
	Mains Adaptor(s) (700 mA at 9V DC nominal unregulated).	10	8.95	
	16K-BYTE RAM pack.	18	29.95	
	Sinclair ZX Printer.	27	59.95	
	8K BASIC ROM to fit ZX80.	17	19.95	
	Post and Packing.			2.95

Please tick if you require a VAT receipt TOTAL £ \_\_\_\_\_

\*I enclose a cheque/postal order payable to Sinclair Research Ltd, for £ \_\_\_\_\_

\*Please charge to my Access/Barclaycard/Trustcard account no. \_\_\_\_\_

\*Please delete/complete as applicable. \_\_\_\_\_ Please print.

Name: Mr/Mrs/Miss \_\_\_\_\_

Address: \_\_\_\_\_

FREEPOST – no stamp needed. PRC06

**sinclair**  
**ZX81**

6 Kings Parade, Cambridge, Cambs., CB2 1SN.  
Tel: (0276) 66104 & 21282.

# Memotech's New Memory System for the ZX81



## Memopar 16K Memory Extension

**-£39.95 incl.VAT**

It is a fact that the ZX81 has revolutionised home computing, and coupled with the new Memopar 16K it gives you a massive 16K of Directly Addressable RAM, which is neither switched nor paged. With the addition of the Memopar 16K your ZX81's enlarged memory capacity will enable it to execute longer and more sophisticated programs, and to hold an extended database. The 16K and 64K Memopars come in attractive, custom-designed and engineered cases which fit snugly on to the back of the ZX81, giving firm, wobble-free connections. See below for ordering information.

## Coming Soon...



A complete range of ZX81 plug-in peripherals  
Memotech Hi-Res Graphics  
Centronics Interface and Software Drivers  
Memotech Digitising Tablet  
RS232 Interface

All these products are designed to fit 'piggy-back' fashion on to each other, and use the Sinclair power supply. WATCH THIS SPACE for further details. We regret we are as yet unable to accept orders or enquiries concerning these products — but we'll let you know as soon as they become available.

## How to order your Memopak.

**By Post:** Fill in the coupon below and enclose your cheque/P.O./Access or Barclaycard number.

**By Phone:** Access/Barclaycard holders please ring Oxford (0865) 722102 (24-hour answering service).

Please make cheques payable to Memotech Limited  
Please debit my Access/Barclaycard account number

*Please delete whichever does not apply.*

SIGNATURE \_\_\_\_\_

DATE \_\_\_\_\_

NAME \_\_\_\_\_ ADDRESS \_\_\_\_\_

Total Enclosed		_____	
Postage	£2.00	64K RAM, Assembled	_____
	£79.00	16K RAM, Assembled	_____
Price	£39.95	Quantity	_____
Total	_____		_____

Please send me:

*have been either opened or damaged in any way.*

When your programming needs have outgrown the capacity provided by 16K RAM, and you find it necessary to further extend your ZX81's capacity, we will take back your 16K Memopak and allow a discount of £15.00 against your purchase of our 64K model.

## Unique 3 month trade-in offer!

With the Memopak 64K extension the ZX81 is transformed into a powerful computer, suitable for business, leisure and educational use, at a fraction of the cost of comparable systems. arrays. 32-64K... 32K of RAM memory for basic variables and large assembly language routines. 16-32K... This area can be used for basic programmes and language routines. 8-16K... This section of memory switches in or out in 4K blocks to leave space for memory mapping, holds its contents during cassette loads, allows communication between programmes, and can be used to run assembly language routines.

## BREAKDOWN OF MEMORY AREAS

The 64K Memopak is a pack which extends the memory of the ZX81 by a further 56K, and together with the ZX81 gives a full 64K, which is neither switched nor paged, and is directly addressable. The unit is user transparent and accepts basic commands such as 10 DIM A(9000).

## Memopak 64K Memory Extension

**-£79.00 incl.VAT**

© R. Branton & G. A. C. Boyd 1982

We want to be sure you are satisfied with your Memopak — so we offer a 14-day money back Guarantee on all our products. Memotech Limited, 3 Collins Street, Oxford OX4 1XL, England Telephone: Oxford (0865) 722102/3/4/5

# From simple arithmetic to A-level chemistry

THE MICROELECTRONICS Education Programme offers some Government support to authors of educational software, but equally important from the publisher's point of view supports teacher training and awareness in the application of microcomputers in education. This is likely to create a larger market, making it more profitable for publishers to enter this area.

A few publishers have already taken the plunge. One of the first to do so is Longman, already well established in the educational book market, who last year announced a proposed micro software series. Two of the earliest packages available are Chemdata and Janeplus, both available in disc and cassette versions for the Pet and RML 380-Z initially.

Chemdata is aimed at those teaching chemistry to GCE A-level and provides graph-plotting facilities on the first 38 elements of the periodic table. Chemdata may be used either to teach a whole class or by individual students, although it is perhaps more suited to the former.

## Simple plotting

The program stores information related to the following: atomic volume, melting point, boiling point, ionisation energy, atomic radius, oxidation states, group numbers, enthalpy of fusion and enthalpy of variation, any of which may be chosen to form the vertical axis. The horizontal axis may be atomic number, transition metals or a group. It is easy to plot the graphs using simple commands, and equally easy to change either or both of the axes. Facilities for printer output are provided to give hard copy of the graphs or the data file.

A useful command available at any time is Help which provides a list of the commands available. The program is carefully designed so that the user is unlikely to find any real difficulties while running the program, although it is advisable to read the brief but clear guide and running the program.

The review copies supplied were on cassette for the 380-Z and disc for the Pet. The 380-Z version plots points on the graph in low resolution; the Pet version draws vertical lines, the height of which represent the values to be displayed. Both versions have to approximate the values to be represented, because of the screen graphics used, but the errors on the Pet screen are more noticeable, in some cases displaying zero as one character on the screen.

The scaling, particularly of the vertical axis, is poor to the point of obscurity,

**Publishers have traditionally been unwilling to risk producing software for schools. Now Michael Trott asks if 1982 is to be the year of educational software.**

displaying only upper and lower values with no intermediate markings.

The printed material consists of a manual which provides details of the design and structure of the program, including subroutines and variables and a full listing of both versions which is clearly explained section by section. The manual also explains how to add routines to the program and must be regarded as a plus point in Longman's favour. A running sheet is also provided for novice users, giving clear instructions on loading for the various versions available.

A teacher/student booklet gives details of the facilities available in the program and a short study guide.

The program is reasonably good value for money and is attractively packaged. However, the facilities of the program are rather limited and a colleague who has taught A-level chemistry for some years and is a keen micro user was not particularly impressed.

Janeplus is aimed at a wider ability and a five-to-18 age range. It is designed to be used by the teacher with groups or individual pupils to encourage children to discuss simple mathematical functions. The program draws small figures on the screen, who change numbers in accordance with the function in question. The teacher then uses this as a basis for class discussion.

There are a number of characters in Janeplus, each of which represents a different function, for example, "add 7" or "multiply by 3". The user may choose a one- or two-function problem from these characters.

A typical run through the program might start with two boxes appearing on the screen with a character called Peter between them. The children are then invited to "give Peter a small number". The answer could then be displayed by pressing A, when Peter appears to transfer the number given to him from the left-hand box to the right, changing it in some way. The children would then be asked to suggest what Peter's function is, i.e., what he has done to the number. From the answers suggested, the children can then proceed to narrow down the possibilities by giving Peter further numbers. When an answer has been agreed

upon it can be checked by giving Peter another number and entering the children's answer. If they are correct the right-hand box is enclosed in stars and a bell sounds if a printer is connected.

Single functions can be used to investigate either addition or multiplication, and two-function problems present a combination of these. By using the inverse situation, subtraction and division can also be examined. The girl characters multiply and the boys add and in each case the range of integers to be used may be selected as between +2 and +6 or -6 and +6. The program provides opportunities and stimulus for class discussion, and pupils responded well to the program.

The teacher's handbook is very clearly set out, providing details of the program and the decision points, observations in the classroom as well as general advice to the teacher. A program listing is also provided with a summary of the drive-chart conventions. The concept of using drive charts was developed by the ITMA project based at the College of St Mark and St John in Plymouth and has been incorporated into a number of programs from that source. Programs from ITMA have been tested and developed in schools.

## Teachers' introduction

A program called Testdrive is supplied with Janeplus. It is an excellent and amusing program intended to familiarise teachers with the use of drive charts by calling up one of three animals: Claude the cat, Wilfred the wolf or Katie the kangaroo. These animals can then be made to wink an eye, wag a tail and move off the screen, using single-key commands. The program, which comes with an accompanying booklet, provides a really excellent means of introducing the novice teacher to the use of a micro for teaching, thanks to the use of drive charts to run the program.

## Conclusions

- Chemdata and Janeplus each cost £12.50 on disc and £9.50 for the cassette version.
- Chemdata is attractively packaged and represents reasonably good value for money, though its facilities are rather limited.
- Janeplus is excellent value for both junior and lower-secondary schools. The program provides ample variety to hold children's interest, and is robust and reliable.

IF YOU LIKE problems to be so subtle as to verge on the insoluble, a good way of spending the best years of your life is to concentrate on a problem in the field of natural language. Any problem in the field will do, since natural language — English, for instance — is something we all know well while being unable to say exactly how we know it.

That is the essence of the matter as far as computers are concerned. A computer usually has to be told exactly what to do in order to do it. When you learned your native language you were not told how to do it.

All that can usually be said with any attempt at concreteness is that people seem to have a language-acquisition mechanism — LAM, as it is usually called. The LAM somehow enables them to learn a language simply by being exposed to it, rather than by being programmed with specific rules for that language. So you can learn English at a very early age. You could have learned German or even Chinese using the same mechanism.

Your computer is rather different. In all the time you have owned the thing, it probably has not learned a single word, no matter how much you shouted at it. A human infant receives language as a stream of sounds. Sounds which are unfamiliar at first become more familiar as time progresses. From these sounds the infant has to join together words one to another if they make phrases.

The infant is receiving what is known as continuous speech, a solid input stream, unmarked at word boundaries. You can give your computer the same input. To avoid complications — after all, this is only a demonstration — give the machine text rather than audio input and present it in a solid stream. For instance, “present it in a solid stream” is input as PRESENTINASOLIDSTREAM

which should give you some idea of the problem facing the infant. It is much harder to read with no spaces or punctuation in it. Equally, continuous speech is hard to disentangle when the beginnings and endings of words run into each other.

Your computer now has something to work on which approximates to continuous speech. In its memory you put nothing that will tell it what the words of the language are, or even what the letters are. It has to work that out for itself.

The computer now has to “listen” to a stream of this text and learn the language by doing so. It does this in two ways:

- By scanning the text and noting all the different elements in it: at first these are just the letters of the alphabet to which it is exposed. You do not give it an alphabet to start with, and it does not learn the alphabet all at once, but only as new letters come along.
- By scanning the text and choosing a pair of elements which it thinks go together. When it finds such a pair it adds them to the lexicon as a new word which it has “learned”.

# Famous first words



**Can computers acquire language naturally?  
Chris Naylor's simple program takes a few faltering steps towards eloquence.**

Figure 1 is based on the text “it is sunny”, which has been turned into a continuous stream “ITISSUNNY” and input to the machine. On input, the program gradually builds up its own lexicon to contain I, S, T, U, N and Y. The program registers in the matrix what letter combinations occur, and the frequency with which they occur.

In this short example no combination occurs more than once, so each element of the matrix contains 0 or 1. With a larger sample, higher-frequency combinations would normally be present.

The program now has to decide which pair of lexicon items can be added together to create a new lexicon item. Having made this decision the lexicon is incremented by one item and the matrix rearranged. Figure 1 shows the arrangement if “it” were to be selected as a word. T disappears from the lexicon, as it ceases to be an item which occurs by itself, and IT is added. The matrix is rearranged to present the new letter combinations considering IT as a letter all by itself.

Programming this much is fairly straightforward. The difficulty lies in choosing which letter pair — in general which pair of lexicon items — to join together. Three types of decision can be made:

A wrong decision: for instance, TI, which is wrong because in this example TI only occurs at a word boundary, not within a word.

A right decision: for instance, IT, which is right because in this example IT only occurs within a word.

An ambiguous decision: for instance, TI, if the text also contained the word “time”. It would be ambiguous because it could occur either within a word or at a word boundary.

With extremely large text samples almost all elements would appear to be ambiguous so the problem would appear, initially, to be academic. However, whereas all the elements may be ambiguous, some are still more likely to occur within words than at word boundaries and consequently some make better selections than others. For instance, if the

**Figure 2. Original text.**

It is summer time. School is over, and the long summer holiday is here.

Jane and Peter talk about their long summer holiday, and what they are going to do.

"I like school," says Peter, "but I am glad the holiday has come."

"Yes, I am glad too," says Jane. "I like sunny days when we have no work to do. There are so many nice things to do in the holiday when it is sunny."

"Yes," says Peter, "and Dad thinks it does us good to get out in the sun. We will be out every day when the sun comes out."

"Do you know there is an old donkey up at the f

**Figure 3. Input text.**

ITISSUMMERTIMESCHOOLISOVERAND  
THELONGSUMMERHOLIDAYISHERE  
JANEANDPETERALKBOUTTHEIRLONG  
SUMMERHOLIDAYANDWHATTHEYARE  
GOINGTODOILIKESHOOLSAYS  
PETERBUTIAMGLADTHEHOLIDAYHAS  
COMEYESIAMGLADTOOSAYS  
JANEILIKESUNNYDAYS  
WHENWEHAVENOWORKTODOTHERE  
ARESOMANYNICETHINGSTODO  
INTHEHOLIDAYWHENITISSUNNY  
YESSAYSPEERANDDADTHINKS  
ITDOESUSGOODTOGETOUTINTHE  
SUNWEWILLBEOUTEVERYDAY  
WHENTHESUNCOMESOUTDOYOU  
KNOWTHEREISANOLDDONKEY  
UPATTHEF

**Figure 4. Analysed text.**

HE	DO	
THE	SUM	SAYS
HO	SUMME	SC
AY	RE	SO
AN	SUMMER	IT
LI	IN	JAN
HOLI	HEN	HIN
HOLID	ER	VER
HOLIDAY	TODD	SCHO
ME	HA	LIKE
SU	PE	SAYSPETER
UT	PET	SUMMER
AYS	PETER	HOLIDAY
TO	IS	ITIS
SUN	WHEN	JANE
AND	KE	

program chose TI early on, it would have a hard job choosing the words "it" and "is" when they occur together. Every time the machine sees "itis" it assumes the segmentation I T I S. The pairs of elements IT and IS are removed from the matrix when TI was formed.

In order to be able to choose which items to join together, the program has to have some information about them. There must be variables associated with the various combinations. However, like a new-born infant, the program knows nothing about the letters themselves — it only knows what it can build up from experience. Obviously such information must be independent of any particular language, otherwise the program could only learn that one language.

Frequency information is available independent of the particular language, and the following variables suggest themselves:

- frequency of occurrence of each combination, A

- frequency of occurrence of the first item in the combination, B
- frequency of occurrence of the second item in the combination, C
- number of items with which the first element occurs, K1
- number of items with which the second element occurs, K2

In the example, IT has A=1, B=2, C=1, K1=2, K2=1. We can then choose which pair to select from the equation.

$$FF = B1 \cdot a + B2 \cdot b + B3 \cdot c + B4 \cdot d + B5 \cdot e$$

B1 to B5 are numerical coefficients and a to e are transformations of the variables derived from an analysis of large samples of text. They are shown in table 1. I, J are the rank order of B and C respectively, and SL is the sum of the rank orders. Thus if B is the most frequent first element it has the rank of 1. The least frequent first element will have the rank LC — the number of items in the lexicon. SL clearly has the value  $1+2+3+ \dots +LC$ . The pair is chosen to give the greatest value for FF.

Figures 2 to 5 show how the program learns words from small samples of English and German text. A simpler mechanism can be used which just works on the basis of selecting the most frequently occurring pair of items each time the program examines the matrix. This can be useful when writing the program to make sure that all of the other parts are working correctly.

Figure 2 contains the first 400 characters from a Ladybird children's reader, *Sunny Days*. The end may seem a little abrupt, but that is the result of arbitrarily deciding to see what happens with 400 characters.

The text is presented to the language-acquisition mechanism with all spaces and punctuation removed, as in figure 3, to simulate continuous speech. The LAM produces a series of segments, in the order shown in figure 4, which are then added to the lexicon.

Though the machine acquires some units of language, it does not find all of them. It finds some which have occurred in the small amount of text it was given, plus a few segments which do not appear anywhere in the text but still happen to be words, e.g. HE, ME, etc. The mechanism has taken a very small amount of text and tried to squeeze as much out of it as possible.

This short demonstration gives some idea of the robustness of the technique, but in practice, the program would be given a threshold level of certainty. It would not form a new segment unless it was sufficiently certain that it was one it wanted. Lacking such certainty, it would simply continue inputting new text until it had sufficient information to make a more certain judgement. It would learn more slowly, but more surely.

You might pause to consider what you would make of 400 characters of unsegmented text in a language you had never

seen before. Viewed in that light, perhaps the machine does not do too badly.

One factor which favours the existence of a language-acquisition mechanism in humans, rather than an innate knowledge of language as such, is the commonplace observation that a human infant learns with equal ease whichever language it happens to be exposed to. So if the computer's language-acquisition mechanism is anything like the human one it should be able to learn foreign languages without any difficulty.

One problem in testing this hypothesis is that different languages use different alphabets. German, for example, uses Ä, Ö, Ü and ß — which approximates to the sound "sz" — in addition to the 26 letters of the English alphabet. On most computers, numerals or graphics characters must be used to represent these.

The segments generated from 400 words of German continuous text are shown in table 5, about 25 percent of which are genuine German words. That this is not as good a performance as it produced in English may, in the absence of further evidence, be due to the nature of the German language, or to the characteristics of the particular passage which was chosen. Nevertheless, it demonstrates in principle that a mechanism could be devised which would enable a computer to learn a fair amount about a language simply by being immersed in it.

(continued on next page)

**Table 1.**

B1= 2,407	a= log(A)
B2= 18.431	b= I/SL
B3= .1123	c= J/SL
B4= 1.184	d= log(LC+.5 -K1)
B5= .8004	e= log(LC+.5 -K2)

**Figure 1.**

LEXICON

MATRIX

	I	T	S	U	N	Y
I	I	0	1	1	0	0
T	T	1	0	0	0	0
S	S	0	0	1	1	0
U	U	0	0	0	0	1
N	N	0	0	0	0	1
Y	Y	0	0	0	0	0

If "IT" is selected as a new word we have:  
(IT) ISSUNNY

LEXICON

MATRIX

	I	S	U	N	Y	(IT)
I	I	0	1	0	0	0
S	S	0	1	1	0	0
U	U	0	0	0	1	0
N	N	0	0	0	1	0
Y	Y	0	0	0	0	0
(IT)	(IT)	1	0	0	0	0

(continued from previous page)

A system of this kind, particularly one which could run on voice input would offer certain advantages. You would not need to program in the "rules" of the language in advance, and you would not have to specify the vocabulary in advance. The machine would build up its own vocabulary and understanding.

If a workable recognition process could be devised, it would have less difficulty with continuous speech than programs which give the computer a prior definition of each word in speech since the machine would have learned its vocabulary from continuous speech. It would, therefore, learn language as it is spoken naturally rather than as it is defined formally.

## Beyond pure form

This approach has yet to be tested in the field of natural languages. Certainly, it holds more promise than pretending that natural languages are just very complicated formal languages analogous to a super-high-level computer language.

The Language program was developed as a simulation of human language acquisition. It is able to select nouns and other fairly "central" words in preference to less directly meaningful items from continuous text. Foreign languages suit it just as well as English.

Given the raw elements on its input, it is a method, specifically expressed as a formula, for starting to acquire a language.

To derive the central equation of the program, a large sample of text was analysed. It was assumed that people, like the program, had to be able to join together separate items as a first step in learning any language. The equation in the program defines a mechanism which would

Figure 5. Analysis of German.

ER	ES	IH
TE	SIE	IM
HER	KA	IMM
AR	HERRM	IN
HERR	HERRMÜ	ING
ND	HERRMÜL	IT
UND	HERRMÜLL	EN
IE	HERRMÜLLER	ÜB
WAR	DER	ÜBER
BE	ZU	ÜBERZIEHER

be likely to acquire the language analysed in the samples.

Over a long period of time, so one theory goes, people have developed their language and reduced it to written form. Their children have been able to acquire this language and have continuously modified it. That being the case, you expect language to be easy for a human infant to learn and to evolve to become even easier. The easiest parts to learn would be those with the highest survival value.

The precise meaning of "easy to learn" is not easy to define. It makes sense to think that language has evolved to match the mechanism which acquires it, and that the mechanism which acquires it has evolved to match the language available. The result is that, quite naturally, an image of the acquisition mechanism must lie somewhere in the properties of the language itself. The properties of the human acquisition mechanism should contain clues for a machine language-acquisition method.

At first sight such a mechanism appears to be of academic interest only. Yet suppose you have an office with memos and reports flying around it. You engage a new filing clerk, who drifts up to you one day with a piece of paper and asks where it should be filed. You look at the paper

and pronounce accordingly. After a while the clerk begins to get the idea and calls out that a given piece of paper seems to be about, say, holidays. Well, you explain, file it under Recreations.

Now transfer that to machine. All of the memos are on disc and they need filing, categorising, call it what you will, so that various people have access to particular documents or have copies printed for them or, at any rate, the memos are actioned in some way.

How do you decide what action to take? The filing clerk has gone and you are reduced to either specifying all the key words in advance, or reading all of the documents in order to build up the key words.

## Sensitive to meaning

A computer could help you by scanning the documents and presenting you with a list of all the different words used. This would enable you to specify key words without having to read all the files, but it is still a considerable effort.

Yet if the language-acquisition technique is used, the system no longer needs to learn words as such because all of that information is present in the segmented text. Furthermore, the mechanism works by learning words in a particular order much as a human observer might. It tends to be picking on those words with the highest "meaning" in the sense of the most concrete terms.

This mechanism could be used to scan documents intelligently, asking about only those words which strike it as "interesting" and asking the operator what to do when it encounters such a word. Subsequent recognition of these words would be easy with normally segmented text, and the operator's response could be

(continued on page 77)

## Static run listing without recogniser.

```

10 HOME : PRINT "LANGUAGE":
11 H1 = 1.184015211:H2 = .0004171
57:H3 = 18.43103375:H4 = .11
2255:09:H5 = 1.625639319:H6 =
1.475639897:H7 = .5
20 W = 1:XT = W:TW = 2:TH = 3:T =
100:TT = 1000:EI = 8:ML = TW
:HI = WHJ = W:TC = TT:TY =
35:CI = B1 + B2 + H5:CC = TW
* (B1 + B2):TS = TT
30 REM :S(C) HOLDS THE I/P STRIN
B.L(C) HOLDS THE LEXICON, PL
X(C) HOLDS LEXICON FREQUENCIE
S.
40 REM :THIS SECTION TAKES IN TH
E (/P STRING AND BUILDS UP A
LEXICON AND FREQUENCY COUNT
.
50 DIM S$(2000),L$(1),PL$(1),L$(
T,T),X$(T),I(C):DEF FN HM
(A) = SGN(A) - W:DEF FN
KP(A) = W - SGN(A - W)
60 INPUT "HOW MANY CHARACTERS AR
E YOU ENTERING AT A TIME?":
SC
61 INPUT "DO YOU HOLD THE CHARAC
TERS ON TAPE? Y/N":AS
62 IF AS = "Y" THEN :PRINT "REC
ALL XX":STOP:FOR I = W TO
SC:S$(I) = CHR$(X(I)):PRINT
S$(I):NEXT I:FOR I = SC +
W TO TT:S$(I) = CHR$(X(I)
):NEXT I:GOTO 95
79 FOR I = W TO SC
80 GET S$(I):X(I) = ASC(S$(I)
)
81 IF ASC(S$(I)) = EI THEN I =
I - W:S$(I) = "":PRINT:PRINT
:FOR J = W TO I - W:PRINT
S$(J):NEXT J:GOTO 80
90 PRINT S$(I):NEXT
91 PRINT:INPUT "DO YOU WISH TO
STORE THESE CHARACTERS ON T
APE? Y/N":AS
92 IF AS = "Y" THEN :PRINT "STO
RE XX":STOP
94 REM :THE NEXT SECTION SETS U
P L$(I,J) AS A JOINT PROBABI
LITY MATRIX.
95 HI = Z:FOR I = W TO SC
110 FOR J = Z TO LC
120 IF S$(I) ( ) L$(J) THEN :NEXT
J
130 PL$(J) = PL$(J) + W:IF J = L
C + W THEN :LC = LC + W:PL$(
C) = S$(I)
140 IF HI THEN L$(HI,J) = L$(HI
,J) + W:L$(HI,Z) = L$(HI,Z) +
FN KP(L$(HI,J)):L$(Z,J) = L
$(Z,J) + FN KP(L$(HI,J))
150 HI = J:NEXT I:PRINT
160 HI = W:HJ = W:GOSUB 700:GOSUB
800
325 NX = SC - W:SL = LC + (LC + W
) / TW:NC = Z:FOR I = W TO
LC:I(I) = I:NC = NC + L$(I,Z
):NEXT I
329 FOR I = TW TO LC:IC = W:CC =
I(I - W)
330 IF PL$(I) = PL$(I - W) THEN
:CC = CC + I(I):C = C + W:I =
I + W:IF I ( ) L$(I) THEN 330
331 IF C ) W THEN :FOR J = I -
C TO I - W:I(J) = CC / C:NEXT
J
332 NEXT :D3 = LC + HF:D1 = H3 /
SL:D2 = B4 / SL:HH = TR - C1
* LOG(NC) + C2 + LOG(LC
) + B5 * LOG(NX) + B6:H =
HH
333 FOR I = W TO LC:FA = B1 * LOG
(D3 - L$(I,Z)) + D1 + I(I):FOR
J = W TO LC
334 IF L$(I,J) THEN :FF = FA + B
2 * LOG(D3 - L$(Z,J)) + D2
* I(J) + B5 * LOG(L$(I,J)
):IF FF ) HH THEN :HI = I:H
J = J:HH = FF
340 NEXT I:NEXT
347 HA = L$(HI,HJ):HB = PL$(HI) -
HA:HC = PL$(HJ) - HA:H = HH -
H + TR:PRINT "COEFFICIENT F
F = "H
349 PRINT "LEXICON ADDITION IS :
"HL$(HI) + L$(HJ)
370 LC = LC + W:SL(LC) = L$(HI) +
L$(HJ)
380 IF L$(HI) ( ) X$ AND L$(HJ)
( ) X$ AND X$ ( ) "" THEN
:PRINT "I SUGGEST THAT "I
383 INVERSE:PRINT X$:NORMAL
385 PRINT " IS A WORD IN ITS OWN
RIGHT"
390 X$ = L$(LC)
+LIST391,850
465 IF LEN(L$(LC)) ) ML THEN :
ML = LEN(L$(LC))
490 I = W
500 IW = I + W:IF S$(I) + S$(IW)
= L$(LC) THEN :S$(I) = L$(L
C):FOR J = IW TO SC - W:S$(
J) = S$(J + W):NEXT J:GOSUB
900:S$(I) = SC - W
510 PRINT S$(I):" "
520 I = IW:IF I ( SC THEN 500
530 IF I = SC THEN :PRINT S$(I)
540 PL$(LC) = PL$(LC) + HA:L$(HI,
HJ) = Z:PL$(HI) = PL$(HI) -
PL$(LC):PL$(HJ) = PL$(HJ) -
PL$(LC):L$(HI,Z) = L$(HI,Z) -
W:L$(Z,HJ) = L$(Z,HJ) - W
550 PRINT:PRINT "SC = "SC
555 GOSUB 700:GOSUB 800
570 GOTO 325
700 REM :SORT ROUTINE
710 IF HJ ( HI THEN :HI = HJ
715 FOR I = W TO LC - HI:C = Z
720 FOR J = HI TO LC - I:JW = J +

```

# The new generation that interfaces with most microcomputers

Mannesmann-Tally's new MT100 series of matrix serial printers for microcomputers is now available from local computer shops and suppliers.

MT100 series printers are utterly reliable. They're a new generation of Europrinters made in West Germany with full technical and service back-up from our headquarters here in the UK.

They give high performance at a very reasonable price. Ideal for professional businesses. Or educationists. Or enthusiasts who value the latest technology.

## Two basic models – MT120 and 140

Main difference is in column width. The MT120 is the 80 columns version whilst the 140 features 132 columns.

Both models come in three variants giving a range of standard features which normally are beyond the scope of microcomputer orientated printers.

9 x 7 matrix, 160 cps high speed output – often doubled by microprocessor control choosing shortest possible print path in either direction.

Selectable 18x40 matrix for **high definition correspondence quality.**

10 different character sets, 96 characters each.

OCR A and B character fonts using 9 x 9 matrix.

Four different character pitches between 10 and 20 cpi, each of which can be printed in double width.

Two colour printing.

All MT100 series printers are small, quiet and highly versatile. End user prices start at £390.

For further pricing and availability **use the MT100 hotlines on Reading (0734) 586446/7/8** or look in at your computer shop. Alternatively write to us for full details.



# MANNESMANN TALLY

*the source of the Europrinter*

● Circle No. 145

Mannesmann Tally Limited, 7 Cremyll Road, Reading, Berkshire RG1 8NQ. Tel: Reading (0734) 580141. Cables: Tally-Reading. Telex: 847028.

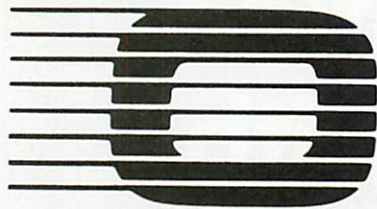

# OSB

**Dual floppy disk drives.** Two 5¼" floppy disk drives provide 100,000 characters each of data storage, or about 60 pages of typed, doublespaced text.

**Diskette storage.** The floppy diskettes can be removed, providing infinite permanent information storage. Two compartments provide storage for up to 25 diskettes.

**RS-232C Interface.** Enables the OSBORNE 1 to connect with serial printers, or other devices using this popular industry-standard interface.

**IEEE 488 Interface.** Connects the OSBORNE 1 to the standard instrumentation bus, for data communication with test instruments.

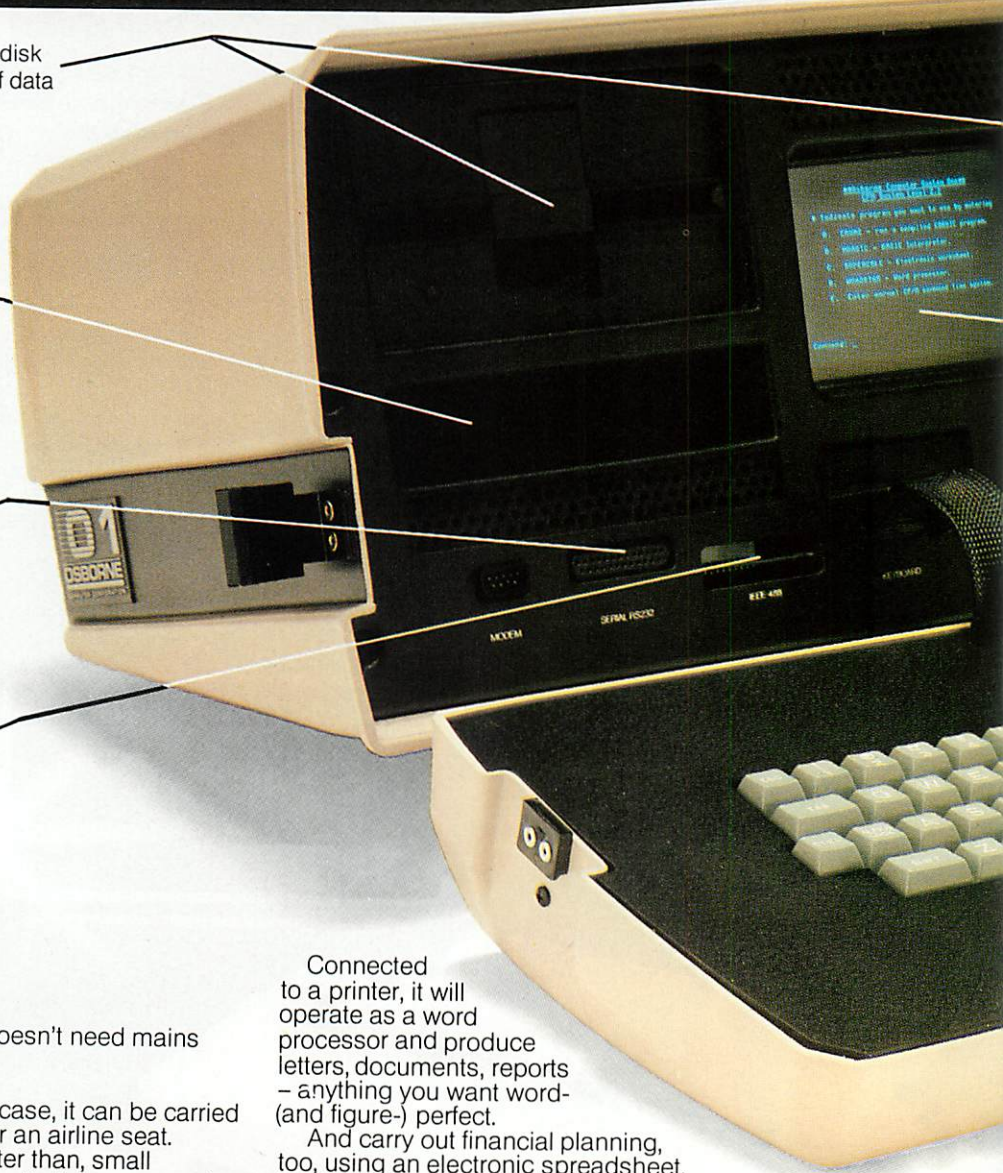

### Osborne 1.

It doesn't need a room of its own.  
Or even a desk of its own.

With its optional battery pack, in fact, it doesn't need mains electricity for up to two hours.

It's - as you can see - portable.

Weighing under 24lb in its weatherproof case, it can be carried in one hand. Or in your car. Or tucked under an airline seat.

But its performance is equal to, often better than, small business computers several times as big and twice as expensive.

The Osborne 1 will achieve in seconds commercial, engineering or scientific calculations which, without a computer, would take days.

And store a whole library of data for instant retrieval and use any time.

Connected to a printer, it will operate as a word processor and produce letters, documents, reports - anything you want word- (and figure-) perfect.

And carry out financial planning, too, using an electronic spreadsheet, providing fast, accurate cash flow forecasts and instant answers to those important 'what if' questions.

You can see an Osborne 1 - and try it out - at any of the dealers listed below.

And then happily walk away with it.

## For £1,250\* the only personal business com

\*excluding VAT.

See the Osborne 1 at any of these authorised dealers:

**LONDON**  
Adda Computers Ltd, Mercury House, Hangar Green, Ealing, London W5 3BA. Tel: (01) 997 6666

Business Computers (Systems) PLC, The Pagoda, Theobald Street, Borhamwood, Herts WD6 4RT. Tel: (01) 207 3344

Byteshop Computerland, 324 Euston Road, London NW1. Tel: (01) 387 0505

Digitus Limited, 10/14 Bedford Street, Covent Garden, London WC2E 9HE. Tel: (01) 379 6968

Equinox Computer Systems Ltd, Kleeman House, 16 Anning Street, New Inn Yard, London EC2A 3HB. Tel: (01) 739 2387/729 4460

Lion Microcomputers, Lion House, 227 Tottenham Court Road, London W1. Tel: (01) 637 8760

Microcomputers at Laskys, 42 Tottenham Court Road, London W1 9RD. Tel: (01) 636 0845

O Computers, 108 Rochester Row, London SW1P 1JP. Tel: (01) 630 5449

Star Computer Group PLC, 64 Great Eastern Street, London EC2A 3QR. Tel: (01) 739 7633

Subscription Services, 70 Warren Street, London W1P 5PA. Tel: (01) 388 2663

The Xerox Store, 84 Piccadilly, London W1V 9HE. Tel: (01) 629 0694

77 High Holborn, London WC1V 6LS. Tel: (01) 242 9596

110 Moorgate, London EC2M 6SU. Tel: (01) 588 1531

**BELFAST**  
Northern Ireland Business Systems Ltd, 7/9 Botanic Avenue, Belfast BT7 1JH. Tel: (0232) 48340

**BIRMINGHAM**  
Byteshop Computerland, 94/96 Hurst Street, Birmingham B5 4TD. Tel: (021) 622 7149

Microcomputers at Laskys, 19/21 Corporation Street, Birmingham B2 4LP. Tel: (021) 632 6303

**BRISTOL**  
\*Microcomputers at Laskys, 16/20 Penn Street, Bristol BS1 3AN. Tel: (0272) 20421

**CAMBRIDGE**  
Cambridge Computer Store, 1 Emmanuel Street, Cambridge CB1 1NE. Tel: (0233) 65334/5

**CHESTER**  
Microcomputers at Laskys, The Forum, Northgate Street, Chester CH1 2BZ. Tel: (0244) 317667

**DERBY**  
Datron Micro Centre, Duckworth Square, Derby DE1 1JZ. Tel: (0322) 380085

**EDINBURGH**  
Microcomputers at Laskys, 4 St James Centre, Edinburgh EH1 3SR. Tel: (031) 556 2914

**GLASGOW**  
Byteshop Computerland, Magnet House, 61 Waterloo Street, Glasgow G2 7BP. Tel: (041) 221 7409

Microcomputers at Laskys, 22/24 West Nile Street, Glasgow G7 2PF. Tel: (041) 226 3349

**GUILDFORD**  
Systematic Business Computers, Braboeuf House, 64 Portsmouth Road, Guildford, Surrey GU2 5DU. Tel: (0483) 32666

**LIVERPOOL**  
Microcomputers at Laskys, 14 Castle Street, Liverpool L2 0TA. Tel: (051) 227 2535

**MANCHESTER**  
Byteshop Computerland, 11 Gateway House, Station Approach, Piccadilly, Manchester 1. Tel: (061) 236 4737

Microcomputers at Laskys, 12/14 St Mary's Gate, Market Street, Manchester M1 1PX. Tel: (061) 832 6087

**NEWCASTLE**  
Sage Systems, Hawick Crescent, Newcastle upon Tyne NE6 1AS. Tel: (0632) 761669

**NOTTINGHAM**  
Byteshop Computerland, 92A Upper Parliament Street, Nottingham NG1 6LF. Tel: (0602) 40576

\*Microcomputers at Laskys, 1/4 Smyth Row, Nottingham NG1 2DU. Tel: (0602) 415150

**PRESTON**  
Microcomputers at Laskys, 1/4 Guildhall Arcade, Preston PR1 1HR. Tel: (0772) 59264

# OSBORNE 1

TM

**Internal electronics.** Z80A™ CPU, 64K bytes RAM memory (60K available to the programmer; 4K used to run the screen.) System software is held in ROM in a separate address space.

**Screen.** Clear, 5", 24-row screen displays a 52-character window on a 128-character line with automatic horizontal scrolling.

**Monitor Interface.** Connects the OSBORNE 1 to any monitor screen.

**Keyboard.** A standard typewriter keyboard plus numeric, adding-machine keypad for fast entry, and cursor control keys for easy cursor movement.

**Case.** The plastic case snaps together to form a weatherproof, 24-pound package that fits underneath the standard airline seat.

**Standard software**

Five outstanding software packages, with a retail value of over £800 are included:

- CP/M® Operating System
- WORDSTAR® with MAIL MERGE®
- SUPERCALC™ ● MBASIC®
- CBASIC®

**Optional extras**

- Modem cable for use with acoustic couplers for telephone transmission of data
- Battery pack
- Double density disk drives with 200K bytes of storage per drive

Trademarks: SUPERCALC: Sorcim Corporation; Z80A: Zilog Corporation.  
Registered Trademarks: OSBORNE 1; Osborne Computer Corporation; CP/M Digital Research; WORDSTAR, MAILMERGE: MicroPro International; MBASIC: Microsoft; CBASIC: Compiler Systems, Inc.

● Circle No. 146

## Computer you can take anywhere.

**SHEFFIELD**  
Watson Micro Centre, 2 Abbeydale Road, Sheffield S7 1FD.  
Tel: (0742) 585490  
Microcomputers at Laskys, 58 Leopold Street, Sheffield  
S1 2GZ. Tel: (0742) 750971

**SLOUGH**  
The Xerox Store, 3/4 William Street, Slough, Berkshire  
SL1 1XY. Tel: (0753) 76957

**SOUTHAMPTON**  
Titan Systems Limited, 23 Cumberland Place,  
Southampton SO1 2BB. Tel: (0703) 38740

**TORQUAY**  
Crystal Electronics, 40 Magdalene Road, Torquay, Devon.  
Tel: (0805) 22699

For further information and full specification, return the coupon to The Marketing Manager, Osborne Computer Corporation (UK) Ltd, 38 Tanners Drive, Blakelands North, Milton Keynes, Buckinghamshire MK14 5BW. Telephone: 0908 615274. Telex 825220  
More information on Osborne 1, please.

Name \_\_\_\_\_

Address \_\_\_\_\_

PC 6 \_\_\_\_\_ Tel \_\_\_\_\_

**OSBORNE**  
COMPUTER CORPORATION (UK) LTD.

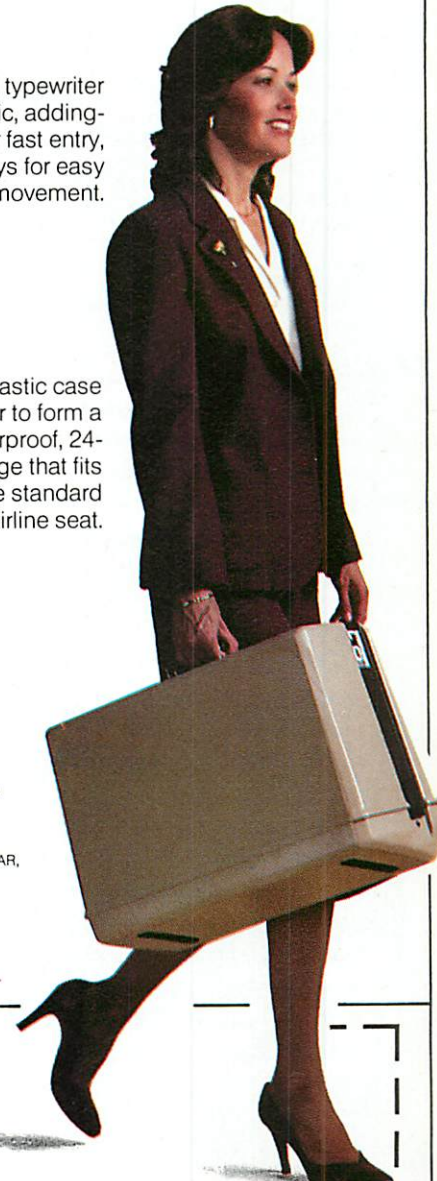

\* Opening shortly

# 5<sup>1</sup>/<sub>4</sub>" WINCHESTERS

- \* Complete Systems Available
- \* Sub-Systems for S100 computers
- \* Sub-Systems for Z80 computers
- \* Fast Drives with Buffered Seeks
- \* Versatile Controller



## Drives Available NOW!

The long-awaited 5.25" Winchester drives are available now from Hotel Microsystems. The greatly improved speed and storage capacity made available by the mini-Winchesters now make feasible many applications, for which floppy drives were too small, too unreliable or too slow. Drives of different capacities ranging from 2.5Mb to 12Mb are available. All the drives we supply have their own microprocessor and are thus able to provide buffered seeking resulting in vastly improved performance.

## Versatile Controller

The XCOMP Winchester controller is a custom designed microprogrammable controller which consists of two printed circuit boards. It has buffered seeking capabilities and is upwards compatible to higher capacity drives.

## Complete Systems

The North Star Horizon microcomputer is now available incorporating any of the mini-Winchester drives featured above.

## S100 Sub-Systems

An upgrade kit for users of S100 microcomputers contains all the hardware required to add a Winchester in place of a mini-floppy drive. The XCOMP ST/S S100 controller is included together with an S100 card which provides the necessary power supplies to connect to the Winchester. Fitting to the microcomputer is straightforward — no soldering is required and the Winchester is housed in the same place as the floppy drive it replaces. Horizon users have a choice of software; either the high-performance HMSOS single/multi-user operating system or CP/M.

## Z80 Sub-Systems

The sub-system for Z80-based microcomputers consists of a packaged drive and controller with power supply. The controller is the XCOMP ST/R custom designed microprogrammable controller. The two printed circuit boards are connected via a 50-way ribbon cable to an interface board which plugs into the Z80 socket in your microcomputer. The sub-system is housed in an alloy cabinet with a power supply. Source listings of CP/M drivers are available.

**Hotel Microsystems Limited**

69 Loudoun Road London NW8 0DQ Telephone 01-328 8737/8 Telex 266828 H M S-G

(continued from page 72)

used to build up a job file of appropriate actions. The system would learn as it goes along and would avoid swamping the operator with queries about every little item.

The mechanism has, in some ways, a sense of attention. It does not look at things randomly, but pays attention to things which look as if they are meaningful or go together in some way. This enables it to pick out words in text as being more "significant" than others even though it does not know what they mean.

The Language program works on a string, S\$(1000). You have to input the number of characters which the program is to consider, in the range 1 to 1000. If the string is not on tape, key it in. The programme uses Get, so the keyboard is on-line. Errors can be corrected by keying left-arrow.

When the given number of characters are keyed in they can be stored using Store X%, where X% is the ASCII equivalent of S\$. Subsequent runs with the same string input can be initiated using Recall X% instead of keying.

The program then operates on the string information, producing new segmentations and displaying them on the screen together with the entire string data, with spaces inserted to show the segmentation process to date. It runs slowly, as it is designed for ease of modification rather than speed. Most of the time is spent on a time-consuming sort which is helpful for analysis.

Segments are formed according to the value of the coefficient FF. The higher the value of FF, the better. By the time FF has dropped to a value of about 3 the segments chosen may contain occasional errors; a value of 4 or more is desirable. Much of the central code is concerned with scaling FF to give a consistent range of values of FF, irrespective of the sample size chosen initially or the subsequent progress of the program. Input characters may be any valid string variable, not just letters of the English alphabet.

This method of running is a static run: the same text is worked to exhaustion without further input. A dynamic run consists of inputting further string information to the mechanism according to a given criterion. For instance, to reduce

the probability of mistakes occurring, a high threshold value of FF may be set — say, 4.5 — and a new segment will only be acquired if it exceeds the threshold. If no FF exceeds this threshold then S\$ is searched for more input for the mechanism. As data is input from S\$ a recognition routine may be used to identify segments within the input stream as segments previously acquired.

If N characters are input there are, in general,  $2^{N-1}$  different ways of segmenting them, so 20 characters may be segmented in a maximum of 524,288 different ways. Fortunately, many of these ways may be excluded as containing segments which the mechanism has not previously acquired. The correct segmentation may occur along with 50 or more other possibilities after only a short run. Recognising the correct segmentation is a considerable problem.

The program runs on an Apple II with cassette recorder and 48K main memory. Disc is not needed and DOS should not be loaded. For large amounts of data all arrays may be converted to disc files or additional RAM or any other method that works.

## Listing with recogniser routine.

```

10 HOME : PRINT "LANGUAGE": INPUT
  "INPUT THRESHOLD (DEFAULT=4) = "FF:
11 B1 = 1.984019211482 = .8004171
  67:85 = 18.43193575184 = .11
  2255309185 = 1.625639319186 =
  1.476563989718F = .5
12 INPUT "DO YOU WANT RECOGNITION
  N ROUTINE? Y/N:":RR#
20 W = 1:XT = W:TW = 2:TH = 3:IT =
  100:TT = 1000:EI = 8:ML = TW
  :HI = WHJ:WTC = TT:TY =
  36:CI = B1 + B2 + B5:CC = TW
  * (B1 + B2):IT3 = IT
30 REM :S$( ) HOLDS THE I/P STRIN
  G,L$( ) HOLDS THE LEXICON, PL
  X( ) HOLDS LEXICON FREQUENCIES
40 REM :THIS SECTION TAKES IN TH
  E I/P STRING AND BUILDS UP A
  LEXICON AND FREQUENCY COUNT
50 DIM S$(2000),L$(T),PLX(T),L$(
  T),T$(T),I(T),B$(C),TY,K
  FX(T):DEF FN RM(A) = SGN
  (A) - W:DEF FN KP(A) = W -
  SGN (A - W)
60 INPUT "HOW MANY CHARACTERS ARE
  YOU ENTERING AT A TIME?":I
  SC
61 INPUT "DO YOU HOLD THE CHARAC
  TERS ON TAPE? Y/N:":R#
62 IF R# = "Y" THEN:PRINT "REC
  ALL XX":STOP:FOR I = W TO
  SC:R$(I) = CHR$(X(I)):PRINT
  S$(I):NEXT I:FOR I = SC +
  W TO TT:S$(I) = CHR$(X(I)
  ):NEXT I:GOTO 95
63 FOR I = W TO SC:GET S$(I):XX
  (I) = ASC (S$(I))
64 IF ASC (S$(I)) = EI THEN:II =
  I - W:R$(I) = "":PRINT:PRINT
  :FOR J = W TO I - W:PRINT
  S$(J):NEXT J:GOTO 80
90 PRINT S$(I):NEXT
91 PRINT:INPUT "DO YOU WISH TO
  STORE THESE CHARACTERS ON T
  APE? Y/N:":R#
92 IF R# = "Y" THEN:PRINT "STO
  RE XX":STOP
94 REM :THE NEXT SECTION SETS U
  P L$(I,J) AS A JOINT PROBABIL
  ITY MATRIX
95 HI = Z:FOR I = W TO SC
110 FOR J = Z TO LC
120 IF S$(I) = L$(J) THEN: NEXT
130 PLX(J) = PLX(J) + W: IF J = L
  C + W THEN:LC = LC + W:PL$(L
  C) = S$(I)
140 IF HI THEN:L$(HI,J) = L$(HI
  ,J) + W:PL$(HI,Z) = L$(HI,Z) +
  FN KP(L$(HI,J)):L$(Z,J) = L
  $(Z,J) + FN KP(L$(HI,J))
150 HI = J:NEXT I:PRINT
160 HI = WHJ:W = GOSUB 700:GOSUB
  800
326 NX = SC - W:SL = LC + (LC + W
  ) / TW:NC = Z: FOR I = W TO
  LC:I(I) = I:NC = NC + L$(I,Z)
  ):NEXT

```

```

329 FOR I = TW TO LC:CC = W:CC =
  I(I - W)
330 IF PLX(I) = PLX(I - W) THEN
  :CC = CC + I(I):C = C + W:
  I = W: IF I = LC THEN:GOTO 330
331 IF C = W THEN:FOR J = I -
  C TO I - W:IF (J) = LC / (I) NEXT
  J
332 NEXT:DS = LC + HF:DI = B3 /
  SL:DO = HA / SL:HH = TR - CI
  + LOG (NC) + C2 + LOG (LC
  ) + HS + LOG (NX) + R6:H =
  HH
333 FOR I = W TO LC:FA = B1 + LOG
  (DS - L$(I,Z)) + DI + I(I):FOR
  J = W TO LC
334 IF L$(I,J) THEN:IF FA + B
  2 + LOG (DS - L$(Z,J)) + D2
  + I(J) + B5 + LOG (L$(I,J)
  ) : IF FF) HH THEN:HI = I:HI
  J = J:HH = FF
340 NEXT J:NEXT I: IF HH = H THEN
  347
345 IF RR# = "Y" THEN:GOSUB 20
  :GOTO 326:WHJ = W:GOSUB 700:
  GOTO 326
347 HA = L$(HI,HJ):HB = PLX(HI) -
  HA:HC = PLX(HJ) - HA:HH = HI -
  H + HI:PRINT "COEFFICIENT F
  F = "H
349 PRINT "LEXICON ADDITION IS :
  "L$(HI) + L$(HJ)
370 LC = LC + W:SL$(LC) = L$(HI) +
  L$(HJ)
475 IF LEN (L$(LC)) = ML THEN:
  ML = LEN (L$(LC))
490 I = W
500 IW = I + W: IF S$(I) + S$(IW)
  = L$(LC) THEN:IS$(I) = FA(L
  C):FOR J = IW TO SC - W:R$(
  J) = S$(J) + W: NEXT:GOSUB
  900:SC = SC - W
510 PRINT S$(I):" "
520 I = I + W: IF I = SC THEN:GOTO 500
530 IF I = SC THEN:PRINT S$(I)
534 TC = TC - HA: FOR I = SC + W TO
  TC:R$(I) = S$(I) + HA: NEXT
  I
540 PL$(LC) = PL$(LC) + HA:L$(HI,
  HJ) = Z:PL$(HI) = PL$(HI) -
  PL$(LC):PL$(HJ) = PL$(HJ) -
  PL$(LC):L$(HI,Z) = L$(HI,Z) -
  W:L$(Z,HJ) = L$(Z,HJ) - W
550 PRINT:PRINT "SC = "H:SC
555 GOSUB 700:GOSUB 800
570 GOTO 326
700 REM :SORT ROUTINE
710 IF HI (HI THEN:HI = HI
715 FOR J = W TO LC - HI:Z =
  Z + W:FOR I = HI TO LC - I:J =
  J + W
730 IF PLX(J) < PLX(JW) THEN:HI =
  PLX(J):PLX(J) = PLX(JW):PLX(
  JW) = HI:R# = L$(J):L$(J) = L
  $(JW):L$(JW) = R#:FOR K = Z
  TO LC:H = L$(K,J):L$(K,J) =
  L$(K,JW):L$(K,JW) = H:NEXT
  J:FOR K = Z TO LC:H = L$(K,
  J):L$(K,J) = L$(K,JW):L$(K,
  JW) = H:NEXT:IC = C + W
750 NEXT: IF C THEN: NEXT
750 IF PL$(LC) = ZERO THEN:L$(L
  C) = "":LC = LC - W:GOTO 75
  0
770 RETURN
800 REM :PRINT LEXICON ROUTINE.
  PRINT "LEXICON = "L$(

```

```

820 PRINT "I","L$(I)": FREQUEN
  CY=PLX(I)
830 FOR I = W TO LC
840 PRINT I,L$(I),PLX(I)
850 NEXT: RETURN
900 REM :ADJUST L$(I,J) ROUTIN
  E
910 C = TW:FOR K = W TO LC
920 IF S$(I - W) = L$(K) THEN:L
  $(K,LC) = L$(K,LC) + W:L$(K,
  HI) = L$(K,HI) - W:C = C - W
  :A = FN KP(L$(K,LC)):B = FN
  RM(L$(K,HI)):L$(K,Z) = L$(K,
  Z) + A:L$(Z,LC) = L$(Z,LC) +
  A:L$(K,Z) = L$(K,Z) + B:L$(Z
  ,HI) = L$(Z,HI) + B
925 IF IW = SC THEN: NEXT: RETURN
930 IF S$(IW) = L$(K) THEN:L$(L
  C,K) = L$(LC,K) + W:L$(HJ,K)
  = L$(HJ,K) - W:IC = C - W:R# =
  FN KP(L$(LC,K)):B = FN RM(
  L$(HJ,K)):L$(LC,Z) = L$(LC,Z)
  + A:L$(Z,K) = L$(Z,K) + A:
  L$(HJ,Z) = L$(HJ,Z) + B:L$(Z,
  K) = L$(Z,K) + B
940 IF C THEN: NEXT
950 RETURN
2000 R# = "":PRINT "STRING I/P T
  O RECOGNISER :-"
2030 FOR I = SC TO SC - ML + W STEP
  - W
2040 R# = S$(I) + R#: IF LEN (R#
  ) < ML - W THEN: NEXT
2045 MS = I:NN = SC - MS + ML
2050 J = Z:PRINT
2060 FOR I = MS - W TO SC + ML -
  W
2062 FOR J = W TO LC
2065 IF S$(I) = L$(K) THEN: NEXT
  B$(J,Z) = K: IF K = LC + W THEN
  :L$(I) = LC + W:L$(LC) = S$(I)
2070 IF J = Z THEN:PRINT L$(K)
  " " : IF I = C = SC THEN:PL
  $(K) = PL$(K) - W:L$(K1,K) =
  L$(K1,K) - W:L$(K1,Z) = L$(K
  1,Z) + FN RM(L$(K1,K)):L$(Z,
  K) = L$(Z,K) + FN RM(L$(K1
  ,K))
2080 IF I = SC THEN:R# = R# + L
  $(K)
2090 K1 = K:J = J + W: NEXT I
2200 PRINT:MI = J - W
2210 X# = R#:J = W:W = W:LEN
  (R#):TK = W: FOR I = W TO TY
  :R$(I) = L#: NEXT
2220 CO = Z: FOR I = W TO LC
2235 IF L$(I) = L# THEN:LEFT$(L#,
  LEN (L$(I))) THEN: NEXT:GOTO
  2270
2240 CO = CO + W: IF CO = W THEN
  :R$(Z,K) = J:R$(J,K) = I:R$(
  K) = R$(K) - LEN (L$(I))
2242 IF CO = W THEN: NEXT:GOTO
  2270
2245 TK = W + W: FOR I = W TO J -
  W:R$(O,TK) = R$(O,K): NEXT:
  R$(J,TK) = I:R$(TK) = R$(L#)
  - LEN (L$(I)) + LEN (L$(
  R$(J,TK))):R$(J,TK) = J
2249 IF TK = K THEN:MK = TK
2250 NEXT
2270 IF TK = W THEN:GOSUB 2500
2350 I1 = LW:FOR K = W TO TK: IF
  R$(K) = Z AND R$(K) = I
  1 THEN:I1 = R$(K):R# = K

```

```

2370 NEXT: IF L1 AND R$(H) THEN
  :R# = R# + R$(H) + R$(L1)
  :J = R$(Z,K) + W:GOTO 2220
2380 TI = TK: IF TK = W THEN:OP =
  W:GOTO 2600
2400 HH = TT + TW: FOR J = W TO Y
  :K#E = Z:CH = Z: FOR J = W TO
  MI:E = E + PL$(R$(J,I)):NEXT
  E = E / MI: FOR J = W TO MI
  :CH = CH + ((PL$(R$(J,I)) -
  E) - TW) / E: NEXT: IF CH <
  HH THEN:OP = I:HH = CH
2440 NEXT:GOTO 2600
2500 REM :RECOGNISER SHRINK
  ROUTINE
2502 FOR I = W TO TK: IF R$(I) =
  Z AND R$(Z,I) < MI THEN:MI =
  R$(Z,I)
2504 NEXT
2510 FOR J = W TO TK
2520 IF R$(Z,I) = MI OR R$(Z,I) =
  MI AND R$(I) THEN:FOR U =
  Z TO R$(Z,TK):R$(U,I) = R$(O,
  TK):NEXT:R$(I) = R$(TK)
  :TK = TK - W:W = I - W
2523 IF I = TK THEN:2530
2525 NEXT
2530 FOR I = W TO TK: IF R$(I) THEN
  :RETURN
2540 NEXT:POP:GOTO 2380
2540 REM :PRINT CHOSEN OPTI(N#)
  AND THEN INTO 3000
2610 PRINT "RECOGNISER GIVES I:"
  :PRINT:FOR I = W TO R$(Z,
  OP):PRINT L$(R$(I,OP)):" "
  :NEXT:PRINT
2620 IF TI = W THEN:PRINT "TIE
  BREAKERS":STOP
3000 REM :ROUTINE TO TAKE ON MOR
  E INPUT
3020 SC = SC - NN + ML - W + R$(Z,
  OP)
3060 FOR I = W TO R$(Z,OP)
3070 PL$(R$(I,OP)) = PL$(R$(I,OP)
  ) + W
3080 NEXT
3090 A = R$(Z,Z) + B:R$(W,OP)
3120 L$(A,B) = L$(A,B) + W:L$(A,Z)
  = L$(A,Z) + FN KP(L$(A,B)
  ):L$(Z,B) = L$(Z,B) + FN KP
  (L$(A,B))
3125 IF R$(Z,OP) < W THEN:316
  0
3130 FOR J = W TO R$(Z,OP) - W
3132 A = R$(I,OP):B = R$(I) + W:OP
  )
3140 L$(A,B) = L$(A,B) + W:L$(A,Z)
  = L$(A,Z) + FN KP(L$(A,B)
  ):L$(Z,B) = L$(Z,B) + FN KP
  (L$(A,B))
3150 NEXT
3160 DI = NN - R$(Z,OP):TC = TC -
  DI: IF DI < Z THEN:FOR I =
  TC TO SC + W STEP - W:R$(I) =
  S$(I + DI):NEXT
3165 J = W
3170 FOR I = SC - R$(Z,OP) + W TO
  SC
3180 S$(I) = L$(R$(J,OP)):J = J +
  W
3190 NEXT
3200 IF DI = Z THEN:FOR I = SC
  + W TO TC:R$(I) = S$(I + DI)
  ):NEXT
3220 RETURN

```

<b>TTLs</b> 74 SERIES	74LS00 25p 7407 25p 7416 25p 7417 25p 7425 27p 74121 27p 74128 45p 74180 50p 74182A 130p 74184A 90p 74185 120p	74LS90 28p 74LS92 40p 74LS93 30p 74LS95 45p 74LS96 100p 74LS107 45p 74LS109 30p 74LS112 34p 74LS113 30p 74LS114 30p 74LS122 42p 74LS123 50p 74LS124 120p 74LS125 35p 74LS126 30p 74LS132 45p 74LS133 30p 74LS136 30p 74LS138 34p 74LS139 36p 74LS145 75p 74LS147 160p 74LS148 90p 74LS151 40p 74LS152 15p 74LS153 40p 74LS154 90p 74LS155 40p 74LS156 30p 74LS157 15p 74LS158 36p 74LS159 15p 74LS160 40p 74LS161 40p 74LS162 40p 74LS163 40p 74LS164 45p 74LS165 100p 74LS166 30p 74LS167 16p 74LS168 30p 74LS170 90p 74LS173 70p 74LS174 45p 74LS175 50p 74LS181 140p 74LS183 250p 74LS190 50p 74LS191 50p 74LS192 50p 74LS193 48p 74LS194 40p 74LS195 48p 74LS196 60p 74LS197 65p	74LS221 60p 74LS240 70p 74LS241 70p 74LS242 80p 74LS243 80p 74LS245 90p 74LS251 40p 74LS253 40p 74LS257 45p 74LS258 41p 74LS259 80p 74LS260 24p 74LS266 25p 74LS273 70p 74LS279 45p 74LS280 250p 74LS283 45p 74LS293 50p 74LS295 200p 74LS298 160p 74LS299 400p 74LS323 250p 74LS324 150p 74LS348 150p 74LS352 100p 74LS353 100p 74LS356 250p 74LS363 160p 74LS364 160p 74LS365 32p 74LS367 32p 74LS368 36p 74LS373 70p 74LS374 50p 74LS375 50p 74LS377 70p 74LS378 60p 74LS390 55p 74LS393 50p 74LS395 190p 74LS399 200p 74LS445 110p 74LS540 135p 74LS541 135p 74LS540 200p 74LS541 200p 74LS564 200p 74LS564 250p 74LS564 250p	74LS668 200p 74LS669 200p 74LS670 170p 74LS682 450p 74LS684 450p	<b>74S SERIES</b> 74S00 60p 74S02 60p 74S04 60p 74S05 75p 74S08 75p 74S10 75p 74S12 60p 74S14 60p 74S16 60p 74S18 60p 74S20 60p 74S22 60p 74S24 60p 74S26 60p 74S28 60p 74S30 60p 74S32 60p 74S34 60p 74S36 60p 74S38 60p 74S40 60p 74S42 60p 74S44 60p 74S46 60p 74S48 60p 74S50 60p 74S52 60p 74S54 60p 74S56 60p 74S58 60p 74S60 60p 74S62 60p 74S64 60p 74S66 60p 74S68 60p 74S70 60p 74S72 60p 74S74 60p 74S76 60p 74S78 60p 74S80 60p 74S82 60p 74S84 60p 74S86 60p
--------------------------	--	--	---	--	---

<b>VOLTAGE REGULATORS</b> FIXED PLASTIC	<b>OTHER REGULATORS</b>
1A +ve -ve 5V 7805 50p 7905 55p 12V 7812 50p 7912 55p 15V 7815 55p 7915 60p 18V 7818 55p 7918 60p 24V 7824 55p 7924 60p 5V 100mA 78L05 30p 79L05 65p 12V 100mA 78L12 30p 79L12 70p 15V 100mA 78L15 30p 79L15 70p	LM309K 135p 78H05KC 550p LM317K 325p 78MGT2C 140p LM312T 200p 78GUIC 200p LM337T 225p 79GUIC 225p LM323K 500p 79HGKC 700p LM723 37p ICL 7660 200p TL494 400p TL497 300p 78S40 300p LM305AH 250p 78HGKC 600p

**★ ACORN ATOM ★**

Full qwerty keyboard — TV/cassette recorder interfaces — Basic assembler in monitor — 6502 microprocessor plus more  
Basic built 8k + 2k £135 Expanded 12k + 12k £180 (£3.00/unit p&p)  
Atom psu £7 + £1.20 p&p. 3A 5V regulated supply £22 + £2 p&p.  
F.P. ROM £20, 1k RAM (2 + 2114L) £2, Toolbox ROM 25.  
6522 VIA £5. DP8304 £4.50. 81LS95 £0.90. PL6/7 £3.50 ea.  
5K6/7 £4 ea. PL5/SK5 £2 ea.  
8K RAM + 16K EPROM or 16k RAM memory expansion PCB £11.50.  
New colour encoder card £32.00.

**SOFTWARE**

Games Pack 1-11	£10 ea.	Chess, 747, Galaxians,	
Atom Life, Adventure	£10 ea.	Invaders	£7 ea.
Soft VDU, Synthesizer	£10 ea.	Fruit Machine, Breakout	£3.50
Maths Pack 1-2, forth	£10 ea.	Astrobirds, Atom Fire,	
*Introductory package		Space Fighter	£7.95
(4 cassettes)	£10	Hyperfire, Adventure	£7.95
3D Astrobirds	£5.95	Music Box, Martians,	
		Warlords, Business Games	£6.95

Atom Vision: Stepper motor driven ultrasonic transducer scans environment — data displayed on TV/monitor screen in radar like picture + distance measurement. Complete kit £46. Software cassette + documentation £4.80. Project described in April/May P.E.  
Atom Sound: The board plugs into Atom bus. The VIA provides two parallel and one serial ports. PSG provides for full audio frequency range output to on board speaker or through board DIN connector to Hi-fi equipment £34.95.

**UK101 & SUPERBOARD II — INTERFACING SYSTEM**

A 2 board system connects to computer exp. skt to provide wide ranging facilities accessible from BASIC or MACHINE CODE.  
1. DECODING MODULE. Provides 5v dual supply. 16 bit prog. I/O port. Extensive decoding for various interfaces incl. PSG kit £27.50  
2. ANALOGUE BOARD. Provides D/A Converter, 8ch multiplexed A/D converter. PSG+VIA provide complex timing and counting functions and 16 bit port. Kit £39.95

**COMPUTER COMPONENTS**

<b>CPU's</b> 1602CE 700p 2650A £12 8502A 400p 8502 £3 6802 £350p 6802B £350p 6802C £350p 6809 £850p 6809B £14 6809E £15 6803 350p 6803B £4 6808A 280p 6808A 450p INS8060 £11 TMS9980 £20 Z8 £24 Z80 320p Z80A 360p Z80B £15 8088 £18	<b>2805IO-0</b> £9 2805IO-1 £9 2805IO-2 £9	<b>MODULATORS</b> 32MHz UHF 375p 8MHz UHF 450p	<b>CRystals</b> 32.768kHz 100p 100kHz 250p 200kHz 280p 1.0MHz 290p 1.008MHz 275p 1.8432MHz 210p 2.00MHz 225p 2.4570MHz 210p 3.276MHz 150p 3.5795MHz 100p 3.686MHz 300p 4.00MHz 150p 4.194MHz 250p 4.433MHz 110p 5.00MHz 175p 6.0MHz 150p 6.144MHz 150p 7.0MHz 150p 7.168MHz 200p 8.00MHz 175p 8.86MHz 175p 10.00MHz 175p 10.7MHz 250p 12MHz 350p 14.3168MHz 150p 16.00MHz 250p 18.00MHz 200p 18.432 250p 19.968MHz 390p 20.000MHz 175p 26.690MHz 300p 27.145MHz 250p 38.667MHz 350p 48.0MHz 300p 55.5MHz 140p 116.000MHz 300p	<b>INTERFACE ICs</b> AD558CJ 775p AD561J £14 AM26S10 350p AM26LS2521 £2 AM26LS31 160p AM26LS32 190p DAC80 £20 DM8131 375p DP8304 450p DS8832 250p DS8833 225p DS8835 225p DS8836 150p LF13002 450p MC1488 65p MC1489 65p MC3418 950p MC3446 300p MC3480 850p MC3485 500p MC3487 300p MC4024 325p MC4044 325p MM58174 £12 ULN2003A 100p ULN2004A 100p MC3446 300p 7510/12 160p 75114/15 160p 75150/9 140p 75154 140p 75182 220p 75361 63 150p 75365 160p 75451/2 72p 76453/4 72p 75491/2 70p 8T26/28 120p 8T95/96 90p 81LS95/96 90p 81LS97/98 90p 9602 220p 9607 160p ZNA255E 8 ZNA26E 8 350p ZNA27E 8 650p ZNA28E 8 500p	<b>ROM &amp; PROM</b> 74S188 325p 74S287 325p 74S288 225p 74S387 325p 74S471 650p 74S473 850p 74S474 650p 74S570 650p 74S571 650p 74S573 650p	<b>EPROMs</b> 1702A 500p 2708 300p 2716 225p 2564 £25 2516 225p 2532 450p 2732 450p 2716 350 £5 2732 350 £7.50	<b>BAUD RATE GENERATORS</b> COM8116 £8 MCI1411 £7 4702A 750	<b>CRT CONTROLLER</b> COM5027 £18 COM5037 £18 SFF9363A £8 TMS9927 £18 6545 952p 6845 875p 6847 £10 SAA5050 £16	<b>DISC CONTROL</b> FD1771 £20 FD1791 £30 FD1793 £32 FD1795 £35 FD1797 £37 WD1691 £15 WD2143 £5.50	<b>TELETYPE DECODER ICs</b> SAA5020 £6 SAA5030 £9 SAA5041 £16 SAA5050 £9	<b>CONNECTOR SYSTEMS</b> <b>JUMPER LEADS</b> 24" cable with DIP header 100kHz 14pin 16pin 24pin 40pin Single 145p 165p 240p 380p Double 210p 230p 345p 540p 24" cable with sockets 20pin 26pin 34pin 40pin Single 160p 210p 270p 340p Double 290p 385p 490p 540p 24" cable with 25 way D. Conn. Male 500p Female 540p <b>ID CONNECTORS (SPEED BLOC TYPE)</b> No. of ways 10 20 36 34 40 Header 90p £1.75 £2.00 £2.44 £2.70 Socket 90p £1.7 £2.00 £2.40 £2.70 Edge Conn. £2.00 £2.50 £3.20 £3.80 £5.60 <b>EURO CONNECTORS</b> Plug Socket DIN41612 2x32way £3.00 £3.50 angled 2x32way £3.50 £4.00 angled 3x32way £4.00 — (for 2x32way specify a+b or a+c) DIN41617 31 way £2.00 £2.00 <b>MIN. D CONNECTORS</b> No. of ways 9 15 25 37 MALE Solder 95p 135p 200p 280p angled 160p 230p 265p 425p FEMALE solder 125p 190p 245p 375p angled 175p 240p 310p 500p Hood 100p 100p 100p 125p (Top or Side Entry) 37 way Centronix Type connector £6.50 <b>DIP HEADERS</b> 14pin 16pin 24pin 40pin Solder type 40p 50p £1 £2 IDC type 120p 140p £2 £2.25 <b>RIBBON CABLE (Grey)</b> per metre 10 way 60p 20 way 105p 40w 265p 14 way 80p 26 way 140p 50w 330p 16 way 90p 34 way 220p 64w 370p <b>DIL SWITCHES</b> 4 way 110p 8 way 140p 6 way 125p 10 way 160p <b>UV ERASERS</b> A range of 3 erasers which will meet most erasing requirements. All erasers are provided with built in safety features to ensure there is no accidental exposure to the UV rays. Remember UV rays are harmful to human eyes and skin. All erasers also fitted with mains indicator. UV1B £47.50 p&p £1.50 (Erases 6 Eeproms in about 20 min) UV140 £61.50 p&p £2.00 (Erases up to 14 Eeproms in 15/20 mins) UV141 £78 p&p £2.00 (As UV140 and with built in electronic timer) Spare tubes for above £10 + £1.50 p&p Direct Mains Operated Tube £10.50 + £1.50 p&p <b>★ SPECIAL OFFER ★</b> 1-24 25-99 2114L-200ns 100p 95p 4116-200 75p 70p 2716 210p 200p 2532 425p 400p
---	--	--	---	---	---	---	--	--	---	--	--

<b>LOW PROFILE DIL SOCKETS BY TEXAS</b>	<b>WIRE WRAP SOCKETS BY TEXAS</b>
8 pin 9p 18 pin 16p 24 pin 24p 14 pin 10p 20 pin 18p 28 pin 26p 16 pin 11p 22 pin 22p 40 pin 30p	8 pin 25p 18 pin 50p 24 pin 70p 14 pin 35p 20 pin 60p 28 pin 80p 16 pin 40p 22 pin 65p 40 pin 100p



**SOFTY II**  
An ideal software development tool. A program can be developed, debugged, verified and then can either be committed to an EPROM or the program can be used in any host computer by plugging the SOFTY into its EPROM socket.  
Most +5v EPROMs can be programmed on SOFTY. See the review in Sept. 81 PE for the various facilities provided on the SOFTY. SOFTY II complete with PSU ROMULATOR and TV LEADS £169 + £2 p&p.  
**MENTA**  
New Z80 Development System. Plugs into TV and cassette recorder. 40 key direct ASSEMBLER/EDITOR. 24 Bits of I/O. Ideal for study, micro control and robotics. Power supply and TV lead included £115 + £1.50 p&p.

**PRINTERS**  
**EPSON MX 80 F/T**  
● Bi directional printing ● Logic seeking ● 80 CPS 80 cols ● True descenders ● Variety of character sizes ● Full high res. graphics capability (F/T2)  
MX80 F/T 1 or 2 £350 + £8 carr.  
**SEIKOSHA GP 100A**  
● 80 cols 30 CPS ● 116 ASCII std characters ● Full graphics ● 10" wide paper ● multiple copies  
GP100A £199 + £8 carr.  
12" BMC Green Screen Monitor £140 + £5 carr. 14" Colour Monitor: In A1 cabinet £200. Open chassis £175 + £5 carr.  
F.D. Drive Mechanisms: Teac FD50A 5" £150 + £3 p&p. Olivetti F501A 5" £150 + £3 carr.

**TECHNOMATIC LTD.**  
MAIL ORDERS TO: 17 BURNLEY ROAD, LONDON NW10 1ED  
SHOPS AT: 17 BURNLEY ROAD, LONDON NW10  
(Tel: 01-452 1500, 01-450 6597. Telex: 922800)  
305, EDGWARE ROAD, LONDON W2. Tel: 01-723 0233

**PLEASE ADD 40p P&P & 15% VAT (Export no VAT)**  
Government, Colleges, etc. **ORDERS WELCOME**  
**BARCLAY & ACCESS CARDS ACCEPTED**  
STOCK ITEMS ARE NORMALLY BY RETURN OF POST

Filling gaps in a sentence is more than just a game. Using Chris Harrison's Cloze program it can provide a scientific test of language ability.

# Watch this space

THE CLOZE testing procedure is a reliable and well-validated system of language testing. The candidate is required to complete a language item such as a paragraph of text by filling in blanks that appear at regular intervals.

This Cloze program gives the tester an instrument which enables a passage of virtually unlimited length to be written to the screen. Words are then deleted at regular intervals and the student fills in the gaps.

## Easily portable

The program is fairly simple, and could be easily modified to draw on prepared and stored texts. It is written for a standard Video Genie, but can be made machine-portable without difficulty. The principal variables are:

A\$ holds individual words of the text, each one defined by the spaces between them. The program shows a Clear of 1000 and a dimension of A\$(100), but both can be increased to the limit if you want a text longer than 100 words.

R\$ holds the student's response, which does not need to be dimensioned.

M is used to count and number the words in the text.

N counts the letters in each word, in case back-spacing is required for corrections. Since each word is defined as soon as a space is added it is not possible to back-space over blanks. If you are not likely to want to make alterations it is better to use Data statements instead, or a routine that calls text from store and then counts words by using the blanks between them. If this is to remain simple, though, the text will be limited to 256 characters.

Text is entered using Inkey\$, and printed to screen. If you are a fast typist, using a lower-case modification, you may find this rather slow but it is satisfactory for most purposes. The Rems in the listing show exactly what is happening and can be omitted from the program.

### Sample run of Cloze program.

```
I ONCE ---- BACK FROM - SKIING TRIP ----- TO FIND ---- A SNOWSTORM --- FALLEN
AT --- AIRPORT AND ---- THE DOOR ----- ON ALL --- CARS IN --- CAR PARK ---- SO F
ROZEN -- THAT IT --- IMPOSSIBLE TO ----- A KEY.
```

COME

NO, BAD LUCK. TRY AGAIN.  
CAME

I ONCE CAME

A

I ONCE CAME BACK FROM A

ABROAD

I ONCE CAME BACK FROM A SKIING TRIP ABROAD

THAT

I ONCE CAME BACK FROM A SKIING TRIP ABROAD TO FIND THAT

WAS

NO, BAD LUCK. TRY AGAIN.  
HAVE

NO, BAD LUCK. TRY AGAIN.  
HAD

I ONCE CAME BACK FROM A SKIING TRIP ABROAD TO FIND THAT A SNOWS

TORM HAD

THE

I ONCE CAME BACK FROM A SKIING TRIP ABROAD TO FIND THAT A SNOWS

TORM HAD FALLEN AT THE

DOOR

NO, BAD LUCK. TRY AGAIN.  
LOCKS

NO, BAD LUCK. TRY AGAIN.  
THAT

I ONCE CAME BACK FROM A SKIING TRIP ABROAD TO FIND THAT A SNOWS

TORM HAD FALLEN AT THE AIRPORT AND THAT

LOCKS

I ONCE CAME BACK FROM A SKIING TRIP ABROAD TO FIND THAT A SNOWS

TORM HAD FALLEN AT THE AIRPORT AND THAT THE DOOR LOCKS

ETC ETC

The inputter is asked what interval is required between spaces. The screen is then cleared and the Clozed text is then printed out, with a message asking the

student to supply a word for the first available blank. Certain areas of the screen are used for messages and replies  
*(continued on next page)*

### Cloze program listing.

```
10 CLS
20 PRINT@410,"C L O Z E";
30 PRINT@597,"BY CHRIS HARRISON 1982";
40 FOR I=1 TO 1000:NEXT
49 REM A$=words of text; R$=students response to
first available blank.
50 CLEAR 1000:DIMA$(200),R$(200)
59 REM asterisk required by Program to show the
end of the Program
```

*(listing continued on next page)*

(continued from previous page)

— see lines 300, 330, 350, 360, 380 — and these locations are all up against the left-hand side of the Video Genie screen, 0 to 960, Step 64.

The student is given three tries, and if unsuccessful is given the correct answer. It should be quite simple to write a routine that allows students to move the cursor to the beginning of a space that they think they can fill, but this refinement is far from essential.

### Reliable test

If you are planning to use the technique, it is advisable to make sure that you understand the research and evaluation on which it is based.

There is little doubt that the regular blanking out of words, say one word in six, gives a very much more reliable measure of language competence than blanking out, say, all prepositions. Alderson reports that deleting every 12th word did not necessarily result in an easier test than deleting every sixth, eighth or 10th word, and that Cloze items are, on the whole, unaffected by content greater than five words. Anderson shows that the Cloze techniques correlate with difficulty levels and discriminate well between students.

### Learning effects

Bialystock shows that it is possible to improve students' inferencing abilities through classroom training. Briere finds that it is possible to discriminate between students of foreign languages according to their level of instruction — first, second or third term — even when the languages involved are different. Darnell reports on ways of scoring Cloze tests, and Oller indicates that Cloze tests are internally consistent, reliable, valid and easily constructed, administered and standardised, and that Cloze tests measure a grammar of expectancy. 

### Key articles

- Alderson, J Charles, "The effect on the Cloze test of changes in deletion frequency", *Journal of Research in Reading* (Leeds), 2 (1979), 108-119.
- Anderson, Jonathan, "The application of Cloze procedure to English learned as a foreign language in Papua and New Guinea", *English Language Teaching* (London), 27 (1972), 66-72.
- Bialystock, Ellen, "Inferencing as an aspect of Cloze test performance", *Working Papers on Bilingualism* (Toronto), 17 (1979) 24-36.
- Briere, Eugène J, "A look at Cloze testing across languages and levels", *Modern Language Journal* (St. Louis, Mo) 62, (1978), 23-26.
- Darnell, Donald K, "Clozentropy: a procedure for testing English language proficiency of foreign students", *Speech Monographs* (New York), 37 (1970), 36-46.

(listing continued from previous page)

```

60 CLS:PRINT@2,"WRITE YOUR TEXT IN HERE WITHOUT USING COMMAS.
    WHEN YOU HAVE FINISHED MAKE A SPACE AND FOLLOW
    IT WITH AN ASTERISK THUS 'END.*'"
69 REM Now we turn on the cursor for INKEY input
70 PRINT:PRINTCHR$(14);
79 REM it's necessary to count and number each
    word
80 M=M+1
89 REM N will set letters in the word counter
90 N=1
99 REM text is now input one letter at a time
100 I#=INKEY#
109 REM a delicate Process thus line 110
110 ON ERROR GOTO 90
120 REM now we allow for erasure. If N<1 then we
    start the word again. If backSpace is used,
    then we must reverse the cursor and ignore the
    previous letter. No backspacing over blanks!
130 IF N<1 THEN GOTO 90ELSE IF I#=CHR$(8)
    THEN A$(M)=LEFT$(A$(M),N-2):N=N-1:ON ERROR
    GOTO 90:PRINT CHR$(8):GOTO100
140 IF I#=""THEN100
149 REM we must ensure that a space isn't counted
    as a word, but we use it to mark off each word
150 N=N+1:IF I#=" " THEN PRINT " ";:GOTO80
159 REM if input ='*' text is finished and Program
    moves on to next stage.
160 IF I#="*"THEN210
169 REM if return key is Pressed no action is taken
170 IF I#=CHR$(13)THEN 100
179 REM Each word is built up from individual letters
180 A$(M)=A$(M)+I#
189 REM now we Print out each letter
190 PRINTI#;
199 REM repeats the Process
200 GOTO 100
209 REM S is used for intervals of spacing.....
210 PRINT:PRINT:INPUT " WHAT INTERVAL DO YOU WANT";S
219 REM....but an entry of '3' means 2 words then
    a blank
220 S=S-1
230 REM OK. now we are ready. Clear screen and.....
240 CLS
249 REM turn off cursor
250 PRINTCHR$(15);
269 REM now we Print a space before each word, and
    Print the words except for those every S-1 when
    we Print as many dashes as there are letters
270 PRINT " ";:FOR I=1 TO MSTEP S:FOR J=I TO I+S-1:
    PRINTA$(J);" ";:NEXT J:
    PRINTSTRING$(LEN(A$(J)),45);" ";:I=I+1:NEXTI
279 REM Now allow for as many answers as there
    are blanks.
280 FOR I=S+1 TO M STEP S+1
299 REM now blank out the Part of the screen (897)
    we will use for messages and allow for answers
300 PRINT@897,STRING$(64,32);:
    PRINT@897,"NOW FILL IN THE BLANKS":INPUT R$(I)
309 REM is the answer correct?
310 IF R$(I)=A$(I)THEN 350
325 IF V>1 THEN PRINT@770,"BAD LUCK. THE
    WORD IS ";A$(I):ELSE 330
326 FOR L=1 TO 300:NEXTL:GOTO 350
329 REM if reply was wrong we give another try
330 PRINT@770,"NO, BAD LUCK. TRY AGAIN.":V=V+1:GOTO300
349 REM if the reply was correct we rePrint the
    original text up to the Point we have reached
350 PRINT@0," ";:FOR K=1 TO I:PRINTA$(K);" ";:NEXT K
359 REM and blank out the 'no' message
360 PRINT@770,STRING$(64,32);
369 REM repeat if more blanks remain
370 V=0:NEXT I
379 REM blank out the request to fill in blanks
380 PRINT@897,STRING$(64,32);
389 REM allow for a re-run
390 PRINT@897,"DO YOU WANT ANOTHER (Y/N)":INPUT R#
400 IF R#="Y" ELSE IF R#="y" THEN 50
410 CLS:PRINT@400,"F I N I S H"
420 GOTO 420

```

# Make the most of your Sinclair ZX Computer...

# Sinclair ZX software on cassette.

## £3.<sup>95</sup> per cassette.



The unprecedented popularity of the ZX Series of Sinclair Personal Computers has generated a large volume of programs written by users.

Sinclair has undertaken to publish the most elegant of these on pre-recorded cassettes. Each program is carefully vetted for interest and quality, and then grouped with other programs to form a single-subject cassette.

Each cassette costs £3.95 (including VAT and p&p) and comes complete with full instructions.

Although primarily designed for the Sinclair ZX81, many of the cassettes are suitable for running on a Sinclair ZX80 - if fitted with a replacement 8K BASIC ROM.

Some of the more elaborate programs can be run only on a Sinclair ZX Personal Computer augmented by a 16K-byte add-on RAM pack.

This RAM pack is described below. And the description of each cassette makes it clear what hardware is required.

### 16K-BYTE RAM pack

The 16K-byte RAM pack provides 16-times more memory in one complete module. Compatible with the ZX81 and the ZX80, it can be used for program storage or as a database.

The RAM pack simply plugs into the existing expansion port on the rear of a Sinclair ZX Personal Computer.

### Cassette 1 - Games

For ZX81 (and ZX80 with 8K BASIC ROM)

**ORBIT** - your space craft's mission is to pick up a very valuable cargo that's in orbit around a star.

**SNIPER** - you're surrounded by 40 of the enemy. How quickly can you spot and shoot them when they appear?

**METEORS** - your starship is cruising through space when you meet a meteor storm. How long can you dodge the deadly danger?

**LIFE** - J.H. Conway's 'Game of Life' has achieved tremendous popularity in the computing world. Study the life, death and evolution patterns of cells.

**WOLFPAK** - your naval destroyer is on a submarine hunt. The depth charges are armed, but must be fired with precision.

**GOLF** - what's your handicap? It's a tricky course but you control the strength of your shots.

### Cassette 2 - Junior

For ZX81 with 16K RAM pack

**CRASH** - simple addition - with the added attraction of a car crash if you get it wrong.

**MULTIPLY** - long multiplication with five levels of difficulty. If the answer's wrong - the solution is explained.

**TRAIN** - multiplication tests against the computer. The winner's train reaches the station first.

**FRACTIONS** - fractions explained at three levels of difficulty. A ten-question test completes the program.

**ADDSUB** - addition and subtraction with three levels of difficulty. Again, wrong answers are followed by an explanation.

**DIVISION** - with five levels of difficulty. Mistakes are explained graphically, and a running score is displayed.

**SPELLING** - up to 500 words over five levels of difficulty. You can even change the words yourself.

### Cassette 3 - Business and Household

For ZX81 (and ZX80 with 8K BASIC ROM) with 16K RAM pack

**TELEPHONE** - set up your own computerised telephone directory and address book. Changes, additions and deletions of up to 50 entries are easy.

**NOTE PAD** - a powerful, easy-to-run system for storing and retrieving everyday information. Use it as a diary, a catalogue, a reminder system, or a directory.

**BANK ACCOUNT** - a sophisticated financial recording system with comprehensive documentation. Use it at home to keep track of 'where the money goes,' and at work for expenses, departmental budgets, etc.

### Cassette 4 - Games

For ZX81 (and ZX80 with 8K BASIC ROM) and 16K RAM pack

**LUNAR LANDING** - bring the lunar module down from orbit to a soft landing. You control attitude and orbital direction - but watch the fuel gauge! The screen displays your flight status - digitally and graphically.

**TWENTYONE** - a dice version of Blackjack.

**COMBAT** - you're on a suicide space mission. You have only 12

missiles but the aliens have unlimited strength. Can you take 12 of them with you?

**SUBSTRIKE** - on patrol, your frigate detects a pack of 10 enemy subs. Can you depth-charge them before they torpedo you?

**CODEBREAKER** - the computer thinks of a 4-digit number which you have to guess in up to 10 tries. The logical approach is best!

**MAYDAY** - in answer to a distress call, you've narrowed down the search area to 343 cubic kilometers of deep space. Can you find the astronaut before his life-support system fails in 10 hours time?

### Cassette 5 - Junior Education: 9-11-year-olds

For ZX81 (and ZX80 with 8K BASIC ROM)

**MATHS** - tests arithmetic with three levels of difficulty, and gives your score out of 10.

**BALANCE** - tests understanding of levers/fulcrum theory with a series of graphic examples.

**VOLUMES** - 'yes' or 'no' answers from the computer to a series of cube volume calculations.

**AVERAGES** - what's the average height of your class? The average shoe size of your family? The average pocket money of your friends? The computer plots a bar chart, and distinguishes MEAN from MEDIAN.

**BASES** - convert from decimal (base 10) to other bases of your choice in the range 2 to 9.

**TEMP** - Volumes, temperatures - and their combinations.

### Cassette 6 - Family Quiz

For ZX81 (and ZX80 with 8K BASIC ROM) with 16K RAM pack.

Four different quizzes, each consisting of 10 questions suitable for the whole family. There's a target time for each quiz, and at the end you're told how long you took to answer the questions - and how many you got right. The quizzes cover a range of topics - including maths, English grammar, and general knowledge.

### How to order

Simply use the order form below, and either enclose a cheque or give us the number of your Access, Barclaycard or Trustcard account. Please allow 28 days for delivery. 14-day money-back option.

# sinclair ZX SOFTWARE

Sinclair Research Ltd,  
6 Kings Parade, Cambridge,  
Cambs., CB2 1SN. Tel: 0276 66104.

To: Sinclair Research FREEPOST, Camberley, Surrey, GU15 3BR.

Please send me the items I have indicated below.

Please print

Qty	Code	Item	Item price	Total
	21	Cassette 1 - Games	£3.95	
	22	Cassette 2 - Junior Education	£3.95	
	23	Cassette 3 - Business and Household	£3.95	
	24	Cassette 4 - Games	£3.95	
	25	Cassette 5 - Junior Education	£3.95	
	26	Cassette 6 - Family Quiz	£3.95	
	17	*8K BASIC ROM for ZX80	£19.95	
	18	*16K RAM pack for ZX81 and ZX80	£29.95	
		*Post and packing (if applicable)	£2.95	
			Total £	

\*Please add £2.95 to total order value only if ordering ROM and/or RAM.

I enclose a cheque/PO to Sinclair Research Ltd for £ \_\_\_\_\_

Please charge by Access\*/Barclaycard/Trustcard no. \_\_\_\_\_

\*Please delete as applicable.

Name: Mr/Mrs/Miss \_\_\_\_\_

Address: \_\_\_\_\_

SOFO7

# Get it out of our system

You'll get a lot more out of Palantir than just a very professional multi processor computer system. Using all standard products, it gives you the flexibility to match your requirements exactly and to expand later at very low cost. And as it is fully compatible, you can use any other terminal or printer you choose.

Palantir gives you all the options - 232C serial ports (2 are standard), ASCII parallel ports, 2 megabyte dual 8" floppy drives, number of terminals expandable from 1 to 24 (more if required).

And each terminal has its own 64K Z80A computer allowing maximum processing speeds with minimum delays.

The hard disc drive with fixed and removable discs allows rapid access of information with a data transfer rate 40

times faster than most floppy discs and expandable from 10-96 megabytes.

And industry standard CP/M allows access to a wealth of existing or special software with all the service and maintenance you would expect.

Simply, it's a more economical way of doing things. You can only really appreciate the potential of the Palantir system by seeing it demonstrated. We'll arrange this, or simply send you literature if you prefer. Just ask.

## Harmer Simpson (U.K.) Ltd.

Ferrari House, 258 Field End Road,  
Eastcote, Ruislip, Middlesex HA4 9UZ  
Tel: 01-429 1266 Telex: 929804 HARMER G

**Expandability Economy Compatability Standardisation**

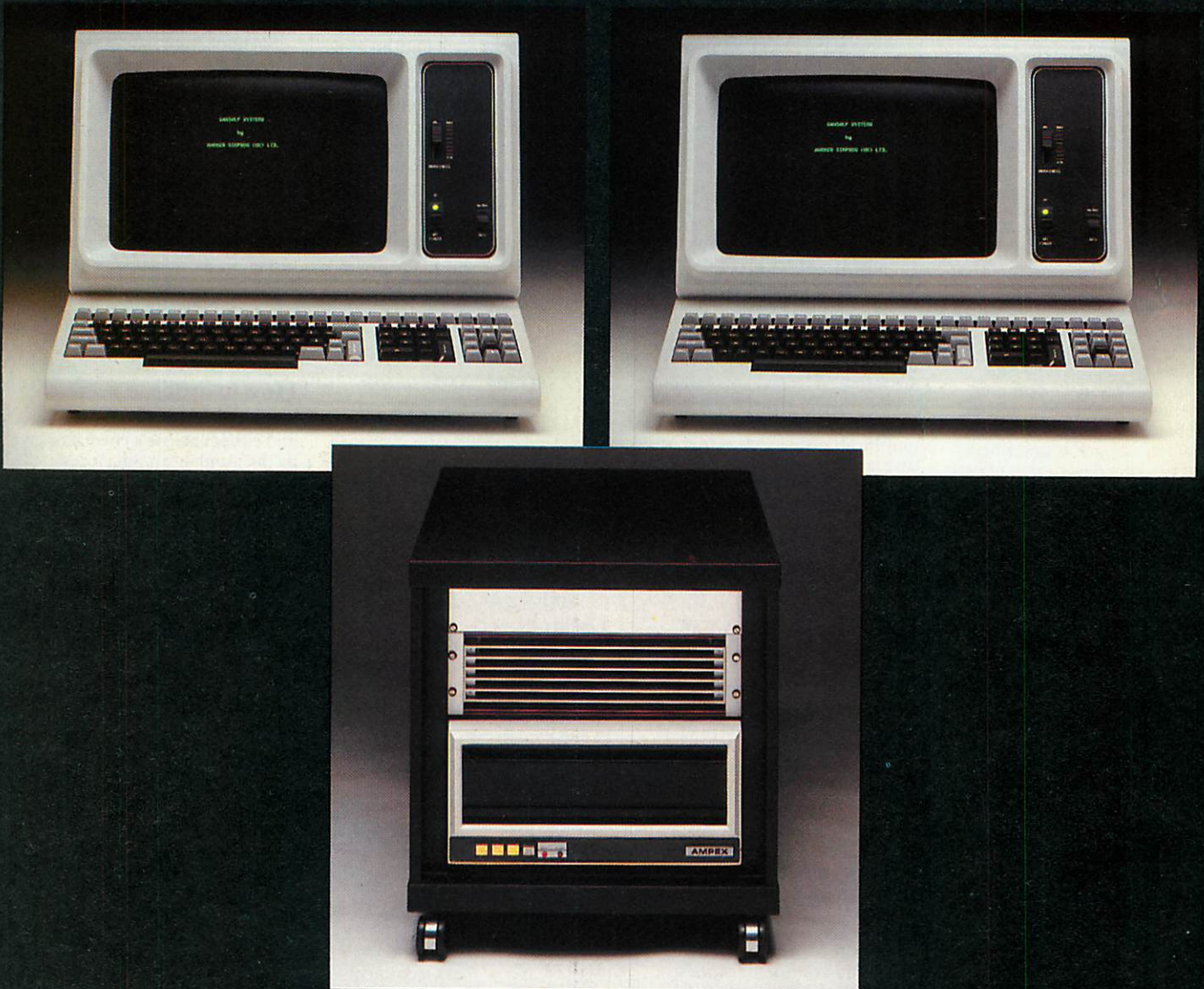

# Palantir

## Multi Processor Computer Systems

# A POWERFUL MULTI-USER SYSTEM FOR UNDER £6,600.

From as little as £6580.00 (plus VAT) you can enter the world of multi-user distributed processing with the CLENLO ACE MULTI-USER SYSTEM.

The only genuine Micro multi-processor system readily available with the full range of multi-user facilities.

With the CLENLO ACE multi-user system up to sixteen users each have exclusive use of a Z-80A processor and 64K RAM mounted on a S-100 board, each with a serial RS-232 I/O port to which the user's VDU is attached.

The multi-user system is housed in a standard S-100 mainframe chassis enabling individual users to run programs independently and simultaneously, while still having access to shared resources (hard disc storage, printers etc.) - via the S-100 BUS Inter Processor Communication channel.

All this activity is controlled by a DPC/OS multi-user operating system running in a Service Processor and creating a complete CP/M Ver 2.2 environment for each user.

The CLENLO ACE multi-user system supports full multi-user facilities:

- Full lock-out at record level.
  - Facility to designate files - private, group or public.
  - Full 4MHz speed for each user.
  - Fast memory to memory data transfer.
  - Enhanced batch submit facility.
  - Floppy disc storage, or Winchester hard disc storage up to 100 Megabytes.
  - Automatic print spooling and de-spooling.
  - Tape back-up facilities available... backed up by the exceptional CLENLO service and highly competitive prices.
- Whether you want a basic two user system incorporating floppy disc storage or the facility of a full sixteen user hard disc based system with high performance, CLENLO can provide the system you need.

For more details of the best, lowest cost multi-user system on the market and our complete range of Microcomputer and business services contact CLENLO COMPUTING SYSTEMS, Telephone 01-670 4202/3.

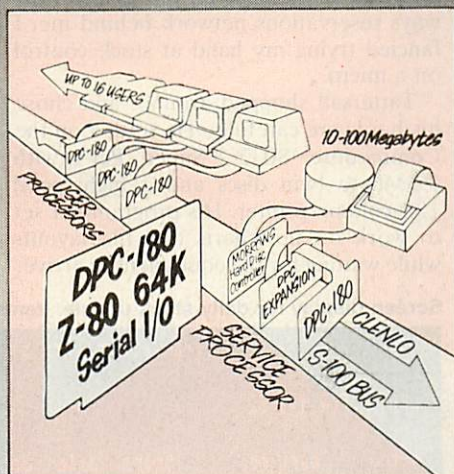

**CLENLO**  
Microcomputers  
designed for business

To: CLENLO COMPUTING SYSTEMS LIMITED,  
Crown House, 18 Gypsy Hill, London SE19 1NL.  
Telephone: 01-670 4202/3.

- Please send me details of your ACE MULTI-USER SYSTEM.
- Please send me details of the complete CLENLO range.

Name \_\_\_\_\_

Position \_\_\_\_\_

Company \_\_\_\_\_

Address \_\_\_\_\_

\_\_\_\_\_

Telephone \_\_\_\_\_

● Circle No. 151

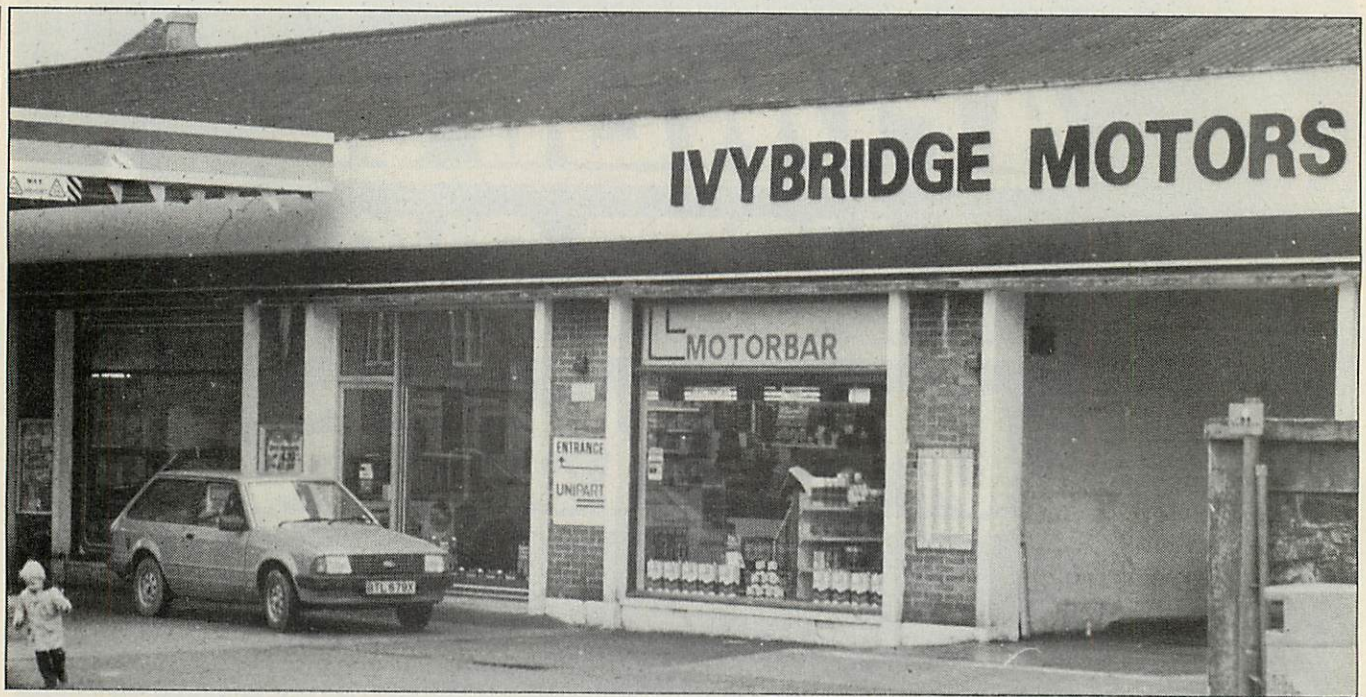

DAVE TATTERSALL runs a thriving garage business in the South Hams town of Ivybridge, on the edge of Dartmoor. As well as selling petrol and offering car repairs and servicing, Ivybridge Motors is a BL retail outlet dealing in BL cars and components. The stores hold over 3,000 lines in BL and Unipart spares, and a wide range of items such as cigarettes, sweets and car accessories are sold in the shop.

### Stock information

Keeping track of such a large and diverse selection of stock is no mean feat — how many of each line you have, where the items are, what it is all worth, and which lines are worth continuing. A comprehensive up-to-the-minute stock information service is the key to profitability in this line of business.

Over the past 18 months, Dave Tattersall had been approached by a number of people touting computerised stock-control systems at prices ranging from £250 to £25,000. The cheapest system offering simply quantity-in-stock for sequentially-numbered stock items, was written off as "Probably great for a toothbrush salesman stocking 50 different lines, useless to us". The most expensive, jointly marketed by ICL and BL, was clearly designed for big main dealers, and was far too high-powered for the pocket or the needs of the High Street retail dealer. Nobody was offering the level of sophistication needed, at a price that was realistic. Convinced that micro-computers held the key to stock management for the High Street retailer, Tattersall concluded that it was up to him to define a system to suit his needs.

I first met Dave Tattersall, and his parts manager Chris Hatch, when they signed up for a short introductory course on computing which I was running at Ivybridge Community College. We

talked over the application he had in mind, and the sort of hardware he was likely to need. I was a little disappointed to hear that they already had someone lined up to write the software, a professional programmer working for a major corporation locally. With substantial real-time experience on the British Airways reservations network behind me, I fancied trying my hand at stock control on a micro.

Tattersall shopped around, and chose his hardware carefully. He settled on the Commodore 8032 "Super Pet" with 0.5Mbyte twin discs and a high-speed 132-column printer. His programmer set to work on flowcharts and file layouts while waiting for the equipment to arrive.

About this time, things started to go awry. There was a hold-up, as ever, in the delivery of this system. By the time it arrived, his programmer had already been told that his firm was pulling out of Devon and he was due to move to the States in a matter of weeks. On his departure, Ivybridge Motors became the proud possessor of an unproved and very unwieldy prototype system, a poor match for the £3,000-worth of hardware supporting it.

### Software misgivings

I was a little surprised to hear from Dave Tattersall again, and listened with some misgivings to his suggestion that I take on software maintenance of his new

Screen display for daily stock update. Items 6 to 10 are used only for new entries.

```

IVYBRIDGE MOTORS STOCK UPDATE.      INPUT

UPDATE FOR 1/1/82

entry  part no.    trans. date  doc. no.    i/r  quantity  new
-----
4      gbfi01       1/1/82       0958        i    1
5      ztb001       1/1/82       0958        i    1
6      ztb024       1/1/82       0958        i    1
7      za024        1/1/82       0958        i    1
-----
1. part no. (or end) GAE201
2. date              1/1/82
3. doc. no. (or del) 0958
4. issue/rec.        I
5. quantity          #    <
-----
6. retail price
7. dis. code
8. bin loc.
9. supplier data
0. description
and changes?

```

# Keeping track of spare parts — they managed it on a micro

Grahame Blackwell took part in a bid to automate a High Street garage's stock list.

programs. After seeing the system in action, I tactfully suggested that instead I work with Chris Hatch on developing a comprehensive stock control system from scratch. A feasibility study soon established that Tattersall's chosen equipment was capable of supporting a real-time system with response times of three to four seconds on an inventory of over 5,000 line items.

The months that followed were very interesting and highly educative for both sides, though not always easy. Few computer users appreciate how long and involved is the path from testing an idea to making it foolproof and fully operational, and Ivybridge Motors was no exception. Getting the best out of the computer in terms of speed, storage and user interaction involved copious reference to *The Pet Revealed* and a few phone calls to Commodore.

Chris Hatch has picked up a good deal of knowledge about computer programs, and has on a number of occasions sat at the keyboard and modified a program as I phoned the amendments to him. For my part I learned a great deal about the garage business, and how to relate a computerised information system to that business.

## User friendly

I also learned how closely Chris Hatch had followed my evening classes; he regularly quoted back at me my bland statement that "It is not up to users to adapt to the computer — it should be the other way round", whenever he felt that a little more programming could make his job easier. This guiding principle has led us to a system that is quick and simple for the non-specialist to use, and which meets all the main record-keeping requirements of Chris Hatch and others in his line of business.

The initial specification was for a system to hold detailed stock information on up to 5,000 line items, and permit access to that information and amendment of it. The system was also to have included a facility to update stock information on a daily basis, reflecting the day's transactions, and to provide a printout of those

transactions suitable for audit trail. The information to be held for each item included:

- part number
- description
- retail price
- cost price
- discount code
- minimum stock level
- quantity in stock
- supplier details
- on-order indicator
- sales category, to indicate throughput

Over the months, various features have been added as the need for them became apparent, such as special handling of sale-or-return stock "Customers' Bench" one-off orders giving a finished system several stages removed from the first draft.

## Justifiably proud

Chris Hatch is more than pleased with the facilities the system now offers him, and is justifiably proud of his part in defining it. In just 10 minutes at the end of the day he can feed in all the information on the day's transactions, including items sold, orders delivered and stock ordered.

At any time he may access comprehensive information on any stock item, and can modify that information if necessary after input of a security code. He may also obtain a full printout of stock information, or of a selection of stock items under one of a number of different categories, including a cost and retail stock evaluation for each line item and for total stock. These printouts are in part-number order corresponding to BL catalogues and price lists, rather than a simple alphanumeric ordering.

After each day's stock update, he is provided with a transaction list, a printout of the new state of stock affected and a reorder list. Special facilities ease the twin burdens of stocktaking and re-pricing. The system monitors monthly throughput of each line item, and a variable indicator gives a constant check on profitability for each.

The package has received the seal of approval from the accountants who act for Ivybridge Motors and they intend to recommend it to other clients. Satisfied

that his first step into the computer world has been amply justified, Dave Tattersall has recently purchased a business accounts package to run on his Commodore system. For a total outlay of under £5,000, he now has a comprehensive management information system which should increase efficiency and profitability and reduce expenditure on other management aids, such as bin price list for stock. He expects the system to have paid for itself in a relatively short period and is now looking to this computer to streamline other facets of his business, such as customer follow-up.

## Vested interests

It is perhaps as well the system was up and running before Dave Tattersall received a BL circular detailing the findings of a consultative committee. It stated, in effect, that it would not be possible to maintain stock information for such a business on a microcomputer. One wonders how such findings are



Chris Hatch explains the system's finer points to manager Dave Tattersall.

arrived at, and whether micros are being judged according to criteria handed down from mainframe experience.

Ivybridge Motors' short-lived initial package bears this out. Its file structures and program layouts were a model of good commercial programming practice, and worked well on test data of 200 items. Yet the full database of over 3,000 items led to an unacceptable four-minute response time, and the system ran out of disc space. Its extravagant file layout, with repetitive record headers and superfluous field delimiter characters, and programs making use of sequential disc searches over large numbers of records were totally inappropriate to the micro environment. The programmer himself was the first to agree that a rethink was needed.

The microcomputer is now the best solution to many medium and large-scale problems in information handling. It would be a shame if vested interest or inflexible outlook were to pronounce it unfit for service. By the same token, those from a mainframe or minicomputer background who are prepared to adapt to the micro's particular operational constraints will be able to bring a much-needed wealth of experience to bear on this fast-growing infant. □

Did you pay too much tax last year? Elizabeth Acraman shows how button. The program can also be modified to assess your 1982/83 liability

# Keeping income tax in

ONE OF THE LEAST popular ways in which the Government raises money is by income tax. It is levied on your total income, with some minor exceptions, less the allowances to which you are entitled during the tax year — the 12-month period ending on April 5 each year. This program will enable you to check your income tax liability according to the present Finance Act. It is written for a 40-column Pet with a GBM 3022 printer.

After establishing your name, the computer asks for your status — male or female; single, married or widowed. If you are a married woman it asks if you wish to calculate income tax just for yourself, in which case you will be

regarded as a single woman, or jointly with your husband, when you will be regarded as a married man.

If you are a widow, the Pet asks if your husband died before April 6, 1981 in order to establish your entitlement to the Special Bereavement Allowance for the year in which your husband died. If applicable, it is calculated by reference to the date of his death.

You are then asked to enter details of your income and outgoings for the year: Earnings — that is salary or wages — including overtime, commission, etc. Benefits in kind, such as company car, cheap loans, etc. Note that some benefits are not taxable and some are only taxable if you

count as "higher paid". Your employer should be able to advise you of the amount of benefit on which you are liable to tax. Allowable expenses, which are defined as those necessary for your work, such as tools, professional subscriptions etc. Pension contributions to your employer's pension fund. This does not include your National Insurance deductions. State pensions receivable which are taxable, such as retirement pension — excluding supplementary, widow's pension, etc. Other pensions receivable, for example, from former employer or personal pension if you were given tax relief on the payments you made into the scheme. Gross amount of any income you receive under a deed of covenant, and the tax deducted from it.

## 1981/82 tax liability check

```

710 PRINT "INCOME TAX : -
720 PRINT "MARRIED" : JUST FOR YOURSELF
730 PRINT "MARRIED" : JOINTLY WITH YOUR HUSBAND
740 PRINT "MARRIED" : PLEASE INDICATE 1 OR 2
750 INPUT SC : IF SC<1 OR SC>2 THEN 760
760 IF SC=1 THEN SS=1 : RETURN
770 SE=1
780 RETURN
790 REM *** MARRIED MAN ***
800 PRINT "MARRIED" : PLEASE ENTER THE SAME
810 PRINT "MARRIED" : DETAILS IN RESPECT OF YOUR WIFE
820 SE=1
830 GOTO 860
840 PRINT "MARRIED" : PLEASE ENTER YOUR INCOME
850 PRINT "MARRIED" : AND OUTGOINGS FOR THE YEAR
860 FOR I=1 TO 12
870 PRINT "MARRIED" : ENTER "1" (P)
880 INPUT O : H(R,C)=INT(O) : NEXT
890 GOSUB 1720
900 R(C,C)=R(C,C)-R(C,C)
910 D(C)=D(C)+R(C,C) : H(C,C)=R(C,C)+R(C,C)
920 D(C)=D(C)+H(C,C) : H(C,C)=R(C,C)+R(C,C)
930 D(C)=D(C)+H(C,C) : H(C,C)=R(C,C)+R(C,C)
940 H(C,C)=H(C,C)+D(C)
950 IF R(C,C)<0 THEN H(C,C)=0
960 H(C,C)=H(C,C)+R(C,C) : D(C)=D(C)+R(C,C) : H(C,C)=H(C,C)+R(C,C)
970 H(C,C)=H(C,C)+R(C,C) : H(C,C)=H(C,C)+R(C,C)
980 GOSUB 1890
990 IF SE=1 THEN SS=2 THEN 990
1000 FOR O=1 TO 12
1010 H(O,1)=H(O,1)+H(O,2)+H(O,3)
1020 H(O,2)=0
1030 H(O,3)=0
1040 NEXT
1050 FOR I=1 TO 12
1060 I=I+H(R,I)
1070 S=S+H(R,I)
1080 M=M+H(R,I)
1090 NEXT
1100 T=I+S+M
1110 SE=0
1120 PRINT "MARRIED" : YOU CLAIM DEPENDENT
1130 PRINT "MARRIED" : RELATIVE ALLOWANCE ?
1140 GOSUB 600
1150 IF Z=1 THEN I170
1160 GOTO 1200
1170 INPUT "FOR HOW MANY RELATIVES ?" : I170
1180 IF SE=2 THEN SS=1 OR (SE=2 AND SS=3) THEN B(4)=145*0 : GOTO 1200
1190 B(4)=100*0
1200 IF SC=3 THEN I240
1210 PRINT "MARRIED" : YOU CLAIM HOUSEKEEPER ALLOWANCE ?
1220 GOSUB 600
1230 IF Z=1 THEN B(5)=100
1240 PRINT "MARRIED" : YOU CLAIM ADDITIONAL
1250 PRINT "MARRIED" : PERSONAL ALLOWANCE
1260 GOSUB 600
1270 IF Z=1 THEN B(6)=270
1280 PRINT "MARRIED" : YOU CLAIM ALLOWANCE ?
1290 PRINT "MARRIED" : OR SON/DAUGHTER SERVICES ?
1300 GOSUB 600
1310 IF Z=1 THEN B(7)=55
1320 PRINT "MARRIED" : YOU CLAIM
1330 PRINT "MARRIED" : AND PARENTS ALLOWANCE ?
1340 GOSUB 600
1350 PRINT "MARRIED" : YOU WISH TO CALCULATE

```

nd out at the touch of a

# check

Gross amount of dividends received, and the tax deducted from them

Total amount of interest received from a National Savings Bank ordinary account last year. In the first and last years of receipt of such interest the amount should be the current year's interest. The first £70 of such interest is tax free, and this will be automatically allowed for in calculating your income tax.

Any other investment income, such as bank interest, local authority loan, etc., and the tax deducted from this.

Interest received from building society accounts. Building society interest is received "tax paid" but for some purposes it must be grossed up for the notional basic rate of tax. This is calculated by the program and the notional tax is treated as tax already deducted.

Mortgage interest allowable, and then any other interest allowable on qualifying loans.

The Pet then asks if you wish to check your entries. If so, each item and the amount you entered will be displayed in turn. You may agree or amend any item. You are then asked if any of your duties were performed abroad; if you worked abroad for the whole year, your earnings will not be subject to income tax. If you worked abroad for more than 30 days in the year, a quarter of your earnings for that period are free of tax, and this will be automatically calculated and allowed.

If you are a married man you are then asked to enter all the information on income, pensions, interest, etc., in respect of your wife. If you were married during the year only your wife's income after your marriage should be entered.

The next stage is to enter your entitlement to various allowances, such as for dependent relative, housekeeper — only available to a widower or widow — additional personal allowance for those bringing up children on their own, son's, daughter's services, and blind person's allowance. You are then asked if you — or your wife if you are a married man — were born before April 6, 1917, to establish your entitlement to Age Relief. This is a higher rate of personal allowance, but is subject to abatement if your taxable income is above a specified level. All the relevant calculations are built into the program.

If you are a married man the program asks if you were married before April 6, 1981. If not, your married man's personal allowance is adjusted to take account of the date of your marriage and, again, this calculation is built into the program. For the year of your marriage your wife is treated as a single woman — with the full

	Present Value (1981/2) £	Variable	Line number(s)
<b>Allowances</b>			
Personal allowance			
single	1375	B(1)	660, 1420, 1470
married man	2145	B(1)	1540, 1670
Age relief (maximum)			
single	1820	B(1)	1450
married	2895	B(1)	1650
trigger for abatement	5900		1460, 1660
Additional personal allowance			
in year of marriage	770		1620
Widows bereavement allowance			
(whole year)	770	B(3)	650
Wife's earned-income relief			
(maximum)	1375	B(2)	1690, 1700
Dependent relative			
for single woman	145	B(4)	1180
other	100	B(4)	1190
Housekeeper	100	B(5)	1230
Additional personal allowance	770	B(6)	1270
Son or daughter services	55	B(7)	1310
Blind person	180	B(8)	1350
<b>Tax</b>			
Tax rate bands			
first	11250		2060, 2100, 3820
next	2000		2090, 3820
next	3500		2110, 3820
next	5500		2130, 3830
next	5500		2150, 3830
Rates of tax			
first	30%		2060, 2080
second	40%		2090, 2100
third	45%		2110, 2120
fourth	50%		2130, 2140
fifth	55%		2150, 2160
top	60%		2170
Investment income surcharge			
trigger	5500		2190, 2200
rate	15%		2200
Notional tax on building			
society interest	30/70	Q	960
Overseas earnings			
minimum number of days eligible			
for relief	30	N	1980
proportion of earnings relieved	25%		1990
Tax-free interest on ordinary			
savings accounts	£70		940
Dates			
date of birth for eligibility to			
age relief	6.4.1917		1390, 1510
beginning of tax year	6.4.1981		590, 1560, 370, 400
current tax year	1981/82		3010

### Variables for checking 1981/82 tax.

single person's personal allowance — for the first part of the tax year up to the date of your marriage. For the second part of the tax year, after the date of your marriage, she is entitled to the wife's earned income relief on her earnings during that period.

Your personal allowances, wife's earned-income relief, if applicable, together with income tax payable at the various rates and investment income surcharge are all calculated by the program. If you are entitled to any repayment of tax, this is also calculated and shown.

You then have the option of having the

calculations displayed on the screen in three sections — Income, Allowances and Tax Payable — or printed out. The program is designed to cater for straight-forward income tax assessments, which covers the majority of cases. If there are individual circumstances which affect your particular case you will need to adjust the calculations to take account of them.

Cassettes of this program for both the 1981/82 and 1982/83 tax years are available from the author at 49 Kingsend, Ruislip, Middlesex for £4, including postage and packaging. 

# EQUINOX

Systems for Business

Kievan House, 16 Aiming Street, New Inn Yard,  
London EC2A 3HB Tel: 01-739 2387 & 01-729 4460  
Tele: 27341

All prices  
exclusive  
of VAT and  
carriage

REGISTERED TRADEMARKS:  
WORDSTAR, MAILMERGE: MicroPro International  
C/M: Digital Research  
M/BASIC: Microsoft  
C/BASIC: Compiler Systems, Inc.

- Compact and mobile - The Osborne 1 simply packs into its own carrying case. Take it wherever your work takes you.
- Comes complete - Z80A 64k computer, dual 100KB disc drives, typewriter keyboard with numeric keypad and 5" screen.
- Capabilities include word processing, data processing and financial planning.
- CPM operating system allows user choice from a wide range of existing written programs.
- Connects to a variety of printers.

Included in the amazing price of just £1250 is over £800 worth of FREE software:-

WORDSTAR for word processing.  
MAILMERGE for name/address database.  
SUPERCALC for financial planning.  
M/BASIC & C/BASIC for programming.

Osborne 1 - The personal business computer for small businesses and busy executives on the move.



INCLUDES SOFTWARE VALUE £800+ + VAT

# £1250

The portable business computer  
With a difference  
**OSBORNE 1**

1340 GOSUB20  
1350 IFZ=1 THEN B(2)=180  
1360 REM\*\*PERSONAL ALL-MARRIED COUPLE\*\*  
1370 IFEZ=1 AND SS=2 THEN I430  
1380 REM\*\*PERSONAL ALL-SINGLE\*\*  
1390 PRINT\*\*WHERE YOU BORN BEFORE 6 APRIL 1917 ?"  
1400 GOSUB20  
1410 IFZ=1 THEN I440  
1420 B(1)=1375  
1430 GOTO210  
1440 REM\*\*SINGLE-HOE RELIEF\*\*  
1450 B(1)=1820  
1460 IF I5900 THEN B(1)=INT(B(1)-((1-5900)\*2/3))  
1470 IF B(1) < 1375 THEN B(1)=1375  
1480 GOTO2010  
1490 REM\*\*MARRIED COUPLE\*\*  
1500 PRINT\*\*WHERE EITHER YOU OR YOUR WIFE  
1510 PRINT\*\*BORN BEFORE 6 APRIL 1917 ?"  
1520 GOSUB20  
1530 IFZ=1 THEN I440  
1540 B(1)=2145  
1550 PRINT\*\*WHERE YOU MARRIED BEFORE"  
1560 PRINT\*\* APRIL 1961 ?"  
1570 GOSUB20  
1580 IFZ=1 THEN I430  
1590 PRINT\*\*ENTER DATE OF MARRIAGE IN NUMBERS"  
1600 GOSUB30  
1610 B(1)=1375+INT(W/12\*770)  
1620 B(1)=1375+INT(W/12\*770)  
1630 GOTO1680  
1640 REM\*\*MARRIED-HOE RELIEF\*\*  
1650 B(1)=2895  
1660 IF I5900 THEN B(1)=INT(B(1)-((1-5900)\*2/3))  
1670 IF B(1) < 2145 THEN B(1)=2145  
1680 REM\*\*WIFE EARNED INCOME\*\*  
1690 B(2)=1375  
1700 IF I1375 THEN B(2)=M  
1710 GOTO2010  
1720 PRINT\*\*WOULD YOU LIKE TO CHECK  
1730 PRINT\*\*YOUR ENTRIES ?"  
1740 GOSUB20  
1750 IFZ=1 THEN I770  
1760 RETURN  
1770 FOR I=1 TO I6  
1780 PRINT\*\*PRINT#(R);R;(C)  
1790 PRINT\*\*THIS IS ONE ALRIGHT ?"  
1800 GOSUB20  
1810 IFZ=1 THEN I640  
1820 RETURN  
1830 RETURN  
1840 INPUT\*\*PLEASE INPUT REVERSE AMOUNT#(R);R;(C)=INT(Q)  
1850 PRINT\*\*DO YOU WISH TO CONTINUE ?"  
1860 GOSUB20  
1870 IFZ=1 THEN I640  
1880 RETURN  
1890 REM\*\*PERSERS EARNINGS\*\*  
1900 PRINT\*\*PERFORMED BEFORE ?"  
1910 PRINT\*\*PERFORMED BEFORE ?"  
1920 GOSUB20  
1930 IFZ=1 THEN I950  
1940 RETURN  
1950 PRINT\*\*HOW MANY DAYS WERE SPENT ABROAD ?"  
1960 INPUT N  
1970 IF N > 364 THEN B(17,C)=(R);C)+4\*(C);C)\*1-1: RETURN  
1980 IF N < 30 THEN B(17,C)=(R);C)+4\*(N/365)  
1990 RETURN  
2000 REM\*\*CALCULATE TAX\*\*  
2010 FOR I=1 TO I8  
2020 B=B+B\*(R)  
2030 FOR I=1 TO I8  
2040 NEXT  
2050 C=T-B  
2060 IF C < 11250 THEN C=11250\*.3: GOTO2090  
2070 IF C < 80702180 THEN C=80702180  
2080 C\*(1)=C\*(1)-80702180  
2090 IF C < 11250 THEN C=11250\*.4: GOTO2110  
2100 C\*(2)=C\*(1)-11250\*.4: GOTO2130  
2110 IF C < 16750 THEN C=16750\*.45: GOTO2150  
2120 C\*(3)=C\*(2)-16750\*.45: GOTO2180  
2130 IF C < 22250 THEN C=22250\*.5: GOTO2150  
2140 C\*(4)=C\*(3)-22250\*.5: GOTO2180  
2150 IF C < 27500 THEN C=27500\*.55: GOTO2170  
2160 C\*(5)=C\*(4)-27500\*.55: GOTO2180  
2170 REM\*\*INVESTMENT INCOME SURCHARGE\*\*  
2180 GOSUB20  
2190 IF I5900 THEN IHE210  
2200 C\*(7)=(1-5500)\*.15  
2210 REM\*\*TOTAL TAX LIABILITY\*\*  
2220 FOR I=1 TO I7  
2230 T=T+C\*(I)  
2240 NEXT  
2250 REM\*\*TRX ALREADY DEDUCTED\*\*  
2260 FOR I=1 TO I4  
2270 E=E+I\*(R)  
2280 NEXT  
2290 REM\*\*NET TRX PAYABLE\*\*  
2300 F=T-E  
2310 PRINT\*\*DO YOU WANT TO --"  
2320 PRINT\*\*1) DISPLAY ON SCREEN  
2330 PRINT\*\*2) PRINT OUT  
2340 PRINT\*\*3) END  
2350 PRINT\*\*PLEASE ENTER YOUR CHOICE (1-3)  
2360 INPUT\*\*1) F1<10> 2) F2<10> 3) F3<10>  
2370 OK=0: GOTO2380  
2380 REM\*\*SCREEN DISPLAY\*\*  
2390 PRINT\*\*" E R N E D  
2400 PRINT\*\*" INVT SELF WIFE"  
2410 FOR I=1 TO I7: FOR K=1 TO I3  
2420 IF I\*(R);K) < 0 THEN HENSUB2450  
2430 NEXT: NEXT  
2440 GOTO2490  
2450 RETURN  
2460 PRINT\*\*" F2<5>-FNR(I);R(1);R(1)  
2470 PRINT\*\*" F2<5>-FNR(I);R(1);R(1)  
2480 RETURN  
2490 PRINT\*\*" F2<5>-FNR(I);R(1);R(1)  
2500 PRINT\*\*" F2<5>-FNR(I);R(1);R(1)  
2510 PRINT\*\*" F2<5>-FNR(I);R(1);R(1)  
2520 PRINT\*\*" F2<5>-FNR(I);R(1);R(1)  
2530 PRINT\*\*" F2<5>-FNR(I);R(1);R(1)  
2540 GOSUB20  
2550 IFZ=2 THEN I210  
2560 PRINT\*\*" ALL MARRIAGES"  
2570 FOR I=1 TO I8  
2580 IF B(1) < 0 THEN HENSUB2610  
2590 NEXT  
2600 GOTO2630

(continued from page 86)

# New Generation NEC Spinwriter Plus '83

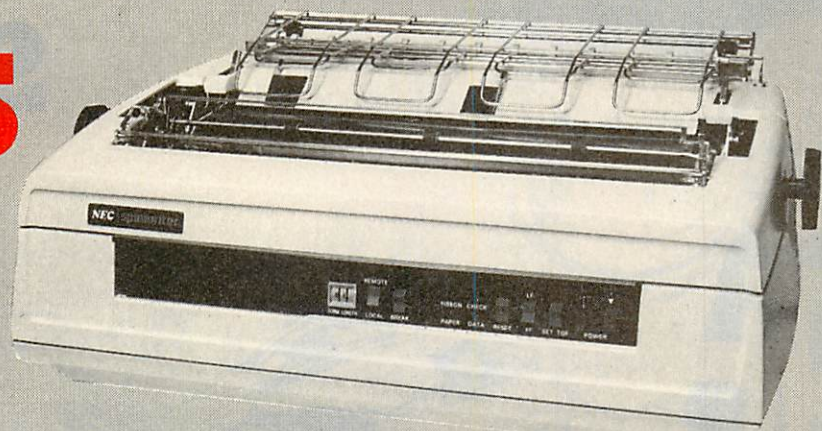

With all the NEC 7710 features, such as: \*55 CPS \*128 characters \*136 columns at 10 characters per inch and 163 columns at 12 characters per inch \*16 inch paper \*6 or 8 lines per inch \*256 char. Receive Buffer \*16 char. Keyboard Buffer etc.

plus these NEW OUTSTANDING features:

- 16K RAM ● 16 BAUD FROM 50-19,200, - SOFTWARE/HARDWARE SELECTABLE ● RS232C CENTRONICS PARALLEL, IEEE PORTS, CURRENT LOOP ● SWITCH SELECTABLE PROTOCOLS: NEC 7710, DIABLO 630, QUME SPRINT 5 ● 24 SWITCH SELECTABLE FUNCTIONS ● AUTO BIDIRECTIONAL PRINTING WITH OPTIMISED THRUPUT ● SHEET FEEDER AND GRAPHICS MODES ● AUTO PROPORTIONAL SPACING AND TAB SETTING ● UPGRADE-ABLE TO LATEST SOFTWARE

Now available from:

**NORTHAMBER**  
**The Printer People**

3, 4 and 5 DAWES COURT, ESHER, SURREY

**LIMITED**

*Importers, Distributors and Wholesalers of Computer Products*

Tel: ESHER (0372) 66397/62071 Telex: 241 23 NAMBER G

(from 01 numbers dial 78-66397 or 78-62071)

# CRASHING

# THE

# SYSTEM

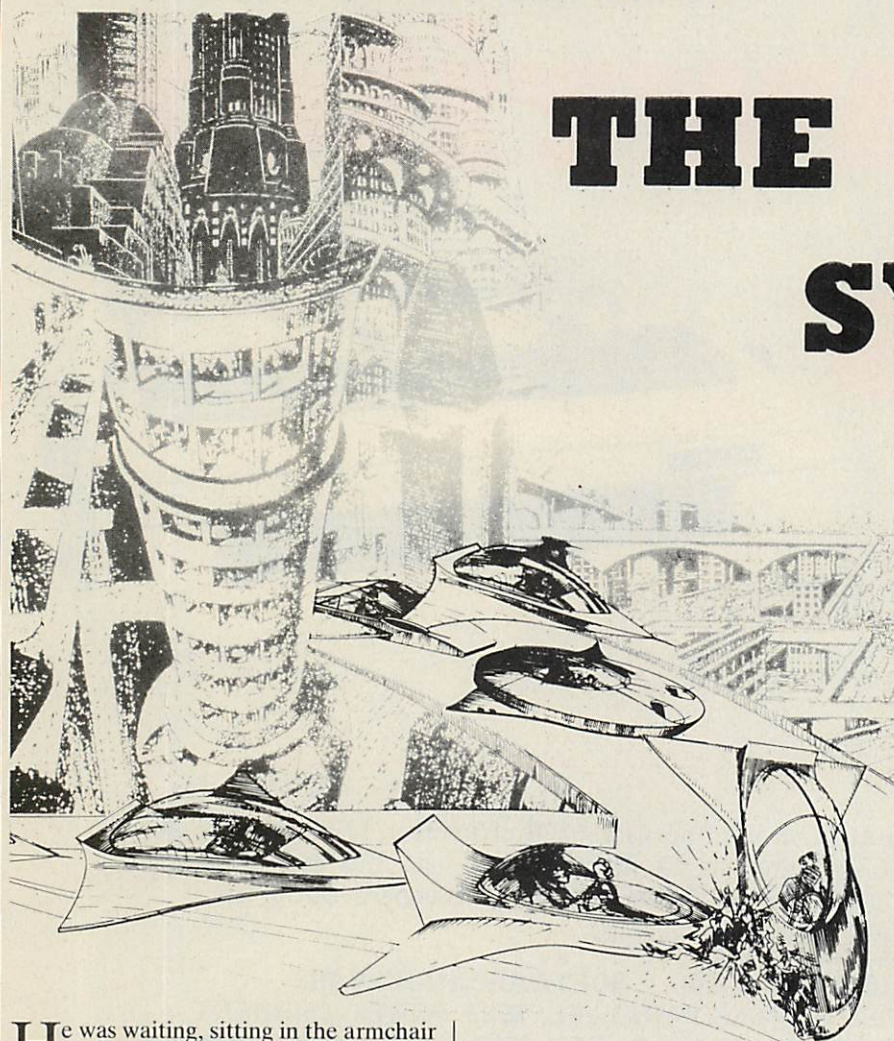

He was waiting, sitting in the armchair and waiting. To be more accurate, he was slumped in the armchair with his legs dangling over one of the arms, watching the VDUs on the wall before him and controlling them through the keyboard on the other arm.

Waiting. His hand moved restlessly across the keys as he flicked from channel to channel. He was playing with time. He was waiting.

"No signal yet"? asked his mother, coming into the room.

"No".

"You know the time selection is random, you could wait for ever you know. Give me screen 4 for a moment, please".

He pressed the keys and transferred screen 4 over to his mother's manual board.

"Thank you".

He pretended to continue his search through the channels. He even set up a game, but in fact the Level 7 Invaderwar continued to play on automatic. He watched his mother interface with the supply computers and order some food and a shirt for his father. He was always intrigued when his mother shopped like this. He could stare at the catalogues for

ages without being able to make a decision.

She finished her orders and checked the updated balance at the bank.

"I must get your father to check our expenditure models", she mumbled, mostly to herself, and keyed that imperative into the personal memory file. She called up the family's nutrition charts for a moment, then flicked over to the news channel.

After absorbing some statistics on today's personnel movement projections

---

by Chris Waugh

---

she gave him back screen 4 complete with a defensive program for Level 7.

"Don't forget your B12s this week", she told him as she left the room and headed for the kitchen. He grinned to himself as he keyed in her defence program.

As he resumed his waiting, only the nervous movements of his hand usurped

the impression of total lethargy which settled again into all the nooks and corners of the screen room. He waited, as he had done for some days now, his glazed eyes seemingly oblivious to the flickering lights of the VDUs.

It was just past 1600 hours, and the grey winter's day was growing dim. The weather projection was for rain within the hour and that seemed an entirely appropriate expression of the day's events.

A signal on screen 3 had activated his body. As he cut the news he leapt into position bolt upright in the armchair, staring intently at screen 3 his eyes bulging. His listlessness was now replaced by intense concentration. Only his hand operating the armchair keyboard seemed to anchor the otherwise chaotic movements.

Screen 3 was distorting badly and the signal would not come through legibly. After trying the standard Signal Approach Programs he checked the system. Whilst the SAPs reran automatically on screen 3, the results of circuit checks and interference analysis came up on screens 1 and 2. His eyes moved mechanically from screen to screen as his hand played on the keys. As the negative check responses flashed up, he entered a Scramble/Code Signal Check.

He found himself waiting again, this time for the result of the S/CS check. Nervously he set up a game of Level 7 to fill the time, but his eyes strayed continually across to the blank space of screen 2.

He sat in the car and waited for a response to his request for route planning and clearance. During the rush-hour it could take up to five minutes for a request to be processed and granted.

As he waited, he tapped a rhythm on the driving console and thought about the news item he had seen earlier about personnel movement. The details having slipped his memory, he turned into the Newsummary channel and indexed PMP.

He read the transcript of the news item and wondered what PM levels were like

five years ago. He had no idea, and the Department of T-CoP's memory problems grew distant as he relaxed his focus on the VDU. The figures flowed into each other and the projections meant nothing. He was nearly asleep, but his hand was still tapping the console.

"You have positive RP and C on your PM request. If you wish to cancel your application please state updated intention immediately. Otherwise your PM will commence as soon as planned. Thank you".

The electronic voice had startled him, but he was fully alert again and waiting to leave. Waiting, always waiting.

Stretched out on the circular couch which filled the rear of the car, playing Level 7, it was some time before he noticed the frequency with which he was getting involved in traffic jams. One always anticipated a few hold-ups on the feeder lanes, but the through routes were usually fast-moving. A particularly long hold-up eventually registered in his mind, and he sat up.

Drops of rain were gradually covering the windscreen, and through this distortion he glimpsed something he had always regarded as being impossible. He fairly leapt from the couch to the control console, his fingers instantly in place on the keys and working to call the information which would explain what he saw. He finished keying and as he waited for the computer response he activated the windscreen wipers.

The information he received through the windscreen was of little use to him: there was too much of it for him to process. He could see a jam of vehicles: a single jam, which stretched away before him along the feeder lane and continued down the through route as far as he could see. The same jam blocked the overhead relief lane under which he was stuck. Other feeder lanes behind him and a subsidiary to his own were clogged with stationary vehicles.

He surveyed the spectacle before him for some time, for once unresponsive to the flashings of the VDU on the control console in front of him. His face, after registering the initial shock, was now a blank. Even when he found himself staring into the eyes of a girl in the car stuck beside his, that steely blankness remained unchanged.

Eventually he recovered sufficiently to consult the information which had been flickering before him for some time. The life came back into his fingers. The update on his particular PM was "delay of unspecified duration". No reason was forthcoming, and the overall PMP was unavailable. The rest of the information he received was irrelevant, so he turned to the news update. On no channel could he find any reference to PM problems. Even more confused than before, he

returned to the back of the car and lay on the couch.

For a while he lay and waited. Outside the car, all was still except for the rain. Inside, only the tapping of his fingers disturbed the atmosphere of calmness. Soon bored, he idly entered the Basic Information and Definition Index and keyed in "Dept. of T-CoP". The response was instant.

Department of Traffic Control Programming (T-CoP), The

This department replaced that of TP (Traffic Planning) in 1994 when the latter's future PM requirement projection came to be considered too inaccurate. It was decided that the only solution to the problem of mass viable PM was a central processor which planned and controlled all PM. Thus the whole concept of PM changed overnight — suitable time having been allowed for the conversion of vehicles to centralised automatic operation. Individual manual operation is now only needed in a few sparsely populated areas, which are outside the system controlled by the department's central processor.

It is estimated that in 1996 the system was already 40 percent more efficient timewise, 32 percent more efficient fuelwise, 74 percent more efficient total running-costwise. . .

He decided to cut the rest of the statistics. Of course it was all totally familiar to him, but somehow he required the confirmation of the existence of this remarkable system. The Index went on to state that "it is generally accepted that nowadays uncontrolled PM based on individual manual operation would be impossible" and he had never accepted anything else. He had been stationary in this one hold-up for nearly half an hour now, and that was a unique event in the history of the Department of T-CoP. It made him uncomfortable.

He decided to check his instructions again, not that he had not done so several times before he left home, but rather he sought some kind of comfort. Reality, perhaps, only confirms itself in the iterative statement of its being.

A-Maze Games Incorporated Presents. . .

The ultimate computer game. . .

The Labyrinth of Reality!!!

Why play with time when you can play though time? Why play on a screen when you can play in 3D space? Why interact with pictures when you can interact with people?

The Labyrinth of Reality Instruction One.

Access PM to PH5618/763L immediately. You will receive further instructions whilst you are travelling.

Signal reference as before.

And that was that. He wondered if his progress was being measured somehow and whether that would affect the timing and even content of his next instructions. Of course, he had no idea and his attempted speculations chased their own tails into a void.

The Labyrinth of Reality, developed in response to demand for leisure activ-

ity, was a game which was unique to each participant. The participant's own talents and resourcefulness were major factors in the game. Early movements in this direction included games where the computer selected at random one of a number of activities which the participant then undertook. Increasing degrees of complexity had been added to this basic framework and so, eventually, the first version of Labyrinth was born.

In theory, all participants are entered in the game computer. The machine allocates various adventures and activities to different people and groups of people. Each person receives instructions and at "game points" these instructions instigate the interaction of two or more participants in one or more events. The result of each interaction is fed back to the game computer which uses this continual update to calculate the next set of instructions.

The game is extremely fluid, existing in real-time and space. By necessity, it is totally secret. It is also claimed, by A-Maze Games, that spontaneous interactions develop and are often indiscernible from game computer co-ordinated interactions. Enrolment in the game can take place at any time simply by responding to advertisements on the commercial channels. Once the enrolment information has been input, the participant awaits confirmation and the instructions which follow at an unspecified time.

Most people only play a game on a part-time basis, having told the computer when they would be available. A-Maze Games stresses that it is secrecy that makes such flexibility possible, as it is the condition for most aspect of the game.

He found himself staring blankly at the girl in the next car, who returned his stare with equal blankness, when he received his next Labyrinth instruction.

"Your destination is unchanged.

"Instruction update requires that you make contact with the girl in the next car beside yours and bring her with you to your destination.

"Instruction updates continue on this signal reference".

For some reason, convinced of a necessity for immediate response, he got out of the car. The unusual turn of events struck him more as a malfunction than a unique happening. His Labyrinth instructions, under these circumstances, assumed the robes of order rather than adventure.

The girl, like him, was in her late teens. She seemed surprised by his action. At first she refused to let him into her car and would only talk to him with the window lowered half-way.

"Are you in the game, too"? was his opening question.

"Sorry, what game"? He looked up

(continued on next page)

(continued from previous page)

and down the queue of cars, and while no one could hear him, he was certainly the centre of attention.

"You know, Labyrinth. Is this meeting in your instructions?"

"Look, if this is your idea of a casual conversation . . ."

"No, you must have heard of Labyrinth — the game, you know". He looked imploringly at her, unable to find more words. He was earnest but wholly out of his element. That much, at least, she could tell.

"OK, yes, I'm in the game and yes this is in my instructions, but I'm not supposed to admit that, it's supposed to be up to you to persuade me to go with you. But after sitting in this mess for an hour I don't feel like playing too many games. So, we've met, what do we do now?"

"Wait", he said smiling.

He had been leaning on the car, bending down to talk at the window. Now he stood up straight in the orange glow of the lamplight. He looked up and down the queue of cars as he had done before, except that now he felt strangely relaxed. He was waiting once again, yes, but he was sure that his waiting was leading to something significant. The rain had turned into a thin drizzle and in the distance he thought he could see the red tail-lights of cars, moving.

When he awoke it was still dark. He listened but could hear no rain. On the control console an orange light was flashing. He looked across at the figure of the girl. She was still asleep. He sat up as the events of the night gradually returned.

The jam had cleared and they had sped off into the darkness of the countryside. For some time they had talked and played games, always speculating on what their next instructions might contain.

The memories faded into action. He sat before the control console and responded to the orange light. This was a signal to indicate that the destination had been achieved, as programmed. He asked for a site report on the destination and then disengaged the vehicle from T-CoP. As he waited for response, he turned round to look at the girl. She was just beginning to stir.

Small green letters informed him that his programmed destination had been one of the system exists, and therefore that was where he was now. System exists were those points where roads left the area controlled by T-CoP, giving access to those few areas where individual manual operation was still allowed.

"Where are we now"? asked a sleepy voice behind him.

"We've achieved our destination. It's one of the system exists. No instruction update as yet".

Almost as he finished speaking, the VDU began to print out a message which

he immediately recognised as an instruction update.

Drive down this road for approximately two miles. You will arrive at a crossroads. This is your destination.

At this site there is a ruined building. There you will find a riddle which, once solved, will give you a clue.

Waste NO time.

Instruction update on this signal reference.

Although he had been taught to drive, he had never had to do so in order to get somewhere. He mastered this necessity with surprising speed, and soon they arrived at the crossroads.

He keyed a request into the console.

"Well", he told her. "It will be dark for another hour. Sunrise will be in an hour and 21 minutes. Weather will continue to improve and tomorrow it will be quite warm and sunny".

"Shall we explore, then"? She need not have asked. The instructions had said "waste no time", and anyway they were both curious to a point where all other considerations were excluded. So they left the car and began to explore.

The ruins were those of a church. Overgrown with brambles and roofless, to them it was just a strange old building. They found a clearing in what would have been the chancel, and doubled their search for the riddle. Having found nothing, they eventually sat on a step and discussed their next move.

"I thought the thing we're looking for would be in some obvious form", she said. "You know, words or numbers or something like that. But all I can find is damp, crumbling walls, soaking wet vegetation and . . ."

She broke off with a shout, and pointed through a gap in the masonry to where a line of lights were approaching the ruin. The light was not the familiar beam of hand-torches or headlights, but of flame.

Half-afraid, and half-convinced that this was the riddle, they extinguished their own lights. Not daring to move, they found themselves holding on to each other for security. The lights approached and they could discern the dim shapes of the advancing group, each one bearing a light. They filed into the clearing, forming a circle around the two frightened people.

There was a silence, a pause, and then a woman, spoke.

"Our instructions were simple, nevertheless you followed them. In several months you are the first to have come this far. You are the first whose desire for satisfaction has been strong enough to overcome the lethargy of the time.

"You have heard of us in two ways. You think we are A-Maze Games who juggle with people's lives in an attempt to bring them some genuine excitement, and indeed we are the people responsible for The Labyrinth of Reality. But we are also the people responsible for that T-CoP

failure you experienced earlier. In fact we used one to engineer the other.

"We are also responsible for those programming problems on Diana Six and a number of other minor malfunctions which do their best to disturb the sterile perfection of our lives. We are responsible for trying to nudge people from security".

"Then you are members of CRASH", the girl replied. "And what are we, hostages or sacrifices"?

"You have heard of us". There was a tone of approval in the woman's voice. "You are neither. You are here because deep down you wish to join us, because you know the only adventure which satisfies is a real one. Labyrinth of Reality is nothing to this".

"We must have time to think, at least, I must". "Of course", she turned to him, "And what about you"?

He was not paying attention any more. It was all happening too fast for him to understand the implications of any decision.

"You too need time to think, I would say. It's a capacity which you will find takes time to develop, but is well worth it in the end".

He looked up. Through the ruins of a window he could see the first beams of sunrise penetrating the morning mist.

Eric waited patiently, sitting before his treasured invention. It was not unusual for decisions to take some time to be made. After all, it was a rather complex piece of machinery, even if he did think so himself. After two years of research he was more interested in the machine and its programming than anything to do with the stories it produced.

As he waited for the story to continue, he stared out of the window and contemplated the program. There were several areas he needed to expand. His attention was drawn back to the computer some minutes later by a soft crackling noise. He looked at the back of the machine to where the sound was coming from.

A shower of sparks spilled out of the casing from a short circuit inside. Before he had time to recover from the shock, a flame sprang up inside the machine and dark, choking smoke began to pour out.

"Oh my God"! he screamed. He tried to smother the flames but already they had spread to his papers on the bench. The screen was going haywire.

It was the laboratory assistant who pulled Eric from the room, and in the nick of time too. Minutes later the side of the building was torn open by an explosion which would most certainly have killed anyone left inside.

Eric watched the activities of the Fire Brigade while his hands were being expertly bandaged. Two years work was lost; he doubted whether it could ever be repeated. □



## **We'd love to market the game you've invented. If we can tear ourselves away from it.**

If your program is compelling enough to glue us to our television sets, then it's just what we're looking for. And if we can leave it alone for long enough to produce it, we'll glue millions of other people to their sets as well.

THORN EMI is looking for video games and other general interest programs, which have been produced for home computers from the following:

Apple, Atari, B.B.C., Commodore, Sinclair or Texas Instruments.

Whether you're a professional programmer or competent amateur, if you have produced a program that you think we may be interested in, we'd love to hear from you.

Please don't send the program direct. Write to Home Computer Software Department, THORN EMI Video Programmes, Upper St. Martins Lane, London W.C.2. and we will send you an application form.

**Leaders in home video entertainment.**



● Circle No. 155

# SOFTWARE FOR CP/M®

HIGH QUALITY SOFTWARE – WITH HIGH QUALITY SERVICE

★ NEW THE FORMULA £300. Application Builder and Reporter. SPELL STAR £125. Option for Wordstar. SUPER CALC £165. Spread Sheet financial planning.

WORDSTAR - Professional word processing software. On-screen formatting, wordwrap, pagination, line and character count on view. Micro-justification on daisy-wheel printer. Search and replace. Block/paragraph manipulation. External file read/write. Background printing during editing etc.	£250	MICROSOFT FORTRAN COMPILER	£205
MAIL-MERGE - Powerful Wordstar enhancement for file merging and document personalisation.	£65	MICROSOFT COBOL	£310
DATASTAR Screen orientated system for Data Entry, Retrieval and Updating.	£175	MAGSAM - Versatile easy to use Keyed File Management System for Microsoft Basic or CBASIC.	£130
SUPERSORT - Sort, merge and selection program.	£125	CIS - COBOL - ANSI' 74 implementation to full level 1 standard. Supports random, indexed and sequential files, features for conversational working, screen control, interactive debugging, program segmentation etc.	£425
CONFIGURABLE BUSINESS SYSTEM (CBS) - Unique information management system with user definable files, powerful report generator, menu-driven for ease of use. No programming experience necessary!	£225	FORMS-2 - Automatic COBOL code generator for screen formats.	£100
ACCOUNTING PACKAGES by Median - Tec: PAYROLL, SALES, PURCHASE, NOMINAL Specially developed by UK software house to exacting specifications. Written in Microsoft Basic each package may be customised by end user, all are widely used. Ledgers are open item. Payroll caters for weekly and monthly pay.	£300 each	PASCAL-Z	£255
PROJECT COST CONTROL/JOB ACCOUNTING - A comprehensive set of programs to monitor budgets, account for expenditure and project completion etc. Ideally suited for contractors. Written in CBASIC-2.	£150	STRUCTURED BASIC - Relocatable compiler	£160
STATISTICS PACKAGE - Over 25 routines including Regression & ANOVA	£100	CBASIC-2 - Extended Disk Basic pseudo compiler and run-time interpreter.	£75
MATHS PACKAGE - Over 40 easily used routines.	£100	SELECTOR III - C2 - Information management system written in CBASIC-2	£185
IBM - CP/M COMPATIBILITY - Powerful utility to transfer data to/from IBM machines in standard disk format.	£110	SELECTOR IV - Upward compatible version of III with enhanced reporting.	£300
MICROSOFT BASIC INTERPRETER	£155	BSTAM - Telecomms facility for exchanging files between CP/M computers.	£100
MICROSOFT BASIC COMPILER	£205	ASCAM - Facility for communicating with other computers.	£95
		TRANSFER - CP/M to CP/M file exchange - telecomms source code	£95
		MACRO 80 - Macro Assembler	£99
		CP/M 2.2 - Standard Version 8" Single Density.	£99
		Please contact us for availability of other products All orders must be PREPAID. Add £1 per item P & P (Minimum £2.00) and VAT CP/M is trade mark of Digital Research	



## TELESYSTEMS LTD

P.O. Box 12, GREAT MISSENDEN, BUCKS, HP16 9DD  
Telephone (02406) 5314



● Circle No. 156

### PAYROLL ?



**SUPERBRAIN QD 64K**

### SALES ?



**APPLE II 48K**

### STOCK ?

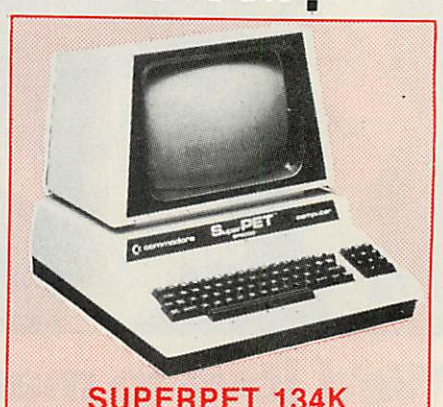

**SUPERPET 134K**

**TRY BEFORE YOU BUY!** If you are considering the acquisition of a microcomputer why not visit our demonstration suite one evening and try our Apples, PETs and Superbrains first. **We can open outside our normal hours to suit you.** Even weekends! Come and see the range of business utilities your competitors are using. We have the full TABS integrated accounting system Nominal, Sales, Purchase Ledgers, Payroll, Stock Control, etc. Video Training films, word-processing, automated filing and financial modelling systems **ready to help you.** We are Authorised Dealers for several micros and are in business to sell you a solution rather than one manufacturer's specific hardware. After all, to a business it's the effort and money you save that's important not the internal machine specifications. We offer our business clients lease/rental terms to bring the benefits sooner, without capital drain.

**FOR EXAMPLE A TYPICAL BUSINESS SYSTEM COMPRISING SAY, AN APPLE II, A DISK DRIVE, MONITOR, PRINTER AND VISICALC CAN BE INSTALLED ON YOUR DESK AND WORKING FOR YOU NEXT WEEK FOR LESS THAN £12.00 PER WEEK EX. VAT AND ALL DEDUCTIBLE!**

Naturally, we provide full support and after-sales service of the highest level.

INTERESTED? CALL NOW FOR DETAILS.

# MASS MICROS

**WELWYN GARDEN  
31436**

WELLSON HOUSE, BROWNFIELDS, WELWYN GARDEN CITY, HERTS. Telex 298641.

● Circle No. 157

# WHEN IT COMES TO MICROCOMPUTER SOFTWARE WE WROTE THE BOOK

How do you stay up-to-the-minute with the rapidly changing world of microcomputer software? Get the Lifeboat Catalogue.

**The latest innovations** The new Lifeboat Catalogue is packed with the latest state-of-the-art software. And if we publish a new program after the latest catalogue has gone to press, we enclose a flash bulletin in your copy.

#### The greatest selection

Because Lifeboat is the world's largest publisher of microcomputer software, our catalogue offers you the greatest selection of programs for business, professional and personal use. Our more than 200 programs range from the integrated accounting and professional practice systems to office tools for book-keepers and secretaries to sophisticated tools for programmers. Included are business systems, word processors, programming languages, database management systems, application tools and advanced system utilities.

We specialise in software that runs on most small business computers. Our more than 60 media formats, including floppy disks, data cartridges, magnetic tape and disk cartridges, support well over 100 different types of computer.

**Get full service** We give the crucial dimension of after-sales service and full support to everything we sell.

That includes:

- An update service for software and documentation.
- Telephone, telex and mail-order services in the London office and at overseas offices in the United States, France, Switzerland, West Germany and Japan.
- Subscriptions to Lifelines,™ the monthly magazine that offers comparative reviews, tips, techniques, identified bugs and updates that keep you abreast of change.

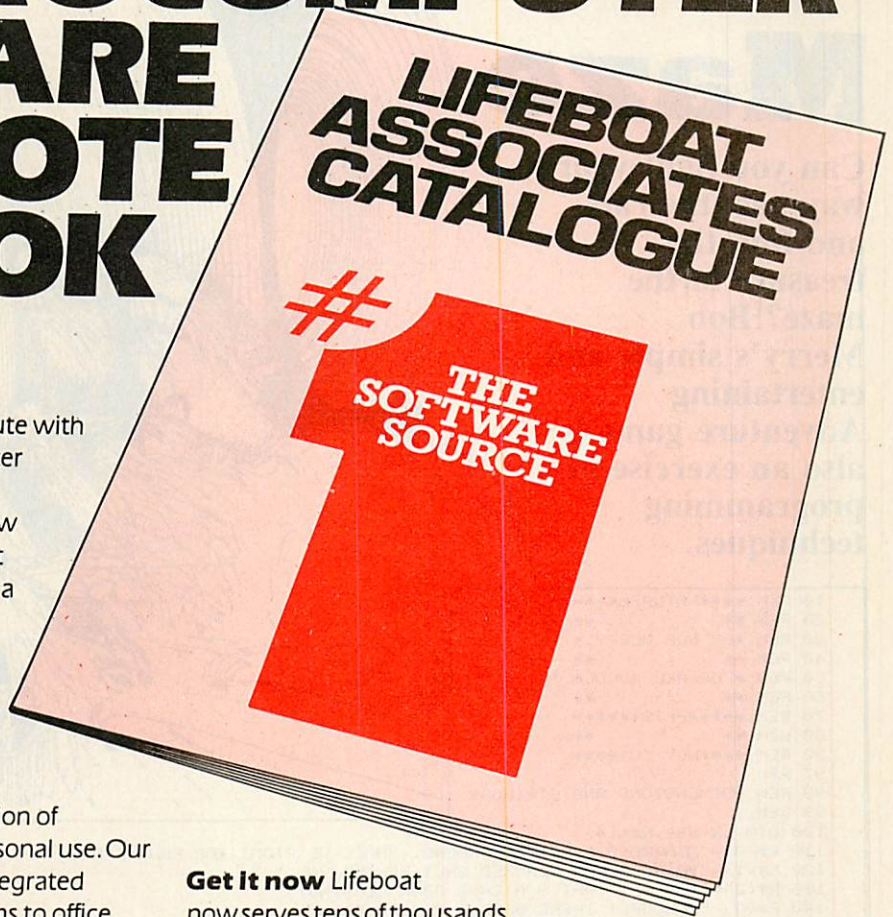

**Get it now** Lifeboat now serves tens of thousands of satisfied customers with our breadth of up-to-date, fully tested, fully supported and competitively priced software.

You may not need all we offer, but we offer just what you need. After all, we wrote the book.

**#1 Lifeboat Associates**  
World's foremost software source

#### Mail coupon to: Lifeboat Associates

PO Box 125, London WC2H 9LU or call 01-836 9028

Please send me a free lifeboat catalogue.

Name \_\_\_\_\_

Title \_\_\_\_\_

Company \_\_\_\_\_

Address \_\_\_\_\_

Postcode \_\_\_\_\_

Copyright © 1981, by Lifeboat Associates.

**Lifeboat Worldwide** offers you the world's largest library of software. Contact your nearest dealer of Lifeboat.

**USA** Lifeboat Associates 1651 Third Ave. New York NY 10028 Tel (212) 860-0300 Telex 640693 (LBSOFT NYK) TWX 710 581-2524 **JAPAN** Lifeboat Inc. OK Bldg. 5F 1-2-8 Shiba-Daimon Minato-ku Tokyo 105 Japan Tel 03-437-3901 Telex 2423296 (LBJTYO) **ENGLAND** Lifeboat Associates Ltd PO Box 125 London WC2H 9LU England Tel 01-836 9028 Telex 893709 (LBSOFTG) **SWITZERLAND** Lifeboat Associates GmbH Hinterbergstrasse Postfach 251 6330 Cham Switzerland Tel 042-36-8686 Telex 865265 (MICO CH) **WEST GERMANY** Intersoft GmbH Schlossgartenweg 5 D-8045 Ismaning W. Germany Tel 089-966-444 Telex 5213643 (ISOFD) **FRANCE** Lifeboat Associates SARL 10 Grande Rue Charles de Gaulle 92600 Asnieres France Tel 1-733-08-04 Telex 250303 (PUBLIC X PARI)

● Circle No. 158

The maze used in Ratmaze has 100 junctions arranged in four levels, each consisting of a five-by-five square. A typical layer is shown in figure 1 — this is not one of the layers in the game itself, but serves to illustrate how the techniques were developed. Each junction can connect to its neighbours in up to six directions: north, south, east, west, up and down. In the diagram the symbol  $\circ$  indicates up and \* indicates down.

The original idea was to use a two-dimensional array, such as L%(99,5), to store the maze data. One dimension, 0 to 99, represents the junctions and the other, 0 to 5, represents the directions. Each element holds the number of the junction to which it is connected, and where there is no connection an out-of-range number is used. Zero cannot be used, as this is one of the junction numbers.

The array as it would look for the start of figure 1 is shown in figure 2. However, this method contains a lot of redundant information. The regular structure of the

YOUR OBJECTIVE is to find the treasure hidden in a maze of passages guarded by packs of ferocious rats which must be killed or beaten off. Ratmaze fits into 8K on any Pet, if the Rems are reduced, and it should also be fairly easy to adapt it to another computer that supports the logical And function in a similar way to the Pet.

### The four levels



# Rat Maze

Can you fight your way past the rats and find the treasure in the maze? Bob Merry's simple and entertaining Adventure game is also an exercise in programming techniques.

10 REM \*\*\*\*\*RATMAZE\*\*\*\*\*  
 20 REM \*\*  
 30 REM \*\* BY BOB MERRY.  
 40 REM \*\*  
 50 REM \*\* FOR ALL 40COL.  
 60 REM \*\*  
 70 REM \*\*\*\*\*PETS\*\*\*\*\*  
 80 REM \*\*  
 90 REM \*\*\*\*\*NOV 78\*\*\*\*\*  
 99 REM  
 98 REM +DIMENSIONS AND STRINGS+  
 99 REM  
 100 DIM L%(99),R%(14)  
 110 R%(0)="THERE'S A RATPACK AHEAD. SHALL WE FIGHT FOR RUN (F/R)?"  
 120 R%(1)="99 DOOR HAS SLAMMED SHUT BEHIND YOU."  
 130 R%(2)="OH-OH! THAT'S A CRAB DOOR CLOSING!  
 140 R%(3)="MHOOPS! THERE GOES A PORTCULLIS!  
 150 R%(4)="THEY'VE BEEN FALLING INTO A PIT!  
 160 R%(5)="MIT'S LOCKED TIGHT AND WILL NOT BUDGE!  
 170 R%(6)="LOOK'S LIKE WE'RE IN THE RAT TRAP!  
 180 R%(7)="MIT'S TOO HEAVY TO LIFT.  
 190 R%(8)="WHEN YOU HEAR A HISsing SOUND?  
 200 R%(9)="MIT'M AFRAID THIS IS THE END.....  
 210 R%(10)="BUT YOU DIED RICH!!  
 220 R%(11)="SORRY! YOU'VE DIED OF EXHAUSTION  
 230 R%(12)="YOUR WOUNDS MAKE IT IMPOSSIBLE TO WALK  
 240 R%(13)="ANOTHER GAME (Y/N)?  
 250 R%(14)="PLEASE WAIT A FEW MOMENTS  
 257 REM  
 258 REM +INSTRUCTIONS+  
 259 REM  
 260 PRINT "\*\*\*\*\*RATMAZE\*\*\*\*\* BY BOB MERRY"  
 270 PRINT "PRESS 'I' FOR INSTRUCTIONS OR 'S' TO  
 280 PRINT "START:CF="IS":GOSUB130  
 290 IFF#=S"THEN430  
 300 PRINT "THE OBJECT OF THE GAME IS TO FIND A  
 310 PRINT "TREASURE HIDDEN IN A MAZE OF TUNNELS.  
 320 PRINT "IT IS GUARDED BY FIERCE RATPACKS. YOU  
 330 PRINT "MAY RUN FROM THEM BUT YOU WILL HAVE TO  
 340 PRINT "FIGHT SOME IF YOU WANT THE TREASURE.  
 350 PRINT "IF THEY MOUND YOU, YOUR AGILITY WILL BE  
 360 PRINT "REDUCED, WHILST THE EFFECT OF FIGHTING  
 370 PRINT "OR HANGERING TOO LONG IN THE MAZE WILL  
 380 PRINT "WEAR YOUR STRENGTH. SOME TUNNELS LEAD TO  
 390 PRINT "DEADLY TRAPS. ALL YOUR DECISIONS ARE  
 400 PRINT "MADE BY PRESSING SINGLE LETTERS. NOW  
 410 PRINT "PRESS 'S' TO START.  
 420 CF="S":GOSUB130  
 430 PRINT#(14)  
 437 REM  
 438 REM +DATA FOR MAZE TUNNELS+  
 439 REM  
 440 DATA 16,56,56,56,18,18,120,72,64,34,34,80,40,16,18,112,112,40,96,34,96  
 450 DATA 80,74,80,72,0,48,24,24,12,100,48,48,24,24,100,96,16,18,96  
 460 DATA 96,80,18,20,72,80,28,24,48,34,48,48,112,120,72,80,104  
 470 DATA 64,80,48,36,98,18,48,68,96,2,80,24,72,0,36,48,12,16,48  
 480 DATA 80,120,40,48,104,48,88,120,120,72,68,48,72,112,8,28,72,16,88,0  
 487 REM  
 488 REM +LOAD DATA FOR TUNNELS AND RANDOM RATPACKS+  
 489 REM  
 490 RESTORE FOR I=0 TO 99  
 500 REDIM L%(I):IFRND(I)>9 THEN L%(I)=L%(I)+1  
 (listing continued on page 104)

maze means that any move north decreases the junction number by 5; a move south increases it by 5; going east adds 1; and west subtracts 1. Moving one level up decreases the junction by 25 and going down a level increases it by 25.

These characteristics can be built into the program itself so that the array only has to hold a series of Go/No-go statements — see figure 3. The next stage was to develop a program using this two-dimensional array. An old-ROM Pet cannot handle arrays with so many elements, so a version was developed using six separate arrays, one for each direction.

Both versions worked well and there is no reason why this technique cannot be used — indeed, something similar would have to be used to define a non-regular maze. Nevertheless, all those 0s and 1s, should be meat and drink to a micro, and it became clear that it must be possible to simplify the program by using them more directly.

## Bit-by-bit basis

In the Pet, the And function is used to compare binary numbers on a bit-by-bit basis. It is also used to compare statements for simultaneous states of truth, for example,

```
300 IF A=64 AND R$="YES" THEN 1000
300 IF A AND R$="YES" THEN 1000.
```

The first part means "if A is true", and the computer accepts any positive value of the variable A to be true, and zero or negative values to be false. This abbreviated form is used in Ratmaze.

Logical And compares binary numbers in the following manner:

```
A=11010110
B=10001100
A AND B=10000100
```

The statement A And B results in a 1 bit wherever a 1 appears in both A and B in the same position; otherwise a 0 is generated.

Junction 26 from figure 3 can be expressed as a binary number:

```
011100
```

If you want to see if you can go north, you simply logical-And this with 100000. The result is 000000 — in logical terms, the condition is False — which means that you cannot go north from junction 26. To go south, you logical-And the same number with 010000. The result is 010000, so the condition is True and you can go south.

## Reduced to binary

All the data for the maze can be reduced to a series of binary numbers, which can be held in a single array using their decimal equivalents. In the case of the maze in figure 1 the data in figure 3 can be reduced to the single numbers shown in figure 4.

There are only six directions that you can take at each junction, while eight-

digit binary numbers can be used to define them, so there is a little spare capacity in this system for holding other information. In Ratmaze program, one of the spare bits is used to show whether there is a rat pack at the junction to be cleared before you continue. This is shown by a 1 in the least significant bit, while the direction information occupies the following six bits. The most significant bit is unused.

In addition to the three-dimensional maze, the player has to face the rat packs which pop up from time to time. You can run away from them, but the program has been designed to place packs at some key junctions where these must be fought. Strength and agility ratings are included in the game. If either reaches zero, then the player loses.

The program starts by setting up two arrays. The integer array L%(99) contains the details of the maze, while the string array R\$(14) contains various phrases that are used; they are loaded into the array in lines 110 to 250. The page of instructions which follows uses the subroutine at 1130. Only letters contained in C\$ will cause the program to continue. While it is waiting for an acceptable response, it runs through random numbers to ensure a different game every time.

## Integer array

After the instructions comes the Data statements for the maze. They are loaded into the integer array in lines 490 to 510 which also include a simple random placing of rat packs, indicated by setting the least significant bit to 1. Lines 520 to 560 place rat packs at five key junctions, if they are not already there. This is checked by seeing if the least significant bit is 1 or 0:

```
IF (L%(12) AND 1)=0 THEN ...
```

Line 570 sets to zero the four variables corresponding to strength S, agility A, current location L and possession of treasure TR. It also defines a simple function used to generate random numbers in the range 0 to X.

During the game line 590 determines whether or not there is a loss in strength and it is to this point that the program loops at each junction. To avoid losing strength during the first run through in a game it is by-passed by line 580.

In lines 600 to 660 the appropriate element of the integer array is inspected and the available directions are printed. This routine uses the And function.

Now the players make their choice using a single-letter response. All six directions are included in the permitted responses C\$, but you need to check whether the chosen response is valid for the junction in question. If it is, the necessary change to the location number must be made in lines 680 to 740. Line 740 is only reached if all the tests in the previous lines are failed.

Line 750 modifies the location number and checks to see whether the number of the new location is divisible by 25. There are four traps in the maze from which there are no exits: they are the ones which are zero in the data statements and are set at regular intervals in the maze. If the player moves into one of them the program diverts to line 870, which determines which of the traps you have fallen into and prints the appropriate elements from the array R\$(14). Line 880 prints end-of-game messages, and 890 to 900 give the option of another game.

## Check for rats

If the traps have been avoided the program checks for the presence of a rat pack, and branches forward to 810 unless it is present. This line is a means of checking whether L is zero — signifying the Exit location — since any non-zero value is logically true, causing the program to loop back to 590. If however L is zero, you are at the Exit and success then depends on whether you have found the

(continued on next page)

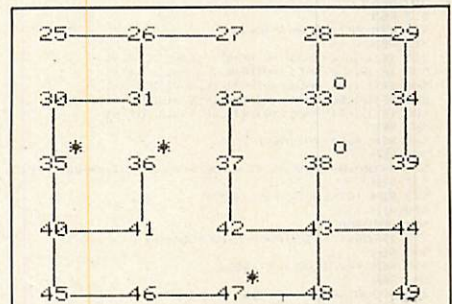

Figure 1.

Element	marker	Direction	Junction				
5							
D							
25	—	—	26	—	—	—	—
26	—	31	27	26	—	—	—
27	—	—	—	27	—	—	—
28	—	33	29	—	—	—	—
29	—	34	—	28	—	—	—
30	—	35	31	—	—	—	—

Figure 2.

	0	1	2	3	4	5
	N	S	E	W	U	D
25	0	0	1	0	0	0
26	0	1	1	1	0	0
27	0	0	0	1	0	0
28	0	1	1	0	0	0
29	0	1	0	1	0	0
30	0	1	1	0	0	0

Figure 3.

Junction	Value
25	8
26	28
27	4
28	24
29	20
30	24

Figure 4.

(continued from previous page)

treasure — the condition TR=1. If not, you have the option to re-enter the maze immediately or quit.

When you encounter a rat pack the first choice is to fight or run. The choice to fight causes a branch to 920; running takes you to 790. Line 790 first backtracks to the previous location, using the modifier still in M. Of course, running away can have its dangers; and if your agility has fallen below 50, subroutine 1240 is called and a random number of wounds — up to 8 — are inflicted. This is reported to you in lines 1250 to 1260, and your agility is further reduced by up to this number of wounds. If A falls below 1, the game is over and this is reported by lines 1170 and 880 to 910.

When you choose to fight, line 920 sets the size of the rat pack to between 10 and 30 rats. They will attack you in waves of five rats at a time, and you will be given the choice of Lunge, Cut or Dodge. A lunge is guaranteed to kill one rat; a cut can kill more, dependent on your

strength, but you may also miss entirely. Dodging will reduce the number of wounds you take, but it depends on your agility, as does the ability to make several cuts in succession.

### Loss of agility

The choice of response is made using subroutine 1180, and lines 930 to 950 branch to the appropriate part of the program. Line 960 makes the one kill for the Lunge option and this is reported by subroutine 1200. Line 970 then gives the choices for continuing the fight. Making a cut depends on agility, but you can always try to dodge. If you try to continue with another lunge, or if you attempt to cut fails, then the rats get too close and all of them wound you, resulting in a loss of agility in subroutine 1260.

The Cut option starts at line 1000, which allows you to kill a number of rats determined by your current strength. Cutting could also sap your strength, so the next line allows for a random loss of strength. As with the loss of strength

when moving about the maze, this could reduce your strength to zero, so this is checked in subroutine 1290.

If all the rats in that wave have been destroyed then the program branches to 1060, where the subroutine to print out S and A is called and the size of the rat pack is checked to see whether there is enough for another wave. Eventually the size of the rat pack will be reduced to four or less, and that location can be cleared of rats by line 1090.

The other option you have is to dodge, and this is covered in lines 1040-1050. This option reduces the number of wounds suffered according to agility, but the rest of that wave gets through and subroutine 1260 reports the number of wounds.

There will always be a rat pack at the treasure location, so you check for this location at the end of the fight sequence before continuing the movement through the maze. Subroutine 1230 is simply a delay to allow you to read some reports before they disappear from the screen.

(listing continued from page 102)

```

510 NEXT
517 REM
518 REM +FIXED RATPACKS+
519 REM
520 IF(L:(L2)AND1)=0THENL:(L2)=L:(L2)+1
530 IF(L:(L3)AND1)=0THENL:(L3)=L:(L3)+1
540 IF(L:(L4)AND1)=0THENL:(L4)=L:(L4)+1
550 IF(L:(L5)AND1)=0THENL:(L5)=L:(L5)+1
560 IF(L:(L6)AND1)=0THENL:(L6)=L:(L6)+1
567 REM
568 REM +SET VARIABLES+
569 REM
570 S=100:A=100:L=0:TR=0:DEFNAX=INT(X/RND(1)+.5)
577 REM
578 REM +STRENGTH REDUCED?+
579 REM
580 GOTO500
590 IFNAX(1)=1THENS=S-.5:GOSUB1290
597 REM
598 REM +AVAILABLE TUNNELS+
599 REM
600 GOSUB1160:PRINT"THE CAN GO ";
610 IFL:(L)AND6 THENPRINT" NORTH ";
620 IFL:(L)AND3 THENPRINT" SOUTH ";
630 IFL:(L)AND1 THENPRINT" EAST ";
640 IFL:(L)AND3 THENPRINT" WEST ";
650 IFL:(L)AND4 THENPRINT" UP ";
660 IFL:(L)AND2 THENPRINT" DOWN ";
667 REM
668 REM +SELECT DIRECTION - CHECK VALIDITY+
669 REM
670 PRINT:PRINT" WHICH WAY (N/S/E/W/U/D)? ";:C#="HSEIUD":GOSUB1130
680 IFR#="N"AND(L:(L)AND6)=0THENM=5:GOTO750
690 IFR#="S"AND(L:(L)AND3)=0THENM=5:GOTO750
700 IFR#="E"AND(L:(L)AND1)=0THENM=1:GOTO750
710 IFR#="W"AND(L:(L)AND3)=0THENM=-1:GOTO750
720 IFR#="U"AND(L:(L)AND4)=0THENM=25:GOTO750
730 IFR#="D"AND(L:(L)AND2)=0THENM=25:GOTO750
740 PRINT"THE CAN'T GO THAT WAY. THINK AGAIN":GOTO670
747 REM
748 REM +MAKE MOVE - CHECK FOR TRAP+
749 REM
750 L=L+M:IFINT((L+1)/25)<(L+1)/25THEN870
757 REM
758 REM +CHECK FOR RATPACK+
759 REM
760 IFL:(L)AND1)=0THEN810
767 REM
768 REM +FIGHT OR RUN?+
769 REM
770 PRINT:(0):C#="FR":GOSUB1130
780 IFR#="F"THEN920
787 REM
788 REM +RUN OPTION+
789 REM
790 L=L-M:IFR(50)THENGOSUB1240
800 GOTO590
807 REM
808 REM +AT EXIT?+
809 REM
810 IFLTHENS90
820 PRINT"THIS IS THE EXIT!"
827 REM
828 REM +WITH TREASURE?+
829 REM
830 IFR=1THENPRINT"WELL DONE!!! YOU'VE WON!":GOTO910
840 PRINT"BUT YOU HAVE NOT GOT THE TREASURE. DO YOU WANT ANOTHER GO (Y/N)?
850 C#="YN":GOSUB1130:IFR#="Y"THEN590
860 GOTO910
867 REM
868 REM +END OF GAME IN TRAP+
869 REM
870 X=INT((L+1)/25):PRINT:(X):PRINT:(X)+4)
880 PRINT:(9):IFTR=1THENPRINT:(10)
890 PRINT:(13):C#="YN":GOSUB1130
900 IFR#="Y"THENPRINT:(14):GOTO490
910 END
917 REM
918 REM +FIGHT OPTION+
919 REM
920 RP=10+FNA(4)*S:PRINT"WHERE THEY COME!
927 REM
928 REM +CHOICE OF RESPONSE+
929 REM
930 RA=5:GOSUB1180:IFR#="L"THEN960
940 IFR#="C"THEN1000
950 GOTO1040
957 REM
958 REM +LUNGE OPTION+
959 REM
960 RP=RP-1:K=1:RA=4:GOSUB1200
970 GOSUB1180:IFR#="C"ANDRND(1)*R(30)THEN1000
980 IFR#="D"THEN1040
990 PRINT"THEY'RE TOO CLOSE!":M=RA:GOTO1050
997 REM
998 REM +CUT OPTION+
999 REM
1000 K=INT(FNA(RA+1)*(S-1)/100):RP=RP-K:RA=RA-K:GOSUB1200
1010 S=S-FNA(2):GOSUB1290
1020 IFR#="D"THEN1060
1030 GOSUB1160:GOTO970
1037 REM
1038 REM +DODGE OPTION+
1039 REM
1040 D=INT(A/25+.7):M=RA-FNA(D):IFW(0)THENW=0
1050 GOSUB1260
1057 REM
1058 REM +END OF FIGHT?+
1059 REM
1060 GOSUB1160:IFRP(4)THEN1080
1070 PRINT"MORE RATS ATTACKING!":GOTO930
1080 PRINT"YOU'VE KILLED MOST OF THEM AND THE REST HAVE RUN OFF!
1090 IFL:(L)=L:(L)-1:GOSUB1230:IFL(0)THEN820
1097 REM
1098 REM +AT TREASURE?+
1099 REM
1100 IFL(370)TR=1THEN590
1110 PRINT"YOU'VE FOUND THE TREASURE! NOW YOU MUST GET OUT.":TR=1
1120 GOSUB1230:GOTO590
1124 REM
1125 REM +SUBROUTINES+
1126 REM
1127 REM
1128 REM +GET REPLY+
1129 REM
1130 GETR#R=RND(1):IFR#=""THEN1130
1140 FORI=1TOLEN(C#):IFR#MID(C#,I,1)THENRETURN
1150 NEXT:GOTO1130
1157 REM
1158 REM +PRINT STRENGTH/AGILITY+
1159 REM
1160 PRINT"STRENGTH:   ";INT(S);TAB(20);"AGILITY:   ";INT(A):RETURN
1167 REM
1168 REM +END OF GAME WITH ZERO S OR A+
1169 REM
1170 PRINT:(R):GOTO880
1177 REM
1178 REM +LUNGE CUT OR DODGE?+
1179 REM
1180 PRINT"DO YOU WANT TO LUNGE, CUT OR DODGE (L/C/D)?":C#="LCD"
1190 GOSUB1130:RETURN
1197 REM
1198 REM +NUMBER KILLED+
1199 REM
1200 PRINT"YOU'VE KILLED"K:R#="IS":IFR(1)THENR#="ARE
1210 IFR#="R"THENRETURN
1220 PRINT"THEY'RE STILL COMING!":RETURN
1227 REM
1228 REM +TIME DELAY+
1229 REM
1230 FORI=1TO2000:NEXT:RETURN
1237 REM
1238 REM +WOUNDS ON RUN+
1239 REM
1240 W=FNA(8):IFW(0)THENRETURN
1250 PRINT"YOU'RE NOT QUITE QUICK ENOUGH
1257 REM
1258 REM +REPORT OF WOUNDS+
1259 REM
1260 PRINT"YOU'VE SUFFERED"W"WOUND":IFW(4)THENPRINT"S";
1270 PRINT":A=FNA(W):IFR(1)THENR=12:GOTO1170
1280 RETURN
1287 REM
1288 REM +STRENGTH TOO LOW?+
1289 REM
1290 IFS(5)THENR=11:GOTO1170
1300 RETURN
READY.

```

# TURBOCHARGED PERFORMANCE: when you need speed without crashing

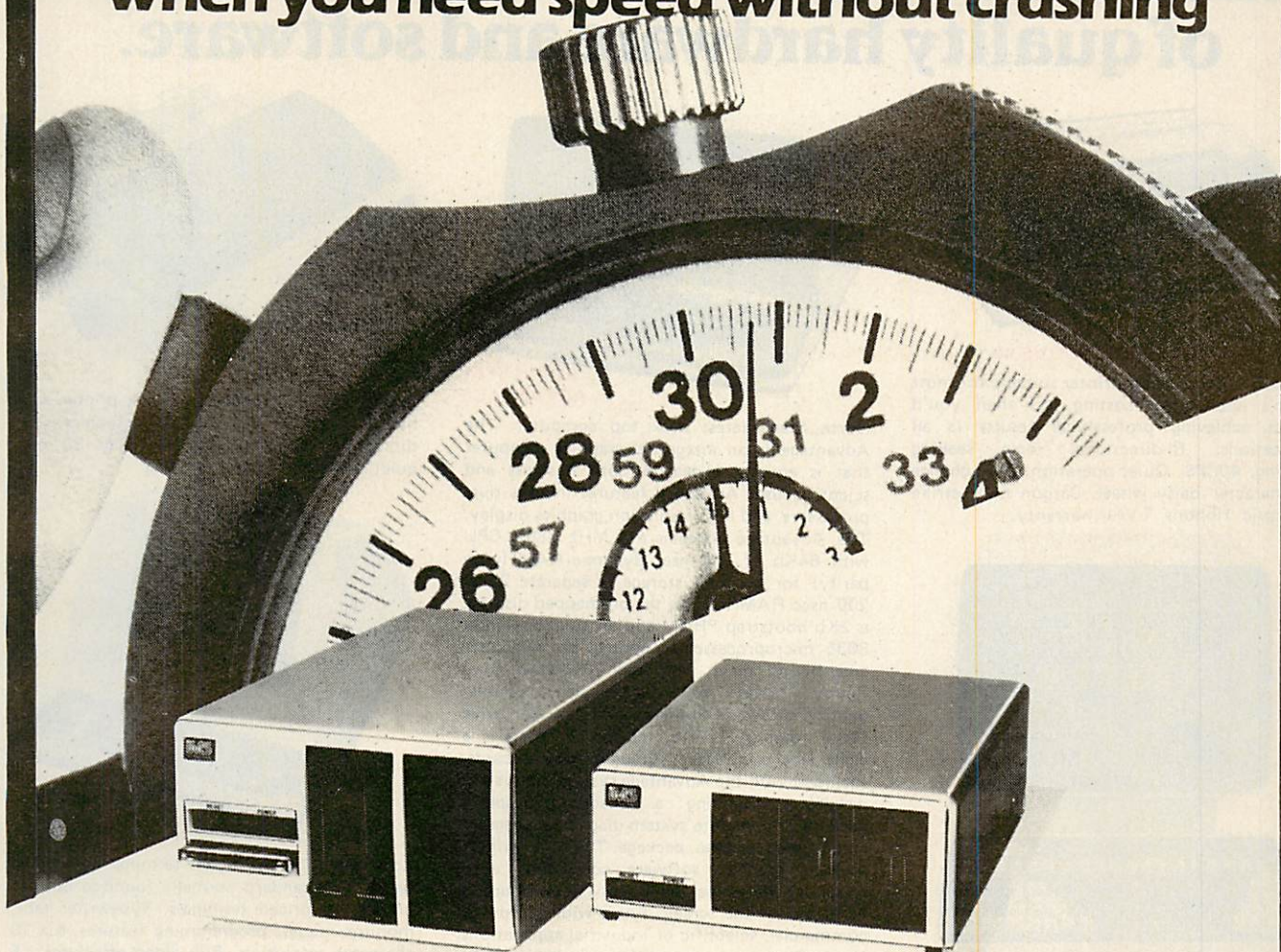

Start a stopwatch on our new Turbocharged Series 5000SX and Series 8000SX microsystems and watch them run rings around other systems.

Built to the highest standard of reliability, they support a mixture of 5in and 8in floppy and Winchester drives with tape back-up units. In other words, a storage capability extending from 400KB to 130MB.

But what makes the Series 5000SX and Series 8000SX really pull away from the rest of the field is their unique and exceptionally powerful disk operating system – TURBOdos. Written specifically for the Z80, TURBOdos loads programs up to six times quicker than CP/M\*. And processes files up to five times faster.

TURBOdos gives the new systems many of the features available only on minicomputers. In multi-user mode, it allows multi-processor network users to share mass storage, printers and other peripherals. And its advanced

failure detection and recovery facility makes a TURBOdos system virtually crash-proof! Other features include:

- Full CP/M compatibility even in multi-user/network systems.
- Up to 30% more data can be stored on each floppy disk, compared to CP/M.
- Support for up to 2000MB of hard disk storage.
- Random access to files up to 67MB.
- Up to 16 users supported in multi-processor mode.
- Automatic concurrent print-spooling support for up to 16 printers.
- File and record-locking facilities.
- Complete diagnostic self-test is performed at every start-up.
- Read after write verification of all disk update operations.
- When errors are detected, operator is given clear diagnostic messages and a variety of recovery options.
- User-defined program auto-load at cold or warm start.
- Disks can be changed at any time without warm start delays.
- Command files may be nested to any depth.
- User programs may activate command files for execution.
- Communications channel interface.
- Real-time clock support.
- Systems are easy to configure due to modular construction.

\*CP/M is a trademark of Digital Research

## EQUINOX

### TURBO SX range

Kleeman House, 16 Anning Street, New Inn Yard,  
London EC2A 3HB. Tel: 01-739 2387 & 01-729 4460  
Telex: 27341

OEM, system house and dealer enquiries are invited.

● Circle No. 159

# WINDOW SHOPPING?

then look no further! we offer a range of quality hardware and software.



### TEC STARWRITER EXECUTIVE 40

A superior daisy wheel printer suitable for most micro's and mini's costing less than you'd expect achieving professional results in all applications. Bi-directional logic seeking Printing, 40CPS. Quiet operation. Easy change 96 character daisy wheel. Carbon multi-strike or fabric ribbons. 1 year warranty.



### NORTH STAR ADVANTAGE

North Star's latest desk top computer. The Advantage is an integrated graphics computer that is equally suited to both business and scientific use. Advanced features include dual processors, and high resolution graphics display. The Advantage contains a 4 MHz Z80A CPU with 64Kb of 200 nsec dynamic RAM (with parity) for program storage, a separate 20Kb 200 nsec RAM to drive the bit-mapped display, a 2Kb bootstrap PROM and an auxiliary Intel 8035 microprocessor to control the keyboard and floppy disks. The two integrated mini-floppy drives are double-sided, double-density providing storage of 360Kb per drive for a total of 720Kb. Inside the chassis is a eight slot mini-bus for plug-in option cards. Included with the Advantage system is a system diskette containing a Business Graphics package, a complete system diagnostic program and a graphics demo. package. The serial printer port is graphics software compatible with Epson printers, making it easy to produce a hardcopy of the screen. For a wide variety of commercial, scientific or industrial applications North Star's graphics version of the industry standard CP/M is offered.



### EPSON MX82 F/T

A first class compact dot-matrix printer with high resolution bit image graphics. Bi-directional logic seeking printing, 80 cps, quiet operation. Plotter printing.



### INSIGHT VDT-6

A new, stylishly designed terminal for use with 'WORDSTAR', it features 31 special Wordstar function keys for higher performance word processing. 80 character x 24 line display with an enhanced contrast screen. Graphic line drawing mode. Detached keyboard with numeric pad. Full video attributes e.g. underline, reverse video, blinking. 16 independent baud rates for interfacing. The most competitively priced Wordstar VDU on the market.



### TELEVIDEO TVI 910

Low cost fully intelligent terminal with many features as standard normally found as options on similar priced terminals. Typewriter tabs, monitor modes, programming features. 8 x 10 character resolution. Full video attributes. 15 baud rates.

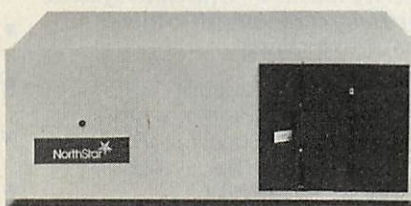

### NORTH STAR HORIZON HARD DISK

The highly regarded Horizon microcomputer with mini-winchester disk drive. This integral hard disk gives a massive 3, 6, 9, or 12 million character storage capacity. More intensive computing power sufficient for virtually all applications. For further capacity, up to four M26 Winchester hard disks can be added externally giving access to over an incredible 100 million characters of data. Using Starlink our enhanced CP/M compatible multi-user operating system this data can be accessed by one or more users in a time sharing or multi-processing environment. Starlink is at the heart of system expansion. Starlink logically integrates the Horizon with a range of Winchester disks and/or additional I/O, memory and processors. Features include independent login and logout, print spooling, file lock and unlock for common files, five priority levels, two-way private communications, mail/news/message facilities etc. In all over 20 utilities are incorporated in the Starlink package.



### RICOH RP1600S

Fast and reliable making it suitable for today's word processing demands. Its heavy duty construction will stand up in harsh working environments. Bi-directional, logic seeking, 65 cps. Options include Tractor feed, automatic sheet feeder.



### INFO SCRIBE 1000

A slickly styled inexpensive dot matrix printer suited to small business and minicomputer systems. Hard to beat low noise performance, touch-sensor controls, and exceptional speed are definite advantages of this printer. Bi-directional logic seeking printing, 180CPS. Low speed correspondence quality printing mode. Double density printing. Double wide printing. 96 characters. Descenders and underlining. Tractor feed included as standard.

## INTEDAM

Microcomputer Specialists

46 Balham High Road London SW12 9AQ Tel: 01-675 5325

Name:
Position:
Company:
Address:
Tel. No.:
PLEASE SEND ME DETAILS OF THESE AND OTHER PRODUCTS

● Circle No. 160

PRACTICAL COMPUTING June 1982

# Two flexible multi-user systems

# The Vector Graphic 5005

# and 5032

## with 5 megabyte and 32 megabyte Winchester hard discs

The Vector Graphic 5005 & 5032 are multiple-user, multi-tasking hard disc systems for general business and word processing applications.

Supporting up to a maximum of 5 users and giving up to 32 megabytes of high-speed totally reliable Winchester disc technology with Vector's automatic error correction feature.

Total flexibility means that the systems terminals can work independently which permits the widest possible range of usage.

One user could use Execuplan for financial planning whilst the second user is entering sales information with accounting software and the third may run correspondence simultaneously with Vector's Memorite III word processing software.

Most other standard CP/M

compatible applications software will run on the system e.g. COBOL, FORTRAN, PASCAL, BASIC COMPILER, ALGOL, PL/I and other statistical and data based management packages.

The Vector Graphic 5005 & 5032 are ideal for application packages, such as accounts, stock control, payroll, word processing, financial modelling and solicitors packages, all available from Almarc.

For further information write or telephone Almarc. Complete sales and servicing facilities are available throughout the U.K.

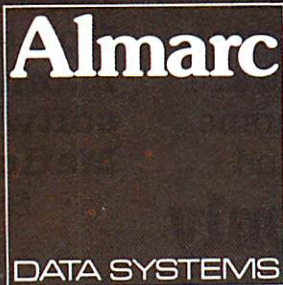

Almarc Data Systems Ltd.,  
Great Freeman Street,  
Nottingham NG3 1FR  
Tel: (0602) 52657/8/9  
Telex: 37407 Almarc/G

Also at:  
Green Street,  
High Wycombe,  
Bucks. HP11 2RF.  
Tel: (0494) 23804



#### APPROVED ALMARC DEALERS

BALDOCK  
BIRMINGHAM  
BRISTOL  
CAMBERLEY  
DONCASTER  
HIGH WYCOMBE  
HARROGATE  
KETERING

Modus Systems  
Taylor Micro Systems Ltd.  
Johnson Micro Computers  
Johnson Micro Computers  
Reed Computing  
Common Sense Business Systems  
Business Microsystems  
Shuttleworth Business Systems

(0462) 894848  
(021) 358 2436  
(0272) 422061  
(0276) 20446  
(0709) 67087  
(0494) 40116  
(0423) 68224  
(0536) 511357

LONDON  
LOUTH  
MACCLESFIELD  
NOTTINGHAM  
OXFORD  
SWANSEA  
TYNE & WEAR  
YEovil

Micro Systems Consultants  
Computa-Crop  
Resolux Ltd.  
Almarc Business Systems  
Johnson Micro Computers  
Business Microsystems  
H.P. Micros  
Dale Computers

(01) 979 4098  
(0507) 604271/2  
(0602) 412035  
(0602) 622501  
(0865) 721461  
(0792) 474082  
(0632) 859923  
(0935) 72000

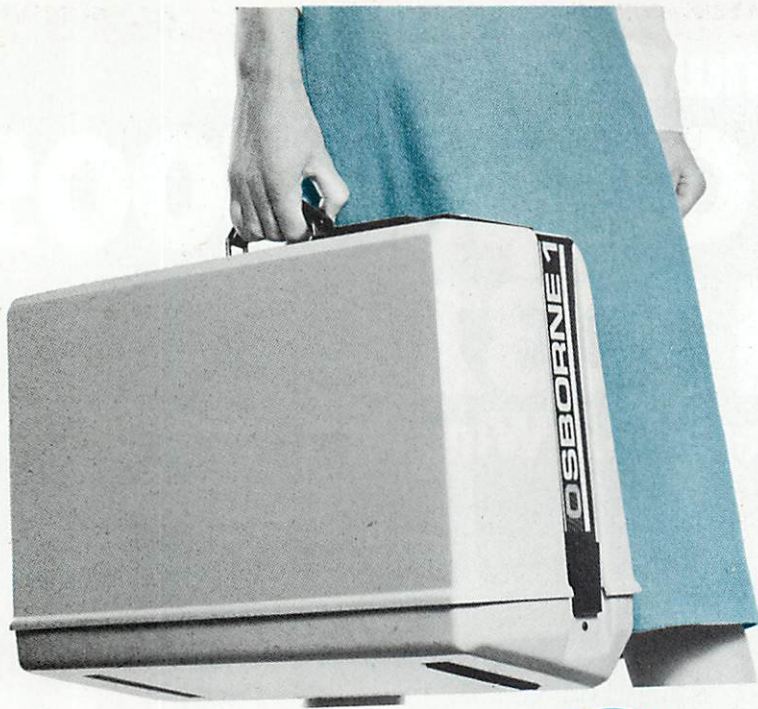

# See Adda for Osborne

Osborne – the business computer that's a personal, portable productivity package! You can confidently tackle tougher jobs, with a vast increase in **personal effectiveness** wherever you are – plane, train, car, office or home. And at Adda you get advice and service from professionals who know what business users need.

**For only**  
**£ 1250**

for a complete system excluding VAT

**THE ADDA-OSBORNE SUPER DEAL INCLUDES:** 12 months parts and labour warranty · Free delivery London and Home Counties · Full set manuals · Comprehensive software including: Wordstar/ Mailmerge word processing · Supercalc financial package · CBasic · MBasic · CP/M operating system · 10 diskettes.

**For further information or to place an order telephone 01-997 6666**

Dot matrix and Daisy Wheel printers available from £399 excl. VAT.

## adda

**Adda Computers Ltd.**  
Mercury House  
Hanger Green  
Ealing London W5 3BA  
Tel: 01-997 6666

Only 20 minutes by car or tube from the West End.



● Circle No. 162

PRACTICAL COMPUTING June 1982

THE DEVELOPMENT of microcomputers over the last year or two has featured one big ingredient which no user will have overlooked — processing ability is going up and cost is going down.

For the manufacturer this has produced a situation where the processor itself is no longer the main cause for concern. The peripheral units are a larger percentage of cost now, have the greatest influence on machine size and are likely to be the real limiting factor to processing ability.

The result is a demand for lower-cost fixed disc storage for microcomputers of a type previously only viable for larger business systems or minis. To answer these demands, disc drive designers are now tending toward compact products suitable for use in shared-logic systems. They tend to incorporate features formerly associated only with large, high-performance devices, especially in the "workhorse" 8in. size.

## Multi-user systems

Capacity requirements are growing beyond the 15Mbyte typically offered in today's 8in. drives. Systems with access time of less than 50ms. will need to be acceptable for large multi-user office systems. At the same time, OEM disc-drive users cannot afford to pay twice as much for their peripherals, even if they get a two-fold improvement in capacity and performance. Cost per megabyte has in the past been in the range of £50 to £100 for 8in. Winchester drives.

The trend toward higher performance in smaller drives has spurred the industry in recent months toward the development of higher-precision, closed-loop servo positioning mechanisms in addition to the already existing open-loop designs. They improve positioning precision and permit improved track densities and access times.

The Shugart Fastrak, for example, has positioning information pre-recorded on the bottom surface of the drive's bottom disc. Under the control of a single-chip microcomputer, the servo head, which is mounted on the actuator assembly, reads the servo information and positions the actuator over the correct cylinder. The actuator assembly mechanically couples the servo head to the data heads to improve positioning accuracy. The effects of mechanical and thermal tolerances associated with the typical stepper motor are thereby reduced.

## Limiting factor

Position feedback is the key in this type of positioning system. The closed-loop servo system continually provides precise servo information which is used to position the data heads. The stepper motor, on the other hand, operates on a sequence of pulses. After 10 step pulses are sensed, for example, the data head should be on track 10; but there is no

**The latest generation of hard discs store up to 35Mbyte on a single 8in. unit. Dave Brodsky of Shugart explains some of the technical innovations which have made this level of performance feasible.**

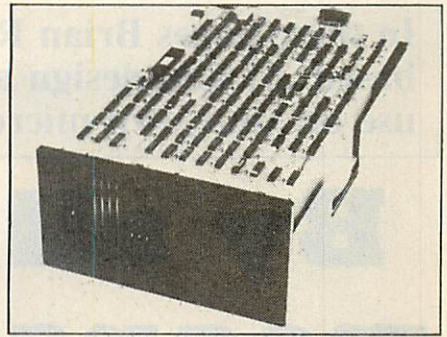

# Developing heads for more figures

positioning feedback signal to tell the system that it really is precisely on track 10.

The lower precision of the stepper motor positioner has been a limiting factor in increasing the track density of drives. Because the positioning is not as accurate, each track has to be wider to allow for the mechanical and thermal tolerances associated with the open-loop stepper principle. This remains acceptable for the low-cost drives used in smaller, stand-alone systems with capacity needs at around 15Mbyte or less, but the new larger and multi-user systems demand the increased performance.

## Track density

With the new servo-controlled system and its improved positioning accuracy, track width is reduced by approximately two-thirds. For example, the track density is raised from 172 TPI on Shugart's original SA-1000 8in. Winchester drive, to 500 TPI on the new SA-1100. A two-platter drive with three available data surfaces provides 20.3Mbyte capacity, and a three-platter drive with five data surfaces provides 33.9Mbyte.

Because a closed-loop servo system correlates the overall seek distance with its actual position, an optimum acceleration/deceleration curve can be generated for each length seek, resulting in a low access time. In an open-loop actuator system, with no position feedback, more cautious movement is required and a 35ms. access time cannot be achieved.

There are other areas, too, where gradual design improvements are lowering manufacturing costs yet stepping up drive performance. In the drive itself, the DC motor gives speed control with a variation of less than one percent. Higher reliability comes from fewer mechanical parts and the elimination of a lateral load on spindle bearings from the belt normally associated with an AC motor. The electronics can also be simplified.

The Shugart SA-1100 drives — see photograph — have been designed with approximately 250 discrete components, arrayed on two printed circuit boards, and early production models are assembled in this form. Later models are to be offered with full custom LSI electronics, reducing the number of components to the under-60 range, and eliminating one of the two printed-circuit boards.

Another development which aims to improve reliability is the dedicated head landing/shipping zone, designed to prevent head and disc damage and provide maximum data protection. The heads are moved automatically to this zone when the drive is powered down, when DC power is lost, or when the disc is moving at less than 80 percent of normal operating speed. Once in the landing zone, the heads are held in place by an automatic actuator parking lock. An automatic spindle brake also keeps the disc from rotating when power is removed.

## Design improvements

Design changes currently emerging from research and development departments involve few problems in upgrading from standard-performance 8in. Winchesters. For example, to upgrade to the Shugart SA-1100 from an SA-1000-based system, only minor hardware and software modifications are required. In the hardware area, a third head-select line already present in the read/write data cable must be activated. The device controller needs to access this line in order to address the five read/write heads on the three platter SA-1100 model.

The SA-1100 interface also includes two optional input signal lines not available with the SA-1000. One is a fault-clear line that clears unsafe conditions, such as a head drawing too much current. The other is a recall line that commands the selected drive to position the read/write heads to cylinder 0 and reset any seek-error conditions, a task formerly handled by the controller, which is now relieved of this burden. □

In these pages Brian Reffin Smith keeps you up to date with computer-based art and design and lays the foundations for graphics routines to use on your own micro.

# By all means fool about

I RECENTLY organised a London show of artists and musicians who use computers in their work. Although the show has now finished in London, it is due to visit Paris, and later on Edinburgh — so if you are a jet-setter, or happen to live there, drop in and visit.

The title of the exhibition is "Artists/Computers/Art", which attempts to convey the fact that here is work done by artists, who just happened to be using computers. So much so-called "computer-art" hardly passes muster as art at all, and most art-oriented people are put off by it.

## Happier each day

Jacques Palumbo has forsaken his native Algeria and now lives in Canada. His work, I must admit, is not in that category of art that I like most. But I wanted Palumbo in the show for an important reason: he has stopped using computers, at least for the time being. In his previous use of the technology in art, he is fairly typical of those who work with systems of numbers, translating them into some visual form. Permutations and systematic variations feature strongly, and no doubt you can think of many examples that have been seen over the years that use similar ideas.

Five frames illustrating a graphics sequence originated by Gerald Hushlack of the University of Calgary.

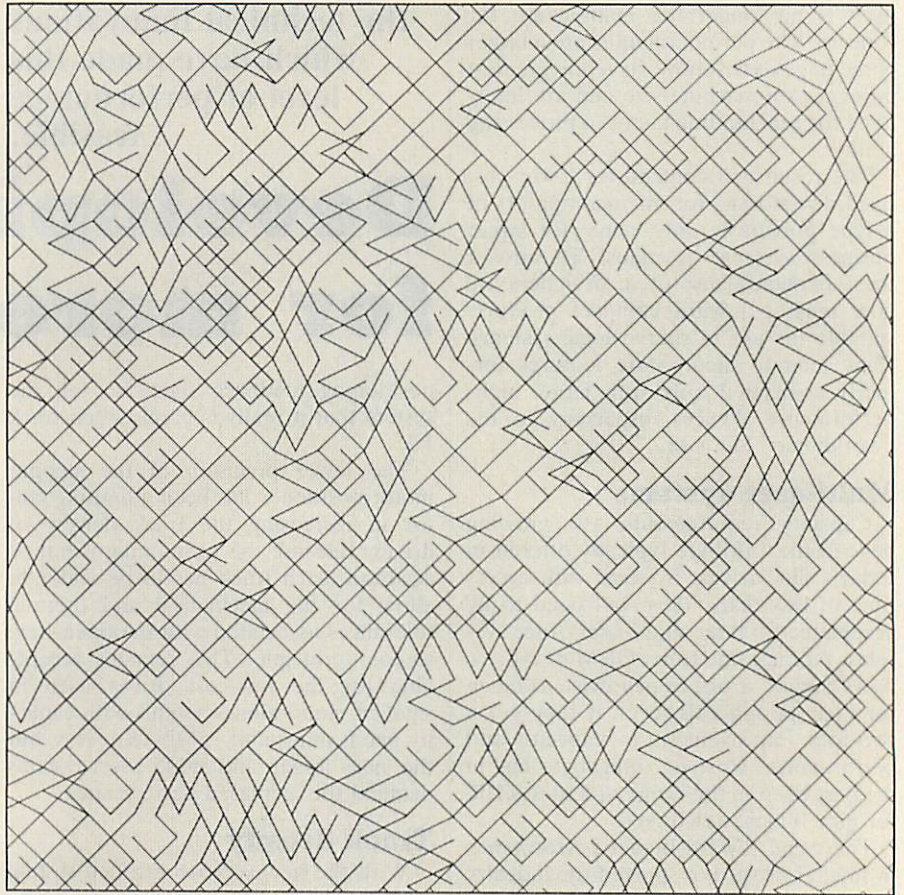

One of Jacques Palumbo's designs — nowadays he prefers to play guitar.

The fact that he has stopped and, as he now says, sits with his partner and "two marvellous children, playing classical guitar and Renaissance lute, getting a bit happier each day", is worth examination. For on one level, it would not be surprising that any human would prefer to do things like that, rather than draw lines on paper, whose positions correspond to some well-defined numerical progression or permutation.

Yet, the same person, surely not an entirely different being, became quite

famous as an artist for doing precisely that, and presumably gained satisfaction from it. He has said previously that he used computers to save him time, allowing the almost instant production of work that would have taken ages by hand. But after a period of this labour-saving approach, he gives up altogether. Could it be that the fact that he hand-drew his earlier work compensated for some other, inherent, sterility? If that is so, does it have any messages for us who use computers — for whatever reason — in our own work?

Gerald Hushlack is Professor of Fine

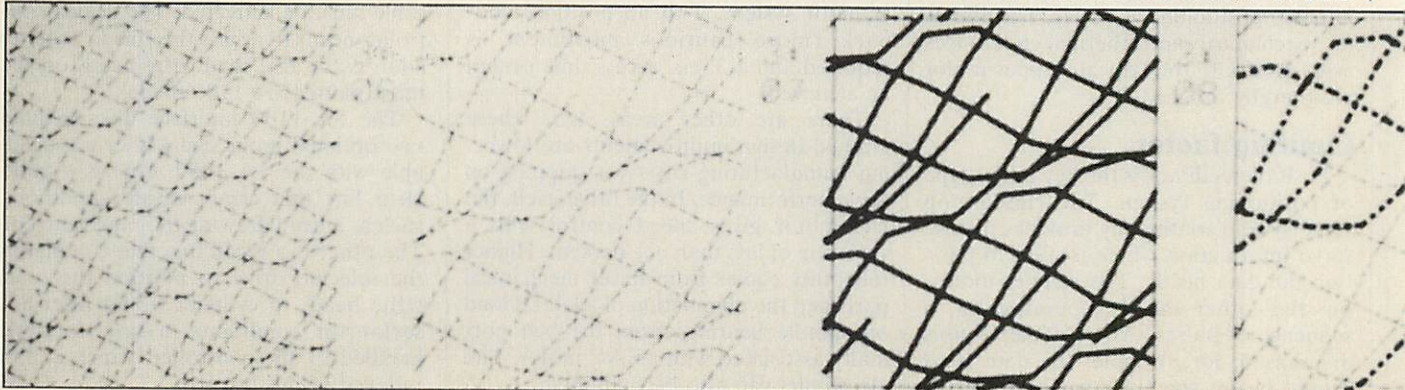

Art at the University of Calgary where he has access to some extremely powerful computing equipment. One reason for such riches of computer graphics devices is that the town is firmly based on oil production: the oil corporations make considerable use of graphics to help them visualise the endless streams of data produced by their many and various tests and explorations.

### Boston Stranglers

Unlike Palumbo, Hushlack revels in using computers. I remember going out with him to drink several "Boston Stranglers", a lethal local cocktail of which vodka, Tia Maria and cream were some of the less brutal ingredients. Suitably refreshed, we then slipped into the silent offices of an oil company to spend hours producing immense sheets of colour graphics. It must be said, however, that Hushlack also does a great deal of painting, and other hand-work too. Maybe that keeps him relatively sane.

Of his work, he says: "Traditionally, machines used in art-making functioned as tools performing only in an external mode". I think he means external to your head. "Today the computer can assist the artist at all levels: selection and organisation; instant visual playback of information; and an instant memory actively addressing data many years old. Most important of all are present software developments which allow subjective inclinations to become workable information for the artist. The artificial intelligence liberates the artist from the drudgery and laborious activities which are so often necessary in art-making. Possible solutions for determining quality may point in directions which require the redefinition of basic notions of art".

### Vital enquiry

Yes indeed — and to see why the use of computers in art may be so important in general terms, you only have to change his final sentence to be about the use of computers in many other spheres. Art, by virtue of its "free" position to explore, play games, fool around and ask strange questions, may become a most vital mode of enquiry into the emerging information environment.

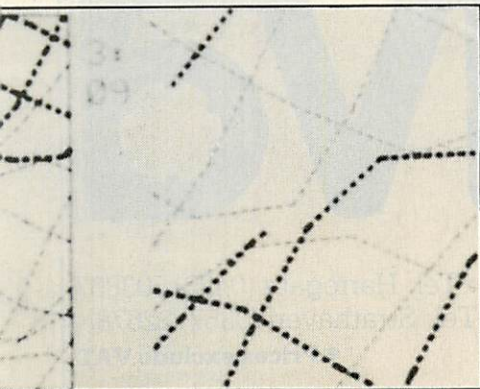

## BEGINNING GRAPHICS

# Loops and turns

```

10 REM Universal 2D rotation A.Goodhew
20 REM For BBC Micro
30 MODE4
40 INPUT "Numbers of Corners:"N
50 DIM X(N),Y(N)
60 FOR I=1 TO N:P:"CORNER ":I:INPUT X(I),Y(I):NEXT I
70 P:INPUT"Centre of rotation - X,Y"CX,CY
80 P:INPUT"Clockwise rotation in degrees"R:R=R*PI/180
90 CLS:REM clear screen
100 GOSUB150:REM draw object
110 GOSUB170:REM rotate it
120 GOSUB150:REM draw image
130 END
140 REM Draw shape in X() & Y()
150 MOVE X(N),Y(N):FOR I=1 TO N:DRAW X(I),Y(I):NEXT I:RETURN
160 REM Rotate shape
170 FOR I=1 TO N
180 X=X(I)-CX:Y=Y(I)-CY
190 D=SQR(X*X+Y*Y):IF X=0 THEN A=PI/2:GOTO 210
200 A=ATN(Y/X)
210 IF X<0 THEN A=PI+A:GOTO 230
220 IF Y<0 THEN A=2*PI+A
230 T=A-R:X(I)=D*COS(T)+CX:Y(I)=D*SIN(T)+CY
240 NEXT I:RETURN
    
```

RATHER THAN introduce any new ideas, this month I want to present the winning entries from the first two competitions, published in the February and March "Art" pages. Other people's programs are always the richest source of graphics routines, and these two are no exception.

This is not to say, of course, that you can steal someone else's ideas wholesale and then go on to use them simply for

your own profit. But music, poetry and other forms of art progress through their practitioners changing, reacting to and, indeed, using the ideas of others. Computing can, and should, do the same.

After all, a For-Next loop is hardly copyright, nor are the by now well-known ways of manipulating shapes on screen or paper. These routines are, rather, the raw materials which the creative computer user exploits to put forward his or her ideas, using the medium of information technology.

As announced last month, John Hardman is the winner of the February competition which called for the best program or artwork based on a For-Next loop. He submitted two versions of his program — the one printed here is for the Research Machines 380-Z. His alternative program for the ZX-81 requires a high-resolution add-on for the micro in order to run properly.

One hopes that all microcomputers introduced in the future, regardless of price, incorporate proper high-resolution graphics capability. After all, what use is a computer without one? Not being able to use graphics to communicate information is rather like motor racing without cars: good for the soul, no doubt, and fine exercise for the drivers as they run round the track, but somehow lacking in finesse.

The competition in March called for a program which rotates a shape about any point by any angle. The winner of the £5 prize is A Goodhew of Eastrea, near Peterborough. We are printing here a version to run on the BBC Micro though the original was, very sensibly, written for the 380-Z.

The program asks for "corners" and puts values into two arrays X() and Y(). If you have access to any kind of digitising device, such as a light-pen, joystick or digitising pad, you will see that you could enter values into X() and Y() automatically.

```

10 REM JOHN HARDMAN
20 PUT12
30 CALL "RESOLUTION",0,2
40 FOR A=0 TO 85 STEP 5
50 X=128+96*SIN(A*.017453292)
60 LET Y=96+96*COS(A*.017453292)
70 LET I=224-Y
80 LET J=X-32
90 LET Q=256-X
100 LET W=192-Y
110 LET E=256-I
120 LET R=192-J
130 CALL "PLOT",X,Y,2
140 CALL "LINE",I,J
150 CALL "LINE",Q,W
160 CALL "LINE",E,R
170 CALL "LINE",X,Y
180 NEXT A
    
```

## Competition

WE ARE LOOKING for any piece of art that you have made, or worked out, using a computer. But please, nothing that could have been done with a Spirograph. Nationwide fame and a £5 prize await the winning entry.

The address for entries is Art, *Practical Computing*, Room L306, Quadrant House, The Quadrant, Sutton, Surrey SM2 5AS. As usual, we cannot return any entries, so keep a copy.

# PRINTERS

## SEIKOSHA GP100

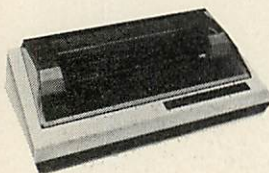

**New Design unbelievably low price printer**

80 columns. 30 cps 5 x 7 dot matrix. Adjustable tractor up to 10 ins. Graphics. double & standard width printing. Parallel interface as standard. RS232, Apple, IEEE & TRS-80 interface options.

£215

## EPSON MX-80 F/T SERIES

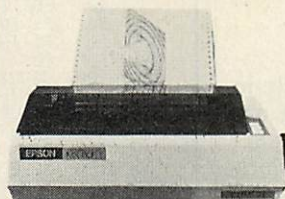

**Probably the most popular printer in the world.**

**Type I:** 80 cps bidirectional printing logic seeking. 9 x 9 matrix with true descenders. 3 way paper handling. 80 columns with condensed emphasised & enlarged characters. FF, VT & HT. Parallel interface.

**Type II:** has programmable form feed & line spacing. Bit image printing.

MX80 FT £399 MX8 FT TYPE II £445

## OKI MICROLINE 80, 82A & 83A.

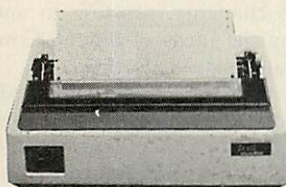

**Compact Printers.**

**80:** Unidirectional 80 cps Parallel interface, pin & friction feed.

**82A:** Bidirectional 80 cps Parallel & serial interface

**83A:** Bidirectional 120 cps 15 ins 132 cpl at 10 cpi. Parallel & serial interfaces. Graphics & fast serial interface options.

ML-80 £325 82A £465 83A £880

## EPSON MX-80T SERIES

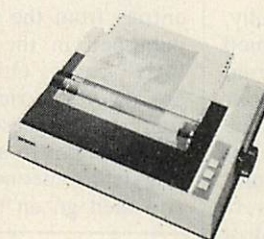

**Low Cost, High Quality. Adopted by PET, HP, IBM, Sharp.**

**MX-80T:** Bidirection, logic seeking. 180 cps. 9 x 9 matrix with true descenders. 80 cols. Adjustable pin feed. Normal condensed & enlarged characters. FF, VT, HT Parallel interface.

**Type II:** has programmable form feed & line spacing. Bit image printing.

MX80-T £360 MX80-T TYPE II £399

## TEC STARWRITER

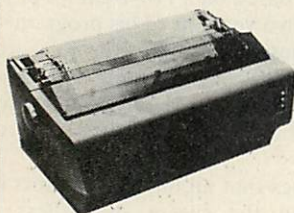

**Best-Buy Daisy Wheel Printer.**

Bi-direction. 25 cps. Low cost supplies. Standard Daisy Wheel. Carbon and fabric ribbons. Parallel or RS232 interface. Sheet feeder options.

£799

## EPSON MX-82 & 100

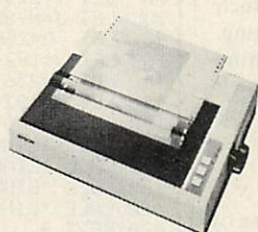

**High Resolution Low cost.**

**MX-82:** As MX-80 spec. plus programmable line spacing & form feed. Bit image printing.

**MX-82 F/T.:** Adds friction feed.

**MX-100:** As MX-82 FT with 15½ ins. carriage.

MX-82 £415 MX-82 F/T £455 MX 100 £575

## ANADEx DP-9000 RANGE

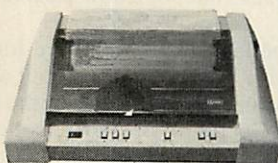

**High Quality Fast, Versatile Printer.**

Six models. Up to 15 inch paper width. Lower case descenders. 160-220 cps bi-directional printing. RS232 current loop & parallel interface. X on X off. Optional 2K buffer. Multiple print densities. Fast print of high-density bit image graphics.

DP-9000L £747 DP-9001 £888 DP-9500 £935  
DP-9000 £841 DP-9500L £841 DP-9501 £982

FROM

# RIVA

## RIVA TERMINALS LTD.

**Head Office:** 9, Woking Business Park  
Albert Drive, Woking, Surrey GU21 5JY  
Tel: Woking (04862) 71001 Telex: 859502

**Northern Office:** Tel: Harrogate (0423) 503867  
**Scottish Office:** Tel: Strathaven (0357) 22678

● Prices exclude VAT

# Great minds think alike.

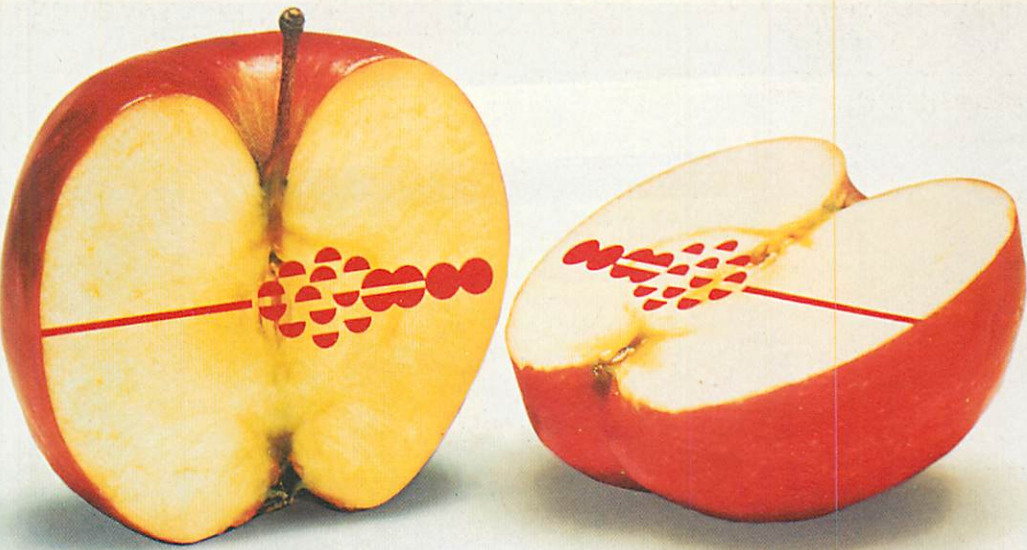

Look inside the top microcomputers on the market and you will find the best business brains in the country. Ours. Because the key to the efficient use of the microcomputer in your business is high quality 'software' — a set of programs which direct and instruct the computers operation. A microcomputer without software is like a car without a driver! And as one of the foremost software organisations in the industry we're amongst the enterprising few whose software packages are compatible with most leading manufacturers models — including the Apple II & III Xerox 820, Phillips P2000, IBM Personal Computer and NEC PC-8000.

It means that whichever of these microcomputers you own, or contemplate purchasing, you have access to the most advanced range of business software currently available — as well as one of the most widely distributed and preferred.

On the financial front for example, there is a definite meeting of minds over the superiority of our software to perform your ledger accounting, payroll, invoicing, cashflow, planning, budgeting and stock control. Word processing, addressing and mailing, job costing and more will be available in the near future.

In the last year alone over 500 companies have invested in our Financial Controller suite of programs and over 2000 packages have been sold in the UK alone — which together with a full complement of Systematics International software is now available at around £250 per package from Currys Micro-C, Beams Business Centres, The Xerox Stores and over 100 of the best microcomputer centres throughout the UK.

Needless to say, the technical excellence of our software is matched by its high commercial quality. All software is supported by comprehensive easy to follow manuals that take you through organising, setting up and using your microcomputer business system — from an International Company with over 10 years experience and hundreds of satisfied customers worldwide. All can be complemented by management and staff training facilities at our computer and business study centre in Suffolk.

## UNDERSTANDING MICROCOMPUTERS— a video tape

To help you decide whether a microcomputer could help you better manage and control your business, Systematics International have prepared a video tape to put you in the picture!

It shows, the elements of a microcomputer business system, how it can help, how to choose, the benefits to be gained and the pitfalls to avoid.

At only £39.95 plus VAT and carriage, it could save you from making an expensive mistake. And considering the business potential of the right microcomputer it's also a small price to pay for success.

So if you really want to get to grips with your business, pick our brains. Everybody else does!

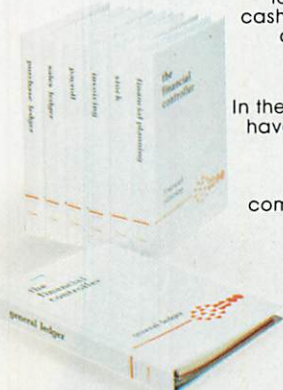

## Systematics International Microsystems Limited

Cleves House, Hamlet Road, Haverhill, Suffolk Tel (0440) 61121 (24hrs) Telex 99431 SIG

Simply the best business software for your microcomputer

### List of Dealers contributing to this advertisement

ENGLAND Avon Beam Business Centre 0272 712291 Currys Micro-C (at Bridgers) 0272 65051 Bedfordshire Computopia Ltd 0525 376600 Currys Micro-C 0582 425079 Berkshire Lynx Computers Ltd 07535 56322 Quipra 0635 48562 Cambridgeshire Sydney Bath 948 20237 Cheshire Fairhurst Instruments 0625 525694 Co. Durham Knowledge Ltd 0385 884782 Cumbria Lakeland Computer Services 09667 210 Devon Diskwise Ltd 0752 267000 Essex Godfrey Computer Centre 0268 29550 Ramrod Computing Ltd 0702 339262 Gloucestershire Beam Business Centre 0242 582368 Gt. Manchester Beam Business Centre 061 831 7096 Currys Micro-C 061 834 0144 Kestrel Computers 0625 532535 Hampshire Currys Micro-C 0703 29676 Herefordshire Local Business Technology Ltd 099 24 66157 Humberside Access Computer Services 070 685 2326 Kent Prince Maine 0732 845640 Lancashire DIMS Ltd 0254 26419 L&P Business Systems 0282 50252 Professional Data Systems 0204 493816 Leicestershire Currys Micro-C 0533 546224 Lincolnshire Estate Computer Systems 0529 305637 London Beam Business Centre 01 380 0388 CW P Computers 01 828 3127 Currys Micro-C 01 381 9278 Electronic Office Services 01 236 9065 Eurocourse 01 739 8692 Group 18 Ltd 01 802 7186 Guestel 01 583 2255 Planning Consultancy Services 01 839 3143 Middlesex Granata Computer Systems 01 843 1971 Norfolk Anglia Computer Centre 0603 29652 24250 Somerset Taunton Electronics 0532 45815 Suffolk Systematics International 0440 61121 Surrey Ferguson Computer Services 09323 45330 Microlines Computers Ltd 01 546 9944 Rothwell Computer Services 0252 519441 Vaga Computers Ltd 01 680 4484 Sussex DataTech 0323 36268 Tynes & Wear Micro Computing Ltd 0632 476018 West Midlands Beam Business Centre 021 429 4631 Currys Micro-C 021 233 1105 Worcestershire Celtic Star Microcomputers Ltd 0562 66201 Yorkshire Currys Micro-C 0532 446601 Wharfedale Business Systems 0229 758021 SCOTLAND Beam Business Centre (Edinburgh) 031 225 3752 Beam Business Centre (Aberdeen) 0224 56161 WALES David Potter Office Equipment Ltd 0222 496785 Sportamay Ltd 06333 72360 IRISH REPUBLIC Softech Ltd 0001 720280 CHANNEL ISLANDS Guernsey Computers 0481 28738

SI software is also available from over 100 additional microcomputer centres in the U.K. and internationally in Chicago, Frankfurt, Johannesburg, Melbourne, San Francisco, Singapore, Stockholm, Tokyo



More information on the available and the name of my nearest stockist.

Your video. Please send me I enclose cheque no. for £47.15 including carriage and VAT

Name \_\_\_\_\_

Address \_\_\_\_\_

LVHS  Betamax (Allow 28 days for delivery)

(PIC)

● Circle No. 164

# SEEING IS BELIEVING

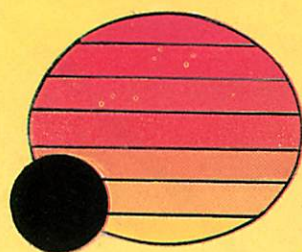

# ACT SIRIUS 1

# NEW ACT SIRIUS 1

## Minicomputer Performance. Personal Computer Price. 16 bit processor: £2,395

**The best price/performance ratio you've ever seen on a personal computer.**

	ACT Sirius 1	Typical Personal Computers	Typical Business Systems
Memory	128K-1024K	32K-64K	48K-256K
Disk Capacity	1.2Mb-10 Mb	140K-1Mb	1.2Mb-10 Mb
Processor	16 bit	8 bit	8 bit
Operating Systems	CP/M-86, MSDOS	CP/M or Machine Specific	Usually Machine Specific
Languages	Microsoft BASIC Compiled BASIC COBOL PASCAL FORTRAN	Microsoft BASIC perhaps one or two others, eg PASCAL	BASIC and perhaps one or two others
Price	£2395	£1800-£3000	£4500-£8500

ACT Sirius 1 is a new generation personal computer. Quite simply, it has no competition at the price.

It's the first personal computer developed from the outset for business and professional use.

It's launched with more software than anything before it.

It's supported and distributed solely by ACT — the biggest name in personal computer software.

And it's developed by Chuck Peddle, formerly of Commodore and generally regarded as the father of personal computing.

### SOFTWARE SPELLS SUCCESS

ACT Sirius 1 has more software than any other new personal computer:

A choice of two operating systems — CP/M-86 or MSDOS, from Microsoft.

### For Software Houses

The ACT Sirius 1 has a language for you. Microsoft BASIC 80, two BASIC Compilers, two COBOLS, PASCAL and FORTRAN.

### For Applications

Wordstar, Mailmerge, Pulsar, SuperCalc and MicroModeller — all the best sellers.

And the ACT Sirius 1 can run any software written for CP/M — that means hundreds of specialised packages.

### THE BODY IN QUESTION

Ergonomics play a vital part in the design of ACT's Sirius 1.

The screen tilts and swivels to suit the user and glare is eliminated.

The display is razor sharp; and the brilliance and contrast can be adjusted using keys on the low-profile detachable keyboard.

### STAYING OUT IN FRONT

The ACT Sirius 1 is designed to keep you out in front. Winchesters, networks, multi-user facilities and colour graphics are all scheduled during the next twelve months. And all at the same record-breaking price levels of the ACT Sirius 1.

### SEEING IS BELIEVING

The ACT Sirius 1 goes through the most exhaustive quality control process of any microcomputer — including the much vaunted Japanese products.

ACT Sirius 1 has been successfully operating in testing field trials for over 6 months already. And now it's at your nearest ACT Dealer — ready to revolutionise your ideas on personal computers.

Clip the coupon for literature. Better still, call David Low now on the hot line 021-454 8585, get the name of your nearest dealer and see a demonstration as soon as you can — because seeing is believing.

PC6

To: ACT (Microsoft) Ltd, FREEPOST,  
Birmingham B16 8BR.

Please send a brochure and name of my nearest dealer

I am interested in dealership — send the dealer pack and ask your sales director to contact me.

Name \_\_\_\_\_

Position \_\_\_\_\_

Company \_\_\_\_\_

Address \_\_\_\_\_

Telephone \_\_\_\_\_

**ACT No.1 in Total Computing.**

● Circle No. 165

# OPEN FOR BUSINESS.



## The complete multi-purpose, multi-terminal desktop computer system for business.

Now you can get the world's most powerful, reliable, easy-to-use, multi-user microcomputer system at an affordable price. The ALTOS® Series 5-5D computer (including 5-MByte Winchester hard disc and the MP/M II™ operating system)\* which will support up to three smart terminals and a printer, for only £4440.

**LOGITEK**

(E.I.C. Electronics Ltd.)  
Logitek House  
Bradley Lane  
Standish  
Greater Manchester  
England WN6 0XQ  
Telephone: 0257 426644  
Telex: LOGITEK G 677354

Our new Altos smart terminals function as independent work stations. Whilst your bookkeeper prepares payroll, other users can be checking inventory, computing cost

estimates, doing word-processing and performing hundreds of other business operations.

We can provide all the system software you need, too. Because we support hundreds of CP/M®, MP/M II and OASIS applications programs for Altos computers.

You can also add software that allows you to communicate with other computers and networks.

Thousands of business users throughout the world have improved their productivity with Altos computer systems. For more information, call or write today.

**ALTOS**  
COMPUTER SYSTEMS

Index House  
Ascot, Royal Berkshire  
UNITED KINGDOM SL5 7EU  
Telex 849426

### Packed with fresh ideas for business.

\*Series 5-5D includes Z80A processor, 192 KB of RAM, one 1 MB minifloppy and one 5 MB micro-Winchester. Series 5-15D includes Z80A processor, 192 KB of RAM, and two 1 MB minifloppies for £2300. ALTOS is a registered trademark of Altos Computer Systems. CP/M is a registered trademark, and MP/M II is a trademark of Digital Research, Inc. OASIS is a product of Phase One Systems, Inc. Z80 is a trademark of Zilog, Inc. © 1982 Altos Computer Systems

# Ink jet: a revolution in printing that will make no impact

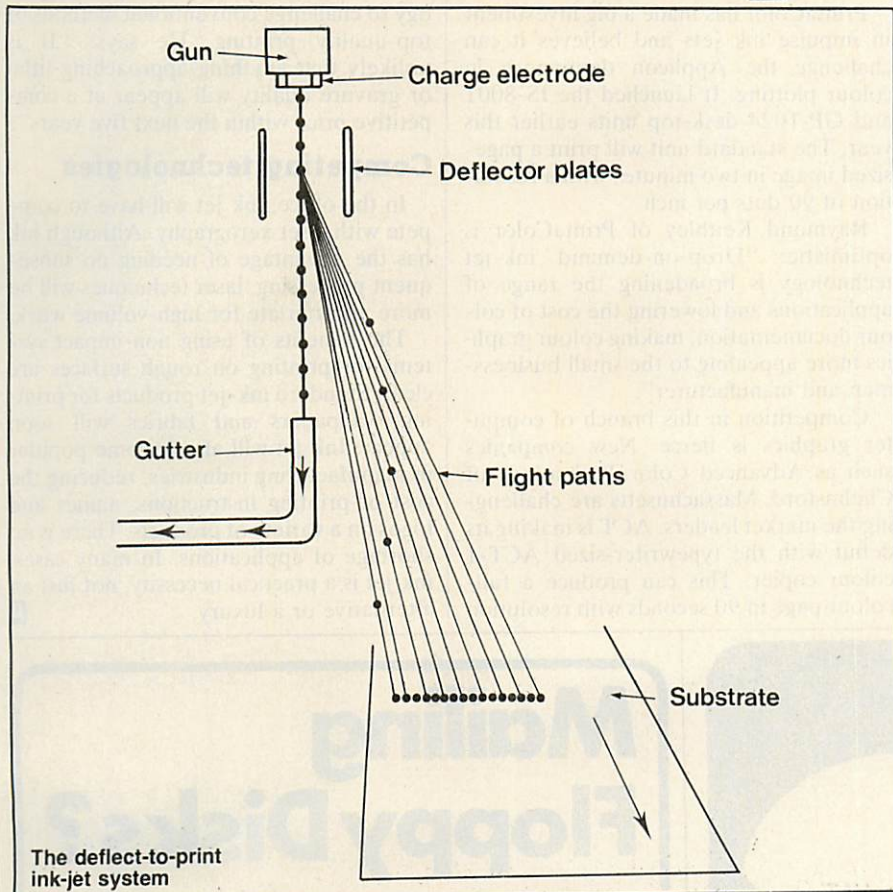

CAMBRIDGE LEPIDOPTERISTS are no longer surprised when they catch a butterfly which bears the marking "CCL" on its wings. The initials stand for Cambridge Consultants Ltd, one of the British firms who are developing the technology of ink-jet printing.

"Yes, most of the butterflies round here do have the company logo", admits director Steve Temple, cheerfully. "With inkjet you can print on the most delicate material without damaging it". Indeed, CCL has demonstrated that ink-jet techniques are ideal for printing on a whole range of unusual or sensitive surfaces because nothing touches the surface which is to be printed, the substrate, except the ink.

## Charged droplets

These non-impact printers break up a flow of ink into minute droplets. The droplets are given small electrical charges which are controlled by a computer. The ink jet follows the computer's instructions, and each drop of ink is directed

**A pen that never touches the paper is starting to make its mark. John Lewell explains how ink jets can print 20 metres of characters a second under complete computer control.**

towards the substrate at a precisely calculated angle.

In the continuous-flow printer, the ink droplets are given individual electrical charges and are then directed by deflector plates which are maintained at a constant potential. Richard Sweet at Stanford University achieves this by deflecting the charged droplets to the substrate while collecting the uncharged droplets in a gutter. Another method, based on the work of Professor Hertz at the Lund Institute of Technology, is to apply the charge to those drops which are not required for printing, and to deflect them out of the way on to an earthed plate. Both methods require the utmost

precision to obtain acceptable resolution.

In the deflected-to-print system, ink is supplied under pressure to a gun which forces it through a nozzle. Inside the nozzle, which may be as small as 35 microns in diameter, the ink is modulated ultrasonically and breaks up into a series of equal-sized drops. These pass through a charge electrode, and a voltage is applied between the electrode and the drop stream.

The electrical charges vary according to the voltage level at the time when the drop separates from the stream. Every drop is thus given a predetermined charge and can be deflected at a calculated angle as it passes the deflector plates.

Until recently, ink-jet printing was restricted to simple tasks like printing addresses for mail-order companies or overprinting "stop press" items. Ironically, though the phrase "stop press" will doubtless continue to be used, ink-jet techniques allow you to change what is being printed without stopping the press — or, for that matter, without "pressing".

## Quality improves

The technology was originally applied to alphanumeric printers where speed rather than quality was needed. Now full-colour computer graphics, acceptable both in quality and in size, can be printed.

A single ink jet will print only on to a very small area, so a number of them work side by side in one machine. The paper, or other substrate, moves at a controlled speed a few millimetres beneath the bank of nozzles. Both flat-bed and drum printers have been designed, and the system is even used in a few advanced typewriters.

The single-nozzle video jet alphanumeric printers made by A B Dick can produce 1,275 characters per second to a resolution of 30 to 70 points per inch. The finest resolution likely to be achieved over the next few years will probably not exceed 16 to 20 points per millimetre. IBM has a high-quality ink-jet document printer, the 6640, which is used in its System 6 word-processing package. This will print 92 characters per second with 10 points per millimetre resolution.

The alternative unvibrated jet, or Hertz technology, has been the basis of the Applicon product range. Applicon's three-colour plotter will print a 22-by-

*(continued on next page)*

(continued from previous page)

34in. sheet in seven minutes with a resolution of 125 points per inch. A rotating drum secures the substrate — a pre-coated diazo-based paper or plastic film — and the jets are moved by a controlled lead screw.

The Applicon system uses a nine-track magnetic-tape unit to transmit data to the printer, so it is a useful product for the mainframe user who wants to build up an image database on tape. Using the subtractive primary colours cyan, magenta and yellow, the system can produce over 4,000 colour shades.

Although relatively slow, this type of equipment has the advantage of producing large pictures to a resolution acceptable for cartography and processing aerial and satellite images.

### Transducer pump

The impulse, or drop-on-demand printer, will jet ink only when the computer instructs it to do so. Ink is supplied at a low pressure so that the natural resistance of surface tension will normally prevent the flow. A ceramic transducer in the print head is given an electrical charge to provide a pumping action. Piezo-electric technology reduces the size of the equipment and makes it cheaper to manufacture.

There have been problems such as the formulation and manufacture of suitable

inks which dry on the page rather than in the nozzle. This is why most impulse jets are suitable only for printing on paper, and not on other surfaces.

Several companies are using the process for alphanumeric printing. Silonics' Quietype character printer has seven nozzles and prints 210 characters per second. Siemens makes the PT 80 serial printer which has a 12-by-nine matrix and prints at speeds up to 270 characters per second.

PrintaColor has made a big investment in impulse ink jets and believes it can challenge the Applicon dominance in colour plotting. It launched the IS-8001 and GP-1024 desk-top units earlier this year. The standard unit will print a page-sized image in two minutes with a resolution of 90 dots per inch.

Raymond Keithley of PrintaColor is optimistic: "Drop-on-demand ink-jet technology is broadening the range of applications and lowering the cost of colour documentation, making colour graphics more appealing to the small businessman and manufacturer".

Competition in this branch of computer graphics is fierce. New companies such as Advanced Color Technology of Chelmsford, Massachusetts are challenging the market leaders. ACT is making its debut with the typewriter-sized ACT-1 colour copier. This can produce a full-colour page in 90 seconds with resolution

of 85 dots per inch vertically and 140 horizontally.

Cambridge Consultants has developed a technique of precision micro-encapsulation — enclosing one droplet of ink inside another. This compound jet could have applications outside the field of printing, perhaps in medical use or in other areas of manufacturing. Mike Keeling, who is in charge of the printing system group at CCL, is sceptical, however, about the ability of ink-jet technology to challenge conventional methods of top-quality printing. He says: "It is unlikely that anything approaching litho or gravure quality will appear at a competitive price within the next five years".

### Competing technologies

In the office, ink jet will have to compete with laser xerography. Although ink has the advantage of needing no subsequent processing, laser techniques will be more appropriate for high-volume work.

The benefits of using non-impact systems for printing on rough surfaces are clear. Standard ink-jet products for printing wallpapers and fabrics will soon appear. Ink jet will also become popular in manufacturing industries, reducing the cost of printing instructions, names and logos on a variety of products. There is no shortage of applications. In many cases, ink jet is a practical necessity, not just an alternative or a luxury.

## SPECIAL OFFER!

48K APPLE II ..... £640 ex VAT  
 APPLE DISK + CTL ..... £335 " "  
 APPLE DISK ..... £270 " "

3SL supply a full range of hardware, software and accessories to meet all your needs at highly competitive prices.

Prices include p&p.

**ORDER NOW FOR EARLY DELIVERY!**

# 3SL

P.O. BOX 19  
 SANDBACH  
 CHESHIRE

Telephone Nos.  
 09363-6031 or  
 09367-3842

# Mailing Floppy Disks?

Use Swan Disk Mailers — and get Safety in the Mail

Now used by over 1,000 computer companies, Swan Disk Mailers provide outstanding postal security at economical prices.

Combining great strength with simplicity of use, Swan Disk Mailers are manufactured from rigid white corrugated, holding up to four disks.

There are two sizes available: 8.75" x 8.75" & 6" x 6"



ring  
**01-607 9938**  
 for Free samples  
 and prices

# How structured is BBC Basic?

Structures encourage economic programming. John Gordon and Tony Shaw show how to build a library of subroutines using BBC Basic.

OVER THE PAST few years there has been a definite move towards structured programming. There has also been criticism of poorly structured languages such as the primitive Basics of the early micros.

Most of the newer dialects of Basic have introduced structured concepts that go some way towards refuting this criticism. Microsoft Basic 5.1 introduced the While-Wend construct. The Acorn Atom introduced the Do-Until and both had If-Then-Else. Other languages such as Comal and the SuperPet Waterloo Basic have attempted to introduce similar structures to those of Pascal. Roy Atherton gave a detailed discussion of these structures in the June 1981 issue of *Practical Computing*.

The BBC Micro is an inexpensive tool for introducing the techniques associated with structured programming. There are some limitations to the BBC Basic procedures such as its lack of the ability to pass arrays, found in Comal. On the other hand, as well as a structured Basic there is high-resolution colour graphics, an assembler, analogue-to-digital converters and very good debugging features.

A fundamental aid to good programming practice is the ability to use long and meaningful variable names. BBC Basic allows variable names such as Gross Pay, Remainder and Totals for Month. Variable names in BBC Basic can be of unlimited length, and embedded key words are allowed. The only restriction is that variable names must not begin with a Basic keyword.

BBC Basic also includes For-Next, as in traditional Basic, and Repeat-Until, which is similar to the Do-Until of Atom Basic but is more standard. The BBC Basic If-Then-Else construct has only a single line whereas in Comal or Waterloo Basic it is possible to have an If construct spread over many lines. However, by allowing up to 240 characters in a Basic line, fairly extensive If statements may be used.

## Criticism justified

BBC Basic does not implement a While-Endwhile construct although the published technical specifications indicate that it was planned. There is also no Case structure, and if a multi-way decision is required On-Gosub must be used. The omission of these two features leaves the BBC Basic open to some criticism, but BBC Basic is entitled to call itself a structured language by virtue of the range of features that it implements.

An additional desirable feature in a structured language is for the programmer to be able to write large programs in the form of a series of smaller procedures, the corner-stones of programming. These procedures can later be combined to form the full program. If the procedures are recorded separately in a library then the language can be effectively extended. These features are present in BBC Basic, and a library of procedures can be built using the cassette-tape storage.

The procedures available in BBC Basic, although not quite of the standard of Comal or Pascal, are well designed and

easy to use. For example, to call the procedure shown in listing 4 you simply state its name following the Proc statement. For example,

```
100 PROCprocedure name
```

calls the procedure Procedure Name which is defined in listing 4. It is equivalent to a Gosub in traditional Basic, except that the subroutine name can be meaningful rather than just a line number.

BBC Basic variables can be declared as local to the procedure. In listing 5, Index takes the values 1 to 10 within the procedure PROCjimmy, but maintains its value of 100 in the main part of the program. Values can be passed to parameters that are used within subroutines where such parameters will be local to the procedure. This is accomplished by

(continued on next page)

Listing 5.

```
>LIST
10 Index=100
20 PROCjimmy
30 PRINT "Index=" Index
40 END
100 DEF PROCjimmy
110 LOCAL Index
120 FOR Index = 1 TO 10
130 PRINT "How's it gawin Jimmy!!!"
140 NEXT Index
150 ENDPROC

>RUN
How's it gawin Jimmy!!!
How's it gawin Jimmy!!!
How's it gawin Jimmy!!!
How's it gawin Jimmy!!!
How's it gawin Jimmy!!!
How's it gawin Jimmy!!!
How's it gawin Jimmy!!!
How's it gawin Jimmy!!!
How's it gawin Jimmy!!!
How's it gawin Jimmy!!!
Index= 100
```

Listing 1.

```
>LIST
100 FOR I=1 TO 10
110 PRINT I,I*I
120 NEXT I
130 END

>RUN
1      1
2      4
3      9
4     16
5     25
6     36
7     49
8     64
9     81
10    100
```

Listing 4.

```
>LIST
1000 DEF PROCprocedure_name:REM all procedure names begin with PROC
1010 REM This procedure only prints a message, normally procedures
    would be more useful
1020 PRINT "This is a silly procedure"
1030 ENDPROC:REM procedure declarations end with ENDPROC
```

Listing 3.

```
>LIST
100 REM This program exhibits the IF..
    THEN..ELSE construct
110 REPEAT
120 INPUT A
130 IF A<10 THEN PRINT "A<10"
    ELSE IF A<20 THEN PRINT "A<10, <20"
    ELSE PRINT "A>20"
140 UNTIL A=100
150 END

>RUN
?3
A<10
?13
A<10, <20
?24
A>20
?100
A>20
```

Listing 2.

```
LIST
100 REM This program shows the
    REPEAT...UNTIL construct
110 Ith=0:Last=10
120 REPEAT
130 Ith=Ith+1
140 PRINT "This is the ",
    Ith"th time around
150 UNTIL Ith=Last
160 END

RUN
This is the 1th time around
This is the 2th time around
This is the 3th time around
This is the 4th time around
This is the 5th time around
This is the 6th time around
This is the 7th time around
This is the 8th time around
This is the 9th time around
This is the 10th time around
```

(continued from previous page)

incorporating a parameter list in the procedure declaration

```
DEF PROCName (parameter 1,
  parameter 2, . . . .)
and a set of values in the procedure call
  PROCName (value 1, value 2, . . .)
```

where value 1, 2 . . . can be literal values, or variables which have values already assigned to them.

In listing 6, the values of the parameters First, Second and Third are assigned when the procedure is called, and if these parameters are equivalent to some variables in the main program then the values in the main program are unaf-

ected. The only variables in the main program that will be affected by the action of the procedure are those such as Result, that is the Global variables. Any variable not declared as Local or not declared in the procedure heading is Global.

## Recursive elegance

An additional feature of procedures in BBC Basic is that they may call themselves recursively. Recursion can be an elegant and concise method of expressing the logic of a program and is much used in mathematical programming. It should however be used with caution. BBC Basic

also implements user-defined multi-line functions, which can also be recursive, as in listing 8.

It would be useful to have the ability to build a library of procedures, functions or subroutines which could be loaded from tape to form a single program. As supplied, the BBC Micro can only use a tape for program storage. When a program is loaded from tape it replaces any other program code in memory, at location 0E00 onwards. Thus, although procedures or subroutines can be written and then saved on tape, there is no command designed to successively load them into program memory to form a single program.

The technique in table 1 will overcome this problem as it allows a series of procedures or subroutines held on tape to be loaded into a continuous area of program memory. To use this technique the programmer must ensure that the line numbers of all stored procedures or subroutines are in a distinct high range, for example 10000 onwards, with the main program line numbers in a low range such as 0 to 9000. Using this technique a library of procedures, subroutines and functions can be built up and later linked together, as required.

**Table 1. Loading procedures from tape to main program.**

Action	Example
Type in or load the main program in the normal way	
Decrease Lomem by 2.	>LOMEM=LOMEM-2
Examine the value of Lomem in hex.	>PRINT~LOMEM
Once this new value of Lomem is known the location in memory into which the procedure is to be loaded can be supplied; xxxx is the hex value of Lomem.	> *LOAD "PROC" xxxx
The micro displays a message that includes the byte length zzzz of the program.	PROC1 yy zzzz
Increment the value of Lomem by the byte count value.	>LOMEM=LOMEM+&zzzz
List the program; this updates the value of Top.	>LIST
Renumber the entire program to ensure that there will be no line number conflict when the next procedure is loaded using the same technique.	>RENUMBER

### Example.

```
>LIST
100 REM MAIN PROG
110 INPUT "enter three numbers ";A,B,C
120 PROCminimum(A,B,C)
130 PRINT "minimum = ";Result
140 PROCsum(A,B,C)
150 PRINT " sum = ";Result
160 END
>LOMEM=LOMEM-2
>PRINT ~LOMEM
    EBA
>*LOAD "minimum" 0EBA

Searching
Loading
minimum 00 007B

>LOMEM=LOMEM+&7B
>LIST
120 REM MAIN PROG
110 INPUT "enter three numbers ";A,B,C
120 PROCminimum(A,B,C)
130 PRINT "minimum = ";Result
140 PROCsum(A,B,C)
150 PRINT " sum = ";Result
160 END
10000 DEF PROCminimum(First,Second,Third)
10010 IF First<Second THEN Result=First
    ELSE Result=Second
10020 IF Third<Result THEN Result=Third
10030 ENDPROC
>RENUMBER
>LOMEM=LOMEM-2
>PRINT ~LOMEM
    F03
>*LOAD "sum" 0F03

Searching
Loading
sum 00 0042

>LOMEM=LOMEM+&0042
>LIST
10 REM MAIN PROG
20 INPUT "enter three numbers ";A,B,C
30 PROCminimum(A,B,C)
40 PRINT "minimum = ";Result
50 PROCsum(A,B,C)
60 PRINT " sum = ";Result
70 END
80 DEF PROCminimum(First,Second,Third)
90 IF First<Second THEN Result=First
    ELSE Result=Second
100 IF Third<Result THEN Result=Third
110 ENDPROC
10000 DEF PROCsum(First,Second,Third)
10010 Result=First+Second+Third
10020 ENDPROC
>RENUMBER
```

### Listing 6.

```
>LIST
100 REM Main program
110 INPUT "Enter three numbers",A,B,C
120 PROCminimum(A,B,C)
130 PRINT"Result= ";Result
140 END
1000 DEF PROCminimum(First,Second,Third)
1010 IF First<Second THEN Result=First
    ELSE Result=Second
1015
1020 IF Third<Result THEN Result=Third
1030 ENDPROC
>RUN
Enter three numbers?5,6,7
Result= 5
```

### Listing 7.

```
100 REM Main program
105 Result=-999
106 PRINT "Result = ";Result
110 INPUT "Enter three numbers",A,B,C
120 PROCminimum(A,B,C)
130 PRINT"Result= ";Result
140 END
1000 DEF PROCminimum(First,Second,Third)
1010 IF First<Second THEN Result=First
    ELSE Result=Second
1015
1020 IF Third<Result THEN Result=Third
1030 ENDPROC
>RUN
Result= -999
Enter three numbers?1,2,3
Result= 1
```

Notice in the above program the values of Result.

### Listing 8.

```
5 REM This program uses recursion to evaluate N factorial
10 INPUT N
20 PRINT FNfactorial(N)
30 END
100 DEF FNfactorial(N)
110 LOCAL K
120 IF N=1 THEN K=1
    ELSE K=N*FNfactorial(N-1)
130 =K
>RUN
?5
```

120

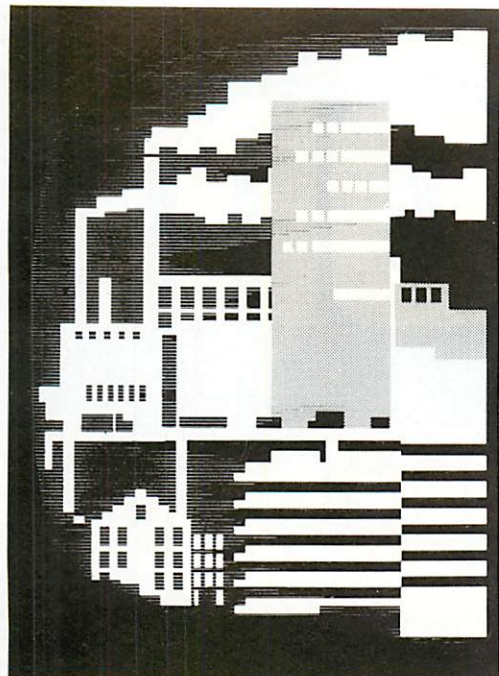

# COMPEC NORTH '82

Belle Vue, Manchester  
June 22-24, 1982

Tuesday: 10.00-18.00  
Wednesday: 10.00-18.00  
Thursday: 10.00-16.30

**The most comprehensive computer exhibition in the north is on again soon in Manchester.**

For computer users, suppliers, systems and software houses, consultants — anyone who is professionally involved with computers — this is the ideal opportunity to see and compare

the whole range of equipment and services.

A day at Compec North is the most effective way of bringing yourself up to date in today's computer market.

## MAKE A NOTE TO VISIT

Admission is by business registration and costs £2 at the door, OR

## SAVE TIME AND MONEY

by sending now for FREE advance tickets.

## COMPEC NORTH '82

COMPEC NORTH is a **ComputerWeekly** exhibition.  
Organised by IPC Exhibitions Ltd.

Please send.....FREE advance registration tickets.  
Compec North '82 tickets. IPC Exhibitions Ltd,  
Surrey House, 1 Throwley Way, Sutton, Surrey SM1 4QQ.

NAME \_\_\_\_\_

COMPANY \_\_\_\_\_

ADDRESS \_\_\_\_\_

(Applications not accepted after June 14. No school parties or children under 16.)

# THE TRANSTEC 1200 VIDEO MONITOR.

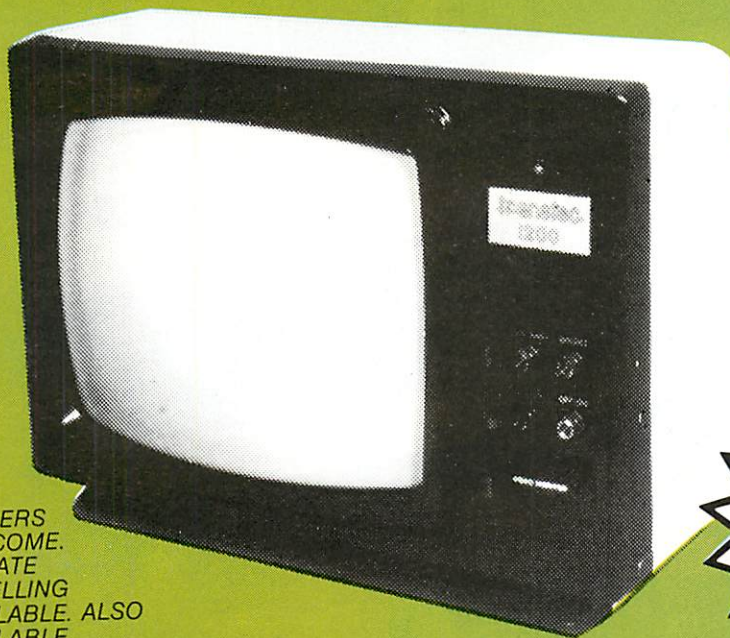

DEALERS WELCOME.  
PRIVATE LABELLING AVAILABLE. ALSO AVAILABLE UNCASED.

At last, a top quality green screen 12" video monitor at a really competitive price.

The Transtec 1200 has a composite video input, compatible with all micro computers and the screen gives a crisp read-out of a full 80 columns.

The unit is housed in a durable plastic cabinet with controls neatly concealed behind a hinged front-access panel.

Why pay more? Send the coupon today for full specification or better still, call us direct in Bristol.

**transtec**

13A Small Street, Bristol W.1.  
Tel: 0272 277462.  
Lisburn Road, Belfast.  
Tel: 24009.  
35 Pearse Street, Dublin 2.  
Tel: 713049.  
I.D.A. Complex, 22 Macken Street, Dublin 2.  
Tel: 713049.

SEND £115 (VAT CARRIAGE INCL.) FOR IMMEDIATE DELIVERY.

I like the Transtec 1200 price — send me more data — fast.

Name \_\_\_\_\_  
Company \_\_\_\_\_  
Position \_\_\_\_\_  
PC 6 82

# JUST £99 COMPLETE.\*

\*vat, postage and parking not included

# pearcom

## The new, APPLE-II\* compatible Euro-PAL colour microcomputer now available

NOW AVAILABLE IN STANDARD 48K RAM VERSION WITH 2K PEARCOM MONITOR.

ex stock **£875**

excl. VAT

### MAIN FEATURES:

Compact computer with the famous 6502 CPU, APPLE-II compatible, so one can use all the APPLE-II hardware and software without any modification.

Many interesting features give the PEARCOM an enormous technical lead.

Just to name a few:

- 14 I/O expansion slots as standard
- On board expandable to 96 Kbyte of RAM, 32K standard
- 6 ROM/EPROM sockets jumper adjustable.
- Professional reed-switch keyboard with numeric pad
- 7 Function keys
- Built-in HF modulator with HF PAL-colour output
- Sound through TV signal and through built-in loudspeaker
- LED indicators for the main-units
- An industrial type, 5 Amp. power-supply
- Bus compatible with the Applesoft Card and the Z80 Softcard from Microsoft, which comes with CP/M and Microsoft BASIC (optional)

ALSO AVAILABLE: THE ASSEMBLED AND TESTED PEARCOM MOTHERBOARD WITH 48K RAM FOR £450. EXCL VAT



### PEARCOM Ltd.

Riverside 1a - Stanstead Abbots - Ware, Herts SG12 BAP - UK

### PEARCOM International Marketing & Publicity Dept.

PO Box 350 - 3720 AH Bilthoven - Tlx 70375 - Holland

### VERGECOURT Ltd. (Distributor)

17 Nobel Square - Basildon - Essex SS13 1LP England - Tel. 0268-728484 - Tlx 995323

DEALER INQUIRES INVITED

\*Apple-II - Trademark of Apple Computer Inc. USA.

### PEARCOM

Int. Marketing & Publicity

P.O. Box 350

3720 AH Bilthoven

● Circle No. 170

# THE **MICROPUTE** CHALLENGE:— FIND A COMPUTER TO COMPARE WITH THE *Sig/net* ... NEVER.



... Because the SIG/NET offers the price advantage of the low cost systems together with the flexibility and infinite expansion capabilities of the high cost systems.

Or in other words a great deal more for a great deal less.

For just **£1,299.00** the standard SIG/NET offers the flexibility to choose the terminal best suited to your requirements, the printer to give the speed and quality you need and disk capacity from 400,000 to 40 Million characters.

The standard SIG/NET 202S .....	£1,299.00
5 Megabyte hard disk system .....	£3,100.00
10 Megabyte 4 User .....	£6,000.00
10 Megabyte 10 User .....	£9,500.00

FOR FURTHER TECHNICAL DATA AND THE NAME OF YOUR NEAREST DEALER SEND THE COUPON **NOW!**

**MICROPUTE**  
Catherine Street, Macclesfield, Cheshire, SK11 6QY. Tel: (0625) 612759.

NAME \_\_\_\_\_ POSITION \_\_\_\_\_

COMPANY NAME \_\_\_\_\_

COMPANY ADDRESS \_\_\_\_\_

\_\_\_\_\_ TEL NO \_\_\_\_\_

Dealer enquiries invited for certain areas of the Midlands and North.

## THERE'S JUST NONE TO COMPARE.

- Unbeatable value for money.
- Advanced and innovative **BRITISH** design.
- **BRITISH BUILT.**
- Unrivalled expansion.
- Faster than comparable systems.
- Full 64K of memory.
- Sold only through approved dealers.
- CP/M compatible.



microcomputer systems

Catherine Street,  
Macclesfield,  
Cheshire,  
SK11 6QY.  
Tel: (0625) 612759.

● Circle No. 171

123



# THE GALAXY 1 COMPUTER

The cost effective solution to your computer needs for only **£1,450\***

The Galaxy 1 desk top computer system can be used in education, small business applications, word processing, stock control and a host of other environments. Our choice of CP/M as the operating system means that our customers can select a suitable application package from the widest possible range.

However, unlike our competitors, we supply not only the hardware but all the essential system software needed to start using the Galaxy 1 as soon as it is installed. We have adopted COMAL-80 as our standard language. This structured basic is rapidly gaining widespread acceptance and popularity especially in the education market, offering much greater flexibility and ease of use than existing Basics. We also supply a very powerful Z80 assembler/editor called GEM ZAP with GEM PEN, a compact but very powerful word processing package. The system software suite is completed with GEM DEBUG, a useful machine code program de-bugging utility.

Modular design means reliability and ease of maintenance. Unlike many other manufacturers Gemini offer a full one year warranty (except Disc heads which are guaranteed for 3 months). Our distributors carry a full range of replacement boards thereby facilitating a quick, efficient and cost effective back up customer service.

#### Features include:

- Twin Z80 Processors
- 64K Dynamic RAM
- 800 K Disc Based Storage
- 80×25 Screen Format
- Dual Printer Interfaces
- Modular Design
- CP/M 2.2 Operating system
- COMAL-80 – Structured Basic
- Z80 Editor/Assembler
- Text Editor & Formatter
- Program De-Bugging Utility

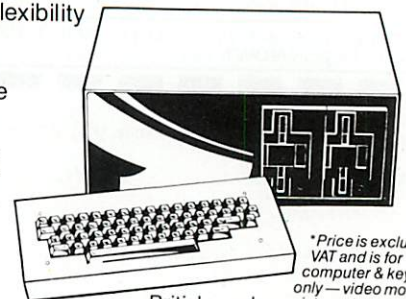

\* Price is exclusive of VAT and is for computer & keyboard only – video monitor & printer extra.

British made



Telephone Amersham 28321 for the name and address of your nearest distributor.  
\* Dealer enquiries invited.

**Gemini Microcomputers** Oakfield Corner, Sycamore Road, Amersham, Bucks HP6 5EQ.

# Get down to the root of the problem

Conventional methods for finding the roots of a polynomial may prove difficult if the function is not well-behaved. Patrick Howden and Noel Kantaris present an original algorithm which does the same job, and is able to deal with closely spaced and complex roots.

TRADITIONAL METHODS for solving for roots of equations depend on being able to differentiate the function concerned. One fairly accurate iterative formula, which usually gives several decimal places of accuracy, is the following:

$$x_0 \approx a_{n+1} = a_n + \frac{F'(a_n)}{F''(a_n)} \times$$

$$\left[ -1 + \left\{ 1 - \frac{2F(a_n)F''(a_n)}{(F'(a_n))^2} \right\}^{\frac{1}{2}} \right]$$

where  $a_n$  is the guessed root,  $F(a_n)$  is the function evaluated with  $a_n$ , and  $F'$  and  $F''$  are the first and second differentials of the function.

Such a method requires the prior calculation of the various differential coefficients and is severely limited if either  $F'$  or  $F''$  is zero, or if the function inside the curly brackets is negative so that its square root is complex. Furthermore, this precision formula does not have much capture range, which is also true of the series methods of calculating roots as a sum of terms. It would therefore be very useful to have a simpler method which can also deal with multiple roots, even those lying close together or of very large magnitude.

Our equation-solving method presented here has been engineered on empirical lines. It achieves great precision after only a few steps on a simple calculator. Any errors that might be introduced along the way are self-correcting, and the capture range from a trial solution — typically zero — is usually indefinitely large.

An equation which can be represented as a function of  $x$  and can be written as  $F(x) = 0$  will have a root at  $x_0$  and trial roots given as  $a_0, a_1, \dots, a_n$ . Near a root,  $x_0$  can be approximated by

$$x_0 \approx a_n \pm Q [F(a_n)]$$

for some function  $Q$  of  $F(a_n)$ , provided  $a_n$  is sufficiently close to  $x_0$  and  $Q$  approaches zero as  $F(a_n)$  approaches zero, that is, as  $a_n$  approaches  $x_0$ . In particular

$$x_0 \approx a_n \pm \frac{F(a_n)}{q}$$

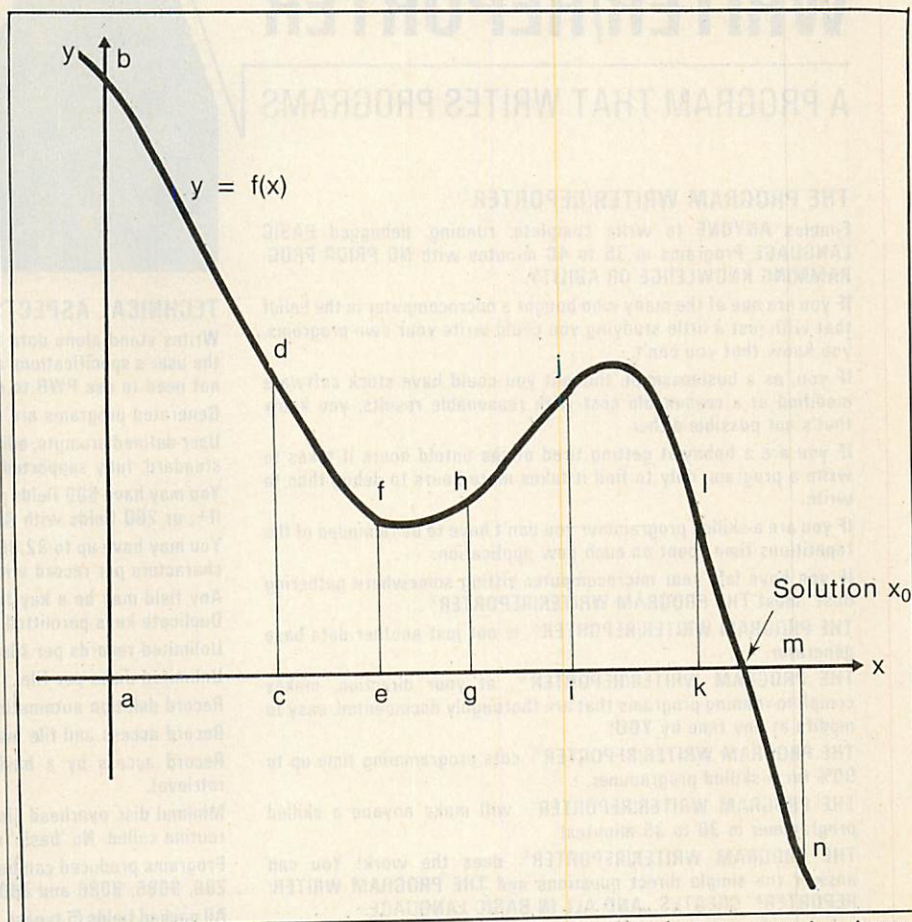

Figure 1. Schematic of  $\sinh^{-1}$  function:  $ac = \sinh^{-1} ab, ce + \sinh^{-1} cd$ , etc; note sign change near the root which gives corresponding halving of increment.

where  $q$  is an appropriate variable number to be derived later.

If any  $a_n$  is substituted into  $F(x)$ , for example,  $a_n = 0$ , then  $F(a_n)$  could be too impossibly large to iterate. Therefore,  $Q$  must act as a well-behaved attenuating function: the larger  $F(a_n)$ , the heavier the required attenuation. Further, the choice of  $Q$  must satisfy two more requirements:

$$Q [F(a_n)] = F(a_n)$$

for small  $F(a_n)$ , and

$$Q [-F(a_n)] = -Q [F(a_n)]$$

Thus,  $Q$  must be monotonic, more or less symmetrical, and must not saturate.

Two such functions were considered and tried. The first,

$$Q = \tan^{-1} [F(a_n)]$$

appeared to be a good choice until an attempt was made to evaluate equations with large answers, say  $x_0 = 100$ . Although the answer was reached eventually, it was rather too slow for comfort. A further disadvantage of this choice is that the  $\tan^{-1}$  function has a limiting value of  $\pm\pi/2$ . A strong advantage, however, is that most reasonably simple calculators support this function.

To overcome the slowness of the  $\tan^{-1}$  function, the inverse hyperbolic sine function  $\sinh^{-1}$  was chosen as a function for  $Q$ . The expression

$$\sinh^{-1} [F(a_n)] = \ln [F(a_n) + \{F(a_n)^2 + 1\}^{\frac{1}{2}}]$$

must be used with those calculators without the  $\sinh^{-1}$  function and in any computer programs.

Another valid form for  $Q$  could be

$$\frac{F(a_n)}{q}$$

where  $q$  is adjusted at each iteration in order to adapt to the conduct of computation — a sort of feed-forward adaptive gain technique. A potential diverging or conversely go-slow tendency, is counteracted by doubling or halving  $q$  before any iteration.  $q$  is a "gain control" or stability control — it stops oscillations.

To meet both criteria, the adapted function is tentatively shown as

$$x_0 \approx a_{n+1} = a_n \pm \frac{\sinh^{-1} [F(a_n)]}{2^r}$$

where  $r$  is a  $\pm$  integer or zero, especially at the first step. It is better adapted to hand calculators.

(continued on page 127)

THE PROGRAM WRITER/REPORTER® enables ANYONE to write complete, running, debugged BASIC LANGUAGE Programs in 35 to 40 minutes with NO PRIOR PROGRAMMING KNOWLEDGE OR ABILITY.

If you are one of the many who bought a microcomputer in the belief that with just a little studying you could write your own programs, you know that you can't.

If you, as a businessman, thought you could have stock software modified at a reasonable cost with reasonable results, you know that's not possible either.

If you are a hobbyist getting tired of the untold hours it takes to write a program, only to find it takes more hours to debug than to write.

If you are a skilled programmer you don't have to be reminded of the repetitions time spent on each new application.

If you have left your microcomputer sitting somewhere gathering dust... meet THE PROGRAM WRITER/REPORTER®.

THE PROGRAM WRITER/REPORTER® is not just another data base generator.

THE PROGRAM WRITER/REPORTER®, at your direction, makes complete running programs that are thoroughly documented, easy to modify at any time by YOU!

THE PROGRAM WRITER/REPORTER® cuts programming time up to 90% for a skilled programmer.

THE PROGRAM WRITER/REPORTER® will make anyone a skilled programmer in 30 to 35 minutes!

THE PROGRAM WRITER/REPORTER® does the work! You can answer the simple direct questions and THE PROGRAM WRITER/REPORTER® CREATES... AND ALL IN BASIC LANGUAGE.

Q. After THE PROGRAM WRITER/REPORTER® has produced a program, can it be modified?  
A. Yes, the resulting program is modular, fully documented and readily accessible for alterations or deletions.

Q. Does the program created use so much disc space that there is very little space left for the record storage?  
A. No, the code produced is extremely compact despite complete documentation. If requested THE PROGRAM WRITER/REPORTER® will even 'pack' or compress information. You may even delete the 'remarks' making it even more space efficient.

Q. Must I be expert or even conversant with Basic Language?  
A. No, all questions to and answers from the operator require no computer language knowledge, simple, every day English will do.

Q. What about maths ability?  
A. If you can count your fingers and toes, you'll have no problems.

Q. Will the programs which I produce with THE PROGRAM WRITER/REPORTER® be bulky, slow or amateurish?  
A. No, the resulting programs will be sophisticated and extremely fast operating. For example, should you create a mailing list or inventory program, the time for any record to be retrieved and displayed from a full disc would take a maximum of 1 second.

Q. Must the programs produced conform to a pre-determined format and file length?  
A. No, you determine format and file size to fit your requirements. You may have as many as 500 fields or as few as 1.

Q. Can I develop my own business programs?  
A. For the most part, yes.

Q. What are the limitations? What programs can I produce with THE PROGRAM WRITER/REPORTER®?  
A. Your own ingenuity and hardware limitations, 100's of different programs.

WOULD YOU LIKE TO HAVE A PROGRAM TO DEVELOP ALL OF THE APPLICATIONS SOFTWARE YOU WILL EVER NEED?..... THEN YOU NEED —

# THE PROGRAM WRITER/REPORTER®

A PROGRAM THAT WRITES PROGRAMS

PLEASE SUPPLY COPIES OF THE FORM FOR APPLE II AT - £275 + V.A.T. (€316,25) APPLE III & APPLE CP/M AT - £325 + V.A.T. (€373,75) CP/M 8" and 5" NEC, OSBORNE, NORTH STAR, VECTOR GRAPHIC, APPLE III & APPLE CP/M AT -

AVAILABLE FOR: —

With the reporter columns may be the result of computations on fields or other columns or intermediate results limited only by the complexity permitted by Microsoft basic. All basic computational functions are permitted, as are all logical and string functions.

Complex selection/exclusion criteria are possible and easily understood when using the reporter.

Programs are compatible, using Microsoft's BASCOM (CP/M only). Can be used with Microsoft basic on CP/M systems.

Multiple file access and update allowed.

All packed fields (5 types) may be updated computationally, (2 types - APPLE II). You may add (or subtract) an amount to a field, or multiply or divide a field by a constant.

Programs produced can be transported between 6800, 6502, 8080, 280, 8085, 8086 and Z8000 based systems.

Minimal disc overhead since there is no special assembly language routine called. No 'basic' overhead.

Record access by a hashing algorithm guaranteeing fast record retrieval.

Record access and file maintenance is user transparent.

Record deletion automatically supported.

Unlimited records per file (disk limited).

Unlimited disks per file.

Duplicate keys permitted.

Any field may be a key field. New keys may be added at any time.

You may have up to 32,000 characters per record with CP/M; 3,000 characters per record with APPLE II+ and APPLE III.

II+ or 200 fields with APPLE III.

You may have 500 fields per record with CP/M; 47 fields with APPLE II+; or 200 fields with APPLE III.

User-defined prompts, edits, error messages and video attributes are standard, fully supported and easily modified.

Generated programs are easily modified.

Writes stand alone data base storage/retrieval/update programs to the user's specifications and generates source code in basic (you do not need to use PWR to run generated programs).

the user's specifications and generates source code in basic (you do not need to use PWR to run generated programs).

Generated programs are easily modified.

User-defined prompts, edits, error messages and video attributes are standard, fully supported and easily modified.

You may have 500 fields per record with CP/M; 47 fields with APPLE II+; or 200 fields with APPLE III.

You may have up to 32,000 characters per record with CP/M; 3,000 characters per record with APPLE II+ and APPLE III.

Any field may be a key field. New keys may be added at any time.

Duplicate keys permitted.

Unlimited records per file (disk limited).

Unlimited disks per file.

Record deletion automatically supported.

Record access and file maintenance is user transparent.

Record access by a hashing algorithm guaranteeing fast record retrieval.

Minimal disc overhead since there is no special assembly language routine called. No 'basic' overhead.

Programs produced can be transported between 6800, 6502, 8080, 280, 8085, 8086 and Z8000 based systems.

All packed fields (5 types) may be updated computationally, (2 types - APPLE II). You may add (or subtract) an amount to a field, or multiply or divide a field by a constant.

Multiple file access and update allowed.

Can be used with Microsoft basic on CP/M systems.

Programs are compatible, using Microsoft's BASCOM (CP/M only).

Complex selection/exclusion criteria are possible and easily understood when using the reporter.

With the reporter columns may be the result of computations on fields or other columns or intermediate results limited only by the complexity permitted by Microsoft basic. All basic computational functions are permitted, as are all logical and string functions.

AVAILABLE FOR: —

CP/M 8" and 5" NEC, OSBORNE, NORTH STAR, VECTOR GRAPHIC, APPLE III & APPLE CP/M AT - £325 + V.A.T. (€373,75) APPLE II AT - £275 + V.A.T. (€316,25)

PLEASE SUPPLY COPIES OF THE FORM FOR APPLE II AT - £275 + V.A.T. (€316,25) APPLE III & APPLE CP/M AT - £325 + V.A.T. (€373,75) CP/M 8" and 5" NEC, OSBORNE, NORTH STAR, VECTOR GRAPHIC, APPLE III & APPLE CP/M AT -

PLEASE SEND FURTHER INFORMATION  TICK BOX

NAME: \_\_\_\_\_ ADDRESS: \_\_\_\_\_ TELEPHONE No. \_\_\_\_\_ DEALER ENQUIRIES INVITED

ASSET LIMITED, 24 Princes Street Southport, Merseyside PR8 1ED Telephone: 0704 43008

Computer Systems and Services

## TECHNICAL ASPECTS

Writes stand alone data base storage/retrieval/update programs to the user's specifications and generates source code in basic (you do not need to use PWR to run generated programs).

Generated programs are easily modified.

User-defined prompts, edits, error messages and video attributes are standard, fully supported and easily modified.

You may have 500 fields per record with CP/M; 47 fields with APPLE II+; or 200 fields with APPLE III.

You may have up to 32,000 characters per record with CP/M; 3,000 characters per record with APPLE II+ and APPLE III.

Any field may be a key field. New keys may be added at any time.

Duplicate keys permitted.

Unlimited records per file (disk limited).

Unlimited disks per file.

Record deletion automatically supported.

Record access and file maintenance is user transparent.

Record access by a hashing algorithm guaranteeing fast record retrieval.

Minimal disc overhead since there is no special assembly language routine called. No 'basic' overhead.

Programs produced can be transported between 6800, 6502, 8080, 280, 8085, 8086 and Z8000 based systems.

All packed fields (5 types) may be updated computationally, (2 types - APPLE II). You may add (or subtract) an amount to a field, or multiply or divide a field by a constant.

Multiple file access and update allowed.

Can be used with Microsoft basic on CP/M systems.

Programs are compatible, using Microsoft's BASCOM (CP/M only).

Complex selection/exclusion criteria are possible and easily understood when using the reporter.

With the reporter columns may be the result of computations on fields or other columns or intermediate results limited only by the complexity permitted by Microsoft basic. All basic computational functions are permitted, as are all logical and string functions.

AVAILABLE FOR: —

CP/M 8" and 5" NEC, OSBORNE, NORTH STAR, VECTOR GRAPHIC, APPLE III & APPLE CP/M AT - £325 + V.A.T. (€373,75) APPLE II AT - £275 + V.A.T. (€316,25)

PLEASE SUPPLY COPIES OF THE FORM FOR APPLE II AT - £275 + V.A.T. (€316,25) APPLE III & APPLE CP/M AT - £325 + V.A.T. (€373,75) CP/M 8" and 5" NEC, OSBORNE, NORTH STAR, VECTOR GRAPHIC, APPLE III & APPLE CP/M AT -

PLEASE SEND FURTHER INFORMATION  TICK BOX

NAME: \_\_\_\_\_ ADDRESS: \_\_\_\_\_ TELEPHONE No. \_\_\_\_\_ DEALER ENQUIRIES INVITED

ASSET LIMITED, 24 Princes Street Southport, Merseyside PR8 1ED Telephone: 0704 43008

Computer Systems and Services

A Computer Software Generator that writes programs... CP/M 8" and 5" NEC, OSBORNE, NORTH STAR, VECTOR GRAPHIC, APPLE III & APPLE CP/M AT - £325 + V.A.T. (€373,75) APPLE II AT - £275 + V.A.T. (€316,25)

(continued from page 125)

The algorithm, unlike the traditional Newton-Raphson method, tends to be more stable under varied conditions. Although there may be better shaping functions than  $\sinh^{-1}$  — calculus of variations schemes would probably reveal them — at best, they could only save a few iteration steps in reaching any desired precision.

Programming is greatly simplified by the adoption of the algorithm

$$x_0 \approx a_{n+1} = a_n \pm 2 \left( \frac{p}{3} - r \right) \sinh^{-1} [F(a_n)]$$

where  $r$  is bumped up by one when the sign of  $F(a_n)$  changes, and  $p$  is bumped up by one when the computation is going too slowly.

### Gain control

The procedure for finding roots is related to electronic analogue-to-digital conversion, while the  $2^r$  divisor is simply a crude averaging method which is simpler than, say, a parabolic or incremental straight-line fit. Thus, if

$$\pm \sinh^{-1} [F(a_{n+1})]$$

is opposite in sign to that of the previous

$$\pm \sinh^{-1} [F(a_n)]$$

you increment  $r$  by one, that is you divide by a further power of 2 while maintaining  $p$  the same as before. When they have the same sign, increment  $p$  by one while maintaining  $r$  at its previous value. This develops the adaptive gain control.

Figure 1 illustrates how the algorithm operates. Newton-Raphson's method would oscillate on this curve unless the starting point were chosen very near the

**Table 1. Solution of one root of seventh-degree trial polynomial.**

Enter values for:  
 $X_{old} = 0$   
 (P = 0 — set by the program)  
 $R = 0$   
 $S_{ign} = -1$   
 (Maximum number of iterations = 100  
 — set by the program)  
 Decimal accuracy = .00001

Iter	P	R	Root
1	1	0	8.65148245
2	1	1	-1.32675618
3	1	2	0.77906635
4	2	2	3.49531867
5	2	3	1.52876973
6	2	4	2.16587852
7	2	5	1.83954148
8	2	6	1.96781340
9	2	7	1.90972184
10	2	8	1.93079275
11	2	9	1.92176434
12	2	10	1.92342333
13	2	11	1.92296889
14	3	11	1.92287386
15	3	12	1.92287964

To change parameters type RUN 50  
 To change function type RUN ROOTS

F(x)	Trial $X_{old}$	R	S = sign op $\pm \sinh^{-1}$	Increment sign $S_1$	Max no. of iterations, N	Decimal accuracy P	Optional fine search mode. Increment L, which raises flags K
Equation to be solved	Often both zero. P = 0	Select to find nearest root	Initially +	Always 100	Typically .00001		

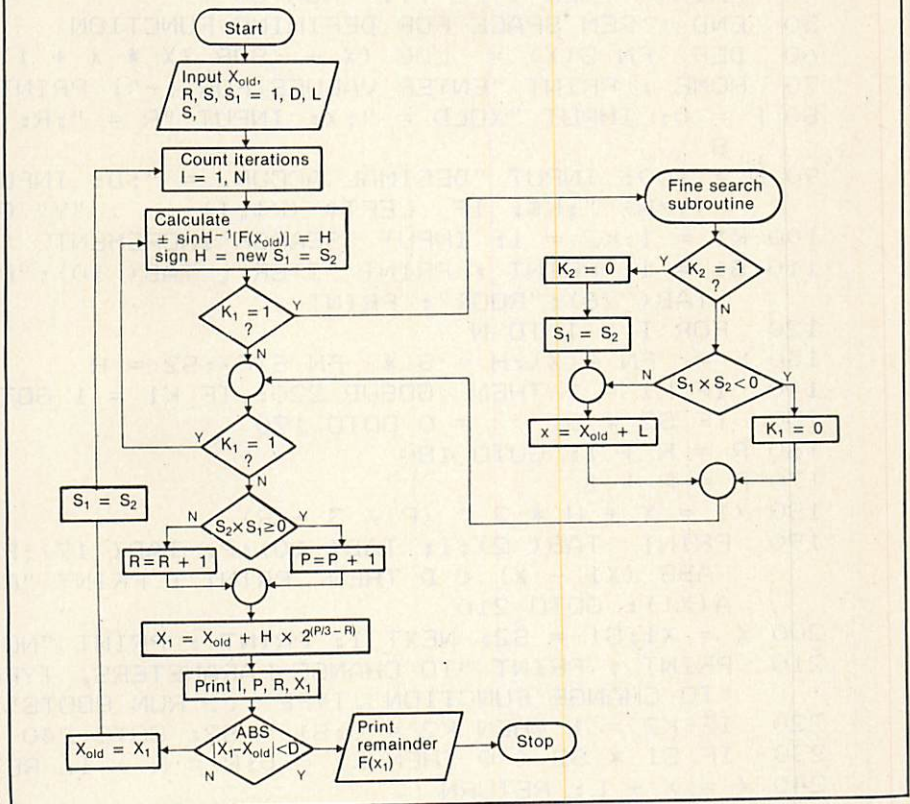

**Figure 2. Flowchart for single roots, including a fine-search routine.**

solution. The flowchart in figure 2, when applied to a polynomial, such as

$$F(x) = x^7 + 28x^4 - 480 = 0$$

adequately illustrates the roots solving technique. Initial conditions are set at  $x = 0$ ,  $p = 0$ ,  $r = 0$ . Sign  $S$  of the  $\sinh^{-1}$  function is taken as negative. If it were chosen positive it would find other answers, not necessarily of any particular sign. The first  $S_1$ , a sort of pre-initial sign, is always assumed positive.

The total number of iterations allowed is pegged at 100 in order to prove the absence of a root in that direction. A root is assumed to have been found if

$$\text{Abs} [F(a_{n+1}) - F(a_n)]$$

is less than a desired decimal accuracy, in this case 0.00001.

The first step is to calculate  $F(0)$ , which is  $-480$  for the particular example. Then  $H$  is found from

$$H = -\sinh^{-1} [F(0)] = -\sinh^{-1} [-480] = +6.866699$$

The sign of  $H$  is stored in  $S_2$ , to be compared with the previous sign  $S_1$ . All that remains is obvious, yielding one solution at  $x = 1.9228816$  after 15 iterations as shown in table 1.

Another solution will usually be found simply by reversing the sign  $S$  with the same initial  $x$ , and  $r = 0$ . However, there happen to be two negative solutions very close together, so that iterating negatively from  $x = 0$  can skip both solutions

altogether, unless the iteration takes very small steps by setting  $r$  as large as 10, for example. Starting at  $x = -2.6$  with  $S$  as negative gives a solution at  $x = -2.57780046$ .

### Fine searching

To find these closely spaced roots a simple fine-search mode subroutine is included in the program. It hunts for a sign change in the value of  $F(x)$ , starting from  $x_{old}$  and stepping by a small increment  $L$ , which is an input parameter. When a sign change is encountered the program continues to evaluate precisely the approximately discovered root as before. In this way, with  $r = 10$ ,  $x = 0$ ,  $L = -0.01$  and  $S = +1$ , the root at  $x = -2.45808973$  is found. Starting from a slightly more negative value of  $x$ , namely  $-2.46$  with  $S = -1$  and the fine-search mode in operation, a third real root is evaluated at  $x = -2.57780046$ . All other roots are thus complex.

Figure 3 shows these solutions where, for instance, in order to compute the  $+1.92$  solution,  $S$  will have to have a negative sign, with an initial  $x$  placed anywhere from the  $-2.45$  solution to  $+\infty$ . Conversely, the  $-2.45$  solution will be found with a positive  $S$  and with  $x$  lying between  $-2.57$  and  $+1.92$ , and so on for the  $-2.57$  solution.

(continued on next page)

Figure 3. Regions in which trial root can start in order to capture a particular root.

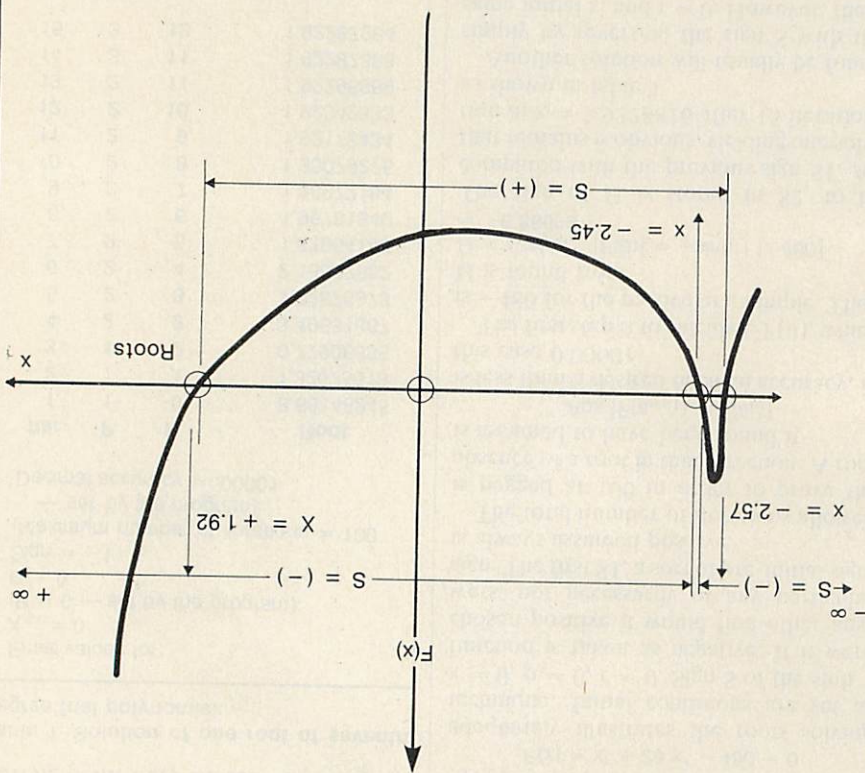

Solution seeking is usually much easier than in this example, where the equation has two roots close together so that they must be approached with the fine-search mode. The same method can be applied, with much less difficulty, to a bridge-cable catenary problem. If the bridge consists of a 300m, heavy cable suspended between two horizontal points 260m apart, you can find out by how much the cable sags by solving for  $x$  in the expression

$$F(x) = x \sinh\left(\frac{x}{130}\right) - 150 = 0$$

and substitute into

$$\text{sag} = x \cosh\left(\frac{x}{130}\right) - x$$

The initial conditions on the algorithm are  $x_{old} = 100$ ,  $r = 0$ ,  $S = +1$ , which gives the root as  $x = 138.325993\text{m}$ , which in turn gives the sag in the bridge cable as 65.7183163m.

The Apple Basic program used to solve these examples is shown in listing 1. When the program is first run, it allows you to specify your function in line 50, which for the first example should be typed as follows:

$$50 \text{ DEF FNA}(X) = X \wedge 7 + 28 * X \wedge 4 - 480$$

To change the equation, simply retype line 50 with the new equation appearing after the = sign.

(continued from previous page)

```

10 REM ROOTS WITHOUT DIFFERENTIALS
20 HOME : PRINT "TYPE YOUR FUNCTION AS PER EXAMPLE": PRINT
40 PRINT "THEN TYPE ... RUN 50"
50 END : REM SPACE FOR DEFINING FUNCTION
60 DEF FN S(X) = LOG(X + SQR(X * X + 1))
70 HOME : PRINT "ENTER VALUES FOR :-": PRINT
80 P = 0: INPUT "XOLD = ": X: INPUT "R = ": R: INPUT "SIGN = " : S
90 N = 100: INPUT "DECIMAL ACCUR" = " : D: INPUT "FINE SEARCH? (Y/N) " : K$: IF LEFT$(K$,1) < "Y" GOTO 110
100 K1 = 1: K2 = 1: INPUT "SEARCH INCREMENTS? " : L
110 S1 = 1: PRINT "ITER": TAB(10): "P": TAB(17): "R": TAB(28): "ROOT": PRINT
120 FOR I = 1 TO N
130 F = FN A(X): H = S * FN S(F): S2 = H
140 IF K1 = 1 THEN GOSUB 220: IF K1 = 1 GOTO 130
150 IF S2 * S1 > 0 GOTO 170
160 R = R + 1: GOTO 180
170 P = P + 1
180 X1 = X + H * 2 * SQR(P / 3 - R)
190 PRINT TAB(2): I: TAB(10): F: TAB(17): R: TAB(25): X1: IF ABS(X1 - X) < D THEN PRINT : PRINT "REMAINDER = " : FN A(X1): GOTO 210
200 X = X1: S1 = S2: NEXT I: PRINT : PRINT "NOT CONVERGING"
210 PRINT "TO CHANGE PARAMETERS, TYPE ... RUN 50": PRINT
220 "TO CHANGE FUNCTION TYPE ... RUN ROOTS": END
230 IF K2 = 1 THEN K2 = 0: S1 = S2: GOTO 240
240 X = X + L: RETURN

```

Listing 1. Apple Basic implementation of solution algorithm.

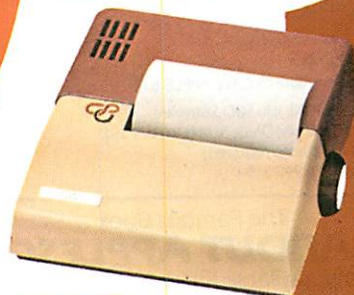
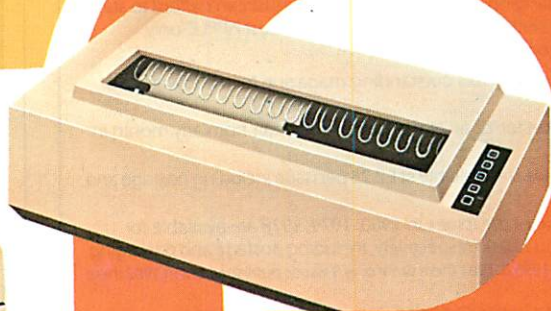

More exclusive, quality products of outstanding value from CPU Peripherals. All backed by our technical support and service organisation.

**PRIMA 165 - £899.\***

British built in our Woking factory, this outstanding dot matrix printer offers:

- 165 cps bi-directional printing
- 80 cps correspondence quality print
- 9 x 9, 96 character sets with lower case descenders
- Downline loading of special character sets
- Pin addressable graphics
- Tractors (1 + 5 copies)
- Superscript/subscript
- 7 channel VFU
- Serial and parallel interface (switchable)
- Buffering up to 3K
- Low noise (58 db)

**DAISYWRITER - £899.\***

A most advanced microprocessor controlled serial impact printer giving letter quality output QUIETLY!

**Printers from CPU Peripherals**

- up to 20 cps bi-directional
- 96 character interchangeable cartridge wheel element
- Snap on/off tractor and sheet feed options
- Parallel or serial interfaces (X-on, X-off, DTR, switch selectable baud rates)
- IBM Selectric Type Cassette Film ribbon
- 1 +5 copies
- 4000 character buffer
- 10, 12, 15 characters per inch
- Forward/reverse paper movement
- 40 cps bi-directional
- Upper/lower case plus graphics
- Silent operation
- Interfaces to popular Micros
- Suitable for data logging and general micro-computer applications

\* One-off End User price

**CPU 100 & 200 THERMAL PRINTERS**  
40 and 80 character per line Printers. From £190\*

Rodd Industrial Estate  
Govett Avenue  
Shepperton Middlesex  
TW17 8AQ

Telephone:  
Walton on Thames 46433/4/5/6  
Telex: 922637



● Circle No. 174

S.B.D. Software is proud to announce their distribution agreement with the most up to date APPLE-only magazine in America.

# CALL A.P.P.L.E. MAGAZINE

In today's fast changing world of the APPLE you just can't afford to stay behind, so don't settle for anything less than the best APPLE-only magazine in America.

Now you can purchase this outstanding magazine for the low price of £1.75 per issue.

Your subscription for 12 or 24 magazines may start from any month in 1981.

Single back issues are available at £2.25 per issue including postage and packing.

A bound volume of the issues in 1980, 1979, 1978 are available for £20.00, £15.00 and £10.00 respectively, including postage and packaging. (Please note that in 1980 & 1981 there were only 9 issues published but in 1982 there will be 12 issues.)

12 issues @ £21.00     24 issues @ £40.00  
Europe Air Mail postage, add £6 per 12 issues

NAME .....

ADDRESS .....

TOWN ..... POSTCODE .....

Please start my subscription ..... Month ..... Year .....

Barclaycard/Access Number ..... Expiry Date .....

Please make cheques payable to CALL APPLE (UK)

Send to:- CALL APPLE (UK), c/o SBD Software,  
FREEPOST, RICHMOND, SURREY TW9 1BR  
(No postage stamp required)  
Telephone: 01-940 5194

The Famous Book  
**"ALL ABOUT APPLESOFT"**  
Now available @ £9.50 incl. P. & P.

● Circle No. 176

## MAGNUM COMPUTERS LTD

156 Northfield Ave., Ealing, London W13 9SB.  
Tel. 01-567 0154

FREE installation and initial training for very **ECONOMICAL** business system packages with **EASY-TO-USE** tailored or ready-made modules written by our programmers in **dBASE II**

systems	price	software	price
SUPERBRAIN 350K	1720	STOCK CONTROL	320
SUPERBRAIN 700K	2120	ORDER/INVOICING	320
N/STAR ADVANTAGE 720K	2190	SALES LEDGER	320
N/STAR 12MBK HARD DISK		PURCHASE LEDGER	320
(multi-user applicable)	3750	NOMINAL LEDGER	320
		PAYROLL	390
<i>printers</i>		INTEGRATED ACCOUNTS	
MICROLINE 80	320	(excl. PAYROLL)	1290
PAPER TIGER 460	680	SPECIAL PROJECTS	POA
NEC SPINWRITER 5520	1675	dBASE II	395

EXAMPLE STOCK CONTROL PACKAGE:

SUPERBRAIN 350K + MICROLINE 80 + dBASE II + STOCK CONTROL  
(handling 600 items & 1000 monthly entries approx) 2755

**dBASE II CONSULTANCY SERVICE AVAILABLE**  
**DEALERS ENQUIRIES INVITED**

**SPECIAL INSTALMENT TERMS FOR PACKAGES**

● Circle No. 175

# FREE ZX81 SOFTWARE!

The June issue of Your Computer contains a FREE software offer of special interest to ZX 81 owners.

This takes the form of a flexi-disc bearing a program for a well-known board game.

An article tells you how to transfer the software from the disc to your ZX 81, thus avoiding the laborious process of keying in program listings.

Also in this issue:

- Review of VIC 20 software
- BBC micro: what the manual didn't tell you
- Writing a word processing package

At all leading newsagents. Price 60p.

Why not place a regular order with your newsagent? Or take out a subscription by completing the coupon.

To **Marketing Department, Room 316, IPC Electrical Electronic Press Ltd**  
**Quadrant House, The Quadrant, Sutton, Surrey SM2 5AS.**

Please send me 12 issues of Your Computer.

I enclose a cheque/PO for £8 UK/£14 Overseas, payable to IPC Business Press Ltd.

Name .....

Address .....

.....

.....

PC 11



# MicroStyle

29 BELVEDERE, LANSDOWN ROAD, BATH

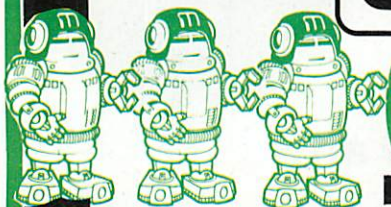

**(0225) 334659.**

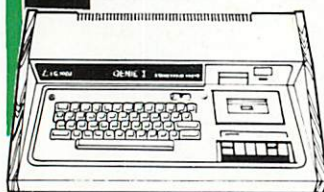
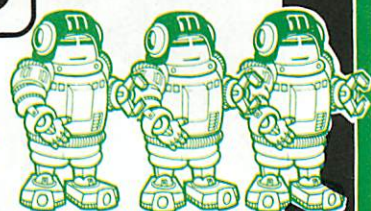

## INGENIOUS Genie 1

All of the original GENIE SYSTEM plus: ★ Machine Language Monitor ★ Fitted Sound ★ Renumber Command ★ Full Lower Case ★ Screen Print ★ 16K ROM 13K RAM **£295** + VAT

## SEIKOSHA GP100A PRINTER

ENTIRELY NEW DESIGN. UNBELIEVABLY LOW PRICE. FULL GRAPHICS CAPABILITY. CENTRONICS PARALLEL INTERFACE. PAPER WIDTH ADJUSTABLE UP TO 10". **£195.00** + VAT



## PRINTERS

EPSON MX80 EPSON MX100 ANADIX PAPER TIGER T.E.C. SCRIPTA MICROLINE 80.

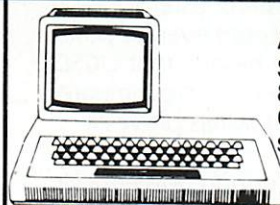

## ACORN ATOM

Sensational New Micro-Pack! 8K ROM 5K RAM, PSU included. Colour fitted. Starter pack software. **£170.00** + VAT



## SHARP MZ80K

Full 48K Microcomputer with built-in cassette deck and monitor. THE ALL IN ONE COMPUTER - NO MESSY WIRES. Full range modular extensions available, printers, disk drives, etc. **£345** + VAT

## GENIE II

The MacroComputer

Offering all the advantages of the Genie I system, with the benefit of advanced design for the professional user.

- ★ Terminal Routines
  - ★ Facility to Upload & Download
  - ★ Screen Print
  - ★ 4 Defineable Function Keys
  - ★ Full Upper & Lower Case
- Price **£299** + VAT

## PROFESSIONAL EXTENSION KEYBOARD

for added efficiency of your ZX81. Plugs straight into existing ZX81 without desoldering. Simply unplug existing keyboard and plug in new one. **£25.00** + VAT

## TANTEL PRESTEL ADAPTER

New ALPHA Numeric keyboard brings PRESTEL into your home. Converts black and white or colour TV. **£195.00** + VAT

## VIDEO MONITORS

All sizes and prices.  
Black/white 9" **£90.00**  
Black/white 12" **£65.00**  
Green Screen 12" **£85.00**  
Amber 9" **£95.00**  
All Plus VAT

## Complete range of VIDEO GENIE PERIPHERALS

can now be linked to your TRS80 for only **£18.00** + VAT with the new 3023 BUS CONVERTOR

**Plus!**

Aculab Floppy Tapes

Special Offers - Ring and find out.

Vast Computer Book Selection.

Just a sample of what's in store for you!

ZX81 Software. TRS80/Video

Genie Software. Diskettes.

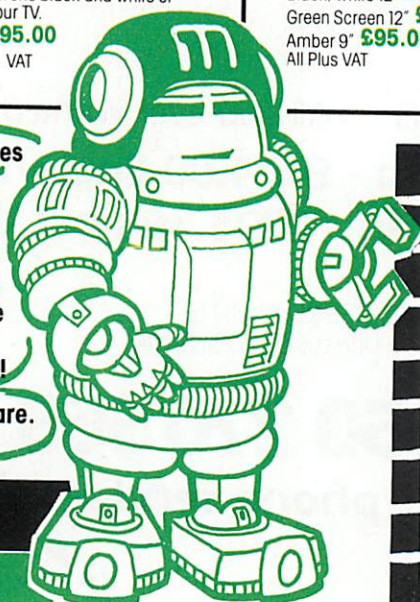

Post to: MICROSTYLE, FREEPOST, 29, Belvedere, Lansdown Road, Bath BA1 1FP

Please send me further details on the following, and your special offers:

PC1

\_\_\_\_\_

Name \_\_\_\_\_

Company \_\_\_\_\_

Address \_\_\_\_\_

Tel: \_\_\_\_\_



● Circle No. 178

# Save memory space — dump your assembler



## Norman Kirkby continues his series on 6502 assembler programming with a method of expanding your available memory by making sure that you only store essential information.

ASSEMBLER MNEMONICS use a large amount of memory, but you can save space by throwing them away after they have done their job of assembling the machine code. Suppose you are designing and entering a program at the keyboard, and as it grows you find the error message Not Enough Room. You have run out of memory.

There is a great deal you can do to make your program use memory more economically. You can use abbreviations such as P. for Print; put as many statements on a line as possible, saving two bytes for each unnecessary line number and one for each line terminator as well as one for each character; and remove all

unnecessary spaces. You can train yourself to write economically; for example,

```
Q = RND; IFQ = 50GOTO ...
uses four more bytes than
IFRND = 50GOTO ...
```

If your program contains a significant number of assembler mnemonics a vastly greater saving can be made if you can find a way to dispose of them after they have done their job of assembling the machine code. On average, one byte of machine code requires at least three bytes of assembler mnemonic. A program consisting of 4,500 bytes of text — of which one-third is assembler with resulting machine code of 500 bytes — contains a total of 5,000 bytes. It could be reduced by at least 1,500 bytes by disposing of the assembler after use.

What is needed, therefore, is a section of memory that is not normally available for program text, or that is not needed until your program is actually running, where you can temporarily park the assembler part. An obvious choice is the Atom's graphics area which starts at

memory location #8200, and will provide 0.5K if you have graphics mode 1, 1K with mode 2, 2.5K with mode 3 and 5.5K with mode 4. Remember that even if your program involves graphics, the graphics memory can still be used temporarily for the assembler part.

To make use of this strategy you must first split your original Basic program into two parts or, if you are writing a new program, write it in two parts. The first will contain only Basic, and the second all the assembler mnemonics and only that Basic needed to make them work.

Enter the Basic part in the normal way, that is at location #2900, or at #8200 on the unexpanded Atom. Enter the assembler part into the temporary memory park, and run it so that it assembles the machine code at the end of the Basic part. The assembler part is now redundant, so amend the Basic part slightly to make it independent of the assembler part. Finally, run the Basic part and save it

*(continued on next page)*

```

10 REM ORIGPROG
20 DIM S(10),AA(5),LL(4)
25 DIM P(-1)
30 [
40:LL0 LDA @65
50:LL1 JSR #FFF4
60 CLC;ADC @1
70 CMP @73;BNE LL1
80 LDA @32;JSR #FFF4
90 RTS
100:LL2 LDA @72
110:LL3 JSR #FFF4
120 SEC;SBC @1
130 CMP @64;BNE LL3
140 RTS
150]
160 AA(5)=7
170 LINK LL0
180 LINK LL2
190 END

```

(continued from previous page)

with the machine code but without the assembler part, using the \*Save routine.

The details of this procedure are much easier to implement than to describe. The OrigProg program, although short and trivial, illustrates the points well enough: it will print letters A to H, a space, and the letters H and A. If you have entered it, execute New to clear it out of the way.

OrigProg is then split into two parts — BasicProg and AssemProg. BasicProg contains only Basic statements, and AssemProg contains all the assembler mnemonics and only that Basic needed to make them work. The line numbers are the same in this example, but they need not be. AssemProg contains the Dim statement for the array LL, but no other arrays or strings from OrigProg, because LL is an array used only for the assembler mnemonics. The End statement is duplicated, of course.

Now enter BasicProg in the usual way, at memory location #2900, for example, and execute

```
PRINT & TOP
```

You will find in hexadecimal the first free byte after the program text. Write this down; if you have entered BasicProg exactly as shown you will get #2954. Now execute

```
?18 = #82
```

and then execute

```
NEW
```

which will switch to the upper text space.

If that memory area is not convenient for any reason, switch to, say, #8400, or #9000, or wherever else is suitable. Now enter AssemProg, leaving the number in line 25 blank for the moment. Add up the total of bytes reserved by the Dim statements in BasicProg, one for each string element that is part of a Dim statement, four for each array element that is part of a Dim statement, and five for each array element part of an FDim statement. An ordinary array element within a Dim statement is a word, and is therefore four bytes long.

Remember to count the zeroth ele-

```
10 REM ASSEMPROG
20 DIM LL(4)
25 F=#2979
30 C
40:LL0 LDA @65
50:LL1 JSR #FFFF4
60 CLC:ADC @1
70 CMP @73:BNE LL1
80 LDA @32:JSR #FFF4
90 RTS
100:LL2 LDA @72
110:LL3 JSR #FFF4
120 SEC:SBC @1
130 CMP @64:BNE LL3
140 RTS
150 ]
190 END
```

```
10 REM BASICPROG
20 DIM S(10),AA(5)
160 AA(S)=7
170 LINK LL 0
180 LINK LL 2
note the two extra spaces
190 END
```

ment. For BasicProg the result is  $11 \times 1$  for string S, and  $6 \times 4$  for array AA, totalling 35 bytes. Execute

```
PRINT & (#2954 + 35 + 2)
```

The result is #2979 — the extra 2 is to provide a safety margin — which is the address in hex of the memory location closest to the end of the text of BasicProg, plus its reserved string and array space, at which it is safe to assemble the first machine code.

If it were assembled at a closer location it would be overwritten by assignments of values to the string and array elements. If it were very close, it would overwrite the end of the text of BasicProg.

Line 25 of OrigProg contains the usual Dim P (-1) statement which instructs the Atom to assemble the machine code with the first code at memory location Top plus the memory locations reserved for strings and arrays by previous Dim statements in the current program — OrigProg, in this case. That is fine for an integral Basic-plus-assembler program such as OrigProg, but with AssemProg the machine code needs to be assembled starting at the safest location closest to BasicProg, not at the safest memory location closest to AssemProg itself.

The number #2979 is the address of that memory location, and line 25 of AssemProg instructs the computer to assemble the machine code, starting at location #2979.

Run AssemProg and confirm from the assembly listing that the first memory location is indeed #2979. Write down the address of the last memory location in the assembly listing: it is #2997 and is called the End address. You will need it later when saving. Now execute

```
?18 = 29
END
```

to switch back to the test space containing BasicProg and reset Top to that program.

After listing BasicProg you come to the step that makes BasicProg finally independent of AssemProg. Line 170 refers to an array element, and the line instructs the Atom to find out the value assigned to that element, treat it as a memory address, and execute the machine-code program that starts there. These LL-type array elements are creatures of AssemProg, and the values assigned to them by AssemProg disappear with it. The address to which line 170 points, is found by executing

```
PRINT & LLO
```

Replace LL 0 in line 170 with that address — it is #2979, of course — and do the same for line 180 and to any other assembler arrays that appear in your

real-life equivalent of BasicProg. There is no need to alter any of the references to array elements that appear only in AssemProg. They are used internally in that program to produce actual addresses in the machine code. Lines 170 and 180 now read

```
170 LINK #2979
180 LINK #298B
```

They originally had two extra spaces each because the statement Link LL0 — that is, without the extra spaces — occupies eight bytes of program text, whereas Link #2979 occupies 10 bytes. Without those extra spaces, putting in the hex number would have lengthened the text of BasicProg, resulting in any assignments to the array elements overwriting the beginning of the machine code.

AssemProg is now redundant, and you can run BasicProg to confirm that it prints out as for OrigProg. To save BasicProg and its machine code you need the End address #2997 which you established earlier. Add 1 to it, and execute

```
* SAVE "BASICPROG" 2900 2998
```

This procedure saves all the contents of memory locations #2900 to #2997. It includes all the text of BasicProg and its machine code.

Now for the acid test. Switch the computer off and on to lose all memory contents. Load BasicProg in the usual way by executing

```
LOAD "BASICPROG"
```

and then run it: out comes the familiar printout without any assembler mnemonics being used.

If your real-life equivalent of AssemProg contains forward references you will need to put the assembler mnemonics and line 25 into a For-Next loop or use two Gosubs. If you have no RAM in the lower text space you could enter your real-life equivalent of BasicProg at #8200 as usual, and your AssemProg at, say, #8300.

In Atom assembler it is possible to refer to Basic variables in two ways. For example, LDA @D means "load the accumulator with the value of the Basic variable D". That works in AssemProg if D has previously been assigned its correct value in BasicProg — one which is no greater than #FF. Without the @ — for example, LDA D — a string must be dimensioned with one element, at least using DIM D(0). LDA D means "load the accumulator with the contents of memory location ?D".

That is obviously a BasicProg variable and so the Dim statement must be part of BasicProg. If, after assembling the machine code, you alter BasicProg such that the length of its text is changed by even one byte either way, the address ?D will also change. So the address in the machine code that refers to ?D, although unchanged, will no longer be correct, and garbage or a crash will be the result. Avoid LDA K or ADC G or similar forms when using this technique. □

# Open File

This regular section of *Practical Computing* appears in the magazine each month, incorporating Tandy Forum, Apple Pie, ZX-80/81 Line-up and the other software interchange pages.

Open File is the part of the magazine written by you, the readers. All aspects of microcomputing are covered, from games to serious business and technical software, and we welcome contributions on CP/M, BBC Basic, Microsoft Basic, Apple Pascal and so on, as well as the established categories.

Each month the best contribution will be awarded £20; others receive £6. Send contributions to: Open File, *Practical Computing*, Quadrant House, The Quadrant, Sutton, Surrey SM2 5AS.

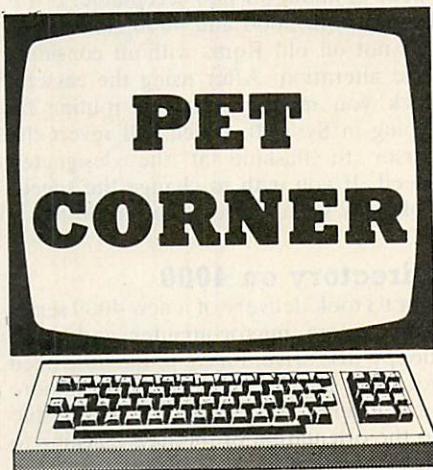

## Typewriter

THIS SHORT PROGRAM by Andy Scott of Chapel-en-le-Frith, Cheshire, has been chosen as this month's best contribution

**Pet Corner:** Typewriter, a mini-word processor; Cursor flashing-speed control; Directory list routine for 4000 series; Maze game **135**

**Tandy Forum:** Moon Lander game; User-definable graphics; Tape name finder; Data-separator routine; Unknown tape loader **141**

**Apple Pie:** Galaxy Invaders; File parameter finder; Text file list **148**

**Z-80 Zodiac:** Sharp printer routine; Upgrading to Z-80B; Backgammon on Nascom **151**

**6502 Special:** Atom EPROM programmer **152**

**ZX-80/81 Line-up:** Volume of solid figures; Hunt game; 10-pin bowling; Obstacle game; Variable list machine-code routine; Superzap game; Circle-drawing program; Programming tips; Data-handling commands in Basic **157**

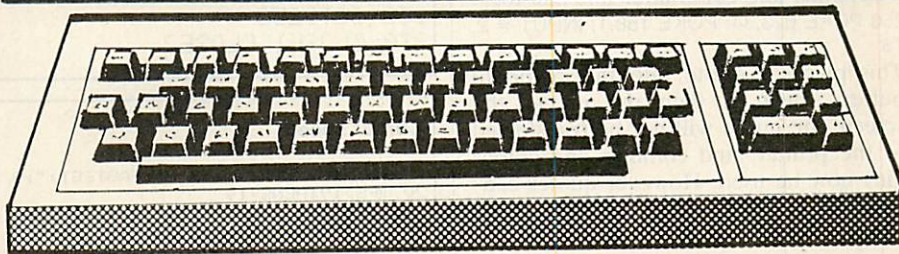

## Guidelines for contributors

Programs should be accompanied by documentation which explains to other readers what your program does and, if possible, how it does it. It helps if documentation is typed or printed with double-line spacing — cramped or handwritten material is liable to delay and error.

Program listings should, if at all possible, be printed out. Use a new ribbon in your

printer, please, so that we can print directly from a photograph of the listing and avoid typesetting errors. If all you can provide is a typed or handwritten listing, please make it clear and unambiguous; graphics characters, in particular, should be explained.

We can accept material for the Pet, Vic and Sharp MZ-80K on cassette, and material for the larger machines can be sent on IBM-format 8in. floppy discs.

to Open File. It should prove useful if you occasionally write short messages or reports but cannot run to a full-blown word-processing package.

The program allows you to write text from keyboard on to the screen, with up to 79 characters on each line, while retaining the use of screen Edit keys. When you are satisfied that the line is correct, pressing the Return key copies the line on to the printer. Unshifted keys are lower case and shifted keys upper case, as on a typewriter.

There are a few basic rules to observe when using the program since the line is inputted from keyboard as a string:

- Leading blanks are disregarded, so for the first leading blanks use shift-spacebar. This creates ASCII character 96 instead of ASCII 32, the normal space used. It is the latter which the Pet Basic removes if they are leading.
- Do not start a line with a ". If you require a

leading quote, type shift-spacebar, and then the".

- Do not make the last character in a line a quote: follow it by shift-spacebar.
- When inputting data the Pet Basic reads up to commas and colons, then comes up with the message Extra ignored. To get round this the program uses [ and ] — the top, right-hand keys on the main alphanumeric block — to replace the comma and colon respectively. When you press Return at the end of a line, the program prints out the appropriate commas and colons.
- No more than 79 characters may be used on each line.
- For a space between lines just press Return.
- When you have finished typing, enter \*Return on a new line.
- Provision is made for automatic paging of the paper in the printer.

The main features of the program are as follows:

Line 180 zeros the line count, and is used for paging.

(continued on next page)

(continued from previous page)

Line 190 opens the keyboard: logical file number 2.

Lines 200-220 prompt for setting up the printer. Location 151 shows which key is being depressed; if the contents are 255, then no key is being pressed.

Line 230 clears the keyboard buffer count.

Line 240 gives lower-case display on screen, clears screen and opens printer.

Line 250 inputs line from keyboard.

Line 260 prints carriage return.

Line 270 checks if contents of line are \*, then close files and end.

Line 280 looks for null string, that is user has only pressed Return.

Lines 290-320 redefine the string, inserting commas and colons if appropriate.

Lines 330-340 replace the line on the screen with corrected line as obtained in 290-320. They also cater for whether line is shorter than 40 characters, between 40 and 79 characters, or no characters. The line is then printed.

Line 350 gives automatic paging on to the next page.

Line 360 receives another line.

Line 370 closes current files and end.

If you would prefer not to use [ and ] for comma and colon alter line 250 to:

```
250 POKE 623,34: POKE 158,1: INPUT # 2, T$
```

This places a quote into the keyboard buffer, which is then put on to the screen. The quote will not be transferred to the printer, and commas and colons may now be used. However quotes cannot now be used within the text — the choice is yours.

## Cursor speed

I FIND the Pet's flashing cursor irritating and I would much rather have a steady cursor like some other machines, complains Ian Payton of Winnersh, Berkshire. I have tried numerous machine-code routines without success. An alternative is to have a cursor flashing at a higher speed than usual.

## Typewriter.

```
100 REM** TYPEWRITER BY ANDY SCOTT
120 REM* TYPE * TO ESCAPE
130 REM* DO NOT LEAD WITH QUOTE "
140 REM* [ USED FOR COMMA,
150 REM* ] USED FOR COLON:
160 REM* TO INSET PARAGRAPH USE SHIFTED SPACEBAR
170 REM*TYPE ONE LINE A TIME TO 79 CHARS
180 PA=0
190 OPEN2,0
200 PRINT"YOUHAVE PUT PAPER AT THE TOP OF A PAGE"
210 PRINT"    PRESS ANY KEY IF READY"
220 IFPEEK(151)=255THEN220
230 POKE158,0
240 POKE59468,14:PRINT"J":OPEN1,4
250 INPUT#2,T$
260 PRINTCHR$(13)
270 IFT$="*"THEN370
280 L=LEN(T$):IFL=0THEN340
290 FORI=1TOL:P=ASC(MID$(T$,I,1))
300 IFP=91THENT$=LEFT$(T$,I-1)+CHR$(44)+MID$(T$,I+1)
310 IFP=93THENT$=LEFT$(T$,I-1)+CHR$(58)+MID$(T$,I+1)
320 NEXT
330 IFLEN(T$)>39THENPRINT"J";
340 PRINT"J";T$:PRINT#1,"J";T$:IFLEN(T$)=40THENPRINT"J";
350 PA=PA+1:IFPA=63THENPA=0:FORI=1T03:PRINT#1:NEXT
360 GOTO250
370 CLOSE1:CLOSE2
```

## Cursor speed.

```
10 INPUT"SPEED (1-19 1=FASTEST)";S
20 IFS>19THENS=19
30 DATA 169,143,141,144,0,169,3,141,145,0,96,165,168,201,20,208,5,169,999
40 DATA 141,168,0,76,888,777
50 INPUT"4000 OR 3000 SERIES ";ND$
60 IFND$="4000"THENA1=85:A2=228
70 IFND$="3000"THENA1=46:A2=230
75 IFND$<>"4000"ANDND$<>"3000"THEN50
80 FORLL=900T0924
90 READPD
100 IFPD=999THENPD=S
110 IFPD=888THENPD=A1
120 IFPD=777THENPD=A2
130 POKELL,PD
140 NEXTLL
150 SYS900
```

## Directory machine-code routine. Listing 1.

LINE#	LOC	CODE	LINE
0001	0000		:AUTO LOAD. AFTER LISTING
0002	0000		:DIRECTORY PLACE CURSOR
0003	0000		:OVER DISIRED PROGRAM AND
0004	0000		:PRESS RETURN
0005	0000		:*****
0006	0000		:
0007	0000		:
0008	0000		CHRGOT = \$70
0009	0000		CHRGOT = \$76
0010	0000		* = \$0700
0011	0700	E6 77	START INC \$77 ; *****
0012	0702	D0 02	BNE L88 ; ROUTINE WHICH
0013	0704	E6 78	INC \$78 ; CHECKS FOR
0014	0706	86 B3	L88 STX \$B3 ; DIRECT MODE
0015	0708	BA	TSX ; IF NOT PROCESS
0016	0709	BD 01 01	LDA \$0101,X ; CONTINUES AT
0017	070C	C9 0F	CMP #\$0F ; CHRGOT (\$0076)
0018	070E	D0 14	BNE L33
0019	0710	BD 02 01	LDA \$0102,X
0020	0713	C9 B4	CMP #\$B4
0021	0715	D0 0D	BNE L33
0022	0717	A5 77	LDA \$77
0023	0719	D0 06	BNE L34
0024	071B	A5 78	LDA \$78
0025	071D	C9 02	CMP #\$02

(listing continued on page 139)

This routine produces a cursor flashing at any speed up to the normal speed. A speed of about 8 I find acceptable. It will run on both 3000 and 4000 series Pets, but not on old Roms without considerable alteration. After using the cassette deck you must restart the routine by typing in Sys 900, which will revert the cursor to flashing at the designated speed. If you wish to change the speed, Poke any value up to 19 into 0396 hex.

## Directory on 4000

SINCE I took delivery of a new 4000 series Commodore microcomputer and 4040 floppy-disc drive, I have found little need for DOS support, writes H V Blackmore of Bridgend, Mid Glamorgan. This is due to the orientation of the new machine to disc operation.

One of the facilities I did not miss was the directory listing command >\$, so I set about writing a machine-code program which not only lists the directory, but also

(continued on page 139)

# 0 to 60<sup>ch's</sup> in one second

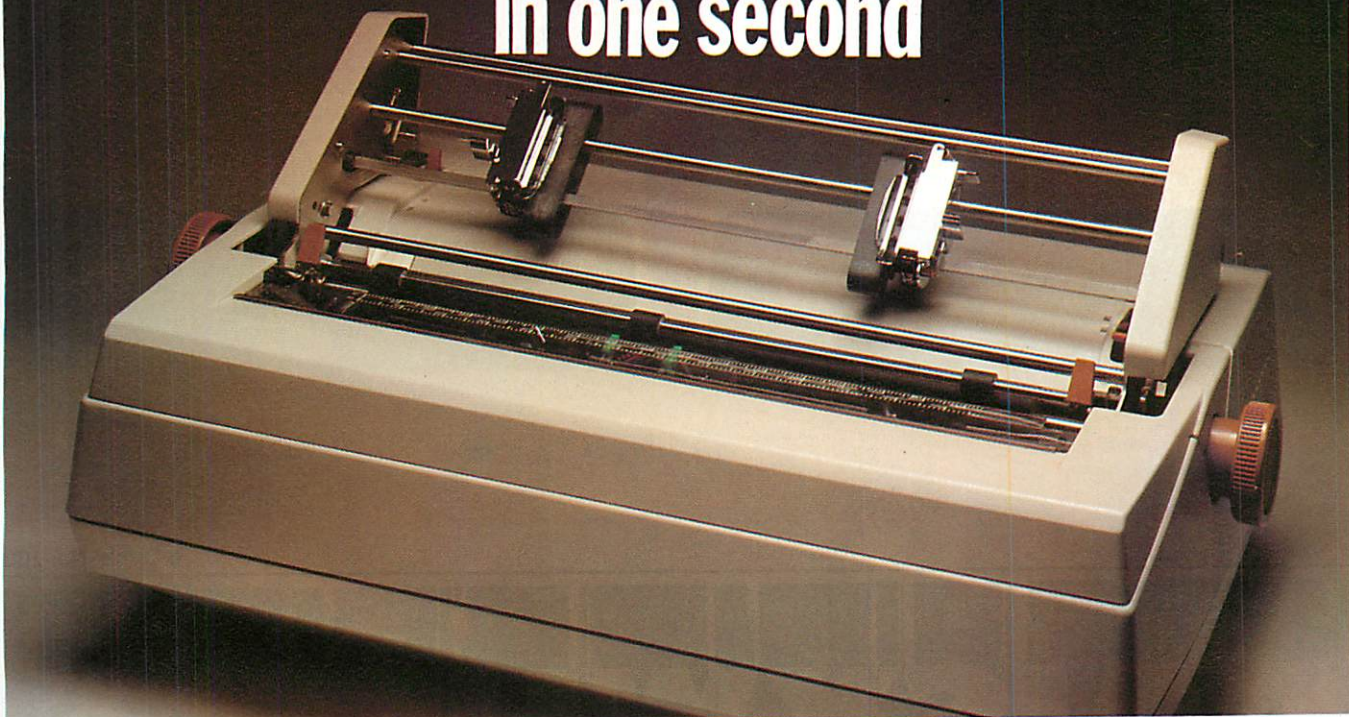

## THE RICOH 1600S

If it's high performance you're looking for, the Ricoh 1600S is for you, offering an amazing 60 characters in just 1 second. An updated version of the tried-and-tested 1600, the new S model has been re-designed and fitted with all sorts of extras. Yet one thing hasn't changed — the price, making the 1600S cheaper than any equivalent model on the market. This superb performer incorporates the Z80 micro-processor, auto bidirectional printing and look-ahead logic, increasing speed and efficiency. Other capabilities include proportional spacing, graph plotting and word processing enhancements. The printer includes a standard centronics interface, and RS232 and IEEE options are available.

The Ricoh 1600S is available only from Micropute and their authorised dealers, all backed up with a nationwide service network. If you're interested in the 1600S either as a customer or as a dealer, send the coupon now.

\*\*Picture shows 1600S fitted with tractor feed option\*\*

Please send me details on the Ricoh 1600S

Name \_\_\_\_\_  
 Position \_\_\_\_\_  
 Company \_\_\_\_\_  
 Address \_\_\_\_\_  
 Tel No \_\_\_\_\_

**RICOH 1600S THE PERFORMANCE HAS RISEN — THE PRICE HASN'T**

### FEATURES    COMPETITORS

	DIABLO 630	QUME SPRINT 5	SPIN-WRITER	RICOH RP. 1600 (10 DATA)	<b>RICOH RP.1600S</b>
PRINT SPEED (CPS)	40	45/55	55	60	<b>60</b>
PRINT ELEMENT	DAISY-WHEEL	DAISY-WHEEL	THIMBLE	DOUBLE DAISY-WHEEL	<b>DOUBLE DAISY-WHEEL</b>
AUTO BIDIRECTIONAL	Yes	No	No	No	<b>Yes</b>
AUTO LOGIC SEEKING	Yes	No	Yes	No	<b>Yes</b>
PROPORTIONAL PRINT CAPABILITY	Yes	Yes	Yes	No	<b>Yes</b>
EXTENDED CHARACTER SET	No	No	Yes	Yes	<b>Yes</b>
LETTER QUALITY PRINT	Yes	Yes	Yes	Yes	<b>Yes</b>
CUSTOM INTER-FACE OPTION	No	No	No	No	<b>Yes</b>
PRICE	£1675	£1950	£1950	£1450	<b>£1450</b>

The above information was gathered from distributors and abstracted from their current literature. Prices shown are those advertised at the present time.

**MICROPUTE**  
microcomputer systems

Catherine Street, Macclesfield, Cheshire.  
SK11 6QY. Tel: Macclesfield 612759

● Circle No. 179

# 5¼" WINCHESTER SUBSYSTEMS FROM ICE

**APPLE - SUPERBRAIN - IBM PERSONAL  
S100 BUS & Z80-BASED MICROS**

FROM 3 TO 42 MEGABYTE CONFIGURATIONS WITH TAPE STREAMER BACKUP



**ICE** 16/18 Littleton Road, Ashford, Middlesex, TW15 1UQ  
Telephone: 07842-47271/47171 Telex: 8952042 (DPCUSTG)

● Circle No. 180

# DAISYWHEELS ARE DOWN

.....down to a new low price!  
For less than the price of some dot matrix printers, the Smith-Corona TP-1 brings the benefits of daisywheel printers within the reach of most micro users. Now letters, documents, forms, invoices, reports, price lists etc., can be printed with the quality that until now was not readily affordable.



- Simple reliable mechanism
- Serial or Parallel interface
- IEEE option
- Single sheet and fanfold paper

**£485**  
+ VAT

Sole Distributors:

**discom**

Dresden House, 51, High Street, Evesham, Worcs. WR11 4DA  
Telephone (0386) 3591 Telex 335402

Please send me details of the TP-1

Name ..... Trade/OEM\*

Address .....

.....

Tel. No ..... \* Delete as necessary

● Circle No. 181

PRACTICAL COMPUTING June 1982

(listing continued from page 136)

```

0026 071F F0 08      BEQ L35
0027 0721 4C 76 00   L34  JMP CHRGET
0028 0724 A6 B3      L33  LDX #B3
0029 0726 4C 76 00   JMP CHRGET
0030 0729 A0 FF      L35  LDY #FF
0031 072B C8        GET  INY
0032 072C B1 77      LDA ($77),Y
0033 072E C9 3E      CMP #3E
0034 0730 D0 02      BNE L46
0035 0732 F0 68      BEQ DIR
0036 0734 C9 20      L46  CMP #20
0037 0736 F0 F3      BEQ GET
0038 0738 C9 30      CMP #30
0039 073A C0 E5      BMI L34
0040 073C C9 3A      CMP #3A
0041 073E 10 E1      BPL L34
0042 0740 C8        TEST INY
0043 0741 B1 77      LDA ($77),Y
0044 0743 C9 20      CMP #20
0045 0745 F0 F9      BEQ TEST
0046 0747 C9 22      CMP #22
0047 0749 F0 0A      BEQ LOAD
0048 074B C9 30      CMP #30
0049 074D C0 D2      BMI L34
0050 074F C9 3A      CMP #3A
0051 0751 10 CE      BPL L34
0052 0753 C0 EB      BMI TEST
0053 0755 A9 53      L43  LDA #53
0054 0757 B5 DA      STA $DA
0055 0759 A9 03      LDA #03
0056 075B B5 DB      STA $DB
0057 075D 20 42 E0   JSR $E042
0058 0760 AD 3B 03   LDA $033B
0059 0763 C9 01      CMP #01
0060 0765 D0 04      BNE L101
0061 0767 A9 31      LDA #31
0062 0769 D0 02      BNE L102
0063 076B A9 30      L101 LDA #30
0064 076D BD 53 03   L102 STA $0353
0065 0770 A9 3A      LDA #3A
0066 0772 BD 54 03   STA $0354
0067 0775 A2 02      LDX #02
0068 0777 A0 07      LDY #07
0069 0779 B1 77      NAME LDA ($77),Y
0070 077B 9D 53 03   STA $0353,X
0071 077E F0 19      BEQ L43
0072 0780 C8        INY
0073 0781 EB        INX
0074 0782 C9 22      CMP #22
0075 0784 D0 F3      BNE NAME
0076 0786 CA        DEX
0077 0787 B6 D1      STX $D1
0078 0789 A9 08      LDA #08
0079 078B B5 D4      STA $D4
0080 078D A9 00      LDA #0
0081 078F B5 96      STA $96
0082 0791 B5 9D      STA $9D
0083 0793 20 08 F4   JSR $F408
0084 0796 4C FF B3   JMP $B3FF
0085 0799 4C 00 BF   L43  JMP $BF00
0086 079C A9 08      DIR  LDA #08
0087 079E B5 D4      STA $D4
0088 07A0 E6 77      INC $77
0089 07A2 D0 02      BNE L100
0090 07A4 E6 78      INC $78
0091 07A6 B1 77      L100 LDA ($77),Y
0092 07A8 C9 31      CMP #31
0093 07AA D0 0C      BNE L23

0094 07AC A9 01      LDA #1
0095 07AE BD 3B 03   STA $033B
0096 07B1 A9 00      LDA #0
0097 07B3 BD 3C 03   STA $033C
0098 07B6 F0 20      BEQ DIRL
0099 07B8 C9 30      L23  CMP #30
0100 07BA D0 0C      BNE L27
0101 07BC A9 01      LDA #1
0102 07BE BD 3C 03   STA $033C
0103 07C1 A9 00      LDA #0
0104 07C3 BD 3B 03   STA $033B
0105 07C6 F0 10      BEQ DIRL
0106 07C8 C9 00      L27  CMP #00
0107 07CA D0 CD      BNE L43
0108 07CC A9 01      LDA #01
0109 07CE BD 3B 03   STA $033B
0110 07D1 BD 3C 03   STA $033C
0111 07D4 A9 00      LDA #00
0112 07D6 F0 02      BEQ DIRL2
0113 07D8 A9 10      DIRL LDA #10
0114 07DA BD 3E 03   DIRL2 STA $033E
0115 07DD 20 7D D8   JSR $087D
0116 07E0 4C FF B3   JMP $B3FF
0117 07E3
0118 07E3
0119 07E3
0120 07E3
0121 07E3
0122 07E3
0123 07E3
0124 07E3
0125 07E3
0126 07E3 A5 34
0127 07E5 38
0128 07E6 E9 E3
0129 07E8 B5 34
0130 07EA B5 C7
0131 07EC A5 35
0132 07EE E9 00
0133 07F0 B5 35
0134 07F2 B5 C8
0135 07F4 B5 72
0136 07F6 A9 4C
0137 07F8 B5 70
0138 07FA A5 34
0139 07FC B5 71
0140 07FE A0 00
0141 0800 B4 5C
0142 0802 A9 07
0143 0804 B5 5D
0144 0806 B1 5C
0145 0808 91 C7
0146 080A C8
0147 080C C0 F5
0148 080D D0 F7
0149 080F 60 6A
0150 0810

LDA $34
SEC
SBC #E3
STA $34
STA $C7
LDA $35
SBC #00
STA $35
STA $C8
STA $72
LDA $4C
STA $70
LDA $34
STA $71
LDY #00
STY $5C
LDA #07
STA $5D
REL  LDA ($5C),Y
      STA ($C7),Y
      INY
      CPY #F5
      BNE REL
      RTS
      .END

```

**Symbol table.**

SYMBOL VALUE		SYMBOL VALUE		SYMBOL VALUE	
CHRGET	0070	CHRGET	0076	DIR	079C
DIRL2	07DA	GET	072B	L100	07A6
L102	076D	L23	07B8	L27	07C8
L34	0721	L35	0729	L43	0799
L8B	0706	LOAD	0755	NAME	0779
START	0700	TEST	0740	REL	0806

**Listing 2. Basic call routine.**

```

0 SYS2019
1 PRINT"### LOAD FROM DIRECTORY LISTING"
2 PRINT"### COMMANDS MUST BE GIVEN IN DIRECT MODE"
3 PRINT"### > = LIST DIRECTORY ON DRIVE 0 AND 1
4 PRINT"### 1 = LIST DIRECTORY ON DRIVE 1
5 PRINT"### PLACE CURSOR ON THE LINE WHICH CONTAINS
6 PRINT"### THE REQUIRED PROGRAM AND PRESS RETURN.
7 PRINT"### THIS FACILITY ONLY WORKS AFTER A DRIVE
8 PRINT"### NUMBER IS SPECIFIED IN THE DIRECTORY
9 PRINT"### LISTING COMMAND"
10 NEW

```

(continued from page 136)

allows you to load a program from the listing. This is achieved by placing the cursor over the program required and pressing Return.

The program also has a relocation routine tagged on to the end. This relocates the main program to the top of

memory as well as changing the CHRGet routine and setting the top of memory pointers for protection. The CHRGet routine is changed in the same way as for DOS support so it has the same restrictions to cohabitation with some programs which use the same technique.

(continued on next page)

**Listing 3. Basic loader.**

```

10 PRINT"### LOAD FROM DIRECTORY LISTING"
20 PRINT"### COMMANDS MUST BE GIVEN IN DIRECT MODE"
30 PRINT"### > = LIST DIRECTORY ON DRIVE 0 AND 1
40 PRINT"### 1 = LIST DIRECTORY ON DRIVE 1
50 PRINT"### PLACE CURSOR ON THE LINE WHICH CONTAINS
60 PRINT"### THE REQUIRED PROGRAM AND PRESS RETURN.
70 PRINT"### THIS FACILITY ONLY WORKS AFTER A DRIVE
80 PRINT"### NUMBER IS SPECIFIED IN THE DIRECTORY
90 PRINT"### LISTING COMMAND"
100 E=PEEK(53)*256+PEEK(52)-1
110 S=E-226
111 S1=INT(S/256)
112 S2=INT((S/256-S1)*256)
114 POKES3,S1:POKES2,S2
120 FOR I=S-13TOE
130 READ N
140 POKEI,N
150 NEXT
180 SYS(S-13)
190 NEW
900 DATA 169,76,133,112,165,52,133,113,165,53,133,114,96
1000 DATA 230,119,208,2,230,120,134,179,186,189,1
1001 DATA 1,201,15,208,20,189,2,1,201,180

```

1002	DATA	208, 13, 165, 119, 208, 6, 165, 120, 201, 2
1003	DATA	240, 8, 76, 118, 0, 166, 179, 76, 118, 0
1004	DATA	160, 255, 200, 177, 119, 201, 62, 208, 2, 240
1005	DATA	104, 201, 32, 240, 243, 201, 48, 48, 229, 201
1006	DATA	58, 16, 225, 200, 177, 119, 201, 32, 240, 249
1007	DATA	201, 34, 240, 10, 201, 48, 48, 210, 201, 58
1008	DATA	16, 206, 48, 235, 169, 83, 133, 218, 169, 3
1009	DATA	133, 219, 32, 66, 224, 173, 59, 3, 201, 1
1010	DATA	208, 4, 169, 49, 208, 2, 169, 48, 141, 83
1011	DATA	3, 169, 58, 141, 84, 3, 162, 2, 160, 7
1012	DATA	177, 119, 157, 83, 3, 240, 25, 200, 232, 201
1013	DATA	34, 208, 243, 202, 134, 209, 169, 8, 133, 212
1014	DATA	169, 0, 133, 150, 133, 157, 32, 8, 244, 76
1015	DATA	255, 179, 76, 0, 191, 169, 8, 133, 212, 230
1016	DATA	119, 208, 2, 230, 120, 177, 119, 201, 49, 208
1017	DATA	12, 169, 1, 141, 59, 3, 169, 0, 141, 60
1018	DATA	3, 240, 32, 201, 48, 208, 12, 169, 1, 141
1019	DATA	60, 3, 169, 0, 141, 59, 3, 240, 16, 201
1020	DATA	0, 208, 205, 169, 1, 141, 59, 3, 141, 60
1021	DATA	3, 169, 0, 240, 2, 169, 16, 141, 62, 3
1022	DATA	32, 125, 216, 76, 255, 179

C = Clear screen  
R = Reverse  
↓ = Down arrow

(continued from previous page)

Once located the program allows you to carry out the following:

List the directory of either drive or both. The command is > [Dn]; the brackets must not be typed, and Dn is the drive number. If no number is given both directories are listed. If a number greater than 1 is typed a syntax error will be given. The listing can be temporarily halted by pressing the space key, and continued by pressing it a second time. Load any program from the directory listing by placing the cursor on the line which contains the required program, and pressing the Return key. Syntax is checked so that the routine only works from a normal directory listing. Program loading will only take place if a drive number is specified in the directory listing command.

The program will only work in direct

mode, so do not try the commands from a Basic program as a syntax error will result.

To set up the program in your machine, first enter the Basic program given in listing 2 which lists the instructions and calls the relocation routine. Enter the monitor by typing Sys4, and key the machine-code routine starting at location \$0700 — see listing 1. If you want an Editor-Assembler you might like to enter the program that way.

Finally save the whole program from the monitor by typing

S "0:LOAD/DIR", 08,0400,0810

use S "1: . . .if saving on drive 1. The program can now be loaded as a Basic Program and run in the usual way.

For those who are not familiar with

machine-code programming, a Basic loader version given in listing 3.

## Maze

THE MAZE GAME by Ian Payton of Winersh, Berkshire makes full use of the Pet's graphics characters and cursor controls although you may be able to adapt it to a computer such as the Sharp MZ-80K by changing some of the Poke addresses. For those who wish to do this, the Pet's top, left-hand screen address is 32768 and the screen is 40 by 25 blocks.

The aim of the Maze is to go round the maze in as short a time as possible, incurring as few faults as possible.

Tape of this program or more information can be provided: please telephone Wokingham (0734) 789775.

## Maze.

```

5 J=5
10 GOSUB1050:PRINT " "
20 PRINT " "
30 IF= " "
40 FOR=1 TO 20:PRINT " "
50 PRINT " "
60 IFL=1 THEN=32849:GOSUB20
70 IFL=2 THEN=32828:GOSUB20
80 POKEA,81
90 GETC:I=I+1:IFC=" " THEN=90
95 IFWL(C)=0 THEN=90
100 B=VAL(C):IF B="0" THEN=100:GOTO120
110 GETC:I=I+1:IFC=" " THEN=B:VAL(C)
120 IFL=708:FOR=108:GOTO120
130 FORL=1 TO 10:HEXTL
140 IFC=" " THEN=100:GOTO10
150 FOR=1 TO 10:PRINT " "
160 IFL=108:FOR=108:GOTO130
170 HE=1
180 IFL=108:FOR=108:GOTO130
190 C=VAL(C)
200 IFC=" " THEN=100:GOTO10
210 IFL=2 THEN=108:GOTO10
220 IFL=3 THEN=108:GOTO10
230 IFL=4 THEN=108:GOTO10
240 IFL=5 THEN=108:GOTO10
250 IFL=6 THEN=108:GOTO10
260 IFL=7 THEN=108:GOTO10
270 IFL=8 THEN=108:GOTO10
280 IFL=9 THEN=108:GOTO10
290 IFL=10 THEN=108:GOTO10
300 IFL=11 THEN=108:GOTO10
310 IFL=12 THEN=108:GOTO10
320 IFL=13 THEN=108:GOTO10
330 IFL=14 THEN=108:GOTO10
340 IFL=15 THEN=108:GOTO10
350 IFL=16 THEN=108:GOTO10
360 IFL=17 THEN=108:GOTO10
370 IFL=18 THEN=108:GOTO10
380 IFL=19 THEN=108:GOTO10
390 IFL=20 THEN=108:GOTO10
400 IFL=21 THEN=108:GOTO10
410 IFL=22 THEN=108:GOTO10
420 IFL=23 THEN=108:GOTO10
430 IFL=24 THEN=108:GOTO10
440 IFL=25 THEN=108:GOTO10
450 IFL=26 THEN=108:GOTO10
460 IFL=27 THEN=108:GOTO10
470 IFL=28 THEN=108:GOTO10
480 IFL=29 THEN=108:GOTO10
490 IFL=30 THEN=108:GOTO10
500 IFL=31 THEN=108:GOTO10
510 IFL=32 THEN=108:GOTO10
520 IFL=33 THEN=108:GOTO10
530 IFL=34 THEN=108:GOTO10
540 IFL=35 THEN=108:GOTO10
550 IFL=36 THEN=108:GOTO10
560 IFL=37 THEN=108:GOTO10
570 IFL=38 THEN=108:GOTO10
580 IFL=39 THEN=108:GOTO10
590 IFL=40 THEN=108:GOTO10
600 IFL=41 THEN=108:GOTO10
610 IFL=42 THEN=108:GOTO10
620 IFL=43 THEN=108:GOTO10
630 IFL=44 THEN=108:GOTO10
640 IFL=45 THEN=108:GOTO10
650 IFL=46 THEN=108:GOTO10
660 IFL=47 THEN=108:GOTO10
670 IFL=48 THEN=108:GOTO10
680 IFL=49 THEN=108:GOTO10
690 IFL=50 THEN=108:GOTO10
700 IFL=51 THEN=108:GOTO10
710 IFL=52 THEN=108:GOTO10
720 IFL=53 THEN=108:GOTO10
730 IFL=54 THEN=108:GOTO10
740 IFL=55 THEN=108:GOTO10
750 IFL=56 THEN=108:GOTO10
760 IFL=57 THEN=108:GOTO10
770 IFL=58 THEN=108:GOTO10
780 IFL=59 THEN=108:GOTO10
790 IFL=60 THEN=108:GOTO10
800 IFL=61 THEN=108:GOTO10
810 IFL=62 THEN=108:GOTO10
820 IFL=63 THEN=108:GOTO10
830 IFL=64 THEN=108:GOTO10
840 IFL=65 THEN=108:GOTO10
850 IFL=66 THEN=108:GOTO10
860 IFL=67 THEN=108:GOTO10
870 IFL=68 THEN=108:GOTO10
880 IFL=69 THEN=108:GOTO10
890 IFL=70 THEN=108:GOTO10
900 IFL=71 THEN=108:GOTO10
910 IFL=72 THEN=108:GOTO10
920 IFL=73 THEN=108:GOTO10
930 IFL=74 THEN=108:GOTO10
940 IFL=75 THEN=108:GOTO10
950 IFL=76 THEN=108:GOTO10
960 IFL=77 THEN=108:GOTO10
970 IFL=78 THEN=108:GOTO10
980 IFL=79 THEN=108:GOTO10
990 IFL=80 THEN=108:GOTO10
1000 IFL=81 THEN=108:GOTO10
1010 IFL=82 THEN=108:GOTO10
1020 IFL=83 THEN=108:GOTO10
1030 IFL=84 THEN=108:GOTO10
1040 IFL=85 THEN=108:GOTO10
1050 IFL=86 THEN=108:GOTO10
1060 IFL=87 THEN=108:GOTO10
1070 IFL=88 THEN=108:GOTO10
1080 IFL=89 THEN=108:GOTO10
1090 IFL=90 THEN=108:GOTO10
1100 IFL=91 THEN=108:GOTO10
1110 IFL=92 THEN=108:GOTO10
1120 IFL=93 THEN=108:GOTO10
1130 IFL=94 THEN=108:GOTO10
1140 IFL=95 THEN=108:GOTO10
1150 IFL=96 THEN=108:GOTO10
1160 IFL=97 THEN=108:GOTO10
1170 IFL=98 THEN=108:GOTO10
1180 IFL=99 THEN=108:GOTO10
1190 IFL=100 THEN=108:GOTO10
1200 IFL=101 THEN=108:GOTO10
1210 IFL=102 THEN=108:GOTO10
1220 IFL=103 THEN=108:GOTO10
1230 IFL=104 THEN=108:GOTO10
1240 IFL=105 THEN=108:GOTO10
1250 IFL=106 THEN=108:GOTO10
1260 IFL=107 THEN=108:GOTO10
1270 IFL=108 THEN=108:GOTO10
1280 IFL=109 THEN=108:GOTO10
1290 IFL=110 THEN=108:GOTO10
1300 IFL=111 THEN=108:GOTO10
1310 IFL=112 THEN=108:GOTO10
1320 IFL=113 THEN=108:GOTO10
1330 IFL=114 THEN=108:GOTO10
1340 IFL=115 THEN=108:GOTO10
1350 IFL=116 THEN=108:GOTO10
1360 IFL=117 THEN=108:GOTO10
1370 IFL=118 THEN=108:GOTO10
1380 IFL=119 THEN=108:GOTO10
1390 IFL=120 THEN=108:GOTO10
1400 IFL=121 THEN=108:GOTO10
1410 IFL=122 THEN=108:GOTO10
1420 IFL=123 THEN=108:GOTO10
1430 IFL=124 THEN=108:GOTO10
1440 IFL=125 THEN=108:GOTO10
1450 IFL=126 THEN=108:GOTO10
1460 IFL=127 THEN=108:GOTO10
1470 IFL=128 THEN=108:GOTO10
1480 IFL=129 THEN=108:GOTO10
1490 IFL=130 THEN=108:GOTO10
1500 IFL=131 THEN=108:GOTO10
1510 IFL=132 THEN=108:GOTO10
1520 IFL=133 THEN=108:GOTO10
1530 IFL=134 THEN=108:GOTO10
1540 IFL=135 THEN=108:GOTO10
1550 IFL=136 THEN=108:GOTO10
1560 IFL=137 THEN=108:GOTO10
1570 IFL=138 THEN=108:GOTO10
1580 IFL=139 THEN=108:GOTO10
1590 IFL=140 THEN=108:GOTO10
1600 IFL=141 THEN=108:GOTO10
1610 IFL=142 THEN=108:GOTO10
1620 IFL=143 THEN=108:GOTO10
1630 IFL=144 THEN=108:GOTO10
1640 IFL=145 THEN=108:GOTO10
1650 IFL=146 THEN=108:GOTO10
1660 IFL=147 THEN=108:GOTO10
1670 IFL=148 THEN=108:GOTO10
1680 IFL=149 THEN=108:GOTO10
1690 IFL=150 THEN=108:GOTO10
1700 IFL=151 THEN=108:GOTO10
1710 IFL=152 THEN=108:GOTO10
1720 IFL=153 THEN=108:GOTO10
1730 IFL=154 THEN=108:GOTO10
1740 IFL=155 THEN=108:GOTO10
1750 IFL=156 THEN=108:GOTO10
1760 IFL=157 THEN=108:GOTO10
1770 IFL=158 THEN=108:GOTO10
1780 IFL=159 THEN=108:GOTO10
1790 IFL=160 THEN=108:GOTO10
1800 IFL=161 THEN=108:GOTO10
1810 IFL=162 THEN=108:GOTO10
1820 IFL=163 THEN=108:GOTO10
1830 IFL=164 THEN=108:GOTO10
1840 IFL=165 THEN=108:GOTO10
1850 IFL=166 THEN=108:GOTO10
1860 IFL=167 THEN=108:GOTO10
1870 IFL=168 THEN=108:GOTO10
1880 IFL=169 THEN=108:GOTO10
1890 IFL=170 THEN=108:GOTO10
1900 IFL=171 THEN=108:GOTO10
1910 IFL=172 THEN=108:GOTO10
1920 IFL=173 THEN=108:GOTO10
1930 IFL=174 THEN=108:GOTO10
1940 IFL=175 THEN=108:GOTO10
1950 IFL=176 THEN=108:GOTO10
1960 IFL=177 THEN=108:GOTO10
1970 IFL=178 THEN=108:GOTO10
1980 IFL=179 THEN=108:GOTO10
1990 IFL=180 THEN=108:GOTO10
2000 IFL=181 THEN=108:GOTO10
2010 IFL=182 THEN=108:GOTO10
2020 IFL=183 THEN=108:GOTO10
2030 IFL=184 THEN=108:GOTO10
2040 IFL=185 THEN=108:GOTO10
2050 IFL=186 THEN=108:GOTO10
2060 IFL=187 THEN=108:GOTO10
2070 IFL=188 THEN=108:GOTO10
2080 IFL=189 THEN=108:GOTO10
2090 IFL=190 THEN=108:GOTO10
2100 IFL=191 THEN=108:GOTO10
2110 IFL=192 THEN=108:GOTO10
2120 IFL=193 THEN=108:GOTO10
2130 IFL=194 THEN=108:GOTO10
2140 IFL=195 THEN=108:GOTO10
2150 IFL=196 THEN=108:GOTO10
2160 IFL=197 THEN=108:GOTO10
2170 IFL=198 THEN=108:GOTO10
2180 IFL=199 THEN=108:GOTO10
2190 IFL=200 THEN=108:GOTO10
2200 IFL=201 THEN=108:GOTO10
2210 IFL=202 THEN=108:GOTO10
2220 IFL=203 THEN=108:GOTO10
2230 IFL=204 THEN=108:GOTO10
2240 IFL=205 THEN=108:GOTO10
2250 IFL=206 THEN=108:GOTO10
2260 IFL=207 THEN=108:GOTO10
2270 IFL=208 THEN=108:GOTO10
2280 IFL=209 THEN=108:GOTO10
2290 IFL=210 THEN=108:GOTO10
2300 IFL=211 THEN=108:GOTO10
2310 IFL=212 THEN=108:GOTO10
2320 IFL=213 THEN=108:GOTO10
2330 IFL=214 THEN=108:GOTO10
2340 IFL=215 THEN=108:GOTO10
2350 IFL=216 THEN=108:GOTO10
2360 IFL=217 THEN=108:GOTO10
2370 IFL=218 THEN=108:GOTO10
2380 IFL=219 THEN=108:GOTO10
2390 IFL=220 THEN=108:GOTO10
2400 IFL=221 THEN=108:GOTO10
2410 IFL=222 THEN=108:GOTO10
2420 IFL=223 THEN=108:GOTO10
2430 IFL=224 THEN=108:GOTO10
2440 IFL=225 THEN=108:GOTO10
2450 IFL=226 THEN=108:GOTO10
2460 IFL=227 THEN=108:GOTO10
2470 IFL=228 THEN=108:GOTO10
2480 IFL=229 THEN=108:GOTO10
2490 IFL=230 THEN=108:GOTO10
2500 IFL=231 THEN=108:GOTO10
2510 IFL=232 THEN=108:GOTO10
2520 IFL=233 THEN=108:GOTO10
2530 IFL=234 THEN=108:GOTO10
2540 IFL=235 THEN=108:GOTO10
2550 IFL=236 THEN=108:GOTO10
2560 IFL=237 THEN=108:GOTO10
2570 IFL=238 THEN=108:GOTO10
2580 IFL=239 THEN=108:GOTO10
2590 IFL=240 THEN=108:GOTO10
2600 IFL=241 THEN=108:GOTO10
2610 IFL=242 THEN=108:GOTO10
2620 IFL=243 THEN=108:GOTO10
2630 IFL=244 THEN=108:GOTO10
2640 IFL=245 THEN=108:GOTO10
2650 IFL=246 THEN=108:GOTO10
2660 IFL=247 THEN=108:GOTO10
2670 IFL=248 THEN=108:GOTO10
2680 IFL=249 THEN=108:GOTO10
2690 IFL=250 THEN=108:GOTO10
2700 IFL=251 THEN=108:GOTO10
2710 IFL=252 THEN=108:GOTO10
2720 IFL=253 THEN=108:GOTO10
2730 IFL=254 THEN=108:GOTO10
2740 IFL=255 THEN=108:GOTO10
2750 IFL=256 THEN=108:GOTO10
2760 IFL=257 THEN=108:GOTO10
2770 IFL=258 THEN=108:GOTO10
2780 IFL=259 THEN=108:GOTO10
2790 IFL=260 THEN=108:GOTO10
2800 IFL=261 THEN=108:GOTO10
2810 IFL=262 THEN=108:GOTO10
2820 IFL=263 THEN=108:GOTO10
2830 IFL=264 THEN=108:GOTO10
2840 IFL=265 THEN=108:GOTO10
2850 IFL=266 THEN=108:GOTO10
2860 IFL=267 THEN=108:GOTO10
2870 IFL=268 THEN=108:GOTO10
2880 IFL=269 THEN=108:GOTO10
2890 IFL=270 THEN=108:GOTO10
2900 IFL=271 THEN=108:GOTO10
2910 IFL=272 THEN=108:GOTO10
2920 IFL=273 THEN=108:GOTO10
2930 IFL=274 THEN=108:GOTO10
2940 IFL=275 THEN=108:GOTO10
2950 IFL=276 THEN=108:GOTO10
2960 IFL=277 THEN=108:GOTO10
2970 IFL=278 THEN=108:GOTO10
2980 IFL=279 THEN=108:GOTO10
2990 IFL=280 THEN=108:GOTO10
3000 IFL=281 THEN=108:GOTO10
3010 IFL=282 THEN=108:GOTO10
3020 IFL=283 THEN=108:GOTO10
3030 IFL=284 THEN=108:GOTO10
3040 IFL=285 THEN=108:GOTO10
3050 IFL=286 THEN=108:GOTO10
3060 IFL=287 THEN=108:GOTO10
3070 IFL=288 THEN=108:GOTO10
3080 IFL=289 THEN=108:GOTO10
3090 IFL=290 THEN=108:GOTO10
3100 IFL=291 THEN=108:GOTO10
3110 IFL=292 THEN=108:GOTO10
3120 IFL=293 THEN=108:GOTO10
3130 IFL=294 THEN=108:GOTO10
3140 IFL=295 THEN=108:GOTO10
3150 IFL=296 THEN=108:GOTO10
3160 IFL=297 THEN=108:GOTO10
3170 IFL=298 THEN=108:GOTO10
3180 IFL=299 THEN=108:GOTO10
3190 IFL=300 THEN=108:GOTO10
3200 IFL=301 THEN=108:GOTO10
3210 IFL=302 THEN=108:GOTO10
3220 IFL=303 THEN=108:GOTO10
3230 IFL=304 THEN=108:GOTO10
3240 IFL=305 THEN=108:GOTO10
3250 IFL=306 THEN=108:GOTO10
3260 IFL=307 THEN=108:GOTO10
3270 IFL=308 THEN=108:GOTO10
3280 IFL=309 THEN=108:GOTO10
3290 IFL=310 THEN=108:GOTO10
3300 IFL=311 THEN=108:GOTO10
3310 IFL=312 THEN=108:GOTO10
3320 IFL=313 THEN=108:GOTO10
3330 IFL=314 THEN=108:GOTO10
3340 IFL=315 THEN=108:GOTO10
3350 IFL=316 THEN=108:GOTO10
3360 IFL=317 THEN=108:GOTO10
3370 IFL=318 THEN=108:GOTO10
3380 IFL=319 THEN=108:GOTO10
3390 IFL=320 THEN=108:GOTO10
3400 IFL=321 THEN=108:GOTO10
3410 IFL=322 THEN=108:GOTO10
3420 IFL=323 THEN=108:GOTO10
3430 IFL=324 THEN=108:GOTO10
3440 IFL=325 THEN=108:GOTO10
3450 IFL=326 THEN=108:GOTO10
3460 IFL=327 THEN=108:GOTO10
3470 IFL=328 THEN=108:GOTO10
3480 IFL=329 THEN=108:GOTO10
3490 IFL=330 THEN=108:GOTO10
3500 IFL=331 THEN=108:GOTO10
3510 IFL=332 THEN=108:GOTO10
3520 IFL=333 THEN=108:GOTO10
3530 IFL=334 THEN=108:GOTO10
3540 IFL=335 THEN=108:GOTO10
3550 IFL=336 THEN=108:GOTO10
3560 IFL=337 THEN=108:GOTO10
3570 IFL=338 THEN=108:GOTO10
3580 IFL=339 THEN=108:GOTO10
3590 IFL=340 THEN=108:GOTO10
3600 IFL=341 THEN=108:GOTO10
3610 IFL=342 THEN=108:GOTO10
3620 IFL=343 THEN=108:GOTO10
3630 IFL=344 THEN=108:GOTO10
3640 IFL=345 THEN=108:GOTO10
3650 IFL=346 THEN=108:GOTO10
3660 IFL=347 THEN=108:GOTO10
3670 IFL=348 THEN=108:GOTO10
3680 IFL=349 THEN=108:GOTO10
3690 IFL=350 THEN=108:GOTO10
3700 IFL=351 THEN=108:GOTO10
3710 IFL=352 THEN=108:GOTO10
3720 IFL=353 THEN=108:GOTO10
3730 IFL=354 THEN=108:GOTO10
3740 IFL=355 THEN=108:GOTO10
3750 IFL=356 THEN=108:GOTO10
3760 IFL=357 THEN=108:GOTO10
3770 IFL=358 THEN=108:GOTO10
3780 IFL=359 THEN=108:GOTO10
3790 IFL=360 THEN=108:GOTO10
3800 IFL=361 THEN=108:GOTO10
3810 IFL=362 THEN=108:GOTO10
3820 IFL=363 THEN=108:GOTO10
3830 IFL=364 THEN=108:GOTO10
3840 IFL=365 THEN=108:GOTO10
3850 IFL=366 THEN=108:GOTO10
3860 IFL=367 THEN=108:GOTO10
3870 IFL=368 THEN=108:GOTO10
3880 IFL=369 THEN=108:GOTO10
3890 IFL=370 THEN=108:GOTO10
3900 IFL=371 THEN=108:GOTO10
3910 IFL=372 THEN=108:GOTO10
3920 IFL=373 THEN=108:GOTO10
3930 IFL=374 THEN=108:GOTO10
3940 IFL=375 THEN=108:GOTO10
3950 IFL=376 THEN=108:GOTO10
3960 IFL=377 THEN=108:GOTO10
3970 IFL=378 THEN=108:GOTO10
3980 IFL=379 THEN=108:GOTO10
3990 IFL=380 THEN=108:GOTO10
4000 IFL=381 THEN=108:GOTO10
4010 IFL=382 THEN=108:GOTO10
4020 IFL=383 THEN=108:GOTO10
4030 IFL=384 THEN=108:GOTO10
4040 IFL=385 THEN=108:GOTO10
4050 IFL=386 THEN=108:GOTO10
4060 IFL=387 THEN=108:GOTO10
4070 IFL=388 THEN=108:GOTO10
4080 IFL=389 THEN=108:GOTO10
4090 IFL=390 THEN=108:GOTO10
4100 IFL=391 THEN=108:GOTO10
4110 IFL=392 THEN=108:GOTO10
4120 IFL=393 THEN=108:GOTO10
4130 IFL=394 THEN=108:GOTO10
4140 IFL=395 THEN=108:GOTO10
4150 IFL=396 THEN=108:GOTO10
4160 IFL=397 THEN=108:GOTO10
4170 IFL=398 THEN=108:GOTO10
4180 IFL=399 THEN=108:GOTO10
4190 IFL=400 THEN=108:GOTO10
4200 IFL=401 THEN=108:GOTO10
4210 IFL=402 THEN=108:GOTO10
4220 IFL=403 THEN=108:GOTO10
4230 IFL=404 THEN=108:GOTO10
4240 IFL=405 THEN=108:GOTO10
4250 IFL=406 THEN=108:GOTO10
4260 IFL=407 THEN=108:GOTO10
4270 IFL=408 THEN=108:GOTO10
4280 IFL=409 THEN=108:GOTO10
4290 IFL=410 THEN=108:GOTO10
4300 IFL=411 THEN=108:GOTO10
4310 IFL=412 THEN=108:GOTO10
4320 IFL=413 THEN=108:GOTO10
4330 IFL=414 THEN=108:GOTO10
4340 IFL=415 THEN=108:GOTO10
4350 IFL=416 THEN=108:GOTO10
4360 IFL=417 THEN=108:GOTO10
4370 IFL=418 THEN=108:GOTO10
4380 IFL=419 THEN=108:GOTO10
4390 IFL=420 THEN=108:GOTO10
4400 IFL=421 THEN=108:GOTO10
4410 IFL=422 THEN=108:GOTO10
4420 IFL=423 THEN=108:GOTO10
4430 IFL=424 THEN=108:GOTO10
4440 IFL=425 THEN=108:GOTO10
4450 IFL=426 THEN=108:GOTO10
4460 IFL=427 THEN=108:GOTO10
4470 IFL=428 THEN=108:GOTO10
4480 IFL=429 THEN=108:GOTO10
4490 IFL=430 THEN=108:GOTO10
4500 IFL=431 THEN=108:GOTO10
4510 IFL=432 THEN=108:GOTO10
4520 IFL=433 THEN=108:GOTO10
4530 IFL=434 THEN=108:GOTO10
4540 IFL=435 THEN=108:GOTO10
4550 IFL=436 THEN=108:GOTO10
4560 IFL=437 THEN=108:GOTO10
4570 IFL=438 THEN=108:GOTO10
4580 IFL=439 THEN=108:GOTO10
4590 IFL=440 THEN=108:GOTO10
4600 IFL=441 THEN=108:GOTO10
4610 IFL=442 THEN=108:GOTO10
4620 IFL=443 THEN=108:GOTO10
4630 IFL=444 THEN=108:GOTO10
4640 IFL=445 THEN=108:GOTO10
4650 IFL=446 THEN=108:GOTO10
4660 IFL=447 THEN=108:GOTO10
4670 IFL=448 THEN=108:GOTO10
4680 IFL=449 THEN=108:GOTO10
4690 IFL=450 THEN=108:GOTO10
4700 IFL=451 THEN=108:GOTO10
4710 IFL=452 THEN=108:GOTO10
4720 IFL=453 THEN=108:GOTO10
4730 IFL=454 THEN=108:GOTO10
4740 IFL=455 THEN=108:GOTO10
4750 IFL=456 THEN=108:GOTO10
4760 IFL=457 THEN=108:GOTO10
4770 IFL=458 THEN=108:GOTO10
4780 IFL=459 THEN=108:GOTO10
4790 IFL=460 THEN=108:GOTO10
4800 IFL=461 THEN=108:GOTO10
4810 IFL=462 THEN=108:GOTO10
4820 IFL=463 THEN=108:GOTO10
4830 IFL=464 THEN=108:GOTO10
4840 IFL=465 THEN=108:GOTO10
4850 IFL=466 THEN=108:GOTO10
4860 IFL=467 THEN=108:GOTO10
4870 IFL=468 THEN=108:GOTO10
4880 IFL=469 THEN=108:GOTO10
4890 IFL=470 THEN=108:GOTO10
4900 IFL=471 THEN=108:GOTO10
4910 IFL=472 THEN=108:GOTO10
4920 IFL=473 THEN=108:GOTO10
4930 IFL=474 THEN=108:GOTO10
4940 IFL=475 THEN=108:GOTO10
4950 IFL=476 THEN=108:GOTO10
4960 IFL=477 THEN=108:GOTO10
4970 IFL=478 THEN=108:GOTO10
4980 IFL=479 THEN=108:GOTO10
4990 IFL=480 THEN=108:GOTO10
5000 IFL=481 THEN=108:GOTO10
5010 IFL=482 THEN=108:GOTO10
5020 IFL=483 THEN=108:GOTO10
5030 IFL=484 THEN=108:GOTO10
5040 IFL=485 THEN=108:GOTO10
5050 IFL=486 THEN=108:GOTO10
5060 IFL=487 THEN=108:GOTO10
5070 IFL=488 THEN=108:GOTO10
5080 IFL=489 THEN=108:GOTO10
5090 IFL=490 THEN=108:GOTO10
5100 IFL=491 THEN=108:GOTO10
5110 IFL=492 THEN=108:GOTO10
5120 IFL=493 THEN=108:GOTO10
5130 IFL=494 THEN=108:GOTO10
5140 IFL=495 THEN=108:GOTO10
5150 IFL=496 THEN=108:GOTO10
5160 IFL=497 THEN=108:GOTO10
5170 IFL=498 THEN=108:GOTO10
5180 IFL=499 THEN=108:GOTO10
5190 IFL=500 THEN=108:GOTO10
5200 IFL=501 THEN=108:GOTO10
5210 IFL=502 THEN=108:GOTO10
5220 IFL=503 THEN=108:GOTO10
5230 IFL=504 THEN=108:GOTO10
5240 IFL=505 THEN=108:GOTO10
5250 IFL=506 THEN=108:GOTO10
5260 IFL=507 THEN=108:GOTO10
5270 IFL=508 THEN=108:GOTO10
5280 IFL=509 THEN=108:GOTO10
5290 IFL=510 THEN=108:GOTO10
5300 IFL=511 THEN=108:GOTO10
5310 IFL=512 THEN=108:GOTO10
5320 IFL=513 THEN=108:GOTO10
5330 IFL=514 THEN=108:GOTO10
5340 IFL=515 THEN=108:GOTO10
5350 IFL=516 THEN=108:GOTO10
5360 IFL=517 THEN=108:GOTO10
5370 IFL=518 THEN=108:GOTO10
5380 IFL=519 THEN=108:GOTO10
5390 IFL=520 THEN=108:GOTO10
5400 IFL=521 THEN=108:GOTO10
5410 IFL=522 THEN=108:GOTO10
5420 IFL=523 THEN=108:GOTO10
5430 IFL=524 THEN=108:GOTO10
5440 IFL=525 THEN=108:GOTO10
5450 IFL=526 THEN=108:GOTO10
5460 IFL=527 THEN=108:GOTO10
5470 IFL=528 THEN=108:GOTO10
5480 IFL=529 THEN=108:GOTO10
5490 IFL=530 THEN=108:GOTO10
5500 IFL=531 THEN=108:GOTO10
5510 IFL=53
```

## TANDY FORUM



### Moon Lander

WRITTEN IN BASIC for a TRS-80 level II, the Moon Lander program by Ian Butcher of Laindon, Essex is in three sections. Section 1 is a simple representation of the flight from the Earth to the Moon. Section 2 is the orbit of the lander with the 5,000ft. level marked.

The descent from 20,000ft. to 5,000ft. also occurs during section 2. It gives the player the opportunity to slow the descent to a reasonable speed for section 3, which is from 5,000ft. to the landing. This stage draws a random Lunar landscape.

During section 3 the player can fly the lander off screen right or left to a new random lunar landscape, as long as there is enough fuel. At the harder levels there is not enough fuel and the player must get down on the initial landscape.

The program uses the TRS-80 set and reset facility to draw the lander and the landscape. Because the program is in Basic the graphics have been kept relatively simple to maintain reasonable speed of play. The program occupies less than 4K of RAM and should be fairly easy to modify for other memory-mapped micros.

The main features of the program are as follows:

- Line 12 ensures that if the crash graphics are off the video map then the program jumps to the lander-destroyed routine.
- Lines 20-90 are the instructions.
- Lines 110-120 set the level of difficulty.
- Lines 125-145 form a short routine depicting the Earth-Moon flight. They may be omitted without detriment to the program.
- Line 240 initialises values: HH, height; S, speed; RA, divisor for screen co-ordinates.
- Lines 250-380 form a routine to draw orbiting lander.
- Line 340 looks for start of descent.
- Lines 390-430 are the main program loop, and look for cursor key input.
- Lines 500-520 form a speed-reduction subroutine.
- Lines 600-640 form a move-left subroutine, which also redraws landscape during section if lander moves off screen.
- Lines 700-740 form a move-right subroutine.
- Lines 800-840 form an instrument-readout subroutine.
- Lines 900-990 form a subroutine to increment

(continued on page 144)

```

5 REM A BASIC LUNAR LANDER PROGRAM BY IAN BUTCHER
10 CLS
12 ON ERROR GOTO 2180
15 T=0
20 PRINT"YOU ARE THE PILOT OF A LUNAR LANDER"
30 PRINT"YOU CAN 'FLY' THE LANDER BY USING THE UP, LEFT,"
40 PRINT"AND RIGHT CURSOR KEYS. THE UP KEY WILL"
50 PRINT"REDUCE YOUR SPEED AND RATE OF DESCENT."
60 PRINT"TO COMMENCE THE LANDING USE THE DOWN"
70 PRINT"CURSOR KEY. TO LAND SUCCESSFULLY YOUR"
80 PRINT"SPEED MUST BE LESS THAN TWENTY FEET/SEC. ON IMPACT"
81 PRINT"THE RADAR DISPLAY IS IN TWO STAGES -- FROM 20000 FT. TO 5000 FT"
82 PRINT"AND THEN FROM 5000 FT TO GROUND LEVEL "
83 PRINT"YOU MUST REDUCE SPEED DURING STAGE ONE "
84 PRINT"IF YOU CANNOT LAND YOU CAN MOVE LEFT OR RIGHT TO A NEW SITE"
85 PRINT"BY USING THE LEFT OR RIGHT CURSORS (<IF YOU HAVE ENOUGH FUEL)"
90 INPUT"TO COMMENCE PRESS THE ENTER KEY";S#
100 CLS
110 PRINT:PRINT:PRINT:PRINT"ENTER YOUR SKILL LEVEL (<1 TO 5 >) --- 5 IS EASY 1 IS
HARD " :PRINT:INPUTA :IF A<1 THEN A=1
116 IF A=5OR A=4 OR A=3 THEN F=800:GOTO125
118 IFA=2THEN F=1400
120 IFA=1 THEN F=3000
125 CLS
130 PRINT@190,"MOON";PRINT@118,"EARTH";
135 FOR Y=ST00STEP-1:Y=126:SET(X,Y):FORT=1T050:NEXT:RESET(X,Y):NEXT
140 FORX=127T00STEP-1:Y=0:SET(X,Y):FORT=1T050:NEXT:RESET(X,Y):NEXT
145 FOR Y=0T0:Y=0:SET(X,Y):FORT=1T050:NEXT:RESET(X,Y):NEXT
150 CLS
170 PRINT:PRINT"COMMAND MODULE TO LANDER"
180 PRINT:PRINT"YOU ARE NOW ENTERING ORBIT"
185 FORTT=1T0500:NEXT
190 PRINT:PRINT:PRINT"THE COMPUTERS HAVE CLOSED DOWN"
195 FORTT=1T0500:NEXT
200 PRINT:PRINT:PRINT"YOU MUST LAND THE MODULE YOURSELF"
205 FORTT=0T0500:NEXT
210 PRINT:PRINT:PRINT"YOU WILL SEE THE RADAR PICTURE SOON"
215 FORTT=0T0500:NEXT
220 PRINT:PRINT:PRINT"GOOD LUCK COMMANDER"
230 FORT=1T0500:NEXT
240 CLS:HH=20000:S=500:RA=454.5:BR=10
250 PRINT@960,"5000 FT. -----";
260 GOSUB800
290 B=1:C=2:D=3:E=3:I=4:G=5:H=0:J=4:K=6
300 FORX=0T0122:GOSUB 5000
310 FORT=1T0100:NEXT
320 GOSUB 6000
330 B=B+2:C=C+2:D=D+2:H=H+2:J=J+2:IF J>127THEN 290 ELSE 340
340 IF PEEK<14426>=16 THEN GOTO 360
350 NEXT
355 GOTO290
360 E=E+2:I=I+2:G=G+2:K=K+2
370 IF K>47 THENK=47:G=46:I=45:E=44
380 GOSUB 5000
390 IF PEEK<14426>=8GOSUB 500
400 IFFPEEK<14426>=32 GOSUB 600
410 IFFPEEK<14426>=64 GOSUB 700
420 GOSUB 900
430 GOTO 390
500 IF T>899 THEN S=S-(7.5-(F#.001)-2)*A:GOTO506
505 S=S-(50-(F#.001)-2)*A#
506 F=F-(50/A)
510 GOSUB 905
520 RETURN
600 GOSUB 6000
610 B=B-2:C=C-2:D=D-2:H=H-2:J=J-2:IF H<0AND HK<5000THEN GOSUB 4000:H=123:B=124
:C=125:D=126:J=127
615 IF H<0 THEN H=123:B=124:C=125:D=126:J=127
620 F=F-(50/A):GOSUB800
630 GOSUB5000
640 RETURN
700 GOSUB6000
710 B=B-2:C=C+2:D=D+2:H=H+2:J=J+2:IFJ>127AND HK<5000THEN GOSUB 4000
:H=0:B=1:C=2:D=3:J=4
715 IF J>127 THEN H=0:B=1:C=2:D=3:J=4
720 F=F-(50/A):GOSUB800
730 GOSUB5000
740 RETURN
800 PRINT@1,"HEIGHT "HH;
810 PRINT@20,"SPEED "S;
815 IF F<150 THEN PRINT@420,"FUEL LOW ";
820 PRINT@45,"FUEL "F;
830 IF F<0 GOTO2000
840 RETURN
900 IF T>899 THEN S=S+1:GOTO905
902 S=S+5
905 T=T+1:TT=TT+1
910 IF T<900 AND HK<5000 GOSUB4000:T=900:TT=900
930 HH=HH-S:RR=INT<HH/RA>:IF RR=YR THEN 940 ELSE 935
935 GOSUB6000
940 E=(44-RR):I=(45-RR):G=(46-RR):K=(47-RR):YR=RR
955 IFEK<3 THEN E=3:I=4:G=5:K=6
960 GOSUB800
970 GOSUB5000
980 IF POINT<H,K+1>=-1 ANDPOINT<J,K+1>=-1THEN3000 ELSE 990
990 IF POINT<H,K+1>=-1THEN 2000
1000 IF POINT<J,K+1>=-1 THEN 2000
1010 RETURN
2000 IF F<0THEN 2010 ELSE 2150
2010 FORX=0T042:GOSUB6000
2020 E=E+1:I=I+1:G=G+1:K=K+1:FOR DT=0T050:NEXT
2030 GOSUB 5000
2150 GOSUB6000
2160 FORX=1T05:B=B-1:D=D+1:E=E-1:I=I-1:G=G-1
2170 GOSUB8000
2175 NEXT:FOR DT=1T0500:NEXT
2180 CLS:PRINT@320,"YOU ARE VERY DEAD !";
2190 PRINT@384,"THE LANDER IS DESTROYED"
2200 GOTO3020
3000 FOR T=1T0500:NEXT:IF S<20 THEN CLS ELSE 2150
3010 PRINT:PRINT:PRINT"CONGRATULATIONS YOU HAVE LANDED"
3020 INPUT"IF YOU WISH TO HAVE ANOTHER GO PRESS ENTER ";S#
3030 GOTO 10
4000 CLS:RANDOM
4010 FORX=0T0125STEP3:Y=RND<9>+38:SET(X,Y):SET(X+1,Y):SET(X+2,Y):NEXT
4020 RA=111
4030 BR=1
4040 RETURN
5000 SET<H,K>:SET<B,I>:SET<C,E>:SET<B,G>:SET<C,G>:SET<D,I>:SET<D,G>:SET<J,K>
5010 RETURN
6000 RESET<H,K>:RESET<B,I>:RESET<C,E>:RESET<B,G>:RESET<C,G>:RESET<D,I>:RESET<D,G>
:RESET<J,K>
6010 RETURN
    
```

# Remember Pearl?

## THE BEGINNING OF A NEW ERA IN MICROCOMPUTER PROGRAMMING

*PEARL ushered in the era where programmers could free themselves from boring, routine and repetitive tasks. Because PEARL handles 60-70% of programming details, which permits programmers to spend their time more creatively, and more productively.*

But that was two years ago.

Today, there's Personal PEARL — to be introduced at the Computer Fair. And it goes a giant step further. Personal PEARL makes the capabilities of the computer available to virtually anyone.

For its £180 price, even people without technical backgrounds can use it to visually create their own applications and reports on any computer.

So the ad you're reading now is announcing an even more important breakthrough in computer and personal productivity.

Just think about the possibilities. Then contact our Personal PEARL Product Manager. PEARL Software Tel: (0202) 741275.

CPU International is the former name of Relational Systems International. PEARL (Producing Error-Free Automatic Rapid Logic)

### WITH INTERNATIONAL ACCLAIM

## PEARL™

Paved the way with Program Generators  
Now once again Pearl Leads with

## PERSONAL PEARL™

The Evolution in Software 1990's in 1982

It does what others are claiming

TM. RELATIONAL SYSTEMS INTERNATIONAL SALEM, OREGON

To: PEARL INTERNATIONAL (UK) LTD, P.O. BOX 34, POOLE, DORSET BH14 8AR  
Please send me details of PERSONAL PEARL.

Name ..... Firm .....

Address ..... Post Code .....

Tel.: .....

Type of Equipment .....

Disc Size and Format .....

● Circle No. 182

**Over forty  
of the world's  
leading  
software  
houses have  
one thing in  
common.**



They support a worldwide standard in software, and so do we.

We understand that one of the most important considerations, before buying a computer, is the software which will be available to you.

This is made easy by the choice of the CP/M operating system. TCL Software, a division of Transam, provides an enormous range of software packages for commercial, scientific, educational and personal needs.

But there is one important difference - we at Transam really understand the CP/M based computer.

CP/M has the advantage of being adopted by an ever

increasing number of software houses. This means that there is a wide range of other software packages written to run on a CP/M based system.

And, of course, any programs you may develop yourself will be compatible with, and can be run on, other systems which are CP/M based.

The Transam range of computers are designed and built in Britain. Our experience gives us the capability to support our users at a very high level, with advice and spares only a phone call away.

Call in to our West End showrooms for all the advice you need about computers and what they can do for you, or for further information write to Transam Microsystems Limited, 59/61 Theobald's Road, London WC1. Telephone 01-405 5240/2113.



(continued from page 141)

speed, calculate screen co-ordinates, select section 2 and move lander down, if appropriate.

Lines 980-1010 test to see if lander is on level ground

Lines 2000-2200 are the crash routine.

Lines 3000-3030 select repeat game.

Lines 4000-4040 generate the landscape for section 2, and reassigns new RA.

Lines 5000-5010 are the set subroutine.

Lines 6000-6020 are the reset subroutine.

The intention was to write a Basic lunar lander which strikes a reasonable balance between graphics and speed. The program is sophisticated enough to be playable by a wide variety of age groups as it stands, but should also provide an incentive for the more accomplished programmer to modify and improve on it. Apart from the set, reset facility the program uses Basic in a way which should allow fairly easy transportation to 6502-based micros.

## User graphics

TWO RELATED PROGRAMS come from John Middleton of Sale, Cheshire. The first prints a £ sign which is not available in the character set of the Tandy Linewriter VII. The other allows any user-defined character to be printed.

User Definable Characters forms characters row by row. Inputting a 1 causes a dot to be printed at a particular point; inputting a 0 causes a blank space to be printed.

## Name finder

IN TANDY FORUM January 1982, M L Arnautov suggests a clever method of loading a system tape with an unknown name. There is, however, a much simpler alternative, writes Tony Edwards of Northwood, Middlesex. Place the tape in the recorder as you would for a normal load and then run the following program

```
10 INPUT#-1,A$;A$;NEW
```

You will be rewarded with the name of the unknown program. Write it down this time, before you forget it again.

If the program on the tape is in Basic the single-character name is printed, but if it is a system tape the full program name is output preceded by the letter U, the machine-code identifier. If the tape was not a program tape at all but a data tape the output is the first piece of data.

This program also responds to Tiny Pascal program tapes as if they were system tapes.

### Data separator.

```
10 DATA "THESE", "ARE", "THE", "FIRST", "TEN", "ITEMS",  
"OF", "THE", "DATA", "LIST", "AND", "WE", "WOULD", "NORMALLY",  
"CONTINUE", "READING", "HERE", "BUT", "NOW", "WE'VE", "CONTINUED",  
"READING", "HERE", "INSTEAD"  
20 GOSUB50:GOSUB 60  
30 GOSUB50:POKE16639,107:POKE16640,67:GOSUB60  
40 PRINT:PRINT:LIST10  
50 PRINT:PRINT:RESTORE:FORI=1TO10:READA$:PRINTA$;  
":NEXT:RETURN  
60 PRINT:FORI=1TO7:READA$:PRINTA$;":NEXT:RETURN
```

### Pound sign.

```
93 REM *****  
94 REM *** POUND SIGN PROGRAM ***  
95 REM *** FOR USE WITH LINE PRINTER VII ***  
96 REM *** WRITTEN BY J.MIDDLETON ***  
97 REM *****  
100 DATA 200,190,169,162,196: DATA FOR POUND SIGN  
105 LPRINT CHR$(18): PUT LINE PRINTER VII IN GRAPHICS MODE  
110 FOR I=0 TO 5:5 COLUMNS PER CHARACTER  
115 READ J  
120 LPRINT CHR$(J):PRINT 1 COLUMN OF POUND SIGN  
125 NEXT J  
130 LPRINT CHR$(30):PUT PRINTER BACK IN CHARACTER PRINT MODE  
140 END
```

### User Definable Characters.

```
10 CLEAR2000:SA=15360:EA=15744  
20 REM *****  
30 REM *** SA=TOP LEFT OF SCREEN ***  
40 REM *** EA=ADDRESS 7 CHARACTERS BELOW TOP LEFT OF SCREEN ***  
50 REM *****  
60 CLS  
70 A$=INKEY$  
80 IF A$="1" OR A$="0" THEN 100  
90 GOTO70  
100 IF T=5 THEN PRINTCHR$(13):T=0:D=D+1:LINE FEED IF 5 CHARACTERS PRINTED  
110 IF D=7 THEN 180  
120 IFA$="1"THEN PRINTCHR$(191):ELSEPRINT".":  
130 T=T+1  
140 GOTO70  
150 REM *****  
160 REM *** COMPUTE CHARACTER PATTERN IN BINARY ***  
170 REM *****  
180 FORI=EA+J TO SA+J STEP-64  
190 IF PEEK(I)=191THEN A$(J)=A$(J)+"1" ELSE A$(J)=A$(J)+"0"  
200 NEXTI  
210 J=J+1  
220 IF J=5 THEN 240  
230 GOTO180  
240 FORI=0TO4:A$(I)="1"+A$(I)  
250 NEXTI  
260 REM *****  
270 REM *** CHANGE BINARY TO DECIMAL ***  
280 REM *****  
290 FORI=0TO4  
300 FORJ=0TO7  
310 IF VAL(MID$(A$(I),8-J,1))=1THEN V(I)=V(I)+2J  
320 NEXTJ,I  
330 REM *****  
340 REM *** SCREEN OUTPUT OF ALTERATIONS TO POUND SIGN PROGRAM **  
350 REM *****  
360 PRINT:PRINT"REPLACE THE DATA IN LINE 100 IN THE POUND SIGN PROGRAM WITH"  
370 FORI=0TO4  
380 PRINTV(I);  
390 NEXTI  
400 PRINT:PRINT"TO REPRODUCE THE CHARACTER DRAWN ON THE SCREEN"  
410 REM *****  
420 REM *** OPTION OF PRINTER OUTPUT OF CHARACTER ***  
430 REM *****  
440 PRINT" DO YOU WANT THE CHARACTER OUTPUT TO THE PRINTER ?"  
450 A$=INKEY$:IFA$=""THEN450  
460 IF A$="Y"THEN 470 ELSE END  
470 LPRINTCHR$(18):PUT PRINTER IN GRAPHICS MODE  
480 FORI=1TO4  
490 LPRINTCHR$(V(I));  
500 NEXT I
```

## Data separator

WHERE PROGRAMS contain long lists of items in Data statements, it is often convenient to be able to access different parts of the list independently, writes Michael Smith of Camborne, Cornwall. There are two methods which are often recommended. The data list shown here,

for example, is evidently intended to be treated as three separate data lists, but Read statements in the program will treat it as one huge list. Successive Reads simply take one item after another until the end of the list is reached. All that can be done to influence the process is to Restore, to start again at the beginning.

What happens if you want to go

### Data separator — example data.

```
1300 REM LIST OF TELEPHONE  
NUMBERS  
1310 DATA "694-0220", "575-3376",  
"283-9501"  
1400 REM LIST OF DISTANCES IN MILES  
1410 DATA 5,8,4,2,9,5,4,6,7,4  
1500 REM LIST OF NAMES  
1510 DATA "JIM", "FRED", "JOE", "TOM"
```

straight to the third list of names? One well-known book on programming for the TRS-80 recommends either that you should be aware of the number of items in each group, and just perform the appropriate number of dummy Reads until you reach the part you want. Alternatively you can precede each group with a unique code and then search for that code, again by Reading until you find it. The second method requires that the code must not otherwise be a data item anywhere in the list. Where the part you want is hidden in the middle of a long data list, both methods can take ages.

There is also a mysterious "imaginary pointer" which points to the next data item after a Read. The Pointer Finder

program helps you to find the pointer. When it is run, the screen displays the following text:

```
THESE ARE THE FIRST TEN ITEMS OF
THE DATA LIST AND WE WOULD
NORMALLY CONTINUE READING HERE
```

```
THESE ARE THE FIRST TEN ITEMS OF
THE DATA LIST BUT WE'VE CONTINUED
READING HERE INSTEAD
```

followed by a listing of Data line 10 so that you can see what has happened.

On the first occurrence of Gosub50, in line 20, the subroutine reads the first 10 data items from the list and prints them. A pointer stored in locations 16639 (LSB) and 16640 (MSB) now points to the comma delimiter after the last item read, that is, to the comma before "and".

The statement Gosub60 in line 20 then reads the next seven items and prints them, just as you would expect.

The procedure is repeated in line 30, but this time, after reading and printing the first 10 items as before, the pointer is reset so that it points to location 17259 (=67\*256+107) in memory. As it happens, this location is where the comma before "but" is stored. When subroutine 60 is performed this time, it Reads and Prints the seven items beginning with "but".

So in order to read selectively any part of a data list, find out where the comma before the first item that you want is stored, or the blank space at the start of a Data statement if that is where you want to begin. Set the pointer to that address and start to Read.

One easy way to find the location you require is to count the data items before the one you want to begin on, read items up to that point with a For-Next loop, and do a Peek (16639), Peek (16640) to see where the pointer is now. Then use those numbers in your program. It certainly beats reading the whole data list into an array and accessing it by indexing — that is just a good way to run out of memory.

## Unknown tape loader

THIS PROGRAM by J A E Bowen of Tamworth, Staffordshire, was originally conceived to permit the loading of system tapes from the second cassette on one of the original Video Genie microcomputers. The program was written in Basic so that it could be loaded from the second cassette on a Video Genie if the internal cassette is faulty. This model had a fixed-level internal cassette only, and it could sometimes be difficult to load a system tape from another source because of recorded level differences.

The main problem was not only to provide a machine-language routine which would allow a system tape to be loaded from the second cassette, but, with only 16K of RAM available, to locate the program in a position where it could not be overwritten and hence abort the loading process. The solution adopted was to initialise the system load from the program and, once past the cassette selection part of the internal routine, jump back into ROM. The routine in the RAM is then redundant and it does not matter if it is overwritten.

The program will load system tapes with unknown names and the selection of either cassette is permitted. As an additional bonus, the name which has been read from the tape during loading is also displayed.

If memory allows, the USR routine may be located in a part of the memory where it will not be overwritten and may be used more than once by calling System and the appropriate entry address displayed by the program. □

### Unknown tape loader.

```
10 CLS
20 PRINT
30 PRINT"*****"
40 PRINT"*   LOADER FOR UNKNOWN SYSTEM TAPES,   *"
50 PRINT"*   EITHER CASSETTE.                   *"
60 PRINT"*****"
70 '
80 DIM A(37):N=0
90 L=219:M=127:K=32731
100 PRINT
110 INPUT"CHANGE LOCATION OF USR ROUTINE";A#
120 IFLEFT$(A#,1)="Y"THENGOTO140
130 IFLEFT$(A#,1)="N"THENGOTO180ELSE110
140 INPUT"ENTER NEW LOCATION";K
150 IFK<20443ORK>65498GOTO160ELSEGOTO180
160 PRINT"NEW LOCATION >20443 AND <65498
170 GOTO140
180 M=INT(K/256):L=K-256*M
190 KK=K
200 IFKK=>32767THENKK=KK-65536
210 FORX=0TO36:READA(X):POKEKK+X,A(X):NEXTX
220 PRINT
230 PRINT"CASSETTE 1      /";L+256*M
240 PRINT"CASSETTE 2      /";L+256*M+5
250 PRINT"END OF USR CODE IS AT";L+256*M+37
260 PRINT:PRINT
270 PRINT"FOR INSTRUCTIONS TYPE <I>"
280 PRINT"TO LOAD SYSTEM TAPE PRESS ANY KEY"
290 S#=INKEY#:IFS#=""THENGOTO290
300 IFS#<>"I"GOTO400
310 CLS
320 PRINT:PRINT
330 PRINT"TO LOAD MACHINE-LANGUAGE (SYSTEM) TAPE "
340 PRINT"PRESS ANY KEY AFTER SETTING UP TAPE IN CASSETTE."
350 PRINT"THE TAPE WILL LOAD WITH USUAL INDICATIONS AND FINAL PROMPT"
360 PRINT"*?. TO RUN LOADED PROGRAMME TYPE / AND NEWLINE AS NORMAL."
370 GOTO410
380 PRINT
390 PRINT"1 OR 2 ONLY"
400 CLS
410 PRINT:PRINT
420 PRINT"SELECT CASSETTE 1 OR 2";
430 INPUTA
440 GOSUB630
450 PRINT
460 PRINT"LOADING PROGRAMME HAS NAME ";
470 IFN<0GOTO530
480 GOTO530
490 POKE16526,L:POKE16527,M
500 RETURN
510 POKE16526,L+5:POKE16527,M
520 RETURN
530 Q=USR(0)
540 PRINT"**** NOT EXPECTED FORMAT"
550 PRINT
560 PRINT"TO LOAD SYSTEM TAPE PRESS ANY KEY":N=N+1
570 DATA 243,175,40,3,243,62,49,205,18,2
580 DATA 205,150,2,205,53,2,254,85,32,13,6
590 DATA 6,205,53,2,205,51,0,16,248,195
600 DATA 234,2,205,248,1,201
610 GOTO290
620 END
630 IFA<10RA>2 THEN GOTO380
640 IFA=1THENGOSUB490ELSEGOSUB510
650 GOTO450
```

# MICRO TRAINING FOR COMPUTER USERS

# 6 Micro courses



Which would you like to attend?

Digitus is running a number of courses to train users and potential users in the basic skills of micro-computing. Conducted at our Central London Workshop, the courses provide hands-on experience of microcomputers, demonstrations of working systems and tutorials on your particular needs.



One day's concentrated information on microcomputing aimed at the potential user in small and large organisations. A practical course which includes business applications of micros, guidelines on selecting microcomputer systems and an introduction to programming.

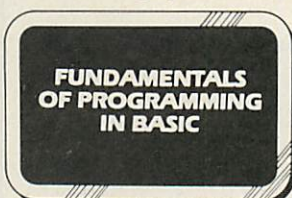

A two day course designed to teach the first principals of programming in BASIC. Aimed at those with some understanding of micros who want to learn how to instruct their computer to perform tasks.



A two day course for those who have learned Basic from hands-on experience and want to brush up their BASIC techniques and learn some timesaving software tools.

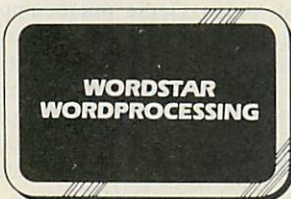

A one day course for people who want to learn the fundamentals of wordprocessing. Uses the popular Wordstar wordprocessing package available on most CP/M micros and teaches by hands-on use.

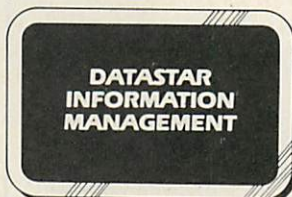

The DataStar data entry, retrieval and management system is a powerful aid which enables the educated user and computer professional to build information systems economically and rapidly.

**Training for Computer Professionals**  
Course in: Micro Technology for Management • Local Area Networks • Micros for Computer Professionals.  
Courses are run at the Workshop or on site. Telephone or write for details.

**Micro Technology Workshop** Set in 8,500 sq.ft in Central London, the Workshop is a few minutes from Covent Garden, Trafalgar Square, Charing Cross, Embankment and Waterloo stations. Specialist areas include: Personal Computers, Technical Systems, Business Systems, 16 bit and Local Network Systems, Bookstore and Training Rooms.

**Booking and Fees** The fee for all courses is £80 per day plus VAT, payable 14 days prior to starting date.



In addition to Wordstar, Micro-Pro Inc have produced a variety of aids to improve productivity in offices and systems departments. This one day course includes: Mail-Merge linked to Wordstar • Supersort sorting utility • CalcStar rows and columns manipulation • DataStar information manager • harnessing the 'Star' products together.

**All courses provide access to an extensive range of micro hardware, software and expertise.**

Note: Wordstar and DataStar are registered trademarks of Micro-Pro Inc.

● Circle No. 184

**Booking Form** (Please complete in BLOCK capitals)  
To Digitus Ltd, 10-14 Bedford Street, London WC2E 9HE. Tel 01-379 6968

Please send me further information     Reserve places as follows:

Name of delegate ..... Date .....

Name of delegate ..... Date .....

Name of delegate ..... Date .....

**Courses/dates**

Introduction to Microcomputers	<input type="checkbox"/> June 7	<input type="checkbox"/> Oct 11
Fundamentals of Programming in Basic	<input type="checkbox"/> June 8/9	<input type="checkbox"/> Oct 12/13
Improve your Basic	<input type="checkbox"/> June 10/11	<input type="checkbox"/> Oct 14/15
Wordstar Wordprocessing	<input type="checkbox"/> July 6	<input type="checkbox"/> Nov 9
Micro-Pro Software Tools	<input type="checkbox"/> July 7	<input type="checkbox"/> Nov 10
DataStar Information Management	<input type="checkbox"/> July 8	<input type="checkbox"/> Nov 11

Company/address .....

Name ..... Position .....

Signature ..... Tel.No. ....

PRC



# SUPERBRAIN AND DYNABYTE IN THE NORTH

Contact us today  
for the information

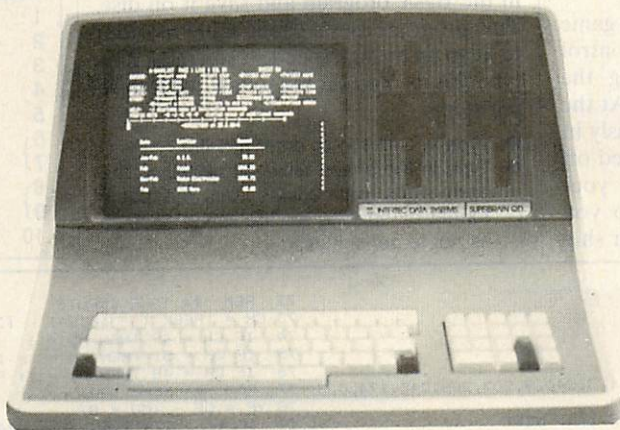

Telephone:  
061-928 4441  
061-941 3972

## CONSULTANCY

Full discussions are provided on customers requirements, the most suitable system is suggested and a full demonstration is arranged.

## SOFTWARE

We have generalised software packages, but our team also prepare tailor made software to meet your requirements.

## SUPPORT

Our Sales Engineers are available to customers, both before and after a system is purchased, to liaise with the appropriate department with DATADIGITAL.

## SUPPLIES

Your microcomputer system will require ribbons, diskettes, continuous stationery etc. We can always supply these from stock.

## TRAINING

Either before or after you buy your microcomputer system.

The DYNABYTE range of microcomputers are fully expandable on the customers premises and range in price from a single user system at less than £4,000 to a fully expanded multiuser system at over £30,000.

The SUPERBRAIN range of desktop microcomputers are suitable for many commercial applications. Datadigital prices are from £1,499. Also available Superbrain QD £1,799 and Superbrain 1.6MBytes £2,100. Retail prices on application.

**Northern distributors for the DYNABYTE and  
SUPERBRAIN range of micro-computers**

# datadigital

COMPUTER SYSTEMS LTD.

Aidina House, Manchester Road, Broadheath, Altrincham, Cheshire WA14 5LZ. Tel: 061-928 4441, 061-941 3972

● Circle No. 185

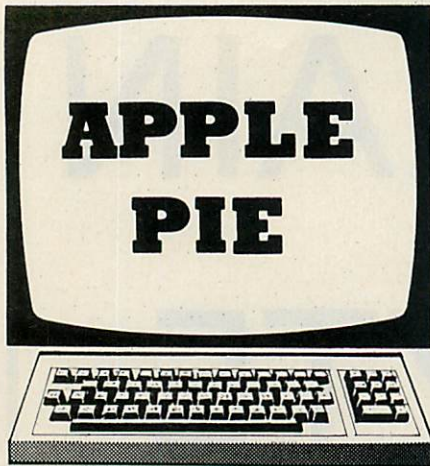

## Galaxy Invaders

GALAXY INVADERS was written by Kevin Irving of Carlisle on an Apple II with Apple DOS. It requires 32 to 48K of memory.

Galaxy Invaders is a fast, difficult game for Space Invader addicts. You control your laser right and left, zapping the Hell's Angels flying down at you. At the same time they are firing continuously in your direction. When you have killed off one fleet you are informed that your commander's ship is in trouble, so you must then save him by docking your ship

with his. By this time you are under attack again by some more Hell's Angels.

The program incorporates superb sound and graphics. Background stars give a three-dimensional effect to make the action more realistic. Multicoloured intergalactic explosions, plenty of sound, and fast graphics make a very interesting game.

You use two sets of keys: set 1 controls your movement and firing when the invaders attack; set 2 controls your moves when you are docking your ship.

### Set 1

1 moves you left  
3 moves you right  
0 fires a laser

### Set 2

W moves you up  
Z moves you down  
Right-arrow key moves you forwards

To set up the game you must first type in the Basic program and save it on disc. This program uses a shape table in order to keep up its high speed so you must now type this in. You should follow the following steps:

- Type in Call-151 to enter monitor.
- Type in the shape table by replacing the dash signs with colons. Use the same format of spacing as the listing does so as not to get confused.

- Type 3D0G.
- You are now back in Basic. You can save the shape table on disc using the following line:  
BSAVE GAL-TT, A\$4000, L\$1B0

Now you may run your program which you saved on disc, and play Galaxy Invaders. When typing in the Basic listing, shorten the Rem statements in lines 71, 137 and 157.

CH — Keyboard scan.

CV — Vertical position of the commander when you dock your ship.

DS — The number of points you must get to dock your ship; it starts at 40 and doubles each time you attempt to dock.

FI — A1 in this location indicates that you want to fire; otherwise FI will equal 0.

FQ and FR — The co-ordinates of your missile, FQ for horizontal, FR for vertical.

### Galaxy Invaders shape table.

Number	Description
1	Your ship
2	Hell's Angel Invader
3	Your fire
4	Invaders' fire
5	Explosion
6	Docking ship, your commander
7	
8	Docking ship, your ship
9	
10	Docking ship, your thrust

### Galaxy Invaders.

```

24 REM ** SET UP SOUND
25 DATA 173,48,192,136,208,5,206,1,3,240,9,202,208,245,174,0,3
  ,76,2,3,96,0,0
26 FOR I = 770 TO 792: READ J: POKE I,J: NEXT
27 REM ** SET SHAPE TABLE
28 POKE 232,00: POKE 233,64 ADDRESS
29 REM ** LOAD TABLE
30 PRINT : PRINT CHR$(4);"BLOAD GAL-TT,A$4000"
31 SCALE=1: ROT=0
32 REM ** SET UP VARIABLES
33 OP = 140:FR = -1:IN = -1:MI = -1:SC = 0:FI = 0:MD = 0:M
  J = 0:NJ = 0:DS = 40
34 REM ** INSTRUCTIONS
35 HOME
36 PRINT "*****";
37 PRINT "***** GALAXY INVADERS. *****";
38 PRINT "*****";
39 PRINT " THE GALAXY IS BEING INVADED BY BEINGS"
40 PRINT "FROM ANOTHER SOLAR SYSTEM . THEY HAVE"
41 PRINT "UNLIMITED HIGH POWER MISSILES WHICH "
42 PRINT "CAN DESTROY YOU INTO MILLIONS OF LITTLE"
43 PRINT "PIECES.": PRINT
44 PRINT "YOU ONLY HAVE ONE SHIP AND ONE LIFE"
45 PRINT "WHEN INVADERS ATTACK,PRESS"
46 PRINT " '0'-TO FIRE"
47 PRINT " '1'-TO MOVE LEFT"
48 PRINT " '3'-TO MOVE RIGHT": PRINT
49 PRINT " WHEN YOU DOCK YOUR SHIP,PRESS"
50 PRINT " W-TO MOVE UP": PRINT " Z-TO MOVE DOWN"
51 PRINT : PRINT " RIGHT ARROW TO MOVE FORWARDS"
52 INVERSE
53 VTAB 22: PRINT "PRESS THE SPACE BAR TO START THE ATTACK."
54 NORMAL
55 CH = PEEK (- 16384) - 128: IF CH < > 32 THEN 55
56 HOME : VTAB 20
57 VTAB 23: HTAB 1: PRINT "SCORE ";SC
58 REM ** SET UP SCREEN
59 HGR
60 FOR ST = 1 TO 150: HCOLOR= ( RND (9) * 7) + 1: HPLLOT RND (9)
  ) * 280, RND (9) * 160: NEXT
61 REM ** PLAY INTRODUCTION
62 POKE 768,50: POKE 769,100: CALL 770
63 POKE 769,100: POKE 768,80: CALL 770
64 PRINT CHR$(7);
65 FOR I = 1 TO 4
66 POKE 768,50: POKE 769,50: CALL 770
67 POKE 768,200: POKE 769,50: CALL 770
68 FOR P = 1 TO 50: NEXT : NEXT
69 POKE 768,100: POKE 769,100: CALL 770
70 XDRAW 1 AT 140,157
71 REM
72 REM ** TAKE INPUTS
73 CH = PEEK (- 16384) - 128
74 IF CH = 49 THEN MO = 1
75 IF CH = 51 THEN MO = - 1
76 IF CH = 48 THEN FI = 1: POKE - 16368,0
77 REM ** MOVE YOU
78 YP = OP - (MO * 8)
79 IF YP > 274 THEN YP = 274
80 IF YP < 6 THEN YP = 6
81 XDRAW 1 AT OP,157
82 XDRAW 1 AT YP,157:OP = YP
83 GOSUB 117
84 REM ** MOVE YOUR FIRE
85 IF FR < 0 AND FI = 1 THEN FI = 0: GOTO 88
86 IF FR = > 0 THEN 89
87 GOTO 95
88 FR = 155:FQ = YP: GOTO 92
89 FR = FR - 30
90 XDRAW 3 AT FQ,FS
91 IF FR < 0 THEN 95
92 XDRAW 3 AT FQ,FR
93 FS = FR
94 GOSUB 114
95 REM ** IS THERE AN INVADER
96 IF IN < 0 THEN IN = 5:JN = RND (9) * 279:FU = RND (9) * 11
  : XDRAW 2 AT JM,IM
97 REM ** MOVE INVADER
98 IN = IN + 5
99 ON FU GOSUB 147,148,149,150,151,152,153,154,155,156
100 XDRAW 2 AT JM,IM
101 IF IN > 155 THEN IN = - 1: GOTO 106
102 IF JN < 10 THEN JN = 270
103 IF JN > 270 THEN JN = 10
104 XDRAW 2 AT JN,IN
105 JM = JN:IM = IN
106 REM ** INVADERS FIRE
107 IF MI < 0 THEN MI = 1:MJ = JM:NJ = IM: XDRAW 4 AT MJ,NJ:MK =
  MJ:NK = NJ
108 NJ = NJ + 20:MJ = MJ + ( SGN (YP - JM) * 18)
109 XDRAW 4 AT MK,NK
110 IF MJ > 279 OR MJ < 0 OR NJ > 159 THEN MI = - 1: GOTO 73
111 XDRAW 4 AT MJ,NJ
112 MK = MJ:NK = NJ
113 GOTO 73
114 REM ** HAVE YOU GOT A HIT
115 IF JN + B > FQ AND JN - B < FQ AND IN + 16 > FR AND IN - 22
  < FR THEN 120
116 RETURN
117 REM ** HAVE THEY HIT YOU
118 IF MJ + 7 > YP AND MJ - 7 < YP AND NJ > 145 THEN 128
119 RETURN
120 REM ** YOU HIT AN INVADER
121 SC = SC + 10
122 XDRAW 2 AT JN,IN
123 FI = 0:IN = - 1
124 XDRAW 3 AT FQ,FR

```

\*\* INVADING ROUTINE \*\*

FS — Previous vertical position of your missile.  
 FU — A random number between 0 and 10 inclusive, which will select a course for the invaders, see lines 146 to 156.  
 JM and IM — Previous co-ordinates of invader; JM for horizontal, IM for vertical.  
 JN and IN — Co-ordinates of invader: JN for horizontal, IN for vertical.  
 MI — Equal to -1 if invaders are not firing.  
 MJ and NJ — Co-ordinates of invaders' missiles: MJ for horizontal, NJ for vertical.  
 MK and NK — Previous co-ordinates of invaders' missiles: MK for horizontal, NK for vertical.  
 MO — Your direction of movement: -1 indicates left, 1 indicates right.  
 OP — Your previous horizontal position.  
 SC — Your score.  
 YP — Your horizontal position.  
 YH — Docking ship, your horizontal position.  
 YV — Docking ship, your vertical position.  
 ZH — Docking ship, your previous horizontal position.  
 ZV — Docking ship, your previous vertical position.

The Rems in the listing explain what each part of the program does. The shape table is stored in high resolution page 2, and high resolution page 1 is used for playing the game. To make the game harder or easier you could change:

- the invader movement functions in lines 146 to 156;

- they multiply-by-eight in line 78 to another value, to change speed;
- line 98, which controls the rate at which the invaders come down;
- line 203, which controls your commander's speed when you are docking your ship.

## File parameter finder

HAVING RECENTLY obtained an Apple 2 Plus with a disc drive, DOS 3.3, Allan Ogg of Dumbarton noticed that you are left out in the cold if you want to disassemble a machine-code program or

inspect a shape table if these are stored on disc and have been saved by someone else, e.g., by a software house or as on the system master diskette.

You can BLoad to a specified address, but you still have no idea of the length of the file, and a disassembled listing at the wrong addresses is very messy. This information is stored on the disc, so this program, which occupies less than 1K, will retrieve it.

The program uses the RWTS sub-  
*(continued on next page)*

### Binary file BSave parameter finder.

```

5 TEXT : HOME : SPEED= 255: VTAB 7: PRINT "BINARY FILE 'BSAVE' PARAMETER
  FINDER.": PRINT
10 BS = 8192:BE = 8221:DB = 8222:T = 8205:S = 8206:P = 11:Q = 221:R = 35
20 FOR I = BS TO BE: READ X: POKE I,X: NEXT
30 INPUT "FILENAME (NONE CANCELS) ";F#: IF F# = "" THEN 220
40 GOSUB 1000
50 FOR I = P TO Q STEP R:FE = DB + I: IF PEEK (FE) = 255 THEN 100
60 IF PEEK (FE + 2) = 4 OR PEEK (FE + 2) = 132 THEN 70
65 GOTO 100
70 N = 3: FOR J = 1 TO LEN (F#)
80 IF CHR# (PEEK (FE + N) - 128) < > MID# (F#,J,1) THEN 100
90 N = N + 1: NEXT J: IF PEEK (FE + N) = 160 THEN 130
100 NEXT I
110 IF L1 = 0 AND L2 = 0 THEN PRINT "FILE NOT FOUND!": GOTO 220
120 POKE T,L1: POKE S,L2: GOTO 40
130 POKE T,PEEK (FE): POKE S,PEEK (FE + 1): GOSUB 1000
140 POKE T,PEEK (DB + 12): POKE S,PEEK (DB + 13): GOSUB 1000
150 AD = PEEK (DB) + L1 * 256:D = AD: GOSUB 2000:AA# = A#
160 LE = L2 + PEEK (DB + 3) * 256:D = LE: GOSUB 2000:L# = A#
170 PRINT : PRINT "PARAMETERS"
180 PRINT : PRINT "ADDRESS =" TAB (20):AD: TAB (30):AA#
190 PRINT "LENGTH =" TAB (20):LE: TAB (30):L#
200 DATA 169,32,160,9,32,217,3,96,0,1,96,1,0,17,15,26,32
210 DATA 30,32,0,0,1,96,0,96,1,0,1,239,216
220 END
1000 CALL BS:L1 = PEEK (DB + 1):L2 = PEEK (DB + 2): RETURN
2000 H# = "0123456789ABCDEF":A# = ""
2010 P = INT (D / 16):Q = D - 16 * P:A# = MID# (H#,Q + 1,1) + A#: IF P >
  0 THEN D = P: GOTO 2010
2020 RETURN
    
```

```

125 SCALE= 3: FOR R = 0 TO 127 STEP 8: POKE 768,250: POKE 769,3
  : CALL 770: ROT= R: XDRAW 5 AT FQ,FR: NEXT : SCALE= 1: VTAB
  23: HTAB 1: PRINT "SCORE ";SC: ROT= 0
126 IF SC = DS THEN DS = DS * 2: GOSUB 157
127 FR = - 1: RETURN
128 REM ** YOU ARE DESTROYED
129 FOR L1 = 1 TO 3
130 POKE 769,10: POKE 768,L1 * 80: CALL 770
131 FOR L2 = 7 TO 1 STEP - 1
132 SCALE= (L2 / 2) + 1: ROT= L1 * 10
133 HCOLOR= L2
134 DRAW 5 AT YP,155
135 POKE 768,L1 * 40: POKE 769,5: CALL 770
136 NEXT : NEXT
137 REM ** END
138 FOR P = 1 TO 50: NEXT P
139 TEXT : HOME : PRINT "YOU SCORED "SC
140 VTAB 10: PRINT "DO YOU WANT ANOTHER GAME <Y/N>?";
141 CLEAR :FR = FRE (0)
142 GET A#
143 IF A# = "Y" THEN 31
144 IF A# = "N" THEN HOME : END
145 GOTO 142
146 REM ** INVADERS MOVEMENT EQUATIONS
147 JN = JN + 3: RETURN
148 JN = JN - 4.5: RETURN
149 JN = JN - 3: RETURN
150 JN = JN + 6: RETURN
151 JN = JN - 6: RETURN
152 JN = JN + 4.5: RETURN
153 JN = JN - SIN (JN) * 20: RETURN
154 JN = JN + SIN (JN) * 20: RETURN
155 JN = JN + COS (JN) * 15: IN = IN - SIN (IN) * 20: RETURN
156 JN = JN - COS (JN) * 15: IN = IN - SIN (IN) * 20: RETURN
157 REM
  ** DOCK YOUR SHIP **
158 REM ** GIVE BRIEFING AND SET UP
159 HGR
160 PRINT : PRINT : PRINT : PRINT
161 IN = - 1:MI = - 1:YP = 140:OP = 140
162 YV = 80:YH = 30:ZH = 13
163 SPEED= 75
164 PRINT "YOUR COMMANDER IS PLEASED WITH YOU FOR FIGHTING WITH
  THE ALIENS.THE COMMANDERS SHIP WAS DAMAGED AND IS DRIFTIN
  G TO A DEAD ALIEN WHERE IT WILL BLOW UP.YOUR INSTRUCTIO
  NS ARE TO DOCK UP WITH THE COMMANDERS SHIP AND SAVE HIM"
165 PRINT "": PRINT "": PRINT : PRINT
166 SPEED= 255
167 REM ** SET UP SCREEN
168 ROT= 0: SCALE= 1
169 XDRAW 2 AT 243,150: XDRAW 2 AT 273,150
170 ROT= 32: XDRAW 2 AT 258,147
171 CV = 40
172 ROT= 0
173 HCOLOR= 7
    
```

```

174 DRAW 7 AT 250,CV
175 HCOLOR= 5
176 DRAW 6 AT 250,CV
177 POKE 768,100: POKE 769,100: CALL 770: POKE 769,10: CALL 770
178 REM ** TAKE INPUTS
179 FOR L1 = 1 TO 4
180 CH = PEEK ( - 16384) - 128
181 IF CH = 21 THEN YH = YH + 3
182 IF CH = 87 THEN YV = YV - 2
183 IF CH = 90 THEN YV = YV + 2
184 REM ** MOVE YOU
185 IF YV > 140 THEN YV = 140
186 IF YV < 10 THEN YV = 10
187 HCOLOR= 0: DRAW 8 AT ZH,ZV: DRAW 9 AT ZH,ZV
188 DRAW 10 AT ZH - 12,ZV
189 HCOLOR= 7: DRAW 8 AT YH,YV
190 HCOLOR= 6: DRAW 9 AT YH,YV
191 IF L1 / 2 = INT (L1 / 2) THEN HCOLOR= 5: DRAW 10 AT YH -
  12,YV
192 ZH = YH:ZV = YV
193 IF L1 < 4 THEN FOR P = 1 TO 15:SO = PEEK ( - 16336): NEXT
194 REM ** CHECK FOR DOCK
195 IF YH > 247 AND YV > CV - 4 AND YV < CV + 3 THEN PRINT "WE
  LL DONE YOU HAVE SAVED HIM.YOU GET AN EXTRA 30 PTS.": FOR
  P = 1 TO 200: POKE 769,9: POKE 768, ABS (100 - P): CALL 770
  : NEXT P:SC = SC + 30: GOTO 211
196 REM ** CHECK FOR CRASH INTO COMMANDER
197 IF YH > 247 AND YV > CV - 14 AND YV < CV + 15 THEN PRINT "
  YOU CRASHED INTO YOUR COMMANDER": FOR P = 1 TO 2: FOR L = 1
  TO 200: ROT= L: SCALE= P: XDRAW 5 AT 250,CV: POKE 769,3: POKE
  768, ABS (100 - L): CALL 770: NEXT : NEXT : GOTO 138
198 REM ** CHECK FOR MISSED COMMANDER
199 IF YH > 247 THEN PRINT "YOU HAVE MISSED YOUR COMMANDERS SH
  IP SO YOU DON'T GET ANY EXTRA POINTS.": PRINT CHR# (7): FOR
  P = 1 TO 300:SO = PEEK ( - 16336): NEXT P: PRINT CHR# (7)
  : GOTO 211
200 NEXT
201 REM ** MOVE COMMANDER
202 HCOLOR= 0: DRAW 7 AT 250,CV: DRAW 6 AT 250,CV
203 CV = CV + 2
204 HCOLOR= 7: DRAW 7 AT 250,CV
205 HCOLOR= 5: DRAW 6 AT 250,CV
206 REM ** HAS COMMANDER CRASHED
207 IF CV > 130 THEN PRINT : PRINT : PRINT "YOU FAILED AND YOU
  R COMMANDER CRASHED": PRINT : FOR O = 1 TO 3: FOR P = 1 TO
  64 STEP 8: ROT= P: SCALE= (P / 16) + 1: POKE 768,(P * 4) -
  1: POKE 769,5: CALL 770: XDRAW 5 AT 250,CV: NEXT : NEXT
208 IF CV > 130 THEN 211
209 GOTO 179
210 REM ** SET UP FOR INVADER ROUTINE & LEAVE
  DOCK SHIP
211 HGR : FOR I = 1 TO 150: HCOLOR= (RND (9) * 7) + 1: HPL0T RND
  (9) * 280, RND (9) * 160: NEXT : PRINT : PRINT : PRINT : PRINT
  : XDRAW 1 AT YP,157
212 SPEED= 75
    
```

### Parameter finder subroutines.

#### RWTS call subroutine.

JCALL-151

\*2000L

```
2000- A9 20 LDA #20
2002- A0 09 LDY #09
2004- 20 D9 03 JSR #03D9
2007- 60 RTS
```

#### DOS IOB and device characteristic table.

```
2008- 00 BRK
2009- 01 60 ORA (#60,X)
200B- 01 00 ORA (#00,X)
200D- 11 0F ORA (#0F),Y
200F- 1A ???
2010- 20 1E 20 JSR #201E
2013- 00 BRK
2014- 00 BRK
2015- 01 60 ORA (#60,X)
2017- 00 BRK
2018- 60 RTS
2019- 01 00 ORA (#00,X)
201B- 01 EF ORA (#EF,X)
201D- D8 CLD
201E- C0 DD CPY #DD
2020- 8C C0 6B STY #68C0
```

#### Program data.

\*2000

```
2000- A9
*
 20 A0 09 20 D9 03 60
*
2008- 00 01 60 01 00 11 0F 1A
*
2010- 20 1E 20 00 00 01 60 00
*
2018- 60 01 00 01 EF D8 C0 DD
*FF
```

(continued from previous page)

routine. It should be convertible to DOS 3.2 with only a few changes to the file-search routine, as the IOB and device-characteristic table are the same format. The RWTS call locations should be easily relocated if necessary — they were placed in high-resolution screen one for simplicity.

The program first sets the RWTS subroutine to read in the first directory sector — track 17, sector 15. It then asks for a file name and enters a loop to search the seven file entries held on each direc-

#### Parameter finder sample run.

```
FILENAME (NONE CANCELS) BOOT13
PARAMETERS DEC. HEX.
ADDRESS = 5888 1700
LENGTH = 2288 8F0
FILENAME (NONE CANCELS) COPY.0BJ0
PARAMETERS DEC. HEX.
ADDRESS = 704 2D0
LENGTH = 267 10B
FILENAME (NONE CANCELS) FID
PARAMETERS DEC. HEX.
ADDRESS = 2051 803
LENGTH = 4686 124E
FILENAME (NONE CANCELS) FPBASIC
PARAMETERS DEC. HEX.
ADDRESS = 53248 D000
LENGTH = 12288 3000
FILENAME (NONE CANCELS) INTBASIC
PARAMETERS DEC. HEX.
ADDRESS = 4096 1000
LENGTH = 12288 3000
FILENAME (NONE CANCELS) MASTER CREATE
PARAMETERS DEC. HEX.
ADDRESS = 2048 800
LENGTH = 1791 6FF
FILENAME (NONE CANCELS) MUFFIN
PARAMETERS DEC. HEX.
ADDRESS = 2051 803
LENGTH = 6397 18FD
FILENAME (NONE CANCELS)
```

tory sector. The files are rejected if the entry is a deleted file, not binary then finally if the file-name does not match.

If the file is not found, the program reads in the next, if any, directory sector and searches again. It continues until the file is found or the directory ends. Once found, the program reads in the file's Track/Sector List from the disc, and from that it reads in the first file sector which contains the necessary information. The parameters are then printed out in decimal and hexadecimal for convenience. The copy of the program gives the parameters of binary files supplied on the system master diskette.

### Source list

I BECAME AWARE of the need for this program while enhancing Apple Spiel and converting it to machine code, writes Neil Lomas of Crewe, Cheshire. The assembly-code routines are now approaching 2,000 lines and take nearly an hour to compile if producing a hard-copy listing.

When creating or amending hundreds of lines of assembly code, there is bound to come a time — however good the editor — when a hard copy of some or all of the code would be helpful. The Editor/Assembler on the DOS Toolkit will only output to the printer during the

assembly phase, which causes many errors to be printed where references are made to labels which have not yet been input.

Source List will produce a formatted listing of any part of a source text file. The formatting is semi-intelligent in that the first three spaces on any line are treated as tabs, without regard to context. This produces a listing which closely resembles the screen listing output by the editor. Six blank lines are thrown after every 60 source lines. Where only part of the source is being printed, the decision to throw blank lines depends on the line numbers, not on the number of lines.

When run, the program asks for the name of the source file and the disc drive number — the slot number is assumed to be the current one — together with the first and last line numbers to be printed. To print to the end of the file, any suitably high end line number may be given.

Although intended for use with the DOS Toolkit Assembler, it should work equally well with any assembler which stores source as serial text files. If your printer does not support line feed, you will need to change line 120. All line numbers ending in 9 may be omitted. There are no Goto's referring to Rem lines.

#### Source list.

```
10 REM ASSEMBLER SOURCE LISTER - N. LOMAS DEC 1981
20 GOTO 250
99 REM FINISH IF PAST END POINT
100 IF YZ > BZ THEN 500
109 REM DON'T PRINT IF START NOT REACHED
110 IF YZ < = AZ THEN 130
119 REM PRINT LF'S IF PAGE THROW DUE
120 IF 60 * INT ((YZ - 1) / 60) = YZ - 1 THEN PRINT L$;L$
;L$;L$;L$;L$
130 PRINT D$;"READ ";F$
139 REM READ NEXT CHAR FROM FILE
140 GET Z$; PRINT D$
149 REM END OF LINE IF 'RETURN'
150 IF Z$ < > CHR$(13) THEN 175
159 REM PRINT LINE IF START REACHED
160 IF YZ > = AZ THEN PRINT Y$
169 REM UPDATE LINE NO AND START NEXT LINE
170 YZ = YZ + 1;Y$ = RIGHT$( " " + STR$(YZ),4):Y$ = Y$ +
" ";Z$ = FRE(0); GOTO 100
175 IF YZ < AZ THEN 130
179 REM APPEND CHARACTER TO LINE IF NOT SPACE
180 IF Z$ < > " " THEN Y$ = Y$ + Z$; GOTO 130
189 REM ADD SPACES TO REACH NEXT TAB
190 IF LEN(Y$) < 13 THEN Y$ = LEFT$(Y$ + " ",13)
; GOTO 130
200 IF LEN(Y$) < 18 THEN Y$ = LEFT$(Y$ + " ",18); GOTO
130
210 IF LEN(Y$) < 28 THEN Y$ = LEFT$(Y$ + " ",28); GOTO 130
219 REM IF LAST TAB PASSED, ADD SPACE
220 Y$ = Y$ + Z$; GOTO 130
250 TEXT : HOME
260 INVERSE : PRINT SPC(40)
270 FOR I = 2 TO 22: VTAB I: HTAB 1: PRINT " ";: HTAB 40: PRINT
" ";: NEXT
280 VTAB 23: HTAB 1: PRINT SPC(40): VTAB 5: HTAB 2: PRINT
SPC(38);: NORMAL : POKE 33,30: POKE 32,9
290 VTAB 3: HTAB 5: PRINT "SOURCE LISTER": VTAB 12
300 INPUT "FILENAME: ";F$
310 INPUT "DRIVE NO: ";D$
320 INPUT "START LINE NO: ";AZ
330 INPUT "END LINE NO: ";BZ
340 D$ = CHR$(4):I$ = CHR$(9):L$ = CHR$(10): POKE 32,0
: POKE 33,40
350 PRINT D$;"OPEN ";F$;"D";D$
360 YZ = 1;Y$ = " 1 "
370 ONERR GOTO 500
380 PRINT D$;"PR#1"
390 PRINT I$;"K";I$;"80N";: PRINT
400 GOTO 100
500 PRINT
510 PRINT D$;"PR#0"
520 PRINT D$;"CLOSE"
```



### Sharp printer interface

THIS SHORT ROUTINE for the Sharp MZ-80K by Simon Brown of Tunbridge Wells, Kent, enables you to output codes to a printer which are otherwise unprintable. For example, the code for Escape is 27 decimal but CHR\$(27) in Basic is converted to a null by the interpreter. Any printer control codes using unprintable numbers are not readily available to the Basic programmer.

This machine-code subroutine uses subroutines in Sharp Basic SP-5025 to output one or more code numbers to the printer. For example,

```
USR (PR), 27, 65, 1
```

would send ESC A <1> to the printer, which is the Epson MX-80 instruction to set the line spacing to 1/72in. The routine should interest Sharp users because it illustrates the use of several of the Basic subroutines.

### Upgrading to Z-80B

RECENT COVERAGE given to the Z-80B processor chip has led to a number of people inquiring about the possibility of replacing standard Z-80 or Z-80A central processor units in their microcomputers with the faster Z-80B, writes John Parker. The substitution is possible, but before it is carried out the following points should be noted. Whatever make or type of microcomputer is involved, the basic configuration will be the same, and the same considerations will apply.

The Z-80B CPU is functionally identical to all other versions of the Z-80. The A and B variants are simply graded examples of the basic chip. Minor variations in the production process mean that some chips are capable of working up to a higher clock frequency than others; a chip is tested to 10MHz before it is given a B designation, though Zilog will not guarantee performance above 6MHz.

The old Z-80 CPU can be unplugged and replaced by a Z-80B, and the system will continue to work perfectly well. The problems only start when the clock frequency is increased.

A complete microcomputer consists not just of a CPU but must also include ROM, RAM, I/O, etc., to enable it to

### Printer interface.

```
12 REM USR(PR),exp1,exp2,...,expN is equivalent to
13 REM PRINT/P CHR$(exp1);CHR$(exp2);...;CHR$(expN);
14 REM For example,USR(PR),27,65,1 outputs ESC A <1> which sets the
15 REM line spacing for EPSON MX80 printers to 1/72".
16 REM However the advantage of the routine is that it allows you to output
17 REM codes to the printer which would normally be converted to nulls by the
18 REM BASIC interpreter.
19 REM Thus it is now possible to use the full set of printer control codes
20 REM conveniently.
21 REM NOTE-This routine uses subroutines within Sharp BASIC SP-5025.
22 REM
23 REM The following code sets up the routine and is executed by GOSUB 1000.
999 REM***** set up printer interface routine *****
1000 PR=50000:LIMIT PR
1010 FOR I=0 TO 22
1020 READ E:POKE PR+I,E
1030 NEXT
1040 E=PR+19
1050 POKE PR+15,E-256*INT(E/256)
1060 POKE PR+16,INT(E/256)
1070 RETURN
1100 DATA 205,151,22,44,205,169,25,123,205,119,60
1110 DATA 205,139,22,44,0,0,24,241,34,1,72,201
1999 REM***** Z80 source code *****
2000 REM SEND CALL 1697H ;skip first comma
2010 REM DEFB "," ;
2020 REM SEND1 CALL 19A9H ;evaluate expression into DE
2030 REM LD A,E
2040 REM CALL 3C77H ;send code to printer
2050 REM CALL 168BH ;look for comma
2060 REM DEFB "," ;if not present
2070 REM DEFW EXIT ;jump to EXIT
2080 REM JR SEND1 ;else loop back to SEND1
2090 REM EXIT LD (4801H),HL ;move text pointer past USR statement
2100 REM RET ;return to BASIC
```

store programs and data and to communicate with external devices. These peripheral devices form part of the microcomputer and must be capable of operating at the same speed as the CPU. The Z-80 has an associated family of peripheral devices — PIO, CTC, SIO, DART, etc. — which are all graded in the same way as the CPU. If a Z-80B is substituted for a basic Z-80, the clock frequency cannot be increased without upgrading the system's peripheral devices at the same time.

During an op-code fetch cycle, the first T state is used for loading program-counter address information to memory. During the memory's access time, the second T state increments the program counter. The third T state is used for loading memory output data into the instruction register or accumulator. If the memory's access time exceeds the length of the second T state, there will be no data on the memory's output bus when the processor requires it.

The length of one T state represents the microprocessor's clock period — which is 500ns. at 2MHz. At this speed, low-cost 450ns. access time memories can be used. At 6MHz, the clock period is 167ns., which is considerably less than the original memory's access time. To enable the system to work at the higher speed, it will be necessary to use memories with a shorter access time, or at least to check that the original memories have this capability.

The printed-circuit board and layout for your microcomputer will have been designed for the maximum clock frequency of the original CPU. At 6MHz,

impedances created by capacitance effects will be correspondingly less, which could be a problem if, for example, unbuffered lines are used on data/address buses and clock outputs.

Remember that changing the clock crystal may not necessarily change the clock frequency as required, which will depend on the clock chip or oscillator employed. In some cases, changing the crystal will suffice, but in others, certain other components will have to be changed to accommodate the new resonant frequency.

### Nascom backgammon

IT ALWAYS SEEMS that the interesting programs are written for other people's machines writes Y. T. Ho from Kuala Lumpur, Malaysia. To modify the Backgammon program — *Practical Computing May 1981* — by Bob Snell and Barbara Colley for the Nascom 2 here are some suggestions:

- The Get command is given in the Nascom manual.
- The cursor commands for the Pet may be replaced by ASCII CHR\$(18) to CHR\$(20).
- As the number of lines on the Nascom is limited follow the printer display shown.
- To generate a truly random drive routine replace the original program lines with:
 

```
9 GOSUB 91:GOSUB 96:
I=RND(-G1*10):O=-1
251 G=USR(O):G1=RND(1):
IF G=0THEN 251
252 A$=CHR$(G):RETURN
```

This samples the pseudo-random sequence RND(1) at varying intervals, depending on the time taken by the player for his responses. □



### Atom EPROM programmer

THE ACORN ATOM has a vacant expansion socket inside for a utility ROM which will accommodate up to a 4K by eight-bit device, writes John Flower of Cowplain, Hampshire. The EPROM which can be fitted is the 2532, which is made by Texas Instruments and a number of Japanese suppliers. This device is a 32K chip organised as 4,000 words of eight bits. The chip is readily available for about £6.

You can program your favourite game or a useful machine-code routine on to this device so that it can become a permanent part of your computer's operating system. You could even write your own toolkit program. The 2532 EPROM is remarkably easy to program with the Atom since most of the necessary circuitry for an EPROM programmer is

already inside the Atom's VIA chip. If you decide to have a go at building this design then you will have to buy and fit the optional 6522 versatile interface adaptor chip to your machine.

For a programmer interface you only need to provide an address latch externally to address each location in turn while the data is presented and the programming operation takes place. The circuitry consists of two LS374 eight-bit latches to hold the address word plus a zero-insertion-force socket to carry the EPROM without risk of bending the pins.

Pin 21 of the 2532 EPROM is connected to +5 volts when reading data. Data is read by pulsing pin 20 low while looking at the data pins. The device works in reverse if pin 21, which is normally held to 5 volts, is taken to 25 volts. In this case data present at the data pins is programmed into the eight locations whose address is present at the address pins. This happens if pin 20 is pulsed low for exactly 50ms.

The program performs the necessary operations to copy, program and verify EPROMs. Programs to be copied from an EPROM or to be programmed into one are stored in the graphics memory from location # 8400 onwards. The program is menu driven and prompts to see what operations you wish to perform.

The VIA chip writes the relevant address on to ports A and B and clocks the address latch to store the 12-bit address. Then the eight-bit data is either presented to or read from port B.

Construction of the circuit should present little difficulty. Only two integrated circuits are involved, plus four resistors, two diodes, an npn transistor and one capacitor. You will need to fit an Acorn bus connector to your computer and buy the appropriate 64-way Eurocard DIN connector mating socket.

The circuit diagram shows the bus connections that are used, viewed from the rear of the programmer card. The 64-way right-angle plug is fitted to the Atom, and the socket is fitted to a piece of Veroboard upon which the programmer is to be constructed.

The light-emitting diode serves to show that Read or Write operations are taking place. The other diode — 1N-914, or similar — ensures that +5V is connected to pin 21 of the EPROM when normal reading of the device occurs. When +25V is applied to the device for programming purposes, the diode becomes reverse-biased so that the 5V power supply is not affected. It is very important to connect this diode the right way round to avoid serious damage to the computer's power supply. The anode of the diode must be connected to the Atom's +5V supply. The cathode is usually marked by a thick painted ring on the diode body and should be connected to pin 21 and the programming switch.

After constructing the circuit you do not need the programmer card to prove that the program is working: with the card unplugged the program will copy

*(continued on page 156)*

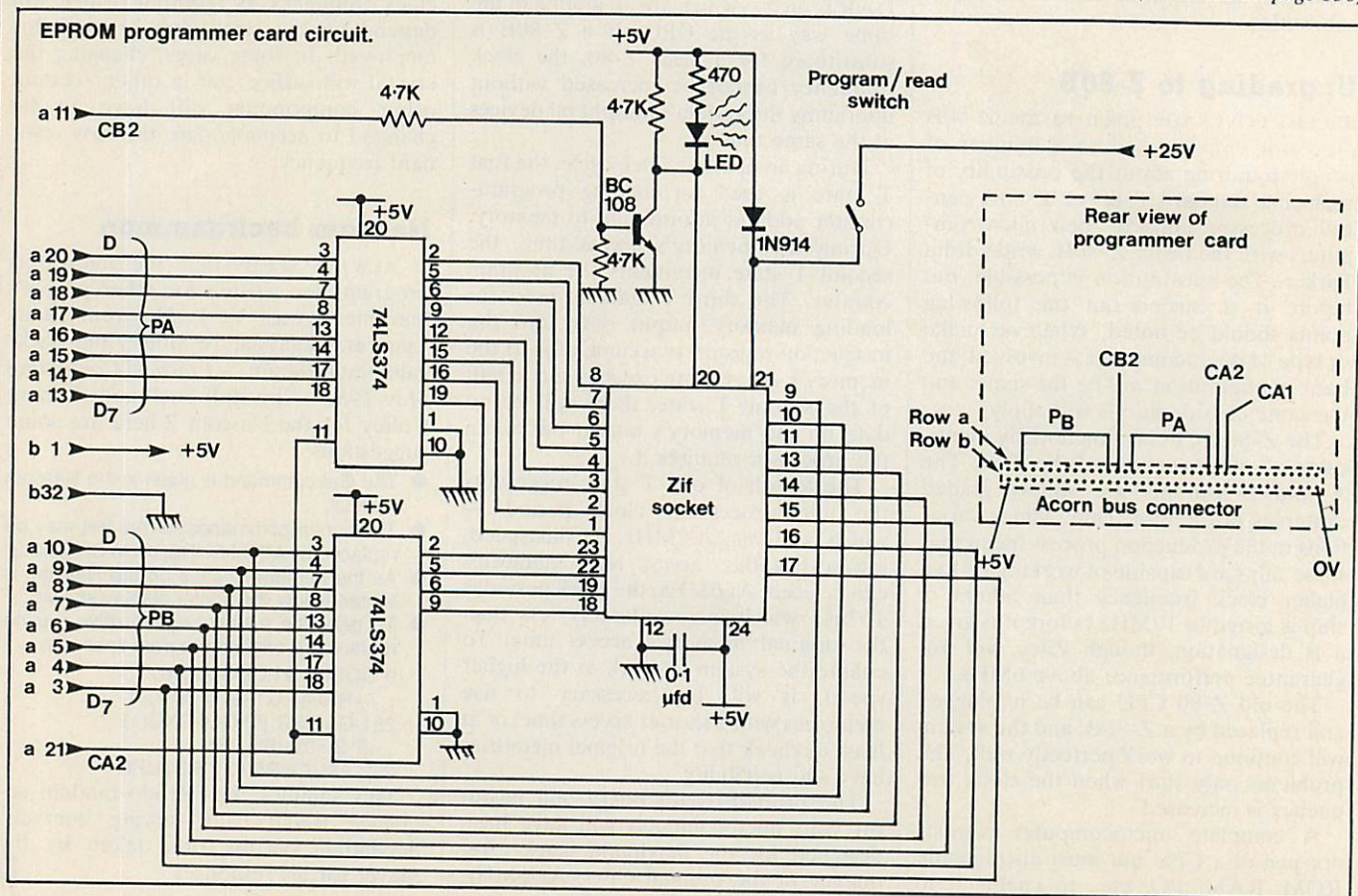

# PERt

PERt Program for PET's & some CP/M machines. 1200 activities under 400 cost codes. Keyboard entered networks give a critical path. Fixed & free float and earliest/latest, start/finish times. Reports can be screened or printed. Activity costing & targeting included. Now with hierarchical cost codes. £205.

# DAI

48k Personal Computer with real world expansion. 16 colour graphics with stereo sound. Socket for printer on RS232 port. A thriving user group is providing software. Paddles and graphics tablet available. £595 inc 14 programs.

# S100

We can supply a host of S100 cards (including RTC's, A/D, battery memories & graphics application) 16 bit cards include 9900 CPU & 256k DRAM. Both UK made. Floppy discs, drives & connectors.

**CODIFIED  
COMPUTER  
SYSTEMS**

'WHITE PLANES'  
255 Archway Road  
Highgate  
London. N6 5BS  
01-340 4582

# DAISY WHEEL REPAIRS

We will repair and/or overhaul your QUME, DIABLO, NEC, TEC or RICOH for £80. If the problem is serious causing us to charge more we will ring you first. If you do not like the estimate there will be £35 handling charge. VAT and carriage extra.

● Circle No. 186

## PROTECT YOUR SOFTWARE INVESTMENT

# APPLE® COPY II PLUS

— the newest and fastest bit-copier  
version 3.0

Apple Copy II Plus gives you the power to make back-up copies of nearly all the "protected" software packages currently available. Several thousand Apple users have already recouped their investment many times over with Copy II Plus.

### RELAX

With the Apple Copy II Plus in your top drawer you can stop worrying about accidental damage to your valuable diskettes. The Copy II Plus allows you to make back-up copies for normal use, so you can keep your originals safely locked away — away from the dangers of spills or stray magnetic fields, or just the wear and tear of everyday usage.

### EXTREMELY VERSATILE

Version 3.0 of Copy II Plus is an advanced bit-copier which can defeat nearly every protection system now in use. It will copy most DOS 3.2 and 3.3 diskettes including: Visicalc 3.3, Desk Top Plan, Magic Window, DB Master (2.4) Dataplan, the Apple Special Delivery Software range and many, many more.

### UNIQUE

- Copy II Plus is the *only* bit-copier that allows you to make back-up copies of itself — for complete peace of mind.
- Copy II Plus is the fastest bit-copier by far. It copies 5 tracks at a time and makes a complete disk copy in only 35 seconds, while ordinary bit copiers take 5–7 minutes!

### FEATURES

- easy to use menu
- comprehensive instructions
- copy with 1 or 2 drives
- track-by-track copy program report
- copies half-track and irregular track spacing
- variable search parameters — for non-standard sync or header nibbles
- "display" option shows data being copied
- "examine buffer" option helps identification of protection system used

### HOW TO GET YOUR COPY II PLUS

Copy II Plus needs 48K DOS 3.3, and at least one disk drive.

Send £45.00 + VAT to:-  
Apple Orchard Ltd  
1 New Cavendish St.,  
London W1  
or Phone 01 580 5816 and quote your Access or Diners Club card

Please allow 7–14 days for delivery — or tell us to rush if that's too long.



Apple is a registered trademark of Apple Computer, Inc.  
Desk Top Plan and Visicalc are registered trademarks of Personal Software Systems.  
Dataplan is a registered trademark of Longsoft Ltd.  
Magic Window is a registered trademark of Bellco Ltd.  
DB Master is a registered trademark of Software Marketing.  
Copyright Apple Orchard Ltd 1982

● Circle No. 187

# TRADE AND EXPORT

Definitely the very best deal for

O.E.M., DISTRIBUTORS AND DEALERS

throughout Europe

THE SINGLE SOURCE FOR MICROCOMPUTER EQUIPMENT,  
PERIPHERALS, SUPPLIES AND SOFTWARE

EPSON - ANADIX - TEXAS INSTRUMENTS - QUME - DIABLO - NEC -  
RICOH - OKI - CENTRONICS - TEC - OLYMPIA - ADLER - APPLE -  
COMMODORE - HITACHI - SHUGART - CONTROL DATA - BASF -  
FACIT - FUJITSU - PRINTRONIX - DATA PRODUCTS - OLIVETTI - ETC. ETC.

Obtain substantial savings by combining your purchases with  
hundreds of other trade buyers throughout Europe

- No commitment to purchase minimum quantity
- Parts and labour warranty
- Fast delivery

Telephone or write for details of

**INFORMEX CONSORTIUM PURCHASE SCHEME**

**INFORMEX-LONDON LTD**

8-12 Lee High Road, London SE13 5LQ

Tel: 01-318 4213 (10 lines) Telex: 892622

**INFORMEX**



AGENTS REQUIRED WORLDWIDE

● Circle No. 188

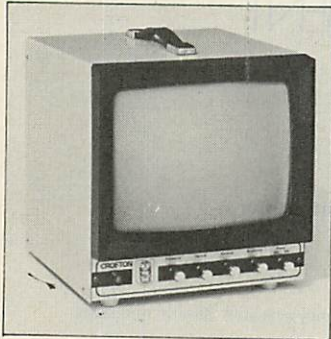

9" PM101

Become part of  
our Dealer  
Network.

Buy from us!  
We'll sell for you.

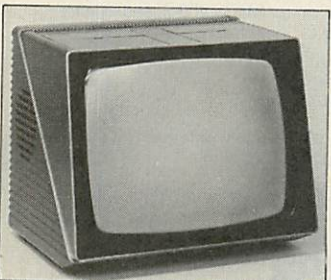

12" PRINCE in Apple colours.

Our Monitors  
probably offer the  
best cost/  
performance ratio  
available.

Send or phone  
for data.

## CROFTON ELECTRONICS LIMITED

35 GROSVENOR ROAD, TWICKENHAM,  
MIDDLESEX TW1 4AD

Telephone 01-891 1923/01-891 1513

Telex 295093 CROFTN G

● Circle No. 189

## PHOTO ACOUSTICS LTD

THE ONE STOP COMPUTER SHOP—

VIC 20 computer	£189.95	CBM 8032	£875.00
Expansion box	£97.95	CBM 8050	£875.00
3K RAM packs	£29.95	CBM 8026	£1,006.00
8K RAM pack	£44.95	CBM 4032	£690.00
16K RAM pack	£74.95	CBM 4040	£690.00
Joysticks	£10.00	CBM 4022	£399.00
C2N cassette deck	£44.95		

*These prices are Cash and Carry. Ring Dick at Watford for quote.*

★★ Software Available ★★

Apple II computer	£784.00	Genie I computer	(Ring for quote)
Disc drive + cont.	£384.00	EG3014 Expansion	£228.00
Disc drive without	£301.00	EG3013 Expansion	£234.00
Eurocolor card	£70.00	EG3013/WExpansion	£264.00
9" Hi-res B/W monitor	£99.00	EG400 disk drive	£243.00
9" Hi-res green monitor	£110.00	12" B/W monitor	£79.00
12" B/W monitor	£79.00	12" green monitor	£87.00
12" green monitor	£87.00		

★★ Games software avail. ★★

★★ Software avail. ★★

58, High Street  
Newport Pagnell  
Bucks.

Tel: 0908 610625



255a St. Albans Road,  
Watford, Herts.

(entrance in Judge Street)

Tel: 0923 32006



ALL PRICES INCLUDE VAT  
CREDIT CHARGE MAIL ORDER

● Circle No. 190

# Better buy Cumana strictly dependable top Quality Products like TEAC... like no one else for price!

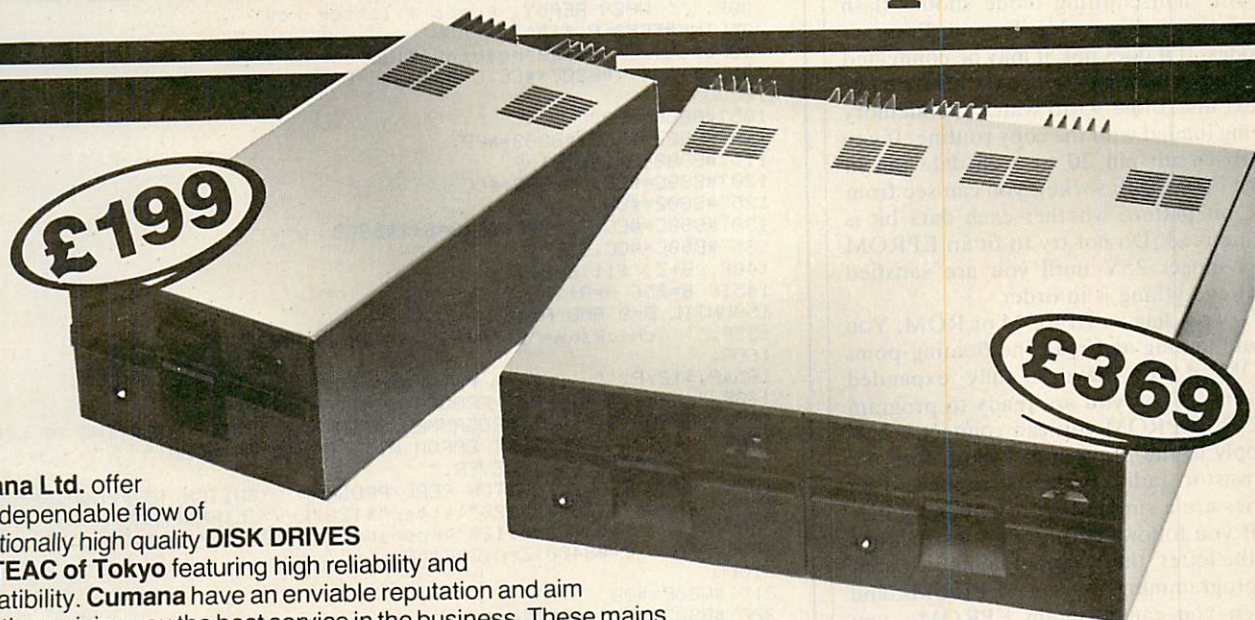

Cumana Ltd. offer you a dependable flow of exceptionally high quality **DISK DRIVES** from **TEAC of Tokyo** featuring high reliability and compatibility. Cumana have an enviable reputation and aim to continue giving you the best service in the business. These mains powered Disk Drive units are designed to interface to a wide range of computers such as **TRS 80 models I and III, Genie I and II, SWTP, Heathkit, Superbrain, Nascom** and the **BBC Micro, Model B**.

## Floppy Disk Drives 40 and 80 Track Cased Units

### Single Disk Units

1x40 Track single sided Drive	<b>£199</b>
1x80 Track single sided Drive	<b>£265</b>
1x80 Track double sided Drive	<b>£429</b>

### Dual Disk Units

2x40 Track single sided Drives	<b>£369</b>
2x80 Track single sided Drives	<b>£495</b>
2x80 Track double sided Drives	<b>£799</b>

### Disk Drive Cables

2 Drive Cable	<b>£15.00</b>
4 Drive Cable	<b>£25.00</b>

Please add VAT to all prices. Delivery at cost will be advised at time of order.

## CUMANA LTD

35 Walnut Tree Close, Guildford, Surrey GU1 4UN. Telephone: (0483) 503121. Telex: 858306.

Call your nearest dealer for a demonstration: Write or 'phone for Data Sheets - Dealer and O.E.M. enquiries welcome.

**RADIO SHACK LTD.**,  
London NW6. Tel: 01-624-7174

**COMP SHOP LTD.**,  
New Barnet, Herts.  
Tel: 01-441-2922

**COMP SHOP LTD.**,  
London W2. Tel: 01-262-0387

**COMP SHOP LTD.**,  
Dublin 2. Tel: 604165

**LONDON COMPUTER CENTRE**,  
London W1. Tel: 01-388-5721

**N.I.C.**,  
London N15. Tel: 01-808-0377

**CROYDON COMPUTER CENTRE**,  
Thornton Heath, Surrey.  
Tel: 01-689-1280

**P J EQUIPMENT LTD.**,  
Guildford. Tel: 0483-504801

**R.D.S. ELECTRICAL LTD.**,  
Portsmouth. Tel: 0705-812478

**TANDY HASTINGS LTD.**,  
Hastings. Tel: 0424-431849

**MICROWARE COMPUTING SERVICES**,  
Bristol. Tel: 0272-279560

**BLANDFORD COMPUTERS**,  
Blandford Forum.  
Tel: 0258-53737

**TAPE SHOP**,  
Brighton. Tel: 0273-609099

**PARWEST LTD.**,  
Chippenham. Tel: 0249-2131

**COMPUTER SHACK**,  
Cheltenham. Tel: 0242-584343

**TANDY GLOUCESTER**,  
Gloucester. Tel: 0452-31323

**COMSERVE**,  
Bedford. Tel: 0234-216749

**CLEARTONE COMPUTERS**,  
Abercarn, Gwent.  
Tel: 0495-244555

**EMPRISE LTD.**,  
Colchester. Tel: 0206-865926

**MAGNUS MICRO-COMPUTERS**,  
Kidlington, Oxford.  
Tel: 08675-6703

**CAMBRIDGE COMPUTER STORE**,  
Cambridge. Tel: 0223-65334

**I.C. ELECTRONICS**,  
Biddenden, Kent.  
Tel: 0580-291816

**MICRO CHIP SHOP**,  
Fleetwood, Lancs.  
Tel: 03917-79511

**HARDEN MICRO-SYSTEMS**,  
Blackpool. Tel: 0253-27590

**AMBASSADOR BUSINESS COMPUTERS LTD.**,  
ShIPLEY, W. Yorks.  
Tel: 0274-595941

**Q-TEK SYSTEMS LTD.**,  
Stevenage, Herts.  
Tel: 0438-65385

**COMPUTER & CHIPS**,  
St. Andrews, Fife, Scotland.  
Tel: 0334-72569

**HEWART MICRO-ELECTRONICS**,  
Macclesfield. Tel: 0625-22030

**KARADAWN LTD.**,  
Great Sankey, Warrington.  
Tel: 0925-572668

**PHOTO-ELECTRICS**,  
Sheffield. Tel: 0742 53865

**ARC ELECTRONICS**,  
Nr. Wakefield, W. Yorks  
WF2 6SL. Tel: 0924-253145

**VICTOR MORRIS LTD.**,  
Glasgow, G2 8LY  
Tel: 041-221 8958

**COMPRITE LTD.**,  
Laisterdyke, Bradford.  
Tel: 0274-663471

**GNOMIC LTD.**,  
Blackhall, Hartlepool.  
Tel: 0783-863871

**BRIERS COMPUTER SERVICES**,  
Middlesbrough, Cleveland. Tel: 0642-242017

**3 LINE COMPUTING**,  
Hull. Tel: 0482-445496

**H.C. COMPUTER SALES LTD.**,  
Gateshead. Tel: 0632-874811

**EWL COMPUTERS LTD.**,  
Glasgow. Tel: 041-332-7642

**EVERYMAN COMPUTING**,  
Westbury, Wilts.  
Tel: 0373-864644



```

10 DIM R(10)
20 LET A=0
30 LET S=0
40 FOR B=1 TO 10
50 FOR E=1 TO 2
60 PRINT "FRAME "B;" " "B...";" "BLL "CHR$(E+156)
70 PRINT "..."
80 LET Z=0
90 FOR C=1 TO 10
100 IF E=2 THEN GOTO 120
110 LET R(C)=52
120 IF E=2 THEN LET S=S+2
130 IF Z>9 THEN LET Z=15
140 IF E=1 AND Z=10 THEN GOTO 350
150 PRINT AT 15,0;"SCORE THIS FRAME IS "Z
160 PRINT " "CHR$(R(1))
170 PRINT " "CHR$(R(2))
180 PRINT " "CHR$(R(3))
190 PRINT " "CHR$(R(4))
200 PRINT " "CHR$(R(5))
210 PRINT " "CHR$(R(6))
220 PRINT " "CHR$(R(7))
230 PRINT " "CHR$(R(8))
240 PRINT " "CHR$(R(9))
250 PRINT " "CHR$(R(10))
260 NEXT C
270 IF R(C)=23 THEN LET Z=Z+1
280 IF R(C)=52 AND INT(RND*2)+1=1 THEN LET R(C)=23
290 GOTO 220

```

**10-pin bowling**

This program by G. L. Stoneman of Wigan, Lancashire is a novel computer simulation of the popular bowling-alley game. The computer prints out the pins before each ball is bowled and automatically keeps your score.

There are 10 frames per game with two balls per frame. If you are lucky enough to make a strike — by knocking down all 10 pins with the first ball of a frame — you are awarded 30 points. Knocking down all 10 pins using both balls wins you 15 points. Otherwise each pin knocked down is worth one point. Pressing New-line rolls the next ball.

The pins still standing are represented by 0 and those that have been knocked down are shown as \*. The program can be run in either Fast or Slow mode.

**10-pin bowling**

This program by Roy Carnell of Kirkcaldy, Fife is designed for use on the 1K ZX-81. It will calculate the volume of a cylinder, sphere or cuboid and display the answer in cubic centimetres, litres and gallons. To use it input the measurements in centimetres of each dimension when asked for by the computer.

Hunt is a game for the 1K ZX-81 in which you are the hunter and the hunted. To score points you must guide your marker O to intercept the moving \*, at the same time avoiding the X which gobbles up everything in its path.

The game ends when you have been "chomped" by the X. To move your marker use keys 5, 6, 7 and 8. Your O will move in the direction of the arrows on the keyboard.

**Volume and Hunt**

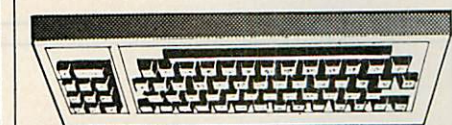

**ZX-80/81**

**LINE-UP**

(continued on next page)

```

5 REM "VOLUME"
10 PRINT AT 8,8;"CYLINDER PRESS 1", AT 10,8;"SPHERE PRESS 2", AT 12,8;"CUBOID PRESS 3"
15 INPUT N
20 CLS
25 IF N=3 THEN GOTO 40
30 PRINT AT 8,12;"RADIUS?"
35 INPUT R
37 IF N=2 THEN GOTO 100
40 PRINT AT 8,12;"HEIGHT?"
45 INPUT H
50 IF N=1 THEN GOTO 90
55 INPUT L
60 PRINT AT 8,12;"LENGTH?"
65 INPUT W
70 PRINT AT 8,12;"BREADTH?"
75 INPUT M
80 LET A = (H*L*M)
85 GOTO 105
90 LET A = (PI*R**2*H)
95 GOTO 105
100 LET A = (4/3*PI*R**3)
105 PRINT AT 8,2:R;" " " "
110 PRINT AT 10,2:R/1000;" " " " LITRES"
115 PRINT AT 12,2:R/1000/4.5461;" " " " GALLONS"
120 STOP
130 REM "HUNT"
140 LET T=0
150 LET C=15
160 LET D=15
170 PRINT AT 7,11;"SCORE "T
180 FOR H=10 TO 18
190 RAND
200 LET B=INT(RND*8)+11
210 PRINT AT B,B;"*", AT B,B;"X" AT B,B;" "
220 IF INKEY$ = "5" THEN LET C=C-1
230 IF INKEY$ = "6" THEN LET D=D+1
240 IF INKEY$ = "7" THEN LET D=D-1
250 IF INKEY$ = "8" THEN LET C=C+1
260 PRINT AT D,C;"C"
270 IF A=D AND B=C THEN GOTO 190
280 IF B=D AND A=C THEN GOTO 220
290 NEXT A
300 GOTO 60
310 PRINT AT D,C;"inverse space" AT D,C;" "
320 PRINT AT D,C;"graphic A" AT D,C;"graphic B" AT D,C;" "
330 LET T = T+1
340 GOTO 50
350 PRINT AT D,C;"CHOMPED", AT D,C;" 7 spaces"
360 GOTO 220

```

**Obstacle**

THE GAME of Obstacle by Loll Holt of Worsley, Manchester, incorporates moving graphics into a 1K ZX-81. The object of the game is to move the asterisk as quickly as possible from the top left-hand corner of the screen to the opposite corner and back again, avoiding the blocks.

The asterisk is moved using the unshifted cursor-control keys. Once it has begun to move, both start and finish are marked by inverse asterisks. The time in seconds is displayed after each move, which begins as soon as the asterisk appears and only appears to end when you are not touching the keyboard.

Memory is obviously very tight, and an Out of Memory error will require you to restart the program. Use the Break key to stop the game.

Average players complete a game in 43 to 50 seconds. The record, so far, is 41.46 seconds.

**Variable list**

HERE is a machine-code routine which, when called, lists the names of the ZX-81's stored variables, writes Ian Stewart of Alva, Clackmannan. The routine works in both 1K and 16K, but since it uses 104 bytes of memory it is really much more useful with 16K machines than with unexpanded ZX-81s.

The routine is relocatable in memory and can be stored in a Rem statement perfectly safely, although if you store it there you must not try to bring the Rem line down with Edit. Perhaps the best place for it is at the top of the memory. To call the routine, type

```
IFUSR XXXXX THEN
```

and then press Newline. The syntax looks odd, but it provides a safe way of running any machine-code program.

The output consists of the names of the variables, but not their values, separated by inverse spaces. For-Next control variables are identified by an asterisk, arrays by a < sign, and strings by the standard \$. These conventions can be changed by using different values in place of the ones in my program — they are underlined in the listing.

The routine should relieve all those who have typed in a Let command some

**Variable list.**

42	127	203	64	215	127	13	35
16	40	111	215	17	40	12	24
64	10	40	17	18	249	13	165
126	203	64	6	0	214	32	214
254	119	24	0	25	128	2	32
128	40	6	25	24	24	62	14
200	12	203	24	200	224	19	1
71	203	111	212	214	14	215	24
62	111	40	214	128	0	35	232
128	40	36	192	215	214	94	214
215	76	24	215	35	96	35	160
120	24	21	62	126	215	86	24
203	21	214	23	203	62	25	248

(continued from previous page)

```
230 PRINT AT 17,0;"SCORE SO FAR":S
240 INPUT U#
250 CLS
260 NEXT E
270 NEXT B
280 PRINT "SCORE FOR THAT GAME WAS":S
290 IF SKY THEN GOTO 310
300 LET Y=S
310 PRINT "HIGHEST SCORE SO FAR":Y:AT 9,0;"PRESS N/L TO PLAY."
320 INPUT U#
330 CLS
340 GOTO 30
350 PRINT AT 7,3;"STRIKE"
360 LET E=2
370 LET S=S+15
380 GOTO 210
```

**Obstacle.**

```
5 RAND
10 FOR I = 1 TO 35
15 PRINT AT RND * 21, RND * 7; "graphic H"
20 NEXT I
25 LET L=0
30 LET C=0
35 POKE 16437, 99
40 POKE 16436, 99
45 PRINT AT L,C; "*"
50 PRINT AT 4,9; (25443 - PEEK 16436 - 256 * PEEK 16437)/50
55 IF INKEY$ = "" THEN GOTO 55
60 PRINT AT L,C; " "
65 PRINT AT 0,0; "inverse asterisk"; AT 21,7; "inverse asterisk"
70 LET M = L
75 LET D = C
80 LET L = L + (INKEY$ = "6") - (INKEY$ = "7")
85 LET L = L + (L < 0) - (L > 21)
90 LET C = C + (INKEY$ = "8") - (INKEY$ = "5")
95 LET C = C + (C < 0) - (C > 7)
100 PRINT AT L,C;
105 IF PEEK(PEEK 16398 + 256 * PEEK 16399) <> 128 THEN GOTO 45
110 LET L = M
115 LET C = D
120 GOTO 45
```

time ago, and then forgotten the variable's name. The listing is in decimal to speed entry. Note that it is to be entered reading down the first column, then down the next, and so on. It is 104 bytes long.

**Superzap**

FROM GEOFFREY HARMAN at Solihull, West Midlands come no less than four entertaining programs for the 1K ZX-81. Superzap is an invader game in which the object is to shoot down as many invaders as possible before the alien lands on Earth. The controls are:

- 0 for up
- 8 for down
- 1 for fire

Be careful not to press two keys at once.

Line 70 contains 26 minus signs, and line 80 contains 26 spaces. Line 150 is simply a delay between each Martian's appearance on the screen. The record score to date is 28.

Martian Invasion is similar to Superzap, but two aliens approach you at the same time. You have to run the program after being told your score. The controls are the same as in Superzap.

Circles allows you to draw circles of any size at any position on the screen. Adding the line

```
80 RUN
```

fills the screen with circles.

The first input asks how far across to draw the circle, and the second how many pixels up. The third defines the size, which cannot be greater than 10.8. The computer starts the drawing to the left of the circle, so this should be borne in mind when specifying the position.

In Lem you have to land a lunar entry module from a height of 1,000 metres. Enter the thrust each time, and the computer calculates altitude, fuel remaining and speed. The program counts the number of turns you need to land. A total of under 20 turns is quite good. The game is over when your velocity reaches zero.

(continued on page 160)

# Wherever you are in the UK there's a Genie dealer nearby

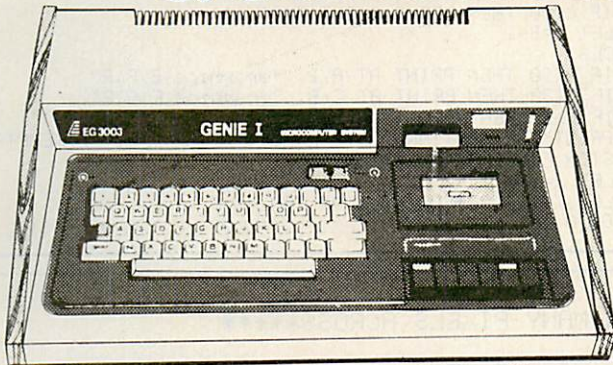

## Genie I & II Approved Dealers

**AVON** Microstyle, Bath, 0225 334659/319705. **BEDFORD** Conserve, Bedford, 0234 216749. **BERKSHIRE** P.C.P., Reading, 0734 589249. **BIRMINGHAM** Ward Electronics, Birmingham, 021 554 0708. Consultant Electronics, Birmingham, 021 382 7247. A. E. Chapman and Co., Cradeley Heath, 0384 66497/8. **BUCKINGHAMSHIRE** Photo Acoustics, Newport Pagnell, 0908 610625. **CAMBRIDGESHIRE** Cambridge Micro Computers, Cambridge, 0223 314666. **CHESHIRE** Hewart Electronics, Macclesfield, 0625 22030. Mid Shires Computer Centre, Crewe, 0270 211086. **CUMBRIA** Kendal Computer Centre, Kendal, 0539 22559. **DORSET** Blandford Computers, Blandford Forum, 0258 53737. Parkstone Electrics, Poole, 0202 746555. **ESSEX** Emprise, Colchester, 0206 865926. **GLOUCESTERSHIRE** Computer Shack, Cheltenham, 0242 584343. **HERTFORDSHIRE** Photo Acoustics, Watford, 0923 40698. Q Tek Systems, Stevenage, 0438 65385. Chrisalid Systems and Software, Berkhamstead, 044 27 74569. **KENT** Swanley Electronics, Swanley, 0322 64851. **LANCASHIRE** Harden Microsystems, Blackpool, 0253 27590. Sound Service, Burnley, 0282 38481. Computercat, Leigh, 0942 605730. **LEICESTERSHIRE** Kram Electronics, Leicester, 0533 27556. **LONDON** City Microsystems, EC2, 01 588 7272/4. Wason Microchip, N18, 01 807 1757/2230. Premier Publications, Anerley SE20, 01 659 7131. **NORTH EAST** Briers Computer Services, Middlesbrough, 0642 242017. General Northern Microcomputers, Hartlepool, 0783 863871. HCCS Associates, Gateshead, 0632 821924. **NOTTINGHAMSHIRE** Midland Microcomputers, Nottingham, 0602 298281. Mansfield Computers, Mansfield, 0623 31202. East Midland Computer Services, Arnold, 0602 267079. Electronic Servicing Co., Lenton, 0602 783938. **NORFOLK** Anglia Computer Centre, Norwich, 0603 29652. Bennetts, Dereham, 0362 2488/9. **OXFORDSHIRE** Micro Business Systems, Whitney, 0993 73145. **SCOTLAND** Escro Computing, Glasgow 041 427 5497. Edinburgh: 031 557 3937. Computer and Chips, St Andrews, 0334 72569. Scotbyte Computers, Edinburgh, 031 343 1005. Victor Morris and Co., Glasgow, 041 221 8958. **SHROPSHIRE** Tarrant Electronics, Newport, 0952 814275. **SOUTH WEST** Diskwise, Plymouth (0752) 267000. West Devon Electronics, Yelverton, 082 285 3434. Bits and Bytes, Barnstaple, 0271 72789. **SUFFOLK** Elgelec Ltd., Ipswich, 0473 711164. **SURREY** Croydon Computer Centre, Thornton Heath, 01 689 1280. **WALES** Tryfan Computers, Bangor, 0248 52042. **WEST MIDLANDS** Allen TV Services, Stoke on Trent, 0782 616929. **WILTSHIRE** Everyman Computers, Westbury, 0373 823764. **YORKSHIRE** Media 5 Ltd; Sowerby Bridge 0422 33580. Advance TV Services, Bradford, 0274 585333. Huddersfield Computer Centre, Huddersfield, 0484 20774. Comprite, Bradford, 0274 668890. Superior Systems Ltd., Sheffield, 0742 755005. Photo Electrics, Sheffield, 0742 53865. **NORTHERN IRELAND** Business Electronic Equipment, Belfast, 0232 46161. Brittain Laboratories, Belfast 0232 28374.



Sole Importers:

# LOWE

## electronics

Chesterfield Road, Matlock, Derbyshire DE4 5LE.  
Telephone: 0629 4995. Telex: 377482 Lowlec G.

## Superzap.

```

1 LET Z=0
2 PRINT, "PRESS 3 TO START"
4 IF INKEY# <> "3" THEN GOTO 4
5 LET A=29
10 LET D=INT(RND*10+5)
20 LET X=10
40 CLS
45 PRINT AT D,A;"graphic E, graphic F, graphic R"
50 IF INKEY#="0" THEN LET X=X-1
55 IF INKEY#="8" THEN LET X=X+1
60 PRINT AT X,3;"graphic H"
65 IF INKEY# <> "1" THEN GOTO 105
70 PRINT AT X,4;"-----"
80 PRINT AT X,4;" "
85 IF X=D THEN GOTO 150
105 LET A=A-1
110 LET D=D+INT(RND*3-1)
115 IF A=2 THEN GOTO 170
130 GOTO 40
150 LET C=SIN 45*SIN56*SQR TAN 54.8
152 CLS
155 LET Z=Z+1
160 GOTO 5
170 PRINT AT 15,2;"YOU ZAPPED ";Z;" ALIENS"
200 RUN
    
```

## Martian Invasion.

```

1 LET Z=0
10 LET A=INT(RND*10+5)
20 LET C=INT(RND*15+3)
30 LET B=28
40 LET X=10
60 IF INKEY#="0" THEN LET X=X-1
70 IF INKEY#="8" THEN LET X=X+1
75 PRINT AT X,3;"inverse space"
80 IF INKEY# <> "1" THEN GOTO 130
90 PRINT AT X,4;"twenty six minus signs"
100 IF X=A THEN LET A=30
110 IF X=C THEN LET C=30
130 IF A=30 AND C=30 THEN GOTO 300
140 IF A<30 THEN LET A=A+INT(RND*3-1)
150 IF C<30 THEN LET C=C+INT(RND*3-1)
170 LET B=B-1
180 CLS
190 IF A<30 THEN PRINT AT A,B;"graphics E,F,R"
200 IF C<30 THEN PRINT AT C,B;"graphics E,G,R"
210 IF B>2 THEN GOTO 50
230 PRINT"THE MARTIANS HAVE LANDED AFTER ";Z;" ATTEMPTS"
240 STOP
300 LET Z=Z+1
310 LET K=SIN 23*COS 65 *SQR TAN 45
320 GOTO 10
    
```

(continued from page 158)

The thrust acts as a brake and reduces speed but slows down descent. The rockets can develop up to 50,000 pounds of thrust. The program also takes into account gravitational force, and you should watch the fuel gauge.

## Effective programming

A J PEGG of Abergavenny, Gwent has some useful hints on making programs for the ZX-81 more efficient. When you want to print blank lines on the screen it is often possible to simply add extra commas to the end of the previous Print statement. For example,

```
PRINT "TITLE", , ,
```

will print a blank line after title.

Every number written in a Basic program, except line numbers, takes up six bytes plus the number of figures in the number. If the same number occurs three times or more in a program it therefore saves space if the number is assigned to a variable for use throughout the program.

A subroutine should be used when a set of instructions or single instruction is used more than once. There is a net saving of space if the repeated routine takes up more than 14 bytes of memory.

When converting ZX-80 Basic for the

### Data commands — sample program.

```

100 FOR A = 1 TO 8
110 GOSUB 50
120 PRINT A#; "(SPACE)";
130 IF A = 2 OR A = 5
    THEN PRINT
140 NEXT A
    
```

### Data commands routine

```

1 LET ZZ=16540
2 GOTO 100
5 REM WORDS OR PHRASES, SHOULD, BE STORED,
10 REM IN REM, STATEMENTS, ANYWHERE, IN THE, PROGRAM,
50 IF PEEK (ZZ+1)<28 OR PEEK (ZZ+1)>63 THEN GOSUB 80
55 LET A#=""
60 LET ZZ = ZZ+1
65 IF PEEK ZZ = 26 THEN RETURN
70 LET A# = A# + CHR$ PEEK ZZ
75 GOTO 60
80 LET ZZ = ZZ + 1
85 IF PEEK ZZ = 234 THEN RETURN
90 GOTO 80
100 START OF MAIN PROGRAM.
    
```

## Circles.

```

5 REM *****HOW MANY PIXELS ACROSS*****
10 INPUT X
15 REM *****HOW MANY PIXELS UP*****
20 INPUT Y
25 REM *****HOW LARGE TO MAKE CIRCLE*****
30 INPUT T
40 IF T>10.8 THEN GOTO 30
50 FOR N=1 TO 13 STEP 0.1
60 PLOT X+(2*(T-T*COS(N/6*PI))),Y+(2*(T+T*SIN(N/6*PI)))
70 NEXT N
    
```

ZX-81, remember that RND (N) produces an integer random number in the range 0 to N. The equivalent statement for the ZX-81 is

```
INT(RND*(N+1))
```

The ZX-80 function TL\$(A\$) has the effect of placing the left-hand characters of A\$ in the string required, and removing it from A\$. For example

```
LET B$ = TL$(A$)
```

would become,

```
LET B$(TO 1)
LET A$=A$(2 TO)
```

in ZX-81 code.

## Data commands

THIS PROGRAM provides the equivalent of Data, Read and Restore commands for the ZX-81, writes Andrew Rushton of Wakefield, West Yorkshire.

The command Gosub 50 puts the next word from the Rem statements into A\$. Words can be placed in Rem statements anywhere in the program, starting from line 3, but operation of the program is faster if the Rems are between lines 3 and 50. Words, letters, numbers and phrases should be separated by commas, and the

## Lem.

```

5 LET V=100
10 LET A=1000
20 LET M=2500
30 LET S=1
40 LET U=0
50 PRINT AT 5,0;S
60 PRINT AT 6,0;"ALTITUDE",A;"
70 PRINT AT 8,0;"SPEED",V
80 PRINT AT 10,0;"FUEL",M-2000-U
90 INPUT F
100 PRINT AT 12,0;"THRUST",F;"
110 IF F>50000 THEN GOTO 90
115 LET S=S+1
120 LET U=F/50000*50
130 LET M=M-U
140 LET V=V-(F/M)-2)
150 LET A=A-V
160 IF A<0 AND V<5 THEN GOTO 300
170 IF M<2000 OR A<0 THEN GOTO 350
180 GOTO 60
300 PRINT AT 18,3;"WELL DONE"
310 STOP
350 PRINT AT 18,3;"YOU CRASHED"
    
```

last character in each Rem statement should also be a comma.

The example program should incorporate the Rem statements given in the main program. The statement

```
LET ZZ = 16540
```

anywhere in the program will take you back to the first words in the Rem statement.

# Superior Systems Ltd.

178 West St, Sheffield S1 4ET. Tel. (0742) 755005

## ACORN

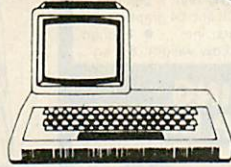

ACORN ATOM 8K rom, 5K ram,  
P.S.U. & COLOUR BOARD 199.00E  
ATOM DISK PACK, 96K  
SINGLE DISK DRIVE 299.00E  
ATOM COLOUR BOARD 39.00C  
WORD PACK ROM 26.00A  
BUSINESS 10.00A  
BUSINESS BOOK 6.95A  
DESK DIARY 10.00A  
DATABASE 10.00A

ADVENTURES 10.00A  
ATOM CHESS 10.00A  
FLOATING POINT ROM 20.00A  
B.B.C. ROM PACK PHONE  
B.B.C. BASIC PROGRAMMING BOOK 5.95B

## NEC

PC 8001 (32k computer) 599.00E  
PC 8011 32K EXPANSION UNIT 489.00E  
PC 8012 32K EXPANSION UNIT 399.00E  
PC 8023 DOT MATRIX PRINTER 399.00E  
PC 8031B DUAL DISK DRIVE 669.00E

PC 8032B ADD ON DUAL DISK UNIT 569.00E  
PC 8041 12" GREEN/ORANGE MONITOR 159.00E  
PC 8043 HIGH RES. COLOUR MONITOR 579.00E  
PC 8045A LIGHT PEN 199.00E  
CP/M DISK & MANUAL 64.00D

## SHARP



MZ80K (48k) PHONE FOR BEST PRICE  
MZ80A (48k) 360.00E  
MZ80B (64k)  
MZ80 P3 PRINTER FOR MZ80K  
MZ80 I/O INTERFACE UNIT MZ80K 95.00E  
MZ80 FB DUAL FLOPPY DISK UNIT 550.00E  
MZ80 EU INTERFACE UNIT FOR MZ80B 46.00B  
MZ80 P6 PRINTER FOR MZ80B 409.00E  
PC 1211 POCKET COMPUTER 69.50D  
PC 1500 POCKET COMPUTER 139.00D  
CE 122 PRINTER INTERFACE (pc1211) 60.83D  
CE 150 4 COLOUR PRINTER (pc1500) 125.00D  
SOFTWARE WORD PROCESSOR (tape) 39.50B

WORD PROCESSOR (disk) 79.95B  
APOLLO WORD PROCESSOR (tape) 34.95B  
DATABASE (cassette based) 29.50B  
MZ80 CALC II 34.50B  
ZEN EDITOR ASSEMBLER 19.50B  
ZEN DOS (editor assembler disk) 37.50B  
ZEN DISASSEMBLER 10.50A  
MZ80K DUST COVER 5.00A  
P3 PRINTER DUST COVER 5.00A

## APPLE

APPLE II (48k) COMPUTER DISK DRIVE WITH CONTROLLER 370.00E  
DISK DRIVE WITHOUT CONTROLLER 290.00E  
12" B.M.C. GREEN SCREEN MONITOR 119.50E  
EPSON MX80 F/T I PRINTER 399.00E  
EPSON-APPLE INTERFACE CARD 85.00D  
GRAPHICS TABLE 480.00E

14" COLOUR MONITOR 250.00E  
D.M.S. COLOUR CARD 90.00D  
APPLE II SOFTWARE VISICALC 104.00D  
MICRO MODELLER 420.00D  
VISIDEX 105.00D  
VISIPILOT 96.00D  
VISITREND/VISIPILOT 135.00D  
VISITERM 80.00D  
APPLE WRITER 39.00D

## VIC 20

VIC 20 COMPUTER PHONE 39.09D  
VIC CASSETTE DECK 200.00E  
VIC PRINTER 344.35E  
SINGLE DISK DRIVE PROGRAMMERS AID CARTRIDGE 30.39B  
MACHINE CODE CARTRIDGE 30.39B  
3K RAM CARTRIDGE 26.04B  
8K RAM CARTRIDGE 39.09B  
16K RAM CARTRIDGE 65.17B  
VIC REVEALED 10.00B  
GETTING AQUAINTED WITH THE VIC 20 7.95B

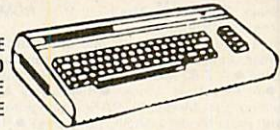

VIC PROGRAMMERS REFERENCE GUIDE 14.95B  
CASSETTE SOFTWARE PACK MAN (high resolution) 7.50A  
SUBMARINE 7.50A  
GUNMAN (high resolution) 7.50A  
NAVAL BATTLE 7.50A  
SPACE INVADERS 7.50A

## ACT SIRIUS ONE

ACT SIRIUS ONE 16 BIT COMPUTER 2395.00  
INCLUDING CP/M MICROSOFT 86 BASIC & UTILITIES.  
MEMORY UPGRADE TO 256K 495.00E  
MEMORY UPGRADE TO 512K 1495.00E  
ACT 911 MATRIX PRINTER 695.00E

ACT 921 DAISY WHEEL PRINTER 1295.00E

SIRIUS SOFTWARE PULSAR ACCOUNTING PACKAGE 495.00D  
PULSAR DATABASE 295.00D  
SUPERCALC 150.00D  
MICROMODELLER 595.00D  
WORDSTAR 295.00D

## VIDEO GENIE

GENIE I COMPUTER 295.00E  
GENIE II COMPUTER 295.00E  
EG 3014 EXPANSION UNIT 199.00E  
EG 3015/16 16K RAM CARD 91.50C  
EG 3015/32 32K RAM CARD 128.80E  
EG 400 SINGLE DISK DRIVE 215.00E  
COLOUR BOARD FOR GENIE I/II 35.00B  
DUST COVER FOR GENIE I/II 5.00B  
SOFTWARE ACQUIRE BUSINESS GAME 11.27B



ADVENTURES (various titles) 11.97 each B  
ADVENTURE SAMPLER 8.75B  
ASTEROIDS 8.75B  
ACCEL II BASIC COMPILER 39.95C  
COPYSIS PROGRAM COPIER 11.25B  
DATABASE 25.00B  
EDITOR ASSEMBLER PLUS 21.70B

## ADLER

SPECIAL ADLER PACKAGE THE ADLER P2 COMPUTER, integral unit with twin disk drives, 12" green monitor,

THE ADLER SE 1010 Typewriter/Printer, & the LEXICOM II WORD PROCESSOR.

SPECIAL PACKAGE PRICE 2900.00E

### Postage Rates

a.75p b.1.00 c.1.50 d.2.50 e.5.00

ALL PRICES EXCLUDE VAT

Prices and offers were prepared many weeks before publication of this magazine, and whilst every possible effort will be made to meet our offers, in some cases, prices may fluctuate and we would advise you to confirm by telephone before ordering.

### MAIL ORDER

Please Supply \_\_\_\_\_

£ \_\_\_\_\_  
£ \_\_\_\_\_  
£ \_\_\_\_\_  
£ \_\_\_\_\_  
£ \_\_\_\_\_  
£ \_\_\_\_\_  
£ \_\_\_\_\_

Name \_\_\_\_\_

Address \_\_\_\_\_  
\_\_\_\_\_  
\_\_\_\_\_  
\_\_\_\_\_

Access/Barclay/Cheque Card No. \_\_\_\_\_

P&P+VAT Total \_\_\_\_\_

Code \_\_\_\_\_ Tel \_\_\_\_\_

● Circle No. 193

**NOW IN STOCK**

**THE NEW & EXCITING TRS80 MODEL III**

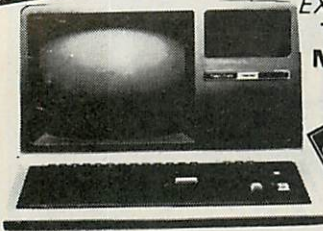

**EXTENDED GUARANTEE BY COMPUKARE**

**48K £599 + VAT**

The Radio Shack TRS-80™ Model III is a ROM-based computer system consisting of:

- A 12 inch screen to display results and other information
  - A 65 key console keyboard for inputting programs and data to the Computer
  - A Z-80 Microprocessor, the "brains" of the system
  - A Real-Time Clock
  - Read Only Memory (ROM) containing the Model III BASIC Language (fully compatible with most Model I BASIC programs)
  - Random Access Memory (RAM) for storage of programs and data while the Computer is on (amount is expandable from "16K" to "48K", optional extra)
  - A Cassette Interface for long term storage of programs and data (requires a separate cassette recorder, optional extra)
  - A Printer Interface for hard copy output of programs and data (requires a separate line printer, optional extra)
  - Expansion area for upgrading to a disk based system (optional extra)
  - Expansion area for an RS 232 C serial communications interface (optional extra)
- All these components are contained in a single moulded case, and all are powered via one power cord.

Disc Drives Kit with 2x40 Track Drives - **£599 + VAT**  
 Disc Drives Kit with 2x80 Track Drives - **£729 + VAT**

**HITACHI PROFESSIONAL MONITORS**



**EXTENDED GUARANTEE BY COMPUKARE**

9" - **£129 £99.95**  
 12" - **£199 £149** } **VAT**

- **Reliability** Solid state circuitry using an IC and silicon transistors ensures high reliability.
- **500 lines horizontal resolution** Horizontal resolution in excess of 500 lines is achieved in picture center.
- **Stable picture** Even played back pictures of VTR can be displayed without jittering.
- **Looping video input** Video input can be looped through with built-in termination switch.
- **External sync operation** (available as option for U and C types)
- **Compact construction** Two monitors are mountable side by side in a standard 19-inch rack.



**ACORN ATOM UNIQUE IN CONCEPT - THE HOME COMPUTER THAT GROWS AS YOU DO**

Fully Assembled **£157.50 + VAT**  
 inc. PSU

**EXTENDED GUARANTEE BY COMPUKARE**

- Special features include:
- Full Sized Keyboard
  - Assembler and Basic
  - Top Quality Moulded Case
  - Optional High Resolution Colour Graphics
  - 6502 Microprocessor

**THE EPSON MX SERIES**



**EXTENDED GUARANTEE BY COMPUKARE**

- 80/132 Column
- Centronics Parallel
- Bi-directional
- Upper & lower case
- True Descenders
- 9x9 Dot Matrix
- Condensed and Enlarged Characters
- Interfaces and Ribbons available

**MX80T £339 + VAT**  
**MX80F/T £389 + VAT**

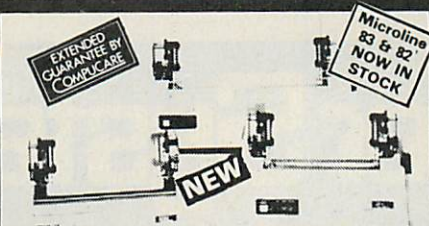

**MICROLINE 80 £289 + VAT**  
 • 80 cps Uni-directional • Small size: 342 (W) x 254 (D) x 108 (H) mm • 160 Characters, 96 ASCII and 64 graphics • 3 Character sizes: 40, 80 or 132 chars/line • Friction and Pin Feed • Low noise: 65 dB • Low weight: 6.5 kg

**INTRODUCING THE NEW SHARP MZ-80B**



**£999 + VAT**  
 • 4 Mhz Z-80 CPU • Dynamic RAM • 2K ROM • BASIC is provided • High Resolution Graphics • 9" High Focus Green Display • Upper and Lower Case • 80/40 Characters x 25 line display • Electro Magnetic Cassette Deck included • ASC11 Keyboard • Numeric Keypad • Sound Output • Built-in Clock and Music.

Available Soon-Discs, Printers and other Accessories.

**EUROPE'S FASTEST SELLING ONE BOARD COMPUTER**

**COMPUKIT UK101**

**★ 6502 based system - best value for money on the market** • Powerful 8K Basic - Fastest around • Full Qwerty Keyboard • 1K RAM Expandable to 8K on board. • Power supply and RF Modulator on board. • No Extras needed - Plug in and go • Kansas City Tape Interface on board • Free Sampler Tape including powerful Disassembler and Monitor with each Kit. • If you want to learn about Micros, but didn't know which machine to buy then this is the machine for you.

**KIT ONLY £99.95 + VAT** } **PLUS £4.60 Post & Packing**  
**Fully Assembled - £149 + VAT** }

**WE ARE NOW STOCKING THE APPLE II AT REDUCED PRICES**



**AUTOSTART EURO PLUS 48K £649 + VAT**

**Getting Started** APPLE II is faster, smaller, and more powerful than its predecessors. And it's more fun to use too because of built-in features like:

- **BASIC** - The Language that Makes Programming Fun
- **High-Resolution Graphics** (in a 54,000-Point Array) for Finely Detailed Displays.
- **Sound Capability** that Brings Programs to Life.
- **Hand Controls** for Games and Other Human-Input Applications.
- **Internal Memory Capacity** of 48K Bytes of RAM, 12K Bytes of ROM, for Big System Performance in a Small Package.
- **Eight Accessory Expansion Slots** to let the System Grow With Your Needs.

You don't need to be an expert to enjoy APPLE II. It is a complete, ready-to-run computer. Just connect it to a video display and start using programs (or writing your own) the first day. You'll find that its tutorial manuals help you make it your own personal problem solver.

**INTRODUCING THE NEW GENIE**

Ideal for small businesses, schools, colleges, homes, etc. Suitable for the experienced, inexperienced, hobbyist, teacher, etc.

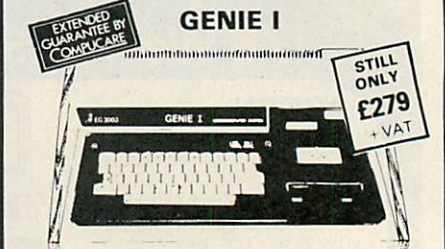

**GENIE I**

**£279 + VAT**

**NOW INCLUDED:** Sound, Upper and lower case, Extended BASIC and Machine Code enabling the Writing and Execution of Machine Codes Programming direct from Keyboard. 16K RAM. 12K Microsoft BASIC Extensive Software Range. Self-Contained PSU UHF Modulator Cassette. External Cassette Interface. Simply plugs into TV or Monitor. Complete and Ready to Go. Display is 6 lines by 32 or 64 Characters Switchable. 3 Manuals included, Users Guide, Beginners Programming and BASIC Reference Manual, BASIC Program Tape Supplied. Pixel Graphics.



**GENIE II**

**£299 + VAT**

The **NEW GENIE II** an ideal Business Machine. 13K Microsoft BASIC in ROM. 71 Keyboard. Numeric Keypad. Upper & Lower Case. Standard Flashing Cursor. Cassette Interface 16K RAM Expanded externally to 48K.

**GENIE I & II EXPANSION UNIT WITH 32K RAM £199 + VAT**

**PARALLEL PRINTER INTERFACE CARD £35.00 + VAT**



**TEAC DISK DRIVES**

**EXTENDED GUARANTEE BY COMPUKARE**

- TEAC FD 50A has 40 tracks giving 125K Bytes unformatted single density capacity.
- The FD 50A can be used in double density recording mode.
- The FD 50A is Shugart SA400 interface compatible.
- Directly compatible with Tandy TRS80 expansion interface.
- Also interfaces with Video Genie, SWTP, TRS80, North Star Horizon, Superbrain, Nascom, etc., etc.
- Address selection for Daisy chaining up to 4 Disks.
- Disks plus power supply housed in an attractive grey case.

<b>40 TRACK</b>		
Single Disk Drive	<b>£225 + VAT</b>	Double Disk Drive <b>£389 + VAT</b>
<b>77 TRACK</b>		
Single Disk Drive	<b>£299 + VAT</b>	Double Disk Drive <b>£499 + VAT</b>



"Europe's Largest Discount Personal Computer Stores"

Delivery is added at cost. Please make cheques and postal orders payable to **COMP SHOP LTD.**, or phone your order quoting **BARCLAYCARD, ACCESS, DINERS CLUB** or **AMERICAN EXPRESS** number.

**MAIL ORDER AND SHOP:** 14 Station Road, New Barnet, Hertfordshire, EN5 1QW (Close to New Barnet BR Station - Moorgate Line). Telephone: 01-441 2922 (Sales) 01-449 6596 Telex: 298755 TELCOM G

**OPEN (BARNET) - 10am - 7pm - Monday to Saturday**

**NEW WEST END SHOWROOM:** 311 Edgware Road, London W2. Telephone: 01-262 0387

**OPEN (LONDON) - 10am - 6pm - Monday to Saturday**  
 \* IRELAND: 19 Herbert Street, Dublin 2. Telephone Dublin 604165

**TELEPHONE SALES**  
**OPEN 24 hrs. 7 days a week**  
**01-449 6596**



## Data Structures using Pascal

By A M Tenenbaum, and M J Augenstein. Hardback £10.95. Prentice-Hall. ISBN 0 13 196501 8.

WHETHER THIS BOOK is mainly about data structures or the limitations of Pascal is not clear, but it is certain that in parts the book is seriously wrong. The authors claim on page 1 that "A computer is a machine that manipulates information", whereas most of us to think that a computer manipulates electrical impulses according to set rules. It is the users who give meanings to these impulses, to enable us to derive information from the bits, bytes and words.

"Information" requires us to give a meaning to patterns. To confuse the notion of information with the presence of patterns might explain why the authors make the absurd assertion on page 6: "Thus we see that information itself has no meaning", a statement, which becomes understandable as "Thus we see that patterning in itself has no meaning".

When they start with more "complex" structures, the authors use Pascal to produce illustrative procedures. By using it, many of Pascal's disadvantages as a proper language appear. For example, on page 73 they discuss how to implement a stack for real numbers: "this can be done simply in Pascal by introducing a new type stackitem and defining a stack in terms of this new type". One defines a set of routines using stackitem and, for an integer stack, one declares

TYPE stackitem = integer

The same routines can be used to manipulate a stack of reals by changing the Type declaration, but this means that one cannot have both real and integer stacks at the same time. In Algol 68 this would not be a problem, for the routines to perform stack manipulation could be set up as operators, and the same named operator could be used for different types of stack. The lack of a proper block structure in Pascal leads to further complications, as does the static allocation of storage.

The chapter on stacks is followed by one on Recursion, and the chapter is as full of imprecisions as ever. I was pleased to read on page 100: "Let us examine a less familiar example" but then I read "The Fibonacci sequence . . ." The Fibonacci sequence is one of the most common of the pointless examples used to illustrate recursion.

I decided that Tenenbaum and Augenstein were sledgehammer users. Unfortunately they are not the only sledgehammer users trying to sell computing textbooks. Though this book is no worse than many I have seen, I cannot recommend it. It conforms to most of my prejudices concerning certain forms of computer science education — as Dijkstra has said, sledgehammers to crack eggs.

Boris Allan

## Pet Interfacing

By James M Downey and Steven M Rogers. Howard W Sams and Co. £11.85.

THERE HAS ALREADY been much written about the Pet and its use as a controller for other hardware, but much of it has been in magazine articles. This book sets out to provide the essentials of Pet interfacing in one place, and to pro-

vide ideas for the use of the various interface connectors provided by the Pet micro-computer.

The first two chapters provide an introduction to the Pet hardware and building instructions for a breadboard to give easy access to the user-port signals. The circuit is used as the basis for all the user-port projects in the book. Included in this chapter is the description of a simple logic probe which eliminates the need for expensive test equipment. The third chapter is concerned with applications using the user port and includes serial input and output as well as the conversion of analogue to digital signals and vice versa.

The next three chapters describe in a similar way the experiments and projects using the memory port. As with the user port there are many useful circuits such as address decoders and more advanced interfacing techniques. Chapter 7 provides a 'miscellany of interfacing techniques including the control of mains and other high-power devices. The final chapter covers the IEEE port in detail and includes circuits for the user of the Pet as both an IEEE bus controller and as a listener/talker. Appendices provide the flowcharts and assembler-program listings

required to implement such facilities.

The book uses a clear step-by-step approach throughout and little is taken for granted. In addition there is comprehensive software support by the provision of routines for inclusion in user programs. This book illustrates why the Pet has been adopted by many sophisticated users for laboratory and other control purposes, the addition of a few pounds worth of components turns it into a very competitively priced controller.

## Conclusions

● A practical book for the experimenter or a useful reference for anyone using the Pet as a controller.

● Although comprehensive, this book is accessible to anyone who has the slightest knowledge of or interest in electronics. The only knowledge required is how to handle sensitive modern devices and how to solder a connection.

● Except for the proprietary circuit board used for the user-port circuits, for which there are suitable alternatives, all the components used are readily available.

● An essential book for Pet enthusiasts who are interested in hooking up their computers to other equipment.

Martin Wilson

## Writing Interactive Compilers and Interpreters

By P J Brown. Paperback 265 pages, £5.95. John Wiley & Sons. ISBN 0 471 10072 2.

THE TITLE is perhaps the worst part of this book. It sounds as if it might describe some particularly dry and dire product of the computer science schools. Instead it is a lively, interesting and practical guide to the hinterland of really tough computing.

Professor Brown, who teaches at the Computing Laboratory of the University of Kent at Canterbury, chose this topic not so much because more than a handful of his readers would ever want to write an interactive compiler, as because if you can write one you can do almost anything. Hidden inside your machine's

Basic which you take for granted every day is some of the cleverest software you will ever use. This book not only explains why it is clever, it also makes the reader understand why it may not be as clever as it could be and what might be done about it.

The author has evidently suffered, and his book is written from a deeply realistic standpoint. For instance, in discussing coding errors and what an interpreter should do about them, he says: "We have emphasised in this book that the error case is the normal case. Thus a parser (the bit of an interpreter that 'reads' program lines) should be regarded as a tool for pointing out syntactic errors in users' programs. Once in a while a user will produce a completely correct program, and will make use of a parser's secondary function — its use

in helping to create the internal program".

Anyone who writes applications software should have this stencilled inside his hat, because it applies to any program. Errors are normal, accurate inputs the exception: programmers ought to realise which is more important.

If Professor Brown earns, as he ought, the gratitude of end users he may well find himself drummed out of the obfuscating fraternity of computer scientists. For instance: "If a user manual looks like a mathematical thesis, most people will never look at it. Many languages have suffered from being presented to the world in a form the world does not understand. It is important to have a formal notation that is both precise and easy for ordinary people to read". These are dangerous words.

Peter Laurie

# SYSTEM 4000 EPROM EMULATOR/PROGRAMMERS

EX-STOCK

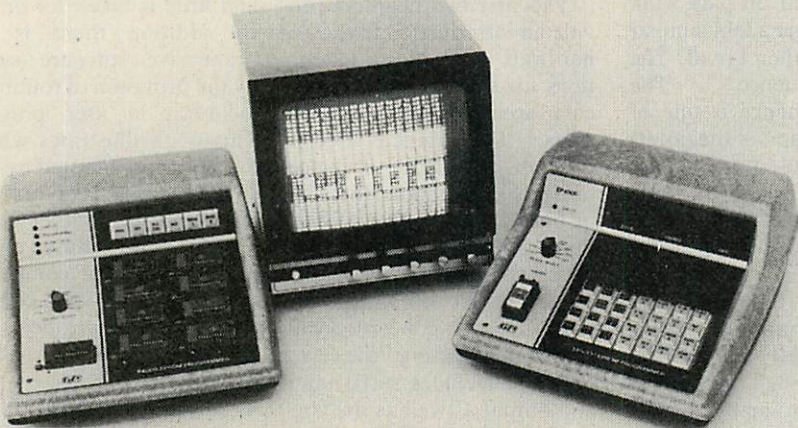

## P4000 PRODUCTION EPROM PROGRAMMER

This unit provides 'simple, reliable' programming of up to 8 EPROMs. It has been designed for ease of operator use — a single 'program' key starts the blank check — program — verify sequence. Independent blank check and verify controls are provided along with mode, pass/fail indicators for each copy socket and a sounder to signal a correct key command and the end of a programming run. Any of the 2704/2708/2716 (3 rail) and 2508 / 2758 / 2516 / 2716 / 2532 / 2732 EPROMs may be selected without hardware or personality card changes.

2 year warranty. Price **£545 + VAT:**  
+ **£12.00 DELIVERY**

## VM10 VIDEO MONITOR

This compact, lightweight Video Monitor gives a clean crisp picture on its 10" screen. Suitable for use with the EP4000, SOFTY and other systems. 12 month warranty. Price **£88 + VAT, carriage paid.**

## MODEL 14 EPROM ERASERS

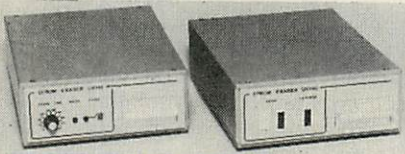

## MODEL UV140 EPROM ERASER

Similar to model UV141 but with out timer. Low price at **£61.50 + VAT, postage paid.**

## EP4000 EPROM EMULATOR/ PROGRAMMER

The microprocessor based EP4000 has been designed as a flexible, low cost, high quality unit for emulating and programming all the popular NMOS EPROMs without the need for personality cards, modules or hardware changes. Its software intensive design permits selection of the 2704 / 2708 / 2716 triple rail EPROMs and the 2508 / 2758 / 2516 / 2716 / 2532 / 2732 single rail EPROMs for both the programming and emulating modes.

The video output (T.V. or monitor) for memory map display in addition to the built-in Hex LED display, for stand alone use, is unique in this type of system. This, with the double function 28 key keypad, powerful editing features, powered down programming socket, buffered tri-state simulator cable and 4k x 8 data RAM gives you the most comprehensive, flexible and compact systems available today.

2 year warranty. Price **£545 + VAT:**  
+ **£12 DELIVERY**

## MODEL UV141 EPROM ERASER

- 14 EPROM capacity
- Fast erase time
- Built-in 5-50 minute timer
- Safety interlocked to prevent eye and skin damage
- Convenient slide-tray loading of devices
- Available Ex-Stock at **£78 + VAT** Postage Paid

EX-STOCK

**DISTRIBUTORS REQUIRED — EXPORT ENQUIRIES WELCOME**

## GP INDUSTRIAL ELECTRONICS LTD,

UNIT E, HUXLEY CLOSE, NEWNHAM INDUSTRIAL ESTATE,  
PLYMOUTH, DEVON PL7 4JN

TELEPHONE: PLYMOUTH (0752) 332961 (Sales) / 332962 (Technical Service).

# SOFTY SYSTEMS

EX-STOCK

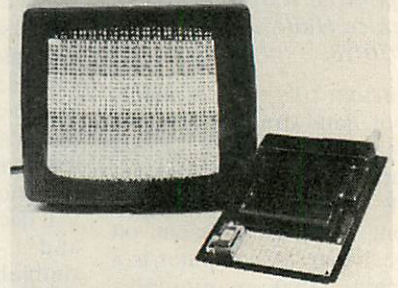

## SOFTY 2 LOW COST 2716 EMULATOR/PROGRAMMER

- Direct output to T.V.
- High speed cassette interface
- On card EPROM Programmer
- Multifunction touch keypad
- 2K Monitor in 2716
- 2K RAM
- 128 byte scratchpad RAM
- 2K EPROM Emulation
- Can program 2732/2532 in two halves
- Editing facilities including — Data entry/deletion, Block shift, Block store, Match byte, Displacement calculation
- Supplied with ZIF socket, Simulator cable, comprehensive manual, Antistatic lined EPROM tray and PSU.

SOFTY 2 **£169 + VAT** (includes p&p)

## SOFTY 1 LOW COST 2704/2708 EMULATOR/PROGRAMMER

- Direct output to T.V.
- High speed cassette interface — On card EPROM Programmer
- Multifunction keypad
- 1K Monitor in 2708
- 1K RAM
- 128 byte scratchpad RAM
- 1K EPROM Emulation
- Comprehensive editing facilities
- Supplied with ZIF socket, Simulator cable and comprehensive manual.

SOFTY 1 (Built and tested)

**£120 + VAT**

SOFTY 1 Power Supply **£20 + VAT**

## SOFTY 1 CONVERSION CARD

Enables SOFTY to program the single rail EPROMs, 2508 / 2758 / 2516 / 2532. Selection of device type and 1K block are by pcb slide switches. ZIF Programming socket. Supplied built and tested. **£40 + VAT.**

## EX-STOCK EPROMS

	1-24	25-99	100 up
2732	6:50	5:75	4:95
2716	2:80	2:60	2:40
2708	2:80	2:60	2:40

ADD VAT AT 15% — POSTAGE PAID

WRITE OR TELEPHONE FOR DETAILS  
ON ANY OF OUR PRODUCTS

● Circle No. 195

# Word search

by Douglas Nunn

```

E E E I L E R A W D R A H R D
L Z B U S A Y B N O E T U R M
I P Y B B G C A M C T X O I O
P R P I H M R S S H U W N V N
M O P C G T P I A I P I U E I
O C O C R O R C C P M N D M T
C E L O A L I O A W O O V A O
M S F B P I N Q F L C I S R R
A S Y O H P T F H E O I J F O
R O R L I G E A N A L G C N B
G R O E C K R I D I S K L I O
O N M T P E H D C I G O L A O
R J E M I C R O S Y S T E M T
P A M D A B N E T T E S S A C
O K P M E T Y B O L I K M L C
    
```

**Word list**

MICRO	KILOBYTE	MONITOR	COBOL	BOOT
COMPUTER	ROM	FLOPPY	ALGOL	MINI
MAINFRAME	RAM	DISK	PILOT	SYSTEM
SILICON	LOGIC	CASSETTE	FORTH	IEEE
CHIP	PROGRAM	MACHINE CODE	CPM	BUS
WORD	HARDWARE	FORTRAN	MEMORY	BIT
PROCESSOR	VDU	PASCAL	MAP	COMPILE
	GRAPHIC	BASIC	PRINTER	

WHEN OUT DIGGING on the island of Skye, a team of anthropologists found this rather strange and apparently random matrix of letters. One of the team, a keen computer user and academic, discovered that among the letters it was possible to find a whole list of words relating to the ultra-modern world of microcomputers.

If you wish to try and recapture the excitement of that discovery then hunt through the letters and try to find those words contained in the word list. Once you have found a word, ring it and tick it on the list.

**Solution to April puzzle**

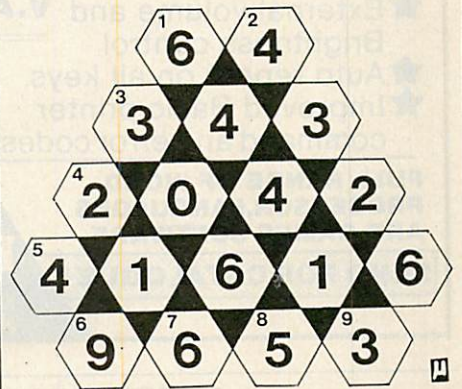

## LEEDS COMPUTER CENTRE



**Apple II EUROPLUS**

48K ..... **£675** + VAT  
 Disk with controller ..... **£360** + VAT  
 Disk without controller ..... **£275** + VAT  
 Monitors b/w or green.  
 Full range of Peripherals, Epson and Paper Tiger printers all discounted, Post & Packing £4.

**VIC-20 £150** + VAT P/P £3.00

FREE 6 programme tape with each C2N cassette recorder £40 inc VAT. Price includes fully tested unit with fitted plug. Complete range of Vic-Peripherals.

**SHARP MZ 80K**

48K MODEL  
 £345 + VAT  
 P/P £5.00

**COMMODORE PET**



**4000SR. WITH LARGE 12" GREEN SCREEN**

32K MODEL  
 P-P- £5.00 **£520** + VAT

Full range of printers Ricoh RP160. Daisy. Epson MX. Range. Walters BD80P.

**COMPLETE RANGE OF COMMODORE EQUIPMENT EX-STOCK**

Official orders welcome: goods dispatched 24hr delivery. Please phone for our lowest prices.

**SALES**

**SERVICE**

**SATISFACTION**

### ADVANCED COMPUTER EQUIPMENT (LEEDS) LTD

95 MEADOW LANE, LEEDS 11

PHONE: 0532 446960

ACCESS AND BARCLAYCARD WELCOME

TELEX: 335909

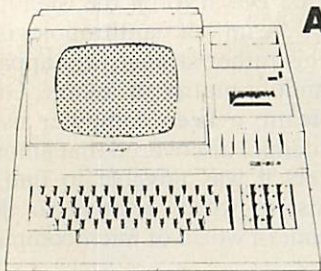

**ANNOUNCING  
THE  
MZ80 - A  
A SHARPER  
SHARP**

**NEW**  
The N.E.C.8023  
100 characters/sec  
at only  
**£399 + VAT**  
enhanced  
proportional  
spacing



**Apple  
For  
Financial  
modelling, word  
processing Data  
Bases etc. etc.**

**Featuring:**

- ★ Professional key board & Numeric pad
- ★ Green Screen, with fast display.
- ★ Scrolling up or down.
- ★ Reverse video.
- ★ Reset switch.
- ★ External volume and Brightness control.
- ★ Auto repeat on all keys.
- ★ Improved Basic printer command and error codes

**PHONE FOR  
OUR  
PACKAGE  
DEALS**

**£549  
including  
V.A.T.**

**FULL RANGE OF WORD  
PROCESSOR, LANGUAGES  
AND GAMES SOFTWARE**

**SEND FOR CATALOGUE!**

**The  
Point  
of  
Kuma  
is  
SHARP**

**Kuma Computers**  
Kuma computers: 11 York Road, Maidenhead Berks.  
phone: Maidenhead (0628) 71778/9 Telex: 849462 TEL FAC.KUM

**KUMA SPECIALISE IN MZ80 - B  
CPM BASED SYSTEMS FOR  
PROFESSIONAL REQUIREMENTS**

Kuma major in, Sharp Software,  
Matrix and Daisy wheel printers.  
ZX81 Software + Books &  
computer Books

**TRADE INQUIRIES  
FOR SHARP SOFTWARE  
WELCOME**

Software authors for  
Sharp  
Please contact Kuma

● Circle No. 198

TRS 80 I & III **WORD  
PROCESSING**

**NEWSSCRIPT offers Professional Word Processing Software with:**

- Easy to use Full Screen Editing.
- Typeahead — never loses keystrokes.
- Headings, Page Numbering, Centering.
- Form Letters, Large Documents.
- Global Search and Change.
- Double Width, Underlining, Boldface.†
- Table of Contents, Indexing.
- Sub-scripts, Super-scripts.†
- Includes handy reference card.
- Based on large mainframe-type systems.

**NEWSSCRIPT controls these printers:**

- Epson MX-80, MX-100, all 12 fonts, plus underlining and block graphics; italics with Grafrax.
- Centronics 737, 739; R.S.-Tandy, L.P. IV, L.P. VIII, Daisy Wheel II, NEC PC-8023A, TEC 8500R, C.I.TOH 8510:- justified true proportional printing.
- Good support for: Diablo, Spinwriter, Starwriter, QUME, Microline, Anadex, modified Selectric.

160 pages of well presented documentation — includes self-study tutorial, and hundreds of examples. Supplied ready-to-run on "tiny" DOSPLUS. Easily transferred to most other D.O. Systems. Requires 48k with one or more disk drives.

† Some features operate only if your printer is mechanically capable.

**NEWSSCRIPT** offers a really professional W.P. System for **£79 + V.A.T. + £2.00 p&p.** in U.K.

**NEWSSCRIPT** with a mailing label facility costs **£92 + V.A.T. + £2.00 p&p.** in U.K.

Please specify Mod. I or III — when ordering.

Catalogue £1.00 (Includes credit vouchers value £5.00)



**E.A. International, 8 High Street, Suite 108, Meldreth,  
Royston, Herts. (0763) 60189**



● Circle No. 197

**CAN YOUR  
COMPUTER  
READ THIS?**



Light-pen and signal conditioning unit enable your computer to read all types of bar code. Typical applications include data collection, ticket identification systems, security checkpoint verification, stock control, identifying assemblies in service, repair or manufacturing environments, programming computers and intelligent instruments, matching of patient and transfusion blood, retail product price information at checkouts etc. Various interface options available for all computers.

Hardware from £149 + VAT .....Further details on request

Professional quality light pens for use with VDUs, graphics terminals etc. Stainless steel construction, glass lens optics, built in buffer amp and touch sense switch.

£50 + VAT .....Data sheet available

'FAST DATA' light pen system (complete hardware/software package) for Commodore PETs. This is a quality product designed for serious use. Typical applications include Computer Aided Design (CAD), wordprocessing, data selection etc. When the pen is pointed at the screen its high resolution coordinates are automatically returned as BASIC variables. Compatible with Supersoft & MTU hires boards.

Complete system £149 + VAT ... Full literature available.

**ALTEK** (PC) 1 Green Lane  
Walton-on-Thames, Surrey  
Phone (093 22) 44110 — 24 hours  
Access ... Visa ... Callers by appointment



● Circle No. 199



In the early 1960s there were widespread fears that computers were about to take over. Boris Allan takes a close look at today's predictions of omniscient expert systems, in the light of what happened to their predecessors.

# What chance 1984?

IT IS 1982 and information technology is really with us, yet some of the futurology produced today is as out of touch as it was 20 years ago.

In 1962 in *Computers and the World of the Future* C P Snow expressed misgivings that a new elite might be formed if only those who are concerned with the computers are going to be knowledgeable about decisions.

So far such elitism has not taken hold, and Snow's worst fears have been unfounded. Snow later argues: "... if we let the individual human judgement go by default, if we give all the power of decision to more and more esoteric groups, then both the moral and intellectual life will wither and die".

## Human paradigm

E E Morison, then Professor of Industrial History at the Massachusetts Institute of Technology, suggested a test of expert systems. The computer would reconstruct a series of historical situations of increasing complexity in which men have acted most successfully.

Morison expected several benefits from this exercise. First, people would have to learn some history. Secondly, we could evaluate the machine by comparing the computer results with actualities; and, finally, the machine would become not so much a problem solver as a learning machine.

In 1962 learning machines were very fashionable. Morison hoped not only that this computer would force us to ask proper questions, but might help us sort out the things that can be thought from the things that can only be felt. In all of Morison's argument there is the assumption that the human is correct and that if the computer is to do what humans have done, it must be judged by comparison with humans.

Marvin Minsky was less impressed with humanity — especially historians — and more impressed with computers. Minsky suggested giving the computer a precise area of history about which not everything is generally known, and then having a group of professional historians study the facts and predict the outcome. He thought that historians had meticulously avoided any such experiments.

Morison agreed, saying that he had made the suggestion to see what other historians might say, and implying that

neither humans nor computers could claim perfection. In the same book N Beecher noted that the training of a person in values took from 21 to 50 years — depending on the society — before that person was judged worthy to make a real decision.

In the final chapter, J R Pierce of Bell Telephone research observed that the superpower confrontation in the early sixties made it urgent to teach more people Russian. He was told, however, by a U.S. Air Force officer that the training would take too long and the Air Force could not wait.

With typical military thoroughness, six projects on the machine translation of languages had been initiated by the Air Force, four by the National Science Foundation, two by the Army, and one by the Navy. There is no evidence that any of these projects has replaced the need for Russian/English translators.

In 1962 Minsky bet that the IBM-704, if properly programmed, could read human script faster than a human. Pierce's comment on Minsky's bet has proved justified:

These are nice bets, but how long do we have to wait? Will I live so long? I do not doubt that it will read script faster, if you do not care how well it reads it. There is a wonderful tendency to talk about things that lie in the future and that you cannot prove will not happen. This is good clean fun . . .

## Failure follows fame

No wonder that Dreyfus claimed that, whereas fame in many fields only came when success was achieved, "artificial intelligence seems to be operating instead on the principle of fame until failure".

This all sets the scene for a recent piece of futurology, which makes many claims for the power of expert systems, and also seems designed to help produce a new elite.

Snow's comments about the political dimension are especially relevant because Philip Virgo's *Learning for Change* has been produced by the Conservative Party's Bow Group to coincide with Information Technology Year. The report set out to diagnose what is wrong with Britain, British education, British industry, and then suggests how we can be rescued from decline. The author is chairman of the Conservative Computer

(continued on next page)

## BUDGET COMPUTER SALES in WEST YORKSHIRE

TRS80 Model III	£
with built in drives	1384.00
Twin TEAC drives	390.00
Single TEAC drives	236.00
Teac Scripta KSR	£798
Epson MX100	550.00
Diskettes	from 1.55

12 Month Warranty  
Prices Exclude VAT

## AMBASSADOR BUSINESS COMPUTERS

For Sales, Service, Help

ASHLEY LANE WORKS, SHIPLEY,  
BD17 7SL. Tel: (0274) 595941

● Circle No. 200



**apple**  
**ACORN**  
Atom & BBC

Your local Fruit and Nut

**NORTHERN COMPUTERS**  
Churchfield Rd, Frodsham,  
Warrington WA6 6RD.  
**0928 35110**



● Circle No. 201

## LOW PRICE — HIGH QUALITY SOFTWARE FOR COMMODORE PET

**PURCHASE AND SALES CONTROL** £50 + VAT

Runs purchase and sales ledgers with VAT typed in or calculated from either the gross or the net amount. Purchase and sales analysis by accounting period with totals for net, gross, VAT and 99 analysis codes. Due for payment report.

**INVOICE PRINT** £50 + VAT

Prints invoices on your own stationery, laid out according to your own instructions which you key in on the first run. This programme is an optional add-on to be used in conjunction with purchase and sales control.

**STOCK CONTROL** £40 + VAT

Keeps detailed stock record including stock location, recorder level, quantity on order, cost and selling prices and stock valuation.

**NOMINAL LEDGER** £40 + VAT

Produces trial balance and up to 20 reports in addition to profit and loss and balance sheet from up to 1000 nominal accounts. This programme is intended for use on its own, but it can read files set up by our purchase and sales control and stock control programmes.

## ELECTRONIC AIDS

(Towkesbury)

Mythe Crest, The Mythe, Tewkesbury,

Glos. GL20 6EB

Phone: (0386) 831020 or (0684) 294003

● Circle No. 202



**RAM BARGAINS**

4116 — 200ns.	80p each.
100+	68p each.
4116 — 250ns.	70p each.
100+	55p each.
2114 — 300ns	85p each.
100+	75p each.
2114 — 450ns.	80p each.
100+	70p each.
2114 low power 300ns.	95p each.
100+	83p each.
6116 — P3.	£4.80 each.
2716 — 5v — 450ns.	£2.40 each.
2732.	£4.70 each.
2532.	£4.30 each.

Other IC's available.  
Add 50p P & P and VAT at 15%.

**ATHANA FLOPPIES**

Minis with free plastic library case and hub rings.	
S/S S/D.	£17.95 for 10.
S/S D/D.	£19.95 for 10.
D/S D/D.	£23.50 for 10.
S/S 77 TRACK.	£26.50 for 10.
8" Discs.	
S/S S/D.	£15.50 for 10.
S/S D/D.	£24.50 for 10.
D/S D/D.	£25.50 for 10.

All other discs available add 85p P & P and VAT at 15%

**OPUS DESKING**

AT LAST COMPUTER FURNITURE MADE BY A COMPUTER COMPANY

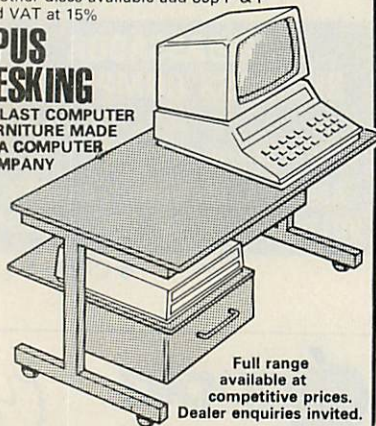

Full range available at competitive prices. Dealer enquiries invited.

24-HOUR TELEPHONE SERVICE FOR CREDIT CARD USERS  
QUANTITY DISCOUNTS AVAILABLE — OFFICIAL ORDERS WELCOME

**OPUS SUPPLIES**

10 BECKENHAM GROVE, SHORTLANDS, KENT. 01-464 5040

● Circle No. 203

**COMMODORE**

Searching for 'best price'

**FOUND 'BEST PRICE' GOTO**

PET	TAPE	RRP	OUR PRICE
C2N		£55	£35
4016	16K	£550	£467
4032	32K	£695	£590
8032	32K	£895	£760
8096	96K	£1195	£1015
<b>DISK DRIVES</b>			
2031	170K	£395	£335
4040	343K	£695	£590
8050	1M	£895	£760
<b>PRINTERS</b>			
4022P	80COL	£395	£335
8023	136COL	£895	£760
8300	DAISY	£1395	£1185

VAT to be added at 15% Carriage — £5 per item.  
IF YOU KNOW WHAT YOU WANT WHY WAIT?  
THESE ARE THE PRICES YOU NEED

**ORCHARD COMPUTER SERVICES**

Orchard House 21 St. Martins St. Wallingford, Oxon.  
Tel. Wallingford (0491) 35529  
Open 6 days per week.

● Circle No. 204

(continued from previous page)

Forum and claims to have worked in the computer industry. On the first page we read, "Fundamental changes to the education system are necessary. Information technology makes these possible at economic cost".

The report consists of six sides of A4 priced at £2. Later we find that he really means computer-assisted learning, CAL not IT, and that he imagines "at the end of a CAL packaged course, each student has reached the same level of understanding, some more quickly than others".

Yet we all know that when all the pupils in a class can recite their tables, only a few can understand what they really mean. Understanding requires more than successfully reaching the end of a task. Real ideas, such as the concept of number, are notoriously difficult to learn by mechanical methods such as tables.

Leonardo da Vinci pointed out that there are ideas which require for their exposition experience rather than the words of others, and in the context of learning this means giving as many different experiences as possible — and not principally a CAL experience. I do not know how a machine can teach morality, or even the meaning of entrepreneurship. The author's belief that "two years and a million or so pounds to assemble quality packages which can be mass-produced on discs or transmitted over the air or down telephone lines, is a lot faster and cheaper than retraining several thousand teachers over a decade or two", has more than a passing similarity to the U.S. Air Force view about Russian/English translation, which has yet to be successfully mechanised. Why should the use of CAL be any more successful? Where are the experts to design the systems?

**Logical skills**

At one point the author states the unthinkable:

... the complex diagnoses that elevate the Harley Street consultant above the local general practitioner, can already be done faster and more accurately by computer.

It would be interesting to know the whereabouts of this marvellous computer, and then see it in action. The report also thinks that lawyers, tax inspectors and accountants can also be easily replaced by computers, because these groups only offer "book-learning and machine-like logical skills". He forgets that judgement is an important part of all these occupations. I would rather trust my tax affairs to an accountant, or myself, than to a computer.

Virgo would have children

"... associate education with reward and relevance. Forget the sport field, swimming pool and minibus ... If you do not feed the mind and teach it how to earn a living all you've got is a physically fit, unemployable delinquent".

He has the same instrumental

approach to higher education, wanting an increased emphasis on training of future employees and applied research to the detriment of academic research and the apprenticeship of future academics.

Virgo certainly would not approve of a scientist who was only playing with mathematical symbolisms because he found it fun — yet this is how Albert Einstein laid the way for nuclear power and the nuclear arms race. In the early 20th century no-one realised the potential consequences of his discovery in theoretical physics.

**Trendy priorities**

Virgo is forever accentuating the need to follow trends and fashions: priority should be given to retraining taxpayers or training their children for jobs in known demand.

In the field of computer software, for instance, Britain is a world leader, but the ideas in *Learning for Change* would have a deleterious effect on just the quality of those very successful ideas.

A further confusion is to take the impressive speed at which technology is changing, and assume that ideas change at the same speed, or that breakthroughs in knowledge are just around the corner. In 1962 there was argument about how long it would be before a computer became World Chess Champion; 20 years later we are still waiting.

The impressive developments in computing since 1962 have been mainly in the hardware. At present CAL is primitive and mainly used in technical areas, so to assume that in one or two years we will be able to teach languages by CAL is to fly in the face of reality.

To talk glibly, as many workers in AI now do, of the up-coming expert systems — especially an expert system to replace a Harley Street consultant — is very reminiscent of the arguments in 1962. How about an expert system to produce translations?

Once the expert system was set up, a few experts and analysts would still be needed to correct faults in the system, and this elite would make sure that their children were taught expert knowledge. For the rest of the population Virgo suggests that too much education is a dangerous thing

Too high a qualification is really a disqualification for a contented, competent employee. All they could expect would be spoon-fed low-grade pap, which is what CAL is best suited to assure.

The ideas contained in *Learning for Change* worry me, but, do not frighten me, because I know that our expert systems are little more expert than they ever were, or are likely to be for a long time.

**References**

*Computers and the World of the Future* edited by Martin Greenberger, MIT Press, 1962.  
*Learning for Change* by Philip Virgo, Bow Publications, 1981.

# BUYERS' GUIDE

## Printers

The Peripherals Buyers' Guide is a survey of printers suitable for small computers. We have excluded any system which costs significantly more than £2,000. The printers are listed in alphabetical order. The addresses of the main suppliers are listed at the end of the guide.

Printers may be divided into several categories. The highest-quality printing is produced by the daisywheel-type which creates text in various type-faces, according to the wheel used. The quality ranges from excellent typing to rather poor book printing and generally there is a proportional-spacing facility. Those machines tend to be expensive and slow. Daisywheels can be either plastic — inexpensive, but must be replaced often — or metal — expensive but durable.

For faster printing, you must turn to dot-matrix machines. The print quality tends to be poor and the machines noisy. Older machines use a 7-by-5 matrix which puts the descenders of letters such as 'y' above the line. That makes bulk text difficult to read. Better printers use a matrix nine dots deep to give true descenders. Recently, several firms have produced dot-matrix printers which give an approximation to typewriter printing and proportional spacing. They are less expensive than daisywheel machines, work faster and could well be used for correspondence-quality work.

Some dot-matrix printers employ sensitised paper to produce printing by more direct electrical effects. They are often quiet and fast, but the paper can be expensive, unpleasant to handle and hard to obtain.

The trend is to build more processing power into printers. That means they offer increasingly varied features, so it is hard to categorise them precisely.

A printer has to be connected to the computer by a cable and a more or less standard interface. The normal interfaces are the Centronics parallel, RS232 serial port — also known as the V-24 — and 20mA current loop. IEEE is a parallel interface used by Pet; 'cpl' means characters per line, 'cps' means printing speed in characters per second. Allow five characters to the word.

The more intelligent printer prints as its head moves in both directions across the paper — bi-directional printing. Still more intelligent ones end the head movement at the ends of short lines. These two features can more than treble the working speed.

Printers use two types of paper: plain paper fed — like a



**\* BIG EARS \*** STOP GO! LEFT! RIGHT!

**SPEECH INPUT FOR ANY COMPUTER**



Hugely successful Speech Recognition System, complete with microphone, software and full instructions.

**BUILT TESTED & GUARANTEED ONLY £49**  
PLEASE STATE COMPUTER: UK101, SUPERBOARD, NASCOM2, Vic 20, Micron, BBC Micro ZX80/81, PET, TRS80, MZ80K, APPLE II

---

**ZX80 ZX81**

**MUSIC SYNTHESISER + 16 LINE CONTROL PORT**



Play 3-part music, sound effects, drums etc. Full control of attack, decay and frequency. Input/Output lines provide control and monitor facility for Home Security, Robot Control, Model Railway, etc. etc. Works with or without 16K RAM.

Add keyboard to make a live performance polyphonic synthesiser! Full instructions/software included.

**AMAZING VALUE AT ONLY £19.50 (KIT)**  
Extra Connector at **£2.50** **£25.50 (BUILT)**

---

**COLOUR MODULATOR** KIT £12  
RGB in. PAL/UHF out BUILT £18

---

**UK101/NASCOM COLOUR GRAPHICS** KIT £45  
Inc. Modulator. Still the best selling system! BUILT £60

Please add VAT at 15% to all prices.  
Barclay/Access orders accepted by telephone

**WILLIAM STUART SYSTEMS Ltd** Dower House, Billericay Road, Herongate, Brentwood, Essex, CM13 3SD. Telephone: Brentwood (0277) 810244

● Circle No. 205

### 'COMPUTER SIGN'

USE YOUR COMPUTER to control an electronic sign. Messages and graphics may be typed, edited, stored in the computer and then displayed on the sign. Two inch high characters are formed on an LED matrix. Messages can move from right to left across the sign.

Programs are available from the PET, ZX81 and others.

The signs are ideal for shops, garages, exhibitions and home.

Full details may be obtained from:-  
**A.D.H. SYSTEMS LTD.**  
209 MACKIE AVENUE  
BRIGHTON  
SX. BN1 8SE



● Circle No. 206

### ZX81

#### CASSETTE ONE (£3.80)

11 programs for 1k ZX81, 7 of them in machine code.

#### CASSETTE TWO (£5)

10 games in Basic for 16k ZX81

#### CASSETTE THREE (£5)

8 programs for 16k ZX81:  
**STARSHIP 'TROIJAN'**  
Fix your starship, despite hazards including radiation, asphyxiation, and escaped biological specimens.

#### STARTREK PRINCESS OF KRAAL

An adventure type game.  
BATTLE (1 to 4 players)  
KALABRIASZ (strange card game)  
CUBE (Rubic cube simulator)  
SECRET MESSAGES

Send your messages in code.

#### MARTIAN CRICKET

Addictive and VERY fast machine code game.

*Recorded on quality cassettes, sent by first class post, from:*

**Michael Orwin**  
26 Brownlow Rd, Willesden  
London NW10 9QL

● Circle No. 207



### ATOM UTILITY ROM £19.95

The Willow Software 4K Utility ROM simply plugs into the spare utility socket in your Atom and provides 18 powerful new commands and facilities including: full renumber, range delete, find, sophisticated auto line numbering, program compression, disassembler, true keyboard scanning, memory dump, variable dump register dump, keyboard sounder and much more. The Utilities are professionally written and fully tested. All standard Atom facilities are unaffected, and no text-space memory is used.

Send cheque/PO for £19.95 for delivery by return of post, or write for further details.

WILLOW SOFTWARE  
PO BOX 6, CREDITON, DEVON  
EX17 1DL

● Circle No. 208

## SHARP MZ-80K

LOWEST PRICE  
ON THE  
SOUTH COAST

CASH  
PRICE **£347** + VAT



XITAN SYSTEMS LTD  
23 CUMBERLAND PLACE  
SOUTHAMPTON SO12BB  
TEL 0703 38740

● Circle No. 209

#### ZX81 2 × 8 Bit Parallel Interface

Features 16 user programmable input/output lines under your control. Use it to control Heating, Lighting, School Experiments, Robots, Printer

Many more applications. Example software and circuit suggestions supplied with each board.

#### APPLE A/D Converter

Reads 8 analogue channels with 8 bit resolution. Bipolar inputs. Turns your Apple into an eight channel data logger/chart recorder/oscilloscope. Supplied with notes and software (Specify DOS 3.2, 3.3 or Cassette), in an attractive ring binder.

APPLE Universal Printer Interface/Real Time Clock Clock gives time/date to tenth sec. and interrupt. Interface includes software to drive most common printers. (Can also be used as 8 bit port.)

ZX81 Card 16.50 + 2.48 V.A.T. + 30p p. & p.  
APPLE A/D Converter 49.95 + 7.49 V.A.T. + 1.00 p. & p.  
APPLE Universal Printer Interface/Real Time Clock 79.00 + 11.85 V.A.T. + 1.00 p. & p.

#### ANDREW DEVELOPMENTS

93 BEACONSFIELD VILLAS, PRESTON PARK,  
BRIGHTON. Tel: (0273) 564629

● Circle No. 210

## MONOPOLY

### TANDY V. GENIE

- \* Computer challenges you at Monopoly as a player.
  - \* For up to 6 players (including computer).
  - \* Unique system featured whereby computer detects the skill of best player then adjusts its skill automatically to match that player.
  - \* Computer's game at highest level is 'strong'.
  - \* Every game different, close, exciting and challenging.
  - \* Game data can be saved on tape to continue game at another time.
  - \* Easy fool-proof entry ideal, even for children to use.
  - \* 2 versions of Monopoly included. 'Standard' — as to rules. 'Popular' — slight variation to rules.
  - \* Many, many hours of fun for all the family.
- On tape for the VIDEO GENIE and TRS-80. Model 1 & 3. Level 2. 16k. **£9.95 inclusive**

COMPUTICS 1 BELL LANE  
MICROSOFT WHEATLEY  
OXFORD OX9 1XY

● Circle No. 211

typewriter — pinch- and pin- or sprocket- or tractor-fed with holes along the margins. That paper can be supplied fan-folded or in rolls.

Pinch feeding is more expensive but is convenient for letters. Only a few machines will accept both pinch- and pin-fed paper. It is possible to obtain headed letter paper bonded lightly on to pin-fed, fan-folded computer paper for word processors.

Some printers allow direct control of the print-head to give graphics. KSR means keyboard, send and receive, ASR means automatic send and receive, RO means receive only. KSR machines can be used as electric typewriters in local mode.

Comb or line printers have a whole line's worth of dot hammers so they can print a line of text at a time. They tend to be very expensive and very noisy but produce an enormous quantity of work.

## ACCESS DATA COMMUNICATIONS

### ADC 1251

Matrix printer, continuous paper, £13 per box, 80 or 132 cpl, 125 cps, 7x9 matrix. RS232, Centronics and IEEE interfaces.

£560

### ADC 2401

9x9 dot-matrix printer, continuous paper, 136 cpl, 240 cps, RS232, Centronics and IEEE interfaces. Available from Access Data Communications.

£1,350

## ADDMASTER

### 400 receive only

Uses 2.5in. Tally roll paper, 16 cpl, 48 cps. Main U.K. agent Clary Ltd.

£242

### 420/426 receive only

Dot matrix grade-one Tally roll paper at £5 for 20 rolls. BCD serial or 10-line serial interfaces, 12 cpl, 36 cps.

£246

## ANADEx

### Main U.K. agent Anadex Ltd

#### DP-500

Dot matrix, tractor feed, parallel interfaces, 18 cpl, 45 cps.

from £367

#### DP-660

Dot matrix, pinch feed for printing labels, uses sprocket feed. Parallel interface. 19 cpl, 57 cps.

from £700

#### DP-750A

Dot matrix, RS232C 20mA current loop, 21 cps, 25 cps.

from £800

#### FP-600

Dot matrix ticket or form printer, from four columns to 19 columns parallel interface, 19 cpl, 44 cps.

from £65

#### DP-9500 Series

Dot matrix, tractor feed, nine-wire print head, bi-directional printing, three ASCII interfaces as standard — parallel bit, RS232C, current loop — 120-200 cps, 132-220 columns, 7x9, 9x9 or 11x9 matrices depending on model. Also from: Peripheral Hardware, Kode Services, Robox, Stack Computer Services and Data Design Techniques Ltd.

£895 upwards

#### DP-8000

Dot matrix, pinch feed, bi-directional printing, fan-fold paper up to 9.5 in. up to three copies. Three ASCII interfaces — parallel bit, RS232C, current loop — 112 cps, 80 column, 9x7 matrix. Also from: Peripheral Hardware, Kode Services, Robox, Stack Computer Services and Data Design Techniques Ltd.

£550

#### DP-1000 Series

Dot matrix, tractor feed, internal data storage, roll-type paper for 40 columns at £11 for box of 10 rolls, three basic ASCII-compatible interfaces are available. 40 cpl, 50 cps, 40 columns, 5x7 matrix. Also from: Peripheral Hardware, Kode Services, Robox, Stack Computer Services.

from £395







## AXION CORPORATION

Main U.K. agent Memec Systems Ltd

### EX-820 receive only

Electro-sensitive dot matrix includes plotting capability for full graphics, paper at £3 for a 240ft. roll, RS232C or 20mA serial and ASCII parallel, 20/40/80 cpl and up to 160 cps, 5x8 matrix.

£500

### EX-850 Video Printer

Electro-sensitive dot matrix, aluminised paper at £3 for a 240ft. roll. Needs only the video signal from user's. Normal resolution 13.5 seconds per screen, high resolution 27 seconds per screen.

£500

### EX801/802 receive only

Electro-sensitive, dot matrix, aluminised paper at £3 for a 240ft. roll, RS232C, Centronics, Apple, Pet, and Tandy interfaces, 20/40/80 cpl, 160 cps, 5x8 matrix.

£279

## BASE 2

### 800-MST

Impact dot matrix, bi-directional, tractor feed up to 9.5in., RS232C, 20mA, IEEE-488, Centronics and parallel interfaces, up to 132 cpl and 60 cps, with 5x7 matrix. Main U.K. agents Microbyte.

from £385

## CENTRONICS

Main U.K. agents Bytech, ITT Electronic Services, Cable and Wireless, Dacoll Engineering.

### Model 150

Table-top demand document dot-matrix printer, 150 cps, bidirectional logic-seeking, using fan fold, roll and cut sheet paper up to 9.5in. wide 80 columns, RS-232 and parallel models available.

£499

### Model 152

As model 150, but 132 columns 15in. wide.

£695

### Model 352

Print station; advanced dot-matrix printer, 132 column 200 cps bidirectional logic seeking printer. Three-way paper-handling with built-in single-sheet feeder. Has second printing mode which at 60 cps gives very high-definition letter-quality printing, and high-quality pin addressable.

£1,400

### Model 353

Print Station; similar to model 352 but with liquid-crystal display for status indication and user-selectable parameter set-up.

£1,740

### Model 739

Table-top correspondence-quality mini-printer with three-way paper handling and proportional character set.

£504

### Model 6300

Industrial 300 line per minute band printer.

P.O.A.

### Model 6600

Same as 6300 but with 600 lines per minute.

P.O.A.

### Model 6080

Very quiet 600 line per minute band printer for office use. Has a variety of interfaces to suit most micro, mini or mainframe computers.

£5,583

## COMPUTER DEVICES INC

### Miniterm 1201, 1202, 1203

Thermal mechanism, uses Thermal Type B paper at £2.40 per roll, RS232 or parallel — 1201 only — interfaces, 80 or 132 cpl, 10/30 cps, 7x5 matrix. Main U.K. agent Teleprinter Equipment Ltd.

from £936

**MICRO SERVICING AND REPAIRS**  
 · APPLE · PET · VIC · BBC · ITT · and other makes  
 Micro Malfunction? Send or drop your micro in to us. We'll repair it in our workshops and return it. Our staff are fully qualified and we are Main Dealers and Software Specialists for most leading makes.  
**ALSO FULL MICRO SERVICE CONTRACTS IN LONDON AND EAST ANGLIA**  
**MICROSTORE MICRO MANAGEMENT**  
 327 King's Rd. LONDON 32 Princes St. IPSWICH SW3. Tel: 01 352 9291 Suffolk. Tel: 0473 57871

● Circle No. 212

## COMPUTERS Bought & Sold

Contact the UK Specialist in Second user systems.

**London Micro Systems**  
 10 Victoria Crescent, London SW19  
**TEL: 01-947 5465.**

● Circle No. 213



**QUME  
 EPSON  
 ANADEX  
 DYSAN**

All Business Applications  
 Full Personal Attention

**Hugh S. O'Neill Computers**  
 111 High Street, Selsey,  
**CHICHESTER, SUSSEX.**  
 Tel. Selsey (024361) 5856

● Circle No. 214

**UNIQUE TELE-CRYSTAL**  
 WORLD PATENTED  
**REDUCES GLARE AND REFLECTIONS BY UP TO 90%**  
**INCREASE OPERATOR EFFICIENCY**  
 \* Specially formulated for VDU and TV Screens  
 \* Reduces Screen Static  
 \* Increases operator efficiency by reducing eye strain  
 \* Will not harm screen surface  
 \* Recommended installed price £18 for up to 26" screens  
 DEALER & O.E.M. ENQUIRIES WELCOME  
 STATIFLECT - GUARD, 55 FAIRBURN DRIVE, GARFORTH, LEEDS LS25 2AR. TEL: (0532) 864981 (24hrs)

● Circle No. 215

## MAILSAFE DISKETTE MAILERS

LOW PRICE HIGH QUALITY

Protect your valuable Software & Data

If you mail floppy disks  
Make sure they arrive safe  
in a MAILSAFE

Available in 5½" and 8" sizes



For free sample & details

### BASIC BUSINESS SUPPLIES

50 Edinburgh Drive, Ickenham,  
Uxbridge, Middx. UB10 8QY.

Tel: Ruislip (08956) 76012

● Circle No. 216

## APPLE II SYSTEMS BARGAIN BUY

48K Apple, 12" monitor, 2 disks, Paper Tiger 445  
printer, parallel card, ribbon, cables.  
Visicalc. Disk Top Plan, Apple Plot, Apple Writer.

Price **£1860** (excl. VAT)  
Subject to Stock

**ELEX SYSTEMS LTD.**  
Crossway House  
Bracknell, Berks.

**Bracknell 52929**

● Circle No. 217

## ZX81★TRS-80★GENIE A MUST FOR ZX81 USERS!!!

Burn your own routines and custom designed graphics  
into 2716 (5V) eproms with the LMX EPROM PROG-  
RAMMER. Doubles as a 2K ROM extension card.  
Only **£17.50** incl. for complete KIT which includes  
software, keyboard overlay and easy-to-follow assem-  
bly and operator's instructions. SAE for further details.

\*\*\*\*\*

### HIGH QUALITY EPROM PROGRAMMER FOR TRS-80\* AND GENIE USERS

An outstanding unit for the professional, student and  
hobbyist. Programs Intel 2758/2716/2732 and Texas  
2758JL0/2508/2516/2532 5V eproms in one pass.  
Excellent software. Powerful editing facilities; 12 com-  
mands; error reports; graphical display during burn;  
automatic verify; and many other features. Z.I.F. soc-  
ket; integral p.s.u. Comprehensive 20-page User's  
Manual.

SAVE £10 — BUY NOW!! SPECIAL INTRODUCTORY OFFER  
(until 12.6.82) **£57.50** incl.

Manual available separately ... **£2.20** incl.

\* TRS-80 Model I Level II 16K

### LANDER MICROSYSTEMS

32 Clockhouse Lane, Collier Row,  
Romford, Essex RM5 3QJ Tel: Romford 26325

● Circle No. 218

## DATAC

### Main U.K. agent Datab Ltd

#### 414 free-standing assembly receive only

£130

Electro-sensitive, matrix printer type 245L, electro-sensitive roll  
paper, 59mm. wide x 30m. long at 90p per roll for 20 off, six-bit  
parallel ASCII, character serial interfaces, 16, 20, 32 or 40 cpl, 32 to  
80 character per serial, 7x5 matrix.

#### DMI-40P free-standing terminal, receive only

£350

Impact, matrix, uses pressure-sensitive roll paper, 10mm.-wide  
ordinary paper version, using ink ribbon. Cost of paper £1 per roll,  
seven-bit parallel ASCII, character serial, RS232C or graphics, 40  
or 20 cpl, up to 80 cps, 7x5 matrix.

#### 411C compact panel mounting, receive only

£209

Electro-sensitive matrix type 245L or R, uses electro-sensitive roll  
paper, 59mm. wide x 30m. long at 90p per roll, six-bit parallel,  
serial interfaces, 16, 20, 32 or 40 cpl, 32 to 80 cps, 7x5 matrix.

#### 411 panel mounting, receive only

£189

Electro-sensitive matrix printer type 245L or R, uses electro-sensi-  
tive roll paper, 59mm. wide x 30m. long at 90p per roll. Interfaces  
include six-bit parallel ASCII, character serial, four-bit parallel  
BCD, character parallel EIA/RS232C, CCITT/V24 and 20mA cur-  
rent loop, under development 40 cpl, 32 to 80 cps, 7x5 matrix.

#### 313 panel-mounting, receive only and 312 free-standing, receive only

£269

Impact matrix type PU-1100, Tally roll paper, 59mm. wide x 36m.  
long at 60p per roll, CCITT/V24 or EIA RS232C or 20mA current loop  
interfaces, up to 20 cpl and up to 36 cps, 7x5 matrix.

#### 412/1 and 412/5 receive only

£255

Electro-sensitive dot matrix type 245L, uses electro-sensitive alu-  
minium-coated paper, 59mm. x 30m. at 90p per roll, six-bit parallel,  
ASCII, character serial and four-bit parallel BCD, character paral-  
lel, RS232C/V24 interfaces, 20mA current loop under develop-  
ment, 16, 20, 32 or 40 cpl, 32-80 cps, 7x5 matrix.

#### 522/1 and 522/4 receive only

£499 (522/1)

£535 (522/4)

Impact matrix type, roll paper, 114mm. x 75m. up to three copies  
plus original, cost of paper £1.10 per roll. Parallel interface and  
RS232C, 20mA current loop and parallel buffered, asynchronous  
interfaces — (522/4). 40 cpl, 100 cps instantaneous rate, 33 cps  
average rate — including CR and LF. 7x5, 7x10.

## DATA DYNAMICS

### Main U.K. agent Data Dynamics Ltd

#### 303 Printer

£980

Dot matrix, up to six-part stationery width from 3m to 15.375in., V24/  
RS232C, 20mA current loop, 132 cpl, 30 or 60 cps, 7x7 matrix.

#### ZIP ASR/K7 twin cassette

£2,000

Dot matrix format, uses standard Teletype roll paper, V24, RS232C,  
or 20mA current loop operating at half or full duplex, 80 cpl, 10 or 30  
cps switch selected, 5x7 matrix.

#### ZIP 30 keyboard printer, RO, ASR, or KSR

ASR £1,800

RO & KSR

£950

Dot matrix, standard roll paper, 20mA half or full duplex current  
loop or V24 RS232C, 80 cpl, 10 or 30 cps — switch selected, 5x7  
matrix.

#### 390 eight-level and 392 five-level

ASR from

£1,250

LSR from £900

RO from £800

ASR, KSR and read-only versions. Impact printers, friction or  
sprocket feed, 8.5in. paper with roll diameter 5in. 74 or 86 cpl, 6.6  
or 10 cps.

#### Models 32 and 33 page printers

ASR from

£1,100

KSR from £800

RO from £700

Available in ASR, KSR and receive-only versions. Friction or sproc-  
ket feed, 20mA or 60mA parallel, up to 86 cpl, 6.6 or 10 cps.



## DATA GENERAL CORPORATION

### Dasher TP1 Printer models 6040 and 6041

6040 standard keyboard and can be used as a typewriter. 6041 is a receive-only terminal printer without keyboard, 30 or 60 cps, switch selectable, EIA-RS232C interfaces, 5x7 dot matrix. Main U.K. agent Data General.

From £1,598

## DATAPLUS

### 400 series receive-only Model 480

Impact dot matrix, uses standard Tally roll, up to 3.75in. side, from 80p per roll, RS232C, V24, 20mA current loop, but parallel IEEE, Pet and Apple interfaces, 30/40 cpl, 110 cps, 7x5 and 7x10 matrices. Main U.K. agent Dataplus Ltd.

£475

## DATASOUTH CORPORATION

### DS-180

Impact, matrix printer, uses fan-fold paper, RS232C, current loop, and parallel interfaces, 132 cpl, 180 cps, 9x7 matrix. Main U.K. agent Datatrade Ltd.

£1,360

## DIABLO

### HY type II receive only

Impact daisywheel plastic or metal print wheel, parallel, interface, 132 10-pitch cpl or 158 12-pitch cpl, 40/45/55 cps. Main U.K. agent Diablo Systems Ltd.

P.O.A.

### 630 receive only

Daisywheel, metal/plastic printwheels, standard listing or single sheet paper, RS232C, V24 with optional bus interface, 132 cpl at 10 pitch, 158 cpl at 12, 198 cpl at 15, up to 40 cps with automatic bi-directional printing. Main U.K. agent Geveke Electronics.

£1,725

## DIGITAL EQUIPMENT

### DecWriter LA34 KSR

Dot matrix, uses roll or fan-fold paper, friction-feed, up to five copies, RS-232 or 20mA interfaces, adjustable up to 256 cpl, 30 cps, 7x9 matrix. Main U.K. agent Bytech.

£824

### A120

7x7 dot matrix, EIA or 20mA option, up to 217 cpl, 180 cps. Main U.K. agent Bytech.

from £1,645

## DIGITRONIX

### Mini-Printer

32 column electro-sensitive, 110-4,800 baud, ASCII Serial inputs at RS232C, 20mA, 64 font at 64 cps. Main U.K. agent Digitronix.

£195

## DRG

### Starwriter FP1500-25

96-character daisywheel printer. Up to 136 cpl, 25 cps, RS232 interface, compatible with sheet feeders. Self-testing, programmable vertical format unit. Available from DRG Business Machines.

£923

## ACCOUNTS-CP/M

Payroll	£400
Sales ledger & invoicing	£400
Job analysis, payments and nominal	£400

### ESTATE AGENTS: MATCH-AND-MAIL

## DATA PROFILE LTD. APEX HOUSE

LAWRENCE ROAD HOUNSLOW MIDDXX  
01-572 6381

● Circle No. 219

## 5 DAY MICROCOMPUTER PROGRAMMING COURSES START EVERY MONDAY INCLUSIVE COST £170

Part-time courses seven days a week

## MICROTEACH

160 Edmund Street, Birmingham

Tel: 021-236 4322

● Circle No. 220

## ASSEMBLY for PET LANGUAGE for VIC

PET from 8K: VIC 20 from 3.5K  
Both books cover WHOLE 6502  
Instruction set, AND CONTAIN

### FULL 6502 ASSEMBLER

PRICES: 2/3/4000 PET & VIC BOOK £10  
ALL PET & VIC: book + ASSEMBLER —  
ON TAPE £15: ON DISK £17.

VIC BOOK  
CONTAINS

M/C LANG MONITOR

SAE details from:

DR P HOLMES (P)

State Machine.

21 Colin Drive  
LONDON NW9 6ES

● Circle No. 221

## TANDY COLOUR COMPUTER OWNERS

Send a first class stamp for software lists from Europe's largest stockists of colour computer software.

### MICRODEAL

DEAL HOUSE  
BRIDGES  
BODMIN  
CORNWALL PL30 5EF

● Circle No. 222

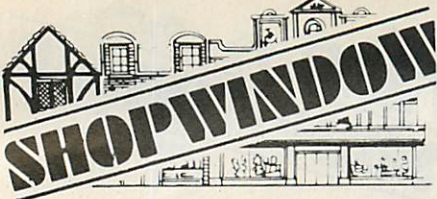

### PUBLIC APOLOGY

We would like to apologise for our extremely low prices but we can't help it. Our 5 1/4" Library Cases really are only £1.90 each; our MX80/Commodore 4022 ribbons are only £5.95 each; our BASF SSSD 5 1/4" discs are only £15.00 per ten; our Verbatim Datalife SSSD discs are only £17.00 per ten; our 11" x 9 1/2" Listing Paper is only £10.00 per box of 2000 sheets; our mailing labels start from £7.00 per 1000 labels; and we could go on. In fact you would be hard put to find better value for money than ConSup when you need consumables for your computer.

We would also like to apologise for having two of the best 4K Eproms ever developed for the Commodore PET. "BASMOM" is an assembler and disassembler with extended monitor functions including interrupt driven M/C Trace; Hex/Dec Convert; Dump; Screen Dump; and many more. "PLUSDOS" has all the usual functions such as Auto-Number; Renumber; Find; as well as many new ones including Join and Merge new programmes. Both chips reside inside the PET and are outstanding value at £35 each or both for £65. (Dealer enquiries welcomed).

We faithfully promise to continue to give good value and reliable service. We've always sold the Commodore system and now we can also supply the new SIRIUS I - Circle the number below and we'll rush you details. Alternatively, write or phone us today.

**ConSup**

62 Tritton Road, London, SE21  
Tel: 01-6704411 (40 lines)

(One last apology - prices do not include VAT or P & P so check with us first).

● Circle No. 223

### "ZX GRAPHICS PROGRAMMING MADE EASY"

Full Colour A4 Manual, 24 pages packed with ZX Graphics Programming techniques and ideas for games and 'serious' Programs. Written in 'easy to understand' language and illustrated at every stage.

Ideas include:  
Information Graphics  
Sketch Pads.  
Saving your 'Art'.  
Making serious programs interesting.  
Graphics Stringing.  
ZX Printer Graphics



**£1-50**

(INCLUDING U.K. POSTAGE)  
Print 'n' Plotter Products (PC)  
19 Borough High Street,  
London SE1 9SE

● Circle No. 224

### NEW BOOKS FOR THE APPLE II

"THE POWER OF VISICALC" - a tutorial and reference manual for Apple's most powerful software tool. Essential reading for users/potential users. 7.95

"6502 ASSEMBLY LANGUAGE FOR THE APPLE II" by Randy Hyde - The best assembly language tutorial for Apple users, written by the author of the LISA assembler. Also covers the SWEET-16 interpreter. 10.95

"BENEATH APPLE DOS" - the ultimate reference manual on the workings of DOS. Essential reading for every Apple owner. 11.20

\*\*\*\*\* HOT OFF THE PRESS \*\*\*\*\*

"BAG OF TRICKS" by the authors of Beneath Apple DOS. Over 100 more pages of valuable information on DOS. PLUS 4 superb utility programs on disk worth the cost alone. 21.95 + VAT

\*\*\*\*\*

"GRAPHICS COOKBOOK FOR THE APPLE" 9.95

"APPLE LOGO" a comprehensive, detailed guide to a widely acclaimed new language 10.95

"WHAT'S WHERE IN THE APPLE" - an atlas for the Apple. Now you can find out what those PEEKS and POKES DO!!! 10.95

Add 75p postage per book.

Send stamped addressed envelope for latest price list.

PROTOCOL COMPUTER PRODUCTS 01-460 2580   
Dept PC6, Apartment 3,  
114 Widmore Road, Bromley, Kent BR1 3BE

● Circle No. 225

### ELECTROGRAPHIC AV

**EG-800 receive only**

Impact, matrix printer, uses any type of paper, parallel, RS232C, TRS-80, Apple interfaces, 80 cpl, 150 cps, 7x5 or 7x6 matrices. Main U.K. agent Electrographic AV Ltd.

from £450

**500 series receive only**

Impact, matrix printer, uses 3.5in. Tally roll paper and flat documents, serial or parallel interfaces, 40 cpl, 120 cps, 7x5 or 7x6 matrices. Main U.K. agent Electrographic AV Ltd.

from £175 for mechanism only

### EPSON

**TX-80**

Impact, dot matrix, friction pin-feed RS232C, V24, 20mA current loop, bit parallel, Centronics, IEEE, Pet, Apple and TRS-80 interfaces, 80 cpl, 150 cps, 7x5 or 7x10 matrices and graphics. Optional PROM chips for high-resolution graphics. Main U.K. agent Data-plus Ltd.

£395

**MX-80**

Impact, dot matrix, accepts any type of paper, Centronics parallel interface, optional serial and IEEE 488 interfaces, 44, 66, 80, 132 cpl, 80 cps, 9x9 matrix - 2.1 x 3.1mm. High resolution graphics.

£425

### EXTEL CORPORATION

**M30 receive only keyboard send/receive and automatic send/receive**

Impact, dot matrix printer, uses roll or fan-fold paper, V24 or 20mA interfaces, 80 cpl, 30 cps (50 with buffer) 5x7 matrix, 5- or 8-level operation. Main U.K. agent Extel.

£895

**M30 B208L keyboard send/receive**

Dot matrix, uses roll paper, V24 or 20mA interfaces, 80 cpl, 30 cps, 5x7 matrix, 5- or 8-level operation. Main U.K. agent Extel.

£1,270

### FACIT

**4520 and 4521**

Seven-wire print head, uses roll paper Telex type (Facit 4520), friction feed, fan-fold (Facit 4521) pin feed, serial, V24/RS232C, Centronics parallel interfaces, both fitted as standard, 80 cpl, 100 cps at 12 characters per inch, 9x7 matrix. Main U.K. agent Facit Ltd.

£583

### GENERAL ELECTRIC, U.S.A.

**ITT 3330**

Impact dot matrix, pin feed, V24 interface, 132 cpl, 10, 20 or 30 cps, 7x9 matrix. Main U.K. distributor ITT Business Systems U.K.

£1,496

### HEATH ELECTRONICS

**WH14**

Dot matrix, uses edge-punched fan-fold paper, 20mA, RS232C interfaces, 80, 96, 132 cpl, 132 cps, 5x7 matrix. Main U.K. agent Heath Electronics U.K. Ltd. (OEM sales).

£510

### INTEGRAL DATA SYSTEMS

**Paper Tiger Model 460**

Dot Matrix, impact printer, pin-feed fan-fold paper, parallel, RS232C, 150 cps, 24x9 matrix. Main U.K. agent Teleprinter Equipment Ltd.

from £700



## LEAR SIEGLER INC

### 300 series

from £965

Dot matrix, uses standard paper, RS232C, 20mA parallel interfaces, Centronics 701/703 type 132 cpl, 180 cps, 9x7 or 9x9 matrices. Main U.K. agent Penny & Giles Data Recorders Ltd.

## LOGABAX

### LX-213

£1,590

Dot matrix printer, plain paper, fan-fold or cut up to six-ply, RS232C or V24 interfaces, 132 cpl, 218 cpl, 180 cps, 9x7 matrix, optimised bi-directional printing. Main U.K. agent Brospa Data Ltd.

## LRC EATON

### 7000+

£250

Dot matrix printer, uses roll paper, RS232, IEEE, current loop and parallel interfaces, 20, 32, 40 and 64 cpl software selectable by option, 40 cps, 7x7 matrix. Main U.K. agent Russet Instruments.

## MALIBU ELECTRONICS CORPORATION

### Masterprint 165

£1,400

Dot matrix, fan-fold paper, RS232C, current loop and parallel interfaces, 132 cpl, 165 cps, 10x9 matrix with 18x9 matrix character set which approaches word-processing quality, graphics. Main U.K. agent MBS Terminals Ltd.

## MANNESMAN TALLY

### Main U.K. agent Data Design Techniques Ltd

#### M-80 MC

from £875

Dot matrix, 9.5in. pin feed paper, all interfaces, 80/132 cpl, 200 cps, 7x9 or 9x9 matrices.

#### T1612 keyboard send/receive

£1,612

Dot matrix, single or multi-part paper, pin feed, RS232C or 20mA interfaces, 132/218 cpl, 160 cps, 7x9 or 9x9 matrices.

#### T1612 receive only

£1,475

#### T1602

£1,395

Dot matrix single- or multi-part paper, pin feed, Data Products, Centronics and serial interfaces, 132 cpl, 160 cps, 7x9 matrix.

## MICRO PERIPHERALS INC

### MPI-88T

£535

Dot matrix printer, uses fan-fold, roll and cut-sheet paper, RS232C, current loop and parallel interfaces, 80/96/120/132 cpl, all software-selectable, 120 cps, 7x7 matrix. Main U.K. agent Russet Instruments.

## NEWBURY LABORATORIES

### Model 8300

from £475

Dot matrix, pin-feed paper up to 9.5in., eight-bit parallel interface or CCITT V24, RS232C interfaces, 10 characters per inch, 125 cps, 7x9 matrix. Main U.K. agent Newbear Computing Store.



## JOYSTICK

### TAMARISK JOYSTICK

£22.50 inclusive

### GAME EXTENSION SOCKET

£6.50 inclusive.

from TAMARISK DESIGN SERVICES

290 Brooklands Rd, Manchester M23  
061-969 8729

● Circle No. 226

## KEYBOARD DUST COVERS FOR PETS

Keep your Pet Commodore keyboard free from contamination by fitting a superb flexible high quality transparent silicone rubber cover. Does not shrink; withstands boiling water, etc.

Keys operate with cover in place, ideal for exposed machines running daily in offices, labs, warehouses, etc. Covers fit all Commodore, Pet/CBM with large keyboard, including the 80 column models (covers will also fit other computers with similar size keyboard).

Price per cover £6 + 90p VAT  
Send cheque/PO to:

D.B.M. Products,  
P.O. Box 6, Melton Mowbray,  
Leicestershire, LE13 1YL.  
Please allow 28 days delivery.

● Circle No. 227

## APPLE DEALER

FOR

## PETERSFIELD & GUILDFORD

WILL DEMONSTRATE COLOUR GRAPHICS  
DATA BASE/MAILING LIST  
TABS ACCOUNTING SYSTEM

FOR SALES & SERVICE:

### ACCESS CONTROL SYSTEMS LTD.

72 WINCHESTER ROAD,  
PETERSFIELD, HANTS GU32 3PW

Tel: Petersfield (0730) 5274



● Circle No. 228

## Mr. RETAILER (C)

### POINT

ACCESS COMPUTERS

2 Rose Yard, Maidstone, Kent ME14 1HN  
Telephone (0622) 58356

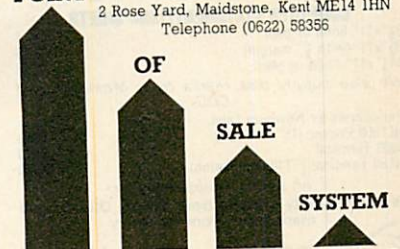

On Entry of Stock no. Receipt is printed Stock updated, VAT updated and year's bookkeeping updated.  
Complete system. Special introductory Price:  
Computer 64K + 700K + Printer + Mr. RETAILER (C)  
£2999 + VAT or Mr. RETAILER (C) £975.

● Circle No. 229

# SHOP WINDOW

## TRS80 Models I+III and VIDEO GENIE

Turn your

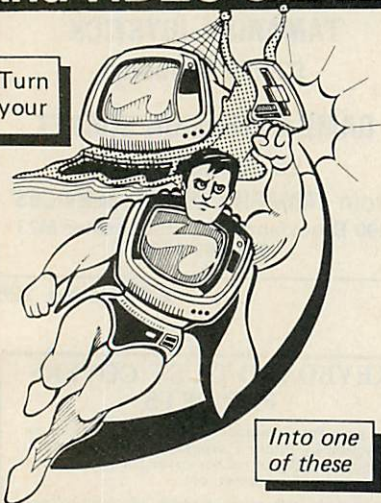

Into one of these

Announcing ACCEL3 — the practical BASIC compiler for home, education, or business.

Are you troubled by gradual graphics, languid loops, tedious table searches, or capricious keyboard response? ACCEL3 is the cure. Highly compatible with interpreted BASIC — correct programs compile without modification.

On Tape or Disk £49.95

**southern software**

PO Box 39, Eastleigh, Hants, SO5 5WQ

● Circle No. 230

## EPSON RIBBONS £2.50

Now you can replace your own EPSON MX 70/80/100 range ribbon and save ££££'s. A simple D.I.Y. task that takes around 5 minutes.

**ALL MODELS ONLY £2.50**

*Introductory offer we pay the V.A.T. Speedy Service Money Back Guarantee.*

DEPT ER  
WORK FORCE  
140 WILSDEN AVE  
LUTON, BEDS.

S.A.E. for details if you're not convinced.

● Circle No. 231

## COMPUTER SUPPLIES

### COMPUTER STATIONERY/1000 SHEETS

9 $\frac{1}{2}$ "x11" lined or plain £4.61  
9 $\frac{1}{2}$ "x11" (with  $\frac{1}{2}$ " margin) £5.96  
14 $\frac{1}{2}$ "x11" lined or plain £6.06

We also supply disk media from Memorex and CDC.

Peripherals by Newbury Labs.  
NL1550 Printer (15", 120 cps) £650  
8003 Terminal £710  
NL80 Terminal (UT100 emulation) £870

All prices include delivery

We also supply printers from Epson, Olivetti and many more from Newbury



**CDP Consultants Limited**

Clavering (079985) 617  
Cash with orders please

● Circle No. 232

## NIPPON ELECTRIC COMPANY

### Spinwriter

£1,500

Combines golf-ball daisywheel and thimble mechanism, uses continuous or single-sheet computer paper, RS232C serial (RO and KSR), Centronics-compatible and Diablo-compatible interfaces, 8080 input bus line, current loop, 55 cps, solid-font matrix. Main U.K. agent Memec Systems Ltd.

## OKI

### Microline 80A

£299

Dot matrix, 9x7, 80 cps, 80 or 132 cpl, pin, traction or friction feed, RS232, 20mA Centronics. Main U.K. agent X-Data.

### Microline 82A

£399

Dot matrix, impact printer, 80 cps, bi-directional logic-seeking, 40, 66, 80 or 132 cpl, pin, friction or tractor feed, serial and parallel interface, 160 characters. Main U.K. agent X-Data.

## QUME

### Sprint 5/45 receive only

£1,795

Daisywheel mechanism, uses plain paper, fan-fold or cut appear A4 up to six-ply, RS232C or V24 interfaces, 156 cpl at 12 pitch, 45 cps. Main U.K. agents, Access Data Communications and ISG Data Sales.

### Sprint 9/35 KSR

£1,400

35 cps daisywheel printer, exceptionally quiet operation, integral keyboard.

### Sprint 9/45 RO and Sprint 9/55 RO

£1,650

Similar to the 9/35 KSR but with no keyboard, 45 or 55 cps. Main U.K. distributor Bytech, ISG Data Sales.

## RAIR

### Main U.K. agent Rair Ltd

#### 820/825 Desk-top printer

£1,090

Dot matrix, RS232C interface, 132 cpl, 75 or 150 cps, 7x7 matrix.

#### DecWriter IV keyboard printer, KSR and read only

£795

Dot matrix, uses standard listing paper, RS232C current loop interface, 215 cpl, 30 or 180 cps, 9x7 matrix.

#### M200

£1,995

Dot matrix, uses continuous paper, parallel or serial interface, 132 cpl, 340 cps, double 7x9 matrix.

#### DecWriter III

£1,550

Dot matrix, uses continuous listing paper, RS232C or 20mA, current loop interfaces, 132-215 cpl, 180 cps, 7x7 matrix.

## RICOH

### RP-1600

£1,295

Daisywheel, uses single-sheet or continuous paper, Centronics and compatible interfaces, 132 cpl, 60 cps. Main U.K. agent Nexos (U.K.) Ltd.

## ROXBURGH PRINTERS

### X80 SP printer/plotter

from £896

Dot matrix, impact printer/plotter, pin-feed, fan-fold paper, RS232C, IEEE488, CBM, Centronics, HP85, 20mA, Tektronix, 80/96 cpl, 100 cps bi-directional, 8x8 matrix, three character generators, various other generators. U.K. dealer Roxburgh Printers Ltd.



**RP 8021** from £176  
Dot matrix, impact printer, Tally roll, parallel, RS232C, 20mA, 21 cpl, 150 lpm, 5x7 matrix, sprocket-feed option for labels. U.K. dealer Roxburgh Printers Ltd.

**RP 8040** from: £197  
Dot matrix, impact printer, Tally roll, parallel, RS232C, 20mA, 40 cpl, 72 lpm, 5x7 matrix, sprocket-feed option for labels. U.K. dealer Roxburgh Printers Ltd.

**RX 8000** from £228  
Dot-matrix impact printer, friction or tractor/friction feed versions. Centronics, RS-232/20mA loop, 80, 96 or 132 cpl, 80 lpm bidirectional logic seeking, 9x7 matrix, double-width characters.

**RX40 — Apple** £152  
Dot-matrix thermal printer, tally roll, direct Apple II connection, 40 cpl, 120 lpm, high-resolution graphics printing, 10 seconds for 1 page. U.K. dealer Roxburgh Printers.

## S FARID (SPECTRONICS) MANUFACTURING

**TP-40 and TP-65 receive only** from £660  
Thermal, matrix, uses thermal paper, cost of paper £1.80 each roll, seven-bit parallel interface, push-button control and self-test, 40 or 64 cpl, 13 or 18 cps, 7x5 dot matrix. Main U.K. agent S Farid (Spectronics) Manufacturing Ltd.

## TALLY

**Main U.K. agent Data Design Techniques Ltd**  
**T1612 keyboard send/receive** £1,612  
Dot matrix, pin-feed, single- or multi-part paper, RS232C or 20mA interfaces, 132-218 cpl, 160 cps, 7x9 or 9x9 matrices.

**T1612 receive only** £1,475  
**T1602**  
Dot matrix, pin-feed, single- or multi-part paper, Data Products, Centronics and serial interfaces, 132 cpl, 160 cps, 7x9 matrix.

## TELETYPE CORPORATION

**Model 43 keyboard send/receive** £800  
Impact matrix printer, uses pin-feed or friction-feed, dual RS232C and 20mA current loop interfaces, 132 cpl, 30 cps, 4x7 matrix on nine-wire printhead. Main U.K. agent Geveke Electronics Ltd.

## TEXAS INSTRUMENTS

**Main U.K. agents Texas Instruments and Rair Ltd**  
**OMNI 800 series** from £1,090  
**Models 810, 820 and 825** to £1,650

Dot matrix printers, uses paper, EIA, current loop, parallel interfaces, 132-216 cpl compressed print (models 820 and 825), 132 cpl (model 810), 75 cps (model 825), 150 cps (models 810 and 820), 9x7 matrix.

**Silent 700, model and 745 portable** £1,250  
Thermal mechanism, uses thermal paper at £1.50 per 100ft. roll, integral acoustic coupler, EIA interfaces, 80 cpl, 30 cps, 5x7 matrix.

**Silent 700, 743 Keyboard send/receive version** £1,105  
Thermal mechanism, uses thermal paper at £1.50 per 100ft. roll, EIA, 20mA current loop interfaces, 80 cpl, 30 cps, 5x7 matrix.

## TRANSDATA

**313 Receive only** £790  
Dot matrix mechanism, uses thermal paper at £60 per box of 24 rolls x 150ft. RS232C and parallel interfaces, designed for use as VDU hard copy, 80/132 cpl, 30 to 45 cps, 7x5 matrix. Main U.K. agent Transdata Ltd.

### MASTER MATHS

The LCL Master Maths package contains every program you will ever need to get you, your pupils or your son or daughter through O-Level Maths or equivalent. It consists of:

- 50 long programs using High-Res. Colour Graphics and sound crammed onto 6 discs
- It is written by a qualified, professional programmer in consultation with schools and colleges
- It includes a quality manual and only costs £90 (including VAT)

It runs on the Apple. Suites of Maths programs are also sold separately to run on the ZX81 and Apple from £5. Send for free catalogue to:  
G. Ludinski B.Sc(Hons) AMBCS,  
LCL, 26, Avondale Ave.,  
Staines, Middx.  
Tel: (0784) 58771

● Circle No. 233

### SOFTWARE FOR YOUR

## BBC MICRO

(MODEL A OR B)

- LAZER BOMBER** — Strike back at the Aliens.
- SKIER** — Dodge the trees, reaction game.
- COMPOSER** — Create, edit and save tunes.

### 'TELETEXT' MODE SCREEN EDITOR

Create, edit and save your own Teletext style pages.

All on one cassette — £4.99 inc. P&P.

Cheque or P.O. payable to:

'SOFTEFEX',

11 ALL SAINTS ROAD,  
CREETING ST. MARY, IPSWICH, IP6 8NF

● Circle No. 234

### THE POWER BANK

Plug your micro computer video unit and Printer into the POWER BANK and forget about a disabling break in the electricity supply. This unit will continue to run your system for up to one hour in the event of a mains failure.

WITH NO INTERRUPTION TO YOUR WORK!



Batteries included

Vital when running business systems. This unit will of course suppress MAINS SPIKES and SURGES.

SIGNWAVE OUTPUT

Retail price £320 + VAT  
Weight 13Kgms Size 43cms x 20cms x 9cms  
**POWER TESTING LTD**

1 St Mary's Lane, Upminster  
Tel: Upminster 26938

● Circle No. 235

### DOES YOUR SUPERBRAIN SUFFER FROM A HEADACHE?

FOR FAST RELIEF  
CONTACT:  
THE NO. 1 MAINTENANCE COMPANY

### Digital Computer Services Ltd.

76-78 Back Wallgate, Wigan,  
Lancs. WN1 1BA  
Tel: 0942 321153/02575 4899

Full field service, depot and module repair service available

● Circle No. 236



# MICROWARE

(London Ltd)

## COMPLETE DISC DRIVE SUB SYSTEMS

For Tandy; Video Genie;  
Nascom

**BBC**  
AND ALL POPULAR MICROS  
FROM ONLY **£175**

- Includes PSU and attractive desk top cabinet
- Fully guaranteed CDC disc drives
  - Cast aluminium chassis
  - 5 mil sec track to track
  - 250k; 500k or 1MB
  - Industry compatible

# Microware

(London Ltd)  
5 Western Court, Huntly Drive,  
London N3 1NX  
Tel: 01-346 8452

● Circle No. 237

## MINI/MICRO COMPUTER MAINTENANCE

DEC  
Superbrain  
North Star  
Diablo

Pets  
Dynabyte  
Anadex  
Qume etc.

CONTACT THE PROFESSIONALS

### Digital Computer Services Ltd.

76-78 Back Wallgate, Wigan,  
Lancs. WN1 1BA  
Tel: 0542 321153/02575 4899

Full field service and depot repair facility available  
Contracts undertaken

● Circle No. 238

## C24 Green Filter Sheet

Enhance VDU contrast ratio  
(typ. from 6:1 to 9:1 for b/w TV screen)

Reduce glare

Improve visual acuity

Reduce eye fatigue

Suitable for white & green phosphors

10" x 12" (up to 14" screen) £ 3:00 p&p  
18" x 23" (up to 26" screen) £ 5:00 vat  
trim to size, fixers supplied inc.

### Mesotec

204 Harrogate Road  
Leeds LS7 4QD

● Circle No. 239

## TRANSTEL COMMUNICATIONS

### AR receive only

Dot matrix, uses standard teleprinter paper, V24, current loop interface, 80 cpl, 30 cps, 7x5 matrix. Main U.K. agent Transtel Communications Ltd.

P.O.A.

## UNITED SYSTEMS CORPORATION

### Main U.K. agent Aviquipo Ltd

#### DigiTec 6320

Electro-sensitive dot matrix, electro-sensitive line roll paper at £1.80 per roll, RS232C or isolated 20mA current loop, 21 or 32 cpl, prints two lines per second, 1,200 Baud receive, 5x7 matrix.

£483

#### DigiTec 6330

Dot matrix, electro-sensitive paper at £1.80 per roll, 8-bit parallel/character serial, 21 or 32 cpl, 5x7 matrix.

£421

#### DigiTec 6410

Dot matrix, electro-sensitive paper at £1.80 per roll, RS232C or 20mA current loop, 21 or 32 cpl, two lines per second, 5x7 matrix.

£237

#### DigiTec 6420

Dot matrix, electro-sensitive paper at £1.80 per roll, 8-bit parallel serial, 21 or 32 cpl, prints two lines per second, 1,200 Baud receive, 5x7 matrix.

£237

#### DigiTec 6450

Dot matrix, thermal paper at £1.80 per roll, RS232C 20mA current loop, 21 cpl, prints two lines per second, 110 or 300 Baud receive, 5x7 matrix.

£266

#### DigiTec 6460

Dot matrix, thermal paper at £1.80 per roll, eight-bit parallel serial 21 cpl, two lines per second, up to 1,000 Baud receive, 5x7 matrix.

£266

#### DigiTec 6550

Dot matrix, thermal paper at £1.80 per roll, RS232C or 20mA current loop, 21 or 32 cpl, prints two lines per second, 110 or 300 Baud receive, 5x7 matrix.

£289

## VECTOR GRAPHIC

### MP printer

Uni-directional seven-wire x five-column dot matrix, original and one copy, maximum paper thickness 0.2mm., uses pin-wheel paper feed, 70 lines per minute, 150 cps, TTL level interface, two parallel output ports and one-parallel input port. Main U.K. agent Almarc Data Systems Ltd.

£599

## WALTERS MICROSYSTEMS

### Dolphin BD-80P

Impact, dot matrix, adjustable sprocket feed, any one of three interface choices, 10 characters per inch, 80 cpl, full ASCII character set, self-testing, 64 graphics characters, 9x7 and 11x7 matrices, double-width characters, bi-directional printing. Main U.K. dealers Texas Instruments or Walters Microsystems.

£525\*

### Dolphin BD-136

Impact, dot matrix, forms tractor, fully interfaceable, 136-226 column width, full graphics capability, 7x9, 9x9 matrices, 32 user-definable characters plus full ASCII set, data-formatting functions, fully logic seeking, self-testing. U.K. dealers Nexos.

£1,200

## WENGER DATENTECHNIK

### Sole U.K. distributor Access Data Communications Ltd

#### Print Swiss Matrix Printer

Dot matrix RS232C, 20mA, 60mA and parallel interfaces, Centronics-compatible, 80 cpl, constant throughout 80 cps, 55-1000 lines per minute, 7x7 matrix. KSR version also available.

from £700

#### Penny & Giles hard copies

Electro-static RMP paper 127mm. x 70m. at £3.50 per roll, RS232C, current loop option, 80/40/20 cpl, 80 columns, 110 lines per minute, 8x5 line printer, 5x7 message printer matrix.

from £365



## WHYMARK INSTRUMENTS

### Main U.K. agent Whymark Instruments Ltd

<b>Model 201</b>	£440
Dot matrix, Tally-roll paper printer, IEEE, RS232C, serial, and parallel interfaces, 40 cpl, 40 cps, 52 character set with four-character sizes.	
<b>Model 204 label printer</b>	£515
Dot matrix, impact printer for self-adhesive labels, IEEE, RS232C, serial and parallel interfaces, 40 cpl, 40 cps, 52 character set with four-character sizes.	
<b>Model 3011 ticket/form printer</b>	£690
Dot matrix, plain paper, options automatic date and time, IEEE, RS232C, 40 cpl, 40 cps, 52 character set with four character sizes.	
<b>Model 501 rack-mounting printer</b>	£625
Dot matrix plain paper, options automatic date and time, IEEE, RS232C, 40 cps, 40 cpl, 52 character set with four character sizes.	
<b>Model 801 80/120 column printer</b>	£750
Dot matrix, plain or fan-fold paper, proportional spacing up to 120 cpl, 120 cps, bi-directional printing, user-definable character set, up to 4K selectable character fonts, graphics, and user-definable characters, also available; very large characters seven lines high.	

## Alphabetical list of suppliers

Supplier	Address
Access Data Communications Ltd, 0895-30831	Unit 17, Eskdale Road, Uxbridge Industrial Estate, Uxbridge, Middlesex UB8 2RT.
Almarc Data Systems Ltd, 0602-52657	Great Freeman Street, Nottingham NG3 1FH
Anadex Ltd, 025672-3401	Weaver House, Station Road, Hook, Hampshire RG27 9HU
Aviquipo of Britain Ltd, 0628-34555	St. Peter's Road, Maidenhead, Berkshire SL6 7QU
Bytech Ltd, 0734-61031	Suttons Industrial Park, London Road, Earley, Reading, Berkshire RG6 1AZ
Cable and Wireless 01-928 0261	83 Blackfriars Road, London SE1 8HQ
Cifer Systems Ltd, 0225-704502	Avro Way, Bowerhill, Melksham, Wiltshire SN12 6TP
Clary Ltd, 01-680 2222	12-14 Lower Addiscombe Road, Croydon, Surrey CR9 6AG
Comma Computers, 0277-811 131	West Horndon Ind Park, West Horndon, Essex CM13 3MJ
Dacoll Engineering Services Ltd, 0438-4381/0506-56565	Gardners Lane, Bathgate, West Lothian
Datac Ltd, 061-941 236/2	Tudor Road, Broadheath, Altrincham WA14 5TN
Data Design Techniques Ltd, 01-207 1717	12 Leeming Road, Borehamwood, Hertfordshire WD6 4DU
Data Dynamics, 01-848 9781	Data House, Springfield Road, Hayes, Middlesex
Data General Ltd, 01-572 7455	3rd and 4th Floors, Hounslow House, 724-734 London Road, Hounslow, Middlesex TW3 1PD
Dataplus Ltd, 0242-30030/37373	39-49 Roman Road, Cheltenham GL51 8QQ
Datatrade Ltd, 0604-22289	17 Billing Road, Northampton NN1 5AW
Davinci Computers Ltd, 01-952 0526	65 High Street, Edgware
Diablo Systems Ltd, 04862-71991	Regent House, 20 The Broadway, Woking, Surrey GU21 5AP
Digitronix Ltd, 0908-566888	10 Burners Lane, Kiln Farm Industrial Estate, Milton Keynes

## TRS 80 & VG

### Software to make life easier

**DISK-R.P.M.** Measure the rotational speed of your disk drives and reveal variations that can be a cause of unexplained errors. Shows current and average speeds. Operates under any D.O.S. 32-48k Mod. I or III or V.G. **£14.50** incl. p&p. + V.A.T.

**FASTER** Analyse your Basic programmes while they run, FASTER will show you simple changes that can reduce run times by up to 50%. Accounting systems, Financial models, Engineering, Scientific, Games all run faster. Large complicated programmes improve the most. 16-48k Mod. I or III or V.G. Tape or Disk **£17.50** incl. p&p. + V.A.T.

**QUICK-Compress** Small (276 bytes), fast (process 800 lines in less than 3 seconds) utility removes blanks and remarks from your Basic programmes. Produces smaller, faster programmes, and doesn't alter the original logic. 16-48k Mod. I or III or V.G. Tape or Disk **£8.90** incl. p&p. + V.A.T.

**SPECIAL: FASTER + QUICK-Compress £22.00** incl. p&p. + V.A.T.

Specify Mod I or III or V.G. and Tape or Disk when ordering.



E.A. International, 8 High Street, Suite 208, Meldreth, Royston, Herts: (0763) 60189  
Catalogue £1.00 (Includes vouchers value £5.00)

● Circle No. 240

### Worcester College of Higher Education

## SUMMER SCHOOL 1982

30th July — 6th August

### USING

## MICROCOMPUTERS

A practical course on using small computers for business, administrative, educational and domestic purposes.

Offers intensive hands-on experience with a wide range of computer systems.

Alternative modules for beginners and those with some experience.

For further information please write to the Director of Summer School, Worcester College of Higher Education, Henwick Grove, Worcester WR2 6AJ. Telephone No. (0905) 428080.

● Circle No. 241

ANYONE HAVE AN ATARI 400 or 800 to swap for H-Fi system (with possible cash adjustment). Hi-Fi consists of Aiwa front loading cassette, AD6300 Dolby/Metal/CRO<sup>2</sup> JVC amp JAS11 30 watts RMS per channel, Philips deck, Solavox speakers, Akai reel to reel 2 speed with Dolby. Tel: (0302) 874977.

ATOM USERS talk down a big jet, a program written by a radar controller for controllers simulating 430 radar approach. Send £5 to Mr Parkes, 22 Pleshey Close, W-S-M, Avon.

## COMPUTER SUPPLIES

Do you need supplies for micro and word processors — if so give us a call on:

**021-771-3000**  
or telex 826843 Dutom G

**We offer:**

Floppy disks, printer wheels, ribbons, storage and cleaning products, office furniture and equipment. All at very competitive prices.

● Circle No. 242

**VIC 20 GAMES TAPE.** Six super games for only £3 incl p&p). Each game features graphics, colour and sound. Four in a row, Mean Maze, Pontoon, Bustabrick, Higher or Lower and Fruit Machine. All run on standard machine, hours of fun. Send now to: M. Gardiner, 103 Holmes Chapel Road, Congleton, Cheshire.

**PET 32K (new ROMs),** with cassette deck, £450. Tel: Worcester 52108.

**ZX80, 8K ROM** with 16K RAM plus motherboard, soundboard, Sinclair manuals, software cassettes and books. £120. Tel: 041-763 1624.

**SARACEN COMPLETE S100 System.** 64K Z80 4 serial, 4 parallel ports. 2 x 8 inch double sided single density drives. CPM 2.2, Steel cabinet Lyme 4003 VDU. DRI 6320 132 column printer with stand. £4,000. Mr. M. R. Wilson, Selborne (042-050) 344.

**BBC/TRS-80/ZX81 Educational Software** by professionally qualified teacher. Over 16 Language and Mathematical programs from £3.50 as reviewed EDUCATIONAL COMPUTING magazine. S.A.E., Bryants, 1 The Hollies, Chalcraft Lane, North Bersted, Bognor Regis PO21 5SX. Tel: Bognor 829478.

**INCREASE YOUR INCOME** using "Midas", a successful inflation beating user friendly program written for a 3032/4032 (32K) PET. Test this £55 program for only £2.99, and confirm that MIDAS & PET make MONEY. All we ask is that within 21 days, you either pay the balance of £52, or simply return the original cassette and owe nothing more. Amron, 21, Grosvenor Road, Southport PR8 2JG.

**TRS-80 MACHINE CODE** games cassette featuring "Breakout", "Invaders" & "Submarine Battle" — £5 inclusive. Money with order, delivery by return. A. Moseley, 59 Plymstock Road, Plymstock, Plymouth, Devon PL9 7NX.

**ZX80.** Both ROMs, manuals, leads, software. As new £55. Phone 059-581 202.

**ZX81 TOPPIX.** Detailed DIY graphics update £2. 16K M/C easyloaders, load REMs without spaces anywhere in listing. HEX and Decimal £4, or £2.50 each. All plus S.A.E. N. J. Petry, 3 Lester Drive, Worle, W.S.M. BS22 0NG.

**PET 'MINI BASIC COMPILER'** on cassette with 20 page manual. All ROMs, all maths functions supported, with up to 15 x speed of interpreter. £16.50. PET machine language guide — details over 30 built in ROM routines. £6. S.A.E. for further details: Adamsoft, 18 Norwich Avenue, Rochdale, Lancs OL11 5JZ.

DRG Business Machines,  
0934-416392  
Electrographic AV Ltd,  
01-573 1826  
Extel,  
01-739 2041

Facit Ltd,  
0634-40172/7  
Fortronic Ltd,  
0383-823121  
Geveke Electronics Ltd,  
04862-71337  
Heath Electronics (U.K.) Ltd,  
0452-29451  
ISG Data Sales Ltd,  
95-57955

ITT Electronic Services,  
0279-26777

ITT Business Systems,  
0273-507111

Kode Services,  
0249-813771

MBS Terminals Ltd,  
09323-53151

Memec Systems Ltd,  
084421-3149

MIBF  
0734-415191

Microbyte,  
01-278 7369

Microsense Computers Ltd,  
0442-48151/41191

Newbear Computing Store,  
0635-30505

Nexos U.K. Ltd,  
084421-3151

Penny & Giles Data  
Recorders Ltd,  
042-5271 511

Peripheral Hardware Ltd,  
01-941 4806

Rair Ltd,  
01-836 4663

Robox Office Equipment Ltd,  
041-776 4388

Roxburgh Printers Ltd,  
07973-3777

Russet Instruments Ltd,  
0734-868147

S. Farid (Spectronics)  
Manufacturing Ltd,  
02013-77337

SEN Electronics  
09328-66744

Stack Computer Services Ltd,  
051-933 5511

Teleprinter Equipment Ltd,  
044282-4011/9

Terminal Display Systems Ltd,  
0254-662244

Texas Instruments Ltd,  
0234-67466

Transdata Ltd,  
01-403 5115

Wilkes Computing Ltd,  
0272-25921

Whymark Instruments Ltd,  
07372-21753

X-Data  
0753 49117

13-14 Lynx Crescent, Winterstoke Road,  
Weston-super-Mare, Avon.  
Printinghouse Lane, Hayes, Middlesex UB3 1AP

Engineering Division, The Exchange Telegraph  
Company Ltd, 73-75 Scrutton Street, London  
EC2 4TA  
Maidstone Road, Rochester, Kent

Donibristle Industrial Estate, Dunfermline

RMC House, Vale Farm Road, Woking, Surrey

Bristol Road, Gloucester GL2 6EE

Unit 9, Fairacre Industrial Estate,  
Dedworth Road,  
Windsor, Berkshire

Edinburgh Way, Harlow, Essex

Crowhurst Road, Hollingbury, Brighton  
BN1 8AN

Station Road, Calne, Wiltshire SN11 0JR

Aldwych House, Madeira Road, West Byfleet,  
Surrey KT14 6BA

Park Industrial Estate, Thame, Oxon

Barclays Bank Chambers, Pegg Lane, Kirkgate,  
Tadcaster, North Yorkshire

Unit 9-10, 1st Floor, 38 Mount Pleasant, London  
WC1X 0AD

Finway Road, Hemel Hempstead, Hertfordshire  
HP2 7PS

49 Bartholomew Street, Newbury, Berkshire

3 Jefferson Way, Thame, Oxfordshire OX9 3FU

Mudeford, Christchurch, Dorset BH23 4AT

Armfield Close, West Molesey, Surrey

30-32 Neal Street, London WC2H 9PS

84 Townhead, Kirk in Tiloch, Glasgow, Scotland

22 Winchelsea Road, Rye, E. Sussex  
TN31 7BR

Unit 1, Nimrod Way, Nimrod Industrial Estate,  
Reading, Berkshire RG2 0EB

Dawkins Road, Industrial Estate, Poole, Dorset  
BH15 4JY

5 London Street, Chertsey, Surrey

290-298 Derby Road, Bootle, Liverpool L20 8LN

70 Akeman Street, Tring, Hertfordshire  
HP23 6AJ

Hillside, Whitbrik Estate, Blackburn, Lancashire  
BB1 5SN

Manton Lane, Bedford MK41 7PA

Battlebridge House, 87-95 Tooley Street,  
London SE1 2RA

Bush House, 72 Prince Street, Bristol BS1 4HU

6 Holmsdale Road, Reigate, Surrey RH2 0BQ

Marish Wharf, St Mary's Road, Langley, Slough,  
Berkshire SL4 1HE



COMPLETE SYSTEM HEATH/ZENITH for sale. Comprises: H8 Computer with 56K RAM; H19 "Intelligent" VDU with graphics; 2-H17 5 $\frac{1}{2}$ " disk drives and H14 dot matrix printer. Includes all software (CP/M Compatible), manuals and 30 discs. Current cost would be in excess of £3,000. Will accept £1,300 or nearest. Telephone Burscough 0704 89 3260.

RTTY RTTY RTTY. See the world of teletype with our Computer interface unit. PC boards — Wired Modules — Boxed units. SAE for details. Mr. J. Melvin, 2 Salters Court, Gosforth, Newcastle-upon-Tyne. Tel: 843028.

48K EXIDY SORCERER, as new, all manuals and leads, UHF modulator, basic rom. Offers over £350 secures. Tel: Winchester (0962) 66720 evenings.

CBM ACOUSTIC MODEMS (2). Connect directly to IEEE bus for communication with other CBM or remote mainframe. £300 the pair or £175 each. Woking 61082.

ACORN ATOM 12K x 12K. Software including Chess, Dodgems and Breakout. £200. Tel: 01-659 2002.

TRS-80 MOD1 16KL2, keyboard unit £350, 32K expansion interface £200, (TEAC) disk-drive & sys disk £200. All very little used. Tel: (0443) 690174 night or (0685) 74397 day.

WANTED — PET 8032/8096 business system. Separates considered. Tel: 0270-67889 after 7.00 p.m.

ITT 2020 (Apple II) 48K micro-computer with Intecer basic Rom card. RTTY/CW software, £550 ono. Tel: 0276 25040.

6502 Line by line assembler and disassembler program in 2K bytes. Adaptable to most 6502 machines with alphanumeric keyboard and memory-mapped VDU. £3 plus transportation costs. For details telephone 0574 4530 weekdays 7.30 p.m. to 11.30 p.m. or S.A.E. to E. Blackburne, 32 Newington Avenue, Larne, Co. Antrim, BT40 1NN.

NORWEGIAN usergroup seeking used ZX81s. Will pay well. Contact Jan Otto Reberg, Bjerkelundveien 15, 1400 Ski, NORWAY.

COMMODORE 32K — 3032 Series PET CPU plus Computhink 800K disc drive units and Commodore Tractor Printer 3022 Series ideal machine for development work, very clean, very little used, £800 the lot. Contact Mike Sibley, Tel: 01-739 3158.

ZX81 Personal Computer, as new, £60 o.n.o. Tel: 051-339 8203

VIC 20 ASTRO PILOT 5K. Cassette £2. Rom Software, Stanhope House, Soames Walk, New Malden, Surrey, KT3 4RZ.

APPLE II PLUS 32K, with Colour Card, Modulator, Paddles, Manuals etc. As new £600. Tel: 03294 43821, Fareham (Hants).

APPLE II PLUS. 48K. £540 incl. software, Apple magazines. Telephone Bedford 856716.

DRI 4000 top loading FED hard disk drive. Unused, tested, suit S100 system. £850 o.n.o. (includes power supply). Phone Bristol 791799 or Winterbourne (Bristol) 772545.

POWER chip £42. COMMANDO-O chip £51. (75% cost price). Manuals included. Both C.B.M. 8032 slot UD12. Tel: 041-639 6626 after 6pm.

PET 2001 16K. New ROM. Large keyboard. Commodore cassette. Phillips mini digital cassette. Printer interface. Assembler, toolkit, superchip ROMs. Software. Books. £600. P. Novis, 108a Milton Road, Clapham, Bedford, MK41 6AS.

ZX81 16K+ printer + extras, vgc, (3 months old) — £175 ono. Call Redhill 61612 after 6pm.

TRS-80 Quick Printer II. Good as new, £75. Tel: 061-973 9877.

VIDEO GENIE. 16K with sound, little used — £225. Tel: 0590 22744.

TRS-80 4K Level 2 VDU, Cassette recorder, manuals, etc. £265 ono. Tel: 01-890 6627.

APPLE II PLUS, 48K, £450. Microhush 100 thermal printer for Apple £75. Tel: Chard (04606) 3814 evenings.

S-100: Morrors 16K S/Ram Boards £71; IMS 8K S/Ram Boards £50; North Star 16K D/Ram Boards £80, Z80 CPU Board £105; Cromemco 2708 Eprom (16K capacity) Boards £35. APPLE M/Softcard CP/M/Basic £165; SSM I/O Card £92. 15in Green Screen D/Drive Monitor £60. Phone Crawley 515201.

FIRST ELECTRONIC CROSSWORD. For ZX81 16K. Graphic display. Tests knowledge of Basic. Also ANAGRAM. Three levels. Two games for £4.95. W. Newman, 3 Thalia Close, Greenwich, SE10 9NA.

SHARP MZ80K software: excellent games programmes available at a fraction of the usual prices. Also cassette Base business systems. SAE. for full details. C. Trevena, 20 Rhosleigh Ave, Sharples, Bolton, BL1 6PP.

ZX81 users, build your own 16K RAM extension. For full circuit information and instructions to build this digital masterpiece, send cheque or postal order for £1 only to MICROTEx, FREEPOST, HULL.

EMDAS Z80 ASSEMBLER/OPERATING system for NASCOMS with Nas-sys1. Written with a 'BASIC' approach to assembler language. An ideal aid for beginners or experienced programmers who wish to learn to write in machine code. 16 page documentation included. On tape (4-2K) £8.50. An assembler program: COSMIC INVADERS (gives a 2K object machine code program) on same tape £5. State if required. Richard Daykin, 7 Holcombe View, Moorside, Oldham OL4 2QD. Telephone (061) 6523969.

PET 2001 32K, green screen, little used, external cassette, large keyboard, manual and games. Telephone John on Stevenage 55421.

UK 101 GAMES SOFTWARE. Details from M. Leslie, 5 Baldwins, Welwyn Garden City, Herts AL7 2BD or phone 35949.

TANDY MODEL 1, 16K, green screen, £100 software, £410 ono 0752663219

ZX81 8K/16K ARCADE GAMES: Fantastic flicker-free moving graphics! Pack 1: Defender, Scramble, U-boat. Pack 2: Missile Control, Air Raid, Monaco. £1.50 per pack (listings). 16K games — s.a.e. for catalogue, free game. Jega Software, 27 Hallcroft Avenue, Countesthorpe, Leicester LE8 3SL.

NASCOM 2 (64K+8K PAGED) using 8in disk drive, >2400 baud tape, RS232, lots of software, system in verocase, 20 diskettes included, fully working, £680. Swanley 67083.

GOING ABROAD TO WORK. Must sell my disk based Exidy word processor. Cost over £3,000 new. Full system includes daisywheel printer. Giveaway price for quick sale, £1,500. No VAT. Phone 01-979 4370.

TRS-80 LII 16K + PSU and CTR/41. Also £50 of software. As new. Offers around £250. Phone (0535) 34402. J. D. Hopcroft.

ZX81. Tape A: 10 1K games, cassette £2.50, listings £3.00. Basic — Connection, Hangman, Defender, Destroyer, Simon, Invasion, M/c Canyon, Galaxians, Shuttle, Asteroids. (SAE details) I. Morrison, 17 Winton Circus, Saltcoats, KA21 5DA.

MZ80K. Games and utility programs. Write 3B South Parade, Bramhall, Stockport, SK7 3BJ.

PR40 (40-col) printer for Pet. £140 plus p&p. Tel 0304 617209.

UK101 8K including many programs such as: Invaders, Assembler, Startrek, £90. 051-228 7971.

ZX81 16K chess on cassette. 6 levels, graphic display. Send £3.90 to W. Hanratty, 15 Forth Court, Port Seton, East Lothian.

48K Apple II Plus, 2 drives, controller board, b&w monitor, paddles, floppies. VGC only £850. Tel Purfleet 4431 office hours.

ACULAB FLOPPY TAPE (TRS80 or Genie) with many programs e.g. Edtasm, Tbug chess, Backgammon, Adventures, Aculab extended Basic and Database etc £150. 01-693 8975.

THE REAL ADVENTURE BEGINS HERE — for Nascom owners with NAS-SYS. Send SAE for details on our versions of the classic mainframe Adventure (Nascom approved product) in machine code to: Syrtis Software, 23 Quantock Road, BRIDGWATER, Somerset.

VIDEO GENIE, eight months old, many books, some tapes, quick sale, £230. Ring 859 4780.

PET GAMES FOR SALE on cassette. 1) Mountain Attack (8K) £7 (Defender type space game). 2) Asteroids (space game) (8K) £7. 3) Carnivorous Caves (16K) £9 (Adventure game). 4) Educational space invaders (8K). (Learn to + - x ÷ the fun way). More available. Cheques and PO made payable to: 36 Highgate Avenue, Fulwood, Preston, Lancs. PR2 4LN.

32K PET SYSTEM comprising 3032 Pet, 3040 dual floppy, 3022 tractor printer and cables. As new condition, £1,800 the lot with 3 month guarantee, or could split. Tel: 09662 4104.

FOR SALE ZX81 1K RAM £45 wanted VIC-20. Alderley Edge 582146.

SHARP MZ80K 48K as new inc. manual, books, software, £375. Phone Hartlepool 74085.

ACORN BUILT 12K + 12K ATOM, PSU, leads, manual, £200 ono. Tel: (0283) 701142.

NORTH STAR HORIZON 32K; twin DD disk units. TTY43 pin feed terminal/printer. Hazeltine 1410 terminal. Disks and some software. All in first class condition. Offers over £2,000. 031-229 0874 (evenings).

# Software for CP/M™

MICRO PRO	LIST
Wordstar™ 3-X	£250
Mail Merge	£ 60
Data Star	£170
Supersort I	£120
Spellstar (USA dictionary)	£120
Calcstar	£150

MICRO SOFT	LIST
Basic-80 Interpreter	£150
Basic Compiler	£190
Fortran-80	£210
Cobol-80	£310

MISC		LIST
Compiler Systems	CBasic-2	£ 65
	CB 80	£280
Sorcim	Pascal/M	£120
Sorcim	Supercalc	£170
Ashton Tate	d Base II	£380
Ecosoft	MicroStat	£150
Organic	Milestone	£160
	(critical path)	

CP/M is TM of Digital Research. WORDSTAR is TM of Micro Pro  
Other Products constantly being added to our range.  
Send large s.a.e. for latest list

## TRADE ENQUIRIES WELCOME

Ordering Instructions:  
Cash with order. Specify disk format.  
Add £3.00 per item P&P. Add 15% VAT



the  
**soft  
option**

BAMBERPLAN LTD  
PO BOX 11 CRANBROOK KENT  
TN17 2DF Tel: (058 080) 310

● Circle No. 257

# DOUBLE your disk capacity

## ONLY £55

KEELE CODES' unique compression utility E40 will compress files written in English to approx 40% of their original size in the same time as it would take to make a copy.

Making backups? – receiving disc lasts twice as long  
Archiving a Winchester? – half as many disc changes  
Data by telephone? – powerful archive commands  
Running out of space? – halve the cost  
Computer/ – double the space you 'see' from computer transfer? – the terminal  
You don't believe it? – part of the package – and twice as fast as a bonus  
If not satisfied return within 30 days – we will refund your money.

## Proven & Working

Fully developed, E40 is the result of extended research at the University of Keele. Optimized for English, E40 will compress any text/data files. Numeric or tabular material compresses to about 50%. Database files can come as low as 20%. All 256 ASCII characters are processed, and the decode program faithfully restores the original file. A third utility transfers E40 files through a serial port.

**CP/M** formats include – Xerox 820, Superbrain, North Star, Osborne, Z80-Apple, IMS 5000, RAI, Vector, NEC, Sharp, Heath/Zenith, 8" IBM. Also available for PDPII and GEC 4080 series.

Write or phone for full details



Keele Codes Limited, University of Keele,  
Keele, Staffs ST5 5BG  
Tel: 0782 629221  
Telex: 36113

## ORDER NOW!

Cut out the coupon  
Access accepted. You may phone your order  
24 hours service. Guaranteed despatch within 72 hours

Please send me

E40 for CP/M..... £55 + VAT (incl postage)

CP/M manual..... £5

Further details.....

Name \_\_\_\_\_

Address \_\_\_\_\_

I enclose a cheque for \_\_\_\_\_ Access no \_\_\_\_\_

My computer is \_\_\_\_\_ Year of purchase \_\_\_\_\_

● Circle No. 258

Stalingrad was a turning point in the war against fascism. This game from *The War Machine* gives you a chance to find out how close the German army came to conquering Russia. You are in General Von Paulus's shoes, and the computer in Marshall Zhukov's.

# EASTERN FRONT



EASTERN FRONT is written in machine code to run in 16K memory on the Atari 800 or 400. It is a simulation of Hitler's Operation Barbarossa in 1941, and runs from June 1941 to March 1942 in weekly turns. You play the Germans while the computer controls the Russians.

When the program is loaded a map of Russia appears, taking up two-thirds of the screen. The rest is occupied by the date of the action and two information panels. The map terrain includes rivers, mountains, swamp, forest and towns. The base colour of the map changes with the seasons, from brown in summer to grey in autumn and white in winter. The rivers change colour if they are frozen.

## Screen information

On top of the map is a large hollowed-out square cursor which is controlled by the ubiquitous Atari joystick. If it is moved to the edge of the screen the map scrolls smoothly in the direction of cursor movement. The map stretches across an area of 10 screens.

Units are shown on the map as squares with different notations inside, depending on whether they are infantry or armour. When the cursor is positioned over the unit marker and the red trigger button is pressed, the unit designation, muster and strength are shown in the information panel at the bottom of the screen. Simultaneously with this an Iron Cross appears over the unit marker and this is the key to movement.

With the trigger pressed to show the cross, each movement of the joystick, up, down or sideways, will move the cross one step in that direction. The computer allows you to take eight steps. Releasing

the joystick will make a green arrow emanate from the unit to the cross to show the path of movement. This is a necessary feature as traffic jams of units can quite easily build up and slow down your unit's progress.

The arrow can be used to check the possible build-up of jams by positioning the cursor and pushing the trigger. The arrow and the unit's cross are then displayed to show the unit's movement.

With the moves sorted out, pressing the start button at the side of the Atari's keyboard will start the computer resolving combat, and moving units. After each turn a number between 0 and 255 appears on the information panel to tell you how well you are doing. If you are a beginner you can press the option key on the keyboard and the muster of German units is increased.

The game plays superbly. All the normal war-game rules are in force, including zones of control, logistics, terrain and combat. Although the computer does all the work resolving combat and movement, it is possible to see how your units

are doing on the screen. Combat is shown by the aggressors flashing on and off, and by the sound of machine-gun fire. Movement is shown as if it were a normal map board.

The tactics that have to be used are similar to those in the real battle. The Germans must use their tanks to break the line and speed towards Moscow and Stalingrad, while using the infantry as support and for mopping-up operations. When the Russian counter-offensive starts you feel like Canute trying to stem the tide.

## Stalingrad crucial

The Germans must not spend too much time finishing off any Russian units behind their lines. It is better to stop them with one unit and starve them out through lack of supply.

To score highly Moscow and Stalingrad must be taken and held, and the Russians pushed as far east as possible. The computer will be planning its own moves while you are inputting yours. It does this by a system known as multi-tasking. It starts with a basic move and gradually refines it.

You can forget about rushing your move; the computer is fast, and will not be caught out by a rapid response from the player. The computer plays an extremely good game and after two months of play I can now score 50 points a game.

According to the excellent manual supplied with the game this rates as good. Apparently it is possible to achieve over 200 points — I must try harder.

*The War Machine* is published monthly by Emjay, 17 Langbank Ave, Rise Park, Nottingham, NG5 5BU. £1.25 an issue, £13 for an annual subscription, postage and packing included.

## Conclusions

- The computer will recognise weak spots, danger, and the use of differing terrain.
- It does not react to the player's strategy, but takes every turn as it sees it.
- A remarkable feat to have fitted so much into 16K.
- Ratings:
 

Physical quality	Good
Perceived complexity	Fair
Subject complexity	High
Realism	Good
Play balance	Demanding
Overall	Very good

# CU-GRAPH

## ACORN COMPATIBLE GRAPHICS CARD

### 8 colours in 512 x 256 pixels

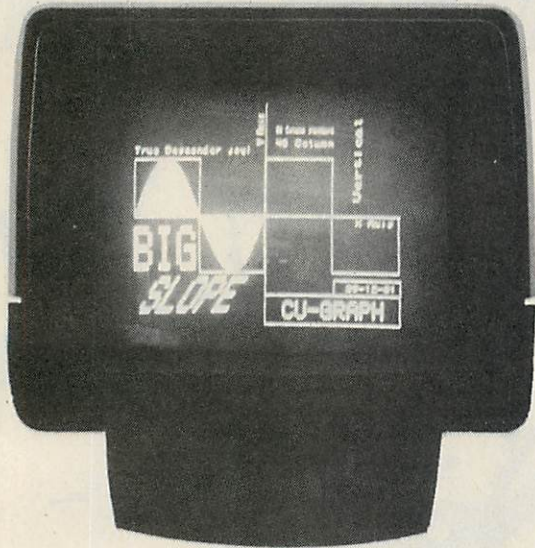

- Uses EF9366 graphics processor chip.
- Each plane of colour (red, green, blue) displays 16kB of memory, giving 512 x 256 resolution; each pixel can be red, blue, green, white, yellow, cyan, magenta or black.
- Only 256 bytes of the host computer memory are used, all 48k bytes of screen memory being on the memory map of the EF9366 only.
- Text display can be superimposed on graphics, and can be up to 85 columns by 32 rows, using an on board character generator. Each character can be scaled for height, width, slope and orientation, all independently.
- Driver software for use on Acorn and Cubit systems is available now, and a high resolution graphics extension to Acorn BASIC will follow later.

£180 Single Eurocard monochrome 16k bytes RAM £360 Eurocard with Piggyback Extension; 48k bytes RAM 8 colours centronics printer interface.

Send to: **CONTROL UNIVERSAL LTD**  
Unit 2, Andersons Ct, Newnham Rd, Cambridge, Tel 0223 358757.

For free catalogue on Cubit, Acorn and Rockwell computers and Associated Peripherals

● Circle No. 259

## THE REVOLUTIONARY TWOSOME

SDM Computer Services are major distributors of the Intertec Superbrain micro computer. This machine has established itself as *the* micro for the serious business user . . . it is not an upgraded hobby system.

Running, as it does, under the CP/M operating system, there is a wealth of readily available commercial software and SDM have their own tried and tested suite of packages covering:

Invoicing ● Stock ● Sales ledger ●  
Purchase & Nominal ledgers ● Payroll

All models are available from double density through the 1.5MB system to the (shortly to be announced) Superbrain W6 which includes a 5MB Winchester.

Full software and engineering support when you buy from SDM.

**MPI-88G — everything you need**

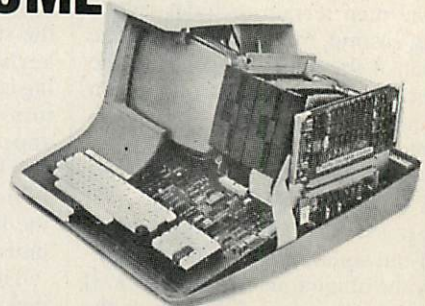
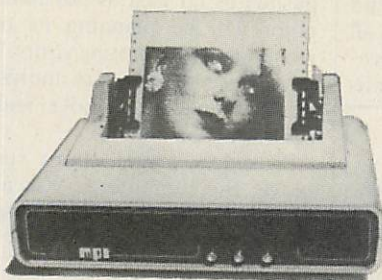

### SUPERBRAIN — built for commerce

This printer has more standard facilities than any other at a similar price:

- RS232 serial and Centronics type parallel, 1K byte buffer
- Upper and lower case 96 character ASCII set, 100 cps maximum
- 10, 12, 16.5 cpi and correspondence font
- High resolution graphics (vertical 72 dots/inch, horizontal 82 dots/inch)
- 6 or 8 lines per inch paper feed
- Full forms control

All the above list and others are *standard* at no additional cost.

Whether it is for your Superbrain business system or any other computer with RS232 or Centronics interfaces you cannot find a better printer.

Supplied ex stock for the amazing price of £475 plus VAT and P & P

## S.D.M. COMPUTER SERVICES

BROADWAY, BEBINGTON, WIRRAL,  
MERSEYSIDE L63 5ND. Tel: 051-608 9365.



● Circle No. 260



# Duplex Communications



Northern Office: Dean House · Dean Hall Lane · Shaw Green · Euxton · Nr. Chorley · Lancs. Tel: 0257 453360  
Midlands Office: 2 Leire Lane · Dunton Bassett · Nr. Lutterworth · Leicestershire. Tel: 0455 209131

● Computer Interfacing ● Equipment Design ● Systems Analysis ● Software Development ●

## PRESENTS The OCTET 121™ a multi-use communicating terminal and electronic typewriter

OLIVETTI ET121

- 4,000 char. memory
- Integral Text Editor
- Battery Back-Up
- KSR 'Control Key' Sequences
- Multiple Baud Rate Selection
- RS232C Connection

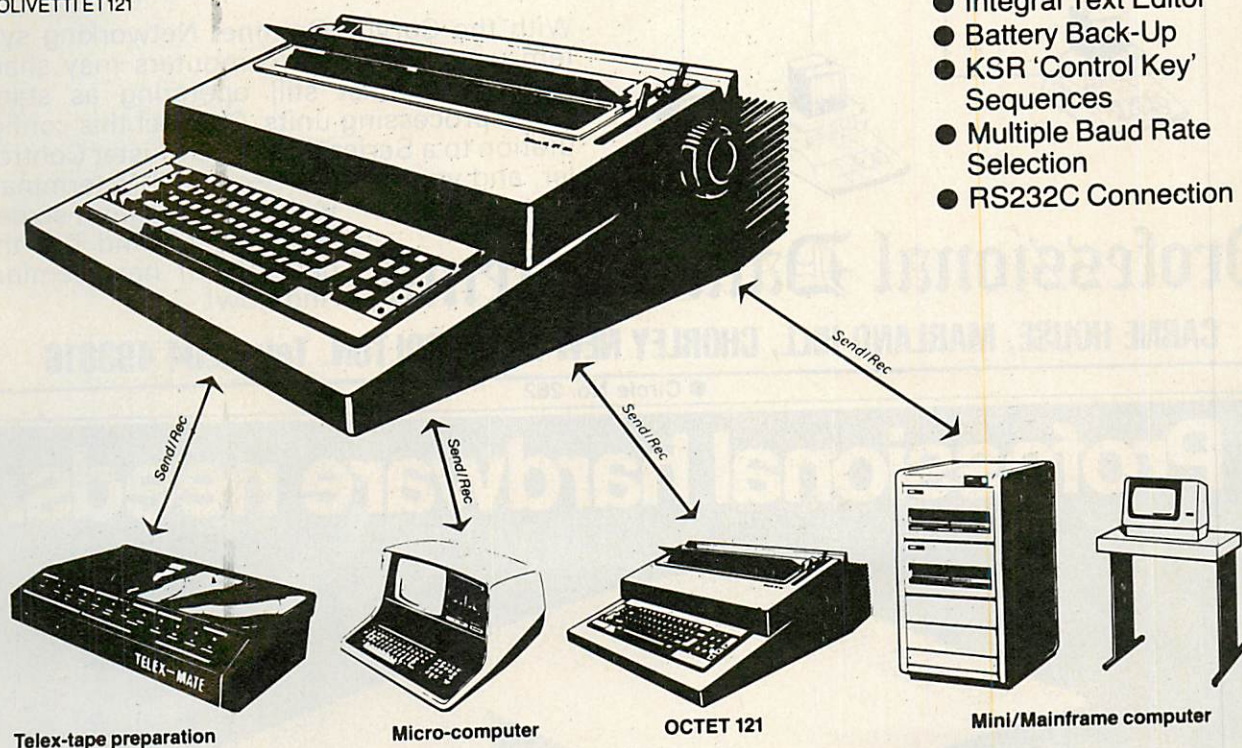

The OCTET 121 is capable of punching man-readable 'headers'. The full 4K of memory can be text-edited prior to punching. The OCTET 121 will also read in tapes where fast telex tape handling is required. Multiple OCTETs to one tape punch station is also available.

Use the OCTET 121 as a letter quality printer. A wide selection of Daisy Wheel typefaces are available. Terminal protocols to control the buffer are standard features.

OCTET 121 communication is achieved by simple cable connection or through an acoustic modem. Ideal for remote offices who would like to use the main office telex facilities. Prepare text at the remote office and transmit to main office to cut tape for forward transmission.

The OCTET 121 is a true KSR with all standard control sequences for operating system use. Ideal for the user who requires 'letter quality' print at all times. Use as a standard typewriter or telex prep. when not in KSR mode.



OCTET 121 has many uses and can be installed very easily in your office.  
Call Duplex Communications Ltd. for more details. Telephone: Leire (0455) 209131 (Leicestershire)

™ OCTET 121 is a trade mark of Duplex Communications

● Circle No. 261



# NETWORKING & COMMUNICATIONS

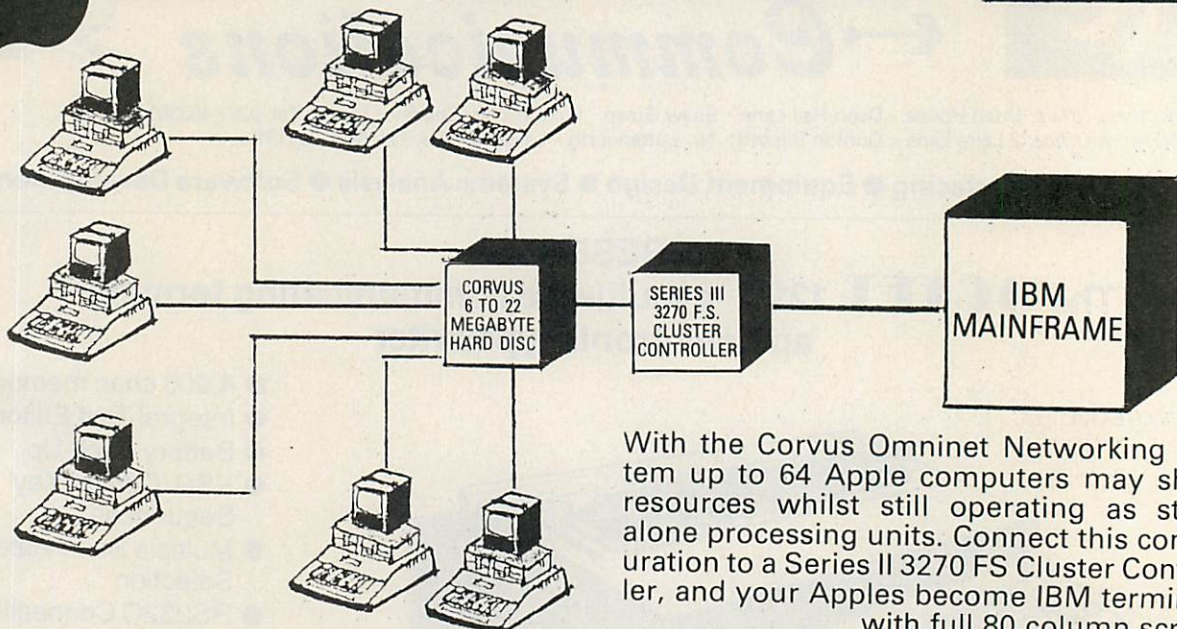

With the Corvus Omnet Networking system up to 64 Apple computers may share resources whilst still operating as stand alone processing units. Connect this configuration to a Series II 3270 FS Cluster Controller, and your Apples become IBM terminals with full 80 column screen facilities. To find out the date of our next seminar ring now!

## Professional Data Systems.

CARNE HOUSE, MARLAND HILL, CHORLEY NEW ROAD, BOLTON. Tel: 0204 493816

● Circle No. 262

# Professional hardware needs...

The Xerox 820



# WHY YOU NEED LOCKSMITH.

You've invested some money and a lot of time in a commercial software program for your Apple. It works well, to the point that you are *dependent* on its day-to-day functioning. But the disks are copy-protected. So you are also dependent on the vendor's back-up (if furnished), on his living up to vague promises of support, even on his ability to stay in business.

No computer user can live with that. So until the situation changes (and it will), you need Locksmith.

Locksmith (new 4.0 version) will copy almost all "protected" diskettes for the Apple. It is the most reliable nibble-copy program you can buy. *Locksmith is suitable only for backups*, because the copies include all serial numbers, codes and protection features of the original (under the new copyright law, you'd have to be pretty foolish to try bootlegging

software that is traceable back to the purchaser).

Locksmith includes nine other utilities, of which these five are vital to the integrity of your system: 1. Media surface check — Never commit data to a flawed diskette again. 2. Disk-drive speed calibration — the most frequent cause of communication bugs between Apples. 3. Degauss and Erase — Make sure no stray data is left over. 4. Nibble-Editor — sophisticated read/write tool for repairing blown disks. 5. Quickscan — Check for unreliable data, find used and unused tracks.

All for just £65.00 at your local dealer or direct. You don't just need Locksmith. You can't afford to be without it. Access or Visa accepted. Add £1.50 P & P. VAT excluded.

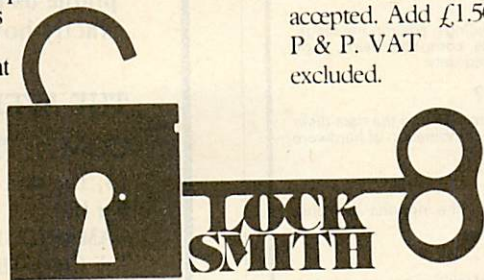

**VERGECOURT LTD**

17 NOBEL SQ., BASILDON  
ESSEX SS13 1LP  
TEL (0268) 728484

Apple is a registered trademark of Apple Computer, Inc.

● Circle No. 263

# professional software for business

ISBS-F — the totally integrated business software system for microcomputers. Designed to perform day to day accounting and administrative functions in most business environments.

A few examples of the key business benefits from using ISBS-F are:

- optimum stock holding to keep costs to a minimum
- speedy invoice productions with stock release and posting to the sales ledger
- statements produced quickly at month end
- VAT analysis at the touch of a button
- improved credit control
- monitor performance easily using budgets and financial reports.

With over 3000 program modules already being used in many different types of industries and professions, ISBS-F offers reliability, backed-up by support, and at reasonable cost.

ISBS-F is available as individual modules or bundles so that configurations can fit the exact business environment. Each module is supplied on floppy disk with comprehensive documentation.

ISBS-F is designed for most popular 8080/286 based microcomputer systems running under CP/M\*. A minimum of 48k memory is required, dual floppy disks and 132 column printer. Versions are also available for the 16 bit microcomputers 8088/8086 running under CP/M 86.

In addition to ISBS-F, we complete our software product range with two other systems — the 2020 series and ISBS-W. The 2020 series includes WP2020 — Word Processor, CM2020 — Configurable Manager and the FP2020 — Financial Planner. ISBS-W is the advanced integrated business system for Hard disk microcomputers running in a single or multiuser environment.

For further details or a demonstration of any of our software products call us today or contact your nearest dealer.

**GRAFFCOM SYSTEMS GROUP**

102 PORTLAND ROAD LONDON W11 4LX 01-727 5561

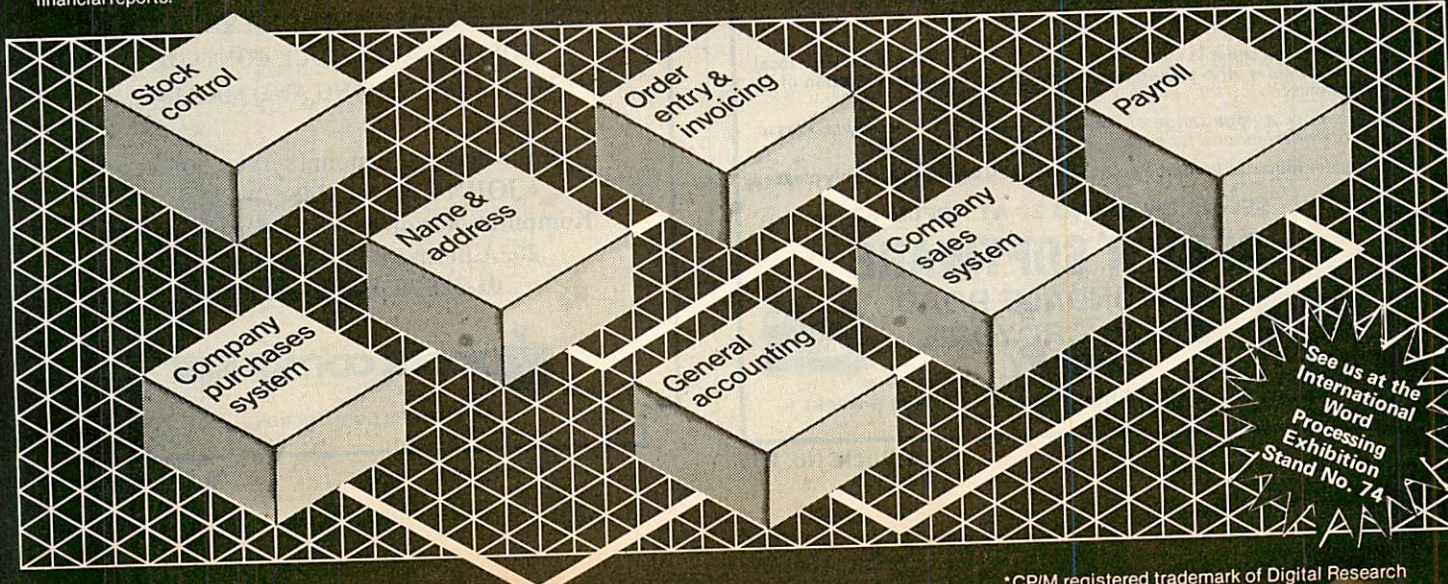

See us at the International Word Processing Exhibition Stand No. 74

● Circle No. 264

\*CP/M registered trademark of Digital Research

## Oh No — NOT ANOTHER Apple Database?!!!

Some Questions and Answers on ACCESS — A new database management system for Apple computers from SPIDER SOFTWARE.

### How many records can I have?

This depends on the size of each record. The maximum record size is 1560 characters. The maximum number of records per disk volume is 7936 but this is dependent on the record size. As an example, if your records are 200 characters long, you may have a maximum of 671 records per volume. A maximum of 40 fields per record is available.

### How long will it take to find a record?

A powerful advanced IRAM (Indexed Random Access Method) is utilised for major record retrieval purposes giving an access speed of either instant recall or within 3 seconds. Any field (or combinations thereof) with multiple search criteria will either give instant recall or will take a maximum of 23 seconds. On the SyMBfile hard disk everything is at least 7 times faster.

### How long will it take to sort a disk full of information?

All sorting is done on an index. If the sort is on the primary index it will take 0.2 seconds regardless of the number of records. To sort out any field which is not indexed involves first creating an index for that field which is then sorted. The time taken depends on the record size (generally less than 3 minutes). Any index can be saved for later use or made into a primary index. Sorting a disk need not involve creating a sorted version of the database.

### How many disk drives do I need?

ACCESS will ideally run on 2 drives. However, it will support a single drive system and a version is available for the SyMBfile 5 megabyte hard drive.

### How about report formats?

Reports are user-configured and can contain report headings, column headings, column sub-totals, brought forward totals, grand totals, computed fields, page numbering etc. Reports can be on selected and/or sorted data.

### What if the dog chews my program disk?

We provide copy routines for backing-up of the program disk and the data disks as many times as you require. The ACCESS system is a combination of hardware and software.

### Is the program menu-driven?

YES. ACCESS constantly displays prompts indicating the options available wherever you may be in the program.

### How is the data stored?

ACCESS creates and uses its own data disks. However, facilities are provided to enable you to produce standard DOS 3.3 text files in either sequential or random access format using any sorted or selected fields. Because of ACCESS's own data storage techniques a very large database may require more than one disk to store the text file(s) produced.

### How easy is it to create records and edit them?

ACCESS has a powerful word processor style screen editor enabling insertion and deletion of characters, etc., full cursor control across fields and pages of a record. A maximum of 40 screen pages are available. Password protected fields are supported as are computed on-screen fields.

### What if I delete a record by mistake?

ACCESS only marks a record as deleted. Facilities are given to either "un-delete" deleted records or purge deleted records from the database.

### My current database takes ages for me to add and save records because it needs to re-structure the entire file to keep the "primary key" in alphabetical order. Will this happen with ACCESS?

No!!! ACCESS uses logic and technique to handle your data; there is no reason (should you have the stamina) why you should not fill an entire disk with information as fast as you can type and immediately retrieve all the information in sorted order or order of entry, etc. All complex and time-critical functions including disk input and output, indexing, sorting, searching, screen display and editing are performed by ACCESS using powerful machine-code routines.

### What hardware do I need?

48K Apple II Plus with DOS 3.3 and 1 or 2 disk drives. Most makes of printer are supported.

### Why should I buy ACCESS and how much is it?

Most facilities in ACCESS are available in other comparably priced database managers. However, ACCESS is more powerful and faster than its competitors in each function. ACCESS has gone beyond the boundary of merely complex facilities, it is powerful and "intelligent" enough to make itself extremely simple to use. The retail price including VAT is £199.95.

A technical sheet is available on the ACCESS system from your local Apple dealer who should be able to give you a demonstration of its flexibility.

We stock a large range of packaged software for the Apple. Please write or telephone for a copy of our comprehensive list.

Dealer inquiries invited. Personal callers by appointment only please.

SEE US ON STAND 29 AT APPLE '82

## SPIDER SOFTWARE

98 AVONDALE ROAD,  
SOUTH CROYDON,  
SURREY.



Tel: 01-680 0267 (24 hours a day — 7 days a week)

● Circle No. 265

## Fighting your way through the silicon jungle?

We carry a comprehensive selection of microcomputer software, hardware and peripherals

Apple ][  
Apple III  
Sharp 3201, MZ80B  
Superbrain  
Altos  
Millbank System 10

Accounting  
Stock Control  
Database Management  
Production Control  
Graph Plotting  
Word Processing

We are to you as Jane was to Tarzan!

Well, perhaps not quite, but please 'phone us for a brochure which explains exactly how we can help

THE AVERY

COMPUTER COMPANY

13, The Mall

Bar Hill

CAMBRIDGE

Tel. Crafts Hill 80991 (24 hours)

● Circle No. 266

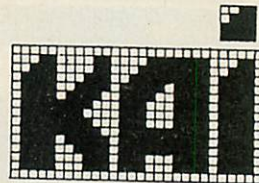

We will assist YOU in your DECISION for Planning, Modelling, Accounting or Commercial systems

We will support YOU in achieving the most from your Microcomputer now, and as your business grows  
VISICALC · MICROMODELLER · MICROFINESSE  
SALES, PURCHASE AND GENERAL LEDGER  
COSTING AND STOCK CONTROL  
WORD PROCESSING AND MAILING

For the best professional service contact:  
JOHN CHANG, MSc, ACMA  
Komputation Automation Information Ltd  
203A Belsize Road, London NW6  
01-328 7038 & 01-328 3968

apple computer

AND OTHER GOOD MICROS

● Circle No. 267

# LONDON COMPUTER CENTRE

Tomorrow's Computing Today

## ACT SIRIUS 1

£2,395

16 bits for the price of 8 bits  
128K. RAM 1.2M Disk storage

### Software Available

Wordstar, Mailmerge, Select, Supercalc, Micro Modeler, Pulsar Accounting, Tabs Accounting, Integrated Accounts, Cobol-Fortran, Pascal-M Basic



### Tele-Video Single-User to Multi-User 802 £2,095

Superbrain Compatibility  
800K Disk Storage  
Green Screen True descenders  
22 function keys  
802E 1.6 M/b Disk Storage £2,595  
802H 10 M/b Hard Disk £4,295



806 £4,495  
Up to 6 user Multi tasking 10 M/b hard disk

800 User stations  
64K RAM  
280 CPU  
Intelligent Terminal

£1,050



### The SPECIAL LCC APPLE SYSTEM

48K two disk drives £1,395  
12" Green monitor £145  
80 Column card with Descenders £95  
CPM Softcard £65  
16K (Integer) Card £75  
Centronics Parallel Card £75  
Serial Printer/Communication Card £75

### EPSON

MX-80 FT  
MX-80 FT2  
MX-100



### SUPERBRAIN with New Extra features Dedicated Keyboard from £1,595

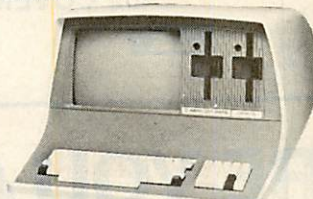

### AUTO SHEETFEEDER £580

New! 12" wide Automatic Sheet Feeder fits all below

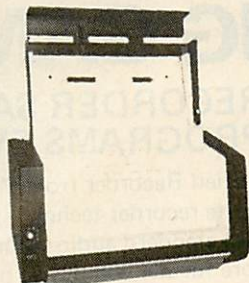

### AUTHORISED TANDY DEALER

Model I. 40K System 2 Disk Drives Green Screen Complete £995  
Model II. with TRS DOS and CPM at No extra charge from £1,995  
Model III. 16K £499' 48K £549' 48K with 2 disk drives £1,350



## PET! APPLE! TRS80! HORIZON! SIRIUS! OWNERS!

### LETTER QUALITY PRINTING

Olivetti ET21, 20 CPS Doubles as typewriter £795  
TEC 40, 40 CPS JAPANESE DIABLO 630 uses Diablo Daisy Wheel and Ribbons £1,235  
Daisy Wheel II, 60 CPS RICOH 1600 Daisy Wheel £995  
Qume SPRINT 5, 45 CPS £1,350  
FLOWRITER RP 1600, 60 CPS  
The most intelligent Daisy. Proportional spacing with right justification on Word Star, Wordpro, Apple Writer, Scripsit etc £1,500  
NEC, 55 CPS £1,650  
FUJITSU, 80 CPS Plastic/metal Wheels £1,695  
DEMONSTRATIONS ON ALL MODELS

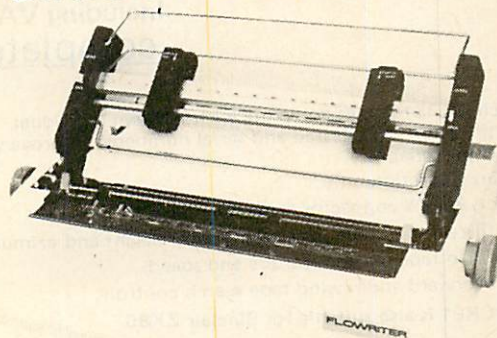

ALL PRICES ARE EXCLUSIVE OF VAT AND DELIVERY  
DEALER ENQUIRIES INVITED ON ALL PRODUCTS.

43 GRAFTON WAY, LONDON W1P 5LA (Opposite Maples )  
OPENING HOURS: 11-7 MON-FRI 12-4 SAT Tel: 388 6991/2  
24 hour answer phone: 01-388 5721

● Circle No. 268

# WHY BUY FROM CAMDEN?

- ★ WE SUPPLY : THE **HARDWARE**
- ★ WE SUPPLY : THE **SOFTWARE**
- ★ WE SUPPLY : THE **BACK-UP**
- ★ WE SUPPLY : THE **EXPERIENCE**
- ★ WE SUPPLY : THE **KNOWLEDGE**

MAIN DISTRIBUTORS FOR ALL THE LEADING MAKES OF MICROCOMPUTERS AND PERIPHERALS.

OFF THE SHELF PROGRAMS TO SUIT MOST APPLICATIONS FROM THE LEADING SOFTWARE HOUSES — WITH PROVEN RELIABILITY.

FROM OUR OWN ENGINEERING WORKSHOPS WITH FULLY QUALIFIED TECHNICIANS OR ON-SITE SERVICE — YOUR CHOICE.

AS ONE OF THE COUNTRY'S LEADING DISTRIBUTORS WITH PROVEN SALES RECORDS — AND ONE OF THE PIONEERS OF THE MICROCHIP.

OUR FULLY TRAINED STAFF WILL ADVISE ON YOUR REQUIREMENTS TO SUIT YOUR NEEDS AND IMPROVE YOUR BUSINESS.

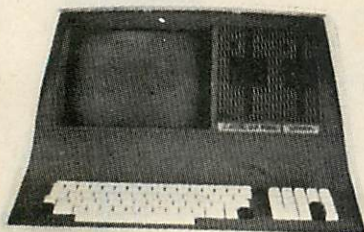

## Superbrain

64K QD MODEL  
PLUS EPSON MX80FT  
PLUS FULLY INTEGRATED  
ACCOUNTS PACKAGE  
**£21 PER WEEK LEASE  
OR PURCHASE**

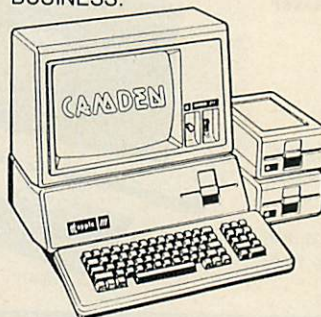

## Apple III

128K MODEL  
INCLUDES MONITOR  
VISICALC III — SOS  
MAIL LIST MANAGER  
AND APPLE BUSINESS BASIC  
PLUS SILENTYPE PRINTER  
PLUS ADDITIONAL DISK DRIVE  
**£21 PER WEEK LEASE  
OR PURCHASE**

## CAMDEN COMPUTER SYSTEMS LTD

462 COVENTRY ROAD, SMALL HEATH, BIRMINGHAM B10 0UG

PHONE: 021-771 3636 (10 lines)

TELEX: 335909 (CAMDEN G)



● Circle No. 269

# ARE YOU A ZX81 USER WHO'S NOT PLAYING GAMES?



**£47.50**  
Including VAT.  
complete

## ECR 81 DATA RECORDER SAVES AND LOADS YOUR PROGRAMS EVERY TIME!

The ECR81 Enhanced Certified Recorder from MONOLITH is a major advancement in cassette recorder technology which minimises the problems associated with standard audio recorders. The unit is a high reliability program store for ZX computers based on a modified, proven cassette mechanism. The two sections of data recording circuitry automatically ensure precise levels are written onto the tape and that optimised signals are received by the computer.

**THE ECR81 IS NOT SUITABLE FOR AUDIO REPRODUCTION  
NO MANUAL VOLUME OR TONE CONTROL ADJUSTMENT PROVIDED**

- Each ECR81 comes complete with its own individual certification tape, tested and serial numbered to prove your machine reliability.
  - Mains Operation only.
  - Mains & DIN connector leads provided.
  - Certification of tape head alignment - height and azimuth.
  - Certified tape tension, torque and speed.
  - Fast forward and rewind tape search controls.
- The ECR81 is also suitable for Sinclair ZX80
- Please allow up to 28 days delivery. ● The ECR81 is backed by our 14 day money-back option.

**MONOLITH**  
electronic products

Telephone: Crewkerne 0460 74321 Telex: 46306

To: MONOLITH ELECTRONICS CO. LTD., 5/7 CHURCH STREET, CREWKERNE, SOMERSET

Please supply me with:

	Price	Total
----- (Qty.) Monolith ECR 81 Enhanced Certified Recorder(s) to be used with my ZX81	£47.50 (Each)	

I also enclose postage & packing per recorder

£2.50

Please print

Prices include VAT

£

Name: Mr/Mrs/Miss.

Address

● Circle No. 270

# 5MB WINCHESTER FOR APPLE II

- LOWEST COST/MBYTE FROM ANY SUPPLIER
- SINGLE APPLE CONTROLLER
- PASCAL COMPATIBLE "DROP IN" BIOS
- LICENSABLE "PROTECTED SOFTWARE" OPERATING SYSTEM (only available to bona-fide software suppliers)
- DEDICATED APPLE II
- FAST DELIVERY

SUBSYSTEM DOES NOT INCLUDE APPLE DRIVE

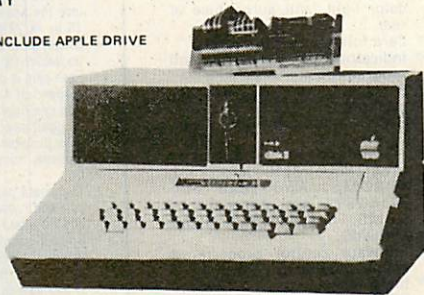

## SYMBFILE

## LOWEST UK PRICES

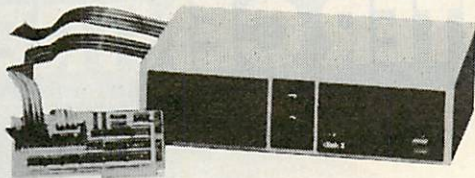

 **apple computer**  
Sales and Service

R.R.P. **£1450**

TO PLACE YOUR ORDER, OR TO MAKE  
FURTHER ENQUIRIES, CONTACT:-

# symbiotic computer systems

85/87 STATION ROAD, WEST CROYDON,  
SURREY CR0 2RD

## 01-680 8606



## MORE FROM MICROSOURCE

MICROSOURCE sells mainly APPLE software, peripherals and books. We cannot list all our products in a short space, so look in back issues and other magazines. We can get hold of most of your wants quickly, and at a competitive price. We specialise in the specials, what you need but cannot get elsewhere. Write or ring for a quote or more information — you can't lose!

### EPSON OWNERS

Are you an APPLE owner with an MX-80 or MX-100 printer? Are you having trouble using VISICALC, GENERAL MASTER or other such software which conflicts with your EPSON TYPE II interface card?

Then we can help you with a replacement ROM to go on your card which now allows the standard APPLE parallel interface commands to set up your printer correctly. For example CTRL-I 80N will set the column width. There is no need to POKE numbers into odd locations. The card supports graphics and uses simple commands such as CTRL-I 16 for default printing of page 1, or CTRL-I GD2 for a double size print of page 2.

Replacement ROM for EPSON TYPE II APPLE INTERFACE CARD ..... **£18**

COMING SOON, A BOOK TO TEACH YOU HOW TO USE THE EPSON.

### OMNIDOS

OMNIDOS is a disk which when booted allows you to make access to either 13 or 16 sector disks using EITHER or BOTH formats SIMULTANEOUSLY.

\*\* This means there is no need to use Muffin, etc. You do not need to know which format the disk is in. YOU DO NOT HAVE TO SWITCH in any way (software or hardware); the DOS does everything for you.  
\*\* Takes up NO EXTRA MEMORY SPACE.

OMNIDOS also has a utility program on the disk which allows you to customise your DOS to:

- \*\* Create disks which will boot on either 3.2 or 3.3 systems leaving you in a 3.2 environment.
- \*\* CHANGE DOS commands, error messages, in memory or on slave or master disks. Gives some program protection.
- \*\* RELOCATE DOS for example low down to leave space for a routine at the top of memory.
- \*\* Prepare DATA DISKS with all the tracks available to the user.
- \*\* PART INIT disks to restore DOS to a disk you have corrupted by starting to INIT the wrong disk.
- \*\* MOVE DIRECTORY to make copying difficult.
- \*\* 22 MENU OPTIONS in all.

OMNIDOS DISK + DOCUMENTATION **£22**

### TREE SORT

TREE SORT is a high-speed utility to allow you to add fast sorting to your programs from data in APPLESOFT arrays.

FAST means 1000 items in 5 seconds; 1000 words in 8 seconds.  
SORTING can be Ascending or Descending. On whole or part of an array. Rewritten or stored as sorted in another array. Zero values may be included or excluded. Can be on single or multiple dimension arrays.

In string arrays fixed fields may be specified and the sort specified by field and field order. Each field can carry its own specification of ascending or descending sort.

Numeric values in the specification may be defined using simple variable names.  
A second array can be specified for referal when two (or more) data are equal. The second array data will then be sorted to determine the actual final order.

COMES WITH EXTENSIVE DOCUMENTATION DEMONSTRATION PROGRAMS complete with explanation in the manual. **£22**

### APPLE SPELLER

APPLE SPELLER is the bridge between the many word processing programs for the APPLE and the large word processors.

APPLE SPELLER works with APPLEWRITER, APPLE PIE, EXECUTIVE SECRETARY, LETTER PERFECT, MAGIC WINDOW, and SUPERSCRIBE II, to name just a few, to verify the spelling of your files.

APPLE SPELLER comes with a 30,000+ dictionary with additional space to add 8,000 of your own words. You can add words, delete words, and create an unlimited number of modified and/or new dictionaries for specific applications. There is thus no need to worry about the problems of the ENGLISH vs American languages.

APPLE SPELLER is unbelievably fast. A 10-page document is proof-read in 1 minute if there are no mistakes and 2 minutes 15 secs if there are an unlimited number of errors.

There are many other features.  
There are other such programs. THIS ONE CAME OUT THE TOP IN THE SOFTALK reviews, which is why we recommend it. **£48.50**  
SPECIAL OFFER

### THE ENHANCER

THE ENHANCER, is a board which fits under your REVISION 7 or later APPLE keyboard, to give you upper and lower case with shift-key ability, besides many more attractive features.

- \*\* REDEFINE THE KEYBOARD
- \*\* DEFINE WORDS OR PHRASES USING SINGLE KEYSTOKES
- \*\* TYPEAHEAD DUFFER allows you to type in 64 characters whilst the APPLE is working on something else.
- \*\* COMES WITH MANUAL AND DISK OF SUPPORTING SOFTWARE. **£100**

ALL PRICES INCLUDE VAT UNLESS SPECIFIC MENTION IS MADE. ALL PRICES INCLUDE P&P

## MICROSOURCE

Tel: Park Street (0727) 72917

1 Branch Road,  
Park Street  
St. Albans.

● Circle No. 272

● Circle No. 271



## CRYSTAL ELECTRONICS CC ELECTRONICS

### FOR YOUR SHARP MZ80K CP/M 2.21 (XTAL)

BASIC CP/M FACILITIES INCLUDE:

- Dynamic file management Fast assembler
- General purpose editor • Advanced debugging utility

YOUR SHARP CP/M 2.21 (XTAL) PACKAGE INCLUDES:

- Hardware modification (if fitted by a SHARP dealer does NOT break the guarantee)
- SHARP CP/M 2.21 (latest version) on disc
- XTAL Monitor and Operating system
- 7 Digital Research manuals
- 12 months guarantee and up-dates (on all our products)

### CP/M 2.21 (XTAL) FROM £150 + VAT

Ask your SHARP dealer for further details or contact CRYSTAL ELECTRONICS

CP/M SOFTWARE HOUSES—XTAL CAN HELP YOU ESTABLISH YOUR SOFTWARE ON THE SHARP.

### XTAL BASIC (SHARP)

Takes 5K less memory, has all the features of SHARP BASIC PLUS Multi dim strings, error trapping, logical operators, machine code monitor, more flexible peripheral handling, improved screen control, increased list control, auto run, if, then, else—and it doesn't stop there—it grows. You can extend the commands and functions at will—10K, 12K, 16K, BASIC? SHARP to XTAL BASIC conversion program is included. **£40 plus VAT.**

Bi-directional serial board for your SHARP RS232 compatible 150 Baud to 2400 Baud adjustable. < 5,6,7,8 Bit words, plugs into MZ801/0 **£99.50 plus VAT.** Includes software for bi-directional use in XTAL BASIC, software for using SHARP BASIC with serial printer and self-diagnostic software for testing Baud rate etc.

Members of Computer Retailers Association & Apple Dealers Association  
Shop open 0930—1730 except Saturday & Sunday  
40 Magdalene Road, Torquay, Devon, England. Tel: 0803 22699

Access and Barclaycard welcome



• Circle No. 273

## PET EPROM PROGRAMMER ACORN EPROM PROGRAMMERS

SUITABLE FOR ALL PET OR ACORN COMPUTERS

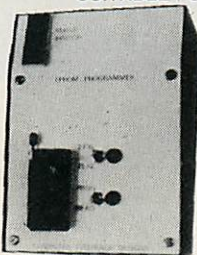

THE  
2716/2532  
MODEL  
PLEASE ADD  
£2.00 P&P

**£46.00**

The programmer includes the software tape for reading/programming the 2716/2532 EPROMS. Plus a FREE programme for making your own Pet graphics on a 2716 EPROM.

Only 6" x 4" x 2"

- Pet IEEE Port Connector and Cable.
- Acorn expansion Port Connector and Cable.
- Independently powered.
- Mains switch with neon indicator light, anti surge fuse at rear.
- Zero force insertion socket.
- Indicator light for read and programme.
- Switch select for read and programme.
- Switch select for 2716/2532 Eproms.
- The programmer can read and programme 2716 and 2532 EPROMS. And read any 2716/2532 pin compatible ROMS, i.e. any Pet ROM/EPROMS.
- Software control programme supplied on tape.
- Instantaneous read of EPROM/ROMS verification of data.
- Total price inc p&p £47.50
- Remittance with order.

2532 compatible EPROMS  
£10.50  
2716 compatible EPROMS £4.50  
Incl P&P

### PET SUPERBOARD 32 NEW

ONLY **£45.50** + £1.50 P&P

PLEASE STATE TYPE OF PET

- This board can be plugged into any ROM socket from \$9000 to \$F000.
- You can plug up to 8 ROM/EPROMS into the board in any combination of 1K or 4K 2716/2532.
- Simply slots onto the expansion port, no soldering or wires required.
- Each chip is programme selectable at a speed of 4µs.
- You can now have viscal, toolkit, etc plugged into one socket.
- It is possible to run a 32K m/c programme from any single ROM location.
- The board plugs onto the expansion port and is compatible with any other add on board.
- Up to 7 boards could be used simultaneously giving a maximum of 244K of on board ROM/EPROM.
- These boards could be used to have several languages residing in the Pet permanently.
- Can also be plugged into the character generator socket to run 8 different character sets.
- SAE for further details

IEEE connectors and cover £6.00 inc p&p

### COMPUTER INTERFACE DESIGNS

4 Albert Road, Margate, Kent CT9 5AN.

Tel: (0843) 294648.

• Circle No. 274

# LONDON COMPUTER CENTRE

TOMORROW'S COMPUTING TODAY!

**SUPERBRAIN TRS80 MODEL II — TRS DOS & CPM**

**APPLE OWNERS!**

## NEW!-Maxi-Byte Hard Disk

Model 6. M6 £185

Model 12. 11.5 M6 formatted £2,295

- Specially designed hybrid
- (linea/switching) power supply
- Data error recovery

DEMONSTRATIONS

ALL PRICES ARE EXCLUSIVE  
OF VAT AND DELIVERY

DEALER ENQUIRIES INVITED ON ALL PRODUCTS

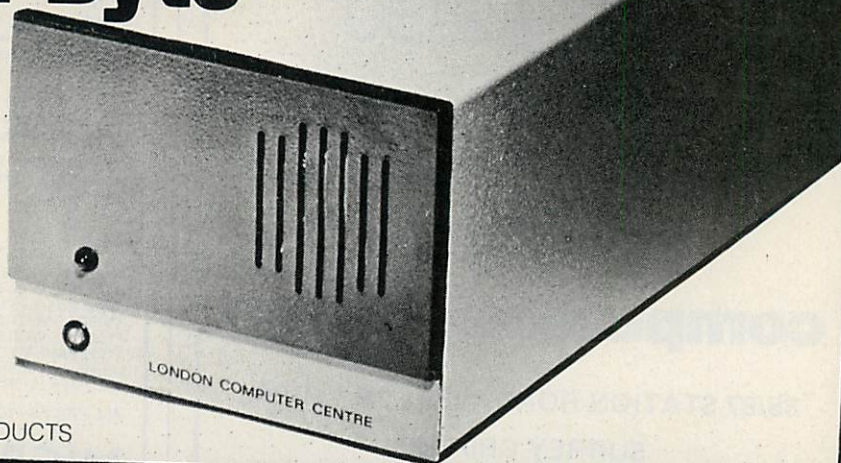

43 GRAFTON WAY, LONDON W1P 5LA (Opposite Maples)

OPENING HOURS: 11-7 MON-FRI 12-4 SAT Tel: 388 6991/2

24 hour answer phone: 01-388 5721

# STOP HERE

APPLE SYSTEMS

WANT TO BUY AN APPLE ] [ ?

## £550.00

HERE'S HOW!!!

PURCHASE OUR HARDWARE PACKAGE

**HARDWARE**

- \* 48K APPLE ] [
- \* DISK W/CONTROLLER
- \* DISK W/OUT CONTROLLER
- \* BMC 12" GREEN SCREEN 1+1 RES MONITOR
- \* M x 80 F/T2 1+1 RES PRINTER
- \* PRINTER INTERFACE

HARDWARE PACKAGE PRICE £1699

**SOFTWARE AVAILABLE**

- INVOICING
- PURCHASE/SALES LEDGER
- STOCK CONTROL
- PAYROLL
- VISICALC
- VISIDEX
- VISITREND/VISPLOT
- WORD PROCESSING



PET SYSTEMS

Ideal For Your Business,

Education,

Word Processing

- |                             |         |
|-----------------------------|---------|
| 8032 32K Computer 80 column | 755.00  |
| 8096 96K Computer 80 Column | 1040.00 |
| 8050 950K Dual Drive        | 755.00  |
| 8023 Tractor Feed Printer   | 785.00  |
- New products now available*
- |                                  |        |
|----------------------------------|--------|
| 8422 22 Megabyte Winchester Disk | P.O.A. |
| 9000 SuperPet 134K Multilanguage | P.O.A. |

- |                           |        |
|---------------------------|--------|
| 4016 16K Computer         | 445.00 |
| 4032 32K Computer         | 560.00 |
| 2031 171K Single Drive    | 349.00 |
| 4040 343K Dual Drive      | 560.00 |
| 4022 Tractor Feed Printer | 350.00 |

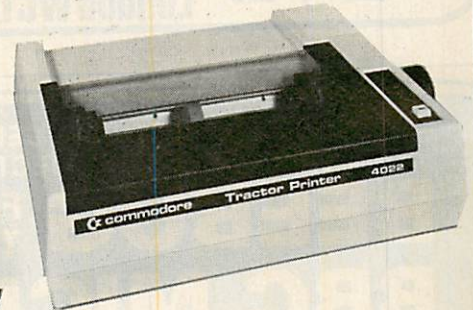
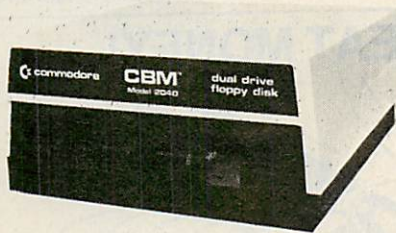

CHOICE OF SOFTWARE PACKAGES AVAILABLE SUCH AS:-  
Wordprocessing, Integrated Accounts with Stock, Invoicing & Financial Planning, and many other applications.

## LONDON'S MAIN EPSON DISTRIBUTOR

**PRINTERS**



- EPSON Mx100 £575**  
15 1/2" carriage, 254 columns, 1+1 RES graphics, true descenders, B1 directional
- EPSON MX80 £359**  
Dot-matrix printer Pet and Apple compatible. True bidirectional, 80 cps.
- EP80 MX82 £399**  
As MX80 plus high Resolution Graphics, parallel and serial interfaces.

- EPSON MX80 FT-1 £399**  
Dual single sheet friction and tractor feed, 9 wire head, true descenders.
- EPSON-MX80 FT/2 £399**  
An FT/1 with high resolution graphics.
- SEIKOSHA GP100 £215**  
Dot matrix 5 x 7, 80 columns, 30 cps graphics, double width characters.

JUST PHONE FOR FURTHER DETAILS

**TERMS**

ALL ITEMS CARRY 1 YEAR GUARANTEE PARTS & LABOUR. DELIVERY AT COST, ALL PRICES EXCLUSIVE OF V.A.T. TELEX 22568 OFFICIAL ORDERS WELCOME



# CHROMASONIC electronics

DEPT PC 48 JUNCTION ROAD, ARCHWAY, LONDON N19 5RD 100yds FROM ARCHWAY STATION & 9 BUS ROUTES  
TELEPHONE 01-263 9493/263 9495 TELEX 22568

● Circle No. 276

# Electronic Brokers Ltd

## VDU & PRINTER OFFERS

## DEC SALE

a selection from our huge stocks

### HAZELTINE H2000 VISUAL DISPLAY UNIT

27 x 74 Display, 64 ASCII, RS232, full half duplex and full editing XY cursor addressing and batch mode, green phosphor CRT, detachable keyboard.

#### SPECIAL QUANTITY DISCOUNT OFFER

1-2 **£299.00** 5-9 **£255.00**  
3-4 **£275.00** 10+ **£250.00**

Also a few remaining H1000 12 x 80 display RS232, 110/300 or 300/1200 baud £199.00

### AJ212 ACOUSTIC COUPLERS

Special Purchase of Anderson-Jacobson Acoustic Couplers suitable for use with RS232 or 20mA devices, full or half duplex, at speeds up to 300 baud. Attractive wooden case. **£125.00**

### VT50 AND VT52 DECSCOPE VDUS

VT50 DECscope, 12 x 80 upper case ASCII, 9 switch-selectable baud rates 75-9600 baud, 20mA or RS232 interface. **£250.00**  
VT52 DECscope, 24 x 80 upper/lower case ASCII, 9 switch-selectable baud rates 75-9600 baud, 20mA or RS232 interface. **£525.00**

### AJ832 DAISY WHEEL PRINTER / PLOTTER

Scoop purchase of Anderson-Jacobson AJ832 Daisy Wheel Printers complete with full keyboard integral stand and RS232 interface

Utilising the famous GUME Printer Mechanism

1-4 **£995.00**  
5-9 **£950.00**  
10+ **£895.00**

### DEC LA35/LA36 and LA180 MATRIX PRINTERS

LA36 30cps keyboard printer with integral stand, 132 column tractor-feed, upper/lower case ASCII LA36 with 20mA **£450.00**  
LA36 with RS232 **£495.00**

LA35 — Receive only version of LA36 — AMAZING VALUE:  
LA35 with 20mA **£250.00**  
LA35 with RS232 **£275.00**

LA180 high-speed output printer with 180 cps printing, 132 column tractor-feed, upper lower case ASCII. Integral stand (NEW) LA180 printer standard parallel (Centronics type) interface **£495.00**

LA180-ED with optional RS232 or 20mA interface **£670.00**

### PROCESSORS

PDP8A 10 1/2 32KW MOS (NEW) **£1,750.00**  
PDP11/04 10 1/2 32KB MOS (NEW) **£3,625.00**  
PDP11/34A 128KB MOS **£5,000.00**  
PDP11/34A 256KB MOS **£6,250.00**  
PDP11/35 32KW Core **£2,350.00**  
PDP11/40 96KW Core, KT11D **£4,650.00**  
PDP11/44 256KB MOS **£11,500.00**  
PDP11/44 256KB TU58, Cab **£12,750.00**  
PDP11/45 32KW Core, Cab **£5,950.00**  
PDP11/45 96KW Core, Cab **£7,450.00**  
PDP11/70 512KB MOS **£30,000.00**

### FLOPPY DISK DRIVES

**SPECIAL PURCHASE — BRAND NEW SURPLUS**  
RX11BD Dual Floppy & Ctl **£995.00**  
RX11BD Dual Floppy & Ctl **£995.00**  
RX8E Dual Floppy & Ctl **£995.00**

### OPTIONS

AR1116 Channel A/D **£750.00**  
BA11FE Expander Box **£995.00**  
BA11KF Expander Box **£1,395.00**  
BA11MF Expander Box **£625.00**  
DH11AD Multiplexor **£4,000.00**  
DJ11AA Multiplexor **£1,250.00**  
DL11 Serial Interface **£250.00**  
DL11W Asynchronous Interface **£395.00**  
DR11W DMA Interface **£625.00**  
DZ11A Multiplexor **£1,395.00**  
DZ11B Multiplexor **£995.00**  
KT11D Memory Management **£750.00**  
M725B Printer Interface **£325.00**  
M9312 Bootstrap Module **£395.00**

All items reconditioned, unless otherwise stated  
ADD 15% VAT TO ALL PRICES  
Carnage and Packing extra



**Electronic Brokers Ltd., 61/65 Kings Cross Road, London WC1X 9LN. Tel: 01-278 3461. Telex 298694**

● Circle No. 278

REGISTERED REFERRAL CENTRE FOR THE BBC PROJECT

## BEEBUG FOR THE BBC MICRO

INDEPENDENT NATIONAL USER GROUP FOR THE BBC MICRO

IF YOU OWN A BBC MACHINE, OR HAVE ORDERED ONE, OR ARE JUST THINKING ABOUT GETTING ONE, THEN YOU NEED BEEBUG.

BEEBUG runs a regular magazine devoted exclusively to the BBC Micro (10 issues per year).

Latest news on the BBC project.

What you should know before you order a machine.

Members' discount scheme on books and hardware.

New program listings, regular advice clinic, and hints and tips pages in each issue.

April Issue: 3D Noughts and Crosses, Moon Lander, Ellipse and 3D Surface.

Plus articles on Upgrading to Model B, Making Sounds, and Operating System Calls.

May Issue: Careers, Bomber, Chords, Spiral and more. Plus articles on Graphics, Writing Games Programs, and Using the Assembler.

Membership  
Introductory offer (closes 30 June)  
6 months **£4.50**  
1 year **£8.50**

After 30 June **£4.90** and **£8.90**  
Send **£1.00** and A4 SAE for sample  
(Overseas add **£1.00** for 6 months, **£1.50** for 1 year)

For technical queries and editorial material, send to:  
The Editor, BEEBUG, P.O. Box 50, St Albans, Herts, AL1 2AR

Make cheques to  
BEEBUG  
and send to:  
BEEBUG, Dept 5,  
374 Wandsworth Rd,  
London, SW8 4TE

● Circle No. 277

## BUGS EAT MONEY!

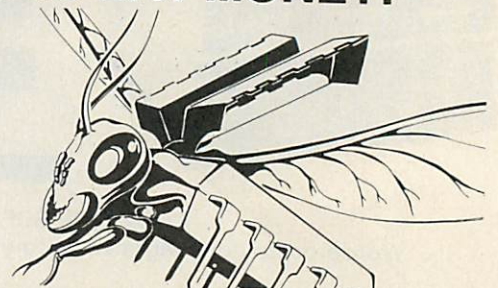

SO NOW THERE'S DISKTOOLS®  
ONE FAMILY  
ONE AIM

TO OVERCOME THE BUG

Recover lost files easily

Dispose of 'bad sectors'

Organise jumbled disks

The best CP/M disk editor in the world

— modifies any byte on a disk!

Intelligent multifile spooler

saves console o/p in file

**DISK REVIVER**

**DISK KLENE**

**DISK ORGANISER**

**DISK EDIT II**

**DISK SPOOL**

**DISK LOG**

PHONE OR WRITE FOR BROCHURE

**GRAM**  
BUSINESS SYSTEMS LTD.

WHETHER YOU HAVE:-  
HARD OR FLOPPY DISKS,  
Z80 OR 8080,  
CP/M V1 OR V2 OR MP/M,  
DISKTOOLS WILL SAVE  
YOU TIME AND MONEY.

48 Hedley St, Maidstone, Kent, ME14 5AD Tel 0622 679595

● Circle No. 279

# ZENITH

# data systems

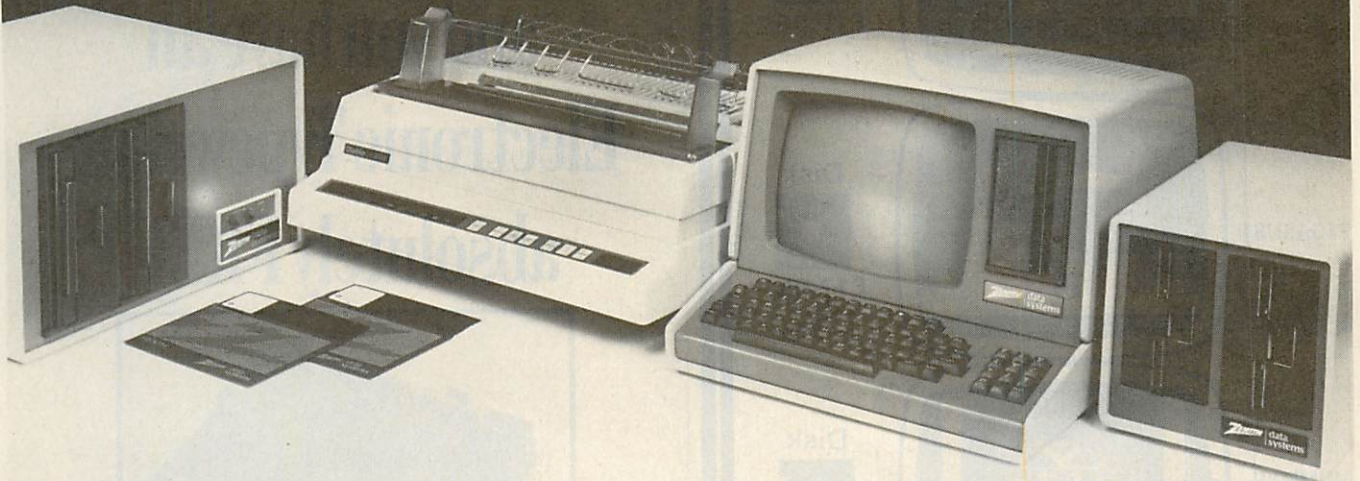

## WHETHER YOU'RE A DEALER OR OEM—

Zenith can offer a product capability that includes:

- Microcomputers, CP/M based with storage to 10 Megabytes
- Systems that start from £1795\*
- Word processing, including letter quality printer from £2985\* (or lease from only £14 per week)
- A comprehensive range of Printers, VDU's, systems and applications software
- 12" green screen Monitor—in Apple colours. (Dealer/OEM's only)

Equally important Zenith is a company that:

- Is supported by the multi million dollar Zenith Radio Corporation of America
- Is committed to holding comprehensive UK stock
- Offers Country-wide service support
- Offers Dealer support including National Advertising Campaign
- Offers Realistic Discount Structures

\*Prices correct at time of going to press.



### NEW DEALER ENQUIRIES WELCOME

I could be interested in a Dealership  I would like to receive details of your OEM terms

Name \_\_\_\_\_ Position \_\_\_\_\_

Company \_\_\_\_\_ Address \_\_\_\_\_

Telephone \_\_\_\_\_

# ZENITH data systems

The quality goes in before the name goes on.

Or call Dave Taylor or Jim Detheridge at:-  
Zenith Data Systems Bristol Road, Gloucester. GL2 6EE. Telephone 0452 29451.

● Circle No. 280

# sbd

Software

BEER RUN

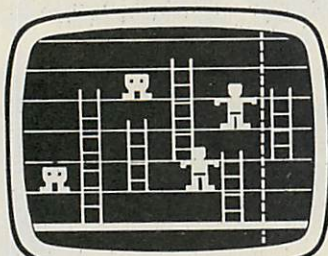

Disk



£19.95

PEGASUS II

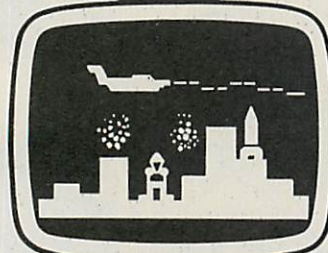

Disk



£17.95

MUMMYS CURSE



Disk



£18.00

COUNTY FAIR

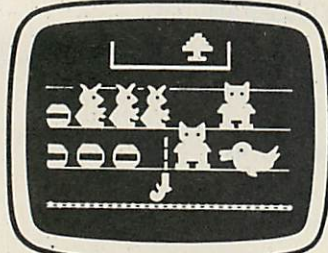

Disk



£16.95

SABOTAGE

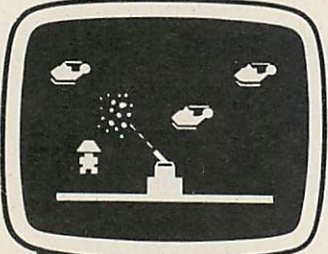

Disk



£12.95

**SBD SOFTWARE**

15 Jocelyn Road, Richmond TW9 2TJ.  
Telephone 01-948 0461  
Telex 22861

Please telephone for a full catalogue, or use the coupon provided.  
Dealer enquiries are welcome. All prices are plus VAT, postage & packing free.

Name \_\_\_\_\_  
Company \_\_\_\_\_  
Address \_\_\_\_\_

● Circle No. 281

## Buy our £475\* Daisy Wheel Printer for your computer and you have an Electronic Typewriter absolutely FREE

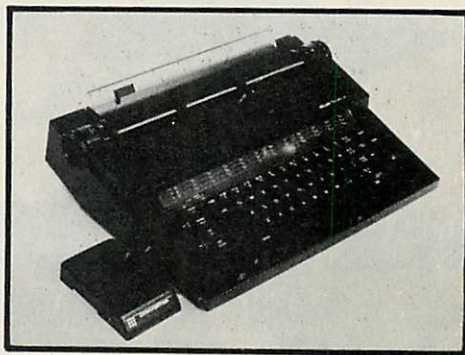

The T/Printer 35 is the lightest weight and lowest cost daisy wheel printer you can buy for your computer. So it will fit within your budget and you can carry it wherever you take your micro. Yet it is tough enough to give years of reliable service. Interchangeable typefaces (standard Olivetti 100 character daisy wheels), variable pitch, multiple copies—all the features you would expect of more expensive word processing printers.

Yet the T/Printer 35 costs only £475 with parallel interface. Operating speed under computer control is approximately 120 words per minute of letter perfect output. What typist can equal that?

Then when you're finished using it as a computer printer, the T/Printer 35 is ready to go right on working as an electronic typewriter.

That's the dual-purpose T/Printer 35—the versatile computer printer that fits your budget.

Orders are shipped within the UK carriage-free. To order or for more information about the T/Printer 35:

\*The T/Printer 35 costs £475 with Centronics compatible parallel interface. With RS-232C interface it costs £535. Prices listed are exclusive of VAT.

# DATARITE

Datarite Terminals Ltd  
Caldare House  
144-146 High Road  
Chadwell Heath, Essex RM6 6NT

Tel: 01-590 1155 ● Circle No. 282

# O FOR AN OSBORNE! WHAT A BARGAIN!

THE INCREDIBLE OSBORNE I - A BEST BUY  
FROM O COMPUTERS.  
**LOOK WHAT YOU GET  
FOR £1,250+VAT**

## THE HARDWARE

- \* 4MHz Z80A Processor, 64K RAM
- \* 2 floppy disc drives (90K)
- \* 5 inch 52 column 24 line monitor
- \* Professional keyboard plus numeric keypad
- \* RS232C serial interface
- \* IEEE 488 interface
- \* Modem connection for communications
- \* Plugs for external monitor or battery

## THE SOFTWARE

- \* CP/M Operating System and utilities
- \* M BASIC interpreter for program-writing
- \* C BASIC quasi compiled language with compiler & interpreter
- \* WORDSTAR the best microcomputer word processing program
- \* MAILMERGE for combining data files with word processed text
- \* SUPERCALC an electronic spreadsheet for financial planning

**AND A SPECIAL INTRODUCTORY FREE OFFER FROM  
O COMPUTERS A SUPERB 12" GREEN MONITOR WORTH £165.**

### PRINTERS

Seikosha GP100A .....	£219
Epson MX80T .....	£320
Epson MX100FT .....	£510
Microline 82A .....	£370
Microline 83A .....	£610
TEC 40cps daisy wheel.....	£1090
TEC 55cps daisy wheel.....	£1420
Qume 45cps daisy wheel.....	£1520

*Printer prices include cables. All prices exclude VAT*

### MORE SOFTWARE

PASCAL M compiler .....	£195
FORTRAN 80 compiler .....	£220
CIS COBOL version 4.3.....	£425
FORMS 2 (used with COBOL).....	£100
BSTAM (links micros).....	£ 95
DBASE II (relational db).....	£380
MILESTONE (project mngmt).....	£160
MICROSTAT (statistics).....	£150
SUPERSORT I .....	£120

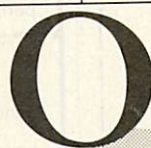

**COMPUTERS**

A company in the C/WP Group, 104-106 Rochester Row, London SW1. Tel: 01-630 5449.  
To reserve your free monitor and get details of the OSBORNE I Call 01-630 5449.

● Circle No. 283

# The biggest Apple event ever held in Britain!



Whether you're an active Apple user, or just fascinated by the rapid development of microcomputing generally, you won't want to miss the action-packed weekend that will make up Apple '82.

From Friday, June 4, to Sunday, June 6, the whole of the ultra-modern Fulcrum Centre in Slough will be completely devoted to the onward march of the micro, when some of Britain's top computing experts will be revealing their secrets.

## FRIDAY

is education day – the staging of the first National Apple Education Forum and a chance for teachers and lecturers to exchange ideas, evaluate software and listen to a series of lectures covering every aspect of computer-assisted learning. Some 25 Apples will be on show, demonstrating a wide range of applications in the school environment.

## SATURDAY and SUNDAY

will be for users generally – the first National Apple Users Convention. So many leading figures in microcomputing want to take part that presentations will be given simultaneously in two adjoining theatres throughout the weekend.

The full timetable of events covers database systems, graphics, music and speech synthesis, Pascal, Cobol and other languages, commercial and industrial applications, hardware and software troubleshooting and micros in medicine.

A central feature of the convention will be a communications workshop, to explore latest developments in linking Apple to Apple, Apple to mainframe, remote information retrieval systems and bulletin boards. It will give a unique insight into a subject that is rapidly becoming one of the most exciting aspects of computing today.

And for light relief, there will also be the national finals of the nail-biting Apple Olympics.

Mail the coupon below for full details of plans for Apple '82 – and about the first-class accommodation that can be reserved for you at some of the best hotels in the area for a modest £17 a night – far below their normal rates.

This major event in the Apple world is attracting users from all parts of the British Isles and overseas. But tickets are limited, so early booking is advisable.

### Send for free Apple '82 fact pack now!

Please send full details of Apple '82 to:

Name \_\_\_\_\_

Address \_\_\_\_\_

\_\_\_\_\_

PC/6

**POST TO: Apple '82, Europa House, 68 Chester Road, Hazel Grove, Stockport SK7 5NY.**

● Circle No. 284

# VisiCalc USERS SpreadSheet

SpreadSheet the communications medium of the International Electronic Spreadsheet Users Group

## InterCalc

is now available in the UK

For free sample of Newsletter and more information send a stamped self-addressed foolscap sized envelope to:

**InterCalc (UK) Branch  
7th Floor, Alpha House  
Rowlandsway, Manchester M22 5RG**

VisiCalc is a registered trade mark of Personal Software Inc

InterCalc is in no way associated with Personal Software

VisiCalc is a copyrighted program of Software Arts Inc  
The name InterCalc is copyright of InterCalc (USA)

● Circle No. 286

**NEW** Programming the **PET/CBM**



**OFFICIALLY APPROVED BY COMMODORE**

*'This book is excellent.'*  
- Jim Strasma

*'Unquestionably the most accurate and comprehensive reference I have seen to date.'*  
- Jim Butterfield

**Bestseller – comprehensive teaching and reference book on all software aspects of Commodores 2000, 3000, 4000 and 8000 microcomputers and peripherals.**

Many programs, charts and diagrams. 17 chapters, appendices, and index. iv + 504 pages. 19 x 26 x 2½cm. Paperback. ISBN 0 9507650 0 7. Price in UK and Europe £14.90 each (incl. post and heavy-duty packing). LEVEL LTD., PO Box 438, Hampstead, London NW3 1BH. Tel: 01-794 9848.

Cut out or copy coupon, or write to:  
**LEVEL LTD., PO Box 438, Hampstead, London NW3 1BH.**

Send ..... copy/ies of *Programming the PET/CBM* at £14.90 (post free)

I enclose cheque/P.O. for £.....or official order.

NAME .....

ADDRESS .....

..... PC 682

*Fast Service – same day despatch*

● Circle No. 285

PRACTICAL COMPUTING June 1982

# O FOR AN OSBORNE! WHAT A BARGAIN!

THE INCREDIBLE OSBORNE I - A BEST BUY FROM O COMPUTERS.  
**LOOK WHAT YOU GET FOR £1,250+VAT**

### THE HARDWARE

- \* 4MHz Z80A Processor, 64K RAM
- \* 2 floppy disc drives (90K)
- \* 5 inch 52 column 24 line monitor
- \* Professional keyboard plus numeric keypad
- \* RS232C serial interface
- \* IEEE 488 interface
- \* Modem connection for communications
- \* Plugs for external monitor or battery

### THE SOFTWARE

- \* CP/M Operating System and utilities
- \* M BASIC interpreter for program-writing
- \* C BASIC quasi compiled language with compiler & interpreter
- \* WORDSTAR the best microcomputer word processing program
- \* MAILMERGE for combining data files with word processed text
- \* SUPERCALC an electronic spreadsheet for financial planning

**AND A SPECIAL INTRODUCTORY FREE OFFER FROM O COMPUTERS A SUPERB 12" GREEN MONITOR WORTH £165.**

PRINTERS	MORE SOFTWARE
Seikosha GP100A ..... £219	PASCAL M compiler ..... £195
Epson MX80T ..... £320	FORTRAN 80 compiler ..... £220
Epson MX100FT ..... £510	CIS COBOL version 4.3 ..... £425
Microline 82A ..... £370	FORMS 2 (used with COBOL) ..... £100
Microline 83A ..... £610	BSTAM (links micros) ..... £ 95
TEC 40cps daisy wheel ..... £1090	DBASE II (relational db) ..... £380
TEC 55cps daisy wheel ..... £1420	MILESTONE (project mngmt) ..... £160
Qume 45cps daisy wheel ..... £1520	MICROSTAT (statistics) ..... £150
	SUPERSORT I ..... £120

*Printer prices include cables. All prices exclude VAT*

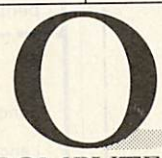

**O COMPUTERS**

A company in the C/WP Group, 104-106 Rochester Row, London SW1. Tel: 01-630 5449.  
To reserve your free monitor and get details of the OSBORNE I Call 01-630 5449.

● Circle No. 283

# The biggest Apple event ever held in Britain!



Whether you're an active Apple user, or just fascinated by the rapid development of microcomputing generally, you won't want to miss the action-packed weekend that will make up Apple '82.

From Friday, June 4, to Sunday, June 6, the whole of the ultra-modern Fulcrum Centre in Slough will be completely devoted to the onward march of the micro, when some of Britain's top computing experts will be revealing their secrets.

## FRIDAY

is education day – the staging of the first National Apple Education Forum and a chance for teachers and lecturers to exchange ideas, evaluate software and listen to a series of lectures covering every aspect of computer-assisted learning. Some 25 Apples will be on show, demonstrating a wide range of applications in the school environment.

## SATURDAY and SUNDAY

will be for users generally – the first National Apple Users Convention. So many leading figures in microcomputing want to take part that presentations will be given simultaneously in two adjoining theatres throughout the weekend.

The full timetable of events covers database systems, graphics, music and speech synthesis, Pascal, Cobol and other languages, commercial and industrial applications, hardware and software troubleshooting and micros in medicine.

A central feature of the convention will be a communications workshop, to explore latest developments in linking Apple to Apple, Apple to mainframe, remote information retrieval systems and bulletin boards. It will give a unique insight into a subject that is rapidly becoming one of the most exciting aspects of computing today.

And for light relief, there will also be the national finals of the nail-biting Apple Olympics.

Mail the coupon below for full details of plans for Apple '82 – and about the first-class accommodation that can be reserved for you at some of the best hotels in the area for a modest £17 a night – far below their normal rates.

This major event in the Apple world is attracting users from all parts of the British Isles and overseas. But tickets are limited, so early booking is advisable.

### Send for free Apple '82 fact pack now!

Please send full details of Apple'82 to:

Name \_\_\_\_\_

Address \_\_\_\_\_

\_\_\_\_\_ PC/6

**POST TO: Apple '82, Europa House, 68 Chester Road, Hazel Grove, Stockport SK7 5NY.**

● Circle No. 284

# VisiCalc USERS SpreadSheet

SpreadSheet the communications medium of the International Electronic Spreadsheet Users Group

## InterCalc

is now available in the UK

For free sample of Newsletter and more information send a stamped self-addressed foolscap sized envelope to:

**InterCalc (UK) Branch  
7th Floor, Alpha House  
Rowlandsway, Manchester M22 5RG**

VisiCalc is a registered trade mark of Personal Software Inc

InterCalc is in no way associated with Personal Software

VisiCalc is a copyrighted program of Software Arts Inc  
The name InterCalc is copyright of InterCalc (USA)

● Circle No. 286

**NEW** Programming the **PET/CBM**

**OFFICIALLY APPROVED BY COMMODORE**

*'This book is excellent.'*  
- Jim Strasma

*'Unquestionably the most accurate and comprehensive reference I have seen to date.'*  
- Jim Butterfield

<p>Bestseller – comprehensive teaching and reference book on all software aspects of Commodores 2000, 3000, 4000 and 8000 microcomputers and peripherals.</p>	<p>Many programs, charts and diagrams. 17 chapters, appendices, and index. iv + 504 pages. 19 x 26 x 2 1/2 cm. Paperback. ISBN 0 9507650 0 7. Price in UK and Europe £14.90 each (incl. post and heavy-duty packing). LEVEL LTD., PO Box 438, Hampstead, London NW3 1BH. Tel: 01-794 9848.</p>
---	--

Cut out or copy coupon, or write to:  
**LEVEL LTD., PO Box 438, Hampstead, London NW3 1BH.**

Send ..... copy/ies of *Programming the PET/CBM* at £14.90 (post free)

I enclose cheque/P.O. for £.....or official order.

NAME .....

ADDRESS .....

PC 682

*Fast Service – same day despatch*

● Circle No. 285

PRACTICAL COMPUTING June 1982

# ANGLO AMERICAN SOFTWARE CO

TRS-80 ≈ ATARI ≈ APPLE ≈ VIC

We know what it is like out there, because that's where we came from. Before we decided to become software entrepreneurs, we were just like you enthusiasts searching through magazines for the ideal mail order software source. What we hoped to find was a single entity that offered an ultra-wide selection for our micro-computer. That pre-selected only the best of many similar sounding programs that reached the market every month. That could give us personal assistance with the purchase-decision process, and that stood behind its products. When we couldn't find it we decided to become it. So **ANGLO-AMERICAN SOFTWARE CO WAS BORN.**

Please state clearly the program(s) you require. Include your name, address and machine type + memory size. Prices include VAT, postage & packing.

## COSMIC PATROL

Skilled players soon master many difficult computer games, but COSMIC PATROL is in a world all its own. The challenge intensifies. Supporting graphics and sound (optional) make each encounter an exciting new experience. It all adds up to a Super 3-8 package ... Skill, Sight and Sound.

The Cosmic Patrol program is not just another search and destroy game. With its fast, real-time action, impressive sound option and superb graphics, this machine-language program is the best of its genre.

**£12.50 CASSETTE**

**£16.25 DISK**

## BATTLEGROUND

Here is a program that should interest you war-gamers:

It is late 1944, and the Allied Forces are sweeping toward Berlin. As General of your sector, you have at your command tanks, planes, artillery, infantry, engineers and vehicles — an awesome array of fighting men and the machines of war. From intelligence reports you know that the enemy General is a shrewd tactician, not to be underestimated. It will take planning and strategy to outwit this wily old campaigner.

The battle map of your sector will fill with markers, each showing the deployment of your forces. You and another player will slip into the roles of opposing German and American commanders as yet another battle unfolds. BATTLEGROUND allows you to experience the total responsibility of a battle-area command. It will be up to you to deploy your forces. On your shoulders rests the decision whether to call for direct artillery gunfire or to order your planes into the air. You will constantly be watching for an enemy airdrop, always carefully manoeuvring your Forces.

The stark reality of World War II comes alive in BATTLEGROUND.

**£8.00 CASSETTE**

## PROGRAM OF THE MONTH

### TLDIS & DLDIS

You've bought a super machine-code program, but now wonder how it works. Maybe you even used a quick PEEK routine to glance through it when it was in memory. If so, you definitely noticed the complete lack of comments in the code, making it almost impossible for you to decipher and understand it.

Well, instant Software's Labelling Disassemblers are the answer to your problem.

TLDIS (Tape-based Labelling DISassembler) and DLDIS (Disk-based Labelling DISassembler) make three passes to assign labels (where appropriate) to the routines in a machine-language program. Their output is almost identical to that of a hand-assembled source code.

You can send the disassembly to a line-printer (Radio Shack parallel port) for either TLDIS or DLDIS. (The difference between these utilities is the storage mode of the disassembly.)

TLDIS can send the disassembly to cassette tape. DLDIS can send it to disk; both send it to the video monitor. The stored disassembly from TLDIS may be reassembled with Radio Shack's EDTASM™ — the disassembly from DLDIS with Apparat's extension of EDTASM™. Because of the use of labels, it is a simple matter to change any object code program by disassembling it and then making changes to the resultant source code, without losing track of jump/load addresses. Labels start with "AA00" and increment up, in even numbered steps (AA02, AA04, etc.) The odd numbers (AA01, AA03, etc.) are left for you to use for the source code during reassembly.

The printing of the disassembly may be temporarily halted by using ((SHIFT)) @ (just as in BASIC) or it may be ended by pressing the ((BREAK)) key. It also has a comments column to display ASCII characters used in a LD or CP opcode.

TLDIS and DLDIS may be relocated in memory to avoid conflict with the program you disassemble.

The next time you need to "climb inside" a machine-code program, take DLDIS or TLDIS with you. We promise that it will be an easier journey.

**TLDIS £11.50 CASSETTE**

**DLDIS £15.50 DISK**

## THE ALL STARS

Here's a collection of our best selling games ... the ones you'll want to play again and again. It includes: SANTA PARAVIA AND FIUMACCIO — Become the ruler of a medieval city state as you struggle to create a kingdom. Up to six players can compete to see who will become the King or Queen.

OIL TYCOON — Avoid oil spills, blowouts and dry wells as you battle to become the world's richest oil tycoon. Two players become the owners of competing oil companies ... and there's room for only ONE at the top!

PARADISE TRADER — You're the captain of a trading schooner, sailing the Caribbean in search of profits. As you sail from island to island beware the dangers of the deep: pirates, ghost ships and hurricanes. Good sailing, skipper!

MILLIONAIRE — Here's \$1000. Can you turn it into a million dollars in fifteen (simulated) years? It depends on your strategy as you buy and sell properties, negotiate bank loans, collect rentals and accept sealed bids.

TIMBER BARON — An in-depth experience of the timber business, from dropping trees, until the milled lumber reaches the market. Your transactions are affected by those unexpected eventualities that can upset even the most careful plans.

BATTLEGROUND — European Theatre, 1944: Your forces are sweeping toward Berlin. At your command are tanks, planes, artillery, infantry, engineers and vehicles. The battle map will fill with markers showing the development of your forces and the location of the enemy in one day of fighting. This two-player game will provide hours of entertainment.

**PRICE £26.50**

## DOCTOR CHIPS

DR. CHIPS is a great icebreaker at cocktail parties. And if the need arose he could entertain your early arriving guests while you finished dressing! Your friends will be asking you how the guy got into the computer.

Why shoulder the burdens of modern life in silence? Put your DR. CHIPS to work today and get it all off your chest!

**£12.50 CASSETTE**

**£14.75 DISK**

**Send 75p for full catalogue**

Refundable against purchase  
Dealer Enquiries Welcome



**ANGLO AMERICAN SOFTWARE CO**

**138a Stratford Road**

**Sparkhill**

**BIRMINGHAM B11 1AG**

**021-771 2995**



24 hour ansaphone

★ ALL PRICES INCLUDE VAT & POSTAGE  
24 Hour answering service  
on 021-771-2995 for Access orders 

PLEASE SUPPLY .....

I enclose a cheque/PO for £ ..... made payable to  
Anglo-American or debit my Access card number

.....

Signature .....

NAME .....

ADDRESS .....

.....

★

# DISK DRIVE DEALS

From KRAM electronics, Victoria House, 17 Highcross Street, Leicester LE1 4PF Telephone (0533) 27556

## 40 TRACK DISK DRIVES

COMPATIBLE WITH TANDY, GENIE, NASCOM, GEMINI, SUPER BRAIN, ETC.

The latest **OLIVETTI** Disk Drives fully cased and complete with Toroidal power supply

(Perhaps not the cheapest but we think these are the BEST)

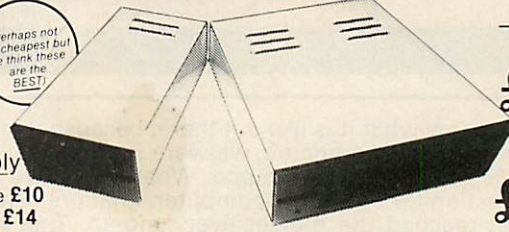

DISK DRIVE Single drive £10  
CABLES Dual drive £14

— SINGLE —  
**£179**  
— DUAL —  
**£349**

# KRAM ELECTRONICS

## ORDERING

You may post your order with a cheque payable to KRAM electronics, or you may telephone your order day or night, any day, giving your ACCESS card number, a full description of the item and your name and address.

## VAT

All the above prices exclude VAT. Please add VAT at the current rate.

## CARRIAGE

Order over £100 ADD £6.  
Orders over £10 ADD £3.  
Orders under £10 ADD .50p

Post to: KRAM Electronics, FREEPOST, Leicester or Tel: (0533) 27556

## GENIE I & II

BOTH INCLUDING \*SOUND \*LOWER CASE \*MODULATOR \*MACHINE CODE MONITOR

Choose either for only

**£299**

GENIE I & II EXPANSION BOX INCLUDING DISK CONTROLLER AND LINE PRINTER INTERFACE AND 32 K RAM

**£199**



**FREE**  
EXTRA  
16K RAM

PARALLEL PRINTER INTERFACE CARD £33

## FREE INTERFACES WITH EPSON PRINTERS\*

\*for RS232, PET, GENIE or ATOM

MX 80T	MX 80F/T	MX 100
<b>£349</b>	<b>£399</b>	<b>£569</b>

## SEIKOSHA GP 100A

**£199** **NEW**

## CONTINUOUS PAPER

8" for GP80A 2000 sheets	<b>£12</b>
9½" for EPSON & GP100A 2000 sheets	<b>£12</b>
5¼" floppy disks	<b>£1.70</b>
4116 RAM CHIPS	<b>-69p</b>
2114 RAM CHIPS	<b>-89p</b>

● Circle No. 288

## ROCK SOLID TRAINING SYSTEMS FROM BRITAIN'S BRIGHTEST EXPERTS

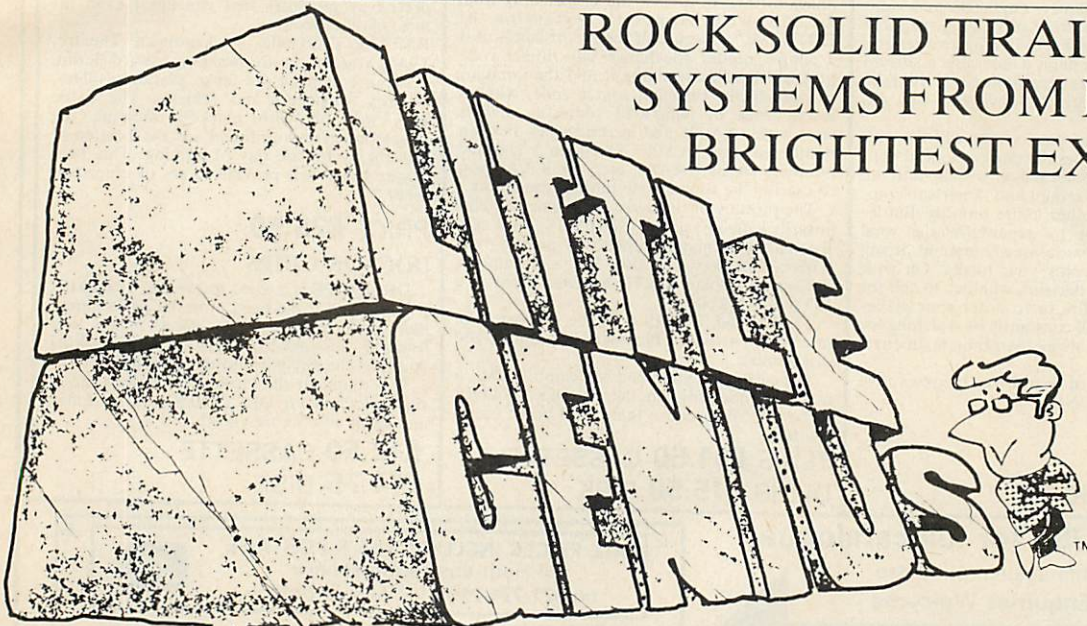

Teach yourself BASIC in 12 hours. Our LITTLE GENIUS self-instruction courses on floppy disk will teach you to master your Micro in 3 easy stages. Each course consists of well-structured fully interactive lessons and is available in 3 separate disk modules.

1. Beginners 2. Advanced 3. Disk operating system at £19.95 each + VAT  
OR take advantage of our SPECIAL OFFER—3-in-one pack price £49.95 + VAT  
BE A LITTLE GENIUS YOURSELF

Courses in BASIC for Apple, IIT 2020, PET and RML 380Z.  
Also PASCAL for Apple.

Available from most computer retailers or direct

In the U.K. write to:  
Little Genius, Suite 504, Albany House,  
324, Regent Street, London W1R 5AA.  
England. Tel: 01-580 6361

In the US write to:  
Little Genius, 34-38 83rd Street,  
Jackson Heights, New York, U.S.A.

● Circle No. 289

Rush me my order for/send information on:

\*BASIC/PASCAL for Machine .....  
Stage Nos. 1, 2, 3 or 3-in-One (Ring as Required)

Name .....  
Address .....

Cheque enclosed/Purchase Order Enclosed/Send C.O.D. \*  
\*Delete as required

# Everything but the kitchen sink.

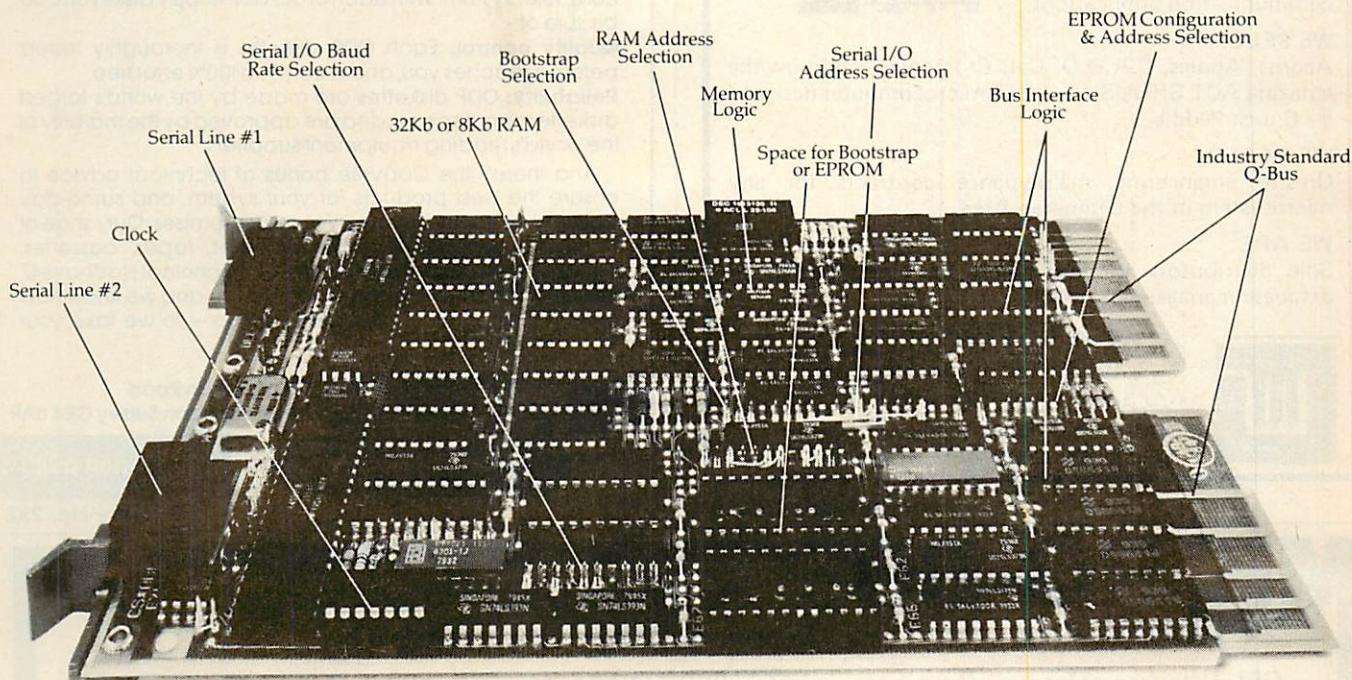

## Digital's MXV11 will change your ideas about micro packaging.

The MXV11 multifunction board measures just 5.2" x 8.9".

Yet it has so much capability, all you have to do is combine it with one of Digital's LSI-11 processors (also 5.2" x 8.9"), and you have a complete, low-cost microcomputer ready to handle a whole range of applications. From instrument control to intelligent terminals. And together they only cost £422.\*

And if that isn't enough, we also offer 9 different memory boards, 11 I/O modules, 9 communications options, and an unmatched selection of peripherals and options. All supported by Digital's consultation, training, and 14,000 service people worldwide.

It's the total approach to micros. And it's why Digital has sold more microcomputers than anyone. Anyone!

- Please send more information on the MXV11 multifunction board and the complete family of microcomputer products.
- Please have a Sales Engineer call.

Name \_\_\_\_\_

Title \_\_\_\_\_

Address \_\_\_\_\_

Telephone \_\_\_\_\_

My application is \_\_\_\_\_

Send to: Digital Equipment Co. Limited,  
Digital Park, P.O. Box 110, Worton Grange,  
Imperial Way, Reading, Berkshire. RG2 0TR.  
Telephone (0734) 868711 Ext. 3717

PC 6

\*Price based on quantity of 200. Correct at time of going to press.

**digital**  
We change the way  
the world thinks.

● Circle No. 290

## If we can satisfy the offshore oil industry - we can satisfy you

Our level of professionalism has to be that demanded by North Sea Oil companies. We offer that same level of microcomputer expertise and service to your business.

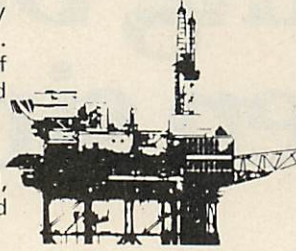

### WE SPECIALISE:

In Business, Process Control, Engineering Database and communication applications.

### WE SELL:

Acorns, Apples, C.A.D.O. Cat, Cromemco, and now the amazing ACT SIRIUS 16 - BIT microcomputer designed by Chuck Peddle.

### WE OFFER:

On-site engineering maintenance contracts for any microsystem in the Grampian Area.

### WE ARE:

Sole distributors for the highly acclaimed CONDOR database management system.



**GRANITE CHIPS**  
MICROCOMPUTERS

21 Bon Accord Street, Aberdeen.  
TEL: (0224) 22520 TELEX: 739740

● Circle No. 291

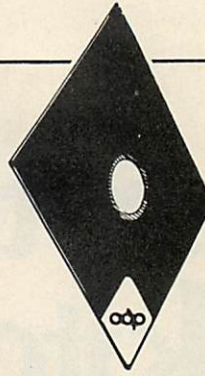

**OUR FLOPPY DISKS STAND UP ON THEIR OWN!**



We at Copyrite Computer Supplies know that our reputation stands on our choice of the best supplies for your computer system. With each of our ODP floppy disks you can be sure of:-

**Quality control:** Each ODP diskette is thoroughly tested before it reaches you, and is certified 100% error free.

**Reliability:** ODP diskettes are made by the world's largest diskette manufacturer, and are approved by the majority of the world's leading equipment suppliers.

And there's the Copyrite bonus of technical advice to ensure the best products for your system, and same-day delivery as stocks are always on our premises. Our range of computer supplies includes diskettes, tapes, cassettes, listing paper and printer ribbons. Our technical staff have 17 years experience in computer products and we know how essential an error-free system is to you - so we take your business very seriously.

**COPYRITE  
COMPUTER  
SUPPLIES LTD.**

505 London Road  
West Croydon Surrey CR4 6AR

**Tel: 01-684 6940**

● Circle No. 292

# MICRO-80

UK Subscription Dept.

24 Woodhill Park Pembury Tunbridge Wells Kent TN2 4NW

GET THIS free software offer when you subscribe to MICRO-80 - The specialist magazine for TRS-80 and VIDEO GENIE.

LOOK AT the programs you get FREE when you subscribe . . .

★ **Level I in Level II** - Convert your Level II TRS-80 to operate as a Level I machine. Opens a whole new library of software for your use.

★ **Copier** - Copies Level II System tapes, irrespective of where they load in memory. Copes with multiple ORG programs.

★ **Z80 MON** - A low memory, machine language monitor which enables you to insert OP codes, edit memory, punch system tapes etc.

★ **Improved Household Accounts** - Powerful enough to be used by a small business.

★ **80 Composer** - A music generating program which enables you to play music via your cassette cord.

★ **Plus Two Games** - Poker and Cube (a version of the Rubiks cube for Disk users)

and don't forget MICRO-80 is now available in monthly cassette edition as well - all the published programs each month ready to load on cassette.

Please enrol me for an annual subscription and send me my FREE cassette program. I enclose £16.00  (magazine only) or £43.60  (magazine and cassette edition).

(enclose your cheque/P.O. made payable to MICRO-80 and send to the above address)

Software offer, and cassette edition prices applies to U.K. residents only. Overseas subscription rates on application.

Name . . . . .  
BLOCK CAPITALS PLEASE

Address . . . . .

PC682

● Circle No. 293

# TEC

## Mail Order Software

# THE MORE YOU TAKE THE MORE YOU GAIN FROM COMPUTING

### MILESTONE: £190

#### Manual alone: £20.-

"Critical path" network analysis program for scheduling manpower, dollars and time to maximise productivity. NEW IMPROVED. Interactive project management program that runs under CP/M. MILESTONE can be used to track paper flow, build a computer, check a department's performance, or build a bridge. MILESTONE can be used by executives, engineers, managers, and small businessmen.

- Produce PERT chart in minutes.
- Find critical tasks that can't be delayed.
- Investigate tradeoffs between manpower, dollars and time.
- Give plans to others using a printed project schedule.
- Change details and immediately see the results on screen.
- Balance time, manpower and costs.

Requires 56K RAM and CP/M. Specify Z80 or 8080. Also available for Apple Pascal, UCSD Pascal or CP/M-86 operating systems. (Milestone-86 version 290 1) Formats: 8, NS, MP, SB, TRS2, OB-1, XX, IPC, IDW.

### ACCESS/80

A report generator and cross-tabulator. Virtually any report that can be described on paper can be generated by using your existing ASCII data files. Produces reports in minutes that would take hours to program in BASIC.

#### — Level I — Report Generator and Cross-Tabulator — £210.- Manual alone £40

Read ASCII files and create sorted reports with subtotaling capability. Provides multi-dimensional cross tabulation and computation. Includes operating system commands.

#### — Level II — Output and Logic Processor — £354.- Manual alone £45

Everything in Level I plus, write out new files in any sorted order (including subtotaling). Load arrays from files. Performs binary search on sorted arrays in memory. Includes control language extensions for complex applications. Requires CP/M and 48K RAM. Formats: 8, NS, MP, CDOS, SB, TRS2, APPL.

### DATEBOOK II: £190

#### Manual alone £18.-

- Schedules appointments for up to 27 different doctors, lawyers, rooms, etc.
- File structure allows for appointments up to one year in advance.
- Searches for openings that fit time of day, day of week and/or day of year constraints.
- Appointments made, modified or cancelled easily.
- Copies of day's appointments can be printed quickly.

Requires 56K RAM and CP/M. Specify Z80 or 8080. Also available for Apple Pascal, UCSD Pascal or CP/M-86 operating systems. Formats: 8, NS, MP, SB, APPL, TRS2, OB-1, XX, 1-5, IPC, IDW.

### QUEST II: £685

#### Manual alone £350

QUEST II is a database management system for customer lists, inventory lists, employee lists or any kind of internal reporting. It may perform several operations on many datafiles simultaneously.

- Up to 55 datafields within a record.
- Inserting new datafields in an existing file.
- Definition of datastructures in the way of Pascal.
- 9 datafield types including: Date, Longmath (double precision integer and reals), Table (one or two dimensional)
- Definition of screen and printing masks.
- Access on any desired keyfield using up to 15 criterias.
- Sorting in ascending or descending order on up to 15 keyfields.
- Default or user defined printing mask.

— Advanced report generator: writing on screen, printer or disk of all or a subset of records, of a user defined subset of datafields.

— Error messages for fast eliminating of bad entries.

— Two special utilities for error check.

Menu selection with one-key-commands. Full data independence from QUEST-using programs. Full data share ability for minimum accesstime. Highest access flexibility. Possibility to use QUEST together with your LOGICALC or other programs by loading the also available interface program LOGQUEST (for complex financial modelling applications like statistics or "what-if?" questions). Format: APPL

### PLAN 80: £190 — Manual alone £20

A financial modelling system that's easy to use and powerful enough to replace your timesharing applications. Lets you calculate IRR and depreciation as well as trig functions effortlessly. You write a PLAN 80 model just the way you would write a letter using any editor or word processing program.

Plan 80 results can be incorporated into any report that requires a financial model. It also tackles any numeric problem that can be defined on a worksheet. You'll remember how you created the model because calculations are defined using real English — not matrix coordinates. What if function.

Requires 56k RAM and CP/M. Also available for CP/M-86. Specify Z 80, 8080, or 8086. Formats: 8, NS, MP, SB, OB-1, XX, 1-5.

### PERSONAL DATEBOOK — 110. Manual alone 20

Time management and appointment scheduling calendar for an individual or small office with up to nine staff members. Displays one appointment schedule on screen at a time. Cancellations can be put into hold file for easy rescheduling at your convenience. Menu driven commands do not require referral to manual.

Requires CP/M 2.x and 56k RAM. Specify Z80 or 8080. Also available for Apple Pascal, UCSD Pascal or CP/M-86 operating systems. Formats: 8, NS, MP, SB, APPL, TRS2, XX, IPC, IDW.

### WHATSIT?

A data base/query/retrieval system that communicates conversationally, accepting questions and updates in simple sentences. Store, index and retrieve information about one or more aspects of related or unrelated subjects. Information is stored under your designated "subject" and "tag" headings, which can be added to, changed or deleted at any time. 116 page manual assumes no programming knowledge. Requires CP/M, CBASIC2 AND 24k RAM. Formats: 8, NS, MP, SB, APPL, OB-1, XX.

### THE FIELD COMPANION £210.-

#### Manual alone £20.-

Created for the needs of the travelling Salesman or Professional. Allows you to track the time spent with your clients, each client having up to four user-defined subfields. Expense accounting is provided and is itemised in a detailed journal for budgeting and tax reporting purposes. Maintains appointments and current customer list including shipping and billing addresses, year-to-date sales and person to contact for follow-up. Invoicing features retrieves required data from both customer and product lists. Special instructions and discounts are supported. Invoice copies may be output to a printer or sent to the home office via modem, permitting electronic transfer of the content of any report. Requires 56k RAM and CP/M or CP/M-86 and 128k RAM. Formats: 8, NS, MP, APPL, SB, XX, IPC, IDW.

### COPYRIGHT:

Access/80 Friends Software; Pearl Relational Systems; Pascal/M, ACT, Trans 86, Supercalc Sorcim, CBASIC 2, CBASIC/86 Compiler Systems; Datebook II, Milestone, Textwriter III Organic Software; Spellguard ISA; CP/M, CP/M-86 Digital Research; Superbrain Intertec Data Systems; S-Basic Topaz Programming; Spellbinder Lexisoft; Selector IV; Selector/86, Glector Micro Ap.

Prices quoted do not include dealer installation and training. Prices and availability subject to change without notice.

### FOOTNOTE £125.-

Automatically numbers and formats footnote calls, footnotes and text, placing footnotes on the bottom of the correct page. At the user's option, the footnotes can also be removed from the text file to a separate note file. Footnotes can be entered singly or in groups, in the middle or at the end of paragraphs. After running FOOTNOTE the user can re-edit the text, add or delete notes, and run FOOTNOTE again to re-number and re-format. Price includes PAIR, a companion program that checks that underline and BOLDFACE commands are properly terminated. Requires CP/M, WordStar, 48k RAM. Formats: 8, NS, MP, SB, APPL, OB-1, XX.

### SPELLBINDER: £260 Manual alone £35.

Full feature word processing system with Office Management capabilities. Its special features include ease-of-use by office personnel, flexible print formatting & output, and powerful macro capability which allows features to be added for the unique requirements of each user. Mail list macro is included for mail merge with form letters.

Requires CP/M & 32K RAM. Formats: 8, NS, MP, CDOS, SB, APPL, XX

### PASCAL/M: £280.- Manual alone £15.-

CP/M compatible language for 8080/Z80 CPUs, supports full Jensen & Wirth plus 45 extensions to Standard Pascal including Random access files., 40 segment procedures & 16 bit BCD real type. Also includes symbolic debugger which features trapping on stores, examining and changing variables and tracing of program execution. Requires CP/M 2.2 & 56K RAM. Formats: 8, NS, APPL, TRS2.

### PASCAL/M for 8086/88: £350.-

#### Manual alone £15.-

All the features of PASCAL/M for the 8086 and 8088 processors running under CP/M-86.

Requires CP/M-86 and K RAM. Formats: 8, 1-5.

### PASCAL: Sort - £140.-

#### Manual alone £14.-

Fully commented source code into which the user simply places the particular file description and sequence requirements to obtain the desired sort. Can run stand-alone or as a overlaid segment of larger program. Uses indirect Shell-Metzner in RAM, interleaved polyphase (Fibonacci) merge on disk, full sector buffering and shortest seek logic. Can match machine language sorts even under Pcode interpretation. Requires CP/M 2.x and 56k RAM and CP/M-86 and 128k RAM. Pascal?M,UCSD Pascal or Pascal /MT. Formats: 8, NS, APPL, XX, MP, TRS2, IPC, IDW.

### SUPERCALC: £190

Allows a layman to manipulate business data in a variety of forecasting and accounting applications. Combines the interactive nature of an electronic spreadsheet with the power and convenience of a simple simulation language. Video display can be scrolled over entire worksheet using cursor controls. Symbolic vector references eliminate repetitive low level data manipulation commands. Easy to use menu driven "Help" commands. Requires CP/M and 48K RAM. Formats: 8, NS, MP, SB, APPL, TRS2. Call for terminal formats.

### SUPERDOS: £100.-

Upgrade of CP/M2.2 for Superbrain. Includes ADM/31 Hazeltine, or Superbrain Terminal emulation mode. Other new features include 132 character keyboard buffer, repeat on all keys, key click, user programmable numeric keypad, 30% disk read/write improvement, real time clock, baud rates to 19.2K on RS232 ports, printer handshake modes, 4 new utilities, and 4 fixes Requires Superbrain 3.0. Format SB.

# HTEC

Datenverarbeitungs-  
und Betriebsberatungs GmbH

# SUPERBRAIN IN THE SOUTH-WEST

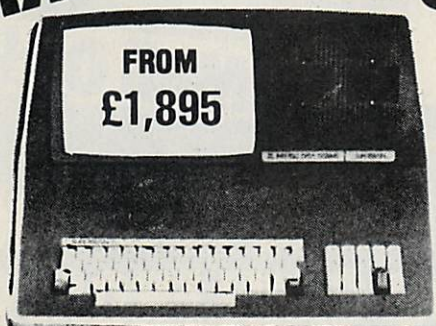

CIS  
COBOL £425

WORDSTAR £230

M BASIC £155

+ OTHERS

MANY MORE

PAYROLL

STOCK

ACCOUNTS

## TOTALLY INTEGRATED MSL ACCOUNTS SYSTEM PROFESSIONAL SERVICE & SUPPORT

FOR QUOTATIONS OR FURTHER DETAILS CONTACT

### EASTFERN LIMITED

19 ALEXANDRA PARADE WESTON-SUPER-MARE AVON TEL: 0934-418346

● Circle No. 295



## L & J COMPUTERS

192 HONEYPOT LANE, QUEENSBURY, STANMORE, MIDDX HA7 1EE. 01-204 7525

THE "PET" SPECIALISTS



### GET THE BEST OF BOTH WORLDS!

WE CAN SUPPLY ALL YOUR 'PET' NEEDS AT CASH & CARRY PRICES

8096	80 co1 96K	£1050	8250	2Mb Disk	£1095
8032	80 co1 32K	£755	8050	1Mb Disk	£755
4032	40 co1 32K	£585	4040	340K Disk	£585
9000	SUPERPET	£1295	2130	170K Disk	£360
8023	PRINTER	£755	4022	PRINTER	£357

OR WE CAN SUPPLY, INSTALL AND TRAIN YOUR STAFF AT THE NORMAL PRICE WITHOUT ANY EXTRAS!!

ALL IN STOCK NOW!

#### Printers

CBM 4022 & 8023  
Centronic 750  
Centronic 737  
Spinwriter 7710

#### Disk Drives

CBM 8050  
CBM 4040  
CBM 3040  
CBM 8250

#### Sundries

Interfaces:  
Disks:  
Paper:  
Labels:

C12 Cassettes  
Library Cases  
(roll & tractor feed)  
Dust covers

NOW IN STOCK! 23 Mb HARD DISK: £3500

For those with 3032's who want 4032's and those with 4032's who sigh for 3032's, all is not lost! Have both, at the flick of a switch — CHIPSWITCH for £57 + ROM's at £38 . . . (with de-glitching facility built-in!!)

TOOL KITS (BASIC 2 & 4), SUPERCHIPS . . . AND ALL SORTS OF OTHER CHIPS . . . UPGRADE YOUR PET EVEN MORE!!

\*PRICES DO NOT INCLUDE VAT

PERSONAL SHOPPERS WELCOME  
Phone & Mail Orders accepted.

ALL GOODS SENT SAME DAY WHEREVER POSSIBLE  
LARGE S.A.E. FOR LISTS ETC.

### SOFTWARE

As well as a full range of programs listed below, we have some highly reliable "Home-Brewed" programs available.

#### STOCK CONTROL & INVOICING

(Handles up to 500 items — 32K) (180 on 16K). Stock depleted on invoicing, search etc. print option. Cassette, disk. **£60**

#### CASH BOOK

Enter daily/weekly amounts — printout and totals, weekly/monthly analysis, totals and balances.

3032, 4032 & 8032 versions

from £90\* to £150\*

#### STOCK TAKING for the licensing trade

Superb new program for 8032

£420\*

#### OUTSIDE SERVICES (For Mini-Cabs, etc.)

New 8032 Version at 3032 price!

£220\*

SAE for free software booklet

SILICON OFFICE : WORDCRAFT : WORDPRO D.M.S.V.

ADMINISTRATOR : DATALEX : BASIC & SUPERPAY

ACCOUNTS : VISICALC

COME AND  
SEE THE NEW

# VIC-20

at £160!\*

FULLY WORKING AND OPERATIONAL  
ASK US ABOUT ALL THE ADD-ON-GOODIES  
THAT GO WITH THE VIC . . . !

MAKELINK

VISA





# Pete & Pam Computers

## SATURN SYSTEMS

128K and 32K boards and VC— Expand  
The 32K BOARD

Comes with utilities to allow the movement of DOS and the use of Integer together with the ability to store subroutines on the board to be called from a main program. The final utility allows the board or multiple of boards to be used as a fast disk drive  
£149.00

## 128K BOARD

Can be used as above with the additional facility to use the card as a fast disk drive in C/PM and PASCAL in addition to BASIC  
£359.00

## VC EXPAND

Is a utility that can be used with either the above two boards to give additional memory for VISICALC models, up to 146K with the 128 board—and more with additional boards  
£55.00

## COMING SOON

A version of VC EXPAND to allow use of VISICALC with the VIDEX 80 column board (VIDEX 80 column board—£185.00) (VISICALC—£105.00)

## MICROSOFT PRODUCTS

MICROSOFT have written most of the BASICS for the World's Micros. As MICROSOFT'S biggest UK distributor we carry a wide range of MICROSOFT products for APPLE

## TASC the Applesoft computer

True machine code programs for your APPLESOFT BASIC  
£109.00

## Z-80 SOFTCARD

THE C/PM System for APPLE. Over 35,000 sold to Apple users world-wide, making APPLE the most popular C/PM system  
£189.00

## A.L.D.S.—Assembly Language Development

System can handle 6502, Z-80 or 8080  
£79.00

## FORTAN 80 £109.00

## COBOL 80 £359.00

## THE ENHANCER II

The dawn of a new era for the APPLE II  
Introducing the ENHANCER II—a new standard which is improving the relationship between Humans and Apples. The Enhancer II can help your Apple II's keyboard become more sociable by remembering words or phrases which can be entered into the Apple by the mere touch of a key. Life can become even easier because the Enhancer II can remember what you typed while your Apple was busy talking to your disk (or doing other things). Naturally, it knows the difference between upper and lower case letters and what shift keys are supposed to do. It even knows to auto repeat any key held down. The Enhancer II replaces the encoder board making installation simple.  
£99.00

## Over 600 items for APPLE

From business to scientific, from education to pleasure. It's here NOW, make sure you get YOUR Copy—write or telex either of our offices now. If you're interested in Apple computers, you can't afford to be without it.



## D BASE II—from Ashton Tate

For Apple II with Z-80 softcard  
A true relational database able to work on multiple files—gives you the power to use your Apple for jobs that were previously reserved for main frames.  
£395.00

MICROSOFT Z-80 SOFTCARD £189.00

## WORD PROCESSING

The Wordstar Family (requires Z-80)

WORDSTAR £145.00

MAILMERGE £69.00

SUPERSOFT £85.00

DATASTAR £140.00

SPELLSTAR £89.00

WORDSTAR Training Manual £19.00

## MACHINE COVERS—only the best material used

Apple only	£5.95
Single Disk	£2.95
2 stacked disks	£4.45
Apple, 2 disks and 9" monitor or Apple and 12" monitor	£8.95
Apple and 2 disk	£7.95
Epson MX 70/80	£5.45
Paper Tiger 445—460	£5.45

 apple computer

# The APPLE Computer Specialists

## Hardware & software distribution is our business — WORLDWIDE

Payment in sterling or dollars  
other currencies by arrangement

## NEW ADDITIONS

### KEYPLUS from Aids Data

A Visicalc compatible keypad with left and right arrows, space bar and escape key in addition to numbers  
£99.00

### CLIP-ON APPLE FAN

With forward facing Apple power switch neon lit  
£49.00

### COOL-STACK

A colour compatible shelf arrangement with integral fan to sit over Apple to accommodate disk drives, act as a stand for a monitor plus allow easy access to the inside of your Apple  
£69.00

### NEW VISISCHEDULE

from the publishers of Visicalc  
A powerful project planner. Allocates all costs, specifies earliest and latest start dates prerequisites and deadlines for each task, automatic calculation and display of critical path. Can link with other Visi programs  
£189.00

### MATHSMAGIC

A unique number processing system designed for linear sequential calculations using a threaded interpretive language. Make your Apple a very powerful programmable calculator  
£59.00

## Authorised Apple Sales and Service

### LONDON RETAIL

98 Moyser Road, London SW16 6SH  
Telephone 01-677 2052/7341

### MAIL ORDER AND DISTRIBUTION

Waingate Lodge, Waingate Close,  
Rossendale, Lanc. BB4 7SQ  
Telephone (0706) 227011

Prices do not include VAT please add 15% to your remittance  
Postage and packing FREE

Telex No. 635740  
Orders welcome by phone or telex  
PETPAM G



● Circle No. 297

## FULLY INTEGRATED ACCOUNTS SYSTEM

### \*SALES & PURCHASE LEDGERS

Open item statements and remittance advices. Payments automatically or manually allocated. Aged Debtors and Creditors listings. Account detail reports etc.

### \*NOMINAL LEDGER

Immediate trial balance. Detailed profit and loss and balance sheet. Print detailed Nominal listings etc.

### \*STOCK CONTROL

Stock movement and value reports. Monitoring stock levels and usage. Price lists, Profit projections etc.

### \*JOB COSTING

Estimate & actual cost comparisons. Display individual Jobs in detail. Full integration with all ledgers.

### \*SALES INVOICING

Maximum automation for repetitive inputs. Discounts, credit limits, audit listings. Immediate posting.

Available on THE 16 BIT SIRIUS I SUPERBRAIN, TANDY MODEL II etc.

- All ledgers are truly integrated and do not require disk changes to facilitate inter-ledger posting.
- We understand what we are selling, can support our products and are prepared to demonstrate free.
- The above system, configured for 128k SIRIUS I microcomputer, EPSON MX80 printer — £4120 + VAT

Dealer enquiries welcome

THE OMICRON DESIGN COMPANY LTD  
22 Bridge Street, Walton on Thames, Surrey. KT12 1AQ  
TELEPHONE: WALTON ON THAMES 23002  
24 hr Answering service

● Circle No. 298



FLEXIBLE DISKS HAVE ALWAYS BEEN YOUR BEST CHOICE FOR VALUE AND PERFORMANCE... NOW THEY'RE EVEN BETTER!!



**EXTENDED PERFORMANCE**  
with reinforcing Hub rings supplied as standard on minidisks.

**EXTENDED PERFORMANCE**  
ODP flexible disks exceed all ANSI and ECMA standards.

**EXTENDED PERFORMANCE**  
that is certified 100% error-free.

**EXTENDED PERFORMANCE**  
through R & D advances that deliver better protection against data-destroying head-to-disk contact, enhance signal resolution and assure unequalled performance.

D.N.C.S. Ltd., dept PC, West Croft Industrial Estate,  
Manchester Old Road, Middleton, Manchester. M24 4PJ.



**WE'RE ALL YOUR  
COMPUTER NEEDS.**

**061-  
643  
0016**

● Circle No. 299

# CITY MICROSYSTEMS LIMITED

65 LONDON WALL, LONDON EC2M 5TU

01-588 7272

## SUPERBRAIN

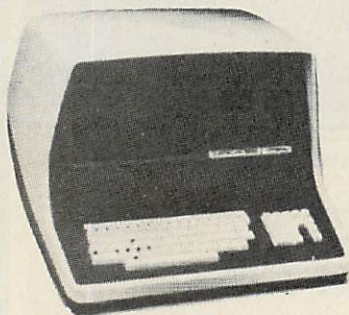

320K, 680K and 1.5MB Diskdrives.  
Full graphics available.  
Wide range of standard packages.

## TELEVIDEO SYSTEMS

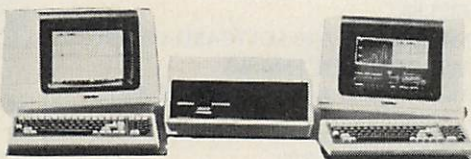

Multi-user, multi-task, multi-processor, televideo reliability with complete expandability.  
One to sixteen users.

## VIDEO GENIE with VISICALC



Complete system £1275, inc. Computer, Monitor, Expander, 1-disk drive printer and Software.  
Vast library of standard software.

Complete business accounting systems from £2000. Word processors from £1420

ADVICE, TRAINING AND MAINTENANCE

ALL YOUR COMPUTER REQUIREMENTS READILY AVAILABLE

**IN THE CENTRE OF THE CITY — LONDON EC2**

VISITORS TO OUR OFFICES MOST WELCOME 10.30am-4.30pm

● Circle No. 300

# ADLER

## TAKING CARE OF BUSINESS

64K P2 Alphatronic includes  
CP/M  
Basic interpreter  
90 days warranty



WORD PROCESSING

**WordStar™  
MailMerge™**

### WORDSTAR

The screen-oriented, integrated word processing system offering unequalled convenience with exceptional capabilities.

**MAIL MERGE** A powerful file merging tool.

FINANCIAL PLANNING

**SuperCalc**

### SUPERCALC

A planning tool you need to make better use of your time and energy having a direct positive effect on your business profits.

ACCOUNTING

**OCSC**

### OCSC

Accounts and payroll system offers incomplete records accounting for the practising accountant, and book-keeping financial accounting and payroll for the needs of the businessman.

A typical business environment comprising computer power with functional software tools at the untypical price of **£2095 + VAT**. A choice of printers is also available — dot matrix/daisy wheel, prices on application.

WORDSTAR, MAILMERGE are trade marks of Micropro International Corporation.  
SUPERCALC is a trade mark of Sorcim Corporation.  
CP/M is a trade mark of Digital Research Corporation.

Adler Alphatronic is distributed and fully supported by

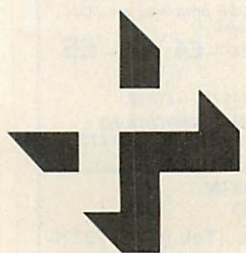

# Plus Business Systems

Plus Business Systems Limited, Ashton Lodge, Ashton Road, Dunstable, Bedfordshire LU6 1NP.  
Telephone Dunstable (0582) 666661

● Circle No. 301

# Flexible Relational Database System



# CONDOR

from M.O.M. (Systems)

## For Business People Who Use English

<b>User Friendly</b>	Business English commands like ENTER, LIST, DISPLAY, SORT, COMPUTE etc.
<b>Advanced</b>	Uses relational commands like:- COMBINE, PROJECT, & JOIN to connect two or more datasets
<b>Screen Formats</b>	Create your own screen formats rapidly
<b>Processing</b>	Calculations of totals, subtotals on many keys. Sorting and selection on one or more keys
<b>Compatible</b>	For use on any Z80 based Micro operating under CPM 2.2 eg: SUPERBRAIN, CROMEMCO, NORTH STAR, TRS etc. or A.C.T. SIRIUS (INTEL 8088)
<b>Flexible</b>	For use by Doctors, Dentists, QS, Estate Agents, Lawyers, Librarians, Engineers, etc, etc. Requires no special programming knowledge to implement systems

**CONDOR** is a product of Condor Computer Systems Inc. It is now available in the U.K. after extensive testing by MOM.

For prices and consultancy call or write to the main U.K. Distributor:-  
**M.O.M. Systems Ltd.** 40/41 Windmill Street, Gravesend, Kent DA12 1BA (0474) 57746  
**Granite Chips Ltd.** 21 Bon Accord Street, Aberdeen AB1 2EA (0224) 22863  
 (Dealer enquiries also welcome)

● Circle No. 302

Dealer Enquiries Welcome

## THE PROFESSIONAL SPELLING CHECKER

- \* TOTALLY BRITISH SPELLING SOFTWARE PRODUCT of the YEAR 1981
- \* Recommended by OSBORNE for the OSBORNE 1 Personal, Portable Computer
- \* Over 3,000 Licensed Users
- \* 20,000+ Word dictionary
- \* Legal, Medical & Financial dictionaries

**BRITISH SPELLGUARD**

- \* The VERY BEST Spelling Checker
- \* The PERFECT PARTNER to Wordstar, Magic Wand, Electric Pencil and many more
- \* The BRITISH version of America's top product

**VISION ASSOCIATES**  
 57 Woodham Lane, New Haw, Weybridge, Surrey KT15 3ND  
 Tel: Weybridge (0932) 55932

● Circle No. 303

## CIDER CARDS FOR THE APPLE

- NEW EPROM PROGRAMMER/VIA BOARD** — 2 in 1  
 Save your important BASIC and MACHINE CODE programs on EPROMS. Programs any pin compatible 2716/2532 eproms. Easy to use — just follow VDU instructions.\* It is also a powerful VIA interface card — see VIA BOARD below. ZIF sockets. Just plug into any Apple slot and go. To store BASIC programs must use CIDERSOFT-BASIC MANAGER and 32K MEMORY BOARD. \*Please specify diskette (3-3 or 3-2-1) or cassettes for programs.  
**£58.00**
- NEW 32K MEMORY BOARD** — can R/W to RAMS too!  
 Reads EPROMS/ROMS/RAMS in any combination. 8 socket to store up to 32K bytes of BASIC and MACHINE CODE programs. Sockets are software selected by ONE instruction. Reads 2716/2532 pin compatible EPROMS/ROMS/RAMS.  
**£38.00**
- NEW VIA BOARD** — Parallel/Serial/Timers all in 1  
 Single VIA 6522 has 2x8 bit programmable bi-directional ports, 4 control lines, 2 programmable timers and 8 bit shift register.  
**£29.50**
- NEW DOUBLE VIA BOARD**  
 As above but with 2 VIA chips giving TWICE the power.  
**£45.00**
- WIRE WRAP PROTOTYPE BOARD**  
 Plugs into Apple sockets for prototype design.  
**£10.50**
- CIDERSOFT — BASIC MANAGER ROM**  
 Contains programs for the 32K MEMORY BOARD which LOAD/CATALOGUE/MANAGE Applesoft Basic programs from memory board.  
**£25.00**
- We also program BASIC (Applesoft) or MACHINE CODE programs on 2K/4K EPROMS. Please send program(s) on diskette(s)/cassette(s).  
 PROGRAMMING 2K — £4 4K — £5
- I.C. and MEMORIES**  
 2716 — £4.50; 2532 — £9.50; VIA 6522 — £9.50; 6116 LP — £10.50  
**SPECIAL OFFER of 10% DISCOUNT for EDUCATIONAL INSTITUTIONS**  
 All prices are inclusive of VAT and P&P. Cheques are payable to CIDER LTD.  
 Please send SAE for details.



**COMPUTER INTERFACE DESIGN**  
**ELECTRONIC RETAIL LIMITED**  
 5 King Street, Margate, Kent. Tel: (0843) 23210

● Circle No. 304

# DEALERS CP/M\* SOFTWARE

## DIGITAL RESEARCH

### Operating Systems

CP/M 2.2 ● CP/M-86 ● CP/M-86 for SBC ●  
MP/M II ● MP/M-86 ● CP/M-86 for Displaywriter  
CP/NET ● CP/M-86 + CBASIC-86 DW

### Languages and Programming Tools

PL/I-80 ● CBASIC ● CBASIC-86 ● CB-80  
PASCAL/MT+ ● PASCAL/MT+ with SPP  
● RMAC, LINKLIB & XREF  
● LINK-80, PLILIB & XREF  
BT-80 ● XLT 86 ● SID ● ZSID



Wordstar – Word Processing  
Spellstar – Proof Reading  
Mailmerge – Merge-Print  
Datastar – Data Base  
Supersort – Data File Sort  
Calcstar – Spreadsheet  
Coming shortly: Infostar

### Other Products

Byrom BSTAM & BSTMS for communications  
Ecosoft MICROSTAT statistics package  
(needs MBASIC)

WP Workshop Wordstar training guide  
CPFILIT, CDOS simulator for CP/M  
Avocet cross-assemblers for CP/M  
Sapphire MARS Management Accounting  
and Report System  
Xitan XBASIC – our very own Basic

Most products are supplied on IBM 8", CDOS  
5.25", SS/SD, CP/M 5.25", CP 100 and NSDD  
formats. A wider range will be available in the  
near future, and every effort will be made to  
meet your specific format requirements.

Established dealers wishing to become  
registered Xitan Software Dealers are invited  
to write or phone for full details.

\* CP/M is the registered trademark of Digital Research Inc.

Xitan Systems offer an ever-growing range of software products, with attractive discounts and credit terms for registered dealers – backed by prompt and friendly service. Xitan Systems are the systems software house and CP/M distributors of the Comart Group, and have recently signed up as Main UK Distributors for Digital Research Inc.

**XITAN** Xitan Systems Limited 23 Cumberland Place  
Southampton SO1 2BB Telephone 0703 38740

● Circle No. 305

**UNIQUE IN CONCEPTION – PERFORMANCE  
& VERSATILITY OF APPLICATION**

## 'REXAGAN' INTERFACE UNIT

links microcomputers to instruments

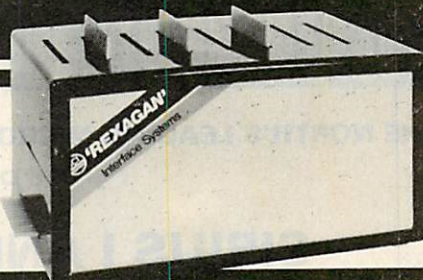

### 'REXAGAN'

units allow the interfacing of microcomputers to laboratory and process instruments for data acquisition and process control.

### 'REXAGAN'

was designed to meet the widely varying needs of ICI scientists and engineers and is used throughout ICI.

### 'REXAGAN'

has been used and tested until it has emerged as a powerful, versatile and integrated unit which can be used by junior laboratory assistants or senior engineers alike.

### 'REXAGAN'

will link to most popular microcomputers, including PET, Apple, VIC, Acorn Atom.

### 'REXAGAN'

can do several jobs at once, collect data, send control signals, monitor power supply, sound alarm signals, etc.

### 'REXAGAN'

is the result of intensive development by ICI and can be used for instrument and system control by any

individual in environments ranging from school laboratories to industrial plants.

### 'REXAGAN'

comes complete with assembly and programming instructions, in a well-written, well-illustrated manual.

### 'REXAGAN'

is made up of the MASTER UNIT, which connects to the microcomputer and various SIGNAL BOARDS which slot into the master unit.

Connector cables run from the signal boards to the control instruments which send data or receive commands.

### How many signal boards?

Up to eight signal boards can be slotted into the master unit for simultaneous use. Each board can go in any slot – there is no 'wrong slot'.

### What do the signal boards do?

There are 9 different signal boards but only 6 different functions.

Analogue Input	Analogue Output
Digital Input	Digital Output
Pulse Counter	Alarm

### Applications include . . .

Laboratory Automation – Data Gathering –  
Chromatography – Plant Control & Monitoring –  
Automatic Test Equipment – Production Sequencing –  
Machine Control – Energy Management – Strain  
measurement & Data logging – Nucleonics – Event  
Counting – Spectral Analysis – Security Systems –  
Photographic Processing – Medical Monitoring –  
Analytical Instrumentation – Psychological Experiments  
– Animal Monitoring.

Manufactured by Imperial Chemical  
Industries PLC, owners of the trade  
mark 'REXAGAN'

WORLDWIDE DISTRIBUTORS  
DYSON INSTRUMENTS LTD

Sunderland House, Station Road,  
Hetton, Houghton-le-Spring,  
Tyne & Wear DH5 0AT,  
England.

Tel: 0783-260433

Telex: 53689

**DISTRIBUTOR  
ENQUIRIES  
WELCOMED**

● Circle No. 306

THE FINEST PRINTER/TYPEWRITER MONEY CAN BUY.

## THE CROWN RANIER ONLY £795 + VAT

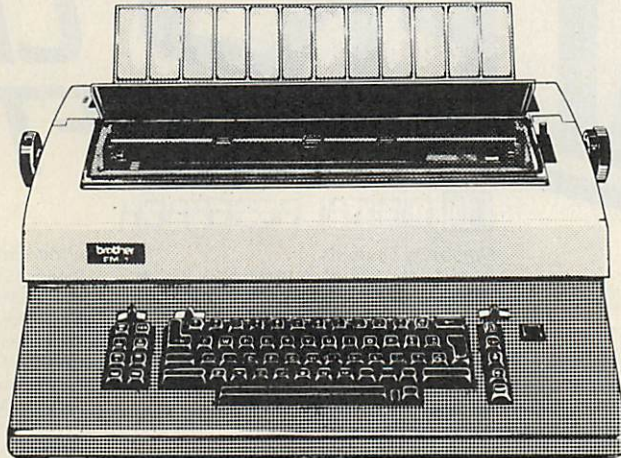

We offer a heavy duty daisy wheel printer/typewriter at the flick of a switch. This machine has the very latest linear motor — no cables or belts to break, stretch or wear. Beware of light weight, low cost machines, these can never give long term reliable service. THIS MACHINE WILL!!

Centronics or IEEE interface. Interchangeable daisy wheels — variable pitch — whole line memory. Uses standard type IBM ribbons and lift off correctors. Perfection as a typewriter (used by local authorities). Perfection as a printer.

Ask your local computer or office equipment dealer for further information. EXSTOCK DELIVERY

**SOLE UK AGENT. TRADE ENQUIRIES INVITED.**



**CROWN BUSINESS CENTRE**  
EASTBOURNE, 56-58 SOUTH ST.,  
SUSSEX. (0323) 639983.

● Circle No. 307

# RAVEN COMPUTERS

THE NORTH'S LEADING MICRO SUPPLIER

PRESENTS

## SIRIUS I AND SOFTWARE



PLUS THE SYSTEM THAT  
DOES WHAT THE  
"LAST ONE" SHOULD  
HAVE DONE

### FMS-80

THE WORLD'S PREMIER  
DATABASE AND  
APPLICATION  
GENERATOR

#### PROVEN PACKAGES FOR:

SALES/PURCHASE/NOMINAL LEDGERS  
ORDER PROCESSING  
STOCK CONTROL  
JOB COSTING  
BILL OF MATERIALS  
FINANCIAL MODELLING  
WORD-PROCESSING  
CRITICAL PATH ANALYSIS

PAYROLL  
FIXED ASSETS  
STATISTICS

**RAVEN COMPUTERS LTD.**  
VICTORIA MILL, MANCHESTER RD,  
DROYLSDEN, MANCHESTER M35 6EP  
TELEPHONE 061-370 0900 ALSO IN LEEDS AND SHEFFIELD

PLEASE SEND DETAILS OF SIRIUS & SOFTWARE

NAME \_\_\_\_\_ POSITION \_\_\_\_\_ COMPANY \_\_\_\_\_ ADDRESS \_\_\_\_\_ TEL No. \_\_\_\_\_

● Circle No. 308

## FOR APPLE USERS, THE WAIT IS OVER!!!

**Question: What's faster than a Winchester, and cheaper than a floppy Disc drive?**

**Answer: A 128K Disk emulator card.**

If your software crawls along because it accesses the disk drives frequently, a disk emulator will speed your system enormously. The Disk Emulator consists of 128K of bank-switched RAM plus software to fool DOS into believing that the card is a disk. Once the software is installed, the card behaves exactly like a disk, except that it operates like lightning. Random access to data files appears instantaneous. Programs are LOADED and SAVED in far less time than with a floppy. The software provides new commands to load from a floppy onto the Disk Emulator, and from the Disk Emulator to a floppy for backup. Instructions are provided to enable the creation of turnkey systems utilising Disk Emulator cards.

The Disk Emulator is fully compatible with all software which uses the DOS 3.3 commands. It will not function correctly with programs that bypass DOS.

PASCAL and CP/M disk emulation is also supported. The Pascal implementation follows the protocol defined in Apple's ATTACH BIOS specification.

VC-PLUS is a software package included in the 128KDE system which allows VisiCalc to use memory on one of the 128KDE cards to give 82K for the VisiCalc model. If two 128KDE cards are installed, 145K becomes available.

Up to four 128K cards may be installed, giving an incredible 512K of instant-access disk space!!!

The cost of a 128K DOS 3.3 Disk Emulator system and VC-PLUS software is less than the price of a floppy drive and controller. Pascal and CP/M emulation software are low-cost optional extras.

Please contact us for further details.

**Special printer offers for this month:**

EPSON MX80 FT/2 printer

QUME Sprint 9/35

Silentype and interface

Stylafont daisywheel and interface

only £345 + VAT

only £1250 + VAT

only £165 + VAT

only £425 + VAT

**BROMLEY COMPUTER SHOP 01-460 2580**  
**49 BECKENHAM LANE 01-464 0541**  
**SHORTLANDS, BROMLEY, KENT BR1 0DA**



● Circle No. 309

pet set 1  
plus £

pet set 2  
plus £

greek  
alphabet  
math  
set

electronic  
symbols and  
games  
set

french  
set

german  
set

russian  
set

hebrew  
set

apl  
set

medium  
density  
plotting  
set

printer  
matching  
sets

BBC RM380Z  
teletext  
keymatch  
set

# 4 DIFFERENT SETS OF CHARACTERS ON SCREEN TOGETHER

FOR 2-3-4-8000 PET/CBM COMPUTERS

ALPHA PLUS

**Avon Computer Rentals**

FREEPOST 4 THORNBURY BRISTOL BS12 1BR  
TELEPHONE (0454) 415460

● Circle No. 310

# YOU'LL FIND NO JOKERS IN OUR DEAL

This DEAL beats all others HANDS down.

We give up to 45% discount on these systems to our registered DEALERS

Demonstration systems available on request

We can guarantee you will find no JOKERS in this PACKAGE

All systems are CP/M based

A  
Insurance  
Brokers  
Accounting  
System

A  
Recruitment  
Agency  
System

A  
Advertisers  
Accounting  
System



**core  
international**

92 Wolverhampton Road, Stafford ST17 4AH, England. Tel: 0785 42611

● Circle No. 311

# BRNIN-POWER from MicroMods Ltd.

**You want**

**Faster Disk Accessing**

**Alternative Character Sets  
or Graphics**

**8" drive interchangeability**

**Increased Capacity &  
Integrity**

**We have**

**SuperBios** £45

**SuperVid** £190

**SuperFloppy** £295

**SuperWinnny** £215

NOTE SuperFloppy & SuperWinnny are interface boards requiring additional hardware.

All prices exclude VAT & carriage.

## MicroMods Ltd.

53 Acton Road, Long Eaton  
Nottingham NG10 1FR  
Tel: (06076) 64264

or contact: **Icarus Computer Systems Ltd.**  
27 Greenwood Place  
London NW5 1NN  
Tel: 01-485-5574

● Circle No. 312

## research ltd.

### A/D BOARD FOR NASCOM

- 8 input channels
- 30 microsec conversion
- Over voltage protection
- Prototyping area
- 8 bit resolution
- Sample and hold
- Full flat/interrupt control
- NASBUS compatible

Price £120 + 15% VAT (post free)

### GRAPHICS BOARD FOR NASCOM

- 384(H) x 256(V) high resolution graphics display
- Fully bit mapped
- Full software control
- Mixed text and graphics
- NASCOM 2 or 4MHz
- NASCOM 1

- Graphics software supplied

Price £55 + 15% VAT (post free)

### EPROM PROGRAMMER

- Programs 3 rail: 2708/2716
- Single rail: 2508/2758, 2516/2716, 2532/2732
- Software supplied for Read/Program/Verify
- Can be used with other machines with 2 parallel ports

Price £63 + 15% VAT (post free)

### DUNCAN

- Fast real time interpreter/control language for NASCOM 1 or 2 (please specify)

Price £12 + 15% VAT (post free)

### MEMORIES

- 4116-150ns 95p each + 15% VAT (min order 8)
- 64K-200ns £6 each + 15% VAT

### MONITORS

- BMC 12" green phosphor - 18MHz

Price £150 + 15% VAT (carriage paid)

6 Laleham Avenue, Mill Hill,  
London NW7 3HL  
Tel: 01-959 0106

● Circle No. 313

## research ltd.

### "PLUTO" COLOUR GRAPHICS PROCESSOR

**Pluto is a self-contained colour display processor on an 8" x 8" NASBUS and 80-BUS compatible card featuring:**

- Own 16 bit microprocessor
- Up to 192 Kbytes of dual-ported display memory for fast flicker-free screen updates. (Outside of the host address space).
- 640(H) x 288(V) x 3 planes (8 colours) - 2 screenfulls OR 640(H) x 576(V) x 3 planes (interlaced display)
- Fast parallel I/O interface usable with ALMOST ANY MICRO. Only single +5v supply required.

**Pluto executes on-board firmware providing high level functions such as:**

- Fast vector draw - over 100,000 pixels/sec. Lines can be drawn using REPLACE, XOR, AND, OR functions
- User-definable characters or symbols
- Spare display memory with memory management facilities for allocating symbol storage space or workspace
- Rectangle Fill and copy using REPLACE, XOR, AND, OR plus 5 other functions
- Fast access to single pixels
- Write protect memory planes during copy
- Double-buffered screen memory for animated displays
- Complex polygon colour fill

**Pluto is expandable. An expansion board will be available later this year to give Pluto up to 8 memory planes with no loss of resolution.**

**AVAILABLE NOW. Please contact us for further details**

6 Laleham Avenue, Mill Hill,  
London NW7 3HL  
Tel: 01-959 0106

● Circle No. 314

# Software for TRS-80 Models I/III

NEWSSCRIPT .....	£69.95
NEWSSCRIPT+LABELS .....	£79.95
FASTER .....	£17.95
QUICK COMPRESS .....	£12.95
FASTER+QUICK .....	£27.95
R.P.M. ....	£13.95
EXTEND 40 .....	£12.95
GRAPHICS EDITOR+JOINER .....	£29.95

Also suitable for Video Genie II,  
most for Video Genie I.

S.A.E. FOR FULL DETAILS

WE ACCEPT ACCESS



## WORDSWORTH

6 Grant Road  
Banchory  
AB3 3UR  
03302-4168

● Circle No. 315

# For the best PET software...

COMMAND-O.....	For Basic IV CBM/PET, 39 functions with improved "Toolkit" commands	£59.95 + Vat
DISK-O-PRO....	For Basic II PET, adds 25 commands including Basic IV, in one 4K rom	£59.95 + Vat
KRAM.....	For any 32K PET/CBM for retrieving disk data by KEYED Random Access	£86.95 + Vat
SPACEMAKER IV	For any PET/CBM, mounts 1-4 roms in one rom slot, switch selection	£29.95 + Vat
" USER I/O	For software selection of up to 8 roms, in any two Spacemaker Quads	£12.95 + Vat
PRONTO-PET....	Soft/hard reset for 40-column PETs	£9.99 + Vat

SUPERKRAM, REQUEST & KRAM PLUS will be available shortly

We are sole UK Distributors for these products, which are available from your local CBM dealer, or direct from us by mail or telephone order. To order by cheque write to: Calco Software, FREEPOST, Kingston-upon-Thames, Surrey KT2 7HR (no stamp required). For same-day Access/Barclaycard service, telephone 01-546-7256. Official orders accepted from educational, government & local authority establishments

## ...at the best prices!

WORDPRO IV PLUS	RRP £395 less £98.75 =	£296.25!
WORDPRO III PLUS	RRP £275 less £68.75 =	£206.25!
WORDPRO II PLUS	RRP £125 less £31.25 =	£93.75!
VISICALC	RRP £125 less £25.00 =	£100.00!
TOOLKIT Basic IV	RRP £34 less £9.50 =	£24.50!
TOOLKIT Basic II	RRP £29 less £7.25 =	£21.75!

The items above are available by mail or telephone order at our Special Offer Price when purchased with any one of our software products. This offer is for a LIMITED PERIOD only. UK - ADD 15% VAT. OVERSEAS airmail postage - add £3.00 (Europe), £5.00 (outside Europe).

# Calco Software

Lakeside House - Kingston Hill - Surrey - KT2 7QT Tel 01-546-7256

● Circle No. 316

SPECIAL OFFERS

### PETS

### APPLES apple

Apple II — 48K Computer.  
Apple III — 128K Computer.  
Video Monitors — Colour and Black & White.  
Disk Drives.  
Silentype Printer.  
All Apple related products available. Please call for prices.

---

### VIC

CBM 4016 — 16K 12" Screen 40 Col. Computer.  
CBM 4032 — 32K 12" Screen 40 Col. Computer.  
CBM 2031 — 170K Single Drive Floppy Disk.  
CBM 4040 — 340K Twin Floppy Disk Drive.  
CBM 4022 — 80 Col. 65cps Tractor Printer.  
CBM 8032 — 32K 80 Col. 12" Screen Computer.  
CBM 8096 — 96K 80 Col. 12" Screen Computer.  
CBM 8050 — 1 Meg. Twin Floppy Disk Drive.  
CBM 8422 — 22 Meg. Winchester Disk Drive.  
Please phone for latest prices.  
We offer some of the best deals around!

---

### BOOKS

Full range of computer books available from Beginners Guides to Advanced Machine Code Programming.

---

### 2'ND HAND

We have a constant changing range of 2'nd hand and ex-demo equipment at considerable savings.

### PRINTERS

Epson MX80FT — 80/132 Col. Friction/Tractor.  
Auto Bi-Directional. 9x9 Head True Descenders.  
Ricoh RP1600 — 164 Col. 60cps Daisy Printer.  
Scripta — 17cps Daisy Printer at low prices.  
We will quote for any type or make of printer available.

---

### SOFTWARE

Word-processing	Sales Ledger
Payroll	Purchase Ledger
Incomplete Records	Record Keeping
Book-keeping	Financial Packages
Invoicing	Time Recording
Stock Control	Silicon Office

---

### INTELLIVISION

Superb TV Game for your TV. Cartridges include: Space Battle, Skiing, Boxing, Poker, Golf, Tennis, Roulette, Horse Racing, Basketball, Backgammon & many others.  
Free soccer game with unit.

---

### ACCESSORIES

All types of accessories and stationery supplied.

Floppy Disks	Stationery
Storage Boxes	Continuous Labels
Printer Ribbons	Daisy Wheels
Tractor Feeds	Auto Sheet Feeders
Cassettes	Dust Covers
Maintenance	Installation & Training

## DEMONSTRATIONS AT YOUR PLACE

We are able to demonstrate complete business systems at your site in our mobile demonstration unit (up to 4 people at a time). Just phone for an appointment anytime.

### DA VINCI COMPUTER SHOP

65 High Street,  
Edgware, Middx.  
HA8 7DD.

Open Mon-Fri 9.00-5.30  
Sat 9.30-5.00  
Telephone: 01-952 0526

● Circle No. 317

PRACTICAL COMPUTING June 1982

213

If that Apple  
is just out of Reach....

*Rent One!*

If you have a short term requirement for a microcomputer system for evaluation, training or just hands-on experience — come to Atlanta Data!

Apart from Apples we have top quality printers, monitors, disk drives and a huge range of software including VisiCalc, Visidex, Wordstar, Format-80, Magic Window, Micromodeller, APM, CIS COBOL and all accounting programs.

A complete system can be working for you within a few days of your enquiry with no capital expenditure!

Line plotters now available.

Rental Hotline 01-729 1411/2

*Atlanta* Data Systems

350/356 Old Street, London, EC1V 9DT. 01-739 5889

● Circle No. 318

# Knights T.V. & COMPUTERS

## SHARP DEALS AT KNIGHTS

Deal A1 — Sharp MZ-80A with BASIC, PASCAL, MACHINE CODE and FORTH LANGUAGES plus 100 programs to get you off to a flying start. ....£477

Deal A2 — Trade in any Sinclair computer and get £50 allowance against deal A1. ....£427

Deal A3 — Everything in Deal A1 plus expansion unit. ....£559

Deal A4 — Complete MZ-80A system — computer, printer, disk, expansion unit, all interface cards, cables, manuals, etc. ....£1399

Deal B2 — Sharp MZ-80B with BASIC, DOBLE PRECISION BASIC, and ASSEMBLER languages plus 70 programs. ....£999

Write for our latest newsletters and price lists — we have hundreds of programs for Sharp micros. All above prices exclude VAT but include delivery.

## KNIGHTS TV AND COMPUTERS

108 Rosemount Place, Aberdeen.

Telephone: (0224) 630526. Telex: 739169 KNIGHT

● Circle No. 319

Microware (London) Ltd., 5 Western Court, Huntly Drive, London N3 1NX Tel: 01-346 8452

# microware

**MEMOREX**  
WHOLESALE PRICES  
FOR END USERS

**FLOPPY  
DISKS**

5 1/4" Single sided £1.59  
Single density

5 1/4" Double sided £1.99  
Double density

8" Single sided £2.39  
Single density

8" Double sided £3.45  
Double density

Soft Sektored  
10 Sector  
16 Sector

DISK STORAGE  
BOXES

from  
£14.95



full range  
of 5 1/4" and 8"  
models available

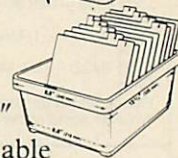

*Dysan Diskettes*

104 1D £3.25

104 2D £3.75

full range  
available



MAIL ORDER

Tel: 01-346-8452

In stock

Dust Covers for Micro's &  
Printers & VDUs from £6.95

Floppy Saver Kits from £7.95

Indexing Systems from £1.50

● Circle No. 320

# A+G COMPUTERWARE

THIS MONTH'S SPECIAL OFFER

## MONITORS

BMC 14" RGB TTL COLOUR MONITOR

Features include:

● BANDWIDTH — 18MHz ● HORZ. RES. 400 DOTS ● DISPLAY FORMAT — 5 x 7 DOTS/25 x 40 CHARACTERS ● FULL CONTROLS — HORZ. & VERT. HOLD, PICTURE & FOCUS ● OVERALL SIZE 16" x 16" x 16" (approx.)

BM — 1401 RGB 14" COLOUR MONITOR £299.00 APPLE RGB CARD AND CABLE £99.00 SHARP MZ80K RGB CARD AND CABLE £230.00 BBC MICRO RGB CABLE £POA RM2 380Z RGB CABLE £POA

PRINCE 12" GREEN SCREEN MONITOR

● VERY HIGH RESOLUTION ● BANDWIDTH 24MHz ● CHARACTER DISPLAY — 24 x 80 CHARACTERS ● RESOLUTION 800 LINES CENTRE/600 LINES CORNERS ● OVERALL SIZE 8" W 12.59" H 10.63" D 10.62" ● SUITABLE FOR APPLE, BBC MICRO, ZX81, ACORN ATOM ETC.

● Please state your micro type when ordering ●

PRINCE 12" GREEN SCREEN MONITOR

£120.00

All prices INCLUDE V.A.T. & carriage

(Offer closes 30th July 1982)

FULL RANGE OF INTERFACES AVAILABLE

## PRINTERS

EPSON MX80FIT £409.00 EPSON MX80T12 £409.00 EPSON MX82FIT £466.00 MICROLINE 80 £318.00 MICROLINE 82A £409.00 MICROLINE 83A £673.00 EPSON MX100 £593.00 EPSON MX82 £397.00

## DISK DRIVES 5.25"

For TRS80 model I & III, Video Genie I and II, Heathkit, BBC model B, Nascom & Superbrain

● TEAC SINGLE SIDED 3540 TRACK £218.50 ● TEAC DUAL SINGLE SIDED 3540 TRACK £391.00 ● SIEMENS APPLE II SINGLE DRIVE £310.00

## CX80 COLOUR PRINTER

Features include:

● 7 COLOURS ● PET GRAPHICS ● INVERSE AND DOUBLE SIZE CHARACTERS ● COLOUR COMPUTER NOT NECESSARY FOR USE ● SWITCHABLE BAUD RATE ● CENTRONICS INTERFACE (STANDARD) ● OPTIONAL — APPLE II, TRS80, IEEE 488 & RS232 ● APPLE II SCREEN DUMP CARD AVAILABLE ● SEND NOW FOR FREE COLOUR BROCHURE

Price £915 (standard interface)

● All prices INCLUDE V.A.T. & carriage ● Write (enclosing large S.A.E.) or phone for further details and price lists ● Payment by cheque or bankers order ● Open 6 days a week (phone any time) ● Mail order only

P.O. BOX 34, CHEADLE, CHESHIRE SK8 4PT

TEL: 061-428 2014

E & O.E.

● Circle No. 322

# ARBOR SUPPLIES

## 5.25" Diskettes — '10 Packs'

DYSAN — UNBEATABLE QUALITY

Single Sided/Single Density	£ 22.00
Single Sided/Double Density	£ 25.50
Double Sided/Double Density	£ 31.00
Double Sided/'Quad' Density	£ 43.00

KYBE ACCUTRACK — With Free Library Box

Single Sided/Double Density £17.50

BLANK LABEL — Economy for APPLE & PET

Single Sided/Single Density £15.00

(PLEASE SPECIFY IF 10 OR 16 SECTOR DISKS REQUIRED)

## Disk Storage — 10 DISK CAPACITY

Genuine 'EGLY' Plastic Library Boxes £ 1.90 ea.

## Drive Head Cleaning Kits

26 Weekly Cleans for £16.60

All Prices exclude Postage and VAT  
UK P&P — Diskettes £0.60 per pack; Library Boxes  
£0.50; Head Cleaning Kits £0.60 ea.  
VAT is calculated at 15% of total goods + P&P value

Please make Cheque/P.C. payable to ARBOR SUPPLIES  
or quote your ACCESS Number

11, CHAMBERLAIN GARDENS, ARBORFIELD CROSS,  
NR. READING, BERKS. Tel. (0734) 470174

● Circle No. 321

PRACTICAL COMPUTING June 1982



## THE State-of-the-Art Microcomputer

- 16 bit processor
- 128K RAM
- 2 x 600K disk store
- 800 x 400 pixel resolution graphics
- CP/M operating system

## PLUS Extremely well-documented, user-friendly state-of-the-art application software

- ACT PULSAR accounting system
- Sapphire systems management accounting and reporting system
- Sorcim SUPERCALC
- Intelligence (UK) MICROMODELLER
- Micropro WORDSTAR

## PLUS A range of high level languages, including Microsoft BASIC-86, Digital Research C-BASIC 86, Micro Focus Cis-COBOL etc, etc.

For more information on the ACT SIRIUS 1 or the above software packages please contact Dr. Gordon Relf at

## DRAGON SYSTEMS LTD.

(0792) 474498

37 Walter Road, Swansea, West Glamorgan

● Circle No. 323

# COMSTAT

THE RELIABLE  
PRINT AND COMPUTER STATIONERY SERVICE

## Suppliers of:

- \* BESPOKE CONTINUOUS INVOICES, STATEMENTS, ORDER SETS, PAYSLIPS ETC.
- \* SELF-ADHESIVE COMPUTER LABELS
- \* TELEPRINTER ROLLS, ANTI STATIC PAPER TAPE
- \* STOCK LISTING PAPER — PLAIN AND MUSIC RULED

## Examples of prices:

For single part, M.R. listing, quantities up to 10,000 with minimum order 1 box — free delivery in the Manchester area.

11 x 9 $\frac{1}{2}$ in at 3.90  
11 x 14 $\frac{1}{2}$ in at £4.60  
11 x 15 $\frac{1}{16}$ in at £4.76  
11 x 17 $\frac{3}{32}$ in at £5.90

Per 1,000 plus VAT. All on good quality 60gm<sup>2</sup> white bonded paper.

Please telephone your enquiries, or send orders, to Comstat Business Forms Ltd., 63 Bollin Drive, Timperley, Cheshire WA14 5QW. Tel: 061-969 7890.

● Circle No. 324

# WHAT'S the CATCH?

HOW COME THESE PRICES ARE SO LOW?  
There is no catch except — you always catch a  
good deal at DEANS



## SHARP

Apple II + 48K	£639.00	PC 1500	P.O.A.
Disk Drive + controller	£329.95	PC 1211 Pocket Computer	£59.95
Disk Drive	£289.00	CE121 cassette interface	£10.95
16K Ram Card	£60.00	CE122 printer	£54.95
Pascal System	£239.95	CSR700 paper roll (40)	P.O.A.
APPLE SOFTWARE		MZ80K	
Visicalc (3.3)	£99.00	MZ80A	P.O.A.
Visiplot	£95.00	(New arrival)	
Visidex	£99.00	MZ80B	P.O.A.
Visitrend/plot	£135.00	MZ80K computer 48k	£329.00
Apple World	£29.95	MZ80 FD dual disk	£550.00
Apple Writer	£34.95	MZ80 P3 dot printer	£350.00
Desk Top plan II	£105.00	MZ80 F1/0 disk interface	£49.95
DOS plus	£19.95	MZ80 F15 disk cable	£8.00
Aplus	£19.95	MZ80 1/0 expansion box	£94.00
Apple guard	£19.95	MZ80T20C machine language	£18.00
WORD PROCESSING		MZ80TU Assembler	£35.00
Apple writer (I)	£34.95	400 16k computer	£295.00
Apple writer II (80 col)	P.O.A.	800 16k computer	£549.00
Magic window	£59.95	16k Ram Upgrade	£49.95
Mailmerge (80 col)	£60.95	DISK DRIVE	£295.00
Wordstar	P.O.A.		
MONITORS		VIDEO RECORDERS	
12" green screen	£115.95	Sony SLC5	£390.95
9" b/w monitor		Sony SLC7	£548.10
9" b/w Hi-Resul	£115.95	JVC HR7200	£451.53
COLOUR MONITOR		JVC HR7300	£477.95
14" JVC PAL/SECAM/MTSC	£299.95	AKAI VS5	
Eurocolour Card	£69.00	FLOPPY DISK	
Integer Card	£95.00	5 1/4" Verbatim SS/DD	£2.30
Language card	£97.50	5 1/4" Verbatim SS/DDX10	£19.95
Parallel Interface card	£87.00	5 1/4" Verbatim OS/DD	£2.60
Communication card	£99.00	BOOKS	
Centronic card	£99.00	Apple	
High speed serial card	£94.50	Apple II Ref Manual	£11.00
PRINTERS		6502 assembly language	£12.10
Silentype	£190.00	DOS 3.2 manual	£6.00
Centronic 737	£345.00	Apple II basic tutorial	
Paper Tiger 445	£490.00	Pascal reference manual	£8.50
Epson		ZX81	
MX80 T2	£399.00	Getting Acquainted with your	
MX80 FT/1	£395.00	ZX81	£5.95
EPSON/Sharp	£65.00	Mastering machine code	
EPSON/Sharp Disk	P.O.A.	on your ZX81 or 80	£5.95
GAMES		The Gateway Guide to	
Space Warrior, Alien Rain	All	the ZX81 and ZX80	£5.95
Snoggle, Galaxy Wars,	at	49 Explosive Games for	
Alien Typhoon, Cribbage		the ZX81	£5.25
Galactic Empire	£12.95		
Star Mines, Apple Panic	All		
Tarturian, Tawala's	at		
Creature Venture	£14.95		
Star Thief, Missile Defence	All		
Epoch, Soft Porn Adven.	at		
The Wizard & the Princess			
Threshold,	£17.95		
Sneakers,			
Oldofo Revenge			
Pegasus II			

Most of our prices are heavily discounted therefore please send cheques payable to DEANS Credit-card Sales add 3%  
Add 15% VAT Postage and Packing free on books + Software.

DEANS of Kensington

191 KENSINGTON HIGH STREET, LONDON W8

Tel: 01-937 7896 ext 8.

Open MON to SAT (9.30am — 6.30pm)

● Circle No. 326

## CROYDON COMPUTER CENTRE

PROUDLY ANNOUNCE

★ ★ ★ Z-ROM 1 ★ ★ ★

A new user aid for all Commodore New Rom & BASIC 4 machines featuring a series of additional BASIC commands, all written in machine code and including:—

- KINPUT** — Outlined window for string/numeric input, cursor cannot escape, no return on null string.
- DEFPARAM** — Set user defined or default parameters for KINPUT.
- HOLD** — Waits for space bar to be pressed.
- GETCHAR** — Gets one character from keyboard if in a user defined list and returns variable equal to position in list.
- PRINT at** — Print at column/row specified.
- D/ESTOP** — Disable and enable run/stop key with clock left on.
- FORMAT** — Formats string variable for finance use.
- SORT** — Alphanumeric sort on single or two dimension string array.
- WSET** — Set up window on 80 column machines.
- H/VPRINT** — Print horizontal/vertical line(s) of user defined characters.
- PRINTUSE** — Print numeric variable(s) from user defined image string.

**PRICE ONLY £34.50 + VAT**

Specify machine, BASIC and socket location (9000 or A000H)

Send for data sheet and free price list. Dealer enquiries welcome.

29a Brigstock Road, Thornton Heath, Surrey CR4 7JJ.  
Tel: 01-689 1280

● Circle No. 325

## MACHINE LANGUAGE MADE SIMPLE ZX80 AND ZX81

★ This new book is a must for any **SINCLAIR** user who wants to make full use of his **SINCLAIR.ZX80** and **ZX81**. Go beyond Basic into the world of **MACHINE LANGUAGE PROGRAMMING** and open computer horizons you never thought possible! Learn how to use the **SINCLAIR** computer's own language and finally find out what PEEK and POKE is all about!

**MORE COMPUTING POWER IN LESS**

**SPACE! FASTER  
RUNNING PROGRAMS!**



Written for the complete beginner as well as for the experienced **SINCLAIR** user, **MACHINE LANGUAGE MADE SIMPLE** has over 120 pages packed with programming techniques, hints and tips.

**WRITE YOUR OWN MACHINE LANGUAGE PROGRAMS...**

★ \* USEFUL BASIC PROGRAM TO EDIT MACHINE LANGUAGE \* COMPLETE DESCRIPTION OF THE INSTRUCTIONS GROUPED BY SUBJECT AND BY \* USEFULNESS \* NUMEROUS SAMPLE MACHINE LANGUAGE ROUTINES DESIGNED SPECIFICALLY FOR THE SINCLAIR 80 & 81 \* SIMPLE EASY TO USE LOOK UP TABLES.

**£8.95 (plus 50P p&p)**

Please send me ..... copies **MACHINE LANGUAGE MADE SIMPLE FOR YOUR ZX80 & ZX81.**

Orders to: Melbourne House Publishers, 131 Trafalgar Rd, London SE10  
Correspondence: Glebe Cottage, Glebe House, Station Rd, Cheddington, Leighton Buzzard, Bedfordshire LU7

Please enclose cheque or P.O. for £9.45 per copy. Orders outside the UK £9.95.

NAME .....  
ADDRESS .....

PC/82

● Circle No. 327

PRACTICAL COMPUTING June 1982

# AT LAST!

A complete and computerised system for the enthusiastic racegoer

## COURSEPLAN '200'

- The product of 10 years' exhaustive statistical research
- Programmed to achieve a *minimum 50%* winning selections
- Unique and safeguarded Staking Plan, built-in to the system

The 1981 Flat season produced 52.61% winners and a paper profit of £4,035 during the 10 week peak period of the program (£10 Base-unit). Level stakes only, would have shown a £1,371 profit. (All figures *after tax* at 10%.)

**COURSEPLAN WILL BE RESTRICTED TO 200 SALES ONLY**  
**THE REASON FOR THIS EXCLUSIVITY SHOULD BE SELF EXPLANATORY**

Full details of this brilliant and long-awaited program will be provided on receipt of your written enquiry to:

**FRANKOFORM,**  
 6 SANSOM STREET,  
 CAMBERWELL,  
 LONDON SE5

● Circle No. 328

## Essential reading for all computers

### FORTH THEORY AND PRACTICE LISP THEORY AND PRACTICE

Two books from Acornsoft that provide a thorough introduction to programming in LISP and FORTH. Many practical examples of programs are included.

Most of the contents of the manuals are applicable to any machine, although the manuals also explain the operations for the Acorn Atom. Both manuals are spiral bound to lie flat and have been produced and laid out clearly and concisely.

Each manual costs £6 including post and packing and is available from dealers or direct from:- Acornsoft Ltd, 4A Market Hill, Cambridge CB2 3NJ.

Credit Card Holders can ring 0223 316039 and order direct.

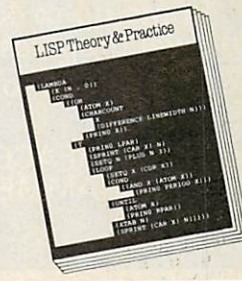

**ACORNSOFT**

● Circle No. 329

## Advertisement Index

<b>A</b>		<b>Crystal</b>	192	<b>K</b>		<b>P</b>	
A & G Computerware	215	Ctec	40	Kai	188	Pearcom	122
A. J. Harding	29	Cumana	26	Keele Codes	182	Pearl	142
Acornsoft	217	CVI	166	KGB	48	Pete & Pam	205
Act	114, 115	CWP	30	Knights TV	214	Photo Acoustics	154
Adda Microshops	108	<b>D</b>		Kram	200	Plus Business Systems	207
Advanced Computer Equipment	165	Data Application	60	Kuma	166	Professional Data Systems	186
Almarc	107	Data Digital	147	<b>L</b>		<b>R</b>	
Altek	166	Datalect	39	L & J Computers	2004	Ravenscarr	210
Altos	116	Dataright	196	Level Ltd.	198	Realtime	23
Anglo American	199	Davinci	213	Lifeboat Associates	101	Riva	112
Anita	38	DDP	187	Little Genius	200	<b>S</b>	
Apple Orchard	153	Deans	217	London Computer Centre	189, 192	SBD	130, 196
Asset	126	Digital Equipment	201	Lowe Electronics	159	SDM	184
Atlanta Data	214	Digitek	51	Lucas Logic	8, 9	Shelton Instruments	65
Avery	188	Digitus	146	<b>M</b>		Sinclair Research	66, 67, 81
Avon Computers	211	Discom	138	Mannesman Tally	73	Sirton	15
<b>B</b>		Disking	54	Mass Micro	100	Southdata	25
Beebug	194	DN Computer Services	206	Melbourne House Publishers	216	Spider	188
BFI Electronics	44	Dragon Systems	215	Memotech	68	Stirling	20
Birkwood	34	Dyson	209	Metrotech	27, 28	Superior Systems	161
Blyth	131	<b>E</b>		Micro 80	202	Swan	118
Bromley Computer	211	Eastern	204	Micro Mods	212	Symbiotics	191
Butel	38	Electronic Brokers	194	Microcentre	2	Systematics	113
<b>C</b>		Euro Micro Ltd	220	Microcomputer Products	10, 11	<b>T</b>	
Calco	213	Equinox	88, 89, 105	Micronetworks	28	Tab	57
Camden	190	<b>F</b>		Micropute	123	Technomatic	78
Chromosonic	193	Franco Form	216	Micropute	137	Telesystems	100
Cider	208	<b>G</b>		Microsource	191	Texas Instruments	20, 21
City Microsystems	206	Gemini	124	Microstyle	132	Thorn EMI	99
Clenlo	83	GP Industrial	181	Microtanic	218	Transam	143
Codified Computers	153	Graficom	186, 187	Microvalue Dealers	16, 17	Transtec	121
Comart	219	Gram	194	Microware Ltd.	214	Triumph Adler	35
Commodore	33, 52	Gramma Winter	18, 19	Millbank	12, 13	<b>V</b>	
Commodore Business	6, 7, 22	Granite Chip	202	MOM Systems	208	Vector International	42
Compec North	121, 164	<b>H</b>		Monolith	190	Vision Associates	208
Compshop	162	Harmer Simpson	82	<b>N</b>		<b>W</b>	
Compsoft	14	Hitec	203	Northamber	95	Watford Electronics	4
Computace	5	Hotel Microsystems	76	<b>O</b>		Willis Computers	31
Computech	32	<b>I</b>		O Computers	197	Windfall	198
Computer Interface	192	I.O. Systems	212	Omicron Design Computers	206	<b>X</b>	
Computer Supermarket	37	Icarus	24, 36, 185, 182	Osbourne Computers	14, 15	Xitan Systems	209
Control Universal	184	Ice	138	Overseas Computer Systems	44	<b>Z</b>	
Copyrite Computer	202	Informex	154			Zenith Data Systems	195
Core International	211	Interam	106				
CPU Peripherals	129	Intercal	198				
Crofton	154						
Cronite Group	218						
Crown Business	210						
Croyden Computer Centre	216						

# MICROTANIC SOFTWARE

ADD A PRINTER TO YOUR 6502 SYSTEM FOR LESS THAN £80

Connect a Sinclair ZX printer (£49.95) to your 6502 computer with:

PRINTERFACE 1 FOR MICROTAN  
PRINTERFACE 2 FOR MICRON/TAN  
RACK

PRINTERFACE 3 FOR ATOM/ACORN  
RACK

PRINTERFACE 4 FOR  
AIM-65/KIM/SYM

PRINTERFACE 5 FOR BBC  
COMPUTER

PRINTERFACE 6 FOR VIC-20

Please ask for others.

Prints up to 43 characters/line or 256  
Pixel graphics.

This page took ten seconds and cost  
0.00½ p.

PRINTERFACE UNIT AND 600 BYTE  
PROGRAMME LISTING: £29.95 INC  
VAT

**NOW AVAILABLE FOR:**

**MICROTAN 65**

**ACORN ATOM**

**BBC COMPUTER**

**AIM-65/KIM/SYM**

**VIC-20**

**MICRON SYSTEM RACK**

Send cheque/P.O. plus 60p post and  
packing to:

**MICROTANIC  
SOFTWARE**

**235 FRIERN ROAD**

**DULWICH, LONDON SE22**

**or TEL: 01-693 7659**

● Circle No. 330

## SIMPLICALC

FOR EVEN 8K PETS.....FROM CRONITE

NOW ON  
VIC-20!

### THE LOW-COST ALTERNATIVE

**SimpliCalc** is a small, powerful work sheet program. It runs on any CBM PET, except "old ROM", even cassette-based. The sheet is viewed on the screen.

**SimpliCalc** makes the "what if" exercise available on all sizes of CBM. On a 32k it provides a much larger useable matrix than any similar program: on an 8k it provides enough space to analyse a capital purchase or personal tax computation.

**SimpliCalc** is freeform. Its uses are many. For instance, it's been calculating chemical weights, projecting profits by product group, and costing out salary reviews. Be inventive.

**SimpliCalc** is simple to use, with 8 single-key commands. Print your sheet out, and save it on cassette or disc depending on version. A comprehensive manual is provided.

To order your copy of this versatile numeric tool, send cheque with details of your system, specifying whether your CBM is \*2001/3000/early 4000 (PEEK (144) = 46) \*late 4000 \*8032 and whether you want cassette £29.90 incl. VAT or disc £36.80 incl. VAT (specify drive type). Security copies available (no backup possible) at £4.00 cassette and £6.00 disk incl. VAT.

**CRONITE COMPUTER SYSTEMS LTD., Montgomery Street, Birmingham B11  
1DT.**

Further details from Mark Turner on 021-773 8281 — telex 338247

VisiCalc is a trade mark  
of Personal Software Inc.

● Circle No. 331

### Main Dealers

**Birmingham**  
Byteshop Computerland  
4/96 Hurst Street  
Tel 021-622 7149

**Bublin**  
Endac Data Systems  
Dawson Street  
Tel 0001 372052

**Glasgow**  
Byteshop Computerland  
Laguet House  
1 Waterloo Street  
Tel 041-221 7409

**Leeds**  
Holdene  
Manchester Unity House  
1/12 Rampart Road  
Tel 0532 459459

**London**  
Byteshop Computerland  
324 Euston Road NW1  
Tel 01-387 0505

**Digitus**  
Lading House  
10/14 Bedford Street  
Covent Garden WC2  
Tel 01-379 6968

**Leamington**  
197/213 Lyham Road  
Brixton SW2  
Tel 01-671 6321

**Manchester**  
Byteshop Computerland  
11 Gateway House  
Piccadilly Station Approach  
Tel 061-236 4737

**Nottingham**  
Byteshop Computerland  
92a Upper Parliament Street  
Tel 0602 40576

**Southampton**  
Xitan Systems  
23 Cumberland Place  
Tel 0703 38740

### Dealers

**Bristol**  
Senton  
27 St. Nicholas Street  
Tel 0272 276132

**Cambridge**  
Cambridge Computer Store  
1 Emmanuel Street  
Tel 0223 65334

**Cheshire**  
Holdene  
82a Water Lane  
Wilmslow  
Tel 0625 529486

**Edinburgh**  
Holdene Microsystems  
48 Great King Street  
Tel 031-557 4060

**Manchester**  
NSC Computers  
29 Hanging Ditch  
Tel 061-832 2269

**Norwich**  
Anglia Computer Centre  
38 St. Benedict's Street  
Tel 0603 29652

**Sheffield**  
Hallam Computer Systems  
Berkeley Precinct  
151 Ecclesall Road  
Tel 0742 663125

**Warwickshire**  
Business and Leisure  
Microcomputers  
6 The Square  
Kenilworth  
Tel 0926 512127

**Watford**  
Lux Computer Services  
108 The Parade  
High Street  
Tel 0923 29513

# Comart Communicator

## Efficiency you'll never outgrow

Microcomputer based business systems provide management and operational information quickly and accurately. Microcomputers put computer power in the hands of your existing staff to improve their efficiency and cost effectiveness whilst increasing your control and flexibility.

Comart Communicator microcomputer systems are British designed and British made. Systems for Management, Sales, Accounting, Production Control, Word and Data Processing are just a few of the applications available. You can select from a range of single or multi-user systems with the option of adding extra data storage and communications facilities at a later date. So you can choose a Communicator system, for today, with the confidence that it can expand to meet the needs of tomorrow.

Comart is the complete microcomputer group. From system development to after sales service. Together with our

nationwide network of dealers, Comart assures you of national support—locally.



For your copy of our business brochure fill in the coupon today or call us on 0480-215005. NOW!

● Circle No. 332



**comart communicator**  
A major expansion opportunity for British Business

Please send me a copy of your brochure "A major expansion opportunity for British business."

Name \_\_\_\_\_

Company \_\_\_\_\_

Position \_\_\_\_\_

Address \_\_\_\_\_

PC/6 \_\_\_\_\_ Tel. No. \_\_\_\_\_

A member of the Comart group of companies

**Comart Limited**  
St. Neots Cambs PE19 3JG  
Tel (0480) 215005  
Telex 32514 Comart G

At Intersystems,  
"dump" is an instruction.

Not a way of life.  
(Or, when you're ready for IEEE S-100, will your  
computer be ready for you?)

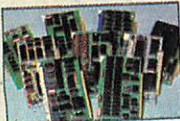

We're about to be gaudies again.

While everyone's been busy trying to convince you that large buses housed in strong metal boxes will guarantee versatility and ward off obsolescence, we've been busy with something better. Solving the real problem with the first line of computer products built from the ground up to conform to the new IEEE S-100 Bus Standard. Offering you extra versatility in 8-bit applications today. And a full 16 bits tomorrow.

We call our new line Series 11™. And even if you don't need the full 24-bit address for up to 16 megabytes (!) of memory right now, they're something to think about. Because of all the perform-

ance, flexibility and economy they offer. Whether you're looking at a new mainframe, expanding your present one or upgrading your system with an eye to the future. (Series 11 boards are compatible with most existing S-100 systems and all IEEE S-100 Standard cards as other manufacturers get around to building them.)

Consider some of the features: Reliable operation to 4MHz and beyond. Full compatibility with 8- and 16-bit CPUs, peripheral and other devices. Eight levels of prioritized interrupts. Up to 16 individually-addressable DMA devices, with IEEE Standard overlapped operation. User-selectable functions addressed by DIP-switch or jumpers, eliminating soldering. And that's just for starters.

The best part is that all this heavy stuff is available now! In our advanced processor—a full IEEE Bus Master featuring Memory Map™ addressing in a full megabyte. Our fast, flexible 16K Static RAM and 64K Dynamic RAM boards. An incredibly versatile and

economical 2-serial, 4-parallel Multiple I/O board, 8-bit A/D-D/A converter. Our Double-Density High-Speed Disk Controller. And what is undoubtedly the most flexible front panel in the business. Everything you need for a complete IEEE S-100 system. Available separately, or all together in our new DPS-1 Mainframe!

Whatever your needs, why dump your money into obsolete products labelled "IEEE timing compatible" or other words people use to make up for a lack of product. See the future now, at your Intersystems dealer or call/write for our new catalog. We'll tell you all about Series 11 and the new IEEE S-100 Bus we helped pioneer. Because it doesn't make sense to buy yesterday's products when tomorrow's are already here.

**Intersystems™**

Ithaca Intersystems (UK) Ltd.,  
Coleridge Lane, Coleridge Road,  
London N8 8ED,  
Telephone: 01-341 2447; Telex: 299568

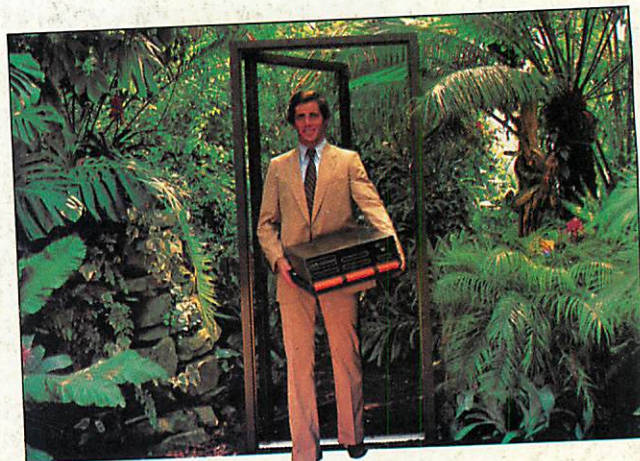

Outside of the garden  
you need a computer that can grow.

For the common or garden hobbyist, a high quality personal computer is a real temptation. But let's face it: in the world of business, engineering and scientific applications, you need a system that has been designed from the ground up to allow flexibility and expandability today allows the

Providing flexibility and expandability today allows the micro to move up to and beyond the level of yesterday's mini. Hard disks for big system memory; more peripherals for big system flexibility; more number crunching capability and programming power can all be added when you need them. And without the feeling that you are turning a good natured toystown machine into a disproportionate monster.

The Ithaca Intersystems DPS-1 has the power and flexibility to 16 individually addressable DMA devices and up to 1 to 16 Megabyte direct addressing from our 280 board with its unique memory management system.

For really serious computing, our optional hardware front panel provides a powerful diagnostic tool for debugging and development. Among its many features are the ability to deposit into and examine memory and set hardware breakpoints. Coupled with an oscilloscope, many other activities usually associated with expensive logic analyzers are possible. No wonder it's fast becoming the standard development system in laboratories and research centres.

expansion, or locked into obsolescence by depending on a single manufacturer. But beware: IEEE 8086 is an 8 bit AND 16 bit standard, not 8 bit only as some would have you believe. True compatibility and later upgrade to 16 bits means you need to stick to the full IEEE 8086/100 standard from the start. So if you've left the common or garden variety applications behind, come to Ithaca Intersystems and get a system that will grow as big as your next idea. Whether starting out with a basic low cost system or needing a sophisticated full feature multiuser system or anything in between... you'll find a solution to your problem with Ithaca Intersystems. With a choice of 5" or 8" drives, hard disks and CP/M or MP/M, and the full range of CP/M compatible software, including the excellent PASCALIZ native code compiler, we probably have what you need. Why not contact us to discuss your requirement! Call today for a catalogue of our products which also contains details of the IEEE S100 bus.

Coleridge Lane, Coleridge Road,  
N8 8ED England  
Telephone: 01-341 2447  
Telex: 299568

Intersystems (UK) Ltd.  
COMPUTERS FOR THE '80s™

SEE US  
NEXT MONTH!

"M... COMPUTERS FOR THE '80s"



Pictured is the SuperFAST™ CACHE BIOS System. For further information and a catalogue of our IEEE S100 products contact us today

Coleridge Lane, Coleridge Road,  
London N8 8ED England  
Telephone: 01-341 2447  
Telex: 299568

ITHACA Intersystems™ (UK) Ltd

● Circle No. 373

**EuroMicro™ Ltd.**

EuroMicro House, Coleridge Lane, London N8 8ED, England.  
Telephone: 01-341 2447

● Circle No. 333

EuroMicro is the Trademark of EuroMicro Inc.