

60p

YOUR COMPUTER

MAY 1982

Vol.2 No.5

Aerial photographs interpreted

Joysticks on the Sinclair

BBC graphics

Vic tank battle

ZX cassettes tested



**Win a Micro Gen
joystick for the ZX-81**

ATARI[®] BRINGS THE COMPUTER AGE HOME



ATARI HOME COMPUTERS BRING A WORLD OF INFORMATION, EDUCATION AND ENTERTAINMENT INTO YOUR LIVING ROOM

Imagine! You just press a few buttons and suddenly you are creating beautiful music, or learning how to converse in French, German or Spanish.

Futuristic? Yes, but it's here today with the ATARI HOME COMPUTER, the personal computer that brings space-age technology down to earth, and right into your own home.

The ATARI HOME COMPUTER is designed to be so simple that when you plug it in and use one of our programmes, it's ready to go. And it's so brilliant, it can create a world of wonderful things for you.

EXHILARATING ENTERTAINMENT

The excitement is electric when you challenge the ATARI computer to a fast-moving, fast-thinking space battle with Space Invaders, Missile Command, or Asteroids.

Please send me FREE a brochure, price list and the address of my nearest stockist.

NAME _____

ADDRESS _____

YCS

Atari International(UK)Inc, RH Associates
5/7 Forlease Rd, Maidenhead, Berks SL6 1RP

Play all your favourite computer games in dynamic colours, sound and amazing graphics.

EFFECTIVE, EXCITING EDUCATION

Learn everything from languages to chess and touch-typing, all at your own pace, from a teacher that never gets tired or impatient.

Learning has never been more effective or more fun.

Learn to invent your own games, create your own music and art, make your own experiments and discoveries.

Or develop a deeper understanding of nuclear energy issues as you simulate the fascinating workings of a power plant.

ATARI Home Computers take you as far as your imagination can go.

THE FRIENDLIEST COMPUTERS IN THE WORLD

The ATARI 400 Home Computer is the perfect way to enter the computer age. It's surprisingly affordable, amazingly easy to use, and extremely versatile.

The ATARI 800 Home Computer is for more advanced applications, including business and science. But it's every bit as simple as the ATARI 400 Computer.

And both grow with you because you can add many new programmes and a variety of accessories.

If you would like to know more about what you can do to bring the space-age into your home send the coupon *today*.



ATARI HOME COMPUTERS

We've Brought the Computer-Age Home

ATARI
A Warner Communications Company

YOUR COMPUTER

YOUR LETTERS: BBC fairy-tale; ZX-81 music.	15	objects on the ground from an aerial photo, by Michael Banks.	34	toured landscape from a flat map, by Brian Smith.
NEWS: ZX-82 reports; Commodore's £1,500 competition.	16	VIC-20 TANK BATTLE: David Prosser's Tank Battle is a game for two players which runs on an unexpanded Vic-20. The object is to destroy your opponent's tank, but watch out for the mines.	37	BASIC TRANSLATIONS: The second article in a series on converting Basic programs from one dialect to another, by Tony Edwards.
COMPUTER CLUB: Aylesbury Computer Club looks at animated graphics on the ZX-81.	19	HOW TO SHOW OFF YOUR ZX-81: C Chambers looks at some simple programs for demonstrating the capabilities of the ZX-81 to the uninitiated.	40	ASIMOV: John Dawson analyses how best to set about writing a word-processing package.
ZX SOFTWARE: The latest software for the ZX-81 is examined by Eric Deeson, who concludes that the quality is fast improving.	20	MAGIC SQUARES: An educational game which uses some of the interesting properties of magic squares, by Rod Hyde.	46	RESPONSE FRAME: Answers to readers' technical queries.
CHESS PROGRAM: John White explains how to build your own chess program.	24	JOYSTICKS FOR THE ZX-81: David Griffen shows how to make your own joysticks, while Patrick Norris explains how to adapt Atari joysticks for the ZX-81.	51	FINGERTIPS: David Pringle's column for calculator enthusiasts.
INTERVIEW: Brendon Gore talks to Richard Turner, chairman and managing director of Artic Computing, about the problems and pitfalls involved in running a software company.	28	MORE ATOM MAGIC: David Berry explains how to use Goto on the Atom using target labels instead of line numbers.	59	SOFTWARE FILE: Eight pages of your programs featuring the BBC Micro, ZX-81, Vic-20, Atom and others.
AERIAL PHOTO INTERPRETATION: How to use an Atom to determine the size of	32	BBC GRAPHICS: How to use the BBC Micro to create a con-		COMPETITION CORNER: The Dire Straits competition result and another puzzle with a £15 book token prize. The Micro Gen joystick crossword falls between pages 18 and 19.

Cover photograph by Stephen Oliver.

Editor

TOBY WOLPE

Assistant Editor

BRENDON GORE

Staff Writer

BILL BENNETT

Sub-editors

MEIRION JONES
JOHN LIEBMANN

Editorial Secretary

LYNN COWLING

Editorial: 01-661 3144

Advertisement Manager

PHILIP KIRBY 01-661 3127

Advertisement Executives

BILL ARDLEY 01-661 3127
PETER RICE 01-661 3127

Midlands Office

DAVID HARVETT 021-356 4838

Northern Office

RON SOUTHALL 061-872 8861

Publishing Director

CHRIS HIPWELL

Your Computer, Quadrant House, The Quadrant, Sutton, Surrey SM2 5AS.
Typesetting by In-Step Ltd, London EC1.
Printed by Riverside Press Ltd, Whitstable, Kent.

Subscriptions: U.K. £8 for 12 issues.

©IPC Business Press Ltd 1982

ISSN 0263-0885

Published by IPC Electrical-Electronic Press Ltd, Quadrant House, The Quadrant, Sutton, Surrey SM2 5AS. Tel: 01-661 3500 Telex/grams: 892084 BIPRESG.

EDITORIAL

NEXT MONTH, with ZX-81 software on flexidisc offered free with every issue, *Your Computer* is presenting a new idea in program storage to the micro market — an idea which could have a dramatic effect on the currently expensive business of buying software. The flexidisc method eliminates the time-consuming chore of entering a program line by line, and if adopted commercially could reduce manufacturing costs to such a point that micro users would benefit from a fall in program prices to one-quarter of their present levels.

The flexidisc is the size of the ubiquitous 7in. forty-five or single, and is made of pliable plastic. In its grooves, in the form of high- and low-frequency sine waves, it can contain the kind of program that would occupy one side of a conventional software cassette. You transfer the software that the flexidisc contains on to one of your own cassettes simply by playing the disc on your record player and recording it. Once the program is safely committed to cassette the flexidisc is stored away as the master copy, to be brought out only if you wish to record another duplicate. Of course, in next month's *Your Computer* there will be full step-by-step instructions on how to use the disc, plus a thorough account of its workings on the technical level.

When the micro enthusiast, hungry for novel applications for his machine, sets about buying new software it is clearly not the cassette itself that concerns him but the quality of the software it contains. Given that the cassette can satisfy the essential loading requirements, all that it becomes is a container for programs — and compared with the flexidisc, an expensive one at that. Reduce the cost of the container but not the quality of the product held in it, and very soon you find yourself on the brink of a software revolution.

For a better idea of the finances of manufacturing cassette software, we could cite one program-producer who recently revealed that a cassette which sells for £5 costs an estimated 22p to make. For that manufacturer to be able to obtain the same percentage profit margin, the selling price for a flexidisc would be 66p on a production price of 3p.

In the ZX-81's short 1½-year life, software prices for the machine have fallen considerably. Micro users look to commercial software for new ideas, and if the flexidisc means that software becomes even more affordable, new ideas will develop quickly and it will herald a breakthrough which will have an impact on both the user's pocket and the development of micro programming.

NEXT MONTH FREE ZX-81 GAME ON FLEXIDISC

MICROAGE ELECTRONICS

LONDON'S BIGGEST ACORN STOCKIST

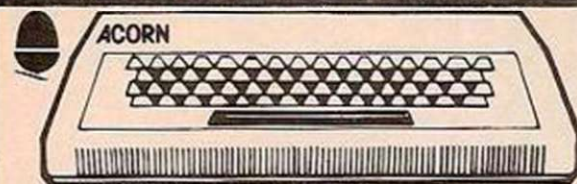

**OFFICIAL
BBC
STOCKIST**

Working BBC machine in stock. Call in for 'hands-on' experience.

ATOM KITS

In our books the best computer kit available. Build yourself an Acorn Atom for **only £135.** plus £2.50 p+p

New Software from Acornsoft. Come and get them all including Atom Chess • Desk Diary • Adventures • Interactive Teaching • FORTH • Atomcalc • Database LISP • Game Packs 1 - 11 • From £11.50 + 30p p&p

BBC ROM

Update your Atom to the BBC operating system.

Atom Discpack. £345

5 1/4 discpack only £345, operating manual, cables, plus £2.50 p+p

The BBC Cassette Recorder £28

As chosen by the BBC, but cheaper! £2.50 p+p

ORDERS TAKEN NOW FOR BBC MACHINE

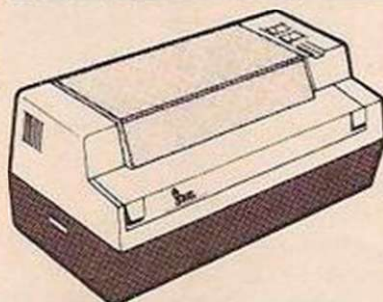

THE GP-80A dot matrix printer. **LOWEST EVER PRICE ONLY £199** £4.50 p+p
Dot Matrix, Full 96 ASC11 character

New! Just arrived. The fantastic GP100A printer. Full printing width.

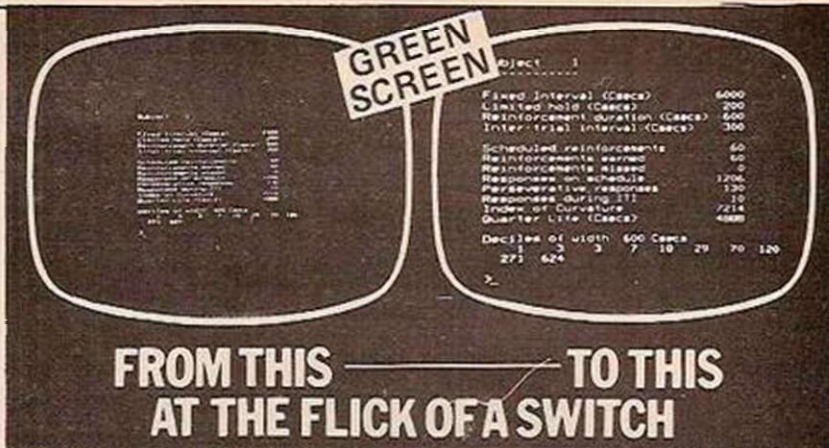

FROM THIS TO THIS AT THE FLICK OF A SWITCH

With the new ZENITH Monitor. Choose between small or large format depending on what you're doing. Small format for definition, large format for display. Full 12" GREEN screen. Only £85 while stocks last. It doesn't change the output from your computer, just changes the size of the display. Ideal for VIC 20, TRS 80, Atom, BBC, + Genie machines. £4.50 p+p



Blank Cassettes 40p each, **£3.50 for 10.** 70p p+p

Also available: 2114 IC's, Paper for most printers, Enormous selection of Books, Leads, etc, etc, etc,

RACOMM COLOUR MONITOR Absolute high resolution. 700x300 pictals 12" £350 + £5 p+p Atom BBC, & Genie machines.

DAI Personal Computer. £684 48K RAM 24K ROM

If it's not in the advertisement, send for our mail order lists.

We accept company/institutional orders.

ALL PRICES INCLUDE VAT ABSOLUTELY NO MORE TO PAY.

MICROAGE ELECTRONICS
135 HALE LANE EDGWARE MIDDLESEX HA8 9QP
TEL: 01-959 7119 TELEX 881 3241

Tansoft

The Software Division of Tangerine Computer Systems Ltd.

NEW PRODUCT

TAN-FORTH: The OFFICIAL version is now available on disc and cassette.

You get all this: Tan-Forth Interpreter/Compiler, Full Forth Assembler, Editor, Random Numbers, Chunky Graphics, Case Statement, 4 Demonstration Games/Routines, plus a printer utility.

Complete with a superb 96 page manual. Requires min 16K Microtan System, disc version £35.00 plus VAT, cassette version £29.95 plus VAT. Please add 75p postage and packing.

THE TANSOFT GAZETTE

The complete bi-monthly magazine for the Tangerine owner. In-depth reviews of products, original programs and software ideas, advanced 'inside' information about how the Microtan System works. Business and games software. Every issue includes a discount voucher for Tangerine products.

Why not subscribe now? Only £15.00 for six issues.

Please make all cheques payable to:

tangerine computer systems ltd

**The Science Park, Milton Road,
Cambridge CB4 4BH**

ATOM USERS!



**ADPROM
4000 UNIT**

for adding on EPROMS as required. Can be used on other computers with 24 pin EPROM sockets (e.g. ZX 80). . . . £32 (excl. vat & p.p.)

WANTED!! Elegant programs for our EPROM and TAPE library service. Details on request with brochure.

ATOM CONSOLE CASE

Case only . . . £25 (excl. vat & p.p.)

Polished teak veneered sides, textured black stelvete and aluminium chassis. Plenty of room inside for RAM Expansion (units available from us), power supplies etc., and T.V. on top. Available as case only, or with integral RAM expansion unit, and/or integral ADPROM 4000.

CASES FOR YOUR OWN PROJECTS

Low priced QUALITY cases - STRONG enough for the workshop - ATTRACTIVE enough for the home.

Matt black plastic end cheeks, textured Stelvete body . . . from £6.25
Teak veneered end cheeks, Aluminium & Stelvete body . . . from £7.88 (excl. vat & p.p.)

FOR BROCHURE & PRICE LIST SEND A5 SAE TO

**ELINCA PRODUCTS LTD., LYON WORKS
CAPEL ST., SHEFFIELD S6 2HL**

— When adult —
**education becomes
 child's
 play!**

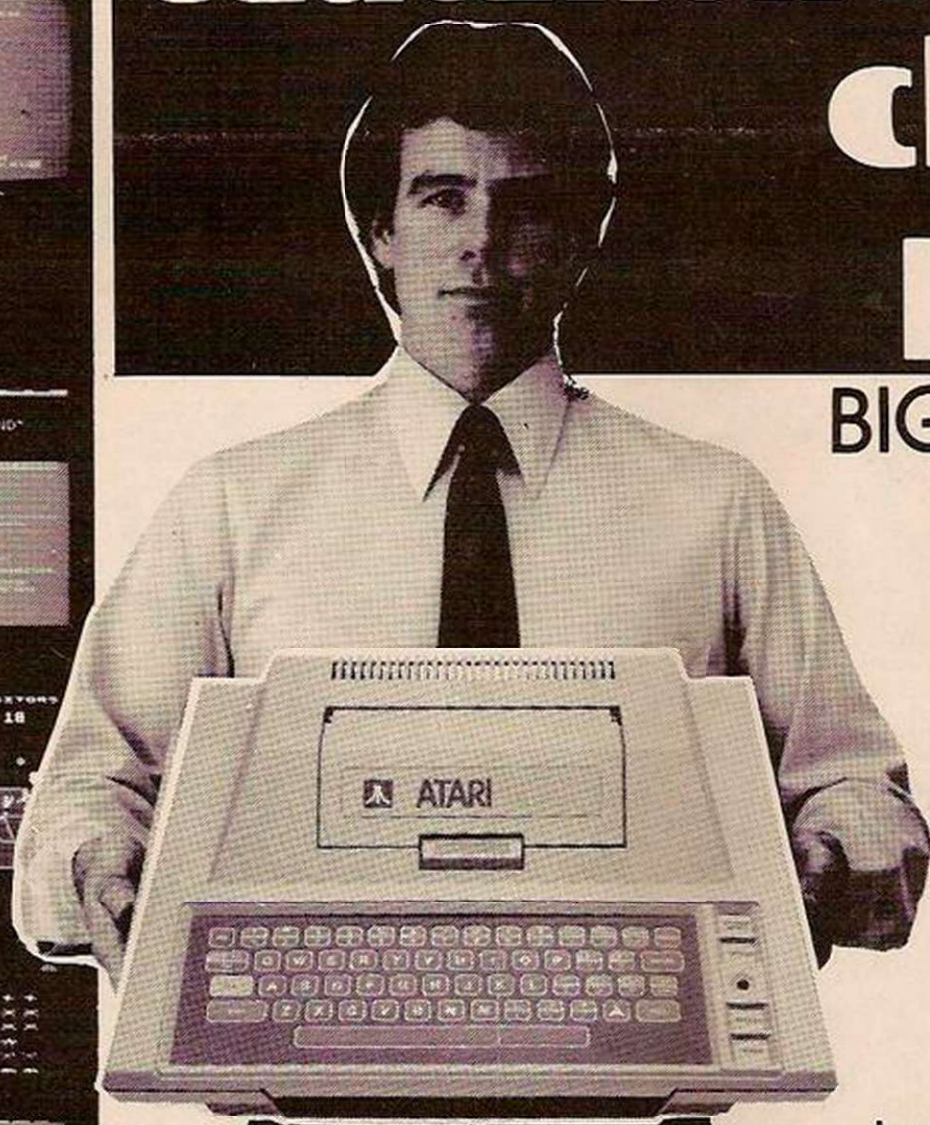

BIG SAVINGS ON

**ATARI
 400**

SPECIAL PRICE ONLY

£299.95
 INC
 VAT

Complete with BASIC
 language cartridge and
 manual

Available whilst stocks last!

plus **ATARI 410**
 CASSETTE RECORDER
 NOW ONLY **£55**

It's here at last!
**B.B.C. Microcomputer
 Games Pack 1**

Suitable for BBC models A & B
 GAMES PACK INCLUDES
 STARWARS — BLACKJACK
 ALIEN INVASION — SIMON — FORTUNE
 Phone for details ACORN ATOM Packages

**MAIN DEALERS FOR
 ACORN ~ VIC 20
 B.B.C. ~ ATARI
 AND SOFTWARE SPECIALISTS**

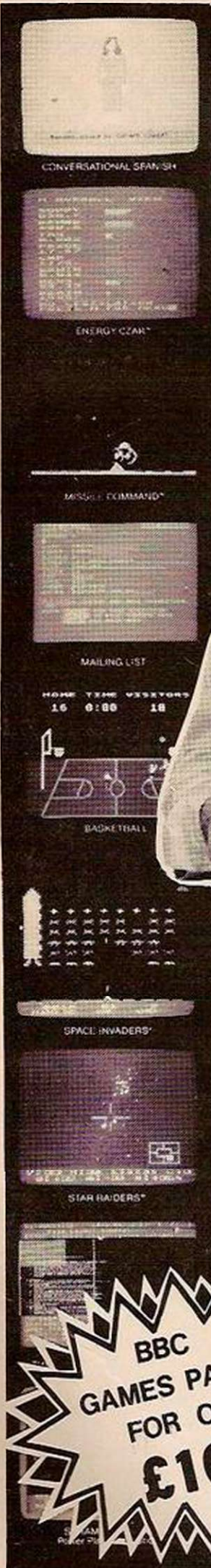

**BBC
 GAMES PACK 1
 FOR ONLY
 £10 + £1
 P&P**

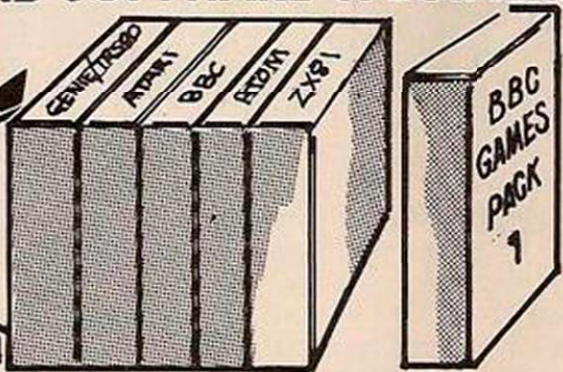

for further information send large S.A.E.

**Computers
 for All**

**72 NORTH STREET,
 ROMFORD, ESSEX.
 TEL 0708 60725**



4K GRAPHICS ROM

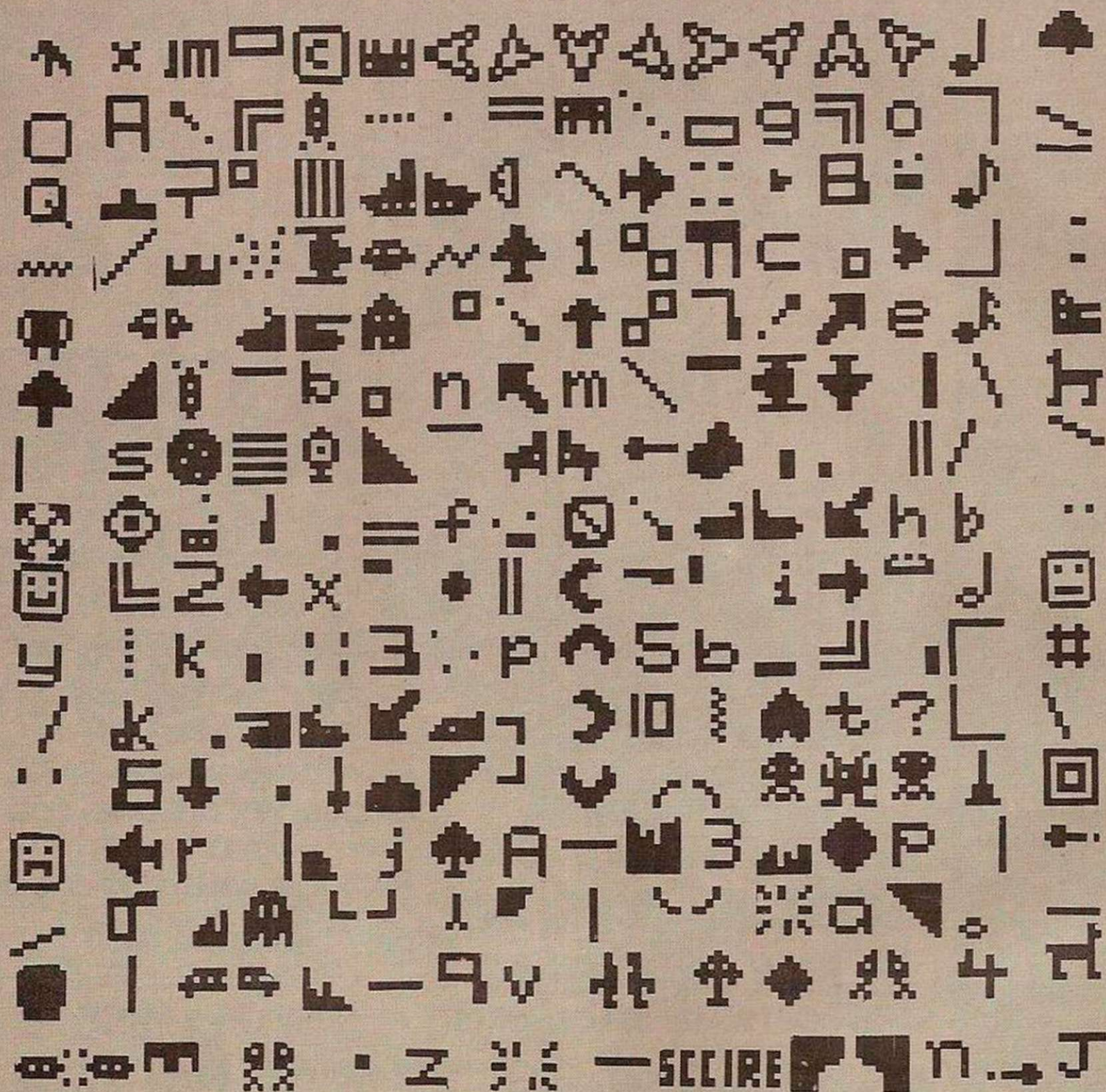

SOME OF THE GRAPHICS NOW POSSIBLE ON THE ZX81

The dK Graphic module is our latest ZX81 accessory. This module, unlike most other accessories fits neatly inside your computer under the keyboard. The module comes ready built, fully tested and complete with a 4K graphic ROM. This will give you 448 extra pre-programmed graphics, your normal graphic set contains 64. This means that you now have 512 graphics and with there inverse 1024. This now turns the 81 into a very powerful computer, with a graphic set rarely found on larger more expensive machines. In the ROM are lower case letters, bombs, bullets, rockets, tanks, a complete set of invaders graphics and that only accounts for about 50 of them, there are still about 400 left (that may give you an idea as to the scope of the new ROM). However, the module does not finish there; it also has a spare holder on the board which will accept a further 4K of ROM/RAM. This holder can be fitted with a 1K/2K RAM and can be used for user definable graphics so you can create your own custom charactor sets. £29.95.

HARDWARE/ SOFTWARE

ZX KEYBOARD

Now with repeat key and facilities to add numeric pad. The keyboard has all the 80/81 functions on the keys.

The keyboard has been specially designed for the Sinclair computer and is supplied ready-built. It also has facilities for 3 extra buttons which could be used for on/off switch, reset, etc. **£27.95**. Numeric add on **£10**.

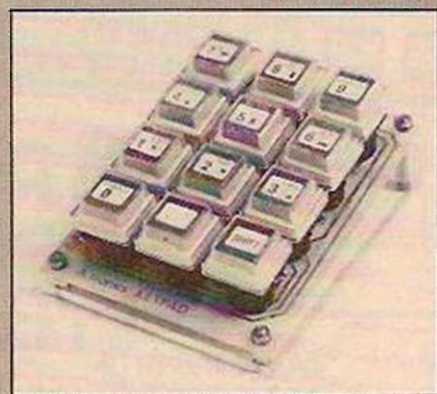
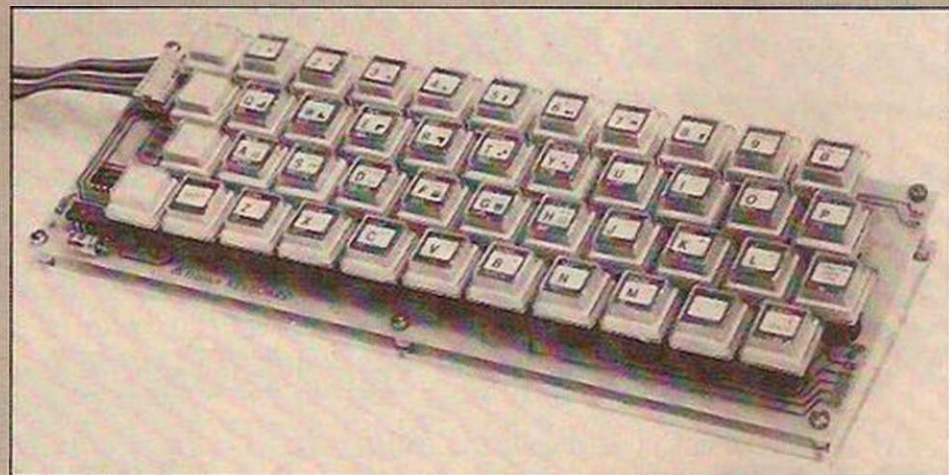

MEMORY 80/ 81

**16K RAM MASSIVE ADD-ON MEMORY
for 80/ 81 £32.95**

16K 81 SOFTWARE

As seen at the ZX Microfair.

DEFLEX. This totally new and very addictive game, which was highly acclaimed at the Microfair, uses fast moving graphics to provide a challenge requiring not only quick reaction, but also clever thinking. One and two player versions on same cassette. **£3.95**.

3D/3D LABYRINTH. You have all seen 3D Labyrinth games, but this goes one stage beyond; you must manoeuvre within a cubic maze and contend with corridors which may go left/right/up/down. Full size 3D graphical representation. **£3.95**.

CENTIPEDE. This is the first implementation of the popular arcade game on any micro anywhere. Never mind your invaders, etc., this is positively stunning, the speed at which this runs makes ZX invaders look like a game of simple snap. **£4.95**.

GRAPHIC ROM SOFTWARE CENTIPEDE. The graphic ROM version of our popular Centipede game. The only real version of Space Invaders on the ZX81.

dK'tronics

23 Sussex Road, Gorleston,
Great Yarmouth, Norfolk.
Telephone: Yarmouth (0493) 602453

MORE POWER TO YOUR POCKET!

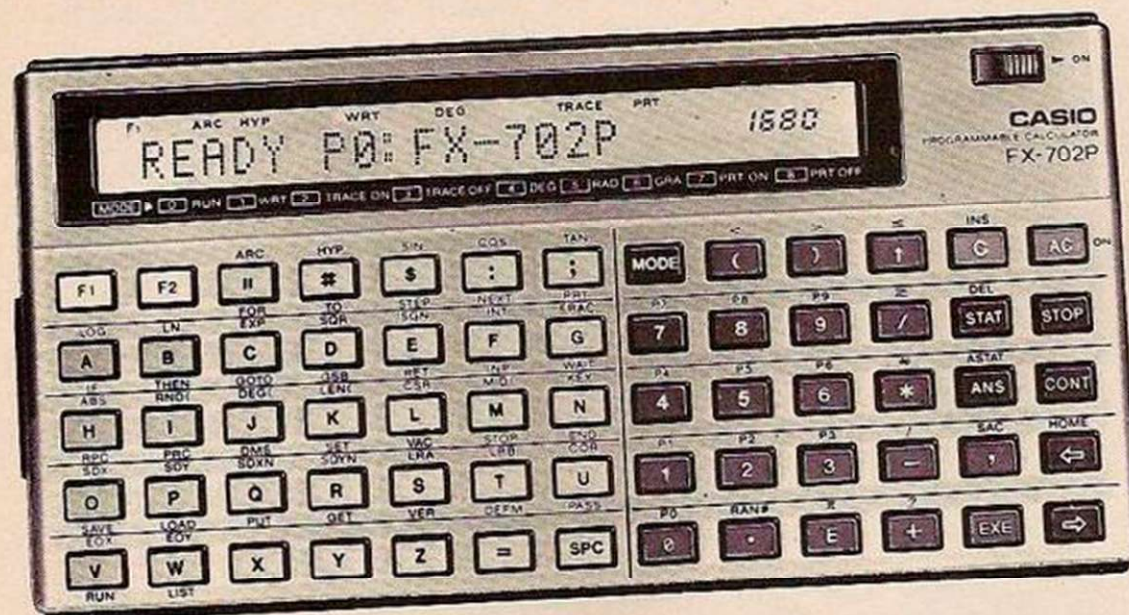

THE FX702P. A pocket computer that communicates in BASIC language.

AVAILABLE AT SPECIALIST CASIO CALCULATOR OUTLETS.
CASIO WHAT WILL THEY THINK OF NEXT?
 CASIO ELECTRONICS CO. LTD., UNIT 6, 1000 NORTH CIRCULAR ROAD, LONDON NW7.

Hand held alphanumeric programmable-BASIC language-holds up to ten different programs simultaneously-subroutines nested up to ten levels-program looping up to eight levels-simplified program editing and debugging-variable programming capacity: between 1680 steps with 26 memories and 80 steps with 226 memories-55 single key routines including log, trig and hyperbolic-built-in routines include standard deviation, regression analysis and correlation coefficient-all programs and memory data retained even when switched off. *Comprehensive library with over 70 program examples. Optional FA2 adaptor for program storage on cassette and FP10 printer.*

R.R.P. £109.95

ZX81 HARDWARE

40 KEY KEYBOARD. Kit £20.95. Built £25.75 (RE77)

- Proper typewriter style keys.
- All legends and graphics in two colours.
- No soldering required to ZX81. Plugs in. (RAM/Printer not affected)
- Complete with all parts, connectors, feet and comprehensive instructions.

24 LINE IN/OUT PORT. Kit £16.95. Built £18.95 (RE98)

- Each line either in or out.
- Controlled by BASIC.
- Allows printer/RAM to be used without a motherboard. (Motherboard version kit £13.50. Built £14.50)

3 CHANNEL SOUND/TIMER BOARD. Kit £16.95. Built £18.95 (RE161)

- 3 independent channels.
- Controlled by BASIC.
- Full range of notes.
- Complete instructions with examples provided.
- Can be used as a sophisticated timer/counter.

MOTHERBOARD. Kit £15.75. Built £18.50 (RE82)

- Two connectors on board.
- Six connector board. TBA.

CONNECTORS & PLUGS

- 23 Way female connector for ZX80/81. (RE80) £2.95.
- 23 Way male connector. (RE87) £1.30.
- 23 Way male connector to fit two female connectors together. (RE90) £1.60.
- 30 Way ribbon cable. £1.40 metre.
- RAM pack connector. Allows RAM pack to be remote from ZX80/81. RE170. £6.95 built.
- In/out connector and sound board connector. (RE78B) £2.95.

BOOKS AND TAPES

- Getting acquainted with ZX81. £4.95.
- Mastering machine code. £5.95.
- Programming for real applications. £6.95.
- Tape for real applications book. £11.44.

Send SAE 5" x 7" for free illustrated catalogue.

All products available ex stock (allow 7 days extra for built products).

PAYMENTS: Cash with order or ACCESS/BARCLAYCARD. Official order welcome. Dealers write for rates.

All prices include p&p and VAT. Overseas add £1.80.

REDDITCH ELECTRONICS, DEPT. YC
 21 Ferney Hill Ave., Redditch, Worcs. B97 4RU
 Tel (0527) 61240.

LOOK! . . . you can't go wrong . . . our
 3 best-selling ZX81 16K cassettes



. . . sell-outs at the ZX Microfairs . . .

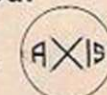

ZX81 LABYRINTH

THE 3-D MAZE GAME FOR 16K

Select your maze dimensions, then see the full maze plan. Which route will you take? The entrance appears, so step forward along the passages (shown as you move in fabulous 3-D effect). Help is always available. Full action replay - relive every step. Every maze is different - so you won't get bored. Very visual, fast (m/c) moves. Almost 14K! We've sold thousands! . . . only £5.95

ZX81 BREAKOUT 3

THREE super versions in one - don't confuse with 1K versions. Can you advance from the PRACTICE to the PROGRESSIVE and ACCELERATION games! Exciting graphics, Single or Double bat. 4 speeds. Best score shown. Fast (m/c) action. This really is the best Breakout cassette around . . . only £5.95

ZX81 CLASSIC 3

Hours of fun with these 3 challenging yet educational classics. HANGMAN - 450 words. 3 levels of difficulty - for all ages! Don't miss the hanging! plus CODE BREAK - Not one but two levels in this test of mastermind type logic. plus PAIRS GAME - Which letters hide the matching numbers? A frustrating test of memory as you select your choices. Can you do it in less than 14 goes? . . . only £4.95

Each cassette has full instructions and load tips
 *Special offer - Buy 2, deduct 90p from total.

ALL 3 only £14.95*

AXIS SOFTWARE FOR MICROS

To: AXIS (YC2), 71 BROOKFIELD AVENUE, LOUGHBOROUGH, LEICS LE11 3LN

I enclose cheque/PO for £ . . . payable to AXIS,

Please send LABYRINTH BREAKOUT 3 CLASSIC 3

Name: _____ Date: _____

Address: _____

CHROMASONIC electronics

48 JUNCTION ROAD, ARCHWAY LONDON N19 5RD 100 yds FROM ARCHWAY STATION & 9 BUS ROUTES
TELEPHONE: 01-263 9493/01-263 9495 TELEX: 22568.

YOUR SOUNDEST CONNECTION IN THE WORLD OF COMPUTERS

VIC 20

- * 24 Colours, 8 for Characters, 8 for Border, 16 for screen mixed as you wish.
 - * 3 tone Generator for sound.
 - * Uses Pet Basic *Plugs into T.V.
 - * Memory expandable to 32K
 - * VIC complete with T.V. Modulator and Power Supply
- ONLY £165.00**

VIC Cassette Deck
ONLY £38.00

Available soon
VIC Dot Matrix Printer
80 Column, 30 CPS,
Tractor Feed
ONLY £199.95

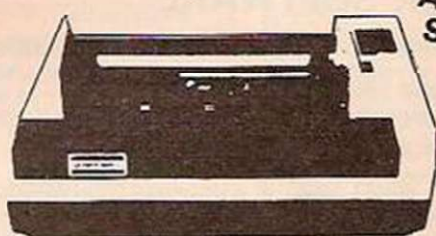
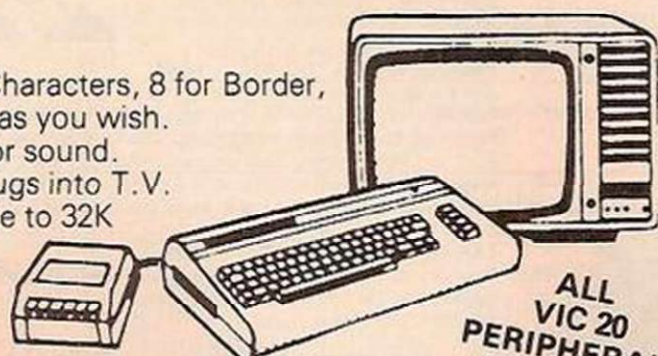

ALL
VIC 20
PERIPHERALS
AVAILABLE
SEND FOR
LIST

UK101

DOWN
IN PRICE

- UK101 Kit inc 8K memory **£125**
 - Ready Built inc 8K memory **£175**
 - Complete in case **£199**
 - 4K Expansion 8x2114 **£10**
 - Parallel Printer Interface **£24.50**
 - Cases **£19.95**
 - Chromasonics Sound Kit **£24.50**
 - Colour Kit **£69.95**
- NEW NEW NEW**
- 32K Dynamic Memory Board only **£89.95**
 - P.I.O. and Eprom Programmer Kit only **£24.50**

APPLE II PLUS

- AUTOSTART "EUROPLUS"
48K Apple Computer **649.00**
Disc Drive with Controller **349.00**
Disc Drive without Controller **299.00**
Colour Card **69.00**
Silentype Printer **199.00**
Graphics Tablet **425.00**
TV Modulator **14.00**

A range of Apple
Accessories and
Software are
available



PET

- 4016 16K RAM **445.00**
- 4032 32K RAM **569.00**
- 8032 32K RAM **755.00**
- 8096 96K RAM **960.00**
- 4040 Disk Drive **585.00**
- 8050 Disk Drive **755.00**
- 4022 Printer 80 Col **357.00**
- 8024 Printer 132 Col **975.00**
- 8026 Printer/Typewriter **835.00**
- 8027 Daisy Wheel **735.00**

A range of Pet
Accessories and
Software are available



PRINTERS



EPSON MX80 £359

Dot-matrix printer with Pet graphics interface. Centronics parallel and serial. Pet and Apple compatible. True bidirectional, 80 cps.

EP80 MX82 £389

As MX80 plus high Resolution Graphics

INTERFACES AND CABLES FOR APPLE II, PET, TRS80, RS232, UK101, SHARP SUPERBOARD - ALL AVAILABLE.

EPSON MX80 FT/1 £399

Dual single sheet friction and tractor feed, 9 wire head, true descenders.

EPSON-MX80 FT/2 £440

An FT/1 with high resolution graphics.

SEIKOSHA GP80A £199

Dot matrix 5 x 7, 80 columns, 30 cps graphics, double width characters.

JUST PHONE FOR FURTHER DETAILS

MONITORS

- | | | | |
|----------------------|---------|----------------------|---------|
| 9" Green Screen | £99.00 | HITACHI PROFESSIONAL | |
| 12" Green Screen | £125.00 | 9" | £99.95 |
| 12" BMC Green Screen | £159.00 | 12" | £149.00 |

VIDEO GENIE

£299 EG3003



Utilises Z80, 12K level II Basic, Integral Cassette Deck, UHF O/P, 16K RAM, all TRS80 features. Simply plugs into monitor or UHF TV. With V.U. Meter.

- PARALLEL PRINTER INTERFACE INC CABLE **£38.00**
- CHROMASONICS PROGRAMMABLE SOUND KIT **£24.50**
- SOUND KIT (FITTING EXTRA) **£8.20**
- LOWER CASE KIT (FITTING EXTRA) **£29.80**
- COLOUR KIT (FITTING EXTRA) **£36.00**
- EXPANSION BOX INC 16K RAM **£199**
- 16K/32K RAM BOARD **£94/ £129**
- NEW GENIE II NOW AVAILABLE **£310**

TANTEL

PRESTEL BY TANTEL
COMMUNICATIONS AT YOUR FINGERTIPS
FOR BUSINESS & HOME. UP TO DATE INFO

180,000 pages of information on Travel, News, Investment, Holidays, Hotels Etc., Etc.

£159

TANTEL IS POST OFFICE APPROVED. SEND FOR DETAILS.
DEMONSTRATION AVAILABLE AT OUR SHOWROOM.

ALL ITEMS CARRY A ONE YEAR GUARANTEE



Please add VAT 15% to all prices. Postage on computers, printers and cassette decks charged at cost, all other items P&P 30. Place your order using your Access or Barclaycard (Min. tel. order £10). Export enquiries welcome. Official orders welcome.



ZX81

HEWSON CONSULTANTS

ZX81

HINTS & TIPS for the ZX81 by ANDREW HEWSON

£4.25

"Good value and quite fascinating . . . a very inexpensive way of acquiring months of programming experience"
Your Computer Nov 1981

"Excellent . . . very good value for money"
SYNC

80 pages explaining how to squeeze a computing quart out of a Sinclair pint pot. Saving Space — vital reading for all ZX81 users. Understanding the Display File — using the display file as memory, clearing a part of the display, using tokens in PRINT statements. Converting ZX80 programs — explaining simply but comprehensively how to convert the hundreds of published ZX80 programs. Chaining programs — revealing techniques for passing data between programs, calling subroutines from cassette and establishing data files. Machine Code Programs — all you want to know about Z80 machine language. Explaining how to write, load, edit and save machine code and how to debug your routines. Routines and programs are scattered liberally throughout the text and the final chapter consists of 12 useful, interesting and entertaining programs such as LINE RENUMBER, BOUNCER, SHOOT, STATISTICS, etc.

16K RAM £37.50

A top-quality add-on memory, simply plugs into the back of your Sinclair computer. Can be used in conjunction with the ZX printer. Neatly packaged in a black plastic shell to match your ZX81. Supplied with one year's guarantee.

ZX81 **SPECIAL OFFER** FREE COPY OF OUR SUPER 'SPACE INTRUDERS' CASSETTE with ANY order for the 16K RAM received by 23.5.82. One copy per customer.

64K MEMORY £79.00

Developed by Memotech this amazing 64K RAM needs NO extra power supply. Simply plugs neatly and firmly into the rear port of your ZX81. Can be used with the ZX printer and other add-on hardware. Just look at these features . . .

- *8-16K can be switched in and out in 4K blocks to leave space for memory mapping.
- *12-16K can be protected against overwriting during loading from cassette.
- *directly addressable and user transparent.
- *up to 15K of basic program.
- *32K or more of variable area.

Z80 OP CODES £1.45

A must for the beginner and the experienced programmer alike. This handy ready reckoner lists all the 600 plus Z80 machine code instructions in decimal and hexadecimal with their mnemonics. Each Op Code is succinctly explained and cross-referenced. Supplied in a protective transparent wallet for easy reference and durability.



16K SOFTWARE

SPACE INTRUDERS £5.95

Not to be missed. All action display. 40 alien ships in each squadron. Automatic option — the machine plays itself. Squadron after squadron of aliens attack your position. Three laser guns. Full score display. Written in machine code for super fast fun.

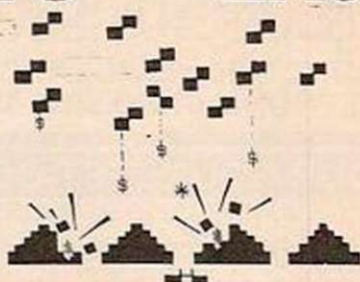

PROGRAMMERS TOOLKIT £6.50

Are you writing your own programs for your ZX81? Then use our TOOLKIT to do the donkey work. Copy into RAM before you start work and then you will have it at your fingertips. Comprehensive LINE RENUMBER including GOSUBS and GOTOS; LOAD, EDIT and RUN machine code programs; INSPECT the ZX81 system routines; COPY them into RAM and PATCH and/or EXTEND them; FIND a given piece of BASIC code and replace all occurrences of it; move blocks of Basic lines with EDIT.

LANGUAGE DICTIONARY £3.75

Now you can construct your own English/French, English/Anything dictionary with our LANGUAGE DICTIONARY. UPDATE the entries, SEARCH for a word, CREATE a new dictionary and save it on tape.

1K SOFTWARE

MINI INTRUDERS for the 1K machine £3.95

An incredibly fast moving game, dodge left and right to avoid falling missiles. Fire Salvo after Salvo at the attacking alien squadron, more aliens join the squadron all the time. Count how many laser bases you lose before you have cut them down.

PLANET LANDER £3.75

Four programs: i) Planet Lander; ii) Space Docking; iii) Stopwatch; iv) Clock.

STATISTICS £3.75

Three programs:
(1) (I) Statistics; prints the current mean and standard deviation after each value is entered. (II) Regression; prints the current mean and standard deviation of the y values, the x values and the intercept and slope of the regression line. (III) Trend; prints the current mean and standard deviation of the y values; the x values and the intercept and slope of the trend line.
(2) Chi square test calculates the value of the chi square statistic for comparing observed and expected values.
(3) Graph plot; plots a graph of data entered from the keyboard.

Special offer
Mini Intruders and Planet Lander £5.00. Offer closes 23.5.82.

Cheque with order or quote access number to:
HEWSON CONSULTANTS, Dept. YC, 7 Grahame Close, Blewbury, Oxon OX11 9EQ. Tel: (0235) 850075

MICROWARE

RETAIL SHOP IN LEICESTER for ZX81

ACCESSORIES, SOFTWARE

Keyboards, Ram Packs, I/O Ports, Monitors, Graphic Rom; Home/Business, Educational, Serious, Games Programs; Books, etc.

★ SPECIAL AT ZX MICROFAIR ★

S/HAND SINCLAIR MACHINES e.g. ZX81's £47.50

also

NEW SPACE-TYPE GAME BY COLLINS
COMPUTING

ORIGINAL GAMES, ENHANCED MOON LANDER
ETC BY COWIE COMPUTING

DORIC COMPUTER SERVICES "ORACLES CAVE"
SCISOFT ORIGINAL EDUCATIONAL PROGS &
"TEACHERS MARK BOOK"

+

'A' LEVEL/TECHNICAL PROGS BY COMPUTER
TRAINING CONSULTANTS
BYG-BYTE 16K RAM PACK, ETC.

MICROWARE

131 MELTON ROAD, LEICESTER
TEL: LEICS 681812

(OPEN 9.30-5.30 — CLOSED THURS, SUNDAY)

See us
on Stand 31, 32

SAE BRINGS
CATALOGUE

MICROWARE

30+ PROGRAMS FOR THE BBC MICROCOMPUTER

This Book contains program listings, with explanations & tips on using the BBC Micro.

GAMES, UTILITIES, EDUCATIONAL, GRAPHICS & MUSIC.

"ASTRO RUN", "SCREENPLAY", "3D GRAPHICS" . . .

Most programs will run on Model A & B. Edited by C. Evans,

various Authors.

£5.00 inclusive of p&p

April 82

CARRYING CASES FOR MICROS

FIBREBOARD		
ZX81	£18.50	Acorn Atom £18.50
BBC Micro	£18.50	Vic £18.50
Apple	£18.50	Atari 400/800 £18.50
2 Apple Disks	£18.50	
Compact black ABS briefcase style, for ZX81		£19.50
p&p all cases	£2.50	

Carrying cases are foam filled with cutouts for: Micro, PSU, & Cassette recorder. ZX81 cases also have room for Ram pack & Printer. Apple cases have room for Micro only. Fibreboard cases can be supplied, modern suitcase style or robust old fashioned style with strengthened corner pads.

Cassette Leads for the BBC Micro

(The BBC Micro comes with an incomplete lead)	
7 Pin Din to 7 Pin Din	£4.65 p&p 35p
7 Pin Din to 5 Pin Din & 2.5mm minijack	£4.65 p&p 35p
7 Pin Din to 2 x 3.5mm & 2.5mm minijacks	£4.65 p&p 35p
7 Pin Din Plugs	Two for £0.65 p&p 35p

Monitor/Video Leads all use 75 ohm coax cable.

BNC plug to Phono plug (ie, BBC Micro to Rediffusion TVRM)	£2.20 p&p 50p
BNC plug to BNC plug	£3.10 p&p 50p
Other leads available. Send SAE for full list of our products	

RAM Chips	4816 As used in the BBC Micro (8 chips required to expand from model A to B capacity)	£5.00 each
	2114 As used in the Acorn Atom	£1.30 each
	(20 chips are required to expand from 2K to 12K)	20 for £24.00
	6116 As can be used to replace Ram chip inside the Sinclair ZX81 to give 2K internal memory	£7.50
	p&p Ram chips	£0.50 per order

Long and short Programs for the BBC Micro wanted, no program too short or long. Programs bought outright or good royalties paid. Hardware designs also wanted.

C. J. E. Microcomputers

25 HENRY AVENUE, RUSTINGTON, W. SUSSEX BN16 2PA

(09062) 74998

All prices inclusive of VAT where appropriate

ANGLO AMERICAN SOFTWARE CO

BBC — TRS-80 — ATARI — PET — APPLE — VIC — ZX81

We know what it is like out there, because that's where we came from. Before we decided to become software entrepreneurs, we were just like you enthusiasts searching through magazines for the ideal mail order software source. What we hoped to find was a single entity that offered an ultra-wide selection for our micro-computer. That pre-selected only the best of many similar sounding programs that reached the market every month. That could give us personal assistance with the purchase-decision process, and that stood behind its products. When we couldn't find it we decided to become it. So ANGLO-AMERICAN SOFTWARE CO WAS BORN.

Please state clearly the program(s) you require. Include your name, address & machine type + memory size. Prices include VAT, postage & packing.

OIL TYCOON

What would it be like to be an oil producer. Find out with this action packed simulation as you try to become an oil tycoon. Explore for new wells get reports, name your own price for oil — but don't get too greedy or beware. The game involves strategy and chance. You could end up as one of the wealthiest men in the country or the bankrupt victim of too many oil spills. You will find OIL TYCOON both challenging and exciting.

PRICE £9.95
CASSETTE

DUNGEON OF DEATH

Your quest is to search for the Holy Grail where you descend through 12 levels, find the Holy Grail and return to the surface. The Grail is guarded by SMAUG the most fearsome monster of all and ten lesser breeds. You can only survive by using all the powers at your command. You can cast magic spells, drink potions that may or may not help you find items to help you fight the monsters. Step softly in the darkness. Treasure or sudden death is only a footfall away in the DUNGEON OF DEATH.

PRICE £10.75
CASSETTE

MASTER DIRECTORY

Wasn't it yesterday you threw the cat into the washing machine because you couldn't find where you had put the last Adventure game you had saved or was it that you gave your mother in law the leftover curry because your three year old had mixed up all your data disks and now you don't know which one is which. Well cheer up MASTER DIRECTORY is here. The M.D. is a storage program that reads the files on your disks, stores the name, extension and even records the free space on each disk. All you do is number your disks. You can use it alphabetically or search for name and ext search for free space. Store 5000 files or 320 disks.
Requires one disk drive.

PRICE £21.00
DISK

THE FLYING CIRCUS

Is a package covering biplane to modern day planes. These seven programs offer you the daring realism of flight.

1. AIR FLIGHT
2. NIGHT FLIGHT
3. AIRMAIL PILOT
4. MOUNTAIN PILOT
5. O'HARE (air traffic controller)
6. APPROACH RADAR
7. JET FIGHTER PILOT

A great combined flying package. Try to master the lot.

PRICE £25.00
DISK

AIR FLIGHT SIMULATION

Instrument takeoffs and landings are no picnic ask any pilot. This computer simulation is sure to keep you on the edge of your seat. You begin with a full tank of fuel and a flight plan to learn simple take-offs and landings. Pay attention to your instrument panel too steep a bank and your air speed — will drop like a stone. . . so will your plane. It's about as close to the real thing as you can get this side of the runway. Fun for all the family when you learn to do acrobatic manoeuvres.

PRICE £9.95
CASSETTE

SANTA PARAVIA & FIUMACCIO

Fancy being a MRS THATCHER well with this program you will come as near to it as you will ever be. Perhaps I should acquaint you with the domain. It is not a wealthy Area but riches and glory are there for the aware. You will have to worry about the serfs requesting more grain if they don't get it they may flee. There is the weather as well if it is good so will the crops be. You may find you have to increase the tax. You may also wish to build a new palace to measure your progress the official cartographer will draw you a map so as to see how to plan your strategy. A very entertaining game.

PRICE £10.50
CASSETTE
PRICE £14.25
DISK

SEND 75p FOR FULL CATALOGUE

Refundable against purchase

Dealer Enquiries Welcome



PROGRAM OF THE MONTH



SPACE SHUTTLE

Save £4.50

5.3 million pounds of thrust sent the space shuttle COLUMBIA into orbit. Now on-board computers will help to bring her safely and gracefully back to earth. SPACE SHUTTLE puts you in the command pilot's chair of the first reusable space vehicle and until commercial flight becomes available this is the closest you will get. We feel this is one of our best programs.

PRICE £17.00 Special offer price of £12.50 CASSETTE.



ANGLO AMERICAN SOFTWARE CO.

138a Stratford Road
Sparkhill
BIRMINGHAM B11 1AG
021-771 2995



24 hour ansaphone

RAM EXPANSION 16K, 32K, 64K, 128K, 256K!

MEMORY 6502 BASED UPGRADE (all are internal modules)

e.g. ATOM, PET,
UK 101, O.S., AIM

16K £45 (Kit) } Prices incl. of
32K £52 (Kit) } PSU components
Ready built
charge: £10

ZX80 BASED (External Ram Packs and internal modules available)

e.g. VIDEO GENIE,
ZX 81, TRS 80

£33 (Kit) } Prices incl. of
£40 (Kit) } PSU components
Ready built
charge: £7

LARGER EXPANSIONS

64K £80 (Kit) } PSU not
128K £120 (Kit) } necessary
256K £200 (Kit) }
Not yet available
Ready built
charge: £10

All prices are inclusive of postage and packing, but please add 15% VAT to all totals.

Discs are fast, but in some cases, not fast enough. You may have a customer waiting for details on the 'phone — and he can quickly become impatient. In such situations, when your computer has got to look through up to a few hundred files, our memory expansion systems really can help.

The memory is divided into 'Random Access Sectors' of 256 bytes each. For example, there will be 1024 sectors in a 256K bytes expansion.

We supply *free* the basic subroutines necessary. Each is roughly 180 bytes long and capable of handling one of the following functions:

1. READ/WRITE program
2. READ/WRITE screen
3. READ/WRITE string and files
4. READ/WRITE numerical array

Take as an example the READ/WRITE screen function for a PET. This literally treats the screen as a piece of paper on which you can draw or write whatever you like. When you have finished, SYS 940 will store the result in one of the 256 screen pages in just 18 milliseconds (the blink of an eye!). Another example: the READ/WRITE string and files function opens to your Micro as many as 1000 files at any one time! If you want the file 100, write string AS with the contents of file 100 — it will take only 8 milliseconds.

Another advantage of memory sectors is that any programs can READ or WRITE into the memory so that several programs can share the same data base.

For further details (we can send you free literature), please ring us on Southend (0702) 613081, or if our line is busy, write to:

AUDIO COMPUTERS
87 BOURNEMOUTH PARK ROAD
SOUTHEND ON SEA, ESSEX

ZXCHESS

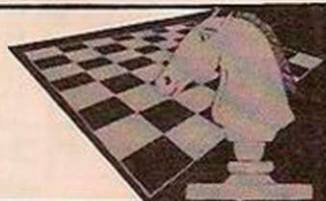

TWO GREAT ZX81 16K CHESS GAMES ZXCHESS (ENHANCED)

- Written totally in machine code.
- Full graphic display of Chess board.
- Six levels of play: Two play within competition time limits.
- Option to play Black or White.
- Plays all legal moves including castling and en-passant.
- Cassette routines for saving unfinished game and returning to later.
- Displays moves of game on screen or printer for analysis.
- Print a copy of the Chess board onto the printer.
- Board can be set up in any position, you can even swap sides midgame.
- Clear whole board with one command: for end game analysis.

£6.50

ZXCHESS II We believe the strongest ZX81 Chess game as no other has beaten it!

- All the features of ZXCHESS plus:
- Book of 32 opening moves.
- Seven levels of difficulty: FOUR play within competition time limits.
- A move is suggested by the ZX81 if wanted.
- Optional Full Graphic version using the QS CHR8 Board.

£12.99

2 copies supplied on cassette with full instructions.
Cheques and postal orders payable to:



ARTIC COMPUTING
396 JAMES RECKITT AVENUE,
HULL HU8 0JA

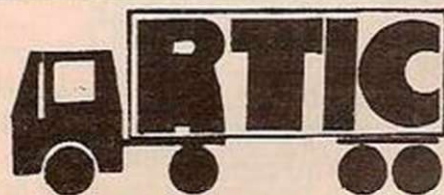

moving ahead
with
ZX software

ZX CHESS & ADVENTURES

PROGRAMS FOR THE ZX81/80 INCLUDING —

ZX CHESS I
reduced to £6.50

Very popular machine code program, with six levels of play and an analysis option. Unbeaten except by:

ZX CHESS II
now only: £12.99

A new improved version, with a faster response time, seven levels of play, and in addition a recommended move option.

**ADVENTURES
ADVENTURE 'A'**
£6.00

Exciting machine code games with instant response, choose from the range below. You find yourself stranded on an alien planet.

ADVENTURE 'B'
£7.00

Can you reach your ship and escape?
In a jungle clearing you come across an Inca temple. You must break in, collect treasure and escape alive. Beware. Includes a cassette save routine.

ADVENTURE 'C'
£8.00

You are unfortunate enough to be drawn to an alien cruiser. Can you reach the control room and free yourself or will they get you first?
Includes a cassette save routine.

GALAXY WARRIOR £3.00

Fast and exciting interactive animated graphics game.
Hunt clingons and go through black holes . . .

1K GAMES PACK £6.00

and many more. For a catalogue giving full details, please send a S.A.E. to:

GALAXIANS £6.50

All the features of the arcade game in a fast machine code program.
Swooping attackers, explosions and personalised scoring.

ZXBUG £7.00

A 30 in 1 machine code tool and disassembler, allows access to registers and search through and modify memory; with cassette routines.



Artic Computing,
396 James Reckitt Avenue Hull, HU8 0JA



19 WAYSIDE AVENUE, WORTHING, SUSSEX, BN13 3JU
 TELEPHONE WORTHING 65691 (Evenings and Weekends only)

16K RAM PACK £35 (\$69.95)

**WHY PAY
 MORE**

Fully built, tested and guaranteed
 Black case
 No 'wobble' problems — fully supported by ZX81
 Fully compatible with printer etc, etc.
 Full refund if not delighted

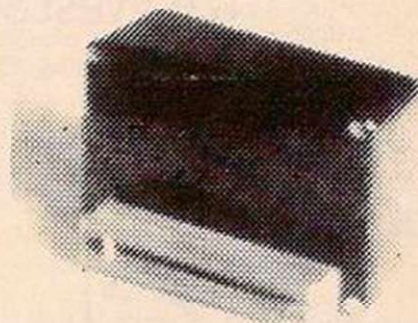

(Please allow 14-21 days for delivery)

An ESSENTIAL addition to your 1K RAM ZX81 (or ZX80 8K ROM)

(please state which when ordering)

TOOLKIT (written by PAUL HOLMES)

Provides the following additional facilities:-

Line renumber — you state starting number and increment value.
 Search and replace — changes every occurrence of a character as you require.
 Free space — tells you how many free bytes you have left

SPECIAL GRAPHICS ROUTINES

Hyper graphics mode — graphics never seen on a ZX81 before.
 Open — instantly sets up as many empty print lines as you require. (1K version only)
 Fill — used in conjunction with OPEN fills your screen instantly with your specified character
 Reverse — changes each character on your screen to its inverse video.

TAPE ROUTINE — provides a system **WAIT** condition until a signal is received in the cassette ear jack — many uses !

All these routines are written in machine code and together take up only 164 BYTES of your precious RAM - an incredible achievement!!

The price is incredible too! ONLY **£3.95 (\$7.90)** for cassette, including FULL instructions and example programs.

ALSO available 16K version ONLY **£4.95 (\$9.90)** which includes all the above PLUS:- GOTO's and GOSUB's included in line renumber.

Search for and list every line containing specified character.

16K VERSION

CASSETTE professionally recorded by SOUND NEWS STUDIOS

GAMES PACK — Beat this for value! . 5 x 16K programs PLUS 2 x 1K programs **£4.95 (\$9.90)**

3-D Battle (M/code-1K) — Fast-moving space battle with continuous count-down of energy units left.

City Bomb (M/code-1K) — Destroy the buildings and land your plane. Your fuel has nearly gone and you circle the city lower and lower.

Warp Wars (Basic & M/code-16K) — Features realistic space-craft moved by M/code for (previously sold at Microfair with instant response. Sweet Tooth for £4.95)

Snake (Basic-16K) — A game of thought and skill. Pass through all the marked squares without crossing or doubling back on your path, but watch out for the expanding black blob. (previously sold at Microfair for £3.95)

Sweet Tooth (Basic & M/code-16K) — M/code routines used to move your fat face round the screen and gobble the sweets.

PLUS Slalom and Black Holes (previously sold together for £4.95)

**OVERSEAS CUSTOMERS
 PLEASE NOTE**

Payment may be made in Sterling (Money Order available at your bank) or \$U.S. (U.S.A. customers only).

ALL GOODS SENT AIRMAIL

Superior Systems Ltd. Sheffield

178 West Street, S1 4ET. Tel. (0742) 755005.



APPLE II 48K.....£670.00
 DISK DRIVE
 WITH CONTROLLER.....£370.00
 DISK DRIVE
 WITHOUT CONTROLLER...£290.00
BMC 12" GREEN MONITOR
 12" GREEN MONITOR....£145.00



SHARP

PC 1211 POCKET COMPUTER.69.50 c
 MZ 80K (48K) COMPUTER. PHONE FOR
 MZ 80B (64K) COMPUTER. CHEAPEST PRICE
 DUAL DISK DRIVE.....550.00
 P3 PRINTER.....360.00
 P4 PRINTER.....745.00
 P6 PRINTER.....420.00
 SPEED BASIC.....10.00
 MACHINE CODE.....17.40 b
 EDITOR/ASSEMBLER.....35.00 b
 PASCAL INTERPRETER.....40.00 b
 MZ 80K DUST COVER.....5.00 a
 APOLLO WORD PROCESSOR...24.95 b
 CALC II.....34.50 b
 DATA BASE.....29.50 b
 ZEN EDITOR ASSEMBLER...19.50 a
 MACHINE LANGUAGE.....17.74 b
 MZ 80K DUST COVER.....5.00 a
 POSIEDON.....5.00 a
 ADDRESS BOOK.....5.00 a
 MOONLANDER.....5.00 a
 COMBAT.....5.00 a

Mail Order Accessories

Postage Rates

a.75p b.1.00 c.1.50 d.2.50 e.5.00

BOOKS

(SEND SAE FOR FULL LIST)

BASIC HANDBOOK.....13.95 c
 SOFTWARE SECRETS(MZ80K)...7.95 b
 APPLE II USER GUIDE.....11.10 c
 BASIC BASIC.....8.95 b
 PROGRAMMING Z80.....11.95 c
 PROGRAMMING 6502.....10.75 c
 PROGRAMMING VIDEO GENIE...5.00 b
 ZX 81 COMPANION.....7.95 b
 ZX 81 POCKET BOOK.....5.95 b
 GETTING AQUAINTED ZX81...4.95 b
 GETTING AQUAINTED ACORN...7.95 b
 HINTS & TIPS ZX81.....4.25 b
 CP/M HANDBOOK.....11.50 c
 6502 GAMES.....10.25 c
 MICROSOFT BASIC.....8.75 b
 ATOM BUSINESS.....6.95 a
 APPLE PASCAL GAMES.....11.45 b
 WORD STAR MADE EASY.....7.60 b

APPLE
 VISICALC.....97.50 b
 VISIPILOT.....95.00 b
 VISITREND/VISIPILOT.....135.00 b
 VISIDEX.....105.00 b
 CIS COBOL.....475.00 b
 MICROMODELLER.....420.00 b
 APM.....119.00 b
 APPLEWRITER.....39.00 b
 MAGIC WINDOW.....79.00 b

VIDEO GENIE
 SOUND MOD.....7.50 a
 COLOUR MOD.....39.46 b
 SYNTHESISER.....45.00 b
 DUST COVER.....5.00 a

ALL PRICES EXCLUDE VAT



VIC 20

VIC 20 COMPUTER.....173.90 e
 VIC CASSETTE DECK....39.09 d
 VIC PRINTER.....200.00
 3K RAM CARTRIDGE.....26.04 b
 8K RAM CARTRIDGE.....39.09 b
 16K RAM CARTRIDGE....65.17 b
 JOYSTICK.....6.52 b
 PADDLES.....11.74 b
 INTRODUCTION TO BASIC
 PART I.....13.00 b
 VIC GAMES ROM CARTRIDGES
 VARIOUS FROM.....17.35 b

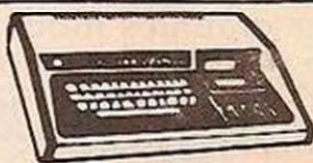

VIDEO GENIE

MKI with sound &
 lower case.....309.00
 MKII
 BUSINESS COMPUTER.....309.00
 EXPANSION UNIT
 WITH 16K ROM.....199.00

ACORN ATOM

ACORN ATOM 8+5
 with colour+PSU.....199.00 d
 ACORN DISK PACK.....299.00 d
 FLOATING POINT ROM...20.00 a
 GAMES PACKS 1-10....10.00each
 WORD PACK ROM.....26.00 a
 COLOUR ENCODER.....39.00 b
 B.B.C. ROM PACK.....PHONE b
 MAGIC BOOK.....5.50 c
 MATHS PACK.....10.00 a
 ATOM CHESS.....10.00 a
 ATOM ADVENTURES.....10.00 a

MAIL ORDER FORM

PLEASE SUPPLY..... £.....
 £.....
 £.....
 £.....

ACCESS/BARCLAYCARD/CHEQUE



CARD No.....

P&P+V.A.T. £.....

TOTAL ENCL.£.....

NAME.....

ADDRESS.....

POST CODE.....TEL.....

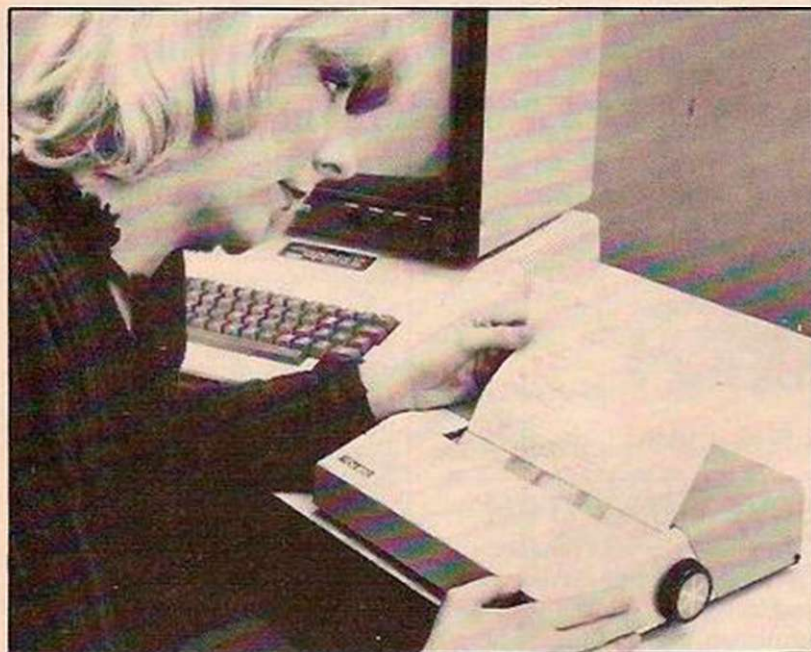

The CPU 100 and 200 thermal printers are suitable for use with most microcomputers. Both models have full line buffering with bi-directional printing and a microprocessor which "looks ahead" to decide on the most efficient print direction for the next line. Text format is 40 characters per 4in. line on the 100 model, and 80 characters per 8in. on the 200 model. Graphics consist of 240 or 480 seven-dot print positions per line and work at 240 positions per second. A parallel TTI-compatible ASCII eight-bit interface permits the printers to be interfaced with most microcomputers. An optional "plug in and go" interface is available for the Apple, Pet, Sorcerer and TRS-80. The CPU-100 and 200 printers cost £236 and £325 respectively from CPU Peripherals Ltd, Rodd Industrial Estate, Govett Avenue, Shepperton, TW17 8AO. Telephone 98-46433.

Galactic Chess from Artic

ZX-GALAXIANS is a machine-code version of the popular arcade game. Suitable for the 16K ZX-81, ZX-Galaxians contains swooping attackers, full explosions, continuous-status reports and personalised high scoring routines. It is available on cassette for £6.50 from Artic Computing, 396 James Reckitt Avenue, Hull, North Humberside.

Artic has also introduced a new version of ZX-Chess II which can be used in conjunction with the Quicksilva character board to produce classical chess pieces on the screen. This program is available on cassette for £12.99. Alternatively, you can buy the program and Quicksilva characters board, motherboard and connector for £45 — a saving of £10.

Goto Luton — do not pass goto

ZX-81 MONOPOLY is a computer simulation of the popular board game. Produced by Work Force, 140 Wilsden Avenue, Luton, Bedfordshire, telephone 0582-418577, it is suitable for the 16K ZX-81 and is available on cassette for £8 including VAT and postage.

Work Force is currently working on a U.S. version of ZX-81 Monopoly and it should be available shortly.

Tandy package offers total word processing

NEWSSCRIPT is a word-processing package for the TRS-80 Model I and III which offers a range of facilities normally found on large mainframe computers.

A full-screen editor allows the user to move the cursor anywhere on the screen or file. Text can be added, deleted, replaced or inserted according to the user's demands. NewsScript can also print multiple copies of one letter, or merge names and addresses from a mailing list into

Sound generator and joystick make Atom more friendly

A SOUND generator and an eight-way joystick for the Acorn Atom are available from R. Shillito, 5 Ingarfield Road, Holland, Clacton, Essex, CO15 5XA.

The sound generator is available with one, two or three AY-3-8910

Tape storage

THE ZX-99 automatic tape drive controller plus software gives the ZX-81 both word-processing and data-retrieval capabilities. Handling up to four tape recorders at once, the ZX-99 enables you to use tape storage to hold data files as well as programs.

A full tape-to-tape copy program is evoked by a single USR command. The ZX-99 can also make directory listings of ordinary program storage tapes. In addition, the ZX-99 has an RS-232C serial output interface which is compatible with standard ASCII printers.

The ZX-99 costs £62.90 from Data-asset, 44 Shroton Street, London, NW1 6UG. Telephone 01-258 0409.

sound chips, built-in amplifier and speaker and up to six eight-bit I/O ports.

The eight-way joystick plugs into one of the sound generator ports, or into a joystick port adaptor. Up to six joysticks can be used simultaneously with the largest sound generator. The standard power supply can be replaced by a 5V/5A supply which uses a toroidal transformer.

The sound generators are priced at £54.95, £64.95 and £79.95 for the one-, two- and three-chip models. The joystick costs £14.95 and the joystick-port adaptor costs £19.95. The standard power supply is sold for £44.95, or £49.95 with built-in mains suppression.

You can bank on your ZX-81

A PERSONAL banking system for the ZX-81 which enables you to keep detailed records of your bank transactions has been introduced by J. Gibbons, 14 Avalon Road, Orpington, Kent, BR6 9AX. All standing orders, be they monthly, quarterly, six-monthly or yearly, are automatically included in your own statements on the correct dates.

The banking system includes a machine-code load/save routine which enables you to store your records in datafiles on cassette separately from the program. This routine saves and loads the program variables and allows the system to access separate add-on programs.

The personal banking system is available on cassette for £9.95, including a 12-page user manual, from J. Gibbons, or from Hilderbay Ltd, 8/10 Parkway, Regents Park, London, NW1 7AA. Telephone 01-485 1059.

a standard letter. Other facilities include centring, page numbering, right-justification and a mailing label option.

NewsScript will support most matrix and daisywheel printers currently available. It requires 48K with at least one disc drive and costs £79 plus VAT and postage from E A International, 8 High Street, Meldreth, Toyston, Hertfordshire, SG8 6JU. The telephone number is 0763-60189.

Texas lone star destroys aliens as Yankee space games go home

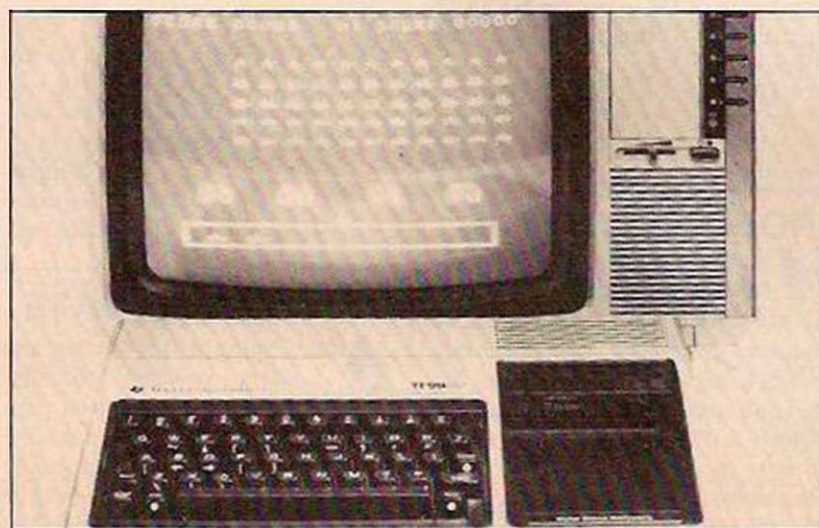

TEXAS Instruments has introduced a Space Invaders module for its TI-99/4A home computer. The Invaders module is similar to the arcade game with the player trying to destroy the advancing aliens before they land.

There is a choice of two skill levels where the invading aliens are either "merely aggressive" or "downright nasty". The aliens come in various forms and are worth a different amount of points.

The plug-in TI Invaders module costs about £40 from Texas Instruments Ltd, Manton Lane, Bedford, MK41 7PA. Telephone 0234-67466.

Teach yourself electronics

SUPERKIT is designed to teach beginners the basics of digital electronics. The kit, which costs £19.90 including post and packing from Cambridge Learning Ltd, contains an instruction manual, seven LS TTL integrated circuits, a EuroBreadBoard and various light-emitting diodes, resistors and capacitors. No soldering is involved, but the user must provide a 4.5V battery or a stabilised 5V power supply.

The kit is supported by Cambridge Learning's courses in digital computer logic, and electronics and digital design. The beginner has the chance to learn about fault-finding, improvisation and subsystem checking as well as Boolean logic, gating, shift registers and ripple counters.

Cambridge Learning is based at Rivermill Lodge, St Ives, Huntingdon, Cambridgeshire, PE17 4EP. Telephone 0480-67446.

Nascom toolkit

EXTENSION BASIC is a new software utility for the Nascom range of microcomputers. This program adds 30 additional statements to standard Microsoft 4.7 ROM Basic and includes extra program editing commands, debugging facilities and structured programming. It is fully compatible with standard Basic and can be used as an interpreter or as a toolkit.

Extension Basic is supplied with a 25-page manual, a relocater program and a demonstration program which includes the games Sweeper and Demon Driver. It is available on cassette for £15 or in ROM for £25 from Level 9 Computing, 229 Hughenden Road, High Wycombe, Buckinghamshire, HP13 5PG. Telephone 0494-26871.

Datron Micro Centre's "Triple-Vision" multi-screen microcomputer display system allows you to run up to 12 different monitors from a Sharp MZ-80K or MZ-80B. The monitors will display high- or low-resolution graphics and computer-generated sound. The system can be used to display scores during chess or other tournaments, or to provide other information during conferences and lectures. A lower-cost Multi-Vision unit provides video and audio output for up to 12 different monitors fitted with audio play-back facilities. Triple-Vision costs £79 plus VAT while Multi-Vision costs £39 plus VAT. Both systems are available from Sharp Dealers and from the Datron Micro Centre, 2 Abbeydale Road, Sheffield, S7 1FD. Telephone 0742-585490.



Commodore's £1,500 competition

COMMODORE HAS launched a £1,500 software competition for the Vic-20 and Pet 4000 series microcomputers. First prize consists of a Vic single-drive floppy-disc unit, printer and programmers' aid cartridge. Second prize is a disc drive and programmers' aid cartridge while the third prize is a printer and an aid cartridge. Runners-up will receive books, magazines and composite discs of the winning entries.

The competition is open to all individuals and schools resident in the U.K. and Ireland. To enter the competition, write a program for the Vic-20 or Pet 4000 series, using up to 32K RAM, and send it to Commodore Software Competition, Department YC, 35 Garway Road, London W2 4QD, by June 30, 1982. Multiple entries on cassette or disc are permissible.

Commodore is looking for programs which are both inventive and educational and that can be used in either primary, secondary or special schools, or in the home. Typical entries will range from physics and chemistry packages to gardening diaries and recipe files. Games programs can also be submitted, but preference will be given to programs that have some educational or practical use.

The judges will include Commodore's technical manager, and educational computer consultant and Mike Todd, chairman of the Vic users' group. The winners will be presented with



their prizes at a formal ceremony in August.

Competition entrants will also be given the chance to benefit from their programs. Commodore plans to market some of the winning programs in association with the authors.

Will the real ZX-82 please step forward

CLIVE SINCLAIR'S new micro-computer is due to be launched this autumn, according to a recent article

in *The Sunday Times*. It claimed that the new computer would cost around £170 and would include colour graphics and a conventional typewriter keyboard. In addition, the computer would probably have a 32K memory and would be marketed under the name of Spectrum.

Clive Sinclair declined to comment on the article other than to say that *The Sunday Times* had the facts wrong: "I do not know where these rumours start", he said. Sinclair refused even to admit to the existence of a new microcomputer.

Speculation had been rife concerning a successor to Sinclair's enormously successful ZX-81. Some stories have hinted at a microcomputer incorporating Sinclair's flat-screen TV, due to be released later this year. Another possibility is a business-orientated microcomputer.

The exact format of the new microcomputer is uncertain. Only Sinclair knows for sure and he is not talking.

Vic Panic

LINE-UP 4 and **Panic Driver** are the first two games for the unexpanded Vic-20 to be released by Terminal Software, 28 Church Lane, Prestwich, Manchester, M25 5AJ. Telephone 061-773 9313. The two games are available on cassette for £4.99 including post and packing.

Terminal Software is planning to release more software for the Vic-20, including **Reversi** and **Scramble**.

TUG launch

THE TANGERINE Users' Group has launched two additional software packages for the Microtan 65. **Forth** is another version of an advanced language while **Columbia** is a business-orientated word-processing package. Columbia can be used with the Epson printer range and includes facilities for mail shots, mail merge and word-wrap.

Other software releases include **Galaxians** and a multi-purpose record files package. More details from the Tangerine Users' Group, 16 Iddesleigh Road, Charminster, Bournemouth, Dorset, BH3 7JR. Telephone 0202-294393.

Tangerine move

TANGERINE Computer Systems Ltd has moved from its Forchill Works base in Ely. The company's new address is The Science Park, Milton Road, Cambridge, CB4 4BH. Telephone 0223-60422.

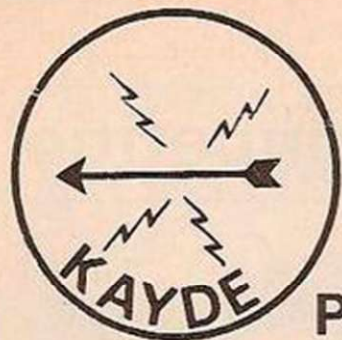

ZX80/1 WAR!

**£37.95
inc. VAT**

Price

ZX KEYBOARD FULLY CASED WITH REPEAT KEY

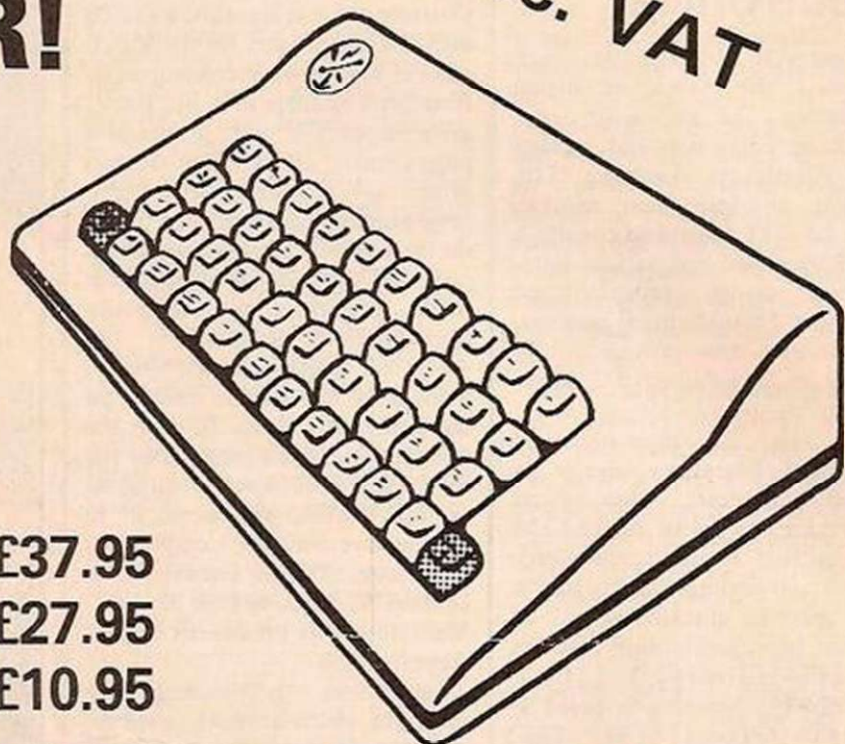

Fully CASED KEYBOARD	£37.95
Uncased KEYBOARD	£27.95
KEYBOARD CASE	£10.95

This is a highly professional keyboard using executive buttons as found on top quality computers. It has a repeat key and comes complete in its own luxury case. This is a genuine professional keyboard and should not be confused with toy keyboards currently available on the market.

16K RAMPACKS

MASSIVE ADD ON MEMORY

**WHY WAIT TO PAY MORE
FAST IMMEDIATE DELIVERY**

**£32.95
inc VAT**

Post to
Dept. YC2
KAYDE Electronic Systems
48/49 Exmouth Road
Great Yarmouth
Norfolk NR30 3DP
Tel: (0493) 57867

All products include VAT and are fully built and tested and come with a complete money back guarantee.

Please send meRAM Packs £32.95 each
Please send meCased Keyboards £37.95 each
Please send meUncased Keyboard £27.95 each
Please send meKeyboard Case £10.95 each

I enclose £.....

Name.....

Address.....

.....

.....

Please add £1.50 p&p and make cheques payable to Kayde Electronic Systems.

COMPUTER CLUB

Computer Club is here to encourage you to start your own local computer club or, if one already exists, to join it and become involved. Each month we will devote the page to new ideas from local clubs. We would like to hear of anything which has made a club a success, or of any projects or programs you are developing.

Aylesbury's graphics made easy

Aylesbury's "gang of four" started meeting last August to talk about their Sinclairs. By January a fully-fledged computer club had formed with 30 people at their annual general meeting. Brendon Gore went to Aylesbury College, Buckinghamshire to find out how they were getting on.



"USING GRAPHICS on the ZX-81 is not difficult", in the opinion of Rod Clayton, chairman of the Aylesbury ZX Computer Club. "Even beginners can create quite sophisticated graphic displays using the Print At statement". Rod Clayton opened his talk on graphics for beginners by printing a character on a large TV screen hooked up to a ZX-81. A simple

```
FOR J=1 TO 8 NEXT J
```

loop generated a row of eight characters on the screen. A comma and a semicolon were used to vary the positions of the printed characters.

Mobile display

A computer needs to know three things in order to print a character from one square to another. It needs to know the square to start printing the character, the square to stop printing the character and the direction in which the character will move. Given this information, it is relatively easy to write a program which will move a character across the screen. See listing 1.

If you input 0 for SX, 0 for SY, 21 for EX, 31 for EY, 1 for X MOVE and 1 for Y

MOVE, the ZX-81 will print a line of stars diagonally across the screen, said Clayton. Making the Y MOVE input 0 will change the direction of the line to the horizontal, and changing the X MOVE input to 0 will result in a vertical line.

Converting the moving character display to an animated character display is quite simple, says Clayton. "All you have to do is print a character at one square, then blank it out, print the same character at the next square, blank it out and so on. This makes the character look as if it is moving".

For an animated graphics display add line 125 Print At Y,X:" " to the program. The space between the " " blanks out the * each time it is printed. But, says Clayton, you must remember to use the same number of spaces as there are characters in the program.

Finally, says Clayton, for a flicker-free display insert lines

```
123 FOR Z=1 TO 10  
124 NEXT Z
```

This introduces a time delay into the program — the higher the second number in line 123, the longer the delay.

After the talk, club members were given the chance to put some of Clayton's ideas into practice. More advanced members joined the hardware and discussion groups or swapped notes on their latest programs. Younger members tended to play the available games software.

Specialist groups

The club's first annual general meeting was held in January this year with more than 30 people in attendance. The original "gang of four" were confirmed in their posts, Clayton as chairman, Nowotnik as secretary, Knight as treasurer and membership secretary and Cornhill as librarian.

The meeting set up three specialist groups: a beginners group for newcomers to micro-computers, a hardware group for electronics buffs and a machine code group for advanced programmers. George Avenell was selected as co-ordinator for the beginners' group, George Morgan was appointed head of the hardware group and Trevor Toms was put in charge of the machine code group.

The club also provides members with a monthly newsheet compiled by secretary David Nowotnik.

The club's subscription costs £5 a year for adults and £2.50 a year for under-17s and old-age pensioners. For further details send a SAE to Ken Knight, 22 Mount Street, Aylesbury, Buckinghamshire.

Local society news

Gwent Amateur Computer Club

THIS CLUB, which caters for the South Wales area, meets regularly at St Mary's Church Hall, Stow Hill, Newport. For more information send a SAE to the club secretary Ian Hazel, 50 Ringwood Hill, Newport, Gwent, NPT 9EB.

Computer Users' Club

THE COMPUTER USERS' CLUB is designed mainly for BBC Micro users, but it will also benefit Video Genie/TRS-80 and Compucolor II users who wish to run BBC-based software and teletext/Prestel software. The club, which

has been included in the BBC's referral scheme, provides a monthly printout of software ideas, programs and advice. Details of the club's activities are available from Tony Latham, 72 Sidmouth Road, Welling, Kent, DA16 1DS.

Cardiff Computer Club

A NEW ZX-81 users club has been formed in Cardiff. It aims to exchange information, help and advice between members. The club also hopes to build up a collection of original programs for members to borrow. Anyone interested in joining the club should contact M Hayes, 69 Morris Avenue, Llanishen, Cardiff, CF4 5JX.

Listing 1.

```
MOVING CHARACTERS PROGRAM  
1 REM "G"  
30 INPUT SX (STARTING X CO-ORDINATE)  
40 INPUT SY (STARTING Y CO-ORDINATE)  
50 INPUT EX (ENDING X CO-ORDINATE)  
60 INPUT EY (ENDING Y CO-ORDINATE)  
70 INPUT X MOVE (DIRECTION OF MOVEMENT)  
80 INPUT Y MOVE }  
100 LET X=SX } (SETS THE STARTING X,Y  
110 LET Y=SY } CO-ORDINATES)  
120 PRINT AT Y,X; "*" (PRINTS THE CHARACTER)  
130 IF X=EX AND Y=EY THEN GOTO 1000 (IF THE END  
SQUARE IS REACHED STOP)  
140 LET X=X+X MOVE (INCREMENT VALUES OF X  
150 LET Y=Y+Y MOVE AND Y)  
160 GOTO 120  
1000 STOP
```

As Sinclair sales head for half a million ZX software has become a lucrative market. New firms have sprung up to take advantage of the wider horizons offered by cheap 16K memories. John Deeson reviews the latest games and application programs for the Sinclair.

AS MORE and more companies enter the market, the quality of available material is rising fast and the prevailing trend seems to be towards applications software, as opposed to games. The second wave of programs from Sinclair Research has still not appeared, and when it is released it will be on to a market where software prices are falling slightly — £3 for a cassette of excellent material is not at all unusual.

The appearance of 16K memories for considerably less than the Sinclair price means that 1K owners, like their ZX-80 counterparts, will experience a dwindling service from the software suppliers. At the same time sales of memories greater than 16K are strengthening,



which will lead to formidable data-handling programs and adventure games which will soon no doubt benefit from colour and sound.

Our criteria for review are novelty, ease of use, clarity of instructions and neatness of graphics — in short, value for money.

Galaxy Invaders, from Bridge Software, is very good value at £3. It is a machine-code program, with Break blocked, which offers the usual ZX invaders game. There are 10 levels of play and your score is displayed with the highest and the previous score, and the number of bases remaining. The cassette is supplied with an adequate leaflet.

Serious ZX users will be pleased that a new version of Bridge Software's Multigraphics is available. It costs £4.50 but is even better than the original program praised in the January survey. It now has animation, paging, reveal and Save.

Stellar Software's SAS Mission Impossible and Space Battle costs £4.95. SAS involves a randomly-generated embassy containing

hostages to rescue, terrorists to kill and bombs to avoid. You have three minutes for your mission and you need it. You are armed with a load of grenades but each change of character position takes two seconds. Although this is a very slow Basic game like Space Battle it is more gripping despite the SAS's recruitment of the garden snail into its ranks. SAS is not easily beaten or crashed. It is original but not outstanding.

Abersoft's Basic adventure is over-priced at £10. This is text only and probably requires the usual million hours to untangle. It just fits into 16K and seems to be based on the classic Crowther Fortran version, with 140 locations to map and explore.

Michael Orwin's £5 Cassette Two is very good value. It contains 10 stolid well designed games which work, offer plenty of variety and choice, and are fun.

Improved quality

J K Greye has improved the quality of its 16K products. Games 2 contains the slow Basic Starfighter in which you shoot the enemy craft in your sights against the clock. It is slow and demanding on the arm muscles but presents a reasonable challenge. Pyramid is a nine-layer Tower of Hanoi implementation and Artist is even better than the beautiful 1K version.

Greye's Catacomb, Games 3, is described as a multi-level graphics adventure. The adventure approach is unexceptional and the graphics adequate. As one wanders through the catacomb one discovers more and more of the maze with its various attackers and rewards. The attacks are not under keyboard control so survival is a matter of luck. Each time you play, you are given a new layout.

Artic Computing, has three variations of adventure. Imaginatively called A, B and C, they are all neat, well-designed and fast-moving non-graphics adventures. Version A, at £7, puts the adventurer on an alien planet, and offers more than 100 commands.

Adventure B costs £9 and has auto-Run and, more important, the facility to Save at any stage. This time you have to rob an Inca temple.

In the £9 Adventure C, you are in space, escaping from an alien cruiser on a rather horrid mission. This is very like the others — text only, a good range of commands; and highly tormenting. It is a high-speed game because of its machine-code program, and its use of fast mode and Scroll.

As the documentation warns, Artic's £3 Galaxy Warrior is at first rather difficult to control. It is a form of Star Trek, with galaxies to be searched through, stars to avoid and menacing Klingons. It is rather slow because it is mostly in Basic and is hard on the fingers. This is an appealing game with full scoring.

Artic's Chess II — at £15 compared with £10 for version I — has seven skill levels, a best-move facility, save and copy, and a printout of the moves at the end. A version has been developed for the Quicksilva character board, overcoming the rather annoying use of alpha characters. It is easy enough to play, although the move-entry routines are rather confusing. ZX Chess II is fast, and plays well at all levels. The board display is enormous, leaving only just enough room for current and last moves.



SURVEY ZX CA

We could not make the move-recommend facility work, but otherwise found this game most impressive.

We had occasion to speak with some disdain in January about Can Of Worms, a cassette of "adult" 1K games whose source is now identified as Automata Cartography. At £3, Love And Death is another collection of disgusting programs. The target of this company's third cassette is God — the Bible costs £5 for 10 programmed blasphemies.

The games stakes

Cadsoft has also recently entered the 1K games stakes. Its Cassette AB is probably best value — £3 for 10 carefully-written programs. They include Coded Word-guess, Towers of Hanoi, Mastermind, Simon and Lander — the old standards, but none the worse for that.

Battle of Britain costs £4.95 and is one of the ZX-81 simulations from Microgame Simulations. The price includes an outline grid of South-East England which nine German



ASSETTES

bomber squadrons are approaching, and from which nine fighter patrols can be scrambled. This is a gripping text-only simulation. During the test, however only four British planes were downed compared with 74 German ones. Despite this patriotic bias, it is a useful simulation and a good game.

The same company's Asset Stripper and Kingdom of Nam are also very useful games for one player against the computer. They also cost £4.95 each and, although written in Basic, are adequately fast. Asset Stripper offers three levels: your task is to do as well as you can with a starting capital of £100,000. The program unfortunately crashes repeatedly with error 5 after a few pages. The simulation is well developed, however, and worthy of development.

The Mine of Information Othello, at £10, is recommended without reserve. It is a superb opponent, with nine skill levels, and is supplied in an attractive box with a superb accompanying booklet. Mine of Information

offers a generous 30-day guarantee period if you have loading problems.

Video Software has released a tape called 1K Party Tricks. The game Shoot involves pressing a number key and hoping that the goal-keeper will not randomly stop the invisible penalty shot. Other programs include a good etch-a-sketch; a program to discover the day of a given date; and random weather forecasts. At £3.95 there is much to amuse your guests.

Significant lead

We assume that Micro-Gen's Amaze and Space Invaders are for use with the ZX-81 paddle; certainly, the keyboard does not operate with either. To market the first ZX paddle gives you a significant lead in a potentially large market, if you have good software.

A tape recorder for £18.50 from G J Henderson, 107 Mersey Road, E17, is sold with a cassette of poorly-recorded 1K games. The recorder is the Hong Kong-made Duette,

which had the task of loading all the programs for this review and presented no problems at all. It is no better and no worse than the Waltham W-167, which is significantly cheaper, or the Sharp RD-620E, which is slightly dearer.

The three 1K programs are a neat Space Invaders using keys 8, 9 and 0 which is a nuisance; a think of a number game; and bingo.

Rose Cassettes, one of the longest-established and reliable suppliers of educational programs, has recently added to its range with Olmaths, a set of three formidable packages on different subjects. Each is menu-driven and authoritative. They are good value at £4.95, but lacking in sparkle.

AVC Software has significantly extended its range of full-graphics teaching programs. These products show the patience and novelty needed for software able to attract a rowdy class or a lone student. The Hangperson range for the nine- to 14-year-olds mentioned in January now has seven titles — two each in physics, biology and human biology for CSE or O level, and one in geography with 50 words and phrases on Britain.

Integral answers

As well as the original Tables, AVC's Countdown series now has first-year French vocabulary, a test on similes, and physics O-level problems. The problems and data are randomly generated each time but always have integral answers. All these programs cost £3.

The War Game costs £5 with a resource booklet and is an attempt to make the facts and feelings about nuclear weapons more real. Hiroshima data are analysed and the potential of modern bombs is explored interactively and graphically. It is not for the very young, who can stay with Atari's Missile Command — a horrifyingly realistic game.

Bridge Software has added a suite of versatile 1K statistics programs, with t and f tests, correlations, confidence limits, as well as the more usual mean/standard deviation. The main failing is the division into several programs, a fact of 1K life. A 16K package is, however, on the way and should be very good. The statistics program costs £3 with instructions; a very useful booklet costs another £2.

Parsons is a new company marketing index-driven Geography and Fun Learning, each offering six adequate programs. The map tests expect too much from ZX graphics. Among the others are rather weak hangman games on several themes and a vocabulary test.

Turner Consultants' two primary mathematics cassettes show a great deal of thoughtful hard work. They are fully bug-trapped, friendly and helpful. Primary level Division and Tables Test are £4.50 each.

In the miscellaneous section, 16K Art and Fun is a cassette of six index-driven programs from Parsons. The cassette has simple but adequate instructions and includes the pleasant, non-interactive Pattern maker as well as standard Sketches and Battleships. The £3 Madame ZX-81 from AVC Software is a relatively sophisticated astrologer, with outputs which include views of the client's zodiacal constellation and a randomly-accessed personality readout.

(continued on next page)

(continued from previous page)

Artic Computing's impressive 4K ZX-Bug, a machine-code enterer/monitor, is very good value. A problem with such programs at the moment is their memory requirement. Artic has done well to minimise the size of this sophisticated product, but it is crashable and not as friendly as some would wish.

Picturesque also offers a machine-code monitor. Called ZXMC, this is a 2.5K product with a superb accompanying booklet. Picturesque has not, however, solved the problems of its duplication system — the copy sent was unloadable. If the program is as good as the booklet, it is first class. At £6.50, it could be very good value.

Resident routines

It is sad, too, that the Picturesque Screen Kit has the same barrier to cross. It costs £4.95, and consists of a set of resident machine-code routines which allow one to call on all kinds of glorious facilities. It, too, would

not load. It features scroll in any of four directions to clear screen; instant clear screen or fill with any character; clear, border, invert

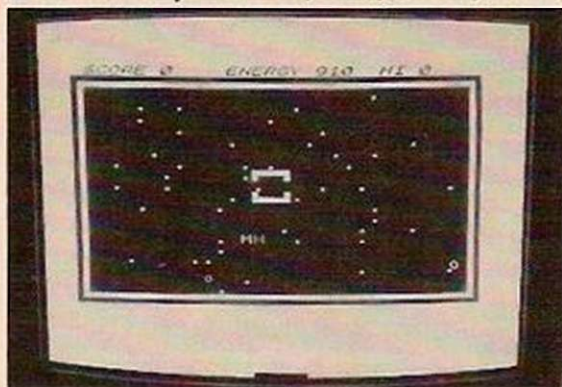

any rectangle from one space to whole screen; flashing cursor at any point; save and load at double speed.

We should see more in the future of firmware like Orme Electronics' Toolkit on ROM and Artic's Forth. Orme supplies the board, which is usable with printer and extra memory that carries the EPROM. It is very reasonably

priced at £11.95, and gives a good range of routines, such as versatile Renumber and partial Delete, as well as a game of Life. Unfortunately, the board fitting is rather difficult when used with extra memory. One has to attach the whole board to a rigid sheet to prevent white-outs. The Toolkit occupies 2K.

Deluxe version

Video Software continues to extend its range of Basic utilities. As usual, each £7.95 cassette has a demonstration, a superb little book of notes and an audio-commentary. For £2 more you can buy the deluxe version in a smart box with spare cassette and planning charts. Video-Sketch lets you build up 12 pages of screen display, page through them as you wish, save, and amend them in use. It is very useful for teaching as well as for the shop window. Video-Ad is similar but offers a great choice in the rate and style of paging. Their main problem is slow creation speed.

Supplier	Program name	Description	Assessment							
			A	B	C	D	E	F	G	H
Games										
2	1K Party Tricks	10 simple games	5	4	3	3	2	3	3	3
4	Galaxy Invaders*	Fast, 10 levels	3	5	5	5	4	4	5	2
5	Love and Death	Eight 1K crudities	3	5	2	2	—	3	2	5
5	The Bible	10 1K crudities	3	5	2	3	—	2	2	5
6	SAS Mission Impossible*	Embassy siege	3	5	2	3	3	2	3	4
7	Games 2*	Three games	3	5	3	3	4	3	4	3
7	Monstermaze*		3	0	—	—	—	—	—	—
7	Catacomb*	Adventure	2	5	4	4	4	4	4	3
8	Amaze*	Smash through	0	5	3	—	—	—	4	4
8	Space Invaders*	Standard	0	5	3	—	4	4	4	2
9	Cassette Two*	10 good games	3	5	4	4	4	4	4	4
10	Adventure*	Classical	2	5	2	2	5	4	—	1
11	Adventure A*	Adventure	3	5	2	4	4	5	—	2
11	Adventure B*	Adventure	3	5	2	4	4	5	—	2
11	Adventure C*	Adventure	3	5	2	4	4	5	—	2
11	Galaxy Warrior*	Star Trek	3	4	4	2	3	2	2	2
11	Chess II*	Good chess	3	5	3	3	5	5	4	3
12	Cassette AB	10 standard games	1	5	2	2	3	3	3	1
13	Battle of Britain*	Simulation	5	5	1	2	5	4	—	4
13	Asset Stripper*	Economy Simulation	4	5	1	3	4	3	—	4
13	Kingdom of Nam*	Social Simulation	4	5	4	3	4	3	—	1
14	Othello*	Powerful	5	0	2	4	5	5	4	3
Education										
1	Olmaths*	Three programs	—	4	3	4	4	4	—	4
1	Family Quiz*	Three general programs	—	5	3	4	3	4	—	4
3	French Countdown*	Vocabulary test	—	5	5	3	3	3	4	5
3	Geography Hangperson*	British revision	—	5	5	5	4	4	5	5
3	The War Game*	Anti-nuclear	4	5	4	4	3	3	3	5
4	Statistics	Six 1K programs	5	5	2	2	3	3	—	2
15	Geography*	Map tests	2	5	3	3	3	3	4	4
15	Fun Learning*	Games	1	5	3	3	2	3	2	3
16	Division*	Drill and help	2	5	3	4	4	3	2	3
16	Tables Test*	Simple	2	5	4	3	3	4	—	3
Miscellaneous										
2	Video-Sketch*	Economy Simulation	5	3	5	3	5	3	5	5
2	Video-Ad*	Economy Simulation	5	3	5	3	5	3	5	3
3	Madame ZX-81*	Economy Simulation	—	5	4	4	—	3	4	5
11	ZXbug*	Economy Simulation	3	5	2	4	4	5	—	2
15	Art and Fun*	Economy Simulation	2	5	3	3	3	4	3	4
17	ZXMC*	Economy Simulation	5	0	—	—	—	—	—	2
17	Screen Kit*	Economy Simulation	3	0	—	—	—	—	—	5
18	Toolkit — EPROM	Economy Simulation	3	—	—	3	3	3	—	5

Notes: **Supplier:** numbers refer to suppliers' list. **Program name:** asterisk shows 16K needed. **Assessment:** 0-5 scale: A, documentation; B, easy of loading; C, format, or screen layout; D, ease of use; E, functional value; F, programming quality; G, quality of graphics; H, novelty.

Suppliers and addresses

1. **Rose Cassettes** 148 Widney Lane, Solihull, West Midlands. Education, general.
2. **Video Software** Stone Lane, Kinver, Stourbridge, Worcestershire. Games, general.
3. **AVC Software** PO Box 415, Birmingham B17 0HD. Education, general.
4. **Bridge Software** 36 Fernwood, Marple Bridge, Stockport, Cheshire, Graphics, games, statistics.
5. **Automata** 65a Osborne Road, Portsmouth. Games.
6. **Stellar Software** 144 Pampisford Road, Purley, Surrey. Games.
7. **Greye** 16 Park Street, Bath, Avon. Games.
8. **Micro-Gen** 24 Agar Crescent, Bracknell, Berkshire. Games.
9. **Orwin** 26 Brownlow Road, London NW10. Games.
10. **Abersoft** 7 Maesafallen, Bow Street, Dyfed. Game.
11. **Artic Computing** 396 James Reckitt Avenue, Hull, Humberside. Games, general, utilities.
12. **Cadsoft** 24 St James Street, Cheltenham, Gloucestershire. Games.
13. **Microgame Simulations** 73 The Broadway, Grantchester, Cambridge. Simulations.
14. **Mine of Information** 1 Francis Avenue, St Albans, Hertfordshire. Game.
15. **Parsons** 23 Coxhill Gardens, River, Dover, Kent. Education, general.
16. **Turner Consultants** 3 Hillgarth Underbarrow, Kendal, Cumbria, Education.
17. **Picturesque** 6 Corkscrew Hill, West Wickham, Kent. Utilities.
18. **Orme Electronics** 2 Barripper Road, Camborne, Cornwall. Utilities on ROM.

MicroStyle

29 BELVEDERE, LANSDOWN ROAD, BATH

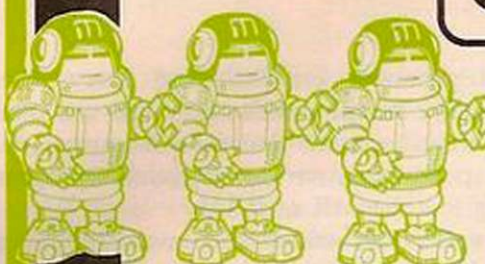

(0225) 334659.

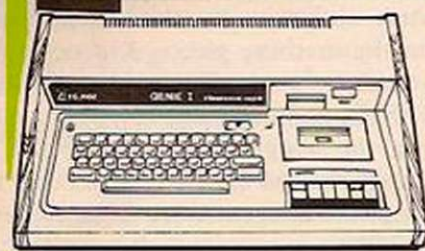
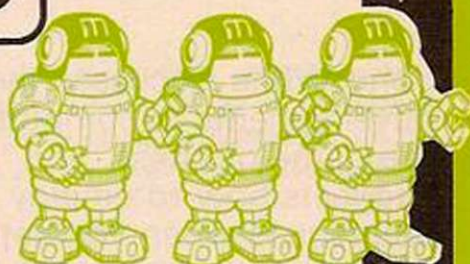

INGENIOUS Genie 1

All of the original GENIE SYSTEM plus: ★ Machine Language Monitor ★ Fitted Sound ★ Renumber Command ★ Full Lower Case ★ Screen Print ★ 16K ROM 13K RAM **£295** + VAT

SEIKOSHA GP100A PRINTER

ENTIRELY NEW DESIGN. UNBELIEVABLY LOW PRICE. FULL GRAPHICS CAPABILITY. CENTRONICS PARALLEL INTERFACE. PAPER WIDTH ADJUSTABLE UP TO 10". **£195.00** + VAT

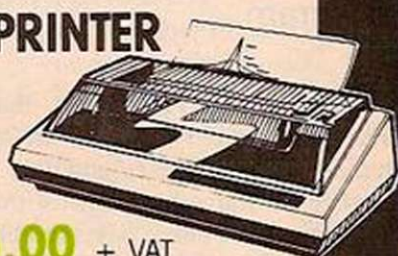

PRINTERS

EPSON MX80 EPSON MX100 ANADEX PAPER TIGER T.E.C. SCRIPTA MICROLINE 80.

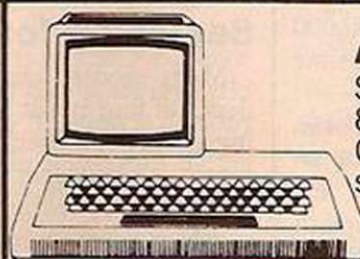

ACORN ATOM

Sensational New Micro-Pack! 8K ROM 5K RAM, PSU included. Colour fitted. Starter pack software. **£170.00** + VAT



SHARP MZ80K

Full 48K Microcomputer with built-in cassette deck and monitor. THE ALL IN ONE COMPUTER - NO MESSY WIRES. Full range modular extensions available, printers, disk drives, etc. **£345** + VAT

GENIE II

The MacroComputer

Offering all the advantages of the Genie I system, with the benefit of advanced design for the professional user.

- ★ Terminal Routines
 - ★ Facility to Upload & Download
 - ★ Screen Print
 - ★ 4 Defineable Function Keys
 - ★ Full Upper & Lower Case
- Price **£299** + VAT

PROFESSIONAL EXTENSION KEYBOARD

for added efficiency of your ZX81. Plugs straight into existing ZX81 without desoldering. Simply unplug existing keyboard and plug in new one. **£25.00** + VAT

TANTEL PRESTEL ADAPTER

New ALPHA Numeric keyboard brings PRESTEL into your home. Converts black and white or colour TV. **£195.00** + VAT

VIDEO MONITORS

All sizes and prices.
Black/white 9" **£90.00**
Black/white 12" **£65.00**
Green Screen 12" **£85.00**
Amber 9" **£95.00**
All Plus VAT

Complete range of VIDEO GENIE PERIPHERALS

can now be linked to your TRS80 for only **£18.00** + VAT with the new 3023 BUS CONVERTOR

Plus!

Aculab Floppy Tapes

Special Offers - Ring and find out.

Vast Computer Book Selection.

Just a sample of what's in store for you!

ZX81 Software. TRS80/Video

Genie Software. Diskettes.



Post to: MICROSTYLE, FREEPOST, 29, Belvedere, Lansdown Road, Bath BA1 1FP

Please send me further details on the following, and your special offers:

Y.C. 1.

Name _____

Company _____

Address _____

Tel: _____



CHESS

PIECING TOGETHER

John White discusses the main developments in computerising the game of chess, and suggests how to employ these techniques when you set about writing your first chess program.

SPEAKING IN 1949, the mathematician Shannon pointed out that an average chess game lasted 40 moves and that there are an average 30 move possibilities during each of those moves. There are, therefore, at least 10^{120} possible games of chess. To search these at the ridiculously high rate of 1,000,000 games per second would require a search time of 10^{108} years to exhaust all possibilities.

When constructing a program to play chess, it is certainly not possible to carry out an exhaustive search. Instead, a search of a few moves is considered and the position which arises is scored. The means of doing this is known as the evaluation function — EF — and the strength of a chess program depends very much on how effective the EF is.

Contrary to popular belief, it is actually relatively easy to write a chess program. The real difficulty lies in constructing a program which meets the following requirements:

- Plays strong chess.
- Makes its move within a reasonable time — certainly not more than five minutes.
- Uses little memory — less than 32K at the outside.

Skilled chess programmers earn high fees, with good reason. It is generally true that good programs are written by highly-experienced machine-code programmers, rather than by good chess players. The mainframe world computer chess champion, Belle, was written by a non-chess player, and relies on brute strength to find its move rather than by making complicated positional assessments. However, some appreciation of good chess play is necessary to write a good program for a micro.

Before embarking on writing a chess program, you should clearly define what you expect from it. The amateur, working in his spare time, is unlikely to be able to produce a program capable of beating one written by a team of full-time, salaried professionals. Nor will the amateur have access to dedicated chess units for his program, and will have to rely on his domestic microcomputer which cannot be expected to run so fast as the dedicated unit would.

On the other hand, writing chess programs will give much pleasure and will also improve your programming skill. With practice, you

will soon find that writing programs becomes much easier; you will not, for example, need to keep rewriting your move generator.

There are also many discoveries waiting to be made in improving evaluation and search procedures. Computer chess is essentially only 30 years old, and the alpha-beta pruning method only half that. The obvious "chopper" pruning mechanism entered commercial chess computers as late as 1981.

As a final inducement, I should mention that many of the chess games available on cassette for domestic micros play a feeble game which could easily be improved — think of the market for the Vic and the BBC Micro.

Searching for checks

Many modern chess computers search to a depth of four-ply at their higher levels, searching deeper for checks and captures. A ply of search is equivalent to one half move, that is, one move by either side. This dictates the choice of programming language. If a machine can choose its best move at one-ply in one second, then it will take 30 seconds to examine its opponent's reply to each of its moves, 900 seconds to examine its own responses to each of the possible opponent moves, and 27,000 seconds — 7.5 hours — to examine the opponent counter responses at the fourth ply. If the program takes 10 seconds to find its best one-ply move, then it will take 312 days to search to a depth of four-ply.

These figures assume a full search of the tree of moves which is constructed by considering all possible permutations of moves to a depth of four-ply. In fact, powerful pruning methods exist to reduce the size of the tree, and a program which can select its best one-ply move in one second can be made to search to a depth of four-ply in about two to three minutes.

To reduce the time spent selecting a move at one ply to 10 seconds or less, machine code or assembly is essential. Out of curiosity, I wrote two chess programs, one in interpreted Basic and one in compiled Fortran, to see how long they would take to run with a one-ply search. The Basic version took three minutes per move, the Fortran version five seconds, and both played ghastly chess due to a minimal EF. A good machine-code program should find its one-ply move within one second.

Another good reason for programming in machine code is the inability of many other languages, including Basic, to perform recursion. I do not know any way of enabling a Basic program to call itself more than once, since the Return statement bears no label. It is desirable to use, say, a move generator at each level of search, rather than to have to write a

fresh generator for each and every level.

Finally, machine-code programs are more economical on space than other languages, and it is possible to write a reasonable program using less than 4K of RAM.

A variety of methods may be used to set up the chessboard. Simplest is a two-dimensional array, where different positive values are assigned to the machine pieces, and negative values to the opponent's. The values may be equated with the nominal value of a piece, so a queen could be assigned a value of 90, a bishop 32 and a knight 29. Loss of the king is fatal, so these are assigned very high values, say, about 5,000.

All moves to a position will then be subject to the constraint that $X * (9-X)$ and $Y * (9-Y)$ — where X and Y are the new co-ordinates on the board — must both be greater than zero.

It is common practice to put the 0th and ninth lines of the array to a number which is distinguishable from the pieces. This marks

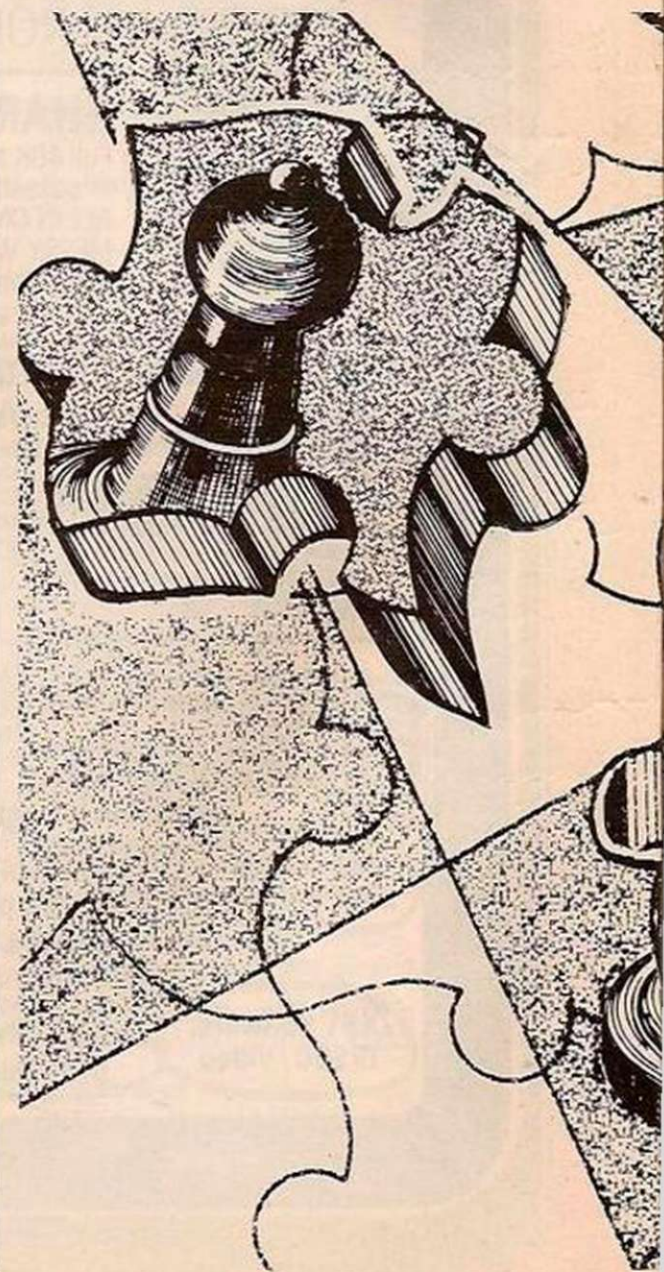

THE BEST MOVES

the rim of the board and saves checking whether a project move has gone off the board.

Picture a rook moving down a file. It can either feel its way down cautiously or it can thunder down until it bounces off the rim. A second rim can also be added to check the legality of knight moves, which may hop over the first rim. Remember that the rim may have to change sign, in some implementations, according to which side is moving.

Separate table

It is also possible to devise chessboards in a one-dimensional array and even to use two two-dimensional arrays, so that all the pieces will appear to be moving in the same direction.

The position of major pieces can additionally be kept in a separate piece table, and this enables attacks on enemy pieces to be found very quickly. This method is used by all the major chess manufacturers.

The move generator simply calculates all the moves for the chess men. A queen is composed of a rook and a bishop. The generator can be written very easily, but remember to test for move legality. A piece can move on to a vacant square, on to an enemy-occupied square but not on to a friendly-occupied square. A piece cannot move through another piece, unless it is a knight.

En passant is also reasonably easy to cater for. A flag is set whenever a pawn makes a move enabling *en passant* by the opponent. Much more difficult is castling where the castling rook must not have been moved, the king must not have been moved, the king must not be in check and the king must not pass through check or settle in check.

A test to see if the king is in check is, therefore, essential and this can also be used to give priority to king protection. The test is done by making legal rook, bishop, pawn and knight moves away from the king, and testing to see

whether the appropriate enemy piece is encountered. Testing to see if the moving piece is giving check is inadequate, since it may miss a discovered check. Incidentally, do not forget to allow for the possibility of double check.

Evaluation function

Two methods are available for working out which move a computer should make. The first is the EF, which assesses and scores a position arising after a piece has been moved. The second is the look ahead — search in depth — which considers responses to machine moves, counter responses, counter-counter responses and so on.

There is considerable debate in computing circles as to whether a chess program should use a sophisticated EF combined with a shallow search — but searching some forcing lines such as captures in greater depth — or

(continued on next page)

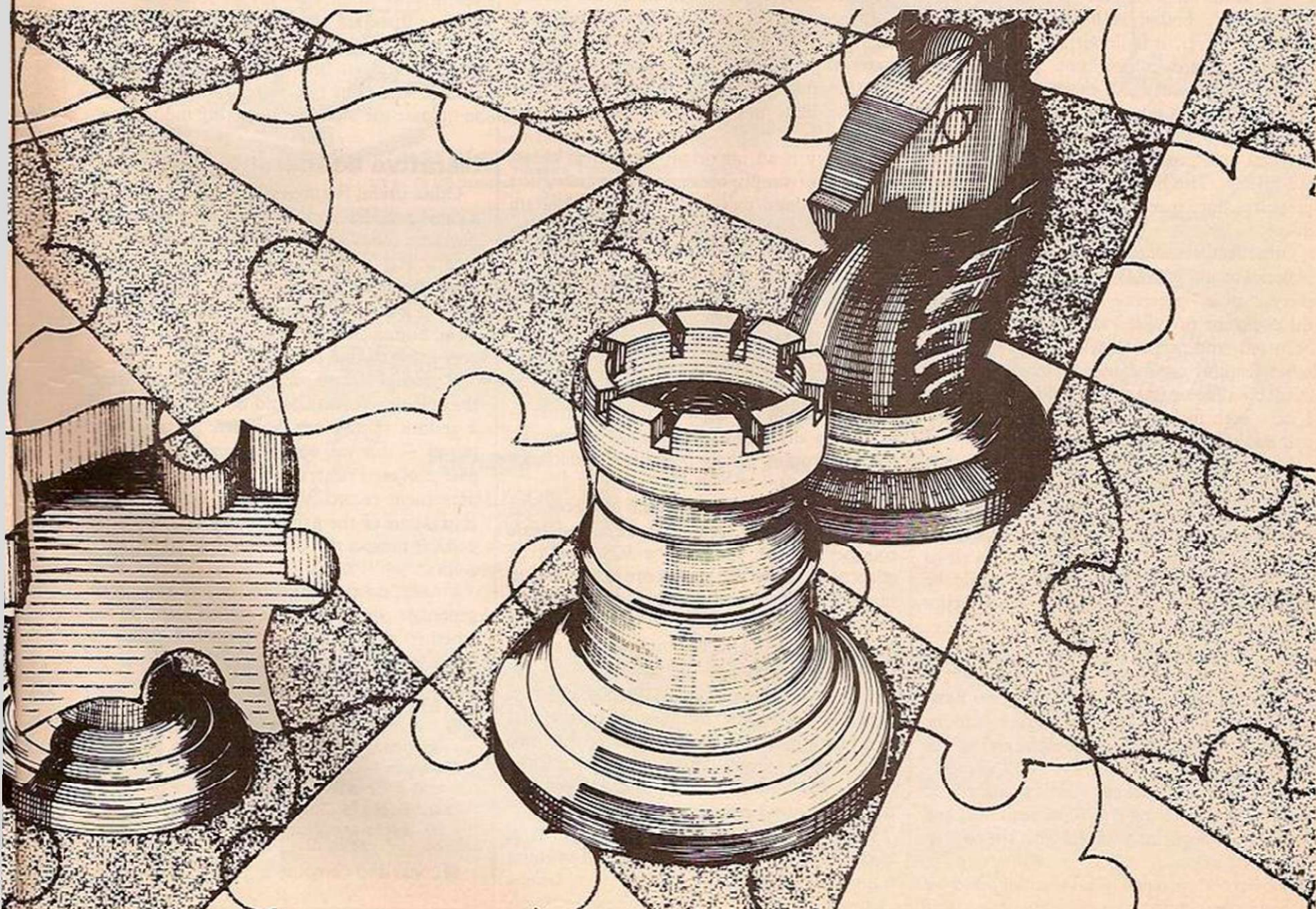

(continued from previous page)

should use a minimal EF with as deep a search as possible. Bearing in mind that the EF is called after every potential move, it must be kept as short — that is, as fast — as possible, particularly for a deep search, and will rarely contain more than 20 elements.

Devotees of the first method point out that a detailed search of only part of the tree, selected by a sophisticated EF, most closely mimics human chess play. David Levy is a believer in this approach, and his company's Philidor program uses special, still secret methods to attain a strong EF capable of considering even strategic factors. Another example is the German Shach computer which plays a respectable game with a look ahead of only one move, but with a very powerful EF.

Adherents of the second approach observe that programmers should concentrate on the computer's greatest strength — its ability to calculate rapidly. The Belle program makes its moves by calculation deep into the chess tree. It is also common to give great consideration to the EF at the first and second ply, but to reduce the EF at all subsequent levels, so as to spend less time searching.

Search routines

By convention, the score from an EF is taken as positive if favourable for the program, negative if unfavourable. An essential feature of any good EF is an evaluation of the number and quality of pieces bearing on any square, particularly in the centre. This is done as described for the search for check on the king, and the same routine can be used for both purposes. However, it is important to remember that for square control one piece hidden behind another may still exert an effect.

For example, a queen on the same diagonal as a bishop — with no intervening piece — will exert its own pressure on the same squares as the bishop. The bishop will exert the greater pressure, since it is more expendable than the queen.

Other features worth including in the EF are material count, attacks on king, queen or lesser pieces, pins, presence of doubled pawns, development of pieces, whether castling has occurred and advancement of pawns. Yet other features can be added, limited only by available time or imagination. Some examples I have seen include fianchettoing the bishop and doubling rooks along a file or row.

So far we have been considering only the evaluation of positions. An alternative method is to evaluate each move as it is made. This is significantly faster than evaluating positions, but unfortunately gives weaker results. It is not suited to chess programs, but could be used for draughts or other games where tactics are more important than strategy.

The ability to search moves in depth is a subject which would require as much space as all the rest of this article put together. Basic principles, with excellent examples, can be found in the references given at the end of this article.

Numerous techniques are available to reduce the size of the tree to be searched, and you should acquaint yourself with the following:

■ Minimax is the name given to a full search of every permutation of moves, i.e., the whole

tree, where the opponent tries to minimise the machine's score while the program tries to maximise it. This is the slowest type of search.

■ Alpha-beta search is a method of pruning which gives the same result as minimax but in less time. The principle is that if any one response to a program move can be found that makes the move weaker than one previously considered, then the program need not waste time calculating other responses to that move.

■ Hard pruning can be effected simply by eliminating all potential moves which fail to achieve a certain minimum score.

■ Razoring makes use of the assumption that the opponent can always find a move that will make things better for him than if he had made no move.

■ Chopper: sometimes the program has only one legal move. This can be made at once without need to calculate all the possible responses and counter responses.

■ Killer heuristic makes use of the assumption that any response which cuts off part of the tree with alpha-beta pruning will also cut off another part at the same level.

The efficiency of many of these pruning methods, especially alpha-beta, can be greatly increased by sorting the moves into decreasing score order. This must not be done too often, or the time spent sorting exceeds the time saved, but can be very effective if carried out after each ply of search.

This leads us to iterative deepening which is used on virtually all the better chess machines now. All the moves are found at the first level. These are sorted into score order and searched to the second ply. These are sorted and searched to third ply and so on. By this means, the best move yet found is always available at each level of search, and this is normally constantly displayed. If a timer is employed, the thinking can be interrupted at any time and the best move becomes the machine's choice.

Mobility is an important concept in chess, and is most simply obtained by summing the number of legal moves made by the program and by the calculated responses to each of its moves. Pruning must not be carried out at the first and second ply or this method will not work.

Normal pruning

Mobility may also be assessed in a sufficiently sophisticated EF — for example, by modification of the square control routines — but slows the program noticeably. However, normal pruning is now permitted, which may compensate.

When the total material count of pieces falls below a minimum level, then extra end-game routines can be called. The EF should be adapted to make the king more active and to make the advance of pawns — especially as chains — more favourable. The depth of search can also be safely increased since less material is available to be moved.

As a guide, the powerful Morphy program enters its end-game routines when material equivalent to two kings, two rooks, two knights and seven pawns remains on the board, and the depth of search is roughly doubled at the higher levels.

Book openings are very useful for games of chess, enabling the program to avoid opening traps and permitting some non-obvious strategic moves to be made. For example, the

black move C7-C5 is thematic in many queen's pawn openings, yet I know of no program which does this early in the game except as part of a book opening.

The only limit on the book is that of memory space, which is unlikely to trouble most owners of micros. The book should be held in an array, matched against move number, and not as part of an opening tree which will take a long time to search.

Random selection between moves of nearly equal merit is a very useful feature, making all games different, and is most simply done by adding a small random number in the EF to the score from each evaluation.

Counter moves

After completing its search, the program will come up with a series of moves and a series of counter moves. These can be stored, which is very expensive on memory but will enable the program — on request — to reject the best move in favour of the next best and so on. This facility is available on several of the programs from the software company Philidor, such as Pet Chess, Intelligent Chess and Chess Champion Mk V.

More commonly, the scores are compared with a store which is initially set at minus infinity, say, -10,000. If the score exceeds the store, the store level is set to the score and the moves creating the score are also stored. Thus the store is constantly upgraded until only the best move remains in the move storage area. For opponent responses, a second store is pre-set to plus infinity — say, +10,000 — and scores that are less than the store are exchanged with the score until the lowest-scoring, and so best, opponent response is stored. The same two stores can also be used to operate the alpha-beta pruning mechanism.

Iterative deepening

Other useful features which can be added to a chess program include the ability to set up a position, use of real-time clocks to record play length and a move counter. For programs using iterative deepening, the clocks can be used to interrupt the machine's thinking, and a halt button can also be made available for the user for the same purpose.

A prompt button can be used to reveal what the machine thinks should be your move, and a restore button can be used to take back moves — this will require memory storage of past moves. Printers can be interfaced for a permanent record, which may be had at the conclusion of the game on request, or as the game is played; the latter requires no memory storage.

Finally, do not forget to couple your move generator with a routine which tests to see whether the opponent's proposed input is legal.

REFERENCES

- The following are essential reading for anyone writing a chess program:
- *Sargon — a computer chess program*, D and K Spracklen, Hayden.
- *Advances in Computer Chess* pages 89 to 97, J A Birmingham and P Kent, Pergamon Press.
- *Chess and Computers*, D Levy, Batsford.

Castle Electronics

Service - at Supermarket Prices!



VIC-20 COLOUR COMPUTER

- Graphics character set
- Plug-in programme/memory cartridges
- Colour
- Sound
- Programmable function keys
- 5K memory expandable to 32K
- Standard PETBASIC
- Full-size typewriter keyboard
- Low-priced peripherals
- Joystick/paddles/light pen
- Self-teaching materials
- Cassette Deck now available £44.95

Only £189-95 INC. VAT

ALL PERSONAL COMPUTER ENQUIRIES
HASTINGS
(0424)
437875

YOU WON'T FIND A BETTER DEAL ANYWHERE IN THE SOUTH



Acorn Atom BRITISH DESIGNED PERSONAL COMPUTER

- | | | | |
|-----------------------------|---------|-----------------------------|---------|
| 8K ROM + 2K RAM kit | £140.00 | 4K Floating Point ROM | £ 23.00 |
| 8K ROM + 2K RAM Ass. | £174.50 | Colour Encoder | £ 21.85 |
| 12K ROM + 12K RAM kit | £255.00 | Mains Power Supply | £ 9.20 |
| 12K ROM + 12K RAM Ass. | £289.50 | | |

TANGERINE microtan

- Microtan 65 Kit
- Microtan 65 Built
- Tanex Min. Config. Kit
- 20 way Keypad

TANTEL PRESTEL ADAPTER - £199.00

We hold a complete stock of all the Tangerine equipment. Send SAE or Phone for details.



COMPUTERS FOR PEOPLE



FROM £345.00 Plus All Accessories Available!

- Model 400 16K
- Model 800 16K
- Cassette
- Disk Drive
- 80 Col. Printer



COMMODORE PET

- 16K PET
- 32K PET
- Dual Disk Drive
- Printer
- External Cassette

Complete range of PET equipment in Stock

CASSETTE SOFTWARE: Strathclyde Basic Course, Basic Basic Course, Invaders, Treasure Trove of Games 1 to 10 (10 Selections of games), Basic Maths, Algebra, Statistical Packs and lots more!

Special Offer!

sinclair ZX81 FOR IMMEDIATE DESPATCH £69.99



BUILT-IN SOUND-HIGH RES. GRAPHICS

- Apple II Plus 48K
- Disk Drive + Controller
- D.D. without Cntrlr
- Pascal Card
- Eurocolour Card
- Hitachi 9" Monitor

We Stock All the Goodies for Apple!



ALL PRICES INCLUDE VAT : ACCESS & BARCLAYCARD WELCOME
ORDERS NORMALLY DESPATCHED DAY OF RECEIPT

WE SPECIALISE IN COST EFFECTIVE SYSTEMS FOR SMALLER BUSINESSES

South East Computers MicroComputers for Business

ASK FOR DETAILS OF OUR TOTAL SUPPORT OPTION

From Only £19 per week

Package A

SILICON OFFICE SYSTEM

- 1 x CBM 8096 Computer
- 1 x CBM 8050 Dual Disk Drive
- 1 x CBM 8023 Matrix Printer

Connecting cables, plus Silicon Software

From Only £43 per week

Package B

ALTOS MULTI-USER HARD DISK SYSTEM

- 1 x ALTOS 8000/10 Computer with 10 Mbyte Hard Disk
- 208Kbyte Memory (4 users)
- 500Kbyte Floppy Disk Drive
- 2 x TVI 912C VDU's
- 1 x OKI Microline 83A Printer

UNBEATABLE OFFERS FOR EDUCATION & TRAINING CONTACT US NOW!

SEC BUSINESS SYSTEMS SUPPLY A WIDE RANGE OF EASY-TO-OPERATE SYSTEMS AND PROGRAMMES TO MEET ALL OF TODAY'S BUSINESS NEEDS + FULL RANGE OF COMPUTER RELATED PRODUCTS + LEASING AGREEMENTS + FULL AFTER SALES SERVICE



The Complete Computer Service!

FOR ALL BUSINESS SYSTEMS ENQUIRIES:-
Phone Nick Rosenberg on Hastings (0424) 426844

15 CASTLE STREET, HASTINGS, EAST SUSSEX TN34 3DY Dept.YC5

Few face Richard Turner's choice of managing a thriving software firm or completing a degree. Brendon Gore finds out how this ex-champion hammer thrower runs Artic without stepping out of the university circle.

RICHARD TURNER'S entry into the world of microcomputers was sheer accident, he says. Both he and fellow Artic director Chris Thornton went to Malet Lambert high school in Hull. In 1979 the school put on a computer course, using a time-sharing scheme on a big Honeywell computer. Chris Thornton signed up for the scheme almost immediately, but initially Richard Turner was not that keen.

"I did not want to go on the course because it meant missing a free lesson during the sixth form", says Turner. "But everyone else seemed to be signing up for the course so I thought I might as well hop on. Two weeks after the course started I was hooked".

This new-found interest in computers did not stop Richard Turner from picking up four A levels, mathematics, physics, chemistry and general studies, but it did persuade his parents to buy him a ZX-80 microcomputer for his 18th birthday.

Middlesbrough-based Linsac, one of the first ZX-80 software houses, was looking for programs to market. Richard Turner sent in a sample program which was accepted.

Richard Turner's partner in programming, Chris Thornton, also had a few months free before starting a degree in computer science at Hull University. Together they began writing programs for Linsac.

"We started writing programs in Basic, but Chris soon moved on to machine code. We didn't have a clue what machine code was about at first, but we got hold of a program from one of the computer magazines and managed to pick out a few of the instructions. This was not too successful so eventually we decided to buy a book on the subject. We got the whole set of instructions from it and started writing machine code".

The pair continued to write programs for Linsac, but found they had less time once their holidays ended. Richard Turner moved to Chelmsford for the first three months of his industrial year with Fords.

In January, 1980, Richard Turner and Chris Thornton decided to form a partnership and go into business for themselves. Artic Computing was born.

"The name comes from an anagram of the initials of our names", explains Richard Turner.

INTERVIEW

ONE DEGREE



"We thought of various different names, most of them terrible, but we settled for Artic. We had not even thought of the articulated lorry, but it became our logo".

For the first six months times were hard — the company made £21. With comparatively heavy spending on advertising, Artic found itself in debt. However the launch of

'I knew I would never go back if I took a year off'

ZXChess proved to be the turning point.

ZXChess was extremely popular, partly because it was the first chess program for the ZX-81 to hit the market. It was also extremely difficult to write, taking over a year from the original idea to the finished product.

Looking back at Artic's formative months, Richard Turner says that their biggest mistake lay in selling programs too cheaply. "There's a snob element in the ZX-81 market. If you sell programs too cheaply they do not sell. I tested this out with one program called Zombies which we were selling in a pack of four

programs for £2. I took the Zombies program out of the pack and sold it on its own for £3.50. Sales immediately took off, which is the reverse of most theories".

During this period Richard Turner moved to the Fords assembly plant at Dagenham, writing Adventure games in his spare time. He finished the control and subsidiary systems for the games while completing his year's industrial training at Enfield.

Originally, Richard Turner had intended to study at Liverpool University as part of his sponsorship deal with Fords. He now decided to switch to Imperial College, London.

Richard Turner is the first to admit that combining a university degree with running a business is not easy. He was offered a year's leave of absence from university to concentrate on running Artic, but turned it down. "I knew I would never go back if I took a year off".

The crunch will come in June with the first-year exams. If he fails he will probably work full-time on Artic, but he thinks he has done enough to pass.

Artic is currently producing 12 different games programs for the ZX-81. The best sellers, says Richard Turner, are ZXChess I and II, Adventure A, B and C, and Galaxians. "ZXChess is our biggest seller on the mail order side, but we

have probably sold more Galaxians because we have just had a big order for 2,500 Galaxians cassettes from W H Smith".

The Galaxians program was written for Artic by William Wray, a Hull schoolboy who is currently doing his O levels at Cottingham grammar school. William Wray first visited Artic with a view to buying some of their programs, but he and Richard Turner started talking and William Wray ended up sending in one of his own programs. With a little help from Artic, Wray's Galaxians program was polished up and marketed under the Artic label.

The order from W H Smith resulted from the ZX Microfair in January. "I saw John Rowland, Smith's market development manager, at the ZX Microfair and told him 'This is a brilliant program, come and have a look'. He came over and his kids started playing it. That always works".

The Galaxians cassettes were only delivered to W H Smith on March 1, so it is still too early to say how well they are selling. But Turner is confident the Galaxians game will be successful and hopes to secure a big repeat order from W H Smith soon.

Artic's biggest problem has been the quality of its cassettes, says Richard Turner, though he is quick to emphasise that there is nothing wrong with their quality now. Initially, when orders were limited to two or three a week, Artic produced all its own cassettes.

A new tape recorder solved some of the problems, but the C10 cassettes supplied by local retailers were still very poor quality. Artic tried two different suppliers, both of whom produced good cassettes at first, but the quality soon faded.

A number of cassettes were returned by dissatisfied customers. At one point Artic was forced to replace 250 ZXChess cassettes because they were unusable. But, as Richard Turner points out, Artic did replace all the faulty cassettes even though it was a relatively expensive operation. In addition, Artic sent letters to all its customers who bought faulty ZXChess cassettes apologising for any inconvenience caused.

Cassette quality is no longer a problem. Artic found another supplier, Work Force of Luton, who produce consistently good-quality cassettes.

IN ARTIC

"I am also trying a little experiment with a tape-duplicating company which is producing the Galaxians and ZXChess programs for us", says Richard Turner. "The company seems very professional and I hope it will take tape production out of our hands".

Another potential problem, which

'We would like to build a cheap computer'

affects Artic and all other software houses, is the vexed question of copyright. "It is a big problem", says Richard Turner. "You have to watch out for other companies trying to rip off your software. We try and protect our programs by making them self-executing, in machine code, so that no one else can break into them. But with a little bit of know-how you could just rewrite the load routine and fix it so that you could copy the program. One of the programs that we sell can actually be used to break into the rest of our programs".

No one has tried a software case in court yet, mainly because it would be extremely expensive, explains

Richard Turner. Everyone is waiting for the test case.

Artic has not caught anyone trying to sell their software, yet, though a number of people have copied it successfully: "Most people are so pleased when they do manage to copy our programs that they write and tell us. We just warn them not to sell it".

One possibility which Artic has discussed with some of the other ZX-81 software suppliers is forming a ZX-81 software-house user group to clamp down on any unscrupulous firms which infringe copyright. "If we found any cases of copyright infringement we could approach the computing magazines and threaten to withdraw our advertising unless they agreed to stop carrying advertisements from the offending company", says Turner.

Copyright is important because computer software is a lucrative business. Artic is not showing any mammoth profits on the balance sheet yet, because all the profits are being ploughed back into the company in the form of reinvestment, equipment and stock. Nevertheless, with Artic taking in about £300 a day in mail orders alone, the company is not doing badly.

The scope for profit will be even bigger when Artic starts marketing software for other microcomputers

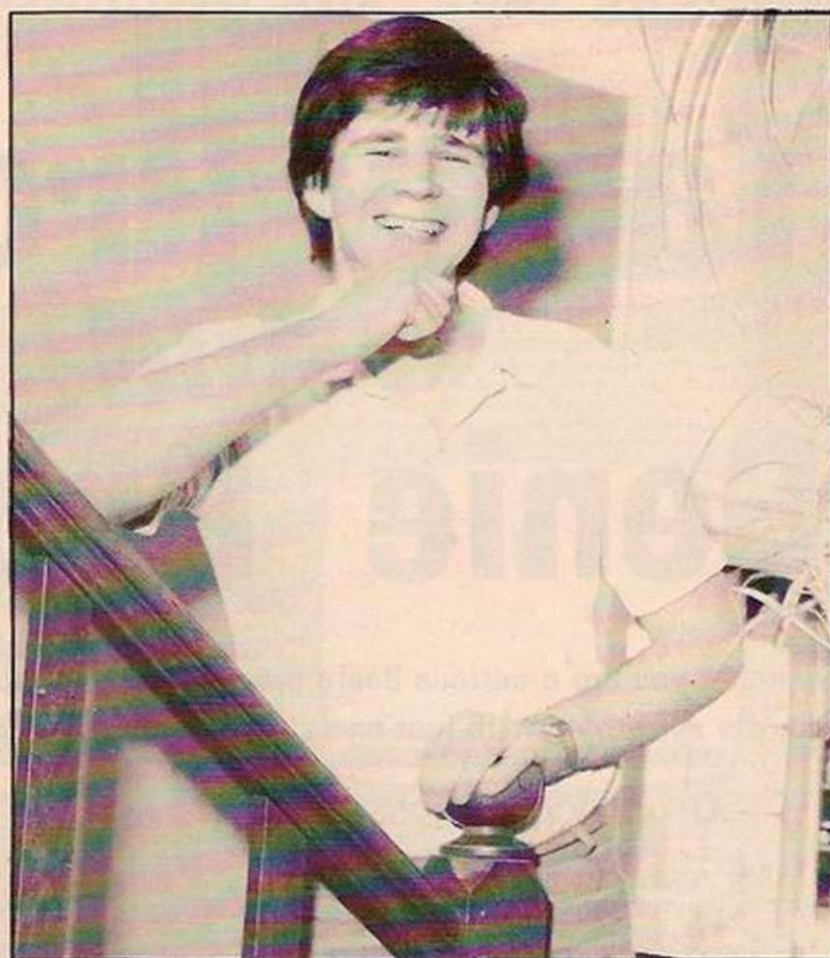

apart from the ZX-81. "At the moment all our machine-code programs are written on a Video Genie and converted to the ZX-81. In theory we could sell TRS-80 and Video Genie software as well.

"We are planning to move on to the BBC Microcomputer, if we can get hold of one. We are meant to be quite high on the list, but have still not seen any sign of one. If we do start writing programs for the BBC machine, which has a 6502 processor, there is no reason why we should not write programs for all the other 6502-based machines such as the Vic-20".

Artic is currently working on a Forth compiler on EPROM and hopes to bring out a prototype by the end of March. This will have a

number of advantages for ZX-81 users, as Forth is 10 times faster than Basic as well as being a structured language. Turner hopes to produce a compiler that users will be able to plug into the back of their ZX-81s without taking out the ROM.

In addition, Artic is developing a board to link two 16K RAM packs together to give a total of 32K RAM. The idea behind the board is to help people with a 16K RAM pack who want to expand their ZX-81 to 32K RAM, explains Turner. At present those people have to buy a new 32K RAM pack and throw away the 16K pack. This board will enable them to keep the original 16K pack. To obtain 32K RAM they simply buy another 16K pack, which is cheaper than buying a new 32K RAM.

Looking a little further ahead, Richard Turner forecasts that Artic will remain essentially a software house. "We will obviously be moving on to better machines", he says. "Eventually we would like to build a cheap computer, but I do not know whether we will ever find enough capital".

Lest you think Richard Turner is some kind of ice-cool whizz kid with electrons coursing through his veins, it is worth recounting a story from his schooldays. At senior school in Hull Richard Turner was the county hammer champion. He competed in the English Schools Athletics Championships twice, but never finished higher than 13th despite being a potential medal winner. "The big occasion cracked me up", says Turner. "I could not throw properly because I was so nervous".

It is somehow refreshing to know that Artic's chairman can suffer from nerves. For all his machine-like competence, Richard Turner is human.



At long last—the ultimate Basic programming aid

Tandy Programmer and Genie Programmer

Whether you are a serious Basic programmer or simply play around with other people's programs, here's something with just one single purpose—to make it easier and more enjoyable

AT YOUR COMMAND:

TRAP How many times have you searched and searched for that elusive Syntax error in program lines, wasting hours in the process? Never no more! Here is an error trapper which shows you the exact location of the error in the line, whether Syntax, FC, MO or whatever. Just think of the time saved!

EXECUTE When Trap shows you the error, no need to go into the Edit mode, for Execute does this for you with a single letter command.

TRACK Still another Kansas original—which Microsoft said couldn't be done!—No longer need you struggle through the Trace function, speeding through and obliterating the screen in the process. Track displays just four line numbers in the top corner of the screen with no loss of display. A command even allows you to step through the execution of the program line by line! Or, if you prefer, at any speed you define. Microsoft couldn't do it, but Kansas programmers can!

PACKER Have you seen the cost of Packer programs? Here's one which works. This allows you to program in short easily manageable lines, then when debugged, join them up together to both save space and speed up execution. You can define the number of lines you want joining, colons inserted for you.

SQUASH A further space saver—this one takes out all the spaces from the program, but leaving them of course in Print statements. Even to telling you how many saved!

KILL If space really is at a premium, or if you like to put in plenty of remarks when programming, Kill will take out all of the REM statements. Handy for tidying up.

MULTI-KEY So you want to make your programming really easy. How about defining any—or all—of the letter keys to print out a complete statement at the touch of a single key? Multi-key allows exactly that, and up to ten characters into the bargain—of your own choice of course.

FIND So you would like to know which lines contain a particular variable? No problem. This command will list out all the lines containing the variable defined. You can even choose to step through these lines one at a time. Especially useful for single stepping through a program listing.

DISPLAY Just think how handy it would be to be able to list all the names and values of every variable used in a program. Think of the hours you've wasted on this little exercise! Not any more though. Display will list them all, including single, double precision and string variables, giving you all the details. It will even output to a printer.

CHANGE Perhaps you want to change some of the variables? Easy, just define the variable and what you want it changed to. Very useful for changing GOTO's GOSUB's etc, when adding extra routines or lines to a program.

MOVE There's always a time when you want to move a line somewhere else in the program, which usually results in having to retype the lot. No need anymore, move it with this.

DUPLICATE Or perhaps you have a particular line you wish to insert a number of times. Just do the line once and then you can put it in as many times as you like under any line number you choose, with this Duplicate command.

RELOCATE If you are ambitious and want to move whole blocks of lines around, this will do it for you, even retaining the same increments in the process. A real work saver!

MERGE Of course, all programmers want to merge either programs or routines, and this one does it very easily, and what is more important—reliably.

RE-NUMBER There just has to be a re-number, and here's one which will do the job efficiently, allowing you to define the starting number, which is of course essential when merging routines and programs. Adjusts all branching lines.

RESCUE We all somehow or another managed to lose all our hard work by either pressing the wrong button or giving the wrong command. This gets it back—even if NEWed.

DISABLE It really is essential to be able to run the program on which you are working without having to lose the host utility. This Disable command allows switching between Programmer and your program with nothing lost.

And it takes up less than 4K!

State whether for the Tandy Model I or Genie. Available for 16K, 32K and 48K and Tandy Model III

Available only from Kansas at a sensible £34 Vat and post paid

IT'S A RELIABLE BRITISH PROGRAM BY BRITISH PROGRAMMERS

Kansas

As publishers (we do not retail other people's programs) we have absolute quality control and thus give an unconditional guarantee on all our software. And of course all programs are always in stock for our famed return first class post service whether ordered by cheque or credit card. Ask for a copy of our free catalogue, you won't find any 'South Coast' prices there! Access and Barclaycard welcome.

Kansas City Systems, Unit 3, Sutton Springs Wood, Chesterfield, S44 5XF. Tel. 0246 850357

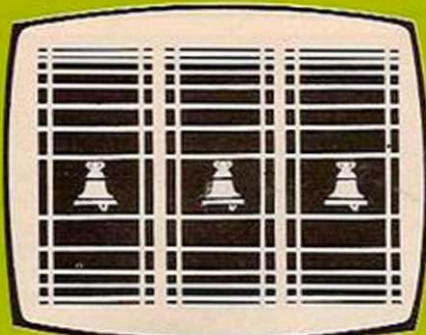

1. FRUIT MACHINE:

This is a computer version of the popular "one armed bandit", with three reels, Nudge reel, and Hold, Nudge and Gamble functions. Incorporating the VIC's normal graphics, colour and sound, it requires an expanded VIC (3/8/16K).

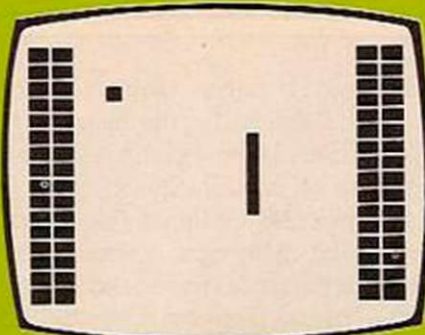

2. BRICKDOWN:

A variation on the game "BREAKOUT": using the keyboard or a joystick controller manoeuvre the bat to try to break through the right hand wall, while protecting the left wall. Requires basic or 8K VIC.

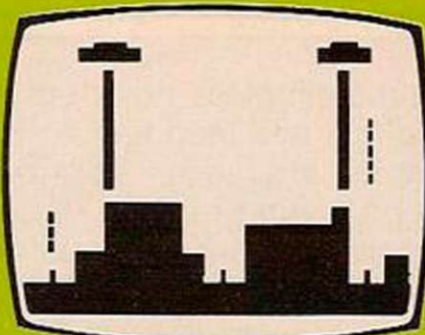

3. BLOCKADE:

Using joystick or keyboard, control your missile base to destroy incoming enemy missiles and protect your fuel dumps. Game ends when you are hit or all fuel dumps destroyed. Uses defined graphics, colour + sound. Runs in basic VIC only.

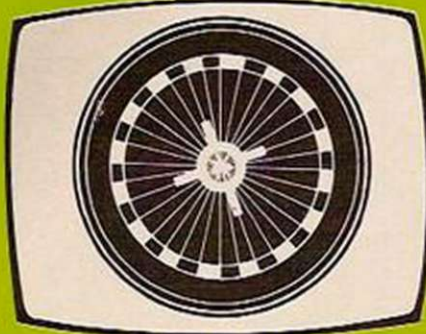

4. ROULETTE:

Complete with accurate full colour "MONTE CARLO" roulette table, you can break the bank without risk of personal loss! Complete with list of odds and allowed bets, you are given £5,000 to play with. Game ends when you lose your shirt. Runs in any VIC, with colour and sound.

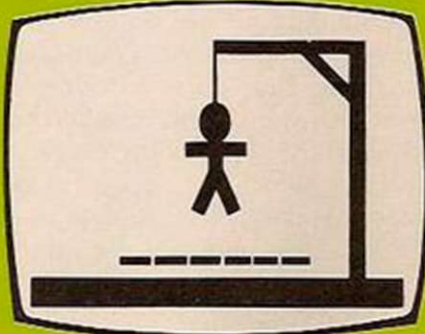

5. HANGMAN:

Play the computer at this version of the popular pen + pencil game. The VIC has a built-in vocabulary of 50 words, to which you can Add, Delete or Replace your own words. Addictive, with colour + sound. Runs in any VIC.

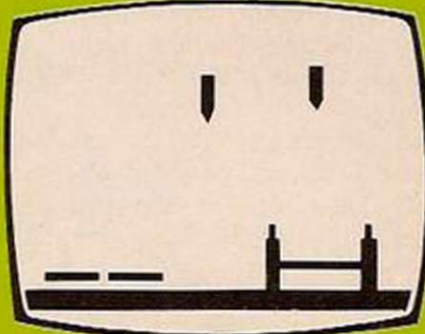

6. TARKUS:

With the joystick or keyboard, control the stretcher bearers to pick up the wounded men, and return them safely to the red cross base. If you are hit by an enemy missile, however, you join the wounded, on the field! Challenging and addictive, with defined graphics, colour + sound. Runs in basic VIC only.

NEW!

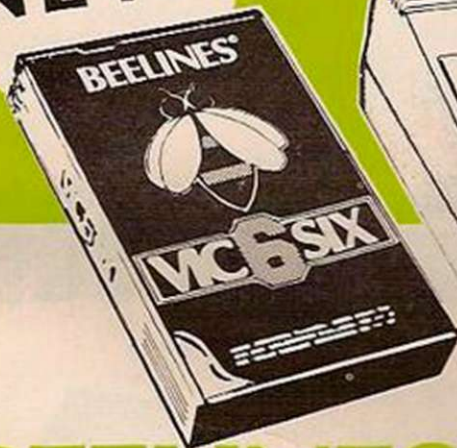

The above are artists impressions only and do not represent the actual displays.

only
£9.95
inc. V.A.T. &
Post & Packaging

BEELINES VIC 6 SIX VOL 1

The Games System in a Cassette!

At last! A really professionally produced piece of games software that will guarantee you hours of fascinating thrills on your VIC computer. The first volume of the 'Beelines VIC 6' gives you exciting colour, arcade quality games that make full use of the power and display quality of the VIC.

The 'VIC 6' is attractively priced so that no VIC user need be without it, and it is available exclusively from Beelines. Just send £9.95.

So fill in the coupon, or phone us with your credit card number, and the 'VIC 6' will be yours within days!



BEELINES (Bolton) LTD
FREEPOST (No stamp required) Bolton BL3 6YZ
Ansaphone (0204) 385299
Reg. office: 124 Newport St., Bolton BL3 6AB.
Dealer enquiries welcome.

Please send me:

Qty.	Item	Price
	Beelines 'VIC 6' Vol. 1 at £9.95	

I enclose cheque/P.O.

OR Please debit my:

Access 5224

Barclaycard 4929

Expiry Date

Name

Address

Code

Tel. (day)

Official orders welcome -

We will ship to approved account holders on receipt of firm order.

Delivery free within mainland UK.

Access and Barclaycard welcome.

Telephone answering machine for 24hr/7 day

credit card orders 0204 385299

Free post: Beelines, FREEPOST,

Bolton BL3 6YZ

YC/5/82



The meaningless tiny dots that buildings and landmarks become when seen from the air can be given precise proportions with Michael Banks' program in Basic.

IF PHOTOGRAPHY is one of your hobbies, you may have tried your hand at taking aerial photographs, or perhaps you have attempted some shots from the observation deck of a tall building or some other high vantage point. If so, you will probably have wondered just how high you were when the photograph was made, or the size of objects on the ground in the picture.

This program gives you the answer to either of these problems, provided of course, you already know one of the variables. The program is written for the Acorn Atom. It makes use of the formula

$$H = \frac{OF}{I}$$

where H is the altitude of the camera when the photograph was taken; O the length of a known object on the ground; I the size of the known object as measured on the negative, and F, the focal length of the camera used.

All measurements should be in metric units. The focal length of most cameras is given in millimetres and so it is easier to measure the relatively small size of images on a negative in

millimetres rather than in inches. Always measure images on the negative because you can never know exactly what proportion a print is of the original.

I originally designed this program for use with the Astrocram, a camera made to be carried by model rocket and designed by Estes Industries of Penrose, Colorado. I have found it to be invaluable for interpreting data quickly from the large numbers of aerial pictures I take.

Since I use the program only with photographs made with the Astrocram, I substitute the 30mm. focal length of the Astrocram for F in lines 120 and 220. You can do the same, using the focal length of your own camera. If you wish to make this modification, be sure to delete lines 110, 210 and 211.

The program can be used to interpret data from standard horizontal shots, as well as from high-altitude ones. To use this program for horizontal photographs, substitute the distance to an object for the altitude when the program requests it.

If you are a stickler for detail and want the computer to address you properly when requesting information, make the changes given in program 1.

Program 1.

```
16 PRINT "A) DISTANCE OF CAMERA
FROM AN OBJECT IN THE PHOTO"
20 PRINT "B) SIZE OF AN OBJECT IN
THE PHOTO"
101 INPUT "WHAT IS THE LENGTH OR
HEIGHT OF AN OBJECT SHOWN IN THE
PHOTO" Z
105 PRINT $10; PRINT "WHAT IS THE
SIZE OF THE SAME"
106 PRINT "OBJECT -- IN
MILLIMETRES -- AS MEASURED"
107 INPUT "ON THE NEGATIVE" B
115 PRINT $12; PRINT "THE DISTANCE
OF THE CAMERA FROM THE"
120 PRINT "OBJECT WAS "Z*F/B"
METRES. "'
200 PRINT $12
201 INPUT "WHAT WAS THE DISTANCE
FROM THE OBJECT TO THE CAMERA" C
215 PRINT $12; PRINT "THE SIZE OF
THE OBJECT"
```

INTERPRETING AERIAL



Program 2.

```
1 DIM A(1)
5 REM ***** AERIAL PHOTOGRAPHY
  CALCULATOR *****
10 REM *** COPYRIGHT (C), 1981,
  MICHAEL A. BANKS ***
15 PRINT $12
16 PRINT "A) ALTITUDE OF CAMERA
  WHEN PHOTO WAS MADE"
20 PRINT "B) SIZE OF AN OBJECT
  ON THE GROUND SHOWN IN THE PHOTO"
25 PRINT $10,$10, /
30 INPUT "WHICH FIGURE DO YOU
  NEED (ENTER 'A' OR 'B')" $A
35 IF $A="A" GOTO 100
37 GOTO 200
40 END
100 PRINT $12
101 PRINT "WHAT IS THE LENGTH --
  IN METRES -- OF AN OBJECT ON THE"
102 INPUT "GROUND IN THE PHOTO" Z
105 PRINT $12, "WHAT IS THE LENGTH
  OF THE SAME OBJECT --"
106 INPUT "-- IN MILLIMETRES -- AS
  MEASURED ON THE NEGATIVE" B
110 PRINT $12, "WHAT IS THE FOCAL
  LENGTH OF THE CAMERA USED TO TAKE
```

```
THIS PHOTO" F
115 PRINT $12; PRINT "THE ALTITUDE
  OF THE CAMERA WHEN THIS PHOTO"
120 PRINT "WAS MADE WAS "Z*F/B"
  METRES."
125 END
200 PRINT $12; PRINT "WHAT WAS THE
  ALTITUDE -- IN METRES -- OF THE"
201 INPUT "CAMERA WHEN THE PHOTO
  WAS MADE" C
205 PRINT $12 "WHAT IS THE SIZE --
  IN MILLIMETRES --"
206 PRINT "OF THE OBJECT WHOSE
  SIZE YOU WISH TO DETERMINE"
207 INPUT "AS MEASURED ON THE
  NEGATIVE" D
210 PRINT $12 "WHAT IS THE FOCAL
  LENGTH OF THE CAMERA USED TO"
211 INPUT "TAKE THIS PHOTO" F
215 PRINT $12; PRINT "THE LENGTH OF
  THE OBJECT"
220 PRINT "IS ".C*D/F, " METRES."
225 END
```

PHOTOGRAPHS

An aerial photograph of a landscape, possibly a coastal or island area, with a camera rig in the foreground. The rig consists of several vertical poles with circular lenses or sensors at the top, extending from a dark surface (likely the camera's housing) down towards the ground. The background shows a mix of land and water, with some structures or buildings visible on the left side. The overall tone is somewhat muted, with a lot of grey and brownish hues.

GAMES

TANK BATTLE

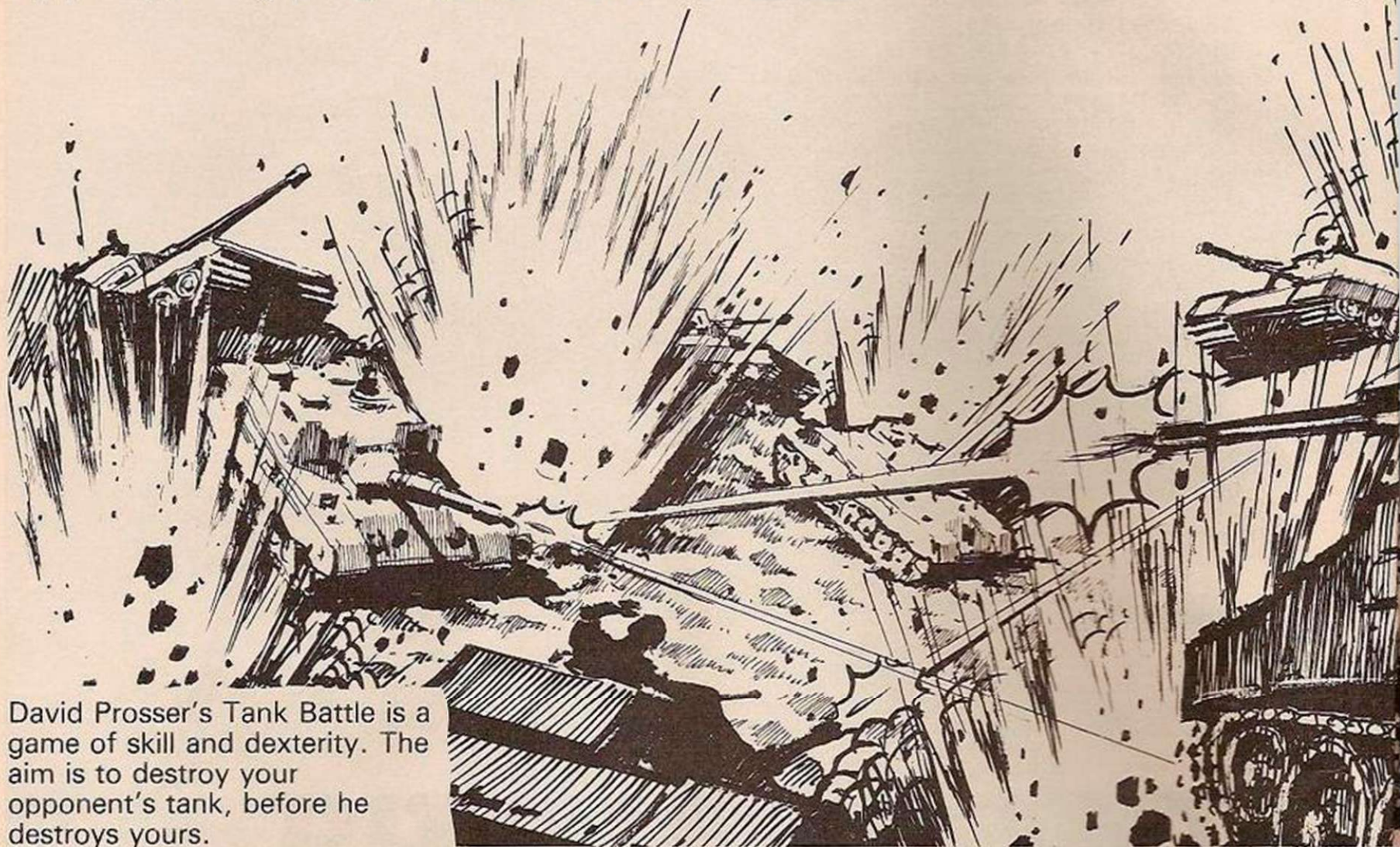

David Prosser's Tank Battle is a game of skill and dexterity. The aim is to destroy your opponent's tank, before he destroys yours.

TANK BATTLE runs on a Vic-20 without any additional memory. It is a two-player game whose object is to destroy your opponent. To do this you may move around using these keys:

Left:
E
S D '3' to fire
X
Right:
@
'-' to fire

As the game progresses, you will notice little green dots on the screen. Beware, these are mines. A shell fired from a tank will not affect them but if a tank should drive over one, it will explode. When this happens the second player's score is increased by one.

The second way to win, by destroying your opponent, involves driving your tank frantically around the maze. Once you press the fire button, a shell which is different for each tank will be fired in the last direction you moved. If this shell hits the wall of the maze, then you are allowed to fire again as your shell vanishes. You cannot, therefore, fire again while one of your own shells is in progress.

There are two versions of this game. Game B is the one I have just described; in game A every time either of the fire buttons are

pressed, a block is plotted on the screen at a random position. After a while the screen may become full of both mines and blocks.

So, to restart the game while also remembering the scores, the user need only press the f1 key. Pressing the key will allow you to swap from either game A or B while remembering the present scores.

The time, which is on the top line of the screen, is the time it takes for either of the tanks to be destroyed.

When run, the program will produce a maze like the one shown in figure 1, assuming the same data is used. The > sign is the left player's tank and the < sign is the right player's tank. The score is printed at the top and in the middle, the time.

After each game, the bottom line of the maze will be replaced by the winner's name and the second line down will carry the question "Another go (Y/N)".

002: this line sets the screen colour for the rest of the program which is a red border and red screen.
004: here any key previously remembered in a Get statement is reset. As well as this, lines 4 and 5 produce coloured blocks at the top and bottom of the screen.
005 to 010: this outputs the title page.

Figure 1

LEFT 0 0045 RIGHT 0

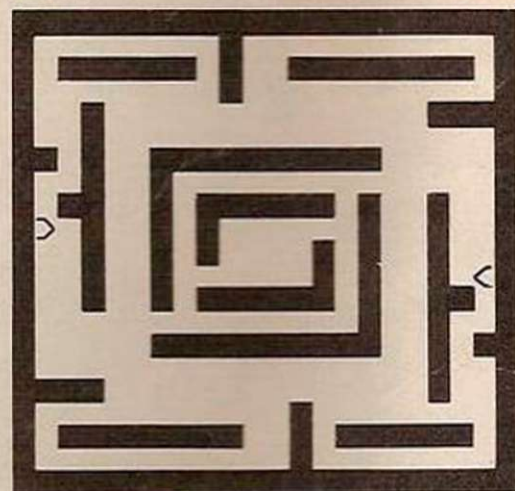

Notice that in lines 6 and 8 there are 13 spaces after the Reverse On command.

011: this sets the variables. S0, S2 and V are all to do with the sound controls on the Vic. S0 and S2 are the two sound-box locations and V is the volume control.
015: notice that there is no need for semicolons in this line.
016: to obtain this graphics symbol, hold down the Commodore key and press Y.

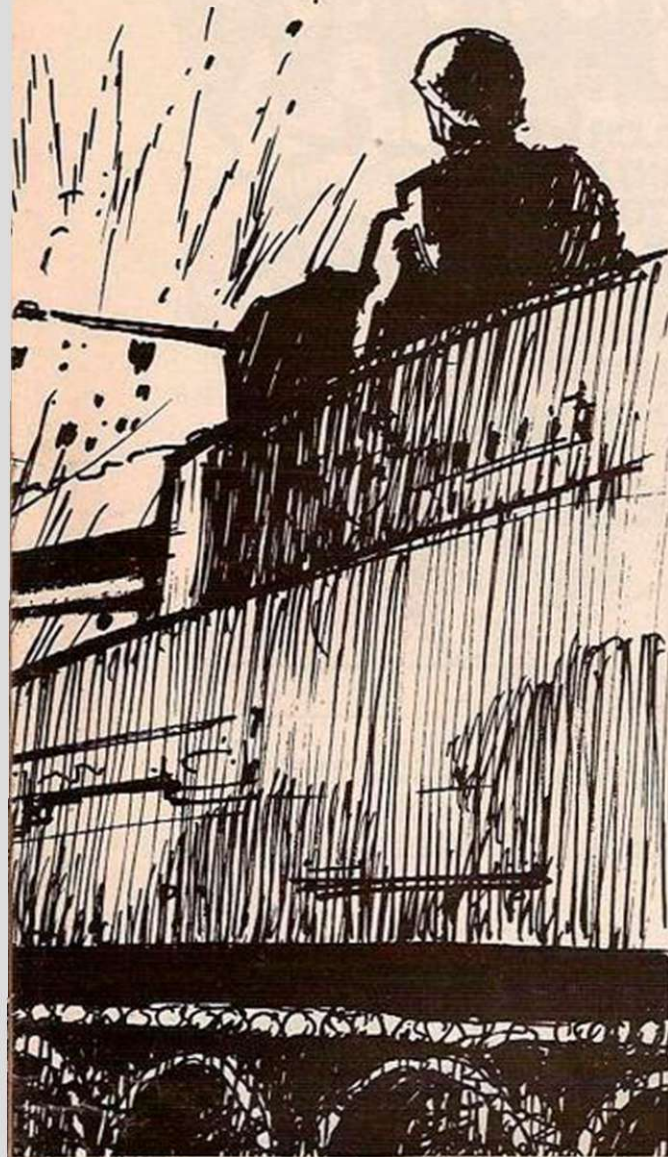

```

0 REM D. PROSSER
1 REM SHELDON HEATH
2 POKE36879,42
4 POKE198,0:PRINT "J":FORA=0T021:POKE7680+A,160:POKE38400+A,(RAND7):POKE8164+A,
160
5 POKE38884+A,(RAND7):NEXT
6 PRINT"MM" " PRINT" " TANK BATTLE " PRINT" "
7 PRINT" " FOR " PRINT" " PRINT" " V I C-2 0 "
8 PRINT" " " PRINT" " BY DAVID FROSSER"
9 PRINT" SHELDON HEATH " PRINT" " HIT A KEY "
10 GETA$:IFA$=""THEN10
11 80=36877:V=80+1:S2=V-2:D1=-22:D2=D1
15 PRINT"J"TAB(5)"TANK BATTLE"
16 PRINTTAB(5)" "
17 PRINT" THERE ARE TWO GAMES TO PLAY,A & B."PRINT"GAME A":PRINT"
18 PRINT"THE COMPUTER WILL PUT UP OBSTRUCTIONS WHEN"
19 PRINT"THE 'FIRE' BUTTON IS PRESSED."PRINT"GAME B":PRINT"
20 PRINT"SAME AS ABOVE BUT HAS NO OBSTRUCTIONS."
22 PRINT"PRESS 'A' OR 'B'":GOTO940
23 GETA$:IFA$=""THEN23
24 IFA$<"A"OR"B">"B"THEN22
26 GM=A$="B"
27 PRINT"J":RESTORE
28 READX,Y:IFX=-1THEN30
29 FORQ=XTOX+Y:POKE7724+Q,160:POKE8185-Q,160:NEXT:GOTO28
30 READX,Y:IFX=-1THEN40
32 FORQ=XTOX+22*YSTEP22:POKE7724+Q,160:POKE8185-Q,160:NEXT
33 GOTO30
40 DATA0,21,56,7,184,5,106,2,46,5,138,9,-1,-1
50 DATA0,20,31,2,91,8,206,1,133,0,178,0,160,5,-1,-1
70 BC=60:WC=62:B=7986:W=7923:J=0:K=0:POKEB,BC:POKEW,WC
86 PRINT"LEFT"ZZ"RIGHT"ZX:TI$="000000"
90 GETA$:PRINT"LEFT"RIGHT"(TI$,4)
91 IFK=1THENGOSUB220
92 IFJ=1THENGOSUB310
93 IFA$=""ANDJ<>1THENB1=B:J=1:D4=D2:GOSUB500:GOSUB400:GOSUB310:POKEB,BC
94 IFA$="3"ANDK<>1THENW1=W:K=1:D3=D1:GOSUB500:GOSUB400:GOSUB220:POKEW,WC
96 IFRND(1)>.98THENGOSUB750
97 IFA$=""THEN90
98 IFASC(A$)=133THEN4
100 IFA$="E"THEND1=-22:GOTO109
101 IFA$="0"THEND2=-22:GOTO112
102 IFA$="S"THEND1=-1:GOTO109
103 IFA$=":"THEND2=-1:GOTO112
104 IFA$="X"THEND1=22:GOTO109
105 IFA$="/"THEND2=22:GOTO112
106 IFA$="D"THEND1=1:GOTO109
107 IFA$=";"THEND2=1:GOTO112
108 GOTO90
109 IFPEEK(W+D1)=32THENPOKEW,32:W=W+D1:POKEW,WC:GOTO90
110 IFPEEK(W+D1)=46THENPOKEW+D1,42:GOSUB800:GOTO356
111 GOTO90
112 IFPEEK(B+D2)=32THENPOKEB,32:B=B+D2:POKEB,BC:GOTO90
113 IFPEEK(B+D2)=46THENPOKEB+D2,42:GOSUB800:GOTO355
114 GOTO90
220 IFPEEK(W1+D3)=32ORPEEK(W1+D3)=87THENPOKEW1,32:W1=W1+D3:POKEW1,81:RETURN
221 IFPEEK(W1+D3)=160ORPEEK(W1+D3)=46THENPOKEW1,32:K=0:RETURN
222 POKEW1,32:POKEW1+D3,81:GOTO355
310 IFPEEK(B1+D4)=32ORPEEK(B1+D4)=81THENPOKEB1,32:B1=B1+D4:POKEB1,87:RETURN
311 IFPEEK(B1+D4)=160ORPEEK(B1+D4)=46THENPOKEB1,32:J=0:RETURN
312 POKEB1,32:POKEB1+D4,87:GOTO356
355 X$="LEFT":GOTO360
356 X$="RIGHT"
360 POKES0,220
380 FORL=15T00STEP-1:POKEV,L:POKEV+1,L:FORQ=1T0300:NEXTQ,L:POKES0,0:POKEV+1,42
390 PRINT"CONTROLLER WINS"
391 ILEFT$(X$,1)="R"THENZX=ZX+1:GOTO600
392 ZZ=ZZ+1:GOTO600
400 POKES0,200:FORQ=1T0100:NEXT:POKES0,0:RETURN
500 IFGM=-1THENRETURN
510 TY=RND(1)*417+7746:IFPEEK(TY)=32THENPOKETY,160
530 RETURN
600 POKE198,0:PRINT"ANOTHER GO"
605 GOSUB900
610 GETA$:IFA$=""THEN610
620 IFA$="Y"THEN27
630 IFA$<"N"THEN600
635 PRINT" " :FORQ=1T0500:NEXT
640 POKE198,0:PRINT"CHANGE GAME"
645 GOSUB900
650 GETA$:IFA$=""THEN650
660 IFA$="Y"THENRUN
670 IFA$<"N"THEN640
680 END
750 TY=RND(1)*417+7746:IFPEEK(TY)=32THENPOKETY,46:POKE30720+TY,7
751 RETURN
800 FORL=1T015:FORQ=200T0220+L*2:POKES2,0:NEXTQ,L:POKES2,0:RETURN
900 POKEV,15:FORA=1T05:PRINT"?" :POKES2,225:FORQ=1T0150:NEXT
910 POKES2,0:PRINT"(Y/N)":FORQ=1T0150:NEXTQ,A:RETURN
940 POKEV,15:FORA=1T05:PRINT" " :POKES2,225:FORQ=1T0150:NEXT:PO
KES2,0
950 PRINT" " :FORQ=1T0150:NEXTQ,A:POKE198,0:PRINT"J":GOTO23

```

017 and 019: these two lines use the graphics symbol obtained by holding down the Commodore key and pressing T.

026: this line saves the use of an If-Then statement by using logic. If GM is set to -1 then A\$ = "B", otherwise GM = 0.

027: the Restore is in case the f1 key is pressed while the game is in progress.

040 and 050: the two data lines are used to plot the maze. From screen location 7724, or the third line down, the screen is numbered from zero to 461. The first data number is from where the line starts, and the second one shows how long the line is to be. Line 40 is the data for all horizontal lines, and line 50, the data for all vertical lines. Both lines require rogue values of -1 at the end of the line.

070: this sets the screen positions and the values for the tanks. Anything with a W is for the left tank; B is for the right tank.

098: this line tests if the f1 key has been pressed.

380: this line outputs an explosion sound, while changing both the screen and border colours

635: note that there are 20 spaces on this line after the cursor-down instruction.

750: after plotting a mine at a random position on the screen, the colour is changed to green.

900-950: these lines should be entered very carefully. They are mug traps which cause the keys to be pressed to flash on and off on the screen five times. During this a beeping sound is output, the purpose of which is to draw the attention of the user to the correct responses.

THE ZX81 POCKET BOOK

A STACK OF GAMES AT YOUR FINGERTIPS

BOOKS

136 PAGE BOOK

Programs

*ZX81 ADVENTURE.

City of Alzan
Create your own

BALL AND BUCKET

PAINT-A-PIC

DIGITAL CLOCK

*SKI RUN

Plus 20 more Programs

Articles

Using machine code
Efficient Programming
String Manipulation
Plus more

**ONLY
£5.95
inc P.P**

*REQUIRE 16K RAM

Also available

ZX81 *Adventure

GREEDY GULCH
MAGIC MOUNTAIN
PHARAOH'S TOMB

ALL 3 for £5.00 inc vat & P.P

***ZX81 Pocket book
Cassette**

All programs & subroutines
from the book on 1 tape

**£5.00 inc vat
& P.P**

BARCLAYCARD



PHIPPS ASSOCIATES

(Mail Order Dept B)

99 East St, Epsom Surrey, Tel 03727 21215

quoting your credit card No, 24hr phone service
Air Mail Europe plus 70 p Elsewhere plus £1.70

SOFTWARE FOR THE VIC 20

PR SOFTWARE — dedicated to the finest value in software for the VIC — bring you PRCI:

6 Programs on 1 cassette for only £7.50

- | | |
|------------------------|---|
| 1. War! | Your artillery and defences, their tanks — a fight to the finish. |
| 2. Smashout | Colour, sound and skill to break through that wall. |
| 3. Blackjack | VIC's big day. |
| 4. Logic | Break the colour code before VIC's big deal. |
| 5. Pick-up-game | Match of the day? |
| 6. Alarm clock | Clock, chime, alarm, snooze. |

All programs run on the unexpanded VIC20

Please send.....copies of PRCI at £7.50 each inc. p&tp

I enclose cheque/PO for £.....

NAME.....

ADDRESS.....

PR SOFTWARE

28 THE FAIRWAY, SOUTH RUISLIP,
MIDDLESEX HA4 0RY

YOUR COMPUTER

is your magazine — every issue is full of articles specially written for the home computer enthusiast.

Reviews of personal computers; Programs; Surveys of software available on the market; New application ideas for your computer; Computer Club — news from your clubs; Calculator page; Letters; Answers to your problems and pages and pages of computer games and program listings.

All for only 60p
Ensure your copy
each month, take
out a subscription
NOW!

SEE THE
SUBSCRIPTION
ORDER FORM BETWEEN
PAGES &
IN THIS ISSUE

HOW TO IMPRESS WITH YOUR ZX-81

Wearied by a barrage of "What does it do?" questions from doting relatives and inquisitive friends, Charles Chambers turned his hand to writing a series of Basic routines which load quickly and are guaranteed to impress.



HOWEVER BRILLIANT a mathematical manipulation, however obscure your machine-code routine, however florid and devious your string handling, it will cut little ice with that uncomprehending uncle who has watched over your shoulder for half an hour and wants to know if your ZX-81 plays space invaders.

Faced regularly with this situation, I quickly reached the conclusion that I had to write some programs which were short and immediately interesting.

These programs, I decided, must be graphic and fascinating — something that catches the eye and holds it for a reasonable amount of time.

It is much better to program in fast mode

because the flash of the screen gives the necessary feedback to signal your key presses. Fast is also, by definition, faster for the machine. So, although not as pretty as slow mode, it is better for both watcher and watched.

My first program is a perfect example of what you can do with a short listing which can be put on the machine in a flash.

```
5 INPUT A$
10 INPUT X
15 FOR N=1 TO INT 672/(X+1)
20 PRINT A$;"space";
25 NEXT N
30 CLS
35 GOTO 15
```

It is an innocuous-looking program, but enter the name of that envious friend or endearing aunt, together with the number of letters in the string, and his or her name is printed in a never-ending cycle on the television screen.

This next program produces a fascinating pattern that at times can be almost three-dimensional. Enter three characters — a space in the string is usually a good ingredient, and fast mode adds an air of expectation.

```
10 INPUT A$
20 PRINT A$;
30 GOTO 20
```

The following program is one taken directly
(continued on next page)

Program 5.

```

1 LET X=1000
2 LET Y=0
3 LET C=1
10 LET Z=INT ((X-Y)/2)
15 CLS
18 PRINT AT 0,0:C
20 PRINT AT 11,10:"NO IS ";Z
30 INPUT R$
40 IF R$=CHR$ 19 THEN LET X=Z
50 IF R$=CHR$ 18 THEN LET Y=-Z
60 IF R$="YES" THEN PRINT AT 11,10:"I THOUGHT SO"

```

```

70 IF R$="YES" THEN STOP
80 LET C=C+1
90 GOTO 10

```

Program 6.

```

10 PRINT AT 11,15:"WAIT"
20 PAUSE (RND*4)*100
30 PRINT AT 11,14:"PRESS NEWLINE"
40 POKE 16436,0
50 POKE 16437,0
60 INPUT A$
70 PRINT (65792-(PEEK 16436+256*PEEK 16437))-5.14

```

(continued from previous page)

from the ZX-81 manual but has one slight modification:

```

10 FOR N=0 TO 63
20 PLOT N, 22+20*SIN(N/32*PI)
30 NEXT N
40 SCROLL
50 GOTO 10

```

The main part of the program creates a full-screen sine wave. With the Scroll command, the wave builds on itself to produce an attractive and constantly moving display. If your machine has only 1K, the program will stop after a few minutes when the memory has filled.

Program 1 can be very impressive, though if you are running a machine with a 16K expansion it is best to detach it because, being Basic, it will run too slowly. With 1K it runs perfectly. When you have keyed it in, enter 0 as the string which will produce a ball bouncing around the screen. After you have watched that for a minute or two, add this to it:

```
6 INPUT G
```

and change line 50 to

```
50 IF Y=31-(G-1) THEN LET P=0
```

All you need to do to send a word, rude or otherwise, bouncing round the screen is to enter it together with the number of letters it contains. If you do not like to remove your expansion unit, the following modification to the program will compensate you for not having been able to run it fast enough before. First, drop line 80. You should be able to see why it will not work on a 1K ZX-81 and why it has a speed advantage over the original program. Add these lines.

```

3 LET K=1
85 IF K=250 THEN LET A$=CHR$
(RND*12+127)
86 LET K=K+1
87 IF K=250 THEN LET K=1

```

Start by inputting any graphic character, which will then draw itself around the screen. After 250 cycles, the character will change into another and, because of the method by which the formula decides the direction of the character's progression, the whole screen will gradually fill.

Because the characters vary and the pattern fills in a rather non-standard way, delightful designs build up and change continually. While everyone watches it, you can go away and read *War and Peace* and still have time for a cup of coffee before they tire of it.

By experimenting with the tuner on your VHF radio, you should be able to pick up the buzz of the computer. If you now save the program, you will hear on the radio the screeching noises of the software being loaded on to the tape. It is even possible to save a program on tape from the radio. With the ZX-80 this can be very useful.

If you have loading problems or are loading a long program, by using a radio you can follow its progress and check that the computer has not missed it.

Program 2 is the first game: a number is displayed in the middle of the screen and you must press the equivalent numbered key before it counts on. This counting from one to nine gives the game a dimension of speed, forcing the player to fluster and to make mistakes. The game lasts for 30 numbers and your score is shown in the top left-hand corner.

If you want to make it a little harder, you can make X a random number between one and nine. This is how you do it:

```
25 LET X=RND*9
```

and drop line 35. This modification will make the program run somewhat faster, but unless you are used to the vagaries of the Sinclair touch-keys, then the first version is difficult enough.

The next program offers, perhaps, less entertainment value but fits the 1K machine with memory to spare and can be entered in a second. It turns a string into one of those magic triangles which read the word down two sides, usually associated with Abracadabra. Apart from peoples names, Abracadabra is about the best word to keep watchers interest, although the longer the word the better.

```

1 LET X=1
2 LET Y=1
10 INPUT A$
20 LET B$=A$(X TO Y)
30 LET Y=Y+1
40 PRINT AT 5+Y, 11; B$
50 GOTO 20

```

Program 3 will be of use to a primary-school child — it prints the multiplication tables, starting with the two-times on to infinity. For

some reason a few always expect the computer to make mistakes and give the wrong answer. Mathematics at such an elementary level might be expected to bore everyone in a few seconds. Yet because the tables are produced by a computer, they suddenly take on a whole new significance for those unfamiliar with these machines.

Program 4 is a battle of logic. The computer picks a number from one to 1,000. All you have to do is to find the number by a process of guesswork and deductions from clues given by the computer. The computer gives you clues by telling you if your number is greater than or less than its. While this is in process, it counts the number of turns you have taken. Of course, if you want to make it more difficult, all you have to do is increase the possibilities of X, by increasing the limit of (RND*_____).

In program 4, you discovered the computer's secret number, now it will discover yours. What is more, it will not go beyond its 11th guess without succeeding. Tell the computer if your number is greater than or less than the computer's guess, using the symbols provided. When it succeeds, type in "Yes". The listing is a little longer than program 4. Remember to enter it in fast mode. You may also find it quicker to Edit, for instance, line 40 into line 50, or line 2 into line 3.

Program 6 is a variation on that old chestnut that tests the speed of your reactions and it is accurate to 0.01 of a second. When you run it, "Wait" is displayed on the screen and after a random time, which can be as long as eight seconds, "Press Newline" appears. When you have done that, your time is displayed. Do not run this in fast mode as the pause command will create havoc. My best reaction time is 0.24 of a second.

Program 1.

```

1 LET X=0
2 LET Y=1
5 INPUT A$
10 LET P=2
15 LET N=2
20 PRINT AT X,Y:A$
25 LET X=X+N-1
30 LET Y=Y+P-1
40 IF X=21 THEN LET N=0
50 IF Y=31 THEN LET P=0
60 IF X=0 THEN LET N=2
70 IF Y=0 THEN LET P=2
80 CLS
90 GOTO 20

```

Program 2.

```

1 LET X=1
2 LET Y=1
3 LET B$="12"
4 LET T=0
10 PRINT AT 11,14;X
15 IF INKEY$>" THEN LET B$=INKEY$

```

```

20 IF X=VAL(B$) THEN LET Y=Y+1
25 LET X=X+1
30 PRINT AT 0,0;Y
35 IF X=10 THEN LET X=1
40 LET T=T+1
50 GOTO 10

```

Program 3.

```

1 LET X=1
2 LET Y=1
9 FOR S=1 TO 12
10 PRINT X;" X ";Y;" = ";X*Y
20 LET X=X+1
30 NEXT S
40 LET Y=Y+1
50 PAUSE 300
60 CLS
70 GOTO 5

```

Program 4.

```

1 LET C=0
10 LET X=INT (RND*1000)
20 INPUT Y
30 IF Y=X THEN PRINT AT 11,15:"YES"
40 IF Y<X THEN STOP
50 IF Y>X THEN PRINT AT 11,15;CHR$ 18
60 IF Y<X THEN PRINT AT 11,15;CHR$ 19
70 LET C=C+1
80 PRINT AT 0,20;C
90 GOTO 20

```

£19 WORTH OF FREE ACCESSORIES WITH YOUR VIC AT

LASKYS

**£199
+ 10%
WORTH OF FREE
ACCESSORIES**



It's here! Britain's best-selling colour computer for under £200 is now in plentiful supply, and you can see it, try it, buy it at your Laskys store!

The VIC 20 can be used as a home computer, as a small business system or as an educational aid. It has excellent colour graphics, superb sound facilities, and runs on a domestic T.V. As well as the basic Computer, a wide range of peripherals are available, turning your VIC into a fully expandable, sophisticated computer system.

The growing range of VIC programmes on the market, means hours of fascinating thrills for the whole family on your VIC!

Laskys unique nationwide coverage enables you to drop into your local store where we have a micro department, and try out the VIC with the help of our friendly and expert sales staff. There are many different ways to buy! Cash, Credit Cards or Laskys Stereo Club, and we have full after-sales maintenance guarantee!

Look into Laskys for your VIC today!

PRICES	TOTAL
Cassette Unit	44.95
8K RAM Cartridge	44.95
Joysticks	7.50
Star Battle ROM Cartridge	19.95
"VIC Revealed" Book	10.00

11 Shops Across the U.K.

OPEN 6 DAYS A WEEK 9-6

Birmingham

19/21 Corporation Street, Birmingham, B2 4LP. Tel: 021-632 6303.
Manager: Peter Stallard. 300 yards from Bullring Centre.

Bristol

16/20 Penn Street, Bristol, BS1 3AN. Tel: 0272 20421.
Manager: Steve Heynes. Between Holiday Inn and C & A.

Chester

The Forum, Northgate Street, Chester, CH1 2BZ. Tel: 0244 317667.
Manager: Jeremy Ashcroft. Next to the Town Hall.

Edinburgh

4 St. James Centre, Edinburgh, EH1 3SR. Tel: 031-556 6217.
Manager: Colin Draper. East end of Princes Street, St. James Centre.

Glasgow

22/24 West Nile Street, Glasgow, G7 2PF. Tel: 041-226 3349.
Manager: David Livingstone. Between Buchanan Street and Central Station.

Liverpool

33 Dale Street, Liverpool, L2 2HF. Tel: 051-236 2828.
Between the Town Hall and Magistrates Courts.

London

42 Tottenham Court Road, London, W1 9RD. Tel: 01-636 0845.
Manager: Vass Demosthenis.

London

7-9 Queensway (off Bayswater Road), London W2 3RX
Tel: 01-229 6425

Manchester

12/14 St. Mary's Gate, Market Street, Manchester, M1 1PX. Tel: 061-832 6087.
Manager: Lesly Jacobs. Corner of Deansgate.

Preston

1/4 Guildhall Arcade, Preston, PR1 1HR. Tel: 0772 59264.
Manager: Jim Comisky. Directly under Guild Hall.

Sheffield

58 Leopold Street, Sheffield, S1 2GZ. Tel: 0742 750971.
Manager: Justin Rowles. Top of the Moor, opposite Town Hall.

**MICROCOMPUTERS
AT LASKYS**



Laskys, the retail division of the Ladbroke Group of Companies

Space Invaders and almost all the other computer games have been condemned by everyone from the Archbishop of Canterbury to the National Union of Teachers. Rod Hyde believes that on-screen skirmishes with the chip have their own value, and presents his own ZX-81 game to prove the point.

GAMES CAN be useful. Even the most despised arcade games develop co-ordination and familiarity with computer interaction.

VALUE OF THE

Educational programs are certainly useful but can also be fun when turned into games. Magic Squares is both educational and fun. The program is structured, as recommended by Eric Deeson in the February 1982 issue, so that it gives practice at the right level for everybody.

The program is based on magic squares. These squares have fascinated men for hundreds of years and were thought to have magic properties. Some claimed magic squares cured melancholy and others even used them as part of the paraphernalia of the occult.

MAGIC SQUARES

```

1 SLOW
10 PRINT AT 0,6;"MAGIC SQUARES"
12 PRINT AT 2,14;"816"
13 PRINT AT 3,14;"357"
14 PRINT AT 4,14;"492"
16 PRINT AT 6,1;"IN THE MAGIC SQUARE SHOWN ABOVE"
17 PRINT AT 7,0;"EACH ROW, COLUMN AND DIAGONAL"
18 PRINT AT 8,0;"ADDS UP TO 15. THERE ARE MANY"
19 PRINT AT 9,0;"DIFFERENT KINDS AND SIZES OF"
20 PRINT AT 10,0;"MAGIC SQUARES AND IN THIS GAME I"
21 PRINT AT 11,0;"CAN MAKE THEM WITH UP TO 49 NUM-"
22 PRINT AT 12,0;"BERS. ONCE I HAVE MADE A MAGIC "
23 PRINT AT 13,0;"SQUARE I WILL DISPLAY IT TO YOU"
24 PRINT AT 14,0;"WITH SOME NUMBERS MISSING. THE"
25 PRINT AT 15,0;"GAME IS FOR YOU TO FILL IN THE"
26 PRINT AT 16,0;"MISSING NUMBERS AS QUICKLY AS"
27 PRINT AT 17,0;"POSSIBLE. IF YOU ARE QUICK YOU"
28 PRINT AT 18,0;"WILL BE PROMOTED TO THE NEXT"
29 PRINT AT 19,0;"BIGGER SQUARE. IF NOT, I WILL"
30 PRINT AT 20,0;"EITHER LEAVE YOU OR RELEGATE YOU"
31 PRINT AT 21,3;" < PRESS RUN WHEN READY > "
32 IF INKEY$<>"R" THEN GOTO 32
35 CLS
40 PRINT AT 0,6;" < MAGIC SQUARES > "
42 PRINT AT 2,1;"THE AIM OF THE GAME IS TO GET"
43 PRINT AT 3,0;"PROMOTED AS HIGH AS POSSIBLE IN"
44 PRINT AT 4,0;"600 SECONDS. THERE ARE THREE"
45 PRINT AT 5,0;"DEGREES OF DIFFICULTY; START AS"
46 PRINT AT 6,0;"A BEGINNER. I WILL ADVISE YOU"
47 PRINT AT 7,0;"WHEN TO GO ON TO THE NEXT LEVEL."
49 PRINT AT 9,1;"EXAMPLE:"
50 PRINT AT 10,7;"MAGIC NUMBER IS 15"
51 PRINT AT 11,12;"■■■■■"
52 PRINT AT 12,6;"ROW1 ■2+7+?■"
53 PRINT AT 13,6;"ROW2 ■9+5+?■"
54 PRINT AT 14,6;"ROW3 ■?+?+?■"
55 PRINT AT 15,12;"■■■■■"
56 PRINT AT 16,0;"ROW1: 7+2=9; 15-9=6 ; SO ?=6"
57 PRINT AT 17,0;"ROW2: 9+5=14; 15-14=1; SO ?=1"
58 PRINT AT 18,0;"ROW3: 2+9=11; 15-11=4; SO ?=4"
59 PRINT AT 19,0;"ROW3: 7+5=12; 15-12=3; SO ?=3"
60 PRINT AT 20,0;"ROW3: 6+1=7; 15-7=8; SO ?=8"
61 PRINT AT 21,3;" < PRESS RUN WHEN READY > "
65 IF INKEY$<>"R" THEN GOTO 65
70 CLS
80 PRINT AT 12,0;"TYPE IN THE DEGREE OF DIFFICULTY"
82 PRINT AT 14,15;"B FOR BEGINNER"
84 PRINT AT 15,15;"E FOR EXPERT"
86 PRINT AT 16,15;"I FOR IMPOSSIBLE"
88 LET D$=INKEY$
90 IF D$="B" OR D$="E" OR D$="I" THEN GOTO 95
  
```

(listing continued on page 42)

Figure 5. Setting up a magic square with an odd number of squares.

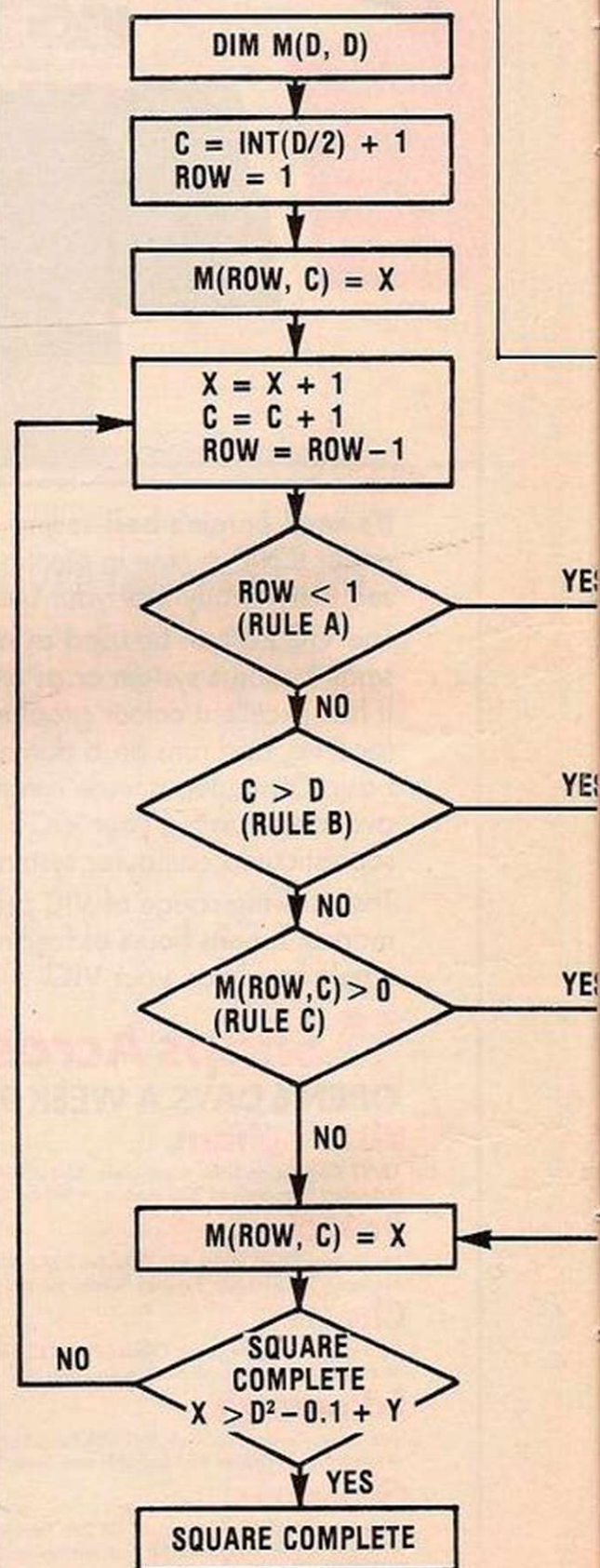

MAGIC SQUARES

A magic square is just a mathematical oddity. It is a set of numbers arranged in a square formation so that the total of each row, column and diagonal is the same.

Order of three

The order of a magic square tells us how many rows and columns there are. As an example, the square in figure 1 has an order of three. There are no magic squares of order two and there is only one third-order square — that is not counting reflections and rotations like the one shown in figure 2. After the third order, the number of magic squares increases astronomically; 880 squares of order four and more than 13 million of order five.

It is possible to make a magic square with an odd number of sides by following some simple rules. Start by putting the 1 in the middle of the top row as shown in figure 3 and then proceed by placing the next number in the square diagonally up and to the right.

Sometimes this is not possible and other rules apply:

When on the top row, the next number goes to the bottom row but still one column to the right, e.g., 1 to 2.

When on the rightmost column, the next number goes on the leftmost column but still one row upwards, e.g., 3 to 4.

If the next square is blocked, go down one, e.g., 5 to 6. This also applies when on the top rightmost square.

I have not found such a convenient method for squares with an even number of rows and columns. The program works out a fourth- and sixth-order square using different methods. I like the sixth-order square formation particularly because it starts by joining up four third-order squares. I used this fact in the program.

After setting up one of the possible 3,000 magic squares, the computer displays it with some numbers missing. The game is to fill in the blanks as quickly as possible. You can do

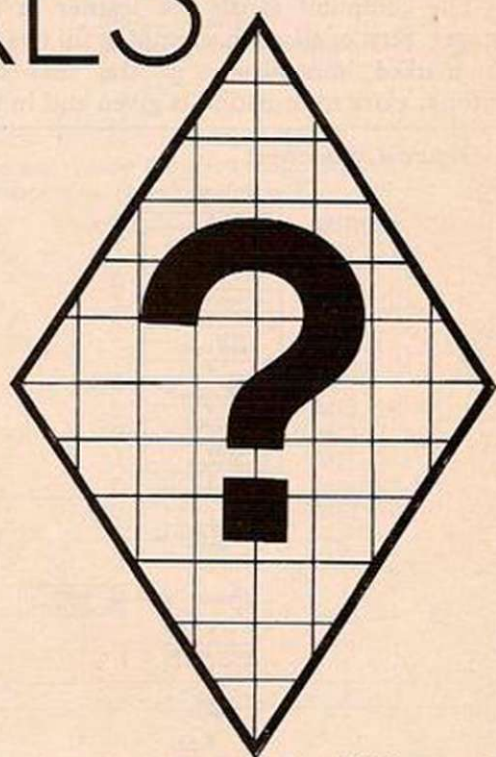

this by a mixture of addition and subtraction, knowing that all the columns, rows and diagonals add up to the same magic number. Sometimes it is possible to notice a pattern in the numbers.

It may seem strange to use a number cruncher to play a mental arithmetic game. After all, what are computers for? However, we all need these mental skills, including pattern recognition, so that computers and calculators can be checked quickly.

Rank of grandmaster

There are three levels of difficulty: beginner, expert and impossible. Most people start as beginners and novices of the magic square. Success at each stage means promotion to larger squares and so to the ranks of challenger, expert, master and finally, grandmaster. You are allowed only 10 minutes.

Do not start to panic as the seconds tick away or your mind will go blank. If you complete a seventh-order square within the time limit, the computer will recommend you to go to the next level of difficulty. On the other hand, if you do not complete a square quickly enough, the computer will construct another square of the same order with slightly easier numbers. A still slower completion time will result in the computer making a square one size smaller as well as demoting you to the ranks.

The computer gives you prompts and hints.

(continued on next page)

ROW1	8 1 6	4 3 8
ROW2	3 5 7	9 5 1
ROW3	4 9 2	2 7 6

Figure 1, a third-order magic square, figure 2, a clockwise rotation of figure 1, figure 3, a fifth-order square.

17	24	1	8	15
23	5	7	14	16
4	6	13	20	22
10	12	19	21	3
11	18	25	2	9

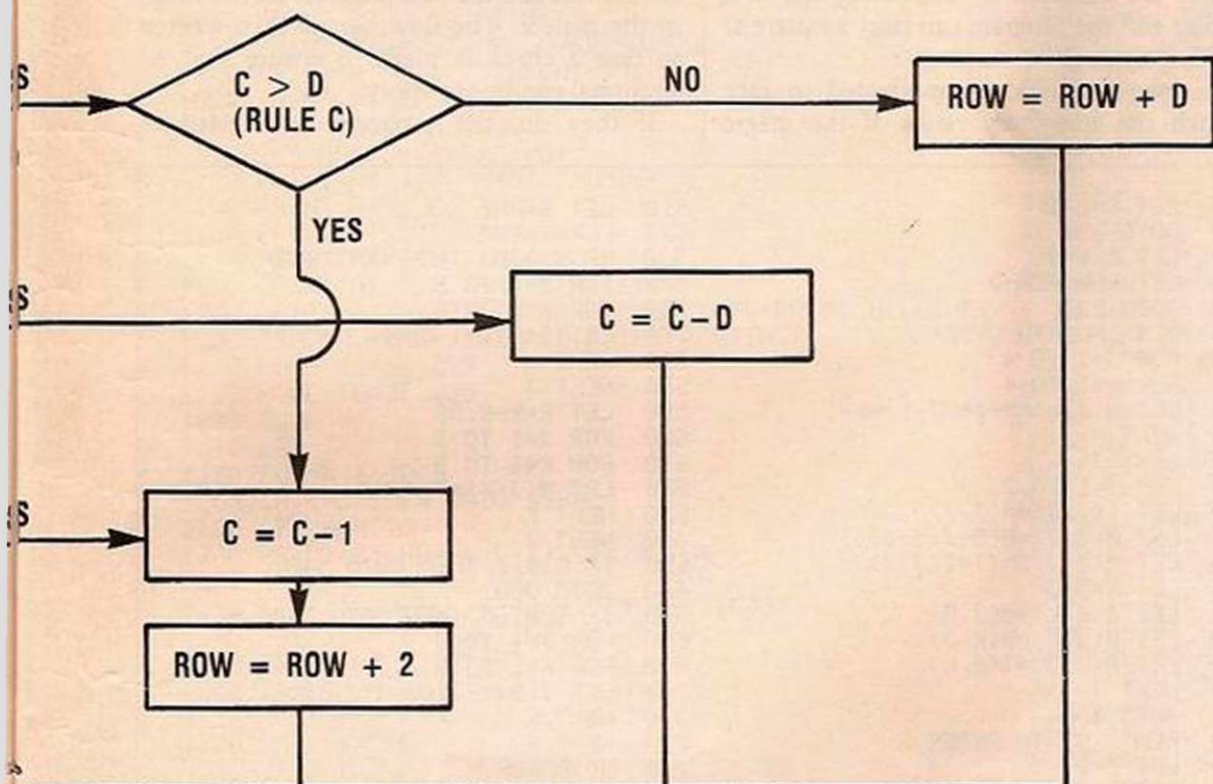

(continued from previous page)

It indicates which number to attempt next. A correct answer is printed out. In the event of an incorrect answer, the computer indicates whether it is too high or too low.

The computer assists the learner in two stages. First of all, each attempt to fill in a gap is marked immediately. If the answer is wrong, extra information is given and in this

Figure 4. Flowsheet.

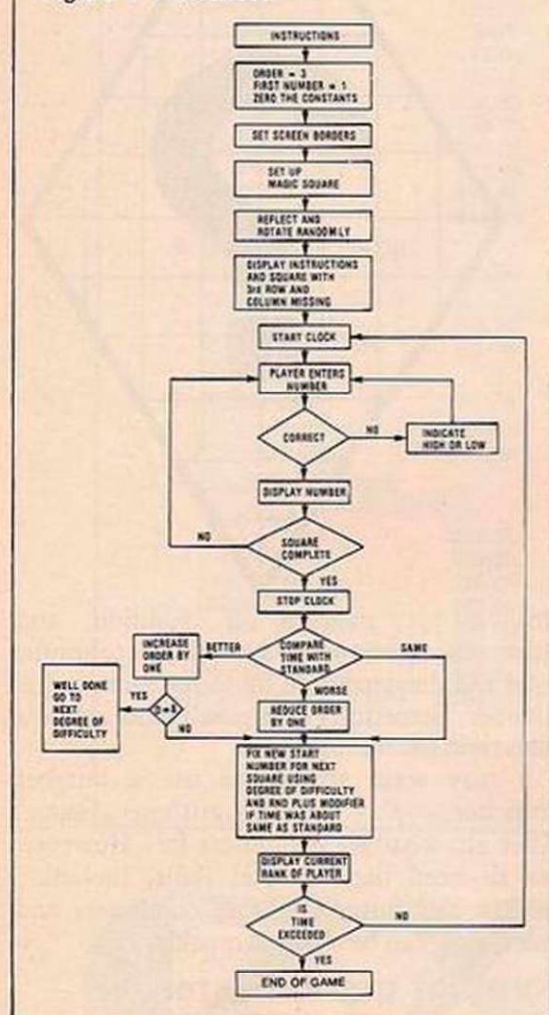

way a forgotten borrow or carry might be remembered.

The computer will not move on to the next gap until a correct response is given. At first sight this might be considered a little tedious. However, it must be remembered that it is impossible for a player to stay for long at a level beyond his ability. Besides, even a difficult combination of numbers is usually solved after two or three attempts when hints are given.

Secondly, the difficulty of the next square set depends solely on the player's performance on the previous square. The primary objective of the program is to provide an enjoyable opportunity to practise mental arithmetic over a wide range of difficulty. As speed and accuracy are of the essence in mental arithmetic, it seems reasonable to use them when evaluating.

Rotate and reflect

So, a fast and, by implication, accurate response is reinforced by making the next square more difficult, whereas for a slower response the next square is the same type or easier depending on how slow the response happened to be.

A player automatically reaches his own level and even if he stays on the same square he will be presented with different arrangements of numbers. This is achieved by rotating and reflecting the squares randomly so that either the original square, or a horizontal or vertical reflection, is rotated up to three times. In addition, the square does not have to start at one. More difficult squares are obtained by increasing the first number and the program can start a square at anything up to 50.

The player should be motivated to race through the imaginary ranks of the magic

squares. This provides the best kind of competition: against oneself, trying to improve on previous attempts. For the player stuck on one square, a bar — an acknowledgement of the distinction — is awarded for each attempt. On promotion and demotion the bars are lost and so even steady responses are encouraged.

Except for the simplest of programs, I always like to start with an overall flowchart showing in outline what I want the program to do. The magic square flowchart is shown in figure 4 beside the relevant statement numbers from the program listing.

Flowcharting is certainly a good method of clarifying thinking during programming, and clarified thought leads to efficient programs. Nevertheless, the final flowchart can nearly always be improved. Flowcharting was especially useful when converting the rules for making magic squares into a program. My attempt is shown in figure 5 and the meaning of the variables is given in figure 6. To make a magic square, all that is needed is the order, D, and the lowest number, X.

From all aspects, programming, printing and storage, it seemed best to arrange the number of the magic square in an array. I have used array M and an example is shown in figure 2. It can be seen that a particular slot can be defined by giving the row and column number. For instance, row 3 and column 2 is 7 and would be written $M(3,2)=7$.

Referring to figure 5, in the first box an array of two dimensions and size D by D is produced. In the second and third boxes, the row and column numbers for the first number are defined and the first number, X, is written in the matrix. The flowchart is then written so that a check is made to ensure that no abnormal conditions apply.

If they do, the program is diverted to

(listing continued from page 40)

```
91 GOTO 88
95 LET Y=0
96 LET PREV=0
97 LET B=0
98 CLS
99 FAST
100 LET D=3
101 FOR J=0 TO 31
102 PRINT AT 9,J;"■"
103 IF J>=9 THEN GOTO 105
104 PRINT AT J,15;"■"
105 NEXT J
109 REM MAGIC SQUARE SETTING
110 LET X=1
120 LET ROW=1
121 FOR J=10 TO 20
122 PRINT AT J,0;" "
123 NEXT J
124 FAST
125 DIM I(D,D)
130 DIM M(D,D)
140 IF D=4 THEN GOTO 350
142 IF D=6 THEN GOTO 400
144 GOSUB 150
146 GOTO 500
150 LET C=INT(D/2)+1
160 LET M(ROW,C)=X
170 LET X=X+1
180 LET C=C+1
190 LET ROW=ROW+1
200 IF ROW<1 THEN GOTO 260
210 IF C>D THEN GOTO 290
220 IF M(ROW,C)>0 THEN GOTO 320
230 LET M(ROW,C)=X
240 IF X>=(D**2-0.1+Y) THEN RETURN
250 GOTO 170
260 IF C>D THEN GOTO 320
270 LET ROW=ROW+D
280 GOTO 230
```

```
290 LET C=C-D
300 GOTO 230
320 LET C=C-1
330 LET ROW=ROW+2
340 GOTO 230
350 REM FOURTH ORDER
352 FOR J=1 TO 4
353 FOR K=1 TO 4
354 LET M(J,K)=X+4*(J-1)+K-1
355 NEXT K
356 NEXT J
360 LET I(J,J)=M(J,J)
362 LET M(J,J)=M(5-J,5-J)
364 LET M(5-J,5-J)=I(J,J)
366 LET K=5-J
368 LET I(J,K)=M(J,K)
370 LET M(J,K)=M(K,J)
372 LET M(K,J)=I(J,K)
374 NEXT J
376 GOTO 500
400 REM SIXTH ORDER
410 LET D=3
420 GOSUB 150
430 LET D=6
432 FOR J=1 TO 3
434 FOR K=1 TO 3
436 LET M(J,K+3)=M(J,K)+18
438 LET M(J+3,K)=M(J,K)+27
440 LET M(J+3,K+3)=M(J,K)+9
442 NEXT K
444 NEXT J
446 FOR J=1 TO 3
448 LET K=1
450 IF J=2 THEN LET K=2
452 LET I(J,K)=M(J,K)
454 LET M(J,K)=M(J+3,K)
456 LET M(J+3,K)=I(J,K)
458 NEXT J
500 REM ROTATION AND REFLECTION
```

```
510 LET R=RND
520 LET S=RND
530 IF S>0.33 THEN GOTO 670
540 FOR J=1 TO D
550 FOR K=1 TO D
560 LET I(K,D+1-J)=M(J,K)
570 NEXT K
580 NEXT J
590 LET R=R-0.33
600 FOR J=1 TO D
610 FOR K=1 TO D
620 LET M(J,K)=I(J,K)
630 NEXT K
640 NEXT J
650 IF R>0.1 THEN GOTO 540
660 GOTO 800
670 IF S>0.66 THEN GOTO 740
680 FOR J=1 TO D
690 FOR K=1 TO D
700 LET I(D+1-J,K)=M(J,K)
710 NEXT K
720 NEXT J
730 GOTO 600
740 FOR J=1 TO D
750 FOR K=1 TO D
760 LET I(J,D+1-K)=M(J,K)
770 NEXT K
780 NEXT J
790 GOTO 600
800 REM PRINT ROUTINES
810 LET VL=17-2*D
820 LET VR=17+D
830 LET HU=14-INT(D/2)
840 LET HL=16+INT(D/2)
850 FOR J=VL TO VR
860 PRINT AT HU,J;"■"
870 PRINT AT HL,J;"■"
880 NEXT J
890 FOR J=1 TO D
900 FOR K=1 TO D
```

complete the necessary special rule. Otherwise the slot is completed normally: that is the next square is one up and one to the right.

Once a flowchart for a complicated piece of logic has been completed, it should be tested. This is done by inventing data that will flow along all the lines of the flowchart and checking that you obtain the answer you would expect. Sometimes a trace table can be valuable.

Relevant data value

In these tables you record the value of all the relevant data at each program stage. If you do have a problem, a trace table will invariably show you where it is. For programs already in the computer, by introducing the correct print statement, you can make the computer draw up a trace table for you.

I checked my flowchart by using it to make up the magic square in figure 1 and it worked! Please see figure 7.

I can send you a cassette including some other mathematical games for £3.50. My address is 53 Holloway, Runcorn, Cheshire.

Figure 6. List of variables

A	attempt at completing square	array	
B	number of bars awarded	M(D, D)	contains the numbers for the magic square
C	column number		
D	order of square	l(d, D)	is used when reflecting and rotating the square.
HU and HL	upper and lower horizontal border respectively for magic square		

J	counter
K	counter
MN	magic number
PREV	time taken to complete previous squares
R	random number, degree of rotation
ROW	row number
S	random number, setting type of reflection
TIME	variable to produce time taken on present square
VL and VR	left and right vertical borders respectively for magic square
X	counter giving number in square
Y	one less than lowest number in square
Z	counter

Figure 7. Trace table for magic square formation - D = 3 and X = 1.

X	ROW	C	M(ROW, C)
1	1	2	M(1, 2) = 1
2	0	3	
3	2	4	M(3, 3) = 2
4	1	1	M(2, 1) = 3
5	3	1	M(3, 1) = 4
6	2	2	M(2, 2) = 5
7	1	3	M(1, 3) = 6
8	0	4	
9	2	3	M(2, 3) = 7
	1	4	
	1	1	M(1, 1) = 8
	0	2	
	3	2	M(3, 2) = 9

```

910 IF J=3 OR K=3 THEN GOTO 960
920 IF M(J,K)<10 THEN GOTO 950
930 PRINT AT HU+J, VL+1+(K-1)*3;M(J,K); "+"
940 GOTO 960
950 PRINT AT HU+J, VL+2+(K-1)*3;M(J,K); "+"
960 NEXT K
970 NEXT J
980 FOR J=HU TO HL
990 PRINT AT J, VL; "■"
1000 PRINT AT J, VR; "■"
1001 NEXT J
1005 PRINT AT 0, 16; "TIME:"
1010 PRINT AT 2, 17; "ALLOWED:600SECS "
1020 PRINT AT 1, 17; "TAKEN : "
1030 PRINT AT 1, 28; "SECS"
1100 REM MAGIC NUMBER
1110 LET MN=(D**3+D)/2+D*Y
1120 PRINT AT 1, 2; "MAGIC NUMBER"
1130 PRINT AT 3, 6; " "
1140 PRINT AT 3, 5; "IS "; MN
1150 PRINT AT 6, 3; "THE CLOCK"
1160 PRINT AT 7, 2; "HAS STARTED"
1170 PRINT AT 21, 0; "ENTER NUMBER THEN PRESS NEWLINE"
1200 REM TIMER SET AND ENTER ROUTINE
1210 POKE 16436, 255
1220 POKE 16437, 255
1230 SLOW
1240 LET J=3
1250 FOR K=1 TO D
1255 IF K=J THEN GOTO 1380
1260 LET A$="??"
1270 PRINT AT HU+J, VL+1+(K-1)*3; A$
1275 INPUT A
1280 LET TIME=PEEK 16436+256*PEEK 16437
1285 LET TOT=(65536-TIME)/45+PREV
1290 PRINT AT 1, 25; INT (TOT)
1305 PRINT AT HU+J, VL+1+(K-1)*3; " "
1310 IF A=M(J,K) THEN GOTO 1350
1320 LET A$="LL"
1330 IF A>M(J,K) THEN LET A$="HH"
1340 GOTO 1270
1350 LET Z=1
1360 IF M(J,K)<10 THEN LET Z=2
1370 PRINT AT HU+J, VL+Z+(K-1)*3;M(J,K);
1374 IF K=D THEN GOTO 1380
1376 PRINT "+"
1380 NEXT K
1400 LET K=3
1410 FOR J=1 TO D
1420 LET A$="??"
1430 PRINT AT HU+J, VL+1+(K-1)*3; A$
1435 INPUT A
1440 LET TIME=PEEK 16436+256*PEEK 16437
1445 LET TOT=(65536-TIME)/45+PREV
1450 PRINT AT 1, 25; INT (TOT)
1465 PRINT AT HU+J, VL+1+(K-1)*3; " "
1470 IF A=M(J,K) THEN GOTO 1510
1480 LET A$="LL"
1490 IF A>M(J,K) THEN LET A$="HH"
1500 GOTO 1430
1510 LET Z=1
1520 IF M(J,K)<10 THEN LET Z=2
1530 PRINT AT HU+J, VL+Z+(K-1)*3;M(J,K);
1534 IF D=3 THEN GOTO 1540
1536 PRINT "+"
1540 NEXT J
1550 PRINT AT 21, 0; "
1560 PRINT AT 7, 9; "OPP"
1600 REM EVALUATION
1610 IF (65536-TIME)/45>D**3*2 THEN GOTO 1680
1620 IF (65536-TIME)/45<D**3 THEN GOTO 1660
1630 LET B=B+1
1640 LET X=INT (0.5*(RND*((CODE D$-38)**2+1)))+1
1645 LET Y=X-1
1650 GOTO 1710
1660 LET D=D+1
1670 GOTO 1690
1680 LET D=D-1
1690 LET B=0
1700 LET X=INT (RND*((CODE D$-38)**2+1)))+1
1705 LET Y=X-1
1710 LET PREV=TOT
1720 IF D=8 THEN GOTO 1910
1730 IF D=2 THEN LET D=3
1740 IF D=3 THEN LET B$=" NOVICE "
1750 IF D=5 THEN LET B$=" EXPERT "
1760 IF D=6 THEN LET B$=" MASTER "
1770 IF D=7 THEN LET B$="GRAND MASTER"
1780 IF D=4 THEN LET B$=" CHALLENGER"
1790 PRINT AT 4, 19; "YOU ARE A"
1795 IF D=5 THEN PRINT AT 4, 27; "AN"
1800 PRINT AT 5, 17; B$
1810 PRINT AT 6, 18; "OF THE MAGIC"
1812 PRINT AT 7, 17; "SQUARE-CLASS "; D$
1825 PRINT AT 8, 16; " "
1826 IF B=0 THEN GOTO 1835
1830 PRINT AT 8, 19; "WITH "; B; " BAR"
1835 FOR J=1 TO 50
1836 NEXT J
1840 IF PREV<600 THEN GOTO 120
1850 PRINT AT 1, 2; "END OF GAME"
1860 PRINT AT 3, 3; "TYPE S TO"
1870 PRINT AT 4, 4; "RESTART"
1890 IF INKEY#<>"S" THEN GOTO 1890
1900 GOTO 95
1910 PRINT AT 1, 2; " EXCELLENT "
1920 PRINT AT 3, 3; "TRY NEXT "
1930 PRINT AT 4, 3; "DEGREE OF"
1940 PRINT AT 5, 3; "DIFFICULTY"
1945 PRINT AT 6, 3; " "
1950 PRINT AT 7, 2; " TYPE RUN "
1960 IF INKEY#<>"R" THEN GOTO 1960
1970 GOTO 70

```

Run **BBC** type BASIC on your ATOM

then switch back to ATOM BASIC

Available now from Acornsoft, a 20k BBC ROM conversion module which can be added inside an Atom. It will support the full set of BBC - type BASIC commands. The BASIC syntax is identical so all programs that don't rely on the BBC hardware can be run on the Atom without any modification.

The module is fitted in parallel with Atom BASIC and may be selected by a switch or from the keyboard if certain modifications are made. It consists of 16k BASIC ROM, 4k operating system ROM and an additional 2k RAM that can be used by the Atom as well.

Complete with manual

A comprehensive BBC - type BASIC manual is supplied with every set giving full operating and fitting instructions, alternatively the module can be fitted by your dealer.

The price is £49.95 including VAT.

If you don't have a dealer near you just write to us with a cheque at the address below, or credit card holders can ring Cambridge (0223) 316039 and order directly.

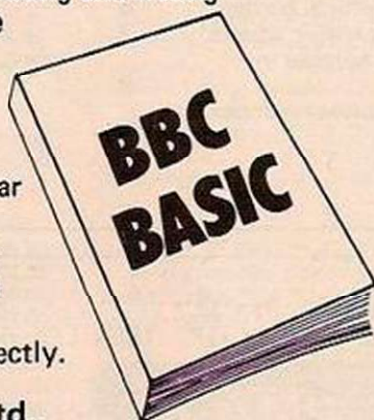

Dept. YC, Acornsoft Ltd.,
4a Market Hill, CAMBRIDGE CB2 3NJ

ACORN

ZX81 MEMORIES with a DIFFERENCE

ANNOUNCING THE END OF THE FLOPPY RAM PACK! — Now, for the first time, all you need to fit up to a full 56K of low power memory INSIDE your ZX81 (as is normal with more expensive personal computers), is a screwdriver. Experience has shown that the two commonest causes of ZX81 memory add-on failure are

1. Lack of rigidity in the connection to the expansion port.
2. Inadequate regulated power supply.

Both these problems have been overcome with our low-power, internally fitting INCREMENTAL and MAXIMEM memories.

INCREMENTAL 1.2

The truly expandable memory system that starts you off at a price you can afford but places no restrictions on your future expansion.

● **EASY TO FIT** — The uniquely designed board plugs straight in to the existing microprocessor (CPU) socket on ZX81 board (See page 162 of ZX81 manual) so, following the instructions provided, you simply open up the ZX81 case, unplug the CPU and plug it into the memory board, then plug the memory board into the vacant CPU socket. Four additional bolts fit through existing holes in ZX81 board to give high rigidity/reliability. Simple to follow instructions makes child's play of fitting (and removing).

● **TRULY EXPANDABLE** — Expandable up to 16K bytes in increments of 2K simply by plugging in memory chips — but does not stop there! Plug and socket switches allow running in conjunction with external memory add-ons — e.g. with Sinclair 16K RAM pack to give up to 32K and with 32K and 48K packs to give up to 48K and 56K (max poss) respectively. Full instructions provided.

● **ULTRA LOW POWER** — A full 16K takes typically less power than existing 1K Sinclair RAM (about 40ma).

● **ECONOMICAL** — Incremental 1.2 with one 2K chip giving 3K of RAM costs only £16.43 (plus VAT) and you won't have to throw it away when you want more memory.

● **MONEY BACK GUARANTEE** — Return within 14 days of receipt secures full refund of price of goods.

Introducing the new —

MAXIMEM 1.1

The ZX81 microprocessor can address a maximum of 64K of memory directly. More than this would require frequent additional statements in programs to switch between different memory banks. 8K of this 64K is already taken up by the Sinclair ROM (containing the Operating system program and Basic interpreter) thus leaving a maximum RAM capacity of 56K (= 64K-8K). The MAXIMEM 1.1 attains this upper limit in one bound by utilising the latest in high density, ultra-low-power-memory. Board design is similar and fitting identical to the Incremental memory described above.

Orders and enquiries to: East London Robotics, Finlandia House, 14 Darwell Close, East Ham, London E64BT. Or call us on 01-471 3308.

Quantity	Item	Price per item	Total
	Incremental 1.2 socketed for max of 8K	£10.50	
	Incremental 1.2 socketed for max of 16K	£11.50	
	2K CMOS 6116 memory chips	£4.93	
	Maximem 1.1 56K memory	£83.50	
	15% VAT		
	TOTAL		

NOTE: Postage 50p for orders under £15
I enclose a cheque/postal order payable to East London Robotics for £

Name: _____

Address: _____

SUPER SOFTWARE AVAILABLE FROM CONTROL TECHNOLOGY NEW RELEASE



Trident (Acorn Atom)

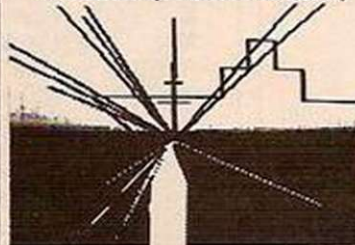

Death Race 2000 (Vic 20)

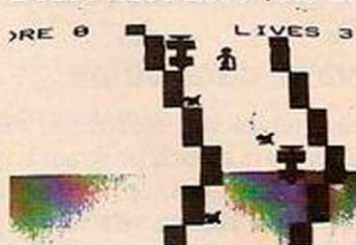

Air Traffic Control (ZX81)

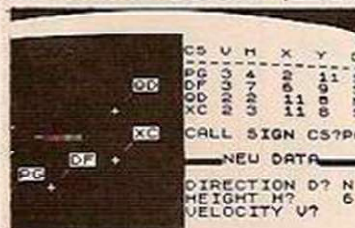

Warlords (Vic 20)

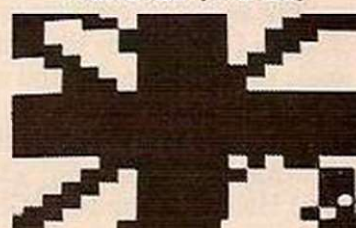

Moroids (Vic)



Astro Battle Zone
(Acorn Atom)

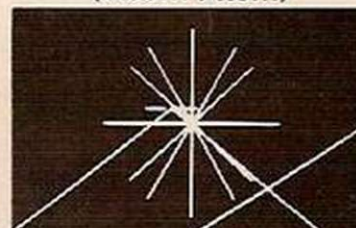

Breakout (Vic 20)

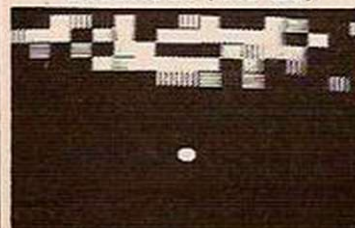

Draughts (ZX81)

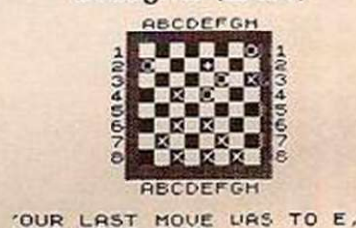

Maze of Death (ZX81)

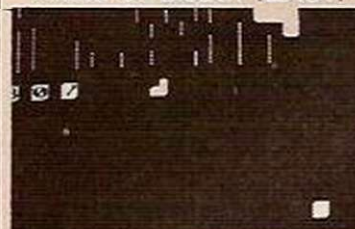

Breakout (ZX81)



Defender (Acorn)

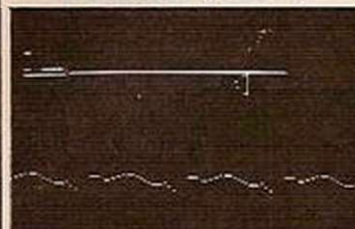

Fruit Machine
(Acorn Atom)

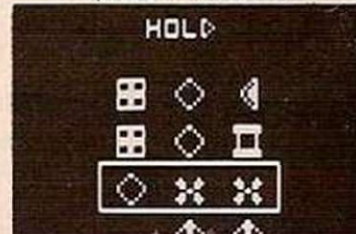

Please send me as soon as possible the following:

_____ £ _____

_____ £ _____

I enclose a Cheque/P.O. for the total £ _____

NAME _____

ADDRESS _____

POSTCODE _____



ZX81 16k SOFTWARE

All our software comes with full instructions and is **SAVEd** and ready to **RUN**, no need to spend hours laboriously typing in from books.

PACK 16/1 includes all of:

AIR TRAFFIC CONTROL: Animated radar screen of busy airport shown, you must bring planes into land; **INVADERS SELF PLAY;** **PHONEBOOK** — keep friends' and relatives' numbers on cassette; **DATE '81** — computer dating program. Who will it pick for you? **ALL ONLY £4.95**

PACK 16/2 includes all of:

ADVENTURE ATLANTIC: You may become very rich or you may be marooned forever; **BREAKOUT: SQUASH PRACTICE;** **LANGUAGE TRANSLATOR** translates any European language to any other; **COMPUTAPRINT** — use this program to predict results of horse races, football pools, etc. **ALL ONLY £4.95**

PACK 16/3 includes all of:

INDI 500; video road racer; **DRAUGHTS;** Computer Chequers; **BATTLESHIPS** — nautical warfare on your own computer. **MASTERMIND** — Brain Tesser, see if you can beat a microelectronic mind. **ALL ONLY £4.95**

The breakthrough you've waited for: **PROGRAM THE ZX81 IN ENGLISH!!!**

With **GAMAL 81** you can now write adventure programs in hours not weeks and with **GAMAL 81** you'll have every adventure you'll ever want for the price of one. Comes on cassette with instruction book, **£7.95**

CONTROL TECHNOLOGY — PERSONAL COMPUTER SCIENCE

Cassette 1½

A super value cassette of 16K and 1K software written in Machine Code and Basic.

Includes:
React, Invaders, Phantom Aliens, Maze of Death, Planetlander, I Ching, Hangman, Invaders, Laser Base, rectangle plus more.
ALL ONLY £4.95

Tapebook 50, Version 3

50 programs for the IKRAM ZX81.
Latest version includes:
SQUASH, BREAKOUT, COLUMBIA, SPLAT, INTEGRATION, CREDIT CARD CALCULATOR, BANK A/C, VATCHECK, TANK BATTLE, TORPEDO, HEXLOADER, BINARY CONVERTER, AND LOTS, LOTS MORE.
Still amazing value at **£8.95** the lot.

ZX-81

PACK 16/1 + 16/2 + 16/3
(any two only £5.95)
**ALL THREE ONLY
£8.95**

TAPEBOOK 50.3 + CASSETTE 1½
**BOTH ONLY
£9.95**

**BOTH OFFERS ARE ONLY £13.95
SPECIAL OFFER
TO ALL ZX81 OWNERS**

All prices include VAT and postage and packing

**CONTROL TECHNOLOGY,
39 Gloucester Road, Gee Cross,
Hyde, Cheshire SK14 5JG
061-368 7658**



Ctech Software Simply Megabytes Ahead!

AT M

DEFENDER: You defend the planet against UFO's, fast moving, Hires Graphics, Sound effects, Thrust, Laser Torpedo, climb, descend, superbly detailed. **G4 + T5 £4.00**

ASTRO BATTLEZONE: fastened in the cockpit of your starcruiser, you view the 3D graphics of the earth revolving silently below, staring down your head up display you suddenly glimpse the enemy hurtling towards you, you turn at them, the horizon rolls over, the engines roar as you climb to the stars. **G4 + T5 £5.00**

FRUIT MACHINE: Our version has HiResgraphics, nudge, collect, respin, gamble and even plays "Oranges and Lemons" when you win. **G3 + T5 £4.00**

POLECAT: Countryside Packman, you must move your Rabbit through the underground maze, but you are being chased by a polecat so you must run like a rabbit until you've collected all your your carrots growing on the top of the Burrow. **G4 + T5 £5.00**

MINEFIELD: You must steer your way through a perilous minefield without exploding any mines; blasting mines can cause chain reactions. **G0 + T5 £5.00**

EARLY WARNING: Atomic Missile Command, destroy the attacking ICBMs using a realistic radar screen and intercept missiles. **G4 + T5 £5.00**

TRIDENT — A brand new release. Excellent value £5.00
N.B. G = GRAPHICS T = TEXT

ANY 3 ONLY £9.00

**Control Technology, 39 Gloucester Rd,
Gee Cross, Hyde, Cheshire SK14 5JG.**

All prices include VAT, P&P.



Full Colour and Superb Sound

VIC-2

SOFTWARE

Our latest **VIC 20** package is **VICSOFT 7**
and includes all of —

BREAKOUT: The noisiest and most colourful you've ever seen.

SQUASH: Will you make a tournament champion?

DEATHRACE 2000: Driving in a crazy road race you must run-over as many pedestrians as you can!!

SOUNDS: A sound effects synthesizer program. Everything from helicopters to birds of paradise — menu driven.

MOROIDS: Your astronaut must avoid the asteroids, very fast graphics!!

MASTERMIND: See if you can beat a microelectronic mind at this full colour brain teaser!

WARLORDS: Protect your castle from giant boulders!!

VICSOFT 7 costs just **£5.95** and
that's inclusive.

Order form for all products on facing page.

THE ZX-81 UNDER BUILD YOUR OWN

Joysticks give an added dimension to most games software. David Griffin shows how you can benefit through building your own joysticks for the ZX-81.

JOYSTICKS GIVE an extra novelty to games. Using them is easy compared with the player's usual confrontation with 40 rather meaningless keys. Most hardware additions such as joysticks are available only on larger, more expensive machines, and then only to those fitted with ports — so that would normally rule out the basic ZX-81.

The joystick I shall describe is eight-directional, but after connection to the ZX-81 only four of these directions can be obtained from Basic. If we want to use the other directions, we must resort to a very simple machine-code subroutine.

The joystick is very easy to construct, made from pieces of wood and metal — see figure 1. Cut a hole in the centre of a suitably sized sheet of metal. This hole should be slightly larger than the bolt being used. This sheet is the base of the joystick.

Figure 1.

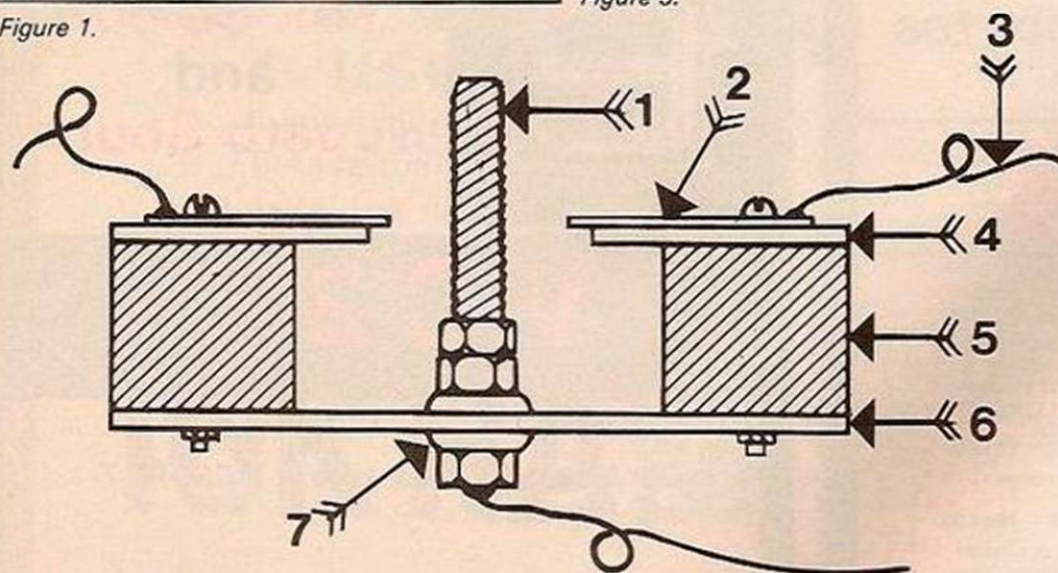

- 1 bolt
- 2 copper plate
- 3 wire soldered to copper
- 4 wood with a square hole cut from the centre
- 5 wooden block
- 6 metal sheet with a hole cut in the middle
- 7 old scalextric tyre, or a piece cut from rubber tubing.

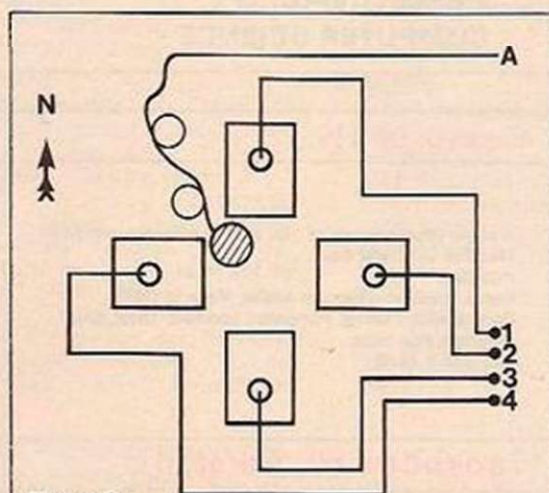

Figure 2.

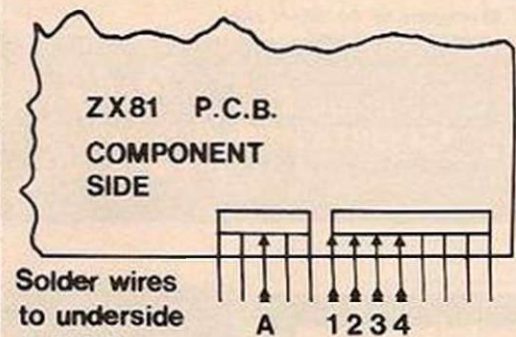

Figure 3.

Fit an old Scalextric tyre — or a piece cut from rubber tubing — around the bolt, and then into the hole. Screw two nuts around the tyre to hold the bolt in place to give a spring-like effect to the motions of the bolt in the hole. Then position wooden blocks around the bolt and metal sheet, as shown in figure 1. The copper plates can be obtained from old piping if you cannot find any in sheet form. Alternatively, use another good conductor in its place.

Arrange the plates as in figure 2. It will be necessary to use five wires to make the connections to your ZX-81; four of the wires should be soldered to the four copper plates, the fifth to the base of the bolt.

After the joystick has been made, attach it to your computer. To do this, the wires from the joystick must be soldered to the keyboard connections on the printed-circuit board. Remove the back from your ZX-81. If you find this difficult, first locate the three screws under three of the rubber feet supporting it. These feet are held in place by sticky tape and should pull off easily.

There is a ribbon cable joining the keyboard to the printed-circuit board. It is to the underside of these connections that the wires from the joystick will be soldered — see figure 3. The wire A from the bolt is to be soldered to one of the five connections on the left-hand terminal. The four wires 1, 2, 3 and 4 will be soldered to any of the eight connections on the right.

Ideally, a ribbon cable should be soldered to all of the connections, and then an edge connector soldered to the other end. Then, any additions such as the joystick should be fixed to a piece of Veroboard slotted into this connector. It is important that your keyboard is fully functional after these modifications.

The joystick works by connecting two wires of the keyboard terminals to give the same result as if a key had been pressed. Depending on which lines your joystick's wires were soldered to, different results will occur to the following:

```
10 SCROLL
20 PRINT INKEY$
30 GOTO 10
```

Type in this little program and run it, testing each position north, south, east and west to see the response. If you used the same positions as in figure 3 the results should be as follows:

```
3: north
8: south
E: east
D: west
```

As you will have discovered if you tried to push the bolt into one of the diagonals, no result will occur. The reason that the diagonals cannot be used in Basic is that two

JOYSTICK CONTROL

keys cannot be pressed at once to create a response on the screen — that is, except with Shift. The problem can be overcome with a little machine-code subroutine.

```
1 REM xxxxxx
POKE 16514,205
POKE 16515,187
POKE 16516,2
POKE 16517,68
POKE 16518,77
POKE 16519,201
```

This program calls a routine in ROM, which returns the value of the key being pressed. This is used in the statement `Inkey$`. It also registers when two, three or even more keys are pressed at once. This is of use for our purposes when two keys — the diagonals — are pressed at the same time.

To discover which values correspond to the connections on the printed-circuit board you have chosen, type:

```
1 REM . . . (machine code)
10 SCROLL
20 PRINT USR 16514
30 GOTO 10
```

and run it, testing each position of your joystick, and noting down the numbers for each. Let:

A = north value
B = north-east value
C = east value
D = south-east value
E = south value
F = south-west value
G = west value
H = north-west value

Substitute the letters in lines 120 to 230 of program 1 for these values. Program 1 allows you to draw on the screen. First, the ZX-81 asks for two inputs; the first is the x co-ordinate of the starting point — 0 to 63 — and the second is the y co-ordinate of the starting

Program 1.

```
1 rem ... (machine code)
2 rem program to draw
  pictures with the
  aid of joysticks
10 input x
20 input y
30 let z=0
40 plot x,y
50 unplot x,y
60 if z=1 then goto 80
70 plot x,y
80 let a$=inkey$
90 if a$="A" then let z=0
100 if a$="W" then let z=1
110 let a=usr 16514
120 if a=A then let y=y+1
130 if a=E then let y=y-1
140 if a=C then let x=x+1
150 if a=G then let x=x-1
160 if a=B then let x=x+1
170 if a=B then let y=y+1
180 if a=D then let x=x+1
190 if a=D then let y=y-1
200 if a=F then let x=x-1
210 if a=F then let y=y-1
220 if a=H then let x=x-1
230 if a=H then let y=y+1
240 goto 40
```

point — 0 to 43. Then proceed to draw in all the directions of the joystick. To rub out at any time, type W and continue to move in the usual directions. To draw again press Q.

If you have only 1K, you must erase lines 160 to 230, but you will be able to move only in the four main directions.

If you want, you can build a button. This can have many applications in games — for firing lasers, for example. This should be made from a keyswitch, like those used in keyboards. The two connections of this should be

fixed to the keyboard terminals, one to each, left and right.

You could also construct an additional joystick. Connect the four wires from the copper plates to any of the connections on the right keyboard terminal. Solder the wire from the bolt to one of the connections of the left terminal. This must be a different one to that used by the first joystick. If you do not take this precaution you will find that the joysticks may register the same result when in certain positions. ■

CONVERTING ATARI STICKS

Patrick Norris explains how you can convert Atari joysticks to work with the ZX-81.

AFTER READING an article by Ian MacLean in the January 1982 issue on interfacing the ZX-81, I conceived the idea of connecting Atari joysticks to the ZX-81. Construction costs are negligible and it took me only one evening to complete the project. Obviously either one or two joysticks are required. I chose Atari sticks because they are robust and, at £6.50 each, not too expensive.

The constructor will require the joysticks, two male and two female in-line five-pin DIN plugs, and about 5ft. of multi-strand wire — the thin, plastic-covered type. Do not use single-strand wire because it is too brittle.

Perhaps surprisingly, the hardest part of the project is making the holes in the side of the ZX-81, to allow access to the male plugs. I achieved this by the judicious use of a wooden dowel, slightly smaller than the outside diameter of the plugs, with emery paper wrapped around it to file the holes to the required size.

There is just enough space to enclose the male plugs under the keyboard. Access to the plugs is on the right-hand side of the case.

Be very careful that the rearmost plug does

Figure 2.

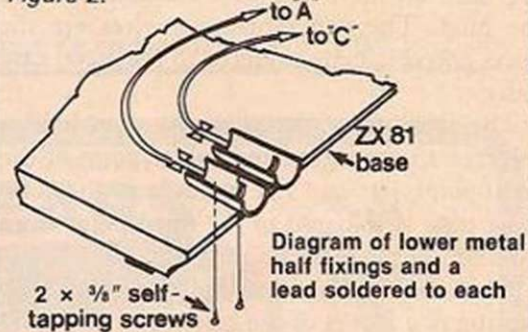

not touch the printed-circuit board when the two halves of the ZX-81 case are put back together.

The lower halves of the metal sections of the male plugs were held to the base of the ZX-81 with 3/8 in. self-tapping screws — see figure 2. Solder one wire to the rearmost metal half and one to the foremost.

The next stage is to wire up the two DIN plugs. Take a wire from pin 1 of one plug to pin 1 of the other, pin 2 to pin 2 and so on, until each plug is linked to the other by five wires. Then solder an extra five wires to the plug that will be in the rearmost position — one wire to pin 1, the second wire to pin 2 and so on.

At this stage you should have two plugs
(continued on next page)

Figure 1.

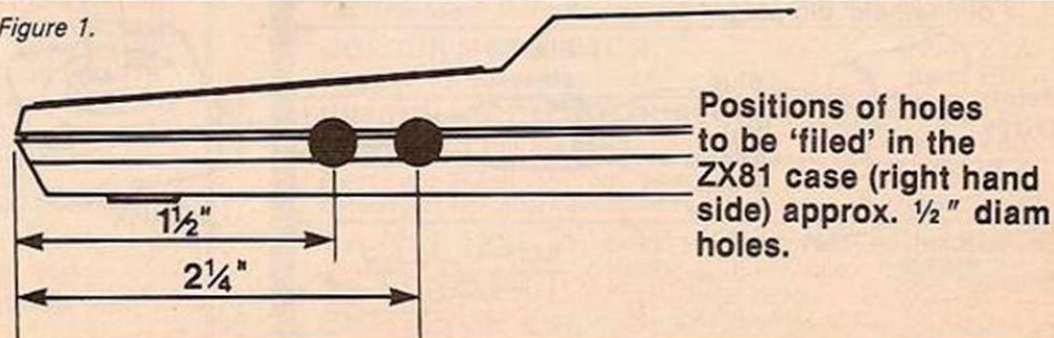

(continued from previous page)

wired together, five wires hanging from one of them and two wires soldered to the metal cases in the base, one wire to each half.

Now place the rearmost plug in its appropriate lower metal-case half, remembering that this plug has five extra wires on it, and place the foremost plug in its half. Put the upper halves of the metal sections in place and tack-solder the two halves of the metal cases together to stop any movement.

The next stage is where the fun starts so be very careful. Before going any further make sure that the soldering iron that you are using is earthed. If it is not then find one that is or you will damage the chips in the ZX-81.

With the base in front of you, the plugs in place, take the main section of the ZX-81 containing the keyboard, and place it to the right-hand side of the base with the main section upside down. You should now be looking at the underside of the printed-circuit board.

On the front left-hand side of the board, as you look at it, will be a neat row of eight solder points running from left to right. Next to this row, slightly to the right will be another five solder points. This is where the main connections will be made.

Using the earthed soldering iron, solder the wire from pin 1 of the rearmost plug to the right-hand solder point of the five solder-point section. Solder the pin-2 wire to the next point to the left, the pin-3 wire to the next left and so on, until all the five points are connected to the plug. The two remaining wires are the wires you originally soldered to the metal case halves.

The wire from the rearmost case half is soldered to the right-hand solder point of the eight-point section. The wire from the foremost plug is soldered to the third point from the right of the eight-point section.

All connections are now complete. Carefully put the two halves of the case together but do not screw it together. Connect up the ZX-81 and test the keys on the keyboard. If nothing happens on the screen, then you have a short in your wiring that will have to be rectified. If everything is satisfactory screw the two halves of the case together and place it to one side. This section is now complete.

When you buy the joysticks, ensure that they are tested because you will have to cut the plugs off the ends and so you will not be able to return them if something is wrong. The same applies if you have an Atari video game; the joysticks will not be able to plug into the game again.

When you have cut off the plugs on the joy-

"Male" 5 pin din plug linkage

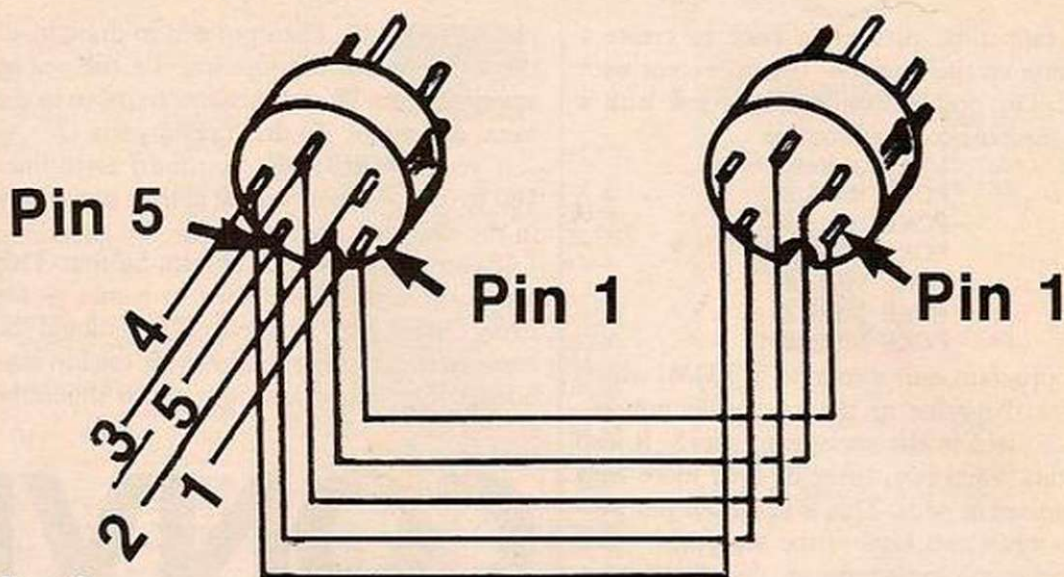

Figure 3.

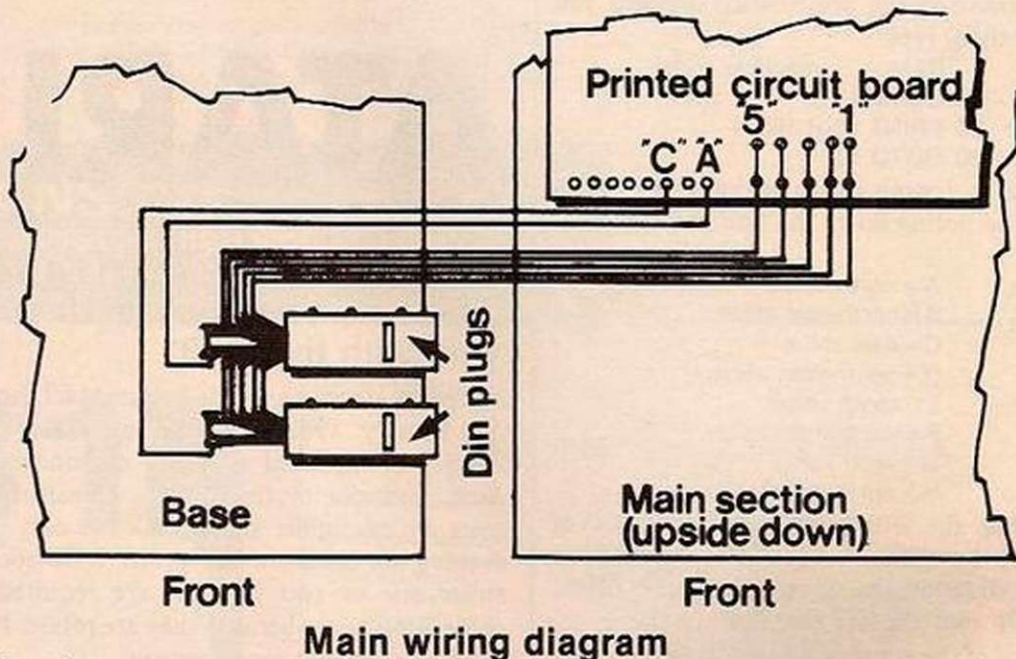

Figure 4.

sticks, pare back the sleeving and you will see six coloured wires.

Take one female section of the five-pin DIN plug and remove the plastic sleeve. Push this sleeve on to the lead connected to the joystick. If you do not do this at this stage, you will regret it later. You are now left with a female five-pin DIN plug insert and two halves of the metal case that encloses it.

Solder the green lead to the pin 1 socket — see figure 5 — white to pin 2, blue to pin 3, brown to pin 4 and orange to pin 5. At this

stage solder the black lead to one half of the metal case. Put the plug together and slide the plastic sleeve over the whole assembly to keep it together. Now you see the point of putting the plastic sleeve on first.

The joystick plugs into the rearmost male plug that was fitted in the case of the ZX-81.

If you have followed these instructions exactly, the configuration is as follows:

- Stick left: equivalent of key 6 pressed
- Stick up: key 7
- Stick down: key 8
- Stick right: key 9
- Fire button: key 0

If you wish to add the second joystick, the wiring is slightly different. Solder the orange wire to the pin 1 socket, brown to pin 2, blue to pin 3, white to pin 4, green to pin 5 and once again the black lead goes to the metal case. For the second joystick the configuration is:

- Stick left: equivalent of key 1
- Stick up: key 2
- Stick down: key 3
- Stick right: key 4
- Fire button: key 5

This second stick plugs into the foremost male plug.

Figure 5.

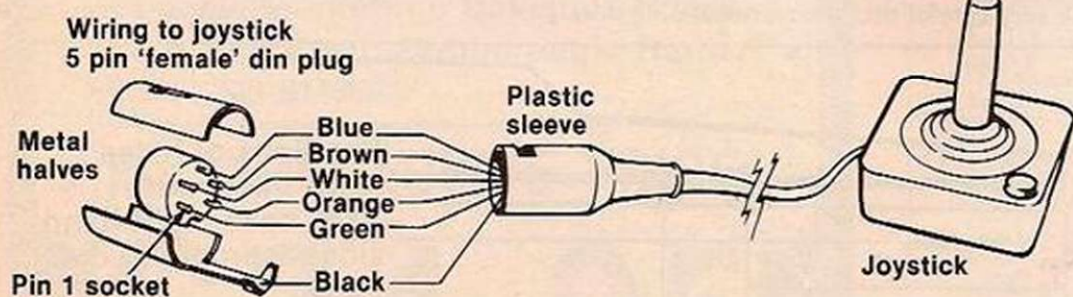

MICROMART make a good deal a good deal better!

VIC-20 only £159.99



The best home computer in the world.

24 colours * 3-tone Generator *

Expandable to 32K. Complete range of peripherals

Cassette Unit — £35.99 8K RAM cartridge — £34.99
 4022 Printer — £189.00 Single Disk Drive — £292.00
 Expansion Board — £99.99

Or step up to a **4000 series PET**

4016 16K PET — £459
 4032 32K PET — £580
 4040 Disk Drive — £580
 Printer — £360

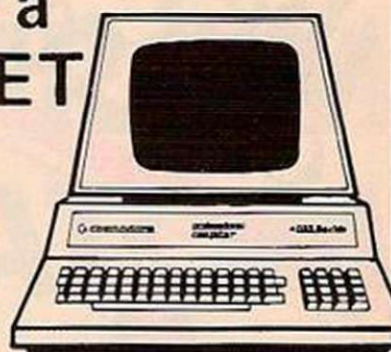

Complete range of printers and supplies including:

Epson MX80 Printer (inc. PET interface) £415 * 77-track disks including Library Box — £28 for box of 10 * plain listing paper 9½" x 11" — £11 for 2000 sheets. Add VAT at 15% and £3 for delivery. (If you can't see what you want - send for our mail order lists.) All products unconditionally guaranteed. To order just write with cheque. Credit card holders can ring 01 637 5551 and order direct. New low prices - same quality.



MICROMART LTD

32 Windmill Street,
 (off Tottenham Court Road)
 LONDON W1P 1HH
 Tel:- 01 637 5551 (24hrs)

143 Cranbrook Road,
 Ilford,
 Essex IG1 4PU
 Tel:- 01 553 3026/7

Personal callers welcome. Open Monday — Friday 9.30 — 5.30

ZX81 16K

ZX-MC

- ELIMINATE MACHINE CODE PROBLEMS with ZX-MC — a new machine code debug/monitor for the ZX81 16K.
- ENTER, RUN & DEBUG your machine code programs independently of Basic commands. ZX-MC resides in RAM, and leaves you 12½K of memory to work with.
- SAVE & LOAD your machine code programs AT DOUBLE SPEED. At last you are freed from storing your M/C in arrays or REM lines.
- REGISTERS DISPLAY & BREAKPOINTS to make de-bugging easier — PLUS many more useful commands.
- A MUST FOR BEGINNERS & ADVANCED USERS — concentrate on your M/C programs, not on how and where to store them.
- ZX-MC is supplied on a high quality cassette, with a 36 page operating manual.

£7.50 Incl. VAT and p&p (C.W.O.)

SAVE & LOAD DATA FILES AT DOUBLE SPEED

SCREEN KIT 1

A suite of machine code routines for use in Basic programs, enhance your screen display, and create DATA FILES on cassette. Screen Kit becomes part of your Basic program.

- DATA FILES — Save & Load, at double speed, just the Basic variables. Load different variables into the same program, or exchange variables between programs.
- DRAW A BORDER • KEYBOARD SCAN + FLASHING CURSOR
- CLEAR PART OF SCREEN • LOAD ANY CHARACTER TO WHOLE SCREEN
- INVERT VIDEO OF PART OF SCREEN • MEMORY LEFT
- CLEAR SCREEN BY SCROLLING UP, DOWN, LEFT OR RIGHT
- Supplied on cassette with instructions

£5.70 Incl. VAT & p&p (C.W.O.)

Send SAE for more details. Allow up to 14 days delivery.

Programs available mail order only. Please make cheques/PO payable to:

PICTURESQUE

6 CORKSCREW HILL, WEST WICKHAM, KENT BR4 9BB
 See us at the ZX Microfair. April 30 and May 1

As seen on BBC TV "Computer Programme"

* BIG EARS *

SPEECH INPUT FOR ANY COMPUTER



Hugely successful Speech Recognition System, complete with microphone, software and full instructions. **£49**

BUILT TESTED & GUARANTEED ONLY £49
 PLEASE STATE COMPUTER: UK101, SUPERBOARD, NASCOM2, Vic 20, Micron, ZX80/81, PET, TRS80, MZ80K, APPLE II, BBC MICRO

ZX80 ZX81

MUSIC SYNTHESISER + 16 LINE CONTROL PORT



Play 3-part music, sound effects, drums etc. Full control of attack, decay and frequency. Input/Output lines provide control and monitor facility for Home Security, Robot Control, Model Railway, etc. etc. Works with or without 16K RAM.

Add keyboard to make a live performance polyphonic synthesiser! Full instructions/software included.

AMAZING VALUE AT ONLY **£19.50** (KIT)
 Extra 23 way connectors at £2.60 £25.50 (BUILT)
 The "Composer" Music Program (16K) £7.40

COLOUR MODULATOR KIT £12
 RGB in, PAL/UHF out (not for ZX) BUILT £18

UK101/NASCOM COLOUR GRAPHICS KIT £45
 Inc. Modulator. Still the best selling system! BUILT £60

Please add VAT at 15% to all prices. All enquiries S.A.E. please
 Barclay/Access orders accepted by telephone

WILLIAM STUART SYSTEMS Ltd

Dower House, Billericay Road, Herongate, Brentwood, Essex CM13 3SD
 Telephone: Brentwood (0277) 810244



the vic
centre

Big savings for starters

If you're looking for a home computer, you'll already know that the VIC does it all. To help you get started, we have put together this attractive cost-saving package.

VIC-20 Colour computer



- + Cassette Deck
- + 10 Blank Cassettes
- + Introduction to Basic Part 1
- + User Manual

- + 12 months warranty
- + Fitted 13 amp plug

for only
£ 212

(price plus VAT £243.80)

NEW

Convert your VIC to a 40 Column 32k machine with this exciting new add-on

32k RAM Expansion + 40 column screen format
£199.95 plus VAT

40 column screen format only
£99.95 plus VAT

Dot Matrix Printer

Tractor feed, 80 characters per line at 30 characters/seconds.
£199.96 plus VAT

Memory Expansion Board

Multi-slot unit used to accept memory and/or game and program cartridges
£85.00 plus VAT

Plug-in Memory Expansion Cartridges

3k - **£26.04**, 8k - **£39.09**,
16k - **£65.17 plus VAT**

Single Drive Floppy Disk Unit
£395.00 plus VAT

The standard features of the Vic are: ★ 5K RAM expandable to 32K ★ 16 screen colours ★ 8 character colours ★ 3 tone generators, each of 3 octaves - plus white noise generator ★ Screen display 22 characters x 23 lines deep ★ Full PET type graphics ★ High resolution graphics capability ★ 8 programmable special functions.

Goods required

Price

_____	_____
_____	_____
_____	_____
_____	_____

Add £4.00 post, packing and insurance for special deal and £1.00 post, packing and insurance for all other items. Add 15% to all prices for VAT

Total £

Name: _____

Address: _____

TERMS AND CONDITIONS: All goods sold subject to Adda terms and conditions of sale. Full details available on request, but include: 7 day money back guarantee. Adda 12-month hardware warranty. Please allow 21 days for delivery. Allow 7 days for personal cheques to be cleared. Quoted prices are exclusive of VAT.

MAIL ORDER to: Adda Home Computers Ltd.
FREEPOST, London W3 6BR or telephone your order (24 hours a day) to 01-992 9904 quoting your Visa, Access or American Express number.

*I enclose a cheque, made payable to Adda Home Computers Limited for

£
*Please charge my Visa/Access/American Express account. My account number is

*Please add my name to your mailing list
*Delete as applicable

Date

SHOP ADDRESS: Adda Home Computers Ltd.
154 Victoria Road, Acton, London, W3.
(near North Acton tube station)
Tel 01-992 9904
OPEN: 10am-6pm (Tuesday-Friday),
10am-5pm (Saturday).

adda

CONJURING MORE FROM YOUR ATOM



Do your Atom programs consist of pages of standard If statements? David Berry uses computed Goto to make those problems disappear before your very eyes.

COMPUTED GOTOS are standard commands; Fortran has one, so do many Basics, including the Atom dialect. However, one problem with the Atom system is that if you prefer the tidiness of using labels rather than line numbers, this facility is not readily available.

One of the useful things about interpreters is that line $n+1$ is not read until line n has been interpreted. This allows the program to make a calculation in line n , convert this to a label code, and Poke the code into any succeeding line.

Label codes

The only other point you need to know before we can write our computed Goto is that the ASCII codes for the labels start at #61 for inverse A and end with #7A for inverse Z.

Program 1 gives an example. In it, line 20 calculates the value to be Poked into line 30. Incidentally, the best way of finding the address of the location into which to Poke the label is to type the program as far as the label with dummy characters inserted into the Poke

address. Then print &Top and replace the dummy characters with the value of Top-2. You can then finish entering the program normally.

To see the effect of the program, run it a few times and after each run, list it. You will notice that the label after the Goto in line 30 changes each time the program is run.

Anyone who doubts the value of the computed Goto should consider how many standard If statements are necessary to achieve the same effect. In program 1, three would be needed to branch to all four labels, and if the program was extended to use the 26 labels available, 25 If statements would then be necessary. Compare this with the two lines needed by the computed Goto.

Programs which use menus often require a series of If statements to direct the sequence of jumps in response to the menu entries selected. It would be much simpler to enter the actual target label and plug this into a Goto.

It would also be useful if a whole string of menu selections could be entered and the program directed to each in turn — program the program so to speak. Program 2 does exactly that.

A string of labels is input by line 20 and stored in the program at line 10 where each

character replaces one of the spaces. The 13 spaces are essential to make the positioning right for the Poke in line 40, which changes the label after the Gosub.

The Do loop in the same line moves the pointer S along the stored string so that the Gosub labels are changed in the same sequence as the string characters. In this example, the string can be up to 13 elements long and can use the labels inverse A to inverse D in any combination — more if you add more lines — but must terminate with inverse E.

The two problems

There are, however, two problems with this approach and if you list the program after a run you will find the first of them — the program will have gained an extra line or even two. This is because the string you have input terminated in a carriage return and the Atom therefore interpreted the two bytes following it as a line number. If you do not delete the lines formed in this way, there should be no problems in running the routine, but it is very untidy programming.

The second problem also applies to program 1: neither of the two programs we have considered so far is relocatable. If you load them into any part of the memory other than

(continued on next page)

(continued from previous page)

that starting at #2900, they will not work. This is because they use absolute addresses for the modifying Pokes. So, while the programs can be loaded anywhere, the modified labels will always be Poked into the same memory location, and thus can be outside the program text.

Program 3 shows how both of these problems can be overcome. First, the base address of the program can be found by Peeking at location #12 and multiplying by #100. In program 3, seven is then added to this value and the result used as the starting address of the input string. This puts the string into the Rem statement in line 10.

Relative addressing

In line 60 an offset of #68 is added to this address so that the location pointed at becomes the one containing the label in the Goto statement in line 70. In other words the label in the Goto is the #6Fth character in the program. Thus we now have relative addressing — the required addresses are simply offsets of the program base address — and this makes the program relocatable.

The extra lines problem is solved by line 40 which simply replaces the string's carriage return with a space; line 120 then looks for a space in the string and terminates the run when one is found.

Labels on the Atom are simply markers placed within the text of the program. When a Goto or similar command is encountered which uses a particular label for the first time, Basic searches through the text to find the label and then stores its address in an area of zero-page RAM from #38D to #3C1.

The arrangement of this storage is quite simple: two locations are provided for each label address, the low byte of the address is put in the first of the pair and the high byte in the second. Thus the address of label inverse A occupies #38D — low byte — and #38E; inverse B occupies #38F and #390, and so on. Knowing this enables us to do two things: find the address of a label — and I will show how this can be useful — and change the address of a label.

Look now at program 4. This program solves the problem of using up labels when addressing a large number of lines. To keep this demonstration simple I have reverted to absolute addressing and kept all the lines from 50 to 80 the same length.

The variable A

Line 20 calculates the address for the label based on the location of the space following the line number 50 — #2951 — the length of the lines 50 to 80, which is 23 characters, and the variable A, which randomly chooses which line will be branched to.

Variable Q then contains the address to which control will be sent when the command Goto inverse A is executed. Line 30 Pokes this address into the two bytes of zero-page RAM associated with label inverse A. Basic is thus fooled into believing that a label inverse A appears on one of the lines 50 to 80.

Because we can now read the position of a label, we can use labels for marking the start of a set of data stored in a program. Program 5

demonstrates this. The seemingly purposeless jump in line 10 is necessary to force Basic into finding and storing the address of label inverse A. This address is then read and assigned to variable S. Line 30 jumps S over the Goto in line 90, and over line number 100 and is ready to start reading the data contained in lines 100 to 170.

One of the problems resulting from the use of machine-code routines is that they often render the whole program non-relocatable. This is true where the machine code is called from Basic by an instruction of the type:

```
LINK #89AB
```

That is, where an absolute address is used in the Link command.

One way out of this problem is to include the desired routine as a set of assembler instructions and assemble the routine every time the program is run. This is, however, very wasteful of precious RAM.

Initialising jump

Program 6, shows a technique for marking the start of a machine-code routine with a label. The machine code must start immediately after the end of the Basic text. Label inverse A is initialised by jumping to it from line 10, as in program 5. Line 50 calculates the address of inverse A and adds eight to the result to cater for the length of line 90 plus the carriage return and program-terminating byte.

This resultant value is the address of the start of the machine-code routine and the Link command can thus make use of it. This technique enables programs incorporating machine-code routines to be totally relocatable.

I have started working on a large program which uses a machine-code routine accessed in the way I have described. I soon became very frustrated, however, because every time I changed a line or character in the Basic segment of the program, I would either overwrite or fall short of the machine-code routine and consequently would have to re-assemble it all.

Terminator file

This is because the monitor shuffles the program text only as far as the Basic terminator byte #FF, and the machine code following this was therefore not moved.

So, include the machine-code routine as a part of the Basic program as follows. Find the location of Top. Top-1 contains the terminating #FF and Top-2 contains a return #0D. Replace the #0D with #3B, which is a semicolon, then assemble the routine starting at Top-1 thus overwriting the #FF.

Note the location of the final byte of the machine code from the listing produced as the routine is assembled. Poke #0D into the next location and #FF into the one following that.

The monitor now treats the machine code as part of the Basic program and moves it with the rest of the text following insertions and deletions. Listing the program can produce strange results depending on the characters the monitor finds when it reaches the machine code. It is, therefore, probably best to list only as far as the last line number.

Program 1.

```
10FA=ABSRND%4
20 ?#2928=(61+A)
30 GOTOa
40aP."SALT "
50bP."MUSTARD "
60cP."VINEGAR "
70dP."PEPPER "
80eP. ;GOTOf
```

Program 2.

```
10 GOTO+;<13 Spaces>
20f INPUT"#= '$#200A
30 S=#2909
40 DO S=S+1;?#2953=?S;GOSUBa
50 UNTIL 0
60aP."SUBR a";RETURN
70bP."SUBR b";RETURN
80cP."SUBR c";RETURN
90dP."SUBR d";RETURN
100eEND
```

Program 3.

```
10 REM <20 Spaces>
20 m=?#12*#100+7;N=M
30 IN.$M
40 DO M=M+1;U.?M=#D;?M=#20
50 M=N
60 xN?#68=?M
70 GOTOa
80aP."AT a";G.z
90bP."AT b";G.z
100cP."AT c";G.z
110dP."AT d";G.z
120zM=M+1; IF?M<#20 G.x
130 END
```

Program 4.

```
10FA=ABSRND%4
20 Q=?#2951+(A*23)
30 ?#38E=Q/#100;?#38D=Q/#100
40 GOSUBa;GOTO+
50 P."LINE 50";RETURN
60 P."LINE 60";RETURN
70 P."LINE 70";RETURN
80 P."LINE 80";RETURN
```

Program 5.

```
10 GOTOa
20bS=?#38E*#100+?#38D
30 S=S+LENS+3
40 DO
50 P.$S
60 S=S+LENS+3
70 UNTIL $S="STOP"
80 END
90a GOTOb
100 THIS
110 IS
120 ONE
130 WAY
140 TO
150 STORE
160 DATA
170 STOP
```

Program 6.

```
10 GOTOa
20b< Programme text >
30 < Programme text >
40 < Programme text >
50 L=(?#38E*#100+?#38D)+8
60 LINK L
70 < Programme text >
80 < Programme text >
90aGOTOb <or> <#FF>
< Machine code routine >
```

MICRO-80

UK Subscription Dept.

24 Woodhill Park Pembury Tunbridge Wells Kent TN2 4NW

WE ARE PLEASED TO ANNOUNCE that MICRO-80 is now available in the UK in CASSETTE EDITION.

Each month we publish at least six programs for the TRS-80 or VIDEO GENIE and . . .

SUBSCRIBERS may now have the benefit of receiving their programs on cassette for IMMEDIATE LOADING.

WE ARE ALSO CONTINUING our special offer of a FREE cassette program to all new subscribers who complete the coupon below — even if you order a subscription to the magazine only.

Please enrol me for an annual subscription and send me my FREE cassette program. I enclose £16.00 (magazine only) or £43.60 (magazine and cassette edition). (enclose your cheque/P.O. made payable to MICRO-80 and send to the above address)

Software offer, and cassette edition prices applies to U.K. residents only. Overseas subscription rates on application.

Name

BLOCK CAPITALS PLEASE

Address

YC5/82

ATOMIC MACHINE CODE

A new book for the Atom owner containing 20+ fully explained machine code programmes

DATA SORTS
DATA STORAGE
KEY SCANS
MODE 4 CHARACTERS
DESIGN LETTERS
PONTOON
POOLS PREDICTION
GAMES
FULL M/C DETAILS
ROM SUBROUTINES

£5.75 inc. P & P

Ecce Productions · 4a Nelson Road
Greenwich SE10 9JB

Mail order only

ATOMIC MACHINE CODE

PUT YOUR MICRO TO WORK!



YOUR MACHINE

CONTROL MACHINES, ROBOTS, FACTORY OR HOME

Have you ever wanted your MICRO to control a machine for you, or manage your house? If so, the MDR 'MICROCOMPUTER CONTROL INTERFACE' will give you isolated channels of OUTPUT (8A @ 250 volts) and switch sensing INPUTS.

Available now for connection to PET USER, PORT, RS232 and IEEE488, allowing expansion up to more than 900 channels. Supplied complete with connecting cables, full data and guarantee from £12.54 per channel. Complete preprogrammed systems or individual components available. Write or phone for details.

M D R (INTERFACES) LTD.
Little Bridge House, Dane Hill,
Nr. Haywards Heath, Sussex RH17 7JD.
Telephone: 0825-790294.

Memotech's New Memory System for the ZX81

It grows as you progress

MEMOPAK 16K



Memopak 16K Memory Extension

- £39.95 incl.VAT

It is a fact that the ZX81 has revolutionised home computing, and coupled with the new Memopak 16K it gives you a massive 16K of Directly Addressable RAM, which is neither switched nor paged. With the addition of the Memopak 16K your ZX81's enlarged memory capacity will enable it to execute longer and more sophisticated programs, and to hold an extended database.

The 16K and 64K Memopaks come in attractive, custom-designed and engineered cases which fit snugly on to the back of the ZX81, giving firm, wobble-free connections. See below for ordering information.

Coming Soon...

A complete range of ZX81 plug-in peripherals:
 Memotech Hi-Res Graphics
 Centronics Interface and Software Drivers
 Memotech Digitising Tablet RS232 Interface



All these products are designed to fit 'piggy-back' fashion on to each other, and use the Sinclair power supply. WATCH THIS SPACE for further details. We regret we are as yet unable to accept orders or enquiries concerning these products - but we'll let you know as soon as they become available.

How to order your Memopak.

- By Post:** Fill in the coupon below and enclose your cheque/P.O./Access or Barclaycard number.
- By Phone:** Access/Barclaycard holders please ring Oxford (0865) 722102 (24-hour answering service).

Please make cheques payable to Memotech Limited
 Please debit my Access/Barclaycard* account number

*Please delete whichever does not apply.

SIGNATURE _____ DATE _____

NAME _____ ADDRESS _____

We want to be sure you are satisfied with your Memopak - so we offer a 14-day money back Guarantee on all our products.
Memotech Limited, 3 Collins Street, Oxford OX4 1XL, England Telephone: Oxford (0865) 722102/3/4/5

MEMOPAK 64K



Memopak 64K Memory Extension

- £79.00 incl.VAT

The 64K Memopak is a pack which extends the memory of the ZX81 by a further 56K, and together with the ZX81 gives a full 64K, which is neither switched nor paged, and is directly addressable. The unit is user transparent and accepts basic commands such as 10 DIM A(9000).

BREAKDOWN OF MEMORY AREAS

- 0-8K ... Sinclair ROM
- 8-16K ... This section of memory switches in or out in 4K blocks to leave space for memory mapping, holds its contents during cassette loads, allows communication between programmes, and can be used to run assembly language routines.
- 16-32K ... This area can be used for basic programmes and assembly language routines.
- 32-64K ... 32K of RAM memory for basic variables and large arrays.

With the Memopak 64K extension the ZX81 is transformed into a powerful computer, suitable for business, leisure and educational use, at a fraction of the cost of comparable systems.

Unique 3 month trade-in offer!

When your programming needs have outgrown the capacity provided by 16K RAM, and you find it necessary to further extend your ZX81's capacity, we will take back your 16K Memopak and allow a discount of £15.00 against your purchase of our 64K model.*

*We reserve the right to reject, for discounting purposes, units which have been either opened or damaged in any way.

Please send me:

	Quantity	Price	Total
16K RAM, Assembled		£39.95	
64K RAM, Assembled		£79.00	
		Postage	£2.00
		Total Enclosed	

© R. Branton & G. A. C. Boyd 1982.

sinclair ZX81 PERSONAL COMPUTER

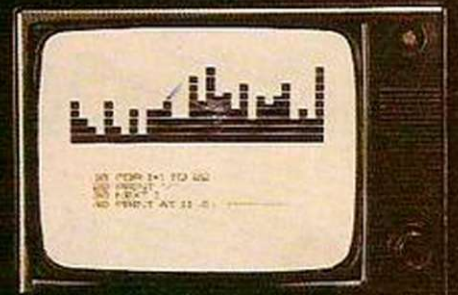

Sinclair ZX81 Personal Computer

the heart of a system that grows with you.

1980 saw a genuine breakthrough – the Sinclair ZX80, world's first complete personal computer for under £100. Not surprisingly, over 50,000 were sold.

In March 1981, the Sinclair lead increased dramatically. For just £69.95 the Sinclair ZX81 offers even more advanced facilities at an even lower price. Initially, even we were surprised by the demand – over 50,000 in the first 3 months!

Today, the Sinclair ZX81 is the heart of a computer system. You can add 16-times more memory with the ZX RAM pack. The ZX Printer offers an unbeatable combination of performance and price. And the ZX Software library is growing every day.

Lower price: higher capability

With the ZX81, it's still very simple to teach yourself computing, but the ZX81 packs even greater working capability than the ZX80.

It uses the same micro-processor, but incorporates a new, more powerful 8K BASIC ROM – the 'trained intelligence' of the computer. This chip works in decimals, handles logs and trig, allows you to plot graphs, and builds up animated displays.

And the ZX81 incorporates other operation refinements – the facility to load and save named programs on cassette, for example, and to drive the new ZX Printer.



New BASIC manual

Every ZX81 comes with a comprehensive, specially-written manual – a complete course in BASIC programming, from first principles to complex programs.

Kit: £49.⁹⁵

Higher specification, lower price – how's it done?

Quite simply, by design. The ZX80 reduced the chips in a working computer from 40 or so, to 21. The ZX81 reduces the 21 to 4!

The secret lies in a totally new master chip. Designed by Sinclair and custom-built in Britain, this unique chip replaces 18 chips from the ZX80!

New, improved specification

- Z80A micro-processor – new faster version of the famous Z80 chip, widely recognised as the best ever made.
- Unique 'one-touch' key word entry: the ZX81 eliminates a great deal of tiresome typing. Key words (RUN, LIST, PRINT, etc.) have their own single-key entry.
- Unique syntax-check and report codes identify programming errors immediately.
- Full range of mathematical and scientific functions accurate to eight decimal places.
- Graph-drawing and animated-display facilities.
- Multi-dimensional string and numerical arrays.
- Up to 26 FOR/NEXT loops.
- Randomise function – useful for games as well as serious applications.
- Cassette LOAD and SAVE with named programs.
- 1K-byte RAM expandable to 16K bytes with Sinclair RAM pack.
- Able to drive the new Sinclair printer.
- Advanced 4-chip design: micro-processor, ROM, RAM, plus master chip – unique, custom-built chip replacing 18 ZX80 chips.



Built: £69.⁹⁵

Kit or built – it's up to you!

You'll be surprised how easy the ZX81 kit is to build: just four chips to assemble (plus, of course the other discrete components) – a few hours' work with a fine-tipped soldering iron. And you may already have a suitable mains adaptor – 600 mA at 9 V DC nominal unregulated (supplied with built version).

Kit and built versions come complete with all leads to connect to your TV (colour or black and white) and cassette recorder.



uter-

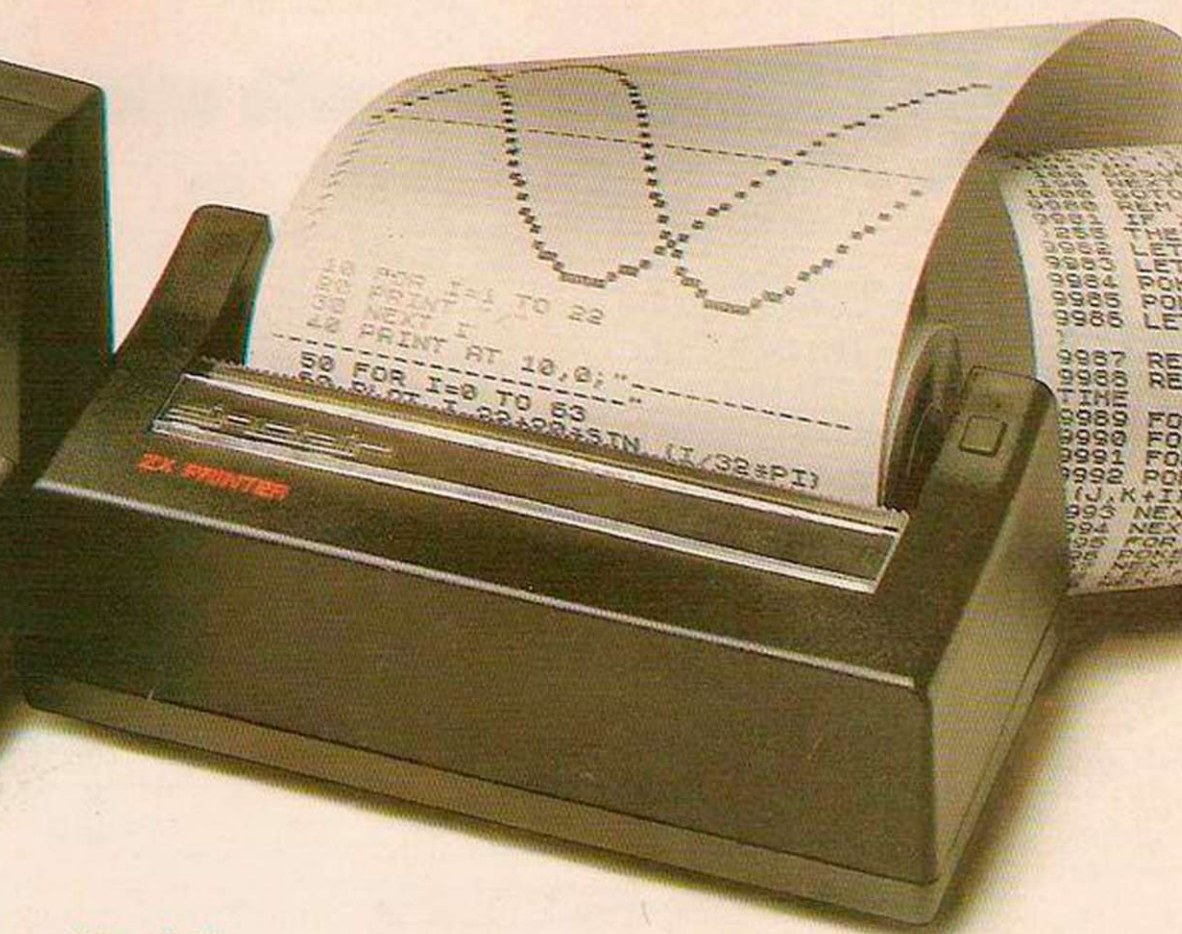
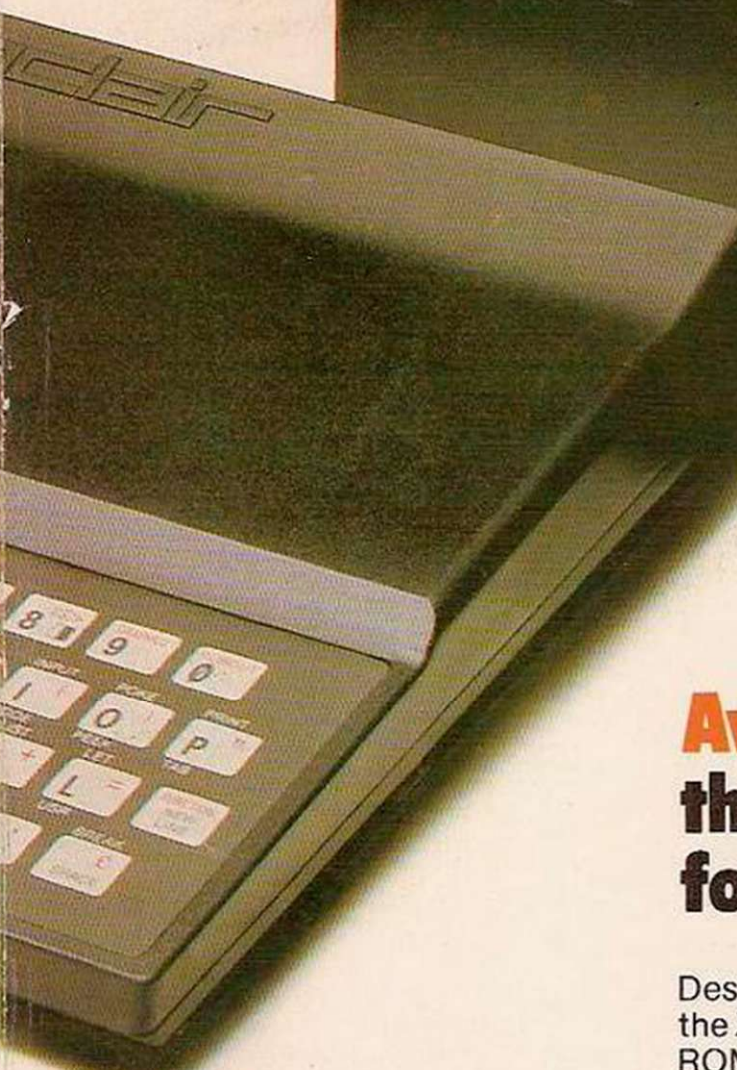

16K-byte RAM pack for massive add-on memory.

Designed as a complete module to fit your Sinclair ZX80 or ZX81, the RAM pack simply plugs into the existing expansion port at the rear of the computer to multiply your data/program storage by 16!

Use it for long and complex programs or as a personal database. Yet it costs as little as half the price of competitive additional memory.

With the RAM pack, you can also run some of the more sophisticated ZX Software – the Business & Household management systems for example.

sinclair ZX81

6 Kings Parade, Cambridge, Cambs., CB2 1SN.
Tel: (0276) 66104 & 21282.

Available now- the ZX Printer for only £49.⁹⁵

Designed exclusively for use with the ZX81 (and ZX80 with 8K BASIC ROM), the printer offers full alpha- numerics and highly sophisticated graphics.

A special feature is COPY, which prints out exactly what is on the whole TV screen without the need for further instructions.

How to order your ZX81

BY PHONE – Access, Barclaycard or Trustcard holders can call 01-200 0200 for personal attention 24 hours a day, every day.

BY FREEPOST – use the no-stamp-needed coupon below. You can pay

At last you can have a hard copy of your program listings – particularly useful when writing or editing programs.

And of course you can print out your results for permanent records or sending to a friend.

Printing speed is 50 characters per second, with 32 characters per line and 9 lines per vertical inch.

The ZX Printer connects to the rear of your computer – using a stackable connector so you can plug in a RAM pack as well. A roll of paper (65 ft long x 4 in wide) is supplied, along with full instructions.

by cheque, postal order, Access, Barclaycard or Trustcard.

EITHER WAY – please allow up to 28 days for delivery. And there's a 14-day money-back option. We want you to be satisfied beyond doubt – and we have no doubt that you will be.

To: Sinclair Research, FREEPOST, Camberley, Surrey, GU15 3BR.

Qty	Item	Code	Item price £	Order Total £
	Sinclair ZX81 Personal Computer kit(s). Price includes ZX81 BASIC manual, excludes mains adaptor.	12	49.95	
	Ready-assembled Sinclair ZX81 Personal Computer(s). Price includes ZX81 BASIC manual and mains adaptor.	11	69.95	
	Mains Adaptor(s) (600 mA at 9 V DC nominal unregulated).	10	8.95	
	16K-BYTE RAM pack.	18	49.95	
	Sinclair ZX Printer.	27	49.95	
	8K BASIC ROM to fit ZX80.	17	19.95	
	Post and Packing.			2.95

Please tick if you require a VAT receipt

TOTAL £ _____

*I enclose a cheque/postal order payable to Sinclair Research Ltd, for £ _____

*Please charge to my Access/Barclaycard/Trustcard account no. _____

*Please delete/complete as applicable. _____

Please print.

Name: Mr/Mrs/Miss _____

Address: _____

FREEPOST – no stamp needed.

YOC 04

How the ZX81 compares with other personal computers

SYSTEM IDENTIFICATION		ZX81	ZX80	ACORN ATOM	APPLE II PLUS	PET 2001	TRS 80 LEVEL I	TRS 80 LEVEL II
ROM		8K	4K	8K	8K	14K	4K	12K
GUIDE PRICE	Basic unit - inc. VAT	£70	£100	£175	£630	£435	£290	£375
	Unit plus 16K RAM (*12K RAM)	£120	£150	£285*	£630	£530	£360	£375
COMMANDS	LIST, LOAD, NEW, RUN, SAVE	●	●	●	●	●	●	●
STATEMENTS	PRINT, INPUT, LET, GOTO, GOSUB/RETURN, FOR/NEXT IF/THEN	●	●	●	●	●	●	●
	STEP	●		●	●	●	●	●
	TAB	●			●	●	●	●
ARITHMETIC	ABS, RND	●	●	●	●	●	●	●
FUNCTIONS	INT	●			●	●	●	●
	ATN, COS, EXP, LOG, SGN, SIN, SQR, TAN	●			●	●		●
	ARCSIN, ARCOS	●						
STRING FUNCTIONS	CHR\$	●	●		●	●		●
	LEN	●		●	●	●		●
NUMBERS	ASC(CODE), STR\$, VAL, INKEY\$	●				●		●
	FLOATING PT $\pm 10^{\pm 99}$	●			●	●	●	●
NUMERIC VARIABLES	INTEGERS		●	●	●	●		●
	A-Z			●			●	
	AA-ZØ				●	●		●
STRING VARIABLES	An-Zn, n = any alphanumeric string	●	●					
	A\$ & B\$						●	
	A\$ to Z\$	●	●	●				
NUMERIC ARRAYS	An\$ to Zn\$, n = any alphanumeric character				●	●		●
	SINGLE DIMENSIONAL		●	●			●	
DISPLAY	MULTI DIMENSIONAL	●			●	●		●
SPECIAL FEATURES	ROWS	24	24	16	24	25	16	16
	COLUMNS	32	32	32	40	40	64	64
	LOW RES GRAPHICS (<7000 pixels)	●	●	●	●	●	●	●
	H I RES GRAPHICS (>40000 pixels)			●	●			
SPECIAL FEATURES	USR (CALL, LINK)	●	●	●	●	●		●
	PEEK, POKE (OR EQUIV)	●	●	●	●	●		●

Sinclair software on cassette.



The unprecedented popularity of the ZX Series of Sinclair Personal Computers has generated a large volume of programs written by users. Sinclair has undertaken to publish the most elegant of these on pre-recorded cassettes. Each program is carefully vetted for interest and quality, and then grouped with others to form single-subject cassettes.

Software currently available includes games, junior education, and business/household management systems. You'll receive a Sinclair ZX Software catalogue with your ZX81 - or see our separate advertisement in this magazine.

The ultimate course in ZX81 BASIC programming.

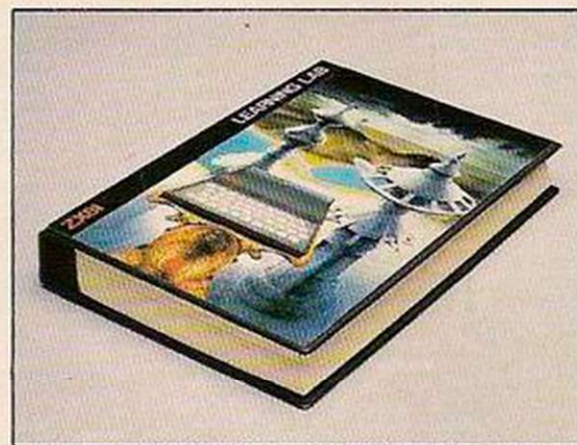

Some people prefer to learn their programming from books. For them, the ZX81 BASIC manual is ideal.

But many have expressed a preference to learn *on* the machine, *through* the machine. Hence the new cassette-based ZX81 Learning Lab.

The package comprises a 160-page manual and 8 cassettes. 20 programs, each demonstrating a particular aspect of ZX81 programming, are spread over 6 of the cassettes. The other two are blank practice cassettes.

Full details with your Sinclair ZX81.

If you own a Sinclair ZX80...

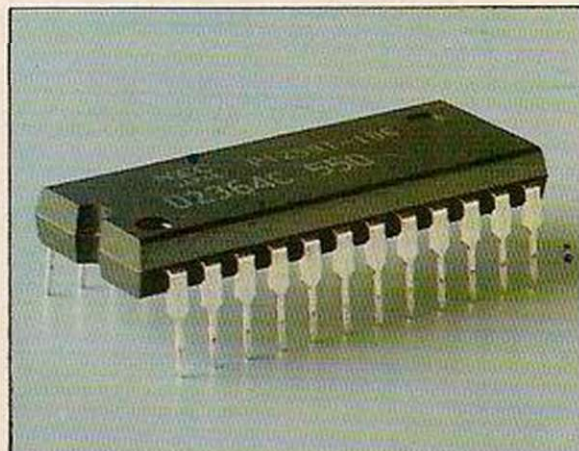

The new 8K BASIC ROM used in the Sinclair ZX81 is available to ZX80 owners as a drop-in replacement chip. (Complete with new keyboard template and operating manual.)

With the exception of animated graphics, all the advanced features of the ZX81 are now available on your ZX80 - including the ability to drive the Sinclair ZX Printer.

sinclair
ZX81

6 Kings Parade, Cambridge, Cambs., CB2 1SN.
Tel: (0276) 66104 & 21282.

BBC BOOSTS GRAPHICS

Until recently micro users could only display information on screen in crude diagrams. Brian Smith reveals a way which will lead you out of the realm of fuzzy bar charts.

INEXPENSIVE high-resolution computers such as the BBC Micro have made it possible to create new, graphic ways of communicating facts, figures, trends, and results.

These graphics can also be used to portray two- and three-dimensional images, to manipulate those images and to hint at ways in which you can produce useful graphics routines of your own, to fit in with your own problems. After all, it is not nearly as much fun creating graphics just for its own sake — far better to begin to use the computer as a tool, possibly even a creative partner, in your work or other activities.

Phenomenal capability

Supplied with the BBC machine is the *User Guide*. Probing into this substantial volume reveals that the graphics capability of the computer is phenomenal. The commands Move and Draw are the simplest ways of moving to a point or drawing a line; but they are just duplicates, for ease of use, of two of the many graphics commands, more generally referred to by words such as Plot, Mode and VDU.

Plot, for example, can have one of 256 codes following it, though some are reserved for

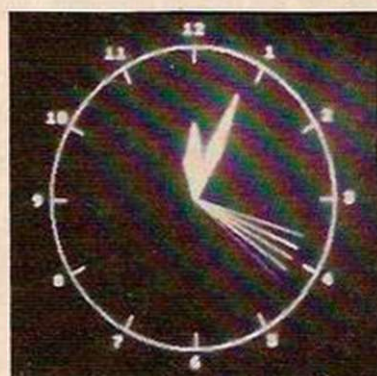

future expansion. VDU presently has 32 ways of working, some of which need another eight pieces of information.

Though this may seem over-complex, I believe that you will only rarely require more than a small proportion of these, as the machine's designers anticipated with their use of Move and Draw to duplicate Plot 4 and Plot 5. The great power of the machine stems from the fact that you can, if you want, superimpose a window on the graphics screen, or link the text and graphics cursors — the graphics cursor allows you to plot text of any colour anywhere on the screen.

The screen resolution is referred to by plotting up to 1,280 points horizontally and up to 1,024 vertically, though this is scaled down automatically to resolutions between 160 by 256 and 320 by 265. The model B, with more memory, goes up to 640 by 256, which means it really needs a monitor rather than a television. My machine is rock-steady on a monitor, and quite passable on a poor-quality, colour television — it can drive both,

and an RGB colour monitor, simultaneously.

Finally, mention should be made of the programmable function keys. There is no reason why you should not, after a little careful programming, draw circles, for example, by pressing one key, and boxes with another.

The photographs show the results of the programs Clock and Photo from the BBC *Welcome* pack.

Program 1 runs on the BBC machine, though it was first written on a 380-Z. Its purpose is to show a matrix of information as a kind of contoured landscape. The original aim was to show heights, taken from points on a flat map, and give a rough idea of what the countryside looked like, but it can, of course, be used to present any information which is of equivalent form.

The result is to show a kind of slice through the landscape, which should really be at a 45° angle on one corner. If, however, you want that, you must also turn your TV on its corner, too!

Line 100 sets the resolution and line 110 the colour. Lines 140 to 160 produce random values for the matrix, but of course you could enter your own data via Read-Data or a series of input statements. The program draws many little lines at 45°, making their length proportional to the value they represent. Then the grid is laid over them, and distorted to fit these lines. Lines 330 to 350 merely make the visible edges neater.

Endless possibilities

Try inputting values, instead of random information. That will generate different types of landscape. Alternatively you could generate them mathematically — the possibilities are endless.

For those with other machines, remember that Move goes to a point without leaving a trace; Draw leaves a line. For those with lower resolution screens, reduce every value of 100, in the program, to 15 or so, and change the 80, in line 150, to 10.

Over the next months, I shall be encouraging you to produce programs which can be of benefit to other users, as well as fitting into the broad theme of this column. ■

Program 1.

```
100 MODE 5
110 GCOL 0,7
120 H=8: V=8: REM .....OR SO
130 DIM X(H,V),Y(H,V),D(H,V)
140 FOR I=1 TO H:FOR J=1 TO V
150   D(I,J)=RND(80)
160 NEXT J:NEXT I
170 FOR I=1 TO H:FOR J=1 TO V
180   MOVE 50+I*100*H/(H-1),J*100*V/(V-1)
190   X(I,J)=(50+I*(100*H/(H-1)))-D(I,J)
200   Y(I,J)=(J*(100*V/(V-1)))+D(I,J)
210   DRAW X(I,J),Y(I,J)
220 NEXT J:NEXT I
240 REM NOW CONNECT UP POINTS STORED IN X()&Y()
250 FOR I=1 TO H:FOR J=1 TO V
260   IF J=1 THEN MOVE X(I,J),Y(I,J) ELSE DRAW X(I,J),Y(I,J)
280 NEXT J:NEXT I
290 FOR I=1 TO V:FOR J=1 TO H
300   IF J=1 THEN MOVE X(J,I),Y(J,I) ELSE DRAW X(J,I),Y(J,I)
320 NEXT J:NEXT I
330 MOVE 50+100*H/(H-1),100*V/(V-1)
340 DRAW 50+H*100*H/(H-1),100*V/(V-1)
350 DRAW 50+H*100*H/(H-1),V*100*V/(V-1)
360 END
```

ZX Users' Club

JOIN YOUR USERS' GROUP — AND MAKE THE MOST OF YOUR MICROCOMPUTER

Join the National ZX80 and ZX81 Users' Club, by subscribing to the official monthly club magazine **INTERFACE**.

- () Please send me the next 12 issues of **INTERFACE**, containing many programs for each machine in each issue, plus hints, tips, software, hardware and book reviews, plus special offers for members. I understand you will be able to help me with problems regarding my computer, and let me know of any local branches of the club in my area. I enclose **£9.50** (UK), **£12.50** (Europe) or **£16.00** (elsewhere).

Please send me the following books:

- () **GETTING ACQUAINTED WITH YOUR ZX81** — by Tim Hartnell — **£5.95**. This great ZX81 book contains over 80 programs in its 128 pages. Takes you from the first steps of programming your ZX81 to quite complex programs such as **WORD PROCESSOR**, **DRAUGHTS** and **LIFE**. You'll find a host of programs to get your ZX81 up and running with worthwhile programs, right from day one. Other programs include **SPACE BOY**, **ROLLER-BALL**, **CHEMIN DE FER**, **GRAFFITI**, **MICRO-MOUSE**, **POGO**, **TOWERS OF HANOI**, **BLOCKOUT**, **SALVADOR**, **BANDIT** and **DODGE CITY**.

As well as programs, there are sections to explain the use of **PLOT**, **UNPLOT**, **PRINT AT**, **MAKING THE MOST OF 1K**, **ARRAYS**, **WRITING PROGRAMS**, **BIO-RHYTHMS**, **ARCADE GAMES**, **RANDOM NUMBERS**, **PEEK AND POKE**, **HOW TO CONVERT PROGRAMS**, **USEFUL ADDRESSES**, **SPECIFICATIONS**, **THE NEW ROM**.

- () **THE GATEWAY GUIDE TO THE ZX81 AND ZX80** — by Mark Charlton — **£6.45**. Explains **ZX BASIC** from first principles. 180 pages, more than 70 programs. Recommended by **Creative Computing**.
- () **MASTERING MACHINE CODE ON YOUR ZX81 OR ZX80** — by Tony Baker — **£7.50**. Warmly welcomed by the computer press, this book has continued to attract praise, because it does exactly what it claims to do in the title.
- () **49 EXPLOSIVE GAMES FOR THE ZX81** (and 29 for the ZX80) — edited by Tim Hartnell — **£5.95**. Every game you need: **DRAUGHTS**, **GALACTIC INTRUDERS**, **STAR TREK**, **DEATH MAZE**, **4-IN-A-ROW** and an 8K **ADVENTURE**-type program **SMUGGLERS BOLD**.
- () **34 AMAZING GAMES FOR THE 1K ZX81** — by Alastair Gourlay — **£4.95**. All programs dumped from the printer and guaranteed to run. This book is the key to making the most of 1K.
- () **GETTING ACQUAINTED WITH YOUR VIC20** — by Tim Hartnell — **£6.95**. This book is the ideal one for first-time users of the **VIC 20**, with over 60 programs.
- () **SYMPHONY FOR A MELANCHOLY COMPUTER** and other programs for the **VIC20** — **£6.95**. A great collection of 24 great games — all dumped direct from the printer — for the **VIC20**.
- () **GETTING ACQUAINTED WITH YOUR ACORN ATOM** — by Trevor Sharples and Tim Hartnell — **£7.95**.
- () **39 TESTED PROGRAMS FOR THE ACORN ATOM** (the best of **INTERFACE**) — **£6.45**.
- () **PASCAL FOR HUMAN BEINGS** — Jeremy Ruston — **£6.45**.

INTERFACE,
44-46, Earls Court Road, Department YC, London W8 6EJ.

ATOM
VIC

Please send me the indicated items. I enclose £-----.

Name -----

Address -----

YC

Untying the strings from Basic dialects

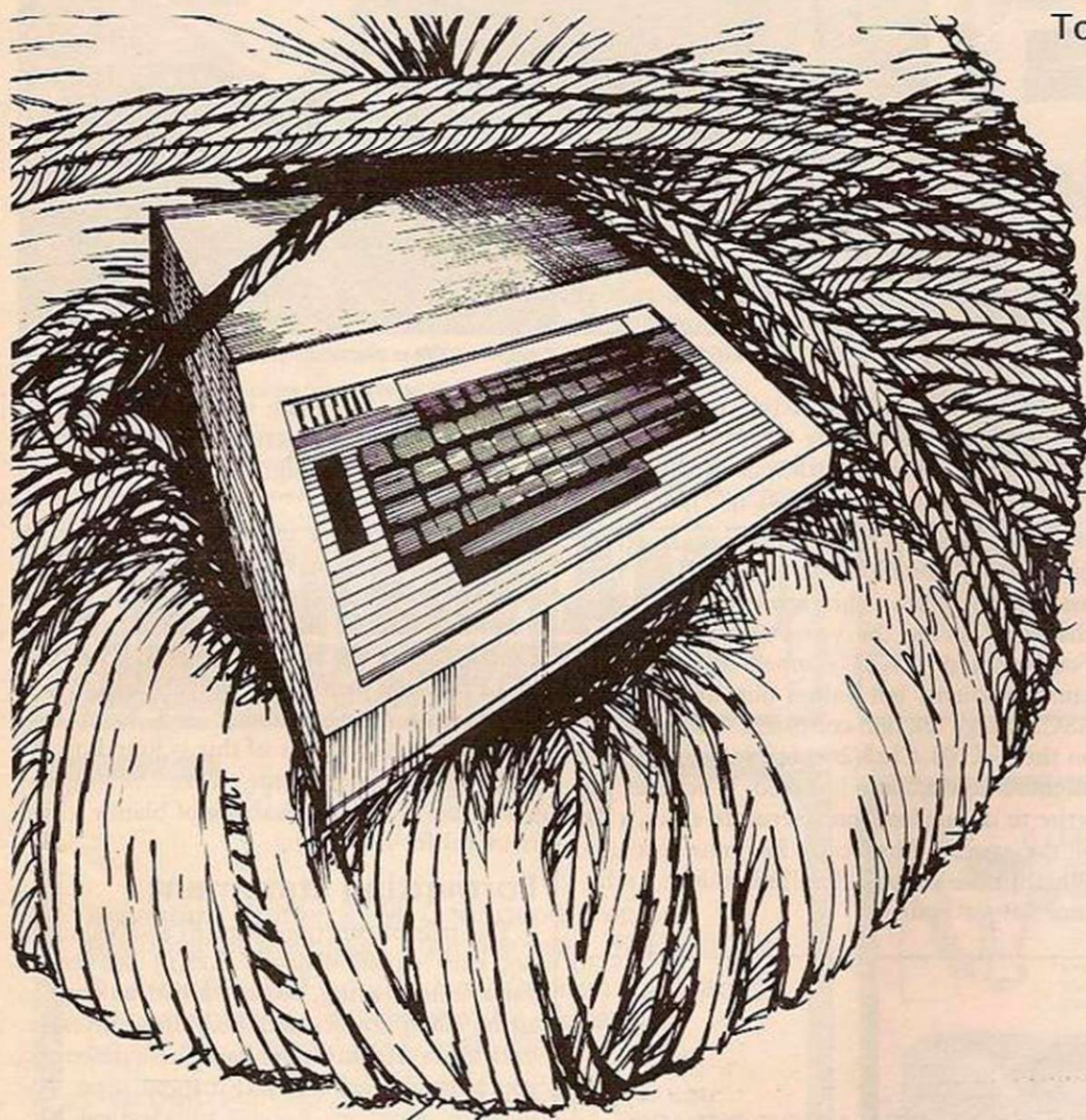

Tony Edwards reveals the essential features of those string-handling commands which form such a powerful weapon in the Basic armoury. On the surface they appear to be different in each dialect, but after a little study you should find you are able to translate most programs to run on your own micro.

crash but, more dangerously, it may simply ignore the extra characters and you will never know — until, that is, the program fails to produce the expected results.

If you run into this problem, the over-long strings must be broken into smaller ones. I would advocate the use of a string array large enough to hold the whole of the oversize string in bits and having the same name.

Reserved words

String names must not contain reserved words — that is, words the interpreters use to identify internal functions. Different machines have different reserved words so learn those relevant to yours and keep an eye open for them when translating. The rules for the use of reserved words also differ.

My machine and the BBC Microcomputer have the reserved word Val but the latter allows the string name Revalue\$ and mine does not. The BBC Microcomputer only forbids reserved words at the start of a word and in upper case. This is a most elusive problem and should always be investigated as the cause of a syntax error in an apparently correct line.

Some computers, such as the Hewlett-Packard HP-83, require the reservation of string space before use. This should not be a problem as you should know if your system requires it, but watch out for an unnecessary Dim(A\$) statement. A Pet user may recognise this as an array dimension statement when in reality on the Pet it is an unnecessary string dimension. Dimensioning unnecessary string arrays is a good way to run out of space.

Clear statement

Other computers provide for reserved string storage space with a Clear statement which is often implicit in a Run. The default value is usually 50 bytes but it can be as high as 200 and so may need redefining with Clear(200). The Clear statement sometimes has the unrelated function of clearing terminal or output buffers.

Many Basics use Fre(A\$) to identify remaining free space for strings, but do not confuse
(continued on next page)

STRINGS PLAY a most important part in many programs, be they for games or commercial use, and the differences from dialect to dialect are not great. The \$ sign is almost universally used as a suffix to denote a string variable so there should be little difficulty in identifying strings in program listings, although \$ is also occasionally used for other functions.

In many Basics, variables can be declared as string variables using the statement

```
DEFSTR A,B,C
```

or

```
DEFSTR A-C
```

both of which cause all variables whose names

begin with A, B or C to become string variables even though they may lack the \$ suffix. If your machine does not have these functions, add \$ to all those variables to be used as strings, but beware of redefinition with Defint, Defsng or Defdbl or by suffixes such as % , ! or #.

Strings have limited length, but that length is variable depending on the interpreter used. At least 16 are usually permissible, but some computers, such as the BBC Microcomputer, allow up to 255 characters. If a program uses very long strings take care that your machine can handle them. Sometimes the program will

Program 1.

```
10 C = P/N
20 C$ = STR$(C)
30 FOR I = 1 TO LEN(C$)
40 IF MID$(C$,I,1) <> "." THEN 70
50 PRINT LEFT$(C$,I-1); "POUNDS";
   MID$(C$,I+1,2); "PENCE"
60 I = LEN(C$) + 1
70 NEXT I
```

Program 2.

```
10 C = P/N
20 PO = INT(C)
30 PE = C - PO
40 PE = INT(PE * 100)
50 PRINT PO; "POUND"; PE; "PENCE"
```

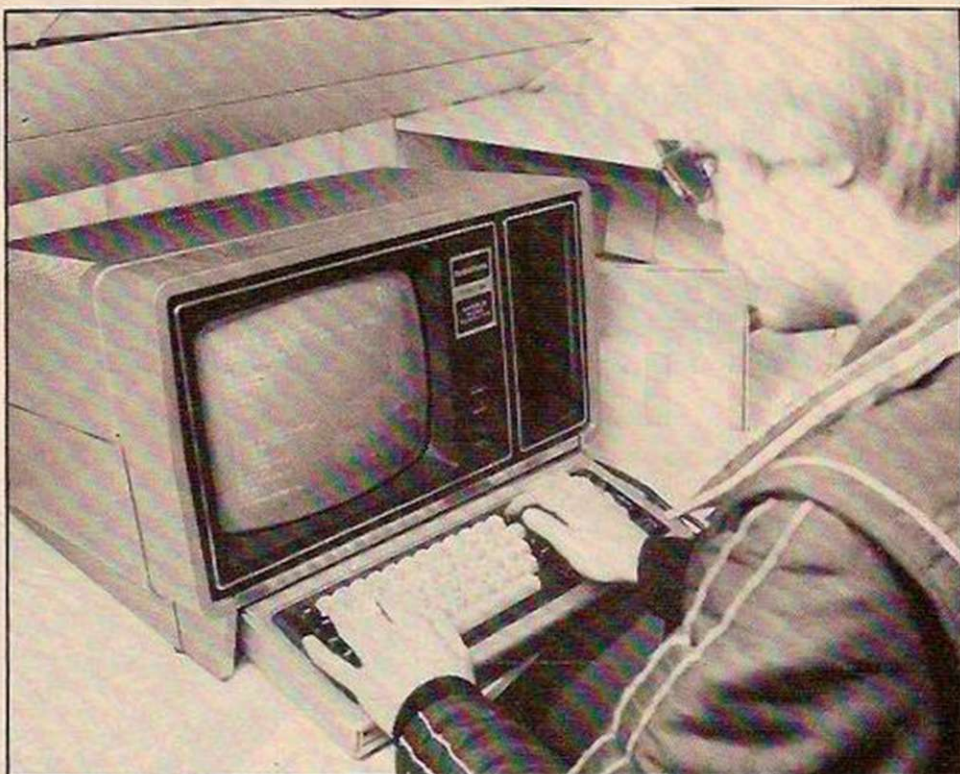

Beware of unnecessary Dim statements on the Pet.

On the TRS-80 CHR\$(26) is a line feed, not Clear Screen.

(continued from previous page)

this with the also common Fre(0) or Free(0) which returns the total amount of free memory remaining — it is similar to the Mem statement.

Equivalent functions

If your Basic dialect has string-manipulation functions, you should recognise the equivalent functions of other dialects without difficulty. Len; Left; Right; and Mid, sometimes with the "\$", are common. One point to watch, however, is the BBC Microcomputer's statement Mid\$(A\$,n) which appears to be a parameter short; it is not.

On this computer Mid\$(A\$,n,m) acts as would be expected; it returns m characters

starting with the nth, but Mid\$(A\$,n) returns all the characters starting with the nth. This could be simulated with the complex function
RIGHT\$(A\$,LEN(A\$)-(n-1))

Some Basics have additional string functions. A common one is Cha\$, Char\$, or more rarely Chr. This retrieves the ASCII character having the value of the argument. For standard ASCII symbols this will not cause problems but values outside the usual ASCII range are non-consistent. For instance, on the UK101 Chr\$(26) clears the screen but on the TRS-80, it is a line feed. Whenever you write to us, enclose, on a separate sheet, a list of the special Chr\$ calls for your machine. When I have enough, I will reproduce a reference list for your use.

An irregularity which will cause translation trouble is the BBC Microcomputer's ability to use only the least significant byte of n in Chr\$(n).

Another common extra string function is String\$(n,m) which returns n characters of ASCII code m. This is often used to assist graphics output. If you do not have this function, look up m in the ASCII Code list and Print n of them. Alternatively, assign n of them to a string variable and Print that variable. A special case of this is found on the TRS-80 and Video Genie where Chr\$(n), if n is above 191, returns a string of blanks which is useful for formatting.

Formatting statement

The pair of functions Str\$(n) and Val(n) do not exist in all dialects. Str\$(n) converts a variable to a string, so that it can be used in string manipulation, and the Val(n) converts it back again. If you do not have these functions, you must use arithmetical manipulation. For instance, programs 1 and 2 are identical.

In this case the arithmetical manipulation is easier, but the example serves as a comparison. In practice, it would be achieved better with a formatting statement, if you have one.

Here is a short test. In our December issue J F Vincent gave the useful program reproduced as program 3 to transpose music from one key to another. Can you translate it for use on your machine?

Worth the effort

This translation is not easy, but it is worth the effort both for the practice and for the program. The main problem lies with line 60 because you will have to guess its non-standard meaning. The [A] [B] etc., in line 20 represent inverse characters. If you have completed the translation and it still will not work, remember it was written for integer Basic so recheck your translation of line 310.

Next month, we shall look at the new BBC Microcomputer's dialect to identify statements which may cause trouble in translation, and to find some equivalents to non-standard functions.

Program 3.

```

10 DIM A$(12)
20 LET A$="A[B]B[C]C[D]D[E]E[F]F[G]"
30 LET T=??(the number of semitones of
  transposition)
40 INPUT B$
50 FOR N=1 TO LEN B$
60 LET P=CODE B$(N)
70 IF P>45 THEN GOTO 300
80 LET P=(P-37)*2
90 IF P=6 OR P=8 OR P=10 THEN LET P=P-1
100 IF P>10 THEN LET P=P-2
110 LET P=P+T
120 IF P>12 THEN LET P=P-12
130 PRINT A$(P)
140 NEXT N
150 PRINT
160 RUN
300 LET P=P-165
310 IF P>=2 THEN LET P=P+P/2
320 GOTO 110
  
```

**From West London's
mail order specialists:**

**ONLY
£240**

incl. cassette deck
+ FREE GAME
+ FREE
DELIVERY

VIC-20

SPECIAL OFFER

Order the superb VIC-20 and cassette deck at £240 (incl. VAT!) and get a FREE game ("Breakout" or "Stunt Cycle") worth £7.99 – and delivery is free, too!

We stock all VIC-20 software, peripherals, paddles, etc – including the full Stack and Arfon range.

The best microcomputers from leading makers (Apple, Commodore, etc) plus peripherals, printers, software, games, books – and all at low prices! Order today from the mail order specialists – send coupon with cheque (or phone your Barclaycard no). Delivery in 28 days or money-back option.

Please supply 1 VIC-20 & Cassette Deck & "Breakout"/"Stunt Cycle" (state which required)

NAME: _____

ADDRESS: _____

TWICKENHAM
COMPUTER CENTRE LTD

72 Heath Rd Twickenham Middx TW1 4BW (01-892 7896/01-891 1612)

THE

**BUFFER
MICRO SHOP**

(NEXT TO STREATHAM STATION)

NEW SOFTWARE SHOP EXCLUSIVELY FOR

ZX81

PROGRAMS, GAMES, "ADD-ONS"

MOST OF THE MAIL ORDER ITEMS ADVERTISED
IN THIS MAGAZINE AVAILABLE OVER THE COUNTER

LOADING PROBLEMS? TRY OUR INTERFACE
BUSINESS & TECHNICAL DATA HANDLING PROGS;
PROPER KEYBOARDS; CONSOLES; VDUS

The BUFFER Micro Shop,
374a Streatham High Road,
London SW16
Tel: 01-769 2887

zx software

Breakout. Written in M/C for good graphics. Try to knock all the bricks from the wall. 1K £3.95.

Dragon Maze. Find your way through the maze – but watch for the dragon, he sometimes breaks the rules in anger. 16K £4.95.

Startrek. As Captain of the ENTERPRISE you must rid the Galaxy of alien Klingons! 16K £4.95.

Life. Written in M/C giving 24 x 32 screen dimension, automatic self step operation plus special 'MOVE' feature. 16K £3.95.

Fruit Machine/Pontoon. Two programs for the impulsive gambler, auto-run and hold features, good graphic display. 16K £2.95.

3D '0 & X's/Connect Four. Both programs written in M/C with choice of level of play. 16K £5.95.

16K RAM Pack

assembled, tested and cased
£37.50 inc (P&P) Allow 21 days delivery

All supplied on cassette with instructions
send cheque, P.O. or Card no. with order



26 Spiers Close, Knowle, Solihull
West Midlands, B93 9ES, England

MACRONICS



**SOMETHING REALLY NEW FROM
TAURUS COMPUTER DESIGN
FOR ZX81 USERS**

The unique TAURUS 16K RAM PACK supplied with powerful EPROM Machine Code utilities monitor which contains 16 software routines giving far reaching control over writing and de-bugging of machine code.

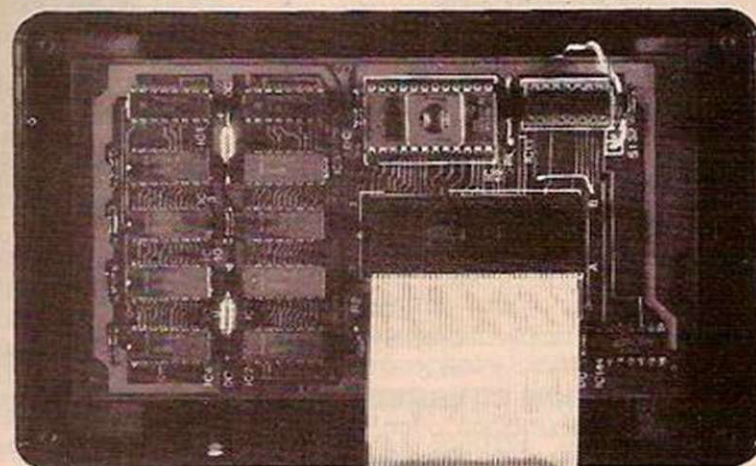

MONITOR UTILITIES INCLUDE:-

- * Memory byte display and alter
 - * Register display and alter
 - * Word fill memory
 - * Block copy
 - * Generation of a REM statement
 - * Tabulated memory display with addresses
 - * Viewable user screen separate from monitor display screen
 - * Hex to decimal and decimal to Hex converter
 - * Routine to enable user to write his own utilities in RAM
 - * Facilities to run machine code and set breakpoints
- Other reasons why you should consider our design in front of all others:
- * Flexible stripline connector eliminates movement and memory wipeout.
 - * Low Power CMOS RAM (switchable 16K RAM or 14K RAM and 2K EPROM)
 - * Socketed EPROM for permanent programs
 - * Comprehensive user manual

**ALL THIS FOR
£54.95 inc.**

16K RAM PACK WITHOUT
MONITOR £45.95 inc.

Make cheques payable to:
**TAURUS
COMPUTER DESIGN,
47 HIGH ST., BALDOCK,
HERTS. SG7 6BG**



THE COMPLETE SINCLAIR ZX81 BASIC COURSE

At last, a comprehensive text for your Sinclair ZX81! The complete BASIC Course is a manual which will immediately become an indispensable work of reference for all your ZX81 programming.

Whether you have never done any programming or whether you are an experienced microcomputer user, the Complete BASIC Course will provide an invaluable aid.

The complete BASIC Course is designed to teach you to write and develop BASIC programs for the Sinclair ZX81 - no other books or aids are necessary. All is revealed in our easy step-by-step guide with programs and "test yourself" exercises all the way through.

As you become more proficient with computing, the Complete BASIC Course will continue to be an essential guide, giving you finger tip references, numerous advanced programming techniques and memory saving devices specifically for the Sinclair ZX81.

HOW TO WRITE PROGRAMS

Even if the idea of writing programs is completely mystifying to you, the Complete BASIC Course will show you just how easy it is. In no time you will be able to write and enjoy complex programs for whatever you desire.

Using the proven "TOP-DOWN" approach, the Complete BASIC Course will show you systematic and simple ways to write programs. Even experienced programmers will benefit from this Course, making programs easier to write and less prone to error!

NUMEROUS EXAMPLES

Every concept, every function is fully described by simple programs that you can enter on your Sinclair ZX81 in minutes.

The Complete BASIC Course contains over 100 programs and examples! These programs illustrate the use and possibilities of the Sinclair ZX81:

- Home use
- Financial analysis and planning
- Educational applications
- Games
- Mathematical applications
- Displays of 'Artificial Intelligence'

EVERY FUNCTION COVERED

No matter what your application, what your confusion about any function, you will find it covered in the Complete BASIC Course.

A full and detailed discussion is included of even traditionally taboo topics such as **USR**, **PEEK** and **POKE**.

A handy alphabetical summary section lists all functions, and provides a short description and example programs of all topics.

A PERMANENT WORK OF REFERENCE

The complete BASIC Course is an excellent reference work for experienced programmers (including tips on using special techniques) as well as a comprehensive step-by-step guide for complete beginners.



Melbourne House is the world's leading publisher of books and software for the Sinclair ZX81.

The following titles are also available if you wish to expand your horizons:

ZX81 ROM Disassembly Part A

This book is for the programmer that needs complete answers about the ZX81. Dr. Logan has examined all routines in the ROM and here he comments on each one. It covers all ROM locations from 0000H to 0F54H, and includes all functions except for the routines used in the floating point calculator.

ZX81 ROM Disassembly Part B

In this companion volume to Part A Dr. Logan covers locations 0F55H to 1DFFH and includes all routines used in the ZX81 floating point calculator. These two books are a must for the experienced programmer.

Not Only 30 Programs for the Sinclair ZX81: 1K -

Not only over 30 programs, from arcade games to the final challenging Draughts playing program, which all fit into the unexpanded 1K Sinclair ZX81 but also notes on how these programs were written and special tips! Great value!

Machine Language Programming Made Simple for the Sinclair -

A complete beginner's guide to the computer's own language - Z80 machine language. Machine language programs enable you to save on memory and typically give you programs that run 10-30 times faster than BASIC programs.

BASIC Course Programs on Cassette -

All major programs in the BASIC Course are available pre-recorded in this set of cassettes.

Understanding Your ZX81 ROM -

A brilliant guide for more experienced programmers by Dr. Ian Logan, this book illustrates the Sinclair's own operating system and how you can use it.

Orders to Melbourne House Publishers
131 Trafalgar Road, Greenwich London
SE10
(Correspondence to
Glebe Cottage, Station Road,
Cheddington, Leighton Buzzard, BEDS LU7
7NA)

NAME

ADDRESS

..... Postcode

The Complete Sinclair ZX81 BASIC Course	£17.50	<input type="checkbox"/>
Basic Course Programs on Cassette	£2.50	<input type="checkbox"/>
Not Only 30 Programs/Sinclair ZX81:1K	£6.95	<input type="checkbox"/>
Machine Language Programming Made Simple	£8.95	<input type="checkbox"/>
ZX81 ROM Disassembly Part A	£7.00	<input type="checkbox"/>
ZX81 ROM Disassembly Part B	£8.00	<input type="checkbox"/>
Understanding Your ZX81 ROM	£8.95	<input type="checkbox"/>
Postage and Packing	£0.80	
Remittance enclosed	£.....	

ASIMOV: WORD PROCESSOR IN MACHINE CODE

Playwrights, journalists, hoteliers, doctors and candlestick makers are all using word processors for their own purposes. John Dawson decided to build his own.

WORD PROCESSORS are one of the phenomenal growth areas of microcomputing. The term "word processing" was coined by IBM in 1964 to describe all automatic equipment that helped in the preparation of text.

There is much evidence to indicate that word processors increase the productivity of people who use them and a report by the Central Policy Review Staff — the Government's think-tank — concluded that the use of word processors instead of conventional typewriters results in consistent productivity gains in excess of 100 percent.

Such an increase in productivity may be achieved without socially unacceptable side-effects; one organisation trebled its workload by the introduction of word processors without any change in the number of people employed. In three other cases, however, there were serious reductions in the number of clerical staff employed by the companies.

As usual, the jargon term "word processors" covers a diversity of different uses and needs. A typist in an office may require fast access to any one of hundreds of standard paragraphs or letters in the production of personal but standard mail.

Another secretary in the same organisation may spend the majority of the time typing and then correcting draft reports — she will have only one document in hand at a time and the prime requirement that she will have is flexible editing and extensive print options. Someone else may need to sort a mailing list according to certain criteria for advertising purposes.

In the beginning

When I started to design Asimov I had about two years experience of using dedicated, commercial word processors and that period of information systems analysis saved time; I knew very largely what I wanted the program to do.

Cassettes are satisfactory for bulk storage if the computer has sufficient RAM to hold the whole of a document, or a convenient subsection of it, in the machine at one time. If you can manipulate a book chapter, or the whole of an article without waiting for a slow floppy disc, why not use fast RAM as virtual disc

memory; with a full TanRAM of 40K connected to the system, the Microtan computer will hold between 7,000 and 8,000 words of text.

Asimov loads text from tape at rather more than 1,000 words a minute. Two minutes at the start and end of a writing session is acceptable for storing and retrieving a document.

Like most programs, Asimov is a combination of top-down ideas and bottom-up programming. I started with the concept that I wanted a word processor built as a series of modules so that as the program developed a new function would consist eventually of a series of subroutine calls to earlier, more primitive, sections of machine code.

Asimov took about six months to write and although I started using the Tangerine assembler in X-Bug, it would have been impossible to complete the program without the ability to store source code on tape for subsequent editing and modification.

So, about one-third of the way through I rewrote several hundred lines of code using the Microtan Software two-pass assembler and then continued to complete the program in slightly less than 3,400 lines, about 33K of source code. The assembled machine code is just over 7K in length.

The dialogue design is vitally important in a program of this kind, where it must become an extension of the writer's thoughts. Plain English messages are displayed at the top of the screen throughout Asimov. For example, when you want to write a text the program asks you first:

DESTROY old text? <Y>

Because the decision is important, you must press Y or y — it makes no difference — rather than the reflex action of pressing the Return key. Then you can write new text by typing on to the screen. Whenever the program needs an unusual response to do something, the correct key entry is shown on the top line of the screen.

In the course of editing a document you have to move the cursor all over the screen and you should be able to do so by pressing one key for one movement. The place to which your finger has to travel should correspond as closely as possible to the direction you would point to move the cursor on the screen.

The cursor can be moved and positioned over the whole screen using the cursor controls illustrated in figure 1.

The effects of pressing the keys on the numeric keypad are: left; right; down one line;

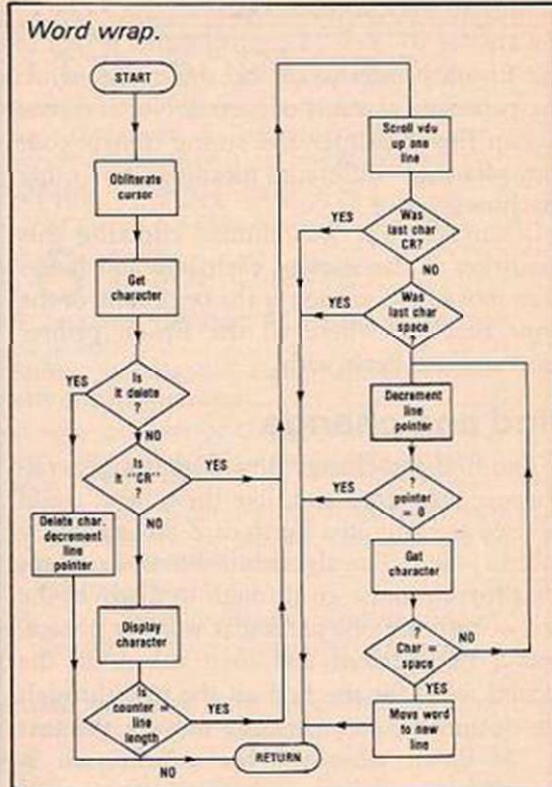

up one line; scroll display up one line; scroll display up 15 lines; cursor to start of next line; cursor to top-left corner of screen; return cursor to start of document.

The full stop in a circle is a command to search the text for a Control W character and then display the next page of text.

There is nothing unusual about this layout. Indeed, it would be a bad sign if there were. However, using the program I think that the functions performed by the 7 key are correct but could have been allocated elsewhere. It would be useful to have a key available to return the cursor to the start of the previous line.

The rate at which a cursor blinks is important and the Human Sciences and Advanced Technology Unit at Loughborough University suggests that the blink rate should be between two and four times a second. Ideally, the user should be able to stop the cursor flashing.

The three flowcharts illustrate some of the problems that have to be overcome in designing a system which will take the burden of computer operating away from a writer. The word-wrap flowchart was part of an article in Tansoft Gazette and is less complex than the final program as it relates only to word-wrap on the bottom line of the screen. The final version of Asimov prevents broken words anywhere on the VDU.

The printer-control flowchart demonstrates how easy it is to overlook tiny details; the first decision in the flowchart is "? single sheet". If

(continued on next page)

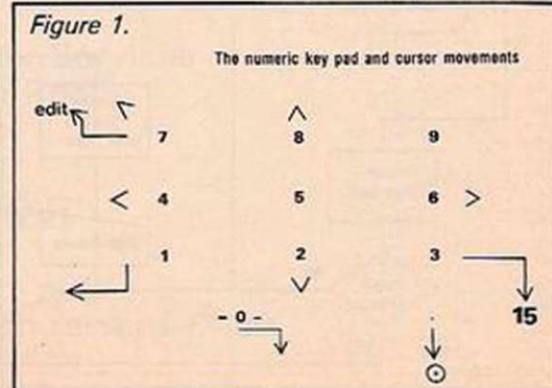

(continued from previous page)

the answer is "Yes", a control signal is sent to the Epson printer to inhibit the buzzer when the paper-out alarm is triggered. Not everyone has an Epson printer and so the control code may have a different meaning for other machines.

In any case, it was clumsy checking this condition at the start of each line and it has been moved to a section at the beginning of the print function where all the Epson printer functions are dealt with.

Find and change

The find-and-change flowchart is a general-purpose algorithm and, like the others, could be used as easily in a Forth or Z-80 assembler-based system. The algorithm shows the stages the program must go through to discover the first occurrence of a particular word or phrase, find a replacement and then substitute the second word for the first all the way through the document, automatically moving the text up or down whenever the substitution is carried out.

The Find command will accept a word or phrase up to 20 characters long. Comparison starts at the beginning of each word and a full stop will match with any other character to allow the automatic correction of sections of words.

For example:tion will match with "automation" and "correction". Dates can be changed automatically by finding .././79 and changing that date to 01/11/83 or 15th March 1984. You can save a good deal of effort in typing a document by using an identifiable code such as XXX every time you need to write "Information Technology Year 1982" or "Trichophyton equinum schonleinii", and then automatically replacing the code with the phrase.

The core edit commands that any word processor must have also include: Delete character, word, sentence or paragraph. Insert text anywhere in an original document. Overwrite the existing text. Move paragraph to a text buffer and bring the paragraph back to the cursor position, once or as many times as you wish. Kill the remainder of the text. Print from the cursor position. Continue writing from the end of the text. All of these are single keystroke commands.

Tape functions allow a user to: Store text on tape. Documents are stored with the printer Layout codes to format the text when it is retrieved. Retrieve text from tape. Text name on tape may be up to 25 characters long and all the characters are significant when Asimov is searching a tape for a document. Append a text from tape to a document already in the computer.

Print commands

Each document on the tape is stored with a comment section so that you can record the stage that a draft document has reached or the date when something was completed without the information forming part of the text itself. The tape speed can be altered simply by typing "T".

The Print commands include: page Layout which can be controlled by setting:

- Right margin
- Left margin
- Line spacing
- Page length
- Form length
- Single sheet or continuous stationery

Automatic page numbering is available starting from page 1, or another number that you set. Alternatively, Asimov will leave the first page for a main title and will then number the subsequent pages.

Up to 20 tabulator stops can be set and these are displayed graphically on the layout screen.

Condensed or emphasised type-styles can be set for the whole document and these can be varied by embedded commands inside the text.

Other instructions allow you to centre a line of text or indent the text by variable amounts to improve the presentation of a document. It is possible to put marginal notes into the left-hand margin and to number paragraphs.

CONCLUSIONS

- Once you have used a real word processor for writing it is very difficult to settle for anything less. However, the "real" needs some emphasis.
- If your first experience of carpentry is a screwdriver with a wobbly handle or a badly-sharpened rule which makes ragged, off-centre holes no matter how careful you are, then you are unlikely to persist in your attempt to become a neat, skilled craftsman.
- Good tools are not flashy, they just do the job. In the same way the dialogue between a computer user and the machine should be unobtrusive and something of which the user is hardly aware.
- The documentation could be made more comprehensive and include additional functions for, say, telecommunications and macro printer commands. Nevertheless, Asimov works well and it is unobtrusive and enormously helpful.
- One further function even counts the number of words in an article — a huge labour-saving benefit. ■

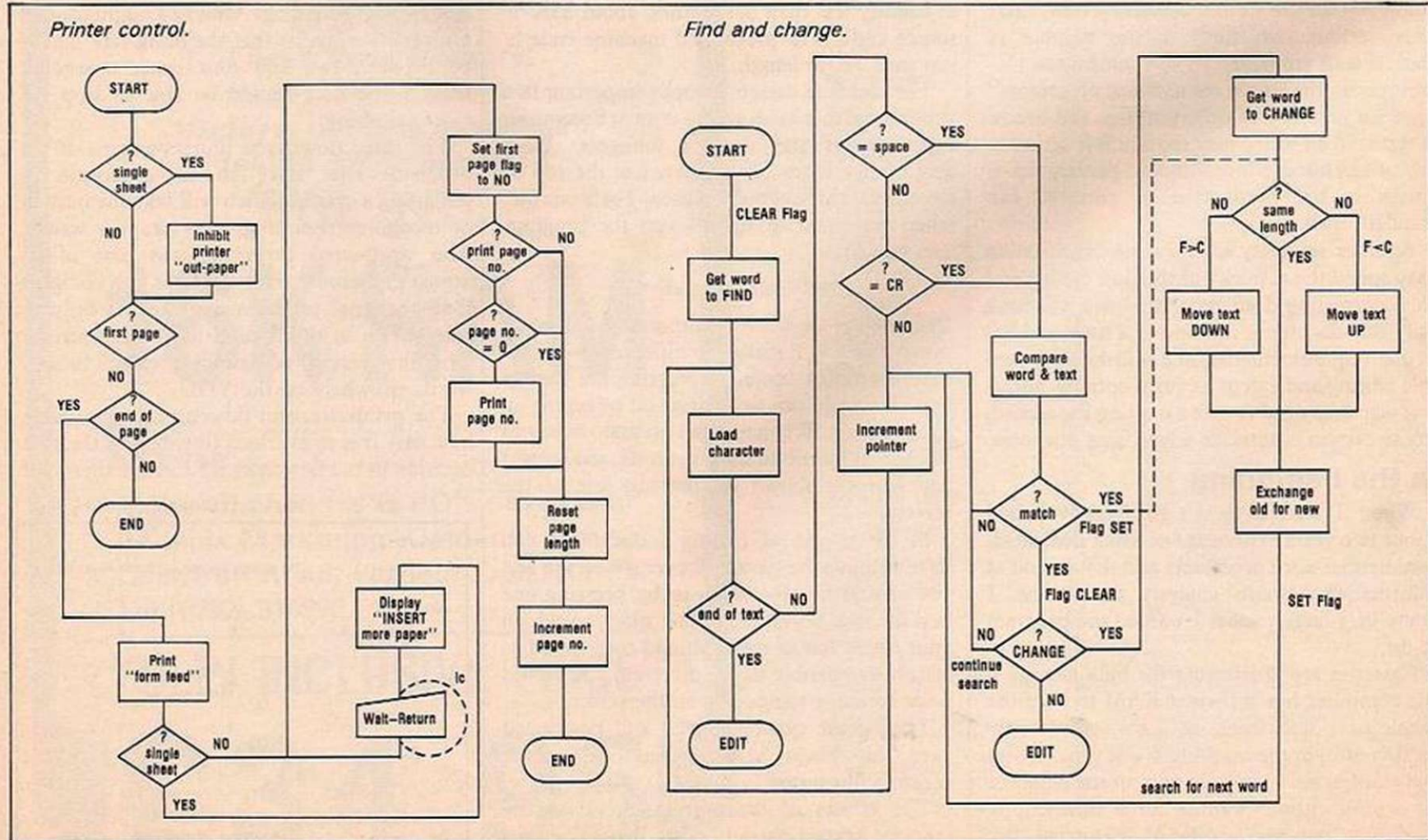

ZX81 owners

Protos

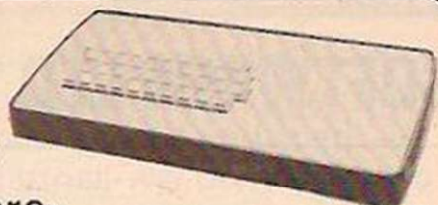

Keyboard is here:

At last! A real, full size keyboard in a top quality case for your ZX-81.

Simply unscrew your ZX-81 printed circuit board from its black Sinclair case and plug into Protos.

FULLY BUILT £64.95 inc. VAT

- More accurate, faster typing with bigger and real keys
- 40 colour coded key-tops for easy reading
- Robust, 'big' computer construction
- PCB prepared for more add-ons to come
- New edge connector provided for Sinclair and other manufacturers' peripherals
- Key legends can be changed for future new ROM functions
- Sinclair PCB fully enclosed — and room for much more

If you feel you've outgrown your ZX-81 don't sell it for peanuts and move to another system. Add it to Protos and make your ZX-81 grow.

For details, large SAE, please. For orders add £2.80 post and packing. Cheques to 'Frome Computing'.

Protos Computer Systems

Frome
Computing,
20 Ashtree
Road, Frome,
Somerset,
BA11 2SF



Bridge
Software

Quality Software

"I have bought numerous other items of software ... Yours are excellent ... They LOAD well, have perfect instructions ... the most user-friendly I have ever met." (P.R. Notts)

New low price! 16K RAM Pack for the ZX81 including FREE "GALAXY INVADERS" cassette ~~£35~~ now only £35-

ZX81 software

GALAXY INVADERS (requires minimum 4K RAM) in machine code. Cassette and instructions£3.00

1K GAMES (Duck Shoot, Moonlander, Hangman, Crossword, Letter Square) Cassette and instructions£3.00

"I have just received your cassette of GALAXY INVADERS which I think is the best on the market ... I am very pleased with your quick service." (S.C. Beds)

MULTIGRAPHICS 2.3 (requires minimum 16K RAM) — create drawings, advertising displays etc. on screen. Displays can be SAVED on tape, printed on your ZX Printer.

Cassette and 20 page illustrated Manual£4.50

"MULTIGRAPHICS ... is most impressive and has clear instructions." (Eric Deeson, "Your Computer" February 1982)

1K GRAPHICS (Kaleidoscope, Large Print, Medium Print, Draw A Picture). Manual only (contains accurate listings, notes, information and ideas)£3.00

Cassette and instruction£3.00

Package of cassette and Manual£4.50

1K STATISTICS (4 programs, descriptive and inferential stats)

Cassette and instruction£3.00

Booklet containing listings, test data etc.£2.00

NEW! INVADERS for the VIC-20 (no additional memory needed) cassette and instructions ~~£6.90~~

Send s.a.e. for further info., detailing your computer, memory etc.

BRIDGE SOFTWARE (Y) "Mail order only"

36 FERNWOOD, MARPLE BRIDGE,
STOCKPORT, CHESHIRE SK6 5BE

Prices include VAT, post and packing in U.K.
European customers add 30p per item. Worldwide, 70p per item

ZX81

users

I need more memory!
please rush me within
10 days, the fully assembled,
tested and guaranteed

'BYG BYTE'

16K RAM

Name
Address

Make all cheques & PO's payable to:
Phoenix Marketing, Oaklands House,
Colartron Road, Farnborough, Hants.
Tel (0252) 514990

FULLY INCLUSIVE PRICE

£34.95

WHAT CAN I DO WITH 1K!

If your answer is "not much", then you must read the new book from V&H, 'What Can I Do With 1K? (40 programs and routines for the 1K Sinclair ZX81)'.

Here at last are some serious (and some fun!) programs which all run in 1K.

Don't be misled by the titles: 'Roulette' actually analyses gambling systems; 'Chinese Horoscope' reveals your birth sign, month sign, element and ascendant; 'Payroll' handles ALL tax bands. These are not just simple programs.

FREE OFFER!!!

A free listing of 'Chess in 1K' is included with all mail-orders mentioning this magazine!

'What Can I Do With 1K?' is available from most good bookshops, computer shops, or direct from:

V&H Computer Services
182c Kingston Road
Staines
Middlesex

Tel: Staines 58041

Price £4.95 (inc. p&p).
Also available on cassette £4.95



40 PROGRAMS & ROUTINES
FOR THE 1K SINCLAIR ZX81

ZX81 SOFTWARE FROM VIDEO SOFTWARE LTD 1K & 16K

16K SOFTWARE

PRICE

£

VIDEO-SKETCH (ZX81 only). Move the cursor to any part of the screen. Draw or rub-out as you move it. Mix in text or graphics. Save picture in memory. Save picture sequence on cassette.

7.95

VIDEO-PLAN (ZX81 only). Performs the function of an analysis book. Arithmetic functions include addition, subtraction, multiplication. Printer options.

£7.95

VIDEO-AD. Rotating display of 16 pages of advertising material. Set-up your own pages and change them as and when required.

£7.95

VIDEO-GRAPH. Planning and design aid. Create pictures/charts/graphs and store within the program. Save on cassette. Combine pictures like an 'identikit'.

£5.95

VIDEO-VIEW. Do it yourself teletext. Create pages of data. Store them within the program. Save on cassette. View on demand.

£5.95

VIDEO-MAP (ZX81 only). Educational game based on maps. Navigate your plane to its destination. Bomb the target and return to base.

£5.95

FORCE-FIELD (ZX81 only). Animated bombardment game. You control the force-field which protects your city against hostile UFOs.

£3.95

SPACE-RACE (ZX81 only). Party game for eight players. Rockets race to build stations in space. Winners gradually take over losers until only one winner remains.

£3.95

TEST-MATCH. Realistic simulation of a test match series. Dynamic scoreboard. Give each player your own ratings for skill, technique, etc.

£3.95

FOOTBALL-LEAGUE. Realistic simulation of an entire season. Every match played and results shown with progressive league table. You give teams ratings for skill, effort, etc.

£3.95

STOCK-MARKET (ZX81 only). An exciting game of skill and judgement. Buy and sell stocks and shares as prices change in response to world events.

£3.95

PACK 1 — VIDEO-PLAN + VIDEO-AD 17.95
PACK 2 — VIDEO-VIEW + VIDEO-GRAPH 13.95
GAMESET — VIDEO-MAP + 5 GAMES 19.95

1K PARTY TRICKS (ZX81 ONLY)

If you don't have a 16K RAM this set of programs is for you. Ten separate programs — some games, some more serious. All completely original, all ten programs included in the price.

4.95

WHAT DO YOU RECEIVE

1. Instruction manual.
2. Two copies of program on side A.
3. Audio commentary on side B. (16K only).
4. Built in demonstration. (16K only).

Cash with orders please.

Prices include VAT.

Mail order customers add £1.00 per order.

Allow 28 days for delivery.

NEW VIDEO-INDEX NEW

Q. How do you store 57000 characters in a 16K RAM.
 A. Use VIDEO-INDEX.

Catalogue your cassettes, your record collection, references to magazine articles. Amazingly versatile. Capacity for 1000 individual references each of which can generate 57 characters of text. Powerful search facilities once the index has been created.

How is it done? The system cannot really fit 57000 characters in a 16K RAM. It gives the illusion of doing so by eliminating duplicates. For instance in an index of articles in computer magazines about the ZX81 certain words occur time and again. VIDEO-INDEX detects these duplications and thereby conserves space.

What do you get?

1. A machine code master program which sits at the top of RAM. This is initially loaded like a BASIC program.
2. A demonstration index containing 1000 references to articles about the ZX81 in the popular magazines.
3. A detailed instruction manual.

You may then proceed to create your own catalogues and indexes and save them on cassette.

This program is fast, efficient and ingenious and is by far the best product we have introduced for the ZX81.

N.B. There isn't room for a commentary on this cassette so you'll have to read the manual.

ZX81 or ZX80 + 8K ROM.

ZX printer is useful but not essential.

Price £9.95.

New Packaging.

We have discontinued our de-luxe boxed programs except for PACK 1, PACK 2 and GAMESET. All programs are now supplied in resealable "minigrip" plastic wallets.

SUPPORTED SOFTWARE

A new catalogue of software produced by named authors is in course of preparation. Watch this space.



STONE LANE,
 KINVER,
 STOURBRIDGE,
 WEST MIDLANDS,
 DY7 6EQ,
 ENGLAND.

Tel: Kinver 2462.
 Std. 059-483-2462.

VIDEO
 SOFTWARE LIMITED

Directors: P. Smith, B.A., D. J. Smith (Director and Secretary). Registered Number: 1085829 England. V.A.T. Reg. No. 278 0685 51

Personal callers welcome during office hours.
 Send s.a.e. for further details.

RESPONSE FRAME

Do you have a problem? Your manual is incomprehensible or you just cannot get the hang of that programming trick you tried — whatever it is, Tim Hartnell will do his best to answer your queries. Please include only one question per letter and mark them "Response Frame".

ACORN STRING

■ Could you please help me? I used to have a Sinclair ZX-81 and have now purchased an Acorn Atom but there does not seem to be an equivalent to the Inkey\$ function. Could you tell me what to do?

Lee Shields,
Shelf, Halifax.

THERE ARE a number of routines for reading the Acorn Atom keyboard. One way is Peeking into address # B005 which usually has the value 255 stored in it. If you press the CTRL key, this value changes to 191, and when Shift is pressed it changes to 127. So if you want a variable such as A to increase when you press CTRL and to decrease when you press Shift, you could include the lines:

```
100 IF ?# B005 = 191 A=A+1
110 IF ?# B005 = 127 A=A-1
Another way, which reads the Shift and Repeat keys, is to use the routine
100 IF ?# B001 & #80 = 0 A=A+1
110 IF ?# B002 & #40 = 0 A=A-1
```

KIT CATASTROPHE

■ Attempts to reach technical staff at Sinclair Research result in a firm but polite refusal and the person to whom I have been referred in the company has no technical knowledge. I built my ZX-81 from a kit and have had problems with the keyboard. Apart from this, the circuit appears to be working. How can I further test my keyboard, to get greater stability under operating conditions?

W J Norman,
Alton.

YOU COULD TEST the keyboard circuit further by connecting a wire to one of the eight keyboard lines. Then tap on one of the KBD0-4 lines, thus imitating the keyboard switch. This will produce at least a keyword on the screen. The lack of stability you mention could be caused by one of two things. One possibility is the floppiness of the edge connection. This can be cured by expanding the printed-circuit board of the ZX-81 by applying solder to the expansion connector. The other is power: mains fluctuations — people pulling out plugs, devices drawing large amounts of power switching off and on nearby — can affect memory. Sometimes this can be caused by people outside your own house. Someone we know has problems at Romford, Essex when the Ford works at Dagenham

switches over its power supplies. The shrinking RAM and white-out seem to be due to the same cause. If at any time the RAM loses power, all its bits reset themselves to zero. Then when the ROM draws from the RAM the next place to go, it resets itself, thus starting a RAM-check program. This RAM check sets the RAMtop variable, so if the power is not there until it reaches 11K then that is what it will consider the top of memory to be. If you wish to check all the component integrated circuits before inserting them on the board, may we recommend the ITT data book on TTL integrated circuits for pin connections and truth tables.

LOST LOADER

■ I recently bought a Sinclair ZX-81 in the hope of gaining some working knowledge of computers. Everything went fine until I tried to load a program into it and here I encountered some difficulty. The problem is that after going through the specified procedure for loading, the TV set gave a picture with light diagonal lines as the Newline key was pressed. The program lines appear as expected, but when the program finishes, the diagonal lines come back, and the only way to get the computer back to normal is to press the Break button. I tried everything, including various tape recorders, checking leads and the like, but to no avail. As a beginner at this, who built the unit from a kit, I thought I had a possible fault, so I sent the complete unit back to Sinclair for checking and repair if found necessary. I then received what looks like a new unit, but no explanation as to whether there was a problem, or if I was at fault. The new unit was set up, but on trying to load a program the same situation arose — diagonal lines. I have even tried the loading procedure without connecting the tape recorder input, but still obtain diagonal lines. I am now at a complete loss. The unit appears to save programs, according to the manual. The program I was trying to load was supplied by Sinclair. I hope you can give me some guidelines as to where I may be going wrong.

I M Hamilton,
Glasgow.

THERE IS one procedure that we know of to discover the most likely set-up for successful loading on the

ZX-81. Discard, for the moment, the Sinclair tape. Buy a C-12 from a computer store, clean and, if you can, demagnetise the recording heads, and always clean them before use. Make sure the leads from the computer to the recorder do not cross the power supply line. Write a very short — say, two-line — program, and save that. Then, after pressing New then Newline, enter

```
LOAD ""
```

with nothing between the quotation marks. Making sure the tape is about half a second before the program starts, start the tape rolling, then quickly press Newline. The program should load — or not, as the case may be — within a few seconds. If you are unsuccessful, move the volume control up a notch, and try again. Do it over and over again, changing the volume slightly each time, until you achieve success. Once you have done so, mark the point where the volume control is, and always put it on exactly this point when loading. If you manage to load a program from the Sinclair tape in due course, immediately make a copy on your own tapes, as you will find it much easier to load programs recorded on your own machine than you would those recorded on other machines. Either cut out the capacitor across the tone control, or fix the tone control at maximum. You may also like to try adjusting the azimuth of the head while playing the Sinclair tape until you make the tape sound at maximum brightness. This should improve matters.

WHICH COMPUTER

■ Could you possibly help me decide between the Acorn Atom and the Microtan/Tanex system? I have pondered for months on each one's merits and failings, and have failed to reach a conclusion. I am impressed by the low starting price of the Microtan 65, but not by the outlay necessary to reach Basic standard. I have experience in Basic already and do not, therefore, require a beginners' course. Nevertheless, my knowledge of assembler or machine code is virtually non-existent, which makes buying the basic Microtan 65 a risk.

The Atom appeals because it constitutes a simple route to a Basic microcomputer, although it lacks the built-in I/O ports available on the Microtan for future experimentation in control of external devices. Also there is no problem in deciding which box or power supply to buy.

Paul Stacey,
Oldham.

THIS IS a variation of the old "which is the best computer to buy" question. There is no simple answer and the longer you delay, the more you will deprive yourself of the delight of owning a machine. You

have, anyway, more or less answered your own question. You say you know Basic, would like a machine which allows you to use Basic, and that the Atom has it. Although Atom Basic is non-standard, Atom users find it a delight once they grow used to it. As well, you will be able to upgrade your Atom to BBC Basic. If you want to know more about the Tangerine system, write to Bob Green at the Tangerine Users' Group. Almost any computer you buy nowadays will give you a great deal of satisfaction. Every month, every machine becomes a little closer to being obsolete. There will never be the "right" time to purchase. Why not take the plunge now and buy a machine? Then, in a year or so, use the experience you have gained in looking for your next computer.

PROS AND CONS

■ Please could you tell me if it is true that a special cassette deck is needed for the Vic? If so, could you tell me why it is so special, or is it another way for the manufacturer to take money from enthusiasts? Why has this important subject been neglected from your reviews and other literature?

M Reddy,
Merseyside.

YES, YOU NEED a special cassette recorder, costing £40 to £50. It is a digital cassette recorder, storing information which is different from that stored by a normal audio recorder. Perhaps the reason it is not mentioned is because — as you suggest — it could deter people from buying the machine. On the positive side, the digital recorder offers much more reliable Loading and Saving than a domestic recorder.

SINCLAIR ON BBC

■ I am considering buying a BBC Microcomputer. I have a number of ZX-81 programs, as well as books of programs written in Microsoft Basic. Will these run on the BBC machine?

Max Harris,
Dagenham, Essex.

PROGRAMS ACTUALLY saved from another computer will not load directly into the BBC machine, but many of them will be relatively easy to convert. Apart from a couple of things, such as the use of the query for Peek and Poke, and P. instead of ? as an abbreviation for Print — the BBC Basic is almost completely standard. It also shows considerable thought. To generate random numbers, for example, in the range one to six, many Basics insist you enter

```
LET D = INT(RND(1)*6) + 1
whereas on the BBC machine — as on the ZX-80 and the Tandy Colour Computer, but on very few, if any, other microcomputers — the line
D = RND(6)
will produce integers in the range one to six.
```

HILDERBAY LTD PROFESSIONAL SOFTWARE

If you don't believe that the Sinclair ZX81 can do real work, come and see us at the Computer Fair Exhibition, Earls Court (23rd-25th April) and the ZX Micro Fair, Central Hall, Westminster, London SW1 (30th April-1st May).

ZX81 & 16K SOFTWARE: Reviewed in "Your Computer" (Feb. 1982).

- ★ **Payroll** for up to 30 employees. Meets all regulations £25.
- ★ **Stock Control** Fast, big, and versatile £25.
- ★ **Budget** £15.
- ★ **Critical Path Analysis** Up to 500 activities £15.
- ★ **VAT & Mortgage & Loan** £8.
- ★ **GOLD:** A really good adventure; together with the intriguing "Pick a Word". £8.
- ★ **RELIABLE 16K RAM Pack** for the ZX81 £42.
- ★ **BEAMSCAN:** Beam analysis for architects and engineers £25.
- ★ **APPLE II Payroll:** £35.
- ★ **HEWLETT PACKARD 9845B:** Superspline (general purpose interpolation and tabulation).
- ★ **MEMOTECH 64K Memopak** £79.

DO YOU HAVE DIFFICULTY LOADING TAPES! We have the answers; and for well under £10. Contact us for more details.

CROFTON PROFESSIONAL KEYBOARDS, MONITORS, VDU's
Prices include VAT, Post & Packing. COD Orders £2 extra.

TAPE HINT: Don't use the first 20 seconds of your cassettes — most tape problems are found near the ends of the tape.

HILDERBAY LTD
8/10 PARKWAY, REGENTS PARK
LONDON NW1 7AA

Enquiries for Hilderbay Ltd. will now be handled
by HOLDCO LTD. Tel. 01-251 3090

ALSO ON ZX81 + 16K

Financial Budget/ Cash Flow Forecast: The program allows thirteen columns (12 months + total). The forecast can be changed and a "WHAT IF?" possibility can be examined on the screen. £25.

Sales Day Book: keeps a record of all invoices, with nett, VAT, zero rated and total. £18.

Purchase Day Book: keeps records of all purchases and VAT. £18.

Petty Cash Book: Keeps a record of all petty cash expenses and allows for VAT to be calculated from total if unknown. £18.

Cash Sales Day Book: as sales day book but with the additional "Method of payment" feature, incl. cash, cheque, postal order, Access, Barclays, sundries and unpaid. £18.

Cassette Recorders: individually tested for ZX81 and supplied with a test tape for loading. £22.

Barcharts for Architects: a simplified version, takes away the tedious task of manually handling the problem £25.

Bank Account: calculate your bank charges whilst keeping your account £5.

Architects Programs: Barchart with S-curve/Dewpoint calculations N.B.S. on computer/Structural programs/etc. etc.

All programs now also available for ATARI and SHARPE

HOLDCO LTD.
14, BRITTON STREET
LONDON EC1M 5NQ
Tel: 01-251 3090

ZX81 4K GAMES

Top quality fast action machine code

GUNFIGHT for one or two players, with stagecoach, bullet display, cacti, timer and two gunfighters.

SCRAMBLE guide your ship through the moving background, avoiding obstacles, missiles, bouncing bombs. Destroy alien installations with laser and bombs. Three phases.

SPACE INVADERS similar to the traditional game. 49 alien ships, flying saucer, deflector shield, static shields and laser base.

GALAXY INVADERS fleets of aliens, each alien has random movement and can bomb or crash into the base.

ASTEROIDS amass points as you fight your way through the asteroid belt using your laser and deflector shield. Beware those that break up into smaller ones.

All have on-screen scoring and are non-flicker.

Hundreds of satisfied customers. Minimum 4K RAM.

Excellent value at £3.95 per program on tape from

J. M. STEADMAN
6 Carron Close,
Leighton Buzzard, Beds. LU7 7XB

FREE
Software

INSTANT INTERACTIVE GRAPHICS ON ZX81

LIGHT PEN SET **£49.50**
for the RD 8100

(includes VAT & P&P)

*DRAW complex graphics with ease on your TV screen and avoid tedious line by line programming.

*Revise your display and SAVE on cassette, while your program runs.

*Push pictures points and pixels with a poke of the Pen and a program PEEK. Try our VIDEO-TIDDLYWINKS!

*MENU SELECTION — without keyboard entry.

The RD 8100 LIGHT PEN SET consists of the RD 8101 'MICROMUM' MOTHERBOARD, the RD 8180 LIGHT PEN with MODULE, and the RD 8100 SYSTEM MANUAL. Plug into your ZX81 — and LOAD, from the FREE RD 8100 SOFTWARE CASSETTE (1K and 16K), or write your own BASIC programs.

All orders are acknowledged, with a firm delivery date. Send just £49.50 (VAT and postal charges are included) to:



RD Laboratories

5 Kennedy Road, Dane End, Ware, Herts.
SG12 0LU (0920 84380)

For details of the Full RD 8100 SYSTEM of ZX81 interfaces, including Logic I/O, Analogue Input, Analogue Output, 8-Channel Analogue Multiplexer, Buffered Motherboard, send us a stamp.

Fingertips is our regular calculator column covering calculator news, programming hints and examples of unusual applications. The column is written and compiled by calculator enthusiast David Pringle who is glad to hear of any of your ideas. *Your Computer* pays £6 for each of your contributions published.

THE PACE AT which the top-of-the-market calculator firms modify and improve their products is stupendous and more than a little disconcerting for those of us who have a small bank balance, or a middle- to lower-end of the market calculator. For any of you in either or both of these categories, forgive me for dangling the following bait in front of you.

To review the past six months of developments I would precis the big three of up-market calculators as follows: Casio, Hewlett-Packard and Texas Instruments. I have kept you abreast of Casio's new range of 500, 600 and 700 series, but what of Hewlett-Packard's peripherals? These must be of interest not only to Hewlett-Packard fans, but to all of us who are interested in seeing how the personal programmable calculator is to develop into the portable pocket computer.

The Hewlett-Packard interface loop (HP-IL) — available in the United States since January — centres on a device which lets the HP-41 control and communicate with other machines and computers. This loop would, for instance, allow someone to gather data in the field and pump it into a larger mainframe computer at a later stage, or vice versa.

The HP-IL is Hewlett-Packard's standard for serial interfacing of its devices, including the 41-C, in a loop and allowing the serial transmission of data around that loop. A staggering number of 981 devices may be attached with maximum data transfer rates of 5,000 bytes per second.

With an HP-41 in the loop, the data transmission rate falls to the order of 200 bytes per second because, for serial transfer, the rate of transmission will be determined by the slowest component in the loop. Bank managers will groan when they hear that none of Hewlett-Packard's old peripherals appear compatible with the loop, and so a whole new series has been developed.

The most exciting is the digital cassette drive which has 128K of memory capacity with 13-second average file access time. This rectifies, admittedly in an expensive manner, a long-standing deficiency of the Hewlett-Packard armoury.

Other peripherals include a 101-character wide thermal printer with parsing and formatting, and a high-resolution video interface. One interesting facility of the loop is the ability to "wake up" any particular peripheral from a power-saving standby mode.

Lowering ourselves to slightly less

expensive planes, Hewlett-Packard has introduced a new extended function memory module. This provides an extra 127 registers of X-RAM and 47 new functions including a programmable Size command and improved assignment and flag-clearing instructions. The most interesting new peripheral, though, is the 82182A timing module which gives several options for alarms, a stop-watch capable of storing up to 319 split times in RAM and a timing resolution of 10ms.

While the machine is turned off, the clock still receives enough power to run and can wake the calculator at any specified time. I must admit that I have not seen the last two in action but they are on general release.

I am absolutely delighted that someone has conceived a useful application for Casio's musical ability. I hand over to Dave Newman of Auld Reekie.

Program P2 — see figure 1 — splits a number in the display into its constituent digits, putting them in memories 09 down to 01, with the exponent and its sign in memories 12 to 14. Numbers are always output in scientific notation. If the number is negative -1 is stored in memory 09 and the eight most significant digits of the number in memories 08 to 01. Memory 12 stores the sign of the exponent; -1 for negative, -2 for positive.

Subroutine P4 then converts these numbers into note codes spread over the whole scale of notes played by the calculator. These 12 notes correspond in increasing pitch +, -, 0, 1, 2, 3, 4, 5, 6, 7, 8, and 9. Figure 2 shows the note codes calculated from the number 1.23456789E+00.

In use, when a calculation has been completed the user presses P2, with the cassette adaptor switch in the Cal position. After allowing

Figure 2.

```

MEMORY LIST
M00-19,F-1F 512steps
FILE : HEAR

M00= 0.
M01= 37.24504366
M02= 44.59041297
M03= 53.38441663
M04= 63.91275051
M05= 76.51745464
M06= 91.60882527
M07= 109.6747185
M08= 131.3044772
M09= 188.2025695
M0F= 1.

M10= 0.
M11= 0.
M12= 225.319384
M13= 157.2
M14= 157.2
M15= 0.
M16= 0.
M17= 0.
M18= 0.
M19= 0.
M1F= 0.

-1.23456789
-1.23456789E 00
    
```

Figure 1.

```

PROGRAM LIST
M00-19,F-1F 512steps
FILE : HEAR

*** P0
MR09
MR08
MR07
MR06
MR05
MR04
MR03
MR02
MR01
MRF
MR12
MR13
MR14
AC

...015steps

*** P2
Min14
9 Min00
2 +/-Min12
MR14 x>=0 GOT00
x1 +/-Min09 m+00=
Min14
LBL0
100 INT MinF +/- 10^X
x MR14
LBL1

- INT IND Min00 = x
10 =
DSZ GOT01
MRF x>=0 GOT02
x 1 +/- Min12
LBL2
+10 - INT Min13 =x
10 = Min14
9 Min00
LBL3
IND MR00
GSP4
IND Min00
DSZ GOT03
MR12
GSP4
Min12
MR13
GSP4
Min13
MR14
GSP4
Min14
1 MinF

...078steps

*** P4
x.18+/- = e^X x 157
.z=

...015steps
    
```

some time for the note codes to be calculated, the user switches the adaptor to music and presses PO to output these notes to a tape recorder. He will hear nine tones for the number followed by a pause and then three tones for the sign and value of the exponent. PO can be pressed again if the user is not sure of the number. Afterwards the adaptor has to be switched to Cal before continuing calculations.

A slow tempo is set in memory F. As the user becomes familiar with the tones, he can speed up the output by changing the last line of the program to put higher numbers into memory F.

While learning the tones, program P1 may be useful — see figure 3. To use enter a single-digit number, e.g., 4, then press P1 and wait until it has had time to calculate the note code. Then change the adaptor switch to the music position and press Exe, whereupon the tone corresponding to 4 is recorded on tape or heard on a monitor earphone.

Note that this program uses all the memories on an FX-501P or 601P, so anything in these memories will be lost on calling P2. If numbers in these memories are needed later, they have to be saved on cassette before listening to a result.

For the FX-502P and 602P, other programs must use memories 10,11 and 15 onwards to keep numbers which are wanted after hearing a result.

On the FX-501P and 601P calculators the programs P0 and P2 must be written with the calculator connected to an FA-1 or FA-2 adaptor with the switch in the Music position — but run with this in the Cal position. Thus Min 12 is written Min.2, etc. The memory 1F used in P1 can be changed to any convenient memory.

It would be interesting to hear from any blind people who succeed in using this program.

Paul Stockwell of Andover asks why there are no programs for the Commodore PR-100. Well, here is his to make up for it.

The purpose of this program is to find the point of intersection of two

straight lines; one is in the calculator's linear regression function, and the other is the user's program.

The program requires only two cartesian (x,y) co-ordinates for each of the lines. Two or more sets of co-ordinates may be entered into the linear regression function, as described in the instruction manual, for the first line which may be of positive or negative slope. The second line can then be entered in memory. Only two co-ordinates may be entered and these are entered in memories 0-3 as shown in table 1. Note this second line must be of negative slope.

When the program is started it will run briefly to evaluate the slope and intercept of the second line and will

```

PROGRAM LIST
M00-19,F-1F 512steps
FILE : HEAR

*** P1
GSP4
MIN1F
HLT
MR1F
AC

...006steps
    
```

Figure 3.

stop to display 0. The value of the first increment is then placed on the display. This is both to speed up the program and to allow the required degree of precision to be set.

If the intersection value was 1, for example, and the increment was 0.001 then the machine would do $1 \div 0.001 = 1000$ loops. If the increment were, say 0.1 then it would do only 10 loops.

This means that a substantial speed increase can be obtained by allowing progressively smaller increments to be entered. This program allows this, and increments from 1 down to 0.000001 can be entered. The second number is the lower limit of accuracy.

If the increment is greater than the intersection value, it will display 0; if not, it will display the most accurate

(continued on next page)

Memory No	Contents
0	value of 1st x ordinate
1	value of 1st y ordinate
2	value of 2nd x ordinate
3	value of 2nd y ordinate
5 to 9	linear regression

Table 1. Memory contents before first run

Memory number	Contents
0	slope of second line m
1	constant of second line c
2	value of x intercept Xi
4	value of increment
5 to 9	linear regression

Table 2. Memory contents after first run.

(continued from previous page)

value of the intersection's x ordinate it can find in the increment range.

The program will also pick the best straight line through a selection of points if they are entered into the linear regression function, before finding the intersection. The no-operation step, number 54, is entered by placing the calculator's three-position switch in the clear mode and pressing the step key once before returning to load mode.

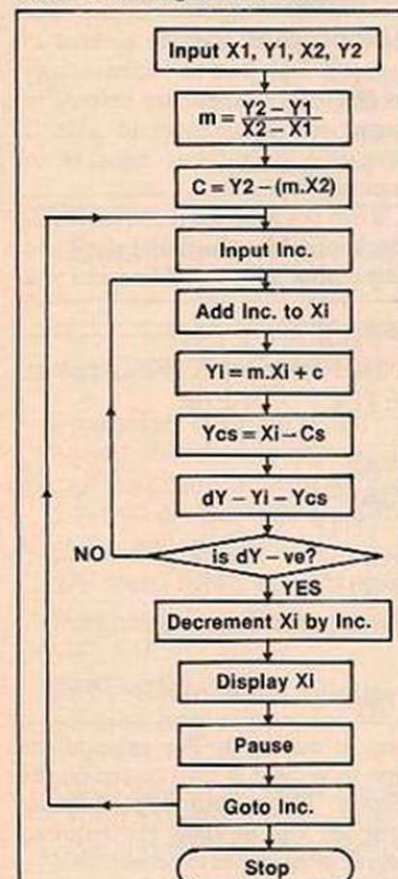

Figure 4. Flowchart for intersection program.

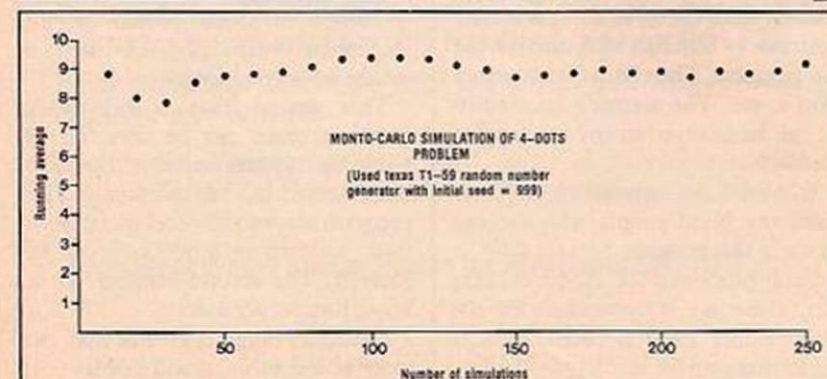

Figure 8.

Figure 5. Intersection program.

STEP NO.	REMARKS	KEY NO.	PNTR.	KEY FUNCT.	STEP NO.	REMARKS	KEY NO.	PNTR.	KEY FUNCT.
1	recall Y2	52	00	MR	36	Inc.	71	35	4
2		81	01	1	37	add Inc.	21	38	F
3	subtract Y1	85	02	-	38	to Xi	84	37	M+
4		52	03	MR	39	in M2	82	38	2
5		83	04	+	40	recall Xi	52	39	MR
6	divide result by X2 - X1	75	05	÷	41		82	40	2
7		64	06	(42	multiply m	74	41	X
8		52	07	MR	43	= m.Xi	91	43	O
9		91	08	0	44	add c	84	44	+
10		85	09	-	45	recall c	52	45	MR
11		52	10	MR	46		81	46	1
12		82	11	2	47		95	47	=
13		65	12)	48	Yi = mXi + c	85	48	-
14	gives m	95	13	=	49	subtract	64	49	(
15	store in memory 0	51	14	M	50		52	50	MR
16	recall X2	91	15	0	51		82	51	2
17		52	16	MR	52	recall Xi	44	52	Cs
18		82	17	2	53	Ycs	65	53)
19	multiply by m	74	18	X	54	1	99	54	step
20		52	19	MR	55	No Op.	95	55	=
21		91	20	0	56	Yi - Ycs	15	56	SKIP
22	subtract from Y2	85	21	-	57	If -ve skip to	14	57	GOTO
23		52	22	MR	58		83	58	3
24		83	23	3	59		71	59	4
25	exchange registers	55	24	X - Y	60	Yi = Yi + Inc	52	60	MR
26	store c	95	25	=	61	If Yi - Ycs	71	61	4
27		51	26	M	62	decrement Xi	21	62	F
28		81	27	1	63		85	63	M-
29	clear M2	91	28	O	64		82	64	2
30		51	29	M	65		52	65	MR
31		82	30	2	66	display Xi	82	66	2
32	pause for inc.	13	31	R/S	67		13	67	R/S
33		51	32	M	68	pause	14	68	GOTO
34		71	33	4	69	input new inc. value	83	69	3
35	recall	52	34	MR	70		81	70	1

If 2nd line to be +ve slope then insert key X+Y in location 55.

If the exchange-registers key is entered into location 54 instead, the machine will find the intersection for a second line with a positive slope only. If the increments entered are smaller than one another by a factor of 10 each time then there will be no more than 10 loops each successive run. If there are too many, try a larger increment, and if this does not work then the lines may not cross.

Finally, a novel attempt at analysing the solution of December's four-dot problem comes from Alan Stevens of Alvaston. To refresh your memory, the problem is: starting at a side dot, what is the expected, or average number of moves to traverse to the dot on the opposite side gives:

Prob. → Left 2 or 3 = Prob. ← Right 2 or 3 = 1/2
 Prob. → Left 1 = 1
 Prob. → Right 4 = 1

1 2 3 4

It is a pleasing problem, he writes — simply stated, but requiring careful thought. Unfortunately, I discovered an analytical solution. This made it seem somewhat pointless trying to perform the numerations to within 10⁻⁶ on the calculator. However, I thought it would be interesting to write a program to perform a Monte Carlo simulation of the problem, using the pseudo random number generator on any Texas Instruments TI-59 calculator.

To run the program store a seed in 09 and the number of simulations to be run through in 06, then press RST and R/S.

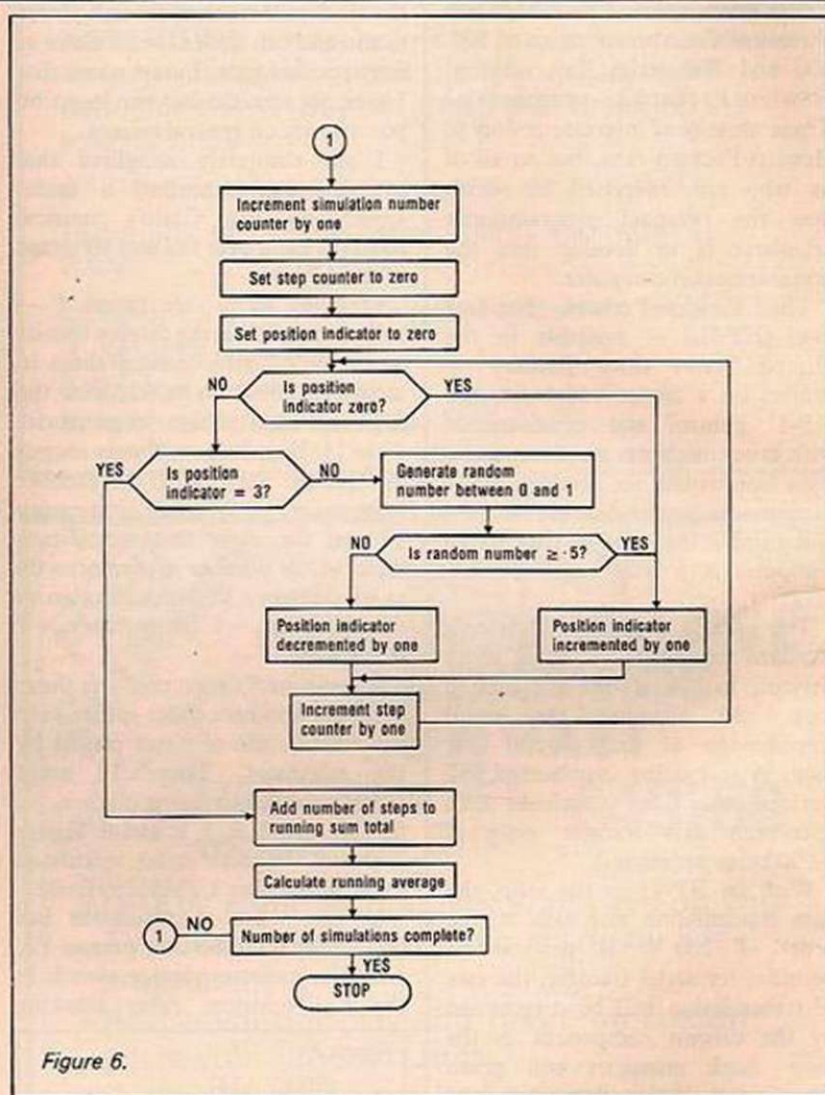

Figure 6.

Op	Contents
21	x>=t 036
CLR	Op 33
STO 02	GTO 038
STO 03	Op 23
RCL 03	Op 22
x=t 036	GTO 007
RCL 03	RCL 02
-	SUM 00
3	RCL 00
=	÷
x=t 043	RCL 01
Psm 15	=
SBR D.MS	STO 04
-	Prt
.5	Isz 6 000
=	R/S

Figure 7.

ZX81 Workstation...



... is a stylish and ergonomic plinth for the ZX81. It raises and tilts the TV to avoid eyestrain, holds the 16KRAM in place and hides the wiring and power supply. This very professional unit costs £15, a built-in power switch is £3, plus postage at £1.50, inc. VAT. Peter Furlong Products, 125 Catford Hill, London SE6 4PR. Callers by appointment, please. Tel 01690 7799. Visa, Access.

COMPUTACALC ZX

MONTHLY BUDGET FIGURES

	DEC	JAN	FEB	MAR	APR	MAY
MORTGAGE	157	167	157	157	157	157
PHONE	42		35			
GAS		52			35	
ELECT.	43			38		
CAR	63	72	63	61	70	58
INSUR.	12	12	12	12	12	12
RENTS			235			
TOTAL	284	293	284	278	284	277

Financial Planning for the ZX81 16K

Ideal for solving "what if" problems at work or home. The screen acts as a window on an "electronic worksheet" consisting of a grid of rows and columns of headings, numbers or formulae.

This powerful piece of software brings the capabilities of the ZX81 into line with much more expensive computers. Computacalc will quickly become the most used program in your library as it takes over from pen, paper and calculator in aiding everyday financial decisions. For further details see Guy Kewney's article in Datalink 30/11/81, send SAE or ring 01-603 6074.

For cassette and full documentation send cheque or P.O. for £7.95 to: **Silicon Tricks, Dept. C5, 3-4 Chichester Rents, Chancery Lane, London WC2.**

*Silicon
Tricks*

BEEBUG FOR THE BBC MICRO

INDEPENDENT NATIONAL USER GROUP FOR THE BBC MICRO

IF YOU'VE GOT A BBC MACHINE, OR HAVE ORDERED ONE, OR ARE JUST THINKING ABOUT GETTING ONE, THEN WE HOPE BEEBUG HAS SOMETHING TO OFFER YOU.

BEEBUG provides a central information point for users of the BBC Micro, and is a registered referral centre for the BBC project.

We run a regular newsletter (10 issues per year) devoted exclusively to the BBC machine.

New program listings in each issue (3-D Noughts and Crosses, and full colour Moon Lander in the April issue). Hardware hints and tips. How to decide between the A and B options. How to upgrade the A option. Reviews of the latest software. A series of articles on getting the most out of your machine. How to add joysticks and games paddles to both the A and B options. Software competition. A beginners guide to BBC BASIC starting in the April issue. Discount software and hardware. Regular advice clinic to answer your queries. Other projects and activities in the pipeline, plus a host of ideas contributed by members.

Dr D. E. Graham,
Sheridan Williams

Membership:
Introductory offer:
6 months £4.50
1 year £8.50

Make cheques payable to BEEBUG or s.a.e. for further details

BEEBUG
PO BOX 50
St. Albans, Herts.

ZX81 BUSINESS SOFTWARE

BUSINESS BANK ACC.

Enables you to enter your debits under nine separate sub headings. Balance totals all the headings. Print-outs can be used for your accounts.

PURCHASE LEDGER

Keeps a complete record of all your receipts under nine separate sub headings. Program also calculates and deducts VAT.

SALES LEDGER

For your invoices, includes separate file for details of each invoice. For small businesses and the self employed. All the programs will accept entries up to £99999.99p. Will enable you to prepare your accounts at the touch of a button, even if you are not VAT registered.

16K Programs accepts 225 entries	£8.75
32K Programs accepts 700 entries	£10.75
Special packs including all three programs	
16K	£25.00
32K	£30.00

Prices include VAT and p&p. Cheques made payable to TRANSFORM LTD.

For further information s.a.e. or phone:

TRANSFORM LTD.,
41 Keats House, Porchester Mead,
Beckenham, Kent. 01-658 1661

Calls welcome by appointment.

TRANSFORM LTD.

3500 BAUD FOR ZX81

THE L.E.S FAST TRANSFER SYSTEM TRANSFERS PROGRAMS AT 3500 BAUD YET USES ANY GOOD QUALITY CASSETTE FOR PROGRAM STORAGE. SOFTWARE TO CONTROL OUR EPROM PROGRAMMER IS BUILT IN.

Just plug into the expansion port to use. Use of the RAM pack is unaffected.

£99.50 inclusive

EPROM PROGRAMMER

PROGRAMS 2716 2732 AND 2764 EPROMS UNDER SOFTWARE CONTROL. THE SOFTWARE TO CONTROL THE PROGRAMMER IS SUPPLIED FREE ON CASSETTE AT 300 BAUD IF REQUIRED

BUILT AND TESTED £42.00 : KIT £36.00

Motherboard

A fully buffered motherboard equipped to hold up to 6 expansion boards. An auxiliary power regulation circuit is fitted if requested.

BUILT £33.50 : WITH AUXILIARY £35.00

Eprom board

The EPROM board will hold 4 X 2716 EPROMs which are switch selected.

KIT ONLY £10.00

All prices inclusive

LANSLOWNE Electronic Systems

25 LANSLOWNE St. DARLINGTON, Co. DURHAM DL3 0NJ

ZX81 2X 8 Bit Parallel Interface

Features 16 user programmable input/output lines under your control. Use it to control:

- Heating
- Lighting
- School Experiments
- Robots
- Printer

Many more applications. Example software and circuit suggestions supplied with each board.

APPLE A/D Converter

Reads 8 analogue channels with 8 bit resolution. Bipolar inputs. Turns your Apple into an eight channel data logger/chart recorder/oscilloscope. Supplied with notes and software (specify DOS 3.2, 3.3 or cassette), in an attractive ring binder.

APPLE Universal Printer Interface/Real Time clock
Clock gives time/date to tenth sec. and interrupt. Interface includes software to drive most common printers. (Can also be used as 8 bit port.)

ZX81 Card £16.50 + £2.48 VAT + 30p p&p.
APPLE A/D Converter £49.95 + £7.49 VAT + £1.00 p&p.
APPLE Universal Printer Interface/Real Time Clock £79.00 + £11.85 VAT + £1.00 p&p.

ANDREWS DEVELOPMENTS,
93 Beaconfield Villas, Preston Park,
Brighton. Tel: (0273) 564629

PROGRAMS for the GENIE and TRS-80 Model I

GAMES: 4K Level II minimum (packing, post and VAT included in these prices).

MONOPOLIST: Beat the computer if you can! Risk an auction. Your micro joins in the famous 'MONOPOLY' game; increased competition and fun; speculation control.
Instructions included. Cassette £7.95 mini diskette £10.95.

WHAT NEXT?/MOTHS/NEW WORLD: Three games to intrigue you, excite you and win you money! Predict your opponent's next move.
Instructions included. Cassette £3.95 mini diskette £6.95.

BUSINESS: (packing and post included, VAT extra).

QUICK-CHANGE: Price list editor; prices of individual items, columns or whole lists changed by factors. 16K level II minimum; state memory size for SS SD diskette.
Instructions included. Cassette £9.95 mini diskette £12.95.

BQ81: Business quotations. Improve quotations, extend consistency yet have flexible adjustment factors. One 30 line library page with built-in tasks, create others for recall/reuse. Run 'what if' pricing and labour variations, optimise quotes, maximise profits. Uses 48K, twin diskette system.
Program and operating instructions. Mini diskette £79.95.

NEWS80: Purpose written newsagents' retail accounting; AM/PM round, price changes, Auto-billing and charging, receipts, payments, enquiries, video-tape hire, customer announcements, wholesale reconciliation, 'holds' etc. Stores 1,500 accounts, 500 titles, 1,500 tapes, 900 video accounts, 30 rounds on twin SS SD diskettes; 48K system.
Version 2 program and handbook. Mini diskette £549.00.
Same system, minus rounds V2R or minus video V2V £499.00.
Similar program, Version 1, but neither rounds nor video £399.00.
Manual separately £7.50.

Also systems for multiple shops; ask for 'NEWS80' brochure.

CTNSTOCK: Stock control for CTN; runs on same system as 'NEWS80'.
Program and handbook. Mini diskette £79.00

MINDOS: Authorised subset of Apparat's NEWDOS+ to run above 40 track packages.
Included on diskette with programs (add VAT) £10.00.
On separate diskette (add VAT) £13.00.

BAUST COMPUTING CONSULTANTS
31 Peak Lane, Fareham, Hants PO14 1RX
Tel: 0329 281480

SOFTWARE FILE

Software File gives you the opportunity to have your programs, ideas or discoveries published. We will accept contributions for any personal computer and will group programs for like machines together in the file. Please double-check your listings before sending them, and specify the memory they require. Mark your letter clearly for *Your Computer*. We will pay £6 for each contribution published.

High resolution

David Rees,
Weybridge,
Surrey.

VIC-20

THE UNEXPANDED Vic is supplied with coarse graphics. To remedy this, I used a fresh approach to user-definable graphics. Instead of presetting the graphics characters, they are filled directly from the program as it calculates pixel co-ordinates. Using these

programs 27,024 or more graphics modes are available, depending on the amount of Vic screen your television can display.

The first part of the program, lines 10 to 40, clears the screen and fills it with character 208, so that the screen does not suddenly fill up with pixels if character 32 is Poked during the program.

A grid of characters is then Poked on to the screen. The example programs give a grid of 16 characters by 10 and gives a resolution of 128 by 160.

HIGH RESOLUTION GRAPHICS PLOTTING

```
10 PRINT"CLR HOME"
20 FOR N=0 TO 505
30 POKE 7680+N,208
40 NEXT N

50 FOR A=1 TO 16
60 FOR N=1 TO 10
70 POKE 7682+22*N+A,N+10*A-11
80 NEXT N
90 NEXT A

100 POKE 36867,27:POKE 36869,253

110 M=5120
120 FOR N=0 TO 2559
130 POKE M+N,0
140 NEXT N

150 FOR A=160 TO 2560 STEP 160
160 FOR N=7 TO 0 STEP -1
170 Y=INT((A-159)/20-N+8)
180 H=PEEK(M+A-Y)
190 F=2^N+H
200 IF F>255 THEN F=H
210 POKE M+A-Y,F
220 NEXT N
230 NEXT A

150 FOR A=160 TO 2560 STEP 160
160 FOR N=7 TO 0 STEP -2
170 Y=SIN(((A-159)/20-N+8)/15)*60+80
180 H=PEEK(M+A-Y)
190 I=PEEK(M+A-Y-1)
200 F=H+2^N+2^(N-1)
210 G=I+2^N+2^(N-1)
220 IF F>255 THEN F=H
230 IF G>255 THEN G=I
240 POKE M+A-Y,F
250 POKE M+A-Y-1,G
260 NEXT N
270 NEXT A

150 A=0:B=0:C=7
160 B=B+160
170 Z=(COS(((B-159)/20+8-C)/15)+0.5)*4
180 X=INT((COS(((B-159)/20+8-C)/15)+0.5)*4)
190 N=INT((Z-X)*8)
200 C=C-1
210 A=X*(-160)
220 IF A>1120 OR A<-1120 THEN 160
230 Y=INT(SIN(((B-159)/20-C+8)/15)*60)+80
240 H=PEEK(M+A-Y+1440)
250 F=2^N+H
260 IF F>255 THEN F=H
270 POKE M+A-Y+1440,F
280 IF C<0 THEN C=8:GOTO 160
290 IF B<2560 THEN 170

300 INPUT R#
310 POKE 36867,46:POKE 36869,240
```

Screen and character generator parameters are set by lines 50 to 90. To use the programs to their fullest, the functions of the first four control registers must be known.

Control register 1 is located at 36864 and controls the horizontal position of the screen. 12 is the normal Poke value. Subtraction from this value results in the screen moving to the left by the length of one graphics character each time. Addition results in movement of the screen to the right. Above 24 the screen becomes distorted.

Control register 2 is located at 36865 and controls the vertical position of the screen. 38 is the normal Poked value. Addition lowers the screen and subtraction raises the screen by the height of one pixel each time.

Control register 3 is located at 36866 and has a normal Poke value of 150. The range from 128 to 158 is useful. With each addition, the line length of the display is increased by one character, from 0 to 29 characters in length.

Control register 4 is located at 36867 and has a normal Poke value of 46. The register controls the number of rows of display area, and whether eight-by-eight or eight-by-16 characters are displayed. With each increase of two in the Poke value, the number of rows is increased by one. Even numbers give eight-by-eight characters and odd numbers give eight-by-16 characters.

Registers 1, 2 and 3 are mainly used with resolutions of extreme length or height. In this program, eight-by-16 characters will be used as they give access to a greater amount of memory and screen area — line 100.

Register 6, located at 36869, controls the location of the character generator. Its normal value is 240; 253 starts the character generator at location 5120 in the user RAM.

Next, the character memory is cleared for plotting lines 110 to 140. By bypassing this subroutine, composite patterns of different functions may be drawn. Now the parameters for point plotting are set up and the graph is drawn — lines 150 to 230.

Line 150 switches progressively from one column of characters to the next. Each column is 160 pixels high — 10 characters with 16 rows each. Line 160 regulates the production of individual pixels from left to right in each byte. Line 170 is the function which is being plotted. In this case it will produce a sloping line. $((A-159)/20-N+8)$ is the variable from which pixel positions are calculated and so should not be changed. Functions should be built around it. If the height of resolution is changed, use the following guide to produce the new variable:

$((A - \text{resolution minus one})/\text{resolution divided by eight}-N+8)^*$

Lines 180 to 210 Poke in new pixels while leaving the display intact. To produce larger pixels use alternative A together with the lines previously listed up to 140.

By adjusting the length of step, number of lines Peeked and Poked and adding $2(N-2)$, $2(N-3)$ etc., pixels ranging from two by two to eight by eight may be created. If step is not consistent with length of the pixels they will overlap.

The last type of program that may be needed is one to plot one function with

(continued on next page)

SOFTWARE FILE

(continued from previous page)

change in another. The alternative B program produces circles or ovals for which sine functions have to be plotted with cosine functions. Lines 10 to 140 are as listed previously.

Lines 170 and 180 contain the horizontal equation. The fractional part of the result is used to calculate N, or the portion in the character byte where the pixel is to be plotted. The whole number, X, is the number of character squares across from the starting position where the value is to be Poked. If the

horizontal function will be both negative and positive, it is best to have the base Poke position midway across the screen.

A separate set of variables is used to calculate the values of the functions, otherwise plotting would give the same values each time a similar horizontal or vertical point is reached.

Finally, for convenience, the following lines may be added to any of the programs so that after viewing the resulting graph, you may easily return to normal mode by pressing return.

300 INPUT R\$

310 POKE 36867,46:POKE 36869,240

Using these programs, the maximum mode possible on an unexpanded Vic is 128 by 192, by starting the character generator at 4096 and Poking from character 32 onwards or after the program memory space finishes. On an expanded Vic, the maximum possible mode is 128 by 256. I prefer the example mode as it has a memory safety buffer against accidental Poking and for extra program material.

BLOCK GRAPH

```

10 POKE 36879,127
20 G=8126:H=0
30 DIM A(11),B(11)
40 PRINT "CLR INPUT DATA FOR:—"
50 INPUT "JAN":A(0)
60 INPUT "FEB":A(1)
70 INPUT "MAR":A(2)
80 INPUT "APR":A(3)
90 INPUT "MAY":A(4)
100 INPUT "JUN":A(5)
110 INPUT "JUL":A(6)
120 INPUT "AUG":A(7)
130 INPUT "SEP":A(8)
140 INPUT "OCT":A(9)
150 INPUT "NOV":A(10)
160 INPUT "DEC":A(11)
170 L=A(0)
180 FOR J=0 TO 11
190 IF A(J)>H THEN H=A(J)+1
200 IF A(J)<L THEN L=A(J)
210 NEXT J
220 M=(H-L)/20
230 PRINT
240 FOR B=H TO L STEP-M
250 PRINT (INT(B*10))/10: NEXT
260 PRINT "SQQQQQQQQQQQQQQQQQQQQQQQ"
270 PRINT " JFMAMJJASOND"
280 FOR J=0 TO 11
290 B(J)=INT((A(J)-L)/M)
300 R=6
310 IF J=0 OR J=2 OR J=4 OR J=6
    OR J=8 OR J=10 THEN R=2
320 FOR S=0 TO B(J)
330 POKE G,160:POKE G+30720,R
340 G=G-22
350 NEXT S
360 FOR S=B(J) TO 0 STEP-1
370 G=G+22
380 NEXT S
390 G=G+1
400 NEXT J
410 GET A$:IF A$="" THEN 410
420 FOR S=0 TO 11
430 X=X+B(S)
440 NEXT S
450 X=INT(X/12)*22
460 G=8126
470 FOR S=1 TO 12
480 POKE G-X,45:POKE G-X+30720,5
490 G=G+1
500 NEXT S
510 GET A$:IF A$="" THEN 510
999 END

```

Block graphs

Jenny Dodsworth,
Aldfield,
North Yorkshire.

VIC-20

HERE IS a small program for the Commodore Vic. It will draw block graphs on monthly data, automatically adjusting the scale. After the graph has been displayed, press any key to find the average.

Not St George's day

P Watson,
Hartlepool,
Cleveland.

ZX-81

IN THIS GAME for the 16K ZX-1 the user acts the part of St George. His mission to reach the damsel at the top of the screen. His task is, however, complicated by the dragons which appear from random positions.

Every time he completes his task he has to start again — this time, with one more dragon. There is a maximum of 12 dragons which can be altered if desired.

The dragons are shown by the £ signs and St George and the damsel by G and * respectively. The player moves by using the arrow keys 5 to 8.

```

10 REM ST GEORGE BY P. WATSON
20 REM 18\2\82
30 DIM M$(20,30)
40 DIM R(12)
50 DIM Q(12)
60 LET Z=1
70 POKE 16418,0
80 FAST
90 CLS
100 PRINT " [32 x ■ ] "
110 PRINT AT 0,6;"THERE ARE";Z;" DRAGONS"
120 REM SET UP LANDSCAPE
130 FOR I=1 TO 20
140 FOR H=1 TO 30
150 LET M$(I,H)=" "
160 IF INT(RND*10)>7 THEN LET M$(I,H)="£"
170 NEXT H
180 PRINT "■";M$(I);"■"
190 NEXT I
200 REM POSITION GEORGE
210 LET GY=19

```

(continued on page 79)

reprints

If you are interested in a particular article/special feature or advertisement in this journal
HAVE A GOOD LOOK AT OUR REPRINT SERVICE!

We offer an excellent, reasonably priced service working to your own specifications to produce a valuable and prestigious addition to your promotional material. (Minimum order 250 copies). Telephone Michael Rogers on 01-661 3036 or complete and return the form below.

To: Michael Rogers, Your Computer, Reprint Department, Quadrant House, Sutton, Surrey SM2 5AS.

I am interested in copies of article/advert. headed featured in this journal on pages, issue dated

Please send me full details of your reprint service by return of post.

Name

Company

Address

Tel. No

See us at the Computer Show, Earls Court 23rd-25th April.

ZX81 HARDWARE/ SOFTWARE

NEW! ANALOGUE PORT II

An 8 channel analogue to digital converter, 8 line digital output and 6 line peripheral select port. Measure up to 8 voltage inputs to an accuracy of 0.30% (8 bit) enabling the monitoring of almost any transducer output.

Specifications:

- 100 us conversion time
- Full scale sensitivity variable up to 5.0V
- Variable gain amplifier for mV sensitivities on channel 0
- Stackable connector for printer and RAM pack
- No external power supply needed
- Digital outputs will drive reed relays directly
- 3 LED's on board

Assembled and tested £29.95

16 pin DIL header plugs £1

ZX81 EXPERIMENTER KIT

- (a) 23 + 23 Edge connector £4
- (b) Stacking strip £1.50
- (c) Both (a), (b) and veroboard with suggested circuits £7.50

FAST FOURIER TRANSFORM SOFTWARE

For frequency analysis of data; on cassette, with manual £15.20. Please add £1 post and packing to cost of order. Delivery normally return of post. Money back guarantee if not satisfied. Cheques and P.O.'s payable to UNIVERSITY COMPUTERS. Bulk order, official orders accepted.

UNIVERSITY COMPUTERS
 5, ST. BARNABAS ROAD,
 CAMBRIDGE CB1 2BU

MICROCOMPUTER COMPONENTS LOWEST PRICES - FASTEST DELIVERY

MEMORIES AT UNBEATABLE PRICES

		1+	25+	100+
2114	Low Power 200ns	0.93	0.89	0.84
2708	450ns	2.25	1.99	1.80
2716	450ns	2.45	2.25	1.95
2532	450ns	4.50	4.25	4.05
2732	450ns	4.95	4.65	4.20
4116	150ns	0.93	0.89	0.84
4116	200ns	0.74	0.70	0.67
4118	200ns	3.90	3.45	2.99
5516	200ns	9.50	8.95	8.50
6116	200ns	5.70	5.35	5.05
6116	Low Power 200ns	7.60	7.20	6.75

*Official orders from educational establishments qualify for 100+ price.

OFFICIAL ORDERS WELCOME



24 HOUR TELEPHONE SERVICE FOR CREDIT CARD USERS



QUANTITY DISCOUNTS AVAILABLE

PLEASE SEND S.A.E. (20p) FOR OUR NEW 1982 CATALOGUE. FREE REPLIED PAID ENVELOPE WITH EVERY ORDER. ALL PRICES EXCLUDE P & P ON ORDERS UNDER £10 (75p) OVER £10 CASH WITH ORDER AT LIST PRICE ONLY AND VAT (15%). ALL ORDERS DESPATCHED ON DAY OF RECEIPT WITH FULL REFUND FOR OUT OF STOCK ITEMS IF REQUESTED.

MIDWICH COMPUTER CO. LTD.
 DEPT YC, HEWITT HOUSE, NORTHGATE STREET,
 BURY ST. EDMUNDS, SUFFOLK IP33 1HQ
 TELEPHONE: (0284) 701321 TELEX: 817670

EDUCATIONAL COMPUTING

Suit children ages 5-11

on the ZX81

No comparable collection offers so much for so little

THE LITTLE PROGRAMMES WHICH ARE BIG EDUCATORS

Here at last. A set of programmes to turn your Sinclair ZX81 into a powerful educational tool. And you don't even need to know programming. There are clear instructions and plenty of tips & advice. Designed to go beyond drill & practice the promote learning through interaction & discovery.

All programmes fit 1K

Creative use of graphics

Many innovative ideas

Fully documented

Includes many games

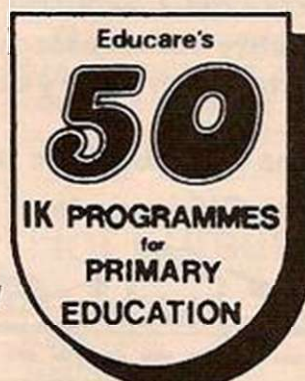

Includes:-

TORTOISE

A simplified version of the famous Turtle programme

CODED MISSILE

Combines the fun of arcade games with learning

£4.95 only incl. p & p

Graph-plotter ● Histogram ● Simon-spell ● Sketchboard ● Times-table ● Sets Series-quiz ● XY-coordinates ● Count ● Equations ● Areas ● Guess-a-Volume Angles ● Upstairs-Downstairs ● Music-notes ● See-saw ● Wipe-out ● Spell Temperature ● Clock ● Money ● Snake Mastermind ● Number-shoot ● + 26 more

EDUCARE

To: EDUCARE
 139a Sloane St.
 London SW1X 9AY

Please send me copies Educare's 50. I enclose cheque/postal order for £
 Name
 Address

Let your child benefit early. Send now.

Cassette Users: Everything you need for enhancing your
SINCLAIR ZX80/81

See us at the **ZX MICROFAIR**
 Stands 12-16

ANNOUNCING



Programme Control of multiple input/output tapes plus serial printer. Business Systems, Word Processing and Information Retrieval are now fast, easy to programme and save time.

ZX99+ AUTOMATIC TAPE DRIVE CONTROLLER
+ SUPER SOFTWARE

- ★ Programme Control for 1 to 4 cassette recorders
- ★ Interface directly to any serial printer (RS232C)
- ★ Single USR command tape to tape copy
- ★ Automatically create directory listings of programme storage tapes.

£59.95
 plus P & P

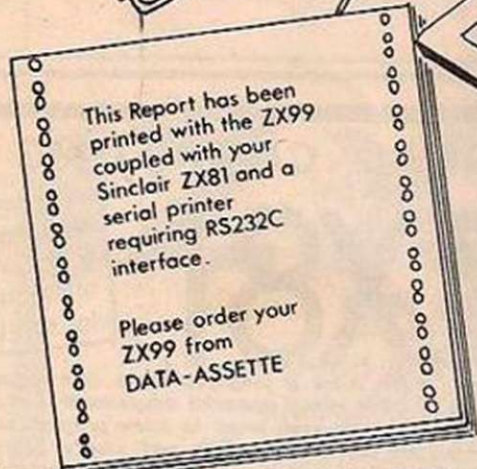
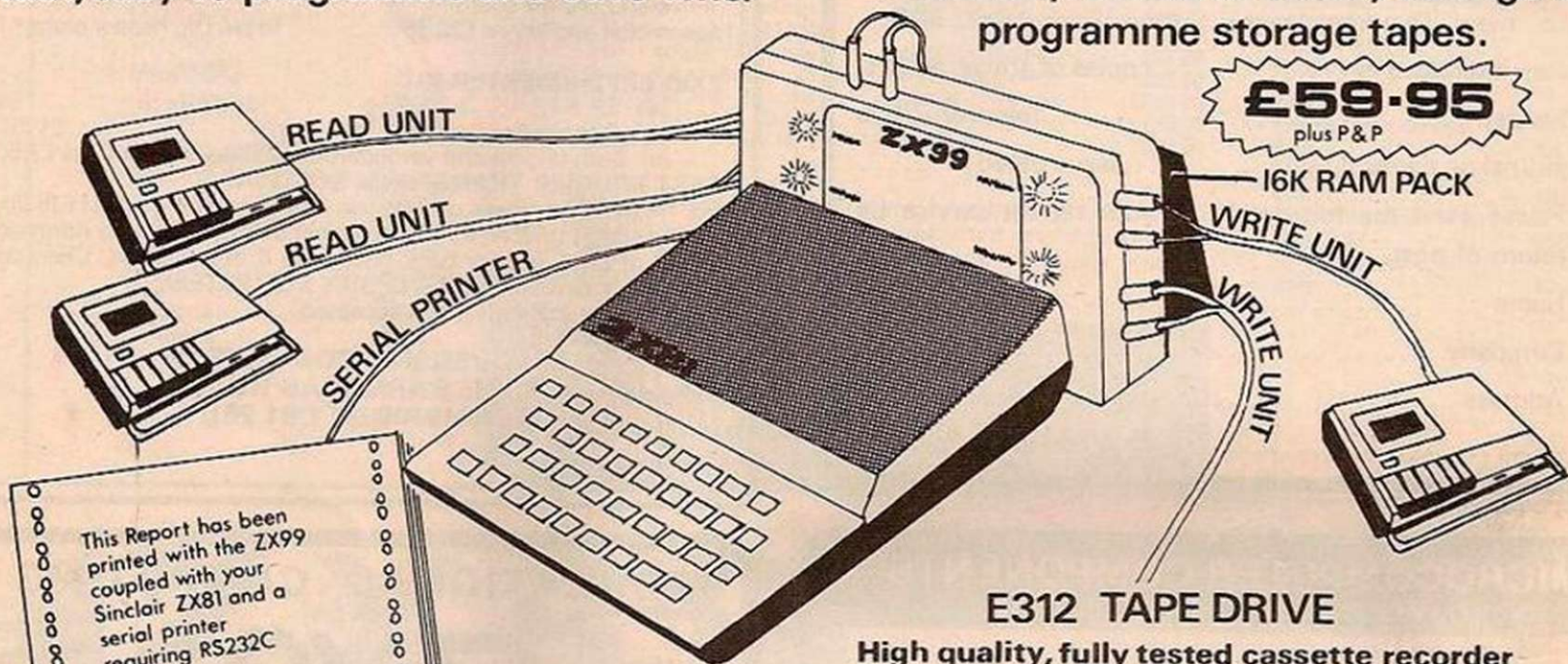

E312 TAPE DRIVE

High quality, fully tested cassette recorder ideal for use with your ZX81, also fully tested with BBC, ACORN etc.

£25
 inc P & P

Tape Counter

Ear Aux Mic/Remote sockets

battery mains

record light

COMPUTER CASSETTES
 High quality screw assembled cassettes with library box

All lengths available (see below)
 inc. C15 leaderless

COMPUTER CASSETTES	QTY	PRICE	TOTAL	ITEM	QTY	Price inc P/P	TOTAL
C5		35p		ZX99 Automatic Tape Controller + Super Software		£62.90	
C10		37p		E312 Cassette Tape Drive		£25.00	
C12		38p					
C15		39p					
C20		41p					
C25		43p					
C30		44p					
C15 Leaderless		£1.00					

Add min £1.50 or 10% P & P

Cheque/PO payable to Storkrose Ltd.
 or
 Charge my Access/Visa card no:

SIGNED _____

ORDER FORM TO:
 DATA-ASSETTE, Dept. YC1
 44 Shroton Street,
 London NW1 6UG Tel: 01-258 0409

Telephone enquiries welcome

NAME _____

ADDRESS _____

TRADE ENQUIRIES welcome from any country!

SOFTWARE FILE

(continued from page 76)

```
220 LET GX=INT(RND*20)+5
230 LET M$(GY,GX)="s"
240 REM POSITION DRAGONS
250 FOR I=1 TO Z
260 LET R(I)=INT(RND*10)+5
270 LET Q(I)=INT(RND*20)+5
280 NEXT I
290 REM MAKE ROOM FOR DAMSEL
300 FOR I=2 TO 4
310 FOR H=15 TO 17
320 LET M$(I,H)="s"
330 NEXT H
340 PRINT AT I+19,0;" [32 x ■ ] ";AT
    I,1;M$(I)
350 NEXT I
360 LET N=0
370 LET S=0
380 SLOW
390 PRINT AT GY,GX;"B";AT 3,16;"*"
400 REM GET PLAYER'S MOVE
410 LET Y=0
420 LET X=0
430 LET X=X-(INKEY$="5")+(INKEY$="8")
440 LET Y=Y-(INKEY$="7")+(INKEY$="6")
450 IF X=0 AND Y=0 THEN GOTO 430
460 REM IS THE POSITION EMPTY
470 IF M$(GY+Y,GX+X)=" " THEN GOTO 610
480 REM CARRY OUT MOVE
490 PRINT AT GY,GX;"s"
500 LET GY=GY+Y
510 LET GX=GX+X
520 PRINT AT GY,GX;"B"
530 REM IS HE HOME
540 IF GY=3 AND GX=16 THEN GOTO 850
550 REM TIME FOR A DRAGON?
560 LET S=S+1
570 IF S/5 <> INT(S/5) OR N+1>Z
    THEN GOTO 610
580 LET N=N+1
590 LET M$(R(N),Q(N))="s"
600 REM MOVE DRAGONS
610 FOR I=1 TO N
620 LET A=0
630 LET B=0
640 LET A=A-(GY<R(I))+(GY>R(I))
650 IF A <> 0 AND M$(R(I)+A,Q(I)) <> " "
    THEN GOTO 710
660 LET A=0
670 LET B=B-(GX<Q(I))+(GX>Q(I))
680 REM IS POSITION VALID
690 IF M$(R(I),Q(I)+B)=" " THEN GOTO 760
700 REM CARRY OUT MOVE
710 PRINT AT R(I),Q(I);"s"
720 LET R(I)=R(I)+A
730 LET Q(I)=Q(I)+B
740 PRINT AT R(I),Q(I);"E"
750 REM IS GEORGE CAUGHT
760 IF R(I)=GY AND Q(I)=GX THEN GOTO 800
770 NEXT I
780 GOTO 390
790 REM ST GEORGE IS CAUGHT
800 PRINT AT 21,5;"GEORGY BOY...YOU ARE DEAD"
810 PRINT AT 23,5;"YOU KILLEDs";Z;"sDRAGONS"
820 PAUSE 3000
830 STOP
840 REM HOME SAFE
850 PRINT AT 21,1;"NICE ONE GEORGE YOU ARE A HERO"
860 IF Z=12 THEN GOTO 930
870 LET Z=Z+1
880 PRINT AT 22,0;"BET YOU CANT SLAYS";Z;"sDRAGONS"
890 PRINT TAB(5);"PRESS ANY KEY TO START"
900 IF INKEY$ <> "" THEN GOTO 80
910 GOTO 900
920 REM ALL DRAGONS SLAIN
930 PRINT AT 23,1;"YOU HAVE KILLED ALL 12 DRAGONS"
940 GOTO 820
's' means space
```

RESISTOR FINDER

```
1 REM ***RESISTOR FINDER***
2 REM ***BY I.WEEKS***
3 REM *** 1982 ***
5 DIM A$(9),B$(9),C$(9)
10 FOR I=0 TO 9
11 READ A$(I):B$(I)=A$(I):C$(I)=A$(I):NEXT
15 PRINT CHR$(12)
20 PRINT TAB(165)"RESISTOR COLOUR CODE":PRINT
30 INPUT" 1ST COLOUR";A$
40 INPUT" 2ND COLOUR";B$
50 INPUT" 3RD COLOUR";C$
60 GOSUB 220
100 D=((A*10)+B)*C
110 IF D<1000 THEN 150
120 IF D<1000000 THEN 160
130 PRINT:PRINT" VALUE= "D/1000000"M.OHMS"
140 GOTO 190
150 PRINT:PRINT" VALUE = "D"OHMS"
155 GOTO 190
160 PRINT:PRINT" VALUE ="D/1000"K.OHMS"
190 PRINT:PRINT"Press 1 to repeat"
195 GET Z
196 IF Z = 1 GOTO 15
199 END
220 FOR I = 1 TO 9
230 IF A$ =A$(I) THEN A = I
240 IF B$ =B$(I) THEN B = I
250 IF C$ =C$(I) THEN C = 10*I
260 NEXT
270 IF A$ ="BLACK" THEN A = 1
280 IF C$ ="GOLD" THEN C = .1
290 IF C$ ="SILVER" THEN C = .01
300 RETURN
310 DATA BLACK, BROWN, RED, ORANGE, YELLOW,
    GREEN, BLUE, VIOLET, GREY, WHITE
```

Resistor finder

I D Weeks,
Prescot,
Merseyside.

MICROTAN

THE MICROTAN 65 program is for calculating the value of resistors from their colour-code bands, and occupies about 0.75K. There should be no problems in running it on other machines except for
15 PRINT CHR\$(12)

which is to clear screen.

The program could easily be converted to find the values of polyester and tantalum capacitors which use the same colour bands, but in picofarads instead of ohms.

Hot pursuit

S A Nicholls,
Keynsham,
Bristol.

ZX-81

THE PROGRAM is entirely in machine code with just line 3 in Basic to run it, and it will just fill the 1K ZX-81 including display. The program also makes use of most of the 33 spare bytes from address 16444.

It is a simple version of a maze chase. The display occupies 18 lines by 17 columns and consists of five overlapping squares with a row of inverse zeros in the last line for the score.

Five minus signs are then placed in the maze and one £ sign. The minus signs will
(continued on next page)

SOFTWARE FILE

16514	01 00 FF FF	RANDOM	36 80	LD (HL),128	7D	LD A,L
	12 00 EE FF	DIRECTION DATA	2A 48 40	LD HL,(16456)	2F	CPL
	2B	DEC HL	11 00 00	LD DE,0	6F	LDL,A
	06 07	LD B,7	ED 52	SBC HL,DE	E6 81	AND
	23	INC HL	22 48 40	LD(16456),HL	28 05	JRZ +5
	36 08	LD (HL),8	2B	DEC HL	11 12 00	LD DE,18
	10 FB	DJNZ -5	-7C	LD A,H	18 10	JR +29
	11 12 00	LD DE,18	85	OR L	7D	LD A,L
	-06 06	LD B,6	20 FB	JRNZ -5	E6 18	AND 24
	19	ADD HL, DE	2A 56 40	LD HL,(16470)	28 05	JRZ +5
	36 08	LD (HL),8	23	INC HL	-11 EE FF	LD DE,-18
	10 FB	DJNZ -5	22 56 40	LD(16470),HL	18 13	JR +19
	06 06	LD B,6	CB 45	BIT 0,L	7D	LD A,L
	2B	DEC HL	28 78	JRZ +120	E6 60	AND 96
	36 08	LD (HL),8	2A 0C 40	LD HL(16396)	28 05	JRZ +5
	10 FB	DJNZ -5	11 43 01 -	LD DE,323	11 01 00	LD DE,1
	06 06	LD B,6	19	ADD HL,DE	18 09	JR +9
	ED 52	SBC HL,DE	7E	LD A,(HL)	7D	LD A,L
	36 08	LD (HL),8	3C	INC A	E6 06	AND 6
	-10 FA	DJNZ -6	FE A6	CP 166	CA 29 41 -	JPZ 16681
	C9	RET	20 05	JRNZ +5	11 FF FF	LD DE-1
16556	11 11 00	LD DE,17	36 9C	LD (HL),156	2A 54 40	LD HL(16468)
	06 11	LD B,17	2B	DEC HL	16880	36 08
	3E 80	LD A,128	18 F5	JR -11	19	ADD HL,DE
	D7	RST 10	77	LD (HL),A	7E	LD A,(HL)
	10 FD	DJNZ -3	3A 3C 40	LD A,(16444)	FE 08	CP 8
	3E 76	LD A,118	32 69 41	LD(16745),A	28 06	JRZ +6
	D7	RST 10	-32 9D 41	LD(16797),A	FE 80	CP 128
	1B	DEC DE	C6 0C	ADD A,12	20 0A	JRNZ +10
	7A	LDA, D	32 6D 41	LD(16749),A	ED 52 -	SBC HL,DE
	B3	OR E	32 A1 41	LD(16801),A	36 0C	LD (HL),12
	20 F1 -	JRNZ -15	2A 00 40	LD HL,(40 XX)	22 54 40	LD(16468),HL
	06 11	LD B,17	ED 5B 00 40	LD DE,(40 XX)	C3 29 41	JP 16681
	3E 9C	LD A,156	36 08	LD (HL),8	16902	2A 0C 40
	D7	RST 10	-E5	PUSH HL	11 33 01	LD DE,307
	10 FD	DJNZ -3	2A 32 40	LD HL,(16434)	19	ADD HL,DE
	3E 76	LD A,118	ED 4B 33 40	LD BC,(16435)	36 B8	LD (HL),184
	D7	RST 10	09	ADD HL,BC	23	INC HL
16584	2A 0C 40	LD HL,(16396)	22 32 40	LD(16434),HL	36 A8 -	LD (HL),168
	11 14 00	LD DE,20	7C	LD A,H	23	INC HL
	19	ADD HL,DE	E6 06	AND 6	36 B4	LD (HL),180
	22 3E 40 -	LD (16446),HL	C6 82	ADD A,130	23	INC HL
	CD 8A 40	CALL 16522	6F	LD L,A	36 B7	LD (HL),183
	11 08 00	LD DE,8	16771	LD H,64	23	INC HL
	19	ADD HL,DE	26 40	LD C,(HL)	36 AA	LD (HL),170
	22 40 40	LD (16448),HL	-4E	INC HL	06 0B	LD B,11
	CD 8A 40	CALL 16522	23	LD B,(HL)	23	INC HL
	11 44 00	LD DE,68	46	LD A,C	7E	LD A,(HL)
	19	ADD HL,DE	79	CP E	FE 9C	CP 156
	22 42 40 -	LD (16450),HL	BB	JRZ +3	20 04	JRNZ +4
	CD 8A 40	CALL 16522	28 03	ADD A,E	36 12	LD(HL),18
	11 44 00	LD DE,68	83	JRZ -29	-10 F6	DJNZ -10
	19	ADD HL,DE	28 E3	POP HL	11 25 00	LD DE,37
	22 44 40	LD (16452),HL	E1	ADD HL,BC	01 21 01	LD BC,289
	CD 8A 40	CALL 16522	09	LD A,(HL)	2A 0C 40	LD HL(16396)
	11 08 00	LD DE,8	7E	CP 128	23	INC HL
	19	ADD HL,DE	FE 80	JRZ -46	7E	LD A,(HL)
	22 46 40 -	LD (16454),HL	28 D2	CP 12	FE 76	CP 118
	CD 8A 40	CALL 16522	FE 0C	JRZ +108	28 FA	JRZ -6
16637	3E 3E	LD A,62	28 6C -	LD (HL),22	16950	C6 81
	32 3C 40	LD(16444),A	36 16	LD (40 XX),HL	77	LD (HL),A
	21 00 19	LD HL,1900h	22 00 40	LD (40 XX),BC	-0B	DEC BC
	22 48 40	LD (16456),HL	ED 43 00 40	LD A,(16444)	78	LD A,B
	2A 0C 40	LD HL(16396)	3A 3C 40	INC A	B1	OR C
	11 16 01 -	LD DE,278	3C	INC A	20 F2	JRNZ -14
	19	ADD HL,DE	32 3C 40	LD(16444),A	01 00 03	LD BC,0300h
	22 54 40	LD(16468),HL	FE 48	CP 72	0B	DEC BC
16658	11 7D 00	LD DE,125	-20 A8	JRNZ -88	78	LDA,B
	ED 52	SBC HL,DE	3E 3E	LD A,62	B1	OR C
	36 25	LD (HL),37	32 3C 40	LD (16444),A	20 FB	JRNZ -5
	06 0A	LD B,10	16820	JR +6	1B	DEC DE
	16 30	LD D,48	18 06		7A	LDA,D
	1B	DEC DE	00		B3	OR E
	7A	LD A,D	02		20 DF	JRNZ -33
	B3	OR E	92	LINE '2 REM'	16971	C9
	20 FB -	JRNZ -5	00			RET (TO BASIC)
	7E	LD A,(HL)	EA		BASIC:	
	3D	DEC A	16828	2A 54 40	1 REM 308 B's	
	77	LD (HL),A	36 0C	LD (HL),12	2 REM 144 B's	
	10 F4	DJNZ -12	CD BB 02	CALL 'KEY ?'	3 RAND USR 16556	

(continued from previous page)

then move at random around the maze attempting to corner and land on the £ sign. The £ sign is controlled by the player and moves at twice the speed of the chasing minus signs. Any key in the top row of the keyboard will move you up — any key in the bottom row, except shift, will move you down. Any right-hand side key in the middle two rows will move you right and any left-hand side key in the middle two rows will move you left.

The movement of the minus signs is not entirely random, for once moving in a certain

direction they will continue to do so until they meet a cross-over at which point they will choose a random change of direction but not return on their original path. Each move of the minus signs will increase the score which gives an indication of the time you have survived in the maze.

Once your £ sign is captured, the game ends with a spectacular flashing screen, where the display runs through the ZX-81 graphics and inverse video set in about three seconds, and ends with your score displayed.

Built into the game are five levels of play

that can be accessed in the following way:

The basic game as listed.

A game that does not allow you to reverse direction, i.e., it erases the maze as you travel but leaves a trail which the minus signs can follow to rebuild the maze. Just type POKE 16881,155 as a direct move.

As game 1, but with speed constantly increasing after each move.

POKE 16881,8 direct command

POKE 16685,5 direct command

As game 2, but the speed increasing

POKE 16881,155 direct command

POKE 16685,5 direct command

SOFTWARE FILE

To change the constant speed of the game in options 1 and 2 Poke address 16644 with any value from 1 to 100. A value less than 25 will make it run faster and greater than 25 will run slower. Anything greater than 100 is really too slow to play.

For anyone who has not tried loading a machine-code program do not be put off by the listing or the time taken — the end program justifies this extra time and care. To start loading the program you will need to work in the fast mode. If you have the 16K RAM then set RAMtop to 1K, as the program will not work with a display file ready set up. Then enter line 1 Rem followed by 308 zeros then line 2 Rem followed by 144 zeros. Unfortunately, the ZX-81 will not accept a single Rem statement with 452 zeros.

As a double-check to ensure that you have the correct number of zeros in the Rem statements type:

PRINT PEEK 16822 direct command

This should give an answer of 118, showing line 1 is correct. Then

PRINT PEEK 16825 direct command

This should give an answer of 146 showing line 2 is correct.

Then, still in fast mode, enter the following hexadecimal-loader program:

```
10 LET X = 16514
20 LET A$ = ""
30 IF A$ = "" THEN INPUT A$
40 IF A$ = "S" THEN STOP
50 POKE X, 16 * CODE A$ + CODE A$ (2) - 476
60 PRINT AT 11,7; X;"SPC"; A$ (1 to 2)
70 LET X = X + 1
80 LET A$ = A$ (3 to)
90 GO TO 30
RUN (IN FAST)
```

You can now enter the hexadecimal codes as in the listing, either in pairs or blocks i.e., 01 newline — 00 Newline — FF Newline or 0100FFFF1200EEFF Newline and so on. Remember there are no spaces between the codes. The hexadecimal-loader program will give a display of the last address and code entered so that you can check the listing as you enter it.

I prefer to run in fast mode because the screen flicker does give an indication that an entry has been made without having to look up from the list to check.

After the last entry, at address 16971, enter S to end. Now type the only line of Basic necessary:

3 RAND USR 16556

and delete lines 10 to 90 as these are no longer required.

The program is best saved at this point, before running, just in case any incorrect entries have been made, which may result in loss of program when run. Should the program fail to run, reload it and check each address using the following Basic:

```
10 FOR X = 16514 TO 16971
20 LET A = PEEK X
30 LET B = INT (A/16)
40 LET C = A - B * 16
50 PRINT X;"SPC"; CHR$(B + 28); CHR$(C + 28)
60 NEXT X
GO TO 10
```

Then, by the use of Cont, you can check through the listing for errors, but remember, if correcting an error then Poke the address with the decimal value of the hexadecimal code. Conversions are at the back of the Sinclair manual.

MILLIKAN

```
10 MODE 4
20 VDU 28,0,5,39,0
30 P.: P.: P. "R....RAISES VOLTAGE"
40 P. "L....LOWERS VOLTAGE"
50 P. "S....STOPS EXPERIMENT"
60 P. "PRESS S AND <RETURN> TO START"
70 INPUT A$
80 IF A$ <> "S" THEN GOTO 30
90 MOVE 0,800: DRAW 500,800: MOVE 620,800:
DRAW 1279,800: MOVE 0,100: DRAW 1279, 100
100 Y = 799
110 A = 0
120 Q = (1.6E-19) * RND(10): V=INT (1.54E-14*9.81 * 5E-3/Q)
130 Z = INT ( 10000/ABS (A-V))
140 GCOL 0,1: GOSUB 250
150 FOR X = 1 TO Z: NEXT X
160 GCOL 0,0: GOSUB 250
170 IF A<V THEN Y=Y-2 ELSE Y=Y+2
180 IF Y>= 800 OR Y<= 100 THEN GOTO 270
190 P=INKEY(1)
200 IF P=82 THEN A=A+50
210 IF P=76 THEN A=A-50
220 IF P=83 THEN GOTO 280
230 IF A<0 THEN A=0
240 VDU 12: P.: P.: P.: P.A;"V": GOTO 130
250 MOVE 597, Y+3: DRAW 603, Y-3: MOVE 603, Y+3: DRAW 597, Y-3
260 MOVE 600, Y-5: DRAW 600, Y+5: MOVE 595, Y: DRAW 605, Y: RETURN
270 P.: P.: P. "EXPERIMENT FAILED!" : END
280 P.: P.: P. "MASS = 1.54E-14KG " : P. "SEPARATION = 5E-3 M" :
P. " VOLTAGE = " ; A;"V"
P. " PRESS S AND <RETURN> TO RESTART"
300 INPUT A$
310 IF A$ <> "S" THEN GOTO 280
320 VDU 12: P.: P.: P. " RADIATION ON - CHARGE ON DROP CHANGING
TO NEW VALVE"
330 FOR I=1 TO 3000: NEXT I
340 GOTO 110
350 END
```

Millikan

John Lewis,
Hillend,
Perth.

BBC

THIS PROGRAM is a simulation of Millikan's experiment, for which he received a Nobel prize in 1923. It is very difficult to set up in practice and yet it is a standard topic in A-level and university physics.

An oil drop charged with a random number of electrons is balanced between two plates across which is a variable voltage. When the correct voltage has been achieved, the experiment is stopped and the correct values should be substituted in the equation

$$Q = mgd/v$$

where Q is the charge on the drop in coulombs, mg is the drop mass, d is the plate separation and V is the balancing voltage.

A blast of X-rays then changes the charge on the drop, the drop must again be balanced and the charge calculated. The experiment must be repeated many times — Millikan did it hundreds of times. The charge on one electron is the smallest interval found between the results for the charge on the drop. The accepted value for the charge on an electron is 1.6E -19 coulombs.

Winning sequence

John Lewis,
Felinfoel,
Llanelli, Dyfed.

ZX-81

THIS PROGRAM imitates those number-sequence puzzles often found in intelligence tests. These usually follow the format: Find the next number in the series 6, 13, 34, 97, ?. But be prepared, this program produces a considerably more difficult puzzle.

The governing equation in line 115 is carefully designed to produce a sequence of random length, and not only puzzles of differing levels of difficulty, but also puzzles

(continued on page 83)

```
1 REM SEQUENCE BY JOHN M. LEWIS, 1981
2 PRINT "COMPLETE THE SEQUENCE OF NUMBERS YOU ARE ABOUT
TO SEE"
3 SLOW
4 PAUSE 200
5 CLS
10 LET B=INT (RND*10) +1
20 LET C=INT (RND*10) +1
30 LET D=INT (RND*10) +1
100 FOR A=0 TO INT (RND*6)+4
110 PRINT B
115 LET B=B+(B+C)-D*B
120 NEXT A
125 FAST
130 INPUT X
140 IF X=B THEN PRINT AT 12,8;" CORRECT, IT WAS ";B
150 IF X<>B THEN PRINT AT 12,8;" WRONG, IT WAS ";B
160 GOTO 3
```

Wherever you are in the UK there's a Genie dealer nearby

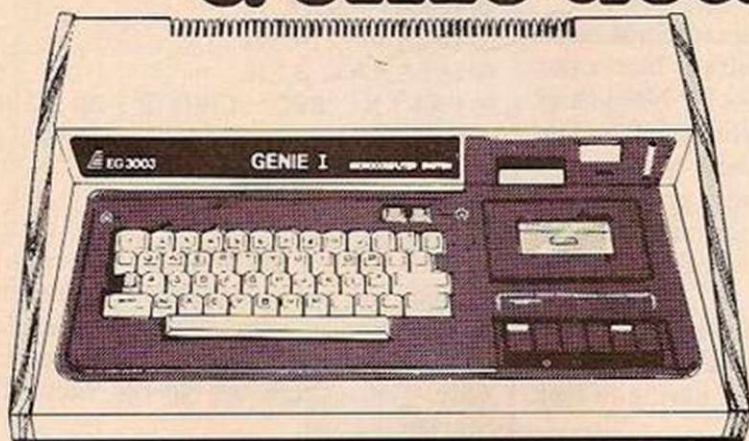

Genie I & II Approved Dealers

AVON Microstyle, Bath, 0225 334659/319705. **BEDFORD** Comserve, Bedford, 0234 216749. **BERKSHIRE** P.C.P., Reading, 0734 589249. **BIRMINGHAM** Ward Electronics, Birmingham, 021 554 0708. Consultant Electronics, Birmingham, 021 382 7247. A. E. Chapman and Co., Cradeley Heath, 0384 66497/8. **BUCKINGHAMSHIRE** Photo Acoustics, Newport Pagnell, 0908 610625. **CAMBRIDGESHIRE** Cambridge Micro Computers, Cambridge, 0223 314666. **CHESHIRE** Hewart Electronics, Macclesfield, 0625 22030. Mid Shires Computer Centre, Crewe, 0270 211086. **CUMBRIA** Kendal Computer Centre, Kendal, 0539 22559. **DORSET** Blandford Computers, Blandford Forum, 0258 53737. Parkstone Electrics, Poole, 0202 746555. **ESSEX** Emprise, Colchester, 0206 865926. **GLOUCESTERSHIRE** Computer Shack, Cheltenham, 0242 584343. **HERTFORDSHIRE** Photo Acoustics, Watford, 0923 40698. Q Tek Systems, Stevenage, 0438 65385. Chrisalid Systems and Software, Berkhamstead, 044 27 74569. **KENT** Swanley Electronics, Swanley, 0322 64851. **LANCASHIRE** Harden Microsystems, Blackpool, 0253 27590. Sound Service, Burnley, 0282 38481. Computercat, Leigh, 0942 605730. **LEICESTERSHIRE** Kram Electronics, Leicester, 0533 27556. **LONDON** City Microsystems, EC2, 01 588 7272/4. Wason Microchip, N18, 01 807 1757/2230. Premier Publications, Anerley SE20, 01 659 7131. **NORTH EAST** Briars Computer Services, Middlesbrough, 0642 242017. General Northern Microcomputers, Hartlepool, 0783 863871. HCCS Associates, Gateshead, 0632 821924. **NOTTINGHAMSHIRE** Midland Microcomputers, Nottingham, 0602 298281. Mansfield Computers, Mansfield, 0623 31202. East Midland Computer Services, Arnold, 0602 267079. Electronic Servicing Co., Lenton, 0602 783938. **NORFOLK** Anglia Computer Centre, Norwich, 0603 29652. Bennetts, Dereham, 0362 2488/9. **OXFORDSHIRE** Micro Business Systems, Whitney, 0993 73145. **SCOTLAND** Esco Computing, Glasgow 041 427 5497. Edinburgh: 031 557 3937. Computer and Chips, St Andrews, 0334 72569. Scotbyte Computers, Edinburgh, 031 343 1005. Victor Morris and Co., Glasgow, 041 221 8958. **SHROPSHIRE** Tarrant Electronics, Newport, 0952 814275. **SOUTH WEST** Diskwise, Plymouth (0752) 267000. West Devon Electronics, Yelverton, 082 285 3434. Bits and Bytes, Barnstaple, 0271 72789. **SUFFOLK** Elgelec Ltd., Ipswich, 0473 711164. **SURREY** Croydon Computer Centre, Thornton Heath, 01 689 1280. **WALES** Tryfan Computers, Bangor, 0248 52042. **WEST MIDLANDS** Allen TV Services, Stoke on Trent, 0782 616929. **WILTSHIRE** Everyman Computers, Westbury, 0373 823764. **YORKSHIRE** Advance TV Services, Bradford, 0274 585333. Huddersfield Computer Centre, Huddersfield, 0484 20774. Comprite, Bradford, 0274 668890. Superior Systems Ltd., Sheffield, 0742 755005. Photo Electrics, Sheffield, 0742 53865. **NORTHERN IRELAND** Business Electronic Equipment, Belfast, 0232 46161. Brittain Laboratories, Belfast, 0232 28374.



Sole Importers:

LOWE electronics

Chesterfield Road, Matlock, Derbyshire DE4 5LE.
Telephone: 0629 4995. Telex: 377482 Lowlec G.

SOFTWARE FILE

(continued from page 81)

which sometimes consist of all positive numbers, and sometimes mixed negative and positive numbers.

Program operation is simple. After running, complete the randomly-generated sequences. If you complete the sequence incorrectly, the computer will print the correct answer. For maximum frustration, all sequences should be attempted mentally.

Colour and sound

Eric Deeson,
Harbourne,
Birmingham.

BBC

THE BBC MICRO is a beautiful machine with a delightful Basic and great flexibility. The provisional user guide is, however, hard to follow and incomplete. Here is a program that has impressed all users, children and adults, and that will help to make sense of the user guide pages together.

It is developed from the remarkable four-line program in the *Welcome* booklet, but utilises colour and sound to great effect.

The syntax for Sound is that it is followed by four numbers. For simple sound, keep the first channel set at 1. The others control loudness, frequency and duration. Note that a sound once specified continues for the set duration whatever else the computer may be doing. Note too that it is a simple matter to connect a superior speaker in the audio circuit provided.

A BBC PROGRAM

```

10 MODE 5 (colour graphics)
20 COLOUR 129 (red background)
30 COLOUR 2 (yellow characters)
40 CLS (form red screen)
50 PRINT TAB(1,3);"what's your name"; (TAB sets away from edge)
60 INPUT N$
70 COLOUR 130 (yellow background)
80 COLOUR 1 (red characters)
90 CLS (form yellow screen)
100 PRINT TAB(1,3);"Thanks, ";N$;","
110 FOR A=1 TO 5000:N. (Pause)
120 VDU 19,1,0,0,0 (change characters to black)
130 REPEAT
140 P.:P.:P.TAB(1);"Give me a number";"between 1 and 10."
150 B=1
160 #FX15,0 (clear INPUT buffer)
170 B=INKEY(400)-48 (accept number within 4sec.)
180 GOSUB 360 ("chime")
190 UNTIL B<2 OR B>9 (break out of loop)
200 CLS
210 FOR A=1 TO 400
220 P.N$; (background pattern on name)
230 N.
240 C=7
250 VDU 19,1,C,0,0 (change background colour)
260 CLS
270 FOR A=1 TO 100
280 GCOL RND(3),RND(7) (random foreground)
290 PLOT 85,RND(1280),RND(1024) (random triangle)
300 SOUND A,A,A,A ("concrete" music)
310 FOR B=1 TO 1000:N. (delay)
320 N.
330 C=C-1
340 IF C=-1 THEN G.20 (restart)
350 G.250 (repeat colour/sound display)
360 FOR C=1 TO 8 ("chime" sub-routine)
370 FOR A=15 TO 25
380 SOUND 1,A,40,6
390 N.:N.
400 RETURN

```

Key options

G E Taylor,
Derby.

ATOM

THE ACORN Atom has three keys which may be checked directly by a program to see if they have been pressed. This program does not require a Return as in a normal Basic input. These keys are sufficient for games which only need right, left and a fire button as in example 1.

If, however you need more options, such as forwards and backwards, some other technique must be used. The Atom Basic ROM contains a routine at location x FE71 which scans the keyboard once and returns the key number in the CPU's Y register — or 255 if no key is pressed.

A short assembler routine must be written to store the Y register at a convenient location for a Basic program to use, as in example 2. Some of the keys are well grouped for use with a computed Goto or Gosub, but do not forget to check first that the key number will

EXAMPLE 1

```

10 IF ?#B001 & 128 = 0 THEN PRINT "SHIFT"
20 IF ?#B002 & 64 = 0 THEN PRINT "REPEAT"
30 IF ?#B001 & 64 = 0 THEN PRINT "CONTROL"
40 PRINT " "
50 GOTO 10

```

EXAMPLE 2

```

100 DIM KK0,P-1
110E
120:KK0 JSR #FE71
130 STY #80
140 RTS; J
150 LINK KK0 : K = ?#80
160 IF K = 255 THEN 150
170 PRINT K
180 GOTO 150

```

EXAMPLE 3

```

170 IF K < 41 OR K > 45 THEN GOTO 150
180 GOSUB (1000 + 100 * (K - 41))
190 PRINT " " ; GOTO 150
1000 PRINT "FORWARD" ; RETURN
1100 PRINT "LEFT" ; RETURN
1200 PRINT "FIRE" ; RETURN
1300 PRINT "RIGHT" ; RETURN
1400 PRINT "BACKWARD" ; RETURN

```

result in a line number that will be valid. Adding the statements of example 3 to example 2 makes it possible to detect the highest numbered key of the group IJKLM which is pressed. This is fine for one fingered use, but if you want to check for simultaneous multiple depressions then a combination of the two techniques must be used.

Fighter raid

C J Hall,
Kinlet,
Worcestershire.

VIC-20

WHEN THE program is run for the first time there will be a short delay which is due to the time it takes to load user-composed characters into the top 2K of Vic's RAM — the subroutine at line 600. If, after the first run, the program is wanted again, the delay can be omitted by typing (RUN2 RETURN)

The object of the game is to shoot down as many low flying fighter planes as you can with 100 rockets. To fire the rocket press any key excluding Ret., Shift, and Run/Stop.

In the listing
(CLR) = Shifted CLR Home key
(HOME) = CLR/Home key not shifted
(CTRL-) = CTRL and 4 key pressed together

FIGHTER RAID

```

1 GOSUB600
2 POKE51,255:POKE52,19:POKE55,255:POKE56,19
3 PR=8158:P=0:B=0:S=0:R=0:O=36877:M=0+2:N=0+1
9 PRINT"(CLR)":POKEM,8
10 FORA=8164TO8185:POKEA,102:NEXT
20 P%=RND(0)*12+5
21 PRINT"(HOME)(CTRL-4)HITS"OUT OF "R
22 POKE8180,102
30 P=7680+(22*P%)
35 FORA=0TO21
40 POKEP,130:POKEP-1,32:POKEPR,128:IFB=1THENPOKEPR+22,
129:POKEPR+44,32
41 P=P+1:FORX=1TO70:NEXT
49 IFB=1THEN56

```

(continued on next page)

SOFTWARE FILE

(continued from previous page)

```

50 GETA#: IFA#=" "THENNEXTA: POKEP-1, 32: GOTO20
55 B=1: R=R+1: IFR>100THENEND
56 POKEN, 15: POKEO, 170: PR=PR-22: IFPR-22=7696THENB=0:
  PR=8158: GOTO59
57 IFPEEK(PR-1)=130THEN500
58 NEXTA: B=0: POKEPR, 32: PR=8158
59 FORZ=7696TO8136STEP22: POKEZ, 32: NEXTZ: POKEP-1, 32:
  POKEN, 0: POKE 0, 0: GOTO20
500 POKEPR, 42: POKEPR-1, 42: POKEPR+22, 42: POKEPR+44, 42
501 POKEM, 159
510 POKEO, 220: FORL=15TO0STEP-1: POKEN, L
520 FORX=1TO200: NEXTX: NEXTL
530 POKEO, 0: POKEN, 0
535 S=S+1: R=R+1: B=0: PR=8158
536 POKEM, 8
537 PRINT"(CLR)": GOTO10
600 FORI=0TO1024
610 POKE5120+I, PEEK(32768+I): NEXTI
630 FORI=0TO1024: READA
640 IFA=-1THEN700
650 POKE6144+I, A: NEXT
660 DATA16, 56, 56, 56, 124, 124, 124, 84
680 DATA0, 128, 192, 224, 254, 255, 255, 0, -1
700 POKE36869, 253: POKE36866, PEEK(36866)OR128
710 RETURN

```

Status display

Paul Kaufman,
Ely,
Cambridgeshire.

MICROTAN

THIS SHORT routine written in Tan-Forth gives a useful display of the current system status. All the required information is stored

in location 00. The program checks each bit to see if it is set or not, and prints the appropriate message.

Temp is a variable used for temporary storage of the contents of 00. The routine Fetch reads 00 and stores it in Temp, and the eight subsequent routines test the individual bits of Temp. This is done by performing a logical And on the desired bit and using the result for the If statement. The final program is defined on line 2 of screen 2 and strings all the preceding routines together. To execute the program type the word Status.

This routine will work with Tangerine's disc or cassette versions of Forth.

SYSTEM STATUS

```

Serial Input  Off
Special Print Off
DC Flag      Off
External O/P Off
Parallel O/P On
Serial O/P   Off
Screen Dis   Off
BASIC Warm  On

```

Ok

SCR # 1

```

0 HEX 0 VARIABLE TEMP
1 : FETCH 0 C@ TEMP ! ;
2 : SERIP CR. " Serial Input " TEMP @ 1 AND 1 = IF. " ON"
3 ELSE ." Off" ENDIF ;
4 : SPEPR CR. " Special Print " TEMP @ 2 AND 2 = IF. " ON"
5 ELSE ." Off" ENDIF ;
6 : DCFLG CR. " DC Flag " TEMP @ 4 AND 4 = IF. " ON"
7 ELSE ." Off" ENDIF ;
8 : EXTOP CR. " External O/P " TEMP @ 8 AND 8 = IF. " ON"
9 ELSE ." Off" ENDIF ;
10 : PAROP CR. " Parallel O/P " TEMP @ 10 AND 10 = IF. " ON"
11 ELSE ." Off" ENDIF ;
12 : SEROP CR. " Serial O/P " TEMP @ 20 AND 20 = IF. " ON"
13 ELSE ." Off" ENDIF ;
14 : SCNDS CR. " Screen Dis " TEMP @ 40 AND 40 = IF. " ON "
15 ELSE ." Off " ENDIF ; -->

```

SCR # 2

```

0 : BASWR CR. " BASIC Warm " TEMP @ 80 AND 80 = IF. " ON "
1 ELSE ." Off " ENDIF ;
2 : STATUS FETCH CLS
3 . " SYSTEM STATUS " CR . " -----"
4 CR CR SERIP SPEPR DCFLG EXTOP PAROP SEROP SCNDS BASWR CR CR ;

```

5
6
7
8
9
10
11
12
13
14
15
OK

Sounds of alarm

Michael Trinder,
Sunningdale,
Berkshire

ZX-80

YOU WILL have noticed that if a program is saved with the TV sound turned up, there is a tone generated through the TV speaker. It is that feature I have utilised to create the alarm in this program for the ZX-80.

```

10 PRINT "ALARM CLOCK BY M.TRINDER"
15 PRINT
20 PRINT " TIME TILL ALARM GOES OFF"
21 PRINT " (IN SECONDS)"
22 INPUT AL
23 CLS
24 PRINT "(V)ISUAL OR (S)OUND ALARM"
25 INPUT AS
26 IF AS = "V" THEN LET Z = 45
27 IF AS = "S" THEN LET Z = 44
28 LET A = 1
29 LET D = 75
30 CLS
31 PRINT "ALARM GOES OFF IN ";AL;" SECONDS"
32 IF Z = 45 THEN GOTO 36
33 PRINT "TURN UP VOLUME ON TELEVISION"
34 PRINT " TO HEAR ALARM"
35 PRINT " DISCONNECT TAPE-RECORDER"
36 PRINT
37 PRINT "-PRESS-NEWLINE-TO-START-"
38 INPUT AS
39 FOR B = 1 TO D
40 NEXT B
41 LET A = A + 1
42 IF A = AL THEN GOTO Z
43 GOTO 39
44 SAVE
45 PRINT " ALARM BEEP-BEEP"
46 GOTO 45

```

Cast the runes

P Horton,
Evesham,
Worcestershire.

PET

FANS OF J R R TOLKIEN may be interested in this program which reproduces runes on the Pet dot-matrix printer. Other readers will find it possible to adapt the program to produce their own characters.

Each character space consists of a six-by-seven grid, for example, the letter 'Y':

	1	2	3	4	5	6
64						
32						
16		•	•	•	•	•
8		•				•
4		•	•	•	•	•
2		•		•		•
1		•		•		•

This is the same principal as the Vic character generator — demonstrated by Nick Hampshire in the October edition of *Your Computer*. Each of the six columns is assigned a value according to the number and position of the dots on the grid. For example, column 4 has the value

$$1+2+4+16=23.$$

The line-entering has been constructed using the Get command to enable the use of commas and colons. If they are entered as part of an input then the computer thinks that you

```

1000 PRINT "GOTO TO TRANSLATE INTO RUNES TYPE IN THE "
1010 PRINT "ENGLISH" A LINE AT A TIME "
1020 OPEN#4
1030 DIM R(26,6)
1040 FOR J=1 TO 26:FOR H=1 TO 6:READ R(J,H):NEXT H:NEXT J
1050 LN=LN+1:PRINT "LINE NUMBER"LN: " ";
1060 GET I$: IF I$="" THEN 1060
1070 IF I$=CHR$(13) THEN 1110
1080 L$=L$+I$: PRINT I$;" ";
1090 IF I$="*" THEN CLOSE#5:CLOSE#4:END
1100 GOTO 1060
1110 PRINT " ":FOR J=1 TO LEN(L$)
1120 C$=LEFT$(L$,1)
1130 A=ASC(C$):A=A-64:IFA>26 OR A<1 THEN PRINT#4,
TAB(J),C$:CHR$(141):GOTO 1170
1140 FOR H=1 TO 6:A$=A+CHR$(R(A,H)):NEXT H
1150 OPEN#5,4,5:PRINT#5,A$
1160 PRINT#4,TAB(J),CHR$(254);CHR$(141):CLOSE#5:A$=""
1170 C$="":L$=RIGHT$(L$,LEN(L$)-1):NEXT J
1180 PRINT#4," ":L$="":GOTO 1050
1190 DATA 0,127,40,20,0,0,0,127,73,42,20,0,0,127,4,2,1,0,0,
62,20,0,20,62,0,127
1200 DATA 32,24,32,127,0,127,20,116,4,124,0,99,20,8,20,99,
0,127,40,20,10,127,0,0,0
1210 DATA 127,0,0,0,0,0,127,0,0,0,127,2,4,2,1,0,127,32,16,
8,0,0,127,80,32,80,127
1220 DATA 0,32,16,127,4,2,0,127,72,36,72,48,0,127,20,20,119,0,0,127,
2,127,40,16
1230 DATA 0,127,68,68,42,17,0,124,4,8,31,0,0,16,32,127,32,16,0,
63,16,8,4,3,0,63,16
1240 DATA 8,4,3,0,127,68,40,16,0,0,96,16,127,16,96,0,31,20,23,20,
31,0,3,4,127,4,3

```

are trying to input two different things and gives an 'extra-ignored' message.

The * command is used to break out of the program, but any other character could be substituted.

Disassembling

Chris Lam,
Redhill,
Surrey.

ZX-81

EVER NEEDED a disassembler and found either it was too laborious to type in or the cassette costs too much? Here is one which disassembles on the first level. You can add this routine to a hexadecimal loader program, making it much more useful and powerful.

All the program does is ask for an address, finds what is inside that address, finds the hexadecimal of it and prints it, and goes round again. However, since this does take a long time it is best run in the fast mode. Use Cont to carry on scanning for the ZX-81.

DISASSEMBLER

```

5 REM DISASSEMBLER - CHRIS LAM 1982
10 PRINT "ENTER DECIMAL ADDRESS"
20 INPUT A
30 LET B=PEEK A
40 LET X=INT(B/16)
50 LET Y=B-X*16
60 PRINT A;" ";CHR$(X+28);CHR$(Y+28)
70 LET A=A+1
80 GOTO 30

```

```

0 REM ** DICE THROWER **
** BY CHRIS TOLLEY **
** (C)2 MARCH 1982 **
*****
10 LET U=1
20 LET T=U+U
30 LET F=T+T
40 LET S=F+T
50 LET X=S+F
60 LET Z=NOT U
70 PRINT "HOW MANY DICE? (MAX 3)"
80 INPUT N
90 IF N>T+U THEN GOTO 70
100 FOR M=Z TO N-U
110 LET D=INT(S*RND+U)
120 FOR A=U TO S+U
130 FOR B=U TO S+U
140 PLOT M*X+A,B
150 NEXT B
160 NEXT A
170 IF D<T<>INT(D/T) THEN UNPLOT X*M+F,F
180 IF D>U THEN UNPLOT X*M+T,T
190 IF D>U THEN UNPLOT X*M+S,S
200 IF D>U+T THEN UNPLOT X*M+S,T
210 IF D>U+T THEN UNPLOT X*M+T,S
220 IF D=S THEN UNPLOT X*M+T,F
230 IF D=S THEN UNPLOT X*M+S,F
240 NEXT M
250 FOR M=U TO S
260 SCROLL
270 NEXT M
280 PAUSE 4E4
290 GOTO X*X

```

Dicing with memory

Christopher Tolley,
Plaistow,
London E13.

ZX-81

THE WAY MY dice generator is written means that it will just squeeze into 1K, if you drop the Rem statement in line 0, and will draw up to three dice. Owners of ZX-81s with more than 1K RAM may change line 90 to draw more.

The point of interest in this program is the use of variables instead of numbers. I did this because numbers consume valuable space in an unexpanded machine. Most of these variables are assigned in lines 10 to 60. The dice are drawn in the loops from 120 to 160, as black squares. Depending on the value generated in line 110, certain of the points in these squares are unplotted in lines 170 to 270. Line 280 waits for you to press Newline before drawing a new set of dice.

The program starts at line 0. This line

number cannot be directly entered without causing a syntax error. The way I did it was to enter the lines as 5 Rem and so on, and then use a direct command.

POKE 16510,0

which changes the line number to zero.

Any line number may be Poked in this way, but it is important to remember when dealing with numbers greater than 255 that they are stored with the more significant byte first — other addresses, such as in the system variables, are stored the other way round. ■

PROGRAM POWER PROGRAM POWER

ATTENTION ALL ACORN

ATOM

OWNERS!



QUALITY PROGRAMS FROM BRITAIN'S LEADING ATOM SOFTWARE HOUSE

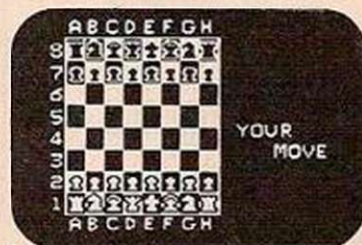

CHESS (12K)
Improved graphics, plays black or white, mid-game level changes, look ahead up to 8 moves, offensive, normal & defensive play. 10 sub-levels, castling, 'En passant' by player. Rejects illegal moves. Take back moves & action replay with take-over. Set up problem games. **£7.95**



ASTROBIRDS (12K)
NEW version of this incredible GALAXIAN type game. Fantastic sound effects! Screaming missiles & swooping bird-men. NOW DOUBLE SPEED OPTION. The best game on the market **£7.95**

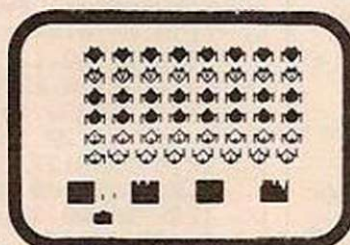

INVADER FORCE (12K)
Terrific version of 'Space Invader' 4 types of invaders, mother ship, great sound, hi-score, 6 skill levels. **£7.95**

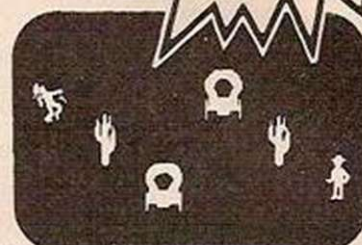

COWBOY SHOOT-OUT (12K)
Full feature, two-player, arcade shooting game. Cactus plants, wagons, animated cowboys. Superb graphics and sound **£6.95**

ALSO FEATURED IN OUR EXTENSIVE RANGE ARE—

SPACE FIGHTER (6K + 3Kgr)
Super High-speed "Defender" game. 5 types of intelligent aliens. Repeating laser cannon, smart bombs, hi-score, rankings, bonus points, 6 skill levels. Exciting sound effects **£7.95**

WARLORDS (12K)
Another High-speed arcade game with the medieval touch. Defend your castle and destroy your opponents. Play against computer or other player. Exciting graphics. **£6.95**

MUNCHYMAN (6K)
Outrun the munchers (or puckmen). Eat your way to a high points score and confrontation with the SUPERMUNCHERS **£4.95**

3D ASTEROIDS (6K + 2Kgr)
Steer through the rolling, hurtling asteroids. Excellent real life graphics **£5.95**

MARTIANS (12K + VIA)
Use your force field to stop them landing. Beware the imposters. Needs quick reactions **£6.95**

LUNAR LANDER (12K)
Superb version of this arcade game, including long and short range score limited fuel supply. **£7.95**

HYPERFIRE (12K)
Aliens have over-run 6 planets. Object to clear them. Super high-speed action. 4 defender ships. Hit alien fuel dumps and alien ships. Aircraft radar shows placement of approaching ships. Thruster control—including diagonal movement. Best sound effects yet! Avoid shots from outside vision scan **£7.95**

ATOM Adventure

ALL THE EXCITEMENT OF A MAIN-FRAME ADVENTURE! CRAMMED INTO A 12K ATOM

Explore the tortuous forests, dark caverns & castle dungeons. Beware the maze of twisting tunnels and the desert wastelands. Outwit the predators. Rescue the PRINCESS and carry off the treasures.

Great skill & imagination are required to play this excellent game & you may still never exhaust all the possibilities. By devising methods of condensing messages, the author has been able to include many features which would otherwise be available only on much larger computers.

Start your adventure now—**£7.95**

SPECIAL OFFER

Deduct £1 per cassette when ordering two or more

WRITTEN ANY PROGRAMS! WE PAY 20% ROYALTIES FOR ATOM, NASCOM & BBC MICRO PROGRAMS

PROGRAMMER'S TOOLBOX

(PACKED 4K EPROM) £24.50

- ★ 1200 BAUD CASSETTE OPERATING SYSTEM
- ★ VISIBLE LOAD & SAVE

TRACE X	READ	ON ERROR	FLX
LTRACE	DATA	RENUMBER X Y	DEFX
STEP	RESTORE	AUTO X Y	GET
FIND	LIST	CURSOR X Y	VECTOR
VAR	WHILE	REPT X Y	ZERO
LVAR	ENDWHILE	KEY X	POP
DELETE X Y	DUMP	INKEY X X	STOP

Please add 55p order P & P + VAT at 15%

Send SAE for our Full Catalogue

PROGRAM POWER

5 Wensley Road
Leeds LS7 2LX
Tel. (0532) 683186

PROGRAM POWER PROGRAM POWER

COMPETITION CORNER

Rodent riddle

BY ANTHONY ROBERTS

THE WIZARD One-eye has been watching the *Hitch-Hiker's Guide to the Galaxy* with his trolls, while you were waiting on them all, hand and hoof. So you all know that the answer to life, the universe, and everything, is 42, and that the question is somehow computed from 9 and 6. The wizard promptly decides that if you do not solve the problem for him he will try turning you into a bowl of petunias — or perhaps a whale — and of course it is easy to solve.

You must, as usual, find your way through the trolls' cave system in which all passages are one-way. This time, as you enter, he offers you some jewel-encrusted mouse-collars as an inducement to succeed in emerging with 42 white mice as required. How many should you take? Here is the cave map.

Competition results

THERE WAS a slight reduction in the number of entries for the Vic-20 software competition in March. However, the standard of the entries was as high as ever, making the task of picking a winner extremely difficult. First place went to John Imrie, Flat C, 18 Jenner Road, Guildford, GU1 3PP, who completed the sentence "I need £100 of Vic-20 software because ..." with "my CPU runneth over with potential". £100 of Vic software is on its way.

Other suggestions which caught the eye included T Bradshaw's "My home-made Tardis won't run without it", G Veale's "I'll save a load on tapes" and F Diamond's "Vic's a big softy at heart". Miss L Meredith

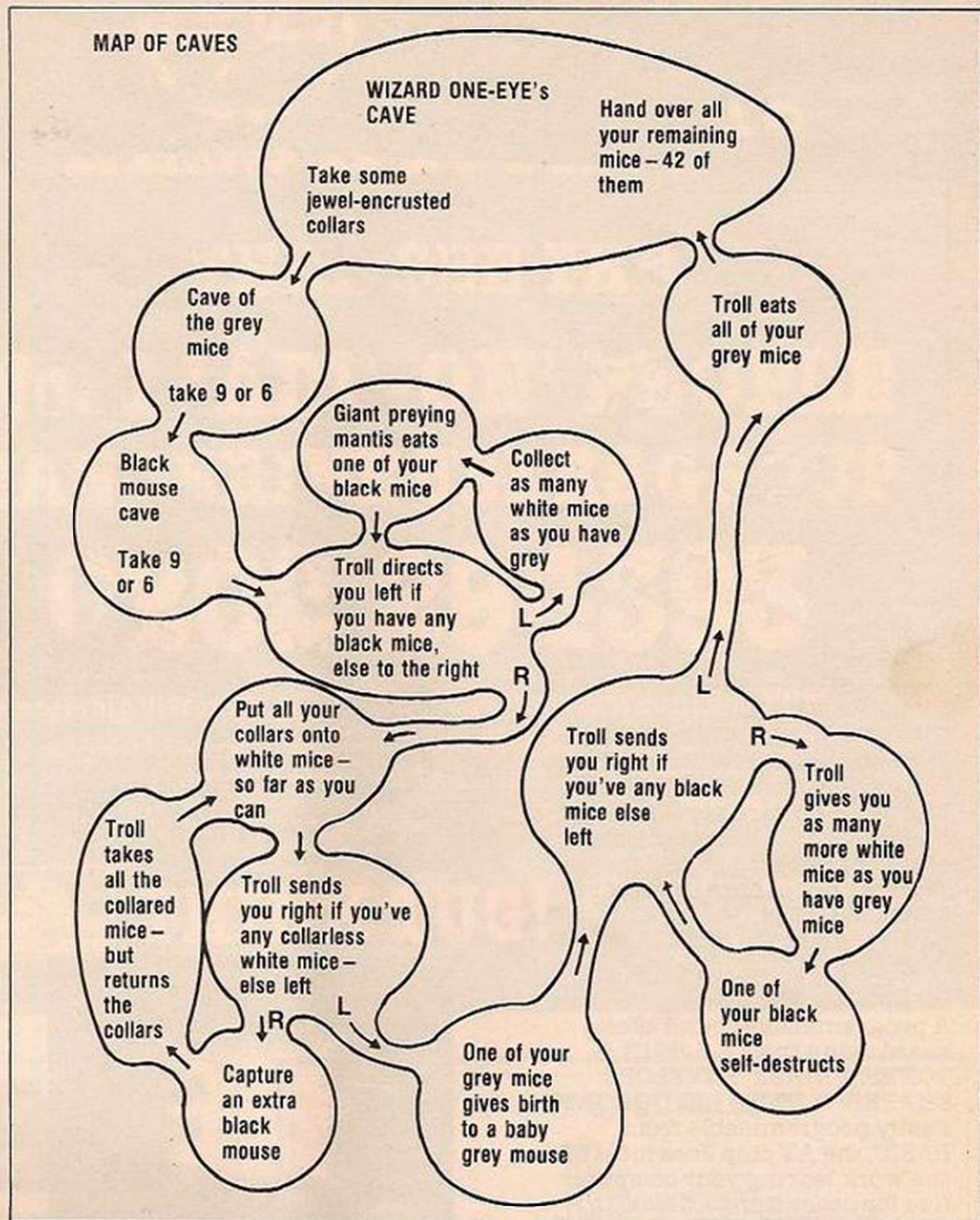

Solution to the March crossword.

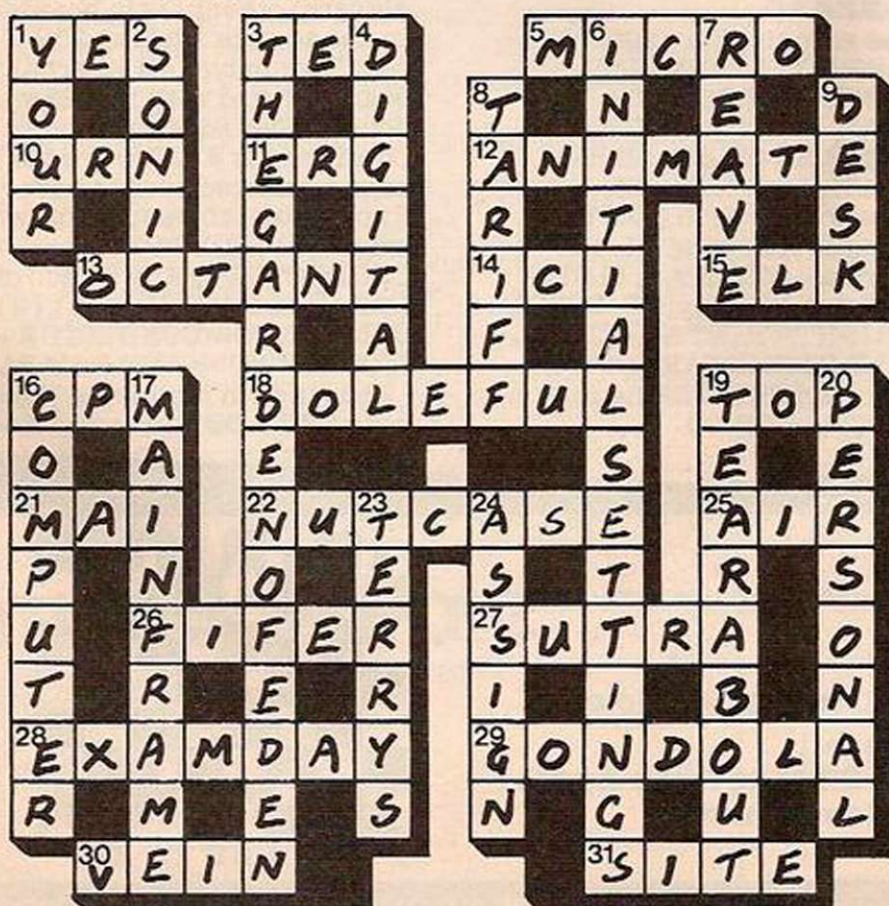

explained that "it changes a vastly ignorant computer into a very intelligent companion" while Paul Bywater proved himself a film buff with "it will help my Vic t'mature".

I Simmons of Welwyn Garden City added a touch of cynicism with "I can sell it for £80 and buy myself a ZX-81". B Zussman revealed that "Poking damages your wealth" while R Keating noted "a Vic program each day will keep the Apple at bay".

The Dire Straits competition included an error in the instructions. Each troll should go to sleep automatically after eating someone, allowing the next person to go through the cave untouched. The troll then wakes up and eats the third person to go through his cave.

The first person to spot this mistake in the puzzle was Andrew Scott, 55 Huntly Grove, Peterborough, PE1 2QW, who has been awarded the £15 book token.

The solution to the puzzle was 76 gems. The puzzle needed a program to model the cave system which would allow you to try each possible location for the six trolls. Troll 5 goes in the top cave, troll 6 in the bottom cave and trolls 3, 1, 2 and 4 in the middle four caves. This means that the fifth, eighth, 10th, 17th, 22nd and 24th men come out alive with 5, 35, 5, 5, 21 and 5 gems respectively for a total of 76.



ZX-81

ZX-80

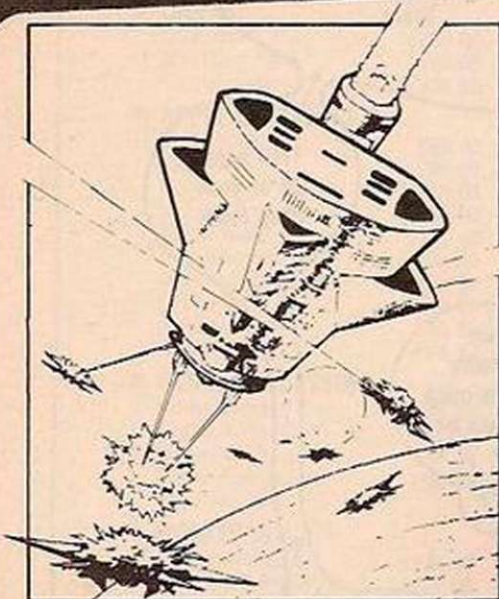
**QS DEFENDER.**

UP - DOWN - THRUST - FIRE
First and only full screen display.
Software to drive QS SOUND BD.
Moving Planetary surface. Up to
84 fast moving characters on
screen at once. On screen scoring.
Ten missiles at once. Increasing
attack patterns. Requires 8K
ROM, and 4K min of RAM. **£5.50.**

QS SOUND BD.

A programmable sound effects
board using the AY-3-8910. 3
TONES; 1 NOISE; ENVELOPE
SHAPER: + TWO 8 BIT I/O PORTS.
Easily programmable from
BASIC, the AY chip does most of
the work leaving your computer
free for other things. Signal O/P
via 3.5 mm Jack socket Ports O/P
via a 16 pin I.C. Socket. **£26.00.**

QS CHRS BD./

A programmable character
generator giving - 128 SEP-
ARATELY PROGRAMMABLE
CHARACTERS. ON/OFF SWITCH.
1K ON BOARD RAM. Enables
creation and display of your own
characters to screen or printer.
Demo cassette of fast machine
code operation routines and lower
case alphabet included. See below
for ZX PRINTER listing. **£26.00.**

QS - LOWER CASE

abcdefghijklmnopqrstuvwxyz

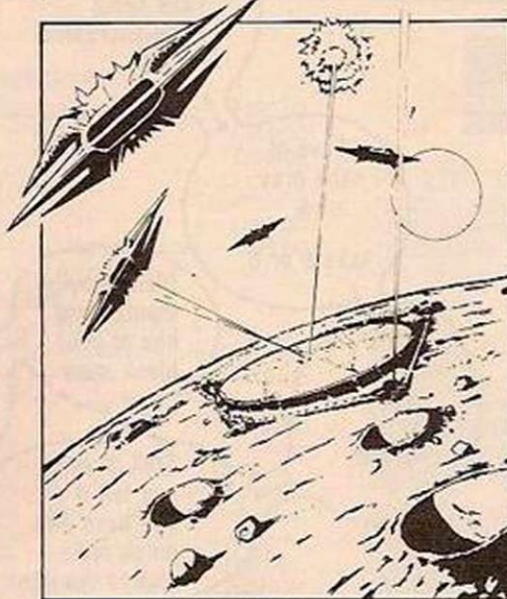
**QS INVADERS.**

LEFT - RIGHT - FIRE
13x7 INVADERS; High score; 3
levels of play; RND saucers; Bonus
base; Drives Sound bd. & CHRS bd.
Requires 7K RAM, 8K ROM + Slow.
£5.50.

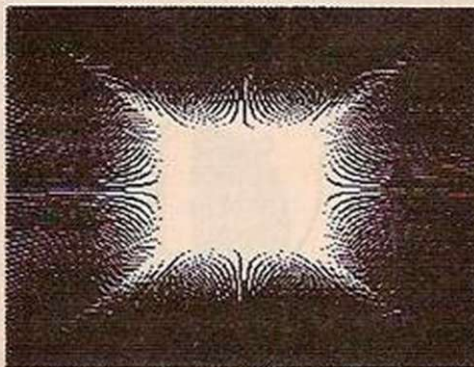
**QS HI-RES BD.**

A Hi-res graphics board giving -
256x192 PIXELS. 6K ON BD.
RAM. SOFTWARE SELECT/
DESELECT. MIXED TEXT AND
GRAPHICS. 2K ON BOARD ROM.
Resident fast machine code
graphics software (in ROM)
provides the following HI-RES
Commands. - MOVE x, y; PLOT x,
y; DRAW x, y; BOX x, y; UP; DOWN;
LEFT; RIGHT; PRINT A\$; SCROLL;
BLACK; WHITE CLEAR COPY. See
above for ZX PRINTER listings
using COPY. **£85.00.**

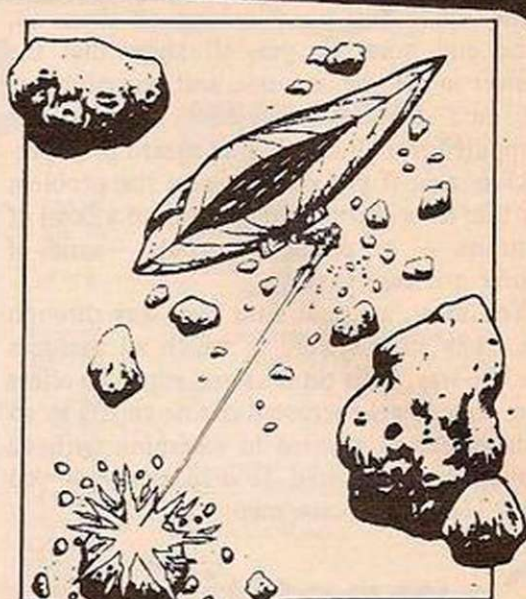
**QS ASTEROIDS.**

LEFT - RIGHT - THRUST - FIRE
Software to drive QS SOUND BD.
Multiple missiles firing in 8
directions. On screen scoring.
Increasing number of asteroids.
Full mobility of ship to all areas of
the screen. Two asteroid sizes.
Bonus ship at 10,000 points.
Requires 8K ROM, 4K min of RAM
+ SLOW function. **£5.50.**

QS 3K RAM Bd.

An extremely reliable static RAM
Bd. which combines with the
computer's memory to give 4K
total. Plugs direct in to the rear
port on your ZX Computer.
£15.00.

QS MOTHER BOARD BD. & QS CONNECTOR.

A reliable expansion system
allowing a total of any RAM pack
plus two other plug in boards to be
in use at once. On board 5V
regulator drives all external
boards. Fitted with two 23 way
double sided edge connectors.
Connector is 2x23 way edge
conns soldered back to back.
Expansion can operate in two
ways - (1) COMPUTER ↔
CONNECTOR ↔ Any QS add on bd.
(but no extra RAM pack). (2)
COMPUTER ↔ CONNECTOR ↔
MOTHER BD ↔ ANY RAM PACK.
(2 bds to fit in mother bd.) Mother
board **£12.00** Connector **£4.00.**

Special offers & news

(1) QS Mother bd. + connector + CHRS bd. + The special Graphics version of
ARCTIC COMPUTING'S ZX CHESS 11. £45.00.
The strongest chess program with 7 levels of play.

(2) QS MOTHER BD + CONNECTOR + either SOUND or CHRS bd. **£40.00.**

We will be at the following shows... Come and see us...

THE COMPUTER FAIR, Earls Court, 23rd to 25th April
3rd ZX MICROFAIR, Central Hall, Westminster.
30th April & 1st May

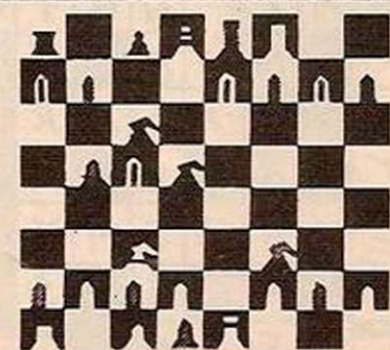

POSTAL AND MONEY ORDERS TO:

QUICKSILVA: 95, UPPER BROWN HILL RD. : MAYBUSH : SOTON : HANTS : ENGLAND.

Please state Type of machine, Which ROM, Memory size, when ordering.

ALL PRODUCTS FULLY GUARANTEED.

DOES YOUR SYSTEM NEED A PICK-UP?

THEN SEE THE

No. 1 'ADD-ON' PEOPLE TANGERINE USERS GROUP

0202 294393

Membership discount scheme: up to 25% discounts available **NOW**
Send large (A4) s.a.e. for our comprehensive hardware and software listings. . . your system need never be alone with **TUG** support. . . get tuggin' it today. Send A4 s.a.e. for membership details - **TUG ON!**



THINK TUG!

TANGERINE USERS GROUP
16 Iddesleigh Road, Charminster,
Bournemouth, Dorset BH3 7JR.

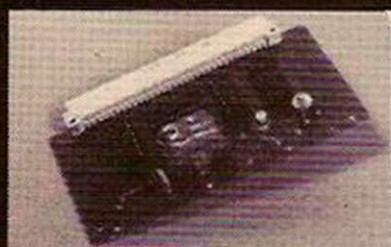

REAL TIME CLOCK

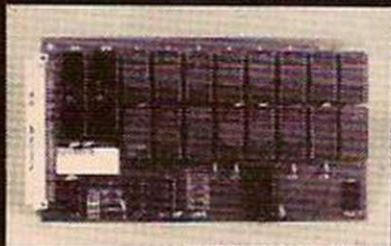

EPROM STORAGE CARD



EPROM PROGRAMMER



PROGRAMMABLE GRAPHICS MODULE

SOFTWARE

for ZX-81(1K & 16K) or BBC Micro

New maths programs - improve your maths and programming skills by playing Simon maths **Games**.
Choose your own level of difficulty - suit ages 10-16.
10 programs on each tape - most incorporate **Moving Graphics** and are fun to run.
Let your computer help you to pass your exams.

- | | |
|----------------|--|
| Maths 1 | Number, Area, Fractions, Decimals, Money, Length, Number, Estimation, Test 1, Game 1. |
| Maths 2 | Volume, Ratio, Percentages, Perimeter, Bases, Time, Number, Estimation, Test 2, Game 2. |
| Maths 3 | Directed Number, Co-ordinates, Angles, Scale, Probability, Density, Temperature, Estimation, Test 3, Game 3. |
| Maths 4 | Square Roots, Indices, Circles, Inequalities, Statistics, Number, Fractions, Angles, Test 4, Game 4. |
| Maths 5 | Equations, Directed Number, Statistics, Probability, Circles, Equations, Pythagoras, Simultaneous Equations, Test 5, Game 5. |

Simon Software

Quality tapes copied at normal speed for better reproduction.

Cassettes £4 each (inc. VAT).

Printed Programs £1 (inc. VAT).

Please add £1 p&p.

FREE! blank tape with each set ordered.

Send cheque/PO to: Simon Software,

Freepost, New End, Redditch,
(State ZX-81(1K),(16K) or BBC)



* ATOM SPECIALISTS *

Atom Kit 8K 2K	£119.00
Atom Assy. 8K 2K	£149.00
Atom Assy. 8K 12K	£172.00
Atom Assy. 12K 12K	£191.00
Atom Assy. 12K 12K with Printer Interface	£199.00
1K RAM Sets	£1.90
Atom Power Supply	£8.00
Atom Econet Interface	£70.00
Atom Eprom Programmer	£40.00
Programmer's Toolbox	£24.50

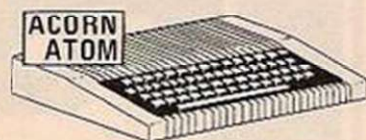

commodore COMPUTER

VIC 20 C.P.U.	£160.00
VIC Cassette	£36.00
VIC Printer	£200.00
VIC Floppy	£325.00
VIC Memory Expansion	£105.00
VIC 3K RAM Expansion	£25.00
VIC 8K RAM Expansion	£37.00
VIC 16K RAM Expansion	£60.00
VIC Joysticks	£6.50
VIC Paddles	£11.70

Printers	
Seikosha GP 80	£195.00
Epson MX 80	£330.00
Epson MX 80 FT1	£355.00
Epson MX 80 FT2	£370.00

VIC-20

Please add 15% VAT to Total Cost.
Orders above £20 post free,
otherwise add 50p.

- Acorn Atom, Bug-Byte and VIC Software.
- Selection of Atom and VIC Books.
- Spares and Repair Service.
- Authorised Acorn Dealer.
- Send for our Price Lists.

D.A. COMPUTERS LTD. Tel: (0533) 549407
184 London Road
LEICESTER LE2 1ND

FULLER FD SYSTEM FOR ZX80/81

THE MOST VERSATILE SYSTEM FOR EXPANDING YOUR ZX

STANDARD KEYBOARD AND CASE

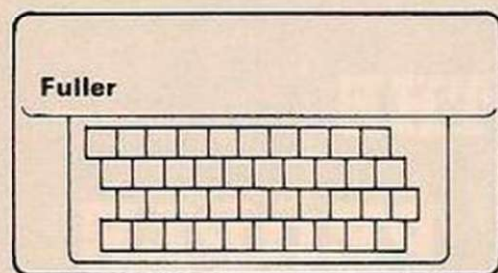

This splendid keyboard and case houses your ZX81 printed circuit board, which is simply screwed into place, the keyboard plugs into the ZX. You can now enter data with ease. The 40 key switch board is a custom unit not made up out of other manufacturers parts. The keytops are our own design and have the ZX Qwerty and functions foil printed onto them. Access to the user port, TV, MIC, and ear sockets are as per the ZX case.

Built keyboard and case £36.70 or £30.70 as a kit plus £2.10 postage and packing.

EXTENDED KEYBOARD AND CASE

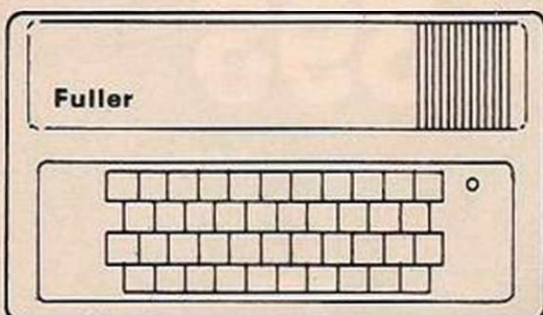

The case is designed to house not only the keyboard and ZX but also our motherboard, power supply, RAM cards and two other boards, not necessarily of our manufacture. The injection moulded case measures 200 mm x 350 mm x 60 mm and houses a 42 keyswitch board, the extra keys can be assigned to other functions. The case is supplied with a "Power On" LED.

Built keyboard and case £39.95 or kit £33.95 plus £2.50 postage and packing. Motherboards £15.95 plus 80p postage and packing. 16k RAM board £35.95. 64k RAM board £79.95.

Keyboard Only Available!
Built £24.95
Kit £18.95 (+P.P. 80p)

Send SAE for details to:-
FULLER MICRO SYSTEMS, The ZX Centre,
Sweeting Street, Liverpool 2.

Tel: 051-236 6109

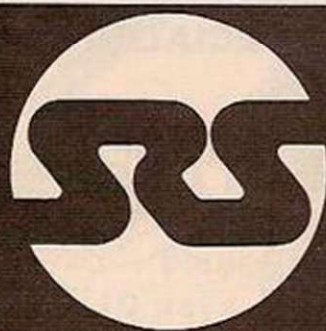

THE SYMBOL OF VALUE

NASCOM

KITS	
Nascom 1, with NAS-SYS 1 less PIO	£112.50
Nascom 2, no user RAM	£202.50
BOARD LEVEL	
Nascom 1, with NAS-SYS 1 less PIO	£126.00
Nascom 2, no user RAM	£238.50
CASED SYSTEMS	
Nascom 3, no user RAM	£338.40
8K user RAM	£36.00
16K user RAM	£90.50
32K user RAM	£103.50
48K user RAM	£117.00
POWER SUPPLY	
Kit form	£29.25
MEMORY CARDS	
RAM B memory card with 16K RAM - kit	£72.00
RAM B memory card with 16K RAM board	£90.00
Additional 16K RAM	£13.50
Additional 32K RAM	£27.00
I/O BOARDS	
I/O boards for 3 x PIO, 1 x CTC, 1 x UART (kit) ex PIO	£40.50
PIO for above I/O	£10.80
CTC for above I/O	£12.60
UART for above I/O	£14.40
DISC SYSTEMS	
Nascom single disc drive (350KB) incl. FDC card	£423.00
Nascom dual disc drive (350KB each) incl. FDC card	£616.50
NAS DOS disc op system	£40.50

SOFTWARE	
NAS-SYS 1 ROM	£10.80
NAS-SYS 3 EPROM	£18.00
ZEAP 2.1 for NAS	
SYS in 4 x EPROM	£26.30
ZEAP 2.1 for NAS	
SYS on tape	£22.50
8K microsoft basic in ROM	£18.00

ATARI

800 Computer	
400 Computer	
Recorder	
Disk Drive	
16K RAM	
Joysticks (pair)	
Blank Diskettes (5)	
Assembler Editor	
Space Invaders (ROM)	
Star Raiders (ROM)	
Missile Command (ROM)	
Asteroids (ROM)	
Invitation to Programming (1)	
Invitation to Programming (3)	
Touch Typing	
Conversational French	
Conversational German	
Conversational Spanish	

TAPES

Blank C12	£4.00
Tapes (6 mins/side) for 10	

SHARP MZ80K (48K RAM)



SHARP PC1211

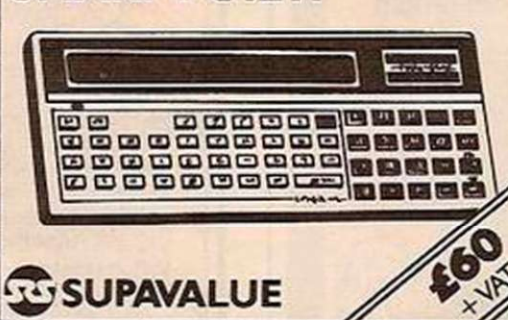

ATARI 800 (16K RAM)

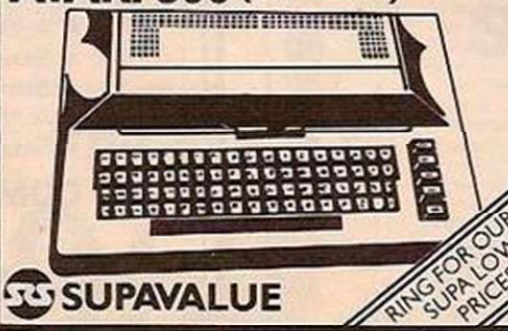

APPLE

Apple II 48K	
Disk drive with controller	
Disk drive without controller	
Parallel printer interface	
High speed serial interface	
Colour card	
Apple Writer	
PASCAL language system	
Silentype printer	
Blank diskettes	

RING FOR OUR PRICES.

ACCESSORIES FOR APPLE (Not Apple Manufacture)

16K RAM card	£85.00
Z80 processor card	£85.00
CP/M disk & manual	£28.75
80 column board	£162.50
Display switch	£18.00
Slot extender	£8.00

BOOKS

Computers for Everyone Science & Eng	£6.00
Prog Apple II Ed	£11.60
Apple BASIC Data	
File Programming	£8.95
Make a success of Micro-computing in your Business	£4.95

Inside BASIC Games	£11.50
Intro to PASCAL	£11.50
PASCAL H'book	£13.95
Program the Z-80	£11.95
Your First Computer	£7.75
6502 Applications Book	£10.25
Advanced BASIC	£8.95
Apple II User's Guide	£11.10
Basic BASIC	£8.95
BASIC Business Software	£7.05
BASIC Computer Games	£5.95
BASIC Comp Progs in Science & Eng	£8.55
BASIC with style	£6.95
BASIC A self teaching guide	£5.95
CP/M User's Guide (Osborne)	£10.10
Game Playing with BASIC	£8.20
Getting acquainted with your Acorn Asom	£7.95
Instant BASIC	£8.75
Micros Vol 0	
Beginner's Book	£3.50
Micros Vol 1	
Basic Concepts	£10.10
Microsoft BASIC	£8.75
More BASIC Games	£6.25
Mostly BASIC	
Applics Apple II	£7.95
Mostly BASIC	
Applics PET	£7.95
Programming a Micro - 6502	£8.05

YOU'LL VALUE OUR EXPERIENCE
YOU'LL VALUE OUR PRICES

ACCESS & BARCLAYCARD WELCOME - HIRE PURCHASE & PART EXCHANGE AVAILABLE
ALL PRICES EXCLUDING VAT E & O L

SRS MICROSYSTEMS
161 Bramley Road, Oakwood, London N14 4XA.
Telephone: 01-363 8060.
(Closed Monday).

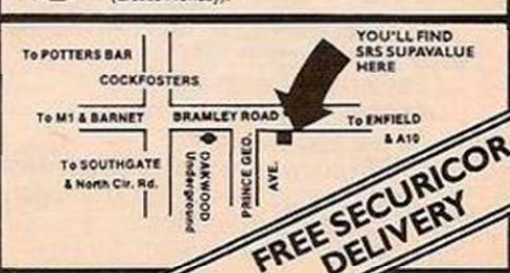

BUG-BYTE

B.B.C. MICRO VIC
ZX81 ATOM

B.B.C. MICRO

SPACE WARP The ultimate Star Trek game - High resolution colour graphics, sound, real time. Probably the most sophisticated Trek type game available. Supplied on cassette together with a 16 page manual, command reference chart and function key labels.

For model B BBC Micro - Price £11.50

CHESS - Model B. Machine code chess game with high resolution graphics. Many levels of play and options. Castling and en-passant.

Price £11.50

GOLF - Model B. An 18 hole, par 72 course, complete with fairways, rough, bunkers, trees, streams and greens. Skill and careful club selection are required to get round with a good score. To make things more difficult, you have to specify a fault in your game, which the program will reproduce, and your handicap. At the end of the round, the program produces your scorecard for the round.

A highly entertaining program, which is likely to have you up late into the night for a par.

Price £7.00

B.B.C. MULTIFILE Versatile multipurpose filing system for model A or B. Allows you to set up your own file structure, modify files, search for files, perform calculations and save and load files. 100's of possible applications. Comprehensive instructions and examples included.

Price £25.00

BACKGAMMON Standard Backgammon game for both model A & B. Fast computer responses. Playing instructions included.

Price £8.00

THE BEEBON A new magazine devoted exclusively to users of the B.B.C. Micro, containing tested programs in each issue, written by professional programmers. Published every two months starting in May.

Annual subscription (6 issues) £7.50

ZX81

ADVENTURES

The Damsel and the Beast £6.50
Dictator £9.00
House of Gnomes £7.00
Star Trek £5.00

UTILITIES

ZXAS Assembler £5.00
ZXDB Disassembler/Debugger £6.50
ZXTK £6.00
RENUM Renumbering program £4.00

GAMES PACKS

Program Pack 1 (1K) £3.50
Program Pack 2 £3.50
Program Pack 3 (1K) £4.50

Program Pack 4 £4.50
Program Pack 5 £4.50
Program Pack 6 £4.50
Program Pack 7 £5.00
Program Pack 8 £6.00

OTHERS

Constellation £8.00
Whist £4.00
Multifile £17.00
Invaders £4.00
1K Breakout £4.50
EDUCATIONAL
Videograph £7.50
Tables teaching & testing £6.00

ATOM

VIC

Fruit Machine 12K £4.00
Chess 12K £9.00
747 12K FP £8.00
Invaders 12K £8.00
Galaxian 12K £8.00
Breakout 4K £4.00
Pinball 6K £4.50
Star Trek 12K FP £5.00
Labyrinth 12K FP £7.00
Backgammon 8K £7.00
Lunar Lander 12K £5.50
Golf 6K FP £5.00
Disassembler 4K £4.00
Typist 6K £4.00
Last run 7K £3.00
2K Programs 1,2&3 £4.50

Vicmen
(For the unexpanded Vic) £7.00
Another Vic in the Wall
(Breakout - unexpanded) £7.00
Vicgammon
(3K expansion) £7.00

ACCESS/BARCLAYCARD ORDERS ACCEPTED
ON 24-HOUR SERVICE ON 051 227 2642

BUG-BYTE, 100 THE ALBANY, OLD HALL STREET,
LIVERPOOL L39EP.

Beelines give your

VIC

a 40 column display
with 32K of extra
RAM as well!

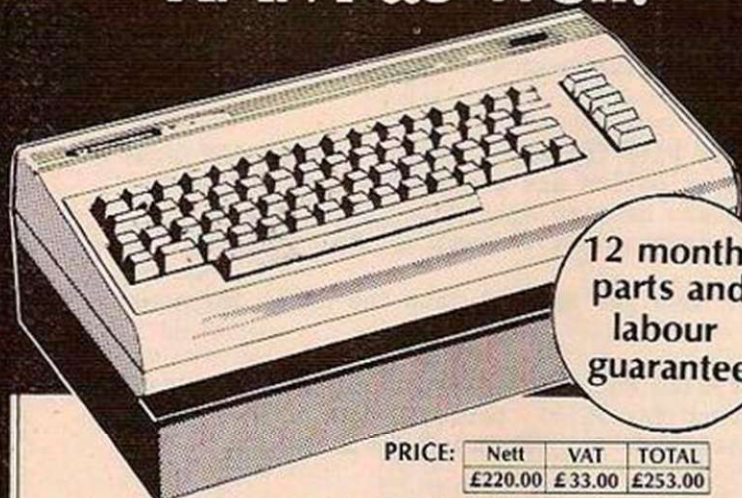

12 months
parts and
labour
guarantee.

PRICE:	Nett	VAT	TOTAL
	£220.00	£33.00	£253.00

The Colour Writer VIC Expansion gives you the most cost effective way of expanding your VIC to 35K AND we give you the added bonus of a 40 Column display free of charge. Now you can have the luxury of a 32K Pet AND Colour to enhance your programs. The Colour screen consists of 960 characters in a 40 column by 24 row layout (to Viewdata standard) with the 25th line for status information. The programmable features include 7 foreground and background colours, flashing, double height characters, block graphics and any combination you care to name; and not content with a 35K VIC, we give you an extra motherboard slot for further expansion.



BEELINES (Bolton) LTD
FREEPOST (No stamp required)
Bolton BL3 6YZ
Telephone (0204) 382741 & 384599

24 hour answer phone: 0204 385299
Reg. office: 124 Newport St., Bolton BL3 6AB.
Dealer enquiries welcome.

Please send me:

Qty.	Item	Price
	Beelines VIC 35K + 40 Column Expansion Unit @ £220 + £33 VAT	

I enclose cheque/P.O.

OR Please debit my:

Access 5224

Barclaycard 4929

Expiry Date

Name

Address

Code

Tel. (day)

Official orders welcome -

we will ship to approved account holders on receipt of firm order.

Delivery free within mainland UK

Access and Barclaycard welcome.

Telephone answering machine for 24hr/7 day

credit card orders 0204 385299

Freepost: Beelines, FREEPOST, Bolton BL3 6YZ

YC.5.82.



TEXAS INSTRUMENTS HOME COMPUTER STOCKISTS

ABERDEEN Dixons ALTRINCHAM Boots ASHFORD Rumbelows
BARNET Rumbelows BASILDON Rumbelows BASKINGSTOKE Boots BATH Wildings, Boots BEDFORD Carlow Radio, Rumbelows, Boots, Comserve BILLERICAY Rumbelows
BIRKENHEAD Dixons BIRMINGHAM Dixons, Hwards Home Stores, Boots BLACKPOOL Boots BLETCHLEY Rumbelows
BOLTON Wildings BOREHAMWOOD Rumbelows BRADFORD Ackroyd Typewriters BRAINTREE Rumbelows BRENTWOOD Rumbelows
BRIGHTON Gamer, Boots BRISTOL Dixons, Wildings BROMLEY Rumbelows, Boots, Wildings BROMYARD Acoutape Sound CAMBRIDGE Rumbelows, Dixons, Wildings, Heffers
CANTERBURY Rumbelows, Dixons CARDIFF Boots, Dixons, Computer Business Systems CARLISLE Dixons CHELMSFORD Dixons, Rumbelows CHESTER Boots CHINGFORD Rumbelows
COLCHESTER Wildings, Rumbelows CORBY Computer Supermarket CROYDON Wildings, Boots, Dixons, Allders
DARTFORD Rumbelows DERBY Datron Microcentre, Boots DORRIDGE Taylor Wilson DUNSTABLE Rumbelows
EASTBOURNE Rumbelows EDINBURGH Robox, Esco, Texas Instruments, Dixons, B.E.M. ENFIELD Rumbelows EXETER Peter Scott, Boots, Dixons GLASGOW Boots, Esco, Robox, Dixons GLOUCESTER Wildings GRAVESEND Wildings
GT. YARMOUTH Rumbelows HANLEY Boots HARLOW Rumbelows HATFIELD Rumbelows HEMEL HEMPSTEAD Rumbelows, Dixons HIGH WYCOMBE Wildings HITCHIN Rumbelows
HODDESDON Rumbelows HULL Radius Computers, Boots, Dixons, Peter Tutty ILFORD Boots IPSWICH Wildings, Rumbelows KINGSTON Wildings, Dixons LEEDS Wildings, Dixons, Boots LEICESTER Dixons, Boots LEIGHTON BUZZARD Computopia LETCHWORTH Rumbelows LINCOLN Dixons LIVERPOOL Dixons, B.E.C. Computerworld
LONDON: Balham Argos Bow Rumbelows Brent Cross Dixons, Boots Camden Town Rumbelows City Road Sumlock Bondain Clerkenwell Star Business Machines Curtain Road Eurocalc Ealing Adda Computers EC1 Argos Edmonton Rumbelows Finchley Road Star Business Machines Goodge Street Star Business Machines Hackney Rumbelows Hammersmith Dixons Holborn Wildings, Dixons Hornchurch Wildings Hounslow Boots Knightsbridge Video Palace, Harrods Marble Arch Star Business Machines Moorfield Dixons Moorgate Star Business Machines New Bond Street Dixons NW1 Mountandene Oxford Street Selfridges, H.M.V. Dixons Regent Street Star Business Machines Tottenham Court Road Landau, Eurocalc Victoria Street Army & Navy Wood Green Boots, Rumbelows Woolwich Wildings Loughton Rumbelows LUTON Dixons, Rumbelows, Wildings MAIDSTONE Dixons, Boots, Rumbelows, Wildings MALDON Rumbelows
MANCHESTER Orbit, Wildings, Boots, Dixons MIDDLESBROUGH Boots, Dixons MILTON KEYNES Rumbelows, Dixons NEWBURY Dixons NEWCASTLE Boots, Dixons NORTHAMPTON Dixons NORWICH Dixons, Rumbelows NOTTINGHAM Bestmoor, Dixons, Boots ORPINGTON Rumbelows OXFORD Science Studio PETERBOROUGH Boots PLYMOUTH J.A.D., Dixons PORTSMOUTH Boots, Dixons POTTERS BAR Rumbelows PRESTON Dixons RAMSGATE Dixons RAYLEIGH Rumbelows READING Dixons ROMFORD Wildings, Rumbelows, Dixons RUSHDEN Computer Contact SANDY Electron Systems SHEFFIELD Datron Microcentre, Dixons SITTINGBOURNE Rumbelows SLOUGH Boots, Wildings, Texas Instruments SOUTHAMPTON Dixons, The Maths Box SOUTHEND Rumbelows, Wildings, Dixons ST. ALBANS Rumbelows STEVENAGE Dixons, Rumbelows STRATFORD Rumbelows SUDBURY Rumbelows SUTTON Wildings SWANSEA Dixons SWINDON Wildings TONBRIDGE Rumbelows WALTHAM CROSS Rumbelows, Wildings WALTHAMSTOW Rumbelows, Wildings WARE Rumbelows WARRINGTON Boots WATFORD Computer Plus, Wildings, Computer Centre, WELWYN GARDEN CITY Rumbelows WETHERBY Bits & Pieces WIMBLEDON Wildings WOLVERHAMPTON Dixons WOODFORD Rumbelows WOOLWICH Rumbelows

With the Home Computer from Texas Instruments, you can converse in the five major languages: BASIC, PASCAL, TI-LOGO, ASSEMBLER and it speaks English!



When you compare the TI-99/4A Home Computer to its competition, you'll find it is a truly remarkable machine. For a start, it enables you to use the most important programming languages. Something that is difficult to find on other comparable computers. What's more, it has a large 16 K Byte RAM memory capacity, expandable to 48 K Byte. With the addition of certain peripherals and a Solid State Software[®] Module a total combined RAM/ROM capacity of 110 K Bytes is available. The TI-99/4A Home Computer plugs into an ordinary TV set and can be expanded into a complete computing system with the addition of peripherals such as two ordinary domestic cassette recorders, remote control units, disk memory drives, speech synthesiser, and thermal printer. Via an RS 232 interface option, other peripherals such as communication modems, impact printers and



plotters can be attached. With its high resolution graphics with 32 characters over 24 lines in 16 colours (256 x 192 dots), three tones in five octaves plus noise, and BASIC as standard equipment and options such as other programming languages - UCSD-PASCAL, TI-LOGO and ASSEMBLER - and speech synthesis, you'll find that the TI-99/4A Home Computer more than compares with competition. Especially when the starting price is £340 or less. When you want to solve problems there are over 600 software programs available worldwide - including more than 40 on easy-to-use Solid State Software[®] Modules.

After all, from the inventors of the micro-processor, integrated circuit and microcomputer, it's only natural to expect high technology at a realistic price.

The TI-99/4A Home Computer: another way we're helping you do better.



Enjoy a new world of learning.

TEXAS INSTRUMENTS
LIMITED

TURN 'LISTINGS' INTO DYNAMIC ZX GRAPHIC PROGRAMS.

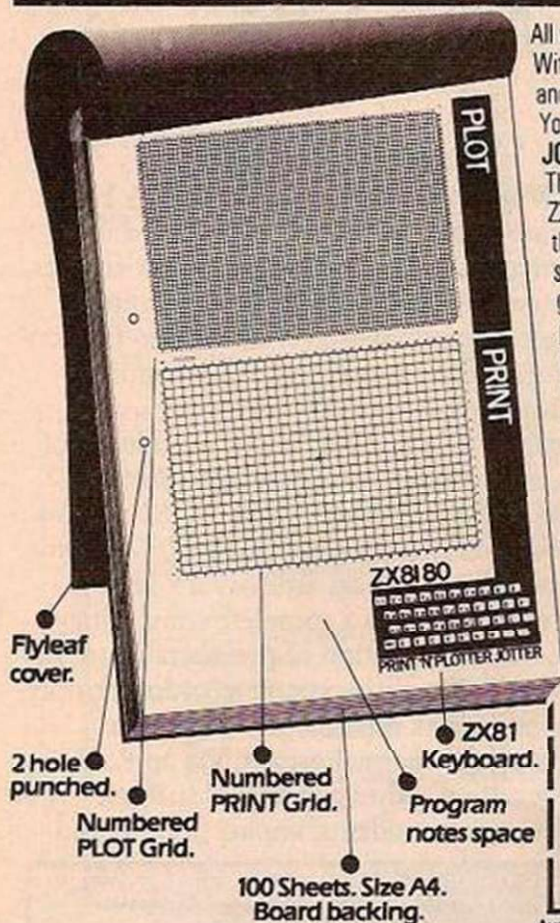

All you need is a pencil, ingenuity, and Print 'n' Plotter Products! Within hours you'll discover all sorts of ways to change "words" into computer "pictures" and produce really dynamic programs!

You can do it easily with the help of a **PRINT 'N' PLOTTER JOTTER and FILM.**

The **JOTTER** is a 100 page Graphics Pad designed for the ZX81/80. Every page has a **PRINT** and **PLOT** grid showing the screen locations. It tells you **any** part of the screen in seconds, and gives you a 'sketchpad' to produce incredible graphics for games, business programs, information panels, tabulations — everything the normal 'listing' lacks!

PRINT 'N' PLOTTER FILM is used with the **JOTTER** and is a matt, transparent, film version with identically-sized grids. Use it to co-ordinate **PRINT** or **PLOT**, or use it to 'copy' photographs, maps, charts, lettering or illustrations to use in programs. You can draw on the matt surface, and rub-out or wash it and use again! Print 'n' Plotter products will help you produce dynamic programs, whether you're converting existing listings or writing an original. Ask for them at your local Comp Shop, or send today for mail order.



GOOD NEWS FOR PRINTER OWNERS

NEW!
24 page manual.
ZX GRAPHICS PROGRAMMING MADE EASY WITH PRINT 'N' PLOTTERS
INTRODUCTORY OFFER: **£1.00**
if purchased with a JOTTER or FILM.
Print 'n' plotter Products

If you do not wish to use this coupon write, stating your requirements, To: **Print 'n' Plotter Products** (YC3) 19 Borough High Street, London SE1 9SE.

- Please send me . . . JOTTERS @ £3.50 Please send me . . . FILMS @ £2.25
 Please send me . . . MANUALS @ £1.00 (£1.50 if ordered without JOTTER or FILM)
 Remittance enclosed Bill my Access/Visa No: _____

Name _____
Address _____

YC3

Note: Orders are usually posted within 48 hours of receipt. If you require 1st Class post please add 50p to order.

Available at • Buffer Micro Shop 374a Streatham High Rd. London SW16 • Denny's Booksellers 2 Carthusian St. London EC1 • Microware 131 Metton Rd. Leicester.

MICHAEL ORWIN'S ZX81 CASSETTES

CASSETTE ONE for 1K ZX81

"I had your Invaders React cassette . . . I was delighted with this first cassette."
P. Rubython,
London NW10

"I have been intending to write to you for some days to say how much I enjoy the games on 'Cassette One' which you supplied me with earlier this month. Please let . . . into the secret of your first time load every time!"
E.H., London SW4

Just two out of over 20 unsolicited testimonials.

Cassette One 1K machine code programs:
React, Invaders, Phantom Aliens, Maze of Death, Planet Lander, Bouncing Letters, Bug Splat.
1K Basic Programs:
I Ching, Mastermind, Robots, Basic Hangman.
PLUS Large screen versions of Invaders and Maze of Death, ready for when you get 16K.

Cassette One costs £3.80.

CASSETTE TWO

Ten games in Basic for 16K ZX81

INVADERS (1K)



PHANTOM ALIENS

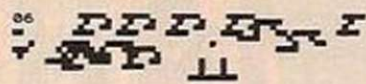

BUG SPLAT

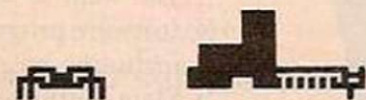

AWARI

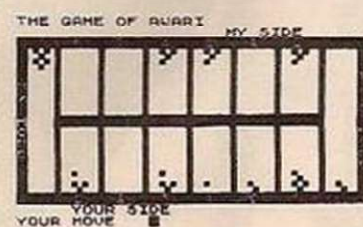

PONTOON

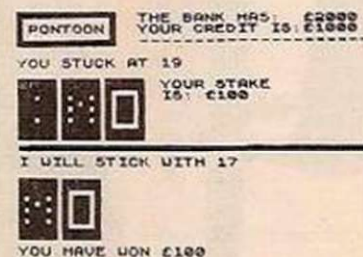

RECTANGLES

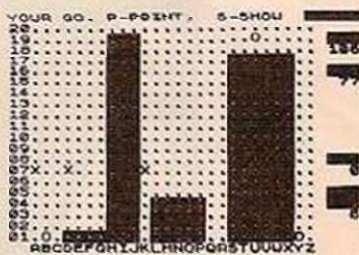

PENNY SHOOT

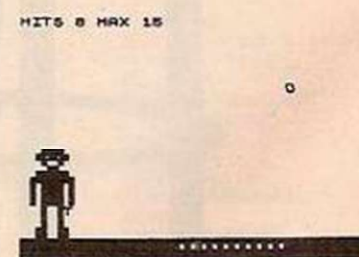

Cassette Two contains Othello, Awari, Laser Bases, Word Mastermind, Rectangles, Crash, Roulette, Pontoon, Penny Shoot and Gun Command.
Cassette Two costs £5.

Recorded on quality cassettes, sent by first class post, from:
Michael Orwin, 26 Brownlow Road, Willesden, London NW10 9QL. (Mail order only please)

"A leading computer company proves that if you've got something worth showing, it's good business sense to make an exhibition of yourself."



THE THIRD INTERNATIONAL COMMODORE COMPUTER SHOW OPENS JUNE 3RD

The Commodore Show is one of the finest opportunities to see the best of today's microcomputer systems in action. A wide range that covers our home colour computer and our selection of sophisticated business systems as well as the latest in software and related products.

Also we'll demonstrate just how they can improve efficiency, whatever line of business you're in.

There'll be seminars on education, communications and a wide variety of business applications.

Guests include knowledgeable and interesting people like Jim Butterfield, who's the foremost authority on the PET and its capabilities.

All in all, it's the biggest and best Commodore Show yet, and definitely not to be missed.

See us at: The Third International Commodore Computer Show, Cunard Hotel, Hammersmith, London.

Thursday June 3rd	12am - 6pm
Friday June 4th	10am - 6pm
Saturday June 5th	10am - 5pm



For further details ring
SLOUGH (0753) 79292

675 Ajax Ave, Slough, Berks.

 **commodore**
COMPUTER
Quite simply, you benefit
from our experience

reprints

If you are interested in a particular article/special feature or advertisement in this journal

HAVE A GOOD LOOK AT OUR REPRINT SERVICE!

We offer an excellent, reasonably priced service working to your own specifications to produce a valuable and prestigious addition to your promotional material. (Minimum order 250 copies). Telephone Michael Rogers on 01-661 3036 or complete and return the form below.

To: Michael Rogers, Your Computer, Reprint Department, Quadrant House, Sutton, Surrey SM2 5AS.

I am interested in copies of article/advert. headed featured in this journal on pages, issue dated

Please send me full details of your reprint service by return of post.

Name

Company

Address

Tel No

BBC SOFTWARE

Wordwise

The Word Processor for the BBC Micro Computer.

Word processor for the Model B Micro. Supplied in ROM and therefore leaving about 27K for text, over 4000 words. All the usual word processor features plus several unusual ones like a fully automatic word count. Available soon for £65.00 + £1.50 p&p + VAT. Ask for leaflet describing WORDWISE in more detail.

RAM UPGRADE kit to increase Model A to 32K RAM. Run Model B programs and graphics. Supplied with instructions — around £30.00 + VAT. Phone or write for latest price and availability.

CASH waiting for any good programs to add to our range. We pay excellent royalties or cash.

COMPUTER CONCEPTS

DEPT YC1
16 WAYSIDE
CHIPPERFIELD
HERTS WD4 9JJ
(09277) 62955

AT LAST! THE ZX T-SHIRT



IF YOU'RE PROUD
OF YOUR ZX81
TELL THE WORLD
WITH A HIGH
QUALITY T-SHIRT
OR SWEATSHIRT.

All shirts machine washable.

Available in black or white with red logo just like your ZX81! State size and style when ordering

Sm
M
L
XL

T. SHIRT	SWEATSHIRT
£4.25	£6.95

ORDER NOW: FIRST 100 ORDERS WILL RECEIVE A FREE C12 CASSETTE

**CHEQUE/ PO TO
PSS
112 OLIVER STREET
COVENTRY CV6 5FE**

PSS IS INDEPENDENT OF SINCLAIR RESEARCH

ZX81 16K RAM Cassettes

This is what BUYERS of our GAMES to test your skill & tactics have said:

"VERY NASTY MOUNTAIN and NASTY INVADERS... are both very well written"; "I would now like to order a copy of NASTY MOUNTAIN... as I am thoroughly pleased with the goods";
Client, London

"NASTY INVADERS... VERY NASTY MOUNTAIN: with no loading problems at all and the literature you included, will certainly purchase from you again";
N.D.H., Huddersfield

"Thanks for the NASTY INVADERS Program — it works fine. Please send VERY NASTY MOUNTAIN";
Client, Eire

"I like NASTY INVADERS... the graphics are excellent; VERY NASTY MOUNTAIN is also an excellent game. These are two of the best games I have for my ZX81";
Michael B. McAllister, Lakenheath, Suffolk

NASTY INVADERS: Get them before your Bosses get you! £4.95
A 20 minute plus Action-Packed Game. You are on duty in the Defence Radar Centre. An invasion starts. Your task is to prevent the Enemy from landing. But you have problems: not only do you have to stop the invaders making repairs to their craft, but there could be personnel trouble too! Good control is rewarded, but errors are penalised. Don't despair — Rank Has Its Privileges!!

NASTY MOUNTAIN: Solve the Clues if you want to Escape £4.95
You are leading an expedition and come to an impassable mountain range. It looks like a long detour until an old goat-herd announces that there is an opening in the rocks into which the occasional animal wanders, but they never re-appear... See if you can solve the mysteries of Nasty Mountain and continue on your travels. Whether you succeed or fail, you can always try again — but somehow it's not quite the same as before!

VERY NASTY MOUNTAIN: But don't CHEAT or you will pay for it! £6.95
An advanced version of the Nasty Mountain Game with 16 Levels of Play. Practice Makes Perfect — but the more clues you solve, the more your tactics are tested!

JUSTIFY YOUR ZX81 AS A BUSINESS EXPENSE

PETTY CASH/VAT: Know where your Money went! £10.00
Enter Date, Narrative and Gross Expenditure for each Cash Purchase. Classifies into 20 Sub-Headings and 13 Main-Headings and gives Gross, VAT, Net and Exempt Subtotals and Totals. It's so good, we use it ourselves.

VAT BOOK INPUTS: Written for the Small Business & Sole Trader £12.00
As the Petty Cash/VAT Program, but with the facility to add in your Cheque and Standing Order Items to give Inputs Bottom Line Totals

Cheques/P.O.s to:

**GILTROLE LTD.,
DEPT. YC, PO BOX 50, RUGBY, WARCS. CV21 4DH**

· JUST OPENED · JUST OPENED · JUST OPENED ·

· LONDON'S ·
· HOME COMPUTER CENTRE ·

· ACORN ·



· BBC ·



· PET ·

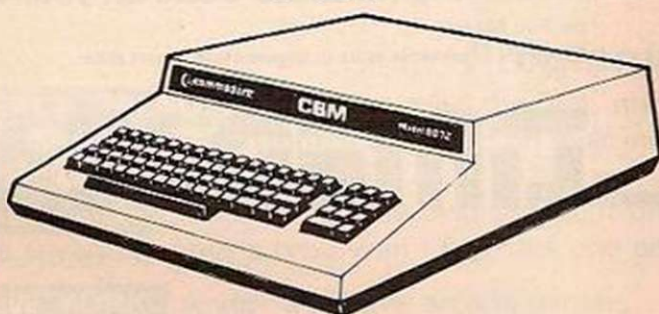

· VIC ·

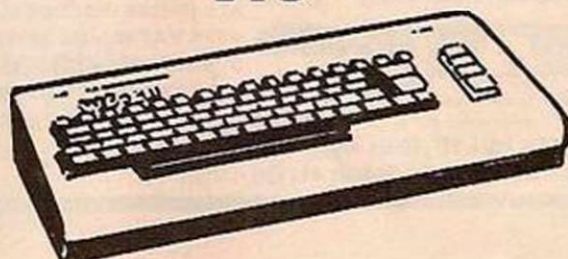

· GAMES · HOME FINANCE · EDUCATION ·
· ALL YOU NEED · ALL EXPLAINED ·

There's a fantastic choice of home computers on the market today. Each one brilliant in its own right. But which one's right for you?

The jungle stops here! At Microstore, we'll understand your requirements and advise you on the best model.

From business or household management, to education or entertainment, there's something for you. Hundreds of items and accessories on display.

Business Computers
Apple II and III

Talk your requirements over with a practical business man. Books, Disks, Printers, Programs, and all the back-up. Also full after-sales-service.

· Come and see them before you buy ·

MICROSTORE

· 327 · KING'S ROAD · LONDON · SW3 ·
· PHONE · 01 · 352 · 9291 ·

MICROSTORE

Support for ATOM and ZX

The Atom Magic Book

A wealth of games and other programs: storing speech in your ATOM, converting programs written in other BASICs, tape recording hints, and many more useful software and hardware tips. £5.50

Getting Acquainted with your Acorn Atom

By Tim Hartnell and Trevor Sharples. 80 programs including Draughts! £7.95

The Memory for your ATOM

16 or 32K BYTE VERSIONS Expand your ATOM to 28 or 38K RAM

Ideal for Word Processing, Chess programs and Business Software.

Fully Compatible with other Acorn ATOM software and hardware

Versions available to fit inside the ATOM while still leaving room for other extensions such as the Acorn ATOM colour/encoder board. Eurocard rack mounting types also available

PRICES: INCLUDING U.K. P&P & 15% VAT

MZ163A 16K Built & tested to fit inside ATOM'S case	£59.50
MZ163B 32K " " " "	£74.00
MZ163C 16K Built & tested, Eurocard rack mounting	£62.00
MZ163D 32K " " " "	£76.50
MZ163E Bare PCB to build any of above with data	£23.00
MP100 DC/DC converter; powers any MZ163 board from unregulated 8V supply such as the ATOM mains adaptor	£8.50

S.A.E. for further details.



ALL PRICES INCLUDE U.K. P&P + 15% VAT WHERE APPLICABLE. OVERSEAS CUSTOMERS ADD £1.50 CARRIAGE PER ORDER. PAYMENT WITH ORDER PLEASE.

TIMEDATA LTD, Dept A, 57 Swallowdale, Basildon, Essex. SS16 5JG Tel: (0268) 411125 (MON-FRI)

The Explorer's Guide to the ZX81

IF YOU'VE GOT A ZX81 THEN YOU NEED THIS BOOK!
Programs for 1K RAM, and programs for 16K RAM. Games, Business and Engineering Applications. RAM & I/O Circuits. Useful ROM Routines. Hints and Tips. 120 pages £4.95

What Can I Do with 1K?

By Roger Valentine. A fresh and original book containing 40 programs and routines for the unexpanded ZX81. £4.95

34 Amazing Games for the 1K ZX81

by Alastair Gourlay. £3.95

The ZX80 Magic Book

With 8K ROM/ZX81 Supplement
Games programs, computer music, converting programs written in other BASICS, improving the picture RAM & I/O circuits, and much more. £4.75

Getting Acquainted with your ZX81

75+ programs including Draughts; by Tim Hartnell £4.95

Mastering Machine Code on your ZX81

by Toni Baker. 180 pages of immense value to beginner and expert alike. £5.95

TIMEDATA

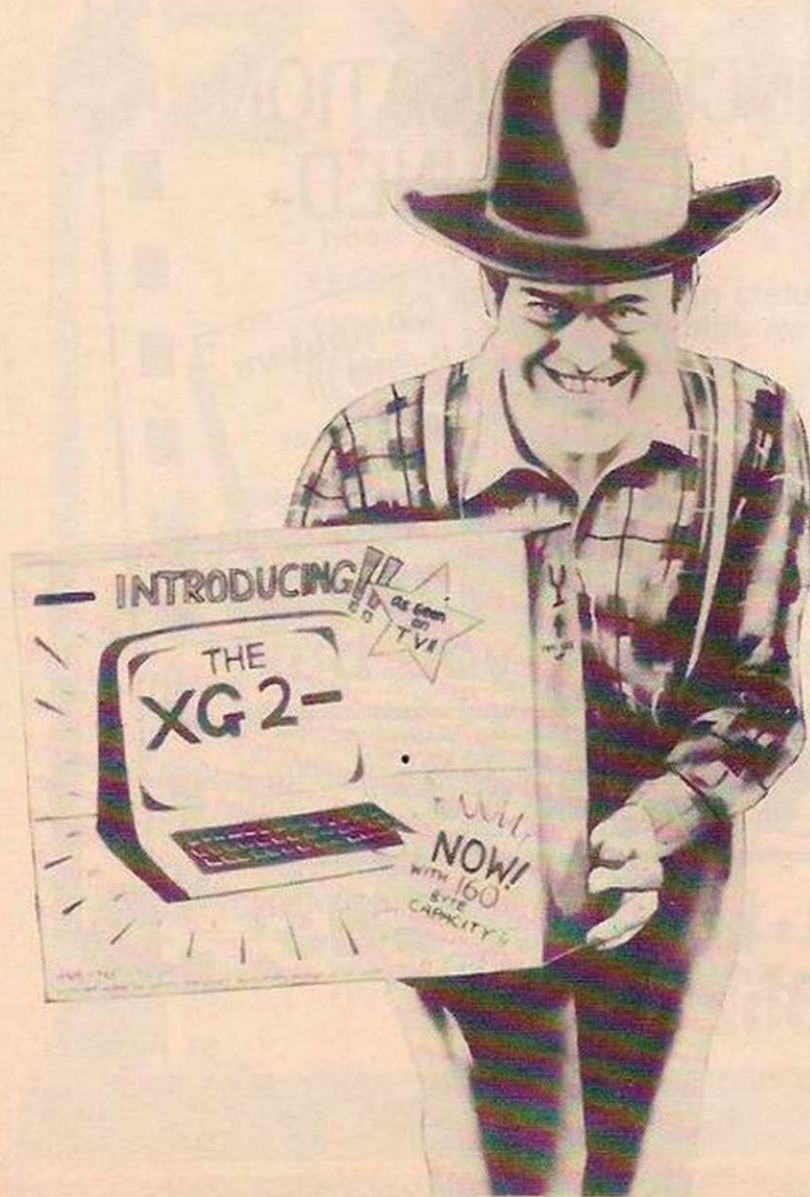

FALL OF THE GIANTS, RISE OF THE COWBOYS?

How will the big computer companies fare in the battle for the personal computer market?

Will the small backstreet people win?

And are they cowboys — or the giants of the future?

Read about Yes Minister,

a new Whitehall game. See our review of Supercalc; tune in to the BBC micro...

... and that's just a sample of Practical Computing together with advice for users of Pet, Apple, Tandy and Sinclair ZX 80/81 computers. Buy Britain's leading personal computer magazine.

**MAY ISSUE ON SALE NOW.
80p AT YOUR NEWSAGENT'S — BUT HURRY.**

Practical Computing

MICRO GEN QUALITY PRODUCTS

ZX81 A/D CONVERTER BOARD

This 4-channel analogue to digital converter, originally developed for joystick control, can be used for such applications as measurement of voltage, temperature, light intensity etc.

The board fits in between the RAM pack and the ZX81. (No skill is required to make this connection, and it actually improves the stability of the RAM pack.)

Price now only £18.50

JOYSTICKS FOR THE ZX81, only £9.60 each

- The most exciting add-on ever for the ZX81, free yourself of that dead, unresponsive keyboard.
- 1 or 2 joysticks may be connected via our A/D board.
- Turns your ZX81 into a true programmable games machine.
- Extends the capability of the ZX81, imagine the tremendous variety of games and applications that now become possible.
- Details supplied on how to use the joysticks in your own programs.

Please note that you cannot connect conventional analogue joysticks directly to the digital input ports found on most I/O boards, an A/D convertor such as ours is required.

A free copy of ZX AMAZE plus any one of the games listed below when ordering a joystick and an A/D board.

Programs available

ZX SPACE INVADERS. You've tried the rest, now try the best.

This program has many features including an ever increasing rate of play (they'll get you in the end).

only £3.95

ZX BREAKOUT. Quite simply the best breakout on the market.

Features seven bat angles (you won't find this one easy.)

only £3.95

ZX NEW YORK. A very addictive arcade game.

Bomb and shoot your way out of trouble, otherwise you are doomed to crash. Generates a different pattern, for a different game each time you play. On the reverse of the cassette is ZX REFLEX, find out how fast you really are.

now only £3.95

ZX CHESS. The original and still the best.

* Graphic display of chessboard. * 5 levels of play. * Displays record of your moves and the computers.

* Board can be set up to any position. * Has ability to change sides or level in mid-game. * PLUS. *

CHESS CLOCK on reverse side, records time taken by each player. * Resetable function. * Single key entry.

NOW ONLY £6.50

All our games are written in machine code, and can be used with joysticks or keyboard (except chess, keyboard only). Supplied on cassette with library case.

To allow you to prove to yourself that our products are second to none, MICRO GEN offers the following terms to our customers.

14 DAYS FREE APPROVAL ON ALL PRODUCTS

All money will be refunded if goods are returned in good condition within 14 days of despatch.

If you write a program which is exceptional, please submit it to us. We will offer a royalty if it is suitable.

Please rush me: (tick items required)

MICRO GEN A/D BOARD £18.50

JOYSTICK £9.60

ZX SPACE INVADERS £3.95

ZX BREAKOUT £3.95

ZX NEW-YORK £3.95

ZX CHESS £6.50

MORE DETAILS

Please add 40p towards post and packing on all orders.

Name

Address

.....

.....

Postcode

Cheques and P.O.'s payable to:
MICRO GEN, Dept. YC4
24 Agar Crescent,
Bracknell,
Berks.

ZX81/ 16K SOFTWARE

"STARTREK"

16K STARTREK: Exciting space adventure game including klingons starbases, phasers, 8x8 galaxy, 4-levels of play, long and short range scanners, etc.

"SUPER-WUMPUS"

16K SUPER-WUMPUS: Can you hunt and catch the mysterious wumpus in his underground labyrinth? Intriguing underground adventure.

"GRAPHIC GOLF"

16K GRAPHIC GOLF: Test your golfing skills on SILVERSOFT'S 18-hole golf course. Many hazards including lakes, trees, streams, rough, etc.

"GAMES PACK 1"

16K GAMES PACK 1: Fantastic value for money, nearly 50K of programs on one cassette. Five games including "Real Time Graphic" Lunar Lander, Starwars, Hammurabi, Minefield, Mastermind.

"3D-MYSTERY MAZE"

16K 3D MYSTERY MAZE: Amazing three dimensional maze. Walk through the maze in 3-dimensions, ultra-fast machine code display, hundreds of different mazes.

"ZX-ZOMBIES"

Can you escape from the man-eating zombies by leading them into the pits? 8-levels of play, increasing difficulty.

NEW!! NEW!! NEW!! ARCADE GAMES! "SPACE-INVADERS"

Simply the best yet, the closest thing to real space invaders on the ZX-81 including 1 or 2 player option and software to drive the QS-character board for real! invaders.

"ASTEROIDS"

Authentic representation of the arcade game with left, right, thrust & fire controls, 5-levels of play & alien spaceships.

"DROPOUT"

Can you stop the aliens from building up in their launch chutes before they drop down & destroy you. Exciting arcade game.

Cheques/POs payable to "SILVERSOFT".

Prices Asteroids & Dropout £5.95 each
The rest £4.95 each
Two or more deduct £1.00

S.A.E. FOR CATALOGUES

Name

Address

.....YC5/82
ZX81, VIC-20 & BBC SOFTWARE WANTED
EXCELLENT ROYALTIES SAE FOR DETAILS

SILVERSOFT (Dept. YC)
40 Empress Avenue, Ilford, Essex.
Tel: 01-518 0877

DOCIMODUS ZX81 16K Software

... one step beyond the ADVENTURE concept,
a LIVE game ...

The Planet Game

This program consists of an active computer model of the planet Docimodus and its many life-forms. This micro-planet comes to life in your ZX81, you just load and join in. See life-forms evolve, compete for better countries and resources, watch all out wars between neighbouring factions, take careful note of the interactions and when you see your chance, land your fleet.

Can you guide your settlers to world dominance? Four different display modes, Tactical, Statistical, Progressive plus Newsflashes on bottom two lines (22 & 23). All displays are updated dynamically.

At the time of writing nobody has yet taken over the planet Docimodus — but we know it is possible so we have included a number of menu driven utilities so that you can create your own planet and life-forms. £5 on cassette.

Multiple Account Budget System

An 80 account budgeting and trend projection package. Allows analyses and projection forward of individual items of spending or groups of items. £9.50 on cassette.

Bank Account

All the usual features of a bank account program plus item reference and automatic file rotation. £4.50 on cassette.

Elephant and Castle

A dynamic graphics adventure game with midgame save, action replay and highest score transfer from game to game. You can break the record score? £5.00 on cassette.

Dominoes

Play against the ZX81 and try to get into the top ten. Most places are currently held by the computer. Full screen graphics. All 28 dominoes can be on screen at the same time. £4.00 on cassette.

DOCIMODUS
161 Walmersley Road, Bury, Lancashire BL9 5DE.

ZX81

ROMAN EMPIRE

— the latest 16K game from
M.C. Associates
(specialists in war games
and simulating in the
Ancient Period)

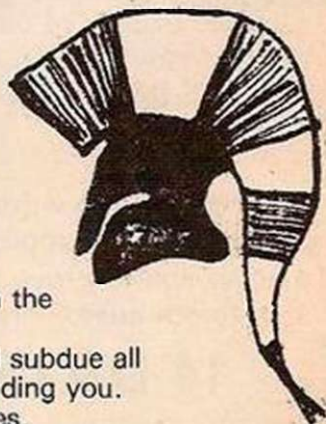

- You are Emperor of Rome in the early days of the Empire.
- *Your Aim* — to conquer and subdue all the hostile countries surrounding you.
- Select Legions to build armies.
- Appoint Generals.
- Launch attacks and fight campaigns.
- Morale, fighting efficiencies, energy etc. all taken into account in this challenging new game. Price £5.95

Also

The very popular and totally addictive game set in Ancient Greece:

TYRANT OF ATHENS

Price £4.95

OR order both games now for only
£10.35.

Cheques or P.O.'s please made payable to:

M.C. Associates
4 GRANBY ROAD, CHEADLE HULME,
CHESHIRE SK8 6LS.

A & F SOFTWARE

G0104 CYLON ATTACK: This 3D all action game in high resolution graphics, takes you into the Science Fiction world of Interstellar Wars.

Strapped in a Starfighter, looking out into the void of space, you glance at the instruments, the long range scanner has the CYLONS pinpointed. You select the nearest target and turn to meet it ready to defend Earth to the end!!!

In keeping with our Companies pricing policy on all ATOM GAMES SOFTWARE this REMARKABLE game is only **£4.95**
5K Text 6K Graphics — NO FLOATING POINT.

NEW RELEASES FOR THE ATOM

G0106 ATOMIC CUBE: Based on the popular cube puzzle, you can now try to solve the atomic cube. Displayed in high resolution 3-dimensional graphics. 5K text 6K graphics in colour or monochrome. Floating point required.

Price **£4.95**

G0107 MISSILE COMMAND: Fast moving version of the popular arcade game. Shoot down the aircraft and missiles before they destroy your cities. 5K text 6K graphics.

Price **£4.95**

G0108 POLARIS: Navigate your sub through dangerous waters and sink the convoy before the escorting warships track you down and sink you. 5K text 6K graphics.

Price **£3.95**

G0109 PONTOON: The first in a series of card games for the atom using high resolution graphics with split screen text. Can you break the bank and beat the micro? 5K text 6K graphics.

£3.95

F ATOM UK101-SUPERBOARD

OTHER TITLES FOR THE ATOM

G010 POLECAT 5K text 6K graphics	£4.95
G0101 EARLY WARNING 5K text 6K graphics	£4.95
G0102 MINEFIELD 5K text ½K graphics	£4.95
G0103 TANGNED 5K text ½K graphics	£3.95
G0105 ROBOT NIM 5K text ½K graphics	£3.95

Watch this space for our Adventure Competition

Superb Prizes ? see next months issue

UK101/ SUPERBOARD RANGE

S0100 MADMAN: Watch out for the guardians as you travel the maze collecting points and bonuses. Can you beat the high score so far — 141,600 by M. Hickling.

Runs in 8K. Price **£4.95**

S0101 PONTOON: The first in a new series of card games for this machine. Excellent graphics. Runs in 8K.

Price **£3.95**

S0102 LUNAR LANDER: Moving graphics display. Long and short range scans. Full instruments readout. Runs in 8K.

Price **£3.95**

2K BASIC TOOLKIT: Nine new commands — Auto, Help, Find, Dump, Step, Trace, Off, Delete, Renumber. Fast load in under 2 mins, with or without another program present.

Loads into top 2K or RAM (independent of memory size) and secures its own boundaries. Price **£7.95**

SPECIAL OFFER DEDUCT £1 PER ADDITIONAL CASSETTE

ORDERS TO:

A & F SOFTWARE, 10 WILPSHIRE AVENUE,
LONGSIGHT, MANCHESTER M12 5TL
24 HOUR TELEPHONE ORDERS ON (061) 320 5482
Orders normally dispatched within 72 hours
Please enclose a SAE with enquiries
Co. Reg. No. 2771093

OAKLEAF COMPUTERS LTD

Education Hobbyist & Small Business Computers



ITS NOT JUST
ACORNS THAT
LOOK BETTER ON AN
**OAKTREE
WORKSTATION**

THE UNIT SUITS BBC
A&B APPLE PET ZX81
VIC 20 TRS 80 ETC.

★ JUST RELEASED ★

TWIN USER JOYSTICK INTERFACE

£12.95 ALL INCLUSIVE

Protect the keyboard of your fully expanded Atom by interfacing Atari joysticks to it. The joysticks plug into the interface which in turn simply plugs to the 64 way bars, (available at £3.99 inc. if ordered with the unit). Now two people can successfully play games or one person can have more control over the Atom. Full software supplied. Some conversions are given for the more popular Atom software packages including Bug Byte, Program Power and Acornsoft.

With a built in accessory drawer, this smart unit turns your set up into a professional and business-like system. The drawer holds up to 50 diskettes or your tape collection and leads etc.

£19.95

ALL INCLUSIVE

Order by telephone quoting your card number or write enclosing your remittance to:

121 DUDLEY ROAD, GRANTHAM, Lincs NG31 9AD
Tel: (0476) 76994

ACORN SPECIALISTS

COLOUR ON A ZX!

From **Ellanbee** (Graphics)

Now you can add a coloured background to your displays with high quality P.V.C. in either blue or green.

ONLY £2.95 + p.p. per pack*

- * No loss of clarity
- * Cuts eye strain considerably
- * Easily removed
- * Strong flexible P.V.C.
- * Each sheet measures 15" x 12" (Larger sizes available on request)
- * Fits most b/w TV's up to 19" screen
- * Full instructions provided

Send cheque/P.O. to:-

Ellanbee (Graphics)
MICHAEL HOUSE, NORTH BURNS
CHESTER-LE-STREET
CO. DURHAM DH3 3TF
Tel: (0385) 886987

- * Pack contains 1 Blue & 1 Green
- Please allow 28 days for delivery
- Postage & Packing 0.55p *

J. K. GREYE SOFTWARE ZX81 GAMES

For the Finest Quality

FED UP WITH BEING RIPPED OFF?
HAVE YOU BOUGHT BORING, WORTHLESS, RUBBISH GAMES?
DON'T DESPAIR - TRY THESE!

GAMESTAPE 1, for 1Konly £3.95



PROBABLY THE BEST VALUE 1K TAPE AVAILABLE! incl. 10 Games:
"KLINGONS": Wipe out the Enemy Fleet, if you can!
"CRASH-LANDING": Can you land the space-craft? A Simulation.
"SIMON": Match the colours, gets more difficult as you progress.
"ARTIST": Highly praised Graphic Designers Aid.
"UFO": Fast and Furious Space Game, very popular.
"CODE": Can you break the 4 digit code?

GAMESTAPE 3, for 16Konly £5.95

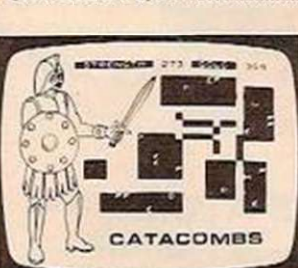

"CATACOMBS": The Ultimate Multi-Level Graphics Adventure. You are alone and lost in the Catacombs, how much Gold can you find? How long can you survive before you starve to death, or one of the many monsters gets you!
Each level can include up to 9 Rooms, 8 Passages, 7 Monsters, Phantoms, Traps, Food, Gold, an Exit (to the next level), and there is an infinite number of levels! This is one Adventure you won't get bored with, it will keep you going for weeks!
NOTE: This is NOT one of the necessarily limited text type of adventures, as sold elsewhere. CATACOMBS uses GRAPHICS, the Monsters will actually chase and attack you!

GAMESTAPE 2, for 16Konly £4.95



"STARFIGHTER": Brilliant Machine Code Galactic Space Battle. Your viewscreen shows you deep Space, with Stars going Nova all around you. Can you hit the wildly dodging Enemy craft, the Explosions are stunning if you can!
Absolutely Superb Graphics!
"PYRAMID": A Game to set you thinking!
The Pharaoh wants you to move the Pyramid.
Sound easy until you realise you can only move it in stages, and then to only one of three bases. If you make one wrong move it will collapse! PYRAMID will keep you going for hours.
"ARTIST": Super Expanded Graphic Designers Aid. Unleash your dormant artistic ability. This program lets you use the screen as a sketchpad, then SAVE your masterpieces on tape. Incl. eight directions, 10 memories (one screen each), RUBOUT, MOVE, SAVE, COPY, CLS, etc.



GAMESTAPE 4, for 16Konly £5.95



"3D MONSTER MAZE": The Game to Top All Others. Can you find your way through the Maze? The EXIT is there somewhere, but then so is a T.REX, and it's after YOU! You use the cursor keys to move through the Maze, which is displayed as you would see it in reality, complete with side passages, ALL IN 3D! The T.REX will actually run toward you in full perspective, you have to see it to believe it!
3D MONSTER MAZE (NOT to be confused with the Monster-less mazes, around), has the most amazing graphics you've ever seen on the ZX81 (or any other machine for that matter), and its Super Fast Machine Code!

GAMES MARKED * Incl. MACHINE CODE

Prices inc. VAT and UK p&p (add appropriate postage on foreign orders)

Cheques/POs to:

J. K. GREYE SOFTWARE, DEPT. Y.C., 16 PARK STREET, BATH, AVON BA1 2TE
Trade enquiries welcome

FOOTBALL MANAGER

A GREAT NEW GAME FROM Addictive Games

for ZX81, ZX80, TRS80, VIDEO GENIE

- ★ AS MANY SEASONS AS YOU LIKE ★ 4 DIVISIONS ★
- ★ PROMOTION & RELEGATION ★
- ★ FULL LEAGUE TABLES ★
- ★ TRANSFER MARKET ★
- ★ INJURIES ★
- ★ 7 LEVELS OF PLAY ★
- ★ SAVE GAME FACILITY ★
- ★ MANAGERIAL RATING ★
- ★ PICK YOUR TEAM FOR EACH MATCH ★ F.A. CUP ★

This is NOT a mere simulation. This is an exciting and highly enjoyable game in which you play the part of a Football Manager coping with the problems and decisions involved in running your club. There are so many features it is impossible to list them here but included are form (top teams NORMALLY win), giant-killings, wage bills to pay, and you can even be sacked! It is a game requiring a great deal of skill, and people play it for literally hours on end (we have proof!).
WE GUARANTEE that this is one of the best computer games you've ever played!
BUT BEWARE, this game is extremely addictive!

FOOTBALL MANAGER IS SUPPLIED WITH INSTRUCTION BOOK - OCCUPIES THE ENTIRE 16K RAM

HARDWARE REQUIRED

ZX81/ ZX80	TRS80/ Video Genie
8K ROM	LEVEL11
16K RAM	16K RAM

To Order send Cheque/P.O. for £7.95 made payable to: ADDICTIVE GAMES at: Dept. Y.C. P.O. Box 278 CONNIBURROW MILTON KEYNES MK14 7NE PLEASE STATE COMPUTER

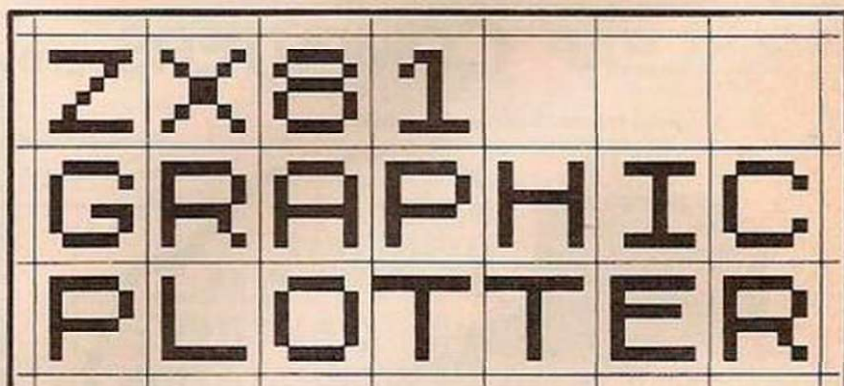

You cannot afford to be without this totally new approach to screen formatting on your ZX81. Numbered coordinates take out the guesswork and make it a simple job to design your display and get it right first time.

Use the pen provided and the Graphic Plotter's special surface will simply wipe clean.

- Numbered grid coordinates - no more guessing
- Wipe clean surface - use it over and over again
- Shows graphic characters - no cross referring
- Double sided for PRINT and PLOT

A pack of 5 Graphic Plotters complete with the special pen costs only £2.50.

Send your order today with a cheque or Postal Order to:

AD-LIB

2A Grovelands Avenue
Hitchin, Herts.
Tel: (0462) 56074

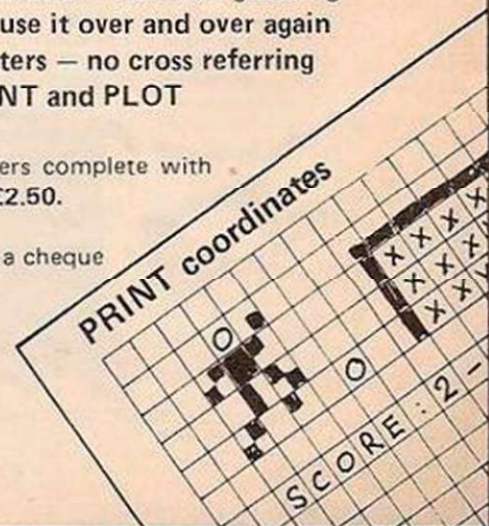

ZX81 owners

have you seen

The Cambridge Collection

A book of
30 PROGRAMS

For Only **£4.95**

NO MEMORY EXPANSION NEEDED

Each program has been designed to fit into 1K of RAM

TEACH YOURSELF PROGRAMMING

Comprehensive explanations of each listing will teach you many techniques of **ZX81** programming.

HOURS OF AMUSEMENT

With titles such as FORTRESS, BALLOON, and ODD MAN OUT, you could easily become a **ZX81** addict. Plus, entirely new implementations of well-known favourites; LUNAR LANDING, MASTER CODE, ORBITAL INVADERS, and many others.

CASSETTE AVAILABLE TOO!

If you order the book you can also buy the programs on a quality cassette for only **£4.95** extra.

Please send me:

copies of the book at
£4.95 each

copies of the book and
cassette at **£9.90** pair

Please send your orders
with cheques/PO's to:
Richard Francis, Dept. YC A/S
22 Foxhollow, Barhill,
Cambridge, CB3 8EP.

Microgame Simulations

ZX81 (16K)

Soccer Supremo Run your favourite club in your own style, controlling game strategy, watching your team play other great sides in the Super League, transferring players, including star names, making boardroom decisions or delegating to solve business problems; improve facilities; spend gate money; lots of the fun and headaches of the soccer boss's lifestyle. Includes graphics.

Balance of Power As leader of a superpower you strive to maintain superiority of arms over a neighbouring country. The problem is that you and your enemy are mutually dependent on each other for raw materials. Can your economic, diplomatic and military judgements prevent a rapid slide towards nuclear war? Use threats, sanctions, force, tactical concessions etc.

Tycoon Start a company producing "widgets" and compete in the market against a computer controlled rival. Start small and build up your business or borrow money and start big. You have to make decisions about financing, staffing, factory space, machinery etc.

Battle of Britain As strategic commander of nine British fighter squadrons you must track and intercept the devious enemy bomber squadrons before they reach London. Micro acts as a flight control and communications centre for patrols, missions, intelligence reports etc. Sketch map provided. May also be played on any map of SE England with standard grid.

Asset Stripper Compete against your computer controlled arch-rival "KO Investments", capitalizing companies on the stock market and bidding for takeovers to gain control of lucrative assets. Can your micro really outwit you?

Kingdom of Nam As ruler of Nam you must control its economy; allocating labour; building cities, factories and ships; importing and exporting; negotiating pay claims and fighting the looming threats of inflation, strikes, starvation, overpopulation and revolution. How long can you stay in power?

All programs 16K for 1 player
Send **£4.95** for 1/£8.90 any 2/£12.85:3/£16.80:4/20.75:5

73 The Broadway, Grantchester, Cambridge CB3 9NQ

REVISE PHYSICS CHEMISTRY or BIOLOGY

8 programs including problems
+ multiple choice type
questions + revision hints

£7.50

REVISE MATHS pt.1

algebra equations + functions
"revision notebook with each
random data problems
answers + progress reports"

£5.00

JUNIOR + REMEDIAL

jungle maths - snakes! pits!
piranhas!
+, -, x, ÷ etc.

you can choose the type
you can set the level

£4.50

spelling test - set a
different test each week on
tape, at the end of term
print out scores and
progress

£3.50

EDUCATIONAL PROGRAM

**16K ZX81
STUDYING FOR
"O"
LEVELS**

S C I S

C O

I F

S O F T

5, minster gdrs
newthorpe
eastwood
notts
sop, p&p
sae for info.
of royalty
structure

FOR TEACHERS

"markbook"

- up to 70 pupils
- 10 sets of marks
- sorts by rank, form or
name
- pupil profile
superb at parents evenings

£4.50

THE PERSONAL COMPUTER BOOK

new edition just published

by **Robin Bradbeer**

co-author of best-selling
BBC Computer Book

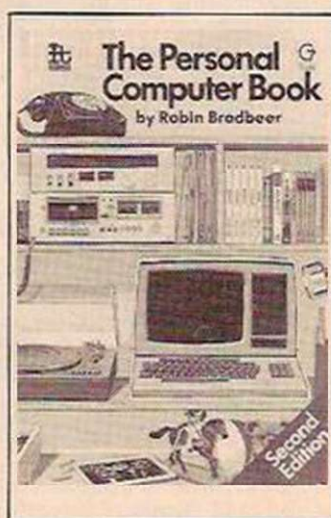

Buying your own micro?

Then you need Robin Bradbeer's Personal Computer Book. It tells you all you need to know about personal computers and includes an illustrated up-to-date survey of 60 micros available in the UK. It contains information on what you can do with micros, details of your nearest computer club and a survey of books and magazines. **Only £5.95.**

Available from W.H. Smith and leading booksellers, or direct from the publishers by sending **£6.95** (including postage and packing) to Virginia Ayers, Dept. YC, Gower Publishing Co Ltd, Gower House, Croft Road, Aldershot, Hants GU11 3HR.

At last 16K ZX81
ASTRO-INVADERS

Just look at these features ...
... then look at the price!

- Superior machine code programming
- Explosive on-screen kill effect
- High-scoring saucers
- Manoeuvring array of 54 attacking aliens
- Photon-torpedoes with rapid fire facility
- Accelerating attack rate
- On-screen kill count with high-score update
- Destructable defence shields
- Fast action space-graphics
- A new dimension in ZX81 value

Astro-Invaders is yours on cassette with **FOUR BONUS GAMES:**

ARCADE GRAND PRIX — drive four levels of machine code skill.

PENALTY — get ready for Spain '82; defend your goal against the sharp-shooting ZX81.

GOLF — judge shot-strength, angle, bunkers ... and maybe hole in one!

plus machine code fun with

SWAT — war on the insect world!

5 Amazing games on one cassette for **ONLY £3.65** (post free in UK). Order yours from:

JOHN PRINCE,
29 Brook Avenue, Levenshulme,
Manchester, M19.

**AMAZING
VALUE**

VIC-20 GAMES

**6 GREAT GAMES
ON ONE CASSETTE!!! including ...**

Acey Ducey: Can you outwit the computer in this Great Card Game.

Grand Prix: Drive your way through two laps of the Monza race circuit.

Red Alert: Can you save the earth in 20 seconds.

Apollo Disaster: Fast shooting and a cool head are needed for this outstanding game (Good Graphics).

Rifle Range: Outshoot your opponent in this thrilling Game.

Bandit: For all Fruit Machine enthusiasts, need we say more.

For instant despatch send cheque/P.O. for £3.95 to the address below:

Can you write programs for the VIC-20? If so send your programs on cassette to the address below or give us a ring between 6pm & 7pm (evenings) we offer 15% royalty or a lump sum.

Basic Consultancy!!! If you have a business with programming problems why not contact:

TITAN PROGRAMS
83, Ashwood Road, Rudloe, Corsham,
Wiltshire SN13 0LG.

Tel: Hawthorn (0225) 810132
(between 6pm & 7pm)

HAVEN HARDWARE

Winner of the Daily Express/
Philishave business award

Products for 9 different computers.

ZX HARDWARE — LARGEST RANGE/LOWEST PRICES. (We have enhanced many of our P.C.B.s and instructions)

PROGRAMMABLE CHARACTER GENERATOR — The First Ever For ZX Computers (June 1981). Provides User-defined characters which can be used together with the standard letters, commands etc. The Programmable Characters can be directly LPRINTED or LCOPIED. Full software control in FAST or SLOW. No Expensive Motherboard Required — Edge Connector Not Used. Complete with the first ever HIGH-RES GRAPHPLOTTER PROGRAMME.

KIT £19.95

BUILT P.O.A.

(UK101, Superboard 2, C1E etc Version still available — £34.95 for Kit)

FULL SIZE KEYBOARD — The first ever which can have REPEAT added.

KIT ONLY £16.95. (P&P £1.00. REPEAT £2.00)

ZX81 INVERSE VIDEO. Our 'Competitors' said this device would be either 'Impossible' or 'Very Expensive' — But its neither. DETAILS AVAILABLE.

REPEATING KEY MODULE — Another Unique Product — KIT £3.50 or BUILT £4.95.

ZX EDGE CONNECTOR (Gold Plated) only £2.20.

3K MEMORY EXPANSION only £16.95. (Sufficient memory for most programmes).

INPUT/OUTPUT PORT KIT £9.95.

MOTHERBOARD P.O.A.

ZX COLOURBOARD — Most people thought this couldn't be done until we demonstrated it in September 1981. Already been in use for several months in various countries. Plugs onto the edge connector and provides a mini-motherboard for expansion. (One direct connection also required). Gives a choice of 16 colours for each character square on the display. Uses a circuit never before seen which is uniquely suited to the ZX80 & ZX81.

KIT £44.95

BUILT P.O.A.

Together with the ZX81 KIT forms the first colour computer for under £100. Available from most of our agents. Being reviewed by several major Magazines.

Our Products are already in use in Schools/Universities/Government Depts./Industries/Homes in Europe/Africa/Asia/America.

S.A.E. for details sheets:

Haven Hardware (UK),
ZX Dept., 4 Asby Road, Asby,
Workington, Cumbria. CA14 4RR.

(Reply by return of post).

HOME COMPUTER PROGRAMMING ZX81 LEARN BY POST

At last it's here. Learn at home at your own speed how to program your ZX81. A structured course of 20 weeks duration especially tailored to your needs. Individual tuition and assessment of each weeks work. Just listen to the instruction tape and learn by doing.

Isn't it about time you stopped buying all those pre-recorded cassettes and started doing it yourself.

As long as you have access to a ZX81 you can start NOW.

Suitable for the raw beginner and the more experienced.

Send this Ad. with your name and address and receive the first part of the course. If not fully satisfied return the tapes and pay nothing.

To go on return cassettes with £3.00 per part or £50.00 lump sum.

Enquiries S.A.E.:

MJE FOR HOME COMPUTING

4, Lavington Close, Ifield, CRAWLEY
W. Sussex. RH11 0HX.
TEL: Crawley (0293) 32709.

THE ZX81 COMPANION

ISBN 0 90721 01 1
Price £7.95 incl. UK P&P

If you have a Sinclair ZX81 and want to use it to its full potential then, as the experts have all agreed, this is the book for you. It contains detailed guidelines and documented programs in the areas of gaming, information retrieval and education, as well as a unique listing of the 8K ROM for machine code applications.

'Far and away the best . . . once again Linsac has produced the book for the serious end of the market'. — *Your Computer*, November 1981.

'The ZX81 Companion is a most professional product . . . with many good illustrative programs, tips and warnings'. — *Education Equipment*, October 1981.

'Bob Maunder's attempt to show meaningful uses of the machine is brilliantly successful . . . thoughtfully written, detailed and illustrated with meaningful programs . . . To conclude — the book is definitely an outstandingly useful second step for the ZX81 user'. — *Educational ZX80/81 Users' Group Newsletter*, September 1981.

Send you cheque for £7.95 to:

LINSAC (YC) 68 Barker Road, Linthorpe
Middlesbrough TS5 5ES



ZX-80&81 OWNERS ACCESS TO THE OUTSIDE WORLD!

Programmable INPUT/OUTPUT Port based on Z80 AP10 giving up to a total of 16 programmable I/O lines all TTL compatible. Port is NOT memory mapped allowing full expansion of memory. Can be used WITH or WITHOUT RAM PACK & PRINTER.

Available in kit form or assembled & comes complete with instructions, software notes & circuit ideas.

£13.50 IN KIT FORM — £15.99 ASSEMBLED

INCLUDES V.A.T. ADD 50p p&p.

NEW ENCASED 4 CHANNEL RELAY BOX — to add on

to I/O Port. Changeover contacts rated at 240v AC/1.5A — 110v AC or 24v DC/3A. Allowing programmable control of mains for motors, lamps etc. **£14.99** complete.

23 + 23, ZX80/81 Edge Connector £2.85

Contact Cleaner (226 grms) £2.30

ALL PRICES INCLUDE V.A.T. ADD 50p p&p.

SAE
FOR DETAILS



THURNALL (ELECTRONICS) ENG.
DEPT Y, 95 LIVERPOOL ROAD,
CADISHEAD, MANCHESTER M30 5BG
TEL: 061-775 4461 (24 hours)



NEW ZX81 16K SOFTWARE

THE DIGGLES KITCHEN
RECIPE CASSETTES
CELEBRATION DINNERS
TO SIMPLE SUPPERS

VOLUME 1

50 PAGES WORLD WIDE RECIPES
£4.99 (inc. P&P and VAT)

VOLUME 2

50 PAGES EUROPEAN RECIPES £4.99
(inc. P&P and VAT)

SPECIAL OFFER both Volumes for only **£9.00
(inc. P&P and VAT).

More Volumes to follow

Please specify which Volume(s) — MAIL ORDER ONLY

Send remittance to:—

MICRO COMPUTER SOFTWARE
Unit D6, Pear Industrial Estate,
Stockport Road, Lower Bredbury,
Stockport SK6 2BP
Tel: 061-494 2441

NEW

Programming the

PET/CBM

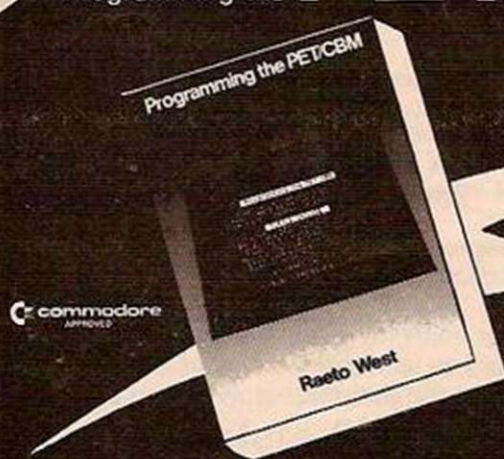

'This book is excellent.'
— Jim Strasma

'Unquestionably the most accurate
and comprehensive reference I have seen to date.'
— Jim Butterfield

Bestseller — comprehensive
teaching and reference book on
all software aspects of
Commodores 2000, 3000,
4000 and 8000
microcomputers and
peripherals.

Many programs, charts and diagrams.
17 chapters, appendices, and index.
iv + 504 pages. 19 x 26 x 2 1/2 cm.
Paperback. ISBN 0 9507650 0 7.
Price in UK and Europe £14.90 each
(incl. post and heavy-duty packing).
LEVEL LTD., PO Box 438, Hampstead,
London NW3 1BH. Tel: 01-794 9848.

Cut out or copy coupon, or write to:
LEVEL LTD., PO Box 438, Hampstead, London NW3 1BH.

Send copy/ies of *Programming the PET/CBM* at £14.90 (post free)

I enclose cheque/P.O. for £.....or official order.

NAME

ADDRESS

Fast Service — same day despatch

YC582

YOUR COMPUTER

is your magazine — every issue is full of articles specially written for the home computer enthusiast.

Reviews of personal computers; Programs; Surveys of software available on the market; New application ideas for your computer; Computer Club — news from your clubs; Calculator page; Letters; Answers to your problems and pages and pages of computer games and program listings.

All for only 60p
Ensure your copy
each month, take
out a subscription
NOW!

SEE THE
SUBSCRIPTION
ORDER FORM BETWEEN
PAGES &
IN THIS ISSUE



Whether you are a BBC Microcomputer owner, have limited access or are merely interested, then **LASERBUG** has something to offer you.

LASERBUG is an independent users group dedicated to the support and enhancement of the BBC Microcomputer.

LASERBUG is a central point for ideas and information — we want to hear from you and pass on your ideas and discoveries. Write to us at the address below — but please enclose a SAE if you want a reply.

LASERBUG newsletter is distributed to members each month and is full of news, reviews, letters, articles, programs, contacts and classifieds (rates on application). Our regular meetings also go a long way to help you get the best out of your BBC Microcomputer.

You want to join? for £12.00 you get a year's subscription to **LASERBUG**, 12 issues of the newsletter and free entry to all **LASERBUG**'s meetings and shows — or send £1 and a large SAE (12" x 9") for a sample copy of the **LASERBUG** newsletter and all the latest information.

Write to:

LASERBUG
4 Station Bridge, Woodgrange Road,
Forest Gate, London E7 0NF.

ZX81 USERS!

We are not the first, but we think we are the best, because we have learnt from the problems of others.

EVEN MORE MEMORY

16K RAM PACK FOR SINCLAIR ZX81

- LIES FLAT — no losing your program at the crucial moment.
- FULL ADDRESS DECODING — maps into any 16K block.
- Uses LOW POWER DYNAMIC RAM with on board refresh circuitry.
- Plugs into ZX81 or mounts onto our EXPANSION MOTHERBOARD to give up to 64K of RAM.

£29.50 + VAT (Total £33.93)

EXPANSION MOTHERBOARD

- FIVE buffered slots plus SINCLAIR edge connector.
- LEDs to monitor Software and Hardware operation.
- ADDITIONAL ADDRESS DECODER to correct Sinclair 'Reflection' problem — full 64K available for RAM/ROM addressing.
- RESET BUTTON to clear memory below RAMTOP without power-down.
- REGULATOR (1 amp 5 volt) for optional extra power supply.
- Can be chained.
- BANK SWITCHING — allows use of SINCLAIR ROM Monitor/Interpreter area modify them to suit your needs.
- Wide range of PLUG IN CARDS under development (includes EPROM BOARD) — SERIAL PARALLEL INTERFACE 16K RAMPACKS available now.
- Optional METAL CASE.
- EVEN MORE EXTRAS — we haven't the space to describe write for full specification

£34.95 incl. VAT

CASSETTE INTERFACE

- HAVING TROUBLE LOADING?
- Interface your ZX81 through this interface and overcome these problems.

£8 + VAT (total £9.20)

COMING SOON

MINI-EXPANSION MOTHERBOARD

- 3 slots
- USE TWO RAM PACKS and INTERFACE CARD
- COST about £10

SERIAL PARALLEL INTERFACE CARD

- CENTRONICS — compatible Parallel Interface
- RS232 Serial Interface

NOW YOU CAN USE ANY REGULAR PRINTER with your ZX81, connect up to a modem, speak up to other computers etc.

All prices include P&P

Write for details or see us at ALCC London Computer Fair
Earls Court
ZX81 Microfair

CAPITAL COMPUTERS

Head Office: 100 Church Street, LUTON
Technical/Sales: 1 BRANCH RD, PARK ST, ST ALBANS, HERTS
(0727 72917)

The Essential Software Company

New from
BIG FIVE
Software

DEFENSE COMMAND



It is the year 2734. Our planet has chosen you to carry out the most important mission of the decade. The following is your top-secret mission briefing!

Several months ago the Kromorkrom Empire invaded our planet and stole some of our newly developed and highly efficient "Krotrium" Star Cruiser fuel cells. Your mission is to infiltrate the Kromorkrom Empire and pass yourself off as commanding officer of one of their fuel transport vessels. Once you have accomplished this, you must recover the fuel so that one of our Star Cruisers can warp in and take it back to our planet. You will be given a small shuttle armed with a powerful laser device. Eventually the aliens will uncover your plot and you will be forced to shoot and destroy them to protect the fuel. While you are defending at least one fuel cell, the aliens will be unable to use any of their high-powered battle equipment, for fear of accidentally destroying a fuel cell. Once the aliens have reclaimed all of the fuel cells they will then be able to unleash their newest and most terrifying weapon ever: the Solar Waster!

ROBOT ATTACK

The Newest and Most Astounding Arcade Game that TALKS has just Reached Planet Earth. You can't help yourself. You have to stop them at all cost. Don't let up. Written especially for high quality graphics you'll simply be dazed and excited by the action.

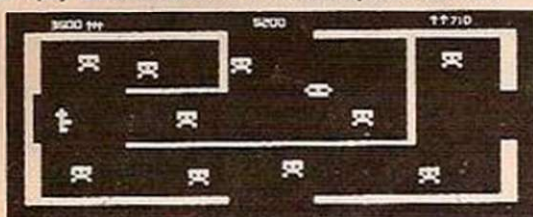

TRS 80 Level II 16K
Video Genie 16K Tape

TRS80 VIDEO GENIE



Gobbleman

As you hurry through the maze collecting modules you score points. But don't let the Gobblemen catch you. If you are crafty, sneak up behind them and neutralise them to gain extra points. Just keep a watch. When they attack you they come in fast. Just don't lose your nerve.

THE ESSENTIAL SOFTWARE COMPANY
(Viscounti Ltd.) 01-837 3154
47 Brunswick Centre, London WC1N 1AF

All Tapes £10-95

I have a microcomputer. Name

Please send me your software catalogue. I enclose a stamped self addressed envelope. Address

Please send me Postcode

I enclose a cheque/postal order for £ My ACCESS No is

(plus 70p post & packing)

The Essential Software Company

Not Only
30 Programs for
the Sinclair
ZX 81:1K -



Machine Language Programming Made Simple for the Sinclair -

A complete beginner's guide to the computer's own language - Z80 machine language. Machine language programs enable you to save on memory and typically give you programs that run 10-30 times faster than BASIC programs.

Sinclair ZX 81 ROM Disassembly by DR. I. LOGAN.

The definitive book for the programmer that needs those answers about the Sinclair ZX 81 ROM.

FREE BLANK CASSETTE **FREE**
WITH EVERY BOOK PURCHASED
OFFER CLOSES 31st MAY 1982

Not only over 30 programs, from arcade games to the most challenging Draughts playing program, which all fit into the unexpanded 1K Sinclair ZX 81 but also notes on how these programs were written and special tips! Great value!

Understanding Your ZX 81 ROM -

A brilliant guide for more experienced programmers by Dr. Ian Logan, this book illustrates the Sinclair's own operating system and how you can use it. Includes special section on how to use machine code routines in your BASIC programs.

The Complete Sinclair ZX 81 BASIC Course

At last, a comprehensive text for your Sinclair ZX 81! The complete BASIC Course is a manual which will immediately become an indispensable work of reference for all your ZX 81 programming.

Order Form:

Orders to
The Essential Software Company, Dept BT1
(Viscounti Ltd.) 01 837 3154
47 Brunswick Centre, London WC1N 1AF

PLEASE SEND.....CASSETTES FREE

NAME:

ADDRESS:

Postcode



- The Complete Sinclair ZX 81 BASIC Course £17.50
- Basic Course Programs on Cassette £ 2.50
- Sinclair ZX 81 ROM Disassembly Part A - 0000H-0F54H £ 7.00
- Not Only 30 Programs/Sinclair ZX 81:1K £ 6.95
- Machine Language Programming Made Simple £ 8.95
- Understanding Your ZX 81 ROM £ 8.95
- Postage and Packing £ 0.70
- Remittance enclosed

ARE YOU A ZX81 USER WHO'S NOT PLAYING GAMES?



£47.50
Including VAT.
complete

ECR 81 DATA RECORDER SAVES AND LOADS YOUR PROGRAMS EVERY TIME!

The ECR81 Enhanced Certified Recorder from MONOLITH is a major advancement in cassette recorder technology which minimises the problems associated with standard audio recorders. The unit is a high reliability program store for ZX computers based on a modified, proven cassette mechanism. The two sections of data recording circuitry automatically ensure precise levels are written onto the tape and that optimised signals are received by the computer.

THE ECR81 IS NOT SUITABLE FOR AUDIO REPRODUCTION
NO MANUAL VOLUME OR TONE CONTROL ADJUSTMENT PROVIDED

- Each ECR81 comes complete with its own individual certification tape, tested and serial numbered to prove your machine reliability.
- Mains Operation only.
- Mains & DIN connector leads provided.
- Certification of tape head alignment - height and azimuth.
- Certified tape tension, torque and speed.
- Fast forward and rewind tape search controls.

The ECR81 is also suitable for Sinclair ZX80

- Please allow up to 28 days delivery.
- The ECR81 is backed by our 14 day money-back option.

MONOLITH
electronic products

Telephone: Crewkerne 0460 74321 Telex: 46306

To: MONOLITH ELECTRONICS CO. LTD., 5/7 CHURCH STREET, CREWKERNE, SOMERSET

Please supply me with:

	Price	Total
.....(Qty.) Monolith ECR 81 Enhanced Certified Recorder(s) to be used with my ZX81	£47.50 (Each)	
I also enclose postage & packing per recorder	£2.50	

Please print

Prices include VAT

£

Name: Mr/Mrs/Miss.

Address



THE PROFESSIONAL ZX81 KEYBOARD

- All-you-need Keyboard Kit £28.95.
- Case only £15.00.

All prices inclusive of VAT, postage and packing.
Please allow 21 days for delivery.

- Plug in – no desoldering.
- Space bar linked to space key.
- Full travel keys. Six spare keys for your own use.
- Case available to hold keyboard and ZX 81 microcard.

- 16K RAM pack clamp supplied with case to eliminate white outs!!

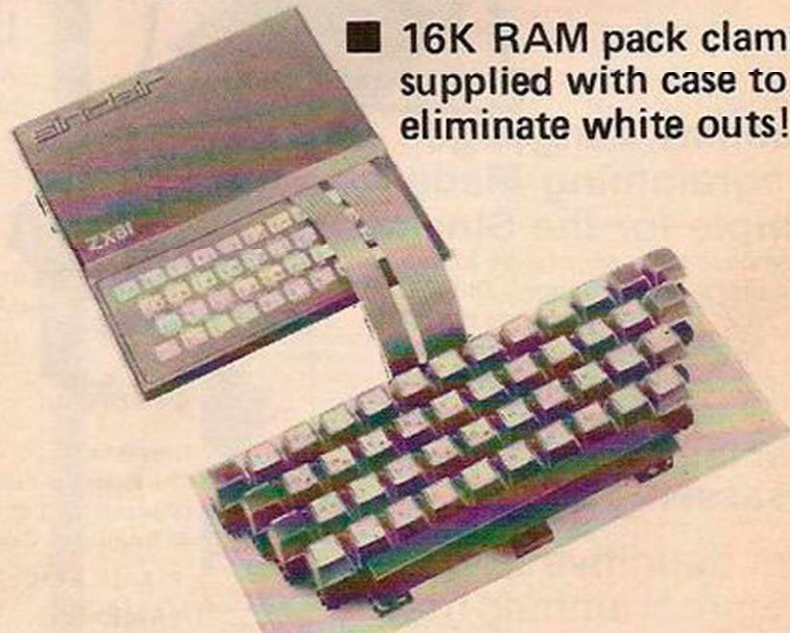

COMPUTER KEYBOARDS DIV.
DEAN ELECTRONICS LIMITED

Glendale Park Fernbank Road Ascot Berkshire England
Dial-a-leaflet 03447 5661 Telex 849242

BARGAIN BYTES

FOR THE 16K ZX81
UNBEATABLE VALUE!
CASSETTE OF 8 PROGRAMS (50K +)

One cassette of 8 programmes
50K Plus, all these for only £5

DEEP SEA ADVENTURE (14K). Discover the treasure chest before you run out of gold or strength. Levels of play from "difficult" to "downright impossible". Also has "Save Game" feature.

BANK ACCOUNT (13½K). Invaluable for controlling your finances. Produces detailed statements and can also keep track of credit card spending.

UNDERGROUND ADVENTURE (6½K). Battle against monsters and obstacles underground. A very difficult and challenging task.

DEPTHCHARGE (2½K). A skilful moving graphics game. Fire your depthcharges to blow up enemy submarines before they destroy your ship.

HANGMAN (11½K). The old family game based on a library of 500 words. Excellent graphics.

LOAN (2½K). Calculates repayments, time, sum borrowed or interest. For Bank Loans or Mortgages.

CODEBREAKER (2K). You have ten guesses at the four digit number held by the computer.

FOREIGN CURRENCY (3K). How many dollars is £110? How many Francs is \$38? See what your money will buy around the world!

ORDER NOW!

For convenience simply quote YC4 and your name and address on the reverse of your cheque/postal order, and your software (on TDK cassette) will then be despatched, first class post, complete with comprehensive instructions.

Send to:

**Richard Shepherd, 22 Green Leys,
Maidenhead, Berkshire, SL6 7EZ.**

Telephone: (0628) 21107. Trade Enquiries Welcome

reprints

If you are interested in a particular article/special feature or advertisement in this journal
HAVE A GOOD LOOK AT OUR REPRINT SERVICE!

We offer an excellent, reasonably priced service working to your own specifications to produce a valuable and prestigious addition to your promotional material. (Minimum order 250 copies). Telephone Michael Rogers on 01-661 3036 or complete and return the form below.

To: Michael Rogers, Your Computer, Reprint Department, Quadrant House, Sutton, Surrey SM2 5AS.

I am interested in copies of article/advert. headed featured in this journal on pages, issue dated

Please send me full details of your reprint service by return of post.

Name

Company

Address

Tel No

BUY ATOM LISP and discover artificial intelligence

Essential for :

- * students learning LISP
- * research
- * hobbyists interested in artificial intelligence
- * systems designers.

ATOM LISP is an interpreter for the language LISP consisting of 5½K of machine - code interpreter plus 2K of initialised LISP utilities and constants which can be deleted if not required.

Important Features

- fully interactive with explicit EVALUATE and VALUE IS messages
- automatic parenthesis count
- SUPERPRINT to format the printing of large expressions
- screen editing or built-in LISP editor
- errors trapped and optional full traceback printed.

ATOM LISP includes a number of extensions to basic LISP, including:

- PEEK, POKE and CALL to control hardware and machine-code programs
- functions can have optional arguments with default values
- improved interactive control structures using LOOP, WHILE and UNTIL functions
- automatic access to COS or DOS commands
- cassette (or disk) input/output control.

The fast compacting garbage collector automatically finds space for numbers, lists, or character strings if there is any space at all remaining. This means that the programmer never need be concerned about the details of storage allocation.

LISP Functions

AND, APPLY, ATOM, BLANK, CALL, CAR, CDR, CAAR, CADR, CDAR, CDDR, CHARP, CHARS, CLOSE, COND, CONS, CR, DEFUN, DIFFERENCE, DOLLAR, EDIT, EQ, ERROR, ERRORSET, EVAL, F, FSUBRP, GET, GETCHAR, GREATERP, LAMBDA, LESSP, LIST, LISTP, LOAD, LOOP, LPAR, MESSOFF, MESSON, MINUS, NIL, NOT, NULL, NUMBERP, OBLIST, OPEN, OR, ORDINAL, PEEK, PERIOD, PLIST, PLUS, POKE, PRINO, PRINT, PROG, PUT, QUOTE, QUOTIENT, READ, READLINE, RECLAIM, REMAINDER, REMPROP, RPAR, RPLACA, REPLACD, SAVE, SET, SETQ, SUBRP, SUPERPRINT, SUPERVISOR, T, TIMES, UNDEFINED, UNTIL, WHILE, WRITE, WRITEQ, ZEROP.

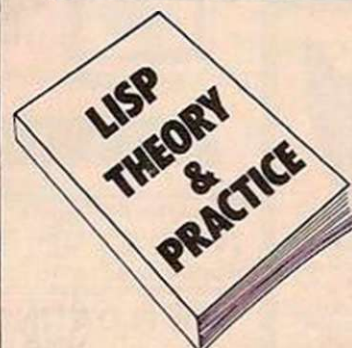

ATOM LISP is available on cassette at only £17.25 inc VAT from your Acorn dealer or direct from Acornsoft. Accompanying 44 page instruction manual "Lisp Theory and Practice" available for £6 (no VAT).

All Acornsoft products are available from authorised Acorn dealers or can be ordered direct from Acornsoft Ltd. 4A Market Hill, Cambridge CB2 3NJ.

Credit card holders can ring 0223 - 316039 and place their orders direct.

ACORNSOFT

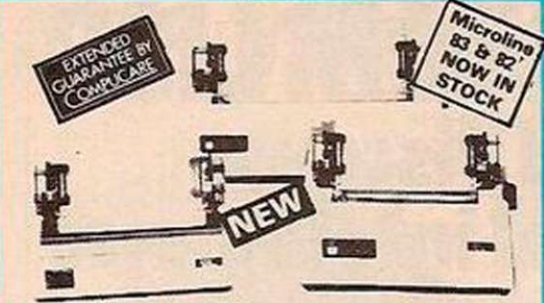

MICROLINE 80 £289 + VAT
 ● 80 cps Uni-directional ● Small size: 342 (W) x 254 (D) x 108 (H) mm. ● 160 Characters, 96 ASCII and 64 graphics ● 3 Character sizes: 40, 80 or 132 chars/line ● Friction and Pin Feed ● Low noise: 65 dB ● Low weight: 6.5 kg

MICROLINE 82 £449 + VAT
 ● 80 cps Bi-directional logic seeking ● Small size: 360 (W) x 328 (D) x 130 (H) mm. ● 160 characters, 96 ASCII and 64 graphics, with 10 National character-set Variants. ● 4 Character sizes: 40, 66, 80 or 132 chars/line. ● Built-in parallel and serial interfaces. ● Friction and Pin Feed ● Low noise: 65dB ● Low weight: 8kg

MICROLINE 83 £649 + VAT
 ● 120 cps bi-directional logic seeking ● 136 column printing on up to 15in forms ● Small size: 512 (W) x 328 (D) x 130 (H) mm. ● 160 characters, 96 ASCII and 64 graphics with 10 National character-set variants ● 3 Character spacings: 5, 10 and 16.5 Chars/in. ● Built-in parallel and serial interfaces ● Friction and Pin Feed ● Low noise 65dB ● Low weight: 13 kg

THE EPSON MX SERIES

MX80T £339 + VAT
MX80F/T £389 + VAT

- 80/132 Column
- Centronics Parallel
- Bi-directional
- Upper & lower case
- True Descenders
- 9x9 Dot Matrix
- Condensed and Enlarged Characters
- Interfaces and Ribbons available

CENTRONICS DOT MATRIX PRINTERS

737 £369 + VAT
739 £469 + VAT

Standard Features

- Proportional Spacing ● Right Margin Justification ● 3 way paper handling ● Upper and lower case ● True Descenders ● Bi-directional Paper Mode ● Underlining capability ● Condensed/Expanded Print ● Sub-Scripts and Super Scripts ● Pin and Friction Feed ● 80/132 Column

739 as above with special feature of Dot Resolution Graphics.

INTRODUCING THE NEW GENIE

Ideal for small businesses, schools, colleges, homes, etc. Suitable for the experienced, inexperienced, hobbyist, teacher, etc.



GENIE I

STILL ONLY £279 + VAT

NOW INCLUDED: Sound, Upper and lower case, Extended BASIC and Machine Code enabling the Writing and Execution of Machine Codes Programming direct from Keyboard. 16K RAM. 12K Microsoft BASIC. Extensive Software Range. Self-Contained PSU UHF Modulator Cassette. External Cassette Interface. Simply plugs into TV or Monitor. Complete and Ready to Go. Display is 6 lines by 32 or 64 Characters Switchable. 3 Manuals included, Users Guide, Beginners Programming and BASIC Reference Manual. BASIC Program Tape Supplied. Pixel Graphics.

THE ANADEX DP9500 and DP9501 A PROFESSIONAL PRINTER

- Bi-directional printing
- Up to 220 chars/line with 4 print densities
- 500 char buffer
- RS232C and Centronics. Parallel interface built in
- Full software control of matrix needles allowing graphics capability
- 200 chars/sec ● Adjustable width tractor feed.

DP9500 — ONLY £845 + VAT
DP9501 — ONLY £895 + VAT

NEC SPINWRITER

only £1490 + VAT

NEC's high quality printer uses a print "thimble" that has less diameter and inertia than a daisy wheel, giving a quieter, faster, more reliable printer that can cope with plotting and printing (128 ASCII characters) with up to five copies, friction or tractor fed. The ribbon and thimble can be changed in seconds. 55 characters per second bidirectional printing — with red/black, bold, subscript, superscript, proportional spacing, tabbing, and much, much more.



GENIE II

£299 + VAT

The **NEW GENIE II** an ideal Business Machine. 13K Microsoft BASIC in ROM. 71 Keyboard. Numeric Keypad. Upper & Lower Case. Standard Flashing Cursor. Cassette Interface 16K RAM Expanded externally to 48K.

WE ARE NOW STOCKING THE APPLE II AT REDUCED PRICES



AUTOSTART EURO PLUS 48K **£649 + VAT**

Getting Started APPLE II is faster, smaller, and more powerful than its predecessors. And it's more fun to use too because of built-in features like:

- **BASIC** — The Language that Makes Programming Fun.
- **High-Resolution Graphics** (in a 54,000-Point Array) for Finely-Detailed Displays. ● **Sound Capability** that Brings Programs to Life. ● **Hand Controls** for Games and Other Human-Input Applications. ● **Internal Memory Capacity** of 48K Bytes of RAM, 12K Bytes of ROM; for Big-System Performance in a Small Package. ● **Eight Accessory Expansion Slots** to let the System Grow With Your Needs.

You don't need to be an expert to enjoy APPLE II: It is a complete, ready-to-run computer. Just connect it to a video display and start using programs (or writing your own) the first day. You'll find that its tutorial manuals help you make it your own personal problem solver.

HITACHI PROFESSIONAL MONITORS

9" — £129 **£99.95** + VAT
 12" — £199 **£149** + VAT

- **Reliability** Solid state circuitry using an IC and silicon transistors ensures high reliability. ● **500 lines horizontal resolution** Horizontal resolution in excess of 500 lines is achieved in picture center. ● **Stable picture** Even played back pictures of VTR can be displayed without jittering. ● **Looping video input** Video input can be looped through with built-in termination switch. ● **External sync operation** (available as option for U and C types) ● **Compact construction** Two monitors are mountable side by side in a standard 19-inch rack.

GENIE I & II EXPANSION UNIT WITH 32K RAM £199 + VAT

PARALLEL PRINTER INTERFACE CARD £35.00 + VAT

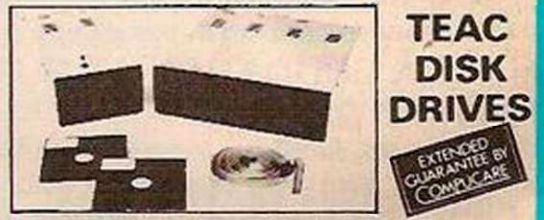

TEAC DISK DRIVES

- TEAC FD-50A has 40 tracks giving 125K Bytes unformatted single density capacity.
- The FD-50A can be used in double density recording mode.
- The FD-50A is Shugart SA400 interface compatible.
- Directly compatible with Tandy TRS80 expansion interface.
- Also interfaces with Video Genie, SWTP, TRS80, North Star Horizon, Superbrain, Nascom, etc., etc.
- Address selection for Daisy chaining up to 4 Disks
- Disks plus power supply housed in an attractive grey case.

40 TRACK
 Single Disk Drive **£225 + VAT** Double Disk Drive **£389 + VAT**

77 TRACK
 Single Disk Drive **£299 + VAT** Double Disk Drive **£499 + VAT**

APPLE DISC II 3.3 Dos

Disc with Controller **£339 + VAT**
 Additional Drives **£289 + VAT**

- Powerful Disk Operating Software Supports up to 6 drives ● Name Access to Files for Ease of Use ● BASIC Program Chaining to Link Software Together ● Random or Sequential File Access to Simplify Programming
- Dynamic Disk Space Allocation for Efficient Storage
- Individual File Write-Protection Eliminates Accidental File Alterations ● Loads an 8K Byte Binary Image in 6.5 sec. (1.2 sec. in Pascal) ● Storage Capacity of 116 Kilobytes (143K Bytes with Pascal) on Standard 5 1/4" Diskettes ● Powered Directly From the APPLE (Up to 6 Drives) for Convenience and High Reliability ● Packaged in Heavy-Duty, Colour Coordinated Steel Cabinet

Colour Monitors for Apple — **£295 + VAT**

ACORN ATOM

UNIQUE IN CONCEPT — THE HOME COMPUTER THAT GROWS AS YOU DO

Fully Assembled **£157.50 + VAT** inc. PSU

Special features include ● Full Sized Keyboard ● Assembler and Basic ● Top Quality Moulded Case ● Optional High Resolution Colour Graphics ● 6502 Microprocessor

4K FLOATING POINT ROOM £19.50 + VAT
COLOUR ENCODER £19.00 + VAT

We give a full one year's guarantee on all our products, which normally only carry 3 months guarantee.

LUXOR 14" COLOUR MONITOR FOR THE APPLE £295 + VAT

A SELECTION OF APPLE INTERFACES ARE NOW AVAILABLE AT OUR EDGWARE ROAD SHOWROOM

SALE MEMORY UPGRADES
 16K (8 x 4116) **£12.90 + VAT**
 4K Compukit (8 x 2114) **£12.90 + VAT**

WE HAVE ONE OF THE LARGEST COLLECTIONS OF COMPUTER BOOKS UNDER ONE ROOF, ALONG WITH SOFTWARE FOR THE GENIE, TRS80 AND APPLE.

IF IT WASN'T FOR THE LOWEST PRICES, THE BIGGEST CHOICE AND THE BEST AFTER SALES SERVICE, WE JUST WOULDN'T BE COMP SHOP



NOW IN STOCK THE NEW & EXCITING TRS80 MODEL III

48K £599 + VAT

The Radio Shack TRS-80™ Model III is a ROM-based computer system consisting of:

- A 12-inch screen to display results and other information
- A 65-key console keyboard for inputting programs and data to the Computer
- A Z-80 Microprocessor, the "brains" of the system
- A Real-Time Clock
- Read Only Memory (ROM) containing the Model III BASIC Language (fully compatible with most Model I BASIC programs)
- Random Access Memory (RAM) for storage of programs and data while the Computer is on (amount is expandable from "16K" to "48K", optional extra)
- A Cassette Interface for long-term storage of programs and data (requires a separate cassette recorder, optional/extra)
- A Printer Interface for hard-copy output of programs and data (requires a separate line printer, optional/extra)
- Expansion area for upgrading to a disk-based system (optional/extra)
- Expansion area for an RS-232-C serial communications interface (optional/extra)

All these components are contained in a single moulded case, and all are powered via one power cord.

Disc Drives Kit with 2x40 Track Drives — £599 + VAT
Disc Drives Kit with 2x80 Track Drives — £729 + VAT

DUE TO IMMENSE POPULARITY SALE CONTINUED UNTIL STOCKS LAST

★ 6502 based system — best value for money on the market. ★ Powerful 8K Basic — Fastest around ★ Full Qwerty Keyboard ★ 1K RAM Expandable to 8K on board. ★ Power supply and RF Modulator on board. ★ No Extras needed — Plug-in and go ★ Kansas City Tape Interface on board. ★ Free Sampler Tape including powerful Disassembler and Monitor with each Kit. ★ If you want to learn about Micros, but didn't know which machine to buy then this is the machine for you.

EUROPE'S FASTEST SELLING ONE BOARD COMPUTER

COMPUKIT UK101



COMPUKIT WITH ALL THE FEATURES THAT MADE IT THE MOST PROFESSIONAL COMPUTER KIT ON THE MARKET. NOW WITH FREE NEW MONITOR (a saving), which includes Flashing Cursor, Screen Editing, & Save Data on Tape.

Build, Understand and Program your own Computer for only a small outlay

KIT ONLY **£99.95 + VAT**
Fully Assembled — **£149 + VAT**

PLUS **£4.60** Post & Packing

NEW MONITOR IN ROM — available separately at **£7.90 + VAT**.
Improved BASIC 3 ROM — revised GARBAGE routine allows correct use of STRING ARRAYS **£4.90 + VAT**
This chip can be sold separately to existing CompuKit and Super board users.

4K Upgrade Kit £12.90 + VAT

FOR THE COMPUKIT — Assembler Editor **£14.90** Case for UK101 **£29.50**
GAME PACKS — 1). Four Games **£5.00** 2). Four Games **£5.00**
Super Space Invaders (8K) **£6.50** Chequers **£3.00** Realtime Clock **£3.00**
10 x C12 Cassettes **£4.00** 40 pin Expansion Jumper Cable **£8.50** All Prices exclusive VAT



SHARP PC1211 £69.95 + VAT

COMPUTER POWER THAT ONCE FILLED A ROOM CAN NOW BE CARRIED IN YOUR POCKET!

- Programs in BASIC
- "QWERTY" Alphabetic Keyboard
- 1.9K Random Access Memory
- Long Battery Life.

SHARP CE122 PRINTER & CASSETTE INTERFACE £75 + VAT

CASSETTE INTERFACE ONLY £14.90 + VAT



INTRODUCING THE NEW SHARP MZ-80B

£999 + VAT.

- 4 Mhz Z-80CPU
- Dynamic RAM
- 2K ROM
- BASIC is provided
- High Resolution Graphics
- 9" High Focus Green Display
- Upper and Lower Case
- 80/40 Characters x 25 line display
- Electro Magnetic Cassette Deck included
- ASC11 Keyboard
- Numeric Keypad
- Sound Output
- Built-in Clock and Music.

Available Soon—Discs, Printers and other Accessories.

YOUR ZX80 IS NOW NO LONGER REDUNDANT

Upgrade your ZX80 to the full animated graphics of the ZX81. (No screen flicker).
FOR ONLY **£12.95 + VAT** IN KIT FORM
Works only in conjunction with **NEW 8K ROM** from Sinclair (Not Included).

OUR NEW SUPER LOCATION IN IRELAND

19 Herbert Street, Dublin 2.
Telephone: Dublin 604165

HEAR OUR ADS ON RADIO NOVA 88.1 VHF Stereo



NEW The PEDIGREE PETS 32K ONLY **£569 + VAT**
RRP £795 for 32K

Very popular for home & business use. 8K Microsoft Basic in ROM. 32K with new improved keyboard. 12" screen. Cassette Deck **£55** extra



8032 80 COLUMN PET ONLY **£825 + VAT**

The reliable value for money system with after sales support, instruction and training facilities and a wide range of programmes.

CASIO VL TONE NEW £31.25 + VAT



It's a new kind of musical instrument. A computer controlled synthesiser that helps you create, play and arrange compositions that normally take years of music training. Also a calculator.

SECK 62 MIXER



Professional audio mixer that you can build yourself and save over £100.
Only **£99.90** plus VAT for complete kit. Plus **FREE** power supply valued at **£25.00**



COMMODORE VIC-20 ONLY **£159 + VAT**

- 16 foreground colours
- 8 background colours
- Real typewriter keyboard with full graphics
- Music in three voices and three octaves
- Language and sound effects

BBC COMPUTER

Please phone for availability and price

Delivery is added at cost. Please make cheques and postal orders payable to **COMP SHOP LTD.**, or phone your order quoting **BARCLAYCARD, ACCESS, DINERS CLUB** or **AMERICAN EXPRESS** number.

MAIL ORDER AND SHOP: 14 Station Road, New Barnet, Hertfordshire, EN5 1QW (Close to New Barnet BR Station — Moorgate Line). Telephone: 01-441 2922 (Sales) 01-449 6596 Telex: 298755 TELCOM G

OPEN (BARNET) — 10am - 7pm — Monday to Saturday

NEW WEST END SHOWROOM: 311 Edgware Road, London W2. Telephone: 01-262 0387

OPEN (LONDON) — 10am - 6pm — Monday to Saturday
★ IRELAND: 19 Herbert Street, Dublin 2. Telephone Dublin 604165
★ COMP SHOP USA, 1348 East Edinger, Santa Ana, California, Zip Code 92705. Telephone: 0101 714 5472526

TELEPHONE SALES
OPEN 24 hrs. 7 days a week
01-449 6596



106 HILARY AVE



VIC-20

See it here, buy it now
AT YOUR LOCAL
BRANCH TODAY!

Birmingham Byteshop Computerland 94/96 Hurst St, B5 4TD **Tel:** 021 622 7149 **London** Byteshop Computerland 324 Euston Road London W1 **Tel:** 01-387 0505 **Nottingham** Byteshop Computerland 92A Upper Parliament St NG1 6LF **Tel:** 0602 40576 **Manchester** Byteshop Computerland 11 Gateway House Piccadilly Station Approach **Tel:** 061 236 4737 **Glasgow** Byteshop Computerland Magnet House 61 Waterloo St, G2 7BP **Tel:** 041 221 7409

A member of the Comart  Group of Companies.