

60p

Win a NewBrain

# YOUR COMPUTER

SEPTEMBER 1982

Vol.2 No.9

**Breaking the ZX-81  
sound barrier**

**Spectrum software survey**

**NewBrain reviewed**

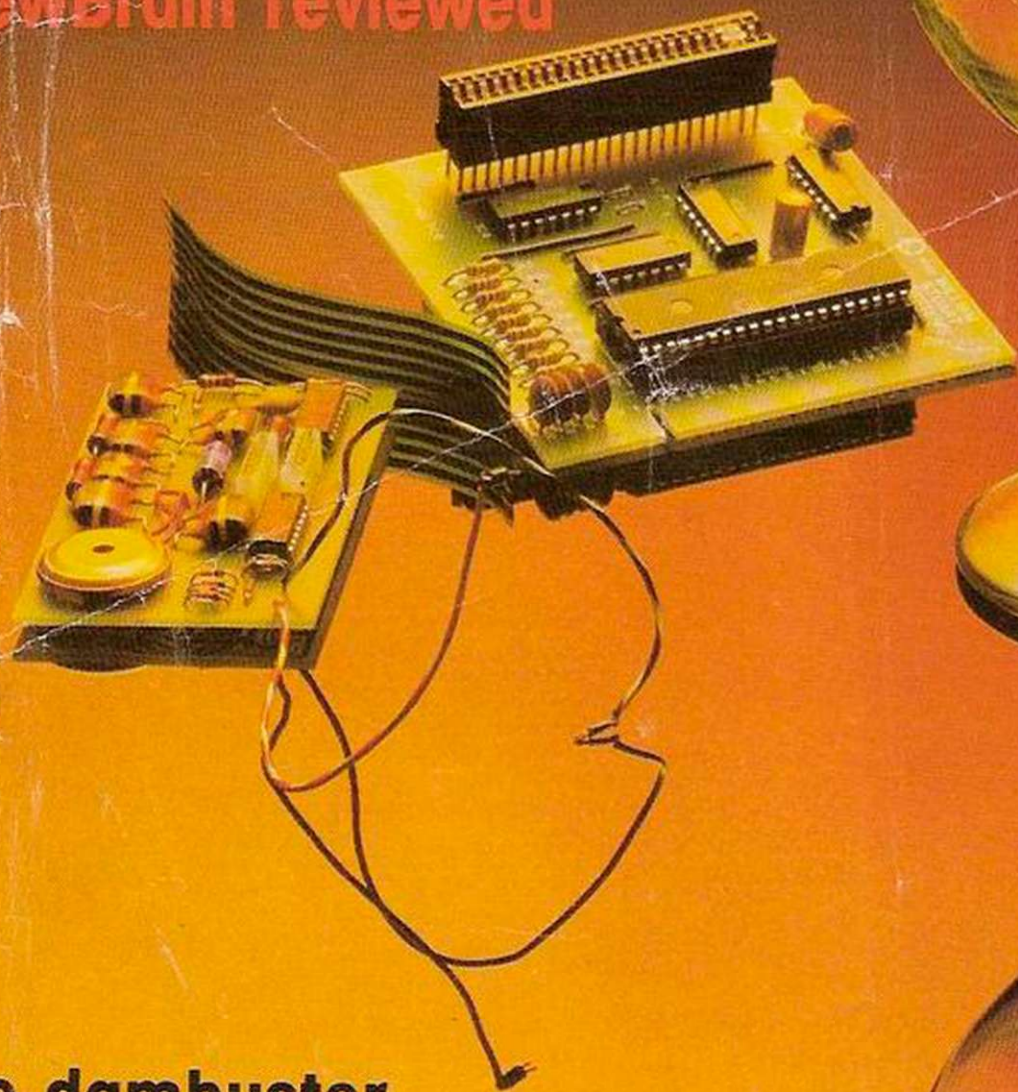

**Vic dambuster**

**6502 assembler**

**More BBC secrets**

**Atom intelligent typewriter**

# PERSONAL CO

age  
nd  
way  
lan,  
ian,  
ese,  
or a  
age.  
s, Se

**LONELY** Genie I Microcomputer, early eighties, with large peripheral family but currently unattached, would like to meet interesting, attractively packaged software, Genie or Tandy specification, for programming, problem solving, entertainment and long-lasting friendship. Reply in confidence. Box No RS232.

LON  
intel  
vatec

ATTI  
wish  
may  
mar

SO  
me  
(m  
tion  
hum

MAI  
to  
wal  
wis

ent  
DIY  
or a  
Vay,

hop  
on

ANSWERING MACHINES  
Office certified



# ingenious ...but lonely!

Buying your first Genie I microcomputer is just the start of a long and enthralling adventure, for it won't be long before you will want to expand your system with some of the wide range of peripherals which make up the complete Genie System.



Firstly there is the **Expansion Box**, which immediately expands your Genie's capacity to 32K RAM, and up to 48K RAM if required. It can be connected to 4 disk drives, a printer, RS232 interface or S100 cards.

The supreme advantage of the Genie I system is its compatibility with the TRS 80, which means that literally 1000's of pre-recorded programs are already available, just waiting to be plugged into your Genie!

The recent improvements in the Genie system, including Extended Basic, sound unit and machine language monitor, make it the ideal system for the committed hobbyist, and an excellent and easy-to-use educational tool.

Then there is the **Printer**,

a compact unit with 80 column, 5 x 7 matrix print-out, which connects to your Genie through the Expander, or via the Parallel Printer Interface.



**SPECIAL TECHNICAL GENIE  
HOT - LINE ON 0629 4995**

for all your technical advice and service back-up on any aspect of the Genie system direct from the experts!

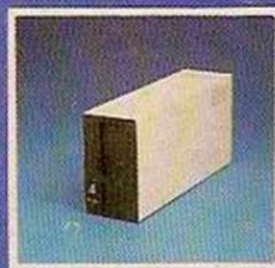

The **Disk Drive** gives you greater storage capacity and full random access file handling, with the option of double-density through a special adapter. New Dual Disk Drive now available!

Finally, there is Genie's very own **12" Monitor**, a must if you want to let the rest of the family watch their T.V. in peace! Available in B & W or green tube.



Please send me FREE, 16 page colour brochure on the Genie Computer System. I enclose 25p postage.

Name \_\_\_\_\_

Address \_\_\_\_\_

Telephone \_\_\_\_\_ YC-82

**LOWE** Chesterfield Road,  
Matlock,  
Derbyshire DE4 5LE.  
**electronics** Telephone: 0629 4995.  
Telex: 377482 Lowlec G.

# YOUR COMPUTER

<b>YOUR LETTERS:</b>	<b>17</b>	<b>INTERVIEW:</b>	<b>38</b>	<b>ZX-81 MACHINE CODE:</b>	<b>72</b>
Poking fun at the Spectrum; machine code.		Hermann Hauser, Acorn's technical director, reveals the Electron's secrets and tells how the BBC Micro was made.		Kathleen Peel continues her guided tour through machine code.	
<b>NEWS:</b>	<b>18</b>	<b>VIC DAMBUSTER:</b>	<b>42</b>	<b>MIDWICH MC</b>	<b>76</b>
Two new £200 colour micros — MPF-II and Colour Genie; Jupiter's £90 fast Forth Ace; Acorn's BBC voice unit.		Stop Dave Smallbrook's Nibblers and save the dam.			
<b>COMPUTER CLUB:</b>	<b>21</b>	<b>INTELLIGENT TYPEWRITER:</b>	<b>47</b>		
This month computers at the Fox and Goose read out poetry to the West London Computer Club.		When it comes to word processing Dave Berry's routines will make your machine brighter than the average Atom.			
<b>BREAK THE SOUND BARRIER:</b>	<b>22</b>	<b>B-52 BOMB-RUN:</b>	<b>50</b>		
		Unless the bomb aimer can clear a landing strip below, S A Nicholls's ZX-81 game will crash.			
Tim Langdell tries everything from bleeps to speech synthesisers as he tries to persuade his ZX-81 to speak and be spoken to.		<b>BBC TIPS:</b>	<b>54</b>	<b>RESPONSE FRAME:</b>	<b>83</b>
		More operating system calls and special effects.		More answers to your technical queries.	
<b>SPECTRUM SOFTWARE:</b>	<b>28</b>	<b>VIC-20 ASSEMBLER:</b>	<b>58</b>	<b>FINGERTIPS:</b>	<b>85</b>
Boris Allan confronts random Beefeaters and looks into a crystal ball as he checks out Spectrum programs.		Philip Horton puts it all together.		Our pocket computer and calculator column.	
<b>NEWBRAIN REVIEW:</b>	<b>36</b>	<b>SPECTRUM DISASSEMBLER:</b>	<b>62</b>	<b>SOFTWARE FILE:</b>	<b>89</b>
Two years after its launch, the NewBrain is now available in quantity. Simon Beesley finds out who needs a NewBrain now.		David Horne takes it all apart.		Eight packed pages of programs for the ZX-81, Spectrum, BBC Micro, Vic and others.	
		<b>BASIC DIALECTS:</b>	<b>64</b>	<b>COMPETITION CORNER:</b>	<b>98</b>
		Tony Edwards makes translating easier.		Result of July's Birdcatcher and a new competition for a £15 book token. NewBrain crossword falls between pages 26 and 27.	
		<b>ZX-81 INDEXER:</b>	<b>68</b>		
		Indexing a record collection or library is simple with John Watson's program.			

Cover photograph by Stephen Oliver.

## Editor

TOBY WOLPE

## Assistant Editor

MEIRION JONES

## Staff Writer

SIMON BEESLEY

## Sub-editor

PAUL BOND

## Editorial Secretary

LYNN COWLING

Editorial: 01-661 3144

## Advertisement Manager

PHILIP KIRBY 01-661 3127

## Advertisement Executives

BILL ARDLEY 01-661 8484

PETER RICE 01-661 8441

## Midlands Office

DAVID HARVETT 021-356 4838

## Northern Office

RON SOUTHALL 061-872 8861

## Advertisement Secretary

JEANETTE MACKRELL

## Publishing Director

CHRIS HIPWELL

Your Computer, Quadrant House, The Quadrant, Sutton, Surrey SM2 5AS.

Typesetting by In-Step Ltd, London EC1.

Printed by Riverside Press Ltd, Whitstable, Kent.

Subscriptions: U.K. £8 for 12 issues.

©IPC Business Press Ltd 1982

Published by IPC Electrical-Electronic Press Ltd, Quadrant House, The Quadrant, Sutton, Surrey SM2 5AS. Tel: 01-661 3500 Telex/grams: 892084 BIPRESG. ISSN 0263-0885

## EDITORIAL

MANUFACTURERS HAVE PUSHED the prices of micros offering colour and sound into a steep nosedive; no-one will be too bothered if they never pull out of it. But to be able to drop so far so quickly the machines at the lowest end of the price range have had to jettison all unnecessary weight. In the name of price-streamlining, full sound facilities are often nudged through the escape-hatch at an early stage.

As a result we have the Spectrum, which seems to have been designed to satisfy popular demand for inaudible noise, and the Dragon 32's endearing croak. This kind of facility makes the whole theme of sound appear limited. Yet until now low-cost computing has neglected everything from music, through synthetic speech to voice recognition.

Sound will be at the very heart of the way micros operate and are operated in the near future, and games-playing may well be the force which will put it in that position. After all, joysticks and track-balls had languished in computer laboratories until the advent of consumer computer games.

The prospect of large sales of games using, say, speech recognition — the most problematical area in sound — could make manufacturers put more money into its development. Then those who enjoy battle games could easily find themselves in command of a squadron of aircraft on the screen, giving verbal "bandits at two o'clock"-type warnings to fellow pilots while fending off attacks using joystick control.

If that sounds too futuristic, there are instances much closer to the present where sound could be used and for which relatively inexpensive hardware already exists. As usual, software development lags behind. Take, for example, computer speech. You can buy specialised chips which hold all the phonemes in English but hours must be spent programming the device to speak even the simplest phrases with the correct pronunciation and inflection. Music must be the most obviously neglected area — the chips exist and a small piano-format keyboard could be offered with most micros for little extra cost. It would be easier to connect than a joystick.

Tomorrow's computer buffs will be mystified that manufacturers only turned to sound when they wanted a new feature to tempt the buyer. As they chat with their machines they will wonder how we ever managed without it.

# ZX99

# AUTOMATIC TAPE CONTROLLER FOR THE SINCLAIR ZX81

## ● DATA PROCESSING

The ZX99 gives you software control of up to four tape drives (two for reading, two for writing) allowing merging of data files. This is achieved by using the remote sockets of the tape drives, controlled by USR statements or commands.

## ● RS232C INTERFACE

The ZX99 has an RS232C output allowing connection with any such printer using the full ASCII character code (you can now print on plain paper in upper or lower case, and up to 132 characters per line) at a variable baud rate up to 9,600

## ● SPECIAL FEATURES

There are so many special features it is difficult to list them all, for example:

**AUTOMATIC TAPE COPY:** You can copy a data file regardless of your memory capacity as it is processed through the Sinclair block by block.

**TAPE BLOCK SKIP:** Without destroying the contents of RAM

**DIAGNOSTIC INFORMATION:** To assist in achieving the best recording settings.

The ZX99 contains a 2K ROM which acts as an extension to the firmware in the Sinclair ROM. The ZX99's ROM contains the tape drive operating system and the conversion to ASCII for the RS232C output.

There is an extension board on the rear to plug in your RAM pack (larger than 16K if required). The unit is supplied with one special tape drive lead, more are available at £1 each.

Now only  
**£49.95**

plus  
**£2.95p+p**



## ● ZX99 SOFTWARE

We now have available "Editor 99", a quality word processing program including mail-merge, supplied on cassette for £9.95. Also following soon:

- \* Stock Control (October)
- \* Sales Ledger (November)
- \* Business Accounts
- \* Debtors Ledger
- \* Tax Accounting

Dept. YC5 Data - Assette, 44 Shroton Street, London NW1 6UG. 01-258 0409

data-assette®

44, Shroton Street  
London NW1  
Tel 01-258 0409

## ● FERGUSON CASSETTE RECORDER £28 inc. p&p.

Tested with ZX81, Acorn, BBC, Dragon etc. etc.  
Features: Din, Ear, Mic. and Remote sockets, Tape Counter, Tone Control, Built-in Mic., Autostop. Battery/mains. Recommended by Acorn for use with BBC computer.

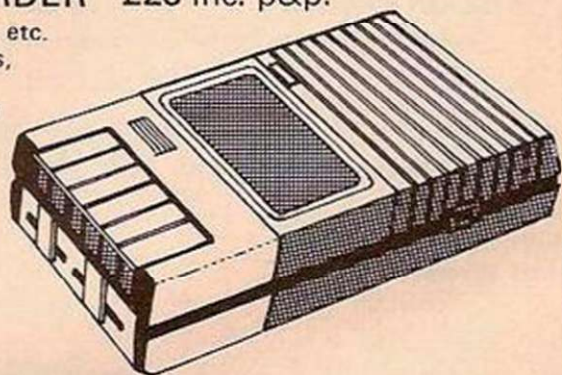

- STAR DP8480 RS232C (SERIAL) **£285** plus £6 Securicor delivery
- CENTRONICS (PARALLEL) **£265** plus £6 Securicor delivery

This professional printer works with almost any computer with very good upper and lower case typeface.

- Bi-directional
- 80 column width (10" paper)
- Switchable - Tractor or Friction Feed
- 80 chrs. per second

- 2,000 SHEETS OF PRINTER PAPER **£19.50** plus £3.50 p&p.

## ● E690 REVOLVING CASSETTE RACK

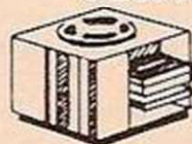

- Single - **£2.99** (holds 32 tapes or 20 in cases)
- Double - **£5.99** (holds 64 tapes or 40 in cases)
- Treble - **£8.99** (holds 96 tapes or 60 in cases)
- Quad - **£11.99** (holds 128 tapes or 80 in cases)

All plus £1 p&p.

## ● BBC CASSETTE LEAD

7 pin plug to two 3.5mm plugs and one 2.5mm plug. Only **£2** inc. P & P.

Other leads available - please telephone.

## COMPUTER CASSETTES

High quality, screw assembled cassettes supplied with library boxes. Any lengths available.

- C5 - 35p      C10 - 37p      C12 - 38p
- C15 - 39p      C20 - 41p      C25 - 43p
- C30 - 44p

P&P 10% (min. charge £1.50)

## ORDER FORM

Dept. YC5 Data - Assette, 44 Shroton Street, London NW1 6UG. 01-258 0409

Code	Item	No.	Price	P & P	Total

Cheques/PO made payable to Storkrose Ltd.  
Charge my Access/Visa No. ....

Signed \_\_\_\_\_ Name \_\_\_\_\_  
Address \_\_\_\_\_

# Software for all

72 NORTH STREET, ROMFORD, ESSEX. TEL 0708 60725

Announce the launch of their range of **BBC** programs

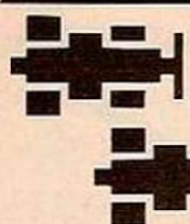

For Model B only. **Grand Prix**

Time Trials around our race track. Includes computer controlled car to hinder your progress. 9 levels of difficulty.

**£5.95**

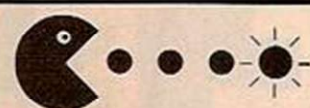

**GHOST MAZE**

For Model B only.

Our own version of this popular Arcade game. With colour & sound. 9 levels of difficulty.

**£6.95**

**BEEBTREN**

For Model A or B, real time advanced Startrek Game. Extra facilities include "probe satellites", "damage reports" & "on-board computer".



**£7.95**

**Cobra/Robo-Swamp**

For Model A or B (please state version required). Two addictive graphic games — insomniacs delight!

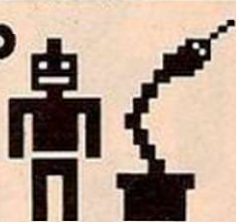

**£6.95**

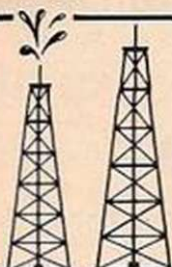

**J.R.**

For Model B only. Two player game, features include exploration, drilling, employment and Price Wars.

**£6.95**

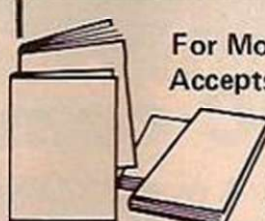

For Model A or B

**DATABASE**

Accepts up to ten definable fields.

Facilities include Quick Search, Sort and Hard copy — capable of storing up to 300 complete records in memory (Model B).

**£9.95**

**INVADERS**

For Model A or B. Classic Arcade game. With colour and sound.

**£6.95**

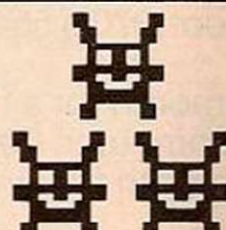

**Character Generator**

For Model B only. Useful utility program enables user to re-define character set using Mode 4. Displays new character in graph form.

**£4.95**

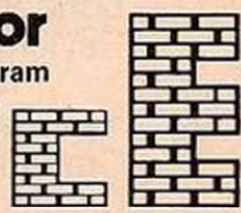

**Programmers**

We are looking for good quality programs covering games, utilities and education. We pay excellent royalty rates. Please write or phone us on (0708) 60725

Dealer enquiries also welcome.

We're only a few minutes from your Post Box. So why not try our mail order service.

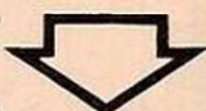

**Paralander VIC-20**

For unexpanded model, graphics and sound are incorporated into this absorbing battle between you (the dare-devil) and the elements.



**£4.50**

**ZX Spectrum**

**Disassembler**

**£4.00** Useful Utility Programme. Fits in 16K.

Please send me:-

Add £1 p&p per order.

..... £ .....

..... £ .....

..... £ .....

I enclose Cheque/P.O. for - £ .....

Please debit my Access/Barclaycard No.

Name .....

Address .....

Make cheques/P.O. payable to: **SOFTWARE FOR ALL**  
72 North Street, Romford, Essex.  
Tel: Romford (0708) 60725



**Attention  
Dragon Owners!  
Software Coming Soon!**

# INTEREST FREE CREDIT

\* Subject to approval which can take up to 48 hours (APR = 0%)

from  
**MAPLIN**

## On Atari & VIC computer hardware

If your order contains over £120 worth of computer hardware apply now for interest free credit by telephoning: Mail-order: (0702) 552911  
London Shop: 01-748 0926 Southend Shop: (0702) 554000 or write to P.O. Box 3, Rayleigh, Essex SS6 8LR

You pay 10% down, then 10% per month for a further nine months. (to nearest penny) Example: VIC20 Colour Computer. Cash Price £199.99. Credit terms: £19.99 down then £20 per month for nine months: Total £199.99. Credit quotations on request.

### The VIC20 Colour Computer

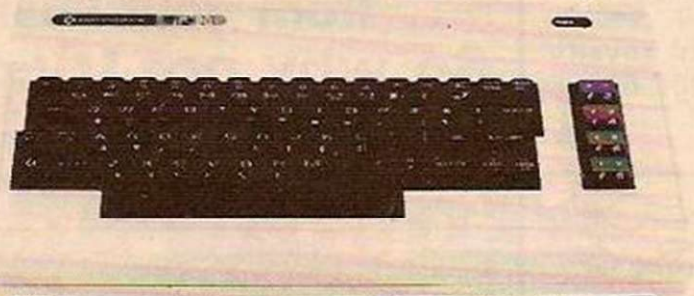

could be yours this week for just  
**£19.99 down.**  
Cash price and total credit price **£199.99.**  
Order as **AF47B**

#### VIC 20 ACCESSORIES:

**C2N Cassette Unit** (AF48C) £44.95

**VIC20 Printer:** (AF49D) £230.00  
80 characters per line, 30 characters per second, tractor feed, full alphanumerics and graphics, double size character.

**VIC20 Disk Drive:** (AF50E) £396.00  
170K storage on standard single-density, single-sided, soft-sectored floppy disks.

**Add-on RAM Cartridges:**  
3K RAM (AF51F) £29.95  
8K RAM (AF52G) £44.95  
16K RAM (AF53H) £74.95

**Memory Expansion Board:**  
6 ports for plug-in cartridges  
(AF54J) £125.95

#### Introduction to BASIC Cassettes

Part 1 (AC57M) £14.95  
Part 2 (AC58N) £14.95

#### Joysticks and Paddles:

Single Joystick (AC53H) £7.50  
Pair of Joysticks (AC37S) £13.95  
Le Stick (AC45Y) £24.95  
Pair of Paddles (AC30H) £13.95

#### Programming Aid Cartridges

Super Expander: 3K RAM and Hi-res graphics (AC54J) £34.95  
Programming Aid: Additional commands, function key programming etc.  
(AC55K) £34.95  
Machine Code Monitor (AC56L) £34.95

#### Game Programs

Avenger Cartridge (AC59P) £19.95  
Star Battle Cartridge (AC60Q) £19.95  
Super Slot Cartridge (AC61R) £19.95  
Jelly Monsters Cartridge (AC62S) £19.95  
Alien Cartridge (AC63T) £19.95  
Super Lander Cartridge (AC64U) £19.95  
Road Race Cartridge (AC65V) £19.95  
Rat Race Cartridge (AC66W) £19.95  
Blitz Cassette (AC67X) £4.99

#### Books About VIC

Learn Programming on the VIC (WA31J) £2.50  
VIC Revealed (WA32K) £11.50  
VIC Programmers Reference Guide (WA33L) £16.50

See us at the  
**Personal Computer  
World Show**  
Barbican Centre  
9-12 Sept



- 4 Consoles available:**
- Atari 400 with 16K RAM (AF36P) £249.95**
  - Atari 400 with 48K RAM (AF37S) £319.00**
  - Atari 800 with 16K RAM (AF02C) £499.00**
  - Atari 800 with 48K RAM (AF55K) £590.00**

- Lots of other hardware:**
- |  |                                     |
|--|-------------------------------------|
| Cassette Recorder (AF28F) £50.00         | 16K RAM Module (AF08J) £55.00       |
| Disk Drive (AF06G) £299.95               | 48K RAM Module (AF44X) £125.35      |
| Thermal Printer (AF04E) £265.00          | 48K Upgrade for 400 (AF45Y) £75.00  |
| Printer Interface for 400 (AF41U) £59.95 | Floppy Disk (YX87U) £2.50           |
| Printer Interface for 800 (AF42V) £59.95 | Le Stick (AC45Y) £24.95             |
| Interface Module (AF29G) £135.00         | Joystick Controllers (AC37S) £13.95 |
| Versawriter (AF43W) £169.00              |                                     |
- For full details ask for our hardware leaflet (XH54J) SAE appreciated

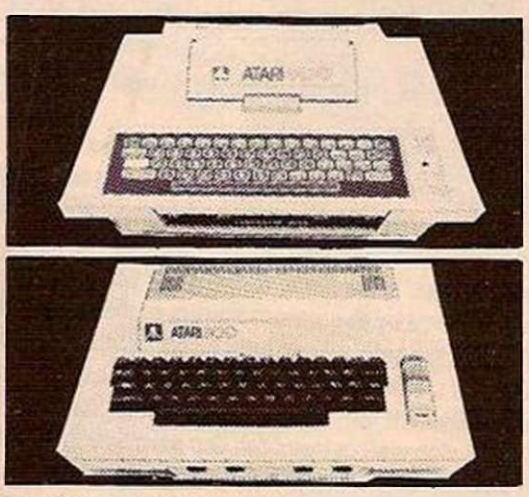

**NOW YOU CAN JOIN THE U.K. ATARI COMPUTER OWNER'S CLUB.** An independent user's group.  
Four issues of the club magazine for only £1.60! Address your subscription to Ron

**THE CHOICEST GEMS OF ATARI SOFTWARE FROM MAPLIN**

<p><b>Adventure Games</b></p> <ul style="list-style-type: none"> <li>Star Warrior -C- 32K-(B024B) £28.95</li> <li>Rescue At Risk -C- 32K-(B021X) £22.45</li> <li>Invasion Orion -C- 32K-(B023A) £18.95</li> <li>Dalestones of Ryn -C- 32K-(B022Y) £14.95</li> <li>Galactic Empire -C- 24K-(B0140) £14.95</li> <li>Hi-Res Adventure #1/2 -D- 48K-(B025C) £24.95</li> <li>Analog Adventure -D- 32K-(B033L) £16.95</li> <li>Adventure Land -C- 24K-(B000A) £14.95</li> <li>Pirates Adventure -C- 24K-(B001B) £14.95</li> <li>Mission Impossible -C- 24K-(B002C) £14.95</li> <li>Woodoo Castle -C- 24K-(B003D) £14.95</li> <li>The Count -C- 24K-(B004E) £14.95</li> <li>Strange Odyssey -C- 24K-(B005F) £14.95</li> <li>Mystery Fun House -C- 24K-(B006G) £14.95</li> <li>Pyramid of Dnom -C- 24K-(B007H) £14.95</li> <li>Ghost Town -C- 24K-(B008J) £14.95</li> <li>Savage Island I -C- 24K-(B009K) £14.95</li> <li>Savage Island II -C- 24K-(B010L) £14.95</li> <li>Golden Voyage -C- 24K-(B011M) £14.95</li> <li>Energy Czar -C- 16K-(Y053H) £9.95</li> <li>Kingdom -C- 8K-(Y055K) £9.95</li> </ul> <p><b>Teach-Yourself Programs</b></p> <ul style="list-style-type: none"> <li>Conversational French -5C- 16K-(Y044X) £39.95</li> <li>Conversational German -5C- 16K-(Y045Y) £39.95</li> <li>Conversational Spanish -5C- 16K-(Y046A) £39.95</li> <li>Conversational Italian -5C- 16K-(Y047B) £39.95</li> <li>Touch Typing -2C- 16K-(Y049D) £15.95</li> <li>States &amp; Capitals -C- 24K-(Y056L) £9.95</li> </ul> <p><b>Learn Programming</b></p> <ul style="list-style-type: none"> <li>Invitation to Programming -C- 8K-(Y043W) £15.95</li> <li>Basics of Animation -C- 32K-(B057M) £11.95</li> <li>Basics of Animation -D- 32K-(B058N) £11.95</li> <li>Player Missile Graphics -C- 16K-(B059P) £18.95</li> <li>Player Missile Graphics -D- 24K-(B060Q) £18.95</li> <li>Display Lists -C- 16K-(B051F) £11.95</li> <li>Display Lists -D- 24K-(B052G) £11.95</li> <li>Horiz/Vertical Scroll -C- 16K-(B053H) £11.95</li> <li>Horiz/Vertical Scroll -D- 24K-(B054J) £11.95</li> </ul>	<p>Page Flipping -C- 16K-(B055K) £11.95</p> <p>Page Flipping -D- 24K-(B056L) £11.95</p> <p>Master Memory Map -Book-(XH57M) £4.00</p> <p><b>Business Programs</b></p> <ul style="list-style-type: none"> <li>Visicalc -D- 32K-(Y039N) £119.95</li> <li>Word Processor -D- 32K-(Y042V) £99.95</li> <li>Calculator -D- 24K-(Y050E) £16.95</li> <li>Graph—H -C- 16K-(Y051F) £13.95</li> <li>Statistics -C- 16K-(Y052G) £13.95</li> </ul> <p><b>Arcade Games</b></p> <ul style="list-style-type: none"> <li>Star Raiders -E- 8K-(Y066W) £29.95</li> <li>Asteroids -E- 8K-(Y060D) £29.95</li> <li>Space Invaders -E- 8K-(Y070M) £29.95</li> <li>Missile Command -E- 8K-(Y064U) £29.95</li> <li>Super Breakout -E- 8K-(Y067X) £24.50</li> <li>Tari Trek -C- 24K-(Y036P) £8.95</li> <li>Tari Trek -D- 32K-(Y037S) £11.95</li> <li>Star Trek 3.5 -C- 32K-(B015R) £14.95</li> <li>Race In Space -C- 16K-(B035D) £14.95</li> <li>Shooting Gallery -C- 16K-(B036P) £14.95</li> <li>Mounjain Shoot -C- 16K-(B012N) £10.95</li> <li>Jawbreaker -D- 48K-(B026D) £20.64</li> <li>Basketball -E- 8K-(Y061R) £24.50</li> <li>Tank Trap -C- 16K-(Y034M) £9.95</li> <li>Tank Trap -D- 32K-(Y035O) £12.95</li> </ul> <p><b>Home Game Programs</b></p> <ul style="list-style-type: none"> <li>Scram -C- 16/24K-(Y058N) £17.50</li> <li>Cypher Bowl -C- 32K-(B020W) £29.50</li> <li>Thunder Island -C- 16K-(B037S) £10.95</li> <li>Rotating Tilt -C- 16K-(B048C) £14.95</li> <li>Lunar Lander -C- 16K-(B016S) £10.95</li> <li>Sunday Golf -C- 16K-(B013P) £10.95</li> <li>Darts -C- 16K-(B042V) £19.95</li> <li>Tournament Pool -C- 16K-(B045Y) £19.95</li> <li>Snooker &amp; Billiards -C- 16K-(B044X) £19.95</li> <li>Chess -E- 8K-(Y063T) £24.50</li> <li>Crabage &amp; Dominoes -C- 16K-(B043W) £14.95</li> <li>Poker Solitaire -C- 16K-(B017T) £10.95</li> <li>Blackjack -C- 8K-(Y062S) £9.95</li> </ul>	<ul style="list-style-type: none"> <li>Fast Gammon -C- 8K-(Y033L) £16.95</li> <li>Reversi (Othello type) -C- 16K-(B019V) £14.95</li> <li>Gomoko -C- 16K-(B018U) £14.95</li> <li>Hangman -C- 8K-(Y054J) £9.95</li> <li>Humpty Dumpty &amp; Jack &amp; Jill -C- 16K-(B038R) £19.95</li> <li>Hickory Dickory Dock -C- 16K-(B039N) £19.95</li> <li>British Heritage Jig-Saw Puzzles -C- 16K-(B040T) £19.95</li> <li>European Scene Jig-Saw Puzzles -C- 16K-(B041U) £19.95</li> <li>Atari Safari (25 Programs) -C- 16K-(B049D) £18.95</li> <li>Atari Safari (25 Programs) -D- 16K-(B050E) £24.95</li> <li>Mind Bogglers (3 Programs) -C- 16K-(Y038R) £11.95</li> </ul> <p><b>Utilities</b></p> <ul style="list-style-type: none"> <li>3D-Super Graphics -D- 48K-(B028F) £29.95</li> <li>3D-Super Graphics -C- 48K-(B029G) £29.95</li> <li>Atari World (Graphics) -D- 48K-(B027E) £43.95</li> <li>Assembler Editor -E- 8K-(Y068Y) £39.95</li> <li>Assembler -C- 16K-(Y032K) £19.95</li> <li>6502 Disassembler -C- 8K-(Y030H) £9.95</li> <li>6502 Disassembler -D- 8K-(Y031J) £12.95</li> <li>Character Generator -C- 16K-(Y027E) £9.97</li> <li>Character Generator -D- 16K-(Y028F) £12.50</li> <li>Telelink -E- 8K-(Y059P) £21.50</li> </ul> <p><b>Music Programs</b></p> <ul style="list-style-type: none"> <li>Music Composer -E- 8K-(Y048C) £35.95</li> <li>Movie Themes (use with Music Composer) -C- 16K-(B034M) £9.95</li> </ul> <p><b>Computer Languages</b></p> <ul style="list-style-type: none"> <li>Operating System A+ -D- 48K-(B030H) £49.95</li> <li>OS Forth -D- 24K-(Y029G) £49.95</li> <li>Pilot (Consumer) -E- 8K-(Y069A) £54.00</li> <li>Basic A+ -D- 48K-(B031J) £49.95</li> <li>Basic A+ &amp; Operating System A+ -D- 48K-(B032K) £99.50</li> </ul>
---	--	--

Send sae now for our new software leaflet with details of all the above programs. Order As XH52G — Issue 2.

Subscribe now to America's leading Atari-only magazine — Analog — 6 issues per year for just £9.00. Order as GG24B.

- New titles this month**
- Learn Programming:**
- Invitation to Programming 2 -C- 16K-(B067X) £22.95
  - Invitation to Programming 3 -C- 16K-(B068Y) £22.95
- Business Programs:**
- Personal Financial Management -D- 32K-(B065V) £49.00
  - Mortgage and Loan -C- 16K-(B066W) £13.95

- Arcade Games:**
- Caverns of Mars -D- 32K-(B069A) £24.50
  - Centipede -E- 16K-(B070M) £29.95
  - Pac-Man -E- 16K-(B071N) £29.95
  - K-Razy Shoot Out -E- 16K-(B063T) £29.95
  - Mous kattack -D- 32K-(B077J) £22.95
  - Ghost Hunter -C- 16K-(B064U) £24.50
  - Galactic Chase -D- 32K-(B061R) £19.95
  - Galactic Chase -C- 16K-(B062S) £16.95

- Home Programs:**
- Video Easel -E- 16K-(B072P) £24.50
- Computer Languages:**
- Microsoft Basic -D- 32K-(B074R) £59.95
  - Pilot (Educator) -E&C- 16K-(B075S) £79.95
- Utilities:**
- Macro Assembler -D- 32K-(B073Q) £59.95
  - K-DOS (Superior disk operating system) -D- 32K-(B076H) £53.95



**Maplin Electronic Supplies Ltd**  
P.O. Box 3, Rayleigh, Essex.  
Tel: Southend (0702) 552911/554155.

**Demonstrations at our shops NOW**  
See Atari and Vic in action at  
159-161 King St., Hammersmith W6  
Tel: 01-748 0926  
or at 284 London Road, Westcliff-on-Sea, Essex.  
Tel: (0702) 554000  
Lynton Square, Perry Barr, Birmingham.  
Tel. (021) 356 7292

Note: Order codes shown in brackets. Prices correct at time of going to press. (Errors excluded).

# Spectrum

Spectrum is a new, rapidly expanding group of independent retailers who specialise in selling a range of popular home computers.

Our group policy is simple: we won't be beaten on price and 'know-how'. We can make this claim because our bulk buying power ensures that we select and buy at the best prices and then can pass on the benefits to you.

We guarantee if you find an item advertised and in stock at any other retailer at a better price than us, we will match that price.

You will see we quote our prices both including and excluding VAT - no hidden 15% to suddenly uplift your bill but also making our prices easier to compare with our competitors.

To ease payment we accept Barclaycard and Access as well as our own Spectrum Charge Card. Longer term credit terms are also available.

We believe our product 'know-how' is crucial to you as a customer. In every one of our centres there are personnel who have been trained by the manufacturers or distributors themselves. So we know what we are talking about on the products we sell and can help every customer, including the complete beginner, find and understand the equipment to suit his or her needs. For us it's not just a matter of simply handing over a box and leaving you on your own to figure it out. Our service includes 'hands on' experience that we can pass on to you.

After sales care is also well catered for. Our own Spectrum Service Centres will insure that should your machine 'go down' we will get it up and running as quickly as possible. We can also offer extended warranties at reasonable prices.

When it comes to mail order delivery we use Securicor for despatch to anywhere in the British Isles. The cost is low and the service is good. Further details are available from your local shop at the time of ordering.

Finally, we should point out that although not every Spectrum centre carries every advertised item, they can always be obtained quickly from our central warehouse. If you have any difficulty, please telephone Spectrum Customer Service on (0727) 66646.

Spectrum Computer Group is a division of Spectrum (UK) Ltd - Britain's largest photographic retailing group.

# ATARI®



The model 400 has 16K of RAM and a touch sensitive keyboard. The 800 model has a professional style typewriter keyboard and a memory which is user expandable to 48K. Add disk drives (up to 4) and a printer and you have a system of adequate power for business uses.

	EXC VAT	INC VAT
ATARI 800 16K COMPUTER (EXPANDABLE)	£434.70	£499.90
ATARI 410 PROGRAM RECORDER	£43.48	£50.00
ATARI 810 DISK DRIVE	£260.83	£299.95
ATARI 822 THERMAL PRINTER	£230.43	£264.99
ATARI 850 INTERFACE FOR DOT MATRIX PRINTER	£117.39	£134.99
ATARI 16K RAM EXPANSION FOR 800	£56.52	£64.99
ATARI GAMES PADDLES (PAIR)	£12.13	£13.95
ATARI GAMES JOYSTICKS (PAIR)	£12.13	£13.95
ATARI THERMAL PRINT PAPER (2 ROLLS)	£3.48	£4.00
ATARI BLANK DISKETTES (5)	£13.91	£15.99
<b>SOFTWARE</b>		
INVITATION TO PROGRAMMING (1)	£13.87	£15.95
INVITATION TO PROGRAMMING (3)	£19.96	£22.95
CONVERSATIONAL FRENCH	£34.74	£39.95
CONVERSATIONAL GERMAN	£34.74	£39.95
CONVERSATIONAL ITALIAN	£34.74	£39.95
CONVERSATIONAL SPANISH	£34.74	£39.95
MUSIC COMPOSER	£31.26	£35.95
TOUCH TYPING	£13.87	£15.95
ASTEROIDS	£26.04	£29.95
MISSILE COMMAND	£26.04	£29.95
PACKMAN	£26.04	£29.95
SPACE INVADERS	£26.04	£29.95
STAR RAIDERS	£26.04	£29.95
SUPER BREAK-OUT	£21.30	£24.50
VIDEO EASEL	£21.30	£24.50
COMPUTER CHESS	£21.30	£24.50
GRAPHIT	£12.13	£13.95
WORD PROCESSOR (DISK)	£86.91	£99.95
ASSEMBLY EDITOR	£34.74	£39.95
DE-RE ATARI	£17.00	No VAT

Developed by the Company famous for its TV and arcade games the Atari Computers have superb colour graphics and facilities for the manipulation of visuals on the screen.

In-built "player-missile-graphics" enable the user to compose games to very professional standards. Any key on the keyboard can be made to produce any character the user wishes on the screen. Atari Computers have an extra microprocessor onboard especially to enable these unique features. There are over 200 programmable colours and tones and a wide range of programmable sounds.

Plug a "BASIC" cartridge in and you have a comprehensive computer.

ATARI 400

**£217.30**

**£249.90 INC. VAT**

**commodore**

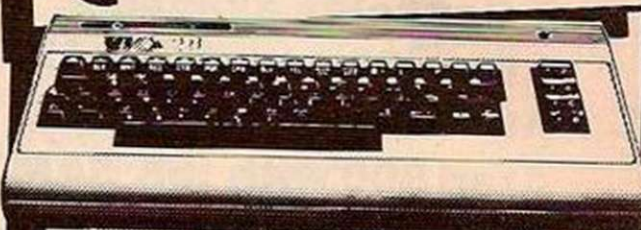

The VIC 20 really is extraordinary value for money. It does so much for so little. It's fully expandable to 27 1/2K user RAM, has a full size typewriter keyboard and plugs straight into your home TV.

**COMMODORE VIC 20**  
**£173.90**  
**£199.99 INC. VAT**

Micro soft "BASIC" is standard but additional machine language is available via plug in cartridges. There is also a choice of other programs for chess, music and languages as well as games. Printer disk drive and other peripherals, software and books are all available to further expand your use and enjoyment.

	EXC VAT	INC VAT
VIC C2N cassette unit	£39.09	£44.95
VIC Printer (plain paper, tractor)	£200.00	£230.00
VIC Single floppy disc drive (5 1/4")	£344.35	£396.00
3K RAM expansion cartridge	£26.04	£29.95
8K RAM expansion cartridge	£39.09	£44.95
16K RAM expansion cartridge	£65.17	£74.95
Super expander Hi Res cartridge	£30.39	£34.95
Joystick	£6.52	£7.50
Games paddles (pair)	£11.74	£13.50
<b>GAMES</b>		
Programmers Aid cartridge	£30.39	£34.95
Machine Code Monitor cartridge	£30.39	£34.95
Introduction to Basic (1)	£13.00	£14.95
"Avenger" (ROM)	£17.35	£19.95
"Star Battle" (ROM)	£17.35	£19.95
"Jelly Monsters" (ROM)	£17.35	£19.95
"Super Lander" (ROM)	£17.35	£19.95
"Road Race" (ROM)	£17.35	£19.95
"Rat Race" (ROM)	£17.35	£19.95
"Blitz" cassette	£4.34	£4.99
<b>BOOKS</b>		
Learn Computer Programming with the Commodore VIC	£1.95	No VAT
VIC Revealed	£10.00	No VAT
VIC 20 Programmers Reference Guide	£14.95	No VAT
VIC Computing Magazine	£0.95	No VAT

## ACCESSORIES

	SPECIAL PRICE	EXC VAT	INC VAT
Prince PC31 - 12" Green Monitor		£86.91	£99.95
<b>SANYO</b>			
Slim 3G Cassette Recorder (for use with Nascom)		£26.04	£29.95
CTT 3106 14" Colour TV Set		£199.96	£229.95
<b>ACCUTRAK</b>			
C12 Cassettes		£0.43	£0.50
Single sided, double density disks (for Commodore, Atari, Apple, Tandy etc.)		£1.70	£1.95
Double sided, double density disks (for Sharp and Superbrain)		£2.87	£3.30
Single sided, double density, double track disks (for Nascom and Commodore 8050)		£2.30	£2.65
Disk Bank Interlocking cases for diskettes		£3.91	£4.50
Disk head cleaner		£13.00	£14.95
Single part 11" x 9 1/2" printer paper, box of 2200 sheets		£10.39	£11.95

<b>ALFRETON</b> Gordon Harwood 69/71 High Street Alfreton Derbyshire Tel: 0773 832078	<b>BASINGSTOKE</b> Fisher's 2/3 Market Place Basingstoke Hants Tel: 0256 22079	<b>BRIGHTON</b> Capricorn 1 Queens Road Brighton Sussex Tel: 0273 29634	<b>DERBY</b> C.T. Electronics The Spot Derby Tel: 0332 44760	<b>HARROW</b> Camera Arts (Micro Computer Division) 24 St Ann's Road Harrow Middlesex Tel: 01 427 5469	<b>LONDON SE9</b> Square Deal 375 Footscray Road New Eltham London SE9 Tel: 01 859 1516	<b>MIDDLESBROUGH</b> McKenna & Brown 190 Linthorpe Road Middlesbrough Tel: 0642 248345	<b>NOTTINGHAM</b> Cameo Computers 8/9/10 Trinity Walk Nottingham Tel: 0602 42912	<b>WALLINGTON</b> Surrey Micro Systems Ltd 53 Woodcote Road Wallington Surrey Tel: 01 647 5636	<b>WIGAN</b> Wilding Ltd 11 Mesnes St Wigan Lancs Tel: 0942 44382
<b>ASHFORD</b> Ashford Computer Centre 2 Station Road Clarendon Parade Ashford Middlesex Tel: 07842 44955	<b>BIRMINGHAM</b> Sherwoods Great Western Arcade Birmingham 2 Tel: 021 236 7211	<b>CAMBRIDGE</b> KP Ltd 12a Kings Parade Cambridge Tel: 0223 68087	<b>GLASGOW</b> Victor Morris Ltd 340 Argyle Street Glasgow G2 Tel: 041 221 8958	<b>HATFIELD</b> Micro World 2 Crawford Road Hatfield Herts	<b>LONDON W11</b> Electroleisure 120 Notting Hill Gate London W11 Tel: 01 221 7029	<b>NEWCASTLE</b> Turners 29-31 High Friars Eldon Square Newcastle Tel: 0632 612901	<b>READING</b> David Saunders Computer Centre 8 Yield Hall Place Reading Berks Tel: 0734 580719	<b>WATFORD</b> SRS Microsystems Ltd 94 The Parade High Street Watford Herts Tel: 0923 26602	<b>WOKING</b> Harpers 71-73 Commercial Way Woking Surrey Tel: 04862 61061
<b>BASILDON</b> Godfrey's 28-32 East Walk Town Centre Basildon Essex Tel: 0268 289379	<b>BRADFORD</b> Photosave 18 Cheapside Bradford BD1 4JA West Yorkshire Tel: 0274 308598	<b>CARDIFF</b> Randall Cox 18-22 High St Arcade Cardiff Tel: 0222 31960	<b>GUILDFORD</b> The Model Shop 23 Swan Lane Guildford Surrey GU1 4EQ Tel: 0483 39115	<b>LEEDS</b> Bass & Bligh 4 Lower Briggate Leeds W Yorkshire Tel: 0532 45445	<b>MACCLESFIELD</b> Camera & Computer Centre 118 Mill Street Macclesfield Cheshire Tel: 0625 27468	<b>NEWCASTLE-ON-TYNE</b> Newcastle Camera & Computer Mart 16 Northumberland Court Newcastle-on-Tyne Tel: 0632 327461	<b>TEDDINGTON</b> "Andrews" 49 Broad Street Teddington Middlesex Tel: 01 977 4716	<b>WEST BROMWICH</b> Bell & Jones 39 Queens Square West Bromwich Tel: 021 553 0820	<b>WORCESTER</b> David Waring Ltd 1 Marmion House High Street Worcester Tel: 0905 27551

# We won't be beaten on prices. *Just compare them!*



**SPECIAL EDITION! UNIQUE TO SPECTRUM**

The Nascom is a British designed and built microcomputer and one of the first home micros to appear in this country, some five years ago. Since then, it has been developed into one of the most powerful and expandable systems around.

It can have up to 206K onboard memory, combined with superb colour graphics, disk drives, printers and various input/output facilities can be added.

Such is the versatility of this micro that it has been adopted for numerous commercial applications including hotel booking systems, blood grouping, weaponry and satellite tracking.

Previously looked upon as a machine for the knowledgeable hobbyist only Spectrum now bring you the opportunity to embark upon this remarkable sphere of computing in the easiest possible way. A ready to plug in and use 'SPECIAL EDITION' Nascom programmable in machine code or BASIC is now available from us. If you are serious about computing the 'SPECIAL EDITION' is your starter pack. The initial machine provides 8K of memory but a simple plug in board upgrades your computer to 56K.

THE NASCOM 'SPECIAL EDITION' . . . . .	EXC VAT £429.95	INC VAT £494.44
'SPECIAL EDITION' 48K RAM BOARD . . . . .	£130.00	£149.50

## SHARP

The MZ80A is the newcomer to the Sharp range with the serious user very much in mind in the design. A complete stand-alone 48K system incorporating a profiled typewriter keyboard with numeric pad and a 9" green display screen. The "BASIC" contains a number of very useful additions over the previous models. A full line up of peripherals further add to the versatility of this machine.

**SHARP MZ80A**  
**£477.38**  
**£548.99 INC. VAT**

SHARP PERIPHERALS FOR MZ80A	EXC VAT	INC VAT
* Twin floppy disk unit (5 1/4")	£590.00	£678.50
* Single floppy disk unit	£400.00	£460.00
* Floppy disk interface card	£100.00	£115.00
* Floppy disk cable	£24.00	£27.50
* Master diskette and manual	£31.00	£35.66
* 80 col printer inc. cable, I/O card and ROM	£415.00	£477.25
* 80 col friction printer, I/O card and ROM	£475.00	£546.25
* 132 col printer, inc. cable, I/O card and ROM	£845.00	£971.75
* Expansion unit (required for disk drive and/or printer)	£100.00	£115.00
* Universal interface card	£45.00	£51.75
* Assembler tapes and manual	£42.00	£48.30
* FDOS	£85.00	£97.75
* MZ80K to MZ80A converter tape	£10.00	£11.50

Hand held computers from Sharp give you a pocket genius at your command. We sell the well established PC1211 and the new 1500.

The PC1211 packs high performance functions with Basic language into a slim, compact body. You can extend your PC1211 with a cassette interface or printer/cassette interface.

The new PC 1500 takes technology close to personal computer ability. Its compact body has 16K bytes of ROM and 3.5K bytes of RAM. With an extended alpha basic numeric. You can then go further with the 4K or 8K RAM upgrades. There's also, for the first time in hand held computers, a four colour graphic printer or a combined printer and cassette interface.

PC1211 Computer . . . . .	£65.00	£74.75
PC1211 Cassette interface . . . . .	£11.26	£12.95

**£75 OF FREE SOFTWARE WITH THE MZ80A**

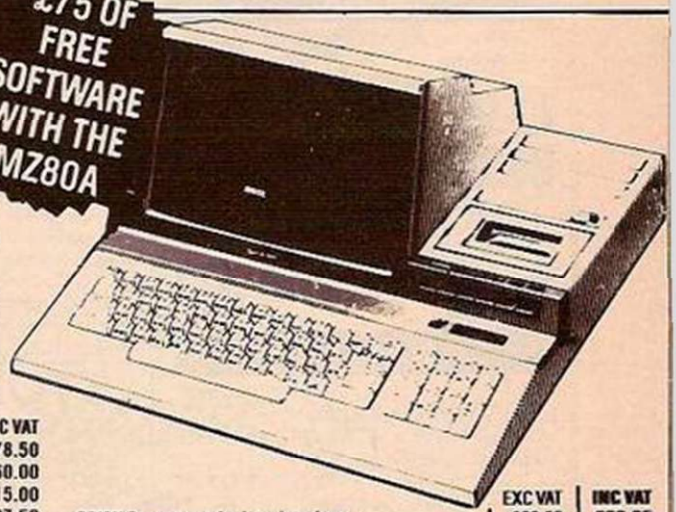

	EXC VAT	INC VAT
PC1211 Cassette and printer interface	£60.83	£69.95
PC 1500 Computer	£147.78	£169.95
PC 1500 Printer/cassette interface	£130.39	£149.95
PC 1500 4K RAM upgrade	£43.43	£49.95
<b>SHARP PERIPHERALS FOR MZ80K</b>		
* Twin floppy disk unit (5 1/4") including I/O card, diskette, manual and cable	£702.49	£807.86
* Dot matrix printer	£378.91	£435.75
* Expansion interface (required for either/both above)	£96.00	£110.40
* Machine code language tape and manual	£17.57	£20.20
* Assembler tapes and manual	£36.00	£41.40
* Basic compiler	£40.00	£46.00
* Pascal	£40.00	£46.00
* Double precision basic	£38.00	£43.70

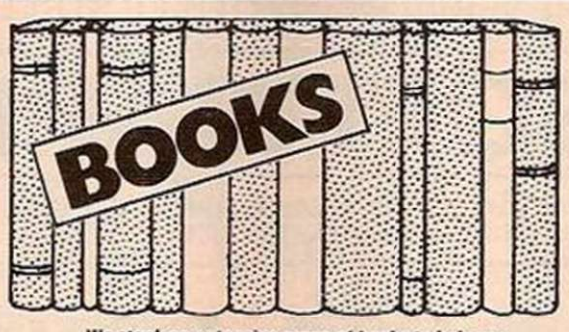

We stock an extensive range of books to help you. Here are just a few to whet your appetite.

CP/M Handbook . . . . .	£11.50
DON'T . . . . .	£9.65
Programming the Z80 . . . . .	£11.95
Programming the 6502 . . . . .	£10.75
Your First Computer . . . . .	£7.75
BASIC Handbook (2nd edition) . . . . .	£14.95
A-Z of Computer Games . . . . .	£5.60
Atari Basic . . . . .	£5.95
Basic 'BASIC' . . . . .	£9.95
BASIC Computer Games . . . . .	£6.95
BASIC Computer Programs for Business (VOL I) . . . . .	£8.55

NO VAT ON BOOKS

## STOP PRESS!

Just arriving very limited quantities of the 'Magic'

### DRAGON 32K COMPUTER

Sensational Value at

**£173.48**  
**£199.50 INC. VAT**

Also the first of the Cartridges from

**£17.35**  
**£19.95 INC. VAT**

Cassettes from

**£6.91**  
**£7.95 INC. VAT**

**DEALERS:** Spectrum Computer Centres operate on an exclusive area basis and if you would like to know more about our group, contact Mike Stern or Alan Warren now on (0727) 66646. Spectrum (UK) Limited, Unit 6, Marlborough Trading Estate, Latimore Road, St. Albans, Herts.

# Spectrum COMPUTER GROUP

# EVERYTHING SPECTRUM OFFER... PLUS

## SHARP

We have in stock the full range listed by Spectrum. **PLUS** The MZ 80B and a full range of peripherals.

## APPLE

Apple II and III Computer Systems in stock and we are an authorised Service Centre for Apple. **PLUS** We are an appointed dealer for Jarman Business Systems.

## NASCOM

	EXC VAT	INC VAT
Nascom 2 (kit) No user RAM	£225.00	£258.75
Nascom 2 (built) No user RAM	£285.00	£327.75
Nascom Power Supply (kit)	£35.00	£40.25
Nascom Micro-ed 8K Computer	£399.00	£458.85
Nascom "Special Edition" 8K Computer	£429.95	£494.44

	EXC VAT	INC VAT
Nascom 3 48K Computer	£499.00	£573.85
Nascom RAM B 16K Board (kit)	£80.00	£92.00
Nascom RAM B 16K Board (built)	£100.00	£115.00
Additional 16K RAM	£15.00	£17.25
Additional 32K RAM	£30.00	£34.50
48K Add-on Memory Board for "Special Edition"	£130.00	£149.50
I/O Board (kit)	£45.00	£51.75
PIO Option	£12.00	£13.80
CTC Option	£14.00	£16.10
UART Option	£16.00	£18.40
Nascom Single Disk Drive inc FDC Card	£470.00	£540.50

## STOP PRESS!

Scoop purchase of manufacturers final stock. **NASCOM IMP Printer** complete with 'IMPRINT' ROM. Previously £325 plus VAT. Now £199.95 exc. VAT. **£229.95 inc. VAT.**

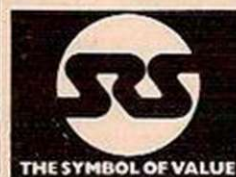

## SRS MICROSYSTEMS

94 The Parade, High Street, Watford, Herts. Telephone (0923) 26602.

YOU'LL VALUE OUR EXPERIENCE, YOU'LL VALUE OUR PRICES. FREE SECURICOR DELIVERY OR POST ON ORDERS OVER £50

Keen prices and knowledgeable staff have created a need for bigger and better new premises in Watford. Access & Barclaycard welcome. Hire purchase and part exchange available. E. & O.E.

**NEW LARGER PREMISES**



## Keyboard with Electronics for ZX81

A full-size, full-travel 43-key keyboard that's simple to add to your ZX81 and requires no soldering in the ZX81.

Complete with the electronics to make "Shift Lock", "Function", and "Graphics 2" single key selections making entry far easier.

Powered from ZX81's own standard power supply - with special adaptor supplied.

Two-colour print for key caps.

Amazing low price only **£19.95** incl. VAT and carriage.

Order As LW72P

Full details in the June 1982 issue of "Electronics - The Maplin Magazine" on sale at all good newsagents price 60p. In case of difficulty send 60p to address below, or £2.40 for annual subscription (4 issues).



Electronic Supplies Ltd

P.O. Box 3, Rayleigh, Essex SS6 8LR. Tel (0702) 552911

Retail shops at  
159 King St., Hammersmith, London W6. Tel 01-748 0926  
284 London Road, Westcliff-on-Sea, Essex. Tel (0702) 554000  
Lynton Square, Perry Barr, Birmingham. Tel: (021) 356 7292  
(Shops closed Mondays). All mail to Rayleigh address.

# PSS

PERSONAL SOFTWARE SERVICES, 112 OLIVER STREET, COVENTRY CV6 5FE.

ZX81  
16K

# SOFTWARE SALE

AS PART OF OUR CONTINUING POLICY OF UNBEATABLE VALUE FOR MONEY, WE ARE OFFERING FOR THIS MONTH ONLY OUR RANGE OF PROGRAMS IN PACKAGE FORM AT UNBELIEVABLE PRICES.

**\*STAR PACK\*** Includes PUCKMAN and MAZE DRAG RACER. These are the best arcade games available and are written in superfast machine code to give unbelievably good results - a brilliant package - highly recommended ..... £4.95

**\*SPACE PACK\*** All the best space games in one package - includes SPACE DEFENDER, STAR TREK, ALIEN and TAILGUNNER. Amazing value at only ..... £4.95

**\*GAMES PACK\*** An excellent selection of games including GRAND PRIX, NIGHTMARE PARK, SUPER-BREAKOUT (M/C) and HIGH RISE (M/C) ..... £4.95

**\*PROGRAMMERS PACK 1\*** ZX COMPILER and ENHANCED BASIC - The compiler has helped many people write in MACHINE CODE - ENHANCED BASIC takes the strain out of programming. Some of its many features include auto renumbering, block deletion etc. .... £4.95

**\*PROGRAMMERS PACK 2\*** WORDFIX and GRAFIX. A complete image plus text manipulation system. Essential for those who need complex images or texts in their programs. .... £4.95

**\*GAMES PACK 2\*** Includes STOCKS & SHARES, BREAKOUT (M/C), DAY AT THE RACES, PONTOON and TOWERS of HANOI. Quality programs at a crazy price ..... £4.95

THESE PACKAGES ARE ALL AVAILABLE AT £4.95 EACH, £6.95 FOR TWO OR £8.50 FOR THREE.

ALL PRICES ARE INCLUSIVE OF VAT AND CARRIAGE BY RETURN OF POST.

SEND CHEQUE/PO TO: PSS, 112 OLIVER STREET, COVENTRY, CV6 5FE. OR SEND TWO 1ST CLASS STAMPS FOR A COPY OF OUR FULLY DETAILED CATALOGUE.

**\*STOP PRESS\*** NOW AVAILABLE - 'QSAVE' THE HARDWARE/SOFTWARE COMBINATION PACKAGE THAT LETS YOU LOAD AND SAVE A FULL 16K IN ONLY 26 SECONDS AND FOR LESS THAN £20.00. SAE FOR DETAILS.

ZX 81 .. SPECTRUM .. B.B.C. MICRO .. ATOM .. VIC

**NEW!**

# Spectral INVADERS

The very first, perfect arcade quality Machine Code game on cassette for the sensational

**SINCLAIR ZX Spectrum**



Just **£5** inclusive  
12 months guarantee

**ORDER YOURS TODAY!**

**BUG-BYTE SOFTWARE**

BUG-BYTE SOFTWARE, FREEPOST (No Stamp req.) LIVERPOOL L3 3AB.

**SPECIAL OFFERS**

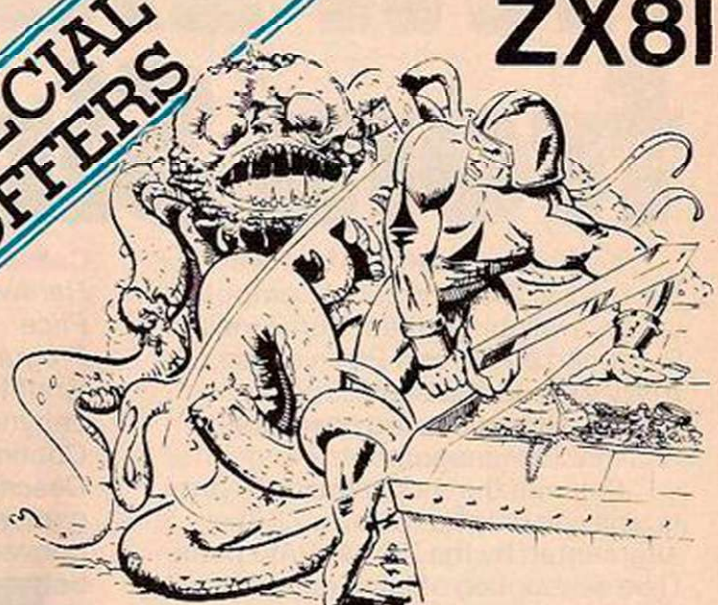

**ZX81**

<b>MAZOGS</b> WAS <del>£10</del> NOW <b>£8</b>	<b>INVADERS</b> WAS <del>£4</del> NOW <b>£3</b>	<b>DAMSEL &amp; THE BEAST</b> WAS <del>£6.50</del> NOW <b>£5</b>
--	---	--

STARTREK _____ £5.00	MULTIFILE _____ £17.50
ZXAS ASSEMBLER _____ £5.00	Dictator _____ £9.00
ZXDB DEBUGGER _____ £5.00	Constellation _____ £8.00
ZXTK TOOLKIT _____ £6.00	PROGRAM PACKS 1-8 each _____ £4.00

## BBC CHESS

The very first, powerful and exciting chess game for the BBC Micro. One thousand levels of play, plus many options including setting up board for chess problems, saving games on tape etc. Deals with castling and en passant. **£11.50 inclusive**

SPACEWARP _____	£11.50
SPACE PIRATES _____	£8.00
POLARIS _____	£8.00
MULTIFILE _____	£25.00
BACKGAMMON _____	£8.00
GOLF _____	£7.00

## VIC-20

ANOTHER VIC IN THE WALL _____	£7.00
VIC GAMMON _____	£7.00
VIC PANIC _____	£7.00
VIC COSMIADS _____	£7.00
VIC ASTEROIDS _____	£7.00

## ATOM

INVADERS _____	£8.00	FRUIT MACHINE _____	£4.00
CHESS _____	£9.00	PINBALL _____	£4.50
747 FLIGHT STIMULATION _____	£8.00	LABYRINTH _____	£7.00
GALAXIANS _____	£8.00	LUNAR LANDER _____	£5.50
BREAKOUT _____	£4.00	GOLF _____	£5.00

ALL PRICES INCLUDE POSTAGE

Please send me \_\_\_\_\_  
 I enclose cheque/P.O. for \_\_\_\_\_  
 OR Please debit my Access 5224 \_\_\_\_\_  
 BARCLAYCARD 4929 \_\_\_\_\_ Expiry date \_\_\_\_\_  
 Name \_\_\_\_\_  
 Address \_\_\_\_\_  
 Code \_\_\_\_\_  
 Dealers Discount Available  
 ACCESS, BARCLAYCARD ORDERS WELCOME ON 24hr  
 ANSAPHONE 051-227 2642, or mail to:  
**BUG-BYTE SOFTWARE,**  
 FREEPOST. (No stamp req.)  
 LIVERPOOL L3 3AB.

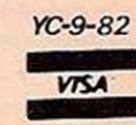

ZX 81 .. SPECTRUM .. B.B.C. MICRO .. ATOM .. VIC

# New ZX81 Software from Sinclair.

A whole new range of software for the Sinclair ZX81 Personal Computer is now available – direct from Sinclair. Produced by ICL and Psion, these really excellent cassettes cover games, education, and business/household management.

Some of the more elaborate programs can only be run on a ZX81 augmented by the ZX 16K RAM pack. (The description of each cassette makes it clear what hardware is required.) The RAM pack provides 16-times more memory in one complete module, and simply plugs into the rear of a ZX81. And the price has just been dramatically reduced to only £29.95.

The Sinclair ZX Printer offer full alphanumeric and highly-sophisticated graphics. A special feature is COPY which prints out exactly what is on the whole TV screen without the need for further instructions. So now you can print out your results for a permanent record. The ZX Printer plugs into the rear of your ZX81, and you can connect a RAM pack as well.

## Games

### **Cassette G1: Super Programs 1 (ICL)**

Hardware required – ZX81.

Price – £4.95.

Programs – Invasion from Jupiter. Skittles. Magic Square. Doodle. Kim. Liquid Capacity.

Description – Five games programs plus easy conversion between pints/gallons and litres.

### **Cassette G2: Super Programs 2 (ICL)**

Hardware required – ZX81.

Price – £4.95.

Programs – Rings around Saturn. Secret Code. Mindboggling. Silhouette. Memory Test. Metric conversion.

Description – Five games plus easy conversion between inches/feet/yards and centimetres/metres.

### **Cassette G3: Super Programs 3 (ICL)**

Hardware required – ZX81.

Price – £4.95.

Programs – Train Race. Challenge. Secret Message. Mind that Meteor. Character Doodle. Currency Conversion.

Description – Five games plus currency conversion at will – for example, dollars to pounds.

### **Cassette G4: Super Programs 4 (ICL)**

Hardware required – ZX81.

Price – £4.95.

Programs – Down Under. Submarines. Doodling with Graphics. The Invisible Invader. Reaction. Petrol.

Description – Five games plus easy conversion between miles per gallon and European fuel consumption figures.

### **Cassette G5: Super Programs 5 (ICL)**

Hardware required – ZX81 + 16K RAM.

Price – £4.95.

Programs – Martian Knock Out. Graffiti. Find the Mate. Labyrinth. Drop a Brick. Continental.

Description – Five games plus easy conversion between English and continental dress sizes.

### **Cassette G6: Super Programs 6 (ICL)**

Hardware required – ZX81 + 16K RAM.

Price – £4.95.

Programs – Galactic Invasion. Journey into Danger. Create. Nine Hole Golf. Solitaire. Daylight Robbery.

Description – Six games making full use of the ZX81's moving graphics capability.

### **Cassette G7: Super Programs 7 (ICL)**

Hardware required – ZX81.

Price – £4.95.

Programs – Racetrack. Chase. NIM. Tower of Hanoi. Docking the Spaceship. Golf.

Description – Six games including the fascinating Tower of Hanoi problem.

### **Cassette G8: Super Programs 8 (ICL)**

Hardware required – ZX81 + 16K RAM.

Price – £4.95.

Programs – Star Trail (plus blank tape on side 2).

Description – Can you, as Captain Church of the UK spaceship Endeavour, rid the galaxy of the Klingon menace?

### **Cassette G9: Biorhythms (ICL)**

Hardware required – ZX81 + 16K RAM.

Price – £6.95.

Programs – What are Biorhythms? Your Biohythms.

Description – When will you be at your peak (and trough) physically, emotionally, and intellectually?

### **Cassette G10: Backgammon (Psion)**

Hardware required – ZX81 + 16K RAM.

Price – £5.95.

Programs – Backgammon. Dice.

Description – A great program, using fast and efficient machine code, with graphics board, rolling dice, and doubling dice. The dice program can be used for any dice game.

### **Cassette G11: Chess (Psion)**

Hardware required – ZX81 + 16K RAM.

Price – £6.95.

Programs – Chess, Chess Clock.

Description – Fast, efficient machine code, a graphic display of the board and pieces, plus six levels of ability, combine to make this one of the best chess programs available. The Chess Clock program can be used at any time.



### **Cassette G12: Fantasy Games (Psion)**

Hardware required – ZX81 (or ZX80 with 8K BASIC ROM) + 16K RAM.

Price – £4.75.

Programs – Perilous Swamp. Sorcerer's Island.

Description – Perilous Swamp: rescue a beautiful princess from the evil wizard. Sorcerer's Island: you're marooned. To escape, you'll probably need the help of the Grand Sorcerer.

### **Cassette G13: Space Raiders and Bomber (Psion)**

Hardware required – ZX81 + 16K RAM.

Price – £3.95.

Programs – Space Raiders. Bomber. Description – Space Raiders is the ZX81 version of the popular pub game. Bomber: destroy a city before you hit a sky-scraper.

### **Cassette G14: Flight Simulation (Psion)**

Hardware required – ZX81 + 16K RAM.

Price – £5.95.

Program – Flight Simulation (plus blank tape on side 2).

Description – Simulates a highly manoeuvrable light aircraft with full controls, instrumentation, a view through the cockpit window, and navigational aids. Happy landings!

## Education

### **Cassette E1: Fun to Learn series – English Literature 1 (ICL)**

Hardware required – ZX81 + 16K RAM.

Price – £6.95.

Programs – Novelists. Authors. Description – Who wrote 'Robinson Crusoe'? Which novelist do you associate with Father Brown?

### **Cassette E2: Fun to Learn series – English Literature 2 (ICL)**

Hardware required – ZX81 + 16K RAM.

Price – £6.95.

Programs – Poets, Playwrights. Modern Authors.

Description – Who wrote 'Song of the Shirt'? Which playwright also played cricket for England?



**Cassette E3: Fun to Learn series - Geography 1 (ICL)**

Hardware required - ZX81 + 16K RAM.

Price - £6.95.

Programs - Towns in England and Wales. Countries and Capitals of Europe.

Description - The computer shows you a map and a list of towns. You locate the towns correctly. Or the computer challenges you to name a pinpointed location.

**Cassette E4: Fun to Learn series - History 1 (ICL)**

Hardware required - ZX81 + 16K RAM.

Price - £6.95.

Programs - Events in British History. British Monarchs.

Description - From 1066 to 1981, find out when important events occurred. Recognise monarchs in an identity parade.

**Cassette E5: Fun to Learn series - Mathematics 1 (ICL)**

Hardware required - ZX81 + 16K RAM.

Price - £6.95.

Programs - Addition/Subtraction. Multiplication/Division.

Description - Questions and answers on basic mathematics at different levels of difficulty.

**Cassette E6: Fun to Learn series - Music 1 (ICL)**

Hardware required - ZX81 + 16K RAM.

Price - £6.95.

Programs - Composers. Musicians.

Description - Which instrument does James Galway play? Who composed 'Peter Grimes'?

**Cassette E7: Fun to Learn series - Inventions 1 (ICL)**

Hardware required - ZX81 + 16K RAM.

Price - £6.95.

Programs - Inventions before 1850. Inventions since 1850.

Description - Who invented television? What was the 'dangerous Lucifer'?

**Cassette E8: Fun to Learn series - Spelling 1 (ICL)**

Hardware required - ZX81 + 16K RAM.

Price - £6.95.

Programs - Series A1-A15. Series B1-B15.

Description - Listen to the word spoken on your tape recorder, then spell it out on your ZX81. 300 words in total suitable for 6-11 year olds.

**Business/household**

**Cassette B1: The Collector's Pack (ICL)**

Hardware required - ZX81 + 16K RAM.

Price - £9.95.

Program - Collector's Pack, plus blank tape or side 2 for program/data storage.

Description - This comprehensive program should allow collectors (of stamps, coins etc.) to hold up to 400 records of up to 6 different items on one cassette. Keep your records up to date and sorted into order.

**Cassette B2: The Club Record Controller (ICL)**

Hardware required - ZX81 + 16K RAM.

Price - £9.95.

Program - Club Record Controller plus blank tape on side 2 for program/data storage.

Description - Enables clubs to hold records of up to 100 members on one cassette. Allows for names, addresses, 'phone numbers plus five lots of additional information - eg type of membership.

**Cassette B3: VU-CALC (Psion)**

Hardware required - ZX81 + 16K RAM.

Price - £7.95.

Program - VU-CALC.  
Description - Turns your ZX81 into an immensely powerful analysis chart. VU-CALC constructs, generates and calculates large tables for applications such as financial analysis, budget sheets, and projections. Complete with full instructions.

**Cassette B4: VU-FILE (Psion)**

Hardware required - ZX81 + 16K RAM.

Price - £7.95.  
Programs - VU-FILE. Examples.  
Description - A general-purpose information storage and retrieval program with emphasis on user-friendliness and visual display. Use it to catalogue your collection, maintain records or club memberships, keep track of your accounts, or as a telephone directory.

**How to order**

Simply use the FREEPOST order form below and either enclose a cheque or give us your credit card number. Credit card holders can order by phone - simply call Camberley (0276) 66104 or 21282 during office hours. Either way, please allow up to 28 days for delivery, and there's a 14-day money-back option, of course.

**sinclair  
ZX81  
SOFTWARE**

Sinclair Research Ltd,  
Stanhope Road, Camberley, Surrey,  
GU15 3PS.  
Tel: Camberley (0276) 66104 & 21282.

To: Sinclair Research, FREEPOST, Camberley, Surrey, GU15 3BR.  
Please send me the items I have indicated below.

Qty	Cassette	Code	Item price	Total
	G1: Super Programs 1	30	£4.95	
	G2: Super Programs 2	31	£4.95	
	G3: Super Programs 3	32	£4.95	
	G4: Super Programs 4	33	£4.95	
	G5: Super Programs 5	34	£4.95	
	G6: Super Programs 6	35	£4.95	
	G7: Super Programs 7	36	£4.95	
	G8: Super Programs 8	37	£4.95	
	G9: Biorhythms	38	£6.95	
	G10: Backgammon	39	£5.95	
	G11: Chess	40	£6.95	
	G12: Fantasy Games	41	£4.75	
	G13: Space Raiders & Bomber	42	£3.95	
	G14: Flight Simulation	43	£5.95	
	E1: English Literature 1	44	£6.95	

Qty	Cassette	Code	Item price	Total
	E2: English Literature 2	45	£6.95	
	E3: Geography 1	46	£6.95	
	E4: History 1	47	£6.95	
	E5: Mathematics 1	48	£6.95	
	E6: Music 1	49	£6.95	
	E7: Inventions 1	50	£6.95	
	E8: Spelling 1	51	£6.95	
	B1: Collector's Pack	52	£9.95	
	B2: Club Record Controller	53	£9.95	
	B3: VU-CALC	54	£7.95	
	B4: VU-FILE	55	£7.95	
	ZX 16K RAM pack	18	£29.95	
	ZX Printer	27	£59.95	
	Post & packing - only if ordering hardware		£2.95	

TOTAL £ \_\_\_\_\_

I enclose a cheque/postal order to Sinclair Research Ltd for £ \_\_\_\_\_

Please charge my \*Access/Barclaycard/Trustcard no. \_\_\_\_\_

\*Please delete as applicable. \_\_\_\_\_

Mr/Mrs/Miss \_\_\_\_\_

Address \_\_\_\_\_

\_\_\_\_\_

\_\_\_\_\_

NSA 20

Tim Hartnell's previous books have been warmly welcomed by the computer press:

"... This is undoubtedly the book to read..." Personal Computer World  
"... A book to be recommended..." Computing Today

# The book you've been waiting for!

This is a book that will allow you to make the most of the ZX Spectrum — a book that will lead to you 'expert programmer' status within weeks.

There are two major sections — the first for those who have no previous experience of computer programming, and the second containing advanced material for really powerful programming. All sections of the book make good use of the full eight colours, sound generation and high-resolution graphics. You're also shown how to make the most of Sinclair BASIC features such as DEF FN, SCREEN\$, MERGE and FLASH.

## Key features of 'Programming Your ZX Spectrum'

- Using the colour effectively — BRIGHT, FLASH, INVERSE and more.
- Sound — there's more to the BEEP than meets the ear.
- Finding your way around the keyboard, the use of every keyword, command and function.
- High resolution graphics — how to use them for stunning displays, how to create your own version of the famous arcade game 'Pacman' with user-defined graphics.
- The ZX Spectrum has the full ASC11 character set and this book includes a word processor program to make best use of it.
- The Spectrum LOAD and SAVE is highly reliable, and the MERGE and VERIFY features increase its flexibility. Programming Your ZX Spectrum outlines simple ways to ensure you never lose a program.



## The ZX Printer

All program listings are dumped direct from the ZX Spectrum, so all programs are guaranteed to run.

## The Microdrive

An appendix to this book details the commands needed to use your ZX Spectrum with the Microdrive microflopppy so you'll be ready when it comes on the market.

Interface,  
Dept. YC  
44-46 Earls Court Road,  
London, W8 6EJ

## Interface Publications

The UK's leading  
publisher of  
proven  
microcomputer  
books

Interface, 44-46 Earls Court Road, London W8 6EJ

Please send me the following:

- Programming Your ZX Spectrum — Hartnell/Jones £6.95
- Getting Acquainted with your ZX81 — Hartnell £5.95
- Mastering Machine Code on your ZX81 — Baker £7.50
- 20 Simple Electronic Projects for the ZX81 — Adams £6.45
- 34 Amazing Games for the 1K ZX81 — Gourlay £4.95
- 49 Explosive Games for the ZX81 — edited Hartnell £5.95

YOUR COMPUTER

Pascal for Human Beings — Ruston

£4.95

## BBC Micro

- Let Your BBC Micro Teach You to Program — Hartnell £6.45
- The BBC Micro Revealed — Ruston £7.95

Total enclosed £

Name

Address

# 100 FREE PROGRAMS

FROM SILICA SHOP — WITH EVERY PURCHASE OF AN

# ATARI 400

# 800

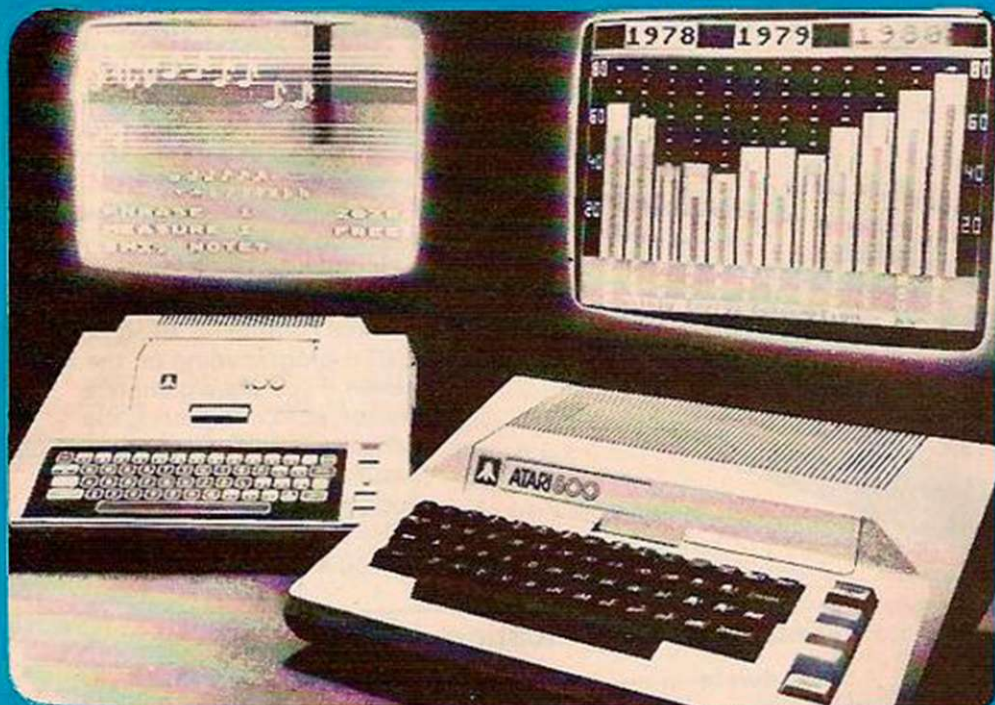
## ATARI PRICES REDUCED

We at Silica Shop are pleased to announce some fantastic reductions in the prices of the Atari 400/800 personal computers. We believe that the Atari at its new price will become the U.K.'s most popular personal computer and have therefore set up the Silica Atari Users Club. This club already has a library of over 500 programs and with your purchase of a 400 or 800 computer we will give you the first 100 free of charge. There are also over 350 professionally written games and utility programs, some are listed below. Complete the reply coupon and we'll send you full details. Alternatively give us a ring on 01-301 1111 or 01-309 1111.

ATARI 400 with 16K	<b>£199</b>
ATARI 400 with 32K	<b>£248</b>
ATARI 800 with 16K	<b>£449</b>

## 400/800 SOFTWARE & PERIPHERALS

Don't buy a T.V. game! Buy an Atari 400 personal computer and a game cartridge and that's all you'll need. Later on you can buy the Basic Programming cartridge (£35) and try your hand at programming using the easy to learn BASIC language. Or if you are interested in business applications, you can buy the Atari 800 + Disk Drive + Printer together with a selection of business packages.

Silica Shop have put together a full catalogue and price list giving details of all the peripherals as well as the extensive range of software that is now available for the Atari 400/800. The Atari is now one of the best supported personal computers. Send NOW for Silica Shop's catalogue and price list as well as details on our users club.

### THE FOLLOWING IS JUST A SMALL SELECTION FROM THE RANGE OF ITEMS AVAILABLE:

<b>ACCESSORIES</b> Cables Cassettes Diskettes Joysticks Le Stick - Joystick Misc Supplies Paddles  <b>ADVENTURE INT</b> Scott Adams Adv No 1 Adventureland No 2 Pirate Adv No 3 Mission Imp No 4 Woodoo Cast No 5 The Count No 6 Strange Ody No 7 Mystery Fun No 8 Pyramid of D No 9 Ghost Town No 10 Sav Island 1 No 11 Sav Island 2 No 12 Golden Voy Angle Worms Deflections Galactic Empire Galactic Trader Lunar Lander	Mountain Shoot Rearguard Star Flite Sunday Golf  <b>AUTOMATED SIMULATIONS</b> Crush Crumble Cmp Datstones of Ryn Dragons Eye Invasion Orion Rescue at Rigel Ricochet Star Warrior Temple of Apsai Upper Reaches Aps  <b>BOOKS</b> Basic Ref Manual Compute Atari DOS Compute Bk Atari Compute Magazine De Re Atari DOS Utilities List DOS2 Manual Misc Atari Books Op System Listing Wiley Manual	<b>BUSINESS</b> Calculator Database Managemt Decision Maker Graph-It Invoicing Librarian Mort & Loan Anal Nominal Ledger Payroll Personal Finl Mgmt Purchase Ledger Sales Ledger Statistics 1 Stock Control Tealink 1 Visicalc Weekly Planner Word Processor  <b>CRYSTALWARE</b> Beneath The Pyram Fantasyland 2041 Galactic Quest House Of Usher Sands Of Mars Waterloo World War III	<b>DYNACOMP</b> Alpha Fighter Chompelo Crystals Forest Fire Intruder Alert Monarch Moonprobe Moving Maze Nominos Jigsaw Rings of The Emp Space Tilt Space Trap Stud Poker Triple Blockade  <b>EDUCATION from APX</b> Aligalic Atlas of Canada Cubbyholes Elementary Biology Frogmaster Hickory Dickory Inst Comptg Dem Lemonade Letterman Mapware	Maths-Tac-Toe Metric & Prob Solvg Mugwump Music Terms/Notatn Musical Computer My First Alphabet Number Blast Polycalc Presidents Of U.S. Quiz Master Starware Stereo 3D Graphics Three R Math Sys Video Math Flash Wordmaker  <b>EDUCATION from ATARI</b> Conv French Conv German Conv Italian Conv Spanish Energy Czar European C & Caps Hangman Invit To Prog 1/2/3 Kingdom Music Composer	Sram States & Capitals Touch Typing  <b>EMI SOFTWARE</b> British Heritage Cribbage/Dominos Darts European Scene Jig Hickory Dickory Humpty Dumpty Jumbo Jet Lander Snooker & Billiards Submarine Commdr Super Cubes & Tilt Tournament Pool  <b>ENTERTAINMENT from APX</b> Alien Egg Anthill Attank Avalanche Babel Blackjack Casino Block Buster Block 'Em Bumper Pool	Castle Centurion Checker King Chinese Puzzle Codecracker Comedy Diskette Dice Poker Dog Date Domination Downhill Eastern Front Galahad & Holy Gr Graphics/Sound Jax-O Jukebox Lookahead Memory Match Midas Touch Minotaur Outlaw/Howitzer Preschool Games Pro Bowling Pushover Rabbitot Reversi II Salmon Run 747 Landing Simul Seven Card Stud	Sleazy Adventure Solitaire Space Chase Space Trek Sultans Palace Tact Trek Terry Wizards Gold Wizards Revenge  <b>ENTERTAINMENT from ATARI</b> Asteroids Basketball Blackjack Centipede Chess Entertainment Kit Missile Command Pac Man Space Invaders Star Raiders Super Breakout Video Easel  <b>ON LINE SYSTEMS</b> Crossfire Frogger	Jawbreaker Mission Asteroid Mouskattack Threshold Ulysses/Golden Fl Wizard & Princess  <b>PERIPHERALS</b> Centronics Printers Disk Drive Epsom Printers Program Recorder RS232 Interface Thermal Printer 16K Memory RAM 32K Memory RAM  <b>PERSONAL INT from APX</b> Adv Music System Banner Generator Blackjack Tutor Going To The Dogs Keyboard Organ Morse Code Tutor Personal Fitness Prg Player Piano Sketchpad	<b>PROGRAMMING AIDS from Atari</b> Assembler Editor Dsembler (APX) Microsoft Basic Pascal (APX) Pilot (Consumer) Pilot (Educator) Programming Kit  <b>SANTA CRUZ</b> Basics of Animation Bobs Business Display Lists Graphics Machine Kids 1 & 2 Horizontal Scrolling Master Memory Map Mini Word Processor Page Flipping Player Missile Gr Player Piano Sounds Vertical Scrolling  <b>SILICA CLUB</b> Over 500 programs write for details
--	---	---	---	--	--	--	--	--	--

## FOR FREE BROCHURES — TEL: 01-301 1111

For free brochures and reviews on our range of electronic products, please telephone 01-301 1111. To order by telephone, just quote your name, address, credit card number and order requirements and leave the rest to us. Post and packing is FREE OF CHARGE in the UK. Express 24 hour delivery available at an additional charge.

- **SHOP DEMONSTRATION FACILITIES** — we provide full facilities at our shop in Sidcup, Monday to Saturday 9am to 5.30pm (closing Thursday 7pm, Friday 8pm)
- **MAIL ORDER** — we are a specialist mail order company and are able to supply goods direct to your door
- **MONEY BACK UNDERTAKING** — if you are totally unsatisfied with your purchase, you may return it to us within 15 days. On receipt of the goods in satisfactory condition we will give you a full refund.
- **PART EXCHANGE SECOND HAND MACHINES** — we offer a part exchange scheme to trade in many makes of T.V. (price for personal computers)
- **COMPETITIVE PRICES** — our prices, offers and service are very competitive. We are never knowingly undercut, and will normally match any lower price quoted by our competitors.
- **REPAIRS SERVICE** — available on the suitability of various computers.
- **AFTER SALES SERVICE** — available on all computers out of guarantee.
- **VAT** — all prices quoted above include VAT at 15%.
- **CREDIT FACILITIES** — we offer credit over 12, 24 or 36 months, please ask for details.

**SILICA SHOP LIMITED**  
Dept. YC 0982, 1-4 The Mews, Hatherley Road, Sidcup, Kent DA14 4DX.  
Telephone: 01-301 1111 or 01-309 1111.



### FREE LITERATURE

I am interested in purchasing an Atari 400/800 computer and would like to receive copies of your brochures and test reports as well as your price list covering all of the available Hardware and Software:

Name .....

Address .....

.....

.....

Postcode .....

YC 0982 — Your Computer — September 1982

# Probably the fastest microcomputer in the universe

## the **JUPITER ACE** only £89.95.



### Key Features

- Revolutionary microcomputer language FORTH.
- Full-size moving-key keyboard.
- User-defined high-resolution graphics.
- Programmable sound generator.
- Floating point arithmetic.
- Fast cassette interface.
- Upper and lower case ascii character set.
- 24 x 32 character flicker-free display.

### The Jupiter Ace uses FORTH

The Ace is set apart from all other personal computers on the market by its use of a revolutionary language called 'FORTH'. Some computer languages are easy for humans to understand, others are easy for computers; FORTH is most unusual in being both. Its underlying principles are so simple that it takes even a newcomer to computers only a few minutes to learn how to do calculations on the Ace, yet the very same principles are powerful enough to allow you to invent your own extensions to the language itself.

At the same time, the memory-saving coded form used to store your programs inside the Ace allows it to obey them very fast — typically in less than a tenth of the time it would take to do the same thing using a different language. Amongst other things, this makes the Ace ideal for games.

FORTH's unique combination of speed, versatility and ease of programming has already made it a prime choice for professional applications as diverse as pub games and radio telescopes, and gained it an enthusiastic national user group. Now the Jupiter Ace can bring this addictive language into your own home.

### Designed by Jupiter Cantab

Leading computer Designers Richard Altwasser and Steven Vickers have a reputation for pushing technology forwards. After playing the major role in creating the ZX Spectrum they formed Jupiter Cantab to develop their latest brainchild the Jupiter Ace.

### All inclusive Price

For £89.95 you receive your Jupiter Ace, a mains adaptor, all the leads needed to connect to most cassette recorders and T.V.s (colour or black and white), a software catalogue and a manual.

The manual is a complete introduction to the world of personal computing and a course in FORTH programming on the Ace.

Even if you are a complete newcomer to computers, the manual will guide you step by step from first principles to confident programming.

The price includes postage packing and V.A.T.

### Technical Specification

#### Hardware

**Processor/Memory**  
Z80A running at 3.25 MHz.  
8K bytes ROM 3K bytes RAM.

#### Input

40 moving-key keyboard with auto-repeat on every key.

#### Output

Memory-mapped 32 x 24 character display with high resolution user graphics. Output to drive normal UHF TV set on channel 36.

#### Sound

Provided by internal loudspeaker.

#### Cassette

Load Save & Verify at 1500 baud, separate data storage.

#### Software, FORTH

##### Data Structures

Integer, Floating point and String data may be held as constants, variables or arrays with multiple dimensions and mixed data types.

##### Control Structures

IF-THEN-ELSE, DO-LOOP, BEGIN-WHILE-REPEAT, BEGIN-UNTIL, all may be mixed and nested to any depth.

##### Operators

Mathematical +, -, X, ÷.  
Logical AND, OR, NOT, XOR.

Comparison <, >, =.

##### Program Editing

FORTH words may be listed, edited and redefined. Comments are preserved when words are compiled.

### Order Form



The **Jupiter Ace** is available only by mail order. Please allow up to 28 days for delivery.

Send cheque or postal order with the form to:—  
JUPITER CANTAB, 22 FOXHOLLOW, BAR HILL, CAMBRIDGE CB3 8EP

Please send me:—

JUPITER ACE MICROCOMPUTER(S) @ £89.95.

Name. Mr/Mrs/Miss

Address

\_\_\_\_\_ F

# YOUR LETTERS

## SEA BATTLE

My program Sea Battle in the July issue contained a few mistakes. The amended lines should read as:

```
120 PRINT TAB(C-1,20)"<=>"
140 IF Z$="Z" THEN D=1
150 IF Z$="X" THEN D=2
154 IF C>37 THEN C=37
190 PRINT TAB(0,23)"BASES
LEFT="";F
212 IF B=20 THEN PRINT TAB
(A,B)" "
422 IF C$="Y" THEN GOTO 23
430 CLS:PRINT"MORE THAN 10
PLANES HAVE LANDED":
GOTO 410
```

Line 200 should be deleted. There should not be any space between Tab and the bracket as shown in the program.

Lakith Leelasena,  
Ilford,  
Essex.

## ZX DEFECTS

Now that I have had my ZX Spectrum for two weeks I feel that I should point out some of its deficiencies.

First, to only be able to have line numbers in the range 0 to 9999 is a serious limitation on a 48K computer. Following the normal convention of line numbering in tens, this only allows 1,000 lines of code and, even using some multi-statement lines, this is not enough.

Secondly, to have to pull out the ear-phone plug each time a program is saved strikes me as a design fault. Thirdly, the keyboard layout would be improved by placing both the shift keys together at the bottom left of the keyboard. Also you can never be sure that the key you have hit has registered with the micro, and the red printing on the grey keys is well-nigh illegible.

M R Farley,  
Maidenhead,  
Berkshire.

## COMPUTER FAIR

In April I went to the Computer Fair,

A charming young lady accosted me there.

"A message from Uncle Clive," she said

And gave me a leaflet before she fled.

"The Spectrum — what's that?" I thought with a smile,

"Another leaflet to add to my pile."

I read it more fully going home on the train,

And shouted "My God! he's done it again."

So I ordered a Spectrum by 'phone on the Sunday,

"Perhaps it will come less than four weeks from Monday."

The next week I sold my ZX-81 And sat back and waited for a Spectrum to come.

I waited and waited for several weeks more, And then a white card dropped through the door. "Your order is being processed for despatch."

On May 26 — I suspected no catch.

A 'phone call or two — and when I get through —

"There's a further delay — and we're sorry too."

Your Computer — July — on page 17,

I read about Spectrum — but what does it mean!

"Sinclair Research say the backlog is cleared."

If that's so why hasn't my Spectrum appeared?

I must be a "backlog" — I ordered so early,

It's such a long time since I met Sinclair's girlie.

Oh what can I do now? — If I write in verse

They won't want another so the delay can't get worse.

I'll chance it — my recorder's all dusty,

And what's more I think my Basic's gone rusty!

D J Shannon,  
Bognor Regis,  
Sussex.

## ALIEN ATTACK

While there was no actual mistake in the hex listing for my program Alien Attack which appeared in the July edition of Software File, two bytes are unclear and I know that some people have had trouble as a result.

Location 16886 should read 9B, not 98. This affects the movement of the bullets — they turn into inverse division signs and stay off the bottom of the screen if this location is incorrect.

Location 16937 should read B4, not E4. This affects the working of the high score. Also, in listing 3, line 12 should read

```
IF A$="" THEN INPUT A$
```

Jon Jones,  
Penylan,  
Cardiff.

## MACHINE CODE

I am pleased to see that a few more people have taken the plunge and are programming their ZX-81s in machine language — Your Computer July 1982. I believe their efforts have been well rewarded with better quality programs.

However, I believe that, as well as increasing the speed of the program, machine language should also occupy the smallest amount of memory possible and, in this context, I think that the program by D Clancy — page 91 of the July issue — could well be improved.

The following one-line program produces exactly the same screen border and only takes 28 bytes. It is

```
1 REM Y#E#RND LN#RND# =
)3#77?;?(RAND 7#47?!
```

UNPLOT TAN

POKE 16529,119

POKE 16531,119

POKE 16538,119

RAND USR 16514

} direct commands.

also entered directly from the keyboard with no need for a hex loader.

The keywords are underlined and Rand/Unplot are entered by typing Then Rand/Then Unplot and rubout the word Then. Perhaps you would like to convert the statement back to machine-language mnemonics to see how it works.

S A Nicholls,  
Keynsham,  
Bristol.

## FAST POKES

At long last my Spectrum has arrived, only 11 weeks after my order. Perhaps other lucky Spectrum owners would like to try the following Pokes, which are all concerned with the keyboard.

Poke 23561,5 — five × 1/50 second — shortens the delay before a key starts to repeat; Poke 23561,255 virtually turns off the repeat; and Poke 23562,1 makes the keys repeat much faster.

In the main Spectrum manual on page 138, it suggests Poking 255 into 23609 to make the keyboard beep, but I find this slows down the repeat too much. Instead, Poke 23609,50 which I feel gives the best compromise between speed and sound.

Stephen J Betts,  
Eaton Bray,  
Bedfordshire.

## CLARIFICATION

With all due respect to Tim Hartnell, his reply to Martin Kuhn in the July's Response Frame is inaccurate: there is no need to put Save "Program Name" in the first line of the program. In fact there are at least two reasons for not putting it there.

First, you may wish to have one or more Rems containing machine code there. Secondly, if the program ends and you Run, the program will first try to Save.

The line, Save "Program Name" can be put anywhere provided the program jumps over it — for example, with a Goto during execution, but the simplest system is to put it at the end:

```
9997 STOP (not always needed)
9998 SAVE "PROGRAM NAME"
9999 RUN
```

Also, Line 9999 can be Goto (line

number) or List or List (Line number). The Goto is necessary if you have saved unlisted variables which will be lost if you Run.

List is sometimes necessary if you wish certain Rems to be read before running. You may need to Poke a particular value before running or to read other instructions. The automatic List prevents you from absent-mindedly running immediately after loading and is really a more useful facility than the automatic Run. Page 110 of the manual covers this method without the List possibility.

Les Simpson,  
Hornchurch,  
Essex.

## STRONG LINE

Congratulations on your strong line July editorial calling on the computer industry to give mail-order consumers a fair deal.

The new Supply of Goods and Services Bill will help micro-computer enthusiasts for it is certain to become law by the end of this Parliamentary session. It makes consumer rights statutory.

That still leaves the problem of the mail-order company that goes to the wall taking its customers' money with it into liquidation.

We are campaigning strongly for the Customers' Prepayment (Protection) Bill, which recently failed in the Commons, to be reintroduced next session. Any support from readers would be most welcome.

Janet Upward,  
Secretary, National Federation  
of Consumer Groups,  
18 Queen Anne's Gate,  
London SW1 9AA.

## VIDEO MEMORY

The eventual introduction of the Sinclair ZX Microdrive for the Spectrum computer will surely spell the end for expensive disc drives. However, I believe the future of mass-memory storage for computers will be on conventional video recorders. These have many of the advantages of magnetic disc drives, as well as high-volume sales hence low production costs.

What the market needs is a video recorder which provides for multi-track audio recording for hi-fi buffs, an on-line data bus for computers and a teletext decoder in addition to video recording.

The recorder could store teletext pages on the tape. The freeze-frame facility of a video recorder could provide for on-line storage or retrieval of information for computers in a similar way to how disc drives work. So virtual memory for computers would not only be massive but cheap.

R Marsden,  
Wakefield,  
West Yorkshire. ■

## Kenneth Kendall and Acorn take on the Daleks from America

NEXT TIME you hear a computer talk it could sound more like a BBC newsreader than the American Dalek



### Micros for primaries

WITHIN TWO years every primary school in the land should have a microcomputer. The Department of Industry will supply 50 percent of the purchase cost of a Sinclair Spectrum, BBC Micro or Research Machines 380Z from a £9m fund.

Whereas secondary schools were required to send two teachers on a "computer awareness" course, primary schools will instead receive a pack containing a self-study guide, a microcomputer reader and 20 sample programs on cassette.

Acornsoft has released the first few programs of what is promised to be an enormous range of educational software for the BBC Micro. The initial programs deal with science, mathematics and English language and cost £8.65 per cassette and £13.65 per disc. Acornsoft is at 4A Market Hill, Cambridge CB2 3NJ.

Wordcraft 20 is a Vic-20 version of a word-processor widely used on Pet computers. The system turns the Vic's screen into a window that can be scrolled up, down, left and right over the text. If a typed line is wider than the screen then the window will automatically follow it. The user can manipulate single characters, words, lines or entire blocks. Wordcraft 20, which includes 8K extra RAM, is supplied as a plug-in cartridge for £125 from Audiogenic, PO Box 88, Reading, Berkshire.

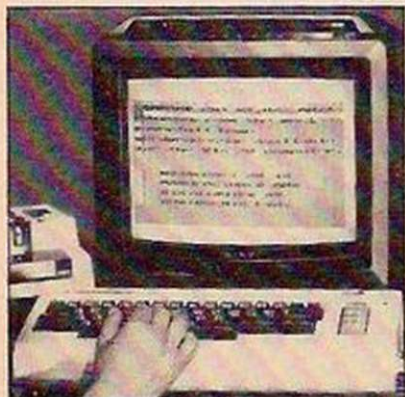

noises we are accustomed to hearing.

Most currently available speech chips were developed several years ago for the American market. Now Acorn has applied the latest technology to ex-newsreader Kenneth Kendall's voice and produced a BBC Micro that speaks BBC English.

According to one of Acorn's engineers this has two advantages: "First of all it is British English and secondly the quality is much better." Acorn will make the speech processor and a ROM containing useful words and numbers available in October for less than £30.

Later in the year they will produce a second ROM which will allow the BBC Micro to generate flowing phonetic speech which will sound remarkably like Kenneth Kendall.

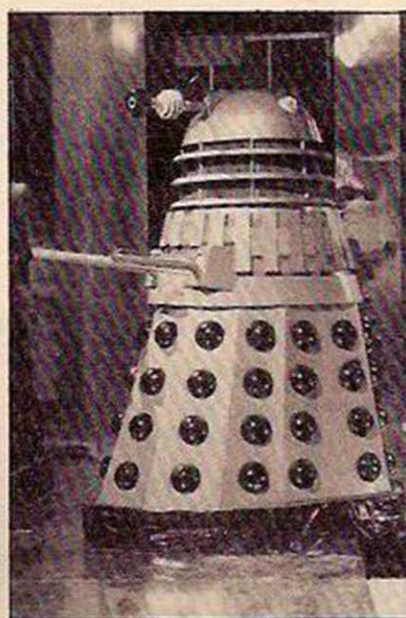

## Black and white £90 Jupiter Ace goes far faster with Forth

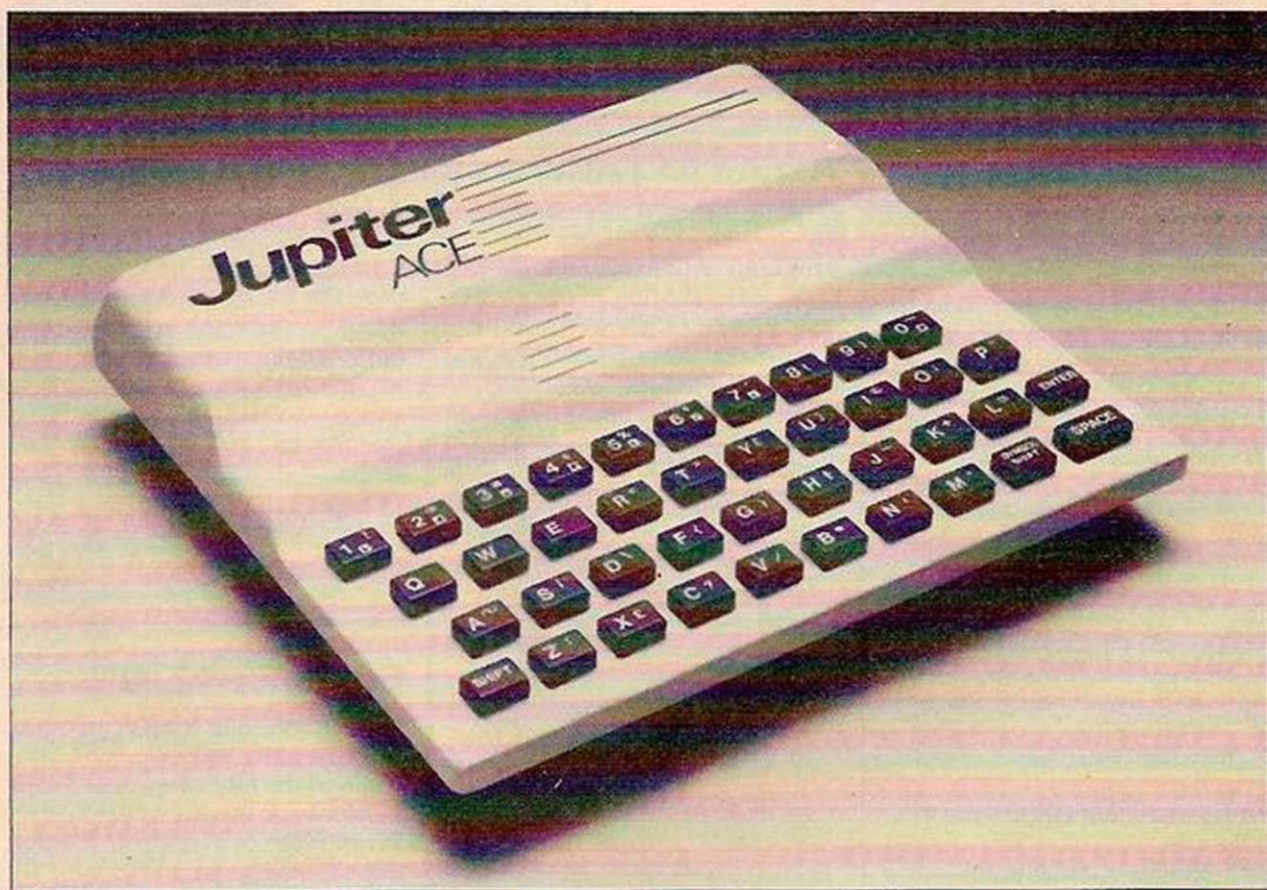

EX-SINCLAIR ENGINEERS Richard Altwasser and Stephen Vickers are launching a new high-resolution black and white computer for £89.95.

The Jupiter Ace will come with 3K RAM and be based around the 3MHz Z-80A. The real surprise though is that the new machine will not use Basic. "We feel that there are many drawbacks to Basic," says Altwasser, "which is why we are using Forth — the language of the future."

Altwasser claims that Forth is easy to learn yet executes far faster than

Basic and at the same time encourages a modular approach to programming. This may make the Jupiter Ace particularly appealing to schools, colleges and scientific establishments.

Unlike many recently released machines the Ace will not have colour but sound has been incorporated.

Although the keyboard lacks a full-size space bar Altwasser describes it as a "full-size moving key" and criticises some of his rivals for producing "keyboards that feel like dead flesh — ours will be more positive."

## Pac-Men snap at Vicmen

ATARI'S LAWYERS are snapping at the heels of Bug-Byte's Vicmen. Now Vicmen, which is similar to Atari's Pac-Man, has been withdrawn from sale for fear of costly legal proceedings.

Atari knows the profits games like Space Invaders or Pac-Man can generate and are keen to prevent others profiting from their ideas. As more people learn to use computers it becomes more difficult to conceal the secrets of programs from prying eyes. Now Atari is resorting to legal action.

Tony Baden of Bug-Byte denies that Vicmen is a straight copy of Pac-Man but he is unwilling to commit limited resources to what might become a long and involved legal battle. "If we had unlimited funds we would like to fight it."

## New Genie conjures up 16K colour and sound

THE ALREADY-CROWDED £200 personal computer market becomes even more cramped with Video Genie's launch of a £199 colour computer. Rob Stead, head of Lowe Computer Division, said "it's a totally new product," not just a colour version of the Genie II.

The Colour Genie, below, offers 16K RAM, a full-size typewriter keyboard, 16 colours, 160 by 96

graphics resolution and 128 programmable characters. Other features include 12K of Microsoft Basic, 40 by 24 characters screen format conforming to Prestel teletext standard, and 1,200 baud transfer rate for cassette. Among the accessories available are a position-detecting light-pen, a printer and, to be released shortly, a Modem facility.

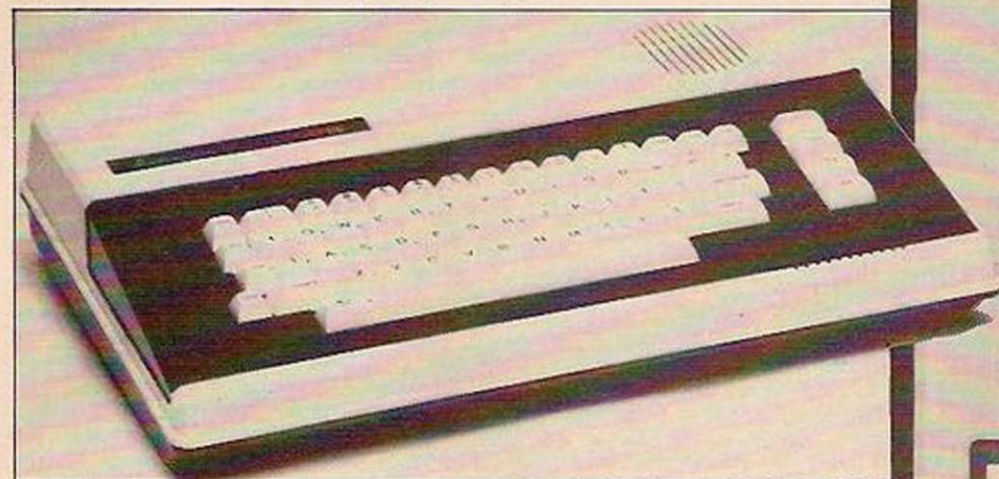

## Multitech has 64K micro up its sleeve

MULTITECH HAS joined the £200 computer battle by launching the Microprofessor MPF-II, shown above right, which is to be built in Taiwan.

Whereas six months ago the Vic-20 was the only machine offering colour and sound in this price range, the MPF-II will now have to take on the Colour Genie, the Dragon, the Spectrum, Atari 400 and Texas TI-99/4A.

The MPF-I was a hexadecimal code hobby computer, but the MPF-II is a fully-fledged personal computer. The ZX-81 sized box offers 64K RAM and six-colour high-resolution graphics with sound, based around a 6502 processor and

games, education and business software will be available on plug-in cartridges and cassettes. Data can be transferred from cassette at 1,000 bits per second.

The MPF-II will output to any printer with a Centronics interface, and Multitech's own thermal printer will print 40 characters per line at 50 lines per minute.

Other options include a full-sized typewriter keyboard to replace the MPF-II's pocket computer-style

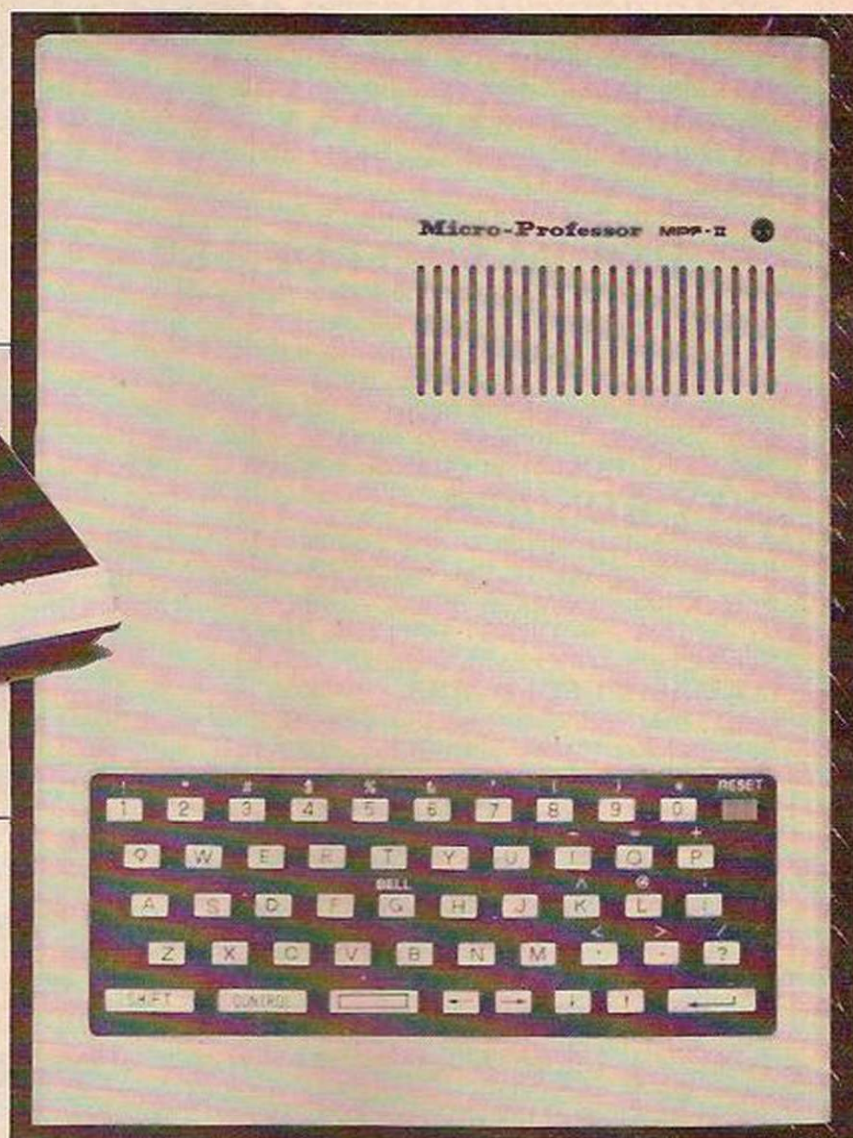

keys, a calculator-sized remote controller and a speech synthesiser.

For an additional £100, Multitech has made available a Chinese-character processor which should be useful for translators not to mention Chinese restaurants and small businesses.

## Sinclair worth waiting for

CLIVE SINCLAIR now admits that many customers have waited 12 weeks for their Spectrums rather than the 28 days still promised in Sinclair's advertising. He claims that production is now running smoothly at 5,000 units per week and that the backlog will be cleared by the end of September.

In the meantime those who have given up waiting for the Spectrum can take advantage of recent price cuts to buy a ZX-81 for £49.95 instead of £69.95.

Next year a Prestel adaptor will be made available for the Spectrum. Using the Spectrum as a Prestel terminal, owners will be able to access nearly 200,000 pages of information.

Sinclair will produce the adaptor at a price "well, well under £100". The company will set up a Prestel base of its own and others' programs. Looking further ahead, Sinclair hopes to set up user networks under the Prestel "umbrella", enabling Spectrum owners to talk to each other.

If telesoftware takes off in the way Sinclair anticipates it will, their company's involvement could prove to be a shot in the arm for the ailing Prestel network.

## Dragon sounds off

IF YOUR DRAGON is a little hoarse or your Spectrum sounds off colour, Computer User Aids new sound-board may be of help.

Musical effects including bass, drums, chords and white noise can be generated on three channels, each with a range of seven octaves. The 1W amplifier can power a built-in speaker or a stereo output. Although the package includes software control for volume, tempo and envelope it does not require user RAM.

The unit costs £29.95 from Computer User Aids, 14 Carlton Road, Romford, Essex RM2 5BD. Telephone 64954.

*Information Technology year, which was supposed to bring electronic mail to the people, has been forced to resort to postage stamps to broadcast its message. This is rather as if Caxton had resorted to writing advertisements by hand for his printing press. Those of you who have not made the transition to a paperless society will find that the stamps use more paper than ordinary commemoratives and that with the wonders of information technology it has become necessary to use three frames to display a message which any other stamp could display in one. The right-hand frame of the 26p stamp shows a high-technology supermarket charging someone £23.86 for a can of beans. Both stamps will be available on a specially designed first-day cover at most post offices from September 8.*



# ARCADE QUALITY SOFTWARE FROM LLAMASOFT!!

## Spectrum ATARI

### GRAPHICS/CHARACTER CREATOR

Now you can define your very own custom character sets. Or edit the existing sets. Results fully displayed on screen in modes 0, 1 and 2. Many exciting features including: Save, Screen Modes, Reflect, Invert etc.

Supplied on cassette with data £8.00

### SPECTRUM SUPERDEFLEX

The idea of this new game is to bounce 'FRED' the space invader around the screen into the power pads. Keeping away, of course, from the devil which chases you around the screen. Steer with your deflex shields, but beware the mines or you may be buried alive. Superb graphics and fantastic sound on the 48K SPECTRUM only. £4.95 on cassette.

### CITY BOMBER

A full feature version of the popular game 'BLITZKRIEG' supplied for the 16K or 48K SPECTRUM only. £2.95. COMING SOON — 48K ADVENTURE — QUEST FOR THE GOLDEN TORQ

Send Cheque/P.O. with order to:

**LLAMASOFT SOFTWARE,**  
Dept YC2, Lindon House, The Green, Tadley,  
Basingstoke, Hants. Tel: (07356) 5038



### WANTED!

GOOD QUALITY SOFTWARE.  
SEND DEMO FOR QUICK  
REPLY.

TRADE ENQUIRIES WELCOME  
PLEASE ADD 50P P&P



### BREAKOUT/ DEFLEX

Unexpanded package a full feature version of the popular arcade Breakout plus a new concept in computer games, Deflex!! Both programs on one cassette only £3.95.

### DEFENDA! m/c

Full feature version of the popular arcade game including; Swarmers, Baiters, Pods, Landers and Humanoids. Controls: Up, Down, Thrust, Reverse, Fire and Smart Bomb. High resolution colour graphics. Joystick controls. 8k or 16k expansion needed. Only £10.00

### TRAXX! m/c

Vic 20 version of the brand new arcade game "Amidar" A Packman/Quix crossbreed. All machine code, fast and fun. Joystick controls. Hi-res colour graphics. 8k or 16k expansion needed. Only £10.00

### RATMAN! m/c

Kill the squeaking rats which fall from the sky before they dig in and prey on you! Game includes rats, hammers, men, mutants and spears. M/c, hi-res colour graphics. 8k or 16k expansion needed. Fast and fun for only £8.95

### BLITZKRIEG (3.5k)

Fly your Vulcan bomber over enemy territory and destroy the city. 25 levels of play. Hi-res colour graphics on the unexpanded Vic 20. Only £4.95

### UTILITY PROGRAMS (for unexpanded Vic 20)

GAME GRAPHICS EDITOR. Create your very own custom characters. Full features include Reflect, Save on Tape etc. SOFTKEY 24.24 key words inc. Peek, Poke, List, Save on your function keys Both programs supplied on one cassette. Only £6.00  
Coming Soon, plug-in games cartridges at under £20 — please ring for details.

# ZX 81 Spectrum

## ABACUS CONTROLLER



Developed to eliminate tedious swapping of plugs when LOADING or SAVING programs on cassette.

**ZX SPECTRUM CONTROLLER:** Single switch selection of SAVE, LOAD & AMP modes. Built in amplifier and loud-speaker boosts Spectrum sound output. Price £14.95

**ZX81 CONTROLLER:** Single switch selection of TALK, SAVE, CUE & LOAD modes. Built in microphone/speaker for fast and reliable program naming and cueing. Price £12.00

All items in this advertisement can be viewed before buying at the Buffer Micro Shop, London.

## ZX Spectrum games

1. ANDROID PIT RESCUE: Rescue the trapped miners before they are trapped in the flooding mines.
2. ICEBERG: Steer your icebreaker through thickening pack-ice to pick up survivors.
3. DESTROYER: Find and destroy the submarines before they sink the merchant ships. Novel use of sound.
4. BATTLE: Destroy missile sites while avoiding mines and the enemy tanks that are out to get you.

All Spectrum games have User Defined Graphics, sound, full colour and highscore.

## ZX81 games

5. DEFENDER: A fast action machine code game with five levels of play, on screen scoring and highscore.
6. AVENGER: Destroy targets on the planet's surface with bombs and lasers while fending off guided missiles. Machine code, five levels of play, time and highscore.

Games 1 & 2 on one cassette price £5.95

All other games price £4.95 each including P&P.

All games are in stock and we guarantee to despatch them within seven days.

**ABACUS  
ELECTRONICS**

**186 St. Helens Ave,  
Swansea, W. Glam.  
Tel: (0792) 05282**

# COMPUTER CLUB

Computer Club is here to encourage you to start your own local computer club or, if one already exists, to join it and become involved. We would like to hear of anything which has made your club a success, or of any projects or programs you are developing.

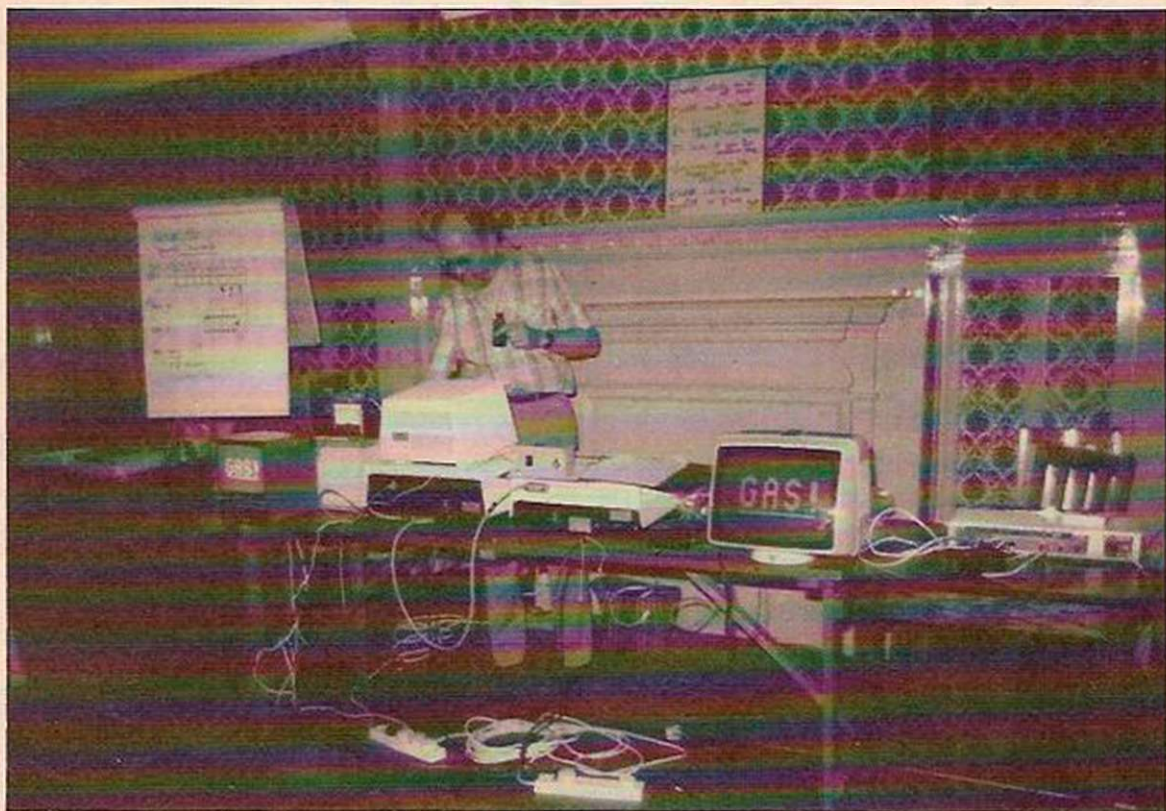

PASS THROUGH the saloon bar of the Fox and Goose, cross the beer garden and you will find the West London Computer Club occupying a room at the back of the pub. Founded almost three years ago, the club recently moved to the Fox and Goose, near Hanger Lane, from Willesden Technical College. The landlord initially billeted them in a smaller room but was sufficiently impressed by their beer consumption to offer them their present spacious accommodation.

As at least half the club's 30 paid-up members are professionally involved in computing, there is a good deal of technical expertise on hand. *Your Computer's* representative soon received advice on how to cure the

## Local news

### Bristol

BRISTOL Computing Club is offering a course in Basic programming from September 15. The club meets on the third Wednesday of every month at the University of Bristol Physics Building. More details from the club secretary on 0454-322071.

### Cheshire

MEETINGS of the Mid-Cheshire Computer Club are held at the main Winsford Library on the second Friday of each month. They usually include a machine demonstration in the proceedings. Telephone Dave Clare on 06065-51374 for more details.

### Newcastle

NEWCASTLE Personal Computer Society has been running since 1978. They are linked with several user sub-groups. Meetings take place on the first Tuesday of the month at Room D103, Ellison Building, Newcastle Polytechnic. You can telephone John Bone on 0632-770036 in the evening.

## WEST LONDON

Simon Beesley discovers the ins and outs of gas detection and synthesised speech in the convivial atmosphere of the West London Computer Club.

irritating loudspeaker buzz on his BBC model A and on how to make the screen display steadier. Four BBC Micros were available at the meeting and other machines owned include Nascoms, ZX-81s, a Pet, a Tuscan and a Vic-20.

You do not have to be an expert, or even own a machine, to enjoy the meetings. Neil Cryer, club chairman and co-author with Pat Cryer of a book on programming the BBC computer, pointed out how mistaken it is for people to think they should wait until they buy a computer before joining a club: computer clubs are ideal places to get advice on possible machines.

The August meeting showed the amount of cross-fertilisation that goes on between London clubs. Bazyle Butcher, who had previously given a talk on building a robot arm for £12, attended from the Harrow CC, and David Annal from the Croydon CC gave a talk that evening on "The Ins and Outs of Interfacing".

The talk mixed technical information on interface chips with a variety of practical demonstrations. Using three monitors linked up to a Pet, he showed how to input information to the computer from a torch via a light-detecting cell, a light-pen, a microphone and a device which detected gas and interrupted a program with an alert. Among the output possibilities demonstrated was an impressive example of synthesised speech, using a "phoneme speech" chip.

The chip can interface with a computer and an amplifier to produce 36 different vowel sounds, 25 consonants, three types of pause and four inflections. These can be combined to synthesise almost any spoken word. Inflections — a voice's rise and fall — make the

difference between monotonous "robotic" speech and a more human-sounding voice.

In a virtuoso programming application, David Annal's speech generating program recited the verses of his poem, Sam, which relates the misadventures of a young lad, Sam, in rhyming couplets. In time with the recital, the program displayed some high quality graphics on the monitor illustrating episodes from the poem and printed the verses at the top.

The club arranges a talk by a member or guest for most meetings. In September, Graham Brain — one of the founder members with Bernie Haylett — will talk about the Pluto colourboard, and in October there will be a talk on CP/M. Meetings take place on the first Tuesday of every month at the Fox and Goose, Ealing Road, West London. For further details telephone Neil Cryer, 01-997 9437, or Bernie Haylett, 01-883 3948.

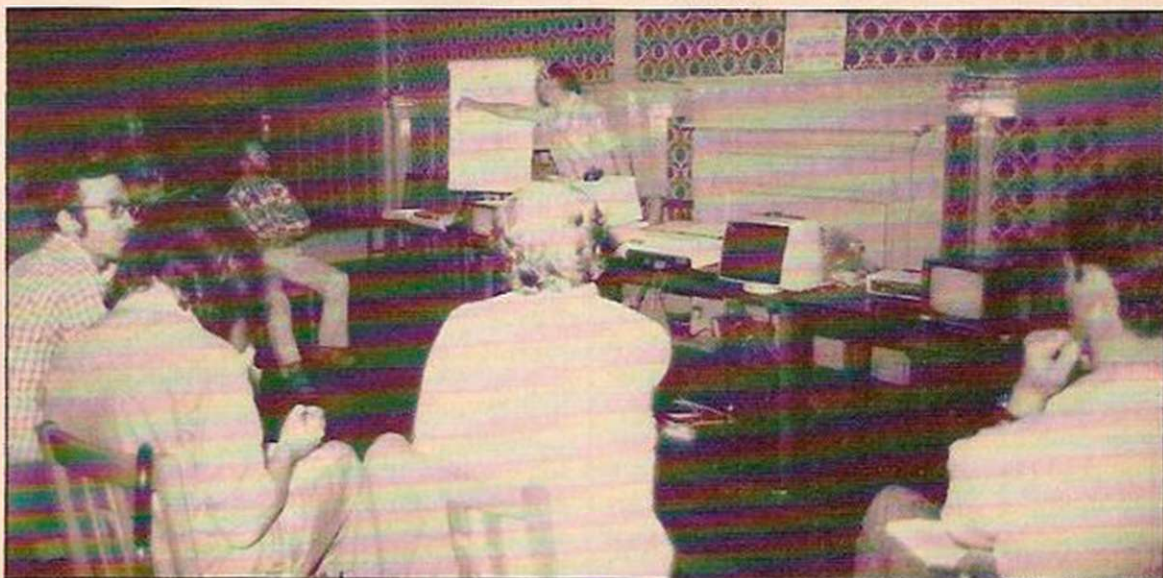

# BREAKING THE SC B

Once upon a time computers that could talk and listen were only found in 2001. Now Tim Langdell looks at devices that could make your ZX-81 come alive — from the humble keyboard bleep to mighty units that can recognise and synthesise speech.

PERHAPS THE most frequent criticism made of the ZX-81 is its unresponsive keyboard. Except for the eagle-eyed, it can be very difficult to be sure that the key pressed has been accepted by your '81. This can be especially frustrating when you are entering large amounts of data or machine code. A keyboard beeper can be a Godsend in situations like this, and the two I tested are the Keyboard Audio Tone from TV Services of Cambridge, and the Fulcrum Electronics Bleep.

Fulcrum's Bleep is the simpler of the two devices and once fitted, pressing almost any key on your ZX-81 will cause a beep. The board is extremely easy to attach and requires no soldering. Ingeniously, Fulcrum has used small, spring-loaded pins on the ends of the leads to be attached to the ZX-81's circuit board.

## Keyboard response

There are clear instructions to explain into which holes in the circuit board the pins are to be pushed. They explain in detail how to open your ZX-81 and how to reassemble it safely. The Bleep's board and piezo-buzzer fit neatly inside the ZX-81's and can be held in place with sticky tabs.

From the 210 characters and keywords possible on the ZX-81, the Bleep will give a noise when any of 198 of them are pressed. The key presses which will not produce a beep are such keys as Edit, Rubout, Newline, Function and Space.

As Fulcrum points out, the fact that there is no beep when these keys are pressed can be useful in drawing your attention to the action you are taking. If only someone could devise a way of giving extra warning when New is pressed.

I have just three minor criticisms of the Bleep. First, because attaching it involves taking one of the ZX-81's fragile keyboard ribbon cables out of its socket and putting it in Fulcrum's one, you will need to be extra careful not to crease the cable. A small break in the ribbon cable can give rise to rather annoying and intermittent problems — keys suddenly fail to work.

Secondly I found the beep sound rather tiresome after a while. It would have been useful to be able to switch off the Bleep when not required. This extra facility would be particularly useful to owners of ZX-81s with larger keyboards fitted where the beep would not always be needed.



Lastly, it would be unwise to assume that if you heard a beep with this board that your ZX-81 has definitely noted your keypress. ZX-81s are relatively slow machines and even with the poor standard keyboard it is not difficult to out-type them.

The Keyboard Audio Tone is a little more sophisticated in that it not only gives a beep when any key is pressed — and all keys give a beep — but it also gives a different toned beep when the ZX-81 is ready for the next piece of information.

Fitting this device does, however, require some soldering. Five wires must be carefully soldered to the ZX-81's printed-circuit board and very clear instructions are given on how to do this.

As with the Bleep, the Audio Tone is fitted neatly inside the ZX-81's case with sticky tabs. In use it makes working with your ZX-81 more like talking to R2D2. Every key press gives a low tone, and you hear a high tone as soon as the ZX-81 has executed the command. This can be particularly useful when working in the Slow mode. If you grow accustomed to listening to the two tones you will never out-type your '81.

## Choice of loudness

This device also gives rather useful feedback when loading programs. At the end of a Load the beep sounds to indicate that the ZX-81 is ready for the next command. Also, the high

# ZX-81 SOUND CARRIER

Right and cover: Fulcrum's ZX-81 bleep and William Stuart's sound synthesiser. Below: Big Ears speech recogniser, Quicksilva sound board, Zon synthesiser and Wideband Speakeasy.

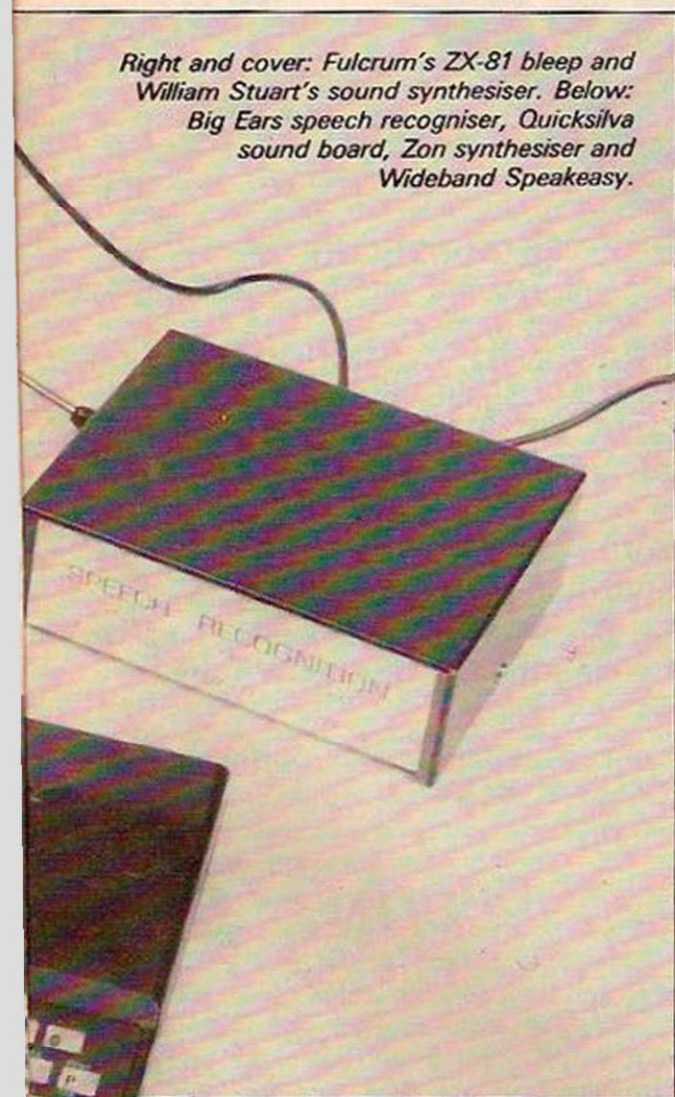

and low tones can be heard occasionally during Loading, which means that you can busy yourself with something else during a long Load and need only listen for the final beep.

The Audio Tone gives you a choice of volume levels, too. You can make the tones louder by changing the position of a wire link on its printed-circuit board. In fact, it would be possible to attach a two-way switch with a centre off position so that you have the choice of loud or quiet tones or no beep at all.

Finally, a very useful feature of this device is that you can introduce a beep into a program by simply putting a Pause of greater than about four. This could provide a simple way of introducing sound to your games programs.

Comparing the two keyboard beepers is not easy. Both do their job well and would be a cheap but extremely useful addition to a ZX-81. My own preference was for the Audio Tone because it offered more facilities at no extra cost — they are both £8.95.

Sound synthesiser boards are also available for the ZX-81, and for around £20 you can add laser sounds to your space invader games, or play your ZX-81 like an organ. There are three sound synthesisers on the market at present: the Quicksilva sound board, Stuart Systems Sound Synthesiser, and Zon-81 from Bi-Pak.

The Bi-Pak uses the versatile AY-3-8192 chip whereas the other two devices use the very similar AY-3-8190 sound synthesiser. Hence all three devices offer very similar facilities. The two AY-3-8190-based ones also offer two eight-bit ports as well as the sound synthesis, whereas the Bi-Pak synthesiser offers only sound.

## Creating specific sounds

A further major difference is that the Bi-Pak and Stuart Systems boards are not memory-mapped in RAM space: they are in the I/O area of the Z-80A's memory, whereas the Quicksilva board is mapped at the top end of the 16K RAM area.

Finally, the boards differ in that the Quicksilva and Stuart Systems boards must be attached to an amplifier whereas the Zon-81 is a fully self-contained unit with amplifier and speaker.

A disadvantage with all three devices is that it is not obvious how one is to obtain a specific sound. A relatively simple gunshot sound, for instance, can take up to 20 lines of program. Forewarned, however, that you may have to devote some time to creating a new noise, these boards can produce an amazing variety of sounds, from steam trains and laser shots to music in three voices in imitation of almost any musical instrument. The three sound synthesisers are supplied with differing amounts of information, which in each case is inadequate.

The Stuart Systems synthesiser is available as a kit as well as ready-made. The instructions on building the kit were very clear and if you have had some experience of building electronic circuits you should find building this device relatively easy.

Because the synthesiser is in the Z-80's I/O area and not memory-mapped in the RAM area it cannot be addressed from Basic with Peek and Poke commands. Instead, a machine-code routine has to be used.

Stuart Systems gives clear instructions as to how to load the routine which is about 100 bytes long and held in a Rem statement. You would need to enter this machine code only once and then save it on cassette for the next time.

Stuart Systems gives an overview of how the AY-3-8190 chip works. This will probably take you a few readings to understand fully,

# SURVEY

but it is, however, reasonably clearly written.

The booklet with the synthesiser covers how to select the various registers in the chip with which you can choose what type of sound will be produced. The several examples given help you understand how the device works, but it

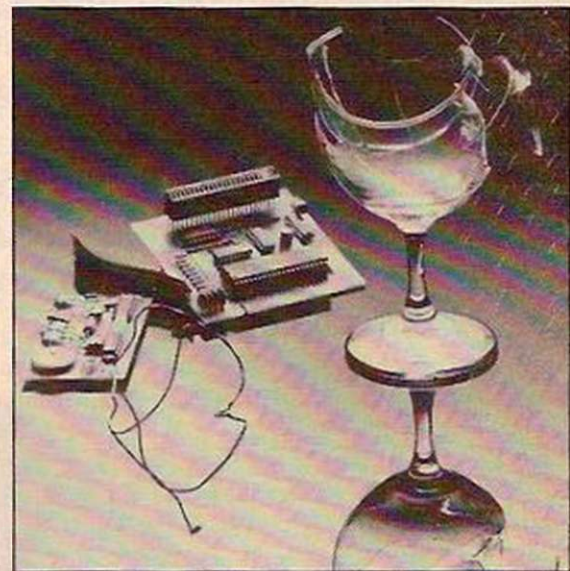

would have been better were there more specific examples of how to obtain sounds you might typically use in games. The only real example of this kind produces a slow steam-train sound.

At the end of the booklet Stuart gives some ideas as to how the output port might be used. Several hardware ideas are offered and information as to the maximum loads which can be applied.

Stuart Systems also offers a Music Composer program on cassette for an extra £6.90. This allows you to easily enter tunes with up to three-part harmony, and allows easy setting of volume, pitch, and decay of each note. The cassette is complete with two demonstration tunes. If you are interested in composing tunes then this cassette could be good value, but you must have a 16K RAM to run the program.

To hear the sounds you create you have to attach your Stuart Systems board to an amplifier. This aspect of the synthesiser is poorly documented, and if you were to read the booklet too quickly you might be forgiven for thinking that the sound comes from your TV's speaker, which it does not.

## Speaker systems

Stuart Systems suggest in a diagram that you attach one of the three outputs to one channel of a stereo amplifier, and another to the other channel. However, there is no reason although Stuart Systems omits to say so, why you should not attach all three outputs to a mono-amplifier.

The Stuart Systems board is well made and has a duplicate connector at the back so that a 16K RAM pack or another add-on can be fitted at the same time.

The Quicksilva sound board is similar in many ways to Stuart Systems device. One major difference, though, is that the Quicksilva

(continued on page 25)

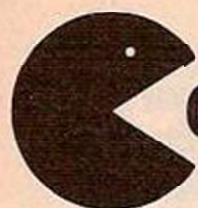

# CHRISCLUB

DRAGON 32  
CUMANA  
GENIE

Can YOU buy AMPEX C12 cassettes for 24p?!  
... a 12" Video Monitor for £55?!

## NO?

You need  CHRISCLUB ...

- \*Generous Hardware and Software Discounts
- \*Newsletters and Special Offer Sheets
- \*Telephone 'Hot Line' for technical queries
- \*Postal Programming Tuition
- \*Discount House prices coupled with Small-Dealer expertise to give YOU the best of both worlds ...

OKI

BBC

VERBATIM

# IT'S THE GREATEST THING FOR THE MICRO-USER SINCE DYNAMIC RAM!

NASCOM

PHOENIX

 CHRISCLUB

represents all the following well-known names:

DRAGON 32, COMMODORE, NASCOM, GENIE, EPSON, OKI, CUMANA, UK101, TRANSTEC, PHOENIX, VERBATIM, AMPEX, and many more ...

WE ALSO HAVE A SELECTION OF SOFTWARE FROM all well-known independent houses ...

All products carry the  CHRISCLUB technical back-up service. Any problems — ring the CHRISCLUB 'hot-line' and talk to the experts ...

Whether you own a micro or are contemplating the purchase of your first machine,  CHRISCLUB is for YOU.

ZX-81  
COMMODORE  
AMPEX  
EPSON  
UK101  
DRAGON 32  
TRANSTEC

WHAT YOU HAVE TO DO TO JOIN  CHRISCLUB



Fill up and cut out the coupon on the right. Send, with your first year remittance of £4.00 (20% off normal membership), to:

Secretary  
CHRISCLUB  
Chrisalid Limited  
13 High Street  
BERKHAMSTED  
Hertfordshire

WELCOME  TO CHRISCLUB

YES! I want to inject new life into my micro-computing ... Please enrol me into  CHRISCLUB. (I enclose cheque/PO for £4.00 or debit my BARCLAYCARD/ACCESS account number \_\_\_\_\_).

Name: \_\_\_\_\_  
Address: \_\_\_\_\_  
Machine type: \_\_\_\_\_  
Date: \_\_\_\_\_ 19: \_\_\_\_\_

(continued from page 23)

board must be used along with Quicksilva's motherboard or one of similar specifications. The only alternative is to use two edge connectors soldered back-to-back, which Quicksilva also supply. Whichever of these two methods you choose, you will have to pay extra on top of the price of the sound board.

As with the Stuart Systems board, Quicksilva does not make it clear that you have to connect the board to an amplifier, or that this connection is made via a 3.5mm. socket at the top of the board. However, the documentation shows that you can alter the output volume of the board to match your amplifier by turning a small potentiometer adjacent to the socket. Unlike the Stuart board, then, the Quicksilva one is designed to work with a mono-amplifier.

The Quicksilva board's sheet of information gives a brief idea of how the 13 registers in the AY-3-8910 work to produce various sounds. Addressing each of the three music channels is covered as well as how to address the noise channel and create envelopes.

### Music programs

Unlike the other two sound synthesisers, this board simply requires you to Poke two locations — 32767 and 32766 — to produce sounds and control the chip. A useful table is provided which enables you to create accurate scales over a five-octave range.

Quicksilva provides a few more example programs than Stuart Systems, and these include a program to play a simple tune, and a phasor-effect sound. The phasor sound is reasonable, but I am sure with perseverance you can produce a sound more like an arcade game's.

Quicksilva gives very little information on connecting hardware to the two user ports other than to say they can be connected up via the on-board 16-pin DIL socket.

The third sound synthesiser is from Bi-Pak. It is supplied in its own black plastic box, with integral speaker, amplifier and volume control. As such, it is much less fuss to set up than either of the other two boards. The booklet provided with it was also more comprehensive and, on the whole, well written.

Apart from summary tables indicating what each register does and a visual idea of the envelope shapes, which both the other board's information included, this booklet was the most informative and easy to read of them all. It gives clear instructions on how to enter the nine-byte machine-code routine which is needed to run this non-memory-mapped device. The Stuart Systems board routine needed 100 bytes.

The booklet's approach is a hands-on discovery of the AY-3-8912 chip's functions, which are identical to those of the AY-3-8910. It is not perfect — you still have to work hard to create any given sound — but it is well written. The booklet contains example programs, all of which are useful. However, the phasor sound Bi-Pak suggests is too much like a simple gun shot.

There is a program to allow you to use the keyboard of your ZX-81 as an electronic organ. An assembly language version of the machine-code routine is included — which Stuart Systems omits — as well as an idea of

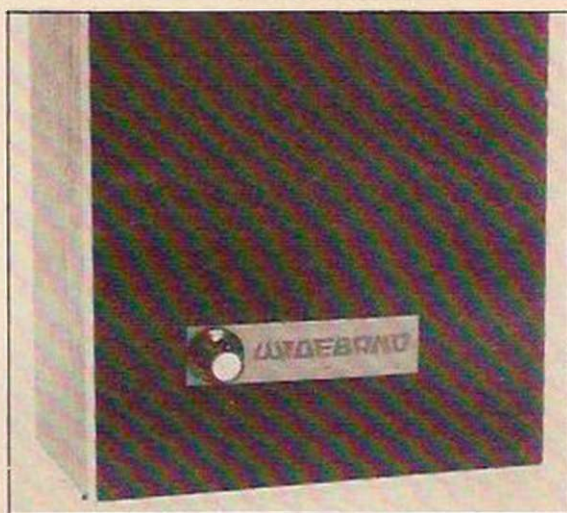

how the chip does its job. The unit does not include a user port like the other two boards, but many of you may feel that this is not an essential feature anyway.

The Zon X-81 also has a rear edge connector which duplicates the one on the rear of the ZX-81 and thus allows you to have a RAM pack fitted at the same time.

If you want a sound synthesiser and an I/O port then you may well be advised to choose either the Stuart Systems or the Quicksilva board. This should be slightly less expensive than buying a separate I/O port as well.

However, both of these boards presented the problem of needing to be connected to an external amplifier which may not always be easy — my own stereo system is not usually within reach of my ZX-81, and vice versa. The Bi-Pak was easier to use for this reason, and had the clearest guide to using the sound synthesis chip.



Top: Wideband Votrax-based speech synthesiser. Above: Zon-81.

As far as price is concerned, the Stuart Systems board is the cheapest at only £19.50 plus VAT in kit form, and £25.50 plus VAT ready-made. The Quicksilva board is £26, but remember that you will either also need a QS connector at £4 or a motherboard at £12. Finally the Bi-Pak Zon X-81 is £25.95 including VAT. This means of course, that it is the cheapest of the three in ready-built form, even though it is supplied boxed and with its own amplifier and speaker.

### Art of conversation

You can also make your ZX-81 speak to you. There are two main types of device on the market which can achieve this. One type uses the Digitalker technique which has a vocabulary in digitised form stored on ROM. The

Digitalker device on the market at present for the ZX-81 is the Speech Pack from DCP. This device is mapped in RAM at locations 49149, if you have just the ROM supplied with the Speech-Pack, and 49148 if you buy further ROMs.

Using the Speech-Pack is very easy and only requires Poking the location in question with a code number given to the word you wish played. A full table of words and their codes is given. There are four ROM word-packs available, but only the first is supplied with the Speech-Pack. This first ROM contains 72 words, giving all numbers from 1 to 19, the tens from 20 to 90, 100, 1000 and 1,000,000.

### Phenomenal phonemes

The letters of the alphabet are also on this ROM — Z is pronounced "zee" — as well as a few words of dubious use such as ampere, case and cent. Clearly, it is an American chip. Rather more useful are the two tones of different pitches which can be sounded during a program as part of a game or whatever. As it stands this first ROM does not appear very useful, and further ROMs cost about £15 each.

The unit is very easy to use, and the words are clear. It is boxed and contains an internal speaker/amplifier. The ZX-81's rear connector is duplicated at the rear of the unit, and facilities to alter the volume of the speech or attach an external speaker are available.

DCP has also just released a Spectrum adaptor which allows the unit to work on a Spectrum using the In/Out commands. DCP has mapped the unit in the Spectrum's I/O

area, and so it does not interfere with memory. However, be warned that the Spectrum's rear connector is not duplicated at the rear of the unit. Any other add-ons, such as the printer, must come between the Spectrum and the Speech-Pack.

The main alternatives to the DCP Speech-Pack are the Votrax-based devices which actually synthesise speech. This chip, which is also American, does not have words stored in ROM like the Digitalker, but instead is capable of producing all the phonemes present in speech. Words are thus built up by continuing several of these phonemes. You can think of the phonemes as being small sound units such as the "er" at the end of "butter" or the "doh" at the start of "dog".

(continued on next page)

(continued from previous page)

There are several such devices on the market: the Wideband, the Voxbox from Mutek at £65, and the Namal Supertalker 1 at £49.95 plus VAT from Namal Associates. The Wideband and the Voxbox are very similar.

The Wideband is encased in a bookshelf speaker box, and has its own amplifier, speaker and power supply. The Wideband is connected to your ZX-81 via a cable and a parallel port. Any parallel port for the ZX-81 should work, but you do need to buy one.

While the Wideband manual is long and generally well written, it does not help you very much with regards attaching the unit to a ZX-81. There is just one page devoted to this which uses the DCP I/O port as an example, but no explicit directions are given.

In fact you need to connect up data lines 0 to 7 on your parallel port to the pins on the Wideband's connector as indicated in the manual. But only the Strobe signal should go to the D7 line. The other D7 they mention for a Busy should be attached to D7 of an input port. It is easy to get this confused from Wideband's literature.

The Votrax chip needs to receive a Strobe signal telling it that message is now on the data lines, much as a printer does. Wideband tells you to use D7 for this and to include Pokes to D7 — by Poking the port location with 128 — to simulate a Strobe signal. While the Votrax chip is producing the sounds, it sends a Busy or low signal to the D7 line of your input port which needs to be tested by a line in your program. Only when this line goes high again, should you try to make the Wideband produce another phoneme.

Once you have grasped these simple rules, programming the Wideband is relatively simple. The Wideband has a long word list with suggested phoneme combinations for each word. The watchword though is to experiment for yourself — you can even produce regional accents.

However, unless you are a linguist programming your own words will take a good deal of time and thought. Wideband offers a phonetic-input program which I would strongly recommend anyone buying the unit should obtain. This program is designed to allow you to enter words more in the form that they are spelt and it decides which are the appropriate phonemes.

The main problem is that the voice is all one pitch, and so sounds rather like a Dalek from *Dr Who*. In general the sound quality is poorer than with the Digitalker system, but there are no limits to the number of words you can produce. This unit can be fun to use and could easily provide an interesting added dimension to games.

The unit has both a volume control and a pitch control to alter the sound from a deep man's voice to a high-pitched man's voice — curiously, it never sounds like a woman's. This pitch control is rather difficult to access and any adjustment involves you in sticking a screwdriver through a hole in the rear of the unit.

A final criticism must be the rather annoying hum that the unit produces. The Voxbox, which has an external knob to change the pitch, hums less. Perhaps Wideband could improve this aspect by changing the smoothing



Above: Big Ears speech recognition system.

capacitors. By the way, do not be surprised if you order a Wideband, or a Voxbox, and receive a cable with it marked "Pet". Wideband does not make up cables for ZX-81s because there are so many different I/O ports available for the machines.

Comparing these two rather different methods of allowing your ZX-81 to talk seems rather unfair as they rely on such different principles. However, a fully expanded DCP Speech-Pack will cost around £95 — the basic unit with one ROM is £49.95. On the other hand the Wideband is complete at £69 plus VAT. You do need a parallel port for it, though, which would typically cost you a further £15 or so. The Voxbox sells for around £65. On the whole the Votrax-based units seem better value for money, but the Digitalker has clearer speech and its

#### Keyboard beepers

- *Keyboard Audio Tone*, TV Services of Cambridge Ltd., Chesterton Mill, French's Road, Cambridge CB4 3NP. £8.95.
- *ZX-81 Bleep*, Fulcrum Products, Hillside, Steep Lane, Findon, Worthing, West Sussex. £8.95.

#### Sound synthesisers

- *Zon X-81*, Bi-Pak, PO Box 6, 63A High Street, Ware, Hertfordshire. £25.95.
- *Stuart Systems Sound Synthesiser*, William Stuart Systems Ltd, Dower House, Billericay Road, Herongate, Brentwood, Essex. £19.50 kit, £25.50 built, plus VAT.
- *Quicksilva Sound Board*, Quicksilva, 92 Northam Road, Northam, Southampton. Sound board £26, Motherboard £12 or QS connector £4.

#### Speech synthesisers

- *DCP Speech*, DCP Microdevelopments, 2 Station Close, Lingwood, Norwich. £49.95 and £14.95 each extra word ROM.
- *Wideband Speakeasy*, Wideband Products, Cambridge Road, Orwell, Royston, Hertfordshire. £69 plus VAT.
- *Voxbox*, Mutek, Quarry Hill, Box, Wilts. £65 including demonstration software.
- *Namal Supertalker 1*, Namal Associates, 25 Gwydir Street, Cambridge. Tel: 0223 355404.

#### Speech recognition

- *Big Ears*, William Stuart Systems Ltd, Dower House, 7 Billericay Road, Herongate, Brentwood, Essex. £49 plus VAT.

vocabulary can be sufficient for many purposes.

The final device in this survey is a Speech Recognition system from William Stuart Systems. This is also known by the unfortunate name Big Ears. This is a very sophisticated piece of equipment allowing your ZX-81 to respond to your spoken commands. The Speech Recognition System (SRS) is housed in its own well-made metal cabinet with plug sockets for a microphone and a connector to attach the unit to an I/O port. You can use any parallel port, but you will need one to be able to use the SRS.

A good-quality microphone is supplied with the unit, as is a cable for connection to the sound board. The connections are simple to make, and there are copious notes. Stuart Systems provides a theoretical article on the subject, written for other machines, but intelligible to ZX-81 owners too.

The SRS is very fussy about setting up and use. You must set up in a quiet room, and talk in a loud voice about a foot away from the microphone. The quality of your voice also has to be consistent or else the SRS will not recognise you. Stuart Systems now supplies a program on cassette which makes setting up the SRS very simple. Whether you use this tape or the other method involving the lengthy program included in the SRS's instructions, you will have to speak each word into the system several times while it learns your voice pattern.

This device certainly works and can be fascinating to experiment with. But it is rather sensitive to changes in your voice, room noise, and so forth. For such reasons, and the fact that it is particular about the way you speak, it is difficult to see this unit being in everyday use with ZX computers. Uses it would be ideal for — such as being able to say "fire" in a space invader-type game — are not really suitable for this unit as it stands.

All in all, if you are interested in speech recognition then you will be delighted with this unit. But if you want a simple futuristic device to enable you to talk to your ZX computer rather than type in words, then I think you will have a little while to wait yet for such a piece of cheap electronics. The Stuart Systems Speech Recognition System costs £49 plus VAT.

# ENTER THE DRAGON

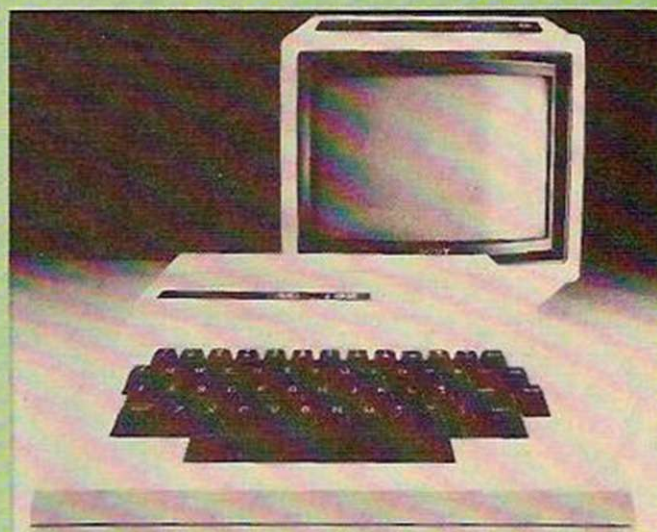

## HARDWARE SPECIFICATION

- ★ 6809E Microprocessor, a great advance on the original 6502 — still used by PET, Apple, Atom, Atari 400, BBC Micro, VIC 20.
- ★ 32K RAM memory as standard — At least twice as powerful as other computers at the same price, expandable to 64K.
- 26K user available after 4 pages of high resolution graphics.
- ★ DRAGON 32, unlike most units, gives EXTENDED MICROSOFT COLOUR BASIC as standard.
- Microsoft basic has become the industry standard (e.g. IBM, Apple, Commodore, Tandy, Atari).
- THIS HAS:—
- Advanced graphics features — set, line, draw, circle, paint, print using.
- Advanced sound feature.
- Automatic control of cassette recorder.
- Full editing features — insert, delete, change.
- ★ DISPLAY:—
- 9 Colours.
- 5 Different resolutions from 512 points of text (16×32) to 49152 points (256×192) at high resolution.
- Home UHF TV set and/or colour monitor.
- ★ KEYBOARD:—
- Professional quality keyboard to the standard on data entry terminals.
- Typewriter layout and feel.
- Guaranteed for 20 million key depressions.
- ★ SIMPLE PLUG-IN CONNECTION FOR:—
- Joystick controllers.
- Audio cassette recorder (inc. Stop/Start).
- Printer (Centronics parallel).
- Games cartridges.
- ★ 160 page "BASIC" training manual — FREE.

## PROGRAMMING STATEMENTS AND COMMAND

### MATHEMATICAL AND LOGICAL OPERATORS

Symbol	Operation
^	Exponentiation
-	Unary minus
*	Multiplication
/	Division
+	Addition
-	Subtraction
>	Greater than
<	Less than
=	Equal to
<>	Not equal to
>=	Greater than or equal to
<=	Less than or equal to
NOT	logical NOT
AND	logical AND
OR	logical OR

BASIC LANGUAGE STATEMENTS	
CLEAR	LINE INPUT
CLS	ON . . . GOSUB
DATA	ON . . . GOTO
DEF	POKE
DEFUSR	PRINT
DIM	PRINT TAB
END	PRINT USING
EXEC	PRINT @
FOR TO STEP NEXT	READ
GOSUB	REM
GOTO	RESTORE
IF	RETURN
INPUT	STOP
LET	

### SOUND GENERATION STATEMENTS

SOUND GENERATION STATEMENTS	
PLAY	SOUND

### PRINTER CONTROL STATEMENTS

PRINTER CONTROL STATEMENTS		
LLIST	OPEN	PRINT

### SYSTEM COMMANDS

SYSTEM COMMANDS			
CONT	LIST	RUN	
DEL	NEW	TROFF	
EDIT	RENUM	TRON	

### GRAPHICS STATEMENTS

GRAPHICS STATEMENTS			
CIRCLE (x,y)	LINE	PCOPY	PUT
COLOUR	PAINT	PMODE	RESET
DRAW	PCLEAR	PRESENT	SCREEN
GET	PCLS	PSET	SET

### STRING FUNCTIONS

STRING FUNCTIONS			
ASC	INKEY\$	LEN	STRING\$
CHR\$	INSTR	MID\$	STR\$
HEX\$	LEFT\$	RIGHT\$	VAL

### NUMERIC FUNCTIONS

NUMERIC FUNCTIONS			
ABS	INT	POINT	SQR
ATN	JOYSTK	POS	TAN
COS	LOG	PPOINT	TIMER
EXP	MEM	RND	USR
FIX	PEEK	SGN	VAPTR

## SOFTWARE AVAILABLE NOW!

### CARTRIDGES

- Ghost Attack* — A Pacman type game for one or two players, fifteen skill levels.
- Berserk* — A challenging shooting game for one or two players.
- Cosmic Invaders* — The infamous game on your own set — 15 levels, 1/2 players.
- Meteoroids* — Pick your way through the treacherous asteroid belt.

### CASSETTES

- Compendium of Games* — A broad range of games to illustrate the abilities of Dragon 32.
- Compendium of Applications* — A selection of routines to get the most from your Dragon.
- Quest* — An adventure game — defeat the dreaded morlock.
- Madness and the Minotaur* — An adult strategy game in real time.
- Computavoice* — Allow you to instruct Dragon 32 how to speak using phoenetic sounds.
- Graphic Animator* — Create simple animated colour cartoons on the screen.

ALL THIS FOR £195  
(VAT INCLUSIVE IN ALL PRICES)

To: JADE COMPUTERS, MAIL ORDER DIVISON, COOMBEND, RADSTOCK, BATH BA3 3AN.  
TELEPHONE (0761) 32570 FOR MORE DETAILS.

Please send me:

Enter quantity in box  
Dragon 32k Colour Computer  ..... £195

### CARTRIDGES

Ghose Attack <input type="checkbox"/>	£24.95
Berserk <input type="checkbox"/>	£19.95
Cosmic Invaders <input type="checkbox"/>	£19.95
Meteoroids <input type="checkbox"/>	£19.95
Joysticks <input type="checkbox"/>	£19.95
Cassette Recorder <input type="checkbox"/>	£39.95

### CASSETTES

Games Compendium <input type="checkbox"/>	£7.95
Application Compendium <input type="checkbox"/>	£7.95
Quest <input type="checkbox"/>	£7.95
Madness and the Minotaur <input type="checkbox"/>	£7.95
Computavoice <input type="checkbox"/>	£7.95
Graphic Animator <input type="checkbox"/>	£7.95

I enclose Cheque/PO Number ..... for £ ..... made payable to  
JADE COMPUTERS LIMITED (Plus £4.50 P&P for Great Britain + Northern Ireland).

Name .....

Address .....

# SURVEY

# SPECTRUM SOFTWARE

Boris Allan examines the first software offerings designed specially for your Spectrum.

ALTHOUGH THE SPECTRUM was announced in April the machine has only become available in large numbers recently. For software suppliers it is still early days. We were therefore relieved to find that most of the programs we received worked first time and reasonably well even if some of them lacked originality.

Most of the software we sampled was based on ZX-81 or arcade games but we also tried out some educational and utility programs. Loading the Spectrum was far less frustrating than the ZX-81. The machine performed well, producing particularly good colours but dis-

is bound to be subjective. To give as objective an assessment as possible we tried out the games on all age groups — even a class of five-year olds.

Both Bug-Byte's Spectral Invaders and Quicksilva's Space Invaders approach the standard of real arcade games. Spectral Invaders is almost an exact copy of Space Invaders, complete with four different colours for invaders, a flying saucer and high score. Some effects are slightly slower than the Atari original but the graphics quality and the use of colour and sound is excellent. Quicksilva's Space Intruders also had a mutant invader that wobbled and was worth extra points and a hold facility to allow you to stop the game at any point.

While the invader programs were written in machine code, Alien Command was written in

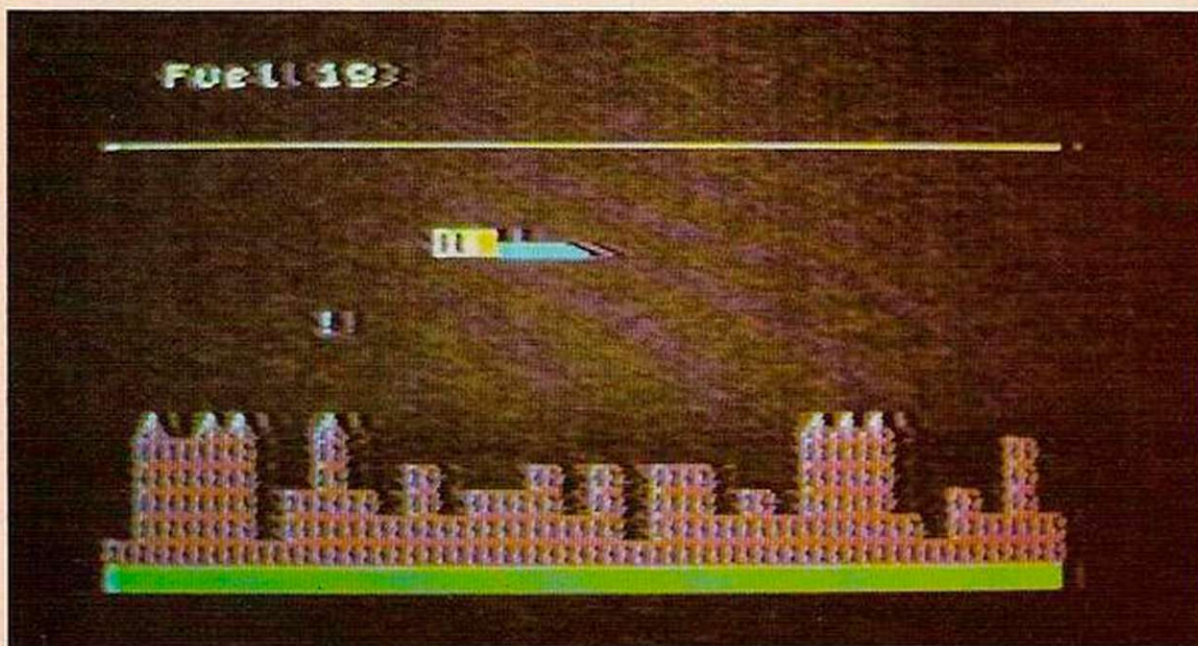

Above: Chromasoft's Bomber. Right: Bug-Byte's Spectral Invaders.

appointing sound. The limitations of the internal speaker can at least be bypassed by taking the cassette out of the recorder, connecting the two Mic sockets and switching on the recorder. Tone and volume can then be controlled with the recorder's own controls.

Games programs are strange things. Long complex programs can be much less enjoyable than a short snappy one incorporating a good idea. So long as the programs are relatively bug-free, as most of these Spectrum games were, then evaluation of any particular cassette

Basic and was too slow and crude for a space game. Winged Avengers from Work Force is a Galaxian-type game in which waves of attackers move down the screen towards the player's missile firer, break formation, circle about and then attack again. Six speeds are offered and the action is fast. But with the exception of a formation of birds, which appear in the second attack phase flapping their wings very effectively, the display is a little dull.

Chromasoft's three programs varied from

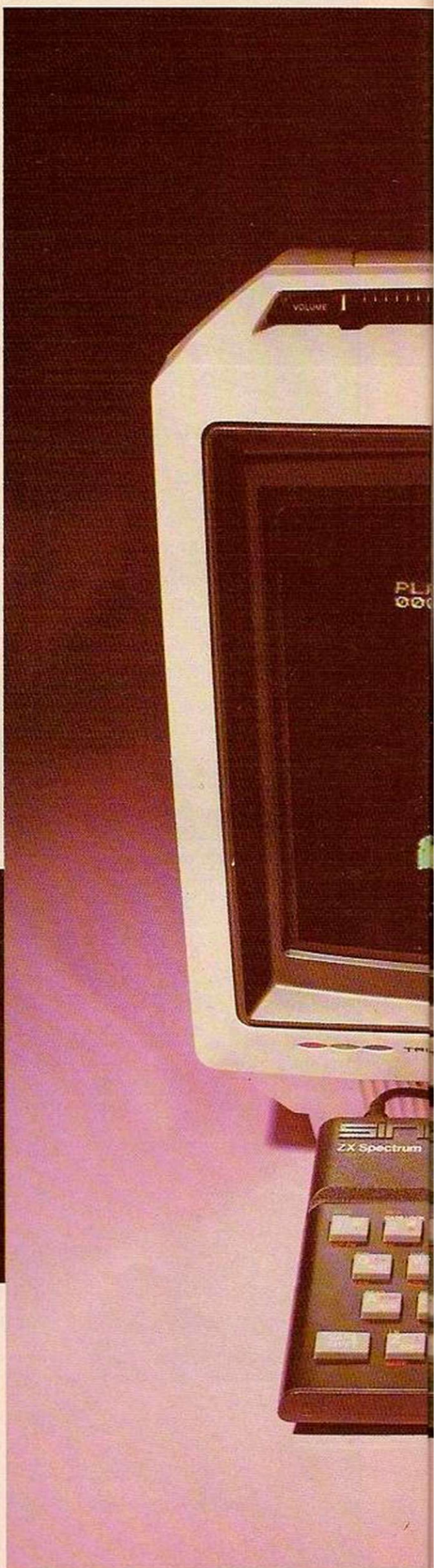

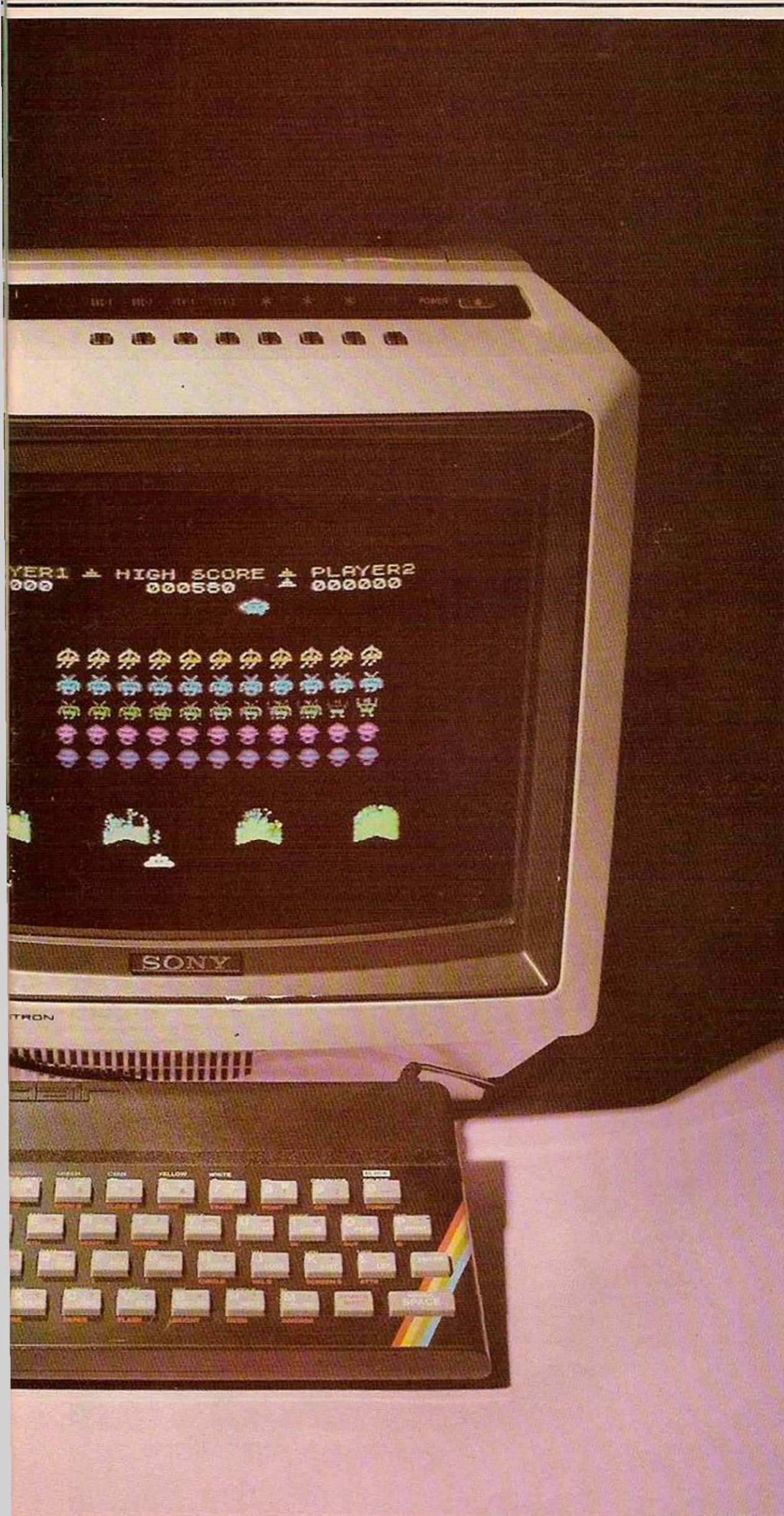

the sublime to the ridiculous. Worm is a simple but clever idea. A worm on the screen has four segments, and the player has to direct the worm around the screen, eating up numbers. Each time a number is eaten, they flash up randomly, the length of the worm increases by that amount. As the worm gets longer, it becomes more difficult to navigate, because you are not allowed to leave the screen or to cross over yourself. One player reached about 125 segments, and could not find any space.

The program is as simple as the display but the idea worked. Defined colours and graphics for the segments would be improvements but only cosmetic. Bomber is an uninspired rendering of Blitz. Golf is not only unexciting but bug-ridden. Amongst other things the game was unwilling to play the right number of holes.

AVC's Fortune could be a useful stand-in for the crystal ball at children's parties. The company's Tables has a more educational objective. The tests of multiplication tables are quite competent but the program would be more useful as a means of generating interest and enthusiasm for mathematics rather than for teaching the tables themselves.

Whoever designed it has a keen appreciation of the minds of primary school children, although AVC is stretching a point when it claims the program can be used to the age of 16. One clever ploy to generate interest was the use of the ZX-Printer to give each child a permanent record of its achievement. One kid described it as "space-age paper". This theme is reinforced by a countdown to the launch of a rocket each time you play.

Time Bandits from Newsoft comprises six separate games on side 1 all combined in an

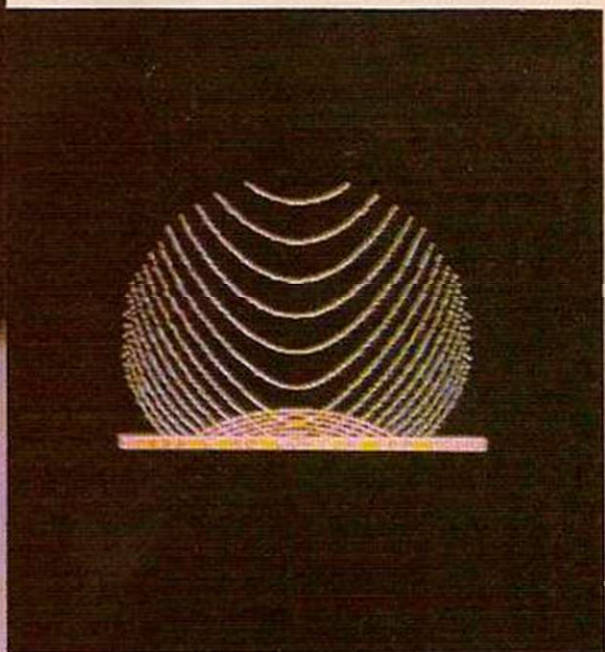

#### *Phantasmagraphics*

Adventure-style game on side 2. Most of the games have pretty graphics but are rather elementary. Minotaur's Labyrinth is a matter of collecting objects in a maze and Napoleon's army is similar — but without the maze. In Titanic you rely on luck to avoid being sunk by an iceberg while Tower of London is at least distinguished by the appearance of random Beefeaters. Combination is just a matter of remembering a number but Castle of Evil is a little more out of the ordinary.

*(continued on next page)*

(continued from previous page)

You have to work out the best strategy to cross a web with hostiles converging on you — rather like the Adventure game which used to be shown on BBC 2. Most of the games had not been carefully thought out. It was sometimes possible for instance to offer bribes of minus amounts of money, and thus become richer.

Backgammon from Keith Archer worked well enough but was easy to beat and again vulnerable to cheating. There was nothing to prevent you putting more than five counters on a point for instance.

Richard Altwasser's Cambridge Colour Collection costs £9.90 for a book of 64 pages and a cassette. Though some of the programs are original, in that they use specific features of the Spectrum, many are not: Maze is marred by a poor algorithm. There is also Breakout, Nim, and most others, including a version of King called Kingdom. The cassette was unfortunately unloadable — the company has had to replace many of the cassettes.

We reviewed two graphics packages. Phantasmagraphics plots 2D and 3D patterns and allows you to modify the patterns by entering height, width, perspective and distortion variables. The program is written in Basic and takes up to six minutes to draw a shape. The program contains a bug which causes it to be interrupted by an "integer out of range" error message for large height and width values.

Superdraw 16 is an exceptional program. For £5 you are supplied with an instruction booklet, a pad of screen design pads, and a cassette with a spoken commentary on one side, all in a polythene bag. No other program gave such value for money. The program is written in Basic and allows the user to design screens which can then be saved for incorporation in other programs, which make use of high- and low-resolution graphics, text, and user-designed alphabets of large letters. The "slide-show" option automatically loads successive screens. High-resolution pictures of a bicycle and southern England among others flash up in turn very much like a slide-show for the unemployed.

Two simulation games are available from Case Computer Simulations. Autochef allows you to work your way up as manager of a small catering company. At first you have to avoid being taken over by Trust House Forte — later if you survive you can try to take over Forte yourself. Airline is exactly the same as Autochef except that you are running a small airline.

The two assemblers were useful because they save you money by not buying at inflated prices books which disassemble the Spectrum ROM. Of the two the Campbell version is more attractive as it is written in Basic, and one can learn from studying the program listing — warts and all.

The Artic version was difficult to follow, as the documentation had not been prepared, but if the Spectrum documentation is as good as the ZX-81 documentation then it will be terrible. Given the incomplete nature of both offerings, the cheaper price, and the ability to convert from hex to dec and vice versa, sometimes with amusing results, the Campbell Systems offering may be better value. ■

Firm	Program (Type)	Comments	Price
QS	Space Intruders (I/W)	High quality invaders	£5.95
C	Worm (RTC)	Addictive, yet simple	£4.50
	Golf (O/M)	Badly written, poorly debugged	for all three games
	Bomber (I/W)	A bad version of a good idea	
JS	Alien Command (I/W)	Far too slow	£5.50
NP	Secret Valley (A)	Has potential. Sound is poor	£4.95
	Time Bandits Side A		£4.95
	Minotaur's Labyrinth (O/M)	Too easy	for Side A and Side B
	Napoleon's Army (RTC)	Too easy	
	Titanic (D)	Tiresome	
	Tower of London (O/M)	Too easy	
	Combination (D)	Any fool can do	
	Castle of Evil (L/M)	Best of the bunch	
	Time Bandits Side B	All the games from side A, randomly chosen except Combination	
KA	Backgammon (IG)	Reasonable, but not very intelligent	P.O.A.
CCS	Autochef (D)	Spelling terrible, and a poor simulation	£4.75
	Airline	A very poor simulation	£4.75
AVC	Fortune (D)	Keeps children happy, possibly useful for events	£3
	Tables (D)	Useful	£3
VSL	Superdraw 16 (U)	Excellent, incredible value for money	£5
ACL	Spectrum Bug (U)	Passable only	£6.95
CS	SPDE Disassembler and Editor (U)	Reasonable, some small problems	£5.95
BB	Spectral Invaders (I/W)	Very good	P.O.A.
WF	Winged Avengers (I/W)	Galaxian	P.O.A.

Suppliers	Firm	Name and address
CCS		Case Computer Simulations 14 Langton Way London SE3 7TL
C		Chromasoft 202 Lower Addiscombe Road Croydon CR0 7AB
QS		Quicksilva 92 Northam Road Southampton SO2 0PB
JS		Jega Software 27 Hallcroft Avenue Countestorpe Leicester LE8 3SL
ACL		Artic Computing Ltd 396 James Reckitt Avenue Hull, North Humberside
NP		Newsoft Products M Newman 12 Whitebroom Road Hemel Hempstead, Hertfordshire
KA		Keith Archer ZX Computer Centre 17 Sweeting Street Liverpool 2
BB		Bug-Byte The Albany Old Hall Street Liverpool L3 9EP
VSL		Video Software Ltd Stone Lane, Kinver Stourbridge DY7 6EQ
WF		Work Force 140 Wilsden Avenue Luton, Bedfordshire
AVC		AVC Software PO Box 415, Harborne Birmingham B17 0HD

Notes: In the category column the following abbreviations have been used: O/M, obstacles or maze game; B, break-out type game; RTC, game with real-time control; I/W, space invaders-type or war game; IG, intelligent games; L/M, logic or mathematical programs; D, demonstration programs; U, utility; A, adventure.

## NEWSOFT PRODUCTS ZX-81/ SPECTRUM

### SECRET VALLEY

SEARCH THE SECRET VALLEY FOR INFALLIBLE SPELLSTONES, THE SWORD OF POWER AND THE CROWN OF LIFE. BATTLE YOUR WAY TO THE DARK TOWER ACROSS THE PLAINS, THROUGH BLACK FORESTS AND MURKY SWAMPS. EXPLORE THE GREY KEEP AND THE HIDDEN CAVERNS. FIGHT MONSTERS IN REAL TIME TO WIN YOUR WAY TO THE TOPMOST BATTLEMENTS OF THE DARK TOWER. CHARACTER CHOICE AND CHARACTER SAVE. 16-K CRAMMED FULL OF TENSION! "DEMONSTRATES HOW EXCITING ADVENTURE GAMES CAN BE."

### RAMPAGE

THE FIRST 'TRULY LOGICAL' ADVENTURE GAME. MEMORY MAPPED ADVENTURE. PEEK AND POKE THROUGH MEMORY LOCATIONS. BUG, POKE OR CRASH RIVAL HOME COMPUTERS. REWARD A FRIENDLY ZX-80 WITH SPARE BYTES. 'RAMPAGE' IS AN EDUCATION AND A GREAT ADVENTURE.

### TIME BANDITS

A NEW IDEA IN ADVENTURE GAMES - TWO PROGRAMS FOR THE PRICE OF ONE! SIDE A HAS FIVE NEW GAMES, MINOTAURS LABYRINTH, TOWER OF LONDON, CASTLE OF EVIL, NAPOLEON'S ARMY AND ESCAPE THE TITANIC! PRACTICE THE GAMES BEFORE LOADING SIDE B OR YOU WON'T HAVE A CHANCE! ON SIDE B THE GAMES ARE COMBINED INTO A GREAT NEW ADVENTURE. KIDNAPPED BY THE 'TIME BANDITS' YOU MUST BATTLE YOUR WAY THROUGH TIME AND SPACE. FIGHT THE BADDIES AND DEFEAT THE PRINCE OF ULTIMATE EVIL!

### ROULETTE

THE ORIGINAL ZX-81 ROULETTE. STILL THE ONLY ONE WHICH PLAYS TO FULL CASINO RULES. MULTIPLE BETS ON EACH SPIN OF THE WHEEL, ONE OR TWO PLAYERS AGAINST THE BANK. USE THIS PROGRAM TO TEST YOUR SYSTEM BEFORE RISKING REAL MONEY!

### THE GREAT WESTERN

WAGONS ROLL ACROSS AMERICA, THROUGH MOUNTAINS AND FORESTS, ACROSS PLAINS, RIVERS AND DESERTS. HUNT FOR FOOD, PROSPECT FOR GOLD, TRAD WITH THE INDIANS (OR ARE THEY HOSTILE?). THE OREGON TRAIL IN AUTHENTIC DETAIL. SUPERB GRAPHICS. A COMPLEX ROLE-PLAYING ADVENTURE. CONTAINS THREE NEW GAMES: "SHOOT THE MOOSE", "DIG FOR GOLD" AND "INDIANS!"

CASSETTES £4.95 each £8.00 for any two.

PLEASE SPECIFY ZX-81 OR SPECTRUM VERSIONS

NEWSOFT PRODUCTS  
12 WHITEBROOM RD.,  
HEMEL HEMPSTEAD,  
HERTS

16-K  
PROGRAMS

## ANIROG Computers

"VIC 20 - AUDIO CASSETTE INTERFACE" uses earphone and microphone sockets of the recorder - built and tested - £10.50.

Motor control via mic switch £2 extra.

3K RAM + 2 ROM SOCKETS

+ PROGRAMMER'S AID + HI-RES GRAPHICS - £49.95.

### SPECIAL VIC - 20 OFFERS

**BEGINNER'S BAG** - VIC 20 + Cassette Drive + introduction to basic (part 1)

+ 3 cassette games + 10 blank cassettes - £240.

**ECONOMY BAG** - VIC 20 + cassette interface + 3 cassette games

+ 2 blank cassettes - £198.

**GAMES BAG** - VIC 20 + Joystick + Cartridge game £205.

### VIC 20 SOFTWARE WITH A DIFFERENCE

ALL ANIROG SOFTWARE IS IN HIGH RES. GRAPHICS AND HAS FAST M/C DISPLAY.

**LOST IN THE DARK** - Occasional flashes of lightning would show you the way to the sacred chalice in the pitch dark maze. The maze is fraught with dangers and hides an unseen beast which is cunning enough to work out your moves almost before you make them. The game stretches your powers of memory and concentration to the limit. A unique maze adventure game - £6.

**SPACE RESCUE** - Rescue the survivors stranded on a devastated star base. You have to thread your way through fast moving debris to land, rescue and then return to dock with the mother ship - £6.

**SLALOM - SKI** - The giant slalom on the scenic mountain slopes. You need nerves of steel and split second reactions - £6.

**GOBLIN'S GOLD** - The gold is well guarded by the goblins and their henchmen. Have you the cunning and agility of mind to outwit them. A high pressure adventure game - £6.

### HUGE SELECTION OF VIC 20 - SPECTRUM - ZX81 BBC MICRO SOFTWARE - COMPUTER BOOKS - ADD ON HARDWARE

Authorised dealer for COMMODORE - ARFON - STACK - BUG BYTE - AUDIOGENIC - LLAMA - DK'TRONICS AND MANY OTHERS

ORDER 2 OR MORE BOOKS OR SOFTWARE FOR 7.5% DISCOUNT

SEND S.A.E. FOR CATALOGUE. PLEASE STATE THE COMPUTER TYPE.

Mail Order -

Payment by cheque, P.O., VISA or ACCESS.

Counter service,  
CO-OP CRAWLEY



26 Balcombe Gardens,  
Horley, Surrey.  
Phone order:  
Horley (02934) 2007/6083

## NEW SOFTWARE SUPERMARKET

### YOUR ONE-STOP POSTAL SHOP FOR ALL THE BEST ZX81 PROGRAMS. FROM £4.50.

Now you can order the very best ZX81 programs with just one postage stamp. We've started SOFTWARE SUPERMARKET to make it easy for you to buy more programs. And, to help you choose, we've selected the games we've enjoyed most: games that give lasting pleasure, games that stretch the ZX81.

All games need a ZX81 with 16K Ram.

**1. MAZOGS.** (Bug Byte). £9.95. "Great," said Popular Computing Weekly "a grossly addictive game." We agree. It's a maze game with great graphics. You'll really feel you're running through the maze, sword in hand. 3 different variations on this one tape. Great value.

**2. ZUCKMAN.** (D.J.L.) £5.95. "Very user-friendly... a fast and interesting game." (Sinclair User). A very good version of the famous arcade game. If you're skillful, your name and score are displayed in the Zuckman Hall of Fame for your friends to admire.

**3. 3D MONSTER MAZE.** (J.K. Greye). £4.95. "The graphics are incredible... and the game is very good indeed." (ZX Computing.) Until you've seen the full-screen tyrannosaurus rex chase you through his 3-D maze, you won't believe it either.

**4. 3D DEFENDER.** (J.K. Greye). £4.95. "Amazing 3-D graphics effects are created as the enemy draws closer... another winner." (Sinclair User). Watch through your spacecraft windows as the alien craft attack in astonishing 3-D detail.

**5. TRADER.** (Pixel). £9.50. The most astonishing graphics as you travel round 6 planets. This is a 48K game but only needs 16K Ram. The print-out alone is 6½ metres long! Starts with a 25-second Test load.

**6. THE ZX ARCADE PACK.** (Control technology). £4.95. A brilliant collection of fastmoving machine code arcade games. Two kinds of invaders, one traditional, the other swooping, soaring Galaxians. Plus 6 more games, including a great graphic gunfight.

**7. VOLCANIC DUNGEON.** (Carnell). £4.50. One of the great adventure games. Rescue the princess, if you can. It took us 3 months - and we never got bored... Fast, single-key entry: map included. PLUS a good graphic HANGMAN game: 400 word vocabulary (or enter your own words). Our children's favourite.

**8. THE DAMSEL AND THE BEAST.** (Bug Byte). £6.50. Another exciting adventure. Find the damsel, then kill the beast (club and torches provided), lead the damsel out before she starves. But wait until she screams... 3 game variations.

**9. ZX OHELLO.** (M.o.I.) £6.95. "Recommended without reserve... it is a superb opponent." (Your Computer). The classic board game in its very best computer form. You'll see plenty of 'Reversi' listings, but this program makes it as challenging as chess.

**10. ZX CHESS II.** (Artic). £9.95. "The seemingly impossible has happened - you can play high resolution chess on a Sinclair." (C. and V.G.) The strongest ZX81 Chess Game around. All legal moves: 32 opening moves: 7 play levels - 4 within competition time limits. (Full Board Graphics available with Quicksilver CHR \$ Board).

To order these games, please complete the coupon. ADDRESSES ABROAD, please add 20p per £ for extra p&p.

PROGRAMMERS! If you would like us to evaluate your software for possible future inclusion, please send cassette, price list.

POST TO: SOFTWARE SUPERMARKET, 87 Howard's Lane, London SW15 6NZ.

I have a 16K ZX81. Please send me the programs indicated below.

I enclose a cheque/PO for £ (total order value) made payable to Software Supermarket.

Name (Mr/Mrs/Miss)

Address

Postcode

U.K. ADDRESSES ONLY. FOREIGN ADDRESSES ADD 20p per £

PROGRAM	PRICE	NO. ORDERED	TOTAL PRICE
1. MAZOGS	£9.95		
2. ZUCKMAN	£5.95		
3. MONSTER MAZE	£4.95		
4. 3D DEFENDER	£4.95		
5. TRADER	£9.50		
6. THE ZX ARCADE PACK	£4.95		
7. VOLCANIC DUNGEON HANGMAN	£4.50		
8. THE DAMSEL AND THE BEAST	£6.50		
9. ZX OHELLO	£6.95		
10. ZX CHESS II	£9.95		
TOTAL ORDER VALUE			£

# The new Dragon 32. So well designed, you'll even understand this ad.

If you're already a computer expert, may we refer you to the box of technical specifications displayed opposite.

If you're not, may we refer you to the new Dragon 32 Family Computer. A computer so easy to understand, you won't understand why all the others seem so difficult.

And the new Dragon 32 costs under £200.

## 32K RAM FOR UNDER £200?\*

When you're comparing computers, the first thing you need to know is the size of the memory. In plain English, the Dragon has approximately 32 thousand units of Random Access Memory. (32K RAM for those who prefer to be blinded by science.) This means that the Dragon's memory is at least twice as powerful as its competitors.

With a memory this powerful, the amount of information the Dragon can store is literally vast. But the Dragon doesn't just make it easy to store information. It makes it easy to use, too.

## USER-FRIENDLY?

You may have heard of the term 'user-friendly.' Reverting to plain English once more, this means simply that the computer will go out of its way to understand you, rather than vice-versa.

The Dragon 32 is so user-friendly, it practically licks your hand.

You tap (literally) its vast resources through a beautifully-designed keyboard that's as easy to use as a typewriter.

On this keyboard, you type in a language which is surprisingly close to the English you talk every day. The Dragon 32 will receive your order. Understand it. Send it to the appropriate section of its massive brain. And then display the appropriate information on your screen. All before you can say 'gobbledygook.'



\*TV not included in price.

SPECIFICATIONS
6809E MICROPROCESSOR. Pet, Apple, Atari 400, BBC Micro, and VIC 20 still have the less powerful 6502.
32K RAM (as standard). At least twice the power of similarly priced machines. Expandable to 64K RAM.
EXTENDED MICROSOFT COLOUR BASIC (as standard). Featuring: ADVANCED GRAPHICS (set, line, circle, paint, print, draw, rotate and print using). ADVANCED SOUND 5 octaves, 255 tones. AUTOMATIC CASSETTE RECORDER CONTROL. FULL EDITING with INSERT and DELETE.
9 COLOUR, 5 RESOLUTION DISPLAY.
USE WITH ANY U.H.F. TV and/or separate P.A.L. monitor.
PROFESSIONAL QUALITY KEYBOARD. Typewriter feel. Guaranteed for 20 million depressions.
PRINTER (Centronics parallel).
JOYSTICK CONTROL PORTS.

### FIRE YOUR IMAGINATION.

Learning how to use the Dragon 32 won't cause you to experience any problems. Learning what you can use it for will cause you to experience something entirely different.

Delight. Surprise. Fascination. And challenge.

The Dragon offers a range of some of the most popular computer games in the world. From those celebrated space battles to mind-boggling adventures in seemingly unfathomable dungeons and caves.

As if by magic, a simple typed message will command the Dragon to create your own drawings. Then it will colour and paint them in 9 colours.

And it's clever enough to create virtually any image you want - circles and arcs as well as straight lines.

The Dragon will also play and compose music with you, with a range of 5 octaves. And it works with any UHF TV or PAL monitor.

### LEARNING THROUGH PLAYING.

All of this makes the Dragon the ideal machine to build your children's interest in the world of computers as they become increasingly more vital. School-children already enjoy using computers.

The Dragon is the first computer specifically for the family - so by enjoying yourselves at home, you and your children can soon become expert enough to create your own programs.

PRODUCT	DRAGON 32	SINGLAIR SPECTRUM	ACORN ATOM	VIC 20	TI 99/4A	BBC MICROV
PRICE	£199	£125	£175	£190	£199	£300
STANDARD RAM SIZE	32K	16K	8K	5K	16K	16K
STANDARD AVAILABLE RAM FOR HIGH RESOLUTION GRAPHICS	26K	9K	N/A	N/A	14K	3K
EXTENDED MICROSOFT BASIC AS STANDARD	YES	NO	NO	NO	NO	NO
PROFESSIONAL-TYPE KEYBOARD	YES	NO	YES	YES	YES	YES

### BRILLIANTLY SIMPLE GUIDE.

The Dragon is living proof that you don't have to be an expert in computerspeak to be an expert in computers. It comes with the easiest-to-understand instruction manual ever written for a home computer.

Every step, every explanation, is made clear - even if you're a beginner. In minutes, it will show you how to write a simple program. Within hours, you'll be fascinated. And from then on, you'll continue to be astounded by the new world which the Dragon's power and versatility will open up to you.

See the new Dragon 32 in your High Street. At under £200, it's not just the first family computer. It also has all the features an expert could wish for.

Except perhaps the jargon.

## **DRAGON 32** The first family computer.

To: Jean Webster, Dragon Data Ltd, Queensway, Swansea Industrial Estate, Swansea, Glamorgan SA5 4EH.  
Tel: 0792 580651.

Please send me further information about the Dragon 32.

Name \_\_\_\_\_

Address \_\_\_\_\_  
\_\_\_\_\_  
\_\_\_\_\_

YC

A member of the Mettoy Group of Companies.

# LET ACORNSOFT OPEN THE DOORS TO YOUR IMAGINATION

## BBC Microcomputer or Acorn Atom

Acornsoft is the software division of Acorn Computers, designers and manufacturers, of the BBC Micro and Atom. They know better than anyone the capability of the machines, they know how to get the very best from the hardware. And they have produced a range of exciting games, exacting business and useful household software.

## The Biggest Range Available

Acornsoft software ranges from authentic arcade games like Snapper to Algebraic Manipulation to Desk Diary to other languages like FORTH and LISP. Striking colour, amazing sound effects and powerful graphics are all used to the full. And it does not stop there. There is a complete range of manuals, accessories and plug-in ROMs.

## Free Brochures

Just clip the coupon or write to us and we will rush our catalogue absolutely free. Can't wait for the post



ring 01-930 1614 now! Don't delay – do it today. Let Acornsoft help you get the best from our machine and open the doors to your imagination. Acornsoft and Atom are registered trade marks of Acorn Computers Ltd.

# ACORNSOFT

4A Market Hill,  
CAMBRIDGE CB2 3NJ.

Please rush me my free literature from Acornsoft.

Atom  BBC Please tick

Name \_\_\_\_\_

Address \_\_\_\_\_

Postcode \_\_\_\_\_

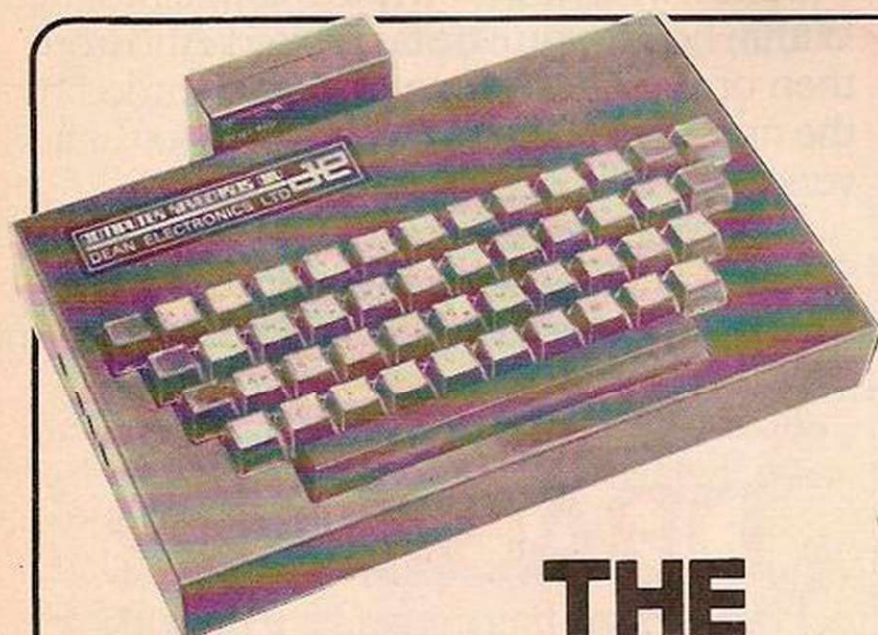

## THE PROFESSIONAL ZX81 KEYBOARD

- All-you-need Keyboard Kit £28.95.
- Case only £15.00.

All prices inclusive of VAT, postage and packing.  
Please allow 21 days for delivery.

- Plug in – no desoldering.
- Space bar linked to space key.
- Full travel keys. Six spare keys for your own use.
- Case available to hold keyboard and ZX 81 microcard.
- 16K RAM pack clamp supplied with case to eliminate white outs!!



COMPUTER KEYBOARDS DIV.  
DEAN ELECTRONICS LIMITED

Glendale Park Fernbank Road Ascot Berkshire England  
Dial-a-leaflet 03447 5661 Telex 849242

# MEMOTECH Explores the Excellence of your ZX81

THIS MONTH -  
**2 NEW  
PAKS!**

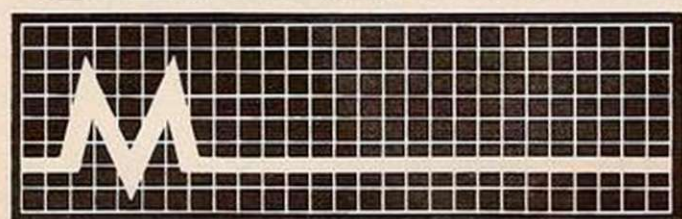

MEMOPAK 16K

MEMOPAK 64K

MEMOPAK HRG

MEMOPAK 32K

**MEMOPAK  
32K RAM**  
Operates in tandem  
with Sinclair 16K Ram  
to give a full 48K!



## Memotech's Memopak Range

All five of the currently available Memopaks are housed in elegant black anodised aluminium cases, and are styled to fit wobble-free onto the back of the ZX81, allowing more add-ons (from Memotech or Sinclair) to be connected.

£68<sup>70</sup>

plus VAT

### MEMOPAK 64K MEMORY EXTENSION

The 64K Memopak extends the memory of the ZX81 by 56K, and with the ZX81 gives 64K, which is neither switched nor paged and is directly addressable. The unit is user transparent and accepts commands such as 10 DIM A(9000).

Breakdown of memory areas...0-8K-Sinclair ROM. 8-16K-This area can be used to hold machine code for communication between programmes or peripherals. 16-64K-A straight 48K for normal Basic use.

£43<sup>43</sup> / £26<sup>00</sup>  
32K / 16K  
plus VAT

### MEMOPAK 32K and 16K MEMORY EXTENSIONS

These two packs extend and complete the Memotech RAM range (for the time being!) A notable feature of the 32K pack is that it will run in tandem with the Sinclair 16K memory extension to give 48K RAM total.

£52<sup>00</sup>

plus VAT

### MEMOPAK HIGH RES GRAPHICS PACK

HRG Main Features — • Fully programmable Hi-Res (192 x 248 pixels) • Video page is both memory and bit mapped and can be located anywhere in RAM. • Number of Video pages is limited only by RAM size (each takes about 6.5K RAM) • Instant inverse video on/off gives flashing characters • Video pages can be superimposed • Video page access is similar to Basic plot/unplot commands • Contains 2K EPROM monitor with full range of graphics subroutines controlled by machine code or USR function

£34<sup>70</sup>

plus VAT

### MEMOPAK CENTRONICS TYPE PARALLEL PRINTER INTERFACE

Main Features — • Interfaces ZX81 and parallel printers of the Centronics type • Enables use of a range of dot matrix and daisy wheel printers with ZX81 • Compatible with ZX81 Basic, prints from LLIST, LPRINT and COPY • Contains firmware to convert ZX81 characters to ASCII code • Gives lower-case characters from ZX81 inverse character set

Coming Soon...



A complete range of ZX81 plug-in peripherals

Digitising Tablet RS232 Interface

We regret we are as yet unable to accept orders or enquiries concerning the above products, but we'll let you know as soon as they become available.

Access/Barclaycard Holders  
Please Tel: Oxford  
(0865) 722102  
(24 hrs)

© R. Branton & G.A.C. Boyd 1982

Please make cheques payable to MEMOTECH Ltd.

Please Debit my Access/Barclaycard\* account number

\*Please delete whichever does not apply

Please send me

	Price	No	Total
64K RAM	£68.70 + £10.30 VAT		£79.00
32K RAM	£43.43 + £6.52 VAT		£49.95
16K RAM	£26.00 + £3.90 VAT		£29.90
HRG	£52.00 + £7.80 VAT		£59.80
CENTRONICS I/F	£34.70 + £5.20 VAT		£39.90
Packaging & Postage	£2.00 per unit		
<b>TOTAL ENC</b>			

SIGNATURE \_\_\_\_\_ DATE \_\_\_\_\_

NAME \_\_\_\_\_ ADDRESS \_\_\_\_\_

TELEPHONE \_\_\_\_\_

We want to be sure you are satisfied with your Memopak - so we offer a 14-day money back Guarantee on all our products. Memotech Limited, 3 Collins Street, Oxford OX4 1XL, England Tel: Oxford (0865) 722102 Telex: 837220 Orchid G

ADVERTISEMENTS for the NewBrain suggest that after using its graphics to impress the board of directors, a businessman can pop the machine into his briefcase and take it home to entertain or instruct the family: Junior can learn a foreign language while mum can . . . You are probably familiar with this rather unconvincing scenario. Despite those claims, it seems clear that the NewBrain has been designed primarily for business applications. Its role as a personal or home computer is only at best a secondary one.

However, since the machine costs little more than a Vic or a Spectrum it is not unfair to consider it in the same light. Could the NewBrain compete with pure and simple personal computers on their own ground?

### Expandable memory

Model A costs £233 and Model AD, which has a single-line fluorescent display on board as an extra feature, costs £267.50. The line display is 16 characters wide and can act as a window on the screen or separately. Both models come with 32K RAM and 29K ROM.

An unusual feature, more appropriate to the NewBrain's business role, is its very large memory expandability. Each expansion module supplies up to 512K RAM. Connecting up to a maximum of four models would make 2Mbytes of memory available.

Despite the unit's compact size, the keyboard has almost a full typewriter span and the keys allow fast typing speeds. At the back there are sockets for two cassettes, TV and monitor, ports for a printer, Modem and expansion board but no power switch. This is an irritating omission as it is not difficult to crash the system.

### Graphic range, no colour

The NewBrain does not offer colour or sound — probably its major failing as an alternative to other similarly-priced home computers. In compensation, it provides a wider range of text characters and graphic symbols than any other micro at this price. By using the control key you can choose one of four character sets, drawn from a total of 512 characters, including more than 150 graphic symbols and the Greek alphabet. A single-statement entry can change the display from a 40-character by 24-line format to 80 by 30.

Although NewBrain's Basic is compiled and conforms to the ANSI standard, its set of terms and functions is more or less the same as that of the more common Microsoft interpreted Basics. The command Put, for example, has a similar but wider function to the BBC's VDU statement: not only can it send cursor-control codes to determine the display output but it can also send control codes or data to any other device such as the line display or printer.

String handling is supplemented by INSTR, which searches a string for a selected character and returns its position, and a facility for defining string functions. A function FNFS(A\$), for instance, could be defined to insert the string A\$ in a given sentence.

The screen editor is one of the most effective available and compares very well with its Spectrum or Vic counterparts. You can readily

Two years have elapsed between the NewBrain's announcement and its appearance on the micro scene. For its £233 home-computer price, it seems to offer many business facilities. Simon Beesley finds out whether Grundy's micro will be happier in the home or in the office.

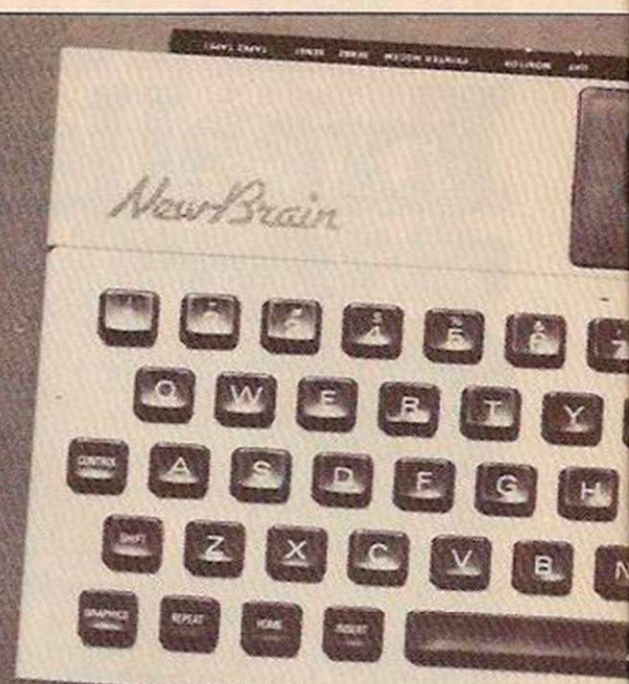

# REVIEW

# NEWBRAIN

delete any part of a program line in front or after the cursor, insert code and split a line into two, using a combination of the Insert, Repeat, Shift and Cursor keys.

So far, straightforward enough. But if you wish to take full advantage of the machine's capability you will need a certain amount of patience and perseverance. The Open statement allows you to open and define, through a list of parameters, an input or output data "stream" to a particular device such as a TV or monitor, or the printer.

Thus, the console stream which links keyboard and display can be redefined to give the display a width of 80 characters and a depth of 100 lines. Only 24 lines will be visible but by using the cursor keys 100 lines of text can be scrolled up and down the screen window.

Alternatively, a separate stream can be opened to write to the line display alone.

In effect this brings a number of input and output routines, which are more commonly submerged in the operating system, under the programmer's control. But given the novelty of this feature, its uses and applications are explained in the manual in too sketchy a fashion.

### Not so user-friendly

Far from being "friendly" at times the system appears to be downright hostile, as one of a total of 120 error codes sends the user scurrying to the error appendix. Much of the blame here can be ascribed to poor documentation.

The procedure for obtaining high-resolution graphics is somewhat cumbersome. First you have to open an area memory for a text screen,

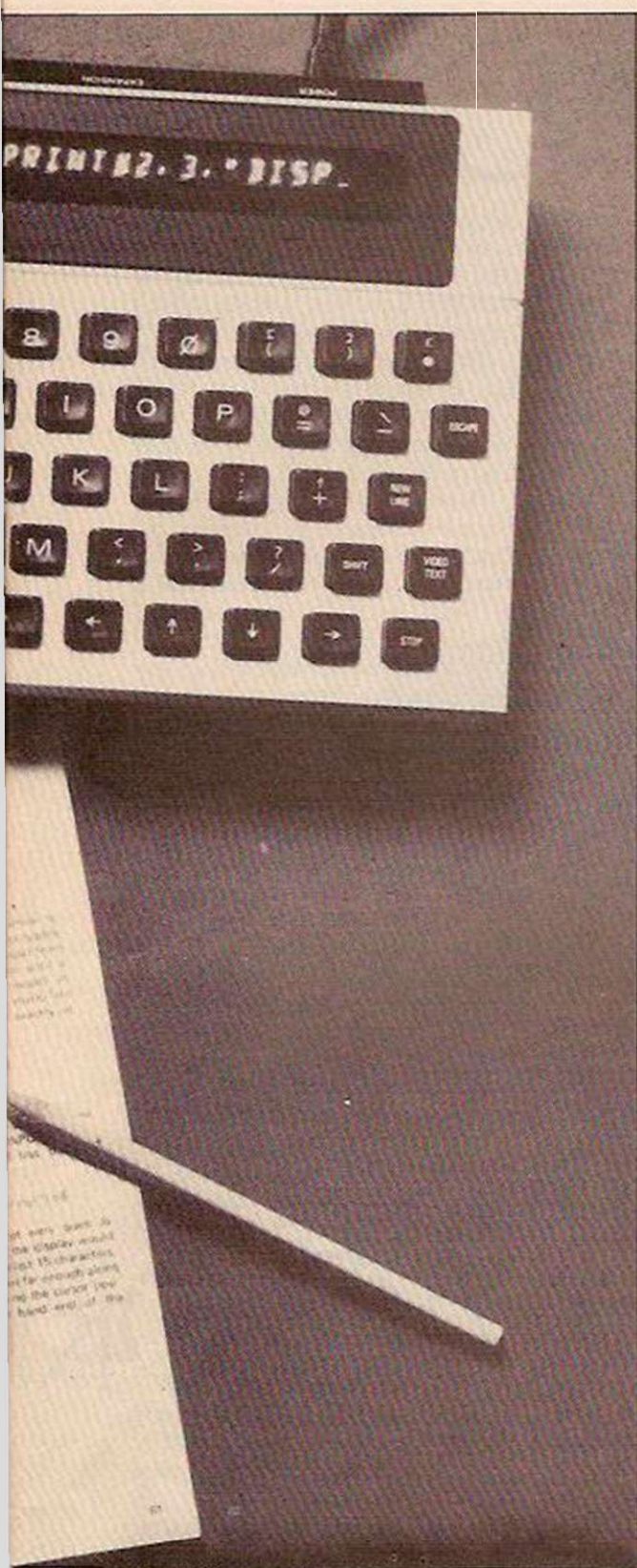

which can then be made available for high-resolution graphics by linking a graphics data stream to the text stream. Once you have accomplished this, you will have a relatively powerful graphics capability at your disposal.

Defining the width and depth of the screen, and as a consequence its resolution, gives a choice of 256, 320, 512 or 640 pixels horizontally and up to 250 pixels vertically. The statements Range and Centre permit you to choose the scale of the x and y pixel co-ordinates and position the origin, while Axes draws and marks off the two axes.

The command Fill fills in an area and Arc draws an arc through a given angle. Other commands allow lines to be plotted either relative to the pen position or in terms of the screen co-ordinates; the pen can be moved or rotated without drawing, and mixing graphics and text is possible.

In common with the Atari and the Dragon, the NewBrain does not hold its screen data in a fixed area of memory. This makes it possible to create multiple screen memories in RAM and switch between them. You could set up a screen page 200 lines deep; scroll it up or down the screen window and then jump to any other page of text or high-resolution graphics.

### Educational applications

This facility has obvious potential for educational applications, graphic games and animation effects. Naturally enough it consumes a good deal of memory: creating a screen page 40 characters wide by 200 lines deep takes up more than 10K.

None of these techniques is, however, covered in sufficient detail by the manual, which bears all the marks of rushed preparation. The released version of the *NewBrain Handbook* contains an errata slip, listing some 35 errors and it was no surprise to find a small error among the slip's corrections.

Those commands that will be relatively new to anyone reared on, say, a Sinclair or Commodore micro are only briefly, and sometimes obscurely, explained. The *Software Technical*

*Manual*, seen in a pre-draft version, describes the various operating system modules and does not enlarge on the *Handbook*.

What is needed is something like the *Programmer's Reference Guide* for the Vic-20, which expands on the manual's explanations before gently initiating the user into the higher mysteries of the operating system.

Admittedly, most manuals leave something to be desired and compared with the BBC's manual — still provisional after all these months — the NewBrain's is a model of thoroughness. Perhaps the *NewBrain Beginners' Guide*, promised for the near future, will make life easier for the newcomer.

### CONCLUSIONS

- As a business machine, the NewBrain should do well: its highly adaptable operating system and large potential memory makes it suitable for applications which were hitherto only within the scope of machines several times as expensive.

- The low quality of its documentation will not matter here since its memory capacity — 4Mbytes of ROM can be accessed through a ROM Buffer expansion module — should encourage the production of easy-to-run, tailor-made software.

- It will also shortly be possible to attach a communications interface enabling 32 NewBrains to share the same peripherals. This could well earn it a place in the micro education market.

- It is unlikely that these features will appeal to the bulk of personal computer buyers, most of whom will be deterred by the lack of colour and sound.

- On the credit side, no other computer under £300 offers such an extensive character set or such high-resolution graphics.

- It could not be recommended to a beginner but could prove attractive to an experienced user who is prepared to explore some of the possibilities only hinted at in the manual. ■



# HERMANN HAUSER:

What made the BBC choose Acorn not Sinclair — and why is Hermann Hauser, Acorn's Technical Director, so sure the Electron will upstage the Spectrum? Meirion Jones hears the inside story.

SIX O'CLOCK ON a bleak December morning and all was far from well. Acorn's design team had been working round the clock since Monday when the man from the BBC had called. Now it was Friday and in a few hours he would be back to see the working prototype he had been promised by the end of the week.

Unless they managed to have the machine working, the BBC might take the project elsewhere. Hermann Hauser had to think quickly. "I said: 'It's very simple — you are cross-linking the clock between the development system and the prototype. If you just cut the link it will work.'"

The tired team was sceptical about "another Hermann suggestion" but they cut the umbilical cord to the machine. "Lo and behold, it worked. It was a great moment — absolutely terrific to see this machine spring into life."

Hermann Hauser's quiet enthusiasm is infectious as I found when I recently witnessed the first successful test of Acorn's new speech synthesiser. As the BBC micro began to give voice "One .. two .. three .." one Acorn engineer was unable to contain himself: "This is much better than we've ever had — it must be the only British English-speaking computer there's ever been."

Predictably, perhaps, the people who brought you the BBC computer are now working on the BBC computer voice. Instead of the Detroit Dalek sound favoured by previous chips Acorn has employed a disembodied Kenneth Kendall to declare "This is an Acorn computer" much as he might have intoned "This is the nine o'clock news".

By October, Acorn will be selling an add-on Kenneth Kendall-speak ROM and speech processor for the BBC machine. The first unit will voice letters, numbers, keyboard symbols and commonly-used commands. Later Acorn will release a more comprehensive allophone package about which the engineer was even more enthusiastic: "Allophone speech will have inflections as well — it will be really amazing."

Hermann Hauser describes the advantages in more measured tones:

"You can concatenate allophones to make any utterance in the English language."

An English language course was what first persuaded Hermann Hauser to leave the attractions of his family's wine business in Austria and come to Cambridge. Although he went back to Vienna to take a physics degree, he soon returned to Cambridge to complete a PhD in solid-state physics at the Cavendish laboratory.

Motivated by an urge "to find out what makes the world tick — in its innermost workings" Hauser developed an interest in artificial intelligence.

Some of Acorn's current ventures involve artificial-intelligence techniques, but Hauser's first venture was more mundane. After persuading Chris Curry to leave Science of Cambridge in 1978, the two of them set up first CPU and then Acorn Computers.

"The first thing we did was a consultancy job for a fruit machine manufacturer". Hauser soon found that although it was easy to make the one-arm bandit do what you wanted, it was difficult to prevent it paying up when it should not: "It lives in a very cruel environment — people bang it and throw beer at it and try to fool it." Eventually Hauser had to build in a VHF radio to detect sparks

## 'Very much an Apple and Pet competitor and beyond'

"so that if anyone walked up to it with a spark gun it would switch the machine off and reset it".

Meanwhile Sinclair was having great success with his Mk14 hobby computer. Once 10,000 had been sold Hauser decided that "the so-called consultancy work we were doing for other people we might as well do for ourselves".

Acorn's first machine, the System 1 was "way above the Mk14 — rather more compact but still aimed at the hobby market. We were in a very exciting field. Everyone knew that whatever the market was going to do, it wasn't going to shrink."

The first sign that micros would become more than hobbyists' toys was when Newbury Laboratories first announced plans for the NewBrain in 1980. Acorn responded within six months by producing the Atom.

Such speed was possible because "at that time the sums needed to develop new machines were not very high and the marketing concept was right thanks to Chris Curry. Also

Acorn works effectively as a team".

"During the development of the Atom, schedules were very tight — the whole design team would take a break about 7pm and discuss things over dinner together then go back and work till 10 or 11pm."

At one of these brainstorming sessions the team heatedly discussed what features they would like to see in the Atom's successor — at that time tentatively called the Proton.

"All these prima donnas in the design department had very strong

## 'Sinclair is comparing chalk and cheese'

ideas of what they wanted. One wanted a double-processor system, another said: 'It can all be done on a single processor'. Andy Hopper said it had to be a 16-bit machine. Chris Curry said: 'Boys, whatever you do don't make it more than £300'."

There seemed to be no way to reconcile all these conflicting demands until the idea of a self-contained but infinitely extendable system was suggested. "The tube solved our problems — everyone could have all they wanted and more. We could start with an inexpensive 6502-based machine and then make a second processor and eventually a 16-bit extension available. We had a good drink after that and got rather self-congratulatory."

Soon afterwards the BBC came along and the race was on to turn the idea of the Proton into a working BBC prototype. Hauser rejects Sinclair's criticism of the BBC deal.

"He seems to have a terrible chip on his shoulder about this because he was not the chosen one. The BBC used us because they came on the Monday with the specifications they wanted and returned on the Friday and saw a working prototype."

"I defy anybody else in this country to build a completely new 32K computer that quickly. "We employed the fastest gun in Cambridge — called Ramany Banerjee — not only is he an excellent designer, he can also wire wrap faster than other people can call out the connections."

Hauser is not afraid of Dragons — or for that matter of Spectrums or any other new micros: "None of them is expandable in the same way as the BBC — that market will be adequately dealt with by the Electron".

"The BBC is very much an Apple and Pet competitor — and in fact beyond that because of the 16-bit extension. It is a very advanced design and we do not see any computers with these features

appearing for another year or so. A very useful extension offering Z-80 and CP/M will be available in the autumn and the 16032, 16-bit extension by the end of the year".

The 16032 is really exciting — you can go up to megabytes of RAM, you can run the Unix operating system and big languages such as Fortran, Cobol and PL-1."

"Sinclair is the only one who has enough arrogance to compare the BBC computer with his own. He is comparing chalk with cheese and it is based on his own exceptional arrogance rather than the facts.

"We thought the appropriate way of dealing with this was to produce a machine which shows him how it is really done. "You get these quantum leaps in electronics — we will leapfrog Clive Sinclair with technology. The Electron will have twice as much ROM, twice as much RAM and an uncommitted logic array (ULA) three times as big as the Spectrum's."

Hauser attributes Clive Sinclair's prominence to his public relations: "He has a remarkable machinery for dealing with the press — second to none in our field. It is quite remarkable the way he fights with this weapon. Despite his claims, his machine is not very complex — whereas ours exploits RAM, ROM and ULA technology to the full. We

# ACORN

do not know of any other company that is capable of doing it. The Electron is right at the cutting edge of technology."

One of the penalties of being on the cutting edge of technology seems to be production difficulties. When the subject of Acorn enthusiasts who have grown old waiting for their BBC micros is raised, Hauser smiles: "We've learnt our lesson." The only lesson learnt by the tens of thousands still waiting for Spectrums and BBC model Bs might be never to trust the word of a micro company — so how does Hermann Hauser



# INTERVIEW



## IN A NUTSHELL

explain the late-delivery problem?

"It is always very difficult to predict the exact numbers people will order, and you can only predict to within a factor of two or three — if you estimate too low you have serious delivery problems — if too high you can go bust because you've ordered too many components.

"We are the only company in this field which designs its own ULAs. This allowed us to produce a computer as versatile as the BBC because we were able to milk the Ferranti processor — but it also meant that we had difficulties in

high-volume production because the yield was too low. There were limitations of the Ferranti processor that neither we nor they knew about.

How does Acorn intend avoiding these problems with the Electron? "We are now of a size which allows us to pick our subcontractors with care — if they say something will arrive in June you can bet it will.

"The chip that we are doing for the Electron is a very much more cautious approach to ULA design — there won't be any problems with the ULA."

Acorn has been accused of profiteering from the delays by raising BBC prices. Hauser answers: "If you look at the specification of this machine it is still too cheap." As for the backlog for model Bs: "I know we have made promises before but we are now in really high-volume production."

Hauser praises Sinclair for trying to develop new storage devices. "The Microdrive heralds a new generation of microfloppies," but then he qualifies this: "Although once again Sinclair is cultivating much better public relations than the other companies, I think he has got it wrong — it is unwise at the

moment to go for a non-standard drive."

Hauser expects the Microdrive to become obsolete quickly because of a lack of real random access. "There will be a standard 3.5in. or 3in. drive which will be produced in worldwide quantities, and will be not only be less expensive but will also provide the facilities the Microdrive

---

### **'The Electron is right at the cutting edge of technology'**

---

lacks." Hauser expects Acorn to be selling its own version of this drive by next Easter.

One of the fruits of Acorn's collaboration with the BBC was the language for the BBC Micro. Hermann Hauser hopes that BBC Basic will become as much of a standard as BBC English.

"No other Basic in our field supports structures which is important if you want to teach good programming. It is very advantageous to split the program into blocks and debug them individually

so you can say: 'Now I know this works I can go on to the next one.'"

Nor is this the only advantage Hauser claims: "Our Basic runs between four and 10 times faster than anybody else's — in particular Sinclair's. As a result you can write programs in Basic which other people have to write in machine code."

Hauser does not believe that Sinclair's Basic has become the standard by virtue of sheer numbers: "There are more people using ZX-81 Basic — but the question really is does one want to standardise on the lowest common denominator. It would be wrong to home in on a standard which leaves out essential elements in the language."

Another spin-off from the BBC deal was Acorn's involvement in setting a telesoftware format which may become the U.K. standard.

Acorn seems determined to maintain a broad range of skills: "We've hardware expertise, software expertise, local-area networks, chip design, all in-house." The company plans to launch a phenomenal number of products over the next few months. In addition to the BBC speech chip and of course the Electron, the company will be launching AcornCalc, a financial planning package, and a networking system for the BBC.

Hauser loves Cambridge but the reasons for Acorn being based there are rather more hard-headed: "The same reason that made Highway 128 in Boston and Silicon Valley what they are — spin-offs from the university — access to good graduates and computer lab facilities. If I do have a problem I can just pick up the telephone."

Microcomputer companies are notorious for not making use of their own technology. But even though there is no sign of a computer in Hauser's office he insists: "We do want to be different there". Plans are in hand to install a network inside Acorn.

Eventually Hauser would like to connect up his BBC at home to the office network. In the meantime: "I use it for games at home like everyone else — I try out new Acorn software — and sometimes find bugs in it that the other boys have missed. Being a physicist I use it for calculations or for working out company problems."

Hauser's continued interest in physics is evidenced by the choice of elementary particles as names for Acorn's computers: Atom, Proton, Electron. At the height of the delays some wit even suggested that the BBC/Proton should have been called the Quark because people had been waiting so long to see one.

So how long will we have to wait for the launch of the Electron? "The other lesson we learnt from the BBC machine is not to announce a product until you are sure you can deliver it — that's why I'm cautious and say it will be out by the end of the year."

Acorn's prototype speech synthesis unit wired up to a BBC Micro.

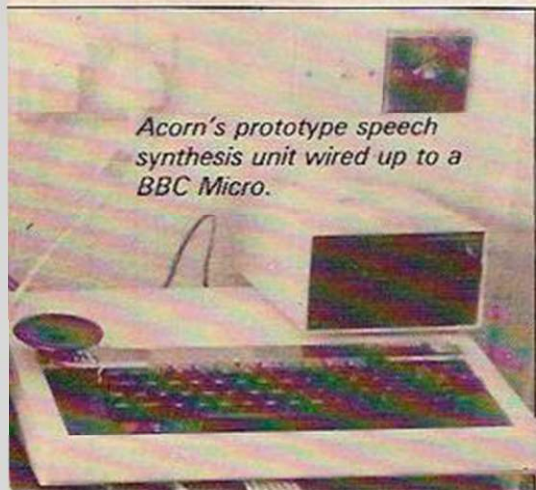

KAYDE Electronic Systems Ltd

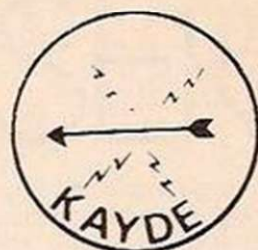

# ZX KEYBOARDS FULLY CASED

## ZX81 WITH REPEAT KEY

This is a highly professional keyboard using executive buttons as found on top quality computers. It has a repeat key and comes complete in its own luxury case. This is a genuine professional keyboard and should not be confused with toy keyboards currently available on the market.

As reviewed by Tim Hartnel  
ZX Computing/Interface

£37.95

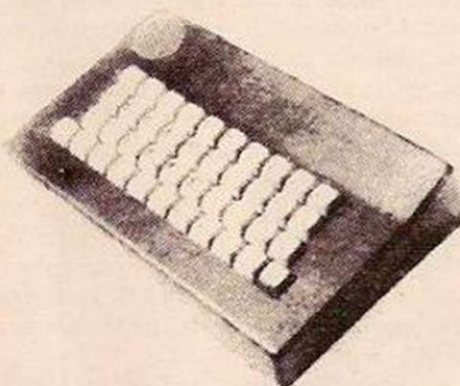

**NEW**

## SPECTRUM

This is a highly professional keyboard, taken from our World Famous and well proven 81 keyboard, it has been redesigned to complement your ZX Spectrum.

BUY NOW BEFORE THE RUSH £37.95

**FULLY CASED  
ZX81**

# RAMPACKS

## MASSIVE ADD ON MEMORY

**NEW  
Spectrum**

MEMORIES YOU CAN RELY ON	<b>64K</b>	<b>£72.95</b>
	<b>16K</b>	<b>£29.95</b>

Up grade your Spectrum now to 48K. Just add our 32K memory extension plug in board to your Spectrum which already has 16K to give you a massive 48K of memory.

**£48.95**

## ZX81 4K GRAPHICS BOARD

The KAYDE Graphics Board is probably our best accessory yet. It fits neatly inside your ZX81. It comes complete with a pre-programmed 4K Graphics ROM. This will give nearly 450 extra graphics and with the inverse makes a total of nearly nine hundred.

The KAYDE Graphics Board has facilities for either 2K of RAM (for user definable graphics) 4K of ROM or our 4K Tool Kit Chips that will be available shortly. All the graphics are completely software controlled therefore they can be written into your programmes. Here are a few examples:

**A full set of space invaders — Puckman — Bullets, Bombs — Tanks — Laser Bases and Alien Ships**  
NO EXTRA POWER NEEDED

**£29.95**

## FLEXIBLE RIBBON CONNECTOR

Stops movement of RAM PACK	£12.95
IN/OUT PORT	£10.95
MOTHER BOARD	
Complete with 5 volt regulator	<b>£18.95</b>

## 16K GRAPHICS BOARD SOFTWARE

PECKMAN The only true ZX version of the popular arcade game.

SPACE INVADERS The best version available anywhere.

CENTIPEDE "In all I think this is the best presented moving graphic programme I've yet seen" — Phil Garratt, INTERFACE

**£5.95  
EACH**

Graphic Software can only be used with a Graphics board

All Hardware comes fully built and tested and complete with a 14 day money back option

Qty	Item	Item price £	Total £
	ZX Spectrum Cased Keyboard s	37.95	
	ZX Spectrum 32K Rampack	48.95	
	ZX81 Cased Keyboard with repeat key	37.95	
	ZX81 64K Rampack	72.95	
	ZX81 16K Rampack	29.95	
	ZX81 4K Graphics Board	29.95	
	ZX81 Flexible Ribbon Connector	12.95	
	ZX81 Mother Board	18.95	
	ZX81 In out port	18.95	
	ZX81 16K Graphic Software	5.95	
	ZX81 16K Software	5.95	
	Vic 20 Software	7.95	
	Name of Software	-p&p	

\*I enclose a cheque postal order payable to KAYDE Electronic Systems Ltd., for £.....

\*Please charge to my Access Barclaycard Trustcard account no.

\*Please delete complete as applicable.

Please print

Signature \_\_\_\_\_

Name: Mr/Mrs/Miss \_\_\_\_\_

Address \_\_\_\_\_

Please allow £1.50 P&P for all Hardware 50p for all software

(Dept YC)

## 16K 81 SOFTWARE

CENTIPEDE "In all, I think this is the best presented moving graphic programme I've yet seen" Phil Garratt — Interface.

3D 3D LABYRINTH A cubit maze that has corridors which may go left, right, up and down.  
**£5.95**

4K Tool Kit full of utilities to aid the programmer in constructing and de-bugging E. PROM version for use with graphics ROM.  
**£9.95**

## VIC-20 SOFTWARE

**THE KAYDE VALLEY**

The ultimate in  
adventure games

**Othello**

Plus many more.

VIC 20 dealer

**£7.95**

SEND FOR A FREE CATALOGUE STATING TYPE OF COMPUTER.



WHY WAIT TO PAY MORE  
FAST IMMEDIATE DELIVERY



Post To **KAYDE ELECTRONIC SYSTEMS LTD**  
Dept **THE CONGE, GREAT YARMOUTH**  
**NORFOLK NR30 1PJ**  
Tel: **0493 57867 (Dept YC)**  
Telex **957247 CHATCOM G**

Don't forget you can always order on the telephone with your credit card  
Dealers welcome



moving ahead  
with  
ZX software

## ZX CHESS & ADVENTURES

PROGRAMS FOR THE ZX81/80 INCLUDING -

NEW  
NEW  
NEW

16K BYTE RAM  
PACKS  
£31.95

Full implementation of FORTH on ZX, No longer held up by the slow BASIC - FORTH runs 10-26 times faster than BASIC.

"Simplicity of BASIC with speed of Machine Code"

'BYG BYTE' Ram pack, no Wobble problems, 1 year guarantee on each Ram Pack. Simply the best you can buy. Immediate Delivery.

1K ZX CHESS!!  
£2.95

We didn't think it was possible but this game plays against you. Two opening moves, needs 1K of RAM to run. Incredible.

ADVENTURES  
ADVENTURE 'A'  
£6.00

Exciting machine code games with instant response, choose from the range below. You find yourself stranded on an alien planet. Can you reach your ship and escape?

ADVENTURE 'B'  
£7.00

In a jungle clearing you come across an Inca temple. You must break in, collect treasure and escape alive. Beware. Includes a cassette save routine.

ADVENTURE 'C'  
£8.00

You are unfortunate enough to be drawn to an alien cruiser. Can you reach the control room and free yourself or will they get you first? Includes a cassette save routine.

**GALAXIANS £3.95**

All the features of the arcade game in a fast machine code program. Swooping attackers, explosions and personalised scoring.

**ZXBUG £7.00**

A 30 in 1 machine code tool and disassembler, allows access to registers and search through and modify memory; with cassette routines.

# ZXCHESS

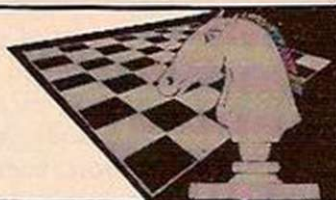

## TWO GREAT ZX81 16K CHESS GAMES ZXCHESS (ENHANCED)

- Written totally in machine code.
- Full graphic display of Chess board.
- Six levels of play: Two play within competition time limits.
- Option to play Black or White.
- Plays all legal moves including castling and en-passant.
- Cassette routines for saving unfinished game and returning to later.
- Displays moves of game on screen or printer for analysis.
- Print a copy of the Chess board onto the printer.
- Board can be set up in any position, you can even swap sides midgame.
- Clear whole board with one command: for end game analysis.

**£6.50**

**ZXCHESS II** We believe the strongest ZX81 Chess game as no other has beaten it!!

- All the features of ZXCHESS plus:
- Book of 32 opening moves.
- Seven levels of difficulty: FOUR play within competition time limits.
- A move is suggested by the ZX81 if wanted.
- Optional Full Graphic version using the QS CHRS Board.

**£9.95**

2 copies supplied on cassette with full instructions. Cheques and postal orders payable to:



ARTIC COMPUTING "Dept IP"  
396 JAMES RECKITT AVENUE,  
HULL HU8 0JA



## ZX81 Workstation...

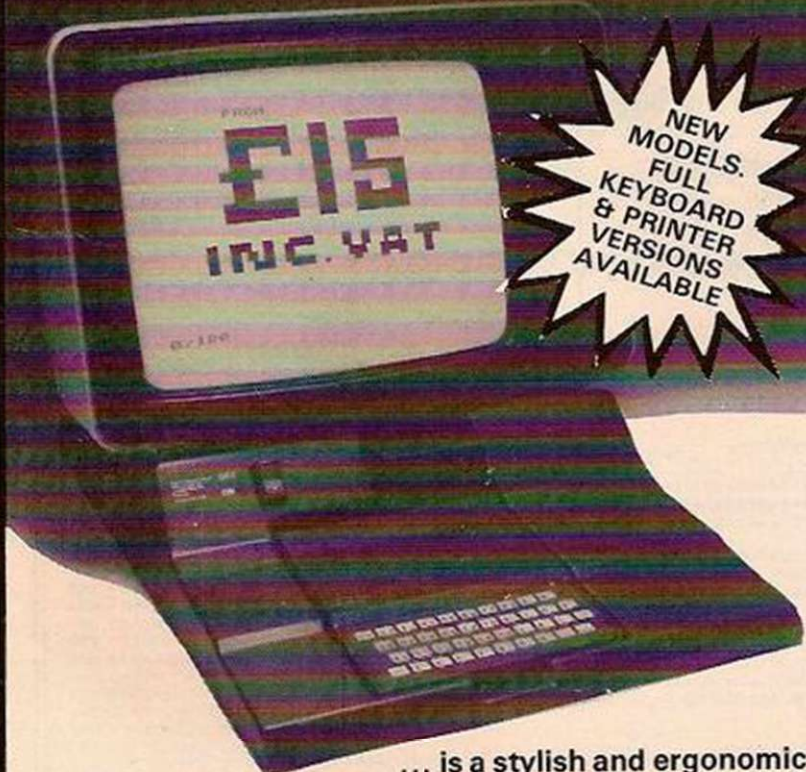

NEW  
MODELS.  
FULL  
KEYBOARD  
& PRINTER  
VERSIONS  
AVAILABLE

... is a stylish and ergonomic plinth for the ZX81. It raises and tilts the TV to avoid eyestrain, holds the 16K RAM in place and hides the wiring and power supply. This very professional unit costs £15, a built-in power switch is £3, plus postage at £2.00, inc. VAT.

Peter Furlong Products, Unit 5, South Coast Road Industrial Estate, Peavehaven, Sussex BN9 8NA.  
Telephone 07914-81637 for C.O.D. and Credit Card Sales.

AND NOW!

## Spectrum workstation



**£16.00**  
plus £2 postage

Extras:  
On/Off switch £3.  
Alloy base £3.50.  
Speaker £3.50  
ACCESS, VISA.

Following the success of our ZX81 plinth we have introduced a workstation for the Spectrum. This stylish ABS plinth raises and tilts the TV for better viewing whilst angling the Spectrum and making typing easier. The PSU is hidden underneath, the printer and cassette may still be used, and a matching, stackable unit for Microdrives will be available.

Peter Furlong Products, Unit 5, South Coast Road Industrial Estate, Peavehaven, Sussex BN9 8NA. Tel. (07914) 81637.

THE DAM AT the head of the valley is under attack from an unidentified source. If the dam bursts, the water will escape and flood the valley, killing thousands. Your mission is to destroy the aggressors, code-named Nibblers, and save the dam.

The Nibbler appears on the right-hand side of the screen and moves across towards the dam on the left. To stop the Nibbler and launch your ship at the same time, you hit the space bar. When you are directly above the Nibbler, press the space bar again to drop your bomb.

If you hit the Nibbler, your score increases by one point and the dam has been saved for a little longer. But if you miss, you forfeit a point and the Nibbler lives on to destroy part of the dam. Another Nibbler will then appear on the right-hand side of the screen.

Once the dam has been totally breached, the water will escape and flood the valley, and you have failed in your mission. You are then told your score and time taken, and asked if you want to try again. Type "Y" for another game and "N" if you wish to stop — nothing else will be accepted.

If the computer has been expanded and so has extra memory you could use the user-definable graphics capability of the Vic to improve the game. If so, the following routine should be added at the end of the program, and line 3 changed to:

```
3 PRINT CHR$(14):GOSUB 1000
1000 FOR I = 0 TO 1024
1010 POKE 5120 + I, PEEK (32768 + I):NEXT I
1020 FOR I = 0 TO 1024:READ A
1030 IF A = 1 THEN 1070
1040 POKE 6144 + I, A:NEXT
1050 DATA 56, 124, 230, 3, 3, 230, 124, 56
1060 DATA 24, 60, 102, 231, 166, 24, 36, 68
1070 POKE 36869, 253:POKE 36866, PEEK
(36866) OR 128
1080 RETURN
```

If this program is used, the Pokes and Peeks will have to be changed — 60 to 128 and 62 to 129.

The main variables used in the program are:

- B — position of ship
- C — position of bomb
- D — position of Nibbler
- O — highest score
- S — score

The other variables are used mainly in For — Next loops etc. Here is a more detailed explanation of the program:

- 3: switches to text mode.
- 4 to 68: print the title page. The graphic symbols are obtained by pressing shift and each of the following: NIBBLERS.
- 65: note that there are eight spaces after the cursor symbols.
- 70 to 150: print out the instructions for the game.
- 70: the graphics symbol is shift and "T".
- 80: the graphics symbol is shift and "N".
- 110: the graphics symbol is shift and "T".
- 120: the graphics symbols are shift, together with "S" and then "N".
- 130: the graphics symbol is shift and "I".
- 140: the graphics symbol is shift and "H".
- 159 to 260: construct the dam and fill the reservoir with water.
- 261 to 262: print the score and resets the timer.
- 270 to 280: set up the random position of the Nibbler.
- 290 to 294: check to see if the Nibbler is hitting the dam or the water.
- 295: turns on the sound register and vibrates screen from left to right.
- 450: if the space bar is pressed then the bomb drops, else continue moving Nibbler.
- 491 to 500: plot the falling bomb.
- 505 to 512: checks to see if bomb has hit the Nibbler or the ground. If not, then continue to plot the bomb.
- 552 to 554: explosion sound effect.
- 565 to 568: vibrate screen up and down.
- 578: restores screen to normal position.
- 590 to 616: plot the water pouring out of the dam.
- 620 to 646: print your score and the time that you lasted for.
- 620: graphics symbol is shift and "T".
- 645: graphics symbol is shift and "Y".
- 650: graphics symbol is shift and "A". Type "Y" for another go, or "N" if you wish to stop.
- 710: switches the computer back into graphics mode.

# GAMES VIC DA

Can you stop the Nibblers destroying the dam? Dave Shambrook's game is for the unexpanded Vic-20.

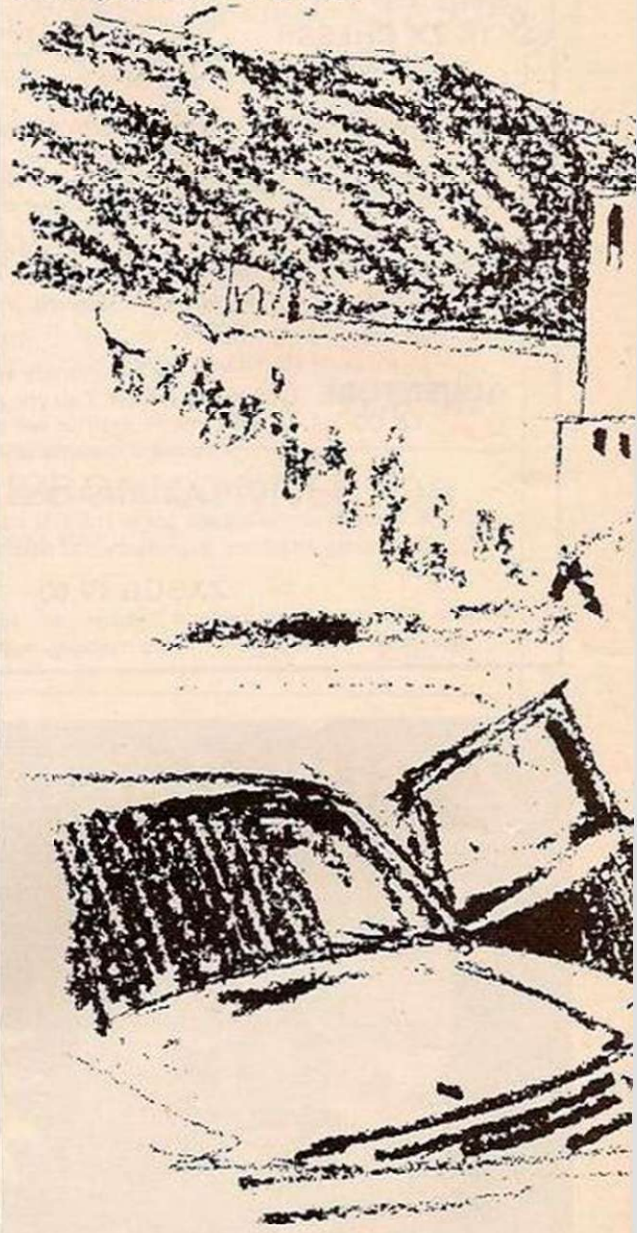

```
0 REM NIBBLERS BY D. SHAMBROOK
1 REMONCAT
2 PRINT "Q":O=-32
3 PRINTCHR$(14)
4 POKE36879,237:POKE36878,15
5 FORN=7680T07701:POKEH,224:NEXT
6 FORN=7762T081645TEP22:POKEH,224:POKEH+21,224:NEXT
7 FORN=8164T08185:POKEH,224:NEXT
8 FORN=1T05
9 POKE36875,200:POKE36876,0
10 FORL=1T0500:NEXT
15 PRINT "#####":FORP=1T0200:NEXT
20 PRINT "S":FORI=1T0200:NEXT
25 PRINT "I":FORP=1T0200:NEXT
27 PRINT "I":FORP=1T0200:NEXT
30 PRINT "L":POKE36876,200:POKE36875,0:FORP=1T0200:NEXT
35 PRINT "":FORP=1T0200:NEXT
40 PRINT "L":FORP=1T0200:NEXT
50 PRINT "":FORP=1T0200:NEXT
65 PRINT "#####":FORP=1T0200:NEXT
69 NEXT
69 POKE36879,25:POKE36876,0
70 PRINT "THE OBJECT OF THE GAME"
80 PRINT "IS TO HIT THE NIBBLERS"
90 PRINT "BEFORE THEY DESTROY":PRINT
100 PRINT "THE DAM":PRINT
110 PRINT "THE CONTROLS ARE":PRINT
120 PRINT "SPACE TO STOP NIBBLER":PRINT:PRINT "AND LAUNCH YOUR SHIP":PRINT
130 PRINT "AND SPACE AGAIN TO":PRINT:PRINT "DROP YOUR BOMB..F YOU "
131 PRINT "MISC YOU LOSE A POINT":PRINT
140 PRINT "IT A KEY TO CONTINUE"
150 GETA:IF A=" " THEN 150
151 POKE36879,191
155 PRINT "Q"
156 FORN=8164T08185:POKEH,224:POKEH+30720,5:NEXT
159 REM***** *CONSTRUCT DAM*****
165 V=12:POKE36878,15
170 R=0
180 FORN=7724T081645TEP22
185 POKE36877,220:FORN=1T05:NEXT:POKE36877,0
190 POKEH+8,224:POKEH+8+30720,6
200 NEXTB
210 R=R+1:IF R<2 THEN 180
220 FORA=0T01
230 FORN=7726T081675TEP22
235 POKE36877,220:FORN=1T05:NEXT:POKE36877,0
240 POKEH+8,102:POKEH+8+30720,6
250 NEXTA
260 NEXTB
261 PRINT "SCORE":S
262 TI="000000"
263 PRINT "#####HIGH"0
264 REM***** ****NIBBLER**** *****
270 R=INT(RND(1)*19)+1:D=7744:B="":F=0
280 FORP=1T08:D=D+22:NEXT
290 IF PEEK(D)<102 THEN R=0:GOTO380
294 IF PEEK(D-1)=224 THEN 590
295 POKE36878,15:POKE36864,11:POKE36877,250:FORM=1T040:NEXT:POKE36877,0:POKE3,3
300 POKE36864,12:GOTO270
380 POKED,60:POKEH+30720,6
385 IF B=" " THEN 400
390 GETB:IF B=" " THEN 430
400 D=D-1
```

# DAMBUSTER

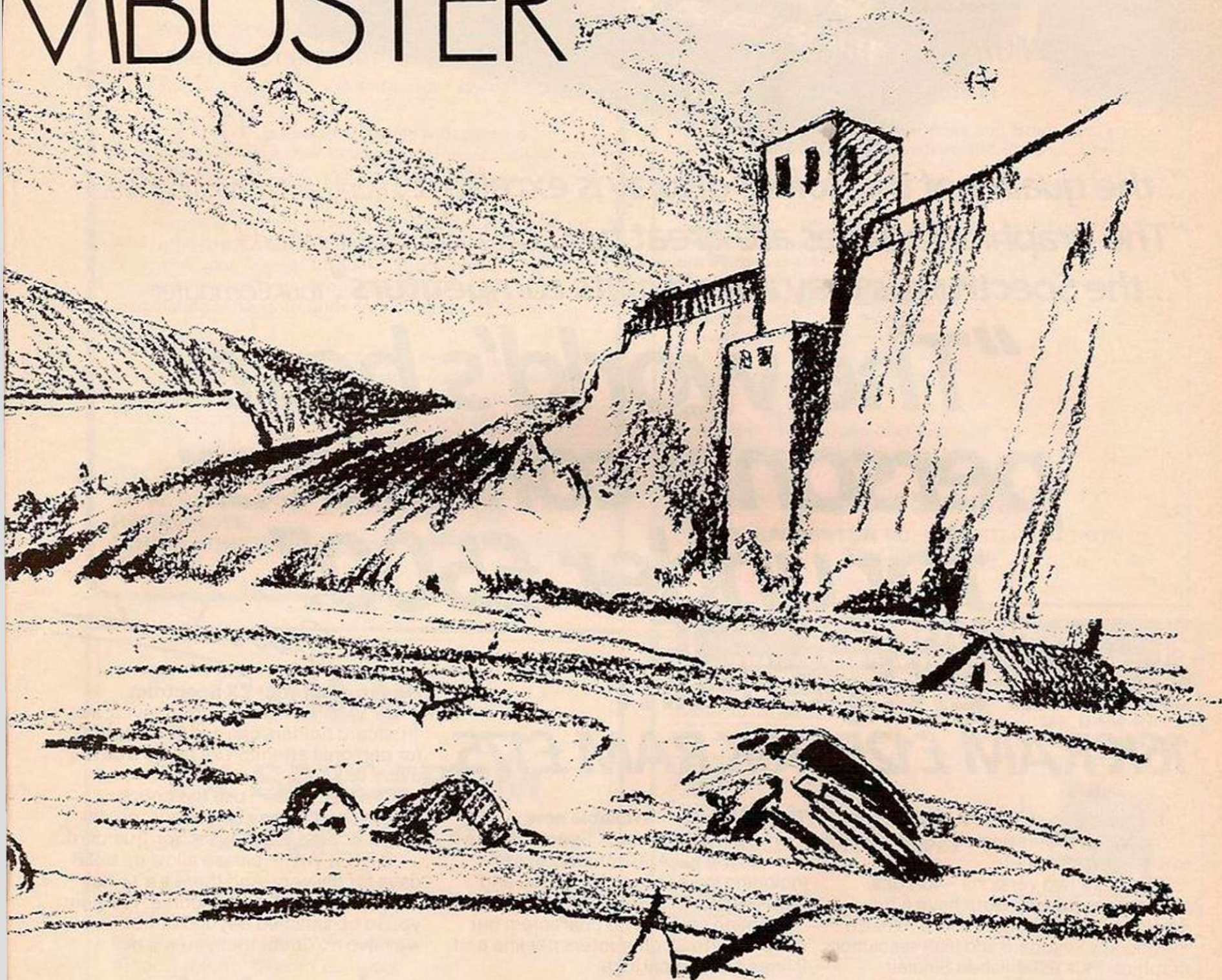

```
405 POKE36878,15:POKE36876,140:FORN=1T020:NEXT:POKE36876,0
410 FORN=1T020:NEXT
420 POKED=1,32:GOTO290
424 REM*****          ****SHIP*****          ****
430 FORN=1T020:NEXT
440 POKEB,62:POKEB+30720,0
445 POKE36878,15:POKE36876,220:FORP=1T05:NEXT:POKE36876,0
450 GETC:IFC=" " THEN490
470 FORP=1T020:NEXT
480 POKEB,32:NEXTB
491 GOTO380
494 REM*****          ****DOND*****          ****
495 L=200
496 FORC=B+22T0B+404STEP22
497 IFD<770T100:GOTO380
498 POKE36878,5:L=L-1:POKE36876,L
500 POKEC,40:POKEC+30720,0
505 IFPEEK(C+22)=60 THEN S=S+1:GOTO550
510 R=0
512 IFPEEK(C+44)=224 THEN POKE36876,0:POKEC,32:R=1:G=5-1:GOTO550
520 FORP=1T030:NEXT:POKEC,32
530 NEXT
540 POKEB,32:GOTO380
550 POKE36878,0:POKEC+22,32:POKEC,32
551 PRINT"SCORE:"G
552 POKE36877,220
553 FORN=1T005STEP-1
554 POKE36878,N
555 IFR=1 THEN POKE36865,37
556 FORN=1T030:NEXT:IFR=1 THEN POKE36865,39
557 FORN=1T030:NEXT:N
558 POKE36877,0:IFR=1 THEN POKE36865,39
559 FORN=1T040:NEXT:POKEB,32
575 NEXT
578 IFR=1 THEN POKE36865,38:GOTO290
580 GOTO270
590 FORZ=0T01:POKED=Z,224:POKEZ=Z+30720,6:NEXT:PRINTCHR$(142):POKED=Z,223:POKED
30722,6
594 POKE36878,4:POKE36877,100
595 FORZ=0+24T0B169STEP22:POKEZ,224:POKEZ+30720,6:NEXT
599 FORZ=0T05T00STEP-1
600 POKEZ,224:POKEZ+30720,6
610 NEXT
620 PRINTCHR$(142):"XXXXXXXXXX THE DAM HAS BEEN":PRINT
630 PRINT"DESTROYED AND ITS ALL":PRINT
640 PRINT"YOUR SCORE:"G:PRINT
644 U=INT((1+0.5)/60)
645 PRINT"YOU LASTED"U" SECS":PRINT
646 PRINT"YOUR SCORE:"G:PRINT
647 IF$O=0 THEN S=0
650 PRINT"DO YOU WANT TO PLAY AGAIN?":PRINT"Y"
655 POKE36877,0
660 GETC
670 IFD="Y" THEN PRINT" ":S=0:GOTO70
680 IFD="N" THEN GOTO660
700 PRINT" "
710 PRINTCHR$(142):POKE650,0
720 END
```



"...the quality of the colour display is excellent". Popular Computing Weekly.

"The graphics facilities are great fun". Personal Computer World.

"...the Spectrum is way ahead of its competitors". Your Computer.

# "The world's best personal computer for under £500."

*Chris Sinclair*

## Sinclair ZX Spectrum 16K RAM £125, 48K RAM £175.

This is the astonishing new ZX Spectrum – a powerful professional's computer in everything but price!

There are two versions – 16K or a really powerful 48K. Both have a full 8 colours, sound generation, a full-size moving-key keyboard and high-resolution graphics. Plus established Sinclair features such as 'one-touch' keyword entry, syntax check and report codes!

### Key features of the Sinclair ZX Spectrum

Full colour – 8 colours plus flashing and brightness-intensity control.

Sound – BEEP command with variable pitch and duration.

Massive RAM – 16K or 48K.

Full-size moving-key keyboard – all keys at normal typewriter pitch, with repeat facility on each key.

High resolution – 256 dots horizontally x 192 vertically, each individually addressable for true high-resolution graphics.

ASCII character set – with upper- and lower-case characters.

High speed LOAD & SAVE – 16K in 100 seconds via cassette, with VERIFY and MERGE for programs and separate data files.

### The ZX Printer – available now

The printer offers ZX Spectrum owners the full ASCII character set – including lower-case characters and high-resolution graphics.

Printing speed is 50 characters per second, with 32 characters per line and 9 lines per vertical inch.

### ZX Microdrive – coming soon

Each Microdrive will hold up to 100K bytes on a single interchangeable microfloppy – with a transfer rate of 16K bytes per second. And you'll be able to connect up to 8 ZX Microdrives to your ZX Spectrum – they're available later this year, for around £50.

### How to order your ZX Spectrum

BY PHONE – Access, Barclaycard or Trustcard holders can call 01-200 0200 for personal attention 24 hours a day, every day.

BY FREEPOST – use the coupon below. You can pay by cheque, postal order, Access, Barclaycard or Trustcard.

EITHER WAY – please allow up to 28 days for delivery. And there's a 14-day money-back option, of course. We want you to be satisfied beyond doubt – and we have no doubt that you will be.

## sinclair ZX Spectrum

Sinclair Research Ltd,  
Stanhope Road, Camberley, Surrey,  
GU15 3PS. Tel: Camberley (0276) 685311.

To: Sinclair Research, FREEPOST, Camberley, Surrey, GU15 3BR.				Order
Qty	Item	Code	Item price £	Total £
	Sinclair ZX Spectrum – 16K RAM version	100	125.00	
	Sinclair ZX Spectrum – 48K RAM version	101	175.00	
	Sinclair ZX Printer	27	59.95	
	Printer paper (pack of 5 rolls)	16	11.95	
	Postage and packing: orders under £100	28	2.95	
	orders over £100	29	4.95	
<b>TOTAL £</b>				

Please tick if you require a VAT receipt  
 \*I enclose a cheque/postal order payable to Sinclair Research Ltd for £ \_\_\_\_\_  
 \*Please charge to my Access/Barclaycard/Trustcard account no. \_\_\_\_\_ Please print.  
 \_\_\_\_\_  
 \*Please delete/complete as applicable.  
 Mr/Mrs/Miss \_\_\_\_\_  
 Address \_\_\_\_\_  
 \_\_\_\_\_  
 \_\_\_\_\_  
 \_\_\_\_\_  
 \_\_\_\_\_  
 \_\_\_\_\_

FREEPOST – no stamp needed. Prices apply to UK only. Export prices on application. YOC 809

BBC SPECTRUM VIC



You don't need to be one to use our  
**Magnetic Character Plotter**  
— it's simply the best thing since sliced bacon!

The **MCP** is designed for use with personal computers having a user definable character facility — SPECTRUM, BBC, VIC and many other.

A quality product having two 8x8 plotting grids on which the black magnetic markers are arranged to create or amend your "Space Invader", Russian scrip, electronic symbols etc. Your only limit is your imagination? Use both grids to plot larger characters.

The **MCP** is manufactured in durable p.v.c. as a pocket wallet so that you can quickly and easily "plot" anywhere — on the bus, lunchbreak, in the bath! Plotting on paper is just plain tedious and old fashioned.

**MCP CO**  
34, WOODSIDE,  
HARROGATE,  
NORTH YORKSHIRE  
HG1 5NG.

**£2.95**  
(Post and packing free)

**NEW**

## ZX SPECTRUM ROULETTE 48K

- Full colour Monte Carlo betting table on continuous display.
- Betting chip placement on table.
- Practically any bet can be placed.
- Suitable for 4 named players.
- Good linear simulation of peripheral wheel numbers with realistic slowing down.
- Ball jumps around before settling.
- All winning numbers, even money, column and dozen bets automatically flashed.
- Each player informed of any wins and bank accounts automatically credited.
- Sound effects.

Tapes including full instructions for play, and postage and packing, obtainable for £4.95, from:—

**DYMOND SOFTWARE,**  
22, HOSPITAL ROAD, ANNAN  
DG12 5HP,  
DUMFRIESSHIRE.

# GEMINI SOFTWARE

## ZX81 (16K) SPECTRUM (48K) STARTREK

Features an 8x8 Galaxy, Klingons and Starbases, short and long range scans, Torpedoes and Phasers, Computer etc.

PLUS Normal or Hyperdrive: choose your speed but watch the energy level.

Galaxy Map: keep track of where you have been. Also, shows whether any Klingons remain there, and where the starbases are.

Visual display of Enterprise's position and movement.

Visual display of photon torpedo.

Messages from crew members.

5 levels of play. And much more.

Cassette plus full instructions.

ZX81 £4.95  
Spectrum £5.95 (colour and sound too)  
See for other programs.

**Gemini Software**

36 BADMINTON RD, LEICESTER LE4 7RQ.  
TEL: (0533) 64915

ZX81

## JRS SOFTWARE

19 WAYSIDE AVENUE, WORTHING, SUSSEX, BN13 3JU  
TELEPHONE WORTHING 65691 (Evenings and Weekends only)

ZX81

**GAME PACK** — Best this for value! 5 - 16K programs PLUS 2 - 1K programs **£14.95**

**70 Battle (M-code-1K)** — Fast moving space battle with continuous round about of enemy units.

**City Bomb (M-code-1K)** — Destroy the buildings and land your plane. Your fuel has nearly gone and you're in the city lanes and River.

**Warp Wars (Basic & M-code-16K)** — Features realistic space craft inspired by Star Trek for Spectrum and Microdrive.

**Snake (Basic-16K)** — A game of thought and skill. Pass through all the marked spaces with a Microdrive, without missing or doubling back on your path for 13.95.

**Sweet Tooth (Basic & M-code-16K)** — 50 levels of excitement in your quest for the sweetest treat and golden rewards.

PLUS **Station and Black Holes** (Spectrum and Spectrum Plus) for £2.95.

As reviewed in "YOUR COMPUTER" March 1982

**16K RAM PACK**  
**£29.95 (\$59.95)**

Quite simply the best available  
+ FREE "Alien Attack" (ZX-M/Code) on cassette — value £5.75.



Fully built, tested and guaranteed.  
Uses existing power supply (min. 600 m.a.).  
Compatible with printer.  
No wobble problems.  
Gold plated edge connector for perfect contact with your ZX81.

Normally despatched within 10 days of receipt of your order.

**AND NOW — 64K RAM PACK**

Same quality as the 16K to give massive memory to your ZX81.

**£62.95 (\$125)**

An ESSENTIAL addition to your 1K RAM ZX81 (or ZX80 8K ROM)

**TOOLKIT** (written by PAUL HOLMES)

Provides the following additional facilities:

Line number — you state starting number and on screen water.

Search and replace — changes every occurrence of a character for any required free space — tells you how many free bytes you have left.

**SPECIAL GRAPHICS ROUTINES**

Hyper graphics mode — graphics never seen on a ZX81 before.

Open — instantly sets up as many empty print lines as you require. (1K version only).

Fill — used in conjunction with OPEN. Fills your screen instantly with your specified character.

Reverse — changes each character on your screen to its inverse without instructions and example programs.

**TAPE ROUTINE** — provides a system WAIT condition until a signal is received in the cassette ear jack — many uses.

All these routines are written in machine code and together take up only 164 BYTES of your precious RAM — an incredible achievement!

The price of incredible too! ONLY **£3.95 (\$7.95)** for cassette, including FULL instructions and example programs.

ALSO available 16K version ONLY **£4.95 (\$9.95)** which includes all the above PLUS GOTO's and GOSUB's included in line numbers.

Search for and hit every line containing specified character. **16K VERSION**

## NEW GRAPHICS TOOLKIT (Another masterpiece by PAUL HOLMES)

22 exciting MACHINE CODE routines that give you control over your screen as never before! (ZX81 - 16K RAM ONLY)

**DRAW UNDRAW** draws or deletes your multi character shape which is defined in a REM statement. You may define as many different shapes as you like and draw or undraw each at will at whichever screen position you choose.

**BACKGROUND ON/OFF** use this to 'protect' existing characters on your screen. When on new shapes will appear to slide behind and re-emerge from other shapes.

**BORDER LINDBORDER** Draws a border round the edges of your screen area. Edit lines can be used if required. Your border is protected when foreground is on.

**FILL** Fills any number of lines you specify, starting at any line you specify, by your chosen character.

**REVERSE** Converts all characters to their inverse video, control as in FILL.

**PRINT POSITION CONTROLS**

UP  
DOWN  
LEFT  
RIGHT

After your next PRINT position in the direction indicated.

**EDITPRINT** Moves next PRINT position to first edit line.

**SCROLL facilities**

UPSCROLL  
DOWNSCROLL  
RIGHTSCROLL  
LEFTSCROLL

Scroll your screen in the direction indicated.

**ONSCREEN OFFSCREEN** turns your screen on or off.

**BACKGROUND ON/OFF** Fills your screen by your specified character. When foreground is on existing information is unaffected and shades will appear to pass in front of your background, without deleting it.

**SEARCH AND REPLACE** will search the screen for every occurrence of the character you specify and replace it with your new character.

**SQUARE** draws a square or rectangle from your specified co-ordinates.

All these routines are in machine code for SUPER-FAST response! Simply load GRAPHICS TOOLKIT, which repositions itself at the end of your RAM, and then your own program for key in a new one! GRAPHICS TOOLKIT uses only 2K of your RAM and that includes space to load the programmers TOOLKIT described above (16K RAM version).

**ALL FOR ONLY £5.95 (\$11.90)** This includes a cassette with 2 copies of the program plus a comprehensive instruction booklet with examples.

NOTE: All prices are fully inclusive — send cheque or P.O. to JRS Software at above address.

OVERSEAS CUSTOMERS Payment may be made in Sterling (Money Order available at your bank) or U.S. (U.S.A. customers only). Prices quoted above are also export prices and include AIRMAIL postage.

# ATTENTION VIC 20 Owners Buy 1 Game

# GET 6 FREE!

EACH CASSETTE CONTAINS:

**7 EXCITING GAMES**  
by Clifford Ramshaw  
for your Standard VIC 20

Clifford Ramshaw is undoubtedly one of the most creative programmers of games for the VIC. He is also the author of *The Wizard and the Princess* and *VIC Arcade Pack*, all available from Melbourne House.

**VIC Innovative Cassette 1** "City Bomber", "Dumper", "Nuclear Attack", "Ganymede", "Space Flight", "Battleship", "Duck Shoot".

**VIC Innovative Cassette 2** "Alien Overrun", "Rat Trap", "Grand Prix", "Warlock", "Bomber Attack", "Hangman", "Siege".

**VIC Innovative Cassette 3** "Hoppy", "Save the Shuttle", "Invasion", "Dragons Lair", "Dungeon", "Blackjack", "Squash".

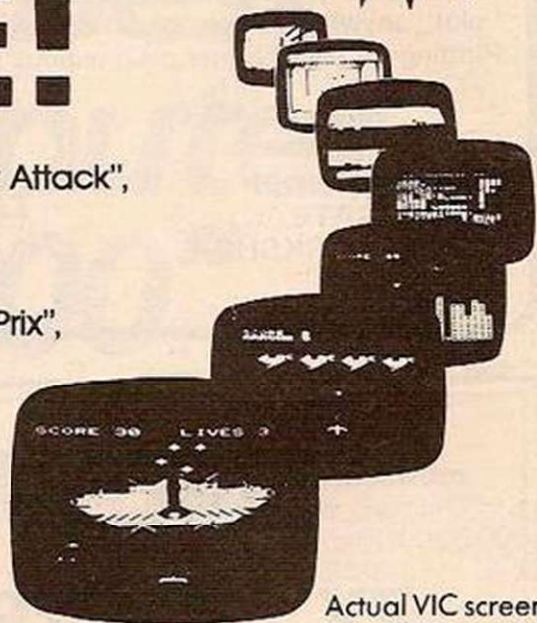

Actual VIC screens for VIC cassette 1

Only £5.95 each

**NOW**

all the above games **PLUS** others  
in this **NEW BOOK**

**VIC  
INNOVATIVE  
COMPUTING**  
by Clifford  
Ramshaw

£6.95



Orders to:

**MELBOURNE HOUSE PUBLISHERS**

131 Trafalgar Road, Greenwich, London SE10.

Correspondence to: Glebe Cottage, Station Road,  
Cheddington, Leighton Buzzard, BEDS LU7 7NA.

Please send me:

VIC 1 £5.95     VIC 2 £5.95     VIC 3 £5.95

VIC Innovative Computing £6.95

(please add 80p for post, pack & V.A.T.)

Name .....

Address .....

..... P'code .....



**MELBOURNE HOUSE PUBLISHERS**

# INTELLIGENT ATOM TYPEWRITER

Dave Berry's machine-code program for the Atom transforms your Acorn into an intelligent typewriter with many of the features of a word processor.



MOST REGULAR users of typewriters and word processors have probably long felt the need for a facility somewhere between the two. It would be useful to be able to edit each line of text before it is printed, since most typing errors are noticed immediately after they are made. Justifying the right margin for neatness, but without the overheads involved in true word processing would be another boon.

Word processors are ideal for reports and such like but for the simple letter, the extra work involved in setting up files and storing text before it can be printed is a distinct nuisance.

"T" fills this gap between typewriters and word processors. Written entirely in 6502 machine-code for the Acorn Atom it is both fast and compact, filling just 767 bytes of

precious RAM. Nevertheless, it is able to support all the following functions:

- Edit before print.
- Right-margin justification.
- Adjustable line spacing.
- Key-blip routine.

The listing shows the Basic and assembler source-code version of "T". This listing has

*(continued on next page)*



NEW softwares for NEW computer

## ZX SPECTRUM ZX81

SOUND & COLOUR ON ALL ZX SPECTRUM PROGRAMS

**SEA WAR:** (ZX-sp £7.00; ZX81 £6.00)

Completely new designed game for one or two players.

Attractive screen display and super control.

**IQ GAME PACK I:** (ZX-sp £4.00; ZX81 £3.50)

This game pack contains three individual programmes. You will have lots of fun with them, and improve your IQ too.

**Adder game:** (ZX-sp £5.00, ZX81 £4.50)

A new idea in which maths is involved in this fast action game.

Send s.a.e. for full details. Mail order only.

(All cheques and postal orders made payable to:

**Panda Software,**

51 Elgin Street, Shelton  
Stoke-on-Trent ST4 2RD

Please send me:

Game	ZX-sp	ZX-81
Sea War	_____ at £7.00	_____ at £6.00
IQ Game Pack I	_____ at £4.00	_____ at £3.50
Adder	_____ at £4.50	_____ at £5.00

I enclose £ \_\_\_\_\_ for above items.

My address is \_\_\_\_\_

My name \_\_\_\_\_ Signed \_\_\_\_\_

All prices included VAT and P&P.  
U.K. delivery: Allow up to 28 days.

## ZX81 ECONOMIC KEYBOARD £11.95

Individually handmade and thoroughly tested before dispatch, unconventional but practical,

A SINCLAIR USER'S ANSWER  
TO A SINCLAIR USER'S PROBLEM

It's reliable, enjoyable and inexpensive; and it comes with a money-back guarantee if you don't agree.

It is NOT a full-sized typewriter keyboard with full-travel keys to be wired up in some way to your computer.

IT IS:

SIMPLICITY ITSELF TO ATTACH fitting directly onto Sinclair's flat keyboard  
NEAT AND UNOBTRUSIVE, in no way interfering with any other expansion  
SURE IN KEYSTROKE  
FAST AND EASY TO OPERATE  
ATTRACTIVE TO LOOK AT

IT HAS:

A SLIM BLACK BOARD with  
ENLARGED AND RAISED KEYS which are  
COLOUR-CODED AND EASY TO READ, and offers  
SWIFT LOCATION OF FUNCTIONS etc.

MAKE YOUR ZX81 A REAL PLEASURE TO USE  
Send cheque/P.O. for £11.95 to:

**DAVID HEARTFORD**  
91, High Street, Evesham, Worcs,  
WR11 4DT

## COMPUTACALC ZX

FAMILY BUDGET FIGURES						
	DEC	JAN	FEB	MAR	APR	MAY
1 MORTGAGE	167	167	167	167	167	167
2 PHONE	42			35		
3 GAS			62			31
4 SELECT		43			35	
5 CAR	62	71	65	61	70	65
6 INSUR	12	12	12	12	12	12
7 RATES			235			
8						
9						
10 TOTAL	284	293	544	275	264	27

An advanced spreadsheet program for the Sinclair ZX81 with 16K RAM.

This versatile software allows manipulation and inspection of data in the most convenient way ever. Ideal for financial planning, personal budgeting, cashflow analysis and countless other business, home, scientific and technical applications.

The screen acts as a window on a much larger grid (up to 38 x 38) of titles and numbers (up to 9 digits). Change one number or formula and all dependant results change automatically. Save on tape or printout for a permanent record.

Tasks that would take hours with pencil, paper and calculator can be performed in seconds with COMPUTACALC ZX.

For cassette and full documentation send £7.95 to: Silicon Tricks, Dept YC9, 2-4 Chichester Rents, London WC2 1EJ. (Tel: 01-603-6074).

**Silicon  
Tricks**

## THE PERSONAL COMPUTER GUIDE TIM HARTNELL

The Complete Handbook to Selecting and  
Using Small Computers

A unique introduction to the exciting world of personal computers, including:

- ★ An explanation of how they work and what they can do for you
- ★ A detailed analysis of the available systems including the BBC, Commodore and Sinclair models, examining specifications, commands, software and other vital information
- ★ How to get the most out of your computer
- ★ A step-by-step guide to programming
- ★ A complete set of over 40 programmes
- ★ Written by Tim Hartnell, the U.K.'s leading authority on small computers

Packed with ideas and fully illustrated with photographs, line drawings and information panels. **ONLY £5.95**

A large format quality paperback  
Available from all good bookshops

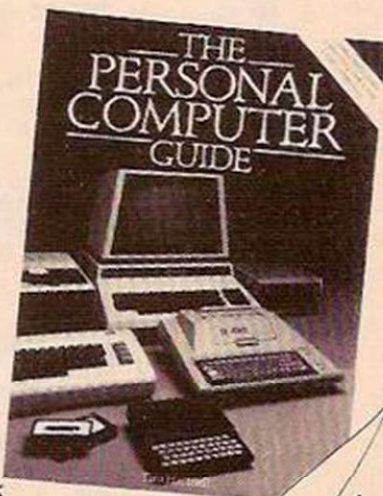

If you want to live to fly another mission, you will have to use your B-52's high-explosive bomb-load to save you. S A Nicholls puts you in the bomb-aimer's seat with his machine-code ZX-81 program.

YOU ARE AT the controls of a B-52 bomber which is rapidly losing altitude. Your only hope of a safe landing is to level the ground beneath you by shooting away the towers which block your path. Survival depends on clearing a safe landing strip for your bomber.

The game is in machine code and has been written for the 1K ZX-81. It is only suitable for a ZX-81 with less than 3.25K RAM. The display occupies the bottom 15 lines of the screen, and is of the wrap-around type. That means the aeroplane is on screen at all times. It does not disappear on reaching the right-hand edge only to reappear moments later complete on the left-hand side as in some machine-code programs.

The jet appears at the top left of the display with 55 shots displayed on its body. The shots can be fired at any time by pressing any key except shift, and may be fired singly or in a salvo depending on the length of time for which the key is depressed.

### Point of contact

The shots travel at twice the speed of the plane in a 45° downward direction and on hitting a tower will destroy it from the point of contact to the ground. The counter on the side of the B-52 will count down with each shot fired. To simulate the jet propulsion, the

exhaust is changed from a hyphen to an asterisk with each move of the aircraft. The towers are random height and random characters to give a different game every time.

The program is written for a line 1 Rem statement containing 287 zeros. When you have written this Rem statement, enter the following hexadecimal-loader program.

```
10 LET X = 16514
20 LET A$ = ""
30 IF A$ = "" THEN INPUT A$
40 IF A$ = "S" THEN STOP
50 POKE X, 16 * CODE A$ + CODE A$ (2) - 476
60 PRINT AT 11,7;X; "SPC", A$(1 TO 2)
70 LET X = X + 1
80 LET A$ = A$ (3 TO)
90 GO TO 30
RUN (IN FAST)
```

You can now enter the hexadecimal codes as in the listing, either in pairs or blocks, i.e., 80 Newline — 80 Newline — 92 Newline or 8080922121A90100 Newline and so on. Remember there are no spaces between the codes. The hexadecimal-loader program will give a display of the last address and code entered so that you can check the listing as you enter it.

I prefer to run it in fast mode because the screen flicker does give an indication that an entry has been made without having to look up from the list to check.

After the last entry, at address 16800, enter S to end. Now type the only line of Basic necessary:

```
10 RAND USR 16520
```

and delete lines 10 to 90 as these are no longer required. The ROM subroutines used are located at the same address in both the old and new 8K ROMs.

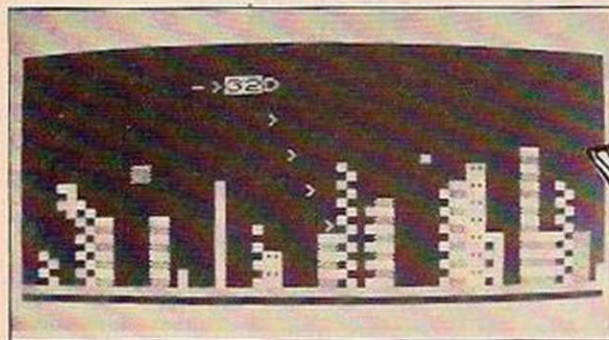

16514	80 80 92		Rocket data
	21 21 A9		
16520	01 00 07	LD BC,0700	Print black background
	CD F5 08	PRINT AT	starting at line 7.
	11 C0 01	LD DE,01C0	
	3E 80	LD A,80	
	D7	RST 10	
	1B	DEC DE	
	7A	LD A,D	
	B3	OR E	
	20 F8	JRNZ F8	
16537	06 20	LD B,20	Print last line grey/black.
	3E 8A	LD A,8A	
	D7	RST 10	
	10 FD	DJNZ FD	
16544	ED 5B 33 40	LD DE,(4033)	Random height for towers.
	2A 32 40	LD HL,(4032)	
	19	ADD HL,DE	
	22 32 40	LD(4032),HL	
	7C	LD A,H	
	E6 07	AND 07	
	C6 0D	ADD A,0D	
	47	LD B,A	
	C5	PUSH BC	
	CD F5 08	PRINT AT	Start printing towers with random characters.
	3A 32 40	LD A,(4032)	
	E6 07	AND 07	
	C6 04	ADD A,04	
	D7	RST 10	
	C1	POP BC	

78	LD A,B	
FE 14	CP 14	Finished tower?
28 03	JRZ,03	
04	INC B	
18 EB	JR,EB	
79	LD A,C	
FE 1F	CP 1F	Finished 32 towers?
28 03	JRZ,03	
0C	INC C	
18 D2	JR D2	
16590	01 00 08	LD BC,0800
16593	C5	PUSH BC
	CD F5 08	PRINT AT
	11 82 40	LD DE,4082
	01 06 00	LD BC,0006
	CD 6B 0B	PRINT STRING
16606	2A 10 40	LD HL,(4010)
	11 21 00	LD DE,0021
	2B	DEC HL
	E5	PUSH HL
	7E	LD A,(HL)
16615	FE A9	CP A9
16617	20 0E	JRNZ,0E
	23	INC HL
	7E	LD A,(HL)
	FE 76	CP 76
	28 FA	JRZ,FA
	FE 80	CP 80
	28 29	JRZ,29
	E1	POP HL
	C3 8D 41	JP,418D
16633	FE 92	CP 92
	20 1E	JRNZ 1E
	36 80	LD (HL)80
	23	INC HL
	7E	LD A(HL)

# B-52

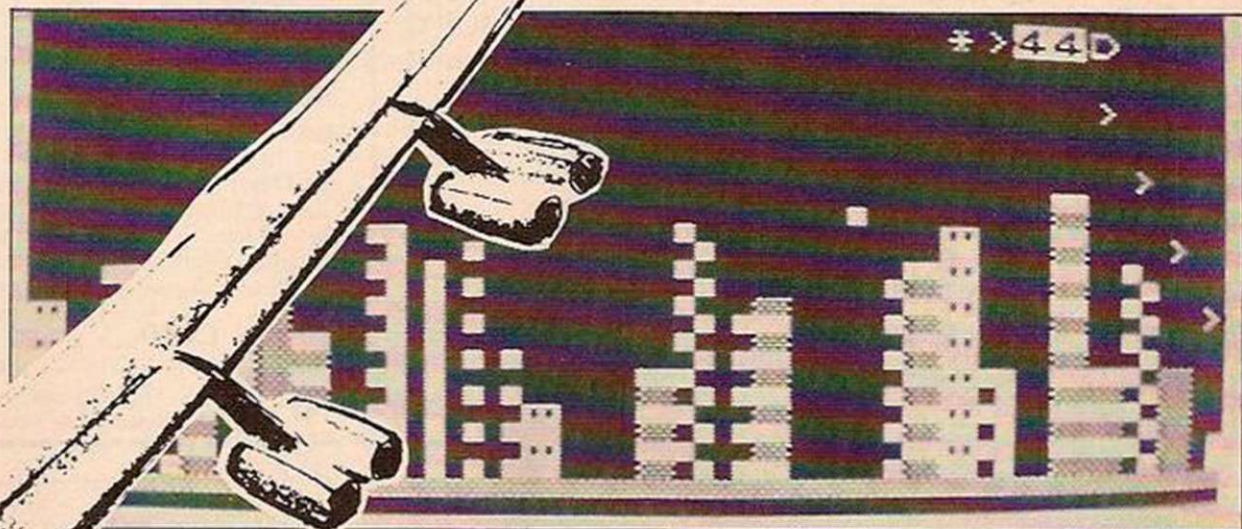

# BOMB-RUN

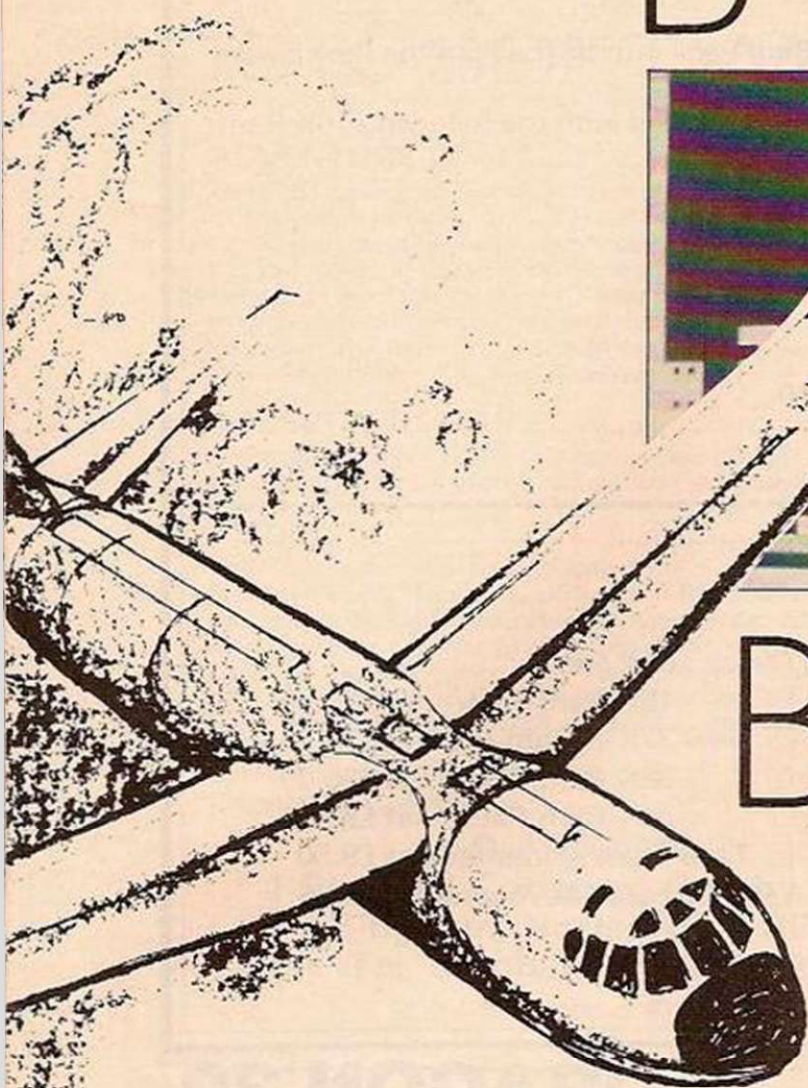

```

FE 76 CP 76
28 FA JRZ FA If 'next' column is
FE 8A CP 8A base line then do
28 12 JRZ 12 not re print shot.
19 ADD HL DE Move down one
7E LD A,(HL) line and check
FE 80 CP 80 for black square.
28 0A JRZ 0A Yes? Goto print.
FE 8A CP 8A If base then
28 08 JRZ 08 skip print
36 80 LD (HL),80 Erase tower down
19 ADD HL DE to base line
7E LD A,(HL) (must be tower)
18 F6 JR F6 Re print shot
36 92 LD (HL) 92 Get original shot
E1 POP HL
    
```

```

3C INC A
28 30 JRZ 30
16701 19 ADD HL,DE Create shot on
7E LD A,(HL) screen below
FE 80 CP 80 front of rocket.
28 0A JRZ 0A If position is top
FE 8A CP 8A of tower then
28 08 JRZ 08 erase tower.
36 80 LD (HL),80
19 ADD HL,DE
7E LD A,(HL)
18 F6 JR F6
36 92 LD (HL),92 Print shot.
16719 21 86 40 LD HL,4086 Reduce shot
7E LD A,(HL) counter on rocket
FE 1C CP 1C body. (part of
20 05 JRNZ .05 rocket data).
36 25 LD (HL),25
28 DEC HL
18 F6 JR F6
3D DEC A
77 LD (HL),A
FE 1C CP 1C
20 0B JRNZ .0B
28 DEC HL
7E LD A,(HL)
FE 1C CP 1C
20 05 JRNZ .05
3E 01 LD A,01
32 3C 40 LD(403C),A If no shots left
16749 C1 POP BC then load 403C,1.
0C INC C Get rocket position
79 LD A,C and move it to
FE 1A CP 1A next screen
20 07 JRNZ .07 position.
78 LD A,B
FE 14 CP 14 Check landed?
28 1F JRZ .1F If yes go to 16792
18 07 JR ,07
FE 20 CP 20
20 03 JRNZ .03
0E 00 LD C,00
04 INC B
79 LD A,C Change rocket flame
E6 01 AND 01 from - to * to - etc.
C6 96 ADD A,96 with each move of
32 83 40 LD(4083),A rocket.
C3 01 40 JP,40D1 Goto 16593.
16781 C1 POP BC Get rocket position
CD F5 08 PRINT AT
06 06 LD B,06 Overprint 6 *'s
3E 97 LD A,97
D7 RST 10
10 FD DJNZ ,FD
16792 3E 21 LD A,21 Reset counter
32 85 40 LD(4085),A
32 86 40 LD(4086),A
16800 C9 RET Return to BASIC
BASIC 10 RAND USR 16520
    
```

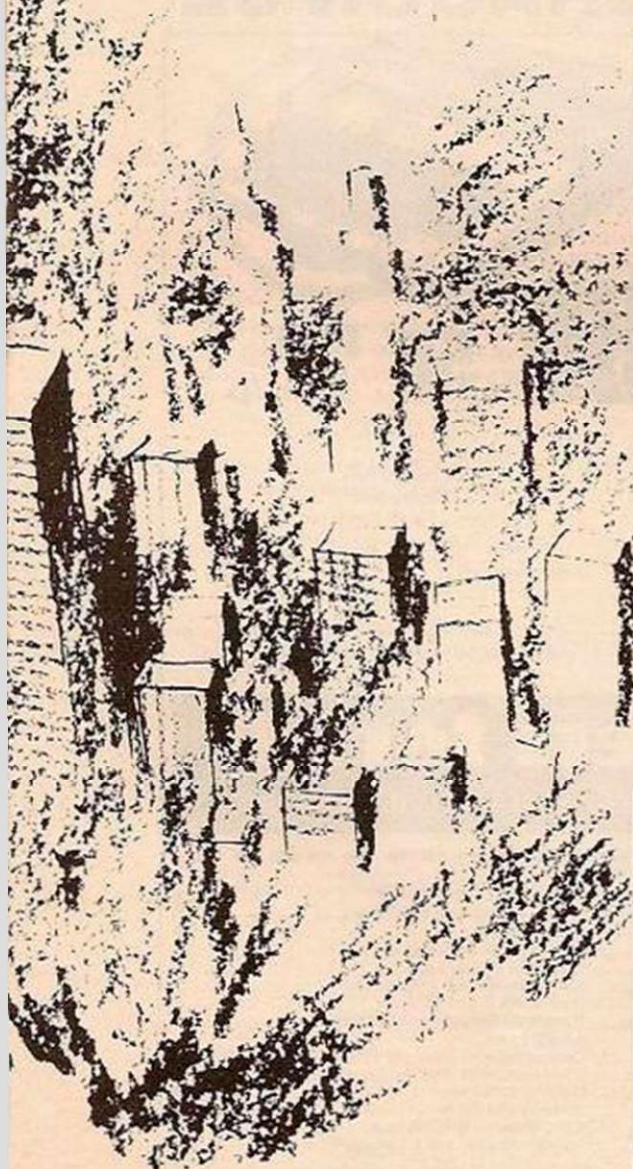

## NEW FOR ZX81 USERS

Even More Memory with our Byger Byte 32K + Ram Pack. Why put aside your 16K Ram Pack when you can use it together with the new Byger Byte 32K + Ram Pack to give you 48K OF MEMORY.

No trailing leads or wires — all you need do is plug the existing 16K Ram Pack into the back of the new Byger Byte 32K + Ram Pack, and bingo 48K OF MEMORY.

Uses existing power supply. The new 32K + Ram Pack is tested and guaranteed with the following 16K Ram Packs: Byg Byte, Sinclair, Downsway.

Also available:

	16K Ram Pack	— £22.00
New	32K + Ram Pack	— £39.50
Standard	32K Ram Pack	— £35.00
	64K Ram Pack	— £53.95

Tape loading Interface — for trouble free loading of Programs — £9.50

New High Quality Keyboard with bleep + reset — £49.95

All Prices are inclusive of V.A.T + Free Postage & Packing

Phoenix Marketing Services,  
Oaklands House, Solartron Road,  
Farnborough, GU14 9QL.

Name \_\_\_\_\_

Address \_\_\_\_\_

Make cheques payable to: **Phoenix Marketing,**

I enclose my cheque for £ \_\_\_\_\_

Please debit my Access/Barclaycard

Signed \_\_\_\_\_

Date \_\_\_\_\_

Please send me

- 16K Ram Pack at £22.00  
 New 32K + Ram Pack at £39.50  
 32K Ram Pack at £35.00  
 64K Ram Pack at £53.95  
 Tape loading interface at £9.50  
 Fully cased keyboard at £49.95



Once upon a time . . .

. . . . in medieval days, there were dark, mysterious Forests, and within these Forests there lived mythical monsters called DRAGONS.

Now in 1982 when buying a computer you enter a technological Jungle; here within this jungle you will also find Dragons. But these Dragons are no myth.

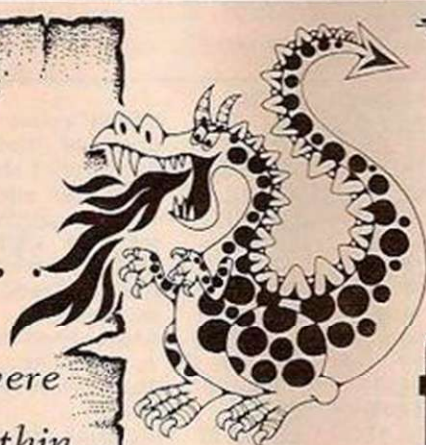

# DRAGON 32



ONLY  
**£199.50** plus  
**£3p/p**

The heart of the system is a 6809E micro-processor, a great advance on the still popular 6502, with a 32K Memory as standard, expandable to 64K. Uses Extended Microsoft Colour Basic, 9 colours available, 5 resolutions of graphics up to 256 x 192, displayed on TV set or composite colour monitor. Generates a full five octave sound range through the TV Speaker. Unlike other systems in this price range it uses a conventional QWERTY Keyboard.

Standard connections include:—  
ROM Cartridge  
2 Joystick controllers  
Remote cassette unit  
Centronics Parallel printer

160 page "BASIC" Manual included with every system.

All this for the unbelievably low price of only £199.50 inc. VAT, plus £3.00 p. & p.

## Computers for All

72 NORTH STREET, ROMFORD, ESSEX. TEL. 0708 752862

NAME _____		Please send me:		TOTAL
ADDRESS _____		<input type="checkbox"/>	Dragon 32 @ £199.50 each	_____
_____		<input type="checkbox"/>	Dragon Joysticks @ £19.95 pair	_____
_____		<b>CARTRIDGES</b>		_____
_____		<input type="checkbox"/>	Ghost Attack @ £24.95 each	_____
_____		<input type="checkbox"/>	Berserk @ £19.95 each	_____
_____		<input type="checkbox"/>	Cosmic Invaders @ £19.95 each	_____
_____		<input type="checkbox"/>	Meteoroids @ £19.95 each	_____
_____		<input type="checkbox"/>	Household Budgeting @ £19.95 each	_____
_____		<b>CASSETTES</b>		_____
_____		<input type="checkbox"/>	Compendium of Games @ £7.95 each	_____
_____		<input type="checkbox"/>	Compendium of Applications @ £7.95 ea.	_____
_____		<input type="checkbox"/>	Quest @ £7.95 each	_____
_____		<input type="checkbox"/>	Madness and the Minotaur @ £7.95 each	_____
_____		<input type="checkbox"/>	Computavoice @ £7.95 each	_____
_____		<input type="checkbox"/>	Graphic Animator @ £7.95 each	_____
_____		<b>TOTAL</b>		_____

I enclose cheque/P.O. for £ \_\_\_\_\_  
 or  
 Please debit my Access/Barclaycard No. \_\_\_\_\_

# ZX81

## 16 K SOFTWARE

### ADVENTURE 1 .....£6.00

The ZX81 generates a random maze of 100 caves. Choose which of two caves to start from. You must find 30 treasures in the caves. Unfortunately you can only carry 6 at once. You must find the exit cave, if you're lucky a singing goblin might tell you. Beware of the Troll, he wanders around looking for you. The evil magician will turn you into a silicon frog if he finds you. A maximum of 8 caves to choose from when moving. Go counter. Game save option. £10 first finishing prize.

### CASSETTE DESIGN .....£5.00

Create and LPRINT your own cassette case designs. 24 lines by 32 columns. Design supplied with fold indicator. Save option.

### AS/DIS .....£5.00

You no longer need type in long REM's .... Hex loader, Hex dump, Hex clear, Hex save, USR run. A REM is reserved with 693 spaces in it. To load in your Hex just type starting address, a space then your Hex code-hit newline and sit back. To check on your code use the Hex dump. Enter start address, finish address and then watch it scroll up. Code no good? Hex clear will clear the REM between two addresses. USR run will run the machine code from a given address.

Prices include P + P.  
Cheques/P.O. payable to:

**D J MOODY**

**1 Starnhill Cottages, Granby Lane,  
Bingham, Notts, NG13 8DH  
Tel. Bingham (0949) 37127**

Also Giro transfer to 40 816 1302



The specialists in internal plug-in memories for ZX computers announce:

## 80K SPECTRUM

now attainable for the price of a 48K model!! with our SP80 low-power Sinclair look-alike.

Functionally identical to the Sinclair 32K internal plug-in expansion but with double the capacity (64K) the SP80 plugs into the sockets provided on the 16K SPECTRUM by Sinclair for his 32K expansion board. Instructions to our usual high standard makes fitting very simple indeed. The SP80 in no way interferes with Sinclair add-ons - ZX Printer, RS232 interface, Microdrive ...

\* New low prices on our highly successful internal memories for ZX81 to: East London Robotics, 'Finlandia House', 14 Darwell Close, LONDON E6 4BT.

Item	Item price	Quantity	Total
CHIPSWITCH kit doubles your ZX81 memory to 2K (this kit requires soldering)	£4.70		
INCREMENTAL internal 2K plug-in memory extension for ZX81 expandable to 16K	£17.75		
Additional 2K chips for above (HM6116P-3)	£4.50		
MAXIMEM 64K internal plug-in memory for ZX81	£49.95		
MINIMAX 16K version of MAXIMEM upgrade-able to 64K with our chip exchange service	£34.95		
SP80 64K internal plug-in memory extension for ZX SPECTRUM giving 80K of user RAM	£50.00		
SP80 Kit version with full instructions	£44.00		
SP80 fitting service (price includes excess p&p)	£9.00		

Telephone enquiries on 01 471 3308 Postage and Packing 45p

All prices already include VAT **TOTAL £**

Please tick if you require a VAT receipt.   
Refunds less £1.50 handling on all items returned within 14 days of receipt. Send stamped addressed envelope plus additional 12½p stamp for catalogue.

Cheque/Postal Order payable to EAST LONDON ROBOTICS £

Name: Mr/Mrs/Miss

Address:

**STOP PRESS!!!** Transfer all your ZX81 BASIC and Machine code programs and data onto your SPECTRUM in minutes with our new SLOWLOADER available soon!!  
·YC8

# DOWNSWAY

ELECTRONICS (UK) LTD.

## MORE MEMORY FOR YOUR ZX81 OR SPECTRUM!

Stand 249

### NEW!



### 32K RAM FOR SPECTRUM

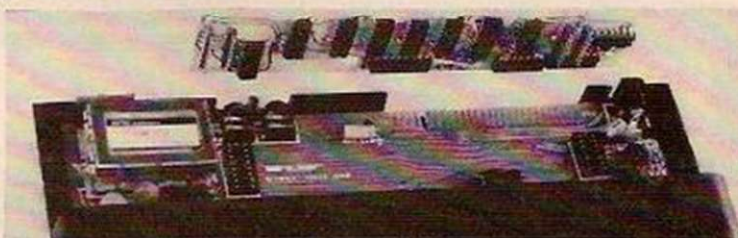

A full 48K of memory for the 16K Spectrum — simple D.I.Y. installation by just undoing 5 screws and plugging in! "State of the art" technology — advanced design using fewer ICs for high performance, reliability and economy.

**ONLY £42.50 plus p & p.**



### MEMORIES FOR THE ZX81

The Downsway 64K Memory\* slots directly on to the computer, without needing an additional power supply, or adding any extra load to the internal 5v regulator. Trade in your old 16K RAM Pack (any make, any age, any condition) for £12.50 against a Downsway 64K Memory to bring the price down to only **£47.45** plus p & p. Without trade-in, it costs just **£59.95** plus p & p — still incredible value!

If you only want 16K of memory for your ZX81, the Downsway 16K RAM Pack offers the same benefits of high quality and low price at only **£24.95** plus p & p.

Both memories measure only 2½ x 1½ x 1in. and are supplied with a foam cushion strip to provide added mechanical stability.

\* Reviewed in ZX Computing Aug/Sept 1982 and Popular Computing Weekly 22/7/82.

Naturally Downsway add-on memories are fully tested and guaranteed, but should you be dissatisfied for any reason, just return the memory within 14 days for a full refund (and your old 16K RAM pack, where appropriate).

Please allow up to 28 days for delivery.

To: Downsway Electronics (UK) Ltd  
Dept. M, Downsway House, Epsom Road,  
Ashted, Surrey.

Please send me:

Qty.	Item	Price	Total
	32K RAM for Spectrum	£42.50	
	64K Memory for ZX81 at trade-in price (my old 16K RAM Pack is enclosed)	£47.45	
	64K Memory for ZX81 at normal price without trade-in	£59.95	
	16K RAM Pack for ZX81	£24.95	
	Post and Packing		£2.00
	<b>Total</b>		<b>£</b>

My cheque/P.O./Money Order is enclosed

NAME: \_\_\_\_\_

ADDRESS: \_\_\_\_\_

YC9

The BBC *User Guide* seems somewhat inscrutable when it comes to defining some of the listed commands. Mark Holmes fills in the gaps with details of the operating-system calls. And for readers interested in creating their own graphics, Ian Thomas takes us on a tour of the BBC's special effects department.

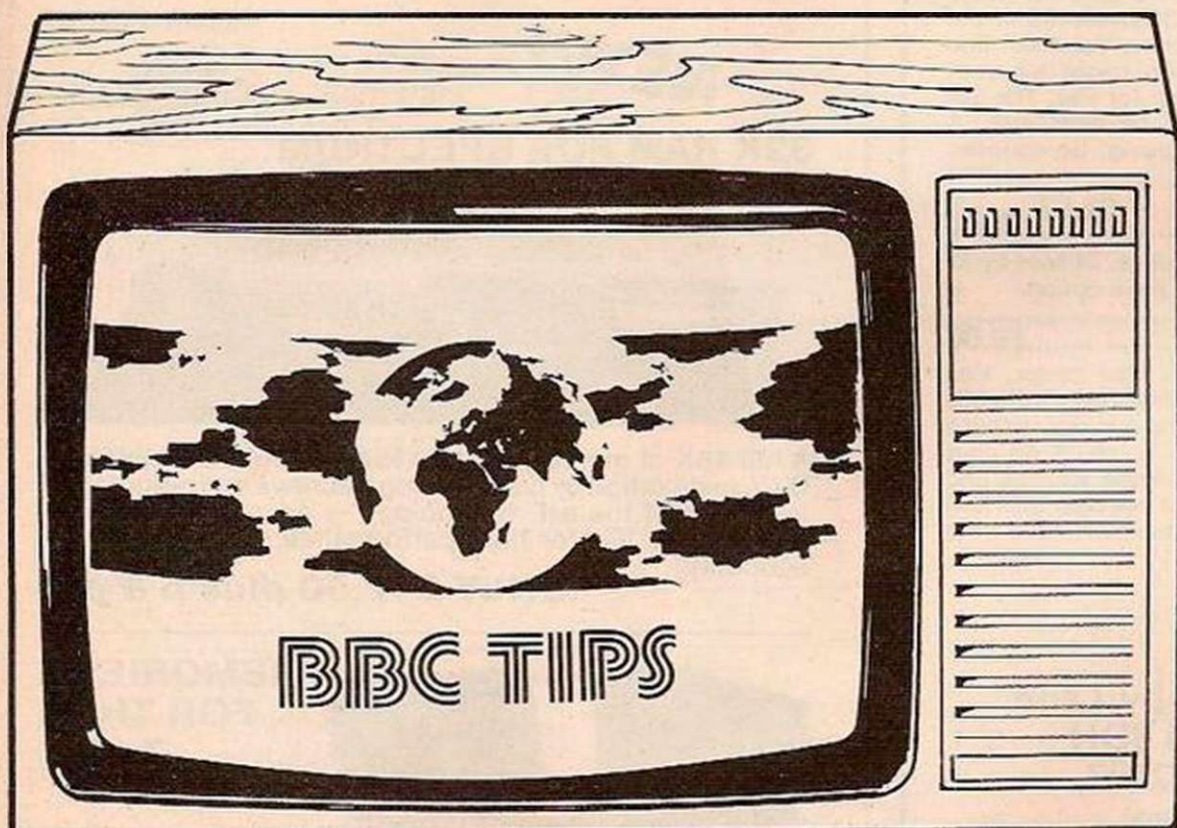

# USER-D

THE MANY POWERFUL routines built into the BBC Micro's operating system can be used for spectacular effects. One of these functions enables you to define characters to resemble anything you desire. This means that it is possible to display graphics in any mode — except for the teletext one.

This is very useful when writing a graphics game which is required to be relatively fast. The Print Tab function displays many individual graphic characters, such as space invaders, whereas the Plot command has to Plot many individual dots to build up a single character. One disadvantage of using defined characters for graphics is that all the graphics have to be in a single colour.

Any character with a code between 224 and 255 can be defined by using the VDU 23 command. VDU 23 is followed by the code of the character to be defined and by eight numbers which, in binary, represent the dark and light dots of the character. The first of the eight numbers represents the top row of the character and the eighth number represents the bottom row. Therefore the character has an eight-by-eight dot matrix.

The easiest way to find these eight numbers is to take a grid of eight by eight squares and

# CALLING THE OPERA

HIGH ON THE list of the *User Guide's* inadequacies is its lack of information on the various calls to the operating system via its command-line interpreter. I studied version 0.10 of the operating system stored in EPROM to glean the details of the system commands.

The version of the operating system resident in a machine may be checked by typing in

```
*FX0
```

to which the computer will respond with the operating-system version number and its storage medium.

If you examine the operating-system code, you will see that the following commands will be recognised by the command-line interpreter.

```
*CAT
*DISC
*DISK
*DEBUG
*EXEC
*FX
*KEY
*LOAD
*MOTOR
*NOTAPE
*OPT
*RUN
*SAVE
*SPOOL
*TAPE
*TV
```

Some of these commands are adequately described in the *User Guide* but many will be new

to most users. The full set of commands indicates the care and consideration which obviously went into the design of the micro and its operating system.

The commands \*Disc, \*Disk and \*Net clearly allude to the switching in of expansion options available. When these commands are typed in, they return with a message reporting the non-availability of these filing systems. \*Notape switches out the tape filing system. After typing in this command, any attempt to manipulate tape files will cause the "No filing system available" message to be printed out.

The \*Exec command is described in the *User Guide* and allows a text file on tape to be read in via the screen just as if it had been typed in at the keyboard. What is not mentioned is the complementary command \*Spool which allows text files to be created. This command causes all text displayed on the screen to be written to a tape file which, when \*Executed, will repeat that output. For example:

```
10 *SPOOL"KEYS"
20 PRINT""KEY0RUN | M"
30 PRINT""KEY1LIST | M"
40 PRINT""KEY2VDU7 | M"
50 PRINT""KEY3WAKE UP"
60 PRINT""KEY10WHO PRESSED BREAK"
70 *SPOOL
```

The \*Spool closes the current output file and so winds up the output file "Keys".

Having created the text files saving your

favourite soft key definitions, they may be "loaded" by typing in

```
*EXEC"KEYS"
```

The \*Spool command may also be used to save a typing session or a program listing which appears as screen output. For instance, using the previous example in program memory, type in the following

```
*SPOOL"KEYSPROG"
LIST
```

to which the computer responds with a listing of the program.

```
*SPOOL
```

\*Execution of this file will retype in the program. A slight element of untidiness emerges with this example when the List and \*Spool commands generate syntax errors.

One of the great beauties of this facility is that subroutines, or procedures, and functions likely to be useful in a number of programs can be stored on tape in this form and entered into each program as required.

To close a file created by the \*Spool command

```
CLOSE#0
```

may be used instead of \*Spool. Close#0 will close all output files currently active and may be used as the output terminator in the previous examples.

The 50 or more \*FX commands are followed by a number and optionally a pair of parameters. The \*FX command is an elegant way of calling subroutines from the operating

# DEFINED GRAPHICS

## Program 1.

```

10 FOR I=255 TO 243 STEP-1
20 READ A,B,C,D,E,F,G,H
30 VDU23,I,A,B,C,D,E,F,G,H
40 NEXT I
50 MODE 5
60 PRINTTAB(6,12)CHR$(255);CHR$(254);CHR$(253);CHR$(252);CHR$(251);CHR$(250);CHR$(249);CHR$(248);CHR$(247)
70 FOR I=1 TO 8
80 PRINTTAB(6+I,13)CHR$(255)
90 NEXT I
100 A$=CHR$(243)+""+CHR$(243)+""+CHR$(243)+""+CHR$(243)
110 PRINTTAB(6,14)A$
120 PRINTTAB(7,15)A$
130 PRINTTAB(6,16)A$
140 PRINTTAB(7,17)A$
150 FOR I=1 TO 8
160 PRINTTAB(6+I,18)CHR$(244)
170 NEXT I
180 PRINTTAB(6,19)CHR$(249);CHR$(240);CHR$(247);CHR$(246);CHR$(245);CHR$(244);CHR$(243);CHR$(242)
190 DATA 0,90,126,60,60,60,126,0
200 DATA 0,8,28,46,126,46,14,0
210 DATA 0,24,52,60,24,60,126,0
220 DATA 0,90,60,24,24,60,126,0
230 DATA 0,24,60,24,90,126,126,0
240 DATA 0,0,24,60,60,24,60,0
250 DATA 255,165,129,195,195,195,129,255

```

```

260 DATA 255,247,227,209,129,209,241,255
270 DATA 255,231,203,195,231,195,129,255
280 DATA 255,165,195,231,231,195,129,255
290 DATA 255,231,195,231,165,129,129,255
300 DATA 255,255,231,195,195,231,195,255
310 DATA 255,255,255,255,255,255,255,255
1000 REK CUPYK16H(C) IAN THOMAS 1982

```

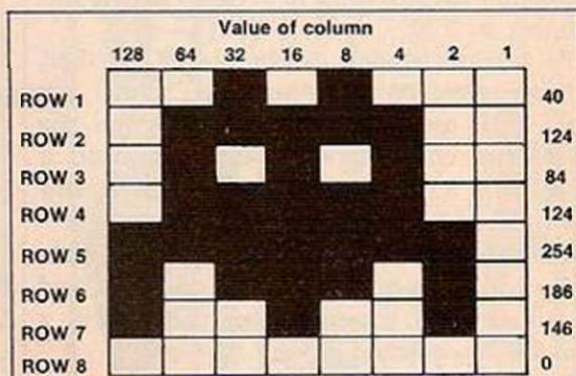

Figure 1.

draw your character on this. Start with the top row of eight squares. Add 128 for a dot in the first column, 64 for a dot in the second column, 32 in the third, right the way to 1 for a dot in the eighth column. Repeat this process for each row of eight, and you will have the

eight numbers for the VDU command. Figure 1 shows this process for the space invader to be used in program 2.

For this invader to be character 255 the command is:

```
VDU 23,255,40,124,84,124,254,186,146,0
```

Here is a simple program to illustrate this:

```

10 MODE 5
20 VDU 23,255,40,124,84,124,254,186,146,0
30 PRINT TAB(10,15) CHR$(255)

```

If you enter and run this program you should see a space invader appear in the centre of the screen. Try changing the last eight numbers in the VDU command to create some of your own characters.

In line 30 of the program the Chr\$ function is used to Print the character, but this is not vital. Instead of using Chr\$, the program could be run without line 30 and the character could be printed by:

```
PRINT CHR$(255)
```

Line 30 could now be entered, but instead of the Chr\$(255) quotation marks could be used, and the character could be copied into the in by the cursor control and copy keys. The line would now read:

```
30 PRINT TAB(10,15)""
```

where the asterisk represents the character which has been defined. Unfortunately the character definitions are not remembered when the program is saved, so the command must appear within the program, and must not be erased once the character has been defined.

Program 1 uses character definition to create a complete set of chess graphics, printing them out as it does so. Program 2 is a simple Space Invaders game which uses defined characters mainly because ordinary graphics and Plotting would be much too slow without resorting to complicated assembler routines.

This second program also uses the sound command, which I mention here because the syntax for this command is not included in the provisional manual which is at present supplied with the computer.

After the command Sound are four numbers which determine what the sound is like. The first number specifies the channel. This must be a number between 0 and 3. Channel 0 is a channel which only produces white noise, so it

(continued on next page)

# ATING SYSTEM

system. A few of the available FX commands are described in the *User Guide*, but here are a few which are not:

- \*FX9,n Sets flash period of first colour of a flashing colour.
- \*FX10,n Sets flash period of second colour.
- \*FX11,n Sets auto-repeat delay for keyboard.
- \*FX12,n Sets auto-repeat rate.
- \*FX11,0 Will switch off the keyboard auto-repeat.
- \*FX12,0 Restores the auto-repeat default values.

Operation of the cassette motor relay is allowed independently using the \*Motor command. \*Motor1 closes the relay and \*Motor opens the relay.

Anyone like me who has spent hours trying to adjust his television set so that the VDU display sits squarely inside the screen with the top line of the display actually visible will curse Acorn for not explaining the \*TV command.

This command allows the VDU display to be moved up or down the television or monitor screen. Typing in \*TV1 followed by a Mode statement will restore the line previously lost off the bottom of the display. \*TV255 will move the display down one line thus restoring the missing top line when the Mode is next changed. 255 represents -1 in a two's complement representation; 254 is -2, 253 is -3, etc.

The screen may be moved up a maximum of three lines and down considerably further

depending on the vertical hold properties of the television being used. A parameter may also be passed with a \*TV command to turn off interlace in Modes 0 to 6 inclusive. For example, \*TV0,1 will turn off interlace.

A value of 1 will turn off interlace and 0 will restore interlace. Interlace, for those who have not encountered it, is a technique by which characters can be rendered less angular by drawing each scan line of the television alternately between adjacent scan lines of the screen.

The effect is to move the entire screen up and down rapidly by about 0.5mm. In practice, I find that I can hardly notice if interlace is on or off. In Mode 7 interlace cannot be turned off by this method. Teletext hardware relies on the fact that interlace is on.

The \*OPT command is briefly mentioned in the *Guide*. Typing in \*OPT1 or \*OPT1,0 switches off all messages from the filing system and \*OPT restores them. \*OPT1,2 expands the information contained in the tape filing system messages so that on reaching the final block, the start address of the file is printed and the execution address specified by a \*Saved program — a Basic program or a text file repeats the start address in this field. The default option is \*OPT1,1.

The \*Debug command has eluded all attempts to fathom its purpose. It has a most promising title and I look forward to hearing from anyone who can tell me about it. ■

(continued from previous page)

cannot be used to produce clean notes.

The second number specifies the volume of the sound. This can be any number between -15 and 0. The loudest is -15 and the quietest is 0. The third number specifies the frequency of the sound. This must be in the range 0 to 255, and unfortunately bears no resemblance to the frequency of the sound produced.

The fourth and final number specifies the duration of the sound, in the same way as the duration in the Inkeys command. A 1 for this number specifies one-hundredth of a second, so to find the duration in seconds divide this number by 100.

All of the channels can be played together, so chords are possible, but one channel can play only one note at a time. When the interpreter encounters a Sound command it stores it in a buffer until the sound generator has finished playing the previous note.

The Sound command is used in the program as a warning noise at the start of the game, and to infuriate you, when the game is over, with a horrible low-pitched noise.

Lines 30 to 70 define the characters to be used in the program. Character 255 is the missile base, 254 is the bomb or missile, 253 is the invader and together 252 and 251 make up a UFO.

Lines 110 to 130 produce the warning noise in channel 1. In line 150 an asterisk represents an invader — Chr\$(253) — which must be copied into the line by use of the cursor control and copy keys. There are eight invaders and nine spaces in line 150, making 17 characters for A\$(I).

You may be puzzled by line 270, \*FX15,0, which clears the input buffer. This is needed because the BBC computer remembers what you type in, and if you keep your finger on a key for too long without this command you would have to wait a long time before the program recognised that you were pressing another key.

In lines 340 and 350 logical operations are used. If what appears within the brackets is true then the value of what appears in the brackets is equal to -1; if it is false then it is equal to 0.

When you run the program you should hear the warning noise, then the invaders appear. These must all be shot down before they reach the bottom of the screen. For each invader you shoot down a random score of between 100 and 500 is added to your total. Your total score is displayed in the middle of the top of the screen. When you have succeeded in shooting all 40 invaders another 40 appear, and the game gradually grows faster as you progress. At random intervals a UFO moves across the top of the screen. If you shoot this down you get a bonus of 1,000.

Invaders drop bombs randomly. If one hits your base you lose one of your three lives. The number of remaining lives is displayed at the top right of the screen. The game is over when you have no lives left, or if the invaders reach the bottom of the screen. You cannot shoot down bombs which have been dropped, nor can you shoot if you have a missile still in play. To move your base press the Z to go left and M to go right. To shoot a missile press V. ■

```
10 HS=0
20 MODE 5
30 VDU23,255,16,16,56,56,255,255,0,0
40 VDU23,254,0,0,16,16,16,16,0,0
50 VDU23,253,40,124,84,124,254,186,146,0
60 VDU23,252,15,31,50,255,255,63,31,15
70 VDU23,251,240,248,76,255,255,252,248,240
80 DIM A$(5),X(5),Y(5)
90 S=0:X=10:Y=7:Z=0:D=3:L=3:A=30:B=0:U=10
100 FOR I=1 TO 20
110 SOUND1,-15,200,1
120 A$=INKEY$(5)
130 NEXT
140 FOR I=1 TO 5
150 A$(I)=" * * * * * * * * "
160 X(I)=0:Y(I)=I*2+8
170 PRINTTAB(X(I),Y(I))A$(I)
180 NEXT
185 F=1
190 FOR I=1 TO 5
200 IF A$(I)="" N=N+1
210 IF A$(I)>" PRINTTAB(X(I),Y(I))" (17 SPACES) "
220 A$=INKEY$(0)
230 X(I)=X(I)+F
240 IF X(I)=0 Y(I)=Y(I)+0.5
250 SOUND0,-15,250,5
260 IF A$(I)>" PRINTTAB(X(I),Y(I))A$(I)
270 *FX15,0
280 IF Y(I)=30 AND A$(I)>" GOTO 630
290 PRINTTAB(B,A-1) " :IF A=30 AND B=X+1 L=L-1:IF L=0 GOTO 630
300 IF A=30 A=20:B=RND(19)
310 IF B=0 GOTO 300 ELSE PRINTTAB(B,A)"CHR$(254)"
320 A=A+1
330 IF A$="" A$=INKEY$(0)
340 X=X+(A$="Z")-(A$="M")
350 X=X+(X=17)-(X=0)
360 PRINTTAB(X,30)" CHR$(255) "
370 IF A$="V" AND Y=7 Y=29:Z=X+1:SOUND0,-15,255,10
380 IF Y=8 AND(Z=U OR Z=U+1) PRINTTAB(U,8) " :S=S+1000:U=18
390 PRINTTAB(Z,Y) "
400 IF Y>7 Y=Y-1
410 IF Y>7 PRINTTAB(Z,Y)"CHR$(254)"
420 FOR J=5 TO 1 STEP -1
430 IF A$(J)="" (17 SPACES) " A$(J)=""
440 IF INT(Y(J))<>Y NEXT:GOTO 520
450 C=(Z-X(J))+1
460 A$=MID$(A$(J),C,1)
470 IF A$<>"CHR$(253)" NEXT:GOTO 520
480 S=S+RND(5)*100
490 A$(J)=LEFT$(A$(J),(C-1))+ " +RIGHT$(A$(J),(17-C))
500 D=(D/50)*49
510 PRINTTAB(Z,Y) " :Y=7
520 NEXT J:IF N=5 GOTO 610
530 PRINTTAB(U,8) "
540 IF X(1)=0 OR X(1)=3 F=F*-1
550 IF U<18 U=U+1
560 IF U=18 AND RND(5)>4 U=0
570 N=0
580 IF U<18 PRINTTAB(U,8)"CHR$(252)CHR$(251)"
590 PRINTTAB(7,5) S;SPC(4);L
600 GOTO 190
610 D=D-1
620 GOTO 140
630 FOR I=1 TO 30
640 SOUND0,-15,250,3
650 A$=INKEY$(10)
660 NEXT
670 IF S>HS HS=S
680 CLS
690 PRINTTAB(0,10)"HIGH SCORE ";HS
700 IF INKEY$(10)="" GOTO 700 ELSE GOTO 90
```

Program 2.

# dk'tronics

# ZX 80/81 Hardware SPECTRUM Software

## ZX KEYBOARD

The case is large enough for both the computer (81 or Spectrum) and the power supply to fit inside. *Requires no soldering*



**Also suitable for Spectrum**  
*REQUIRES NO SOLDERING*

**Fully cased with numeric pad £45**  
**Uncased with numeric pad £30**  
**Case £15**

## NEW FROM dk'tronics

- (A) 16K Ram Massive Add On Memory Fully assembled and tested £19.95
- (B) 64K Memory Expansion £49.95
- (C) 4K Tool kit full of utilities to aid the programmer in constructing and de-bugging E. Prom version for use with graphics Rom £9.96  
Cassette version £6.95
- (D) Flexible ribbon connector (as illustrated) £10

The DK Graphic module is our latest ZX81 accessory. This module, unlike most other accessories fits neatly inside your computer under the keyboard. The module comes ready built, fully tested and complete with a 4K graphic ROM. This will give you an unbelievable 448 extra pre-programmed graphics, your normal graphic set contains only 64. This means that you now have 512 graphics and with their inverse 1024. This now turns the 81 into a very powerful computer, with a graphic set rarely found on larger more expensive machines. In the ROM are lower case letters, bombs, bullets, rockets, tanks, a complete set of invaders graphics and that only accounts for about 50 of them, there are still about 400 left that may give you an idea as to the scope of the new ROM. However, the module does not finish there, it also has a spare holder on the board which will accept a further 4K of ROM/IRAM. This holder can be fitted with a 1K/2K/IRAM and so you can create your own custom character sets.

**£29.95**

## 4K Graphics Rom



SOME OF THE GRAPHICS NOW POSSIBLE ON THE ZX81

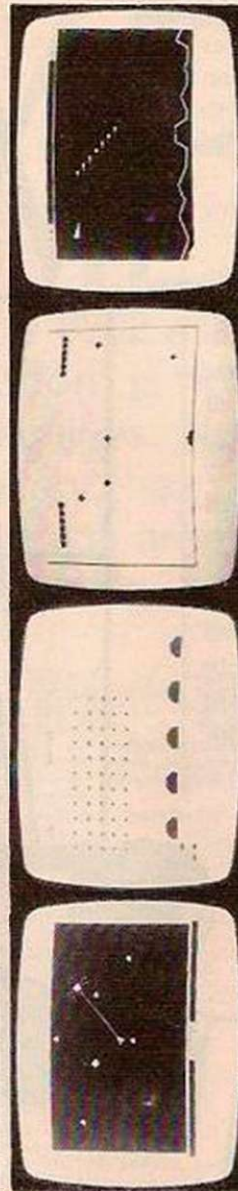

## 16K GRAPHICS ROM SOFTWARE

★ ASTEROIDS

★ SPACE INVADERS

★ CENTIPEDE

★ DEENDER

# dk'tronics

Send off the coupon today or telephone Great Yarmouth 0493j 602453 for our answering service (available 24 hours a day, 7 days a week) quoting Barclaycard or Access number (please add on £1 for P/P)

**23 Sussex Road,  
Gorleston,  
GREAT YARMOUTH,  
Norfolk.**



Please send me ..... @ £ .....  
Please send me ..... @ £ .....  
Please send me ..... @ £ .....  
Please send me ..... @ £ .....  
Please send me ..... @ £ .....  
Please add on £1.25 for P/P. I enclose £ .....

Name  
Address

Cheques/P.O. payable to D.K. Tronics.

THIS ASSEMBLER was developed on a Vic-20 with 16K RAM pack. The program occupies slightly less than 9K but requires more than 13K to run. I have found that the best way to store the assembled code is near the top of memory — locations 53 to 56 on the Vic — Poked low because string variables grow downwards and can interfere.

Although it has been written on a Vic, it can be entered on a Pet with no alterations at all, and with little alteration on most 6502 micros. The source code is entered as if it is a Basic program — that is, each line has a line number and the assembler sorts these into numerical order. The lines are input to the machine by opening a file to the keyboard. This means that there is no “?” prompt, and also enables screen editing.

To list your whole program, type List and press Return. The program is then displayed 15 lines at a time. After each section press E to stop listing, or any other key to continue. Do not press the Stop key as you will break out of the assembler, not the listing.

Other direct commands are as follows:

- LISTx will display the program as above, but beginning at line x.
- NEW clears your program.
- ASSEMBLE displays a hexadecimal assembly of your program.
- ASSEMBLEM as above, but also loads the machine code into memory, as specified within the source code.
- SAVE “program name” outputs the source code to tape as a file named “program name”.
- LOAD “program name” loads “program name” from tape.
- \*SAVE “program name” x-y saves memory from location x to location y and names it “program name”.
- \*LOAD “program name” loads “program name” into memory, returning start and end addresses.
- DISASSx disassembles from location x, codes as for the assembler. One screen is displayed at a time. Hit E to end or any other key to continue.
- ?Hx returns the hexadecimal value of the denary number x.
- ?Dx returns denary value of hexadecimal x.
- END exits the assembler.

Commands are not altogether standard, and spaces are very important — they enable the main assembler routines to split each line into its different sections. Necessary spaces are marked here as [S]. Numbers can be entered in three different forms — as labels, denary or hexadecimal numbers. Labels are preceded by a full stop, and hexadecimal numbers by a \$. Labels can be defined as follows:

```
10DL[S] SCREEN[S] 4096
```

This defines a label called Screen, and sets it equal to the denary number 4096. Alternatively:

```
20.LOOP[S] STA[S].SCREEN
```

On reaching this line, the label Loop is set equal to the location of the command follow-

# VIC-20

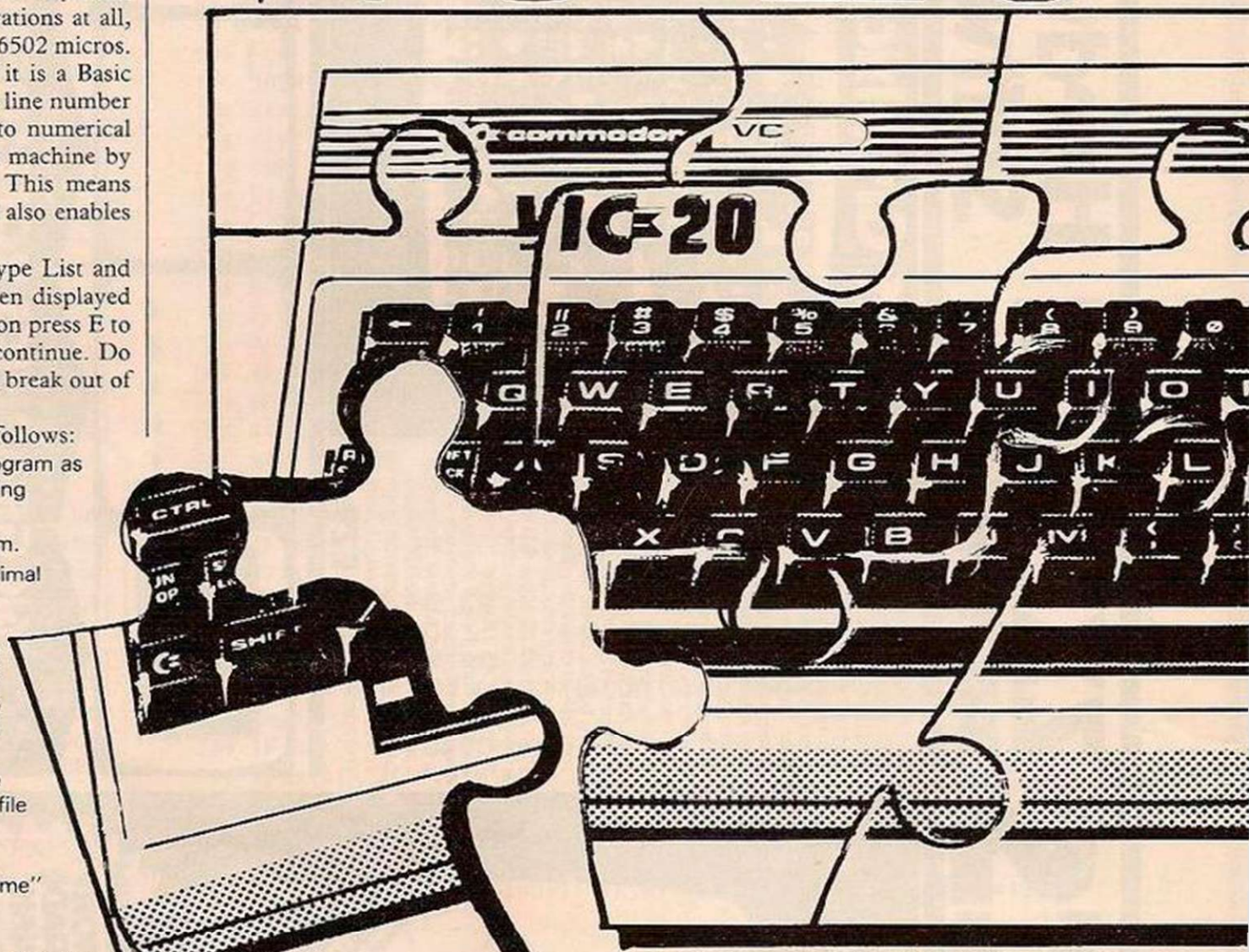

ing — the Sta command.

Also, the label Screen would on assembly by 4096. be substituted

You are not confined to calculating your own location values. Up to 10 numbers or can follow the commands. For example:

```
20.LOOP[S] STA[S].SCREEN+$FF-200
```

This will be calculated by the assembler to give 4151 denary.

To enter a series of letters or graphics, the Byt command is used. This has two alternatives:

```
10 BYT 'THIS IS A TEST
```

The apostrophe before “This” tells the assembler to use ASCII codes.

```
20 BYT PTHIS IS A TEST
```

The P tells the assembler to use CBM screen codes. Branching can be done to either a label or a specified location.

To specify the load location the “\*=” command is used. For example,

```
10 *= s 675
```

continues assembly from 675 denary.

```
50 *= s $fff
```

continues assembly from fff hexadecimal. The last line of the source code must be an End command, otherwise the program will loop indefinitely.

For absolute addressing the mnemonic is typed, followed by a space and then the

location — number or label. For example:

```
10 LDA[S] SCREEN
```

In immediate addressing, the mnemonic is typed, followed by a #, a space, and then the number or label. For example:

```
10 LDX# [S] 200
```

For absolute indexed addressing, the index register to be used is placed immediately after the mnemonic, then a space, then the location. For example:

```
10 LDAX[S] 1000
```

```
20 INCY[S].LOC
```

With zero-page addressing, a Z follows the mnemonic, before any index register:

```
10 LDAZ[S] 100
```

```
20 DECZX[S] 100
```

In indirect addressing, the index register required is placed in brackets after the mnemonic:

```
10 LDA(Y)[S] 100
```

```
20 STA(X)[S] 150
```

An indirect jump has an I in brackets:

```
10 JMP(I)[S] 2000
```

For accumulator addressing, the shift and rotate instructions to be carried out on the accumulator are followed by an A:

```
10 LSRA
```

```
20 ROLA
```

Here are the main sections of the program:

10 to 70 read mnemonic data and number of bytes per command.

100 to 440 run through your program and supply each line with its memory

# ASSEMBLER

This 6502 assembler, written by Philip Horton, is not solely applicable to Vic machines. Numbers can be entered as denary, hex numbers, or as labels — and you are not confined to calculating your own location values.

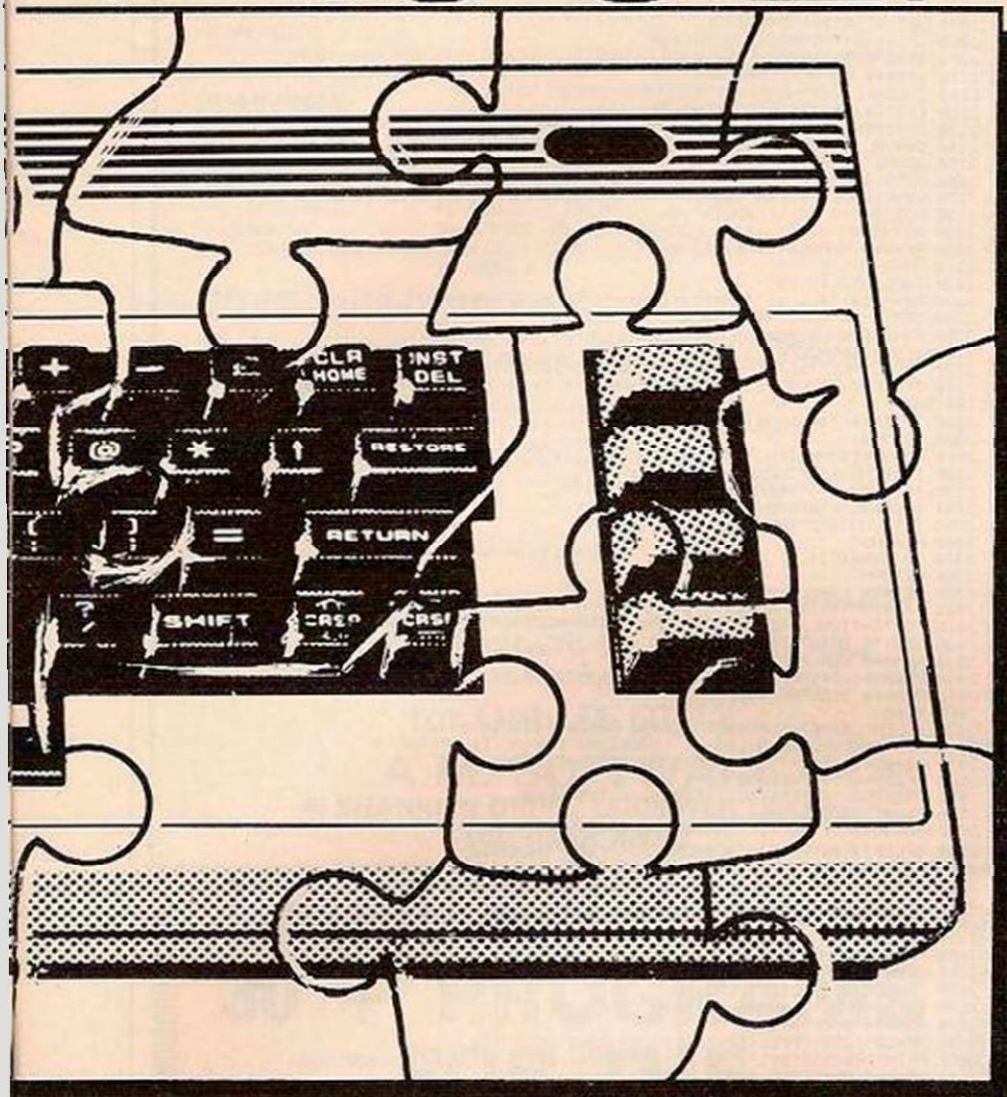

```
10 CLR:PRINT "J":DIM L$(200),A$(255),LA$(50),P(50),D$(200),C$(200)
20 DIM A$(255):FOR J=0 TO 254:READ A$(J):NEXT
30 FOR J=0 TO 255:IFA$(J)="" THEN READ A$(J)
40 NEXT
50 PRINT "JM 6502 ASSEMBLER"
60 PRINT "
70 PRINT "(C) P.J. HORTON 1982M"
80 GOTO 1410:REM *** INPUT ROUTINE ***
90 J=0
100 REM *** SETUP FOR ASSEMBLY ***
110 J=J+1:C=0:D$(J)=0
```

```
120 ILEFT$(L$(J),1)="." THEN 370
130 ILEFT$(J)="END" THEN 450
140 C=C+1:IF C=LEN(L$(J)) THEN 190
150 IEND$(L$(J),C,1)="" THEN C=C+1:MID$(L$(J),C,1):GOTO 140
160 IFC$(J)="BYT" THEN GOSUB 1050:GOTO 110
170 IFC$(J)="*" THEN GOSUB 230:GOTO 110
180 IFC$(J)="DL" THEN GOSUB 290:GOTO 110
190 FOR F=0 TO 255
200 IFC$(J)="" OR A$(F) THEN NEXT:PRINT "SYNTAX ERROR IN":ER=1:GOTO 1900
210 D=D+A$(F)
220 GOTO 110
230 REM *** NEW MEM LOC ***
240 FOR K=1 TO LEN(L$(J)):IF MID$(L$(J),K,1)="" THEN NEXT:PRINT "SYNTAX ERROR IN":
ER=1:GOTO 1900
250 T$=RIGHT$(L$(J),LEN(L$(J))-K)
260 C$(J)="M"
270 GOSUB 2200
280 D=VAL(T$):AD=D:RETURN
290 REM *** DEF LABEL ***
300 NL=NL+1:C=0
310 C=C+1:IF MID$(L$(J),C,1)="" THEN NL$(NL)=L$(NL)+MID$(L$(J),C,1):GOTO 310
320 T$=RIGHT$(L$(J),LEN(L$(J))-C):GOSUB 2200:P(NL)=VAL(T$)
330 IFL=1 THEN 350
340 FOR F=1 TO NL-1:IF LA$(F)=LA$(NL) THEN PRINT "LABEL REPEATED IN":ER=1:GOTO 1900
350 NEXT
360 RETURN
370 REM *** LABEL ***
380 NL=NL+1:C=1
390 C=C+1:IF MID$(L$(J),C,1)="" THEN NL$(NL)=L$(NL)+MID$(L$(J),C,1):GOTO 390
400 IFL=1 THEN 430
410 FOR F=1 TO NL-1:IF LA$(F)=LA$(NL) THEN PRINT "LABEL REPEATED IN":ER=1:GOTO 1900
420 NEXT
430 P(NL)=D
440 GOTO 140
450 REM *** ASSEMBLE ***
460 PRINT "M LOC CODE" SC=0
470 M=0
480 PRINT:FOR F=1 TO J-1
490 IFC$(F)="M" THEN AD=D+(F+1):GOTO 700
500 IFC$(F)="DL" THEN 700
510 IFC$(F)="B" THEN GOSUB 1050:GOTO 690
520 PRINT:PRINT D$(F):N=N+1
530 FOR K=0 TO 255:IFA$(K)="" OR C$(F) THEN NEXT
540 DN=K:GOSUB 740
550 PRINT TAB(12);H$;
560 IFLA=1 THEN GOSUB 1350
570 IFA$(K)=1 THEN PRINT:GOTO 690
580 ILEFT$(C$(F),1)="B" AND C$(F)="" BIT THEN GOSUB 850:GOTO 690
590 IFA$(K)=2 THEN GOSUB 940:GOTO 690
600 REM *** 2 BYTE JMP ETC. ***
610 FOR K=LEN(L$(F)) TO 1 STEP -1:IF MID$(L$(F),K,1)="" THEN NEXT
620 T$=RIGHT$(L$(F),LEN(L$(F))-K)
630 GOSUB 2200
640 T=VAL(T$):D1=INT(T/256):D2=T-D1*256
650 DN=D2:GOSUB 740:PRINT TAB(15);H$;
660 IFLA=1 THEN GOSUB 1350
```

(continued on next page)

location, and also set up any labels — either defined or from a full-stop command.

450 to 1400 assemble your program, into memory if required. These lines include:

740 to 840 denary to hex converter for numbers up to 65535 — FFFF.

1010 to 1040 hex to denary converter.

1290 this line converts a letter or graphic into CBM screen Poke codes.

1410 to 2190 contain the input routine which accesses all other parts of the assembler.

2200 to 2380 one subroutine used by all parts of the program to convert the string T\$ to a denary number. It is returned as T\$.

2450 to 2660 are where the disassembler is accessed by the input routine.

2660 is where the CHR\$ commands open inverted commas and then delete them. This prevents, for example, a clear screen command from interfering with any printout.

2670 to 2890 are the subroutines which output memory to tape and vice versa.

2900 to 3150 hold mnemonic data and data to give the number of bytes required by each command.

Now here are the variables:

A\$(n) 6502 mnemonics.

A%(n) number of bytes required by each of the commands.

L\$(n) each line of your program.

C\$(n) the command on each line of your program.

D%(n) the location of each line of your program in memory.

Each of the last three arrays are Dimensioned to 200 elements, but this can be altered as required, by changing line 10.

NL the number of labels so far encountered.

LA\$(n) the names of the above labels.

P(n) the location in memory of each of the above labels.

The label arrays are Dimensioned to 50 elements, but can also be altered as required at line 10.

L\$ the line that the input routine is currently working on.

N the number of lines in your program.

DN denary number for conversions.

H\$ hex number for conversions.

LA flag used to give "Load on assembly".

C counter used to control the position in the line of program that the assembler is dealing with.

ER error report flag, to give a line number after an error in the source code.

SC the number of lines so far printed on the screen for List, Disass, etc.

Finally, here are the error reports.

SYNTAX A direct command has not been understood.

ERROR There is a mistake in line x of the source code.

SYNTAX ERROR IN x The label defined in line x has already been used in the code.

LABEL REP-EATED IN x The label mentioned in line x has not been defined.

NO SUCH LABEL IN x The user has tried assembling with no code in the memory.

ERROR

(continued from previous page)

```
670 IN=D1 GOSUB740 PRINTTAB(15);H#
680 IFLA=1THENGOSUB1250
690 SC=SC+1 IFSC=11THENGOSUB720
700 NEXT RETURN
710 REM*** SCREEN FULL ***
720 GETZ IFZ="" THEN720
730 PRINT "Z" SC=0 RETURN
740 REM*** DEC-HEX ***
750 H1=INT(DN/4096)
760 D2=DN-N1*4096 N2=INT(D2/256)
770 D3=D2-N2*256 N3=INT(D3/16)
780 D4=D3-N3*16 N4=D4
790 H5=CHR(N1+48-(N1>9)*7)
800 H6=H5+CHR(N2+48-(N2>9)*7)
810 H7=H6+CHR(N3+48-(N3>9)*7)
820 H8=H7+CHR(N4+48-(N4>9)*7)
830 ILEFT$(H5,1)="0"ANDLEN(H5)>2THENH5=RIGHT$(H5,LEN(H5)-1) GOTO830
840 RETURN
850 REM*** BRANCH ***
860 FORK=LEN(L$(F))TO1STEP-1 IFMID$(L$(F),K,1)="" THENNEXT
870 T=RIGHT$(L$(F),LEN(L$(F))-K)
880 GOSUB2200
890 IN=VAL(T$) T=IN(F) IFINDTTHENDN=DN-T-2 GOTO910
900 DN=255-(T-DN+1)
910 GOSUB740 PRINTTAB(15);H#
920 IFLA=1THENGOSUB1350
930 RETURN
940 REM*** 1 BYTE JMP ETC. ***
950 FORK=LEN(L$(F))TO1STEP-1 IFMID$(L$(F),K,1)="" THENNEXT
960 T=RIGHT$(L$(F),LEN(L$(F))-K)
970 GOSUB2200
980 IN=VAL(T$) GOSUB740 PRINTTAB(15);H#
990 IFLA=1THENGOSUB1350
1000 RETURN
1010 REM*** HEX-DEC ***
1020 DN=0 FORH=1TOLEN(H#)
1030 DN=DN+(ASC(MID$(H#,H,1))-48+(ASC(MID$(H#,H,1))>57)*7)*16+LEN(H#)-H) NEXT
1040 RETURN
1050 REM*** BYT ***
1060 FORJ=LEN(L$(J))TO1STEP-1 IFMID$(L$(J),J,1)=""ANDMID$(L$(J),K,1)="" THEN
NEXT GOTO1080
1070 D=MID$(L$(J),J,1) C=J="B" RETURN
1080 PRINT "SYNTAX ERROR IN" ER=1 GOTO1900
1090 REM*** ASSEMBLE BYT ***
1100 FORJ=LEN(L$(F))TO1STEP-1 IFMID$(L$(F),J,1)="" THEN1130
1110 IFMID$(L$(F),J,1)="" THEN1250
1120 NEXT GOTO1200
1130 B=RIGHT$(L$(F),LEN(L$(F))-J)
1140 FORJ=1TOLEN(B$) PRINT
1150 PRINTD$(F)+J-1; DN=ASC(MID$(B$,J,1)) GOSUB740 PRINTTAB(12);H#
1160 IFTP=1THENPRINT#1;H#
1170 IFLA=1THENGOSUB1350
1180 SC=SC+1 IFSC=11THENGOSUB720
1190 NEXT RETURN
1200 REM*** NUMBER ***
1210 T=RIGHT$(L$(F),LEN(L$(F))-J)
1220 GOSUB2200
1230 IN=VAL(T$) GOSUB740 PRINTTAB(12);H#
1240 IFLA=1THENGOSUB1350
1250 REM*** POKE ALPHA ***
1260 B=RIGHT$(L$(F),LEN(L$(F))-J)
1270 FORJ=1TOLEN(B$) PRINT
1280 PRINTD$(F)+J-1;TAB(12);
1290 DN=(ASC(MID$(B$,J,1))AND128)/20R(ASC(MID$(B$,J,1))AND63)
1300 GOSUB740 PRINTTAB(12);H#
1310 IFTP=1THENPRINT#1;H#
1320 IFLA=1THENGOSUB1350
1330 SC=SC+1 IFSC=11THENGOSUB720
1340 NEXT RETURN
1350 REM*** ASSEMBLER LOADER ***
1360 IFDN=255THENPRINT "NUMBER TOO LARGE IN" ER=1 GOTO1900
1370 POKEAD;DN:AD=AD+1 RETURN
1380 REM*** END ***
1390 IFTP=1THENPRINT#1;"END" CLOSE1
1400 GOSUB720 GOTO1900
1410 REM*** INPUT ***
1420 REM
1430 OPEN2:0
1440 PRINT"READY."
1450 INPUT#2;L$ PRINT
1460 IFLA="NEW"THENFORJ=1TON L$(J)="" NEXT N=0 GOTO1440
1470 ILEFT$(L$,4)="LIST" THEN1980
1480 IFLA="END" THENPRINT"J" END
1490 ILEFT$(L$,5)="DISASS" THEN2450
1500 ILEFT$(L$,1)="" THEN2100
1510 ILEFT$(L$,8)="ASSEMBLE" THEN1800
1520 ILEFT$(L$,4)="LOAD" THEN1700
1530 ILEFT$(L$,5)="*LOAD" THEN2700
1540 ILEFT$(L$,4)="SAVE" THEN1750
1550 ILEFT$(L$,5)="*SAVE" THEN2670
1560 N1=VAL(L$) IFN1=0THENPRINT "SYNTAX ERROR" GOTO1450
1570 IFLA=STR$(VAL(L$))-1+LEN(L$) THEN1650
1580 N=N+1 IFN=1THENL$(1)=L$ GOTO1450
1590 FORJ=1TON-1 IFVAL(L$(J))<N1 THENNEXT
1600 IFVAL(L$(J))=N1 THENL$(J)=L$ N=N-1 GOTO1450
1610 FORK=NTONJSTEP-1
1620 L$(K)=L$(K-1) NEXT
1630 L$(J)=L$
1640 GOTO1450
1650 REM*** SPLAT LINE ***
1660 FORK=1TON IFVAL(L$(K))<VAL(L$) THENNEXT GOTO1450
1670 FORL=KTON L$(L)=L$(L+1) NEXT N=N-1
1680 IFN=0THENN=0
1690 GOTO1450
1700 REM*** LOAD ***
1710 OPEN1:1:0 RIGHT$(L$,LEN(L$)-4)
1720 INPUT#1;H FORJ=1TON
1730 INPUT#1;L$(J) NEXT
1740 CLOSE1 PRINT "PRINT"READY." GOTO1450
1750 REM*** SAVE ***
1760 OPEN1:1:1 RIGHT$(L$,LEN(L$)-4)
1770 PRINT#1;H FORJ=1TON
1780 PRINT#1;L$(J) NEXT
1790 CLOSE1 PRINT "PRINT"READY." GOTO1450
1800 REM*** ENTERED ***
1810 LA=0
1820 IFRIGHT$(L$,1)="" THENLA=1
1830 IFN=0THENPRINT "NO CODE ERROR" GOTO1440
1840 PRINT "PRINT"WORKING..."
1850 FORJ=1TON
1860 H=VAL(L$(J)) H<LEN(STR$(H))-1
1870 L$(J)=RIGHT$(L$(J),LEN(L$(J))-H)
1880 ILEFT$(L$(J),1)="" THENL$(J)=RIGHT$(L$(J),LEN(L$(J))-1) GOTO1830
1890 NEXTJ SN=H GOTO900
1900 REM*** RETURNCOHT ***
1910 IFEF=1THENER=0 PRINT10*J
1920 IFE2=1THENER=0 PRINT10*F
1930 H=SN FORJ=1TON L$(J)=STR$(10*J)+" "+L$(J) GOTO1450
1940 L$(J)=RIGHT$(L$(J),LEN(L$(J))-1) NEXT
1950 FORJ=1TON L$(J)="" NEXT N=0
1960 PRINT"K"
1970 GOTO1440
1980 REM*** LIST ***
1990 SC=0
2000 IFLA="LIST" THENSN=1 GOTO2040
2010 SL=VAL(RIGHT$(L$,LEN(L$)-4))
2020 FORJ=1TON IFSL>VAL(L$(J)) THENNEXT GOTO1440
2030 SL=J
2040 FORJ=SLTON PRINTL$(J)
2050 SC=SC+1 IFSC=15THEN2070
2060 NEXT GOTO1440
2070 GETZ IFZ="" THEN2070
2080 IFZ="" THENPRINT GOTO1440
2090 SC=0 GOTO2050
2100 REM*** CONVERSIONS ***
2110 IFLA="C" THENPRINT "SYNTAX ERROR" GOTO1440
2120 IFMID$(L$,2,1)="" THEN2170
2130 IFMID$(L$,2,1)="" THENPRINT "SYNTAX ERROR" GOTO1440
2140 DN=VAL(RIGHT$(L$,LEN(L$)-2))
2150 GOSUB740 PRINT"HEX" H#
2160 GOTO1440
2170 H=RIGHT$(L$,LEN(L$)-2)
2180 GOSUB1010 PRINT"DEC" DN
2190 GOTO1440
2200 REM*** NUMBER T# ***
2210 N=0
2220 FORL=2TOLEN(T$)
2230 A=MID$(T$,L,1) IFA="" ORA="" ORA="" ORA="" THEN2240
2240 NEXTL N=N+1 T$(N)=A
2250 FI=0 FORNU=1TON
2260 IFNU=1THEN2280
2270 S=(NU)<LEFT$(T$(NU),1) T$(NU)=RIGHT$(T$(NU),LEN(T$(NU))-1)
2280 ILEFT$(T$(NU),1)="" THENH=RIGHT$(T$(NU),LEN(T$(NU))-1) GOSUB1010 T$(NU)=
STR$(DN)
2290 ILEFT$(T$(NU),1)="" THEN2400
2300 NEXTNU
2310 FORNU=1TON IFNU=1THENFI=VAL(T$(1)) GOTO2360
2320 IFS$(NU)="" THENFI=FI+VAL(T$(NU))
2330 IFS$(NU)="" THENFI=FI-VAL(T$(NU))
2340 IFS$(NU)="" THENFI=FI*VAL(T$(NU))
2350 IFS$(NU)="" THENFI=FI/VAL(T$(NU))
2360 NEXTNU
2370 T$=STR$(FI)
2380 RETURN
2390 REM*** LABEL ***
2400 A=RIGHT$(T$(NU),LEN(T$(NU))-1)
2410 FORTE=1TON IFLA$(TE)=A THENL$(NU)=STR$(P(TE)) GOTO2300
2420 NEXTTE PRINT "NO SUCH LABEL IN" E2=1 GOTO1900
2430 REM*** NEW N# ***
2440 N=N+1 T$(N)=LEFT$(T$,L-1) T$(N)=RIGHT$(T$,LEN(T$)-L+1) GOTO2220
2450 REM*** DISSASS ***
2460 SC=0
2470 IFLA="C" THENPRINT "SYNTAX ERROR" GOTO1440
2480 T=RIGHT$(L$,LEN(L$)-6) GOSUB2200 D=VAL(T$) PRINT"J"
2490 SC=SC+1 IFSC=11THENGOSUB720 IFZ="" THEN1440
2500 IFD2=5535 THEN5399
2510 PRINTD2; A=PEEK(D2) IFA(A)="" THEN2550
2520 PRINTTAB(7);A(A)
2530 IFA(A)=1 THENPRINT "GOTO2590
2540 ILEFT$(A$(A),1)="" ANDA$(A)="" BRK" THEN2610
2550 IFA(A)=2 THENDN=PEEK(D2+1) D2=D2+2
2560 IFA(A)=3 THENDN=PEEK(D2+1)+(PEEK(D2+2)*256) D2=D2+3
2570 PRINTTAB(13);DN
2580 PRINT "GOTO2490
2590 D2=D2+1
2600 PRINT "GOTO2490
2610 REM*** BRANCH ***
2620 IFPEEK(D2+1)=127 THEN2640
2630 DN=D2+PEEK(D2+1)+2 D2=D2+2 GOTO2570
2640 REM*** BACK ***
2650 DN=D2-(255-(PEEK(D2+1)+1)) D2=D2+2 GOTO2570
2660 PRINTTAB(7);"BYT";TAB(14);CHR$(34);CHR$(20);CHR$(A) GOTO2590
2670 REM*** NEW TAPE ***
2680 FORJ=6TOLEN(L$) IFMID$(L$,J,1)="" ORCHR$(34) THENNEXT PRINT "SYNTAX ERROR" GOTO
1440
2690 NS=J+1
2700 FORJ=NS+1TOLEN(L$) IFMID$(L$,J,1)="" ORCHR$(34) THENNEXT PRINT "SYNTAX ERROR" G
OTO1440
2710 NS=J-1
2720 F=MID$(L$,NS,NS-NS+1)
2730 FORJ=NS+2TOLEN(L$) IFMID$(L$,J,1)="" THENNEXT PRINT "SYNTAX ERROR" GOTO14
40
2740 T=MID$(L$,NS+2,J-NS-2) GOSUB2200 D2=VAL(T$)
2750 T=RIGHT$(L$,LEN(L$)-J) GOSUB2200 DE=VAL(T$)
2760 OPEN1:1:1;F#
2770 PRINT#1;D2;PRINT#1;DE FORJ=D2TODE
2780 N1=PEEK(J) PRINT#1;N1;NEXT CLOSE1 GOTO1440
2790 REM*** TAPE-NEW ***
2800 FORJ=6TOLEN(L$) IFMID$(L$,J,1)="" ORCHR$(34) THENNEXT PRINT "SYNTAX ERROR" GOTO
1440
2810 NS=J+1
2820 FORJ=NS+1TOLEN(L$) IFMID$(L$,J,1)="" ORCHR$(34) THENNEXT PRINT "SYNTAX ERROR" G
OTO1440
2830 NS=J-1
2840 F=MID$(L$,NS,NS-NS+1)
2850 OPEN1:1:0;F#
2860 INPUT#1;D2;INPUT#1;DE
2870 FORJ=D2TODE INPUT#1;N1;POKEJ;N1;NEXT CLOSE1
2880 PRINT"START ADDRESS";D2
2890 PRINT"END ADDRESS";DE GOTO1440
2900 REM*** MNEMONIC DATA ***
2910 DATASR(L,OR(X)), ORAZ,ASLZ,,PH,ORAW,ASL,,OR,ASL,,EPL
2920 DATADRA(Y), ORAZ,ASLZ,,CLD,ORAY,,ORAY
2930 DATASLX,,JSR,AND(X), BITZ,ANDZ,ROLZ,,PLP,ANDW,ROLA,,BIT,AND,ROL,,SMI
2940 DATAND(Y), ANDZ,ROLZ,,SEC,ANDY,,ANDY
2950 DATAROLX,,RTI,EOR(X), EORZ,LSRZ,,PH,EOB,LSRA,,JMP
2960 DATAEOR,LSR,,BVC,EOR(Y), EORZ,LSRZ,,CLI,EOR,,EORX
2970 DATALSRL,,RFS,ADC(X), ADCZ,ROAZ,,PLA,ADD,ROA,,JMP,I
2980 DATAROR,,RVS,ADC(Y), ADCZ,ROAZ,,SEI,ADY,,ADCY
2990 DATAROP,,STAX,,STYZ,STAZ,STXZ,,DEV,TVR,,STY,STA
3000 DATASTX,,BCC,STAY,,STVZ,STAZ,STXZ,,TVR,STAY,TMS,,STAV,,LDY#
3010 DATALDA(X),LDX,,LDVZ,LDZ,LDVZ,,TRV
3020 DATALDAW,TRV,,LDV,LDZ,LDX,,SCS
3030 DATALDA(Y), LDVZ,LDZ,LDX,LDVZ,,CLV,LDAY,TXV,,LDYX,LDAY,LDY,,CPY#
3040 DATACMP(X), CPVZ,CMPZ,DECZ,,INV,CMP#,,DEY,,CPY,CMP,DEC,,BNE
3050 DATACMP(Y), CMPZ,DECZ,,CLD,CMPY,,CMPY,DEC,,CPY#
3060 DATASBC(X), CPVZ,SBZ,INZ,,INV,SBZ,NOP,,CPY,SBZ,INC,,BEQ
3070 DATASBC(Y), SBZ,INZ,,SED,SBZ,,SBZ,INZ
3080 REM*** BYTES DATA ***
3090 DATA1,2,2,2,1,2,1,3,3,2,2,2,1,3,3,3,2,2,2,2
3100 DATA1,2,1,3,3,3,2,2,2,2,1,3,1,3,1,2,2,2,1,2,1,3,3,3
3110 DATA2,2,2,2,1,3,3,3,1,2,2,2,1,2,1,2,3,3,2,2,2,1,3
3120 DATA3,3,2,2,2,2,1,1,3,3,3,2,2,2,2,2,1,3,1,3,2,2,2
3130 DATA2,2,2,1,2,1,3,3,3,2,2,2,2,2,1,3,1,3,3,3,2,2,2,2
3140 DATA1,2,1,3,3,3,2,2,2,2,1,3,3,3,2,2,2,2,2,1,2,1,3,3,3,2,2,2,2
3150 DATA1,3,3,3
READY.
```

# ZX81 EDITOR

FOR ALL ZX81 PROGRAMMERS

Based on the editing facility available on a DED system 10 mainframe computer the ZX81 EDITOR provides 7 powerful editing functions for the 16K ZX81.

*Demonstration program:*  
 5 LET A\$="VT4;ZA9EPKN>7QUZJKS"  
 10 LET B\$=""  
 15 FOR N=1 TO 19  
 20 LET B\$=B\$+CHR\$(CODE A\$(N)+PEEK 256)  
 25 IF N=5 OR N=16 THEN LET B\$(N)=""  
 30 PRINT B\$  
 35 NEXT N

■ **MERGE**  
 Combine editor with any other program. Option to continue combining indefinitely; available RAM only limitation.

■ **RENUMBER**  
 "R increment"  
 eg) "R 10"

■ **SUBSTITUTE**  
 "S old text\$new text\$line no"  
 eg) "SN\$X\$15:35"

■ **EXTEND**  
 "E line no"  
 eg) "E 5"

■ **TRANSFER**  
 "T first line no, last line no:new first line no, increment"  
 eg) "T15,35:100,1"

■ **DELETE**  
 "D line no:line no" Delete any block of program.

■ **SCROLLED LISTING**  
 "S line no" Continuous scrolling list starting at beginning of program unless otherwise specified. Listing can be stopped at any time for editing.

■ All standard editing functions provided by Sinclair can be used as normal. Quality cassette + full documentation

for Only **£5.50** inc VAT  
 + p & p  
**A.M. SOFTWARE**  
 45 SHANKLIN DRIVE, LEICESTER LE2 3QE.  
 TEL: (0533) 706240.

## 30 + PROGRAMS FOR THE BBC MICRO

This Book contains program listings, with explanations and tips on using the BBC Micro  
 GAMES UTILITIES GRAPHICS & MUSIC  
 'ASTRO RUN' 'SCREEN PLAY' '3D GRAPHICS' ...  
 Most programs will run on Models A & B  
 Edited by C.J. Evans, various Authors. April 82  
 £5.00 inclusive of p&p

## CASSETTE LEADS FOR THE BBC MICRO

The BBC Micro comes with an incomplete lead  
 7Pin Din to 7Pin Din  
 7Pin Din to 5Pin Din & 2.5mm minijack  
 7Pin Din to 2x3.5mm & 1x2.5mm minijacks  
 7Pin Din PLUGS  
 PRINTER CABLE (Centronics type) Two for

£4.65 p&p 35p  
 £4.65 p&p 35p  
 £4.65 p&p 35p  
 £0.65 p&p 35p  
 £17.00 p&p 50p

## RAM CHIPS

4816 As used in the BBC Micro 8 Chips gives 16k  
 2114 As used in the Acorn Atom 20 Chips gives 10k  
 6116 As can be used to replace the Ram chip inside the ZX81 to give 2k internal Ram

£4.00 each  
 £1.20 each  
 £7.50 each  
 p&p Ram chips 50p per order

Programs & Hardware designs for the BBC Micro wanted.  
 VAT INCLUDED WHERE APPLICABLE  
 Send SAE for full Price List

**C.J.E. MICROCOMPUTERS**

25 HENRY AVENUE, RUSTINGTON,  
 W. SUSSEX BN16 2PA (09062) 74998

# NEW ZX PRODUCTS FROM PRINT 'N' PLOTTER



**ZX GRAPHICS PROGRAMMING MADE EASY**  
 Professionally-produced full colour A4, 24 page Manual packed with ZX Graphics Programming techniques Information Graphics Sketchpads. Saving your 'Art' Graphics Stringing and ZX Printer Graphics.  
 Only **£1.50**

Illustrated at every stage

## ZX PRINTER PAPER £10.95!

## GOOD NEWS FOR PRINTER OWNERS

**ZX PRINTER PAPER**  
 Five rolls of Printer paper – identical to Sinclair's but a quid cheaper! each roll is approximately 65 feet long – excellent printing standard ... fast delivery  
**£10.95** for 5 rolls.

### Also available:

**Print 'n' Plotter Jotters** – 100 pages of Print and Plot grids in fully-bound Pad . only £3.50.  
**Print 'n' Plotter Films** – The re-usable transparent film version of the Jotter ideal for copying graphics from photos, illustrations, charts etc only £2.25.

Post today to: Print 'n' Plotter Products (Y7) 19 Borough High Street London SE1 9SE (or detail your requirements in a letter).  
 Please forward me .....

..... Manuals @ £1.50 each.  
 ..... Packs of Printer Paper @ £10.95 each.  
 ..... Print 'n' Plotter Jotters @ £3.50 each.  
 ..... Print 'n' Plotter Films @ £2.25 each

All prices include U.K. VAT, postage and packing.  
 Remittance enclosed.  Please bill my Access/Barclaycard/Visa

Name \_\_\_\_\_ No: \_\_\_\_\_  
 Address: \_\_\_\_\_

**Print 'n' Plotter Products**

Figure 6. Pointer table REM 1.

00	000000	000000	000000
01	000000	000000	000000
02	000000	000000	000000
03	000000	000000	000000
04	000000	000000	000000
05	000000	000000	000000
06	000000	000000	000000
07	000000	000000	000000
08	000000	000000	000000
09	000000	000000	000000
0A	000000	000000	000000
0B	000000	000000	000000
0C	000000	000000	000000
0D	000000	000000	000000
0E	000000	000000	000000
0F	000000	000000	000000
10	000000	000000	000000
11	000000	000000	000000
12	000000	000000	000000
13	000000	000000	000000
14	000000	000000	000000
15	000000	000000	000000
16	000000	000000	000000
17	000000	000000	000000
18	000000	000000	000000
19	000000	000000	000000
1A	000000	000000	000000
1B	000000	000000	000000
1C	000000	000000	000000
1D	000000	000000	000000
1E	000000	000000	000000
1F	000000	000000	000000
20	000000	000000	000000
21	000000	000000	000000
22	000000	000000	000000
23	000000	000000	000000
24	000000	000000	000000
25	000000	000000	000000
26	000000	000000	000000
27	000000	000000	000000
28	000000	000000	000000
29	000000	000000	000000
2A	000000	000000	000000
2B	000000	000000	000000
2C	000000	000000	000000
2D	000000	000000	000000
2E	000000	000000	000000
2F	000000	000000	000000
30	000000	000000	000000
31	000000	000000	000000
32	000000	000000	000000
33	000000	000000	000000
34	000000	000000	000000
35	000000	000000	000000
36	000000	000000	000000
37	000000	000000	000000
38	000000	000000	000000
39	000000	000000	000000
3A	000000	000000	000000
3B	000000	000000	000000
3C	000000	000000	000000
3D	000000	000000	000000
3E	000000	000000	000000
3F	000000	000000	000000
40	000000	000000	000000
41	000000	000000	000000
42	000000	000000	000000
43	000000	000000	000000
44	000000	000000	000000
45	000000	000000	000000
46	000000	000000	000000
47	000000	000000	000000
48	000000	000000	000000
49	000000	000000	000000
4A	000000	000000	000000
4B	000000	000000	000000
4C	000000	000000	000000
4D	000000	000000	000000
4E	000000	000000	000000
4F	000000	000000	000000
50	000000	000000	000000
51	000000	000000	000000
52	000000	000000	000000
53	000000	000000	000000
54	000000	000000	000000
55	000000	000000	000000
56	000000	000000	000000
57	000000	000000	000000
58	000000	000000	000000
59	000000	000000	000000
5A	000000	000000	000000
5B	000000	000000	000000
5C	000000	000000	000000
5D	000000	000000	000000
5E	000000	000000	000000
5F	000000	000000	000000
60	000000	000000	000000
61	000000	000000	000000
62	000000	000000	000000
63	000000	000000	000000
64	000000	000000	000000
65	000000	000000	000000
66	000000	000000	000000
67	000000	000000	000000
68	000000	000000	000000
69	000000	000000	000000
6A	000000	000000	000000
6B	000000	000000	000000
6C	000000	000000	000000
6D	000000	000000	000000
6E	000000	000000	000000
6F	000000	000000	000000
70	000000	000000	000000
71	000000	000000	000000
72	000000	000000	000000
73	000000	000000	000000
74	000000	000000	000000
75	000000	000000	000000
76	000000	000000	000000
77	000000	000000	000000
78	000000	000000	000000
79	000000	000000	000000
7A	000000	000000	000000
7B	000000	000000	000000
7C	000000	000000	000000
7D	000000	000000	000000
7E	000000	000000	000000
7F	000000	000000	000000
80	000000	000000	000000
81	000000	000000	000000
82	000000	000000	000000
83	000000	000000	000000
84	000000	000000	000000
85	000000	000000	000000
86	000000	000000	000000
87	000000	000000	000000
88	000000	000000	000000
89	000000	000000	000000
8A	000000	000000	000000
8B	000000	000000	000000
8C	000000	000000	000000
8D	000000	000000	000000
8E	000000	000000	000000
8F	000000	000000	000000
90	000000	000000	000000
91	000000	000000	000000
92	000000	000000	000000
93	000000	000000	000000
94	000000	000000	000000
95	000000	000000	000000
96	000000	000000	000000
97	000000	000000	000000
98	000000	000000	000000
99	000000	000000	000000
9A	000000	000000	000000
9B	000000	000000	000000
9C	000000	000000	000000
9D	000000	000000	000000
9E	000000	000000	000000
9F	000000	000000	000000
AA	000000	000000	000000
AB	000000	000000	000000
AC	000000	000000	000000
AD	000000	000000	000000
AE	000000	000000	000000
AF	000000	000000	000000
B0	000000	000000	000000
B1	000000	000000	000000
B2	000000	000000	000000
B3	000000	000000	000000
B4	000000	000000	000000
B5	000000	000000	000000
B6	000000	000000	000000
B7	000000	000000	000000
B8	000000	000000	000000
B9	000000	000000	000000
BA	000000	000000	000000
BB	000000	000000	000000
BC	000000	000000	000000
BD	000000	000000	000000
BE	000000	000000	000000
BF	000000	000000	000000
C0	000000	000000	000000
C1	000000	000000	000000
C2	000000	000000	000000
C3	000000	000000	000000
C4	000000	000000	000000
C5	000000	000000	000000
C6	000000	000000	000000
C7	000000	000000	000000
C8	000000	000000	000000
C9	000000	000000	000000
CA	000000	000000	000000
CB	000000	000000	000000
CC	000000	000000	000000
CD	000000	000000	000000
CE	000000	000000	000000
CF	000000	000000	000000
D0	000000	000000	000000
D1	000000	000000	000000
D2	000000	000000	000000
D3	000000	000000	000000
D4	000000	000000	000000
D5	000000	000000	000000
D6	000000	000000	000000
D7	000000	000000	000000
D8	000000	000000	000000
D9	000000	000000	000000
DA	000000	000000	000000
DB	000000	000000	000000
DC	000000	000000	000000
DD	000000	000000	000000
DE	000000	000000	000000
DF	000000	000000	000000
E0	000000	000000	000000
E1	000000	000000	000000
E2	000000	000000	000000
E3	000000	000000	000000
E4	000000	000000	000000
E5	000000	000000	000000
E6	000000	000000	000000
E7	000000	000000	000000
E8	000000	000000	000000
E9	000000	000000	000000
EA	000000	000000	000000
EB	000000	000000	000000
EC	000000	000000	000000
ED	000000	000000	000000
EE	000000	000000	000000
EF	000000	000000	000000
F0	000000	000000	000000
F1	000000	000000	000000
F2	000000	000000	000000
F3	000000	000000	000000
F4	000000	000000	000000
F5	000000	000000	000000
F6	000000	000000	000000
F7	000000	000000	000000
F8	000000	000000	000000
F9	000000	000000	000000
FA	000000	000000	000000
FB	000000	000000	000000
FC	000000	000000	000000
FD	000000	000000	000000
FE	000000	000000	000000
FF	000000	000000	000000

David Horne's ZX-81 disassembler prompted many readers to ask for a similar facility for their new Sinclairs. Now you can disassemble your Spectrum.

# SPECTRUM DISASSEMBLER

THIS SPECTRUM disassembler is based on the ZX-81 disassembler that appeared in the July issue of *Your Computer*. The method used for creating the long Rem statement is repeated and the use of tables to point to commands is also retained. I know from your letters that

many of you have already successfully produced a Spectrum disassembler from the original article, but for those who did not, here is how to do it.

We use three tables to decode the machine-code listings. The first table in Rem 1 points to the mnemonics of the assembly language in Rem 2 and Rem 3. Figure 1 shows a typical output and figure 2 shows how the output was achieved. The first character of Rem 1 points to the command table Rem 2 and the second and third characters point to the extension table Rem 3.

The initial problem is to produce the first Rem which contains 768 bytes. Create Rem 1 with 100 characters — see figure 3. Edit the line number to create REMs 2 to 7 inclusive. Then type Rem 8 with 26 characters. It helps if you Poke 23609, 255 first.

8 REM 123 . . . 3 4 5 6 (26 characters)  
Save the code produced so far by Save "1". To check, type

PRINT PEEK 24528  
This should give the answer 13. Type in the following for one long Rem statement

POKE 23757, 2  
POKE 23758, 3

Then type  
2 REM  
3 REM  
LIST  
POKE 23756, 0

to prevent editing this line and Save "2".  
Next enter the data loader. Type:

2 For A = 23760 to 24527  
3 Input B  
4 Poke A, B  
5 PRINT A ; TAB 8 ; B  
6 NEXT A

Bytes table Rem 4  
Number of parts to Z-80 op code

CB	IX IY	ED
All ones	All ones except	All ones
	034 3	
	052 2	
	053 2	
	054 3	
	070 2	
	078 2	
	086 2	
	094 2	
	102 2	
	110 2	
	112 2</	



In the last part of this series, Tony Edwards explains the use of flowcharts in computer-language translation.

WHERE THE DIALECT of Basic to be translated is so alien to the one your machine uses, the kind of direct translation discussed in the previous articles in this series is difficult or impossible to apply. This is, of course, also applicable to translations from one language to another.

The method I shall use is to revert to flowcharting — that basic step in programming which we all know is essential, but which we usually manage to do without.

Our regular readers will have seen a form of flowchart in this magazine each month. It is heavily disguised as a puzzle and will be found

in *Your Computer's Competition Corner*. The type of flowchart we will use is more stylised so that it can be more readily transformed into Basic, your dialect of the language. Once you have mastered the art, you should be able to change the Competition Corner puzzle into a stylised flowchart and then into Basic so your computer can solve it for you.

A flowchart is a number of symbols joined up by usually one-way paths. Different programmers use different symbols, but so long as they are consistent within a chart that does not matter. The symbols I use are shown in figure 1.

The start, stop, go to and from symbols are self-evident. The input and output symbols are graphic: they represent an input card and a roll of used copy output. The assignment

# FLUEN

statement box is to contain a list of statements assigning values to variables or altering the value of variables.

These statements must be in a set order and contain no branching or double flows. They are just a series of operations to be undertaken in order. Branching takes place in the decision boxes. These contain a simple statement which can be answered "yes" or "no" and the path leading from the box is chosen dependent on the answer.

Only decision boxes have two paths away, but any type of box could have multiple paths leading to it. The cardinal rule is that at each part of the diagram there is only one path to take.

Let us produce a flowchart to play the game of noughts and crosses. My suggestion is shown in figure 2. If you prefer another one it does not matter. Provided there is only one path from each part of the diagram, all flowcharts are equally valid and there are numerous ways of arranging this game.

Check through this flowchart to see that it complies with the rules I have just set out. It is usual to number at least some of the boxes so that they can be referred to, but the sequence of these numbers has no significance.

The next step is to enlarge the boxes maintaining the structure of the diagram so that it adheres to the rules of your programming language. If you are not familiar with flowcharting, it is worth working through the whole chart to produce the Basic code for the game. Here I shall content myself with the boxes 1, 6 and 9.

I have decided to set up an array for the game board and will call it A(9). If your dialect does not have arrays use the variables A1 to A9. Figure 3 is the next stage of the flowchart and figure 4 is the final stage which is practically the code for the program. Work through these to see the logical connections. You will see that box 1 has been split into boxes 1.1 and 1.2 and the others likewise.

The final step is to write out the code with the correct Gotos and to clean it up. Eagle-eyed programmers will see that I have jumped out of a For-Next loop in 6.1 and 9.1, but my method of making this possible is in a previous article or you could use the methods shown in the listing of program 1.

```
10 DIM A(9) : DEFINT A-Z : RANDOM
20 R! = RND(0)
30 IF R! > .5 THEN 100
40 (input players move)
```

```
(*DICE THROW*)
VAR LINE : INTEGER ;
PROC RANDOM ;
VAR M, N, P : INTEGER;
BEGIN
REPEAT
M := N*125
IF M < 0 THEN
M := ABS(M)
N := M ; P := M
P := P MOD 7 ;
UNTIL P < 0
WRITE (P#)
```

```
END ;
BEGIN
WRITE (28, 31, 220, 'DICE') ;
FOR LINE := 1 TO 8 DO
WRITE (13, 220)
```

```
N := 99
RANDOM
WRITE (32, 32)
RANDOM
END
Program 4.
```

```
10 N = 99 : REM SEED FOR RANDOM
NOS
20 GOSUB 1000
```

```
1000 REM SUBROUTINE FOR RANDOM
DICE THROW
1010 M = N * 125
1020 IF M < 0 THEN M = M * -1
1030 N = M
1040 P = M
1050 P = P - INT (P/7) * 7
1060 IF P = 0 THEN 1010
1070 PRINT P
1080 RETURN
Program 5.
```

```
100 FOR I = 1 TO 9
110 IF A(I) <> 0 THEN 110
120 A = I : I = 10
130 NEXT I
140 A(A) = 1 : B = 0
150 FOR I = 1 TO 9
160 IF A(I) = 0 THEN B = 1
170 NEXT I
180 IF B = 1 THEN 40 ELSE (game drawn)
Program 1.
```

```
1000 IF A < 10 AND IF B < 0 THEN Z = 0
ELSE Z = 1
1010 IF C < 100 AND IF Z = 0 THEN C = C
- 100 ELSE Z = 1
1020 IF Z = 0 GOSUB 2000 ELSE GOSUB
3000
1030 ON D GOSUB 100, 200, 400, 400
Program 2.
```

```
10 IF A < 10 THEN 30
20 IF B < 0 THEN 40
30 Z = 1 : GOTO 50
40 Z = 0
50 IF C < 100 THEN 70
60 Z = 1 : GOTO 120
70 IF Z = 0 THEN 90
80 GOTO 120
90 C = C - 100
100 GOSUB 2000
110 GOTO 130
120 GOSUB 300
130 IF D = 1 THEN 100
140 IF D = 2 THEN 200
150 GOTO 400
Program 3.
```

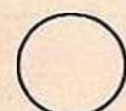

Stop/Start

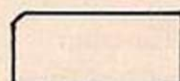

Input

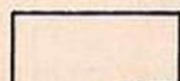

Output

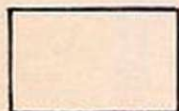

Assignment/Statement

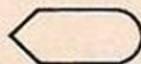

From/Goto

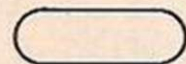

Decision

Figure 1.

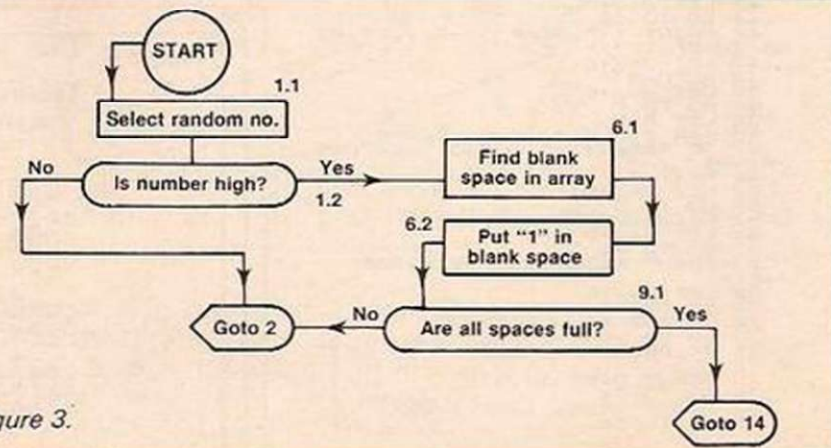

Figure 3.

# NT BASIC

When then is this flowcharting to do with translation? Logic is two-way so that it is possible to change a language code back to a flowchart. Thus when faced with a piece of untranslatable code you should convert it into a flowchart then reconvert it into your dialect.

First a simple example. Program 2 is a small part of a complex program listing. If you do not have If-Then-Else and On-Go To statements in your Basic dialect you could have considerable trouble with the translation. However, it is easily converted to the flowchart at figure 5, and then to the listing in your dialect — for example, program 3.

It is listings like this which give Basic a bad name as an unstructured language, but at least with the help of a flowchart you can keep control of the logic, and can in many cases, including this one, improve on the flow of the program at the flowchart level before encoding it in Basic.

Now for a more complex example. If the

program you wish to translate is not in Basic, but in some other language it is not usually possible to translate directly as different programming languages have different structures. Nevertheless they are all developed, at least theoretically, from common flow diagrams.

Thus if we can convert the "foreign" language to a suitable flow diagram we can then convert the flow diagram to Basic. So let us try.

Program 4 is in the language Pascal. It is a program to simulate a dice throw. In this case it would be reasonable to reprogram it in Basic from scratch, but by way of an illustration we will flowchart it. Even if you do not know the language, or know it only slightly, it is usually possible to develop a suitable flowchart especially if you know what the program is intended to do. My flowchart from program 4 is at figure 6. Can you see the correspondence between the two?

For those readers not familiar with the basics of Pascal some explanation is in order. The Proc or procedure in Pascal is similar to a subroutine. In this simple example it is only necessary to flowchart the Proc as the rest of the program is just house-keeping, screen clearing, Tabbing, and so on. The symbol :=, unfamiliar to Basic users, is the assignment statement and can be read as "becomes". For example,  $A := B$  means A becomes B. This is similar to  $a =$  in Basic. The rest of the Proc is reasonably simple to follow.

Having arranged the flowchart we can forget its Pascal origins and transform it into Basic statements. I have resisted the temptation to simply replace it with

$10 P = \text{RND}(5) + 1 : ? P$

as this would not help you understand the technique. The flow diagram is simply a method of generating pseudo-random numbers using modular arithmetic and is encoded into Basic without difficulty — see program 5.

The only problem is with the box 4 statement  $P = P(\text{Mod } 7)$ , which is a standard, if obscure, mathematical expression meaning P is the remainder when P is divided by 7. For example, if P originally was 22 then  $P(\text{Mod } 7)$  would be 1 as  $P \div 7 = 3$  remainder 1. ■

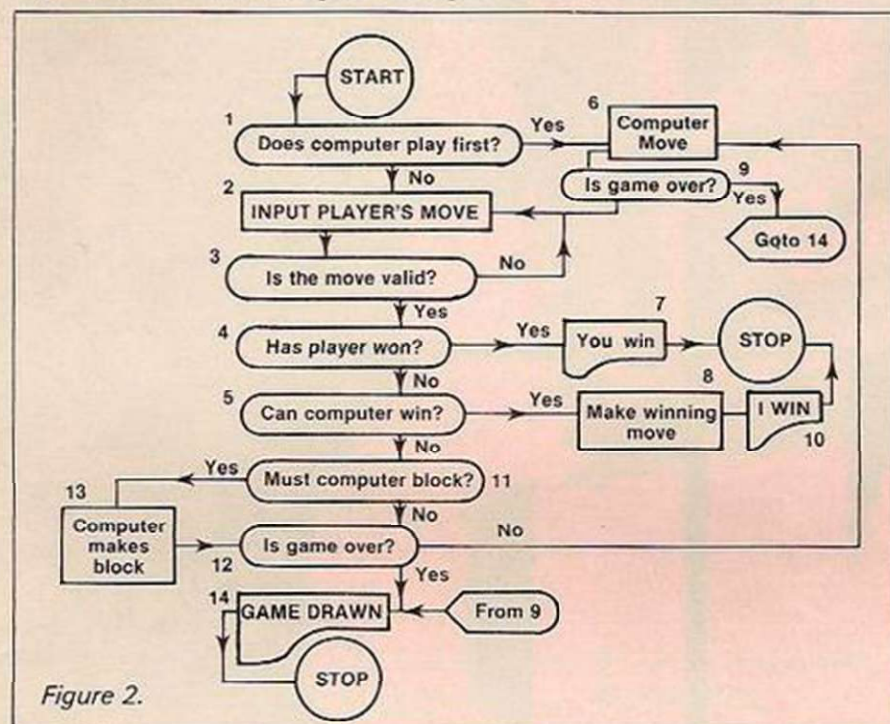

Figure 2.

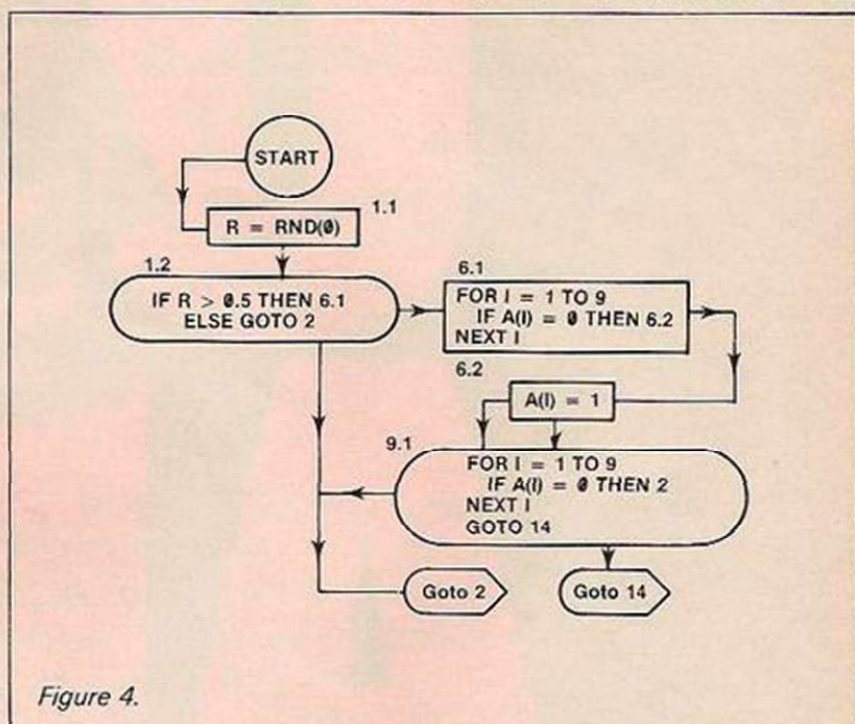

Figure 4.

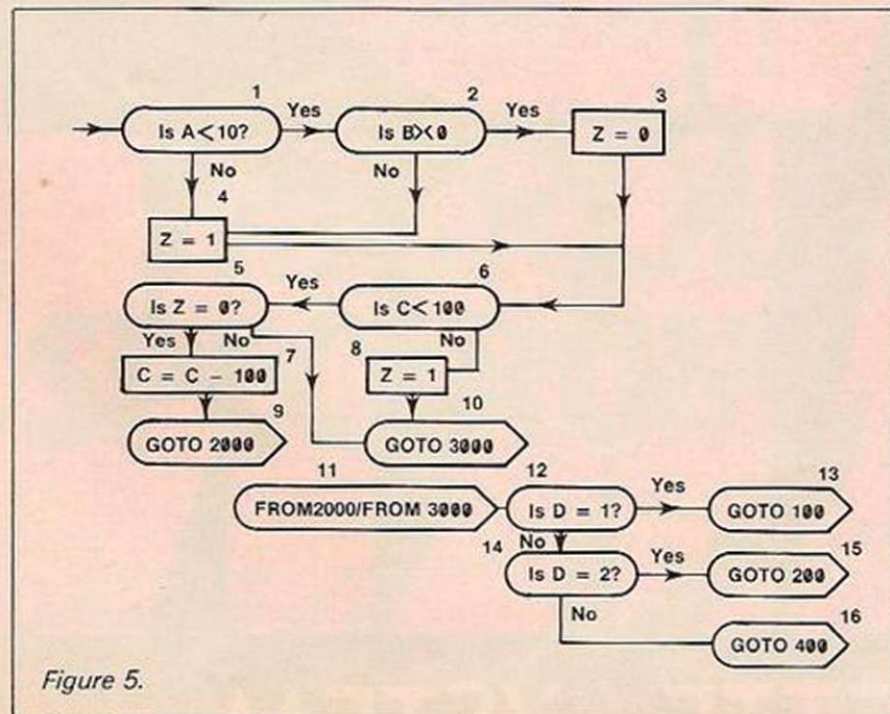

Figure 5.

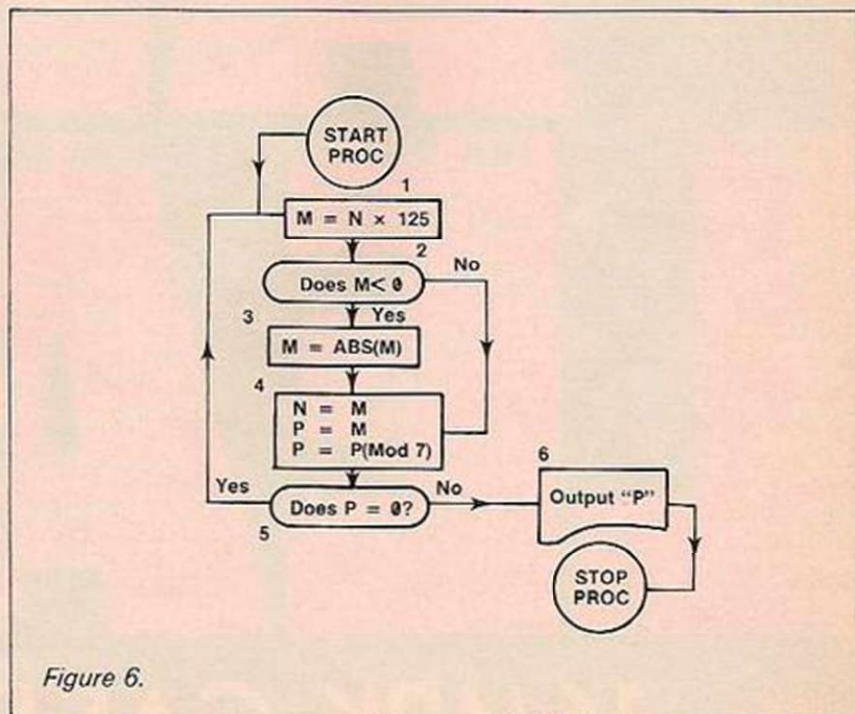
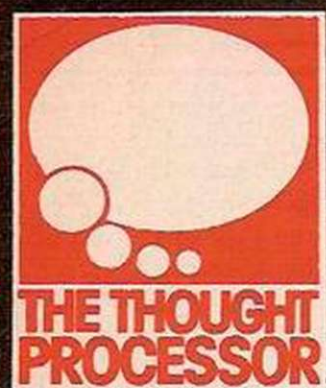

Figure 6.



# MICROL<sup>©</sup>

# SPECTRUM

# USE AND LEARN

16/48K CASSETTE SYSTEM

# VOL.1: 25 BASIC PROGRAMS AVAILABLE NOW

## USE

25 PRACTICAL BASIC programs you can put to work immediately Programs to demonstrate the wide-ranging potential of your 16 or 48K Spectrum:— World Atlas — Cassette and Videocassette Index — Music Composer — Computer Term Glossary — Star Maps ... Personal Programming Aids to help you write your own programs more effectively:— Memory Map Monitor — System Diagnostic — Program debugging aids ... Time-saving Routines to use in your own programs:— Text Editor — Flexible graph drawing routines — Sort and Search routines ... Plus much more. And, of course, original games to entertain and challenge you.

# £9.95

programs more reliable — Ideas to make your games more exciting — How and when to use trees, tables, sorts and searches (do you know the MonkeyPuzzle sort?) ... Facts at your Fingertips:— Memory and runtime Bench marks for every command — Display File Memory Map — Important PEEK and POKE locations you won't find in your Spectrum manual ... PLUS:— All 25 BASIC programs explained line by line — a goldmine of practical hints and tips.



## AVAILABLE NOW! ONLY £9.95

Send today for USE AND LEARN Volume 1 — 25 BASIC Programs, and we'll also keep you posted with details of further important MiCROL products for your Spectrum. And, of course, USE AND LEARN comes with MiCROL's full 14-day money-back Guarantee.

## LEARN

New ways to get the most from your Spectrum. Over 100 pages packed with — Powerful programming techniques:— use Structured Programming to save time and make your

To order simply complete the coupon, and FREEPOST with your cheque, made payable to **MiCROL** (UK Mail Order). Allow 28 days for delivery. **Telephone orders** — credit card holders can order by telephoning (0223) 312 866 from 9-5.30 Monday to Saturday, stating name and address, Card No. (Access & Barclaycard) and item(s) required.

**MiCROL**  
THE THOUGHT PROCESSOR  
**SPECTRUM**

**(0223) 312866**

Distributed Worldwide Exclusively by Tempus of Cambridge.  
**38 Burleigh Street,  
Cambridge CB1 1BR.**

Post to — **MiCROL (UK Mail Order)**  
Freepost, 38 Burleigh Street, Cambridge

Please send me . . . . . number of copies of Use and Learn  
I enclose cheque/P.O. £9.95 + 50p p + p (£10.45 total)

I wish to pay by Access/Barclaycard  
(Delete whichever not applicable)

Please Print Name & Address

Card Number . . . . .

Signature . . . . .

Name . . . . .

Address . . . . .

Credit card valid if signed by cardholders.

YC/9

COMPILING AN index is, at best, a long and rather tedious job. If funds do not run to a professional indexer, the author has to do the job himself. Traditionally, indexes are compiled on cards, which are sorted into order — just the kind of job which could be done easily on a computer.

The Indexer program was written to help me compile a short index for a book but could, of course, be used equally well for an index of records, tapes, or whatever you like.

Inevitably, the ZX-81's 16K memory places some limitations on what can be done. A balance must be struck between the facilities the program offers and the amount of space it leaves for the index entries. I ended up with a program of slightly more than 6K, including system variables and display file, leaving about 10K for the index itself. The way the program is designed allows a maximum of 340 index entries — enough for a large record collection, or for the index of an average textbook.

## Using the program

Rather than describe in detail the way the program is constructed, I will begin by giving a set of instructions for using the Indexer. The program is intended to be as user-friendly as possible, and having used a number of expensive commercial software packages, I think it is as good as most. The use of Inkey\$ for commands justifies, I am sure, the small amount of extra memory used, compared with Input — which requires two key pushes instead of one.

Similarly, the program is difficult to crash, and rejects most kinds of incorrect entry. At least I have not yet found anything that can lead to loss of data. Finally, before the operator instructions, I should mention that I use a typewriter keyboard for the ZX-81, and Fast mode. This enables you to type at almost normal speed.

First, load the program from the tape under the name

"INDEXER"

The program will start with the menu. Select option 1 from the menu to start:

1 BEGIN NEW INDEX

This clears all previous data and selects entry mode for the index. The screen will show a heading marked "Entry" and "Page", and a number, 0, in the top-left corner.

Entries can be typed into the Indexer in random order. No entry can be longer than 27 characters, and no page number larger than 999. The maximum number of entries is 340.

Type in the entry, followed by Newline, then the page number, followed by Newline. The counter at the top-left will record the total number of entries. The program will automatically reject any entry that is empty, and any page number larger than three digits or starting with a non-numeric character. To delete incorrect entries before pressing Newline, use Rubout in the usual way. After Newline has been pressed you must use the Edit Index facility.

To return to the menu, key 0 as if it were an entry, not a page number. Note that entry mode returns to the menu via a sort routine that may take several minutes, depending on the number of entries.

### 2 KEY ENTRIES

This works in the same way as option 1 Begin New Index, except that existing data is not deleted. This enables you to continue adding to the index after saving and loading the existing entries. The counter records the total number of entries.

### 3 SAVE ENTRIES

Option 3 allows you to save the program and data on tape. Save time will vary according to the contents of the index, but you should always allow at least 10 minutes' worth of tape for saving.

The Indexer and contents is loaded from the tape with a Load "Indexer" command.

### 4 PRINT INDEX

Option 4 prints out the index on the screen or printer, merging identical entries and listing page numbers in numerical order. The index is printed out in strict alphabetical order, regardless of the order in which entries were keyed.

You are given the option to print on the screen or printer. When printing on the screen, the index is printed from the beginning in screen-sized blocks. Pressing any key moves on to the next block. When the last block is reached, an End message is displayed at the top of the screen; the next key push returns to the menu — it may take a few seconds for the menu to reappear. During printing, the computer operates in fast mode

# ZX-81

for just over half a minute between screens.

If the printer option is selected the screen is not used. The printer prints out the index in blocks; computing time between blocks is just over half a minute. When the printing is finished, the screen displays the last block of the index and the End message. Any key returns to the menu after a short delay.

### 5 EDIT INDEX

Option 5 provides an editing facility. The index is listed, unmerged, on the screen. Cursor controls can be used to step through the index — the keys, without shift, can be held down for continuous stepping. The down-cursor control moves down the index eight lines at a time for rapid stepping through the index; the up cursor moves up one line at a time.

The lowest entry on the screen is highlighted with a cursor or inverse first character. This is the line affected by any editing. Key E

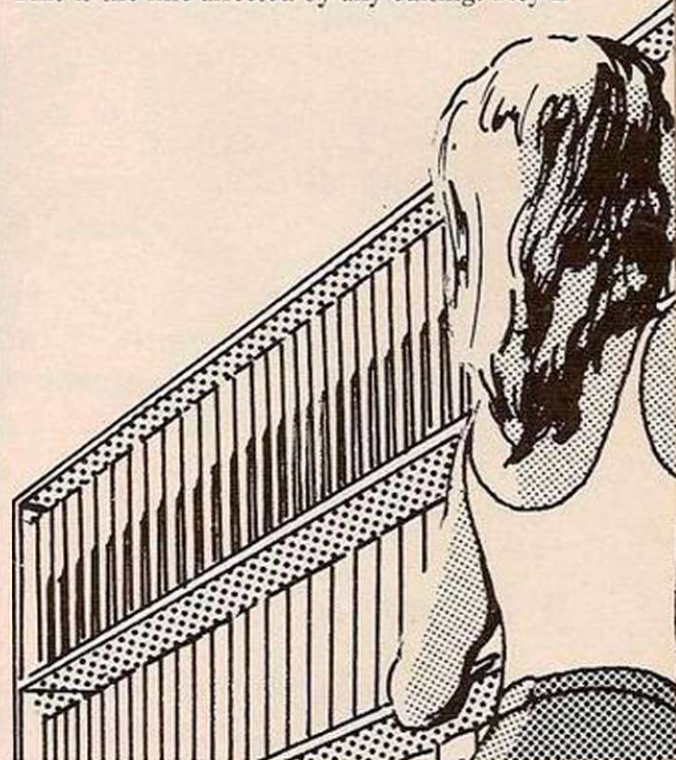

```

0 REM (C) JOHN WATSON, 1982
1 DIM A$(241,30)
2 LET CT=0
3 GOTO 100
10 LET X=325-CT
11 LET CD=0
12 FAST
13 CLS
14 FOR N=1 TO 17
15 PRINT A$(X)
16 LET X=X+1
17 NEXT N
18 LET X=X-1
19 PRINT AT 15,0;CHR$(CODE A
$(X))+128)
20 PRINT AT 20,0;"0=MENU, F=END
IT, D=DELETE OR CURSOR UP OR
DOWN TO NEW PAGES."
21 SLOW
22 GOTO 550
100 CLS
105 SLOW
110 PRINT " INDEXER "
120 PRINT
125 PRINT "1 BEGIN NEW INDEX"

```

```

130 PRINT
135 PRINT "2 KEY ENTRIES"
140 PRINT
145 PRINT "3 SAVE ENTRIES"
150 PRINT
155 PRINT "4 PRINT INDEX"
160 PRINT
165 PRINT "5 EDIT INDEX"
170 LET K$=INKEY$
175 IF K$="1" THEN GOTO 200
180 IF K$="2" THEN GOTO 350
185 IF K$="3" THEN GOTO 100
190 IF K$="4" THEN GOTO 100
195 IF K$="5" THEN GOTO 10
200 GOTO 100
205 CLS
210 PRINT AT 11,0;"DELETING THIS
DELETES ALL DATA. KEY Y TO GO
ON, 0 FOR MENU."
215 IF INKEY$="Y" THEN GOTO 455
220 IF INKEY$="0" THEN GOTO 100
225 GOTO 215
455 CLEAR
460 DIM A$(241,30)
465 LET CT=0

```

# INDEXER

John Watson's Basic program for the ZX-81 means you can compile an index for your library of books or for your record and cassette collection.



for edit. The whole line can then be re-entered, as in entry mode. The line will appear correctly when either cursor control is moved.

Key D for delete, having made sure that cursor is at the line to be deleted. Note that you cannot fill the gap left by a deleted line while in edit mode: to insert new entries you need to go to option 2 Key Entries from the menu. Again, to return to the menu key 0. Remember that Edit mode also returns to the menu via what can be a lengthy sort.

In case of an accident, like keying Break by mistake, the program can be restarted by Goto 100. The printed index has gaps between each block of 10 lines or so; this is intentional, and improves legibility if the index is to be retyped.

It is not a good idea to enter all 340 entries unless you have to — after 340, the program leaves entry mode, and goes back to the menu, but with an unsorted list. To make it sort, go to Edit mode, option 5, then immediately key 0 to go back to the menu again through the sort routine.

## How it operates

Here is how the program works. The index entries are stored in a string array, which is dimensioned as A\$(341,30). The last entry is not used, but is necessary for the program operation. CT counts the number of entries. The main menu is at lines 105 to 220.

Keying 1 goes first to a "do you really mean it?" message at 230 to 250, then redimensiones the array, deleting all data. It then goes into the main key entries routine at 496. This prints the heading and the current entry number, and warns when the index is nearly full. When the index is filled right up, the program returns to the menu — this is more helpful than going through the sort routine in the usual way, as it provides some idea of what has happened. Unexpectedly launching into the sort routine, with its several minutes' worth of blank screen, can make you think the program has crashed.

Line 520 goes to the entry-checking subroutine at 5010. The index entry C\$ is checked for an empty string, a blank first character, or for 0 which is the "leave entry mode" command. The page number B\$ is

(continued on next page)

```

400 FAST
401 CLS
402 LET X=1
500 PRINT X=1
TRY ***** DT 0,0; DT *****EN
505 IF CT>300 THEN PRINT DT 0,4
; INDEX ALMOST FULL
510 IF CT>340 THEN GOTO 100
520 GOSUB 5010
530 SCROLL
540 GOTO 0
550 LET X#0
560 IF X#="7" THEN GOTO 600
570 IF X#="8" THEN GOTO 620
580 IF X#="9" THEN GOTO 640
590 IF X#="0" THEN GOTO 660
600 GOTO 0
610 LET X=X+1
620 IF X>320-CT THEN LET X=320-
CT
630 GOTO 10
640 LET X=X-8
650 IF X>324 THEN LET X=324
660 GOTO 10
670 IF A$(X,1)=" " THEN GOTO 55
680 LET A$(X)=" "
690 LET CD=CD+1
700 GOTO 600
710 LET CT=CT-CD
720 GOTO 600
730 IF A$(X,1)=" " THEN GOTO 55
740 LET CT=CT-1
750 GOSUB 5010
760 GOTO 600
1000 PRINT DT 20,0;"PRINTER (P)
OR SCREEN (S)?"
1004 LET P#=""
1005 LET P#="INKEY#"
1006 IF P#="P" OR P#="S" THEN GO
TO 2000
1007 GOTO 1005
2000 LET X=341-CT
2005 FAST
2006 CLS
2010 IF PEEK (PEEK 16396+256*PE
EK 16397)+67) <>0 THEN GOTO 2200
2020 SCROLL

```

(listing continued on next page)

(continued from previous page)

checked to see if it is empty, or if it starts with a non-numerical character. It did not seem worth checking all three figures, as this is not a mistake likely to be made during entry — forgetting to put in the page number is a possibility, but putting in an alpha-numeric page number seemed far-fetched. Anyway, you can pick it up during editing.

Lines 5070 to 5090 are interesting, as they range the page number to the right-hand end of the string holding the entry. The number is always held at the extreme end of the string so that it is sorted properly. Without ranging right, page 150 would be sorted before page 35.

Entry is always followed by a sort — at lines 8000 to 8260. Regular readers will recognise the excellent Shell-Metzner sort routine by David Lawrence, published in the April 1982 edition of *Your Computer*. Why rewrite a good program?

Option 5 on the menu, edit index, takes us to line 10 which prints out the index on the screen, and waits for a command from a secondary menu at 46 to 50 and 550 to 580. Line 40 prints the first letter of the entry affected by edit, in inverse. Up and down cursor controls work through the index, 0 goes back to the menu, and D deletes an entry, not forgetting to make the necessary correction to the entry counter, line 655.

Note that all the entries end up in the array in reverse order after sorting; CD is used to store the number that has to be subtracted from the total counter after editing is finished. The next sort — automatically after editing, line 690 — gets rid of the empty strings. Note line 650, which prevents re-deletion of deleted strings — this would upset the entry counting.

Option 4, print index, also includes the merging routine. The entries are merged only during printout, so that they are available for editing separately if required later. Since entries are printed from the bottom of the screen and moved up with scroll to place them in the correct order, there has to be some way of checking when a screenful has been supplied.

This is done by line 2010 which Pecks the second line of the display file to see if there is anything there. If there is, then the program either waits for a key push, line 2210, or Copies the screen, according to whether screen or ZX printer has been selected. The actual printing and merging takes place from line 2040.

Line 2040 prints out the entry, and if the string is empty — that is, it is the one after the last-used string — goes on to the winding up routines at 2260 which scrolls the entries up to the top of the screen to avoid an odd gap when the last part of the index is printed out.

If the string is not empty, the entry part is

stored in Z\$ and is compared with the same part of the next entry, line 2100, and just the number, preceded by a comma, from the next string is printed — line 2160 — if the next entry is identical. The subroutine at 3000 finds the print position for the page numbers, which should be just after the entry and not at the far end of the line.

Note that there are two Saves at the end of the listing. The one at 8600 should be used when you save the master copy of the program, with Clear and then Goto 8600. This saves the program without the string array — Save/Load time is about two minutes. The other Save routine, from 8500 to 8530, is used from the menu to save the program with the array, which takes far longer. If you do not know the "line 0" trick, do not bother entering the first Rem statement in the listing.

There is certainly room for improvement and the program is a good example of Basic spaghetti. It typifies the program that has been put together piecemeal, but on the other hand, it would have taken me far longer to write in any other language, because several points occurred to me during, rather than before, writing. Also, it badly needs a Renumber.

Obviously, owners of bumper-size RAM packs can store more entries. Each entry takes 30 bytes. To change the size of the array, you will need to alter lines 1, 10, 486, 505, 510, 605, 630, 2000, 2135, and 8040.

(listing continued from previous page)

```

20030 SCROLL
20040 LET Z$=A$(X, TO 27)
20045 IF Z$(1)=" " THEN GOTO 2260
20050 PRINT AT 19,0;Z$
20055 LET X=X+1
20070 LET Y#=A$(X, TO 27)
20080 GOSUB 3000
20090 PRINT AT 19,C;"", "A$(X-1,2
0 TO 30);
20095 LET C=C+5
20100 IF Y#<>Z# THEN GOTO 2010
20110 GOTO 2160
20120 LET Z#=Y#
20130 LET X=X+1
20135 IF X>341 THEN GOTO 2260
20140 LET Y#=A$(X,1 TO 27)
20150 IF Y#<>Z# THEN GOTO 2010
20160 PRINT " ", "A$(X,28 TO 30);
20165 LET C=C+4
20170 IF C>28 THEN GOSUB 2500
20175 GOTO 2120
20200 IF P#="P" THEN GOTO 2240
20205 PRINT AT 0,0;"", ADDRESS ANY
KEY TO CONTINUE
20210 PAUSE 33000
20215 CLS
20220 GOTO 2010
20240 COPY
20245 CLS
20250 GOTO 2010
20260 IF PEEK ((PEEK 16396+255*PE
K 16397)+07) (>0 THEN GOTO 2300
20270 SCROLL
20280 GOTO 2260
20300 IF P#="P" THEN COPY
20310 PRINT AT 0,0;"END"
20320 PAUSE 33000
20330 GOTO 180
20350 SCROLL
20360 PRINT AT 19,0;
20370 LET C=0
20380 RETURN
20400 LET C=27
20410 IF A$(X-1,C) <> " " THEN RETU
RN
20420 LET C=C-1
20430 IF C<1 THEN RETURN
20440 GOTO 3010
20450 GOTO 100
5010 INPUT C$
5020 IF C$="0" THEN GOTO 8000
5025 IF C$=" " THEN GOTO 5010

```

```

5030 IF C$(1)=" " THEN GOTO 5010
5035 LET A$(X)=C$
5040 LET CT=CT+1
5045 PRINT AT 19,0;A$(X, TO 27);
";
5050 INPUT B$
5055 IF B$=" " OR LEN B$>3 THEN G
OTO 5050
5060 IF B$(1) > "9" OR B$(1) < "0" T
HEN GOTO 5050
5070 LET S=LEN B$
5080 FOR I=0 TO 1 STEP -1
5085 LET D$(X,31-I)=B$(I+1)-5)
5090 NEXT I
5095 LET X=X+1
5100 PRINT AT 19,29;B$
5110 RETURN
5200 FAST
5210 LET C=0
5220 LET S=0
5230 LET D=1
5240 LET Z=340
5250 IF Z#>27 THEN GOTO 8000
5260 LET D=D+1
5270 GOTO 5050
5280 LET F=2**D-1
5290 LET F=INT (F/2)
5300 IF F=0 THEN GOTO 100
5310 LET D=Z-F
5320 LET B=1
5330 LET D=D
5340 LET E=D+F
5350 LET C=C+1
5360 IF A$(D) > A$(E) THEN GOTO 82
00
5370 LET B=B+1
5380 IF B>0 THEN GOTO 8090
5390 GOTO 5130
5400 LET S=S+1
5410 LET T#=A$(D)
5420 LET A$(D)=A$(E)
5430 LET A$(E)=T#
5440 LET D=D-F
5450 IF A<1 THEN GOTO 5170
5460 GOTO 5140
5470 PRINT AT 20,0;"PREPARE TAPE
- NEWLINE TO START"
5510 INPUT K$
5520 SAVE "INDEXED"
5530 GOTO 100
5600 SAVE "INDEXED"
5610 GOTO 1

```

**£8.95**  
plus 55p p+p

*Educational*

# Very Important Cassettes

A.S.K. announce the first four programs in a series of educational cassettes for the VIC 20. These programs have been written by a team of teachers and professionally programmed specifically for use in the home.

They are of proven educational value, complementing work done at school, yet all the programs are designed to be fun to use – not just once, but over and over again. We believe that these programs will give you and your family and friends hours of worthwhile enjoyment. They will help your children to learn at home in a relaxed yet stimulating way.



**We Want To Count.** A program for young children learning to count which involves the numbers 1 to 5. Children often find it easier to recite numbers than to count things correctly. Four different games give the child a variety of objects to count, and are presented in an exciting and stimulating way. Suitable for children aged 3 and upwards.

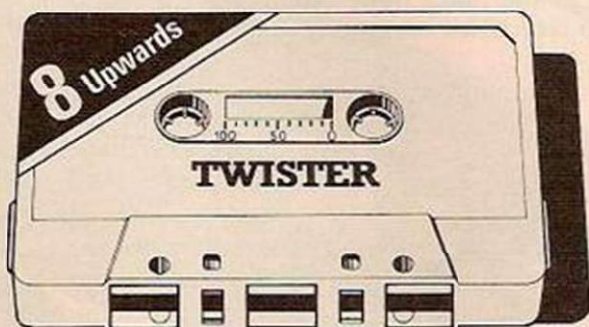

**Twister.** A geometric puzzle that will tie you in knots, testing and improving your thinking skills and powers of concentration. The purpose is to rearrange coloured squares so that no row or column contains a repeated colour. Set your own puzzle and test the whole family. Suitable for children aged 8 and upwards.



**Facemaker.** This program is designed to help improve spelling, expand vocabulary and sharpen observational skills. There are thousands of characterful faces you can make with the program. Perhaps someone you know? Suitable for children aged 5 to 12.

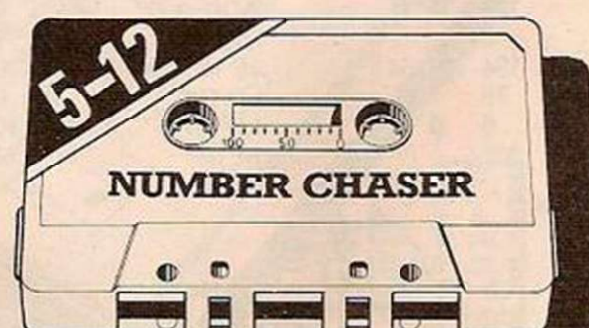

**Number Chaser.** A car race provides an opportunity to practice and improve estimating and multiplication skills. You can choose the level of difficulty you want making it different every time you play. Suitable for children aged 5 to 12.

Each cassette comes in an attractively labelled box together with a colour booklet which gives detailed loading instructions and tells you how to use the program.

N.B. Because these programs make extensive use of computer memory and colour graphics, a 16K RAM PACK (or 8K RAM PACK for Numberchaser only) and colour T.V. are essential for their operation.

If you do not have a 16K RAM PACK, we will be pleased to supply one at the discounted price of £67.50 with your order for one or more A.S.K. programs.

**NO QUIBBLE GUARANTEE**

If you are dissatisfied with any A.S.K. program, return it to us within 7 days of delivery and we will give you a full refund without question.

Not convinced? Then see our programs at The Vic Centre, 154 Victoria Road, London W3, opp. North Acton tube.



A.S.K. LIMITED, London House,  
42 Upper Richmond Road West,  
London SW14 8DD

To A.S.K., Freepost, London SW14 8BR (no stamp required)

Please send me:

	Quantity	Unit price inc. VAT + 55p p+p	Total
We Want To Count		£9.50	
Twister		£9.50	
Facemaker		£9.50	
Number Chaser		£9.50	
16K RAM PACK		£67.50	
<b>TOTAL</b>			

I enclose my Cheque/P.O. for £ \_\_\_\_\_ made payable to A.S.K. LTD

Name \_\_\_\_\_

Address \_\_\_\_\_

Please allow 28 days for delivery

2/YC9

THE SIMPLEST Z-80 processor command is Code 0. This means no operation and is intended to act as a delay, but we will use it initially as a fill-in command to space code out. It also assists in program fault-finding. Its use will be demonstrated later in the first example.

Remember that each piece of machine code is entered into its own address. We start at 16514 and we can jump to any address. That is called an "absolute jump". Alternatively, we can jump forward or backwards a small number of addresses which is known as a "relative jump".

So, if you are at address 16600, a relative jump forward of 50 would take you to address 16650, or we could jump backwards 50 to address 16550. One uses the same command for selective jumps whether they are forwards or backwards. For a backward relative jump, subtract the size of the jump from 256. For example, to jump four bytes backwards jump 252.

The relative jump commands are:

```
JR DIS    24  N
JR Z DIS  40  N
JR NZ DIS 32  N
```

Dis equals displacement and is in fact simply a number, N, between 0 and 255. These commands can be conditional on the state of the F variable, as are the absolute jumps.

Now for an example to demonstrate the use of these commands. Load program 4, which multiplies two numbers, into the Basic program given in program 1. What we will do initially is to change the absolute-address jump to a relative-address jump. After you have entered the program, add the following changes and save 4a.

```
POKE 16524, 32 )
POKE 16525, 252 ) JR NZ DIS
POKE 16526, 0 ) NOP
```

Now program 4a when Run should give precisely the same result as program 4. Re-enter the machine code of program 4a, but enter, say, eight or nine NOPs first. Then Save this as program 4b and run. This should give exactly the same answer as programs 4 and 4a.

If you had used program 4 with the leading NOPs, the absolute address JP NZ NN would have been wrong. What we have here is a piece of code which we can start at any address and it will work with no changes. This is very useful as it enables the programmer to write blocks of code without having to worry about absolute addresses.

Program 4a shows the point from which we count backwards and forwards, this point is always the next instruction past the relative jump, and for the purpose of simplicity, the maximum count in either direction can be considered to be 120.

# JUMP, I

There is a further refinement which can be made by the use of

CODE 16 (DJNZ DIS)

This command automatically decreases variable B by one and if the F variable is not equal to zero, jumps the given displacement forwards or backwards. If the F, or flag, variable is equal to zero it continues with the next command.

Program 4c demonstrates its use. Either re-load 4 and:

```
POKE 16523, 16 ) DJNZ DIS
POKE 16524, 253 )
POKE 16525, 0 ) NOP
POKE 16526, 0 ) NOP
POKE 16528, 0 ) NOP
POKE 16529, 0 ) NOP
```

or enter the code program 4c and Run. Does this give the same result again? What we are doing is gradually refining the simple multiply program to see the effect of the different commands.

Two additional but related commands that we need to examine are Push and Pop. Push places the values held in the relevant pair of variables into a position in memory, otherwise known as the stack.

We can push as many pairs of variables on to the stack as we wish. The command Pop retrieves the variables from the stack. Note, however, that Pop pulls off the last values Pushed. Thus: PUSH HL  
POP BC

can be used to transfer the contents of HL to BC. It is also very useful for saving the flag variable for later use, and effectively obtaining more than three pairs of variables.

At this point let me explain that when we first call our USR routine, we push a Return address on the stack. This is how the machine knows where to return to. The command Return Pops the next stack address and jumps to it.

Let us now return to the playing board and use some of these commands to simplify the coding. Program 5 is the original and program 5a the simplified version. We no longer have a Basic program equivalent, as we did last month. In its place I have entered comments. The program as entered will produce the same board, in a program of approximately half the size, but it also has other capabilities. Make the following changes:

```
230 PRINT AT K, 11; "*"
POKE 16528, 10
POKE 16562, 10
POKE 16538, 13
RUN
```

and then try:

```
220 FOR K = 2 TO 15
POKE 16541, 12
POKE 16552, 12
RUN
```

We can also move the board anywhere on the screen. The only way of really understanding what is happening is to experiment — continue until the machine-code routines do exactly what you think they should do. It really is a case of practice.

(continued on page 74)

Address	Machine code	Mnemonic	Basic
16514	33 30 65	LD HL NN	1 LET HL = 16670
	70	LD B (HL)	2 LET B = PEEK HL
	35	INC HL	3 LET HL = HL + 1
	78	LD C (HL)	4 LET C = PEEK HL
	62 0	LD A N	5 LET A = 0
16522	129	ADD A C	6 LET A = A + C
16523	5	DEC B	7 LET B = B - 1
16524	194 138 64	JP NZ NN	8 IF B <> 0 THEN GOTO 6
16527	79	LD C A	9 LET C = A
16528	6 0	LD B N	10 LET B = 0
16530	201	RET	11 PRINT C

Multiply two numbers Program 4.

Address	Machine code	Mnemonic	Comments
16514	33 30 65	LD HL NN	
	70	LD B (HL)	
	35	INC HL	
	78	LD C (HL)	
	62 0	LD A N	
16522	129 ← 252	ADD A C	( If the F variable is N2 then
	5 ← 253	DEC B	( jump Dis.
16524	32 ← 252 ← 255	JR NZ DIS	
	0 ← 256	NOP	
16527	79 ← 1	LD C A	
	6 ← 0 ← 3	LD B N	
	201	RET	

Multiply two numbers Program 4a.

  

Address	Machine code	Mnemonic	Comments
16514	33 30 65	LD HL NN	
	70	LD B (HL)	
	35	INC HL	
	78	LD C (HL)	
	62 0	LD A N	
16522	129 ← 253	ADD A C	( Decrease by one variable B
	16 ← 253 ← 254	DJNZ DIS	( and if not equal to zero
	0 ← 256	NOP	( jump Dis i.e., back to
	0 ← 1	NOP	( address 16522
16527	79 ← 2	LD C A	
	0 ← 3	NOP	) B is already zero
	0	NOP	
	201	RET	

Multiply two numbers Program 4c.

# PUSH POP, AND RUN

Part 2 of Kathleen Peel's machine-code course for beginners tells you how to jump, push and pop. If you want to learn how to write fast machine-code programs read on.

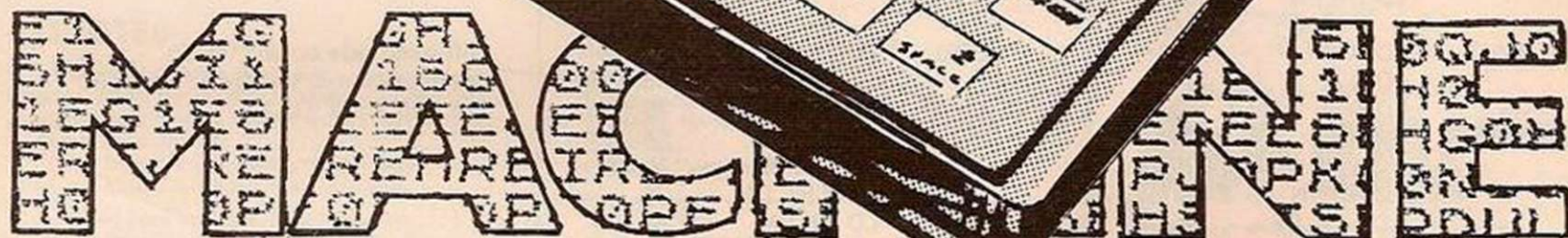

### CodeMnemonic

0 NOP  
24 JR DIS  
40 JRZ DIS  
32 JR NZ DIS  
16 DJNZ DIS  
245 PUSH AF

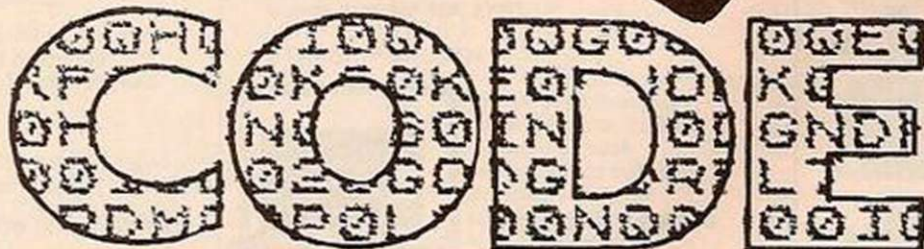

197 PUSH BC  
213 PUSH DE  
229 PUSH HL  
241 POP AF  
193 POP BC  
209 POP DE  
225 POP HL

```

1 REM 12345678901234567890123
45678901234567890123456789012345
57890123456789012345678901234567
89012345678901234567890123456789
0123456789012345678901234567890
2 REM █████
200 CLS
250 LET C=USR 16514
300 STOP
600 FAST
801 FOR K=16514 TO 16664
810 SCROLL
820 INPUT J
830 POKE K,J
840 PRINT AT 7,0;K;TAB 8;J
850 NEXT K
    
```

```

1 REM 12345678901234567890123
45678901234567890123456789012345
57890123456789012345678901234567
89012345678901234567890123456789
0123456789012345678901234567890
200 CLS
210 SLOW
220 FOR K=2 TO 7
230 PRINT AT K,0;"*"
240 NEXT K
250 LET C=USR 16514
300 STOP
600 FAST
801 FOR K=16514 TO 16664
810 SCROLL
820 INPUT J
830 POKE K,J
840 PRINT AT 7,0;K;TAB 8;J
850 NEXT K
    
```

Program 1, above, and right, program 1a.

(continued from page 72)

Program 5.			Program 5a.			Comments
Address	Mnemonic	Machine code	Address	Mnemonic	Machine code	
16514	LD HL NN	33 12 64	16514	LD HL NN	33 12 64	
	LD E (HL)	94		LD E (HL)	94	
	INC HL	35		INC HL	35	
	LD D (HL)	86		LD D (HL)	86	(16521)
	LD HL NN	33 3 0		LD HL NN	33 3 0	( One more than X in Basic program
	ADD HL DE	25		ADD HL DE	25	( 220 FOR K = X TO 7
	LD A L	125		PUSH HL	229	
	LD C A	79				
	LD A H	124				
	LD B A	71				
16528	LD (HL) N	54 135	16525	LD (HL) N	54 135	Line across (16528)
	INC HL	35		LD B N	6 7	( One less than X in Basic program
	LD (HL) N	54 131		INC HL	35	( 230 PRINT AT K,X;""
	INC HL	35		LD (HL) N	54 131	
	LD (HL) N	54 131		DJNZ DIS	16 251	
	INC HL	35		INC HL	35	
	LD (HL) N	54 131		LD (HL) N	54 4	
	INC HL	35				(16538)
	LD (HL) N	54 131				
	INC HL	35				
	LD (HL) N	54 131				
	INC HL	35				
	LD (HL) N	54 4				
16555	LD DE NN	17 10 0	16537	LD DE NN	17 10 0	( Two more than X in Basic Program
	ADD HL DE	25		LD B N	6 4	( 230 PRINT AT K,X;""
	LD (HL) N	54 5		ADD HL DE	25	
	ADD HL DE	25		LD (HL) N	54 5	Right-hand line down (16541)
	LD (HL) N	54 5		DJNZ DIS	16 251	One less than X-Y in Basic Program
	ADD HL DE	25		ADD HL DE	25	220 FOR K = Y TO X
	LD (HL) N	54 5		LD (HL) N	54 1	
	ADD HL DE	25				
	LD (HL) N	54 5				
	ADD HL DE	25				
	LD (HL) N	54 1				
16572	LD A C	121	16550	POP HL	225	Left-hand side down (16552)
	LD L A	111		LD B N	6 4	One less than X-Y in Basic Program
	LD A B	120		ADD HL DE	25	220 FOR K = Y TO X
	LD H A	103		LD (HL) N	54 133	
	ADD HL DE	25		DJNZ DIS	16 251	
	LD (HL) N	54 133		ADD HL DE	25	
	ADD HL DE	25		LD (HL) N	54 2	
	LD (HL) N	54 133				
	ADD HL DE	25				
	LD (HL) N	54 133				
	ADD HL DE	25				
	LD (HL) N	54 133				
	ADD HL DE	25				
	LD (HL) N	54 2				
16591	INC HL	35	16561	LD B N	6 7	Bottom line across (16562)
	LD (HL) N	54 3		INC HL	35	
	INC HL	35		LD (HL) N	54 3	One less than X in Basic Program
	LD (HL) N	54 3		DJNZ DIS	16 251	230 PRINT AT K,X;""
	INC HL	35		RET	201	
	LD (HL) N	54 3				
	INC HL	35				
	LD (HL) N	54 3				
	INC HL	35				
	LD (HL) N	54 3				
	INC HL	35				
	LD (HL) N	54 3				
	INC HL	35				
	LD (HL) N	54 3				
	RET	201				

99 Bytes

55 Bytes

# FINANCIAL GAMES

for

## ZX81 SPECTRUM BBC

### GREAT BRITAIN LIMITED:

You are P.M. and Chancellor of 'Great Britain'. You must select the party you wish to represent and your AIM is to stay in office for as long as possible.

You must control INFLATION and UNEMPLOYMENT, maintain the EXCHANGE RATE, introduce SOCIAL REFORMS and stay POPULAR. The game is split into SECTORS: COUNTRY PROFILE; SHOPPING BASKET; BUDGET DAY (A) & (B); REFORM OPPORTUNITIES; and most important ELECTION NIGHT (every 5 years).

A facility exists to SAVE your game to continue later.

**INHERITANCE:** A 2 part game full of excitement. Prove your financial acumen in PART 1 by investing wisely at the STOCK and METAL MARKETS. (If desperate for funds try the CASINO or HORSE RACES). Enter the world of BIG BUSINESS in PART 2. Find the secret formula for PARADISE COLA; manufacture & market the drink and cope with STRIKES, FIRES, and FRAUDS. Your AIM is to become a MILLIONAIRE.

Large RAM versions for SPECTRUM and BBC contain major enhancements and many extra features to take full advantage of these Machine's extra facilities.

	ZX81 16K	SPECTRUM 48K	BBC 32K
1 GAME:	£4.95	£ 5.95	£ 5.95
2 GAMES:	£8.25	£10.25	£10.25

Further details of these and other games available on request.

**SIMON W HESSEL**  
DEPT. Y,  
15 LYTHAM COURT, CARDWELL CRESCENT,  
SUNNINGHAM, BERKSHIRE.  
TEL. ASCOT 25179

All games are fully guaranteed

Fast service

## SPECTRUM & ZX81 KEYBOARDS



**ZX80/81 KEYBOARD £24.95** (illustrated)  
2 Shift keys  
Large space key  
Large Newline key

Single keys for EDIT,  
RUBOUT & FUNCTION.  
Full Repeat

also for above 4 single key cursor control keys extra £3.

### ZX SPECTRUM £26.95

4 shift keys — one for each level. No more awkward, finger knotting exercises!

All keyboards are fully assembled and just plug into your ZX81 or Spectrum. All keyboards etc. are in 3 colour (4 for Spectrum) under hard wearing clear caps. Proper keyswitches — full size. Full fitting instructions & 12 month guarantee naturally.

Payment — Cheque, Postal Orders, Access or Cash on delivery. Phone order welcome. Prices include postage (overseas add £2) etc.

**HARRIS & LOCKYER ASSOCIATES**  
DEPT YC  
33 PEDMORE CLOSE, WOODROW SOUTH  
REDDITCH, WORCS B97 7XB.  
ENGLAND.

Phone: — Redditch (0527) 24452

# MICHAEL ORWIN'S ZX81 CASSETTES

The best software (by various authors) at low prices.

### QUOTES

"Michael Orwin's £5 Cassette Two is very good value. It contains 10 stolid well designed games which work, offer plenty of variety and choice, and are fun."

from the ZX Software review in  
*Your Computer, May '82 issue.*

"I had your Invaders/React cassette ... I was delighted with this first cassette."

P. Rubython, London NW10

"I have been intending to write to you for some days to say how much I enjoy the games on 'Cassette One' which you supplied me with earlier this month."

E. H., London SW4

"I previously bought your Cassette One and consider it to be good value for money!"

Richard Ross-Langley  
Managing Director  
Mine of Information Ltd.

### CASSETTE 1

(eleven 1K programs)

machine code:

React, Invaders, Phantom aliens, Maze of death, Planet lander, Bouncing letters, Bug splat.

Basic:

I Ching, Mastermind, Robots, Basic Hangman. PLUS Large screen versions of Invaders and Maze of Death, ready for when you get 16K.

Cassette One costs £3.80.

### CASSETTE 2

Ten games in Basic for 16K ZX81

Cassette Two contains Reversi, Awari, Laser Bases, Word Mastermind, Rectangles, Crash, Roulette, Pontoon, Penny Shoot and Gun Command.

Cassette Two costs £5.

### CASSETTE 3

8 programs for 16K ZX81

#### STARSHIP TROJAN

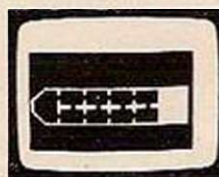

Repair your Starship before disaster strikes. Hazards include asphyxiation, radiation, escaped biological specimens and plunging into a Supernova.

**STARTREK** This version of the well known space adventure game features variable Klingon mobility, and graphic photon torpedo tracking.

**PRINCESS OF KRAAL** An adventure game. **BATTLE** Strategy game for 1 to 4 players. **KALABRIASZ** World's silliest card game, full of pointless complicated rules.

**CUBE** Rubik Cube simulator, with lots of functions including 'Backstep'

**SECRET MESSAGES** This message coding program is very txp qexi jf.

**MARTIAN CRICKET** A simple but addictive game (totally unlike Earth cricket) in machine code. The speed is variable, and its top speed is very fast.

Cassette 3 costs £5.

### CASSETTE 4

8 games for 16K ZX81

#### ZX-SCRAMBLE (machine code)



Bomb and shoot your way through the fortified caves.

#### GUNFIGHT (machine code)



#### INVADERS (machine code)



**GALAXY INVADERS** (machine code)  
Fleets of swooping and diving alien craft to fight.

**SNAKEBITE** (machine code)  
Eat the snake before it eats you. Variable speed (very fast at top speed)

**LIFE** (machine code)  
A ZX81 version of the well known game.

**3D TIC-TAC-ONE** (Basic)  
Played on a 4x4x4 board, this is a game for the brain. It is very hard to beat the computer at it.

7 of the 8 games are in machine code, because this is much faster than Basic. (Some of these games were previously available from J. Steadman).

Cassette 4 costs £5.

Recorded on quality cassettes, sent by first class post, from:

**Michael Orwin, 26 Brownlow Rd. Willesden, London NW10 9QL** (mail order only please)

# CONTROL MIDWICH MC

The Midwich MC is a control computer which should prove very useful in school and university labs for teaching and research. John Dawson interfaces with reality.

IT SEEMS that almost everyone wants to use their computer to make things happen in the real world. Aircraft simulators, robot arms, timing circuits for model racing cars, solar-heating controllers are all popular subjects in both the U.K. and America. But the problem is simply that most amateur or domestic machines are not designed for those purposes.

Either you are in the single-board, machine-code league or the dominant routes in and out of the computer are the keyboard and television. The BBC Micro, model B, is one of the few computers to offer analogue to digital (A-D) converters for measuring a changing input voltage. Nevertheless, you need your own expansion board and your own programs if you want to do very much more than determine the position of a joystick for game playing.

When I opened the box containing the Midwich MC Microcontroller the machine inside seemed to be exactly the computer with connections to the real world that I had been promising myself I would build for the last four years.

The Midwich Microcontroller, like several other British computers, originates from the Silicon Plains of East Anglia. Prices for the machine start at £299 for the 12V version; the mains version reviewed here costs £375, but a £30 discount is available for educational buyers.

## Very powerful commands

The Midwich Computer Company Ltd was established in 1979 to distribute and manufacture small computers. The first machine that the company handled was the Nano-computer by SGS-ATES. Production ceased for that micro at the end of 1980 and yet it seemed that there was a hole in the market that could be filled by a British computer.

David Clarke, Tom Hogan and Ian Johnson thought that the gap was at the low-cost end of the market, and that the plug should be a real-time, user-friendly computer which could educate people in the use of computers for control purposes, while at the same time providing a serious microcontroller in its own right.

While this was happening, Midwich was thinking about a project for batch reactor control using software developed at Oxford

University. The special, high-level language written for the reactor-control job evolved into the version of Basic built into the Midwich Microcontroller.

The Basic in the Midwich Microcontroller is similar to Microsoft in many respects and you will have no difficulty in adapting programs or thought patterns to this machine, but I doubt that you will have ever encountered instructions such as DI, EI, Wait, RTI, Sched, Overlay, or DSched.

These are the instructions used to run two programs simultaneously so that you can enter immediate commands from the keyboard while the computer is actually running another entirely separate program. These commands are very powerful and, as far as I know, are unique to the Microcontroller Basic.

## Electrical safety

The Midwich Microcontroller is a single-board computer mounted on a substantial steel base plate. The machine is enclosed in a very robust structural foam case — the Apple II uses a similar one although its case is more sharply styled.

The two halves of the case are held together by 15 proper metal screws inserted into brass nuts moulded in the structural foam. This is important because you can open and re-assemble the case as often as you like without stripping the screw threads.

The electrical safety design of the computer is excellent, absolutely first-rate, with wire

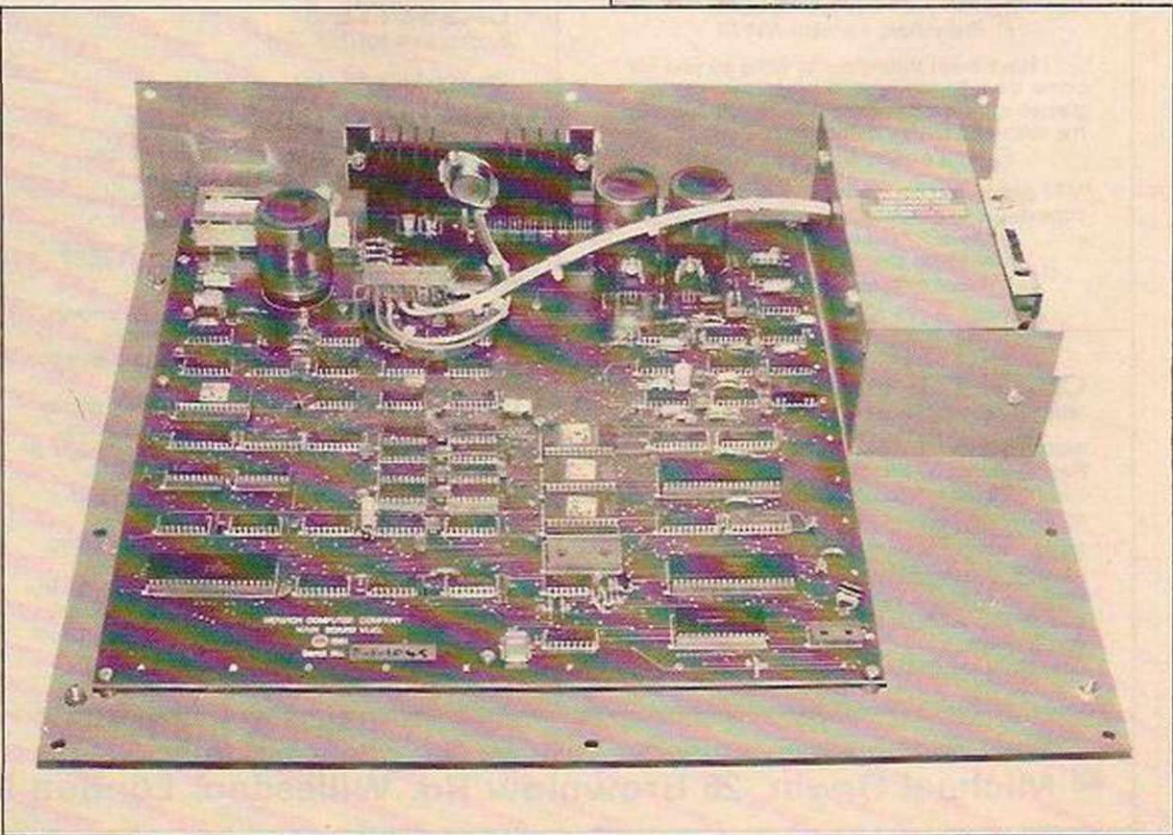
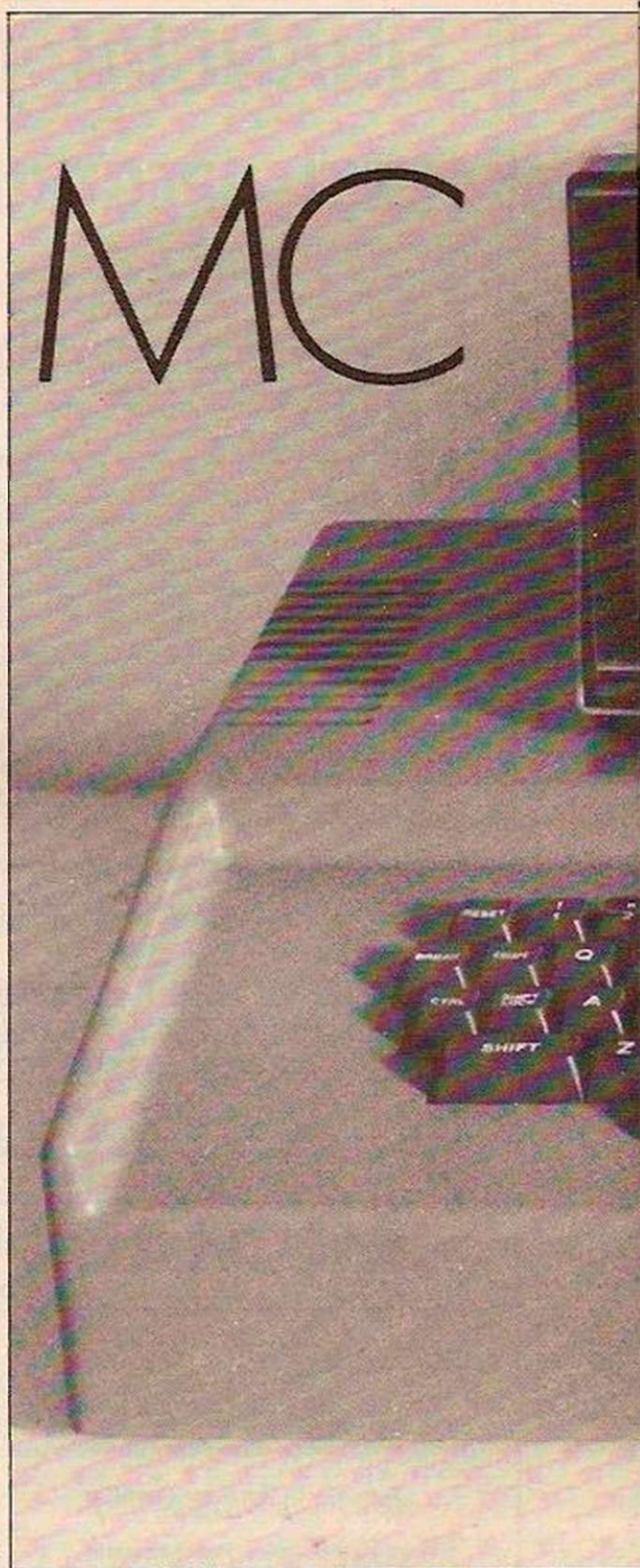



mesh over the ventilation slots to prevent little fingers sticking little spanners into the works.

When you look inside, you see that in terms of personal safety — never mind shorting the integrated circuits — the mesh was not necessary because the mains side of the power supply is heavily insulated. You can safely run the computer outside its case for demonstration purposes.

The Midwich Microcontroller uses a single Z-80 microprocessor running at 2 MHz and 16K of dynamic RAM are included on the single board. Figure 1 illustrates the interconnections between various sections of the computer.

### Educational plus

There is 12K of ROM which houses the monitor and control Basic interpreter. A Z-80 counter timer chip (CTC) provides a real-time clock and a number of other facilities, and there is one Z-80 PI/O used for the keyboard interface and the cassette I/O.

The expansion unit has a spare 4K EPROM socket. A second board is screwed to the upper

half of the case and that holds 57 keys for the keyboard. There are no defined cursor-control keys and no separate numeric keypad. The keyboard is laid out in the standard QWERTY pattern and can generate the full ASCII character set.

At the rear of the computer are sockets for 230V mains power or, with a different power-supply unit, 12V AC. Other sockets provide signals for a cassette recorder, motor control as well as input and output. There are also phono and BNC sockets for UHF signals and video for your VDU. Finally — and this is the Microcontroller's real claim to educational pre-eminence — there is a socket for a bus interface which brings 50 lines out to the experimental unit.

The experimental unit is a double-sided printed-circuit board with a breadboard block mounted as an integral part of the unit. There is a 30-way terminal block which will take ordinary wires from other circuits in your experiments and connect them to four lines from each of the six accessory slots on the experimental unit.

Digital-to-analogue and analogue-to-digital boards can be plugged into the accessory slots and you may then take signals from the real world and convert them into numbers which the Microcontroller can process.

When your program has drawn conclusions from the data you have acquired the machine can send numbers to the D-A converters which will output analogue voltages to the terminal block to control and modify your experimental process.

The breadboard allows you to build a prototype circuit using integrated circuits and other components to connect special transducers such as pH probes, thermocouples, wind-speed sensors, humidity detectors, photocells and pressure gauges to the Microcontroller.

You can buy more experimental units so that several people can prepare hardware for an experiment before plugging it on to the computer bus and devices such as oscilloscopes to run their program.

### Versatile form of Basic

Up to six accessory boards can be plugged into the sockets on the experimental unit. Currently available boards include an eight-bit A-D converter, an eight-bit D-A converter and an eight-bit digital input/output board.

Three ranges are provided for both the incoming and outgoing analogue boards: 0V to +10V, -10V to +10V, and 4mA to 20mA positive input or output. The basic range on each type of board is 0 to +2.5V.

The A-D board will accurately follow fast signals as the Ferranti ZN-427 converter chip is placed after a National Semiconductor LF-398 sample and hold chip. The time taken to convert an analogue voltage into a number can make a simple A-D converter inaccurate at quite low frequencies but the Midwich Microcontroller has a professional approach to overcome the problem.

The company has announced two more accessory boards, a 2732 EPROM programmer card and a 12-bit analogue-input board. An IEEE-488 interface should become available within the next three months.

The software is one of the few versions of Basic that takes account of devices other than printers connected to the computer. The Midwich Basic interpreter deserves to be widely copied. It is fast; keywords can be abbreviated to single letters and a full stop; it has a wide range of commands for taking data from the experimental unit and sending information back; and it permits you to work in four different number bases.

### Ease of translation

Some like to measure the success of a computer language by the ease of transfer into machine code or assembler — the Midwich Control Basic is very successful in these terms. The format of a USR statement — jump to a machine-code subroutine instruction — is:

USR e1, (v1,v2,v3, . . . vn)

where "e1" is the address of the routine and "v" represents a series of variables or array elements. Each variable will pass a value to the machine-code subroutine. Both of the following instructions are legal calls to machine-code subroutines:

*(continued on page 79)*

# BIG VIC SAVERS from the Experts

## The VIC CENTRE



PERSONAL COMPUTING ON THE JOY STICK  
AN INTRODUCTION TO BASIC - PART 1

**SAVE £20!**

### FOR STARTERS

The complete VIC-20 colour computer kit to get you started.

Your VIC Starter Kit saves £20 on RRP (before VAT) and will be mailed complete and ready to go.

The VIC is friendly, clever and very powerful. Our Starter Kit comes complete with:

- The VIC 20 colour computer
- The VIC cassette deck
- 10 blank cassettes
- The VIC games joystick
- The teach yourself "Introduction to Basic, Part 1" and the VIC User Manual.

We supply a 13 amp plug and give you the VIC Centre twelve months warranty

# £217

excl VAT

Total price £249.55 incl VAT + £4 post & packing and insurance.



TV Monitor and VIC computer not included in offer

COMMODORE VIC-20 PROGRAMMER'S AID CARTRIDGE

**SAVE £20!**

### GETTING BIGGER

Got a VIC 20? Then you will probably want to expand its memory capacity and use cartridges such as the Programmers Aid or the Super Expander. With the VIC Centre Expansion Package you can take your VIC up to 30K with the Arfon Expansion Unit with its seven slot mother board and integral power supply. The aluminium cover will allow you to neatly position your monitor or TV set.

A 16K Ram expansion cartridge  
A choice of either *Programmers Reference Guide* or *VIC Revealed* and a choice of *Super Expander* or *Programmers Aid* or *Machine Code Monitor* cartridges

# £180

excl VAT

Total price £207.00 incl VAT + £4 post & packing and insurance.

For just £180 excluding VAT the Getting Bigger kit saves you £20 and has:

- The Arfon Expansion Unit
- Cover to take TV

## HAVE FUN AT OUR EXPENSE

Any three VIC Centre cassette games for just £17.50 excl VAT

Choose from:

- Blitz
- Canyon Fighter
- Star Wolf
- Tunesmith
- PR Software
- Packman
- Invader Fall
- Vic Cube
- Othello
- Super Moon Lander

Total price £20.12 inc VAT + £2 post & packing

**Any 3** excl VAT

# £43.50

Any three VIC cartridge games from the VIC Centre for just £43.50 excl VAT

Choose from:

- Super Slot
- Road Race
- Avenger
- Super Lander
- Alien Game
- Amok
- Bounce Out
- Alien Blitz
- City Bomber
- Black Hole

Total price £50.02 inc VAT + £2 post & packing

**Any 3** excl VAT

# £17.50

The VIC Centre, 154 Victoria Road, Acton, London W3 (near North Acton tube station) has the widest range of VIC accessories. All the items below are available mail order - just telephone with your credit card number

Hardware and Peripherals	Price excl VAT		
RS 232C Cartridge	30.39	Simple Simon	6.08
IEEE Cartridge	47.39	Masterwits	6.08
Vic 3K Rampack	26.04	Kiddie Checkers	6.08
Vic 8K Rampack	39.09	Wallstreet	6.08
Vic 16K Rampack	65.17	Alien Blitz	6.95
Programmers Aid	30.39	Vicalc	7.82
Super Expander (High Resolution)	30.39	Hangman-Hangmath	6.95
Machine Code Monitor Cartridge	30.39	Ski-Run	4.34
Joystick	6.52	Dune Buggy	4.34
Lightpen	25.00	Super Worm	4.34
Joystick (plotting)	13.00	Worm	3.47
Lowcost RS232C	22.99	Cosmic Battle	4.34
Tool Kit	25.00	Codebreaker	2.60
Vic Kit II	29.00	Viterm A	8.49
Games Port Adaptor Cable	17.25	Star Wars	6.08
ROM Switchboard	29.00	Crazy Balloon	7.82
RS232C fully implemented	49.00	Jungle	4.34
<b>Cartridges</b>		Rabbit Functions	4.34
Satellites & Meteorites	21.73	<b>Cassettes requiring additional 3K memory</b>	
Cloudburst	17.38	A-Maz-Ing	6.08
Renaissance	21.73	Missile Command	7.82
Star Battle	17.35	3D-Maze	6.95
Jelly Monsters	17.35	Dragon Maze	6.95
Spiders from Mars	21.73	Asteroid Belt	7.00
Meteor Run	21.73	VPM	7.82
Omega Race	17.35	Vicat	7.82
<b>Cassettes</b>		Skymath	6.08
Introduction to Basic (Part I)	13.00	Space Division (Level 1)	6.08
Codebreaker Codemaker	6.95	The Alien	6.95
Vic Seawolf, Trap, Bounce Out	7.82	Frogger	7.82
Monster Maze, Math Hurdler	6.95	Charset 20	4.34
Amok	6.08		

All the above prices are excl VAT, add £1 per order, postage & packing.

To order Send mail order to:  
 ADDA Home Computers Ltd, FREEPOST, London W3 6BR - you do not need a stamp - enclosing details of your order + cheque to include VAT + postage & packing  
 Instant telephone orders: Telephone the VIC Centre on 01-992 9904 and quote your Visa, Access or American Express number

**adda**  
 HOME COMPUTERS LTD

(continued from previous page)

USR HEX 3C00, (A(B),N)  
USR W, (B,H)

In the first case, the address of the subroutine is at 3C00 hexadecimal and in the second it is at the address stored in the variable marked "W".

The documentation is profuse and excellent. There are many examples to help you with familiar and unfamiliar concepts and while it will take you some time to appreciate the potential of the system, the manual will let you go as far and as fast as you want to.

For example, the following Basic program is given in the manual with a circuit diagram and a good explanation as a trial application. It sets up the computer as an automatic ranging voltmeter:

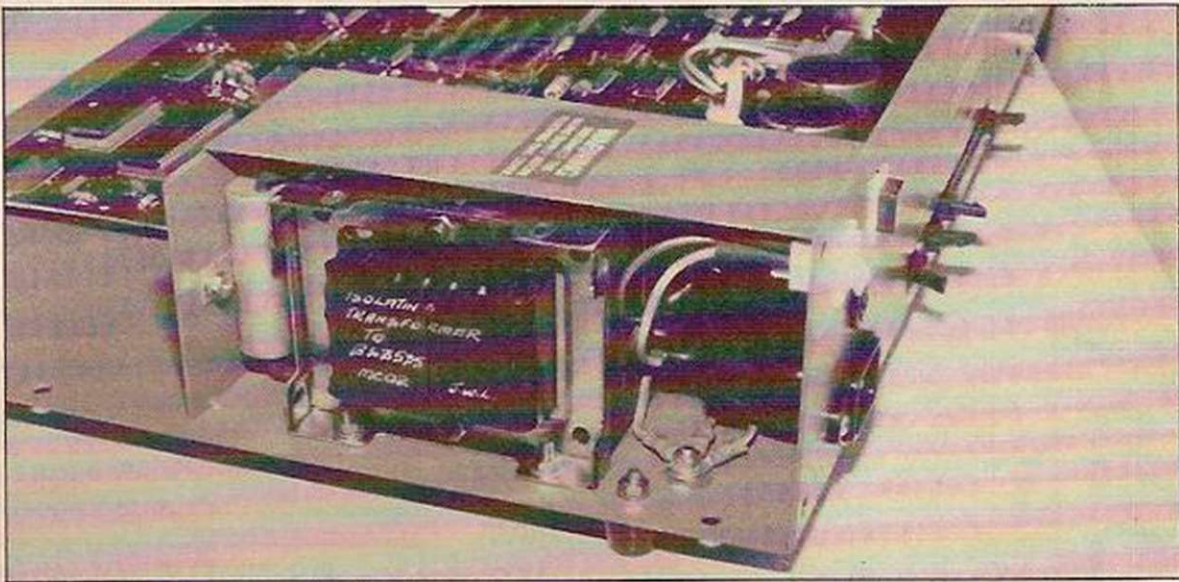
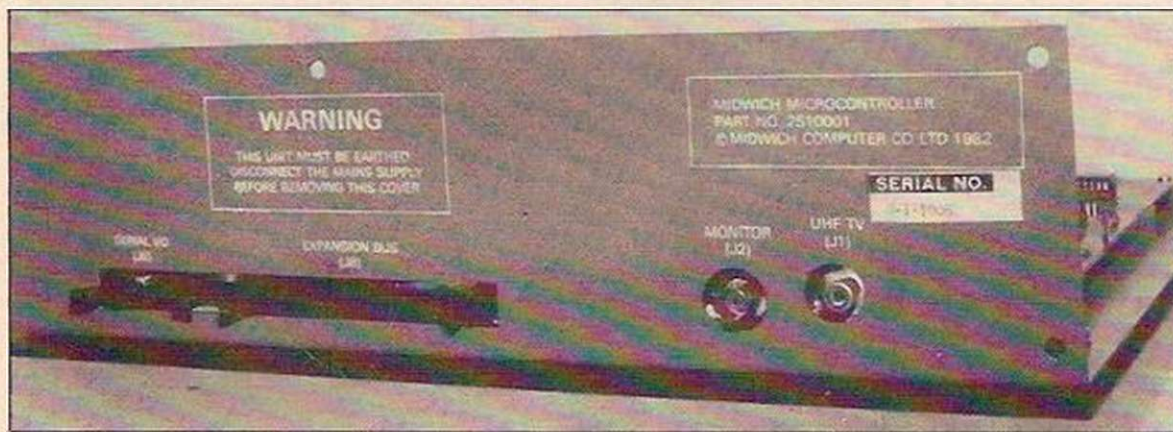
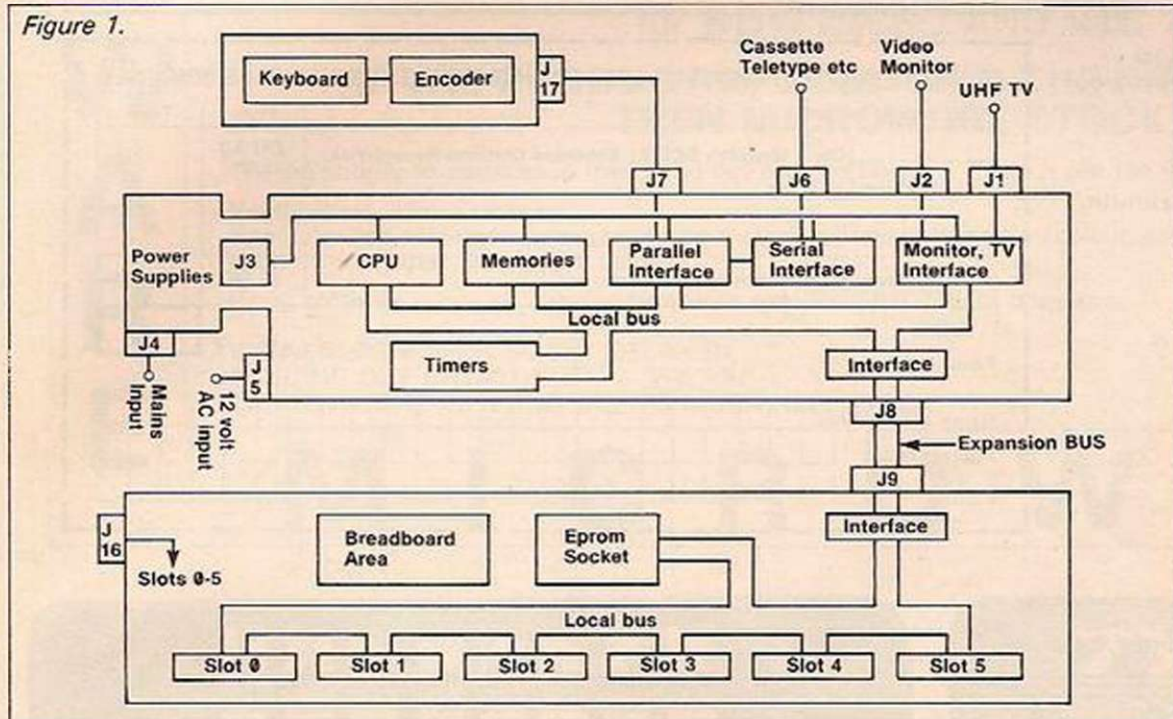

Figure 1.



```

10 P. = 12, : EI
20 OUT (2,15)           Sets port A
                          as output
30 OUT (0,1)           Sets op amp
                          on highest
                          gain
                          Gain = 100

40 C = IN(8) : N = 8
50 IF C < 255 THEN GOTO 1000
60 OUT (0,2)
70 C = IN(8) : N = 4   Gain = 50
80 IF C < 255 THEN GOTO 1000
90 OUT (0,4)
100 C = IN(8) : N = 2   Gain = 25
110 IF C < 255 THEN GOTO 1000
120 OUT (0,8)
130 C = IN(8) : N = 1   Gain = 12
140 IF C < 255 THEN GOTO 1000
150 PRINT "Voltage must be too
high. DISCONNECT
IMMEDIATELY" : GOTO 1500
1000 V = (C/255 * N)

```

```

1010 PRINT V, "Volts"
1020 Wait (20)
1030 GOTO 10
1040 STOP

```

There are other applications in the extensive documentation for controlling, among other things, lights, demonstrating "aliasing" between an input signal and the sampling rate.

The Microcontroller is available from Datac Ltd, Tudor Road, Altrincham, Cheshire WA14 5TN.

Griffin and George, well-known scientific supplier to the educational market, is distributing the machine and the special 12V version. Griffin and George will also be offering a range of transducers with any necessary electrical interfaces and educational buyers should write to the company, 285 Ealing Road, Alerton, Wembley.

## CONCLUSIONS

■ The Midwich Microcontroller is a strong competitor with the RML 380-Z for the educational market. The system is less expensive and more attractive in several ways. The concept of the computer as a control device is in the warp and weft of this system.

■ The computer is more strongly built than the Acorn Atom and has a greatly increased capability for taking in information, processing it and displaying the results.

■ I have a few niggling criticisms of the machine: I did not like the character design and the keyboard is positioned too high by ergonomic standards. But this machine will not be used for word processing by an 80 words-per-minute typist; it does its job and looks able to go on doing it for a long time.

■ I would like to have had a cage to protect the accessory boards from accidental knocks, but most users should be able to build something suitable.

■ An assembler program is soon to be available and the manual for that looks very good, but I would have thought that this machine was an absolute natural for Forth; I expect to see a version written very shortly by a user, even if Midwich does say that it has no plans for another high level language.

■ A high compliment was paid to the Microcontroller unintentionally by a colleague who said he thought it was too well engineered — a case of technical overkill. He clearly did not realise that young engineers and scientists need the best tools. If you are learning a subject you need predictable, reliable machinery so that you can rely on the measurements you make. You should not have to worry about errors contributed by your tools.

■ I like the whole system very much. The Microcontroller should be carefully investigated by any science faculty in secondary education considering a computer system for teaching and research. ■

# ARE YOU A ZX81 USER WHO'S NOT PLAYING GAMES?



**£47.50**  
Including VAT.  
complete

## ECR 81 DATA RECORDER SAVES AND LOADS YOUR PROGRAMS EVERY TIME!

The ECR81 Enhanced Certified Recorder from MONOLITH is a major advancement in cassette recorder technology which minimises the problems associated with standard audio recorders. The unit is a high reliability program store for ZX computers based on a modified, proven cassette mechanism. The two sections of data recording circuitry automatically ensure precise levels are written onto the tape and that optimised signals are received by the computer.

THE ECR81 IS NOT SUITABLE FOR AUDIO REPRODUCTION  
NO MANUAL VOLUME OR TONE CONTROL ADJUSTMENT PROVIDED

- Each ECR81 comes complete with its own individual certification tape, tested and serial numbered to prove your machine reliability.
- Mains Operation only.
- Mains & DIN connector leads provided.
- Certification of tape head alignment - height and azimuth.
- Certified tape tension, torque and speed.
- Fast forward and rewind tape search controls.

The ECR81 is also suitable for Sinclair ZX80

- Please allow up to 28 days delivery. ● The ECR81 is backed by our 14 day money-back option.

**MONOLITH**  
electronic products

Telephone: Crewkerne 0460 74321 Telex: 46306

To: MONOLITH ELECTRONICS CO. LTD., 5/7 CHURCH STREET, CREWKERNE, SOMERSET

Please supply me with:

.....(Qty.) Monolith ECR 81 Enhanced Certified Recorder(s)  
to be used with my ZX81

Price Total

£47.50 (Each)

I also enclose postage & packing per recorder

£2.50

Please print

Prices include VAT £

Name: Mr/Mrs/Miss

Address

Dept. YC, 36 Fernwood,  
Marple Bridge, STOCKPORT, Ches. SK6 5BE

**RAM Pack** with **£1 OFF**  
BS software

FOR THE ZX81

Both RAM packs fully assembled in neat black ABS plastic case (only 27 x 47 x 76 mm).  
Supplied with foam strip connector to improve mechanical stability. No annoying trans-  
hiss, guaranteed. Fully compatible with ZX Printer. Sent by return, first class post.

**16K RAM £26.95** **64K RAM £59.95**

All inclusive prices. When ordering, deduct £1 from price of any software  
item. NOTE 56k of the 64k RAM is user-addressable. Memory is in four areas:

- 0-8K Sinclair BASIC ROM (read only)
- 8-16K Machine code area unaffected by CLEAR, NEW, LOAD, SAVE.
- 16-32K BASIC program and display area.
- 32-48K BASIC variables and arrays and/or machine code.

for the ZX80, ZX81, SPECTRUM, BBC, VIC 20.

**Quality Software** FOR THE ZX81

- BRIDGEMAN** (BBC "B") ..... £7.90  
Bridge Software's version of the popular gobbler game. Hi-res, colour, sound.
- LYNCHMOB** (ZX81 16k) ..... £4.95  
A competitive game for 2 to 6 players loosely based on Hangman. Animated graphics. Full on-screen scoring. Great fun, educational too.
- LYNCHMOB** (ZX Spectrum 16k) ..... £6.50  
As for the ZX81, but developed to make full use of Spectrum's hi-res graphics, colour and sound.
- VIC INVADERS** (unexpanded VIC 20) ..... £6.90  
Machine code, colour, sound.
- 4K INVADERS** (ZX81 4k minimum) still available while stocks last at ..... £3.00  
(GALAXY INVADERS) Machine code, 10 difficulty levels. Top scoring game in Your Computer's May 1982 review of ZX81 software. "Deservedly popular... Good value" Pop. Comp. Weekly. "Great game!" S.F. Glos.
- SUPER INVADERS** (ZX81 16k) ..... £4.95  
Enhanced version of 4k INVADERS, including on-screen league tables etc.
- MULTIGRAPHICS 2.3** (ZX81 16k) ..... £6.90  
A user-friendly menu-driven package of procedures giving you full control of the ZX81 graphics functions to compose designs, drawings, adverts etc. Incorporates advanced sketchpad, 3 sizes of text (including lower case), animation, printer output, SAVE displays etc. 20 pp. Manual included.
- MULTIGRAPHICS 64** (ZX81 64k - i.e. 56k RAM) ..... £7.90  
An advanced version of MULTIGRAPHICS with enhanced animation facilities.
- GRAPHICS STARTER PACK** (ZX81 1k) Four 1k programs with 12pp. manual ..... £4.50
- STATISTICS PACKAGE** (ZX81 1k) Four 1k stats programs with 4pp. manual £4.00  
Mean, SD, variance, regression, t and F tests etc. Data correction.
- MULTITEXT** (ZX80, 4, 8 or 16k RAM) ..... £3.50  
Send s.a.e. for further details, specifying your computer.  
Prices include 1st class, return-of-post mail in U.K.

European customers please add 30p. per software item; 70p worldwide (Air Mail).  
Overseas customers, please write for details of hardware mailing charges.  
Available by mail order or from leading computer stores. Trade enquiries welcome.

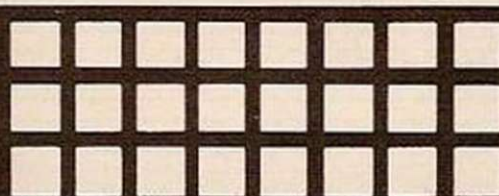

Cambridge Computer Store

**Two Great Micros  
in stock now!**

**BBC  
Computer**



A to B  
UPGRADE  
AVAILABLE



SINCLAIR  
16K RAM  
DOWN TO  
£29.95

**Sinclair  
ZX81**

Price includes VAT.

**Cambridge Computer Store**

1 Emmanuel Street, Cambridge CB1 1NE  
Phone (0223) 358264/65334

Also in our 'Budget Micros' Dept: Commodore VIC-20

M  
I  
C  
R  
O  
W  
A  
R  
E

# MICROWARE

131 MELTON ROAD, LEICESTER  
TEL: 0533 681812

See us at MICROSCENE  
ZX FAIR - BIRMINGHAM  
SEPT 11TH

M  
I  
C  
R  
O  
W  
A  
R  
E

THE FIRST MIDLANDS REGION RETAIL SHOP SPECIALISING IN  
**SINCLAIR COMPUTER ACCESSORIES**

Come and see our ever-increasing range of Hardware, Software, Books and Magazines.

Keyboards, Rom Packs, Graphic Boards, Light Pens, I/O Parts, etc.

- \* Games, Serious/Business
- \*\*\* and Educational Programs
- \* Green Screen 12" Monitors. Only £68!
- \*\*\* Bronze Screen 9". Only £90.
- \* Limited Period only!

Due to expansion we are now stocking Software and Books.

for **BBC MICRO AND VIC 20**

**IF THE PRODUCT IS GOOD AND THE PRICE IS RIGHT — THEN MICROWARE STOCK IT!**

We are shortly to commence marketing our own software — "watch out for the MICROWARE label".

Ready Now! Alien Command  
Spectrum 16K testing Invader style game making full use of Spectrum colour, sound and excellent graphics £5.50 from shop or mail order. Immediate delivery.

Good software required. Excellent royalties paid for SPECTRUM programs.

WE APOLOGISE FOR SLIGHT DELAY IN  
SENDING OUT CATALOGUES — WE ARE  
CURRENTLY RE-PRINTING DUE TO MUCH NEW STOCK.

Open 9.30-12.00  
12.30- 5.30  
Closed Thursday. SAE Brings Catalogue

# MICROWARE

## SOUND with ZX-81!

**MAKE AMAZING SOUND EFFECTS WITH YOUR ZX-81**



**£25.95 THE ZON X-81**  
incl p&p & V.A.T.

- Music
- Helicopters
- Explosions
- Gun-shots
- Drums
- Organs
- Bells
- Tunes
- Chords etc., or whatever you devise!
- Uses 3-channel sound chip giving programme control of pitch, volume of tones and noise, all with envelope control.
- Easily added to existing games or programmes using a few simple "BASIC" lines.

- \* The ZON X-81 SOUND UNIT is completely self-contained and especially designed for use with the ZX-81. It just plugs in — no dismantling or soldering.
- \* No power pack, batteries, leads or other extras.
- \* Manual Volume Control on panel — ample volume from built-in loudspeaker.
- \* Standard ZX-81 — 16K Rampack or printer can be plugged into ZON X-81 Sound Unit without affecting normal ZX-81 operation.

FULL instructions with many examples of how to obtain effects and the programmes, supplied. Fully Guaranteed.

**BI-PAK**

Dept. YC8 P.O. Box 6,  
63A High Street,  
Ware, Herts.



Access & VISA accepted  
Ring 0920 3182 for  
immediate despatch.

## ZX Software

### SCREEN KIT 1 MORE POWER TO YOUR SCREEN

- in Basic programs*
- BORDERS** — any size — anywhere on screen
- SCROLL** — in ALL FOUR directions
- FILL SCREEN** — any graphic or character
- CLEAR and REVERSE PART OF SCREEN** — any part
- FLASHING CURSOR** — anywhere on screen — simulates INPUT

ZX81  
4K to 64K  
most routines work on  
ZX80, 8K ROM

with **DATA FILES** SAVE BASIC VARIABLES on cassette  
LOAD back into ANY program.  
all at DOUBLE SPEED

- 880 bytes of machine code gives INSTANTANEOUS SCREEN RESPONSE
  - Becomes part of your Basic program
  - No need to Load separately
  - Can be added to existing program
- £5.70**  
SUPERB VALUE Inc VAT & P&P C.W.O.

### ZX-MC MACHINE CODE DE-BUG/MONITOR

- At last, COMPLETE FREEDOM FROM BASIC for machine code programmers
- Versatile entry commands for Hex code and String entry.
  - Comprehensive Run & De-bug commands, including REGISTERS DISPLAY & BREAKPOINTS.
  - Hex dump to printer for hard copy.
  - 16 essential commands for M/C programming.
  - Occupies 2½K RAM in Basic area.
  - Supplied on cassette with 36 page manual.

SAVE, LOAD, VERIFY AT DOUBLE SPEED from any part of RAM.

Fast machine code routines operating from Basic area of RAM.  
Write your M/C programs above Basic area — Screen memory (D-FILE) never moves.  
SELF CONTAINED design, for the serious programmer — cannot be used with Basic programs.

**£7.50**  
Inc VAT & P&P. C.W.O.

ZX81  
4K to 64K  
ZX SPECTRUM  
version available soon

### REM-LOAD MACHINE CODE ENTRY/DE-BUG

- A version of ZX-MC without the SAVE/LOAD/VERIFY facilities
- ENTER, RUN, DE-BUG machine code in Basic REM lines.
- Operates from above RAMTOP.
- Compatibility with Basic.
- Supplied on cassette with 30 page manual, for ONLY

SAE for more details of software Inc VAT & P&P. C.W.O.

ZX81, 16K to 64K  
ZX SPECTRUM  
version available soon

6, CORKSCREW HILL,  
WEST WICKHAM, KENT, BR4 9BB  
Mail order only — Allow 14 days delivery  
PLEASE STATE COMPUTER MODEL

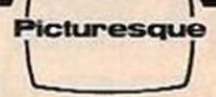

# Attention all BBC & ATOM Owners!!

## Acorn ATOM MACHINE CODE PROGRAMS

**Dog Fight (12K)**  
Exciting, two player combat program - in HI RES Graphics. Engage your aircraft carriers and attack your opponents. Defend the enemy fighters in a battle to the death. £5.95

**Stock-Car (12K)**  
HI RES. Two Player contest around any of 16 different race tracks. Steering, acceleration and braking controls. Set the level of difficulty for driver and choose the no. of laps. £5.95

**Astro Warrior (12K)**  
The ASTEROIDS IDEA, but developed and improved!! Flying around the screen you must shoot your way out of difficulty. Aliens attack in increasing numbers. Refuel at specified fuel dumps before you run out. A HI RES game for experts. £5.95

**Super Breakout (3K plus 3Kgr plus Fl. Pt.)**  
NOT just ANOTHER version!! Equally good in colour and black and white, the program has the advancing wall(s) feature plus genuine curved bar action with 6 ball angles. Terrific sound effects make it a MUST for arcade game addicts. £4.95

**Swarm (12K)**  
Alien Killer Bees are swarming the Earth. The Queen Bee is indestructible. Your only hope is to destroy the grubs and new born males before they wipe you out. You get three lives with a bonus at 10000 points. (HI RES graphics) £4.95

**ROM SELECTOR BOARD**  
Suffering from congestion? (PROGRAMMER'S TOOLBOX WORD PROCESSOR etc.) Switch between up to 4 ROMS located at Hex A000. Assembled and tested unit with compact, professionally produced PCB and good quality components. Fits easily into the Utility Socket (IC 24). Only £19.50

## Adventure

**ALL THE EXCITING, INTRIGUE AND FRUSTRATION OF A MAIN-FRAME ADVENTURE!** 12K  
Explore the tortuous forests, dark caverns and castle dungeons. Beware the maze of twisting tunnels and the desert wastelands. Outwit the predators. Rescue the PRINCESS and carry off the treasures. Great Skill and imagination are required to play this excellent game and you may still never exhaust all the possibilities. By devising methods of condensing messages, the author has been able to include many features which would otherwise be available only on much larger computers. Start your adventure now - £7.95



**Chess (12K)**  
Improved graphics, plays black or white, mid game level changes, look ahead up to eight moves, offensive, normal and defensive play. Ten sub-levels, castling. 'En passant' by player. Rejects illegal moves. Take back moves and action replay with take over. Set up problem games. £7.95

**Cowboy Shoot-Out (12K)**  
Full feature, two player, arcade shooting game. Cactus plants, wagons, animated cowboys. Superb graphics and sound. £6.95

**Hyperfire (12K)**  
Aliens have over-run six planets. Object to clear them. Super high-speed action. Four defender ships. Hit alien fuel dumps and alien ships. Aircraft radar shows placement of approaching ships. Thruster control - including diagonal movement. Best sound effects yet! Avoid shots from outside vision scan. £7.95

**Air Attack (12K)**  
Command an East Coast anti-aircraft battery. Destroy enemy fighters, bombers and doodle-bugs. Ingenious graphics depict planes approaching, veering and flying off. Search the sky and scan the landscape through 360 degs. GOOD SOUND, GREAT ENTERTAINMENT. £7.95

**Space Fighter (6K 3Kgr)**  
Super High Speed "Defender" game. Five types of intelligent aliens. Repeating laser cannon, smart bombs. hi-score, rankings, bonus points, six skill levels. Exciting sound effects. £7.95

**NEW**

**NEW**

**NEW**

**NEW**

**NEW MODEL B (or 32K MODEL A)**

**Space Invaders**  
Sensational, high speed program with an abundance of features. Brilliant use of colour graphics and sound. 48 strong Invader Fleet of three different types plus Mothership scoring mystery bonus. Choice of six invader speeds and three bomb speeds. Vertical, angled and exploding missiles. Options to replace defences and suppress new fleet advance. Bonus bases awarded each new sheet. Scoring according to overall difficulty level. Ongoing display of score and hi-score and end of game ranking of top five scores.  
This program has many unique extras e.g. a 'battle analysis' showing number of each invader shot down, how many Motherships destroyed, number of sheets cleared, shots fired, percentage hits and bases lost. £6.95  
If you needed a reason to upgrade to 32K, now you have it!

**Timetrek**  
The ultimate 'real-time' Startrek, with Battle Zone indecision your main enemy. Brilliant colour and sound. 'One-screen' presentation. Twenty skill levels. Panic Button for 'once-only' space leap. Torpedo sight control. A programming masterpiece!! £7.95

**Eldorado Gold**  
Welcome to a past age, when cowboys ruled the roost and Indians terrorised the new settlers. In ELDORADO COUNTY many fortunes were made - and nearly as many lost! Legend has it that Old Bill McCluskey, who met a rather sudden death, had built up a vast treasure somewhere in the nearby territory. Can you end up a rich man where many have failed? If the robbing Apaches or Big Jake's gang don't get you, you may die of thirst in the desert or starve to death in jail. £7.95

**World Geography**  
Beautifully drawn HI RES colour map and graded testing of world capitals and populations, makes learning of geographical facts a pleasure. 160 countries covered in total. Pin-pointing of each location in turn aids general awareness. £5.95

**Space Maze**  
You have crash landed in the legendary labyrinth of Titan, inhabited by alien monsters known as 'Froogs'. Find your way out to the 'Transmat' probe before being cornered and eaten. Eight skill levels and 3D colour graphics. £5.95

**Astro Navigator**  
Navigate your way through a variety of treacherous caverns, inhabited by killer rockmites. Avoid the dangers with your climb, dive, reverse and thruster controls. 5 Skill Levels. Top 5 scores ranked. Excellent colour graphics and sound in this exciting 'real-time' game. £4.95

**Chess**  
High quality chess game with castling, 'en passant', play black or white, rejection of illegal moves and six levels of play. Set up problem games. £4.95

**Micro-Budget**  
Proven personal finance program which enables you to record, review, analyse and budget your income and expenses for twelve separate monthly periods. Coding system gives sub-totals, selective summary of entries and cumulative cash flow. All figures can be saved to tape. £6.95

**Munchyman**  
Colourful and highly entertaining version of this popular arcade game. Munch your way to a high score, before the 'munchers' devour you. Reverse roles by munching the stars. The more you score, the harder the game gets. £5.95

**Other programs available:**  
Startrek £5.95/Gomoku £3.95/Disassembler £5.95  
Cat & Mouse £4.95/Zombies (New) £3.95

WRITTEN ANY PROGRAMS!  
WE PAY 20% ROYALTIES  
FOR ATOM, NASCOM &  
BBC MICRO PROGRAMS

**1250  
ATOM USERS  
CAN'T BE  
WRONG!**



## PROGRAMMER'S TOOLBOX

(PACKED 4K EPROM) £24.50  
★ 1200 BAUD CASSETTE OPERATING SYSTEM  
★ VISIBLE LOAD & SAVE

- TRACE (X)
- LTRACE
- STEP
- FIND
- VAR
- LVAR
- DELFTE X, Y DUMP
- READ DATA
- RESTORE
- ELSE
- WHILE
- ENDWHILE
- ON ERROR RENUMBER X, Y
- AUTO X, Y
- CURSOR X, Y
- BEEP X, Y
- KEY X
- INKEY SX
- HEX
- IHX
- OFF
- VECTOR
- ZERO
- POP
- STOP

(● VIA chip required)  
Suitable for any memory size.  
Greatly enhances ATOM existing facilities

**SPECIAL OFFER**  
Deduct £1 per cassette when ordering two or more.

MICRO POWER LTD.  
8/8A REGENT STREET,  
CHAPEL ALLERTON  
LEEDS LS7 4PE.  
Tel. [0532] 683186

Please add 55p order P & P + VAT at 15%

**Please Note:**  
All programs are now available at all good dealers or direct from MICRO POWER LTD.

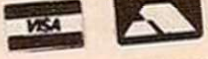

# RESPONSE FRAME

Do you have a problem? Your manual is incomprehensible or you just cannot get the hang of that programming trick you tried — whatever it is, Tim Hartnell will do his best to answer your queries. Please include only one question per letter and mark them "Response Frame".

## BBC GUIDE

■ I have just bought a BBC model B machine, and although the provisional guide supplied with the machine is good, it makes no mention of the more advanced features of the machine. Could you tell me if the new guide has been completed, and if so whether it contains an introduction to machine code?

*Jonathan McFarlane,  
Didsbury, Manchester.*

THE BBC says the guide is ready, and will be sent out shortly. My own copy of the new guide, which arrived at the beginning of July, is a massive work of 516 pages. There is a chapter in it called "Assembly Language" which explains reasonably clearly how to use assembler on the computer. It explains how an assembly-language program is 'held' within a Basic program using square brackets, in the same way as assembly-language programs could be easily placed within Basic ones on the Atom. You will find that the explanation of the advantages of staying away from high-level languages such as Basic is sufficiently clear to enable you — with some care — to become proficient at the lower stages of programming other than in Basic. There is a comprehensive discussion of machine-code entry points, and a list of operating system calls.

## MORE RAM

■ As you probably know, Mode 7 on the BBC Micro does not offer a high-resolution graphic memory map and as a result uses the least RAM of all the eight modes. It is obviously useful for programs which do not require high-resolution graphics, but need more RAM, such as in an Adventure Game. Is it possible to do the same on the ZX Spectrum resulting in a low-resolution screen memory map and about 14K of RAM for the user, as opposed to the 9K available when high-resolution graphics are utilised? If so, how?

*Howard Skoyles,  
Great Yarmouth, Norfolk.*

THE ANSWER, I am afraid to say, is no. There is no trade-off on the Spectrum, as there is on other micros which have high-resolution graphics, between the degree of resolution and available RAM. The resolution for Plot is firmly fixed at 256 by 192, no matter what you do. Therefore, on a 16K Spectrum you are stuck with 9K. However, remember that Sinclair Basic is

efficient at packing a good deal into a little RAM space — especially with the use of the one-key entry which stores all the keywords far more economically than most other micros. Therefore, you can enter a surprising amount into the 9K. As well as this, there are a number of well-publicised techniques for making the most of the ZX-81 memory. These techniques will also help you with the Spectrum.

## MIC AND EAR

■ I have a question regarding the ZX-81's tape recorder compatibility. As you know, the ZX81 incorporates two sockets marked Ear and Mic, both of which should be connected to their respective two sockets on the recorder. My problem is that I have a Panasonic recorder with only one auxiliary five-pin DIN socket marked REC/PB. Can I load and save ZX-81 programs with my Panasonic, and if so, how?

*Keith Richmond,  
Enfield, Middlesex.*

THE SIGNAL sent out by the ZX-81, and expected back by it, is not suitable for an auxiliary plug. You need to plug the Mic output of the ZX-81 into the microphone, and not the Aux, input of the cassette recorder, and the Ear lead of the computer should go into either the headphone or earpiece socket. You may need to have special plugs to make this work. Without adding an extra amplifier between the computer and the recorder, there is no way you can get the computer to work satisfactorily with a DIN arrangement of the type you describe.

## COUNT THE DAYS

■ For part of a program for the ZX-81 with 32K I require a method of counting the number of days between specific dates as a double check, and to know the day of the week of the latest date. I have solved the second part of the problem by using part of another program: the first, however, is giving me nightmares especially where the period is longer than a year, and where leap years are involved. I would be grateful if you would either solve the problem or point me in the right direction.

*Derek Chadwick,  
Kingston, Surrey.*

A SUITABLE program — written for a ZX-80 but which can relatively easily be converted to the ZX-81 — is on page 139 of the book *The*

*Gateway Guide to the ZX-81 and ZX-80* by Mark Charlton. Because of the difference in the way the ZX-80 and the ZX-81 evaluate logic, you will have to change some minus signs to pluses, and vice versa.

## WRONG NUMBER

■ I am experiencing a most irritating arithmetic problem with my Sinclair ZX-81, with and without 16K. The following simple program demonstrates the problem:

```
10 LET A = 1234.99 + 1234.99
   + 1234.99
20 LET B = 1234.99 + 1234.99
   + 1235 -.01
30 PRINT A - B
```

When this program is Run, the answer — which of course should be 0 — is 9.5367422E-7. If all the values in the program are multiplied by 100 the problem disappears. I need to use this checking routine in a program I am writing for my work — I am an accountant. Please could you explain why this problem occurs and how to cure it?

*A R Sampson,  
Stroud, Gloucestershire.*

NO COMPUTER holds every number exactly, and the ZX-81 is no exception. The degree of accuracy of a computer, and a calculator for that matter, depends on the number of decimal places the number is held to within the computer, and the number of places which is finally displayed. Often this is one less than the number of places to which the computer works. People often make an enormous fuss over these minute errors within computers, forgetting that in the real world we generally work to accuracies which are several orders of magnitude less. The "wrong answer" you claim the computer gives is actually less than .000001 above the true answer. If you are dealing with money in your programs — which seems likely if you are an accountant — you need only two-figure, or at most, three-figure accuracy to represent pounds and pence. If the problem still bothers you, simply multiply everything by 100 while working, and then divide the final answer by 100. Whenever you are working with numbers when the accuracy is important, try to eliminate as many intermediate steps as possible, as each of these can introduce some slight error which can accumulate to a substantial error at the end.

## VIC PRINTER

■ I have had a Vic-20 for some months now and I am delighted with it. However, I am taking an O level in computing, and for it I need to write three programs. I need a printer to be able to document it. However, I cannot afford a printer. I would be pleased if you could tell me: Can a printer be rented, and from where and for how much? Is it

worth buying the interface that allows the ZX-81 printer to be used with the Vic. This is taking into consideration that I would like to be able to print graphics on it?

*Paul Hampson,  
Cheddleton, Leek.*

FIRSTLY, I do not know whether you can rent a Vic printer in your area. I know the Vic printer is relatively expensive, especially when compared with the price of the computer. Perhaps you could contact the dealer from whom you bought the computer, and ask if it would be possible to visit the shop with a cassette with your three programs on it, and dump them there. I would not be too pushy about this, and you could be considered nothing but a nuisance. However, if you do decide to do this, make sure you have no trouble finding the three programs on your tape. I suggest you make up a tape just with the three on it so you do not tie the shop or the printer up for longer than is strictly necessary. If graphics are important, you should certainly consider buying the interface, as you can easily dump the contents of the screen, graphics and all, with the ZX printer.

## SPECTRUM BASIC

■ Having just bought a Sinclair Spectrum, I would like to know whether it is possible to translate some of the wide range of ZX-81 software now available into Spectrum Basic. Is this feasible, and what are the relevant differences in the Basics that need to be considered?

*H T Garston Smith,  
Broadstairs, Kent.*

THE VAST majority of the software sold for the ZX-81 is written in machine code, and the problems of converting that into Spectrum Basic are too horrible to contemplate. However, nearly all ZX-81 program listings can be converted into Spectrum programs without too much trouble. The only command in ZX-81 Basic which does not exist in Spectrum Basic is Unplot, and this can be emulated on the Spectrum with Plot Over. However, Plot works on a much finer grid on the Spectrum than it does on the ZX-81, so you may well want to change the display completely from the ZX-81 program. As well as this, Peeking and Poking into the display file on the Spectrum is far from simple, whereas it can be achieved fairly easily on the ZX-81. There are additional commands, including ATTR and Screens, which are simpler to use than Peeking into the display file, and are available on the Spectrum. I would suggest you type a ZX-81 program in, exactly as it is listed, then set about adding user-defined graphics, colour, sound and so on to make it better. In your early stages of such conversions, I would avoid any program which uses Peek or Poke. ■

## COMPUTING IS EASY

David Parker and Martin Hann

*Computing is Easy* has been written for first-time computer users, and younger readers in particular will find it a simple and friendly introduction. It tells you what a personal computer is, how to program it, and how to get it working for you. The easy-to-follow style and amusing cartoons will help you to learn about computer programming in BASIC.

0 408 01203 X 128 pages £3.95

## INTERFACING TO MICROPROCESSORS AND MICROCOMPUTERS

Owen Bishop

Consists of a series of practical projects for the home constructor by which a micro system may be linked to the world around it, e.g. light sensor or sound effects generator. The theory and circuits of each interface are fully explained.

Full constructional details, stripboard layouts, lists of components and hints on alignment and trouble-shooting. Also included are flowcharts and suggestions for methods of programming the system to operate with the interface.

0 408 01129 7 160 pages £4.95

## ZX81 USER'S HANDBOOK

T J Terrell and R J Simpson

ZX81 owners wishing to learn more about their computer will want this book. It answers many questions about BASIC and machine code programming, including graphics. It explains the ZX81 hardware and how it operates and Programs in BASIC and machine code are included.

0 408 01223 4 144 pages £4.95

OTHER TITLES OF INTEREST:-

### ZX81 BASIC Book

Robin Norman

0 408 01178 5 176 pages £4.95

### Learning BASIC with your Sinclair ZX80

Robin Norman

0 408 01101 7 160 pages £4.50

### Practical Microprocessor Systems

Ian R Sinclair

0 408 00496 7 144 pages £5.45

Send for our NEW microcomputer leaflet TODAY Order NOW from your local Bookseller In case of difficulty send cheque/PO with order to Publicity NTB-9 at the address below:-

# Newnes Technical Books

Borough Green, Sevenoaks, Kent. TN15 8PH Tel. Borough Green (0732) 884567

(YC/9.82)

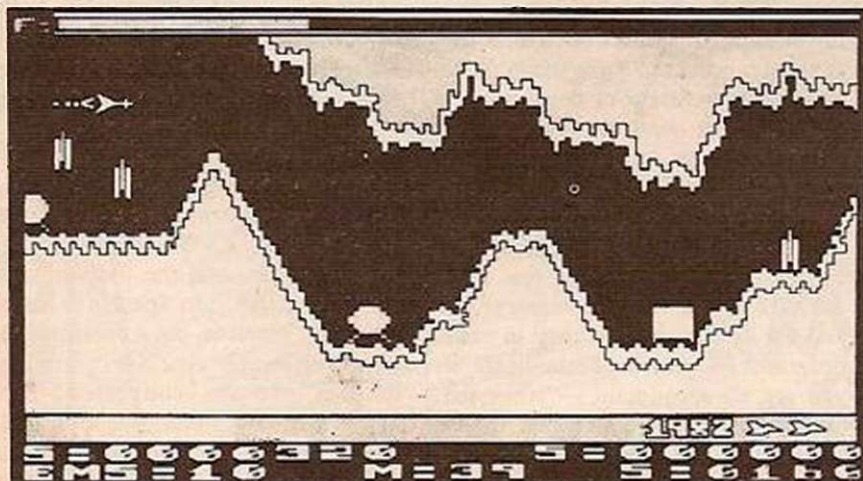

## AIRSTRIKE For The ATARI 400/800

• INTRODUCING THE NEW ARCADE GAME FOR ATARI COMPUTERS!  
• SUPERB SCROLLING GRAPHICS WITH DAZZLING COLOURS!  
• 100% MACHINE CODE PROGRAMME FOR ONE OR TWO PLAYERS!  
• MULTIPLE SKILL LEVELS - FIGHT YOUR WAY THROUGH CAVERNS AND TUNNELS WITH ATTACKING MISSILES, FUEL AND AMMO DUMPS TO CONTEND WITH!  
• AVAILABLE NOW: 16K CASSETTE £15.95 Plus 50p P & P  
32K DISK £18.95

**2 YEAR GUARANTEE**

ON **ATARI COMPUTERS**

WE SERVICE ALL **ATARI & COMMODORE COMPUTERS**

**ATARI INDEPENDENT SERVICE CENTRE**

**FAST NATIONWIDE MAIL ORDER ON ALL PRODUCTS.**

# GEMINI ELECTRONICS

ATARI Dept. Y.C. 50 Newton St., Off Piccadilly, Manchester M1 2EA. Tel: 061-236 3083.



**COMPUTER CHESS GAMES**  
**Commodore VIC-20**  
PLUS GAMES NOW IN STOCK!

# VIC-20

**WE STOCK** ATARI 400/800 COMPUTERS  
COMMODORE VIC COMPUTERS **CALL FOR BEST PRICES!**

**WE STOCK** ALL ATARI, APOLLO, ACTIVISION & IMAGIC CARTRIDGES **CALL FOR BEST PRICES!**

**WE STOCK** LOTS & LOTS OF VIC SOFTWARE **CALL FOR BEST PRICES!**

**WE STOCK** LOTS & LOTS OF ATARI SOFTWARE E.g. Time Warp, Nautilus, Canyon Climber, Apple Panic, Centipede, Venus Voyager, Slime, Intruder, Alien Swarm, Preppie, Pacman, Mathpack, Shamus, Ali Baba, Micropainter, Clowns & Balloons - plus many, many more titles - Call now for our latest batch of detailed brochures! We will keep you up to date on all the new software releases!!!

# FINGERTIPS

Fingertips is our regular calculator column covering calculator news, programming hints and examples of unusual applications. The column is written and compiled by calculator enthusiast David Pringle who is glad to hear of any of your ideas. *Your Computer* pays £6 for each of your contributions published.

THE FINGERTIPS COLUMN receives a great number of programs and suggestions — not always totally complimentary. In spite of the advances of the cheap micro, calculator fiends have kept their resolve.

Only a month ago I saw a fully-fledged paper from the Theoretical Physics department of the Lawrence Berkeley Laboratories containing three statistical programs written for experimentalists — and an HP-35 calculator.

Many of you ask what criterion we use for selecting your programs. If there was one word to sum it up it must be imagination. In other words, an entry which has modified the last two lines of a previous month's Hi-Lo program is hardly likely to wake us up as quickly as a Three-Dimensional Chess simulator in 35 lines. In general a game has to be novel. We get about 20 moon-lander programs per month.

We also appreciate some programs which show the calculator as a working beast and not just a toy. For the more technically oriented, any new information or interesting quirks — synthetic programming and all that — tends to send us rushing fastest to our well-fingered calculators. Write a program incorporating one of these and it's like icing on the cake. Hand it in well-typed and the money and instant fame are nearly yours. Still, whatever your entry we're glad to receive it and will always read it.

The most frequent suggestions were from readers who take personal affront to the singling out of the large and expensive calculators in this column. Remember — write an interesting article on your cheap programmable, and we'll publish it. But just for you here is a program written for the Casio FX-180P by Mike Shallcross of London with

something more serious than games in mind.

As an accountant, he has devised and used the program for checking VAT registration numbers, which use a divisor of 97, but it will work for any normal check digit system. The International Standard Book Numbers, for instance, use a divisor of 11.

Program 1 runs on a Casio FX-180P or equivalent but could doubtless be adapted for most programmable calculators with four memories and conditional loop. It has been made self-initialising as far as possible, and so it is slightly longer than is strictly necessary.

To run the program, if the "K" memories have been cleared or used for other calculations in the meantime, the following steps are necessary:

- Store the divisor in K1
- Without clearing the display, run P1 in order to initialise memories K2 to K4
- To find or verify the check digit(s) for any number, key in the non-check digits and run P1
- For further numbers using the same divisor, simply repeat the last step.

Peter Dewell of Redditch follows up the suggestion of more Commodore PR-100 programs — *Your Computer*, May 1982 — with a non-iterative solution to Paul Stockwell's Intersection of two straight lines program. The two or more points for the lines are entered using the regression data key Ci.

(Ci Egn 1) F slope M0 F Intup M1 OM5 M6 M7 M8 M9 R/S.  
(Ci Egn 2) F slope M2 F Intup-MR1 (MR0-MR2 = R/S Cs R/S.

If an error message occurs check the contents of M0 and M2 for the same slope, otherwise the error is

## Program 1.

Initialise:	MODE 0	
	INV PCL	
	(divisor, e.g., 97)	
	Kin 1	
	P1	
Program:	MODE 7 0	INV X-K 4
	÷	÷
	1	Kout 1
	0	=
	Kin + 2	Kin - 2
	-	Kout 2
	Kin 3	-
	.	.
	5	5
	=	=
	INV RND	INV RND
	Kin - 3	Kin - 2
	INV X-K 3	Kout 1
	x	Kin x 2
	Kout 2	1
	=	0
	Kin + 4	INV X-K 2
	Kout 3	INV RND
	INV x>0	MODE 9
Leave LRN mode:	MODE	

due to the intersection being out of range.

C Rawlinson has come up with a fishy little program for the Sharp PC-1500 — program 2.

If Roy Sirl will step forward and give us his address he will receive £6 for program 3.

$$\frac{C_m^a \times C_{n-m}^b}{C_n^{a+b}}$$

$$\text{where } C_y^x = \frac{x!}{y!(x-y)!}$$

To run it press 2nd inv c.t.

RST  
a STO 4  
b STO 5  
m STO 6  
n STO 1  
R/S

After a minute or two the required probability appears. The formula is most useful when applied to a pack of 52 playing cards. In this case a, b, m and n have the following meaning. a is the number of cards you want.

b is the number of cards you do not want.

m is the number of cards (of the kind you want) that you want.

n is the number of cards you take.

For the probability of three kings in a pack of 52 cards, including four kings in 10 draws.

a = 4, b = 48, m = 3, n = 10

P(a,b,m,n) = 0.0186167.

The TI-57 does not have a factorial button so this is the function of subroutine 0. The subroutine also correctly gives 0! x 1. The program is written without a subroutine to calculate the combinations to, paradoxically, save space. Instead there are nine calls of the factorial routine and some juggling with the memories. The program can be applied to bridge, poker or other card games. For instance, what is the probability in bridge of being dealt all four aces? Here a = 4, b = 48, m = 4, n = 13  
p(a,b,m,n) = 0.00264  
this is about one hand every 380 deals.

I have compiled tables of the probability of getting x cards out of y cards that I want (x y) for y up to 12.

We had a very lively letter from New Zealander Henry Falkner who has some harsh things to say about all programmables and seems to prefer his Casio 602 to the 702 which he later bought. In his spare time he appears to be the musician for the City of Auckland Morris dancers — is he honest or are we naive? He says that he finds the music adaptor invaluable for some of his songs. Enter the Cloggies.

Finally — this month's program challenge. Write a program to calculate the number of people needed in a group before there is a probability of 60 percent for any two of the people to have identical birth-dates.

(continued on next page)

Program 2. It is remarkable how the non-technically-minded are more impressed by simple programs than by the most complex and difficult ones. This one never fails to amuse the uninitiated. After the Print statement in lines 20, 30 and 40, a fish swims lazily across the display.

```

10: WAIT 100
20: PRINT " THIS is what you get" (3 spaces)
30: PRINT " for using a" (7 spaces)
40: PRINT " LIQUID crystal display" (2 spaces)
50: C1S
60: WAIT 0
70: FOR C = 0 TO 155
80: GCURSOR C
90: GPRINT 65;34;62;28;28;28;28;62;62;62;62;62;63;63;
127;127;127;127;127;127;127
100: GPRINT 127;127;58;62;28;8 (90 AND 100 PRODUCE THE FISH)
110: GCURSOR C
120: GPRINT 0
130: GCURSOR 0 (IT IS NOT OBVIOUS WHAT THESE TWO LINES DO,
140: GPRINT 0;0;0;0;0;0 BUT TRY IT WITHOUT AND SEE)
150: NEXT C
160: END
    
```

# FINGERTIPS

(continued from previous page)

Program 3. The TI-57 probability program.

Key	Loc	Code
RCL 4	00	33 4
SUM 3	01	34 3
SBR 0	02	61 0
STO 2	03	32 2
RCL 5	04	33 5
SUM 3	05	34 3
SBR 0	06	61 0
2nd Prd 2	07	39 2
RCL 1	08	33 1
SBR 0	09	61 0
2nd Prd 2	10	39 2
RCL 6	11	33 6
SBR 0	12	61 0
2nd INV Prd 2	13	-39 2
RCL 3	14	33 3
SBR 0	15	61 0
2nd INV Prd 2	16	-39 2
RCL 1	17	33 1
INV SUM 3	18	-34 3
RCL 3	19	33 3
SBR 0	20	61 0
2nd Prd 2	21	39 2
RCL 6	22	33 6
INV SUM 1	23	-34 1
INV SUM 4	24	-34 4
RCL 1	25	33 1
INV SUM 5	26	-34 5
SBR 0	27	61 0
2nd INV Prd 2	28	-39 2
RCL 5	29	33 5
SBR 0	30	61 0
2nd INV Prd 2	31	-39 2
RCL 4	32	33 4
SBR 0	33	61 0
2nd INV Prd 2	34	-39 2

Key	Loc	Code
RCL 2	35	33 2
RIS	36	81
RST	37	71
2nd Lbl 0	38	86 0
STO 0	39	32 0
2nd Lbl 1	40	86 1
RCL 0	41	33 0
X	42	55
2nd Dsz	43	56
GTO 1	44	51 1
2nd x=t	45	66
CLR	46	15
1	47	01
=	48	85
INV SBR	49	-61

Cloggies' program.

```

*** P1
Min6 Min6 Min5 Min4
NR4 Min8 Min3 Min5
Min5
.
NR5 Min6 Min5 Min4
NR2 Min2 Min5 Min4
Min3
NR4
AC
*** P2
Min4
NR5 Mini
NR1 Mini Min5 Min5
Min6
.
NR7 Min6 Min5 Min4
Min6 Min7 Min8 Mini
Min4 Min3
    
```

NR4	GSBP1
NR5 Mini	GSBP1
NR1 Mini Min5 Min5	GSBP2
Min6	GSBP1
NR7 Min6	GSBP2
.	GSBP1
NR7	GSBP1
NR6 Min5	GSBP1
.	GSBP2
NR4	GSBP1
NR6 Min7	GSBP1
.	GSBP2
NR8	GSBP1
NR1 Min4	GSBP1
.	GSBP2
NR3	GSBP1
NR4	GSBP1
AC	HLT
	GSBP2
	AC
*** P0	
M+F	
GSBP1	
GSBP1	
GSBP1	
GSBP2	
GSBP1	
GSBP1	
GSBP2	
GSBP1	
GSBP1	
GSBP2	
GSBP1	
GSBP1	
GSBP2	

MEMORY LIST

MF=	7.
M9=	48.
M8=	54.
M7=	61.
M6=	64.
M5=	72.
M4=	82.
M3=	87.
M2=	97.
M1=	118.
M0=	0.



## YOUR COMPUTER

As a reader of *Your Computer* you'll agree that every issue is an invaluable reference.

To keep your copies in order you'll need a binder, specially designed for *Your Computer*, to ensure every issue remains in good condition for your future use.

To order your binder complete the coupon below and return it to us, with your cheque. Prices, including VAT, postage and packing, are as follows:

UK	£3.45
Europe	£4.00
Rest of the World	£5.00

To: General Sales Manager, Room 108, Quadrant House, The Quadrant, Sutton, Surrey SM2 5AS, England.

Please send me.....*Your Computer* binders at £.....each.

I enclose my cheque/postal order for £.....made payable to IPC Business Press Ltd.

Name.....

Address.....

.....

.....

# P.E.P.

## THE PROGRAM ENHANCEMENT PACKAGE FOR THE ZX81 (16K)

A suite of easy to use machine code routines designed to transform your Basic programs.

- DEFINED SCROLL REGION 1 line to whole screen
- SCROLL up or down ■ FILL SCREEN any character
- CHANGE BACKGROUND ■ CHANGE FOREGROUND
- INVERSE VIDEO ■ FLASH SCREEN
- CLEAR SCREEN without changing print position

Supplied on tape with a 6K DEMO PROGRAM and a FULL instruction booklet

ONLY £5.95 Incl. p & p

SEND TO

# R & R

## SOFTWARE

34 BOURTON ROAD  
GLOUCESTER GL4 0LE

### GOLF (9K)

A full feature game for 1 or 2 players. 9 or 18 hole course to test your skill. Fantastic full screen graphics with rough, bunkers, trees, water hazards, fairway and the green

ONLY £3.75

### MINEFIELD (5K)

Guide your tank to safety. Hidden mines will explode on contact and send you back to the start. With only nine lives to play with you must remember your route so far

ONLY £3.75

### BOMBER (5K)

Destroy the enemy city in this all action machine code game. Beware the cities defenders fight back. Complete with high score feature

ONLY £4.95

## 16K GAMES

ZX81 & 16K

# THE TOMB OF DRACULA!

## 3D HORROR ADVENTURE GAME!

Occupying over 13½K of memory, a superb 3D graphics adventure game for the ZX81 with 16K RAM, for only £3.95! Enter Dracula's tomb at 30 minutes to sunset ... wander through the tomb's pre-mapped 300 vaults in search of the fabled Vampire's Treasure ... pick up valuable silver stakes and use them to defend yourself against the lurking horrors ... ghouls, zombies, pits of primaeval slime ... See them all on the ZX81's plan of the tomb ... when it will let you! Take a chance on a Mystery Vault ... if your dare! And all the time the minutes are ticking by to sunset ... when Dracula rises from his coffin and comes after you! Each of the infinite levels of the tomb has its own 300 vaults ... go as deep as you like, the Prince of Darnkess will seek you out in his blood-lust! **WARNING:** people of an exceptionally nervous disposition should play this game only during the hours of daylight! Special facility enables a game in progress to be saved on tape so you can continue it whenever your choose.

Price of only £3.95 includes ready-to-load cassette with library case and inlay, full instructions, postage and packing. Order today! Money refunded if not delighted! Send cash, P.O. or cheque to:

MOVIEDROME VIDEO (DEPT. YC3)  
19 Leighton Avenue, Pinner, HA5 3BW.

SPOCK: "Computer! Calculate the value of Pi to ten thousand decimal places".  
COMPUTER: "Working..."

## CAN YOUR COMPUTER SPEAK?

The **WIDEBAND SPEAKEASY** speech synthesiser adds voice response to any computer with a parallel port including PET, ZX-81, VIC, BBC, ATOM, HORIZON etc.

for Only £69 + VAT

- \* UNLIMITED VOCABULARY
- \* EASY TO PROGRAM
- \* LOW MEMORY OVERHEAD
- \* COMPLETE MANUAL WITH DICTIONARY, SAMPLE SOFTWARE AND TUTORIAL ON SPEECH PRODUCTION.



Also includes high flux speaker and power supply, all housed in high quality wood cabinet, with volume control and rear pitch control.

Programmed with simple phonetic codes. Apart from the obvious applications of voice response in manufacturing, testing, blind terminals etc., this product also teaches a great deal about linguistics and speech production.

Software is available in BASIC and Z-80 and 6502 assembly for direct input in PHONETIC SPELLING closely related to the ARPABET international phonetic alphabet.

For your nearest dealer contact:

**WIDEBAND** PRODUCTS, CAMBRIDGE RD.,  
ORWELL, ROYSTON, HERTS. TEL: 0223 208017

A subsidiary of Sands-Whiteley Research and Development

## IS YOUR ZX81 + 16K PROGRAMMED FOR PROFIT?

### Or is it just another toy?

Today's Successful Business Man requires Fast, Accurate and Up To The Minute Information about his business to assist him to make the correct decisions to plan his company's growth and profitability.

#### WOULD YOU KNOW THE ANSWERS TO THESE PROBLEMS NOW?

- What is my Monthly Income over the next year?
- What are my Future Cash Requirements?
- How are my Costs rising eg. Sales, Materials, etc. And how will they effect my Profitability?
- What are the Trends in my business and where will I be if they continue?
- How can I test my Future Projects and Plans to find out their implications on my business?
- How can I convince my Bank and Creditors that my Forecasts are not just Guesses?
- How can I do all this easily from my normal business records and accounts with no special knowledge of Maths, Business Techniques, or Computing (other than how to operate my ZX81)?

#### HOW MANY TIMES HAVE YOU WANTED THAT TYPE OF INFORMATION TO HAND?

The answers to these problems and the relationship they have to your business are now available to you as often as you require with the use of your ZX81 and a specially created program for the business user. THIS POWERFUL (over 500 lines), BUT EASY TO USE PROGRAM was created by a Business Consultant with over 30 years experience of small and medium size business problem.

#### THE PRICE OF YOUR PEACE OF MIND = £15

Complete with professional grade cassette, instruction manual, and input charts.

Cheques or P.O.s to:

P.R. Herberg M.B.I.M. The Consultancy,  
13 Greenend Close, Spencers Wood, Reading, RG7 1EH.



# Stonechip Electronics



PRODUCTS FOR VIC-20, SPECTRUM, ZX81

## ZX SPECTRUM OWNERS

UPGRADE YOUR 16K SPECTRUM  
TO A FULL 48K WITH OUR  
FULLY ASSEMBLED AND GUARANTEED

### MASSIVE 32K RAM MEMORY EXPANSION

EASILY FITTED INTERNALLY. SUPPLIED WITH FULL  
INSTRUCTIONS

**£39.95**

## SPECTRUM ECHO

MAKE FULL USE OF YOUR SPECTRUM'S SOUND  
FACILITY BY AMPLIFYING IT! ENABLES LOADING AND  
SAVING TO TAPE WITHOUT SWITCHING LEADS  
NO ADDITIONAL POWER SUPPLY REQUIRED

OTHER FEATURES INCLUDE:

- \* TONE AND VOLUME CONTROL
- \* AUDIBLE CUEING FACILITY
- \* DIN COMPATIBILITY
- \* ATTRACTIVELY CASED

**£23.50**

## SPECTRUM CONVERTER

ALLOWS USE OF ZX81 ADD-ONS WITH YOUR NEW  
SPECTRUM  
SIMPLY PLUGS INTO YOUR EXPANSION PORT WITHOUT  
INHIBITING ITS USE

**£15.00**

## ZX81 USERS THE ZX-PANDA



UNIQUELY EXPANDABLE 16K RAM  
PACK

EXPANDABLE INTERNALLY BY PLUG-IN MODULE TO  
FULL 32K

ATTRACTIVE CUSTOM MADE CASE CONTOURED TO  
REAR OF ZX81 FOR MAXIMUM STABILITY  
COMPACT SIZE. LED POWER INDICATOR

COMPATIBLE WITH MOST EXPANSION SYSTEMS

ZX-PANDA 16K EXPANDABLE ROM **£25.00**

ZX-PANDA 16K EXPANDABLE MODULE **£19.95**

OR FULL 32K EXPANDED

**GIANT PANDA £39.95**

## VIC-20 OWNERS

*Fully Assembled, Cased and Guaranteed*

### MASSIVE 16K RAM MEMORY EXPANSION

PLUGS DIRECTLY INTO YOUR VIC-20 OR  
MOTHERBOARD

**£39.95**

EXPAND YOUR VIC-20 WITH

## Tandem

3+1 EXPANSION UNIT

FOR USE WITH MEMORY AND GAMES CARTRIDGES  
MORE THAN 1 UNIT CAN BE USED IN TANDEM TO GIVE  
EVEN MORE EXPANSION

INCLUDES ROM SOCKET

PLUGS DIRECTLY INTO YOUR VIC-20 EXPANSION PORT  
ATTRACTIVELY CASED

**£34.95**

## ZX81 KEYBOARD

KEYS WITH POSITIVE CLICK ACTION AND PROTECTED  
LEGEND

AUTO REPEAT FACILITY

FITS DIRECTLY ONTO YOUR ZX81 WITH SIMPLE PLUG-  
IN CONNECTIONS TO EXISTING SOCKETS

**£24.95**

SEE US ON STAND 214 AT PCW SHOW

PLEASE SEND ME: .....

.....

.....

.....

I enclose £ .....

.....

NAME .....

ADDRESS .....

.....

.....

.....

YC9

*Send now to:*

**STONECHIP ELECTRONICS,  
UNIT 4, HOSKINS PLACE, WATCHETTS RD, CAMBERLEY,  
SURREY. TEL: (0276) 681131  
MAKE CHEQUES OR P.O.'s PAYABLE TO: STONECHIP LTD**

ALL PRODUCTS FULLY ASSEMBLED, TESTED AND GUARANTEED  
ALL PRICES FULLY INCLUSIVE  
ALLOW 28 DAYS DELIVERY



# SOFTWARE FILE

(continued from previous page)

## Program 10.

```
START 17335
2A 26 40 7E FE 12 01
30 00 08 01 01 00 C9
FINISH 1734E
```

## Program 11.

```
4 REM ** (C) G. OWEN, JUNE 1982 **
5 LET C=0
6 RAND
10 FOR S=16514 TO 16517
11 POKE S,28
12 NEXT S
13 PRINT AT 0,0;"0000";AT 0,31
14 "
```

```
15 POKE 16520,142
16 POKE 16521,64
17 POKE 16522,RND*3
18 POKE 16523,RND*3
20 LET OF=PEEK 16396+256*PEEK
16397
24 REM ** LINE 25, WITH CREDIT A
ND THANKS TO T. GILBERT (FEB. 82) **
25 POKE 16418,0
30 PRINT AT 0,4;"0"
35 PRINT "
40 PRINT AT 23,0;"
75 LET SP=DF+334
80 POKE 16518,SP-256*INT (SP/2
95)
85 POKE 16519,INT (SP/256)
100 IF INKEYS="0" THEN IF (USR
16955) OR (USR 16992 AND 0) THEN
GOTO 400
110 IF USR 16800 THEN GOTO 400
130 LET M=USR 16857+USR 16915
```

```
135 IF USR 17190 OR USR 16955 T
HEN GOTO 400
140 LET M=USR 16992
150 IF USR 16800 OR USR 17190 O
R USR 17335 THEN GOTO 400
160 IF PEEK (PEEK 16520+256*PEE
K 16521)=11 THEN GOTO 500
190 GOTO 100
400 LET SP=PEEK 16518+256*PEEK
16519
410 POKE SP,146
430 LET C=C+1
435 PRINT AT 0,31;S-C
440 IF C=5 THEN GOTO 500
445 FOR S=2 TO 22
450 PRINT AT S,0;"
455 NEXT S
460 GOTO 75
500 POKE 16520,142
510 POKE 16521,64
520 GOTO 100
600 PRINT AT 10,5;"GAME OVER"
8999 STOP
```

## Life expectancy

Bharat Patel,  
Shaw,  
Oldham.

VIC-20

LIFE EXPECTANCY runs on a Vic-20 without any additional memory. It is made up of Print

statements and is very easy to follow. If anything is printed that does not answer a question, a message is given to repeat the correct answer. There are some unusual marks in the program listing; these are only graphic symbols — they provide capital letters when run — and are obtained via the Shift key or the Commodore flag.

The program asks you many questions on your daily life and activities and at the end the computer will produce an expected date to which you should live — it also tells you if your habits are so bad that you should be dead. The questions go into detail about your fitness, age, family, whether you smoke — and if so how many a day — and many other things.

```
1 REM "LIFE EXPECTANCY"
2 PRINTCHR$(14)
3 L=100
5 PRINT "Q"
10 PRINT "NAME PLEASE": INPUT N$
20 PRINT "AGE PLEASE": INPUT A$
25 PRINT "Q": PRINT "ARE YOU -EMALE OR -ALE?": PRINT "PRINT" (\ OR -)
27 INPUT S$
28 IF S$="M" THEN LET S=69
29 IF S$="F" THEN LET S=74
30 BIRTH=1981-A$
100 PRINT "Q OUR BIRTHDAY, M, D, Y"
110 PRINT " WAS IN " BIRTH: FOR I=1 TO 2000: NEXT I
200 PRINT "Q": " ARE YOU MARRIED?": INPUT M$
210 IF M$="Y" OR M$="YES" THEN LET L=L-1: GOTO 220
212 IF M$="N" OR M$="NO" THEN GOTO 220
215 IF M$="?" THEN PRINT "ON'T UNDERSTAND": FOR U=1 TO 2000: NEXT U: GOTO 200
220 PRINT "Q": " ARE YOU -IGH OR -OOR OR -IDDLE (R-P-M)
230 INPUT R$
240 IF R$="R" OR R$="P" THEN LET L=L-2: GOTO 250
242 IF R$="M" THEN LET L=L-1: GOTO 250
243 IF R$="?" THEN PRINT "ON'T UNDERSTAND": FOR V=1 TO 2000: NEXT V: GOTO 220
250 PRINT "Q": " ARE YOU OVERWEIGHT?": PRINT "PRINT" ( I OR -)
260 INPUT W$
270 IF W$="Y" OR W$="YES" THEN LET L=L-1: GOTO 280
272 IF W$="?" THEN PRINT "ON'T UNDERSTAND": FOR X=1 TO 2000: NEXT X: GOTO 250
280 PRINT "Q"
290 PRINT "Q YOU EXERCISE OFTEN?": PRINT "PRINT" (1 - ALWAYS 2 - /EVER
300 INPUT E$
310 IF E$="2" THEN LET L=L-1: GOTO 330
320 IF E$="3" THEN LET L=L-0: GOTO 330
322 IF E$="?" THEN PRINT "ON'T UNDERSTAND": FOR Y=1 TO 2000: NEXT Y: GOTO 280
330 PRINT "Q": " DO YOU -RINK?": PRINT "PRINT" (1 - /ODERATELY
340 PRINT "3 - /EVER"
350 INPUT F$
360 IF F$="2" THEN LET L=L-1: GOTO 400
370 IF F$="1" THEN LET L=L-0: GOTO 400
380 IF F$="?" THEN PRINT "ON'T UNDERSTAND": FOR VV=1 TO 2000: NEXT VV: GOTO 330
400 PRINT "Q": " DO YOU SMOKE ( I OR -)
410 INPUT S$
420 IF S$="Y" OR S$="YES" THEN LET L=L-1: GOTO 422
421 IF S$="?" THEN PRINT "ON'T UNDERSTAND": FOR S0=1 TO 2000: NEXT S0: GOTO 400
422 IF S$="Y" OR S$="YES" THEN PRINT "Q HOW MANY A DAY?": INPUT H$
423 IF H$="0" THEN LET L=L-2
424 IF H$="1" THEN LET L=L-1
425 IF H$="2" THEN LET L=L-2
430 PRINT "Q": " ARE YOU OFTEN ILL?": PRINT "PRINT" ( I OR -)
440 INPUT I$
450 IF I$="Y" OR I$="YES" THEN LET L=L-1: GOTO 455
451 IF I$="?" THEN PRINT "ON'T UNDERSTAND": FOR XX=1 TO 2000: NEXT XX: GOTO 430
455 PRINT "Q"
460 PRINT "Q ARE YOU OFTEN TENSE?": PRINT "PRINT" ( Y OR N)
470 INPUT T$
480 IF T$="Y" OR T$="YES" THEN LET L=L-1: GOTO 490
485 IF T$="?" THEN PRINT "ON'T UNDERSTAND": FOR XX=1 TO 2000: NEXT XX: GOTO 455
490 VOL=36878
495 POKE 36878,15
500 PRINT "Q": " FORVV=128 TO 140: POKE 36879,VV: POKE VOL,15: POKE 36875,210: FORG=1 TO
100: NEXT G
503 POKE 36878,0: NEXT VV
510 POKE 36879,122
520 PRINT "***** LIFE EXPECTANCY *****"
530 PRINT "PRINT"
540 X=(L/100)*SE
550 X1=X*Y
560 PRINT " YOU WILL LIVE UNTIL " X1 " YEARS OLD "
570 X3=INT(X/AGE)
580 IF X3="0" THEN PRINT " YOU SHOULD HAVE BEEN BURIED -- BY NOW ---" END
590 PRINT "*****"
600 PRINT "PRINT" "PRINT" " HEREFORE YOU SHOULD LIVE UNTIL " X3 " YEARS "
READY.
```

## Change of memory

Gavin Warren,  
Redbarn,  
Hertfordshire.

VIC-20

WHEN THE Vic is expanded to have more than 8K of RAM, the system reshuffles the screen and the start of Basic text, and this makes running any machine-code programs written for the unexpanded Vic impossible.

To solve the problem I wrote a simulator program. The program changes memory size, sets the screen start to 7680 again and sets the start of Basic to 4096 as on the unexpanded Vic.

If the program is loaded and run before using the desired program, no problems should be encountered.

```
10 POKE 648,30
20 POKE 36866,150
30 POKE 55,0: POKE 56,30
40 POKE 52,0: POKE 53,30
50 POKE 643,0: POKE 644,32
60 POKE 641,0: POKE 643,16
70 CLR
80 PRINT "(CLR) (BLUE)"
90 POKE 36869,240
100 POKE 43,1: POKE 44,16
110 POKE 4096,0
120 NEW
```

## Key routine

P J Mills,  
Tongham,  
Surrey.

ATOM

IN MAY SOFTWARE File, G E Taylor gave some examples of the use of subroutines # FE71 in the Atom monitor. Since machine-code routines run far faster than Basic programs, it is best to obtain the fastest possible running speeds for, say, games, and then slow them down to the desired speed.

This program will not only read the keyboard, but also takes no action if # FF is returned in the Y register, and will reject all but the keys used by the program. The advantage of the program is that it checks for the valid keys in the assembled program so it does not have to be re-linked every time an incorrect key is pressed.

As an extra, the two subroutines will move a variable-sized cursor across the bottom of the screen in Mode 0. The keys I used were A and D. Remember that the value returned in the Y register is the ASCII value of the key minus # 20. A or D must be pressed before the cursor will appear on the screen. The program requires 855 bytes.

- 5 Set space for labels
- 7 Choosing of bat size
- 10 Clear graphics mode
- 15 Set up basic constants
- 25-55 Read keyboard
- 60-65 Set # 80 if A pressed
- 70-75 Set # 80 if D pressed
- 85 Run assembled program
- 90-100 Set up Gosub jump
- 110 Rerun assembled program
- 1000-1030 Move left subroutine
- 1200-1230 Move right subroutine
- 1010/1210 Rub out cursor in last position
- 1020/1220 Reprint cursor in new position

Here are the constants and variables:

- X nth cursor position
- Z n-1 cursor position used in right subroutine
- C n-1 cursor position used in left subroutine
- M May be changed, gives a very crude speed control
- QQ Assembler labels
- W Value returned from assembler program — also used in subroutine or Next loop
- E Calculated Gosub

As there are some forward jumps in the assembler program the program must be run twice. Therefore once the screen goes blank, press Break followed by typing Old and then Run.

# SOFTWARE FILE

```

5 DIM QQ(3), P(-1)
7 INPUT "BAT SIZE", T
10 CLEAR @
15 X = 20; Z = 0; C = 0; M = 1
20 PRINT #21
25 C
30 :QQ0 JSR #FE71
35 CPY @#FF; BEQ QQ0
40 CPY @#21; BEQ QQ1
45 CPY @#24; BEQ QQ2
50 \ANY NO. OF KEYS CAN BE
51 \CHECKED IN THIS WAY
55 JMP QQ0
60 :QQ1 LDA @0; STA #80
65 RTS
70 :QQ2 LDA @200; STA #80
75 RTS
80 J
82 PRINT #6
85 LINK QQ0
90 W = ?#80; E = 1000 + W
100 GOSUB E
110 GOTO 85
200 END
1000 X = X - (T + 1); C = X + (T + 1)
1010 FOR W = 0 TO T; PLOT 15,(C + W),0; NEXT; X = C - M
1020 FOR W = 0 TO T; PLOT 13,(X + W),0; NEXT
1030 RETURN
1200 X = X + (T + 1); Z = X - (T + 1)
1210 FOR W = 0 TO T; PLOT 15,(Z + W),0; NEXT; X = Z + M
1220 FOR W = 0 TO T; PLOT 13,(X + W),0; NEXT
1230 RETURN

```

## The Pac-Man trail

Chris Lam,  
Redhill,  
Surrey.

**SPECTRUM**

THIS IS A Pac-Man-type program for the 16K Spectrum. While playing you are constantly

informed of your score, the number of lives you have left, and power. When you eat an asterisk — a power pill — it will boost your score by 10 and your power by 40. When your power is not zero, you can eat the ghost and gain 50 points.

You have four lives and if you are good enough, the game could last for ever. Lines 50

and 55 detect the movement of the Pacman controlled by the cursor keys. Lines 220 and 230 make the ghost follow you randomly. Depending on line 220, the Pacman is a @ symbol and the ghost is a "c".

Lines 1000 to 1150 can be changed to make the maze larger. You must also make appropriate changes to lines 50 and 55.

```

1 REM "PAC-MAN" © Chris Lam
2 LET power=0: LET ss=0: LET
L=0
3 BORDER @: PAPER @: INK @: C
LS
5 LET ll=4: LET count=0: LET
91x=15: LET 91y=10
6 PRINT AT 19,10;"Lives=";AT
1,12;"Score=";AT 2,12;"Power="
10 LET ll=ll+1
11 RESTORE 1000
20 FOR n=0 TO 18: READ n$: PRI
NT AT n,10;n$: NEXT n
30 LET X=21: LET Y=17
40 PRINT AT 19,10;ll;AT 1,10;=
s;" :AT 2,10;power;"
41 PRINT AT Y,X;"@": LET XX=X:
LET YY=Y
43 IF power<>0 THEN LET power=
power-1
45 PRINT AT 91y,91x; OVER 1;"@
"
50 LET X=X+(INKEY$="A" AND X<2
1)-(INKEY$="S" AND X>11)
55 LET Y=Y+(INKEY$="D" AND Y<1
7)-(INKEY$="7" AND Y>4)
56 LET S$=SCREEN$(Y,X)
57 IF CODE S$=@ OR !CODE S$>12
7 AND CODE S$<144 THEN GO TO 10
@
58 IF S$="*" THEN LET power=40
: LET ss=ss+10
60 IF S$="." THEN BEEP ,25,4:
LET ss=ss+1: LET count=count+1
63 IF count/L=105 THEN GO TO 1
@
64 GO SUB 200
65 PRINT AT YY,XX;" "
70 GO TO 40
100 LET X=XX: LET Y=YY: GO TO 5
8
200 REM move ghost
210 LET 91xx=91x: LET 91yy=91y
220 LET rx=RND
230 LET 91x=91x+(rx)>.3 AND 91x<
x AND 91x<21)-(rx)>.3 AND 91x>x A
ND 91x>11)
240 LET 91y=91y+(rx)>.5 AND 91y<
17)-(rx<.5 AND 91y>4)
250 PRINT OVER 1;AT 91yy,91xx;"
@"
255 IF 91xx=x AND 91yy=y THEN G
O TO 270
256 IF 91x=x AND 91y=y THEN GO
TO 270
260 RETURN
270 IF power<>0 THEN GO TO 300
280 LET ll=ll-1: IF ll=-1 THEN
GO TO 290
285 PRINT AT YY,XX;" " : GO TO 3
290 PRINT " Hard Luck!" "You're
too slow" "Ha! Ha! Ha!": STOP
300 REM Eaten Ghost
301 LET power=0
302 LET ss=ss+50
303 LET 91x=16: LET 91y=10
305 RETURN
1000 DATA "
1010 DATA " * . . . . * "
1020 DATA " . . . . . "
1030 DATA " . . . . . "
1040 DATA " . . . . . "
1050 DATA " . . . . . "
1060 DATA " . . . . . "
1070 DATA " . . . . . "
1080 DATA " . * . . . * "
1090 DATA " . . . . . "
1100 DATA " . . . . . "
1110 DATA " . . . . . "
1120 DATA " . . . . . "
1130 DATA " . . . . . "
1140 DATA " . . . . . "
1150 DATA "

```

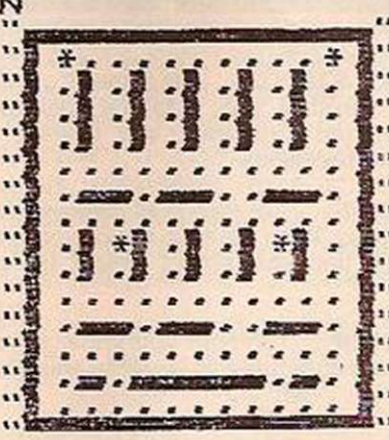

## Cartoon time

J P Riggs,  
Gosport,  
Hampshire.

**BBC**

THIS PROGRAM will give you an insight into the graphical possibilities of the BBC micro-computer. It starts in a living-room of a house, with a television in one corner showing *The Space Programme* where you are about to

witness the take-off of an *Apollo* rocket into space. It lands on the moon's surface, takes off again, orbits the earth and plunges into the sea awaiting rescue.

The program is designed for the B machine but with small modifications will be able to run in lower modes. Converters to lower modes should note that lines 50, 170, 320 and 400 are where modes are set and text and graphic windows are defined. Sound has been incorporated for added realism.

Line 50 makes the screen white by drawing two

triangles and filling them in using the Plot 85 command.

60 to 70 give the room its walls and ceiling. 80 to 100 draw the plush carpet on the floor. 110 to 270 draw the television, door, picture, etc. Line 170 defines the text window — see VDU statements in manual. Line 320 defines the graphics window. 330 to 380 are the calls procedures. The main body of the program. 390 to 420 ends the program resetting windows. 430 to 440 clear the television's screen.

(continued on page 93)



## WHAT PEOPLE ARE SAYING ABOUT OUR . . . BBC MICRO GAMES

"... I bought all your tapes to date for the BBC Micro and I think they are just super, especially STAR TREK, and the sound effects in CANDY FLOSS really made me sit up! Well done and keep them coming!"  
J. S., Paisley

"... I was very impressed, not only with the cassette, but also at the speed at which it came!"  
— R.L., Cheshire

"... I must congratulate you on your MUTANT INVASION cassette. I have had it for two weeks now and it is really superb. Incidentally, I have beaten your high score of 4,500 — mine is 7,580!"  
— S.L., Berks

### GAMES FOR MODELS A AND B

#### CASSETTE ONE

(i) STAR TREK. A superb version with 8 x 8 Galaxy, Klingons, Phasers, Torpedoes etc.  
(ii) CANDY FLOSS. A tremendous new game in which you run a candy floss stall on Blackpool's Golden Mile. But watch the weather and the donkeys!  
ONLY £5.95 inc.

#### CASSETTE TWO

Contains an exciting collection of games with music and graphics to keep the family amused for hours: HANGMAN (in which you can even enter your own category), KRYPTOGRAM, DICE, BEETLE, GRAND NATIONAL and MUSIC.  
ONLY £3.95 inc.

#### CASSETTE THREE

Contains, for the arcade fanatics, — MUTANT INVADERS. A brilliant new "Space Invaders" type game. Can you destroy the mutants before they land and try to destroy you with their radioactivity.  
WARNING — VERY ADDICTIVE!  
ONLY £5.95 inc.

#### CASSETTE FOUR

Contains BREAKOUT. A terrific version of the popular arcade game. Practice your wall demolition with 6 skill levels and 1 or 2 player option!  
ONLY £3.95 inc.

### GAMES FOR MODEL B ONLY

#### CASSETTE FIVE

Contains BEEBUNCH. Our version of the record breaking 'Pacman' arcade game, and we believe one of the best versions available. Stunning hi-resolution colour graphics including multi-ghosts, tempting fruits, super points, screams etc. Liven up your micro with this tremendous game.  
ONLY £5.95 inc.

#### CASSETTE SIX

Contains SUPER HANGMAN. The special feature of this version is the hi-resolution animated man. Watch the expression on his face change as the noose tightens around his neck. Marvel at the detail of his clothing — but don't take too long, he grows very impatient! Contains many categories from educational to just plain fun!  
ONLY £3.95 inc.

#### CASSETTE SEVEN

Contains 3-D MAZE. Pit your wits against the computer's logic in this highly realistic graphical game. The computer sets up logical mazes (you choose the size). And then it shows the view you have of the maze in 3-D each step you take as you battle against the clock to escape!!  
ONLY £3.95 inc.

ALL CASSETTES AVAILABLE NOW FROM: **SINCLAIR (I. J. K. Software)**

(All our software is available before we advertise)

55 Fitzroy Road, Bispham, Blackpool, Lancs

VIC 20

16K

ZX81

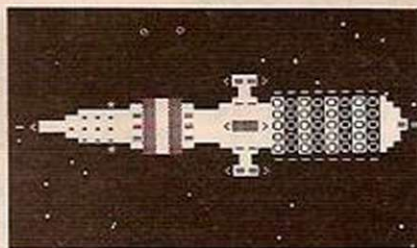
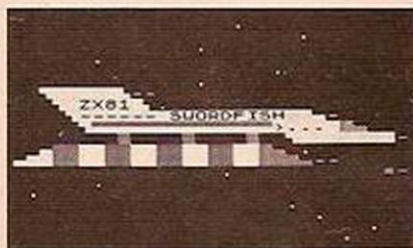

**SUBSPACE STRIKER** . . . It comes from out of nowhere and then vanishes back into the shadows. With your deadly Antimat torpedoes, you unleash havoc in the Federation spacelanes.

**STARQUEST** . . . A voyage of discovery and adventure in the cosmos. With the help of your onboard computer, you seek a habitable planet amidst the perils of deep space.

**ENCOUNTER** . . . Would you know what to do if you were abducted by alien beings? In this game the space invaders play YOU!

**TRADER** . . . A Trilogy of full 16K programmes that are chained to give a fantastic 48K graphic adventure. As an intergalactic trader you seek your fortune and deal with some very bizarre customers indeed.

Pixel games are a delightful change from the usual arcade rip-offs. Full screen animated graphics and good value too at only £9.50 for VIC 20 and £5.50 for ZX81 per 16K game. Trader is £10.50 for ZX81 only at present. Ask your dealer now or send to us for tapes by return of post.

# PIXEL

Pixel Productions 39 Ripley Gdns., London SW14 8HF

# adventure

SPECTRUM ZX81 **BBC** nascom

Colossal Adventure .. 16K/32K .. £8/£10  
The classic mainframe game "Adventure", with all the treasures and creatures of the original. And with 70 extra rooms!

Adventure Quest ..... 16K/32K .. £8/£10  
From the Great Forest, up Orc Mountain, braving fire, swamp and caverns on a quest against Tyranny. Face vampires, demons, wizards, 200-foot worms...

Adventure games are fascinating. You enter English phrases and the computer acts as a window to worlds of magic.

Every Level 9 adventure has over 200 individually described locations and a game may take weeks to solve! Only our combination of data and code compaction allows so much to be provided.

FREE P&P. NO VAT. Money back if unhappy. Supplied on TDK cassettes. Send order, describing your computer, or a SAE for full details of all our programs to:

**LEVEL 9 COMPUTING**

229 Hughenden Road, High Wycombe, Bucks

# SOFTWARE FILE

(continued from page 91)

450 to 600 are the re-entry Procedure and draw Earth and the rocket orbiting.

610 to 650 are the wait Procedure, and delay the program for "s" seconds.

660 to 740 are the take-off Procedure and draw Cape Canaveral with its launch-pad and rocket, and after a 10-second countdown ignition commences.

750 to 810 make the rocket travel through the

void of endless space, forever coasting. 820 to 950 draw the moon and make the lander craft descend, land and take-off again ready for its trip back to Earth.

960 to 1070 create the final descent to Earth.

## >LISTING OF MOONLANDING ON TV By J.Riggs

```

10 REM Moonlanding on Television
20 REM By J.P.Riggs 1982
30 REM GOSPORT
40 ON ERROR GOTO390
50 MODE0:MOVE0,0:DRAW0,1024:PLOT85,1280,1024:MOVE1280,0:PLOT85,0,0
60 MOVE200,200:PLOT7,200,800:PLOT7,1080,800:PLOT7,1080,200:PLOT7,200,200
70 MOVE200,800:PLOT7,0,1024:MOVE1080,800:PLOT7,1280,1024
80 FORX=0TO1280 STEP5
90 MOVEX,0:PLOT7,(880/1280)*X+200,200
100 NEXT
110 MOVE300,200:PLOT7,300,600:PLOT7,475,600:PLOT7,475,200
120 MOVE880,620:PLOT7,1000,620:PLOT7,1000,500:PLOT7,880,500:PLOT7,880,620
130 MOVE870,630:PLOT7,1010,630:PLOT7,1010,490:PLOT7,870,490:PLOT7,870,630
140 MOVE477,285:PLOT7,477,315:MOVE477,515:PLOT7,477,485
150 FORX=0TO4:MOVE(305+X),385:PLOT7,(305+X),389:NEXT
160 MOVE890,630:PLOT7,940,700:PLOT7,990,630
170 VDU4:VDU28,48,25,63,22:VDU5:GCOL0,0
180 MOVE904,600:PRINT;"Home":MOVE900,570:PRINT;"Sweet"
190 MOVE904,536:PRINT;"Home":VDU4:VDU28,48,25,63,22:GCOL0,1
200 FORX=1TO9:MOVE(765+X),170:DRAW(765+X),100
210 MOVE(1026+X),170:DRAW(1026+X),100
220 MOVE(790+X),170:DRAW(790+X),110:MOVE(1045+X),180:DRAW(1045+X),110:NEXT
230 GCOL0,1:MOVE750,160:DRAW750,350:PLOT85,1050,350:MOVE1060,360
240 DRAW1060,170:PLOT85,750,160:PLOT85,1050,160:GCOL0,0
250 MOVE1050,160:DRAW750,160:DRAW750,350:DRAW760,360
260 DRAW1060,360:DRAW1060,170:DRAW1050,160:DRAW1050,350
270 DRAW750,350:MOVE1050,350:DRAW1060,360
280 CLS:PRINT" The"" Space"" Programme"
290 PRINT" PRESS 'H':;VDU5
300 REPEAT:UNTILGET=ASC("H")
310 MOVE0,0:877=0:GCOL0,1:PROCclear
320 VDU24,&02,&03,&C3,&00,&00,&04,&3E,&01
330 PROCtakeoff
340 PROCinflight
350 PROCmoonland
360 PROCinflight
370 PROCre_entry
380 PROCsplash
390 CLS:VDU5:GCOL0,1:MOVE865,280:PRINT"THE":MOVE865,245:PRINT"END"
400 VDU4:VDU28,0,31,79,0
410 #FX15,0
420 END
430 DEF PROCclear:FORX=771 TO 1024 STEP2:MOVEX,195:PLOT7,X,318
440 MOVE(X+1),195:DRAW(X+1),318:NEXT :ENDPROC
450 DEF PROCre_entry
460 VDU5:GCOL0,1:MOVE770,318:PRINT;"Re-entry"
470 K=20:L=256:M=895
480 FORX=0TO360 STEP10
490 A=SINRAD(X):B=COSRAD(X)
500 MOVEM,L:DRAW (A*K+M),(B*K+L)
510 NEXT
520 K=60
530 X=0:REPEAT:X=X+8
540 A=SINRAD(X)*K+M:B=COSRAD(X)*K+L
550 MOVEA,B:DRAW(A+2),(B+2):DRAW(A-2),B
560 PROCwait(0.15)
570 MOVEA,B:PLOT7,(A+2),(B+2):PLOT7,(A-2),B
580 K=K*0.97
590 SOUND1,-15,RND(255),1:UNTILX=305
600 ENDPROC
610 DEF PROCwait(s)
620 LOCAL D
630 D=TIME+(100*s)
640 REPEAT:UNTILTIME=D
650 ENDPROC
660 DEF PROCtakeoff:VDU5:MOVE895,250:PRINT;"N.A.S.A."
670 FORX=806TO808:MOVEX,195:DRAWX,256:NEXT:MOVE808,245:DRAWB12,245
680 MOVE820,195:DRAW830,260:PLOT85,840,195:FORX=10TO0 STEP -1
690 PROCwait(1):MOVE770,305:PRINT" ";CHR$127;CHR$127;X:NEXT
700 FORX=0TO250 STEP4:GCOL0,1:MOVE820,(195+X):DRAW830,(260+X)
710 PLOT85,840,(195+X):SOUND0,-15,100,2
720 GCOL0,0:MOVE820,(195+X):PLOT7,830,(260+X):PLOT85,840,(195+X)
730 NEXT
740 ENDPROC
750 DEF PROCinflight
760 CLS:VDU5
770 FORX=770TO1024 STEP5
780 GCOL0,1:MOVEX,235:DRAW(X+70),250:PLOT85,X,265
790 SOUND0,-15,100,3
800 GCOL0,0:MOVEX,235:PLOT7,(X+70),250:PLOT85,X,265:NEXT
810 ENDPROC
820 DEF PROCmoonland
830 GCOL0,1:FORX=-27TO27 STEP0.8:MOVE895,165
840 DRAW(SINRAD(X)*300+895),(COSRAD(X)*300-70):SOUND0,-15,100,1:NEXT
850 VDU5:MOVE850,215:GCOL0,0:PRINT"MOON":FORX=320TO225 STEP-2
860 GCOL0,0:MOVE870,(X+2):DRAW870,(X+22):PLOT85,890,(X+22)
870 DRAW890,X:PLOT85,870,(X+22):GCOL0,1:MOVE870,X:DRAW870,(X+20)
880 PLOT85,890,(X+20):DRAW890,X:PLOT85,870,(X+20)
890 SOUND1,-15,100,1:NEXT
900 PROCwait(4):FORX=235TO320 STEP2
910 GCOL0,1:MOVE870,X:DRAW870,(X+20):PLOT85,890,(X+20)
920 DRAW890,X:PLOT85,870,(X+20):GCOL0,0:MOVE870,(X-2)
930 DRAW870,(X+18):PLOT85,890,(X+18):DRAW890,X:PLOT85,870,(X+18)
940 SOUND1,-15,100,1:NEXT
950 ENDPROC
960 DEF PROCsplash
970 CLS:FORX=200TO216 STEP16:MOVE770,Y
980 FORX=770TO1020:H=SINRAD((X-770)*20)*6+Y:DRAWX,H:NEXT:NEXT
990 VDU5:MOVE925,280:PRINT"NASA":MOVE925,255:PRINT"rescue"
1000 FORX=470TO220STEP-2:GCOL0,0:MOVE870,(X+2):DRAW870,(X+22)
1010 PLOT85,890,(X+22):DRAW890,X:PLOT85,870,(X+22)
1020 GCOL0,1:MOVE870,X:DRAW870,(X+20):PLOT85,890,(X+20)
1030 DRAW890,X:PLOT85,870,(X+20):SOUND1,-15,(X-222),2:NEXT
1040 FORX=0TO90 STEP8:A=(SINRAD(X-90)*100+895):B=(SINRAD(90-X)*100+895)
1050 C=(COSRAD(X-90)*100+220):D=(COSRAD(90-X)*100+220)
1060 MOVEA,C:DRAW895,220:DRAWB,D:SOUND0,-13,102,4:NEXT
1070 PROCwait(5):ENDPROC

```

## Grid of design

Bill Longley,  
Colchester,  
Essex.

**SPECTRUM**

PROGRAMMING THE user-definable graphics on a ZX Spectrum is not as easy as some would have you believe. For each character, a total of eight Pokes are needed. Also, you need to work out the design on a piece of paper beforehand, and then convert to binary.

This program makes both tasks much simpler. You decide the key you want the graphic to be on — any of the letters from A to U — and enter it in response to the prompt.

Then you can enter the design on a grid on the screen. The usual cursor keys move the flashing cursor over the grid — you cannot move out of it — while 1 and 2 enter or erase a point respectively. Finally, pressing 0 enters the graphic into the character set.

The first thing you see on running the program are the instructions, which can be ignored by pressing any key. There are several separate routines in the program. These are:  
Lines 10 to 20: these set up the variables and call the instructions.  
Lines 30 to 50: these draw the grid on the screen.  
Line 60: clears the array holding the character information, and asks for the character.  
Lines 100 to 160: move the cursor, fill in the appropriate spaces, and check if the zero key

is pressed. If so, the character-setting routine is called.  
Lines 500 to 540: find out if another graphic is wanted. If so, run again; if not, stop.  
Lines 1000 to 1030: instructions.  
Lines 2000 to 2070: enter the graphic into the character set. If this is changed to suit your machine, the rest of the program can be changed easily to fit a BBC Micro, Vic-20, or another micro with programmable characters.  
Note lines 20, 150, 530 and 2070 are acceptable in Sinclair Basic, but the variables would have to be entered in lower case to work on a BBC, and on other micros, changed to normal numbers. I use this trick to make programs more readable, and hope that others will take up the idea. (continued on next page)

# SOFTWARE FILE

(continued from previous page)

```

1 REM CHARACTER GENERATOR
2 REM FOR ZX SPECTRUM
3 REM © BILL LONGLEY 1982
4 REM
10 LET X=8: LET Y=8: LET DEFIN
E CHARACTER=90: LET NEXT CHARACT
ER=500: LET INSTRUCTIONS=1000: L
ET SET CHARACTER=2000
20 GO SUB INSTRUCTIONS
30 CLS : PLOT 63,112: DRAW 65,
0: DRAW 0,-65: DRAW -65,0: DRAW
0,65
40 FOR G=63 TO 128 STEP 6: PLO
T G,112: DRAW 0,3: PLOT G,47: DR
AW 0,-3: NEXT G
50 FOR G=47 TO 112 STEP 6: PLO
T 63,G: DRAW -3,0: PLOT 128,G: D
RAW 3,0: NEXT G
60 DIM K(8,8): INPUT "Graphic
to be programmed? ";P$
100 LET X$=SCREEN$(X,Y): PRINT
AT X,Y: PAPER 6: " ": PAUSE 8: P
RINT AT X,Y: PAPER 7: X$
110 IF INKEY$="1" THEN PRINT AT
X,Y: INK 0: "X": LET K(X-7,Y-7)=
2
120 IF INKEY$="2" THEN PRINT AT
X,Y: INK 0: " ": LET K(X-7,Y-7)=
0
130 LET X=X+(INKEY$="6" AND X<1
5)-(INKEY$="7" AND X>8)
140 LET Y=Y+(INKEY$="8" AND Y<1
5)-(INKEY$="5" AND Y>8)
150 IF INKEY$="0" THEN GO TO SE
T CHARACTER
160 GO TO 100
500 CLS : PRINT TAB 6: "CHARACTE

```

```

R PROGRAMMED.": AT 20,0: "Another?
"
510 INPUT "(Y/N) ";S$
520 IF S$="N" OR S$="n" THEN ST
OP
530 IF S$="Y" OR S$="y" THEN GO
TO DEFINE CHARACTER
540 INPUT "Y OR N!!!!";S$: GO
TO 520
1000 PRINT TAB 4: "USER DEFINED G
RAPHSICS."
1010 PRINT "..." When you ha
ve read these instructions, pres
sing any key will draw a grid
in the centre of the screen."
" You can then enter the graphi
c character you want to program,
and then you draw the graphic o
n the grid. The cursor is moved
using the arrowed keys; to fill
a square, press 1, to empty it,
press 2. Pressing 0 sets the
design in the memory."
1020 IF INKEY$="" THEN GO TO 102
0
1030 CLS : RETURN
2000 PRINT AT 20,0: "Programming
this graphic:"
2005 FOR G=1 TO 6
2010 LET A=0
2020 FOR H=1 TO 6
2035 IF K(G,H)<>0 THEN LET A=A+K
(G,H): PRINT (8-H)
2040 NEXT H
2050 POKE USR P$+G-1,A
2060 NEXT G
2070 GO TO NEXT CHARACTER

```

## Lower case

Brian Cadge,  
Yardley,  
Birmingham.

ZX-81

MY PROGRAM for the 16K ZX-81 extends the character set of the printer to upper- and lower-case letters, plus the additional characters ! and & and %. Before typing it in, you should change RAMtop to 31744, by Poking 16389,124 and 16388,0.

The main body of the program is used in initialising the array of L\$, which holds the characters. There is still plenty of memory left after this program if you want to use it as part of a main program. Line 90 shows how to incorporate it into a larger program.

When using the program the following characters are allowed:

CHR\$ 0 to 63: normal symbols and alpha- numerics

Inverse video A to Z for lower case a to z; to the power of ; %; and !

AND: shifted 2 for &

Each element in the array of L\$ is one character and each is eight characters long. As you may find some confusion about which character is being used in the listing here is an alternative set out of the codes of the characters used in tabular form.

Finally, you may be forgiven for thinking that this program is rather laborious to enter.

However, as you can see, the results are well worth it. Also by creating your own characters, a whole new field of uses for the ZX-81 and printer reveals itself.

Character in L\$(8)

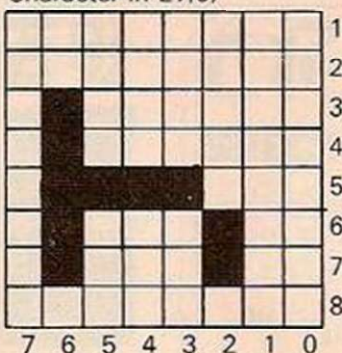

If we take for example the letter h, the numbers vertically, 1 to 8, are the character positions in the element of the L\$ array. The numbers along the bottom, 7 to 0, represent the dot above of each column. We raise 2 to the power of this number if we want the dot to be on, and sum the numbers for each row to give the character. Thus, for h:

CHR number	Code
1	0
2	0
3	2 <sup>6</sup> : 64
4	2 <sup>6</sup> : 64
5	2 <sup>6</sup> + 2 <sup>5</sup> + 2 <sup>4</sup> + 2 <sup>3</sup> : 120
6	2 <sup>6</sup> + 2 <sup>2</sup> : 68
7	2 <sup>6</sup> + 2 <sup>2</sup> : 68
8	0

Characters used in L\$ array.

Array number Codes of characters used:

1	0 0 56 4 60 68 60 0
2	0 0 64 64 120 68 120 0
3	0 0 0 60 64 64 60 0
4	0 0 4 4 60 68 60 0
5	0 0 56 68 124 64 56 0
6	0 24 32 32 112 32 32 0
7	0 0 56 68 60 4 56 0
8	0 0 64 64 120 68 68 0
9	0 16 0 16 16 16 16 0
10	0 8 0 8 8 8 112 0
11	0 64 72 80 96 80 72 0
12	0 16 16 16 16 16 16 0
13	0 0 40 84 84 84 84 0
14	0 0 0 24 36 36 36 0
15	0 0 56 68 68 68 56 0
16	0 0 56 68 120 64 64 0
17	0 0 56 68 68 124 4 0
18	0 0 0 28 32 32 32 0
19	0 0 56 64 56 4 56 0
20	0 0 32 112 32 36 24 0
21	0 0 0 36 36 36 24 0
22	0 0 0 68 68 40 16 0
23	0 0 0 130 146 170 68 0
24	0 0 68 40 16 40 68 0
25	0 0 68 40 16 32 64 0
26	0 0 56 8 16 32 56 0
94	0 48 72 48 52 72 52 0
95	0 0 100 104 16 44 76 0
96	0 16 16 16 16 0 16 0

L\$ 27 to 93 are copied from the ROM by the program itself.

```

1 REM LOWER-CASE LETTERS
PROGRAM BY BRIAN CADGE
2 IF NOT (PEEK 16388+256+PEEK
16389=31744) THEN STOP
3 REM COPY LPRINT ROUTINE
FROM R.O.M.
4 FAST
5 FOR I=0 TO 112
6 POKE 31744+I,PEEK (2161+I)
7 NEXT I
8 POKE 31600,63
9 POKE 31857,201
10 DIM AS(32,8)

```

```

11 GOTO 24
12 REM SUBROUTINE TO PRINT
FILL PRINTER-BUFFER AND
PRINT OUT CHARACTERS
13 FOR I=1 TO 32
14 FOR J=1 TO 8
15 POKE 32255+J+8*(I-1),CODE A
$(I,J)
16 NEXT J
17 NEXT I
18 REM FILL BUFFER
19 FOR I=1 TO 32
20 POKE 16443+I,I-1

```

```

21 NEXT I
22 LET PRINTOUT=USR 31744
23 RETURN
24 DIM L$(96,8)
25 LET L$(1)=" S,U"+CHR$ 68+"
U
26 LET L$(2)=" ANDAND"+CHR$ 1
20+CHR$ 68+CHR$ 120+CHR$ 2
27 LET L$(3)=" WANDANDU "
28 LET L$(4)=" "+CHR$ 4+CHR$
4+"U"+CHR$ 68+"U "
29 LET L$(5)=" S"+CHR$ 68+CHR
$ 124+"RND$ "

```

# SOFTWARE FILE

```

30 LET L$(6) = "/44"+CHR$ 112+"
44
31 LET L$(7) = " S"+CHR$ 68+"L
S
32 LET L$(8) = " RND RND"+CHR$ 1
20+CHR$ 68+CHR$ 68+CHR$ 0
33 LET L$(9) = " f { { { {
34 LET L$(10) = " "+CHR$ 3+" "+C
HR$ 8+CHR$ 8+CHR$ 8+CHR$ 112+CHR
$ 0
35 LET L$(11) = " RND"+CHR$ 72+C
HR$ 68+CHR$ 96+CHR$ 80+CHR$ 72+"
36 LET L$(12) = " ( { { { { {
37 LET L$(13) = " C"+CHR$ 84+CH
R$ 84+CHR$ 84+CHR$ 84+"
38 LET L$(14) = " /888 "
39 LET L$(15) = " S"+CHR$ 68+CH
R$ 68+CHR$ 68+"S "
40 LET L$(16) = " S"+CHR$ 68+CH
R$ 120+"RND RND "
41 LET L$(17) = " S"+CHR$ 68+CH
R$ 68+CHR$ 124+"S "
42 LET L$(18) = " 0444 "
43 LET L$(19) = " S RND S "
44 LET L$(20) = " 4"+CHR$ 112+"
45
45 LET L$(21) = " SSS/ "
46 LET L$(22) = " "+CHR$ 68+CH
R$ 80+"C (
47 LET L$(23) = " L3"+CHR$ 68
+"
48 LET L$(24) = " "+CHR$ 68+"C (
C"+CHR$ 68+"
49 LET L$(25) = " "+CHR$ 68+"C (
4 RND "

```

```

50 LET L$(26) = " S"+CHR$ 8+" (4
$
51 LET L$(94) = " K"+CHR$ 72+"KO
"+CHR$ 72+"O "
52 LET L$(95) = " "+CHR$ 100+CH
R$ 104+" (G"+CHR$ 76+" "
53 LET L$(96) = " { { { { {
54 REM COPY CHR$ 0 TO 63 FROM
R.O.M. AND PUT INTO L$
55 FOR I=0 TO 63
56 LET K$=""
57 FOR J=0 TO 7 STEP 2
58 LET K$=K$+CHR$ (PEEK (7680+
I+8+J))+CHR$ (PEEK (7680+I+8+J+1
))
59 NEXT J
60 LET L$(30+I)=K$
61 NEXT I
62 SLOW
63 REM PROGRAM TO CONVERT
MESSAGE IN Z$ TO UPPER
AND LOWER CASE LETTERS
64 PRINT "THIS PROGRAM PRINTS
ONE LINE AT A TIME. USE THE FOLLO
WING : " "NORMAL CHARACTERS 0 TO
63 FOR NORMAL PRINT-OUT" "INVE
RSE VIDEO 0 TO 63 FOR LOWER CASE
" " * (TO THE POWER OF) FOR PER
CENT SIGN" " * FOR EXCLAMATION MA
RK" " AND (SHIFTED 2) FOR AND SI
GN"
65 PRINT
66 DIM Z$(32)
67 PRINT "TYPE IN SENTENCE?"
68 INPUT Z$
69 IF Z$(1) = " STOP " THEN STOP

```

```

70 FAST
71 FOR I=1 TO 32
72 IF Z$(I)=CHR$ 218 OR Z$(I)=
CHR$ 216 OR Z$(I)="" THEN GOTO
85
73 IF Z$(I)="" THEN GOTO 83
74 IF CODE Z$(I) < 64 THEN GOTO
81
75 IF CODE Z$(I) > 191 OR CODE Z
$(I) < 166 THEN GOTO 83
76 LET A$(I) = L$(CODE Z$(I) - 165
)
77 NEXT I
78 GOSUB 13
79 SLOW
80 GOTO 68
81 LET A$(I) = L$(CODE Z$(I) + 30)
82 GOTO 77
83 LET A$(I) = "
84 GOTO 77
85 IF Z$(I) = CHR$ 218 THEN LET
A$(I) = L$(94)
86 IF Z$(I) = CHR$ 216 THEN LET
A$(I) = L$(95)
87 IF Z$(I) = "" THEN LET A$(I)
= L$(96)
88 GOTO 77
89 REM
90 REM IF YOU WANT TO USE THIS
AS PART OF A MAIN PROGRAM
THEN CHANGE LINE 54 TO GOTO
FIRST LINE NO., LINE 80 TO
RETURN AND USE GOSUB 70 TO
PRINT OUT MESSAGE IN Z$
WHICH MUST HAVE BEEN
DIM Z$(32) BEFORE.

```

## Automatic Rem

K Young,  
Watford,  
Hertfordshire.

ZX-81

WHEN USING machine code on a ZX-81, it is usual to put the code in a Rem statement. If a long Rem statement is required and one is not available on tape, you must type one in from the keyboard. This soon becomes tedious and time-consuming as, even in fast mode, the ZX-81 slows down considerably as the line length increases.

The program enables a large Rem to be created quickly. In use any long program is

loaded from tape, and then appended with line 1 and lines 9000 to 9120. Goto 9000 is typed to run the program, which expands the Rem of line 1.

```

1 REM EXPANDER
9000 PRINT "HOW MANY BYTES REQUIRED?"
9010 INPUT N
9020 LET L1 = PEEK 16511 + 256 * PEEK 16512
9030 LET L2 = PEEK (L1 + 16515) + 256 * PEEK
(L1 + 16516)
9040 LET L3 = L1 + L2 + 4
9050 LET X = INT (L3 / 256)
9060 POKE 16511, L3 - 256 * X
9070 POKE 16512, X
9080 POKE L1 + 16512, 0
9090 IF L1 + L2 + 2 < N THEN GOTO 9020

```

```

9100 POKE 16514, 118
9110 POKE 16515, 118
9120 PRINT "REM LENGTH = "; L3 / 2; "BYTES"

```

If you attempt to create too large a Rem, then the expander program is over-written, causing an error before completion. If no suitably large program is available on tape, or no tape recorder available, then the following procedure can be used.

Type in or load the expander program, type in a short Rem in line 1, edit this to give an identical line 2, run the expander typing 1 at the input. This effectively doubles the length of line 1, and the procedure may be repeated, doubling the length of the Rem every time.

## Filing point

S A Nicholls,  
Keynsham,  
Bristol.

ZX-81

THIS SHORT machine-code program may be of use to all ZX-81 owners who, like myself, have less than 3.25K RAM, and wish to set up a display file without using up too much of their precious RAM. A 22-line by 32-column file is set up in about two seconds, and uses about half the memory of its Basic counterpart.

The program is entered direct from the keyboard and can be edited to give any size and character display. I have underlined any keywords used and all but Clear and Pause can be entered directly. To enter Clear and Then Pause first type Then Clear and Then Pause and using Rubout delete the word Then in each case.

```

1 REM : - 4 Y NOT ( CLEAR Y V * NOT $ 4 PAUSE TAN
2 RAND USR VAL "16514"
TO CHANGE PARAMETERS
POKE 16515, Lines required.
POKE 16517, Columns required.
POKE 16519, Code of background
character required.

0E 16 LD C, 22 Lines.
06 20 NEXT LD B, 32 Columns.
3E 80 LD A, 128 Black character.
D7 PRINT RST 10 Print a character.
10 FD DJNZ PRINT Print a line.
3E 3B LD A, 59 Load A with 59 and
17 RLA multiply by 2
(LD A, 118 not available from keyboard
and would corrupt LISTING of BASIC
program.)

D7 RST 10 Print newline character
0C DEC C Reduce lines by one.
20 F2 JRNZ NEXT If lines not zero then print next line.
C9 RET Return to basic.

```

I WROTE this small program on a Genie which allows statements such as

Z\$ = Z\$ + T\$

This will need changing for other Basics. The aim of the program is to provide a multiple-character response to a single key-

stroke which I find very useful when using Impakt and LDOS.

Other features that could be added are a routine to change the phrases called during running time; a help call to display the phrases available and perhaps graphics.

## Multiple response

John Wilkinson,  
Chesterfield,  
Derbyshire.

GENIE

```

10 REM MULTIKEY - MULTIPLE REPLY SUBPROG BY JOHN WILKINSON 21 WHEATCROFT CLOSE
DANESMOOR CHESTERFIELD DERBYSHIRE
20 CLEAR 256
30 READ NT: DIM Z$(NT)
40 FOR N=1 TO NT
50 READ Z$(N): REM SUB ROUTINE DATA LOADING
60 NEXT N
70 CLS: REM DEMO PROG
80 PRINT "TYPE IN ANYTHING AND CALL LONG PHRASES BY USING
SLASH (DIVISION SIGN) THEN THE CALL LETTER." A BACK
90 FOR C=1 TO 40
100 GOSUB 140: REM INPUT SUB ROUTINE
110 PRINT#;
120 NEXT C
130 REM SUBROUTINE FOR KEY INPUTS
140 PRINTCHR$(95): REM PREVENTS A BACKSPACE ON
THE FIRST KEY INPUT
REM GET A SINGLE CHARACTER
150 Z$=INKEY$:
160 IF Z$="" THEN 150
170 IF Z$=CHR$(47) THEN GOTO 280: REM 32=DIVIDE. OTHER CODES COULD BE USED
180 PRINTCHR$(24): REM REMOVE LAST CURSOR PRINTED
190 PRINTZ$:
200 PRINTCHR$(95):

```

(continued on next page)

# SOFTWARE FILE

(continued from previous page)

```

210 TS=TS+ZS: REM BUILD TEMPORARY STRING
220 IF ZS=CHR$(13) THEN 240: REM TEST FOR END OF WORD
230 GOTO150: REM GET ANOTHER CHARACTER
240 AS=TS:TS="": REM GIVES TEMP. STRING TO AS
250 PRINTCHR$(24): REM REMOVE LAST CURSOR PRINTED
260 RETURN: REM AND CLEARS TEMP. STRING
270 REM MULTIPLE REPLY SUB ROUTINE
280 PRINTCHR$(24): REM REMOVE LAST CURSOR PRINTED
290 MS=INKEY$: REM GET THE CALL KEY
300 IF MS="" THEN 290
310 IF ASC(MS)<65 OR ASC(MS)>90 THEN 290
320 REM THIS LINE CHECKS THE CALL KEY IS WITHIN CHOSEN LIMITS
330 REM THESE COULD BE WIDENED TO INCLUDE CHR# ABOVE OR BELOW
340 REM THE ALPHABET EG CHR$(63)=? THE FULL 10 NUMBERS COULD
350 REM ALSO BE INCLUDED IN ANOTHER AND/OR CLAUSE
360 N=ASC(MS)-64: REM FIND THE RIGHT CALL INDEX NO.
370 ZS=Z$(N): REM GIVES THE CALL STRING TO THE PROG VARIABLE
380 GOTO190
390 REM

```

## DATA SECTION

```

400 DATA 26: REM AMOUNT OF MULTIPLE CHARACTERS AVAILABLE TO CALL
410 DATA A LONG WORD, BE GOOD TODAY, CHOOSE CAREFULLY, DONT PUSH YOUR LUCK, " EVERY
420 DATA ONE DIDN'T, DID YOU", FREE AT LAST, GOT YOU NOW, HAVE YOU ANY, I DONT KNOW

```

```

, JUST WAIT AND SEE, KILL THAT BUG!!!, LOST AND FOUND, MY HOW YOUVE GROWN
420 DATA NO THANK YOU, OPEN SUNDAYS, PLEASE, QUEUE THIS SIDE ONLY, REST IN PEACE
, STOP THAT AT ONCE, THANKYOU VERY MUCH, USUALLY I EAT ALONE, VERY WELL THANK YOU, WI
LL YOU CALL AGAIN, XYLOPHONE, YOU SHOULD SEE WHAT HE HAS, 200
1000 REM

```

```

MINIMUM PROGRAM LISTING FOR QUICK TYPING IN.
1010 CLEAR256: READNT: DIMZ$(NT): FORN=1 TO NT: READZ$(N): NEXTN: CLS: PRINT"TYPE IN ANY
THING AND CALL LONG PHRASES BY USING A BACK SLASH (<DIVISION SIGN>)
THEN THE CALL LETTER." : FORC=1 TO 40: GOSUB1011: PRINTA$: NEXTC
1011 PRINTCHR$(95):
1012 ZS=INKEY$: IFZS="" THEN1012
1013 IFZS=CHR$(47) THEN1018
1014 PRINTCHR$(24):
1015 PRINTZ$: PRINTCHR$(95): TS=TS+ZS: IFZS=CHR$(13) THEN1017
1016 GOTO1012
1017 AS=TS: TS="" : PRINTCHR$(24): RETURN
1018 PRINTCHR$(24):
1019 MS=INKEY$: IFMS="" THEN1019
1020 IFASC(MS)<65 OR ASC(MS)>90 THEN1019
1021 N=ASC(MS)-64: ZS=Z$(N): GOTO1015: DATA26
1022 DATA A LONG WORD, BE GOOD TODAY, CHOOSE CAREFULLY, DONT PUSH YOUR LUCK, " EVERY
ONE DIDN'T, DID YOU", FREE AT LAST, GOT YOU NOW, HAVE YOU ANY, I DONT KNOW, JUST WAI
T AND SEE, KILL THAT BUG!!!, LOST AND FOUND, MY HOW YOUVE GROWN
1023 DATA NO THANK YOU, OPEN SUNDAYS, PLEASE, QUEUE THIS SIDE ONLY, REST IN PEACE, STO
P THAT AT ONCE, THANKYOU VERY MUCH, USUALLY I EAT ALONE, VERY WELL THANK YOU, WILL Y
OU CALL AGAIN, XYLOPHONE, YOU SHOULD SEE WHAT HE HAS, 200

```

## Course of shots

N R Civeton,  
Bishops Stortford,  
Hertfordshire.

**SPECTRUM**

GOLF, WRITTEN FOR THE ZX Spectrum, is great

fun to play. I used the ATTR function to work out what was in any particular square. So, if you want to change either the Paper or Ink, or perhaps stop something flashing or brightening the screen, all the ATTR numbers will have to be changed accordingly. The program asks you the direction, which

can be anything from 0 to 12. Direction 0 is straight up, 3 is to the right, 6 down, and 9 left. You then input strength on a 0 to 200 scale, depending on the distance of hole. If your ball falls into a bunker, do not despair; the computer will chip it out — but in a random direction.

```

1 POKE USR "a", BIN 00001000:
POKE USR "a"+1, BIN 00011100: POK
POKE USR "a"+2, BIN 00101010: POK U
SR "a"+3, BIN 00011100: POK USR
"a"+4, BIN 00101010: POK USR "a"
+5, BIN 00001000: POK USR "a"+6,
BIN 00001000: POK USR "a"+7, BIN
00001000
2 POKE USR "b", BIN 00101000:
POKE USR "b"+1, BIN 11010110: POK
POKE USR "b"+2, BIN 00000001: POK U
SR "b"+3, BIN 01110000: POK USR
"b"+4, BIN 10001101: POK USR "b"
+5, BIN 00100010: POK USR "b"+6,
BIN 11010001: POK USR "b"+7, BIN
00001110
3 POKE USR "c", BIN 00110011:
POKE USR "c"+1, BIN 11001100: POK
POKE USR "c"+2, BIN 00110011: POK U
SR "c"+3, BIN 11001100: POK USR
"c"+4, BIN 00110011: POK USR "c"
+5, BIN 11001100: POK USR "c"+6,
BIN 00110011: POK USR "c"+7, BIN
11001100
4 PAPER 5
5 BEEP .5, 15: BEEP .5, 15
6 POKE 23609, 150
9 GO TO 100
10 LET L=LEN AS
20 FOR I=0 TO (Y1-L)*S1+L
30 PRINT AT X1+I, Y1+I, "9 for a
short game"
40 NEXT I
45 BEEP .1, 20: BEEP .1, 20: BEE
P .1, 20
50 RETURN
100 PRINT INK 2: "Enter number
of holes you wish to play"
110 PRINT INK 1, AT 3, 6: "9 for a
short game"
120 PRINT INK 1, AT 5, 6: "18 for
a long game"
130 INPUT G1
140 IF G1<9 AND G1>9 THEN GO
TO 130
150 CLS
160 PRINT INK 2: "Enter handicap
"
170 PRINT INK 1, AT 3, 5: "1)=Expe
rt", AT 6, 5: "2)=Average", AT 9, 5: "
3)=Duffer"
200 INPUT HC
210 IF HC<1 OR HC>3 THEN GO TO
200
220 LET HC=HC-2
500 LET PS=PI/6
510 LET COURSE PAR=0
530 LET HOLE=0
535 LET GREEN=3E3
540 LET BUNKER=3500
545 LET TREES=4E3
550 LET LAKE=4500
555 LET ROUGH=5E3
565 LET RUF=0
570 LET KS=""
600 LET PAR=INT (3+3*RND)
610 LET SHOTS=0
620 LET YARDS=10*INT (10*(PAR-2
+RND))
622 LET S1=32/YARDS
625 LET HOLE=HOLE+1
630 LET OS="T"
640 CLS
650 LET PAR=PAR+HC
1000 FOR I=0 TO 21: PRINT INK 5:
":: BEEP .1, 25: NEXT I
1005 GO TO 1105
1030 FOR I=2 TO 28 STEP 2
1040 LET L=5+5*RND
1050 FOR J=L TO 11+5*RND
1070 PRINT INK 4, AT J, I: "███";
1080 NEXT J
1090 NEXT I
1095 BEEP .5, 10: BEEP .5, 10
1100 GO TO 1205
1105 LET F=50
1130 LET Y1=3
1140 LET X0=0
1150 LET X1=20
1155 LET KLO=0
1160 LET AS=""
1170 FOR Z=1 TO 2
1180 LET Y0=5+20*RND

```

```

1190 GO SUB 10
1200 NEXT Z
1202 GO TO 1255
1205 LET X0=3: LET Y0=2: LET X1=
15: LET Y1=25: LET KLO=7: LET AS
="" : LET F=4: GO SUB 10
1250 GO TO 1270
1255 LET AS=""
1260 LET KLO=0
1265 GO SUB 10
1270 FOR Z=1 TO 2
1280 LET X0=INT (15*RND+1)
1290 LET Y0=20*RND+5
1300 FOR I=X0 TO X0+2+2*RND
1320 LET Y1=Y0+2*RND
1340 PRINT INK 1, AT I, Y1: "~~~~~
(TO 2+4*RND)
1350 NEXT I: BEEP .1, RND*10: NEX
T Z
1380 LET HOLEX=INT (3+15*RND)
1400 FOR I=1 TO 5
1410 PRINT INK 6, AT (HOLEX-3)+I,
25:
1420 NEXT I
1430 PRINT AT 0, 13: "HOLE": HOLE, A
T HOLEX, 29: INK 2: FLASH 1: "H"
1435 LET PH=INT (RND*14+3): LET
BALLX=PH: LET BALLY=2
1470 PRINT AT 0, 0, YARDS: "YDS": AT
0, 27: "PAR": PAR
1500 PRINT INK 3, AT PH, 2: "T"
1501 PAUSE 15
1502 PRINT INK 3, AT PH, 2: "t"
1505 PAUSE 15
1510 IF INKEY$="" THEN GO TO 150
1515 PRINT AT 21, 0: KS: AT 21, 0: "D
irection (0 to 12)?"
1520 INPUT ANG
1525 IF ANG>12 THEN GO TO 1520
1530 LET ANG=ANG*PI/6
1540 PRINT AT 21, 0: KS: AT 21, 0: "S
trength (0 to 200)?"
1550 INPUT S
1560 PRINT AT 21, 0: KS
1565 IF S>200 THEN LET S=200
1570 LET S=S*5/11
1575 IF RUF THEN LET S=S/4
1581 IF OS="" THEN PRINT AT BAL
LX, BALLY: INK 4: "█"
1582 IF OS="S" THEN PRINT AT BAL
LX, BALLY: INK 1, 0
1583 IF OS="P" THEN PRINT AT BAL
LX, BALLY: INK 4: "█"
1584 IF OS="L" THEN PRINT AT BAL
LX, BALLY: INK 5: "█"
1585 IF OS="R" THEN PRINT AT BAL
LX, BALLY: INK 6: "█"
1600 LET SHOTS=SHOTS+1
1610 LET RUF=0
1620 LET BALLX=BALLX-S*COS ANG
1630 LET BALLY=BALLY+S*3*IN ANG
1635 IF ABS (BALLX-10) <=10 AND A
BS (BALLY-15.5) <=15.5 THEN GO TO
1700
1640 IF BALLX<0 THEN LET BALLX=0
1650 IF BALLY>20 THEN LET BALLY=
20
1660 IF BALLY<0 THEN LET BALLY=0
1670 IF BALLY>31 THEN LET BALLY=
31
1675 LET SHOTS=SHOTS+1
1680 PRINT AT 21, 0: "Out of bound
s-penalty shot": AT 0, 22: SHOTS
1700 IF ATTR (BALLX, BALLY)=178 T
HEN GO TO 2100
1705 IF ATTR (BALLX, BALLY)=54 TH
EN GO TO GREEN
1710 IF ATTR (BALLX, BALLY)=52 TH
EN GO TO 2E3
1720 IF ATTR (BALLX, BALLY)=83 TH
EN GO TO ROUGH
1730 IF ATTR (BALLX, BALLY)=49 TH
EN GO TO LAKE
1740 IF ATTR (BALLX, BALLY)=55 TH
EN GO TO BUNKER
1750 IF ATTR (BALLX, BALLY)=43 TH
EN GO TO TREES
1760 GO TO 1700
2000 LET BEE=20: LET BEEP=20
2001 LET OS=""
2004 PRINT AT 0, 22: SHOTS
2005 PRINT FLASH 1: AT BALLX, BALL
Y: "B"

```

```

2006 BEEP .2, BEE: BEEP .1, BEEP
2010 IF INKEY$="" THEN GO TO 200
2020 GO TO 1515
2100 LET PAR=SHOTS-PAR
2105 PRINT AT 3, 12: INK 0: "HOLE
": HOLE: AT 6, 6: "holed it in": SHO
TS: SHOTS
2110 IF SHOTS=1 THEN PRINT FLASH
1: INK 3: AT 5, 8: "*****"
2115 IF NOT PAR THEN PRINT AT 9,
15: "par, well done"
2116 IF PAR=-1 THEN PRINT AT 9, 6
: "A birdie, not bad"
2117 IF PAR=-2 THEN PRINT AT 9, 2
: "My God... a great big eagle."
2118 IF PAR=-3 THEN PRINT AT 9, 8
: "An albatross, superb"
2120 IF PAR=-4 THEN PRINT AT 9, 0
: "4 under, I don't know what that
is, a Dodo perhaps!!!"
2121 IF PAR>0 THEN PRINT AT 9, 12
: "par": PAR
2122 LET COURSE PAR=COURSE PAR+P
AR: PRINT AT 12, 6: "Overall":
2123 IF COURSE PAR THEN GO TO 21
30
2124 PRINT "on par"
2125 GO TO 2140
2130 PRINT ABS COURSE PAR:
2135 IF COURSE PAR<0 THEN PRINT
"Under par"
2136 IF COURSE PAR>0 THEN PRINT
"Over par"
2140 IF HOLE>=G1 THEN GO TO 2500
2142 FOR I=1 TO 15
2143 BEEP .1, I
2144 NEXT I
2145 PAUSE 100
2150 GO TO 600
2500 FOR I=20 TO -20 STEP -1
2502 BEEP .01, I: NEXT I
2504 BEEP .1, 20: PAUSE 5: BEEP .
1, 20
2508 PRINT AT 19, 0: "End of game.
have a pint at the nineteenth o
r press "ENTER" to start agai
n"
2509 IF COURSE PAR<=7 THEN PRINT
AT 15, 1: "Your handicap is suspi
ciously low, better change it t
o be around"
2510 INPUT "Again?", AS
2520 IF AS="" THEN RUN
2530 STOP
3000 PRINT AT 21, 0: KS: AT 21, 0: "O
n the green in": SHOTS
3005 LET OS="P"
3010 GO TO 2004
3500 PRINT AT 21, 0: KS: AT 21, 0: "B
unker, a chip shot"
3505 PAUSE 20
3506 LET OS=""
3510 LET SHOTS=SHOTS+1
3520 GO SUB 3600
3530 PRINT AT BALLX, BALLY: INK 7
: "███": AT 0, 22: SHOTS
3540 LET BALLX=BALLX+3*RND-1
3550 LET BALLY=BALLY+2*RND
3560 GO TO 1700
3600 FOR I=1 TO 10: BEEP .01, I:
NEXT I
3610 RETURN
4000 PRINT AT 21, 0: KS: AT 21, 0: "I
n the trees-penalty shot"
4005 LET OS="T"
4010 LET SHOTS=SHOTS+1
4015 LET BEE=25: LET BEEP=10
4020 GO TO 2004
4500 PRINT AT 21, 0: KS: AT 21, 0: "I
n the lake, penalty shot"
4505 LET OS="S"
4510 LET SHOTS=SHOTS+1
4515 LET BEE=25: LET BEEP=10
4520 GO TO 2004
5000 PRINT AT 21, 0: KS: AT 21, 0: "I
n the rough-better hack it"
5005 LET OS="L"
5010 LET RUF=1
5015 LET BEE=10: LET BEEP=20
5020 GO TO 2004
5030 SAVE "GOLF"
5040 RUN

```

## Windmills

S J Bennett,  
Scarborough,  
North Yorkshire.

ZX-81

YOU HAVE BEEN sent by your firm to an island in the Outer Hebrides. Your task is to build windmills in the most profitable areas of the island. For each mill you build, you receive one lorry to transport corn and coal, to and from the mill.

Try to build your mills in areas where the wind conditions are good, and therefore use less coal for the donkey engine. The maximum number of years you can stay on the island is 50. For each year you stay you are given a report of the cost of coal, petrol and other expenses. Be careful of the price you charge

per bag of corn as the farmers may argue with you. When you decide to leave, you are shown the nett income for each year, and then a total for the full period on the island.

The island has been split into co-ordinates A to P inclusive, and 1 to 8 inclusive. To enter a mill, type number first, then letter. After entering your positions, you will be shown a display of weather conditions.

- 1 3P Windswept Area
- 2 4A Sheltered Area
- 3 6M Windy Valley

The first column is the mill; the second column the location; and the third the weather conditions for that area. After the weather conditions, you can alter the locations of any of your mills, or ask for a report on mills already built.

Here are the variables used.

- A = Control variable
- B = Control variable
- C = Coal used
- H = Corn harvested
- P = Petrol used
- MW = Miller's wages
- TA = Total expenses
- AE = Charge per bag
- YRT = Total years on island
- TC = Total coal used
- TP = Total petrol used
- XX = Tax paid
- ZA = Random number \* 10
- ZX = Gross earnings
- D(B) = Distance variable
- X(B) = Letter co-ordinate
- Y(B) = Number co-ordinate
- Z(B) = Co-ordinates of mills built

```

1 DIM W(50)
2 GOSUB 3000
3 LET YR=1
4 CLS
5 PRINT AT 2,0;"WINDMILLS YEAR";YR
6 PRINT
7 PRINT "HOW MANY MILLS WOULD YOU LIKE?"
8 PRINT "(MAXIMUM NUMBER ALLOWED IS 10)"
9 PRINT AT 7,0;"YOU MUST ENTER A NUMBER FOR 1ST"
10 PRINT "YEAR, FOR 2ND YEAR ONWARDS, YOU CAN ENTER ZERO TO RE-TRAIN THE ORIGINAL NUMBER YOU STARTED WITH"
11 INPUT B
12 CLS
13 IF YR<=1 AND B=0 THEN GOTO 5
14 IF B>=11 THEN PRINT "NOT ENOUGH SPACE FOR ";B;" MILLS"
15 IF B>=11 THEN FOR I=1 TO 10
16 IF B>=11 THEN NEXT I
17 LET TC=0
18 LET TP=0
19 IF YR>=2 AND B=0 THEN GOTO 250
20 LET A=B
21 PRINT AT 4,0;"ENTER LOCATION NUMBER FIRST"
22 PRINT "THEN LETTER, EXAMPLE 3F"
23 PRINT
24 DIM D(B)
25 DIM X(B)
26 DIM Y(B)
27 DIM Z(B)
28 DIM Z$(B,2)
29 FOR B=1 TO A
30 GOSUB 2000
31 PRINT A$;" ";
32 NEXT B
33 PRINT AT 9,0;"PRESS NEW LINE WHEN READY"
34 INPUT B$
35 CLS
36 IF B$="R" THEN GOTO 400
37 IF CODE B$=51 OR B$=" " THEN GOTO 250
38 PRINT AT 13,0;"ENTER THE NUMBER OF"
39 PRINT "THE MILL TO BE ALTERED"
40 INPUT B
41 CLS
42 PRINT AT 13,0;"ENTER NEW LOCATION"
43 GOSUB 2000
44 PRINT AT 13,0;"TYPE .A. TO ALTER LOCATION OR"
45 PRINT "NEW LINE FOR WEATHER CONDITIONS"
46 INPUT B$
47 CLS
48 IF B$="A" THEN GOTO 180
49 PRINT AT 2,0;"WEATHER CONDITIONS"
50 PRINT
51 FOR B=1 TO A
52 IF X(B)>=5 AND D(B)<=40 THEN LET Z(B)=4
53 IF D(B)<=40 THEN IF X(B)<=4 THEN LET Z(B)=5
54 IF X(B)>=5 AND D(B)>=50 THEN LET Z(B)=3
55 IF D(B)>=50 AND D(B)<=80 THEN IF X(B)<=4 THEN LET Z(B)=2
56 IF D(B)>=90 THEN IF X(B)<=4 THEN LET Z(B)=1
57 PRINT B;" ";Z$(B);" ";K$(Z(B))
58 NEXT B
59 PRINT "DO YOU WISH TO ALTER ANY OF YOUR LOCATION S"
60 PRINT "TO RE-LOCATE MILLS TYPE .Y"
61 PRINT "FUEL CONSUMPTION REPORT TYPE .R"
62 GOTO 160
63 PRINT AT 2,0;"REPORT ON FUEL AND COAL USED"
64 PRINT AT 4,0;"COAL";TAB 12;"PETROL"
65 PRINT
66 FOR B=1 TO A
67 LET ZA=INT((RND*5)+1)*10
68 IF Z(B)=1 THEN LET C=3
69 IF Z(B)=2 THEN LET C=10
70 IF Z(B)=3 THEN LET C=5
71 IF Z(B)=4 THEN LET C=ZA
72 IF Z(B)=5 THEN LET C=ZA
73 LET TC=TC+C
74 LET P=D(B)/10
75 IF P<0 THEN LET P=A*P/-P
76 LET TP=TP+P
77 PRINT "MILL ";B;" ";C;"TAB 12;"LORRY ";B;" ";P
78 NEXT B
79 PRINT "TOTAL=";TC;"TAB 12;"TP
80 INPUT S$
81 LET H=A*150
82 GOTO 650
83 PRINT AT 2,0;"EARNINGS AND EXPENSES"
84 PRINT "CORN HARVESTED=";H;" BAGS"
85 PRINT "CHARGE PER BAG £";AE
86 LET ZX=H*AE
87 PRINT "EARNINGS=£";ZX
88 PRINT
89 LET TC=TC*5
90 PRINT "COST OF COAL £";T
91 PRINT "COST OF PETROL £";T
92 LET MW=(TC+TP)/3
93 LET MU=INT MW
94 PRINT "MILLERS WAGES £";M
95 LET XX=ZX/4
96 PRINT "TAX ON EARNINGS £";X
97 PRINT
98 LET TA=TC+TP+MW+XX
99 PRINT "TOTAL EXPENSES £";TA
100 LET W(YR)=ZX-TA
101 PRINT "TOTAL NETT EARNINGS £";ZX-TA
102 PRINT AT 17,0;"DO YOU WISH TO CONTINUE"
103 INPUT U$
104 CLS
105 IF CODE U$=62 THEN GOTO 610
106 IF CODE U$=51 THEN PRINT AT 19,0;"REPORT FOR .";YR;" YEAR S"
107 IF CODE U$=51 THEN SCROLL
108 LET YRT=0
109 FOR B=1 TO YR
110 PRINT AT 20,0;"YEAR ";B;" NETT EARNINGS=";W(B)
111 SCROLL
112 LET YRT=YRT+W(B)
113 NEXT B
114 FOR N=1 TO 50
115 NEXT N
116 CLS
117 PRINT AT 10,0;"CALCULATING TOTAL"
118 FOR N=1 TO 50
119 NEXT N
120 CLS
121 PRINT AT 10,0;"EARNINGS FOR .";YR;" YEARS=£";YRT
122 STOP
123 LET YR=YR+1
124 GOTO 5
125 PRINT AT 19,0;"ENTER PRICE YOU WISH TO"
126 PRINT "CHARGE PER BAG OF CORN MILLED"
127 INPUT AE
128 CLS
129 IF AE*H>=3001 THEN PRINT AT 10,0;"PRICE TOO HIGH"
130 IF AE*H>=3001 THEN GOTO 650
131 IF AE*H<=3000 THEN GOTO 491
132 STOP
133 SAVE "WINDMILLS"
134 GOTO 3
135 STOP
136 INPUT A$
137 IF A$="" THEN GOTO 2000
138 IF CODE A$(1)-29>=8 THEN GOTO 2000
139 LET Z$(B)=A$
140 IF CODE A$(2)-33<0 OR CODE A$(2)-38>=10 THEN GOTO 2000
141 LET X(B)=CODE A$(1)-29
142 LET Y(B)=CODE A$(2)-38
143 LET D(B)=Y(B)*10-40
144 RETURN
145 DIM K$(5,25)
146 LET K$(1)="WINDSWEPT AREA"
147 LET K$(2)="OCCASIONAL WINDS"
148 LET K$(3)="WINDY VALLEY"
149 LET K$(4)="LIGHT WINDS AREA"
150 LET K$(5)="SHELTERED AREA"
151 RETURN

```

## Rem memory

Andrew Norman,  
St Albans,  
Hertfordshire.

ZX-81

LARGE REM statements are useful for storing machine code and databases. This simple procedure can generate very large Rem statements on an expanded ZX-81 without a repeat key.

The program combines lines 1 and 2, which may be of any positive length, into a single Rem statement at line 1. This may be dupli-

cated at line 2, using Edit, and the process repeated as often as necessary. Alternatively, store a Rem statement of convenient length at line 3 and duplicate at line 2 each time for more controlled growth of line 1.

I have produced a 12,000-character Rem statement with a 64K Super-Z board. Slightly larger statements should be possible by this method, with enough room in the first 16K for the program and display file.

- 1 REM (e.g., two full stops)
- 2 REM (e.g., four full stops)
- 10 LET TL1 = 256 \* PEEK

- 16512 + PEEK 16511
- 20 LET LL1 = 4 + TL1
- 30 LET PTL2 = 16508 + LL1 + 3
- 40 LET TL2 = 256 \* PEEK (PTL2 + 1) + PEEK PTL2
- 50 LET NTL = TL1 + 4 + TL2
- 60 POKE 16512, INT (NTL/256)
- 70 POKE 16511, (NTL - 256 \* PEEK 16512)
- 80 POKE (16508 + LL1), 128
- 90 PRINT (NTL - 2); "AVAILABLE BYTES IN LINE 1"
- 100 PAUSE 200
- 110 CLS
- 120 LIST

# COMPETITION CORNER

## JAILBREAK

BY ANTHONY ROBERTS

AS USUAL, the Wizard One-eye has put you to the test: you must enter the trolls' cave system and try to rescue the Wizard's friends in the prisoners' cell.

It is clearly important to enter the first cave at just the right time. What time must that be, and how many prisoners are there?

A £15 book token will be awarded to the first correct solution drawn from the competition bag. All entries must be at the *Your Computer* offices by the last working day in September. The name of the winner, the solution, and a competition report will be published in the November issue of *Your Computer*.

If you want to set a competition for Competition Corner, remember that the simplest solution should be calculable by a short program rather than by any other form of reckoning.

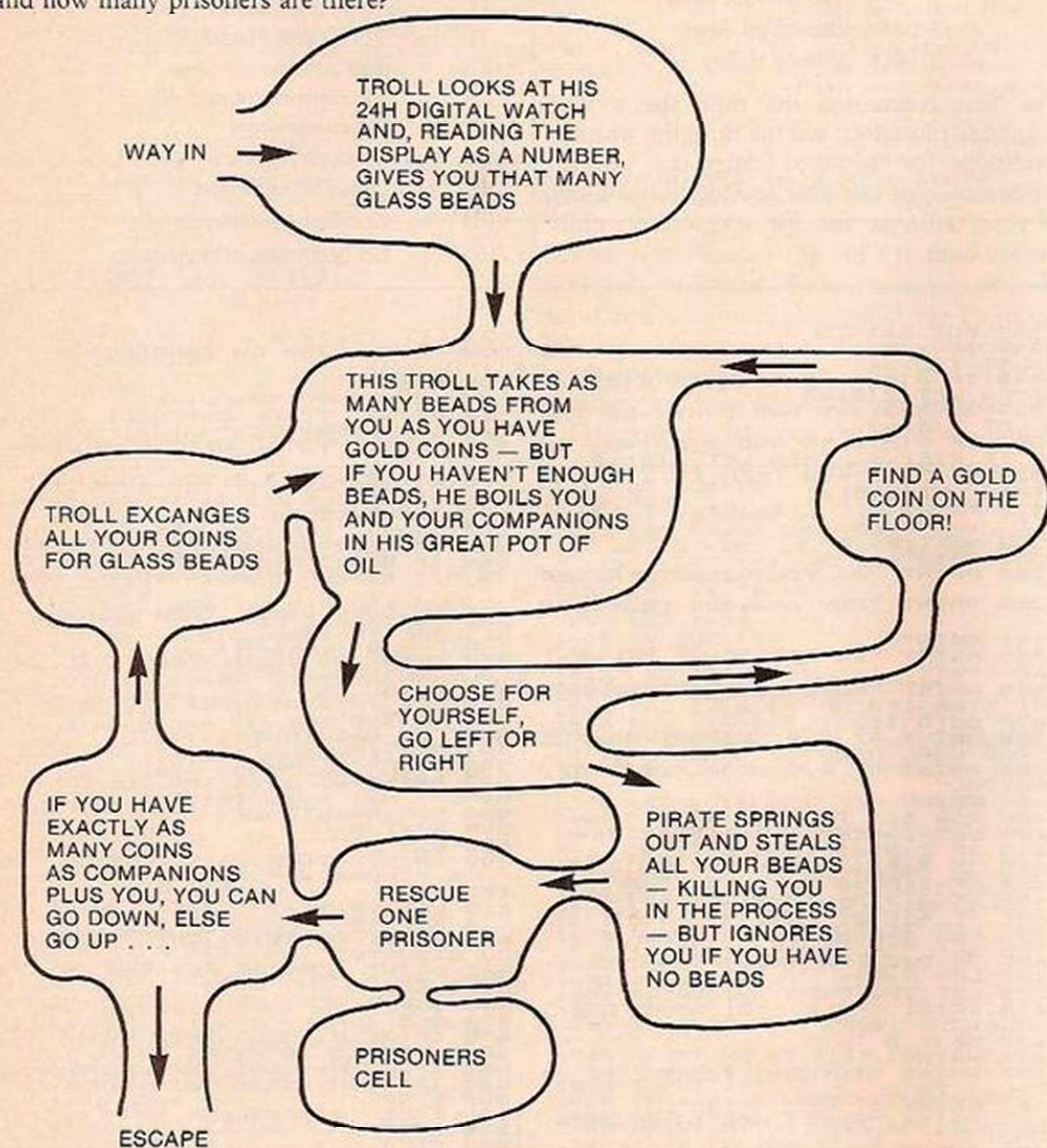

Program to solve the Bird Catcher problem.

```

10 LET Z = 1
20 LET Z = Z + 2
25 LET N = Z
30 LET X = 1
40 LET X = X + 2
50 LET Y = X
60 LET A = 0
70 IF Y = 0 THEN 110
80 LET A = A + X
90 LET Y = Y - 1
100 GOTO 70
110 IF A > N THEN 190
120 LET Y = A
130 IF Y < X THEN 40
140 IF Y = X THEN 170
150 LET Y = Y - X
160 GOTO 130
170 IF B = 0 THEN 1000
180 PRINT "DONE IT"; Z
185 STOP
190 IF B = 1 THEN 1000
200 LET B = 1
210 LET Y = 2
220 LET N = N - 1
230 IF N = 0 THEN 260
240 LET Y = 2Y
250 GOTO 220
260 LET N = Y - 1
270 GOTO 30
1000 PRINT "FAILED"; Z
1010 LET B = 0
1020 GOTO 20
    
```

Z = INITIAL NUMBER OF CAGES; N = NUMBER OF CAGES DURING TRIP X = BLACKBIRDS; Y = BLUEBIRDS; A = SONGBIRDS; B = PARROTS

## Competition results

JULY'S COMPETITION drew almost 1,000 entries. Rainbow, Aurora, Eclipse, Harlequin, Senator, Parrot, Tardis, Lakertron, Arthur Ascii, Sinclair Power Pixie were some of the names suggested for the Spectrum. We awarded the prize of a ZX Spectrum to R Burgess, 51 Constance Crescent, Hayes, Kent for his "Spectre - there is only a ghost of a chance of seeing one". This was not the only entry suggesting "Spectre", just the lucky one.

Other entries were more rapturous, like the "Miracle" and the "Dazzler", but I Hunt's "the Messiah because it's a Godsend" seemed to be carrying admiration too far. Some people thought the Spectrum should have been called... the Spectrum. As R Fletcher added "now there's a coincidence".

More original was A Swale with "the Botham, the great all-rounder that hits the opposition for six", while G Robbins thought the Spectrum should have been called "to my attention earlier". The last word must go to G Wright for his "Rom Greenwood - this time we will get it right".

A number of people pointed out an inconsistency in the rules for July's Bird Catcher problem. The box beginning "If you have a parrot..." tells you to release all but two of your blackbirds, but by this stage you will have already released all your blackbirds. This understandably deterred most people from proceeding further.

If you ignore the inconsistency and assume that you can exit from the box with two blackbirds, a solution is possible. The following program translates each instruction into a Basic statement and gives an answer of 13 cages. Line 210 translates the amended instruction. The closest solution came from J Clark, 32 Bencombe Road, Purley, Surrey, CR2 4DG, who has been awarded the £15 book token.

Solution to the July crossword.

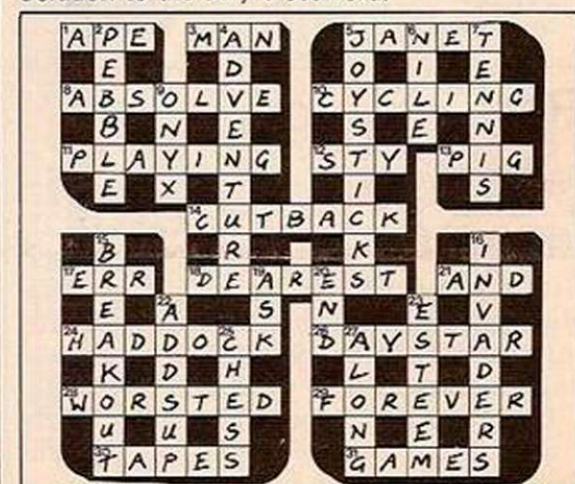

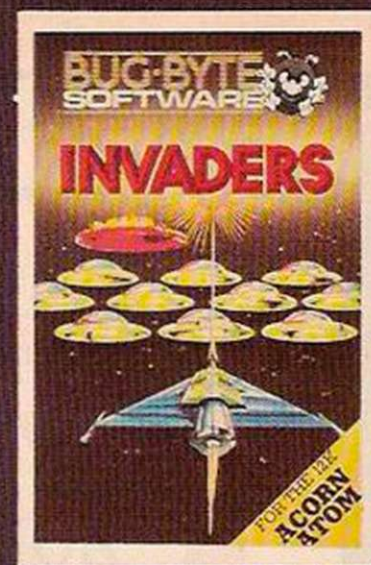

# WHAT'S YOUR GAME?

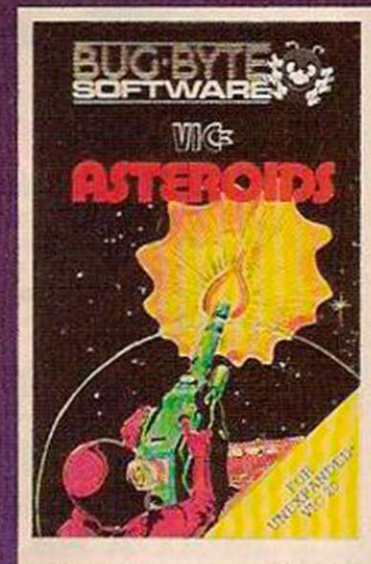
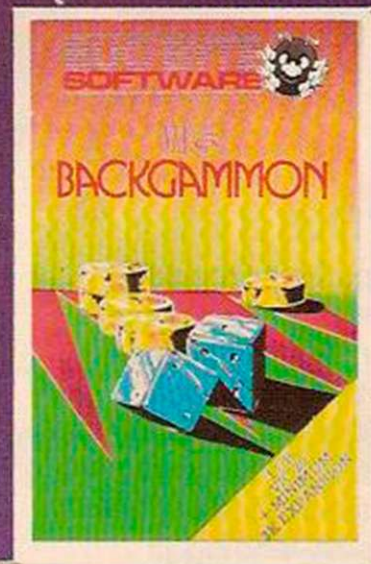
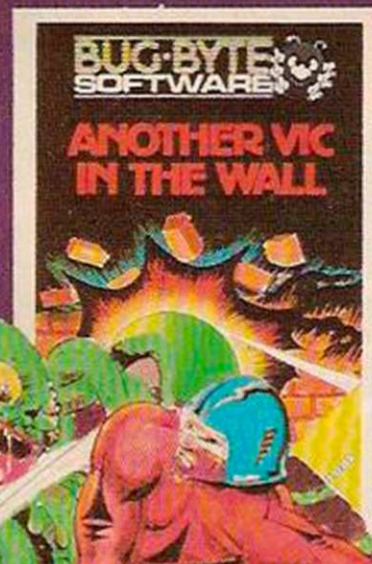
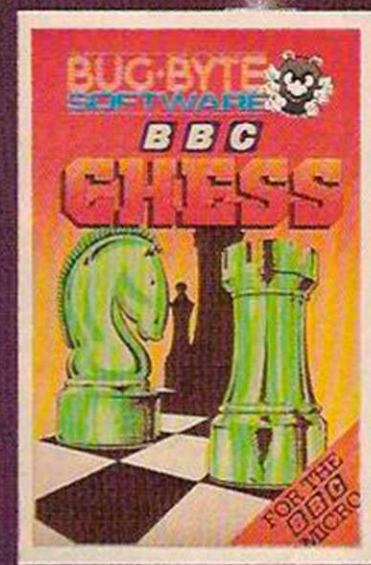
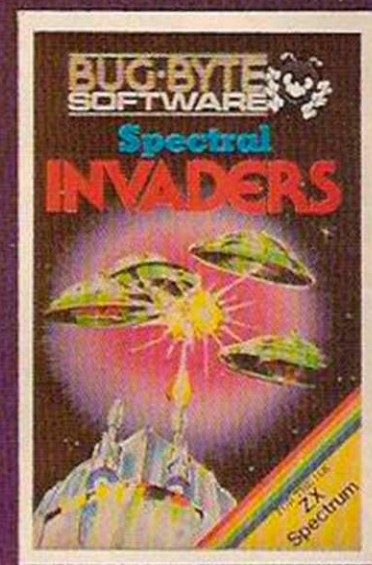
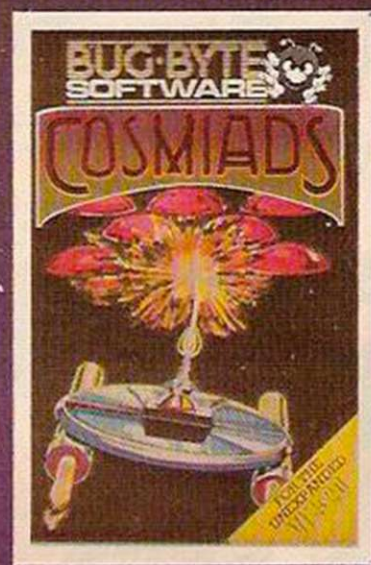
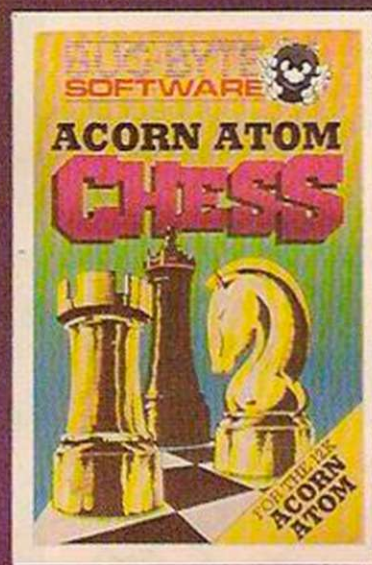

## FOR OWNERS OF ZX81, SPECTRUM, BBC MICRO, ATOM, COLOUR GENIE, VIC.

Bug-Byte games are best sellers. Tens of thousands of contented customers testify to that, so do consistently hot reviews in the popular micro-press. If your game isn't shown, don't worry, we probably have more quality games for more machines than any other software house - we just couldn't fit them all in. Bug-Byte games are available at good computer shops everywhere, or direct from our Liverpool office.



FREEPOST (NO STAMP REQUIRED) LIVERPOOL L3 3AB.

PLEASE SEND ME FULL DETAILS, MY COMPUTER IS \_\_\_\_\_  
NAME: \_\_\_\_\_  
ADDRESS: \_\_\_\_\_  
\_\_\_\_\_  
\_\_\_\_\_

ATTENTION DEALERS! For special introductory pack send coupon and business card to Mark Butler

**"ZODIAC"**

Following the success of our 1st Adventure Competition (winner to be published next month). We are launching our second Adventure Competition (we have doubled the prize money as well). "Zodiac" is your greatest challenge yet from A&F. Solve the problem of this Astrological Adventure and you could win £100.

Full machine code program requires 12K RAM.

Price £6.00

Closing date 30/11/82 the winner will have £100 in his hand in time for Christmas.

**ATOM \* UTILIKIT EPROM**

FOR JUST £16.00 ADD 22 BASIC COMMANDS AND FIVE FEATURES!! TO YOUR ATOM

(SUPPLIED FULLY DOCUMENTED ON 4K EPROM)

**COMMANDS** Read; Restore; Data; Tone; Key X; Clr; Disassemble; On Error; On Escape; Var; Hex; At; List (controlled list with up & down scroll facility); Renumber; Find; Search & Replace; Auto; Delete; Block Move; Cold; Warm; Fast; Slow.

**\*1200 BAUD CASSETTE OPERATING SYSTEM FEATURES** Visible Load/Save; Audio indication of successful Load/Save; Extended Lines (ie up to 208 characters per line); Auto Repeat on all keys (except Break & Lock); Auto list of line when an error occurs.

**THE BEST VALUE FOR MONEY TOOLKIT AVAILABLE! WHAT! ALREADY GOT A TOOLKIT FITTED?** Why not buy our Add-an-Eprom Board - add up to 4 Eproms for only £18.00 (free program when ordering both items)

**The Best Software**  
**The Best Prices**

**BBC****ROADRUNNER MOD. B**

The opposition will stop at nothing to get you. In this arcade style car chase: dodge through the Sunday traffic, weave to avoid their fire as the black cars try to shoot you off the road! Beware the hells angels who assist them!

Can you survive? £6.00

**EARLY WARNING MOD. B**

Destroy the attacking waves of ICBMs using a radar tracking system and intercept missiles. 48 Levels - Each one harder than the last.

£6.00

**NEW "TOWER OR ALOS"****MOD. A & B**

A fully interactive adventure program for the BBC. Clear "ALOS" of its monster and demons. Fight your way to fame and fortune.

£6.00

**\*SPECIAL OFFER\***

DEDUCT £1 PER ADDITIONAL CASSETTE ORDERED.

Orders to A&F Software, 830, Hyde Road, Gorton, Manchester M18 7SD.

Orders by mail or phone (061) 223 6206

\*All prices fully inclusive no hidden extras\*

Micro-Link \* A&F's Showroom now open

Address as above.

We pay 25% royalties on ATOM/ BBC programs

**NEW ATOM****TORPEDO RUN**

Another fantastic high resolution (clear 4) real time game for the "Atom". Can you complete your mission and destroy the enemy convoy? Will you return to a heroes welcome or is Davy Jones Locker your final resting place!!

5K Text 6K Graphics Price £4.95

**ESCAPE**

The invader P.O.W.s are out for exercise. You, a guard have to catch them, enthrall and frustrate your family all at the same time.

5K Text 3K Graphics Price £4.95

**NEW****CYLON ATTACK  
A FAST MOVING 3D SPACE BATTLE**

As you sit in your starfighter looking out into the void of space remember the CYLON race only want Mankind for food!! You glance up at your long range scanner, the CYLON fleet is in range. Quickly you select a target and turn to meet it ready to defend Earth to the end!!

5K Text 6K Graphics Price £4.95

**MISSILE COMMAND**

A fast moving version of the popular arcade game. You have three bases from which to fire your defence missiles, protecting your cities and bases from the missiles and aircraft attacking you!!

SCORE/HI SCORE/MULTIPLE LEVELS/SOUND  
5K Text 6K Graphics Price £4.95

**POLARIS**

Your submarine is ordered to sink an enemy convoy. By using skill, cunning and strategy can you avoid the escorting warships and dangerous shallows to succeed with your mission?

5K Text 6K Graphics Price £3.95

\*SPECIAL OFFER, DEDUCT £1 PER ADDITIONAL CASSETTE ORDERED

**BBC MOD B ONLY**

A superb reproduction of the popular arcade game: Four skill levels, realistic sound and fantastic graphics. Long range and close up Luna Landscape Displays. A safe soft landing is your target. But can you do it?

PRICE ONLY £6.00



**A**



THE  
**Northern  
Computer  
Fair**

Personal computers  
Home computing  
Small business systems

**MANCHESTER,  
NOV 25-27**

## Bringing it all back home...

...to Manchester, birthplace of computing in Britain. To Belle Vue from November 25th to 27th — the obvious place for the Northern Computer Fair.

Following the incredible success of our London show 'the biggest-ever personal computer exhibition' where over **38,000** people visited us in 3 days, we're going to repeat the performance in Manchester.

Whatever your specialised line of business — personal computers; home computing; small business systems; associated software — this is the exhibition designed for you.

It's the ideal showcase for companies who need to demonstrate to a fast expanding and increasingly well informed audience all aspects of personal computing.

...you cannot afford to ignore it.

For further details about exhibiting at the Northern Computer Fair, contact the Advertisement Manager, Your Computer, Room L215, Quadrant House, The Quadrant, Sutton, Surrey SM2 5AS. Telephone: 01-661 3127.

Name: \_\_\_\_\_

Position in Company: \_\_\_\_\_

Company: \_\_\_\_\_

Address: \_\_\_\_\_

\_\_\_\_\_

\_\_\_\_\_

Telephone: \_\_\_\_\_

Don't let its size fool you.  
If anything NewBrain is like the Tardis.

It may look small on the outside, but inside there's an awful lot going on.

It's got the kind of features you'd expect from one of the really big business micros, but at a price of under £200 excluding VAT it won't give you any sleepless nights.

However, let the facts speak for themselves.

You get what you don't pay for.

NewBrain comes with 24K ROM and 32K RAM, most competitors expect you to make do with 16K RAM.

What's more you can expand all the way up to 2 Mbytes, a figure that wouldn't look out of place on a machine costing ten times as much.

We've also given you the choice of 256, 320, 512 and 640 x 250 screen resolution, whereas most only offer a maximum of 256 x 192.

Big enough for your business.

Although NewBrain is as easy as ABC to use (and child's-play to learn to use) this doesn't mean it's a toy.

Far from it.

It comes with ENHANCED ANSI BASIC, which should give you plenty to get your teeth into.

And it'll also take CP/M® so it speaks the same language as all the big business micros, and feels perfectly at home with their software.

# NO OTHER MICRO HAS THIS MUCH POWER IN THIS MUCH SIZE FOR THIS MUCH MONEY.



So as a business machine it really comes into its own.

The video allows 40 or 80 characters per line with 25 or 30 lines per page, giving a very professional 2000 or 2400 characters display in all on TV and/or monitor. And the keyboard is full-sized so even if you're all fingers and thumbs you'll still be able to get to grips with NewBrain's excellent editing capabilities.

When it comes to business graphics, things couldn't be easier. With software capabilities that can handle graphs, charts and computer drawings you'll soon be up to things that used to be strictly for the big league.

#### Answers a growing need.

Although NewBrain, with its optional onboard display, is a truly portable micro, that doesn't stop it becoming the basis of a very powerful system.

The Store Expansion Modules come in packages containing 64K, 128K, 256K or 512K of RAM. So, hook up four of the 512K modules to your machine and you've got 2 Mbytes to play with. Another feature that'll come as a surprise are the two onboard V24 interfaces.

With the aid of the multiple V24 module this allows you to run up to 32 machines at once, all on the same peripherals, saving you a fortune on extras.

The range of peripherals on offer include dot matrix and daisy wheel printers, 9", 12" and 24" monitors plus 5 1/4" floppy disk drives (100 Kbytes and 1 Mbyte) and 5 1/4" Winchester drive (6-18 Mbytes).

As we said, this isn't a toy.

#### It doesn't stop here.

Here are a couple of extras that deserve a special mention.

The first, the Battery Module, means you won't be tied to a 13 amp socket. And, even more importantly, it means you don't have to worry about mains fluctuations wreaking havoc with your programs.

The ROM buffer module gives you a freedom of another sort.

Freedom to expand in a big way. It gives you additional ROM slots, for system software upgrades such as the Z80 Assembler and COMAL, 2 additional V24 ports, analogue ports and parallel ports.

From now on the sky's the limit.

#### Software that's hard to beat.

A lot of features you'd expect to find on software are actually built into NewBrain so you don't need to worry about screen editing, maths, BASIC and graphics.

However, if you're feeling practical you can always tackle household management, statistics and educational packages. And because NewBrain isn't all work and no play, there's the usual range of mind-bending games to while away spare time.

#### Waste no more time.

To get hold of NewBrain you need go no further than the coupon at the bottom of the page.

With your order we'll include a hefty instruction manual so you'll know where to start, and a list of peripherals, expansion modules, and software so you'll know where to go next.

® CP/M is the registered trade mark of Digital Research Inc.



NewBrain, Grundy Business Systems Ltd., Grundy House, Somerset Road, Teddington TW11 8TD.

Each NewBrain order will include a FREE comprehensive user manual, a catalogue of expansion modules and peripherals, and a detailed list of available software.

Please send me the following:-

Quantity	Item	Price per item (Inc. VAT & p&p)	Total
	NewBrain A	£233.00	
	NewBrain AD with onboard single line display	£267.50	
	Printer	£466.00	
	Monitor 12"	£142.50	
		Total £	

I enclose a cheque/Postal Order for £\_\_\_\_\_ payable to Grundy Business Systems Reader Account.  
NewBrain, Grundy Business Systems Ltd., Grundy House, Somerset Road, Teddington TW11 8TD.

Please debit my Access Card No: \_\_\_\_\_ my Barclaycard No: \_\_\_\_\_

Signature \_\_\_\_\_

Name \_\_\_\_\_

Address \_\_\_\_\_

Postcode \_\_\_\_\_

Registered Number 1522978

VAT Number 358661618

Please allow up to 28 days for delivery.

**NEWBRAIN** YC 9

Sponsored by Practical Computer and Your Computer



# Meet some of the best brains in Britain

at *THE* **Northern Computer Fair**  
*Personal computers  
Home computing  
Small business systems*

**BELLE VUE, MANCHESTER  
NOVEMBER 25-27, 1982**

Opening Times 10am-6pm each day

The brains we're talking about are the printed circuit, silicon-chip variety and you'll find them (thinking hard) in the vast range of exhibits at The Northern Computer Fair. The show covers the fields of personal computing, home computing, small business systems and associated software, through computer books to video games, with a special attraction being the ZX 81 Sinclair Village. So whether you're a businessman (or woman) who needs to keep up to date with the latest developments in this fascinating field, a die-hard computer enthusiast, or simply interested in the subject, you'll find what you're looking for at the Northern Computer Fair.

Ticket prices at the door are £2.00 for adults and £1.00 for children under 16, but special party rates are available for 20 people or more with the organiser admitted free. For more information contact IPC Exhibitions, Surrey House, 1 Throwley Way, Sutton, Surrey SM1 4QQ. Tel: 01-643 8040.

## HALF PRICE ADMISSION VOUCHERS

for readers of *YOUR*  
**COMPUTER**

 <b>THE Northern Computer Fair</b> <i>Personal computers Home computing Small business systems</i> Cut this coupon and exchange for half-price ticket at the door. YC	adult £1.00	<b>THE Northern Computer Fair</b> <i>Personal computers Home computing Small business systems</i> Cut this coupon and exchange for half-price ticket at the door. YC	child 50p
--	----------------	---	--------------

# A bigger range than the Himalayas



## The Acorn Atom From £118 plus VAT.

### Personal Computing – Instructional and Fun

To get the best out of personal computing you need two things – hardware that is powerful and reliable – software that uses the hardware to the full. The Atom range is just that.

### The Atom – tried and tested

The Atom was designed to last – inside and out. Outside a rugged, high impact case with a proper keyboard. Tested to withstand children as well as adults. Inside a powerful operating system that will never be bettered. It is available in several versions so you can choose what you want. And there is an enormous range of additional boards that fit inside the casing – start where you like – add more power, more versatility when you need it.

### The Accessories – something for everyone

Diskpacks, printers, monitors, plug-in ROM's, manuals, other languages, arcade-type games, business and household software. Whatever you want to do – teach your children, run your business – you can't do better than choose the Atom range.

### Available Nationwide

Not just mail order, the Atom range can be bought through a national dealer network – they will help and advise you. And in the unlikely event of breakdown they will be there. Like our equipment Acorn Computers are here to last.



Acorn Computers Limited,  
Fulbourn Road, Cherry Hinton,  
Cambridge CB1 4JN  
Tel: (0223) 245200.

### FREE Catalogue

For full details of the complete range and a list of dealers just fill in the coupon or write to us.



To: Acorn Computers Ltd,  
Fulbourn Road, Cherry Hinton,  
Cambridge CB1 4JN Tel: (0223) 245200.

Please rush me a complete list of the Atom range.

Name: \_\_\_\_\_

Address: \_\_\_\_\_

Postcode: \_\_\_\_\_

# SPECTRUM BOOKS

Available from booksellers

Games to Play on your ZX Spectrum £2.50 Martin Wren-Hilton  
ISBN 0 906812 28 3

Computer Puzzles: For Spectrum and ZX81 £2.50 Ian Stewart & Robin Jones  
ISBN 0 906812 27 5

Easy Programming for the ZX Spectrum £5.95 Ian Stewart & Robin Jones  
ISBN 0 906812 23 2

Further Programming for the ZX Spectrum £7.50 (approx) Ian Stewart & Robin Jones  
ISBN 0 906812 24 0

Spectrum in Education £6.50 (approx) Eric Deeson  
ISBN 0 906812 29 1

Published by: **Shiva Publishing Limited**  
4 Church Lane, Nantwich, Cheshire CW5 5RQ  
Telephone: (0270) 628272



# ADD ON, PLUG IN, PRINT OUT

## AMBER 2400 MATRIX PRINTER

the flexible print out facility for home computers.

At long last it's possible for every home computer user to have a hard copy of program listings. The AMBER 2400 Matrix Printer is the first low-cost complete printer with the flexibility of parallel or serial inputs to make it compatible with most home computers.

Priced at just £69.99 plus VAT, the AMBER 2400 is available for the first time this August and has a most impressive specification.

- 24 characters per line standard text
- Full graphics capability - each dot is individually programmable
- Conventional 25 pin 'D' type plug
- Serial and parallel input
- CTS/Busy output
- Serial baud rate selectable from 75 to 9600 baud
- Mains Powered
- Injection moulded case for strength
- Size of just 80mm x 160mm x 160mm (H x W x D)
- Uses low-cost plain paper rolls (90ft for 45p)
- This is not a thermal or spark discharge type printer

This is the printer you need, write now telling us what computer you use, including a SAE, and we'll send you the AMBER 2400 Matrix Printer leaflet. We're also accepting advance orders for the AMBER 2400.



**AMBER CONTROLS LTD.**

Central Way, Walworth Industrial Estate,  
Andover, Hampshire.



## ZX81 OWNERS

**SPECIALISED PRODUCTS  
MODULAR EASY TO USE  
FOR HOME/INDUSTRY &  
EDUCATION**

**TE10 INPUT/OUTPUT PORT** — Easy to use. Fits between ZX & RAM PACK/PRINTER (if required). No skill required to connect. Can be used for such things as: — motor control; sound/music generators, connection to printers/floppy discs/light pens/other computers, temperature monitoring, square wave generating, control of rotating aerials, even train sets etc. Port has 16 programmable I/O lines and may be used without any electronics knowledge to connect other add-ons. Motherboard required ONLY when two or more add-ons are used at any one time.

**FULLY ASSEMBLED KIT (WITHOUT CASE)** £17.95  
£14.95

**TE12 4 CHANNEL RELAY BOX** — To suit Port Contact rating: — 240V AC/1.5A — 24V DC or 110V AC/3A. Up to 4 units i.e. 16 relays can be operated £14.95

**TE15 8 WAY TRANSISTOR DRIVER** — £9.95

**TE17 8 WAY SWITCH UNIT (EDUCATIONAL)** — £12.95

**TE18 8 WAY INDICATOR UNIT (EDUCATIONAL)** — £12.95

**TE20 JOYSTICK & FREE GAME** — (2 Joysticks may be connected via Motherboard.) £12.95

**TE30 MOTHERBOARD** — Allows multiples combinations of add-ons — up to 16 I/O lines may be used — £15.95

**TE126 POWER SUPPLY** — 6/7.5/9V DC at 300 mA — Required for use with add-ons TE12/15 & 18 £4.95

23 + 23 WAY ZX Edge Con £2.85. Contact cleaner £2.30.

16 WAY SINGLE SIDED EDGE CON £1.95. EXTENDED PIO NOTES £1.

PRICES INCLUDE VAT

Receipts always provided: — Delivery normally ex-stock. ADD 50p towards p&p on all orders under £20.00, with the exception of accessories, e. g. Edge on. Full instructions and examples with all products.  
SEND S.A.E. FOR CATALOGUE. TELEPHONE ORDERS ACCEPTED.

**THURNALL (ELECTRONICS) ENG.**  
DEPT Y, 95 LIVERPOOL ROAD,  
CADISHEAD, MANCHESTER M30 5BG  
TEL: 061-775 4461 (24 hour)



**NEW**

**ZX 81 16K  
SOFTWARE**

# DIGGLES KITCHEN



**SIMPLE SUPPERS  
TO  
CELEBRATION DINNERS**

## VOLUME 1

50 PAGES OF WORLDWIDE RECIPES  
£4.99 (inc. P&P and VAT)

## VOLUME 2

50 PAGES EUROPEAN RECIPES  
£4.99 (inc. P&P and VAT)

**Special price for two volumes  
£9 (inc. P&P and VAT)**

More volumes to follow  
Please specify  
which volume(s) —  
Mail order only  
Send remittance  
to:-

**NOW  
AVAILABLE  
FOR VIC20  
WITH 16K  
EXTENSION**

**MICRO COMPUTER SOFTWARE**

Unit D6, Pear Industrial Estate, Stockport Road, Lower Bredbury,  
Stockport SK6 2BP. Tel: 061-494 2441

## YOUR QUICK-LEARN WAY TO BASIC OR COBOL

**IN YOUR OWN  
HOME,  
IN YOUR OWN  
TIME,  
AT YOUR OWN  
PACE.**

Learn computer programming quickly and easily through the renowned ICS "Open College" system, taking the course at your own pace and in your own time.

Use the famous ICS study texts, backed up by your own expert tutor, and learn computer programming, the proven way, with ICS home study.

Courses:

**Introduction to Computer  
Programming**

**Programming in BASIC**

**Programming in COBOL**



Approved by CACC Member of ABCC



**ALL DETAILS FREE—SIMPLY RETURN THE COUPON BELOW**

Please send me your prospectus on Computer Programming



Name \_\_\_\_\_

Address \_\_\_\_\_



Post to: Dept 349Y  
ICS School of Computer Programming  
160 Stewarts Road,  
London SW8 4UJ



# EPC Express Programmes Company

## ZX 81 GAMES

**Cassette 1, for 1k**

10 games incl. Destroyer, Kaleidoscope,  
Sub Chase, Star Fighter Grand Prix, Roulette etc.

**£4.50**

**Cassette 2, for 16k**

3 games. 3D Noughts and crosses 2 versions,  
one played on a 3x3x3 grid and one on a  
4x4x4 grid and Connect 4.

**£4.50**

**Cable Extension Leads**

For connection of ZX81 to TV Cassette Player.  
Braided cable for protection from external interference.  
2 Metre TV Cable **£1.50** 0.7 Metre Cass. Cable **£1.50**

We offer very competitive royalties on quality programmes.  
Send SAE for full details.

Prices inc. Postage and Packing.  
Make cheques/Postal Orders Payable to:-

**EPC,  
Express House, City Road,  
BRADFORD BD8 8ER  
West Yorkshire**

# ZX Spectrum

## 20 Programs £6.95

The ZX Spectrum has brought advanced computing power into your home, The Cambridge Colour Collection, a book of 20 programs, is all you need to make it come alive.

**No experience required.** Simply enter the programs from the book or load them from tape (£2.95 extra) and run.

**Amazing effects.** All programs are fully animated using hi-res graphics, colour and sound wherever possible.

**Entirely original.** None of these programs has ever been published before.

**Proven Quality.** The author already has 30,000 satisfied purchasers of his book of ZX81 programs.

### Hours of entertainment

- **Lunar Landing.** Control the angle of descent and jet thrust to steer the lunar module to a safe landing on the moon's surface.
- **Maze.** Find your way out from the centre of a random maze.
- **Android Nim.** Play the Spectrum at the ancient game of Nim using creatures from outer-space.
- **Biorhythms.** Plot the cycles of your Emotional, Intellectual and Physical activity. Some would say this is not a game at all.

### Improve your mind

- **Morse.** A complete morse-code training kit. This program will take a complete beginner to R.A.E. proficiency.
- **Maths.** Adjustable to various levels, this program is an invaluable aid to anyone trying to improve their arithmetic.

### Run your life more efficiently

- **Home Accounts.** Keeping track of your finances with this easy-to-use program will enable you to see at a glance where the money goes and plan your spending more effectively.
- **Telephone Address Pad.** Instant access to many pages of information.
- **Calendar.** Displays a 3 month calendar past or future, ideal for planning or tracing past events.

### ORDER FORM:

Send Cheque or P.O. with order to:-  
Dept. C., Richard Francis Altwasser, 22 Foxhollow, Bar Hill,  
Cambridge CB3 8EP

Please send me

- Copies Cambridge Colour Collection Book only £6.95 each.  
 Copies Cambridge Colour Collection Book & Cassette  
£9.90 each

Name: \_\_\_\_\_

Address: \_\_\_\_\_



Due to excessive enquiries from all parts of the U.K., LASERBUG is now a national independent user group.

Membership is £12.00 per year for 12 issues of LASERBUG newsletter.

For trial copy, send £1.00 plus large S.A.E. (12" x 9") to:

**LASERBUG**  
4 Station Bridge,  
Woodgrange Road,  
Forest Gate,  
London E7 0NF.

# reprints

If you are interested in a particular article/special feature or advertisement in this journal

## HAVE A GOOD LOOK AT OUR REPRINT SERVICE!

We offer an excellent, reasonably priced service working to your own specifications to produce a valuable and prestigious addition to your promotional material. (Minimum order 250 copies). Telephone Michael Rogers on 01-661 3036 or complete and return the form below.

To: Michael Rogers, Your Computer, Reprint Department, Quadrant House, Sutton, Surrey SM2 5AS.

I am interested in ..... copies of article/advert. headed ..... featured in this journal on pages ....., issue dated .....

Please send me full details of your reprint service by return of post.

Name .....

Company .....

Address .....

..... Tel No .....

## ZX81/ 16K SOFTWARE

**"STARTREK"** £4.95

**16K STARTREK:** Exciting space adventure game including klingons starbases, phasors, 8x8 galaxy, 4-levels of play, long and short range scanners, etc.

**"SUPER-WUMPUS"** £4.95

**16K SUPER-WUMPUS:** Can you hunt and catch the mysterious wumpus in his underground labyrinth? Intriguing underground adventure.

**"GRAPHIC GOLF"** £4.95

**16K GRAPHIC GOLF:** Test your golfing skills on the computer's 18-hole golf course, each hole is different and is graphically displayed on screen, many hazards including lakes, streams, rough etc.

**"GAMES PACK 1"** £4.95

**16K GAMES PACK 1:** Fantastic value for money, nearly 50K of programs on one cassette. Five games including "Real Time Graphic" Lunar Lander, Starwars, Hammurabi, Minefield, Mastermind.

### ZX-ARCADE ACTION!!

**NEW!!**

**"MUNCHER!!"** £5.95

At last! Pacman for your ZX-81 full feature arcade game including 4-types of monsters, high-score, 10-skill levels etc., all entirely in m/c code.

**"SPACE-INVADERS"** £4.95

This version is simply the best yet, features include 3-lazer bases, high scorer, bonus points, alien motherships, authentic space invader movement and ever increasing speed, 10-skill levels.

**"ASTEROIDS"** £5.95

Authentic representation of the arcade game with left, right, thrust & fire controls, 5-levels of play & alien spaceships. FASTEST! version available.

**"ALIEN-DROPOUT"** £5.95

Can you stop the aliens from building up in their launch chutes before they drop down & destroy you. Exciting NEW arcade game.

Cheques/POs payable to "SILVERSOFT"  
TICK BOXES REQUIRED

Two or more deduct £1.00  
S.A.E. FOR CATALOGUE

I enclose a cheque/PO for £.....

ZX81, VIC-20, SPECTRUM & BBC SOFTWARE WANTED  
EXCELLENT ROYALTIES (Probably the best around)

Name.....

Address.....

..... YC/82

**SILVERSOFT** (Dept. YC)  
35 Bader Park, Bowerhill,  
Melksham, Wiltshire.

**NEW! ATOM NEW!**  
**ALL ACTION PACKED M/CODE ARCADE GAMES**



**DEFENDER £7**

The most realistic version of this amazing Arcade game available for the Atom. Defend your humanoids from mutation and destroy the Aliens in this hyper fast, action packed game. Moving planetary surface, repeating lasers and smart bombs, thrust, space, increasing Attack Waves, 4 types of Aliens, Sound Effects, Top score and excellent mode 4 graphics are some of the features in this exciting game.

**CENTIPEDE £6**

The first and only version of this popular Arcade game for the Atom. Shoot down the spitting centipede as it swirls through the mushroom field. Also inhabiting the game are Spiders, Bugs and Snails. The action increases until only skill and quick thinking can save you. Excellent high speed mode 4 graphics. Sound Effects and Top score.

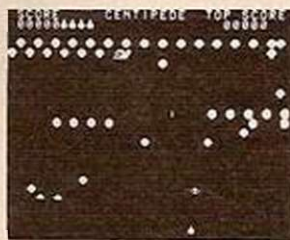

**OMEGA MISSION £7**

The first and only version of the superb Scramble Arcade game. Moving landscape! Fly over mountains, through caves and tunnels. 5 different stages. Ground to Air Missiles, Fire Balls, Space Craft, Mutants and the narrow twisting Tunnel. Movement in 8 directions, laser cannon. Excellent COLOUR graphics (give Black & White on monochrome T.V.) mode 3a, Sound Effects, Top score.



**PUCKMAN £5**

One of the best versions of this popular Arcade maze chaser game. Eat all the dots in the maze but watch out for the hungry ghosts! Eat an Energy Blob and the chase reverses. Each maze cleared brings a new one with faster ghosts. Excellent high speed mode 4 graphics. Sound Effects and Top score.

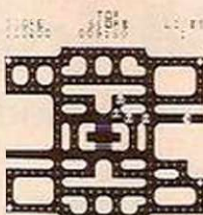

**ALL 12K RAM**  
**PRICES INCLUDE P&P. FAST 2 DAY DESPATCH!**  
**micromania**  
**14 LOWER HILL RD. EPSOM. SURREY.**

# 16K ZX SPECTRUM GRAPHICS SUPERDRAW16

# 16K ZX SPECTRUM GRAPHICS

- 16K Spectrum graphics pack.
- Full screen high resolution colour.
- Moving cursor control.
- Large alphabet facility.
- Pictures saved on cassette.
- Automatic "slide show" option.
- Menu driven, easy to operate, crash proofed.
- Documented to usual high Video Software standard.
- Demonstration slide show.
- Audio commentary on reverse of cassette.

If you've now got your Spectrum you will be wanting to explore its graphics potential. SUPERDRAW16 will help you get the best from it.

Price: £5.00 inc. VAT, P. & P. Immediate delivery.



**VIDEO**  
SOFTWARE LIMITED

# Sumlock

Manchester

## microcomputer world

### SHARP

### MZ-80A

SHARP

*First and foremost*

MZ 80A 48K COMPUTER **£549.00 (inc VAT)**

THE NEW FULL KEYBOARD COMPUTER FROM SHARP

**\*COMPLETE WITH SOFTWARE PACK:**

**EDUCATION** — HANGMAN, GEOGRAPHY, ARITHMETIC

**GAMES** — LUNAR LANDER, TEN-PIN BOWLING, SPACEFIGHTER, IDENTIKIT, CLEVER CRIBBER, D-DAY, BREAKOUT, STAR TREK, SCRAMBLE, SPACE INVADERS

**HOME FINANCE** — HOME BUDGET, BANK RECOCUL, BANK LOAN, MORTGAGE

**BASIC TUTORIAL** — BASIC TUTORIAL 1

BASIC TUTORIAL 2

BASIC TUTORIAL 3

BASIC TUTORIAL 4

PLUS BASIC BASIC and THE BASIC ENCYCLOPAEDIA  
two very useful additions to your library

**TWO YEAR WARRANTY ON SHARP**

**HARDWARE parts and labour**

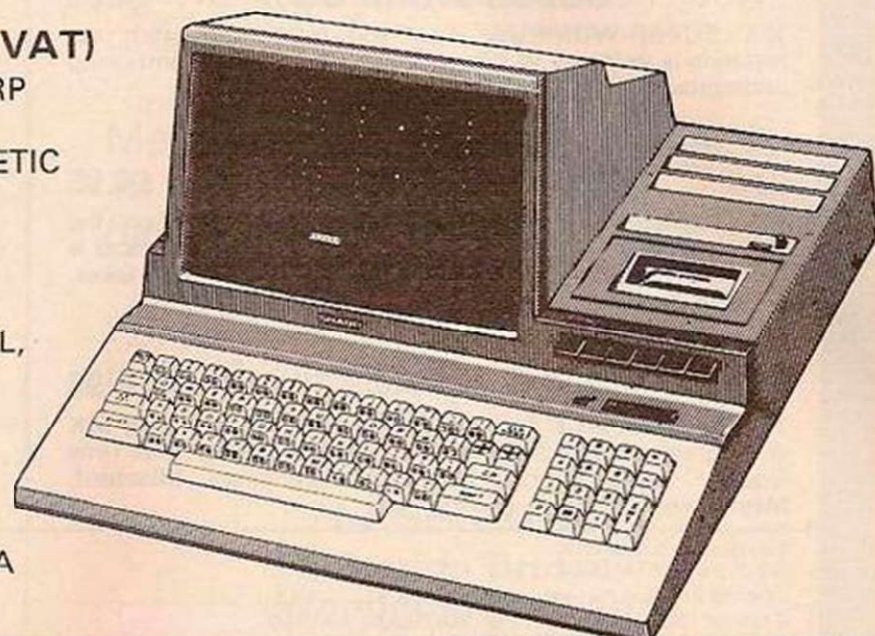

### VIC 20

### CARTRIDGE RENTAL SERVICE RING FOR DETAILS

VIC 1001	VIC 20 computer	£189.95	VIC 2803	Programmers reference guide	£14.95
VIC 1530	C2N cassette deck	£44.95	VP 014	Spiders from Mars ctg.	£24.95
VIC 1515	VIC printer	£230.00	VP 010	Amok	£6.99
VIC 1540	Single floppy disc	£396.00	VP 026	Alien blitz	£7.99
VIC 1210	3K RAM cartridge	£29.95			
VIC 1110	8K RAM cartridge	£44.95			
VIC 1111	16K RAM cartridge	£74.95	SC 09	<b>STACK ACCESSORIES</b> Paddles (1 pair)	£11.50
VIC 1212	Programmers aid ctg.	£34.95	SC 12	Light pen	£28.00
VIC 1212A	Super expander ctg.	£34.95	SC 11	Analogue joystick	£14.95
VIC 1213	Machine code monitor ctg.	£34.95	SC 14	Low cost RS232 interface	£19.84
VIC 1311	VIC joystick	£7.50	SC 16	Games port multiplexer	£37.95
VIC 1312	VIC paddles (1 pair)	£13.50	GPA	Games port adaptor cable	£19.84
VIC 2501	Introduction to Basic (1)	£14.95	SC 13	Rom switch board	£44.00
VIC 1901	Avenger ctg.	£19.95	SC 06	Full RS232C interface	£56.00
VIC 1902	Star battle ctg.	£19.95	SC 15	Memory expansion board — with 3K RAM expandable with chips to full VIC capacity (29K)	£56.35
VIC 1904	Super slot ctg.	£19.95	VIC KIT2	Hi resolution and toolkit command single ROM to fit in SC15	£33.25
VIC 1905	Jelly monsters ctg.	£19.95			
VIC 1906	Alien ctg.	£19.95	DUST COVERS for VIC 20 and C2N (approved CBM product)		£3.75 per set
VIC 1907	Super lander ctg.	£19.95			
VIC 1909	Road race ctg.	£19.95			
VIC 19	Rat race ctg.	£19.95			
VIC 2801	Learn computing with VIC 20	£1.95			
VIC 2802	VIC revealed	£10.00			

### COMPLETE LIST OF HARDWARE AND SOFTWARE AVAILABLE BY REQUEST

We only advertise what we have in stock at the time.

All items are ex stock. Telephone/mail order  
despatched within 24 hours. Carriage free U.K. mainland

**Sumlock Manchester**

Dept YC2

Royal London House

198 Deansgate

Manchester

M3 3NE

OPEN MONDAY TO SATURDAY  
PARKING WATSON ST. N.C.P.

keep up to date  
join our free mailing list

# 061 834 4233

**TI-99/4A \* VIC 16K \* ATARI 400/800 \* SHARP  
MZ-80K/A/B \* BBC MICRO \* SINCLAIR SPECTRUM**

**Functional cassette software by Dale Hubbard  
Buy 2 at £19.95 — take 1 at £5.95 FREE!!!**

**DATABASE**

The program that everyone needs. Facilities include sort, search, list, delete, change, totals, save file, one print if required, etc. etc. Can be used in place of any card index application.

£19.95

**STOCK CONTROL**

All the necessary for keeping a control of stock. Routines include stock set up, user reference no., minimum stock level, financial summary, line print records, quick stock summary, add stock, delete/change record, and more.

£19.95

**MAILING LIST**

A superb dedicated database to allow for manipulation of names & addresses & other data, with selective printing to line printer. Features include the facility to find a name or detail when only part of that detail is known. Will print labels in a variety of user-specified formats.

£19.95

**DECISION MAKER**

A serious program that enables the computer to make a sound decision for you based on various criteria. If you want to buy a car, hi-fi, house, etc., or you don't know which woman to marry then you need this one.

£5.95

**INVOICES AND STATEMENTS**

Ideal for the small business. A complete suite of programs together with generated customer file for producing crisp and efficient business invoices and monthly statements on your line printer. All calculations including VAT automatic and provision for your own messages on the form produced. \*Not Spectrum

£19.95

**RUBIK SOLVER**

It's not our policy to offer games but we make an exception here for a program to solve the cube from ANY position. Shorthand notation makes learning the solution by heart possible for most active brains.

£12.95

**THE CATALOGUER**

This dedicated database is ideal for use in any situation where a catalogue could be utilised. E.g. stamp collection, coins, photos, slides, books, records etc.

£19.95

**COMMERCIAL ACCOUNTS**

A gem of a program, all for cassette, with the following features:

Daily Journal	Sales Ledger
Credit Sales	Purchase Ledger
Cash Sales	Bank Account
Credit Purchases	Year to Date Summary
Purchases — other	

A fully interactive program suitable for all businesses. Files can be saved and loaded and totals from one file carried forward to another on cassette.

Particularly useful from a cash flow point of view, with an immediate accessibility to totals for debtors and creditors. Bank totally supported with entries for cheque numbers, credits and, of course, running balance.

£19.95

**HOME ACCOUNTS**

£19.95

Runs a complete home finance package for you with every facility necessary for keeping a track of regular and other expenses, bank account, mortgage, H.P. etc etc etc!! You'll wonder how you ever managed without it.

**CHOPIN — LES ETUDES**

Six beautiful studies from Opus 10 and 25 performed for you live by Mr. Computer. Spellbinding!!!

\*Not Spectrum

£5.95

**MOTOR ACCOUNTANT**

Find out exactly what the car is costing you and keep a data file with all your expenses therein!

£5.95

**RECIPE FILE**

Let all those computer widows have a bash! The wives will really enjoy the fun of this program designed to keep all her recipes. Will even suggest a menu for the day/week! Excellent value.

£19.95

All programs supplied with exhaustive documentation.  
Send cheque or P.O. or Cash (registered) or Credit Card no. to:

**Gemini Marketing Ltd**

DEPT. YC9, 9 SALTERTON ROAD, EXMOUTH, DEVON EX8 2BR.

Or telephone us with your credit card order on (03952) 5832  
All orders despatch by return — no waiting.  
All prices include VAT and post & packing except Hardware.  
Full range of Sharp peripherals available — please phone for quotations.  
Please state machine type and memory size when ordering software.



Access Welcome

Now! For the SPECTRUM 48K!

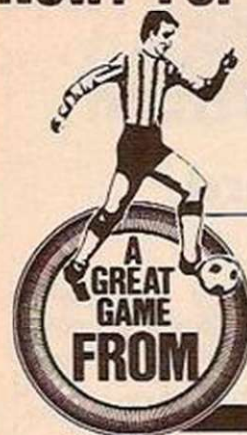

# FOOTBALL MANAGER

Addictive  
Games

for  
ZX81  
SPECTRUM  
TRS80  
VIDEO GENIE

★ AS MANY SEASONS AS YOU LIKE ★ 4 DIVISIONS ★

★ PROMOTION & RELEGATION ★

★ FULL LEAGUE TABLES ★

★ TRANSFER MARKET ★

★ INJURIES ★

★ 7 LEVELS OF PLAY ★

★ SAVE GAME FACILITY ★

★ MANAGERIAL RATING ★

★ PICK YOUR TEAM FOR EACH MATCH ★ F.A. CUP ★

JUST  
LOOK AT  
THESE  
FEATURES

This is NOT a mere simulation. This is an exciting and highly enjoyable game in which you play the part of a Football Manager coping with the problems and decisions involved in running your club. There are so many features it is impossible to list them here but included are form (top teams NORMALLY win), giant-killings, wage bills to pay, and you can even be sacked! It is a game requiring a great deal of skill, and people play it for literally hours on end (we have PROOF!).

WE GUARANTEE that this is one of the best computer games you've ever played!

BUT BEWARE, this game is extremely addictive!

#### HARDWARE REQUIRED

Spectrum 48K RAM	TRS80/ Video Genie
ZX 81 16K RAM	LEVEL II 16K RAM

To Order send Cheque/P.O. £7.95  
made payable to: ADDICTIVE GAMES  
at: Dept. Y.C. P.O. BOX 278  
CONNIBURROW  
MILTON KEYNES MK14 7NE  
PLEASE STATE COMPUTER

MEMORY DEVICES FROM:

## GCC ELECTRONICS

Tel: 0223 21044

Telex: 817672

EPROMS		6500 Family		MEMORIES	
2708	200p	6502	375p	2114LP-2	90p
2716+5V	200p	6520	285p	2114-450	85p
2732	385p	6522	375p	4116-150	90p
2532	365p	6532	520p	4116-200	88p
2764	1200p	6545-1	900p	4816-2+5V	250p
				4164-200	410p
				6116-150	350p
				5516-250	635p
6800 Family		Z80 Family			
6800	270p	CPU	315p		
6802	325p	ACPU	350p		
6810	110p	CTC	270p		
6809	850p	ACTC	290p		
6850	135p	PIO	340p		
6821	110p	APIO	350p		

We supply 74LS TTLs, CMOS 4000 Diodes, Transistors, etc., etc. All components are guaranteed prime parts, from leading manufacturers.

Orders from Government, Educational and Overseas buyers welcome. Special prices for volume enquiries. Please add £1 post and packing plus VAT at 15%. Minimum order £15.00.

## GCC ELECTRONICS

18 CLAYGATE ROAD, CHERRY HINTON  
CAMBRIDGE CB1 4JZ

TEL: 0223 210444

TELEX: 817672

# ZX DIARY

A completely secure diary stored on tape. At last you can write anything you like in your diary with no fear of it being read by others. Not even if they know how to load the programme.

- Type in text
- Fast recall on screen or printer. Lines end neatly. Nothing chopped in half
- Automatic "Contents" page. Select any part for printing
- Automatic paragraphs
- Edit your text. Flashing cursor
- Choose your own UN-CHEATABLE 7 digit security code

For 16K or bigger ZX 81.

2 recordings on C12 cassette with full clear instructions.

Price £5.50 inc VAT, P&P. CWO

Order from: RB SOFTWARE  
BROOK HOUSE  
5 WAYS  
NESTON  
SOUTH WIRRAL  
L64 7TW

Immediate despatch. No delay. Or send small SAE for free descriptive leaflet.

## Morris Associates (Computing)

### PUCKMAN



The all new fast moving machine code game for the VIC-20 that's taking the U.S.A. by storm. Devour the dots in the maze but watch out for those ghosts. You can chase them if you eat a power pill but be quick, the effect doesn't last for ever and they will be after you once again. Points for all those dots will add up to a bonus life and you have three lives!!! Great fun for all the family. On side one you have a keyboard version, and on side two the new joystick control.

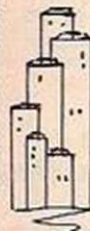

### DIVE BOMBER

You have on board your damaged fighter plane, a supply of bombs. You must guide them to the enemy city below and clear the ground for the plane to land. As you improve, the game begins to get more and more difficult with buildings getting higher and fuel dropping lower as you manoeuvre. Keyboard and joystick controls.



All on the 3.5K VIC-20 from

Spectrum and BBC Software will be available in a short time and dealer enquiries will be welcomed. We are also interested in hearing from writers of high quality software for this category of hardware. Please send a demonstration copy for a quick reply and we will advise you on the marketing possibilities.

37 ST. CATHERINES ROAD, BAGLAN,  
PORT TALBOT, WEST GLAM. SA12 8AT.  
PHONE 0639-813206

Please send \_\_\_\_\_ PUCKMAN GAME CASSETTE/S @ £6.50

\_\_\_\_\_ DIVE BOMBER GAME CASSETTE/S @ £4.95

NAME: \_\_\_\_\_

ADDRESS: \_\_\_\_\_

POSTAL ORDER/CHEQUE: £ \_\_\_\_\_

PLEASE INCLUDE AN EXTRA 50P FOR PACKAGING AND POSTAGE. ALL PRICES ARE INCLUSIVE OF V.A.T.

# Wherever you are in the UK there's a Genie dealer nearby

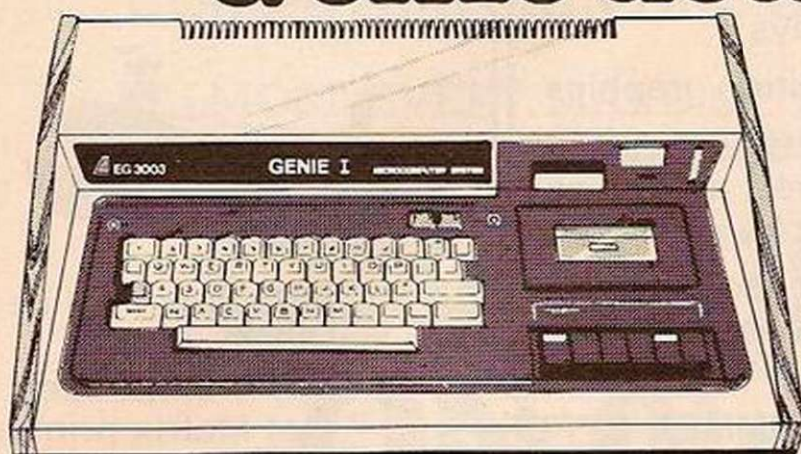

## Genie I & II Approved Dealers

**AVON** Microstyle, Bath, 0225 334659/319705. **BEDFORD** Comserve, Bedford, 0234 216749. **BERKSHIRE** P.C.P., Reading, 0743 589249. Castle Computers (Windsor), 07535 58118. **BIRMINGHAM** Ward Electronics, Birmingham, 021 554 0708. Consultant Electronics, Birmingham, 021 382 7247. A. E. Chapman and Co., Cradeley Heath, 0384 66497/8. **BUCKINGHAMSHIRE** Photo Acoustics, Newport Pagnell, 0908 610625. **CAMBRIDGESHIRE** Cambridge Micro Computers, Cambridge, 0223 314666. **CHESHIRE** Hewart Electronics Macclesfield, 0625 22030. Mid Shires Computer Centre, Crew, 0270 211086. **CORNWALL** A B & C Computers, 11 Brockstone Road, St. Austell, Cornwall, St. Austell 64463. **CUMBRIA** Kendal Computer Centre, Kendal, 0539 22559. **DORSET** Blandford Computers, Blandford Forum, 0258 53737. Parkstone Electrics, Poole, 0202 746555. **ESSEX** Emprise, Colchester, 0206 865926. **GLOUCESTERSHIRE** **HAMPSHIRE** Fareham Computer Centre, Fareham, Hampshire, Fareham, 231423. **HERTFORDSHIRE** Photo Acoustics, Watford, 0923 40698. Q Tek Systems, Stevenage, 0438 65385. Chrisalid Systems and Software, Berkhamsted, 044 27 74569. **KENT** Swanley Electronics, Swanley, 0322 64851. **LANCASHIRE** Harden Microsystems, Blackpool, 0253 27590. Sound Service, Burnley, 0282 38481. Computercat, Leigh, 0942 605730. BEC Computerworld (Liverpool) 051-708 7100. **LEICESTERSHIRE** Kram Electronics, Leicester, 0533 27556. **LONDON** City Microsystems, EC2, 01 588 7272/4. Wason Microchip, N18, 01 807 1757/2230. Premier Publications, Anerley SE20, 01 659 7131. **NORTH EAST** Briers Computer Services, Middlesborough, 0642 242017. General Northern Microcomputers, Hartlepool, 0783 863871. HCCS Associates, Gateshead, 0632 821924. **NOTTINGHAMSHIRE** Midland Microcomputers, Nottingham, 0602 298281. Mansfield Computers, Mansfield, 0623 31202. East Midland Computer Services, Arnold, 0602 267079. Electronic Servicing Co., Lenton, 0602 783938. **NORFOLK** Anglia Computer Centre, Norwich, 0603 29652. Bennetts, Dereham, 0362 2488/9. **OXFORDSHIRE** Micro Business Systems, Whitney, 0993 73145. Peblegglow Ltd. (Thame) 084421 5368. **SCOTLAND** Esco Computing, Glasgow 041 427 5497. Edinburgh: 031 557 3937. Computer and Chips Ltd. St. Andrews, 0334 76206. Scotbyte Computers, Edinburgh, 031 343 1055. Victor Morris and Co., Glasgow, 041 221 8958. **SHROPSHIRE** Tarrant Electronics, Newport 0952 814275. **SOUTH WEST** Diskwise, Plymouth (0752) 267000. West Devon Electronics, Yelverton, 082 285 3434. Bits and Bytes, Barnstaple, 0271 72789. **SUFFOLK** Elgelec Ltd., Ipswich, 0473 711164. **SURREY** Catronics, Wallington, Surrey, 01 669 6700/1. Croydon Computer Centre, Thornton Heath, 01 689 1280. **WALES** Tryfan Computers, Bangor, 0248 52042. **WEST MIDLANDS** Allen TV Services, Stoke on Trent, 0782 616929. **WILTSHIRE** Everyman Computers, Westbury, 0373 823764. B&D Computing (Swindon), 0793 762449. **YORKSHIRE** Media 5 Ltd; Sowerby Bridge 0422 33580. Advance TV Services, Bradford, 0274 585333. Huddersfield Computer Centre, Huddersfield, 0484 20774. Comprite, Bradford, 0274 668890. Superior Systems Ltd., Sheffield, 0742 755005. Photo Electronics, Sheffield, 0742 53865. Ebor Computer Services (York) 0904 791595. **NORTHERN IRELAND** Business Electronic Equipment, Belfast, 0232 46161. Brittain Laboratories, Belfast 0232 228374.



Sole Importers:

# LOWE electronics

Chesterfield Road, Matlock, Derbyshire DE4 5LE.  
Telephone: 0629 4995. Telex: 377482 Lowlec G.

# COME AND MEET VIC AT YOUR NORTH LONDON VIC CENTRE

## SALE — VIDEO GENIE — SALE

EG3003	£240.00	EG400	£195.00
GENIE I	£269.00	EG3020	£35.00
GENIE II	£269.00	EG3022	£55.00
EG3014	£185.00	EG3015	£85.00

## VIC SINGLE FLOPPY DISK

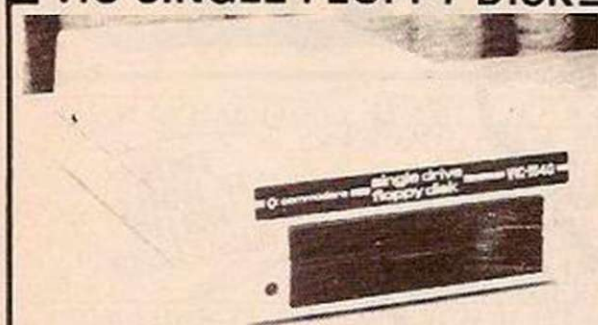

- \* 174K Byte Storage
- \* Direct Interface to VIC
- \* Direct Compatibility with printer

**ONLY £335.00**

## VIC CASSETTE DECK

- \* Direct Interface to VIC
- \* Tape Counter

**ONLY £34.00**

supplied with Free cassette with 6 Programmes

## VIC EXPANSION UNIT

- \* 7 Slot expansion board, for: extra memory, Programming, Games, etc.
- \* Modulator Holder
- \* Enclosed Power Supply

**EXPANSION UNIT  
with LID  
ONLY £85.00**



**\*\* SPECIAL SUMMER OFFER \*\***  
EXPANSION UNIT WITH LID AND MACHINE  
CODE MONITOR CARTRIDGE **ONLY £100.00**

## VIC 20 COMPUTER

- \* A Typewriter Keyboard.
- \* 5K memory-expandable to 29.5K.
- \* 8 programmable function keys.
- \* High resolution graphics
- \* Music in three voices and three octaves, as well as sound effects
- \* Eight border colours and sixteen screen colours

### \*\* SPECIAL SUMMER OFFER \*\*

**ONLY £165.00 + FREE  
CHOICE OF GAMES  
CARTRIDGES**  
(Worth over £17.00)



## SALE — UK101 KITS — SALE

P.P.I.	£19.95	Colour
Prog. Sound	£19.95	£59.95
P108 Eprom	£19.95	Memory
J1 Expand	£ 9.95	£79.95

## VIC PRINTER

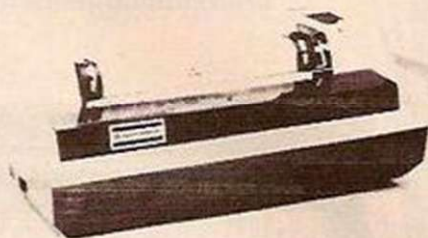

- \* 80 characters per line
- \* 30 characters per sec
- \* Dot Matrix printer
- \* Tractor Feed

**ONLY £185.00**

## CARTRIDGES

8K Memory **£34.00**  
16K Memory **£56.00**  
Programmers Aid  
**ONLY £27.50**

Super Expander  
High Resolution  
graphics with 3K  
RAM  
**ONLY £27.50**

\* **SPECIAL SUMMER OFFER\***  
**MACHINE CODE  
MONITOR  
ONLY £25.00**

## TERMS OF BUSINESS

Please add 15% VAT to all Prices.  
Deliver charged at Cost. Prices valid  
for coverdate of this magazine.  
Phone or Send your Order **TODAY**  
using

**ACCESS  
OR  
BARCLAYCARD**



Please send me a copy of your '**VIC  
LIST**' containing Software, Hard-  
ware and Books for the VIC 20

NAME \_\_\_\_\_

ADDRESS \_\_\_\_\_

YC

# CHROMASONIC electronics

48 JUNCTION ROAD, ARCHWAY, LONDON N19 5RD 100 yds FROM  
ARCHWAY STATION TEL: 01-263 9493/01-263 9495 TELEX: 22568..

# BEFORE YOU BUY YOUR MICRO!

COMPUTER, PRINTER, DISC DRIVES & ACCESSORIES

ALMOST EVERY MAKE OF POPULAR COMPUTER STOCKED  
AT PRICES WELL BELOW RECOMMENDED RETAIL

## GIVE US A RING ON 01-441 2922 AND SAVE £££'s WITH THE LOWEST PRICE GUARANTEE

All products carry a 1 year guarantee (parts & labour)  
Pay and extra 10% for a 2 year guarantee

Shelves  
of  
Computer  
Books

Spares & repairs on  
all products, even if  
you didn't buy from  
Comp Shop

EXPRESS  
MAIL ORDER  
SERVICE

New  
products  
arriving  
daily

'Phone  
your order  
to  
reserve

Many items  
over stocked  
on Sale Offer

INSTANT CREDIT  
just pay the  
deposit by Credit  
Card and  
take it away

SATISFYING PRICE  
CONCIOUS CUSTOMERS  
FOR NEARLY 5 YEARS

P.S.  
Hopeless  
on Software

# COMP SHOP

"Europe's Largest Discount  
Personal Computer Stores"

TELEPHONE SALES  
OPEN 24 hrs. 7 days a week  
01-449 6596

MAIL ORDER SHOP

14 Station Road, New Barnet,  
Hertfordshire, EN5 1QW  
(Close to New Barnet BR Station -  
Moorgate Line)

Telephone: 01-441 2922 (Sales) 01-449 6596  
Telex: 298755 TELCOM G  
OPEN (BARNET) - 10am - 7pm -  
Monday to Saturday



BARCLAYCARD  
VISA

# New From Fuller

## FD System for the

# ZX SPECTRUM

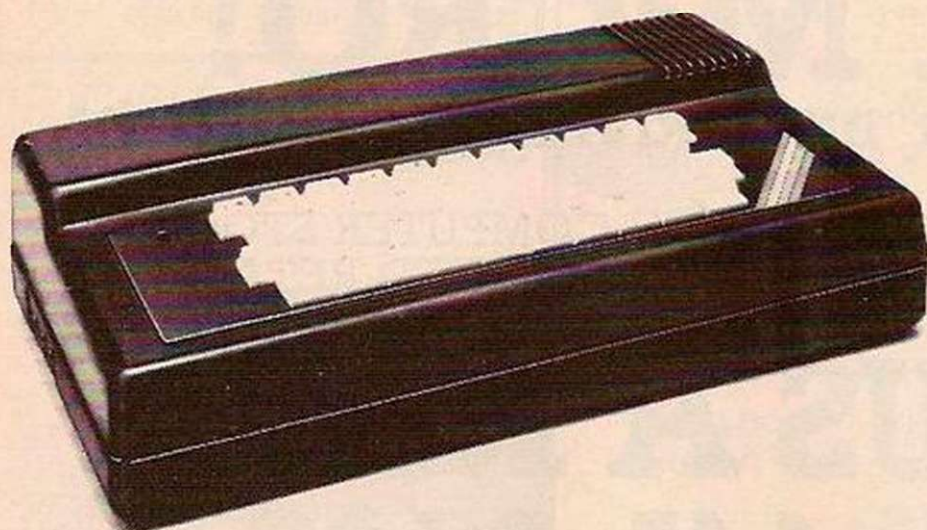

**£39.95**

+ £2.50 p & p.

### Professional Keyboard & Case —

This unit has the same high standard as our ZX81 unit.

Tough A.B.S. Plastic case encloses our Keyboard, the Spectrum Printed Circuit Board and the Power Supply.

Our own Power supply is available:- 9 volts DC at 2 amps.

Mains either 110v or 240v AC at £5.95 + 80p. p & p.

**The Keyboard** has 42 keys with all the spectrum functions printed onto them, the full travel key switches have gold plated contacts and a guaranteed life of 10<sup>6</sup> operations.

**INSTALLATION** - Simply unscrew the ZX printed circuit board from its case and screw it into the FD case, plug in the keyboard and that's it. No technical know how or soldering required, the built unit is tested and comes with a money back guarantee.

### Spectrum Keyboard and Case Kit £33.95

Our Mother Board for the spectrum has 2 slots at £15.95 or 3 slots at £19.95, this unit also fixes inside the case. p & p 80p.

### SPECTRUM SOUND AMPLIFIER £5.95 + 80p p & p.

Complete with leads, volume control and loud speaker in tough ABS Plastic case measuring 5" x 3" x 1" just plugs into your spectrum MIC input.

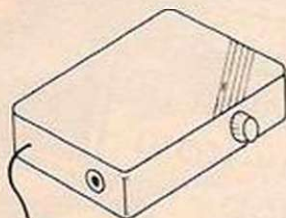

### SPECTRUM PLUG PLANNER — £18.95 + £1.00 p & p

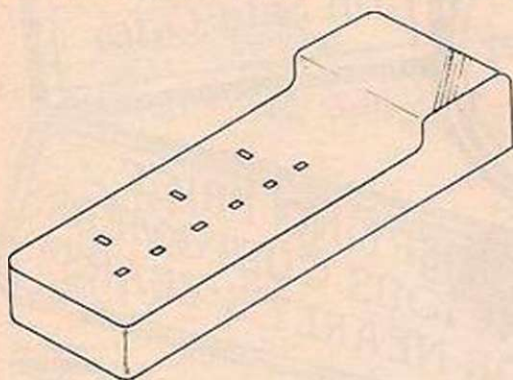

Complete with 3 metres of cable, three 13 amp sockets for TV, Tape etc AND 9 volt at 2 amp power supply with power jack to fit Spectrum or ZX81

**The ever popular FD42 Keyboard and case for ZX81 £39.93 including VAT & Post**  
**FD42 as a kit £33.95 including VAT & Post**  
**FD42 Built only £24.95 including VAT & Post**  
**FD42 Keyboard Kit £18.95 including VAT & Post**

**GUARANTEED 14 DAYS DELIVERY FROM RECEIPT OF ORDER, OR CALL TO THE ZX CENTRE.**

Mail to **FULLER MICRO SYSTEMS,**  
 The ZX Centre, Sweeting Street, Liverpool 2. England, U.K.

AD Code

Please Supply:-

Name .....

Address .....

SAE for more details — Enquiries: Tel. 051-236 6109

**FULLER FD SYSTEM**

## Pitman's Programming Pocket Guides

Essential reading for anyone interested in programming: beginners, students, of computer science, professional programmers and home hobbyists.

These handy guides are specially designed for quick, easy access. They are ideal reference and revision, and can stand upright for use beside a terminal. Place your order today.

Order from your bookseller or send this form to: Cashpost Service, Book Centre, Southport PR9 9YF. Postage and packing are FREE. Please send me

- Pocket Guide to Programming** by John Shelley  
ISBN 0 273 01705 5/£2.25
- Pocket Guide to BASIC** by Roger Hunt  
ISBN 0 273 01685 7/£2.25
- Pocket Guide to COBOL** by Ray Welland  
ISBN 0 273 01650 4/£2.25
- Pocket Guide to FORTRAN** by Philip Ridler  
ISBN 0 273 01683 0/£2.25
- Pocket Guide to PASCAL** by David Watt  
ISBN 0 273 01649 0/£2.25

I enclose a cheque\*/postal order\* for £\_\_\_\_\_ Alternatively, please debit my Barclaycard Visa\*/Access\*/Diners Club\*/ American Express\* account number \_\_\_\_\_

(\*Delete as appropriate)

Signed \_\_\_\_\_  
Name (Capitals Please) \_\_\_\_\_  
Address \_\_\_\_\_

PG/9/82

Pitman Books Limited, 128 Long Acre, London WC2E 9AN

Pitman Books

## What's

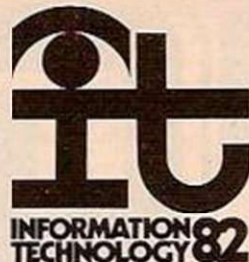

## all about?

## Information Technology Peter Zorkoczy

This is the year of Information Technology.

What is Information Technology? Where did it come from? How did it develop? Where is it going? What can it do? How does it do it?

This new book gives straightforward, no-nonsense answers to these questions. No specialist knowledge is assumed. Order it now. Paperback/152 pages/Published September 1982.

Order from your bookseller or send this form to: Cashpost Service, Book Centre Limited, Southport PR9 9YF. Postage and packing are FREE.

Please send me \_\_\_\_\_ copy\*/copies\* of **Information Technology**, ISBN 0 273 01798 5/£4.50

I enclose a cheque\*/postal order\* for £\_\_\_\_\_, made payable to Pitman Books Limited. Alternatively, please debit my Barclaycard Visa\*/Access\*/American Express\*/Diners Club

account number \_\_\_\_\_  
(\*Delete as appropriate)

Signed \_\_\_\_\_  
Name (Capitals Please) \_\_\_\_\_  
Address \_\_\_\_\_

YC/9/82

Pitman Books Limited, 128 Long Acre, London WC2E 9AN

Pitman Books

## ZX81 HEWSON CONSULTANTS SPECTRUM

### HINTS AND TIPS FOR THE ZX81 by Andrew Hewson £3.95

The most complete book at the price

Good value and quite fascinating... a very inexpensive way of acquiring months of programming experience. *Your Computer Nov 1981*

80 pages explaining how to squeeze a computing quart out of a Sinclair pint pot. Saving Space - vital reading for all ZX81 users. Understanding the Display File - using the display file as memory, clearing a part of the display, using tokens in PRINT statements. Converting ZX80 programs - explaining simply but comprehensively how to convert the hundreds of published ZX80 programs. Chaining programs - revealing techniques for passing data between programs, calling subroutines from cassette and establishing data files. Machine Code Programs - all you want to know about ZX80 machine language. Explaining how to write, load, edit and save machine code and how to debug your routines. Routines and programs are scattered liberally throughout the text and the final chapter consists of 12 useful, interesting, entertaining programs such as LINE RENUMBER, BOUNCER, SHOOT, STATISTICS, etc.

### 16K MEMORY

THE BEST VALUE FOR MONEY 16K RAM on the market. Coming complete with case, simply plugs into the port at the back of your Sinclair. Money back guarantee.

£24.95

### 48+8K NEW

0-8K \*Sinclair Rom  
8-16K \*The contents of this area of RAM are unaffected by loading programs from cassette. Can be used to store machine code routine or to store data for use by more than one program.  
16-32K \*Basic program area and display file.  
32-64K \*Variable and array area. Massive memory area for storage of data.  
\*Directly addressable and user transparent.  
\*Facts sheet FREE with each RAM purchased.

£61.95

### 64K MEMOPACK

0-8K \*Same as 48+8K  
8-16K \*Can be switched out in 4K blocks to leave room for memory mapping and vacant addresses for graphics etc ROMs. The contents of this area of RAM are unaffected by loading programs from cassette. Can be used to store machine code routine or to store data for use by more than one program.  
16-32K \*Same as 48+8K  
32-64K \*Same as 48+8K

£79.00

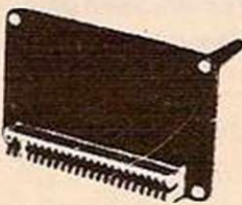
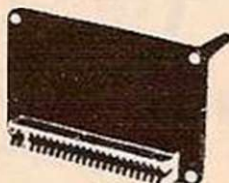

### SPECTRUM SOFTWARE AVAILABLE NOW! SPACE INTRUDERS FOR THE ZX SPECTRUM

Features include:  
Full sound and colour action!  
3 Laser bases, 4 Defences,  
M/C Super fast action  
High score display, descending aliens,  
64 Aliens in each squadron  
Squadron after squadron attack your position  
All this yours for only

£5.95

### Z80 OP CODES

£1.45

A must for the beginner and the experienced programmer alike. This hand ready reckoner lists all 600 plus Z80 machine code instructions in decimal and hexadecimal with their mnemonics. Each Op Code is succinctly explained and cross-referenced. Supplied in a protective transparent wallet for easy reference and durability.

### PROGRAMMERS TOOLKIT FOR THE ZX81

£6.50

The Programmer's Friend and Slave! Are you writing your own programs for the ZX81? How can you do that without our Toolkit? It will encourage you to go on to write bigger, better and more sophisticated programs by doing your own key work.

Simply create 3K of space above Ram top and then load the Toolkit in the normal way. The Toolkit hides above the Ram top awaiting your command. You can now load existing programs from cassette for the Toolkit to operate on. Or type in a whole new program!

Toolkit functions include:  
\* RENUMBER including the destination lines of GOTO's and GOSUB's.  
\* START and Finish lines and Step size specified by you.  
\* DELETE part or all of a program as your command.  
\* REPLACE characters (or tokens) with an equal number of others specified by you.  
\* EDIT to create sub-routines at a stroke by moving blocks of basic program lines.  
\* FIND a basic program string specified by you.  
\* INPUT prompts for a two digit hexadecimal code and pointer in a specified address.  
\* Separate version available for 48+8 and 64K memories (resides at 8192)

LINE RENUMBER £4.95  
FULL LINE RENUMBER  
RESIDES ABOVE RAMTOP

### PUCKMAN NEW! FOR THE ZX81

£5.95

- All action display
- Scour the maze for food
- Dodge the ghosts who come to devour you
- Automatic option - the machine plays itself
- Full keyboard display
- Full instruction display
- Continuous scoring
- Beat the best score to date
- Super graphics when used with Quick Silva graphics board

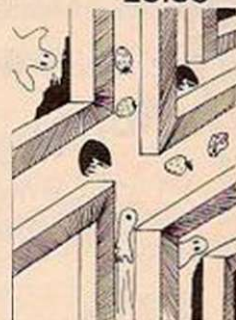

### PILOT ★ FOR THE ZX81 ★ NEW!

£5.95

New and exciting Pilot challenges you to take off, fly between beacons then land whilst watching wind speed and dodging craggy mountains - either could lead to disaster! If you take the challenge, you may soon learn to fly solo - so detailed are the flying instructions. Coast along in Autopilot - just to gain confidence, then battle your way through 6 further modes, 6 different ways of trying to steer your plane safely back to base, increasing in difficulty, testing your skills. Good luck with your fight against the unpredictable elements!

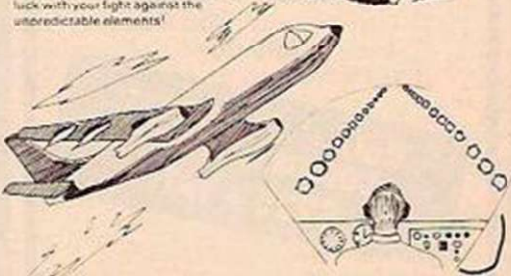

SEND S.A.E. FOR FULL CATALOGUE OF HARDWARE, SOFTWARE & LATEST PRICES

Cheque with order or quote Access or Barclaycard number to: HEWSON CONSULTANTS, Dept YC, 60A St Mary's Street, Wallingford, Oxon OX10 0EL.

# MicroStyle

29 BELVEDERE, LANSDOWN ROAD, BATH  
47 CHEAP STREET, NEWBURY  
67 HIGH STREET, DEVENTRY

**NEW SHOP  
WILL OPEN  
IN NEWBURY  
IN SEPTEMBER**

## SEIKOSHA GP100A PRINTER

ENTIRELY NEW DESIGN.  
UNBELIEVABLY LOW PRICE.  
FULL GRAPHICS CAPABILITY.  
CENTRONICS PARALLEL  
INTERFACE. PAPER WIDTH  
ADJUSTABLE UP TO 10".

**£195.00 + VAT**

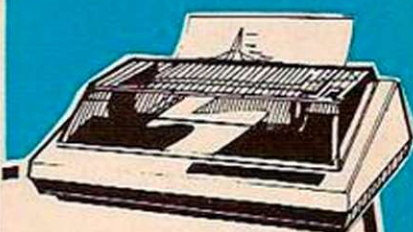

## PRINTERS

EPSON MX80  
EPSON MX100  
ANADEX  
PAPER TIGER  
T.E.C.  
SCRIPTA  
MICROLINE 80.

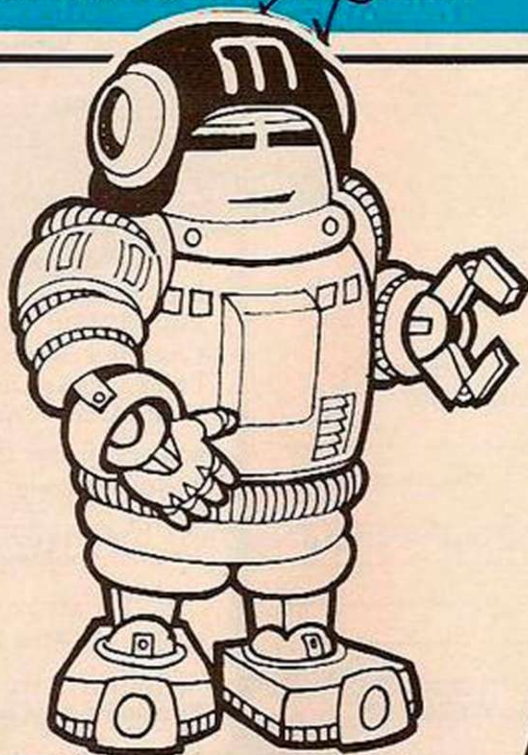

**SHARP  
MZ 80A & MZ 80B  
ALWAYS ON DISPLAY**



**(0225)**



**334659.**

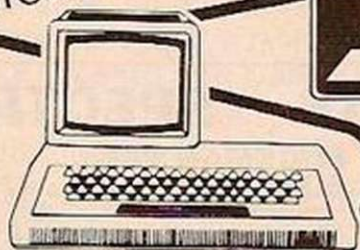

## ACORN ATOM

Sensational New Micro-Pack!  
8K ROM 5K RAM, PSU included.  
Colour fitted. Starter pack  
software.

**£170.00 + VAT**

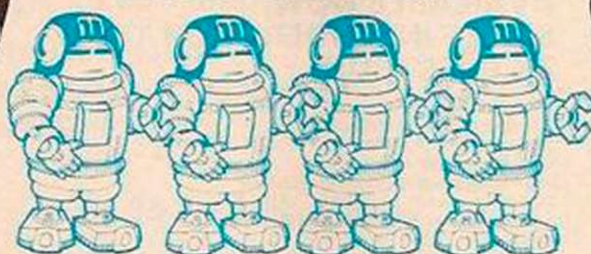

## THE TI-99/4A FROM TEXAS INSTRUMENTS.

- 16K RAM (Expandable to 48K)
  - Keyboard: 48 key QUERTY
  - Sound: 5 octaves, 3 simultaneous tones plus noise generation • Colours: 16
  - Resolution: 192 x 256 (24 x 32 characters)
  - Built-in software: 14K byte BASIC interpreter.
- Vast range of Educational  
and Pre-school early  
learning modules!

**£199 incl. VAT**

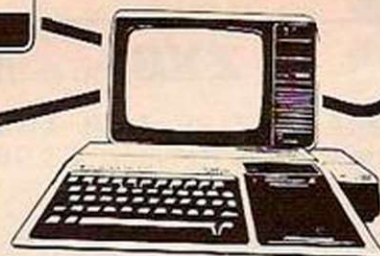

## VIDEO MONITORS

All sizes and prices.  
Black/white 9" **£90.00**  
Black/white 12" **£65.00**  
Green Screen 12" **£85.00**  
Amber 9" **£95.00**  
All Plus VAT

**BBC - COMPATIBLE  
COLOUR MONITOR  
£225 + VAT**

**EXTENSIVE RANGE OF  
BOOKS AND SOFTWARE  
ALSO AVAILABLE**

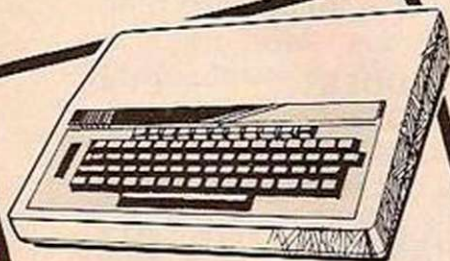

## BBC MICROCOMPUTER SYSTEM

Complete BBC support:  
books - software - peripherals  
Model "B" ex-stock

**Plus Lots More.**

Post to:  
**MICROSTYLE, FREEPOST,**  
29 Belvedere, Lansdown Road, Bath BA1 1FP  
Please send me further details on the  
following, and your special offers:

Name .....  
Company .....  
Address .....

Tel. ....

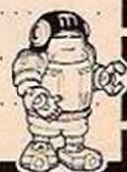

# BBC ELTEC SERVICES LTD

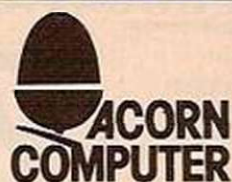

## BBC MICROCOMPUTERS

BBC Model "A" (Available Now!)	£326.00
BBC Model "B"	£435.00
BBC Model "A" partially or fully converted to Model "B" as per your requirements	from £367.86
16K HITACHI memory (as fitted by ACORN)	£41.86
RGB socket	£2.01
Printer Interface	£17.25
14" Full colour MONITOR (Used in BBC Computer programmes)	£309.35
12" Green Screen MONITOR	£126.00
RGB Monitor Lead	£5.00
GP100 A Printer	£247.25
Printer Cable	£18.40
Cassette Recorder	£24.00
Cassette Lead (7 pin DIN/3 Jacks)	£5.00

## SOFTWARE

Sinclair Cassette 1 (Star Trek, Candy Floss)	£5.95
Sinclair Cassette 2 (Hangman, dice etc.)	£3.95
Sinclair Cassette 3 (Mutant Invaders)	£5.95
Sinclair Cassette 4 (Breakout)	£3.95
FULL RANGE of ACORNSOFT BBC CASSETTES	all £9.95
NEC 30hr Basic	£5.50

Practical Programmes for the BBC Computer Johnson-Davies	£5.95
Basic Programming on the BBC Computer Cryer	£5.95

## ATOM MICROCOMPUTER

ACORN ATOM, assembled, 8K ROM, 2K RAM	£172.50
ACORN ATOM, assembled, 12K ROM, 12K RAM	£225.00
Power Supply	£9.20
ACORN 96K SINGLE DISK PACK	£343.85
Disk Buffer Pack	£11.75
GP100A Printer	£247.25
2114L RAM Chips	per K ** £2.50 **
Word Pack ROM	£30.00

** UTILITY ROM SWITCH **	
Up to 4 ROMs keyboard selected	£41.79

FULL RANGE OF SOFTWARE, ICs, CONNECTION LEADS etc.

Atom Magic Book	£5.50
Getting Acquainted with your Acorn Atom	£7.95

Prices are VAT inclusive. P&P 50p Books, cassettes, chips.

Hardware items £3.00 delivery by Securicor

ELTEC SERVICES LTD  
231 Manningham Lane, Bradford BD8 7HH  
Tel (0274) 491372

# WRITE EFFICIENT ZX81 BASIC

- Improve your ZX BASIC Programming skills with this new book
- Assumes knowledge of the Sinclair ZX81 BASIC manual only
- Illustrated by over 25 useful and enjoyable programs, demonstrating the rules described, while making the most effective use of 1K
- Many of the principles listed are of more general application, most particularly to ZX SPECTRUM Basic
- Send £5 to:

Ivor Killerbite,  
10, Elson Road,  
Formby,  
Liverpool L37 2EG.

## MIDWICH MICROCOMPUTERS CO. LTD.

MAIL ORDER SPECIALISTS

Lowest Prices — Fastest Delivery

### MEMORIES \*\*NEW LOWER PRICES\*\*

2114 Low Power 200ns	0.80	4116 200ns	0.70
2708 450ns	2.79	4116 150ns	1.10
2716 450ns (5V)	2.10	4118 150ns	3.38
2716 350ns (5V)	3.59	4164 200ns (TI)	4.65
2716 450ns (3 rail)	5.95	4816/4516 100ns	3.25
2732 450ns	3.90	5516 200ns	9.38
2732 350ns	4.40	6116P3 150ns	4.30
2532 450ns	3.60	6116LP3 150ns	5.75

### BBC MICRO UPGRADE KITS

\*\*NEW LOWER PRICES\*\*

As some parts are still in short supply please check availability before ordering.

BBC1 4516/4816 x 8 100ns	25.50
BBC2 Printer/User I/O kit (IC69,70 + PL9,10)	8.00
BBC4 Analogue input kit (IC73,77 + SK6)	6.70
BBC5 Serial I/O and RGB kit (IC74,75 + SK3,4)	11.45
BBC6 Expansion bus and tube kit (IC71,72,76 + PL11,12)	6.25
BBC21 Printer cable complete	13.00
BBC22 Connector for user port with 36" cable	2.00
BBC44 Analogue input plug with Cover	2.25
BBC55 5 and 6 pin DIN plugs for Serial I/O and RGB input	0.99
BBC66 Connector for Bus port with cable	3.50

VISA

24 HOUR TELEPHONE SERVICE FOR CREDIT CARD USERS



★ All prices exclude VAT and Carriage (0.75 + VAT) on orders under £10 ★  
★ All orders despatched on day of receipt with full refund on O/S items if requested ★  
★ Order receipted & returned with goods. If full VAT invoice required please add 0.50 + VAT ★

### MIDWICH MICROCOMPUTERS CO. LTD.

DEPT YC, HEWITT HOUSE, NORTHGATE STREET,  
BURY ST. EDMUNDS, SUFFOLK IP33 1HQ  
TELEPHONE: (0284) 701321 TELEX: 817670

## EDUCATIONAL COMPUTING

Suit children ages 5-11

on the  
**ZX81**

No comparable collection offers so much for so little

THE LITTLE PROGRAMMES WHICH ARE BIG EDUCATORS

Here at last. A set of programmes to turn your Sinclair ZX81 into a powerful educational tool. And you don't even need to know programming. There are clear instructions and plenty of tips & advice. Designed to go beyond drill & practice to promote learning through interaction & discovery.

All programmes fit 1K

Creative use of graphics

Many innovative ideas

Fully documented

Includes many games

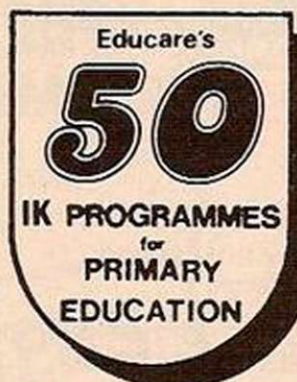

Includes:-

### TORTOISE

A simplified version of the famous Turtle programme

### CODED MISSILE

Combines the fun of arcade games with learning

**£4.95 only**  
incl. p & p

Graph-plotter • Histogram • Simon-spell • Sketchboard • Times-table • Sets Series-quiz • XY-coordinates • Count • Equations • Areas • Guess-a-Volume • Angles • Upstairs-Downstairs • Music-notes • See-saw • Wipe-out • Spell • Temperature • Clock • Money • Snake • Mastermind • Number-shoot • +26 more

## EDUCARE

To: EDUCARE 103 College Road Margate Kent CT9 4AA	Please send me.....copies Educare's 50. I enclose cheque/postal order for £..... Name..... Address.....
---	--

Let your child benefit early. Send now.

## SIR Computers Ltd. Cardiff

BBC MICRO COMPUTERS available direct from stock  
BBC Micro Computer Model A ..... £320.00  
BBC Micro Computer Model B ..... £400.00  
Conversion of your Model A to B ..... £92.00

### ATOM PRICES SMASHED!

8K ROM + 2K RAM ..... £149.50  
8K ROM + 12K RAM ..... £175.00  
12K ROM + 12K RAM ..... £199.00  
ATOM DISC DRIVE ..... £299.00

Large range of Atom and BBC software in stock

### DRAGON 32 NOW IN STOCK

### ZX SPECTRUM HARDWARE

8 bit input/output port ..... £11.00  
8 bit input/output port with LED display ..... £15.50  
4 channel analogue port (for joysticks) ..... Price on application  
Joysticks (analogue board also needed) ..... P.O.A.  
"Centronics" printer interface ..... P.O.A.

All Add-Ons are ZX81 compatible

All prices are inclusive of V.A.T.  
Please add £10.00 for Securicor delivery of BBC Computers  
+ Atom Disc Drive, £7.00 for delivery of Atom  
£1.00 for all other items.

**SIR Computers Ltd.**  
38 DANYCOED ROAD, CYNCOED,  
CARDIFF CF2 6NB, WALES  
Tel: 0222 - 759015

# The ultimate SINCLAIR ZX 81 (16K) DATABASE FILING SYSTEM

by DALE HUBBARD

Fed up with boring games — make your ZX81 work for you!  
*The one you've been waiting for!!*

Cassette based  
Clear "menu" operation  
Facilities include sort, search, list, delete, change, total numeric field, save and load file, line print, etc.  
Complete with demonstration file and full instruction/application leaflet.  
Requires 16K Ram pack.

Applications: Recipe file  
Stamp/coin collections  
Inventory Control  
Employee Data  
Record Collections  
Magazine article catalogue  
May be used for any application where fast access is required to stored information

Access accepted  
Send cheque or P.O. or credit card number to:  
**GEMINI MARKETING LTD.**  
9 Salterton Road, Exmouth, Devon EX8 2BR.  
Or telephone us with your credit card order  
on Exmouth (03952) 5832

DESPATCH BY RETURN

**ONLY**  
**£5.95 FULLY INCLUSIVE!**

**Special Offer**  
**FREE**  
Computerised decision  
making program

**PRICE BREAK-THROUGH ON  
EXTRA MEMORY FOR ZX81 !**

The **NEW EconoTech 16K RAM PACK**  
adds 16-times more memory to your ZX81 at a budget price!

Fully assembled, tested and  
guaranteed - neat and compact.  
fits snugly to eliminate wobble.  
Compatible with ZX Printer.

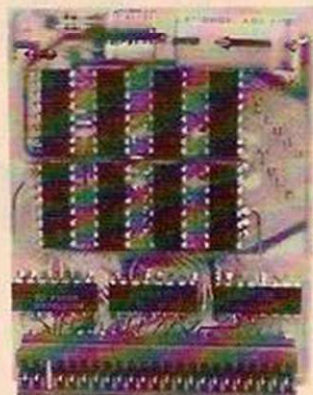

**ONLY £19.95 !**

plus £1.50 post & packing  
to anywhere in the world

Full refund if not fully satisfied - simply return within  
14 days of purchase. Allow up to 28 days for delivery.  
Fill in the coupon below and send with cheque or P.O.

To:  
**EconoTech, 30 Brockenhurst Way, London SW16 4UD**  
Please send me .... 16K RAM Packs @ £19.95 each,  
plus £1.50 post and packing.

Name .....

Address .....

**ZX81 Spectrum  
16K**

**MANAGEMENT GAMES**

**AIRLINE**

Can you compete with British Airways? You must decide on the number of aircraft to operate, whether to buy or charter, whether to enter into a loan or a fuel contract and the levels of staffing and maintenance. Problems encountered are tax demands, strikes, cancelled flights, hijacks and aircraft crashes.

**AUTOCHEF**

As MD of a Catering Company you must negotiate for leases, decide on menu prices, level of wages, advertising and dividends. Each year you must predict the inflation rate. You are also given options on consignments of wines and food and loan contracts. You will be made to resign if you are not successful. There are 3 levels of difficulty.

**PRINT SHOP**

You own a small printing company and are required to decide on (a) the number and type of staff you employ and when to increase or reduce staff (b) the amount and type of paper you stock (c) the week in which work is scheduled (d) the quotation for each job. Are you an entrepreneur? Test your business acumen to the limit! There are 3 levels of difficulty.

These simulations are realistic and are not only fun to play but are educational. The user will learn to interpret Trading Profit and Loss Accounts and Balance Sheets. Our programs are very comprehensive and fully utilise the memory.

ALL PROGRAMS INCLUDE DETAILED INSTRUCTIONS.

£4.75 for one, £8.00 for any two or £12 for three.

**C.C.S.**

Please state computer type and send  
cheque to: DEPT S  
**CASES COMPUTER SIMULATIONS**  
14 Langton Way  
London SE3 7TL.

**£4.75**

**ZX81 GAMES**

from  
**J.K. GREYE SOFTWARE LTD**  
**THE NEW GENERATION SOFTWARE HOUSE**

"Without question the finest machine code games available  
today!"..... J.N. ROWLAND Product Manager for W.H. SMITH.

**GAMESTAPE 1 for 1K** ..... only **£3.95**  
10 Games incl. ASTEROIDS, UFO, CODE, BOMBER,  
GUILLOTINE, KALEIDOSCOPE, etc.  
**PROBABLY THE BEST VALUE 1k TAPE AVAILABLE.**



We've done in 1k, games which some of our competitors  
require 16k to do!



**GAMESTAPE 2 for 16K** ..... only **£3.95**  
**\*STARFIGHTER** Superb machine code Space Battle. Set  
against a background of twinkling stars, with stunning  
explosions - if you can hit the enemy!  
**PYRAMID** Can you move the Pyramid? Make a mistake and  
it will collapse! A Thinkers game.  
**ARTIST** The ultimate Graphic Designers aid. 8 Directions, 10  
Memories. SAVE. COPY. RUBOUT. CLS, etc.

**GAMESTAPE 3 for 16K** ..... only **£4.95**

**\*CATACOMBS** A Multi-Level Graphics Adventure. Each  
level can contain up to 9 Rooms, 8 Passages, 7 Monsters,  
Food, Gold, Traps, Phantoms, an Exit (to the next level),  
and there's an infinite number of levels.  
NOTE. . . . This is NOT one of the necessarily limited text  
Adventures as sold elsewhere.  
"An excellent addictive game which will keep you amused  
for hours." . . . COMPUTER & VIDEO GAMES.



**GAMESTAPE 4 for 16K** ..... only **£4.95**  
**\*3D MONSTER MAZE** The Game to Top All Others.  
Unbelievable Graphics! Can you find your way through the  
Maze? The EXIT is there somewhere, but then so is a T.REX,  
and its after YOU! All in 3D (the T.REX will actually run  
towards you in full perspective!), you've never seen anything  
like this before!  
"3D MONSTER MAZE is the best game I have seen for the  
ZX81" . . . COMPUTER & VIDEO GAMES

"If I had to choose just one programme to impress an audience with the capabilities of  
the ZX81, then J.K. Greye's 3D MONSTER MAZE would be the one without doubt"  
. . . . ZX COMPUTING. "Brilliant, brilliant, brilliant!" . . . POPULAR COMPUTING WEEKLY

**GAMESTAPE 5 for 16K** ..... only **£4.95**

**\*3D DEFENDER** The Ultimate Space Game. Super fast  
Machine Code 3D version of the Arcade favourite. You have  
to save your home planet from the marauding Alien Spacecraft.  
This is all in 3D, your viewscreen shows you the view out  
of your fighters cockpit window. The backdrop moves when  
you turn, or fly up or down (8 flight directions), just as if you  
were really flying it! But then YOU ARE! The Enemy Saucers  
will actually zoom towards you in 3D, and shoot you if you let them! Your display  
includes Score, Shield Strength, Altitude, Proximity, Forward Radar and your viewscreen,  
which shows your rotating home planet, backdrop of Stars, Meteors, Explosions,  
Plasma Blasts, your Photon Beams, up to 4 Enemy Saucers and of course its all in  
full 3D!



**A SMASH HIT at the ZX Microfair (most of the other software houses wanted a  
copy), a game not to be missed!**



**GAMESTAPE 6 for 1K** ..... only **£1.95**  
**\*BREAKOUT** Super Fast Full Screen Display Game. Your  
all time favourite with an added twist. See how much Money  
you can win and watch the pounds convert to Dollars. All  
in Machine Code for Fast Action with 3 Speeds, 2 Bat Sizes  
and three angles of rebound! The best BREAKOUT around  
and at this price you can't go wrong!

**GAMES MARKED \* INCL. MACHINE CODE.**

Prices include VAT and U.K. P. & P.

(Add appropriate Postage on Foreign Orders). Cheques/P.O.s to

**J.K. GREYE SOFTWARE LTD**

16 Brendon Close, Oldland Common, Bristol BS15 6QE.

**CREDIT CARD SALES:** Phone: 01-930-9232 (9 a.m. - 7 p.m.)  
FOR INSTANT DESPATCH

If you prefer to see before buying, our range of **GAMESTAPES**  
are stocked by the following stores.

**BUFFER MICROSHOP** ..... 374A Streatham High Rd., London SW16;  
**GAMER** ..... 24 Gloucester Rd., Brighton;  
**GEORGES** ..... 89 Park St., Bristol, Avon;  
**MICROSTYLE** ..... 29 Belvedere, Lansdown Rd., Bath, Avon;  
**MICROWARE** ..... 131 Melton Rd., Leicester;  
**SCREEN SCENE** ..... 144 St. Georges Rd., Cheltenham, Glos;  
**W.H. SMITH** ..... Over 200 Computer Branches;  
**ZEDXTRA** ..... 5 School Lane, Bournemouth, Dorset;

**TRADE & EXPORT ENQUIRIES WELCOME**

Great games packs for 16K ZX81 ...

## PACK 1

### ASTRO-INVADERS

Just look at these features ...  
... then look at the price!

- Superior machine code programming
  - Rapid-firing with explosive on-screen kill effect
  - High-scoring saucers ● 54 aliens ● accelerating attack
  - Destructable defence shields ● On-screen kill count
  - High-score update
  - Fast action space graphics
- a new dimension in ZX81 value

Astro-Invaders is yours on cassette for **ONLY £3.65** with **FOUR BONUS GAMES:**  
**ARCADE GRAND-PRIX** — drive four levels of machine code skill  
**PENALTY** — defend your goal against the sharp-shooting ZX81  
**GOLF** — judge shot-strength, angles, bunkers ...  
plus machine code insect fun with **SWAT**

## PACK 2

### PLANET DEFENDER

— blast aliens in planet orbit ...

- ultra-dynamic machine code action ● hostile alien-waves
  - fast responsive controls: ship up/down, thrust, laser-bolt, and smart bomb ● comprehensive scoring
  - explosive graphics .....
- ..... explosive price!

Planet Defender comes on cassette for **ONLY £3.65** with machine code **STORM-FIGHTERS** — combat 5 fleets of swooping aliens as you blast through space, **BREAKOUT** (machine code) — race against the clock, plus **GRAPHIC HANGMAN**.

16K ZX81 cassette packs 1 and 2 are £3.65 each (post free in U.K.). Fast despatch from

John Prince  
29 Brook Avenue, Levenshulme,  
Manchester, M.19

## ATOM USERS! WIN AN ADPROM 4000

IN OUR "ONE LINE" PROGRAMME COMPETITION.  
DETAILS IN OUR BROCHURE. DON'T FORGET S.A.E.

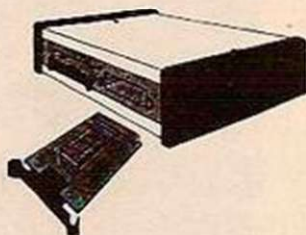

### ADPROM 4000 WITH 2 CARDS

Problem! Two or more Eproms and only one socket on your Atom. SOLUTION! is an ELINCA ADPROM unit and use any as required for only £39.10 incl. VAT etc.



### ATOM CASE CONSOLE

Type AC155 £31.63 incl. VAT etc. can be supplied with single Adprom as in photograph.

FULL DETAILS OF ALL OUR PRODUCTS WILL BE SENT  
ON RECEIPT OF AN A5 S.A.E.

ELINCA PRODUCTS LTD (Dept. C)  
LYON WORKS, CHAPEL STREET  
SHEFFIELD S6 2HL

NEW SHAPE  
COMMAND

## CORN ATOM

NEW 4K EPROM PLUGS STRAIGHT  
INTO UTILITY SOCKET FLASHING CURSOR  
1200,600,300 BAUD CASSETTE OPERATING SYSTEM.  
VISIBLE AND AUDIBLE INDICATION OF LOAD & SAVE.

Draw complex graphic shapes with one instruction  
using our special 'SHAPE' command

### 33 NEW COMMANDS

- SHAPE N X,Y — draw shape number N at X,Y
- BLOCK — draw block of any size, any graphic mode
- POINT — test if graphic point set or clear
- FIND — print lines which contain a given string
- KEY — scans keyboard for use in real time games
- ZERO — zero all basic variables
- SCREEN — set cursor to screen location (0 to 511)
- STOP — debugging program command
- STRG — print strings in graphic modes
- MC — monitor — memory change, Hex & textdump
- RENUMBER — including GOTOs and GOSUBs
- AUTO — automatic line numbering
- DELETE — delete block of program lines
- VERIFY — verify programs after recording on tape
- PACK — removes non significant spaces
- TONE — sound a note of any duration and tone

PLUS: READ, DATA, RESTORE, BSAVE, APPEND, TAPE ...  
BSTRG, CHAR, POP, VAR & BLEEP

Fits any size memory Atom

Full Documentation included

EXTRA SPECIAL PRICE £16.95 ALL INCLUSIVE

Ross  
Software

RUSH YOUR ORDER TO: Ross Software  
44 Premier Avenue, Grays, Essex RM16 2SD  
Send S.A.E. for details.



NEW FROM  
CAMEL PRODUCTS



## AN INNOVATIVE PRODUCT FOR YOUR ZX81

*Faster than a Floppy  
Easier than an EPROM*

### MEMIC-81

Just enter  
**PRINT USR X**  
and you've LOADED  
your BASIC program  
from CMOS RAM  
WHY PUT UP WITH THE  
DATA CORRUPTION  
AND TIME WASTAGE  
OF TAPE?

2 kB MEMIC-81 £24.95 + VAT  
4 kB MEMIC-81 £29.95 + VAT

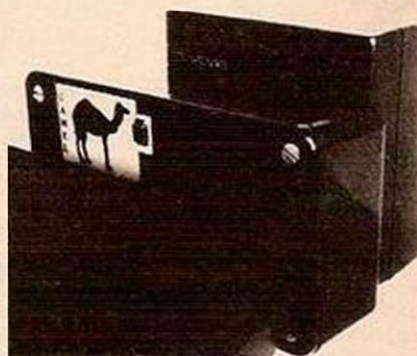

### OTHER CAMEL PRODUCTS

MEMIC T	2 kB Towerblock version for any System	£29.95 incl.
MEMIC L	2 kB Low Profile version with cabled connector	£29.95 incl.
PIO-81	8+8 Ch. latched Input/Output ZX81 card	£13.00 + VAT
ROM-81	2kB-8 kB ROM/EPROM Unit for ZX81	£14.94 + VAT



Cambridge Microelectronics Ltd, One Milton Rd, Cambridge, CB4 1UY Tel (0223) 314 814

## The Atom Magic Book

By Mike Lord. A wealth of games and other programs: storing speech in your ATOM, converting programs written in other BASICs, tape recording hints, and many more useful software and hardware tips. £5.50

## Getting Acquainted with your Acorn Atom

By Tim Hartnell and Trevor Sharples. 80 programs including Draughts! 184 pages. £7.95

## Practical Programs for the BBC Computer & Acorn Atom

By David Johnson-Davies £5.95

## The Memory for your Atom

(Or other 1MHz 6502/6800/6809 machine)

16 or 32K BYTE VERSIONS. Expand your ATOM to 28 or 38K RAM. Ideal for Word Processing, Chess programs and Business Software.

Fully Compatible with other Acorn ATOM software and hardware, including the Acorn disc drive.

Versions available to fit inside the ATOM while still leaving room for other extensions such as the Acorn ATOM colour encoder board. Eurocard rack mounting types also available.

**NEW!** Versions of the above boards designed to run from a single +5V supply. s.a.e. for details.

## ATOM Cassettes.

We stock a selection of the best ones available, including:

CAAD:	Muncher + Mancala + Target + Life 7K	£6
CAAE:	Galaxian 12K	£8
CAAF:	Chess 12K	£9
CAAG:	Invaders 12K	£8
CAAH:	747 12K	£8
CAAI:	Backgammon 7K	£7
CAAJ:	Labyrinth 12K + FP	£7
	(CAAE-J from Bug-Byte)	

## THE EXPLORER'S GUIDE To The ZX81

The Book for the ZX81 Enthusiast.

By Mike Lord, 120 pages.

Programs for 1K RAM, and programs for 16K RAM. Games, Business and Engineering Applications. RAM & I/O Circuits. Useful ROM Routines. Hints and Tips.

£4.95

## What Can I Do with 1K?

By Roger Valentine. A fresh and original book containing 40 programs and routines for the unexpanded ZX81. £4.95

## The ZX80 Magic Book

\*With 8K ROM/ZX81 Supplement\* £4.75

## Mastering Machine Code on your ZX81

By Toni Baker. 180 pages of immense value to beginner and expert alike. £7.50



ALL PRICES INCLUDE U.K. P & P AND 15% VAT WHERE APPLICABLE. OVERSEAS CUSTOMERS ADD £1.50 CARRIAGE PER ORDER.

TIMEDATA LTD Dept A 57 Swallowdale, Basildon, Essex SS16 5JG Tel: (0268) 411125 (MON-FRI)

# TIMEDATA

## ZX SPECTRUM HARDWARE

### 24 line programmable Input/Output Port

This new port has been designed exclusively for the ZX Spectrum and utilises MOS technology to minimise bus loading.

The main features are:

- 3 x 8 bit ports
- Port mapped using IN and OUT commands
- 3 basic modes of operation
- Direct Bit Set/Reset capability
- Outputs capable of sourcing 1mA at 1.5 volts
- Access via 3 x 16 pin DIL sockets and 28 way edge connector

The port is available fully built together with a set of detailed instructions and suggested control applications. The port can either be used with our new Motherboard thus allowing a further card to be used, or with a stackable connector. Either way, it means that Micro-Drives, Printers etc. will run happily with the port.

ZX Spectrum PPI Port	£16.50
ZX 2 Slot Motherboard	£16.95
ZX Stackable Connector	£5.50

The prices are inclusive of VAT but postage must be added at 70 pence for a single item (100 pence for 2 or more items).

Please note that we shall continue to support the ZX81 and that we also offer a 16 bit port for the 81 based on a Z80A PIO at £15.50 inc.

## KEMPSTON ELECTRONICS

60 Adamson Court, Hillgrounds Road,  
Kempston, Beds MK42 8QZ

## ZX81 Klik-Keyboard

This is a full, forty key, moving keyboard which fits into the recess left after peeling off the existing 'touch-sensitive' keypad. Consider the following advantages:

- Positive feedback from keys
- Fits onto the ZX81
- No trailing wires
- No special case needed
- Elegant design with two colour legends

The fully built keyboard requires *absolutely no soldering* since two flexible connectors plug into the ZX81 sockets. Alternatively, the keyboard is available as an easy to build kit at a considerable saving. Other ZX81 products available include a two-tone keyboard bleeper (fits inside the case) at £8.95 built, and a Repeat key kit at £3.95. Now available with 41 keys, the extra key can be used to give a repeat or reset facility £26.50 (built) £23.00 (kit).

Your Name and Address \_\_\_\_\_

			Date	
Quantity	Description	Unit Price	Amount	
	ZX81 Keyboard Kit	£22.50		
	ZX81 Keyboard Assembled	£26.00		
	ZX81 User I/O Port	£15.50		
	ZX Spectrum PPI Port	£16.50		
	ZX 2 Slot Motherboard	£16.95		
	ZX Stackable Connector	£5.50		
			Sub total	
			Carriage	70
			Total due	

Cheques/P.O. made payable to  
**KEMPSTON ELECTRONICS**  
Please allow 21 days for delivery

# TOMORROW

The 5th Personal Computer World Show this September will be the largest and most exciting microcomputing exhibition ever held in the UK.

There will be over 25,000 square feet of display space in the newest and most prestigious exhibition venue in the country.

It's the only micro computing show to offer literally hundreds of stands covering micros for home, business and educational uses. Previous visitors to the PCW Show will get some idea of the size of this year's event if we tell you that it will be approximately *three times* the size of last year's bash! (Last year's show was, in its turn, twice the size of the year before. Statistically minded persons will calculate that at this rate the PCW Show will cover the face of the planet by the year 1995.)



Features of The 5th Personal Computer World Show will include a Sinclair City and Acorn/BBC Arcade offering the very latest software and add-ons for these popular machines, computer chess competitions as always, and an opportunity for you to challenge a micro to a game of Computer SCRABBLE®.

From the business angle there's free consultancy with the National Computer Centre and more

The 5th  
**Personal  
Computer**  
World  
Show

**50p**

**DISCOUNT VOUCHER**

This voucher is worth 50p off the price of admission to the PCW Show. Only one voucher valid for each visitor. Not exchangeable for cash.

# THE WORLD!

# 5th Annual Personal Computer World Show

but if you bring along a coupon from PCW it's only £2.00 per person.

If you're a business user (or potential user) of microcomputers just write with your cheque for £2.00 (payable to the Personal Computer World Show) to Tim Collins, PCW Show, 11 Manchester Square, London W1, enclosing your business card. We'll send you a special 'Fast Lane' ticket to save you the trouble of queuing.

It really is going to be a great show with a tremendous variety of machines and software on display. Be warned, you'll need to make a day of it (remember we're open four days this year, not three as in previous years) so give yourself plenty of time and wear comfortable shoes! See you there. . .

demonstration machines and business software than you could get to see in a year at your own office. But you needn't risk divorce to evaluate them. . . your wife (or husband!) and the kids can be looking at the vast array of home and educational micros in one of the other halls. It's £2.50 to get in

**BARBICAN CENTRE,  
CITY OF LONDON  
9-12 September 1982**

© SCRABBLE is the copyright of J W Spear & Sons plc, Enfield.

# CUT-PRICE COMPANIONS

*"Far and away the best" — Your Computer magazine*

**THE ZX81 COMPANION** by Bob Maunder is now available at **ONLY £4.95** with a **FREE SUPPLEMENT** on the ZX Spectrum! This offer ends on 30 September, so hurry!

LINSAC is also producing a **SPECTRUM COMPANION** series, and the first title. 'The Spectrum Games companion' is available from October at £5.95.

The above prices include UK postage. Send cheques to:

**LINSAC** LINSAC (YC),  
68 Barker Road,  
Middlesbrough TS5 5ES.

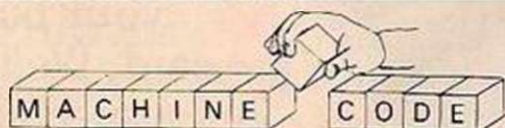

ZX Spectrum — ZX81

In 1981, ACS Software published ACSEMBLER and DIS-ACSEM. These are now generally regarded as quite simply the best assembler and disassembler programs available for the ZX81.

*"The disassembler... is really fantastic."* A.M., London  
*"I am very pleased with the assembler and I feel that you have a real winner in this program."* R.B., Gloucester  
*Your programs are first class. Looking forward to more."* A.J., Norway.

*"... the single biggest step to proficiency in machine code programming."* SINCLAIR USER

Now, with the superior facilities of the ZX Spectrum, ACS Software have done it again. **Ultraviolet** and **Infrared** are assembler and disassembler programs that will extend your Spectrum. Look at the facilities that Ultraviolet offers:

Works entirely in decimal (no hex problems); all Z80 instructions correctly assembled; supports the pseudo-instructions EQU, ORG (multiple ORGs allowed), DEFB, DEFW and DEFS; code can be assembled at one location and then re-located; allows alphanumeric labels of any length; full listings of assembled code and mnemonics can be output to the printer; full error trapping with faulty instruction clearly indicated; comments can be included in the source file.

So now there is no need to be intimidated by machine code - with Ultraviolet and Infrared it's child's play! Buy them from the machine code specialists - ACS Software.

**ULTRAVIOLET - £7.50      INFRARED - £6.75**

The following programming aids are available for the 16K ZX81 at £5.50 each. SAE for details. Prices include postage and packing for UK orders, overseas clients please add appropriate postage.

ACSEMBLER: DIS-ACSEM: ACS DEBUG: PROGSTORE: TOOLKIT:  
PROGMERGE (version 2): TAPEKIT  
PROGMERGE and TAPEKIT won't make a Spectrum out of your ZX81 but they will give it some interesting new facilities!



**ACS SOFTWARE** 7, Lidgett Crescent,  
Roundhay,  
Leeds LS8 1HN

## ZX81 Software Business Software 16k & 32k

**BUSINESS BANK ACCOUNT** This program enables you to make debits under 11 subheadings. The search facility will enable you to list & total all payments to one supplier, or all payments from one client. You can also list all entries under one subheading. The statements include totals of all your subheadings.

**PURCHASE DAY BOOK** Keeps a complete record of all your purchases under 11 subheadings. The search facility will enable you to list & total all invoices from one supplier, or all entries under one subheading. The program will also calculate & deduct VAT.

**SALES DAY BOOK** For all your invoices. This program can be used to prepare statements for your clients of outstanding invoices. The search facility will enable you to list & total all invoices to one client. The program will also calculate VAT.

All programs will accept entries up to £99999.99. It will also enable you to prepare accounts for both VAT returns & your accountant. Programs can also be used by companies not registered for VAT.

16k Programs accept 150 entries .....£8.75  
32k Programs accept 440 entries .....£10.75

Special 16k Pack including all 3 programs .....£25.00  
Special 32k Pack including all 3 programs .....£30.00

**QUARTERLY ANALYSIS** for all your Purchase, Sales and Bank Account totals  
£4.75

## 32k Memory ..... £49.95

We now have available the new MEMOTECH 32k Memory for use with our programs.

**TRANSFORM LTD.** For details send S.A.E. to  
41, Keats House, Porchester Mead, Beckenham, Kent.  
01-658 1661 Callers welcome by appointment.

All prices includes VAT Post & Packaging.

**TRANSFORM LTD.**

# PUT YOUR MICRO TO WORK!



YOUR MACHINE

## CONTROL MACHINES, ROBOTS, FACTORY OR HOME

Have you ever wanted your MICRO to control a machine for you, or manage your house? If so, the MDR 'MICROCOMPUTER CONTROL INTERFACE' will give you isolated channels of OUTPUT (8A @ 250 volts) and switch sensing INPUTS.

Available now for connection to PET USER, PORT, RS232 and IEEE488, allowing expansion up to more than 900 channels.

Supplied complete with connecting cables, full data and guarantee from £12.54 per channel. Complete preprogrammed systems or individual components available. Write or phone for details.

### MDR (INTERFACES) LTD.

Little Bridge House, Dane Hill,  
Nr. Haywards Heath, Sussex RH17 7JD.  
Telephone: 0825-790294.

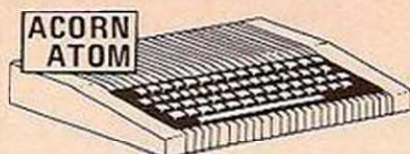

# VIC-20

	£		£
ATOM 8K + 2K Kit	119.00	VIC-20 CPU	150.00
ATOM 8K + 2K Assy.	149.00	VIC-20 C2N Cassette	34.00
ATOM 8K + 12K Assy.	170.00	VIC Printer	187.00
ATOM 12K + 12K Assy.	199.00	VIC Floppy Drive	304.00
ATOM Power Supply	8.00	VIC Memory Exp. Board	98.00
ATOM Econet	70.00	VIC 3K RAM Cartridge	23.50
ATOM Eprom		VIC 8K RAM Cartridge	35.00
Programmer	40.00	VIC 16K RAM Cartridge	56.50
Prog. Power Toolbox	24.50	VIC Programmer's Aid Cart.	27.00
ATOM Disc Pack	275.00	VIC Super Exp. High Res.	27.00
ATOM-BBC ROM	43.00	VIC Machine Code Cart.	27.00
2114L RAM	0.89	VIC Joystick	6.50
*10% off Acorn & Bug-Byte ATOM Software		*10% off VIC Tapes and Games Cartridges	

### PERIPHERALS

Printers (Atom or B.B.C.)

MX80T	290.00
MX80T/3	299.00
MX80FT/3	340.00
MX82	330.00
MX82FT	362.00
MX100/3	440.00
GP 80	185.00
BBC or ATOM Jumper	15.00
Monitors (B.B.C.)	
BMC	240.00
Microvitec	260.00
FP Rom	19.00

### B.B.C.

A - B Expansion + Test	90.00
Part Expansion (32K RAM + Printer I/face) + Test	46.00
RAM Expansion Kit	26.00
Printer Interface Kit	9.83
Bus Expansion Kit	8.65
Analogue Input Kit	9.90
* Please Add 15% V.A.T *	
* Orders Over £20 Post Free *	
* Orders Under £20 Add 50p. Postage *	
Analogue joysticks per pair	19.50

Books & Software — Spares and Repair Service  
Send for Stock/Price Lists

D.A. Computers Ltd.

184, London Road, Leicester, LE2 1ND.  
Telephone (0533) 549407

## THE BUFFER MICRO SHOP (NEXT TO STREATHAM STATION)

NEW SOFTWARE SHOP EXCLUSIVELY FOR

# ZX81

PROGRAMS, GAMES, "ADD-ONS"

MOST OF THE MAIL ORDER ITEMS ADVERTISED IN THIS MAGAZINE AVAILABLE OVER THE COUNTER

LOADING PROBLEMS? TRY OUR INTERFACE BUSINESS & TECHNICAL DATA HANDLING PROGS; PROPER KEYBOARDS; CONSOLES; VDUs

The BUFFER Micro Shop,  
374a Streatham High Road,  
London SW16  
Tel: 01-769 2887

# BBC

SERVICE CENTRE  
OFFICIAL STOCKISTS

We can upgrade your Model A to Model B

Large range of software in stock



ACORN  
OFFICIAL STOCKISTS

In stock — wide range of software

# VIC-20

**BANKRUPT STOCK!**

VIC-20: £170 incl VAT

ALSO SOME MEMORY PERIPHERALS & SOFTWARE  
Few items only — first come, first served!

EPSON FT/2: ONLY £400 incl VAT

Micro Tantel

Turns your TV into a Prestel receiver — or download software form Prestel with your Apple

ONLY £160 incl VAT

Alpha Numeric Tantel

ONLY £200 incl VAT

**anel**

# TWICKENHAM COMPUTER CENTRE LTD

72 Heath Rd Twickenham Middx TW1 4BW (01-892 7896/01-891 1612)

# Scramble

from **MIKRO-GEN**

the leaders  
in ZX games

The high-speed arcade game. Easily the fastest available. 32 zones, thrust and altitude controls.

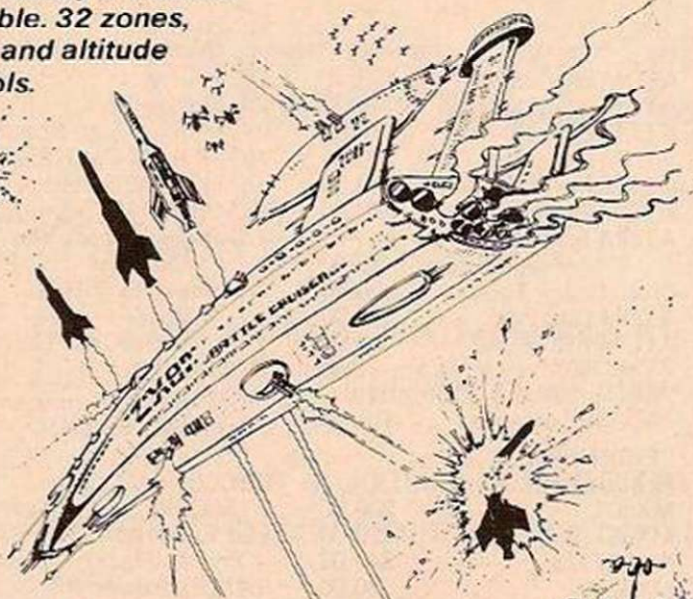

### Other great ZX programs from Mikro-Gen:

Space Invaders ★ Breakout ★ Bomber ★ Frog  
Paxman ★ Sorcerer's Castle ★ DeBug (Disassembler/Monitor)

All on cassette, with library case

**ONLY £3.95 EACH**

Write for full details of the Mikro-Gen range of programs and add-ons, available from local stockists or direct from the manufacturers (please make cheques/PO's payable to Mikro-Gen and add 40p post & packing)

Suppliers of Software to Sinclair

# MIKRO-GEN

24 Agar Crescent Bracknell Berks RG12 2BK Tel: Bracknell (0344) 27317

BRITAIN'S LARGEST SINGLE  
MICRO USER GROUP

# BEEBUG FOR THE BBC MICRO

INDEPENDENT NATIONAL USER  
GROUP FOR THE BBC MICRO

IF YOU OWN A BBC MACHINE, OR HAVE ORDERED ONE, OR ARE JUST THINKING ABOUT GETTING ONE, THEN YOU NEED BEEBUG. BEEBUG runs a regular magazine devoted exclusively to the BBC Micro (10 issues per year). Now 36 pages.

Latest news on the BBC project.

What you should know before you order a machine.

Members' discount scheme on books and hardware.

New program listings, regular advice clinic, and hints and tips pages in each issue.

*April Issue:* 3D Noughts and Crosses, Moon Lander, Ellipse and 3D Surface. Plus articles on Upgrading to Model B, Making Sounds, and Operating System Calls.

*May Issue:* Careers, Bomber, Chords, Spiral and more.

Plus articles on Graphics, Writing Games Programs, and Using the Assembler.

*June Issue:* Mazetrap, Mini Word Processor, Polygon; plus articles on Upgrading, The User Port, TV set and Monitor Review, Graphics Part II, More Assembler Hints, Structuring in BBC Basic, plus BBC Bugs.

July issue (36 pages) Invaders and patchwork programs. Fix for BBC cassette Bugs, Mode 7 explored, User define Keys, Software reviews, High res graphics printout, RS423 receive fix.

### Membership

6 months £4.90

1 year £8.90

Send £1.00 and A4 SAE  
for sample

(Overseas add £1.00 for 6 mths,  
£1.50 for 1 year)

Make cheques to  
BEEBUG

and send to  
BEEBUG, Dept 4,  
374 Wandsworth Rd.,  
London, SW8 4TE.

## Autoram

The sole ZX81 agent for the Arab World is interested in software, publications, add-ons, etc.

**Don't miss this opportunity  
— ACT NOW!**

Send samples of all you have to:

P.O. Box 147, Jeddah,  
Saudi Arabia, Tel: 6604212,  
Telex 402 276 Autoram S.J.

## ZX-FORTH!

- \*FULL FIG-79 STANDARD (NON-DISK)
- \*FASTER THAN BASIC
- \*EASIER THAN MACHINE CODE
- \*SUPPORTS ZX-PRINTER

Forth, for those who are not already converts, is perhaps the closest yet to the ultimate all-purpose computer language. It is designed to be fast, portable and extremely flexible. A FORTH program consists, largely, of definitions of new FORTH words, enabling a user to develop a unique, application oriented, vocabulary. It is even possible to alter the syntax to suit your application (or just your style of program!).

\*TAPE & DOCUMENTATION . . . £10

### GAMES PACKS 1&2

Pack 1 includes: Space Torpedo, Reverse, M/C Life and more.  
Pack 2 includes: Robot chase, Nim, Music, Mini Adventure etc.

### UTILITIES PACK

Enhance your BASIC Programs with this set of useful machine code routines.

GAMES PACKS . . . £6 each

UTILITY PACK . . . £5

\*\*\*COMING SOON\*\*\*

PILOT: the educational language

ALL PRICES INCLUDE VAT & P&P  
QUALITY STACKABLE CASSETTES

## Quasar Computational Paraphernalia

SOFTWARE

11c HERCIES ROAD · UXBRIDGE · MIDDLESEX

# MORE MEMORY FOR MICROS!

look at what we can offer:



**RAMPACKS**  
for SINCLAIR ZX81

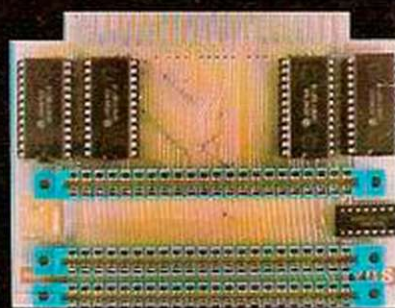

**VCS 8K for VIC**  
8k RAM+3 slots **£44**

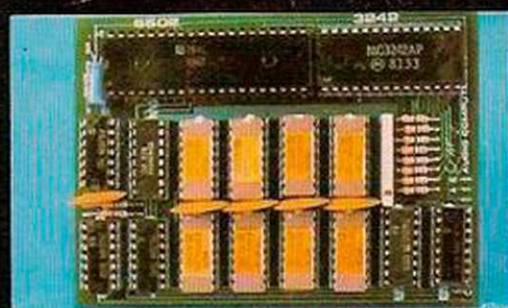

**DUO1 for ATOM**  
64k RAM only **£70**

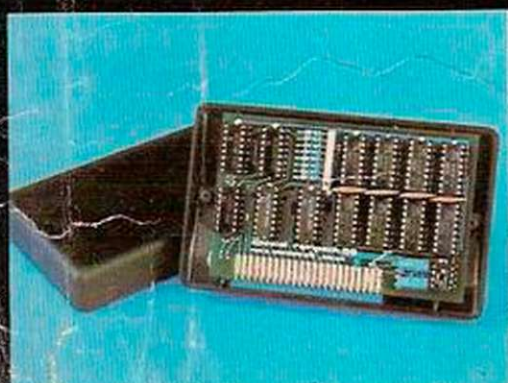

add up to 20k RAM+16k ROM

**16K** - the only upgradable  
to 56k on the market - **£36**

**VCR 20 for VIC**  
4K-£24, 2k increment-£5

**DRC for PET**  
64K-£80 128K-£130

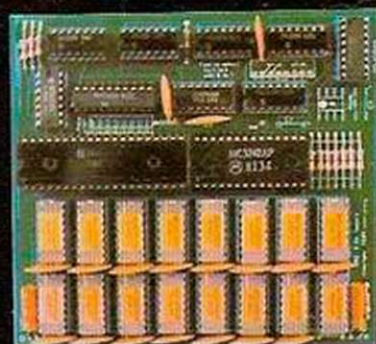

OUT OF STOCK

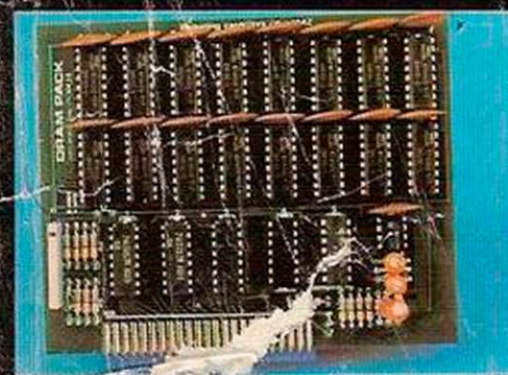

32K bytes - **£29**



32K add on RAM **£46**

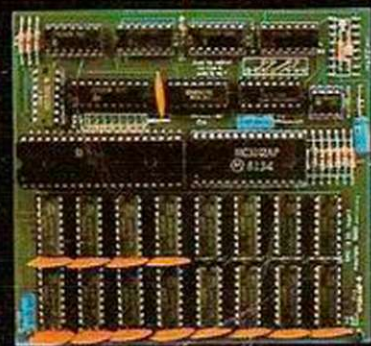

32K add on RAM **£69**

## TRS80-V.GENIE UK101:

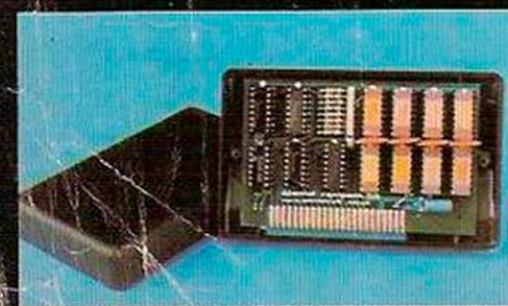

**56K** - exceptional low  
power consumption - **£44.90**



**64K + Eprom programmer &  
user port** - only **£79**

FOR A FREE BROCHURE, RING LINDA OR  
SUE ON SOUTHEND (0702) 613081  
FOR CREDIT CARD ORDERS, RING JACKIE  
OR PAM ON SOUTHEND (0702) 618144

CHEQUES AND P.O.'s TO:

## AUDIO-COMPUTERS

87 BOURNEMOUTH PARK ROAD,  
SOUTHEND ON SEA - ESSEX SS5 2JJ

ALL PRICES INCLUDE V.A.T. AND POSTAGE

TELEX 995337 G AUDCOM

A TRADEMARK OF SOLIDISK LTD.

We can adapt the above products for ZX81 to fit your new Spectrum for just £5 Extra.

106 Midway



# Spectrum Software

## MISSILE COMMANDER AND LUNAR LANDER

**Missile Commander:** defend your city against ICBM's streaming from the heavens, causing a series of multicoloured, noisy explosions. You must also deal with marauding enemy bombers. There are 10 skill levels, and/or on screen score.

**Lunar Lander:** falling towards the lunar surface your lander must be brought to a safe halt on the green moon. A new surface is generated on each run.

PRICE: £5.00

## POLECAT AND BREAKOUT

**Polecat:** A completely original and ingenious maze program in which you are a rabbit and the computer is a Polecat. The action takes place in one of over a million underground mazes. The plot involves the rabbit collecting carrots and bringing them back to his burrow whilst avoiding the attention of the ravenous Polecat.

**Breakout:** See if you can bombard the wall until it falls, whilst trying to keep the ball in motion.

PRICE: £5.00

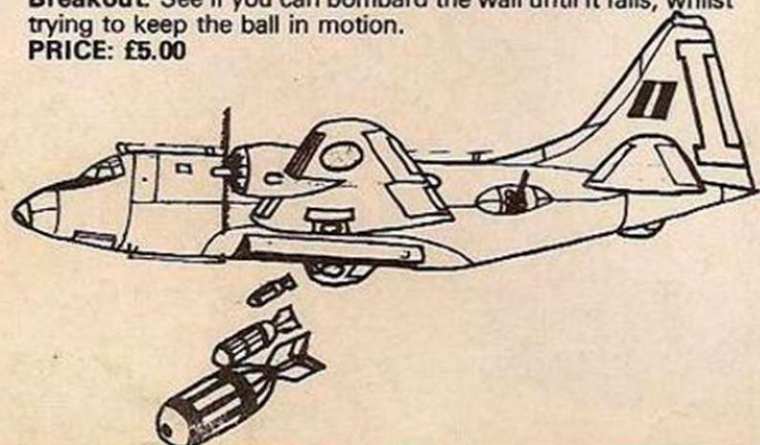

## YOUR SOFTWARE WANTED NOW

WE PAY AUTHORS THE BEST RATES FOR THE BEST SOFTWARE.

## BOMBER AND FRUIT MACHINE

**Bomber:** This fast-action game involves the destruction of cities quickly before you crash into the buildings.

**Fruit Machine:** Similar to the familiar one-armed bandit, with very realist graphics.

PRICE: £5.00

## CRAZY RACE AND SUBHUNT

**Crazy Race:** You are driving around a racing track. How many obstacles can you run over before you crash?

**Subhunt:** You are a helicopter pilot firing down at submarines, destroying them before they destroy you.

PRICE: £5.00

# ZX81 — Software

## ZX VIDEO GAMES

This latest package of software to be released must surely be the most amazing available in the world. It features on one cassette all the fast action machine code games that other companies would sell for £5.00 each, but we are able to bring you all the following Machine Code Arcade games for that price. Not only are they excellent value for money but they are of the finest quality available for the ZX81. ZXVG contains:

### UFO BOMBER

You are on a mission to destroy enemy fuel pumps and installations, eight directions of movement through caves, fuel dumps and over rocky lunar terrain. You drop smart bombs and can strafe with your gun that fires streaming laser shells. This game is completely addictive, and gives you on screen and Hi scores.

### SPACE INVADERS

This is not our "version", this is just like the real thing, with four types of crawling invaders, defences that crumble as they are hit, UFO's for extra scores, Onscreen scoring and Hi scores. This game is brilliant!

### GALAXIANS

Wave after wave of sweeping invaders drop their bombs at you. Your only hope is to dodge and destroy them. This is a most addictive game, and we guarantee that this game will make your ZX81 really come to life.

This game pack contains some other exciting machine code games, but you'll have to get a copy to find out what they are!

We absolutely guarantee that this will be the best value pack of video games software you have ever had, for quantity and quality. To make sure, just ask someone who has had this pack, enquire at your local computer shop, or send off for it to us.

## NEW SHOWROOM NOW OPEN

830, HYDE RD, GORTON, MANCHESTER.  
MAIL ORDER DEPT TO CONTROL TECHNOLOGY  
39, GLOUCESTER RD, GEE CROSS, HYDE,  
CHESHIRE SK14 5JE.

(061-368 7558)

ALL PRICES INCLUDE VAT AND P&P.



## ZX BUSINESS SYSTEM

Now installed in many businesses, comes with PURCHASE, SALES LEDGER for 100+ entries per week, does daybook analysis, VAT incl. and excl., totals, password protection plus many more excellent features. You also get a STOCK CONTROL, MAIL LIST and PHONEBOOK. Easy to use, designed for everyday small businesses. Includes instruction book and tape. £17.00 incl. VAT. And does the job of systems costing hundreds of pounds.

## 16K PACK 123

Pack 1, 2 & 3 include all of:

**AIR TRAFFIC CONTROL:** Animated radar screen of busy airport shown. You must bring planes into land; **INVADERS SELFPLAY:** PHONEBOOK — keep friends' and relatives numbers on cassette. **COMPUTER DATING,** who will it pick for you and those around you for a laugh. **ADVENTURE ATLANTIC:** you may become very rich or marooned forever. **BREAKOUT:** **SQUASH:** **LANGUAGE TRANSLATOR:** translates any European language to any other. **COMPUTAPUNT:** predict horse races and football pools with you ZX. **INDISCO,** video roadracer. **DRAUGHTS** computer chequers, with kings. **BATTLESHIPS,** nautical naval battle at home. **MASTERMIND:** brain teaser, see if you can beat a microelectronic mind.

THIS MASSIVE PACK OF SOFTWARE IS ONLY £5.00

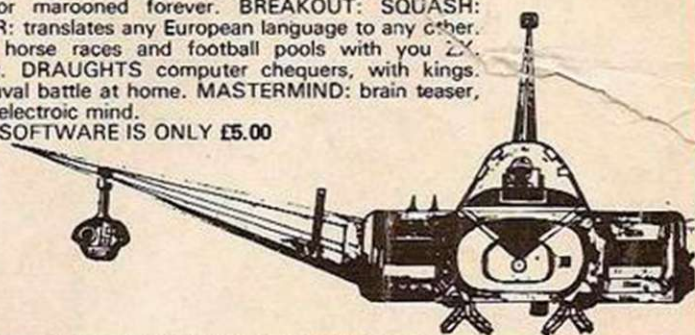

Please send me as soon as possible the following:

\_\_\_\_\_ £ \_\_\_\_\_

\_\_\_\_\_ £ \_\_\_\_\_

I enclose a Cheque/P.O. for the total £ \_\_\_\_\_

NAME \_\_\_\_\_

ADDRESS \_\_\_\_\_

POSTCODE \_\_\_\_\_