

Toshiba and
Einstein reviews

YOUR

COMPUTER

SEPTEMBER 1984

BRITAIN'S BIGGEST-SELLING HOME COMPUTER MAGAZINE

Vol. 4 No. 9

85p

HOW FRANKIE GETS TO HOLLYWOOD

Music and micros: two tribes in harmony

Spectrum Manic Climber

ZX-81 Sprites

CBM-64 Bullion

BBC Backgammon

Amstrad Sky Drop

Hell's Bells and Filing for Dragon

Vic Robot Attack

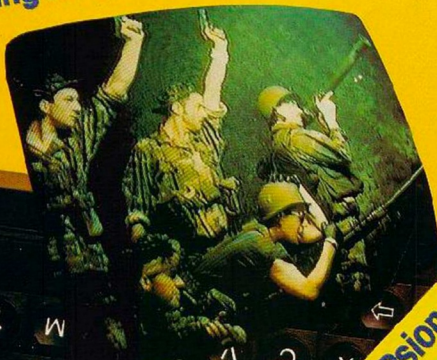

Three Psion Organisers
up for grabs

KOKOTONI WILF



'Kokotoni Wilf is an arcade adventure whose undisguised intention is to steal the title of "best arcade adventure program bar none" from Jet Set Willy.'

As Kokotoni Wilf you must recover all the pieces of the legendary Dragon Amulet (which has been scattered throughout time) for your master the great magician, Ulrich.

Throughout the quest Wilf comes up against many dangers from huge lumbering prehistoric dinosaurs, to hostile alien robots, but the reward for recovering all the pieces warrants the risk.

The 48K program features a number of major advances over Jet Set Willy. The games designer, Elite, stresses that each of the games 60 plus screen settings is genuinely high resolution, as opposed to pseudo hi-res, and doesn't require a title to explain what you're looking at. Furthermore, the sprite characters are of cartoon quality and exhibit their own personalities. Impressive claims. Jet Set Willy fans will no doubt feel both sceptical and intrigued.....

Watch this space!

48K Spectrum and Commodore 64
available Sat. 15th September.

elite

YOUR COMPUTER

Contents

SEPTEMBER 1984

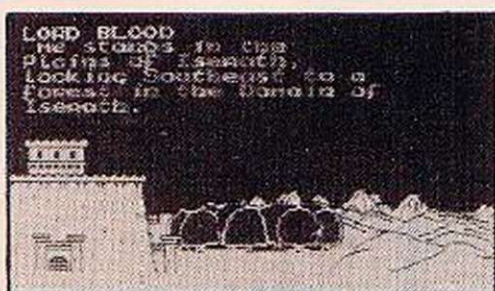

Software shortlist — page 43.



Toshiba HX-10 review — page 48.



Music hardware — page 65.

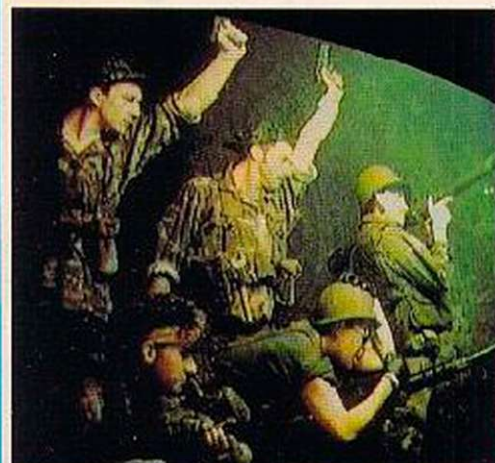

Frankie in Hollywood — page 75.

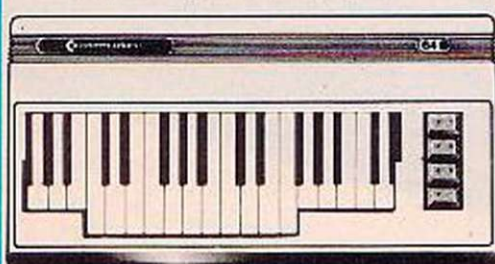

Musik 64 — page 80.

- 42 EDITORIAL AND YOUR LETTERS:** The man who got his money back from Oric, the man who urges us to go easy on the QL and multifarious tips.
- 34 NEWS:** Stranglers' adventure game album, Sega SC3000 computer, the search for the Enterprise and cricket for Iceland.
- 37 VIC-20BYTES:** The art of structured programming: micro intelligence. **41 COMPUTER CLUB:** To be or not to be? Paul Bond in Stratford-on-Avon.
- 43 SOFTWARE SHORTLIST:** Taste the rightlife with the Arabian Nights, the Lords of Midnight, and Bozo's Night Out. Play tennis or join the evil dead.
- 47 QUEST CORNER:** Regular feature on adventure games. **48 TOSHIBA HX-10 REVIEW:** The tip of the MSX iceberg.
- 50 COMPETITION CORNER:** Your chance to get organised. This month's exciting conundrum could win you the new box of tricks from Psion.
- 52 TATUNG EINSTEIN REVIEW:** Built-in disc drive alleged CP/M compatibility, OK memory. Bill Bennett decides if this machine is relatively good.
- 57 PSION ORGANISER:** Kathleen Peel tries Psion's first hardware. **60 BBC SOFTWARE:** Jim Taylor turns on and tunes in.
- 65 ELECTRONIC MUSIC AND HOME COMPUTERS:** At last a concise explanation of the basics of music synthesis. Kendall Wrightson looks at musical hardware.
- 70 BBC KEYBOARD:** You could construct your own keyboard, but you don't have to in order to use this Richard Hines program.
- 75 HOW FRANKIE GETS TO HOLLYWOOD:** Tribes and chips. **77 MUSIC SOFTWARE:** Stuart Kelling plays the field.
- 80 MUSIK 64:** Aural sprites? Graham Barbour provides easy to use sound commands for your Commodore 64.
- 85 DRAGON DISCO:** Synchronised strobe simulation with Ron Gardler. **88 MANIC CLIMBER:** H C Derelli drives your Spectrum up the wall.
- 90 MAD JUMP:** Put some bounce back into your Oric or Atmos programming with Matthias Gyllerup's top-happy game of skill.
- 92 ZX-81 BARREL BARRAGE:** Hard task to pass the casks. **96 VIC-20 ROBOT ATTACK:** David Hodgetts shows you how to defend.
- 100 HELLS BELLS:** If your Dragon's got the hump this will soon put it right. Drew Marshall's program about the dangers of campanology.
- 107 AMSTRAD SKYDROP:** Sandwiched between the acid clouds and the acid sea, drop bombs without being laser-sliced. And you thought acid rain was bad.
- 108 CBM-64 BULLION:** Grab the gold, dodge the droids with R Dunk. **114 BBC BACKGAMMON:** Keith Miles makes the first move.
- 116 ZX-81 SPRITES:** 256 sprites! Make them bounce back or wrap around the screen! They appear above, below or at the same level as other characters. Malachy Devlin.
- 120 HULK:** John Dawson looks at a quasi-expert system for the BBC. **125 TEXT COMPRESSION:** Alan Tobias squeezes more in.
- 131 MICRODRIVE FILE:** Kathleen Peel continues this series on applications for the revolutionary new Sinclair storage device.
- 135 DRAGON FILES:** Bernard Hammel re-opens the case on Dragon 32 file storage capacity. Harnesses the speed of machine code, providing sophisticated databases.
- 141 EXTENDED BASIC FOR THE ZX SPECTRUM:** Robert Newsman gives the Spectrum extra commands without recourse to Interface 1.
- 147 RESPONSE FRAME:** Tim Hartnell tries to help you. **149 SOFTWARE FILE:** Ten pages of software for most micros.
- 166 COMPETITION RESULTS:** who won the CPC-464? **193 DATABASE:** Paul Bond lists computer events.

The computer system that won't give you any arguments at home.



£239

Computer complete with green screen VDU (GT64)

£349

Computer complete with colour monitor (CTM640)

CPC 464
complete
with
monitor
and
datacorder



It's eight in the evening. The weekly soap is about to start on the box. And you're in the middle of a program.

Either way, there's going to be trouble.

The new CPC464 gets round the problem very neatly.

It comes complete with its own colour monitor or green screen VDU. Yet it costs around half the price of a comparable home micro system.

That's not all. As well as the monitor, the CPC464 includes a built-in cassette data recorder, 64K of RAM (42K available), 32K of ROM, typewriter style keyboard and a very fast extended BASIC.

And it comes complete and ready-to-go. Just plug it in.

High resolution graphics. Stereo sound.

The quality of the graphics on the CPC464 screen beats the micro/domestic TV combination out of sight.

That's because our monitor drives each colour on the screen directly from the computer. Nothing gets in the way of the best possible picture. And you won't have tuning problems.

It sounds good, too. Especially when you feed the 3-voice, 7-octave stereo output through a hi-fi amplifier and speakers.

64K RAM.

With 64K of RAM there's plenty of room for sophisticated and complex programs.

Over 42K is available to users thanks to the implementation of ROM overlay techniques.



Pound for pound, other micros simply can't match the CPC464's memory.

Amsoft. Exciting software range.

Arcade games, educational programs and business applications are all designed to utilise the CPC464's impressive graphics, sound and processing abilities.

A rapidly expanding range of programs is already available. High quality software that takes advantage of the CPC464's high specification and speed-loading capability. Which means even complex programs can be loaded quickly.



Amstrad. Join the Club.

The CPC464 User Club is run by Amsoft, our software division, which provides software, peripherals and publications for members.

As a member, you'll enjoy immediate benefits like the privilege card, Club binder, regular magazine, competitions for valuable prizes and contact with other Amstrad users.

Whether you're a games fanatic or interested in serious commercial applications, you'll want to join the Club.



BOOTS COMET Dixons
Menzies RUMBELOWS AND OTHER
COMPUTER STORES



CPC464 green screen VDU (GT64)

Green screen VDU.

Perfect for data management with high resolution screen, 80 column text display and up to 8 text windows.

An optional power supply and modulator (MP-1) is available for use with a colour TV.

CPC464. Unlimited scope for expansion.

We're with you all the way. That's why there's a built-in parallel printer interface. A low cost optional disk drive system including CP/M* and LOGO. A joystick port. And the virtually unlimited potential of the Z80 data bus with sideways ROM support.



Optional disk drive DDI-1 including interface CP/M* and LOGO £199.95

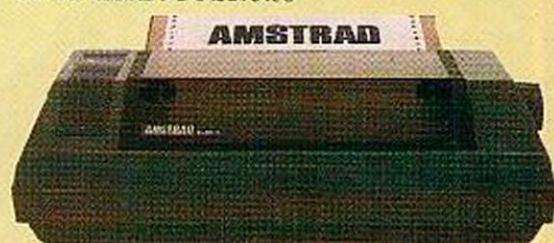

Optional 80 column dot matrix printer DMP-1. Offers high performance computerised text processing for only £199.95.

AMSTRAD

ONE GREAT IDEA AFTER ANOTHER

*Trade mark Digital Research

I'd like to know more about the incredible CPC464 complete computer system. Please send literature right away.

NAME

ADDRESS

POSTCODE

YC 1

To: Amstrad Consumer Electronics plc, Brentwood House, 169 King's Road, Brentwood, Essex CM14 4EF. Tel: Brentwood (0277) 228388.



Peripheral perfection

JOYSTICK INTERFACE



For ZX Spectrum

No more fumbling with the game control keys, now you can have joystick control on the ZX Spectrum. The Kempston joystick interface allows all joysticks in the Kempston range (and others that are Atari compatible) to be used with the Spectrum. Simply plugs into the edge connector. No modifications necessary.

ONLY £11.50

PRO JOYSTICK INTERFACE

NEW

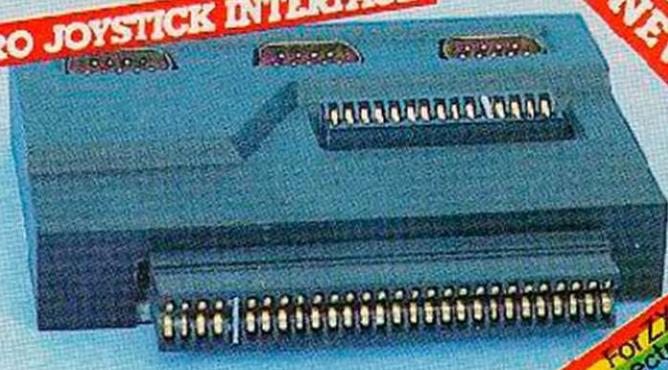

For ZX Spectrum

Compatible with ZX Interface 1 the Pro-Interface has three 9-way D Sockets. Two of the sockets allow compatibility with Sinclair Psion software whilst the third offers the dual facility of both Kempston joystick software and cursor key software. The Pro-Interface also features a cartridge slot for ROM based software.

ONLY £19.95

JOYSTICK PRO 3000



Maximum arcade quality features at a reasonable price. Features: Top fire button for one handed thumb control Trigger button for one handed index finger control Base fire bar for left or right handed control 8-way arcade quality leaf switches Rubber return action 1.5 metre cable. Commodore and Atari compatible. See joystick interface for Spectrum compatibility.

ONLY £12.75

RS 232 INTERFACE

NEW



For ZX Spectrum

At last an RS 232 interface for the ZX Spectrum allowing connection to any printer which follows the RS 232 protocol. The interface has its own EPROM, allowing the use of keywords LLIST, LPRINT and COPY. We recommend the Brother EP44 Printer for use with this interface. Interface complete with cable and connector.

ONLY £45.00

JOYSTICK PRO 5000



The ultimate joystick for the home computer. Features: Ergonomic design and nylon covered steel shaft 8-way arcade quality leaf switches Dual fire buttons for left or right handed play Rubber return action for smoothness 1.5 metre cable. Commodore and Atari compatible. See joystick interface for Spectrum compatibility.

ONLY £13.50

CENTRONICS INTERFACES MODELS E&S



For ZX Spectrum

The Kempston centronics interface will allow you to utilise a vast range of printers with an industry standard centronics input port on the ZX Spectrum. Interface E has all operating commands held in an EPROM, so plug in and its ready to use. ONLY £49.99 Interface S offering similar features as above but software routines are provided separately to initialise the interface before use. ONLY £35.00

KEMPSTON

MICRO ELECTRONICS LTD

Full details on all our products are available on request. S.A.E please. Most products are available from WH Smith, Boots, Spectrum Computer Centres, good computer shops or direct. All prices include VAT and P & P. Please allow 21 days for delivery.

Kempston Micro Electronics Ltd, Singer Way, Woburn Road Industrial Estate, Kempston, Bedford MK42 7AF. Tel: (0234) 856633 Telex: 826078 KEMPMI G

Trade Enquiries Welcome



DON'T MISS THE MAGNIFICENT SEVENTH

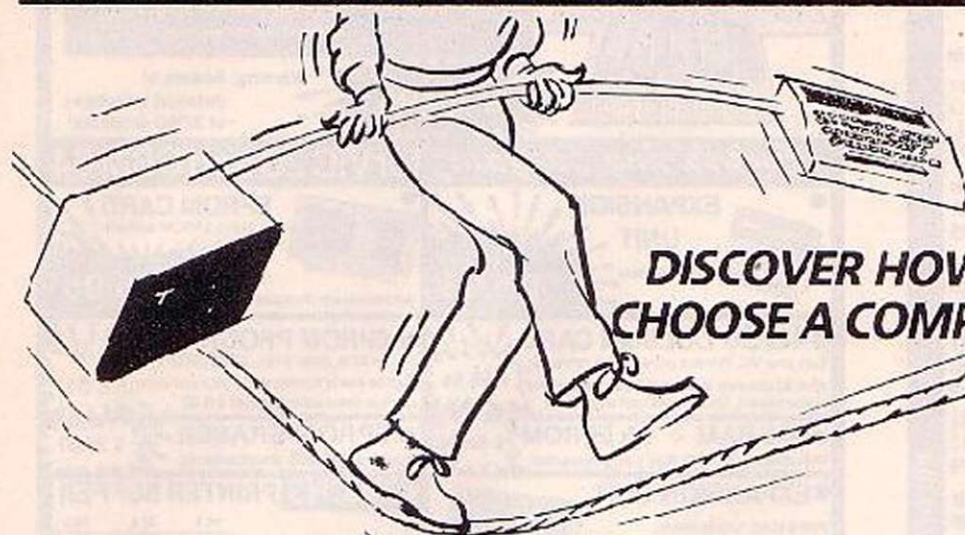

DISCOVER HOW TO
CHOOSE A COMPUTER



GET A BALANCED
VIEW ON COMPUTERS



CONSIDER ALL THE OPTIONS



AVOID TAKING RISKS IN THE
COMPUTER JUNGLE



If you're really interested in the world of micro-computers there's only one place to be in September. The most popular micro-computer show in the world. The 7th Personal Computer World Show at Olympia 2 from September 20th to the 23rd.

Mingle with the giants of the micro world. Find out what's new and up and coming your way. We think you'll profit from the experience.

So if you want to be in the know, you know where to be in September.



September 19th - Trade/Press day only.

The greatest micro show on earth.

TIMES: 10 am-7 pm Thursday-Saturday. 10 am-5 pm Sunday. FEATURES INCLUDE: Business Advisory Centre. The Leading Edge - the latest innovations. BBC Radio Live. Top 20 Games sponsored by Websters. Amateur Computer Club. Top 20 Computer Books. ADMISSION: £3.50 p.p. Business Ticket - on production of business card £3.00 p.p. Group ticket - minimum 10 people £2.50 p.p. Children under 12 £1.50 p.p. Advance tickets available from: P.C.W. Show Ticket Office, 11 Manchester Square, London W1M 5AB. Telephone: 01-486 1951 (cheques payable to Montbuild Ltd). Access and Barclaycard payments welcome.

CAMEL PRODUCTS

EPROM PROGRAMMER

AT LAST! for the Spectrum user. Put your programs, utilities, Assemblers into EPROMs for instant load from the unique ROM-SP.



ROM-SP for Spectrum
 Ingenious unit for Spectrum, with 2 x 28 pin sockets and a Reset button allows up to 16K of Basic or M/C program to RUN or LOAD instantly from EPROMS. Cabled connector and full extender card.
 NOTE: Does not disable Sinclair ROM. £29.95

PROMER-SP for Spectrum
 A brand new Spectrum programmer for 2764/128. Zero insertion force socket & software on tape. £29.95

PROMER-81S for Spectrum
 The very popular FROMER-81 for the ZX81 has been adapted to the Spectrum, and the price kept low. £22.95

ROM-81 for ZX81
 Provides two 24 pin sockets for up to 8K of EPROM memory in the 8-16K area. Can use 2516/32 or 2716/32 £14.95

PROMER-81 for ZX81
 At last! A low cost reliable programmer for 2516/32, 2716/32 EPROMS. Requires 4 x PF3 batteries £19.95

DHIOBI 1 UV ERASER
 Compact. Mains powered. Safe. Fully cased. Up to 3 EPROMS £18.95

PRINT-SP NEW for Spectrum
 Centronics interface with standard centronics cable. Plus free introductory offer, SPWRITE text processor. £31.25

NIKE NEW for Spectrum/ZX81/ATMOS
 Simple to use, rechargeable nickel-cadmium back-up power supply unit providing OVER 30 minutes extra LIFE in the event of mains failure. £17.35

BLOPROM-SP
A uniquely sophisticated EPROM PROGRAMMER

In use at various labs incl. Sinclair
 Eprom programmer for the 251b, 2716/32/32A/64/64A/128/128A, yes even the 64A/128A from Intel. Check, Read, Program + Verify all or part of Eprom.

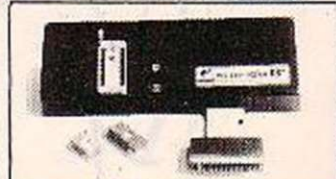

So immensely user friendly you'll hardly need the manual. Designed for the beginner but includes a single key entry route for the professional. Supplied as firmware, the m/c driver routine alone is worth more than the price of BLOPROM-SP. No personality

SAVE NO. OF SYSTEM — 16K
 EPROM TYPE — 2728
 RAM START ADDR — 4000
 EPROMS — 999
 JOB LENGTH — 4999
 TASK — CRICK

WHICH TASK DO YOU WISH TO DO?
 WE CHECK THAT EPROM IS CLEAN
 X READ THE CONTENTS OF EPROM INTO RAM
 Y BLOW AN EPROM WITH DATA FROM RAM
 Z VERIFY THAT EPROM DATA IS THE SAME AS IN RAM
 0 STOP
 1 TO RESTART

FAST CODES AVAILABLE
 D H POR WYZ

Cards, or other additions, just a Spectrum. Several inbuilt safety features. On-board Vpp generation. 28pin ZIF socket. Cabled connector and extender plug. ABS case. £89.95

BLOPROM-81 £70.95
 As above but for ZX81. Programs 2516, 2716/32/32A/64 & 27128.

INTRODUCING MULTEPROM £TBA
 The most economical, sophisticated gang copier in the world. Based on BLOPROM.

CRAMIC-81 £79.95
 16K CMOS RAM with lithium battery to CO-exist in same memory area as ordinary RAM.

MEMIC-81 £29.95
 4K CMOS RAM with lithium battery Easy SAVEing, 10yr storage and instant retrieval of programs.

DREAM-81 £59.95
 64K Rampack with link options to disable 0-8-16K. Plus EPROM socket for 2716, 2732/2764 and 27128. In an ABS case with an LED indicator.



PRINTER/MONITOR ACCESSORIES
 MSB Monitor Stand for BBC. 17" x 12" x 3.75".

P&P £3.50 £19.95
 PSS Standard printer stands for OKI, Epson etc. 15" x 12" x 4.5".
 P + P £3.50 £16.95

PSC-3 for Epson MX-100 etc. £22.95
 POT Printer Output Tray for etc. 21" x 14" x 3.75" 11" fanfold paper P&P £3.50
 P&P £3.50 £16.95



UK. VAT extra. No VAT on exports P + P UK. Free. Europe +5% — overseas + 10% TLX 815/4 CML

Cambridge Microelectronics Ltd. One Millip Rd. Cambridge CB4 3JY Tel: 02231 31481

SPECIAL OFFER for CBM 64

80-COLUMN/GRAFFICCARD

- Digital clock
- Mixpossibility of 80-column screen with Hires CBM64-screen (also in colour)
- Grafc pictures; can be switched to background
- Upper line can be locked (for comments etc.)
- Adjustable line spacing for greater clarity on text screens

FREE ADDED! : Sophisticated Wordprocessor with extended manual

£ 59.95

* Warning: Beware of (inferior) imitations of ZERO-products!

...Surprising Bargains for VIC20 and CBM 64

| | |
|--|---|
| <p>EXPANSION UNIT with 2 slots £ 5.95</p> | <p>EPROM CARD two 2Kx4K EPROM sockets. Addresses are changeable. £ 5.95</p> |
| <p>40/80 COLUMN CARD Turn your VIC20 into a professional computer. 40 x 80 columns instead of 32, very sharp and stable picture. Try it out without obligation! £ 55.95</p> | <p>EPROM PROGRAMMER for 2716, 2732, 2764, 27128, 2532 EPROMS Can be easily connected to your computer. Control software in EPROM £ 6.50 £ 31</p> |
| <p>64 k RAM + 2 k EPROM With software for RAM files. Easily connected. £ 55.95</p> | <p>EPROM-ERASER Erases 4 EPROMS simultaneously £ 26.50</p> |
| <p>EXPANSION UNIT With 5 slots, fully buffered, switches for deselection slots, and on-board power supply. VIC 20 £ 29.95 * CBM64 £ 36.95</p> | <p>MACH3 PRINTER BUFFER 16k 32k 48k par. input - par. output £ 86 £ 98 £ 109 serial input - par. output £ 94 £ 109 £ 123</p> |

for all our products: Dealer inquiries invited!

zero ELECTRONICS

149 KINGSTREET + GT. YARMOUTH NR30 2PA + TEL: (0493) - 2023 (NASH HOUSE)

- All prices exclude VAT. Shipping costs £ 1.50
- Supplier to schools, universities and government departments.
- We have good documentation of all our products, free of charge.
- All equipment can be tried out without obligation: if returned undamaged within 10 days, you only pay postage and packing costs.

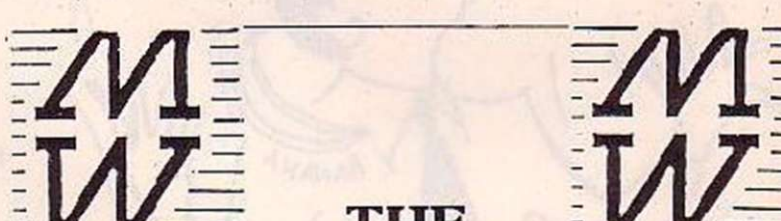

THE MICRO WORKSHOP
MICRO COMPUTER SPECIALISTS

(Spectrum Group Member)

Software and hardware over the counter for Sinclair Spectrum, ZX-81, BBC., Vic-20, CBM-64, Memotech, Amstrad, etc.

- * COMPUTERS
- * JOYSTICKS
- * KEYBOARDS
- * TAPES
- * RAMPACKS
- * BOOKS
- * DISCS
- * LIGHT PENS
- * COMPONENTS *

Business/Serious Programs available
 Located directly opposite Epsom Main Line Station. Visit us or ring for friendly service. See and try before you buy.

Overseas/Export orders welcome

12 STATION APPROACH
EPSOM, SURREY.
EPSOM 21533

M I C R O P O W E R M I C R O P O W E R M I C R O P O W E R M I C R O P O W E R



LOOKING FOR A HOME COMPUTER? ALL ROADS LEAD TO MICRO POWER

MEMOTECH MTX500

An excellent choice for both the beginner and the Spectrum owner wishing to upgrade.

Features: 32K, Z80A processor, SN76489A sound chip (the same as in the BBC Micro), 256 x 192 graphics resolution, 16 colours, 32 sprites (easily programmed moveable objects to make games writing easier), two Atari-type joystick ports, composite video socket, number pad. Sophisticated utilities to aid programming include built-in Assembler/Disassembler and monitor.

Complete with 5 cassettes including Draughts, Toado and a Head Cleaner.

SPECIAL OFFER!
SPECIAL PRICE £275
£249

MEMOTECH MTX512

This computer has the same specification as the MTX500, but has 64K RAM (Random Access Memory).

SPECIAL OFFER!
SPECIAL PRICE £345
£299

COMMODORE 64 PLUS COMPATIBLE CASSETTE RECORDER

Features: 64K, Microsoft BASIC, 16 colours, 8 multi-coloured sprites, sound synthesiser (producing the best sound on any micro), 320 x 200 graphics resolution, four function keys, two Atari-type joystick ports, cartridge slot, parallel printer interface.

SPECIAL OFFER!
SPECIAL PRICE £268.95
£229.95

CASSETTE RECORDERS

(All Recorders have an integral index counter.)

| | |
|--|--------|
| Acorn Recorder (including leads) | £35.00 |
| Morwood Recorder (including leads) | £29.95 |
| Sanyo DR101 Recorder | £39.00 |
| Leads for above | £3.50 |

MAIL ORDER ADDRESS:
DEPT. Y09
MICRO POWER LTD.
SHEEPSCAR HOUSE
SHEEPSCAR STREET SOUTH
LEEDS LS7 1AD
Tel: (0532) 434006

SHOWROOM ADDRESS:
MICRO POWER LTD.
NORTHWOOD HOUSE
NORTH STREET
LFFDS LS7 2AA
Tel: (0532) 458800

M I C R O
P O W E R



BBC MODEL B PLUS CASSETTE RECORDER AND 5 MICRO POWER OR SELECTED ACORN SOFTWARE TAPES

Features: 32K, BBC BASIC (the fastest on any home computer), 8 display modes, 16 colours, 640 x 256 high resolution graphics, 3 voice sound plus noise channel, RS423 and Centronics printer interfaces, joystick port, built-in Assembler, 10 user definable function keys. Complete with a 16 program cassette and 512 page User Guide.

SPECIAL OFFER!
£399

ACORN ELECTRON PLUS CASSETTE RECORDER OR 5 MICRO POWER TAPES

The scaled down version of the BBC Micro. Features: BBC BASIC, 32K, 7 display modes (including 80 column text mode and 640 x 256 graphics resolution), 16 colours, 9 octave sound plus noise channel, built-in Assembler. Complete with an Introductory Cassette containing 16 programs, a User Guide, and a book: "Start Programming on the Electron".

SPECIAL OFFER!
£199

SANYO GREEN SCREEN MONITOR DM2112 £74.95

PRICES CORRECT AT TIME OF GOING TO PRESS. ALL PRICES INCLUSIVE OF VAT. HIRE PURCHASE AVAILABLE. PLEASE CONTACT US FOR FURTHER DETAILS. CARRIAGE FREE FOR BBC AND MEMOTECH. ALL OTHER COMPUTERS £5.00.

U.K. MAINLAND ONLY. AMPLE FREE PARKING!

We also stock a wide range of printers, monitors, disk drives, joysticks, light pens, books, software and much more! Please send for our complete list.



M I C R O P O W E R M I C R O P O W E R M I C R O P O W E R M I C R O P O W E R

MEMOTECH BBC CBM64 SPECTRUM ORIC1 LYNX NASCOM ATARI

Trapped in a fiendish Level 9 Adventure?
Your lamp burning low? Every exit guarded?

You need escape plans! Send for one of Level 9's great new clue sheets for help. The clue sheets are free and each answers hundreds of questions: follow the instructions supplied with your adventure to get one. (Don't forget to send a stamped self-addressed envelope and tell us which game you have.)

NEW REVIEWS: "Level 9 are fast establishing a name for themselves among computer adventurers as the Number 1 producers of quality adventure software. All their adventures are text only, but because of a special coding they have developed, the amount of description and the number of locations packed in 32K is truly amazing."

— Midweek, 10 May 84

"Quicksilver call themselves the 'Game Lords'. That might be open to argument. But there can be no doubt that Pete Austin and the team at Level 9 are the 'Lords of Adventure'."

— Central Press Features, April 84

"Play Lords of Time and get nine times the pleasure!"

— Your Computer, May 84

AVAILABLE FROM: WH Smith and good computer shops nationwide.

If your local dealer doesn't stock Level 9 adventures yet, ask him to contact us or: Centresoft, Drake Distribution, Farranti & Craig, Hi-Tech, Lime Tree, Microdeal, R&R or Wonderbridge.

Level 9 Computing

Colossal Adventure: the original mainframe adventure with 70 extra locations

Adventure Quest: an epic journey across the weird landscape of Middle Earth

Dungeon Adventure: a truly massive game which completes the Middle Earth Trilogy

Snowball: could this be the biggest SF adventure in the world?

Lords of Time: an imaginative romp through World History

I ENCLOSE A CHEQUE/PO FOR £9.90 EACH

My name:

My address:

My micro is a:
(one of those listed on the arch above, with at least 32K of memory).

Contact:

LEVEL 9 COMPUTING

Dept. 7, 229, Hughenden Road
High Wycombe, Bucks. HP13 5PG
Telephone: (0494) 26871

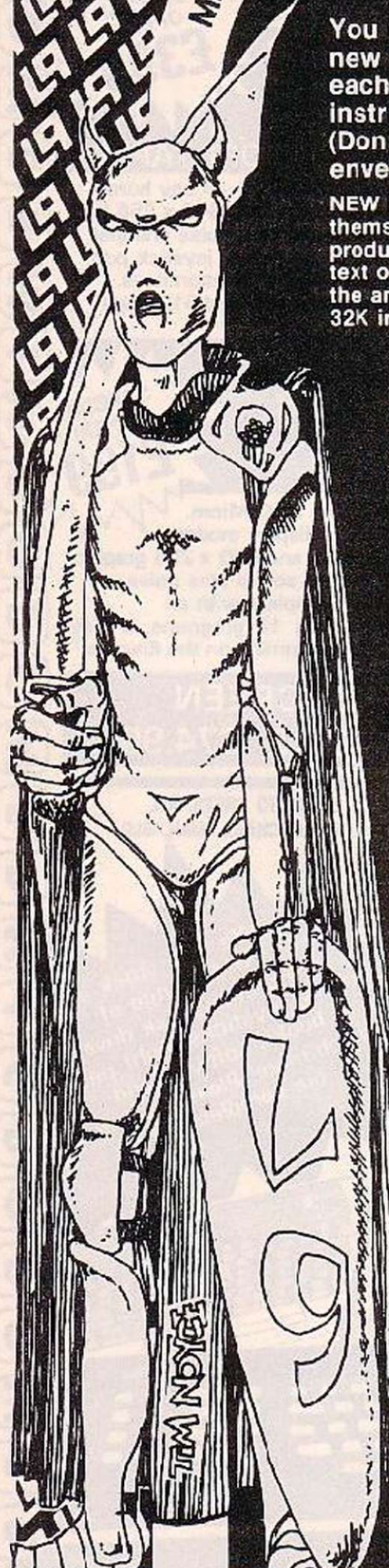

Introducing, for the first time on-screen,
the evil and unwholesome
RAPSCALLION THE ROGUE, the
ultimate arch-enemy who features
in this extraordinary, fully
animated cartoon adventure
for the 48 K Spectrum.
In your high street now

£6.95
compatible with
most popular
joysticks.



BUG-BYTE

Bug-Byte Ltd, Mulberry house, Canring Place, Liverpool ☎ 051-708 7071

The new Electron from Acorn. Ask any child at school why it's worth £199.

Most British children have one thing in common with the new Electron microcomputer: they speak the same language.

You see, the Electron is the first micro remotely in this price range to use BBC Basic, the computer language that is rapidly becoming the standard in British schools.

But that's not all. Most children will feel at home with the Electron as soon as they lay hands on it.

This is because it has developed out of the Micro that has been chosen by over 80% of schools participating in the Government's current Micros In Schools project. It has a similar keyboard and has most of the functions of this much acclaimed (but naturally, more expensive) machine.

So now children will be able to continue their computer studies at home. They'll be able to use the same educational programs they use at school. And, if asked nicely, they'll be able to help willing adults take their first steps into computing.

All this for only £199.

A micro technology break-through.

And now a few reasons for adults why

NOW YOU'VE MASTERED MONSTERS,
WE COULD MOVE ON TO MONEY
MANAGEMENT.



the Electron is such an exceptional machine at the price.

The Electron is neat and compact. Yet it is fast and powerful. (Full details, for the technically minded, are in the box opposite.)

It produces high quality sound using its own internal speaker.

And it offers a range of facilities many larger more expensive machines just cannot match.

For example the Electron's colour graphics have the highest resolution of any home computer.

This is because the chip that controls the graphics, specially designed by Acorn, is one of the most advanced of its kind. As a result,

the Electron delivers twice as many characters across the screen as its closest competitor.

Built to last and to grow.

The Electron has been designed and built to be a permanent part of the family, year in year out.

Particular care has been paid to the keyboard. It is electric typewriter style; robustly constructed with a good, solid 'feel'. It has a space bar, and single entry keys for key commands.

In other words it's comfortable and easy to use, avoiding the need for the manual gymnastics sometimes associated with calculator style keyboards.

And it will grow with you via expansion modules, that Acorn are developing, to take peripheral additions such as printers and disc drives. So as your knowledge, interest and ambitions develop, the Electron can develop with you.

Additionally, to give you all the support you'll need to generate your own applications software, we've established a phone-in service attended by specialists to give advice, encouragement and practical help.

A gentle teacher.

The Electron plugs straight into virtually any TV set and cassette player so you will be



ready to go as soon as you get it home.

It comes not only with a comprehensive user guide, which describes the machine and its functions, but also with a book that takes you step by step through the basic principles of programming.

A free taste of its versatility.

You will also receive an "Introductory" cassette which will put the Electron through its paces showing you a little of what it can do with its 64k of memory (32k ROM, 32k RAM).

The cassette will give you a taste of those exceptional colour graphics we mentioned earlier; of its ability to play and notate music, and show you how it might help in home accounting. It will challenge you to a few games and will, if you ask it, do your whole family's biorhythms in a matter of seconds.

You will in short, through the 15 separate programs it contains, get a glimpse of the Electron's potential. But only a glimpse, for that potential is as limitless as your own interest and imagination.

A widening range of software.

To help you realise some of that potential, Electron software already ranges from "Personal

Money Management" through "Starship Command" to "Creative Graphics" (which, incidentally, includes some spectacular three-dimensional rotating shapes). Naturally, with its strong educational links, educational software will be extremely

EXPERTS LIKE 'WHAT MICRO?' AND ME RATE THE ELECTRON HIGHER THAN ANY OF THE COMPETITION.

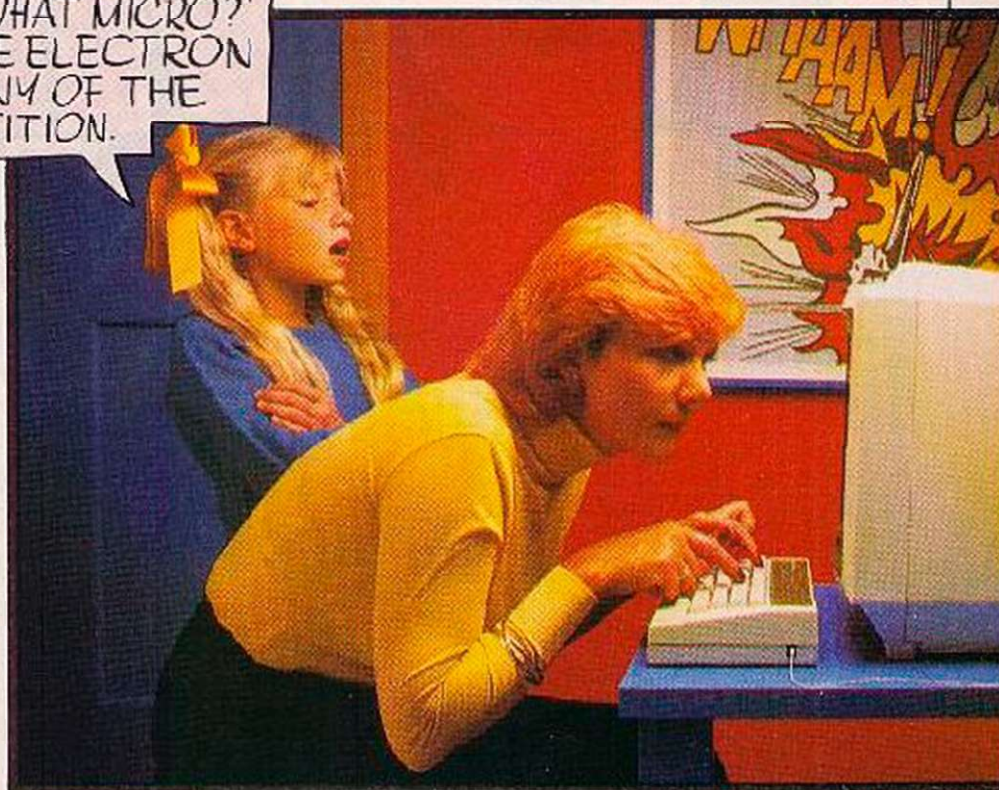

important for the Electron and even now O and A Level revision papers are being processed for Electron users.

How to get your Electron.

The Acorn Electron can be found at local Acorn dealers and major high street stores. However, if you would like to order one with your credit card, or if you would like the address of your nearest supplier, just phone 01-200 0200.



Technical Specifications

Hardware.

2MHz 6502.
32K ROM 32K RAM (64K total).
High resolution graphics 640 x 256 max.
Seven display modes.
8 colours and 8 flashing colours.
1200 baud CUTS tape interface with motor control.
Expansion bus for add-on interface modules.
Internal loudspeaker.
PAL UHF output to colour or black and white domestic TV.
RGB output for colour monitor.
56 key full travel QWERTY keyboard with spacebar.

Software.

BBC BASIC.
Extensions include integer, floating point and string variables, multi dimensional arrays: IF... THEN... ELSE, REPEAT... UNTIL, procedures with local variables.
Operating system allows plot, draw and fill commands.
Event timing.
Built-in assembler.
6502 assembly language can be mixed with BASIC.

The Acorn  Electron.

COMBAT LYNX

From **DURELL**
(Technical Support from Westland Helicopters)

Available now from most retail outlets

COMMODORE 64 – SPECTRUM 48k

Available soon

ORIC – BBC – AMSTRAD



DURELL sales dept., Castle Lodge,
Castle Green, Taunton, Somerset, TA1 4AB

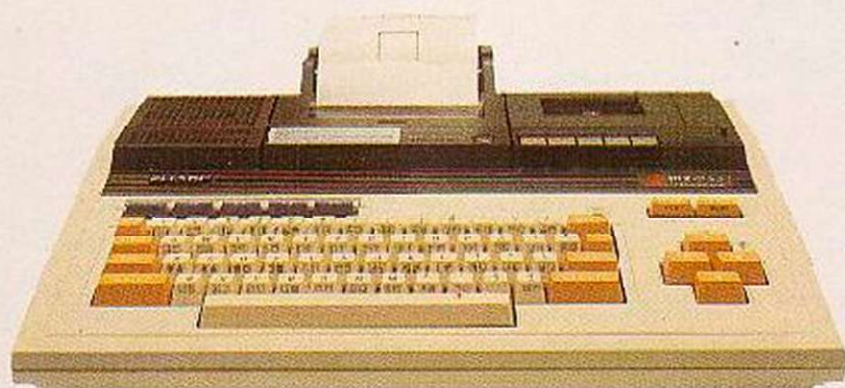

And with his help you may just escape from the 3-D horrors of the 1,000-chamber maze. DRAGON CAVES is one of over 130 different titles in the free colour catalogue for Sharp's MZ 700 series computer. Software for the MZ 700 series ranges from the

Don't worry. He's on your side.



High-skill dog-fighting of FIGHTER COMMAND to the frightening fun of NIGHTMARE PARK. And prices start as low as £3.95.

Cut the coupon and get the horrors. Before they get you.

Sharp Electronics (UK) Ltd., Home Computer Division,
Sharp House, Thorp Road, Newton Heath,
Manchester M10 9BE. Telephone: 061-205 2333
Please send me the FREE Software catalogue for the
SHARP MZ 700 series computer.

Name

Address

The world of
SHARP
where great ideas come to life



Where do 100,000 DP Managers obtain their computer supplies? - From Inmac

Better solutions for professionals-faster!

These days there are dozens of companies offering to supply your computer needs. They come — and they go.

Yet more and more computer professionals are turning to Inmac for all their requirements.

You don't need a computer to work out why. Inmac are themselves truly professional in every aspect of their business. They don't quote silly prices on loss-leaders — and make it up elsewhere. They provide competitive prices and top-quality service across the board.

And everything carried must be quality. Inmac look after your bottom line — help you provide a more cost effective computer service over all.

Inmac carries many products for leading name equipment: like Centronics, DEC, Data General, Diablo, Hewlett Packard, IBM, NEC, Qume, Systime and Texas Instruments.

In addition you get:

- * 30 day risk-free trial,
- * 12 months' minimum replacement guarantee on most products.
- * Next day delivery and same day in the London area.



Protect it!

Your computer system is vital — and vulnerable. Inmac supply a whole range of safety and security devices from special fire extinguishers to clever security locks.

PRODUCT OF THE MONTH

Your 5 star DEC cartridge service

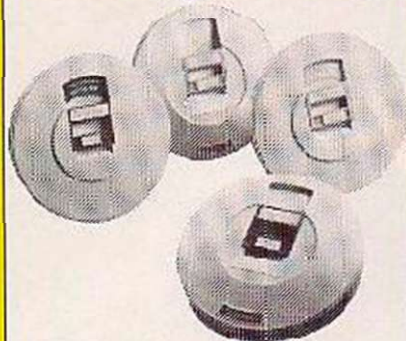

3 YEAR GUARANTEE

30 day risk free trial Free Advisory Service
Next day delivery Original DEC quality

We also supply most other major manufacturers disk cartridges. Just call us to check your requirements.

PRINT PERFECT

Whatever the make, whatever the type of printer or typewriter, Inmac have the right ribbon for your needs. Precision manufactured, with high yield and quality results. Print wheels? Ours are compatible with Dable, Qume Olivetti etc.



'T'SWITCHES

You won't find a larger range than Inmac — we supply everything from a simple two device switch up to the super sophisticated Auto-T-Switch which "speaks" to you and cues you automatically.

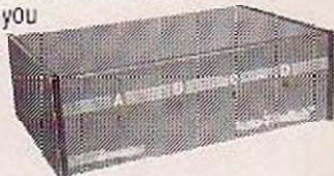

CABLES AND CONNECTORS

Just tell us what connections you need to make — we will supply your requirements from stock today. We can also custom build cables to your specification in only 5 days. Inmac prices can save you up to 20% and still give you next day delivery, no minimum order and a 3 year risk-free guarantee.

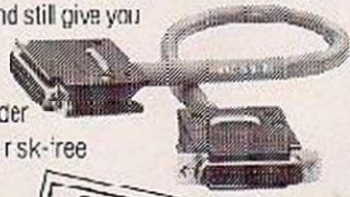

Get a better deal all round

The products described on this page are just a tiny selection from the total Inmac range. If you see what you need here — phone us now and we'll deliver it tomorrow or sooner. Just phone us and talk to our free advisory service — we'll do our best to help meet your needs.

Name _____
 Title _____
 Company _____
 Address _____

 Postcode _____
 Telephone No. _____
 My computer system is _____
INMAC (UK) LIMITED 822

Ring for our catalogue containing over 1,000 great ideas.

09285 67551 or 01740 9540
 INMAC (UK) LIMITED INMAC (UK) LIMITED
 Dept 822, Javy Road, Dept 822, 16 Silver Road,
 Astroor London W12 7SC
 Runcorn Cheshire. United Kingdom.
 WA7 1PZ Telex: 924313
 telex: 629819



The Unsurpassable Experience.

synsoft

The Official

ZAXXON

SEGA

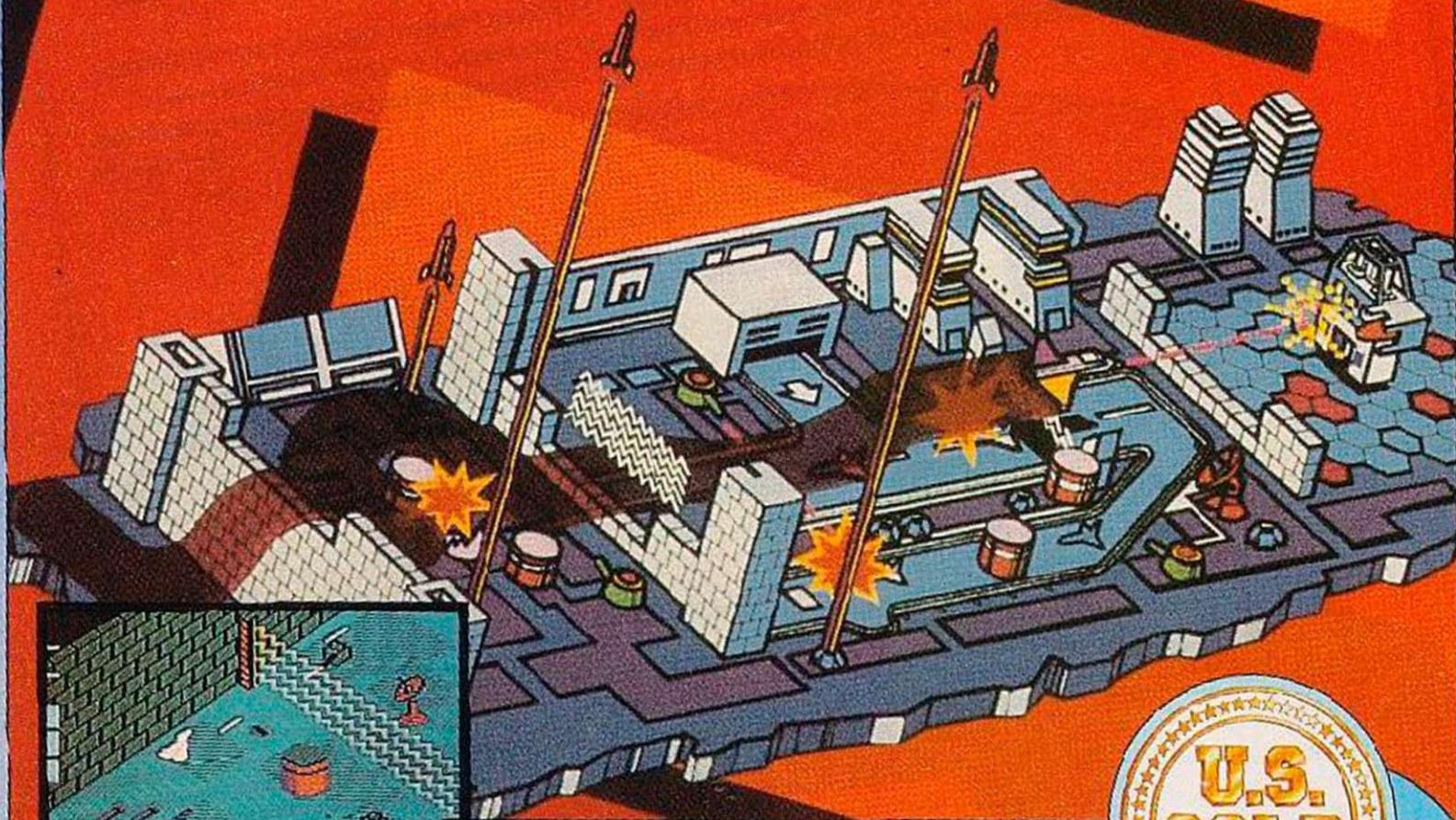

Now you can play one of the most challenging arcade games on your Commodore 64 home computer. ZAXXON's incredible 3-D graphics, diagonally scrolling screen and supersound are reproduced in great detail. Everything you love about the arcade game is here - and much more. ZAXXON is now more difficult than ever before! So hang onto your joystick and keep firing. Then practice. You may eventually encounter the deadly ZAXXON himself.



synsoft

Commodore 64



THE ULTIMATE IN AMERICAN SOFTWARE FOR YOU ON U.S. GOLD
U.S. Gold is stocked by all leading computer stores including:



John Menzies

WHSMITH WILDINGS

WOOLWORTH

CASSETTE

£9.95

DISK

£14.95

U.S. Gold Ltd., Unit 24, Tipton Trading Estate, Bloomfield Road, Tipton, West Midlands DY4 9AH Telephone: 021-5207591 Telex: 333248

MODEM.

HIGH-SPEED

COMPUTER TALK

FROM PROTEK

Inter-computer communication is easy in anyone's language, thanks to the Protek Modem. Acoustic coupling provides a reliable link between the computer and the telephone line. There are no connection charges, the unit is totally portable. The flexible link between the mouth and ear-pieces ensures a reliable connection between most telephones.

For £59.95



● British Telecom Approved

Protek

Protek Computing Ltd, 1A Young Square,
Brucefield Industrial Park, Livingston, West Lothian. 0506 415353.

Tune-in to Jet-Boot Jack. The massive hit from English Software.

NOW
AVAILABLE
FOR
COMMODORE
64

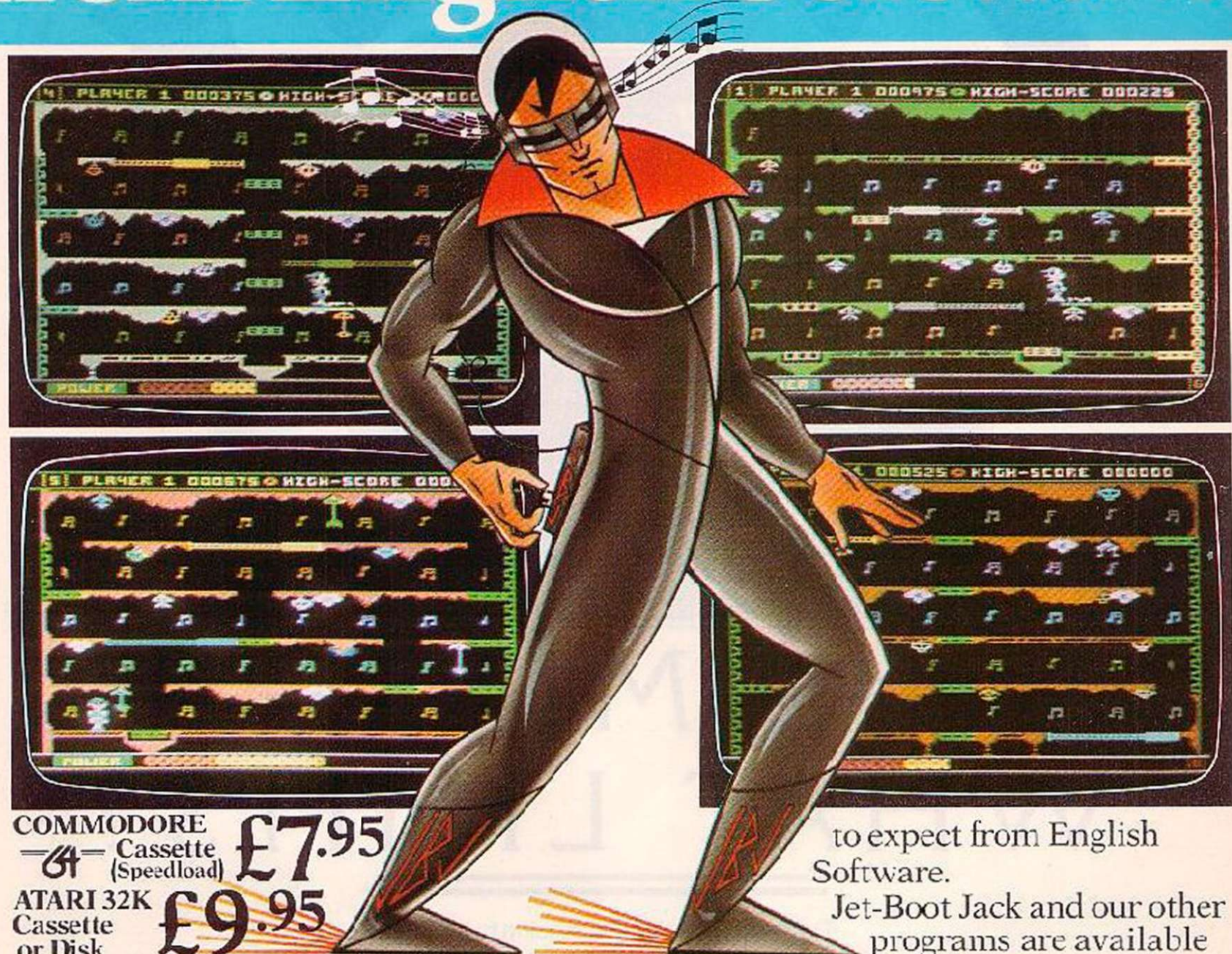

COMMODORE
64 Cassette (Speedload) **£7.95**
ATARI 32K Cassette or Disk **£9.95**

Jet-Boot Jack is fast heading for No 1 spot in the Atari games charts.

Because he's absolutely unique.

Jet-Boot Jack is the space-age jet-powered jogger who takes you on a chase through the vaults of the Record Pressing plant, collecting his favourite music as he goes.

Evil creatures try to thwart his every move, but Jack's special bouncing powers send them hurtling to their deaths!

Sliders and elevators provide access to new levels – but sometimes they turn nasty!

With 10 different screens and 6 skill levels Jet-Boot Jack will stretch your abilities to the limit.

Which, after all, is what you've come

to expect from English Software.

Jet-Boot Jack and our other programs are available from branches of Laskys, Greens and all good software dealers.

Telephone Sales Hot Line
(Access and Visa) 061-835 1356

JET-BOOT JACK

© Copyright 1983 English Software
Program written by Jon Williams and Mark Taylor.

ENGLISH
ENGLISH
SOFTWARE
SOFTWARE

THE POWER OF EXCITEMENT

The English Software Company, Box 43,
Manchester M60 3AD Trade Enquiries Tel: 061-835 1358

(all English Software programs are sold according to the English Software Terms of Trading, copies of which are available on request).

'Stranded' by English Software. The challenge that's light years ahead.

Special Agent Sid's First Graphic Adventure

Imagine you're Special Agent Sid of the SAS. The year is 2510 AD and you're marooned on a strange planet.

Getting home is the challenge to you from English Software! And 'STRANDED' is the name of the game.

It's Sid's aim to find his starship and return home safely. But not before he's encountered and defeated all the hazards of this lonely, unfriendly planet. And with over 35 graphic screens, that's quite a tall order.

It could be a long mission. — but we know you'll want to test your skills against everything that 'STRANDED' can throw at you.

Written in machine code, game progress can be saved to cassette or disk.

To make things even simpler, send us the completed coupon below together with your cheque or postal order OR use our

Telephone Sales Hot Line

061-835 1356

(for immediate Access/Visa service).



COMMODORE 64
Cassette (Speedload) **£7.95**

ATARI 32K Cassette
or Disk **£9.95**

'STRANDED' written by C. Hughes and D. Woodhouse.

All English Software Programs are sold according to the English Software Terms of Trading, copies of which are available on request.



The English Software Company Box 43,
Manchester M60 3AD Trade Enquiries Tel: 061-835 1358

COMMODORE 64
ATARI 400/800
600XL/800XL
32K

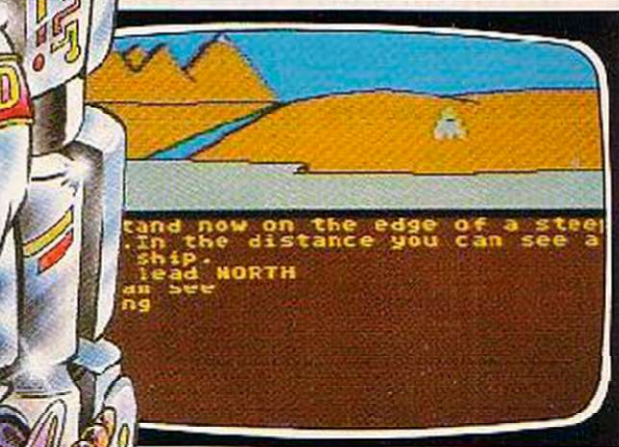
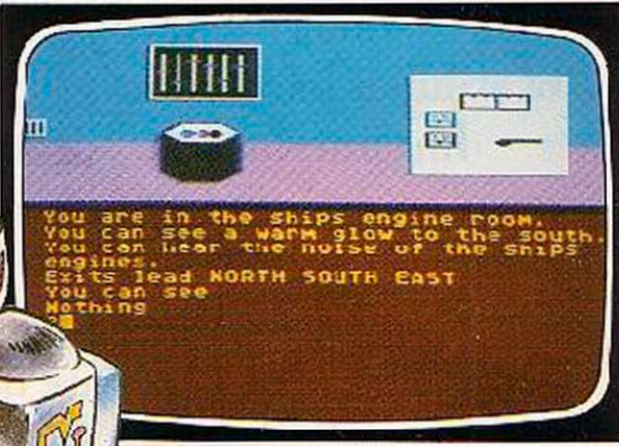
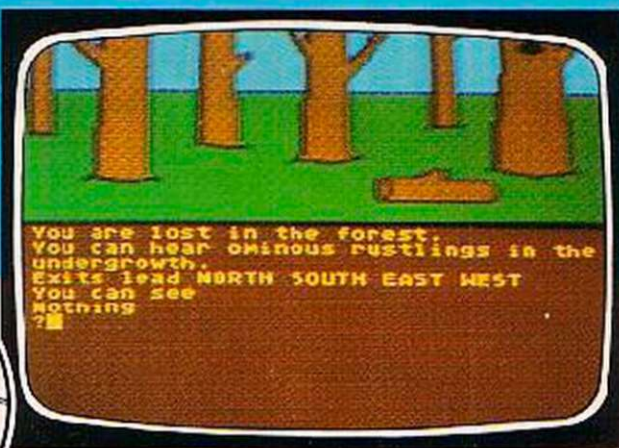

Find us at Boots,
Laskys, Greens
and all good
software dealers.

To: The English Software Company,
Box 43, Manchester, M60 3AD.

Please rush me cassette/disk* of 'STRANDED'
for Commodore 64/Atari*.

I enclose cheque/PO* for £ _____ (post-free) or debit
my Access/Visa Card No _____ *Delete as applicable.

NAME _____

ADDRESS _____



Rebalance this sh

The BBC Micro can now give an astonishing new account of itself.

Because with Acornsoft's new 16K ViewSheet ROM, it develops a head for figures which can save you a vast amount of arduous brainwork.

Imagine, for instance, that you had to make several adjustments to a balance sheet.

If you made those adjustments on ViewSheet, it would revise the balance automatically in a split second.

Or imagine that you had to add 15% VAT to every figure on a price list containing 500 items.

ViewSheet can add the tax to each and every one of those items simultaneously. And once again, in virtually a second.

As simple as pencil and paper.

ViewSheet is a computer-based spreadsheet, the figure processing version of a word processor.

With 255 columns in width and 255 rows in depth, it's also one of the largest spreadsheets on the market.

Originating the sheet is as easy as originating an ordinary worksheet with pencil and paper.

Because ViewSheet comes with an easy-to-follow reference card.

It enables even the most inexperienced users to feed all the data they need to use, and store on disc or cassette, into the BBC Micro.

You can nominate headings and sub-headings. And you can create bar charts to display figures graphically.

Ten windows for perfect vision.

The sheer size of ViewSheet makes it impossible for the whole sheet to be visible on the monitor at once.

That's why ViewSheet has ten windows, enabling you to see up to ten different sections of the sheet at any one time.

You can summon the windows onto

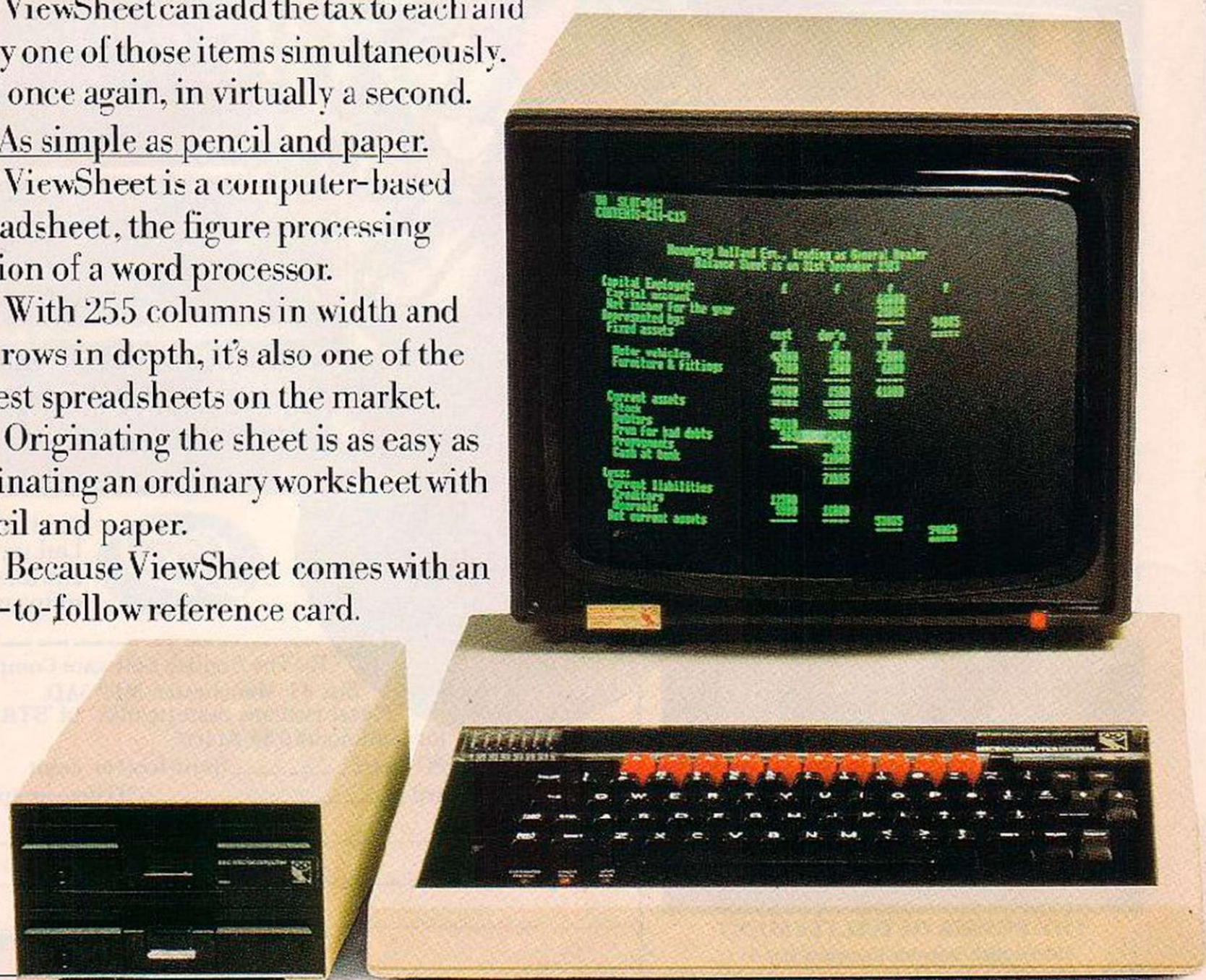

heet in one second.

the screen at the press of a key.

You can cross-reference sections, or even reposition them on the sheet, whenever you need to.

And you can print them out individually, as well as all together.

The possibilities are virtually endless.

By creating special disc files from ViewSheet, you can link two or more spreadsheets together. This means you can build models much bigger than the BBC Micro's considerable memory.

ViewSheet is also compatible with Acornsoft's View word-processing package. This enables you to produce reports and documents which combine text and figures.

In addition, you can use ViewSheet in any screen mode,

making the most of the BBC Micro's potential. And if you use it with the 6502 second processor, you'll have no less than 30K of workspace in any mode.

For only £59.80,

you too can have figures like this.

The ViewSheet ROM can be fitted by your BBC Micro dealer in less than three minutes. And with its straightforward user guide, function

key card and reference card, it'll soon have you juggling figures at lightning speed.

Indeed, at only £59.80, it's an invaluable asset for anyone involved in professional or personal finance, forecasts, formulae and analysis.



ViewSheet's operations and functions in brief.

The operations supported by ViewSheet are: addition, subtraction, multiplication, division, exponentiation and bracketed operations.

And the functions supported are: ABS, ACS, ASN, SIN, SGN, RAD, ATN, COS, DEG, EXP, INT, LN, LOG, PLSQR, TAN, MIN, AVERAGE, MAX, CHOOSE, LOOKUP, COL, IE, READ, ROW and WRITE.

ACORNSOFT

c/o Vector Marketing, Denington Estate, Wellingborough, Northants NN8 2RL. Tel: 0933 79300.

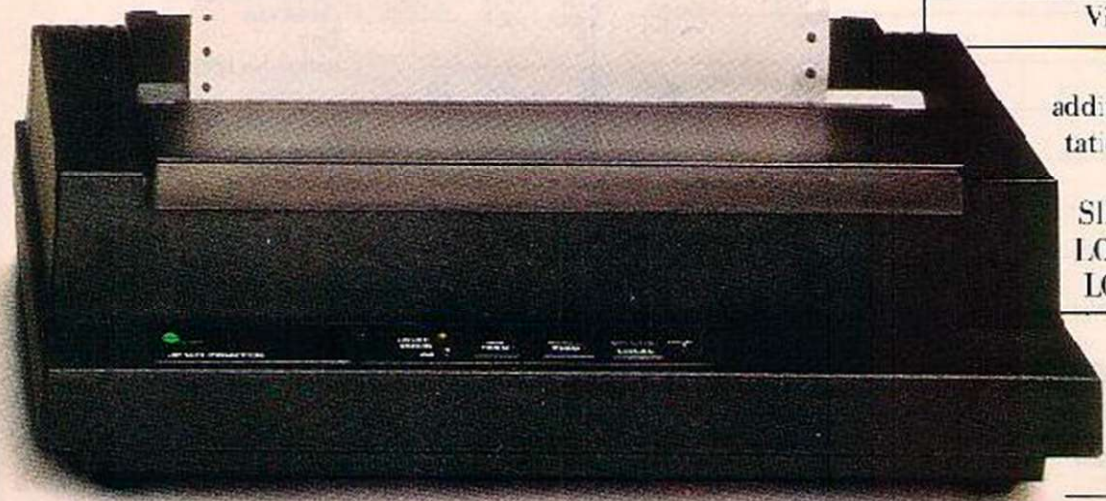

Challenging, sophisticated, advanced, extra special.



Be the world's greatest sleuth — in the most advanced and challenging adventure game ever.

For the first time ever, here is an adventure game in which you can talk with intelligent characters, ask them questions and argue with their conclusions — all in everyday English sentences.

Work against time to solve the mystery as you travel about Victorian England. Villains, suspects and witnesses all live out their lives in a realistic manner, and you can never be sure of who or what you will find anywhere. You must be alert because nobody is above suspicion.

In 'Sherlock', the world of the famous private detective comes vividly to life. Time passes naturally: day turns to night, racing towards the inescapable deadline. You must ensure Sherlock has sufficient time for sleep, money to travel on public transport and other necessities. And you can rely on Dr. Watson to help you collate information, or gather clues.

'Sherlock' makes the maximum use possible of the 48K Spectrum and is the result of 15 months' work by a team led by programmer Philip Mitchell, the author of 'The Hobbit'. The text and graphics of 'Sherlock' makes it the most exciting and sophisticated adventure game yet devised.

Study the clues, question the suspects, make the deductions — and match your wits against the most dastardly criminals in history.

Melbourne House makes the choice of your next computer adventure elementary.

A real adventure!

- Please send me your free catalogue.
 Please send me Spectrum 48K Sherlock Holmes @ £14.95

All Melbourne House cassette software is unconditionally guaranteed against malfunction.

| | |
|---|-------------|
| I enclose my cheque/money order for £ | £ |
| Please debit my Access Card No. _____ Expiry Date _____ | £ + p/p .80 |
| Signature _____ | Total |
| Name _____ | £ |
| Address _____ | |
| Postcode _____ | |

Order to:
Melbourne House Publishers
33 Millon Trading Estate
Avington, Oxon OX14 4TD

Correspondence to:
Church Yard
Tring
Hertfordshire HP23 5UJ

Access orders can be telephoned through on our 24-hour ansafone (0235) 83 5006.

All prices include VAT where applicable. Please add 80p for post and pack. Trade enquiries welcome.

Melbourne House

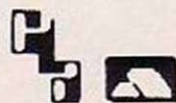

YCSA

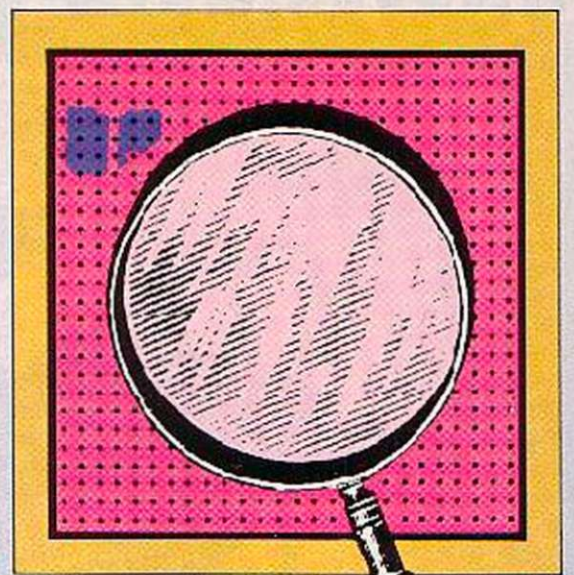
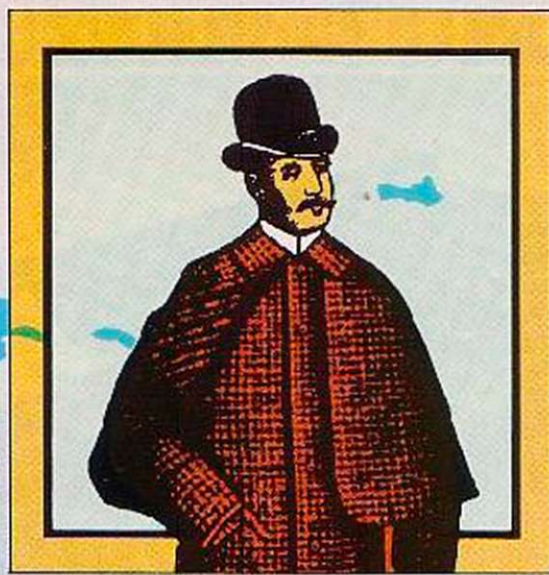

PROTOCOL 4 GAME CONTROLLER CUSTOMISING INTERFACE for the ZX SPECTRUM

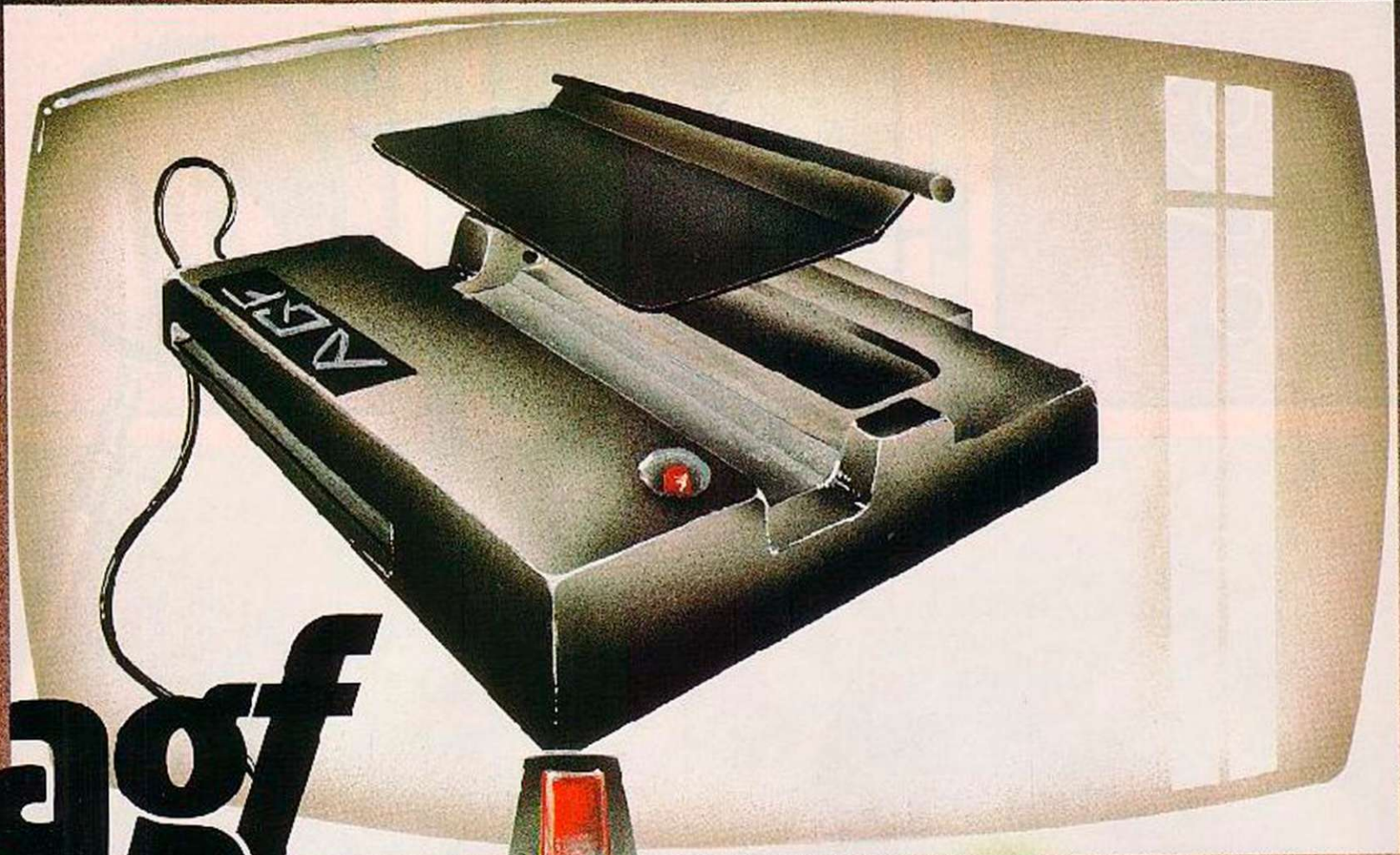

FEATURES

- * Fully Programmable
- * Compatible with ALL Spectrum software.
- * Hardware programmed by unique 'Custom Cards' that simply clip into place.
- * Supplied with four preset cards and a blank for immediate use with AGF/ Protek, Kempston or Sinclair Interface 2 options.
- * Blank cards are infinitely resettable for any key replication.
- * Automatic eight direction control.
- * Uses no memory or back up software and is not power dependent.
- * Accepts any joystick, including Quickshot II with 'rapid fire' or trackball.
- * Side entry joystick socket maintains the low profile of the system.
- * Recessed Computer Reset button for clearing machine code games without pulling the power plug.
- * Low power design - up to five Protocol 4's can be simultaneously connected for multiple control applications - only possible with the hardware programmed design approach.
- * Fully guaranteed for 18 months.

**DON'T SETTLE FOR LESS . . .
CHOOSE AGF**

AGF HARDWARE, DEPT. L, FREEPOST, BOGNOR REGIS, WEST SUSSEX PO22 9BR or Tel. (0243) 823337

Send to: AGF HARDWARE, DEPT. 1, FREEPOST, BOGNOR REGIS, WEST SUSSEX PO22 9BR or Tel. (0243) 823337

| QTY | ITEM | ITEM PRICE £ | TOTAL £ |
|-----|---------------------------------|--------------|---------|
| | AGF PROTOCOL 4 | 30.95 | |
| | EXTRA PACK(S) OF 5 CUSTOM CARDS | 3.95 | |
| | QUICKSHOT II JOYSTICK | 12.95 | |
| | FINAL TOTAL | | |

Please tick appropriate box:-

I enclose a cheque/Postal Order payable to AGF HARDWARE for £

Please charge my Access/Barclaycard Account No.

Signature

From MR/MRS/MISS

ADDRESS

Please send me more information about AGF PROTOCOL 4.

Please allow up to 28 days from receipt of your order although we normally despatch from stock within 7 days. All AGF products are supplied on a 14 day money back undertaking. AGF Hardware, Bognor Regis, West Sussex. Telephone 0243 823337

Triple GOLD

ATRIO OF AMERICAN HITS

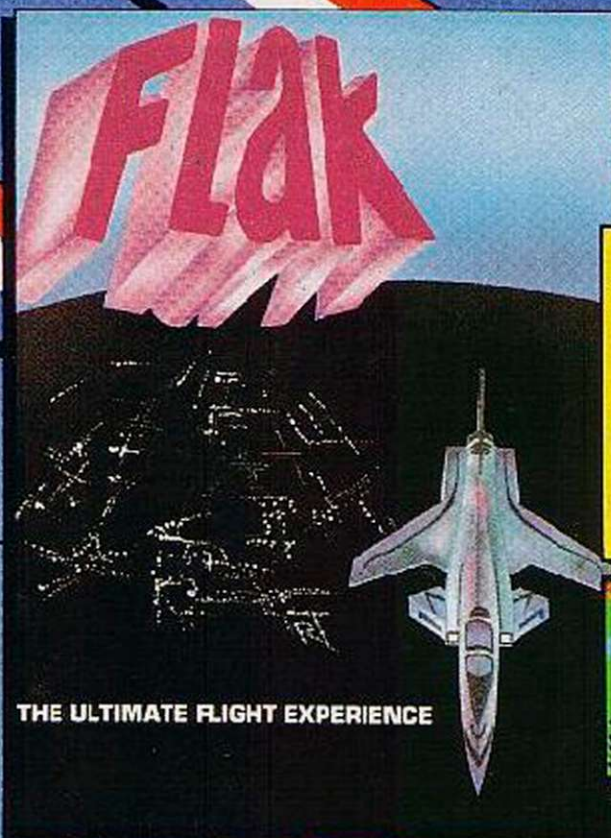

Put yourself in the Pilot's seat of an advanced AGX hypersonic fighter! You'll fly in low over awe inspiring scenery whose beauty might just be your end. Guarding the approach to the fortress is an endless array of computer controlled flak batteries. You fire, evade, fire again... Can you take it? Will you survive the FLAK?



DISK
£14.95

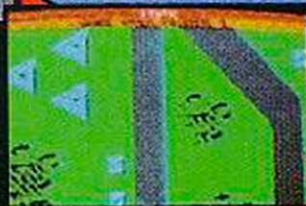

Mystic Mansion

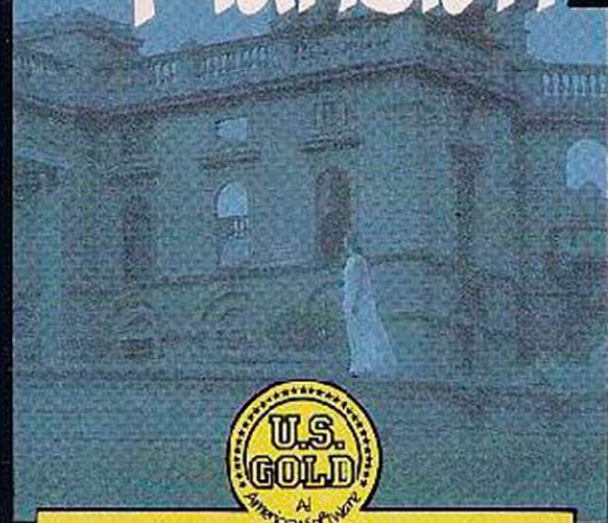

Explore the evil and mysterious mansion's 60 rooms, and race against time to collect the 40 treasures it hides. You'll need quick thinking and an analytical mind in this unique game that blends all the excitement of arcade and adventure games in one challenge.



CASSETTE **£8.95**
DISK **£12.95**

Scheduled Release Date: August



When you help Snokie rescue his girlfriend Cara the action really starts! Cara, held captive by the Grodies, needs to be rescued now! It won't be easy. Snokie will face all the natural perils of the arctic, including snow boulders, glacier crevasses, moving ice blocks and falling icicles. Also there are ice lasers and cold rays installed by the Grodies. Take the challenge!



CASSETTE **£9.95**
DISK **£12.95**

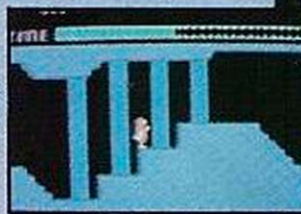
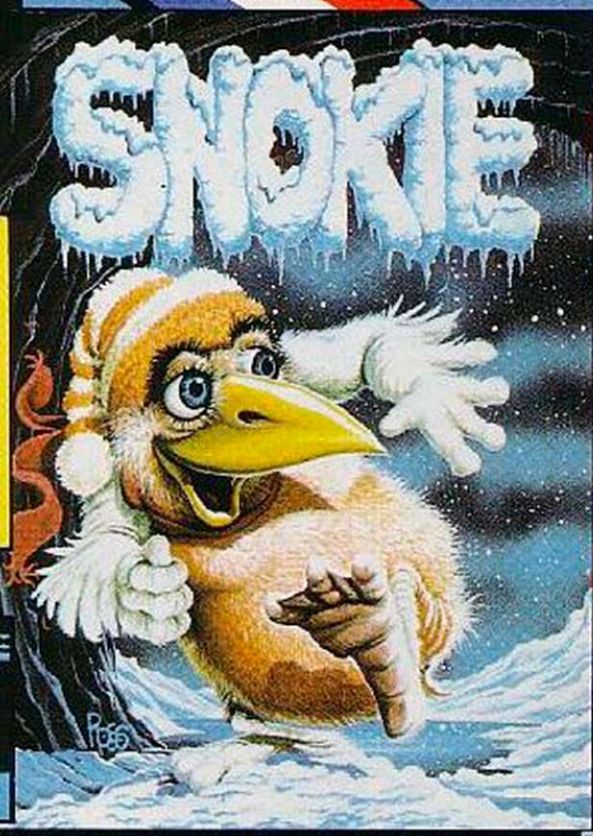

THE ULTIMATE IN AMERICAN SOFTWARE FOR YOU ON U.S. GOLD

U.S. Gold is stocked by all leading computer stores including:

BOOTS WHSMITH JOHN MENZIES WILDINGS

DEALERS: For information on how to become a U.S. Gold Stockist write to: CentreSoft Ltd., Unit 24, Tipton Trading Estate, Bloomfield Road, Tipton, West Midlands DY4 9AH
Telephone: 021-520 7591. Telex: 337268.
Overseas enquiries welcome.

U.S. GOLD

All American Software

Llamasoft

ORIGINAL SOFTWARE DESIGN

49 MOUNT PLEASANT, TADLEY, HANTS. RG26 6BN.

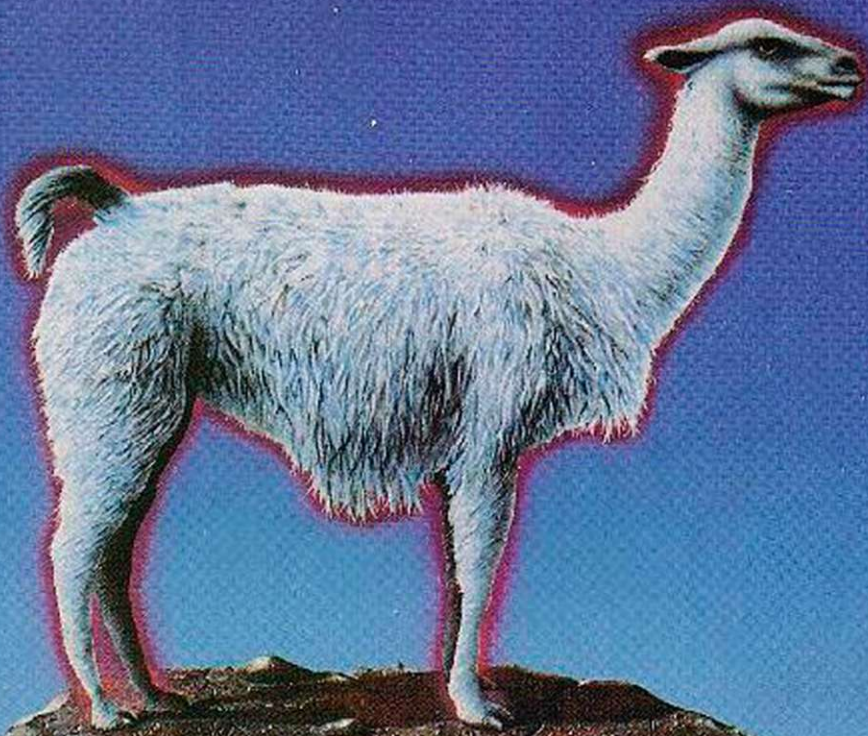

SEND S.A.E. FOR (FREE NEWS LETTER) 'THE NATURE OF THE BEAST'.

TRAXX



VC 20 LA 12003 £5.00

HELL GATE



VC 20 LLA 21007 £5.00
CBM 64 LLA 21006 £5.00

METAGALACTIC
LLAMAS BATTLE



VC 20 LLA 11008 £5.00
CBM 64 LLA 21010 £5.00

ABDUCTOR



VC 20 LLA 11001 £5.00

MATRIX



VC 20 LLA 12005 £5.00
CBM 64 LLA 21006 £5.00

LASERZONE



VC 20 LLA 12004 £5.00
CBM 64 LLA 21004 £5.00

GRIDRUNNER



VC 20 LLA 11002 £5.00
CBM 64 LLA 21005 £5.00
ATAR LLA 11001 £5.00

SHEEP IN SPACE



CBM 64 LLA 21003 £7.50

HOVER BOVVER



CBM 64 LLA 21005 £7.00

ATTACK OF THE
MUTANT CAMELS



CBM 64 LLA 21001 £9.00
ATAR LLA 11003 £7.50

REVENGE OF
MUTANT CAMELS



CBM 64 LLA 21007 £7.50

Packing & Postage 50p



WOOLWORTH, W H SMITH



John Menzies



Packing & Postage 50p

DEALERS may order direct from CBS Telesales 01-960 2155 quoting account number, LLA code number and quantities. Goods delivered within 48 hours.

Campbell systems

for spectrum 48k

Can YOUR Database Handle This?

PROFESSIONAL FILE MANAGEMENT, DATA RETRIEVAL AND PRESENTATION
ANY ADDRESS LISTS, INVENTORY, CUSTOMER OR PERSONNEL RECORDS...

With MYRMIDON'S
Micro-Print[®]
up to 51 columns!

MASTERFILE can!

Microdrive commands included; 32, 42 or 51 characters per line!; 26 fields per record; Unrestricted number of records; 36 user defined Display/Print formats; Fast search & sort facilities; Around 32K of RAM available for data!

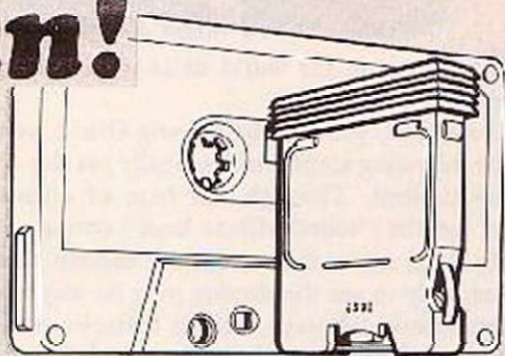

Now with **MF-PRINT** and MASTERFILE version 09, you can format your data for a full width printer!

Works with most popular printer interfaces. Fully variable report widths (over 100 columns) and lengths. Powerful numeric editing and column totals. Almost no reduction in space available for data.

Many more products available. Send SAE for details!

| | |
|--------------------------|--------|
| MASTERFILE version 09 | £15.00 |
| MF-PRINT | £ 6.95 |
| MASTERFILE with MF-PRINT | £19.95 |

All programs mailed 1st class by return.
Prices include VAT and postage within Europe.
New Address: Campbell Systems
(Dept.YC) 57 Trap's Hill, Loughton,
Essex. IG10 1TD. England 01-508 5058



YOUR ONE-STOP SOURCE OF COMPUTER BOOKS

and

SUBSCRIPTION AGENCY FOR ALL BRITISH AND AMERICAN COMPUTER MAGAZINES

Here is your chance to subscribe to one or more of the 50 leading magazines on

COMPUTERS - ELECTRONICS - VIDEO

Also NEW Books on Programming Languages and Techniques, Graphics, Microelectronics, Software Eng., etc. from all publishers.
All countries served throughout the world.

Please write for catalogues:

Computers Books and Magazines
Haulsterm Ltd. 91 Exeter House,
Putney Heath, London SW15, England
Telephone 01-788 8746

HALLÅ SKANDINAVIEN!!!

Du som bor i Skandinavien och söker bra program till din hemdator.

KONTAKTA OSS!!!

Vi har det mesta som finns i denna tidning till **samma** låga priser som gäller i England. Dessutom får vi in alla nyheter **samtidigt** som de släpps i England.

SVENSKA MASKINKODSPROGRAM

Ja, nu släpper vi även en svensk serie maskinkodsprogram.
Miss inte vår jättesuccé "SPELDORADO"

OBS!!! Vid katalogbeställning v.g. medsänd 5:- Skr i frimärken för portot.

SWESCOT

Box 213
121 02 Johanneshov
Sverige
08/39 27 00 - 08/81 18 01

YOUR LETTERS

LET AN EX-50 FIGHT FOR YOU



Oric-1 owners of the world unite — you have nothing to lose but your bugs!

If, like myself, you bought an early Oric-1, you will be familiar with the following scene: you've finally got Zap the exploding serial attribute to load. Through the haze of colour crawl, you go straight for the "sound effects loud" option. As the first alien gingerly floats across the screen, you eagerly hammer away at the spacebar, only to see the display ping its way into obscurity, and the alien shuttle sideways with its tentacles over its ears.

Before you can say "verify", the move-left button has stuck and the poor old 6502 has cucked under its shell like a One-Gun Turtle. With a sigh, you take out your pen and start another letter of complaint to Oric, consoling yourself with the thought that at least you'll get a free issue of *Oric Owner* out of it.

For a year, this is how my hobby went. But then, something snapped. No, not the power supply cable, my patience. Armed only with a Form EX-50, free at any county court, I sued Oric for a refund on the grounds that it was a faulty machine which did not live up to the advertising. Within a few weeks, I was cashing a cheque after Oric made an out-of-court settlement.

After my experiences, I do not think I'll invest in an Atmos. However, if that had been my choice, I certainly found a much cheaper way of going about it than Oric's £60 upgrade. If other owners follow suit, this could prove to be very costly for Oric. Hopefully this will teach them a lesson, that they should not bombard the public with faulty and incomplete machines. I wonder if Clive Sinclair is reading this?

Peter Braham,
Wakefield,
West Yorkshire.

ZX PANEL

In the documentation of ZX Panel in the July issue, the final sentence in paragraph 4, page 124, should read "it is moved by typing shifted 6" referring to moving the register cursor.

Alan Lee,
Tring,
Hertfordshire.

BIPODS

The ZX-81 Bipods program in the July 1984 issue shows what can be done on what appears to be a very limited machine. However there was one small error which caused the program to crash every time that it was run: line 5 should be Rand USR 16595 instead of 16592. When this has been corrected the program will run correctly.

Another area in which improvement can be made is to set the high score to 000000 instead of 003780. This can be done by setting the bytes between addresses 17400 and 17405 to 19 decimal. I hope that you will continue to print programs for the ZX-81 as they are much appreciated.

Jonathan Casiot,
London SW18.

SAVING BLOCKS

Owners of MTX micros may be a little perturbed by the fact that they cannot save and load blocks of data due to the lack of Basic commands. This problem can be overcome by a short machine-code routine which can be easily entered using the resident assembler:
LD HL, START OF BLOCK
LD DE, LENGTH OF BLOCK
LD A, DATA1
LD (#FD68), A
LD A, DATA2
LD (#FD67), A
CALL #0AAE
RET
DATA1 = 0 FOR SAVE, 1 FOR LOAD
OR VERIFY
DATA2 = 0 FOR SAVE OR LOAD,
1 FOR VERIFY

J Mallins,
Leeds,
West Yorkshire.

WILLY CHANGES

If you did not particularly like Matthew Smith's sneaky random hazards feature in Jet Set Willy which pulverises you after a visit to the attic, and you want an easier route and easier game proceed as follows.

Rewind the Jet Set Willy tape, and

```
1 DATA 162,110,150,30,134,4,132,5,32,45,27,162
2 DATA 138,160,30,134,4,132,5,32,45,27,162,30
3 DATA 160,31,134,4,132,5,32,45,27,162,118,160
4 DATA 31,134,4,132,5,32,45,27,96,165,4,133
5 DATA 6,165,5,133,7,198,4,160,22,177,4,201
6 DATA 10,240,8,201,12,240,4,135,208,243,96,169
7 DATA 32,145,4,145,6,136,240,19,177,4,201,15
8 DATA 240,13,201,16,240,9,169,10,145,4,159,11
9 DATA 145,6,96,169,32,145,4,160,22,169,10,145
10 DATA 4,96,0,0,32,90,25,32,144,26,96,0
11 DATA 0,0,0,0,0,0,0,0,162,0,160,30
12 DATA 134,2,132,3,32,145,27,230,3,32,145,27
13 DATA 96,163,255,177,2,201,11,240,8,201,13,240
14 DATA 17,136,208,243,96,169,13,145,2,136,169,12
15 DATA 145,2,200,76,157,27,169,11,145,2,136,169
16 DATA 10,145,2,200,76,157,27,0,0,0,0,0
17 DATA 162,6,254,112,28,202,208,250,162,0,160,30
18 DATA 134,0,132,1,32,215,27,230,1,32,219,27
19 DATA 96,234,234,160,255,177,0,201,15,240,8,201
20 DATA 16,240,11,136,208,243,96,169,16,145,0,76
21 DATA 231,27,169,15,145,0,76,231,27,96,96,0
22 DATA 96,0,0,0,0
90 PRINT"*****JET MAN PART 3*****"
95 PRINT"PLEASE WAIT....."
100 FORA=6912TO7168:READN:T=T+N:IFN=0THENM=S+1
110 POKEA,N:NEXT
120 IF T<23502THENPRINT"DATA ERROR":END
130 IF S<27THENPRINT"ZERO MISSING ERROR":END
135 IF S>27THENPRINT"TOO MANY ZEROS ERROR":END
140 PRINT"NOW LOAD THE NEXT PART"
```

enter:

MERGE""

Press play on the cassette recorder. Once the first part of the program has loaded, stop the cassette and enter:

CLEAR 32767
LOAD ""CODE

Start the cassette. After the main part of the program has loaded, enter:

POKE 60231,0
POKE 42183,11
POKE 59901,82

POKE 56876,4

If you would like to save the new version of Jet Set Willy, prepare a blank tape and enter:

SAVE "JETSET"LINE 10
SAVE "JSW"CODE 32768,32768

If not, to play the new version, enter:

GO TO 40

Remember when saving to change recorder leads.

Software Projects,
Wahon,
Liverpool.

QUELLING THE QL BASHERS

One point overlooked by Kathleen Peel, and QL reviewers in general, is that QL machine code runs some two to three times faster than ZX Spectrum and other eight-bit CPU codes. Benchmark comparisons between one plodding Basic and another are as meaningless as comparing cars by their performance in first gear. Who needs to know? If you are talking speed, you are talking machine code, Forth or Pascal.

Now that the Sinclair bashing season is again in full swing, could I put in a plea for less cataloguing of bugs and more hard connector and interface layouts, interrupts, and documentation?

All computers have bugs and it takes more than a handful of reviewers to find them all. My own theory is that bugs exist in direct proportion to the complexity and versatility of the product. A near perfect computer would take so long to produce it would be obsolete before it hit the streets.

We now seem to be entering a new phase of computer journalism where computers are judged mainly on their freebie software. A case of "Never mind the hardware, just feel the programs". If Psion really has fallen down on the job, some other software house will be only too pleased to plug the gap with a superior and inexpensive product.

The Psion software should be seen for what it is, a plastic toy in the cornflake packet. Also, I cannot understand this fuss is about multi-tasking. You can do it on a ZX-81. If you run several programs, type, print, and Microdrive all at the same time, it will tie your brain in knots, and there would be no excuse to go and make a cup of tea, and have a good think. Multi-masochism I call it!

On a more optimistic note, the mind boggles at the market potential for software authors afforded by 125K plus, 16 bits, and user-friendly 68000 code. Let's face it, without Sinclair, many of us would be on the dole anyway, so why knock it?

Doug Bollen,
London N5.

JET SET ERROR

My letter in the June edition about the Spectrum program Jet Set Willy contains a mistake. Line 25 should be at line 36. Also the letter implied that the Pokes at line 25 would get round the code-checking problem altogether. This is not true.

The Pokes will reduce the number of squares that the program chooses from 180 to 2. The two squares that the program will choose are B2 and C2. So all the user has to do is write down the code for the two squares and then he will not need the card.

Mark Sanderson,
St Andrews,
Fife.

ROM PEEKER

To me, half the pleasure of owning a computer is pottering about, Peeking into the ROM. I was much saddened on discovering that my latest pride and joy, and brand-new Amstrad CPC-464, was better protected than Colditz. Try as I might, I could not Peek into the ROM, and notes in the manual suggested that you could have access to such well guarded secrets as the operating system or paying the ransom for the Advanced User Manual — no doubt another £20.

Surely Mr Sugar you can take pity on such mere "Beginners" as I who have only owned three previous micros and yearn to know how we might examine his mysterious machine.

Matthew Leech,
Leeds,
West Yorkshire.

ATMOS SMASH

Here are some changes which allow my Ori: Smash program published in the May issue to run on the Atmos.

First, type in the machine-code as normal then enter the following commands:

DOKE41583,64464
DOKE41647,6432C
DOKE41663,6432C
DOKE41679,6432C
DOKE42497,6427E
DOKE42569,6429E

Additionally, make line 10 of the screen-generating program read:
10DOKE634,4800L:POKE638,28

Finally, a reassuring word for owners of the Atmos who keep on setting the Errors Found message when loading programs. It does not mean that there are errors in the program just that the volume is probably too high.

M Duniop,
Buckfastleigh,
Devon.

CORRECTIONS

In the July issue the following two lines were left out of listing 1 for the Spectrum Beanstalk program:

1300 DATA 64,255,192,255,64,
63,0,0

1500 DATA 1,3,7,14,28,56,112,32

The last eight lines of listing 3 for July's Vic program, Jetman, were missing. They are given above left.

THE OVERCOATED FIGURE advances into the floodlights. He drops a package in the middle of the barren strip that separates East from West and turns back quickly towards the barbed wire, the dogs and the Kalashnikovs. From the British side a representative of a leading U.K. software house edges forward to retrieve the parcel that contains the latest computer game written by his Warsaw Pact contact.

Not a setting for a new Cold War arcade game. In fact relations between British software companies and Hungarian programmers are particularly warm and cordial. Many of our firms have been reversing the controversy over technological exports to the Eastern Bloc by importing games software from behind the Iron Curtain.

In an attempt to inject some new life into a U.K. software scene which is rapidly running dry of original ideas, program publishers such as Virgin Games, K-tel, Ocean, Mirrorsoft and PSS have looked abroad. Perhaps because Hungarian programmers have not been subjected to decadent Western influences their games writing seems refreshingly original if sometimes a little too relaxed. Chinese Juggler, Bath Time and Felix the Cat are some of the better-known examples of the Hungarians' skill.

This desperate search for originality is an admission of failure. Behind the bankruptcies and belt-tightening that have made this a black summer for the software industry lies the fact that computer owners have grown tired of being sold thousands of variations on the same program themes.

Piracy and the slack summer months may have

taken the blame: the real culprit is the lack of genuinely new software ideas.

A survey of 12 to 17-year-olds by Gowling shows that they are becoming increasingly critical of commercial games. Arcade programs were all too similar.

One way out of the problem would be to make these programs more interactive so that the players could devise new variations of their own once the original structure became tedious. But that flexibility costs memory and many of the best games at the moment are already using the big-selling micros' memories to the full.

Over the last three years progress in software has been carried along on the back of the rapid development of new machines. Now that hardware innovation at the bottom end of the market has slowed to a trickle and the program writers' techniques push existing machines to their limits, imagination now seems to be the problem.

So, what new hardware could help them on? Larger memories and cheaper storage would be a good place to start but the real transformation will occur when the laser discs behind arcade smashes such as Firefox and Dragon's Lair become available to home micro users. The Japanese are already working on a single system which would incorporate laser data storage with video and compact audio discs.

Unless new software ideas come along soon computing will become a static fad and everyone knows that fads die. Locking the stable door and then shooting the horse is not the subtlest way of making sure that you keep your audience captive.

How to write for Your Computer

We called this magazine *Your Computer* precisely because we welcome your views, tips and hints and even your criticism of machines and software in general. If you would like to see your name in print, whether on a Software File program or a full-blooded article, here is how to go about it. Ideally, all articles should be typed double-spaced on one side only of uniform sheets of paper. If listings can be dumped directly from a printer — you can always use a friend's or user group's — this minimises the risk of error. In a perfect world a cassette would accompany the article. That considerably speeds up the checking process. Not only do you get to air your own discoveries and opinions, but we will even pay you for the privilege. We pay £35 per published page — that's as it appears in the magazine and includes illustrations.

Why not give it a try? You have nothing to lose but your postage.

Editor
TOBY WOLPE

Assistant Editor
MEIRION JONES

Software Editor
SIMON BEESLEY

Production Editor
IAN VALLELY

Sub-editor
PAUL BOND

Editorial Assistant
LEE PADDON

Editorial Secretary
LYNN DAWSON

Editorial: 01-661 3144

Subscriptions: U.K. £11.50 for 12 issues.

Printed in Great Britain for the proprietors
Business Press International Ltd, Quadrant House, The
Quadrant, Sutton, Surrey SM2 5AS. Tel: 01-661 3600
Telex/grans: 892084 BIPRESG. ISSN 0263-0865.
Printed by Riversdale Press Ltd, Whitstable, Kent, and
typeset by Instep Ltd, London EC1.

ABC

154,334

January-June, 1984.

Advertisement Manager
SHOBHAN GAJJAR 01-661 3127

Assistant Advertisement Manager
NICHOLAS RATNIEKS 01-661 8548

Advertisement Executives
NIGEL BORRELL 01-661 3660
JULIAN BIDLAKE 01-661 8458
KAY FILBIN 01-661 8484

Northern Office
RON SOUTHALL 061-872 8861

Advertisement Secretary
MAXINE GILL

Classified
LUCY O'SULLIVAN 01-661 3036

Publishing Director
CHRIS HIPWELL
Your Computer, Quadrant House, The
Quadrant, Sutton, Surrey SM2 5AS.

© Business Press International Ltd 1984

Stranglers search for an ear in an Aural Quest adventure



THE STRANGLERS become the second bunch of punks from 1977 to stick a computer game on their new album. After Pete "Spiral Scratch" Shelley's XI.1 now The Stranglers, are putting an adventure game for the 48K Spectrum on Aural Quest, their new album which will be released in November.

Dave Greenfield, whose keyboards on Rattus Norvegicus reminded so many people of The Doors, swaps a piano keyboard for a Qwerty when he gets home and becomes a made keen adventure player.

The game on Aural Quest will be search for pieces of the ear with

bursts of Stranglers music and lyrics providing some of the clues. Mike Turner of Star Dreams wrote the

program using Gilson's Quill — a sausage machine for making instant adventures.

The search for the Enterprise — mission accomplished

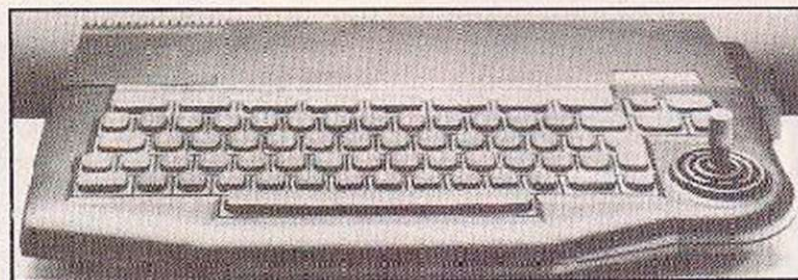

ENTERPRISE computers may be in the shops by the end of September according to marketing manager Mike Shirley. "Unlike the others" says Mike "we're not making any silly claims." Enterprise should certainly know about silly claims — in September 1983 when the Enterprise then calling itself the Elvan was launched the company claimed that the first Enterprises would be in the shops by April 1984.

Dragon alive but in Spain

DRAGON DATA just lost the race to develop urgently needed new products before the company collapsed. While new machines including Dragons with built-in disc drives and OS-9 operating system were being demonstrated at shows in London over the summer the Receiver was on his way in. Now a Spanish firm, Eurohard SA, already producing Dragon components has bought Dragon for a million pounds and will start production in Spain this autumn.



Mike Shirley says "There's no product that's come out in the last 12 months which puts us in the shadow."

GEOFF HOLLINGTON who featured in our January 1984 issue as leader of the external design team for the Flan — sorry, Enterprise — has not been idle as he waited for his creation to finally go on sale. He has designed an infra-red joystick for the Spectrum which does away with the need for wires. The stick will be sold by Chetran.

Big in Japan isn't big enough or Sega the Tokyo-based video games company which is now trying to find an importer for its



Dreams are made of this

ELECTRIC DREAMS is a simple tale of boy meets girl, boy meets computer, computer meets girl but the production company Virgin Films, "You've bought the record, you've flown the airline, you've pirated the computer game now see the film" sees it as a story fit for our epoch.

"Gone with the Wind added romance to the depression-defeated 30's. John Wayne's pugnacious patriotism reflected the war-torn 40's. Doris Day and Sandra Dee movies symbolised the innocence of the 50's. While Woodstock and Easy Rider caught the beat of the 60's, Star Wars and Raiders of the Lost Ark delivered the heroes missing in the real life of the 70's. An apt film for the mid 80's is Electric Dreams, a contemporary fairytale about a computer who falls in love." Try telling that to the average ZX-81 owner.

SC-3000 home computer in Britain. The 32K machine has a real keyboard and cartridge slot with a price tag of £150.

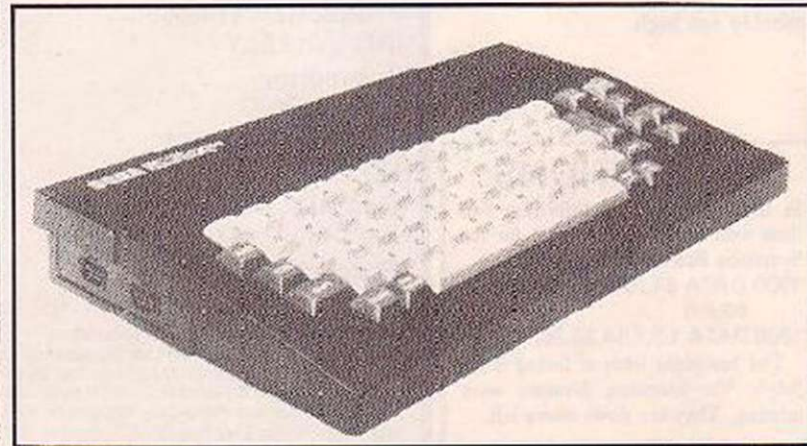

YOUR COMPUTER TOP 20

| Game | Company | Machine |
|---|-------------------------|----------|
| <input type="checkbox"/> Arabian Nights | Interceptor | CBM 64 |
| <input type="checkbox"/> Beachhead | US Gold | CBM 64 |
| <input type="checkbox"/> Blue Thunder | Foundry System | Spectrum |
| <input type="checkbox"/> Cuthbert in the Jungle | Microdeal | Dragon |
| <input type="checkbox"/> Decathlon | Activision | CBM 64 |
| <input type="checkbox"/> Football Manager | Addictive Games | BBC |
| <input type="checkbox"/> Fortress | Amcom | BBC |
| <input type="checkbox"/> Frak | Aardvark | BBC |
| <input type="checkbox"/> Hulk | Adventure International | CBM 64 |
| <input type="checkbox"/> Jet Set Willing | Software Projects | Spectrum |
| <input type="checkbox"/> Lords of Midnight | Beyond | Spectrum |
| <input type="checkbox"/> Matchpoint | Psion | Spectrum |
| <input type="checkbox"/> Mugsy | Melbourne House | Spectrum |
| <input type="checkbox"/> Sabre Wolf | Ultimate | Spectrum |
| <input type="checkbox"/> Squirm | Mastertronics | CBM 64 |
| <input type="checkbox"/> Sub Commander | Creative Sparks | Vic 20 |
| <input type="checkbox"/> Tornado Low Level | Vortex | Spectrum |
| <input type="checkbox"/> Tronman | New Generation | Spectrum |
| <input type="checkbox"/> Zaxxon | Starzone | Spectrum |

More new ROM antics

SINCLAIR ARE NOW SENDING ROM refit vouchers to all customers who have received the early EPROM QLs with FB, PM or AH operating systems. Those very early customers with FB or PM versions must also return the software package for an upgrade.

A prepaid parcel label is supplied and a turn round time of 10 days of receipt at Camberley is promised. In order to achieve the fast turn round, customers may not receive back their own machine but the guarantee period will commence from the time of the ROM upgrade. A Sinclair spokesperson said those customers who would find it difficult to be without the QL for a short period of time could apply for the ROM set in lieu, each case would be treated sympathetically.

The QLs will be given the JM ROM set which is AH with what is described as cosmetic change to tidy things up. For those still unaware of the JM bug state, the major problems are Pi, which causes overflows on some 0° and 90° trigonometric calculations. Solutions use Rads instead, and the RS-232 interface where there appears to be a timing problem with many of the other less expensive printers which do not work with the QL.

The one that got away

IF YOU ARE still looking for the August issue of *Your Computer* it seems only fair to tell you that there wasn't one. We weren't on holiday but on strike. Subscribers will have an extra issue added on at the end of the year.

England search for fast bowlers spreads to Iceland

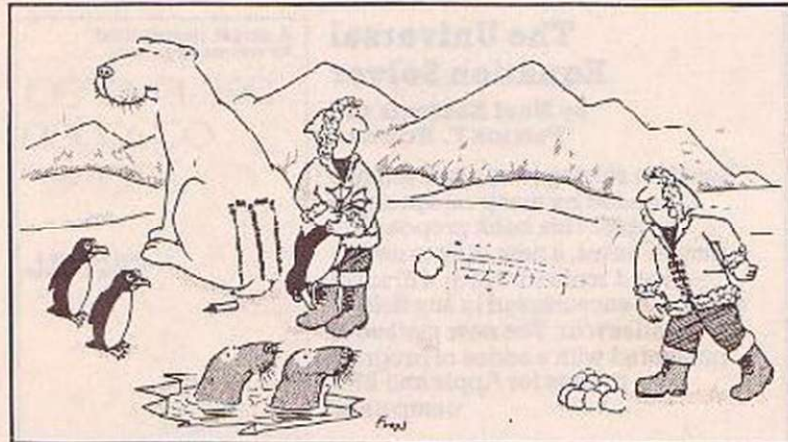

DESPEATE MEASURES are being taken in the wake of England's 5-0 drubbing by the West Indies. Peaksoft is exporting Tim Love's Cricket for the Commodore 64 and Dragon to Iceland in the hope of encouraging the Norsemen to put together an Eleven which Gower and

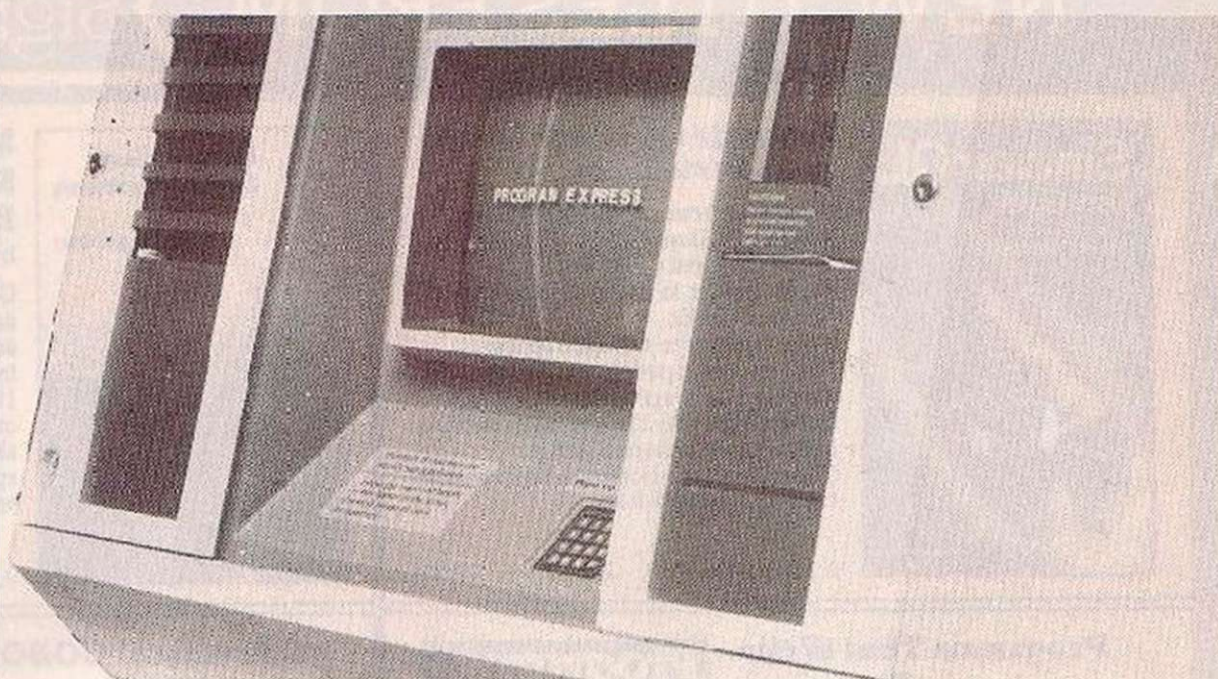

The vending machine with a difference

THIS IS WHAT the software shop of the future may look like if Program Express has its way. Eventually you could see them on street corners like cash vending machines outside banks although the first units are being

Pools fortune hunters

HARTLAND SOFTWARE is kicking off the new season with a new BBC version of the football pools prediction program which has already sold well on the ZX-81 and Spectrum. Unfortunately, it does not include a database of this year's fixture list so you have to enter that yourself. Hartland is on 01-385 1939.

installed inside branches of John Menzies. Each unit has a stock of blank cassettes, cartridges and floppy discs and a telephone link to a central computer which stores the programs.

CRL's Magic Roundabout

BOING! said Zebedee, and well he might on finding out that Clement Chambers of CRL had signed up the Magic Roundabout along with Thunderbirds and Terra Hawks. CRL has six full-time programmers including Richard Taylor who learnt his trade writing articles for *Your Computer* plus a large number of part-timers and freelancers.

The programs will be available this autumn — first on the Spectrum then on the Commodore 64. In Magic Roundabout Dougall has to build a house of sugar while facing raids by Ermintrude the cow, Mr McEnry and all the other characters. "Time for bed" said Zebedee BOING!

The struggle to turn the Electron into a BBC continues with Broadway Electronics £30 Mushroom sideways ROM card. This allows you to plug in word processing, graphics or spreadsheet ROM chips as you can on the BBC.

You just ask for the game or piece of business software you want and the shop assistant runs off a copy for you. The claimed advantage is that the shop can never run out of stock.

Cheap at the price

BARGAINS ARE THIN on the ground this autumn but some shops have been selling Dragons for as little as £99, Electrons for £170, and BBC Bs for £350. Ring up and tell us if you see any cheaper prices. Officially, Sinclair and Acorn are discouraging discounting but going for added value offers instead.

Sinclair is offering £56 of free software with every 48K Spectrum sold — and for once this includes some of the best programs around including Scrabble and Chequered Flag. Chess, Survival, Make a Crisp and Herace Goes Skiing make up the rest of the bundle. Acorn is offering a free data recorder with five free programs with every BBC sold.

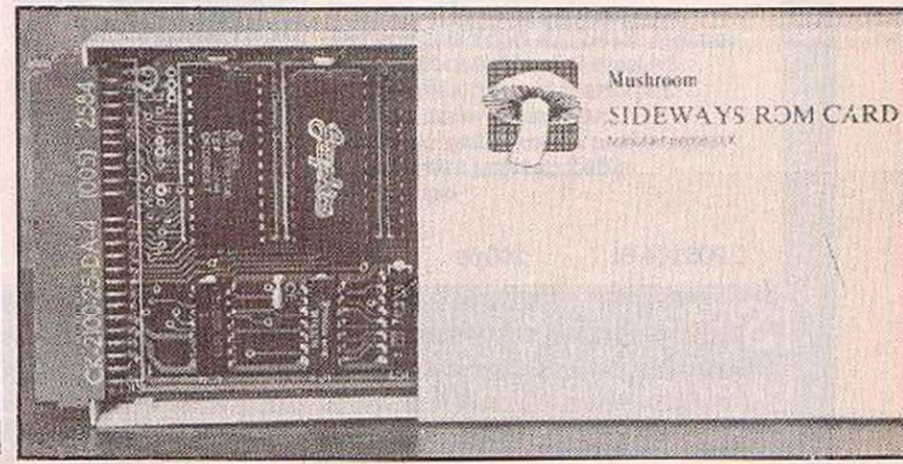

NEW TITLES FROM Sigma Press



Sinclair QL: User Guide

by Lionel Fleetwood
 Whatever your requirements, the Sinclair QL User Guide will help you to get the most out of your new purchase - or to decide if you should purchase a QL. It shows how to produce letters, keep records, prepare accounts and draw useful graphs. Examples are drawn from real life and each section can be used independently. Throughout the book the language is clear and jargon-free.

0 905104 92 7 180pp £7.50



Microcomputer Speech Synthesis and Recognition

by Adrian Poulton
 Computerised speech synthesis and its counterpart, speech recognition, are emerging as one of the most important technologies of the mid-1980s. This book explains the origins of artificial speech and shows you how to make your micro speak to the world and how you can speak back to it!

0 905104 39 C 202pp £7.95

Programs That Write Programs

by Chris Naylor

In this thought-provoking book Chris Naylor explains exactly what a program generator is and exactly what it can and cannot do. With the emphasis on the business user, he examines the situations commonly found in any programming project and shows the interaction between the problem to be solved and the software tools available to implement any solution.

0 903104 43 9 226pp £7.95



Practical COBOL for Microcomputers

by Kevin Sullivan

BASIC is a fine language, but most business applications use COBOL, which is now widely available for all popular microcomputers. And, it's not a difficult language to learn: Kevin Sullivan takes you from writing the simplest possible COBOL program, through the use and design of screen layout, right up to handling all types of file.

0 905104 60 9 160pp £6.95

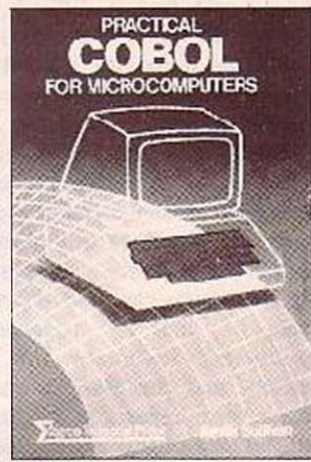

Operating Systems

-a user friendly guide



Operating Systems: A User Friendly Guide

by Alan Trevenor

A 'friendly' guide that uses the widely-used Digital Equipment Corporation's operating systems for its examples and spans the range of large minicomputers, all the way down to the new micros. After describing the major components of all operating systems, the author describes how files are handled, error handling, hardware features and optimisation of hardware and operating systems.

0 905104 66 8 180pp £8.50

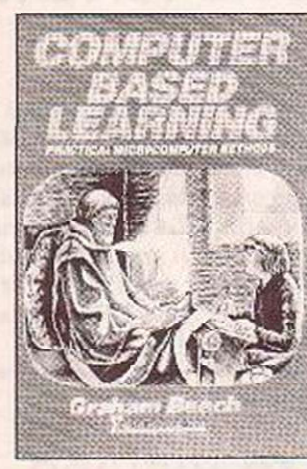

Computer Based Learning: Practical Microcomputer Methods

by Graham Beech

This is a definitive but practical book for all those wishing to educate, learn or train with the help of a microcomputer. To instil confidence, there is a comprehensive review of existing successful applications. These all use affordable microcomputers, and so can you!

0 905104 45 5 302pp £8.50

All About Computer-Aided Design and Manufacture

by James Fellows

Confused about CAD/CAM? Then, this is where to start. No more seminars, no piles of books and leaflets. Read this book and you will be able to understand all the important concepts that are so necessary when you are responsible for installing computer aided design/manufacture equipment.

0 905104 61 7 200pp £9.95



The Universal Equation Solver

by Noel Kantaris and Patrick F. Howden

Equation solving is an art or science needed by many categories of people. This book proposes, in simple terms, a new easy to understand method which will solve equations encountered in any field of endeavour. The new method is presented with a series of program listings for Apple and BBC computers.

0 905104 40 4 120pp £6.50

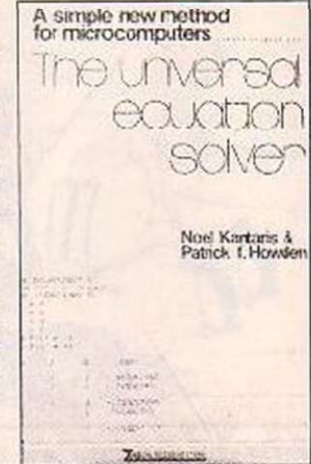

SIGMA PRESS publish a wide range of books relevant to all aspects of microcomputing. Available through good bookshops and computer stores.

Σ The key to better computing

MARKETED BY JOHN WILEY & SONS LTD, RAFFINS LANE, CHICHESTER, SUSSEX PO19 1UD, ENGLAND

I could do that...

June's problem drew such a disappointing response that we decided to give you another chance. Do not be intimidated by the term Artificial Intelligence. We are simply looking for a program which allows you to have a conversation with the computer. What we have in mind is a dialogue along the lines of "who's there?" — "John" — "go away, John", but the wittier or more intelligent the computer's responses the better. The program should not be longer than 20 single statement lines. June entries will be held over.

We will award the £15 prize to the program whose questions and responses are judged to be the most amusing, or apparently intelligent.

BEGINNERS

First Bytes

Starting out in home computing? First Bytes is for you. Just write to *Your Computer* with any hardware or software problems, no matter how small or simple.

Artificial Intelligence

THE IDEA THAT one day a computer brain may be more intelligent than you may seem unlikely as you struggle with the funny keys on your Spectrum. But when the first computers were built in the 1950s, many programmers believed that the dream of artificial intelligence or AI was not only realisable, but also just a matter of time.

It still is, but rather more time than they thought. Nowadays we are a little bit more realistic in what we expect from our bits of silicon.

(continued on page 39)

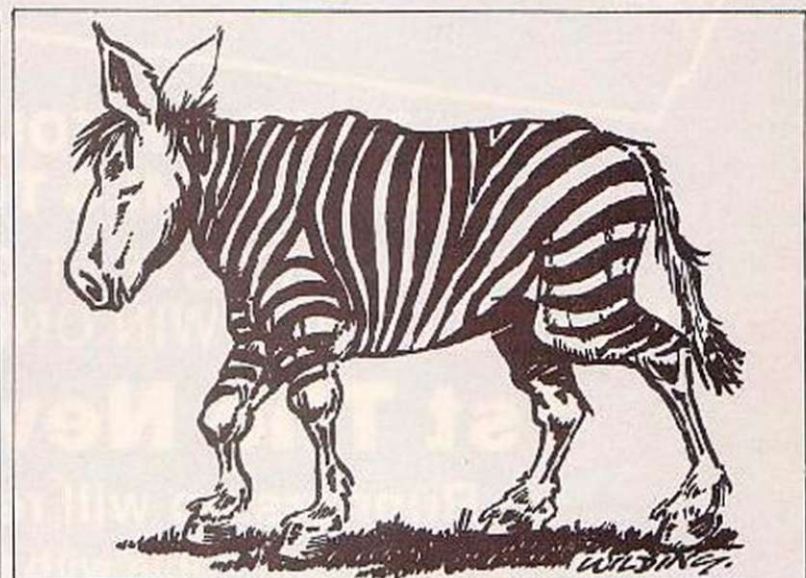

How to design and produce structured programs

YOU ARE THE PROUD new owner of a microcomputer. You've tried the "Welcome" tape, and perhaps typed in the programs in the manual and one or two listings from *Your Computer*. Now it's your turn: you've got a great idea and off you go, charging through the program using all those neat tricks you saw in the manual.

However, if the program is any more than about 10 lines long, the chances are that it won't run first time. What a disaster, your program is doing all the wrong things and you can't understand why.

When you look back at your program you find it's got more tangles than a plate of spaghetti. Frankly the chances of untangling it all are so slim that you might just as well pull the plug and start again.

So what is the answer? Right from the start you must develop a disciplined approach to your programs. Professional software writers use "structured programming" techniques.

They first express the problem they must solve in terms of functional blocks and then dissect these blocks into individual procedures and decisions. Only after all this do they get down to the relatively easy task of turning this plan into code that the computer will actually execute.

Perhaps this is asking too much of the amateur, after all, all he wants to

do is get a result out of his program as quickly as possible. He is not interested in winning points for neatness and style. However, if a little of this sort of discipline is used, you may find that your programs become easier to write, and above all, easier to put right when things go wrong.

Try to write some sort of flowchart for your program. This will allow you to see what the program is going to do next. Hopefully you will be able to work out how things should look as you go from one part of your program to another. Now you come to actually writing the code.

Since you will probably be using Basic, at least to start with, what should you look for in a well structured program? Well, there should be a series of subroutines, each corresponding to one of the boxes on your flowchart. This means that the pieces of your program are small, and so you should be able to list the whole routine on your screen at the same time.

The routine should perform a clearly defined function, and it should be possible to test it independently of the main program; you put test values in, of the sort you expect, and you make sure that when the subroutine has been run, the results are what you expected.

To take a simple example. Suppose your program needed to calculate the area of a circle. The subroutine to do

this would look something like this:

```
999 REM CALCULATE AREA OF  
CIRCLE RAD US R  
1000 A=3.14159*R*R  
1010 RETURN
```

Although rather trivial it demonstrates the principle. The subroutine performs one simple function and could easily be tested. You would simply type in:
R=3:GOSUB 1000:PRINT A

With a bit of luck, it should come back with 28.274 or thereabouts. Once that is done, you can forget about that module. A further refinement would be to check that the value of R was within a certain range. If it was not then a suitable error message could be printed or a flag set so that the main part of the program knew that a mistake had been made.

So what should a more sophisticated subroutine look like? Obviously, since you must use the Return statement to return to the part of the program the routine was called from, control must pass in an orderly fashion from the first statement to the last.

There should be no jumps from the subroutine, except to other subroutines, and there should be no loose ends when you have finished the routine. This means there should be no For-Next loops still uncompleted. In this way the subroutine can be easily pulled apart should anything go wrong.

Basic is perhaps not the best language for developing this disciplined approach to programs. It lets you get away with too much. The For-Next loop is often a source of trouble. For instance the following seems reasonable enough.

```
100 FOR I=1 TO 100  
110 GET KPS  
120 IF KPS<>" " THEN 350  
130 NEXT I
```

This is a simple reaction test routine. It gives the player a certain length of time to press a key. If the player does then the program goes on to find out which key was pressed, if not the program continues with the routine.

However, you have just jumped out of the middle of the loop. Better to use a Repeat-Until structure. If your Basic does not have this command, then you will have to make do with the following fudge.

```
99 REM KEY PRESSED?  
100 FOR I=1 TO 100  
110 GET KPS  
120 IF KPS<>" " THEN I=100:  
KP=1  
130 NEXT I  
140 IF KP=1 THEN GOSUB 1000:  
REM KEYPRESS ROUTINE  
150 RETURN
```

In line 120, I is set to its limit value and a flag is set. As I has reached 100, the computer exits from the loop and, by looking at the value of KP, now tests to see if a key has been pressed. If it is 1, then the computer

(continued on page 39)

Win a Fabulous **SINCLAIR QL COMPUTER!**



**TIRED OF YOUR OLD TAPES?
NEW GAMES TOO EXPENSIVE?**

**JOIN THE FASTEST GROWING SWOP CLUB
AND YOU COULD WIN ONE OF EIGHT GREAT PRIZES!**

1st The New Sinclair QL

Runners up will receive the following
(compatible with their own computer)

- 2nd Disc Drive Unit**
- 3rd Alphacom Printer**
- 4th Protek Modem**
- 5th Voice Synthesizer**
- 6th Stack Light Rifle**
- 7th Triga Command Joystick**
- 8th Light Pen**

Or cash equivalent if you prefer! Just send 3 x 17p stamps
and completed coupon for intro pack and competition entry form.

FULL NAME

ADDRESS

..... POST CODE

COMPUTER MAKE MODEL MEMORY

YC2

Swoppatape

PO BOX 18 · HESWALL · WIRRAL · MERSEYSIDE · L60 1YN

Artificial Intelligence

(continued from page 37)

Instead of trying to copy some vague concept like "intelligence" which includes everything from perception, recognition, logic, intuition, and guesswork to commonsense, wisdom and perhaps even emotions, AI limits itself to very tiny specific areas.

These are often called expert systems because, like a human expert, they have detailed knowledge but only in a limited area. For example programs have been written that "know" as much as anybody about blood diseases, chemical analysis or oil prospecting, and which can be used by anyone who understands the technical terms.

Expert systems are becoming increasingly common in hospitals, laboratories and industry.

It is a strange fact that it is much easier to program a computer to be a world expert on obscure diseases than it is to get it to understand an English sentence. But it is precisely in these everyday activities that the secret of our intelligence seems to lie.

Recognising people and places, being able to pick out one conversation when several people are talking at once, or even just moving across a room without falling over or hitting something are things we take for granted but which, so far, have defeated the most sophisticated programs on the largest computers.

Part of the problem is finding the right way of programming. In Basic you tell the computer what to do at every point in the program: it is an imperative language. But to recognise some rare blood disease or a badly pronounced word we can hardly spell out to the computer how it should find the answer; if we could, then we would not need the computer. Instead, programming languages and techniques have to be developed that enable the computer to find its own way to the solution.

One of the first languages used in AI was Lisp, short for List Processing. This grew out of the idea that a lot of our knowledge is based on lists of things — words, facts, ideas. So, the language is built around the easy handling of lists.

More recently, the language Prolog has been gaining in popularity. The name comes from Programming in Logic and moves a step closer to intelligence by building in the same ideas of logic that we use.

If you want to try your hand at turning your micro into some expert system, Lisp is available for a number of home machines including the BBC. Prolog is still limited to the more expensive professional micros, but will doubtless filter down eventually. Another language that is becoming increasingly popular in the AI field is Logo, better known for its turtle graphics.

For the real enthusiast who wishes to make AI do something there is always the micro-mouse competitor which combines AI and robotics. An

independent microcomputer-controlled device has to find its way to the centre of a maze in the shortest time. It is allowed several tries and can therefore gradually learn the plan and use its intelligence to work out the quickest route. This is all good fun but clearly AI has rather a long way to go before we produce the all-singing, all-dancing intelligent android.

BEGINNERS

first bytes

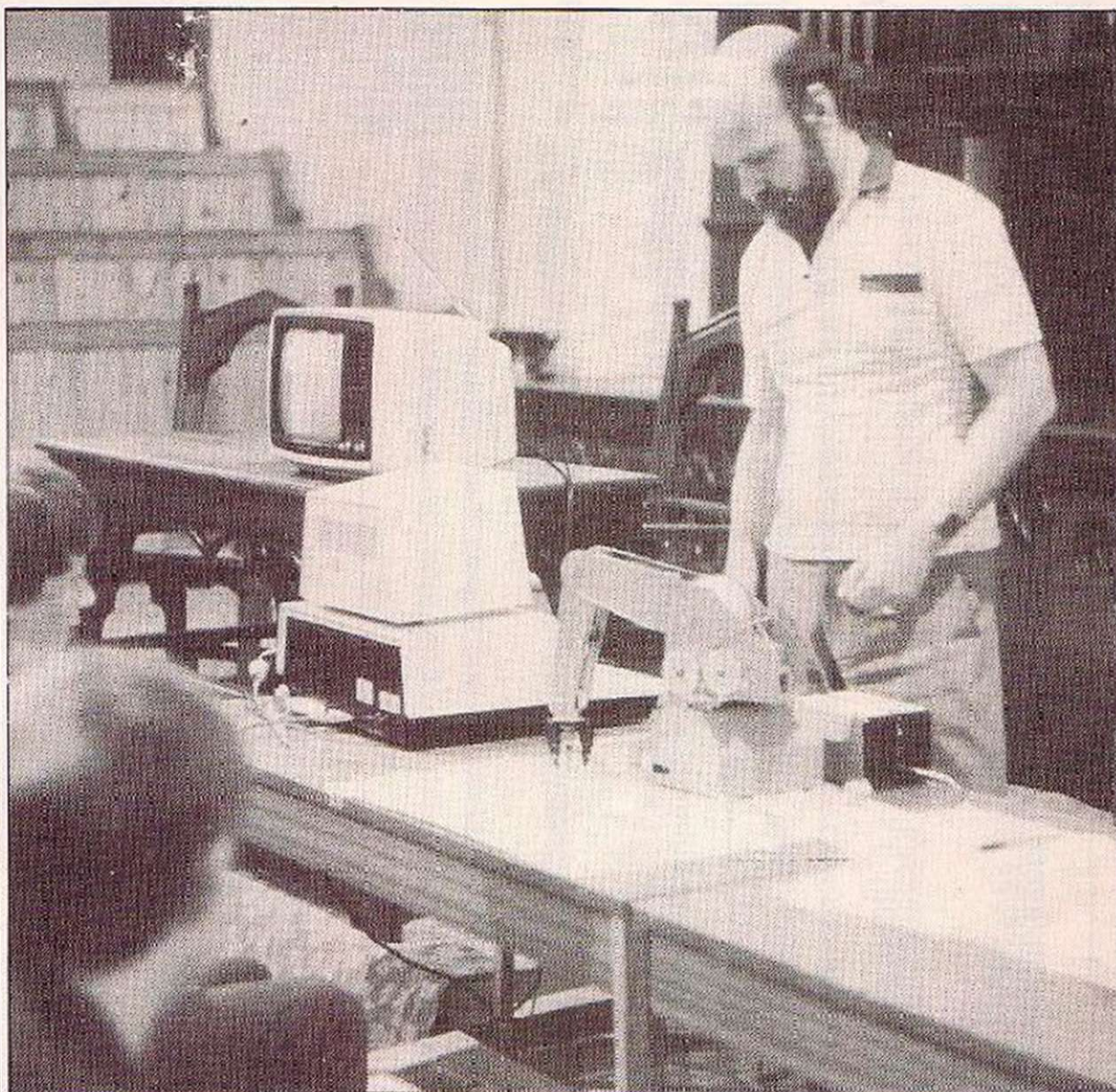

How to produce structured programs

(continued from page 37)

goes to the keypress subroutine. Of course KP would have to be set to zero before this routine was used again.

So much for the subroutines, what about the main program. This should start at the beginning, go to the end, and there stop. Control should flow from the first line to the End statement calling subroutines as it goes. Avoid Goto like the plague, especially the computed Goto.

You may think this is a recipe for a very dull program; if you can not change the direction of the flow of the program how will it do anything different? That is simple, your main routine will call subroutines according to what happens, just like the keypress example given above.

The beauty of subroutines is that as long as they have been written correctly, they always pass control

back to the point they were called from, preserving the linear flow of the program.

Ideally all these subroutines should be placed after the main program, fenced off from it by an End statement. However, as I am sure you are aware, Basic interpreters look for lines from the top down. So if you require speed, your most often called subroutines will have to be at the beginning of your program. This means that the very first line of your program will have to be a Goto statement which will skip the subroutines and start executing the main program. Hardly pretty, but effective.

There is so much more that can be said about good programming technique; this article has concentrated on just one aspect: making sure you know where your program is going. Tracing the path

taken through your program when it is being executed is vitally important, a task made a lot easier if you have some sort of trace command in your Basic vocabulary.

It cannot be emphasised enough that if you jump around all over the place and leave loose ends hanging around, sooner or later you are going to be tripped up. Perhaps you will get away with it to start with, but as your programs become more involved the problem will get worse. You may also have a tough time if you want to add a bit to your program at a later date to enhance it. You will have forgotten exactly how you wrote it.

Should you start to use machine-code, exactly the same principles apply, only more so. Losing control of a machine-code routine will usually result on the machine hanging up as the processor blindly blunders on through your code.

If you have anything of interest to tell us about your computer club why not contact us on 01-661 3144.

Local news

Harrow

LUG is the acronym for Lynx Users Group. It takes over from NILUG, as Mr R Poate is closing down operations. Are you a Lynx user feeling out in the cold? Contact Mr R B Jones, 209 Kenton, Harrow, Middlesex. Telephone: 01-907 3406.

Burnley

The International Sinclair User Group was formed in August 1983, following the closure of Tim Hartell's National ZX User Group. ISUG now boasts members in Elre, Germany, Spain, Malaysia and Saudi Arabia. Membership brings a monthly newsletter and 20 per cent discounts on a wide range of software. Contact ISUG, 189 Rosehill Road, Burnley, Lancashire.

Truro

The Truro and St Austell Colour Genie User Group keep the flame burning in the Tandy Shop, St Austell, Cornwall on the first Friday of every month except May and July. 50p per meeting to cover expenses. For more details, contact Janine Allen, Floghoeth, Point Road, Carnon Downs, Truro, Cornwall.

Shrewsbury

The 32K Vic-20 Users Club shies away from gross commercialisation, but has been set up to give more to this minority group of users. Anyone who wishes to join can submit and request programs, just paying the postage required. There will also be a regular newsletter. Contact M Valentine, 101A Underdale Road, Monkmoor, Shrewsbury, Shropshire SY2 5EF.

COMPUTER

If Shakespeare had been born 400 years later, would he have been a printed circuit bard? Paul Bond goes in search of micros in the great man's birthplace.

IF ALL THE YEAR were playing holidays, to sport would be as tedious to work. Thus the great bard of Avon on moderation in recreation; nevertheless, since it is that time of the year when most computer clubs experience a slight drop in attendance, due to the "playing holidays", it was understandable that the Stratford-upon-Avon computer club should have less than a full house when *Your Computer* paid its visit.

John Williams, editor of the club newsletter, was in control of things on the evening of our visit, as club secretary Chris Parry was occupied with technical rehearsals at the local Shakespeare Theatre, where he is in charge of stage lighting.

The club was formed in May 1983 to promote greater interest in personal computing and to help its members use, learn about and understand personal computers in general.

There were 98 members at the last count, encompassing machines ranging from Nascom IIIs to TI-99/4As to ones which have enjoyed greater commercial success on the open market.

John Williams has about 33 RML 480Zs in his care at the South Warwickshire College of Further Education, where he is a computer technician. Nevertheless he has managed to avoid being roped in to the teaching events which the club runs apart from its regular meeting on the second Wednesday of every month at the Wesley Hall, opposite Trinity Church, Stratford-on-Avon.

A Methodist minister from Wellsbourne, the Reverend Farthing, has been giving a series of exhaustive lectures on Z-80 machine code, and other members teach Basic at various levels.

John Williams had given a talk about Pascal: "Most people have



seen a bit of Basic, but very few get opportunities to glimpse any other language."

Stratford-on-Avon is becoming a bit of a haven for would-be computer users, it would seem. There are summer schools at the aforementioned South Warwickshire College of Further Education, attended by people from all over Great Britain, who want to revel in the local scenery and cultural heritage at the same time.

Sisters Caroline and Julia Tate had the advantage of a BBC Micro at home and had to admit that they were keen games players, though they didn't subscribe to any of the popular myths about girls particularly liking Pac-Man. Neither did Caroline's computer class at school find it necessary to segregate boys and girls in order to make sure that girls get a fair chance.

Adam Tate, who denied any familial connections with the previous two was the proud owner of

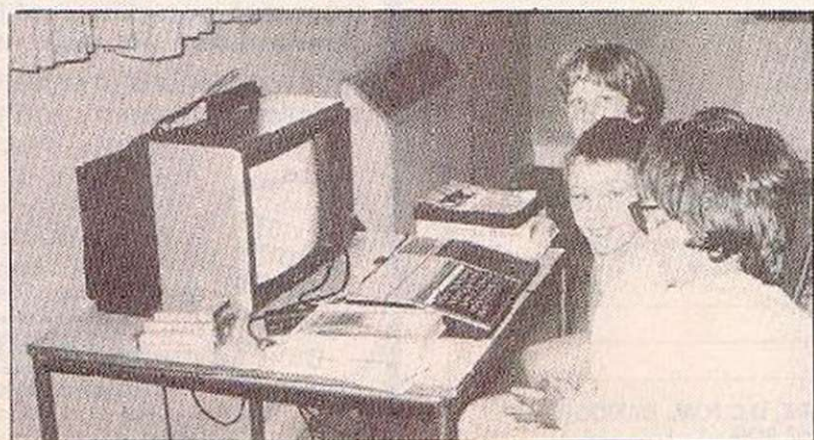

a TI-99/4A. He was more than happy with the implementations of Space Invaders and Wumpus on this machine, and spoke of rumours of the machine's coming back into production in much the way NewBrain owners are known to do.

An exalted use for the humble BBC, not immediately thought of as a laboratory tool, was revealed by Barry Lancashire from the National Vegetable Research Station, at Wellesbourne. Nevertheless, this is the micro recommended by the Agricultural Food Research Council (AFRC). The NVRS uses it for image analysis of crops photographed from the air by a radio controlled video camera suspended by gimbals from aeroplanes, kites, balloons, balloons-cum-kites. "We've tried everything except Microlites," said Mr Lancashire.

The BBC is also used for transient waveform analysis of information from pressure transducers.

As far as image analysis goes, Mr Lancashire said. "It's not the image, but the way of getting it. Colour and tone can be confused: pale green foliage might be confused with pale dry soil, for example. Infra-red photography seems most successful." Despite its cost-cutting exercises the NVRS, whose work is valuable to third world countries, finds itself facing the axe from a government more concerned with defending people than with feeding them.

The club itself also looks forward to a more hi-tech approach: facilities for control projects are to be provided by a local company, SI-Plan Electronics. Club info from Chris Parry on Stratford-on-Avon 68080.

Half a box is better than one?

50 s/s d/d disks + box - £50 plus VAT and P + P
 50 d/s d/d disks + box - £75 plus VAT and P + P

25 s/s d/d disks + box - £29 plus VAT and P + P
 25 d/s d/d disks + box - £39 plus VAT and P + P

Every order of 25 or 50 comes packed in the same rigid plastic storage box with four dividers, and all disks carry our five year guarantee.

To order, just clip the coupon below.

We accept orders from all government bodies, schools, universities, libraries, armed forces
 We despatch on receipt of an official purchase order.

If you can't raise a cheque without an invoice please post or telephone your order and we'll send you a proforma by return.

Disco Technology Limited, 20 Orange Street, London WC2H 7ED. Telephone 01-930 1612



Please rush me (qty) box(es) with 50 s/s disks at £59.50. (qty) box(es) with 50 d/s disks at £87.25.
 (qty) box(es) with 25 s/s disks at £33.65. (qty) box(es) with 25 d/s disks at £47.15.
 (qty) empty box(es) at £11.

(Prices include VAT and P + P. I enclose cheque for _____
 or debit my Access card no. _____

Name _____ Signature _____

Address _____

Postcode _____ Telephone _____

To Disco-Technology Ltd,
 20 Orange Street,
 London WC2H 7ED



PCW/8/84

© Certain Advertising Ltd 0-930 1612

Akadimias

EDUCATIONAL SOFTWARE

STUDY AIDS FOR GCE & DEGREE STUDENTS

RIGOROUS MULTIPLE CHOICE QUESTIONS SET BY SPECIALISTS
 TIME BASED TESTS • DIFFERENTIAL SCORING
 4 SKILL LEVELS • REVIEW, TEST & RANDOM TEST MODES
 PACKAGE INCLUDES PROGRAM, STUDY NOTES & READING LISTS

SERIOUS SOFTWARE FROM THE UNIVERSITY COLLEGE OF NORTH WALES

CURRENT TITLES INCLUDE:

- HY01 TUDOR ENGLAND, by Professor D.M. Loades.
- HY02 STUART ENGLAND by Dr. A.J. Dyer
- HY03 BRITISH HISTORY 1714-1815, by Dr. A.J. Crozier.
- HY04 NINETEENTH CENTURY ENGLAND, Roberts Canning.
- HY05 ENGLAND IN THE AGE OF TOTAL WAR, by Dr. A.J. Crozier.
- HY06 RENAISSANCE EUROPE, by Dr. J.P. Canning.
- HY07 16TH EUROPE, Forthcoming.
- HY08 17TH EUROPE, Forthcoming.
- HY09 18TH EUROPE, by Dr. A.D. Dyer.
- HY10 EUROPE 1789-1870, by Dr. I.A. Talbot.
- HY11 EUROPE 1870-1950, by Dr. I.A. Talbot.
- HY12 THE FRENCH REVOLUTION, by R. Axworthy.
- EG01 ANTONY & CLEOPATRA, ed. by Dr. Margarette Smith.
- EG02 THE TEMPEST, ed. by Paul Davies.
- EG03 HENRY IV PT.1, ed. by Paul Davies.
- EG04 MANCHESTER PARK, ed. by Dr. Margarette Smith.
- EG05 THE TRUMPET MAJOR, ed. by Paul Davies.
- EG06 JMB POEMS, ed. by Paul Davies.
- EG07 HAMLET, ed. by Dr. Margarette Smith.
- EG08 CHAUCER PROLOGUE, ed. by Me Jones.
- SC01 'A' LEVEL SOCIOLOGY, by John Eorland.
- EM01 'A' LEVEL ECONOMICS, Forthcoming.
- P101 'O'/'A' LEVEL PHYSICS DEFINITIONS, by Dr. D. Wright.

Please tick the boxes for titles required at £9.95 per title (inc. P & P) and specify for (BBC/B) or (Spectrum 48K) (delete) or send S.A.E. for further details.

I enclose cheque/postal order for £ _____ payable to
 The University College of North Wales

MR/MRS/MISS _____

ADDRESS _____

Send to: AKADIMIAS SOFTWARE, U.C.N.W., BANGOR,
 GWYNEDD LL57 2DG

TURN YOUR COMMODORE 64 INTO A PROFESSIONAL MICROCOMPUTER

FIELDMASTER high quality programs are for the serious user of the home computer. The very latest programming techniques have been used to create clear, easy to use software that must be the finest value available.

We have a program for all your needs:-
 Powerful spreadsheet, full function 80 column word processor, versatile 'card index' database, accounts management, and even a logo & poster printer.

For applications in small business, education, the professions, industry and the home, etc.

Prices from £21.95 to £84.95 inc VAT tax and disk. From your local computer shop or direct from us by our fast mail order service. Access/Barclaycard welcome.

For a FREE copy of our software guide, packed with program information, just write or telephone.



Fieldmaster Software Company
 Dept YC, 107 Oakwood Park Road, Southgate, London N14 6QD. Tel: 01-886 6709
 a division of Young Electronics Ltd. (Established 1970)

Star★ chart

Alcatraz Harry

48K Spectrum:
Graphic adventure:
£1.99:
Mastertonic:

★ ★ ★

Alcatraz Harry is bent on escape, and so travels around Alcatraz picking up escape gear. Once this has been accomplished you thread your way through a mine-field to a hole in the outer fence. Nothing very taxing, not bad for the money.

Psycho Shopper

8/16K Vic-20:
Arcade:
£1.99:
Mastertonic:

★ ★ ★

Breathes new life into the Frogger concept. It provides not just one but four different busy thoroughfares to cross with the added complication that you must pick up objects on the way. The game climaxes in a supermarket where you have to dash across the floor and raid the shelves.

Maze Gold

Unexpanded Vic-20:
Maze game:
£5.95:
Visions

★ ★ ★

A ponderous variation on the maze theme. You jump from character space to character space collecting gold bags and dodging nasties. If your interest holds out you can then exit to another screen for more of the same.

Horace Goes Skiing

Dragon 32:
Novelty:
£5.95:
Melbourne House

★ ★ ★

A two-stage game in which you must first guide Horace across a road and back before you get a crack at the slalom course. Not surprisingly the road is packed with speeding cars and juggernauts.

SOFTWARE

Tales of the Arabian Nights

■ CBM-64
■ £7.00
■ Interceptor Micros

★ ★ ★

AT THE START of Arabian Nights a voice through the TV speaker sets the scene for the opening screen: "Imrahil began his cues: on Sinbad's ship, sailing the perilous waters of the Red Sea." In all there are eight different screens and each is introduced by a few lines of computer-generated speech. Sounding rather like someone speaking under water, the voice is notably indistinct but it adds considerably to the enjoyment of this Manic Miner style game.

In the first screen you have to work your way round a galleon, collecting golden jugs by climbing the masts and jumping from platform to platform. At the same time there are hazards to be avoided in the form of octopuses, cannonballs, and a large flying bird — possibly a roc. Following this you find yourself on a raft floating down a crocodile-infested river.

Later screens include a fortress, a desert landscape, and an Arabian city. Since the game draws inspiration from the Arabian Nights, naturally there are also palm trees, flying carpets and turbaned genies.

The interest in this sort of game

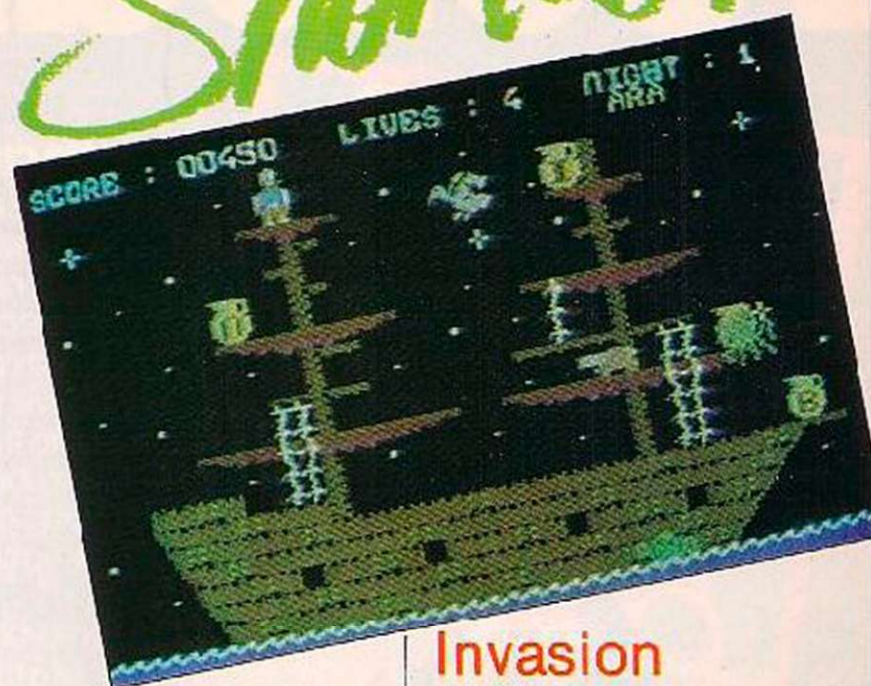

lies in working out the correct route, in finding the right sequence of objects to be collected and jumps to be taken. In this respect Tales of the Arabian Nights is fairly demanding although it does not require the degree of accuracy and tortuous attention to detail that make Manic Miner so engrossing.

Nor are the graphics as finely drawn or as wittily original as they are in Manic Miner. Nonetheless — comparisons aside — the game has a high entertainment value.

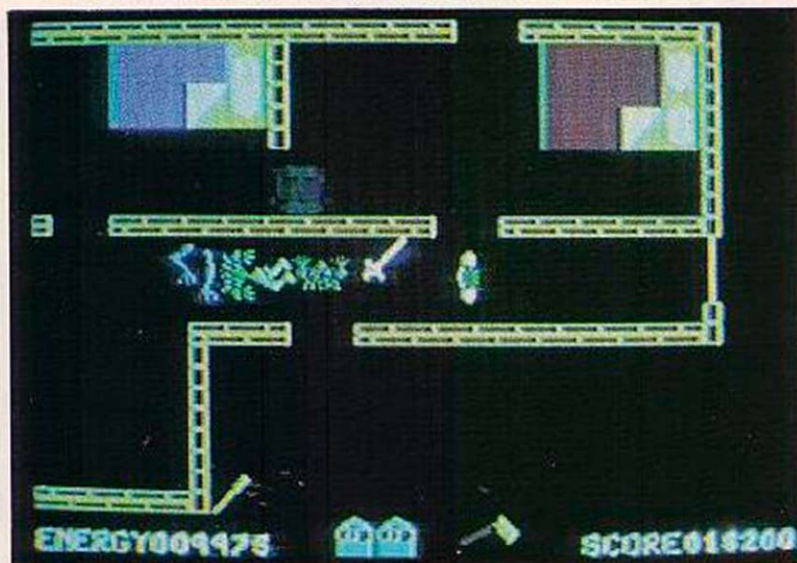

Evil Dead

■ CBM-64
■ £6.99
■ Palace Software

★ ★ ★

A WHILE BACK THERE was a flurry of concern at the possibility that video nasties would spawn a generation of equally unpleasant computer games — computer nasties.

At the time you might have wondered if home computer graphics were capable of the sort of gory special effects video nasties trade in.

The Evil Dead would confirm your doubts. It is a spin-off from the horror film of the same name but there is nothing here to keep even the most unworldly 12-year-old awake at night.

The computer version is said to follow the plot of the film. Ashley, a naive teenager, together with four chums is trapped in an isolated house inhabited by the spirits of the undead.

Translated to the computer screen the game turns out to be a distant

(continued on page 45)

Invasion

■ 48K Spectrum
■ £6.99
■ Argus Press Software

★ ★ ★

IF YOU ARE fed up with zapping aliens in real time with amazing graphics, sound the works, then here's something that might be more up your street. The Reds are coming and it's up to you to defend your homeland.

The invading hordes enter from the top of your 8-by-12 grid which represents the homeland. You have eight armies under your command with which to attempt to repel the foreign hordes. Scattered over the map are 14 cities which you must defend, lose the lot and it's the firing squad for you. The unkindest cut of all is also meted out if you allow any of the invaders to march off the bottom of the map — presumably because they then threaten something vital, like the Presidential Country Retreat.

Each turn you are given 10 resource points per town under your control. These can be used to build new units or allow ones you already have to attack. Attacking seems to be a good idea in this game, so these supplies are vital. You can then give each army one command, either change its strength or move it. The effectiveness of an army is affected by its morale: if it gets badly mauled, its morale sinks; an easy victory and its morale and effectiveness rise.

All this leads to some tricky decisions for would-be Patons. Trying to defend every inch tends to be an expensive and morale-sapping exercise.

However, the choices and strategies open to you seem somewhat limited and once the right mix of the two mentioned above has been discovered, I doubt if the game has that much more to offer.

The No.1 Football Game

ZX81 16K, ZX Spectrum 48K

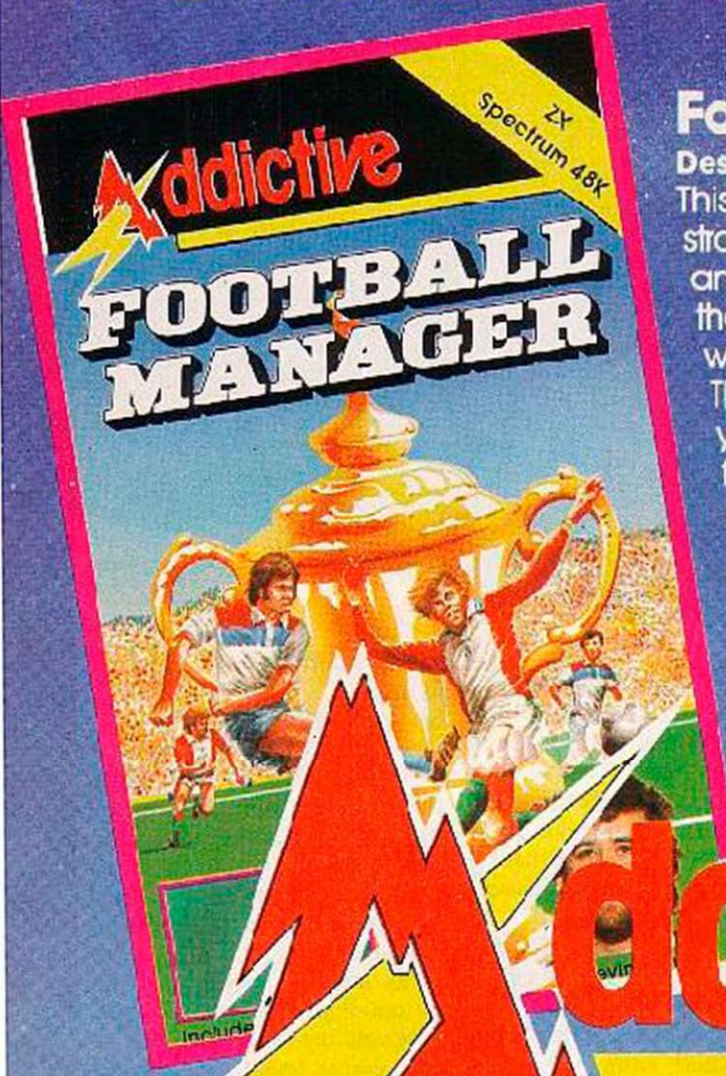

Football Manager

Designed by Kevin Toms

This outstanding game of skill and strategy is now widely available and you can join the many thousands of satisfied customers who have purchased the game. This is no five minute wonder – you will be playing this game for hours over many weeks (we know – our customers tell us!).



Kevin Toms

Some of the features of the game:–

- ★ Matches in 3D graphics
- ★ Transfer market
- ★ Promotion and relegation
- ★ F.A. Cup matches
- ★ Injury problems
- ★ Full league tables
- ★ Four Divisions
- ★ Pick your own team for each match
- ★ As many seasons as you like
- ★ Managerial rating
- ★ 7 skill levels
- ★ Save game facility

Addictive

*ZX81 Chart, Home Computing Weekly 16.8.83

Comments about the game from press and our customers

"FOOTBALL MANAGER is the best game I have yet seen on the Spectrum and my personal favourite of all the games on any micro ... To the ordinary person it is an excellent view of what can be done in the field of computer games ... The crowning glory of this game is the short set pieces of match highlights which show little stick men running around a pitch, shooting, defending and scoring ... It is a compulsive game but people who cannot take game sessions of 9 hours or so, which happened on one happy Sunday, will be grateful to know that there is a 'save to tape' option. FOOTBALL MANAGER has everything it could ... The

originator, Addictive Games, certainly deserve the name." Rating: 19/20 (Practical Computing – August 1983).

"When I first received this game I spent the best part of the weekend playing it. Since then I have returned to it more often than any other. The truly addictive quality of this game is the remarkable way it mirrors the real football manager's problems ..."

(Personal Computer Games – Summer 1983)

Versions coming soon for
BBC 'B' (End of March)
Commodore 64
Oric 48K, Dragon
etc.

"I am writing to say what a great game it is. I have spent over 45 hours on it." (Mr. D. Feam – Gloucestershire.)

Programmers

We want your software. Send us a sample, if accepted, we will supply generous royalties plus cash advances plus free advice from Kevin himself!



Action from the Spectrum version

Available from computer software stockists nationwide, including **Booth** & **John Menzies**

Prices: Spectrum 48K £6.95
ZX81 16K £5.95

(N.B. 3D GRAPH CS ARE NOT INCLUDED IN THE ZX81 VERSION)

Overseas orders add £1.50

To order by mail (p&p free) send cheques or postal orders to:

Addictive Games

7A RICHMOND HILL, BOURNEMOUTH, BH2 6HE

Dealers! For urgent stocks send your headed notepaper direct to our address.

Star★ chart

Gravitar

Oric-1/Atmos 48K:

Eat-em-up:

£7.50:

Severn Software

★ ★ ★

With four controls: rotate left, right, thrust and tractor beam, you have to guide your in-repid spaceship around the screen picking up fuel pods, avoiding the gunfire from enemy emplacements, and avoiding a low flying spaceship. If this wasn't bad enough, you've got momentum and gravity to cope with. The game calls for patience and very delicate control.

Crusoe

48K Spectrum:

Adventure:

£6.00:

Automata

★ ★ ★

In this graphics adventure you take the part of the well-known castaway trudging round a desert island with 75 items to track down. The program is nicely presented with several screens for you to explore. William Bones has left plenty of clues strewn around the place for you to solve. The text appears in Treasure Island script, with suitably rustic messages.

Classic Racing

Oric-1/Atmos 48K:

Boardgame:

£7.95:

Salamander

★ ★ ★

For one to six players, each player has a stable of 16 horses of unknown form. Your job is to attempt to find out which horses are most suitable for what sort of going — and which are most suited to the glue factory — in time for the big meetings at the end of the season. With less than six players, the computer plays the other stables. A whole season of 16 meetings can provide a long and absorbing game. Fortunately you can load and save games at any point.

relation of Atic Atac, in which you have to move from room to room fighting off hostile beasts. The difference between this and Atic Atac is that there is no ultimate goal: your object is simply to stay alive for as long as possible.

To cope with the monsters in your path you have a supply of destructive energy which can be replenished by picking up a weapon. Alternatively, you can attempt to shut them out by closing windows and doors.

Once attacked the monsters split into parts which in turn enter the fray. As your four friends are also likely to mutate into monsters you find the house soon fills up with a variety of Evil Spirits, zombies, pink things and dismembered limbs. Clearing the screen becomes uphill work.

The Evil Dead sports some excellent graphics particularly in the way the characters are animated. A computer nasty it is not: anyone who fears, or hopes, that it might be a real sickener will be disappointed. But there is enough variety in it to keep the interest alive for a good few playing hours.

Lords of Midnight

48K Spectrum

£9.95

Beyond

★ ★ ★

THE LORDS OF MIDNIGHT is a graphics adventure based loosely on Tolkien's *Lord of the Rings*. Saying this is rather like saying a Porsche 924 is a motor car based on the Model T Ford. This program is simply in a different league from graphic adventures that have gone before.



Bozo's Night Out

CBM-64

£6.90

Taskset

★ ★ ★

BOZO'S NIGHT OUT puts you in charge of Bozo, an inveterate drinker. It is your responsibility to guide him home after a hard night in the pub. Getting him safely home racks up a score of five pints, whereupon you can pick him up at the pub

SOFTWARE

Shortlist

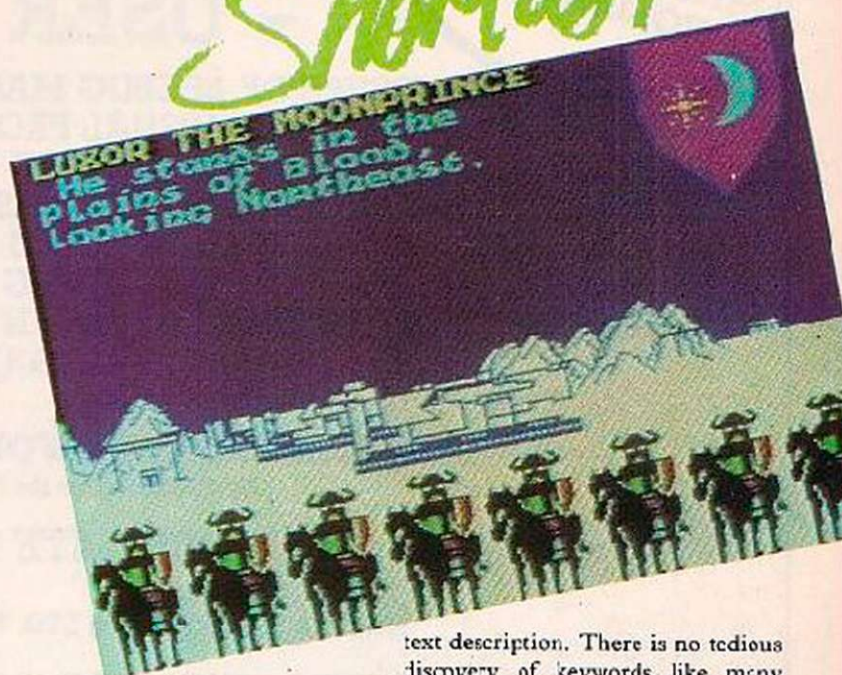

At the start of the game, you, Luxor, the Moon Prince, are standing with your three chums surveying the Land of Midnight; the forces of Doomdark the Witchking are preparing to give the land of the free — the good guys — a hard time. If you've read *Lord of The Rings*, the rest of the plot will be fairly familiar to you. There are two ways that you can defeat Doomdark: capture his ring of power, or defeat him in battle; neither is a picnic.

Beyond claim to have crammed 30,000 locations into the game. The effect is truly breathtaking. While at any of these locations you can look in eight directions and the computer quickly draws the view and gives a

text description. There is no tedious discovery of keywords like many adventures, the whole thing is menu driven, different options being available depending on location.

The game proceeds by you giving instructions in turn to the various characters under your command. As you are moving them, you can find objects, recruit men and other leaders, which you can then in turn move, and of course you can do battle with the forces of midnight.

Once you have completed a character's actions for the day, you go on to another. When all your characters have been moved, you press the Night button, and the computer sets to work moving the forces of darkness around and working out the outcome of battle.

Gems of Stratus

Amstrad CPC-464

£7.95

Kuma

★ ★ ★

GEMS OF STRATUS is one of the first independent software releases for the new Amstrad computer. The game is an adventure with graphics which uses the Amstrad screen windows to good effect: you put your commands into one window and the machine's replies come back on two others and the view of your present location is in a fourth.

Movement is by use of cursor keys and full use is made of the keyboard buffer which, once you have made a map, allows you to move very rapidly around the maze of rooms: you simply hit the appropriate cursor keys the required number of times, and sooner or later the machine catches up with you.

Your object is to find the hidden treasure room and "the hidden wealth of AM". Well we have to admit we never found them.

The game is rather frustrating, but if the clues were too easy the game would soon lose its value.

door the following night.

Bozo has a choice of two routes, along the street or a shortcut through the park. On the pavement he is threatened by policemen, muggers and ladies of the night, while the park contains an assortment of unpleasant creatures and malevolent plants. Using the joystick you need to steer Bozo.

This scenario is illustrated by some amusing cartoon-style graphics.

It might have been more realistic and exciting if Bozo were given a chance to defend himself.

LOOK WHAT YOU
MISSED IN BEEBUG
VOLUME TWO

BBC MICRO - USER SUPPORT -

● 10 ISSUES OF BEEBUG MAGAZINE MAILED FREE TO MEMBERS ● 30
EXCITING GAMES AND VISUAL PROGRAMS ● 43 SOFTWARE REVIEWS ● 33
HARDWARE REVIEWS ● 16 BOOK REVIEWS ● 150 HINTS AND TIPS ● 25
APPLICATION PROGRAMS ● SERIES OF ARTICLES FOR BEGINNERS ● MANY
ADVANCED TECHNICAL ARTICLES ● NEWS AND PRODUCT INFORMATION
● PLUS SPECIAL OFFERS ● BIG DISCOUNTS ON A WIDE RANGE OF
PRODUCTS ● EVENTS ● BRAIN TEASERS ● LOCAL CLUBS ● FULL
MAGAZINE INDEX

A YEARS SUBSCRIPTION WOULD HAVE BOUGHT YOU ALL THIS

Figures based on the 10 issues of BEEBUG Volume 2.

BUT IT'S NOT TOO LATE TO JOIN FOR VOLUME THREE

BEEBUG PUBLICATIONS LTD. PO BOX 109, HIGH WYCOMBE, BUCKS

PLEASE ENROL ME FOR VOLUME 3 of BEEBUG AT £9.90 (10 ISSUES)

NAME

ADDRESS

AMOUNT ENCLOSED

BEEBUG HAS BEEN ESTABLISHED
FOR TWO YEARS AND NOW HAS
OVER 25,000 MEMBERS. IT OFFERS
TOTAL USER SUPPORT TO ALL BBC
MICRO USERS.

PLEASE MAKE CHEQUES MADE PAYABLE TO BEEBUG PUBLICATIONS LTD.
AND SEND TO:- DEPT 4 PO BOX 109, HIGH WYCOMBE, BUCKS.
(DISTRIBUTION AGENTS FOR BEEBUG)

COMMODORE 64 TAPE COPIER

**COPYCAT — THE ULTIMATE
BACK-UP COPIER**

- ★ COPIES ALMOST ALL PROTECTED SOFTWARE
- ★ INCORPORATES SPECTACULAR MULTICOLOURED LOAD AND SAVE
- ★ 100% MACHINE CODE COPIER
- ★ COPIES MACHINE CODE, BASIC, OR MIXTURE
- ★ WIZARD AUDIO WARNINGS AT THE END OF EACH SECTION
- ★ CASSETTE MAGIC SENSE
- ★ WRITTEN BY A COMPUTER PROFESSIONAL
- ★ FULL INSTRUCTIONS WITH THIS EASY TO USE COPIER

CAN YOU FIND A PROGRAM THIS WON'T COPY? — WE CAN'T!

Dispatch of orders within 24 hours!

CHEQUES/P.O.S. TO:

£5.95
incl. VAT & P&P

**WIZARD SOFTWARE
69, THE MARLES
EXMOUTH
DEVON
EX8 4NE**

WATCH OUT! Coming soon from WIZARD SOFTWARE... LIGHTNING LOAD — A program which converts almost all your favourite software into a form which will allow loading at six times normal speed!!! A 12 minute program takes just 2 (two) minutes to load!

NOW 3RD GREAT YEAR!

HIRE

**SPECTRUM
ZX81 and
COMMODORE 64
TAPES**

HUGE RANGE!

- ADVENTURE GAMES
- ARCADE and SIMULATION GAMES
- BUSINESS and PRACTICAL PROGRAMS
- UTILITIES
- M/C COMPILERS
- EDUCATIONAL

FROM OVER 60 TOP SUPPLIERS

FREE

ILLUSTRATED QUARTERLY MAGAZINE WITH TIPS, NEWS, REVIEWS, DISCOUNT OFFERS

LIFE MEMBERSHIP
£5.00
TAPE HIRE FROM 50P INCLUDING VAT

OVER 3,000 DELIGHTED MEMBERS!

SPECIAL OFFER!
YOUR FIRST TWO TAPES FREE
IF YOU USE THIS COUPON!

or send £1 for magazine & details.
Proprs: ALEC FRY ARPS, FRSA and ERNA FRY, BA

To: SOFTWARE LIBRARY, Farnham Road, West Liss, Hants GU33 6JU.

NAME.....Machine.....

ADDRESS.....

Special offer from this issue: LIFE MEMBERSHIP £5
(normally £9.50). Overseas (Europe only) £10, or join local branch in W. Germany, France, Holland, Belgium, Scandinavia, South Africa, Ireland—send Int. Repl. Coupon and we'll forward your enquiry.

Y.C.

NEWS

o a e o
r s s u
t t t t
h h

The crystal ball

The Adventurer's Notebook is a new volume from Duckworths. Priced at £3.95, it includes ready made maps and notepads for use when playing, a history of adventures, a personal list of the best, and a useful set of synonyms and suggestions for when you're stuck.

Salamander Software are bringing out their Dan Diamond trilogy in a single package for the Spectrum. The trio consists of Dan Diamond, Lost in Space and Fishy Business.

If you've a disc drive, look out for Infocom's Sorcerer — the second in the Enchanter series — and Seastalker — the latest Tale of Adventure. Retailing at around £40 each, they're worth going into the red for.

Commodore have secured the publishing rights to the magnificent Zork trilogy, Infocom's earlier masterpieces. Disc only but well within your pocket at the new low price of £11.95 each.

A helping hand

Hobbit players now have the excellent Melbourne House "Guide to Playing The Hobbit" (£3.95) so no help from me as well — fair's fair!

For fans of Micrograf's BBC Adventure, Flint's Gold:— At the platform but can't cross the lake?

LLEB GNIR:TAUG PORD

In the Gloomy Room but can't locate a hidden treasure map?

KOOL:GELGEP

TFG:KOOL:LOTSIP ERIF

For Phipps' Colditz Prisoners:— Hacksaw breaks trying to open grate?

(REVIRDWERCS HTIW)

ETARG WERCNSNU

Yours in flame and

frustration.
HUGO NORTH

QUEST

Corner

Our man with the brass lamp and the key to a thousand mysteries sheds light on new adventure programs. Lost? Never fear, Hugo North is here.

Wizard's Challenge

- BBC B
- £7.95
- Program Power

WITH A TITLE like that and a mission to recover 12 treasures for an evil wizard, you might think you'd be plunged straight into a mystic wood or into an eerie underground labyrinth. In fact you start off on some school playing fields. Exploring this rather unusual jumping off point, you'll find, among other places, a tuck shop, changing rooms and dining hall. What on earth can you do with a school dinner (except perhaps to use it as a weapon, if mine were anything to go by).

Further searching may result in you getting wounded — it may be only a cut finger but it could finish you off before you've barely begun your quest.

A lamp is soon located which can only area one thing — you'll shortly be going to places deep, dark and dangerous. However, when you do go down, things are not at first what you might expect. A Brutish Rail (yes, Brutish) underground station is the first of several surprises.

There are over 100 locations and some 50 problems to solve in this enjoyable text adventure. Response to input is immediate and although there are one or two spelling errors, it doesn't mar what is an entertaining program.

Paradox

- Spectrum 48K
- £7.50
- Runesoft

THERE HAS BEEN a surge in the number of Spectrum adventures, due mainly to the availability of Gilsoft's

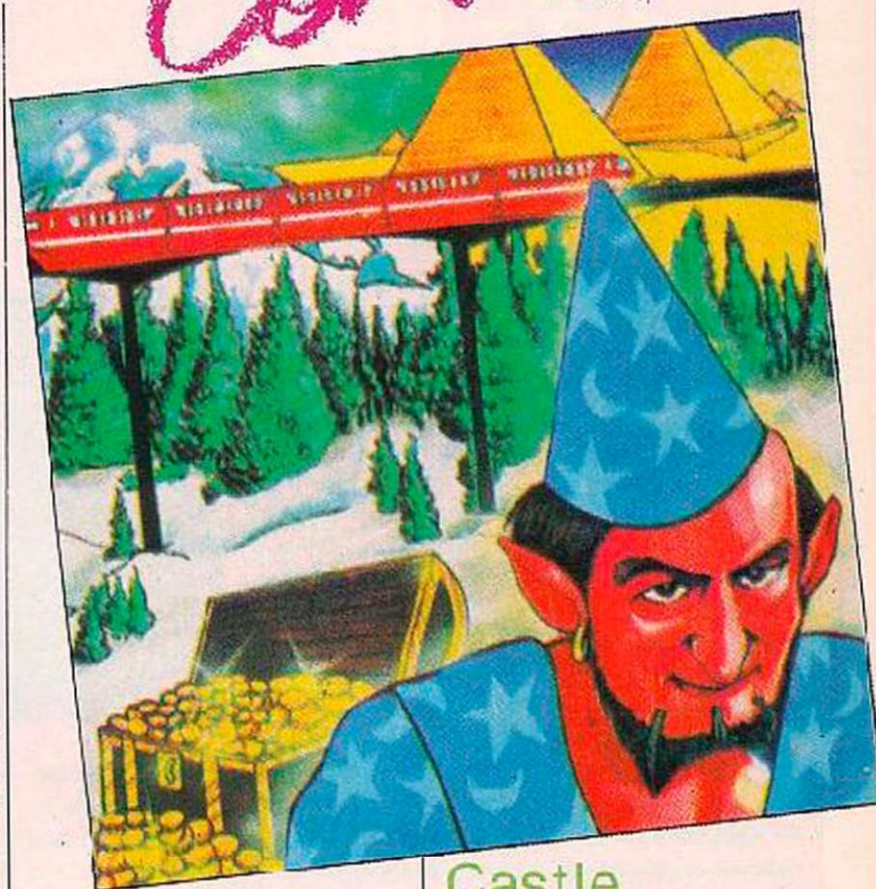

Castle Blackstar

- Spectrum 48K
- £8.95
- SCR Adventures

FOR THOSE who like their text adventures meaty, Castle Blackstar should prove toothsome fare. It is a complex, puzzle-rich quest that challenges you to score a maximum of 240 points which are gained by finding and returning treasures, performing certain actions and accomplishing the main objective of your mission — to find and return the lost orb to the Lady Artemis.

You start your journey in the vale of Castle Blackstar. Wander too far from the path and you'll be lost in a forest maze. Experienced adventurers will be well aware that the best way to map out a maze is to drop objects along the way so make sure you find some before going on a forest jaunt.

There are plenty of intriguing and unusual objects and puzzles, many of which will undoubtedly have you reaching for the aspirins. As a small taste of what's in store, difficulties along your way include an invisible hand, eagle eggs and a water-logged boat.

Original and challenging puzzles, fast response, a comprehensive vocabulary and plenty of atmosphere make Castle Blackstar a worthy contender for your hard won gold.

"The Quill" adventure generator Paradox is such a Quill produced program, and a pretty interesting one it is too.

The environment you are invited to roam is divided up into four main areas: the Tunnel — where you start — the Gamesboard, the Crystal Palace, and the Magicians' Rooms. One feature of this adventure is that it only tells you of exits other than the one that leads back to where you have just come from — and even then, you can't always guarantee that you'll be able to return the way you came.

The Tunnel is what you would anticipate — various interconnected chambers where you'll find useful objects or sudden death. You can't afford to fiddle around too long — a raging thirst drives you to find water.

The Gamesboard will provide clues and riddles — unless you solve them, you won't gain access to the Crystal Palace.

With 150 different locations and puzzles and paradoxes aplenty, this text adventure may well keep you occupied until Christmas.

TOSHIBA HX-10

Graham Bland looks at what the vanguard of the MSX invasion has to offer

IN A BID TO REPEAT their success in Japan, a number of manufacturers recently announced their intention to launch MSX systems in the U.K. Toshiba has emerged as the pace setter in the race to customise a micro for the more sophisticated British market. The HX-10 Home Computer seems likely to beat Sanyo's Wavy 10 and Sony's Hit-Bit to a place on the MSX shelves this month, albeit by a narrow margin.

Toshiba's machine is unexciting when compared with other systems from the land of the rising sun. The HX-10 does not have any of the goodies promised with some other MSX micros such as video interfacing, robot arms, and music synthesizers. But what it will have is a more competitive price tag.

Cosmetically, the HX-10 appears functional rather than glamorous — a slab-like dark-brown box, not exactly ugly, but it is hardly inspiring either. The overall construction is very workmanlike, a solid heavy micro that looks as if it could take a good bashing and has the endearing habit of staying put while you are typing.

Interfacing made easy

Communication with the outside world is relatively simple. At the back of the machine are phono socket connections for output to TV set or monitor, and a DIN socket to hook up a cassette recorder. Also hidden round the back is the bus connector which is ominously marked "For Only Toshiba Use". This expansion bus connector will come into use when disc interfaces become available, as well as RS-232 drivers and the like. On the side of the machine are two D-type joystick sockets and a Centronics printer socket.

The all-important cartridge slot is accessed from above. How often this slot is used will depend on how many U.K. software houses opt for cartridge media in favour of cheaper



and more popular cassettes.

As keyboards go, the HX-10's is a long way ahead of those found on the Sord M-5 and the Spectrum, but not quite in the league of the BBC model B or Electron. As such, it represents a reasonable compromise between low-cost and usability. Of the 73 keys, five are programmable function keys — or soft keys as they are sometimes known.

A rich set of foreign characters are available from the keyboard using the Code key, including French, Spanish and Greek, as well as graphics characters which are produced using the bright-green Graph key. The minor points which annoyed me while using the HX-10's keyboard were the tiny backspace key, the cramped cursor keys and the absurd colour scheme adopted, green, blue, brown and white.

In Japan, Toshiba was one of the few companies to offer a 64K machine. Seemingly, Tokyo's man-on-the-street is quite happy with a measly 16K computer. Of the two systems that Toshiba had available in Japan, they wisely adapted the 64K version instead of the 32K model.

If the promise of 64K seems mouth-watering, prepare for a sudden loss of appetite when you switch on the HX-10. After the copyright

message you are informed that there is only about 28K available to MSX-Basic programs. Graphics support immediately claims 16K and the rest of the missing memory is squirreled away for some undisclosed purpose — perhaps lying dormant awaiting the arrival of a disc-operating system.

Displayed at the bottom of the screen are the values of the first five function keys. The second five values may be displayed simply by holding down the Shift key. To remove this display, the command Key Off will do the trick. You can assign your own character strings to any of the function keys. For example:

```
KEY 1, "? FRE(0)" + CHR (13)
```

will print out the amount of free memory every time function key number 1 is pressed.

MSX-Basic is very nearly an 8-bit IBM PC Basic, offering a nice spread of arithmetic functions, good graphics and sound and a few other elegant touches which must make it one of the best home micro Basics around.

All arithmetic is calculated to double precision — up to 14 decimal places — which does tend to slow programs down a bit, but this trade-off is acceptable if accuracy is the most important consideration. Data types can be declared as binary, hexadecimal and octal as well as the standard characters, integers etc.

Entering programs displays both a weakness and strength in the Basic. Unfortunately, the interpreter does not check lines as they are entered. To compensate, there is an excellent full-screen editor. It is a shame that the designers could not combine both these features in the way Atari has on the 800XL.

As mentioned earlier, the HX-10's character set is fairly complete. There is a full range of scientific symbols, a music note, signs for



REVIEW



integration and differentiation and so forth. These characters, plus the foreign ones, point to the possible educational uses that MSX systems might have.

Program output can be formatted using the Print Using statement. This is a fairly flexible and powerful statement which is particularly useful for making numeric output look nice. If, for example, the results of a tax calculation are to be displayed to two decimal places, the following statement will ensure a uniform output:

```
10 PRINT USING "##.#",TAX
```

Other options allow field fillers, + or - signs, and the insertion of a string variable into a constant string.

Powerful sound chip

The sound available from MSX Basic is also quite impressive. At the heart of every MSX micro lies a dedicated sound chip — General Instruments AY-3-8910 — the same chip used by the Oric Atmos and Memotech MTX series, in fact. It is capable of producing three notes simultaneously over a range of eight octaves with an optional noise channel to produce helicopter and explosion noises. To kick this chip into life, you can use one of two Basic commands: Sound or Play.

Sound is the most flexible of the two but much harder to use. It is little more than a specialised Poke instruction; values are sent to one of the sound chips' 13 registers accessible from the Basic. Not having a manual available

you will have to study the sound chip quite fully.

The Play command is much more straightforward. You are restricted to musical notes in this case, with instructions being given to the sound chip via the Music Macro Language. Music is set out in a character string, with letters like C, F and G# corresponding to the same notes as musical notation.

Note length, octave, tempo and other features will, with practice, allow most tunes to be played. All music played using this command is placed in a music queue for summary execution. So once told what it is to play, the HX-10 can continue to perform some other task.

With 16K of your precious memory dedicated to graphics support, you get the feeling that the graphics capabilities of this machine ought to be quite good. Though not in possession

with the HX-10, I can only hope that this feature is well documented. There are no equivalents of the Oric's Zap and other sound commands. If you want these from MSX Basic, an ultra-high resolution screen like the Beeb's, the HX-10 can squeeze quite a lot from its fairly moderate 256 by 192 resolution screen. The nicest thing about MSX Basic's graphics statements is that they are very easy to use, and due to the allocated video RAM, reasonably quick too.

There are commands to draw circles, lines and boxes, a Paint command, and 16 colours available. Best of all, you can declare up to 32 sprites. Fortunately, there are no Poke instructions required to set up a sprite thanks to the provision of a special variable called Sprite\$. Sprites are placed on the screen using the Put Sprite command. A number of these graphics statements such as PSet, Circle, and Put Sprite have the option to specify absolute or relative co-ordinates.

By putting the word Step in front of a set of co-ordinates, the shape or point is placed relative to the last point addressed on the graphics screen. This speeds up the movement of sprites etc. across the screen as there is no need to waste time calculating the object's next position.

Text and graphics

There is, however, no easy way to put text into a graphics screen. What you have to do is: open the graphics screen as a named file (GRP:) and use a Print# statement to send a character string to the screen. This is hardly convenient particularly as the character string will be placed at the last point addressed on the screen.

Possibly the best feature of this Basic is its interrupt statements. Rather than polling for an event such as the spacebar being pressed, you can set an interrupt which will cause a branch to a subroutine when the event occurs. The following short program will print out the product of 100 by 100 repeatedly until the spacebar is pressed, when it will print out "HELLO":

```
10 strig(0) on
20 on strig gosub 40
30 print 100 * 100 : goto 30
40 print "HELLO" : return
```

Interrupts may be set up to monitor the function keys, sprite collision, time intervals, and trap events such as errors and the production of a Ctrl-Sop signal. This feature of the language makes up for the omission of a While-Wend statement. ■

CONCLUSIONS

■ Overall, the Toshiba HX-10 is a pleasurable system to use. It does have its drawbacks but these are generally too few to worry about. It is much better than the ill-fated Spectravideo — almost an MSX computer but not quite — being curiously faster with the obvious advantage of a full-pitch keyboard.

■ It will be a long time before the full impact of MSX is realised in the U.K. The standard promises cheaper and

plentiful software, lower-cost systems and peripherals, every micro owner's dream in fact. It will probably be next year at the earliest before software houses have the courage to reduce MSX software prices, depending, of course, on whether MSX takes off in the U.K.

■ Judging by the Toshiba MSX system, the decision to purchase one manufacturer's system against another may well rest on a single factor — price.

| | |
|------------------------|--|
| Database: | |
| Name: | |
| Address: | |
| Pocket-sized | |
| Re-usable datapacks | |
| Own program language | |
| Speedy data access | |
| Software library | |
| Rugged construction | |
| Battery powered | |
| Permanent data storage | |

PSION ORGANISER

Competition

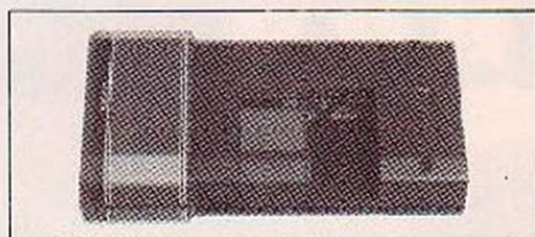

PSION'S ORGANISER is a truly pocket sized computer with a built-in database facility. Once you have slotted in an 8K datapack you can use it to store over 10,000 characters permanently. After creating your database you can then access its information in a matter of seconds.

There is also scope for writing programs — using the machine's own language, POPL. Or you could buy one of a range of specialist programs supplied on program packs.

Not least of the Organiser's merits is the fact that the datapacks are inexpensive and can be re-used up to 100 times.

In this month's competition Psion is giving us three Organisers as prizes. Each comes with a Utility Pack and a 16K datapack. In addition the winners will be able to choose one of four program packs: Finance, Maths, Science or

Link-Up Communications.

To enter you need to put eight of the Organiser's features in order of importance. Then as a tie-breaker we would like you to suggest an original way of using the database facility — what sort of information would you store in the Organiser's datapack?

Put a 1 against the feature you consider most important, a 2 against the second most important and so on until you have filled all the boxes. Now think of an original database and send this coupon to Your Computer, L-221, Quadrant House, The Quadrant, Sutton, Surrey, SM2 5AS.

RULES

- The winners of the competition will be the people who number the Organiser's features correctly and, in the view of the editor, make the most original suggestion on the use of the database.
- The names of the winners will be printed in the November issue of Your Computer.
- All entries must arrive at the Your Computer offices by the last working day in September 1984.
- Each person may enter the competition only once.
- Entries to the competition cannot be acknowledged.
- No employee of Business Press International or their relatives may enter the competition.
- The decision of the editor is final.
- No correspondence on the result of the competition will be entered into.
- Business Press International assumes no responsibility or liability for any complaints arising from this competition.

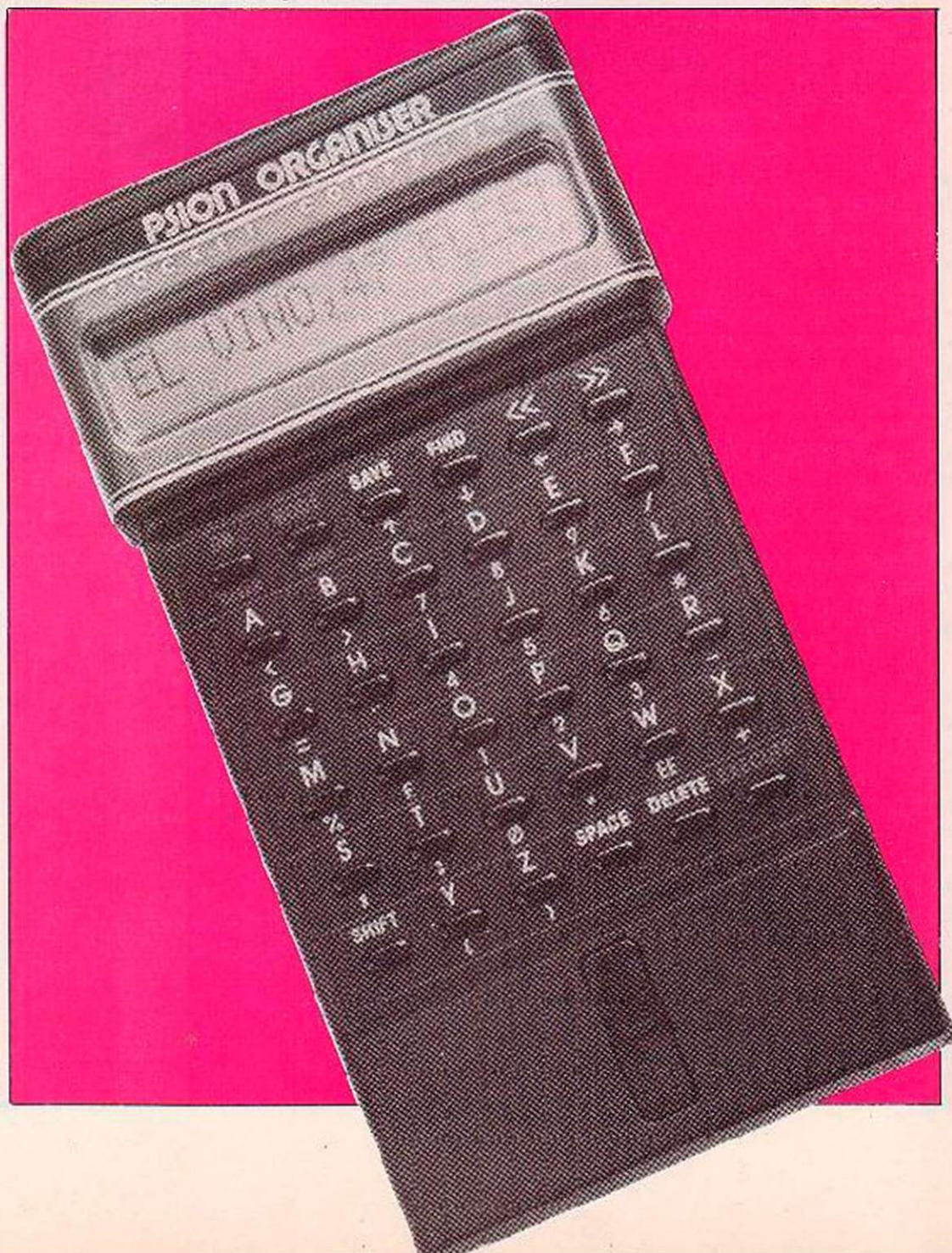

A COMPLETE COLOUR MICRO WITH NO HIDDEN EXTRAS FOR AROUND £499.

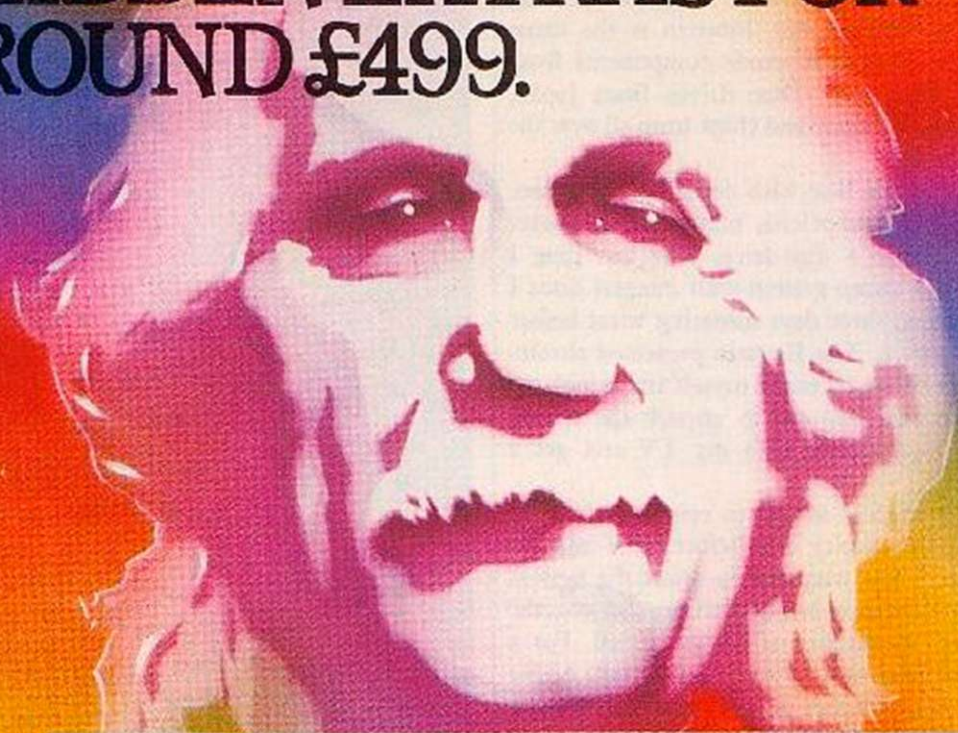

The title of 'genius' is not bestowed lightly on man or machine: those extraordinary qualities and powers of intellect are rare.

Einstein had them in full measure. And so now does the new micro computer from Tatung, designed and built in Britain and appropriately named - Einstein.

Einstein was created by Tatung, one of the world's leading electronic companies, and given the capacity and the remarkable capabilities to compete with computers costing far more.

Its simplicity of operation will appeal to the first time buyer and to businessmen who don't want to lose staff to expensive and time-consuming training courses. At the same time its operating system is both powerful and sophisticated to satisfy the most advanced requirements.

For those who have outgrown their existing primitive machine, the speed and capacity of the 500K built-in disc drive will make all the difference. And for the small businessman, the ability to store and retrieve all information in seconds will be as important as Einstein's built-in flexibility, which allows the system to grow as the business develops.

BUILT-IN 80K MEMORY

Total memory capacity 80K RAM divided into 64K 'user' memory and 16K for colour graphics production.

BUILT-IN DISC DRIVE

500K 3" compact floppy disc drive. Potential for massive extra storage with a second 500K disc drive internally.

BUILT-IN 16 COLOUR GRAPHICS

High resolution graphic animation from 32 sprites (definable shapes), 16 vivid colours.



BUILT-IN EXPANSION PORTS

Connection to both TV and optional colour monitor, most printers and other computers via RS232C interface. Also twin joystick ports, 8 bit user port, exclusive Tatung Pipe.

BUILT-IN FLEXIBILITY

Powerful Crystal BASIC. Multi-lingual plus ability to run CP/M.

BUILT-IN VERSATILE SOUND

Sound synthesiser facility includes chromatic music with three voices. Substantial speaker with volume control. Provision for speech synthesiser.

Einstein has them all. Feature for feature, it meets the needs of the novice and the experienced operator, both at home and in the office.

Einstein, designed and built in Britain, is a complete colour micro computer with no hidden extras.

And for under £500 is sheer genius.

TATUNG
Einstein

SHEER GENIUS: AT WORK, AT HOME.

DIAL 100 AND ASK FOR FREEFONE EINSTEIN FOR YOUR NEAREST STOCKIST.

CP/M is a trade mark of Digital Research Inc

YOU WOULD NEVER guess it from the name, but the Tatung Einstein is a British micro. Made by a Taiwanese company based in Shropshire and named after a German, Jewish, American scientist, the Einstein is the usual electronic cocktail of exotic components from around the world. Disc drives from Japan, Basic from Torquay and chips from all over the shop.

I opened the box with some apprehension. Here was a mid-priced, mid-range computer complete with a disc-drive. The last time I looked at a cheap system with integral discs I had to spend three days soldering wires before it would work. The Einstein presented absolutely no problems. I timed myself and it took me less than two minutes to unpack the micro, plug it in, connect it to my TV and get a picture.

It took slightly longer to retune the TV to optimise the display but, before three minutes were up, I had managed to insert the system disc that comes with the machine, and load the directory. A number of things helped. For a start the plug was already connected. Many micros come without plugs so you have to hunt around for one to "borrow" for the computer. But, most of all, the integral disc saves worrying about cables, interfacing and the like.

Albert Einstein would never have won a beauty competition and neither would his computer ramesake. However, the design of the machine is elegantly utilitarian. It is moulded out of a fairly tough-gauge plastic so you can comfortably sit a monitor or TV on top. I would not recommend this though as you would have to sit much nearer to the screen than is good for you.

Above the keyboard are two LEDs that do little more than tell you that the computer is working and what mode the keyboard is in. Next to this is the disc unit. It accepts the little 3 in. Hitachi-style microfloppies which are posted into the slot like letters into a pillar box. A button below the slot unposts the discs for you when you need to swap them.

There is a space on the right-hand side of the machine to add an extra disc unit. This would be almost essential if you were using the Tatung as a workaday business computer but a bit excessive for the home user. Between the disc and the potential disc is a grill which I thought was probably there to help aircool the insides. It turned out to be a loudspeaker, loud being the operative word.

I thought that the Oric was a touch strident with its built-in speaker but the Einstein is positively in the Motorhead class. In front of this is the keyboard. Topped by a row of seven function keys, the keyboard contains no surprises. I don't like to see the graphics characters printed on the front of the keys, it looks messy, and most people only use them occasionally anyway. However, it does seem to be de rigueur in micro circles. I doubt if anyone will miss the Tab key, which the Einstein doesn't have.

Along the rear of the micro are a number of interfaces. If you are going to make use of them I would suggest that you find a permanent home for the micro. They are not the sort of things that take kindly to being constantly plugged in and unplugged. There is, of course, a printer port, an interface for more disc units, up to a total of four drives and a user input

TATUNG

Single 3in. disc, 64K, colour and sound for £499: Bill Bennett meets Einstein and talks relativity.

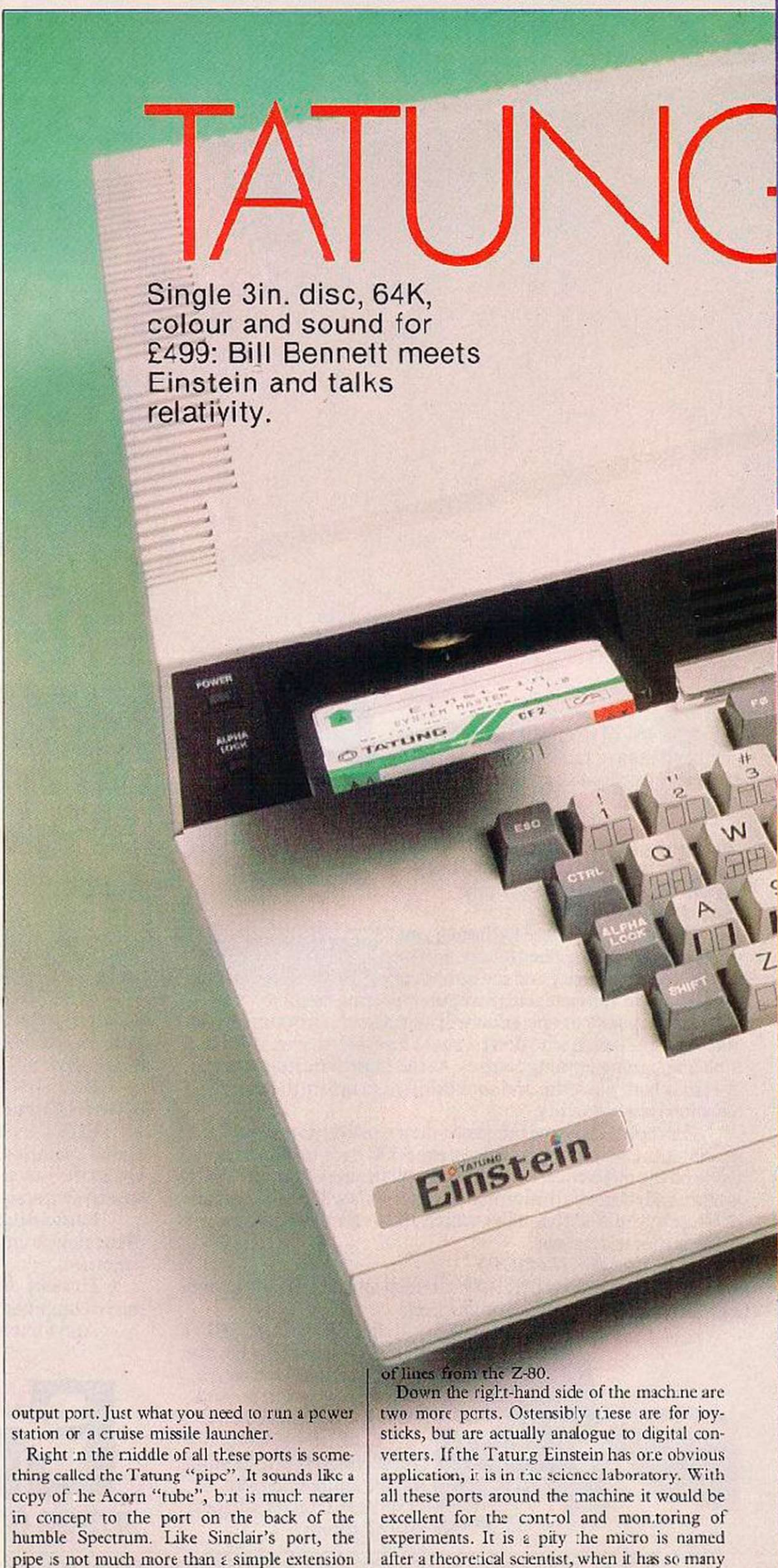

of lines from the Z-80.

output port. Just what you need to run a power station or a cruise missile launcher.

Right in the middle of all these ports is something called the Tatung "pipe". It sounds like a copy of the Acorn "tube", but is much nearer in concept to the port on the back of the humble Spectrum. Like Sinclair's port, the pipe is not much more than a simple extension

Down the right-hand side of the machine are two more ports. Ostensibly these are for joysticks, but are actually analogue to digital converters. If the Tatung Einstein has one obvious application, it is in the science laboratory. With all these ports around the machine it would be excellent for the control and monitoring of experiments. It is a pity the micro is named after a theoretical scientist, when it has so many

REVIEW TATUNG'S EINSTEIN



practical features

Next to the analogue ports is the almost obligatory RS-232 port, though it uses a DIN socket so you will have to worry about soldering your own cables to make use of it. And, best of all, a volume control knob. Until I found this, I actually had a neighbour come round and complain about the noise.

Nobody will be surprised to discover the TV output on the right-hand side of the micro's case, but I was disappointed to find that there is no monitor output. A computer with as many user ports as the Tatung Einstein could do with a simple RGB output as well. There is a special Tatung colour monitor to go with the Einstein, costing £240, but because there is no RGB output you cannot easily use any other manufacturer's monitor.

The Einstein is a "soft machine", that is its resident language and operating system are not actually resident at all. They come on disc and are loaded into the machine in a ritual the user must perform each time he or she uses the micro. Yet there is an 8K ROM which includes the machine-code monitor system. This makes the Einstein an attractive micro for the enthusiast but hardly ideal for the beginner.

Should you want to develop machine-code software, you could do so without ever entering the disc operating system. But most people will want to use Basic at some time and it has to be loaded from disc. To do this you must first load the disc operating system or DOS.

XtalDos is the operating system used by the Einstein. Because it comes supplied on disc, there is no reason why you couldn't use another operating system. No others are available at the moment, but should XtalDos mark II appear, or should some enterprising programmer devise a version of CP/M for the micro, you will only have to pay for that disc.

XtalDos is remarkably similar to CP/M, so much so that I managed to get started knowing only CP/M and not XtalDos. But XtalDos — pronounced crystalDOS — is not CP/M and will not run all CP/M software. This is a bit naughty because on the computer's box is the boast: "Ability to run CP/M software". There are more than 5,000 CP/M software packages available so you could be forgiven for thinking that buying an Einstein gives you access to a huge back catalogue of programs.

The Einstein does have the ability to run some CP/M software, it is just that you cannot buy genuine CP/M for it yet. What is more, it will not be cheap when it is available — CP/M system discs generally cost around the £50 mark. Further to this is the fact that, as yet, there is no CP/M standard for 3 in. discs. This means that even if there was a true implementation of CP/M for the Einstein, you would not be able to stroll down to your neighbourhood store and buy a software package off the shelf with any confidence that it will run on your micro.

I hope that someone does implement CP/M just as soon as the 3 in. standard is decided because, quite frankly, XtalDos is a minority operating system. There will never be enough

(continued on page 55)

PRICES THAT'LL KNOCK YOU OFF YOUR FEET!



DAISY WHEELS

| | |
|--------------------------------------|----------|
| Alphacom 32 Printer | £59.99 |
| Brother HR15 | £335.00 |
| Brother HR25 | £555.00 |
| Daisy Step 2000 (20CPS) | £246.00 |
| Diablo 330 (API) | £320.00 |
| EP 44 Personal Elec. Printer | £195.00 |
| Juxi 6130 | £335.00 |
| Queen-Data Daisy Wheel Printer | £235.00 |
| Qume 11/40 (RO) | £190.00 |
| Qume 9/45 (RO) | £590.00 |
| Qume Lette Pro 20 | £599.00 |
| Richo FP1300 | £899.00 |
| Richo FP1600 | £1239.00 |
| Smith Corona TPI Daisy Wheel Printer | £175.00 |

- * Guarantees available
- * Wholesale prices!
- * Export facilities arranged
- * Superb stock of computers and peripherals
- * Express delivery

RING 01-947 8562

Official suppliers to the U.K. government departments, British Telecom and many multi-national organisations.

PERIPHERALS

| | |
|---|---------|
| Commodore 170 Colour Monitor | £175.00 |
| Sanyo 2112 Green Screen 15MHz | £65.00 |
| Sanyo 3125 Col. Med. Res. 400PIX | £175.00 |
| Sanyo 3115 Col. V.Hi Res. 800PI | £399.00 |
| Commodore 154 Disk Drive | £156.52 |
| Oric Disk Drives | £229.00 |
| Sinclair Microdrives | £50.00 |
| Keyboard | £140.00 |
| Sinclair Interface '1' | £50.00 |
| Commodore C2N Cassette | £35.00 |
| Software: Wordstar | £250.00 |
| Sage Accounts | £295.00 |
| All loading software games available | POA. |
| Taiormade software written by our inhouse software team | POA. |

Keyboards, cable, interfaces, tractor feeds, sheet feeds, disks, software, up grades listing paper, ribbons, daisy wheels available for most products.

COMPUTERS

| | |
|-----------------------------------|----------|
| Apricot 256K 1x215 D/D + Monitor | £1349.00 |
| Apricot 256K 2x215 D/D + Monitor | £1499.00 |
| Apricot 256K 2x720 D/D + Monitor | £1599.00 |
| Apricot 256K 10MB HD.D + Monitor | £2379.00 |
| Commodore 64 | £52.18 |
| Commodore VIC20 Starter pack | £88.69 |
| Commodore SX 64 (Portable) | £209.00 |
| Epson QX10 + RX80 + cable | £1599.00 |
| Epson Portable PX 5 | £649.00 |
| Epson Portable PX + FAM | £799.00 |
| Kaypro 2 | £199.00 |
| Kaypro 10MB | £209.00 |
| Oric Atmos 48K | £45.00 |
| Sanyo MBC555 2x16CK D/D + Monitor | £899.00 |
| Sinclair ZX Spectrum 48k | £90.00 |
| Sinclair 2x81 | £33.00 |
| Sirius 1 128K 1.2MB | £1650.00 |
| Sirius '1' 256K 1.2 + 10.6MB | £2950.00 |
| Televideo | POA. |

DOT MATRIX

| | |
|---------------------------|---------|
| Aradex DP 9000 | £799.00 |
| Brother HRC | £130.00 |
| Canon PW1080A (NLD) | £299.00 |
| Commodore MTS 801 | £175.00 |
| Commodore 1526 Printer | £250.00 |
| Epson 3X8CT | £199.00 |
| Epson 3X8C F/T | £225.00 |
| Epson FX8C | £325.00 |
| Epson 3X100 F/T Printer | £345.00 |
| Epson 3X100 F/T | £425.00 |
| Mannesmann Tally MT80 | £199.00 |
| Mannesmann Tally MT160 | £399.00 |
| Mannesmann Tally MT180 | £599.00 |
| OKI Microline 82A Printer | £259.00 |
| OKI Microline 83A | £399.00 |
| OKI Microline 92 (P) | £399.00 |
| OKI Microline 84 (P) | £635.00 |
| Radix 10 (NLD) | £499.00 |
| Seikosa GP100A | £179.00 |
| Seikosa GP100/C | £175.00 |
| Shinwa CP80 F/T | £185.00 |
| Star Gemini 10X | £209.00 |
| Star Delta 11 | £319.00 |
| TEC 1550 (P) | £469.00 |

IBV: Telephone for a quotation on your configurations.

All prices excluding V.A.T.

WORLDWIDE COMPUTERS

Spa House, 11-17 Worple Road, Wimbledon, London SW19 4JS Tel: 01-947 8562 Telex: WOWICD 895588E

The name of the Game...



..IS COMING!

M-JS EDUCATIONAL M-JS SOFTWARE

BBC MICRO B

FRACTIONS

Tutorial cassettes with an unlimited number of exercises
 Introduction 6.95 And available in September
 Addition 7.95 Subtraction 7.95
 Subtraction 7.95 Division 7.95

TOPICS in English for 6-9 year olds

Multiple choice programs designed to improve vocabulary, spelling, word power and comprehension. Each program has five topics of 10 exercises.
 Topics 1 and 2 6.95 Topics 3 and 4 6.95

QUIZ

A competitive general knowledge game for individuals or teams.
 Quiz 1 6.95

TOWERS OF HANOI

Learn and develop logical skills in an attractive game. It can be set to suit all ages.
 Towers of Hanoi 6.95

MICRO-NINERS

Develop word power and solve clues with an intriguing word game £6.95

All educational text has been prepared or have been set with the advice of I.F.A. teachers. Word game texts written by graduates and programs by professionals. All prices include P&P and VAT.

Please write or phone for further details or send cash with order to:

MICRO-JENN SOFTWARE LTD
 81 SQUIRRELS HEATH ROAD
 HAROLD WOOD, ESSEX RM3 6LR 04023-4280

(continued from page 53)

XtalDos systems in circulation to justify a large software base.

There is one other possibility. The Einstein is physically able to run MSXDos. The micro has most of the right hardware and it would be a logical direction for Tatung to move in.

Despite my severe reservations about mirorily operating systems, XtalDos is jolly near. So is Xtal Basic, the native language of the Einstein. It has met with a degree of acclaim from programmers but is not a good language for beginners. I found that it contained a lot of commands that could be found elsewhere but are not standard.

Xtal Basic may be better than other Basics but there will be precious few games listings published in it and there will be hardly any good books about it. But, again, because Xtal Basic comes on disc and not ROM, it is an option. There is no reason why standard Microsoft Basic could not be implemented on the Einstein or, for that matter, Forth, Pascal, Prolog or Logo. Any versions of these languages developed for CP/M could be adapted fairly easily, though it might not be an economic proposal.

The system disc comes with a few example programs which don't show the Einstein off to its best advantage. I realise that Tatung must have bent over backwards to trim the costs to achieve the sub-£500 price tag, yet it would have been so much better if the supplied software was more imaginative. The Othello game was easy to beat and the snakes game downright boring.

I may be asking a lot but for this price I would like to have a second disc containing a word processor and a spreadsheet. This way you would be able to buy a complete system, ready to work or and for a good price.

Xtal Basic is not new, I remember seeing a version ages ago on the Sharp M7-80K. It has a lot more commands than common or garden Basic, complete with things like Deek and Doko which are two-byte versions of Peek and Poke, strictly for the enthusiast. However, Xtal Basic is very good at handling the sound and graphics of the Einstein.

Sound is often the Cinderella feature on a computer, so my heart naturally warms to Tatung's serious treatment of it. The Basic commands and the sheer volume and the flexi-

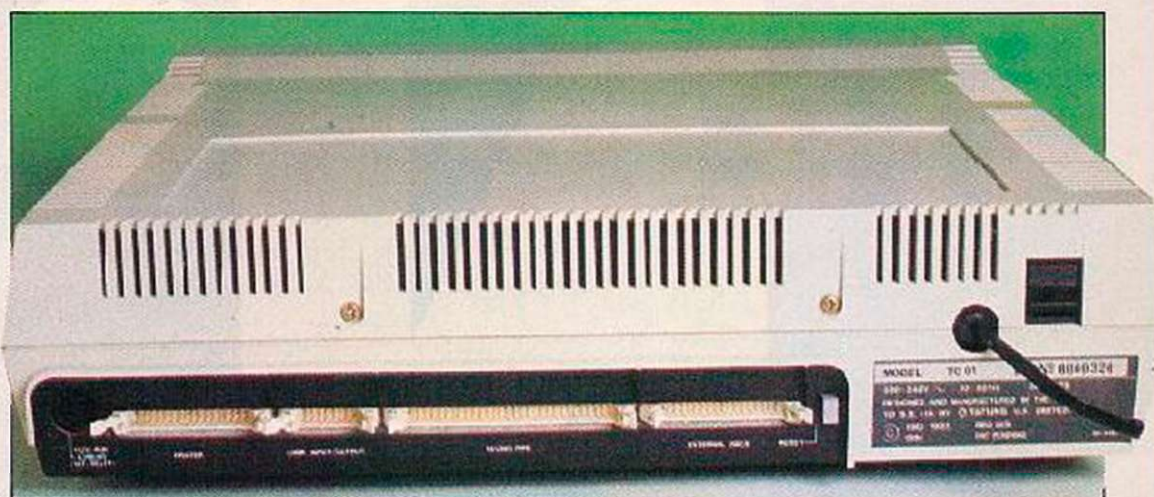

bility of the hardware are all plus point for Tatung. Unfortunately, the other half of the sound and vision equation is not so good.

For a start, the colours are dingy. The red is more like a washed out pinky orange than the colour of the people's flag and the blue just isn't true blue at all, but a woody purple tint.

The Basic commands controlling graphics are extensive and flexible enough and 32 sprites should keep most zappers in aliens for days. Apparently, the Einstein uses the same video chip as MSX machines. If that is the case then the Japanese invasion will be nothing to fear because the high resolution isn't all that high, the colour not very colourful and the sprites none too spritely.

Maximum resolution on the screen gives 192 by 256 pixels — hardly high resolution for a £500 micro. There are 16 colours but, because they are so dull, it is difficult to tell some of them apart. Although they are easy to control from Basic it isn't enough for 1984's model.

While the graphics might be a little disappointing from the point of view of the games player, they are not all that useful for the business user either. You can select either 40 or 32 columns across the width of the screen, but both sets of characters do not look as attractive as those to be found on other micros. More importantly, I found my eyes were feeling the strain after about an hour's use. So word processing — which anyway should really have 80 columns — on the Einstein might not be a serious proposition.

The colour resolution of the Einstein is only to the nearest character position. That is colours are defined on a 32 by 24 or 40 by 24

grid. This is about the same as on the Spectrum — hardly impressive. Drawing a diagonal line results in the chunkiest graphics you have ever seen because the lit pixels fill the whole of their row within a character space.

The manuals don't help much either. They are so unbelievably boring that I thought they must have been written by Jeffrey Archer.

The "DOSMOS" booklet, now there's a name to conjure with, is much more useful than the introduction book yet every bit as dull. It contains information about the machine code monitor and how to use the disc operating system. A third book is supplied with the machine called the Basic Reference Manual. It is the programmer's bible, yet suffers from the same shortcomings as the other two books; it is dull, contains no index, and no sensible appendices. It should at least contain a section full of memory map diagrams, screen address diagrams and the like.

I was impressed by the inclusion of a quick reference card, similar to that sent out with the Dragon 32. However, it turned out to be not as useful as I expected with no adequate description of the Basic keywords. This would be especially useful as certain Xtal Basic keywords are slightly exotic.

Although I have reservations about this micro, it does compare favourably with other systems in the same price range. The machine sits uncomfortably between computers like the BBC Micro, which is definitely a home computer with business possibilities, and the £700 ACT F1 which is a business computer with home possibilities. You can now buy a BBC for around £350 or less. It has better graphics than the Einstein, similar sound, better Basic and better manuals. But it doesn't have discs, nor does it have as much memory as the Einstein which comes with a full 64K plus 16K of video RAM. In practice this means a 64K memory, because the video RAM lies parallel to the main RAM.

Although the BBC has a wide user base and all the advantages that brings, add-ons are expensive. The Einstein will be able to use standard add-ons thus reducing costs considerably. If you want compatibility with educational users the BBC would be a better buy, but hackers might choose the disc-based system.

Compared with the Sinclair QL, the Einstein is not very fancy, but its 3 in. discs are a sight more standard than Sinclair's Microdrives. They are also more useful, more likely to last and can hold more — 190K per side as opposed to 100K per cartridge. If you want to play games the QL will be a better bet, but for serious use the Tatung should win.

CONCLUSIONS

- The Einstein does not fit into the current spectrum of available micros very well being neither a good enough games machine nor a powerful enough business system. The cop-out answer is that it is an educational computer but that is one role it is particularly unsuited to fill.
- Anyone purchasing the Einstein may have to reconcile themselves to owning a ghetto machine. I cannot see the dedicated software base ever getting large enough to be anything else. And as for CP/M compatibility, someone is going to have to copy each package across into the Einstein disc format and, in many cases, rewrite the software for the 40- or 32-column screen.
- In my opinion there is a serious design fault. Had the disc drive been a standard 5 1/4 in. unit, then users would

have immediate access to all the available CP/M software. I realise that this would have added to the cost but it would also add greatly to the utility of the machine.

- There is one other problem that will be familiar to owners of the Sharp micros which have a lot in common with the Einstein, thanks to versions of Basic not stored in ROM. Should Tatung ever be tempted to make changes to Xtal Basic — the installed version is 1.11 — then software may no longer be transferable between machines.

- All these reservations aside, the Einstein is a very low-cost way of buying a disc-based system. It is built from reliable tested technology and is unlikely to have the teething troubles of the QL. It is especially suited for control purposes and will thrill the hacker with its Xtal Basic and extensive machine-code monitor.

THE

NUMBER ONE

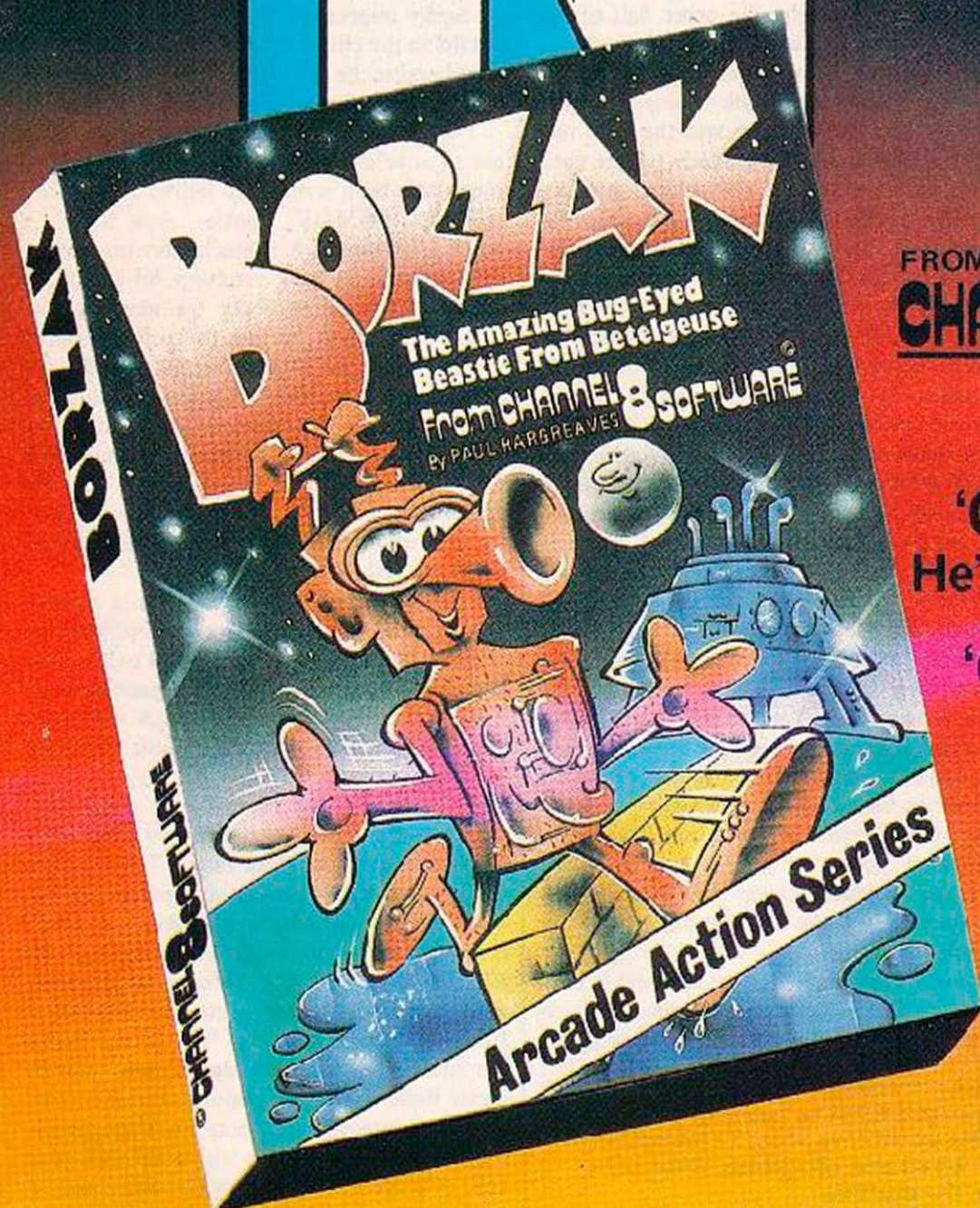

FROM
CHANNEL 8 SOFTWARE

'Oh Borzak ★■?!'
 He's just fallen in the bog.

'Oh Borzak ★■?!'
 He's just been hit
 by a piranha.

Borzak the amazing bug eyed beastie from Betelgeuse is our Number One, maybe he will be yours.

Borzak runs, jumps and ducks on the way to his spacecraft, on 48k Spectrum and Commodore 64 with keyboard or joystick control. Price £6.95 including VAT.

'Oh Borzak ★■?!' Don't curse too loud if you can't get him back to his ship.

OTHER CHANNEL 8 SOFTWARE TITLES

SHEAR PANIC
 THE BLACK SQUID
 THE CONSTRUCTOR
 I SPY FOR KIDS LANDER
 PRIMARY MATHS
 MATHS TUTOR TODDLER TUTOR
 'GOTCHA' MATHS
 ASTRAL ZONE

FEASIBILITY EXPERIMENT
 TEN LITTLE INDIANS
 THE WIZARD AKYRZ
 ARROW OF DEATH PT. 1
 ESCAPE FROM PULSAR 7

Mysterious Adventures

THE GOLDEN BATON
 ARROW OF DEATH PT. 2
 PERSEUS & ANDROMEDA
 THE TIME MACHINE
 WAXWORKS CIRCUS

CHANNEL 8 SOFTWARE
 51 Fishergate, Preston,
 Lancs PR1 8BH.
 Tel: (0772) 53057



Selected titles available from larger branches of , Greens at Debenhams, Lewis's, Spectrum dealers and good computer shops everywhere, (in case of difficulty send P.O. or Cheque direct).

PSION

PSION, THE SOFTWARE COMPANY that produces much of the Sinclair Spectrum official software and the bundled software — Quill, Archive, Abacus and Easel — for the new Sinclair QL, has branched out into the computer hardware business, an area that has seen many recent failings by both large and small companies.

The excursion into the apparently risky hardware manufacturing side of the business comes about by the desire to produce what Psion describe as a new type of computer product called the Psion Organiser.

The Psion Organiser is a calculator-sized pocket computer featuring a 16-character LCD display, a 36-key keyboard and an 8K plug-in Eprom memory pack or datapak. The calculator-type keys are protected while in the pocket by a sliding cover which, when withdrawn, exposes the plug-in memory underneath the keyboard and the display contrast adjuster control on the right-hand side of the display. Complete withdrawal of the cover gives access to the PP3 9 volt battery compartment.

The computer is based on the Hitachi 63C1X CMOS 8-bit processor, which contains 4K of on-chip ROM. This is supported by 2K of RAM for the calculator working registers, system variables and an 8K Eprom for program and/or data storage.

For £100 the user gets a bare bones calculator with a 16-character alpha-numeric LCD display — no scientific functions with parenthesis limited to a depth of two — and a built in database facility, capable of searching the 10K of character storage — 8K Eprom — for a specific number or character string within five seconds.

The Organiser is activated by using the On/Clear key and powers up with the display showing the time, date and month. The time may readily be adjusted as indeed it needed to be. The machine provided for review stopped

ORGANISER

the real-time clock from running when the machine was switched off, the replacement machine had no such problems.

The Mode key selects the current operating mode, that is:

Enter for general purpose free format database entries and editing.

Call for performing calculations.

Off which the user Executes to switch off.

Each individual process is performed by use of the Execute key — calculations are entered in the normal manner and the Execute key pressed instead of the more usual calculator = or Enter key.

Data is simply typed while in the Enter mode using the alphanumeric keyboard, each file being saved using the Save key with the display indicating whether the data is saved in datapak 1, or 2 if two datapaks are installed, according to the user's choice.

The database needs to be fairly static, data changes simply overwrite the existing data in memory to make it unreadable and the new file is written into a clean area of memory. Fast changing databases will become extremely wasteful of memory.

The database in each datapak must be consistent; the user can store telephone numbers, train timetables and appointments together within one datapak but there is no way of restricting a search to a specific segment or groups of files in an individual datapak.

Find2 string\$ will find every occurrence of string\$ within all the databases in datapak2. Therefore as an electronic notepad, the user is required to keep with the Organiser all the necessary databases separately which could

(continued on page 59)



Kathleen Peel tests the pocket computer that fills the same space as £100.

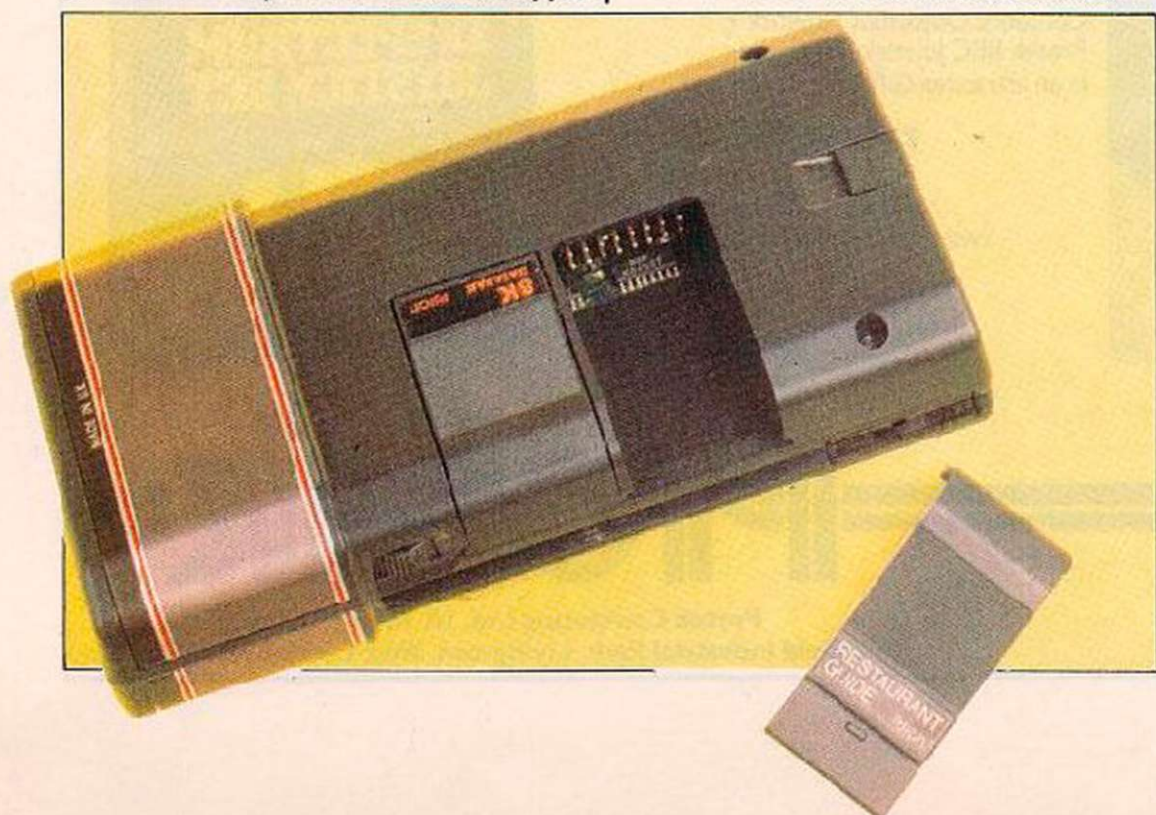

GET TO GRIPS WITH ARCADE ACTION!

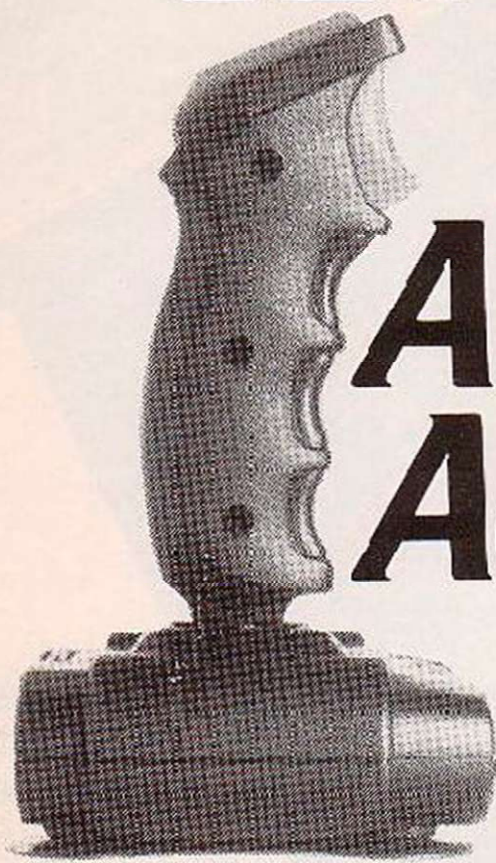

QUICKSHOT II £11.95

New improved design • Trigger + Top Fire Button • Auto Fire • Built in Stabilizing Suction Cups • For use with any computer with a 9 pin D' type connector. (Atari Compatible).



1700 Baud
Modem Now
Available
£59.95.



QUICKSHOT I £9.95

New improved styling • 3 Fast action fire buttons • 4' foot long cord • Arcade Control • For use with any computer with a 9 Pin D' Type connector. (Atari Compatible).

BBC JOYSTICK INTERFACE £11.95

Simply plugs in • Compatible with any Atari type Joystick, e.g. Quickshot and Games Master • Suitable for use with all standard BBC Software.

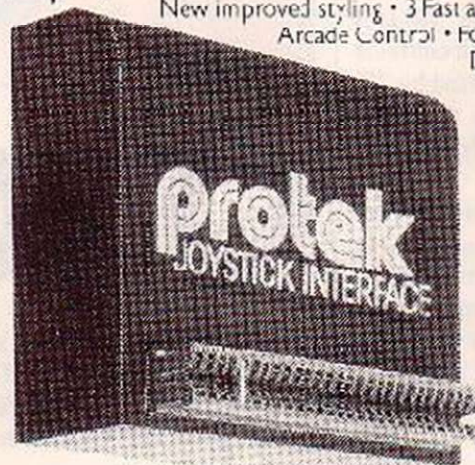

ZX SPECTRUM SWITCHABLE INTERFACE £19.95

No programming required • Simply plugs in • No additional software • Compatible at the flick of a switch with Prottek (Cursor Keys) Kempston and Sinclair Joystick Software. Compatible with any Atari Type Joystick e.g. Quickshot or Games Master.



BBC JOYSTICK SET £19.95

Contents: Quickshot I Joystick • Prottek BBC Joystick Interface • In an attractive Gift Box.

ZX SPECTRUM JOYSTICK SET £29.95

Contents: Quickshot I Joystick • Switchable Joystick Interface • Airliner - A Full Flight Simulation Program (16K) • In an attractive Gift Box.



Prottek

Prottek Computing Ltd, 1A Young Square,
Brucefield Industrial Park, Livingston, West Lothian. 0506 415353.



(continued from page 57)

become expensive in terms of datapak cost, and add considerably to the amount the user has to carry around.

The 8K Eprom can store about 200 names, addresses and telephone numbers. A search may be conducted using the Findn string\$ function, every record containing string\$ will be displayed, otherwise the computer keeps searching for a match. If there is no match, the message "not found" is displayed. If a string\$ is not given for the search, the computer will step through every file within the database.

By adding a program pack — £30 Finance, Mathematics or Science Paks are available — the Organiser is provided with further modes of operation:

Copy for copying between datapaks.

Ctrl used to access programs.

The Organiser is also capable of performing the same trigonometrical and scientific functions as found in the more comprehensive calculators.

And lastly a procedural language POPL is added. Each procedure is limited to a length of 200 characters, with an individual line not exceeding 100 characters. POPL supports 26 variables and can pass parameters between procedures — there is Goto a label and looping facilities.

Under normal conditions, rewriting code is not a problem as the program storage media is reusable. With the Eproms it is not and once written to, that space cannot be re-used until the datapak is re-formatted which clears the

whole of the datapak ready for a fresh start.

The Organiser may be expanded to incorporate two 16K Eprom datapaks, these cost £20 each but increases them in memory storage capacity up to 40,000 characters. The user may install 8K Eprom datapaks which cost £13, but either way strikes me as being pretty expensive for storing data.

The datapaks may be re-used up to 100 times by reformatting — wiping clean all of the Eprom; remember you cannot selectively erase. This will cost £3.50 if done by your local stockist or the large user may purchase a Formatter for £45 which can reformat two datapaks in 30 minutes.

The manual supplied is 1/4 A4 size of about 50 pages of text and diagrams. Most details are explained twice but for those who so far have shown no interest in computing, the documentation will be difficult to understand. The average computer user will find no problems other than the programming requirement of learning yet another language, POPL, which can hardly be of use in any other context.

The RS-232 expansion unit, which costs £25, permits the user with a modem to download load data via a telephone line to a remote computer. Computer to computer data transfer is also possible.

CONCLUSIONS

- Although very simple to operate as a database with a single integrated data file, the Organiser cannot handle separate databases residing on the same datapak.
- The database being searched needs to be fairly static, if it is going to change daily as a stores inventory might do, then the necessary changes to the database are going to use up the available memory space extremely quickly.
- Program development is likely to suffer the same fate. It is not possible for a user to write and enter a program without faults, and the Organiser will allow the user to work on only one procedure in RAM at any one time.
- The Organiser is going to be very expensive to run as a computer. The development of software which is

always subject to change and revision does not lend itself to the type of storage media employed in this computer design.

- The use of Eproms as the storage media imposes restraints on the programmer, a requirement for a local Eprom formatting service and fairly substantial power requirements on the hardware designer.
- The Organiser appears to fit those types of market where data security is essential and, of course, using Eproms gives a very high level of security, but logistically I'm not sure. The data typed in is secure, but whether it can be entered correctly using the calculator-type keyboard and very small screen display without a lot of careful checking at the time of data entry, which the average person is unlikely to perform, is doubtful.

What the competition hasn't been waiting for.

Latest version of Forth for the BBC (is not rehashed Forth 79 Code)

Unique Stack Display Utility



16k Eprom type 27128

Multi-tasking operating system for Real-Time use.

Here is the Forth Eprom for the BBC Micro that makes all others out of date.

It's Multi-Forth 83 from David Husband who has built his reputation for Quality Forth products with his ZX81 Forth ROM, Spectrum Forth-I/O Cartridge and now New Multi-Forth 83 for the BBC Micro. This is not rehashed Forth 79 Code, but a completely new version of the Forth 83 Standard. It's unique in that it Multi-tasks, and therefore the user can have a number of Forth programs executing simultaneously and transparently of each other.

Multi-Forth 83 sits in the sideways ROM area of the BBC along with any other ROMs in use. It is compatible with the MOS and specially vectored to enable a system to be reconfigured. It contains a Standard 6502 Assembler, a Standard Screen Editor, and a Unique Stack Display Utility.

With this Forth, David Husband has provided the BBC Micro with capabilities never before realised. And being 16K rather than 8K is twice the size of other versions. Multi-Forth 83 is supplied with an

extensive Manual (170 pages plus) and at £45+VAT it is superb value.

Order it using the coupon adding £2.30 p&p (£5 for Europe, £10 outside) or if you want more information, tick that box instead. Either way, it will put you one step ahead of the competition.

Please send me Multi-Forth 83 for BBC Micro, £45+VAT. Disc £80+VAT. Cheques to Skywave Software Readers' A/C (or enter Visa No.)

Name _____

Address _____

Post code _____

Please send me more information:

Multi-Forth 83

ZX81-Forth ROM

Spectrum Forth-I/O Cartridge

Skywave SOFTWARE

SUBJECT TO AVAILABILITY. FOR LOANS ONWARDS. Send to Skywave Software, 73 Curzon Road, Bournemouth, BH 4PW, Dorset, England. Tel: (0202) 302385

MULTI-FORTH 83 FOR THE BBC MICRO

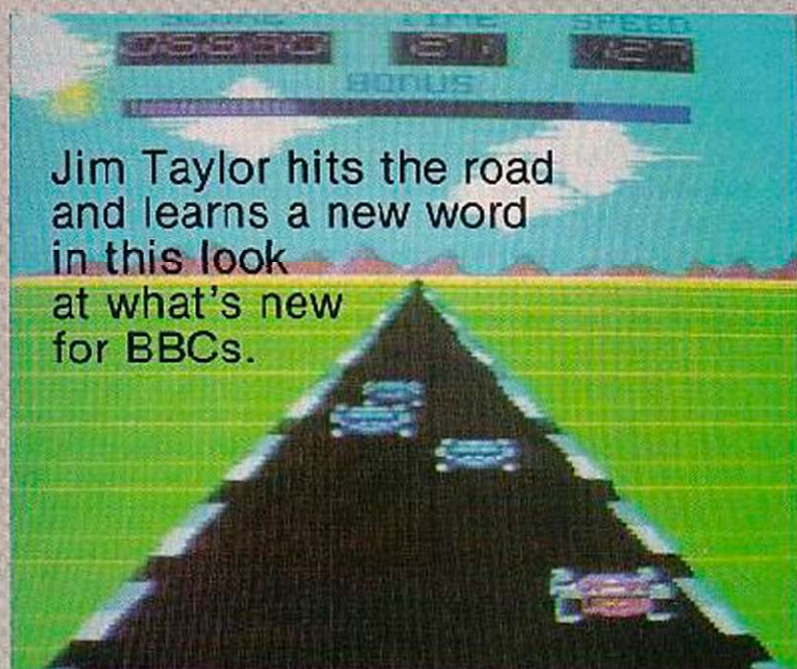

Jim Taylor hits the road and learns a new word in this look at what's new for BBCs.



BBC SOFTWARE

FRAK! A NEW WORD enters the English language, courtesy of Orlando and Aardvark Software. Use it when you're frustrated, when you drop your toast jam side down or simply when you lose yet another life playing the compulsive new game with the title Frak!

It's a bold change for Orlando, the programmer who brought you the classic shoot'em-up Zalaga. There's no frenzied and murderous action in this latest offering, just superb graphics and a witty variant of the platform game.

You are cast in the role of Trogg, a cavemar-

with a belly worthy of a champion darts player. Trogg's forte, though, is the yo-yo, with which he can knock the various monsters off their perches.

On the first screen his opponents are the Scrubblies, large purple creatures who just get in the way without being at all aggressive. On the second screen, should you ever get there, you will find Poglets squatting on logs and on the final screen are Hooters which have the prominent facial feature suggested by their name.

Throughout the game there is danger in the

form of balloons floating up and daggers drifting diagonally across the screen. As you climb ladders and hop along platforms it's difficult to avoid them. Each time you lose a life a cartoon-style balloon emerges from your mouth as you utter the fatal word 'Frak!'

The gameplay in Frak! is consistently entertaining and, although quite a simple idea, provides a real challenge. But the game is remarkable chiefly for the quality of its graphics — they are undoubtedly superior to anything else currently available on the BBC.

Trogg is drawn in great detail even down to the stubble on his Neanderthal chin. The monsters are original and colourful and the game scrolls with exceptional smoothness. Frak! makes most other games look prehistoric.

For instance, Microdeal's Arena 3000. This is supposed to take place in 3000 AD, but games don't seem to have come along much in all that time. What you get is a version of Robotron, the rush-your-little-man-around-the-screen-shooting-everything-in-sight game.

As such, it's not bad. Everything happens quickly enough, the graphics are reasonable even if the figures are a little small and the

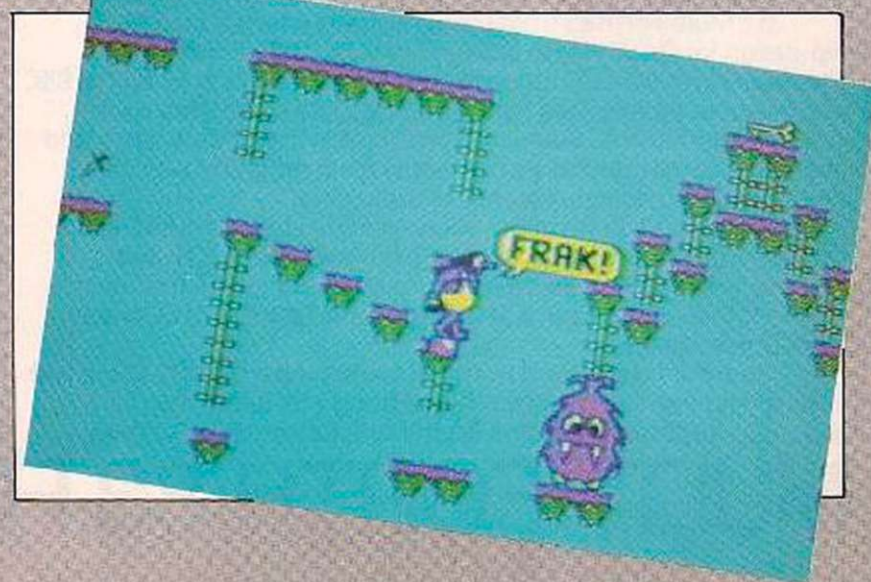

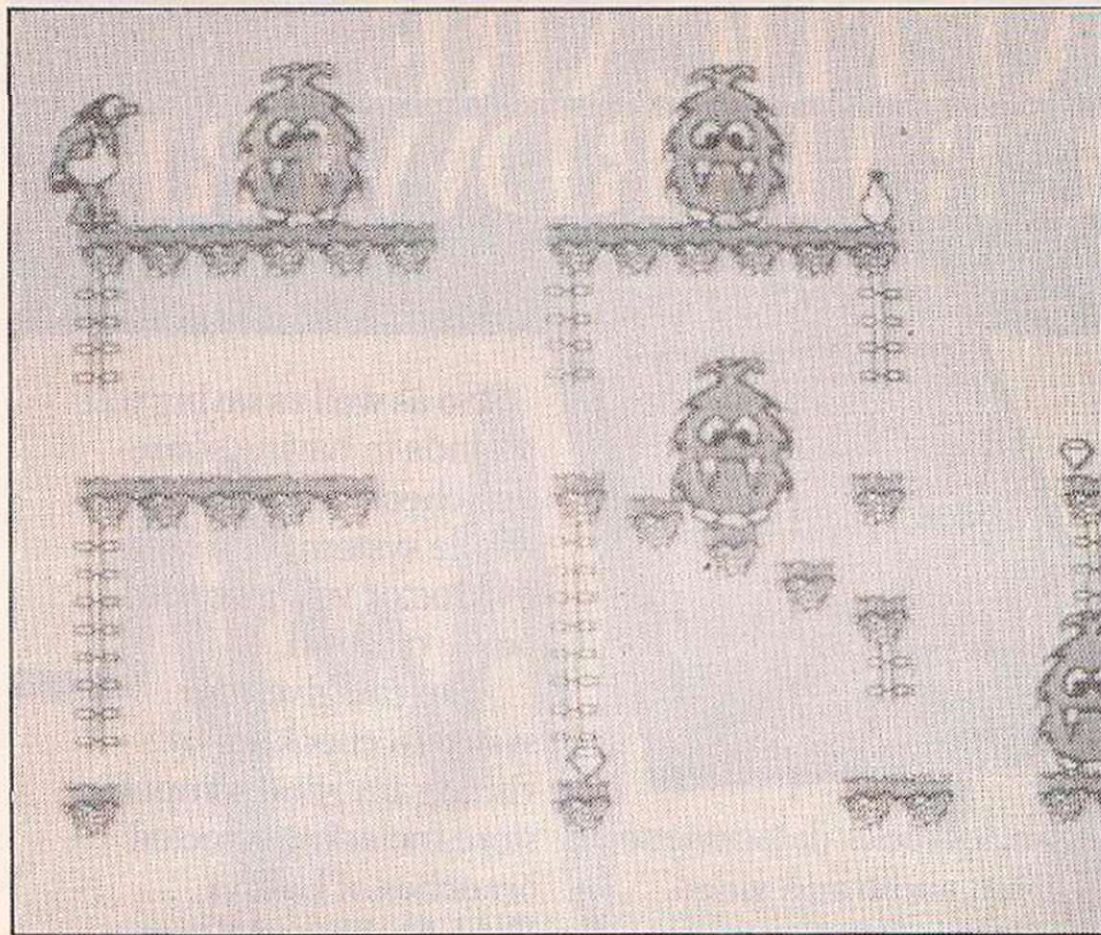

movement is pretty smooth. But it's completely unoriginal and, ultimately, pretty boring.

If that other arcade classic, Pengy, is more your style then you will be spoilt for choice: there are no less than three versions in the recent releases. In Pengy you are a penguin who must push around ice-blocks to crush your enemies the Sno-Bees, as well as performing other tasks such as lining up special blocks.

Visions' Pengi is a very good version of the game. 'Poor old Pengi is locked up in the freezer again!', and your job is to line up the ice diamond blocks and crush the nasty Snow Bees, rotund monsters with large noses.

Pick up a penguin

A bonus in this version is that the perimeter of the screen is electrified so that Pengi can fry Snow Bees if he can lure them onto it. The game has good colourful graphics and moves very smoothly. The music is sprightly, keys are user-definable and there are up to 30 screens.

Competition comes in the form of Percy Penguin from Superior Software. The idea is virtually the same, but the execution lacks the sophistication of the Visions version.

The Sno-Bees are again blobbish creatures, but they now have large floppy ears which give them an incongruously cuddly appearance. There's no electrified fence, the colours are not so vibrant and the movement is slightly jerky.

Better than both these versions, though, is Program Power's Rubble Trouble which represents a great leap forward in the theory and practice of Pengy.

In this game there are no penguins and no Snow Bees. Instead, the post-holocaust

scenario gives you a caveman battling it out with the Krackats, 'mutated turtle-like creatures' who hatch from the rocks which have replaced ice-blocks.

The principle is the same — crush your enemies — but the innovation is that the boulders bounce back if they don't get a Krackat. They move so quickly that you're likely to splat yourself if you're not careful.

The graphics are excellent, with a bland caveman and very nasty green Krackats. Movement is very smooth and when you lose a life you ascend to heaven with a halt. It doesn't take too much imagination to turn a tired old game into something which seems almost original.

Original is not an adjective which could be applied to Simonsoft's Super Fruit. It is, of course, a one-armed-bandit simulation, and a very good one at that. It provides all the expected options and has excellent graphics and sound. The main virtue of this program, though, is that it moves particularly smoothly. If, for whatever obscure motive, you want to play a fruit machine on your BBC, you are unlikely to find anything better than this.

There haven't been too many motor-racing games available on the BBC, but Superior Software has just brought out Overdrive while Program Power is now offering Stock Car.

Overdrive is a multi-stage 3D race through ice, snow, desert and riverside. You must first qualify for the race by finishing in the top 12 — no easy task to begin with. You begin on the black track heading straight as an arrow through the green fields to the red mountains in the distance. Accelerate quickly or you'll get flattened by the other vehicles coming from behind.

Graphics are good and the motor noises are most convincing. The game is challenging

enough to keep you at it for quite some time.

Stock Car's graphics are much cruder — blobs on a track seen from above — but the fun of the game is a little more robust. As in the real thing you try to get round the track first while causing as much damage as possible to other competitors.

There is a choice of six tracks and you can also get optional hazards such as oil slicks and skids. Playing against the computer can be a bore, but competition with another humanoid is much more exciting.

Ghouls, from Program Power, is not only exciting but infuriating as well. You have to rescue your power jewels from a creepy mansion on top of a hill. There are four spooky screens to battle through, although I have yet to meet the man who has successfully completed this game.

Ghoul dodging

You are required to jump over gaps, walk on magic platforms and dodge the ghouls. It is all pretty difficult. Although your little yellow man is plucky enough he's really up against it. The grotesque red blob of a ghoul descends slowly from the top of the screen; when you snuff it he actually smiles while the sound produces a derisive whine. Everything about this excellent game is calculated to have you making frequent trips to the keyboard and the drinks cabinet.

Jet Power Jack, also from Program Power, is just as well made, with excellent graphics and sound, but is not such a compulsive game.

Your task is to collect fuel pods scattered around the space garage in which Nogrob the Terrible has imprisoned you. On your back is a turbopack which allows you to thrust around and avoid, if you're lucky, such opponents as the "nasty space Googjies".

There are five screens and a great variety of creepy space monsters to overcome until you get through to Wilfrid the hideous Yugg monster at the very end. Inventive and colourful graphics give this game its high quality, but you should be warned that the thrust controls take a considerable time to master.

Landscape with tanks

In Dynabyte's 3D Tank Zone colour has been sacrificed for high-resolution — to good effect. The game is a Battlezone variant. Through the windows of your command centre you scan the landscape for enemy tanks, get them in your sights and then blast them to bits. Very satisfying when it comes off. But there are also aerial invaders to cope with.

Helicopters and fighters come zooming in to blast you with their rockets. So you have two sets of controls; one for your anti-tank guns and another for anti-aircraft cannon. Both at the same time can be pretty hectic, but the program does allow you to practice on each one separately. The game is by no means original, but is implemented skilfully. ■

HEALTHCARE FOR YOUR HARDWARE

When your Commodore 64 seems distinctly unwell it's hard to know what to do.

Which is why you need 64 Doctor.

This special program will find the fault by a series of short diagnostic tests. And tell you exactly where the problem lies.

Included are tests for RAM, keyboard, disc-



drive, joysticks, datacassette, printer, audio and video displays.

So as well as saving you pounds in having someone check through the whole system for a fault, 64 Doctor will give you peace of mind.

You can give your system a check-up by visiting any good computer store including selected branches of Laskys, W.H. Smith and Boots.

64 Doctor Tape £17.95 inc. VAT. Disc £19.95 inc. VAT

 PRACTICORP

Practicorp, Goddard Road, Whitehouse Industrial Estate, Ipswich IP1 5NP. Tel: 0475 462721

Educational Software **LCL**

MICRO ENGLISH



NEW
BBC Micro
ZX Spectrum
unexpanded VIC
Electron
ZX81
Apple
PET
Commodore 64
Dragon (book on y)
All software for the
above computers.

MICRO ENGLISH (BBC/Electron) Complete O-level English language self-tuition or revision course of 24 programs, includes "Speak and Spell" programs; 2 disks/tapes. £24.50.

MICRO MATHS 24 program revision or self-tuition course to O-Level £24.50 (except ZX81 £12.00)

BRAINTEASERS (BBC, Electron, CBM 64, Spectrum, Dragon, Vic) £5.95.

"The book is a collection of 25 program listings, each one an interesting and amusing challenge... You'll like this" **ELECTRON USEF**

ANIMATED ARITHMETIC Teachers using moving colour pictures (no words) Ages 3-8. £6.50 (disc £7.50).

MASTER MATHS (Apple, Pet and CBM 64 only). 50 program O level course or teacher's aid, amazing graphics.

"... the programming standard is high". **TIMES EDUCATIONAL SUP** Immediate dispatch. Micro Maths, Micro English and Master Maths. Phone or send orders or requests for free catalogue (200 programs) to:

World leaders in Maths educational software
(distributors in 24 countries)

LCL

26 Avondale Ave.
Staines, Middx.
Tel: 0784 58771



GENEROUS TRADE
DISCOUNTS

24 hrs. Orders

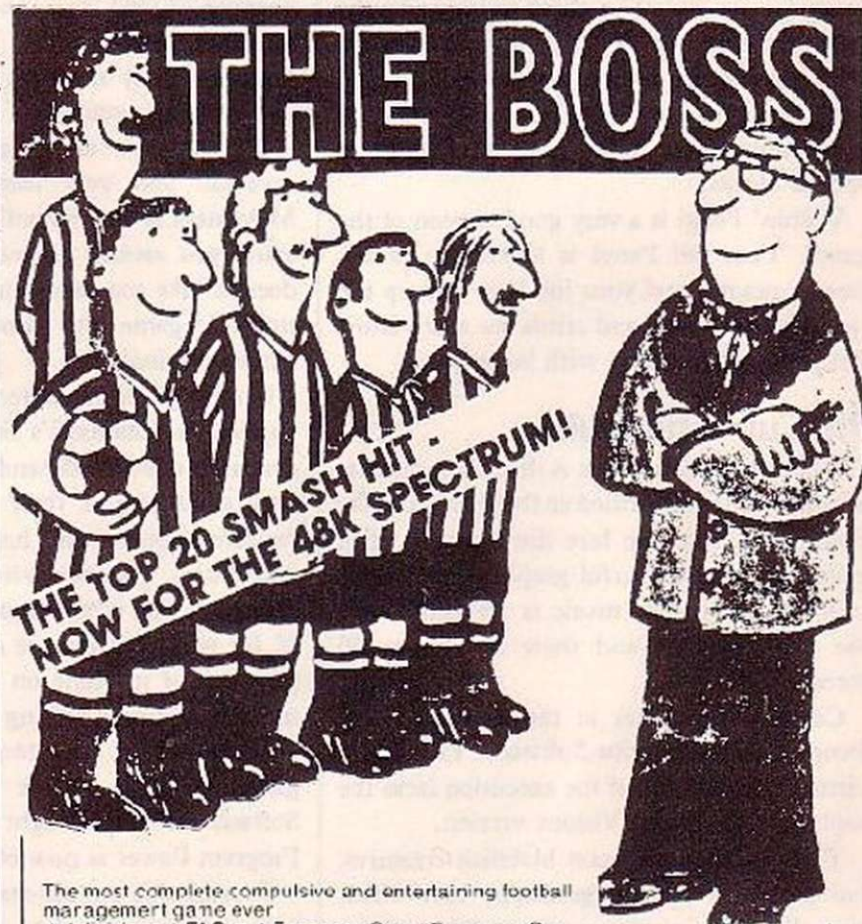

The most complete compulsive and entertaining football management game ever

★ 4 Divisions ★ FA Cup ★ European Cup ★ European Cup-Winners Cup ★ Replays ★ Promotion/Relegation
★ Transfers ★ Suspensions ★ Injuries ★ Substitutes
★ Name team ★ Team selection ★ Name players ★ Choose/change team formation
★ Weekly league tables ★ Fixtures/Results table ★ Reserve squad ★ Soy or other clubs
★ Minute-by-minute goal facts ★ Goals feature.

IF WE DON'T DESPATCH YOUR ORDER ON THE DAY WE RECEIVE IT YOU CAN HAVE THE GAME FREE!

PEAKSOFT, 48 QUEEN STREET, BALDERTON, NEWARK, NOTTS. Tel: 0636 705230

Rush me The Boss for my 48K Spectrum. I enclose a cheque or PO for £6.95

Name:
Address:

 or Phone your access number



**ARE YOU
GETTING YOUR
WIRES CROSSED?**

MICROMATE

**LET MICROMATE
TIE UP YOUR
LOOSE ENDS.**

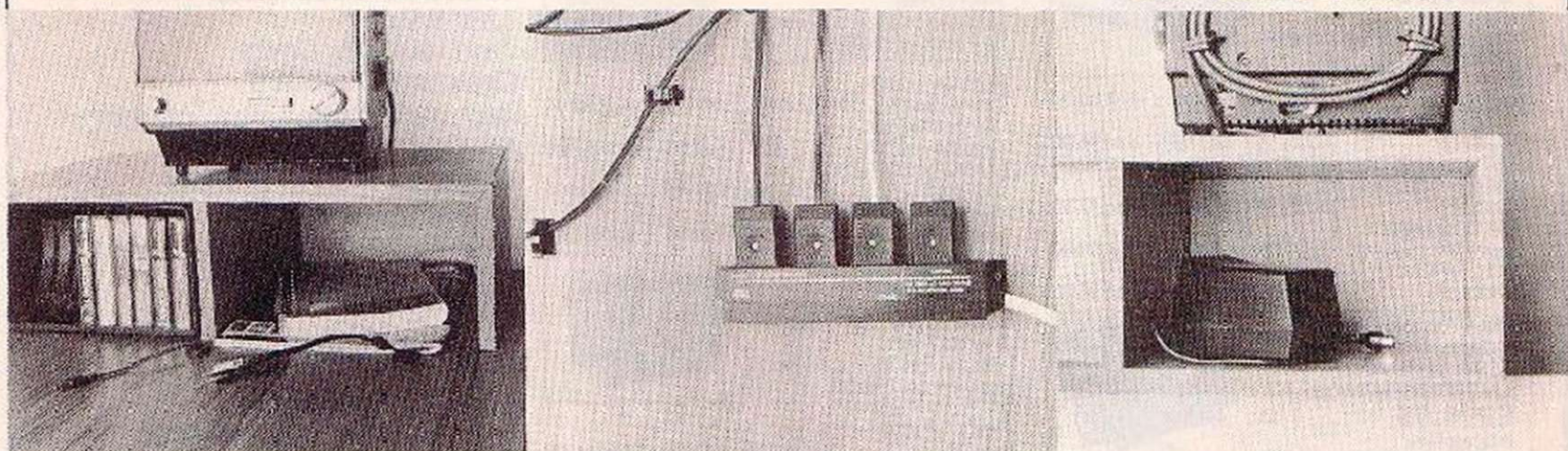

Cassette rack, slots for wires

Mains distribution unit
complete with plugs

Storage at rear for transformers

Have you ever wished that you could spend more time with your computer and less setting it up and putting it away? Your valuable hardware is at risk on the floor or the kitchen table and the leads lying everywhere are a hazard to all and sundry.

The simple answer is the attractive and practical MICROMATE. Its teak veneer top, measuring 34" x 26" will take a monitor, cassette or disc drive, joy stick and keyboard up to the size of a BBC computer. A quick release cassette rack is provided, there is space for magazines/

manuals and transformer storage at the rear of the trolley.

Slots provided in the working surface take all the wires to a Mains Distribution Unit neatly hidden under the desk. This unit is complete with 4 plugs so that just one lead to the mains is required.

The MICROMATE has a strong tubular frame, is easy to move around and is an attractive piece of furniture for the children's bedroom or your own study. It comes ready for assembly, a job which takes minutes but will give years of reward. The cost is only £69.95 + £6.95 p & p.

24 hour answering service (05436 77156)
Visa, American Express, Access and Diners Club
accepted. Please remember to leave your name
and address and credit card number.

Belcot Leisure Industries Limited reserve the right to alter specifications without notice.
Copyright and registration of design applied for.

Mr/Mrs/Miss: _____

Address _____

Postcode _____

Signature _____

Card Number: _____

Please make cheques payable to Belcot Leisure Industries Limited

Belcot Leisure Industries Ltd., Cinder Road, Chase Terrace, Nr. Walsall, Staffs WS7 8XD.

INTEREST FREE CREDIT on Micro Computers and Peripherals

In addition to offering computers and peripherals at low, low prices, Vision Store now offer Interest Free Credit i.e. paying over 6 or 9 months with no interest charge. To take advantage of our Interest Free Credit Scheme come to one of our stores where our friendly staff will help you complete the form. Then subject to status, after paying the deposit, you can take the goods away with you. It's as simple as that!

COMPUTERS

COMMODORE

Price | Deposit | Payments

CBM 64 Business Package
including 1541 disk drive,
801 dot matrix printer and
£205 worth of FREE software
£629.95
Interest Free
Deposit £77.95 + 6 monthly
payments of £92.00



| | | | |
|--|---------|--------|----------|
| CBM 64 | £204.95 | £24.95 | 6x£30.00 |
| CBM 64 with C2N Cassette | £249.95 | £33.95 | 6x£36.00 |
| CBM 1541 Disk Drive | £219.95 | £27.95 | 6x£32.00 |
| CBM 801 Dot Matrix Printer | £225.95 | £30.95 | 6x£32.50 |
| CBM 1526 Letter quality dot printer | £339.95 | £39.95 | 6x£50.00 |
| CBM 1701 Colour Monitor | £229.95 | £31.95 | 6x£33.00 |

SX64 Portable Computer
including Disk Drive and
Colour Monitor plus
£210 of FREE Software
£799.95
Interest Free
Deposit £205.99 + 6 monthly
payments of £95.00



| | | | |
|---|---------|--------|----------|
| VIC 20 PACKAGE inc VIC 20 C2N Cassette Joystick 5 Game Cassette Game Cartridge Usual Price £169.95 | £149.95 | £17.95 | 6x£22.00 |
|---|---------|--------|----------|

ATARI

Atari 800XL 64K computer
with FREE Software
£249.99
Interest Free
Deposit £33.99 + 6 monthly
payments of £36.00

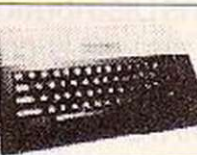

| | | | |
|----------------------------------|---------|--------|----------|
| 630XL with 1010 Cassette Deck | £209.90 | £23.90 | 6x£31.00 |
| 830XL with 1010 Cassette Deck | £299.90 | £35.90 | 6x£44.00 |
| 830XL with 1050 disk drive | £549.90 | £57.90 | 6x£82.00 |
| 1050 disk drive | £299.90 | £35.90 | 6x£44.00 |
| 1020 Colour printer/ plotter | £199.90 | £19.90 | 6x£30.00 |
| 1027 Letter quality printer | £299.90 | £35.90 | 6x£44.00 |

Interest Free Credit available to Mail
Order Customers. Phone or write for
details.

VISIONSTORE KINGSTON
3 Eden Walk Precinct, Kingston,
Surrey. Tel: 01-546 8974

BBC MODEL B £399.95 NOW AVAILABLE ON INTEREST FREE TERMS

£99.95 Deposit + 6 monthly
payments of £50.

BBC

Price | Deposit | Payments

BBC Model B - computer
cassette deck and cables
£439.95
Interest Free
Deposit £49.95 + 6 monthly
payments of £65.00



| | | | |
|---|---------|--------|----------|
| BBC B with Disk I/F plus 100K Cumana Disk Drive | £689.95 | £95.95 | 6x£99.00 |
|---|---------|--------|----------|

Cumana CSX100 Disk Drive
£185.95
Interest Free
Deposit £29.95 + 6 monthly
payments of £26.00



| | | | |
|------------------------------------|---------|--------|----------|
| CUMANA 1x200K Disk Drive CSX200 | £229.95 | £37.95 | 6x£32.00 |
| CUMANA 2x100K Disk Drive CD200 | £359.95 | £47.95 | 6x£52.00 |
| CUMANA 40/80TR 2x200K CD400 | £539.95 | £71.95 | 6x£78.00 |
| CUMANA 40/80TR 2x400K CD800 | £579.95 | £99.95 | 6x£80.00 |

**Microvitec Cub RGB
Colour Monitor**
£229.95
Interest Free
Deposit £44.95 + 6 monthly
payments of £30.00

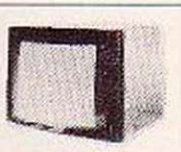

| | | | |
|--|---------|---------|-----------|
| SANYO 14" RGB Monitor Std | £249.95 | £33.95 | 6x£36.00 |
| TORCH Z80 Disk Pack inc C/PM Programs Perfect Speller Perfect Writer Perfect Filer | £859.95 | £259.95 | 6x£100.00 |

PRINTERS

DOT MATRIX

**Epson RX80
Dot Matrix Printer**
£259.95
Interest Free
Deposit £37.95 + 6 monthly
payments of £37.00

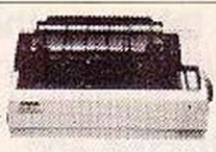

| | | | |
|-----------------|---------|--------|----------|
| EPSON RX80 F/T | £299.95 | £59.95 | 6x£40.00 |
| EPSON FX80 | £439.95 | £49.95 | 6x£65.00 |
| EPSON MX100 F/T | £489.95 | £57.95 | 6x£72.00 |
| EPSON FX100 F/T | £579.95 | £53.95 | 6x£86.00 |
| SEIKOSHA GP100A | £179.95 | £23.95 | 6x£26.00 |
| SEIKOSHA GP300A | £179.95 | £23.95 | 6x£26.00 |
| SEIKOSHA GP550A | £229.95 | £37.95 | 6x£32.00 |
| SEIKOSHA GP700A | £349.95 | £49.95 | 6x£50.00 |
| SHINWA CP8C | £279.95 | £39.95 | 6x£40.00 |
| STAR DPS15 | £319.95 | £43.95 | 6x£46.00 |
| STAR GEMINI 10X | £259.95 | £35.95 | 6x£44.00 |
| Brother EP4 | £239.95 | £35.95 | 6x£34.00 |

DAISY WHEEL LETTER QUALITY

Price | Deposit | Payments

**Smith-Corona TPI
Daisy Wheel Printer**
£259.95
Interest Free
Deposit £37.95 + 6 monthly
payments of £37.00



| | | | |
|--------------|---------|--------|----------|
| JUKI 6100 | £439.95 | £49.95 | 6x£65.00 |
| BROTHER HR15 | £455.95 | £53.95 | 6x£67.00 |

Memotech MTX500 32K
£199.95 Interest Free Deposit £19.95 +
6 monthly payments of £30.00

Memotech MTX512 64K
£279.95 Interest Free Deposit £39.95 +
6 monthly payments of £40.00

New Additions - Just In

Sanyo MBC 555

16 bit business computer
128K RAM
Twin 160K Disk Drives
Detachable Keyboard
With the following FREE Software: -
MS-DCS - operating system
Wordstar - Word Processor
Calcstar - Spreadsheet
Infostar - Database
Spellstar - Spelling Checker
Worth £1,400 FREE
Interest Free Deposit £340 + 9 monthly
payments of £90.00

£1,150 inc VAT
(please note Monitor is extra)

Cash Sales Only

| | |
|---|----------------|
| Sinclair Spectrum 48K inc. Free games 6-pack worth £56.70 | £125.95 |
| Sinclair Interface 1 and Micro Drive inc. 5 Free programs | £97.95 |
| Anstrad Computer inc. cassette + green screen monitor | £239.95 |
| Acorn Electron Commodore Vc-20 inc. 4 Games Cartridges (worth £39.95) | £199.95 |
| Brother HR5 Printer | £159.95 |

SOFTWARE

Don't forget -
We are London's largest stockist of Micro Computer
Software. Over 1,000 programmes in stock for games,
educational and business. Continuous demonstrations.

EXPORT

All our hardware and software is available Tax-Free to
overseas customers, please send for our comprehensive
list. Please contact our Croydon office.

MAIL ORDER

We send our whole range anywhere in the UK by FRFF
Insured Securicor Delivery. Please contact our Croydon
office.

All Prices include VAT

VISION STORE

VISIONSTORE CROYDON
96-98 North End, Croydon,
Surrey. Tel: 01-681 7539

MUSIC HARDWARE



Kendall Wrightson opens the lid on electromusic.

MAJOR ELECTRONIC MUSICAL instrument manufacturers such as Yamaha, Roland and Sequential Circuits have not been slow in incorporating the latest technology into their machines. The rate at which synthesizers, sequencers and drum machines appear is almost as staggering as the facilities they offer.

Most home computers have sound facilities. The better ones, musically speaking, like the CBM-64 can produce reasonable results if you have the patience and aptitude to write your own programs.

Dedicated synths involve a lot of clever hardware as well as software and the more professional musical home computer packages either include extra hardware such as voice cards to transform the micro into a synth, or use the micro to control a dedicated synth as we shall discover.

Synthesizers utilize many techniques to create imitative sounds. The most common method, known as subtractive synthesis, involves control of the frequency of one or more oscillators from a music keyboard, guitar or computer.

The oscillators produce wave forms of complex harmonic structure, like triangle, sawtooth and square waves. These wave forms are then modified by a sort of special tone control called a filter.

Varying the filter's cut-off frequency removes harmonics of the complex wave form — hence the term subtractive. However harmonics may also be greatly emphasised by increasing the filter's resonance or Q.

The filtered tone then enters an amplifier, Below: CBM-64 and Drumtrax.

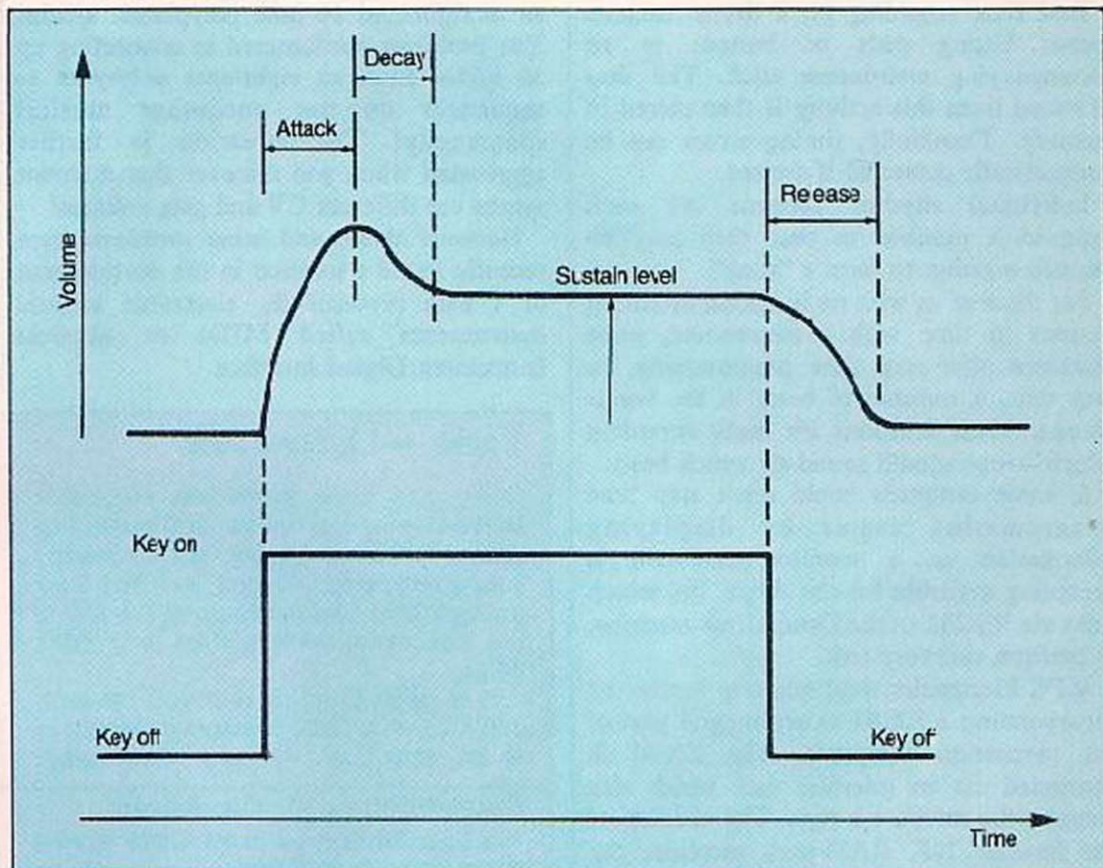

Figure 1. ADSR envelope.

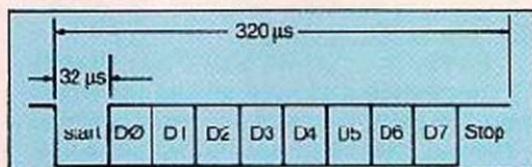

Figure 2. MIDI serial.

but will sound uninteresting to the human ear, because it is static. This is overcome by generating modulation signals which can be routed to the filter, the amplifier and the oscillators. These modulating signals may be

generated by low frequency oscillators or LFO's, velocity and pressure sensors fitted to the keyboard, and by performance controls.

One special kind of modifying signal is an envelope — so called because of the way it shapes sound. The envelope's parameters, attack decay, sustain and release — ADSR — are set up by the user. When applied to the amplifier, the envelope shapes the volume of the sound applied to its input in the following way — having played a note, the attack rate controls the time taken for the sound to reach a maximum level. Decay is the time taken for the sound to reach a sustain level. The sound will remain at this sustain level until the key is released whereupon the sound will die away at a rate dependent upon the release setting — see figure 1.

A collection of control settings is called a patch. Before the advent of the micro-processor and cheap memory, a change of patch involved twiddling all the control knobs to their appropriate positions — a somewhat time consuming activity, particularly during a live performance!

These days life is made easier because patches are stored in memory and may be instantly recalled. Modern synths also allow patches to be saved to and loaded from tape.

(continued on next page)



(continued from previous page)

Other methods of synthesis include frequency modulation techniques or FM, additive synthesis and more recently, the sampling of real sounds. However, the terminology described above may be applied to any method of synthesis.

Simulating drum sounds electronically is extremely difficult. For this reason contemporary drum machines use samples of real drum sounds. The sounds are digitised through an analogue to digital converter — ADC — and stored in Eprom. So when you hit the trigger pad or press the button, the Eprom's contents are clocked out through a digital to analogue converter, or DAC, under microprocessor control.

Real time recording on a drum machine means hitting pads or buttons to an accompanying metronome click. The data provided from this activity is then stored in memory. Thankfully, timing errors can be automatically corrected if desired.

Individual rhythm patterns are each assigned a number so that they may be chained together to form a "song".

For those of us with no intention of hitting buttons in time with a metronome, some machines offer step time programming. In step time, a number of beats to the bar is chosen. Then decisions are made regarding which drums should sound on which beats.

A home computer could make step time programming easier by displaying information on a monitor. Software is becoming available for the Apple IIe, which links via RS-232 to the Drumulator machine, to perform this very task.

MPC Electronics went one step further by incorporating a ZX-81 as an integral part of the percussion computer. The ZX-81 is connected via an interface unit which also contains the software it runs. The addition of the Sinclair 16K RAM-pack increases the machine's memory, while the software allows the loading and saving of patterns, as well acting as a visual aid to composing.

Sequencers, like drum machines, record data with respect to time. The difference is that sequencer data represents keyboard depressions and the length of time that keys are held down, so why not make a conventional analogue recording?

Well, first, a sequencer can play back at different tempos, without affecting pitch. Secondly, the sequence may be played back using a different pitch to the one it was programmed with. Thirdly, sequencers offer the non-musician the chance to compose music through step time note entry, where pitch and timing information is entered

separately.

Again, like drum machines, sequences can be chained together to form "songs". The sequence order can be changed if it is unsatisfactory.

Originally, synthesisers used to generate a control voltage or CV — proportional to the pitch played, and a gate signal — proportion to the length of time a key was held down. It was these signals, after analogue to digital conversion, that sequencers used to record. This was fine for synths which were capable of playing only one note — monophonic — since it would require only four cables to connect a synth to a sequencer for record and playback.

Modern integration developments have led us to eight and 16 note polyphonic synths. The problems encountered in connecting up 32 cables from an eight-note polysynth to sequencer do not encourage musical spontaneity! The situation is further aggravated when you discover that different synths use different CV and gate voltages!

However these, and other problems have recently found a solution in the development of a data protocol for electronic musical instruments called MIDI or Musical Instrument Digital Interface.

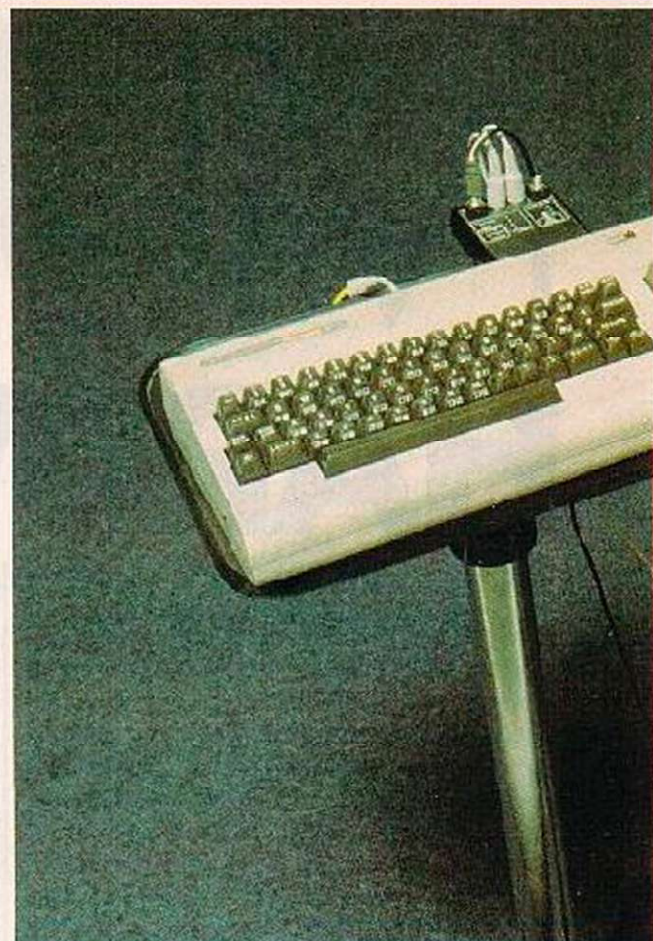

Casio — ZX Spectrum

Casio has been producing electronic keyboards by the million in the last few years. Indeed a recent survey asking young people to list their favourite toys, had portable keyboards up at the top of the list along with micros and BMX bikes.

It is good to know that you can now link a Casio MT-200 portable keyboard to a ZX Spectrum — and most other

popular micros — via the Casio PA1 interface. The software, listed in the MT-200 manual turns the Spectrum into a sequencer with editing facilities.

Alternatively the software is available on cassette from Micro Musical Limited, which is also working on a system called Microlink 2. This will allow the linking of two existing Casio models — the MT800 and PT-80 — to the Spectrum to provide a sequencer which can also turn the Casio auto-rhythms on and off.

Soundchaser for the Apple

The Soundchaser turns an Apple II or IIe micro into a dedicated synth, through the insertion of three cards into the Apple's magic slots. Also provided is a four octave music keyboard.

Passport Design's Four Track Performance Software makes the Apple act like an eight voice polyphonic synth. There are two soft oscillators per voice, each with independent ADSR's and one LFO which can independently frequency modulate either oscillator.

Because the oscillators are soft, you can edit existing waveforms or waves on the VDU, using a joystick or create your own. You can also build up a wave by controlling the amplitudes of a table of 16 harmonics. This is additive synthesis mentioned earlier.

All waves displayed may be printed, as can voice parameters.

The Soundchaser also provides a filter, and although you cannot control it dynamically with the ADSR envelopes, it's possible to type in the cut off frequency then see as well as hear the result. It is this combination of both additive and subtractive synthesis which makes the Soundchaser produce such a wide variety of sounds.

Also included in the software is a four track real time polyphonic sequencer, although step time editing software is available. The sequencer allows four different patches to play up to eight notes simultaneously. All voice and sequencer information can be stored on disc as wave or track files.

The Hardware and Four Track Performance Software costs £1,369, which may seem a lot, but comparable dedicated systems cost between £3,000 and £8,000.

PDSG for the BBC

A similar system to the Soundchaser is being developed for the BBC Micro by Clef Products. The Programmable Digital Sound Generator or PDSG, allows 8-32 note polyphony from a five-octave music keyboard which is included in the provisional retail price of £400. Software being developed includes waveform creation and sequencing. It will be interesting to see how the PDSG compares to the Soundchaser when it is formally launched.

Figure 3.

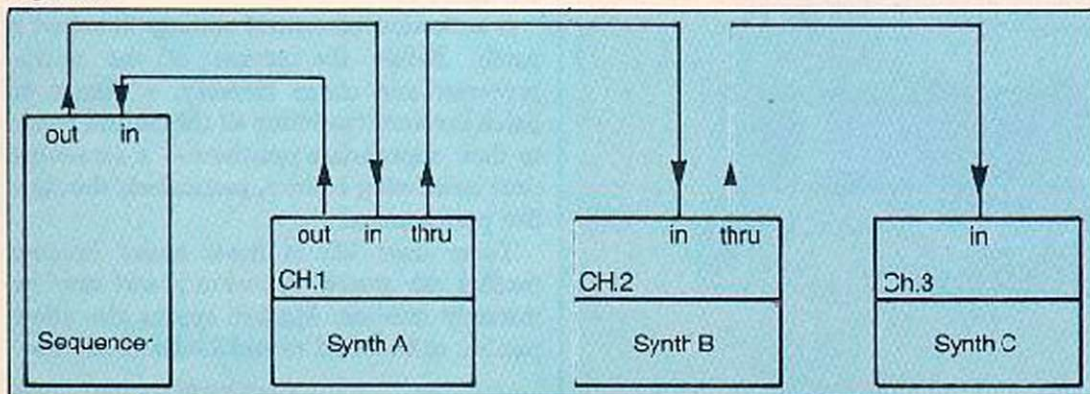



Above: CBM-64 and Sixtraks.

MIDI is a new word to add to your vocabulary of computer-speak. It came about, like MSX, out of a need to standardise a very non-standard world. Things begin to get very exciting when synths, drum machines and sequencers operate together as an integrated unit. However, before MIDI was agreed by the major synth manufacturers, it was difficult to get excited about such things due to the inherent non-compatibility of products. Each drum machine had its own way of telling the outside world it had started, then there's the sequencer problem mentioned earlier.

MIDI cures such problems, as well as allowing the transfer of much more specific messages.

Physically, MIDI appears as two or three 5-pin 180 deg. DIN sockets on a synth, drum machine or sequencer — MIDI In, Out and Through. The MIDI Through socket outputs a direct copy of data entering the MIDI In socket. A manufacturer does not have to fit a MIDI Through facility. Only two of the five DIN pins are used, so MIDI transmits and receives data serially.

This particular facet of MIDI was heavily debated because it was felt by some manufacturers that a serial link would be too slow. In practice there have been complaints of noticeable delays when transmitting keyboard data to more than three synths at once. However, the convenience of using single 5-pin DIN leads rather than multicore cables must have tipped the balance for the supporters of serial transmission.

MIDI runs at 31.25 Kbaud asynchronous. The word format is shown in figure 2. So, to MIDI-fy your micro, wire up an asynchronous communications interface adaptor or ACIA, like the Motorola 6850 to the expansion orifice of your micro. Address the ACIA nicely and tell it to transmit and receive as in figure 2, i.e., one stop bit, one start bit and no parity.

Wire the ACIA transmit output and input to

appropriate 5-pin DIN sockets.

Don't forget to opto-isolate the MIDI In input otherwise nasty earth loops could develop. Now write some brilliant software and make lots of money! Seriously though, for anyone considering designing their own interface, the MIDI hard and software specification is available from the MIDI Users Group, 8426 Vine Valley D.R. Sun Valley, CA91352, U.S.A.

The MIDI data format is divided into two categories — channel commands and system commands. The channel command format allows for 16 unique channels for communication between instruments.

One of the most fundamental tasks MIDI must allow is for one synthesiser to play another. The channel command structure gives three ways or modes of performing this task.

In omni mode, all synthesisers connected together will transmit and receive on all channels. In poly mode each synth is set by the user to receive on only one channel. The synth will therefore ignore any incoming data which is not on its assigned channel. Figure 3 shows a typical poly mode set up. Note that Synth A. is used as the MIDI transmitter.

Mono, the third possible mode, allows the allocation of different MIDI channels to individual voices within one synth. This opens up the exciting opportunity of one synth playing different patches on each voice. However, at the time of writing, the only reasonably priced synth capable of mono mode operation is the Sixtraks made by Sequential Circuits.

Let's take a meaningful example — suppose a middle C is played on a synth. In the MIDI scheme of things this is called a note on event. Three bytes will be transmitted from the synth's MIDI Out socket to represent this:

First Byte — 1001 nnnn

Where 1001 means note on event and nnnn



is the MIDI channel number (0 to 15).

Second Byte — 0kkk kkkk

Where kkk kkkk is the key number — 0 to 127 in semitones.

Third Byte — 0vvv vvvv

Where vvv vvvv is the velocity at which the note was played (0-127 levels). So, if you delicately stroked the key, you would generate a velocity byte equal to 1. If, however, you hit the key with a large mallet, you would generate a velocity of 127 — this practise is not advised.

Synths which do not have velocity sensitive keyboards transmit a velocity byte of 64 (decimal) as a de-fault value. So, if a middle C was played on a non-velocity sensitive synth set to MIDI channel 1, the data transmitted would be:

144,60,64. (decimal)

90,3C,40. (hex)

10010000, 00111100, 01000000 (Binary)

Other channel commands include note off event — 3 bytes — and patch change request — 2 bytes.

The second category of commands, systems commands, is divided into three types: system common; system exclusive and system real time.

System common commands are those intended for all devices in the system. An example is asking synths to tune their oscillators, a tune request — 1 byte.

System exclusive commands are those applicable between instruments of the same internal design. The system exclusive command, 240 (decimal) is therefore followed by a number representing the manufacturer —

(continued on next page)



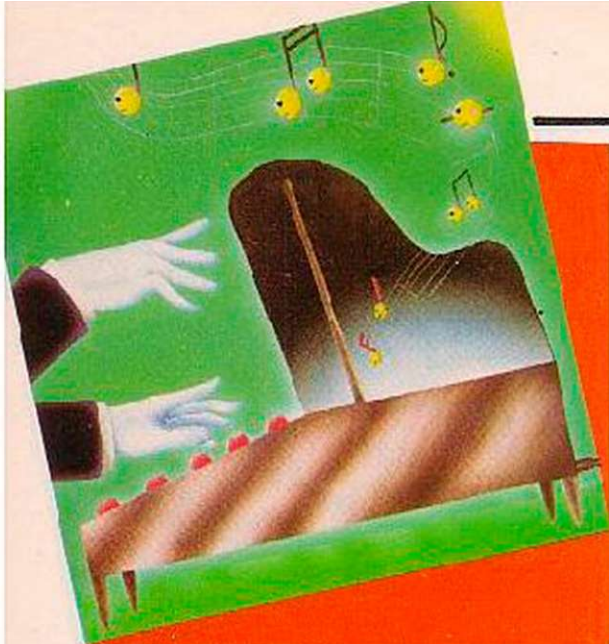

(continued from previous page)
Sequential Circuits' number is 01.

The number of bytes which follow is dependent on the nature of the data to be transmitted. An end of system exclusive is flagged by transmitting 247. Examples of system exclusive information are patch dumps and specific control knob changes.

The third category of system commands,

system real time, are those messages concerned with synchronisation. They can be transmitted at any time by sequencers or drum machines. Examples are, Start, Stop, Reset and Timing Clock. The timing clock pulses are sent at a rate of 24 clocks per quarter note. Most MIDI drum machines and sequencers have Trigger, Clock or Sync outputs like their non-MIDI counterparts so as not to alienate customers with pre-MIDI equipment.

A micro fitted with suitable MIDI interface could perform wondrous tasks as part of a MIDI set up. Here are some examples:

- Sequencer.
- Patch data dump to take on disc.
- Patch data display.
- Music transcription.
- Intelligent arpeggiator.
- Educational software.

The following is a survey of commercially available interfaces and software for home micros. The list is not exhaustive, the criteria being to cover as many micros as possible. Manufacturers and retailers addresses can be found at the end of the article.

CONCLUSIONS

■ MIDI, though still very young, has definitely caught the imagination of both manufacturers and public. Its now almost impossible to sell any electronic musical instrument that doesn't feature MIDI in its specification.

■ Both the Soundchaser and PDSG systems are likely to incorporate MIDI shortly.

■ At present, the cheapest polyphonic synthesiser with MIDI is about £650; the cheapest MIDI drum machine is £950. So, assuming you use a MIDI home micro as the sequencer, a professional set up is going to cost about £1,750. However, the prices of synths and drum machines has been falling sharply over the past five years and this is a trend that is sure to continue.

■ It's clear that there are plenty of ways of getting extremely musical with your micro, even if your micro has not expressed a musical bent in the past. Why not take the plunge? It could prove to be a very rewarding experience.

USEFUL ADDRESSES

M.P.C. Percussion Computer:
M.P.C. Electronics,
The Gables,
Willingham,
Cambridgeshire.
Tel. (0954) 60264

Upstream MIDI Interface:
Upstream Computer Systems Ltd.
49, Bransgrove Road,
Edgware,
Middlesex.
Tel. 01-952-9105

Soundchaser, Drumulator, Model 64 Sequencer, Sixtracks, DX series synths, CX5 Computer, Passport Designs Software:
Syco Systems Ltd.
20, Conduit Place,
London W2.
Tel. 01-724-2451

Micron MIDI:
X.H.I. Systems,
10, Sunnybank Road,
Sutton Coalfield,
West Midlands.
Tel. 021-382-6048

PDSG:
Cleff Products (Electronic) Ltd.
44a, Bramhall Lane South,
Bramhall,
Stockport,
Cheshire.
Tel. 061-439-3297

BBC "MIDITRACK" Software and Interface:
Electro-Music Research,
14, Mount Close,
Wickford,
Essex.
Tel. 03744 67221

Casio MT-200 Interface: and MicroLink-2, Micro Musical,
37, Wood Lane,
Shilton,
Coventry.
Tel. 0203 616760

CBM 64

Sequential Circuits, the pioneer of MIDI, has taken the CBM-64 under their wing and come up with a 4000 note real time sequencer called the Model 64.

The Model 64 allows overdubbing, auto time correction and transposition. Its six tracks can be chained together and both sequences and songs may be dumped to tape or disc. A drum machine sync input is provided, although

Apple

The MIDI/4 software can also run on an Apple II or IIs using Passport's Apple interface card. This card is also used for music transcription software called Polywriter. The software is a four note

sequences may be recorded without a drum machine connected.

Passport Designs — designer of the Soundchaser software — will shortly be launching a MIDI card for the CBM-64. The card includes MIDI In, Out and drum sync connections. The MIDI/4 software provides 16 real time tracks, each of which can be assigned its own MIDI channel and instrument name.

polyphonic version of the Notewriter monophonic transcriber for the Soundchaser system. Polywriter allows printouts in eight different formats, ranging from single, treble and bass clef parts, to large orchestral scores.

Spectrum

The ZX Spectrum is popular among the small entrepreneurs, like Upstream whose software consists of a six track, 3500 note real/step time sequencer. The interface, which is included in the overall price of £179, boasts a trigger output along with MIDI In, Out and Through connections. Optional extras include editing facilities and a dot and staff graphics display.

XRI Systems is asking £108 for its MicronMidi interface and software for the Spectrum. Micron is an 8,000 note real time sequencer with MIDI In, Out and Through connections as well as a trigger output. The Micron can also handle step time note entry in eight tracks, each of which can hold 3,000 notes. Tracks may then be merged or "bounced" onto one track to make space available for further recording.

Yamaha CX5

If you are considering changing your micro, then Yamaha's MSX computer, the CX5 may well be worth the wait. It is expected in November.

The CX5 is actually going to be marketed as a musical instrument as well as a home computer in this country, due to the fact that it comes fitted with MIDI interface and an FM voice module as standard.

The Yamaha CX5 is not the same as

the Yamaha YIS503 MSX computer reviewed by the British computer press recently.

Having typed Cal Music, the CX5 becomes an eight note polytechnic, 48 patch synth. There is also a rhythm box which unfortunately is rather weak.

The CX5 also allows 48 of your own FM synth patches which are used in the CX5's built-in real time sequencer. The CX5 is expected to retail for about £560, fair dos for its synth facilities alone.

BBC

The BBC Model B gets the MIDI treatment from Electro-Music Research (EMR). Its Miditrack software is step time only onto six tracks, however dynamics can be programmed. The interface which connects to the Beeb's 1MHz Bus, provides MIDI In, Out and drum machine synchronisation facilities. The interface and software is expected to go for about £120.

Kuma

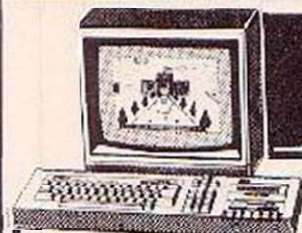

AMSTRAD

ZEN 1.0 Editor/ Assembler/Debugger

The most advanced Z-80 code generating system available featuring Assembler, Disassembler, Editor, Machine code Monitor, and Debugger. Complete with full assembly listing. A full professional product.

Home Budget. A complete extensive home accounting system which takes care of forecasts/estimates of future expenditure/income.

Gems of Stradus. An amazing graphics adventure game.

TATUNG Einstein



Wordprocessor,
Communications, Databases,
VAT Accounts, Expenses, Home Accounts, Arcade
Games, Adventures, Entertainment, Educational,
High level languages, Editor/Assemblers and
much more.

Kuma — No. 1 for Tatung

Send for details.



SHARP MZ700

Star Avenger £9.95, Cosmic Scramble £5.95, Gunman £6.95
Chessman £6.95, Breakthrough £5.95, Super Space
Invaders £3.95, Quadrex £5.95, Pinball King £6.95,
Pelmanism £5.95, Moonlander I £5.95, Athlete £5.95, Startrek Plus £6.95, Cursed Chambers
£6.95, Speech Synthesis £14.50. Books The MZ700 Explained £5.95, Peeking and Poking the MZ700 £6.95.
... plus lots more



EPSON PX-8

ZEN Editor/Assembler/ Disassembler

The first program to be released in our PX-8 Software
Library £45.43 Phone for further details.

EPSON HX-20

DM2 Word Processor £33.93
DM3 Spread Sheet Calculator £33.93
DM9 RAM Database £33.93, Tiny Pascal Compiler £45.43
User Definable Graphics £20.13. Home Budget £19.95
plus a full range of books. Phone for details



CASIO

DM2 — Wordprocessor £29.50, Machine Code Support Pack MCSP1 £86.25
DM6 — Decision Maker £19.95, Metric to Imperial Conversion £9.95
DM17 — Port £29.50. For further details Phone 073 57 4335

ALL PRICES INCLUDE V.A.T.

SIRIUS apricot

Basic
Tool Kit
Ten major
sub routines
£97.75

commodore 64

BC BASIC £57.50
A complete 9K extension supplied in ROM pack
PAINTPIC £19.95
Drawing/Painting using a multi-colour bitmap

SINDAIR SPECTRUM

Frog Shooter £6.95
Vegetable Crash £6.95
Alien Destroyer £6.95
Home Budget £8.95
Logo £9.95

Dealer and Distributor enquiries welcomed

PHONE NOW (073 57) 4335

or SEND FOR DETAILS

Please tick box for information required, and send coupon to:

Kuma Computers Ltd.
12, Horseshoe Park,
Horseshoe Road,
Pangbourne,
Berkshire RG8 7JW

| | | | | | |
|--|--------------------------|--|--------------------------|--|--------------------------|
| Hardware | Software | Hardware | Software | Hardware | Software |
| <input type="checkbox"/> AMSTRAD CPC 464 | <input type="checkbox"/> | <input type="checkbox"/> TATUNG EINSTEIN | <input type="checkbox"/> | <input type="checkbox"/> NEWBRAIN | <input type="checkbox"/> |
| <input type="checkbox"/> SIRIUS | <input type="checkbox"/> | <input type="checkbox"/> CASIO FP 200 | <input type="checkbox"/> | <input type="checkbox"/> COMMODORE 64 | <input type="checkbox"/> |
| <input type="checkbox"/> APRICOT | <input type="checkbox"/> | <input type="checkbox"/> EPSON PX-8 | <input type="checkbox"/> | <input type="checkbox"/> ELECTRONIC MAIL | <input type="checkbox"/> |
| <input type="checkbox"/> SHARP 700 | <input type="checkbox"/> | <input type="checkbox"/> EPSON HX-20 | <input type="checkbox"/> | <input type="checkbox"/> PRINTERS | <input type="checkbox"/> |
| <input type="checkbox"/> SHARP A | <input type="checkbox"/> | <input type="checkbox"/> EPSON QX-10 | <input type="checkbox"/> | <input type="checkbox"/> SPECTRUM | <input type="checkbox"/> |
| <input type="checkbox"/> SHARP FC-5000 | <input type="checkbox"/> | | | | |

NAME ADDRESS

POST CODE

I use a micro-computer

THIS SOFTWARE AND hardware combination stemmed from a desire to create good music without the need for talent. At first a series of short sequencing programs emerged. Soon I realised that music sounded much better played by hand and this was the result.

There are two programs outlined one of which uses a specially made keyboard costing under £50 to build and the other which uses the much inferior computer's keyboard.

The circuit diagram for the keyboard is shown in figure 1. All the connections to the BBC microcomputer are made through the user port. Six bits of data are output by the computer, two of which select one of three banks of 16 keys using a 74LS139 demultiplexer. The outputs from the 74LS139 go to the enable inputs of the three 74LS154, 1 of 16 decoder/demultiplexers.

The enabled one of these then uses the other four bits to make one of the 48 keyboard lines go low. If this key is pressed, the low signal is passed on to the output line from the keyboard which is normally kept high by the 1K resistor. This signal is then read by the computer to see if the key is pressed. In effect, the computer sends a key number to six bits of the port and then reads the seventh to see if the key is pressed.

The easiest way to build the main circuit board, which consists of the four chips and the 1K resistor, is to use the Verowiring system. Using this system the chips can be placed in the specially made boards and simply wired up using the pen and soldering

Figure 1.

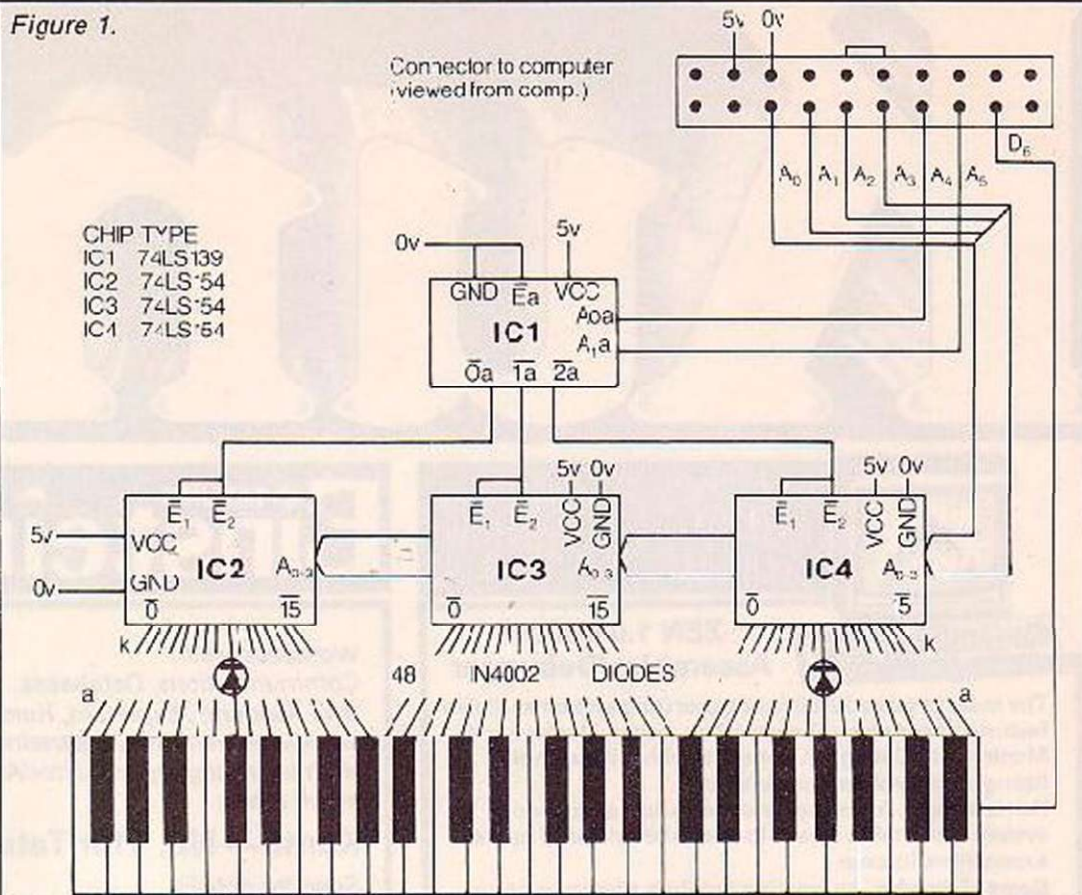

KEYBOARD FOR

Figure 4.

```

* 10 DIMP 300
20 DIMF 50
30 FLAGS=F
* 40 FOR J=0 TO 7
50 READ A
60 P?I=A
70 NEXT
* 80 STBL=F
* 90 ST=P+8
100 OSBYTE=&FFF4
110 OSWORD=&FFF1
120 FOR I=0 TO 2 STEP 2
130 P?I=ST
140 [OPTI
150 .START LDX #0
160 STX &70
170 LDX #17
180 STX &71
190 INX
200 STX &72
210 INX
220 STX &73
230 .LOOP LDX #0
240 LDY #0
250 LDA #129
260 JSR OSEYTE
270 CPY #&1B
280 BNE NTE5C
290 LDA #126
300 JSR OSEYTE
310 RTS
320 .NTE5C LDX &70
* 330 STX &FE60
* 340 LDA &FE60
* 350 AND #&40
360 BNE NPRSD
370 LDX &70
380 LDA #0
390 CMP FLAGS,X
400 BNE NKEY
410 LDA &73
420 ORA #64
430 LDX &72
440 STX &73
450 LDX &71
460 STX &72
470 STA &71
480 AND #31
490 LDX #48
500 .LOOPA CMP FLAGS-1,X
510 BNE NTHIS
520 TAY
530 LDA #1
540 STA FLAGS-1,X
550 TYA
560 .NTHIS DEX
570 BNE LOOPA
580 LDX &70
590 STA FLAGS,X
600 STA STBL
610 LDA #1
620 STA STBL+2
630 .D LDA #10
640 STA STBL+6
650 JSR SND
660 .NKEY LDX &70
670 INX
* 680 CPX #48
690 BNE STORE
700 LDY #0
710 .STORE STX &70
720 JMP LOOP
730 .NPRSD LDX &70
740 LDA FLAGS,X
750 TAY
760 LDA #0
770 STA FLAGS,X
780 TYA
790 CMP #2
800 BCC NKEY
810 ORA #64
820 CMP #71
830 BNE J1
840 LDX &72
*1330 LJA #25
1340 CLC
1350 AJC STEL+4
1360 STA STBL+4
1370 LDA #7
1380 LDX #STBL MOD 256
1390 LDY #STBL DIV 256
1400 JSR OSWORD
1410 RTS
1420 J
1430 NEXT
1440 ONEERRORGCTO1820
  
```

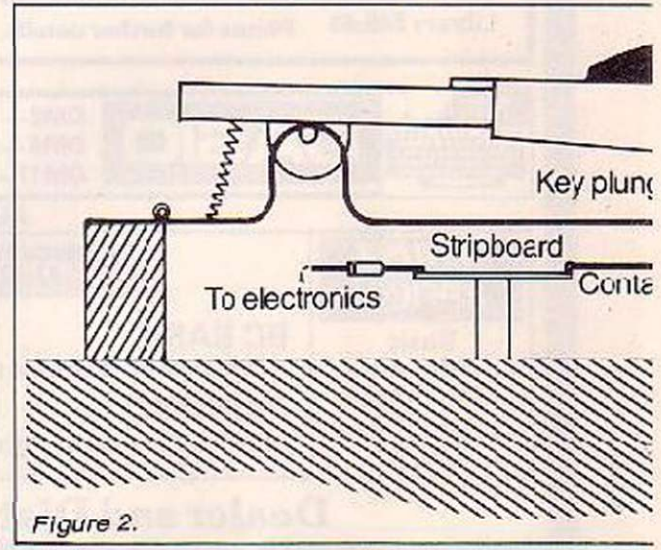
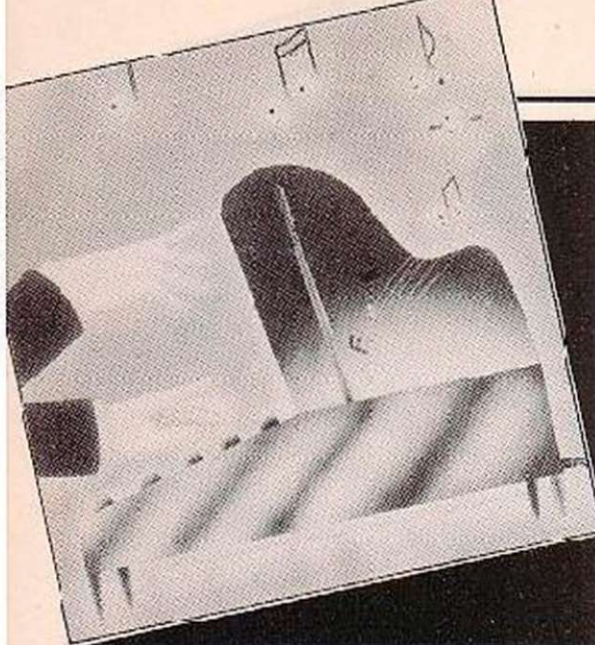

Figure 2.

```

1450 FOR I=0 TO 7 STEP 2
1460 CLC
1470 [OPTI
1480 PROCOSB I,C,129,FE60
1490 [OPTI
1500 [OPTI
1510 [OPTI
1520 [OPTI
1530 [OPTI
1540 [OPTI
1550 [OPTI
1560 [OPTI
1570 [OPTI
1580 [OPTI
1590 [OPTI
1600 [OPTI
1610 [OPTI
1620 [OPTI
1630 [OPTI
1640 [OPTI
1650 [OPTI
1660 [OPTI
1670 [OPTI
1680 [OPTI
1690 [OPTI
1700 [OPTI
1710 [OPTI
1720 [OPTI
1730 [OPTI
1740 [OPTI
1750 [OPTI
1760 [OPTI
1770 [OPTI
1780 [OPTI
1790 [OPTI
1800 [OPTI
1810 [OPTI
1820 [OPTI
1830 [OPTI
1840 [OPTI
1850 [OPTI
1860 [OPTI
1870 [OPTI
1880 [OPTI
1890 [OPTI
1900 [OPTI
1910 [OPTI
1920 [OPTI
1930 [OPTI
1940 [OPTI
1950 [OPTI
1960 [OPTI
1970 [OPTI
1980 [OPTI
1990 [OPTI
  
```

(continued on opposite page)



(continued from previous page)
decaying/decayed.

The other important variable is stored at 70H. This is the number of the key being processed from 0 to 47.

The block diagram for the machine code is shown in figure 3 and the program for the music keyboard is in figure 4. For those who do not wish to build the keyboard, figure 5 shows the alternative lines. Those lines which occur in figure 5 as alternatives are marked with an asterisk in figure 4.

The machine code goes through the following functions cycling through the 48 keys — 41 in the computer keyboard version. First it tests the Escape key and returns to Basic if it is pressed — lines 230 to 360. Next the key is tested — lines 320 to 360. If it is found that the key is being pressed the program looks in the table to see if it was pressed when last scanned — lines 370 to 400.

If it was, then the program goes on to the next key. If it was not, a sound must be initiated. The lowest priority sound channel is read from 73H and the other two moved down. The one just removed is then marked as sounding and placed in the highest priority position. Lines 410 to 470 do this.

The flags table is then searched for the key corresponding to the previous sound on this channel, if there was one. This key is then marked as pressed but not sounding — lines 480 to 570. The new key allocation is then marked — lines 580 and 590 — and the sound started — lines 600 to 650. The next key is then scanned — lines 660 to 720.

If the key scanned is not being pressed the table is tested to see if it was sounding when it was last scanned — lines 730 to 800. If it was not sounding, the next key is scanned. If this key was sounding, then the sound channel used is found in the priority table and the rest moved up — lines 810 to 990. This is then marked as decaying and stored in the highest priority non-sounding position — lines 1000 to 1150.

Finally the decaying sound is produced — if its duration is not 0 — and the next key scanned — lines 1170 to 1260. It should be noted that in line 1180 the program actually inspects itself! This is because line 1850 sets the durations of the sounds by altering the constants in the program.

The Basic program is used to provide an easy way of defining the two envelopes. Lines 10 to 110 initialise the various arrays and constants. Lines 120 to 1430 assemble the machine code after which the key table is

initialised — line 450. Next the display is created and the envelope array initialised in lines 1460 to 1620.

The numbers are entered and the cursor moved by lines 1630 to 1810. When Escape is pressed the error is detected by line 1440 sending the execution to line 1820. This then sets up the envelopes and calls the machine code. The final section starting at line 1920 is the data for the program.

The program is designed to run in Mode 7 but will run in any. When Run, it gives a display of a column of names and two of numbers. Underneath these it says "Define envelopes". In this mode the cursor keys are used to choose the number to be altered. The number can then be typed in and entered either by moving the cursor or by pressing Return.

Note that if play mode is entered before doing this the number will be displayed but not entered. If the number is too large, the old one will be restored when the number is entered. The last parameter is not an envelope one but the duration of the sound.

In order to start playing, Escape must be pressed. The bottom of the screen now says "Play". If the keys are then pressed the correct sounds should be heard. Note that in order to hear the desired effect the first envelope should not decay but the second should. Other interesting effects can be created by not adhering to this pattern.

That irritating hiss which many BBC

Figure 5.

```

10 DIMP 350
40 FDR1=01048
80 STEL=P+41
90 BT=P+49
325 LDA P,X
330 TA)
335 LDY #MFF
340 LDA #129
345 JSR DSBYTE
350 CPY #3FF
680 CP) #41
1550 LDA #5
1912 DATA%5E,%AE,%BD,%CD,%AD,%9C,%7C,%7B
1914 DATA%AB,%AA,%BA,%9A,%99,%A9,%5B,%AB
1916 DATA%97,%FF,%CF,%EF,%CE,%DE,%EE,%DD
1918 DATA%CC,%EC,%DC,%BC,%BB,%CA,%EA,%DA
1919 DATA%C9,%C9,%DB,%CB,%BE,%E7,%C7,%37,%D7

```

computers seem to have can be removed with ease. This is done by fitting a plug to the 1MHz bus under the computer and soldering a 1k0 resistor between pins 16 and 1.

The second improvement which can be made is to use external amplification. This can be done by placing a 1/4 inch jack plug in the normally unused hole marked Reset on the back of the computer. This can then be connected via screened cable to PL16 on the circuit board. To find this, first remove the cover from the case and unbolt the keyboard.

There is no need to unplug this, just fold it away over the rest of the board. On the far left of the circuit board, looking from the front, very close to the side, and hidden in the middle of some components are two pads clearly marked PL16. The output from this is low level and can be used to supply a high quality amplifier. Please note that connection of devices, or modifications to your computer are done at your own risk.

Figure 3. Machine-code block diagram.

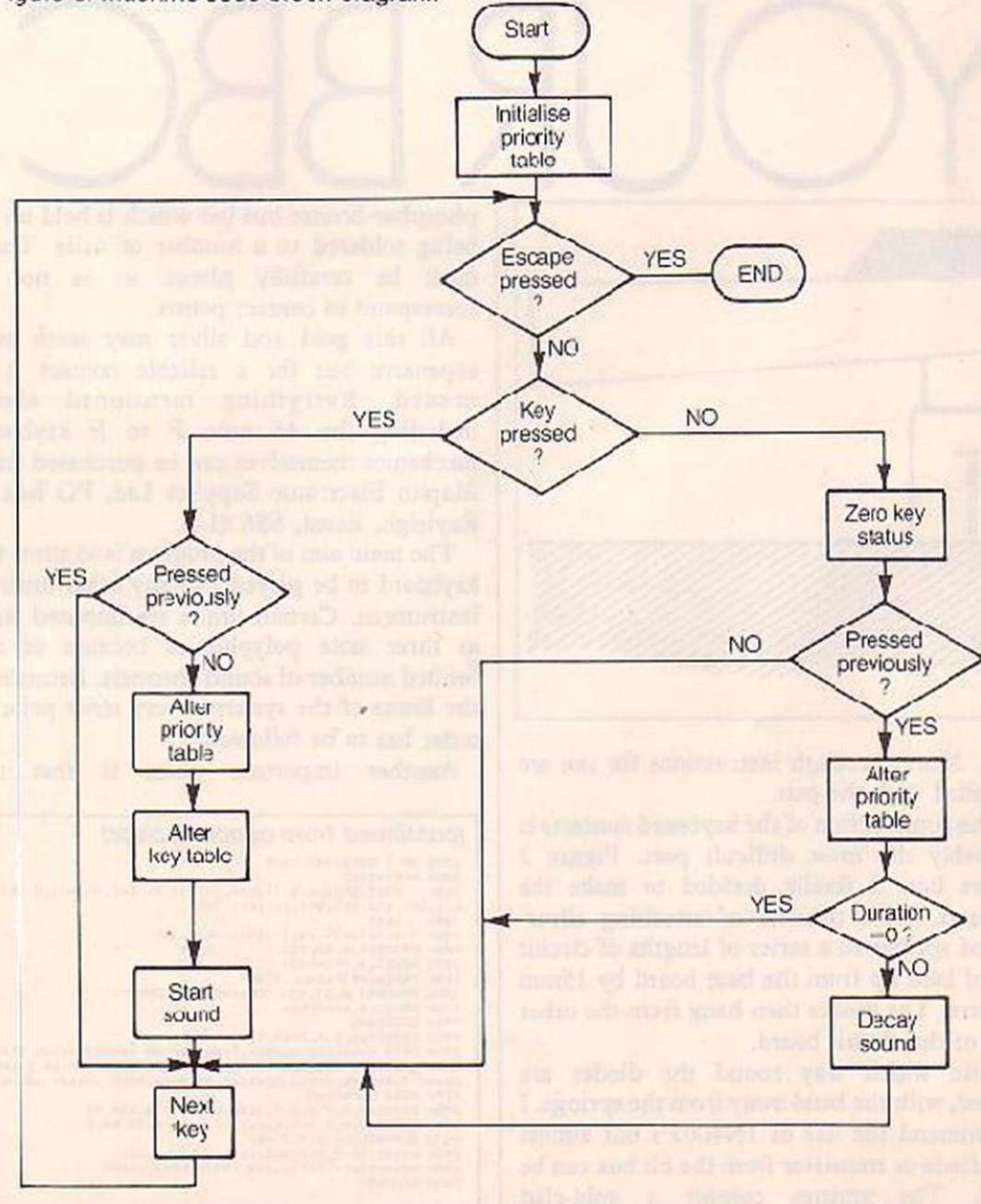

ALL-IN-ONE



Spectrum Interface

Drive Unit 1

Drive Unit 2

RS232 Interface

Centronics Interface

Spectrum owners! Imagine what great use you could make of all these components. Rotronics have integrated them all into one attractively styled compact unit. All the power and convenience of floppy disk can now be yours, but at a fraction of the cost.

A complete package

Wafadrive is extremely versatile. Five major components are housed within this one unit – the micro interface, two 128K drives, RS232 serial and Centronics parallel ports. Also included in the package are a blank wafer and Spectral Writer – a superb word processor program. The micro interface forms the nerve centre of Wafadrive, controlling all its major functions. The dual drive configuration and the ability to connect standard peripherals directly provides professional system flexibility. All this without a mass of separate components and vulnerable cables. Wafadrive transforms your Spectrum into a very powerful system.

Speed, reliability and capacity

The wafers contain an endless loop of specially developed magnetic tape driven at high speed past a read/write head. The result is fast access without data loss.

Three sizes of wafer are available with minimum formatted capacities of 16K, 64K and 128K. The 128K wafer costs £3.95.

Data transfer rate is approximately 2K per second. Access time is proportional to capacity. 16K wafers are ideal for program development, with the larger capacity wafers being more suitable for general use and archiving of completed programs and data. Mechanical longevity is assured by the use of high grade materials throughout and full interchangeability between machines is guaranteed.

Extensive software applications

Wafadrive provides intelligent file handling and rapid access to data. Program development and other applications can be performed with ease. Start word processing immediately with the specially developed software package included with Wafadrive. Or battle with a spectacular interactive games program. Whatever your mood, you'll find the sophisticated Wafadrive software challenging and rewarding. Future versions of Wafadrive will be available for most popular home micros, so software back-up will be comprehensive.

For further information contact us now for our full colour brochure.

ALL-IN-ONE PRICE
£129.95 (Inc. VAT)

Rotronics Limited, Santosh House, Marlborough Trading Estate, West Wycombe Road, High Wycombe, Bucks. HP11 2LB Tel: (0494) 452757

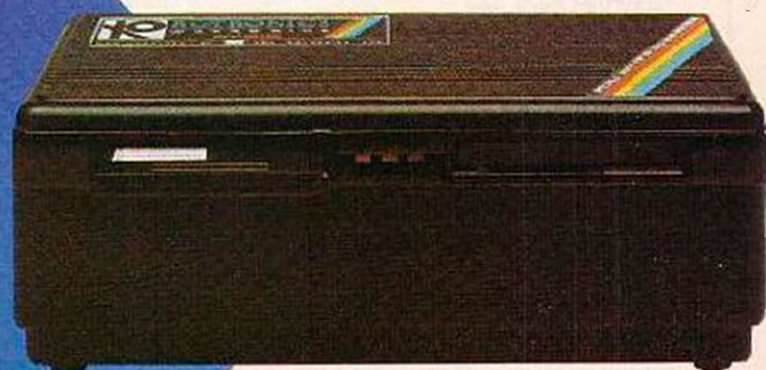

ROTRONICS
WAFADRIVE

Attention all Software producers

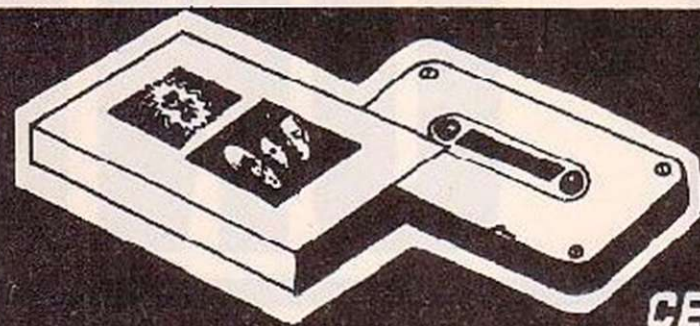

HIGH SPEED CASSETTE DUPLICATION

CASSETTE LABELS

FINISHED ARTWORK

CELLOPHANE WRAPPING OF CASSETTES

FULL COLOUR LAMINATED INLAY CARDS

IN FACT THE MOST COMPLETE AND COMPETITIVE SERVICE AVAILABLE TO SOFTWARE HOUSES LARGE AND SMALL.

CASSETTE DUPLICATION: Performed entirely in our premises on the world's fastest and most sophisticated machines. Only the highest quality tape used in screwed together cassettes.

AVAILABLE FOR: SINCLAIR SPECTRUM, COMMODORE 20/64, BBC A/B, AMSTRAD, ORIC ATMOS, DRAGON 32/64, ELECTRON, MENOTECH, AND ALL MSX COMPUTERS.

FULL COLOUR LAMINATED INLAY CARDS: From your camera ready artwork or produced by our own artist. Also artwork and positives for Press advertising (Colour or Mono) and of course Cassette Labels.

CELLOPHANE CLEAR WRAPPING: For that true professional finish cellophane wrapping with a tear tab is available at a competitive rate (Cellophane Wrapping is **FREE** to all our customers using our **PACKAGE PLAN**).

LOGICOPY

31, WOODBRIDGE CRESCENT,
BECKETT PARK,
LEEDS, LS6 3LN.
TEL. (0532) 788758

Orders can be little as 200 copies

Why not write for a free quotation (please outline your requirements) or Price List.



WIN THE POOLS???

48k

SPECTADRAW 3 - THE LATEST VERSION OF THE ORIGINAL AND BEST POOLS PREDICTION PROGRAM FOR THE 48K SPECTRUM!!

"The most user friendly of the programs reviewed, making full use of the Spectrum's colour facilities... better than my own methods of the national newspapers". *Personal Computer World March 1984*

- SUPPLIED WITH A DATABASE TAPE CONTAINING DATA ON OVER 10000 MATCHES SINCE 1990!
- DATABASE UPDATED EACH WEEK BY USER, BUT NO TEDIIOUS TYPING AS THE TEAM AND DIVISION NAMES ARE ALREADY IN THE PROGRAM
- ERRORS CAN EASILY BE CORRECTED - THE PROGRAM EVEN CHECKS YOUR ENTRIES!
- COMPREHENSIVE INSTRUCTION MANUAL AND MENU DRIVEN PROGRAM - EVEN A NEWCOMER TO COMPUTING CAN EASILY USE SPECTADRAW3!
- WILL FORECAST THE LEAST LIKELY DRAWS FOR THOSE WHO PREFER TO BET ON FIXED ODDS!
- NOW INCLUDES SPECTASCHT - THE PERM GENERATION PROGRAM THAT TAKES SPECTADRAW'S PREDICTIONS AND TURNS THEM INTO A PERM. COMPLETE YOUR COUPON DIRECT FROM THE SCREEN!
- FULLY MICRODRIVE COMPATIBLE - LOADS AND SAVES THE DATA FROM YOUR MICRODRIVE IN SECONDS!
- COMPATIBLE WITH THE CURRAH MICROSPEECH SYNTHESISER - THE FIRST POOLS PREDICTIONS PROGRAM THAT WILL READ YOU ITS PREDICTIONS! (I.E. THIS FACILITY WILL ONLY WORK IF YOU HAVE A CURRAH MICROSPEECH UNIT CONNECTED TO YOUR COMPUTER)
- THE INTERNATIONALLY POPULAR POOLS PREDICTION PROGRAM (NOW IN USE IN 14 DIFFERENT COUNTRIES) STILL AT THE UNDEATABLE PRICE OF £9.95 INCLUSIVE (CHEQUES / P.C.s PAYABLE TO B.S. McALLEY)
- (WE DISPATCH EVERY MONDAY DURING THE FOOTBALL SEASON WITH THE DATABASE MADE UP TO INCLUDE ALL MATCHES TO THE DATE OF DISPATCH)

SPECTADRAW (Dept YC) | COWLEAZE, CHINNOR, OXFORD OX9 4TD (TEL: 0844-5246)

MAIL ORDER PROTECTION SCHEME

If you order goods from Mail Order advertisements in this magazine and pay by post in advance of delivery, *Your Computer* will consider you for compensation if the Advertiser should become insolvent or bankrupt, provided that:

- (1) You have not received the goods or had your money returned; and
- (2) You write to the Publisher of *Your Computer* summarising the situation not earlier than 28 days from the day you sent your order and not later than two months from that day.

Please do not wait until the last moment to inform us. When you write, we will tell you how to make your claims and what evidence of payment is required.

We guarantee to meet claims from readers made in accordance with the above procedure as soon as possible after the Advertiser has been declared bankrupt or insolvent.

This guarantee covers only advance payment sent in direct response to an advertisement in this magazine not, for example, payment made in response to catalogues etc., received as a result of answering such advertisements. Classified advertisements are excluded.

WITH FRANKIE GOES TO HOLLYWOOD'S new album due out in weeks Steve Lipson stares across a mixing desk into the void of a recording studio trying to improve on the great sounds he engineered for Relax and Two Tribes/War.

At the console he strikes a pose worthy of Captain Kirk at the controls of the USS Enterprise but Steve is under no illusions that he is a man with a mission. "I don't want to be Mother Theresa", he says. "I am the person who is employed to help defraud the public — and rightly so — because if the public honestly believe what they see they deserve to be defrauded."

"Frankie are nothing out of the ordinary. I've read articles which say they don't play on their records. This is a slight twist of the truth. In fact they play on their records then we make what they do better which is a perfectly logical thing to do. They're 20 years old — we're much older — we've had experience of making records and can make what they do sound a hundred times better. The artist becomes a performer. He's the guy who fronts the whole thing which is how it should be. If you have a tremendously good group to start with you limit the amount of input your production side can put in."

Steve's fraud factory is Sarm Studios in London. Outside it looks like the shabby derelict warehouses you expect to find at the wrong end of the Portobello Road. The only clue to its true purpose is a couple of fans on the steps in long black and white Relax T-shirts. They look like a pair of lost zebras as they wait for a glimpse of their heroes.

Inside, Steve Lipson is busy at the controls of his Sinclavier computer. Apart from the usual Qwerty keyboard and TV screen this has a 20 Megabyte hard disc storage unit — that's 500 times the capacity of a Commodore 64 — and a piano keyboard. Steve uses the Sinclavier mainly as a sampling machine. He can take any noise whether it is a bamboo cane hitting a shopping trolley or somebody hitting a snare drum and then produce a sequence of sounds based on that to create a new instrument.

Steve makes it sound very simple: "some geezer bangs a snare in the air. I get it to sound as wonderful as I can, stick it in the Sinclavier, organise it so that it's occupying as little space as possible for maximum effect and then proceed to sequence it. Then it is reverse compiled into script language." With his right hand Steve plays a bass line from Relax on the piano keyboard while his left hand on the Qwerty throws it on to screen as script language. On screen, phrases can be edited and repeated — just like word processing with sounds.

Another stab at the keyboard shows the file catalogue for two of the tracks from the new album, Only Star in Heaven and Black Night, White Light. Steve keeps most of the 20 Megabyte memory in use most of the time, making back up copies of any material he does not need immediately so he can free space. It is reassuring to know that even with such expensive equipment things can go wrong. The cartridge machine which should make the back-up copies on to tape is malfunctioning so Steve is having to use floppy discs "and 20 Megabytes is something like 200

Two Tribes — music and micros: Meirion Jones talks to the man who mixes them for Frankie.

FRANKIE GETS TO HOW

Frankie's engineer Steve Lipson relaxes.



OHOLLYWOOD

discs so it's hopeless."

More and better equipment solves some problems but also creates new ones. "With Relax the problem was we were using an analogue tape recorder. Now we're using a digital — big difference." But on the new album "a lot of the bass sounds we're using now are two machines synchronised together which poses a great deal of problems."

While Steve deals with the technical side producer Trevor Horn is the man with the golden ears who seems to know what the public want to hear. "I am working with the best producer around. I will be working on a track for days and days and Trevor will walk in — he's very good at looking at the overview — and he'll say, 'No this track is rubbish, start again' ... Trevor signed Frankie goes to Hollywood because he thought they were ridiculous — good singer but absolutely ridiculous. He had two attempts to recording them, both dismal failures. I got recommended to him — it's not what you know it's who you know — I started engineering and did Relax."

The phone rings — oh no it's Trevor — but this time he is not asking for a track to be scrapped but just for a snare drum to be taken off one of the songs on the new album and

replaced with another snare drum and a tambourine. If it's a simple part Steve can do that in a matter of minutes. "If it's a complicated part it could take me four or five hours. It's easy now but the very first time I did it, it took me a whole day."

With a virtually unlimited budget for new equipment Steve can afford to dream of tomorrow's machines. "You will have an infinite track tape recorder, you will record something and then be able to move it wherever you want to." But this will require new forms of computer storage — "hard disc is so primitive".

Steve does not feel that the empires of the big recording studios are under threat from home computer-based systems using converted Commodore 64s and Midi compatible Yamaha CX-5s. "Nothing is going to happen with all that stuff. Midi's useful but going to run out shortly. There will be a Midi 2."

"8-bit sounds are unusable — the Fairlight's different because it has got a graunch noise of its own. It just lowers the quality of what we're going to be hearing. Very few people have got all the gear and then everyone else with their CX-5s and Commodore 64s will be struggling desperately hard with not really a hope in hell, apart from the odd genius." ■

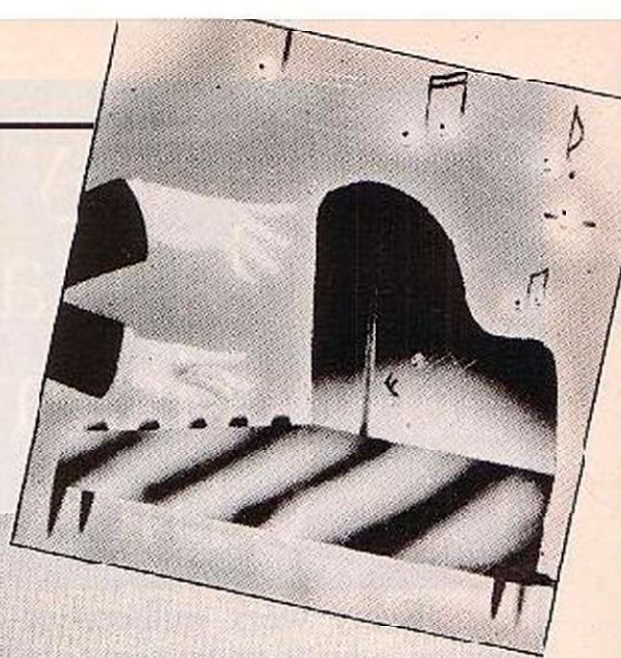

It's easy to complain about advertisements. But which ones?

Every week millions of advertisements appear in print, on posters or in the cinema.

Most of them comply with the rules contained in the British Code of Advertising Practice.

But some of them break the rules and warrant your complaints.

If you're not sure about which ones they are, however, drop us a line and we'll send you an abridged copy of the Advertising Code.

Then, if an advertisement bothers you, you'll be justified in bothering us. 
The Advertising Standards Authority.
 If an advertisement is wrong, we're here to put it right.

ASA Ltd, Dept 2 Brook House, Torrington Place, London WC1E 7HN

This space is donated in the interests of high standards of advertising.

At last, the first joystick that puts the firing button where it should have been in the first place.

TRIGA COMMAND

IS HERE!

THE TOP AMERICAN JOYSTICK IS NOW AVAILABLE IN THE U.K. . . .



To fit your **SPECTRUM** ONLY **£19.99** + £1.50 P+P

- Including Interface to plug straight into the Spectrum.
- The first Joystick to give you "Arcade" feel and control.
- "Jet Style" heavy duty, diamond cut grip.
- Fire Trigger placed under your index finger . . . the finger with the fastest reflex action. • Self centring, 360° action.
- Compatible with most of the latest Software (Kempton system).

Also available for Commodore / Atari / BBC /

NEW NEW NEW NEW ONLY **£29.99**

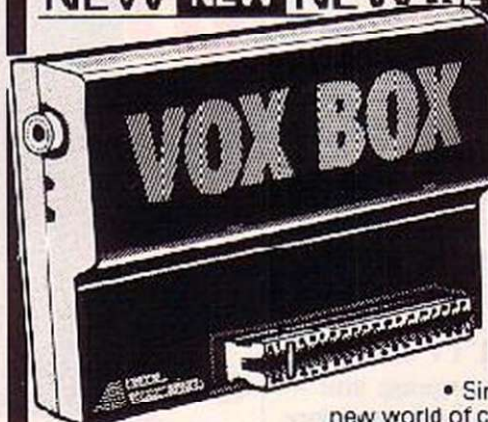

SPEECH SYNTHESIZER WITH BUILT IN JOYSTICK INTERFACE FOR THE SPECTRUM

- Simply plug into an exciting new world of computer speech synthesis.
- Latest State of the Art Electronics. • Uses the Allophone system. • Produces any word or phrase from an unlimited vocabulary. • Speaks directly through TV speaker. • Also Amplifies Spectrums own sound through TV speaker! • Built in Joystick Interface accepts any Atari type joystick for full games control. (Kempstor compatible). • Complete with Demo Cassette.
- Full Instructions.

NOW for the Commodore 64
The COMMVERSA
SPEECH SYNTHESISER
CARTRIDGE

£24.99 + £1.50 P+P
PRICE BREAKTHROUGH.



- Simply plug into the exciting world of Speech Synthesis.
- The Commversa has an unlimited vocabulary using the now standard Allophone System. • Programming is so easy and sentences can be made up in minutes! • Comes complete with full instructions + Free Demo Tape. No extras required.

| | |
|--|--------|
| <input type="checkbox"/> Triga Command Spectrum | £19.99 |
| <input type="checkbox"/> Triga Command Atari | £9.95 |
| <input type="checkbox"/> Triga Command Commodore | £12.99 |
| <input type="checkbox"/> Triga Command BBC | £19.99 |
| <input type="checkbox"/> Vox Box, Spectrum | £29.99 |
| <input type="checkbox"/> Vox Box and Triga Command | £39.99 |
| <input type="checkbox"/> Commversa Commodore 64 | £24.99 |

Postage Please Add £1.50
 TRADE ENQUIRIES WELCOME

24 HR CREDIT CARD LINE  

ALLOW 7 DAYS

DATTEL ELECTRONICS UNIT 9, FENTON INDUSTRIAL ESTATE, DEWSBURY ROAD, FENTON, STOKE-ON-TRENT
 TEL: 0782 273815



COURSEWINNER

The Punters Computer Program

COURSEWINNER allows you to use the power of your computer to get the edge on the bookmaker.

- COURSEWINNER contains a database full of detailed information on all English and Scottish flat courses. The ten leading jockeys and trainers, and effect of the draw is detailed for each course.

This information can be displayed on the screen at any time.

- The program analyses these factors combined with the results of the last three outings, starting price and weight carried.

- COURSEWINNER is simple and quick to use, yet very powerful.
- Boxed with detailed instruction booklet.

Price £12.50 all inclusive IMMEDIATE DISPATCH (RETURN OF POST)

Available for: SPECTRUM (48K), BBC(B), COMMODORE 64, DRAGON, APPLE II/IIe, ATARI (48K)

POOLSWINNER

The Ultimate Pools Prediction Program

- POOLSWINNER is the most sophisticated pools prediction aid ever produced. It comes complete with its own massive database.
- Can be used for Scoredraws, Draws, Aways and Homes.
- The database contains over 20,000 matches (10 years league football). It updates automatically as results come in.
- The precise prediction formula can be set by the user. This allows development of your own unique method.
- Package is complete with program, database and detailed instruction booklet.

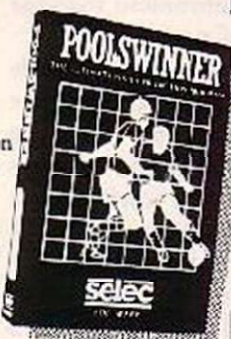

Price £15.00 all inclusive IMMEDIATE DISPATCH (RETURN OF POST)

Available for: SPECTRUM (48K), ZX81 (16K), BBC(B), COMMODORE 64, DRAGON, APPLE II/IIe, ATAR: (48K)

Available from Dealers or direct (return of pos.) from:



selec



SOFTWARE

37 Councillor Lane, Cheadle, Cheshire. Phone: 061-428 7425

MUSIC AND COMPUTERS have been on a collision course for some time now, and the noisy impact is imminent. You only have to switch on the radio to hear computer-generated rhythms and music. A whole new language has evolved that talks of sampling and the Midi interface.

Everyone knows that Frankie Goes To Hollywood uses a digitised version of Led Zeppelin's drums, and that the modern keyboard instrument has enough computing power to run your local power station.

Soon this technology will be available in people's homes. Already microchip pianos and organs are pushing out the steam-driven versions. While that other popular piece of household furniture, the micro, is being revamped as a musical beast. The next wave of computers will be more musical than the last, but for now we will have to make do with existing technology.

Micro musicians have two options. They can take the hardware route, or the software route. Hardware involves expense and even sometimes the horrors of a soldering iron, while there are a number of interesting, yet simple software solutions available.

Music Processor

Quicksilver — BBC B

ONCE LOADED, the screen displays a parameter map which allows access to various musical functions — for example, instrument tone, volume and octave selection for each of four channels — and an optional metronome facility. These are changed using the function keys — not a difficult technique to master easily. However, with a maximum of only nine numerical values for each function, there is not a great deal of resolution, and the

difference between one value and another can be extreme.

There are also drive functions — play, fast forward, and rewind — which are accessed via the cursor keys. The remainder of the screen is taken up with details of the four channels as you record and play music.

Recording is also a fairly simple affair, using the shift and keys. The counter ticks away, and off you go in real time, using the QWERTY keyboard. The Return key takes you out of the record mode, and a one-key function plays the tune back, warts and all.

Overdubbing is achieved by changing channel, key F, which enables the original tune, as well as the overdub, to be heard. Channel 4, by the way, is reversed purely for noise for rhythm purposes. The whole procedure is quite straightforward, but as always there are drawbacks.

First, the real-time input is difficult on the QWERTY keyboard, and it is all too easy to make mistakes. Although there are editing facilities, we found it difficult to make them work. The sounds themselves are less than brilliant, but that has more to do with the limitations of the BBC B than with the



MUSIC SOFTWARE

software — after all, there are not many variations to a square-wave beep.

The software is well-written, and the author is obviously musically aware. With the addition of a standard keyboard and better sound chips, it could be a potent system. As it is, both the music programmer and the programming musician are likely to be disappointed.

Synth

Worm Software — BBC B

SYNTH TURNS your BBC into an organ. Page 1 gives you Play, whereby the QWERTY becomes a musical keyboard with the top part a monophonic beep, and the bottom part playing chords of the major, minor or seventh variety.

One amazing shortcoming is that you cannot play both melody and chords at the same time, which would seem to negate the provision of such a facility — unless you have multi-track recording equipment, in which case you probably would not want to use the somewhat lack-lustre BBC B tones.

Page 2 allows you to modify the envelope of the sound, and thereby its tone, but again the

sounds obtained may be more suitable for a Pac-Man game than a synthesiser melody. Page 3 is a Help page, containing information on how to use the program. Were it possible to program a tune into one channel and chords into another, this might be a useful package. This failing, taken with the limited tonal range, makes this piece of software disappointing.

Multisound Synthesiser

HOMIK — CBM-64

THIS PACKAGE is by far the best of the bunch. The flexibility and range of the Commodore's sound chips mean that the system's potential greatly exceeds that of many other computer-based instruments. The basis of operation lies with three screen displays — control panel, special effects panel, and the keyboard.

Switching from one to the other is a one-key operation, and an easy-to-follow explanation of basic sound synthesis is provided in the manual, covering the simple wave-shapes — figure 1 — and use of filters to control the harmonic content of the sound — figures 2 and 3.

The control panel features wave and filter controls, each with single-key representation, and envelope (ADSR) control is simply done incrementally. The sounds are actually produced in the keyboard mode, again using the QWERTY keyboard. Your tune is created

(continued on page 79)



THE OFFICIAL

Eddie Kidd

JUMP CHALLENGE



If you've ever wondered how it feels to be Eddie Kidd... defying danger and gravity, soaring on a motor-bike over a long line of cars... here's your chance to find out!

This fabulous new game - Jump Challenge - has been produced for you by Martech, with a lot of help from Eddie himself.

At the age of 12, Eddie Kidd was jumping over oil barrels on a bicycle. At 18, he shattered the world record with his astounding leap of 190 feet - clearing 14 double-decker buses. Can you match his skill, courage, control and ice-cool nerve? Jump Challenge will show how you compare with the King of Motor-Cycle Stunts!

Just like Eddie, you'll start by trying to clear barrels on a bicycle... gradually working up to attempting Eddie's daring leaps which have thrilled millions around the world!

- 100% machine code
 - separate control of bike and rider for incredible realism
 - dangerous headwinds for added difficulty
 - scoring system - for successful jumps
 - joystick or keyboard option
 - PLUS!!! You can enter the Official International Jump Challenge Competition!
- Details on cassette insert

Available from leading software retailers OR order today by mail, price £6.95 (48K Spectrum) or £7.95 (Commodore 64, BBC 'B', & Electron) including VAT and P&P. Please make cheque or postal order payable to Software Communications Ltd. Allow 7 days for delivery.



SPECTRUM



SPECTRUM



CBM 64

martech

Martech is the registered trade mark of Software Communications Limited
Martech House, Bay Terrace, Pevensey Bay, East Sussex BN24 6EE

TRADE ENQUIRIES WELCOME. PHONE: (0323) 768456 TELEX: 87465 EXIM Brighton



48K SPECTRUM · COMMODORE 64 · BBC 'B' · ELECTRON

(continued from page 77)

by single-key selection, and playing in real time. You can then add more music if you wish, and you can opt for the computer's own, "auto-spaced", tempo and note length.

You will not be able to alter the speed of playback while the tune is being played, but you can choose the right tempo before recording. Playing is monophonic, with the highest note taking priority if two keys are pressed simultaneously. One useful feature is the two playback modes. Mode II, for example, enables the player to vary the playback speed by using the < and > keys. In addition, the background playing mode means that overdubbing is possible. Nine tunes may be stored in the computer's memory, but only one will play back at a time.

Operation is made easier by use of a cursor for each note played, providing a visual aid for those unsure of their touch on the keyboard. Editing is a simple task, and the multisound also has a drum mode, consisting of eight built-in patterns selected from the control panel. Any drum pattern acts as a background tune, and the rhythm sound can be altered through the ADSR selectors. You can also write your own drum routine in the same way as a background tune.

The two main factors in this package's appeal are ease of use and the sounds available. Programmers and musicians may find this a useful writing tool, as well as a source of pleasure.

Features such as oscillator and envelope sweeping, ring modulation and wave-form synchronisation controlled by the special effects panel, add greatly to the machine's sound potential, while the software is sensibly written and well explained.

Musicmaster

Incognito Software — 48K Spectrum
AGAIN, A WELL-WRITTEN package limited by the Spectrum's sound capability. A keyboard overlay is provided to simplify playing, and two modes are available. The first is Stave, giving a two-octave range of notes and matching stave screen display; the second is Keyboard, giving a 17-note playing range.

A series of reminders display length of note, rests, deletion, and so on. Bar signs are inserted automatically, indicating this system's usefulness as an educational aid.

The package is limited — for example, only one tune can be retained at any one time — but operation is very simple, and tunes, once entered, can be amended easily. Familiarity with this instrument may help your keyboard literacy if you are just starting out, and may be a useful refresher for those who have forgotten their music theory.

From the point of view of a poverty-stricken musician, many of the available software packages for computer base synthesisers will be disappointing, due either to the poor sound range, or the limitations imposed by the software itself. The Commodore program is, in effect, a useful link between the standard play as you learn material, and the impending invasion of specialist packages such as Yamaha's new range.

This is not to deny that the BBC and Spectrum programs can fulfil a role — they

are certainly excellent educational instruments — but it is doubtful whether they will be suitable for someone intending to use the computer as a serious writing tool.

Musicians — like everybody else — will soon be facing a bewildering choice if they intend to make use of new technology. The only advice that can really be given is to be sure of what you want before you buy it. This may seem fatuous, but there is nothing more frustrating than buying a package which turns out to be a shelf-filler and nothing else.

If you want to use the computer as a complete system, you will have to be more selective. ■

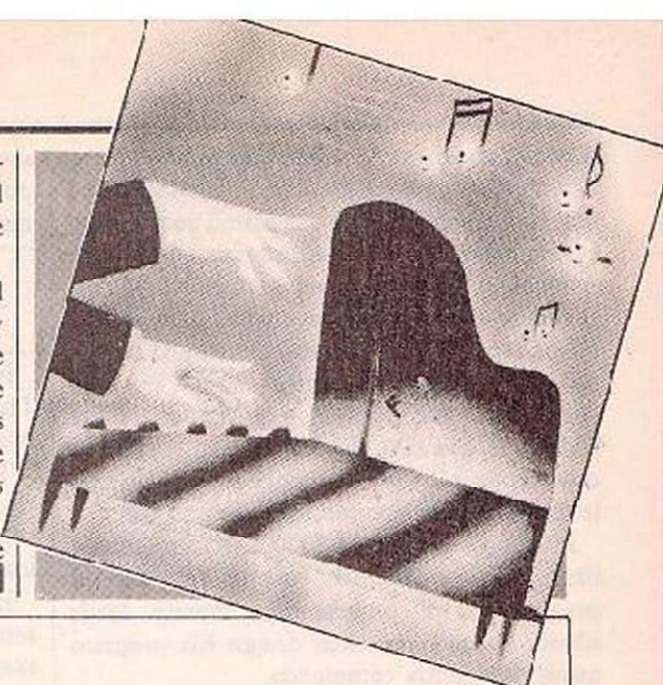

Figure 1. Saw tooth.

The sawtooth wave-form produces a tinnier sound, similar to a plucked string instrument.

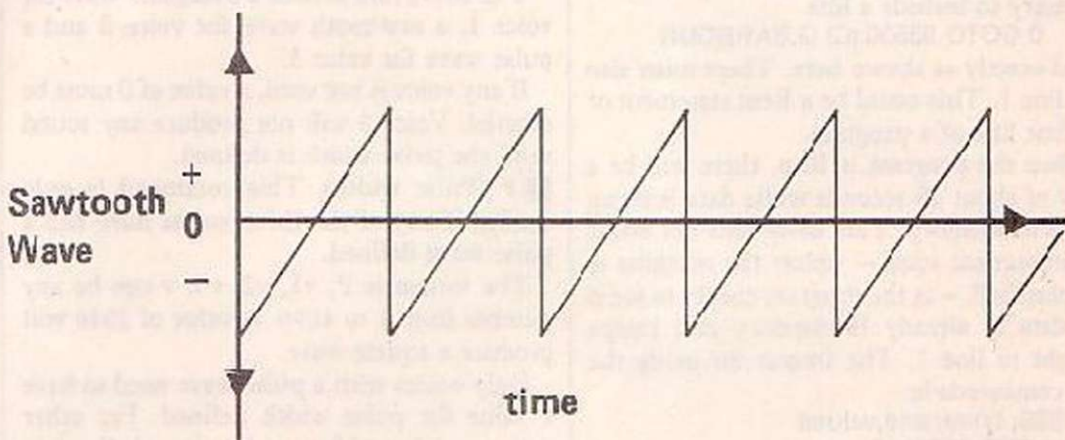

Figure 2. Low-pass filter.

The low-pass filter allows all notes below the cut-off point to pass unchanged. Notes above the cut-off point are muted at a rate of 6dB per octave.

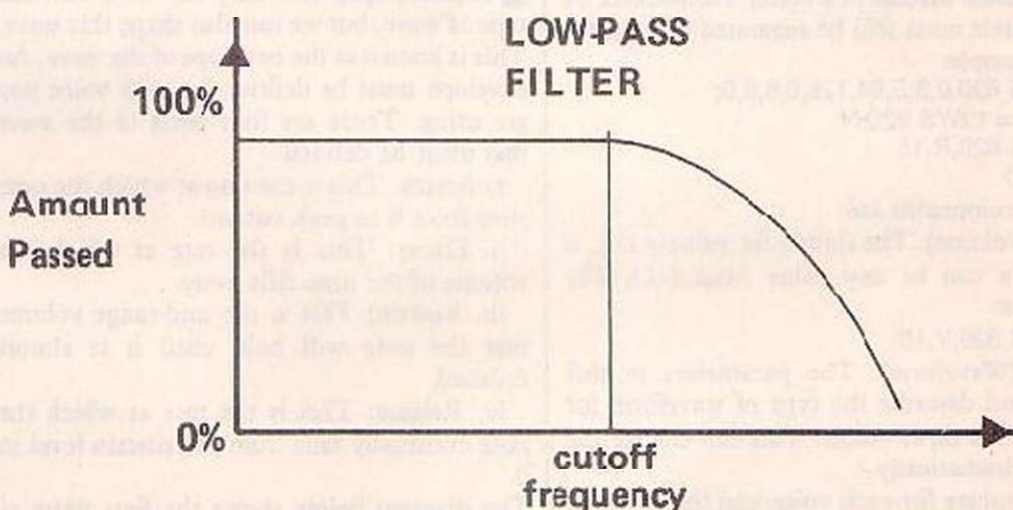
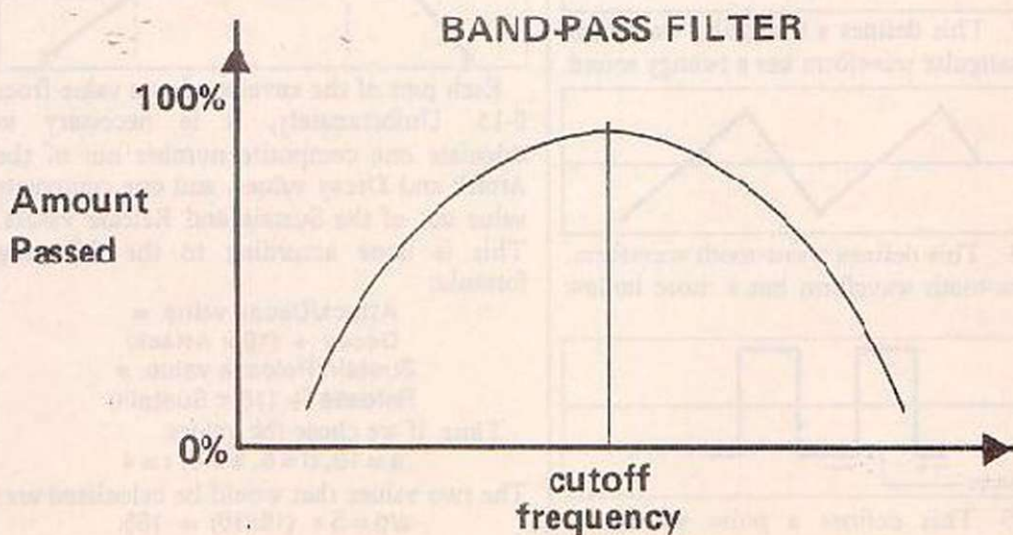

Figure 3. Band-pass filter.

The band-pass filter mutes notes both above and below the cut-off at a rate of 6dB per octave.



WHILE COMPILING music programs using the Commodore 64 synthesiser, I soon realised that it was sorely lacking in sound commands. It also necessitated the memorising of a large number of Poke addresses in order to be able to define the volume, wave-type, wave-shape, filters etc. For this reason I developed Musik 64 — a program which adds 13 new commands and which requires only one address — Sys 820. To use each of these new commands it is only necessary to type a single letter e.g., V for volume, S for sound etc.

Musik 64 uses lines 63500 onwards, leaving lines 1-63499 free for writing any desired program. The programmer merely loads Musik 64 and can then design his program using these extra commands.

In order to get the program to run it is necessary to include a line

```
0 GOTO 63500:(C) G.BARBOUR
```

typed exactly as shown here. There must also be a line 1. This could be a Rem statement or the first line of a program.

When the program is Run, there will be a delay of about 20 seconds while data is being stored in memory. This delay will not occur on subsequent runs — unless the machine is switched off! — as the program checks to see if the data is already in memory and jumps straight to line 1. The format for using the new commands is:

```
SYS 820,command,value  
eg., 10 SYS 820,V,15
```

Several different Musik 64 commands may be used in a single line using only the one Sys 820, as long as each command is separated by a semi-colon instead of a colon. Non Musik 64 commands must still be separated by a colon. For example:

```
10 SYS 820,0,3;E,64,128,C,0,0,0;  
V,15:A=1::SYS 820,N  
20 SYS 820,R,15  
30 END
```

The commands are:

■ V (Volume). The format for volume is V, x where x can be any value from 0-15. For example:

```
10 SYS 820,V,15
```

■ W (Waveform). The parameters in this command describe the type of waveform for each of the three voices. This can change the sound dramatically.

The values for each voice and the shape of wave they represent are:

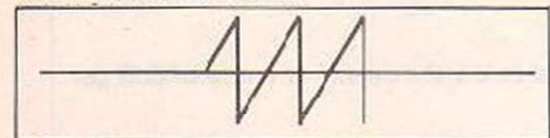

i. 17 This defines a triangular waveform. The triangular waveform has a twangy sound.

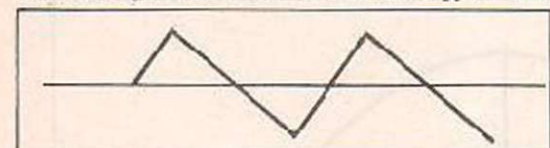

ii. 33 This defines a saw-tooth waveform. The saw-tooth waveform has a more hollow sound.

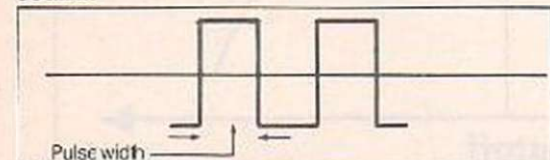

iii. 65 This defines a pulse waveform. This waveform can give a wide range of

sounds, due to the fact that the width of the pulse must be defined before it will play (see next command).

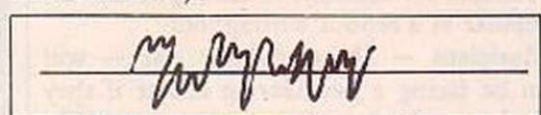

iv. 129 This defines the noise waveform. This is a random wave which can be used for sound effects.

The format for this command is W, v1, v2, v3, where the v1, v2 and v3 refer to the three voices. v must be chosen from the values listed above, viz. 17, 33, 65 or 129.

Each voice may have a different value or some or all the voices can be the same. For example:

```
45 SYS 820,W,17,33,65
```

The above line defines a triangular wave for voice 1, a saw-tooth wave for voice 2 and a pulse wave for voice 3.

If any voice is not used, a value of 0 must be entered. Voice 3 will not produce any sound until the pulse width is defined.

■ P (Pulse width). This command is only needed if any of the three voices have had a pulse wave defined.

The format is P, v1, v2, v3. v can be any number from 1 to 4096. A value of 2048 will produce a square wave.

Only voices with a pulse wave need to have a value for pulse width defined. For other voices, a value of 0 must be entered. For line 45 to work, a line such as the following is necessary:

```
47 SYS 820,P,0,0,2000
```

■ E (Envelope). Not only can we define the type of wave, but we can also shape this wave. This is known as the envelope of the wave. An envelope must be defined for each voice you are using. There are four parts to the wave that must be defined.

i. Attack: This is the rate at which the note rises from 0 to peak volume.

ii. Decay: This is the rate at which the volume of the note falls away.

iii. Sustain: This is the mid-range volume that the note will hold until it is almost finished.

iv. Release: This is the rate at which the note eventually falls from the sustain level to 0.

The diagram below shows the four parts of the wave envelope.

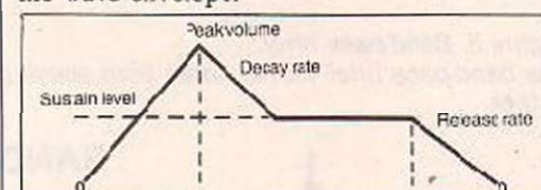

Each part of the envelope has a value from 0-15. Unfortunately, it is necessary to calculate one composite number out of the Attack and Decay values, and one composite value out of the Sustain and Release values. This is done according to the following formula:

$$\begin{aligned} \text{Attack/Decay value} &= \\ & \text{Decay} + (16 \times \text{Attack}) \\ \text{Sustain/Release value} &= \\ & \text{Release} + (16 \times \text{Sustain}) \end{aligned}$$

Thus, if we chose the values:
a = 10, d = 5, s = 9, r = 4

The two values that would be calculated are:
 $d/d = 5 + (16 \times 10) = 165$
 $s/r = 4 + (16 \times 9) = 148$

Graham Barbour's baker's dozen of sound commands puts some yeast in your 64

The format is:

```
E, ad, sr1, ad2, sr2, ad3, sr3.  
e.g. 40 SYS 820, E, 64, 128, 5, 10, 50, 200.
```

■ S (Sound). This command allows you to play a note or a chord for a specific duration, after which the sound is turned off. This ability to define a duration is sorely needed on the 64. This new command replaces the numerous For commands formerly required. The format is:

```
S,n1,r2,n3,d
```

The value for n can be from 0-65536 and can be found in the note table in the Programmer's Reference Guide. The value must be taken from the table marked "Decimals".

If you only have the 64 Manual, these values must be calculated using the formula:
 $n = (\text{Hi freq.} \times 256) + \text{Lo freq.}$

The values for Hi and Lo freq. are found on page 152 of the manual.

If you do not want a sound from a particular voice, a value of 0 must be defined for that voice — this represents a rest.

The duration can be any value from 0-65535; each unit represents 1/60th of a second. Thus 60 will represent a duration of 1 second.

If a value of 0 is used, the note will play continuously until switched off or until another S command is encountered. For example:

```
50 SYS 820, S,4000,5000, 6000, 120
```

■ 0 (Off). This command is used to zero or switch off all sound addresses (Waveforms,

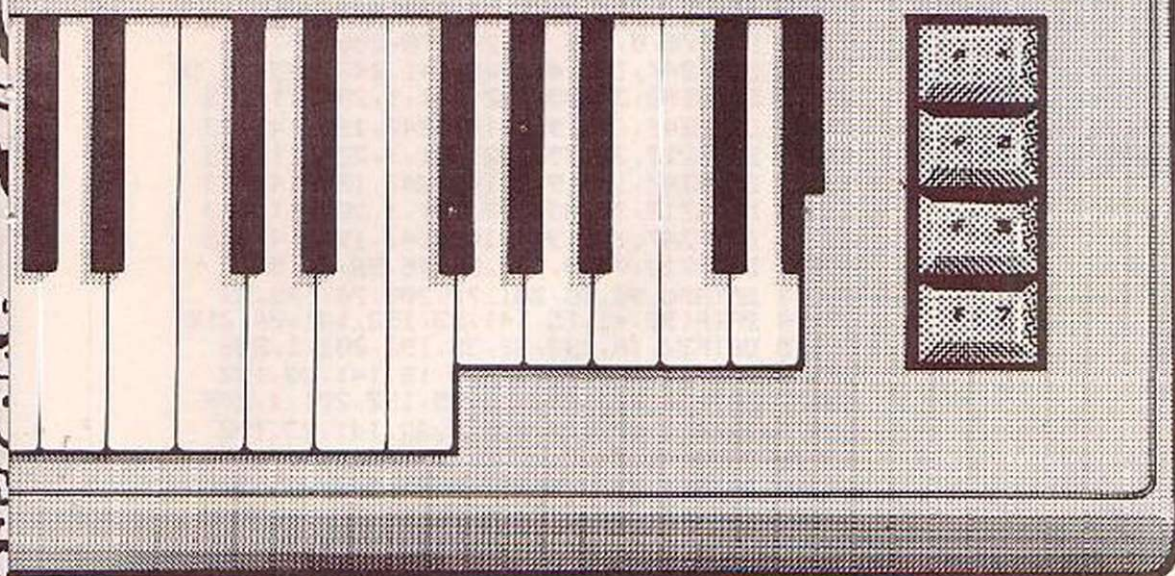

MUSIK 64

Volumes etc.). This usually takes about 20 secs. in Basic, but this new command does it almost instantaneously.

The format is:

`O,v`

v can be from 1 to 3.

A value of 1 clears voice 1; 2 clears voices 1 and 2, while 3 clears all three voices. Any value clears all filters and the volume.

The following four commands are used to set the sound filters. The filters are used to change the harmonic structure of the wave. With the 64 we have three different types of filtering. These may be used separately, or two or more can be used simultaneously. There are a number of controls which must be set when using a filter.

F (Filter set). This command defines which voices are to be filtered and which not. The format is

`F,v1,v2,v3`

If v is given the value 1, then that voice will be filtered — if v is zero, that voice will not be filtered. For example:

`70 SYS 820,F,1,0,1`

In this case, voices one and three will be filtered while voice two remains unchanged.

The next three commands will only affect the voices you have selected to be filtered. There is not a different filter for each voice — the chosen filter will act on all the voices you have decided to filter.

C (Cut-off point). This tells the computer the exact stage in the wave cycle where the filtering process must begin — it is a reference

point for the filter. The format is:

`C,v`

v can be any value from 0-255. For example: `70 SYS 820,C,100`

M (Filter mode). This command defines the type of filter to be used. The 64 has three filter modes, which can be combined.

a. Highpass: This passes over all values above the cut-off point while attenuating the frequencies below.

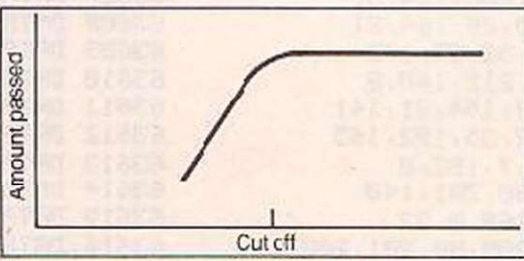

b. Low-pass: This passes over all the low frequencies while attenuating the others.

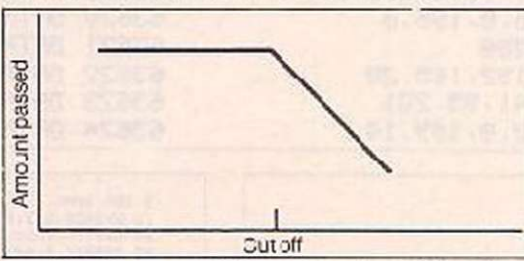

c. Band pass: This attenuates all values except a narrow band around the cut-off point.

The format is: `M,HP,LP,BP`

A value of 1 sets that type of filter while 0 clears it. For example: `80 SYS 820,M,1,0,0`

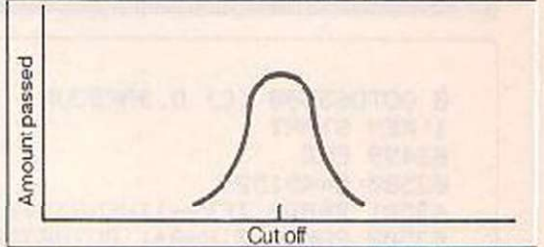
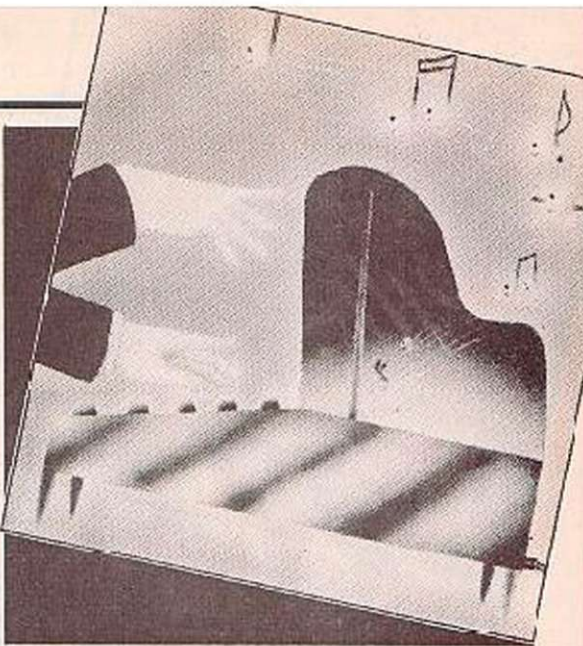

In this example a high pass filter has been selected.

R (Resonance). This is the last filter command which sets the resonance of the filter. The format is:

`R,v`

v can be from 0-15. For example:

`100 SYS 820,R,14`
`110 GOTO 10`

The last three commands are extremely useful. They allow a program, which plays a tune, to be built in memory using voice 1. When the program is executed, it plays in the background, allowing another program to run simultaneously. This is very effective for designing games, allowing the game to be played while music plays in the background. The music can even play while you are programming, and adjustments can be made to the music program — Volume, Waveform, Envelope etc. — while it is actually playing. Because only voice 1 is used, voices 2 and 3 are left free for additional sound effects.

N (New). This will rub out any tune in memory. It should be used before making up a tune. The format is:

`N`

For example:

`110 SYS 820,N`

D (Data). This will store the next note and duration in memory. Format is:

`D,n,d`

n can be any number from 0-65000. See Sound command; line 50.

d (duration) can be 0-255. (60 is equal to 1 sec). For example:

`120 SYS 820,D,2000,120`

These values could be read from a data statement — see program 2.

X (Execute). When your tune is finished, this command will cause it to play. Format:

`X`

For example: `130 SYS 820,X`

When a program, which plays a tune, is run, the tune will repeat until the 0 (Off) command is encountered.

Although constants have been used for the values in the above examples, it is permissible to use variables for the values in any of the commands — as has been done in the demonstration programs. (continued on next page)

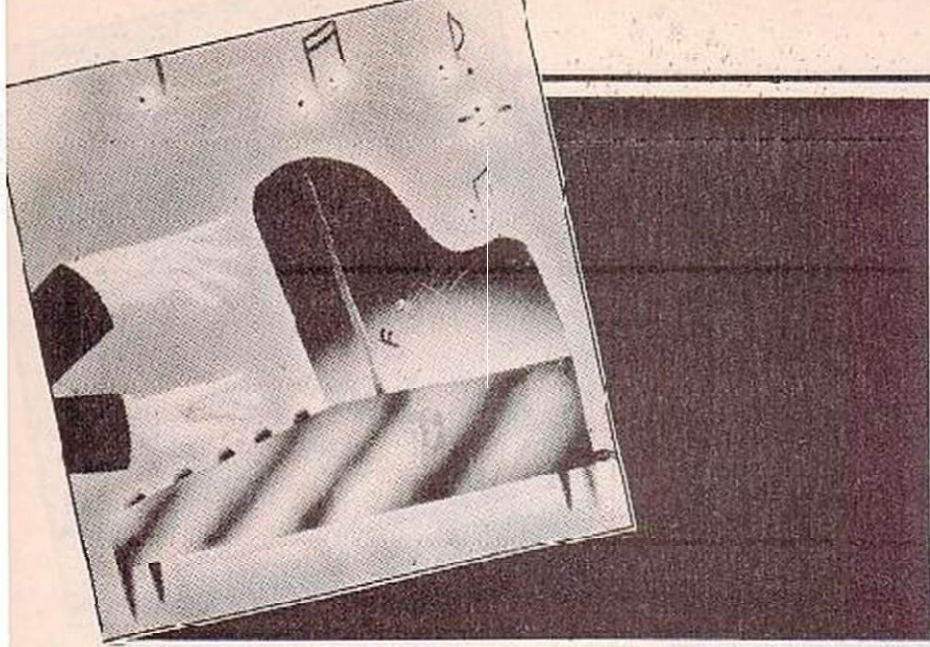

```

0 GOTO63500:(C) G. BARBOUR
1 REM START
63499 END
63500 A=49152
63501 READB:IFB=-1THEN63503
63502 POKEA,B:A=A+1:GOTO63501
63503 SYS50192:GOTO1
63504 DATA169,76,141,52,3,169,48,141,53
63505 DATA3,169,192,141,54,3,95,230,122
63506 DATA208,2,230,123,96,0,0,0,198
63507 DATA122,201,255,208,2,199,123,0,32
63508 DATA253,174,32,158,173,32,247,183,165
63509 DATA20,96,0,32,115,0,201,65,144
63510 DATA9,201,91,176,5,76,69,192,234
63511 DATA234,162,11,108,0,3,141,0,201
63512 DATA201,86,208,20,32,16,192,32,35
63513 DATA192,169,240,45,23,192,76,208,193
63514 DATA234,234,234,234,234,234,201,87,208
63515 DATA33,32,16,192,32,35,192,165,20
63516 DATA141,4,212,141,96,201,32,35,192
63517 DATA155,20,141,11,212,141,97,201,32
63518 DATA35,192,165,20,141,18,212,76,250
63519 DATA192,0,0,201,69,208,55,32,16
63520 DATA192,32,35,192,165,20,141,5,212
63521 DATA32,35,192,165,20,141,6,212,32
63522 DATA35,192,165,20,141,12,212,32,35
63523 DATA192,165,20,141,13,212,32,35,192
63524 DATA165,20,141,19,212,32,35,192,165
63525 DATA20,141,20,212,76,0,196,0,201
63526 DATA80,208,55,32,16,192,32,35,192
63527 DATA165,20,154,21,141,2,212,140,3
63528 DATA212,32,35,192,165,20,164,21,141
63529 DATA9,212,140,10,212,32,35,192,165
63530 DATA20,164,21,141,16,212,140,17,212
63531 DATA76,0,196,0,0,0,0,141,98
63532 DATA201,76,0,196,201,83,208,124,32
63533 DATA16,192,32,35,192,165,20,164,21
63534 DATA141,0,212,140,1,212,32,35,192
63535 DATA165,20,154,21,141,7,212,140,8
63536 DATA212,32,35,192,165,20,164,21,141
63537 DATA14,212,140,15,212,32,35,192,165
63538 DATA20,164,21,201,0,208,7,192,0
63539 DATA208,3,76,0,196,141,80,201,140
63540 DATA81,201,152,0,160,0,169,0,32
63541 DATA219,253,32,222,255,205,80,201,208
63542 DATA248,226,81,201,208,243,169,0,141
63543 DATA0,212,141,1,212,141,7,212,141
63544 DATA8,212,141,14,212,141,15,212,141
63545 DATA80,201,141,81,201,76,0,196,0
63546 DATA0,0,0,0,0,0,201,79,208
63547 DATA97,32,16,192,32,35,192,165,20
63548 DATA201,1,208,0,169,7,141,85,201
63549 DATA76,167,193,201,2,208,8,169,14

```

```

63550 DATA141,85,201,76,167,193,169,25,141
63551 DATA85,201,169,0,169,0,153,0,212
63552 DATA200,204,85,201,208,247,169,0,141
63553 DATA23,192,141,24,212,169,0,141,23
63554 DATA212,141,247,193,76,224,195,0,0
63555 DATA0,0,0,0,0,141,23,192,165
63556 DATA20,13,23,192,141,23,192,141,24
63557 DATA212,76,0,196,96,96,96,96,201
63558 DATA67,208,17,32,16,192,32,35,192
63559 DATA165,20,141,22,212,76,0,196,0
63560 DATA96,96,201,82,208,34,32,16,192
63561 DATA32,35,192,169,15,45,247,193,141
63562 DATA247,193,173,247,193,6,20,6,20
63563 DATA6,20,6,20,5,20,141,247,193
63564 DATA76,0,196,96,201,70,208,76,173
63565 DATA247,193,41,240,141,247,193,32,16
63566 DATA192,32,35,192,201,1,208,11,173
63567 DATA247,193,9,1,141,247,193,141,23
63568 DATA212,32,35,192,201,1,208,11,173
63569 DATA247,193,9,2,141,247,193,141,23
63570 DATA212,32,35,192,201,1,208,11,173
63571 DATA247,193,9,4,141,247,193,141,23
63572 DATA212,76,0,196,96,96,96,96,96
63573 DATA96,96,96,201,77,208,76,173,23
63574 DATA192,41,15,141,23,192,141,24,212
63575 DATA32,16,192,32,35,192,201,1,208
63576 DATA11,173,23,192,9,16,141,23,192
63577 DATA141,24,212,32,35,192,201,1,208
63578 DATA11,173,23,192,9,32,141,23,192
63579 DATA141,24,212,32,35,192,201,1,208
63580 DATA11,173,23,192,9,54,141,23,192
63581 DATA141,24,212,76,0,196,96,96,96
63582 DATA96,0,201,68,208,97,172,191,194
63583 DATA192,255,240,85,32,16,192,32,35
63584 DATA192,172,191,154,153,0,149,165,21
63585 DATA153,0,150,32,35,192,172,191,194
63586 DATA153,0,151,76,19,195,172,191,194
63587 DATA153,0,152,165,21,153,0,153,32
63588 DATA35,192,172,191,194,153,0,154,32
63589 DATA35,192,172,191,194,153,0,155,165
63590 DATA21,153,0,156,32,35,192,172,191
63591 DATA194,153,0,157,200,140,191,194,76
63592 DATA0,196,0,0,0,0,0,162
63593 DATA16,108,0,3,234,234,234,234,234
63594 DATA201,78,208,50,160,0,169,0,153
63595 DATA0,149,153,0,150,153,0,151,153
63596 DATA0,152,153,0,153,153,0,154,153
63597 DATA0,155,153,0,156,153,0,157,200
63598 DATA192,0,208,224,141,191,194,32,16
63599 DATA192,76,0,196,0,0,0,0,0
63600 DATA201,88,208,92,169,1,141,112,201
63601 DATA141,114,201,141,116,201,169,0,141
63602 DATA113,201,141,115,201,141,117,201,234
63603 DATA234,234,234,234,234,120,169,149,141
63604 DATA20,3,169,195,141,21,3,83,32
63605 DATA16,192,76,0,196,96,96,96,72
63606 DATA138,72,152,72,205,112,201,173,112
63607 DATA201,201,0,208,46,172,113,201,169
63608 DATA0,141,4,212,185,0,149,141,0
63609 DATA212,185,0,150,141,1,212,185,0
63610 DATA151,141,112,201,200,140,113,201,173
63611 DATA96,201,141,4,212,204,191,194,208
63612 DATA5,160,0,140,113,201,104,168,104
63613 DATA170,104,76,49,234,96,96,96,96
63614 DATA96,96,120,169,49,141,20,3,169
63615 DATA234,141,21,3,88,76,0,195,96
63616 DATA96,197,96,96,79,204,96,96,225
63617 DATA96,226,96,96,96,11,212,160,0
63618 DATA177,122,201,59,240,1,96,76,48
63619 DATA192,96,96,96,96,160,0,185,13
63620 DATA0,217,35,196,208,0,200,192,13
63621 DATA208,243,76,0,192,0,67,41,32
63622 DATA71,45,66,65,82,66,79,85,82
63623 DATA0,96,253,253,253,253,253,253,253
63624 DATA-1

```

```

1 REM DEMO OF REAL TIME MUSIC
10 SYS20,D,3:IN:V,15:W,17,0,0:E,64,128,0,0,0,0
20 READA:IFB=-1THEN3000
30 READB:SYS20,D,A,B:GOTO30
1003 DATA2408,15,2703,15,2864,30,2703,30,2408,30,2108,15,2703,15,2864,15
1013 DATA 3608,15,2703,15,2864,15,2408,30
1023 DATA2408,15,2703,15,2864,30,2703,30,2408,30,2108,15,2703,15,2864,15
1033 DATA 3608,15,2703,15,2864,15,2408,30
1043 DATA2864,15,3215,15,3408,15,3608,5,3100,15,3100,15,3608,15,3215,15,2703,15
1053 DATA2864,15,3215,15,3215,15,3215,15,3215,15,2864,15,2408,15
1063 DATA2703,15,2864,30,2703,30,2408,30,2408,15,2703,15,2864,15,3608,15,2703,15
1073 DATA 2864,15,2408,30
2000 DATA-1
3000 SYS20,X

```

```

1 REM DEMO
10 SYS20,C,3:E,144,144,144,144,144:V,15:W,65:Z,65:P,20000,0,50000
20 SYS20,E,3215,0,0,80:8,3215,6430,0,80:8,3215,6430,12860,60
25 SYS20,E,6430,12860,25710,60
30 REAIR:L:IFB=-1THEN100
40 SYS20,S,N,N2,N,L:30:GOTO30
100 DATA6430,3,6430,3,8101,3,10314,3,9534,3,8101,3,6430,3,8101,1
110 DATA8101,3,8101,1
120 DATA6430,3,6430,3,8101,3,10314,3,9534,3,8101,3,6430,3,8101,1
130 DATA7217,1,7217,3,7217,1
140 DATA6430,3,6430,3,8101,3,10314,3,9534,3,8101,3,6430,3,8101,1
150 DATA8101,3,8101,1
160 DATA6430,3,6430,3,8101,3,10314,3,9534,3,8101,3,6430,3,8101,1
170 DATA6430,3,6430,1,1,1

```

SABRE WOLF

ULTIMATE
PLAY THE GAME

48K SINCLAIR ZX SPECTRUM
£9.95

star

ATTRACTIONS

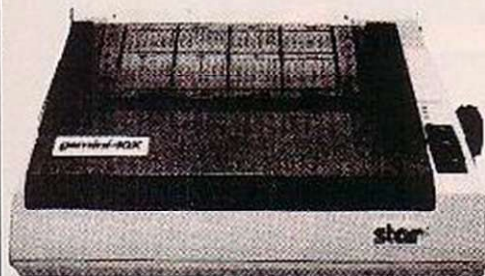

Gemini-10X

£189.95

+ VAT = £218.44
12C CPS • BI-DIRECTIONAL LOGIC SEEKING • FRICTION TRACTOR AND ROLL HOLDER STANDARD • DOWNLOADABLE CHARACTERS • ULTRA HIGH RESOLUTION • 80 COLS. IBM PC VERSION NOW AVAILABLE



14 Inch
Colour Monitor



12MHZ VIDEO BANDWIDTH
RGB AND COMPOSITE VIDEO

£169.95

+ VAT = £195.44

LOOK!

NEW LOWER PRICES ON EPSON STAR & BROTHER

DAISYWHEEL PRINTERS

| | |
|----------------|-------------------------|
| BROTHER HR 15 | £349.95 + VAT = £402.44 |
| JUKI 6100 | £325.00 + VAT = £373.75 |
| DAISYSTEP 2000 | £225.00 + VAT = £258.75 |
| STAR POWERTYPE | £328.95 + VAT = £378.29 |
| EPSON DX 100 | £369.95 + VAT = £425.44 |

DOT MATRIX PRINTERS

| | |
|-----------------|-------------------------|
| EPSON RX 80 | £198.95 + VAT = £228.79 |
| EPSON RX 80 F/T | £228.95 + VAT = £263.29 |
| EPSON RX 100 | £384.95 + VAT = £442.69 |
| EPSON FX 80 | £319.95 + VAT = £367.94 |
| EPSON FX 100 | £498.95 + VAT = £573.79 |

| | |
|------------------|-------------------------|
| STAR GEMINI-10X- | £189.95 + VAT = £218.44 |
| STAR DELTA 10 | £319.95 + VAT = £367.94 |
| STAR RADIX 10 | £498.95 + VAT = £573.79 |

THERMAL MATRIX PRINTERS

| | |
|---------------|-------------------------|
| STAR STX 80 | £129.95 + VAT = £149.44 |
| BROTHER HR 5 | £129.95 + VAT = £149.44 |
| BROTHER EP 44 | £216.95 + VAT = £249.49 |

Cables - Paper - Ribbons - Sheet Feeders
Tractor Feeds - Interfaces - Call for Best Prices

CREDIT CARD

HOT LINE

01-482 1711

Please add £10 + VAT for delivery.
Post your cheques/POs to:

DATASTAR SYSTEMS UK

Unicom House 182 Royal College Street
London NW1 9NN

Telex 295931 UNICOM G
TAX-FREE EXPORT & DEALER
ENQUIRIES WELCOME



An end to monitor madness and glare fatigue.

An Easy-Eye anti-glare screen is the answer to those frustrating headaches and eyestrains.

Measuring approximately 12" x 9" it adheres to your TV screen or monitor to cut right through annoying glare.

You'll be able to improve on existing high-scores and program in comfort for hours!

Please send me E.Z.I. screens at £3.50

I enclose cheque/PO to the sum of £

made payable to TRT Design.

Name

Address

Postcode

TRT Design, 216 Sussex Gardens, London W2



TOP SAVINGS

PRINTERS

| | EX VAT | INC VAT |
|---------------|--------|---------|
| BROTHER HR 15 | 349.00 | 401.35 |
| TRACTOR | 63.00 | 75.20 |
| SHEETFEEDER | 195.00 | 224.25 |
| KEYBOARD | 142.00 | 165.30 |

| | | |
|----------------|--------|--------|
| EPSON FX80T | 215.00 | 247.25 |
| EPSON FX80F/T | 242.00 | 276.30 |
| EPSON FX80P/T | 329.00 | 376.35 |
| EPSON MX100F/T | 375.00 | 431.25 |
| EPSON FX100F/T | 430.00 | 494.50 |
| FX80 TRACTOR | 30.00 | 34.50 |

| | | |
|-----------|--------|--------|
| JUKI 6100 | 345.00 | 396.75 |
|-----------|--------|--------|

| | | |
|------------------------|--------|--------|
| MANNESMANN TALLY MT 80 | 199.00 | 228.85 |
|------------------------|--------|--------|

| | | |
|--------------------|--------|--------|
| OKI MICROLINE 80AP | 180.00 | 207.00 |
| OKI MICROLINE 82A | 289.00 | 332.35 |
| OKI MICROLINE 83A | 435.00 | 500.25 |
| OKI MICROLINE 82P | 399.00 | 454.25 |

| | | |
|-----------------|--------|--------|
| SEIKOSHA GP100A | 175.00 | 201.25 |
|-----------------|--------|--------|

| | | |
|------------|--------|--------|
| SHIWA CP80 | 170.00 | 201.25 |
|------------|--------|--------|

| | | |
|-----------------|--------|--------|
| STAR GEMINI 10X | 199.00 | 228.85 |
|-----------------|--------|--------|

COMPUTERS

| | | |
|------------------------|--------|--------|
| COMMODORE 64 | 156.51 | 179.99 |
| COMMODORE 1541 DISK | 165.21 | 189.99 |
| COMMODORE C2N CASSETTE | 36.51 | 41.99 |
| INTERFACE 64-PAREL | 55.50 | 66.43 |

| | | |
|-----------------|---------|---------|
| APRICOT 2+C+MON | 1575.00 | 1811.25 |
|-----------------|---------|---------|

| | | |
|--------------|--------|--------|
| SANYO MBC555 | 795.00 | 918.85 |
|--------------|--------|--------|

| | | |
|------------|---------|---------|
| EPSON QX10 | 1600.00 | 1840.00 |
|------------|---------|---------|

MAYFAIR MICROS

362 YORK ROAD, LONDON SW18 1SP

01-870 3255

DRAGON DISCO LIGHTS

THIS PROGRAM generates on-screen colour graphics in time with music that is played through the cassette port. In other words it simulates disco lights.

I had originally programmed this in Basic, but as usual, it proved to be too slow so I converted it to machine code. Although it sounds very complicated it is, in fact, very simple.

The first job is to turn the cassette motor and audio on; this is done in lines 0008 and 0009. Both lines call the respective ROM routines although it is just as easily done by the controlling program. Then the screen is cleared to black — lines 0010,0011. The ROM routine at 47737 clears the screen to the character in accumulator B — if you call 47735 then the screen is cleared to green.

The guts of the program come next; a byte is taken from the cassette recorder in line 0012 — this ROM routine is one of many that deal with the cassette port, see figure 1. Lines 0013-0027 then divide this byte by 31 to get it into the range of 0-8 because we only have nine colours. Lines 0028-0044 then send control to a routine which places the graphics on screen.

These are all very similar so we will just look at the first one. The first line of all the routines looks at the top right-hand corner of the graphics to see if it is On — colour — or Off — black. If it is On then it is turned Off and visa versa. Control is then passed back to the "byte-in" routine and the whole process is repeated.

To enter the program use the hex loader to enter the code from the hex dump. When you've finished save it by typing: CSAVEM "DISCO", &H6000, &HE114, &H6003

When the program is in memory place a music cassette into your cassette recorder and press Play. Type
EXEC &H6003

and hit Enter. If all is well then you should see some coloured graphics appearing on your screen and the music should be playing through the speaker, if not then reload the code and check through it.

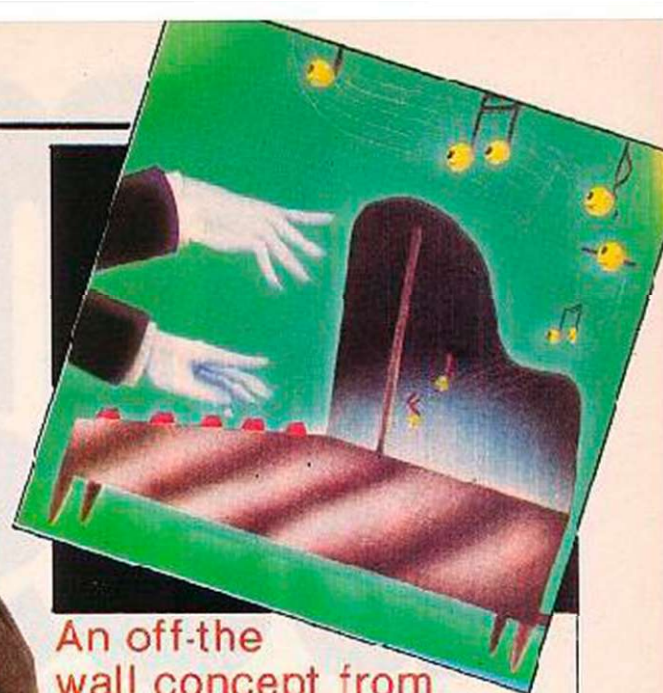
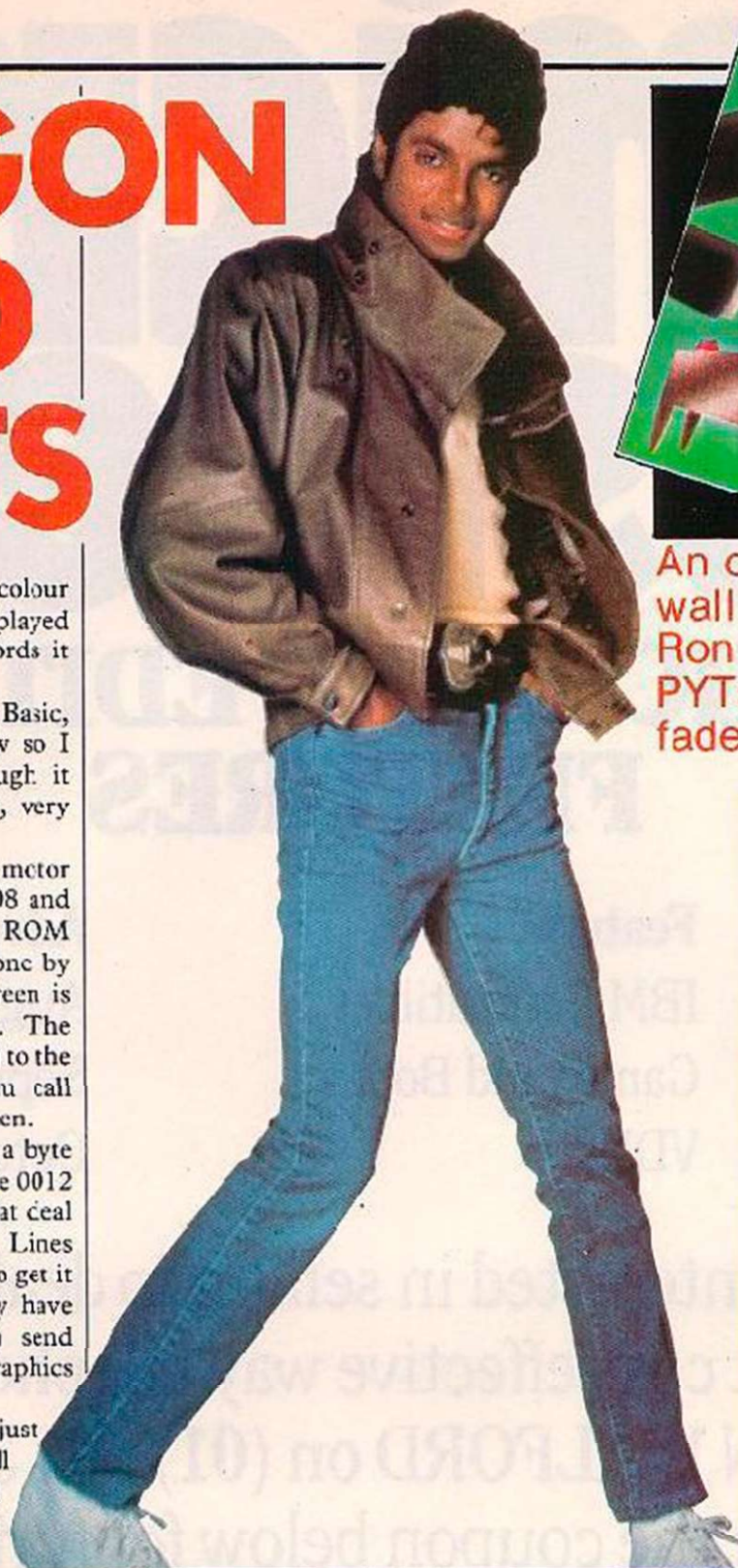

An off-the-wall concept from Ron Gardler. Impress PYTs with your ability to fade away and radiate.

Program 2.

| | |
|-------|---------------------------|
| 24576 | : 4E0000BDB015BDBA = 791 |
| 24584 | : ECC680BDBA798DB0 = 1375 |
| 24592 | : 24E76000B61FB760 = 759 |
| 24600 | : 01E608B76002F660 = 766 |
| 24608 | : 004F5849B1600125 = 551 |
| 24616 | : 04E060015C7A6002 = 589 |
| 24624 | : 24F091012722B102 = 612 |
| 24632 | : 2733B1032744B104 = 462 |
| 24640 | : 2755B1052766B106 = 534 |
| 24648 | : 2777B107102700B6 = 483 |
| 24656 | : B1C8102700920B6 = 333 |
| 24664 | : B6C400B1BF2704C6 = 699 |
| 24672 | : BF2002C6B0B0E400 = 649 |
| 24680 | : 17C09520A1B6040B = 562 |
| 24688 | : B19F2704C69F2002 = 722 |
| 24696 | : C6E0B0E40B1700B0 = 634 |
| 24704 | : 20BCB60416B1AF27 = 723 |
| 24712 | : 04C6AF2002C6B0BE = 879 |
| 24720 | : 04168D6C16FF77B6 = 853 |
| 24728 | : 04A0B1BF2704C6BF = 916 |
| 24736 | : 2002C6B0B0E40A0B = 807 |
| 24744 | : 5716FF62B604B6B1 = 959 |
| 24752 | : CF2704C6CF2002C6 = 887 |
| 24760 | : B0EE04B68D4216FF = 940 |
| 24768 | : 4DB60540B1DF2704 = 723 |
| 24776 | : C6EF2002C6B0B0E5 = 928 |
| 24784 | : 40BD2D16FF3BB605 = 770 |
| 24792 | : 4BE1EF2704C6EF20 = 955 |
| 24800 | : 02C6B0B0E54BBD1B = 715 |
| 24808 | : 16FF23B60556B1FF = 969 |
| 24816 | : 2704C6FF2002C6B0 = 856 |
| 24824 | : BE05568D0316FF0E = 668 |
| 24832 | : 1F98CA0510BF000A = 554 |
| 24840 | : A7E0313F26FA30BB = 879 |
| 24848 | : 165A26F039 = 447 |

Figure 1.

I/O routines in ROM.

&H8015.....turn the motor on.
&H8018.....turn the motor off.
&H801E.....prepare cassette for writing.
&H801E.....put out byte to cassette from A.
&HA006.....outputs a block of data.
&H8021.....prepares cassette for input.
&H8024.....input a byte (into A).
&H8027.....input a bit (into carry bit of CC).

&HA006.....get block in.
Locations used by the above routines.
&H90/91.....leader byte count.
&H95/96.....cassette motor delay.
&H7C.....block type: 0 = file header.
1 = data
255 = end of file.
&H7E/7F.....base address of bytes to put out.
&H81.....error code, cleared if read and verified correctly.

To achieve the best results adjust the cassette volume and the colour/brightness controls of your television and then turn the lights out.

If anyone does not wish to type in all the data then please send £2, an S.A.E. and a blank cassette to: R. Gardler, 23 Dorchester Road, Hazel Grove, Stockport SK7 5JR. ■

Program 1. The hex loader.

```
10 REM HEXLOADER
20 REM ENTER THE STRING OF HEX DIGITS FIRST
30 REM AND THEN THE CHECKSUM
50 FOR N = 24576 TO 24852 STEP 8
60 PRINT N;": ";
65 TT=0
70 INPUT A$
75 Z=0
```

```
80 FOR G=1 TO LEN(A$) STEP 2
90 P=VAL("&H"+MID$(A$,G,2))
95 TT=P+TT:POKE (N+7),P
100 Z=Z+1
110 NEXT
120 PRINT " = ";
130 INPUT T$
150 IF VAL(T$)<>TT THEN PRINT "ERROR":GOTO 50
160 NEXT
```

micro business

FORTHCOMING EDITORIAL FEATURES

| Issue | Feature | Advertising Copy Date |
|-----------|-----------------|-----------------------|
| September | IBM Compatibles | August 10 |
| October | Games and Books | September 12 |
| November | VDUs | October 10 |

If you're interested in selling to dealers in the most cost-effective way telephone:-
KEN WALFORD on (01) 661 3139
or complete the coupon below for further details.

micro business

Please send me further details
on advertising in Micro Business.

Please return replies to:
**Ken Walford, Micro Business,
Quadrant House, Sutton, Surrey SM2 5AS.**

Name

Job Title

Company

Address

Feature of interest: IBM Compatibles Games & Books VDU's

Telephone

Telex

M I C R O P O W E R M I C R O P O W E R M I C R O P O W E R M

SWOODOP

[SUPER-FAST LOADING TIME]
commodore 64
electron
B.B.C. MICRO



COMMODORE 64 VERSION



Defend the space lanes against wave after wave of relentless, screaming Birdmen. Dodge the missiles raining down from the phalanx above and keep clear of the explosive eggs left by escaping creatures. Features three types of Birdmen, and level selection (except BBC version). £6.95. (ELECTRON and BBC MICRO versions £7.95)

M I C R O P O W E R

MICRO POWER LTD.,
NORTHWOOD HOUSE, NORTH STREET,
LEEDS LS7 2AA TEL: (0532) 458800
SELECTIVE BRANCHES OF BOOTS, CO-OP,
MENZIES W. H. SMITH, WOODWORTHS AND ALL
GOOD DEALERS.
AUTHORS WE PAY 20% ROYALTIES!

IF I WERE YOU, I'D ALSO BUY FELIX IN THE FACTORY, CYBERTRON MISSION AND GHOULS!



M I C R O P O W E R M I C R O P O W E R M I C R O P O W E R M

Hugh Dereli's
program will soon
have you
climbing the walls

MANIC

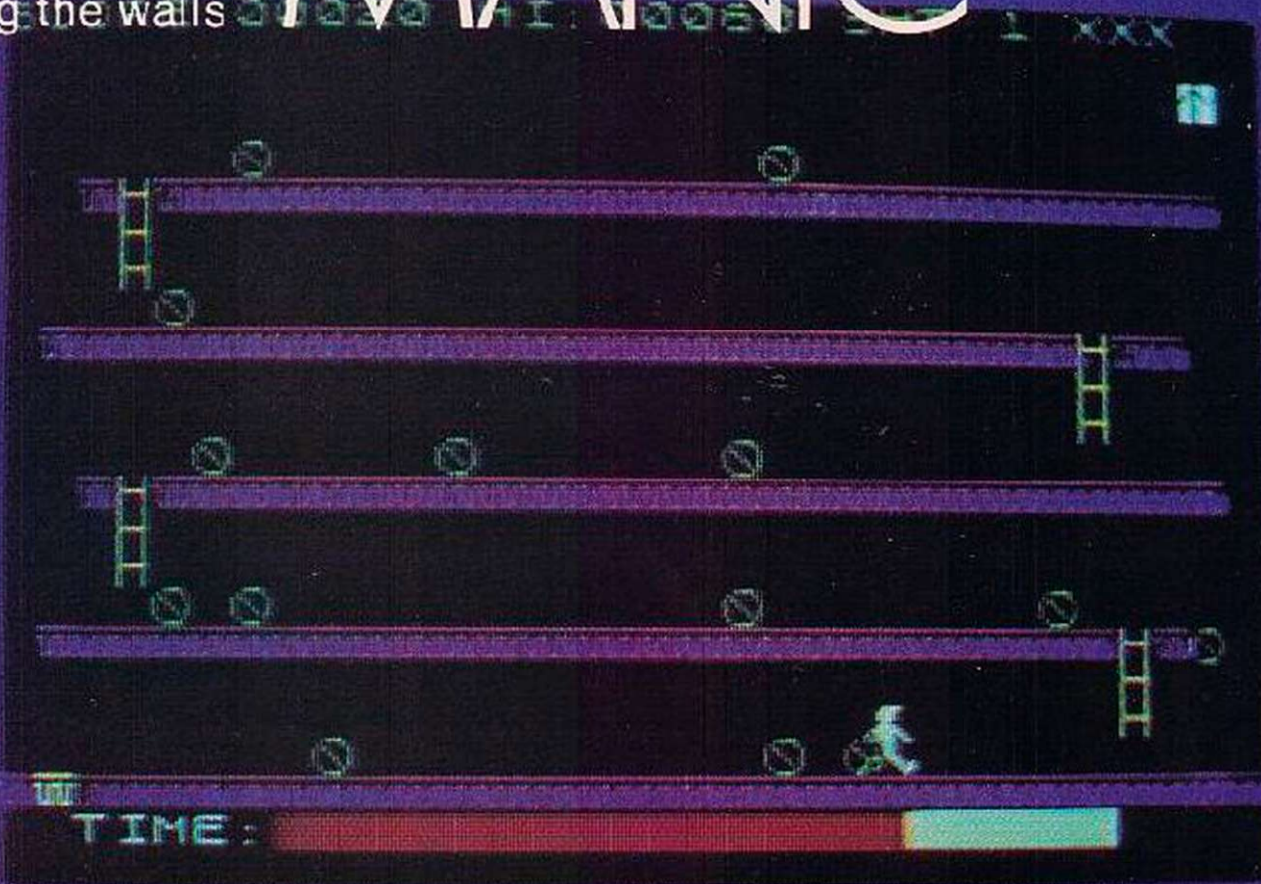

CLIMBER

Listing 2.

```

29300 7E 00 01 03 03 01 03 =73
29307 07 08 13 03 03 03 06 =52
29314 0C 18 0C 00 00 20 00 =630
29321 80 C0 E0 D0 C0 20 00 =1330
29328 C0 60 34 1C 08 00 07 =383
29335 03 03 01 03 07 0B 13 =47
29342 07 03 03 02 2C 30 10 =131
29349 00 80 C0 C0 B0 20 E0 =1050
29356 D0 C8 C0 C0 C0 50 30 =1128
29363 18 30 00 1E 3C 3C 18 =246
29370 7C 7E 7E 7E 7E 3C 3C =484
29377 18 18 18 1C 00 7B 3C =280
29384 3C 18 3C 7E 7E 7E 7E =648
29391 3C 3C 18 18 18 3B 3C =308
29398 42 A1 91 89 85 42 3C =748
29405 3C 42 A1 91 89 35 42 =768
29412 3C FF 00 00 55 55 55 =791
29419 77 00 42 42 42 7E 42 =509
29426 42 42 42 EF C7 4B 6D =916
29433 EF EF EF EF 00 3C 7E =1142
29440 00 7E 3C 00 00 3C 42 =312
29447 B5 89 91 A1 42 3C 10 =718
29454 92 54 38 10 D6 3B 10 =588
29461 B1 42 24 18 18 24 42 =381
29468 B1 00 00 00 00 00 00 =129
29475 00 00 00 00 00 00 00 =0
29482 00 00 00 00 00 00 00 =0
29489 00 00 00 00 00 00 00 =0
29496 00 00 00 00 C3 7E 7B =441
29503 C3 75 77 21 00 58 01 =553
29510 C0 02 3A F0 5B 57 72 =784
29517 23 08 78 B1 20 19 19 =125
29524 3A CA 73 FE A2 20 06 =329
29531 3E 9D 32 CA 73 C9 3E =349
29538 A2 32 CA 73 C9 AF 32 =755
29545 90 8C 3E 18 D7 AF 87 =724
29552 1E 02 21 4A 5B E5 4E =537
29559 23 46 23 3E 20 16 07 =263
29566 CD EB 73 04 CD 04 73 =109
29573 FE 44 28 23 FE 04 28 =697
29580 3A FE 07 28 32 05 56 =496
29587 FE 43 20 1D CB 42 20 =583
29594 05 CB C2 72 18 14 F5 =305
29601 74 CR C7 FF FF CR 87 =1355
29608 77 F1 18 17 01 1F 01 =440
29615 3E 01 77 18 0F C5 79 =539
29622 82 4F CD D4 73 FE 04 =999
29629 20 03 C1 18 01 F1 E1 =719
29636 71 23 70 23 23 3E 9D =549
29643 16 04 CD EB 73 1D 20 =542

```

```

29650 A2 C9 E5 05 C5 6B 26 =1144
29657 00 29 29 29 29 29 06 =211
29664 00 09 01 00 5B 09 7E =233
29671 C1 D1 E1 C9 05 E5 F5 =1515
29678 7A 32 BF 5C 05 3E 16 =688
29685 D7 C1 7B C3 07 C1 79 =1254
29692 C5 D7 C1 F1 F5 C5 D7 =1503
29699 C1 F1 E1 01 C9 3E FF =1386
29706 32 90 5C 3E 15 07 3E =646
29713 01 D7 ED 4B FA 5B CB =1074
29720 C7 75 3A FC 5B 57 CB =1007
29727 5A 2B 4F 04 C4 CD D4 =634
29734 73 05 05 FE C6 F5 2B =670
29741 0B 3E 06 04 CD D4 73 =615
29748 05 FE 06 20 15 C5 01 =516
29755 FE FE ED 70 C1 C8 F7 =1508
29762 FE FF 2B 05 F1 04 C3 =994
29769 CB 74 F1 B 7D F1 FE =1204
29776 03 28 78 FE 46 29 74 =643
29783 FE 04 2B 70 FE 43 20 =773
29790 6C 3A FD 5B FE 00 20 =796
29797 65 04 21 FE 5B 34 CD =740
29804 E6 75 C3 9A 75 C5 04 =1014
29811 CB 04 73 C1 FE 04 29 =1025
29818 4C C5 04 0C CD D4 73 =821
29825 C1 FE 06 28 41 C5 04 =759
29832 04 CD D4 73 C1 FE 03 =986
29839 2B 3A FE 4A 79 3A FE =770
29846 06 2B 32 FE 43 23 2E =503
29853 C5 04 04 0C CD D4 73 =749
29860 C1 FE 03 2B 22 FE 44 =848
29867 2B 1E FE 06 2B 1A FE =650
29874 43 2B 16 3A FD 53 FE =735
29881 00 2D 0F 04 21 FE 5E =429
29888 34 CD E6 75 C3 9A 75 =1070
29895 F5 C3 39 74 3A FE 5E =1016
29902 5F AF 32 FE 5B 3C 0E =752
29909 BB DA 70 77 3A FD 5B =1038
29916 FE 00 2D 0D C5 01 FE =779
29923 FB ED 7B C1 CB F7 FE =1505
29930 FF 2B 30 3E 03 CD 37 =658
29937 76 FE 20 20 27 C5 0E =645
29944 CD D4 73 C1 FE 03 2E =1022
29951 1D 5F 3A FC 5B C8 5F =823
29958 7B 2D 2B C5 05 05 00 =595
29965 D4 73 C1 FE 03 28 09 =826
29972 05 3E 37 32 FD 5B CD =673
29979 15 76 3A FD 5B FE 00 =795
29986 2B 04 3D 32 FD 5B C5 =676
29993 01 FE 3F ED 7B C1 CB =1231

```

```

30000 F7 FE FE 20 2C 3A FC =1141
30007 5B CB 5F 3E 90 C5 20 =824
30014 03 CA 08 0C 77 FC 5B =614
30021 3E 1F B9 20 04 0D 3E =391
30028 98 32 FC 53 3E 03 CD =815
30035 37 76 E1 FE 00 2B 07 =699
30042 44 4D 3E 98 32 FC 5B =752
30049 25 01 FE DF ED 7B C1 =1225
30056 CB F7 FE FD 20 2C 3A =1091
30063 7C 5B CB 5F C5 3E 9A =1054
30070 2B 03 D6 06 0D 32 FC =578
30077 5B 3E FF B9 20 06 0C =643
30084 3E 9A 32 FC 5B 3E 03 =674
30091 2D 37 76 E1 FE 00 2B =897
30098 07 44 4D 3E 9A 32 FC =670
30105 5B ED 43 FA 5B CD C7 =1140
30112 75 21 B0 5C 3A 00 3E =534
30119 04 CD 37 76 FE 00 2B =676
30126 02 CB C6 3E 47 CD 37 =796
30133 76 FE 00 2B 02 CB CE =823
30140 3E 05 CD 37 76 FE 00 =699
30147 CB CB D6 C9 C5 3A FC =1325
30154 5B 16 07 C3 EB 73 04 =679
30161 3C CD CD 73 CB 5F C1 =1106
30168 C0 0C 3C C3 EB 73 3C =879
30175 04 CD EB 73 05 0D C9 =778
30182 C5 3A FE 5B 87 87 57 =987
30189 87 87 82 4F 24 00 11 =866
30196 5A 00 19 3E 02 11 64 =296
30203 00 D5 E5 F5 CD B5 03 =1076
30210 F1 E1 D1 01 06 00 09 =691
30217 EB 01 07 00 ED 42 EB =781
30224 3D 20 E9 C1 C9 C5 11 =924
30231 14 00 3E 04 21 CB 00 =319
30238 D5 E5 F5 C3 B5 03 F1 =1317
30245 E1 D1 01 06 00 ED 42 =744
30252 EB 01 0A 00 09 EB 3D =551
30259 2D E9 C1 C9 C5 57 CD =1148
30266 53 76 04 CD 53 76 3A =669
30273 FC 5B CB 5F 20 0B 0C =693
30280 CD 53 76 05 CD 53 76 =817
30287 3E 00 C1 C7 CD D4 73 =9EB
30294 BA 00 C1 C1 3E 01 C9 =1C2B
30301 3E 15 D7 AF D7 AF 32 =913
30308 90 5C 21 64 5B 1E 01 =491
30315 E5 46 23 4E 23 D5 16 =682
30322 07 3E 2D CD EB 73 0C =648
30329 0C ED EB 73 0D CB EB =1C20
30336 73 00 11 5B 1A 20 =7E0
30343 4B 7A CB 3F CB 3F CB =932

```

```

30350 3F CE 3F E6 07 C6 03 =767
30357 B8 2C 04 CB FE 1B 35 =754
30364 C7 49 77 F5 05 F1 2B =928
30371 2D E5 D5 C5 3E 15 D7 =982
30378 3E 01 D7 3E FF 32 90 =789
30385 5C E1 4B FA 5B CD C7 =1147
30392 75 05 CD C7 75 ED 43 =947
30399 FA 5E AF 32 FD 5B 3E =972
30406 15 D7 AF D7 AF 32 90 =995
30413 5C C1 D1 E1 1B 3D 7A =926
30420 E5 0F C6 05 B8 20 04 =668
30427 C3 BE 18 31 CD 49 77 =863
30434 F5 04 F1 2B 29 E5 05 =1013
30441 C5 3E 15 D7 3E 01 D7 =773
30448 3E FF 32 90 5C ED 4B =915
30455 FA 5E CD C7 75 04 CD =1071
30462 C7 75 ED 43 FA 5B 3E =1023
30469 15 D7 AF D7 AF 32 90 =995
30476 5C C1 D1 E1 D5 16 03 =957
30483 3E 82 CB EB 73 0C 0C =772
30490 C3 EE 73 04 0D 3E A4 =798
30497 CD EE 73 05 3E BF CD =970
30504 E3 73 3E 85 04 0D 16 =584
30511 01 CE CD 73 0C 0C 3C =645
30518 BA CD EB 73 0D 0D 05 =724
30525 D1 E1 70 23 71 23 23 =764
30532 13 C2 6B 76 C9 3A FB =958
30539 59 3C 3C 9B 20 19 3A =512
30546 FA 5B B9 30 0F 3C B9 =834
30553 20 11 3A FC 5B CB 5F =748
30560 20 0A AF FE 01 C9 3D =734
30567 77 37 B9 3A FA AF FF =1033
30574 00 C5 CD C7 75 1B 2F =793
30581 E3 73 F8 5B ED 4B FA =1253
30588 5B CD C7 75 CD 9A 77 =1090
30595 C3 DE 77 CD BF 77 CD =1263
30602 E7 77 CD 9A 77 CD BF =1224
30609 77 CE 36 78 EB EB 79 =1043
30616 13 E6 CD 08 74 3A 80 =817
30623 5C CE 47 2B 0B 01 F4 =659
30630 01 ED 7B F8 5B C9 CB =1104
30637 57 C4 C6 77 CB 4F CB =1082
30644 3A 78 78 FE 00 C0 01 =748
30651 D0 07 18 EB 06 05 FB =733
30658 75 10 FD C9 21 7B 7B =864
30665 35 3E 15 D7 AF D7 ED =978
30672 4B FA 5B CD C7 75 01 =938
30679 EB 03 1B CC 3A DB 5B =831
30686 FE 0C C8 32 6A 76 C3 =923
30693 5D 76 CD 54 73 3A E0 =897

```

Listing 1.

```

2 REM ENTER CODE
5 CLEAR 29300
10 LET a=10: LET b=11: LET c=1
2: LET d=13: LET e=14: LET f=15
15 INPUT "START ADDRESS>":add
17 LET check=0
19 PRINT add;TAB 6;
20 FOR i=-1 TO 7
30 INPUT LINE i$: POKE add,VAL

```

```

i$(1)*16+VAL i$(2)
32 PRINT i$;" ";
35 LET check=check+PEEK add: I
ET add=add+1
40 NEXT h
45 PRINT "=";CHECK
50 GO TO 17
55 REM CHECK CODE
60 INPUT "START ADDRESS>":add
65 PRINT add;" ";
70 LET check=0

```

```

75 FOR f=1 TO 7
80 LET i=PEEK add
A? LET j=INT (i/16)
B5 PRINT CHR$ (j+48+(j>9)*7):C
HR$ (i-j*16+48+(i-j*16>9)*7):" "
:
90 LET check=check+PEEK add: L
ET add=add+1
100 NEXT f
110 PRINT "=";check
120 GO TO 65

```

IN THIS FAST multi-sheet machine-code game for the 16/48K Spectrum, you control Fred the builder who works on a construction site building a skyscraper. Fred must journey up the girders and ladders of the unfinished building to get to the top. Unfortunately, barrels are rolling down the girders towards our hero. Fred must jump over or avoid these. To get onto the next sheet he must collect all the hamburgers first.

Other hazards include lifts and poisoned weeds. You must also be careful that your time doesn't run out and don't fall too far either. If you manage to make it through all nine sheets, the game will begin again only this time the action will be faster. The keys are shown in the centre column of this page.

Q to T Jump/up ladder
Caps Shift to V Down ladder
O Left
F Right

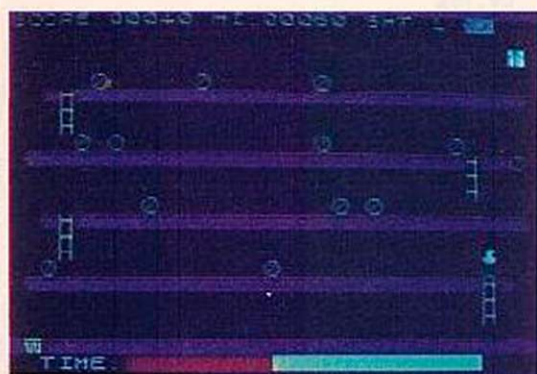

Now to typing in the game itself. First, type in your favourite hex loader. If you do not have one, use listing 1. This version includes a hex checker as well. Now enter and check the code in listing 2.

Now type:

NEW

Do not worry — the program is above RAMtop and will not be destroyed. Now type in the main Basic listing — listing 3. You can now save the whole program by typing: SAVE 'ManicClimb' LINE 0:SAVE "code" CODE 29300,4000

Now rewind and verify with:

VERIFY "";VERIFY "";CCDE

Now, you can load it back in with LOAD ""

Listing 3.

```

5 DEF FN a$(x) = ("0000"+STR$ x
)(LEN STR$ > 4)
6 POKE 23675,117: POKE 23676,
114
10 CLEAR 29300
20 LOAD "CODE
30 LET hi=0
40 LET b$=CHR$ 13
42 POKE 30656,51: POKE 31079,0
50 LET a$=b$+"Missior controls
r"+b$+b$+"B-T.....uo ladde
r/jump"+b$+"CAPS SHIFT-V,down la
dder"+b$+"D.....lef"+b$+"
P.....right"
55 BORDER 7: INK 0: PAPER 7: C
LS
60 LET a=.1
70 FOR f=1 TO LEN a$
80 PRINT a$(f): IF a$(f)="P"
13 THEN PAPER 1+RND*6: INK 9
90 IF INKEY$<">" THEN GO TO 30
0
100 LET a=a+.1*0.4: BEEP .05,q

```

```

110 NEXT f
120 PAUSE 60
121 FOR f=1 TO 15
122 FOR a=0 TO 7
123 BEEP f/500,q
124 PAUSE 1
125 BORDER q
126 IF INKEY$<">" THEN GO TO 50
0
127 NEXT a
129 NEXT f
130 PRINT #0:TAB 5: FLASH 1:"PR
PSS ANY <V TO START"
140 FOR f=0 TO 13 STEP 3: BEEP
.005,f: NEXT f
150 IF INKEY$=">" THEN GO TO 110
300 LET sc=0: LET f=0: LET q=0
302 LET i=0
310 INK 7: PAPER 0: BORDER 0: C
LS
320 GO SUB 4000
340 POKE 23659,0: PRINT AT 22,2
:"TIME": INK 2: PAPER 7:"
345 BORDER 1
350 POKE 23656,i

```

```

360 PRINT " : RANDOMIZE USR 2950
0
380 FOR f=1 TO 3: BEEP .15,1: B
EEP .15,5: BEEP .4,1: BEEP .5,-4
0: NEXT f
390 PRINT " : GO TO USR 2950C
510 BEEP .9,1: BEEP .9,-0: BEEP
.9,-1
320 LET i=i+1-1
325 LET a$="B A M E D V E R":
327 PRINT AT 10,7:
330 IF i.<>0 THEN GO TO 310
340 FOR i=1 TO LEN a$
350 PRINT a$(f):
357 FOR q=1 TO 40: NEXT q
360 NEXT f
361 FOR a=0 TO 56 STEP 2:
365 POKE 23556,a: PRINT " : RAND
OMIZE USR 29506
367 NEXT a
370 FOR i=1 TO 800: NEXT f
380 IF a$<h THEN LET h=a$
390 GO TO 40
1000 FOR f=13 TO 0 STEP -3: BEEP
.005,f: NEXT f
1010 LET sc=sc+20: GO SUB 4000

```

```

1020 GO TO 390
2000 LET f=42: LET q=16
2005 POKE 30794,128
2010 POKE 30791,201
2021 POKE 23556,f: PRINT " : RAND
OMIZE USR 29506
2022 LET f=(f-42)*21+(f-21)*42
2025 PRINT " : LET i=USR 30774: P
OKE 23657,2
2027 POKE 30531,237
2028 IF i=50 THEN GO TO 2900
2030 LET sc=sc+53
2040 PRINT AT 0,6:FN a$(q)
2050 BEEP .004,q: LET q=q-.4
2060 GO TO 2020
2500 LET q=q+1
2505 IF q>8 THEN POKE 30656,PEEK
30656-2: POKE 31079,PEEK 31079+
1: LET q=0
2510 GO TO 310
4000 INK 4: PRINT AT 0,0:"SCORE:
"FN a$(sc):" HI:"FN a$(hi):
4010 PRINT " : SRT:"s+1:" "
4020 FOR f=1 TO 11: PRINT INK 5:
FLASH 1:"X": NEXT f
4030 INK 7: RETURN

```

```

30700 58 FE 00 28 12 2A E1 =670
30707 58 22 73 73 32 71 73 =635
30714 2A E3 59 22 AD 73 CD =887
30721 67 73 3A E5 5B FE 00 =850
30728 28 12 2A E6 5B 22 73 =570
30735 73 32 71 73 2A E8 5B =753
30742 22 AD 73 CD 67 73 3A =803
30749 EA EB FE 00 28 12 2A =679
30756 EB 5B 22 73 73 32 71 =753
30763 73 2A E3 5B 22 AD 73 =807
30770 00 67 73 3A E5 5B 22 =857
30777 AF D7 3E 11 D7 3E 07 =753
30784 07 2E 13 D7 AF D7 2A =940
30791 7B 7B 11 00 00 A7 ED =671
30798 52 22 73 7B DA A9 77 =857
30805 AF 32 69 5C 7C 06 16 =576
30812 C6 C7 47 16 3A 3E BA =561
30819 CB 7D 29 02 3E 8F CD =780
30826 CD 73 02 3E 20 CD CB =896
30833 73 3E 02 32 6B 5C C9 =629
30840 6 13 E5 03 AF 32 21 =532
30847 00 14 22 76 78 AF 32 =519
30854 00 5C 3A F0 59 97 97 =895
30861 5F 87 57 87 82 83 5F =808
30868 DD 21 60 7C 16 00 DD =717
30875 19 3E 03 D1 6E 00 DD =642
30882 AA 01 57 73 7E FE 00 =804
30889 5B 16 E6 3F 57 23 4E =571
30896 23 46 D5 16 03 3E 9E =563
30903 CD ED 73 D1 0C 15 20 =829
30910 F3 1B 24 FE 40 3B 16 =699
30917 23 4E 23 46 E6 3F 57 =598
30924 D5 16 06 3E 9F CD EB =902
30931 73 D1 04 15 20 F3 1B =648
30938 0A 4F 23 46 23 56 23 =350
30945 7E CD EB 73 1D 20 DD =931
30952 DD 6E 02 D1 66 03 22 =693
30959 FA 5B 21 90 00 22 FC =804
30966 5B AF 32 FE 5B 32 80 =887
30973 5C 21 E0 5B 1E 03 DD =694
30980 7E 04 77 D1 4E 05 23 =588
30987 71 DD 46 06 23 70 ED =794
30994 43 73 73 CD DD 4E 07 =800
31001 23 71 DD 46 0B 25 70 =594
31008 23 ED 43 AD 73 FE 00 =881
31015 CA D8 79 E3 F5 71 23 =1159
31022 70 23 36 01 23 3D 20 =330
31029 F6 F1 C1 AF 3C DD 56 =1254
31036 09 D5 E5 FE 32 71 73 =974
31043 3E 1B 32 BD 73 CD 67 =748

```

```

31050 73 3E 20 32 8D 73 F1 =804
31057 E1 D1 15 20 E7 DD BF =1129
31064 04 20 DE 01 05 00 DE =486
31071 09 1D 20 60 D3 7E 04 =581
31078 C6 00 32 4A 73 DD 23 =698
31085 DD 7E 04 DD 23 32 7B =780
31092 7B DD 6E 04 D3 66 0E =783
31099 11 64 5B DD 7E 06 32 =611
31106 DB 5B FE 00 C3 E5 FE =1238
31113 47 80 80 4F 05 00 ED =649
31120 80 D1 5A E1 D3 21 64 =1054
31127 5B DD 46 00 D3 4E 01 =682
31134 16 03 3E 83 CD EB 73 =773
31141 0C 0C CD EB 73 00 3E =654
31148 8F 00 8B 73 02 07 7E =1058
31155 02 E6 0F C6 05 F5 3E =757
31162 A4 04 0C 16 03 CD EB =645
31169 73 DD 3E 85 15 04 CD =554
31176 CD 73 00 00 3E BA CD =779
31183 EB 73 DD 0F D1 8B 20 =833
31190 E1 C9 C1 1B 00 01 FE =1026
31197 FE ED 7B CB F7 FE FC =1567
31204 C0 FE FE F7 E3 7B CB =1261
31211 F7 01 FC D0 21 02 7A =1102
31218 01 00 00 7E FE 0B CC =598
31225 08 00 CD EB 73 0C 23 =610
31232 1B F3 2B 63 29 20 4B =551
31239 2E 43 2E 44 65 72 65 =543
31246 6C 69 0D 11 E3 00 15 =488
31253 DD 01 11 DD 02 0B DD =696
31260 01 09 DD 02 05 43 1C =353
31267 11 43 03 DD 43 1B 09 =203
31274 43 03 05 01 15 46 9E =325
31281 1E 15 43 9E 01 11 43 =361
31288 9E 1E 0D 43 9E 01 09 =436
31295 43 9E 1E 02 47 A0 0E =502
31302 12 05 A1 14 05 43 9E =434
31309 16 E0 00 1D 03 11 =506
31316 DD 02 0D 0D 01 09 DD =688
31323 02 05 43 1C 11 43 03 =189
31330 0D 43 1B 09 43 03 05 =191
31337 01 15 46 9E 1E 15 43 =368
31344 9E 01 11 43 9E 1E 00 =444
31351 43 7E 01 09 45 9E 1E =490
31358 02 47 A0 0E 12 05 A1 =431
31365 00 0A 05 A1 C3 14 12 =409
31372 C3 10 0E C3 0E C5 =643
31379 0E 06 14 C3 43 7E 1A =293
31386 E0 00 15 05 03 14 C9 =690
31393 16 13 C5 1A 10 D8 03 =499

```

```

31400 0F C5 04 0B DC 0A 0B =456
31407 F4 1B 0B C3 1C 0C C6 =467
31414 1A 07 CD 0B 0E C5 05 =457
31421 05 C3 02 04 42 1D 10 =317
31428 43 04 0B 43 1E 07 1F =217
31435 13 43 9E 19 0E 43 9E =505
31442 1F 07 43 9E 0E 06 43 =347
31449 9E 09 0F 43 9E 1B 10 =447
31456 05 A1 05 08 05 A1 15 =366
31463 03 47 A0 00 01 05 A1 =401
31470 01 15 46 9E 0A 14 8B =467
31477 1D E0 00 15 CA 16 10 =514
31484 CB 1B 0C C3 01 0C CC =648
31491 05 0C D0 00 0E D0 01 =442
31498 04 C3 12 04 C3 16 04 =447
31505 43 1E 0C 47 0E 0D 43 =266
31512 02 0D 1F 09 0E A1 03 =224
31519 0D 05 A1 00 05 05 A1 =354
31526 00 01 03 A1 1F 01 47 =270
31533 A0 00 15 46 9E 1F 15 =461
31540 46 9E 11 15 43 9E 10 =507
31547 0C 43 9E 00 0E 43 9E =470
31554 0F 44 43 7C 12 05 04 =271
31561 43 13 05 0A 43 14 05 =379
31568 04 43 0A 05 04 A3 43 =416
31575 01 04 1C 12 0E A1 24 =253
31582 E0 00 1E CE 0C 11 04 =664
31589 0E 12 CD 13 11 CD 13 =496
31596 0D CD 01 0D CE 00 09 =446
31603 C3 14 09 C9 02 05 CC =645
31610 13 05 43 01 11 43 14 =194
31617 0D 43 00 09 43 1D 05 =190
31624 1F 15 46 9E 1F 12 05 =334
31631 A1 00 11 43 9E 0D 11 =433
31638 46 9E 13 0B 46 9E 1F =519
31645 11 43 9E 13 0B 43 9E =499
31652 0D 43 9E 19 0A 05 291
31659 A1 05 0A 04 A3 01 09 =353
31666 43 9E 1F 09 43 9E 0B =501
31673 25 43 9E 05 02 47 A0 =468
31680 11 01 04 A3 0C 15 46 =276
31687 7E 1F 02 05 A1 02 06 =365
31694 05 A1 0F 01 04 A3 10 =365
31701 01 04 A3 02 0E 05 A1 =350
31708 1D 0E 05 A1 21 E0 00 =466
31715 15 CE 00 11 C4 0E 12 =472
31722 CD 13 11 CD 13 0D CD =682
31729 01 0D CD 00 09 CC 14 =452
31736 09 09 02 05 CC 13 05 =445
31743 43 01 11 1F 15 46 9E =365

```

```

31750 1F 12 05 A1 00 11 43 =299
31757 9E 0D 11 44 9E 13 0B =444
31764 46 9E 1F 11 43 9E 13 =520
31771 0D 43 9E 0D 0D 43 9E =489
31778 19 0A 05 A1 05 0A 04 =220
31785 A3 01 09 43 9E 1F 09 =438
31792 43 9E 0B 05 43 9E 05 =471
31799 02 47 A0 11 01 01 A3 =418
31806 00 15 46 9E 1F 02 05 =287
31813 A1 02 06 05 A1 0F 01 =351
31820 04 A3 10 01 04 A3 02 =353
31827 0E 05 A1 1D CE 05 A1 =389
31834 0B 0F 9C 0D 12 CF 11 =437
31841 7A 00 13 00 2C 5B 14 =296
31848 01 1E 0A 00 5B 14 01 =153
31855 0D 04 0A 5B 14 01 14 =223
31862 14 01 F2 7A 00 00 99 =538
31869 7A 00 13 03 2C 5B 08 =290
31876 01 14 03 00 5B 00 01 =129
31883 13 02 4A 5B 1F 01 18 =242
31890 0D 03 F2 7A 00 00 F5 =625
31897 7A 00 13 00 2C 5B 08 =287
31904 01 14 02 00 5B 11 01 =132
31911 13 01 4A 5B 15 01 18 =231
31918 0D 05 5D 7C 01 00 4B =313
31925 7A 00 13 00 2C 5B 14 =296
31932 01 1C 00 00 5B 14 01 =154
31939 0E 06 4A 5B 14 01 12 =224
31946 0D 02 F2 7A 00 00 5B =472
31953 7B 02 13 04 2C 5B 0A =293
31960 01 19 03 00 5B 12 01 =139
31967 0F 05 4A 5B 13 01 0F =220
31974 11 06 5A 7C 01 00 99 =391
31981 7A 00 13 05 2C 5B 08 =292
31988 01 14 06 00 5B 00 01 =132
31995 13 06 4A 5B 1F 01 18 =246
32002 0D 03 F2 7A 00 00 5B =473
32009 7B 02 13 09 2C 5B 08 =299
32016 01 0E 05 00 5B 12 01 =128
32023 0F 07 4A 5B 13 01 0B =214
32030 0C 06 5A 7C 01 00 E0 =457
32037 7B 02 13 0B 2C 5B 08 =296
32044 01 0C 05 00 5B 12 01 =128
32051 09 07 4A 5B 13 01 0A =211
32058 09 06 5A 7C 01 00 F5 =475
32065 7A 16 0E 07 2C 5B 0F =315
32072 01 09 04 00 5B 10 01 =122
32079 09 03 4A 5B 15 01 0B =212
32086 0A 05 5D 7C 01 00 00 =233
32093 00 00 00 00 00 00 00 =0

```

```

0 PAPER 0:INK7:CLG:PRINT>Please wait..
..
1 FOR F=CA000 TO 42916
2 READ A:POKE F,A
3 NEXT F
5 DATA :62,0,214,100,208,26,181,108,20
1,32,208,12,169,21,149,108,3
7,47
6 DATA :60,149,100,24,144,8,169,32,149
,108,169,4,149,100,232,224,8,
208
7 DATA 221,96,0,0,0,0,0,0,0,0,173,4,
3,41,63,56,201,40,176,3,105,5
,96
8 DATA 233,35,96,0,0,0,0,0,0,0,0,0
9 DATA :69,130,133,130,169,187,133,131
,165,108,133,132,32,231,160,1
69
10 DATA 250,133,130,169,187,133,131,16
5,109,133,132,32,202,160,169,
114
11 DATA 133,130,169,188,133,131,165,11
0,133,132,32,231,160,169,234,
133,130
12 DATA 169,188,133,131,165,111,133,13
2,32,202,160,169,98,133,130,1
69,189
13 DATA 133,131,165,112,133,132,32,231
,160,169,218,133,130,169,189,
133
14 DATA 131,165,112,133,132,32,202,160
,169,82,133,130,169,190,133,1
31,165
15 DATA 114,133,132,32,231,160,169,202
,133,130,169,190,133,131,165,
115,133
16 DATA 132,76,202,160,0,0,0,0,0,0,0,0
,0,0,0,160,1,177,130,136,145,1
30,200
17 DATA 200,192,36,208,245,165,132,136
,145,130,96,0,0,0,0,0,0,0,0,0
,0
18 DATA 160,34,177,130,200,145,130,136
,136,192,255,208,245,165,132,
200,145
19 DATA 130,96,0,0,0,0,0,0,0,0,0,0,160
,1,177,130,201,122,208,10,170
,169,32
20 DATA 145,130,138,136,145,130,200,20
0,192,36,208,235,136,56,165,1
30,233
21 DATA 120,133,128,165,131,233,0,133,
129,177,128,201,122,208,6,145
,130,169
22 DATA 32,145,128,96,0,0,160,34,177,1
30,201,122,208,10,170,169,32,
145,130
23 DATA 138,200,145,130,136,136,192,25
5,208,235,200,56,165,150,233,
120,133
24 DATA 128,165,131,233,0,133,129,177,

```

```

128,201,122,208,6,45,130,169
,32,145
25 DATA 128,96,0,0,0,0,0,0,169,162,133
,130,169,190,133,131,32,56,16
1,169,42
26 DATA 133,130,169,190,133,131,32,4,1
61,169,178,133,130,169,189,13
3,131
27 DATA 32,56,161,169,58,133,130,169,1
89,133,131,32,4,161,169,194,1
33,130
28 DATA 169,188,133,131,32,56,161,169,
74,133,130,169,188,133,131,32
,4,161
29 DATA 169,210,133,130,169,187,133,13
1,32,56,161
31 DATA EE6,99,169,32,141,197,190,96,0
,0,0,0,0,0,0,0
32 DATA EAD,0,2,EC9,180,ED0,3,E4C,0,16
2,EC9,172,ED0,3,E4C,114,162,E
C9,156
40 DATA ED0,3,E4C,228,162,EC9,188,EF0,
228,E4C,187,163
50 DATA 000,000,000,000,000,000,000,00
0,000,000
51 DATA 000,000,000,000,000,000,000,00
0,000,000
60 DATA E:8,EA,124,E69,1,E85,126,EA5,
125,E69,0,E85,127,EA0,2,EB1,1
26,EC9,16
70 DATA ED0,13,E38,EA5,126,EE9,35,E85,
126,EA5,127,EE9,0,E85,127,EA9
,105
80 DATA EB5,116,EA9,106,E85,117,EA5,12
0,EC9,0,ED0,14,EA2,11,E86,1
8,EEB
90 DATA E06,117,EA2,1,E86,120,24C,128,
163,EC9,1,ED0,14,EA2,107,E86,
118,EEB
100 DATA E86,119,EA2,2,E86,120,E4C,128
,163,SHOO^A2,109,E86,118,EEB,
E86,119
110 DATA EA2,0,E86,120,E4C,128,163
120 DATA 000,000,000,000,000,000,000,0
00,000,000
121 DATA 000,000,000,000,000,000,000,0
00,000,000
130 DATA E38,EA5,124,EE9,1,E85,126,EA5
,125,EE9,0,E85,127,EA0,0,EB1,
126
140 DATA EC9,16,ED0,13,E:8,EA5,126,E69
,35,E85,126,EA5,127,E69,0,E85
,127
150 DATA EA9,97,EBE,116,EA9,98,E85,117
,EA5,120,EC9,0,ED0,14,EA2,103
160 DATA EB6,118,EEB,EB6,119,EA2,1,E86
,120,E4C,128,163,EC9,1,ED0,14
170 DATA EA2,99,E86,118,EEB,EB6,119,EA
2,2,E86,120,E4C,128,163,EA2,1
01

```

```

180 DATA EB6,118,EEB,EB6,119,EA2,0,E86
,120,E4C,128,163
190 DATA 000,000,000,000,000,000,000,0
00,000,000
191 DATA 000,000,000,000,000,000,000,0
00,000,000
200 DATA EA2,113,E86,116,EEB,EB6,117,E
EB,EB6,110,EEB,EB6,119,EA2,4,
164
201 DATA EA2,80,EA2,131,166
210 DATA E20,0,160,E20,72,160,E38,EA5,
124,EE9,40,E85,126,EA5,125,EE
9,0
220 DATA EB5,127,EA2,117,E86,116,EEB,E
86,117,EEB,EB6,118,EEB,EB6,11
9
230 DATA EA0,0,EB1,126,EC9,32,EF0,3,EA
C,88,164,ECB,EB1,126,EC9,32,E
F0,3
240 DATA E4C,88,164,E20,149,163,E38,EA
5,124,EE9,40,E85,126,EA5,125,
EE9,0
250 DATA EB5,127,EA0,0,EB1,126,EC9,155
,ED0,3,E4C,106,164,EC9,32,EF0
,3
260 DATA E4C,00,164,ECB,EB1,126,EC9,32
,EF0,3,E4C,88,164,E20,149,163
,E38
270 DATA EA5,124,EE9,40,E85,126,EA5,12
5,EE9,0,E85,127,EA9,1,E85,123
280 DATA EA2,100,E20
290 DATA 131,164,E4C,128,163,000,000,0
00,000,000
291 DATA 000,000,000,000,000,000
300 DATA EA0,40,EB1,126,EC9,122,ED0,3,
E20,150,166,ECB,EB1,126,EC9,1
22,ED0,3
310 DATA E20,150,166,E20,223,163,E20,3
7,164,EA5,126,E85,124,EA5,127
,E85,125
320 DATA E20,4,164,E60
330 DATA 000,000,000,000,000,000,000,0
00,000,000
331 DATA 000,000,000,000,000,000,000,0
00,000,000
340 DATA EA2,117,E86,116,EEB,EB6,117,E
EB,EB6,118,EEB,EB6,119,E4C,4,
164
350 DATA 000,000,000,000,000,000,000,0
00,000,000
351 DATA 000,000,000,000,000,000,000,0
00,000,000
360 DATA EA9,32,EA0,0,E91,124,ECB,E91,
124,EA0,40,E91,124,ECB,E91,12
4,E60
370 DATA 000,000,000,000,000,000,000,0
00,000,000
371 DATA 000,000,000,000,000,000,000,0
00,000,000
380 DATA EA5,116,EA0,0,E91,124,ECB,EA5

```

One small step for Ivan could be a major jump for an Oric. One step beyond with Matthias Gyllerup.

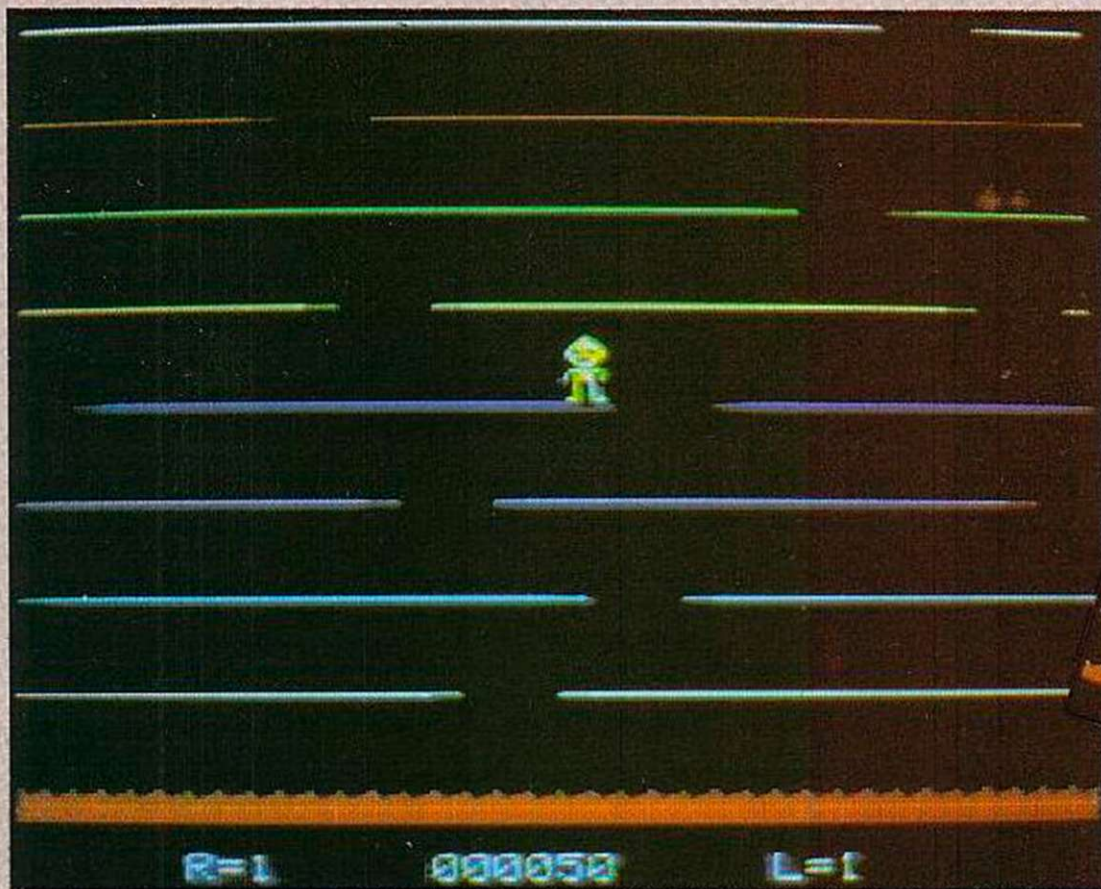

MAI

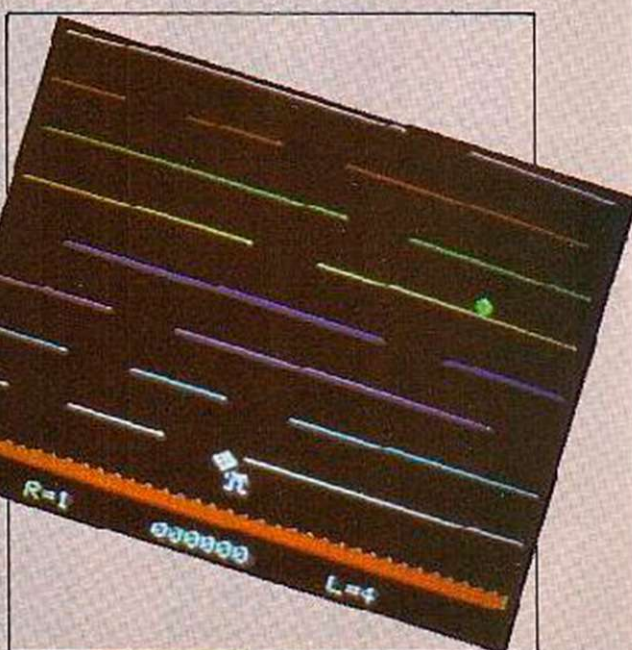

```

,117,£91,124,£A0,40,£A5,118,£
91,124
390 DATA %CB,£A5,119,£91,124,260
400 DATA 000,000,000,000,000,000,000,0
00,000,000
410 DATA £A9,1,£BD,225,2,£A9,0,£BD,227
,2,£A9,3,£BD,229,2,£A9,10,£BD
,231,2
420 DATA £20,182,251,£A9,0,£BD,225,2,£
BD,227,2,£BD,229,2,£BD,231,2
430 DATA £20,182,251,£60
440 DATA 000,000,000,000,000,000,000,0
00,000,000
450 DATA £20,149,163,£A9,0,£B5,116,£60
460 DATA 000,000,000,000,000,000,000,0
00,000,000
470 DATA £20,149,163,£A9,1,£B5,116,£60
480 DATA 000,000,000,000,000,000,000,0
00,000,000
490 DATA £A5,99,£C9,0,£D0,1,£60,£A5,98
,£F9,0,£F0,1,£60,£A5,121,£B5,
98,£C6,99
500 DATA £A9,122,£BD,210,187,£60
510 DATA 000,000,000,000,000,000,000,0
00,000,000
520 DATA £A0,40,£B1,124,£C9,122,£D0,3,
£20,150,166,£C8,£B1,124,£C9,1
22,£D0,3
525 DATA £20,150,166,£A0,80,£B1,124,£C
9,32
530 DATA £D0,31,£C8,£B1,124,£C9,32,£D0
,24,£20,237,164,£A0,80,£D1,12
4
540 DATA £C9,123,£D0,13,£A5,123,£C9,0,
£D0,3,£A0,88,164,£A9,0,£B5,12
3
550 DATA £A5,123,£C9,1,£D0,6,£20,42,16
5,£20,18,244,£A9,0,£B5,123,£6
0
570 DATA £20,187,163,£18,£A5,124,£69,4
0,£B5,126,£A5,125,£69,0,£B5,1
27
580 DATA £20,149,163,£18,£A5,124,£69,4
0,£B5,126,£A5,125,£69,0,£B5,1
27
590 DATA £20,149,163,£18,£A5,124,£69,4
0,£B5,126,£A5,125,£69,0,£B5,1
27
600 DATA £A5,0,£B5
610 DATA 123,£A2,100,£20,151,166,£A0,6
7,165,000
620 DATA £A0,5,£B5,159,191,£A4,£EB,£E0
,58,£F0,5,£EA,£F9,159,191,£60
,£A9,48
630 DATA £95,159,191,£B8,£D0,234,£60
00,000,000
640 DATA £20,150,166,£A0,128,163,000,0
00,000,000
650 DATA £A8,£A5,57,£C9,1,£D0,7,£A9,2,
£B5,97,£A0,154,165,£C9,2,£D0,
7,£A9,3
660 DATA £B5,97,£A0,187,165,£C9,3,£D0,

```

```

7,£F9,4,£E5,97,£A0,222,165,£D
9,4,£D0,7
670 DATA £A9,3,£B5,97,£A0,166,£C9,7,
£D0,7,£A9,6,£B5,97,£A0,222,16
5,£C9,6
680 DATA £D0,7,£A9,7,£B5,97,£A0,187,16
5,£A9,1,£B5,97,£A0,154,165
690 DATA 000,£A5,0,£BD,208,183,£BD,209
,183,£BD,210,183,£BD,213,183
700 DATA £BD,211,103,£BD,215,183,£A9,1
2,£BD,211,183,£BD,212,183,£68
710 DATA £A0,3,236,000,£A9,0,£BD,208,1
83,£BD,209,183,£BD,214,183,£B
D,215,183
720 DATA £A9,12,£BD,210,183,£BD,213,18
3,£A9,30,£BD,211,183,£BD,212,
183,£68
730 DATA £A0,3,236,000,£A9,0,£BD,208,1
83,£BD,215,183,£A9,12,£BD,209
,183
740 DATA £BD,214,183,£A9,30,£BD,210,18
3,£BD,213,183,£A9,63,£BD,211,
183
750 DATA £BD,212,183,£68
760 DATA £A0,3,236,000,£A9,12,£BD,208,
183,£BD,215,183,£A9,30,£BD,20
9,183
770 DATA £BD,214,103,£A9,63,£BD,210,18
3,£BD,211,183,£BD,212,183,£BD
,213,183
780 DATA £68,£A0,3,236
790 DATA £C6,0,£A5,0,£C9,255,£D0,5,£E6
,0
800 DATA £20,205,161,£A5,123,£C9,1,£D0
,10,£A2,50,£A0,255,£A9,£D0,25
3,£C9,£D0
801 DATA 248
802 DATA £20,0,160,£20,72,160,£A5,116,£
C9,0,£D0,1,£60,£C9,1,£D0,1
810 DATA £50,£20,112,161,£20,124,164,£
A5,99,£C9,0,£F0,2,£D6,98,£20,
160,164
820 DATA £A5,116,£C9,0,£D0,1,£60,£A2,8
0,£A0,255,£B8,£D0,253,£A0,£D0
,248
830 DATA £A0,37,144
840 DATA 000,000,000,000,000,000,000,0
00,000,000
850 DATA £A0,255,£B8,£D0,253,£A0,£D0,2
48,£60
860 DATA 000,000,000,000,000,000,000,0
00,000,000
870 DATA £A9,10,£B5,0,£20,187,163,£FA,
99,£A2,32,£B6,116,£B6,117,£A2
,124
880 DATA £B6,118,£E3,£B6,119,£A0,4,164
890 DATA £A0,0,£B9,189,166,£99,3,183,£
C8,£C0,232,£D0,245,£60
900 DATA 1,3,6,15,31,6,3,1,43,56,60,62
,38,12,24,48,3,5,9,3,2,6,4,23
,56,52,52

```

```

910 DATA 24,12,6,2,14,3,5,7,1,1,1,1,7,
56,52,52,48,48,48,48,15,3,
7,4,4,28
920 DATA 0,0,56,52,50,16,24,12,4,28,3,
7,5,31,25,12,6,3,32,48,24,60
,62,24,48
930 DATA 32,7,11,11,6,12,24,16,23,48,4
0,36,48,16,24,8,14,7,11,11,3,
3,3,3,3
940 DATA 48,40,36,32,32,32,32,36,7,11,
19,2,6,12,8,14,60,48,56,8,8,1
4,0,0,0,0
950 DATA 3,7,13,15,6,19,0,32,48,56,44,
60,24,50,9,7,3,9,13,15,9,56,3
6,56,48
960 DATA 36,44,60,36,7,1,3,7,13,15,5,3
,1,32,40,56,44,60,24,48,32,7,
11,11,2
970 DATA 2,2,2,14,56,52,52,16,16,16,16
,28,63,0,0,0,0,0,0,0,51,30,45
,63,45,33
971 DATA 63,30
980 DATA 33,55,63,63,63,63,63,63
990 DATA 0,0,0,1,33,63,63,63,0,0,12,30
,59,59,62,28
1900 R=1:L=5:SC=0:SC#="000000":POKE 12
1,252:POKE 98,0:POKE99,
1910 CALL 42671
1920 POKE £26A,10
2000 CLS:POKE 0,0:POKE48038,32:POKE 48
039,32
2001 A#="77711122233344455566677717777
777"
2002 C=1
2003 FOR F=08 TO 115:POKE F,121:NEXT F
2299 FOR F=48000 TO 49080 STEP 40:A=VAL (MID
$(A#,C,1)):POKE F,A:POKE F+1,16
2499 POKE F+39,16:C=C+1:NEXT F
2500 DOKE 124,48900
2510 DOKE 126,48900
2511 PLOT 15,25,SC#:PLOT 15,15,32
2519 FOR F=00 TO 107:POKE F,RND(1)*20
+5:NEXT F
2520 FOR F=08 TO 115:POKE F,121:NEXT
F
2521 PLOT 1,23,"((((((((((((((((((((
((((((((((((((((((((
2522 FOR F=47963 TO 47999:POKE F,155:N
EXT F
2523 FOR F=48002 TO 48037:POKE F,121:N
EXT F
2524 CALL 4:951:DOKE 124,48900:DOKE 12
6,48900
2525 FOR F=2 TO 20 STEP 3:PLOT 1,F,"VV
YYYYYYYYYYYYYYYYYYYYYYYYYYYYYYYY
YYYYY"
2526 NEXT F:PLOT 27,25," "
2527 PLOT 8,25,STR$(R):PLOT 7,25,"R="
2528 PLOT 27,25,STR$(L):PLOT 26,25,"L="
2529 IF AA=0 THEN DOKE 553,42317
2530 POKE 0,0:CALL 42533:DOKE 553,6041
9
2531 IF PEEK(116)=0 THEN L=L-1:IF L=-1
THEN GOTO 2700
2533 IF PEEK(116)=1 THEN R=R+1:FOR F=1
TO 10*R:CALL 42282:NEXT F:L=L
+1
2534 IF PEEK(116)=1 THEN POKE 99,R:OB=25
2/R:POKE 98,0:POKE 121,OB:GOTO
2600
2550 WAIT 100:GOTO 2520
2600 SC#=""
2605 FOR F=49056 TO 49061:SC#=#SC#+CHR#
(PEEK(F)):NEXT F
2610 AA=INT(RND(1)*6)
2615 ON AAGOTO 26:7,2619,2621,2623,262
5
2616 GOTO 2600
2617 POKE 47056,51:POKE 47057,30:POKE
47058,45:POKE 47059,63:POKE 4
7060,45
2618 POKE 47061,33:POKE 47062,63:POKE
47063,30:GOTO 2000
2619 POKE 47056,0:POKE 47057,0:POKE 47
058,63:POKE 47059,45:POKE 470
60,63
2620 POKE 47061,12:POKE 47062,12:POKE
47063,51:GOTO 2000
2621 POKE 47056,63:POKE 47057,45:POKE
47058,63:POKE 47059,12:POKE 4
7060,12
2622 POKE 47061,12:POKE 47062,12:POKE
47063,51:GOTO 2000
2623 POKE 47056,12:POKE 47057,30:POKE
47058,63:POKE 47059,45:POKE 4
7060,63
2624 POKE 47061,63:POKE 47062,51:POKE
47063,30:GOTO 2000
2625 POKE 47056,12:POKE 47057,30:POKE
47058,63:POKE 47059,45:POKE 4
7060,63
2626 POKE 47061,51:POKE 47062,30:POKE
47063,51:GOTO 2000
2700 PLOT 14,10,"GAME OVER"
2710 PLOT 12,11,"PRESS ANY KEY"
2720 GET A#:WAIT 300:GET A#:GOTO 1900

```

D JUMP

IVAN IS A character with long legs and a big head and the object of this game is simply to make him jump up eight platforms to the top of the screen. The screen is divided by horizontal lines and gaps appear in these lines at intervals. When a gap appears directly above Ivan, he is able to leap into the air and ascend a level.

If you fall down through a gap or run into a monster you will become temporarily stunned. But if you knock your head into something or fall down on the ground you will lose one of your six lives.

There are six different hazards — a flame, some monsters and Leggy — which roam the platform. Each completed screen adds a bonus, increases number of lives and adds new hazards.

Ivan is controlled from the keyboard with

the Cursor keys.
 Cursor Left to make him move left;
 Cursor Down to make him move right;
 Cursor Up to make him jump;
 Cursor Right to pause — you can not pause when you are stunned.

For those interested in machine code the main subroutines and their addresses are given below, in case you wish to disassemble them.

- 41032 — Move holes.
- 41328 — Move hazards.
- 41421 — Read keyboard and move Ivan.
- 42021 — Sound.
- 42221 — Fall down.
- 42282 — Score.
- 42533 — Main routine.
- 42648 — Draw stunned Ivan.
- 42317 — Interrupt routine that makes the flames burn.

BARREL BARRAGE

Miquel van Smoorenburg ushers in a scenario of simian mayhem, specially tailored for the Sinclair ZX-81.

THE AIM OF the game is to get the keys which are displayed on the top of the screen without losing a life. You lose a life if you get hit by a rolling barrel but you are able to jump over such obstacles and only three at most are present.

At the beginning of the game there is only one rolling barrel present. If you reach the top of the screen you can get a key. There are three keys at the start of the game. When there are two keys left there will be two rolling barrels and if only one key is left there are three rolling barrels. However, if you manage to get your hands on the last key you will get a bonus of 100 points. Then you start again, with three keys and one barrel, but with one difference — the speed increases. Scoring is as follows: you still start with five lives but this

and the starting speed are adjustable — it is even possible to start off with 38 lives. The game has on-screen scoring and a high-score.

Jump over a barrel: 10 points
Grab a key: 50 points
Get the last key: 100 points

The code is kept as short as possible; that is why I made the high-score in Basic. For entering the code, you need a Rem statement with at least 640 characters. This may look a lot but it isn't if you follow the instructions.

Type in:
2 REM 0000 etc.
You must enter 87 characters after the Rem. Now edit this line some times, and when you have seven of these lines — 2 Rem to 8 Rem — you can enter 1 Rem with nothing following it (continued on page 94)

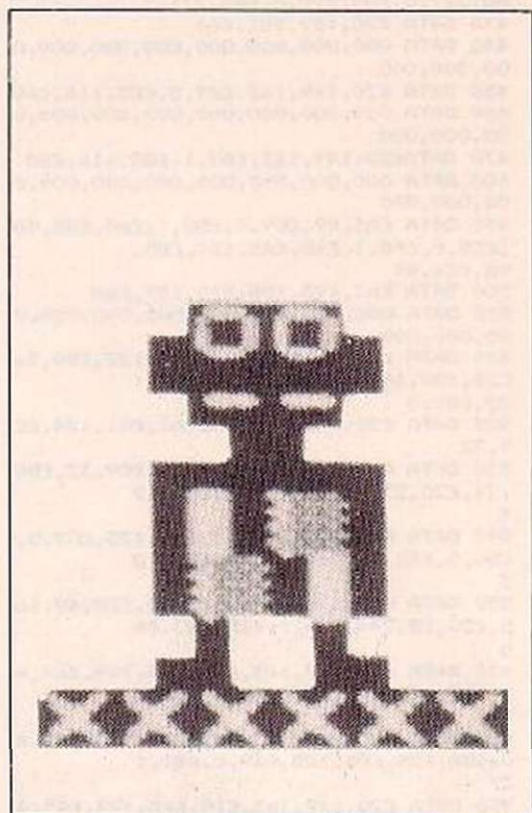

Program 2. Machine code program.

| | | | | | |
|--------|-------------------|--------|--------|-------------------|--------|
| 16514: | 7678030041E50505 | = 1355 | 16934: | 7E32774035172275 | = 587 |
| 16522: | 0DB302444D511420 | = 572 | 16942: | 40003A7840FE0020 | = 793 |
| 16530: | 043E001804008007 | = 523 | 16950: | 043E00327840E052 | = 772 |
| 16538: | 7E01D1E109292042 | = 1072 | 16958: | 133B201040010500 | = 292 |
| 16545: | 0100000922794001 | = 387 | 16965: | 09E05B0040011903 | = 442 |
| 16554: | 580000027B402130 | = 413 | 16974: | EDB0C09F40C02341 | = 1149 |
| 16562: | 400001E36000210F8 | = 455 | 16982: | 3E00322140CDB340 | = 554 |
| 16570: | 0A21403047213042 | = 443 | 16990: | 003241FE342879FE | = 1042 |
| 16578: | 1800901054600500 | = 593 | 16998: | 182375FE000808ED | = 893 |
| 16585: | 013240E042157E01 | = 699 | 17005: | 4B324008788120F8 | = 780 |
| 16594: | 030018300110E609 | = 770 | 17014: | 18E33528E500B942 | = 1034 |
| 16602: | 7E4FE237E473E0002 | = 501 | 17022: | E161F70F0B788120 | = 954 |
| 16610: | 080000FE78000103 | = 454 | 17030: | FB35801936A03500 | = 747 |
| 16618: | 55007840E0423005 | = 815 | 17038: | 3277402A78402275 | = 813 |
| 16625: | E13E0012130E1121 | = 601 | 17045: | 4000B4420505050D | = 934 |
| 16634: | 006005197E7E3023 | = 635 | 17054: | 00420110F93A2140 | = 384 |
| 16642: | 067E16200244403E | = 631 | 17062: | 30322140FE0320FD | = 559 |
| 16650: | 0400E17163701804 | = 759 | 17070: | 060500004210F62A | = 891 |
| 16658: | ED5FE60FE0002080 | = 1051 | 17078: | 00400135000536A8 | = 384 |
| 16665: | 3E0112E043794071 | = 691 | 17085: | 232336A8E032336A8 | = 563 |
| 16674: | 237018B009784022 | = 610 | 17094: | 3E003621402A3240 | = 365 |
| 16682: | 7548210600027740 | = 431 | 17102: | 01E006E042038001 | = 665 |
| 16690: | 1101000A75400007 | = 613 | 17110: | 58020022324003F7 | = 689 |
| 16698: | 49FE100A0041FE24 | = 1107 | 17118: | 41E0067540360000 | = 776 |
| 16705: | 0000237E7E762010 | = 635 | 17125: | BA4200B842E17E75 | = 1005 |
| 16714: | 031819FE21200023 | = 456 | 17134: | 069736177E068977 | = 661 |
| 16722: | 7E7E760010251600 | = 626 | 17142: | 110020187A6320F8 | = 556 |
| 16730: | FE032009397740FE | = 825 | 17150: | 10F2F1772A004001 | = 737 |
| 16738: | 002002E052E519E5 | = 831 | 17158: | 2900007E3D77FE10 | = 539 |
| 16745: | 7E7E34000042E17E | = 1058 | 17165: | 2005E0460040092A | = 668 |
| 16754: | E1112100FE002800 | = 770 | 17174: | 784022754003F741 | = 989 |
| 16762: | FE0000000397840FE | = 646 | 17182: | 2A00400516237E7E | = 563 |
| 16770: | 002000193E003278 | = 295 | 17190: | 76200310F8090680 | = 944 |
| 16778: | 403A7840FE012001 | = 594 | 17198: | 7718F22A00400011 | = 520 |
| 16785: | 19FE002804303278 | = 554 | 17105: | 0A0019237E7E10D8 | = 604 |
| 16794: | 407E7E002810F620 | = 799 | 17114: | FE260034FE252005 | = 689 |
| 16802: | 0800FE0408FE1608 | = 1034 | 17122: | 36102818E7090000 | = 589 |
| 16810: | FEA8082A7540E52A | = 1119 | 17130: | 002A104001050009 | = 138 |
| 16818: | 75407E7E1FE3408E5 | = 1267 | 17138: | EB2A0040011903ED | = 619 |
| 16825: | 2A75403A774077E1 | = 608 | 17145: | 0009 = 377 | |

TOP
S
wi
ap
lea
pa
bo

T
D
N
S
E
P
E
P
P
B

SCORE: 000040
LIVES: 1

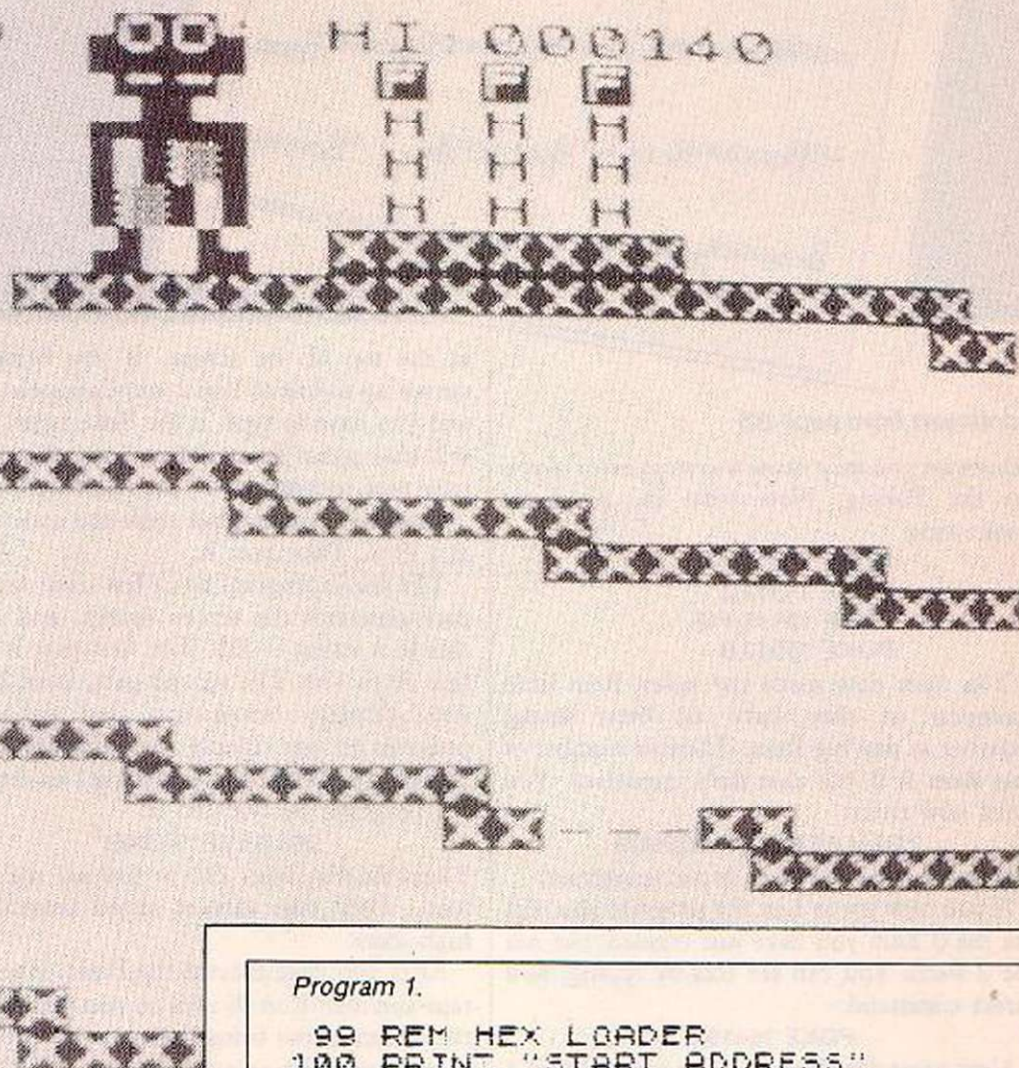

Program 1.

```

99 REM HEX LOADER
100 PRINT "START ADDRESS"
110 INPUT S
120 PRINT "FINISH ADDRESS"
130 INPUT F
140 FOR N=S TO F STEP 8
150 LET T=0
160 PRINT N;" - ";
170 INPUT A$
180 PRINT A$;" = ";
190 INPUT TOT
200 PRINT TOT
210 LET Z=0
220 FOR K=1 TO LEN A$ STEP 2
230 LET C=(CODE A$(K)-28)*16+00
DE A$(K+1)-28
240 LET T=T+C
250 POKE N+Z,C
260 LET Z=Z+1
270 NEXT K
280 IF TOT=1 THEN GO TO 310
290 PRINT "ERROR - PLEASE INPUT
AGAIN"
300 GO TO 150
310 NEXT N

```

Program 3. The Basic program.

```

6 REM -----
6 REM MIQUEL VAN SMOORENBURG
7 REM 20 BALJUWSTRAAT
8 REM TER-ARR P.CODE 24615L
9 REM HOLLAND.
202 PRINT "-----CRAZY AB
-----"
212 PRINT " SEND YOUR MAN UP
TO GET THE " KEYS AND JUMP OVER
THE ROLLING
222 PRINT " BARRELS. AFTER YOU
HAVE COLLEC- TED 3 KEYS, YOU STAR
T WITH 3 KEYS AGAIN. HOWEVER,
THE SPEED"
232 PRINT " HAS INCREASED...."
242 PRINT " CONTROL YOUR MAN
WITH:"
252 PRINT " A. MOVE RIGHT", "
B. MOVE LEFT", " C. JUMP", "TO
CLIMB THE LADDER, PRESS D", "AND T
HEN HOLD DOWN 7."
262 PRINT " AT THE BEGINNING
OF EACH GAME " YOU MUST SELECT
SPEED: 0-15. " 0 IS VERY FAST, A
ND 15 IS VERY " SLOW."
265 SAVE "KON"
272 PRINT AT 21 0: " PLEASE
SELECT SPEED:"

```

```

282 POKE 16418,2
292 INPUT SPEED
298 IF SPEED>15 OR SPEED<0 THEN
GOTO 290
302 RAND 1000+100*SPEED
312 LET L=6+USR 16516
322 LET S#=""
332 FOR X=1 TO 6
342 LET S#(X)=CHR# PEEK (L+X)
352 NEXT X
362 IF VAL S#>VAL D#(23 TO 26)
THEN LET D#(23 TO 26)=S#
365 PRINT AT 13,6:"**** GAME "
" OVER ****"
370 IF INKEY#="" THEN GOTO 370
380 IF INKEY#="" THEN GOTO 380
390 GOTO 270
400 REM -----

```

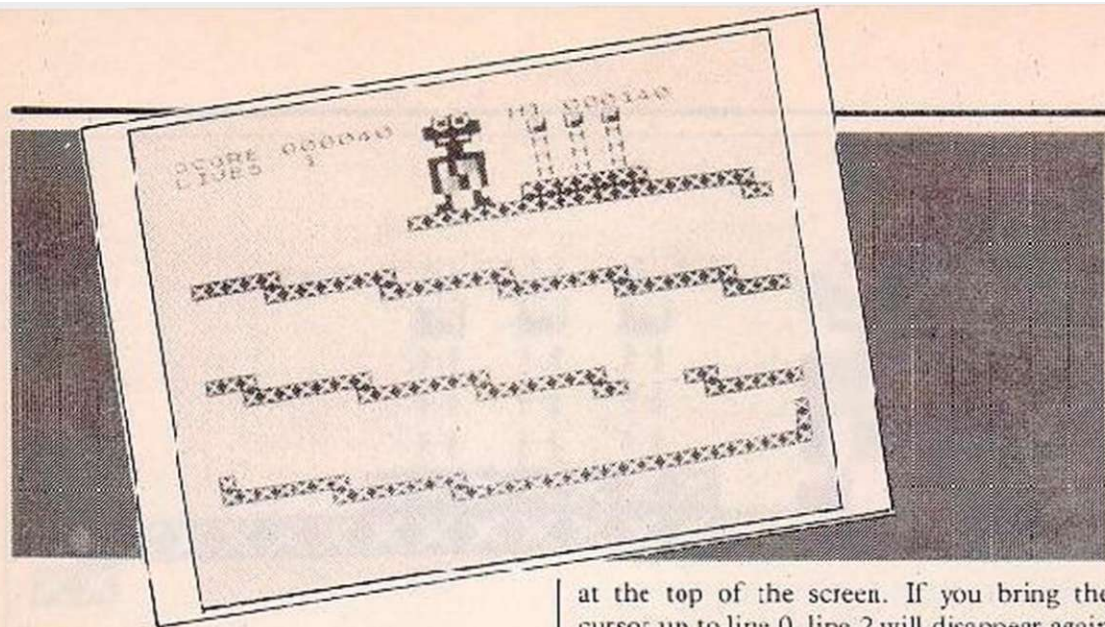

(continued from page 92)

otherwise you may cause a system error if you do the Poking. Now type in, as direct commands:

```
POKE 16511,141
POKE 16512,2
POKE 16515,118
POKE 16510,0
```

You have now made the sever. Rem lines disappear as they have all been strung together as one big Rem. The line number of this Rem is 0, but that isn't important. You must now enter:

```
2 REM START PROGRAM
```

What follows the Rem is not important.

If you now try to List the program you will see the 0 Rem you have just created, but not the 2 Rem. You can see this by typing, as a direct command:

```
POKE 16419,2
```

Now press Newline and you will see line 2

at the top of the screen. If you bring the cursor up to line 0, line 2 will disappear again and you have to type in the Poke again. This will also occur if you delete line 2. You must now type in program 1, the hex loader.

Run the program and enter the code a line at a time. Then save it.

The Basic program has a few uses: the first part generates the screen layout, and stores this in a string — DS. The first part is from line 10 to 170. The second part, lines 200 to 265, displays instructions and saves the program on tape. Ignore the Rem before Save in line 265 — this was something I used to test the program. So line 265 is:

```
265 SAVE "KONG"
```

Then, finally, lines 270 to 390 are the main loop. They take care of speed control and high-score.

After you have entered the Basic, save it on tape and then Run. If all is correct you will see the screen layout being built and the program should stop with an error message: 9/170. If it

doesn't, check the Basic. If there are mistakes there is a fault in the machine-code starting from address 17130. This is a routine to store the screen layout in the Basic variable DS, so by

```
PRINT DS
```

you should see the screen layout with many \$'s around the screen. If all this works delete lines 10 to 170. Be sure not to use Run or Clear, as this will destroy the variables. Now set your recorder to record-mode and type in as a direct command:

```
GOTO 200
```

If everything is alright you will see instructions being printed and the program saves itself. Now you will be asked to select speed. You must enter a number between 1 and 15, anything else will be ignored. Choose one and the game will start. If you have followed all my instructions then the game should work properly now.

The speed of the game is controlled by Rand (value). In my listing, it works as follows:

```
290 INPUT SPEED
300 RAND 1000 + 130 * SPEED.
```

So the Rand has a minimum of 1000 and a maximum of 2950.

Score, high-score and lives start off with a value given in the Basic listing in line 60. Score and high-score must be a number with a minimum zero, lives can be any characters between 0 and Z. Thus, it is possible to enter:

```
80 PRINT AT 0,0;"SCORE:095870";
HI:987320";"LIVES: G"
```

In this example lives will count down from G to 0. This is in alphabetical order. ■

HISOFT

ULTRAKIT £9.45

The most powerful toolkit yet for ZX BASIC. All the features you will ever need; AUTO insert, full RENUMBER, block DELETE, CLOCK, ALARM, error trapping, break trapping. Full TRACE with single-step and much, much more. Makes ZX BASIC easy-to-use and powerful.

DEVPAK £14

An excellent assembler, an advanced line-editor, a comprehensive disassembler and a superb 'front panel' debugger all in one package. Used by many leading software houses to write their games. "Buy it!" Adam Denning 1984.

PASCAL £25

A powerful and almost full implementation of Pascal - not a Tiny Pascal. A valuable educational and development tool, programs typically run 40 times faster than a BASIC equivalent. Spectrum version includes Turtle Graphics package. "I haven't seen any other compiler that could match Hisoft's Pascal"



HISOFT

180 High Street North
Dunstable, Beds. LU6 1AT
Tel: (0582) 696421



HISOFT



for the ZX Spectrum

Hisoft is pleased to announce a new compiler for this popular and effective systems programming language. Not a tiny-C but an extensive, easy-to-use implementation of the language. Allows direct execution of compiled statements. Supplied with junction library. Available direct from Hisoft for £25, or write for further details.

All prices, UK delivered, relate to 48K ZX Spectrum versions. Our software is available for many other Z80 machines e.g. Amstrad CPC 464, MSX, Memotech, SHARP MZ700, New-Brain, CP/M etc. Please write for details.

Just Arrived!

TWO OF YOUR ALL-TIME CINEMA & T.V. FAVOURITES

THE LEGENDARY

BRUCE LEE

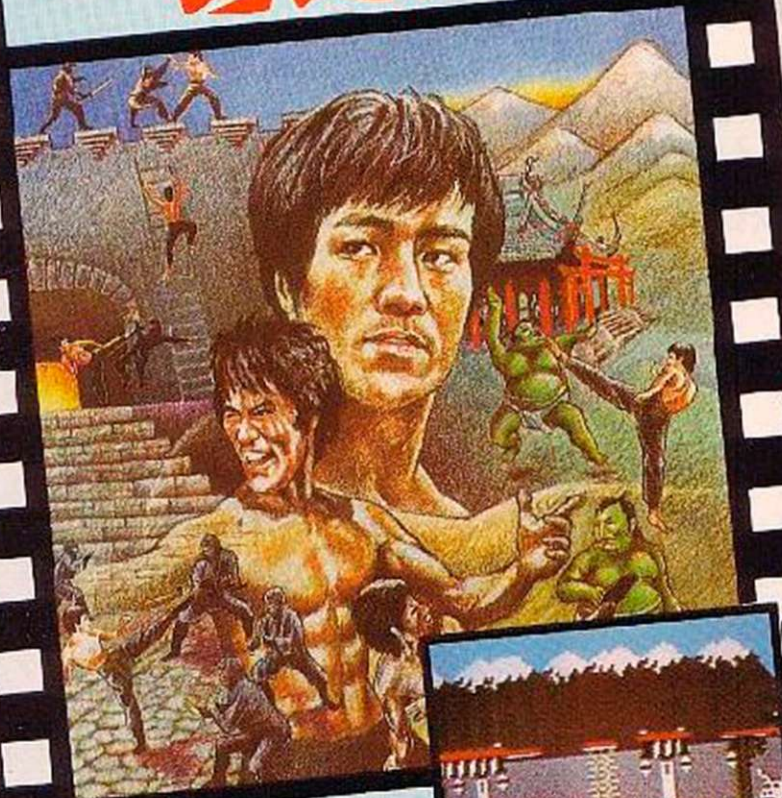

Your chance to relive the deadly skills and awesome power of the legendary Bruce Lee.

- Twenty secret chambers.
- Dazzling graphics and animation.
- Unique multiple player options.



Disk and Cassette

£14⁹⁵



Danger, Intrigue, Suspense! You'll need all your wits and skill when you take on the ruthless J.R. and face the many hidden enemies in the search for oil that is...

The DALLAS Quest

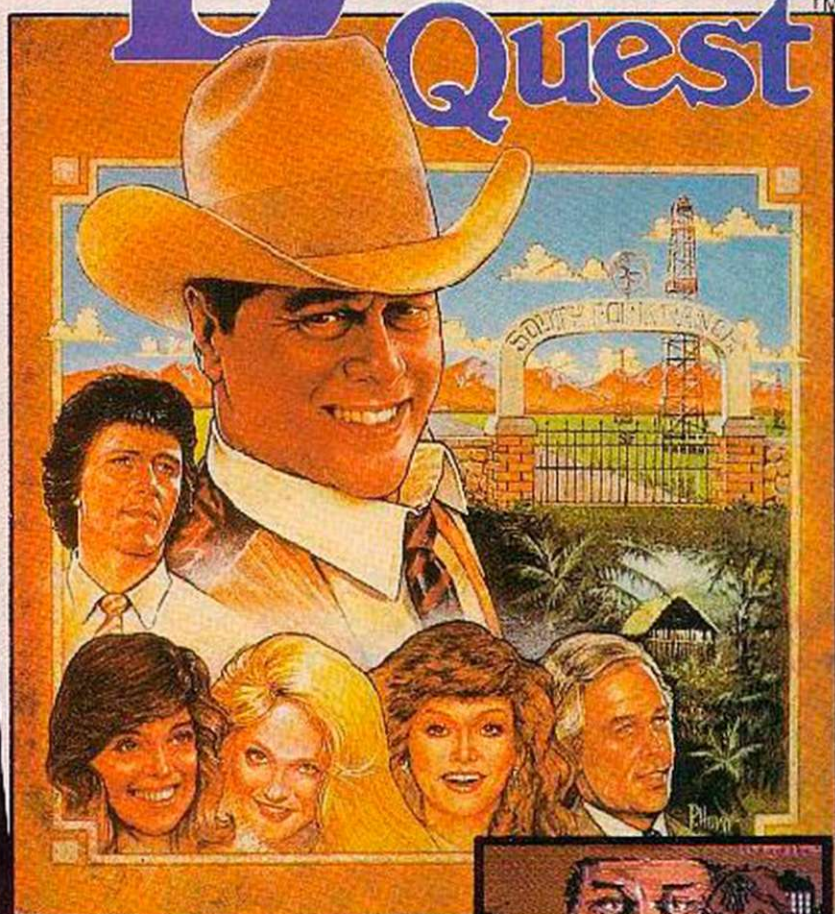

- A unique graphic adventure.
- Choose your level of difficulty.
- Scores of colourful scenes.



Disk only £14⁹⁵

Two more quality products from **Datasoft** Datasoft Software.

THE ULTIMATE IN AMERICAN SOFTWARE FOR YOU ON U.S. GOLD
U.S. Gold is stocked by all leading computer stores.

DEALERS! For information on how to become a U.S. Gold Stockist write to: CentreSoft Ltd., Unit 24, Tipton Trading Estate, Bloomfield Road, Tipton, West Midlands DY4 9AH. Telephone: 021-520 7591. Overseas enquiries welcome.

U.S. GOLD

All American Software

Program 1.

```
1 DATA 162,233,160,31,134,0,132,1,162,233,160,151
2 DATA 134,2,132,3,160,0,177,0,201,3,208,3
3 DATA 32,44,25,201,2,208,3,32,67,25,201,4
4 DATA 208,3,32,90,25,76,107,25,160,0,169,32
5 DATA 145,0,160,21,177,0,201,1,240,76,169,3
6 DATA 145,0,169,5,145,2,96,160,0,169,32,145
7 DATA 0,160,23,177,0,201,1,240,53,169,2,145
8 DATA 0,169,3,145,2,96,160,0,169,32,145,0
9 DATA 160,22,169,4,145,0,169,7,145,2,96,56
10 DATA 165,0,198,2,233,1,144,5,133,0,76,16
11 DATA 25,198,3,198,1,133,0,165,1,201,29,208
12 DATA 139,96,169,38,145,0,169,240,141,13,144,141
13 DATA 163,2,96,0,0,0,0,0,0,0,0
14 DATA 0,0,0,0,173,163,2,240,43,234,169,0
15 DATA 141,163,2,169,48,162,4,221,148,30,208,5
16 DATA 202,224,255,208,241,162,3,254,6,30,169,58
17 DATA 221,6,30,208,10,169,48,157,6,30,202,224
18 DATA 255,208,236,234,162,23,189,227,31,201,4,240
19 DATA 4,202,208,246,96,174,61,3,169,4,157,43
20 DATA 30,96,0,32,0,25,32,160,25,32,80,26
21 DATA 32,128,26,96,0,0,0,0,0,0,0
50 DATA 169,76,141,119,2,169,79,141,120,2,169,65
51 DATA 141,121,2,169,68,141,122,2,169,13,141,123
52 DATA 2,169,82,141,124,2,169,213,141,125,2,169
53 DATA 13,141,126,2,169,9,133,198,96,0,0,0
100 FORA=6400TO6651:READN:POKEA,N:T=T+N:NEXT
110 IFTC>23157THENPRINT"DATA ERROR":END
120 T=0:FORA=673TO720:READN:POKEA,N:T=T+N:NEXT
130 IFTC>4690THENPRINT"DATA ERROR":END
140 POKE35879,8:PRINT"OK":SYS673
```

Program 2.

```
1 DATA162,22,160,30,134,0,132,1,160,22,177,0
2 DATA 201,1,208,3,32,44,26,32,29,26,165,1
3 DATA201,32,208,236,96,24,165,0,105,1,175,3
4 DATA133,0,96,230,1,133,0,96,160,22,169,32
5 DATA145,0,160,0,177,0,201,32,240,3,76,165
6 DATA26,169,1,145,0,96,169,38,145,0,169,240
7 DATA141,13,144,141,163,2,96,0,32,0,26,162
8 DATA22,169,7,157,227,151,157,227,31,202,208,245
9 DATA162,23,169,32,157,20,30,202,208,248,173,12
10 DATA144,240,3,206,12,144,173,13,144,240,3,206
11 DATA13,144,76,128,25,0,0,0,162,211,189,44
12 DATA30,201,33,176,16,202,208,246,162,255,189,253
13 DATA30,201,33,176,10,202,208,246,96,222,44,30
14 DATA76,137,26,222,255,30,76,149,26,201,2,240
15 DATA9,201,3,240,5,201,4,208,142,96,169,255
16 DATA141,163,2,76,66,26,0,0,0,0,0,0
17 DATA173,43,28,41,1,208,4,24,76,204,26,56
18 DATA110,43,28,110,44,28,110,51,28,110,52,28
19 DATA96,0,0,0
100 FORA=6655TO6873:READN:POKEA,N:T=T+N:NEXT
110 IFTC>21803THENPRINT"DATA ERROR":END
120 SYS673
```

Program 3

```
1 DATA169,0,141,19,145,169,127,141,34,145,169,5
2 DATA141,60,3,120,169,28,141,20,3,169,27,141
3 DATA21,3,88,96,206,60,3,240,3,76,192,27
4 DATA120,172,61,3,169,32,153,205,31,169,5,141
5 DATA60,3,169,16,44,17,145,208,3,32,130,27
6 DATA169,129,44,32,145,208,3,32,118,27,169,32
7 DATA44,17,145,208,3,32,152,27,172,61,3,185
8 DATA205,31,201,32,208,12,159,0,172,61,3,153
9 DATA205,31,88,76,176,27,169,255,141,161,2,169
10 DATA0,172,61,3,153,205,31,76,192,27,173,61
11 DATA3,200,192,23,240,14,140,61,3,96,173,61
```

(continued on opposite page)

Is it a seagull? Is it a plane? No, it's the first of the robots in David Hodgett's Vic-20 game.

ROBOT ATTACK IS A game for the unexpanded Vic-20 and a joystick. It uses a fair amount of machine code to give it extra speed, and features a rapid fire, and a laser base with variable speed which can be set by the user.

The game comes in five parts, the first three of which are for the machine code, the fourth is for the graphics and the fifth part is the game itself.

The first four parts are all data and each program has its own check sum as, if you make a mistake in the machine code, it could cause the computer to crash. If there is a mistake you will get a Data Error. If this happens then re-check the data. After the five parts have been entered and checked you may

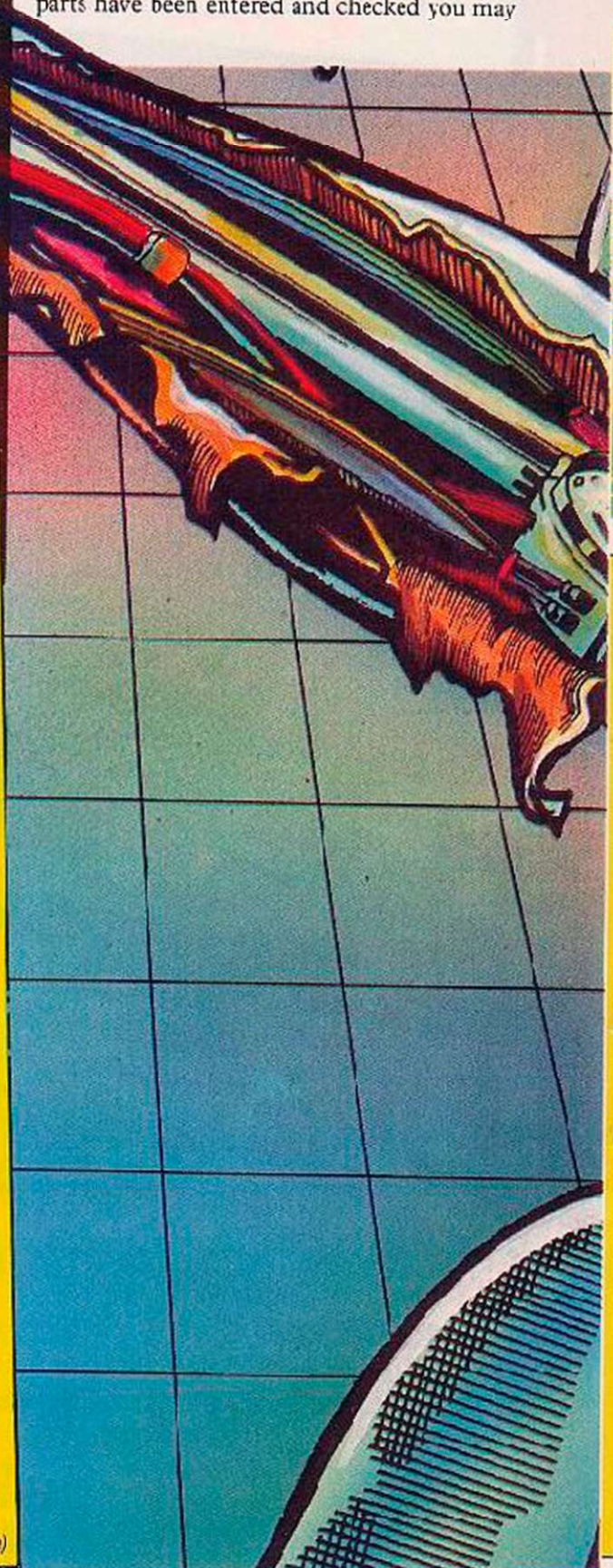

load and play the game. To do this hold down the Shift key and tap the Run/Stop key and, providing there are no data errors, all the programs will load automatically.

At the start of the game you will be confronted with an options page: F1 determines the speed of the laser base; F3 gives the fire rate and fire to start the game.

There are two kinds of alien — the robots which travel down the screen diagonally and the pods which are indestructible and fall from directly above you. When a pod reaches the bottom of the screen it warps back to the top and again falls from directly above you. The longer you last the more pods will be added. Each robot scores 10 points.

The time before another pod is added can be changed while on the options page by using F5. The lower the number the faster.

ROBOT ATTACK

(continued from opposite page)

```

12 DATA3,136,240,10,140,61,3,96,169,1,141,61
13 DATA3,96,169,22,141,61,3,96,206,63,3,208
14 DATA18,169,6,141,63,3,172,61,3,169,1,150
15 DATA183,31,169,240,141,12,144,96,172,61,3,169
16 DATA3,153,205,151,76,192,27,0,0,0,0
17 DATA172,61,3,185,205,31,201,0,208,156,76,191
18 DATA234,0,0,0,120,162,191,160,234,142,20,3
19 DATA140,21,3,88,96,0,0
100 FORA=6912TO7134:READN:POKER,N:T=T+N:NEXT
110 IFT<>21101THENPRINT"DATA ERROR"END
120 SYS673

```

Program 4.

```

1 DATA 24,24,24,36,36,189,231,189,24,24,24,24
2 DATA 24,24,24,24,153,219,36,60,36,60,66,195
3 DATA 153,219,36,60,36,60,66,195,24,60,60,126
4 DATA 126,60,60,24,1,14,63,51,51,63,14,1
5 DATA 128,112,252,51,51,252,112,128,0,255,255,255
6 DATA 0,0,0,0,0,0,0,0,0,0,0,0
7 REM
8 DATA 0,0,0,0,0,0,0,0,0,66,36,0
9 DATA 0,36,66,0,0,0,0,0,24,24,24,24
10 DATA 0,0,0,24,36,231,36,66,0,0,0,255
11 DATA 24,36,36,66,0,129,102,24,255,36,36,66
12 DATA 36,36,24,255,24,36,36,66,0,0,0,0
13 REM
14 DATA 56,108,206,214,214,230,108,56,24,56,120,24
15 DATA 24,24,126,126,56,108,68,12,24,48,126,125
16 DATA 124,126,6,62,62,6,126,124,28,68,108,204
17 DATA 255,255,12,12,254,254,128,252,254,2,254,252
18 DATA 6,12,24,56,124,198,198,124,252,254,14,28
19 DATA 56,112,224,192,124,254,130,254,254,130,254,124
20 DATA 124,198,198,126,28,56,112,224,0,0,0,0
90 FORA=0TO500:POKE7:68+A,PEEK(32768+A):NEXT
100 FORA=7168TO7240:READN:POKER,N:T=T+N:NEXT
110 IFT<>5244THENPRINT"DATA ERROR"END
120 T=0:FCRA=7425TO7480:READN:POKER,N:T=T+N:NEXT
130 IFT<>2271THENPRINT"DATA ERROR"END
140 T=0:FCRA=7549TO7634:READN:POKER,N:T=T+N:NEXT
150 IFT<>5968THENPRINT"DATA ERROR"END
200 SYS673

```

Program 5.

```

0 POKE56,24:POKE52,24
1 LB=2:FR=2:FR=4
10 POKE36869,255:GOSUB500:POKE36879,0
11 POKE6959,LB+3:POKE7070,FR+4
20 POKE829,11:POKE831,1:T1$="000000"
30 PRINT"GAME SCORE:#####":LV=3
40 SYS6912:SYS6631:POKE573,0:X=0:Y=0:POKE36878,15
50 FORA=0TOD5:SYS6631:IFPEEK(673)=255THENL00
60 NEXT:IFVAL(T1$)>PATHEMPOKE7720,4:T1$="000000"
70 POKE7724+RND(1)*22,(RND(1)*2)+2
80 GOTO50
100 SYS7121:POKE36877,129:POKE36876,0
110 S=PEEK(829):FORA=15TO0STEP-1:POKE36878,F:POKE8141+S+X,38
120 POKE8141+S+Y,38:X=X-23:Y=Y-21:SYS6631:POKE35877,129:FORD=0TO20:NEXT NEXT
130 FCRA=0TO10:SYS6784:FORS=0TO50:NEXT NEXT
135 LV=LV-1:JFLV>0THEN40
140 FORS=0TO18:SYS6848:NEXT:PRINT"#####GAME OVER"
150 FCRA=15TO0STEP-1:POKE36878,A
160 FORS=0TO100STEP10:POKE36874,150+S:POKE36877,150+S
170 NEXT NEXT:POKE36874,0:POKE36877,0:RUN
500 POKE36879,10:PRINT"GM"
510 PRINT"#####ROBOT ATTACK#####(C)1984 BY D.HODGETTS"
550 PRINT"#####PRESS FIRE TO PLAY"
560 SYS6848:IF(PEEK(37151)&AND32)=0THENRETURN
570 GOSUB500:FORS=0TO70:NEXT:GOTO560
600 GETA:IFAS=""THENLB=LB+1:IFLB>5THENLB=0
610 IFAS=""THENFR=FR+1:IFFR>5THENFR=0
620 IFAS=""THENPA=PA+1:IFPA>5THENPA=0
630 PRINT"#####LASER BASE SPEED":LB
640 PRINT"#####FIRE RATE":FR
650 PRINT"#####TIME TO PODS ARRIVAL":PA
660 RETURN

```



Amazing how played out some things be



s become.

Will you think the same of your micro in 6 months' time?



Remember the days when every record player was gifted with a needle instead of a stylus. 45's were "in," 78's were "out."

Before the days of hi-fi and laser discs. When a graphic equaliser was a breakthrough on the football pitch instead of in music technology.

Look at a record player now and it's a museum piece.

It's like that with micros too. The machine you thought would give endless hours of fun and interest often becomes a five minute wonder. Played out within months. Or so you thought.

But imagine communicating with other micro users on a nationwide mainframe system. Updating yourself

daily with the very latest computer news and reviews. Paging a special Bulletin Board. Feasting from "Prestel's vast menu. Even downloading a choice of software *absolutely free.*

In fact, imagine 30,000 pages at your fingertips and you've imagined what it's like to be on line with the Micronet 800 system.

For just £13 a quarter (and, for most of you, a local telephone call whenever you want to connect up) you could subscribe to the Micronet system.

The only extra you need to connect up is a modem unit. Which is a small enough outlay for what it buys.

Micronet's features are almost limitless and constantly updating so why not see it in action at John Lewis stores, selected W. H. Smith shops and Spectrum UK dealers.

Or fill in the coupon for our brochure. You'll find you won't want to play on anything else.



Please send me the full facts about Micronet 800.

Name _____

Make/Model of Micro _____

Address _____

Telephone _____

MICRONET 800, Durrant House, 8 Herbal Hill, London EC1R 5EJ. Telephone 01-278 3143. VC.8

MICRONET 800, Durrant House, 8 Herbal Hill, London EC1R 5EJ. Telephone 01-278 3143.

*Prestel and the Prestel symbol are trademarks of British Telecommunications.

Making the most of your micro.

EVENTUALLY, AFTER many months of disappointment, decent arcade games are appearing on the Dragon market, most often under the title Microdeal. However, I had never been able to get my hands on a Hunchback type game. After seeing my friend's version on a CBM-64, I just couldn't wait for Mr Kalish to relieve my pangs.

So I sat down and threw a version together. Realising the potential of the game I became more interested in it and began designing a brickwall and animated graphics. When I had finished it was difficult to stop playing.

The idea of the game is to control your small blue knight along the side of the castle wall in search of the legendary 16th bell.

Your Queen has equipped you only with a blessing and the cape of unreal strength and agility. You must leap the dangerous fissures where knights hide waiting to spear you with their gruesome pikes while avoiding the flaming balls of oil and the deadly poison tipped arrows which will pierce your heart!

Back to reality, to type the game in first type in the hex loader — listing 1 — and then run using the data from the listing provided. The data is checked after each line so there should be no mistakes. However, save the game before running just in case.

To save the game type:
CSAVEM CASTLE',&H5400,&H616A,21555
Once you have typed it in and saved it can be run using EXEC21555. However, once it has been loaded EXEC will do fine.

If there are any problems write to me at: 12 Yonge Close, Radcliffe-on-Trent, Nottingham NG12 2EE. Enclose a stamped addressed envelope and your problem. I will be happy to help out with any difficulties you meet.

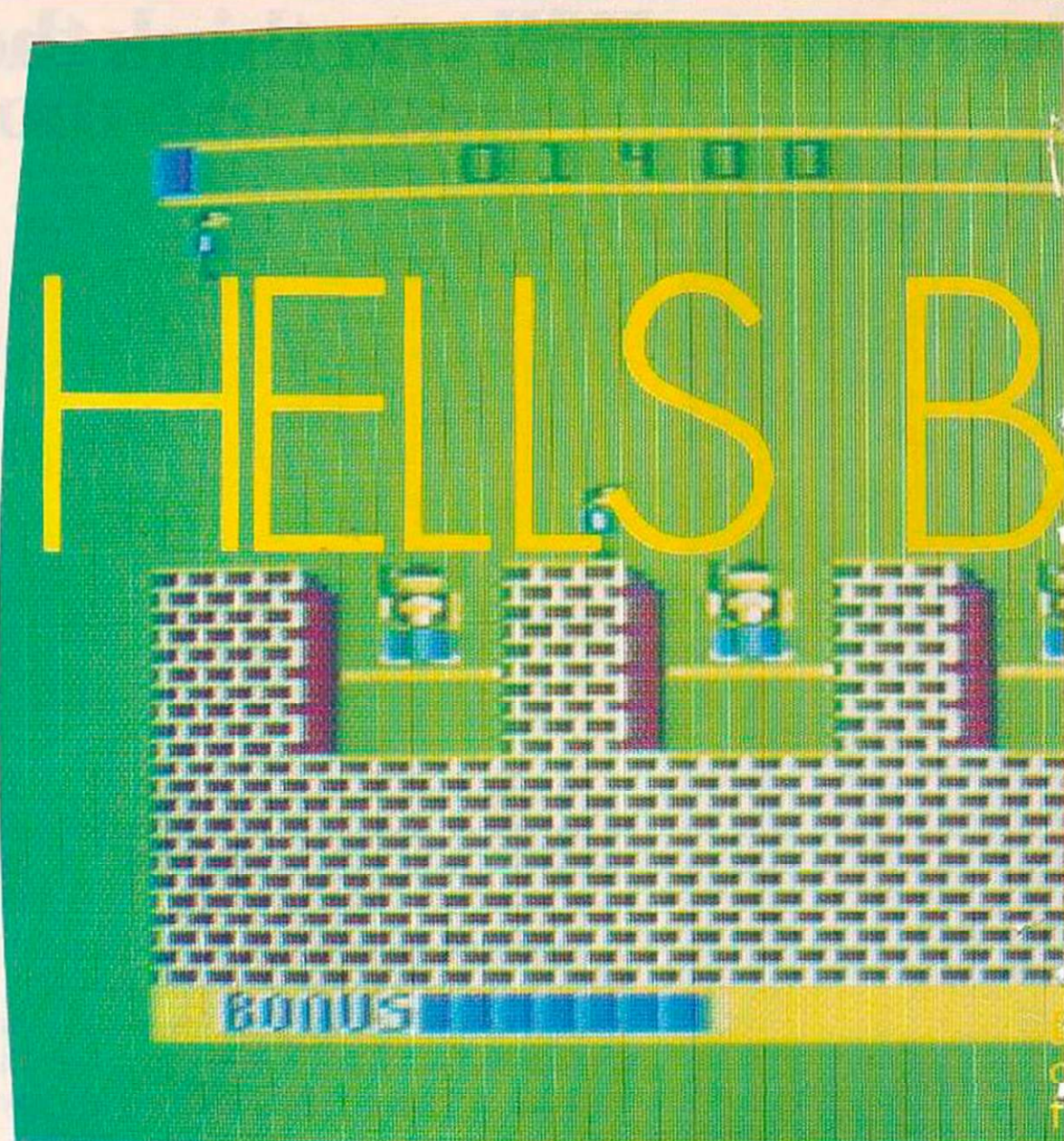

```

21504 : 00,00,00,00,01,00,FF,00,100
21512 : FF,14,C2,00,FF,0E,6F,0F,360
21520 : E2,0E,79,00,FF,00,FF,00,367
21528 : FF,00,FF,00,10,00,03,02,213
21536 : 00,00,01,00,00,01,00,20,22
21544 : 00,00,00,00,00,1D,80,06,D3
21552 : 68,09,73,8D,5D,59,8D,5F,373
21560 : 04,8D,5A,DD,8D,5A,13,7F,3A1
21568 : 01,12,7F,01,13,8D,5A,03,1C0
21576 : 8D,5B,FD,8D,54,9A,8D,54,4D1
21584 : E3,86,54,15,10,26,04,05,231
21592 : 8D,56,EC,8D,57,5D,8D,55,482
21600 : 4C,8D,55,21,10,8E,54,1C,2ED
21608 : 31,3F,2A,FC,7E,54,45,39,2E2
21616 : EE,54,28,30,86,A6,84,B7,3A1
21624 : 54,2D,1F,98,8B,54,2D,A7,31B
21632 : 84,8E,54,2C,A6,84,B1,09,346
21640 : 22,08,30,1F,8C,54,28,26,1A7
21648 : F3,39,6C,1F,80,0A,A7,84,36C
21656 : 20,F0,8E,54,28,36,10,A6,306
21664 : 84,C6,08,3D,1F,7D,10,8E,314
21672 : 54,2F,8E,60,3F,30,86,C6,32C
21680 : 08,A6,80,A7,A4,31,AB,20,372
21688 : 5A,26,F6,8E,54,2F,30,02,2E9
21696 : BF,54,2F,37,10,30,01,8C,246
21704 : 54,2D,26,D1,8E,06,68,BF,333
21712 : 54,2F,39,FC,54,31,B1,01,2EF
21720 : 10,27,02,2F,C1,00,27,06,156
21728 : C0,05,FD,54,31,39,C6,FA,440
21736 : 4A,FD,54,31,8E,1C,C7,C6,403
21744 : 55,86,14,E7,80,4A,26,FB,3C1
21752 : 30,0C,8C,1D,C7,23,F2,B6,377
21760 : 54,31,8E,1C,C7,C6,AB,36,39A
21768 : 10,31,86,10,BF,54,2D,E7,2FE
21776 : 80,BC,54,2D,26,F9,37,10,323
21784 : 30,8B,20,3C,1D,C7,26,E7,355
21792 : 39,86,54,2D,81,02,27,1B,22A
21800 : BE,54,09,10,8E,5F,6F,C6,34D
21808 : 07,5A,10,27,07,EB,A6,A0,2D0
21816 : A1,84,10,26,01,CD,30,8B,2E1
21824 : 20,20,EE,0E,54,09,10,8E,2E7
21832 : 5F,E6,20,E3,B6,54,04,27,37D
21840 : 25,C6,08,86,06,BE,54,0F,2A0
21848 : 8C,0F,E0,10,27,00,DF,1C,2AD

```

```

21856 : FE,69,84,69,1F,30,8B,20,34B
21864 : 4A,26,F4,5A,26,ES,BE,54,3DB
21872 : 0F,30,1F,BF,54,0F,B6,54,28A
21880 : 02,27,23,C6,08,86,06,BE,256
21888 : 54,11,8C,0E,60,10,27,00,196
21896 : C6,1C,FE,69,84,69,1F,30,395
21904 : 8B,20,4A,2A,F4,5A,26,ES,371
21912 : BE,54,11,30,1F,BF,54,11,296
21920 : 86,54,03,27,25,C6,08,86,2AD
21928 : 05,8E,54,0D,8C,0E,60,10,22E
21936 : 27,00,AD,1C,FE,69,84,69,344
21944 : 1F,30,8B,20,4A,26,F4,5A,285
21952 : 26,E5,8E,54,0D,30,1F,BF,338
21960 : 54,0D,B6,54,06,27,25,C6,202
21968 : 08,86,05,8E,54,08,8C,0F,24B
21976 : E0,10,27,00,94,1C,FE,69,32E
21984 : 84,69,1F,30,8B,20,4A,26,254
21992 : F4,5A,26,ES,BE,54,08,30,3A6
22000 : 1F,BF,54,08,B6,54,17,27,285
22008 : 25,C6,08,86,06,BE,54,1A,2AB
22016 : 8C,0F,FE,10,27,00,78,10,267
22024 : FE,66,84,66,01,30,8B,20,327
22032 : 4A,26,F4,5A,26,ES,BE,54,3DB
22040 : 1A,30,01,BF,54,1A,B6,54,282
22048 : 01,81,02,10,26,06,FA,BE,278
22056 : 01,12,8C,00,32,23,64,BC,1E4
22064 : 00,4B,10,23,00,82,8C,00,18C
22072 : B2,10,23,00,AB,39,86,08,224
22080 : BE,54,0F,8D,61,16,8E,0F,2F2
22088 : FF,BF,54,0F,7E,55,76,86,3F0
22096 : 08,8E,54,11,8D,61,16,8E,2ED
22104 : 0E,7F,BF,54,11,7E,55,A0,324
22112 : 36,05,8E,54,0D,8D,61,16,2DE
22120 : 8E,0E,7F,BF,54,0D,7E,55,30E
22128 : CA,86,05,8E,54,08,8D,61,390
22136 : 16,8E,0F,FF,BF,54,08,7E,34E
22144 : 55,F4,86,08,BE,54,1A,8D,3C0
22152 : 51,16,8E,0F,E0,BF,54,1A,321
22160 : 7E,56,1E,7F,54,23,8E,0F,285
22168 : A6,8D,56,A9,8E,0F,AE,8D,46A
22176 : 56,A9,8E,0F,B6,8D,56,A9,40E
22184 : 39,C6,16,86,C0,AA,84,A7,430
22192 : 84,30,8B,20,5A,26,F4,39,309
22200 : 3E,0F,A6,8D,56,D0,8E,0F,3C3

```

```

22208 : AE,8D,56,D0,EE,0F,B6,8D,4A1
22216 : 56,D0,85,01,E7,54,23,39,314
22224 : 86,54,23,10,26,06,4A,4F,202
22232 : C6,0F,A7,84,30,8B,20,5A,332
22240 : C1,00,26,F6,39,7F,01,12,2A8
22248 : 7F,01,13,39,EE,54,09,A6,28D
22256 : 89,02,20,81,FD,10,26,00,25F
22264 : 12,A6,84,81,3F,10,27,06,239
22272 : 20,81,FC,10,27,06,1A,7E,272
22280 : 57,08,39,8E,00,A0,BF,54,2DC
22288 : 26,8D,61,39,8E,00,45,BF,30F
22296 : 54,26,8D,61,39,C6,50,8D,3A4
22304 : 5C,EE,8E,00,20,BF,54,26,331
22312 : 8D,61,39,8E,54,09,30,8B,52A
22320 : 20,4F,A7,83,E0,BF,54,09,39A
22328 : 5A,26,E4,10,8E,FF,FF,31,431
22336 : 3F,26,FC,84,54,1E,4A,87,38A
22344 : 54,1E,B1,00,22,06,8D,5D,235
22352 : A1,16,FC,E2,8E,0F,82,3F,473
22360 : 54,09,16,FC,DC,86,FF,3E,45E
22368 : 01,50,A7,80,8C,01,60,26,28E
22376 : F9,8D,80,05,81,5A,27,4E,38C
22384 : 81,58,27,0D,81,0C,10,27,1D1
22392 : 00,D1,01,0D,10,27,02,26,1DE
22400 : 39,86,54,25,81,01,10,27,221
22408 : 02,61,86,01,87,54,25,97,2D1
22416 : 54,22,86,08,8E,54,09,C6,2E5
22424 : 10,66,84,65,01,30,8B,20,239
22432 : 5A,26,F6,4A,81,00,26,8C,353
22440 : 8E,54,09,30,01,BF,54,09,26E
22448 : BE,5C,59,8E,54,09,8C,0F,328
22456 : 9D,10,27,00,46,39,8E,54,265
22464 : 05,8C,0F,8D,10,23,05,59,185
22472 : 86,54,25,81,01,10,27,02,1E0
22480 : 26,86,01,87,54,25,86,02,265
22488 : 87,54,22,8E,54,09,8D,5D,362
22496 : 2E,86,08,8E,54,09,C6,10,2AC
22504 : 69,84,69,1F,30,8B,20,5A,2A7
22512 : 26,F6,4A,81,00,26,8C,8E,3B7
22520 : 54,09,30,1F,BF,54,09,8D,285
22528 : 5E,22,39,7C,54,00,86,54,292
22536 : 0C,81,0D,22,1F,8E,0F,82,1EE
22544 : BF,54,09,86,02,F6,54,31,31F
22552 : C1,09,22,0C,8D,54,70,8C,345

```

FALLS

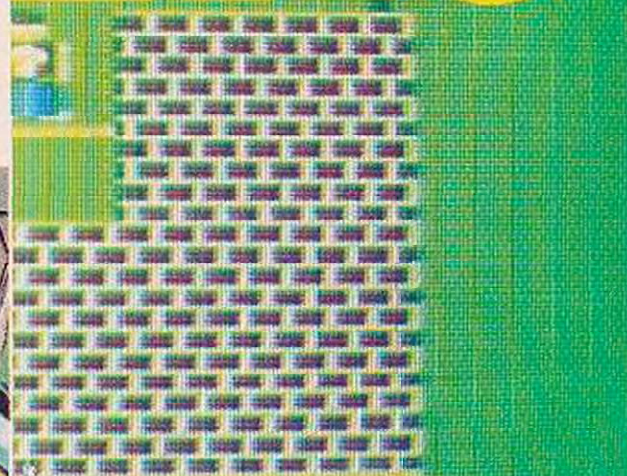

new keyboard settings some changes with a program or boosting Dragon potential

```

10 INPUT "START ADDRESS"; SA
20 PRINT SA; ": ";
25 REM INPUT THE ENTIRE LINE AFTER THE ADDRESS
26 REM INCLUDING COMMAS AND CHECKSUM
27 REM PRESS BREAK TO STOP
30 LINEINPUT A$
40 IF LEN(A$) < 25 THEN PRINT "TOO SHORT": GOTO 20
50 FOR I=1 TO 8
60 B$=LEFT$(A$,2): B=VAL("&H"+B$)
70 T=T+B
80 POKE SA,B: SA=SA+1
90 A$=RIGHT$(A$,LEN(A$)-3)
100 NEXT
110 IF T <> VAL("&H"+A$) THEN PRINT "ERROR: STOP
120 T=0: GOTO 20
    
```

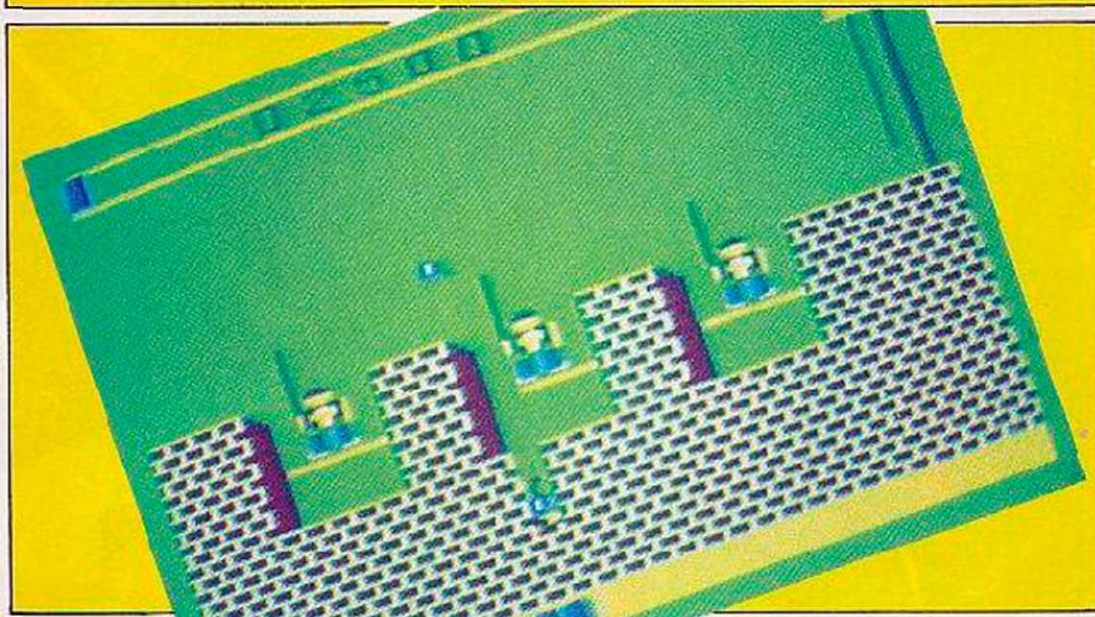

```

22560 : 0A,05,FD,54,31,BD,54,39,2DB
22568 : C5,09,20,F0,8E,00,7F,BF,3AB
22576 : 54,26,E6,0F,BD,51,39,4A,2B0
22584 : 26,FA,7F,54,00,8E,54,1C,321
22592 : 8C,00,C0,27,CB,30,89,FE,332
22600 : D4,20,C2,8E,00,30,BF,54,3B7
22608 : 25,BD,61,39,86,01,B7,54,30F
22616 : 15,7F,54,21,39,86,01,B7,2B0
22624 : 54,25,B6,54,22,B1,02,10,238
22632 : 27,C0,A3,81,03,10,27,01,185
22640 : 3F,E6,54,21,81,00,27,1B,22D
22648 : 81,C1,27,34,81,02,27,13,19A
22656 : 81,07,27,61,81,08,27,28,1E3
22664 : 81,C9,27,59,81,0A,27,70,222
22672 : 7E,58,B0,C6,07,8E,54,09,36E
22680 : 30,68,F0,8F,54,09,86,00,33A
22688 : A7,69,02,00,3D,5C,59,5A,2FE
22696 : 26,EB,7C,54,21,7E,54,5E,332
22704 : 1C,FE,8E,54,09,C6,08,A6,3A7
22712 : 01,10,26,FE,4E,A6,89,02,2B4
22720 : 00,10,26,FE,4E,86,10,8E,2CE
22728 : 54,09,66,84,66,01,30,8B,266
22736 : 20,4A,26,F6,5A,26,EE,7C,370
22744 : 54,21,8E,54,09,30,01,BF,280
22752 : 54,09,7E,54,5E,C6,07,8E,31B
22760 : 54,09,30,8B,20,BF,54,09,251
22768 : 4F,A7,8B,E0,8D,5C,59,5A,42A
22776 : 26,ED,7C,54,21,7E,54,5E,33A
22784 : 7F,54,15,86,01,B7,54,22,29C
22792 : 7F,54,21,7E,54,5E,86,54,32E
22800 : 21,81,00,27,1B,81,01,27,18D
22808 : 34,81,02,27,13,81,07,27,1A0
22816 : 41,81,08,27,28,81,09,27,1FA
22824 : 59,81,0A,27,70,7E,59,4D,29F
22832 : C6,07,8E,54,09,30,8B,E0,380
22840 : EF,54,09,36,00,A7,89,02,2D4
22848 : C0,8D,5D,22,5A,26,EB,7C,323
22856 : 54,21,7E,54,5E,1C,FE,8E,37D
22864 : 54,09,C6,08,A6,1F,10,26,226
22872 : FD,81,86,89,01,FE,10,26,412
22880 : FD,A9,86,10,8E,54,09,69,3C0
22888 : 84,69,1F,30,8B,20,4A,26,254
22896 : F4,5A,26,EE,7C,54,21,8E,413
22904 : 54,09,30,1F,BF,54,09,7E,246
    
```

```

22912 : 54,5E,C6,07,8E,54,09,30,2CA
22920 : 8B,20,BF,54,09,4F,A7,8B,342
22928 : E0,8D,5D,22,5A,26,ED,7C,40D
22936 : 54,21,7E,54,5E,7F,54,15,23D
22944 : 7F,54,21,7E,54,5E,86,01,2AB
22952 : 87,54,15,86,03,87,54,22,294
22960 : 86,54,21,81,00,10,27,FE,2E1
22968 : DA,81,01,10,27,FE,D4,81,356
22976 : 02,10,27,FE,CE,81,03,27,230
22984 : 1C,81,04,27,1B,81,05,10,176
22992 : 27,FF,12,81,06,10,27,FF,2F5
23000 : 0C,81,07,10,27,FF,06,81,231
23008 : 00,10,27,FF,1D,7C,54,21,24A
23016 : 7E,54,5E,7C,54,25,86,01,29C
23024 : 87,54,22,8D,5C,64,39,7C,33F
23032 : 54,25,86,02,87,54,22,8D,2EB
23040 : 5D,2D,39,8D,5C,6F,8D,5C,354
23048 : 31,8D,5C,93,8D,5C,C9,8D,42C
23056 : 5C,AF,39,8D,5C,59,86,01,33D
23064 : 87,54,22,8E,0A,05,BF,54,20D
23072 : 31,7F,54,17,7F,54,04,7F,271
23080 : 54,02,7F,54,05,7F,54,03,204
23088 : 7F,54,01,7F,54,15,7F,54,23F
23096 : 21,86,54,00,8E,6C,C2,81,35C
23104 : 00,27,05,30,06,4A,26,FB,1CD
23112 : A6,84,81,01,26,0E,10,8E,27B
23120 : 0E,79,10,BF,54,11,87,54,226
23128 : 02,A6,01,81,01,26,6B,10,12C
23136 : 8E,0F,FF,87,54,04,10,8F,37A
23144 : 54,0F,A6,02,81,01,26,08,18E
23152 : 10,8E,0F,EA,87,54,05,10,287
23160 : BF,54,0B,A6,03,81,01,26,26F
23168 : 0B,10,8E,0F,72,10,8F,54,24C
23176 : 0D,87,54,03,A6,05,81,01,24B
23184 : 26,37,86,02,87,54,01,8E,27F
23192 : 11,86,10,8E,5F,B2,EC,A1,303
23200 : ED,84,30,8B,20,1C,83,00,2DC
23208 : 00,26,F3,CC,55,55,ED,1F,39B
23216 : ED,01,ED,8B,1F,ED,8B,21,41B
23224 : DC,14,46,26,0C,8E,11,8E,245
23232 : 8D,5A,9A,8E,11,96,8D,5A,3FD
23240 : 9A,39,81,02,26,9C,86,01,29F
23248 : 87,54,17,10,8E,0F,EO,10,2BF
23256 : 8F,54,1A,20,8D,8D,61,2D,325
    
```

```

23264 : 86,54,00,8E,60,C2,81,00,33B
23272 : 27,05,30,06,4A,26,FB,A6,273
23280 : 04,81,01,10,27,00,94,8E,10F
23288 : 11,80,C6,0B,86,10,8D,5C,311
23296 : 42,30,02,4A,26,FB,30,89,295
23304 : 00,F0,5A,76,FF,86,55,8F,38A
23312 : 06,00,A7,84,A7,89,01,80,2E2
23320 : 30,01,8C,06,40,2E,F3,86,2A1
23328 : AA,8E,06,20,A7,84,A7,8B,38B
23336 : 1F,30,8B,20,8C,07,60,23,20D
23344 : F3,8E,1C,A0,86,55,A7,80,43F
23352 : BC,1E,00,26,F9,1C,8E,60,207
23360 : DF,0C,1C,C2,36,10,A6,A0,397
23368 : 81,00,27,07,A7,84,30,8B,292
23376 : 20,20,F3,37,10,30,01,8C,237
23384 : 1C,C7,8C,EB,86,54,F3,86,363
23392 : 87,54,1F,10,27,01,8A,8E,2DA
23400 : 54,09,BF,54,2D,8E,07,E1,313
23408 : BF,54,09,8D,5C,59,86,54,39B
23416 : 1F,4A,10,27,00,06,7C,54,176
23424 : 0A,8D,5C,59,8E,54,2D,BF,37A
23432 : 54,09,39,86,01,87,54,01,229
23440 : 8D,5A,F7,10,8E,11,84,30,371
23448 : A4,4F,A7,84,A7,01,A7,02,36F
23456 : A7,03,A7,04,30,8E,20,8C,2B9
23464 : 16,84,25,EE,31,28,10,8C,2A2
23472 : 11,9C,25,E3,86,CC,8E,11,39A
23480 : A4,A7,84,A7,0E,A7,8E,10,3BD
23488 : 30,8B,20,8C,16,84,25,F1,314
23496 : 81,C0,10,26,00,89,8B,20,2AB
23504 : 8E,11,C4,8D,5B,89,8B,10,3CF
23512 : 8E,11,E4,8D,5E,89,8B,03,3E7
23520 : 8E,12,04,8D,5E,89,8B,04,304
23528 : 8E,12,24,8D,5E,89,8B,02,322
23536 : 8E,12,44,8D,5E,89,4C,8E,38F
23544 : 12,64,8D,5B,89,86,F0,8E,44B
23552 : 11,7F,A7,84,30,8B,E0,8C,3DF
23560 : 0B,BF,24,F6,CC,FF,FF,30,4DB
23568 : 89,00,9E,ED,84,ED,8B,E0,4ED
23576 : CD,00,C0,ED,8E,A0,ED,8B,5BF
23584 : 80,10,8E,60,11,ED,A1,ED,409
23592 : 84,30,8B,20,10,83,00,00,1EF
23600 : 26,F3,86,C0,3C,8B,E0,C6,4BD
    
```

CYBERTRON MISSION

Fort Cybertron, the most well-protected stronghold in the galaxy. Obliterate the Spinners, Clones and Cyberdroids as you explore the 64 room complex in search of the Fort's riches. Avoid touching the walls with their sizzling high voltage charge and watch out for the relentless spook who glides through walls in hot pursuit.

£6.95. (ELECTRON and BBC MICRO versions £7.95)



commodore 64
(SUPER-FAST LOADING TIME)

electron B.B.C. MICRO

MICRO
POWER

MICRO POWER LTD.,
NORTHWOOD HOUSE, NORTH STREET,
LEEDS LS7 2AA TEL: (0532) 453800
SELECTIVE BRANCHES OF BOOTS, CO-OP,
MENZIES, W. H. SMITH, WOOLWORTHS AND ALL
GOOD DEALERS
AUTHORS! WE PAY 20% ROYALTIES!



COMMODORE 64 VERSION

SWOOP,
GHOULS AND FELIX
IN THE FACTORY ARE
ALSO IN THE SHOPS,
AND THEY'RE
AVAILABLE
NOW!



2360B : 20, A7, 01, 30, 88, 20, 50, 26, 22D
 2361b : F8, 39, 34, 36, 10, EE, 60, 2B, 2C4
 23624 : EC, A1, ED, 54, 30, EB, 20, 10, 3E6
 23632 : B3, 00, 00, 26, F3, 35, B6, 39, 2C0
 23640 : 39, BE, 5F, 5F, 10, EE, 54, 09, 2C0
 23648 : 8D, 5D, 07, 39, BE, 5F, B1, 10, 2D0
 23656 : BE, 54, 07, 0D, 5D, 07, 39, 00, 32D
 23664 : 54, 05, 10, 27, 00, FB, BE, 5F, 22B
 23672 : 93, 10, BE, 54, 0B, ED, 5D, 07, 2E1
 23680 : 39, B6, 54, 03, 10, 27, 00, 99, 216
 23690 : DE, 5F, 93, 10, BC, 54, 00, 0D, 36C
 23696 : 5D, 07, 39, B6, 54, C2, 10, 27, 1E0
 23704 : 00, 87, B6, 54, 24, 10, 27, 00, 1E0
 23712 : 77, 7F, 54, 24, BE, 3F, 99, 10, 324
 23720 : BE, 54, 11, B0, 5D, 07, 39, B6, 333
 23728 : 54, 17, 27, 5D, B6, 54, 24, 10, 23D
 23736 : 27, 00, 93, 7F, 54, 24, BE, 5F, 29E
 23744 : 99, 10, BE, 54, 1A, ED, 5D, 07, 2F6
 23752 : 39, B6, 54, 04, 27, 53, B6, 51, 20D
 23760 : 24, 10, 27, 30, B6, 7F, 54, 24, 100
 23768 : BE, 5F, 99, 10, BE, 54, 0F, B0, 374
 23776 : 5D, 07, 39, BE, 5F, 60, 10, BE, 2FB
 23784 : 54, 13, 0D, 5D, 07, 39, 0C, 5F, 2AC
 23792 : 6F, 10, BE, 54, 09, 31, A9, 02, 276
 23800 : 00, A6, B0, 10, 27, 00, 22, A7, 226
 23808 : A4, 31, AB, E0, 20, F3, 39, A6, 44F
 23816 : 00, 01, 00, 10, 27, 00, 11, A7, 1F0
 23824 : A4, 31, AB, 20, 10, BC, 1D, FF, 355
 23832 : 22, 03, 7E, 5D, 07, 7E, BB, 26, 266
 23840 : 39, 39, BE, 5F, E6, 10, BE, 54, 367
 23848 : 07, 0D, 8D, 07, 39, 0C, BF, F0, 34D
 23856 : 10, BE, 54, 09, B0, 5D, 07, 39, 285
 23864 : B6, 01, B7, 54, 24, BE, 60, 0A, 2AE
 23872 : 7E, 5C, A7, B6, 01, B7, 54, 24, 337
 23880 : BE, 60, 0A, 7E, 5C, B6, 01, 374
 23888 : B7, 54, 24, BE, 60, 0A, 7E, 5C, 301
 23896 : C1, B0, 5D, B2, B6, 08, B7, FF, 4D1
 23904 : 22, BE, 5D, BF, 10, BE, 04, 00, 26E
 23912 : A4, B0, B1, 20, 10, 27, 01, 4E, 2AE
 23920 : B1, 2E, 27, 0B, 81, 5E, 10, 27, 1FA
 23928 : 01, 6A, B0, 40, A7, A0, CC, 07, 345
 23936 : 00, B3, 00, 01, 10, B3, 00, 01, 11B
 23944 : 26, F7, 10, BC, 05, 20, 26, D3, 29C
 23952 : BE, 5E, E9, 10, BE, 05, 63, A6, 3B1
 23960 : B0, A7, A0, 10, BC, 05, 79, 25, 307
 23968 : F6, B0, B0, 06, B1, 00, 27, F9, 30A
 23976 : 0C, 00, CC, DF, 54, 24, B0, 41, 3D3
 23984 : 39, 39, B6, BF, BE, 04, 00, A7, 2F0
 23992 : B0, BC, 06, 00, 26, F9, 39, 20, 28A
 24000 : 41, 20, 54, 20, 54, 20, 41, 20, 10A
 24008 : 43, 20, 49, 20, 20, 4E, 4E, 20, 1AP
 24016 : 2E, 2E, 2E, 2E, 2E, 2E, 2E, 20, 162
 24024 : 20, 20, 20, 20, 20, 20, 20, 20, 100
 24032 : 20, 20, 20, 20, 20, 20, 43, 41, 144
 24040 : 53, 54, 4C, 45, 20, 47, 4B, 41, 22B
 24048 : 53, 54, 47, 4B, 4F, 52, 41, 4B, 260
 24056 : 20, 20, 20, 20, 20, 20, 20, 20, 100
 24064 : 57, 52, 49, 54, 54, 45, 4E, 20, 24D
 24072 : 42, 55, 20, 44, 52, 45, 57, 20, 20B
 24080 : 40, 41, 52, 53, 48, 41, 4C, 4C, 254
 24088 : 2E, 20, 53, 4D, 4F, 47, 20, 20, 1C4
 24096 : 43, 4F, 50, 59, 52, 49, 47, 4B, 265
 24104 : 54, 2F, 4E, 45, 59, 53, 20, 54, 232
 24112 : 4F, 20, 55, 53, 45, 20, 41, 52, 20F
 24120 : 45, 2E, 2E, 2E, 20, 20, 20, 20, 14F
 24128 : 5E, 5E, 5E, 5E, 5E, 5E, 5E, 2F0
 24136 : 5F, 5F, 5F, 5F, 5F, 5E, 5E, 2F0
 24144 : 5E, 5E, 5E, 5E, 5E, 5E, 5E, 2F0
 24152 : 5E, 5E, 5E, 5E, 5E, 5E, 20, 274
 24160 : 20, 43, 4C, 45, 41, 52, 2E, 2E, 1E3
 24168 : 2E, 2E, 2E, 4A, 55, 4D, 50, 20, 1E6
 24176 : 20, 20, 20, 20, 20, 20, 20, 20, 100
 24184 : 20, 20, 20, 20, 20, 20, 20, 20, 100
 24192 : 20, 58, 20, 20, 20, 20, 2E, 2E, 154
 24200 : 7F, 7F, 7F, 57, 49, 47, 4A, 54, 20B
 24208 : 20, 20, 20, 20, 20, 20, 20, 20, 100
 24216 : 20, 20, 20, 20, 20, 20, 20, 20, 100
 24224 : 20, 5A, 20, 20, 20, 20, 2E, 2E, 156
 24232 : 2E, 2E, 2E, 4E, 4E, 4A, 54, 20, 1D5
 24240 : 20, 20, 20, 20, 20, 20, 20, 20, 100
 24248 : 20, 20, 20, 20, 20, 20, 20, 20, 100
 24256 : 20, 45, 4E, 54, 45, 52, 2E, 2E, 1FA
 24264 : 7F, 7F, 7F, 47, 4F, 55, 4E, 43, 201
 24272 : 45, 20, 20, 20, 20, 20, 20, 20, 125
 24280 : 20, 20, 20, 20, 20, 20, 20, 20, 166
 24288 : B0, 7E, 5D, 7C, B6, CC, 7E, 5D, 404
 24296 : 7E, 5D, 57, 45, 53, 53, 20, 41, 26A
 24304 : 4E, 59, 20, 4B, 45, 59, 20, 54, 224
 24312 : 4F, 20, 53, 54, 41, 52, 54, 20, 21D
 24320 : 47, 41, 4D, 45, B6, E5, 37, FF, 43B
 24328 : 22, B7, FF, C3, B7, FF, C5, B7, FF, D0
 24336 : FF, C7, B6, 00, BE, 06, 00, A7, 3B7
 24344 : B0, BC, 1E, 00, 26, F9, 3E, 0F, 2E6
 24352 : B2, BF, 54, 09, 7F, 54, 15, 7F, 305
 24360 : 54, 20, B6, 00, B7, 54, 00, 7F, 79A
 24368 : 54, 21, 7F, 54, 01, 7F, 54, 13, 22F
 24376 : 7F, 54, 23, B6, 01, B7, 54, 24, 2AC
 24384 : B7, 54, 25, 7F, 54, 2B, 7F, 54, 2FE
 24392 : 79, 7F, 54, 2A, 7F, 54, 2R, 7F, 2A3
 24400 : 54, 2C, CC, 06, 68, FD, 54, 2F, 33A
 24408 : CC, 0A, 05, FD, 54, 31, B6, 01, 2E4
 24416 : B7, 54, 22, BE, 10, 00, 3F, 54, 2DE
 24424 : 1C, B6, 03, B7, 54, 1E, 39, 3F, 24A
 24432 : F4, F5, D4, 20, A0, 98, 9B, 9B, 545
 24440 : A6, 30, 30, 30, 30, 30, 30, 30, 1E0
 24448 : 00, 3F, F4, F5, D4, 20, 00, 9B, 454
 24456 : 9E, 9A, AB, 30, 30, CC, FF, 470
 24464 : F3, 00, 00, 02, 0B, FC, 08, 02, 203
 24472 : 0C, 3C, E7, DB, E7, DB, 3C, 00, 3FE
 24480 : 3C, 7E, FF, 3C, 24, 3C, 7E, 56, 329
 24488 : 6F, 56, 7E, 66, 66, 66, 66, E7, 3BD
 24496 : E7, C0, 03, C0, 0F, F0, 0F, F0, 3AB
 24504 : 05, 50, 45, 50, 41, 40, 7F, FD, 2E7
 24512 : 7D, 7D, 75, 5D, 75, 5D, 7D, 7D, 39B
 24520 : 7D, 7D, 00, 71, 03, C1, 2B, 2B, 24C
 24528 : 2B, 2B, 2B, 2B, 2B, 2B, 2B, 2B, 140
 24536 : 6B, 29, 54, 15, 00, 00, 02, 07, 103
 24544 : 07, C2, 02, 02, 02, 00, FC, 1F, 12A
 24552 : 5F, 17, 0B, 0A, 2E, 26, 24, 2A, 124
 24560 : 0C, CC, 0C, 0C, 3C, 3C, 00, 00, AB
 24568 : FC, 1F, 5F, 17, 0B, 0A, 26, 26, 1EF
 24576 : 16, 1A, 2A, 0C, 0C, 33, 33, CF, 1A7
 24584 : 00, C0, 3C, 0F, C7, 0B, E7, 3C, 3FC
 24592 : 00, C1, 40, 05, 50, 05, 50, 05, F0
 24600 : 50, C5, 50, 15, 34, 15, 54, 15, 18C
 24608 : 54, 15, 54, 15, 54, 15, 54, 55, 1E4
 24616 : 55, C0, 00, 55, 55, FD, FD, FD, 3FC
 24624 : FD, FD, 55, 55, DF, DF, DF, 43E
 24632 : 0F, DF, DF, 55, 55, 00, 00, FF, 446
 24640 : C3, C3, C3, C3, C3, C3, FF, F0, 681
 24648 : 30, 30, 30, 30, 30, 30, FC, 3C, 25B
 24656 : C3, C3, C3, 30, CC, C0, FF, 3C, 3BD
 24664 : C3, C3, C3, C3, C3, C3, C3, CC, 2AC
 24672 : CC, CC, FC, 0C, 0C, 0C, 0C, 3F, 303
 24680 : 00, CC, FF, 03, 03, C3, 3C, 3F, 3C3
 24688 : C0, C0, FF, C3, C3, C3, C3, FF, 603
 24696 : 03, C0, C0, C0, C0, C0, C0, 3C, 37B
 24704 : C3, C3, C3, C3, C3, C3, 3C, 3C, 483
 24712 : C3, C3, C3, 3F, 03, 03, 03, 03, 334
 24720 : 99, 99, 99, 99, 99, 99, A5, 00, 447
 24728 : 65, 99, 99, 99, 99, 99, 99, 65, 460
 24736 : C0, 65, 99, 99, 99, 99, 99, 99, 3FB
 24744 : 99, 00, 02, 99, 99, 99, 99, 99, 42F
 24752 : 99, 65, 00, 69, 95, 95, 69, 59, 353
 24760 : 59, 59, A5, 00, B0, 20, 3F, 20, 256
 24768 : 00, 00, 00, 01, 00, 00, 00, 00, 81
 24776 : C0, 00, 00, 00, 01, 00, 00, 00, 1
 24784 : C0, 00, 01, 01, 01, 00, 00, 00, 3
 24792 : C1, 00, 00, 00, 00, 01, 01, 01, 4
 24800 : C0, 00, 01, 00, 01, 01, 00, 02, 5
 24808 : C0, 00, 01, 00, 00, 07, 00, 00, 3
 24816 : C1, 01, 00, 00, 01, 01, 01, 00, 5
 24824 : C1, 01, 00, 00, 01, 00, 01, 02, 6
 24832 : C0, 00, 01, 00, 01, 02, 01, 00, 5
 24840 : C0, 00, 00, 07, 00, 01, 01, 01, 5
 24848 : 01, 01, 00, 00, 01, 01, 01, 00, 85
 24856 : 10, 27, F5, EF, BC, 06, 00, 10, 28D
 24864 : 23, F5, E8, 5F, E7, B4, 30, B8, 482
 24872 : 20, 49, 26, FF, 39, 4F, FF, 0A, 7A4
 24880 : 00, A7, B0, BC, 1E, 00, 26, F9, 2F0
 24888 : 39, 34, 32, B6, FF, 23, BA, 0B, 309
 24896 : B7, FF, 23, BE, 00, 01, B6, FD, 3EB
 24904 : B7, FF, 20, BE, 16, 7F, FF, 20, 417
 24912 : B0, 11, 30, 01, BC, 54, 26, 25, 22A
 24920 : ED, B5, FF, 23, B4, F7, B7, FF, 5F6
 24928 : 23, 35, B2, 1F, 12, 31, 3F, 26, 1D1
 24936 : FC, 39, FF, FF, FF, FF, FF, FF, 72F

Spectre
 ENFIELD HOUSE
 SWARDESTON
 NORWICH
 NORFOLK

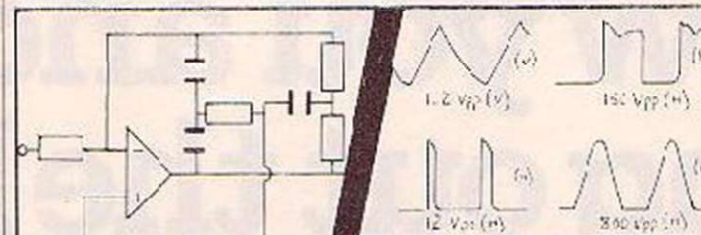

ELECTRONICS £ 9.95

DIGITAL CIRCUIT DESIGNER. Electronics allows you to draw your circuit diagram on screen using standard symbols for logic gates, transistors, resistors, capacitors, diodes, triacs, diodes, etc., etc... Symbols can be rotated, wiring interconnected or crossed over as required. Once complete the computer will 'power up' your circuit - high voltage levels turn red, low levels turn green. Circuits can be de-activated, modified and re-activated until they function as required, all without touching a soldering iron! Over 1000 standard electronic symbols are available for use and displays can be sent to the printer. All components are fully interactive i.e. they can change the state of sections previously activated in the sequence - even oscillators can be seen oscillating. Warning is given of short-circuits. 65 defined graphics are employed.

LINNET £ 14.95

LINEAR NETWORK ANALYSER. Characteristics of complete networks, including sub-circuits, are entered. The computer performs either time or frequency domain analysis, presenting the output data in any of a choice of forms, both graphical and written. The program detects the presence of a printer and, if connected, can produce detailed graphical displays by printing lengthways along the paper. Happily deals with highly complex networks - the instruction book provides numerous examples using resistors, I.C.s, bandpass filters, op amps, etc., etc... An invaluable tool for both professional and amateur designers.

48 K SPECTRUM

SKC MINI FLOPPY DISK
 PERFECTION ASSURED

FLOPPY DISKS MEET ANSI, DIN, ECMA, IBM, JIS AND SHUGART SPECIFICATIONS. EVERY DISK IS CERTIFIED AND GUARANTEED TO BE 100% ERROR FREE.
 5 1/4" D SKETTES Certified for Single OR Double Density media with hub ring. PRICES EXC VAT

| | QUANTITY | | PRICE PER DISC |
|-----------------------------------|----------|-------|----------------|
| | 1-10 | 10-40 | 50-90 100 |
| 48 tpi suitable for MD-S/S 48 tpi | 1.51 | 1.17 | 1.12 1.05 |
| 40 track MD-D S/S 48 tpi | 1.70 | 1.23 | 1.17 1.10 |
| 96 tpi MD2-D D/S 48 tpi | 2.00 | 1.44 | 1.37 1.29 |
| suitable for MD1-DD S/S 96 tpi | 1.86 | 1.41 | 1.35 1.28 |
| 80 track MD2-DD D/S 96 tpi | 2.33 | 1.76 | 1.68 1.60 |

VIDEO TAPES

| | Price per Box of 10 | Carriage Chgs. Please send £2 for box of ten - any quantity above 10 allow £5 for next day delivery. |
|--------------------|---------------------|--|
| VHS E-180 | £35.00 | |
| Beta L-750 | £38.00 | |
| Computer Cassettes | cat. C10 C15 C20 | playing time per 100 1C minutes £23.00 15 minutes £24.00 2C minutes £25.00 |

High quality low noise cassette tapes. Short play, leaderless construction for use with computer cassette systems. Each tape in individual plastic library case with index card.

HOW TO ORDER For disks allow 50p per box of ten for p&p. First class mail for small packets - next day delivery for heavier ones. For cassettes allow £5 carriage costs (min. order is 100) for next day delivery. Post/carriage costs include VAT.

P.V. TUBES
 Dept. C, 104 Abbey Street,
 Accrington, Lancs BB5 1EE

Telex: 635562 Griffin G for PV
 Telephone: (0254) 36521 (0254) 32311
 PLEASE ADD 15% VAT TO ALL PRICES

First, a question.

Who do you think are the world's most avid consumers of microcomputers?

The ingenious Japanese? The fashionable French? The acquisitive Americans?

Believe it or not, it's we British who own more micros per person than any other nation on earth.

Yet, despite its amazing impact, the microcomputer has only just begun to scratch at the surface of our lives. Without doubt, the best is yet to come.

Use and Abuse.

In several recent surveys, some astonishing facts about micro use and abuse were revealed.

It was discovered that the micro is hopelessly under-utilised. If you're already a micro owner, your own experience may well confirm this unhappy state of affairs.

Brainpower. A source of knowledge.

For thousands of years, the key to self improvement has been in the hands of the written word. Now, thanks to the Brainpower range, it's very much in the hands of the micro.

As the Brainpower range demonstrates, this does not require prior knowledge of micros, or how they work.

The Brainpower concept has been devised as *integrated* applications and educational software. And its aim

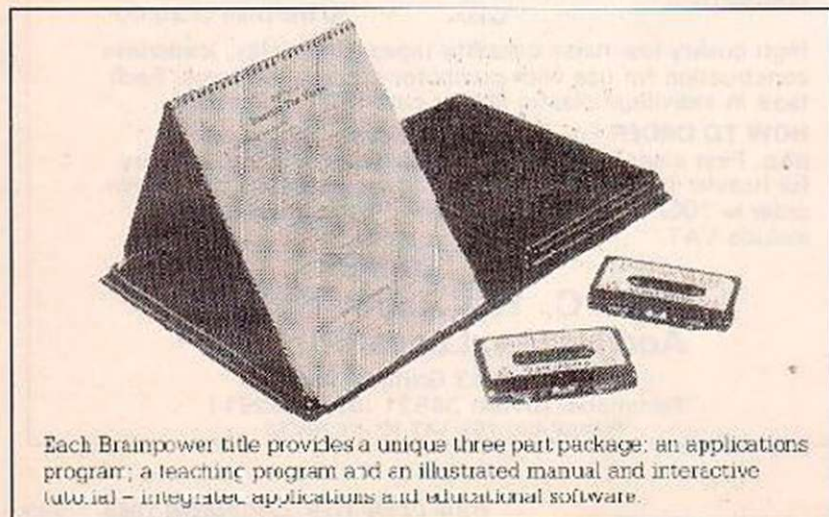

Each Brainpower title provides a unique three part package: an applications program; a teaching program and an illustrated manual and interactive (a.i.e.) - integrated applications and educational software.

WHEN WILL HE STOP
USING ME LIKE A TOY AND
START USING ME LIKE
A COMPUTER ?

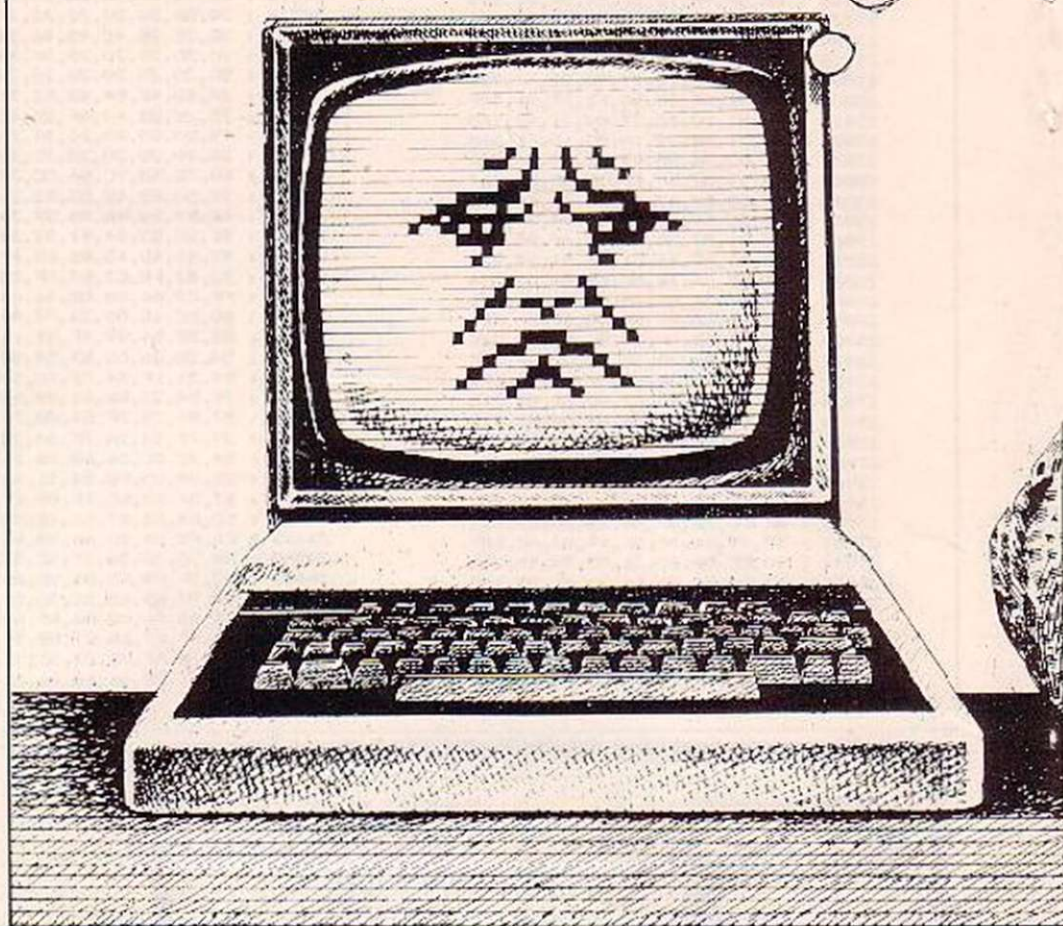

Now you and y bring out the be

is to stretch both your mind and your imagination.

It offers a unique way to realise your own full potential and that of your micro. In a way you could never hope to achieve from the printed word alone.

In this respect, the Brainpower range stands on its own.

A unique concept.

All the Brainpower titles share one thing in common, apart from their stimulating subject matter, that makes them unique.

You will find each title comprises three distinctive elements: A teaching program that helps you to get to grips

KNOW HE'S GOT A
BRAIN IN THERE. IF ONLY
I COULD DISCOVER THE
BEST WAY OF USING
IT.

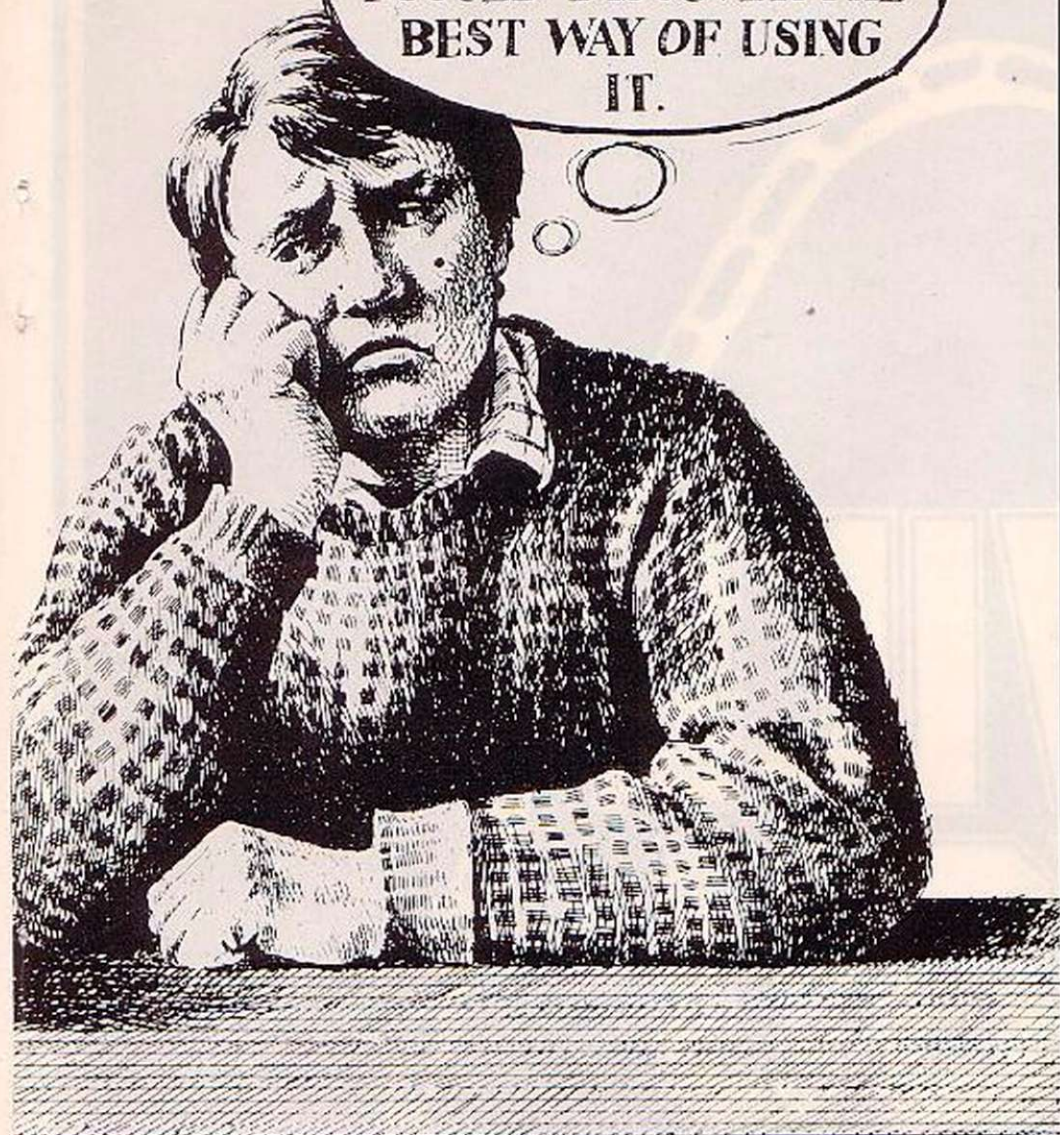

Your micro can do it best in each other.

with the subject at your own pace. An applications program to put what you learn into action. And finally, with each package, you get an expertly written book and interactive tutorial.

STAR WATCHER

The secrets of the heavens are yours. Isolate all the constellations as well as main stars for easy identification. Even turn stars and constellations on and off at will. Screen by screen, you will see exactly how the 1,500 brightest stars move through time and space. And all from any point on the Earth's surface at any time of the year.

Star Watcher is without doubt the definitive home observer.

DECISION MAKER

Should you buy a new house? Change jobs? Have children? Start your own business? Such decisions should not be taken lightly. Armed with Decision Maker, you can be quite sure of examining every avenue, and arriving at a rational, structured answer.

If you value the way you run your life, you need Decision Maker.



NUMBERS AT WORK

Tackle all the number problems you're likely to face in daily and business life. From straightforward multiplication and division of fractions, through decimals, percentages, ratios, mark-ups and margins to compound interest, depreciation, VAT and PAYE.

Numbers at Work gives you a distinct edge, since you will be able to both understand and manipulate numbers at will.

PROJECT PLANNER

Project Planner teaches you how to divide even the most complex project down into meaningful components. Learn how to determine the length and importance of every single task, and those elements critical to the fulfilment of your plan. Even anticipate problems you hadn't envisaged.

You have the measure of any situation because you have the fullest possible grasp of all the factors which affect it.

FORECASTER

Forecaster takes the guesswork out of forecasting, by accepting that tomorrow's events will be best predicted on the basis of today's facts. Armed with Forecaster, sales targets and growth trends, even sporting events and election results can be accurately and very quickly predicted.

Invaluable to you in both your private and business life.

ENTREPRENEUR

Entrepreneur teaches you all the steps required to plan and start your own business. It will forecast your first 18 months' cash flows, generate your Profit and Loss Account and Balance Sheet. Help you in discussions with your bank manager and partners. Explain the notions of assets, liabilities, overheads, working capital, cash flow and break even point.

Invaluable to anyone who is planning a business venture.

| | SPECTRUM 48K | BBC B Type | BBC B DISK 40/80 Tract | COMMODORE 34 Type | COMMODORE 64 Disk |
|------------------|-----------------|---------------|------------------------------|-------------------------|-------------------------|
| Tick your choice | £14.95 | £19.95 | £24.95 | £13.95 | £24.95 |
| Decision Maker | | N/A | N/A | | |
| Numbers at Work | | N/A | N/A | | |
| Star Watcher | | N/A | N/A | N/A | N/A |
| Entrepreneur | | N/A | N/A | | |
| Project Planner | N/A | | | | |
| Forecaster | N/A | | | | |

Please add £1.50 for postage and packing

* I enclose a cheque or postal order, crossed and made payable to Triptych Publishing Ltd for £.

* Please debit my Access/
Barclaycard number



NAME _____

ADDRESS _____

POSTCODE _____

TELEPHONE _____

SIGNATURE _____

Send to: Triptych Publishing Ltd, (IBL Book Service Ltd) FREEPOST,
CAMBERLEY, SURFEY GU15 3BR. All goods fully tested and returnable if in any
way defective. Allow 28 days for delivery. *Delete as applicable.

YCB4

BRAINPOWER

IT'S IN THE AIR

WILL
YOU
CATCH
IT!

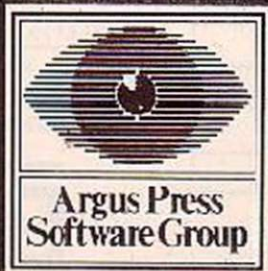
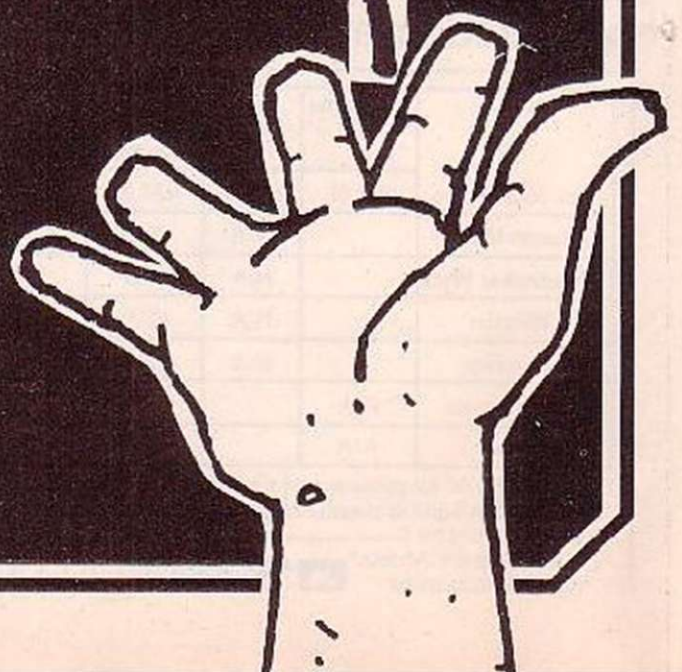
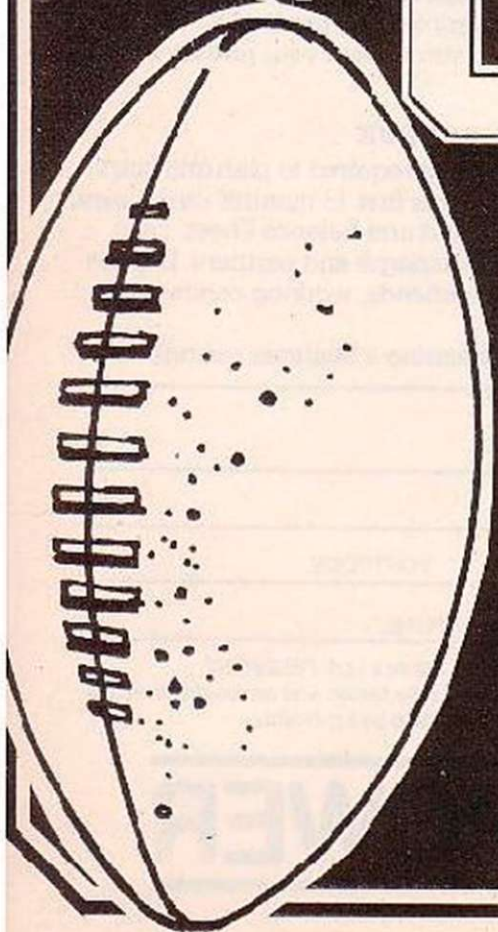

I HAVE TRIED to incorporate as many of the advanced features of Locomotive Basic as possible into this game for the Amstrad CPC-464; for example, high-res moving graphics and three channel-sound. Three well-known tunes have been included in the game — *Star Wars*, *Funeral March*, *Congratulations*.

The game is set on a hostile planet where the atmosphere is hydrochloric acid vapour. When clouds form, the vapour condenses to make concentrated acid. The sea at the bottom of the screen is also acid. At the start, a small skycraft hovers along to the middle of the screen. A small device is dropped from it and the idea of the game is to guide this device on to a randomly moving acid-proof platform which is floating on the acid sea.

Rod Markham puts the Amstrad through its paces.

SKY DROP

As both the sea and the clouds are acid, they must both be avoided. There is also a laser field which fires eight blasts then rests for two. To get past this, the craft must hover just above the laser beam until it stops firing. To do this the thrust key is used. Thrusting uses up fuel so be careful as there are only 30 units.

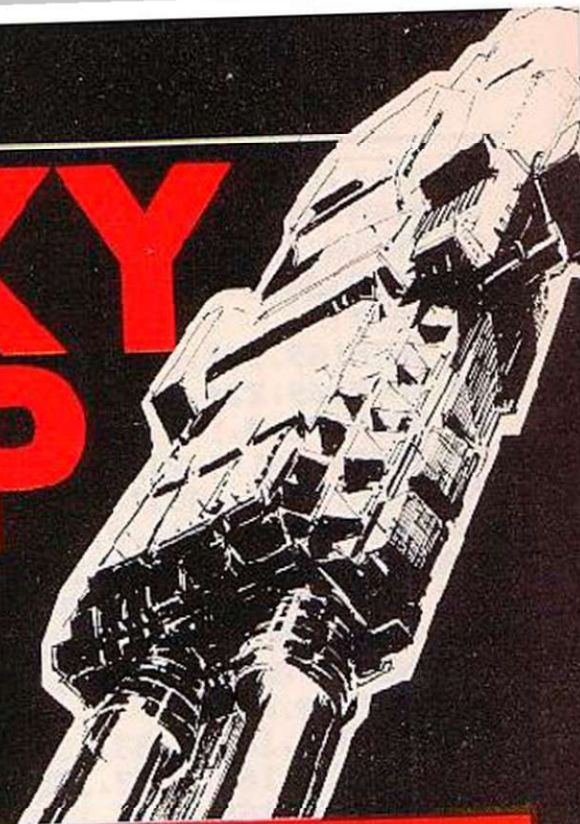

```

20 REM*****SKY DROP*****
30 REM*****BY R.MARKHAM*****
40 REM*****AND S.JOHNSON.*****
80 GOSUB 1560
90 INK 2,20
100 INK 2,6
110 INK 1,0
120 HI=0
130 CL:H=150
140 LIVES=3
150 SCORE=0
160 ENV 6,15,-1,1
170 ENT 1,30,10,1
180 ENV 5,15,-1,10
190 FUEL=30
200 SYMBOL AFTER 209
210 SYMBOL 221,8,15,3,3,15,63,111,127
220 SYMBOL 222,0,0,224,224,128,255,201,2
230 SYMBOL 223,0,0,0,0,192,32,248
240 SYMBOL 212,111,63,4,31,0,0,0,0
250 SYMBOL 213,255,255,4,255,0,0,0,0
260 SYMBOL 214,255,129,0,0,0,0,0,0
270 SYMBOL 215,0,0,0,0,0,3,2,6
280 SYMBOL 216,0,0,0,0,0,X110110,X110010
01,X1001001,2
290 SYMBOL 217,0,0,0,0,0,128,64,64
300 SYMBOL 218,X1101,X1111100,X10000C,X
X100000,X1001000,X1111111,3,0
310 SYMBOL 219,0,0,0,0,0,144,255,255,0
320 SYMBOL 220,X111000C,X110001000,X11
00,X110010,X1100010C,X111111000,X110000
00,0
330 BORDER 1:INK 0,0
340 CLS
350 MODE 0
360 X=5
370 RESTORE 1430
380 READ NOTE,DUR
390 SOUND 1,NOTE,DUR,15
400 PEN X
410 PRINT"*****SKY DROP*****"
420 X=X+1:IF X>13 THEN 440
430 GOTO 380
440 READ NOTE,DUR:IF NOTE=9999 THEN GOTO
500
450 SOUND 1,NOTE,DUR,15
460 PEN X
470 PRINT"*****SKY DROP*****"
480 X=X-1
490 GOTO 440
500 PEN 7:PRINT "*****SKY DROP*****"
510 PEN 6:PRINT "*****SKY DROP*****"
520 PEN 5:PRINT "*****SKY DROP*****"
530 FOR K=1 TO 2000:NEXT K
540 CLS:MODE 1
550 WINDOW 4,36,2,5
560 BORDER 18:INK 0,11
570 ENV 1,10,-1,2
580 ENV 2,15,1,3
590 ENV 3,1,0,2,15,-1,20
600 S=6
610 CLG
620 DROP=200
630 BASE=250
640 DRIFT=290
650 FLOT 38,392,1:DRAWR 544,0:DRAWR 0,-
71:DRAWR -044,0:DRAWR 0,73
660 TAG
670 FLOT 0,0,1
680 FOR X=1 TO DRIFT-4 STEP 2
690 MOVE X,DROP+32
700 PRINT CHR$(221);CHR$(222);CHR$(223);
213);CHR$(214);
720 PITCH=INT(RND(1)*60)+12
730 SOUND 2,PITCH,2,15,0,0,1
740 NEXT X
750 MOVE 1,175:PRINT CHR$(246);
760 MOVE 624,175:PRINT CHR$(247);
770 TAGOFF
780 CLOUD=250
790 CLOUD2=BASE
800 REM*****START LOOP*****
810 TAG
820 PLOT 0,0,1
830 MOVE X,DROP+62:PRINT CHR$(221);CHR$(
222);CHR$(223);
840 MOVE X,DROP+16:PRINT CHR$(212);CHR$(
213);CHR$(214);
850 TAGOFF
860 FUEL=30
870 IF A=0 THEN ST=-1 ELSE ST=1
880 A=INT(RND(1)*20)+10
890 FOR P=1 TO A STEP ST
900 PEN 3:LOCATE 1,2:PRINT"FUEL=";FUEL
910 LOCATE 1,3:PRINT"DRIFT=";DRIFT
920 LOCATE 1,1:PRINT"LIVES=";LIVES
930 LOCATE 1,4:PRINT"DROP=";DROP
940 LOCATE 12,4:PRINT"SCORE=";SCORE
950 SCORE=SCORE+1
960 BUTT=INKEY#
970 IF BUTT=LF THEN DRIFT=DRIFT-S
980 IF BUTT=RF THEN DRIFT=DRIFT+S
990 IF BUTT=T THEN FUEL=1 THEN DROP=DR
P+S:FUEL=FUEL-1:IF FUEL<1 THEN FUEL=0
1000 DROP=DROP-S:IF DROP<8 THEN 1230
1010 BASE=BASE+P*(6/5):IF BASE<0 THEN B
ASE=1
1020 IF BASE>=575 THEN BASE=575
1030 CL:H=CL:H-1
1040 TAG
1050 PLOT 0,0,1
1060 MOVE BASE,12:PRINT " ";CHR$(209);CH
R$(189);CHR$(211);" ";
1070 CALL 8019
1080 CLOUD=CLOUD+(INT(RND*6))-3
1090 CLOUD2=BASE
1100 MOVE CLOUD,220:PRINT " ";CHR$(215)
;CHR$(216);CHR$(217);" ";MOVE CLOUD,204
:PRINT " ";CHR$(218);CHR$(219);CHR$(220)
;" ";
1110 MOVE CLOUD2,CL:H:PRINT " ";CHR$(215)
;CHR$(216);CHR$(217);" ";MOVE CLOUD2,C
L:H-16:PRINT " ";CHR$(218);CHR$(219);CHR$(
220);" ";
1120 MOVE DRIFT,DROP:PRINT CHR$(46);
1130 IF DRIFT<=CLOUD+16 AND DRIFT<=CLOU
D+8 AND DROP<=220 AND DROP>=204 THEN 12
30
1140 IF DRIFT>=CLOUD2+16 AND DRIFT<=CLO
UD2+8 AND DROP<=CL:H AND DROP>=CL:H-16
THEN 1230
1150 TAGOFF
1160 IF LASER <=7 THEN INK 2,6:PLOT 16,1
68:INK 2,6:DRAW 620,168,2:SOUND 1,10,30,
-5,0,1:IF 168<=DROP AND 168>=DROP-16 THE
N SOUND 7,0,150,15,5,0,15:GOTO 1230
1170 LASER=LASER+1:IF LASER=11 THEN LASE
R=0
1180 INK 2,11
1190 NEXT P
1200 GOTO 370
1210 REM*****TEST LAND*****
1220 IF DRIFT<=BASE-16 AND DRIFT<=BASE+
50 THEN GOTO 1320
1230 TAGOFF:LOCATE 12,1:PEN 15:PRINT "YO
U FAILED! TRY AGAIN";
1240 FOR V=1 TO 150:C=INT(RND*15)+1:SOUN
D 1,0,3,15,0,0,C:NEXT V
1250 LIVES=LIVES-1
1260 CL:H=150-SC
1270 RESTORE 1410
1280 READ NOTE,DUR:IF NOTE=9999 AND LIVE
S=1 THEN 1430
1290 IF NOTE=9999 THEN 540
1300 SOUND 1,NOTE,DUR,0,2
1310 GOTO 1280
1320 RESTORE 1420
1330 LOCATE 12,1:PEN 15:PRINT "YOU SUCC
EDED!";
1340 LOCATE 12,3:PEN 15:PRINT "TRY A HAR
DER LEVEL";
1350 SCORE=SCORE+(FUEL+10)+100
1360 SC=SC+10:CL:H=150-SC
1370 READ NOTE:IF NOTE=9999 THEN 540
1380 SOUND 4,NOTE,20,15,1
1390 GOTO 1370
1400 DATA 478,50,319,50,358,13,379,13,42
6,13,239,60,319,60,358,13,379,13,426,15,
239,60,319,60,358,15,379,15,358,15,426,7
0,9999,9999
1410 DATA 1911,120,1911,80,1911,40,1911,
120,1607,80,1703,40,1703,00,1911,40,19,1
,00,3025,40,1911,120,9999,9999
1420 DATA 69,53,47,45,60,0,45,47,45,40,5
3,0,53,47,45,36,40,40,45,45,47,53,47,60,
9999
1430 REM *****END*****
1440 MODE 0:CLS
1450 SPEED INK 30,30
1460 BORDER 7,12
1470 INK 0,7
1480 IF SCORE>HI THEN HI=SCORE
1490 LOCATE 5,1:PEN 14:PRINT"SCORE=";SC
ORE
1500 LOCATE 5,5:PEN 15:PRINT"H=";SCORE:
41
1510 LOCATE 7,10:PEN 6
1520 PRINT"DO YOU WANT ANOTHER GO?"
1530 LOCATE 7,15:INPUT"Y/N";Z#
1540 IF Z#="Y" THEN GOTO 130
1550 END
1560 MODE 1:INK 0,0:INK 2,10:INK 1,10:BO
RDER 1
1570 PRINT"*****SKY DROP INSTRUCTIONS
*****"
1580 PRINT
1590 PRINT" You must guide a small dev
ice,which is dropped from a hovering sp
ace craft, onto a moving platform.This p
latform is floating on an ACID sea,so
if the device misses,it will be diss
olved."
1600 PRINT" To make the task more dema
nding,there are several hazards which mus
t be avoided.
ACID clouds,which drift ab
ove the sea,are also able to diss
olve the device."
1610 PRINT" Also,there is an automatic
laser field,which gives regular bur
sts of fire.You must wait above this unti
l it stops to re-energize,using THRUST.W
hen it stops,you must quickly drop t
hrough it."
1620 PRINT"before it starts up again.
You will have THREE chance
s to land the device before the game en
ds.
Remember that you can only
use THIRTY fuel units.When there
are none left,you will drop."
1630 PRINT" PRESS 'SPACE' TO CONTINUE
"
1640 IF INKEY#="" THEN GOTO 1660
1650 GOTO 1640
1660 CLS
1670 PRINT"*****CONTROL S*****
*****"
1680 PRINT
1690 PRINT
1700 PRINT
1710 INPUT" KEY FOR LEFT=";L#
1720 INPUT" KEY FOR RIGHT=";R#
1730 INPUT" KEY FOR THRUST=";T#
1740 RETURN

```

Program 1. Music.

```

10 FORT=0T02:FORX=0T0255
20 READA:IFA=-1THEN40
30 POKE36864+T*256+X,A:NEXTX
40 NEXTT
50 DATA169,146,141,21,3,169,0,141,20,3,96,-1
60 DATA169,234,141,21,3,169,49,141,20,3,96,-1
70 DATA172,0,147,192,17,240,57,206,1,147,173,1,147,201,0,208,44,238,0,147,169
80 DATA0,141,4,212,169,10,141,5,212,169,0,141,6,212,169,17,141,4,212,185,0,147
90 DATA185,0,148,141,1,212,185,0,149,141,0,212,185,0,150,141,1,147,76,49,234
100 DATA169,0,141,0,147,141,4,212,24,144,242,-1
110 POKE37632,0:POKE37633,0
120 FORT=0T0202:READHF,LF,D
130 POKE37888+T,HF:POKE38144+T,LF:POKE38400+T,D
140 NEXT:POKE37380,T+1
142 DATA28,49,8
143 DATA31,165,8,33,135,8,42,62,8,28,49,8
144 DATA31,165,8,33,135,8,42,62,8,28,49,8
145 DATA31,165,8,33,135,8,42,62,8,28,49,8
146 DATA31,165,8,33,135,8,42,62,8,28,49,8
147 DATA31,165,8,33,135,8,42,62,8,28,49,8
148 DATA31,165,8,33,135,8,42,62,8,28,49,8
149 DATA31,165,8,33,135,8,42,62,8,28,49,14
150 DATA21,31,14,21,31,14,22,96,14,22,96,14
160 DATA21,31,14,21,31,14,22,96,14,22,96,14
170 DATA21,31,14,21,31,14,22,96,14,22,96,14
180 DATA21,31,14,21,31,14,28,49,14,28,49,14
190 DATA26,156,30,37,162,14,37,162,30,37,162,14
200 DATA33,135,60,21,31,14,21,31,14,22,96,14
210 DATA22,96,14,21,31,14,21,31,14,22,96,14
220 DATA22,96,14,21,31,14,21,31,14,22,96,14
230 DATA22,96,14,21,31,14,21,31,14,28,49,14
240 DATA28,49,14,26,156,30,44,193,14,44,193,30
250 DATA44,193,14,42,62,60,21,31,14,37,162,14
260 DATA37,162,30,33,135,7,33,135,45,33,135,15
270 DATA31,165,14,31,165,30,33,135,7,31,165,7
280 DATA28,49,50,37,162,14,37,162,30,33,135,14
290 DATA33,135,30,33,135,14,31,165,14,31,165,30
300 DATA33,135,7,31,165,7,28,49,45,28,49,14
310 DATA28,49,14,31,165,14,31,165,14,28,49,14
320 DATA28,49,14,31,165,14,31,165,14,28,49,14
330 DATA28,49,14,31,165,14,31,165,14,28,49,14
340 DATA28,49,14,33,135,14,33,135,14,31,165,30
350 DATA21,31,14,22,96,14,18,209,14,21,31,14
360 DATA15,195,14,18,209,14,15,210,14,21,31,14
370 DATA22,96,14,18,209,14,21,31,14,16,195,14
380 DATA18,209,14,15,210,14,16,195,45,28,49,14
390 DATA31,165,14,33,135,14,28,49,14,31,165,14
400 DATA33,135,30,33,135,14,28,49,14,31,165,14
410 DATA33,135,30,31,165,14,28,49,14,33,135,14
420 DATA33,135,30,28,49,3,28,49,70
430 DATA28,49,14,31,165,14,33,135,14,28,49,14
440 DATA31,165,14,33,135,45,33,135,14,28,49,14
450 DATA31,165,14,33,135,45,31,165,14,28,49,14
460 DATA33,135,12,33,135,28,28,49,60,28,49,14
470 DATA44,193,45,50,60,7,44,193,7,37,162,14
480 DATA42,62,60,44,193,14,42,62,14,44,193,14
490 DATA42,62,14,28,49,14,37,162,45,33,135,28
500 DATA31,165,28,28,49,14,31,165,14,33,135,14
510 DATA28,49,14,31,165,14,33,135,45,31,165,14
520 DATA28,49,14,33,135,10,33,135,28,28,49,60
530 DATA42,62,12,42,62,12,42,62,12,42,62,12
540 DATA21,31,7,28,49,7,33,135,7,42,62,7
550 DATA39,223,12,39,223,12,39,223,12,39,223,12
560 DATA39,223,12,39,223,12,22,96,7,28,49,7
570 DATA33,135,7,42,62,35,31,165,14,28,49,14
580 DATA33,135,10,33,135,35,28,49,45
1000 POKE54296,15:SYS36864

```

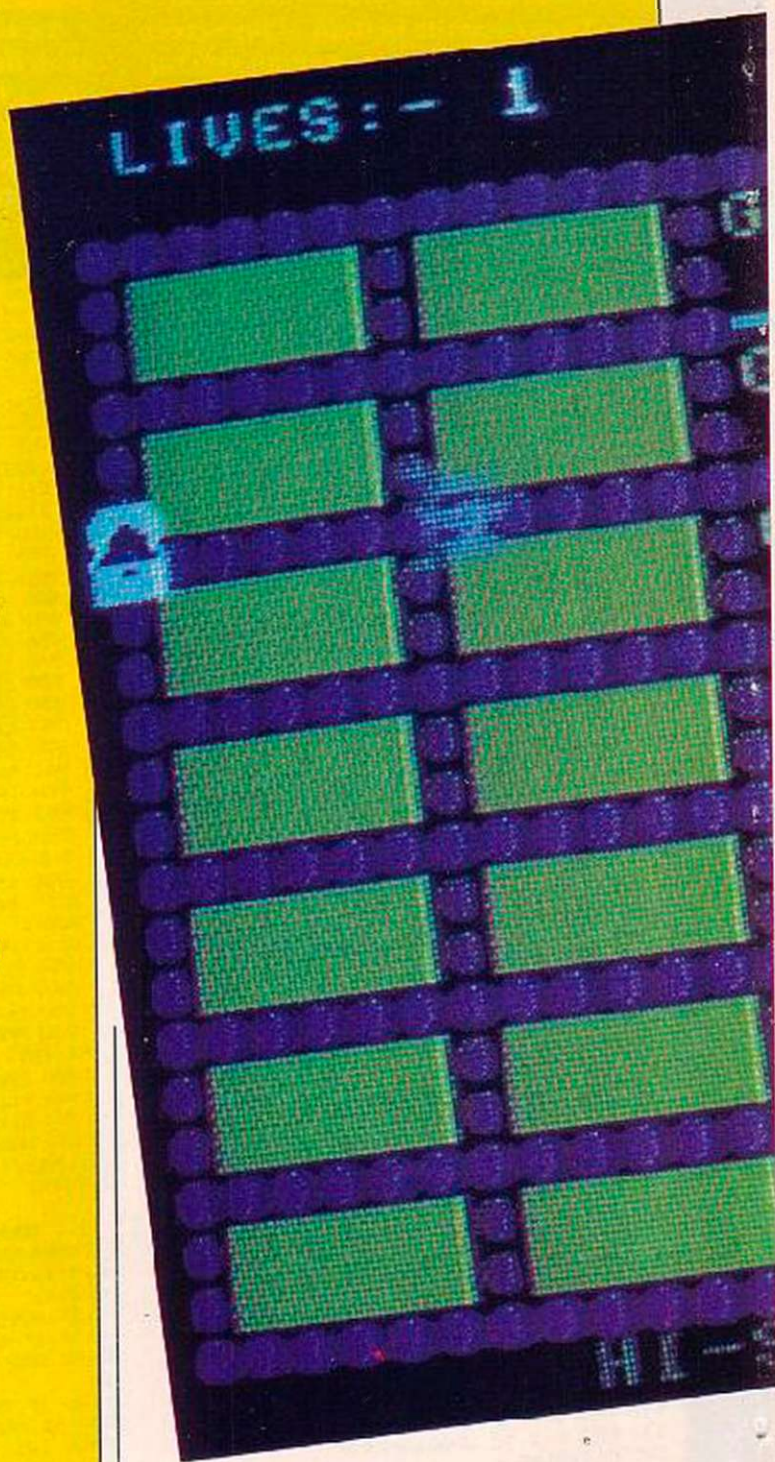

BULLION FOR THE CBM-64 is split into two parts: part one is loaded first and run. This part, called Music, uses the system interrupt to play the background music for the game. It is initiated by the command

SYS36864

and is stopped by the command

SYS36864+256

For this particular game I have stored the music data in locations 9000 (hex) onwards. There is, however, no reason why anybody with machine-code knowledge could not use this program to make music for their own games, and re-locate the data to wherever they wish.

In the listing for music, lines 10 to 40 are the loader, line 50 is the machine-code data to

Locations and their uses.

| | | | | |
|---------|--|-------------------------|---------|---|
| 251 | This holds the direction of your man. 1 = left; 2 = right; 3 = up; 4 = down. | number one's direction. | 679-686 | These store the Y positions of the grid for use in comparisons for sprite movement |
| 252-253 | These hold the X and Y position used in the Kernel Print Routine to print the man's footsteps. | 164 | 711-716 | These locations are used to store the vertical positions of the grid for use in the check block routines. |
| 255 | This holds monster | | 700-706 | These hold the X positions. |
| | | | 620 | This location is used to call the "Pirates" again. |

(continued from previous page)

```

652 REM ***** MOVE LEFT *****
653 DATA 0,208,201,30,208,7,173,16,208,41,1,240,16,56,208,0,208
654 DATA 208,0,208,208,9,173,16
655 DATA 208,73,1,141,16,208,24,76,0,194
656 REM ***** MOVE RIGHT *****
657 DATA 0,208,201,12,208,7,173,16,208,41,1,208,16,24,238,0,208
658 DATA 208,0,208,208,9
659 DATA 173,16,208,73,1,141,16,208,24,76,0,154,-1
660 REM ***** FINI X CO-ORDINATE *****
661 DATA 0,208,162,0,56,233,8,144,3,208,208,248,136,192,2,48,1,24,144,5
662 DATA 24,165,32,168,132,232
663 REM ***** FINI Y CO-ORDINATE *****
664 DATA 1,208,162,0,56,233,8,144,3,232,208,248,202,202,202,202,202,134,253
665 REM ***** PLOT CURSOR POSITION *****
666 DATA 164,252,166,252,32,248,255,165,208,148,257
667 REM ***** PRINT COLOUR UNDER CURSOR *****
668 DATA 156,32,210,255,169,113,32,210,255,76,0,135,-1
669 REM ***** LOAD ONE'S *****
670 DATA 0,169,1,153,208,2,208,192,41,240,3,24,144,243
671 REM ***** CHECK BLOCKS 1-5 TOP LINE *****
672 DATA 2,162,1,185,80,4,201,81,208,16,152,221,199,2,240,3,200,208,240
673 DATA 2,162,1,185,80,4,201,81,208,16,152,221,199,2,240,3,200,208,240
674 REM ***** CHECK BOTTOM LINE *****
675 DATA 2,162,1,185,208,4,201,81,208,16,152,221,199,2,240,3,200,208,240
676 REM ***** CHECK UPRIGHTS *****
677 DATA 2,162,1,185,120,4,201,81,208,11,192,32,240,19,189,199,2,168,232
678 DATA 208,238,169,0,157,205,2,202,157,205,2,232,208,233
679 DATA 2,162,1,185,168,4,201,81,208,11,192,32,240,19,189,199,2,168,232
680 DATA 208,238,169,0,157,205,2,202,157,205,2,232,208,233
681 REM ***** CHECK BLOCKS 6-10 *****
682 DATA 2,162,1,185,208,4,201,81,208,16,152,221,199,2,240,3,200,208,240
683 DATA 2,162,1,185,208,4,201,81,208,16,152,221,199,2,240,3,200,208,240
684 REM ***** CHECK BOTTOM LINE *****
685 DATA 2,162,1,185,80,4,201,81,208,16,152,221,199,2,240,3,200,208,240
686 DATA 2,162,1,185,80,4,201,81,208,16,152,221,199,2,240,3,200,208,240
687 REM ***** CHECK UPRIGHTS *****
688 DATA 2,162,1,185,120,4,201,81,208,11,192,32,240,19,189,199,2,168,232
689 DATA 208,238,169,0,157,205,2,202,157,205,2,232,208,233
690 DATA 2,162,1,185,168,4,201,81,208,11,192,32,240,19,189,199,2,168,232
691 DATA 208,238,169,0,157,205,2,202,157,205,2,232,208,233
692 REM ***** CHECK BLOCKS 11-15 *****
693 DATA 2,162,1,185,80,4,201,81,208,16,152,221,199,2,240,3,200,208,240
694 DATA 2,162,1,185,80,4,201,81,208,16,152,221,199,2,240,3,200,208,240
695 REM ***** CHECK BOTTOM LINE *****
696 DATA 2,162,1,185,208,4,201,81,208,16,152,221,199,2,240,3,200,208,240
697 DATA 2,162,1,185,208,4,201,81,208,16,152,221,199,2,240,3,200,208,240
698 REM ***** CHECK UPRIGHTS *****
699 DATA 2,162,1,185,120,4,201,81,208,11,192,32,240,19,189,199,2,168,232
700 DATA 208,238,169,0,157,205,2,202,157,205,2,232,208,233
701 REM ***** CHECK BLOCKS 16-20 *****
702 DATA 2,162,1,185,80,4,201,81,208,16,152,221,199,2,240,3,200,208,240
703 DATA 2,162,1,185,80,4,201,81,208,16,152,221,199,2,240,3,200,208,240
704 REM ***** CHECK BOTTOM LINE *****
705 DATA 2,162,1,185,208,4,201,81,208,16,152,221,199,2,240,3,200,208,240
706 DATA 2,162,1,185,208,4,201,81,208,16,152,221,199,2,240,3,200,208,240
707 REM ***** CHECK UPRIGHTS *****
708 DATA 2,162,1,185,120,4,201,81,208,11,192,32,240,19,189,199,2,168,232
709 DATA 208,238,169,0,157,205,2,202,157,205,2,232,208,233
710 REM ***** CHECK BLOCKS 21-25 *****
711 DATA 2,162,1,185,80,4,201,81,208,16,152,221,199,2,240,3,200,208,240
712 DATA 2,162,1,185,80,4,201,81,208,16,152,221,199,2,240,3,200,208,240
713 REM ***** CHECK BOTTOM LINE *****
714 DATA 2,162,1,185,208,4,201,81,208,16,152,221,199,2,240,3,200,208,240
715 DATA 2,162,1,185,208,4,201,81,208,16,152,221,199,2,240,3,200,208,240
716 REM ***** CHECK UPRIGHTS *****
717 DATA 2,162,1,185,120,4,201,81,208,11,192,32,240,19,189,199,2,168,232
718 DATA 208,238,169,0,157,205,2,202,157,205,2,232,208,233
719 REM ***** CHECK BLOCKS 26-30 *****
720 DATA 2,162,1,185,80,4,201,81,208,16,152,221,199,2,240,3,200,208,240
721 DATA 2,162,1,185,80,4,201,81,208,16,152,221,199,2,240,3,200,208,240
722 REM ***** CHECK BOTTOM LINE *****
723 DATA 2,162,1,185,208,4,201,81,208,16,152,221,199,2,240,3,200,208,240
724 DATA 2,162,1,185,208,4,201,81,208,16,152,221,199,2,240,3,200,208,240
725 REM ***** CHECK UPRIGHTS *****
726 DATA 2,162,1,185,120,4,201,81,208,11,192,32,240,19,189,199,2,168,232
727 DATA 208,238,169,0,157,205,2,202,157,205,2,232,208,233
728 REM ***** CHECK BLOCKS 31-35 *****
729 DATA 2,162,1,185,80,4,201,81,208,16,152,221,199,2,240,3,200,208,240
730 DATA 2,162,1,185,80,4,201,81,208,16,152,221,199,2,240,3,200,208,240
731 REM ***** CHECK BOTTOM LINE *****
732 DATA 2,162,1,185,208,4,201,81,208,16,152,221,199,2,240,3,200,208,240
733 DATA 2,162,1,185,208,4,201,81,208,16,152,221,199,2,240,3,200,208,240
734 REM ***** CHECK UPRIGHTS *****
735 DATA 2,162,1,185,120,4,201,81,208,11,192,32,240,19,189,199,2,168,232
736 DATA 208,238,169,0,157,205,2,202,157,205,2,232,208,233
737 REM ***** CHECK BLOCKS 36-40 *****
738 DATA 2,162,1,185,80,4,201,81,208,16,152,221,199,2,240,3,200,208,240
739 DATA 2,162,1,185,80,4,201,81,208,16,152,221,199,2,240,3,200,208,240
740 REM ***** CHECK BOTTOM LINE *****
741 DATA 2,162,1,185,208,4,201,81,208,16,152,221,199,2,240,3,200,208,240
742 DATA 2,162,1,185,208,4,201,81,208,16,152,221,199,2,240,3,200,208,240
743 REM ***** CHECK UPRIGHTS *****
744 DATA 2,162,1,185,120,4,201,81,208,11,192,32,240,19,189,199,2,168,232
745 DATA 208,238,169,0,157,205,2,202,157,205,2,232,208,233
746 REM ***** CHECK BLOCKS 41-45 *****
747 DATA 2,162,1,185,80,4,201,81,208,16,152,221,199,2,240,3,200,208,240
748 DATA 2,162,1,185,80,4,201,81,208,16,152,221,199,2,240,3,200,208,240
749 REM ***** CHECK BOTTOM LINE *****
750 DATA 2,162,1,185,208,4,201,81,208,16,152,221,199,2,240,3,200,208,240
751 DATA 2,162,1,185,208,4,201,81,208,16,152,221,199,2,240,3,200,208,240
752 REM ***** CHECK UPRIGHTS *****
753 DATA 2,162,1,185,120,4,201,81,208,11,192,32,240,19,189,199,2,168,232
754 DATA 208,238,169,0,157,205,2,202,157,205,2,232,208,233
755 REM ***** CHECK BLOCKS 46-50 *****
756 DATA 2,162,1,185,80,4,201,81,208,16,152,221,199,2,240,3,200,208,240
757 DATA 2,162,1,185,80,4,201,81,208,16,152,221,199,2,240,3,200,208,240
758 REM ***** CHECK BOTTOM LINE *****
759 DATA 2,162,1,185,208,4,201,81,208,16,152,221,199,2,240,3,200,208,240
760 DATA 2,162,1,185,208,4,201,81,208,16,152,221,199,2,240,3,200,208,240
761 REM ***** CHECK UPRIGHTS *****
762 DATA 2,162,1,185,120,4,201,81,208,11,192,32,240,19,189,199,2,168,232
763 DATA 208,238,169,0,157,205,2,202,157,205,2,232,208,233
764 REM ***** CHECK BLOCKS 51-55 *****
765 DATA 2,162,1,185,80,4,201,81,208,16,152,221,199,2,240,3,200,208,240
766 DATA 2,162,1,185,80,4,201,81,208,16,152,221,199,2,240,3,200,208,240
767 REM ***** CHECK BOTTOM LINE *****
768 DATA 2,162,1,185,208,4,201,81,208,16,152,221,199,2,240,3,200,208,240
769 DATA 2,162,1,185,208,4,201,81,208,16,152,221,199,2,240,3,200,208,240
770 REM ***** CHECK UPRIGHTS *****
771 DATA 2,162,1,185,120,4,201,81,208,11,192,32,240,19,189,199,2,168,232
772 DATA 208,238,169,0,157,205,2,202,157,205,2,232,208,233
773 REM ***** CHECK BLOCKS 56-60 *****
774 DATA 2,162,1,185,80,4,201,81,208,16,152,221,199,2,240,3,200,208,240
775 DATA 2,162,1,185,80,4,201,81,208,16,152,221,199,2,240,3,200,208,240
776 REM ***** CHECK BOTTOM LINE *****
777 DATA 2,162,1,185,208,4,201,81,208,16,152,221,199,2,240,3,200,208,240
778 DATA 2,162,1,185,208,4,201,81,208,16,152,221,199,2,240,3,200,208,240
779 REM ***** CHECK UPRIGHTS *****
780 DATA 2,162,1,185,120,4,201,81,208,11,192,32,240,19,189,199,2,168,232
781 DATA 208,238,169,0,157,205,2,202,157,205,2,232,208,233
782 REM ***** CHECK BLOCKS 61-65 *****
783 DATA 2,162,1,185,80,4,201,81,208,16,152,221,199,2,240,3,200,208,240
784 DATA 2,162,1,185,80,4,201,81,208,16,152,221,199,2,240,3,200,208,240
785 REM ***** CHECK BOTTOM LINE *****
786 DATA 2,162,1,185,208,4,201,81,208,16,152,221,199,2,240,3,200,208,240
787 DATA 2,162,1,185,208,4,201,81,208,16,152,221,199,2,240,3,200,208,240
788 REM ***** CHECK UPRIGHTS *****
789 DATA 2,162,1,185,120,4,201,81,208,11,192,32,240,19,189,199,2,168,232
790 DATA 208,238,169,0,157,205,2,202,157,205,2,232,208,233
791 REM ***** CHECK BLOCKS 66-70 *****
792 DATA 2,162,1,185,80,4,201,81,208,16,152,221,199,2,240,3,200,208,240
793 DATA 2,162,1,185,80,4,201,81,208,16,152,221,199,2,240,3,200,208,240
794 REM ***** CHECK BOTTOM LINE *****
795 DATA 2,162,1,185,208,4,201,81,208,16,152,221,199,2,240,3,200,208,240
796 DATA 2,162,1,185,208,4,201,81,208,16,152,221,199,2,240,3,200,208,240
797 REM ***** CHECK UPRIGHTS *****
798 DATA 2,162,1,185,120,4,201,81,208,11,192,32,240,19,189,199,2,168,232
799 DATA 208,238,169,0,157,205,2,202,157,205,2,232,208,233
800 REM ***** CHECK BLOCKS 71-75 *****
801 DATA 2,162,1,185,80,4,201,81,208,16,152,221,199,2,240,3,200,208,240
802 DATA 2,162,1,185,80,4,201,81,208,16,152,221,199,2,240,3,200,208,240
803 REM ***** CHECK BOTTOM LINE *****
804 DATA 2,162,1,185,208,4,201,81,208,16,152,221,199,2,240,3,200,208,240
805 DATA 2,162,1,185,208,4,201,81,208,16,152,221,199,2,240,3,200,208,240
806 REM ***** CHECK UPRIGHTS *****
807 DATA 2,162,1,185,120,4,201,81,208,11,192,32,240,19,189,199,2,168,232
808 DATA 208,238,169,0,157,205,2,202,157,205,2,232,208,233
809 REM ***** CHECK BLOCKS 76-80 *****
810 DATA 2,162,1,185,80,4,201,81,208,16,152,221,199,2,240,3,200,208,240
811 DATA 2,162,1,185,80,4,201,81,208,16,152,221,199,2,240,3,200,208,240
812 REM ***** CHECK BOTTOM LINE *****
813 DATA 2,162,1,185,208,4,201,81,208,16,152,221,199,2,240,3,200,208,240
814 DATA 2,162,1,185,208,4,201,81,208,16,152,221,199,2,240,3,200,208,240
815 REM ***** CHECK UPRIGHTS *****
816 DATA 2,162,1,185,120,4,201,81,208,11,192,32,240,19,189,199,2,168,232
817 DATA 208,238,169,0,157,205,2,202,157,205,2,232,208,233
818 REM ***** CHECK BLOCKS 81-85 *****
819 DATA 2,162,1,185,80,4,201,81,208,16,152,221,199,2,240,3,200,208,240
820 DATA 2,162,1,185,80,4,201,81,208,16,152,221,199,2,240,3,200,208,240
821 REM ***** CHECK BOTTOM LINE *****
822 DATA 2,162,1,185,208,4,201,81,208,16,152,221,199,2,240,3,200,208,240
823 DATA 2,162,1,185,208,4,201,81,208,16,152,221,199,2,240,3,200,208,240
824 REM ***** CHECK UPRIGHTS *****
825 DATA 2,162,1,185,120,4,201,81,208,11,192,32,240,19,189,199,2,168,232
826 DATA 208,238,169,0,157,205,2,202,157,205,2,232,208,233
827 REM ***** CHECK BLOCKS 86-90 *****
828 DATA 2,162,1,185,80,4,201,81,208,16,152,221,199,2,240,3,200,208,240
829 DATA 2,162,1,185,80,4,201,81,208,16,152,221,199,2,240,3,200,208,240
830 REM ***** CHECK BOTTOM LINE *****
831 DATA 2,162,1,185,208,4,201,81,208,16,152,221,199,2,240,3,200,208,240
832 DATA 2,162,1,185,208,4,201,81,208,16,152,221,199,2,240,3,200,208,240
833 REM ***** CHECK UPRIGHTS *****
834 DATA 2,162,1,185,120,4,201,81,208,11,192,32,240,19,189,199,2,168,232
835 DATA 208,238,169,0,157,205,2,202,157,205,2,232,208,233
836 REM ***** CHECK BLOCKS 91-95 *****
837 DATA 2,162,1,185,80,4,201,81,208,16,152,221,199,2,240,3,200,208,240
838 DATA 2,162,1,185,80,4,201,81,208,16,152,221,199,2,240,3,200,208,240
839 REM ***** CHECK BOTTOM LINE *****
840 DATA 2,162,1,185,208,4,201,81,208,16,152,221,199,2,240,3,200,208,240
841 DATA 2,162,1,185,208,4,201,81,208,16,152,221,199,2,240,3,200,208,240
842 REM ***** CHECK UPRIGHTS *****
843 DATA 2,162,1,185,120,4,201,81,208,11,192,32,240,19,189,199,2,168,232
844 DATA 208,238,169,0,157,205,2,202,157,205,2,232,208,233
845 REM ***** CHECK BLOCKS 96-100 *****
846 DATA 2,162,1,185,80,4,201,81,208,16,152,221,199,2,240,3,200,208,240
847 DATA 2,162,1,185,80,4,201,81,208,16,152,221,199,2,240,3,200,208,240
848 REM ***** CHECK BOTTOM LINE *****
849 DATA 2,162,1,185,208,4,201,81,208,16,152,221,199,2,240,3,200,208,240
850 DATA 2,162,1,185,208,4,201,81,208,16,152,221,199,2,240,3,200,208,240
851 REM ***** CHECK UPRIGHTS *****
852 DATA 2,162,1,185,120,4,201,81,208,11,192,32,240,19,189,199,2,168,232
853 DATA 208,238,169,0,157,205,2,202,157,205,2,232,208,233
854 REM ***** CHECK BLOCKS 101-105 *****
855 DATA 2,162,1,185,80,4,201,81,208,16,152,221,199,2,240,3,200,208,240
856 DATA 2,162,1,185,80,4,201,81,208,16,152,221,199,2,240,3,200,208,240
857 REM ***** CHECK BOTTOM LINE *****
858 DATA 2,162,1,185,208,4,201,81,208,16,152,221,199,2,240,3,200,208,240
859 DATA 2,162,1,185,208,4,201,81,208,16,152,221,199,2,240,3,200,208,240
860 REM ***** CHECK UPRIGHTS *****
861 DATA 2,162,1,185,120,4,201,81,208,11,192,32,240,19,189,199,2,168,232
862 DATA 208,238,169,0,157,205,2,202,157,205,2,232,208,233
863 REM ***** CHECK BLOCKS 106-110 *****
864 DATA 2,162,1,185,80,4,201,81,208,16,152,221,199,2,240,3,200,208,240
865 DATA 2,162,1,185,80,4,201,81,208,16,152,221,199,2,240,3,200,208,240
866 REM ***** CHECK BOTTOM LINE *****
867 DATA 2,162,1,185,208,4,201,81,208,16,152,221,199,2,240,3,200,208,240
868 DATA 2,162,1,185,208,4,201,81,208,16,152,221,199,2,240,3,200,208,240
869 REM ***** CHECK UPRIGHTS *****
869 DATA 2,162,1,185,120,4,201,81,208,11,192,32,240,19,189,199,2,168,232
870 DATA 208,238,169,0,157,205,2,202,157,205,2,232,208,233

```

```

870 DATA 0,173,3,208,217,167,2,240,8,200,192,0,208,246,76,0,202,169,0,133
871 DATA 255,76,0,202
872 DATA 0,173,3,208,217,167,2,240,8,200,192,0,208,246,76,0,202,169,2,133
873 DATA 255,76,0,202,-1
874 DATA 255,201,1,2,0,30,201,2,140,56,201,0,240,11
875 DATA 173,3,208,201,228,240,3,238,3,208,96
876 DATA 173,3,208,201,62,240,3,206,3,208,96
877 DATA 173,2,208,201,30,208,7,173,16,208,41,2,240,15,56,206,2,208,208,9,173,16
878 DATA 208,73,2,141,16,208,24,56
879 DATA 2,200,201,16,208,7,173,16,208,41,2,200,10,2,238,2,208,208,9
880 DATA 173,16,208,73,2,141,16,208,24,56,-1
881 REM ***** MONSTER #2 MOVE *****
882 REM *****
883 REM *****
884 REM *****
885 REM *****
886 REM *****
887 REM *****
888 REM *****
889 REM *****
890 REM *****
891 REM *****
892 REM *****
893 REM *****
894 REM *****
895 REM *****
896 REM *****
897 REM *****
898 REM *****
899 REM *****
900 REM *****
901 REM *****
902 REM *****
903 REM *****
904 REM *****
905 REM *****
906 REM *****
907 REM *****
908 REM *****
909 REM *****
910 REM *****
911 REM *****
912 REM *****
913 REM *****
914 REM *****
915 REM *****
916 REM *****
917 REM *****
918 REM *****
919 REM *****
920 REM *****
921 REM *****
922 REM *****
923 REM *****
924 REM *****
925 REM *****
926 REM *****
927 REM *****
928 REM *****
929 REM *****
930 REM *****
931 REM *****
932 REM *****
933 REM *****
934 REM *****
935 REM *****
936 REM *****
937 REM *****
938 REM *****
939 REM *****
940 REM *****
941 REM *****
942 REM *****
943 REM *****
944 REM *****
945 REM *****
946 REM *****
947 REM *****
948 REM *****
949 REM *****
950 REM *****
951 REM *****
952 REM *****
953 REM *****
954 REM *****
955 REM *****
956 REM *****
957 REM *****
958 REM *****
959 REM *****
960 REM *****
961 REM *****
962 REM *****
963 REM *****
964 REM *****
965 REM *****
966 REM *****
967 REM *****
968 REM *****
969 REM *****
970 REM *****
971 REM *****
972 REM *****
973 REM *****
974 REM *****
975 REM *****
976 REM *****
977 REM *****
978 REM *****
979 REM *****
980 REM *****
981 REM *****
982 REM *****
983 REM *****
984 REM *****
985 REM *****
986 REM *****
987 REM *****
988 REM *****
989 REM *****
990 REM *****
991 REM *****
992 REM *****
993 REM *****
994 REM *****
995 REM *****
996 REM *****
997 REM *****
998 REM *****
999 REM *****
1000 REM *****
1001 REM *****
1002 REM *****
1003 REM *****
1004 REM *****
1005 REM *****
1006 REM *****
1007 REM *****
1008 REM *****
1009 REM *****
1010 REM *****
1011 REM *****
1012 REM *****
1013 REM *****
1014 REM *****
1015 REM *****
1016 REM *****
1017 REM *****
1018 REM *****
1019 REM *****
1020 REM *****
1021 REM *****
1022 REM *****
1023 REM *****
1024 REM *****
1025 REM *****
1026 REM *****
1027 REM *****
1028 REM *****
1029 REM *****
1030 REM *****
1031 REM *****
1032 REM *****
1033 REM *****
```



They're here! Two of the world's most sophisticated, imaginative languages.

LOGO and micro-PROLOG.

Now they're both available for the 48K Spectrum. So you can sample the programs thousands of computer owners can only talk about!

LOGO and micro-PROLOG are exciting, new-generation languages. They let you create descriptive, imaginative and powerful programs.

And—for such sophisticated languages—they're available at astonishingly low prices: £24.95 for micro-PROLOG and £39.95 for LOGO!

LOGO is a powerful programming language based on logic.

It's very easy to learn, so it's proved highly successful in schools.

LOGO puts you in command of a graphic 'turtle' (a moving, on-screen cursor). Each program instruction you make has a direct effect on the turtle. You can change its

position, alter the direction it points in, and then use it to create complex shapes, images or designs.

With LOGO, you've the means to develop very imaginative ideas—and see the results immediately!

The Sinclair version of LOGO comes with two comprehensive manuals. It features turtle graphics, colour and sound, and has full list processing capabilities. It's also Microdrive-compatible, and can control a mechanical turtle or robot.

micro-PROLOG lets you explore powerful aspects of artificial intelligence.

It's a fifth generation language, specially adapted from PROLOG—the language chosen by the Japanese for the next generation of artificial intelligence machines.

Using micro-PROLOG, you develop a dialogue with your computer. First, it allows you to construct a database of relationships

using simple English phrases. And then, you can ask the computer questions relating to the database.

Your micro-PROLOG package includes a front-end program called SIMPLE (for newcomers to the language), plus a User Manual and 300-page Primer. For more advanced users, a micro-PROLOG Reference Manual is available separately at £9.95.

Without doubt, LOGO and micro-PROLOG set new standards for future computer languages. You'll find them in major stores and all good computer shops—or from Griffin & George, E.J. Arnold and EDCO.

Sinclair Research Ltd. Camberley (0276) 685311.

© Sinclair, ZX and ZX Spectrum are trade marks of Sinclair Research Ltd.

sinclair

CheetahSoft



Soft we're not

FOR SPECTRUM 48K



CONQUEST

CONQUEST A tactical game which even veteran players will find both challenging and rewarding.

Mediterranean Europe is divided into grid squares. Your aim, as Emperor, is to gain 100 squares of territory as quickly as possible – at the same time dealing with Barbarian counter-attacks, plagues, civil war and rival Emperors.

5 levels of skill, plus a continuous 'Conquest' game where all the difficulty levels are thrown in together.

3D BAT ATTACK An all action, 3 dimensional maze game where you gather up blocks of gold, at the same time pitting your wits against vicious vampire bats whose only purpose in life is to locate, hunt and kill you.

4 levels of skill. At each level the game gets faster and more complicated, and the vampires more dangerous.

CheetahSoft



Soft we're not

FOR SPECTRUM 48K



3D BAT ATTACK

AFTER THESE, THE REST IS KIDS STUFF.

Are you ready for CheetahSoft?

There's only one way to find out.

But be warned: these vampire bats know a good meal when they see one. And our friend with the scythe has had years of experience...

CheetahSoft

Soft we're not



So don't play unless you're ready to play the game for real. Because you'll find there's one sure thing about CheetahSoft: Soft we're not.

£6.95 at all good stores.

THE KEY TO PROFESSIONAL GAMES DESIGN ON THE SPECTRUM 48K

THE GAMES LANGUAGE OF THE 80'S!

Now, without any knowledge of machine code, you can write fast, smooth, professional, totally original games and market them **without paying royalties**.

Even if you have already mastered machine code, we believe that the time and problems saved by writing in **White Lightning's** FORTH-based high level language could revolutionise commercial games writing for years to come.

IDEAL IDEAL is an interrupt Driven Extendible Animation sub Language. Once you have mastered IDEAL's easy to learn set of over 80 commands and just a little FORTH, you will be ready to produce a 'race-quality' game even if you don't know machine code. Up to 255 Sprites, each with its own user-defined dimensions can be moved around the screen (or memory), scrolled, spun, reflected, enlarged or inverted with amazing speed and smoothness. Operations are possible between screen windows, Sprites and Sprite windows. Sprites can even stretch across several screens, so those difficult scrolling landscapes that form the basis of so many games are easy to achieve. Sinclair's own sound and graphics commands such as CIRCLE, DRAW and BEEP are fully supported, and there are some unique collision detection facilities.

MULTI-TASKING Because **White Lightning** uses interrupts, you can effectively run two programs at once. This means of course, that games like *Space Invaders* and *Defender* can be written without complex timing calculations. So while one

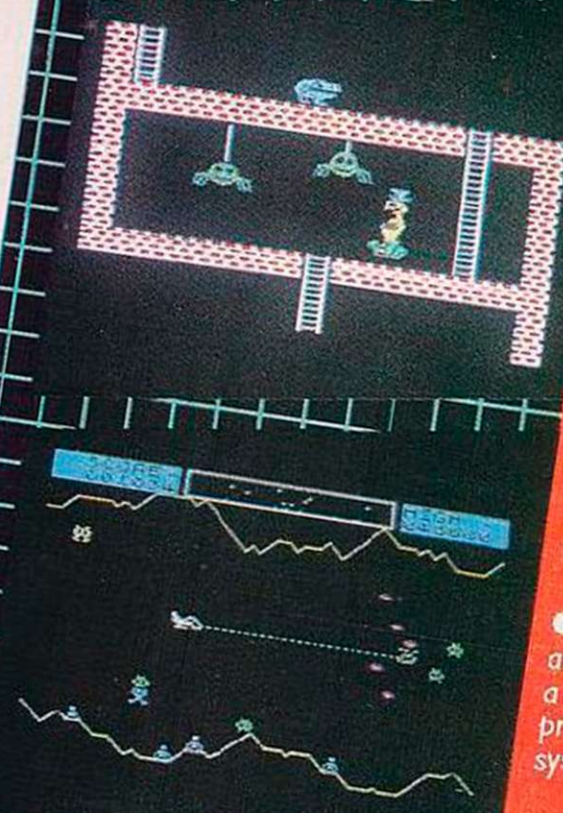

- Produces real machine code programs which run independently of **White Lightning**.

- A multi-tasking animation language AND a Sprite Development program together in one system-pack.

WHITE LIGHTNING

program smoothly scrolls the landscape, the second animates the other characters. This is undoubtedly one of **White Lightning's** most powerful features.

MARKETING AND PORTABILITY Although **White Lightning** uses an integer FORTH as its host language, programs can be written in a combination of BASIC, FORTH, IDEAL and machine language.

What is more, programs written in FORTH/IDEAL will be highly portable between the Spectrum and implementations under development for other popular micros.

When it comes to marketing your completed games, there's no problem either. In fact Oasis themselves will offer to market outstanding software.

SPRITE DESIGN **White Lightning** comes complete with a separate 20K program for developing the Sprites used in the main system. Not only can you use this to design your own Sprites from scratch, it also comes complete with 168 pre-defined characters covering games like *Asteroids*, *Pac-Man*, *Assault Course*, *Defender*, *Space Invaders*, *City Bomber*, *Lunar Lander*, *Frogger*, *Centipede*, *Donkey Kong* and many, many, more. These characters are ready to use or can be enhanced. And Sprites can be saved to tape between editing sessions before being finally loaded into the main program.

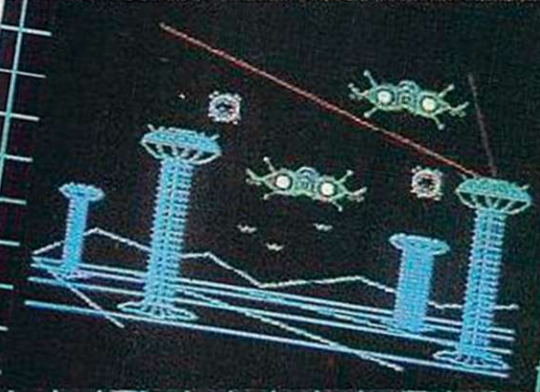

- Supplied with a FREE 16-minute demo, and a 130-page, easy-to-follow manual.



The High Level
Graphics Development
System for the
SPECTRUM 48K.....

OASIS SOFTWARE

AND COMING SOON!
the power of **White
Lightning** on the
COMMODORE 64!

If your local dealer doesn't stock **White Lightning**, just send off this coupon for our rapid-despatch service.

Please send me White Lightning System Packs at £14.95 each. I enclose my cheque/P.C. for £.....

Name: _____
Address: _____

Oasis Software 9a Alexandra Parade, Weston-super-Mare, Avon, BS23 1QT Telephone: (0934) 419921. Every product carries a lifetime guarantee. All prices include extensive manual, VAT and p&p.

24 Hour
Access Tele-ordering on (0934) 419921.

```

1MODE4:PROCI
20DIFAX(30),CX(30),EX(30),DX(2),BX(4,
2),E(2),A(5):PROCC:PROCSG:ME=0:YOU=0:
TV255
30MODE5:PROCC:PRINT"BACKGAMMON.":IN
PUT"Game level 1-6 .1V:1FLV/6 1V=6
40PRCCI:VDU28,0,31,19,1,12,26:PROCCD:
FORL2=1T024:PROCP:NEXT:PROCB:IX=RND(20):
gm=1
50PRULDI:1FJX(1)=DX(2) F40LUSD:GOTO50
60db=1:1FDX(1)DX(2) IX=DX(1):DX(1)=D
X(2):DX(2)=IX:db=-1:GOTO180
70PROCC:PRINT"my go with ";DX(1);":
DX(2):PROCB:PROCC:PRINT"MY MOVES-":FOR
IX=1TOM:IFBX(IX,1)=0ANDBX(IX,2)=0 PRINT"
0:0 ";:GOTO110
80IFEX(IX,1)=25 PRINTCHR$228:"CHR$(6
4+B%IX,2)";":GOTO110
90IFEX(IX,2)=0 PRINTCHR$(64+B%IX,1)
":CHR$227";":GOTO110
100PRINTCHR$(64+B%IX,1):CHR$(64+B%
(IX,2)";":
110NEXT:PROCP:PROCR:IFAX(27)=15 X=1:G
OTO250
120gm=1:1fdb>0 PROCC:GOTO170
130IFd=64THEN170ELSEPROCD9BC:IFA$<"D"
THEN170
140PROCG:PROCC:IF gm=1THEN160
150PROCDR:GOTO330
160db=1:PROCAD:PROCDSD
170PROCCI
180PROCC:PRINT"Your go with ";DX(1);":
";DX(2);PROCLG:IFgm<>1 VDU7:PRINTTAB(0,0
)'ILLEGAL-TRY AGAIN':PROCR:GOTO180
190PROCC:PRINT"YOUR MOVES-":FORIX=1TOM
:IFBX(IX,1)=0ANDBX(IX,2)=0 PRINT"0:0 ";:
GOTO530
200IFBX(IX,1)=0 PRINTCHR$228:"CHR$(64
+B%IX,2)";":GOTO230
210IFBX(IX,2)=25 PRINTCHR$(64+B%(IX,1)
):CHR$227";":GOTO230
220PRINTCHR$(64+B%(IX,1):CHR$(64+B%
(IX,2)";":
230NEXT:PROCP:IFA$(28)=-15 PROCC:X=0:
GOTO290
240PROCR:PROCC:gm=1:IFdb<0THEN280
250IFd=64THEN280ELSEPROCD7:IFgm=0THEN2
80
260PROCCD:IFA$="R" X=1:PROCDR:GOTO330
270db=-1:PROCAD:PROCDSD
280PROCCI:GOTO70
290gm=1:JX=19-18*X:IFA$(27+X)<>0THEN33
0
300gm=2:IFA$(F+X)<>0 gm=3:GOTO330
310FORIX=JX TOJX+5:IFA$(IX)<>0 gm=3
320NEXT
330CLS:Y=gm*d:IFX=1 PRINT"1";:ME=ME+Y:
GOTO350
340PRINT"YOU";:YOU=YOU+Y
350PRINT"ve won ";Y;":un.t";:IFY>1 PR
INT"s."
360IFgm=2 PRINT"(GAMMON)"
370IFgm=3 PRINT"(BACKGAMMON)"
380PRINT"my score";ME:PRINT"your sco
re";YOU:"Do you want another "game (Y/
N)?";:PRJCYN:CLS:GOTO30
390DEFPROCG
400gm=0:PROCRG:IFLX<50THEN420
410IFA$(29)+AX(A)<(3*LX+220)/40 gm=1:G
OTO430
420PROCR:IFPX<GX+2 gm=1
430ENDPROC
440DEFPROCRT
450PX=0:GX=0:FORIX=1T024:IFA$(IX)>0 PX
=PX+AX(IX)*INT((IX-1)/4+1)
460IFA$(IX)<0 GX=GX-AX(IX)*INT((24-IX)
/4+1)
470NEXT:PX=PX+AX(F)*7:GX=GX-AX(26)*7
480ENDPROC
490UL=PKULBBB
500C=1:KX=0:E(1)=KX:E(2)=KX:JX=C:IFCX(
26)<0 JX=2
510FORIX=1T024:IFCX(IX)<0 JX=2
520IFCX(IX)<0 C=1:GOTO570
530IFJX=2 KX=1
540IFCX(IX)=1 C=1:GOTO570
550E=h+S-IX:IF(E(1)-(E)h) E=1
560E(JX)=E(JX)+E(C):C=C+.5
570NEXT:B=E(2)+AX(A)-CX(A)+.01*(CX(27)
-AX(27)):IFKX>C B=B+e(E(1)+kw
580IFB<G THEN640
590E(1)=X:E(2)=Y:FORIX=1T0p1:IFCX(IX)<
0 THEN630
600DRS=1T02:LX=IX-5*(S-1):FORJX=1T36:
KX=h-JX-TFKX=C KX=-S:JX=6:S=2:GOTO620
610IFCX(KX)<C B=B-E(S)*(F-IX)
620NEXT:NEXT:IFKX<0 IFCX(26)<0 B=B-E(-
KX)*(F-IX)
630NEXT
640ENDPROC
650DEFPROCRG:LX=-AX(A):IFLX>AX(29) LX=
AX(29)
660ENDPROC
670DEFPROCDY:gm=0:PROCRG:IFLX>99THEN77
0
680JX=:IFA$(28)<0 JX=100
690(FLX<50THEN720)
700N=-AX(29)-AX(A):IF(N<(3*LX+100)/40)
-(N>35*JX) THEN770
710GOTO730
720PKULR1=N-GX-PX:IF(N:2)-(N)16*JX) THE
N770
730FORIX=1T07:JX=F-IX:IFA$(JX)>0 JX=IX
:IX=7
740NEXT:IFJX>7 gm=1:GOTO770

```

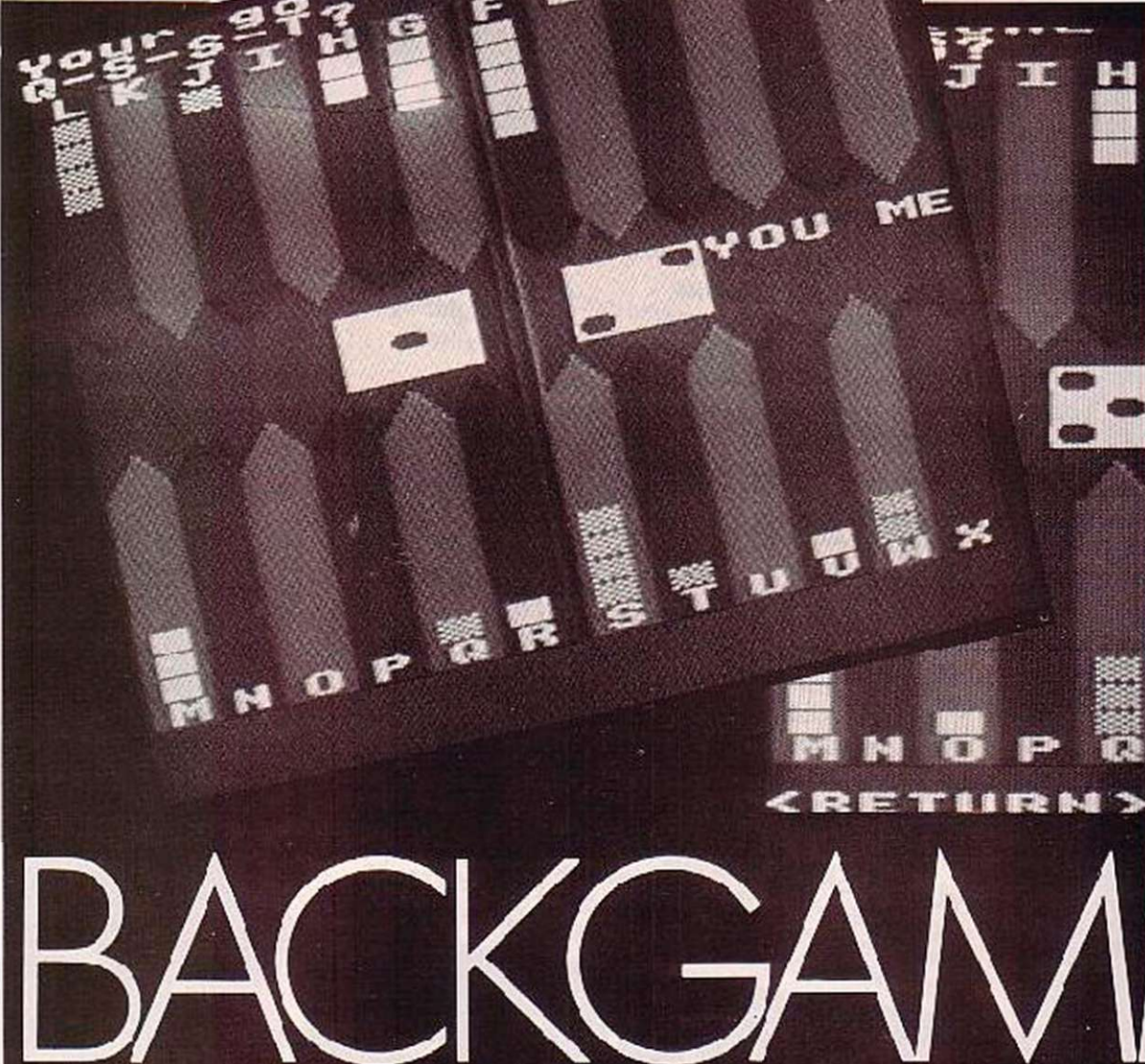

```

750KX=0:FORIX=JX TO12:JX=F-IX:IFA$(JX)
<-1 KX=KX+1
760NEXT:IFKX<4 gm=1
770ENDPROC
780DEFPROCBBC:M1=1:N=0:R=1:U=0:G=-999:
FORIX=1T03:EX(IX)=L:NEXT:p1=1B:h=5:px=.2
5:kw=U:IX=DX(1)+DX(2):1FDX(1)=DX(2) IX=1
X=2
790IX=IX-AX(25)-AX(A):IF IX<(3*AX(29)+
380)/40THEN810
800kw=-99:p1=13:h=1:ax=1
810PROCBBC:IFN=1 THEN850
820U=U+1:IF(U/1)*N(N) THEN850
830PROCBBC:IF(B-G)*(N-M) THEN810
840G=B:M1=N:FORIX=1TOM:EX(IX)=BX(IX,1)
:EX(IX+4)+BX(IX,2):NEXT:GOTO810
850FORIX=1TOM:BX(IX,1)=EX(IX):BX(IX,2)
=EX(IX+4):NEXT
860FORIX=1T0A:CX(IX)=AX(IX):NEXT:<F=1:
FORIX=1T0A:A1=BX(IX,1):A2=BX(IX,2):PROCM
:NEXT:FORIX=1T0A:AX(IX)=CX(IX):NEXT
870ENDPROC
880DEFPROCBBC:IFN>0THEN1130
890R=1
900N=1:GX=24:FORIX=1T0A:CX(IX)=AX(IX):
NEXT
910S1=0:1T-DX(R):IFN<0: 1T=DX(3-R)
920IFCX(F)=0THEN950
930KX=F-1T:IFCX(KX)<-1THEN1100
940BX(N,1)=F:BX(N,2)=KX:GOTO1080
950PX=0:FORJX=S1 TO1STFP-1:GX=JX:IFCX(
JX)<0THEN980
960KX=JX-1T:IFKX<0 PX=.1JX=1:GOTO980
970IFCX(KX)>=-1 PX=2:JX=1
980NEXT
990IFPX=0THEN1100
1000IFPX=1THEN1020
1010BX(N,1)=GX:BX(N,2)=KX:GOTO1080
1020IFKX=0 KX=7
1030IFKX=0 KX=GX+1
1040PX=0:FORIX=KX TO24:IFCX(IX)>0 PX=1:
IX=24
1050NEXT
1060IFPX=1THEN1100
1070BX(N,1)=GX:BX(N,2)=0
1080A1=BX(N,1):A2=BX(N,2):KF=1:PROCM:IF
N=N THEN1230
1090N=N+1:GOTO910
1100IFN>M1 THEN1220
1110IFN=1THEN1190
1120N=N-1
1130IFBX(N,1)=F THEN1190
1140IFBX(N,2)=0THEN1110
1150S1=BX(N,1)-1:IFS1<0THEN1110
1160FORIX=1T0A:CX(IX)=AX(IX):NEXT:(T=DX
(R):IFN<0: 1T=DX(3-R)
1170KX=N-1:IFKX=0THEN950
1180KF=1:FORIX=1T0KX:A1=BX(IX,1):A2=BX(
IX,2):PROCM:NEXT:GOTO950
1190IF(M=4)-(R=2) THEN1210
1200R=2:GOTO900
1210N=1
1220FORIX=N TOM:BX(IX,1)=0:BX(IX,2)=0:N
EXT:N=N-1
1230ENDPROC
1240DEFPROCM:IFA1=A2 THEN1320
1250LX=(G9-KF)/2:CX(LX)=CX(LX)+A2-A1:IF
A1=0 CX(26)=CX(26)+1:GOTO1290
1260IFA1=F CX(F)=CX(F)-1:GOTO1260
1270CX(A1)=CX(A1)-KF
1280IFA2=0 CX(27)=CX(27)+1:GOTO1320
1290IFA2=F CX(28)=CX(28)-1:GOTO1320
1300IFCX(A2)<>KF CX(A2)=CX(A2)+KF:GOTO
1320
1310CX(A2)=KF:LX=55-LX:CX(LX)=CX(LX)-KF
:LX=4+LX:CX(LX)=CX(LX)-A2:IFLX=25 CX(LX)
=CX(LX)+F
1320ENDPROC
1330DEFPROCLG:FORIX=1TOM:BX(IX,1)=0:BX(
IX,2)=0:NEXT
1340S=" "
1350*F4,1
1360PROCGT:*FX4,0
1370IFASC(A$)=13 VDU26:GOTO1450
1380IFASC(A$)=127 PRINTL$' 'L$F$;A$="
":GOTO1460
1390IX=ASC(A$)-64:IFIX=75 IX=25:A$=CHR$
227
1400IFIX=74 IX=C:A$=CHR$228
1410IF(IX)-1*(IX<26) 75=STR$IX:GOTO143
0
1420Z$=""
1430B$=B$-Z$
1440PRINTA$;:GOTO1350
1450PRINT:GOTO1310
1460B=LENB$:IFRIGHT$(B$,1)="" E=LEN(B$)
-1:GOTO1480
1470IF(IX)>? B=LEN(B$)-2ELSEB=LEN(B$)-1
1480IFB<0 PRINTTAB(0,1)A$;:GOTO1340
1490IFB<1THEN1350
1500B$=LEFT$(B$,B):GOTO1440
1510B=LEN(B$):KX=0:LX=1:FORIX=1TOM:UNJ
X=1T02
1520KX=KX-1:IFKX>B IX=M:JX=2:GOTO1570
1530A$=MID$(E$,KX,1):IFA$<>"- "THEN1560
1540IFLX=1 THEN1570
1550LX=1:GOTO1570
1560BX(IX,JX)=BX(IX,JX)+10+VALA$:LX=0:G
OTO1520
1570NEXT:NEXT:gm=0:FORIX=:T0A:CX(IX)=AX
(IX):NEXT:E(1)=DX(1):E(2)=DX(2):FORIX=1T
OM:M1=BX(IX,1):M2=BX(IX,2):IFM1<M2 THEN
1720
1580IFIX<>1THEN1630
1590KX=DX(1):PROCR:IFgm=0THEN1970
1600IFDX(1)=CX(2) THEN1680
1610KX=DX(2):PROCR:IFgm=1THEN1680
1620GOTO1970

```



BACKGAMMON ENABLES the user to play against the computer and instructions are included within the program. Briefly, the program plays the traditional rules of backgammon, including the use of a doubling cube. The points are labelled alphabetically from A to X. The dice are shown graphically as is whether the player or the computer has the doubling cube.

Moves are made by entering two pairs of information comprising the point from which a piece is to be moved and the destination point for each die.

For example, a six and three are thrown. To move a piece six places from the C point and a piece three places from the F point type C:J F:I. To move the piece the full nine places of the throw type C:I I:L. To return from the bar use the down arrow key as the point references. To bear off use the up arrow key as the destination.

The player must use both throws of the dice if at all possible. If this is not possible simply press Return after entering the move possible — if any can be made.

The program checks for legal moves and will not allow the player to cheat. The computer plays a strong game and on the lower levels will enable the novice to become familiar with backgammon. On the higher levels it presents a challenge for even the experienced player.

The program itself is written in compressed form.

```

1630K%=DZ(3-J%):PROCCOK:IFGM=>THEN1970
1640IFDX(3-J%)>DZ(J%)THEN1670
1650K%=DZ(J%):FORL=1TOA:EX(L%)-CZ(L%):
CZ(L%)=AX(L%):NEXT:PROCCOK:FORL=1TOA:CZ(
L%)=EX(L%):NEXT:IFGM=1THEN1980
1660GOTO1970
1670IFIX=1THEN1980
1680GM=0:JX=I%:R=0:FORK%=JX:TM=1FBX:
KX,1)>BX(KX,2):R=1:KX=M
1690NEXT
1700IFR=1THEN1970
1710GOTO1980
1720IF(M1(0)-(M1)24)THEN1970
1730IF(M2(1)-(M2)F)THEN1970
1740IFM1<0THEN1800
1750IFCZ(26)>0THEN1970
1760J%=0:FORK%=1TO2:IFM2=DZ(KX):JX=KX
1770NEXT:IFJX=0THEN1970
1780KX=CZ(M2):IFKX>1THEN1970
1790GOTO1950
1800IF(CZ(26)<0)-(CZ(M1)>0)THEN1970
1810IFM2=F:THEN1860
1820JX=CZ(M2):IFJX<1THEN1970
1830R=M2-M1:FR=DZ(1):JX=1:GOTO1950
1840IFR=DZ(2):JX=2:GOTO1950
1850GOTO1970
1860R=F-M1:S=0:FORK%=1TO2:JX=3-FX:IFR<
CZ(JX):S=1:KX=2
1870NEXT
1880IFS=0THEN1970
1890FORK%=1TO18:IFCZ(KX)<0:S=0:KX=18
1900NEXT
1910IFS=0THEN1970
1920IFR=DZ(3):THEN1950
1930KX=M1-1:FORK%=19TOX:IFCZ(LX)<0:S=
1:LX=KX
1940NEXT:IFS=0THEN1970
1950A1=M1:A2=M2:KP=1:PROCH:FM=2:DZ(JX)
=0
1960GOTO1990
1970GM=2
1980IX=M
1990NEXT
2000IFGM=2:DZ(1)=E(1):DZ(2)=E(2):GOTO20
20
2010GM=1:FORL=1TOA:AX(L%)-CZ(L%):NEXT
2020ENDPROC
2030DEFPROCOK:GR=0:IFCZ(26)=0THEN2060
2040IFCZ(LX)<2THEN2180
2050SUBROUT160
2060S=0:FORK%=1TO24:IFCZ(LX)>0THEN2090
2070KP=LX-KX:IFKP>24:S=LX:LX=24:GOTO209
0
2080IFCZ(KX)<1:S=1:LX=24
2090NEXT
2100IFS=0THEN2160
2110IFS=-1THEN2180
2120IFKP=F:KP=18
2130IFKP>F:KP=5-1

```

```

2140S=0:FORK%=1TOKP:IFCZ(LX)<0:S=1:LX=K
F
2150NEXT:IFG=>THEN2:00
2160GM=1
2170ENDPROC
2180DEFPROC
2190IF(LX=0)-(LX=F)THEN2320
2200VDL5,30:JX=AX(LX):FX=ABS(JX)
2210IFLX>12:DZ=295:AX=((LX-12)*100)-60:
MOVEAX,CX:GOTO2230
2220DZ=775:AX=((13-LX)*100)-60:MOVEAX,D
X
2230IF(LX>18)-(LX<7):AX=AX+20:MOVEAX,DZ
2240FORK%=5TO1STEP-1:IFPKK%:PROCC:PRIN
TNS:GCLO,0:DZ=DZ+32:MLVEAX,DZ:GOTO2300
2250IF(JX>KX)*(KX<5):PROCC:PRINTS:MC
VEAX,DZ:GCLO,3:PRINTM%DZ=DZ+32:MOVEAX,
DZ:GOTO2300
2260IF(JX<=KX)*(KX<5):PROCC:PRINTS:M
OVEAX,DZ:GCLO,3:PRINTY%DZ=DZ+32:MOVEAX,
DZ:GOTO2300
2270IFJX=KX:PROCC:PRINTS:MOVEAX,DZ:GC
LO,3:PRINTM%DZ=DZ+32:MOVEAX,DZ:GOTO230
0
2280IFJX=-KX:PROCC:PRINTS:MOVEAX,DZ:GC
LO,3:PRINTY%DZ=DZ+32:MOVEAX,DZ:GOTO23
00
2290PROCC:PRINTS:MOVEAX,DZ:GCLO,3:PR
INTR:GHT$(STR$(P%)),1:DZ=DZ+32:MOVEAX,DZ
2300IFLX>12:DZ=DZ-64:MOVEAX,DZ
2310NEXT:VDU4,23,1,0;0;0;0;0
2320ENDPROC
2330DEFPROCMP:FORL=1TOA:LX=BX(LX,1):PR
OCC:PROCC:IX=AX(LX,2):PROCC:PROCC:NEXT
:PROCC:ENDPROC
2340DEFPRCCB:PRINTTAB(0,17):PZ=7-INT(A
Z(F)/2):JZ=PZ+AZ(F):R=7-INT(-AZ(26)/2):F
X=R-AX(26):PRINTUS" "STRINGS(6,L%):
FORL=1TO15:IF(LX>PZ)*(LX<=JZ):PRINTUSM%
D%:
2350IF(LX>R)*(LX<=KX):PRINTUSY%D%:
2360NEXT:PRINTD%
2370ENDPROC
2380DEFPRCCAD:PROCC:PRINTTAB(0,0)"DOUBL
E ACCEPTED":ENDPROC
2390DEFPRCCSD:D=D:D=A-RIGHT$(STR$(D),
D):PRINTAB(15,15)" ":IFD=0:PRINTTAB(
15,15)A%
2400PRINTTAB(18,15)" ":IFD=0:PRINTTA
B(18,15)A%
2410PROCC:PROCC
2420ENDPROC
2430DEFPRCCBBC
2440PROCC:VDU7:PRINT"HIT <D> TO DOUBLE"
"ELSE HIT <RETURN>":A%=GET$:PROCC:IFA%
="D":ENDPROC
2450IFASC(A%)=13:PROCC:ENPROC
2460GOTO2440
2470DEFPRCCDD

```

```

2490PROCC:VDU7:PRINT"DOUBLE? <A> - <R>
- refuse":A%=GET$:IFA%<>"A"ANDA%<>"R"TH
EN2480
2490PROCC:VDU26
2500ENDPROC
2510DEFPRCCDR:CLS:PRINT"Double refused.
":GM=1:ENDPROC
2520DEFPRCCDI:LOCAL P%,Q%,T,Z
2530P%=RND(6):Q%=RND(6):T=TIME
2540IFTIME-T>200THEN2560
2550P%=P%+1:IFP%>6:P%=1
2560Q%=Q%+1:IFQ%>6:Q%=1
2570FORZ=1TO150:NEXT
2580PRINTC$(P%)*STRING$(2,R%)+STRING$(
2,U%)+A$(Q%):IFTIME-T<350THEN2540
2590DZ(1)=Q%:DZ(2)=P%:IFDZ(1)=DZ(2):M=4
:GOTO2620
2600M=2:IFDZ(2)<DZ(1)THEN2620
2610IFGM=0:IX=DZ(1):DX(1)=DZ(2):DZ(2)=1
%
2620ENDPROC
2630DEFPRCCI:lv=lv*(lv*2):A=30:d=1:db=0
:X=7/18:Y=1/9:FORIX=1TOA:AX(LX)=0:NEXT:A
Z(27)=167:AX(A)=167:F=7%:AX(1)=7:AX(17)
=-5:AX(17)=-3:AX(17)=-5:AX(24)=2:AX(13)
=5:AX(8)=3:AX(6)=5:ENDPROC
2640DEFPRCCD:VDU19,1,4;0;19,2,4;0;
2650COL=1:GCLO,129:MOVE20,960:FORIX=20
TO520STEP100:MOVEIX+100,960:PL0T87,IX,55
0:PL0T87,IX+100,650:PL0T87,IX+50,600:MOV
EIX+100,960:IFCOL=1:COL=0:GCLO,130ELSECO
L=1:GCLO,129
2660NEXT:MOVE640,950:FORIX=640TO1140STE
P100:MOVEIX+100,960:PL0T87,IX,650:PL0T87
,IX+100,650:PL0T87,IX+50,600:MOVEIX+100,
960:IFCOL=1:COL=0:GCLO,130ELSECOL=1:GC
LO,129
2670NEXT:COL=0:GCLO,130:MOVE20,100:FOR
IX=20TO520STEP100:MOVEIX+100,100:PL0T87,
IX,410:PL0T87,IX+100,410:PL0T87,IX+50,40
0:MOVEIX+100,100:IFCOL=1:COL=0:GCLO,130
ELSECOL=1:GCLO,129
2680NEXT:MOVE640,130:FORIX=640TO1140STE
P100:MOVEIX+100,100:PL0T87,IX,410:PL0T87
,IX+100,410:PL0T87,IX+50,460:MOVEIX+100,
100:IFCOL=1:COL=0:GCLO,130ELSECOL=1:GC
LO,129
2690NEXT:VDU19,1,4;0;19,2,5;0;GCLO,12
9:MOVE20,100:PL0T7,620,960:GCLO,130:MO
VE640,100:PL0T7,640,960:VDU5:GCLO,130:MO
VE40,955:TZ=12:FORIX=40TO540STEP100:MOVEI
X,955:PRINTCHR$(TZ+64):TZ=TZ+1:NEXT:MOV
E660,955
2700FORIX=660TO1160STEP100:MOVEIX,955:P
RINTCHR$(TZ+64):TZ=TZ+1:NEXT:MOVE40,130
:TZ=13:FORIX=40TO540STEP100:MOVEIX,130:P
RINTCHR$(TZ+64):TZ=TZ+1:NEXT
2710MOVE660,130:FORIX=660TO1160STEP100:
MOVEIX,130:PRINTCHR$(TZ+64):TZ=TZ+1:NEX
T:VDU4,23,1,0;0;0;0;0
2720PRINTTAB(14,14)"YOU ME"
2730DEFPRCCSG:L%=CHR$3:R%=CHR$5:U%=CHR$
11:D%=CHR$10:C%=CHR$30:STRING$(14,D%)&S
TRINGS(5,R%)&S-CHR$225:F%=D%&STRINGS(3,L
%):Y%=CHR$230:Y4=CHR$231
2740R0%=STRING$(3,CHR$225):R1%=CHR$225+
STRINGS(2,CHR$225):R2%=CHR$225+CHR$225+
CHR$225:R3%=STRING$(2,CHR$225)+CHR$226:R4
%=CHR$226+CHR$225+CHR$226
2750A$(1)=R0%+F%+R2%+F%+R0%:A$(2)=R3%+F
%+R0%+F%+R1%:A$(3)=R3%+F%+R2%+F%+R1%:A$(
4)=R4%+F%+R0%+F%+R4%:A$(5)=R4%+F%+R2%+F
%+R4%:A$(6)=R4%+F%+R4%+F%+R4%
2760ENDPROC
2770DEFPRCCCH:VDU23,226,255,255,255,255
,255,255,255,255,23,226,255,195,129,129,
129,129,195,255,23,230,0,254,254,254,254
,254,234,254,23,231,0,170,84,170,84,170,
84,170,23,227,16,56,124,254,36,36,36,36,
23,228,56,56,56,56,254,124,56,16
2780ENDPROC
2790DEFPRCCCYn
2800A%=GET$:IFF%<>"Y"ANDA%<>"N"THEN2800
2810IFA%="Y":ENDPROC ELSECLS:END
2820DEFPRCCD:VDU28,0,1,19,0,12,26:ENDPR
OC
2830DEFPRCCU:VDU28,0,31,19,29,12:ENDPRU
C
2840DEFPRCCGT:PRINT"?":L%=A%=GET$:ENDPR
OC
2850DEFPRCCP:PROCC:VDU7:PRINT"<RETURN>
when ready":A%=GET$:PROCC:VDU26:ENDPROC
2860DEFPRCCRS:VDU23,1,0;0;0;0;19,2,5;0
:19,3,7;0;19,0,4;0;0:ENDPROC
2870ENDPROC
2880DEFPRCCD:IFLX=0:GCLO,1ELSEGCLO
LO,2
2890ENDPROC
2900DEFPRCCJN:VDU19,0,4;0;PRINT"BACKG
AMMON. . . . This version of the game pla
ys the "standard rules of Backgammon in
cluding the use of a doubling cube whic
h you can read about in any good book on
the game."
2910PRINT"MOVEMENT. . . . Points are la
bed alphabetically. To move from point
A to B and from Q to U, type A-B-Q-U. T
o return from the bar""press the down c
ursor key, and the up""key to bear off.
If you are unable to"
2920PRINT"Use all you" throw, press ret
urn after you have used that part which
you can. . . . The Computer plays a fair
game, so if you are a novice start on t
he lower "levels of play." "PRESS SPAC
E TO START":A%=GET$:ENDPROC

```

MAKER

ALL BEGINNERS at computers learn to program using Basic; this is fine since it is easy to learn and easy to use. However, its real disadvantage is that it is usually slow in comparison to machine code. This means that if any fast moving graphics are required in the program then they will have to scrap the idea, or use my program which equips the ZX-81 16K with sprite Basic.

The sprite Basic can handle up to 256 sprites which can be at three levels:

- Underneath the characters
- Same level as the characters
- Over the characters.

Also when the sprite hits the edge of the screen it can either stop, bounce or wrap-around. If this sounds like what you want then roll up your sleeves and begin the hard work. First, type in

```
1 REM (118 characters)
```

followed by lines 2 to 9 which have a Rem statement containing 128 characters. Now enter:

```
POKE 16509,0
POKE 16510,0
POKE 16511,168
POKE 16512,4
POKE 16514,118
POKE 16515,118
```

You have now produced a Rem statement with 1190 characters, and when listed should appear as 0 Rem. If not then begin again. Type in the hex loader — listing 3 — and enter all the machine code in listing 1.

Now delete the loader and add the lines in listing 2. The complete sprite Basic has been entered. It should now be saved under an appropriate name.

In order to test the program I must explain what the sprite commands are, how to use them, and their syntax. The first and longest is **Sprite**: it takes the form:

```
LET Z=USR SPRITE
```

PRINT number; on or off; velocity; flag\$; xcoord; ycoord; xmove; char\$

Number: this is the sprite number. Range: 0 to 255.

On or Off: this is either 1 for on or 0 for off.

Velocity: this is not really the true velocity but it is the number of times the Move command is called before the sprite moves.

N.B. if velocity is zero the sprite will move with a velocity of 256. Range of velocity is 0 to 255

Flag\$: this is a string which is seven characters long and consists of 0s or 1s eg., "0010110" "0010111"

This tells the computer what level the sprite is at and what it does at the edge of the screen.

If the seventh character is 1 then the sprite wraps around.

If the sixth character is 1 then the sprite bounces.

If the sixth and seventh character is a 0 then it stops at the edge of the screen; if they are both 1s then it will wrap-around.

Now let us consider the fourth and fifth characters.

If the fifth is 1 it goes under the characters. If the fourth is 1 it goes over the characters, but if they are both 0s then it travels at the same level as the characters on screen.

The third character is not used by the sprite Basic.

The second character is only used if the sprite is at the same level as the characters on the screen. If this is 1 when a sprite collides with some character on screen then it continues but if it is 0 the sprite will stop.

Finally if the first character is 1 it will remain stationary or if 0 it allows the sprite to move normally.

Xcoord: this is the initial x co-ordinate.

Ycoord: this is the initial y co-ordinate also 24 lines of screen are used.

Xmove: this is the distance the sprite will move horizontally.

Y move: same as xmove except vertically.

Char\$: this is a string four characters long which contains the characters that go to make up the sprite as follows:

```
1 2
3 4
```

(continued on next page)



```

0000 LET F#(1) = "00000001"
0000 LET F#(2) = "00000010"
0000 LET Z=USR SPRITE
0010 PRINT C;1;1;F#(INT (RAND*2) +
#2;+1);(2);(RAND*2);(RAND*3);A#(INT (RAND
0020 LET C=C+1
0030 LET F=C*240 THEN GOTO 390
0040 POKE NUM,C+1
0050 PRINT AT 0,0;C
0060 LET Z=USR MOVE
0070 LET INKEY#="" THEN GOTO 350
0080 LET INKEY#="" THEN GOTO 390
0090 GOTO 000
000 000
000 000
400 PRINT AT 10,0; "NOW FOR SOME
REAL SPEED"
410 FOR F=1 TO 100
420 NEXT F
430 POKE NUM,3
440 LET Z=USR INIT
450 STOP
1000 FOR F=0 TO 3
1010 LET Z=USR SPRITE
1020 PRINT F;1;F+1;F#;RAND*32;RAND
#2; ;(RAND*3);(RAND*3);A#(F+1)
1030 NEXT F
1040 RETURN

```



(continued from previous page)

The number represents where that character is in the string, this also means that all sprites are 2'x 2.

Note this command can be abbreviated to

```
LET Z = USR SPRITE
PRINT number,on or off
```

in order to switch sprites on or off only. This is the only possible abbreviation.

The second command is Move and takes the form:

```
LET Z = USR MOVE
```

This calls the sprite moving routine which moves sprite 0 to whatever number specified by NUM command (see next command)

Num takes the form:

```
POKE NUM,number of sprites + 1
```

Therefore to have no sprites POKE NUM,1

Flag takes the form:

```
LET Z = USR FLAG
PRINT number of sprite
```

This puts either 0,1,2 or 3 into Z, depending on the condition of the sprite.

If Z=0 then the sprite has hit nothing and is

allowed to move

Z=1 sprite has stopped ie. if it is at the same level as characters then it has hit a character over and under sprites won't affect this flag simply because they will either go over or under the characters and can't hit them.

Z=2 sprite has collided; if it is a same level sprite and it collides with a character on the screen then Z=2, or if the sprite has stopped at the edge then Z=2 but the 'stopped' flag is not set.

Z=3 sprite has stopped and collided; see Z=1 and Z=2

Coord takes the form:

```
LET Z = USR COORD
PRINT number of sprite
```

This returns with Z equal to ycoordinate + 256 * xccordinate and

```
PEEK 16507 = yccordinate
```

```
PEEK 16508 = xccordinate
```

of the sprite defined in the Print statement.

Motion takes the form:

```
LET Z = USR MOTION
PRINT number of sprite
```

This is the same as Coord except that the x and y movements are found.

Init takes the form:

```
IFT7 = USR INIT
```

This allows the Move routine to be interrupt driven. So you could run a program and when it has finished sprites can still be moving around. However the drawback is that only two sprites can be used, any more causes the screen to jump.

This command is turned off by the following commands:

FAST,SLOW,LPRINT,LLIST,COPY,LOAD,SAVE,DATA (new command) or when entering a program line.

Data takes the form:

```
RAND USR DATA
PRINT number of sprites
```

The data for the sprites is stored in a Rem statement after the machine code and 16 bytes is required for each sprite and two 'Newline' characters at the start to blank out the data. So to do this you use this command which produces enough bytes for: the number of sprites in the Print statement.

REPORT CODES

T: no line after command which requires PRINT statement

W: flagS not correct length

U: charS not correct length

C: data missing in PRINT statement

One other thing is that if an 'over' sprite passes over another sprite it may leave part or all of that sprite behind but usually when it runs over anything it will not do this, but some very good 3-D effects can now be easily created.

Any commands which require a Print statement after them will change this Print to a Rem so if you edit the line with a Rem then this Rem must be converted back to a Print.

You can now test the program by entering some commands for yourself or type in the demonstration program. This program begins with four sprites bouncing around, now hit a key and they will wrap-round. Hit a key again and a sprite begins moving randomly, now every time a key is hit another sprite is added, the number of sprites on the screen is shown at the top left-hand corner of the screen. If the 0 key is pressed then the program ends but leaves two sprites moving around.

If a crash does occur reload the saved program and type in listing 4 and run it checking the output with listing 1.

If you have keyboarditis and don't feel up to keying in this program then I will send you a cassette with SP.Basic and the demonstration program for £3.Malachy Devlin 50 Ruskey Road, Cookstown, Co. Tyrone, BT80 0AH.

Listing 3.

```
99 REM HEX LEADER
100 PRINT "START ADDRESS"
110 INPUT S
120 PRINT "FINISH ADDRESS"
130 INPUT F
140 FOR N=5 TO F STEP 8
150 LET T=0
160 PRINT N; " - ";
170 INPUT A$
180 PRINT A$; " = ";
190 INPUT TOT
200 PRINT TOT
210 LET Z=0
220 FOR K=1 TO LEN A$ STEP 8
230 LET C=(CODE A$(K)-28)*16+00
240 A$(K+1)=28
250 LET T=T+C
260 PEEK N+Z,C
270 LET Z=Z+1
280 NEXT K
290 IF TOT=0 THEN GO TO 310
300 PRINT "ERROR - PLEASE INPUT AGAIN"
310 GO TO 100
310 NEXT N
```

64K User RAM and not a bit less...

New Prices!
MTX 512
£275.00
INC. VAT

The MTX512 comes with 64K RAM, expandable to 512K. Add to this another 16K VideoRAM dedicated solely to handling the screen memory, and you've got 80K. But how much user RAM is left when you're running high resolution graphics programs? Unlike other machines, the answer is still 64K, because the MTX512 uses the 16K VideoRAM plus a second processor – the Texas TMS9929A – to take care of screen graphics. The main processor used in the MTX512 is the Zilog Z80A, which gives the MTX Series CP/M compatibility – CP/M was written around the Zilog Series. And the Z80A inside the 512 operates at 4MHz.

Expansion is no problem with the MTX Series, because it is designed as an interlocking system – from the MTX512 up to the powerful Memotech Silicon Disc Systems.

MEMOTECH MTX512 MAJOR FEATURES

STANDARD I/O PORTS

- Variable rate cassette port (up to 2400 baud)
- Two joystick ports using Atari configuration
- Centronics-type parallel printer port
- ROM cartridge port
- Uncommitted parallel input/output port
- Internal ROM board port
- Hi-Fi output port
- 4-channel sound through TV speaker
- PAL composite video colour Monitor port

THE RS232 COMMUNICATIONS BOARD

(required for disc expansions)

- Two independent RS232 ports
- 60-way Disc Drive Bus supporting up to four 5.25 and/or 8 inch floppy disc drives, Memotech Silicon Discs, and Hard Discs

USER RAM

- Expandable to 512K in increments of 64, 128, or 256K

24K OF ROM which includes:

- MTX BASIC
- Noddy, a simple, text-handling language
- A powerful Assembler/Dissassembler – sections of machine code can be created and run by calling the Assembler from within BASIC
- The sophisticated Front Panel, which displays the contents of all registers (including the F flag register) and pointers during program execution
- All four languages can be used interactively with each other, and with the user

ROM EXPANSIONS - up to 72K

- MTX NewWord, a 32K word processing package
- Hisoft PASCAL, written specially for the MTX Series

THE KEYBOARD

- Full size, 79-key, full-stroke professional quality keyboard incorporating:
- Main Block with typewriter-style layout
- A separate 12-key numeric/editor keypad
- Eight programmable function keys (16 with shift)

GRAPHICS FACILITIES

HI-RES GRAPHICS MODE

- 256 x 192 pixel resolution plus
- 32 x 24 Text in 16 foreground and background colours
- All 16 colours (i.e. 15 colours plus transparent) are available on the screen together
- 32 user-definable easily controllable sprites
- 128 separate GENPAT statements providing a huge range of user-defined characters

TEXT MODE

- Text resolution is 40 x 24 characters plus
- 128 user-defined characters
- Eight user-definable virtual screens or "windows"

SINGLE 5.25" DISC DRIVE – £399.00 inc VAT

Comprising one Qume double-sided, double-density 500K drive, plus the Memotech Floppy Disc Controller Board, with power supply, expansion sockets, and sturdy aluminium case.

Single Disc System Software: MTX Single Disc BASIC extensions on ROM, plus Renumber, 40 Column Text and Graphics Screen, Binary to Hex to Decimal Converter, Data save and load plus five games.

For further information, please contact:

MEMOTECH

MEMOTECH LIMITED STATION LANE INDUSTRIAL ESTATE WITNEY
OXON OX8 6BX TELEPHONE: (0993) 2977 TELEX: 83372 MEMTECG

NewWord is a registered trademark of NewStar Software Inc.
CP/M is a registered trademark of Digital Research Inc.



DOES TRANSCENDENTAL meditation produce the effects that are claimed for it? The HULK, a program for Bayesian analysis on the BBC microcomputer, can't give you a definitive answer to that question, but it can, as the name implies, Help Uncover Latent Knowledge.

The HULK is a set of three programs, one editor, and three demonstration files supplied on tape. The programs in the suite can be used for many different applications. If you can measure a number of things about a series

of objects then the HULK can be used to classify the objects and make predictions about a related group of objects.

Transcendental meditation is described as a state of silent awareness devoid of any thought process. Large claims have been made for the techniques of transcendental meditation in terms of a reduction of stress, improvement in psychological and physical agility tests, and changes in the subject's electro-cardiogram.

Papers have been published in very respectable journals such as *Scientific American* (vol.

226, 1972, pp 84-90) and the *Lancet* (no.7651, 1970, p833) describing various aspects of the physiological changes that are said to occur during transcendental meditation.

The data shown in table 1 relates to the blood pressure of a number of subjects before, during, and after transcendental meditation. It has been taken from a PhD thesis by Dr. R. K. Wallace from the University of California at Los Angeles. Data files for analysis by programs in the HULK suite are typed into the BBC micro like any Basic program but must be structured to a format described in the HULK User Guide.

Unlike the data for the subject's heart rate the blood pressure data showed no significant decrease during the meditation phase. Indeed, it is difficult to draw any conclusions from the information in table 1. For the purposes of experimenting with the programs, however, I typed in four sets of data, one of which showed highly significant results — heart rate.

Three of the sets had seven variables, that is the elapsed time during the experiment and the number of samples, the subjects, varied in each set. One set of data stopped before the final 70 minute reading, consequently there

Table 1.

| Minutes Subject | Mean Blood Pressure | | | | | | |
|-----------------|---------------------|------|------------|------|------|-------|------|
| | Pre. | | Meditation | | | Post. | |
| | 10 | 20 | 30 | 40 | 50 | 60 | 70 |
| 13 | 70.0 | 67.5 | 62.5 | 62.5 | 65.0 | 67.5 | 65.0 |
| 2 | 78.0 | 78.0 | 73.0 | 75.5 | 78.0 | 79.5 | 80.0 |
| 21 | 76.0 | 74.0 | 71.5 | 76.0 | 76.0 | 77.0 | 79.0 |
| 6 | 90.0 | 90.0 | 87.5 | 90.0 | 91.0 | 91.0 | 87.5 |
| 14 | 70.0 | 72.5 | 72.5 | 72.5 | 67.5 | 67.5 | 70.0 |
| Mean | 76.8 | 76.4 | 73.4 | 75.3 | 75.5 | 76.5 | 76.3 |
| S.E. | 3.7 | 3.8 | 4.0 | 4.4 | 4.6 | 4.4 | 4.0 |
| N | 5 | 5 | 5 | 5 | 5 | 5 | 5 |

$p = <0.500$

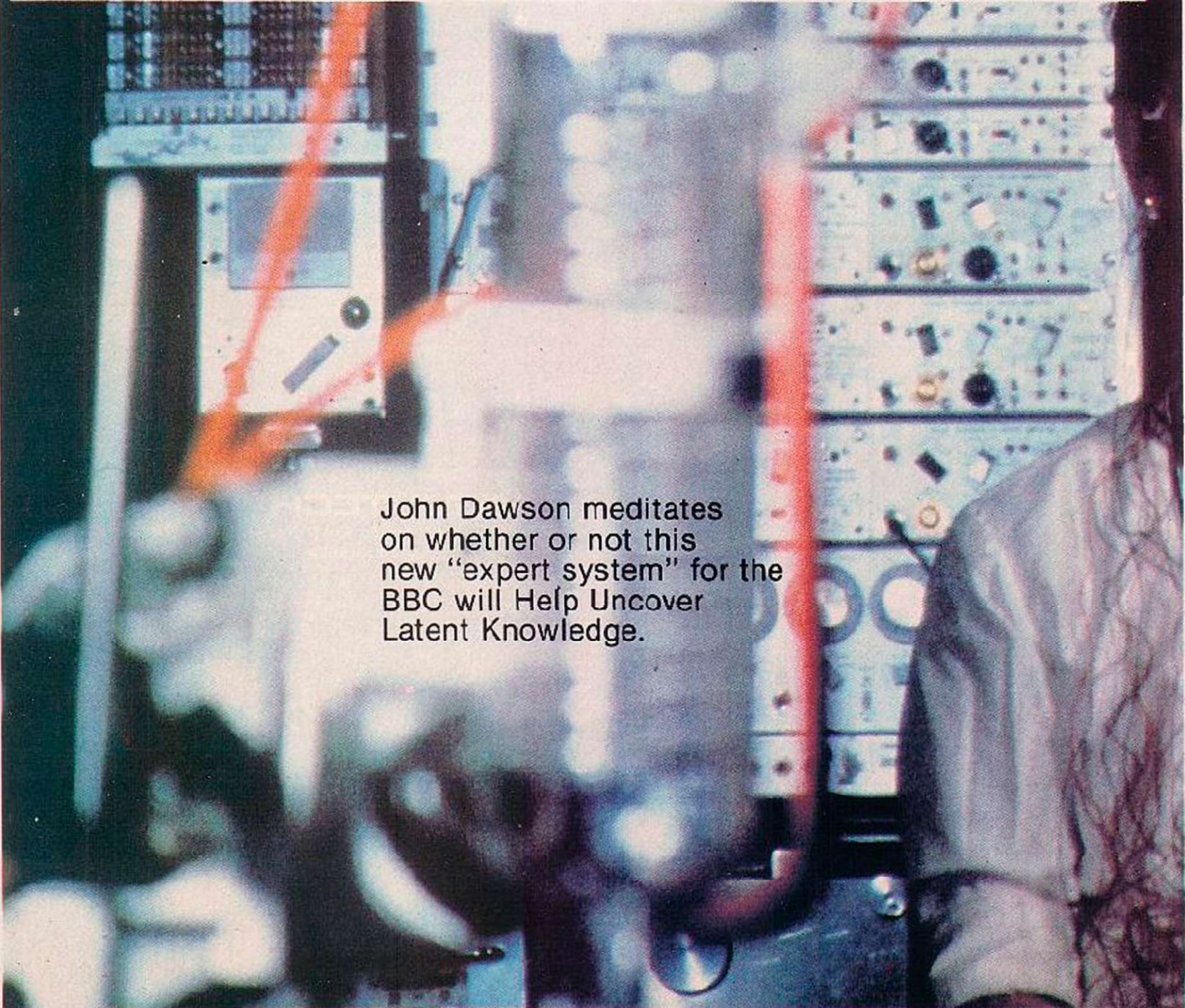

John Dawson meditates on whether or not this new "expert system" for the BBC will Help Uncover Latent Knowledge.

HULK

are only six variables in this set.

PRESCAN is a HULK program that asks you for a hypothesis — an idea about the data in the sample that you think might be true — and then carries out a rough analysis on the basis of your hypothesis. From this program you can get some idea as to the variables that can be usefully incorporated into rules to refine or improve your hypothesis.

The success/failure tables show how the hypothesis is linked to each variable. In this run the hypothesis was successful when nine samples were analysed and the each variable is then analysed by successful or failed samples.

A potentially valuable variable for the rule building process using LOOK is identified with two stars — as it happened there were none in this run.

LOOK is the first of the two major programs in the HULK. LOOK helps you to build a rule set to improve the discrimination that you have decided on in the hypothesis. In table 2, for example, a small set of rules — TMR — has been created to support the

hypothesis that the average value of the variable being measured — blood pressure, heart rate and so on — is lower during the period of transcendental meditation than it is afterwards:

$$(tm30 + tm40)/2 < pc60$$

Using LOOK I found that both rule 1 ($tm30 < pc20$ — a drop in the measured parameter, heart rate, for example, would be expected after the subject had started to meditate) and rule 2 ($tm50 < pc60$ — a rise in heart rate would be expected after meditation had stopped) helped to improve the success rate of the original hypothesis on the heart rate data.

Table 3 shows how LEAP, the second major component of the HULK suite, can apply a hypothesis and a set of rules to a data file. I repeated the LEAP program run for the other three sets of data and the results are printed without the rules. The second part of table 3 shows the application of a second set of rules to the same blood pressure data.

Several points emerge from the tables. First, you need to be fairly statistically literate to make the best use of the results generated by

(continued on next page)





(continued from previous page)

LEAP. Unlike Tim de Dombal's program for helping to identify the cause of abdominal pain which produces a bar chart of the probability of various conditions, the HULK has no graphics capability.

However, the program can be modified for your own purposes; this is one of the most attractive features of the HULK programs.

Second, you need to understand the problem when you start to formulate your hypothesis, and you must be able to express yourself in logical and mathematical terms using the BBC microcomputer's arithmetic, comparator and logical operators.

"Proper" expert systems are said to have a number of features in common. Among them are:

■ An expert system should be able to acquire greater competency as rules are added to the system. Conversely, the absence of a rule should leave a gap in the system's capability.

■ An expert system should have an English-language dialogue and some provision for help.

■ An expert system should be able to explain: why a fact is necessary in a line of reasoning and how an answer was generated.

■ Expert systems should be capable of learning from experience.

■ Expert systems should be able to provide answers in conditions of uncertainty and should be capable of probabilistic reasoning.

(adapted from *Byte* magazine May 1984 p. 152)

Clearly the HULK scores more on some of these items than on others. The user's dialogue with the program is entirely logical and statistical with the exception of the starred ratings for "correctness" or usefulness of a variable.

Improving the system's performance is not automatic and depends heavily on the user to complete the loop from data put into the system, to the output, to modification of the next rule set and selection of data to type in.

Nevertheless, the HULK is well suited to providing answers where there is uncertainty in the data you are working with. The system can acquire greater competency as you work to refine the rules that you run over the data and I have no doubt that it can give you a greater insight into the relationships within a set of data. As the scrupulously honest User Guide says 'All you need is a data set, (and) some curiosity ... Think of it as a research assistant.'

Brainstorm Computer Solutions say that the

HULK is intended as a introduction to knowledge-based systems, and I think it is fair comment for them to claim that "the HULK lets you dip your toes into the warm blue lagoon of expert systems and find out what all the fuss is about."

The company proposes to carry on the development of the programs and wants feedback from users by way of a user group. Until the group is established you may need some additional reading material if you are not familiar with Bayes theorem.

The LOOK and LEAP programs are rather over 500 lines long and the point is well made in the User Guide that you will find the HULK frustrating to use from cassette tape. The sample coal mining data files supplied with the program have 64 samples of 30 variables and you must reload the data each time you wish to use LEAP or LOOK.

I am not sure whether that is a necessary part of the process, because, for example, the data is modified in the course of the analysis, or whether the program can be altered to allow you to run a different rule set over the same data without having to reload it.

All the programs are written in straightforward Basic and can be copied from tape to disc without any trouble. Any company that gives you a telephone number to ring and a program that you can build on for your own purposes must be good. The HULK will keep you absorbed for hours and may make you look at the world in a new, probabilistic, light.

And does transcendental meditation produce the effects claimed for it? Ah well ...

Table 2. PRESCAN printout.

HYPOTHESIS: (tm30+tm40)/2 < pc60

| Variable 1 | pc10 | SUCCESS 9 | FAILURE 2 |
|-------------------------|-------|-----------|-----------|
| average: | 70.89 | | 77.00 |
| std. dev.: | 7.08 | | 7.07 |
| difference-score = 1.11 | | | |
| Variable 2 | pc20 | SUCCESS 9 | FAILURE 2 |
| average: | 70.22 | | 76.50 |
| std. dev.: | 6.83 | | 7.73 |
| difference-score = 1.05 | | | |
| Variable 3 | tm30 | SUCCESS 9 | FAILURE 2 |
| average: | 66.78 | | 76.00 |
| std. dev.: | 7.69 | | 8.49 |
| difference-score = 1.41 | | | |
| Variable 4 | tm40 | SUCCESS 9 | FAILURE 2 |
| average: | 65.00 | | 73.00 |
| std. dev.: | 5.05 | | 8.49 |
| difference-score = 1.28 | | | |
| Variable 5 | tm50 | SUCCESS 9 | FAILURE 2 |
| average: | 66.67 | | 71.00 |
| std. dev.: | 6.98 | | 12.73 |
| difference-score = 0.47 | | | |
| Variable 6 | pc60 | SUCCESS 9 | FAILURE 2 |
| average: | 69.89 | | 72.50 |
| std. dev.: | 6.39 | | 6.36 |
| difference-score = 0.52 | | | |
| Variable 7 | pc70 | SUCCESS 9 | FAILURE 2 |
| average: | 68.89 | | 77.50 |
| std. dev.: | 6.25 | | 14.85 |
| difference-score = 0.80 | | | |
| Data from: HR | | | |

Table 3. LEAP printout using first rule set.

HYPOTHESIS IS:
(tm30 + tm40)/2 < pc60

Rule 1: tm30 < pc20
Likelihood ratios:
1.43 0.70
0.77 1.30

Rule 2: tm50 < pc60
Likelihood ratios:
3.33 0.30
0.59 1.70

| SAMPLE | Prob. | Success |
|---------|-------|---------|
| 1 *S01 | 0.99 | 1 |
| 2 *S21 | 0.99 | 1 |
| 3 *S06 | 0.99 | 1 |
| 4 *S13 | 0.99 | 1 |
| 5 S10 | 0.99 | 0 |
| 6 *S20 | 0.99 | 1 |
| 7 *S23 | 0.97 | 1 |
| 8 *S02 | 0.97 | 1 |
| 9 *S22 | 0.97 | 1 |
| 10 *S24 | 0.75 | 1 |
| 11 *S05 | 0.47 | 0 |

Data from: HR
Rules used: TMR
Success rate = 90.9090909%

| SAMPLE | Prob. | Success |
|--------|-------|---------|
| 1 *S21 | 0.99 | 1 |
| 2 *S02 | 0.99 | 1 |
| 3 *S13 | 0.99 | 1 |
| 4 *S06 | 0.75 | 1 |
| 5 *S14 | 0.47 | 0 |

Data from: EP
Rules used: TMR
Success rate = 100%

| SAMPLE | Prob. | Success |
|--------|-------|---------|
| 1 S23 | 0.99 | 0 |
| 2 *S13 | 0.99 | 1 |
| 3 *S14 | 0.99 | 1 |

| | | |
|---------|------|---|
| 4 *S07 | 0.99 | 1 |
| 5 *S09 | 0.99 | 1 |
| 6 *S20 | 0.97 | 1 |
| 7 *S22 | 0.97 | 1 |
| 8 S01 | 0.75 | 0 |
| 9 S06 | 0.75 | 0 |
| 10 *S02 | 0.75 | 1 |

Data from: FO2
Rules used: TMR
Success rate = 70%

| SAMPLE | Prob. | Success |
|--------|-------|---------|
| 1 *S03 | 0.97 | 1 |
| 2 *S05 | 0.97 | 1 |
| 3 *S01 | 0.97 | 1 |
| 4 S02 | 0.97 | 0 |
| 5 *S06 | 0.75 | 1 |
| 6 *S04 | 0.47 | 0 |

Data from: RQ
Rules used: TMR
Success rate = 83.3333333%

LEAP printout using second rule set

HYPOTHESIS IS:
(pc10 + pc20)/2 > pc60

Rule 1: tm30 < pc20
Likelihood ratios:
3.57 0.28
0.71 1.40

Rule 2: (tm30 + tm40 + tm50)/3 < pc60
Likelihood ratios:
0.10 9.80
3.10 0.32

| SAMPLE | Prob. | Success |
|--------|-------|---------|
| 1 *S14 | 0.77 | 1 |
| 2 *S06 | 0.03 | 0 |
| 3 *S21 | 0.03 | 0 |
| 4 *S02 | 0.03 | 0 |
| 5 *S13 | 0.03 | 1 |

Data from: BP
Rules used: TMR3
Success rate = 80%

NEW RS 232 & PARALLEL PRINTER INTERFACE for ZX SPECTRUM

Connect to professional printers with this improved and cheaper printer interface.

£34.95
cable £9.95
inc. VAT

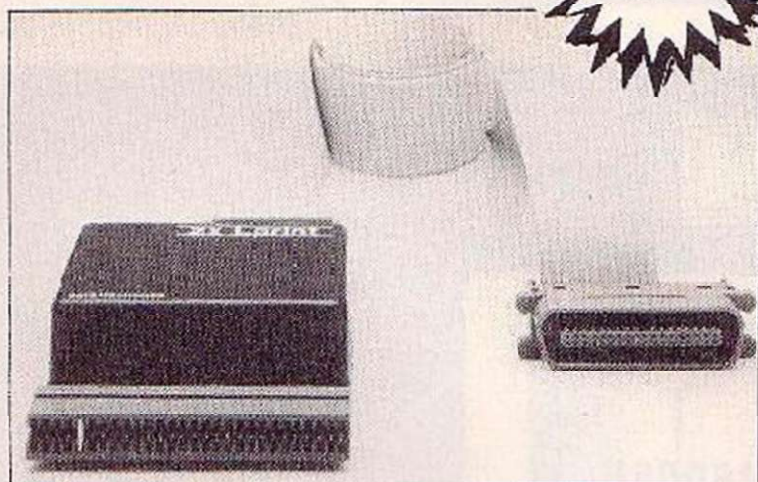

ZXLprint II interface enables your ZX Spectrum computer (16 or 48k) to print on almost any dot matrix or daisywheel printer with RS 232 or Centronics input. Just plug in ZXL print III and LPRINT and LLIST commands will work. COPY works without any additional software on Seikosha 100 & 250, Hi-res Epsoms, Star 510, 515, STX 80, Gemini & Delta, Walters WM80, Shinwa and CTI... Plus Seikosha GP 700 in full colour. COPY on other printers coming soon. (Microline, CGP and MCP) And because NO additional software is needed all of your RAM is free to take Tasword 2 or Kemp Business Accounts, Viewfile etc.

●WORD PROCESSING

●HIGH RESOLUTION SCREEN DUMPS

●PRINTS SPECTRUM AND USER DEFINED GRAPHICS

●JUST PLUG IN FOR LPRINT LLIST and COPY

●COMPATIBLE WITH MICRODRIVES & PRESTEL ADAPTOR

EUROELECTRONICS

ORDER: To EUROELECTRONICS, 26 Clarence Square,
Choltenham, Glos. GL50 2JP Tel: (0684) 292448

From: Name: _____

Address: _____

This order is for: _____ (Quantity)

ZXLPRINT III at £34.95 _____

Centronics Cable at £9.95 _____

RS 232 Cable at £9.95 _____

Tasword 2 at £13.90 _____

Please add £1.45 p&p

Cheques/PO payable to
EUROELECTRONICS

Amount enclosed _____
Microdrives adaptor for ZX Lprint I and
II £4.50 - 70p p&p

SINCLAIR, ATARI
COMMODORE

COMPUTER REPAIRS
by the
SPECIALISTS

Walkers
COMPUTER SERVICE
AND REPAIRS
Telephone: 021 643 5474
Telegrams:
Shuplog Birmingham
Telex 337124 TWSLIII G

WALKERS will repair your MICRO quickly and efficiently.

Services available to suit the Customers requirements include "one-off" repairs and Quotations.

Most Repairs will be in the range
£15 to £30
subject to machine

FOR INFORMATION
PHONE 021-643 5474

CALL IN AT
58 OXFORD STREET, BIRMINGHAM, B5 5NX

OR SEND S.A.E. FOR DETAILS

Hartland Software's Famous FOOTBALL POOLS PROGRAM

- * This program lists out, in order of preference, the sixteen most likely score-draws; also the sixteen most likely homes, draws (including 0-0) and aways. For each forecast, it will also give you the probability that the forecast is correct.
- * It picks out the results on the bookmakers' FIXED ODDS coupons that have been given over-generous odds. It calculates your expected profit!
- * The program will be initialised to the English and Scottish league tables. You will be able to update these league tables week by week as results come in — or enter a complete new set of league tables. You will then be able to save the new league tables on another cassette; in other words the program will never become "out of date".
- * Australian pools in the summer? No problem! You will be able to alter the built-in team names, and save them on another cassette.
- * Advanced probability theory is used to make all forecasts — no guesswork or random numbers. A brief description of the theory is contained within the instruction leaflet. Only top quality cassettes are used — Sony, TDK or Agfa.

"I HAVE SEEN THE OTHER PROGRAMS WHICH A FRIEND OF MINE HAS, BUT I LIKE YOUR PROGRAMS THE BEST. I HAVE USED IT ON THE POOLS SEVERAL TIMES, AND I HAVE BEEN VERY NEAR TO THE BIG DIVIDEND." Mr J. O., London N21.

This program will not cost you a fortune either! It is available for the ZX81 (16K) and the ZX Spectrum (48K) for just £6.95, and the B3C model "B" for £8.95.

HARTLAND SOFTWARE (Dept. Y),
32 IVOR PLACE, LONDON NW1 6DA.

**Britain's biggest selling
computer magazine has put
on 26% more weight**

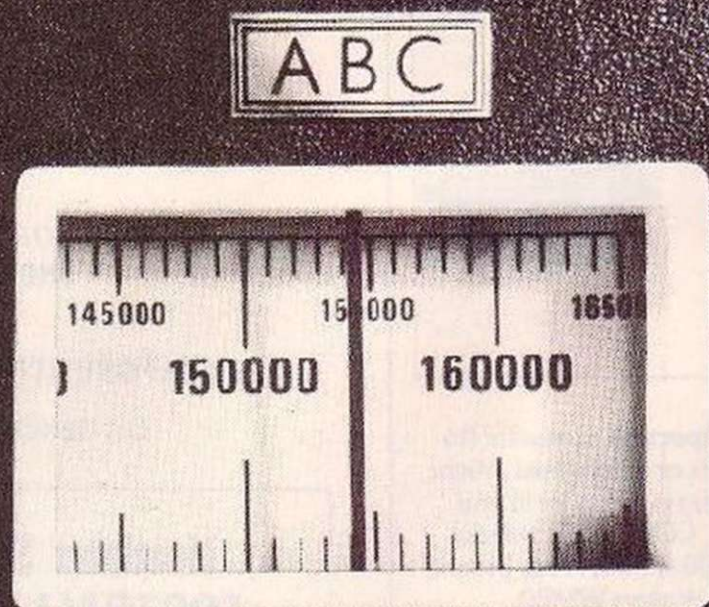

(It must be all those chips.)

It's hardly surprising that the ABC figures for January – June 1984 show yet another leap in circulation for Your Computer, to 154,334.

The fact is that more people find it more to their taste than any other computer magazine.

Not that all these extra readers are going to cost our advertisers any more. Because Your Computer's cost-per-thousand has actually fallen to just £5.05.

For more details contact Shobhan Gajjar on 01-661 3127 and he'll explain why other home computer magazines could well have had their chips.

**YOUR
COMPUTER**
ELECTRICAL-ELECTRONIC PRESS
A DIVISION OF BUSINESS PRESS INTERNATIONAL LTD

TEXT

TEXT COMPRESSION METHODS have been in use on computer systems for a number of years and a variety of techniques are available. A recent article in *Your Computer* (L.F. Boulton, Vol.4, No.3) demonstrated such a technique for the ZX-81 where the unused character codes were used to represent the more commonly found character pairs. This type of tokenisation has been used widely with the unused ASCII codes 128 to 255 being taken to represent groups of letters, words or even frequently occurring phrases. However, a limitation of this method is due to the fact that only 128, or at most 255, token values are possible, i.e. the text may be only partially tokenised. I will describe a simple text compression technique which overcomes this limitation and enables any piece of text to be totally tokenised.

The principle of tokenising text appears very attractive since it is easy to see that commonly occurring words or phrases can be replaced by tokens of far fewer bytes than the original text. Single byte tokens, having values in the range 0 to 255, impose severe limitations as we have already noted. Two byte tokens, with values in the range 0 to 65535, are obviously excessive. However, when we consider the number of different words likely to be found in an adventure text database, or even in every day usage, we find that this number is only a few thousand. Therefore, if we use two bytes per token and limit the number of items in the dictionary to 2048, which is more than adequate for the majority of applications, then the token number may be stored in 11 bits only with the 5 remaining bits being used to convey additional information about the text. In developing this technique I decided to use these bits to describe details of the text punctuation and layout.

Before proceeding, we should note that one of the most commonly occurring characters in any passage of text is a space. Furthermore, we can see that, with the exception of words which terminate exactly at the end of full width lines (including any commas or



COMPRESSION

Alan Tobias goes in for a little letter crunching on the Spectrum.

periods), all words may be regarded as having a trailing space. Thus, if our decoding/expansion routine is able to apply this simple rule then there is no need to code spaces explicitly.

An obvious application of some of the unused token bits is to indicate the presence of commas or periods following any word. By using a separate bit for each of these it is

possible to accommodate words which are followed by both.

When we construct the dictionary of different words which appear in the text, it is obviously desirable that any word occurring both at the start and in the middle of a sentence is stored in the dictionary once only. Therefore, it would be advantageous to use one of the token bits to indicate that a word should be output with a capital letter at its start. This requires that all words stored in the dictionary should have their first letters converted to lower case. Again it is possible for our decoding routine to apply some simple rules, namely that a word should be automatically output with a capital letter at the start of any text message or following a period. It will therefore be necessary to code the capital letter flag bit only when these are required in the middle of a sentence.

Another punctuation item which could usefully be coded in a token bit is the presence of a newline character following a word plus its trailing blank, period or comma. However, we can again minimise the text coding by having the decoding routine provide a newline character automatically if the next word to be output will not fit within the current line. Thus, it will be necessary only to code those newline characters which are specifically required at particular points in the text.

In setting up the two byte tokens I have taken care to minimise the number of bits which will be set for any word. This means

(continued on page 127)

Table 1. Special input characters

| Character | ASCII Code | Interpretation |
|-----------|------------|-------------------------------------|
| @ | 64 | Treat as a space within phrases |
| . | 94 | Insert newline character after word |
| - | 95 | End of input for current message |

Listing 1. The hex loader.

```

10 REM hex loader
20 DEF FN h$(a)=CHR$(INT (a/16)+48+7*(a>159))+CHR$(a-16*INT (a/16)+48+7*((a-16*INT (a/16))>9))
30 DEF FN h(h$)=CODE h$-48-7*(CODE h$>57)
40 INPUT "Start Address:";s
50 INPUT "Finish Address:";f
60 FOR n=s TO f STEP 3
70 PRINT n;": ";
80 LET tot=0
90 INPUT a$
100 IF a$="END" THEN STOP
110 PRINT a$
120 FOR b=0 TO 7
130 LET z=FN h(a$)*16+FN h(a$(2))
140 LET tot=tot+z
150 POKE (n+b),z
160 LET a$=a$(4 TO )
170 NEXT b
180 PRINT " = ";
190 INPUT t
200 IF t<>tot THEN PRINT "Data input error": GO TO 70
210 PRINT t
220 NEXT n
230 STOP

```

COMCON

Programmable
Joystick Interface for
the Spectrum

£19.95

incl. VAT and P & P



QUICKSHOT 2+2 JOYSTICK

modified to incorporate
2 independent fire actions
and no rapid fire option

£13.95

incl. VAT and P & P

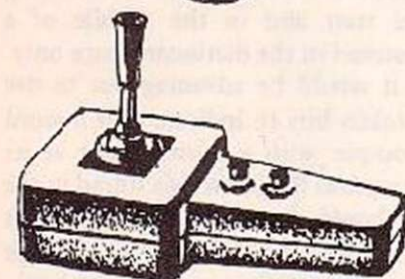

FLIGHTLINK JOYSTICK

with 2 independent
fire actions

£10.50

incl. VAT and P & P

CURRAH µSPEECH UNIT

fits into COMCON extension slot

£29.95

incl. VAT and P & P

Simple and fast programming:
Plug the six function connectors
into the required Spectrum key
positions — Ready!

Two independent fire actions:
Photon Blasters and Neutron Bombs
at the touch of your fingertips.

Extension port for Currah Micro-
speech unit: Combine joystick with
sound and speech for ultimate
arcade action.

Compatible with all Atari type
joysticks including Quickshot II
(without rapid fire action).

Interface operates joystick parallel
to keyboard: Joystick action com-
patible with any add-ons including
Microdrives

The affordable alternative: Lowest
price yet for programmability.

| Qty | Code | Item | Item Price | Total £ |
|-----|------|------------------------|------------|---------|
| | 01 | Comcon Interface | @ £19.95 | |
| | 02 | Flightlink Joystick | @ £10.50 | |
| | 03 | Quickshot 2+2 Joystick | @ £13.95 | |
| | 04 | Comcon + Quickshot 2+2 | @ £31.90 | |
| | 05 | Comcon + Flightlink | @ £28.45 | |
| | 06 | Currah µSpeech unit | @ £29.95 | |

I enclose a cheque/postal order made payable to FREL LTD for: £

Dealer Enquiries Welcome
Phone Ludlow (0584) 4894

Mr/Mrs/Miss _____ Address: _____

Postcode: _____

Send to:

FREL LTD.

Hockeys Mill, Temeside,
Ludlow, Shropshire SY8 1PD

(continued from page 125)

that for the large majority of words in a passage of text the token will contain the word's dictionary number only. For dictionary numbers less than 256 a single byte token would thus suffice in many cases. However, we need some means of telling the decoding routine whether it should expect a one- or two-byte token. This can be achieved by using the one remaining unused bit of the token which, through necessity, will be located in the first byte of the token together with the low order bits of the dictionary item number. This arrangement will permit single byte tokens for dictionary numbers less than 128 when the words require no punctuation flag bits.

The one remaining item we need to define

is the means of terminating each string of tokens which represent a message. For this we require some unique byte value. If in the tokens we add 1 to the dictionary numbers, so that there is a maximum of 2047 dictionary entries numbered from 1 to 2047, we find that a zero value byte will provide a suitable message terminator. Thus, if we want to print out any text message then it is necessary only to locate the appropriate occurrence of a zero byte and begin printing at the token which follows it.

For the present it is assumed that the total number of different text messages within the data base will not exceed 256. The required message number for output may then be specified by a single byte. Applications having more than 256 different text messages may be

accommodated by permitting a suitable number of message lists all based upon a single text dictionary.

In storing the text dictionary we need some means of marking the end of each entry. A suitable method of doing this appears in the Spectrum ROM and has been used here. It is done by setting bit 7 of the final character in each entry thus giving it an ASCII code of greater than 127. Any required dictionary entry is then found by locating the appropriate occurrence of a dictionary byte in which bit 7 has been set.

Earlier, we saw that it was not necessary to code trailing spaces explicitly. Therefore, if we want to define phrases which are to be tokenised then it is necessary to consider other

(continued on next page)

Listing 2.

| | | |
|---------------------------------------|---------------------------------------|---------------------------------------|
| 31000: FE 00 C4 3E 79 3E 08 32 = 753 | 31168: 00 C8 43 3E 01 18 02 06 = 362 | 31352: 35 79 AF 77 23 22 35 7B = 715 |
| 31008: D1 79 7E FE 00 CB 16 C0 = 945 | 31176: 00 CB 7E 23 28 FB 10 F9 = 920 | 31360: C9 D3 E5 D5 E5 11 00 00 = 1110 |
| 31016: 5F 23 CB 43 28 02 06 23 = 563 | 31184: 3D FE 00 20 F2 C9 E5 D5 = 1232 | 31368: 21 37 78 7E FE 00 20 06 = 629 |
| 31024: CB 1A CB 1B 1B E5 C5 CD = 1117 | 31192: C5 D7 C1 D1 E1 C9 01 CD = 1446 | 31376: 23 7E FE 00 28 47 DD 2A = 769 |
| 31032: 4A 79 C1 E1 18 E4 C5 47 = 1133 | 31200: 6B 0D 3E 02 CD 01 16 3A = 470 | 31384: 2F 78 DD 2B 21 3E 7B 3A = 710 |
| 31040: 7C 23 FE 00 20 FA 10 F8 = 961 | 31208: 80 5C ED 4B 2F 7B 2A 31 = 841 | 31392: 3D 78 47 DD 23 DD 7E 00 = 858 |
| 31048: C1 C9 C5 E1 CD B6 79 CD = 1529 | 31216: 7B C3 18 79 DD 21 01 5B = 809 | 31400: CB BF BE 23 20 18 78 FE = 1049 |
| 31056: 97 79 3A BE 79 E2 57 AF = 1113 | 31224: DD 7E 00 FE 5F CA 77 7A = 1139 | 31408: 01 27 06 00 CB 00 7E 28 = 651 |
| 31064: CB 5A 28 02 2E E0 86 CB = 958 | 31232: 1E 00 16 00 4A 21 3E 7B = 344 | 31416: 0D 1B 06 DD CB 00 7E 20 = 625 |
| 31072: 5F FE 40 20 02 3E 20 CD = 842 | 31240: DD 7E 00 DD 23 FE 5E 28 = 991 | 31424: 05 10 E0 15 18 3A DD CB = 964 |
| 31080: D6 79 AF CB 7E 23 28 EE = 1152 | 31248: 4C FE 20 28 34 FE 2E 20 = 786 | 31432: 00 7E DD 23 28 F8 DD 2B = 934 |
| 31088: CB 42 28 07 3E 2E CD D6 = 875 | 31256: 04 CB E1 18 2C FE 2C 20 = 830 | 31440: 13 21 37 7B 7E EB 20 C4 = 771 |
| 31096: 79 3E CB 32 BE 79 3E 2C = 690 | 31264: 04 CB E9 18 24 77 7A FE = 995 | 31448: 23 7E BA 20 FF 2A 37 7B = 790 |
| 31104: CB 4A C4 D6 79 3A 88 5C = 1126 | 31272: 00 20 15 7E FE 5B 30 10 = 506 | 31456: E5 23 22 37 7B 2A 33 7B = 692 |
| 31112: FE C1 3E 20 C4 D6 79 3E = 942 | 31280: FE 41 38 0C C6 20 77 3A = 794 | 31464: DD 21 3E 7B 3A 3D 7D 47 = 762 |
| 31120: 0D CB 7E C4 D6 79 C9 E5 = 1291 | 31288: DE 79 FE 00 20 02 CB D9 = 1051 | 31472: DD 7E C0 DD 23 77 23 10 = 773 |
| 31128: D5 C5 3A 88 5C 3D 3D CB = 1021 | 31296: 23 14 1C 3A 00 5B BB 3C = 467 | 31480: F7 2B CB FE 23 22 33 7B = 990 |
| 31136: 7E 23 28 FA CB 62 28 01 = 793 | 31304: DF 1C 7A 00 5B BB 38 14 = 631 | 31488: AF CB 41 28 01 3C 32 DE = 848 |
| 31144: 3D CB 6A 28 01 3D FE 20 = 758 | 31312: DD 7E 00 FE 20 20 06 1C = 699 | 31496: 79 D1 3A 35 7B 13 7A E6 = 919 |
| 31152: 38 2B 3E 0D 18 23 7A E6 = 532 | 31320: DD 23 DD 7E 00 FE 5E 2C = 903 | 31504: C7 E1 57 AF CB 13 CB 12 = 889 |
| 31160: C7 FE 00 C4 C7 79 7B FE = 1154 | 31328: 03 1C CB F1 7A 32 3E 7B = 831 | 31512: 7A FE 00 28 02 CB C3 73 = 931 |
| | 31336: CD 81 7A 3A 00 5B BE 3C = 840 | 31520: 23 CB 43 28 02 77 23 22 = 535 |
| | 31344: 91 2A 35 7B AF 77 C5 2A = 900 | 31528: 35 7B E1 D1 DD E1 C9 00 = 1257 |

Listing 3.

```

10 REM *TEXT COMPRESSION SYSTEM*
20 REM A. Tobias: June 1984
30 REM ** Main Driving Routine
40 BORDER 1: PAPER 1: INK 7
50 CLS: PRINT " TEXT COMPRESS
SION SYSTEM": PRINT "
": PRINT " PRI
NT
60 PRINT TAB 9; INK 0: PAPER 5
:"* A.Tobias *": PRINT
70 PRINT TAB 13; PAPER 7: INK
0:"MENU": PRINT "
80 PRINT " 1. Reset Message
Pointers 2. Input Text vi
a Keyboard 3. List Stored T
ext 4. List Current
Dictionary 5. Compression S
tatistics 6. Save Dictiona
ry/Text 7. Load Dictiona
ry/Text"
90 INPUT "Required Option ?":o
pt
100 IF opt<1 OR opt>7 THEN GO T
O 90
110 PRINT AT (opt+8),3; FLASH 1
:opt
120 PAUSE 100
130 GO SUB (opt*1000)
140 GO TO 40
150 CLEAR 30999
160 LOAD "CODE
170 GO TO 10
200 LET x=nd: GO SUB 940
210 POKE 31543,1: POKE 31544,F
220 LET x=nm: GO SUB 940
230 POKE 31545,1: POKE 31546,h
240 LET x=ct: GO SUB 940
250 POKE 31547,1: POKE 31548,h
260 RETURN
300 LET nd=PEEK 31543+PEEK 3154
4*256
310 LET nm=PEEK 31545+PEEK 3154
6*256
820 LET ch=PEEK 31547+PEEK 3154
8*256
830 RETURN
900 PAUSE 30
910 PRINT E1:AT 1,0:"Press any
key to continue."
920 IF CODE INKEY$=0 THEN GO TO
920
930 RETURN
940 LET h=INT (x/256)
950 LET l=x-h*256
960 RETURN
1000 REM ** Reset Pointers **
1010 BORDER 1: PAPER 1: INK 7
1020 CLS
1030 PRINT "Reset Dictionary Sto
rage ?": PRINT
1040 INPUT rs
1050 IF rs="n" OR rs="N" THEN GO
TO 1160
1060 IF rs<>"y" AND rs<>"Y" THEN
GO TO 1040
1070 PRINT "Dictionary Base Addr
ess ? (0 for no change)"
1080 INPUT x: IF x=0 THEN GO TO
1100
1090 GO SUB 940: POKE 31535,1: P
OKE 31536,h
1100 POKE 31543,0: POKE 31544,0
1110 POKE 31539,PEEK 31535
1120 POKE 31540,PEEK 31536
1130 POKE 31547,0: POKE 31548,0
1140 PRINT "Dictionary has been
reset.": PRINT
1150 GO TO 1200
1160 PRINT "Reset Text Storage ?
": PRINT
1170 INPUT rf
1180 IF rf="n" OR rf="N" THEN GO
TO 1270
1190 IF rf<>"y" AND rf<>"Y" THEN
GO TO 1170
1200 POKE 31545,0: POKE 31546,0
1210 PRINT "Text Base Address ?
(0 for no change)"
1220 INPUT x: IF x=C THEN GO TO
1240
1230 GO SUB 940: POKE 31537,1: P
OKE 31538,h
1240 POKE 31541,PEEK 31537
1250 POKE 31542,PEEK 31538
1260 POKE 31547,0: POKE 31548,0
1270 PRINT "Text Storage has bee
n reset."
1280 GO SUB 900
1290 RETURN
2000 REM ** Input Text **
2010 BORDER 5: PAPER 5: INK 0
2020 GO SUB 800
2030 IF nd<2000 THEN GO TO 2070
2040 CLS: PRINT FLASH 1:"WARNIN
G"
2050 PRINT "No. of Dictionary It
ems > 2000"
2060 GO SUB 900
2070 CLS: PRINT "Message No.":n
m
2080 POKE 31198,1
2090 INPUT a#
2100 LET a=LEN a#
2110 IF a=0 THEN GO TO 2090
2120 IF a<255 THEN GO TO 2150
2130 PRINT AT 20,0:"Error - stri
ng > 255 Characters Please retyp
e input"
2140 GO TO 2090
2150 POKE 23296,(a-1)
2160 FOR i=1 TO a
2170 POKE (23296+i),CODE a$(i)
2180 NEXT i
2190 RANDOMIZE USR 31220
2200 IF a$(1)="_" THEN GO TO 227
0
2210 PRINT AT 1,0:
2220 LET c=PEEK 31198
2230 POKE 23728,nm: RANDOMIZE US
R 31207
2240 POKE 31198,c
2250 LET ch=ch+a

```

(listing continued on next page)

(continued from previous page)

ways of representing spaces within these phrases. A simple solution is to represent them by some other character, preferably one which is unlikely to be found elsewhere in the text. The system described here has been designed to interpret the character '@' (ASCII 64) as a 'phrase space'. When found in a phrase this character is stored explicitly in the dictionary entry whereas during output it is replaced by a true space.

Using the hex loader shown in listing 1, you can load the Z-80 machine-code routines which will both compress and expand text according to the system described above. Listing 2 gives a hexadecimal dump of the Z-80 machine-code routines. The decoding routine occupies 199 bytes beginning at location 31000 and the compression routine occupies 315 bytes starting at location 31220. The code beginning at location 31199 merely sets up the registers for the expansion routine as used by this overall program.

The first location of the printer buffer (23296) holds the total number of characters in an input line or lines of text while the remainder of the buffer — 23297 to 23551 — is used to store the input text.

Listing 3 gives the Basic program which will drive the text compression routines described above. It is menu driven and is simple to use. Option 1 enables you to reset the base addresses for both the dictionary and the tokenised messages. It is essential that you select this option prior to initial text input.

During operation of the program the dictionary of words and phrases is built up as

Figure 1. Text Example and corresponding tokens.

Message: You are in a dark, damp cellar with a narrow passageway leading south.

| Word/Phrase | Token Value(s) |
|-------------|----------------|
| You are in | 2 |
| a | 4 |
| dark, | 7, 64 |
| damp | 8 |
| cellar | 10 |
| with | 12 |
| a | 4 |
| narrow | 14 |
| passageway | 16 |
| leading | 18 |
| south. | 21, 32, 0 |

No. of token bytes in compressed message = 4

the text input is scanned. This method of operation is sensible since, for large text databases, it is unlikely that both the original and compressed text may be stored simultaneously. In order to take full advantage of the use of single byte tokens it is advisable to enter some dummy text messages initially which contain the words you believe to occur most frequently in your text. When you have done this, reset the message storage but retain the dictionary.

Because the program given here has been devised to compress text as it is input from the keyboard, it enables you to lay out the text as required. During input you may type in up to eight lines of text at once — maximum of 255 characters — and each section of input does not have to finish at the end of a sentence. It is only necessary to ensure that you leave a space

between each word.

When you have completed the input for a message type the character "-" (ASCII 95) as the first character of a new single item of input. As was noted above, newline characters are automatically provided if the next word to be printed will not fit into the current line. Additional newline characters can be inserted into the text by including a "^" character (ASCII 94) at the appropriate place.

With the exception of the characters shown in table 1, for which special interpretation applies, all ASCII characters with codes in the range 32 to 127 will be treated as normal text characters.

Note that if you want to save some compressed text for subsequent extension then it is essential that this is done by the program so that all pointers are preserved. These pointers are required only for the compression system's book-keeping and are not needed by any program which will use the compressed text. Similarly, the compression routine, stored in locations 31220 to 31534, may be omitted from the target program. You will, however, require the heart of the expansion routine — stored in locations 31000 to 31198, or suitably relocated as required. On entry to the start of this routine, register 'a' should contain the required message number and register pairs 'hl' and 'bc' should point to the start addresses of the text tokens and dictionary respectively. Since these are saved as 'code' and are position independent they may be loaded into any region of memory for your target program. ■

(listing continued from previous page)

```
2260 GO TO 2090
2270 LET nm=nm+1
2280 INPUT "Any more text?" ; r#
2290 IF r#="y" OR r#="Y" THEN GO
TO 2070
2300 LET nd=PEEK 31543+PEEK 3154
4*256: GO SUB 700
2310 IF nd<2000 THEN GO TO 2330
2320 CLS: PRINT FLASH 1: "WARNIN
G": PRINT "Dictionary Almost Full
!"
2330 GO SUB 900
2340 RETURN
3000 REM ** Print Stored Message
s **
3010 BORDER 4: PAPER 4: INK 0
3020 GO SUB 800
3030 IF nm=0 THEN RETURN
3040 FOR i=0 TO nm-1
3050 POKE 23728,i
3060 RANDOMIZE USR 31199
3070 PRINT AT 21,0: "Message No."
: i
3080 GO SUB 900
3090 NEXT i
3100 RETURN
4000 REM ** Print Dictionary **
4010 BORDER 5: PAPER 5: INK 1
4020 GO SUB 800: IF nd=0 THEN RE
TURN
4030 LET wds=PEEK 31535+PEEK 315
36*256: CLS
4040 FOR i=1 TO nd STEP 20
4050 CLS: PRINT PAPER 1: INK 7:
"DICTIONARY ITEM": TAB 20: "ENTRY
NO.": PRINT
4060 FOR i=i TO i+19
4070 LET c=PEEK wds: LET wds=wds
+1
4080 LET d=c: IF c>128 THEN LET
c=c-128
4090 PRINT CHR# c:
4100 IF d<128 THEN GO TO 4070
4110 PRINT TAB 20: j
```

```
4120 IF j=nd THEN GO TO 4140
4130 NEXT j
4140 GO SUB 900
4150 NEXT i
4160 RETURN
5000 REM ** Compression Statisti
cs **
5010 BORDER 6: PAPER 6: INK 1: C
LR
5020 GO SUB 300
5030 PRINT "COMPRESSION STATISTI
CS": PRINT "-----"
--": PRINT: PRINT
5040 PRINT "Uncompressed Text": T
AB 20: ch: TAB 27: "bytes": PRINT:
PRINT
5050 LET c1=PEEK 31539+PEEK 3154
0*256-(PEEK 31535+PEEK 31536*256
)
5060 PRINT "Dictionary Items": TA
B 20: nd: PRINT
5070 PRINT "Dictionary Size": TAB
20: c1: TAB 27: "bytes": PRINT
5080 LET m1=PEEK 31541+PEEK 3154
2*256-(PEEK 31537+PEEK 31538*256
)
5090 PRINT "Compressed Text": TAB
20: m1: TAB 27: "bytes": PRINT: P
RINT
5100 PRINT "Dictionary + Text": T
AB 20: (d1+m1): TAB 27: "bytes": PR
INT: PRINT
5110 LET x=INT (1000*(1-(d1+m1)
/ch))/100
5120 PRINT "Compression Factor":
TAB VAL "20": FLASH VAL "1": x: "
%"
5130 GO SUB 900
5140 RETURN
6000 REM ** Save to Tape **
6010 BORDER 0: PAPER 0: INK 7
6020 GO SUB 700
6030 CLS: PRINT "Load tape and
prepare to record."
```

```
6040 PRINT: PRINT "Saving Point
ers."
6050 SAVE "Pointers" CODE 31535,1
5
6060 LET x=PEEK 31535+PEEK 31536
*256
6070 LET l=PEEK 31539+PEEK 31540
*256-x
6080 PRINT "Done.": PRINT: PRIN
T "Saving Dictionary."
6090 SAVE "Dictionary" CODE x,1
6100 LET x=PEEK 31537+PEEK 31538
*256
6110 LET l=PEEK 31541+PEEK 31542
*256-x
6120 PRINT "Done.": PRINT: PRIN
T "Saving Compressed Text."
6130 SAVE "Text" CODE x,1
6140 PRINT "Done."
6150 GO SUB 940
6160 GO SUB 900
6170 RETURN
7000 REM ** Read from Tape **
7010 BORDER 0: PAPER 0: INK 7
7020 CLS: PRINT "Load tape in r
ecorder and start."
7030 PRINT: PRINT "Loading Poin
ters"
7040 LOAD "" CODE 31535
7050 PRINT: PRINT "Loading Dict
ionary"
7060 LET x=PEEK 31535+PEEK 31536
*256
7070 LOAD "" CODE x
7080 PRINT: PRINT "Loading Comp
ressed Text"
7090 LET x=PEEK 31537+PEEK 31538
*256
7100 LOAD "" CODE x
7110 GO SUB 940
7120 GO SUB 900
7130 RETURN
9500 SAVE "Comptext" LINE 150
9510 SAVE "Code" CODE 31000,550
```

synsoft
presents...

The World's Greatest Games!

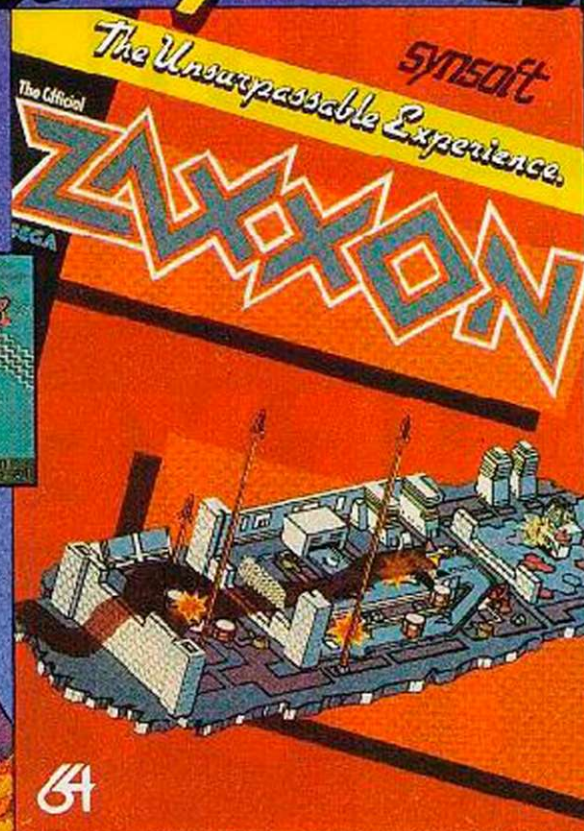
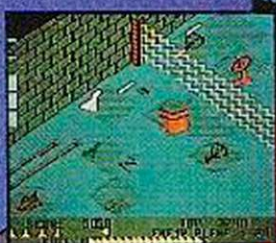

Selected Titles
available soon for
Spectrum

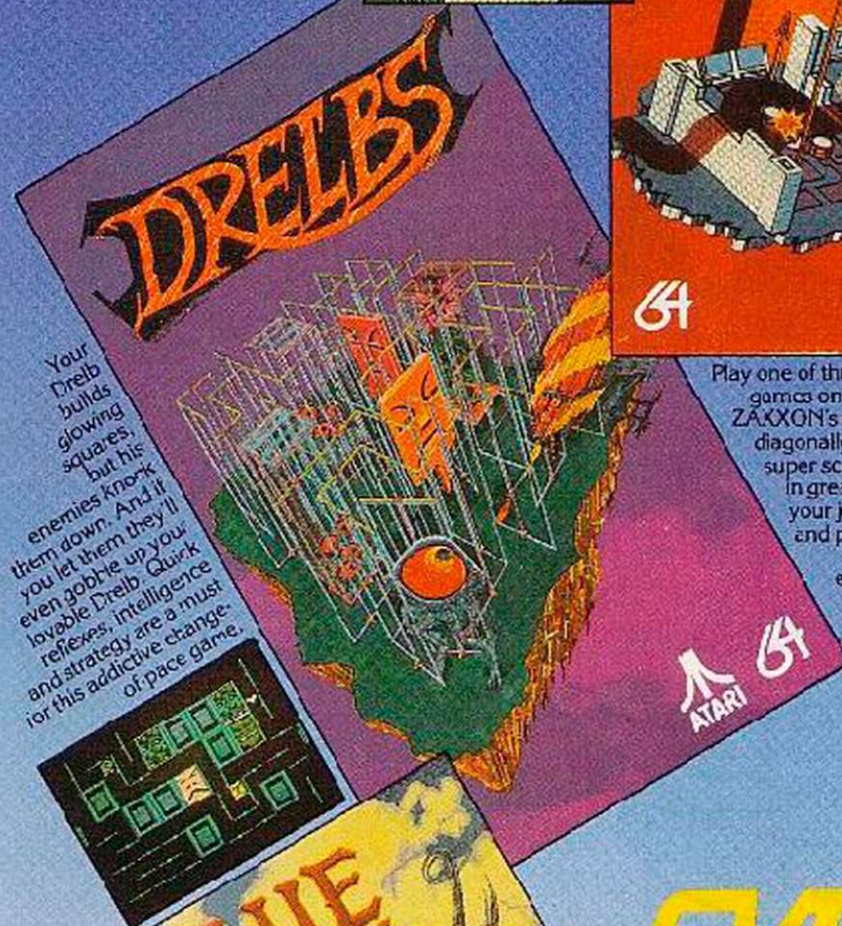

Your Drelbs builds glowing squares, but his enemies knock you let them they'll even gobble up your reflexes, intelligence and strategy are a must for this addictive change-of-pace game.

Play one of the most challenging arcade games on your C-64 computer. ZAXXON's incredible 3-D graphics, diagonally scrolling screen and super sound are reproduced in great detail. Hang onto your joystick, keep firing and practice. You may eventually encounter the deadly Zaxxon himself!



Exciting 3-D action! The most realistic point-of-view game you've ever played! Navigate through asteroid belts, destroy enemy ships, track air battles, stars through intergalactic minefields. Now can you prevent the enemy capturing your planet?

synsoft

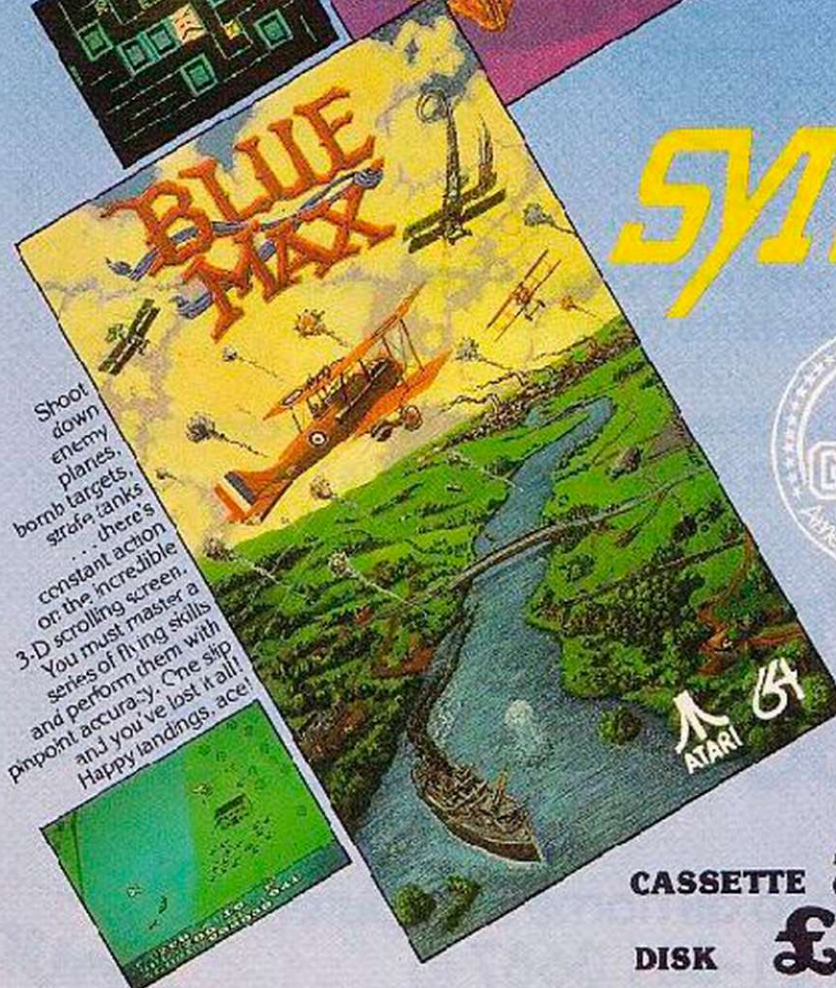

Shoot down enemy planes, bomb targets, strafing tanks... there's constant action on the incredible 3-D scrolling screen. You must master a series of flying skills and perform them with pinpoint accuracy. One slip and you've lost it all! Happy landings, ace!



Play this multi-level extravaganza three different ways. Fire on vile enemies, navigate deadly hazards, rescue 18 trapped friends, make your way through treacherous caves! Super graphics, unerring sounds and constant scrolling screen.

CASSETTE **£9.95**
DISK **£14.95**



THE ULTIMATE IN AMERICAN SOFTWARE FOR YOU ON U.S. GOLD

U.S. Gold is stocked by all leading computer stores including:



John Menzies

WHSMITH WILDINGS WOOLWORTH

ARE YOU THE HOME COMPUTER RETAILER OF THE YEAR?

1984



Micro Business, the monthly journal for computer dealers, and Websters Software are organising a major competition to find the Home Computer Retailer of the Year.

If you have an established, imaginative or particularly successful approach to home computer retailing, you could become the Micro Business Websters Software Retailer of the Year.

| | | |
|------------------|------------------|------------------|
| 1st Prize | 2nd Prize | 3rd Prize |
| £1,000 | £500 | £250 |

This easy to enter competition is open to all home computer/software dealers. To enter telephone 01-661 3687 to receive your entry form.

Electrical Electronic Press, Marketing Department Quadrant House,
The Quadrant, SUTTON, Surrey SM2 5AS.

**Phone now for your
entry form.**

MICRODRIVE

Kathleen Peel with an appraisal of Microdrives after eight months' use.

IT IS EIGHT MONTHS since a Microdrive first appeared on my desk so it is about time I presented a brief long-term appraisal of the reliability of not only the drives, but also the Microdrive operating system.

During the eight month period, nearly all the reviews I have written have used a Microdrive-based word processor. Also much software development has taken place for the Spectrum and the now extinct Timex 2068.

This has resulted in almost continuous use for cartridges employed in software development over a period of weeks and a periodic exercise for the cartridges used for the reviews.

Combined with this almost continuous use of the Spectrum Microdrives can be coupled preliminary thoughts on the QL drives and the QL's operating system, which have received a great deal of my attention lately.

Although the Spectrum Microdrives have worked without losing any files — and not all disc drives can have that said about them — that does not mean they are without minor niggling faults.

The restraints placed on program transfer restrict the ability to produce a simple Basic back up program to transfer all the programs and data on the cartridge to cassette tape and back again. The cost of cartridges makes it very expensive to create a library as they only have a fraction of the storage capacity of a cassette and there is also no convenient way of storing cartridges.

One of the early problems was in finding somewhere safe to store the very small cartridges, they are very much smaller than the new 3-inch Japanese micro-floppies.

The plastic wallet now supplied free with cartridges bought in packs of four is a great help in overcoming the problem of misplacing a cartridge, or more likely its cover. It would have been perfect if the wallet could have been made to fit the cassette racks.

Another problem that arises as a result of the small size of the cartridges is indexing contents. Cassettes cases are provided with an inlay card for this very purpose, a quick glance along a cassette rack will normally find a tape — with the cartridges this is not possible.

A solution for two-drive setups is for drive 1 to contain the working files and drive 2 the

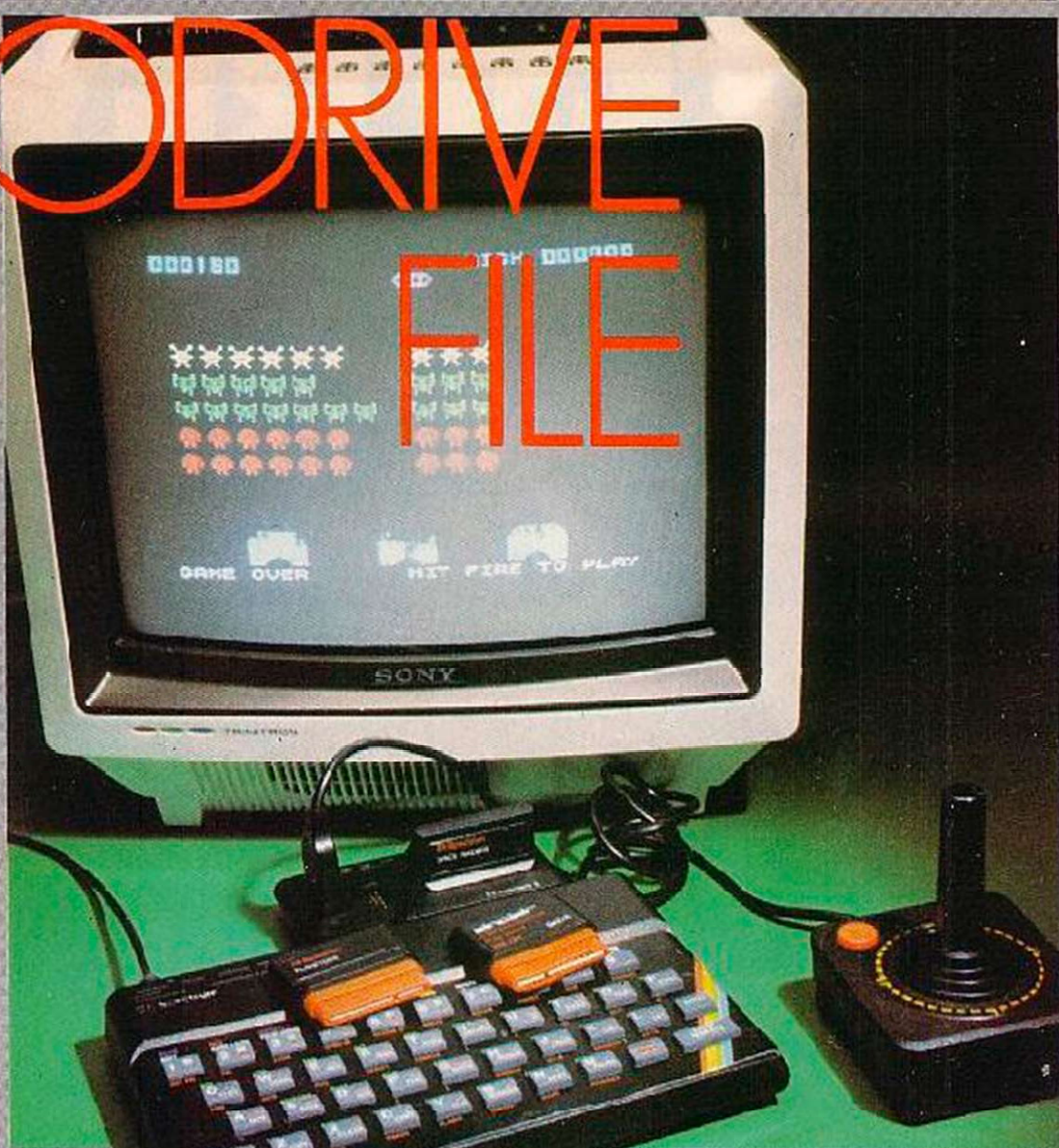

utilities and system index. This works well provided none of the utilities are very large.

Although the Microdrives perform adequately for speed, on cartridges with a lot of free space I tend to double-save each program as it does make the drives load even quicker.

There was a stage when I started writing utilities to handle the rather long syntax command entries but, after a while, these became restrictive as they used up space which could be better used elsewhere.

The QL drives have been extremely erratic and so far have frequently refused to load programs that have just been saved. As this problem does not afflict all programs on the cartridge, it can be assumed that the problem lies with the QL's operating system — QLOSS.

My impression is that the QL seems to lose track of where it has just loaded or saved a file, possibly due to changes to the stack pointer brought about by breaks. As none of the

programs contain machine-code or memory Pokes, they are purely Basic, this is very disappointing.

There appears to be no vertical restraint for the cartridges at the front edge. This can lead to the cartridge rocking between the top and bottom surfaces of the Microdrive causing a rhythmic banging of the cartridge case, a problem that also appears in the Spectrum drives.

If you already have Spectrum Microdrives, they can be used with the QL in a read only mode. Format and save are not possible — I'm not sure why saving is not possible at the moment. Just remember to use QL formatted and written cartridges. The Psion cartridges make reference to a specific Microdrive and may not work.

The Interface 1 is extremely good — the only minor problem is the lack of a Tab function, but that can be overcome if necessary.

The RS-232 capability has allowed connection to virtually everything that I have tried and the Spectrum to Spectrum networking is also very good and extremely fast.

Strange, then, that the QL should not be fully able to link with the Spectrum over the network. The Spectrum passes tokenised keywords which the QL cannot read. This may well be compounded by adding two incompatible sets of timings.

Overall, the performance of the Spectrum Microdrives is highly satisfactory and complaints revolve around minor details of logistics.

The drives have virtually the same
(continued on page 133)



A STEP BEYOND.



QUICKSILVA

All Titles available mail order from:
QUICKSILVA MAIL ORDER P.O. Box 6, Wimborne, Dorset BH21 7PY. Tel: (0202) 891744.

| | | | | | | | |
|--|--|---|--|--|--|--|--|
| <p>FRED THE FIRST BORN OF THE QUICKSILVA</p>  <p>SPECTRUM 48K £6.95 COMMODORE 64 £7.95</p> | <p>SNOWMAN The Snowman</p>  <p>SPECTRUM 48K £6.95</p> | <p>BOOGABOO BUGABOO QUICKSILVA</p>  <p>COMMODORE 64 £7.95 SPECTRUM 48K £6.95</p> | <p>VELNOR'S LAIR VELNOR'S LAIR QUICKSILVA</p>  <p>ORIC/ATMOS £6.95 SPECTRUM 48K £6.95</p> | <p>ANT ATTACK ANT ATTACK QUICKSILVA</p>  <p>SPECTRUM 48K £6.95 COMMODORE 64 £8.95</p> | <p>MINED OUT MINED OUT QUICKSILVA</p>  <p>ELECTRON £6.95 BBC £6.95 LYNX £6.95 SPECTRUM 48K £14.95 ORIC/ATMOS £6.95</p> | <p>DRUMKIT DRUMKIT</p>  <p>BBC £9.95 (IN A BOX - BOOKLET)</p> | <p>GATE CRASHER GATE CRASHER</p>  <p>BBC/ELECTRON £6.95</p> |
|--|--|---|--|--|--|--|--|

NEW NEW GENERATION ON COMMODORE 64
TRASHMAN £7.95
3D TUNNEL £7.95
ESCAPE £7.95

NEW
ELECTRO-ART
ELECTRON
£14.95

WARNING: These programs are sold according to QUICKSILVA Ltd's terms of trade and conditions of sale, copies of which are available on request.



Available at
WHSMITH



WOOLWORTH

John Menzies

and leading multiple retailers and specialist computer stores

NEW GAMES AVAILABLE NOW
HAVE YOU JOINED THE GAME LORDS YET?
Send S.A.E. for details and catalogue

(continued from page 131)

performance as the disc drives I have used recently except for the lack of random access to Spectrum files

I have a feeling that the high cost of cartridges is being used to restrict demand for the cartridges while production builds up.

The performance of the QL Microdrives is far less satisfactory. There appears to be a major design problem in the software which allows a user to create non-loading files from Basic programs which do not contain machine-code or system Pokes.

The simple little program, right, provides the new ROM entry position of the Microdrive commands. The reader can get a better understanding of the Microdrive operation by producing a disassembled listing from the start of each of these commands. The code tends to jump around but sections can be used quite easily within your own programs.

Recently, I reported that the QL Microdrives in the FB ROM machines (check by typing: Print ver\$) were prone to lose programs and data by becoming unreadable. You will be pleased to hear that the latest version of the QL seems to have cured the problem which means it must have been a software problem in the old ROM.

Using the "new" QL for a period of weeks has provided the data integrity that a user would require and given a much higher level of confidence in the drives. All that remains are the two problems of excessive cartridge costs — £5 is still daylight robbery — and disappointingly long and frequent QL Microdrives accessing times especially when using the Psion software packages.

```
1 CLEAR 30000
2 SAVE *"m";1;"urom"CODE 435:61
3 LOAD *"m";1;"urom"CODE 30000
4 PRINT " Syntax check entry points"
PRINT
5 FOR a=30003 TO 30053 STEP 5
6 PRINT CHR$(206+PEEK a), : GO SUB 10
: PRINT b
7 NEXT a
8 PRINT : PRINT " Extend Vector Address"
: PRINT : LET a=a-2: GO SUB 10: PRINT
,(PEEK b+256*PEEK (b+1))
9 ERASE "m";1;"urom": STOP
10 LET b=PEEK (a+2)+256*PEEK (a+3): RETURN
9000 CLEAR #: FORMAT "t";600: OPEN #3;"t"
": STOP
9999 ERASE "m";1;"ufile1": SAVE *"m";1;"
ufile1": CAT 1: STOP
```

Write your own machine code adventures

Without any knowledge of machine code whatsoever

THE QUILL

THE QUILL is a major new utility written in machine code which allows even the novice programmer to produce high-speed machine code adventures of superior quality to many available at the moment without any knowledge of machine code whatsoever.

Using a menu selection system you may create well over 200 locations, describe them and connect routes between them. You may then fill them with objects and problems of your choice. Having tested your adventure you may alter and experiment with any section with the greatest of ease. A part formed adventure may be saved to tape for later completion. When you have done so THE QUILL will allow you to produce a copy of your adventure which will run independently of the main QUILL editor, so that you may give copies away to your friends.

THE QUILL is provided with a detailed tutorial manual which covers every aspect of its use in writing adventures.

FOR THE 48K SPECTRUM AT £14.95

Now available in W H Smith, and from many computer shops nationwide, or direct from us by post or telephone.

SAE for full details of our range.

Dealer enquires welcome.

GILSOFT

30 Hawthorn Road
Barry
South Glamorgan
CF6 8LE
☎(0446) 732765

Credit Card Order line
Personally manned for 24 hours
☎(0222) 41361 Ext 430



The Sinclair

QL

and you



Exploring the Sinclair QL — An Introduction to SuperBASIC

Andrew Nelson, £4.95

The QL has a rich, new programming vocabulary, and this great book gives you the chance to master the host of new words Sinclair has added. Sure, you can use the QL more or less just like a Spectrum, but if you do, you are missing the extraordinary power which lies behind the radical concepts of SuperBASIC. Command by command, statement by statement, Andrew Nelson takes you through the richness of QL SuperBASIC in *Exploring the Sinclair QL — An Introduction to SuperBASIC*. Just £4.95 and available from most book and computer shops. In case of difficulty, you can order it directly from Interface Publications, using the coupon below. (Trade only: Interface Publications are distributed exclusively in the UK and Eire by W H S Distributors. Export orders handled by Interface Publications.)

Interface Publications, Department QYC,
9-11 Kensington High Street, London W8 5NP.

Please send me the following books.
I enclose a total of £ _____

- Exploring the Sinclair QL — An Introduction to SuperBASIC — Andrew Nelson, ISBN 0 907563 84 8 £4.95
- 49 Explosive Games for your ZX Spectrum — Tim Hartnell, ISBN 0 907563 53 8 £4.95
- Delving Deeper into your VIC 20 — Philip Campbell, ISBN 0 907563 62 7 £4.95
- Creating Adventure Games on your Dragon 32 — Clive Gifford, ISBN 0 907563 57 0 £4.95
- Dynamic Games for your VIC 20 — Matthew Boek, ISBN 0 907563 34 1 £4.95
- Creating Adventure Programs on your Computer — Andrew Nelson, ISBN 0 907563 36 8 £4.95
- Putting your VIC 20 to Work — Tom Lau, ISBN 0 907563 46 5 £4.95
- The Easy Way to Program your New Computer — Tim Hartnell, ISBN 0 907563 60 0 £3.95
- Creating Adventures on your ZX Spectrum — Peter Shaw & James Mortimer, ISBN 0 907563 58 9 £4.95
- Practical Uses for the Microcomputer in the Home — David Hole, ISBN 0 907563 59 7 £4.95
- Mastering Machine Code on your Commodore 64 — Mark Greenshields, ISBN 0 907563 69 4 £7.95
- Making the Most of your TI 99/4A — Scott Vincent, ISBN 0 907563 66 X £4.95
- Dynamic Games for your Electron — Neal Cavalier-Smith, ISBN 0 907563 67 8 £4.95
- The 3-D Animated Apple — Phil Cohen, ISBN 0 907563 78 3 £4.95
- The Art of Structured Programming — Peter Juliff, ISBN 0 907563 79 1 £5.95
- Dynamic Games for your TRS-80 — Gail Duns & Tim Hartnell, ISBN 0 907563 63 5 £3.95

Name.....

Address.....

.....

..... QYC

INTERFACE
PUBLICATIONS 

— We're the experts! —

Bernard Harmel puts the Dragon on file.

THIS PROGRAM, which is entirely in machine-code, allows you to store, search look at and save data in the form of a card-index in the memory of the computer.

The program has been realised on a Dragon 32 with the EDTASM + cartridge. It occupies 1,971 bytes and leaves approximately 29,200 bytes free for data storage. For first time loading, switch the machine off, then on, and load the decimal machine-code in listing 1 using the Basic program supplied — listing 2. A checksum is included at the end of each line to prevent errors.

After that save the code on tape as a machine-code file:

```
CSAVEM "$FILESS", 30920, 32400, 0
```

Turn the machine off, then on, and type:

```
POKE 25, 6      Enter  
NEW             Enter } to reserve them  
CLEAR 20, 1690 Enter
```

Then you must set RAMtop.

That is to say you must tell the

computer from where it must store the data — min. 1,701; max. 30,900 — that is done by Poking the value 210 in the desired address. Poke 170., 210 receive the maximum place for data storage and Poke 30900 the minimum. Finally, type:

```
EXEC 31921
```

The menu must appear on the screen. Let us suppose that we want to classify books — each book is identified by a file specifying the author, title, year, price.

We must first define a model file collecting these different pieces of information. Command 1 allows you to do that. Press 1, the screen turns green and a cursor appears in the left-hand corner of the screen. You have 10 lines to create your model file; if you try to write on the 11th you get an end of file error. Press ↑ and continue. Use the four arrow keys to move the cursor and the other keys to write. To clear a character put the cursor on

the left and press ←. When data first appears after an item it must be followed by:

```
(CHRS(58))
```

For our example, the model file could be like this — use command 1 to create it.

BOOKS

AUTHOR:

TITLE:

YEAR:

PRICE:
(WITHOUT VAT)

32 Columns

When the model file is finished just press Enter and the message File Recorder will appear on the screen. Press any key to return to the menu.

(continued on next page)

DRAGON FILES

```
Listing 2 Decimal loader.  
10 CLS  
20 FOR F=30920 TO 32391 STEPS  
30 S=0:PRINT@32." "  
40 PRINT@0.F:" --> "  
50 FORB=0 TO 4  
60 INPUT  
70 PRINT@6*4+10.P  
80 POKEF+6.P  
90 S=S+P  
100 NEXT B  
110 INPUT"CHECKSUM ":P  
120 IF P<>S THEN PRINT"TRY  
    AGAIN PLEASE":GOTO 30  
130 PRINT@64." "  
140 NEXTF
```



(continued from previous page)

The command allows you to complete the model file with information. Press 2 and the model file will appear. Use the arrow key to move the cursor near the items and type the information corresponding to the item between

(CHRS(34))

If an item has no information it must be followed by "". If you forget a "" you will get a Syntax Error — use the arrow keys to correct.

When every item is followed by the information press Enter and you get OK. If you press:

Break: return to menu and file is recorded.

N : the file is cleared and you can write it again any other key: You record the file and make offers the model file and the cursor ready to write the next file.

Example:

BOOKS

AUTHOR: "H. G. Wells"
 TITLE: "War of the Worlds" YEAR: "1964"
 PRICE: "3.5"
 (WITHOUT VAT)

Command 3 allows you to search a string among all the files stored in memory. Press 3 — Searching will appear at the bottom of the screen with the cursor. Type your string followed by

(CHRS(35))

and press Enter. If you make an error use ← to correct it. Example — Searching: WAR#. If the string searched is in memory the corresponding file is displayed on the screen and, at the bottom of the screen, the message 'Space' Dump to Printer. If you press: Space: you will get a copy of the screen on the printer.

Break: return to the menu:

Any other key will make the computer continue the research.

If the string is present several times in the file, it is displayed several times also. If the string isn't in memory the program displays Finished. Press a key to get the menu. Command 4 allows you to save the card index and also to leave the program. Press 4 several times and you are in Basic. You can type:

(continued on page 138)



Listing 1. Decimal dump.

| | | | | | | | | | | | | | | | | | | | | | | | | | | |
|-------|-----|-----|-----|-----|-----|-----|---|-----|-------|-----|-----|-----|-----|-----|-----|---|-----|-------|-----|-----|-----|-----|-----|-----|---|------|
| 30920 | --> | 70 | 73 | 76 | 69 | 32 | - | 320 | 31170 | --> | 60 | 65 | 84 | 73 | 79 | - | 369 | 31420 | --> | 13 | 16 | 37 | 3 | 70 | - | 141 |
| 30925 | --> | 49 | 69 | 67 | 79 | 82 | - | 379 | 31175 | --> | 76 | 72 | 49 | 33 | 85 | - | 295 | 31425 | --> | 129 | 9 | 39 | 41 | 129 | - | 347 |
| 30930 | --> | 69 | 69 | 68 | 70 | 73 | - | 348 | 31180 | --> | 78 | 69 | 32 | 70 | 75 | - | 322 | 31430 | --> | 8 | 39 | 33 | 129 | 94 | - | 302 |
| 30935 | --> | 70 | 73 | 83 | 72 | 69 | - | 375 | 31185 | --> | 67 | 72 | 69 | 32 | 32 | - | 272 | 31435 | --> | 39 | 43 | 129 | 10 | 39 | - | 260 |
| 30940 | --> | 68 | 39 | 83 | 80 | 65 | - | 335 | 31190 | --> | 66 | 82 | 69 | 65 | 75 | - | 357 | 31440 | --> | 34 | 246 | 127 | 245 | 193 | - | 845 |
| 30945 | --> | 67 | 69 | 39 | 58 | 68 | - | 301 | 31195 | --> | 32 | 32 | 32 | 32 | 69 | - | 247 | 31445 | --> | 0 | 38 | 11 | 140 | 5 | - | 194 |
| 30950 | --> | 85 | 77 | 80 | 32 | 84 | - | 358 | 31200 | --> | 84 | 79 | 85 | 32 | 32 | - | 362 | 31450 | --> | 63 | 35 | 8 | 189 | 128 | - | 410 |
| 30955 | --> | 79 | 32 | 80 | 82 | 75 | - | 346 | 31205 | --> | 65 | 85 | 32 | 77 | 69 | - | 328 | 31455 | --> | 114 | 126 | 122 | 170 | 185 | - | 721 |
| 30960 | --> | 78 | 84 | 69 | 82 | 79 | - | 392 | 31210 | --> | 78 | 85 | 113 | 32 | 32 | - | 340 | 31460 | --> | 122 | 146 | 126 | 122 | 170 | - | 686 |
| 30965 | --> | 75 | 32 | 63 | 48 | 32 | - | 250 | 31215 | --> | 32 | 68 | 69 | 70 | 73 | - | 312 | 31465 | --> | 198 | 255 | 126 | 122 | 250 | - | 951 |
| 30970 | --> | 32 | 68 | 85 | 77 | 80 | - | 342 | 31220 | --> | 78 | 73 | 84 | 73 | 79 | - | 387 | 31470 | --> | 198 | 1 | 126 | 122 | 250 | - | 697 |
| 30975 | --> | 32 | 32 | 32 | 32 | 49 | - | 177 | 31225 | --> | 78 | 32 | 68 | 32 | 85 | - | 295 | 31475 | --> | 198 | 32 | 126 | 122 | 250 | - | 726 |
| 30980 | --> | 32 | 32 | 67 | 76 | 69 | - | 276 | 31230 | --> | 78 | 32 | 71 | 69 | 66 | - | 316 | 31480 | --> | 198 | 224 | 48 | 133 | 102 | - | 780 |
| 30985 | --> | 65 | 82 | 83 | 69 | 65 | - | 364 | 31235 | --> | 65 | 82 | 73 | 84 | 32 | - | 336 | 31485 | --> | 127 | 245 | 129 | 0 | 38 | - | 535 |
| 30990 | --> | 32 | 67 | 72 | 73 | 78 | - | 372 | 31240 | --> | 32 | 32 | 32 | 32 | 114 | - | 242 | 31490 | --> | 11 | 40 | 5 | 63 | 35 | - | 254 |
| 30995 | --> | 71 | 58 | 69 | 78 | 69 | - | 344 | 31245 | --> | 32 | 32 | 32 | 83 | 84 | - | 263 | 31495 | --> | 5 | 89 | 129 | 114 | 126 | - | 560 |
| 31000 | --> | 32 | 79 | 70 | 32 | 70 | - | 283 | 31250 | --> | 79 | 67 | 75 | 65 | 71 | - | 357 | 31500 | --> | 122 | 70 | 140 | 4 | 0 | - | 436 |
| 31005 | --> | 73 | 76 | 69 | 83 | 89 | - | 390 | 31255 | --> | 69 | 32 | 68 | 32 | 73 | - | 274 | 31505 | --> | 37 | 11 | 191 | 127 | 248 | - | 614 |
| 31010 | --> | 78 | 84 | 85 | 88 | 32 | - | 347 | 31260 | --> | 78 | 70 | 79 | 80 | 77 | - | 306 | 31510 | --> | 193 | 255 | 38 | 4 | 198 | - | 688 |
| 31015 | --> | 69 | 82 | 82 | 79 | 82 | - | 394 | 31265 | --> | 65 | 84 | 73 | 79 | 78 | - | 379 | 31515 | --> | 96 | 231 | 132 | 126 | 122 | - | 707 |
| 31020 | --> | 79 | 85 | 84 | 32 | 77 | - | 359 | 31270 | --> | 83 | 32 | 32 | 32 | 32 | - | 211 | 31520 | --> | 173 | 142 | 4 | 0 | 127 | - | 443 |
| 31025 | --> | 70 | 32 | 77 | 69 | 77 | - | 325 | 31275 | --> | 32 | 115 | 32 | 32 | 32 | - | 243 | 31525 | --> | 127 | 254 | 16 | 190 | 127 | - | 714 |
| 31030 | --> | 79 | 82 | 89 | 78 | 77 | - | 407 | 31280 | --> | 82 | 69 | 67 | 72 | 69 | - | 350 | 31530 | --> | 250 | 16 | 191 | 127 | 252 | - | 836 |
| 31035 | --> | 32 | 83 | 84 | 65 | 82 | - | 346 | 31285 | --> | 82 | 67 | 72 | 69 | 32 | - | 322 | 31535 | --> | 166 | 128 | 140 | 5 | 63 | - | 502 |
| 31040 | --> | 94 | 73 | 78 | 71 | 32 | - | 338 | 31290 | --> | 68 | 32 | 73 | 78 | 70 | - | 321 | 31540 | --> | 34 | 87 | 129 | 98 | 38 | - | 386 |
| 31045 | --> | 80 | 79 | 73 | 78 | 84 | - | 394 | 31295 | --> | 79 | 82 | 77 | 65 | 84 | - | 387 | 31545 | --> | 245 | 246 | 127 | 254 | 193 | - | 1065 |
| 31050 | --> | 32 | 40 | 50 | 49 | 48 | - | 219 | 31300 | --> | 73 | 79 | 78 | 85 | 32 | - | 345 | 31550 | --> | 0 | 38 | 7 | 198 | 134 | - | 377 |
| 31055 | --> | 41 | 32 | 70 | 79 | 85 | - | 307 | 31305 | --> | 32 | 32 | 32 | 115 | 32 | - | 244 | 31555 | --> | 231 | 160 | 124 | 127 | 254 | - | 896 |
| 31060 | --> | 78 | 68 | 106 | 106 | 105 | - | 464 | 31310 | --> | 32 | 32 | 83 | 65 | 86 | - | 298 | 31560 | --> | 166 | 128 | 140 | 5 | 63 | - | 502 |
| 31065 | --> | 106 | 106 | 106 | 106 | 105 | - | 530 | 31315 | --> | 69 | 32 | 70 | 73 | 76 | - | 320 | 31565 | --> | 37 | 27 | 185 | 125 | 125 | - | 501 |
| 31070 | --> | 106 | 106 | 106 | 106 | 105 | - | 530 | 31320 | --> | 69 | 117 | 32 | 32 | 32 | - | 282 | 31570 | --> | 16 | 190 | 127 | 252 | 16 | - | 601 |
| 31075 | --> | 106 | 106 | 106 | 106 | 105 | - | 530 | 31325 | --> | 70 | 69 | 87 | 32 | 32 | - | 298 | 31575 | --> | 191 | 127 | 250 | 139 | 126 | - | 883 |
| 31080 | --> | 106 | 106 | 106 | 106 | 105 | - | 530 | 31330 | --> | 32 | 32 | 32 | 32 | 32 | - | 160 | 31580 | --> | 80 | 142 | 4 | 0 | 191 | - | 422 |
| 31085 | --> | 106 | 106 | 106 | 106 | 105 | - | 530 | 31335 | --> | 32 | 32 | 32 | 32 | 32 | - | 160 | 31585 | --> | 127 | 248 | 185 | 122 | 170 | - | 856 |
| 31090 | --> | 106 | 106 | 106 | 106 | 105 | - | 530 | 31340 | --> | 32 | 32 | 32 | 32 | 32 | - | 160 | 31590 | --> | 126 | 123 | 32 | 57 | 129 | - | 468 |
| 31095 | --> | 48 | 82 | 85 | 71 | 79 | - | 345 | 31345 | --> | 30 | 32 | 32 | 32 | 32 | - | 160 | 31595 | --> | 98 | 39 | 20 | 157 | 160 | - | 484 |
| 31100 | --> | 78 | 32 | 70 | 73 | 76 | - | 329 | 31350 | --> | 32 | 32 | 32 | 118 | 32 | - | 246 | 31600 | --> | 16 | 190 | 127 | 252 | 16 | - | 601 |
| 31105 | --> | 59 | 32 | 32 | 32 | 32 | - | 197 | 31355 | --> | 32 | 32 | 73 | 78 | 83 | - | 298 | 31605 | --> | 210 | 189 | 125 | 132 | 189 | - | 845 |
| 31110 | --> | 32 | 66 | 69 | 82 | 73 | - | 327 | 31360 | --> | 80 | 69 | 67 | 81 | 73 | - | 373 | 31610 | --> | 126 | 85 | 126 | 124 | 198 | - | 659 |
| 31115 | --> | 65 | 82 | 68 | 32 | 72 | - | 719 | 31365 | --> | 79 | 78 | 32 | 60 | 95 | - | 342 | 31615 | --> | 126 | 123 | 72 | 134 | 128 | - | 583 |
| 31120 | --> | 55 | 82 | 77 | 69 | 76 | - | 369 | 31370 | --> | 32 | 70 | 73 | 67 | 72 | - | 314 | 31620 | --> | 167 | 160 | 16 | 171 | 127 | - | 661 |
| 31125 | --> | 106 | 106 | 106 | 106 | 105 | - | 530 | 31375 | --> | 73 | 69 | 82 | 129 | 63 | - | 416 | 31625 | --> | 250 | 126 | 123 | 47 | 134 | - | 680 |
| 31130 | --> | 106 | 106 | 106 | 106 | 105 | - | 530 | 31380 | --> | 34 | 5 | 139 | 64 | 126 | - | 368 | 31630 | --> | 210 | 167 | 164 | 189 | 123 | - | 853 |
| 31135 | --> | 106 | 106 | 106 | 106 | 105 | - | 530 | 31385 | --> | 122 | 159 | 190 | 127 | 248 | - | 846 | 31635 | --> | 228 | 142 | 4 | 0 | 16 | - | 390 |
| 31140 | --> | 106 | 106 | 106 | 106 | 105 | - | 530 | 31390 | --> | 6 | 167 | 128 | 191 | 127 | - | 619 | 31640 | --> | 190 | 127 | 252 | 166 | 128 | - | 862 |
| 31145 | --> | 106 | 106 | 106 | 106 | 105 | - | 530 | 31395 | --> | 248 | 57 | 128 | 96 | 126 | - | 655 | 31645 | --> | 140 | 5 | 63 | 35 | 43 | - | 286 |
| 31150 | --> | 106 | 106 | 106 | 106 | 105 | - | 530 | 31400 | --> | 122 | 159 | 190 | 127 | 248 | - | 846 | 31650 | --> | 246 | 127 | 255 | 193 | 0 | - | 821 |
| 31155 | --> | 106 | 106 | 106 | 69 | 78 | - | 465 | 31405 | --> | 230 | 132 | 134 | 124 | 167 | - | 787 | | | | | | | | | |
| 31160 | --> | 84 | 67 | 62 | 32 | 32 | - | 299 | 31410 | --> | 132 | 189 | 126 | 85 | 231 | - | 763 | | | | | | | | | |
| 31165 | --> | 32 | 86 | 65 | 76 | 73 | - | 332 | 31415 | --> | 132 | 189 | 126 | 106 | 129 | - | 682 | | | | | | | | | |

THE FIRST GENERATION of Eye-friendly Filters.

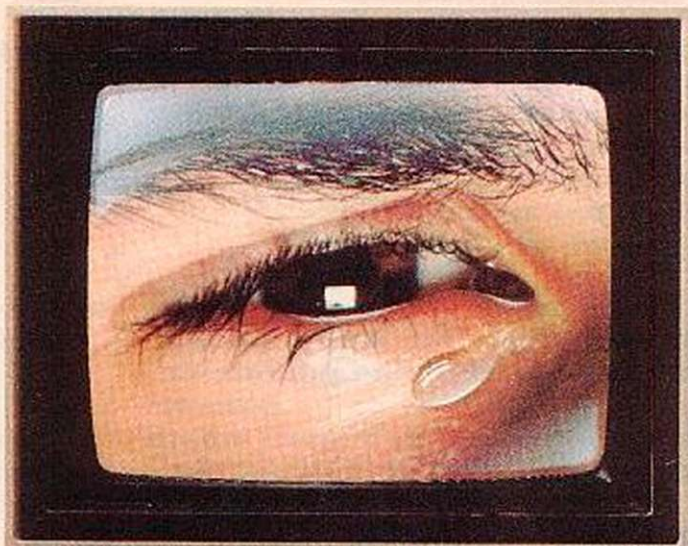

Treat your eyes to a Romag CEAF. Only £19.95

Unique technology: British made laminated glass, aspherically curved Contrast Enhancement Antiglare Filter.

Up to now, contrast-enhancing filters have always been flat—and so has their performance, because the screen of your TV, monitor or VDU is curved.

Up to now, most filters have been plastic because it takes mindbending technology to bend optical-quality laminated glass.

Up to now, filters have been expensive—awkward production techniques have meant price tags from around £50 to well over £100.

Forget all that: the Romag CEAF is here. British designed and

manufactured by space age military technologists, CEAF is profiled to fit your display screen, giving you the ultimate in contrast enhancement and antiglare performance. For under £20, this first generation of eye-friendly filters diffuses all specular reflections, gives sharper image clarity from edge to edge of the screen and greatly enhances display colours.

Mounted and removed in seconds by invisible velcro fastenings, the anti-static, anti-shatter CEAF is a major step forward in the operational safety of

computer displays—unprotected screens can cause blurred vision, watery and itchy eyes, headaches and (according to such authorities as the Institute of Ophthalmology) even permanent changes in eyesight.

Scratch-resistant, durable and easily cleaned without expensive sprays and agents, 9", 12" and 14" CEAFs are available from leading retailers at only £19.95 including VAT.

Or fill in the Freepost coupon and your CEAF will be despatched within 48 hours. Orders can also be placed around

the clock by phoning the CEAF Department on (091) 414 5511, quoting your Access Card number. For other screen sizes, please ring or write—the CEAF prices for 'specials' would be considered very competitive.... if there was any competition!

To ROMAG, FREEPOST, CEAF Dept. YC, Blaydon on Tyne, Tyne & Wear NE21 4BR. Telephone: (091) 414 5511.

My TV/Monitor/VDU is: _____ (make) _____ (model) _____ (size)

My Computer is: _____ (make/model)

Please send me: _____ 9" CEAF(s)

_____ 12" CEAF(s)

_____ 14" CEAF(s)

at £19.95 each, inc. P&P.

Enclose cheque/P.O. No. _____ for £ _____ made payable to ROMAG.

OR My Access Card No. is

Name _____

Address _____

Tel: _____

ROMAG CEAF

The filter which eliminates all competition
CEAF is a Registered Trade Mark.

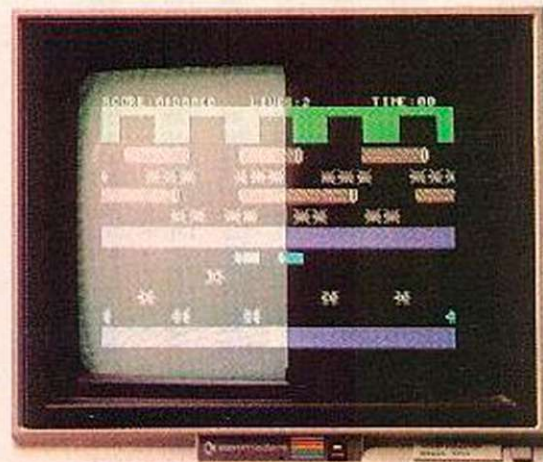
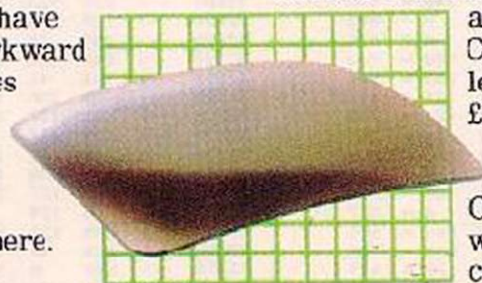

From Alders • Boots • Dixons • Harro's • House of Fraser Group • Laskys • John Lewis Group • John Menzies • Selfridges • W.H. Smith • and other leading home computer retailers.

ROAD FROG by courtesy of Ocean Software.

MTA 1625

(continued from page 136)

1. CSAVEM "MODEL", 32420, 32740, 0 save the model file.
 2. CSAVEM "\$FILES\$", 30920, 32400, 0 save the program.
 3. CSAVEM "FILE", 1700, RAMTOP, 0 save the card-index.
- where RAMtop = 256*PEEK(32762)+PEEK(32763).

Command 5 allows you to reset the memory. This command is error trapped. Press 5 — OK? appears at the bottom of the screen. If you press 0 (not zero) this command is executed. All the memory is cleared and RAMtop is set at 1700. Any other

returns you to the menu.

Command 6 allows you to look at your card-index sequentially and to clear certain files. Press 6 and the first file is displayed with the message 0 Dump 1 Clear. If you press 0 you will see 'Space': Dump to Printer. If you press — Space: you will get a copy of the screen on the printer. Any other key displays the following file.

If you press 1 the present file is cleared from the screen and from memory and the next file appears on the screen. If you press Break you return to the menu.

If you press any other key the next file will be displayed. The message Finished appears when the exploration of the card index is terminated. Press any key for the menu.

Messages.

| | |
|-------------------------|-------------------------|
| File recorded | see command 1 |
| Finished | " " 3, 6 |
| 'Space: Dump to Printer | " " 3, 6 |
| OK? | " " 2 |
| 0 dump and clear | " " 3 |
| End of File | " " 1 |
| Syntax Error | " " 2 |
| Out of Memory | " " The memory is full. |

The message No Starting Point (210) Found can appear after an

EXEC31921

The program explores the memory searching RAMtop (210); if it doesn't find it it displays that message. When you load a card-index again you must not set RAMtop — it is automatic.



(decimal dump continued from page 136)

| | | | | | | | | | | | | | | | | | | | | | | | |
|-----------|-----|-----|-----|-----|-----|---|-----|-----------|-----|-----|-----|-----|-----|---|-----|-----------|-----|-----|-----|-----|-----|---|-----|
| 31655 --> | 16 | 30 | 2 | 92 | 16 | = | 163 | 31905 --> | 126 | 121 | 48 | 31 | 191 | = | 517 | 32155 --> | 90 | 193 | 0 | 38 | 246 | = | 567 |
| 31660 --> | 142 | 170 | 244 | 198 | 4 | = | 703 | 31910 --> | 127 | 250 | 150 | 127 | 245 | = | 743 | 32160 --> | 57 | 16 | 142 | 121 | 11 | = | 347 |
| 31665 --> | 189 | 125 | 147 | 109 | 126 | = | 775 | 31915 --> | 191 | 127 | 252 | 126 | 124 | = | 823 | 32165 --> | 198 | 10 | 142 | 5 | 96 | = | 451 |
| 31670 --> | 85 | 129 | 78 | 38 | 9 | = | 339 | 31920 --> | 72 | 189 | 126 | 121 | 145 | = | 649 | 32170 --> | 109 | 126 | 150 | 151 | 127 | = | 782 |
| 31675 --> | 190 | 127 | 252 | 191 | 127 | = | 887 | 31925 --> | 120 | 180 | 16 | 36 | 3 | = | 352 | 32175 --> | 236 | 189 | 122 | 170 | 142 | = | 859 |
| 31680 --> | 250 | 126 | 125 | 75 | 129 | = | 705 | 31930 --> | 710 | 40 | 31 | 191 | 127 | = | 607 | 32180 --> | 6 | 165 | 16 | 150 | 127 | = | 504 |
| 31685 --> | 3 | 16 | 39 | 0 | 252 | = | 310 | 31935 --> | 250 | 127 | 127 | 245 | 127 | = | 875 | 32185 --> | 236 | 230 | 160 | 153 | 99 | = | 918 |
| 31690 --> | 126 | 125 | 75 | 29 | 122 | = | 577 | 31940 --> | 127 | 255 | 124 | 128 | 142 | = | 785 | 32190 --> | 39 | 33 | 16 | 140 | 5 | = | 223 |
| 31695 --> | 38 | 202 | 166 | 60 | 129 | = | 695 | 31945 --> | 4 | 0 | 151 | 127 | 243 | = | 570 | 32195 --> | 255 | 36 | 181 | 247 | 27 | = | 846 |
| 31700 --> | 128 | 39 | 196 | 29 | 210 | = | 702 | 31950 --> | 167 | 128 | 140 | 6 | 3 | = | 441 | 32200 --> | 240 | 166 | 128 | 129 | 210 | = | 873 |
| 31705 --> | 39 | 208 | 127 | 34 | 39 | = | 549 | 31955 --> | 38 | 249 | 142 | 4 | 0 | = | 433 | 32205 --> | 39 | 44 | 177 | 127 | 240 | = | 627 |
| 31710 --> | 242 | 147 | 128 | 26 | 123 | = | 786 | 31960 --> | 16 | 142 | 121 | 86 | 193 | = | 563 | 32210 --> | 39 | 230 | 126 | 125 | 182 | = | 707 |
| 31715 --> | 209 | 16 | 142 | 4 | 0 | = | 371 | 31965 --> | 96 | 189 | 125 | 8 | 142 | = | 560 | 32215 --> | 191 | 127 | 242 | 166 | 130 | = | 856 |
| 31720 --> | 142 | 126 | 164 | 66 | 128 | = | 726 | 31970 --> | 4 | 128 | 16 | 142 | 121 | = | 411 | 32220 --> | 129 | 134 | 38 | 250 | 48 | = | 599 |
| 31725 --> | 167 | 160 | 16 | 140 | 3 | = | 488 | 31975 --> | 182 | 198 | 54 | 189 | 125 | = | 748 | 32225 --> | 1 | 191 | 127 | 252 | 124 | = | 695 |
| 31730 --> | 63 | 35 | 246 | 57 | 189 | = | 590 | 31980 --> | 8 | 48 | 136 | 42 | 16 | = | 230 | 32230 --> | 127 | 255 | 189 | 123 | 145 | = | 839 |
| 31735 --> | 126 | 93 | 189 | 122 | 170 | = | 700 | 31985 --> | 142 | 121 | 236 | 198 | 109 | = | 806 | 32235 --> | 127 | 127 | 255 | 189 | 126 | = | 824 |
| 31740 --> | 142 | 4 | 0 | 16 | 142 | = | 304 | 31990 --> | 189 | 125 | 8 | 40 | 136 | = | 506 | 32240 --> | 127 | 127 | 255 | 189 | 126 | = | 824 |
| 31745 --> | 176 | 144 | 166 | 128 | 167 | = | 781 | 31995 --> | 9 | 16 | 142 | 122 | 09 | = | 308 | 32245 --> | 8 | 129 | 3 | 39 | 18 | = | 197 |
| 31750 --> | 160 | 140 | 5 | 64 | 37 | = | 406 | 32000 --> | 198 | 57 | 189 | 125 | 0 | = | 577 | 32250 --> | 190 | 127 | 242 | 126 | 125 | = | 810 |
| 31755 --> | 247 | 16 | 142 | 120 | 200 | = | 725 | 32005 --> | 126 | 125 | 26 | 166 | 160 | = | 605 | 32255 --> | 182 | 16 | 142 | 120 | 213 | = | 673 |
| 31760 --> | 198 | 13 | 189 | 125 | 147 | = | 672 | 32010 --> | 129 | 32 | 38 | 2 | 131 | = | 335 | 32260 --> | 170 | 0 | 189 | 123 | 147 | = | 667 |
| 31765 --> | 189 | 126 | 85 | 126 | 124 | = | 650 | 32015 --> | 192 | 128 | 61 | 167 | 120 | = | 679 | 32265 --> | 189 | 126 | 85 | 57 | 16 | = | 473 |
| 31770 --> | 177 | 189 | 126 | 93 | 16 | = | 601 | 32020 --> | 90 | 193 | 0 | 38 | 239 | = | 560 | 32270 --> | 142 | 120 | 221 | 199 | 23 | = | 704 |
| 31775 --> | 142 | 120 | 244 | 198 | 4 | = | 708 | 32025 --> | 57 | 189 | 126 | 85 | 129 | = | 586 | 32275 --> | 189 | 125 | 147 | 189 | 126 | = | 776 |
| 31780 --> | 189 | 125 | 147 | 189 | 126 | = | 776 | 32030 --> | 49 | 16 | 39 | 254 | 211 | = | 569 | 32280 --> | 85 | 199 | 32 | 39 | 4 | = | 107 |
| 31785 --> | 85 | 129 | 79 | 16 | 38 | = | 347 | 32035 --> | 129 | 50 | 70 | 4 | 189 | = | 412 | 32285 --> | 189 | 126 | 106 | 57 | 142 | = | 620 |
| 31790 --> | 0 | 150 | 142 | 6 | 164 | = | 462 | 32040 --> | 125 | 75 | 126 | 124 | 198 | = | 648 | 32290 --> | 4 | 0 | 127 | 127 | 244 | = | 502 |
| 31795 --> | 134 | 210 | 167 | 128 | 140 | = | 779 | 32045 --> | 129 | 51 | 38 | 6 | 189 | = | 413 | 32295 --> | 246 | 127 | 244 | 193 | 31 | = | 641 |
| 31800 --> | 120 | 180 | 37 | 249 | 126 | = | 712 | 32050 --> | 125 | 94 | 126 | 124 | 198 | = | 667 | 32300 --> | 34 | 36 | 124 | 127 | 244 | = | 565 |
| 31805 --> | 124 | 177 | 142 | 6 | 165 | = | 614 | 32055 --> | 129 | 52 | 39 | 48 | 129 | = | 397 | 32305 --> | 166 | 128 | 140 | 5 | 63 | = | 502 |
| 31810 --> | 151 | 127 | 252 | 189 | 126 | = | 885 | 32060 --> | 53 | 16 | 39 | 254 | 218 | = | 580 | 32310 --> | 34 | 12 | 129 | 95 | 37 | = | 308 |
| 31815 --> | 53 | 190 | 127 | 252 | 191 | = | 853 | 32065 --> | 129 | 54 | 30 | 213 | 189 | = | 623 | 32315 --> | 2 | 128 | 64 | 189 | 128 | = | 511 |
| 31820 --> | 127 | 246 | 189 | 126 | 106 | = | 794 | 32070 --> | 124 | 63 | 126 | 124 | 198 | = | 635 | 32320 --> | 15 | 126 | 126 | 34 | 134 | = | 435 |
| 31825 --> | 166 | 132 | 127 | 210 | 16 | = | 653 | 32075 --> | 189 | 126 | 93 | 189 | 123 | = | 720 | 32325 --> | 13 | 169 | 128 | 15 | 189 | = | 534 |
| 31830 --> | 39 | 1 | 162 | 191 | 127 | = | 520 | 32080 --> | 228 | 142 | 4 | 0 | 191 | = | 565 | 32330 --> | 128 | 15 | 189 | 123 | 15 | = | 475 |
| 31835 --> | 252 | 124 | 127 | 255 | 189 | = | 947 | 32085 --> | 127 | 248 | 189 | 22 | 170 | = | 856 | 32335 --> | 126 | 126 | 24 | 134 | 13 | = | 423 |
| 31840 --> | 123 | 45 | 127 | 127 | 255 | = | 777 | 32090 --> | 189 | 123 | 33 | 57 | 189 | = | 591 | 32340 --> | 189 | 120 | 15 | 126 | 126 | = | 584 |
| 31845 --> | 16 | 191 | 127 | 252 | 16 | = | 602 | 32095 --> | 126 | 93 | 124 | 27 | 245 | = | 715 | 32345 --> | 31 | 189 | 20 | 6 | 129 | = | 483 |
| 31850 --> | 147 | 70 | 248 | 198 | 19 | = | 727 | 32100 --> | 189 | 126 | 161 | 227 | 127 | = | 729 | 32350 --> | 0 | 39 | 249 | 57 | 142 | = | 487 |
| 31855 --> | 189 | 125 | 147 | 189 | 126 | = | 776 | 32105 --> | 245 | 57 | 189 | 26 | 121 | = | 738 | 32355 --> | 4 | 0 | 198 | 96 | 231 | = | 529 |
| 31860 --> | 85 | 129 | 3 | 16 | 39 | = | 272 | 32110 --> | 191 | 127 | 250 | 57 | 16 | = | 641 | 32360 --> | 128 | 140 | 6 | 0 | 37 | = | 311 |
| 31865 --> | 1 | 140 | 129 | 48 | 30 | = | 354 | 32115 --> | 142 | 121 | 21 | 98 | 1 | = | 493 | 32365 --> | 349 | 57 | 16 | 142 | 8 | = | 469 |
| 31870 --> | 6 | 189 | 126 | 8 | 126 | = | 452 | 32120 --> | 176 | 125 | 147 | 16 | 142 | = | 854 | 32370 --> | 64 | 198 | 96 | 231 | 16 | = | 749 |
| 31875 --> | 124 | 72 | 129 | 49 | 39 | = | 413 | 32125 --> | 121 | 32 | 199 | 12 | 126 | = | 489 | 32375 --> | 16 | 140 | 5 | 96 | 37 | = | 294 |
| 31880 --> | 3 | 126 | 124 | 72 | 190 | = | 515 | 32130 --> | 125 | 147 | 15 | 42 | 121 | = | 551 | 32380 --> | 248 | 57 | 142 | 6 | 164 | = | 617 |
| 31885 --> | 127 | 246 | 16 | 190 | 127 | = | 706 | 32135 --> | 44 | 198 | 13 | 126 | 125 | = | 506 | 32385 --> | 166 | 120 | 140 | 120 | 180 | = | 734 |
| 31890 --> | 252 | 191 | 127 | 252 | 166 | = | 988 | 32140 --> | 147 | 16 | 142 | 121 | 57 | = | 483 | 32390 --> | 36 | 4 | 129 | 210 | 38 | = | 417 |
| 31895 --> | 160 | 167 | 128 | 16 | 140 | = | 611 | 32145 --> | 158 | 29 | 142 | 5 | 64 | = | 438 | | | | | | | | |
| 31900 --> | 120 | 180 | 37 | 246 | 189 | = | 772 | 32150 --> | 166 | 160 | 189 | 122 | 146 | = | 783 | | | | | | | | |

Tel: 0344 427317

AUTOMANIA

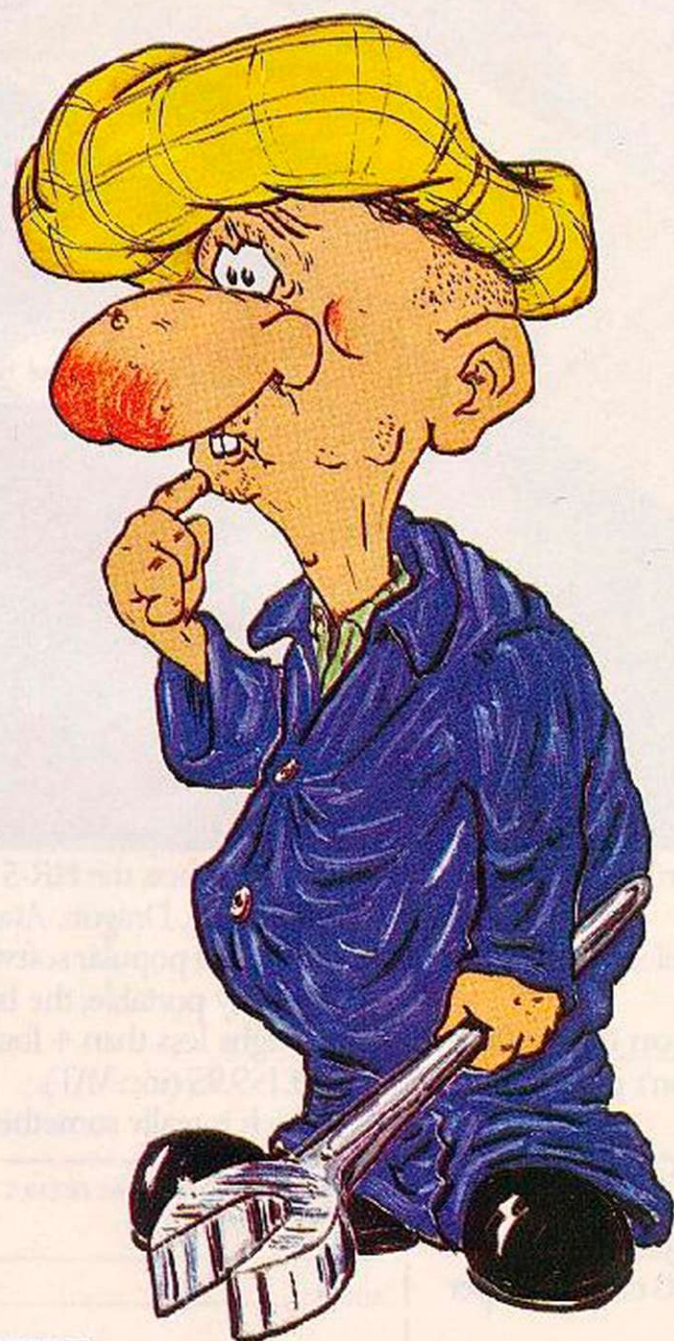

WALLY WEEK
is here!

FOR COMMODORE 64 AND 48K SPECTRUM

Little Brothers should be seen but not heard.



**NOW ONLY
£159.95
inc.VAT.**

A maxim which eloquently describes the Brother HR-5.

Less than a foot across, it's nonetheless loaded with features.

The little printer that's low on decibels.

There's one thing the HR-5 won't give you. Earache.

For the annoying 'clickety clack' many printers produce is mercifully absent from the HR-5.

Quietly efficient, it delivers high definition dot matrix text over 80 columns at 30 characters per second (maximum)

Text or graphics with ease.

The HR-5 also has something of an artistic bent. Being capable of producing uni-directional graphics and chart images together with bi-directional text. What's more it will hone down characters into a condensed face, or extend them for added emphasis.

At home with home computers.

Incorporating either a Centronics parallel or

RS-232C interface, the HR-5 is compatible with BBC, Spectrum, Oric, Dragon, Atari and most other home computers and popular software.

Perfectly portable, the battery or mains operated HR-5 weighs less than 4 lbs, and has a starting price of only £159.95 (inc. VAT).

Which is really something to shout about.

PLEASE SEND ME MORE DETAILS OF THE REMARKABLE BROTHER HR-5 PRINTER.

NAME _____

ADDRESS _____

TEL NO _____

AVAILABLE FROM: BOOTS, RYMANS, WLDINGS, SELFRIDGES AND ALL GOOD COMPUTER EQUIPMENT STOCKISTS.

brother

63900, 1465

62150

Nine new commands for Spectrum Basic, courtesy of Robert Newman

I HAVE WRITTEN a machine-code routine which adds nine new commands to Spectrum Basic which will run with or without Interface I.

The machine-code routine must be loaded and initialised before either writing a program, or loading a program which uses the new commands. If you do this it is not necessary to save the machine code again when you save your program.

A short Basic program, listing 1 (16K) or listing 2 (48K), is used to load the machine code above RAMtop, and perform the initialisation. This program should be typed in, and then saved on a cassette or Microdrive cartridge to auto-run from line 3. If you use a Microdrive, the program can be given the filename "run", ie:

```
SAVE "m";1;"run" LINE 3 or
SAVE "BASIC+" LINE 3
```

New the computer, then type in and Run listing 3, the machine code loader program. Copy the machine code bytes from either listing 4 or 5 depending upon memory size. Great care must be taken while copying from the machine code dump, since a single mistake could cause the computer to crash.

You should now have a working copy of the Basic interpreter. To test it, rewind the tape and clear the computer by typing Randomise USR 0. Then load the initialisation program and machine code, and type *ZAP which should produce a laser type sound effect.

Graphic characters

*USE (Nchars), (Memory): (Nchars) is the number of different graphic characters that you want to use, and can take values from 1 to 255. (Memory) is the memory size in bytes needed for storing those characters. To calculate the number of bytes required to store each character, divide its width by 8, and add 1 for any remainder, then multiply by its height.

This command causes part of the memory to be reserved for the storage of your graphics characters. The total number of bytes required is (Memory) + (Nchars)*4 bytes. For example, the command *USE 8,256 reserves 288 bytes. If you try to reserve more memory for your graphics than the spare memory available, this will halt your program with a runtime error.

The graphics memory area is situated just before the start of the machine code. If



EXPANDED BASIC

necessary, RAMtop will be lowered — and the machine stack and Gosub stack moved — to make room for the graphics memory. The routine will only lower RAMtop, and never moves it to a higher address. This is to allow your own machine-code routines to be used with extended Basic provided that they are located between the graphics memory and RAMtop.

The *Use command clears the graphics memory and character-size definitions — see *Def — and can be used more than once in a program for this purpose. If there is no *Use command in a program, the command *USE 8,256 is assumed by the routine.

*DEF (Char), (Width), (Ht): After *Use, the *Def command is used to set the size of a graphics character. (Char) is the character number, which can take values from 1 to (Nchars). (Width) and (Ht) are the sizes of this character in pixels — from 1 to 256 pixels wide, and from 1 to 176 pixels high. You must set the size of a character before using it in one of the remaining commands, which are:—

*GET (char), (xpos), (ypos)

*PUT (char), (xpos), (ypos)

*CLR (char), (xpos), (ypos)

Lines 2,3 and 4 of the initialisation program can be deleted once the machine code has

(continued on page 143)

Listing 1. 16K initialisation.

```
1 POKE PEEK 23613+256*PEEK 23614,206: POKE 1+PEEK
  23613+256*PEEK 23614,PEEK 23733-6
2 GO TO 4
3 CLEAR 31131: LOAD "16KMC" CODE: GO TO 1
4 CLS: PRINT "16K BASIC+ (C) Robert Newman 1984"
```

Listing 2. 48K initialisation.

```
1 POKE PEEK 23613+256*PEEK 23614,206: POKE
  1+PEEK 23613+256*PEEK 23614,PEEK 23733-6
2 GO TO 4
3 CLEAR 63999: LOAD "48KMC" CODE: GO TO 1
4 CLS: PRINT "48K BASIC+ (C)
  Robert Newman 1984"
```

Listing 3. Machine code loader.

```
1 REM listing 3
10 CLEAR 31131+32768*PEEK 23733-255:
20 LET K48=(PEEK 23733-255)
30 LET mc=31132+32768*K48
40 FOR j=mc TO mc+22: POKE j,0: NEXT j
50 LET sum=0
60 FOR j=mc+23 TO mc+1464
```

```
70 PRINT j;TAB 7;
80 INPUT n: POKE j,n
90 PRINT n: LET sum=sum+n
100 NEXT j
110 LET checksum=161457+16*28 AND K48
120 IF sum<>checksum THEN PRINT "Checksum error": STOP
130 LET a4=(PEEK mc AND NOT K48)+("48KMC" AND K48)
140 SAVE a# CODE mc,1465
150 REM or SAVE "m";j;a# CODE mc,1465
```

Sinclair QL User Guide

Lionel Fleetwood

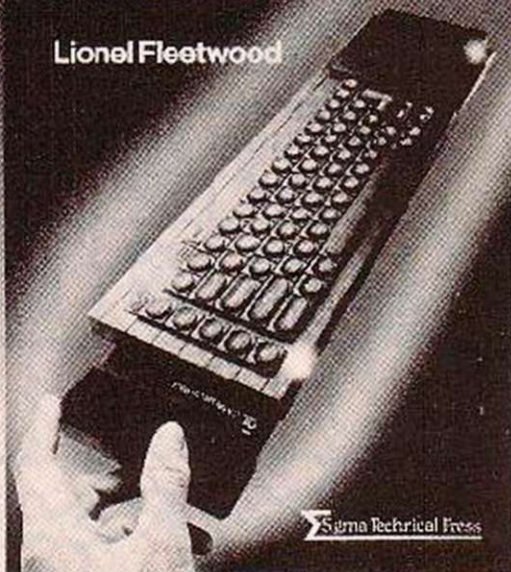

Sigma Technical Press

Read before you leap.

Sinclair have taken their leap — now it's your turn. And with the expert guidance of Lionel Fleetwood's *Sinclair QL User Guide* you can take that leap in the right direction.

Step by step it will enable you to exploit the potential of this revolutionary new micro. The self-contained sections make quick overviews possible when you've a particular problem to solve, and real life examples show how to produce letters, keep records, prepare accounts and create useful graphs.

Bits and bytes don't appear until you get to the technical section on Super BASIC, file handling and other advanced QL features.

Even here you'll find the language remains clear and reader-friendly.

Priced £7.50, this guide will prove invaluable reading to both owners and prospective buyers alike.

You can obtain your copy through good bookshops and computer stores or simply by using the coupon below.

Published by Sigma Press (180 pages, ISBN 0905194 927) and marketed by John Wiley & Sons Ltd.

To: Carol Sutton, John Wiley & Sons Ltd, Baffins Lane, Chichester, FREEPOST, Sussex PO19 1YP (No stamp required)

Please send me _____ *Sinclair QL User Guide(s)* at £7.50 each

I enclose PO/cheque for _____ (payable to John Wiley & Sons Ltd.)

OR charge my credit card (Date of expiry _____)

Card No.

Access/Bardycard/Visa/American Express/Dine's Club (delete)

OR telephone your credit card order — dial 100 (UK only) and ask for FREEPHONE 3477

Name/Address _____

Signature _____

Sigma Press

MARKETED BY JOHN WILEY & SONS LTD (Reg. No. 641132 Eng and) YC

COMPUTER LINK

| CONNECTORS IDC | | | IDC SHROUDED HEADERS WITH EJECTING LOCKING ARMS | | | IDC D CONNECTORS | | |
|---|--------------------|---------|--|-------------|---|---|--------------|-----------|
| Card Edge | (Trans) PCB Socket | 2 Rew | Straight | Right Angle | 9-way | Male | Female | |
| 10 way | £1.20 | £0.85 | £0.80 | £0.80 | 15 way | £2.70 | £3.20 | |
| 14 way | — | — | £0.90 | £0.90 | 25 way | £3.20 | £3.70 | |
| 16 way | £1.60 | £1.20 | £1.00 | £1.00 | 37 way | £3.80 | £4.45 | |
| 20 way | £1.90 | £1.35 | £1.20 | £1.20 | | £5.90 | £6.80 | |
| 26 way | £2.40 | £1.60 | £1.45 | £1.45 | IDC 25-WAY D CONN | | | |
| 34 way | £3.10 | £1.95 | £1.80 | £1.80 | Jumper Lead Ribbon Cable (RS232) Assembly | | | |
| 40 way | £3.40 | £2.00 | £1.85 | £1.85 | 8" long Single End Male £4.65 | | | |
| 50 way | £3.85 | £2.25 | £2.00 | £2.00 | 8" long S. End Female £5.10 | | | |
| 60 way | £4.80 | £2.60 | £2.25 | £2.25 | 36" long D. Endec. M/F £9.75 | | | |
| | | | | | 36" long D. Endec. F/F £10.00 | | | |
| | | | | | 36" long D. Endec. M/F £9.85 | | | |
| IDC AMPHENOL PLUGS | | | D CONNECTORS | | | DI PLUG (Headers) IDC | | |
| 34-way (Centronics) | £5.20 | | Solder Bucket | Male | Female | Pins | | |
| RIBBON CABLE (Price per ft) | | | 9-way | .75 | £1.00 | 14 | £0.90 | |
| 9-way | Grey | Rainbow | 15-way | .95 | £1.50 | 16 | £1.00 | |
| 10-way | .13 | .24 | 25-way | 1.50 | £1.90 | 24 | £1.40 | |
| 14-way | .18 | .32 | 37-way | 2.40 | £3.25 | 40 | £2.15 | |
| 15-way | .20 | .36 | HOODS 35 | | | DC JUMPERS 36 SINGLE ENDED | | |
| 16-way | .22 | .40 | BBC OR SPECTRUM JOYSTICK INTERFACES | | | Ways | 2 Row Socket | Card Edge |
| 20-way | .30 | .60 | FOR USE WITH ANY ATARI TYPE JOYSTICK | | | 10 | £1.35 | £1.55 |
| 24-way | .38 | .80 | ONLY £11.26 | | | 14 | £1.70 | — |
| 25-way | .40 | .85 | COMPUTER LEADS | | | 16 | £1.90 | £2.15 |
| 26-way | .45 | .95 | BBC PRINTER LEAD | | | 20 | £2.20 | £2.35 |
| 34-way | .60 | 1.00 | 1 METRE — £10.40 | | | 26 | £2.95 | £3.35 |
| 37-way | .65 | 1.05 | Single disk drive 1m £7.25 | | | 34 | £3.40 | £4.20 |
| 50-way | .70 | 1.10 | Dragon Printer Leads | | | 40 | £4.50 | £5.35 |
| 60-way | £1.10 | £1.40 | 1 METRE — £10.40 | | | 50 | £5.25 | £6.35 |
| 64-way | £1.15 | £1.50 | 36-way Amphenol to 36-way Amphenol 1m £15.20 | | | 60 | £6.25 | £8.20 |
| EDGE CONNECTORS | | | CUSTOM ASSEMBLIES | | | JOYSTICKS | | |
| 2x23-way ZX81 | £1.85 | | ANY COMBINATION OF IDC & RIBBON CABLE LEADS MAKE TO ORDER | | | A tough rugged high speed performance two fast action fire buttons Atari type joystick with suction caps | | |
| 2x26-way Spectrum | £2.10 | | COMPUTER CASSETTES | | | SPECTRUM | | |
| 2x6-way VC20/34 | £1.20 | | HIGH GRADE C12 46p: £15.47p Qty. once 100 off 39p each | | | IDC 56-way card edge £4.25 | | |
| DOUBLE SIDED PLUG BOARDS | | | 5 Pin DIN Plug 50p | | | 6 inch extr. cable dnl end M to F £10.50 | | |
| 2x61/23-way | £1.25 | | 6 Pin DIN Plug 50p | | | 12 inch extr. cable dnl end M to F £10.75 | | |
| Spectrum 28-way | £1.50 | | 7 Pin DIN Plug 50p | | | Other configurations made to order — write or phone for quote. | | |
| COMPUTER CASSETTES | | | 5 Pin DIN Plug 50p | | | | | |
| HIGH GRADE C12 46p: £15.47p Qty. once 100 off 39p each | | | 6 Pin DIN Plug 50p | | | | | |
| | | | 7 Pin DIN Plug 50p | | | | | |
| | | | 8 Pin DIN Plug 50p | | | | | |
| | | | 5 Pin DIN Plug 50p | | | | | |
| | | | 6 Pin DIN Plug 50p | | | | | |
| | | | 7 Pin DIN Plug 50p | | | | | |
| | | | 8 Pin DIN Plug 50p | | | | | |
| | | | 5 Pin DIN Plug 50p | | | | | |
| | | | 6 Pin DIN Plug 50p | | | | | |
| | | | 7 Pin DIN Plug 50p | | | | | |
| | | | 8 Pin DIN Plug 50p | | | | | |
| | | | 5 Pin DIN Plug 50p | | | | | |
| | | | 6 Pin DIN Plug 50p | | | | | |
| | | | 7 Pin DIN Plug 50p | | | | | |
| | | | 8 Pin DIN Plug 50p | | | | | |
| | | | 5 Pin DIN Plug 50p | | | | | |
| | | | 6 Pin DIN Plug 50p | | | | | |
| | | | 7 Pin DIN Plug 50p | | | | | |
| | | | 8 Pin DIN Plug 50p | | | | | |
| | | | 5 Pin DIN Plug 50p | | | | | |
| | | | 6 Pin DIN Plug 50p | | | | | |
| | | | 7 Pin DIN Plug 50p | | | | | |
| | | | 8 Pin DIN Plug 50p | | | | | |
| | | | 5 Pin DIN Plug 50p | | | | | |
| | | | 6 Pin DIN Plug 50p | | | | | |
| | | | 7 Pin DIN Plug 50p | | | | | |
| | | | 8 Pin DIN Plug 50p | | | | | |
| | | | 5 Pin DIN Plug 50p | | | | | |
| | | | 6 Pin DIN Plug 50p | | | | | |
| | | | 7 Pin DIN Plug 50p | | | | | |
| | | | 8 Pin DIN Plug 50p | | | | | |
| | | | 5 Pin DIN Plug 50p | | | | | |
| | | | 6 Pin DIN Plug 50p | | | | | |
| | | | 7 Pin DIN Plug 50p | | | | | |
| | | | 8 Pin DIN Plug 50p | | | | | |
| | | | 5 Pin DIN Plug 50p | | | | | |
| | | | 6 Pin DIN Plug 50p | | | | | |
| | | | 7 Pin DIN Plug 50p | | | | | |
| | | | 8 Pin DIN Plug 50p | | | | | |
| | | | 5 Pin DIN Plug 50p | | | | | |
| | | | 6 Pin DIN Plug 50p | | | | | |
| | | | 7 Pin DIN Plug 50p | | | | | |
| | | | 8 Pin DIN Plug 50p | | | | | |
| | | | 5 Pin DIN Plug 50p | | | | | |
| | | | 6 Pin DIN Plug 50p | | | | | |
| | | | 7 Pin DIN Plug 50p | | | | | |
| | | | 8 Pin DIN Plug 50p | | | | | |
| | | | 5 Pin DIN Plug 50p | | | | | |
| | | | 6 Pin DIN Plug 50p | | | | | |
| | | | 7 Pin DIN Plug 50p | | | | | |
| | | | 8 Pin DIN Plug 50p | | | | | |
| | | | 5 Pin DIN Plug 50p | | | | | |
| | | | 6 Pin DIN Plug 50p | | | | | |
| | | | 7 Pin DIN Plug 50p | | | | | |
| | | | 8 Pin DIN Plug 50p | | | | | |
| | | | 5 Pin DIN Plug 50p | | | | | |
| | | | 6 Pin DIN Plug 50p | | | | | |
| | | | 7 Pin DIN Plug 50p | | | | | |
| | | | 8 Pin DIN Plug 50p | | | | | |
| | | | 5 Pin DIN Plug 50p | | | | | |
| | | | 6 Pin DIN Plug 50p | | | | | |
| | | | 7 Pin DIN Plug 50p | | | | | |
| | | | 8 Pin DIN Plug 50p | | | | | |
| | | | 5 Pin DIN Plug 50p | | | | | |
| | | | 6 Pin DIN Plug 50p | | | | | |
| | | | 7 Pin DIN Plug 50p | | | | | |
| | | | 8 Pin DIN Plug 50p | | | | | |
| | | | 5 Pin DIN Plug 50p | | | | | |
| | | | 6 Pin DIN Plug 50p | | | | | |
| | | | 7 Pin DIN Plug 50p | | | | | |
| | | | 8 Pin DIN Plug 50p | | | | | |
| | | | 5 Pin DIN Plug 50p | | | | | |
| | | | 6 Pin DIN Plug 50p | | | | | |
| | | | 7 Pin DIN Plug 50p | | | | | |
| | | | 8 Pin DIN Plug 50p | | | | | |
| | | | 5 Pin DIN Plug 50p | | | | | |
| | | | 6 Pin DIN Plug 50p | | | | | |
| | | | 7 Pin DIN Plug 50p | | | | | |
| | | | 8 Pin DIN Plug 50p | | | | | |
| | | | 5 Pin DIN Plug 50p | | | | | |
| | | | 6 Pin DIN Plug 50p | | | | | |
| | | | 7 Pin DIN Plug 50p | | | | | |
| | | | 8 Pin DIN Plug 50p | | | | | |
| | | | 5 Pin DIN Plug 50p | | | | | |
| | | | 6 Pin DIN Plug 50p | | | | | |
| | | | 7 Pin DIN Plug 50p | | | | | |
| | | | 8 Pin DIN Plug 50p | | | | | |
| | | | 5 Pin DIN Plug 50p | | | | | |
| | | | 6 Pin DIN Plug 50p | | | | | |
| | | | 7 Pin DIN Plug 50p | | | | | |
| | | | 8 Pin DIN Plug 50p | | | | | |
| | | | 5 Pin DIN Plug 50p | | | | | |
| | | | 6 Pin DIN Plug 50p | | | | | |
| | | | 7 Pin DIN Plug 50p | | | | | |
| | | | 8 Pin DIN Plug 50p | | | | | |
| | | | 5 Pin DIN Plug 50p | | | | | |
| | | | 6 Pin DIN Plug 50p | | | | | |
| | | | 7 Pin DIN Plug 50p | | | | | |
| | | | 8 Pin DIN Plug 50p | | | | | |
| | | | 5 Pin DIN Plug 50p | | | | | |
| | | | 6 Pin DIN Plug 50p | | | | | |
| | | | 7 Pin DIN Plug 50p | | | | | |
| | | | 8 Pin DIN Plug 50p | | | | | |
| | | | 5 Pin DIN Plug 50p | | | | | |
| | | | 6 Pin DIN Plug 50p | | | | | |
| | | | 7 Pin DIN Plug 50p | | | | | |
| | | | 8 Pin DIN Plug 50p | | | | | |
| | | | 5 Pin DIN Plug 50p | | | | | |
| | | | 6 Pin DIN Plug 50p | | | | | |
| | | | 7 Pin DIN Plug 50p | | | | | |
| | | | 8 Pin DIN Plug 50p | | | | | |
| | | | 5 Pin DIN Plug 50p | | | | | |
| | | | 6 Pin DIN Plug 50p | | | | | |
| | | | 7 Pin DIN Plug 50p | | | | | |
| | | | 8 Pin DIN Plug 50p | | | | | |
| | | | 5 Pin DIN Plug 50p | | | | | |
| | | | 6 Pin DIN Plug 50p | | | | | |
| | | | 7 Pin DIN Plug 50p | | | | | |
| | | | 8 Pin DIN Plug 50p | | | | | |
| | | | 5 Pin DIN Plug 50p | | | | | |
| | | | 6 Pin DIN Plug 50p | | | | | |
| | | | 7 Pin DIN Plug 50p | | | | | |
| | | | 8 Pin DIN Plug 50p | | | | | |
| | | | 5 Pin DIN Plug 50p | | | | | |
| | | | 6 Pin DIN Plug 50p | | | | | |
| | | | 7 Pin DIN Plug 50p | | | | | |
| | | | 8 Pin DIN Plug 50p | | | | | |
| | | | 5 Pin DIN Plug 50p | | | | | |
| | | | 6 Pin DIN Plug 50p | | | | | |
| | | | 7 Pin DIN Plug 50p | | | | | |
| | | | 8 Pin DIN Plug 50p | | | | | |
| | | | 5 Pin DIN Plug 50p | | | | | |
| | | | 6 Pin DIN Plug 50p | | | | | |
| | | | 7 Pin DIN Plug 50p | | | | | |
| | | | 8 Pin DIN Plug 50p | | | | | |
| | | | 5 Pin DIN Plug 50p | | | | | |
| | | | 6 Pin DIN Plug 50p | | | | | |
| | | | 7 Pin DIN Plug 50p | | | | | |
| | | | 8 Pin DIN Plug 50p | | | | | |
| | | | 5 Pin DIN Plug 50p | | | | | |
| | | | 6 Pin DIN Plug 50p | | | | | |
| | | | 7 Pin DIN Plug 50p | | | | | |
| | | | 8 Pin DIN Plug 50p | | | | | |
| | | | 5 Pin DIN Plug 50p | | | | | |
| | | | 6 Pin DIN Plug 50p | | | | | |
| | | | 7 Pin DIN Plug 50p | | | | | |
| | | | 8 Pin DIN Plug 50p | | | | | |
| | | | 5 Pin DIN Plug 50p | | | | | |
| | | | 6 Pin DIN Plug 50p | | | | | |
| | | | 7 Pin DIN Plug 50p | | | | | |
| | | | 8 Pin DIN Plug 50p | | | | | |
| | | | 5 Pin DIN Plug 50p | | | | | |
| | | | 6 Pin DIN Plug 50p | | | | | |
| | | | 7 Pin DIN Plug 50p | | | | | |
| | | | 8 Pin DIN Plug 50p | | | | | |
| | | | 5 Pin DIN Plug 50p | | | | | |
| | | | 6 Pin DIN Plug 50p | | | | | |
| | | | 7 Pin DIN Plug 50p | | | | | |
| | | | 8 Pin DIN Plug 50p | | | | | |
| | | | 5 Pin DIN Plug 50p | | | | | |
| | | | 6 Pin DIN Plug 50p | | | | | |
| | | | 7 Pin DIN Plug 50p | | | | | |
| | | | 8 Pin DIN Plug 50p | | | | | |
| | | | 5 Pin DIN Plug 50p | | | | | |
| | | | 6 Pin DIN Plug 50p | | | | | |
| | | | 7 Pin DIN Plug 50p | | | | | |
| | | | 8 Pin DIN Plug 50p | | | | | |
| | | | 5 Pin DIN Plug 50p | | | | | |
| | | | 6 Pin DIN Plug 50p | | | | | |
| | | | 7 Pin DIN Plug 50p | | | | | |
| | | | 8 Pin DIN Plug 50p | | | | | |
| | | | 5 Pin DIN Plug 50p | | | | | |
| | | | 6 Pin DIN Plug 50p | | | | | |
| | | | 7 Pin DIN Plug 50p | | | | | |
| | | | 8 Pin DIN Plug 50p | | | | | |
| | | | 5 Pin DIN Plug 50p | | | | | |
| | | | 6 Pin DIN Plug 50p | | | | | |
| | | | 7 Pin DIN Plug 50p | | | | | |
| | | | 8 Pin DIN Plug 50p | | | | | |
| | | | 5 Pin DIN Plug 50p | | | | | |
| | | | 6 Pin DIN Plug 50p | | | | | |

(continued from page 141)

loaded, but you must not delete line 1, otherwise none of the new commands will be recognised when you Run your program.

During runtime, if the command cannot be executed, the error message produced is code Q - "Parameter error."

*BRK 0 and *BRK 1: These commands allow the break key to be disabled (*BRK 0), or re-enabled (*BRK 1).

*ZAP: This command gives a laser-type zap sound.

*NSE (Length): This command gives white noise for a time depending upon (Length) which can take values from 1 to 255.

Depending upon the length, this can sound like an explosion, gunshot etc. A machine-gun type sound can be made using a loop - eg., FOR j=1 TO 10: *NSE 50: PAUSE 10: NEXT j *SCR (Paper), (Ink): This command changes the Paper and Ink colours of the screen without erasing its contents. Paper and Ink can take values from 0 to 9 as with the normal colour commands.

The remaining commands are concerned with printing of user-defined graphics. These can be copied from the screen into graphics memory with *Get and then printed anywhere on the screen with *Put. The routine can handle graphics of any size from 1

by 1 pixels to 256 by 176 pixels, and caters for up to 255 different graphics characters.

First, you need to decide how much memory you want to set aside for the storage of graphics characters. This is done with the *Use command.

In all three commands, (Char) is the character number - the size of which must have previously been defined with *Def. (Xpos) and (Ypos) are the pixel co-ordinates of a point on the screen at the top left hand corner of the area from where the graphic character information is to be copied from, printed to, or erased.

(continued on next page)

Listing 4. 16K machine code dump.

Table of machine code dump for Listing 4, showing addresses and hex values in columns.

Checksum = 161457

Listing 5. 48K machine code dump.

Table of machine code dump for Listing 5, showing addresses and hex values in columns.

Checksum = 177055

Listing 6. Demonstration program.

```

1 PEEK PEEK 25619:256+PEEK 25614,206: PEEK 1+PEEK 25613:256+PEEK 25611,
PEEK 22733-a
50 CLS: PRINT "EXTENDED BASIC Robert Newman."
60 REM ***** demo *****
65 BORDER 1:scr 4,0
70 PRINT "This program shows how the new commands of the extended BASIC
C can be used."
80 PRINT "There are two new sound commands"
90 GO SUB 8000
100 PRINT " *zap gives this sound."
110 FOR j=1 TO 5:zap: PAUSE 2: NEXT j
120 PAUSE 30
130 PRINT "You can also make white noise for explosions or gunshots et
c. with the command ---"
140 PRINT TAB 10;"*nse n""
150 PRINT "where n is a number from 1 - 255 to set the length of the sou
d."
160 FOR j=1 TO 50:ase 50: NEXT j
170 GO SUB 9000
180 PRINT "There is a command for disabling/enabling the BREAK key."
190 PRINT " *brk 0 disables BREAK."
200 PRINT " *brk 1 re-enables it."
210 *brk 0
220 PRINT "Try pressing BREAK while the counter is running up to 1000
..."
230 FOR j=1 TO 1000
240 PRINT AT 12,15;j
250 NEXT j
260 *zap: PRINT AT 15,0;"BREAK is now re-enabled."
270 *brk 1
280 GO SUB 9000
300 PRINT "There are several new graphics commands."
310 PRINT TAB 7;"*scr (paper), (ink)"
320 PRINT "Will change the paper and ink colours of the whole screen"
330 PRINT "without erasing the contents."
340 PRINT "Paper and ink colours can take values from 0 to 9 as with th
e normal commands."
350 PRINT AT 16,2;"PRESS A KEY to change colour"
360 FOR j=0 TO 4
370 PAUSE 0
380 *scr j,9
390 NEXT j
392 PRINT AT 16,0;
395 FOR w=1 TO 200: NEXT w
400 GO SUB 9000
410 PRINT "The remaining commands allow you to print graphics at any place
on the screen."
420 PRINT "You can use up to 255 graphics characters, and these can be a
s large as you wish - even up to 256 x 176 pixels."
430 PRINT "First you must decide how many characters you need, and how
much memory is required to store"
440 PRINT "them. The command is:"
450 PRINT " *def (chcr), (xpos), (ypos), (memory)"
460 PRINT "where chcr= no. of characters, memory = store size in bytes,
"
470 PRINT "will then allocate space by lowering RAMTOP (if necessary
)."
480 PRINT "If you exit this command,"
490 PRINT " *use 8,256 is assumed."
500 GO SUB 9000
540 PRINT "After allocating graphics space with *use, you can set the siz
e of each character by:"
550 PRINT " *TAB 4; *def (char), (width), (int)"
560 PRINT "char = character number"
570 PRINT "width = 1 to 256 pixels"
580 PRINT "int = 1 to 176 pixels"
590 PRINT "You cannot change the size of a character once defined."
600 GO SUB 9000
610 PRINT "The *get command then gets data for the graphic character from
off the screen, and it can then be reprinted anywhere using *put:"
620 PRINT " *get (char), (xpos), (ypos)"
630 PRINT " *put (char), (xpos), (ypos)"
640 PRINT " (xpos and ypos are the x and y pixel coordinates at the top
left of a box on the screen from"
650 PRINT "where the graphic is to be *act""

```

```

660 PRINT "or *put""
670 PRINT AT 15,0;"Press key to demonstrate *put "
671 *use 1,256
672 *def 1,256,8: *get 1,0,55
680 *brk 0
681 PRINT "The above line has been *get as a 256x8 pixel graphic charac
ter and it can now be moved across the screen one pixel at a time."
682 PRINT "N.B. *put prints with wrap-over."
683 *brk 1: INK 7
690 FOR j=1 TO 200: *put 1,j,50: NEXT j
692 FOR j=255 TO 1 STEP -1: *put 1,j,55: NEXT j
715 *zap: *scr 1,7
770 GO SUB 9000
780 PRINT " *clr (char), (xpos), (ypos)"
790 PRINT "Will erase a character at the specified position, or it can
be used to clear part of the screen"
800 PRINT "That is the last of the new commands. The complete list
is:-"
810 PRINT " *zap " *ase (length) " *brk 0/1 " *scr (paper), (ink) " *use (n
char), (memory) " *def (char), (width), (int) "
820 PRINT " *get (char), (xpos), (ypos) " *put (char), (xpos), (ypos) " *clr (
char), (xpos), (ypos) "
830 GO SUB 9000
840 PRINT "Finally, a short demo using the extended BASIC commands to mov
e graphics around the screen."
850 PRINT "First, *set is used to copy the graphic characters:-"
855 REM the characters in the next line are user graphics
860 PRINT " *set (x1,x2,y1,y2) (x3,y3)"
870 *use 5,200: *def 1,22,15: *def 2,22,15: *def 3,22,15: *def 4,15,8: *def 5,4,
11
880 *set 1,5,27: *set 2,25,127: *set 3,68,127: *set 4,104,127: *set 5,132,127
890 DIM a(5): DIM x(5)
900 FOR i=1 TO 5
910 LET a(i)=0
920 LET x(i)=INT (1-RND*4)
930 NEXT i
940 GO SUB 9000
950 CLS: *scr 4,3
955 PRINT TAB 3;"Place your bets now !!!"
960 FOR i=1 TO 50
970 FOR j=1 TO 5
980 *put 1,x(i),j*25
990 NEXT j
1000 FOR k=1 TO 5: *put 2,x(k),k*25
1010 LET a(k)=a(k)+a(0)
1020 NEXT k
1030 NEXT i
1040 *zap: CLS: *scr 0,2
1050 FOR j=1 TO 2
1060 FOR k=0 TO 255 STEP 1
1070 *put 1,k,150: NEXT k
1080 FOR k=257 TO 0 STEP -3
1090 *put 3,k,150: NEXT k
1100 NEXT j
1110 *put 4,150,10: *zap: *scr 40
1120 FOR j=0 TO 24
1130 *put 5,j*6,150: *put 5,154,30+5*j
1140 *put 5,j*6+3,150
1150 NEXT j
1160 *nse 150: *clr 5,147,150
1170 STOP
8000 RESTORE 8050
8010 FOR j=0 TO 103
8020 READ a
8030 POKE USR "A"+j,a
8040 NEXT j
8050 DATA 192,64,19,60,64,287,92,8,12,16,32,240,168,188,202,64
8060 DATA 1,1,7,15,21,27,34,41,49,57,66,74,82,91,102,112,124,136,148,160,172,184,196
8070 DATA 2,1,2,4,2,1,0,0
8080 DATA 0,0,0,0,193,33,31,30,0,0,192,128,130,94,123,179
8090 DATA 31,60,48,96,64,128,128,0,248,104,124,64,4,1,0
8100 DATA 0,0,1,3,65,175,31,31,64,224,128,172,202,127,184,196
8110 DATA 31,12,4,4,2,2,1,0,1,24,8,16,16,32,32,64,0
8120 RETURN
9010 PRINT AT 21,0;"PRESS A KEY FOR NEXT PAGE."
9020 IF INKEY="" THEN GO TO 9015
9030 CLR: RETURN

```

(continued from previous page)

The *Get command will copy a character from the specified position on the screen, and store it in the graphics memory. It can then be printed anywhere on the screen using *Put. If the values of (Xpos) and (Ypos) cause part of the character to go over the edge, then it will

wrap-around to the opposite side of the screen. The *Clr command can be used to erase a character, or alternatively it can be used to clear a window on the screen.

For example, the instructions
*DEF 1,16,16: *GET 1,0,175: *PUT 1,240,15
would copy an area of the screen 16 by 16

pixels in size from the top left of the screen to the bottom right.

If you would like a cassette tape of the machine code and demonstration programs, please send £3 to 47, Wellingborough Road, Broughton, Kettering, Northants, NN14 1PD.

Listing 7. Demonstration program

```

10 PEEK PEEK 25619:256+PEEK 25614,206: PEEK 1+PEEK 25613:256+PEEK 25611,
PEEK 22733-a
50 CLS: PRINT "EXTENDED BASIC Robert Newman."
60 REM ***** demo *****
65 BORDER 1:scr 4,0
70 PRINT "This program shows how the new commands of the extended BASIC
C can be used."
80 PRINT "There are two new sound commands"
90 GO SUB 8000
100 PRINT " *zap gives this sound."
110 FOR j=1 TO 5:zap: PAUSE 2: NEXT j
120 PAUSE 30
130 PRINT "You can also make white noise for explosions or gunshots et
c. with the command ---"
140 PRINT TAB 10;"*nse n""
150 PRINT "where n is a number from 1 - 255 to set the length of the sou
d."
160 FOR j=1 TO 50:ase 50: NEXT j
170 GO SUB 9000
180 PRINT "There is a command for disabling/enabling the BREAK key."
190 PRINT " *brk 0 disables BREAK."
200 PRINT " *brk 1 re-enables it."
210 *brk 0
220 PRINT "Try pressing BREAK while the counter is running up to 1000
..."
230 FOR j=1 TO 1000
240 PRINT AT 12,15;j
250 NEXT j
260 *zap: PRINT AT 15,0;"BREAK is now re-enabled."
270 *brk 1
280 GO SUB 9000
300 PRINT "There are several new graphics commands."
310 PRINT TAB 7;"*scr (paper), (ink)"
320 PRINT "Will change the paper and ink colours of the whole screen"
330 PRINT "without erasing the contents."
340 PRINT "Paper and ink colours can take values from 0 to 9 as with th
e normal commands."
350 PRINT AT 16,2;"PRESS A KEY to change colour"
360 FOR j=0 TO 4
370 PAUSE 0
380 *scr j,9
390 NEXT j
392 PRINT AT 16,0;
395 FOR w=1 TO 200: NEXT w
400 GO SUB 9000
410 PRINT "The remaining commands allow you to print graphics at any place
on the screen."
420 PRINT "You can use up to 255 graphics characters, and these can be a
s large as you wish - even up to 256 x 176 pixels."
430 PRINT "First you must decide how many characters you need, and how
much memory is required to store"
440 PRINT "them. The command is:"
450 PRINT " *def (chcr), (xpos), (ypos), (memory)"
460 PRINT "where chcr= no. of characters, memory = store size in bytes,
"
470 PRINT "will then allocate space by lowering RAMTOP (if necessary
)."
480 PRINT "If you exit this command,"
490 PRINT " *use 8,256 is assumed."
500 GO SUB 9000
540 PRINT "After allocating graphics space with *use, you can set the siz
e of each character by:"
550 PRINT " *TAB 4; *def (char), (width), (int)"
560 PRINT "char = character number"
570 PRINT "width = 1 to 256 pixels"
580 PRINT "int = 1 to 176 pixels"
590 PRINT "You cannot change the size of a character once defined."
600 GO SUB 9000
610 PRINT "The *get command then gets data for the graphic character from
off the screen, and it can then be reprinted anywhere using *put:"
620 PRINT " *get (char), (xpos), (ypos)"
630 PRINT " *put (char), (xpos), (ypos)"
640 PRINT " (xpos and ypos are the x and y pixel coordinates at the top
left of a box on the screen from"
650 PRINT "where the graphic is to be *act""

```

```

1000 IF j=256 THEN *put w(1),FN a(1),FN y(1)
1200 NEXT j
1210 GO SUB 7000
2300 LET a=INKEY: IF a="" THEN GO TO 2000
2310 IF a="A" THEN GO TO 3000
2320 IF a="B" THEN GO TO 3000
2330 IF a="C" THEN GO TO 3000
2340 IF a="D" THEN GO TO 3000
2350 IF a="E" THEN GO TO 3000
2360 IF a="F" THEN GO TO 3000
2370 IF a="G" THEN GO TO 3000
2380 IF a="H" THEN GO TO 3000
2390 IF a="I" THEN GO TO 3000
2400 IF a="J" THEN GO TO 3000
2410 IF a="K" THEN GO TO 3000
2420 IF a="L" THEN GO TO 3000
2430 IF a="M" THEN GO TO 3000
2440 IF a="N" THEN GO TO 3000
2450 IF a="O" THEN GO TO 3000
2460 IF a="P" THEN GO TO 3000
2470 IF a="Q" THEN GO TO 3000
2480 IF a="R" THEN GO TO 3000
2490 IF a="S" THEN GO TO 3000
2500 IF a="T" THEN GO TO 3000
2510 IF a="U" THEN GO TO 3000
2520 IF a="V" THEN GO TO 3000
2530 IF a="W" THEN GO TO 3000
2540 IF a="X" THEN GO TO 3000
2550 IF a="Y" THEN GO TO 3000
2560 IF a="Z" THEN GO TO 3000
2570 IF a="0" THEN GO TO 3000
2580 IF a="1" THEN GO TO 3000
2590 IF a="2" THEN GO TO 3000
2600 IF a="3" THEN GO TO 3000
2610 IF a="4" THEN GO TO 3000
2620 IF a="5" THEN GO TO 3000
2630 IF a="6" THEN GO TO 3000
2640 IF a="7" THEN GO TO 3000
2650 IF a="8" THEN GO TO 3000
2660 IF a="9" THEN GO TO 3000
2670 IF a=" " THEN GO TO 3000
2680 IF a="." THEN GO TO 3000
2690 IF a="," THEN GO TO 3000
2700 IF a=";" THEN GO TO 3000
2710 IF a=":" THEN GO TO 3000
2720 IF a="@" THEN GO TO 3000
2730 IF a="#" THEN GO TO 3000
2740 IF a="$" THEN GO TO 3000
2750 IF a="%" THEN GO TO 3000
2760 IF a="&" THEN GO TO 3000
2770 IF a="*" THEN GO TO 3000
2780 IF a="+" THEN GO TO 3000
2790 IF a="=" THEN GO TO 3000
2800 IF a="<" THEN GO TO 3000
2810 IF a=">" THEN GO TO 3000
2820 IF a="?" THEN GO TO 3000
2830 IF a="!" THEN GO TO 3000
2840 IF a="~" THEN GO TO 3000
2850 IF a="_" THEN GO TO 3000
2860 IF a="|" THEN GO TO 3000
2870 IF a="`" THEN GO TO 3000
2880 IF a="'" THEN GO TO 3000
2890 IF a="(" THEN GO TO 3000
2900 IF a=")" THEN GO TO 3000
2910 IF a="{" THEN GO TO 3000
2920 IF a="}" THEN GO TO 3000
2930 IF a="[" THEN GO TO 3000
2940 IF a="]" THEN GO TO 3000
2950 IF a=":" THEN GO TO 3000
2960 IF a=";" THEN GO TO 3000
2970 IF a="," THEN GO TO 3000
2980 IF a="." THEN GO TO 3000
2990 IF a="/" THEN GO TO 3000
3000 IF a="\" THEN GO TO 3000
3010 IF a="|" THEN GO TO 3000
3020 IF a="_" THEN GO TO 3000
3030 IF a="`" THEN GO TO 3000
3040 IF a="'" THEN GO TO 3000
3050 IF a="(" THEN GO TO 3000
3060 IF a=")" THEN GO TO 3000
3070 IF a="{" THEN GO TO 3000
3080 IF a="}" THEN GO TO 3000
3090 IF a="[" THEN GO TO 3000
3100 IF a="]" THEN GO TO 3000
3110 IF a=":" THEN GO TO 3000
3120 IF a=";" THEN GO TO 3000
3130 IF a="," THEN GO TO 3000
3140 IF a="." THEN GO TO 3000
3150 IF a="/" THEN GO TO 3000
3160 IF a="\" THEN GO TO 3000
3170 IF a="|" THEN GO TO 3000
3180 IF a="_" THEN GO TO 3000
3190 IF a="`" THEN GO TO 3000
3200 IF a="'" THEN GO TO 3000
3210 IF a="(" THEN GO TO 3000
3220 IF a=")" THEN GO TO 3000
3230 IF a="{" THEN GO TO 3000
3240 IF a="}" THEN GO TO 3000
3250 IF a="[" THEN GO TO 3000
3260 IF a="]" THEN GO TO 3000
3270 IF a=":" THEN GO TO 3000
3280 IF a=";" THEN GO TO 3000
3290 IF a="," THEN GO TO 3000
3300 IF a="." THEN GO TO 3000
3310 IF a="/" THEN GO TO 3000
3320 IF a="\" THEN GO TO 3000
3330 IF a="|" THEN GO TO 3000
3340 IF a="_" THEN GO TO 3000
3350 IF a="`" THEN GO TO 3000
3360 IF a="'" THEN GO TO 3000
3370 IF a="(" THEN GO TO 3000
3380 IF a=")" THEN GO TO 3000
3390 IF a="{" THEN GO TO 3000
3400 IF a="}" THEN GO TO 3000
3410 IF a="[" THEN GO TO 3000
3420 IF a="]" THEN GO TO 3000
3430 IF a=":" THEN GO TO 3000
3440 IF a=";" THEN GO TO 3000
3450 IF a="," THEN GO TO 3000
3460 IF a="." THEN GO TO 3000
3470 IF a="/" THEN GO TO 3000
3480 IF a="\" THEN GO TO 3000
3490 IF a="|" THEN GO TO 3000
3500 IF a="_" THEN GO TO 3000
3510 IF a="`" THEN GO TO 3000
3520 IF a="'" THEN GO TO 3000
3530 IF a="(" THEN GO TO 3000
3540 IF a=")" THEN GO TO 3000
3550 IF a="{" THEN GO TO 3000
3560 IF a="}" THEN GO TO 3000
3570 IF a="[" THEN GO TO 3000
3580 IF a="]" THEN GO TO 3000
3590 IF a=":" THEN GO TO 3000
3600 IF a=";" THEN GO TO 3000
3610 IF a="," THEN GO TO 3000
3620 IF a="." THEN GO TO 3000
3630 IF a="/" THEN GO TO 3000
3640 IF a="\" THEN GO TO 3000
3650 IF a="|" THEN GO TO 3000
3660 IF a="_" THEN GO TO 3000
3670 IF a="`" THEN GO TO 3000
3680 IF a="'" THEN GO TO 3000
3690 IF a="(" THEN GO TO 3000
3700 IF a=")" THEN GO TO 3000
3710 IF a="{" THEN GO TO 3000
3720 IF a="}" THEN GO TO 3000
3730 IF a="[" THEN GO TO 3000
3740 IF a="]" THEN GO TO 3000
3750 IF a=":" THEN GO TO 3000
3760 IF a=";" THEN GO TO 3000
3770 IF a="," THEN GO TO 3000
3780 IF a="." THEN GO TO 3000
3790 IF a="/" THEN GO TO 3000
3800 IF a="\" THEN GO TO 3000
3810 IF a="|" THEN GO TO 3000
3820 IF a="_" THEN GO TO 3000
3830 IF a="`" THEN GO TO 3000
3840 IF a="'" THEN GO TO 3000
3850 IF a="(" THEN GO TO 3000
3860 IF a=")" THEN GO TO 3000
3870 IF a="{" THEN GO TO 3000
3880 IF a="}" THEN GO TO 3000
3890 IF a="[" THEN GO TO 3000
3900 IF a="]" THEN GO TO 3000
3910 IF a=":" THEN GO TO 3000
3920 IF a=";" THEN GO TO 3000
3930 IF a="," THEN GO TO 3000
3940 IF a="." THEN GO TO 3000
3950 IF a="/" THEN GO TO 3000
3960 IF a="\" THEN GO TO 3000
3970 IF a="|" THEN GO TO 3000
3980 IF a="_" THEN GO TO 3000
3990 IF a="`" THEN GO TO 3000
4000 IF a="'" THEN GO TO 3000
4010 IF a="(" THEN GO TO 3000
4020 IF a=")" THEN GO TO 3000
4030 IF a="{" THEN GO TO 3000
4040 IF a="}" THEN GO TO 3000
4050 IF a="[" THEN GO TO 3000
4060 IF a="]" THEN GO TO 3000
4070 IF a=":" THEN GO TO 3000
4080 IF a=";" THEN GO TO 3000
4090 IF a="," THEN GO TO 3000
4100 IF a="." THEN GO TO 3000
4110 IF a="/" THEN GO TO 3000
4120 IF a="\" THEN GO TO 3000
4130 IF a="|" THEN GO TO 3000
4140 IF a="_" THEN GO TO 3000
4150 IF a="`" THEN GO TO 3000
4160 IF a="'" THEN GO TO 3000
4170 IF a="(" THEN GO TO 3000
4180 IF a=")" THEN GO TO 3000
4190 IF a="{" THEN GO TO 3000
4200 IF a="}" THEN GO TO 3000
4210 IF a="[" THEN GO TO 3000
4220 IF a="]" THEN GO TO 3000
4230 IF a=":" THEN GO TO 3000
4240 IF a=";" THEN GO TO 3000
4250 IF a="," THEN GO TO 3000
4260 IF a="." THEN GO TO 3000
4270 IF a="/" THEN GO TO 3000
4280 IF a="\" THEN GO TO 3000
4290 IF a="|" THEN GO TO 3000
4300 IF a="_" THEN GO TO 3000
4310 IF a="`" THEN GO TO 3000
4320 IF a="'" THEN GO TO 3000
4330 IF a="(" THEN GO TO 3000
4340 IF a=")" THEN GO TO 3000
4350 IF a="{" THEN GO TO 3000
4360 IF a="}" THEN GO TO 3000
4370 IF a="[" THEN GO TO 3000
4380 IF a="]" THEN GO TO 3000
4390 IF a=":" THEN GO TO 3000
4400 IF a=";" THEN GO TO 3000
4410 IF a="," THEN GO TO 3000
4420 IF a="." THEN GO TO 3000
4430 IF a="/" THEN GO TO 3000
4440 IF a="\" THEN GO TO 3000
4450 IF a="|" THEN GO TO 3000
4460 IF a="_" THEN GO TO 3000
4470 IF a="`" THEN GO TO 3000
4480 IF a="'" THEN GO TO 3000
4490 IF a="(" THEN GO TO 3000
4500 IF a=")" THEN GO TO 3000
4510 IF a="{" THEN GO TO 3000
4520 IF a="}" THEN GO TO 3000
4530 IF a="[" THEN GO TO 3000
4540 IF a="]" THEN GO TO 3000
4550 IF a=":" THEN GO TO 3000
4560 IF a=";" THEN GO TO 3000
4570 IF a="," THEN GO TO 3000
4580 IF a="." THEN GO TO 3000
4590 IF a="/" THEN GO TO 3000
4600 IF a="\" THEN GO TO 3000
4610 IF a="|" THEN GO TO 3000
4620 IF a="_" THEN GO TO 3000
4630 IF a="`" THEN GO TO 3000
4640 IF a="'" THEN GO TO 3000
4650 IF a="(" THEN GO TO 3000
4660 IF a=")" THEN GO TO 3000
4670 IF a="{" THEN GO TO 3000
4680 IF a="}" THEN GO TO 3000
4690 IF a="[" THEN GO TO 3000
4700 IF a="]" THEN GO TO 3000
4710 IF a=":" THEN GO TO 3000
4720 IF a=";" THEN GO TO 3000
4730 IF a="," THEN GO TO 3000
4740 IF a="." THEN GO TO 3000
4750 IF a="/" THEN GO TO 3000
4760 IF a="\" THEN GO TO 3000
4770 IF a="|" THEN GO TO 3000
4780 IF a="_" THEN GO TO 3000
4790 IF a="`" THEN GO TO 3000
4800 IF a="'" THEN GO TO 3000
4810 IF a="(" THEN GO TO 3000
4820 IF a=")" THEN GO TO 3000
4830 IF a="{" THEN GO TO 3000
4840 IF a="}" THEN GO TO 3000
4850 IF a="[" THEN GO TO 3000
4860 IF a="]" THEN GO TO 3000
4870 IF a=":" THEN GO TO 3000
4880 IF a=";" THEN GO TO 3000
4890 IF a="," THEN GO TO 3000
4900 IF a="." THEN GO TO 3000
4910 IF a="/" THEN GO TO 3000
4920 IF a="\" THEN GO TO 3000
4930 IF a="|" THEN GO TO 3000
4940 IF a="_" THEN GO TO 3000
4950 IF a="`" THEN GO TO 3000
4960 IF a="'" THEN GO TO 3000
4970 IF a="(" THEN GO TO 3000
4980 IF a=")" THEN GO TO 3000
4990 IF a="{" THEN GO TO 3000
5000 IF a="}" THEN GO TO 3000
5010 IF a="[" THEN GO TO 3000
5020 IF a="]" THEN GO TO 3000
5030 IF a=":" THEN GO TO 3000
5040 IF a=";" THEN GO TO 3000
5050 IF a="," THEN GO TO 3000
5060 IF a="." THEN GO TO 3000
5070 IF a="/" THEN GO TO 3000
5080 IF a="\" THEN GO TO 3000
5090 IF a="|" THEN GO TO 3000
5100 IF a="_" THEN GO TO 3000
5110 IF a="`" THEN GO TO 3000
5120 IF a="'" THEN GO TO 3000
5130 IF a="(" THEN GO TO 3000
5140 IF a=")" THEN GO TO 3000
5150 IF a="{" THEN GO TO 3000
5160 IF a="}" THEN GO TO 3000
5170 IF a="[" THEN GO TO 3000
5180 IF a="]" THEN GO TO 3000
5190 IF a=":" THEN GO TO 3000
5200 IF a=";" THEN GO TO 3000
5210 IF a="," THEN GO TO 3000
5220 IF a="." THEN GO TO 3000
5230 IF a="/" THEN GO TO 3000
5240 IF a="\" THEN GO TO 3000
5250 IF a="|" THEN GO TO 3000
5260 IF a="_" THEN GO TO 3000
5270 IF a="`" THEN GO TO 3000
5280 IF a="'" THEN GO TO 3000
5290 IF a="(" THEN GO TO 3000
5300 IF a=")" THEN GO TO 3000
5310 IF a="{" THEN GO TO 3000
5320 IF a="}" THEN GO TO 3000
5330 IF a="[" THEN GO TO 3000
5340 IF a="]" THEN GO TO 3000
5350 IF a=":" THEN GO TO 3000
5360 IF a=";" THEN GO TO 3000
5370 IF a="," THEN GO TO 3000
5380 IF a="." THEN GO TO 3000
5390 IF a="/" THEN GO TO 3000
5400 IF a="\" THEN GO TO 3000
5410 IF a="|" THEN GO TO 3000
5420 IF a="_" THEN GO TO 3000
5430 IF a="`" THEN GO TO 3000
5440 IF a="'" THEN GO TO 3000
5450 IF a="(" THEN GO TO 3000
5460 IF a=")" THEN GO TO 3000
5470 IF a="{" THEN GO TO 3000
5480 IF a="}" THEN GO TO 3000
5490 IF a="[" THEN GO TO 3000
5500 IF a="]" THEN GO TO 3000
5510 IF a=":" THEN GO TO 3000
5520 IF a=";" THEN GO TO 3000
5530 IF a="," THEN GO TO 3000
5540 IF a="." THEN GO TO 3000
5550 IF a="/" THEN GO TO 3000
5560 IF a="\" THEN GO TO 3000
5570 IF a="|" THEN GO TO 3000
5580 IF a="_" THEN GO TO 3000
5590 IF a="`" THEN GO TO 3000
5600 IF a="'" THEN GO TO 3000
5610 IF a="(" THEN GO TO 3000
5620 IF a=")" THEN GO TO 3000
5630 IF a="{" THEN GO TO 3000
5640 IF a="}" THEN GO TO 3000
5650 IF a="[" THEN GO TO 3000
5660 IF a="]" THEN GO TO 3000
5670 IF a=":" THEN GO TO 3000
5680 IF a=";" THEN GO TO 3000
5690 IF a="," THEN GO TO 3000
5700 IF a="." THEN GO TO 3000
5710 IF a="/" THEN GO TO 3000
5720 IF a="\" THEN GO TO 3000
5730 IF a="|" THEN GO TO 3000
5740 IF a="_" THEN GO TO 3000
5750 IF a="`" THEN GO TO 3000
5760 IF a="'" THEN GO TO 3000
5770 IF a="(" THEN GO TO 3000
5780 IF a=")" THEN GO TO 3000
5790 IF a="{" THEN GO TO 3000
5800 IF a="}" THEN GO TO 3000
5810 IF a="[" THEN GO TO 3000
5820 IF a="]" THEN GO TO 3000
5830 IF a=":" THEN GO TO 3000
5840 IF a=";" THEN GO TO 3000
5850 IF a="," THEN GO TO 3000
5860 IF a="." THEN GO TO 3000
5870 IF a="/" THEN GO TO 3000
5880 IF a="\" THEN GO TO 3000
5890 IF a="|" THEN GO TO 3000
5900 IF a="_" THEN GO TO 3000
5910 IF a="`" THEN GO TO 3000
5920 IF a="'" THEN GO TO 3000
5930 IF a="(" THEN GO TO 3000
5940 IF a=")" THEN GO TO 3000
5950 IF a="{" THEN GO TO 3000
5960 IF a="}" THEN GO TO 3000
5970 IF a="[" THEN GO TO 3000
5980 IF a="]" THEN GO TO 3000
5990 IF a=":" THEN GO TO 3000
6000 IF a=";" THEN GO TO 3000
6010 IF a="," THEN GO TO 3000
6020 IF a="." THEN GO TO 3000
6030 IF a="/" THEN GO TO 3000
6040 IF a="\" THEN GO TO 3000
6050 IF a="|" THEN GO TO 3000
6060 IF a="_" THEN GO TO 3000
6070 IF a="`" THEN GO TO 3000
6080 IF a="'" THEN GO TO 3000
6090 IF a="(" THEN GO TO 3000
6100 IF a=")" THEN GO TO 3000
6110 IF a="{" THEN GO TO 3000
6120 IF a="}" THEN GO TO 3000
6130 IF a="[" THEN GO TO 3000
6140 IF a="]" THEN GO TO 3000
6150 IF a=":" THEN GO TO 3000
6160 IF a=";" THEN GO TO 3000
6170 IF a="," THEN GO TO 3000
6180 IF a="." THEN GO TO 3000
6190 IF a="/" THEN GO TO 3000
6200 IF a="\" THEN GO TO 3000
6210 IF a="|" THEN GO TO 3000
6220 IF a="_" THEN GO TO 3000
6230 IF a="`" THEN GO TO 3000
6240 IF a="'" THEN GO TO 3000
6250 IF a="(" THEN GO TO 3000
6260 IF a=")" THEN GO TO 3000
6270 IF a="{" THEN GO TO 3000
6280 IF a="}" THEN GO TO 3000
6290 IF a="[" THEN GO TO 3000
6300 IF a="]" THEN GO TO 3000
6310 IF a=":" THEN GO TO 3000
6320 IF a=";" THEN GO TO 3000
6330 IF a="," THEN GO TO 3000
6340 IF a="." THEN GO TO 3000
6350 IF a="/" THEN GO TO 3000
6360 IF a="\" THEN GO TO 3000
6370 IF a="|" THEN GO TO 3000
6380 IF a="_" THEN GO TO 3000
6390 IF a="`" THEN GO TO 3000
6400 IF a="'" THEN GO TO 3000
6410 IF a="(" THEN GO TO 3000
6420 IF a=")" THEN GO TO 3000
6430 IF a="{" THEN GO TO 3000
6440 IF a="}" THEN GO TO 3000
6450 IF a="[" THEN GO TO 3000
6460 IF a="]" THEN GO TO 3000
6470 IF a=":" THEN GO TO 3000
6480 IF a=";" THEN GO TO 3000
6490 IF a="," THEN GO TO 3000
6500 IF a="." THEN GO TO 3000
6510 IF a="/" THEN GO TO 3000
6520 IF a="\" THEN GO TO 3000
6530 IF a="|" THEN GO TO 3000
6540 IF a="_" THEN GO TO 3000
6550 IF a="`" THEN GO TO 3000
6560 IF a="'" THEN GO TO 3000
6570 IF a="(" THEN GO TO 3000
6580 IF a=")" THEN GO TO 3000
6590 IF a="{" THEN GO TO 3000
6600 IF a="}" THEN GO TO 3000
6610 IF a="[" THEN GO TO 3000
6620 IF a="]" THEN GO TO 3000
6630 IF a=":" THEN GO TO 3000
6640 IF a=";" THEN GO TO 3000
6650 IF a="," THEN GO TO 3000
6660 IF a="." THEN GO TO 3000
6670 IF a="/" THEN GO TO 3000
6680 IF a="\" THEN GO TO 3000
6690 IF a="|" THEN GO TO 3000
6700 IF a="_" THEN GO TO 3000
6710 IF a="`" THEN GO TO 3000
6720 IF a="'" THEN GO TO 3000
6730 IF a="(" THEN GO TO 3000
6740 IF a=")" THEN GO TO 3000
6750 IF a="{" THEN GO TO 3000
6760 IF a="}" THEN GO TO 3000
6770 IF a="[" THEN GO TO 3000
6780 IF a="]" THEN GO TO 3000
6790 IF a=":" THEN GO TO 3000
6800 IF a=";" THEN GO TO 3000
6810 IF a="," THEN GO TO 3000
6820 IF a="." THEN GO TO 3000
6830 IF a="/" THEN GO TO 3000
6840 IF a="\" THEN GO TO 3000
6850 IF a="|" THEN GO TO 3000
6860 IF a="_" THEN GO TO 3000
6870 IF a="`" THEN GO TO 3000
6880 IF a="'" THEN GO TO 3000
6890 IF a="(" THEN GO TO 3000
6900 IF a=")" THEN GO TO 3000
6910 IF a="{" THEN GO TO 3000
6920 IF a="}" THEN GO TO 3000
6930 IF a="[" THEN GO TO 3000
6940 IF a="]" THEN GO TO 3000
6950 IF a=":" THEN GO TO
```

Settle down with two beautiful opponents ~
Suzi & Melissa ~ for a sizzling game of...

Strip POKER

GREAT
FOR
PARTIES!

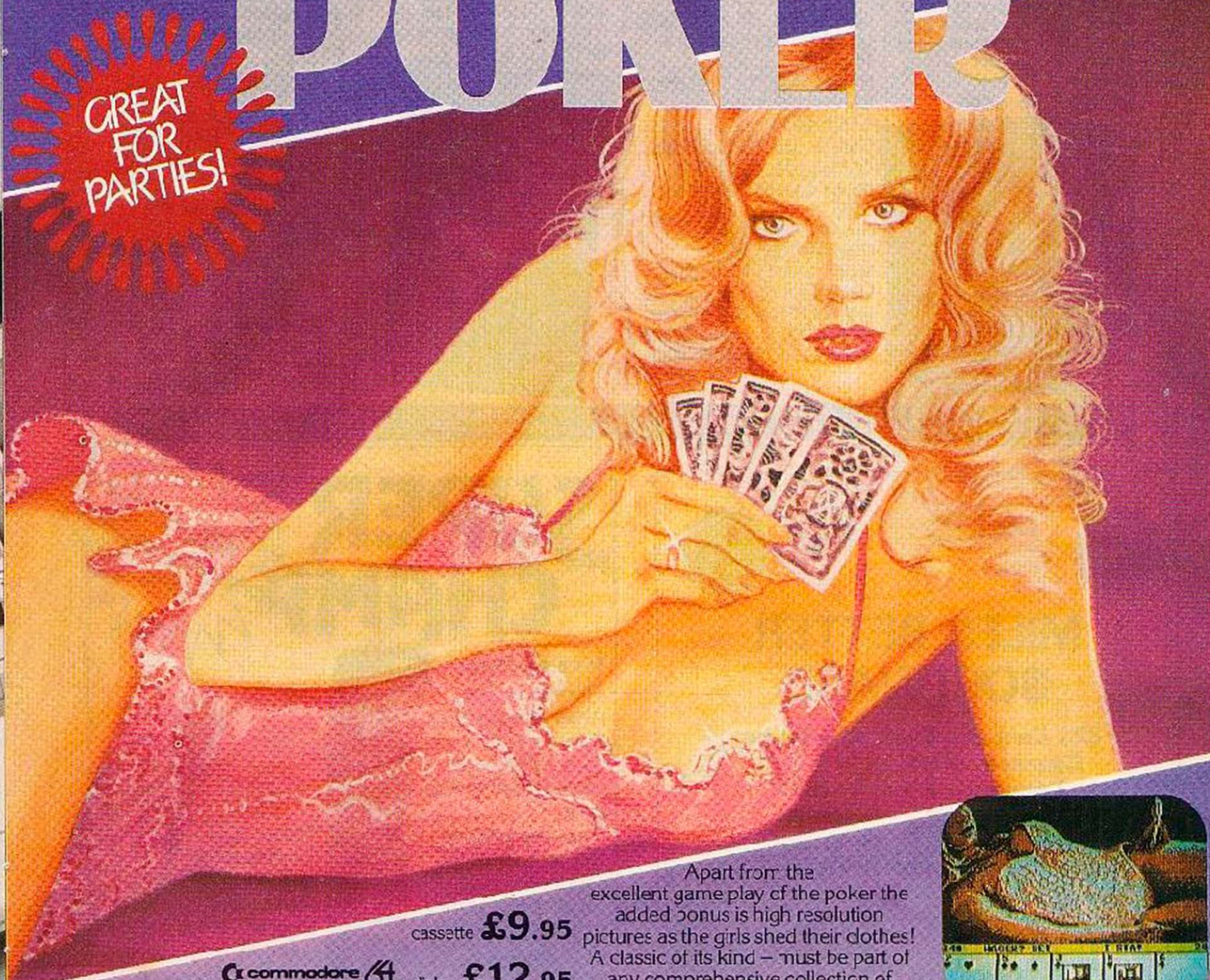

Commodore



cassette **£9.95**
disk **£12.95**

Apart from the excellent game play of the poker the added bonus is high resolution pictures as the girls shed their clothes! A classic of its kind - must be part of any comprehensive collection of software.

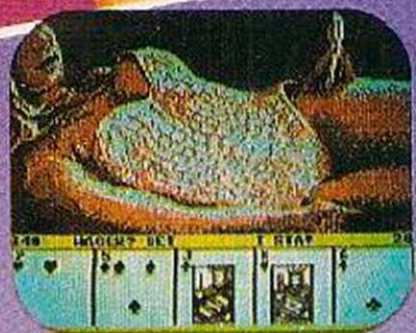

THE ULTIMATE IN AMERICAN SOFTWARE FOR YOU ON U.S. GOLD
U.S. Gold is stocked by all leading computer stores.

DEALERS! For information on how to become a U.S. Gold Stockist write to: CentreSoft Ltd., Unit 24, Tipton Trading Estate, Bloomfield Road, Tipton, West Midlands DY4 9AH. Telephone: 021-520 7591. Telex: 337268. Overseas enquiries welcome.

U.S. GOLD

All American Software

GAMES . . . GAMES . . . GAMES

THE VIRGIN COMPUTER GAMES SERIES

£££££'s of Entertaining Games for only £2.95

Each book contains more than 20 quality games programmes, each one specially written for the series and unavailable elsewhere. Moving graphic games, arcade games, reflex flexers and brain stretchers are all here and guaranteed to provide hours of entertainment.

Only £2.95 each



- GAMES FOR YOUR ZX 81
- MORE GAMES FOR YOUR ZX 81 (£3.50)
- GAMES FOR YOUR ZX SPECTRUM
- MORE GAMES FOR YOUR ZX SPECTRUM (£3.50)
- GAMES FOR YOUR VIC 20
- MORE GAMES FOR YOUR VIC 20
- GAMES FOR YOUR BBC MICRO
- MORE GAMES FOR YOUR BBC MICRO
- GAMES FOR YOUR DRAGON
- MORE GAMES FOR YOUR DRAGON
- GAMES FOR YOUR ATARI
- GAMES FOR YOUR ATARI 600XL
- GAMES FOR YOUR TRS 80
- GAMES FOR YOUR ORIC
- MORE GAMES FOR YOUR ORIC
- GAMES FOR YOUR COMMODORE 64
- MORE GAMES FOR YOUR COMMODORE 64
- GAMES FOR YOUR ACORN ELECTRON
- GAMES FOR YOUR T 99/4A

THE PERSONAL COMPUTER HANDBOOK

3rd Annual Edition

TIM HARTNELL

The complete guide to selecting and using small computers, including an explanation of how they work and what they can do for you, a detailed analysis of the available systems on the market and how to buy them, and how to get the most from your computer with an extended step-by-step guide to programming.

Only £4.95

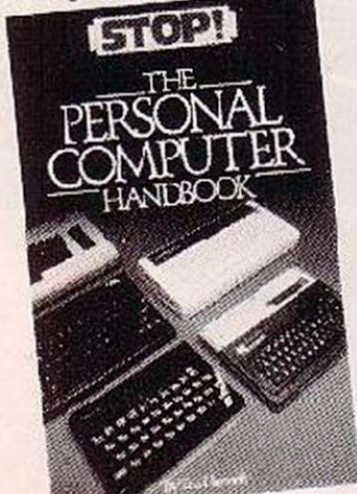

WRITING SOFTWARE FOR PROFIT

A.J. HARDING

Most software authors begin writing programs at home and many have dreams of seeing their hardwork published. With this in mind, this book examines how to choose the right machine and the right computer software before explaining in depth the best approach to program writing and submitting your finished program.

£4.95



Available from all good bookshops, or direct from the publishers adding 12½% to the price of each book ordered to cover our postage and packing. Please make cheques/P.O.'s payable to Virgin Books and send to: Computer Books Offer 3, Virgin Books, 61-63 Portobello Road, London W11 3DD



MILES BETTER SOFTWARE

221 Cannock Road, Chadsmoor
Cannock, Staffs WS11 2DD
Telephone (05435) 3577

U.S. GOLD SOFTWARE

| | | |
|------------------|--------|-------|
| BEACH HEAD | 9.00 | 12.00 |
| SOLO FLIGHT | *12.00 | 12.00 |
| FORBIDDEN FOREST | * 8.00 | 11.00 |
| AZTEC CHALLENGE | * 8.00 | 11.00 |
| SINKY | * 8.00 | 11.00 |
| DALLAS QUEST | *N/A | 12.00 |
| FLAK | *N/A | 12.00 |
| NATO COMMANDER | * 8.00 | 12.00 |
| SPITFIRE ACE | * 8.00 | 12.00 |
| POOYAN | * 8.00 | 11.00 |
| MYSTIC MANSION | * 8.00 | 11.00 |
| SNUKI- | * 9.00 | 12.00 |

* Available for the Atari

Phone for software availability and top software list for the CBM 64 and Atari

SUPER CHAMP

NEW
10 ft retractable cable

It's a knockout!

The top selling American Joystick Control with a 10 ft retractable cable stored in the base.

Two fire buttons and self-centering action. Suction cups hold it firm to a flat surface. Very robust - arcade proven.

For -
Commodore
and Atari.
Acom and
Sinclair with
suitable interfaces.



£12.95
+£1p.p.
Barclay/Access

Dealer enquiries welcome

DEAN ELECTRONICS LIMITED

Glerda e Park Fernbank Road Ascot
Berks Tel. 0344 885661 Telax 349242

RESPONSE FRAME

Do you have a problem? Your manual is incomprehensible or you just cannot get the hang of that programming trick you tried — whatever it is, Tim Hartnel will do his best to answer your queries. Please include only one question per letter and mark them "Response Frame".

QL TIMING

I have finally, after months and months and months of waiting, got my QL. I am writing a game in which the time it takes a player to enter a move is crucial — there is a limited number of seconds to enter the answer. I thought the inbuilt clock would be ideal for this. However, I can't get it to work as it claims it does in the manual, and to extract parts of the Date\$ — although the manual suggests this is the same as extracting 'slices' of any string — seems impossible. How can I do it?

*Ian Cavalier,
Huntingdon.*

I HAVE ALSO HAD some problems working out how to use the clock. I suggest you define two procedures: The first one, which you could call something like Setclock, would just reset the clock to zero after each move, with the line

```
SDATE 1984,9,3,0,0
```

or you could just include this within the program, if you didn't want to set up a separate procedure.

The second one, to print just the part of the time you want on the screen, could be called Printclock. It would need to include

```
CLOCKS = DATE$:PRINT CLCCK$(13 TO 20)
```

to get minutes and seconds, or

```
CLOCKS(19 TO 20)
```

just to get the seconds. The last two characters of Clock\$ can also be checked for their numeric value if you want the program to do something after a specific time has elapsed.

THREE AND ONE

On reading that some Issue Three ZX Spectrum owners are experiencing difficulty loading commercial software, I am writing to inquire where you've heard of Issue One owners having problems loading some of the latest software releases. Quicksilver's Ant Attack just will not load on my Spectrum, and yet it will run on my friend's Issue Three machine. Could it be that software writers have now mastered the Issue Three problems at the expense of Issue One owners, or could it be that my trusted Issue One is feeling its age?

*Brian Richardson,
Sittingbourne,
Kent.*

THERE SHOULD BE NO problems with Ant Attack as I have seen it running

quite happily on an Issue One machine. However, I have been told that there is some current software which "hiccups" a little on Issue One's. I suggest you go back to the store where you bought Ant Attack, tell them it won't load, and get another copy. If that doesn't work, perhaps your machine is feeling its age and either an overhaul is called for, or you'll have to settle for some other program.

BBC SUBSTITUTE

I used to own a 48K Spectrum, and was very happy with it. I especially like the Screen\$ and ATTR commands. Now I have a BBC Model B. To my surprise — and disappointment — I have found that this computer does not use those commands, so I feel very restricted in what I can do. Is there any way I can substitute these commands on my BBC Micro?

*Nauman Butt,
Dean Park,
Rushmore.*

YOU CAN USE the Point command to return the colour of a single pixel. This does not work in Mode 7. Alternatively, and far more satisfactorily, you could investigate the operating system call which provides the functions you want. It is explained on page 432 of the user guide, where there is a program of 110 lines or so to demonstrate how it is done.

ACE IN THE HAND?

I am interested in learning Forth and have noticed that the Jupiter Ace is now available from some sources for as low as £29.95. However, I am reluctant to buy a machine from a company which is out of business and for which there is no expandability and little software. Can one get a colour board and, if so, is it possible to generate a true hi-res display?

*C.J. Slade,
Rochester,
Kent.*

IT SEEMS IT WOULD be hard to go wrong with a £29.95 machine, although the Ace is becoming increasingly difficult to get hold of. An add-on memory is the only peripheral which I have seen widely advertised. It might well be a better buy to get a Spectrum, and then buy one of the available Forth programs such as that produced by Artic, than start going down a dead-end street.

WHAT ADD-ONS?

I have a BBC Model B, and am very pleased with it. However, now that I've been using it for a year — and have saved up some more money — I would like to expand the hardware. I would appreciate it if you could give me some ideas of the priorities I should assign to various bits of add-on hardware, so I would know which ones to buy first.

*Martin Kersh,
Southsea.*

THIS QUESTION IS, I'm afraid, almost impossible to answer as you do not indicate the prime use of your BBC Micro, nor do you tell me what hardware you already have. However, keeping in mind that your letter suggests you have a "basic" Model B, and that your activities with the computer presumably include playing commercial software and writing your own programs, I would suggest the following should be considered first.

A disc drive is a tremendous asset to have, and you'll soon wonder why you put up with cassettes for so long. A wide range of drives is available, from around £160 for 5 1/4 inch 40 track, single-sided drives, dual drives of a similar standard are around £340, and a double-sided 5 inch Microdrive — which is totally compatible with 5 1/4 inch drives — is available from around £230.

A joystick will add a lot to your game playing, and these start from around £10. If writing your own programs is a higher priority than running commercial games, you might consider adding the Second Processor. Full details on this are available from Azorn Computers Ltd., Fulbourn Road, Cherry Hinton, Cambridge, CB1 4JN.

EASY REMS

In an earlier issue of *Your Computer*, there was a game called Frogger, which required one long Rem statement of 6208 characters. Please could you tell me an easy and reliable way to do this, as I have not yet fully mastered machine code on my ZX-81?

*R.G. Simmons,
Studley,
Warwickshire.*

THERE ARE MANY ways of solving the problem. A particularly elegant way — developed by the former chairman of the Dutch ZX Users Group, Han van Abbe of Wassenaar, and passed on to me by Jan Verhoeven — suggests Poking the machine code into a Print statement. The procedure is as follows. Type in a Print statement with the structure

```
PRINT 0-0+0+0+0+... etc.
```

Every combination of a zero and a plus sign takes up one byte for the character zero, one byte for the delimiter (126), five bytes for the floating point representation, and

one byte for the plus sign. Altogether this yields eight bytes of memory space, with only two bytes of screen space. You next enter the line,

```
POKE 16513,234
```

to change the Print token to Rem, and then use your hex loader to fill the Rem.

Another method, devised by Jan Verhoeven himself, uses a single large Rem statement, which takes up about 200 spaces. This line is repeatedly edited, and during every edit the line number is changed. You first type in the large Rem statement, and use Edit to alter the line number several times. Next you enter the statement

```
LET L = PEEK 16511 + 256 * PEEK 16512
```

to get L as the length of one line. Add 4 to L, and add the new L to the old L. Poke a Newline (118) in locations 15514 and 16515 to prevent the display from uncontrolled scrolling during listings. Repeat these steps until enough space is reserved. But, take care, as a mistake is easily made.

COPYRIGHT

We are setting up a software business, and are wondering what to do about copyright. Also, what tape do you suggest we use for sound and speech?

*Simon Martin and Craig Seager,
Lynsted,
Kent.*

THE PROBLEM OF copyright is a difficult one. At the moment, despite the best efforts of the Guild of Software Houses, it seems impossible to stop people copying your tapes if they want to, although a few ingenious systems — such as providing a hard-to-photocopy colour code card which tells you which numbers to enter at the beginning of a load — have been tried.

As to sound and speech, I'm afraid you'll have to develop your own routines, if you are to include them with your programs.

In this column a few months ago, I said in response to a reader's question, that I had had difficulty including Verify within a Spectrum program. Many readers contacted me to point out that it is, in fact, very easy to do. Among those who took the trouble to point this out was Ian Hoare, author of the Bugbyte program Computer Cookbook. He says he uses a standard Verify line at the end of each of his programs — which is still there on the commercially-available cassettes of his work. The line is as follows:

```
9999 CLS: SAVE "name of program"  
LINE0 : SAVE "name" CODE  
55120,415: VERIFY "name of  
program": PRINT "PROGRAM  
OK": VERIFY "name" CODE:  
PRINT "CODE OK"
```

ANIROG

**NEW
TURBO 64
GAMES**

P.C. FUZZ

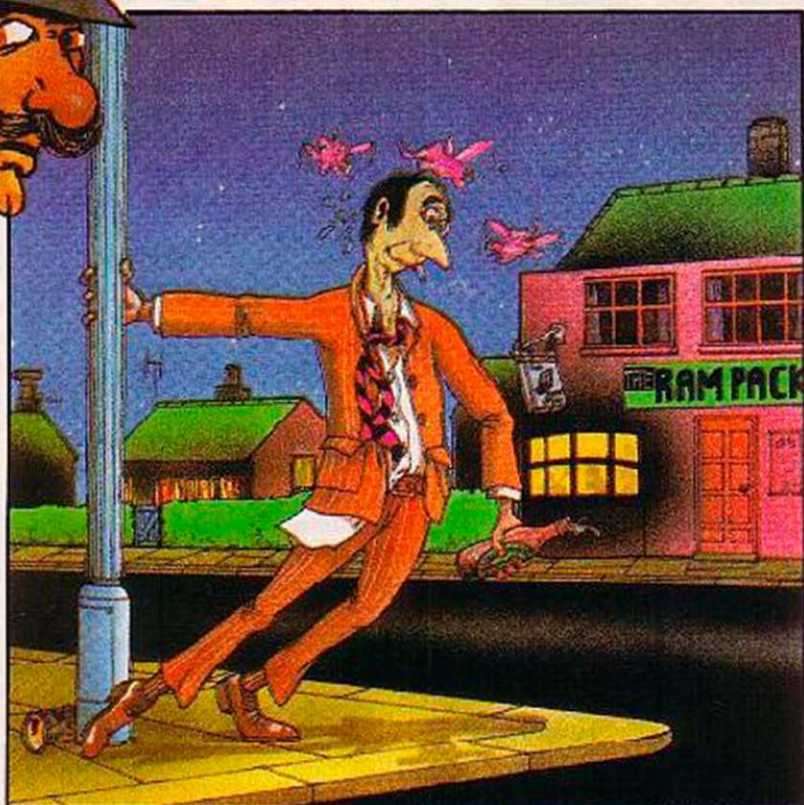
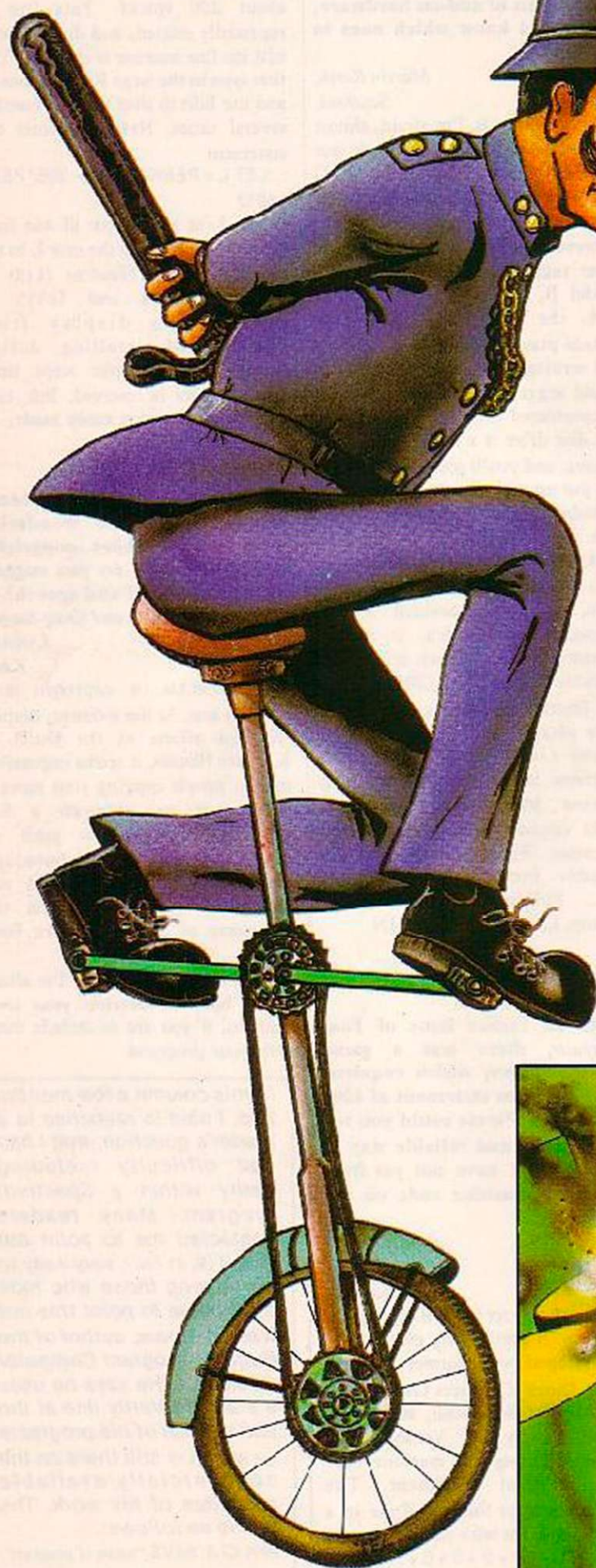

Aggro at closing time at the local. Getaway car screeches to a halt outside a bank. Ingenious methods employed by the Mafia to literally spirit away the loot from the High Street. Never fear - P.C. Fuzz is on patrol.

COMMODORE 64 £7.95

ZARGA MISSION

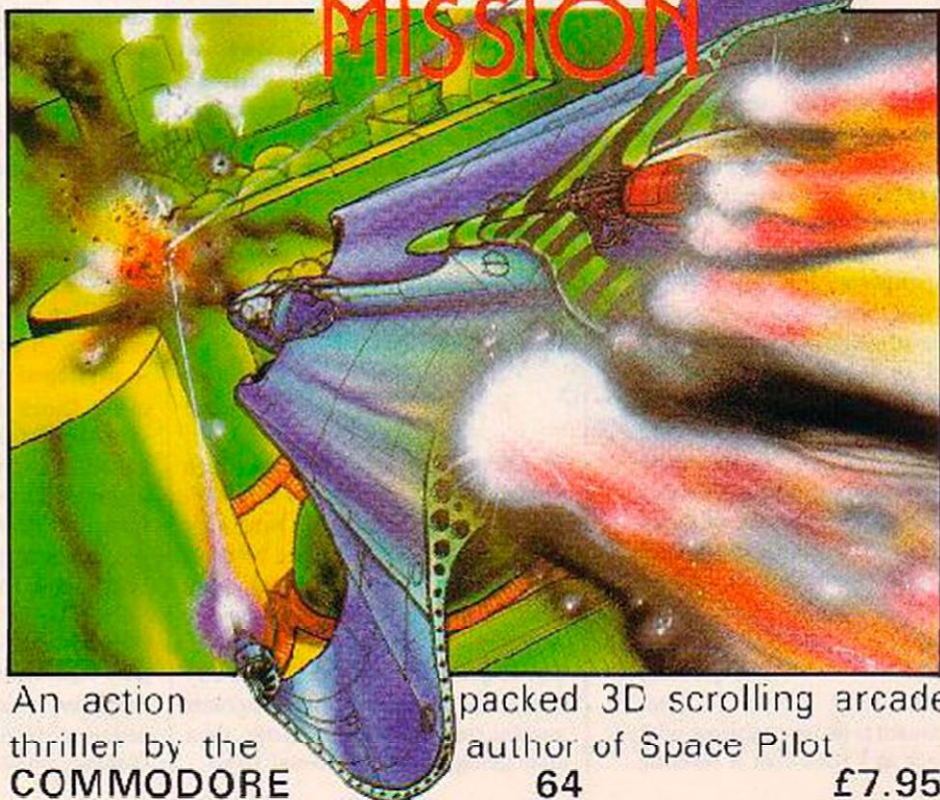

**Also available on
Disk at £9.95**

An action thriller by the author of Space Pilot
COMMODORE 64 £7.95

TRADE ENQUIRIES: ANIROG SOFTWARE LTD. 29 WEST HILL DARTFORD KENT (0322) 92513/8
MAIL ORDER: 8 HIGH STREET HORLEY SURREY 24 HOUR CREDIT CARD SALES HORLEY (02934) 6083
PAYMENT BY CHEQUE P.O. ACCESS/VISA 50p POSTAGE & PACKAGING

SOFTWARE FILE

Software File gives you the opportunity to have your programs, ideas and discoveries published. We will accept contributions for any home computer provided they are submitted to *Your Computer* exclusively. Please double-check your programs and specify the memory they require before sending them, preferably on cassette. We pay between £6 and £36 for contributions published.

Rhythmix

Timothy Closs,
Shepperton,
Middlesex.

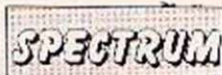

RHYTHMIX ENABLES you to record digitally up to six separate sounds which may then be replayed manually on the computer keyboard. Alternatively, they can be programmed into a fixed sequence to give rhythmic accompaniment while you play another musical instrument. As a visual extra, the screen border can be made to flash in time with the rhythm.

When you run the program, a menu will be displayed:

1. RECORD
2. PLAY
3. PROGRAM
4. RUN
5. BORDER FLASH

RECORD sets up your cassette player as in figure 1 and type in a number from 1 to 6. Generate your first sound near the microphone — it will be stored by the computer, to be recalled under Play or Run below. Now type in your second number, generate your second sound, and so on up to a maximum of six. It is worth experimenting with a wide variety of sounds — including the human voice — as the results can be quite surprising, but the duration of each should not exceed about 0.5 seconds.

PLAY: By tapping the keys 1 to 6 you can

now reproduce sounds from your rhythm tank to accompany other musicians. Amplification is achieved through the set-up in figure 2. Pressing E at any stage will Escape to the menu.

PROGRAM: First enter the number of beats you want in your rhythm sequence — anything from 1 to about 60 might be suitable. Then tap out the sounds using keys 1 to 6 as above. The sounds will be heard as you program them in. Typing R records a rest i.e., a period of silence equal in length to each of the sounds. An audible beep confirms that the rest has been entered.

RUN: The computer will ask you for the required speed. Returning 1 gives the fastest rate of replay, while higher numbers give successively slower and lower frequency rhythms. Your programmed rhythm will now be repeated over and over until the menu is called by pressing E.

BORDER FLASH: Using the normal border colour numbers — for example 2 is red — enter first the colour for sound on and then the colour for sound off.

```

6 POKE 23658,8: GO SUB 6000:
GO TO 500
100 REM *****RHYTHMIX*****
110 REM *****BY TIM CLOSS*****
120 REM *****
500 CLS : POKE 32050,1: PRINT "
*****RHYTHMIX*****MAIN MENU*****
": PRINT : PRINT "(1)-RECORD": P
RINT : PRINT "(2)-PLAY": PRINT :
PRINT "(3)-PROGRAM": PRINT : PR
INT "(4)-RUN": PRINT : PRINT "(5
)-BORDER FLASH"
501 IF INKEY$="4" THEN GO TO 40
00
502 IF INKEY$="5" THEN GO TO 50
00
505 IF INKEY$="1" THEN GO TO 51
3
506 IF INKEY$="2" THEN GO TO 20
00
507 IF INKEY$="3" THEN GO TO 30
00
512 GO TO 501
513 INPUT "SOUND NO. ? ";S: LET
S=S-1
514 POKE 32002,128+(S*20)
515 PRINT AT 15,10;"ENTER SOUND
NOW"
    
```

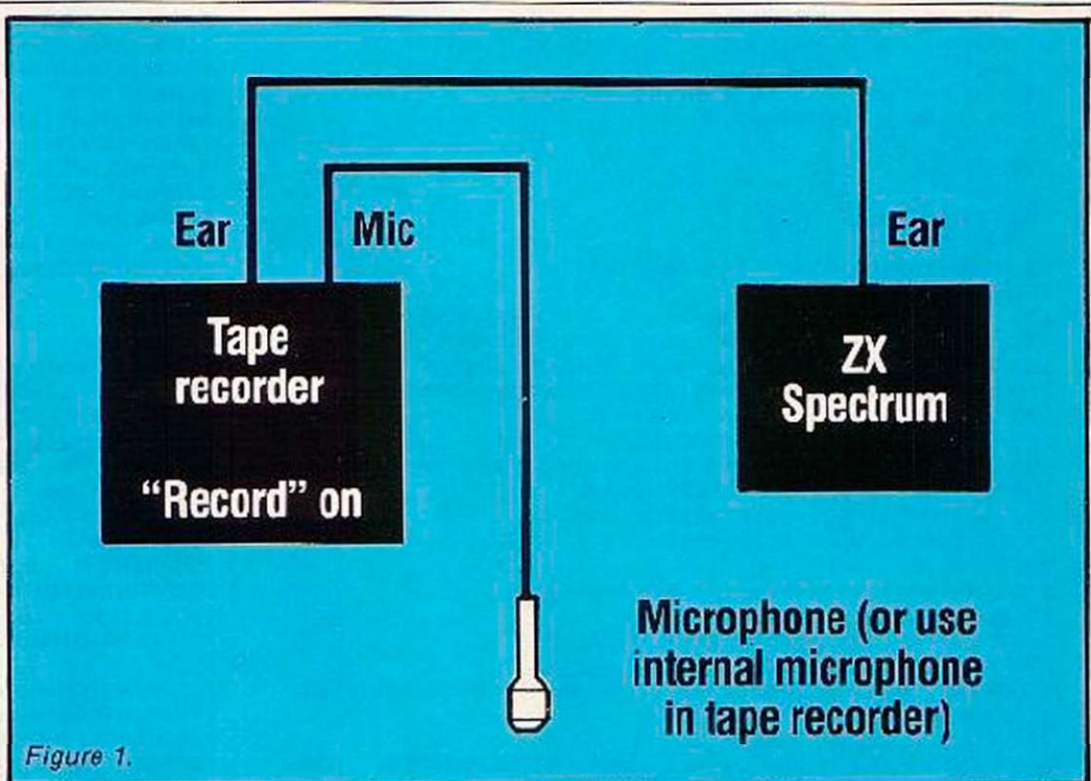

Figure 1.

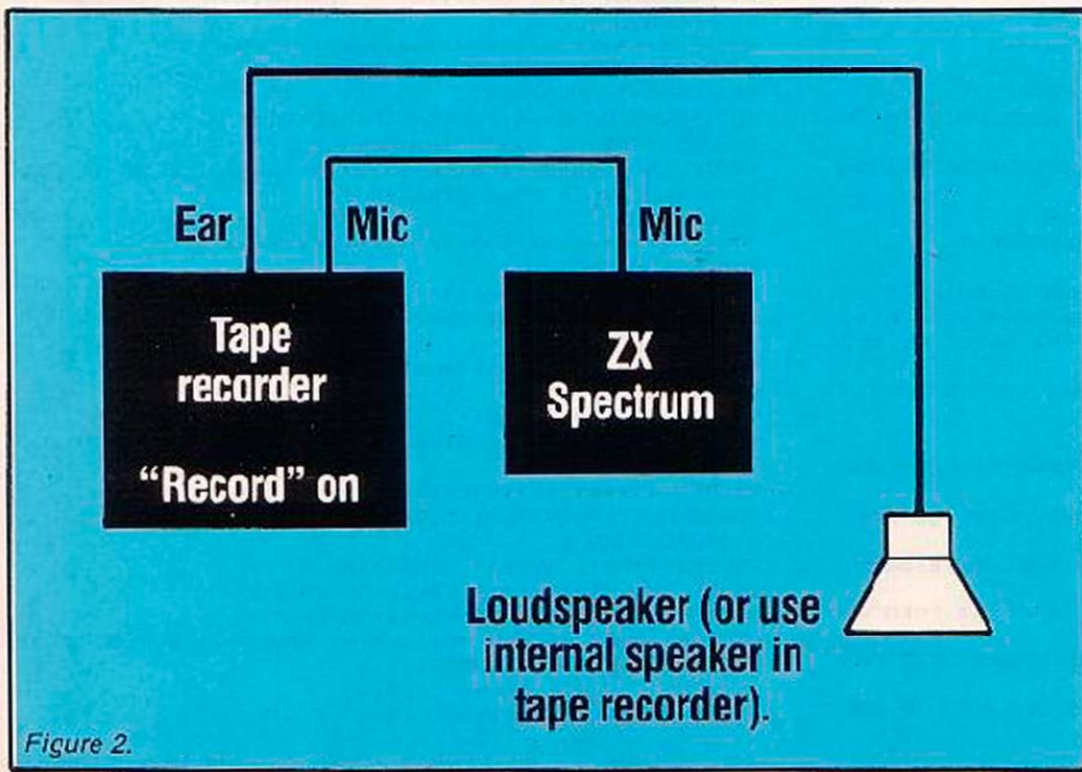

Figure 2.

```

520 IF IN 61438=255 THEN GO TO
520
530 LET A=USR 32000
535 PRINT AT 15,10;"SOUND RECEI
VED
"
540 PAUSE 0
550 GO TO 500
2000 LET E$=INKEY$
2005 IF E$="E" THEN GO TO 500
2010 IF E$="1" THEN POKE 32032,1
28: LET A=USR 32030: GO TO 2000
2011 IF E$="2" THEN POKE 32032,1
48: LET A=USR 32030: GO TO 2000
2012 IF E$="3" THEN POKE 32032,1
68: LET A=USR 32030: GO TO 2000
2013 IF E$="4" THEN POKE 32032,1
88: LET A=USR 32030: GO TO 2000
2014 IF E$="5" THEN POKE 32032,2
08: LET A=USR 32030: GO TO 2000
2015 IF E$="6" THEN POKE 32032,2
28: LET A=USR 32030
2030 GO TO 2000
3000 INPUT "BEATS ? ";B
3010 DIM G(B)
3020 FOR H=1 TO B
3021 IF INKEY$="R" THEN BEEP .2,
10: LET G(H)=10: GO TO 3025
    
```

(continued on next page)

SOFTWARE FILE

(continued from previous page)

```
3022 IF CODE INKEY$<49 OR CODE I
NKEY$>57 THEN GO TO 3021
3023 LET G(H)=(CODE INKEY$)-49
3024 POKE 32032,128+(20*G(H)): L
ET A=USR 32030
3025 NEXT H
3030 GO TO 500
4000 INPUT "SPEED ? ";S: POKE 32
050,S
4005 FOR H=1 TO B
4006 IF G(H)=10 THEN FOR D=1 TO
```

```
26+(PEEK 32050): NEXT D: GO TO 4
015
4010 POKE 32032,128+(20*G(H)): L
ET A=USR 32030
4015 IF INKEY$="E" THEN GO TO 50
0
4020 NEXT H
4030 GO TO 4005
5000 INPUT "OFF COLOUR ? ";O: IN
PUT "ON COLOUR ";N
5010 IF O<0 OR O>7 OR N<0 OR N>7
THEN GO TO 5000
5020 POKE 32044,O
```

```
5030 POKE 32061,16+N
5040 GO TO 500
6000 FOR G=32000 TO 32065
6010 READ D: POKE G,D: NEXT G
6020 RESTORE: RETURN
6030 DATA 33,0,128,6,20,197,6,0,
62,254,219,254,119,197,6,1,16,-2
,193,35,16,-14,193,16,-20,201,0,
0,0,0,33,0,128,6,20,197,6,0,62,1
91,190,40,17,62,7,211,254,35,197
,6,1,16,-2,193,16,-18,193,16,-24
,201,62,16,211,254,24,-19
```

Back beat

David Quinney,
Solihull,
West Midlands.



THIS PROGRAM, WITH a bit of skill, will produce a reasonable backing beat. A lot of the program could be cut down in length, but in its present state it is much easier to read and thus debug after entering.

The program is written in Mode 1 due to the size of the screen and has 16 steps each

which will produce four different beats simultaneously. The 16 steps can be decreased by altering the two stars at the edge of the screen. The main instructions are included in the program.

Program breakdown.

Lines 110-250 Main loop for entering beat
240-490 Instructions
500-580 Set up variables
590-810 Draw screen
820-980 Move cursor, update screen
990-1130 Play beat pattern

1140-1200 Speed
1210-1230 Move step pointer
1240-1410 Save beat pattern
1420-1580 Load beat pattern
1590-1660 Draws pattern after saving or loading
1670-1730 Clear beat pattern
1740-1750 Error routine

Variables.

A%,B% - co-ordinate of cursor
O% - step pointer
L% - speed
M%(3,15) - array for beat pattern
All £ should be read as #

```
10REM (C) D.A.QUINNEY 1984
20REM 'BEAT MACHINE'
30REM
40REM For all in listing type £
50*KEY100-D:MGOTO16E0:M
60MDE?
70PROCINST
80MDE:
90PROCSETJP
100PROCSCREEN
110PRINTTAB(A%,B%)>"TAB(A%+2,B%)<"
120*FX21,0
130 IF INKEY(-42)=-1 AND B%<23 C%=1:PROCMOVE
140 IF INKEY(-58)=-1 AND B%>8 C%=2:PROCMOVE
150 IF INKEY(-26)=-1 AND A%>9 C%=3:PROCMOVE
160 IF INKEY(-122)=-1 AND A%<33 C%=4:PROCMOVE
170 IF INKEY(-67)=-1 PROCBEAT
180 IF INKEY(-104)=-1 PROCBEAT
190 IF INKEY(-73)=-1 AND O%(B%-8) PROCSTAR
200 IF INKEY(02)=-1 CLS:PROCSAVE
210 IF INKEY(-87)=-1 CLS:PROCLoad
220 IF INKEY(-56)=-1 GOTO990
230GOTO110
240REM*****
250DEFPROCINST
260PRINTTAB(13)CHR#129"BEAT MACHINE"
270PRINTTAB(13)CHR#129" "
280PRINT "Do you want instructions?";G$=GET$:IF G$
="N" ENDPROC
290VDU28,0,23,59,2:CLS
300PRINT"These controls are used in"CHR#129"EDIT MOD
E :-"
310PRINT"CHR#129" 'X' "CHR#135" Make beat."
320PRINTCHR#129" '.' "CHR#135" -To clear."
330 PRINTCHR#129" 'S' "CHR#135" -SAVE DATA."
340PRINTCHR#129" 'L' "CHR#135" -LOAD DATA."
350PRINT"CHR#129" 'P' "CHR#135" -Put machine into"CH
R#131"PLAY MODE."
360PRINT"CHR#131" '*' "CHR#135" -Move"CHR#131"pointe
r"CHR#135"to CURSOR position"
370PRINTCHR#129" '>' '<' "CHR#135" -CURSOR."
380PRINTCHR#129"CURSOR Keys to move CURSOR."
390PRINT"CHR#131"POINTEK."
400PRINT" On either side of the screen there is a po
inter. Where ever the pointer is the machine will play
to this position and then return to the start of you
r beat pattern."
410PRINTTAB(6)CHR#136CHR#133"PRESS ANY KEY TO CONTIN
UE."
420G$=GET$:CLS
430PRINT"These controls are used in"CHR#131"PLAY MOD
E :-"
440PRINT"CHR#131" '>' '<' "CHR#135;" -Make beat go fast
er."
450PRINTCHR#131" '<' "CHR#135" -Make beat go slower."
460PRINT"CHR#129"ESCAPE"CHR#135"-Put machine into"CH
R#129"EDIT MODE."
470PRINT"CHR#129"BREAK will clear unwanted beat pat
tern."
480PRINTTAB(6,20)CHR#136CHR#133"PRESS ANY KEY TO CON
TINUE.":G$=GET$
490ENDPROC
```

```
500REM*****
510DEFPROCSETUP
520ON ERROR GOTO:750
530VDU23;B202;0;0;0;
540IM M%(3,15)
550L%=15:LX=1000:AZ=9:BZ=B
560ENVELOPE1,2,0,0,0,0,0,0,126,60,60,0,126,60
570ENVELOPE2,1,0,0,0,0,0,0,126,-10,0,-1,126,100
580ENDPROC
590REM*****
600DEFPROCSCREEN
610BZ=&5
620CLS
630COLOUR1
640PRINTTAB(13)"BEAT MACHINE"
650PRINTTAB(13)"-----"
660COLOUR3
670PRINT"Type 'X' for beat, '.' to clear,"
680PRINT" 'P' to play, 'ESCAPE' to stop beat,"
690PRINT"and '*' to return to start of beat."
700PRINT"Finally 'S' to SAVE and 'L' to LOAD"
710COLOUR1
720PRINT " Indic. BASS SNARE BLEEP TRIANGLE"
730FORR%=1TO16:PRINTR%:NEXT
740COLOUR3
750FORR%=8TO23:FORL%=10TO34STEP8:PRINTTAB(L%,R%)".":
NEXT,
760PRINTTAB(0,30)"CURSOR KEYS TO MOVE EDITOR"
770PRINTTAB(0,26)" '<' '=SLOWER, '>' '=FASTER."
780COLOUR1:PRINT" SPEED (0=Fastest)= 14"
790PRINTTAB(15,24)"EDIT MODE"
800COLOUR2:PRINTTAB(0,23)"*"TAB(36,23)"*":COLOUR3
810ENDPROC
820REM*****
830DEFPROCMOVE
840FORR%=1TO80:NEXT
850IFC%=3 OR C%=4 FORR%=:TO1000:NEXT
860PRINTTAB(A%,B%) "TAB(A%+2,B%) "
870IF C%=1 BZ=BZ-1 ELSE IF C%=2 BZ=BZ-1 ELSE IF C%=3
AZ=AZ-E ELSE IF C%=4 AZ=AZ+B
880ENDPROC
890REM*****
900DEFPROCBEAT
910PRINTTAB(A%+1,B%) "X"
920M%((A%-1)/8-1,B%-8)=1
930ENDPROC
940REM*****
950DEFPROCBEAT
960PRINTTAB(A%+1,B%) ". "
970M%((A%-1)/8-1,B%-8)=0
980ENDPROC
990REM*****PLAY*****
1000COLOUR2:PRINTTAB(15,24)"PLAY MODE"
1010FORR%=0TODX
1020PRINTTAB(1,R%-7)"TAB(1,R%+8)">"
1030IF INKEY(-104)=-1 LZ=LZ-50:PROCU?
1040IF INKEY(-103)=-1 LZ=LZ+50:PROCU?
1050IFM%(0,R%)=1 AND M%(1,R%)=1 SOUND0,1,5,2:GOTO1080
1060IFM%(0,R%)=1 SOUND0,1,6,2
1070IFM%(1,R%)=1 SOUND0,1,4,2
1080IFM%(2,R%)=1 SOUND1,-15,97,1
```

(continued on page 155)



Orders to:
Melbourne House Publishers
39 Milton Trading Estate
Abingdon, Oxon OX14 4TD

Correspondence to:
Church Yard
Tring
Hertfordshire HP23 5LU

All Melbourne House cassette software is
unconditionally guaranteed against malfunction.

Trade enquiries welcome.

Please send me your free catalogue.
Please send me:

COMMODORE 64

- Zim Sala Bim £9.95
- Commodore 64 The Hobbit £14.95
- Commodore 64 Hungry Horace £5.95
- Commodore 64 Horace Goes Skiing £5.95
- A.C.O.S. I £8.95
- Commodore 64 Classic Adventure £5.95
- Commodore 64 Star Trooper £5.95

SPECTRUM

- Spectrum Sherlock Holmes 48K £14.95
- Spectrum The Hobbit 48K £14.95
- Spectrum Peneator 48K £5.95
- Temr-Daktil 411 48K £6.95
- Melbourne Draw 48K £8.95
- H.U.R.G. 48K £14.95
- Abersoft Forth 48K £14.95
- Spectrum Classic Adventure 48K £5.95
- Spectrum Mugsy 48K £6.95

VIC 20

- VIC Cosmonauts £5.95
- The Wizard and the Princess £5.95

DRAGON 32

- Hungry Horace £5.95
- Horace Goes Skiing £5.95

BBC/ELECTRON

- BBC Model B The Hobbit £14.95
- BBC/Electron Classic Adventure £6.95

ORIC-1/ATMOS

- Oric-1/48K The Hobbit £14.95

All versions of 'The Hobbit' are identical with regard to the adventure program. Due to memory limitations, BBC cassette version does not include graphics.

Please add 80p for post & pack £ 80

TOTAL £

I enclose my cheque money order for £

Please debit my Access card No.

Expiry Date

Signature

Name

Address

Postcode YC9C

Access orders can be telephoned through on our 24-hour ansafone (0235) 83 5106.



DESERT STRETCHES OUT IN FRONT OF YOU.
I CAN SEE: NOTHING SPECIAL
YOU ARE OUTSIDE THE PALACE WALLS. THE
DESERT STRETCHES OUT IN FRONT OF YOU.
YOU ARE IN FRONT OF A LARGE GATE LEAD-
ING INTO THE PALACE.
I CAN SEE: NOTHING SPECIAL



YOU ARE HANGERING IN THE DESERT.
I CAN SEE: NOTHING SPECIAL
THERE IS A BRICK UP-WELL HERE AND THE
BRICKS CAN BEEN BLEN IN THE DISTANCE.
I CAN SEE: A BLOCK OF FLINT



YOU ARE IN THE ENTRANCE HALL OF THE
PALACE. THERE IS A PASSAGE LEADING TO A
CORRIDOR BEHIND YOU AND THE ENTRANCE
ON THE OTHER SIDE OF YOU.
I CAN SEE: NOTHING SPECIAL

Zim Sala Bim — a totally new adventure experience!

This program has it all:

- * Smooth, arcade-style graphics.
- * Every location brilliantly displayed in 3-dimensional graphics.
- * Murder, mystery and adventure in the malicious Sultan's kingdom.
- * Exciting challenging problems full of variety and intrigue.

Zim Sala Bim brings to the Commodore 64 a new thrilling experience — you move your character through the Arabian desert and hopefully the Sultan's seemingly impenetrable palace by using joystick or cursor controls. Every object and obstacle is immediately graphically illustrated, and you will need all your adventuring skills to overcome the Sultan's evil influence!

Draw your sword and prepare to meet your fate!

ZIM SALA BIM

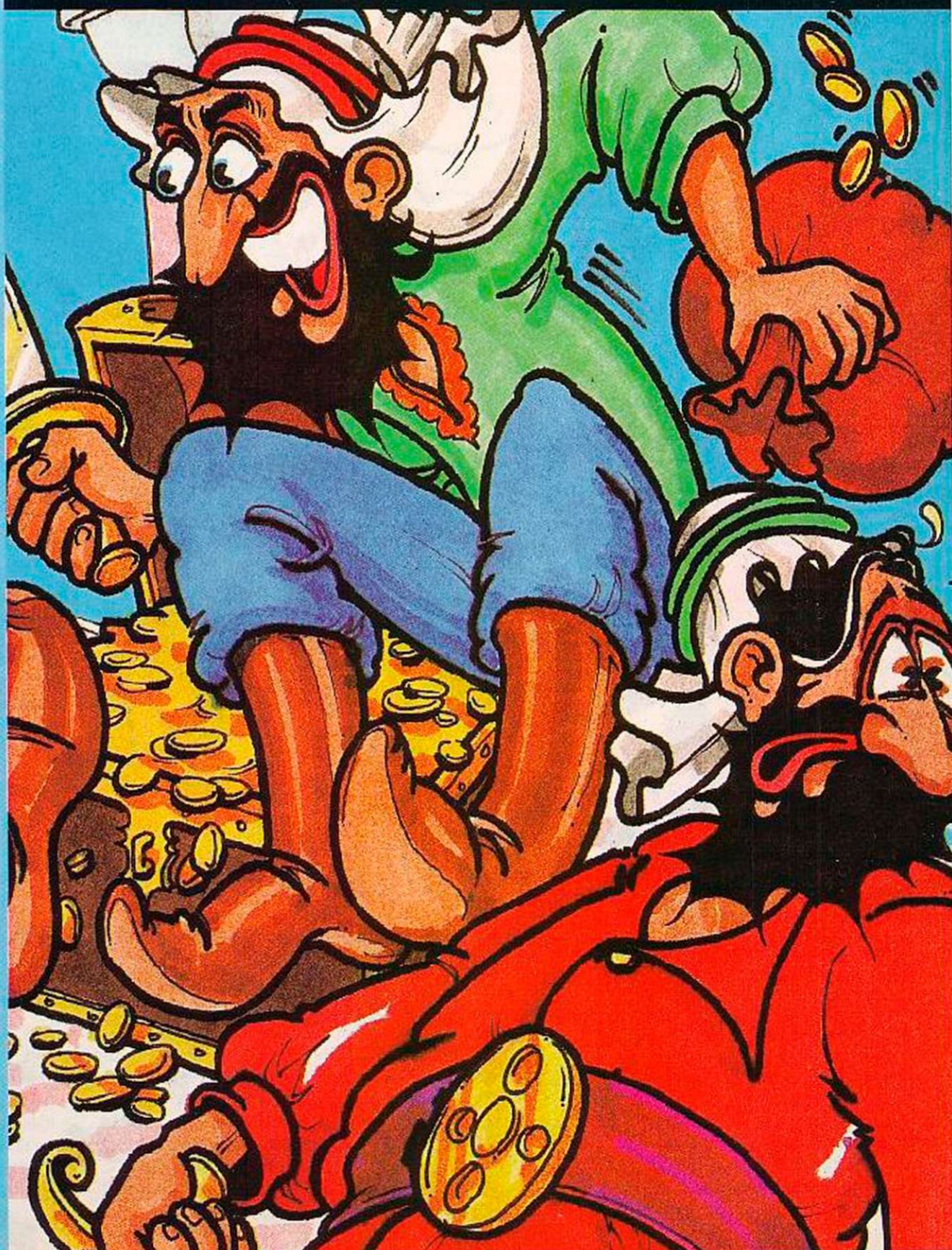

9 Out of 10 said they Argus

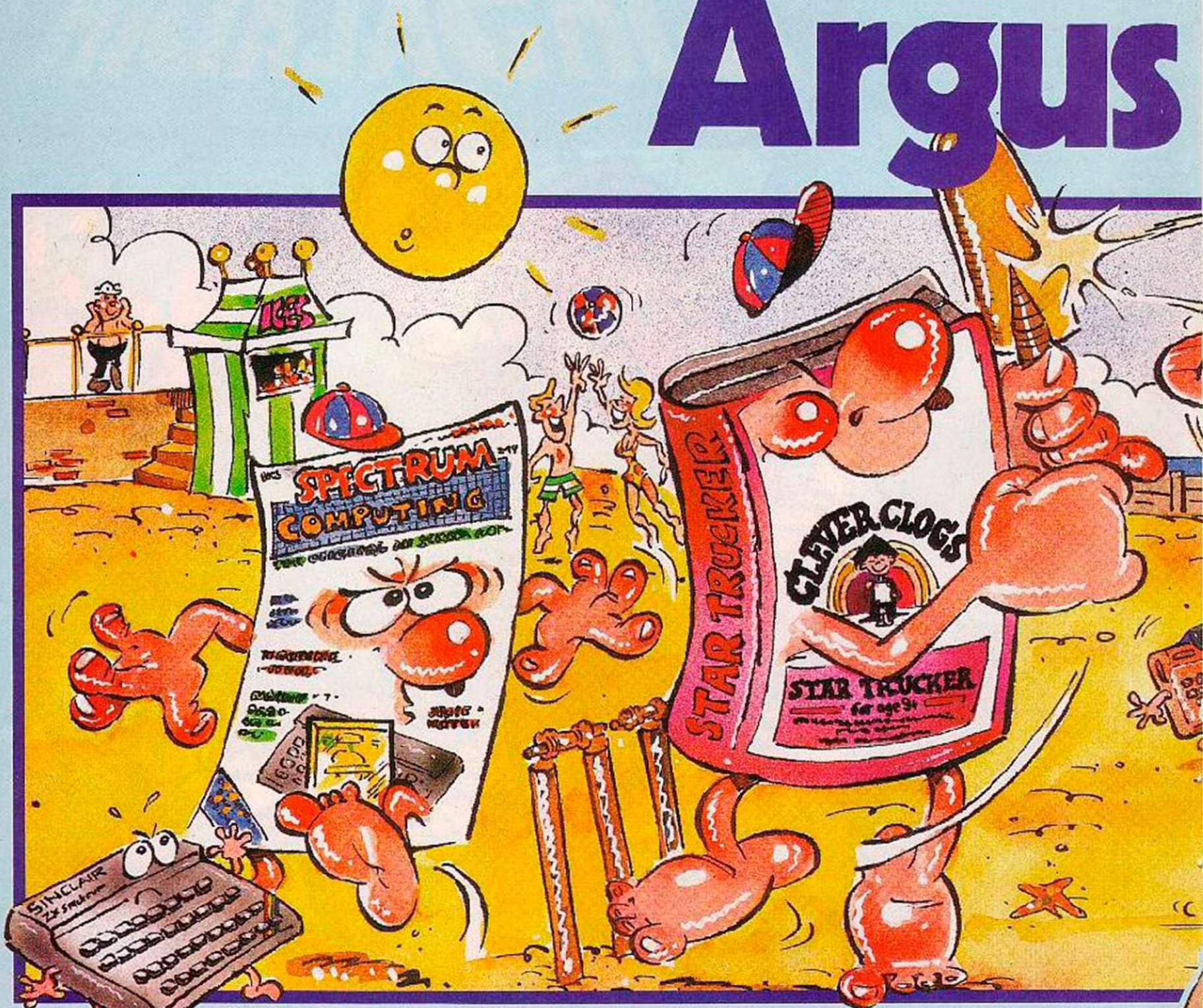

Tape Magazines

Great games, great utilities all for only £3.99. Available for Spectrum, Atari, Vic 20, BBC B, and CBM 64 through W.H. Smith, Menzies and computer stores.

Really use your computer this summer.

Clever Clogs

8 great fun games for whizzkids. Change the difficulty with data packs on Science, The Arts & General Knowledge.

On sale in W.H. Smith. Keep your Clever Clogs busy all summer long! Available for Spectrum at £6.95.

Mind Games:

Recently launched, the new name in quality strategy and adventure games. Top writers and programmers open the door to the world of imagination and fantasy.

Have an adventure this summer with Star Force Seven, Quest for Eternity, and

Orion Quest. Spectrum £7.99, BBC B, and CBM 64 £9.99.

Fall of Rome

Five million barbarians, an army or two of Persians, several thousand upset Armenians, fifty legions of itinerant Italians and you!

Have a holiday at home and save civilisation. Available for Atari, BBC B, Spectrum & Commodore 64.

No.1 Golden Square, London W1R 3AB

Computers* preferred Software



The House for Heroes!

The Game Lords join the Argus Press team. Consistently in the top ten with great games like Ant Attack, Boogaboo, Fred, Mined Out and Snowman. Prices from £4.95 to £7.95. Available from W.H. Smith, Boots and Menzies and leading Computer Stores worldwide.

*When asked to express a preference

The problems of looking after your Micro...



As well as providing the solution however do present more than a Like how do you prevent stop it from getting kicked divert the dog from



to many a problem. Micros few of their own. it gathering dust when not in use, when Mum's clearing the lounge, showing it's affect ons, or even ensure it at least "arrives" safely when Dad decides to take it down to the local. We at P.A.S. realising these needs, have now developed a range of three superbly made protective cases designed specifically for Micro's. Each case is constructed from Solid Resin Fibreboard has a fully protective foam lining a carrying handle in metal retaining strap, a double snap-fastening lid and a price that defies even Micro logic.

HCA
£21.45
INCL. VAT and P&P

HCI
£14.85
INCL. VAT and P&P

HCI2
£18.45
INCL. VAT and P&P

Prices apply to U.K. only.



PAS COMPUTER PRODUCTS LIMITED
UNIT 18, CENTRAL TRADING ESTATE,
STAINES, MIDDLESEX TW18 4UX.
Telephone: Staines (STD 0784) 62781

CASE HCI1 Takes Micro's - ZX81, ZX Spectrum, Oric 1, CGLM5. CASE HCI2 Takes Micro's - VIC20, BBC 'B', Commodore 64, Texas TV99, Oric 1, Dragon 32, Coour Gene, Sharp MZ00, Acorn Electron, Lynx, Tandem Colour, Atari 500XL, Acorn Atom. CASE HCA Can be adapted to take any of the above computers and various accessories such as Tape Recorder, printer, etc.

Please help, I am a long suffering Micro owner and wish to purchase case/s (tick appropriate box)

HCI1 HCI2 HCA

I enclose cheque/P.O. to the value of

NAME

ADDRESS

Please allow 21 days for delivery. Track orders only.

Computers for Export

Sinclair
Oric
Commodore
Atari
Texas
Epson
Coleco

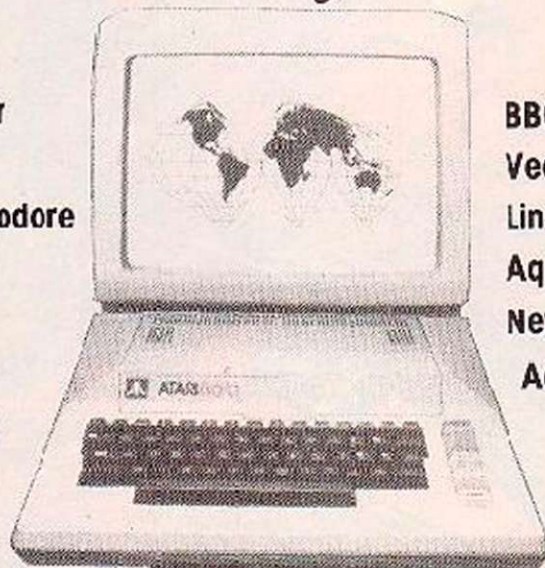

BBC
Vectrex
Linx
Aquarius
New Brain
Acom

Plus Printers, Disc Drives, Memory Expansion, Software
Quantity discounts available

No tax charge for equipment shipped abroad
Write for our price list or call our 24hr answer phone
01-686 6362

**Galaset Ltd, 30 Bayford Road,
Littlehampton, West Sussex,
England. Telex. 8954018 Acurat G**

ADAPTED FROM THE POPULAR T.V. SERIES!!!

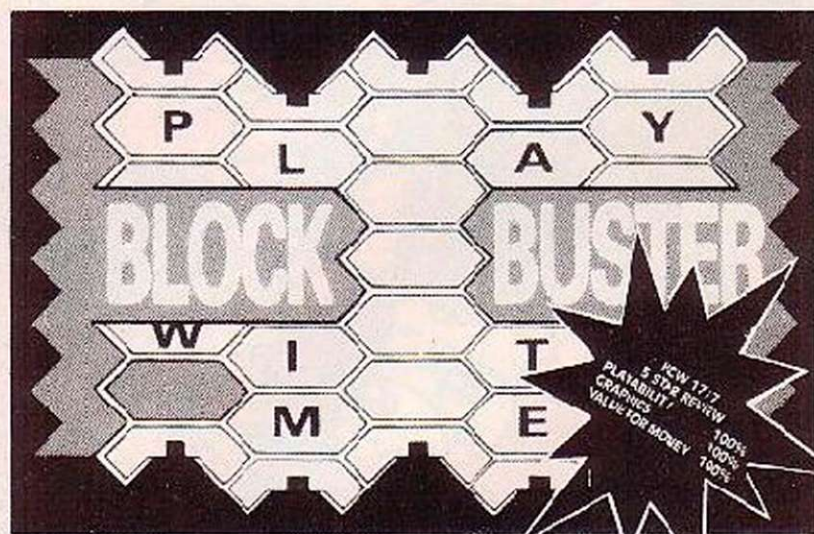

BLOCK-BUSTER is an exciting quiz game for ONE or TWO players and will appeal to a wide range of ages and skills with nine levels of play against the clock. The game tests speed of recall involving anticipation of the question as it 'unfolds' across the screen and speed of response dependant on the level of play.

BLOCK BUSTER is supplied with the FIRST ADDITIONAL QUESTION TAPE FREE to maintain the challenge of the game. Now available at good computer shops or direct with cheque/P.O. for £5.95 inclusive. ACCESS and VISA orders taken on our 24 Hour Hotline.

COMPUSOUND

DEPT HCW, 32-33 LANGLEY CLOSE, REDDITCH, WORCS B98 0ET
TELEPHONE (0527) 21429 (21439 24 Hr. HOTLINE)

SOFTWARE FILE

(continued from page 150)

```

1090IFM%(3,R%)=1 SOUNDS,2,245,1
1100FORE%-1TOL%:NEXT
1110NEXT
1120PRINTTAB(1,R%+7) " "
1130GOTO1010
1140REM*****
1150DEFPROCUP
1160COLOUR1
1170IFL%<300 LZ=300
1180PRINTTAB(18,27) "TAB(18,27)(LX/50)-6
1190COLOUR3
1200ENDPROC
1210REM*****
1220DEFPROCSTAR
1230PRINTTAB(0,0%+0) "TAB(36,0%+0) ":COLOUR2:PRINT
AB(0,B%) "TAB(36,B%)" *:COLOUR3:0%+8:ENDPROC
1240REM*****
1250DEFPROCSAVE
1260*FX200,1
1270COLOUR2
1280PRINTTAB(15) "SAVE MODE"
1290PRINTTAB(14) "-----"
1300PRINTTAB(5,10) "PLEASE PRESS ";
1310Z%=OPENOUT "BEAT"
1320PRINT "PLEASE WAIT"
1330 FORE%=0T03
1340FORR%=0T015
1350PRINTLZ%,M%(E%,R%)
1360NEXT,
1370CLOSELZ%
1380VDU7
1390PROCRAW
1400*FX200,0
1410ENDPROC
1420REM*****
1430DEFPROCLoad
1440*FX200,1

```

```

1450COLOUR2
1460PRINTTAB(15) "LOAD MODE"
1470PRINTTAB(14) "-----"
1480PRINTTAB(1,10) "Play tape and please wait for DATA
to load"
1490Z%=OPENIN "BEAT"
1500FORE%=0T03
1510FORR%=0T015
1520INPUTEZ%,M%(E%,R%)
1530NEXT,
1540CLOSELZ%
1550VDU7
1560PROCRAW
1570*FX200,0
1580ENDPROC
1590REM*****
1600DEFPROCRAW
1610PROCSCREEN
1620FORE%=0T03
1630FORR%=0T015
1640IFM%(E%,R%)=1 THEN PRINTTAB(E%*B+10,R%+8) "X"
1650NEXT,
1660ENDPROC
1670REM*****
1680NODE1
1690COLOUR1
1700PRINTTAB(15,15) "CLEARED"
1710PRINTTAB(14) "-----"
1720FORR%=1T05000:NEXT
1730GOTO90
1740REM*****
1750 IF ERR=17 PRINTTAB(1,R%+8) ":COLOUR1:PRINTTAB(1
5,24) "EDIT MODE":COLOUR3:GOTO110 ELSE MODE7:REPORT:PRI
NT" AT LINE ";ERL

```

Boggled

D Harris,
Great Barr,
Birmingham.

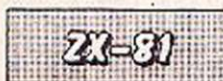

BOGGLED IS BASED on a popular table game and although exciting to play, a few problems become apparent after playing the game a few times.

One of the players has to shake the box containing the dice, remove the lid without looking at the dice in position and lastly start the timer. I then decided to program the game on my ZX-81 which would solve all these problems and also enable more than four people to take part with these added benefits:

- No shaking of dice — no noise.
- All players have equal advantage in seeing the playing grid one way up. Normally, four players would sit around a table and the board will appear different in each position. This results in some players finding some words and maybe higher scoring words, easier.
- The screen goes blank to end the game when the timer is finished. This stops the

players writing on after time if the timer has been missed finishing. Here is a breakdown of the program and what it does:

- | | |
|--------------------|--|
| Lines 30 to 190 | Minimum three-letter word game on a four by four grid. |
| Lines 380 to 536 | Letters as displayed on the grid. |
| Lines 700 to 732 | Timer. |
| Lines 734 to 744 | Attracts players' attention that the game is about to start. |
| Lines 750 to 860 | Timer countdown. |
| Lines 870 to 890 | Blank out screen to end game. |
| Lines 892 to 910 | Re-display grid with scoring details. |
| Lines 920 to 1140 | Introduction. |
| Lines 1150 to 3120 | Instructions and rules. |
| Lines 3125 to 3150 | Choice of grid size. |
| Lines 4000 to 4180 | Minimum four letter word game on a five by five grid. |

This program chooses a random letter from one "die" and then randomly places that letter on the grid. This is achieved by putting all the letters into one string and using the string slicing to remove one die at a time. The machine-code routine at the beginning of the

program is used to find an empty position on the grid in which to print the letter.

I would like to give credit to Alan Potter of Glasgow for this routine. It is much quicker than the
LET P = PEEK (PEEK 16398 + 256*PEEK 16399)
Basic line and reduces the time waiting for the grid to be set up.

Direct commands

When typing in the program line 1 is typed as:

```
1 REM E: RND ? TAN
```

or the line can contain seven characters and then entering as direct commands:

```

POKE 16514,42
POKE 16515,14
POKE 16516,64
POKE 16517,78
POKE 16518,6
POKE 16519,0
POKE 16520,201
POKE 16510,0

```

Line 1 now becomes 0 and the rest of the program can now be entered.

```

00000 REM E: RND ? TAN
00001 REM "BOGGLED" BY D.H.HARRIS
00002 MOY 1983
00003
00004
00005
00006
00007
00008
00009
00010
00011
00012
00013
00014
00015
00016
00017
00018
00019
00020
00021
00022
00023
00024
00025
00026
00027
00028
00029
00030
00031
00032
00033
00034
00035
00036
00037
00038
00039
00040
00041
00042
00043
00044
00045
00046
00047
00048
00049
00050
00051
00052
00053
00054
00055
00056
00057
00058
00059
00060
00061
00062
00063
00064
00065
00066
00067
00068
00069
00070
00071
00072
00073
00074
00075
00076
00077
00078
00079
00080
00081
00082
00083
00084
00085
00086
00087
00088
00089
00090
00091
00092
00093
00094
00095
00096
00097
00098
00099
00100
00101
00102
00103
00104
00105
00106
00107
00108
00109
00110
00111
00112
00113
00114
00115
00116
00117
00118
00119
00120
00121
00122
00123
00124
00125
00126
00127
00128
00129
00130
00131
00132
00133
00134
00135
00136
00137
00138
00139
00140
00141
00142
00143
00144
00145
00146
00147
00148
00149
00150
00151
00152
00153
00154
00155
00156
00157
00158
00159
00160
00161
00162
00163
00164
00165
00166
00167
00168
00169
00170
00171
00172
00173
00174
00175
00176
00177
00178
00179
00180
00181
00182
00183
00184
00185
00186
00187
00188
00189
00190
00191
00192
00193
00194
00195
00196
00197
00198
00199
00200
00201
00202
00203
00204
00205
00206
00207
00208
00209
00210
00211
00212
00213
00214
00215
00216
00217
00218
00219
00220
00221
00222
00223
00224
00225
00226
00227
00228
00229
00230
00231
00232
00233
00234
00235
00236
00237
00238
00239
00240
00241
00242
00243
00244
00245
00246
00247
00248
00249
00250
00251
00252
00253
00254
00255
00256
00257
00258
00259
00260
00261
00262
00263
00264
00265
00266
00267
00268
00269
00270
00271
00272
00273
00274
00275
00276
00277
00278
00279
00280
00281
00282
00283
00284
00285
00286
00287
00288
00289
00290
00291
00292
00293
00294
00295
00296
00297
00298
00299
00300
00301
00302
00303
00304
00305
00306
00307
00308
00309
00310
00311
00312
00313
00314
00315
00316
00317
00318
00319
00320
00321
00322
00323
00324
00325
00326
00327
00328
00329
00330
00331
00332
00333
00334
00335
00336
00337
00338
00339
00340
00341
00342
00343
00344
00345
00346
00347
00348
00349
00350
00351
00352
00353
00354
00355
00356
00357
00358
00359
00360
00361
00362
00363
00364
00365
00366
00367
00368
00369
00370
00371
00372
00373
00374
00375
00376
00377
00378
00379
00380
00381
00382
00383
00384
00385
00386
00387
00388
00389
00390
00391
00392
00393
00394
00395
00396
00397
00398
00399
00400
00401
00402
00403
00404
00405
00406
00407
00408
00409
00410
00411
00412
00413
00414
00415
00416
00417
00418
00419
00420
00421
00422
00423
00424
00425
00426
00427
00428
00429
00430
00431
00432
00433
00434
00435
00436
00437
00438
00439
00440
00441
00442
00443
00444
00445
00446
00447
00448
00449
00450
00451
00452
00453
00454
00455
00456
00457
00458
00459
00460
00461
00462
00463
00464
00465
00466
00467
00468
00469
00470
00471
00472
00473
00474
00475
00476
00477
00478
00479
00480
00481
00482
00483
00484
00485
00486
00487
00488
00489
00490
00491
00492
00493
00494
00495
00496
00497
00498
00499
00500
00501
00502
00503
00504
00505
00506
00507
00508
00509
00510
00511
00512
00513
00514
00515
00516
00517
00518
00519
00520
00521
00522
00523
00524
00525
00526
00527
00528
00529
00530
00531
00532
00533
00534
00535
00536
00537
00538
00539
00540
00541
00542
00543
00544
00545
00546
00547
00548
00549
00550
00551
00552
00553
00554
00555
00556
00557
00558
00559
00560
00561
00562
00563
00564
00565
00566
00567
00568
00569
00570
00571
00572
00573
00574
00575
00576
00577
00578
00579
00580
00581
00582
00583
00584
00585
00586
00587
00588
00589
00590
00591
00592
00593
00594
00595
00596
00597
00598
00599
00600
00601
00602
00603
00604
00605
00606
00607
00608
00609
00610
00611
00612
00613
00614
00615
00616
00617
00618
00619
00620
00621
00622
00623
00624
00625
00626
00627
00628
00629
00630
00631
00632
00633
00634
00635
00636
00637
00638
00639
00640
00641
00642
00643
00644
00645
00646
00647
00648
00649
00650
00651
00652
00653
00654
00655
00656
00657
00658
00659
00660
00661
00662
00663
00664
00665
00666
00667
00668
00669
00670
00671
00672
00673
00674
00675
00676
00677
00678
00679
00680
00681
00682
00683
00684
00685
00686
00687
00688
00689
00690
00691
00692
00693
00694
00695
00696
00697
00698
00699
00700
00701
00702
00703
00704
00705
00706
00707
00708
00709
00710
00711
00712
00713
00714
00715
00716
00717
00718
00719
00720
00721
00722
00723
00724
00725
00726
00727
00728
00729
00730
00731
00732
00733
00734
00735
00736
00737
00738
00739
00740
00741
00742
00743
00744
00745
00746
00747
00748
00749
00750
00751
00752
00753
00754
00755
00756
00757
00758
00759
00760
00761
00762
00763
00764
00765
00766
00767
00768
00769
00770
00771
00772
00773
00774
00775
00776
00777
00778
00779
00780
00781
00782
00783
00784
00785
00786
00787
00788
00789
00790
00791
00792
00793
00794
00795
00796
00797
00798
00799
00800
00801
00802
00803
00804
00805
00806
00807
00808
00809
00810
00811
00812
00813
00814
00815
00816
00817
00818
00819
00820
00821
00822
00823
00824
00825
00826
00827
00828
00829
00830
00831
00832
00833
00834
00835
00836
00837
00838
00839
00840
00841
00842
00843
00844
00845
00846
00847
00848
00849
00850
00851
00852
00853
00854
00855
00856
00857
00858
00859
00860
00861
00862
00863
00864
00865
00866
00867
00868
00869
00870
00871
00872
00873
00874
00875
00876
00877
00878
00879
00880
00881
00882
00883
00884
00885
00886
00887
00888
00889
00890
00891
00892
00893
00894
00895
00896
00897
00898
00899
00900
00901
00902
00903
00904
00905
00906
00907
00908
00909
00910
00911
00912
00913
00914
00915
00916
00917
00918
00919
00920
00921
00922
00923
00924
00925
00926
00927
00928
00929
00930
00931
00932
00933
00934
00935
00936
00937
00938
00939
00940
00941
00942
00943
00944
00945
00946
00947
00948
00949
00950
00951
00952
00953
00954
00955
00956
00957
00958
00959
00960
00961
00962
00963
00964
00965
00966
00967
00968
00969
00970
00971
00972
00973
00974
00975
00976
00977
00978
00979
00980
00981
00982
00983
00984
00985
00986
00987
00988
00989
00990
00991
00992
00993
00994
00995
00996
00997
00998
00999
01000
01001
01002
01003
01004
01005
01006
01007
01008
01009
01010
01011
01012
01013
01014
01015
01016
01017
01018
01019
01020
01021
01022
01023
01024
01025
01026
01027
01028
01029
01030
01031
01032
01033
01034
01035
01036
01037
01038
01039
01040
01041
01042
01043
01044
01045
01046
01047
01048
01049
01050
01051
01052
01053
01054
01055
01056
01057
01058
01059
01060
01061
01062
01063
01064
01065
01066
01067
01068
01069
01070
01071
01072
01073
01074
01075
01076
01077
01078
01079
01080
01081
01082
01083
01084
01085
01086
01087
01088
01089
01090
01091
01092
01093
01094
01095
01096
01097
01098
01099
01100
01101
01102
01103
01104
01105
01106
01107
01108
01109
01110
01111
01112
01113
01114
01115
01116
01117
01118
01119
01120
01121
01122
01123
01124
01125
01126
01127
01128
01129
01130
01131
01132
01133
01134
01135
01136
01137
01138
01139
01140
01141
01142
01143
01144
01145
01146
01147
01148
01149
01150
01151
01152
01153
01154
01155
01156
01157
01158
01159
01160
01161
01162
01163
01164
01165
01166
01167
01168
01169
01170
01171
01172
01173
01174
01175
01176
01177
01178
01179
01180
01181
01182
01183
01184
01185
01186
01187
01188
01189
01190
01191
01192
01193
01194
01195
01196
01197
01198
01199
01200
01201
01202
01203
01204
01205
01206
01207
01208
01209
01210
01211
01212
01213
01214
01215
01216
01217
01218
01219
01220
01221
01222
01223
01224
01225
01226
01227
01228
01229
01230
01231
01232
01233
01234
01235
01236
01237
01238
01239
01240
01241
01242
01243
01244
01245
01246
01247
01248
01249
01250
01251
01252
01253
01254
01255
01256
01257
01258
01259
01260
01261
01262
01263
01264
01265
01266
01267
01268
01269
01270
01271
01272
01273
01274
01275
01276
01277
01278
01279
01280
01281
01282
01283
01284
01285
01286
01287
01288
01289
01290
01291
01292
01293
01294
01295
01296
01297
01298
01299
01300
01301
01302
01303
01304
01305
01306
01307
01308
01309
01310
01311
01312
01313
01314
01315
01316
01317
01318
01319
01320
01321
01322
01323
01324
01325
01326
01327
01328
01329
01330
01331
01332
01333
01334
01335
01336
01337
01338
01339
01340
01341
01342
01343
01344
01345
01346
01347
01348
01349
01350
01351
01352
01353
01354
01355
01356
01357
01358
01359
01360
01361
01362
01363
01364
01365
01366
01367
01368
01369
01370
01371
01372
01373
01374
01375
01376
01377
01378
01379
01380
01381
01382
01383
01384
01385
01386
01387
01388
01389
01390
01391
01392
01393
01394
01395
01396
01397
01398
01399
01400
01401
01402
01403
01404
01405
01406
01407
01408
01409
01410
01411
01412
01413
01414
01415
01416
01417
01418
01419
01420
01421
01422
01423
01424
01425
01426
01427
01428
01429
01430
01431
01432
01433
01434
01435
01436
01437
01438
01439
01440
01441
01442
01443
01444
01445
01446
01447
01448
01449
01450
01451
01452
01453
01454
01455
01456
01457
01458
01459
01460
01461
01462
01463
01464
01465
01466
01467
01468
01469
01470
01471
01472
01473
01474
01475
01476
01477
01478
01479
01480
01481
01482
01483
01484
01485
01486
01487
01488
01489
01490
01491
01492
01493
01494
01495
01496
01497
01498
01499
01500
01501
01502
01503
01504
01505
01506
01507
01508
01509
01510
01511
01512
01513
01514
01515
01516
01517
01518
01519
01520
01521
01522
01523
01524
01525
01526
01527
01528
01529
01530
01531
01532
01533
01534
01535
01536
01537
01538
01539
01540
01541
01542
01543
01544
01545
01546
01547
01548
01549
01550
01551
01552
01553
01554
01555
01556
01557
01558
01559
01560
01561
01562
01563
01564
01565
01566
01567
01568
01569
01570
01571
01572
01573
01574
01575
01576
01577
01578
01579
01580
01581
01582
01583
01584
01585
01586
01587
01588
01589
01590
01591
01592
01593
01594
01595
01596
01597
01598
01599
01600
01601
01602
01603
01604
01605
01606
01607
01608
01609
01610
01611
01612
01613
01614
01615
01616
01617
01618
01619
01620
01621
01622
01623
01624
01625
01626
01627
0
```

SOFTWARE FILE

```

32 FORM=1:TO16:FORN=1:TO2:PUT(40,BMX)-(51,
BMX+16),BL,FSET:EXEC2500:PUT(40,BMX)-(5
1,BMX+16),DL,FSET
33 IF UP>=99 THEN BMX=BMX+UP:IF POINT(42,B
MX+16)=0 THEN UP=-99:TYPE=1
34 IF UP<=-99 THEN UP=UP+8:WHEEL=0
35 IF UP>16 THEN UP=16
36 ON TYPE GOSUB 55,60
37 IF RND(10)=5 AND N=1 AND TRAK=1 THEN
TRAK=2 ELSE IF RND(20)=5 AND N=1 THEN GOSUB
55
38 ON TRAK GOSUB 63,64,63
39 IF RND(40)=5 AND TRAK=1 THEN DRAW"BM2
53,"+STR$(HITE-1)+"EDU14"
40 IF RND(10)=5 AND TRAK=1 THEN DRAW"BM25:,"
+STR$(HITE-1)+"U2R02LD"
41 IF TRAK=1 AND RND(30)=5 THEN PUT(250,HITE-
18)-(254,HITE-1),DRNK,PSET
42 COPY2:TO6:PCOPY3:TO7
43 IF (PEEK(65280) AND 1) <> 1 AND UP=-99 THEN
EN UP=-16:TYPE=2
44 IF (JOYSTK(0)=0 OR JOYSTK(1)=63) AND WHEEL
=0 THEN WHEEL=5:TYPE=2
45 IF WHEEL>0 THEN WHEEL=WHEEL-1:IF WHEEL=0
THEN TYPE=1
46 IF BMX>100 THEN 65
47 IF (POINT(42,BMX+16)=5 AND UP=-99) OR (P
POINT(56,BMX+16)=5 AND TYPE=1) THEN UP=13:TY
PE=2
48 S=S+DRNK
49 READ A,B,C
50 PLAY"8000"+STR$(PL)+PL#+"0"+STR$(PL+1
)+PL#
51 NEXT N:IF TRAK=3 THEN TRAK=1
52 IF TRAK=2 THEN TRAK=3
53 NEXT M:RESTORE:IF DRNK>0 THEN LINE (DRNK*1

```

```

2+65,170)-(DRNK*10+69,177),PSET,BF:PCOPY
4:TO3:DRNK=DRNK-1
54 GOTO32
55 IF HITE=118 THEN HITE=02 ELSE HITE=1
18:RETURN
56 PUT(40,BMX)-(57,BMX+16),BMX,FSET
57 IF POINT(53,BMX+17)=0 THEN PLAY"01U31DU
22CV23CV19CV15CV11CV7CV3C":S=S+500:IF S<0
THENS=0
58 IF POINT(60,BMX+4)=0 THEN PLAY"U31D1C32
C03C04C05C01E02E03E4E05E01G02G03G04G05G
":S=S+2000:IF DRNK(10) THEN DRNK=DRNK+1:PJT
(DRNK*10+65,170)-(DRNK*10+69,177),DRNK,P
RESET:PCOPY4:TO8
59 RETURN
60 PUT(40,BMX)-(57,BMX+16),STNT,PSET
61 IF POINT(62,BMX+10)=0 THEN PLAY"01J31DU
22CV23CV15CV15CV11CV7CV3C":S=S+500:IF S<0
THENS=0
62 RETURN
63 DRAW"EM247,"+STR$(HITE)+TRAK*(N):RET
URN
64 DRAW"EM247,"+STR$(HITE)+TRAK*(N+2):R
ETURN
65 CLS:PLAY"U31":FOR Z=1 TO 6:FOR V=8 TO 1 STEP
-1:A$=STR$(U):PLAY"01:"+A$+"C2:"+A$+"03:
"+A$+"04:"+A$+"05:"+A$+"NE>TU,2
66 PRINT STRING$(38,"*"):G A M E O U
E R * :STRING$(38,"*")
67 S=S/100000:PRINT,," SCORE.....
.....":PRINT USING"###";S
68 DRNK=DRNK+100:PRINT,," DRINK....
.....":PRINT USING"##";DRNK
69 PRINT,," PRESS SPACE BAR TO PLAY AG
AIN."
70 SCREEN0,1

```

```

71 IF INKEY="" THEN 71
72 PLAY"01G02F03E04D05C"
73 RUN10
74 DATA 2,"U31C",2,"U0C",2,"U31G",2,"U0C
",2,"U31C",2,"U0C",1,"U31G",1,"U31AH"
75 DATA 2,U31C,2,U0C,2,U31G,2,U0C,2,U31C
,2,U0C,1,U31G,1,U31AH,2,U31C,2,U0C,2,U31
G,2,U0C,2,U31C,2,U0C,2,U31C,2,U31D#
76 DATA 2,U31F,2,U0C,3,U31C,3,U0C,2,U31F
,2,U0C,1,U31G,1,U31AH
77 RE1
78 RE1 =====
79 RE1 = A.J.HERBERT =
80 RE1 ===== AND =====
81 RE1 == J.P.DOWER ==
82 RE1 =====

```

Program 2.

```

10 CLEAR 200,26000
20 FOR N=26001 TO 26226
30 READ A$
40 POKE N,VAL("&H"+A$)
50 NEXT N
60 END
100 DATA 8E,0C,00,A5,01,A7,A0,AC,18,06
110 DATA 25,F2,8E,0C,00,B6,FE,A7,84,30
120 DATA 88,20,8C,18,1F,25,F6,39

```

Guess-Who-Man

AJ Hodgson,
Bury,
Lancashire.



FOR THOSE of you who were disappointed at being unable to load Hermann Hirsch's Vicman program in the January edition of *Your Computer* because you did not have the required memory, here is another program entitled Guess-Who-Man which will run comfortably on the unexpanded Vic-20, leaving enough space for a small but quite useful moritor.

You will probably be familiar with the basic idea of the game by now: you guide your man round a maze, gobbling up dots/power pills/oxygen tablets as you go while a number of particularly vicious ghosts/taxmen/monsters try to catch you. Normally the monsters are inedible but by eating an ambiguous diamond shaped object these monsters change colour and can then be eaten.

Features that my game includes are:

- Three melodies
- Four very intelligent ghosts
- On-screen scoring
- Highest score displayed
- 100 percent machine-code action

The code itself, including screen, graphics and tunes data occupies just over 2,700 bytes,

which leaves enough room for the simple monitor in figure 1. You do not have to use my monitor, but make sure that the one you use does not require any of the locations 4976-7679 inclusive. If you have the 3K expansion it will be possible to use a much longer, more sophisticated, and more user-friendly monitor.

If you want to use my monitor, then type it in exactly as shown, because it only just fits into the 880 bytes when variable storage space is included, and save it on tape. On running it you will be asked FI? Typing Y at this point will load any machine code that you have previously entered and saved on tape — it is advisable to use a separate cassette for the Guess-Who-Man program so that you know exactly where this code is saved — otherwise you may load the wrong program and will also waste time in positioning the cassette.

Typing anything except Y after FI? will take you to the prompt ST ADD? and at this point you should enter the decimal location at which you are going to start typing the code which is listed in figure 2: locations are in decimal, the code is in hexadecimal.

If you enter V after ST ADD? you will be able to view 15 bytes of code, the locations of the first byte being decided by your entry after the prompt WH?. If you entered SA after ST ADD the code will be saved on to tape with no name.

If you just entered a start address then you will be asked Co [Location]? after which should be entered the hexadecimal number for the relevant location, as listed in figure 2. You will be asked for 15 bytes of code before being asked for a start address again. Both V and SA can be entered after the code prompt and have exactly the same effect as previously.

When you have completed the task of typing in all the hex — and it is advisable to spread this job over a few days to minimise the risk of error — you should save it, just to be on the safe side. Now to test it enter:

POKE 36879,14:POKE 36878,15:SYS4973

You should now hear a version of Bach's *Tocatta and Fugue* in D Minor which should at least sound tuneful, and nothing else will happen. If you press F1, though, you should be taken into the game itself which you should play for a while so as to thoroughly test it — movement keys are Z for left, X for right, K for up, and M for down.

Now reset and new the Vic, and enter the presentation program listed in figure 3 and Save it, without rewinding the tape afterwards. Re-load the monitor, and run it, typing N when asked FI? and enter SA after ST ADD? Now it is possible to save the code immediately after the presentation program.

To run, load the presentation program and run it — this program will automatically load and run the machine code.

Figure 1.

```

1 POKE55,112:POKE56,19:POKE51,112:POKE52,19
10 INPUT"FI?":IF"Y"=INKEY THEN 20
11 POKE780,2:POKE781,1:POKE782,0:SYS65466:POKE780,0:POKE781,251:POKE782,252:SYS5
5469
12 POKE780,0:POKE781,0:POKE782,21:SYS55499:RUN
20 INPUT"ST ADD,":IF"0"=INKEY THEN 50
21 IF"V"=INKEY THEN 70
22 SEVAL(0):GOTO 30
23 INPUT"WH?":GOTO 40
24 IF"V"=INKEY THEN 50
25 IF"SA"=INKEY THEN 70
26 GOSUB100:POKE V:IF"0"=INKEY THEN 41:GOTO 30
40 GOTO 30
50 POKE780,1:POKE781,1:POKE782,1:SYS65466:POKE780,0:POKE781,251:POKE782,252:SYS
55469
60 POKE251,112:POKE252,19:POKE280,251:POKE281,255:POKE282,29:SYS65496:END
70 INPUT"FI?":FOR N=1 TO 4:GOTO 80
71 POKE N,VAL("&H"+INKEY)
72 POKE N,VAL("&H"+INKEY)
73 POKE N,VAL("&H"+INKEY)
74 POKE N,VAL("&H"+INKEY)
75 POKE N,VAL("&H"+INKEY)
76 POKE N,VAL("&H"+INKEY)
77 POKE N,VAL("&H"+INKEY)
78 POKE N,VAL("&H"+INKEY)
79 POKE N,VAL("&H"+INKEY)
80 POKE N,VAL("&H"+INKEY)
81 POKE N,VAL("&H"+INKEY)
82 POKE N,VAL("&H"+INKEY)
83 POKE N,VAL("&H"+INKEY)
84 POKE N,VAL("&H"+INKEY)
85 POKE N,VAL("&H"+INKEY)
86 POKE N,VAL("&H"+INKEY)
87 POKE N,VAL("&H"+INKEY)
88 POKE N,VAL("&H"+INKEY)
89 POKE N,VAL("&H"+INKEY)
90 POKE N,VAL("&H"+INKEY)
91 POKE N,VAL("&H"+INKEY)
92 POKE N,VAL("&H"+INKEY)
93 POKE N,VAL("&H"+INKEY)
94 POKE N,VAL("&H"+INKEY)
95 POKE N,VAL("&H"+INKEY)
96 POKE N,VAL("&H"+INKEY)
97 POKE N,VAL("&H"+INKEY)
98 POKE N,VAL("&H"+INKEY)
99 POKE N,VAL("&H"+INKEY)
100 POKE N,VAL("&H"+INKEY)
101 POKE N,VAL("&H"+INKEY)
102 POKE N,VAL("&H"+INKEY)
103 POKE N,VAL("&H"+INKEY)
104 POKE N,VAL("&H"+INKEY)
105 POKE N,VAL("&H"+INKEY)
106 POKE N,VAL("&H"+INKEY)
107 POKE N,VAL("&H"+INKEY)
108 POKE N,VAL("&H"+INKEY)
109 POKE N,VAL("&H"+INKEY)
110 POKE N,VAL("&H"+INKEY)
111 POKE N,VAL("&H"+INKEY)
112 POKE N,VAL("&H"+INKEY)
113 POKE N,VAL("&H"+INKEY)
114 POKE N,VAL("&H"+INKEY)
115 POKE N,VAL("&H"+INKEY)
116 POKE N,VAL("&H"+INKEY)
117 POKE N,VAL("&H"+INKEY)
118 POKE N,VAL("&H"+INKEY)
119 POKE N,VAL("&H"+INKEY)
120 POKE N,VAL("&H"+INKEY)
121 POKE N,VAL("&H"+INKEY)
122 POKE N,VAL("&H"+INKEY)
123 POKE N,VAL("&H"+INKEY)
124 POKE N,VAL("&H"+INKEY)
125 POKE N,VAL("&H"+INKEY)
126 POKE N,VAL("&H"+INKEY)
127 POKE N,VAL("&H"+INKEY)
128 POKE N,VAL("&H"+INKEY)
129 POKE N,VAL("&H"+INKEY)
130 POKE N,VAL("&H"+INKEY)
131 POKE N,VAL("&H"+INKEY)
132 POKE N,VAL("&H"+INKEY)
133 POKE N,VAL("&H"+INKEY)
134 POKE N,VAL("&H"+INKEY)
135 POKE N,VAL("&H"+INKEY)
136 POKE N,VAL("&H"+INKEY)
137 POKE N,VAL("&H"+INKEY)
138 POKE N,VAL("&H"+INKEY)
139 POKE N,VAL("&H"+INKEY)
140 POKE N,VAL("&H"+INKEY)
141 POKE N,VAL("&H"+INKEY)
142 POKE N,VAL("&H"+INKEY)
143 POKE N,VAL("&H"+INKEY)
144 POKE N,VAL("&H"+INKEY)
145 POKE N,VAL("&H"+INKEY)
146 POKE N,VAL("&H"+INKEY)
147 POKE N,VAL("&H"+INKEY)
148 POKE N,VAL("&H"+INKEY)
149 POKE N,VAL("&H"+INKEY)
150 POKE N,VAL("&H"+INKEY)
151 POKE N,VAL("&H"+INKEY)
152 POKE N,VAL("&H"+INKEY)
153 POKE N,VAL("&H"+INKEY)
154 POKE N,VAL("&H"+INKEY)
155 POKE N,VAL("&H"+INKEY)
156 POKE N,VAL("&H"+INKEY)
157 POKE N,VAL("&H"+INKEY)
158 POKE N,VAL("&H"+INKEY)
159 POKE N,VAL("&H"+INKEY)
160 POKE N,VAL("&H"+INKEY)
161 POKE N,VAL("&H"+INKEY)
162 POKE N,VAL("&H"+INKEY)
163 POKE N,VAL("&H"+INKEY)
164 POKE N,VAL("&H"+INKEY)
165 POKE N,VAL("&H"+INKEY)
166 POKE N,VAL("&H"+INKEY)
167 POKE N,VAL("&H"+INKEY)
168 POKE N,VAL("&H"+INKEY)
169 POKE N,VAL("&H"+INKEY)
170 POKE N,VAL("&H"+INKEY)
171 POKE N,VAL("&H"+INKEY)
172 POKE N,VAL("&H"+INKEY)
173 POKE N,VAL("&H"+INKEY)
174 POKE N,VAL("&H"+INKEY)
175 POKE N,VAL("&H"+INKEY)
176 POKE N,VAL("&H"+INKEY)
177 POKE N,VAL("&H"+INKEY)
178 POKE N,VAL("&H"+INKEY)
179 POKE N,VAL("&H"+INKEY)
180 POKE N,VAL("&H"+INKEY)
181 POKE N,VAL("&H"+INKEY)
182 POKE N,VAL("&H"+INKEY)
183 POKE N,VAL("&H"+INKEY)
184 POKE N,VAL("&H"+INKEY)
185 POKE N,VAL("&H"+INKEY)
186 POKE N,VAL("&H"+INKEY)
187 POKE N,VAL("&H"+INKEY)
188 POKE N,VAL("&H"+INKEY)
189 POKE N,VAL("&H"+INKEY)
190 POKE N,VAL("&H"+INKEY)
191 POKE N,VAL("&H"+INKEY)
192 POKE N,VAL("&H"+INKEY)
193 POKE N,VAL("&H"+INKEY)
194 POKE N,VAL("&H"+INKEY)
195 POKE N,VAL("&H"+INKEY)
196 POKE N,VAL("&H"+INKEY)
197 POKE N,VAL("&H"+INKEY)
198 POKE N,VAL("&H"+INKEY)
199 POKE N,VAL("&H"+INKEY)
200 POKE N,VAL("&H"+INKEY)

```

Figure 2.

```

1 POKE36879,14:POKE36878,15:PRINT"FI?":GUESS-WHO-MAN
5 PRINT" GUESS-WHO-MAN IS A NAME OF THE VIC-20/4000 GENRE."
10 PRINT"USE THESE KEYS:"
15 PRINT"Z LEFT X RIGHT K UP M DOWN"
20 PRINT"MONSTERS SCORE 4200"
25 PRINT"DOTS SCORE 410"
30 PRINT"FRUIT SCORES RANDOMLY"
35 PRINT"*****HIT A KEY"
40 POKE100,0:GOTO 100
45 PRINT"*****ALLAN HODGSON 1984"
50 PRINT"END"
111 POKE780,2:POKE781,1:POKE782,0:SYS65466:POKE780,0:POKE781,251:POKE782,252:SYS
55469
112 POKE780,0:POKE781,0:POKE782,21:SYS55499
115 PRINT" HIT F1 TO START."
120 SYS4973

```

(continued on page 159)

The Best in Books and Software for the BBC Micro from WILEY

ADVENTURE INTO BBC BASIC

by Miles Ellis and David Ellis

A book with a difference! This is far more than a conventional teach yourself programming book. By using a sophisticated and exciting adventure game Miles Ellis, with the aid of his twelve-year-old son, has designed a program which will be enjoyable from the outset as well as teaching the beginner the basic principles of good programming style, the use of sound effects, colour, graphics, program editing, and the storage and reloading of tapes.

An accompanying cassette tape and disc of the Adventure Game are also available for the BBC Microcomputer Model B

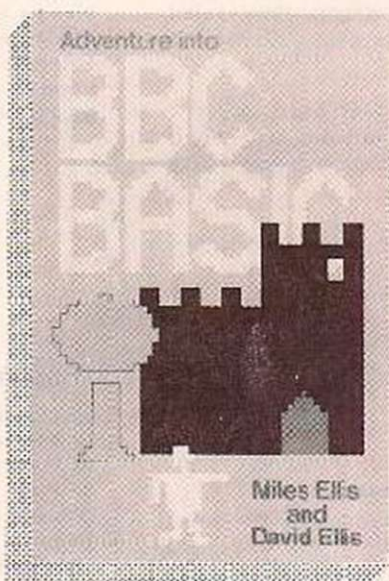

Book
0 47190171 7 £6.95
Book and Cassette
0 47190531 3 £12.95
Book and Disc
0 47190530 5 £14.95

AVIATOR for the BBC

Microcomputer Model B

The flight simulator puts you in the pilot's seat of a Spitfire Mark II single seater fighter. You can make it fly just like the real thing — taking off, turning, climbing and landing. In fact, you can do virtually all the things that the real aircraft can — loop the loop, rolling and any aerobatics you wish to attempt.

Incorporated in Aviator is a three-dimensional world ready for you to explore (map provided). Your score is based on successful landings and tests of skill such as flying between skyscrapers or under bridges.

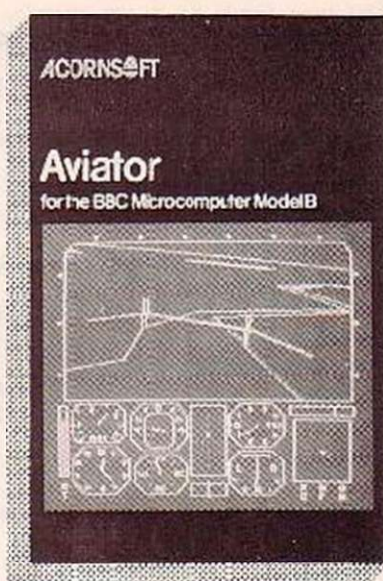

Cassette
0 40500029 4 £14.95
Disc
0 40500187 8 £17.65
Published by Acornsoft Ltd. and marketed by John Wiley & Sons Ltd.

MICROTEXT for the BBC Microcomputer

Developed by the National Physical Laboratory

Microtext is a programming package designed to simplify the production of a wide range of man/computer dialogues. Using Microtext's simple commands the user can draw up any number of 'frames', each containing text and/or graphics. A series of frames builds up to a complete module, whose maximum size depends on available memory. Using Microtext, experts in any field can construct their own complete courses of computer-based instruction material. Applications include interviewing systems, teaching packages, training courses and interactive demonstrations and simulations.

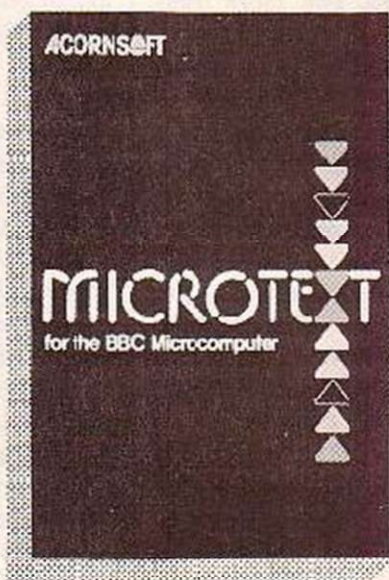

Book/Cassette
0 40500365 0 £49.85
Published by Acornsoft Ltd. and marketed by John Wiley & Sons Ltd.

CREATIVE GRAPHICS on the BBC Microcomputer

by John Cowrie

This book describes how to exploit the excellent graphics facilities provided by the BBC Microcomputer. Starting with first principles the book proceeds to explore more advanced routines, explaining in detail the individual procedures that go to make up whole programs.

There are listings for 36 programs which will run on either the A or B Model to produce a dazzling range of pictures and patterns in full colour, including animated pictures, recursively-defined curves, and rotating three-dimensional shapes.

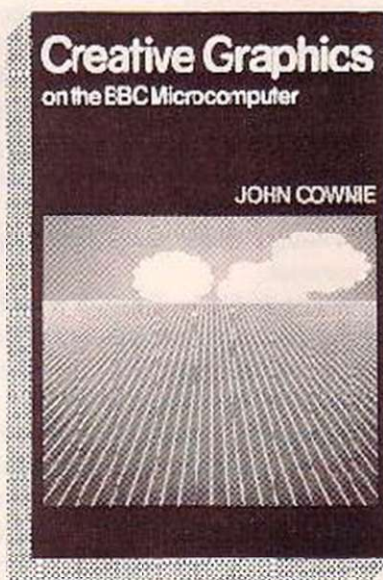

A complete cassette of the programs described in the book is also available.
Book
0 907876 03 X £1.50
Cassette
0 405001 73 8 £9.95
Published by Acornsoft Ltd. and marketed by John Wiley & Sons Ltd.



John Wiley & Sons Ltd., Baffins Lane, Chichester, Sussex PO19 1UD



These four outstanding titles have been selected for the Book Marketing Council's *Mastering the Micro* promotion taking place in bookshops throughout the UK during September 1984.

Together with the wide range of computer books and software marketed by Wiley (for all popular micros) they can be obtained through your usual bookseller.

SOFTWARE FILE

(continued from page 157)

Figure 2.

| | | | | | | | | | | | | | | | | | | | | | | | | | | | | | | | | | | | | | | | | | | | | | | | | | | | | | | | | | | | |
|------|----|----|----|----|----|----|----|----|----|----|----|----|----|----|----|----|----|------|----|----|----|----|----|----|----|----|----|----|----|----|----|----|----|----|----|----|----|----|----|----|---|---|---|---|---|---|---|---|---|---|---|---|---|---|---|---|---|---|---|
| 4990 | 1F | 20 | 0C | 19 | A2 | 07 | 20 | 75 | 1A | 09 | 05 | 05 | 08 | 14 | 20 | 12 | 13 | 6320 | 95 | FB | C9 | DF | D0 | 17 | A5 | FC | C9 | 1E | 70 | 0 | FB | 20 | 7E | 18 | D0 | E2 | 60 | F9 | DC | 36 | | | | | | | | | | | | | | | | | | | |
| 4995 | FF | 8D | 6C | 03 | A9 | 50 | 03 | 6D | 03 | A9 | 50 | 03 | 6D | 03 | A9 | 50 | 03 | 6330 | 00 | 11 | A9 | 01 | 9D | 38 | 03 | A9 | 04 | 9D | 70 | 20 | ED | 6F | 03 | F0 | 0C | AA | A9 | 20 | 9D | F2 | | | | | | | | | | | | | | | | | | | |
| 5000 | 84 | 8D | 70 | 03 | A9 | IC | 03 | 6F | 03 | A9 | 50 | 03 | 6D | 03 | A9 | 50 | 03 | 6340 | 37 | 03 | 9D | 38 | 03 | A9 | 00 | 85 | 01 | A0 | 70 | 0 | 0 | 0 | 0 | 0 | 0 | 0 | 0 | 0 | 0 | 0 | 0 | 0 | | | | | | | | | | | | | | | | | |
| 5010 | CI | 8D | 6E | 03 | A9 | 10 | 03 | 71 | 03 | A9 | 50 | 03 | 6D | 03 | A9 | 50 | 03 | 6350 | M1 | 4Y | V1 | 98 | 38 | 03 | A9 | FK | 9D | 3D | 70 | 0 | 0 | 0 | 0 | 0 | 0 | 0 | 0 | 0 | 0 | 0 | 0 | 0 | | | | | | | | | | | | | | | | | |
| 5020 | 1F | 20 | 72 | 03 | A9 | 3C | 03 | 6F | 03 | A9 | 50 | 03 | 6D | 03 | A9 | 50 | 03 | 6360 | 03 | A5 | FC | 9D | 36 | 03 | A9 | ED | 38 | 03 | 70 | 0 | 0 | 0 | 0 | 0 | 0 | 0 | 0 | 0 | 0 | 0 | 0 | 0 | | | | | | | | | | | | | | | | | |
| 5030 | 0E | 8D | 69 | 03 | A9 | 21 | 03 | 69 | 03 | A9 | 50 | 03 | 6D | 03 | A9 | 50 | 03 | 6370 | FE | 20 | F1 | 1A | 37 | 03 | A9 | F1 | FB | A5 | 70 | 0 | 0 | 0 | 0 | 0 | 0 | 0 | 0 | 0 | 0 | 0 | 0 | 0 | | | | | | | | | | | | | | | | | |
| 5040 | 1E | 2D | 36 | 03 | A9 | 19 | 03 | 69 | 03 | A9 | 50 | 03 | 6D | 03 | A9 | 50 | 03 | 6380 | 00 | 20 | 7E | 13 | F2 | 0A | 86 | 00 | A9 | 00 | 70 | 0 | 0 | 0 | 0 | 0 | 0 | 0 | 0 | 0 | 0 | 0 | 0 | 0 | 0 | | | | | | | | | | | | | | | | |
| 5050 | 26 | 07 | 2D | 3A | 22 | F9 | 20 | 91 | 20 | 03 | A9 | 50 | 03 | 6D | 03 | A9 | 50 | 6390 | 8D | 00 | 00 | 10 | 00 | 17 | AD | 00 | 02 | 05 | 70 | 0 | 0 | 0 | 0 | 0 | 0 | 0 | 0 | 0 | 0 | 0 | 0 | 0 | | | | | | | | | | | | | | | | | |
| 5060 | A9 | 01 | 2D | 33 | 20 | 71 | 1E | D0 | E1 | | | | | | | | | 6400 | FB | AD | 6D | 03 | 05 | FC | 20 | AD | 1B | 4C | 70 | 0 | 0 | 0 | 0 | 0 | 0 | 0 | 0 | 0 | 0 | 0 | 0 | 0 | | | | | | | | | | | | | | | | | |
| 5070 | A9 | 88 | 8D | 3C | 23 | F9 | 19 | 81 | 40 | 03 | | | | | | | | 6410 | 60 | 16 | F2 | 64 | A5 | 3C | 05 | FC | 3D | 10 | 71 | 0 | 0 | 0 | 0 | 0 | 0 | 0 | 0 | 0 | 0 | 0 | 0 | 0 | 0 | | | | | | | | | | | | | | | | |
| 5080 | A9 | 01 | 8D | 41 | 33 | F2 | D0 | 38 | 43 | 03 | | | | | | | | 6420 | 19 | 8D | 03 | 90 | AC | C5 | C9 | 27 | 30 | 06 | 71 | 0 | 0 | 0 | 0 | 0 | 0 | 0 | 0 | 0 | 0 | 0 | 0 | 0 | 0 | 0 | | | | | | | | | | | | | | | |
| 5090 | E8 | 8E | 4A | 03 | E8 | 8E | 51 | 03 | A9 | 93 | | | | | | | | 6430 | A9 | 00 | 0D | 03 | 96 | 60 | E0 | 49 | 30 | 12 | 71 | 0 | 0 | 0 | 0 | 0 | 0 | 0 | 0 | 0 | 0 | 0 | 0 | 0 | 0 | 0 | 0 | | | | | | | | | | | | | | |
| 5100 | 20 | D2 | FF | 20 | EE | 12 | A2 | 00 | 0E | 00 | | | | | | | | 6440 | A9 | 1E | 05 | FC | 15 | 18 | 20 | AD | 1B | F9 | 71 | 0 | 0 | 0 | 0 | 0 | 0 | 0 | 0 | 0 | 0 | 0 | 0 | 0 | 0 | 0 | 0 | 0 | 0 | | | | | | | | | | | | |
| 5110 | 1E | E8 | 8E | 01 | 1E | E8 | 02 | 1E | E8 | | | | | | | | | 6450 | 3C | 85 | FC | 4C | 31 | 19 | 18 | 20 | AD | F9 | 71 | 0 | 0 | 0 | 0 | 0 | 0 | 0 | 0 | 0 | 0 | 0 | 0 | 0 | 0 | 0 | 0 | 0 | 0 | | | | | | | | | | | | |
| 5120 | 8E | 0D | 1E | E8 | 0E | 12 | A9 | 16 | 05 | | | | | | | | | 6460 | 1E | CA | D0 | CE | 4C | 0C | 19 | A2 | 23 | F9 | 71 | 0 | 0 | 0 | 0 | 0 | 0 | 0 | 0 | 0 | 0 | 0 | 0 | 0 | 0 | 0 | 0 | 0 | 0 | 0 | | | | | | | | | | | |
| 5130 | F3 | A9 | 1E | 05 | FC | A9 | 37 | 85 | FD | 1F | | | | | | | | 6470 | 28 | 85 | FC | 8D | 33 | 1A | 00 | 08 | 30 | 20 | 71 | 0 | 0 | 0 | 0 | 0 | 0 | 0 | 0 | 0 | 0 | 0 | 0 | 0 | 0 | 0 | 0 | 0 | 0 | 0 | | | | | | | | | | | |
| 5140 | H3 | 14 | 03 | FE | H0 | 00 | 01 | H0 | C9 | FF | | | | | | | | 6480 | AD | 1B | CA | D0 | FE | A2 | 03 | A9 | 31 | 20 | 71 | 0 | 0 | 0 | 0 | 0 | 0 | 0 | 0 | 0 | 0 | 0 | 0 | 0 | 0 | 0 | 0 | 0 | 0 | 0 | 0 | 0 | | | | | | | | | |
| 5150 | D0 | 03 | 4C | 1D | 16 | 91 | FB | 20 | ED | 1B | | | | | | | | 6490 | 85 | 1A | AD | 63 | 03 | 38 | E3 | 04 | 3D | 0D | 71 | 0 | 0 | 0 | 0 | 0 | 0 | 0 | 0 | 0 | 0 | 0 | 0 | 0 | 0 | 0 | 0 | 0 | 0 | 0 | 0 | 0 | | | | | | | | | |
| 5160 | H5 | FD | 18 | 69 | 01 | 85 | FD | A5 | FE | 69 | | | | | | | | 6500 | 03 | 4C | 91 | 13 | A2 | 18 | 00 | 57 | 1A | 65 | 71 | 0 | 0 | 0 | 0 | 0 | 0 | 0 | 0 | 0 | 0 | 0 | 0 | 0 | 0 | 0 | 0 | 0 | 0 | 0 | 0 | 0 | | | | | | | | | |
| 5170 | 00 | 85 | FE | D0 | E3 | 20 | 0F | 13 | 13 | 13 | | | | | | | | 6510 | FC | 20 | C2 | 19 | 03 | 00 | 00 | 3D | 7D | 1F | 72 | 0 | 0 | 0 | 0 | 0 | 0 | 0 | 0 | 0 | 0 | 0 | 0 | 0 | 0 | 0 | 0 | 0 | 0 | 0 | 0 | 0 | 0 | | | | | | | | |
| 5180 | 13 | 13 | 13 | 13 | 13 | 13 | 13 | 13 | 13 | 13 | | | | | | | | 6520 | CA | 30 | 0F | 38 | H0 | 70 | 00 | 09 | 4C | 00 | 72 | 0 | 0 | 0 | 0 | 0 | 0 | 0 | 0 | 0 | 0 | 0 | 0 | 0 | 0 | 0 | 0 | 0 | 0 | 0 | 0 | 0 | 0 | 0 | 0 | | | | | | |
| 5190 | 13 | 13 | 13 | 13 | 13 | 13 | 13 | 13 | 13 | 13 | | | | | | | | 6530 | 70 | 03 | F0 | 03 | 4C | 51 | 13 | R2 | 30 | 0D | 72 | 0 | 0 | 0 | 0 | 0 | 0 | 0 | 0 | 0 | 0 | 0 | 0 | 0 | 0 | 0 | 0 | 0 | 0 | 0 | 0 | 0 | 0 | 0 | 0 | | | | | | |
| 5200 | 06 | 06 | 06 | 06 | 06 | 06 | 06 | 06 | 06 | 06 | | | | | | | | 6540 | 50 | 03 | D0 | 61 | 03 | 00 | 00 | DD | 51 | 03 | 72 | 0 | 0 | 0 | 0 | 0 | 0 | 0 | 0 | 0 | 0 | 0 | 0 | 0 | 0 | 0 | 0 | 0 | 0 | 0 | 0 | 0 | 0 | 0 | 0 | 0 | | | | | |
| 5210 | 06 | 06 | 06 | 06 | 06 | 06 | 06 | 06 | 06 | 06 | | | | | | | | 6550 | 00 | 00 | 00 | 00 | 00 | 00 | 00 | 00 | 00 | 00 | 72 | 0 | 0 | 0 | 0 | 0 | 0 | 0 | 0 | 0 | 0 | 0 | 0 | 0 | 0 | 0 | 0 | 0 | 0 | 0 | 0 | 0 | 0 | 0 | 0 | 0 | 0 | 0 | | | |
| 5220 | 14 | 06 | 0F | 13 | 13 | 13 | 13 | 13 | 13 | 13 | | | | | | | | 6560 | 00 | 00 | 00 | 00 | 00 | 00 | 00 | 00 | 00 | 00 | 73 | 0 | 0 | 0 | 0 | 0 | 0 | 0 | 0 | 0 | 0 | 0 | 0 | 0 | 0 | 0 | 0 | 0 | 0 | 0 | 0 | 0 | 0 | 0 | 0 | 0 | 0 | 0 | | | |
| 5230 | 06 | 13 | 13 | 13 | 13 | 13 | 13 | 13 | 13 | 13 | | | | | | | | 6570 | 00 | 00 | 00 | 00 | 00 | 00 | 00 | 00 | 00 | 00 | 74 | 0 | 0 | 0 | 0 | 0 | 0 | 0 | 0 | 0 | 0 | 0 | 0 | 0 | 0 | 0 | 0 | 0 | 0 | 0 | 0 | 0 | 0 | 0 | 0 | 0 | 0 | 0 | | | |
| 5240 | 14 | 20 | 14 | 06 | 14 | 20 | 14 | 06 | 14 | 06 | | | | | | | | 6580 | 00 | 00 | 00 | 00 | 00 | 00 | 00 | 00 | 00 | 00 | 75 | 0 | 0 | 0 | 0 | 0 | 0 | 0 | 0 | 0 | 0 | 0 | 0 | 0 | 0 | 0 | 0 | 0 | 0 | 0 | 0 | 0 | 0 | 0 | 0 | 0 | 0 | 0 | | | |
| 5250 | 06 | 06 | 06 | 06 | 06 | 06 | 06 | 06 | 06 | 06 | | | | | | | | 6590 | 00 | 00 | 00 | 00 | 00 | 00 | 00 | 00 | 00 | 00 | 76 | 0 | 0 | 0 | 0 | 0 | 0 | 0 | 0 | 0 | 0 | 0 | 0 | 0 | 0 | 0 | 0 | 0 | 0 | 0 | 0 | 0 | 0 | 0 | 0 | 0 | 0 | 0 | 0 | | |
| 5260 | 14 | 06 | 14 | 06 | 14 | 06 | 14 | 06 | 14 | 06 | | | | | | | | 6600 | 00 | 00 | 00 | 00 | 00 | 00 | 00 | 00 | 00 | 00 | 77 | 0 | 0 | 0 | 0 | 0 | 0 | 0 | 0 | 0 | 0 | 0 | 0 | 0 | 0 | 0 | 0 | 0 | 0 | 0 | 0 | 0 | 0 | 0 | 0 | 0 | 0 | 0 | 0 | | |
| 5270 | 06 | 0F | 13 | 10 | 06 | 0F | 13 | 10 | 06 | 14 | | | | | | | | 6610 | 00 | 00 | 00 | 00 | 00 | 00 | 00 | 00 | 00 | 00 | 78 | 0 | 0 | 0 | 0 | 0 | 0 | 0 | 0 | 0 | 0 | 0 | 0 | 0 | 0 | 0 | 0 | 0 | 0 | 0 | 0 | 0 | 0 | 0 | 0 | 0 | 0 | 0 | 0 | | |
| 5280 | 20 | 20 | 14 | 06 | 14 | 20 | 14 | 06 | 14 | 13 | | | | | | | | 6620 | 00 | 00 | 00 | 00 | 00 | 00 | 00 | 00 | 00 | 00 | 79 | 0 | 0 | 0 | 0 | 0 | 0 | 0 | 0 | 0 | 0 | 0 | 0 | 0 | 0 | 0 | 0 | 0 | 0 | 0 | 0 | 0 | 0 | 0 | 0 | 0 | 0 | 0 | 0 | 0 | |
| 5290 | 13 | 17 | 06 | 12 | 13 | 1 | 06 | 12 | 13 | 11 | | | | | | | | 6630 | 00 | 00 | 00 | 00 | 00 | 00 | 00 | 00 | 00 | 00 | 80 | 0 | 0 | 0 | 0 | 0 | 0 | 0 | 0 | 0 | 0 | 0 | 0 | 0 | 0 | 0 | 0 | 0 | 0 | 0 | 0 | 0 | 0 | 0 | 0 | 0 | 0 | 0 | 0 | 0 | |
| 5300 | 06 | 18 | 13 | 13 | 13 | 13 | 13 | 13 | 13 | 13 | | | | | | | | 6640 | 00 | 00 | 00 | 00 | 00 | 00 | 00 | 00 | 00 | 00 | 81 | 0 | 0 | 0 | 0 | 0 | 0 | 0 | 0 | 0 | 0 | 0 | 0 | 0 | 0 | 0 | 0 | 0 | 0 | 0 | 0 | 0 | 0 | 0 | 0 | 0 | 0 | 0 | 0 | 0 | 0 |
| 5310 | 06 | 06 | 06 | 14 | 06 | 06 | 06 | 06 | 06 | 06 | | | | | | | | 6650 | 00 | 00 | 00 | 00 | 00 | 00 | 00 | 00 | 00 | 00 | 82 | 0 | 0 | 0 | 0 | 0 | 0 | 0 | 0 | 0 | 0 | 0 | 0 | 0 | 0 | 0 | 0 | 0 | 0 | 0 | 0 | 0 | 0 | 0 | 0 | 0 | 0 | 0 | 0 | 0 | |
| 5320 | 06 | 06 | 06 | 14 | 06 | 06 | 06 | 06 | 06 | 14 | | | | | | | | 6660 | 00 | 00 | 00 | 00 | 00 | 00 | 00 | 00 | 00 | 00 | 83 | 0 | 0 | 0 | 0 | 0 | 0 | 0 | 0 | 0 | 0 | 0 | 0 | 0 | 0 | 0 | 0 | 0 | 0 | 0 | 0 | 0 | 0 | 0 | 0 | 0 | 0 | 0 | 0 | 0 | |
| 5330 | 14 | 06 | 0F | 13 | 06 | 14 | 06 | 0F | 13 | 13 | | | | | | | | 6670 | 00 | 00 | 00 | 00 | 00 | 00 | 00 | 00 | 00 | 00 | 84 | 0 | 0 | 0 | 0 | 0 | 0 | 0 | 0 | 0 | 0 | 0 | 0 | 0 | 0 | 0 | 0 | 0 | 0 | 0 | 0 | 0 | 0 | 0 | 0 | 0 | 0 | 0 | 0 | 0 | |
| 5340 | 19 | 12 | 13 | 10 | 06 | 14 | 06 | 13 | 10 | 06 | | | | | | | | 6680 | 00 | 00 | 00 | 00 | 00 | 00 | 00 | 00 | 00 | 00 | 85 | 0 | 0 | 0 | 0 | 0 | 0 | 0 | 0 | 0 | 0 | 0 | 0 | 0 | 0 | 0 | 0 | 0 | 0 | 0 | 0 | 0 | 0 | 0 | 0 | 0 | 0 | 0 | 0 | 0 | |
| 5350 | 14 | 20 | 14 | 0 | | | | | | | | | | | | | | | | | | | | | | | | | | | | | | | | | | | | | | | | | | | | | | | | | | | | | | | |

ZX MICROFAIR

EVERYTHING FOR SINCLAIR COMPUTERS

THE GREATEST SHOW ON EARTH

ONCE AGAIN AT ALLY PALLY
SEPTEMBER 8th 1984

FEATURING A GALAXY OF EXHIBITORS
WITH SPECIAL OFFERS AT THE SHOW!

SEE THE MIGHTY KINGDOM OF SOFTWARE!
THRILL TO THE COMPUTER HARDWARE!
GASP AT THE RANGE OF ADD-ONS, BOOKS, PERIPHERALS!
WITNESS THE OUTSTANDING FEATS OF THE QL, SPECTRUM AND ZX81!

One Day Only! Don't Miss It!
Only £1.25 (Adults) 60p (Kids)



SEND NOW FOR REDUCED-PRICE ADVANCE TICKETS

Post today and you can have Advance tickets at £1 (Adults) and 50p (Kids). Please include a stamped addressed envelope with your reply and make cheques/PC's payable to ZX Microfair.

Name

Address:

Please send me advance tickets @ £1.00

Please send me advance tickets @ 50p

Post to Mike Johnston, ZX Microfair, 71 Park Lane Tottenham, London N17 0HG.

EXHIBITORS! Phone Mike Johnston on 01-801 1172 for details and availability of stands at the show!

12th
ZX MICROFAIR
at Ally Pally on
8th September 1984

SOFTWARE FILE

(continued from page 159)

```

Y,0:WAIT20:UNTILY=26:WAIT200
1502 CLS:PRINT"YOU JUMPED INTO OUTER S
PAGE":LI=LI+1
1505 WAIT200:IFLI<3 THENGOTO7000+SS+10
1510 PRINT:PRINT"YOU SCORED "SC" POINT
S":PLOT10,26,"PRESS ANY KEY T
O PLAY AGAIN
1520 GET A$:RUN
1998 :
1999 REM ### DEFINE CHARS ###
2000 FORC=1TO13:READA:FORD=0TO7:READB:
POKE46080+B*A+D,B:NEXTD,C:RET
URN
2010 DATA 97,7,31,63,63,31,47,26,7
2020 DATA 98,56,62,63,63,62,59,46,56
2030 DATA 99,12,18,33,45,45,30,12,0
2040 DATA 100,3,7,5,7,15,27,2,4
2050 DATA 101,48,56,40,62,58,48,16,32
2060 DATA 102,7,9,11,7,1,29,47,0
2070 DATA 103,56,36,52,56,32,16,61,0
2080 DATA 104,3,5,15,58,47,59,38,51
2090 DATA 105,48,24,52,63,21,63,41,51
2100 DATA 106,10,17,36,33,40,21,10,5
2110 DATA 107,42,1,40,1,42,20,40,16
2120 DATA 108,7,9,17,23,19,31,15,0
2130 DATA 109,56,36,34,58,50,62,60,0
2998 :
2999 REM <<< REDEFINE VARS >>>
3000 A=15:L=15:F=15:H=15:J=15:B=7:M=7:
G=7:I=7:K=7:X=15:Y=15:::R=0
3010 TEST(1)=0:TEST(2)=0:TEST(3)=0:TES
T(4)=C:RETURN
3998 :
3999 REM *** DEFINE SCREEN ***
4000 FING:CLS:LORES0:Z=48377:FORC=0TO6
:FORD=0TOC:DOKEZ+4*D,25185:PO
KEZ+4*D-1,S
4010 NEXTD:Z=Z+70:NEXTC:PRINT:PRINT"
PYRAMANIAC":POKE48
082,1C
4020 PRINT" PYRAMANIAC":PO
KE48003,4:POKE40122,10:POKE40
123,2
4030 PRINT"CHANGE":PRINT" TO":PRINT"
ab":POKE48243,E:PRINT:PRINTS
C$

```

```

4040 FORC=1TO3-LI:PLOT 35,10+C,"cc":PL
JT34,10+C,4:NEXTC:RETJRN
4993 :
4994 M=M ((( DEFINE FUNCTIONS )))
5000 DEF FNA(P)=P+2*SSN(RND(1)-.5)
5010 DEF FNC(P)=P+2*((X<=P)-(X>P))
5020 DEF FNG(P)=P-2*((Y>P)-(Y<=P))
5030 DEF FNQ(P)=P+2*((A$="Q")+(A$="N")
-(A$="J")-(A$="I"))
5040 DEF FNY(P)=P+2*((A$="Q")+(A$="W")
-(A$="J")-(A$="I"))
5050 RETURN
5998 :
5999 REM ... INSTRUCTIONS ...
6000 CLS:(NKO:FJR C=1TO24:READB$:PRINT
CHR$(27);B$:NEXTC
6010 DATA"Q YOJ ARE IN A PYRAMID CONS
TRUCTED OF"
6020 DATA"Q DISKS"
6030 DATA"R ab ab ab ab ab ab ab ab
ab ab ab"
6040 DATA"V YOU MUST CHANGE ALL THE DI
SKS TO THE"
6050 DATA"V SPECIFIED COLOUR BY JUMPIN
G ON THEM"
6060 DATA" T WATCH OUT FOR THE ALIENS,S
ENT BY THE"
6070 DATA" T THE MAD DRUMMER"
6080 DATA" R fg and hi BOUNCE DOWNWARDE
"
6090 DATA" R jk WILL FOLLOW YOU SO BE C
ARE FULL!"
6100 DATA" R de CHANGES THE DISKS LULU
R AND"
6110 DATA" R KILLS YOU"
6120 DATA" U IF YOU KILL THE MANIAC DRU
MMER 1n "
6130 DATA" U YOU WILL GAIN A GREAT DEAL
OF POINTS"
6140 DATA" Q WATCH OUT OR HIS CEAGLESS
DRUMMING"
6150 DATA" Q WILL SEND YOU MAD AS WELL
!!!!!!"
6160 PLOT 10,26,"PRESS ANY KEY TO PLAY
":GET A$
6170 DATA" P"," T YOU CAN ONLY JUMP DIAG
ONALLY"
6180 DATA" T USING KEY Q FOR UP/LEFT"

```

```

6190 DATA" T W UP/RIGHT"
6200 DATA" T N DOWN/LEFT"
"
6210 DATA" T M DOWN/RIGH
T"
6220 DATA"","","R BY ANDREW GORDON"
6998 :
6999 REM === CONTROLLING SEQ ===
7000 S=1:E=2:SC$="SCREEN 1":W=20:GOSUB
10
7010 C=3:C=4:SC$="SCREEN 2":W=15:LM=TR
UE:GOSUB10
7020 S=5:E=6:SC$="SCREEN 3":W=10:LM=0:
FG=TRUE:GOSUB10
7030 S=2:E=3:SC$="SCREEN 4":W=10:LM=TR
UE:GOSUB10
7040 S=1:E=3:SC$="SCREEN 5":W=15:FG=0:
LM=0:HI=0:GOSUB10
7050 S=6:E=7:SC$="SCREEN 6":W=5:FG=TRU
E:GOSUB10
7060 S=4:E=5:SC$="SCREEN 7":W=10:FG=0:
HI=TRUE:GOSUB10
7070 S=2:E=4:SC$="SCREEN 8":W=10:LM=TR
U:GOSUB10
7080 S=3:E=5:SC$="SCREEN 9":W=10:LM=0:
HI=TRUE:GOSUB10
7090 S=4:E=6:SC$="SCREEN10":W=5:LM=TRU
E:GOSUB10
7100 S=5:E=7:SC$="SCREEN11":W=5:FG=TRU
E:GOSUB10
7120 S=1:E=4:SC$="SCREEN12":W=10:FG=0:
HI=0:LM=C:GOSUB10
7150 S=2:E=2:SC$="SCREEN13":W=5:FG=TRU
E:HI=TRUE:GOSUB10
7140 S=3:E=6:SC$="SCREEN14":W=5:FG=FAL
SE:LM=TRUE:GOSUB10
7150 S=4:E=7:SC$="SCREEN15":W=0:FG=TRU
E:GOSUB10
7160 S=1:E=6:SC$="SCREEN16":W=5:LM=C:G
OSUB10
7170 S=2:E=7:SC$="SCREEN17":W=0:FG=TRU
E:GOSUB10
7180 S=1:E=7:SC$="SCREEN18":W=0:GOSUB1
0:GOTO7000
7999 :
8000 REM **** PYRAMANIA ****
8010 REM By ANDREW GORDON.

```

Darts

Mike Hyams,
Edgware,
Middlesex.



AT LAST YOU CAN be Eric Bristew or John Lowe on your 48K Spectrum. This version of the standard pub game has several built-in options. One or two players, 501 or 301 start, and starting with a double or straight off. When presented with the selection page you should press keys one to six to change the type of game to the one you require, and then start the game by pressing S.

Each dart throw takes place in two moves. First by stopping the radar-probe on the dartboard, and then by stopping the multiplier under the blackboard. Pressing almost any key will stop these markers, hopefully where you want them to stop. The keys with a different use are O and Q. O will drop the dart

being thrown — useful for unsure players near the end of a game — and Q quits the game, returning to the title screen — useful when you have just failed your 16th attempt at double one and can't face another go.

As usual, all games must end on a double and if there are two players the winner will have a leg added to his/her score. Each set is five legs so the first to win three legs wins the set.

The alternative game, the Arcade Challenge, is so called because of its resemblance to arcade-style games rather than the traditional pub game. The computer presents you with a score which you must better with three darts. If you do not equal or beat this score then you lose one of your three lives.

The score to beat starts at 50 and rises in steps of 10 up to 150. If you survive this far then the score to beat drops back to 70, but things speed up. Only a true champion will

turr. through this cycle three times.

A score of 180 is rewarded with lots of buzzing and flashing, and a bonus of 500 points. A top five high score table is presented at the end of each arcade game.

First type in listing 1, and save to tape using

SAVE "DARTS" LINE 9999

Then new the computer. Next type in listing 2. This program produces the dartboard screen and takes nearly 20 minutes to run so now is a good time to go and make a cup of coffee. When the program is finished an alarm will sound to alert you. You will be asked to prepare the cassette for saving. This should be saved directly after the Darts program.

Listing 2 takes a long time to finish but as it is only needed to produce the screen display which has now been saved, it can be discarded. The machine code used to retrieve the screen is almost instant, a slight improvement on 20 minutes.

```

10 GO TO 2000
20 FOR S=0 TO 255:OUT 254,S
OUT 254,S:NEXT S
30 RETURN
40 INK 0:PAPER 6
50 PRINT AT 20,24,"@5DS308"R
60 OVER 1
100 LET I=INT(RND*20)+1
110 PLOT 20,24
115 OUT 254,21
120 DRAW B(I):F(I)
130 IF INKEY$(0) THEN GO TO 20
140 PLOT 20,24
145 OUT 254,21
150 DRAW B(I):F(I)
160 LET I=I-1:IF I=21 THEN LET
I=1
170 GO TO 110
200 OVER 0
201 IF INKEY$(0) THEN LET J=0:
GO TO 300
202 IF INKEY$(0) THEN GO TO 21
203 BEEP .25,-10
204 LET J=INT(RND*7)+1
205 FOR V=1 TO 50:NEXT V
210 PRINT AT 20,24;T$(J)
220 FOR V=1 TO WAIT:NEXT V
230 IF INKEY$(0) THEN GO TO 30
240 LET J=J+1:IF J=9 THEN LET
J=1
250 GO TO 210
300 BEEP .25,-5
310 PLOT 20,24
320 DRAW OVER 1;E(I),F(I)
330 INK 7:PAPER 0
335 LET Y=I(I)
340 IF J=0 THEN LET I=0
350 IF J=5 THEN LET I=10
360 IF J=7 THEN LET I=10
370 IF J=1 THEN LET I=10
380 IF J=3 THEN LET I=10:GO TO
400
390 LET J=1
400 RETURN
999 REM *****
* CHOOSE A GAME *
*****
1000 CLS
1010 PRINT AT 1,10,"* DARTS *"
1020 PRINT AT 4,8;B$(1):"1 - ONE
PLAYER"
1030 PRINT AT 6,8;B$(2):"2 - TWO
PLAYERS"

```

(continued on next page)

SOFTWARE FILE

(continued from previous page)

```

1040 PRINT AT 8,8;B$(3);"3 - 501
START"
1050 PRINT AT 10,8;B$(4);"4 - 30
1 START"
1060 PRINT AT 12,8;B$(5);"5 - 00
UBLE START"
1070 PRINT AT 14,8;B$(6);"6 - ST
RAIGHT OFF"
1080 PRINT AT 16,8;"5 - START GA
ME"
1090 PRINT AT 18,4;"A - THE ARCA
DE CHALLENGE"
2000 REM *****
2005 H:MINI H 20,10; FLASH 1;"PR
EASS A KEY"
1105 FOR Z=1 TO 2000
1110 LET Z$=INKEY$
1120 IF Z$<>" " THEN GO TO 1100
1125 NEXT Z
1130 GO TO 9100
1135 IF Z$<>"1" THEN GO TO 1140
1140 LET A$(1)=0; LET B$(2)=0;
1145 GO TO 1010
1150 IF Z$<>"2" THEN GO TO 1150
1155 LET B$(2)=0; LET B$(1)=0;
1160 GO TO 1010
1165 IF Z$<>"3" THEN GO TO 1160
1170 LET B$(3)=0; LET B$(4)=0;
1175 GO TO 1010
1180 IF Z$<>"4" THEN GO TO 1170
1185 LET B$(4)=0; LET B$(3)=0;
1190 GO TO 1010
1195 IF Z$<>"5" THEN GO TO 1180
1200 LET B$(5)=0; LET B$(6)=0;
1205 GO TO 1010
1210 IF Z$<>"6" THEN GO TO 1190
1215 LET B$(6)=0; LET B$(5)=0;
1220 GO TO 1010
1225 IF Z$<>"A" AND Z$>"S" THEN
GO TO 1010
2000 REM *****
***** PLAY A GAME *****
2001 LET PLAYER=1
2002 BRIGHT 0
2003 LET S1=0; LET S2=0
2004 LET L1=0; LET L2=0
2005 LET U=0
2010 IF B$(2)=0 THEN LET PLAYER
=2; LET U=1
2015 IF Z$="A" THEN GO TO 5000
2020 LET START=50
2030 IF B$(4)=0 THEN LET START=
301
2040 IF BEGIN=1
2050 LET B$(6)=0 THEN LET BEGIN=
5
2060 LET X(1)=START
2070 LET X(2)=START
2080 LET WAIT=1
2100 RANDOMIZE USR 48020
2105 PRINT #1;" @ 1984 M. HY
AMS"
2106 INK 0; PAPER 6
2110 PRINT AT 0,24;"PLAYER"
2120 PRINT AT 2,23;"ONE";AT 3,23
; INK 7; PAPER 3; START
2121 IF U=1 THEN PRINT AT 4,23
; INK 7; PAPER 3; START;AT 3,23"
2130 IF PLAYER=2 THEN PRINT AT 2
,29;"TWO";AT 3,29; INK 7; PAPER
3; START
2140 LET SC=4
2150 GO SUB 8000
2210 FOR N=1 TO PLAYER
2215 IF U=1 THEN LET U=0; NEX
T N
2220 PRINT AT 19,21; INK 6; PAPER
0;" ";AT 20,21;" ";AT 21,21
;" "
2230 PRINT AT 2,23+6*(N-1); OVER
1; FLASH 1; BRIGHT 1
2240 INK 6; PAPER 0
2245 LET TOT=0
2250 FOR M=1 TO 3
2270 GO SUB 90
2275 LET ZZ=1
2280 IF BEGIN=0 THEN GO TO 2300
2281 IF ZZ=50 THEN GO TO 2300
2285 IF X(N)-TOT=START AND U=0
THEN LET ZZ=0
2300 PRINT AT 18+M,21;" " AND Z
Z+10;ZZ
2310 LET TOT=TOT+ZZ
2311 IF X(N)-TOT=0 AND (U=1 OR I
=50) THEN GO TO 4000
2312 IF X(N)-TOT<2 THEN PRINT AT
2,24; FLASH 1;" BUST " GO T
O 2330
2320 NEXT X
2330 IF X(N)-TOT>1 THEN LET X(N)
=X(N)-TOT; IF TOT=180 THEN GO SU
B 20
2350 PRINT AT 30,23+6*(N-1);X(N)
2370 PLOT 185+48*(N-1);(22-SC)+8
2375 DRAW 20,7
2380 IF SC=17 THEN FOR A=0 TO 17
PRINT AT A,23+6*(N-1); INK 7;
PAPER 0;" " NEXT A; PRINT AT
3,23+6*(N-1);X(N)
2385 FOR O=1 TO 100; NEXT O
2390 PRINT AT 2,23+6*(N-1); OVER
1; FLASH 0; BRIGHT 0;"
2400 NEXT N
2410 LET S1=SC+1
2420 IF SC=18 THEN LET SC=4
2430 LET WAIT=WAIT+.5
2500 GO TO 2210
4000 REM *****
***** WIN ROUTINE *****
4010 GO SUB 20
4015 RESTORE 4050
4020 FOR M=1 TO 5
4030 READ A,B

```

```

4040 BEEP A,B
4050 NEXT M
4060 IF N=1 THEN LET L1=L1+1; IF
L1=3 THEN LET L1=0; LET S1=S1+1
LET L2=0
4065 IF N=2 THEN LET L2=L2+1; IF
L2=3 THEN LET L2=0; LET S2=S2+1
LET L1=0
4080 DATA .5,0,.25,-.5,.5,0,.25,-
.5,1,5
4084 IF U=1 THEN LET U=-1
4090 IF U=2 THEN LET U=1
4095 IF PLAYER=1 THEN GO TO 9100
4095 PRINT AT 20,23;" " AT 19,21;
OVER 1;" "
4100 PRINT AT 20,20;"SETS ";S1;T
AB 20,30
4110 PRINT AT 21,20;"LEGS ";L1;T
AB 20,30
4120 PRINT #1;AT 0,1;"PRESS "3"
TO FINISH THE MATCH OR ANY OTH
ER KEY FOR NEXT LEG"
4130 IF INKEY$="0" THEN GO TO 91
00
4140 IF INKEY$=" " THEN GO TO 45
00
4150 GO TO 4130
4500 PAPER 3; CLS; GO TO 2000
4999 STOP
5000 REM *****
***** ARCADE GAME *****
5005 DIM U(2)
5006 LET U(1)=3; IF PLAYER=2 THE
N LET U(2)=3
5010 RANDOMIZE USR 48000
5015 PRINT #1;" @ 1984 M. HY
AMS"
5016 PRINT AT 0,23;"THE";AT 1,23
;"ARCADE";AT 2,23;"CHALLENGE"
5020 PRINT AT 0,20;"HI-SCORE ";A
T 5,24;HI
5025 INK 7; PAPER 0
5030 PRINT AT 9,23;"PLAYER 1"
5040 IF PLAYER=2 THEN PRINT AT 1
0,23;"PLAYER 2"
5050 INK 7; PAPER 0
5060 PRINT AT 10,23;" * * * * "
5070 IF PLAYER=2 THEN PRINT AT 1
4,23;" * * * * "
5100 LET WAIT=3
5105 GO SUB 8000
5110 LET TOP=50
5120 PRINT AT 19,29;" "
5125 PRINT AT 18,23;"SCORE TO ";
AT 19,23;"BEAT- "; FLASH 1;TOP
5130 FOR N=1 TO PLAYER
5135 IF U(N)=0 THEN GO TO 5600
5140 PRINT AT 9+4*(N-1),23; OVER
1; FLASH 1
5150 PRINT AT 19,29;" * * * * " AT 20,2
0;" * * * * " AT 21,20;" * * * * "
5160 LET TOT=0
5170 FOR M=1 TO 3
5180 GO SUB 90
5190 LET ZZ=1
5195 PRINT AT 10+M,20;" " AND Z
Z+10;ZZ
5200 LET TOT=TOT+ZZ
5210 NEXT M
5220 IF TOT=TOP THEN GO TO 5300
5230 BEEP .7,-10; BEEP .7,-15
5270 PRINT AT 10+4*(N-1),20+U(N)
+3;" "
5280 LET U(N)=U(N)+1
5290 IF U(N)=0 THEN PRINT AT 10+
4*(N-1),23;"GAME OVER"; BEEP .7;
-20
5295 GO TO 5610
5300 LET X(N)=X(N)+U(1)
5301 IF TOT=180 THEN PRINT AT 20
,24; FLASH 1;"BCNUS+ ";AT 21,24
; FLASH 1;"500 PTS "; GO SUB 20;
LET X(N)=X(N)+500
5305 PRINT AT 11+4*(N-1),24;X(N)
5310 PRINT AT 9+4*(N-1),23; OVER
1; FLASH 0;"
5320 IF U(1)=0 AND U(2)=0 THEN GO
TO 5300
5325 FOR A=1 TO 100; NEXT A
5330 NEXT N
5340 NEXT M
5345 LET HI=A(1)
5350 GO TO 5600
5355 FOR Z=5 TO N+1 STEP -1
5360 LET A$(Z)=A$(Z-1)
5365 LET A(Z)=A(Z-1)
5370 NEXT Z
5380 PRINT AT 7,3;"CONGRATULATIO
N";AT 8,7; FLASH 1;"PLAYER ";M
5390 PRINT AT 10,3;"ENTER YOUR N
AME";AT 11,2;"FOR HI-SCORE TAELE
"
5410 INPUT FLASH 1;"NAME ";F$
5420 LET A$(Z)=F$
5430 LET A(Z)=X(M)
5450 GO TO 5300
5460 BEEP .3,0; BEEP .3,12; BEEP
.3,7
5470 BEEP .3,10; BEEP .3,9
5480 BEEP .3,7; BEEP .3,9
5490 RETURN
5499 STOP

```

```

9000 REM *****
***** INITIALISE *****
***** *****
9001 RESTORE 9020; FOR N=0 TO 23
READ A; POKR USR "A"+N; NEXT
N
9010 DATA 0,2,4,50,30,127,30,50,2
4,0,0,0,60,200,0,0,2,60,65,150,
155,155,150,900,300
9011 DATA 0,30,0,0,61,32,52,55,38
,51,20,65,0,61,20,52,36,38,52,20
,61
9012 DIM B(20); DIM F(20)
9013 FOR N=1 TO 20
9014 IF N=11 THEN RESTORE 9011
9015 READ F(N); READ B(N)
9016 IF N<5 AND N>16 THEN LET F(
N)=-F(N)
9017 IF N=10 THEN LET B(N)=-B(N)
9018 NEXT N
9020 LET H=0
9021 DIM T$(8,12)
9022 LET T$(2)="0SDST305"
9023 LET T$(3)="0SDST305"
9024 LET T$(4)="0SDST305"
9025 LET T$(5)="0SDST305"
9026 LET T$(6)="0SDST305"
9027 LET T$(7)="0SDST305"
9028 LET T$(8)="0SDST305"
9029 LET T$(11)="0SDST305"
9030 DIM A$(5,5)
9031 FOR N=1 TO 5
9032 LET A$(N)="??"?"?"
9033 NEXT N
9040 POKR 23658,8
9041 DATA 20,1,18,4,13,6,10,15,2
,17,3,19,7,16,0,11,14,9,12,5
9042 DIM I(20)
9043 FOR N=1 TO 20; READ I(N); N
EXT N
9050 DIM A(5)
9060 DIM B(3,2)
9064 LET C$=CHR$(20+CHR$ 0
9065 LET C$=CHR$(20+CHR$ 1
9066 LET B$(1)=C$
9067 LET B$(2)=C$
9068 LET B$(3)=C$
9069 LET B$(4)=C$
9070 LET B$(5)=C$
9071 LET B$(6)=C$
9100 OVER 3; INK 0; BRIGHT 1; 50
ORDER 5; PAPER 6; CLS
9101 DIM X(2)
9105 PRINT AT 2,12;"DARTS"
9110 FOR N=0 TO 21; EP 2
9120 PRINT AT N,0;"@";AT N,31;"@
"
9130 NEXT N
9170 FOR N=20 TO 20
9180 BEEP .01,N
9190 NEXT N
9210 BEEP 1,-20
9230 PRINT AT 4,8;"RAY MIKE HYAMS"
9240 PRINT AT 6,8;" * * * * @ 1984 * * * * "
9250 PRINT AT 10,5;"PRESS ANY KE
Y TO START"
9260 PRINT AT 12,4;"OR "M" FOR I
NSTRUCTIONS"
9300 PAUSE 1; PAUSE 500
9320 IF INKEY$="I" THEN GO TO 94
00
9330 IF INKEY$<>" " THEN GO TO 10
00
9340 GO TO 9500
9400 CLS
9430 PRINT AT 0,6;"DARTS - INSTR
UCTIONS"
9435 BEEP 2,0
9450 PRINT AT 2,0;"PRESS ANY KEY
, EXCEPT "0" OR "0" TO STOP T
HE DART PROBE " ON TH
E BOARD"
9455 BEEP 2,5
9456 PRINT " " PRESS ANY KEY I
N STOP THE " " MULTIPLE
3"; PRINT TAB 10;"5 - SINGLE";
PRINT TAB 10;"0 - DOUBLE"; PRINT
TAB 10;"T - TRIPLE"; PRINT TAB
10;"0 - 25"; PRINT TAB 10;"@ - B
JLL"
9457 BEEP 2,10
9460 PRINT " " PRESS "0" TO "DR
OP" A DART " PRESS "0" TO QUI
T THE GAME"
9470 BEEP 2,15
9480 PRINT " " BEAT THE SCOR
E IN THE " " OR
LOSE A LIFE"
9490 BEEP 2,20
9500 FOR N=-50 TO 50 STEP 3
9510 BEEP .1,N
9525 IF INKEY$<>" " THEN GO TO 96
00
9530 NEXT N
9540 PAUSE 4; PAUSE 500
9550 GO TO 9100
9560 CLS
9610 PRINT AT 2,9;" * * * * DARTS * * * * "
9615 PRINT AT 4,5;"THE ARCADE CH
ALLENGE"
9620 FOR N=1 TO 5
9630 PRINT AT N+2+4,10;A$(N);TAB
18,A(N)
9640 BEEP 1,N+5+10
9650 NEXT N
9700 PAUSE 1; PAUSE 200
9710 GO TO 9100
9900 CLEAR 47999; LOFD "CODE
RUN

```

(continued on page 164)

Printer Problem? 0730 68521 any day including Sunday and we will sort it out!

EPSON PRICE SPECIALS

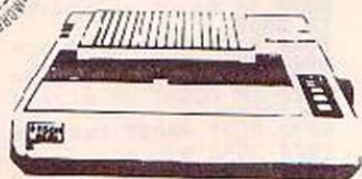

| | | | |
|-------------------------------------|-----------------|-------------|-----------------|
| EPSON RX80 (DOT MATRIX) | £249 | £209 | + VAT = £240.35 |
| EPSON RX80FT (DOT MATRIX) | £285 | £239 | + VAT = £274.85 |
| EPSON FX80 (DOT MATRIX) | £438 | £324 | + VAT = £372.80 |
| EPSON MX100 (DOT MATRIX) | £475 | £365 | + VAT = £419.75 |
| EPSON RX100 (DOT MATRIX) | £450 | £385 | + VAT = £442.75 |
| EPSON FX100 (DOT MATRIX) | £569 | £499 | + VAT = £573.85 |

NEW! Canon PW-1080A £269.00

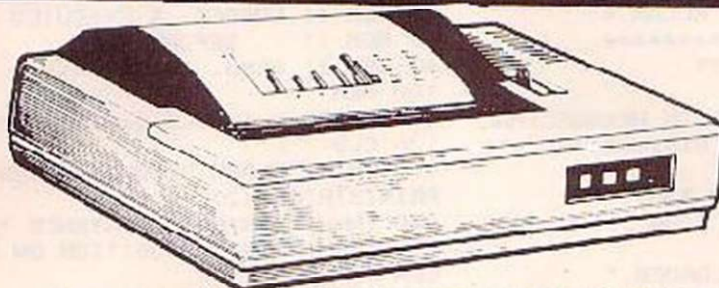

+ VAT = £309.35
80 cols; High speed printing, 160 CPS; bi-directional logic seeking; fantastic 27 CPS near letter quality; 23 x 18 matrix; very quiet - less than 80 dB; 4, 5, 6, 8 10, 12, 17 CPI; down loading for user-optional characters; high resolution graphics; handles various forms, roll paper, fan fold, single sheet and multipart copy paper.

ALSO AVAILABLE THE CANON PW1156A as above but 156 cols **£369.00** + VAT = £424.35

PHONE 0730 68521 INCLUDING SUNDAY!

JUKI 6100 just £349 + VAT = £401.35

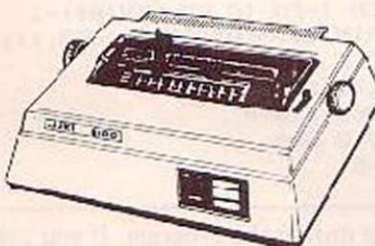

20CPS; Bidirectional & Logic 10, 12, 15 & Proportional Spacing; Wordstar compatible 2K Buffer; 13 inch Platen Underline; backspace & lots more Centronics Interface Standard

OPTIONAL RS232 TRACTOR AND SHEET FEEDER

SHINWA CP80 £179.00 + VAT = £205.58

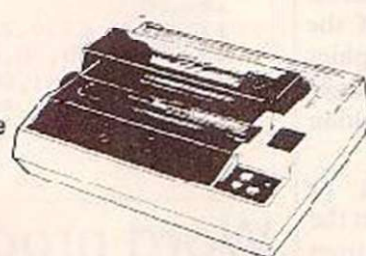

Friction and tractor feed as standard. 80cps. Bi-directional logic seeking 13 x 9 dot matrix giving true descenders, sub and superscripts Italic printing and auto underlining Condensed, emphasised, expanded and double strike (can be mixed in a line). Parallel interface fitted as standard

**WE WILL MATCH ANY GENUINE PRICE ADVERTISED
SCI(UK) IS NEVER BEATEN ON PRICE**

MANY MORE PRINTERS AVAILABLE 1,000s OF BARGAINS SEND NOW FOR THE FAMOUS SCI(UK) CATALOGUE



FIDELITY 14" COLOUR MONITOR & COMPOSITE VIDEO

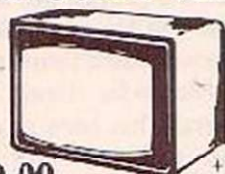

£189.00 + VAT = £217.35

We have interfaces for all types of computers, including CBM 64, Vic 20, APPLE, TRS 80, IBM, BBC, SPECTRUM, QL ETC



24 hour nationwide delivery by Securicor £9.50 + vat. Bankers Orders; Building Society Cheques; Postal Orders; - same day despatch. All orders covered by the Mail Order Protection Scheme. Nationwide maintenance contracts arranged. Educational discounts very welcome.



SCI(UK)
TEL: 0730 68521

FREEPOST
(No Stamp Needed)
PETERSFIELD
HANTS GU32 2BR
TELEX 86626 MYNEWS G

DEALER ENQUIRIES WELCOME WRITE FOR DETAILS PERSONAL CALLERS WELCOME

12 HIGH STREET, PETERSFIELD, HANTS GU32 2 JG

MORE BARGAINS SEE PAGES 000 & 000

URGENT ORDER
PLEASE SUPPLY
Name _____
Address _____
Credit Card _____
Number _____
SCHUKO FREE POST NO STAMP NEEDED PETERSFIELD, HANTS GU32 2BR

JUNE'S COMPETITION offered two prizes, as the first prize an Amstrad CPC-464 which comes with a colour monitor, and as the second the same machine with a monochrome monitor. All you had to do to enter was place eight features of computer games in order of preference. For a tie-breaker we also asked you to think of an original title for a computer game.

To pick what was to be the winning order we assembled a panel of hardened games players. Between them they brought years of arcade experience to bear on the problem. In effect their task was to define the ingredients of a best-selling game.

As it turned out it proved almost impossible to reach an agreement. For example, everyone on the panel agreed that high-resolution graphics deserved a place near or at the top of the list, but what about realism? Surely realism in a game and high-res graphics amount to the same thing? On the other hand several of the most successful games have a cartoon style which is far from realistic — and so the argument continued.

One judge wanted to give easy loading priority on the grounds that without it a game is unplayable. But most games load without any trouble; this would seem to be more a precondition for playing games rather than a favourite feature.

Our final decision was a compromise. You probably will not agree with it exactly but it broadly reflects the preference of our panel, indeed, of most of the entries: 1. High-resolution graphics. 2. Sound effects. 3. Different screens. 4. Quick reactions. 5.

AMSTRAD

competition

RESULTS

Realism. 6. Problem solving. 7. Easy loading. 8. User definable controls.

Two contestants came up with the same list as our judges. We awarded the first prize to Michael Burdass, 6 Town Hill, Broughton, Near Brigg, South Humberside. His title, Pea Pod Pete, was thought to be more appealing than AKA — Death, which was suggested by the second prizewinner, Carl Chippendale, 93 Common Road, Huthwaite, Sutton-in-Ash, Nottingham.

A look at the rest of the entries — almost 2,000 of them — turned up some highly entertaining titles. Anagram makers went to town on the name Amstrad and sent in, by the dozen, Mad Star or Mad Rats. More original were C Robinson's surreal Underparts in Space, D Walker's topical Picket Panic — a sequel to Manic Miner — and R Avery's

mystifying Catbird Ten Twenty.

From A Karhumaki in Finland came The Rise of the Patriotic People of Finland against the Military Power of Imperialism and for the Sprouting Independence of their Nation; while from Spain E Diaz suggested Crazy Eullight. C Oakes almost matched the Finnish entry in length with Revenge of the 90 Foot High, Pan Dimensional, Laser Spitting, Kamikaze, Combat Hamsters.

There were many others deserving of a mention. Here's a small selection from them: Jet Lag Willy, Tebbit Attack, Stompicator, Boku Boku the Exterminator, Lost in Tesco's, Armadillo Nights, Cambridge Clive and the Temple of Delays, Tutencarman, Attack on Amstradam, Bunfight at Theo Kay's Corra, Half a Worn-out Toothbrush Bristle, Invasion of the Killer Odour Eaters.

SLOGGER SOFTWARE

MACHINE CODE GAMES FOR BBC 'B', ELECTRON, SPECTRUM 16/48K

A MAZE IN SPACE

DOG FIGHT

Use Joysticks or Keyboards to navigate your Starship to the planet surface and then into the maze below. Having been told in which section of the maze your target is hidden, your objective is to seek out and destroy it to complete a mission. Beware of the numerous alien defence systems. Two levels of difficulty! Horizontal and diagonal scrolling! How many missions can you complete?

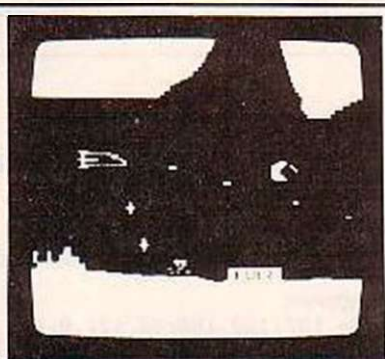

| Available now | Cassette | Disc |
|---------------------------------------|----------|---------------|
| BBC 'B' | £9.95 | £11.95 |
| Special Offer | | |
| Dogfight and A Maze In Space together | | |
| Cassette - | £14.95 | Disc - £16.95 |

Please state 40 or 80 Track if disc

Still undoubtably the most exciting 2-player game available. The objective is to fire sufficient shots into your enemy aircraft to force it to explode. Eight levels of difficulty. Sun, moving cloud, lightning, ground all provide real combat environment. Can you beat your friends?

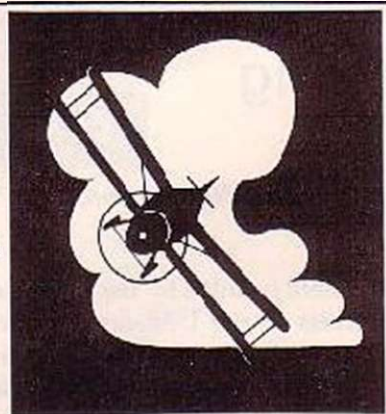

| Available now | Cassette | Disc |
|---------------|----------|--------|
| BBC 'B' | £9.95 | £11.95 |
| Electron | £7.95 | n/a |
| Spectrum | £5.50 | n/a |

All prices include VAT and postage

SLOGGER SOFTWARE

215 BEACON ROAD
CHATHAM, KENT
Tel: (0634) 811634



AMERICAN

Big, Bold and Beautiful...

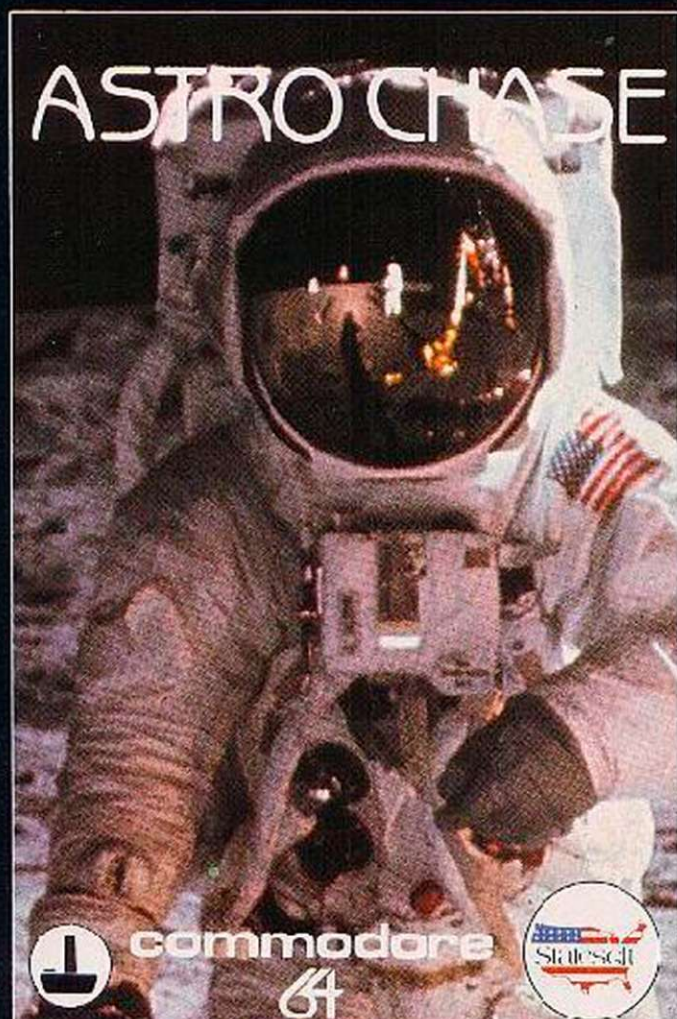

34 SCREENS

3D Graphics and Cartoon Animation
... Most Innovative Software, 1983
Software Showcase, Chicago, USA
Computer Game of the Month
The Witz Kid, Dealerscope Magazine, USA
Science Fiction/Fantasy Game of the Year, 1984
Electronic Games Magazine, USA



36 SCREENS

3-D FLIP AND FLOP, join Flip the Kangaroo and Mitch the Monkey in their escape from the zoo of the future to join their friends back at the circus. Great animations, 36 levels of play, 13 different game screens, fully orchestrated music, 1 or 2 player option and more and more Guaranteed to make you Flip!



Cassette £8.95
Disk £10.95



Really Something Else



State soft in association with 'First Star' N.York, USA

STATE SOFT LIMITED,
BUSINESS AND TECHNOLOGY CENTRE,
BESSEMER DRIVE,
STEVENAGE, HERTS. TEL: 0438 316561

I wish to pay by cash/cheque/postal order/Access
To ACCESS -
I authorize you to debit my Access
Account with the amount of £
My ACCESS No. is
Name (as on Access card) _____
Cardholder's address _____
Sign on _____

ANIROG

THE SKILFUL

Flight Path 737



ADVANCED PILOT TRAINER

FLIGHT PATH 737

For the skilful an advanced Pilot Trainer. Written by a flight simulator instructor and pilot. Panoramic Pilot's eye view.

| | |
|--------------|-------|
| COMMODORE 64 | £7.95 |
| VIC 20 | £7.95 |
| AMSTRAD MSX | £6.95 |

THE COURAGEOUS

Space Pilot



SPACE PILOT

For the courageous realise your dreams of being king of the open skies. Fly your aircraft into unrelenting dog fights with enemy fighters. Prove how well you can handle your craft. Five stages of tough engagements.

| | |
|--------------|-------|
| COMMODORE 64 | £7.95 |
| AMSTRAD | £6.95 |

COMMODORE
AMSTRAD
MSX

THE TERRIFYING

House Of Usher

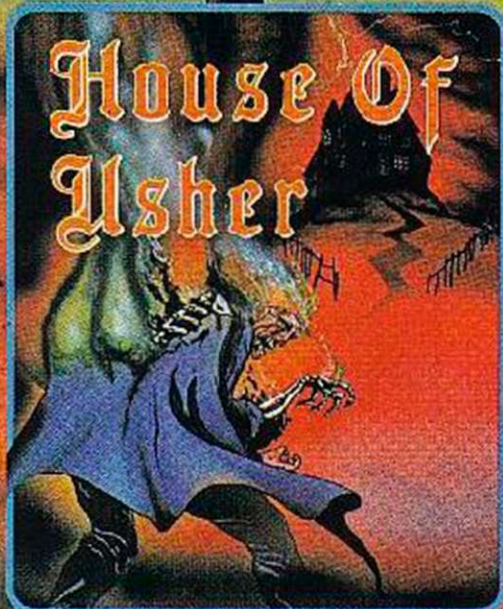

HOUSE OF USHER

Dare you enter the House of Usher. Behind each locked door of this nine room mansion a different style of arcade action awaits you.

| | |
|--------------|-------|
| COMMODORE 64 | £6.95 |
| AMSTRAD | £6.95 |

COMMODORE 64 AVAILABLE ON DISK AT £9.95

TRADE ENQUIRIES: ANIROG SOFTWARE LTD. 29 WEST HILL DARTFORD KENT (0322) 92513/8
MAIL ORDER: 8 HIGH STREET HORLEY SURREY 24 HOUR CREDIT CARD SALES HORLEY (02934) 6083
PAYMENT BY CHEQUE P.O. ACCESS/VISA 50p POSTAGE & PACKAGING

M I C R O P O W E R M I C R O P O W E R M I C R O P O W E R M

(SUPER-FAST LOADING TIME)  electron B.B.C. MICRO MEMOTECH

FELIX

IN THE FACTORY

£6.95
(ELECTRON
and BBC MICRO
versions £7.95)

Race along the conveyor belt leaping the packages, and shin up the ladders to the shopfloor. Pitchfork the Gremlins off the walkways, use the poison pouch to trap the Giant Rat, and retrieve the oilcan to keep the generator topped up.



COMMODORE 64 VERSION



I THINK YOU'LL FIND SWOOP, GHOULS AND CYBERTRON MISSION ARE WINNERS AS WELL!

M I C R O P O W E R M I C R O P O W E R M
MICRO POWER LTD., NORTHWOOD HOUSE, NORTH STREET, LEEDS LS7 2AA TEL: (0532) 458800
SELECTIVE BRANCHES OF BOOTS, CO-OP, MENZIES, W. H. SMITH, WOOLWORTHS AND ALL GOOD DEALERS
AUTHORS! WE PAY 20% ROYALTIES!

M I C R O P O W E R M I C R O P O W E R M

New

High Flyers!

from MicroProse Software



The action is simulated-
The excitement is REAL!

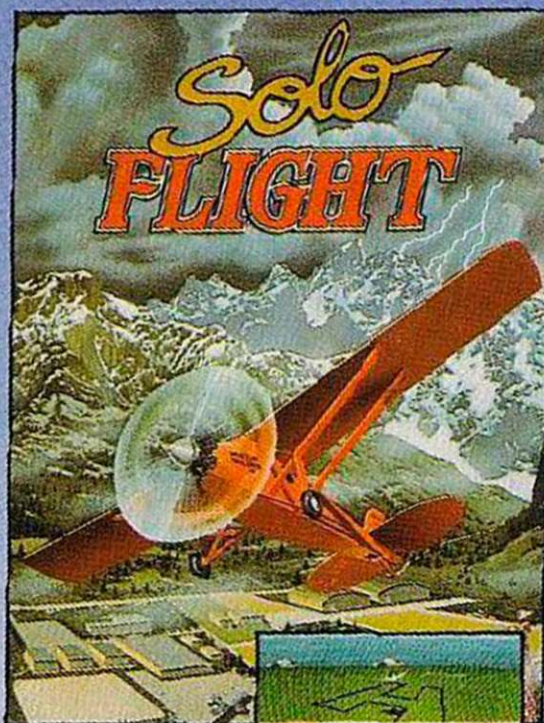

Grab your joystick and take off with this user friendly flight simulator that is 'All the flying challenge you can handle!' Includes outstanding 3D graphics, full cockpit instrumentation, dual VORs, ILS, 21 different airports, landing, scoring, and real life challenges from weather, instrument and mechanical emergencies.

DISK/CASSETTE £14.95

No.1
Flight
Simulation

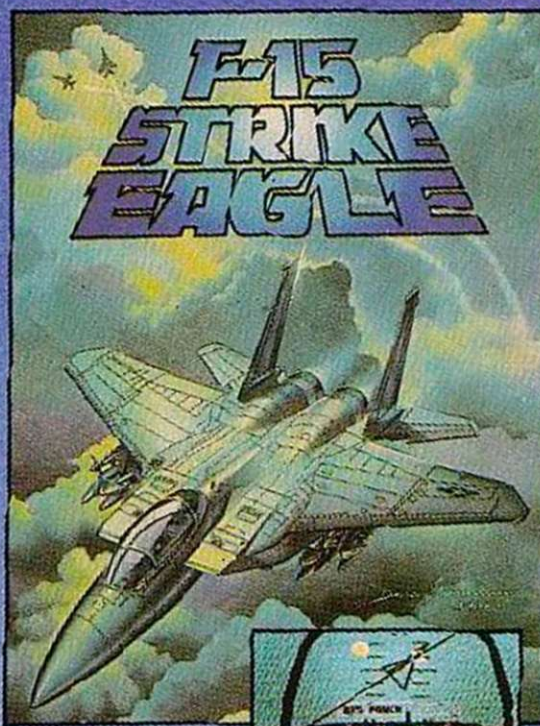

F-15 Strike Eagle features superb 3-D graphics, F-15 manoeuvrability, computer assisted targeting including a modern fighter Heads Up Display, airborne radar, air to air missiles, surface to air missile defence, ground target bombing, full aerobatics, and multiple combat scenarios.

DISK/CASSETTE £14.95

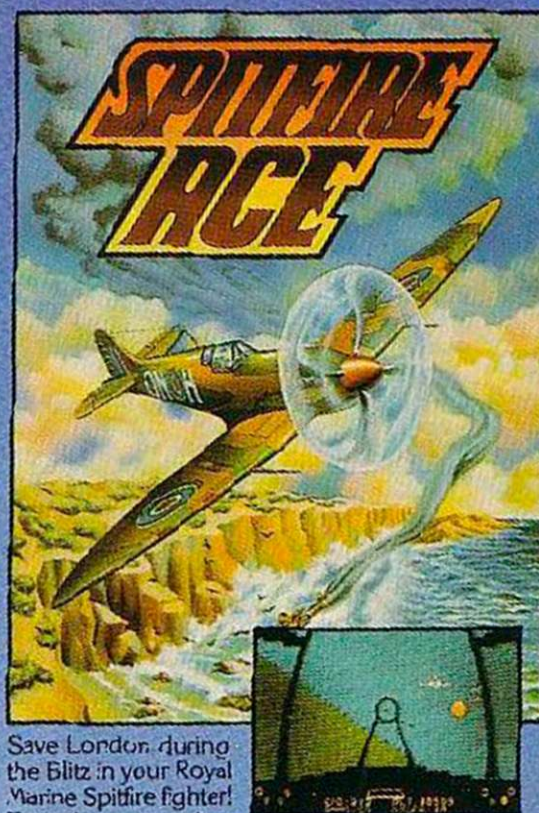

Save London during the Blitz in your Royal Marine Spitfire fighter! Featuring outstanding out-of-the-cockpit 3-D graphics, Spitfire Ace provides 14 different combat scenarios and fast paced action. For 1-4 players.

CASSETTE £9.95
DISK £12.95

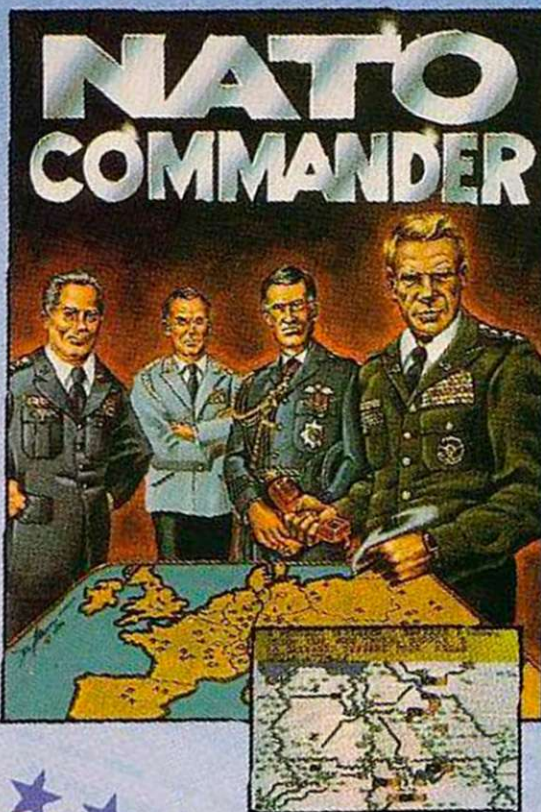

Defend Europe in a heart pounding, accelerated real-time war situation! Use your full continent scrolling battle map to destroy, manoeuvre and command the battle unit, including infantry, armour, helicopters, air forces, and tactical nuclear weapons to stop the ever advancing Warsaw Pact battle units.

CASSETTE £9.95
DISK £12.95

THE ULTIMATE IN AMERICAN SOFTWARE FOR YOU ON U.S. GOLD

U.S. Gold is stocked by all leading computer stores including:
BOOTS WH SMITH JOHN MENZIES WILDINGS
DF&I FRS! For information on how to become a U.S. Gold Stockist write to: CentreSoft Ltd., Unit 24, Tipton Trading Estate, Bloomfield Road, Tipton, West Midlands DY49AH
Telephone: 021-520 7591. Telex: 337268.
Overseas enquiries welcome.

U.S. GOLD
All American Software

MAKE SURE YOUR HOME COMPUTER WORKS... FOR YEARS AND YEARS

Guarantee years of service from your home computer. Protect your investment by joining the MICRO REPAIR CLUB. After your warranty has run out can you afford the manufacturers' repair charges which can be as high as £60 minimum? THE MICRO REPAIR CLUB is a brand new organisation offering a unique scheme which guarantees that should your computer break down, it will be repaired at absolutely no cost. THE MICRO REPAIR CLUB has been formed to save you money and ensure that your computer is in tip-top working condition for years to come.

A one-year membership that guarantees all repairs to your micro costs only £24.95, with an annual renewal of £14.95.
A two-year membership costs £35.95, three years £46.95.
For incredible value for money a four-year membership costs only £57.95.

All prices are inclusive of VAT
 THE MICRO REPAIR CLUB is backed by one of the world's largest insurance groups and the actual repair work will be carried out by Computeraid Services, a division of Thorn EMI Information Technology Ltd.

There can be no greater protection. So if you own a Sinclair, BBC, Acorn, Dragon, Commodore or any other home computer join the Club by ringing the HOTLINE or 01-946 7777 or clip the coupon below and send it to:

Micro Repair Club Limited, Swan Court, Mansel Road, Wimbledon, London SW19 4AA.

Members watch out for more great bargains in the future

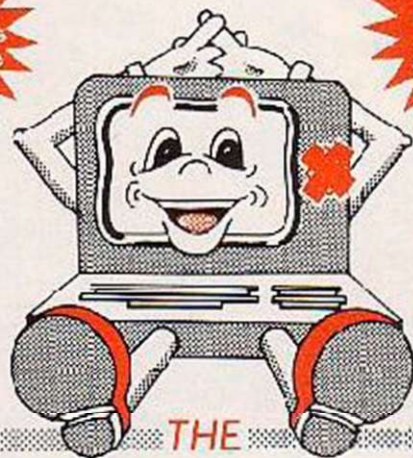

Teachers find out about our special offer for schools

THE
**MICRO
 REPAIR**
 CLUB

I would like to join the MICRO REPAIR CLUB for _____ years and look forward to receiving my full membership pack.

I enclose a cheque for £24.95 One year's membership*
 £35.95 Two years £46.94 Three years £57.95 Four years

Made payable to Micro Repair Club Limited *Please tick relevant box

Please debit my Visa/Access card No: _____

Name _____

Address _____

I own a _____ home computer and it is in working order.

COLOUR GENIE 32K SPACE TREK

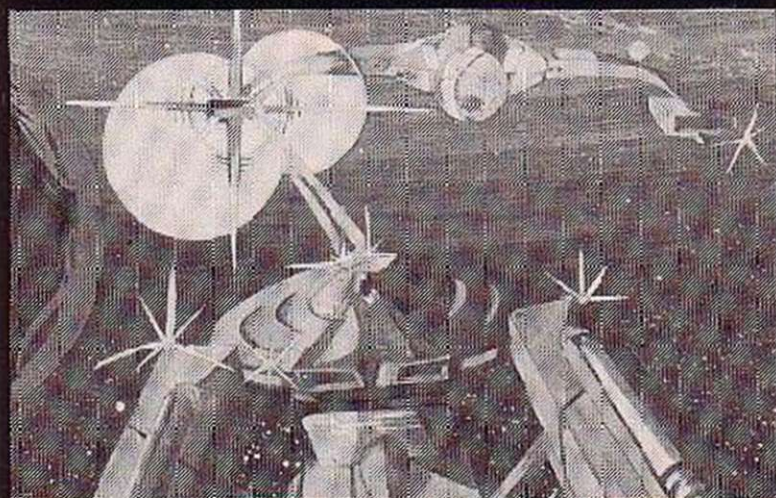

Defeat the Klingon Invasion fleet. Includes 5 skill levels. Hi-res graphics. Quadrant display. 8 x 8 galaxy phasors. photon torpedos. Long range scans and much more. Full instructions included.

Only £6.50 incl. p & p

Send cheque or P.O. or telephone with Access / Visa for immediate despatch.

Apex Software

Hastings Road, St. Leonards-on-Sea, East Sussex
 TN38 8EA, Tel Hastings (0424) 53283

Trade Enquiries Welcome



*Commodore-64
 *Dragon 32/64
 *Atari 400/600/800 (48K)

*Acorn Electron
 *BBC Model/B
 *Tandy c/c (32K)

747 Flight Simulator

from DACC — The Simulation specialists



Actual screen photograph (BEC version)

Unrivalled and unbeatable for accuracy and realism — the DACC 747 Flight Simulator is the most successful of its kind on home computers. The only simulator which shows all the essential flight and engine instrumentation of the Jumbo Jet, as they really are — real dials — and with a precise 3D view of the runway. The control and response of the 747 are faithfully reproduced using genuine aero-dynamics formulae. Start options include take-off, random landing approach, passenger and fuel load selection, etc. You control the throttles, elevators, ailerons, flaps, spoilers, landing gear, brakes, reverse thrust, etc. Joysticks are optional on all but Dragon and Tandy versions.

Cassette £9.95 (inc. VAT and P&P)

Special Officer on Joysticks

Normally £17.95 per pair. Yours for only £12.95 if ordered with 747 Simulator (Atari & CBM-64 types £14.95).

Please state type of computer on all orders.

WE DESPATCH WITHIN 48 HOURS

Order direct from:

DACC Ltd. (Dept YC2)

**23, Waverley Road, Hindley, Nr. Wigan,
 Lancs. WN2 3BN.**

"I'll swap four of my tapes for your Activision."



"No way!"

You know the feeling. A couple of plays and the best you can hope for from so much of the software around, is swapping it for something better. Well, the something better has arrived. Activision.

One thing you can be sure of. Buy any Activision software and you'll find you're walking slap, bang into a totally new experience. One that lasts. See the first titles in your usual software store now.

BEAMRIDER · DECATHLON · H.E.R.O · PITFALL · PITFALL II
RIVER RAID · TOY BIZARRE · ZENJI



ACTIVISION®
Your computer was made for us.

This November move your shop to Olympia

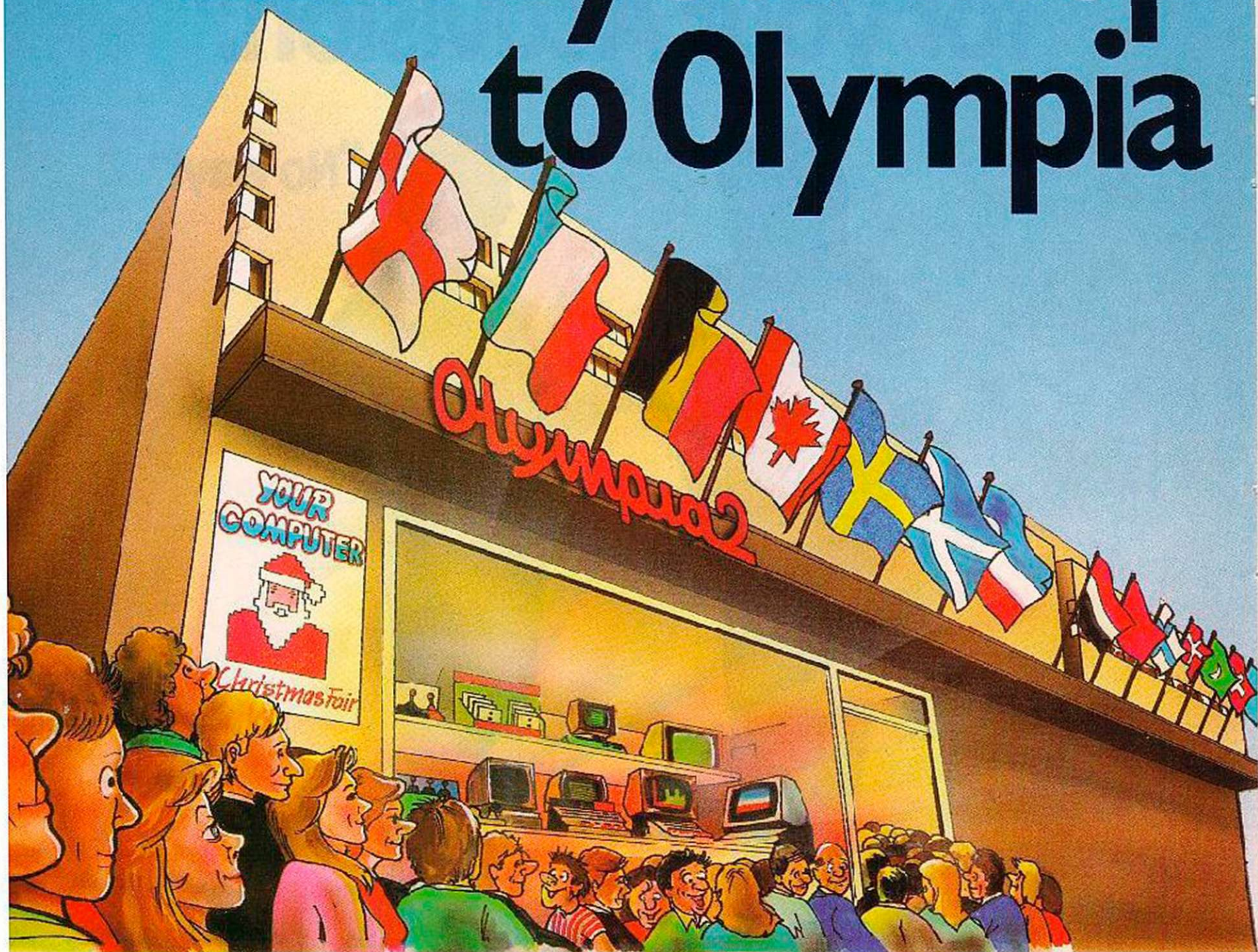

This year, pre-Christmas sales of home computers are expected to exceed £340 million. And that's without software and add-ons. Which is why a stand at the Your Computer CHRISTMAS FAIR makes more sense than ever before.

You'll get thousands of customers on a spending spree.

And this year, the Your Computer CHRISTMAS FAIR will be bigger, better and earlier than ever before. So you will get an even larger slice of a booming market.

You'll get the benefit of a mammoth promotion in top-selling computer magazines, national press and on radio.

You'll get all the comfort and convenience of the fabulous new Olympia 2 exhibition centre, right in the heart of London — Britain's biggest computer market.

Yet getting your share of this enormous market will cost less than you think.

To find out full details, just fill in and post the coupon today.

Your Computer Christmas Fair

November 30 to December 2.

Sponsored by

**YOUR COMPUTER —
Britain's leading home
computer magazine.**

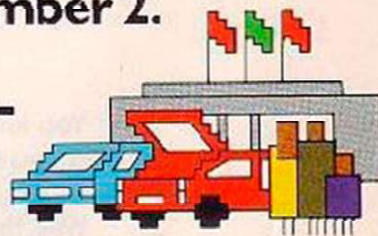

I'd like to know more about taking a stand at
YOUR COMPUTER CHRISTMAS FAIR.
Please send me full details.

Name _____

Position _____

Company _____

Address _____

Telephone _____

Send to:
The Advertisement Manager, Your Computer Christmas Fair,
Quadrant House, The Quadrant, Sutton, Surrey SM2 5AS
Tel: 01-661 3127

**YOUR
COMPUTER
Christmas Fair**



Melbourne House

Adventure



SHERLOCK HOLMES Be the world's greatest sleuth — in the most advanced and challenging adventure game ever. For the first time ever, an adventure game in which you can argue with intelligent characters. Study the clues, quest on the suspects, make the deductions — and match your wits against the most dastardly criminals in history.

MUGSY gives a totally new direction for thrill seekers — comic animation in text, stunning graphics and a full arcade game! Mugsy is your one and only chance to become the greatest gang leader with definite ill-repute. 'Da best graphics.' POPULAR COMPUTING WEEKLY. Mugsy is also definitely different. The graphics are terrific.' COMPUTER CHOICE

CLASSIC ADVENTURE This is the program that started it all. Now you can discover the excitement of Classic Adventure on your Spectrum 48K. If you are masterful enough, you too could become a Master Adventurer. 'The classic brain teaser.' MICRO ADVENTURER. 'It's excellent but be warned: it's also very addictive.' HOME COMPUTING WEEKLY

THE HOBBIT Visit J.R.R. Tolkien's Middle Earth in the most amazing adventure yet devised. 'A game by which future games will be judged.' PERSONAL COMPUTING TODAY. 'Superior to any other adventure game.' YOUR COMPUTER. 'Pure Excellence.' GAMES COMPUTING. 'More of an Experience than a program.' POPULAR COMPUTING WEEKLY

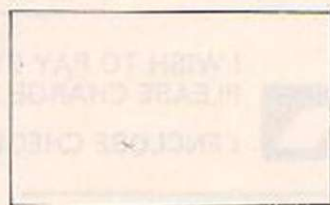
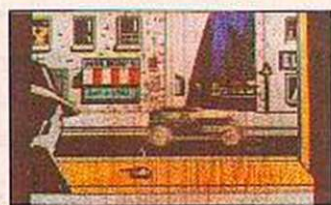

Melbourne House Adventure Games

- Please send me your free catalogue.
- Please send me:
 - Spectrum Sherlock Holmes £14.95
 - Spectrum Mugsy £6.95
 - Spectrum Classic Adventure £6.95
 - Spectrum The Hobbit £14.95

- Commodore 64 Zim Sala Bim £9.95
- Commodore 64 Classic Adventure £6.95
- Commodore 64 The Hobbit £14.95
- EBC/Electron Classic Adventure £6.95
- EBC Model B The Hobbit £14.95

All Melbourne House cassette software is unconditionally guaranteed against malfunction.

Orders to: Melbourne House Publishers, 33 Milton Trading Estate, Avington, Oxon OX14 4TD
 Correspondence: Melbourne House Publishers, Church Yard, Tring, Hertfordshire HP23 5LU
 Access orders can be telephoned through on our 24-hour ansafone (0235) 83 5006.

I enclose my cheque/money order for £ _____

Please debit my Access Card No. _____ Expiry Date _____

Signature _____

Name _____

Address _____

Postcode _____

£ _____

£ 1 p/p .80

Total

£ _____

All prices include VAT where applicable. Please add 80p for post and pack. Trade enquiries welcome.



One of America's most popular games
THE ULTIMATE IN BATTLE ACTION...

BEACH-HEAD™

NOW AVAILABLE FOR 48K SPECTRUM £17.95



- Incredible 3-D Graphics
- Unbelievable Sound Effects
- Unique Games Concept
- Multiple Screens
- High Resolution Scenario

| TOP FIFTY | | | | |
|-----------|-------|-------|--------------------------|---------|
| RANK | ISSUE | SCORE | TITLE/PUBLISHER | SYSTEM |
| 1 | 10 | 2 | Beachhead Access/US Gold | SPEN 64 |
| 2 | 35 | 2 | Mugsy Melbourne House | |
| 3 | | | Sabre Wolf Ultimate | |
| 4 | 2 | 6 | Psytron Beyond | |

Voted by U.S. Billboard magazine as the best game for sound and graphics on the Commodore 64

It's a unique arcade experience in sound and vision and a stunning display of Commodore 64 capabilities.

Another quality product from **ACCESS** Software.



Available on **CASSETTE** £9.95 **DISK** £12.95



THE ULTIMATE IN AMERICAN SOFTWARE FOR YOU ON U.S. GOLD

U.S. Gold is stocked by all leading computer stores including:

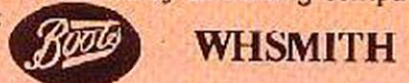

DEALERS! For information on how to become a U.S. Gold Stockist write to: Centresoft Ltd., Unit 24, Tipton Trading Estate, Bloomfield Road, Tipton, West Midlands DY4 9AH. Telephone: 021 520 7591. Overseas enquiries welcome.

U.S. GOLD

All American Software

The Key to Spectrum Machine Code Success.

Picturesque's MACHINE CODE SYSTEM is used and recommended by professional software writers, yet the excellent documentation and the friendly, easy-to-use programs have been highly recommended for beginners.

You will only buy one Machine Code System, so buy the best, the one the professionals use.

NEW IMPROVED PROGRAMS — MICRODRIVE COMPATIBLE

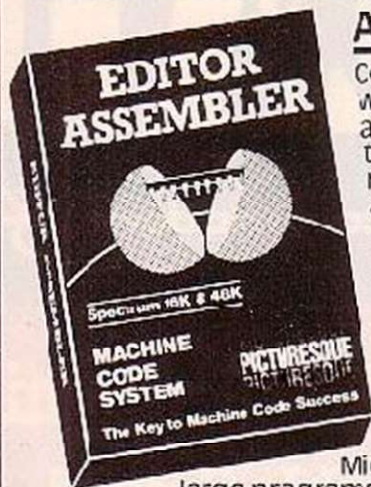

ASSEMBLER

Completely self-contained with its own line editor, giving an easy-to-read 40 column tabulated listing. Auto line numbering, line renumbering and auto tabulation make this one of the fastest and easiest Assemblers to use. 5-character abel names. Decimal, Hex or ASCII constants. SAVE/LOAD/VERIFY both the listing and Machine Code to cassette/MICRODRIVE/NETWORK.

Assemble from cassette or Microdrive into memory for very large programs. Customise to most Centronics printer interfaces, or RS232 (with Interface 1) for 80 column printout. FAST ASSEMBLY — 1k of code in 7 seconds. Assembler Directives:— ORG, END, DEFB, DEFW, DEFM, EQU, DEFL. (Microdrive and Centronics facilities only operate with 78K machines.)

£8.50

INCL. VAT & P&P.

Programs supplied on cassette with option to save onto Microdrive (cartridge not supplied)

Existing owners can obtain the new programs by returning the cassette only to Picturesque, along with a cheque/PO for £1.50 per program (inc. VAT & P&P). New cassettes will be supplied by return of post.

Available from the "SPECTRUM" chain of stores, branches of John Menzies and all good computer shops, or by mail order by sending cheque/PO to:

PICTURESQUE, 6 Corkscrew Hill, West Wickham, Kent, BR4 9BB. Send SAE for details.



MONITOR

The ideal tool to help the beginner get started, yet it contains all the commands for the experienced programmer to run and de-bug machine code programs. Inspect and alter memory contents in Hex or ASCII. Breakpoints and full register display. NOW WITH SINGLE STEPPING through RAM or ROM. Disassemble any part of memory, RAM or ROM. Dec-Hex-Dec number converter. Printer output to ZX printer or via RS232 (with interface 1) or customise to most Centronics printer interfaces. General memory management commands include Hex dump, Insert, Delete, Fill and Move. Can reside in memory with the Assembler (48K machines only) to give a complete Machine Code programming system.

£7.50

INCL. VAT & P&P.

PICTURESQUE
PICTURESQUE
PICTURESQUE

HIRE SPECTRUM SOFTWARE

OVER 280 different tapes for hire including **ARCADE, ADVENTURE, BUSINESS, EDUCATIONAL**, etc. — even an **MS/C** Compiler. **FREE** 26 page catalogue. **FREE** newsletter, with hints, tips and our top tape chart.

OVER 3000 tapes in stock, with up to 60 copies of each title for fast service. All tapes sent by 1st class post.

LOWEST PRICES — hire up to 3 tapes at a time, from 63p each for two weeks hire. (Plus p&p and VAT). European members welcome.

Tapes for sale at **DISCOUNT** prices. Telephone 01-631 9240 (9am - 5pm) or write for further details, or complete the coupon and **JOIN TODAY** — you've nothing to lose!

SAVE £3.00!!

For a limited period, we are offering **HALF-PRICE** membership to readers of this magazine. Join now. **LIFE** membership is only £3.00 (normally £6.00).

SWOP SHOP

A new service from N.S.L. **SWOP** your unwanted tapes with tapes from other members for a small handling charge of only 60p (plus p&p and VAT).

NATIONAL SOFTWARE LIBRARY

200 Mugrave Road, Chesham, Surrey SM2 6JT.

Enclose cheque/postal order for £3.00 for LIFE membership. Please rush my membership kit to me. If, within 28 days, I'm not delighted with your service you'll refund my membership fee.

Name _____

Address _____

YC8

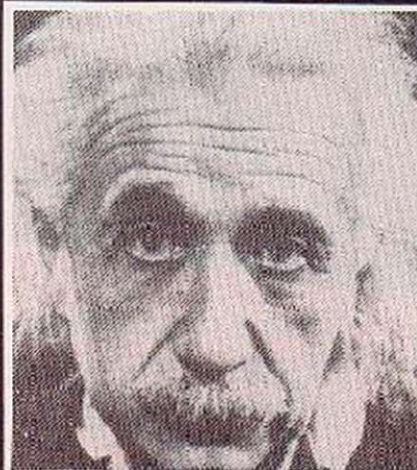

We use only 10% of our mental potential

These are the words of Albert Einstein, the greatest physicist of recent times. L. Ron Hubbard's discoveries in the field of the mind prove today that Einstein was right!

In his book **DIANETICS® The Modern Science of Mental Health** L. Ron Hubbard takes one more giant step in this direction. He demonstrates how anyone can use his discoveries to get rid of the barriers that have so far prevented him from using his mental potentials fully.

More and more people from all walks of life including technicians, artists, G.P.s, scientists, workers and managers alike, use **DIANETICS** technology today. And the thousands of written reports on their success are the best proof for the quality of this book. Get your own copy today.

BUY AND READ DIANETICS by L. Ron Hubbard. Ask for it in your local bookshop, or send directly £3.95 to:

DIANETICS Dept C., Freepost, St. Hill Manor, East Grinstead, Sussex RH19 4ZB

Your copy of this 470 page book will be sent by return post.

DIANETICS is a registered name

The SV-328 just goes on growing...



With sophisticated 3-channel ADSR sound, high resolution sprite graphics and a rapidly expanding library of software, the Spectravideo SV 328 is all you'd expect in a great games machine.

A slick word processor-style keyboard, CP/M* compatibility and massive RAM (expandable to full 144K) puts it in the business league.

Spectravideo SV 328: Memory - 32K ROM expandable to 96K, 80K on board RAM expandable to 144K. **Keyboard** - full word processor type, 87 keys, 10 function keys, built in cursor control. **Graphics** - 16 colours, 256x192 high resolution graphics, 32 sprites. **Sound** - 3 channels, 8 octaves per channel. **CP/M* compatibility** - to over 3000 existing software packages. **Storage** - cassette drive, 256K disk drive capacity. **Suggested retail price** - £262.

And for keen programmers, the easy-to-use and space saving extended BASIC gives total control of all standard functions.

There's room to grow too - with a complete range of peripherals already available, including some of the best joysticks in the business.

At £262 the SV328 is great value for money!

Spectravideo Peripherals: Cassette Drive; Disk Drive - single; Disk Drive - double; Disk Drive - full Business Pack; Mini Expander; Super Expander; Monitor; Printer with Interface Card; Centronics Interface; RS 232 Interface; 6K RAM Pack; 64K RAM Pack; 80 Column Card; Coleco Adaptor; Quick Shot Joysticks.

Also available **Spectravideo SV 318:** Suggested retail price - £186.

SPECTRAVIDEO™

Tomorrows Computers - Today

Spectravideo Ltd, 65 Garth Road, Morden, Surrey SM4 4LH
Telephone: 01-330 0101. Telex: 28704 MMH VANG

Fill in the coupon today and we'll mail you a full technical brochure and latest test reports of the amazing Spectravideo range, or see it for yourself at:

DG
LEISURE
CENTRES

Carried away at
Fenwick
OF NEWCASTLE

spectrum

and most leading computer stockists.

* CP/M is a registered trade mark of Digital Research Inc.

To: Spectravideo Ltd, 165 Garth Road, Morden, Surrey SM4 4LH

I am interested in Spectravideo computers and peripherals. Please send me the latest reports together with a full technical specification brochure.

Name: _____

Address: _____

Tel. No: _____ STD Code: _____

YC9/84



**We're as enthusiastic
about computers as you are.**

If you use computers at work or at home, Practical Computing magazine is essential reading. Every month it takes a long hard look at the most important issues in computing. It's informative, very useful and immensely readable.

It reviews both hardware and software, discusses the latest innovations and helps you get the most out of all the popular computers.

It's always entertaining, never dull. And it's at your newsagent now.

**Practical
Computing**
At work. At home

A New Leader Emerges

protek
JOYSTICK INTERFACE

**Protek
Switchable
Joystick
Interface**

It is so easy to use—there's no software patch tapes or programming required. Simply plug in and flick the switch for compatibility with all games requiring a joystick.

Available for immediate delivery,
retailing at £19.95

Protek Computing Ltd, 1A Young Square,
Brucefield Industrial Park, Livingston, West Lothian. 0506 415353.

Protek



TOUCH TABLET from KOALA.
The friendly, easy way to use your computer, as a graphics tablet to write or draw on the screen, as a paddle controller or joystick, as a custom keyboard, as a way to make music, play games, create graphs, all at the Touch of a Tablet!



SORCERER from INFOCOM.
The most powerful leader of the Enchanters must be found, tracked through treacherous mists of time, avoiding the evil sorcery where terrible death awaits, and gaining the powers and cunning of a true sorcerer.



THE ENTERTAINERS

FLIGHT SIMULATOR from MICROSOFT
A highly accurate simulation of flight in a single-engine aircraft, with working instruments, panoramic out-of-the-window graphic views, and real-time flight conditions. All the excitement of flying in a real plane!

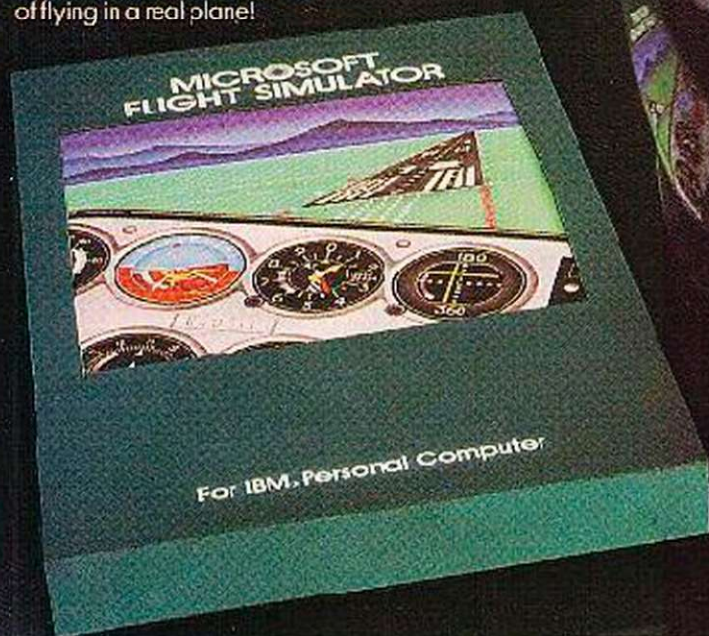

The Softsel dealer has all the software you should need: recreation, home, education and business. When you want the best service, go to a Softsel dealer who has the best back-up in the world.

Alderley Glamorgan Inkey Computer Services (0685) 861328. Birmingham Home Entertainment (021) 643 9100. The Software Shop (021) 622 3289. Bradford Peace Software Supplies (0274) 729 300. Brighton Gamer (0273) 698 424. Bristol Software City (0272) 877 245. Chalfont St Peter's Softshop (0753) 88501. Chester Computer Link (0244) 316516. Guernsey Guernsey Computers (0481) 28738. Jersey Audio & Computer Centre (0534) 7400. Leighton Buzzard Milton Keynes Music (0525) 376622. London Games Workshop NW10 (01) 965 3733. New Technology Centre SF9 (01) 859 7696. Chronosonic Personal Computers N19 (01) 263 9493. Davinci Computers NW4 (01) 202 2272. Pilot Software City W1 (01) 636 2666. Programs Unlimited W1 (01) 487 3351. Software City 382 Kings Road SW3 (01) 352 9220. Vic Caddens SE1 (01) 403 1988. Videc Palace W1 (01) 637 0366. Woodlanc Software W1 (01) 960 4877. The 64 Software Centre WC1 (01) 430 0954. Tomorrow's World Today W1 (01) 437 2040. Maidstone Galaxy Video (0622) 682575. Manchester Quodpart (061) 969 3729. Paignton Devon Computers (0803) 526303. Preston, Lancs Channel 6 Software (0772) 53 057. Redditch MCL (0527) 26051. Siccup Silica Shop (01) 301 1111. Skipton Singleton (0755) 60078. Slough Silicon Chip (75) 70639. Southampton Microchips (0703) 38899. Stafford Computroms (0785) 41899. Teddington Photographical and Optical Services (01) 977 3498/9. Willasey Microbyte (051) 630 6933. Waterlooville G.B. Microland (0705) 259911. Weymouth Silicon Chip Comps (0305) 87592. Whitstable 64 Supplies (0227) 266269. Worthing Data Direct (0903) 40309. York York Computer Centre (0904) 64 862.

SOFTSEL
The number one source for software. In the world.

*Registered trademarks.

STACK 100 LIGHTPEN - £28.75 GIVES YOUR COMPUTER EYES!

Available for: CBM 64, VIC 20, BBC/B, ATARI

SLR
(STACK LIGHT RIFLE)



AS SEEN ON T.V.!

Available for the CBM 64, VIC-20 and 48K Sinclair Spectrum, this quality rifle comes complete with three exciting games and connects to your computer with 12 feet of cable. *The SLR puts you in a different league.*

£29.95

JUST TWO OF THE EXCITING PRODUCTS IN THE STACK 100 RANGE

THE STACK 100 RANGE

CBM 64 Accessories

Cartridges:-

HELP - over 20 extra commands, disassembler and machine code monitor, DOS **£28.75**

SUPERHELP - as 'HELP' but with a comprehensive 2 pass assembler **£40.25**

ARROW - loads and saves a 32K program faster than a 1541 disk drive (use with 1530/C2N cassette deck) **£33.35**

ARROW PLUS - as 'ARROW' but with a comprehensive 6502 assembler **£44.85**

4-SLOT MOTHERBOARD - (switched) **£33.35** and a full range of printer interfaces.

Please send me a Free brochure, price list and the address of my nearest stockist

Name

Address

E. & O.E.

STACK 100

CUSTOMER INFORMATION CENTRE

290-298 Derby Road, Bootle, Liverpool L20 8LN

Trade Enquiries: 051-933 5511 ask for Trade Sales

All prices are inclusive of VAT and delivery.

Ring for sample Printout, Full Spec and latest Price

PRINTER BARGAINS

| | |
|--------------------------------|-----------------|
| STAR DP 8480 (RS232) 197 | £207.00 INC VAT |
| STAR GEMINI 10X | £235.00 INC VAT |
| STAR GEMINI 15X | £390.00 INC VAT |
| STAR DELTA 1C | £368.00 INC VAT |
| JUKI 6100 | £420.00 INC VAT |
| CANON FW1080A | £385.00 INC VAT |

Securicor delivery £8.00

CJE Micros BBC Printer Packs for Star, Canon & Juki Printers.

1. the Printer.
2. Delivery by Securicor.
3. Cable to the BBC 1-3 Meters.
4. Screen Dump Program (M/C Source).
5. Text Dump Program.
6. Function Key Set Up Program, for use with word wise.
7. Function Key Label Printing Program for use with above.
8. View Printer Driver.
9. 100 Sheets of Paper.
10. A Mains Plug with a 3 amp plug.
11. Booklet giving details of using the Printer with a BBC.

| | |
|---|------------------------|
| PRINTER PACK PRICE | Printer Price + £20.00 |
| CJE Printer Packs for other Micros include - Printer Cable, Paper, Mains Plug & Delivery. | |
| BBC Model B | £399.00 |
| BBC Model B + D1 | £469.00 |
| ELECTRON | £199.00 |

Phone Credit card orders welcome

CJE MICROCOMPUTERS
Dept YC, 78 Brighton Rd, Worthing,
West Sussex.
(0903) 2139100

BETA BASIC 1.8

**ENHANCED BASIC FOR SPECTRUM 48K
FOR GRAPHICS - STRUCTURED PROGRAMMING
- DATA HANDLING**

Release 1.8 is more powerful than ever! We don't have space to do this program justice - if you can't believe the ad, send us a large S.A.E. for further information.

Features: Commands are single-entry keywords in graphics mode. Syntax is checked on entry. Fully compatible with Spectrum Basic. Microdrive compatible. Comprehensive manual.

NOTE: Release 1.0 is still available for 16/48K Spectrum at £11.00.

ALTER screen colours (general or specific)
AUTO line numbering
BREAK out of code loops
CLOCK (digital) clock
CURSOR CONTROL CODES allow strings to have complex shapes
DEF KEY user definable keys
DELETE a block of lines
DO LOOP structure
DPOKE double poke
EDIT specified line
ELSE used with IF... THEN
EXIT leave DO-LOOP

FILL enclosed area with specified ink or color
GET wait for keyboard
JOIN two program lines
KEYIN a string
KEYWORDS new keywords on/off
LISTLIST like TO and
USED used with GOTO, COSUB
ON ERROR trap errors (with LINE, STAT and ERROR)
PLOT a string may contain cursor control codes
POKE a string
POP Basic's stack
PRINT, **USER PRINT**, **PRINT PROC** (for named procedures)

RENUM versatile renumber
RPL all or part of screen in any direction by specified number of pixels, with or without attributes
SCROLL like RPL, but without wrap-around
SORT arrays (very fast)
SPLIT program lines
TRACE program execution
UNTIL used with DO or LOOP
USING used with PRINT
WHILE used with DO or LOOP
XDE, **YDE** move PLOT origin
XR2, **YR2** change PLOT scale

AND (bit-by-bit)
BINE decimal to binary
CHARS number to 2 characters
COSE fast cosine
DEC hexadecimal to decimal
DPOKE double PEEK
FILLED fill area

FUNCTIONS

HEX9 decimal to hexadecimal
INSTREQ string search
MEM free memory
MEMORY all of memory as a string
MOD modulus
NUMBER 2 characters to number
OR (bit-by-bit)

RNDM fast RND
SCRNS recognises user graphics
SINE fast sine
STRINGS reports strings
TIMER current time
USING format numbers
XOR (bit-by-bit)

Only £11.00 inclusive! (Upgrade price for Release 1.0 owners is £4.00. This includes a 12-page supplement to your manual. Please quote date of purchase. If you did not purchase from us state supplier and return original cassette.)

Please send me:
Beta Basic, Release 1.8. Payment of £11.00 is enclosed.
(or £11.50 for foreign orders). Cheques payable to BETASOFT.

I don't believe it! Please send me full details of Beta Basic 1.8. I enclose a stamped addressed envelope.

NAME:

ADDRESS

BETASOFT
92 OXFORD ROAD, MOSELEY,
BIRMINGHAM B13 9SQ.

SINCLAIR
 ORIC, COMMODORE
 ACORN, MEMOTECH, ETC

MICRO

We export Microcomputers
 and Peripherals to all Countries
 Any make. Any Quantities
BIG DISCOUNTS

EXPORT

send for comprehensive price list to

Dept H
 MICRO-X LTD
 765-767 HARROW ROAD, LONDON NW10 5NY
 TELEPHONE 01 968 5622 TELEFAX 915866 MICROX G

REPRINTS

a ready made sales aid



If you are interested in a particular article or advertisement in this publication why not take advantage of our reprint service. We offer an excellent, reasonably priced service. For further details and a quotation

Ring Michael Rogers on 01-661 3457

CURRAH μ SPEECH



Speech Synthesiser for ZX Spectrum

The **CURRAH μ SPEECH** is ready to talk immediately on power-up, has an infinite vocabulary and outputs speech and ZX Spectrum sound through your TV speaker. There is no software to load with **μ SPEECH** — sophisticated Gate Array technology means you can just plug in and start constructing words and sentences like this:

LET SS = "sp[ee]k [nn][oo] [ee]vil" will say "speak no evil." Further commands control the "voicing" of keys as they are pressed, and an intonation facility allows you to add expression to the speech.

μ SPEECH is fully compatible with ZX Interface 1 and may be used with the **CURRAH μ SLOT** Expandable Motherboard, allowing easy expansion of your ZX system. **μ SPEECH** and **μ SLOT** will also be compatible with the **CURRAH μ SOURCE** unit when it arrives later this year, allowing you to write **Assembler** and **FORTH** statements directly into your **BASIC** programs!

Top selling games like **ULTIMATE'S Lunar Jetman** feature **μ SPEECH** voice output — watch out for other titles from Bug-Byte, CDS, Ocean, Quicksilver and PSS.

μ SPEECH is available from COMET, W.H. SMITH, WOOLWORTHS, GREENS, BOOTS, JOHN MENZIES, SPECTRUM STORES and good dealers nationwide — or use the form to order the **CURRAH μ SPEECH** — winner of the CTA 'Product of the Year' award 1984.

CURRAH

To: MicroSpeech Offer, P.O. Box 1, Gateshead, Tyne & Wear, NE8 1AJ

Please supply **MicroSpeech** unit(s) at **£29.95** each incl. VAT & P & P

..... **MicroSlot** unit(s) at **£14.95** each incl. VAT & P & P

Name (please print)

Address (please print)

Postcode

I enclose a cheque/PO payable to 'MicroSpeech Offer' value £

or debit my Access/BarclayCard No.

Cardholder Signature

Credit Card Hot line 091 - 482 4683 Please allow 28 days for delivery. Offer valid UK only

See us at the PCW Show Stand 329

YOUR COMPUTER CLASSIFIED

01- 661 3036

Contact: Claire Notley

ADVERTISEMENT RATES

Copy Date

Lineage: 50p per word
(Min 20 words)

Box No: £4.00 extra

Lineage advertisements are prepayable and the order form published in this section should be completed and returned with remittance. Credit Card facilities are available.

Display — rates per scc (Min. 2scc)

| | | |
|-------------------|---|-------|
| One insertion | : | £9.00 |
| Three insertions | : | £8.70 |
| Six insertions | : | £8.50 |
| Twelve insertions | : | £8.00 |

Display advertisers should preferably reserve space by phone.

Closing date for Classified advertisements is the 24th Aug. for the Oct. edition.

Post to

Your Computer, Classified Department, Room H211, Quadrant House, The Quadrant, Sutton, Surrey SM2 5AS.

Britain's Biggest Selling Home Computer Magazine

VIC-20 USERS

Cartridge and Cassette Back-up

Protect your software investment — Save Cartridge & port wear. Back-up cartridges run like originals — Customise your machine

Victrix 1: Cassette Back-up (5 ways)
Victrix 2: Cartridge Back-up (onto tape)
Victrix 3: Reset & Slot Power Add on's

Send £2.50 each or £8 for all 3 to:

M. Parker, 52 Laurie Avenue, Forest Fields, Nottingham NG7 6PN.

(Mail order only please)

JETSET WILLY

Monsterless mansion, bugless attic, unlimited lives. £1.50 only.
SONICSOFT, 20 Coakstown Rd, Dublin 14, Ireland.

ORIC 1 Single joystick interface. Atari compatible joysticks, software programmable for any keys. Operates some commercial games. £9.99 inclusive. Marder Electronics, 26 River Clcae, Abingdon, Oxon.

PROGRAMS WANTED expanding on Spectrum, Oric, Atmos and Commodore (disk). Anything considered, excellent royalties paid. Membership available. Eagle enterprises. 354

16K ZX81 Tank Battle. Two player m/code game with mires option. Send £3.50 to Robert Harvey, 159 Wynchgate, London N21.

BRUNWORD FOR THE MEMOTECH

- Wordprocessor for MTX 500/512.
- No additional hardware required.
- Uses memory similar to discs (MTX 512 will store up to 12 pages).
- TEXT mode with insert/overwrite, word wrap, continuous screen edit, full cursor control & right justify.
- ESCAPE mode based on key words but only the first letter is typed. SAVE, LOAD, DIRECTORY, GET from memory, MEMORY save, KILL, PRINT, TEAR, WEAVE, REMOVE, INITIALISE, CLEAR ON SCREEN, FIND.
- % AUTOMATIC FORMATTING UP TO 130 columns.
- PRINTER CONTROLS, can be embedded in the text (single character).
- ONLY £19.50 inc (OR SEND FOR FREE 14 PAGE MANUAL).



**BRUNNING SOFTWARE
34 HELSTON ROAD,
CHELMSFORD, ESSEX CM1 5JF.**

SWAPT!

IF YOU'RE BORED WITH YOUR SPECTRUM SOFTWARE There's 200+ titles you can have Cheap & easy, only 99p per swap, incl. P&P (UK) NO EXTRA COST SEND A SAE + 5p (REFUNDABLE) TO SWAPT!, 5 Longhey Road Wythenshawe Manchester M22 7JA (5p ie 5p coin)

ANTICS - complete map of next, plus how to find Boris. £1 plus stamp: A. Gattner, 105 Cabell Road, Guildford, Surrey GU2 6JD.

EDUCATION

Whether it be SPECTRUM, ZX81 or BBC B, we hold in stock probably the largest range of educational software available, currently in excess of 30 DIFFERENT EDUCATIONAL CASSETTES produced by the major software houses. SAE for catalogue and SPECIAL OFFERS. Also GAMES TAPES: 3 for price of 2. LOCATOR, 12 FERNHALL DRIVE, REDBRIDGE, ESSEX, IG4 5BN.

tel: 01-530 5575

GRAPHICS TOOLKIT 16/48K Spectrum 30+ routines, accounts, tape catalogue system and strategy game. All for £2 + s&e to I. West, 90 Anson Road, Shepshed, Loughborough, Leics. 356

SPECTRUM 16/48K "Raquel" presents her games pack for age 16 and over. Only £3.99. I. Brooks, 1/ Malvern Coleman Street, Southend, Essex.

TOP PROGRAMS — TOP DISCOUNTS

SPECTRUM 48K:
£4.95 Luvator, Iscoro, Uustman, Factory Breakout, Jack & Beansalk, Kuzmo, Kangu Twilight Zone (BK), Worst things happen at Sea, T.L.L.
£5.95 Automania, Code Name Matt, Full Throttle, Antics, World Cup Football, Mugs.
£5.50 War of Worlds, Psytron.
£9.95 Hulk Adventure, Lords of Midnight, Sabre Wolf.
COMMODORE 64:
£5.95 Cavalor, Gilligans Gold, Blue Thunder, Gyropod.
£5.95 Wembleton, Bango, Cybotron, Automania, Football Manager
£7.95 Arnie Challenge, Forbidden Forest, Slinky.
£9.95 Beach Head, Hulk Adventure, Cybotron disk.
ORIC 48K (All ATMS compatible):
£5.95 Harrier Attack, Pasta Blast, Scuba Dive, The Ultra.
£3.50 Green Cross Road, Invaders, Probe 3.
£5.95 Xenon, Zorgus Revenge, Rat Splat, Ultima Zone.
EDUCATIONAL:
Kosmos French, German, Spanish A or B (Spec BBC, Eccl) £1.50. Longman Chemistry Physics, Maths; C Level Comp. Studies Spec, CBMC4) £6.95.
SPECIAL OFFERS:
Cascade 50 Games (Spec, Atari, BBC, C3M64) Drag, Disc 1) £9.50.
D.A.C.C. 747 Flight Sim (Atari, BBC, CBMC4, Drag, Eccl) £9.95.
JOYSTICKS — Quickshot II £9.95, Quickshot I £7.95.
Spectrum Interface Protek II £17.95, Kempston Type £1.95.
Pieces incl. P&P (Europe +10, others +£1.00)
C4P.O. 10

SUPER BREAKER

For the Commodore 64, this utility will make back-up copies of tape programs onto tape or disk. Also now available a tape to disk utility for transferring cassette software onto disk. Both are supplied with full written instructions. Available on tape at £4.99 each or on disk at £6.99 each. Fast despatch. (Not for use on 'Fast Loader' programs). Send cheque/PO, or sae for details, to

**CLARK KENT SOFTWARE
26 North Cape Walk,
Corby, Northamptonshire**

AMSTRAD, Atmos & Oric-1 Software Club. Send SAE for details. 26 Beechey Drive, Cardiff CF5 3SN.
ATARI 64K Disc-drive recorder platter-printer software value £1000 plus sell for £700 s.n.c.o. tel: 01-902 4267 (W 455 0463 (H) Ask for Rev.

DATA DUPLICATION

**M.G. Copies, Burntwood, Walsall,
West Midlands WS7 0ES
0543-480387 or 05436-75375
(24 Hrs)**

Duplication, quality cassettes, printing with competitive prices and efficient turn-around.

**OJ SOFTWARE
(sae for list, state machine)
273 Mossy Lea Road,
Wrightington, Wigan, Lancs
WN6 9RN**

COMPLETED detailed character analysis, lucky attributes & prediction. Disk only. £12.50 to G. James, 120 High Street, Hurstierpoint BN6 9PX. 353

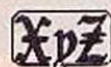

SPECTRUM SOFTWARE



48K Graphik Adventure
DM 34.90 | £6.49



16 & 48K Poker Game
DM 22.90 | £5.95



48K Arcade Action
DM 31.90 | £7.95

SABRE WOLF, ATIC ATAC, JET SET WILLY, MT. OF KET, TPL. OF VRAN, FRED ...

XYZ ANTONIUSSTR. C D 4100 MUENSTER.
TEL. 0251/56583

Spezial de neuem Programmier- und Software!

COMMODORE SPECTRUM

(S)TOP SECRET(S)

48K Spectrum/Commodore 64/Mic 20. Puts you back in FULL control of your MICRO. A machine code UTILITY to S UP most basic/machine code incl. HEADERLESS Programs. Protected or not, without crashes. If you can stop them you can learn their SECRETS/LEARN/LIST/MODIFY. Ideal MICRODRIVE/ DISK DRIVE companion. PLUS Mach. Code DISASSEMBLER. List Mach. Code/BASIC/Hidden Basic.ROM. PLUS an advanced HEADER READER. PLUS HEX/DEC DEC/HEX converters. PLUS SECRET INFORMATION about how the professional keep their secrets hidden. CASS-£5.95 DISK-£9.95 MICRODRIVE-1.95 previous customers EXCHANGE previous tape plus £1.50; for NEW copy.

BYTE BACK

Complete companion to (S)TOP SECRET(S). A hardware/software package containing: (i) A RESET device which plugs into your micro, no mods needed. (ii) A m/code program which completely RESTORES programs after reset. (iii) A mach. code ASSEMBLER, enter mach. code easily in understandable form. IDEA for MODIFYING or writing programs. (iv) A superb m/code DISASSEMBLER which lets you examine, and explains mach. code. PLUS with BYTE BACK it is virtually impossible to CRASH your own programs. CASSETTE - £6.95/DISK £9.95.

SUPERKIT 64

COMMODORE 64 ONLY

SUPERB TOOLKIT of m/code routines: Complete RE-NUMBER/AUTO LINE/TRACE/FIND/AUTO RUN/BLOCK DELETE/MEMORY SAVE and more. Software controlled flexibility, and at a sensible price. CASSETTE - £6.95/DISK - £9.95 with SUPERKIT 64, BYTE BACK and (S)TOP SECRET(S) you have almost unbeatable STOPPING power and all the EXTRA UTILITIES for writing/modifying programs. SPECIAL DISCOUNT for COMMODORE OWNERS. Buy all three programs - £2.00p discount. Eliminate C2N Dataset Problems.

REKORDAKIT 64

HEAR your Dataset performing. Keep C2N in tip top condition. Simple to use plug-in device which reproduces audio output and a TEST TAPE to ensure tape heads are correctly set. £5.95.

REMEMBER state Computer.

Check/PO to:
ASH BYPRODUCTS,
P.O. Box 510
Birmingham B17 9ES

TYPERIGHT (T.M.) learn touch-typing, structured course. Give yourself and your children the right start in this important skill. For Commodore, VIC 20, Acorn, Dragon, Spectrum, Tandy. Only £3.50. Robsoft, Swysfa Conwy Rd., Penmaenmawr, Gwynedd. 339

MICROCRIVE Menu Generator - Programs/Code erased/loaded off any microdrive via automatic menu. User friendly. Copies itself. Listing F1 25, cassette F4 25, cartridge F6 50. MSDFT, 14 Slade Road, Barry, S. Wales. 330

EXPORT YOUR PRODUCT

Major New Zealand Mail Order House requires new products to market. All types of Hardware, Programs, Utilities, Books etc. Send details & samples to:

RODA IMPORTS
P.O. Box 26-074
Auckland, N.Z.

BLANK TAPES & DISKS

- delivered to your door

10 x C15.....£4.50
10 x C20.....£4.80

Datalife or 3M floppy disks
5 1/4" s.s. d.d.... 10 for £19.99
5 1/4" d.s. s.s..... 10 for £39.99

Prices include op and VAT. Send large SAE for details of our full range. For immediate despatch send cheque/P.O. to:

CAROUSEL TAPES
P.O. Box 5,
Dursley, Glos. GL11 5TX
Tel. 0453 844061
(24 hr answering service)

DRAGON Clone-it will back-up copy all m/code programs upto 30k including Cuthberts, 100% m/code 16 K. Hunter, 7 Balladen Rossendale, Lancashire. 335

THE BIZ! The amazing new Spectrum 48K Record World game. £3.50 includes postage, payable M. Taylor, 58 Aspinall Road, London SE4. 336

STUDY Bookkeeping and Accounts at home using our 'O' level cassette course. Also short courses on computer programming, wages, PAYE, VAT. Trevor Burton, Banbury, Cheshire CW6 5SX. Tel. 0829 260888. 338

ORIGINAL programs urgently needed Onic and Commodore 64. Educational or Games. Cash payment or royalties. Professional ethics strictly adhered to. Send your program for consideration. Knight Products (UK) Ltd., 71 Colne Road, Earby, Lancashire BB8 6XL. 257

FAVOURITES

ZAXXAN Spectrum.....£4.95
JET SET WILLY Spectrum.....£5.35
TFASHMAN Spectrum.....£5.35
FOOTBALL MANAGER Spectrum.....£5.25
MANIC MINER CBM64.....£5.35
CAVELON CBM64.....£6.21
THE BOSS CBM 64.....£8.05
BEACH HEAD CBM 64.....£8.95
COSMIC CRUISER BBC.....£4.95
FCRTRESS BBC.....£8.05
SNOOKER BBC.....£8.05
AVIATOR BBC.....£13.45

and more
Please state your machine and send SAE for list.

Cheques/PO's to:
DEPARTMENT YC,
UNIVERSAL PUBLISHING,
P.C. BOX 458,
LONDON SE27 0NS.

BASCODE Skilled and friendly machine code programmes wanted for most popular home micros to join our team of advisors helping BASICODE users by phone. Working from home, evenings and weekends, September-December - £5.00 per hour. For further details write to: BASCODE Helpline, PO Box 7, London W3 6XJ.

ARROW TRAPSEER
Transfer your favourite games to disk both multi part and Auto Runs, works with most software.....£7.00

ARROW DISKDOCTOR
Now you can recover scratched files easily, edit any byte on any disk. In Hex or Alpha, alter programs, edit the directory, format disks.....£8.00

ARROW MICRO SERVICES
20 Portmeadow Walk
London SE2

SPECTRUM CLUB!

FREE ADVENTURE GAME

- Enjoy Games, Adventures, Utilities, Educational Software etc. from JUST 12½p PER WEEK!
- Exchange your unwanted games from just 50p.
- Buy new games at the best possible discounts.
- OVER 300 TOP TITLES now available.
- Regular Newsletter full of news and information.
- Every new member gets a FREE "CREEPY CASTLE" CASSETTE (normal price £4.95) to keep!
- All the benefits of other clubs and MUCH MORE.

Send just £3.95 and we will rush your Membership Kit and FREE GAME to you - SPECTRUM SOFTWARE CLUB. (YC), 287-291 HIGH STREET, EPPING, ESSEX, CM16 4DA.
(or send a 16p stamp for catalogue)



SUPERIOR TAPE COPIER

We are convinced that the new 007 SPY is the very best Spectrum tape copier available on cassette. Find a better one offering better value for money, and TWICE your money will be refunded.

- Can copy multipart programs all in one go automatically.
- Can copy a genuine 48K long program.
- Certainly the easiest copier to use.
- Has copied all programs we know of.
- Microdrive Compatible AND includes program to transfer tapes to your Microdrive.
- Post free even to Europe.

007 SPY IS JUST £3.95

ZX-GUARANTEED (Dept YC)
39 Chadderton Drive, Unsworth,
Bury, Lancs. Tel. 061-766 5712

Very short but powerful programs
Strongly recommended by educational authorities

EDUCARE'S 50

Book of fifty programs for primary education

Spectrum ZX81 11K1 £5.95 BBC Micro/ Electron £7.95

EDUCARE 139; Sleena St.
London SW1X 9AY.

SUPER BREAKER

For the Commodore 64, this utility will back-up most popular cassette programs onto tape or disk. Also now available a tape to disk utility for transferring cassette software onto disk. Both are supplied with full written instructions. Available on tape at £4.99 each or on disk at £6.99 each. For a fast turn round or orders, by first class post, cash cheque/P.O., or SAE for details, to:

CLARK KENT SOFTWARE
26 North Cape Walk
Corby, Northamptonshire.

QL Software

Microcosmic will shortly be writing games utilities and educational programs for the Sinclair QL.

For a list of available software (all on microdrive cartridge) send a large SAE to:

MICROCOSMIC

Sales Dept.
6 Robertsfield, Thatcham,
Newbury, Berks.

123

Dealer enquiries welcome

AMSTRAD COMPUTERS - GREEN
£217.50 - COLOUR £297.50
BROTHER, HRS PRINTERS £147.50
SPECTRUMS 48K £119.90
SPECIAL OFFER, V.A.T. INC P&P FREE.
PAY COMPUTEC,
135-137 Glasgow Road, Glasgow
G69 6TA. Tel. 041 771 0074

AVAILABLE NOW

Supplied on Microdrive
@ £10.95 each
H. Gostling, 45 Aintree Close,
Newbury, Berks.

Spectrum Markbook (48k)

A full teacher's markbook on computer. Holds all your classes; easily updated; automatic totals, percentages, orders of merit, mean & S.D. graphs etc. Now completely revised. More features than ever. £3.50 with manual and demo.

Mentor Software
69 Beech Rd, Halton, Lancaster

STOP-REVEAL

A unique cassette for the 48K Spectrum. Genuinely lets you:

- STOP virtually all programs, BASIC, MACHINE-CODE and even HEADERLESS-FILES, protected or not.
 - REVEALS the hidden Basic in Machine-Code programs. (Could be dues in adventure games).
 - LISTS actual Machine-Code on your video.
- Now you can STOP, LIST, MODIFY, STUDY most Spectrum programs at your leisure. (And cassette is Microdrive compatible). Includes a DISASSEMBLER so can even study Sinclair ROM, etc, plus the most Advanced HEADER-READER ever written, plus pages of SECRETS OF THE TRADE explaining professional methods used to hide lines/programs, etc.
- YOU CANNOT GET A MORE POWERFUL CASSETTE
- Even STOPS/REVEALS programs which are a genuine 48K long!

POST £5.95 FREE
(Europe add £1. Other areas add £2)
KERR, 24/25 HIGH STREET,
KING'S LYNN, PE30 1BP.

Don't read my name in Roman Britain. I specialise in software development and data processing for most cassette based systems. Don't forget to buy the book.

FAST TUNING 0869 252831 COMPETITIVE PRICES

Do not forget to buy the book 'The Book of the Month' cassette. Write to: **Book of the Month Ltd.** 01-438 9481. For more information about our services please contact us by phone.

FREEPOST TO: WINDY HILL, LAMINGTON, BRISTOL, GSKA 910.

SPECTRUM 48K***HISTOGRAMS LINE GRAPHS*****PIE CHARTS**

At Last! 4 practically very useful programs supplied on TWO cassettes or microdrive cartridges designed for 48k Spectrum users to display E record Data on Coloured charts/graphs in seconds.....

1) CASSETTE 8410
Side 1 - Histogram Program. Up to 28 bars, clustered bars.
Side 2 - Line graph program. 20 lines, 28 points per line.

2) CASSETTE 8420
Side A Stacked Bar Chart Program. 14 stacks, 12 bars.
Side B - Pie Chart Program. 12 Pies, 20 segments per pie.

★ User - friendly Menu
Drive Options
★ Selectable 1-3 alternate coloured bars/lines/segments.
★ Automatic scaling & labelling of the vertical axis.
★ Exponent indicator.
★ Built in options for labelling the horizontal axis/pies/segments.
★ Facility to design your own labels. Tabulation of data & descriptions.
★ Expansion of displayed data.
★ Save to tape facility
★ Print ★ Photograph
★ Microdrive facility

A MUST for ALL performance analysis and small businesses.
Interested? Send cheque/P.O. for £7.50 per cassette incl P&PI or £14.95 per microdrive cartridge to:
R. E. MAJOR, B. Tech (Hons)
49, Wesbury Road,
Brerewood,
Essex CM14 4JS
Supplied with Comprehensive Instructions
QUICK DESPATCH

MicroDrive Users Club

CALLED Microdrive Exchange.
This news letter club is designed to help by the exchange of info and ideas.
Did you know you can pay up to £5 50 for a cassette to transfer tapes to microdrive and then they DON'T RUN?
Issue 1 will include: How to avoid this, plus transferring programs which normally over-write the microdrive map, transferring VL-File, Zoom, etc, etc.
Membership is £5 per year. Europe £8 per year.
Please make cheques payable to ZX Guaranteed.
Microdrive Exchange is run by
ZX GUARANTEED
29 Chedderton Drive, Unsworth,
Bury, Lancs.
Tel: 061-766 5712

AMSTRAD COMPUTER DUST COVERS

Made in one piece, from matching proofed anti-static nylon. Piped in green with Amstrad CPC 464, printed keyboard section £5.95. State mono or colour.
BDD Covers
39 Manse Ave.,
Wrightington, WN6 9RP.

SPECTRUM ZX81 £25 KEYBOARDS £25

Cased keyboard D socket accepts Atari type joysticks keypads etc. No need to buy expensive interlocks, 42 full travel read magnet keys fast positive action, 2 shift keys plus spacebar 12" x 9" x 3" case, computer and power supply fit inside case. No soldering, easy fitting. 7-14 days delivery
Phone 0662 474973

DO IT WITH TRANS-EXPRESS

Would you like to transfer your Spectrum programs from

① MICRODRIVE TO MICRODRIVE ③ TAPE TO TAPE
② TAPE TO MICRODRIVE ④ MICRODRIVE TO TAPE

Then do it with
TRANS-EXPRESS

TRANS-EXPRESS is the most comprehensive package of four microutilities for transferring Spectrum programs. They are user-friendly, simple to use, reliable & very efficient. They go much beyond what similar attempts failed, enabling you to transfer any kind of program up to the full 480K length - provided you do not infringe copyright. TRANS-EXPRESS is an essential microdrive companion and an invaluable software back-up utility.
We are offering the entire package for £9.95 or a combination of TAPE TO MICRODRIVE & MICRODRIVE TO MICRODRIVE for £7.50. You can also buy each of the four programs separately for £5.50 only. 244

TAPE TO TAPE

Please send me a copy of TRANS EXPRESS ①②③④ please tick when applicable I enclose cheque/P.O. for YC
Name (Please add £1.00 for orders outside UK)
Address 215
ROMANTIC ROBOT 113 Melrose Ave, London NW2

VIC TAPE BACKUP will backup most Vic-20 programs, in BASIC, machine code, or both. Detailed instructions are printed on the card inlay. VIC Tape Backup is easy to use, with prompting by colour and by sound - when the colours change and the tone sounds, the copier is ready! Load errors are signalled, so poor originals can be tried again. Works with all memory configurations - one machine-language program allows automatically for memory differences! Send crossed cheque/P.O. for £7.95 to: **Level Software Ltd, PO Box 55, Shirley, SOLIHULL B90 7SL. Tel: 021 643 6728.**

AGENTS WANTED
To supply hardware/software to clubs home, schools, etc.
Up to 25% commission.
£20.00 worth of free software with your first accepted order.
Send for details to Home Base Micro Supplies: 4 Queenswood Avenue, Northampton.

COMMODORE 64 AND VIC 20 PROGRAM COPIERS

They copy most cassette based BASIC, machine code and multi-part programs of any size. Both copiers are written in machine code. Programs using a range of protection techniques can be copied easily. Audio and visual prompts are used for easy operation. Full instructions are contained in the programs.
VIC IMITATOR £6
IMITATOR 64 £6
Please state which is required and make cheques/P.O.s payable to IAN WAITE.
Send orders to:
IAN WAITE, Dept YC,
11 Hazletarrow Road,
Sheffield, S1 8AU.

REPRINTS

a ready made sales aid



If you are interested in a particular article or advertisement in this publication why not take advantage of our reprint service. We offer an excellent, reasonably priced service. For further details and a quotation

Ring Michael Rogers on 01-661 3457

SPECTRUM CHESS

**Dare you face
The Turk**

The original Turk was an eighteenth century automation, a life-size mechanical figure resplendent in Turkish costume and seated behind a wooden cabinet on which a chess board and pieces were placed.

OCP now offer you the twentieth century equivalent of that Turk — a chess-playing computer program. **The Turk challenges you to a game of chess!**



**MANY
OPTIONS
INCLUDE:**

- 6 Levels of Difficulty
- Demonstration Mode
- Board Editor
- Games Printout Facility
- Blitz Chess Against the Clock
- Two Player Mode
- Unfinished Games can be Stored
- Recommended Move

**FULL INSTRUCTIONS
PROVIDED**

**CHESS THE TURK
ONLY £8.95**

Post order to
**Oxford Computer
Publishing,
P.O. Box 99, Oxford.**

134/4

VIC-20 Tape Copier. Copies almost all games, any HAM. Money back guarantee. £3.95. Griffiths, 8 Moss Close, Rugby, Warks. CV22 6SD.

LYNX COPY CAT

This is a collection of programs for serious and non-serious programmers alike. COPY CAT will Load/Save/Verify, with or without auto-run m/c, basic, and multi-part programs and make security copies at a different speed to the original. Two full disassemblers, DISM at ram top, DISB at the bottom of program ram, so that all of the coding can be examined. BFEAK a short relocatable m/c program that activates the 'BREAK' key so that in the event of a program crash, or whilst a program is running, a press on the key will return you to the monitor.

Send cheque/PO for £7.50 tax

AUTRAC COMPUTING
1 Fox Road, Mashbury,
Chelmsford, Essex, CMI 4TJ

MAKE YOUR OWN TV MOVIES

using

SPECTRUM 48K PROGRAM

Tape your movies and pay back to amuse friends. ZX-81 and Spectrum morse-code reading progs.

for details:

PINEHURST DATA STUDIOS
69 Pinchurst Park, W. Moors
Wimbome, Dorset BH22 0BP

COPYMATE 64

Simply the best CEM 64 tape back-up utility you can buy. SAVES TO TAPE AND/OR DISK. Two programs on one cassette gives UNEQUALLED RANGE. A professional product supplied on a quality cassette with full instructions. £5.75

RESET SWITCH for CBM 64 and Vic-20, simply plugs into your computer, with free program on tape to recover control from lockouts, auto runs, etc. £5.99

HORIZON SOFTWARE
15 Bamburg Close
Corby, Northants NN18 9PA

SPECTRUM SHADOW — ROM disassembly. Fully commented. Cassette with printing program £2.50. Printed £5.95. Millsot 54 Petters Road, Ashted, Surrey.

TECTEL ROBOTICS CONTROL BOARDS FOR HOME COMPUTERS

ORIC
ORIC DUBBRY £24
1 of 16 channel controller
ORIC ADC £34
Superfast 8 channel analog — digital scanner, 8 bit resolution.
ORIC I/O port £39
15 programmable channels
ORIC PRINTER £95
25 co. matrix, graphics double sized print, ink & ribbons

ZX81
ZX81 DUBBRY £22.50
1 of 16 channel controller
ZX81 ADC £34
Superfast 8 channel analog — digital scanner, 8 bit resolution.
ZX81 I/O port £34
16 programmable channels
ZX81 HI-RESOLUTION GRAPHICS £28
stunning results.

TEXT SOFTWARE a new range of educational programs.

TODDLERS (pre school)
LEARN your A-PHABET
LEARN to COUNT
LEARN your COLOURS
LEARN your SHAPES
ABOUT the HOUSE
ABOUT the KITCHEN
ABOUT CLOTHES
£3.95 each

MUMS & DADS
TEXT cookbook (English)
TEXT cookbook (Chinese)
TEXT cookbook (Italian)
TEXT cookbook (Indian)
TEXT Wine & Beer Making
TEXT Cookbook Desserts
TEXT Cookbook Confection
£5.35 each

Send cheque or Postal Order to:

TECTEL

Telford Opportunities Centre, Halesfield 14,
Telford, Shropshire.
Tel. 0952-581738

P&P £1.50 for control boards £1 for tapes

New Releases

of computer software for the CBM64 BBC, Spectrum, Atari, new list every 13 weeks. Also software for the Ti99/4A, Cragon, Electron, Lynx, Sharp MZ700, Tandy, Vic 20, ZX81. Please state computer business and games software.

M. J. SEAWARD
St. Olafs Road, Stratton,
Nr. Bude, Cornwall.

G. A. BOBKER DOES IT YET AGAIN

How long will it be before competitors begin to catch up to this program? New TAPE 3 lets you STOP Headerless Files and unmergeable Basic programs so can study them and/or transfer to Microdrive. Includes pseudo disassembler which gives all the relevant info in clear plain English.
TAPE 3 — £3.50 (£3 to MDX members)

ZX-GUARANTEED (Dept YC)
29 Chaderton Drive, Unsworth,
Bury, Lancs. Tel. 061 766 5712

totally confused?
made comparisons?
nearly compromised?
come to
northern
computers
completely committed!

**THE
Showroom
for all
the
leading
micros**



- ◆ BBC ◆ Electron ◆ Sinclair ◆ VIC64
- ◆ Dragon ◆ Printers ◆ Disk Drives
- ◆ Plenty of Software
- ◆ Books/Games ◆ Help & Advice
- ◆ Secondhand Computers

Churchfield Rd
FRODSHAM Ches.
WA6 6RD

**northern
computers**

Telephone:
FRODSHAM
0928 35110
0 Lines

THE computer centre of the NORTH

Programming the

PET/CBM

By Raeto West

**The Reference Encyclopedia for Commodore
PET and CBM Users**

Comprehensive teaching and reference book on programming Commodore's 2000, 3000, 4000 and 8000 microcomputers and peripherals.

Many programs, charts and diagrams. 17 chapters, appendices, and index. In a 404 page large-format paperback. ISBN 0 1507650 07. Price in UK and Europe £14.90 each, includes post and packing. 48 hour order turnaround guaranteed.

From dealers and booksellers or direct:
Trade Manager, Edward Arnold (Publishers) Ltd,
Woodlands Park Avenue, MAIDENHEAD, Berks
SL3 3LX.

Tel: (062882) 3104
"A masterpiece" — Creative Computing
"Essential" — Educational Computing
"Excellent" — Jim Strazma
"Comprehensive & Accurate" — Jim Zutterfeld

Send orders and make cheques payable to:
Trade Manager, Edward Arnold (Publishers) Ltd,
Woodlands Park Avenue, MAIDENHEAD, Berks SL3 3LX.

Send copies Programming the PET/CBM at £14.90

Enclose cheque/PO for £.....

NAME.....

ADDRESS.....

BACK-UP TAPE COPIERS

Unique machine code programs to allow security back-up copies of the majority of protected software.

Available for:

| | | | |
|--------------|-------|----------|-------|
| COMMODORE 64 | £5.95 | ELECTRON | £5.95 |
| VIC 20 | £5.95 | ATARI | £5.95 |
| BBC | £5.95 | SPECTRUM | £5.95 |

TAPE TO DISK TRANSFER UTILITIES

Speed loading and transfer your games, etc to disk.

Available for:

| | |
|--------------|-------|
| COMMODORE 64 | £9.95 |
| BBC | £9.95 |
| ATARI | £9.95 |

ALL COMPLETE WITH FULL INSTRUCTIONS



Price includes VAT,
Post & Packing. Cheques or
Credit Card Number to:



EVESHAM MICRO CENTRE

Bridge St, Evesham, Worcestershire

Tel: 0386 49641

NEW SHOP NOW OPEN - Micro Centre,
1756 Pershore Rd, Cotteridge, Birmingham Tel: 021-458 4564

International Software House

seeks Hackers with original programs and ideas. We offer development assistance, loan equipment, and high international royalties. Send sample or details to:

Keith Dean
Box 100,
33 Church Street,
Rickmansworth,
Herts, WD3 1DH.

LEADERS IN COMPUTER GAMES REQUIRE PROGRAMS AND PROGRAMMERS

1. Original game programs for the Spectrum or Commodore 64 are urgently required: Arcade, Strategy or Adventure. We pay top royalties or tailor a contract to suit your needs - world-wide sales ensure the best possible deal.
2. Programmers to work in 280 or 6502 assembly language for contract work or translation coding - best results.

Phone or write in confidence to:
Software Development
Ocean House, 6 Central Street
Manchester M2 5NS
Telephone: 061-832 6633

QUANTUM HARDWARE Sinclair Repair Centre

We have the spares for all repairs to:
SPECTRUM's ZX81, RAM PACK & ZX PRINTER
All repairs carried out by qualified staff, units repaired to original standard
ZX81 £11.50
RAM PACK £9.95
SPECTRUM £18.00
ZX PRINTER £18.00

(subject to received conditions)
Prices include return postage and packing.

Also available C10 Computer Tapes 65p
C15 Computer Tapes 70p
Cassette Lead Spectrum £2.20
TV Lead Spectrum £2.20

All prices include postage & packing
Spares subject to availability

Cheques & postal orders made payable to: QUANTUM
Self addressed envelope for enquiries to:

QUANTUM
33 CITY ARCADE, COVENTRY CV1 3HX.

ATLANTIS COMPUTER SOFTWARE LIMITED

URGENTLY REQUIRE MORE HIGH QUALITY GAMES

If you have written an exciting and original game for the CBM 64, Vic 20 or ZX Spectrum we would like to talk to you. If the game is good, we will pay high royalties on world-wide sales.

In the first instance, send a copy of your game, together with any instructions to: -

MICHAEL COLE

Atlantis Computer Software Limited
19 Prebend Street, London N1 8PF.

MEGASAVE FANTASTIC SAVINGS

| SPECTRUM | COMMODORE | SPECTRUM |
|------------------------------|-------------------------------|----------------------------------|
| SABRE WOLF.....8.25 | SON OF BLAGGER.....6.50 | ATICA TAC.....4.75 |
| PSY'RON.....6.30 | BEACH HEAD.....8.50 | AUTOMANIA.....5.75 |
| MUGSY.....5.95 | VAIHALLA.....11.50 | BLUE THUNDER.....4.75 |
| JACK & BEANSTALK.....4.95 | QUILL.....11.50 | INFERRA.....5.50 |
| FIGHTER PILOT.....6.25 | SHEEP IN SPACE.....6.40 | ODDE NAME MAT.....5.20 |
| TORNADO LOW LEVEL.....4.75 | GYROPOD.....5.50 | MILLIONAIRE.....4.50 |
| HILL.....8.50 | LOCC.....6.50 | STOP THE EXPRESS.....5.00 |
| LORDS OF MIDNIGHT.....8.50 | HULL.....8.50 | SINK THE TITANIC.....6.75 |
| KOSMIC KANGA.....5.10 | ARABIAN NIGHTS.....5.95 | SPECGRAPH.....8.25 |
| JET SET WILLY.....4.75 | SOLC FLIGHT.....12.50 | COSMIC CRUISER.....4.25 |
| BEAKY.....4.85 | BOZO'S NIGHT OUT.....5.50 | WORLD CUP F'BALL.....5.95 |
| AD ASTRA.....4.95 | STAR TRUJPER.....5.75 | WORSE THINGS HPN AT SEA.....4.95 |
| NIGHT GUNNER.....5.50 | CAVELON.....5.55 | CULL.....10.75 |
| FOOTBALL MANAGER.....5.55 | ENCOUNTER.....8.75 | WHITE LIGHTNING.....12.50 |
| TRASHMAN.....4.75 | HOUSE OF USHER.....5.85 | BLADE ALLEY.....4.75 |
| MUON ALERT.....4.99 | FOOTBALL MANAGER.....6.95 | 30 LUNA ATTACK.....4.75 |
| ANTICS.....5.75 | AUTOMANA.....6.85 | CAESAR THE CAT.....5.95 |
| WAYS OF THE WORLD.....6.75 | FELIX IN THE FACTORY.....6.85 | PYRAMID.....4.95 |
| LES FLICS.....5.50 | ALLET INTERCEPTOR.....5.85 | ANDROID II.....4.75 |
| CAVELON.....4.95 | ALL 17.95 AIRBOR.....0.30 | AUF WIEDERSEIN PET.....4.95 |
| MICRO OLYMPICS.....4.95 | TRASHMAN.....8.85 | STAR BLITZ.....5.85 |
| DOOMSDAY CASTLE.....5.30 | BLUE THUNDER.....5.85 | FACTORY BREAKOUT.....4.95 |
| DEATHCHASE.....5.25 | WIMBLEDON.....6.85 | AIR TRAFFIC CONTROL.....3.50 |
| HARRIER ATTACK.....4.95 | JACK & THE BEANSTALK.....5.85 | HOBBIT.....11.50 |
| SCUBA DIVE.....4.75 | ANDROID I.....5.90 | FANTASIA DIAMOND.....3.25 |
| WHEELIE.....4.95 | WHEELIN WALLY.....5.85 | RULL THROTTLE.....3.95 |
| CAVERN FIGHTER.....4.95 | FLIGHT PATH 757.....6.30 | CRIC ATTACK.....3.10 |
| TRIMBLE TROUBLE.....4.95 | THE EVIL DEAD.....6.85 | TOWER OF EVIL.....3.10 |
| GLUG GLUG.....4.75 | PYRAMID.....5.50 | AMSTRAD |
| 3D TANK DUEL.....4.95 | GILGANS GOLD.....5.75 | HARRIER ATTACK.....7.85 |
| KRAKATOA.....4.75 | PINBALL WIZARD.....5.75 | CODE NAME MAT.....7.85 |
| OFF-ROAD.....4.75 | SUPER PIPELINE.....5.50 | HUNTER KILLER.....7.85 |
| FREJ.....5.90 | AZTEC CHALLENGE.....7.50 | GUIDE TO AMS BASIC 13.00 |
| 3D ANT ATTACK.....5.90 | SKULL.....6.85 | VC-20 |
| BUCABOO.....5.90 | FORBIDDEN FOREST.....7.50 | FLIGHT 737.....3.50 |
| SNOWMAN.....5.90 | HEATHROW A.T.C.....6.85 | HOWL OF EVIL.....3.45 |
| VAIHALLA.....11.50 | CYBERTRON MISSION.....6.85 | COMPUTER WAR.....3.45 |
| MESS FROM ANDROMEDA.....4.75 | ORACLE CAVE.....6.85 | SUB COMMANDER.....3.45 |
| MATCH POINT.....6.85 | SWOOP.....6.85 | TANK COMMANDER.....3.45 |
| LORD OF TIME.....8.50 | GHOULS.....6.85 | CHARIOT RACE.....5.95 |

PLEASE STATE WHICH MICRO
SEND CHEQUE P.O. TO: FAST SERVICE

MEGASAVE
Dept B, 76 Westbourne Terrace, London W2

PROM SERVICES

ANALOGUE CONVERTERS
for ZX81 and SPECTRUMS

8 bit 8 channel input £23.95
8 bit 3 channel output £26.95
12 bit 8 channel input £57.95
3 slot motherboard £16.95
23:28 way edge cards 75p,
connectors £2.50.

SAE for details of these and many other interfaces.

EPROM SERVICES
3 Wedgewood Drive,
Leeds LS8 1EF.
Tel. (0532) 667183

BECOME A PROGRAMMER

Improve your prospects in the industry of the 80's. We'll develop your skills more quickly and more professionally with our home study Programming Course, based on Spectrum. Write for Free brochure.

IDEAL SCHOOLS
Ref: YC2. Freepost Woking, Surrey GU21 4BR.

10% OFF ALL GAMES

ORIC, BBC, DRAGON, COMMODORE, SPECTRUM

| | Spectrum | Dragon | DD | GA | Oric |
|-------------|----------|--------|-------|-------|------|
| Magic Miner | 6.35 | | | 7.15 | |
| Hobbit | 13.15 | | 13.45 | 13.45 | |
| Curbert | | 7.20 | | 7.20 | |
| Chess | 5.35 | 8.95 | | 8.25 | 8.00 |
| Right | 7.15 | 7.25 | 7.20 | 7.15 | 4.25 |
| Horace | 5.35 | 5.35 | | 5.25 | |

Send SAE for complete lists.
Send Cheque or PO to: P. McDermott
Ace Software, 8 Scaw Road,
Workington, Cumbria, CA14 4LU.

DRAGON 32 CASSETTE COPIER

DUPLICAS £7.95inc

(Please add £1 for orders outside the UK)

Cheques and POs made payable to:

QUICKBEAM SOFTWARE
67 Old Nazeing Road
Broxbourne, Herts EN10 6RN

Previous customers please send old tape + £1.50 for latest version

16/48K Spectrum Games

Zap Attack:
Amazing extra smooth graphics. Defend earth from increasing numbers of blood drinking aliens. Compatible with Interface 2 and Kempston joysticks as well as keys. Mine for gold while avoiding the pit monsters. Increasing numbers and speed. Compatible with Interface 2 and keys. Both games have 100% machine code fast action and amazing continuous sound effects.

Send £4.95 each or £7.95 for both on 1 cassette to: COSMIC Software, 8 Apex Drive, Highbridge, Somerset.

ATAFI 400/600/800/XL

Cartridge Backup System
Back up 3/16K cartridge to tape and disc. 400/800 with 48K ram. De luxe version has gold edge blades on cartridge simulator.
Cartridge to tape & disc.....£15.00
de luxe £20.00
Spare simulator board.....£12.00
de luxe £17.00

XL Cartridge Backup
600 XL £25.00
800 XL £30.00
Specify Tape or Disk

Tape Duplicator
Duplicate almost any single or multistage tape. BASIC program. 48K ram recommended.
Tape Duplicator.....£6.00

Fast Loader
Reduce tape loading time of almost all of your single multistage tapes by up to 49%
Fast Loader.....£6.00

600 XL Memory Upgrade
Upgrade your 16K to 64K. Complete kit with full instructions.
Memory Upgrade.....£75.00

Services
Listing and prom blowing services also available. Send for details.
Send large SAE for further details or any/all of the above and new products. All prices are inclusive of p&p. Utilities are for 400/800/XL/800XL unless otherwise specified.

S. Terrell
17 Cock Close Road, Yaxley,
Peterborough PE7 3FJ

RETAILERS

For fast speedy distribution service contact
Drake Distribution on 0752 671606

We can offer you:
• 24-hour delivery in UK
• The Best Discounts
• Starter packs available
• All the latest software
• Personal weekly delivery service throughout the UK
• Export enquiries welcome
• 48-hour delivery can be arranged

As retailers ourselves we know the titles that sell. — Phone or write for a price list now.

DRAKE DISTRIBUTION
36 New Street, Barbican, Plymouth.

SPECTRUM SOFTWARE CLUB!

LOWEST COST FREE CASSETTE!

- * Hire and Exchange games from just 50p
- * Buy new games at the best possible discounts
- * Hundreds and hundreds of games to choose from
- * Regular Newsletter with details of new releases etc
- * Every new member gets a FREE BLANK CASSETTE!
- * All the benefits of other clubs at HALF THE PRICE!

Send just £3.95 and we will rush you your Membership Kit and Free Cassette:

SPECTRUM SOFTWARE CLUB (YC)
287-291 HIGH STREET, EPPING, ESSEX CM16 4DA
(or send a stamp for catalogue)

SUPER BREAKER

For the COMMODORE 64, this utility will back-up most popular cassette programs onto Tape or Disk. Also now available a TAPE TO DISK UTILITY for transferring cassette software onto Disk. Both are supplied with full written instructions on a data cassette and both priced at just £4.99 each. For a fast turn round of orders, by First Class Post, Rush Cheque/P.O. or SAE for details, to:

Clark Kent Software
26 North Cape Walk,
Corby, Northamptonshire.

The Publishers take all reasonable care to ensure that classified advertisements are genuine, but readers must satisfy themselves that they will be obtaining what they require before entering into transactions, particularly if they involve large sums of money.

SUPERIOR TAPE COPIER

We are convinced that the new 007 SPY is the very best Spectrum tape copier available on cassette. Find a better one & TWICE your money back if you find a better copier offering better value.

- a. Can copy complete programs all in one go.
 - b. Can make copies of programs upto 80K long. (Yes, I did say 80K long).
 - c. Very simple to use.
 - d. Has copied all programs we know of.
 - e. Microdrive Compatible AND includes a program to copy tapes to micro-drive.
- WARNING: You can buy a cheaper 'Mickey Mouse' copier which copies only one section at a time & has to be reloaded after each. 007 SPY stays in Spectrum till told to go. 007 SPY is just £3.95

ZX-GUARANTEED (YC)
25 Chadderton Drive, Unsworth,
Bury, Lancs.
Tel: 061-766 5712

HOME ACCOUNTS

Put your house in order! Probably the best home use for your computer! Comprehensive coverage of bank accounts, credit cards, HP, etc. Inbuilt accuracy check for all transactions. Project cashflow for any period ahead. Available for CBM 64 or Vic-20. £7.50 or free details from:

DISCUS SOFTWARE
FREEPOST, Windmill Hill
Brixham TQ5 9BR
Tel: 080 45 55532

SPECTRUM Software Library club, news etc. Almost every new release in stock. Life membership £3.50. REM Software, 27 Mossdale Road, Blackburn, West Lothian EH47 7DN.

BACK-UP TAPE COPIERS

Unique machine code programs to allow security back-up copies of the majority of protected software.

Available for:
COMMODORE 64 £5.95 ELECTRON £5.95
VIC 20 £5.95 ATARI £5.95
BBC £5.95 SPECTRUM £5.95

TAPE TO DISK TRANSFER UTILITIES

Speed loading and transfer your games, etc to disk.

Available for:
COMMODORE 64 £9.55
BBC £9.55
ATARI £9.55

ALL COMPLETE WITH FULL INSTRUCTIONS

EVESHAM MICRO CENTRE

Bridge St, Farnham, Wiltshire
Tel: 0386 49641
NEW SHOP NOW OPEN - Micro Centre
175b South Rd, Sutton Coldfield, Birmingham Tel: 021 350 4364

The Jet Set Willy editor. 100% machine code program. Will totally redesign Jet Set Willy and create an extra three rows. £3.50 incl. p&p. Send cheques or postal orders to:

Softtricks,
1 Rowan Place, Dundee,
DD3 0PH.

DRAGON 32 CASSETTE COPIER

DUPLICAS £7.95inc

(Please add £1 for orders outside the UK)

Cheques and POs made payable to:

QUICKBEAM SOFTWARE
67 Old Nazeing Road
Broxbourne, Herts EN10 6RN

DISCOUNT MAIL ORDER SOFTWARE

ZAXXON £4.15
TRASHMAN £5.35
JET SET WILLIE £5.35
FOOTBALL MANAGER £6.25
MANIC MINER £5.35
THE BOSS £8.05
COSMIC CRUISER £4.95
SNOOKER £8.05

And more.
State title and machine
S.A.E. for lists.

Cheque/P.O. To Dept YC
Universal Publishing
65 Thurlow Park, London, SE21 8JP

Dee-Kay Systems

THE HOME COMPUTER RAIL
GAME SPECIALIST

DRIVE A TRAIN. We have two games to choose from in our train driver simulation series.

FLYING SCOTSMAN. Drive from Kings Cross to Doncaster in an HST Daltic or Brush 47. Performance of motive power is accurately portrayed within this game. There's plenty of scope for spirited running but watch out for signals.

CORNISH RIVIERA EXPRESS. Step aboard a Class 50, HST or Brush 47 and drive from Paddington to Exeter not forgetting your Reading stop. All your concentration will be required on the Berk and Hants section with its many speed restrictions.

Both simulations contain an end of game performance rating to score well you must keep on your toes.

Simulation available for BBC 'B' and Spectrum 48K.

SPOTTING GAMES for Steam Railway Enthusiasts.

SCOTTHAIL, MIDRAIL and WESTRAIL - Three great games to take you back to travel as it was in the early sixties. Several hundred steam engines to be seen in each game whilst travelling the length and breadth of the region, with well over one hundred stations in each game. Each engine is graphically depicted with name and number. Treat yourself to a fireside railrover.

Spotting games are the Spectrum 48K only.

Dee Kay Systems
18 Salford Close, Woodrow, South
Redditch, Worcs B98 7UN

Available from address as above.

All games £7.50 inc. p&p

QUICKDRAW FOR THE BBC (D)

Probably the easiest drawing program available. Use colour, lines, triangles, circles, add text anywhere, save/load and print displays. Single key commands with inlay. Superb for design work. Only £6.00 incl.

Cheque to Selective Software,
64 Brooks Road, Street, Som.

SELL IT WITH YOUR COMPUTER

CLASSIFIED ORDER FORM

Classified Rates

Linage: 50p per word (Min 20 words) — prepayable

Linage advertisers should complete the form provided in BLOCK CAPITALS. Phone number counts as 2 words. Name and address to be paid for if used in advertisement. Box number if required is £4.00 extra.

Display — rates per sec (Min 2sec)

One insertion : £9.00
Three insertions : £8.70
Six insertions : £8.50
Twelve insertions : £8.00

Display advertisers should provide separate copy and preferably reserve space by phone (01-661 3036).

Method of Payment

Cheques etc. should be made payable to Business Press International Ltd, and crossed. I enclose herewith cheque/PO for

£.....
Please debit my Access/Visa/Barclay Card/American Express/Diners Club Int'l as below



SIGNATURE

SIGNATURE

Post to:

Cut out the order form and return together with your remittance to:
Classified Department, Your Computer,
Room H211, Quadrant House, The
Quadrant, Sutton, Surrey SM2 5AS.
011 661 3036

Please insert the following advertisement in Your Computer Classified Section

| | | | | LINAGE |
|--|--|--|--|--------|
| | | | | £10.00 |
| | | | | £12.50 |
| | | | | £15.00 |
| | | | | £17.50 |
| | | | | £20.00 |
| | | | | £22.50 |
| | | | | £25.00 |

No. of insertions required Box No. required YES/NO

NAME (Please include initials)

ADDRESS

Payment by credit card please state address card is registered

Daytime tel. no

THIS FORM SHOULD BE RETURNED BY 24th AUG. FOR OCT. ISSUE PUBLICATION

Company Registered Number: 151537 (England) Registered Office: Quadrant House, The Quadrant, Sutton, Surrey SM2 5AS.

Hot★ lines

Acorn Computer
Telephone: Cambridge 0223-245203

Atari
Telephone: Slough 0753-24561

Computers
Telephone: Cambridge 0223-315063

Commodore CBM
Telephone: Slough 0753-74111

Dragon Data
Telephone: Bridgend 0658-744725

Sharp
Telephone: Manchester 061-2652333

Sinclair
Telephone: Cambridge 0276-681666

Sord
Telephone: London 01-930 4214

Tandy Corporation
Telephone: Birmingham 021-5566101

Texas Instruments
Telephone: Bedford 0234-6321

DATABASE

Local, national and international micro events are updated here. To publicise your event, phone Paul Bond on 01-661 3472.

Adventure Games Exhibition

On the Board, Computer and Role-playing adventure games exhibition. September 1-2 is Games Day at the Royal Horticultural Hall. More details from Games Workshop, 27-29 Sunbeam Road, London NW10. Telephone 01-965 3713.

Personal Computer World Show

From September 19-23, at Olympia 2. Telephone 01-486 1951 for more details.

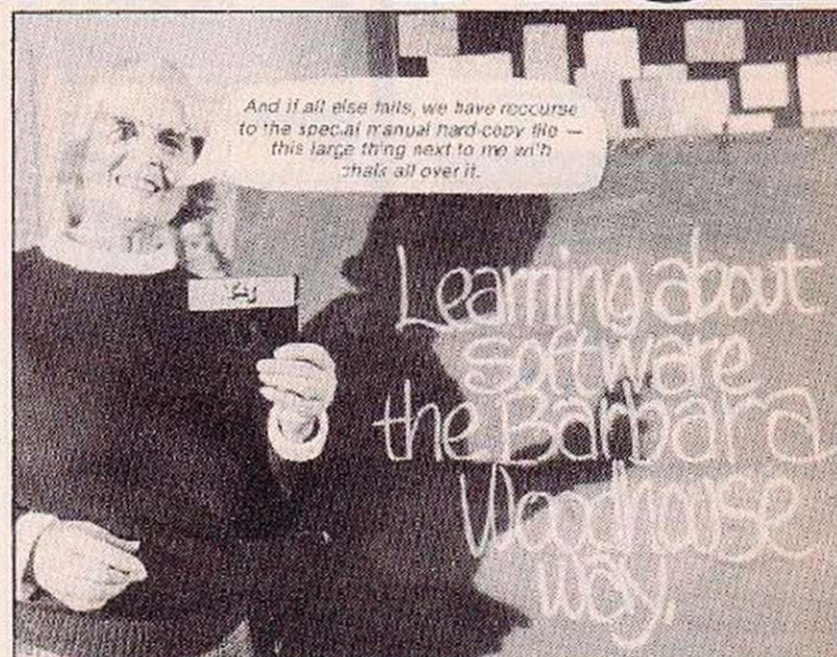

Barbara Woodhouse working the Lotus way showing users how to get the best from their PC's through 1-2-3 software.

Electron & BBC Micro User Show

Takes place at Alexandra Palace from October 25-28. Telephone: Database Publications, 061-456 8383 for more info.

**COLOUR
ADVERTISEMENTS
ATTRACT
ATTENTION!**
For further details ring
661 3036

INDEX OF ADVERTISERS

| | | | | | | | |
|---------------------------------|---------------|------------------------------|-------------------|---------------------------|--------------------|-------------------------|--------------------|
| A | | E | | | | | |
| AGF Hardware | 28 | English Software | 21, 23 | Memo:ech | 119 | Sharp | 16, 17 |
| Acorn Computers | 12, 13 | Euro Electric | 123 | Micro Jeni | 54 | Sinclair Research | 111 |
| Acornsoft | 24, 25 | | | Micro Repair Club | 172 | Skywave Software | 59 |
| Activision | 173 | F | | Microbusiness | 86, 130 | Slogger Software | 84 |
| Addictive Games | 44 | Fieldmaster Software | 42 | Micronet 800 | 98, 99 | Softsel | 182 |
| Advertising Standards Authority | 164 | Frel Ltd | 126 | Micropower | 9, 37, 102, 169 | Software Communications | 78 |
| Acadimies | 31 | | | Micro X | 184 | Software Library | 46 |
| Anstrad | 4, 5 | G | | Mikrogen | 139 | Spectdraw | 74 |
| Anirog | 148, 168 | Galaset | 154 | Miles Better Software | 146 | Spectravideo | 179 |
| Apex | 172 | Gilsoft | 133 | | | Spectre | 103 |
| Argus Press Software | 106, 152, 153 | Goldstar | 74 | N | | Stack Computers | 183 |
| | | | | National Software Library | 178 | Statesoft | 167 |
| B | | H | | | | Stonech p | 170 |
| Beebug | 46 | Hartland Software | 123 | O | | Swescot | 31 |
| Bellcott Leisure | 76 | Haulstorm | 42 | Oasis Software | 113 | Swoopalape | 38 |
| Batasoft | 183 | Hisoft | 94 | Ocean Publishing | Back Cover | | |
| Brother Industries | 140 | | | | | T | |
| Bugbyte Software | 11 | I | | P | | TRT Design | 34 |
| | | Industrial Process | 142 | PAS Computers | 154 | Tatung UK | 51 |
| C | | Inmac | 18 | PCW Show | 7 | The Microworkshop | 8 |
| CJE Micros | 183 | Interceptor Micro | Inside Back Cover | PV Tubes | 103 | Thoughts & Crosses | 40 |
| Cambridge Micro Electronics | 8 | Interfaces | 134 | Peaksoft | 62 | Triptych | 104, 105 |
| Campbell Systems | 31 | | | Picturesque | 178 | | |
| Channel 8 | 56 | J | | Plus 80 | 176 | U | |
| Cheetahsoft | 112 | John Wiley | 36, 142, 158 | PowerSoftware | 54 | US Gold | 19, 29, 35 |
| CompuSound | 154 | | | Practical Computing | 180 | | 129, 145, 171, 177 |
| Computer Link | 142 | K | | Practicorp | 62 | Ultimate Play the Game | 33 |
| Crystal Computing | 22 | Kempston Micro | 6 | Protek | 20, 58, 181 | | |
| Currah Computers | 185 | Kuma Computers | 69 | | | V | |
| | | | | Q | | Virgin Books | 146 |
| D | | L | | Quicksilver | 132 | Visionstore | 54 |
| DACC | 172 | _CL | 62 | | | W | |
| Datastar | 84 | Level 9 Computing | 10 | R | | Walkers Software | 123 |
| Date | 79 | Lamasoft | 30 | Reprints | 184 | Wizard Software | 46 |
| Dear Electric | 146 | | | Richard Wilcox | Inside front cover | Worldwide Computers | 54 |
| Dianetics | 178 | M | | Romac | 137 | Your Computer | 124, 174, 186 |
| Diaco Technology | 42 | Mail Order Protection Scheme | 74 | Rotronics | 73 | | |
| Durrell Software | 14, 15 | Wayfair Micros | 84 | | | Z | |
| | | Welbourn House | 26, 27, 151, 175 | S | | ZX Microfair | 160 |
| | | | | Se (UK) | 163 | Zero Electronics | 8 |
| | | | | Sec Software | 79 | | |

TALES OF THE ARABIAN NIGHTS

Full of Eastern Promise!

FROM
INTERCEPTOR
SOFTWARE

THE SAGA OF IMRAHIL
THE KALENDAR PRINCE
ON A QUEST TO FREE
THE PRINCESS ANITRA
FROM THE HAREM OF THE
EVIL SULTAN SALADIN.

WRITTEN BY IAN GRAY
CONTAINS OVER 3 MINUTES
OF EASTERN MUSIC BY CHRIS COX
PRODUCED BY RICHARD PAUL JONES

ONLY
£7.00
ON CASSETTE
£9.00
ON DISK

CONTAINS
SPEECH
NO HARDWARE REQUIRED

SUITABLE FOR THE
commodore 64
NOW WITH **ULTRA LOAD** FAST LOADING

INTERCEPTOR
MICRO'S

LINDON HOUSE, THE GREEN, TADLEY, HAMPSHIRE

TEL (07356) 71145

AVAILABLE NOW
FROM
ALL GOOD COMPUTER
RETAILERS

Another No.1 from Ocean

DALEY THOMPSON'S

DECATHLON

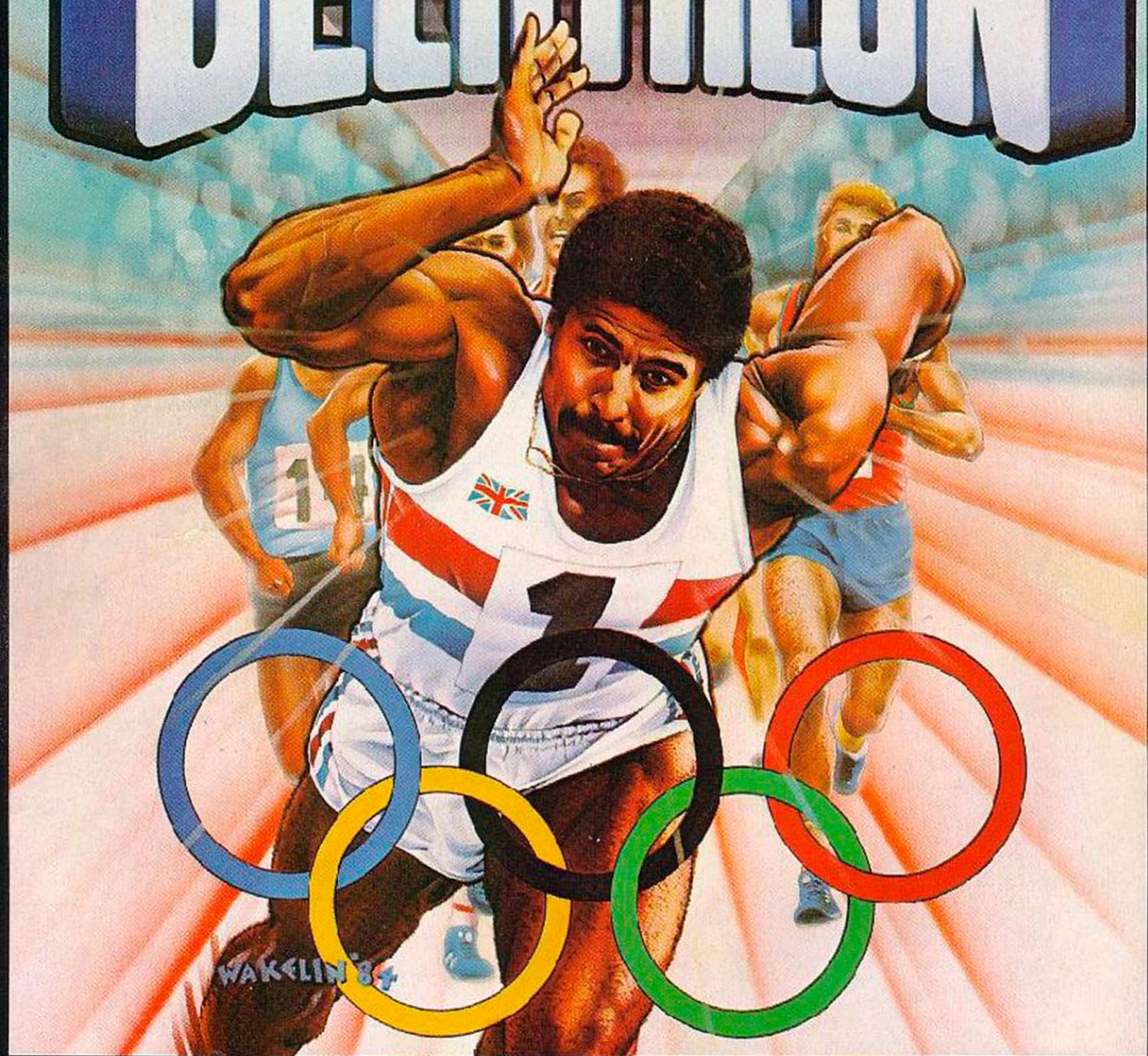

GO FOR GOLD!

SPECTRUM 48k

6.90

ocean

COMMODORE 64

7.90

Ocean House · 6 Central Street · Manchester M2 5NS Tel: 061 832 6633

Ocean Software is available from all good software dealers and selected branches of:

WOOLWORTH, WHSMITH,  John Menzies, LASKYS, Rumbelows and Spectrum Shops.