

£1	Denmark	DKr.	36.00
	France	Fr.	52.50
	Germany	DM.	9.50
	Greece	Dra.	360.00
	Holland	DFI	8.90
	Italy	L.	4300
	New Zealand	NZ\$	3.70
	Spain	Pts.	425.00

Your COMPUTER

▶ JANUARY 1986 VOL. 6 NO. 1

BRITAIN'S BIGGEST-SELLING HOBBY MAGAZINE

KNIGHT-CLUBBING
WE MUST OPEN THE REAL SIR CLIVE

▶ **NUMBER CRUNCHER AND CHEEKAH'S SPECTRUM EXPLOITS**

▶ **PARADROID II: HEWSON'S URIDIUM WARS**

CLEAR ROUND: WIN A SANYO STEREO WITH HARVEY SMITH

▶ **BUDGET PRINTERS PLUS SERIOUS SOFTWARE**



▶ **COMPUTERISE YOUR DROID**

▶ **AMSTRAD END ZONE AND CBM-64 SNOWBOT**

SCOOP!



MASTERTRONICS' PRICE-ZAPPERS



Datasoft



ATARI & COMMODORE 64/128
 £ 14.95 DISK £ 9.95 CASS
 COMING SOON ON
 SPECTRUM 48K £7.95
 AMSTRAD
 DISK £14.95 CASS £9.95



From the RICHARD DONNER Production

THE

Based on the Story by STEVEN SPEILBERG



GOONIES

Exciting Multiscreen Action and Adventure!

U.S. Gold Limited, Unit 10, The Parkway Industrial Centre, Heneage Street, Birmingham B7 4LY. Telephone 021-359 3020. Telex: 337268.



Datasoft is a registered trademark of Datasoft Inc. The Goonies is a trademark of Warner Bros. Inc. © 1985 Warner Bros. Inc. All rights reserved. Warner-Tamerlane Publishing Corp. and Reilly Music Corp. All rights reserved. Used by permission © 1985 Datasoft Inc.



LETTERS

25 Unfair to Eugene; Harry Seldon exposed; recursion yet again.

HARDWARE HITLIST

29 Keyboards for the Spectrum and an RS-232 interface for the Amstrad, which downloads Prestel software.

CHART PAGE

33 Gallup's top 30 computer games; finding out the poll position.

SOFTWARE SHORTLIST

35 From the Lord of the Rings to the Last V-8, plus Rambo, Commando — all the hits.

AMSTRAD END ZONE

56 Stan Cartwright has created an innovative new grid game for the Amstrad.

CHESS SURVEY

58 More knight-clubbing. Martin Bryant checks out contrasting programs and delivers a black-and-white verdict.

COMPUTERISE YOUR DROID

68 A chumblie of your own. John Dawson assesses a particular range of personal robots.

SPECTRUM NUMBER CRUNCHER

74 A spreadsheet supreme from Terence Simons.

CBM-64 SNOWBOT

80 Keith Suddick proves that there's no people like snow people.

BBC SOFT SPEECH

86 No add-ons needed — David Hoskins, software-driven speech synthesis.

HOTSHOTS

91 Ace pokes for great games. Hints, tips and wrinkles to get you to the top.

INTERACTIVE ADVENTURES

92 James Hartley helps you shed your hang-ups when talking to trolls.

QUEST CORNER

95 Hugo North tells you what's new in the field of CAGs.

CBM-64 TRANSDISK

96 Geoff Hatto facilitates file-copying with this useful program.

BBC LOCOMOTION

101 Defend your railway against aeroplanes and the C-5s that ate Paris.

CONTENTS

50

KNIGHT-CLUBBING

The real inside story; the machines that never were; the blunders and the shortcuts; all you ever suspected about Sinclair but never actually wanted to believe.



44 46

MASTERTRONICS AND HEWSON

Paul Bond meets the people behind Britain's most successful software house and lifts the lid on the next Braybrook blockbuster from Hewson.

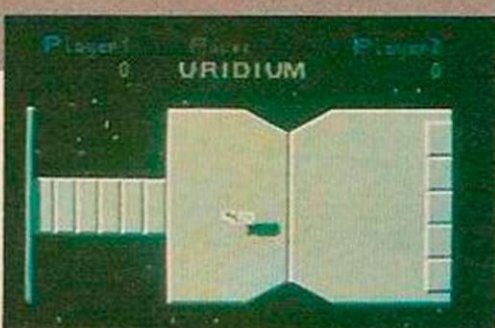

30 48

BUDGET PRINTERS AND SERIOUS SOFTWARE

Paddon gets into hard copy from as cheap as £20 up to about £450. And Simon Beesley gets serious with utility programs — including the first example of an integrated program on a home computer.



74

CHEEKAH'S EXPLOITS

Screen and screen again of non-stop Spectrum mayhem from Julian Woods — you can even add extra screens of your own design.



89

HARVEY SMITH SHOW JUMPING COMPETITION

Win a Sanyo stereo system plus 30 runners up prizes of Software Project's new game.



Thrifty micro owners choose the new MT80+

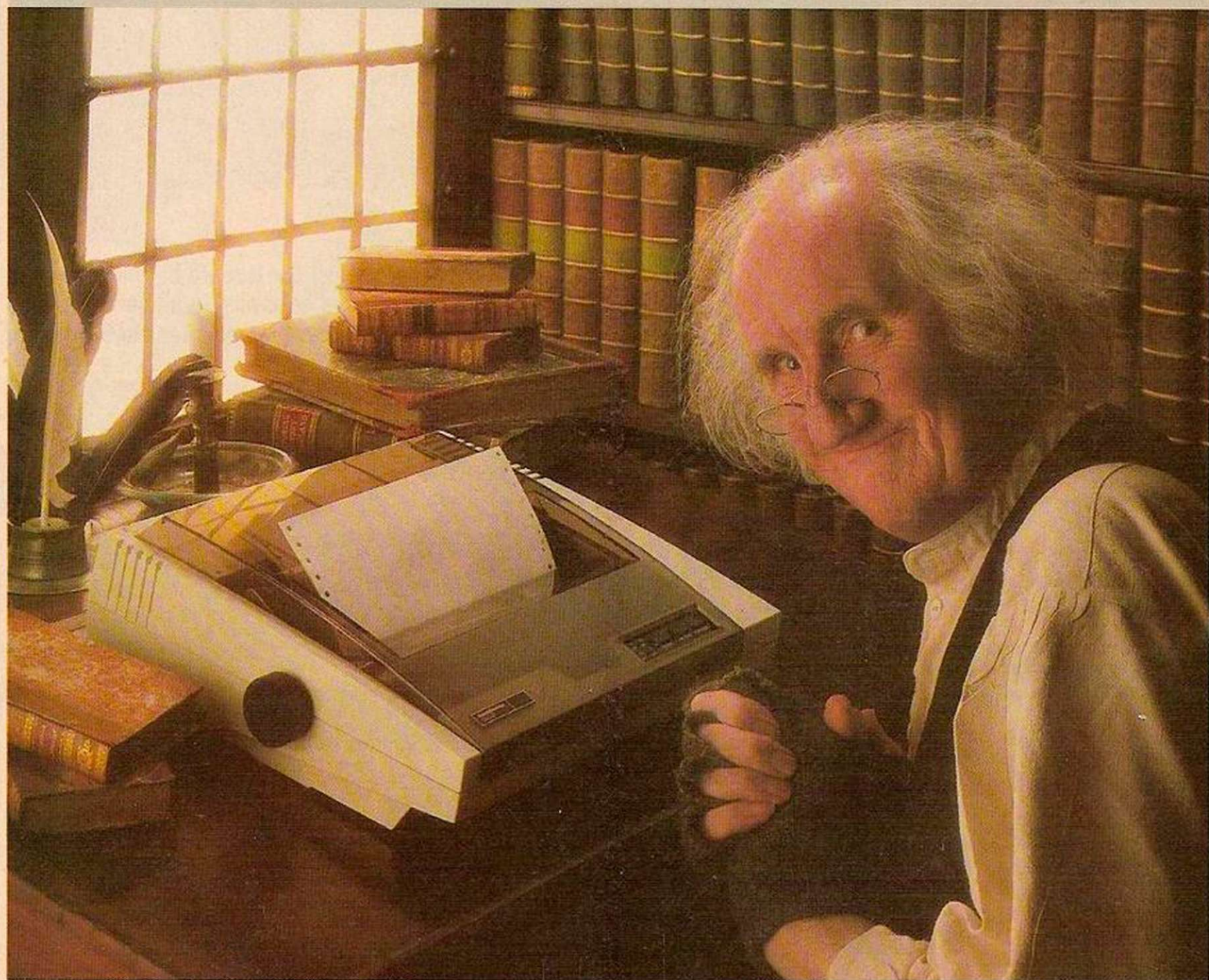

Keen on saving money? But not prepared to sacrifice quality and performance? Then the new MT80+ serial matrix printer has plenty to offer at a price that will have you rubbing your hands with glee.

The MT80+ prints at 100 cps and is compatible with just about any popular office or home micro. For true print

flexibility, there's compressed and expanded print, subscripts and superscripts, bold print, italics and, of course, graphics.

You'll have to see the print quality to believe it, thanks to the outstanding film ribbon cassette. Continuous fanfold stationery or friction fed single sheets pose no problem. And if you're in a hurry

the quick tear facility is a real bonus.

The new MT80+ from Mannesmann Tally. Europe's leading matrix printer manufacturer. You'll be laughing all the way to the bank. Contact us now for our literature pack.



**MANNESMANN
TALLY**

· AIR · COMBAT · EMULATOR ·

· BY CASCADE GAMES ·

£10.95
INC. FREE WATCH
AND POSTAGE

1-3 Haywa Crescent Harrogate

T

HE FASTEST GAME ON TWO WINGS! AND A FREE MULTIFUNCTION CALCULATOR WATCH

The AIR COMBAT EMULATOR, packed with exciting features, is by far the fastest, most realistic flight simulator available. For the first time on a home computer, feel what it is really like to fly a high performance military jet and engage tanks, missiles, ships, helicopter gun-ships and two types of cunning intelligent enemy aircraft.

Featuring over 300 sprite images, ACE has the smoothest, most detailed cockpit view of hills, trees and other ground objects ever achieved thanks to specially developed Dynamic Graphic Technique (D.G.T.™) allowing sensational high speed solid 3D graphics.

In combat, your head will spin as you struggle with the help of the advanced avionics which include a rear-view camera and radar, to stay alive long enough to do some damage to the enemy.

The unique two seat flying option (pilot, navigator/weapons man) and **Synchro Speech™** which passes vital aircraft condition information to the flight crew without freezing the action combined with dynamic tactical map, take offs and landings, summer, winter and night-time flying and a remarkably realistic in-flight refuelling option makes ACE the ultimate AIR COMBAT EMULATOR.

ACE SCENARIO

A vast invasion fleet has landed on your southern shores and discharged scores of tanks supported by helicopter gun-ships and protected by mobile surface to air missiles. Squadrons of enemy fighters give the enemy forces air cover. Advancing ruthlessly they are conquering your homeland, facing no opposition.

You are the last fighter pilot with only three A.C.E. Mark 21 multi role All Weather All Terrain (A.W.A.T.) combat aircraft. Based at an allied airbase, your task is to attack and destroy the numerically superior enemy land and air forces and drive them from your shores. The final stage of the conflict, having already destroyed the enemy land forces and shot down their air force, is to sink the enemy fleet as it evacuates its defeated army.

ACE - EXPERIENCE IT NOW

Every computer game fan will love ACE - just look at these features:-

- 100% optimized machine code uses all available memory.
- Featuring Dynamic Graphic Techniques (D.G.T.™)
- The smoothest, fastest and most detailed cockpit view of any flight simulation.
- Views of hills, trees, tanks and other ground objects. Aerial combat, ground attack and naval attack.
- **Synchro Speech™** i.e. the speech does not freeze the action.
- Two seat option - fly and fight with the aid of a friend.
- Sensational 3D solid (not boring wireframed) graphics.
- High score saving system.
- A.W.A.T. operation (All Weather All Terrain).

* Note due to memory limitations ACE on the C16 and VIC20 (+8K Ram) do not have any ground objects.

FREE 20 KEY MULTIFUNCTION CALCULATOR WATCH

- 12/24 Hour Time Mode
- Alarm Mode
- Calendar Mode
- Calculator Mode



FREE!!!

Order ACE today and receive this fantastic 20 KEY MULTIFUNCTION CALCULATOR WATCH

ABSOLUTELY FREE!!!

PRICE £10.95 (CBM 16 and VIC 20 £9.95)

Postage FREE in U.K. Add £1 for overseas orders.

Allow 28 days for delivery.

I enclose cheque/postal order for (£.....) made payable to Cascade Games Ltd.

Or through any Post Office by Transcash (Giro No. 655 6655).

For even faster ordering when charging to Access, Barclaycard and Trustcard Visa use our 24 hr service (Tel. 0423 504663).

ENTER CREDIT CARD NO. IN BOX:-



VISA

C-64

C-16

C-VIC 20 (with 8K RAM expansion)

C-PLUS 4

C-128

Please tick box

NAME _____

ADDRESS _____

POSTCODE _____

COUNTRY _____

Please complete and send to:-

Cascade Games Ltd.

1-3 Haywa Crescent

Harrogate HG1 5BG, England.

Tel. (0423) 504663

Registered No. 1755554



cascade



Screen shots are for CBM 64 version. Other versions may vary.

ACE - EXPERIENCE IT NOW!



Most home computers.

As you can see, the Amstrad CPC 464 is no ordinary home computer.

For a start, it comes complete with an integral cassette datacorder.

And in addition, you get the choice of either a superb quality green screen or a full colour monitor.

With £100 of free software to get you going all you have to do is plug in and start computing.

The 64k of RAM means you'll have plenty of memory to play with. And there are over 200 Amsoft games, that you

can play, many exclusive to Amstrad.

But games are only half the fun on the Amstrad CPC 464. In fact using it can also be quite an education.

The kids can learn spelling and arithmetic with software like Wordhang and Happy Numbers.

Whilst adults will love the way it helps around the house with budgetting and accounts.

Put the 464 to work and it will take care of a number of business-like functions, such as wordprocessing and spreadsheet.





The complete home computer.

To help you get the most from your CPC 464, there's the Amstrad User Club as well as a number of books and user magazines devoted to this most versatile home computer.

And your 464 will be made even more complete with the simple connection of joysticks, printers, disc drives, speech synthesisers and light pens.

But perhaps the most extraordinary thing about the Amstrad CPC 464 is the price.

Just £199 with green screen, or £299 with full colour monitor.

For more information about the complete home computer, all you have to do is complete the coupon.



Please send me more information

YC/464/2

Name _____

Address _____

Amstrad CPC 464
The complete home computer.

Amstrad, P.O. Box 462, Brentwood, Essex CM14 4EF.

SABOTEUR!

DURELL

software getting harder



**SPECTRUM
&
AMSTRAD**

R.R.P. £8.95

DURELL sales dept.,
Castle Lodge, Castle Green, Taunton TA1 4AB

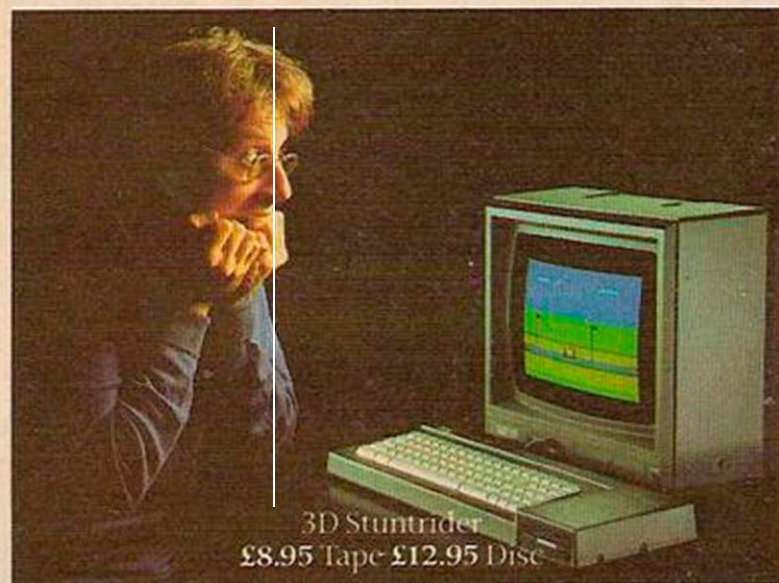

3D Stuntrider
£8.95 Tape £12.95 Disc

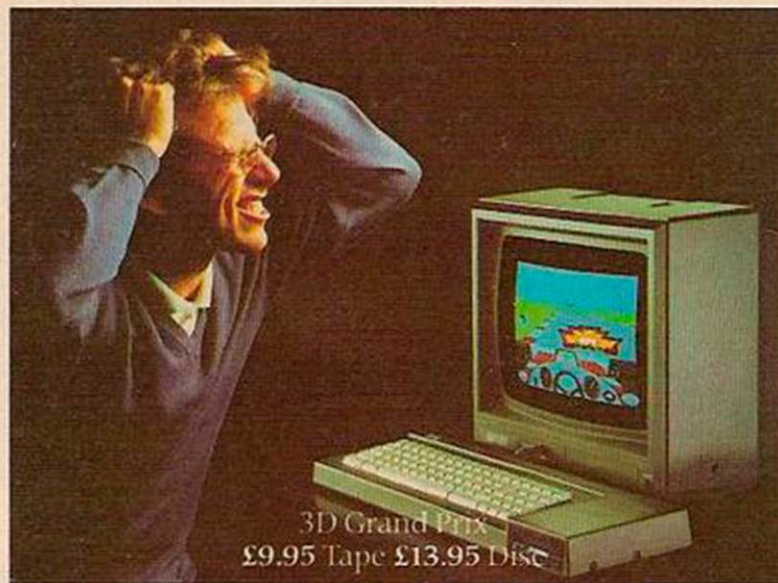

3D Grand Prix
£9.95 Tape £13.95 Disc

When it comes to computer games you can't beat an Amstrad.

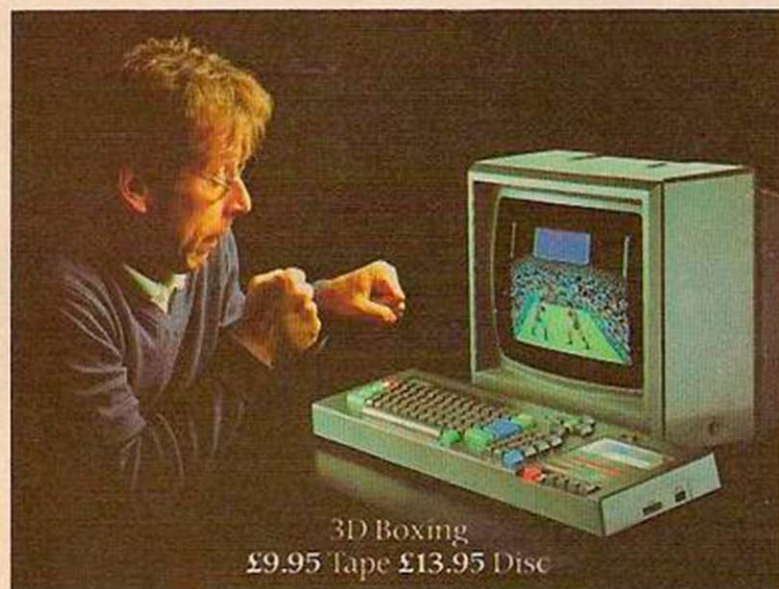

3D Boxing
£9.95 Tape £13.95 Disc

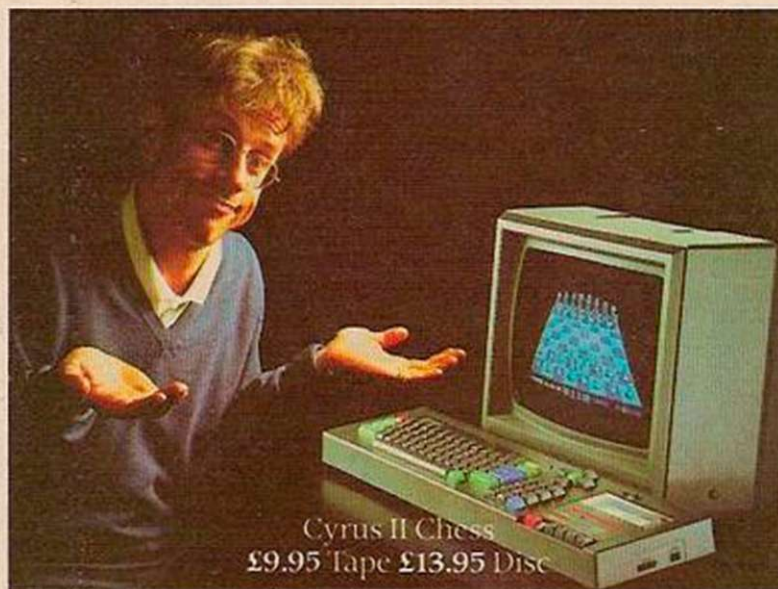

Cyrus II Chess
£9.95 Tape £13.95 Disc

We've enlisted the help of some particularly wicked program designers to put our entertainment software range together.

They've come up with over 200 Arcade and Adventure games.

Many of them exclusive to Amstrad (like those shown above). All of them mindbenders you'll find hard to beat.

And all at prices that are as competitive as the games, from £12.95 on disc and £8.95 on tape.

But the software is only one of many good reasons for buying an Amstrad computer.

The 64k CPC 464 computer comes complete with built-in datacorder and a choice of green screen or full colour monitor.

The CPC 6128 is a big memory 128k computer with built-in, fast-loading disc

drive and again, it's own colour monitor or green screen.

Both are available at an all-inclusive price you'll find hard to match.

In fact, with Amstrad's unbeatable software, unbeatable hardware and unbeatable prices, how can you lose?

VC/S/1

Tell me more about the Amstrad range of software.

Name _____

Address _____

Amstrad. Loads more fun.

Amstrad, P.O. Box 462, Brentwood, Essex CM14 4EF.



AVAILABLE FOR

- C64
- AMSTRAD
- ATARI
- BBC/ELECTRON
- VIC 20 + 16K
- PLUS 4 ● C16 + 16K
- SPECTRUM

£7.95 each

TRADE ENQUIRIES: Anirog Software Ltd. Unit 10 Victoria Industrial Park Victoria Road
Dartford Kent (0322) 92513/8

MAIL ORDER: 8 High Street Horley Surrey Horley (02934) 6083 (0322) 91649/92518

Payment By: ACCESS/VISA/BARCLAYCARD CHEQUE or P.O.

JUST YOU AND A CAR NAMED
"KITTY"

KNIGHT RIDER



THE ULTIMATE DRIVING TEAM.

SPECTRUM 48K

£7.95

SPECTRUM 48K

FROM

ocean

COMMODORE 64

£8.95

AMSTRAD

Ocean Software Limited, 6 Central Street, Manchester M2 5NS. Telephone: 061-832 6633 Telex: 669977 Oceans G

Ocean Software is available from selected branches of:

WHSMITH, John Menzies, WOOLWORTH, LASKYS, Rumbelows, Greens, Spectrum Shops and all good software dealers. Trade enquiries welcome.

Strap yourself into your ejection seat and get ready for modern jet fighter combat with F-15 Strike Eagle!! F-15 features superb Three-Dimensional graphics, F-15 manoeuvrability, computer assisted targeting including a modern fighter HUD (Heads Up Display), airborne radar, air-to-air missiles, surface-to-air missile defence, ground target bombing, full aerobatics, and multiple combat scenarios. F-15 will thrill and challenge you and give you the chance to

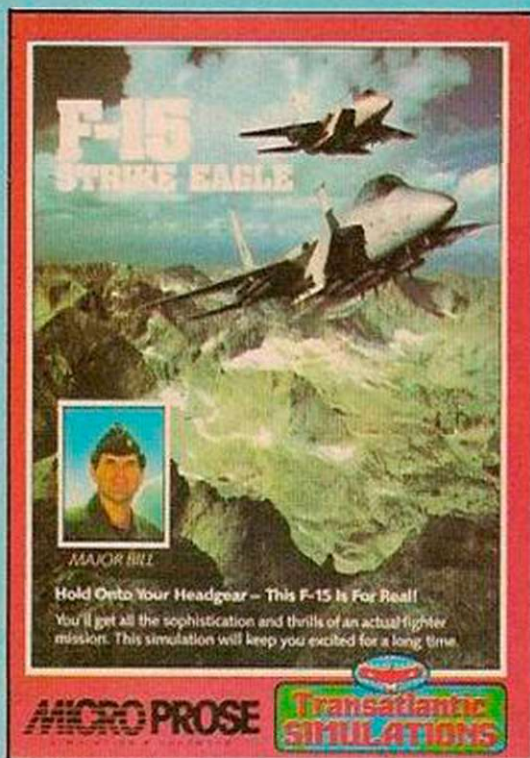

F-15 STRIKE EAGLE

prove you have the "Right Stuff" of an EAGLE fighter pilot!!

F-15 COMPARISON		
Feature	"Real" F-15	F-15 Strike Eagle
1. Multiple Weapon Systems		
• Cannon	Yes	Yes
• MK-82 Bombs	Yes	Yes
• Air-Air Missiles	Yes	Yes
2. Sophisticated Electronics		
• Heads Up Display	Yes	Yes
• Radar	Yes	Yes
• Electronic Counter Measures	Yes	Yes
• Inertial Navigation	Yes	Yes
3. Real Combat Missions	Yes	Yes
4. Developed and tested by Real Fighter Pilots	Yes	Yes
5. Aerobatic Flying (Loops, Splits and Yo Yos)	Yes	Yes

C-64/128 & Atari Cassette	£14.95
C-64/128 & Atari Disk	£17.95



U.S. Gold Ltd.,
Unit 10, The Parkway Industrial Centre,
Heneage Street, Birmingham B7 4LY.

The action is

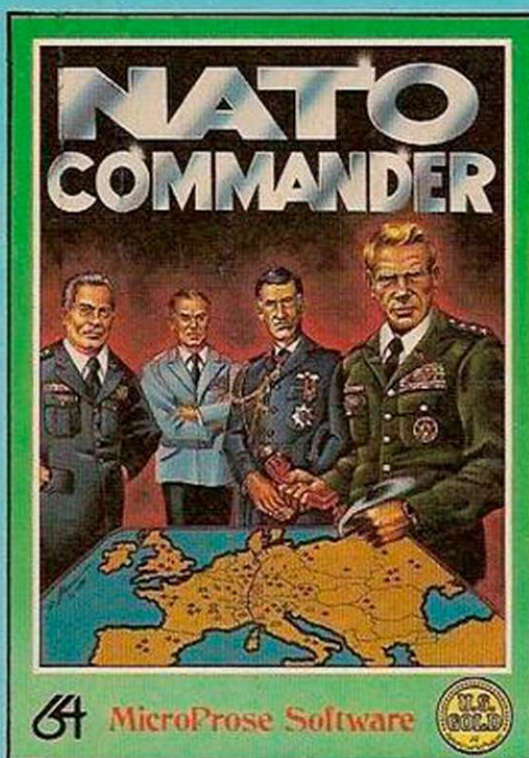

NATO-COMMANDER

Pin on the four stars of a Nato General and defend Europe in a heart pounding, accelerated Real-Time war simulation! React to the combat radio, teletype, and news service messages from the battle front, and use your full continent scrolling battle map to deploy, manoeuvre, and command the battle units, including infantry, armour, helicopters, air forces, and tactical nuclear weapons in real time to stop the ever advancing Warsaw Pact battle units! Nato Commander is great fun and challenge for wargamers and arcaders alike!

C-64/128 & Atari Cassette	£9.95
C-64/128 & Atari Disk	£12.95

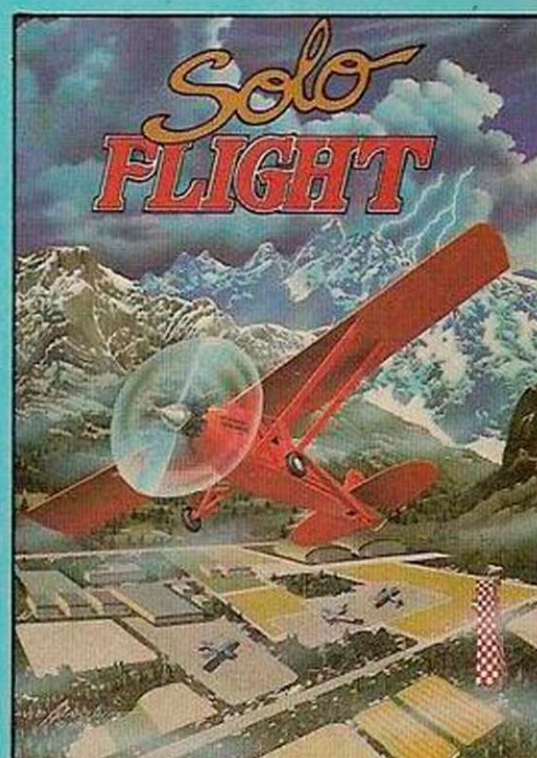

SOLO FLIGHT

Solo Flight is an outstanding flight simulator that will provide you with the thrill, excitement, and joy of flying your own aircraft. Solo Flight uses superior three dimensional graphics to provide realistic take-offs, landings, and cross country navigation under both visual and instrument flight rules among 21 different airports, in three different geographical areas of the United States. Options include touch and go's, visual or instrument flying, full cockpit instrumentation, dual VOR navigation radios, an instrument landing system (ILS), multiple air navigation maps, four difficulty levels, and emergency procedure practice. In the game mode the player uses his superior skills to deliver the U.S. Mail quickly and safely among the various airfields. This simulation is a realistic trainer and outstanding fun for all ages!

C-64/128 & Atari Cassette	£14.95
C-64/128 & Atari Disk	£14.95



The excitement

s simulated-

See, feel and hear all the action! Kennedy Approach is the FIRST simulation to include realistic high-quality speech right from your computer. Bad weather, in-flight emergencies, instrument failures and other variables provide an ever changing environment. You control the action in the skies of our busiest airports, twenty different aircraft could be calling you at the same time and may be vying for the same runway!

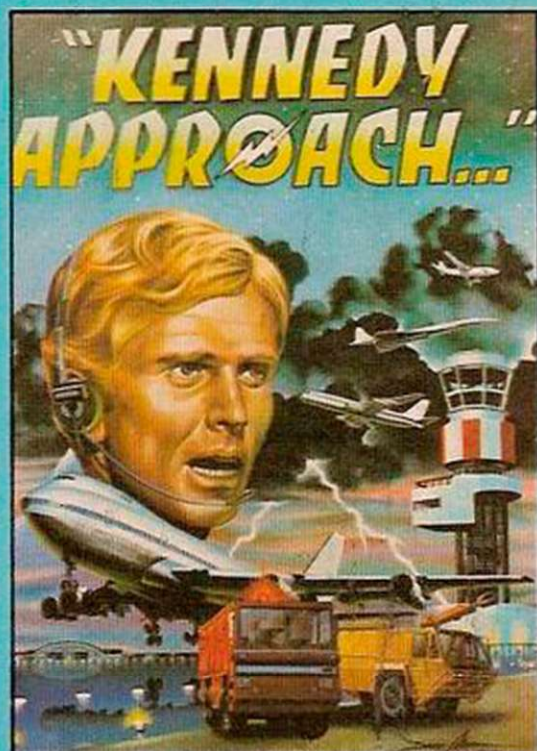
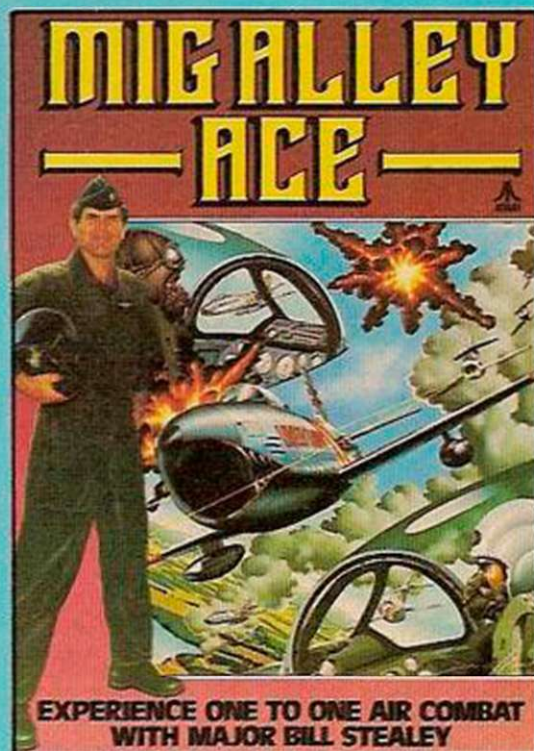
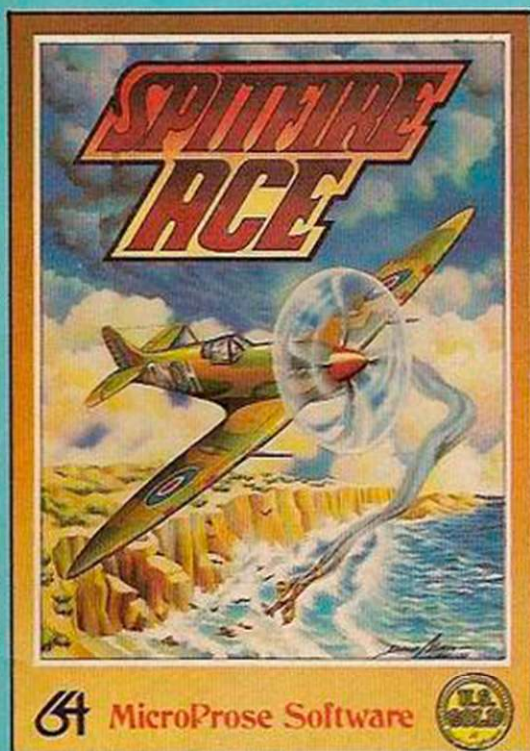

SPITFIRE ACE

Strap on your parachute and man your fighter!! Save London during the Blitz in your Supermarine Spitfire!! Fly loops, Immelmans, and all the real air-to-air combat manoeuvres using outstanding, out of the cockpit 3-D graphics!! SPITFIRE ACE (European Theatre) provides at least 9 different Combat scenarios and fast paced action that puts you right on the edge of the real personal danger of being shot out of the sky!! For 1-4 players!!

C-64/128 & Atari Cassette £9.95
C-64/128 & Atari Disk £12.95



MIG ALLEY ACE

MIG Alley Ace is an exciting and action packed split screen head-to-head aerial combat flying simulation. The game allows two players to fly against each other in their own jet fighter and each receive outstanding graphics and flight information as if they were in the cockpit of their own F-86 Sabre Jet. The game play consists of a series of actual fighter pilot manoeuvres, from loops and High-G turns to Hi-Yo-Yo's, as each player attempts to centre his opponent's aircraft in his gun sights and shoot him down. Additional game options include a solo mode against one to three enemy aircraft, and a cooperative mode where two human players can fly against two computer controlled enemy aircraft. Five actual Korean War scenarios are included, each with five different skill levels. MIG Alley Ace is an outstanding simulation that requires superior fighter pilot skills and guts to survive and win the Silver Wings of a Jet Ace!

C-64/128 & Atari Cassette £9.95
C-64/128 & Atari Disk £12.95

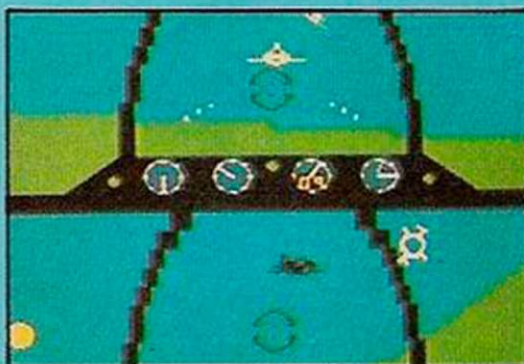

KENNEDY APPROACH

You will hear both their radio calls and your broadcast messages in high-quality speech. All commands can be given using the joystick. This simulation is immediately playable and enjoyable. The safety of hundreds of passengers is in your hands as you guide jet airliners, private planes, and even the supersonic "Concorde" to and from their destinations.

ARE YOU READY TO TAKE CONTROL... YOU'LL BE GLAD WHEN THIS SHIFT IS OVER!!!

C-64/128 & Atari Cassette £14.95
C-64/128 & Atari Disk £17.95

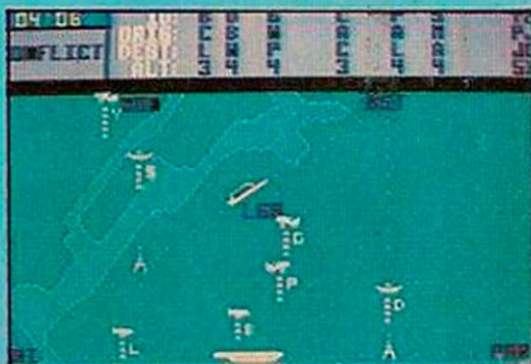

ent is REAL!



Enter the world of computer adventure. Each adventure takes several weeks to master, providing hours of fascination and intrigue. You must use your imagination and logic to unlock the mysteries of each adventure.

Map skills are essential; each adventure contains full-colour computer generated images which lead you in every direction. You'll need to muster up all your wit and logic and perseverance for each of our adventures will prove a test to your imagination and ingenuity.

The Wizard & The Princess from Sierra On-Line

Become the hearty and steadfast adventurer who rescues the fair princess from the dreadful wizard, Harlin. He has taken her to his towering castle beyond the great mountains. You must outwit and outmanoeuvre the mystical power of the wizard which has grown dark and potent through time. Begin your adventure in the village of Serinia, but take heed, everything is not as it may appear.

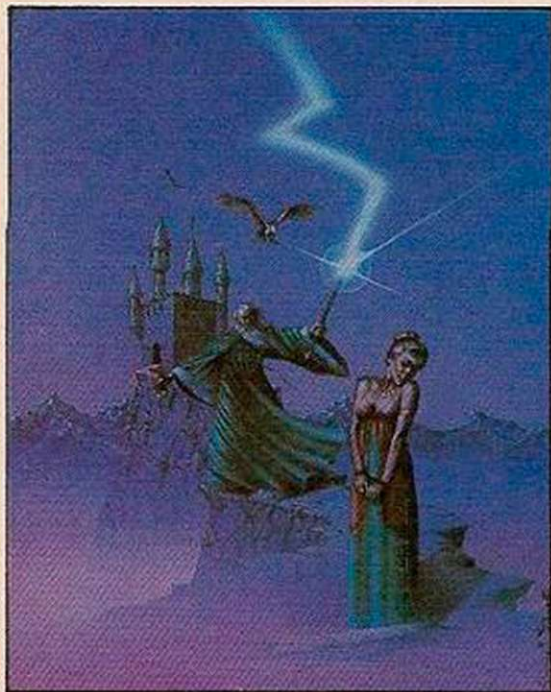

Exodus-Ultima III from Origin Systems

Upon escaping the crumbling ruins of Shadowguard, the black fortress of Minax, you lay your weary body on the now-sacred ground. As you rest, you remember your first encounter with the evil wizard of Mondain, whom you later tracked down and destroyed. The existence of his apprentice, Minax, was soon revealed and the crusade was begun again. Younger and more cunning than her mentor, she has been much more difficult to vanquish. But now your sense of accomplishment is touched by a chilling fear. Have all vestiges of evil been removed? Somehow, you sense that your treacherous foes have not been eliminated. Without further feats of skill, daring, and perseverance, all of your past accomplishments may be lost. You stand up, prepare your armour, and walk to the dimension door. Stepping in, the hunt resumes.

BORED WITH SHOOT 'EM then it' VENTURE IN

An Epic Fantasy Role-Playing Experience

- Up to 20 character roster
- A 1 to 4 character party
- Individual player movement
- 16 long and short range weapons
- 8 armour types
- Magic weapons, armour and items
- 32 magic spells
- 11 character classes. 5 races
- New combat mode
- New ship to ship or shore combat
- Full colour visuals throughout
- New advanced dungeon graphics
- New animated outdoor graphics
- Sound on/off toggle
- New navigational strategies
- Adventure style verb entry
- New astrological influences

Ulysses & The Golden Fleece from Sierra On-Line

Protected by the gods, the "Golden

Fleece", legendary treasure of ancient mythology, has been kept from man for many decades. Many valiant men have attempted its recovery, but none have been successful in possessing it for any amount of time. The setting is ancient Greece and YOU are Ulysses. The king has requested an audience with you, to assign you the task of retrieving the "Golden Fleece", and returning it safely to him. On your voyages you will encounter many of the same foes dealt with by your predecessors. (The wicked "Sirens", whose beautiful songs lure unsuspecting seamen to their deaths on the island's treacherous shores: the Cyclops, son of king Neptune; Pluto mythological god of the underworld and others). Highlighting your journey is an encounter with the magnificent winged horse "Pegasus".

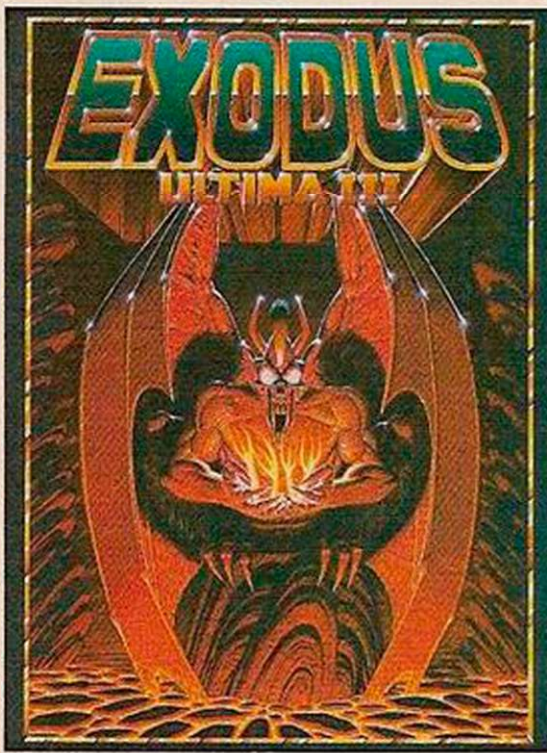

Wizard & The Princess C64 Disk **£14.95**

Exodus-Ultima III C64/Atari Disk **£19.95**

Ulysses C64 Disk **£14.95**

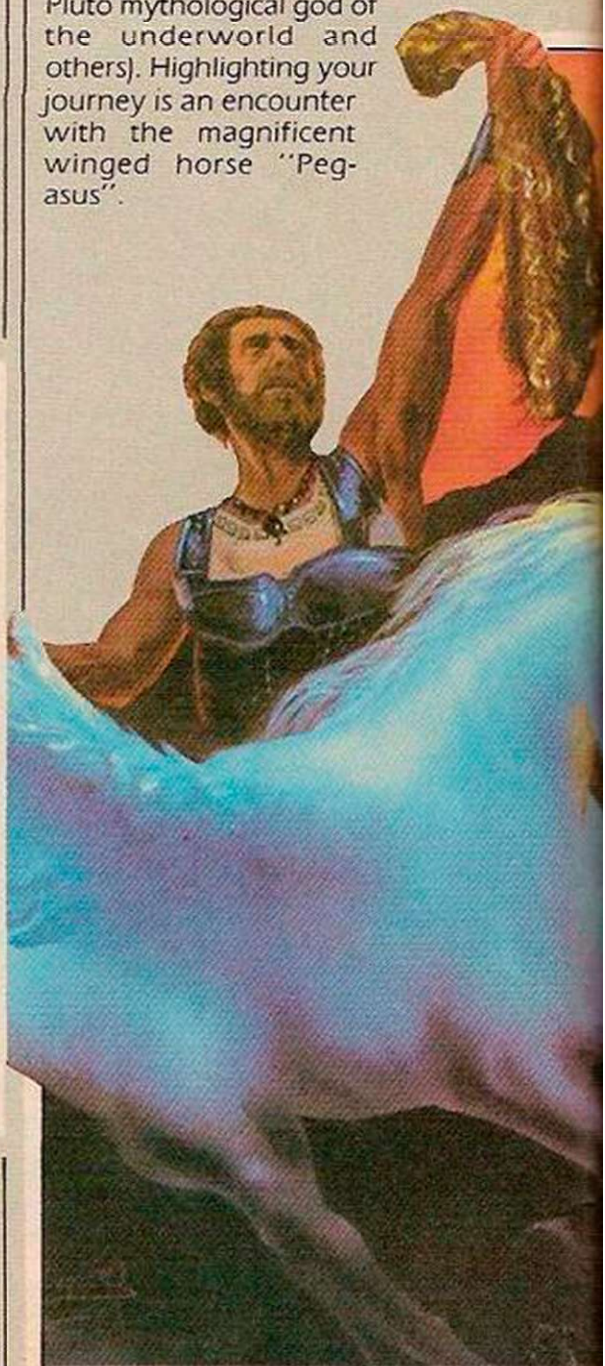

UP SPACE INVADERS?

It's time to

TO THE UNKNOWN

Legend acclaims Ulysses as the most daring and skilled seaman of all time. Clad in a pocketed "toga" and chain armour, it's up to you to prove it!

Mission Asteroid from Sierra On-Line

A terrible tragedy is about to happen... An asteroid of incredible size is headed for a direct collision with the Earth. The predicted impact could destroy all life here — unless something is done quickly. As an astronaut, it's your duty to rocket to the asteroid and attempt to alter its course.

There's no time to lose! If you don't do things exactly right and travel fast enough, there will be DISASTER!

The asteroid will collide with Earth at a pre-determined time. You are wearing a watch, which, if checked periodically, will let you know how much time you have left.

If you're quick and careful, you will save us all from oblivion. If not, don't bother landing on Earth again, you will have no home to return to... Good luck!

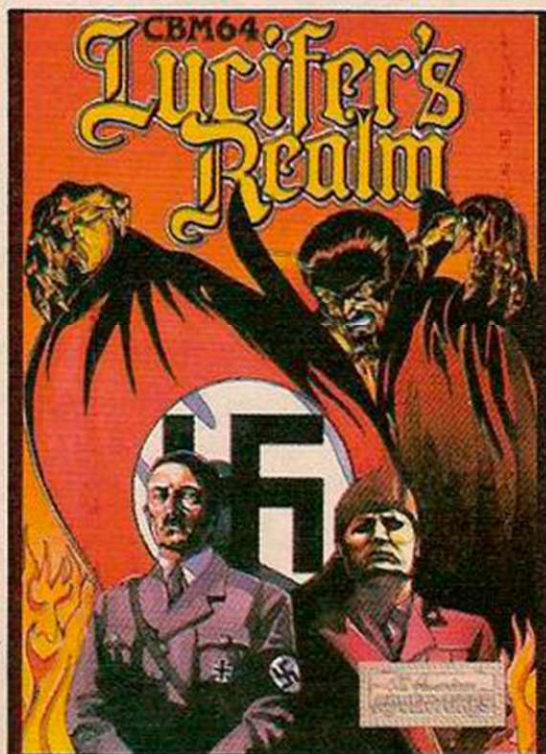
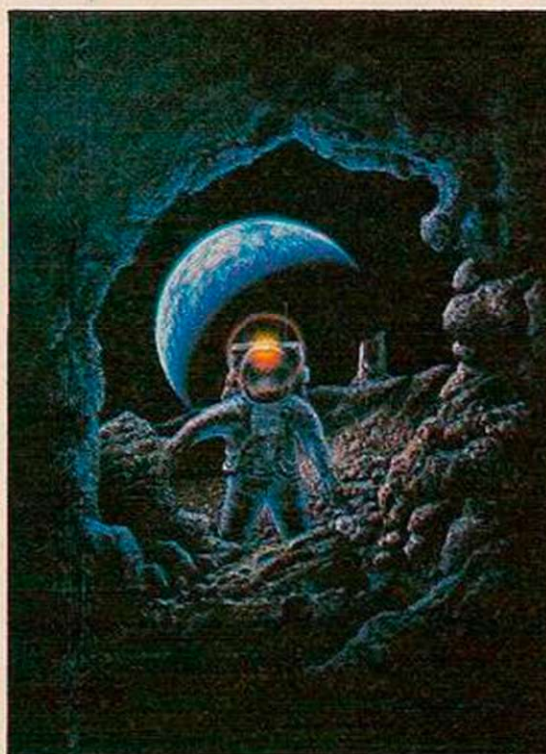

Lucifer's Realm from American Eagle

By some tragic twist of fate your departure from this life leads not to Heaven as expected, but a journey which deposits you in Hell!

On coming face to face with Lucifer you find he is strangely kind to you. A path to Heaven can be yours but tread carefully — this journey is littered with the likes of Adolf Hitler and Benito Mussolini.

Masquerade from American Eagle

It turned out to be the toughest case of your detective career. Clues have led to nothing but dead ends. Nobody is talking. Meanwhile, the crime boss you are after is still operating from somewhere. You're about to throw in the towel. But wait! Something breaks. You trail a stooge of the crime organisation to a cheap, seedy hotel, hoping to pump some answers out of him. You break into the hotel room and with the butt end of your trusty .44 magnum, you knock him cold. This could be the lead you've waited for. Maybe, just maybe, if you could find some clues...

Mission Asteroid C64 Disk **£14.95**

Lucifer's Realm C64/Atari Disk **£14.95**

Masquerade C64 Disk **£14.95**

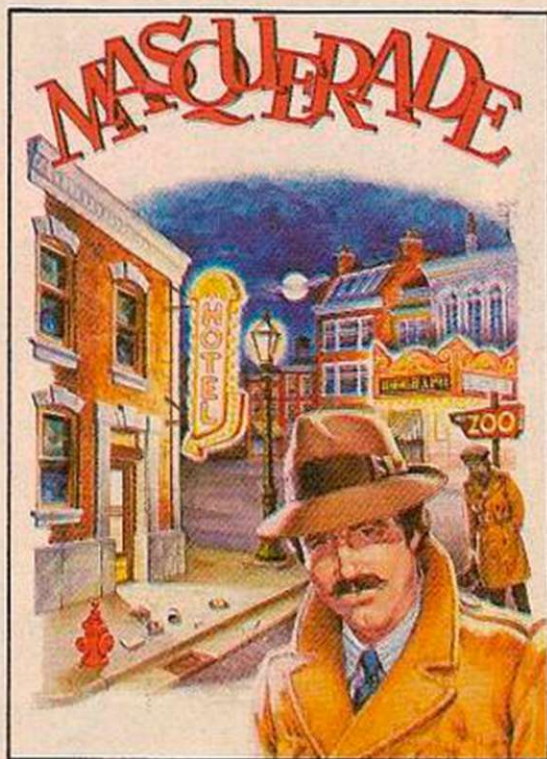

ALL AMERICAN ADVENTURES
UNIT 10,
THE PARKWAY INDUSTRIAL CENTRE,
HENEAGE STREET, BIRMINGHAM B7 4LY.

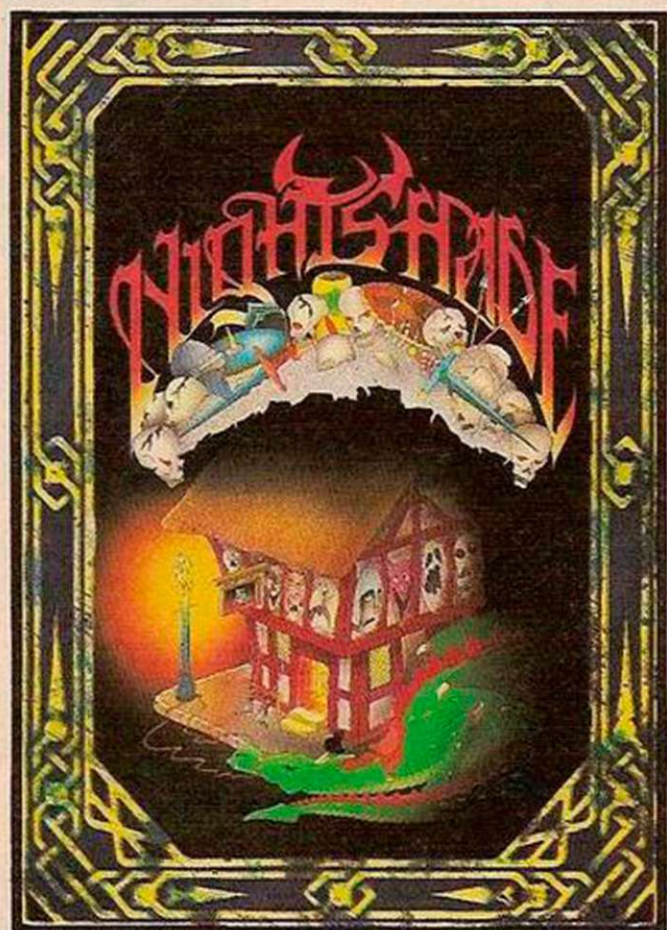
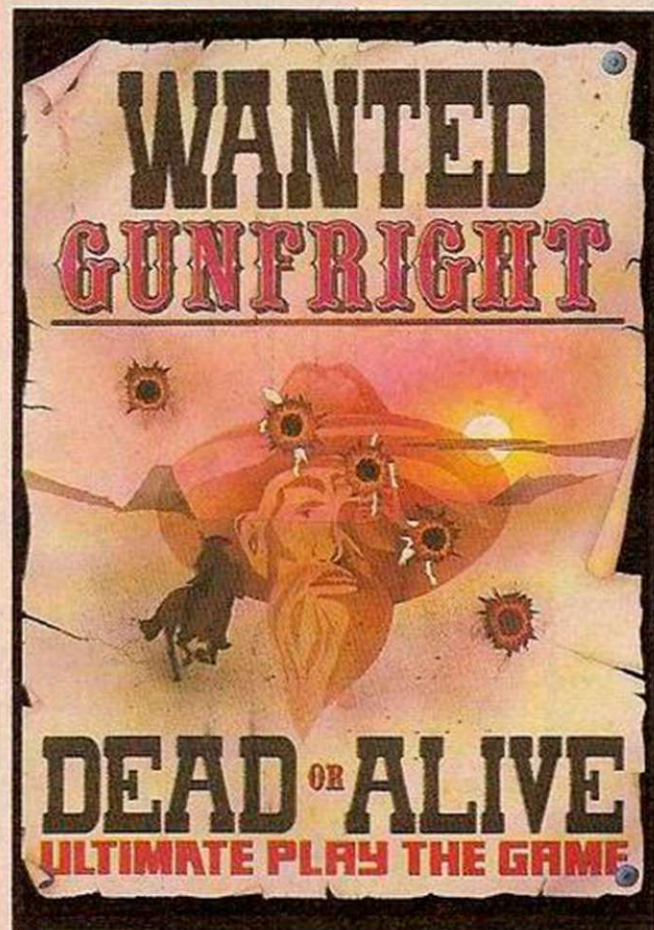
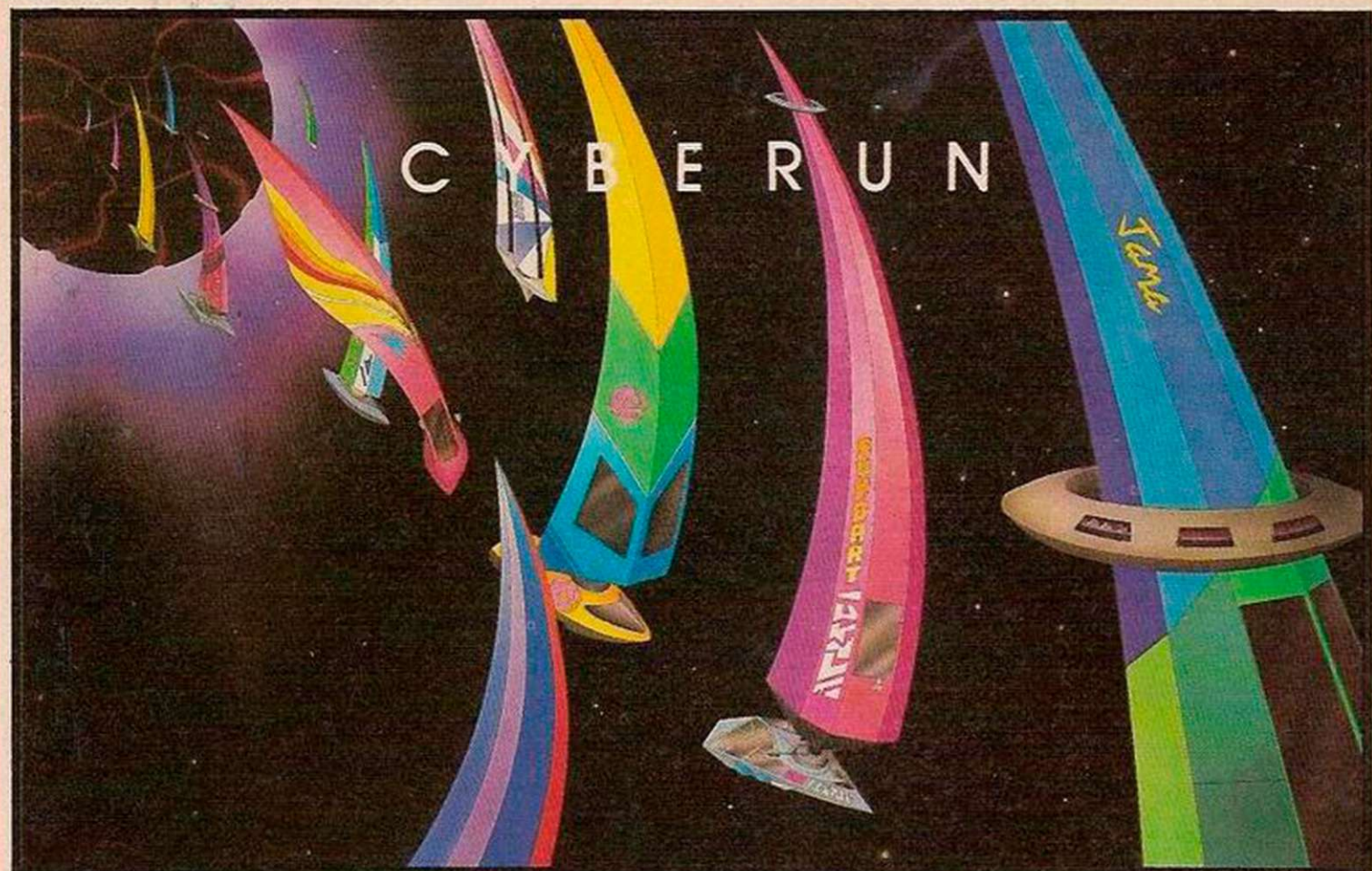

"CYBERUN", "GUNFRIGHT", "NIGHTSHADE" recommended retail price £9.95 inc VAT.
Available from W.H.SMITHS, BOOTS, J.MENZIES, WOOLWORTHS
and all good software retail outlets. Also available from
ULTIMATE PLAY THE GAME, The Green, Ashby-de-la-Zouch, Leicestershire LE6 5JU
(P&P are included) Tel: 0530 411485

ULTIMATE
PLAY THE GAME



= CHA os weapon. The Master reports 'promising' results. (LIVE ALIEN cortical preparation.) Mine/Factory S...
 Machine skill VITAL. Doctor: ultimate risk scenario. Your intervention urgently requested. ??? **HELP?** ??? Disable TIR...
 Regain

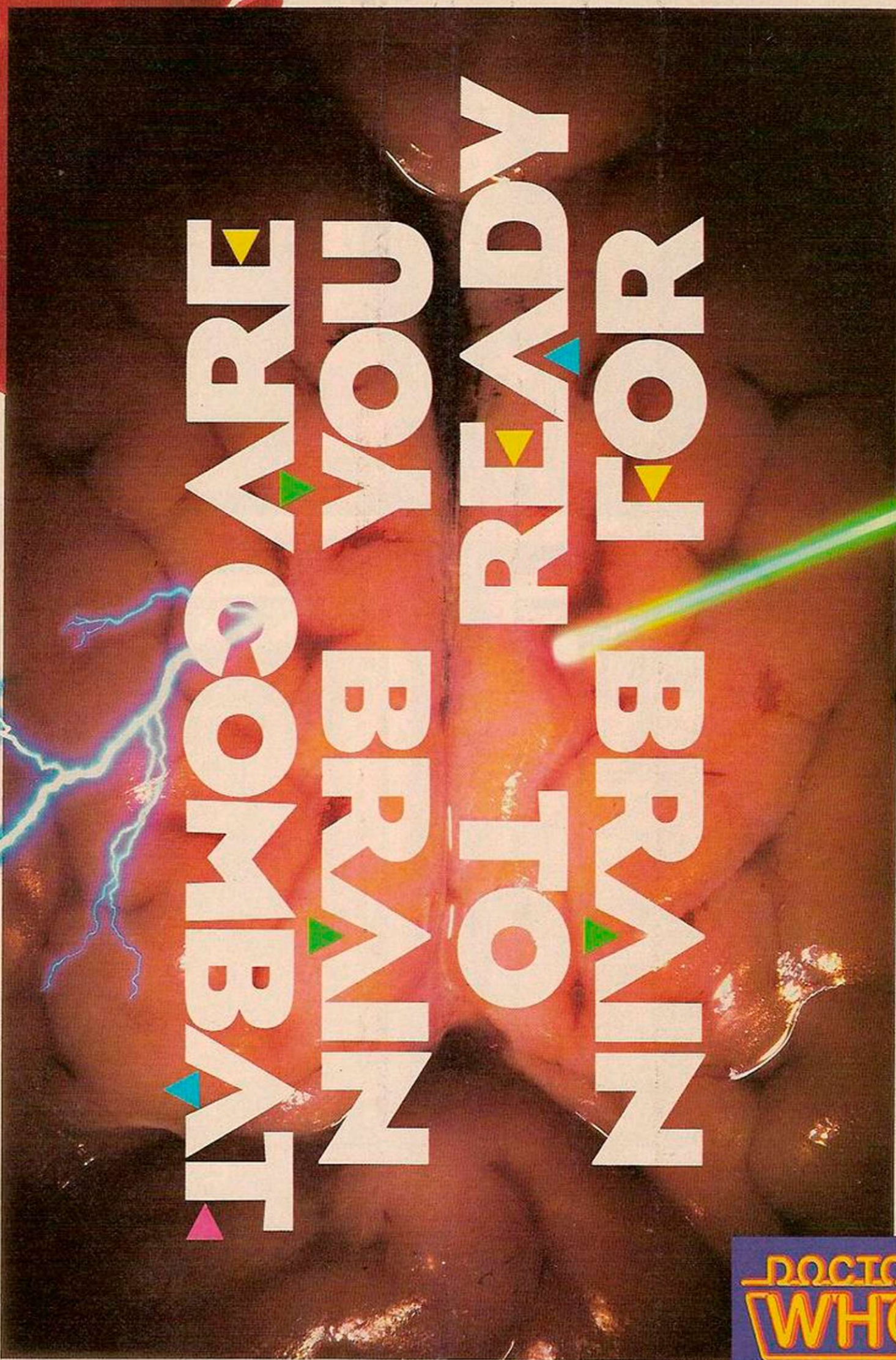

DOCTOR WHO AND THE MINES OF TERROR

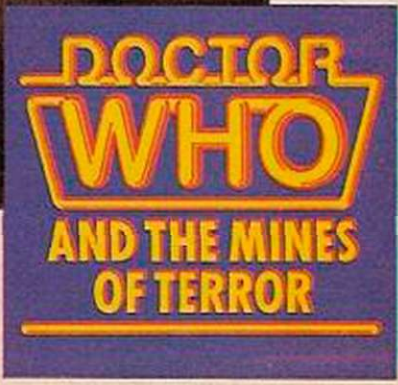

MICROPOWER

IN ASSOCIATION WITH THE BBC

SPECTRUM COMMODORE £14.95
AMSTRAD (CASSETTE)

$Zi(Ur_4(\overset{13}{C}_5H_5N)_8O_4Fl_8)OH_4 \cdot 16H_2O$ } ◆ ● — 2nd Moon Rihar. —
 Use invisible cat + code: string ◆ etc. Full cerebral combat status needed.

Blue print (part) supplied. Ky-Al-Nargath construction. MEGA SECURE !!!
 all times. Halt Heatonite prod. Access via VDU. Programme concealed in game Pack Who would think of a Police box?

(ROM/CASSETTE) £18.95
 (KSI/DISK) £18.95
 (ROM/DISK) £18.95
 BBC

48K SINCLAIR SPECTRUM

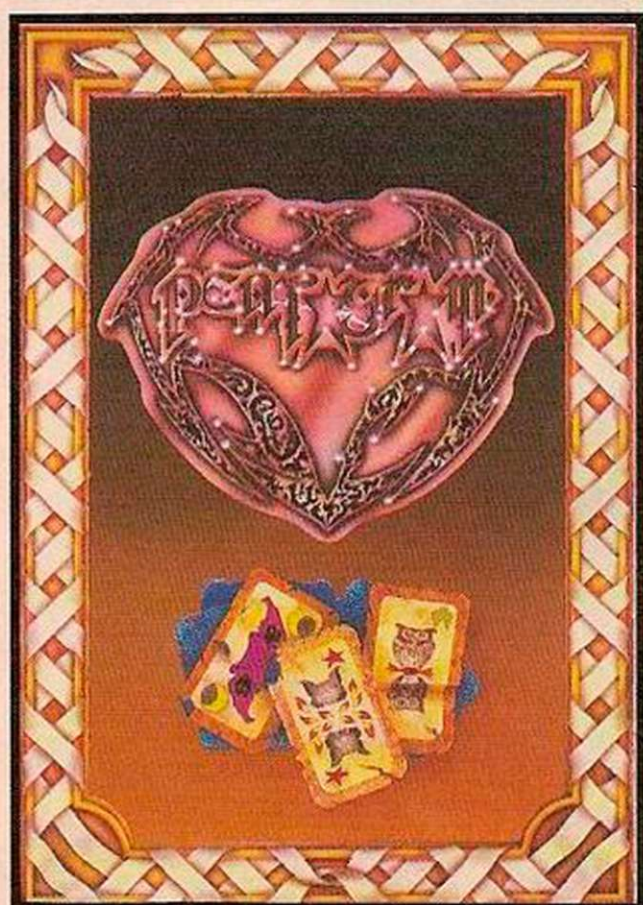
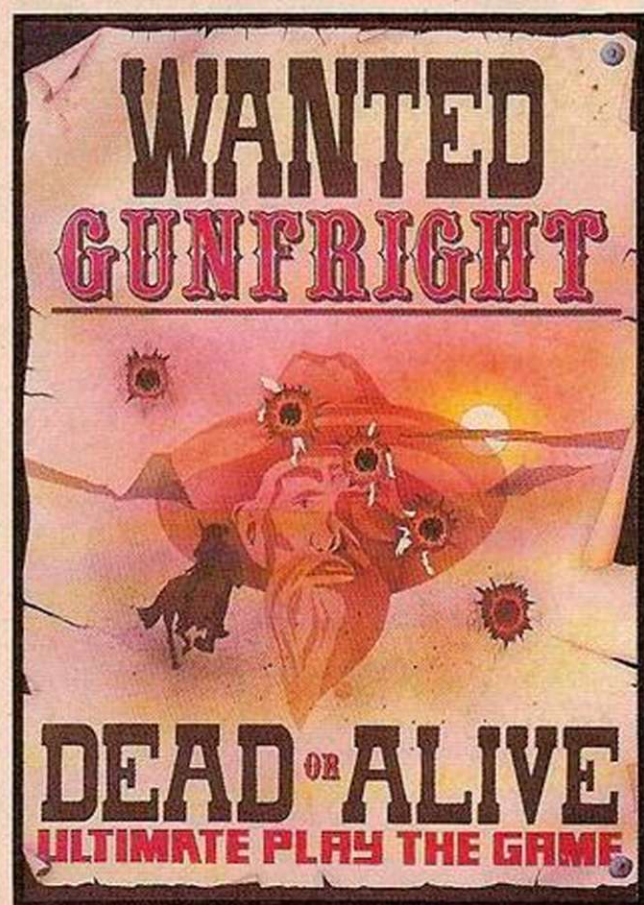
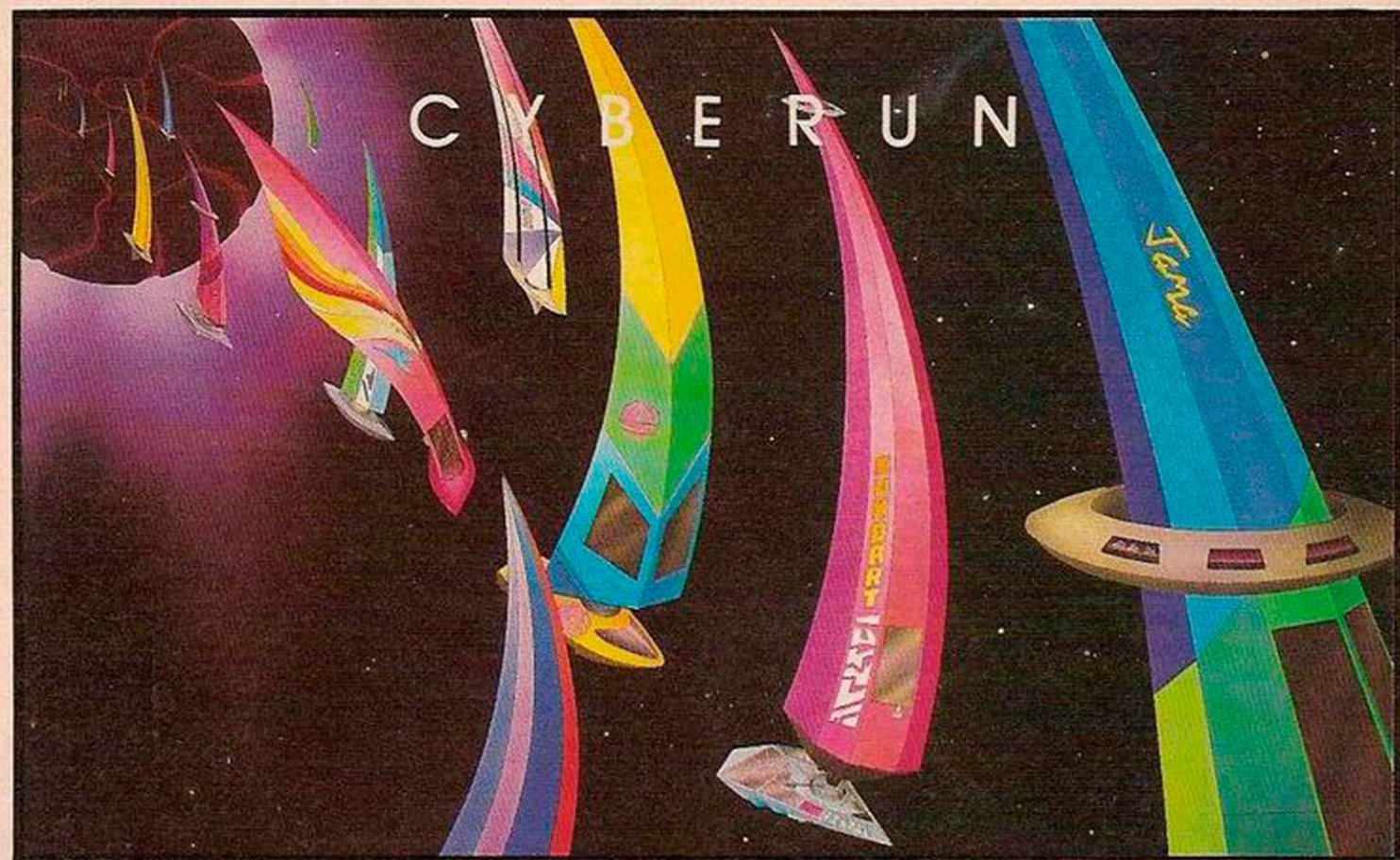

"CYBERUN", "GUNFRIGHT", "PENTAGRAM" recommended retail price £9.95 inc VAT.
Available from W.H.SMITHS, BOOTS, J.MENZIES, WOOLWORTHS
and all good software retail outlets. Also available from
ULTIMATE PLAY THE GAME, The Green, Ashby-de-la-Zouch, Leicestershire LE6 5JU
(P&P are included) Tel: 0530 411485

ULTIMATE
PLAY THE GAME



DOCTOR WHO AND THE MINES OF TERROR IS AVAILABLE AT THE FOLLOWING OUTLETS:

ENGLAND

ACCRINGTON

P V Tubes (Computers), 104 Abbey Street, 0254 36521

ALTON

Alton Computers, 62 High Street, 0420 87998

BANSTEAD

Computerama, 17 Nork Way, 07373 54717

BOURNEMOUTH

Lansdown Computer Centre, 1 Lansdown Crescent, 0202 290165

BRIGHTON

The Gamer, 71 East Street, 0273 728681

BROMLEY

The Data Store (Micro Computers), 6 Chatterton Road, 01 460 8991

BRISTOL

The Model Shop, 64 Fairfax Street, 0272 27344

CAMBRIDGE

Heffers Booksellers, 19 Sydney St., 0223 358241

CHALFONT ST. PETER

Softshop Limited, 55 St. Peter's Court, 0753 889010

CHEADLE

Q.E.S. Computers, 60 Stockport Road, 061 428 6912

CHELTENHAM

Computer Shack, 14 Pitville Street, 0242 584343

CHICHESTER

Computermania, Southgate, 0243 779263

DORCHESTER

Seven Counties, 20 High East Street, 0305 66022

EXETER

Seven Counties, 7 Paris Street, 0392 211211

FAREHAM

Timatic Systems, Fareham Market, 0329 236727

FAREHAM

Electronequip, 36 - 38 West Street, 0329 230671

GRAYS

H Reynolds & Sons, 28A Southend Road, 0375 31641

GUILDFORD

The Model Shop, 23 Swan Lane, 0483 39115

HULL

The Computer Centre, 26 Anlaby Road, 0482 26297

KINGS LYNN

Electronequip, 17 Tenneyson Avenue, 0553 773782

LEAMINGTON SPA

Leamington Hobby Centre, 121 Regent St., 0926 29211

LEEDS

Virgin Games, Briggate, 0532 432606

LEEDS

MicroPower, Northwood House, North Street, 0532 458800

LITTLEHAMPTON

Computermania, 17 The Lanes, 0903 716187

LONDON SE1

Vic Oddens, 6 London Bridge Walk, 01 403 1988

LONDON

Schkana Computer Services, 221 Tottenham Court Road, 01 800 3156

LUTON

Hobbyte Limited, Unit 1G, Arndale Centre, 0582 457195

MAIDSTONE

Kent Micro Computers, 57 Union Street, 0622 52784

MANCHESTER

N.S.C. Computer Shops, 29 Hanging Ditch, 061 832 2269

SOUTHEND-ON-SEA

Computerama, 88-90 London Road, 0702 335443

SOUTHPORT

Central Studios, 38 East Bank Street, 0704 31881

STRETFORD

Courtgrant Computers, Arndale Centre, 061 864 2010

STROUD

The Model Shop, 22 High Street, 045 36 5920

SWINDON

Barbury Computers, 89 Victoria Road, 0793 611487

UXBRIDGE

J.K.L. Computers, 7 Windsor Street, 0895 51815

WELWYN GARDEN CITY

D.J. Computers, 40 Fretherne Road, 0438 65501

SCOTLAND

ABERDEEN

Micro Shack, 18 Chaple Street, 0224 636081

ABERDEEN

James G. Bissett, 12-14 Upper Kirkgate, 0224 644528

WALES

CARDIFF

Cardiff Micros, 46 Charles Street, 0222 373072

CARDIGAN

Cardigan Electronics, Chancery Lane, 0239 614483

LLANELLI

Positron Computing, 15 Central Precinct, 0554 759624

GLAMORGAN

Bucon Limited, 35-36 Singleton St., Swansea 0792 467980

EIRE

BRAY

Bit by Bit, 6 Castle Street, 0001 868541

CHANNEL ISLANDS

GUERNSEY

Art Products (Gruts), 3-5 The Pollet, St Peter Port, 0481 24682

DISTRIBUTORS

BULLDOG DISTRIBUTION 0260 277611

CENTRESOFT 021 359 3020

GEM DISTRIBUTION 0279 444615

GREYHOUND MARKETING 0532 436300

LAZER DISTRIBUTION 0392 50434

LEISURESOF LIMITED 0604 46658

MICRO DEALER U.K. 0462 37171

R & R DISTRIBUTION 0977 795544

TBD DISTRIBUTION LIMITED 0782 620321

THORN EMI SOFTWARE 0252 543333

TWANG (WHOLESALE) LIMITED 0734 580200

WAYFARER DISTRIBUTION 0743 66922

WEBSTERS SOFTWARE 0483 62222

WONDERBRIDGE LIMITED 01 995 9060

DOCTOR WHO AND THE MINES OF TERROR WILL ALSO BE AVAILABLE AT MOST MAJOR HIGH STREET SHOPS

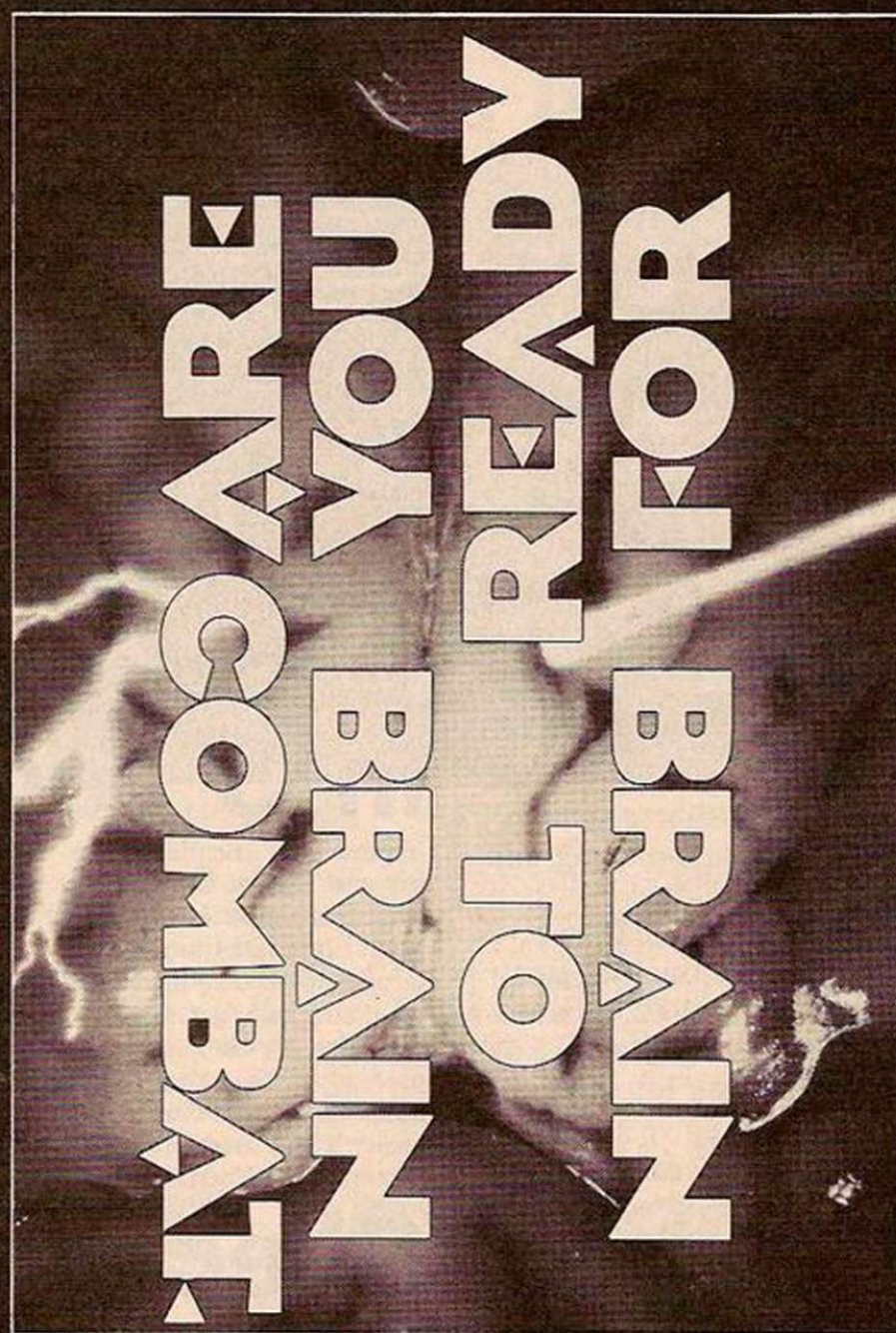
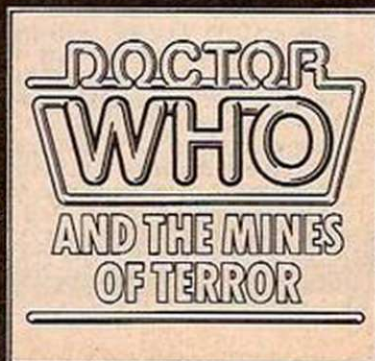

MANSFIELD

Mansfield Computers, 33 Albert Street, 0623 31202

NORTH FINCHLEY

Adams World, 779 High Road, 01 446 7170

NELSON

Suntaxsoft, Unit 109, Glenfield Park, Glenfield Road, 0282 698849

PLYMOUTH

Georges Booksellers, 141 Armada Way, 0752 661011

PLYMOUTH

The Model Shop, 11 Old Town Street, 0752 21851

POOLE

Lansdown Computer Centre, 14 Arndale Centre, 0202 670901

REDCAR

Multicoloured Micro Shop, 8 Dundas Street, 0642 486643

ST. ALBANS

Hobbyte Limited, 10 Market Place, 0727 41396

ST. HELENS

Microman, Mill Lane, Rainford, 074488 5242

SOUTHAMPTON

Computerama, 112 East Street, 0703 333958

MICROPOWER

MicroPower Ltd., Northwood House, North Street, Leeds LS7 2AA

Edit...

GOOD TIMES, BAD TIMES

Don't believe what they tell you. The truth is that despite the disasters of 1985 computers and software have sold better than ever this Christmas.

It may be difficult to credit it after a year when Acorn twice had to hide behind Olivetti's Turin shroud to escape oblivion, and Sinclair and Commodore managed to clock up millions — in losses.

Clearly all that adds up to a lot more than just a bad attack of hiccups. But that isn't the whole picture. While most of the hardware manufacturers were gasping for cash, the survivors of the software industry were breathing new life into games.

Programs like Alien 8, with its superb graphics, Frankie goes to Hollywood, which brought icons and windows to home computing, and Way of the Exploding Fist, which did to animation what sound did to movies, all pushed game-playing and programming to new heights.

To be honest, even on the hardware side it wasn't catastrophes all the way. No one can deny that Amstrad, thanks to the 6128 and 8256, is now a major force in European computing. And Stateside, although the noises coming out of the Commodore make it sound as if they've sat on another financial whoopee cushion, Tramiel's STs are making people take Atari seriously again.

Let's try forgetting 1985 for a moment, and try a bit of guesswork about the future. When Sinclair decides to start pushing the Spectrum 128 in this country it will be the first time that the top-sellers from all the manufacturers will sport the same size memories. Think what that will do for the software houses.

The accent may shift away from eight-bit technology. As the Japanese regroup after the MSX rout, Western micro-makers will have to come up with something very special to beat them off for a second time. Let's hope it does come to a fight — it will stop the big boys from becoming too complacent. It may make them sweat but the exercise should do them good. And in the long run we'll be the winners.

Editor: TOBY WOLPE; Software Editor: SIMON BEESLEY; Commercial Software Editor: PAUL BOND; Staff Writer: LEE PADDON; Editorial 01-661 3144. Advertisement Manager: NICK RATNIEKS 01-661 3127; Assistant Advertisement Manager: KEN WOLFORD 01-661 8548; Northern Office: CHRIS SHAW 061 872 8861; Classified: IAN FAUX 01-661 3036; Publisher: RICHARD HEASE. Your Computer, Room L221, Quadrant House, The Quadrant, Sutton, Surrey SM2 5AS. © Focus Investments Ltd. Printed in Great Britain for the proprietors Focus Investments Ltd, Wells House, 80-82 Upper Street, London N1 0NU. Tel: 01-359 3525. Printed by Riverside Press Ltd, Whitstable, Kent, and typeset by Instep Ltd, London EC1. Subscriptions: U.K. £14 for 12 issues. ABC 131,769 July-December, 1984.

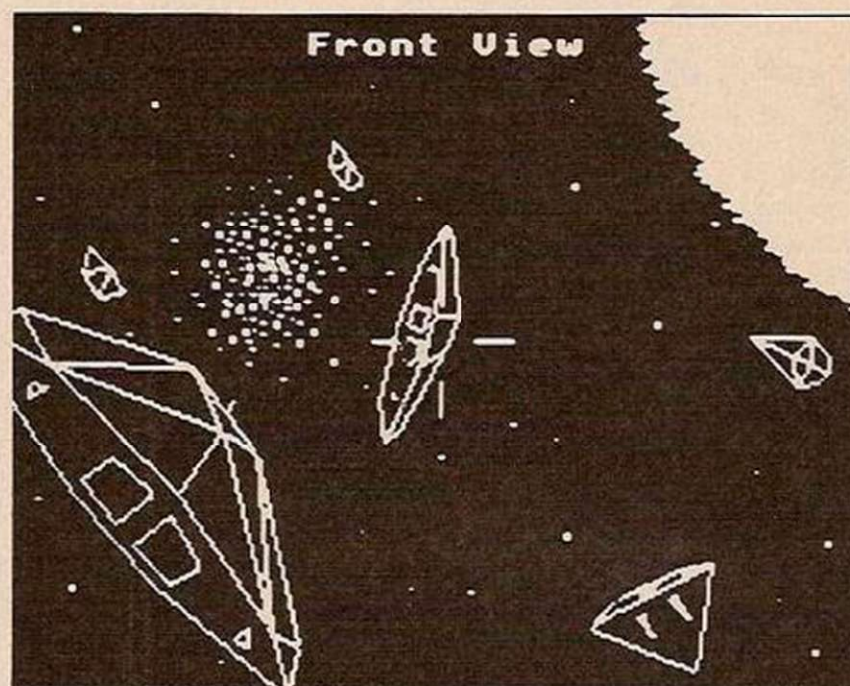

Join the Elite in 3 seconds

Impress your friends, be the life and soul of the party. With this simple bug, you can reach Elite status in three seconds. Step one, load the tape; step two, get through the hideously complex Lenslok procedure (OK we were lying about the three seconds). Now press "Y" to load new commander. When on the

save/load screen press "2" to save, press return when it asks for a name. After saving press "3" to exit and — voila! Elite with all the credits and cargo you can eat.

Unfortunately, the security code generated by this method won't fool those guys at Firebird and get you into the monthly play-offs.

Spectrum loads for Enterprise

Spectrum Basic programs can be loaded directly into the Enterprise computer, with the aid of Basic to Basic. Once the £19.95, program from Enterprise is running, tapes containing Spectrum Basic files can be loaded into the Flan. The program then converts the Spectrum Basic into Enterprise Basic, highlighting areas of the program which the user may

have to rewrite.

Any Spectrum owners thus tempted to rush out and buy one might like to consider a bundling deal from McIntyre Marketing. Enterprise 128 and Fidelity TV/Monitor for £229.95, or Enterprise 128 with a cassette recorder and joystick adapter for £199.95. Anyone interested should contact McIntyre Marketing on 051-708 8141.

Battle of the Planets

Bryan Hulme, 24, an unemployed motor mechanic from Cheshire, has won the National Computer Games Championship. The contest, organised by Micro Gen was held on December 12th at the

Savoy Hotel, London.

The four finalists had 15 minutes to battle it out on a new game called "Battle of the Planets" which is due out from Microgen around Christmas.

Hard News

PRICE SLASHERS 128 shake-up starts here

High Street giant W H Smith has dropped the price of the Sinclair Spectrum Plus to £99.95 in a bid to capture the elusive Christmas market. Meanwhile, the new 128K version of the machine is waiting in the wings. The long awaited Spectrum 128 is expected to make its debut early in 1986. When it arrives it will mean that the flagship machine of each of the major micro manufacturers will have the same memory capacity for the first time.

Elsewhere, the Spectrum Plus is being sold as part of a package including a joystick and interface together with some software, all for around £139. At Currys you can get all this plus a cassette player for the same price, however the recommended retail price of the micro remains at £129.

Commodore owners can trade in their old 64s for a 128, getting £50 off the



Spectrum 128: Sinclair's shy star waits in the wings.

current retail price. This brings down the cost of owning a CBM-128 to £220. Other computer owners cannot trade in their equipment, but will receive a free Datasette — which Commodore claim is worth

£45, with any CBM-128 purchased at full cost.

Comet, Greens and Ultimate are selling the Commodore Plus/4, together with a Datasette, joystick and 10 pieces of software for just £99.99.

Some go East, some go West

He who laughs last laughs longest so we can look forward to large quantities of inscrutable oriental mirth. The in joke last year and early this year was MSX. The xenophobic, parochial Brits just couldn't take it seriously. Now the boot is on the other foot. By offering a quality product at a good price they are getting the sales. Next year MSX will be the best selling computer, globally.

Amstrad's current crop of machines are well made, well marketed and good value. They are not, however, technically interesting. This is obviously a situation that cannot go on forever. Their 68000, 1/2 megabyte, WIMP etc machine is a lot nearer

DIARY

than some people imagine. Amstrad are just much better at keeping things under their hats than most companies. On past performance we can expect better price/performance than the rest of the Amiga, S.T. crop. Especially when those three inch disk drives are rumoured to only cost Amstrad £12 a piece.

Next time you see screen shots in a game advert or insert card take a closer look. One or two software houses have got into the naughty habit of using C64 screenshots for the Sinclair Spectrum version. Some have gone so far as to use proper arcade machine screen shots on both the C64 and Spectrum versions. Slap wrists.

A certain Liverpool software house recently had a moderate hit with their version of "Underwulde"

(continued on page 23)

Mickey Mouse contest

A trip to the Epcot centre is the prize on offer in an essay competition being run by the Association of Young Computer Enthusiasts.

The catch is that to enter, you have to be a member — which costs £5 a year. The other catch is that the closing date is January 15. The essay should not be longer than 2,000 words, and should describe a computer system for running a club. The Association is an offshoot of the British Computer Society, and for your £5 you get a monthly magazine, with competitions and special offers.

For more information contact Elizabeth Davies on 01-637 0471.

Big boys face cash crisis

Sinclair Research and Commodore Business Machines both announced losses during the last few weeks of 1985. Sinclair's figures for the year to March '85 were bad enough, showing a loss of more than £18 million, but Commodore, being American, had to go one better and managed to lose nearly £30 million in the three months before September.

While Sinclair's problems are blamed on the retailers — who overstocked by as many as 400,000 computers early in 1985. Commodore's woes are due to investment in new machines such as the 128 and the Amiga.

Commodore's figures are

much worse than expected, and industry analysts in the U.S. claim that if these figures are not turned around quickly, the company could be in serious trouble.

On the other hand, Sinclair has done much better than most forecasts expected, especially so considering the abortive deal with Robert Maxwell last summer.

Currently Sir Clive Sinclair is trying to raise £10 million, in order to build the next range of computers.

Meanwhile if you are feeling charitable this Christmas, spare a thought for poor old Sir Clive — his wages have been cut from £77,000 to a mere £53,000.

SOFT TOUCHES

Add a touch of communications genius to your computer and modem with these packages!

BBC

The DATABEEB ROM-based comms package gives your BBC Computer access to PRESTEL*, MICRONET*, MICROLINK*, Viewdata, telex, electronic mail, databases, and bulletin boards, handling baud rates of 1200/1200, 75/1200, 1200/75 and 300/300. Features include carousel facility, Macro Command File, error trapping and telesoftware downloading. The package includes full fitting instructions, User Guide and Function Key Guide.

£25.00 exc VAT
£28.75 inc £

ATARI

The DATATARI/MULTI-VIEWTERM serial interface plus software package is unique, because it gives full PRESTEL facilities, including graphics, to Atari* users. Allows access to MICRONET, MICROLINK, Viewdata, telex, electronic mail, databases and bulletin boards, handling baud rates of 1200/1200, 75/1200, 1200/75 and 300/300. 850 interface not required. For models 400, 800, 600XL, 800XL, 65XE, 65XEM and 130XE. Software on disk or cassette.

£52.13 exc VAT
£59.95 inc £

SPECTRUM

The DATASPECTRUM interface and software package puts your 48K Spectrum* in touch with Viewdata, telex, electronic mail, bulletin boards and databases, plus PRESTEL, MICRONET AND MICROLINK. The interface handles baud rates of 300/300, 1200/75 and 75/1200. Software features include Mailbox Editor, Frame Processor, Save, Print, and Telesoftware Downloader. The package includes interface, cable, cassette and full User Guide. Software is transferable to Micro-drive.

£39.95 exc VAT
£45.94 inc £

APPROVED for connection to telecommunication systems specified in the instructions for use subject to the conditions set out in them.

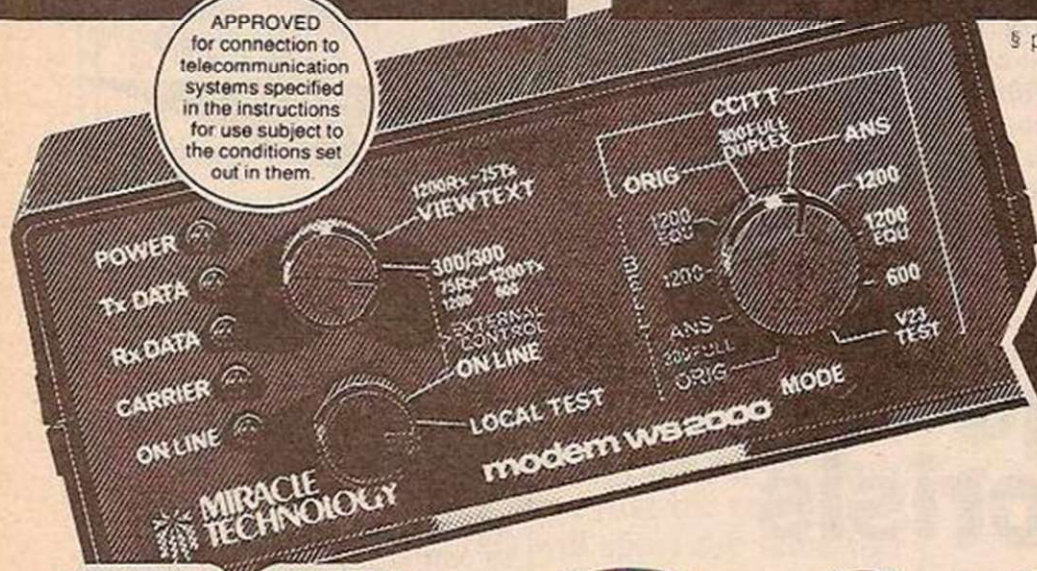

£ postage free when bought with WS2000. Otherwise, please add £1.15 UK p/p.

MODEM WS2000

To use these brilliant comms packages you need a modem, so get the best — the multi-speed, multi-standard modem WS2000! It's the versatile, flexible communications tool that thousands of users depend on. This world-famous modem was a 1985 British Microcomputing Awards Finalist, PCN Best Buy, and is MICRONET recommended. It comes complete with BT telephone lead, mains power lead, comprehensive user manual and free introductory subscriptions to MICRONET and MICROLINK.

£129.95 exc VAT
£154.73 inc VAT & UK delivery

* reg'd trade marks of the companies concerned.

phone your Access or Visa order today, or send your cheque/official order etc to the address below.

FROM MIRACLE TECHNOLOGY

MIRACLE TECHNOLOGY (UK) LTD ST PETERS STREET IPSWICH IP1 1XB ENGLAND
☎ (0473) 216141 6 LINES TELECOM GOLD 79: KEY 001 (Dealerlink 72 DTB 10135)
☐ 946240 CWEASY G 19002985 PRESTEL MAILBOX 919992265

Soft News

ELECTRIC FUTURE

(continued from page 21)

So far so good, nothing unusual in that. What is surprising is that they are threatening to sue another Liverpool software house. They feel their copy has been copied.

Rumour about the Sinclair business computer seems to be firming up. Best guess is that it will use the OS9 68K multi-tasking operating system. This might have a wimp front end written by Metacomco, of Amigados fame. Most likely RAM is 1/2 a megabyte, though one megabyte is always possible. The end result is probably a cheaper, more elegant Atari 520 ST look-alike. Knowing Sinclair this could all be just a rumour.

On January 23rd at their Annual General Meeting in America, Apple will announce the Mac plus. With one megabyte of RAM a 128K ROM and double sided 800K disk drives it offers a potent package. Upgrade kits will be available for existing Mac Owners. In September Apple will offer an even more powerful Mac, codenamed Carla. This will have four megabytes of RAM and a built in hard disk. It promises to make an ideal games machine.

By selling off U.S. stocks of the BBC Micro to British American Scientific Instruments of Texas for just under a million pounds, Acorn has paved its way to the Latin American computer market. The Texan company has a Mexican parent organisation, Dataum, which has developed Spanish language software and a special keyboard to sell the computer to hispanic users.

As part of the deal Acorn has granted the company assembly rights to build and sell the computer throughout the Americas. Meanwhile, Acorn's parent organisation, the Italian giant Olivetti, will be selling the BBC Micro in Eastern Europe.



Steven Spielberg may have the Midas touch — but with a 20th century embellishment: his movies turn into computer games. Hard on the heels of US Gold's Goonies comes Electric Dreams' Back to the Future — the movie that toppled Rambo from its number one US position.

Faithful to the storyboard of the movie, you zoom back in time in your psychedelic DeLorean and must bring your parents together — otherwise you cease to exist. At the bottom right-hand of the screen is a photo of three people which fades as time goes by, just like in the

movie. Using digitised sequences from the film the icon-driven game breaks new ground in having an on-screen kiss! Sloppy, huh? But if your mom Lorraine and your pop George don't kiss, then you, Marty will never exist.

The design concept was developed by Mark Eyles of Quicksilva fame and uses Huey Lewis and the News' Power of Love as background music. Scheduled for release at the end of this month, Back to the Future will sell at £9.95 on the CBM-64, closely followed by an Amstrad version.

Stone age

That modern stone-age family, the Flintstones, have been popping onto our screens in re-runs that seem to stretch back to the original Stone Age.

The aim of the game is to help Fred Flintstone build a house with stones from the local quarry and win the affections of Wilma his wife-to-be.

Players can win a holiday in Los Angeles including a visit

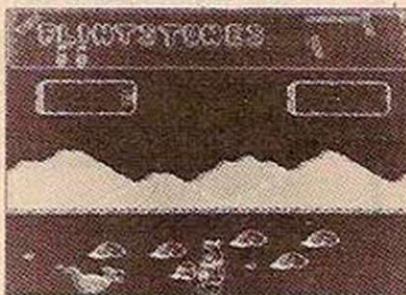

to Hanna-Barbera studios.

The Quicksilva game boasts excellent animated graphics and will be available on CBM-64, Spectrum and Amstrad at £7.95. Do Flintstones and Electric Dreams' Back to the Future augur a worrying new trend in games? In both you have to bring two people together instead of slaughtering hundreds of aliens.

ZAP A ZOID

Zoids, Tomy's popular cybernetic dinosaurs were around when Transformers were no more than a marketing concept. Now you can join in the internecine conflict on Zoidstar where the Red Zoids have smashed Zoidzilla, the Blue leader into eight pieces.

Martech's Zoids on Spectrum at £7.95 and the CBM-64 and Amstrad at

£8.95, gives you a chance to claw your way to the top of the Zoid hierarchy until you control a Zoid yourself. This will make it a lot easier for you to assemble the missing bits of Zoidzilla.

The game includes a 3D sequence in which you, as a guided missile zoom towards the evil Red Horn and try to destroy him. Zoids will be zoids.

Elsie Dee

LONDON'S LARGEST DISPLAY OF PRINTERS MONITORS COMPUTERS AND PERIPHERALS

DON'T TAKE A CHANCE

—COMPARE BEFORE YOU BUY

**OVER 40
PRINTERS ON
DISPLAY — MOST ON
DEMONSTRATION**

HI VOLTAGE

UK's Best Printer Prices

DOT MATRIX PRINTERS

Brother HR5	£78.21 + VAT =	£89.95
Brother M1009 (P+S)	£130.40 + VAT =	£149.45
Brother EP44 typewriter	£189.90 + VAT =	£218.39
Epson P40 Thermal AC/DC	£49.90 + VAT =	£57.39
Epson FX85/FX105/RX100	POA	
Epson LX80/GX80 NLQ	£199.90 + VAT =	£229.88
Epson LQ1500 NLQ	£799.00 + VAT =	£918.85
Epson JX80 Colour	£449.90 + VAT =	£517.39
Canon PW1080A NLQ	£289.90 + VAT =	£333.39
Canon PW1156A NLQ	£365.90 + VAT =	£420.79
Commodore MPS801	£60.82 + VAT =	£69.95
Commodore MPS803	£86.91 + VAT =	£99.95
Panasonic KP1091 NLQ	£255.90 + VAT =	£294.29
Oki-Mate 20 Colour	£217.30 + VAT =	£249.90
Shinwa CPA80	£179.90 + VAT =	£206.88
Micro P. 165 NLQ	£260.78 + VAT =	£299.90
Seikosha GP50S (Sinclair)	£69.90 + VAT =	£80.39
Seikosha GP500A	£89.90 + VAT =	£103.38
Seikosha SP1000 VC NLQ (CBM 64)	£199.90 + VAT =	£229.89
Seikosha SP1000 NLQ	£199.90 + VAT =	£229.88
Smith Corona Fastext 80	£110.90 + VAT =	£127.53
Smith Corona D100, D200 NLQ & D300 NLQ	POA	
Star SG10 (IBM) NLQ	£226.00 + VAT =	£259.90
Star SG/SD/SR range	POA	
Kaga Taxan KP810 NLQ	£249.90 + VAT =	£287.39
Kaga Taxan KP910 NLQ	£379.90 + VAT =	£436.89

DAISYWHEEL PRINTERS

Brother HR10	£249.90 + VAT =	£287.39
Brother HR15 (P)	£315.00 + VAT =	£362.25
Brother HR25	£609.00 + VAT =	£700.35
Brother HR35 + sheet feed	£819.90 + VAT =	£942.89
Daisystep 2000	£219.90 + VAT =	£252.89
Diablo 630	POA Silver Reed	POA
Juki 6000	£199.90 + VAT =	£229.89
Juki 6100	£324.90 + VAT =	£373.64
Juki 2200 typewriter P or S	£257.30 + VAT =	£295.90
Smith Corona TP1	£179.90 + VAT =	£206.89
NEC, Ricoh, Gume, Tec	POA	
Epson DX100	£315.00 + VAT =	£362.25
Commodore DPS1101	£165.17 + VAT =	£189.95
Uchida DWX 305	£199.00 + VAT =	£228.85

All popular interfaces, cables, etc. available from stock.
Custom cables made to order.

Let our experts match your computer to the printer of your choice.

Printers — All models parallel-centronics interface Serial RS232C available at same or slightly higher prices.

MONITORS

Microvitec Colour		
1431 DS STD RES RGB	£182.53 + VAT =	£209.90
1431 MZ STD RES Spectrum	£199.90 + VAT =	£229.89
1451 DS MED RES RGB	£229.90 + VAT =	£264.39
1451 DQ MED RES QL	£229.90 + VAT =	£264.39
1451 APDS MED RES RGB/Composite	£289.90 + VAT =	£333.39
1441 DS High RES RGB	£389.90 + VAT =	£448.29
1456 LI MED RES IBM PC	£395.90 + VAT =	£455.29
1456 DA MED RES Apricot	£299.90 + VAT =	£344.88
Philips Monitors Full Range	POA	
Ferguson Monitors Full Range	POA	

COMPUTERS

Amstrad		
CPC 464 Green	£167.78 + VAT =	£192.95
CPC 464 Colour	£252.13 + VAT =	£289.95
CPC 6128 Green	£252.13 + VAT =	£289.95
CPC 6128 Colour	£339.09 + VAT =	£389.95
PCW 8256	£394.90 + VAT =	£454.14
Apricot — Special Price Limited Quantity		
F1E 256K RAM 1x315K Disk	£499.00 + VAT =	£573.85

Atari		
800XL/Cass/Games	£83.43 + VAT =	£95.95
520ST inc Disk + Monitor	£642.90 + VAT =	£739.34
BBC		
BBC inc DFS	£346.91 + VAT =	£398.95
BBC PLUS 128K	£429.90 + VAT =	£494.39
Cumana and Opus Disk Drives		
1 x 100K	£84.74 + VAT =	£97.45
1 x 400K Switchable	£127.13 + VAT =	£146.20
2 x 100K	£186.48 + VAT =	£214.45
2 x 400K Switchable	£279.74 + VAT =	£321.70
Opus Disk Drives now with 2 Year Guarantee		
Commodore		
64	£130.39 + VAT =	£149.95
64 + 1541	£252.13 + VAT =	£289.95
1541 Disk Drive	£121.69 + VAT =	£139.95
C128	£226.04 + VAT =	£259.95
C128 + 1570	£391.21 + VAT =	£449.90
1570 Disk Drive	£169.52 + VAT =	£194.95
MSX		
Toshiba HX10	£69.52 + VAT =	£79.95
Sanyo, Sony, Panasonic	POA	
MSX Disk Drives, Printers, etc in stock		
Sinclair		
48K Spectrum	£78.22 + VAT =	£89.95
Spectrum PLUS	£95.60 + VAT =	£109.95
QL 128K	£169.52 + VAT =	£194.95

SUPERDISKS Prices per box of ten ex VAT

	SSDD 40TR	DSDD 40TR	SS96TP1 80TR	DS96TP1 80TR
BASF 5 1/4"	£10.00	£15.80	£17.50	£19.20
3M 5 1/4"	£13.50	£19.50	£19.90	£23.90
VERBATIM 5 1/4"	£12.20	£15.20	£15.20	£19.90
DYSAN 5 1/4"	£13.75	£18.00	£18.00	£23.90
TDK 5 1/4"	£15.90	£14.50	—	£29.50
SONY DS/DD 3 1/2"	£32.90		MAXELL 3"	£38.90

Add 70p for P&P per order of Disks or Ribbons

PRINTER RIBBONS (Ex-VAT Prices)

Single prices, deduct 10% for 5+

Brother HR15 Corr	£2.90	Epson LX80	£4.00
Brother HR15 MS	£5.50	Epson 100 Series	£4.50
Brother HR5	£2.90	Juki 6100 SS	£1.90
Brother EP44	£2.90	Juki 6100 MS	£2.70
Brother M1009	£3.90	Juki 2200	£2.40
Canon PW1080A	£5.90	Kaga KP810	£5.90
CBM 801	£6.90	Mannesman MT80	£6.50
CBM 802/1526	£6.50	Seikosha GP50	£6.90
CBM 1525	£4.50	Seikosha GP100	£4.50
CBM DPS1101 MS	£2.70	Seikosha GP500	£6.90
Daisystep 2000	£3.40	Seikosha GP700	£18.50
Epson MX/RX/FX 80	£3.50	Shinwa CP80	£6.50

All equipment fully guaranteed — Credit terms available

Mail Order + Export + Trade Hot Line Phone 01-686 6362



Delivery by Securicor (3 day) please add £5.00 + VAT per item.
Delivery by T.N.T. (overnight) please add £9.50 + VAT per item.

Send off or order by 'phone quoting your Access.
Barclaycard No. 'Phone 01-686 6362. Immediate
despatch on receipt of order or cheque clearance.



Or you can Telex your order on: 946240 Attn 19001335

OPEN MONDAY-SATURDAY 9 AM-6 PM

OPEN MONDAY-SATURDAY 9 AM-6 PM

ALSO VAST RANGE OF DISK DRIVES, JOYSTICKS, DISK BOXES, INTERFACES, SHEETFEEDERS, ETC.

HI VOLTAGE 53-59 High Street, Croydon, Surrey CR0 1BD.

Prices correct at copy date. Subject to change without notice due to currency fluctuations etc. E. & O.E.

Your letters

Write to: Your Letters, Your Computer, Room L221, Quadrant House, The Quadrant, Sutton, Surrey SM2 5AS. Our Prestel mail box number is 01 9991 800.

BACK TO EARTH

Earthlings, I think your correspondent "Harry Seldon" — obviously a pseudonym — should stick to building his Foundations and not spout such twaddle about Aliens coming to destroy us through misunderstanding our video games. After all, if they don't even recognise the games as such, how likely are they to recognise the zapping or the blobs, sorry — "invaders", as such?

Seriously, however, there has been much furore recently about Amstrad's twin-deck cassette unit, and about Interface III-type devices. Once again, we are told that such devices "breach copyright" and should therefore be banned.

There seems to be a misconception — deliberately fostered, in part, by the software houses themselves — as to what, exactly, copyright is and what rights the consumer gets under it. Contrary to popular belief, the copyright

Dear Eugene Evans,

I have had the pleasure of knowing you and your family for over five years. Then you were an enthusiastic and well-mannered 14-year-old. I employed you to work as a Saturday boy in my Liverpool shop, Microdigital. Being keen and intelligent you quickly became a microcomputer expert and a highly valued employee. As soon as you were old enough you left school and worked for Bug Byte and then Imagine. This was a great mistake.

Imagine seized on you as a PR opportunity. The story of working-class teenager earning a fortune in Liverpool was a natural for the mass media. You had a fleeting fame in newspapers and on television, with strong undertones of John Lennon involved. What you didn't seem to realise is

that Imagine didn't do it as a favour for you, they did it for themselves. In fact what they did for you was the exact opposite of a favour.

Back in reality you wrote a simple game on the 3K Vic called Wacky Waiters that was just tolerable. Catcha Snatcha which followed was unplayable. Frantic was so bad the company had to withdraw it. Then you converted to the Commodore 64 with an attempt to put Arcadia on it: it was a travesty.

The last few months of Imagine were wasted playing around while pretending to work on a game called Psyclipse. All these attempts at programming were on the relatively simple 6502. You never could handle the more complex Z-80. The 68000 must seem as



difficult as playing Rachmaninov backwards on a mouthorgan.

Now you are wisely not trying to program. The problem you have in life is that you are left with no skills or qualifications. You do have a misplaced loyalty that is seriously holding you up in life. The time has come to escape from the past. There is only one logical course of action. You must make the most of your undoubted potential by going back to school.

Bruce Evans

laws are not intended to block legitimate usage of items for which the consumer has paid good money. Magnetic media are not infallible; indeed, on the contrary, my experience is that protection schemes are self-defeating, forcing me to break the protection and make a copy

simply so that I have one which will load.

It is true that these gadgets could be used to break the law, making multiple copies to give or sell to others, but "could be" is nowhere near strong enough a reason to ban them. Whilst condemning the lawbreaking

potential of their customers, the software people all ride around in cars. Don't they know that cars could be used to kill people? That's far worse than a few illicit copies! So, let's ban cars, knives, headache tablets etc., before working our way round to the much lesser menace of copier devices and software.

*Gaal Dornik,
Hardinville,
Terminus City,
Anacreon Sector,
Stardate: 6.12.85.*

IN TOUCH How to write for Your Computer

We called this magazine *Your Computer* precisely because we welcome your views, tips and hints and even your criticisms of machines and software in general. Here's how you go about getting your name into print. Your article should be typed, double-spaced, on A4 paper. A name and address on each sheet would help. Don't forget to tell us which machine it runs on. With programs please include a cassette or disc and some indication of how long it is. Please put what

machine it's for on the envelope. Don't forget full instructions to us how to load and list your program and how to enter it for the readers.

The article must be submitted exclusively to *Your Computer*. We pay £35 per published page — that's as it appears in the magazine and includes illustrations.

Telsoft

Telsoft is *Your Computer's* software downloading service. Any program for the Spectrum or the BBC and the Commodore which has a telephone symbol next to it is available on the service. Both 1200 and 300 baud speeds are

catered for. For more details call Colchester (0206) 8068. No more lonely nights typing in hex

Message service

You can get messages to us in two ways. Either use the Prestel Telex Link to 892084 BISPRES G or you can use our very own modem, day or night on 01-661 8978. The modem is V21, 300 baud, even parity, 10 bits per character. You simply transmit in upper case "YRC" — our address code, and wait for the acceptance code "+ + + STF GO". Then off you go. Don't forget to tell us who it's for. Sign off with "NNNN" — again in upper case.

DOWN IN THE DUMPS

Goodness knows what Basic screen dump A J Torlesse was using for his Spectrum/HR5 system — Letters, November. I thought *my* routine — adapted from the Epson routine in *Mastering your Microdrive* — was slow at about 5½ minutes.

Got the time down to 1¼ minutes by modifying another routine and have ended up with the Tascopy suite of m/c routines for small and large

(continued on page 27)

ACORN, ATARI, SINCLAIR, & MORE!
 AMSTRAD
 COMMODORE, ACT

MICRO

We export Microcomputers
 and Peripherals to all Countries
 Any make. Any Quantities
BIG DISCOUNTS

send for comprehensive price list to:

Dept 0186
MICRO-XLTD
 765-767 HARROW ROAD, LONDON NW10 5NY
 TELEPHONE 01-968 6622 TELEX 915866 MICROX G.



MAKE YOUR INTERESTS PAY!!

Train at home for one of these Career Opportunities

More than 8 million students throughout the world have found it worth their while! An ICS home-study course can help you get a better job, make more money and have more fun out of life! ICS has over 90 years experience in home-study courses and is the largest correspondence school in the world. You learn at your own pace, when and where you want under the guidance of expert 'personal' tutors. Find out how we can help YOU. Post or phone today for your **FREE INFORMATION PACK** on the course of your choice.

Introduction to Computer Programming	Programming in BASIC
Programming in COBOL	Electronics
Electrical Engineering	Electronic Engineering
Elec. Contracting/Installation	Radio, Audio and TV Servicing
GCE over 40 'O' & 'A' level subjects	

Course of Interest

Name

Address

P. Code



International Correspondence Schools, Dept. ETS-16,
 312/314 High St., Sutton, Surrey SM1 1PR.
 Tel: 01-643 9568 or 041-221 2926 (24 hours)

Computers by Post

PRINTERS	P.O.A.	COMPUTERS	
Anadex	£197	Amstrad PCW8256	£389
Epson LX80	£309	Amstrad 128 Green	£249
Epson FX80	£324	Amstrad 128 Colour	£339
Epson RX100FT	£425	Apricot F1E	£519
Epson LQ1500	£895	Apricot F1	£699
Brother HR5	£82	Apricot F2 + Mouse	£1145
Brother M1009	£127	Apricot F10 + Mouse	£1745
Brother HR10	£239	Apricot FP1 Portable	£495
Brother HR15	£312	Atari 520ST	£609
Brother HR25	£599	Commodore C64	£119
Brother HR35	£695	Commodore C128	£219
Commodore MPS 801	£61	Commodore 1541 Disk	£125
Commodore MPS 803	£87	Commodore 1570 Disk	£169
Commodore DPS 1101	£164	Commodore PC10	£949
Canon PW1080	£234	Sonyo MBC555	£649
Canon PW1156	£355	Sinclair QL	£169
Daisystep 2000	£219	Sinclair Spectrum Plus	£95
Kaga Taxan KP810	£234	(P + P to Europe £11.00)	
Kaga Taxan KP910	£355	MONITORS	
Juki 6000	£199	Microvitec 1431DS	£175
Juki 6100	£309	Microvitec 1451DS	£219
Smith Corona Fastext 80	£109	Microvitec 1451DQ (QL)	£226
Smith Corona D100	£179		
Star SG10	£195	Send for our full price list on all Computer Products, Peripherals, Consumables and Disks.	
Shimwa CPA80	£165	4 Day Insured Delivery £7 + VAT	
Seikosha GP500A	£95	24 Hour Insured Delivery £10 + VAT	

CREDIT CARD HOT-LINE



01-760 0014

All prices exclude VAT
 Export Enquiries Welcome

**Galaset Ltd, 30 Bayford Road,
 Littlehampton, West Sussex.**

Your letters

(continued from page 25)

black-and-white copies, plus a "shade copy" which prints sideways to give a near-A4 size copy with shading of increasing density simulating the screen shades from white through the colours to black. The code for each is only 256 bytes long, and resides the printer buffer, not used except for printing to the ZX printer.

There's also a probable reason for his Poking, in that the early HR5s had an incremental feed of 1/36", whereas the current model is twice as fine, with 1/72". Thus for bit image printing the control code had to call for 4 times 1/36" for a 1/9" feed, but now requires 8 x 1/72" for the printer to advance the paper by the same amount.

Incidentally, Brother changed my HR5 from 1/36" to 1/72" feed free of charge when I dropped it in at their Manchester service centre.

I've seen so many different cable connections stated for the Spectrum-HR5 link, some of which could not work, that I quote the "official" connections as stated by Brother.

Interface	HR5
2.....	2
3.....	3
4.....	20
7.....	7
5.....	5
and link.....	4
to.....	6
and.....	8

QL	HR5
1.....	1
2.....	2
3.....	3
4.....	20
5.....	5
and link.....	4
to.....	6
and.....	8

P R King,
Hassocks,
Sussex.

RECURSION, AGAIN...

In First Bytes November '85 you have said that Forth has an advantage over Basic in its ability to support recursion. It has been stated so many times that you cannot do recursive techniques with Basic that some people are even beginning to

believe it! It isn't true.

Any computer with Gosub and Return commands can solve any recursive problems. The only stipulation is that the return addresses must stack so that you can nest the subroutine calls. This not only means that Basic is perfectly suitable, it probably also means that virtually any language will support recursion whether high-level or assembly language.

It is easy to write recursive programs for a ZX-81 or Spectrum and I guess even Commodore Basic would do. The best book which explains how to do it is *The Complete Programmer: A Guide to better programming in Basic* by Mike James. This dedicates a chapter to recursion and gives a first class treatment of the subject.

Peter Erskine,
Colchester.

DRAWER

I feel I must write in and congratulate Paul Rhodes on his excellent program Drawer, *Your Computer* November '85, for the Sinclair Spectrum. As

LAST MONTH

Part of listing two in Roy Dictus' Sound Sampler, published in December, has been smudged. The last six characters in the second and third lines from the end — Line 110—should read:
f7ed78
4c04c9

If you are having trouble with October's Spectrum Melody Master, note that there should be a plus sign at the beginning of line 810, i.e.,
810 LET NO = NO + ...

Paul points out, it is not possible to see the attribute grid if using the program with an RGB monitor, however it is possible to alter the program to make the grid visible.

Simply Poke 26613 with 32. This will make the attribute grid white and green and is perfectly satisfactory. You can use any other colour by Poking the above address and the formula

Paper x 8 — i.e., green is Paper 4 x 8 = 32.

As far as I am aware this has no detrimental effects on the rest of the program. By the way this has no effect on the transparent grid and this still does not show up on a RGB monitor.

Anthony Challis,
Peterborough,
Cambridgeshire.

AUTODIAL WITH TELSOFT

There appears to be a slight problem with my Autodialler program, published in your November issue. It works perfectly with the D1 and D2 programs that are available on Telsoft, but won't work with the Telsoft listing in the magazine, as they have different start addresses. To allow for this, line 1240 of my program should be:

1240 DATA 76,56,199,32,53,
193,96,234,234,234

if you are using the Telsoft listing on page 102.
David Derrick,
Cheddar,
Somerset.

SCRABBLE A CHEAT?

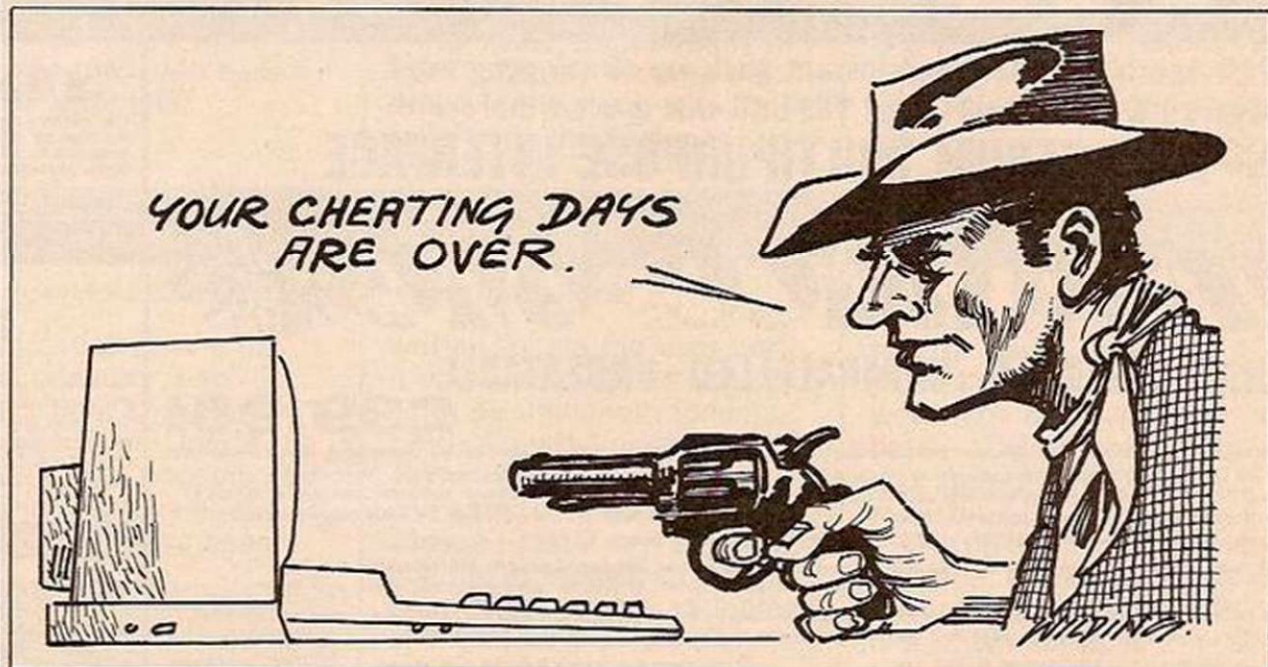

In September's Update you talked about reworking old games. Chess programs are regularly updated, so why doesn't somebody do the same for Backgammon and Scrabble?

CP Software describe their Backgammon as "excellent". Not true. No doubling cube, no score, very little colour. It doesn't compete with Psion's and that one has its problems.

Psion's Backgammon occasionally generates extra pieces for me and then hangs up by not allowing me to play my last piece into my home table if it's on the bar.

Psion's Scrabble is super but, oh, some of those words: "squits" and "vison" do not appear in any of the dictionaries that I have — Chambers and Pocket Oxford.

Please all you superb programmers can we have updates of Backgammon and Scrabble for the good players out here, professional jobs too — no kid's stuff.

I'll buy two of each. And if ever I see Scrabble for the Amstrad 6128 based on a good dictionary I'll buy a 6128.

Peter J Turner,
Norway.

POOLSWINNER

THE ULTIMATE POOLS PREDICTION PROGRAM

- **MASSIVE DATABASE** Poolswinner is a sophisticated Pools prediction aid. It comes complete with the largest database available - 22000 matches over 10 years. The database updates automatically as results come in.
- **PREDICTS** Not just SCOREDRAWS, but ALWAYS, HOMES and NO SCORES.
- **SUCCESSFUL** SELEC guarantee that Poolswinner performs significantly better than chance.
- **ADAPTABLE** Probabilities are given on every fixture - choose as many selections as you need for your bet. The precise prediction formula can be set by the user - you can develop and test your own unique method.
- **SIMPLE DATA ENTRY** All team names are in the program. Simply type in the reference numbers from the screen. Or use FIXGEN to produce fixture list automatically (see below).
- **DISC/MICRODRIVE COMPATIBLE** Tapes supplied with conversion instructions.
- **PRINTER SUPPORT** Full hard copy printout of data if you have a printer.



Boxed, with detailed instruction booklet

AVAILABLE FOR Spectrum (48K), Commodore 64, VIC 20 (+16K), AMSTRAD, BBC B, Atari (48K), ZX81 (16K), Dragon, Apple II, ELECTRON

PRICE £15.00 (all inclusive)



FIXGEN 85/6

AT LAST! No more struggling for hours to get the fixture list into the computer. FIXGEN has been programmed with all English and Scottish fixtures for 1985/6. Simply type in the date, and the full fixture list is generated in seconds. Fully compatible with Poolswinner.

POOLSWINNER with FIXGEN £16.50 (all inclusive)

COURSEWINNER V3

THE PUNTERS COMPUTER PROGRAM

NOT JUST A TIPSTER PROGRAM, Coursewinner V3 can be used by experts and occasional punters alike.

You can develop and test your own unique winning system by adjusting the analysis formula, or use the program in simple mode. Coursewinner V3 uses statistical analysis of major factors including past form, speed ratings, course statistics, prize money, weight, going, trainer and jockey form etc. etc. It outputs most likely winners, good long odds bets, forecasts, tricast etc. The database includes vital course statistics for all British courses. You can update the database - never goes out of date.

AVAILABLE FOR Spectrum (48K), Commodore 64, BBC (B), AMSTRAD, Atari (48K), Apple II

PRICE £15.00 (all inclusive) includes Flat AND National Hunt versions.

Send Cheques/POs for return of post service to ...



phone 24 hrs



phone 24 hrs



phone 24 hrs

37 COUNCILLOR LANE, CHEADLE, CHESHIRE. ☎ 061-428 7425
(Send for full list of our software)

ATARI COMPUTERS



Atari 520ST computer with 3.5" disc drive, mouse, monitor and software £675 (£670) £730. We can quote for alternative monitor and disc drive options on this package. 500K ST disc drive £139 (£138) £158. 1000K ST disc drive £182 (£179) £199. 10 Megabyte ST hard disc £487 (£435) £475. ST Colour monitor 130XE computer + disc drive + software £248 (£249) £279. 130 XE computer + disc drive + 1027 printer + software £335 (£333) £393.

SINCLAIR COMPUTERS



Sinclair pocket TV £97 (£95) £101. Sinclair QL Computer £194 (£196) £229. QL Floppy disc interface (See Cumana disc section below for suitable disc drives) £86 (£84) £94. Sinclair Spectrum Plus Computer 48K £123 (£127) £147. Spectrum Plus Computer + cassette + 4 games + joystick with interface £139 (£139) £169. Original 48K Sinclair Spectrum £96 (£102) £123. Kit to upgrade the Spectrum to Spectrum Plus £40 (£40) £50. Microdrive £49 (£50) £60. RS232 interface 1 £49 (£50) £60. Special offer: Microdrive + Interface 1 + 4 cartridges £97 (£99) £107. Blank microdrive cartridges £2-£50 (£3) £4. Spectrum floppy disc interface (See Cumana disc section for suitable disc drives) £107 (£99) £109. Interface 2 £20-45 (£20) £24. 32K memory upgrade kit for 16K spectrum (issue 2 and 3 only) £31 (£28) £30. Spectrum Centronics printer interface £46 (£42) £47.

COMMODORE COMPUTERS

Commodore 128 £250 (£249) £279. 1570 Disc drive £187 (£186) £206. Commodore 128 + 1570 Disc drive £419 (£409) £459. Commodore 64 + recorder + musicmaker keyboard + software £187 (£213) £243. Commodore 64 + disc drive £278 (£280) £340. Converter to allow most ordinary mono cassette recorders to be used with the Vic 20 and the Commodore 64 £9-78 (£9) £11. Centronics printer interface for Vic20 and the Commodore 64 £45 (£41) £46. Disc drive £191 (£186) £217. MPS801 Printer £118 (£121) £151.

AMSTRAD, ACORN, ENTERPRISE AND MSX COMPUTERS

Amstrad PCW8256 £449 (£450). Amstrad 464 Colour £297 (£322) £402. Amstrad 464 Green £197 (£230). £310. Amstrad 6128 Colour £397 (£420) £500. Amstrad 6128 Green £297 (£322) £402. Acorn Electron £99 (£99) £119. Enterprise 64 computer £172 (£170) £190. Enterprise 128 £233 (£229) £249. 3.5" 1000K Disc drives for Enterprise: single £109 (£115) £135. dual £193 (£195) £225. Goldstar MSX £112 (£115) £145. Sanyo MPC100 MSX £120 (£123) £153.

CUMANA DISC DRIVES

To suit disc interfaces of Sinclair QL, Spectrum and BBC B. 3.5" 80 track double sided, cased and with power supply: single £109 (£115) £135. dual £193 (£195) £225.

PRINTERS

New Epson LX80 £249 (£249) £282. Tractor for LX80 £20 (£20) £30. Epson GX80: printer £247 (£247) £280. cartridges £52 (£52) £58. tractor £20 (£20) £30. Epson FX85 £426 (£418) £468. Brother HR5 £148 (£152) £184. Brother M1009 £201 (£203) £234. Shinwa CTI CPA80 (£222) £258. Cannon PW1080A £309 (£306) £356. Microperipherals MP165 £284 £333. Brother EP44 £224 (£220) £240.

SECOND HAND COMPUTERS

Phone before ordering. Superboard II 8K £45 (£50) £95. Genie 1 16K £55 (£65) £105.

SWANLEY ELECTRONICS

The Computer Export Specialists

Dept. YC, 32 Goldsel Rd., Swanley, Kent BR8 8EZ, England

Tel: SWANLEY (0322) 64851

Official orders welcome. UK prices are shown first and include post and VAT. The second price in brackets is for export customers in Europe and includes insured airmail postage. The third price is for export customers outside Europe (including Australia etc) and includes insured airmail postage.

ROMANTIC ROBOT present

56K Spectrum extension? Instant back-up of any program? Joystick & video interfaces? YES! All this & even more with
NO.1 SPECTRUM MULTIPURPOSE INTERFACE

Multiface ONE



UNPRECEDENTED - UNPARALLELED - UNBEATABLE
at £39.95!

- * Internal 8K ROM and 8K RAM open new concepts in Spectrum computing: 100% reliable saving of anything, anytime and onto all types of peripherals with extra 8K at user's disposal and with a full peek & poke facility covering the entire 56K. MULTIFACE ONE does not take any part of Spectrum RAM & does not need any additional software. Just push a button to freeze a program, save it and restart from the same point next time. Peek/poke facility and 8K RAM (say with a monitor disassembler) are also ideal for studying, modifying, developing programs.
- * Menu-driven with prompts & one-touch commands: 1) Push button 2) Select function: exit/return/save/poke 3) Input name 4) Save to: tape/cartridge/wafer/opus/beta
- * Extremely powerful & efficient compressing for fast re-loading & using minimal room on cartridges, tapes, wafers, disks. A 7K screen can be compressed to a few hundred bytes, the whole RAM into a few K (depending on a program).
- * Option to save a full 24-line screen only
- * Pressing the button & return can restart a "crashed" computer
- * Through extension bus for connecting other peripherals
- * User friendly, fully error trapped, simply magic
- * Users must ensure the copyright laws are not infringed

Expand your Spectrum to 56K and stretch its capabilities even further with

Multiface ONE ESSENTIAL SPECTRUM COMPANION

I enclose a cheque/PO for £..... (UK & Europe orders please add £1 overseas £2)

or debit my No

Name..... Card expiry.....

Address.....

Please send me (tick as applicable):		MULTIFACE	£39.95 <input type="checkbox"/>
TRANS-EXPRESS cartridge	£9.95 <input type="checkbox"/>	tape (for m'drive)	£ 7.95 <input type="checkbox"/>
disk (Opus Discovery)	£9.95 <input type="checkbox"/>	wafer (Rotronics)	£ 9.95 <input type="checkbox"/>
MUSIC TYPEWRITER	£ 7.95 <input type="checkbox"/>	with supplement	£ 9.95 <input type="checkbox"/>
WRIGGLER Spectrum tape	£4.95 <input type="checkbox"/>	or cartridge	£ 6.95 <input type="checkbox"/>
WRIGGLER Amstrad tape	£ 7.95 <input type="checkbox"/>	or disk version	£ 11.95 <input type="checkbox"/>

ROMANTIC ROBOT 77 Dyne Road London NW6 7DR ☎ 24 hrs orders 01-625 9463 ☎ YC

HARDWARE HITLIST

SPECTRUM KEYBOARDS

► Spectrum • Saga System • Transform • Both cost £80

What do you get the Spectrum owner who has everything? Possibly one of the two new deluxe keyboards. At around £80, they have to offer something a bit special.

The new Transform keyboard looks likely to stand up to anything. A diecast metal case contains a full set of sculpted stepped keys. These are embossed in colour with the Spectrum keywords.

There is a separate numeric keypad and a few separate functions keys as well as an extended mode key. Fitting is simple and just needs the top whipped off the Spectrum. There is plenty of room for Interface 1, and the Microdrives can be connected without using an extension. There is an on/off switch, and room to mount the transformer in the case.

As you might expect at this price, the feel of the keyboard was up to the best professional standards.

The other contender, the Saga Elite 3 goes for a plastic IBM look alike keyboard. Again the feel is very nice. They have gone a bundle on extra function keys. No less than 10 down the left side with a full numeric keypad with cursor keys and arithmetic operators.

The only disappointment is the lack of keywords on the keys. These are supplied on a chart which clips just above the keypad. Not a problem for the Spectrum fanatic, but off-putting for the casual user.

Hardware compatibility is maintained by keeping the board in the same position in relation to the back and

bottom of the case, although Microdrives will have to stick up in the air.

If you've got this sort of money to spend on a keyboard, then there isn't much to choose between the two. For me the Transform gets it by a short head because of the colour embossed keys and last-for-ever metal case. Transform telephone number is 01-658 6350 and Saga are on (04862) 22977.

OPPOSITE

● The Saga 3 Elite. For the Spectrum owner who would rather be tapping away on an IBM PC.

BELOW

● The Skywave Multiport lets you plug in to free Prestel software for £100.

MULTIPOINT

► Skywave • RS232 interface • Any Amstrad • £99.95

The unit consists of a full 25-way connector, two sideways Rom sockets and a 24-way user port. One of the Rom sockets is occupied by the Skycom software, and as yet no software has been

written to use the user port; it may eventually be used to control intelligent modems for unattended operation.

The two main tasks of software like this is to access Prestel and bulletin boards. In Prestel mode, there are four colours instead of the usual eight. Some dynamic pages seem a problem, but apart from that, it does an adequate job. Pages can be printed or stored in Ram or disc/tape, although it was unclear how to retrieve pages from storage for printing. Most commands are accessed using cntrl + key combinations, with windows and menus to help.

The bulletin board software

has the usual choice of parameters for baud rate, word type and 40/80-column option. The same printing and saving facilities are available.

This looks like a promising package. Obviously there are many facilities one would like which are absent — file transfer and offline mailbox editor to name but two.

At the moment it has stolen a march on the competition where software downloading is concerned, but the dismal standard of software available does not make this a winning advantage.

Multipoint is available from Skywave on 0202 302385. The interface plus modem deal is from Modem House. ●

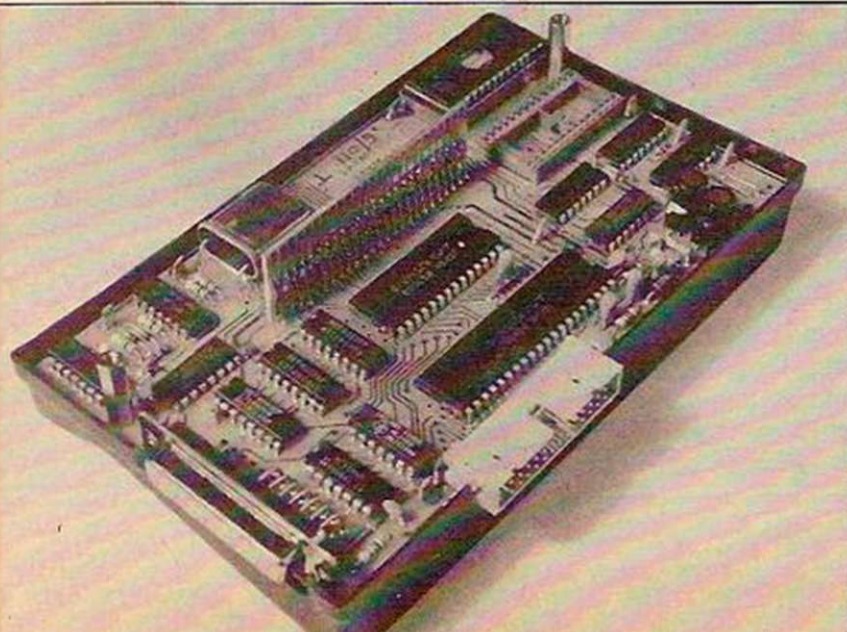

Budget Printers

From £20 to £450, Lee Paddon takes a short hand look at hard copy for the hard-up.

The DMP-200 gives good-value quality, and not just for Amstrad owners. Right, the Epson GX-80 for those who want a famous name. Below, the Okimate 20: fast, colourful for £260.



A printer is often the first add-on that new users consider when they decide their micro is going to be something more than a games machine. It is vital if you want to do your own programming as it is impossible to see your whole program on the screen at one time and thus root out persistent bugs. You may also want to use your computer as a word processor — the most important “serious” application for home micros.

For listings, almost any printer will do. Obviously speed is useful as this will allow you to get on with the job more quickly. Print quality and paper size are probably less important. On the other hand, if your major application is word processing, then your major criterion will be the appearance of the finished work. There is no point spending time and effort getting the spelling and appearance right if it's printed illegibly on paper which would look more at home on a toilet roll.

Another application is graphic

presentation. This is important if you want to use your computer to plot graphs, charts, or do screen dumps. For this sort of work the important thing to bear in mind is whether the software you have will drive the printer you want and whether you need colour.

There are four basic varieties of printer which use different methods of forming characters: dot matrix, where characters consist of a series of dots, a daisy-wheel, thermal printers and plotters.

Plotters consist of one or more coloured pens which are moved over the paper to produce lines and characters. Up until recently these were very expensive but there are now several makes which produce accurate results for a reasonable outlay. Some are flat-bed plotters, which work on a single sheet of A4 or A3. Others like the much cloned MCP-40 have roll feed; possibly only worth considering if you are primarily interested in graphics as they are usually too slow for general-purpose work.

Daisy-wheels were once considered the Rolls Royce of printers, being mainly found in offices. However, they are rapidly falling in price, and you might be able to pick up a second-hand bargain. But they are quite slow and have no graphics capability. Be careful about availability and price of ribbons.

Thermal printers are about the cheapest way of getting into print. An outstanding example is the Alphacom printer from Dean Electronics, which is now available for the Spectrum at £20. Softek also does an interface for CBM-64 and Vic computers. Brother also has a range of thermal printers which are good value. The main drawback with this type is they are somewhat sluggish and the paper is costly and sometimes not readily available.

Lastly, there are dot matrix printers. Frankly if you can afford around £300 for a printer you should look no further. Within this class you should find a printer to suit your needs. Ideally it should be Epson

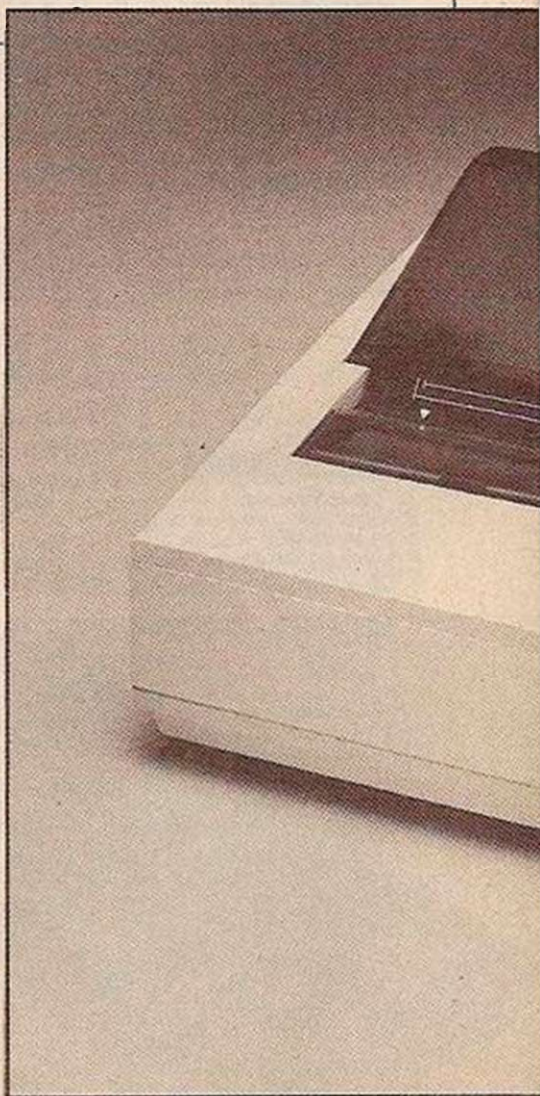

compatible — i.e., its graphics and character set should conform to those of the Epson printer range. It should print with a range of character sets, including NLQ, and you should be able to redefine the character set.

Buffers are also useful; your computer is free to get on with computing while your printer does the printing. NLQ — or Near Letter Quality — is a recent development. The printer prints a line twice, the second time half a dot lower. This increases the vertical resolution to the standards of daisy-wheels. Most printers now offer this facility and it really is a must these days, even if you're only going to use it for your CV or to impress the bank manager.

Laser and inkjet printers are starting to make an impression in business. How long before their presence is felt in the home market is hard to foresee. The major advantages of these printers are speed and quietness. These are not important considerations in the home market unless their prices change dramatically. Epson has plans to

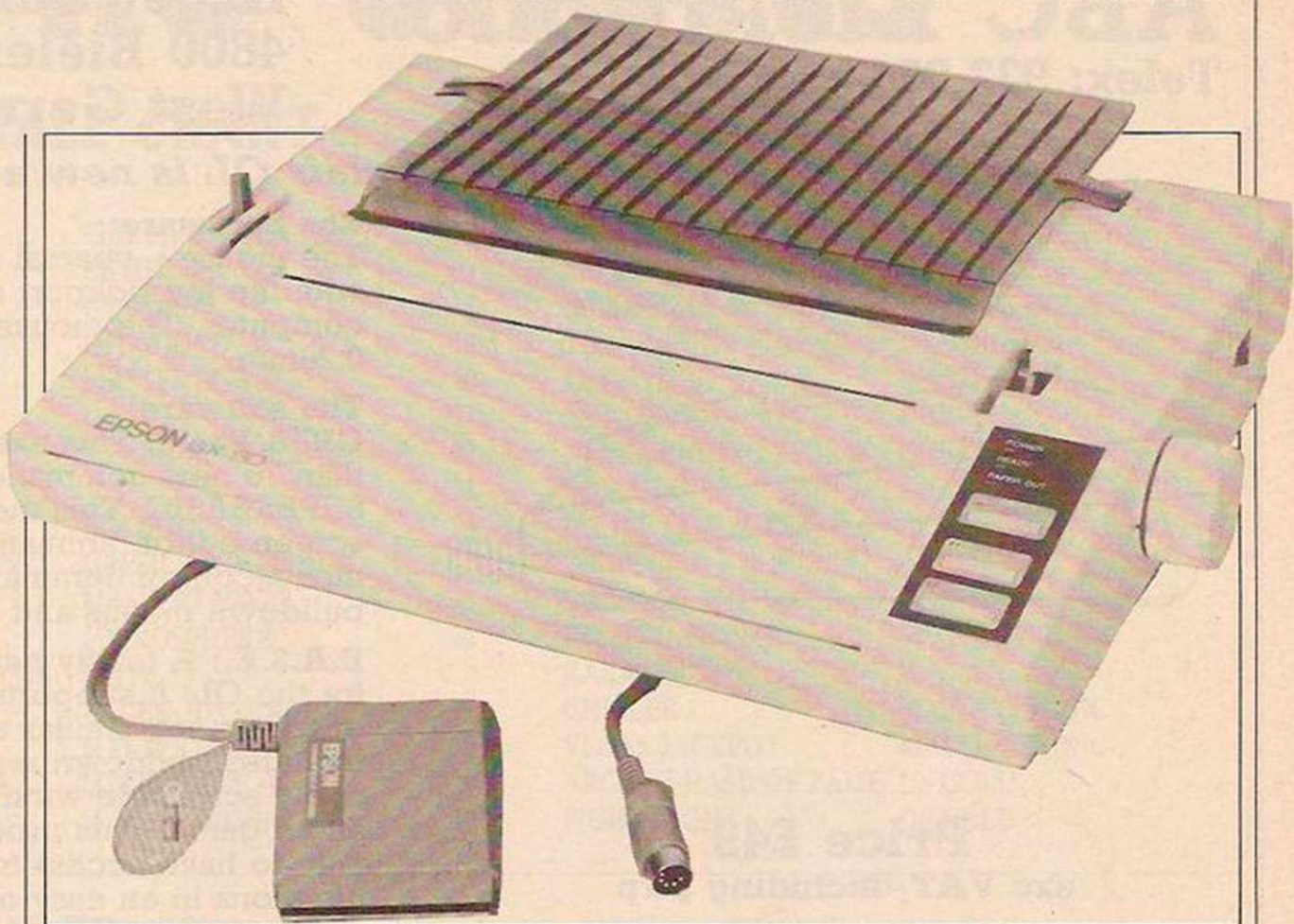

launch a smaller version of the SQ-2000 to match its portable computer but its performance is not that much better than many dot-matrix printers.

If you need colour you now have a number of technologies to

choose from. There are dot-matrix printers from Epson and Seikosha which use multi-coloured ribbons to produce up to eight colours. Plotters normally come equipped with a variety of pen colours and some, like the Penman plotter, will take Pentel pens, giving you a wide variety to choose from. Another approach is the Okimate 20 which claims to produce up to 100 different shades. At £259 it is certainly very competitive even offering a correspondence quality type-face.

If colour isn't important but you want the flexibility of dot matrix and NLQ then the Amstrad DMP-2000 is a good choice at £159. It has a standard Centronics interface, although the cable you get thrown in will be useless and the colour scheme may jar a bit. The manual is very clear and also written with other computers in mind.

Epson has dominated the upper end of the market for a long time with its FX and MX range. These workhorse printers have acquired a deserved reputation for reliability. However, in terms of facilities for the money, they may well not be the best value for money. The Taxan KP-810 gives a spritely 160 cps — characters per second — with a choice of three NLQ faces* as opposed to the single NLQ face of the comparable Epson LX-80.

Also worth considering is the Star range of printers. One of their important plusses is that some use normal, cheap and readily available typewriter ribbons so running overheads will be low. Generally, they are a little more expensive than the Taxan and offer similar facilities. Another consideration for Spectrum and Commodore owners is the interface. For the Commodore, more and more manufacturers are bringing out CBM versions of their printers, including Star, Brother and Epson.

There are a number of Spectrum printer interfaces on the market. Probably the best known is the Kempston interface. Although expensive, it offers all the facilities you are ever likely to need and is compatible with a wide range of printers.

Printer technology is a never-ending source of ingenuity and, despite the basic requirement of delivering ink to paper, is one of the fastest moving areas in the home computer world. At the moment dot matrix would seem to offer the best all round performance and there are some excellent deals on offer this Christmas.

Next year another variation on present technology may reign supreme. And then you can start all over again.



ABC Electronic

Telex: 932 974 budde d

Hügelstraße 10-12
4800 Bielefeld 1
West Germany

The Giga Soft Mouse for the Sinclair QL is now available!

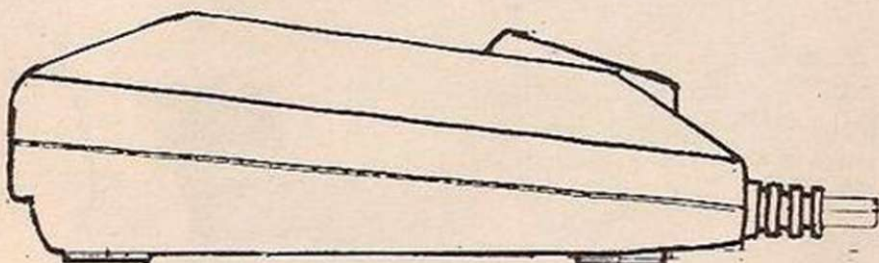

Price £49
exc VAT, including p&p

How to order: (1) Send a cheque to ABC; (2) Transfer money to Postcheckamt Dortmund to Mr Budde, Account No. 902 83 469; (3) Send an order to the address above, we will send the package with post cash on delivery.

The hardware:

The mouse + special interface to use with the joystickport of the QL computer. The mouse resolution is 0.26mm.

The software:

GIGA Basic: This extension adds more than 70 new commands to SUPERBASIC. This includes a full screen editor, animated sprites, mousecontrol commands, GEM style pull-down menus and many more.

E.A.S.E.: A totally new user interface for the QL. It supports a desktop environment, similar to GEM. It includes pull-down menus, icons, really scrollable windows, a calculator and a game. This program enables the user to have access to all system functions in an easy manner.

Our first show was an outstanding success . . .

This time we've got many more surprises and lots more room to wander around!

★ Amstrad goes striding into 1986 as the most innovative and profitable computer company in Britain. Come and see for yourself the ever-growing range of products that puts its head and shoulders above the rest.

★ So many people turned up for the first-ever Amstrad Show in October that entry had to be restricted and lengthy queues formed outside. Not this time! We've almost doubled the floor area - so you'll be able to move around with ease.

★ Every stand was taken at the October show, and many potential exhibitors had to be turned away. This time they've booked well in advance! Well over a hundred exhibitors will be there.

★ On display will be just about every piece of hardware and software that has yet been produced for the Amstrad range. And that means lots more products - and lots more bargains! A big feature of the October show was the way exhibitors entered into the spirit of excitement that pervaded the show and slashed their prices. This time many thousand more visitors will be going home with some really worthwhile bargains!

★ One thing you'll get for nothing - and lots of it - is advice! Waiting to talk to you, and answer any problems you may have about Amstrad computing, are some of Britain's top Amstrad experts. They'll all be there!

AMSTRAD COMPUTER SHOW

Organised by
Database Publications

Champagne Suite,
Novotel,
Hammersmith,
London W6

Saturday **Sunday**
January 11 January 12
10am-6pm 10am-5pm

Avoid the queues!

Get your
ticket in
advance . . .

**SAVE £1
A HEAD!**

Special prices for groups of 10 or more.
Phone 061-480 0171 for details.



Advance
ticket
order

AMSTRAD
COMPUTER
SHOW

Name _____

Address _____

Signed _____

PHONE ORDERS: Ring Show Hotline: 061-480 0171
Please quote credit card number and full address.

Admission at door: £3 (adults), £2 (under 16s)

Please supply:

Adult tickets at £2 (save £1) _____ £

Under-16s tickets at £1 (save £1) _____ £

TOTAL £ _____

Cheque enclosed made payable to
Database Publications Ltd.

Please debit my credit card account: _____

Expiry date: / /

Access _____

Visa _____

Post to: Amstrad Show Tickets, Europa House,
68 Chester Road, Hazel Grove, Stockport SK7 5NY.

YC

The charts

TOP 30 OVERALL CHART

1	ELITE	FIREBIRD/ACORNSOFT	16	RAMBO	OCEAN
2	COMMANDO	ELTIE	17	DALEY THOMPSON'S SUPER TEST	OCEAN
3	WINTER GAMES	US GOLD	18	IMPOSSIBLE MISSION	EPYX/US GOLD
4	THEY SOLD A MILLION	HIT SQUAD	19	YIE AR KUNG FU	IMAGINE
5	FORMULA ONE SIMULATOR	MASTERTRONIC	20	LAST V8	MASTERTRONIC
6	WAY OF THE EXPLODING FIST	MELBOURNE HOUSE	21	SABOTEUR	DURELL
7	COMPUTER HITS (10)	BEAU JOLLY	22	NEVER ENDING STORY	OCEAN
8	MONTY ON THE RUN	GREMLIN GRAPHICS	23	TOMAHAWK	DIGITAL INTEGRATION
9	FINDERS KEEPERS	MASTERTRONIC	24	LITTLE COMPUTER PEOPLE	ACTIVISION
10	BACK TO SCHOOL	MICROSPHERE	25	ROBIN OF THE WOOD	ODIN
11	FRANK BRUNO'S BOXING ELITE	ELITE	26	INTERNATIONAL KARATE	SYSTEM 3
12	BEACH HEAD 2	ACCESS/US GOLD	27	CHILLER	MASTERTRONIC
13	BMX RACERS	MASTERTRONIC	28	VEGAS JACKPOT	MASTERTRONIC
14	FIGHTING WARRIOR	MELBOURNE HOUSE	29	ARCADE HALL OF FAME	US GOLD
15	ACTION BIKER	MASTERTRONIC	30	FIGHT NIGHT	US GOLD

BUBBLING UNDER

1	FRIDAY THE 13TH	DOMARK	6	ROCKMAN	MASTERTRONIC
2	GOONIES	U.S. GOLD	7	THUNDERBIRDS	FIREBIRD
3	SUPERMAN	BEYOND	8	SWORDS & SORCERY	PSS
4	NOW GAMES 2	VIRGIN	9	CAVES OF DOOM	MASTERTRONIC
5	GYROSCOPE	MELBOURNE HOUSE	10	SPELLBOUND	MASTERTRONIC

COMMODORE SALES

THIS	LAST	MTHS	TITLE	PUBLISHER
01	01	2	WINTER GAMES	US GOLD
02	NE	01	COMMANDO	ELITE
03	NE	01	RAMBO	OCEAN
04	NE	01	LAST V8	MASTERTRONIC
05	NE	01	LITTLE COMPUTER PEOPLE	ACTIVISION
06	NE	01	FIGHT NIGHT	US GOLD
07	03	02	SUMMER GAMES 2	EPYX/US GOLD
08	NE	01	THEY SOLD A MILLION	HIT SQUAD
09	02	02	WHO DARES WINS 2	ALLIGATA
10	NE	01	RACING DESTRUCTION SET	ARIOLASOFT

AMSTRAD SALES

THIS	LAST	MTHS	TITLE	PUBLISHER
01	NE	01	THEY SOLD A MILLION	HIT SQUAD
02	05	02	GRAND PRIX 3D	SOFTWARE INVASION
03	06	02	FORMULA ONE SIMULATOR	MASTERTRONIC
04	01	02	FINDERS KEEPERS	MASTERTRONIC
05	08	02	SOUL OF A ROBOT	MASTERTRONIC
06	NE	01	YIE AR KUNG FU	IMAGINE
07	03	02	NONTERRAQUEOUS	MASTERTRONIC
08	NE	01	CHILLER	MASTERTRONIC
09	NE	01	RAID	US GOLD
10	02	02	WAY OF THE EXPLODING FIST	MELBOURNE HOUSE

SOURCE: GALLUP/MICROSCOPE

SPECTRUM SALES

THIS	LAST	MTHS	TITLE	PUBLISHER
01	NE	01	ELITE	FIREBIRD
02	NE	01	COMMANDO	ELITE
03	NE	01	BACK TO SKOOL	MICROSPHERE
04	02	02	DALEY THOMPSON'S SUPER TEST	OCEAN
05	06	02	MONTY ON THE RUN	GREMLIN GRAPHICS
06	NE	01	SABOTEUR	DURELL
07	NE	01	TOMAHAWK	DIGITAL INTEGRATION
08	NE	01	INTERNATIONAL KARATE	SYSTEM 3
09	01	02	WAY OF THE EXPLODING FIST	MELBOURNE HOUSE
10	NE	01	THEY SOLD A MILLION	HITSQUAD

Quiz Quest - The computer game with all the right questions

AMSTRAD

SPECTRUM
48K

I like the sport questions
The test of knowledge, fun of learning that knows no limits
It's fun for all the family



CBM
64/128
out mid Dec

helped me with exams

Alligata Software Limited

also available
BBC Disk

Can you supply the right answers?

Over 200 questions on each subject, General Knowledge 1, Sport, TV, Pop Music, General Knowledge 2, plus a self programme tape.

Hours of enjoyment for friends and families in this light hearted challenge.

Also available

the following 10 subjects are available on a second Quiz Quest tape. Over 2,000 questions on: -

- * Brain Teasers * The Arts * Films * World of Science
- * History * Home and Garden * Natural History
- * Bookworm * Geography/Tourism * Junior Knowledge



Alligata Software Ltd. 1 Orange Street, Sheffield S1 4DW. Tel: (0742) 755796.

BETA BASIC 3.0

SINCLAIR USER, JAN. 85 (ABOUT RELEASE 1.8): "HAS ESTABLISHED ITSELF AS THE STANDARD EXTENDED BASIC FOR THE SPECTRUM...TURNS SINCLAIR BASIC FROM A GOOD VERSION OF THE LANGUAGE TO A FANTASTIC ONE..." NOW, WITH RELEASE 3.0, BETA BASIC BECOMES PROBABLY THE MOST POWERFUL BASIC AVAILABLE ON ANY 8-BIT MICRO!

- PROCEDURES - a very full implementation that lets you extend Basic easily. With parameter passing by value or by reference (including arrays), LOCAL variables, recursion, DEFAULT parameter values, and the ability to handle parameter LISTS of any length. No PROC keyword is needed; e.g. you can use things like: swap a,b or draw_box 10,20,5 or addup b(),sum.
- GRAPHICS - up to 128 WINDOWS, each with its own character size (giving 1-64 chars/line) and attributes. ROLL and SCROLL any part of the screen by any number of pixels in any direction! Use GET to store parts of the screen, then put them back anywhere at different magnifications. Fast FILL, ALTER attributes, PLOT strings. DRAW TO a point, change scale and origin.
- TOOLKIT features: Remember with block move or copy; block DELETE, search and/or change (e.g. ALTER applies to al. 36 User-defined keys. List the variables, list a procedure, list DEF KEYS.
- EDITOR - lets you move the cursor around the screen 10 times faster! And you can move the cursor up and down within edited lines. AUTO, EDIT, JOIN and SPLIT commands.
- LISTINGS with optional automatic indentation of loops, IF, procedures etc. Works on existing programs e.g. you can choose to list:
10 FOR n=1 TO 10: PRINT n: NEXT n
as: 10 FOR n=1 TO 10
PRINT n
NEXT n
- KEYWORDS can all be entered by typing them in full, or by the 'single entry' method, or both in the same line; e.g. the line:
10 print "hello"; if x=1 THEN goto 100 will be recognised and listed normally.
- Upgrades to Release 1.8 customers: If you bought direct from us, there is no need to return your cassette - just quote the (approximate) original purchase date with your order; otherwise return your cassette and name your supplier. The upgrade price of £6.95 (£7.50 overseas) includes a new manual.
- ARRAY and string handling features include fast INSTRING (100,000 chars/sec) and INARRAY search functions. You can JOIN arrays together, delete, transfer and insert sections, change dimensions without data loss. LENGTH function gives dimensions. Ultra-fast array SORT - e.g. a\$(500,30) will sort in about 3 seconds!
- MICRODRIVE commands let you use simple forms, or exactly the same commands you normally use for tape - just enter: DEFAULT m1 or m2. Some possible Microdrive commands: SAVE "name", ERASE "name", LOAD 1, "name", SAVE 10 TO 100; "part prog", SAVE a "slicer" or just the variables, MOVE programs, CODE, array. MERGE auto-running programs. End-Of-File function.
- OTHER FEATURES, new or improved, are too many to describe: DO - LOOP structure with WHILE, UNTIL and EXIT IF; BREAK, CLEAR, CLOCK, CONTROL CODES, EDIT variables, ELSE, GET, KEYIN (programs can write themselves!) MULTI-LET, (LIST a "slicer", ON (works with line nos, procs, etc.) ON ERROR, OVER 2, POKE strings, POP, READ LINE, TRACE, USING, DPOKE, Faster GOTOs, GOSUBs and FOR-NEXT loops.
- 26 FUNCTIONS: AND, OR, XOR, DEC, HEX\$, BIN\$, fast SINE, COS\$, RNDM\$, CHARS, NUMBER, DPEEK, EOF, FILLED, INARRAY, INSTRING, ITEM LENGTH, MEMO\$, MEM, MOD, SCRN\$, SHIFTS, STRINGS, TIMES, USING\$.
- Spectrum Basic compatible - you can run existing programs. Transferable to Microdrive. Syntax check on entry. Extra error messages. Compatible with most printer interfaces (please specify). Wait-drive and DISCOVERY versions available.
- Comprehensive A5-size manual. More than 80 pages, with many examples.
- To show you the power of Beta Basic's procedures, we include a FREE TURTLE GRAPHICS package!
- Release 1.8 remains available, at a lower price of £8.95 (£9.50 overseas). You can upgrade later to Release 3.0 for £6.95 (£7.50 overseas).
- TRANSFORM your Spectrum with BETA BASIC 3.0 for just £14.95 inclusive! (£15.50 overseas).

(TICK AS APPROPRIATE.) PLEASE SEND ME:
 BETA BASIC 3.0. PAYMENT OF £14.95 (OR £15.50 OVERSEAS) IS ENCLOSED.
 BETA BASIC 3.0 UPGRADE. PAYMENT OF £6.95 (£7.50) IS ENCLOSED.
 BETA BASIC 1.8. PAYMENT OF £8.95 (£9.50) IS ENCLOSED.
 MORE INFORMATION ON... I HAVE/DID NOT HAVE RELEASE 1.8 ALREADY.
 A STAMPED ADDRESSED ENVELOPE IS ENCLOSED.

BETA
SOFT

92 OXFORD RD.
MOSELEY
BIRMINGHAM
B13 9SQ



British computers in Belgium



apricot

sinclair



The English Computer Shop

Willem Ogierplein 2
B 2000 Antwerp
Tel. 03/233 59 06

Rue Grétrystraat 31
B 1000 Brussels
Tel. 02/218 60 26

SOFTWARE SHORTLIST

COMMANDO

► Spectrum & Commodore 64 • Elite • Arcade • £7.95 and £9.95 • Paul Bond

- GRAPHICS ●●●●●
- SOUND ●●●●●
- PLAYABILITY ●●●●●
- VALUE FOR MONEY ●●●●●
- OVERALL RATING ●●●●●

SCREENS

● Commando: An amazing programming feat.

Bitter battling has not been confined to the game itself — Elite forced Alligata to make alterations to their excellent Who Dares Wins II in order to delay its production — and it would seem both games are superseded in complexity and variety by Ocean's Rambo.

What all the games have in common is an upward scrolling scenario depicting a feisty little soldier battling his way past the enemy, past gun emplacements, bridges all the way to the fortress.

This game is particularly striking on the Spectrum — the animation and detail are so good it makes Sir Clive's little box of tricks look like an arcade machine. The sound quality on the Commodore is excellent and adds to the whole atmosphere of



generally frothing stupidly at the mouth that is essential to partaking in warlike activity.

Developed with the aid of Capcom to create the closest possible duplication of the original arcade game, Elite's

Commando has the cachet of being the official version. A lot of people will think they are doing well if they get as far as the fortress wall, but beyond here there are troop carriers and tanks to defeat.

RAMBO

► Commodore 64 • Ocean • Arcade • £9.95 • Paul Bond

- GRAPHICS ●●●●●
- SOUND ●●●●●
- PLAYABILITY ●●●●●
- VALUE FOR MONEY ●●●●●
- OVERALL RATING ●●●●●

SCREENS

● Rambo: Just one of those sixties kids who decided to make war, not love.

Rambo is just one of those sixties kids who decided to make war not love, and even in the US Army declined to use the Sylvester Stallone creation as part of their recruiting drive — it was not the kind of thing they wished to be associated with.

Stallone fans are probably fed up with being told that their hero spent the Vietnam war working as a gym coach in a girls' school in Switzerland — but maybe it proves that he's smarter than he looks.

Now to review the game. Martin Galway's excellent soundtrack ensures that this will probably be the biggest thing to hit the market since Ghostbusters — especially since Activision's contributions this Christmas

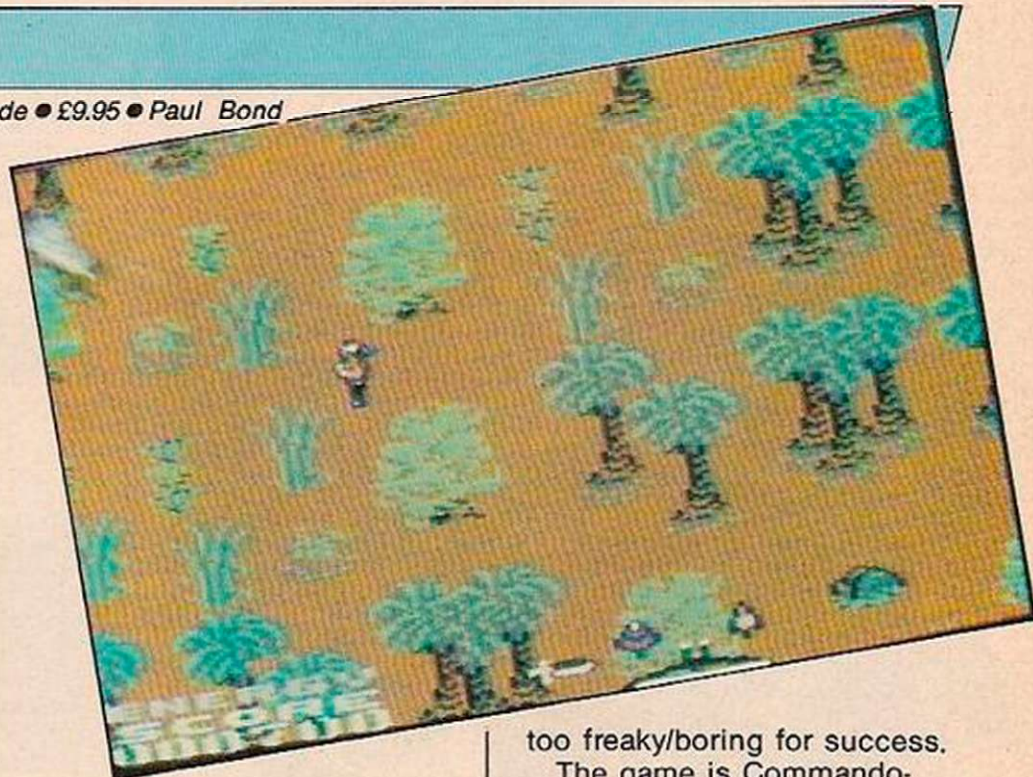

— Hacker and Little Computer People — are far

too freaky/boring for success.

The game is Commando-esque, it must be said, but the greater variety of weapons and the ability to move back down the screen make it radically different from the two Commando clones currently available. There is more plot and strategy, too. You discover Banks, your former comrade in the compound.

The screen display makes use of icons, using the space bar you can choose between explosive arrows, rocket launchers — everything the well-dressed man-about-jungle is wearing these days.

Strategy requires you to approach the camp as quietly as possible.

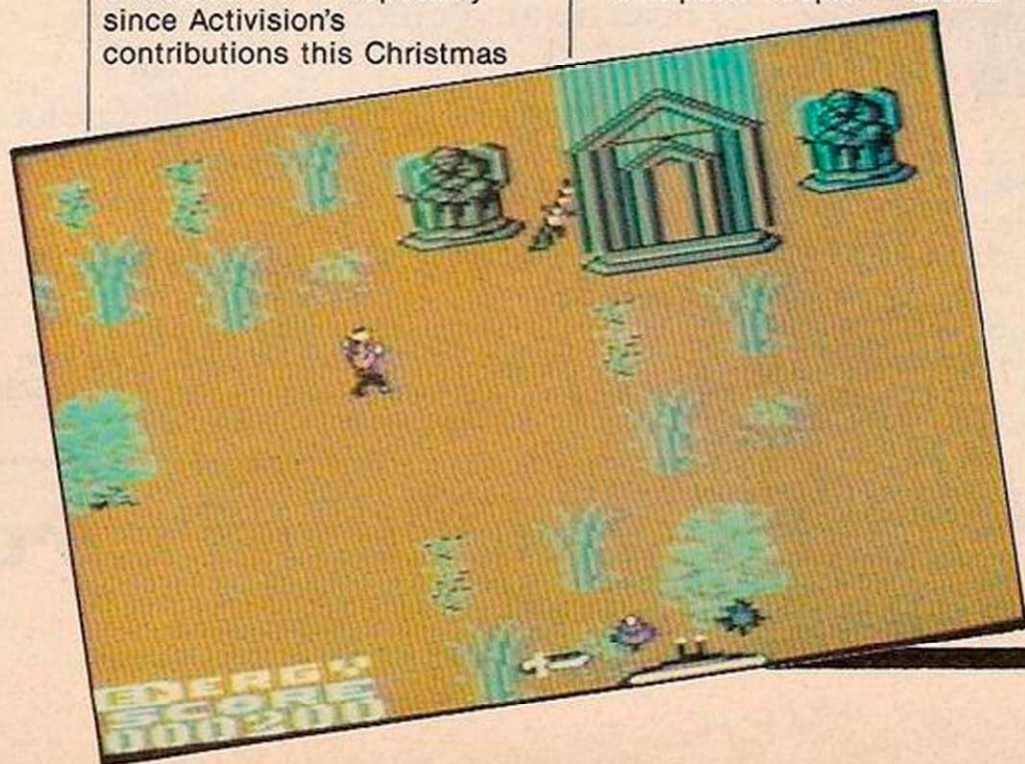

THE COMMODORE 128. HARD FACTS ABOUT THE SOFTWARE.

PAZAZZ

Have you ever wished you could create a whole theatrical performance of your own? Do you have your own ideas about scenery, costumes, music, choreography...? Now you have the opportunity to try out your ideas, to experiment with different effects, and to develop a performance that the professionals would be proud of.

Using PAZAZZ you can:

- * design scenery
- * design costumes
- * write music, and
- * choreograph the action.

Four complete performances are included in the package to get you started, after that it's down to you and your imagination. So come on all you budding National Theatre Directors, it's never too soon (or too late) to start.

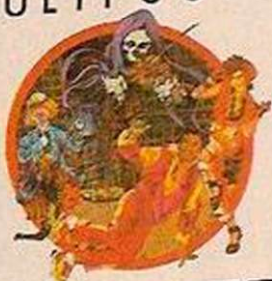

PAZAZZ

MULTISOFT

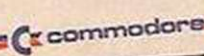

PERSONAL MONEY MANAGEMENT

Personal Money Management helps you make the money go round. It is a straightforward, simple-to-use budgeting program for personal finances with which you can control your domestic cash flow and make the most of your income. With Personal Money Management you need never again be caught by the unexpected bill and no money to pay it.

The program is extremely easy to use. You enter your income and expenses, and Personal Money Management calculates your total annual expenses together with the amount you need to set aside each month to meet those expenses. In this way no bill can arrive that you do not have the money to pay, and the money you have set aside is working for you earning interest in a bank or building society account.

Personal Money Management makes planning and budgeting easy, no household should be without it.



PERSONAL MONEY MANAGEMENT

MULTISOFT

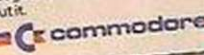

Script 128 is the intelligent, fully professional word processor for your Commodore 128. It offers you all the usual advantages of word processing - cut and paste editing, mail merge, tabs, search and replace, print preview, plus other advanced features such as an arithmetic function for totaling rows and columns, a second text area, wordwrap, 80 or 40 column display and customized printer output with programmable options.

- Some of Script 128's powerful features:
- Menu driven operation throughout - with shortcut command options for time saving
 - Print-preview providing instant feedback on layout changes
 - Two text areas in 128k machines, allowing two separate documents to be held in memory simultaneously
 - Support for all main printer types, and customising to suit individual user's printing requirements



COMMODORE 128

PERSONAL COMPUTER APPLICATIONS



With hundreds of software packages available never has a more useable machine been launched.

Three modes mean you can use software for the Commodore 64, software for the CP/M system and new software specially written.

Here are just three new examples of what is available.

Visit your local dealer for your 128 software or call the Commodore Information Centre on Corby (0536) 205252 for more information.



SOFTWARE SHORTLIST

REPTON II

► BBC • Superior Software • Arcade Adventure • £9.95 tape £11.95 disc • Simon Beesley

GRAPHICS



SOUND



PLAYABILITY



VALUE FOR MONEY



OVERALL RATING



SCREENS

- Repton II: A rattling good play

When you'd got over the fact that it wasn't Boulderdash — despite the teasing similarities — Repton II turned out to be a pretty good game. More relaxing than rivetting, it placed the emphasis firmly on problem solving and map making, rather than strenuous activity.

Repton II is more of the same with a new twist in the form of Transporters. As before you tunnel through the earth collecting diamonds, keys, and pieces of a jigsaw puzzle. This time, though, there are 64 Transporters to whisk you from one of the 16 levels to another. The trouble is, the transport system in Repton II makes British Rail seem a model of efficiency. There are no signposts so the only way to discover where you are going to end up, is to step into a transporter and see.

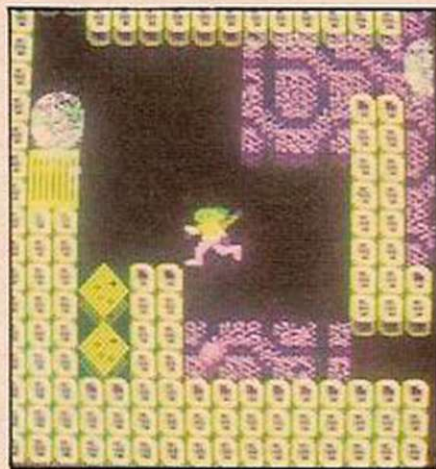

Advance planning is vital; otherwise you might re-materialise two stages back, or in a cul de sac. And once you have used a transporter it self-destructs.

Stamina is also a factor. To complete the game you must dig out 4744 earth sections, collect 1634 diamonds, kill all 18 monsters, use all 64 transporters, pick up 42 jigsaw puzzle pieces. Do this

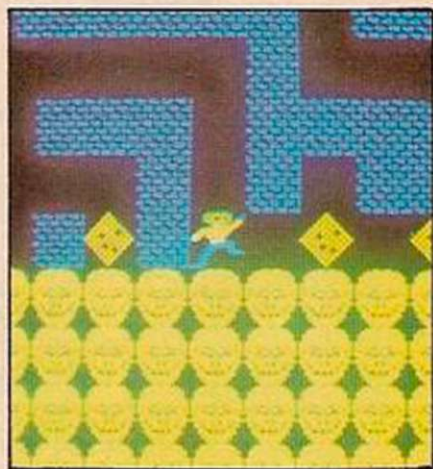

before April 1986 and you'll be in the running for a T-shirt bearing the legend, "I've completed Repton II".

It is still hard to avoid comparisons with Boulderdash — the rocks are too few and play only a minor part in the game. There is also an irritating flicker at the edges of the screen when it scrolls sideways. But Repton is a rattling good play.

CITADEL

► BBC • Superior Software • Arcade Adventure • £9.95 • Simon Beesley

GRAPHICS



SOUND



PLAYABILITY



VALUE FOR MONEY



OVERALL RATING



SCREENS

- Citadel: 100 screens — is this a record?

100 screens, a host of animated characters, secret rooms, a teleport system...Excited? Well, maybe not. Even on the BBC, epic arcade adventures are nothing new.

But new titles of any sort on the BBC are scarce these days, so owners should certainly be grateful for Citadel. And, to be fair, 100 screens is probably a record number to pack into the machine's limited memory space.

The game's graphics and general level of invention are not in the same league as Castle Quest's. But Citadel is a tough nut to crack, nonetheless. Even getting past the first few screens proved almost too much for this reviewer.

One of the nice things about the game is that you don't lose lives but energy. Falling down a chute leaves you severely weakened rather than dead. If you get caught in the grips of something nasty, manual control is overridden and you are hurled back across the room to the point where you came in. Losing your life by running into a toxic bush or mistiming

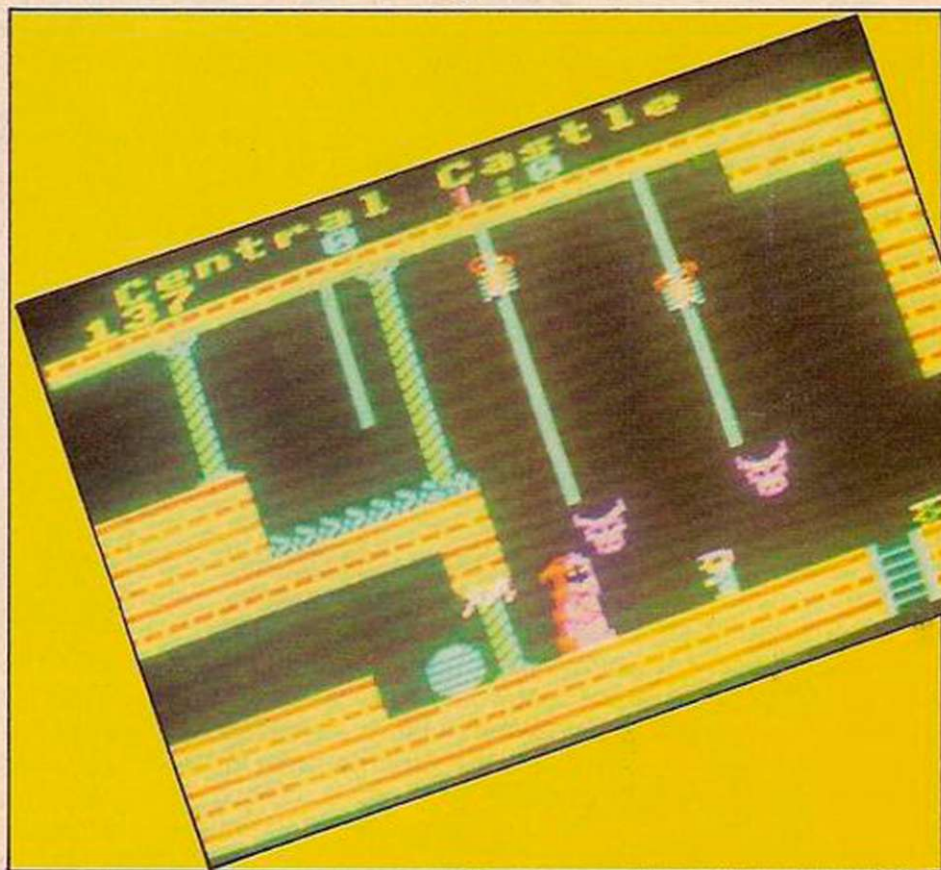

a jump is the more normal fate in arcade adventures, so this kind of safety scheme is a welcome feature.

Also pleasing is the sheer variety of different locations. The story so far is that Marduk the Dictator has set up camp in an old deserted castle. Your job is to find the five crystals on the island,

teleport yourself to his redoubt on an alien planet, and locate the bejewelled figurine. Then it's back to Earth in time to destroy the teleport system.

Interplanetary travel in an arcade adventure can't be bad, and the scale of the game makes up for any lack of novelty.

TAU CETI

► Spectrum • CRL • Shoot'em-up • £9.95 • Lee Paddon

GRAPHICS
 ● ● ● ● ● ● ● ●
SOUND
 ● ● ● ● ● ● ● ●
PLAYABILITY
 ● ● ● ● ● ● ● ●
VALUE FOR MONEY
 ● ● ● ● ● ● ● ●
OVERALL RATING
 ● ● ● ● ● ● ● ●

It seems that the days of the old meat-and-potatoes shoot-'em-up may be numbered. Spectrum owners are having to handle ever more sophisticated craft. In Tau Ceti your skimmer is positively bristling with missiles and lasers. You also have scanners, an on board computer, and even a computerised memo pad! A cross between a sort of 2D Elite, Legend's Complex and Impossible Mission, you start the game with a map of the major cities on Tau Ceti. Apparently it's another bad case of revolting robots.

You've got to go in there and blow away all the robots and restore order out of chaos by shutting down the reactor. To do this you have to visit each city in turn, skimming along the ground. You have to dock with the reactor substations and pick

up cooling rods. These have to then be assembled and then you enter the main reactor building.

Meanwhile you have to fight off various hostile forces using lasers, missiles, anti missiles and flares. The flares come in handy at night especially if your infra red night vision has been put out of action. You must also try to avoid shooting "innocent" buildings. You start off docked with your main supply ship, to which you must return for all but the most minor repairs and supplies. At this stage commands are entered to your computer as words.

There are 20 of these commands, which basically help you move around the planet and assemble your fuel rods. Entering "launch" will put you into flight mode which gives an out of the

cockpit view in any direction of the planet's surface. Your instruments tell you how much ordinance you've got left and give a scan of objects in your vicinity, there is also a little window for the computer to give you cheerful messages like "your laser is mangled".

Tactics seem to be the usual mix of aggression tinged with caution. It's tough to work out what's shooting at you when you've zipped into the middle of town at high speed, but on the other hand, it's against the clock. Sorting out the reactor rods is not easy either.

A well thought out game with a strong overall theme linking up the series of essentially straight forward shoot'em-up scenarios. Only one difficulty level, so to start off with, you hardly get out of the airlock.

LORD OF THE RINGS

► Spectrum • Melbourne House • Adventure • £15.95 • Paul Bond

GRAPHICS
 ● ● ● ● ● ● ● ●
SOUND
 ● ● ● ● ● ● ● ●
PLAYABILITY
 ● ● ● ● ● ● ● ●
VALUE FOR MONEY
 ● ● ● ● ● ● ● ●
OVERALL RATING
 ● ● ● ● ● ● ● ●

SCREENS

● Lord of the Rings: Anachronisms abound.

I was Merry. The hobbit, you understand, not the state of mind. And as Meriadoc Brandybuck, the first thing that struck me about Michel Delving is that it looked rather like its name — a small suburb whose branch line station was probably closed down by Beeching in the early sixties. In short, the graphics in this game show a distinct lack of enterprise. Things have moved on since the legendary days of Melbourne Houses's first foray into Middle Earth, The Hobbit, and while the structural side of this program is excellent, I suspect something a little more eye-catching is needed to tempt the punters away from their zapping.

Another worrying thing about this game is the incursion of certain futuristic anachronisms. In the beginner's program Frodo looks at a noticeboard which has some photographs pinned to it. Now although hobbits smoke and love to compile family trees, one thing that The Lord of the Rings is thankfully free from is continued heated debates

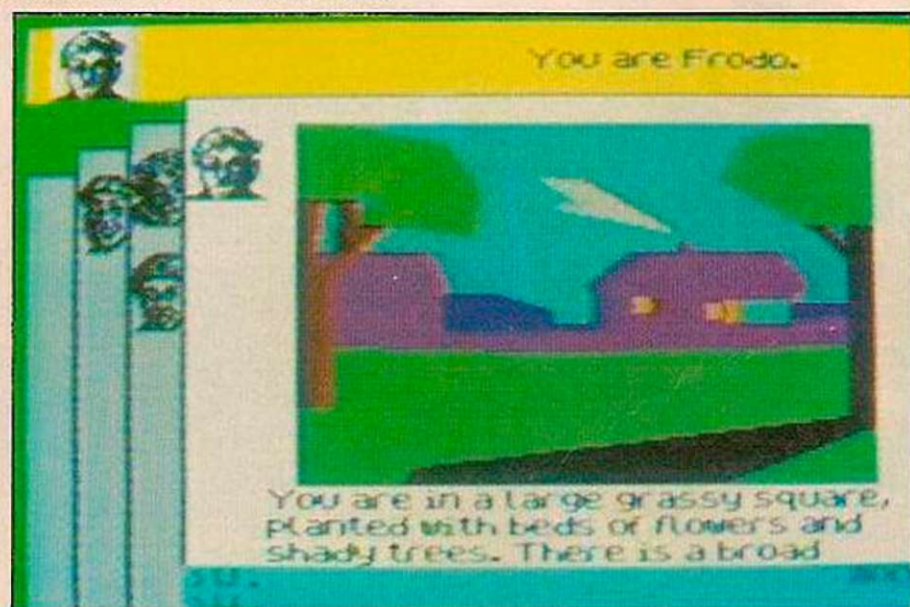

between Merry and Pippin as to the F-stop their cameras should be on when they see a flock of Nazgul flying by. There would have been whole chapters where the irrepressible hobbits tried to cajole the preoccupied Gandalf into posing for a shot — giving a lump of sugar to Shadowfax, maybe. And you can imagine how difficult it must have been to get colour film in the land of Mordor, especially since Sauron cancelled his subscription to *Amateur Photographer*.

Give'em their due, it's true

to the map, in the book. Get on to the main east-west road through the Shire, leading east and you'll soon come to the Last Bridge. Melbourne House have designed it lovingly, obviously based on the programmer's favourite bridge on the M5. All that is missing is a sign telling how far it is to Heston Services.

There is a bit of a problem with Black Riders at this time of the evening, of course, but if you know the back doubles, south through the forest glade, east into the thick forest and back up north

THINK

► Spectrum • Ariolasoft • Board-game • £7.95 • Lee Paddon

GRAPHICS
● ● ● ● ● ●
SOUND
● ● ● ● ● ●
PLAYABILITY
● ● ● ● ● ●
VALUE FOR MONEY
● ● ● ● ● ●
OVERALL RATING
● ● ● ● ● ●

SCREENS

● Think: Very well presented.

Board-games on computers have had a chequered history. Playing games like Connect-4 is just as easy with a pencil and paper as on a computer. But Ariolasoft think they have a winner on their hands with a board-game which can only easily be played on a computer.

The board consists of a six-by-six grid. You play counters alternately to either the bottom row or the right-hand column. If you play to a column, that column, all counters and spaces, move up one, and the same with rows. The object is to get four pieces in a row Connect-4 style.

The fact that a whole row or column moves when just one piece is played makes it very hard to look more than a couple of moves ahead to try and force a win.

The game is designed by Tigress Marketing, and a lot

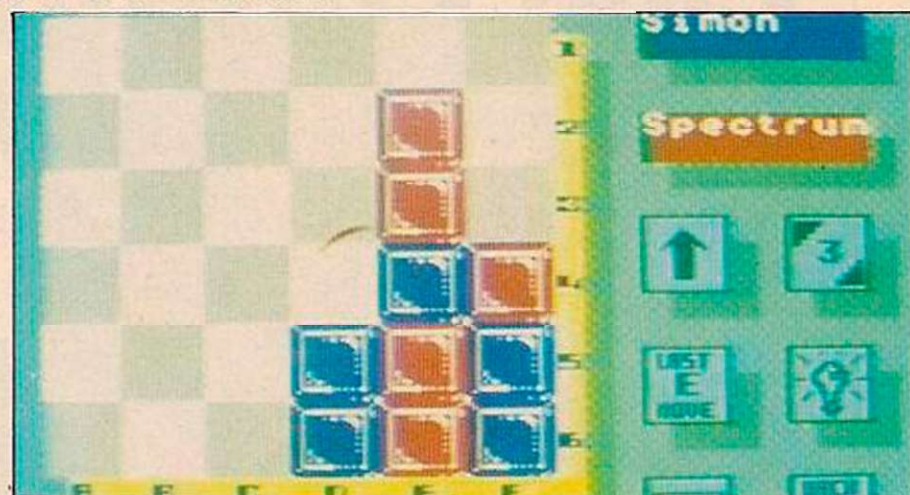

of time and effort appears to have gone into attractive presentation.

The "front-end" of the game is nicely designed, with icons allowing you to select various game options. Seven levels of computer opponent, normal, timed or "blitz" play, sound, colour and joystick options.

Although easy to learn, it takes a great deal of time to master. Even beating the

computer at a low level is quite an achievement. At the higher levels the computer takes rather a long time, but you can prompt it to move when you get fed up. There is a tutorial mode, where the computer gives you points for the quality of your moves, there is a problem-solving mode and a move take back feature. An intriguing, original board-game well presented.

THE LAST V-8

► CBM-64 • Mastertronic M.A.D • Arcade Driving • £2.99 • Paul Bond

GRAPHICS
● ● ● ● ● ●
SOUND
● ● ● ● ● ●
PLAYABILITY
● ● ● ● ● ●
VALUE FOR MONEY
● ● ● ● ● ●
OVERALL RATING
● ● ● ● ● ●

SCREENS

● The Last V-8: Excellent value for money.

through the ravine with unclimbable sides, you can dodge this particular bottleneck. The Shire Watch are experimenting with contra-flow, but if you keep you palantir tuned to MEBC (Middle Earth Broadcasting Corporation) or one of the local stations you should make Rivendell and be quaffing a few ales at Elrond's gaff in no time flat.

Melbourne House's special English language is supposed to make adventures less hard to play — but real adventurers will be glad to know that things have not really been made easier for the younger generation. Ask Gildor for help and you will be told that the computer doesn't know "for". Ask Gildor to help and the computer is sorry, but it doesn't know how to do that. Of course it lets you talk to Gildor but you never get to know what the conversation was about. It doesn't know the word "listen" and a really good wheeze is typing in "Hear Gildor". This generates some of the most spectacular rubbish I have ever seen a computer utter. Good fun for adventure freaks.



"V-8, return to base". The computer issues this order in suitably stentorian tones at the beginning of the game — you only have a limited amount of time to get your souped-up, post-holocaust runabout back in the garage before the radiation gets you. The screen display is an aerial scrolling view of the terrain. This is a race against time as opposed to a race against another car, but like most racing games you have to remember to take the curves slowly and you have to get to know the route.

Created by David Darling, the game has incessant

synthesised music, smooth-scrolling graphics, and, in short, all the hallmarks of a much more expensive game. Value for money it definitely is, which is the purpose of the Mastertronic Advanced Design range — and still well within the range of the average pocket-money customer. Surely one of this company's best defences against piracy is price — which is not to say that their games don't get pirated.

It's tough and will require what little co-ordination you have left to get yourself into the city.

Five Fantastic Games

Keep your eyes peeled for NOW GAMES 2. Five major software hits jostle for your attention on this packed-solid-with-fun cassette.

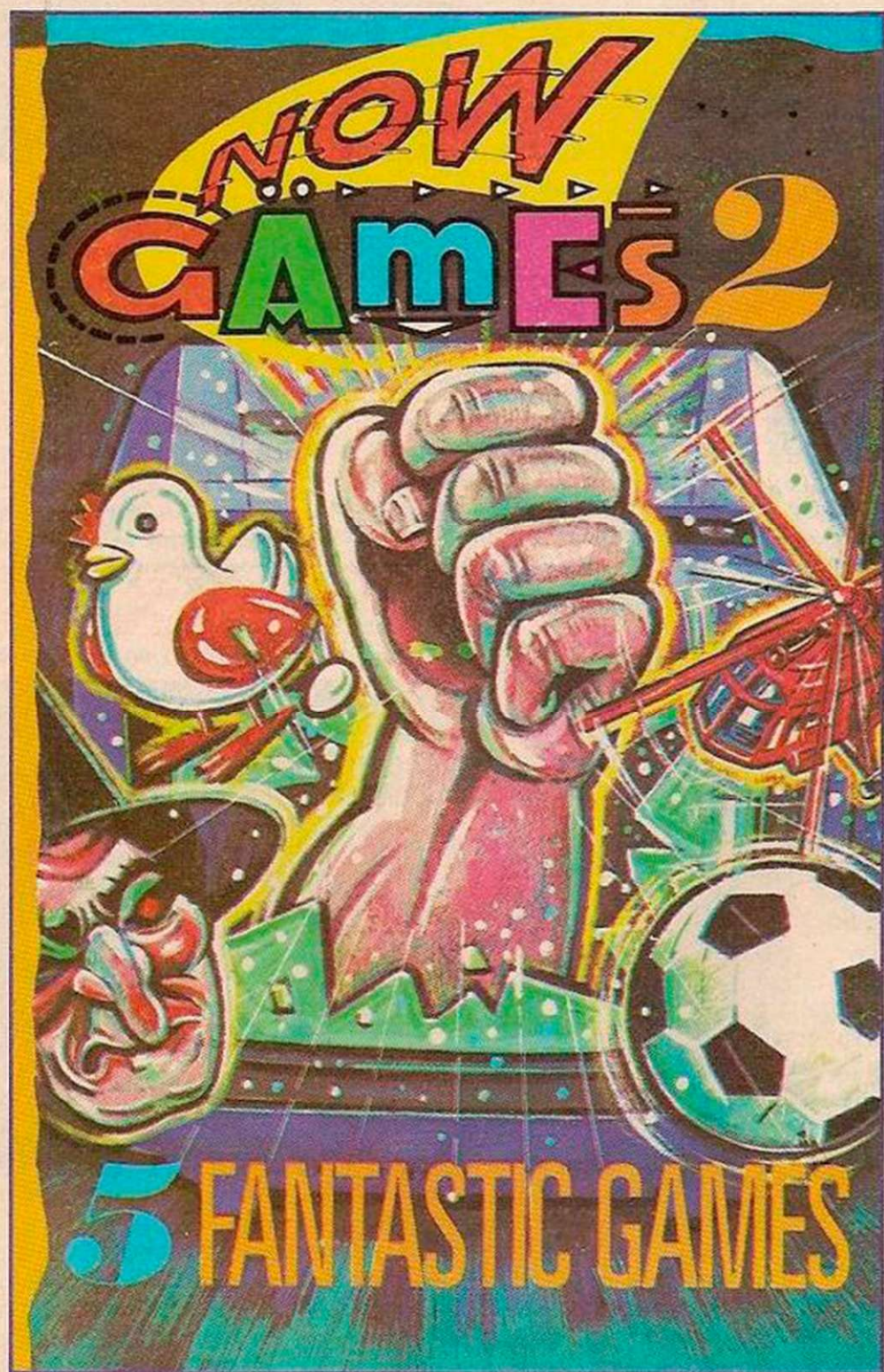

Available for
COMMODORE 64 and SPECTRUM 48K
and for only

£8.95



1. AIRWOLF – Elite Systems Ltd
Stringfellow Hawke must use his helicopter to free five imprisoned scientists in this exciting arcade game which takes place in a subterranean terrorist base!



2. TIR NA NOG – Gargoyle Games
This remarkable interactive graphic adventure allows you to play the mythological Celtic, Cuchulainn, searching for the fragments of the Seal of Calum.



3. CAULDRON – Palace Software
Take up the witches' challenge and unravel the mysteries of this beautiful land in this striking arcade adventure.



4. CHUCKIE EGG 2 – A & F Software
Help Hen House Harry in the smooth running of the A & F Chocolate Egg Factory! He must find equipment and find out where to use it in this amusing arcade game.



5. WORLD CUP – Artic Computing
This great football simulation lets you re-enact the tough fight to the World Cup Final. Play a friend or the computer (a pretty tough opponent)!

Now that's what I call value



STILL AVAILABLE – NOW GAMES

featuring
*Lords of Midnight, Brian Bloodaxe, Strangeloop,
Pyjamarama, Arabian Nights and Falcon Patrol II*
for only

£8.95

Available from all good software retailers

Also available directly from: Virgin Games Mail Order, 2-4 Vernon Yard, Portobello Road, London W11 2DX

SOFTWARE SHORTLIST

SIR FRED

► Spectrum • Mikro-Gen • Arcade adventure • Lee Paddon

GRAPHICS



SOUND



PLAYABILITY



VALUE FOR MONEY



OVERALL RATING



SCREENS

● Sir Fred: Takes the arcade adventure to new heights.

With Rambos mowing down everything in sight and Supermen juggling skyscrapers, this offering represents a return to Elizabethan values. The gallant Sir Fred has to rescue a princess from a castle. Glossing over the sexism endemic in computer games — when has a princess ever done any rescuing? — this is another from the ever popular arcade adventure genre.

All the rooms you can eat, with nasty things trying to drain your strength, lots of objects to pick up, and then work out what to do with.

It's a tricky game to master, one for the real aficionados to drool over. If you thought Jet Set Willy was a piece of cake, then this could be right down your dungeon.

Despite only the usual controls of up, down, left right, select and use, a lot of extra moves have been crammed in by combinations of the keys. Climbing, running, swimming, there is apparently no end to his

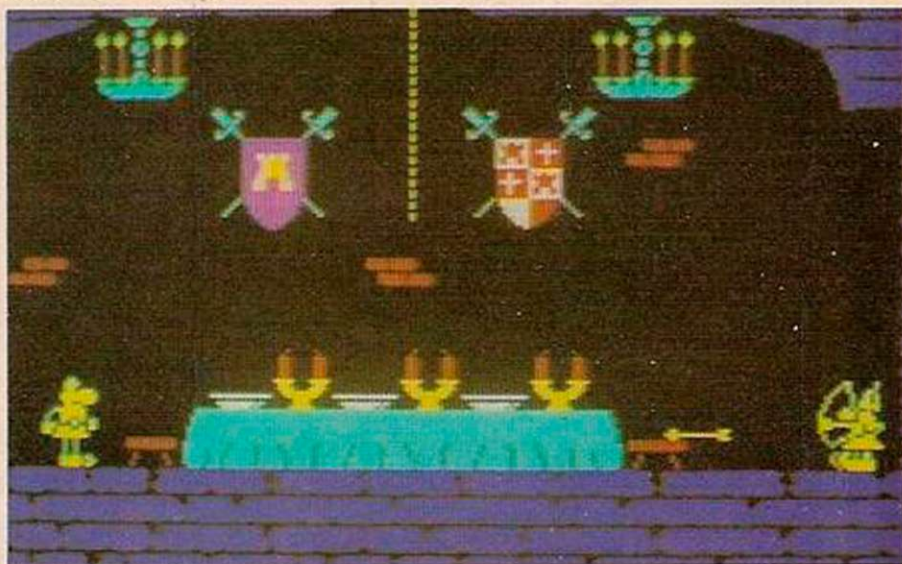

talents.

The graphics are up to Wally standards, despite the fact that it was written by a Spanish company, rather than the Wally programmers. Another of Sir Fred's many talents is swinging on ropes. However, this is where the game rather falls down — or at least I did.

You are meant to swing on the rope by pressing alternately left and right; I must have been defeated by keybounce or something, but all that kept happening is the

intrepid knight would end up going spurs over helm.

Just to cater to the mobs of computer games players conditioned to handing out mindless violence to all who get in their way, you get scoundrels and footpads to put to the sword. This rather goes against the grain of normal arcade adventures where the philosophy is to avoid things rather than kill them.

Odious overtones apart, this game takes the arcade adventure to new heights.

ELITE

► Spectrum • Firebird • Shoot'em-up • £14.94 • Lee Paddon

GRAPHICS



SOUND



PLAYABILITY



VALUE FOR MONEY



OVERALL RATING



A year after the battlestar Elite was launched, it has at last made contact with the universe of the Spectrum owner. Perhaps the most talked about computer game ever, has it lost anything in translation?

The game has virtually been rewritten by Firebird's Torus team, and is a very impressive piece of programming. All the best features of the BBC game are there — very fast vector graphics, good instrument display and of course tremendous depth.

You start off as "Harmless" with a real bucket of a ship and 100Cr to your name. Your ambition is to attain the fabled combat status of "Elite", and line your pockets at the same time. The game starts slowly while you get the hang of the controls and make a paltry profit shuttling between safe planets, then the pace begins to quicken as

you fill you hold with highly profitable cargo, and equip your ship to allow you to go where no man has traded before.

To attain the status of Elite you have to blow away some 8,000 ships. To break up this somewhat monotonous process, you are called upon to perform a couple of missions for the Galactic Navy.

What, of course, sets this game apart is the use of vector graphics and challenging combat sequences with, if you're unlucky, up to a dozen ships and general bits of debris floating around the place. The number of ships is a reflection of your legal and combat status, the type of planet and your cargo.

Shooting peaceful traders and trading in narcotics are good ways to get rich quick, but the police take a dim view of it. Things can soon

get sticky with half a dozen ships whittling down you energy as you twist and turn trying to escape. However, once you're equipped with a military laser — affectionately known as The Can Opener by pilots everywhere — life becomes a little easier. If it really gets nasty, it's time to hyperspace out, or perhaps try out the smart bomb.

Although it's difficult at this early stage to tell whether Firebird have succeeded in bug eradication, there does seem to be a problem with the space stations which are sometimes placed too far away from the planet, and on one occasion in the middle of the planet.

On the plus side, your status is constantly displayed on all screens and the display is very fast, even when a lot is happening on the screen.

Frankly a program no self-respecting Spectrum owner can afford to be without.

WILLOW PATTERN

► CBM-64 • Firebird • Graphic adventure • £3.95 • Toby Wolpe

GRAPHICS



SOUND



PLAYABILITY



VALUE FOR MONEY



OVERALL RATING



SCREENS

- Willow pattern. An adventure on a plate

Everyone knows about the game-of-the-book, game-of-the-film, game-of-the-teeshirt syndrome. But this must be the first game to be based on a blue-and-white tea service.

All those fond of Chinese food will be pleased to know that if you manage to save Princess Koong-Shee you'll be chased out of the maze by her father, that well-known oriental dessert Li Chi. Let's try forgetting food for a minute — which is difficult given that Firebird is the first company to hand you an adventure on a plate.

Apart from the setting, there's nothing terribly original about the Willow Pattern plot. You have to guide the hero, Chang, around a maze of suitably Far Eastern complexity. His aim is to gather items on route — the most important one is the key — which will help free the Princess.

Although the game view and playing techniques resemble Sabre Wolf, there are none of those tiresome nasties which litter Ultimate games. In their place you'll find maze guardians at key points. These touchy warriors can only be passed if you have a sword to hurl at them.

Some of these Chinese bouncers stand there impassively blocking your path, others fling swords which you can dodge, pick up and use to hack down their former owners with.

An important tip is never to use words unnecessarily. If you do, you'll find it impossible to get past certain guards later on. It's not even worth collecting a sword until

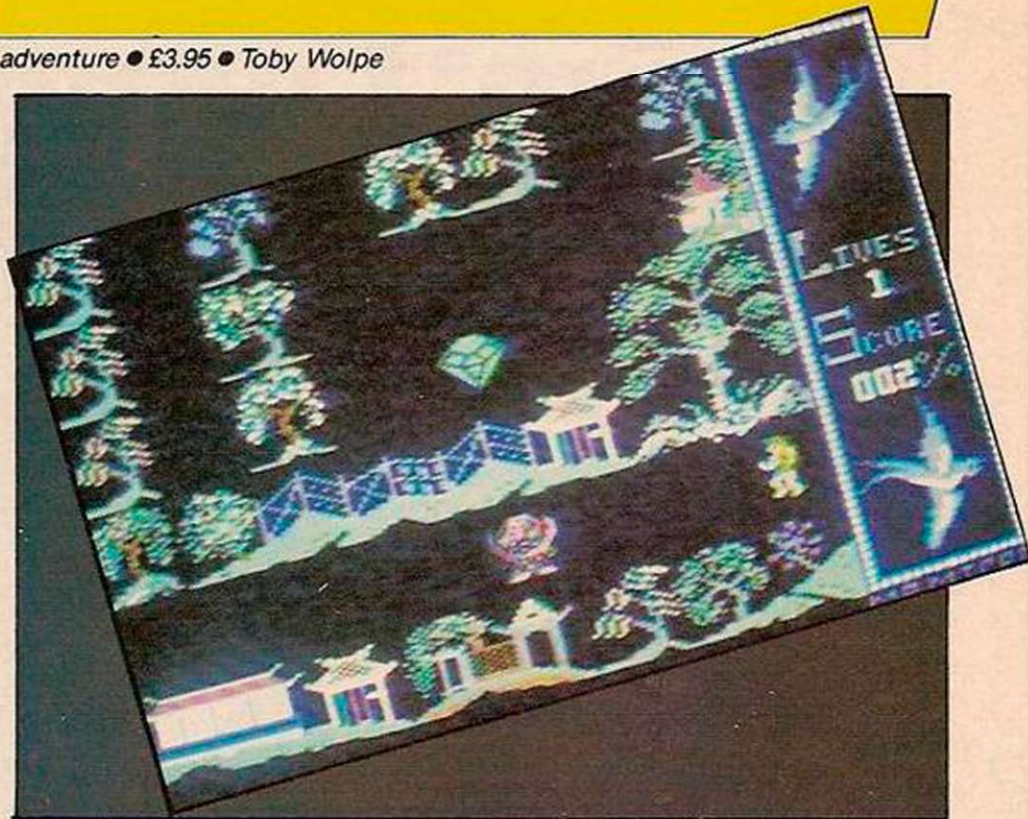

you're sure what to use it for.

A nice touch is the way the tempo of the Chinese take-away music picks up when you're holding a sword.

Of course Willow Pattern wouldn't be Willow Pattern without those little wooden bridges. But if you try to cross one you find yourself in a different playing sequence

that doesn't seem to match the rest of the game. As Chang hops across the stepping stones under the bridge a pack of giants try scooping him.

The smooth graphics and tinkling music are very good given Willow Pattern's £4 price tag. The maze is just right, too.

SPEECH

► BBC • Superior Software • Utility • £9.95 • Simon Beesley

VALUE FOR MONEY



OVERALL RATING



Speech without a speech chip. It's hard to think of a more entertaining utility than this one. You can easily insert the program's 7K of code on someone else's disc, write a short Basic loader, and ask them to boot it up. Lo! a spoken message. The surprise effect alone is worth the price; like seeing colour on a ZX-81 screen.

Speech's speech may not

always be intelligible if the words are not printed on the screen at the same time. But it is unusually easy to use.

*SAY voices any English sentence, while *PITCH sets the pitch. If you are willing to put a bit of effort into it you can improve the program's enunciation by using *SPEAK which directly accesses a set of 49 phonemes. One of the demo programs will even take

a text file — from Wordwise, or View, for example — and painstakingly talk it through — if you can bear to listen to it.

Although speech has been generated before on the CBM-64 and Spectrum, through the sound chip alone, this is the first time on the BBC. Elsewhere in this issue Speech's author, David Hoskins, explains how.

INDIANA JONES, J.R. & BRUCE LEE JOINED THE U.S. GOLD CLUB.. ..NOW YOU CAN TOO!

You are aware only too well, the ability of U.S. Gold to bring to you the very best of American Software at British prices. Previously American Software, whilst recognised as being of brilliant concept and quality, has been prohibitive in cost compared to home produced packages.

In April 1984 that situation became history!

During 1985 U.S. Gold will be releasing titles from the following well known software houses: DataSoft/Synapse/Segal/Microprose/Cosmi/Access/Sydney/Sierra On Line/Advantage/Mindscape/American Eagle/S.S.I./Big 5/Funsoft/Penguin/PDM—and that's only sixteen excellent reasons to join the U.S. Gold Club. Here's some more:

Membership to the U.S. Gold Club will guarantee you a regular newsletter featuring software reviews, advertising material and future product information. There will be regular U.S. Gold Software offers and U.S. Gold merchandise offers. Be 'In the Know' before your friends.

Become a member of the U.K.'s Premier Software Club

Membership Fee—£9.99 + 75p p+p includes:

- U.S. GOLD SWEATSHIRT
- U.S. GOLD BADGE
- POSTER
- NEWSLETTER
- U.S. GOLD MEMBERSHIP CARD

WARNING:

Desire for U.S. Gold Software might seriously affect your bank balance!!



To U.S. Gold Ltd., Unit 10, Parkway Ind. Est. Heneage St., Birmingham B7 4LY.
I would like to become a member of the U.S. Gold Club. I OWN A
COMMODORE 64/SPECTRUM/AMSTRAD/BBC/MSX/ATARI. (Delete as appropriate)

I have enclosed a cheque/Postal Order for £9.99 + 75p (p+p) to U.S. GOLD CLUB
For my Membership Fee I will receive a Sweatshirt (26/28" 30/32"
S M L). U.S. Gold Badge, U.S. Gold Poster, and my first Newsletter. I will
receive a regular Newsletter and special U.S. Gold offers exclusive to members.

Name

Address

Post Code



Master Pieces

April 1984. It began quietly, insidiously. Rumours about cheap software — “pocket-money games”. The establishment scoffed. It couldn't be done — look at the overheads; paying distributors, duplicators, artwork and advertising costs — sometimes even the programmers wanted a cut. Anyway the product would be cheap and nasty and would blemish the noble escutcheon of the British games software industry — which apparently, was so altruistic it made Dr Barnado look like Richard Branson.

“Companies that said Mastertronics were bad for the industry have gone. They're not around and we are,” points out John Maxwell who selects the programs for the company stable. “Activision, Ocean, Melbourne House — those kind of companies are all far too professional, far too good to worry about the penetration of other people into the market place.”

Mastertronics is more than the sum of its parts. John Maxwell heads Artificial Intelligence Products which deals with the raw programs, Colin Johnson is Dream Promotions which handles Mastertronics' artwork and promotions — and Mastertronics itself is represented by Martin Alper, managing director responsible for the American side of the business and matters other than the UK sales, production and distribution handled by UK sales director Alan Sharham.

Martin Alper, already comfortably ensconced in the video business, effectively founded Mastertronics when he bought a tape and data duplicating facility. “I asked the guy how much it cost to duplicate a tape — he said about 30p; then I asked him how much they sold the games for — about eight or nine pounds. I couldn't understand

the massive difference, so I took a closer look.”

Savings in volume is the keynote of Mastertronics philosophy — to be profitable Colin Johnson says their games must outsell competitors at a ratio of 4 to 1. “But, for example, in Boots we are selling at a ratio of about six or seven to one, so we are outperforming considerably.”

How did little acorns Mastertronics manage to grow into a mighty oak dominating a mammoth 18.47 per cent of the entertainment software market (according to Gallup)? “We went over the heads of the distributors,” says Martin Alper. Websters, Terry Blood, Centasoft — none of these firms would have touched the burgeoning company with a barge-pole. But Martin Alper had his own sales force: “We already had about 18 or 20 salesmen; we just hired another 12. Within 14 days of launch we hand the product in WH Smiths — then the distributors had to sit up and take notice.

Shuttlesoft is the firm's marketing arm responsible for getting all those cassettes into your local corner-shop. This is the basis for Mastertronics GmbH, Mastertronics SAS, Mastertronics PVBA and

Mastertronics International Inc. All selling into Germany, Italy, Belgium and the United States.

But is it quantity rather than quality? “At the start we certainly went for bulk”, agrees John Maxwell. “We wanted to build up a team of people we could rely on. We get about 200 games sent in every month. We look at everything — if there's a spark of something we contact that person. A good machine-code programmer is not your average run-of-the-mill person. They're very serious, thirsting after knowledge all the time.

“We estimate that there are as few as 100 really top-class machine-code programmers in the country. We also believe in religious payment of royalties — a lot of our programmers were surprised when they got paid promptly, which in turn surprised us. We didn't realise how badly some quite big companies behaved.”

David Darling, who wrote one of Mastertronics all-time hits, Chiller, learnt to program with his brother Richard while living in the USA. Mastertronics

believe in encouraging talent — hence David Darling's promotion to the new MAD range, priced at £2.99 as opposed to the standard £1.99 range. But Chiller, successful though it is, had some problems — namely its Michael Jackson Thriller sound-alike soundtrack. Rocksoft, a company set up to protect royalties of musicians, took Mastertronics to court. “A very clever girl wrote down the music of both Chiller and Thriller, and proved that they were not identical. But the barrister said it would cost us £60,000 to prove we were in the right. It was cheaper for us to settle out of court”, said John Maxwell. “Rocksoft is no longer functioning, I believe.”

But David Darling is, and his new program, The Last V-8 with synthesised speech and super-smooth scrolling graphics adds a touch of Mad Max to the MAD (yes, it stands for Mastertronics Advanced Design) range. Set in 2008, just after a nuclear war you have to

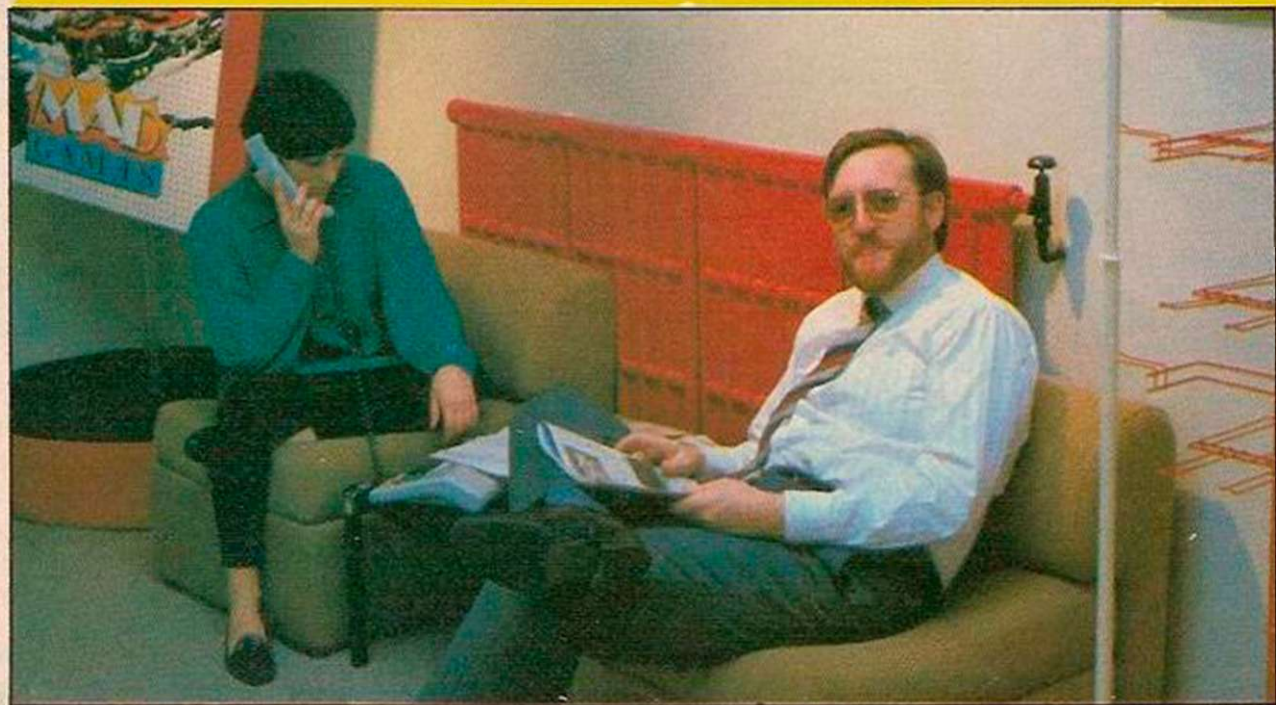
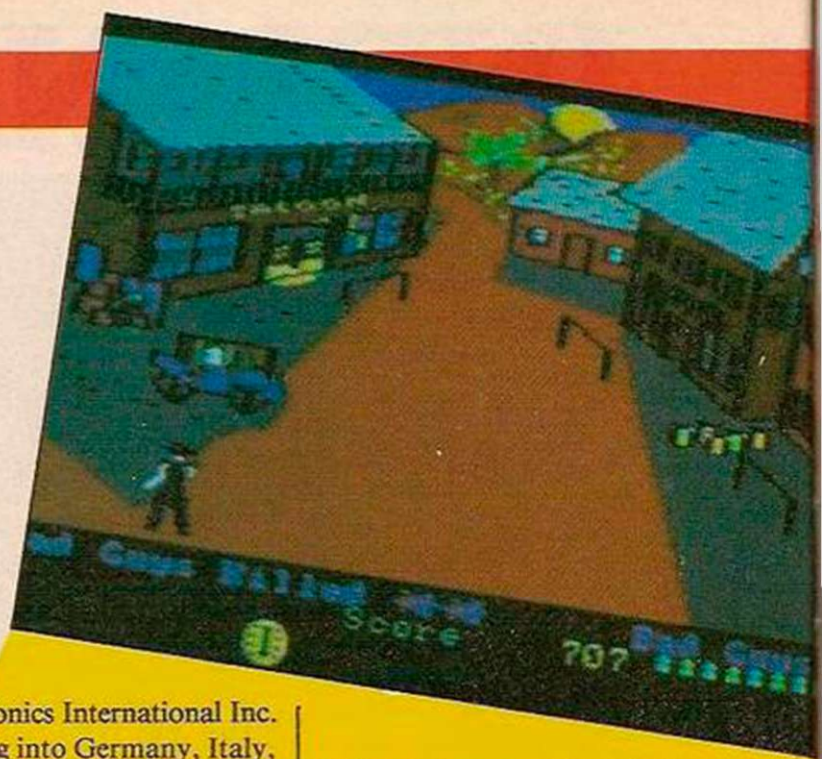

Paul Bond meets Mastertronics: a threat to the establishment or a promise?

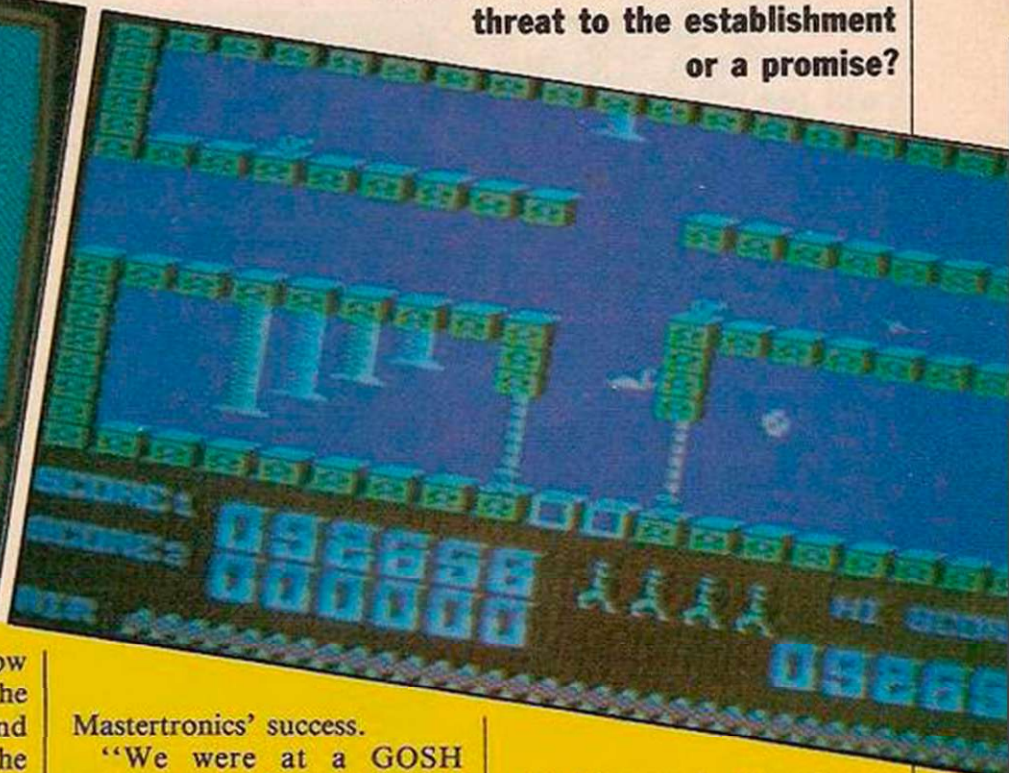
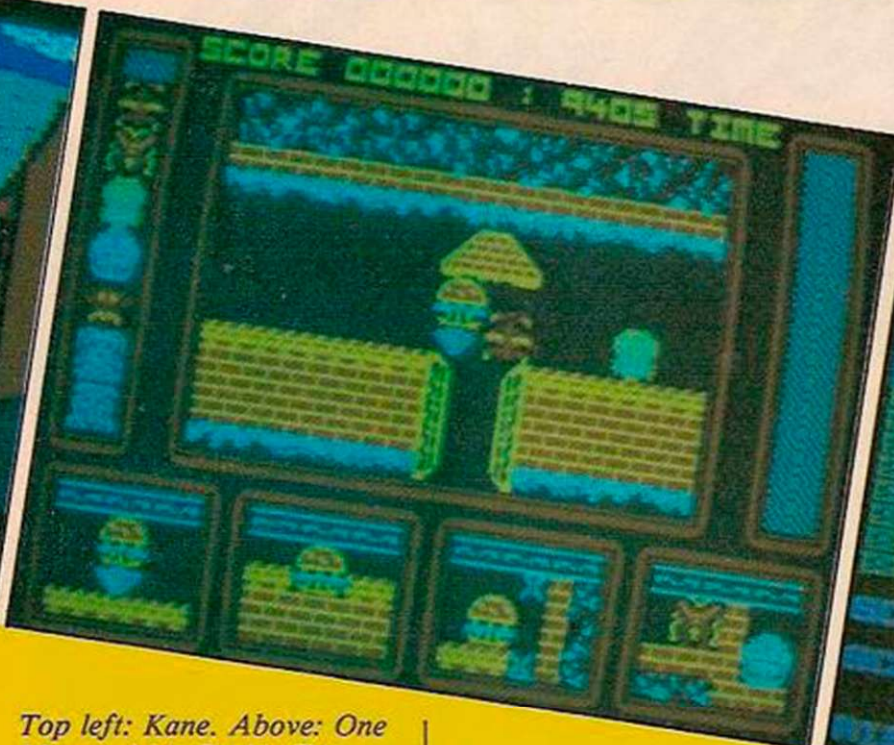

Top left: Kane. Above: One Man and his Droid; Top Right: Big Mac. Below left: Colin Johnson, Alison Beasley and, below right: Spellbound.

return to base before disaster overwhelms you — see Software Shortlist for full review. Along with Sean “Kikstart” Southern’s Hero of the Golden Talisman, an all-action arcade adventure, and David “Finders Keepers” Jones, The Last V-8 forms part of a three pronged assault on the quality end of the market. “It also means we can pay the programmers a bit more”, John Maxwell is keen to emphasise.

How far up-market will Mastertronics go? They are very proud of their acquisition of Ski-Writer an extremely user-friendly word-processing program developed by Ken Skier for Wang in the United States. Marketed over there for about \$69 by Prentice-Hall, Mastertronics have acquired rights to Apple and CBM versions. It will be sold here for the CBM-64 at £13.95 (Cassette) and £14.95 (disc).

Part of the secret is to put all the help functions into the program itself, rather than a bulky accompanying manual — this cuts costs and provides a utility at considerably less cost than Commodore’s home-grown word processor — it might stop a lot of 64 owner trading their micro in for an Amstrad PCW. You can get the equivalent of 22,000 characters into the Editor before downloading.

But fear not — Mastertronics

will not desert their zap-pow roots. Recent releases for the CBM-64 include Kane and Zizz, plus Specventure for the Spectrum and Big Mac for the C-16? According to a recent Gallup survey it’s Britain’s fourth biggest selling machine after the Spectrum, C-64 and Amstrad machines. “And there’s not much software for it,” says John Maxwell. Like everything the company have done from day one, this exemplifies the secret of

Mastertronics’ success.

“We were at a GOSH meeting the other day,” said Colin Johnson. A man for a software house stood up and asked the WH Smith’s representative why they had dropped his company’s entire range. The rep replied that he had just explained that Smith’s no longer carried BBC/Electron software — which was all this guy’s company did.”

In other words, identify your market. “Yes — Mastertronics always assumed there was a market for high-playability impulse-purchase games with a short life-cycle. Even if kids bought one every two weeks, they would still take two months to spend the same amount of money that they would spend on a full-price game.” ●

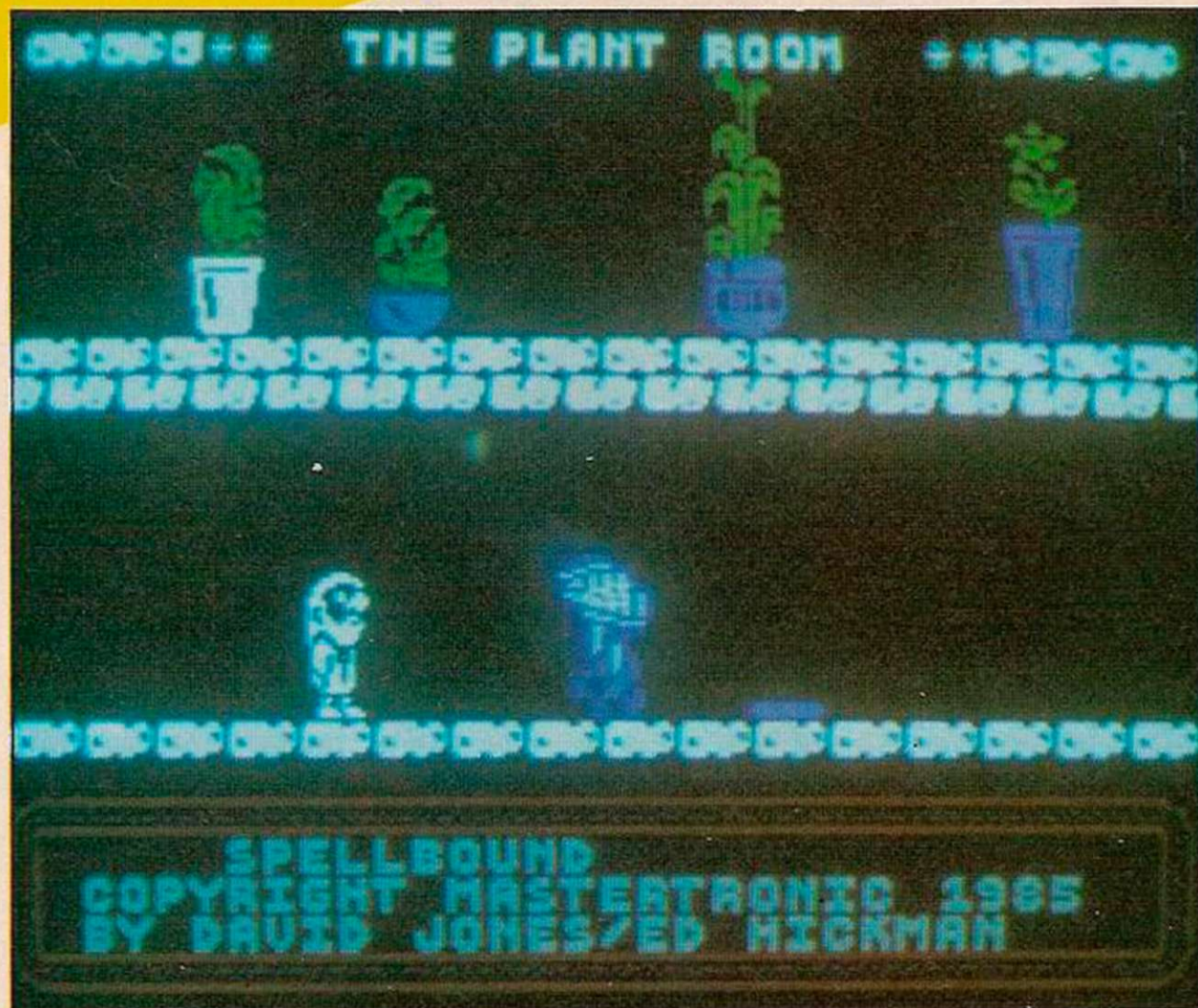

Hewson

If you thrilled to **Paradroid**, Hewson's new stunner, **Uridium**, will really knock your socks off. Paul Bond reveals all.

Ust when you thought it was safe to go back into outer space, hard on the heels of Hewson's **Paradroid** comes **Uridium** — another Andrew Braybrook masterpiece. With the same hard-edged three dimensional graphics that make your 64 look like an arcade machine and some brain-twisting sequences this game stands apart from the run-of-the-mill shoot'em-up.

The pictures here show the program under development — you pilot a small spacefighter attacking a gigantic armed starship. Your craft can spin, wheel and loop the loop — during all these manoeuvres its shadow is faithfully etched on the space leviathan beneath you by the harsh unscintillating light of the local star.

Naturally you must incapacitate the on-board defence systems of the ship — turrets, but also its own on-board defence squadron, scrambled from exterior launch-tracks on the outer hull — still under development at the time these pictures were taken. The attacking craft will have the same realistic movement as your own scoutship, but will attack in waves composed of up to six vehicles flying in formation, peeling off one by one as they attempt to rupture the fragile shell that separates you from the airless depths of the cosmos.

As in **Paradroid**, there will be more than one ship, **Uridium** being the name of the final craft that you must destroy. Andrew Braybrook is toying with the idea of a hyperspace transfer sequence that will echo the mind-control section in **Paradroid**. The program is scheduled for release before Easter but Hewson are cagey about making promises that they may not be able to meet. A lot of us are still waiting for Novagen's **Mercenary** at the time of going to press.

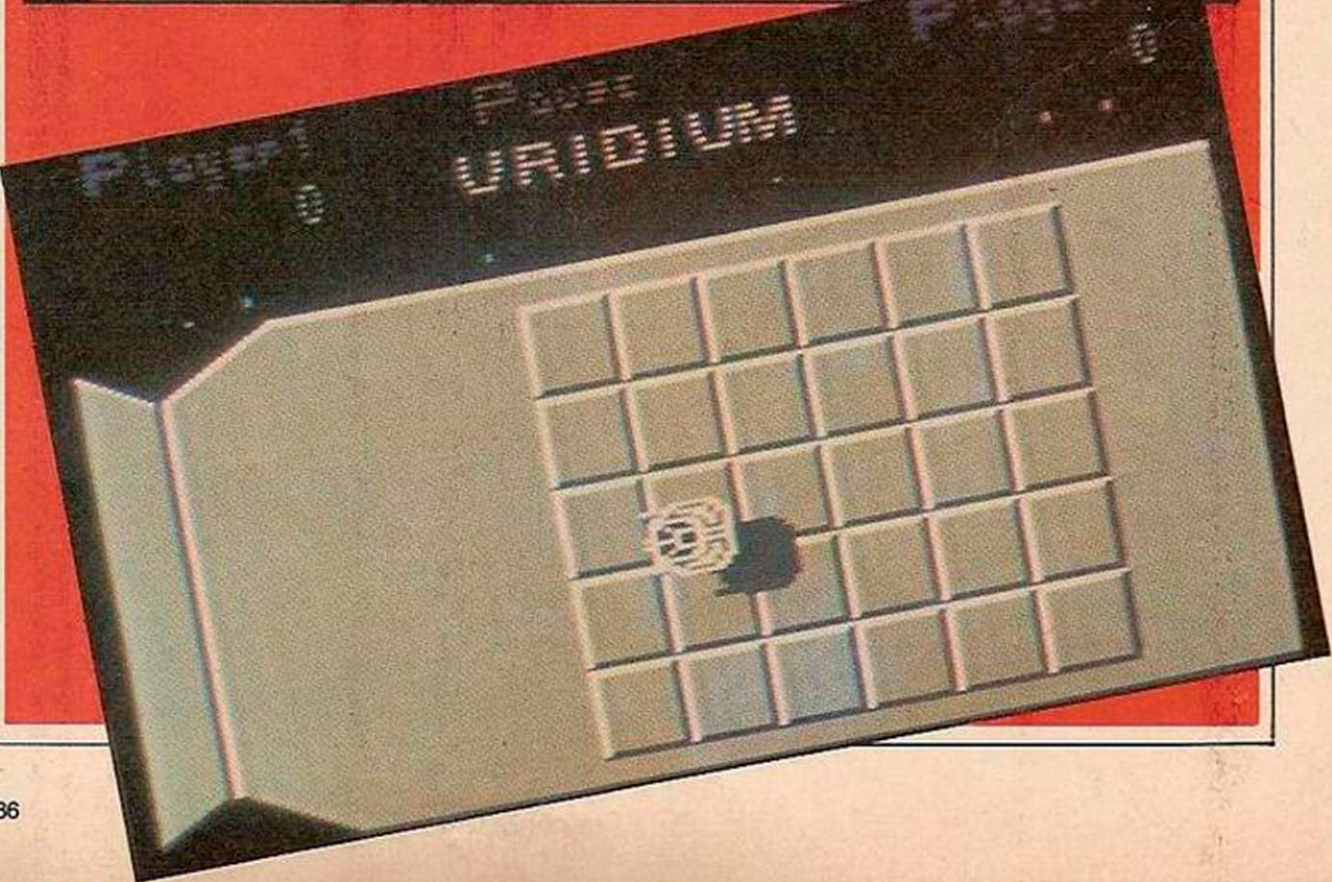
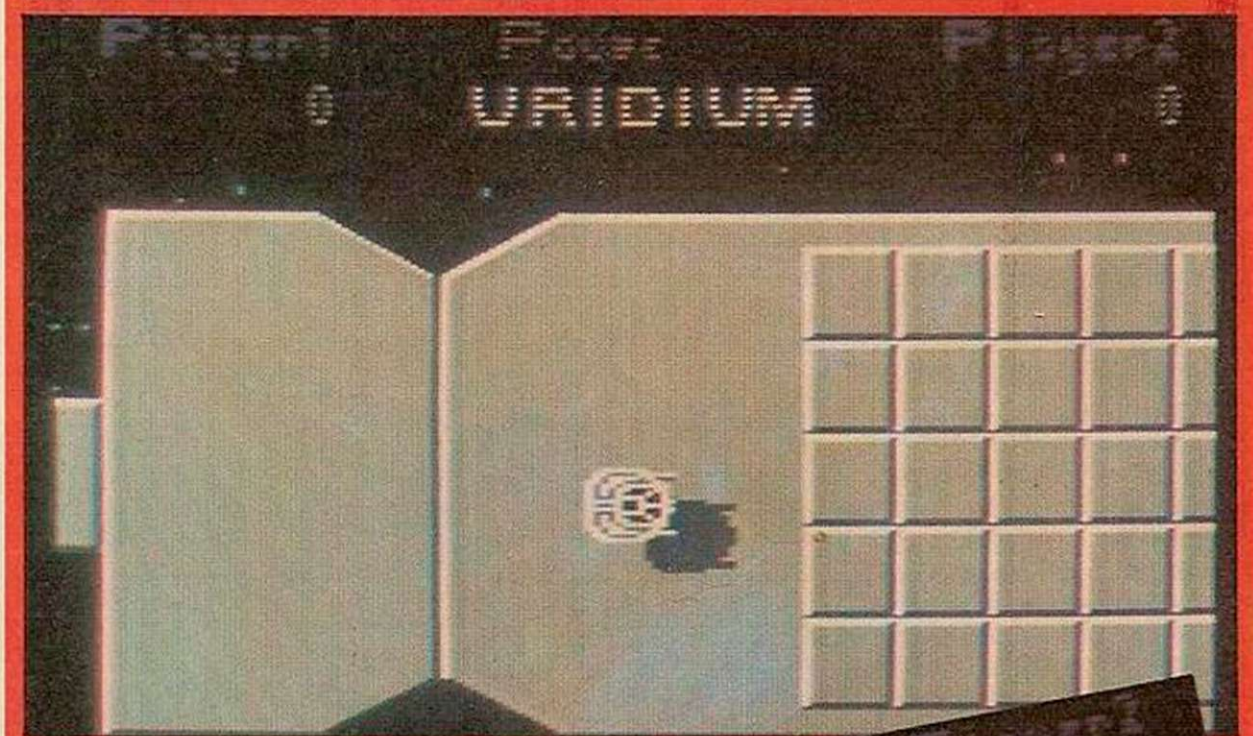
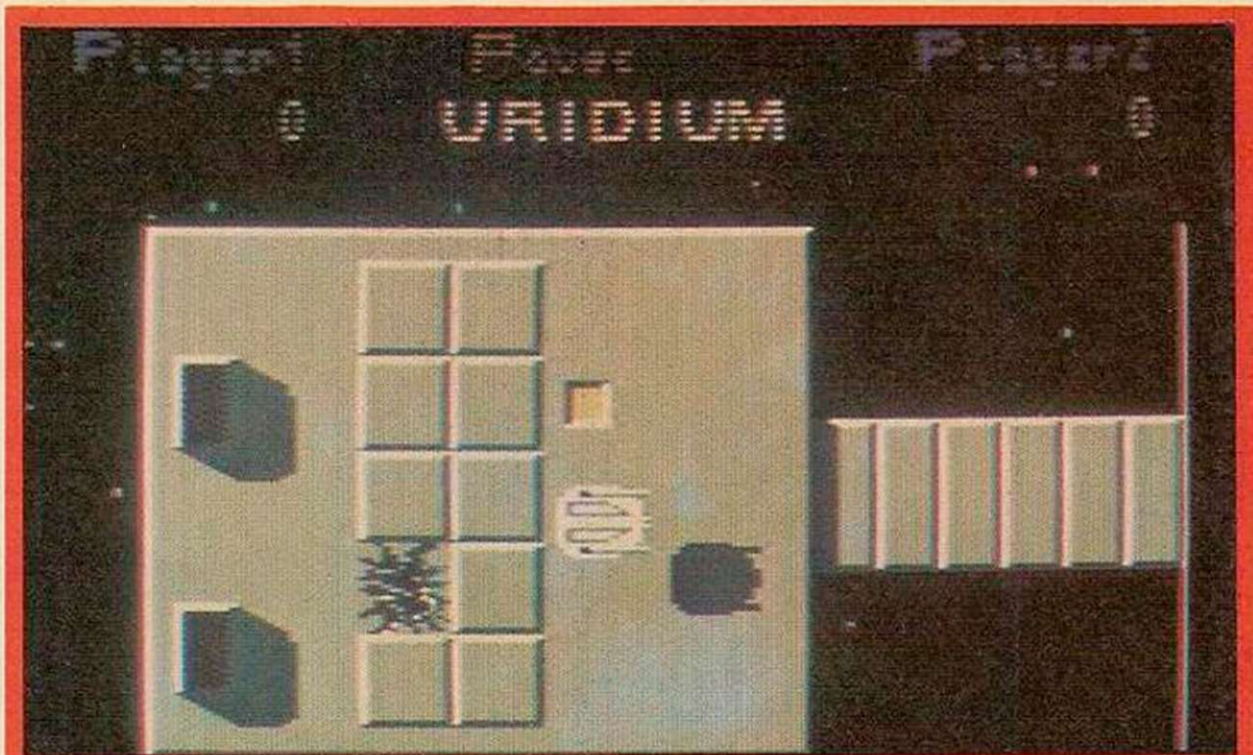

Your key to communications!

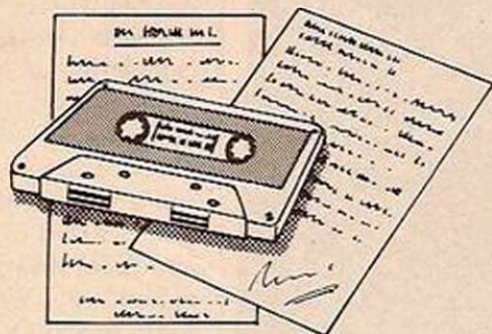

PRESTEL

FREE Electronic Mail . . . International Telex . . . 10 National Chatlines (Interactive Bulletin Boards) . . . 70,000 users across the UK . . . Teleshopping . . . Multi-User Interactive Strategy Games

Instant computer news . . . Hardware and software reviews . . . Technical features . . . Hints and tips

FREE and discounted quality software to download direct to your micro - **24 hours a day**

300,000 pages of information on the huge Prestel database

for just 20p a day

Micronet 800-
The ultimate peripheral

Micronet 800
8 Herbal Hill, London EC1R 5EJ
Telephone: 01-278 3143

To: Micronet 800, 8 Herbal Hill, London EC1
Please send me a brochure on Micronet 800

Name _____

Address _____

_____ Telephone No _____

Age _____ Micro _____

YC JAN '86

There's life beyond games. Simon Beesley settles down to some serious software reviewing.

A popular misconception about home computers says that they are not really suitable for running business software. If you are starting from scratch, people advise you to buy a 16-bit micro. This means buying an IBM PC or one of the legion of IBM compatibles.

In point of fact, now is a very good time for 8-bit business software. Amsoft has started to release CP/M classics such as Supercalc at a fraction of the price they were selling at two years ago — £50 as compared to £200; while Computer Concepts has launched the first two of four integrated business programs for the BBC. Called Rom-link, this package will be the first serious application of the integrated software concept to home micros.

To run business software a home computer needs to meet at least three requirements: it must have a decent keyboard, an 80-column screen mode and, of course, an adequate range of software. These conditions rule out all but the CP/M based micros — Amstrad, Memotech, Tatung Einstein, and Enterprise — and the BBC.

Software on Rom

You can run CP/M software on the BBC by adding a second processor; but its main asset is the range of programs on Rom. Despite being limited to 16K, BBC Rom programs are often just as effective as their larger CP/M counterparts. This review looks at business software in general, and the BBC variety in particular.

Leaving aside specialist programs such as accounting packages, business software falls into three categories: wordprocessors, spreadsheets, and databases. Business software, however, is perhaps a misleading term. It suggests that you actually need to be involved in running a small business to make use of them.

In fact, wordprocessing programs have a much wider appeal. The beauty of a word-processor is that it allows anyone to produce a professional-looking document without being a competent typist. Take the problem of typing a letter designed to impress, say,

a bank manager or a prospective employer. Unless you are a trained secretary, to do it properly usually means an exercise in frustration, resulting in a bin full of crumpled writing paper.

With a wordprocessor even one-finger typists can produce Tixel-free letters remarkably quickly. Just as important, they can also lay them out correctly.

On the BBC, Computer Concepts' Wordwise and Acornsoft's View illustrate two different ways of entering text. View displays a document exactly as it will appear when printed out. If you want to enter text over more than 80 columns the screen can be scrolled sideways.

By contrast, Wordwise only allows text to be entered in 40

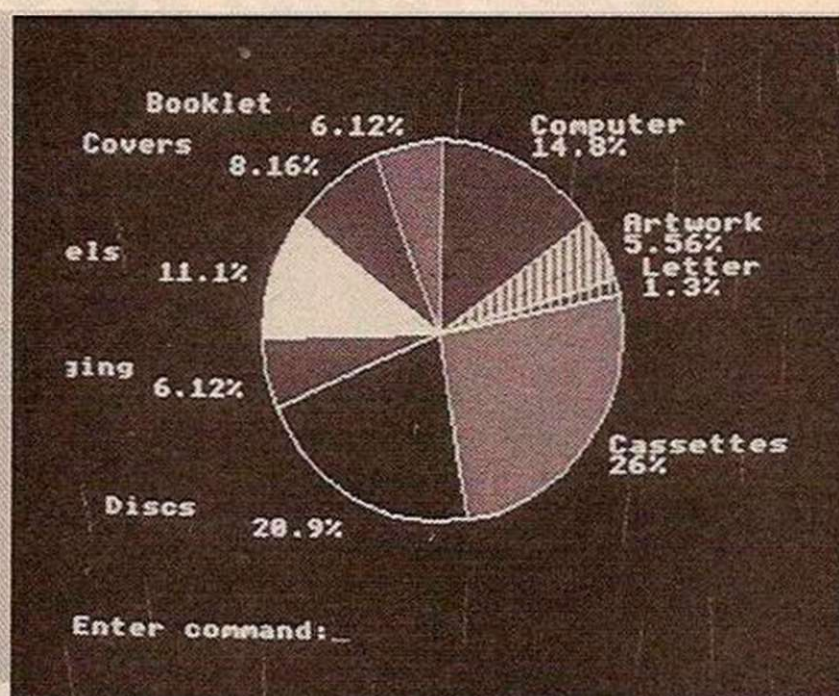

Computer Concepts' Interchart solves the integration problem.

Item	Quantity	Price	Total
Computer	1	250.00	£ 250.00
Business cards	200	25 per 200	£ 50.00
Letter heads	200	25 per 200	£ 50.00
Cassettes	100	2.00	£ 200.00
Discs	100	2.00	£ 200.00
Packages	100	0.22	£ 22.00
Cassette labels	100	0.22	£ 22.00
Cassette box covers	100	1.50 per 1000	£ 15.00
Instruction booklet	100	1.50 per 1000	£ 15.00
Total:			£ 1650.00

Item	Quantity	Price	Total
Cassettes	270	7.00	£ 1890.00
Discs	70	10.00	£ 700.00
Total:			£ 2590.00

Computer Concepts' spreadsheet on Rom, Intersheet.

column mode. To format a document you insert sequences of command characters. There is a preview mode which allows you to see how the text will look after formatting. However, laying out tables over a number of columns can be a fiddly business.

What gives Wordwise a decisive edge over View is the inclusion of a programming language, similar to Basic, with 70 commands. When you consider that CBM-64 Basic has no more than 70 commands, you will realise what a powerful feature this is. Among other things, it allows you to instruct the computer to print out a document as many times as you want; or run a mail merge; or

produce a page index.

Both View and Wordwise can hold their own against larger CP/M programs such as Wordstar. And because they have been written specifically for the BBC they are much faster. To shift text on the screen CP/M programs have to work through a layer of operating system routines. This makes them noticeably slower in scrolling or reformatting a document.

Speed is also a feature of Computer Concepts' new spreadsheet program for the BBC, Inter-Sheet. Not only is it much faster than Supercalc II on the Amstrad, it also outstrips most spreadsheets for 16-bit micros. Supercalc II, on the other hand, has a greater range

of commands and options.

For an idea of what a spreadsheet does, take a look at the Spectrum version in this issue. Put simply, it provides a grid on which you can manipulate figures as easily as a wordprocessor handles words. Each cell or box in the grid can hold either a figure, or a formula calculating a result from any other figures in the grid, or a label.

For example, you could lay out a balance sheet with Costs down rows 1 to 8 in column A, and Sales down rows 1 to 5 in column F. Working out the total profit or loss is just a matter of entering in a cell below, the formula, SUM(F1:F5) — SUM(A1:A8). If you now want to change a figure or insert a new item, you can do so almost immediately, and get a result almost immediately.

Complex or simple?

Obviously spreadsheets lend themselves to far more complex applications than this example. Yet the principle remains the same, even with elaborate financial models which relate hundreds of cells via complex formulae: calculating a result, after you have re-adjusted figures or changed a formula, takes no more than a few seconds.

Again, you do not need to be involved in business, to find a spreadsheet program useful. Both Supercalc II and Inter-Sheet are equally suitable for sophisticated financial planning or tightening up your household

Get Serious

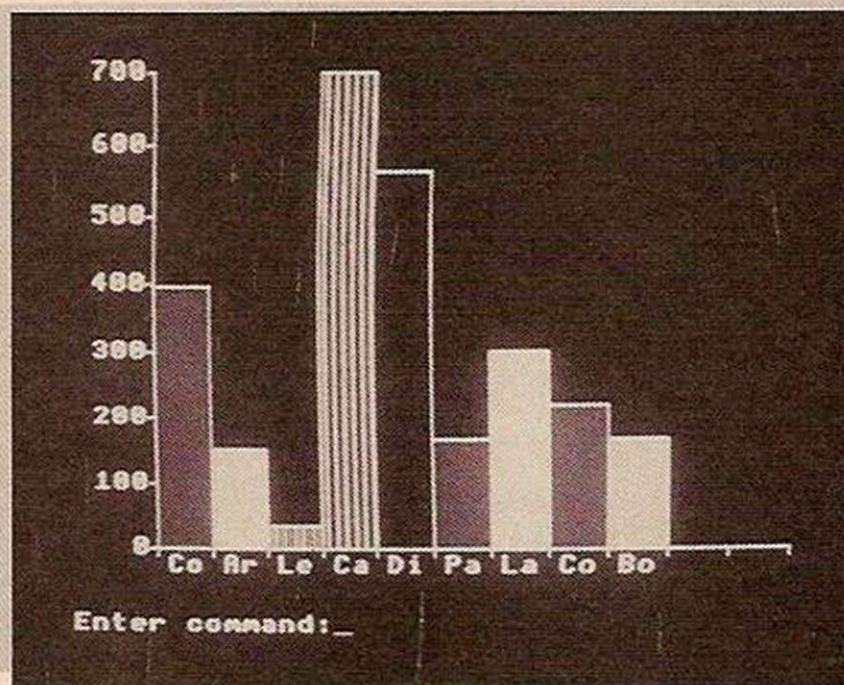

Spreadsheet data presented in a bar chart.

budget.

It is less easy to make the same claims for database software. A database is simply a computerised filing system. Files are usually organised as a collection of records, which in turn break down into fields. Thus, a single record might hold a name, address and telephone number in separate fields.

For many purposes a database program is more trouble than it is worth. Why store your friends' telephone numbers on a computer when you can look them up more quickly in an address book?

In the *Your Computer* office we still use old technology in the form of filing cabinets. The business of typing into a computer files containing product and company information, contributors' addresses, and so on, would be too time consuming.

Where databases come into their own is in their ability to sort and select data. Recently we had to prepare a list of all the games titles currently available for home micros, for *Your Computer's* Top 100. Together

with each game we wanted to give the machines it ran on, and the company name. And we wanted the list sorted into alphabetical order. At a rough estimate we thought the task would require a file of over 100K; far larger, in fact, than the memory capacity of most home computers.

Acornsoft's ViewStore, which comes on a 16K Rom, was the database we chose. It is one of the few programs that gives you an almost unlimited file size — Starbase from GCC Ltd is another, for the BBC. This it does by treating the disc as "virtual memory", in other words as an extension to Ram. The maximum size of a file is nearly 2 megabytes.

As a consequence the program needs to be continually accessing the disc, and slows down considerably when you add a record to a large file. But by comparison with other home micro databases ViewStore is exceptionally powerful. Among other things, it provides extensive facilities for indexing data, reformatting it, and selecting data to create new files or

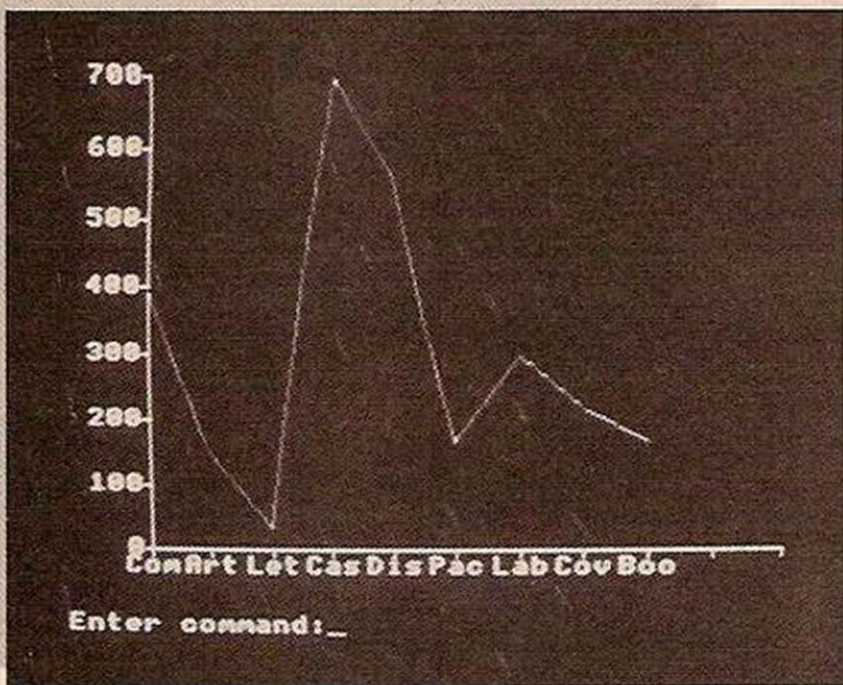

Interchart's line graph option.

to generate reports. Especially useful is its utility for printing labels from a mailing list.

The major drawback to ViewStore is that it is not easy to use. It took us 15 minutes to discover how to print out our list; and another 15 minutes to prepare the file for printing. Part of the blame can be ascribed to the manual, but, to be fair, the more sophisticated the program, the harder it is to master. A reviewer recently complained that it was months before he could find his way round Psion's integrated software package, Xchange.

For 16-bits only

Psion's program only runs on 16-bit micros, costs over £500, and calls for at least 256K Ram. Lotus' Symphony — a development of the first best-selling integrated program, Lotus 123 — needs 512K, and costs over £600. Naturally, these packages are far more extensive than anything you are likely to find on a home computer.

The idea behind integrated software is that different programs can use the same data. To some extent you can do this anyway with programs like Wordwise and View, by spooling files so that characters are stored as Ascii codes. In this way it is possible to edit Basic programs or exchange files between Wordwise and View. But it does not allow quite different types of software to share the same data. Typically, an integrated package includes

a wordprocessor, spreadsheet, and database, each of which can work on the same files.

Integration is also taken to mean having the various programs resident in the computer at the same time. Lack of memory is the main bar to including this last feature on a home computer. But this is just what Computer Concepts has done with its Rom-Link series.

You can create a spreadsheet on Inter-Sheet, then switch in Inter-Chart — by typing *ICHART — and see your figures displayed on a bar chart with the labels beneath them. Inter-Chart is a chart and graph plotting program, so you can equally well display the spreadsheet file as a pie chart or a line graph.

Impressive solution

Computer Concepts' ingenious and impressive solution to the integration problem takes advantage of the BBC's sideways Rom facility, whereby the machine can accommodate up to 16 Roms at the same time. The other Rom-Link programs will be Inter-Base, a database program with a built-in programming language, and Inter-Word, an 80 and 105 column wordprocessor.

When Computer Concepts releases these two products early next year, you will be able to plug in — to a Rom extension board — a bank of Roms, all instantly available, and all perfectly integrated.

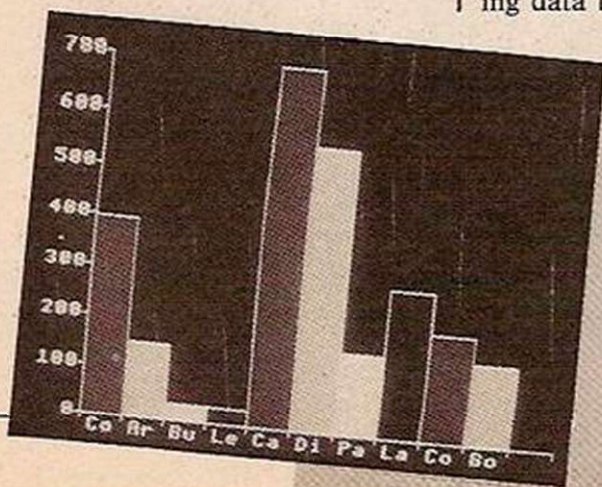

More business graphics from Interchart.

KNIGHT-CLUBBING

Ian Adamson, Richard Kennedy and Freda Trovato do some Sinclair research.

How and why did Sir Clive Sinclair come to acquire his current high-profile reputation as "inventor", "innovator", "visionary" and general balding boffin around town? What we have found has changed our view of Clive in many ways. We've uncovered a consistent history as a sort of technological barrow-boy, a provider of technical toys he thinks the public should want. Sometimes they do — ZX-81 and Spectrum — and sometimes they don't — C5 and Microvision.

The book we have just finished, *Uncle Clive — Soul of the Sinclair Machine* — investigates the corporate career of Sir Clive Sinclair. This ranges further afield than the home computing area in which millions have come to know of "Uncle" Clive.

From the start, back in 1962, Clive has combined minimum component cost and mail-order merchandising. Full-scale advertising campaigns bring the money flooding in from the punters to pay your bills before you've sent anything out.

This practice of "forward financing" has stuck as a bit of a habit with our Clive, as many readers will know. Then as now

some ads attracted complaints because of unjustified claims, and products were rushed into production quickly, with resulting design and quality-control problems. Demand exceeding supply became a familiar phrase used to justify delays. Sound familiar?

Mostly the hobbyists didn't complain too much, just as the computer consumers and computer press nowadays are far too willing to forgive and forget commercial and marketing tactics from Sinclair that demonstrate an unfortunate lack of professionalism and an indifference verging on contempt for the consumers who provide the profits.

Get rich quick

Clive's computers, with the possible exception of the ZX-81 — which did provide genuine cheap computer power if you could stop your Ram pack dumping the program and if it didn't give up through overheating — have hardly served the cause of computing, if this is understood as pressing processing power into service to perform functional tasks.

They *have* served to enrich Clive, and make him into a household name. They have also given us the computer games industry, for all the good that will do mankind, by providing the cheapest available means of playing poor imitations of arcade games on a flickering and colour-crawling TV screen, but not much else.

Sir Clive poses with two of his most far-out brainchildren; in deep prayer before the C-5 Juggernaut, and left, the QL monolith. Innovations or high-tech toys

The avuncular Uncle Clive, posing as some sort of Ronald MacDonald of information technology, with his cheap keyboards, minimal components, impotent speakers and quirky Basics has in fact served the cause of consumer electronics alone, which is the art of providing technological gimmickry at a low enough cost so you can grab the innovative toy and gadgeteer market.

The success of the Spectrum is a creation of, and is still sustained by, the software rather than the minimal, but high profit-margin, hardware.

Sinclair Research was set up as Clive's lifeboat from the sinking ship of his first company, Sinclair Radionics, when the NEB took over control. It produced the MK14, a microprocessor trainer kit using the National Semiconductor SC/MP or Scamp chip. It was, relatively speaking, a great success, and confirmed the computer market potential.

Although the official history has it that Clive left Radionics and then started to work on the ZX-80, this obscures the truth of the matter. Since work had started in April on the Basic for the ZX-80, which implies a certain amount of hardware design, it was a lot more than a gleam in Clive's eye when he departed the doomed Radionics in August.

Demon seed

The ZX-80 wasn't much of a computer. Five years after its launch in February 1980, Sinclair cheerfully admits that the machine's specifications had more to do with marketing considerations than application.

At the end of the seventies, personal computers weighed in at around £300. Clive's aim with the ZX-80 was simply to bring out a machine for less than £100; whatever the effects of such a constraint on the ultimate usefulness of the product.

It's often argued that technical innovation (specifically Clive's) has always been at the heart of Sinclair's ability to successfully undercut the competition. Although this is certainly true of the ZX-81 with Ferranti's revolutionary ULA a determining factor in the

machine's low price, there was nothing remotely innovative about the ZX-80.

For the purposes of this history, the machine is only important because it inadvertently established the hard- and software foundations for the entire ZX range. The ZX-81 was a ZX-80 upgrade, the Spectrum was a ZX-81 with colour and the QL was . . . well, we'll worry about the QL later.

In short, everything you've learned to dread about a Sinclair computing product has its roots in the ZX-80's design. For example, keyboard layout.

On the face of it, single keystroke Basic is a great idea



for beginners. However, as an entire generation of ZX programmers will testify, the advantages of the system are insufficient compensation for the horror of the keyboard.

Single keystroke Basic was the result of a marketing decision. Clive decided that few of his customers were likely to be typists, and that the ability to enter entire keywords with a single keystroke would be a valuable sales feature. The inspiration for such a system came from an old Wang machine at Radionics which used an obscure single-keystroke dialect.



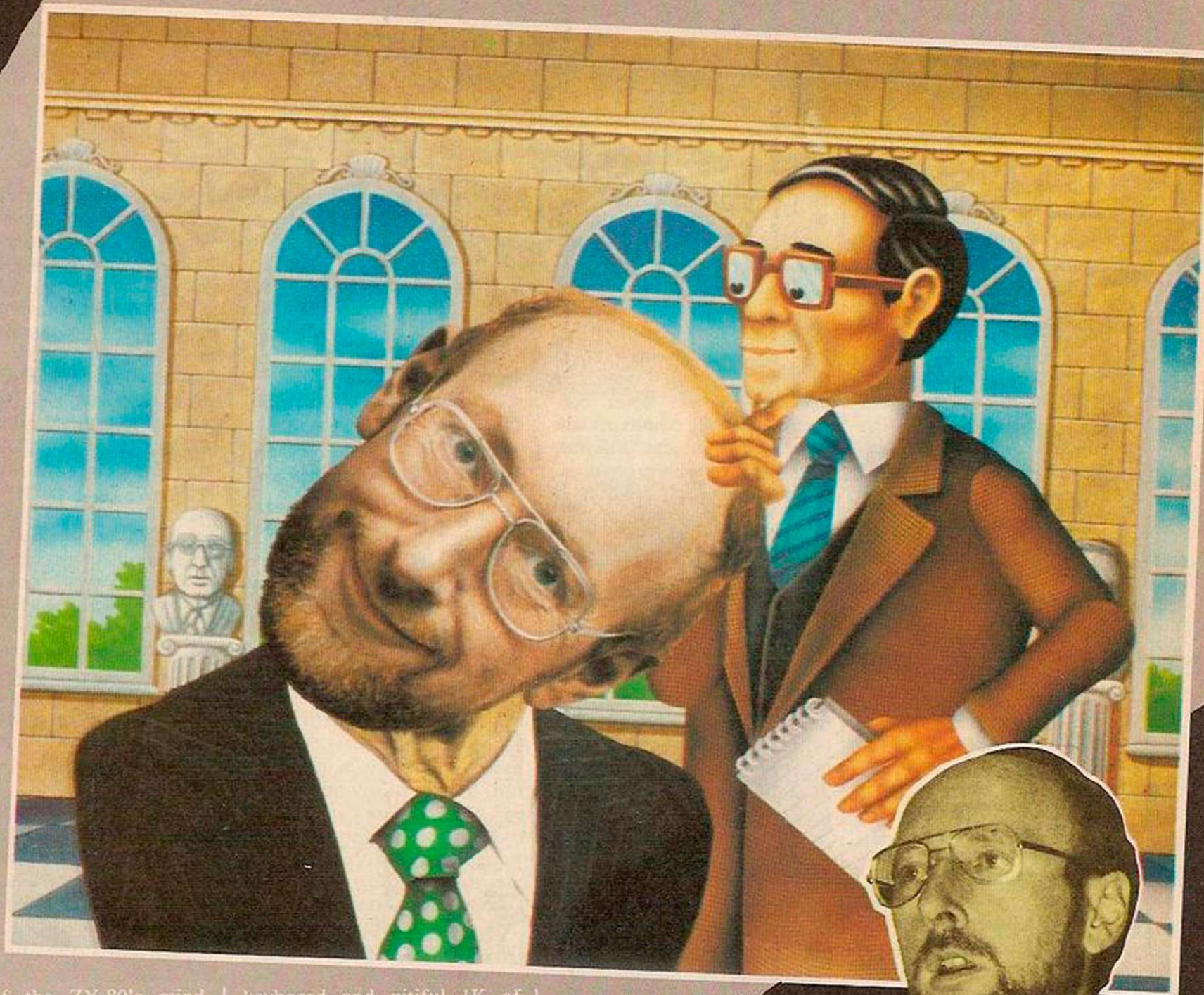

As if the ZX-80's mind-numbing, multi-function keys weren't enough, the machine also boasted the first manifestation of the hideous membrane keyboard. Touch-insensitive and consistently fallible, the design is only remarkable in that it is entirely without supporters. Apart from Clive, of course.

In the final analysis, the ZX-80 was conceived, first and foremost, as an economy of components. As Clive has subsequently explained, his target audience was the old-style electronics hobbyist who on this occasion would hopefully be joined by a new breed of consumer electronics enthusiast.

Sinclair was gambling on the support of the professional for whom a computer (however useless) would prove an irresistible image accessory. And the gamble paid off with a vengeance.

As far as the gritty world of "real" computing was concerned, the ZX-80 was little more than a portentous gizmo. With its integer only mathpack, the infamous screen flicker, joke

keyboard and pitiful 1K of Ram, reviewers felt they could safely dismiss Sinclair's new product. In the year that followed, 25,000 unit sales revealed the error of their ways. Clive's time had come.

To his credit, Sinclair was under no illusions about the ZX-80. In a charitable frame of mind, the machine could perhaps be considered a tolerable learning aid for would-be programmers; it was certainly nothing more. In early 1980, John Grant and Steven Vickers at Nine Tiles set about the task of turning the ZX-80 into a proper computer, the first priority being the improvement of the mathpack.

In the opinion of Tony Tebby, author of QDOS, the QL's (almost) flawless operating system, the ZX-81 is far and away the best product to emerge from the Sinclair stable. With its expanded floating-point math package, improved dis-

Keep taking the tablets. A rare picture of Sir Clive shortly after descending from the mountain. Mail-order customers certainly needed to have the patience of a saint, if they wanted a Spectrum.

(continued on next page)

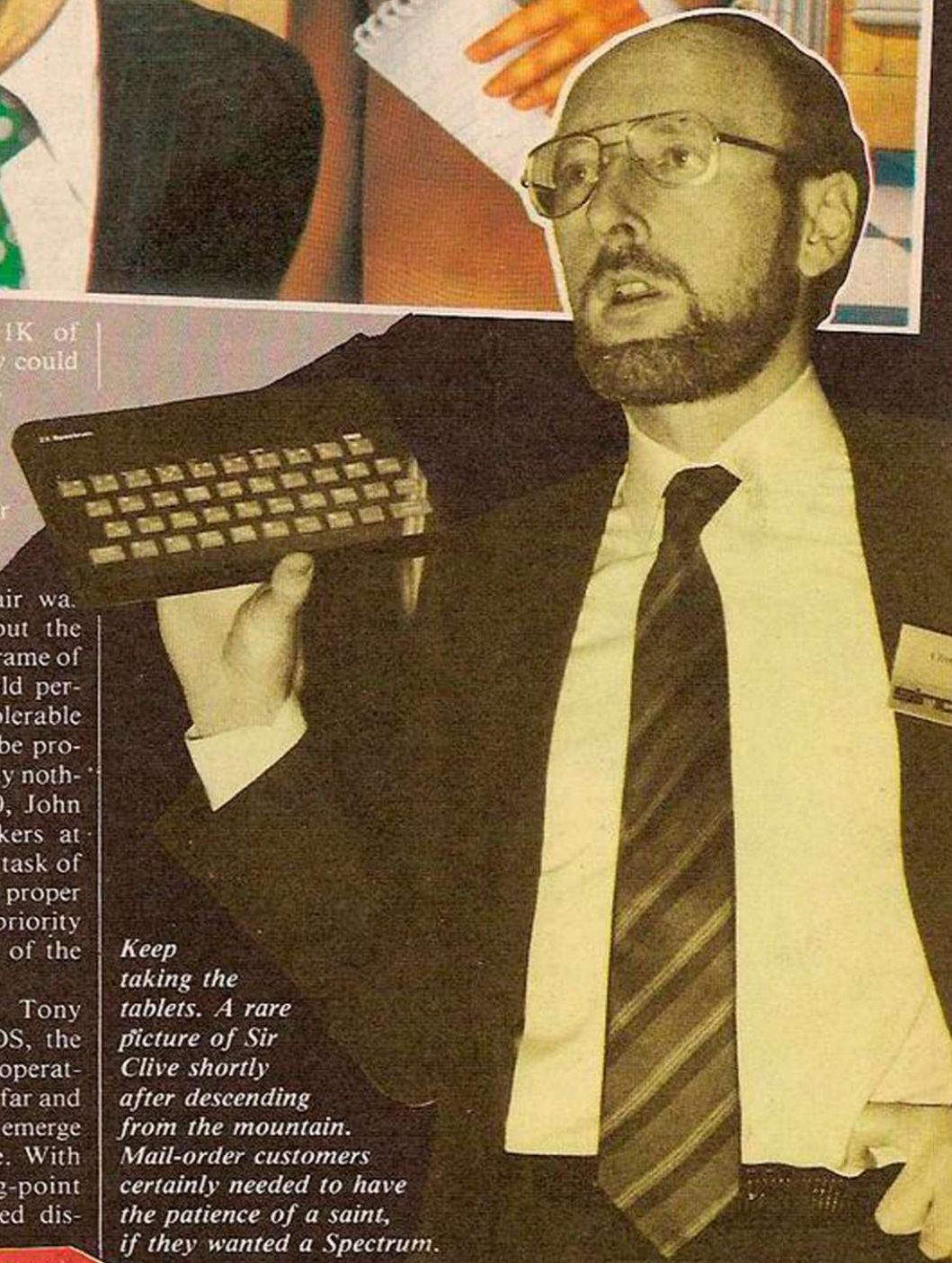

(continued from previous page)

play and partially improved storage capacity, the ZX-81 was in every way a "real" computer for less than the price of its predecessor.

A critical but hidden element in the rise and fall of Sinclair's ZX range is the software that Nine Tiles created for the ZX-80. Whatever the shortcomings of the machine, it is generally recognised that John Grant's software for the ZX-80 is a masterpiece of efficient and economic coding. Since this early work would become the foundation for the entire ZX range, its quality and objectives were crucial to future developments.

Although obvious given a moment's thought, most people are unaware of the literally linear evolution of the software for the ZX range.

According to his technical staff, Clive seems to have very little interest or expertise in any aspect of software development. This goes some way towards explaining why he failed to realise that, although inspired, the ZX-80 software was simply an elegant solution to a very specific problem.

Like the NewBrain, the ZX-80's Basic was loosely based

on the ANSI Minimal dialect. Grant saw his brief to be the creation of as full an implementation as possible given the constraints of the hardware.

In short, the design and structure of the ZX-80's software were specifically tailored to a machine with very little memory. It was never considered that the resultant code would serve as the software foundations for an entire range of machines with wildly different memory capacities.

Sinclair graft

Despite opposition from the programmers, when commissioning software for the ZX-81 and Spectrum, Clive insisted that existing code remain untouched, and any expansions effectively grafted on to the old software. This decision had little effect on the efficiency of the ZX-81, but would have serious consequences for the poor old Spectrum.

While investigating ways of refining the ZX-80's hardware for the new machine, Clive hit upon an innovation in chip design that was to make him a fortune. Ferranti had announced a new kind of chip known as an Uncommitted Logic Array or ULA.

The wonder of ULAs is that

they enable limited customisation of an "off-the-peg" chip to suit a specific application, while avoiding the expense or delays of commissioning a full-blown custom chip. One of the problems with the ZX-80's hardware was its relatively high component count.

After speaking with Ferranti, Clive knew he could slam the contents of 17 ZX-80 chips onto a single ULA, thus reducing the new machine's chip count from 21 to four. The manufacturing economies were astounding. Ferranti's innovation enabled Sinclair to market an improved machine at a lower price, and in the process establish a market lead to intimidate the most determined competition.

The phenomenal success of the ZX-81 has been extensively chronicled over the years and hardly merits yet another re-run. Suffice to say that by the end of 1982 more than 500,000 units had been consumed by the technology-hungry masses of the world. The ZX-81 whisked Clive out of the world of the mail-order merchant and into the relative respectability of mainstream retailing.

By January 1981, Sinclair had signed an exclusive retail agreement with WH Smith. Both parties made significant

fortunes out of the arrangement, which continued to flourish until a disagreement following the lukewarm response to the Spectrum.

The Spectrum earned its place in history as the world's first low-cost colour micro. More than any other product it is responsible for Sinclair's international reputation, but in the cold light of 1986 the old warhorse looks less than impressive.

The membrane keyboard is still there, it's raised rubber keypads — "like the touch of a deadman's hand" — only an inspiration to ZX-81 owners with limited ambition. These days the most impressive effect of the machine's additional features is that they make the keyboard even more awkward.

Code overload

Bestowed upon an expectant world in April 1982, the Spectrum's launch marked the end of an era for the ZX range. It was the last machine that used Nine Tiles for its software development. According to John Grant, coding structures originally designed for the ZX-80 finally collapsed beneath the demands of the Spectrum's massively expanded memory.

Code which had been clever and efficient handling data for a 1K system proved totally inadequate when applied to the processing requirements of a 16K or 48K Spectrum. In particular the neat but quirky system for storing variables, which used the 80's limited memory to its own advantage, was proving a liability on the Spectrum.

Nine Tiles recommended that the existing code be radically restructured for the Spectrum and Clive declined the suggestion. Grant insists that a £15,000 rewrite would have massively improved the Spectrum's capabilities and in the process extended its market life.

But it was not to be, and the result was an erratic, sluggish performance from the last of the ZX range. Ironically, the R&D of the most successful ZX product was plagued by technical disputes and financial disagreements.

Sinclair Research and the future

As far as the future goes Sinclair Research is still dependent upon the home/personal computer market. Plans for a Cellnet telephone and future computers will require income from the current products in the meantime. Sinclair Research has just revamped its image and corporate structure drastically, to make the company more attractive to the financial partners they need for the wafer-scale project. They need computer sales to keep the action going in the meantime, however. The gospel according to Clive on new computers was given to us in an interview.

The Spectrum 128, already out in Spain, will be released "in spring" next year, but since the QL has virtually abandoned all pretence of being a business machine, Sinclair will have a somewhat cluttered market for their own products, sub-£200. The Pandora portable, under development now, bears a remarkable resemblance in Clive's descriptions to the original ZX-83/QL concept — flat screen, portable, add-on modem, a "totally professional keyboard" (another membrane design, we presume), and since Clive said: "I can't tell you that", when we asked him if it used Microdrives, it presumably may well have 3in. discs. Whether the concept matches the machine will be a measure of whether Sinclair has got its act together. Oh, it will use the Z-80 chip. What price progress?

The only other potential computer is the Proteus, a 68000-based portable. Clive says "it's a hypothetical machine".

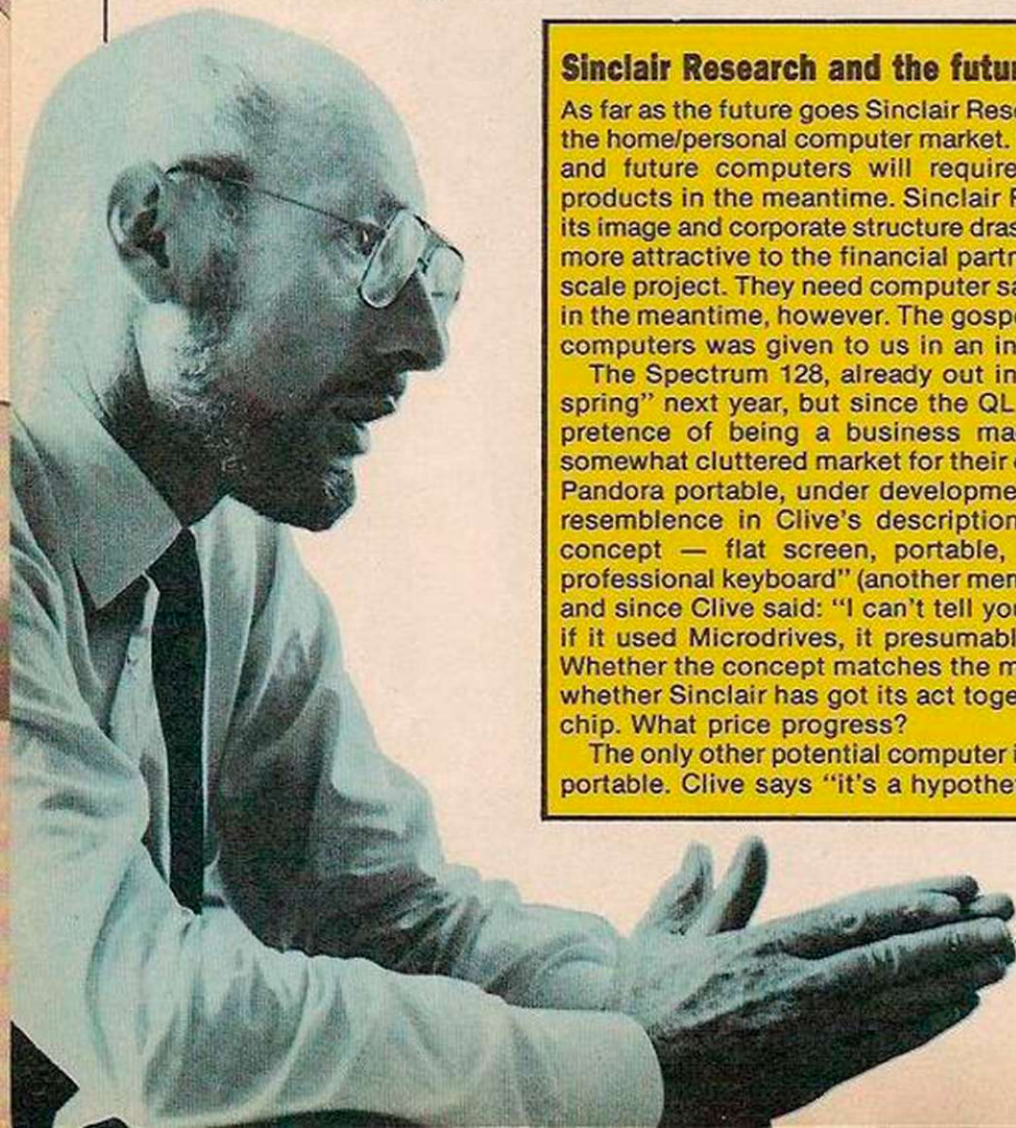

Most of the graft on the Spectrum's software was performed by Steven Vickers at Nine Tiles, while Richard Altwasser at Research handled the hardware and acted as a buffer between the two companies. When Altwasser and Vickers left their respective employers to design and market the Jupiter Ace, an already fraught development fell into disarray.

Although, on the face of it, only the I/O software remained to be completed, a difficult task was made impossible by an absence of working peripheral prototypes coupled with daily changes of brief.

In the end, the pressure of the launch deadline prompted Sinclair's decision to send out the first wave of Spectrums with unfinished Roms. The original QL or ZX-83 spec called for a Z-80 based portable machine, with the flat screen, Microdrives, built-in modem and bundled software. From this initial vision, progress was mainly downhill.

Chip changes

While problems with earlier machines can be laid at the door of Clive, those of the QL end up being assigned to Nigel Searle and his team, since Clive had little to do with it.

Having got his funding for the C5 electric bidet project when 10 per cent of Sinclair was sold — remember when the company was worth £130 million temporarily — Clive promptly moved out of Willis Road and Searle took over his office. However the initial vision was Clive's, and certain other decisions, like the chip.

The chip was changed to the 68008 in late '82, more for reasons of marketing than any benefits it offered. Apart from its capability to perform 32-bit arithmetic directly, and a larger memory addressing capability, this poor relation of the 68000 family has little going for it in computing terms. The restriction of the eight-bit address bus slows the whole thing down, and a Z-80 could run faster.

The cost differential now between the 16-bit 68000 and the 68008 is down to a few dollars. When Sinclair chose a



new hip chip, more to create the capacity to claim innovation and a "32-bit chip" in the ads than to improve their machine, the price differential was a lot more, 68000s being five times the price of 68008s.

Never one to spend a penny more on components than he has to (the QL hasn't got an On/Off switch either), Clive took the 68008, despite being told by Motorola at the time that they could now plastic package the 68000 — it was originally ceramic-packaged and hence pricey — and the price would drop.

Effectively, this decision has lumbered the QL with an illusorily advanced chip which renders it uncompetitive with Macintosh's 520STs and the like. Even if Digital Research can port the GEM system across to the QL, who's going to want it if it runs at half its original, itself boringly sedate, speed?

Monitor dropped

With the flat screen aborted, they went the monitor route. The idea of having a Sinclair monitor to go with the machine was dropped because they thought you couldn't sell a machine complete with a monitor — a fact Amstrad haven't noticed yet? Hedging their bets for the home market, a bodged TV outlet was added.

Portability also vanished, since the Dram chips would eat up too much power, even if the Microdrives would work quite happily on fairly small power requirements. With a flat screen they might have still tried it, but certainly not with a conventional TV tube.

Loss of portability also meant there were no good arguments for using the slow Microdrives, since they are not significantly cheaper to produce than 3.5in. disc systems are to buy. However the mindset at Sinclair says they have to be used, since they

Above: inside the Spectrum.
Below: Clive and the QL.



are part of the "innovation".

It's the same thinking that gave us the QL keyboard, inappropriate for a "business" machine, despite the fact that a proper keyboard would cost less than a pound or more. Indeed, Sinclair had samples of such keyboards produced, but chose to do it his way.

The modem chip never got designed past the notional stage, let alone offered for BT approval, because of the other hardware problems in what was described to us as the "disorganised shambles" of QL design.

Meanwhile another machine, the SuperSpectrum, was started. With similar hardware to that of the QL, it was to be a 128K, 60008-based machine with Interface I and II built in — when they got them working — and aimed at the Spectrum market.

It was also to have a new Basic, which Jan Jones was recruited to write. When the QL development program went wrong, and the QL spec came

resemble the SuperSpectrum as features were cut out, they dropped it.

The other machine that came along in '83 was the "low-cost colour computer" or LC-3, developed in response to the threat of a product from the East that would undermine the Spectrum's market. Produced in a very short time, it existed as a TTL prototype, complete with an OS and demo software.

It used a Z-80 and memory management, and was designed for Rom software, with data on battery-backed Cmos Ram packs. Apart from the initial cost advantages — it was to cost less than £50 — it had two advantages over the QL in the autumn of '83.

First, it could run full overlapping windows, and secondly, there was a full prototype. It was never developed further, presumably because profit margins didn't look as good as those of the QL. So much for cheap computing power!

Although QLs now work, it took up to D12 (the twelfth revision of the board) and a year to do so. There are still hangovers from a flawed design process, however.

Sinclair launched the QL without a working prototype. Despite a note of realism struck in the first draft of the press release, promising machines by "end-April", it went out as "end-February" because the ads said 28 days delivery, so the press release couldn't say any different". Decent, legal and honest?

The bugs in SuperBasic and the kludge deserve a mention. Up to a month before the launch, the QL was to have no Basic — it was supposed to be a business machine, remember — but then it was decided to use SuperBasic. Trouble was, SB was 22K in unfinished form, and another 4K of code was added to SuperBasic a month after the launch.

The OS, originally contracted to GST, had been produced for 2*16K Rom sockets. Tony Tebby's QDOS had been produced as a back-up, and would fit along with SuperBasic into a total of 48K. Hence the infamous kludge, pending 32K Roms.

TAKE A CLOSER LOOK AT:

GRUMPY GUMPHREY

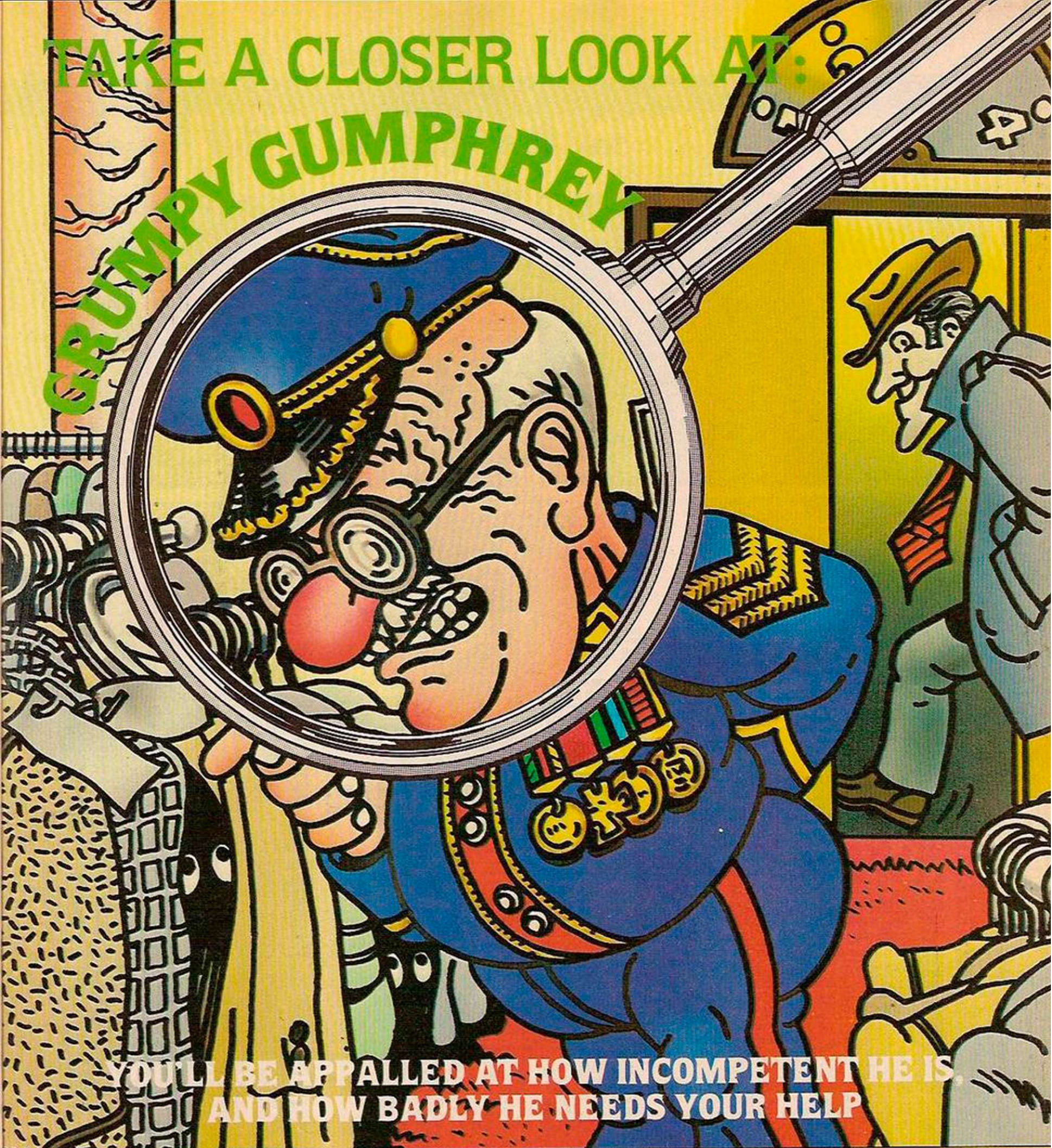

YOU'LL BE APPALLED AT HOW INCOMPETENT HE IS,
AND HOW BADLY HE NEEDS YOUR HELP

GRUMPY GUMPHREY

SUPERSLEUTH

SPECTRUM
48K

Available soon Amstrad

£7.95

Ageing, losing his sight and panic stricken with overwork can Grumpy Gumphrey, the geriatric store detective, hold down his position in this department store fantasia. A kind assistant is needed to help round-up the thieves, cage the gorilla and tidy the warehouse. Would you fit the bill?

AVAILABLE FROM ALL GOOD SOFTWARE STOCKISTS

Gremlin Graphics Software Ltd., Alpha House, 10 Carver Street, Sheffield S1 4FS. Tel: (0742) 753423



**S. Cartwright
with a fast-
moving arcade-type
game for the Amstrad**

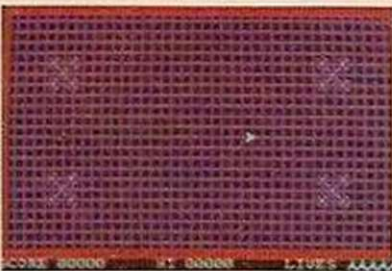

End Zone is a machine code arcade-type game for Amstrad computers. At the start of each round your arrow head craft appears in the middle of the grid. Pressing one of the direction keys starts the craft moving in the chosen direction until you hit the perimeter of the grid, you change direction or get zapped!

Steer craft over spores.

Points are scored for steering your craft over the pattern of

UDG's. Oops! Sorry; dormant nasty space spores! While avoiding the deadly plasma bolts of the patrolling guardians. When all the spores are collected you will enter a new grid with a different pattern. There are 10 different grids to attempt. Playing keys are shown at the beginning of each game.

To enter the program type in the Basic loader. Then save it in case of mistakes. Run the program and if the Ready appears type New. Don't worry, the code is still in memory.

Enter as line 1:

1 MEMORY 34999:LOAD

"EZcode": CALL 35000

Then as a direct command:

SAVE "ENDZONE": SAVE

"EZCODE",B,35000,4875.

Program with auto run

This will save the program to auto run. To load the game type RUN "ENDZONE" or RUN"" (CTRL and small Enter keys).

If you cannot be bothered to type in the program I will supply the game on cassette for £2.00. Send to S. Cartwright, 21 Maelog Place, Gabalfa, Cardiff.

Listing 1.

```
1 REM ***** AMSTRAD END ZONE COPY
2 RIGHT 1985 S.CARTWRIGHT ***** 2
10 MEMORY 34999:FOR N=35000 TO 39875:
  READ D:POKE N,VA(L" "&"+D):NEXT N
20 REM TO SAVE THE PROGRAM ONCE THE
  DATA HAS BEEN POKED TYPE NEW
21 THEN ENTER THEN TYPE:-
22 THEN ENTER THEN TYPE:-
23 1MEMORY 34999:LOAD "EZCODE":
  CALL 35000
24 THEN ENTER THEN TYPE
25 SAVE "ENDZONE":SAVE "EZCODE":
  B.35000,4875
100 DATA 11,20,0,21,10,A4,CD,AB,BB
110 DATA 6,16,3E,A5,21,DE,88,C5,E5,F5
120 DATA CD,A8,BB,F1,3C,E1,11,8,0,19
130 DATA C1,10,F0,C3,8B,89,18,18,3C,3C
140 DATA 7E,7E,E7,C3,C3,E7,7E,7E,3C,3C
150 DATA 18,18,3,F,3E,FC,FC,3E,F,3
160 DATA C0,F0,7C,3F,3F,7C,F0,C0,C3,81
170 DATA 24,18,18,24,81,C3,0,0,0,18
180 DATA 18,0,0,0,18,24,42,42,24
190 DATA 18,0,3C,42,81,81,81,42,3C
200 DATA 3C,18,A5,C3,C3,A5,18,3C,FF,C3
210 DATA A5,99,99,A5,C3,FF,18,66,42,99
220 DATA 99,42,66,18,E3,A1,27,18,18,E4
230 DATA 85,C7,7E,BD,FF,FF,DD,BD,7E
240 DATA 18,3C,66,C3,C3,66,3C,18,5A,99
250 DATA 24,C3,C3,24,99,5A,83,CE,58,64
260 DATA 26,1A,E3,C1,24,5A,81,42,42,81
270 DATA 5A,24,0,0,0,1,3,6,C
280 DATA C,6,3,1,0,0,0,30,60
290 DATA C0,80,0,0,0,0,0,0,0
300 DATA 80,C0,60,30,24,5A,89,46,62,91
310 DATA 5A,24,21,0,0,22,65,95,21,0
320 DATA 0,22,5D,95,3E,5,32,67,95,3E
330 DATA 1,32,96,95,3E,1,21,7A,94,CD
340 DATA BC,BC,3E,2,21,87,94,CD,BC,BC
350 DATA 3E,3,21,94,94,CD,BC,BC,3E,4
360 DATA 21,A1,94,CD,BC,BC,3E,3,21,A5
370 DATA 94,CD,BC,BC,CD,DF,89,CD,37,92
380 DATA CD,DF,89,3A,67,95,FE,0,28,B8
390 DATA CD,DF,89,C3,E,8A,3E,1,CD,E
400 DATA BC,3E,0,1,0,0,CD,32,BC,3E
410 DATA 1,6,6,E,6,CD,32,BC,3E,2
420 DATA 6,0,E,0,CD,32,BC,1,0,0
430 DATA CD,38,BC,3E,3,6,1A,E,1A,CD
440 DATA 32,BC,C9,3E,1,32,6F,95,32,77
450 DATA 95,32,4C,99,3E,12,32,6E,95,32
460 DATA 76,95,3E,5,32,71,95,32,79,95
470 DATA 3E,1,32,70,95,32,78,95,3E,28
480 DATA 32,73,95,32,78,95,3E,5,32,72
490 DATA 95,32,7A,95,3E,22,32,75,95,32
500 DATA 7D,95,3E,18,32,74,95,32,7C,95
510 DATA 3E,AA,32,7E,95,3E,AB,32,83,95
520 DATA AF,32,84,95,32,85,95,32,92,95
530 DATA 32,93,95,32,94,95,32,95,95,3E
540 DATA D,32,86,95,32,88,95,3E,15,32
550 DATA 87,95,32,89,95,3E,2,CD,90,BB
560 DATA 26,2,2E,2,E5,CD,75,BB,3E,9F
570 DATA CD,5D,BB,E1,24,3E,28,BC,20,F0
580 DATA 26,2,2C,3E,18,BD,20,E8,3E,1
590 DATA CD,90,BB,6,14,C5,2E,1,60,CD
600 DATA 75,BB,3E,8F,CD,5D,BB,C1,C5,2E
610 DATA 18,60,CD,75,BB,3E,8F,CD,5D,BB
620 DATA C1,C5,2E,18,3E,29,90,67,CD,75
630 DATA BB,3E,8F,CD,5D,BB,C1,C5,2E,1
640 DATA 3E,29,90,67,CD,75,BB,3E,8F,CD
650 DATA 5D,BB,C1,10,C4,6,C,05,26,1
660 DATA 3E,D,90,6F,CD,75,BB,3E,8F,CD
670 DATA 5D,BB,C1,C5,26,28,3E,D,90,6F
680 DATA CD,75,BB,3E,8F,CD,5D,BB,C1,C5
690 DATA 26,1,3E,C,80,6F,CD,75,BB,3E
700 DATA 8F,CD,5D,BB,C1,C5,26,28,3E,C
710 DATA 80,6F,CD,75,BB,3E,8F,CD,5D,BB
720 DATA C1,10,BE,16,1A,D5,3E,2,42,4A
730 DATA CD,32,BC,6,A,CD,F,92,D1,15
740 DATA 3E,1,BA,20,EC,3E,3,CD,90,BB
750 DATA 26,1,2E,19,CD,75,BB,21,B2,94
760 DATA 6,6,CD,3C,9B,2A,5D,95,CD,59
770 DATA 9B,26,11,2E,19,CD,75,BB,21,B8
```

```
780 DATA 94,6,3,CD,3C,9B,2A,65,95,CD
790 DATA 59,9B,26,1E,2E,19,CD,75,BB,6
800 DATA 6,21,68,95,CD,3C,9B,3A,67,95
810 DATA 47,C5,3E,A5,CD,5D,BB,C1,10,F7
820 DATA 3E,1,CD,9F,BB,CD,F7,92,CD,6C
830 DATA 94,3E,1,CD,90,BB,2A,76,95,CD
840 DATA 75,BB,3E,8F,CD,5D,BB,3E,3,CD
850 DATA 90,BB,2A,6E,95,22,76,95,CD,75
860 DATA BB,3A,7E,95,CD,5D,BB,3E,1,CD
870 DATA 90,BB,2A,78,95,CD,75,BB,3E,8F
880 DATA CD,5D,BB,3E,3,CD,90,BB,2A,70
890 DATA 95,22,78,95,CD,75,BB,3A,7E,95
900 DATA CD,5D,BB,3E,1,CD,90,BB,2A,7A
910 DATA 95,CD,75,BB,3E,8F,CD,5D,BB,3E
920 DATA 3,CD,90,BB,2A,72,95,22,7A,95
930 DATA CD,75,BB,3A,7E,95,CD,5D,BB,3E
940 DATA 1,CD,90,BB,2A,7C,95,CD,75,BB
950 DATA 3E,8F,CD,5D,BB,3E,3,CD,90,BB
960 DATA 2A,74,95,22,7C,95,CD,75,BB,3A
970 DATA 7E,95,CD,5D,BB,3A,7E,95,3C,FE
980 DATA AD,20,2,3E,AA,32,7E,95,3E,2C
990 DATA CD,1E,BB,28,13,CD,B6,BC,2E,1
1000 DATA CD,48,9B,CD,1B,BB,38,FB,CD,18
1010 DATA BB,CD,B9,BC,CD,1F,9B,11,77,EC
1020 DATA A7,ED,52,38,7,3E,1,32,7F,95
1030 DATA 18,10,CD,1F,9B,11,88,13,A7,ED
1040 DATA 52,30,5,3E,FF,32,7F,95,3A,7F
1050 DATA 95,2A,6E,95,85,FE,1,28,7,FE
1060 DATA 18,28,3,32,6E,95,CD,1F,9B,11
1070 DATA 77,EC,A7,ED,52,38,7,3E,1,32
1080 DATA 80,95,18,10,CD,1F,9B,11,88,13
1090 DATA A7,ED,52,30,5,3E,FF,32,80,5,3E
1100 DATA 3A,80,95,2A,70,95,84,FE,1,28
1110 DATA 7,FE,28,28,3,32,71,95,CD,1F
1120 DATA 9B,11,77,EC,A7,ED,52,38,7,3E
1130 DATA 1,32,81,95,18,10,CD,1F,9B,11
1140 DATA 88,13,A7,ED,52,30,5,3E,FF,32
1150 DATA 81,95,3A,81,95,2A,72,95,85,FE
1160 DATA 1,28,7,FE,18,28,3,32,72,95
1170 DATA CD,1F,9B,11,77,EC,A7,ED,52,38
1180 DATA 7,3E,1,32,82,95,18,10,CD,1F
1190 DATA 9B,11,88,13,A7,ED,52,30,5,3E
1200 DATA FF,32,82,95,3A,82,95,2A,74,95
1210 DATA 84,FE,1,28,7,FE,28,28,3,32
1220 DATA 75,95,2A,88,95,CD,75,BB,3E,2
1230 DATA CD,90,BB,AF,CD,9F,BB,3E,9F,CD
1240 DATA 5D,BB,3E,1,CD,9F,BB,2A,86,95
1250 DATA 22,88,95,CD,75,BB,3E,3,CD,90
1260 DATA BB,3A,83,95,CD,5D,BB,3A,92,95
1270 DATA FE,1,20,3D,2A,8A,95,E5,11,CD
1280 DATA 94,ED,53,5B,95,CD,18,92,E1,44
1290 DATA 4D,CD,8A,90,3A,4C,99,FE,0,CA
1300 DATA D2,89,24,22,8A,95,3E,28,BC,28
1310 DATA 14,CD,18,92,ED,4B,8A,95,CD,8A
1320 DATA 90,3A,4C,99,FE,0,CA,D2,89,18
1330 DATA 4,AF,32,92,95,3A,93,95,FE,1
1340 DATA 20,3D,2A,8C,95,E5,11,BB,94,ED
1350 DATA 53,5B,95,CD,18,92,E1,44,4D,CD
1360 DATA 8A,90,3A,4C,99,FE,0,CA,D2,89
1370 DATA 2C,22,8C,95,3E,18,BD,28,14,CD
1380 DATA 18,92,ED,4B,8C,95,CD,8A,90,3A
1390 DATA 4C,99,FE,0,CA,D2,89,18,4,AF
1400 DATA 32,93,95,3A,94,95,FE,1,20,3D
1410 DATA 2A,8E,95,E5,11,CD,94,ED,53,5B
1420 DATA 95,CD,18,92,E1,44,4D,CD,8A,90
1430 DATA 3A,4C,99,FE,0,CA,D2,89,25,22
1440 DATA 8E,95,3E,1,BC,28,14,CD,18,92
1450 DATA ED,4B,8E,95,CD,8A,90,3A,4C,99
1460 DATA FE,0,CA,D2,89,18,4,AF,32,94
1470 DATA 95,3A,95,95,FE,1,20,3D,2A,90
1480 DATA 95,E5,11,8A,94,ED,53,5B,95,CD
1490 DATA 18,92,E1,44,4D,CD,8A,90,3A,4C
1500 DATA 99,FE,0,CA,D2,89,2D,22,90,95
1510 DATA 3E,1,BD,28,14,CD,18,92,ED,4B
1520 DATA 90,95,CD,8A,90,3A,4C,99,FE,0
1530 DATA CA,D2,89,18,4,AF,32,95,95,3A
1540 DATA 92,95,FE,1,28,3E,3A,6E,95,47
1550 DATA 3A,86,95,88,20,34,3E,4,CD,AD
1560 DATA BC,6E,80,20,6,21,A9,94,CD,AA
1570 DATA BC,3E,1,32,92,95,2A,6E,95,2A
1580 DATA 22,8A,95,11,CD,94,ED,53,5B,95
1590 DATA CD,18,92,ED,4B,8A,95,CD,8A,90
1600 DATA 3A,4C,99,FE,0,CA,D2,89,3A,93
1610 DATA 95,FE,1,28,3E,3A,71,95,47,3A
```

```
1620 DATA 87,95,88,20,34,3E,4,CD,AD,BC
1630 DATA E6,80,20,6,21,A9,94,CD,AA,BC
1640 DATA 3E,1,32,93,95,2A,70,95,2C,22
1650 DATA 8C,95,11,BB,94,ED,53,5B,95,CD
1660 DATA 18,92,ED,4B,8C,95,CD,8A,90,3A
1670 DATA 4C,99,FE,0,CA,D2,89,3A,94,95
1680 DATA FE,1,28,3E,3A,72,95,47,3A,86
1690 DATA 95,88,20,34,3E,4,CD,AD,BC,E6
1700 DATA 80,20,6,21,A9,94,CD,AA,BC,3E
1710 DATA 1,32,94,95,2A,72,95,25,22,8E
1720 DATA 95,11,CD,94,ED,53,5B,95,CD,18
1730 DATA 92,ED,4B,8E,95,CD,8A,90,3A,4C
1740 DATA 99,FE,0,CA,D2,89,3A,95,95,FE
1750 DATA 1,28,3E,3A,75,95,47,3A,87,95
1760 DATA B8,20,34,3E,4,CD,AD,BC,E6,80
1770 DATA 20,6,21,A9,94,CD,AA,BC,3E,1
1780 DATA 32,95,95,2A,74,95,2D,22,90,95
1790 DATA 11,BB,94,ED,53,5B,95,CD,18,92
1800 DATA ED,4B,90,95,CD,8A,90,3A,4C,99
1810 DATA FE,0,CA,D2,89,3E,43,CD,1E,BB
1820 DATA 20,7,CD,24,BB,E6,1,28,10,AF
1830 DATA 32,84,95,3E,1,32,85,95,3E,A5
1840 DATA 32,83,95,18,58,3E,45,CD,1E,BB
1850 DATA 20,7,CD,24,BB,E6,2,28,10,AF
1860 DATA 32,84,95,3E,FF,32,85,95,3E,A6
1870 DATA 32,83,95,18,3A,3E,27,CD,1E,BB
1880 DATA 20,7,CD,24,BB,E6,4,28,10,AF
1890 DATA 32,85,95,3E,FF,32,84,95,3E,A7
1900 DATA 32,83,95,18,1C,3E,1F,CD,1E,BB
1910 DATA 20,7,CD,24,BB,E6,8,28,10,AF
1920 DATA 32,85,95,3E,1,32,84,95,3E,A8
1930 DATA 32,83,95,3A,84,95,FE,FF,20,D
1940 DATA 3A,87,95,3D,FE,1,28,3C,32,87
1950 DATA 95,18,37,FE,1,20,D,3A,87,95
1960 DATA 3C,FE,28,28,2B,32,87,95,18,26
1970 DATA 3A,85,95,FE,1,20,D,3A,86,95
1980 DATA 3D,FE,1,28,17,32,86,95,18,12
1990 DATA 3A,85,95,FE,FF,20,B,3A,86,95
2000 DATA 3C,FE,18,28,3,32,86,95,2A,86
2010 DATA 95,CD,75,BB,3A,4D,99,47,CD,60
2020 DATA BB,88,20,4B,3E,2,CD,AD,BC,E6
2030 DATA 80,20,6,21,98,94,CD,AA,BC,26
2040 DATA 7,2E,19,CD,75,BB,AF,CD,9F,BB
2050 DATA 2A,5D,95,11,5,0,19,22,5D,95
2060 DATA CD,59,9B,3E,1,CD,9F,BB,3A,4B
2070 DATA 99,3D,32,4B,99,20,16,3A,96,95
2080 DATA 3C,32,96,95,FE,B,20,5,3E,1
2090 DATA 32,96,95,CD,CD,91,C3,D2,89,C3
2100 DATA 8F,BB,C9,3A,86,95,B9,C0,3A,87
2110 DATA 95,8B,C0,AF,CD,9F,BB,CD,A7,BC
2120 DATA 21,BB,94,CD,AA,BC,3E,A9,32,50
2130 DATA 99,6,7,C5,6,40,11,BD,94,C5
2140 DATA 1A,47,3A,86,95,80,6F,13,1A,47
2150 DATA 3A,87,95,80,67,D5,7D,D6,2,FE
2160 DATA 16,30,10,7C,D6,2,FE,26,30,9
2170 DATA CD,75,BB,3A,50,99,CD,5D,BB,D1
2180 DATA 13,C1,10,D3,3A,50,99,3C,32,50
2190 DATA 99,C1,10,C3,AF,32,4C,99,3A,67
2200 DATA 95,3D,32,67,95,3E,1,CD,9F,BB
2210 DATA 3A,67,95,FE,0,C2,CD,91,2A,65
2220 DATA 95,ED,5B,5D,95,A7,ED,52,30,5
2230 DATA 62,6B,22,65,95,3E,25,32,63,95
2240 DATA 3E,15,32,64,95,3E,2,32,62,95
2250 DATA 32,61,95,CD,A7,BC,AF,CD,9F,BB
2260 DATA 3E,1,CD,90,BB,6,B,C5,3A,63
2270 DATA 95,47,C5,CD,3,92,3A,62,95,3C
2280 DATA 32,62,95,C1,10,F2,3A,64,95,47
2290 DATA C5,CD,3,92,3A,61,95,3C,32,61
2300 DATA 95,C1,10,F2,3A,63,95,47,C5,CD
2310 DATA 3,92,3A,62,95,3D,32,62,95,C1
2320 DATA 10,F2,3A,64,95,47,C5,CD,3,92
2330 DATA 3A,61,95,3D,32,61,95,C1,10,F2
2340 DATA 3A,64,95,D6,2,32,64,95,3A,63
2350 DATA 95,D6,2,32,63,95,3A,61,95,3C
2360 DATA 32,61,95,3A,62,95,3C,32,62,95
2370 DATA C1,10,96,3E,2,CD,90,BB,3E,A8
2380 DATA 32,4D,99,6,C,05,78,CD,1,47
2390 DATA 4F,3E,2,CD,32,BC,3E,55,32,4B
2400 DATA 99,21,51,99,22,4E,99,CD,FE,93
2410 DATA 3A,4D,99,3C,32,4D,99,C1,10,D
2420 DATA 2E,5,CD,48,9B,C9,CD,A7,BC,21
2430 DATA 0,C0,36,F0,11,1,CD,6,8,C5
2440 DATA 1,FF,7,CD,19,BD,ED,B0,6,3C
2450 DATA CD,F,92,C1,10,EF,1B,1B,36,0
```

End Zone

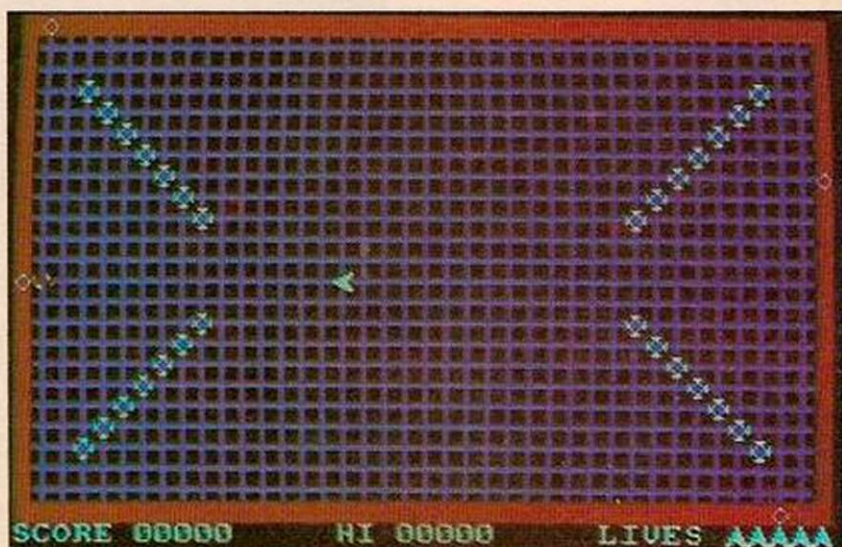
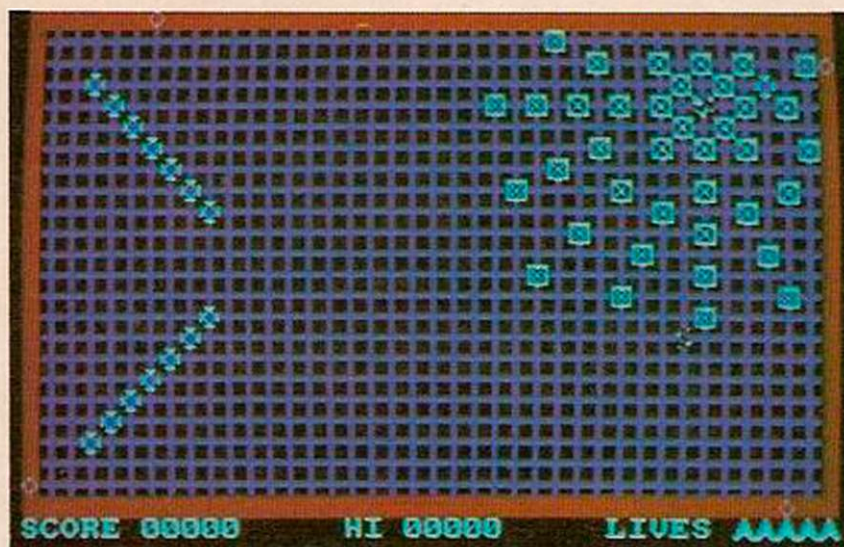

```

2460 DATA 6,8,C5,1,FF,7,CD,19,BD,ED
2470 DATA B8,6,3C,CD,F,92,C1,10,EF,C9
2480 DATA 2A,61,95,CD,75,BB,3E,E9,CD,5D
2490 DATA BB,C9,C5,6,FF,10,FE,C1,10,F8
2500 DATA C9,25,2D,CD,1A,BC,ES,ED,5B,5B
2510 DATA 95,E,8,6,2,1A,AE,77,13,23
2520 DATA 10,F9,E1,CD,26,BC,ES,D,20,EF
2530 DATA E1,C9,3E,1,6,2,E,7,CD,32
2540 DATA BC,26,1,2E,1,CD,3E,BC,3E,1
2550 DATA CD,90,BB,3E,1,CD,E,BC,26,D
2560 DATA 2E,6,CD,75,BB,21,FB,99,6,F
2570 DATA CD,EB,92,26,D,2E,7,CD,75,BB
2580 DATA 21,A,9A,6,10,CD,EB,92,26,D
2590 DATA 2E,8,CD,75,BB,21,1A,9A,6,10
2600 DATA CD,EB,92,26,D,2E,9,CD,75,BB
2610 DATA 21,2A,9A,6,10,CD,EB,92,26,D
2620 DATA 2E,A,CD,75,BB,21,3A,9A,6,F
2630 DATA CD,EB,92,26,B,2E,C,CD,75,BB
2640 DATA 21,49,9A,6,14,CD,EB,92,26,D
2650 DATA 2E,D,CD,75,BB,21,5D,9A,6,E
2660 DATA CD,EB,92,26,C,2E,E,CD,75,BB
2670 DATA 21,6B,9A,6,11,CD,EB,92,26,B
2680 DATA 2E,F,CD,75,BB,21,7C,9A,6,10
2690 DATA CD,EB,92,26,B,2E,10,CD,75,BB
2700 DATA 21,8C,9A,6,14,CD,EB,92,26,D
2710 DATA 94,C9,C5,7E,E5,CD,5D,BB,E1,23
2720 DATA C1,10,F5,C9,3A,96,95,FE,1,20
2730 DATA 14,3E,14,32,4B,99,3E,A9,32,4D
2740 DATA 99,21,97,95,22,4E,99,CD,FE,93
2750 DATA C9,3A,96,95,FE,2,20,14,3E,1C
2760 DATA 32,4B,99,3E,AD,32,4D,99,21,BF
2770 DATA 95,22,4E,99,CD,FE,93,C9,3A,96
2780 DATA 95,FE,3,20,14,3E,40,32,4B,99
2790 DATA 3E,AE,32,4D,99,21,F7,95,22,4E
2800 DATA 99,CD,FE,93,C9,3A,96,95,FE,4
2810 DATA 20,14,3E,24,32,4B,99,3E,AF,32
2820 DATA 4D,99,21,77,96,22,4E,99,CD,FE
2830 DATA 93,C9,3A,96,95,FE,5,20,14,3E
2840 DATA 2A,32,4B,99,3E,B0,32,4D,99,21
2850 DATA BF,96,22,4E,99,CD,FE,93,C9,3A
2860 DATA 96,95,FE,6,20,14,3E,3C,32,4B
2870 DATA 99,3E,B1,32,4D,99,21,13,97,22
2880 DATA 4E,99,CD,FE,93,C9,3A,96,95,FE
2890 DATA 7,20,14,3E,24,32,4B,99,3E,B2
2900 DATA 32,4D,99,21,8B,97,22,4E,99,CD
2910 DATA FE,93,C9,3A,96,95,FE,8,20,14
2920 DATA 3E,70,32,4B,99,3E,B3,32,4D,99
2930 DATA 21,D3,97,22,4E,99,CD,FE,93,C9
2940 DATA 3A,96,95,FE,9,20,14,3E,28,32
2950 DATA 4B,99,3E,B4,32,4D,99,21,B3,98
2960 DATA 22,4E,99,CD,FE,93,C9,3E,24,32
2970 DATA 4B,99,3E,B5,32,4D,99,21,3,99
2980 DATA 22,4E,99,CD,FE,93,C9,3A,4B,99
2990 DATA 47,ED,5B,4E,99,C5,1A,6F,13,1A
3000 DATA 67,D5,CD,75,BB,3A,4D,99,CD,5D
3010 DATA BB,D1,13,C1,10,EB,C9,CD,1B,BB
3020 DATA 3B,FB,3E,3,CD,90,BB,11,A0,9A
3030 DATA 6,7F,C5,D5,26,28,2E,19,CD,75
3040 DATA BB,1A,CD,5D,BB,6,2,C,5,11,80
3050 DATA C7,6,8,CD,19,BD,CD,19,BD,C5
3060 DATA D5,62,6B,23,1,4F,0,ED,B0,D1
3070 DATA EB,CD,26,BC,EB,C1,10,ED,C1,10
3080 DATA DE,A7,CD,1B,BB,38,7,D1,13,C1
3090 DATA 10,C4,1B,BD,D1,C1,C9,AF,CD,AD
3100 DATA BC,E6,80,C0,21,7E,94,CD,AA,BC
3110 DATA C9,3,64,A,14,1,1,0,0,2
3120 DATA 0,2,80,0,3,64,3,1,1,2
3130 DATA 0,C8,0,5,1,0,64,3,F,1
3140 DATA 1,2,3,0,0,0,A,F,32,0
3150 DATA 3,3C,FF,A,3,1E,FF,A,4,4
3160 DATA 3,50,0,F,1,50,0,53,43,4F
3170 DATA 52,45,20,48,49,2,11,CC,33,88
3180 DATA 77,0,33,88,11,CC,0,EE,11,CC
3190 DATA 33,88,0,0,0,44,88,EE,DD,FF
3200 DATA FF,BB,77,11,22,0,0,FF,FF
3210 DATA 1,1,1,FF,FF,1,FE,0,2,FE
3220 DATA 0,2,FE,FE,FE,2,2,2,0,FE
3230 DATA 2,0,FC,0,0,FC,0,4,4,0
3240 DATA 4,FC,FC,4,FC,FC,4,4,6,0
3250 DATA 0,FA,0,6,FA,0,FE,FB,2,5
3260 DATA 2,FB,5,2,FB,FE,5,FE,FE,5
3270 DATA FB,2,3,FB,0,8,FB,FD,7,3
3280 DATA FA,6,0,FB,8,0,FA,FA,F9,3
3290 DATA 6,FA,3,7,FB,0,7,FD,FD,F9

```

```

3300 DATA 6,6,FD,7,9,FC,F8,8,F8,F8
3310 DATA 8,8,4,F7,0,A,F6,0,9,4
3320 DATA FC,F7,FC,9,8,F8,F7,FC,A,0
3330 DATA 0,F6,F7,4,4,9,0,0,0,0
3340 DATA 39,30,0,0,0,0,0,0,5,4C
3350 DATA 49,56,45,53,20,0,1,1,0,0
3360 DATA 20,19,0,0,1,1,0,0,20,19
3370 DATA 0,A9,0,0,0,0,A5,0,0,0
3380 DATA 0,0,0,0,0,0,0,0,0,0
3390 DATA 0,0,0,0,1,6,6,8,21
3400 DATA 12,7,11,23,8,B,13,6,13,21
3410 DATA 6,23,6,21,7,7,13,23,8,6
3420 DATA 13,8,11,6,8,2,3,12,22,6,8
3430 DATA 11,8,7,22,11,21,7,7,10,20
3440 DATA 5,24,15,4,4,8,21,13,23
3450 DATA F,A,9,A,1F,15,25,13,6
3460 DATA 5,5,4,25,11,8,12,22,14,5
3470 DATA 6,6,6,23,14,24,A,A,12,7
3480 DATA F,1F,7,22,10,9,9,20,8,8
3490 DATA 11,21,2,2,14,5,4,25,13,27
3500 DATA 2,6,16,2,12,2,17,23,2,22
3510 DATA 7,27,17,26,7,2,4,2,17,7
3520 DATA 14,24,5,27,5,5,17,4,15,27
3530 DATA 2,25,14,2,2,4,17,21,2,27
3540 DATA 17,24,4,4,6,2,17,5,15,25
3550 DATA 2,8,8,2,15,4,2,23,11,27
3560 DATA 17,8,17,2,3,27,3,3,11,2
3570 DATA 16,27,17,22,5,24,2,7,8,27
3580 DATA 2,21,17,27,3,2,13,2,17,6
3590 DATA 16,26,2,24,3,26,2,5,16,3
3600 DATA 12,27,6,27,5,2,15,2,14,27
3610 DATA 17,25,2,3,17,3,2,26,4,27
3620 DATA C,6,F,25,11,4,B,22,8,4
3630 DATA E,22,C,4,A,25,9,5,F,4
3640 DATA C,23,E,7,B,5,D,25,C,21
3650 DATA A,4,F,23,8,25,D,21,A,23
3660 DATA B,7,E,24,B,24,D,4,D,6
3670 DATA 11,25,C,8,C,25,F,6,9,24
3680 DATA E,5,A,6,10,24,D,8,D,23
3690 DATA 10,5,5,B,12,12,9,19,5,1A
3700 DATA 10,15,9,10,A,1B,5,E,6,10
3710 DATA 14,15,7,19,8,C,10,13,6,1E
3720 DATA 5,1C,7,B,12,17,13,13,A,E
3730 DATA 5,1B,9,1C,7,10,13,16,5,D
3740 DATA 9,D,8,1D,11,12,5,F,8,19
3750 DATA A,F,11,17,A,1A,6,B,5,1D
3760 DATA 10,16,5,C,6,19,14,14,5,1E
3770 DATA 8,10,7,1E,10,14,15,15,16
3780 DATA 5,14,14,17,6,13,13,18,7,12
3790 DATA 12,19,8,11,11,1A,9,10,10,1B
3800 DATA A,F,F,1C,B,E,E,D,C,D
3810 DATA D,1E,D,D,C,1E,E,E,B,1D
3820 DATA F,F,A,1C,10,10,9,1B,11,11
3830 DATA 8,1A,12,12,7,19,13,13,6,18
3840 DATA 14,14,5,17,15,15,4,16,14,16
3850 DATA 5,15,13,17,6,14,12,18,7,13
3860 DATA 12,17,7,14,12,16,7,15,12,15
3870 DATA 7,16,12,14,7,17,12,13,7,18
3880 DATA 13,14,6,17,14,15,5,16,13,16
3890 DATA 6,15,13,15,6,16,3,4,3,3
3900 DATA 4,3,15,3,16,3,16,4,16,25
3910 DATA 16,26,15,26,4,26,3,26,3,25
3920 DATA 7,8,7,7,8,7,11,7,12,7
3930 DATA 12,8,12,21,12,22,11,22,8,22
3940 DATA 7,22,7,21,B,C,B,B,C,B
3950 DATA D,B,E,B,E,C,E,1D,E,1E
3960 DATA D,1E,C,1E,B,1E,B,1D,8,E
3970 DATA 11,E,11,1B,8,1B,4,E,15,E
3980 DATA 15,1B,4,1B,8,4,11,4,11,21
3990 DATA 4,21,6,6,13,6,13,23,6,23
4000 DATA 6,C,13,C,4,1F,11,1E,11,A
4010 DATA 8,7,8,21,15,A,4,A,15,25
4020 DATA 8,A,11,7,6,1D,8,25,11,25
4030 DATA 13,1D,15,8,4,8,8,1F,15,1F
4040 DATA 4,4,4,25,15,21,15,4,12,1B
4050 DATA 4,C,5,1B,8,1D,11,C,11,1C
4060 DATA 8,23,11,23,8,C,15,C,15,1D
4070 DATA 13,1B,4,6,15,6,13,4,6,4
4080 DATA 4,23,6,1B,11,5,8,5,4,1D
4090 DATA 15,23,14,B,8,8,7,B,7,22
4100 DATA 14,22,11,D,11,8,8,6,11,1F
4110 DATA 4,1E,8,22,11,22,11,8,7,4
4120 DATA 4,5,11,24,14,1B,8,1C,8,B
4130 DATA 15,5,4,24,4,1C,12,D,11,1D

```

```

4140 DATA 15,22,11,6,13,5,15,1C,12,24
4150 DATA 8,24,6,1C,4,D,15,B,13,1C
4160 DATA 15,1E,15,24,15,7,5,D,5,4
4170 DATA 7,1B,15,D,14,4,6,5,8,1E
4180 DATA 12,4,5,24,8,D,4,7,4,B
4190 DATA 4,22,2,12,D,A,B,20,15,14
4200 DATA 5,16,B,E,D,1C,17,19,2,19
4210 DATA B,B,17,12,F,1F,E,E,4,14
4220 DATA 8,1D,15,17,E,B,D,21,14,15
4230 DATA C,F,4,17,E,1D,F,D,A,C
4240 DATA A,1F,5,15,F,1E,F,C,14,16
4250 DATA 3,18,D,F,C,1C,A,1E,16,13
4260 DATA C,21,A,D,3,13,16,18,E,20
4270 DATA C,A,4,E,16,1B,2,1C,16,D
4280 DATA 2,F,3,1A,17,F,17,19,2,C
4290 DATA 17,C,17,1C,2,19,17,1A,3,D
4300 DATA 16,F,3,1C,2,D,15,1B,3,F
4310 DATA 17,D,4,1B,3,E,16,1C,2,10
4320 DATA 15,E,17,1B,2,E,16,E,17,1D
4330 DATA 17,10,2,1A,3,1B,16,1A,2,1D
4340 DATA 17,E,2,1B,0,1,0,0,0,0
4350 DATA 11,11,9,1D,A,A,10,1D,8,13
4360 DATA B,16,10,A,E,17,12,18,8,19
4370 DATA 7,B,4,C,7,1E,2,1C,16,F,14
4380 DATA B,C,12,1F,8,10,F,D,E,1E
4390 DATA B,1A,F,10,10,18,B,1E,A,13
4400 DATA 12,1C,9,16,E,B,E,19,F,1C
4410 DATA 11,D,7,D,11,17,9,1A,9,11
4420 DATA 10,13,7,1F,7,16,12,12,8,A
4430 DATA B,1D,7,11,11,A,8,1D,A,10
4440 DATA E,10,11,1C,10,D,7,1A,7,1D
4450 DATA B,B,F,17,F,9,12,E,1C
4460 DATA 12,B,7,C,12,19,7,12,F,A
4470 DATA A,D,B,1F,8,17,B,13,11,13
4480 DATA 9,A,E,14,10,1C,9,13,E,C
4490 DATA 9,1E,8,1A,12,17,8,16,9,10
4500 DATA 10,11,11,1E,9,18,10,17,A,16
4510 DATA E,1D,A,1A,B,A,1D,E,18
4520 DATA 96,9A,9A,9A,9C,0,20,20,20
4530 DATA 9E,96,9A,9A,C3,95,20,20,20,20
4540 DATA 95,B7,C3,20,20,95,20,20,B7
4550 DATA C3,97,9A,9D,20,95,20,B7,C3
4560 DATA 20,95,95,20,20,20,95,95,20,20
4570 DATA 20,20,95,20,20,B7,C3,95,95,20,20
4580 DATA 20,B6,C0,93,9A,9A,C0,96,9A
4590 DATA 20,20,B7,99,9A,9A,C0,96,9A
4600 DATA 9A,9C,20,C2,9A,C3,20,96,C3,20
4610 DATA 20,20,9E,96,9A,9A,9C,B6,C0
4620 DATA C2,B8,20,B7,C3,95,B7,C3,20,20
4630 DATA 95,95,B6,C0,20,95,20,20,95
4640 DATA 95,20,B7,C3,20,95,97,9A,9B,B6
4650 DATA C0,20,20,C1,B9,20,86,C0,95,20
4660 DATA 20,B7,C3,95,95,93,9A,9A,99,20
4670 DATA C1,9A,C0,20,9B,20,20,20,B7,99
4680 DATA 93,9A,9A,9A,9A,20,31,39,38
4690 DATA 35,20,57,49,4E,4B,59,57,41,4E
4700 DATA 4B,59,20,53,4F,46,54,57,41,52
4710 DATA 45,20,4C,74,64,2E,20,20,4B,45
4720 DATA 59,53,3A,2D,20,51,2D,55,50,20
4730 DATA 41,2D,44,4F,57,4E,20,3C,2D,4C
4740 DATA 45,46,54,20,3E,2D,52,49,47,48
4750 DATA 54,20,4F,52,20,4A,4F,59,53,54
4760 DATA 49,43,4B,20,20,20,20,48,20
4770 DATA 74,6F,20,48,4F,4C,44,20,20,20
4780 DATA 20,20,70,72,65,73,73,20,61,6E
4790 DATA 79,20,6B,65,79,20,74,6F,20,73
4800 DATA 74,61,72,74,20,20,20,20,20,20
4810 DATA 20,20,2A,5F,95,E5,29,29,29,29
4820 DATA 29,29,29,29,D1,19,11,29,0,1B
4830 DATA 22,5F,95,C9,7D,C6,30,CD,5A,BB
4840 DATA C9,7E,F5,C5,CD,5D,BB,C1,E1,23
4850 DATA 10,F5,C9,6,0,C5,6,0,10,FE
4860 DATA C1,10,F8,2D,AF,BD,C2,48,9B,C9
4870 DATA 11,10,27,CD,8B,9B,CD,35,9B,EB
4880 DATA 11,EB,3,CD,8B,9B,CD,35,9B,EB
4890 DATA 11,64,0,CD,8B,9B,CD,35,9B,EB
4900 DATA 11,A,0,CD,8B,9B,CD,35,9B,EB
4910 DATA 11,1,0,CD,8B,9B,CD,35,9B,C9
4920 DATA 7A,2F,57,7B,2F,5F,13,ES,AF,67
4930 DATA 6F,E3,7A,B3,20,2,E1,C9,6,11
4940 DATA CB,15,CB,14,38,11,10,F8,18,15
4950 DATA E3,E5,19,D2,B0,9B,E3,E1,E3,CB
4960 DATA 15,CB,14,E3,CB,15,CB,14,E3,10
4970 DATA EB,D1,CB,2A,CB,1B,0,9999

```

**Colossus and White Knight
author Martin Bryant rates
the mates.**

ideo games may come and go, but chess programs just grow bigger and better every year! In this article I will take a look at the latest and best available on a variety of machines.

The programs chosen were Colossus Chess 4.0 (CBM-64), Cyrus II Chess (CPC-464), Psion Chess (QL), Superchess 3.5 (Spectrum) and White-Knight MK12 (BBC). All of these packages have existed for several years and have been written by enthusiastic computer-chess programmers. This is a very important guide to the programs' quality because today's chess programs, have reached such a level that no new program written by a casual programmer catch up on the years of development that have gone into the commercial offerings.

The programs' abilities are compared in table 1. Of course, an overall verdict of the "best" program is impossible, because people have different requirements from their programs. Also the hardware which the programs run on varies greatly so direct program comparison is impossible.

Where relative comparisons of features are possible, the best program has been given 10 out

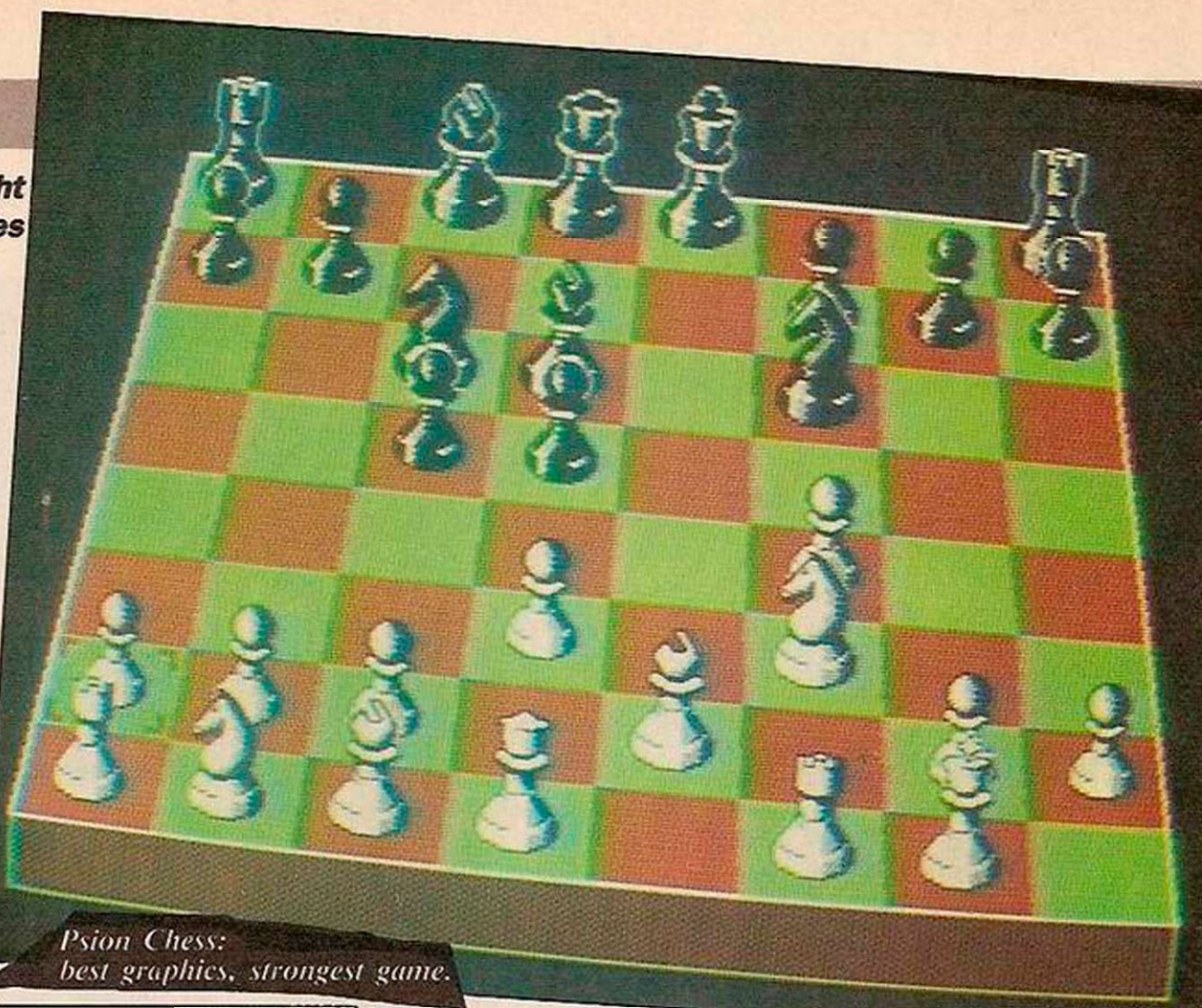

White Knight MK12 finds Rf2-a2 in 29 seconds. See how long your own program takes...

Examples.

.. BQ	BK8
..	7
..	6
..	9
.. BQ	4
.. WB	2
.. WK	1

a b c d e f h h
(Forsyth notation:
1q5K/4R3/8/8/1p6/1B6/5R2/1K6)

of 10 and the others a relative score. Other features are simple yes/no facts.

Gone are the days of chess programs which couldn't even beat a casual player on a bad day and programs took minutes to solve a simple mate-in-two.

Today's programs can give even the best club players a run for their money on tournament of blitz levels, and mates-in-two should now take at most a few seconds. Several programs are

**Colossus Chess 4.0 versus
Cyrus II Chess.**

- | | |
|------------|--------|
| 1. e2-e4 | e7-e5 |
| 2. f1-c4 | g8-f6 |
| 6. d2-d3 | b8-c6 |
| 4. b1-c3 | f8-c5 |
| 5. g1-f3 | d7-d6 |
| 6. e1-g1 | c8-g4 |
| 7. c1-e3 | c5xe3 |
| 8. f2xe3 | e8-g8 |
| 9. a1-c1 | d8-d7 |
| 10. d1-d2 | a7-a6 |
| 11. c1-d1 | b7-b5 |
| 12. c4-b3 | a8-b8 |
| 13. c3-d5 | f6xd5 |
| 14. e4xd5 | c8-e7 |
| 15. e3-e4 | b5-b4 |
| 16. b3-c4 | b8-b6 |
| 17. f1-f2 | f8-b8 |
| 18. d1-f1 | f7-f6 |
| 19. h2-h3 | g4xf3 |
| 20. f2xf3 | e7-g6 |
| 21. d2-f2 | g6-f4 |
| 22. g1-h1 | b8-b7 |
| 23. f2-e1 | d7-a4 |
| 24. f1-f2 | a4-e8 |
| 25. b2-b3 | e8-g6 |
| 26. e1-f1 | g6-h5 |
| 27. a2-a4 | a6-a5 |
| 28. c4-b5 | b7-a7 |
| 29. h1-g1 | h5-g6 |
| 30. b5-c6 | f6-f5 |
| 31. g2-g3 | f4-h5 |
| 32. e4xf5 | g6-h6 |
| 33. f1-e1 | h5-f6 |
| 34. g3-g4 | h6-g5 |
| 35. e1-e2 | g5-c1+ |
| 36. f2-f1 | c1-b2 |
| 37. e2-f2 | e5-e4 |
| 38. d3xe4 | f6xe4 |
| 39. f2-e3 | e4-f6 |
| 40. g4-g5 | b2xc2 |
| 41. g5xf6 | c2-c5 |
| 42. e3xc5 | d6xc5 |
| 43. f3-g3 | g7-g5 |
| 44. g3xg5+ | g8-f7 |

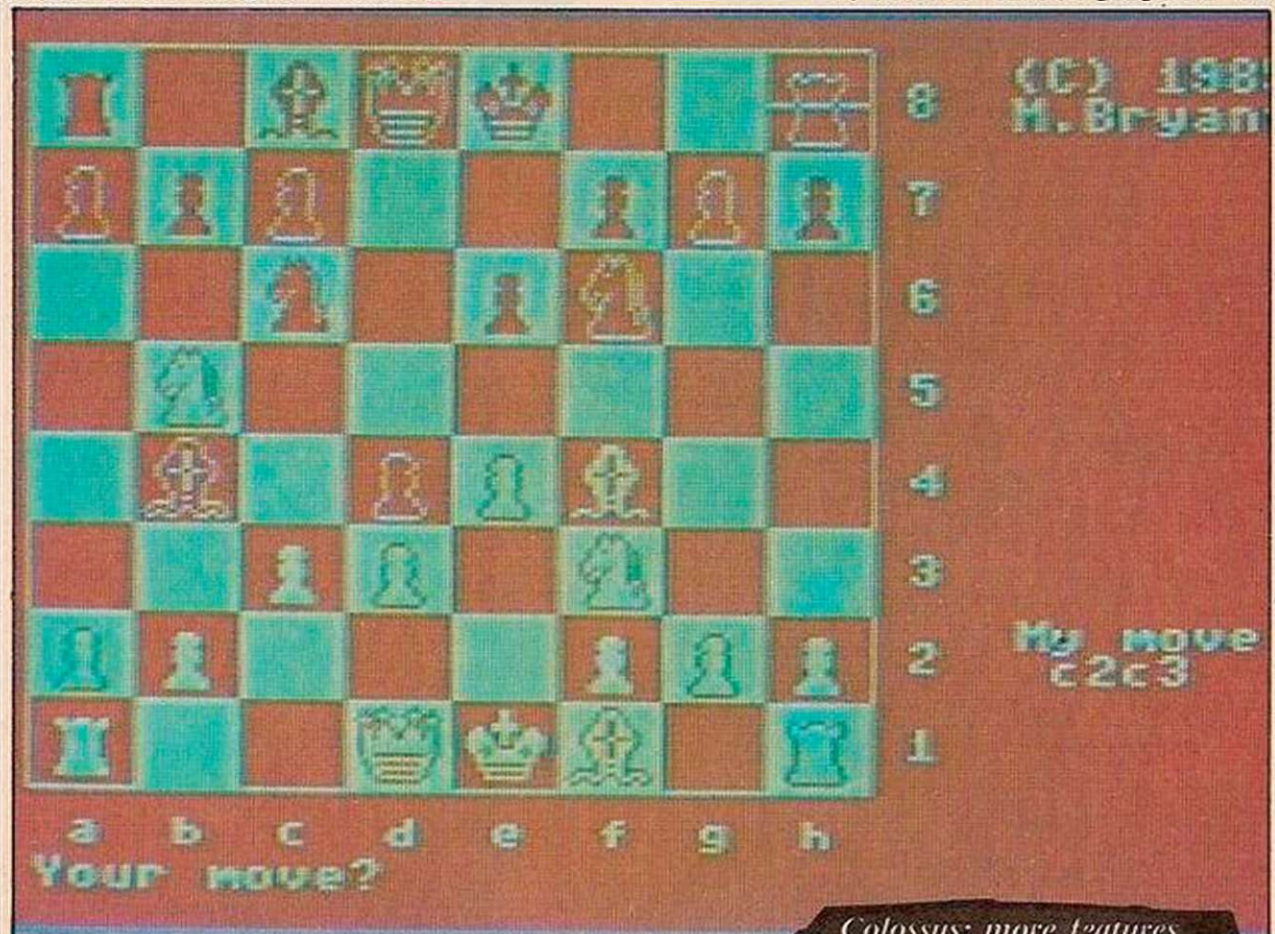

Colossus: more features than its rivals.

Chess Mates

- 45. g5-g7+ f7xf6
- 46. g7xh7 b6-a6
- 47. h7-h5 f6-e5
- 48. f5-f6+ e5-d6
- 49. f6-f7 a7-a8
- 50. c6-e8 c7-c6
- 51. f7-f8/9+ d6-c7
- 52. f1-f7+ c7-b6
- 53. d5xc6 a6-a7
- 54. f8xc5+ b6-a6
- 55. c5xa5+ checkmate

now able to spot some mates-in-five or even six on blitz levels in the middlegame. Psion Chess is the strongest home-computer chess program at the moment. It does run on much better hardware than the opposition — faster, better processor/more memory — of course than the opposition, but would still be a strong program with lesser hardware.

A version of Psion Chess, running on a Sage computer — about three times faster than a QL — came equal first with three other programs in the 1984 World Microcomputer Chess Championships. From the comparison table you'll also see that its rival are no pushovers!

Most modern programs will now think on the opponent's time by anticipating your move and continuing its search. If you play the more it was expecting it can save itself a lot of time and thus search further ahead and play much better. Problem-solving has come a long way too. Colossus Chess now offers the ability to solve not only normal mates but self-mates and help-mates up to seven moves ahead. This is the only commercial program to offer these features.

White-Knight Mk12 is actually used by international chess grandmaster John Nunn to aid in problem solving and design. If a grandmaster finds it helpful, think how much it can help club players, or anybody interested in chess problem-solving. Also, the better programs offer the ability to check problems for "cooks", i.e. alternative solutions to the one the problem-author intended.

Nowadays, the programs usually offer more than the standard levels. The move is towards modes-of-play and levels being totally user-selectable by

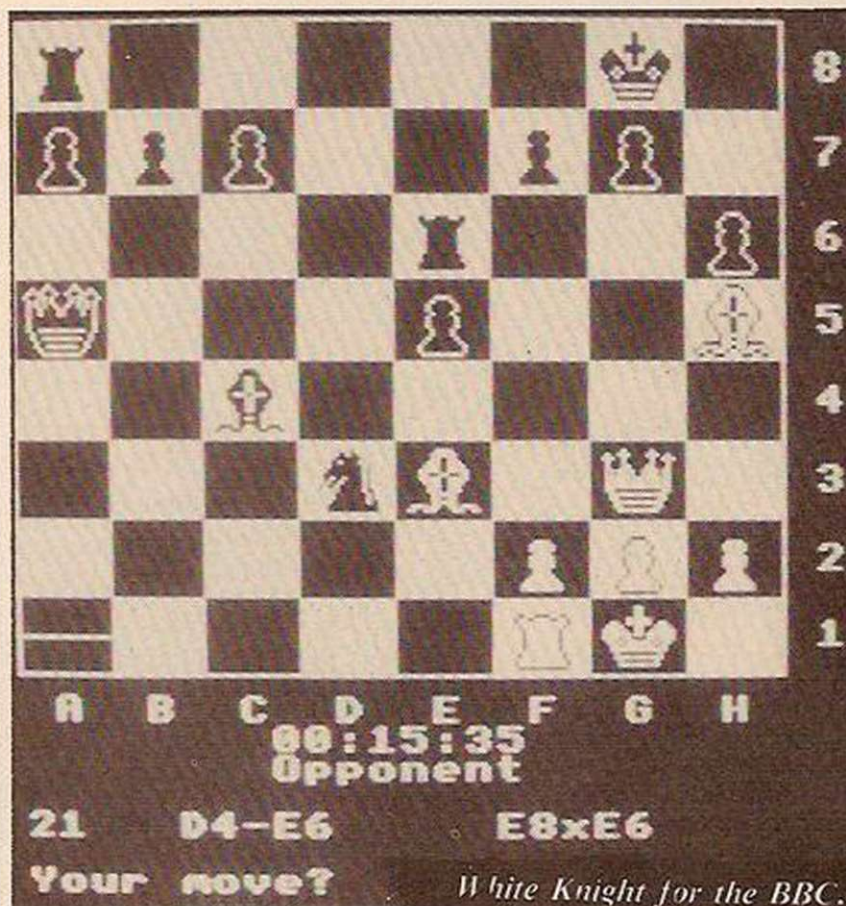

entering an average move time you wish to play at, thus providing thousands of levels. The new modes of play add to the normal averaged-move-time levels and they include easy-play where the program deliberately plays more weakly so that even

useless players stand a chance; all-the-moves where — as in most casual games in chess clubs — the whole game must be completed within a certain pre-agreed time or the slowest player loses on time; equal-time where the program kindly monitors your rate of play and adjusts its own accordingly — if you play

fast, it plays fast, if you slow down, so does it; infinite-search where the programs just looks further and further ahead until told to stop — useful for postal games where you can just leave the program to ponder a position overnight or even all week. Colossus provides six modes-of-play, more than any of the other programs.

The latest gimmick is of course 3D graphics. The quality will of course depend on the hardware available. I've seen one display where it was totally impossible to make out the pieces in a complex middlegame, making the display useless. On the other hand, the QL, which uses 32K screen memory — as opposed to 8K in the CBM-64 — can provide an excellent display which is a pleasure to use. Actually most of the recent attempts at 3D are much clearer and more usable.

Loading times are generally much better now. Colossus Chess 4.0 uses a turbo-loader, Psion Chess comes on Microdrive, Superchess can be transferred to Microdrive if you want, White-Knight loads quickly because the BBC's normal loading is quick, and the program is very compact. However, Cyrus II Chess takes forever to load on the CPC-464. ●

Table 1.

Program	COLOSSUS CHESS 4.0	CYRUS II CHESS	PSION CHESS	SUPER CHESS	WHITE-KNIGHT MARK 12
Playing Strength	8	7	10	4	7
Graphics (overall)	8	8	10	6	8
3D	Y	Y	Y	N	N
Analysis display	10	5	7	9	9
Anticipate	Y	Y	Y	N	Y
Book (Size, on/off)	10	6	10	3	0
Display (Text)	10	7	10	6	10
Manual	10	7	7	3	10
Sound (Variety, use)	10	6	7	6	10
Alter-position	10	9	9	4	10
Back-Forward step	10	8	10	0	10
Blindfold play	10	0	0	3	7
Clocks	10	8	8	6	10
Colour (Adjustable)	10	0	2	10	10
Force move	Y	Y	Y	Y	Y
Joystick move entry	Y	N	Y	Y	Y
Legal moves display	Y	N	Y	N	N
Modes-of-play/Levels	10	3	6	5	8
New-Game	Y	Y	Y	Y	Y
Next-best move	Y	Y	Y	N	N
Orientation change	Y	N	Y	Y	Y
Play self	Y	Y	Y	Y	Y
Printer	Y	Y	Y	Y	Y
Problem Solving	N	Y	Y	N	Y
Replay game	10	5	8	N	N
Save/Load games	10	0	7	N	7
Supervisor	Y	Y	Y	N	0
Volume/Sound (on, off)	10	0	5	N	Y
				0	10

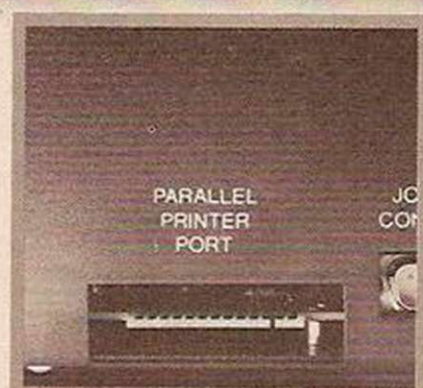
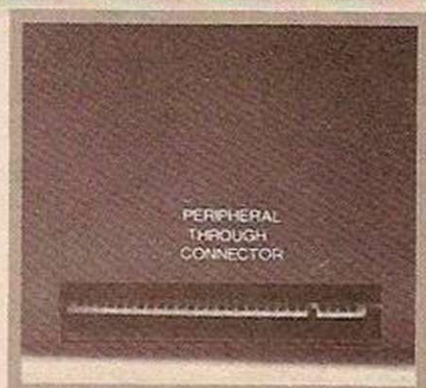
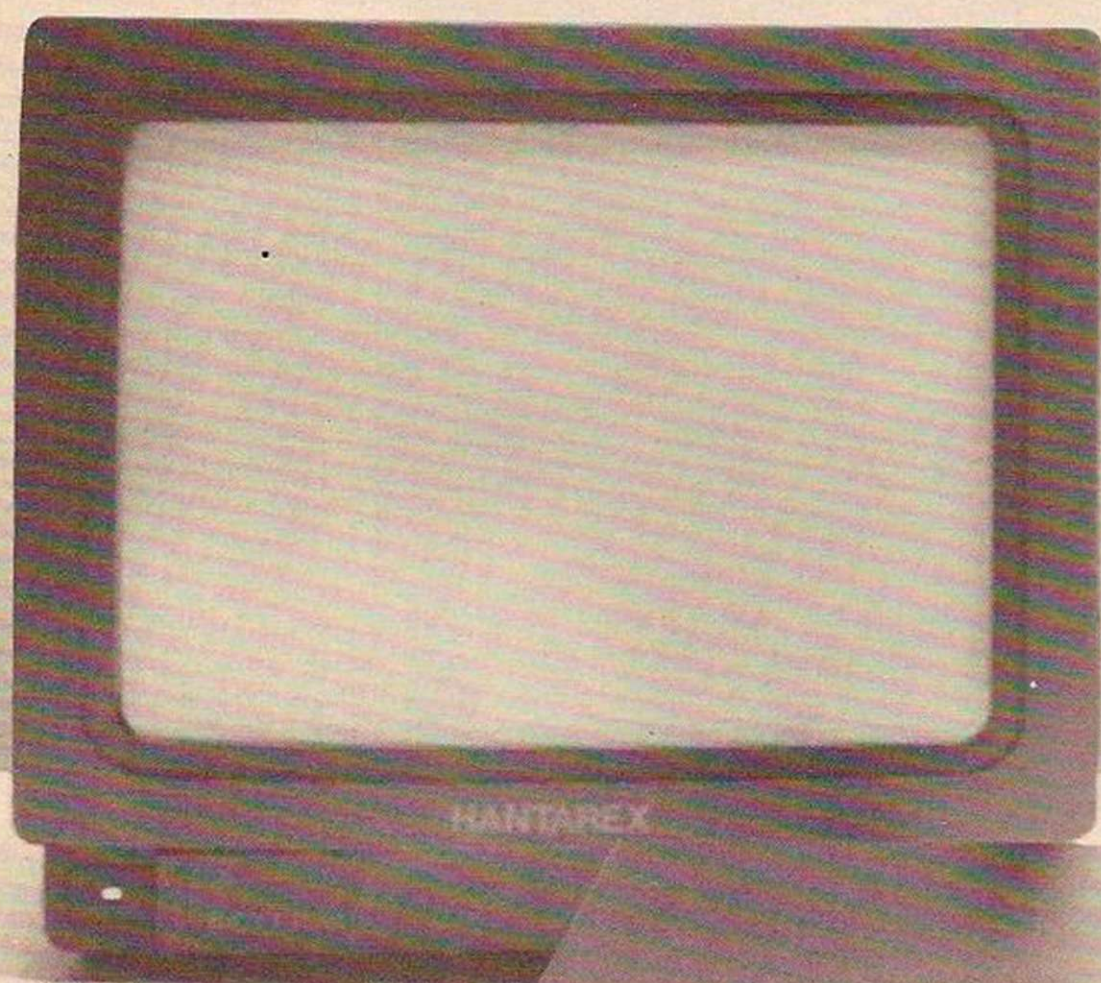

TECHNICAL DETAILS

3.5" 250 K disc drive
Double density disc interface
Parallel printer interface
Joystick interface
Video monitor interface
Peripheral through connector
Built-in power supply
Utilities on ROM including format and verify
RAM disc facility
Random access files fully supported
Connections for second drive upgrade
Comprehensive user manual
Total: £199.95 inc. VAT

Discovery — helps your Spectrum make all the best connections for only £199.95

In one simple step you can now transform your Spectrum into a complete computer system. Discovery from Opus Supplies is a sophisticated computer nerve centre combining not just a powerful disc drive and double density disc interface but the most comprehensive range of interfaces capable of running printers, monitors, joysticks and other peripherals.

No other system can offer your Spectrum so many options — allowing you to play the very latest games or providing facilities for serious business use. Discovery's specification includes over £300 worth of Spectrum peripherals and yet, at just £199.95, this remarkable all-in-one system costs less than a disc drive and interface combination.

Just connect Discovery to the rear of your Spectrum and you've started the transformation. Now you have immediate access to the very latest Japanese 3½" disc drive controlled via a powerful and ingenious double density disc interface. The unit's built-in power supply feeds both Discovery and your computer allowing you to dispense with your Sinclair power supply.

The Opus system takes no user memory from your computer giving you full compatibility with all tape-based software including programs designed for use with microdrive and Discovery even has its own RAM disc allowing you super fast access times.

Now the choice is yours. Connect up a joystick or a printer to the built-in Discovery interfaces, link-up to a video monitor or incorporate your own choice of peripheral using the through connector.

Whether you choose Discovery for games or business use you can rely on a complete range of readily available disc software produced by many of Britain's leading software companies, and our price of £199.95 includes an unbeatable two-year free warranty and free delivery.

Discovery is available nationwide from Boots and from all good computer stores across the country. Ring us now on 0737-65080 for details of your nearest dealer, or to order your Discovery.

Trade and export enquiries welcome.

*Price quoted refers to Discovery unit only.

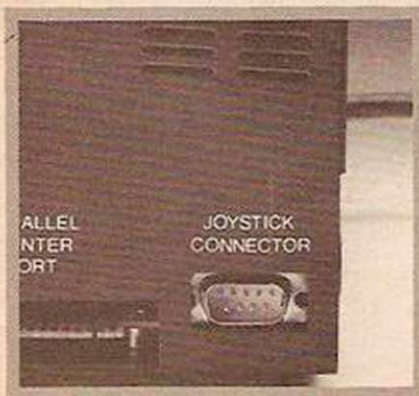

"Recommended" — Sinclair User Buyers' Guide

Opus.
Opus Supplies Ltd.

Opus Supplies Ltd,
55 Ormside Way,
Holmethorpe Industrial Estate,
Redhill, SURREY RH1 2LW.

exploits

Listing 1.

```
10>DEF FN f(g)=a$(g)<"0" OR a$(g)>"F" OR a$(g)>"9" AND a$(g)<"A"  
20 DEF FN h(g)=CODE a$(g)-48-(7 AND a$(g)>"9")  
30 CLEAR 27999: INPUT "Line number? ";L: IF INT L<>L OR L>340 OR L<0 THEN BEEP .3,0: GO TO 30  
40 FOR a=L TO 340  
50 POKE 23658,8: INPUT "Enter line ";(a);": LINE a$: IF a$="
```

```
X" THEN GO TO 100  
60 LET c=0: IF LEN a$<>28 THEN BEEP .2,0: GO TO 50  
70 FOR b=1 TO 28 STEP 2: IF FN f(b) OR FN f(b+1) THEN BEEP .2,-10: GO TO 50  
80 LET d=16*FN h(b)+FN h(b+1): LET c=c+d: POKE 27999+b/2+a*13,d: NEXT b: LET c=c-d: IF d<>c-256*INT (c/256) THEN BEEP .2,10: GO TO 50  
90 PRINT "0" AND a<10;"0" AND a<100;a;" ";a$: NEXT a  
100 SAVE "CODE"CODE 28000,a*13
```

Listing 4.

```
10>CLEAR 32299:LOAD ""CODE :  
CLS : PRINT USA 32614
```

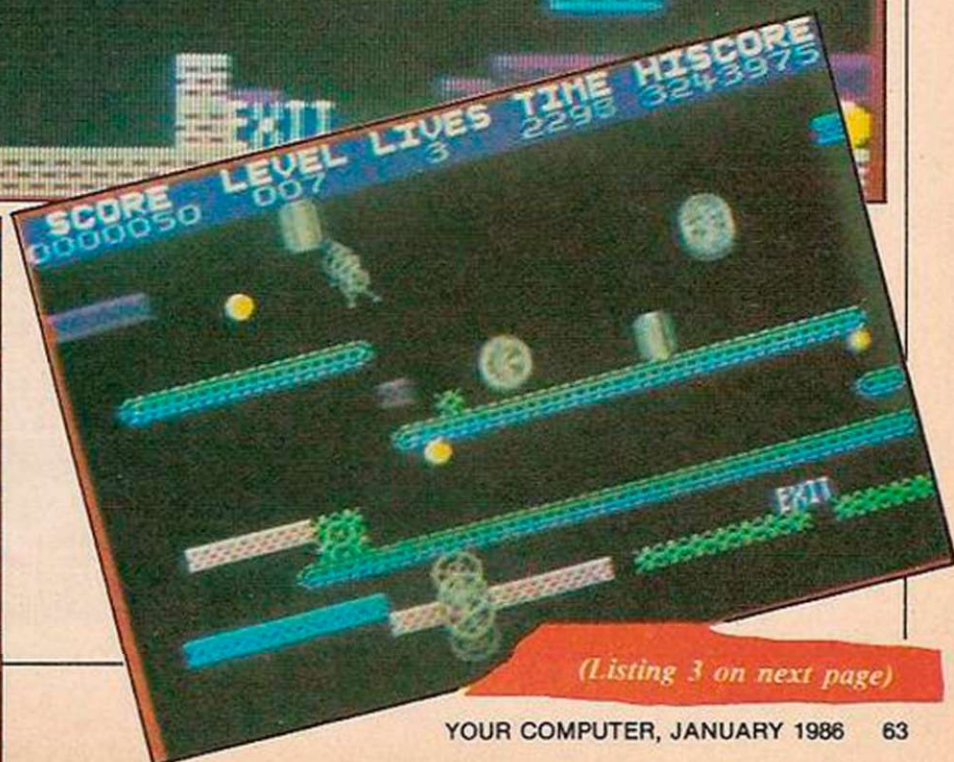
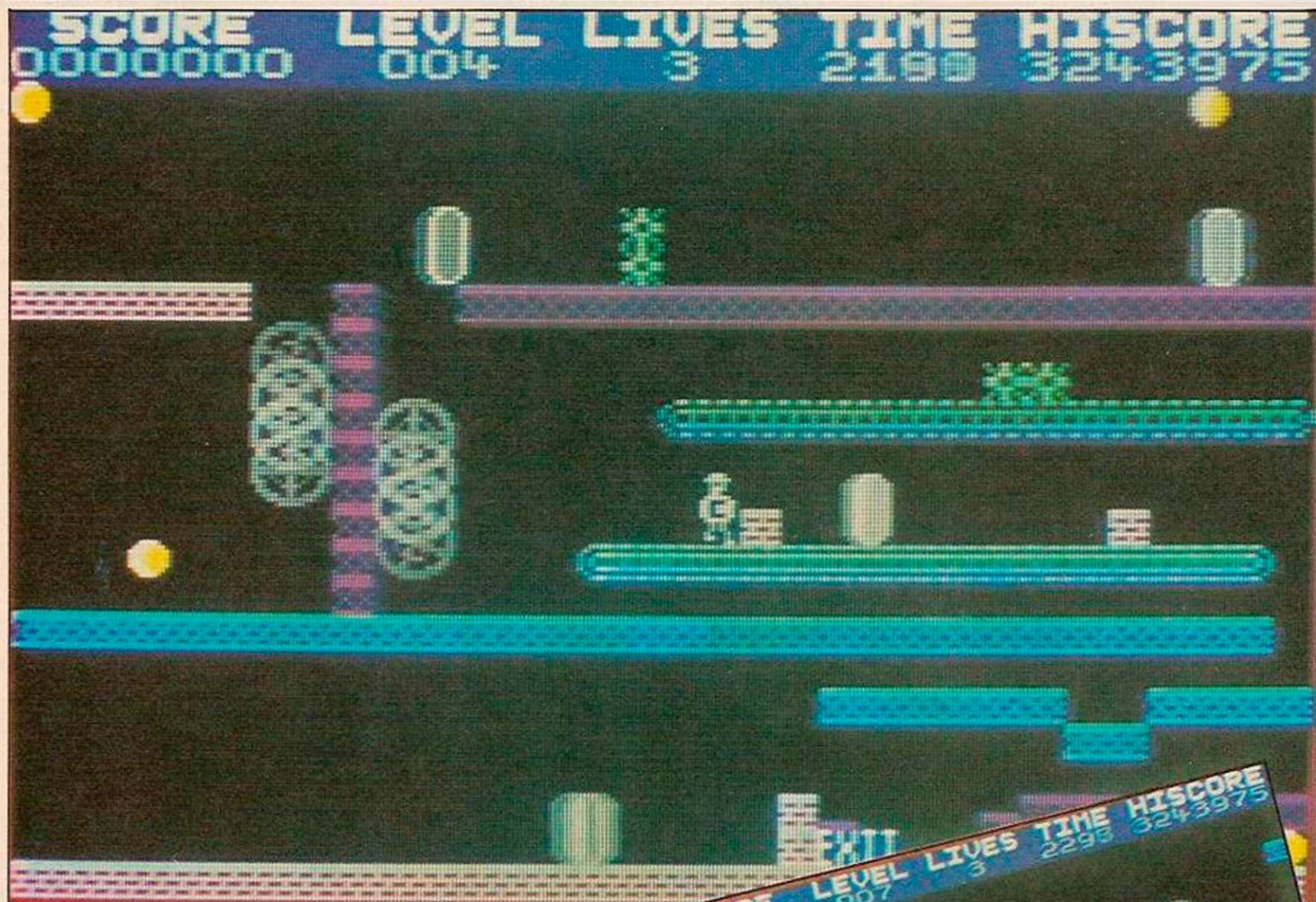

(Listing 3 on next page)

Cheekah's exploits

Listing 3.

```

000 07074FED43105BCDA36DCD696772
001 E1C93010087A8837C07BB9D8082F
002 81BBD0911680C9087BB937C07AB1
003 B2D80880BAD8901600C911C0604A
004 FB5E2003114061790F26000F0FCA
005 0FE6600F19EBC92A2B58ED52C949
006 21045BE5CD2F69E135C83A215B5E
007 FEFD26F2C9A2D5B46234E78B776
008 20142A295B23237EB7C8236E671D
009 CD0C69CBFE2CCBFEC9CD446D084F
010 11345B1AE67FFE03200606CB7790
011 208108EB2B35EB281A131ACB7F40
012 26873CFE8420073E033D20023EF2
013 8012E57FC60EC3956823AFBE2843
014 211826CDBA68CD466C010503592F
015 CDEC6821175BC80ECB8E210E5B20
016 AF77233605321F5B2A295B232324
017 232322205B21335B361323360344
018 C93A045BB7C8DF76621346201C3
019 0780CD0B572A135BAF32045BCGE1
020 7E668D5C51CAFCD9568CB7A20027C
021 0D041D20FC1D1C9210E5B34CB25
022 9621665B3A305BB7C8475E23C54B
023 46234E2378CB7B280179BE20021A
024 C8C323BE2002CB83235623CB7BC1
025 280435203E72E52B2B2B2B2B2B18
026 73C5CB7B280CCB432004D0D1816
027 170C0C18133E100F1520FC80CB33
028 4320049090ED44473A0E5B5F523BA
029 702371D5CD5A67D1F1C13DCD5A4E
030 67E1C123109C921125B35F5CD26
031 3768010A011E0ACDECE68F1C921CF
032 B062CDA56921000220A5B220C03
033 5B3E0432175B3C32125BC9DBFEFE
034 2FE61FC93EF7CD2A6F20073EEFEC
035 CD2A6F280BAFCD2A6F20FACD2ABF
036 6F28FB3EFDCCD2A6F20063EBFCD23
037 2A6FC621175B7EE04777C91E03C5
038 0F3814CB5EBC8E200CE5CDE16F1B
039 2DCDF06FE1C80D0BFC90F3813FE
040 CB5ECBCDE83E5CD16F2CCDF06FF4
041 E1C80C0CBFC91D2000C9CD0C6961
042 7EFE07C8FE06C8FE03280FE63F74
043 FE05200522315B37C97E7E18C933
044 C5D5E5CDS171CDD166D51A141419
045 B726FAE17CC60767924704280F7E
046 541515A77251510FA702570E139
047 1806702570E13607D1C137C9794C
048 0F0F0FE61F6F780F0FE61F6B2
049 C979E607C0CD0C693E17BEC8111D
050 2000198EC878E6072002B8C919E3
051 7EFE17C9ED48105B780C821172E
052 5B5C5C5CD36DC6967CDD26DC12C
053 110F5B1AFE05304278FE80282D86
054 E6072039CDE16F2424CD916F0880
055 79E60728062CDD946F351508381D
056 1221175B1A9E05260DAF321F5BAA
057 3E02C8E618653E05123A1F5BFE75
058 283806CD2168C31F7121175B1ABC
059 FE052048CBA6E52A315B7CB57E29
060 E1280ACB77CC636FC47A6F181BD3
061 7E1F38273EFCDBEFCBFECD5E6F62
062 300C3ED0FDFE17CD5E6F3002CBE0
063 E6CB4620753EFCED2A6F20073E93
064 7FCD2A6F2867AF321F5B3E2FB1820
065 06CB76CBF62803CB63C320F5B8C
066 3DFE0426883CF58047F1F5E5CB7D
067 7F2007211F5B8677182878FE1004
068 3816CDE16FCD0C697E7E17280B73
069 79E60728132C7E7E17200D2117C5
070 5E3E40AE77E1F1ED4418BEE11FA9
071 CB56200ED178B9D52008CB5ECC56
072 696FC47F6FD179FEPA380148ED3D
073 43105B78BAF5E5CD3A6DCDA0676B
074 E1CB6E260ACBAE01FF031E01CD8A
075 EC68F1C282A1A1E103006229296B
076 C35E697DE61F4F7CE603477DE66A
077 E0B007070747C93A0E5B4ECB71E2
078 28040603ED447043E0FC60310A7
079 F05F2C070E61F28047EB928F650DA
080 2D2D147D3CE61F28047EB928F4AB
081 2CCD51717E21000022315BC37E49
082 6B219977ED582B58CBECDA96BD4
083 ED521920F6C9CDD0663E013207B2
084 5BCD7569110907CDE56621B8657D
085 22055BCD206F2110666222958CDE8
086 466C3E0D32175BC3F6E213363D2
087 CDA569CD4C722805CDF26918C598
088 083E02CD7569CD9D710830052132
089 010022135BCDEE7518AECDD116FD4
090 CDD066CD75697C95CC346C381016
091 EBCD1C6C380ACB7E280B214E62FC
092 CD376CDDC06D18E1034D972D2AF6C
093 712A295BCBFE219977ED582B5BE7
094 CB7E28C8DA96BDE21920F45D53
095 9D71188BCD2B6ECD1A673A17CB41
096 CB4F2808CDFE6CAD36918EBCB58
097 7F28111F08ED58155BCD486801E5
098 01011E0AC3EC68CB57C47D69CDDA
099 1A67CD38E6CD1A67CD0D70CD1AC6
100 672A315B7CB5C462713A175B1FB0
101 300DCD18697BF0E0FC8FE1C37C8F7
102 18AACD306FCD12683CFEDBFE1FA9
103 389D3E7FDFBFE137896C9CDD06624
104 21175B7C85AF32185B11070FCD6C
105 E55621DC610100017E23087ECD9F
106 95680C0C2379FE1E20F1210F0B19
107 22085BC3AE73CD2F692A085BE540
108 CD0C69CB8BE13A215B5FFE0620E5
109 057D8728012D7BF0E920067DFEB2
110 1F28012C7BFE0820042520012483
111 FE0720067CFE1728012422085B8E
112 E5CD0C69CBFEE13A215BC92A29A3
113 5BE5CD9A96BECDBA6D4440E8D14D
114 2802EDB0ED532B5B01D1D10C99A
115 21045B7EB7280435CC626E6E766
116 72FE23CC2D73FE3028E5FE372897
117 E0FE32CC8D74FE2B2012CDDC4743D
118 30D3D1D1D1D1DC06D219977C335
119 0976FE35CC0975FE0A20C1E5CD97
120 5D6EE17C3DC0AFBD280E477D048F
121 D60338AE260F978FE0A28A7C1C1A9
122 E532185B2673CD5A69E1010DC6162
123 3A185B076F2500097EF640082331
124 7E011F01C395682425C8CD0C6962
125 772600C93E072A195B8C0C573C816
126 22195B2A1B5B8CD573C8C22185B9B
127 2A1D5B8CD573221D5B8C92D497393
128 E5CD0C69CB8E3A185BFE092680C98
129 7EFE362807FE07C22D75363826E0
130 4CDA5A69E13A185B8C9CDD732118
131 1574E5CDEF7322195BFE03DA3C4A
132 75FE09CA0E77CDFE73221B5BFE90
133 08DAA775CDEF73221D5B8C3307630
134 2A295B8DAB6B79FE02D6E8A2B22
135 5B2323FCE08200123A7F78E280A01
136 D1D1D1D1D122262C3376CE51BCD1C
137 BA6D444D1928D1ED532B581BED9B
138 B823C9DD21255B1102003E7FC9C1
139 119977D5DDE1A7CDBA6DEBC92124
140 7F64CD0667CD2F693A215BFEFD033
141 28F6216664CD0667CD7774CDB981
142 7406327610FD081743E80CDB935
143 74C35569CD604FBD80D12138645A
144 1842216064CD06673CD7774F55A
145 CDE174CD8174F13CF5CDE174F119
146 30D63C586908F3CD6205FB08C14F
147 3E7FDBFE1F08F1300B08214664BC
148 300E21226418090821556430031B
149 212C64C0376C217564CD0667A7F2
150 18B9E5D51CE5CD0C697EE1FE0732
151 200D24CB422802252C1D20CE0D1D3
152 E1C9E1E1E1E1210A621605D101218A
153 F061C3376C1100004787280C3D37
154 200F7DFE1F28E41C1418067CFD9D
155 17280D1CE5CDCF73E1CD127578D7
156 FSFE02F5E5CD4074C1F13004787B
157 B72010F17023712BB7CA4D06D3D7F
158 CA966BC35F6BD121A065C376C8B5
159 E0077CBA200C7B9530040CED44F1
160 6B5F1601C97D8B209A7A943004DE
161 0CED446E5F1600C9ED58195847E0
162 CD8575E5CDCF73E1CD127578FE66
163 03F52006BC42CA0F57551D5E5CDD77
164 407401D17B0F0A0FE5E0B07723FE
165 70707E660B1CB0A62772BF1CA64
166 708BC346B8CDE74CDDC06D0CF680
167 6B8E7AB32813CE1C6C38F0CD87BF
168 72CD468CDD626EAF187418E52A0E
169 2B5D22295B060BCD77BE2320D135
170 10F922265BEB219977474FC5CDF5
171 A96BC103ED521920F5ED431358E
172 18C3A305BFE09CA7F75342A1BE3
173 5B8ED5B195B8CD8575CA3675CB0A28
174 CB11CB4143ED5B1D5C828167CBA5F
175 20147B8D381E7D80CB412004FEF
176 1F2823B85318107DB8C236757AFB
177 BC38077C80FE162810BADA367534
178 7CFE182807CB4120077DFDE1FCA58
179 2F750458E5CDCF73E1E5DDE142BA
180 51CD127524C5B422002252CDD1228
181 7550D0D5E5C5C808CD4074E521EE
182 1264CD0667CD2F693A215B0602A3
183 FE0430F4F5CD626EAF1E1C1CB192F
184 1F1F1FD1827743D17A0F0F0FE6F8
185 E0B02377237A070707E6C01D8335
186 070707CB991F772B2BDD21685B95
187 C3928CDD816DD85F3E0708C3783B
188 6E46234E3E01CDF476D8AF772BDC4
189 77D1C9E4B2A295BA7C0FF7623CD83
190 FF76060623AFBE2829C505C0D38E
191 2366F1FE053728027E077A3DD1F0
192 CDF476C138E423E5EBCDBA6D1516
193 18444DE1EDB0ED532B5B0C9100099
194 23AFBEC0D05E7BE61F47237EE6D9
195 1F4F237E0F0FE61F3CC6B62801CD
196 37D1F5C5CD816DC1300EF1C50436
197 3802050CDD816DC138CFF5F1CD81
198 FE7604C067A2002050CCDF9762349
199 E5E21305535CD8A6D1818A51491
200 00151E0E06051C0680800D26000AR
201 6DA30C980F9C00F60800D049DAR
202 119F00349E6B92699700F7E03187
203 9710960E880E84289800F441B410
204 F4803342AFB989419D69C390A94D
205 8911000311160403050A05121102
206 1002006706678154267281008256
207 8E430E058F25912312258800313C
208 E93400990006DB33CDD08392E942
209 93499DA90A4A8E000865379A0C04
210 9500E64E0E08519900131F160118
211 1410030E00A4614D0B00054A5454
212 B10B9C00A9A22580C43F13900FC
213 F7E0959B9580719B00E21800F566
214 0552C620852B50A70FE311B20ED7
215 0E0015001614021D0E003161F02B4
216 0000EA300ECE00F7E035130D9284
217 0D9BA78000072875B487CB88822B
218 94729C339AD0E0002986250F0014
219 A510B8C23939CB7E699C7C91D65E5
220 0035F5C1310015010301113051361
221 0F13190F01021600F7E0EF890062
222 2D8FA78BE78000E992679408895C
223 00359E139A11E068B00008080723
224 8700F57326F529210C918D08B711
225 8D25940A000B0F0D10101F1413DD
226 1419141E0A16070F160100E48717
227 002E300F9EC21000D111B582284E
228 0F008D8B8DB2B1822426118A15C3
229 8B0E23004C950B9600B6F2B3824B
230 528246288D00021FC131A05070D9F
231 1E0D0D0028A24CC11672F1E00DF
232 8F83348A948E00C4E00A8C000430
233 9FF3820088E2F092F08749CD400
234 9400E260F605B09445B994A8B203
235 96D2AC92001602141206120E18E2
236 091F0D14050E07170044A60064C8
237 51268200A8B2CE99A922D9EAC78
238 B24B920B8BA8286B3A5B2D9292FB
239 ED9556A5A82DA827099E8792E7C8
240 98A8B20093B2B7B200069F0D9DF4
241 0B9569B200F112B35723362C0ED
242 7900D0E0D0F1601161E020E02D0
243 110C020C1D0309030B0314031692
244 00004FA20E8C2E134FB40E9E2EA9
245 018B28B888B938B9900A5C5E9B6
246 8CF18CB5CA7A9B3A900F7E0E6F75
247 8E5B8E238F4B014B1E00227F08BA
248 920B8D0395038A00ED942210181D
249 96100396ED6221001601171E02FD
250 090E040F030801061C0216000072
251 85E152E28D0E2EDC36A4E1483D512A
252 A8B1AF796C781E78B64E2A52045
253 00ED015D1CA73E4714470973007A
254 255F00000E8300E2AA2AE521F0C1
255 E8CA1EEC5500021802160B0098
256 05175171616181302021F00D8
257 00579600469600769C9495928E24
258 90878E808C878A8E8895669C44B3
259 96000596059816970B8900024556
260 D0424CD0825D3D0C25AD0EC400CF7
261 A80F368FC39EFC09E0012051485
262 000301081B0815006EA8000D73A
263 E000A25F47AFA7A02AC8A091EB
264 809485B28A84908D850028100AE
265 E5A081A5C8A98E060025CCE4B71
266 6B950E4692EF408CF56068B290A3
267 9200031F14000200141F090B091A
268 140D170D081104111B0000F7E065
269 678E3C5FA9EB8C000A5B2A538
270 A00000424F80AC9AED29B1F124
271 4553B500F000151F031E031611C9
272 0611101114111E07300D76000BC
273 A5A2A5B28E4E521C2E148E200C
274 2790AE2AF07AF08AF0E40FAFDE
275 15AF16AF1CAF1D00179F624000C9
276 00F57817F59196F5AA15F5C394A0
277 A34153A924FA0003001319020C3B
278 0217101E141F00D261C5E089633E
279 0062A022HDE298C6E000168036DE
280 8FAD96651F003627358BBD81CDE
281 8B1098001780378F7411740E0097
282 F08155E7807653778E537B8E0057
283 160F031B041304160C100502069D
284 03070207160A1600702000A49916
285 A799A99AD9900E23F02200096A2
286 B254C18B004F8C0681C5332BC198
287 00068200E81A7EB1427C2A99C58
288 EE6125A5142700160213010F0291
289 08130C18101D0006000E40F2E6E
290 2F079000C4A00149F128E00868083
291 68858A8A9208990A4328D952E7E
292 37919AB821CAE80B2802C8734877E
293 000F810F830044769D84FB2DEC11
294 4090E200B002F11400021B1200A0
295 0300031F030C031311160080D93
296 1700F0A07760004C00C404C1F65D
297 C4188D9B8D80ADA900C401402FD
298 C403C41CC41DC41EA40DA40EA471
299 0FA410A11A1425090D28D6C8861
300 5C940042384227A413A4C90B38D
301 D58D00EC8C82805A035160A0B99
302 B88FAB408CF30D16E007A0EA0831
303 BA00021F0B05071C0703151A0E55
304 0F1210030000C9A0C931332100EB
305 002584259A11B600649C64C664BD
306 80650F6510CB04D11F2D8F718EE3
307 B58D0028970798270788800AF0
308 2E8AF3AD9137D8E13D60E216F8
309 93B3168F000412021E0809006A9E
310 982696003690348E328C308A2E85
311 8802E3FC4A300869A68D8AAAE4
312 8222822100258F0E08A9A95A8D19B
313 124199980B6C95857A0500151E64
314 0B1E051D0802091E0B0800CD2180
315 EDB07734752100C4C1A49A8781AA
316 E7C836130000A240CAB1AA12B5CB
317 8F0037A23588358400E5016A4F7D
318 EF9D4F2D9E4F319E2E20176001532
319 04171B10010C050B040A050B0687
320 0F130F1B031702070068A188B1B1
321 0032A0A391A396004BCD2E2CF0A3
322 1345A20077A022202E3A2E2A00C95
323 860C40000B85EE12EE140E930049
324 F28B8F4E2A9EA3E224001517163D
325 1E0A19161D00C10068402D9700ED
326 24C10070C0659349972D9D0077AE
327 E05100B101A912A9138200005490
328 1AEDA200E221F4916A92A641C5D9
329 00130112110D1200F7E0B0480025
330 49864990479347892C9B498C8876
331 96002F84C820003581478000ED98
332 88ED950002418C02498C424C94D2
333 025690425194425BA002538C426F
334 599042479400151F0402101A0670
335 0A05130073E26BE100F7E00D80F28
336 E681A68CE65900861E001580A82C
337 E0319E003105328A3110329700AB
338 F5991385B312750D12352711F51
339 8110ED08194AD68956D4F962D36F2
340 97000000000000000000000000097

```

Tandy Printers.. More of what it takes.

So what's Tandy® got the others haven't? Quite simply we've got more. A range of computers that's second to none and a complete range of printers to fulfil most hard copy requirements. And for those who need IBM compatibility in daisy wheel or dot-matrix format we offer you more for your money. Check out what Tandy can do for your business and like thousands of other businesses who've already chosen Tandy you'll find out for yourself that Tandy has got what it takes.

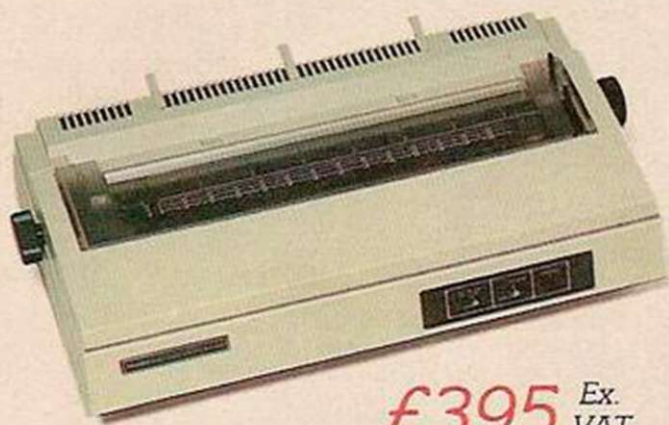

£395 Ex.
VAT

DWP 220. Accurate, concise printing for word processing programmes. Prints clearly defined characters at a speed of over 200 words per minute.

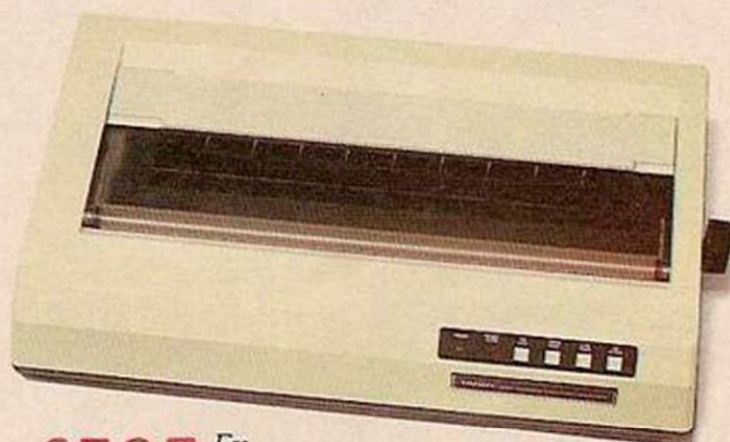

£595 Ex.
VAT

DMP 430. Gives a high quality print return, accommodating a whole host of specifications including correspondence fonts, up to 180 cps., Micro, Italic, double high and elongated fonts and graphics.



£299 Ex.
VAT

DMP 130. This amazing Triple-Mode 9" printer will perform a variety of tasks for the price of only one machine! The choice is yours, whether you require Word Processing, Data Processing or Dot-Addressable graphics.

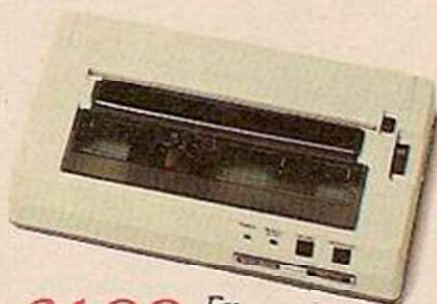

£199 Ex.
VAT

TRP 100. Has the advantage of printing both texts and graphics on regular and thermal paper. A versatile machine that responds with sheer perfection.



£995 Ex.
VAT

DMP 2100P. High quality printer at a price that's hard to beat. Accommodates Data Processing, Graphics and correspondence quality fonts.

TANDY®
COMPUTERS

The range that's clearly superior

Tandy Corporation (Branch UK), Bridge Street, Walsall, West Midlands WS1 1LA. Telephone: 0922 648181
For further information dial the operator and ask for

Freefone Tandy Computers

Available from selected Tandy Stores, Dealers and AT ComputerWorld.



You're an Olympic athlete competing in eight key events at the SUMMER GAMES. How well can you score in track, swimming, diving, shooting, gymnastics and more? So realistic, there's even an opening ceremony and awards presentation after each event.

Unlike other "Olympic-like" games, SUMMER GAMES has incredible realism, superb state-of-the-art graphics and sound effects, including national anthems from eighteen countries and true action-



Compete with up to seven other contestants in your favourite individual event, or go for it all in the grand competition. Some events, like cycling, rowing and fencing even challenge you with realistic head to head competition!

You have a choice of eighteen countries to represent and you will need the correct strategy and mental toughness, not just speed and agility to excel in each of the eight events. That's why we included a feature that lets you practice each event until

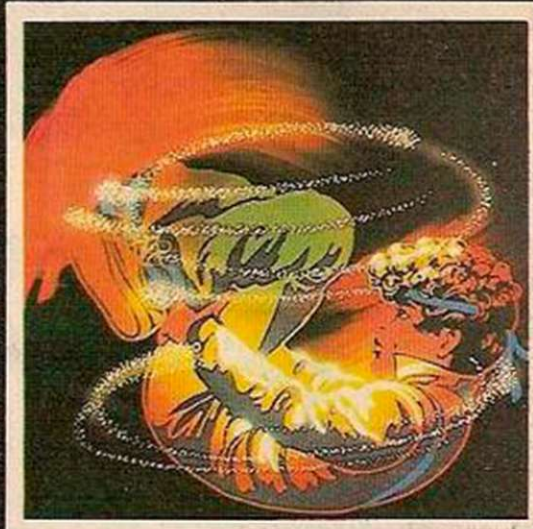

BREAKDANCE is more than a game, it's four games in one. In the first you "go down" to "battle" row after row of breakers as they attempt to invade your turf. A second game lets you "break" with the famous "Hot Feet" in a contest to see who really has the most "juice" in town. A third challenges you to figure out the right sequence of steps to perform a backspin or suicide without getting "whacked." Or, you might want to start with the free-form section where you choreograph your moves

EPYX MAKES EVER

SUMMER GAMES

strategy game play. In each event you must plan and execute your game strategy in order to maximise your score. It's not just a matter of how fast you can move the joystick.

So change into your running shoes, grab your joystick and GO FOR THE GOLD!

- Opening Ceremony and Awards Ceremony.
- 8 Different Sports Events.
- Action and strategy elements in each event.
 - Compete against an opponent on the computer.
 - Individual and Team play.
 - Joystick Controlled.
 - One or more players.

Available for:

Commodore 64 Cassette	£9.95
Commodore 64 Disk	£14.95
Atari Disk	£14.95

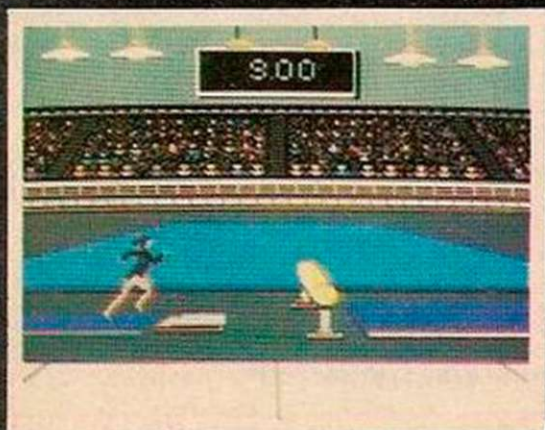

SUMMER GAMES II

you're ready for the real competition. Remember, it's not too early to get ready for 1988. With the right diet and training you might just make it: but in the meantime grab your joystick and try eight new ways to go for Gold!

- Includes Cycling, Fencing, Kayaking, Triple Jump, Rowing, High Jump, Javelin & Equestrian Events.
- Opening, Closing & Awards Ceremonies with National Anthems.
- Individual & Head to Head Competition.
 - One to Eight Players.

Available for:

Commodore 64 Cassette	£9.95
Commodore 64 Disk	£14.95

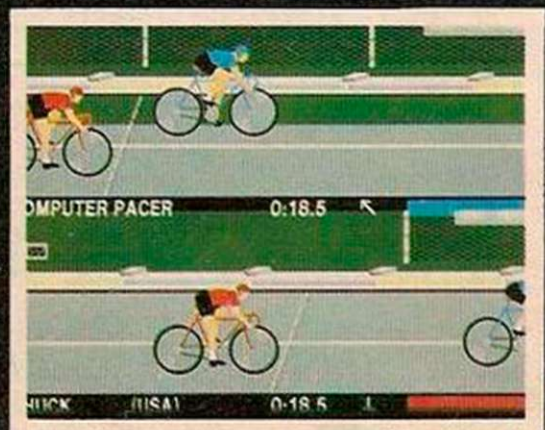

BREAKDANCE

and watch the computer act them out in slow motion or at normal speed.

It's up to you, play it alone or against a friend either way... Breakin' is now made easy with BREAKDANCE!

- Over 100 different steps in all.
- Complete with breaking music.
- Includes: Moon Walk, Turtle Up Rocking.
- Head Spin, Suicide, Back Spin and more.

Available for:

Commodore 64 Cassette	£9.95
Commodore 64 Disk	£14.95



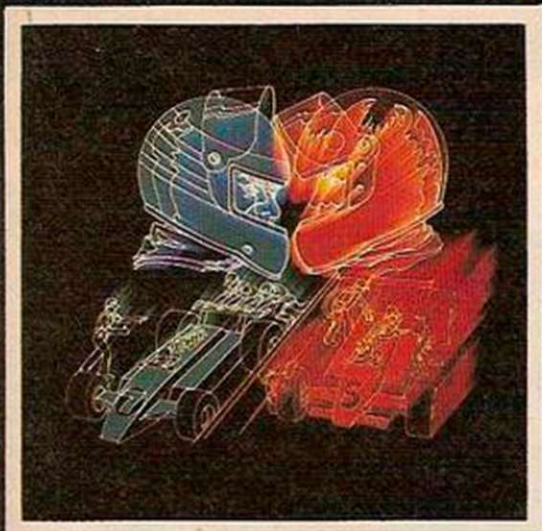

Introducing true competitive auto racing, both on the track and in the pits.

A split screen display allows two players to race against each other, fighting for the lead on the track and struggling to be first out of the pits.

You'll need a race strategy good enough to beat an opponent. But remember, his strategy might be as good as yours. Then it comes down to a test of nerves, a test of guts.

Grit your teeth and hope that your tyres and fuel hold



Your mission is to foil a horrible plot. From an underground laboratory, Elvin, the scientist, is holding the world hostage under the threat of nuclear annihilation. You must penetrate his stronghold, avoid his human-seeking robots and find the pieces of the security code.

Somersault over the robots or use a precious snooze code to deactivate them long enough to search each room. Use the Agency's computer to unscramble the passwords from the code pieces, or

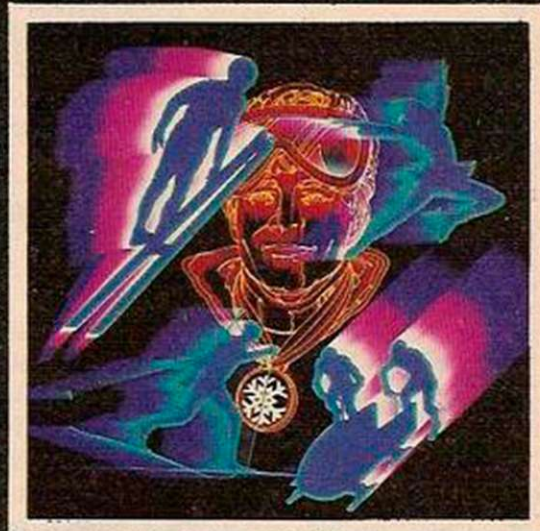

You've captured the gold in Summer Games™ and Summer Games II™ — now it's on to the Winter Games! And what an incredible setting — a completely realistic winter wonderland featuring six action-packed events. You can compete against your friends or the computer.

First choose the country you want to represent. Then it's practice, training and learning a winning strategy for each event. Now the Opening Ceremony and the competition begins. Will you be the one who takes

EVERYTHING POSSIBLE.

PITSTOP II

out for another lap, because if you 'pit' now it may cost you the race!

- Head to Head Motor Racing.
- 6 Different Circuits.
- On Screen Map.
- Full Pit Facilities.

Available for:

Commodore 64 Cassette	£9.95
Commodore 64 Disk	£14.95

IMPOSSIBLE MISSION

try to solve them yourself. You've got to reach Elvin's control centre, but you'd better beware....

This mission is stamped IMPOSSIBLE!

- Over 30 Rooms.
- Over 80 Different Robots.

Available for:

Commodore 64 Cassette	£9.95
Commodore 64 Disk	£14.95
Spectrum 48K Cassette	£7.95
Amstrad Cassette	£9.95
Amstrad Disk	£14.95

WINTER GAMES

the gold at the Awards Ceremony? The quest for the gold continues... And it's all here — the strategy, the challenge, the competition, the art and pageantry of Winter Games!

- Six Winter Events: Bobsled, Ski Jump, Figure Skating, Free-Style Skating, Hot Dog Aerials and the Biathlon
- Opening, Closing and Awards Ceremonies complete with National Anthems
- Compete Against the Computer or Your Friends and Family

Available for:

Commodore 64 Cassette	£9.95
Commodore 64 Disk	£14.95
Spectrum 48K Cassette	£7.95

Coming soon:

Amstrad Cassette	£9.95
Amstrad Disk	£14.95

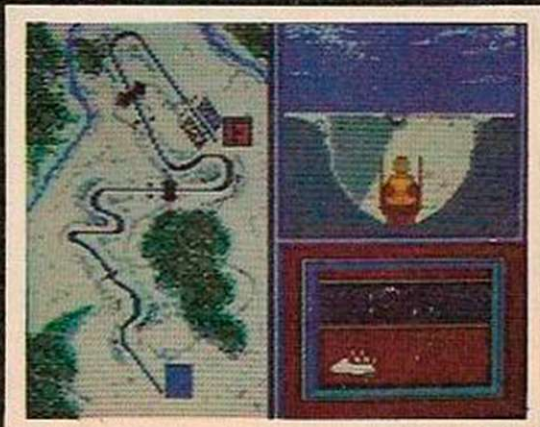
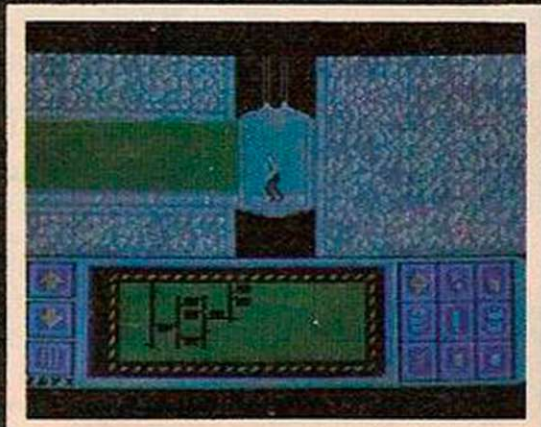
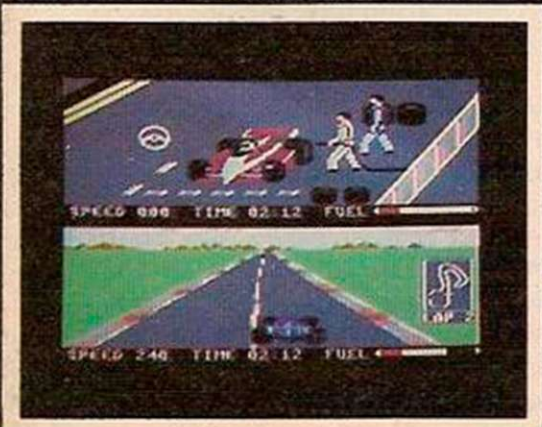

```

40 PROCINITIALISE
50
60 R = 2: D = &FF
70 PROC_OUTPUT (R,D)
80
90 R = 0: D = &F0
100 PROC_OUTPUT (R,D)
110
120 END
130
140 DEF PROCINITIALISE
150 OSBYTE = &FFF4
160 ENDPROC
170
175 DEF PROC_OUTPUT (R,D)
180 AX = 151
190 X% = R + 96
200 Y% = D
210 CALL OSBYTE
220 ENDPROC

```

The Robotix kits from Milton Bradley are a new addition to toy shop shelves. Each kit contains plastic beams, wheels, bearings and trimming pieces that allow you to build any number of different moon buggies, asteroid scanners, dune detectors, and star crabs; as well as more mundane cranes, lorries and "walking" machines.

The heart of the system is a small, but very tough electric motor. The smallest kit has one motor and the largest has four. Each motor can be controlled separately by a manually operated switch and will turn clockwise or anticlockwise.

The second key element in the design of the system is the hexagonal plug and socket method by which different components are joined together. Everything,

John Dawson looks at Milton Bradley's Robot kits.

from axles and swivel joints, to beam and gears, uses the same six-sided connections. Both Fischer Technik and Lego have produced construction kits that can be used for serious computer-controlled projects and the different methods have advantages and disadvantages.

Fischer Technik components lock precisely and solidly together but the gear will rely on



Above: Milton Bradley Robotix motor.

Below: Controlling the arm using a BBC micro.



friction between the axle and the wheel to transmit force. Lego plugs together less decisively than Fischer Technik but its gear trains use axles with splines to hold the gears rigidly in place. Neither system is inadequate provided that you stay with the forces with which it was designed to cope.

In the same way the Robotix system relies on a tight push fit between the male and female components of the connectors if useful loads are to be supported and driven.

The Robotix motors are about 5.5 by 3 by 3 cms in size. An output shaft emerges from one side and there are connectors on four other sides of the oblong casing. The motor can be mounted so that the output shaft rotates in any one of three axes. The unit is powered by three volts DC and incorporates a 1300:1 reduction gear train.

When it's running free with no load the shaft rotates at about six revolutions per minute (rpm) so the motor itself is rotating at about 7800 rpm. Milton Bradley says that there is an integral clutch inside the casing which prevents damage if the motor is connected to the two arms to make a "hand" for holding objects.

Motors are impressive

Using fresh batteries I measured the free running current taken by the motors as approximately 60 mA. On load the current rose to about 180 — 200 mA and when the motor was stalled, that is with the output shaft stationary, the current rose to around 400mA.

There seemed to be about two or three degrees of play at the output shaft which is not surprising given that there is a substantial reduction gear train between the output and the motor. The maximum torque is said to be 3.5 kg/cm. In other words the motor will lift 3.5 kg on a lever one centimetre long fixed to the output shaft. If the lever is made longer, the weight that can be raised is reduced. At five centimetres — about 2in. — the motor will raise a weight of 700 milligrams, roughly 1.25 pounds.

The motors, made in Hong Kong, are very impressive pieces of cheap mass production engineering.

The instructions in the Robotix kits are based on photographs of completed models with a list of the parts required printed at the side. The photographs are very nice but not particularly easy to follow if you want to slavishly build one of the Milton Bradley designs. Leaving that aside, the kits offer enormous scope for constructing working models that are both fun and instructive.

I had intended originally to use the Fischer Technik robotics kit to illustrate how you can build an interface between a microcomputer and a device that you wish to control. However, the Fischer Technik kits are expensive and difficult to obtain from local toy or model shops. The Robotix kits are marketed widely and you get more motive power for your money.

What the Milton Bradley kits lacks are the sensors like

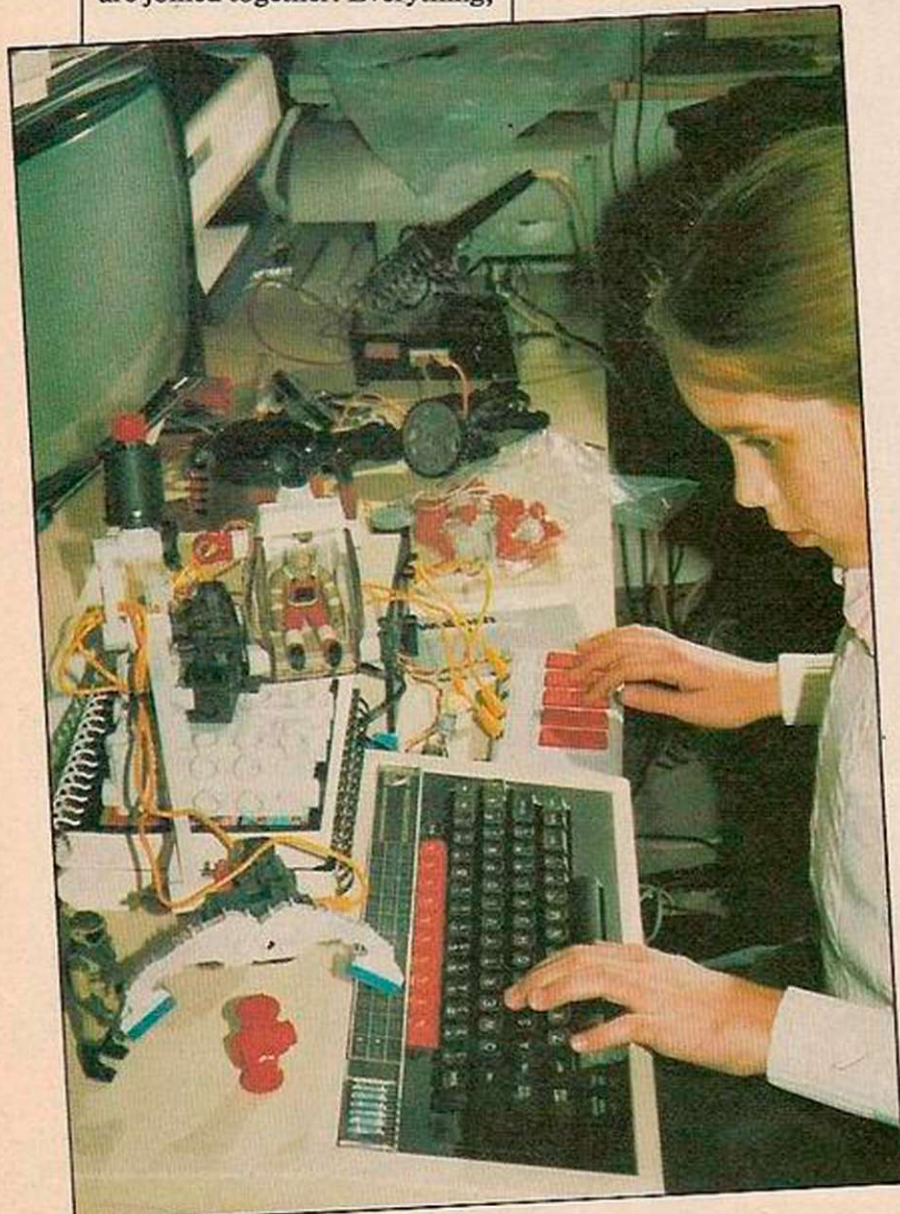
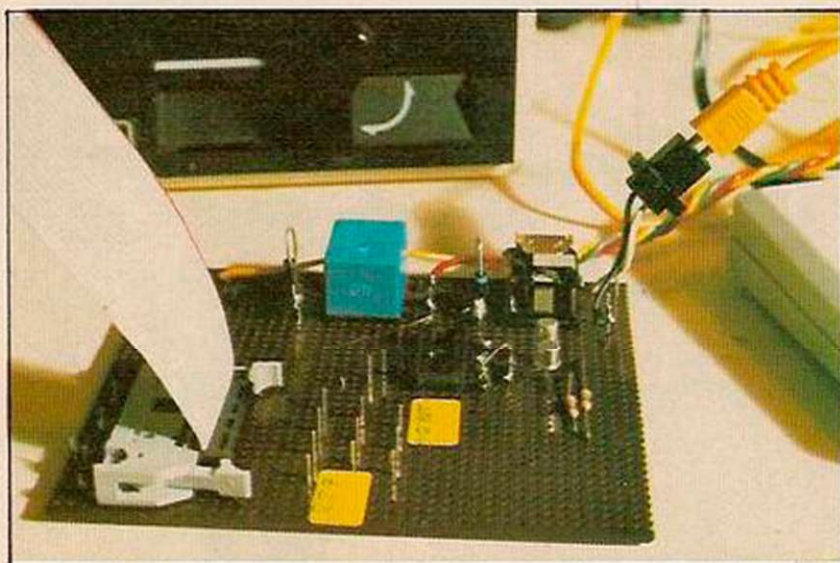

Figure 2.

```

40 PROCINITIALISE
50 PROC_OFF
60
70 REPEAT
75 PRINT TAB(10,5); "PRESS Up Down Quit Stop (Space bar)"
78 PRINT TAB(10,7); "Status ";
80 K# = GET#
110 IF K# = "U" THEN PROC_OUTPUT(0,&01); PRINT TAB(19,7);"UP "
120 IF K# = "D" THEN PROC_OUTPUT(0,&02); PRINT TAB(19,7);"DOWN "
130 IF K# <> "U" AND K# <> "D" THEN PROC_OFF
140 UNTIL K# = "Q"
150
160 END
170
180 DEF PROCINITIALISE
190 CLS
200 OSBYTE = &FFFA
210 R = 2; D = &FF
220 PROC_OUTPUT(R,D)
230 ENDPROC
240
250 DEF PROC_OUTPUT(R,D)
260 AX = 151
270 XX = R + 96
280 YX = D
290 CALL OSBYTE
300 ENDPROC
310
320 DEF PROC_OFF
330 PROC_OUTPUT(0,0)
340 PRINT TAB(19,7); "ALL OFF"
350 ENDPROC

```



microswitches and photocells that are easily available for Fischer Technik, and also some of the precision that can be achieved using Fischer Technik components. The first problem can be overcome and the second may or may not matter to you.

Figure 1 is the original program that I typed into my BBC microcomputer to control the lines from the user port. The program was copied from *Interfacing and Control on the BBC Micro* which is a National Extension College publication — ISBN 0 86062 400 4. Figure 2 shows how the program developed to show on-screen the status of the interface, and to obtain an input from the keyboard which will switch the interface to move active state — moving up — to a second active state — moving down — or to an inactive state — both outputs off: all off.

Principle is quite simple

The principle of the program is quite simple although the chip involved in sending the data to the interface is almost as complex as the 6502 central processor unit itself; it is certainly less well understood by most people.

The uses of 6522 Versatile Interface Adapter (VIA) are described in the *Advanced User Guide to the BBC Micro*, *6502 Software Design* by Leo J Scanlon — ISBN 0 672 21656 — and several other books about the 6502 microprocessor. For these purposes the 6522 VIA can be treated as a simple input/output chip which takes data from a memory location and outputs this information on

the eight data lines.

The output lines coming from the user port continue to hold their on or off status until new information is written into the memory location.

The superb machine operating system in the BBC micro makes everything easy in both machine code and Basic. Price Output — lines 250 to 300 in figure 2 — sets up an Osbyte call which will write to one of the memory locations associated with the user VIA. The "memory location" is actually one of the registers in the 6522 chip which is treated as through it were part of the computer's ordinary Ram. Initialisation is carried out by sending Data &FF to Register 2 in lines 210 and 220. This sets up all the eight data lines as outputs rather than inputs.

Proc Off transmits 0 to register 0 which sets all the output lines to off, that is about zero volts. When a line is set on the voltage rises to more than 2.4 volts in theory and a little less than the 5 volt supply in practice — 4.8 volts typically.

A line is turned on by setting one bit of the data byte to a one

Far left: Unpacking the pieces. Left: The interface. Below: The "hand" made out of two opposed "fingers" driven by a motor.

instead of a zero. Remember that each byte has eight bits:

0 0 0 0 0 0 0 0

7 128 64 32 16 8 4 2 1

one byte shown as binary bits bit number

value of each bit in decimal So the byte shown above has a decimal value of four. I have used the two lowest bits to control two lines from the user port and these are turned on by writing either &01 or &02 to the VIA register. Programming books will show you how to twiddle individual bits using the various Boolean operators - And Or Not XOR. If you want to control each data line independently you will need these techniques because the only alternative is to turn off all the lines at the same time by sending &00 to the VIA.

More than one process

The advantage of controlling each line separately is that it permits you to have more than one process operating at the same time. For example, you may wish a robot arm to turn clockwise while the wrist joint

is also extending to position the object it is holding correctly before it is placed at its destination. If the wrist turning movement is completed before the rotation you must turn off the wrist motor or actuator while the other continues to run.

It doesn't matter that the software that you use to start controlling a robot is very simple. There is a sense of wonder when you press a key on the BBC micro and see this translated into a movement of something that you have built. The excitement of making the first steps will lead you quite certainly into developing more complex and capable software.

The electronics of controlling a robot or some other machine can be as sophisticated or as simple as you like. The interface that I built is very primitive indeed but it works and could be developed further.

Most of the components for the interface came from the local Tandy shop. I don't like going to Tandy's particularly because their electronic bits and pieces are more expensive than they should be, but otherwise you may have to order what you want by mail. You will need a lead to plug into the BBC micro user port — 20 way ribbon cable and one, preferably two, 20 way insulation displacement plugs — IDC plugs. I used a small piece of Veroboard to mount the interface components and bought a 20 way socket to connect to the remote end of the lead from the BBC computer.

The VIA in the computer will not drive the motors in the Robotix kit directly. The reasons why not, and some commercial alternatives to doing it yourself, are well explained in Richard Pawson's excellent book *The Robot Book* published by Windward — W H Smith and Son Ltd — ISBN 0 7112 0413 6. I decided to use

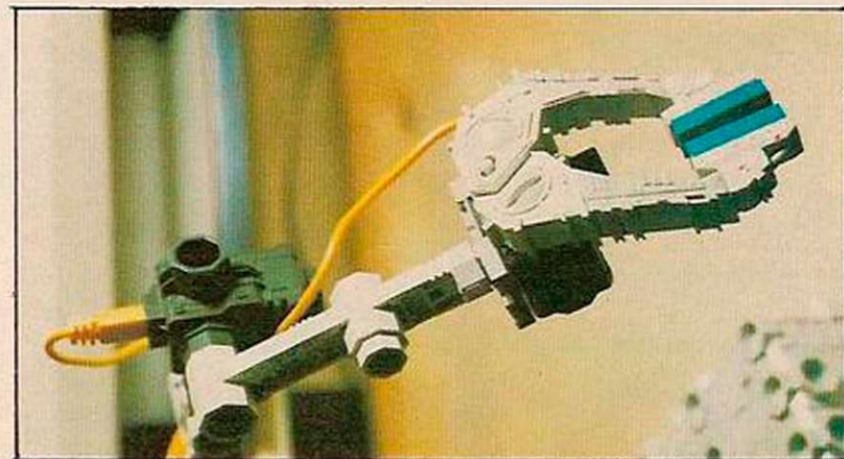

(continued on page 71)

Released early
January '86

In the beginning
was Quasimodo...
then came his
"Revenge"... now
you can take a swing
into...

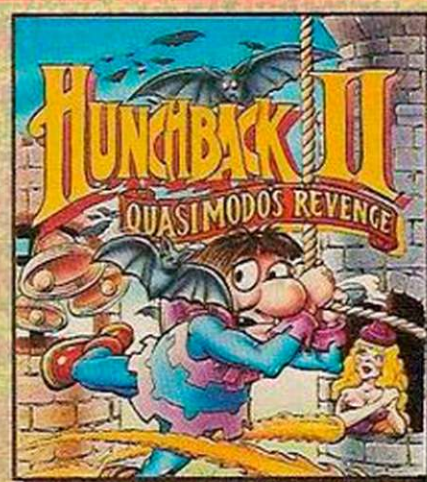

ocean

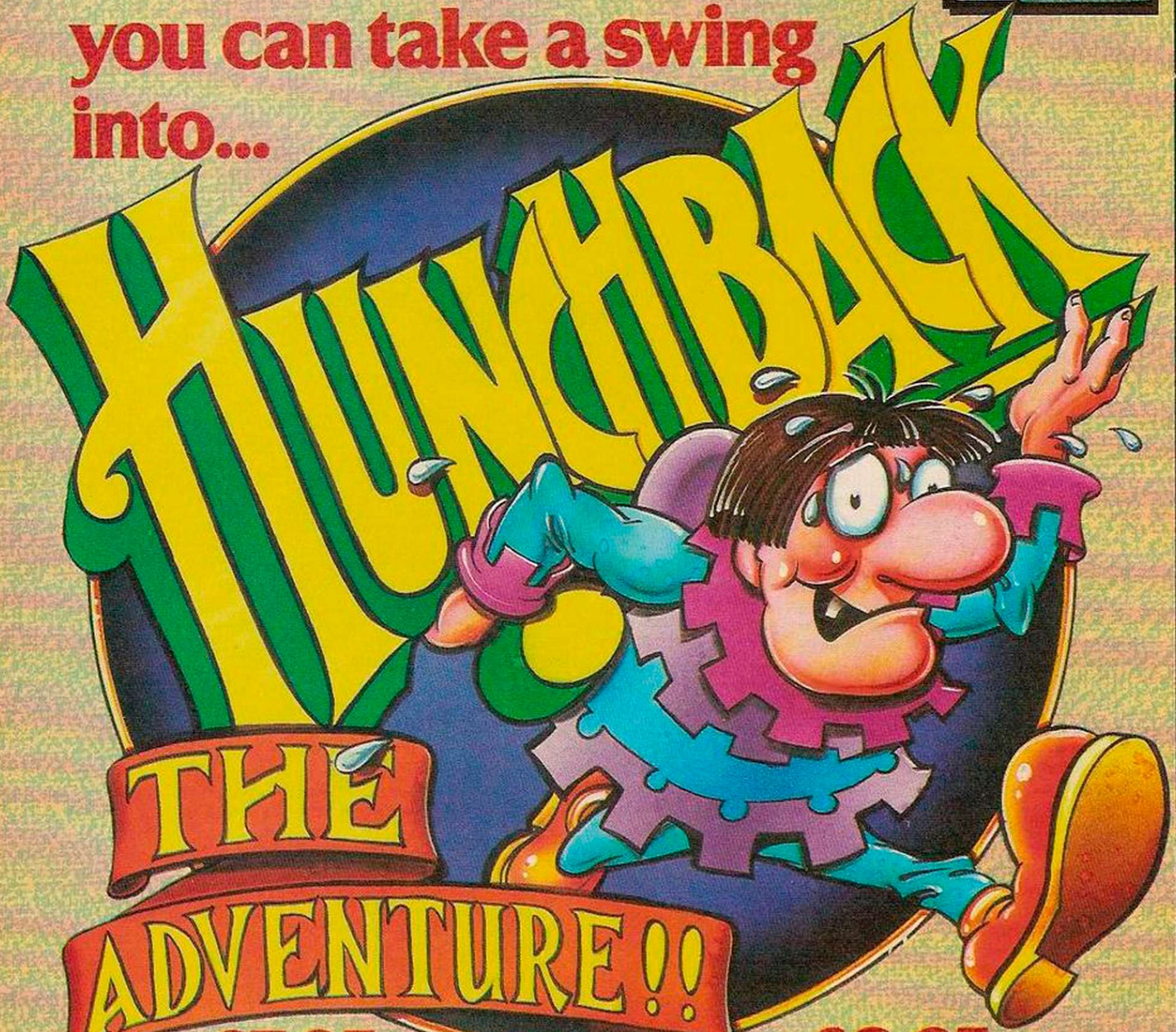

£7.95

SPECTRUM 48K

£8.95

AMSTRAD
COMMODORE 64

Ocean Software Limited
6 Central Street · Manchester

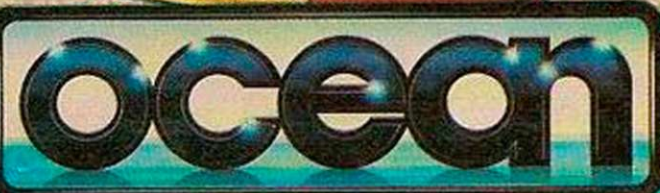

Telephone: 061 832 6633
Telex: 669977

Ocean Software is available from selected branches of: *Boots*, WHSMITH, John Menzies, WOOLWORTH, LASKYS, Rumbelows, Greens, Spectrum Shops and all good software dealers. Trade enquiries welcome.

Robot kits

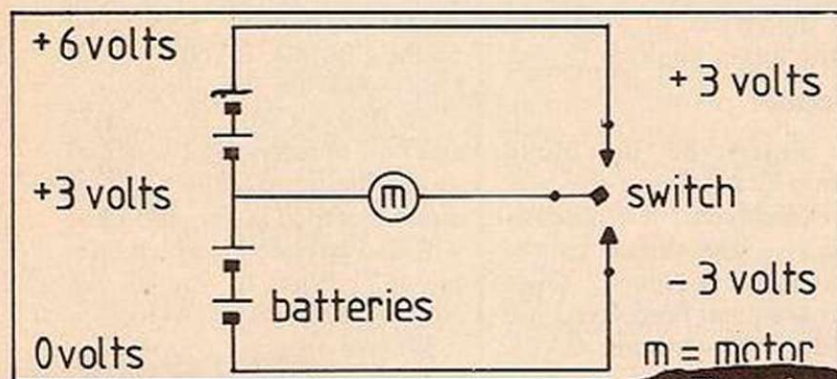

Figure 3.

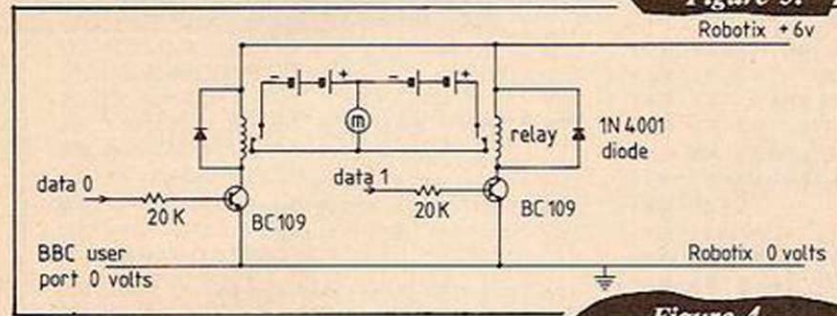

Figure 4.

(continued from page 69)

ordinary relays to switch the motor power supply because they provide good isolation between the electrically noisy motor circuits and because they make reversing — rotating the motor in two directions: forward and reverse — far easier than doing the same thing using transistors.

The circuit diagram of the original Robotix switches is shown in figure 3. You can see that one side of the motor is connected to the middle of the four 1.5 volt batteries. Pressing on the rocker switch connects the other side of the motor to either end of the stack of batteries — 3 volts positive or 3 volts negative — which makes the motor rotate clockwise — forward — or anticlockwise — reverse. When the switch is left untouched it is not connected to either the positive or the negative supply.

The interface is designed simply to replace the two actions of the switch and figure 4 shows the circuit diagram. The test version that I built and that is shown in the photographs can control only one motor. You can control four motors using eight relays by duplicating the circuit and connecting each input to a transistor to one of the data lines from the user port.

Alternatively, you can use some of the data lines to switch other devices like electro-

magnets for lifting things, light bulbs, solenoids to open or close gates, and motors that have to turn in one direction only. Darlington transistors — the TIP 120 and TIP 125 are typical — can be connected to the data lines and, because the transistor has a very high gain of more than 2000, can control directly a Direct Current (DC) load of up to four or five amps at 50-60 volts. So, if you have one or two motors in the Robotix kit these can be supplemented by other devices that you make yourself.

The 20K Ohm resistor — 20,000 Ohms — between the user port line and the base of the transistor prevents an excessive current being drawn from the VIA in the computer. The relay requires about 70 mA at 5 volts to operate reliably and the BC109 NPN transistor uses the voltage change on the data line to switch hard on and hard off, turning the relay on and off as

it does so.

Any general purpose NPN transistor will do for this application provided that its maximum collector current is sufficient and that it has a DC gain of more than 60. The 1N4001 diode is connected across the coil of the relay to prevent a spike of reverse voltage which might destroy the transistor when the current through the relay is turned off.

I can never remember which way round diodes should go and for this application the band round the diode, which marks the positive end or anode, should be soldered to the side of the coil connected to the positive supply.

The batteries in the Robotix kit are used to supply power to the transistor/relay circuit. With the exception of the Tandy relays, the cost of the interface can be counted in pennies. You don't need the IC socket shown in one of the photographs, it was part of my experimenting with an opto-isolator on the way to the interface given in figure 4.

I guess that it will take you a little while to get over the thrill of seeing a buggy or a robot arm moving under the control of pressing keys on the BBC micro. But what would happen if the Robotix machine disappeared out of sight? You are responsible for every move that the machine makes and it's your eyesight that is closing the loop that runs from the BBC micro keyboard to the VIA, to the interface, to the motors, to your eyes and back to the keyboard through your fingers.

If the computer could detect when a robot arm had reached the right place, it could then take the appropriate action

CONCLUSIONS

- The Robotix motor and "hand" lifted a solid glass ball about 1.5 inches in diameter. The ball weighed approximately 4 ounces. That was the heaviest object I tried to hold in the soft rubber palms of the plastic fingers. Six revs per minute doesn't sound very fast but the end of an extended robot arm will complete 90 degrees of rotation in 2.5 secs — quite fast enough if you are trying to position the hand over something you want to pick up.

- The design of the Robotix component is clever and it would be good to see a firm producing sensory add-ons for the kits. Flight Electronics have been marketing robotic equipment to connect to the Micro-professor range of computers.
- You won't make a fortune, I don't think, with a robot built out of Milton Bradley parts and run by your BBC microcomputer but you can't fail to enjoy watching a mechanism you have designed and built being controlled by software you have written.

without your invitation.

Motors, loudspeakers and electromagnets are called "effectors" because they allow a robot to effect an action or movement. Position detectors such as microswitches, potentiometers, ultrasonic rangefinders and photocells, and other measuring devices like temperature probes are known as 'sensors' because they sense or detect information which can be used by the robot's computer to make decisions.

For example, a simple micro-switch mounted at the front of a remotely controlled turtle or buggy can be made to switch on when the buggy collides with an object. The Adval command in BBC Basic can be used to detect the On/Off status of two input lines — intended originally for the fire buttons on joysticks — as well as to read the values of the four analogue to digital converters.

Related to the Milton Bradley Robotix kits, the Adval instruction could be used quite easily to read the position of four potentiometers monitoring each of the four motors in the Master set while one of the switched inputs could be connected to a microswitch mounted so that it is turned on when an object is held securely between the fingers of the motorised "hand".

No special electronics are required to couple the potentiometer to the A-D inputs.

Beyond this you can start to make up sensors and designs to suit your own purposes. For example, you may wish to weigh a number of packages as they pass along a conveyor belt.

The weight of the package, in terms of either too light or OK, can be detected by using rubber bands to bias a microswitch so that it closes only when the tension in the cord supporting the electromagnet is more than a certain amount. If the package is too light the arm can be used to lift it off the conveyor belt.

Wychwood, the plotter control program described in the October and November, 1985 issues of *Your Computer*, could be adapted without difficulty to work through a series of instructions to make a robot carry out a set process. ●

Telsoft

The programs given here will enable Spectrum, BBC, and CBM-64 owners to download via Your Computer's Telsoft service. Each month for each machine we transmit least one — and usually two — of the main programs appearing in the current issue. Also available is the full user to user communica-

tions program Dialsoft. So far OE LTD's Telemod 2 and the VTX 5000 modems have been tested with the BBC and Spectrum but the service also works with a number of other makes. For the CBM-64 it will initially only be available with the OEL Comms pack together with the Telemod 2 or similar modem; later we hope to

adapt the service to work with Commodore's modem.

Hexloader

To enter the download program first type in the hexloader for your machine — figure 1 — and then enter the machine code — figure 2. Once the program has been saved you can run it by entering CALL

&6000 on the BBC, SYS 51000 on the CBM 64, RANDOMIZEUSR 60000 on the Spectrum.

To find out what is available and how to receive software dial up Colchester (0206) 8068. This audio recorded information line will also advise you which telephone numbers to ring for the 300 and 1200 bits/ services.

When a program you want to

Figure 1. CBM-64.

```

5 REM HEX LOADER FOR CBM 64 FIG. 1
6 REM
10 FOR I=680 TO 727:READA:POKEI,A:T=T+A
20 NEXT I:IF T=6716 THEN GOTO 100
30 PRINT"ERROR IN DATA ".T=6716:END
40 DATA 169,1,133,186,169,1,133,184
50 DATA 133,185,169,8,133,183,169,208
60 DATA 133,187,169,2,133,188,169,56
70 DATA 133,251,169,199,133,252,169,251
80 DATA 162,231,169,206,32,216,255,96
90 DATA 68,79,87,78,76,79,65,68
100 SA=51000:LA=52855
110 INPUT"START ADDRESS":A
120 IF (ACSA) OR (ACLA) THEN GOTO 140
130 IF A/8=INT(A/8) THEN GOTO 150
140 PRINT"PRINT ADDRESS ERROR":GOTO 110
150 T=(A-32768)AND255:PRINT:INPUTD#
160 IF D#="END" THEN GOTO 900
170 IF LEN(D#)=20 THEN GOTO 190

```

```

180 PRINT"WRONG LENGTH":GOTO 150
190 FOR B=0 TO 7:BS=MID$(D#,2*B+1,2)
200 GOSUB 300:IF E=1 THEN GOTO 280
210 POKE A+B,D:T=T+D:NEXT
220 BS=MID$(D#,18,3):GOSUB 300
230 IF E=1 THEN GOTO 280
240 IF T=D THEN GOTO 260
250 PRINT"CHECKSUM ERROR":GOTO 150
260 A=A+B:IF A<LA THEN GOTO 150
270 GOTO 800
280 PRINT TAB(8+2*B+D)C;"??"
290 B=8:NEXT GOTO 150
300 E=0:D=0:FOR N=1 TO LEN(B#)
310 C#=MID$(B#,N,1):GOSUB 400
320 IF E=1 THEN D=N:N=4:NEXT:RETURN
330 D=D+16*X:NEXT:RETURN
400 X=ASC(C#)-48:IF X<0 THEN E=1:RETURN
410 IF X<10 THEN RETURN
420 X=X-7:IF X<10 THEN E=1:RETURN
430 IF X<15 THEN E=1
440 RETURN

```

```

500 H#="0123456789ABCDEF"
510 FOR A=SA TO LA:STEP 8
520 PRINT A:"? ".T=(A-32768)AND255
530 FOR B=0 TO 7:X=PEEK(A+B):GOSUB 600
540 T=T+X:NEXT:PRINT" ".
550 Y=INT(T/256):PRINT MID$(H#,Y+1,1).
570 X=255 AND T:GOSUB 600:PRINT
580 NEXT GOTO 900
600 PRINT MID$(H#,INT(X/16)+1,1):
610 PRINT MID$(H#,1+(XAND15),1):RETURN
800 SYS 600:C#=CHR$(34)
810 PRINT PRINT" 10 RELOAD CODE "
815 PRINT PRINT" LOAD"C#"DOWNLOAD".
820 PRINTC#".1.1 (RETURN)"
825 PRINT PRINT" THEN TYPE NEW".
830 PRINT" (RETURN)"
835 PRINT PRINT"TO RUN THE PROGRAM".
840 PRINT" SYS 51000 (RETURN)".
900 PRINT PRINT"1 ENTER DATA"
910 PRINT PRINT"2 PRINT DATA"
920 PRINT PRINT"3 SAVE DATA"
930 INPUT Z:ON Z GOTO 100,500,800

```

Figure 2. CBM-64.

51000 ? A9068021108020D0=3E2	51456 ? C8A008070CE8C7D=447	51920 ? CEADCFCE8D10CARD=401	52384 ? A90C20BCC20950C=46D
51008 ? A90F8D8602A90E20=2E4	51464 ? CE20D2CBB0F091FE=5BF	51928 ? D0CE8DD2CE18ADD1=639	52392 ? 60A9058E81CEAAA9=4E6
51016 ? D2FFA9008D15D0A9=4DD	51472 ? 202ECCC8C77CED0=4D3	51936 ? CE6DCFC8E8DCFEAD=68F	52400 ? 2020D2FFCFD0FAFE=603
51024 ? FF8D8A02B8AE92CE=510	51480 ? F020D2CBB0E00D7C=59E	51944 ? D2CE6DD0CE8DD0CE=6BE	52408 ? 81CE600914F008C9=505
51032 ? 20C0C92007CE20F8=4D5	51488 ? CEF008A95820D2FF=4D8	51952 ? 8005CECECEDEE660=625	52416 ? 7FF00160A91460A9=456
51040 ? CADD80CE931F023=532	51496 ? 4C57C820D2CBB0CE=40E	51960 ? 20630CA90F8D8602=414	52424 ? 7F6020E4FFC9C190=504
51048 ? C935F0140936D006=43F	51504 ? CD7DCEFA034C23C9=473	51968 ? A95185FDA9C8D5FE=575	52432 ? 07C9D8B00338E960=4AF
51056 ? 208EC74C5BC7A914=410	51512 ? 20A0C82030C8AD75=409	51976 ? A000209DCC2025C0=343	52440 ? 60C941900EC95B90=494
51064 ? 20D2FF202FCB00DB=52E	51520 ? CE8A90099930EAD=506	51984 ? 209DCC209DCC209D=3DF	52448 ? 08C9619006C97BB0=49C
51072 ? 203FC8A92020D2FF=461	51528 ? 84CE9020D2CBB0CE=436	51992 ? CC2022CD20A9CC20=3A6	52456 ? 02492060488A8008=2D5
51080 ? 4C93C94C4AC82063=411	51536 ? CBA9C820F3CBA955=568	52000 ? 95CC2022CD20950C=411	52464 ? 20E1FFD0034C50C8=533
51088 ? CC2022CD20A95F85FD=4F1	51544 ? 2016CDA95020F3CB=432	52008 ? 202FCB20D2FF608E=421	52472 ? 2868AA6860AD00DE=485
51096 ? A9CE85FE2028CDA0=547	51552 ? 20C70C8C73CE888=54F	52016 ? 81CE8C82CE2069C0=4B0	52480 ? 49016A9003A90060=250
51104 ? 0020950C202FCBC9=404	51560 ? B993CED02398D0F7=5D4	52024 ? 20ECCC20CACC900=48F	52488 ? AD01DE6048AD00DE=327
51112 ? 44F00BC954D0ED20=4E1	51568 ? 4C5BC7A9552016CD=3DF	52032 ? D00D20FD0CC931F0=4F0	52496 ? 49026A6A6860200C=203
51120 ? D2FFA901D007A944=4EF	51576 ? 20F1CB4C63C9AC77=4EF	52040 ? 0620010C4035C8B0=314	52504 ? CDB0FB8D01DE20EC=508
51128 ? 20D2FFA90885BA20=4B9	51584 ? CE20D2CBB0D0FA20=57D	52048 ? 80CEAE81CEAC82CE=597	52512 ? 0C602025CD2028CD=373
51136 ? 25CDA90820A8C0A9=4A3	51592 ? D2CB20D2CB4C7C9=53E	52056 ? 60AE92CE9A4C5B07=4CE	52520 ? A90D20D2FF604829=3A0
51144 ? BD85FDA90D85FEA0=6A0	51600 ? 4C5CC8A52B85FBA5=4F5	52064 ? 2022CD20A920950C=411	52528 ? F06A6A6A6A0930C9=30A
51152 ? 0020950C2025C0D0=383	51608 ? 2C85F0A000B1FB99=52A	52072 ? CE85FEA00020950C=4DA	52536 ? 3A300318690720D2=21F
51160 ? 95CC9848A0048C83=4CC	51616 ? 2200C8B1FB8523F0=4CE	52080 ? 2025CD20FA92099=393	52544 ? FF68290F0930C93A=318
51168 ? CE20D0C968A92025=4C4	51624 ? 0BA52285FA52385=447	52088 ? 93CE88D0FA8D93CE=619	52552 ? 300318690720D2FF=2F4
51176 ? 0D20950C9848A906=4C5	51632 ? FC4C9BC918A5FB69=57D	52096 ? 202FCBC914D010C0=417	52560 ? 60444F574E4C4F41=2C4
51184 ? 8D83CE20D0C9ADA7=5E3	51640 ? 0285D0852F8531A5=37B	52104 ? 00F0F520D2FF68A9=58F	52568 ? 44204D454E552131=243
51192 ? CE85FBAD80CE85FC=6EA	51648 ? FC690085E2853085=412	52112 ? 209993CE4C80C0C9=50A	52576 ? 2020205245434549=228
51200 ? 68A82060CBA90185=38A	51656 ? 326020630CA9028D=3E1	52120 ? 0DF00B20D2FF9993=4BD	52584 ? 5645213520202045=1FE
51208 ? B885B998A293A0CE=539	51664 ? 84CEA908D02DE60=4A3	52128 ? CEC8C01D0D0A9A20=579	52592 ? 58495420544F2042=28A
51216 ? 20BDFFAEA90CEA8A=567	51672 ? 8E81CE8C82CE200A=533	52136 ? 20D2FF60A92020D2=484	52600 ? 4153494321362020=22F
51224 ? CE8D001C82025CD=479	51680 ? A9098D0CCE202FCB=4D4	52144 ? FFA94F2D02FFA94B=58C	52608 ? 2053415645204259=28A
51232 ? A9FB20D0FF20F1CB=597	51688 ? C914F016C90DF051=4E2	52152 ? 20D2FF60A9138D00=452	52616 ? 5445532128205553=285
51240 ? 6020D0C0C90D000B=3FE	51696 ? C924D01920D2FF8D=544	52160 ? DEA9128D00DE60A9=4CD	52624 ? 4520122053544F50=26D
51248 ? A90085C7A92020D2=3E0	51704 ? C3CEE84CE5C9E000=64B	52168 ? 538D00DEA9528D00=40E	52632 ? 209220544F205245=2C4
51256 ? FFA90D20D2FF60A9=4E7	51712 ? D0E3E000F0DF20D2=554	52176 ? DE60A996188D87CE=547	52640 ? 545524E20544F20=2CC
51264 ? 0D2029C8A90D20D2=306	51720 ? FFC84CE5C9C93090=554	52184 ? 8C82CEAC82CE2004=4D4	52648 ? 4D454E5520292145=28C
51272 ? FF6020630C0A00A9=43F	51728 ? D4C93A901548ADC3=444	52192 ? CC20EAC0CE87CED0=677	52656 ? 4E54455204E554D=2F9
51280 ? FF9993CEC8D0FA20=5FB	51736 ? CEC924F004684CE5=460	52200 ? 02386020FDCC0EE=509	52664 ? 424552021494620=281
51288 ? D2CB90FB20D2CBB0=5ED	51744 ? C968C94190BFC947=4BA	52208 ? 60A9FAC82CEA820=597	52672 ? 414445245535320=2E6
51296 ? FB8D72CEA0008C7C=4D0	51752 ? B0BB20D2FF38E930=4D5	52216 ? 04CC88D0FAAC82CE=616	52680 ? 195320494E204845=2C8
51304 ? CE8C7DCE202ECCAD=4D4	51760 ? C90A9002E907E005=36A	52224 ? 602004CC8A8208CA=3EE	52688 ? 582C119D9D9D9D9D=476
51312 ? 72CE29F0C980D0E4=5C6	51768 ? F08B9D03CE824CE5=61A	52232 ? D0FDA82069C0E020=454	52696 ? 9D9D9D9D9D9D9D9D=5C0
51320 ? 20D2CBB0DA9973CE=599	51776 ? C9E000F0A0E001D0=52A	52240 ? 25CDA90220A8CC20=364	52704 ? 9D9D9D9D50524546=481
51328 ? C8202ECC0009D0F0=4EB	51784 ? 07ADC30CE924F095=4FF	52248 ? 95CCAD8E0CE20D2FF=573	52712 ? 4958205749544820=305
51336 ? A000AD76CE298D00=492	51792 ? A92020D2FFA9FF9D=54F	52256 ? A92020D2FFA90320=3A6	52720 ? 2421535441525420=2E3
51344 ? 0FA52B85FB18A52C=3D8	51800 ? C3CEA2008E0CFCE8=544	52264 ? ABCC20D0C9604D7D=48A	52728 ? 414445245535320=31E
51352 ? 6D75CE85FC4C8A0C=587	51808 ? D0CE8ED10CE8D2CE=659	52272 ? CE8D7DCEA208AD7D=4FA	52736 ? 464F522041524541=220
51360 ? AD78CE85FBAD79CE=607	51816 ? ADC30CE924D006A9=512	52280 ? CE2A9010AD7DCE49=411	52744 ? 202146494E414C20=1D3
51368 ? 85FC20D2CBB0820=55E	51824 ? 0F8DC0CE8BDD3CE=5D0	52288 ? 088D7DCEAD7DCE49=460	52752 ? 414445245535320=236
51376 ? D9CC20D2FFC820D9=607	51832 ? C9FFF01D20C8C8A9=5B2	52296 ? 108D7DCE2E7DCE2E=3D5	52760 ? 464F522041524541=236
51384 ? CC202ECC010D0EA=528	51840 ? 3418D0C30CE6D0CE=524	52304 ? 7DCEAD0E160A000=516	52768 ? 202150524F475241=22C
51392 ? A92020D2FFAD75CE=56A	51848 ? 8D0CEA9006DD0CE=566	52312 ? A9009900D40C018=40E	52776 ? 4D205449544C4520=237
51400 ? 202ECC20D2CBB087=4D7	51856 ? 8DD0CE8020E84C75=534	52320 ? D0F660A99320D2FF=5B3	52784 ? 284D415820313620=1E5
51408 ? CD70CEFA08A95820=503	51864 ? CAD0CFEAC830E99=642	52328 ? 6048A5A2290FD01F=37E	52792 ? 4348415227532920=219
51416 ? D2FF2030C84C57C8=52C	51872 ? A3CEC8ADD0CE99A3=660	52336 ? ASD448A5A22910F0=4A1	52800 ? 21124E4F54205641=21B
51424 ? 20D2CBB0F8CD7DCE=65D	51880 ? CE8188C830EAC82=561	52344 ? 05A9A44C800C8A920=42B	52808 ? 4C4944922C205452=2A5
51432 ? D0E8AD75CEA8E993=637	51888 ? CE881CE602025C0=4ED	52352 ? 20D2FFA90085D4A9=51C	52816 ? 5920414741494E20=249
51440 ? CED00E2030C9A991=4EE	51896 ? A200D41CE0921F0=500	52360 ? 9D20D2FF6885D468=53F	52824 ? 3A20214449534320=216
51448 ? 20D2FF4C7FC4C57=51F	51904 ? 0720D2FF684C8ACA=570	52368 ? 6020D2FFC8B1FD09=620	52832 ? 4F52205441504520=26B
	51912 ? 4CDEC9ADCCE8DCE=65E	52376 ? 21D0F6C8602025CD=489	52840 ? 2820442F54202920=1E0
			52848 ? 3F21000000000000=0D0

A reminder of how to use the Telfost service.

download is on line, make sure your modem is set up and dial the number appropriate to its speed. As soon as you hear the modem tones switch the modem to line and replace the receiver. Select Option 1 from the menu — Receive. After a block of data is received you will see "OK" printed if there are no errors, otherwise the program

will wait for the blocks to come round again. When the "Program loaded OK" message appears return to the Telfost menu and select Option 5. You can now save and run.

Option 6 for CBM-64

Note that CBM-64 owners will need to use Option 6 if machine code is to be saved.



Figure 1. BBC.

```
10 REM BBC HEX CODE LOADER
15 HIMEM=&69FF
20 CLS:PRINT
30 INPUT " START ADDRESS (Hex)";A$
40 A=EVAL("&"+"A$")
50 IF A>&6F87 THEN 280
60 IF A<&2A00 OR A>&6FE7 THEN 20
70 PRINT "A " ;
80 INPUT " : " B$,C$
90 IF LEN(B$) <>16 THEN 50
100 T=0
```

```
110 FOR N=0 TO 7
120 X$=MID$(B$,2*N+1,1):GOSUB 300
130 IF E=1 THEN 260
140 X$=MID$(B$,2*N+2,1):GOSUB 300
150 IF E=1 THEN 260
160 B=EVAL("&"+"MID$(B$,2*N+1,2)")
170 ?A=B:A=A+1:T=T+B
180 NEXT
190 FOR M=1 TO LEN(C$)
200 X$=MID$(C$,M,1):GOSUB 300
210 IF E=1 THEN A=A-1:GOTO 260
220 NEXT
```

```
230 IF T=EVAL("&"+"C$") THEN 50
240 PRINT "CHECKSUM ERROR !"
250 A=A-8:GOTO 50
260 PRINT "TYPING ERROR !"
270 A=B*(A DIV 8):GOTO 50
280 *SAVE "DOWNLOAD" &A00 6F87
290 END
300 E=0:IF ASC(X$)<48 THEN E=1:RETURN
310 IF ASC(X$)<58 THEN RETURN
320 IF ASC(X$)<65 THEN E=1:RETURN
330 IF ASC(X$)>71 THEN E=1
340 RETURN
```

Figure 2. BBC.

```
6A00 :A9CBA0FEA20120F4,4C6
6A08 :FF20616C20486DC9,38A
6A10 :31F00BC934F8E9C9,4CB
6A18 :35F0084C0C6A4C7,200
6A20 :6AA90C20E3FA9E8,482
6A28 :A000A2FF20FAFA9,4FD
6A30 :03A2020F4FFA9A2,363
6A38 :A22220FAFFA9CBA0,4C9
6A40 :FEA2020F4FFA9A9,4BC
6A48 :0C20E3FF20F76BA9,439
6A50 :15A20120FAFFA080,3EB
6A58 :A9FFB899056FD0FA,507
6A60 :A915A20120FAFF20,394
6A68 :0C6C90F8200C6C80,34B
6A70 :F8A000847784788A,416
6A78 :79847A8478057020,38B
6A80 :056DA57029F0C980,489
6A88 :08E2200C6C80D099,46B
6A90 :7100C820D56DC009,364
6A98 :08F00000A5742908,422
6AA0 :0800A51C857618A5,354
6AA8 :1D65738577200C6C,289
6AB0 :888520E3FFC020D5,524
6AB8 :6DC01009F0A57320,435
6AC0 :826D200C6C80A0C5,3CC
6AC8 :7AF000A95820E3FF,478
6AD0 :20E7FF4C676A200C,34F
6AD8 :6C800CC57F80BA9,40C
6AE0 :5820E3FF20E7FF4C,4AC
6AE8 :676AA573A89956F,43E
6AF0 :0800E20E7FA90820,38B
6AF8 :E3FF4C636A4C676A,469
6B00 :A800047A847B200C,2C9
```

```
6B08 :6CB0F2917620D56D,477
6B10 :C8C475D0F1200C6C,45A
6B18 :80E3C57AF00BA958,4CE
6B20 :20E3FF20E7FF4C67,48B
6B28 :6A200C6C80CFC57B,3C1
6B30 :F000A95820E3FF4C,447
6B38 :676A20C76B20E7FF,429
6B40 :A573A8A90099056F,3F6
6B48 :A58AC902D05020D7,419
6B50 :68A9C82055CA955,38B
6B58 :20306EA95020556C,298
6B60 :A915A20120FAFF20,394
6B68 :F76BA471C8008985,505
6B70 :6FD05198D0F7A90C,4A4
6B78 :20E3FF20A56DA95A,437
6B80 :0502A96F8583A987,3D7
6B88 :20006E20F8AD20A8,2D8
6B90 :6DA9052000EA980,2DA
6B98 :20E3FF20F86DA9D2,582
6BA0 :20E0FF4C0C6AA955,3BF
6BA8 :20306EA95020556C,2DE
6BB0 :4C6A6BA475200C6C,2D2
6BB8 :88D0FA200C6C200C,316
6BC0 :6C4C48694C6C6AA9,336
6BC8 :2020E3FFA96F20E3,43D
6BD0 :FFA96820E3FF680A,51E
6BD8 :9CA000A680A0020A,41C
6BE0 :08A21320FAFFA212,307
6BE8 :20FAFF68A29723F4,4C8
6BF0 :E2A29620F4FF68A9,553
6BF8 :9CA000A680A0020A,41E
6C00 :EBA25320FAFFA252,4E7
6C08 :20FAFF6018A99685,44F
6C10 :8F847EA991A20820,38D
6C18 :FAFF8009C007D005,448
6C20 :68684C8C6AA47E20,2D4
```

```
6C28 :496CC60F00823868,374
6C30 :A58AC902D0062079,369
6C38 :6E80EC60A991A201,447
6C40 :20FAFF98A47E80DF,55C
6C48 :600AA2D2CAE8CAD0,5AA
6C50 :F8AA68A900847EA8,458
6C58 :2049C80D0FAA47E,449
6C60 :68A9E8A000A2FF20,452
6C68 :F4FFA900850AA90C,460
6C70 :20E3FF20A86DA90A,3E4
6C78 :20006EA9089582A9,2F0
6C80 :6F8583A00020F86D,39C
6C88 :20156DC941F008C9,378
6C90 :42F011C943F0174C,3A2
6C98 :616CA900A20120F4,335
6CA0 :FFAC766CA900A203,3C4
6CA8 :20FAFF4C676CA908,433
6CB0 :A28420FAFF68AA5,4CE
6CB8 :7C20E3FFA47E20A8,468
6CC0 :6DA90820006E20F8,2C4
6CC8 :6DA081720156DC94,200
6CD0 :F000C942F011C943,413
6CD8 :F0174C616CA907A2,372
6CE0 :0120F4FF4C096DA9,37F
6CE8 :07A20320FAFF4C09,314
6CF0 :6DA907A20420FAFF,3D6
6CF8 :E68AA58AL707D009,443
6D00 :A9E8A000A20120F4,3E0
6D08 :FFA57C20E3FF20E3,495
6D10 :6C20536C8020A86D,2E3
6D18 :A90520006E20F86D,2C1
6D20 :20A86DA90820006E,274
6D28 :20F86D20A86DA905,36B
6D30 :20006E20F86D20A8,2DE
6D38 :6D847EA99320006E,2A9
6D40 :A9D220E0FF857C68,4DB
```

```
6D48 :A90C20E3FF20A86D,3EF
6D50 :A90720006EA99A85,306
6D58 :82A96E8583A00020,361
6D60 :F8D20A86D020996D,3C0
6D68 :20996D20996D20A8,317
6D70 :6DA90A20006E20F8,2C6
6D78 :6D20A86DA9072008,278
6D80 :6E20F86D20A86D20,348
6D88 :E7FFA9D220E0FF48,5A8
6D90 :A907200020FAFF68,3D5
6D98 :68A90820006E20F8,287
6DA0 :6D20A86D6820A86D,35A
6DA8 :28A86D20E7FF20E7,445
6DB0 :FF68A29F06A6A6A,3FE
6DB8 :6A0930C93A300310,1F1
6DC0 :698720E3FF68298F,312
6DC8 :0930C93A30031069,1F8
6DD0 :0720E3FF68457885,3AE
6DD8 :78A20A57B2A900C,308
6DE0 :A57849888578A57A,398
6DE8 :4910057A267A267B,299
6DF0 :CAD0E86020E3FFC8,5AC
6DF8 :B182C90D006C860,4F7
6E00 :867DAAA9200E3FF,478
6E08 :CAD0FAA67D68C97F,55F
6E10 :D008A98620FAFF0E,4FD
6E18 :80081A2A97C9288B,3C3
6E20 :0EC90A0F08AC90DF,3A1
6E28 :86C907F002A90060,2D1
6E30 :857C867D847EA991,448
6E38 :A20120FAFFA983A2,484
6E40 :0720FAFFA996A208,403
6E48 :20FAFF9829820FA,48A
6E50 :A47CA997A20920F4,41F
6E58 :1FFA903A20420FAFF,464
6E60 :A991A20820FAFF08,49F
```

```
6E68 :09C007D00568064C,2C1
6E70 :0C6AA57C67DA47E,3DC
6E78 :68847E867DA996A2,446
6E80 :0820FAFF982981F0,3CD
6E88 :08A996A20920FAFF,408
6E90 :98189001386A7DA4,348
6E98 :7E68444F574E4C4F,281
6EA0 :4144494E47204D45,215
6EA8 :4E55803120202852,193
6EB0 :4543454956450034,1F2
6EB8 :202028534552042,1AE
6EC0 :6175642852617465,2E6
6EC8 :8035202820455849,188
6ED0 :5428544F20424153,200
6ED8 :494380454E544552,217
6EE0 :204E554042455200,1F6
6EE8 :2820555445204354,1EC
6EF0 :524C2D4720544F20,1F5
6EF8 :524555524E2054,234
6F00 :4F204D454E552029,1ED
6F08 :8053455420545241,208
6F10 :4E534D4954204261,24E
6F18 :7564205261746500,292
6F20 :4120282837352042,16F
6F28 :6175640042282033,1FC
6F30 :3838284261756400,209
6F38 :4320313230302042,188
6F40 :6175640053455420,253
6F48 :5245434549564520,223
6F50 :4261756420526174,2C3
6F58 :65080524F475241,23D
6F60 :4D20284C4F414445,1F2
6F68 :4420286F80D5052,200
6F70 :45535328414E5920,213
6F78 :48455928464F5220,218
6F80 :4D454E5500202020,1A2
```

Figure 1. Spectrum.

```
5 REM SPECTRUM 48k fig 1
10 REM Hex Code Loader
15 CLEAR 59000
20 POKE 23658,8:CLS:PRINT
30 INPUT "Start Address ";a
50 IF a>61135 THEN GO TO 280
60 IF a<60000 THEN GO TO 28
70 PRINT a;
```

```
80 INPUT " i";b$
85 IF B$="END" THEN GO TO 280
90 IF LEN b$<>20 THEN GO TO 260
100 LET t=a-256*INT(a/256)
110 FOR n=0 TO 7
120 LET x=b$(2*n+1)+B$(2*n+2)
125 GO SUB 300:LET y=x
130 IF e=1 THEN GO TO 260
140 LET x=b$(2*n+2)+B$(2*n+1)
145 GO SUB 300:LET y=y+16*x
```

```
150 IF e=1 THEN GO TO 260
170 POKE a,y:LET a=a+1
180 LET t=t+y:NEXT n:LET y=0
190 FOR e=1 TO 3
200 LET x=b$(17*n TO 17*n+1)
205 GO SUB 300:LET y=y+16*x
210 IF e=1 THEN LET a=a-1:GO TO 260
220 NEXT n
230 IF t=y THEN PRINT " i";b$:GO TO 50
```

```
240 PRINT "Checksum Error"
250 LET a=a-8:GO TO 50
260 PRINT "Typing Error"
270 LET a=INT(a/8):GO TO 50
280 SAVE "download"CODE 60000,1136
290 POKE 23658,0:STOP
300 LET e=0:LET x=CODE x$-48-7*(x$>'9')
310 IF x<0 OR x>15 THEN LET e=1
320 RETURN
```

Figure 2. Spectrum.

```
60200 :CD15EDC307ECCD15,4C7
60208 :EDCD36ECCD66EDCD,631
60216 :50EDCD47EE38FB9C,5AF
60224 :8BEDFE31CA99EAFA,69A
60232 :35CAB7EAC366EACD,5D8
60240 :15ED3EFA00B4EDCD,5FD
60248 :15EDC9CD15EDC366,553
60256 :EACD66ED11E5EE06,58C
60264 :803EFF121310FCCD,45B
60272 :15EE11CDE0E6173E,3D2
60280 :20121310FCCD1FEF,3DA
60288 :30F0C050EDCD1FED,58B
60296 :38FB3265EF3E0032,3E9
60304 :6CEFF326FEF3270EF,544
60312 :3A65F0CDEBEC3A65,5A1
60320 :EFA6F0F08020DE0E,627
60328 :09116E5FCD1FEDDA,501
60336 :AAEA1312CDEBEC0D,552
60344 :28F23A69FEF68020,51A
60352 :0D214853CA68FE0E,3DC
60360 :084709226BEF0E00,16A
60368 :11CDECD1FED39FA,47F
60376 :12130CDEBEC3789E,45C
60384 :1820F03A68EFCDB1,447
60392 :ECCD1FEDDA00A21,574
60400 :6FEFBE28133E5811,326
```

```
60408 :E0EE12133E0012CD,348
60416 :D7ECCDA6ECC3AAEA,681
60424 :CD1FEDDA00A2170,518
60432 :E0E30E121E5EE3A,524
60440 :68E8F56F3E00C67,3CC
60448 :3E008E200BCDD7EC,40F
60456 :3E2132083CC3FFEB,482
60464 :3E00326FEF3270EF,3C7
60472 :ED5B6BEF0E00CD1F,48C
60480 :EDDA00A3273EFC0,634
60488 :EBEC3A68E008020,586
60496 :053A69FEF6803A73,432
60504 :EF12130C3A6A8F9,3FC
60512 :20DCDD1FEDDA00A,5DB
60520 :216FEFBECD22DE0C,584
60528 :1FEDDA00A2170EF,5A2
60536 :9ECC22DEB3E0F32E,589
60544 :EE3E6B32E3E3E00,498
60552 :32E4EE3A0883CE21,501
60560 :2803CD15EEDD7E0C,553
60568 :CDA6EC21E5EE3A68,5C5
60576 :EF856F3E008C6736,422
60584 :0021E5EED4B66EF,561
60592 :0C7EFE00C28DEA23,4FC
60600 :8D20F63EACD84ED,589
60608 :3E01D3FEC366EACD,5E8
60616 :1FED30FBC30EAF3,594
60624 :0603AFD3FF10FB3E,3DB
60632 :40D3FF3E007D3FF,56F
```

```
60640 :31D3FF3E007D3FF,56F
60648 :328D5C32485C3E01,250
60656 :D3FE21915CC89E5F,568
60664 :C850EDC366EACD,52F
60672 :EECD66ED3E01D3FE,556
60680 :2165EE3E00C0DFEC,442
60688 :CD84ECCDA3ECCDA6,654
60696 :EC23C77ECCD77E,58F
60704 :CDA8ECCDB4ECCDA6,661
60712 :E8233E0DC0DFECCD,4CF
60720 :84EC23CDA3ECC3E03,498
60728 :CDBFECCDB4ECC9CD,688
60736 :A3EC3E07CDBFECCD,561
60744 :84EC23C97E00C8,528
60752 :C823E0DC0DFECCD,4CF
60760 :1008BF53E2CDBED,528
60768 :F13DC30FECDDA0E,65D
60776 :CDA3ECCDA6ECC3E0,5A6
60784 :CDBED3C97E00C8,528
60792 :C9F513E6F0C81F0C,68C
60800 :1FCB1FCB1FF68FC,68C
60808 :3AFAC6ECC6071213,498
60816 :F1E0FF630FE3AFA,686
60824 :DAECC6071213C921,46C
60832 :CDEE5CDB4ECC186,69C
60840 :173E20772310FC3E,339
60848 :0077C9E52170EFAE,538
60856 :77C50E087EA7C817,449
60864 :300D7EE080773A6F,3C9
```

```
60672 :EFEE10326FEF3721,3D5
60680 :6FEFCB1623CB160D,358
60688 :20E2C1E1C9110501,394
60696 :181E00C0D8503C93E,32F
60704 :963277EFCDA7EDDA,529
60712 :2EEDF1C366EACD,5C0
60720 :ED7BE681F682D3FE,548
60728 :AF2177EF3200237,2FC
60736 :C9CD77ED38EBC9CD,5F0
60744 :47E00FECBC037C9,5E6
60752 :F30BFF3A81E0FE00,5C7
60760 :28843E3618023E37,187
60768 :D3FFD87FF1C9F53A,675
60776 :81E0FE0028043E36,376
60784 :D3FFCD50EDF1C93E,644
60792 :080BFF6E0837C8B8,59,
60800 :1FFE6237C8D8F0E,626
60808 :3020840B7FA7C93A,3E0
60816 :81E0FE0028043E37,397
60824 :18023E36D3FFD87F,452
60832 :1C9CD47ED3A73EFD,5DE
60840 :F1C366EAF53ED23D,5EE
60848 :28DF1C9CDACED3D,62A
60856 :20FAC95D05E5F5FE,78D
60864 :7F2813CDF9EDFE0C,537
60872 :288C80D28053E28,28A
60880 :D73E0DD710103E28,34F
60888 :073E0DD73A8053FE,4E8
60896 :2128033E0DD73E5F,2E6
```

```
60904 :D73E0DD71E1D1C1,648
60912 :C9FE072B1CFECC28,4F3
60920 :19FE0C2014FE0828,388
60928 :10FE00C0D8503C93E,367
60936 :08FE0E08FA11EE3E,48A
60944 :80C93E07C9CD688D,32C
60952 :3E02CD01163E1832,1C4
60960 :895CC93E121681CD,352
60968 :1122C93E121680CD,287
60976 :1122C93E05E53E02,3E8
60984 :CDB116CD47EE38F8,451
60992 :CD5CEE1D1C1C93A,5CD
61000 :385CC86F280C3A08,28F
61008 :5CF521385CCBAEF1,4C3
61016 :A7C937C9F5111000,3DE
61024 :CD10EDF1E0C444F57,484
61032 :4E4C4F4144494E47,284
61040 :284D454E55003128,216
61048 :2820524543454956,276
61056 :4508332028204578,217
61064 :697428726F2846F20,328
61072 :7369638028205573,2DF
61080 :652053796D626F6C,393
61088 :285368696674202D,388
61096 :284708746F205265,2C9
61104 :747526E20746F20,39C
61112 :40454E5528290845,278
61120 :4E54552804E554D,389
61128 :4245522000000000,1C1
```

Cruncher

Terence Simmons presents a spreadsheet program for the Spectrum with many important features including individual cells and windows

Number cruncher is a spreadsheet program for the 48K Spectrum with the following features.

- Labels and formulae may be entered into a matrix of up to 26 rows by 24 columns and referenced to one another, thus enabling scientific, financial, mathematical and other tables or complex models to be generated.
- Individual "Cells" are selected for data input by moving a cursor about the screen. Numbers and formulae may be changed at will on the spreadsheet, which can then be

rapidly recalculated; this enables all kinds of "What if" situations to be evaluated.

- The program utilises Paul Rhodes' "Character Print" routine — YC, October 1984 — to give about 50 characters per line and enable a 6 column by 20 row "window" on the matrix, in which the labels, and values relating to formulae entered, are shown.
- All Spectrum maths and logical functions are supported. The contents of cells may be edited similarly to Basic program lines.
- Formulae may be replicated relatively or absolutely. Columns and rows may be inserted or deleted and calculation references in the cells moved are automatically adjusted to maintain the spreadsheet integrity.
- The spreadsheet may be recalculated repeatedly to enable iterative solutions.
- Titles may be set.
- A hard copy of the entire

spreadsheet is obtained on a ZX-compatible printer, by printing the columns out sideways.

The program may be entered by first typing out the Basic Listing 1; save this on tape and New the computer. Then enter listing 2 and run it. The program pokes in the hex code, which consists of the sideways character set, print routine and proportional characters, at the addressed prompted.

Save the code with the command.

SAVE "chars" CODE 62900,2380

When the complete program is it will auto-run from line 7900 and present a Menu of available commands which are discussed below. Pressing any key then presents a blank spreadsheet with two axes; the vertical one shows a series of alphabetical characters referring to the

Rows, while the numbers on the horizontal axis designate the first six columns.

The green cursor in the top left-hand corner relates to cell A (1). The cursor may be moved about the screen to refer to different cells using Caps Shift 5,6,7 and 8.

If you try to go off the screen you will be prompted:- Jump: No. of Columns — or Rows, depending whether you were moving horizontally or vertically. Enter the number of lines along or down the spreadsheet you wish the window to be shifted, the axis range will the change to reflect your response.

To Input into the spreadsheet, press! to enter a value or formula, and "to enter a descriptive Label. The string entered, or its value, will appear in the spreadsheet at the cursor position; the contents of the

Listing 1.

```
20 GO SUB 8000
40 LET l=(l+(kS=CHR$ 10)-(kS=CHR$ 11))
50 LET c=c+S+(kS=CHR$ 9)-(kS=CHR$ 8)
60 IF c>26 AND c>=c1 THEN LET c=26: LET s=1: GO SUB 5000
70 IF c<1+(tv+5) AND c<=c1 THEN LET c=1+(tv+5): LET s=-1: GO SUB 5000
80 IF l<1+th AND l<=l1 THEN LET l=1+th: LET s=-1: GO SUB 5050
90 IF l<20 AND l<=l1 THEN LET l=20: LET s=1: GO SUB 5050
90 PRINT OVER 1; PAPER 0; AT l1, c1:
92 LET l1=l: LET c1=c
93 LET co=INT ((c-1)/5)+1
94 LET lo=l+V-1
95 PRINT OVER 2; PAPER 4; AT l, c)
96 OVER 0: LET as=ds(lo,co): PRINT INK 7; PAPER 1; AT 21,0; as
99 IF INKEY$="" THEN PRINT PAPER 1; AT 19,31; CHR$ (ll+64); AT 20,31; INT (cl/10); AT 21,31; cl-10+INT (cl/10)
100 PAUSE 0: LET ks=INKEY$
110 IF ks=CHR$ 32 THEN BEEP .1
115 GO SUB 7000
125 IF ks=CHR$ 7 THEN GO SUB 2000
130 GO TO 30
300 REM recal
310 FOR i=1 TO cl: LET co=i: FOR j=1 TO ll: LET lo=j: LET l=lo+1-v
311 LET as=ds(lo,co)
312 IF as(1)<>"!" THEN GO TO 320
315 GO SUB 4000
320 NEXT j: NEXT i: LET l=l1: RETURN
350 REM iterate
355 LET m=1
360 PRINT AT 21,0;"Iteration ";
m: GO SUB 300
370 IF INKEY$="" THEN RETURN
380 LET m=m+1: GO TO 360
400 REM insert
410 INPUT "Insert Row or Column (r/c)? ";gs: LET c2=co: LET l2=lo
420 IF gs="r" THEN LET tv=0: GO TO 500
430 IF gs="c" THEN LET th=0: FOR n=1 TO ll: FOR j=c1 TO c2 STEP -1: LET as=ds(n,j): IF as(1)<>"!" THEN LET ss(n,j+1)=as(2 TO 3): GO TO 470
440 LET k=1
450 IF as(k)>CHR$ 64 AND as(k)<CHR$ 90 AND as(k+2)=STR$(co) THEN LET as(k+2)=STR$(VAL as(k+2)-1)
455 IF as(k)="" OR k=29 THEN GO TO 470
460 LET k=k+1: GO TO 450
470 LET ds(n,j+1)=as: NEXT j: LET ds(n,j+1)=""
485 NEXT n: LET cl=cl+1: GO SUB 300: GO SUB 5100: RETURN
499 REM insert row
500 FOR n=1 TO cl: FOR j=l1 TO l2 STEP -1: LET as=ds(j,n): IF as(1)<>"!" THEN LET ss(j+1,n)=as(2 TO 3): GO TO 570
540 LET k=1
550 IF as(k)>CHR$ (64+lo) AND as(k)<CHR$ 90 THEN LET as(k)=CHR$(CODE as(k)+1)
560 LET k=k+(k<30): IF as(k)="" THEN GO TO 570
565 GO TO 550
570 LET ds(j+1,n)=as: NEXT j: LET ds(j+1,n)=""
580 NEXT n: LET ll=ll+(ll<26): GO SUB 300: GO SUB 5100: RETURN
705 INPUT "Delete Row or Column (r/c)? ";gs: IF gs<>"r" AND gs<>"c" THEN GO TO 705
720 IF gs="r" THEN LET tv=0: GO TO 800
725 REM del col
730 LET th=0: FOR n=1 TO ll: FOR j=co TO cl: LET as=ds(n,j+1+(j<26)): IF as(1)<>"!" THEN LET ss(n,j)=as(2 TO 3): GO TO 770
740 LET k=1
750 IF as(k)>CHR$ 64 AND as(k)<CHR$ 90 AND as(k+2)=STR$(co) THEN LET as(k+2)=STR$(VAL as(k+2)-1)
760 LET k=k+1: IF as(k)="" THEN GO TO 770
765 GO TO 750
770 LET ds(n,j)=as: NEXT j
785 NEXT n: LET cl=cl-1: GO SUB 300: GO SUB 5100: RETURN
800 FOR n=1 TO cl: FOR j=lo TO ll: LET as=ds(j+(lo<26),n): IF as(1)<>"!" THEN LET ss(j,n)=as(2 TO 3): GO TO 870
840 LET k=1
850 IF as(k)>CHR$ (64+lo) AND as(k)<CHR$ 90 THEN LET as(k)=CHR$(CODE as(k)-1)
860 LET k=k+1: IF k=29 OR as(k)="" THEN GO TO 870
865 GO TO 850
870 LET ds(j,n)=as: NEXT j
880 NEXT n: LET ll=ll-1: GO SUB 300: GO SUB 5100: RETURN
2000 REM edit
2010 LET as=ds(lo,co): LET n=1
2015 LET ss=as(1): IF ss="" THEN N POKe 23858,8
2020 LET js=as( TO n): LET ls=as(n+1 TO )
2030 OVER 0: PRINT AT 21,0;js;" "
"ls
2040 PAUSE 0
2050 LET ks=INKEY$
2053 IF ks=CHR$ 13 THEN LET as=jS+ls: PRINT PAPER 1; AT 21,0; as: GO TO 7090
2055 IF ks=CHR$ 12 THEN LET js=jS( TO n-1): LET n=n-1: LET as=js+ls
2057 IF ks>CHR$ 13 THEN PRINT AT
```

current cell will be reflected in the blue band at the bottom of the window. For example, suppose cell A (1) contains the value 12 and we want to calculate 25 per cent of this and put the result in A(2). Move the cursor across one column and enter A(1)*.25

The value 4 will appear in the spreadsheet at the cursor position, while the formula is printed in the Cell Contents line.

A formula in a particular cell can be up to 29 characters long; longer expression may be handled by splitting them up. The value or label will be displayed in the spreadsheet up to eight or nine characters long, scientific notation being used to display greater values.

The contents of the Current Cell may be edited by pressing Caps Shift 1. The relevant string

will then appear at the bottom of the screen and may be altered using the left-right cursor and Delete keys. Note that Extended Mode functions such as Sin may not be edited in this way, the string may have to re-entered.

Commands are accessed by pressing the (/) symbol (S Shift V) — instead of the (!) or (") keys — followed by the character specific to the function required.

ε — RECALCULATE — Recalculates the Spreadsheet row by row. This is used when a value or formula is altered.

\$ — DECIMAL FORMAT — Specifies the number of decimal places displayed. Defaults to two.

a — REPEATED RECALCULATION — This allows problems requiring iterative calculations to be solved. The number of the

current calculation sequence is printed at the bottom of the screen. The iterative process is halted by pressing the Space bar when the problem has converged to the required degree of accuracy (keep the bar pressed until the current calculation sequence is complete). As an example of the use of this command. The spreadsheet above (fig. 1) has to be iterated by adjusting the value of I(2) until the two values in N(2) and O(2) were identical within acceptable limits. This was achieved by adding the differ-

ence between N(2) and O(2) to I(2) with each loop, i.e. the formula in I(2) was set at I(2) + -O(2)/7. The iteration procedure was halted manually when the difference printed in P(2)) was less than 1.

b — BLANK CELL — Clears the current Cell.

c — CONCEAL CELL — Clears the cell on the Spreadsheet but retains the formula/

(continued on next page)

```

5065 LET v=v+(n*s)
5070 IF v>=7 THEN LET v=7
5075 IF v<=1 THEN LET v=1
5080 BRIGHT 1: FOR g=1 TO 20: PR
INT PAPER 2: OVER 0: AT g,0: CHR$
(g+v*83): NEXT g: BRIGHT 0
5090 IF tv>0 THEN PAPER 1: OVER
0: FOR n=1 TO 20: FOR m=0 TO tv
-1: PRINT AT n,(m*5)+1: "
PRINT #9: AT n,(m+1)*40-32: s$(n
+v-1,m+1): NEXT m: NEXT n: PAPER
0
5100 REM print screen
5105 LET x=19-th: LET y=u+5-tv
5110 OVER 0: FOR i=0 TO (cl<=y)*
cl+(cl>y)*y: LET co=i+tv
5120 FOR l=0 TO ((cl<=y)*ll+(ll>y
)*x)
5125 PRINT AT l+1+th,((co-u)*5)+
1:
5130 PRINT #9: AT l+1+th,((co+1-u
)+40)-32: s$(l+v+th,co)
5140 NEXT l: NEXT i
5150 LET l=l: RETURN
6000 REM replicate
6010 LET z$="": INPUT "Replicate
hor or vert?": g$
6012 IF a$(1)="": THEN INPUT "Ab
solute or Relative (A/R)?": z$
6015 INPUT "Range (25/24)?": n
6018 LET b$=a$(1): LET c$=a$(2 T
O)
6020 IF g$="v" THEN GO TO 6100
6040 REM repl hor
6045 LET d=co: FOR j=d+1 TO d+n:
LET co=j
6050 IF a$(1)=CHR$ 34 OR z$="a"
THEN LET s$(lo,co)=c$: LET e$=c$
: GO TO 6080
6060 IF b$="!" THEN LET e$=c$: F
OR k=1 TO LEN c$
6065 IF c$(k)>CHR$ 64 AND c$(k)<
CHR$ 90 THEN LET e$(k+2)=STR$(U
AL c$(k)+j-d)
6070 NEXT k: LET a$=b$+e$: GO SU
B 4000
6080 LET d$(lo,co)=b$+e$: NEXT j
: IF co>cl THEN LET cl=co
6085 IF a$(1)=CHR$ 34 THEN GO SU
B 5100
6090 RETURN
6100 REM repl vert
6110 LET d=lo: FOR j=d+1 TO d+n:
LET l=j: LET lo=j
6120 IF a$(1)=CHR$ 34 OR z$="a"
THEN LET s$(l,co)=c$: LET e$=c$
: GO TO 6180
6130 IF b$="!" THEN LET e$=c$: F
OR k=1 TO LEN c$
6140 IF c$(k)>CHR$ 64 AND c$(k)<
CHR$ 90 THEN LET e$(k)=CHR$(COD
E c$(k)+j-d)
6150 NEXT k: LET a$=b$+e$: GO SU
B 4000
6160 LET d$(l,co)=b$+e$: NEXT j
: IF lo>ll THEN LET ll=lo
6165 IF a$(1)=CHR$ 34 THEN GO SU
B 5100
6170 RETURN
6820 REM print
6821 LET chars=62544: POKE 23606
,180: POKE 23607,244

```

```

6822 FOR c=1 TO cl: FOR w=1 TO 8
: LET m=0: FOR j=ll TO 1 STEP -1
6825 LPRINT s$(j,c,w): LET m=m+
1
6830 FOR i=1 TO ((ll<9)+(ll<12))+
((ll<17)): LPRINT " ": LET m=m+1:
NEXT i
6837 NEXT j: FOR b=1 TO 32: LP
RINT " ": NEXT i
6840 NEXT w: FOR b=1 TO 32: LPRI
NT " ": NEXT b: NEXT c: POKE 23
606,0: POKE 23607,60: RETURN
6910 REM load
6920 FOR j=1 TO ll: FOR k=1 TO c
: LET a$=d$(j,k): IF a$(1)=CHR$
34 THEN LET s$(j,k)=a$(2 TO)
6930 IF a$(1)="!" THEN LET lo=j:
LET co=k: GO SUB 4000
6940 NEXT k: NEXT j: CLS: GO SU
B 6010: GO SUB 5100: RETURN
7000 OVER 0: IF k$="/" THEN PRIN
T PAPER 1: AT 21,0: "COMMAND: @SAB
CDIJMPSTX": GO SUB 7300: BEEP .
1.1: GO TO 30
7010 IF k$<>"!" AND k$<>CHR$ 34
THEN RETURN
7030 IF lo>ll THEN LET ll=lo
7040 IF co>cl THEN LET cl=co
7050 IF k$="!" THEN PRINT PAPER
1: AT 21,0: "Value": POKE 23658,8
7055 IF k$=CHR$ 34 THEN PRINT PA
PER 1: AT 21,0: "Label"
7060 DIM a$(29): INPUT LINE a$
7070 IF k$="!" THEN POKE 23658,0
7080 PRINT PAPER 1: AT 21,1: a$: L
ET a$=k$+a$
7090 IF a$(1)=CHR$ 34 THEN LET s
$(lo,co)=a$(2 TO): PRINT #9: AT
l,((co+1-u)+40)-32: s$(lo,co)
7100 IF a$(1)="!" THEN GO SUB 40
00
7110 LET d$(lo,co)=a$
7120 LET k$="": OVER 1: RETURN
7300 POKE 23658,0: PAUSE 0: LET
k$=INKEY$: PRINT AT 21,1: k$
7302 IF k$="0" THEN GO SUB 300:
RETURN
7325 IF k$="b" THEN LET d$(lo,co
)="": PRINT AT l,c: "
LET s$(lo,co)="": IF a$="!" THEN GO
SUB 4000: RETURN
7330 IF k$="t" THEN LET tv=co-1:
LET th=lo-1: FOR n=1 TO th: PRI
NT OVER 1: PAPER 1: AT n,1: "
n: FOR n=1 TO 20: FOR m=0 TO tv
-1: PRINT OVER 1: PAPER 1: AT n,(
m*5)+1: "
NEXT m: NEXT n:
RETURN
7340 IF k$=" " THEN LET th=0: LE
T tv=0: LET q=0
7345 IF k$="a" THEN GO SUB 350
7350 IF k$="r" THEN GO SUB 6000
7360 IF k$="i" THEN GO SUB 400
7365 IF k$="d" THEN GO SUB 700
7370 IF k$="s" THEN INPUT "No. o
f Decimal Places?": p: LET f=10^
p
7376 IF k$="x" THEN INPUT "Clear
-Enter y to Confirm": LINE z$:
IF z$="y" THEN GO TO 7910
7377 IF k$="m" THEN CLS: GO TO

```

```

20
7380 IF k$="c" THEN LET s$(lo,co
)="": PRINT AT l,c: "
LET a$=d$(lo,co): LET a$(2 TO)=""&"+
a$(2 TO): LET d$(lo,co)=a$(1)+a
$(2 TO)
7385 IF k$="j" THEN INPUT "Sprea
dsheet Depth (<=26)?": ll: INPUT
"Spreadsheet Width (<=24)": cl:
LOAD "" DATA d$(1): GO SUB 6910
7386 IF k$="s" THEN GO SUB 9002
7395 IF k$="p" THEN GO SUB 6820
7400 RETURN
7699 REM Start
7900 BORDER 0: PAPER 0: OVER 0:
INK 7: CLEAR 62899: LOAD ""CODE
: CLS
7910 RANDOMIZE USR 63744: GO SUB
8004
7920 LET f=100: LET q=0: LET th=
0: LET tv=0: LET u=1: LET v=1: L
ET ll=1: LET cl=1: LET l1=1: LET
c1=1: LET l=1: LET c=1: LET k$
="": GO TO 20
8000 POKE 23606,0: POKE 23607,60
: REM menu
8001 PRINT "ENTER LABEL....."
"ENTER FORMULA....."REFER TO
CELL...X(n)"/"COMMANDS:""/T....
.....SET TITLES"/"B.....
.....BLANK CELL"/"C.....CONC
EAL CELL"/"R.....REPLICATE C
ELL"/"I.....INSERT ROW/COL"/
"/D.....DELETE ROW/COL"/"E..
.....RECALCULATE"/"A.....
.....ITERATE"/"S.....DECI
MAL FORMAT"/"X.....CLEAR SPREA
DSHEET"/"M.....MENU
"/"J.....LOAD DATA"/"S
.....SAVE DATA"/"P.....
PRINT SPREADSHEET"
8003 PRINT AT 21,2: INK 2: PAPER
6: "PRESS ANY KEY TO CONTINUE"
PAUSE 0: CLS: GO SUB 5010: GO S
UB 5080: RETURN
8004 CLS: LET co=24: LET lo=26:
LET m=31
8005 DIM A(co): DIM I(co): DIM B
(co): DIM C(co): DIM D(co): DIM
E(co): DIM F(co): DIM G(co): DIM
H(co): DIM J(co): DIM K(co): DIM
L(co): DIM M(co): DIM N(co): DIM
O(co): DIM P(co): DIM Q(co):
DIM R(co): DIM S(co): DIM T(co):
DIM U(co): DIM V(co): DIM W(co)
: DIM X(co): DIM Y(co)
: DIM Z(co): DIM s$(lo,co,8): D
IM d$(lo,co,w)
8006 RETURN
8010 BRIGHT 1: FOR g=1 TO 21: PR
INT PAPER 2: AT g,0: CHR$(g+84):
NEXT g: FOR j=0 TO 5: PRINT PAPER
R 2: AT 0,j: s$": j+1: "
NEX
T j: BRIGHT 0
8020 RETURN
9000 SAVE "multicalc" LINE 7900:
SAVE "chars"CODE 62900,2360
9001 VERIFY "multicalc": VERIFY
"chars"CODE 62900,2360
9002 INPUT "Filename?": g$: SAVE
g$ DATA d$(1)
9003 VERIFY g$ DATA d$(1)

```

	1	2	3	4	5	6
AS04 in S Slurry	0					
B0	0					
DEF BRINE	41500	10375	252	157	6	
GRI BRINE	34841	5904	254	167	0	
IPURGE	3470.42	586.5	25.33	16.65	0	
J to hrs	1.17					
K to hrs	39.54					
L OVERFLOW	8936.37	2234.59	53.63	33.96	1.22	
M NSALIF 1	10526.58	6611.95	78.96	24.21	7.37	
N NSALIF 2	11632.64	7305.3	87.24	26.75	8.14	
O OMET RETB	1104.06					
P CC FEED	31370.57	5317.49	228.66	150.34	0	
T	6300.91					
! 200000 / (13826 + .081 * I (2))						



THE 520ST. OVER QUAL

AVON BRISTOL
 Computer Exchange.
AVON BRISTOL
 Laskys.
AVON BRISTOL
 Radford Hi Fi.
BEDS BEDFORD
 Bedford Computers.
BEDS LUTON
 Hobbyte Ltd.
BEDS LUTON
 Laskys.
BELFAST
 CEM Micro-Computer Services Ltd.
BELFAST
 Computer All Ltd.
BELFAST
 Education Company Ltd.
BELFAST
 Ideal Radio.
BELFAST
 N.P.O.
BERKS READING
 HMV Micro Shop.
BERKS. READING
 Laskys.
BERKS SLOUGH
 Laskys.
BERKS SLOUGH
 Silicon Chip.
CAMBS CAMBRIDGE
 Cambridge Computer Store.
CAMBS CAMBRIDGE
 Laskys.
CAMBS PETERBOROUGH
 Laskys.
CENTRAL FALKIRK
 Microplus.

CHESHIRE CHESTER
 Laskys.
CHESHIRE CREWE
 Woottons TV.
CHESHIRE WARRINGTON
 Warrington All Computers.
CHESHIRE WILMSLOW
 Fairhurst Instruments Ltd.
CLWYD WREXHAM
 Micro Computer World.
CLWYD WREXHAM
 Micro Computer Centre.
CO.DERRY
 Donaghy Brothers.
CO. DOWN WARREN POINT
 Visions Video.
CO. DURHAM
DARLINGTON
 Darlington Computer Shop.
DERBYSHIRE
CHESTERFIELD
 R.A.W. Electronics.
DEVON EXETER
 Laskys.
DEVON PLYMOUTH
 Laskys.
DEVON PLYMOUTH
 Syntax Ltd.
DORSET BOURNEMOUTH
 Lansdowne Computer Centres.
DORSET POOLE
 Lansdowne Computer Centres.
ESSEX COLCHESTER
 Colchester Computer Centre.
ESSEX COLCHESTER
 Capricorn Computers.
ESSEX COLCHESTER
 Laskys.

ESSEX HARLOW
 Achter Instruments Ltd.
ESSEX HARLOW
 Laskys.
ESSEX ROMFORD
 Laskys.
ESSEX SOUTHEND
 Laskys.
ESSEX SOUTHEND
 Estuary Computers.
ESSEX WESTCLIFF-ON-SEA
 Sterling Resources.
FIFE GLENROTHES
 Computer Services (Scotland) Ltd.
GLOUS CHELTENHAM
 Laskys.
GLOUS GLOUCESTER
 Laskys.
GRAMPIAN ABERDEEN
 Laskys.
GRAMPIAN ABERDEEN
 Microshack.
GT. MANCHESTER BOLTON
 Computer Annex.
GT. MANCHESTER FAIRWOODFIELD
 Mighty Micros.
GT. MANCHESTER MANCHESTER M4
 Laskys.
GT. MANCHESTER MANCHESTER M1
 Laskys.
GT. MANCHESTER MANCHESTER
 Lewis's Ltd (Sound & Vision).
GT. MANCHESTER MANCHESTER
 NSC Computershops.

GT. MANCHESTER STOCKPORT
 New Mills Micro Centre.
MERSEYSIDE LIVERPOOL
 Lewis's Ltd (Sound & Vision).
GWENT EBBW VALE
 Computability.
HANTS PORTSMOUTH
 Microchoice.
HANTS SOUTHAMPTON
 AMS Systems Limited.
HANTS SOUTHAMPTON
 Laskys.
HERTS ST ALBANS
 Hobbyte Ltd.
HERTS WATFORD
 Laskys.
HIGHLAND INVERNESS
 Nova Computers.
HUMBERSIDE HULL
 Golding Computer Services.
HUMBERSIDE HULL
 Tommorrow's World.
KENT BECKENHAM
 Transform Ltd.
KENT BEXLEY HEATH
 Laskys.
KENT BROMLEY
 Laskys.
KENT MAIDSTONE
 Kent Microcomputers.
KENT MAIDSTONE
 Laskys.
KENT ORPINGTON
 Lever Computers.
KENT SEVENOAKS
 Chalk Hill Computers & Office Supplies.
KENT SWANLEY
 Swanley Electronics.

KENT SIDCUP
 Silica Shop.
KENT WELLING
 K.E.C.M. Computers.
LANCS ACCRINGTON
 PV Micros.
LANCS BLACKPOOL
 Lewis's Ltd (Sound & Vision).
LANCS BOLTON
 Computer World.
LANCS BURNLEY
 Bytes And Pieces.
LANCS DARWEN
 Grahams Micro Shop.
LANCS LANCASTER
 Castle Computers.
LANCS LANCASTER
 Online Computer Services.
LANCS OLDEHAM
 Home & Business Computers.
LANCS PRESTON
 Laskys.
LEICS HINCKLEY
 Leigh Computer Systems.
LEICS LEICESTER
 Dimension Computers.
LEICS LEICESTER
 May's Hi Fi Ltd.
LEICS LEICESTER
 Lewis's Ltd (Sound & Vision).
LEICS LEICESTER
 Laskys.
LEICS LEICESTER
 Data Nest.
LINCS GRANTHAM
 OakLeaf.
LONDON BROCKLEY
 Homeview Video.

LONDON NW4 Laskys.
LONDON NW5 Zoomsoft.
LONDON SW13 LEWISHAM
 Laskys.
LONDON W5 EALING
 Laskys.
LONDON W9 MAIDA VALE
 Micro Monde Ltd.
LONDON W1 Compuface Ltd.
LONDON W1 Laskys.
LONDON W1 Laskys.
LONDON W1 Micro Anvika.
LONDON W1 Silica Shop.
LONDON W1 Selfridges.
LONDON W1
 Computers of Wigmore St.
LOTHIAN EDINBURGH
 Laskys.
LOTHIAN EDINBURGH
 Silicon Centre.
LOTHIAN EDINBURGH
 The Games Master Ltd.
MERSEYSIDE LIVERPOOL L1
 Laskys.
MERSEYSIDE LIVERPOOL L2
 Laskys.
MERSEYSIDE SOUTHPORT
 Central Studios.
MERSEYSIDE ST HELENS
 Microman Computers.
MIDDLESEX ENFIELD
 Jennings Stores Ltd.
MIDDLESEX ENFIELD
 Laskys.
MIDDLESEX NORTHWOOD
 Screens.

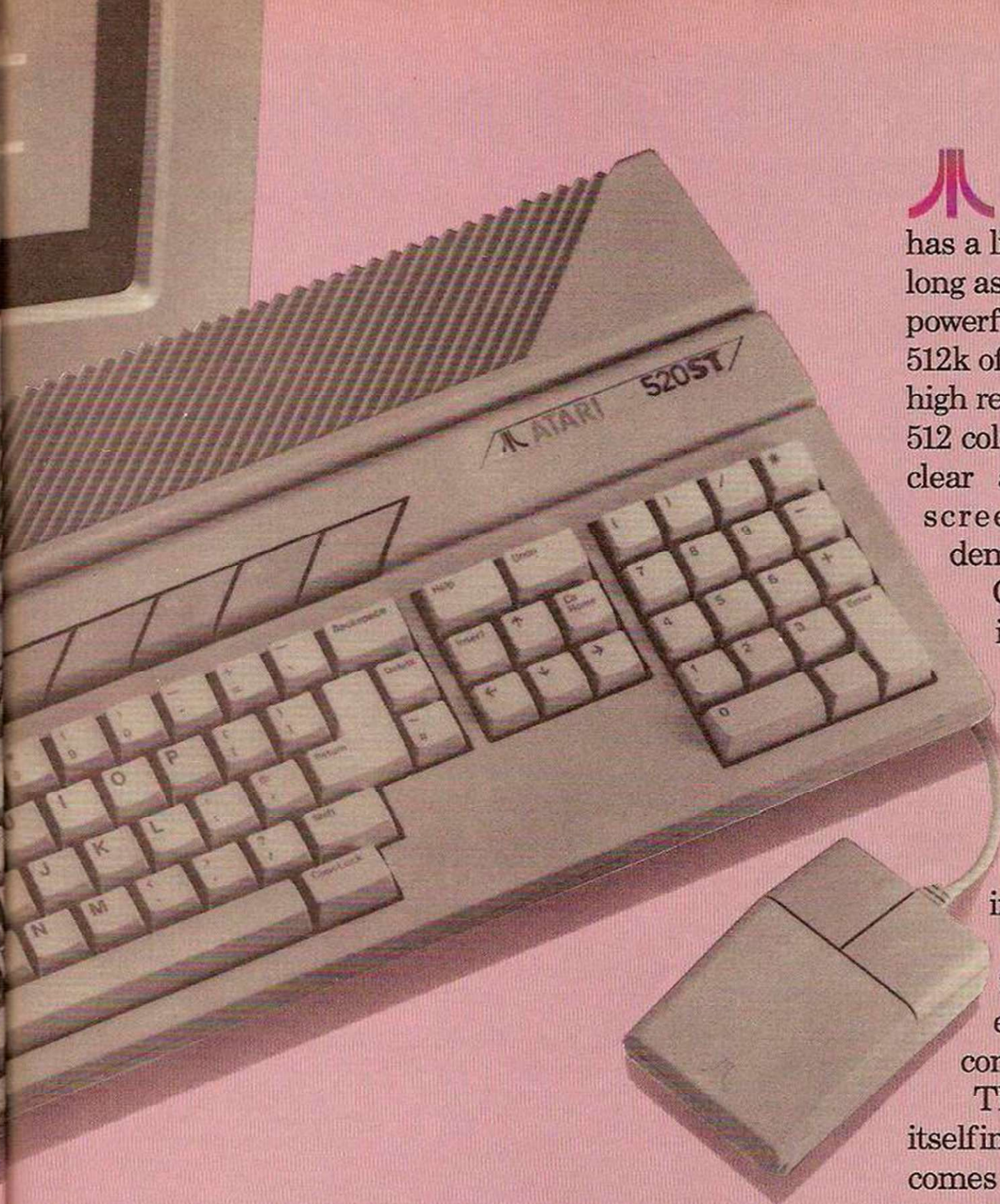

THE ATARI 520ST
Personal Computer
 has a list of qualifications as long as your arm. With a powerful 16 bit processor and 512k of memory linked to high resolution graphics and 512 colours its work is fast, clear and sharp on your screen, no matter how demanding the task.

Controlling the 520ST is easy through its mouse and unique operating system incorporating GEM desk top manager, whilst its eleven peripheral connectors including MIDI interface enables it to mix and communicate easily with other computer products.

The ST which presents itself in smart modern styling comes with powerful BASIC

IFIED AND UNDERPAID.

MIDDLESEX PINNER
 P & H Micro.
 MIDDLESEX RUISLIP MANOR
 Intech Software Ltd.
 NORFOLK GT YARMOUTH
 The Micro Shop.
 NORFOLK NORWICH
 Tetranite (Spectrum).
 N. YORKSHIRE YORKS
 Laskys.
 N. YORKSHIRE YORK
 Microbridge.
 N. YORKSHIRE YORKS
 York Computer Centre.
 N. YORKSHIRE RIPON
 Arthur Yates Ltd.
 NOTTS HUCKNALL
 S P Electronics.
 NOTTS MANSFIELD
 Mansfield Computers.
 NOTTS NOTTINGHAM
 Intoto.
 NOTTS NOTTINGHAM
 Laskys.
 NORTHANTS NORTHAMPTON
 Laskys.
 NORTHANTS NORTHAMPTON
 Northampton Home Computers.
 NOTTS REDDINGTON
 GA Computers.
 OXON HEADINGTON
 Maddison Computers.
 OXON OXFORD
 Laskys.
 OXON OXFORD
 Selfridges.
 ORKNEY STROMNESS
 Get Taped.

PERTSHIRE BLACKFORD.
 Silicon Glen Ltd.
 SHETLAND LERWICK
 Tomorrows World.
 S. GLAMORGAN CARDIFF
 Cardiff Micro Computers.
 S. GLAMORGAN CARDIFF
 Laskys.
 S. GLAMORGAN CARDIFF
 South World Computers.
 S. YORKSHIRE DONCASTER
 Danum Computer Systems.
 S. YORKSHIRE ROTHERHAM
 Rotherham Computer Centre.
 S. YORKSHIRE SHEFFIELD
 Just Micro.
 S. YORKSHIRE SHEFFIELD
 Laskys.
 STAFFS. STOKE-ON-TRENT
 Lewis Ltd (Sound & Vision).
 STAFFS. STOKE-ON-TRENT
 Town Computers.
 STRATHCLYDE GLASGOW
 Laskys.
 STRATHCLYDE GLASGOW
 Lewis Ltd (Sound & Vision).
 STATHCLYDE GLASGOW
 Unitsoft.
 SUFFOLK SUDBURY
 Sudbury Microsystems.
 SURREY CROYDON
 Laskys.
 SURREY FARNHAM
 Farnham Computers.
 SURREY GUILDFORD
 Laskys.
 SURREY KINGSTON
 Laskys.

SURREY LEATHERHEAD
 Evergreen Ltd.
 SUSSEX BRIGHTON
 Brighton Computer Exchange.
 SUSSEX BRIGHTON
 Brighton Computer Centre.
 SUSSEX BRIGHTON
 Laskys.
 SUSSEX CRAWLEY
 Laskys.
 SUSSEX WORTHING
 Data Direct.
 TAYSIDE DUNDEE
 Cursor Keys.
 TAYSIDE DUNDEE
 Micromania.
 TAYSIDE PERTH
 VICS.
 TYNE AND WEAR GATESHEAD
 Currie & Maughn.
 TYNE AND WEAR
 NEWCASTLE UPON TYNE
 Laskys.
 WARWICKS LEAMINGTON SPA
 Spa Computer Centre.
 WARWICKS NUNEATON
 Micro City.
 WARWICKS NUNEATON
 Warwick Computers.
 W. MIDLANDS BIRMINGHAM
 Lewis Ltd (Sound & Vision).
 W. MIDLANDS BIRMINGHAM
 Software Express.
 W. MIDLANDS BIRMINGHAM
 Laskys.
 W. MIDLANDS BIRMINGHAM
 Lee Computers.
 W. MIDLANDS COVENTRY
 Coventry Micro Centre.

W. MIDLANDS COVENTRY
 Laskys.
 W. MIDLANDS DUDLEY
 Central Computers.
 W. MIDLANDS
 WOLVERHAMPTON
 Laskys.
 W. MIDLANDS
 WOLVERHAMPTON
 Micro Business Centre.
 WORCS KIDDERMINSTER
 Central Computers.
 WORCS REDDITCH
 Ampower Video and Computers.
 W. GLAMORGAN SWANSEA
 Bucon Ltd.
 WEST LOTHIAN
 LIVINGSTONE
 Computer Centre.
 W. YORKSHIRE BRADFORD
 CNA Computing.
 W. YORKSHIRE HALIFAX
 Abacus Computers.
 W. YORKSHIRE
 HECKMONDWIKE
 Thought & Crosses.
 W. YORKSHIRE
 HUDDERSFIELD
 Microworld.
 W. YORKSHIRE LEEDS 12
 Farnells.
 W. YORKSHIRE LEEDS 6
 Interface Engineering Ltd.
 W. YORKSHIRE LEEDS
 Lewis Ltd (Sound & Vision).
 W. YORKSHIRE LEEDS
 Laskys.
 W. YORKSHIRE LEEDS
 Microworld.

plus Logo programming languages, a word processor and drawing programme, yet costs only £652* including disc drive and black and white monitor.

Why? Because at Atari we bring up our products to work hard for their living.

ATARI
 Power Without the Price™

*This price is exclusive of VAT.
 GEM® is a registered trademark of Digital Research.



ATARI ST 520ST

POWER WITHOUT THE PRICE

ATARI 520ST SPECIFICATION

MEMORY
512K RAM (524,288 bytes)
16K ROM (expandable to 320K)
Port for add-in 128K plug-in ROM cartridges
200K TOS operating system

GRAPHICS
Individually addressable 32K bit-mapped screen with 3 screen graphics modes
320x200 pixels in 16 colours (low resolution)
640x200 pixels in 4 colours (med resolution)
640x400 pixels in monochrome (high res)
16 shades of grey in low res mode
512 colours available in low/medium res
8 levels of each in red, green and blue

ARCHITECTURE
4 custom designed chips
GLUE Chip - MMU Memory Mngmt Unit
DMA Controller - Graphics Processing Unit
16/32 bit Motorola 68000 processor at 8MHz
eight 32 bit data registers
eight 32 bit address registers
16 bit data bus/24 bit address bus
7 levels of interrupts/56 instructions
14 addressing modes/5 data types

DATA STORAGE
High speed hard disk interface
Direct memory access 1.33 Mbytes per second
CD (Compact Disc) interface
Built in cartridge access
Dedicated floppy disk controller

DISK DRIVE
500K (unformatted) 3.5" floppy drive
349K (formatted) storage capacity

SOUND AND MUSIC
Sound Generator
Frequency control from 30Hz to above audible 3 voices (channels) in wave shaping sound in addition to a noise generator
Separate frequency and volume controls
Dynamic envelope controls
ADSR (Attack, Decay, Sustain, Release)
Noise generator
MIDI interface for external music synthesizers

KEYBOARD
Separate keyboard microprocessor
Standard QWERTY typewriter styling
Ergonomic angle and height
86 keys including 10 function keys
Numeric keypad - 16 keys including ENTER
One touch cursor control keypad

MONITOR
12" screen - high res monochrome monitor
640x400 monochrome resolution

Note: Some of the above specifications are pre-release and may therefore be subject to change

MACINTOSH v F16 v 520ST

"Imagine a Fat Mac - the 512K Apple Macintosh - but with a bigger screen, a far bigger keyboard with numeric keypad, cursor and function keys, and colour. That gives you some idea of what the Atari 520ST is like, except for two important things. First the Atari seems faster. Second the Atari system is about one third of the price." June 1985 - Jack Schofield - PRACTICAL COMPUTING

FEATURES OF BASIC SYSTEM	APPLE	APRICOT	ATARI
	MACINTOSH	F16	520ST
Price includes B/W Monitor	YES	NO - extra £200	YES
Keyboard size mm (LxDxH)	330x147x50	450x167x28	470x240x80
Keyboard size ins (LxDxH)	13x5 7/8x2	17 1/2x6 1/2x1	18 1/2x9 1/2x2 1/2
3 1/2" D/Drive (Unformatted)	500K	500K	500K
3 1/2" D/Drive (Formatted)	399K	315K	349K
WIMP (Window, Icon, Mouse...)	Apple	ACT - Activity	GEM
Real-time Clock	YES	YES	YES
Polyphonic Sound Generator	YES	NO	YES
RS232 Serial Port	YES	YES	YES
Centronics Parallel Printer Port	NO	YES	YES
Dedicated Floppy Disk Controller	NO	YES	YES
Hard Disk DMA Interface	NO	YES	YES
Full stroke keyboard	YES	YES	YES
Number of keys on keyboard	59	92	95
Numeric Keypad	NO	YES (16 Keys)	YES (18 keys)
Cursor Control Keypad	NO	YES	YES
Function keys	NO	10	10
16-bit processor	68000	Intel 8086	68000
Processor running speed	8MHz	4.77MHz	8MHz
RAM size	512K	256K	512K
Number of graphics modes	1	4	3
Number of colours	Monochrome	16	512
Max Screen Resolution (pixels)	512 x 342	640 x 256	640 x 400
Mouse included	Single Button	NO - extra £95	Two Button
Replaceable External Power Pack	NO	NO	YES
Cartridge Socket	NO	NO	YES
Joystick Ports	NO	NO	YES (two)
MIDI Synthesiser Interface	NO	NO	YES
Monitor Size	9"	9" - extra £200	12"
RGB Video Output	NO	YES	YES

System Cost with: Mouse - Monochrome Monitor - 512K RAM - 500K Disk Drive

Price of basic system (exc VAT)	£2595+VAT	£595+VAT	£852+VAT
* Mouse	Included	£95+VAT	Included
* Monochrome Monitor	Included	£200+VAT	Included
* Expansion to 512K RAM	Included	£295+VAT	Included
Price of complete system (exc VAT)	£2595+VAT	£1185+VAT	£652+VAT

PRICE rounded down including VAT
£2,984 **£1,362** **£749**

THE NEW ATARI 520ST

Under the new leadership of Jack Tramiel (former boss and founder of Commodore Business Machines), Atari Corporation have marked their entry into the world of business/personal computers with a machine which leaves the competition standing. Tramiel's slogan 'Power Without the Price' has been implemented in the manufacturing of the new 512K Atari 520ST colour computer which offers the user amazingly high performance at an incredibly low price. Launched as a work-station, this new system incorporates seven software packages as well as the 520ST computer with 512K RAM, mouse controller, high resolution monochrome monitor (640x400), 95 key keyboard (with 16 key numeric keypad), MIDI interface, GEM and a 500K 3 1/2 inch disk drive, all for the package price of only £651.30 (+VAT = £749). Dubbed the 'Mac beater' and the 'Jackintosh' (after Atari's Chief, Jack Tramiel), Atari's new machine has been directly compared with the Apple Macintosh RRP £2595 (+VAT = £2985) which offers similar features and capabilities but at a much higher price. Favourably reviewed by the UK's highly critical specialist computer press, the 520ST is likely to make a great impact in this country as a sophisticated alternative to an IBM PC, APRICOT or APPLE MACINTOSH. Unlike its overpriced competitors, the Atari 520ST can be linked up to a colour monitor to unleash a choice of up to 512 colours. The addition of colour brings out the full potential of graphics packages such as GEM.

USER FRIENDLY GEM OPERATING SYSTEM

The power of the ST is harnessed and made user friendly by the new operating system 'GEM' from Digital Research. GEM stands for Graphics Environment Manager and allows a user friendly colour or B/W graphics interface which closely resembles that of the Macintosh. This similarity extends to the use of moveable resizable windows, icons to represent objects such as disks and disk drives, and the use of pull down menus and a mouse. The advantage of all this is that the computer becomes extremely easy to use. GEM has now been implemented for the Acorn, ACT, Atari, IBM, ICL, and Olivetti. Software written for GEM on one computer should also run under GEM on another computer. This will enable the market to quickly produce a large library of standard interchangeable software.

FREE SOFTWARE AND FUTURE EXPANSION

The Atari 520ST comes supplied with seven free software packages as listed below: 1) TOS - Tramiel Operating System based on CPM 68K. 2) GEM Graphics Environment Manager by Digital Research (DR) giving a WIMP (Window, Icon, Mouse, Pull down menu) environment. 3) DR GEM Paint for creating graphics masterpieces. 4) DR GEM Write for word processing. 5) Logo learning language to enable you to write your own programs easily using turtle graphics. 6) DR Personal Basic a powerful user friendly version of the Basic programming language. 7) BOS operating system giving you access to dozens of business applications packages already available on the market. Designed with future expansion in mind, the ST also features a host of different interfaces to the outside world and an impressive list of accessories is planned. Atari will soon be releasing a 1000K (1MB) 3 1/2 inch disk drive, and a 15MB hard disk storage system as well as a mass storage compact disc (CD) player capable of storing an entire 20 volume encyclopedia on one disk. A full range of inexpensive printers are planned including dot matrix, daisywheel and thermal colour printers. With its unbeatable graphics, speed and software at a price which is far below that of any comparable personal computer currently on the market, the ST is all set to do battle with the competition. To receive further details of the ST from Silica Shop, just fill in the coupon below with your name and address details and post it to us.

Silica Shop Price: £651.30 + £97.70 VAT = £749.00 This price includes:
 ★ 512K RAM ★ B/W MONITOR
 ★ MOUSE ★ 500K 3.5" DISK DRIVE
 ★ GEM ★ KEYBOARD (95 KEYS)

£749

PRESS COMMENT

"The new Atari ST computers truly represent to the consumer what Jack Tramiel is saying - easy-to-use computing power without the price." March 1985 **ANALOG COMPUTING**

"It (the ST) uses the most modern technology that is affordable, in a package that gives a professional impression." May 23rd 1985 **POPULAR COMPUTING WEEKLY**

"The Atari ST is one of the most elegant designs I have seen... Atari has used an original and elegant method of memory management which should make the ST faster than any other PC on the market - in any price bracket... The 64K dollar question is would I go out and spend money for one? To which the only answer is 'Try and stop me!'" John Lambert July 1985 **ELECTRONICS & COMPUTING**

"The 520ST is technically excellent... The 520ST hardware is the new standard by which others will be judged." July 1985 **YOUR COMPUTER**

"Atari's new corporate image as an aggressive low cost computer maker is likely to mirror that of Commodore where Mr. Tramiel established the maxim that 'Business is war'." August 21st 1984 **FINANCIAL TIMES**

"This is the only personal computer I know of that comes with a MIDI interface as standard." Peter Bright March 1985 **PERSONAL COMPUTER WORLD**

"The (GEM) version running on the Atari 68000 machines will have the additional advantage of leaving the PC version standing." April 8th 1985 **PERSONAL COMPUTER NEWS**

"It would seem that GEM offers the ideal operating system..." March 7th 1985 **POPULAR COMPUTING WEEKLY**

"I found it (GEM) extremely easy to use and was very impressed with the way in which it disguises the unfriendly hardware and operating systems lurking under the surface." Peter Bright Feb 1985 **PERSONAL COMPUTER WORLD**

SILICA SHOP

ATARI WE ARE THE UK'S NO1 ATARI SPECIALISTS ATARI

At Silica we have been successfully dedicated to Atari ever since their products first appeared on the UK market. We can attribute our success largely to the Atari specialisation which we practice and to the user back-up we provide. Rest assured that when you buy a piece of Atari hardware at Silica you will be fully supported. Our mailings giving news of software releases and developments will keep you up to date with the Atari market and our technical support team and sales staff are at the end of the telephone line to deal with your problems and supply your every need. With our specialist bias, we aim to keep stocks of all the available Atari hardware, software, peripherals and accessories. We also stock a wide range of Atari dedicated books and through us, the owners on our list can subscribe to several American Atari dedicated magazines. We can provide a full service to all Atari owners and are now firmly established as the UK's NUMBER ONE Atari specialists. Here are just some of the things we can offer to our customers.

- ★ FREE POST & PACKING ON MAIL ORDERS
- ★ FREE NEXT DAY SECURICOR DELIVERY
- ★ INFORMATION MAILING SERVICE
- ★ TECHNICAL SUPPORT TEAM
- ★ HIGHLY COMPETITIVE PRICES
- ★ AFTER SALES SUPPORT SERVICE
- ★ REPAIR SERVICE ON ATARI PRODUCTS

If you would like to be registered on our mailing list as an Atari computer owner, or as a person interested in buying an Atari machine, let us know. We will be pleased to keep you up to date with new Atari developments free of charge. So, return the coupon today and begin experiencing a specialist Atari service that is second to none.

SILICA SHOP LTD, 1-4 The Mews, Hatherley Road, Sidcup, Kent, DA14 4DX
SEND FOR FREE ATARI ST LITERATURE

To: Silica Shop Ltd, Dept YC.01.86, 1-4 The Mews, Hatherley Road, Sidcup, Kent, DA14 4DX

PLEASE SEND ME FREE LITERATURE ON THE NEW ATARI 520ST COMPUTER

Mr/Mrs/Ms: Initials: Surname:

Address:

Postcode:

Do you already own a computer
 If so, which one do you own?

SILICA HOTLINE 01-309 1111

Snowbot

George is the park-keeper at the local park and as it was getting near Christmas he decided to put the park's Christmas tree up. He spent all day decorating it and the last thing he did was to hang lights on it.

During the night however a strange electrical storm caused havoc in the town, but worse than that it caused all the snowmen that the children had built in the park to turn into evil robots — Snowbots.

The Snowbots needed energy to keep them going and the first thing they found was George's Christmas tree so they stole all the lights from it. When George found out about this he realised he had to try and get the lights back and destroy the Snowbots.

After thinking for a while he remembered that he had some flares left over from the fireworks display. He soon discovered that not only did the Snowbots not like the flares, the heat actually melted them and gave George an opportunity to get the lights back.

He also found out he had to be doubly careful because Snowbots can make huge icicles come crashing down from the trees. Armed with a supply of

flares he set off into the park to confront the Snowbots...

Needless to say, George isn't that bright and he needs a bit of help — a joystick plugged into port 2 will let you control George's movement, the fire button will make him throw a flare — use the spacebar to pause.

Each Snowbot you manage to dispatch earns you 10 points, each icicle is worth 20 points and there is a bonus of 50 points for each light bulb you recover. The light bulbs are hidden inside some of the Snowbots and they will automatically be displayed with any others you have. There are eight light bulbs in a set and each screen ends when you have a complete set. The bottom line of the screen shows the set of lights and any bulbs you have will light up. The small flag on the bottom line indicates the level of play you are currently at. The

top of the screen shows the usual — score, lives left and the highest of the recorded high scores. The game will record five entries of names and high scores and they are displayed during the title sequence.

Typing the program brings the usual problem of Commodore control characters. I have tried to make things easier by including Remark statements after most of the difficult lines. Unfortunately some of the lines are too long to be treated this way but none of these lines contain anything very complicated so they should not prove too much of a problem.

There is a considerable amount of data to be dealt with — definitions of sprites and the machine-code routines used to move the sprites, smooth scroll the screen etc. For the two large sections of data I have included a checksum which should show if there are any data errors. Part

Keith Suddick and his evil robots — with a Christmas game for the CBM-64.

1 of the data is lines 15000-15999 and part 2 is lines 16000-16999 in case it finds an error. It takes quite a while to read the data in but this is only done once when the program is first run. If the data is correct then even stopping the program and re-running it will not re-read the data.

One very important point, the program uses a rather unconventional method of getting the game started and for this to work line 0 must be typed exactly as shown, no extra space or anything even though it may look wrong. If you are typing the program in don't forget to save a copy before you run it. I do not recommend attempting to save a copy after running it — whether it works or not. The program interferes with the normal interrupt routines and interrupt sources, so unpredictable things may happen during saving. If you would rather not type the listing then I can supply tape copies for £2.00. Please write to Keith Suddick 6 Ravel Court, Jarrow, Tyne & Wear, NE32 3BW.

Table 1.

cd	cursor down	ron	ctrl+9	pur	ctrl+5	gr2	C=+5
cu	cursor up	rof	ctrl+0	gm	ctrl+6	lgr	C=+6
cl	cursor left	hm	home	blu	ctrl+7	lbu	C=+7
cr	cursor right	clr	shift+home	yel	ctrl+8	gr3	C=+8
sp	space	ins	shift+del	s/	shift + following character		
blk	ctrl+1	ora	C=+1	c/	ctrl + following character		
wht	ctrl+2	brn	C=+2	=/	Commodore key + following character		
red	ctrl+3	lrd	C=+3				
cyn	ctrl+4	grl	C=+4				

Leading numbers indicate repetitions

```

0 PRINT"U":POKE56,128:RUN9000:GO
T018:GOTO7000
1 PRINT"SU"TAB(RND(U)*T)"B."TAB(
RND(U)*T1+T)".S" :POKE1,UL:RET
URN
10 POKES,0:S=0:M=3:L=0:EL=1:POK
E2,0:POKEFX,199
100 FORX=0T07:POKESM+X,:NEXT:GO
SUB900:POKEIS,U
110 SN=(SM+U)AND3:RN=SN*2:IFPEEK
(SM+RN)=.THENGOSUB200
120 IFPEEK(KB)=60THENGOSUB1000
130 H=PEEK(2):H3=HAND3:OH3+UGO
T0150,300,500
140 POKE2,:GOTO110
150 IFPEEK(IC)THEN110
160 IFRND(U)<<(32-L/4)*IQ)THEN11
0
170 X=INT(RND(U)*2):POKE10,X:POK
E1V,64
180 POKE1X,128-127*(X=.)-97*RN(
U):POKEIC,94:GOTO110
200 POKESP+2+SN,6:IFRND(U)>.7THE
NRETURN
210 POKEU0+4+RN,RND(U)*16:POKEU1
+4+RN,RND(U)*80+128
220 IFL>15THENLY=7:LX=3:GOTO240
230 LY=L/2:LX=L/8
240 POKESM+RN,XS(RND(U)*2,LX)OR1
28*INT(RND(U)*2)
250 POKESM+U+RN,YS(RND(U)*3,LY):
RETURN
300 POKEIS,:POKEU0+22,199:POKES
P,13
310 POKEG3,128:POKEF3,8:POKEG3,1
29
320 FORV=PEEK(U1)T00STEP-1:POKEU
1,V
330 POKEG1,16:POKEF1,9/6:POKEG1,
17
340 FORX=1T010:NEXT:NEXT
350 M=M-U:IFM<0THEN800
390 GOTO100
400 POKEF1,20:POKEG1,65:POKESP+6
,14:POKEIC,U:PT=20:GOSUB600
410 POKEIX,:POKESP+6,12:POKE2,:
GOTO110
500 POKEG1,64:POKEFC,U:HS=FNB(H)
-2:IFHS>3THEN400
510 POKEF1,10:POKEG1,65:RN=HS*2:
POKESM+RN,:POKESP+2+HS,14
520 PT=10:GOSUB600:LD=LD-U:IFLD<
HEN590
530 POKELP+2*LT,81:LD=INT(RND(U)
*XL/2+2)
560 PT=50:GOSUB600:LT=LT+U:IFLT=
8THEN700
570 POKEF2,80:FORX=1T05:POKEG2,1
6:POKEG2,17
580 FORV=1T050:NEXT:NEXT
590 POKEU1+4+RN,:POKE2,:GOTO11
0
600 S=S+PT:PRINT"SUUUUUU"5
610 IFS>H(0)THENPRINT"SU"TAB(20)
S
620 IFELTHENIFS>1000THENM=M+1:EL
=.GOSUB3000:PRINT"SU"TAB(34)M
630 RETURN
700 PRINT"U":POKEU1,160:POKES,U
:POKEIS,:POKESP,8:POKEU0+22,199
:L=L+1
710 PRINT"SS":FORX=1T025:GOSUB
1:NEXT
720 PRINT"SUUUUUUU":FORX=1T039
:PRINTPR$:NEXT
730 PRINTP1$X$"SU"TAB(27)T1$P1$
L$(1)
740 PRINTTAB(23)"SU"
"SPC(27)"I [LEVEL "L,TAB(35)"C1"
750 PRINTTAB(23)"I"SPC(11)"I"SPC
(27)"I [COMPLETED [I"SPC(27)"
760 FORX=0T020:PRINTP1$X$(XAND1)
:POKEF1,(X+5)*5:POKEG1,64:POKEG1
,65
765 FORV=0T080:NEXT:NEXT:POKES,
770 FORX=1T015:GOSUB1:NEXT:PRINT
"SUUV"SPC(8)"
780 PRINTTAB(8)"I [NOW TRY LEVEL
"L+1TAB(28)"I"
790 PRINTTAB(8)"
" :FORX=1T09:GOSUB1:POKEF1,(
10-X)*5
799 POKEG1,64:POKEG1,65:NEXT:FOR
X=1T080:NEXT:GOTO100
800 POKES,:POKECL,10:PRINT
810 PRINTTAB(8)"I"
820 PRINTTAB(8)"I [G A M E 0
U E R [I
830 PRINTTAB(8)"
840 FORX=1T02000:NEXT:PRINT"SS
$
850 FORX=1T025:GOSUB1:NEXT:HP=-1
860 FORX=4T00STEP-1:IFS=>H(X)THE
NHP=X
870 NEXT:IFHP<0THEN8000
880 GOTO2000
900 POKE251,199:POKES,0:SYS3689
2
910 PRINT"LS"SCORE"S,TAB(15)"HIG
H"TAB(29)"LIVES"5
930 PRINT"LL$RS"SUUV":FORX=1T0
40:PRINTPR$:NEXT:PRINT
940 PRINT"SUUUUUUUUUUUUUUUUU"LL$
950 PRINT"SUUUUUUUUUUUUUUUUU"SU
-C SU-C SU-C SU-C SU-C SU-C SU
-C SU-C SU-C SU-C SU-C SU-C SU-C
"TAB(33)"SU"SU"SU"SU"SU"SU"SU"
SU"SU"
960 I=INT(RND(U)*4):FORX=0T03:IF
TT(X,I)=.THENPRINT"SUUV"TAB(TT(X
,I))T$
970 NEXT
980 LD=INT(RND(1)*4+1):LT=0
990 POKEIC,U:POKEFC,U:POKEF3,50:
RETURN
1000 Q1=PEEK(15):POKEIS,0
1010 Q2=PEEK(U0+22):POKEU0+22,19
9
1020 POKECL,23:PRINT:PRINTTAB(22)
)SU PAUSED [
1030 WAITKB,60,255:WAITKB,60
1040 PRINTTAB(22)"
SU"
1050 POKEU0+22,Q2:POKEIS,Q1:RETU
RN
2000 PRINT"SU"TAB(8)"HIGH SCOR
E REGISTRATION
2010 PRINTTAB(8)"SU
2020 GOSUB2900:PRINTTAB(10)"SU [E
NTER YOUR NAME FOR
2030 PRINTTAB(11)"HIGH SCORE TA
BLE.
2040 PRINTTAB(14)"SUUUUUUUUUUUUU
-C SUUUUUUUUUUUUUUUUU"
2100 NS="" :PRINT"SU"SU":POKE198,0
2110 GETKS:IFKS=""THEN2110
2120 IFKS=R$THEN2200
2130 IFKS=D$ORKS="I"THEN2170
2140 IFKS<>"ANDKS<>" :THENIFKS
<>"ORKS">"Z"OR(KS)>"9"ANDKS<>"A")T
HEN2110
2150 IFLEN(NS)>9THENKS=""
2160 NS=NS+KS:PRINTKS"SU"SU":GOTO2
110
2170 IFNS=""THEN2110
2180 PRINT"SU"SU":NS=LEFT$(NS,L
EN(NS)-1):GOTO2110
2200 IFHP<4THENFORX=3T0HPSTEP-1:
NS(X+1)=NS(X):H(X+1)=H(X):NEXT
2205 NS(HP)="" :H(HP)=S:IFNS=""TH
EN8000
2210 FORX=1T0LEN(NS):KS=MID$(NS,
X,1)

```

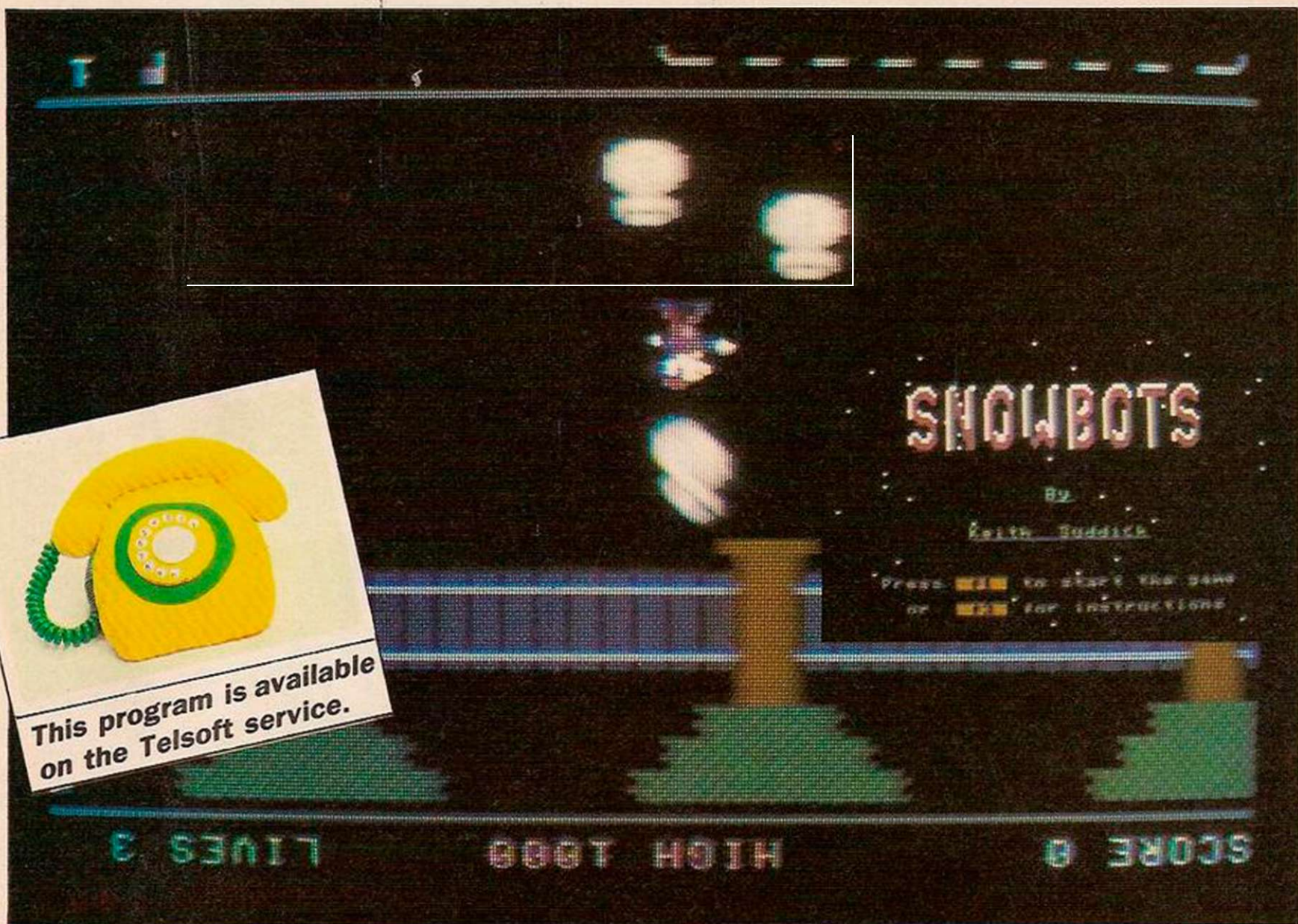

This program is available on the Telsoft service.

```

2220 IFK$>"@ANDK$<"E"THENK$=CHR
5(ASC(K$)OR128)
2230 M$(HP)=M$(HP)+K$:NEXT:GOTO8
800
2900 FORX=0TO20 FORY=50TO120STEP
10
2910 POKE1,Y:POKE61,64:POKE61,6
5:NEXT:NEXT:RETURN
3000 FORX=50TO120STEP10:POKE1,X
:POKE61,64:POKE61,65:NEXT:RETURN
7000 SYS36888:PRINT"*****LLS"
*****:PRINTLLS"II
II-SU"
7010 PRINTTAB(15)"THIS IS GEORGE
E THE LOCAL
7020 PRINTTAB(15)"PARK-KEEPER WH
O HAD JUST
7030 PRINTTAB(15)"PUT UP THE CHR
ISTMAS TREE IN
7040 PRINTTAB(15)"THE PARK. DU
RING THE NIGHT
7050 PRINTTAB(15)"A FREAK ELECTR
ICAL STORM HAS
7060 PRINTTAB(15)"TURNED ALL TH
E SNOWMEN INTO
7070 PRINTTAB(15)"ROBOTS * TO
GET THE POWER
7080 PRINTTAB(15)"THEY NEED THE
Y HAVE STOLEN
7090 PRINT" THE LIGHTS FROM THE
CHRISTMAS TREE AND
7100 PRINT" GEORGE MUST TRY TO G
ET THEM BACK.
7110 GOSUB7900
7200 POKES,,:PRINT"*****LLS"
*****:PRINTLLS"II
II-SU"
7210 PRINTTAB(15)"GEORGE HAD
SOME FLARES
7220 PRINTTAB(15)"LEFT OVER FROM
THE FIRE
7230 PRINTTAB(15)"WORKS DISPLAY

```

```

AND HE FOUND
7240 PRINTTAB(15)"THAT THESE FLA
RES WOULD MAKE
7250 PRINTTAB(15)"THE SNOWBOTS M
ELT SO THAT HE
7260 PRINTTAB(15)"COULD GET THE
CHRISTMAS TREE
7270 PRINTTAB(15)"LIGHTS BACK.
THE ONLY OTHER
7280 PRINTTAB(15)"PROBLEM IS TH
E ICICLES THAT
7290 PRINT" THE SNOWBOTS CAN M
AKE FALL FROM THE
7300 PRINT" TREES ONTO GEORGE !
7310 GOSUB7900
7400 POKES,,:PRINT"*****LLS"
*****:PRINTLLS"II
II-SU"
7410 PRINTP25X$P25L$(1)"SU"
7420 PRINTTAB(20)"S C O R I N G
"SPC(27)"
7430 POKES,4:PRINTTAB(15)"SNOW
SNOWBOTS.... :10 POINTS
7440 POKES,12:PRINTTAB(15)"SNOW
ICICLES.... :20 POINTS
7450 PRINTTAB(15)"SNOWPLUS BONUS
OF :500 POINTS
7460 PRINTTAB(17)"FOR EACH LIGH
T BULB
7470 PRINTTAB(17)"FOR EACH CON-
TAINER
7480 PRINT" EACH SCREEN IS
COMPLETED WHEN ALL
7490 PRINT" THE LIGHT BULBS H
AVE BEEN RETURNED
7499 GOSUB7970
7800 GOTO8000
7900 PRINTP25X$P25L$(1):POKES,1
7920 TP=35934:TC=0
7930 FL=(FL+1)AND7:PRINTP25L$(FL

```

```

/2):TP=TP+1:Q=PEEK(TP):IFQ=.THEN
7970
7935 IFQ=42THENPOKES,3
7940 IFQ>128THENTP=TP+TM(QAND127
):GOTO7930
7950 TC=(TC+1)*(TC<4):POKETP+CS
,TC(TC):GOTO7930
7960 GOTO7968
7970 POKECL,22:PRINT:PRINT"
PRESS RETURN TO CONTINUE
7980 FL=(FL+1)AND7:PRINTP25L$(FL
/4):GETK$:IFK$<>RSTHEN7980
7990 RETURN
8000 POKES,,:POKES,,:PRINT"*****
*****:TS=0
8010 ONTS+1GOTO8100,8200,8300,84
00
8020 TS=(TS+1)AND3
8040 POKECL,20:PRINT:PRINT"*****
*****:PRESS F1 TO START THE GA
ME "
8050 PRINT"*****OR
F3 FOR INSTRUCTIONS"
8060 FORTD=1TOTW:SYSKC:NEXT:GOTO
8010
8100 SYS36888
8120 POKES,255:FORX=0TO7:FORY=0
TO13:POKEV1+2*X,Y*8
8130 GOSUB1:SYSKC:NEXT:POKEV1+2*
X,96:NEXT
8140 FORX=5TO49:POKECL,SC(X/10):
GOSUB1:SYSKC:NEXT
8150 PRINT"*****SPC(13)"
*****:GOSUB1
8160 PRINT"*****SPC(12)"*****KEITH
BUDDICK " :GOSUB1:GOSUB1
8170 PRINT"*****SPC(19)"*****:GOSU
B1
8180 PRINT"*****SPC(18)"*****IV "
8190 FORX=0TO11:GOSUB1:SYSKC:NEX
T:TW=1000:GOTO8020

```

```

8200 FORY=96TO50STEP-1:POKEV,Y:
SVSY
8210 GOSUB1:SYSKC:POKEC2,2+(YAND
4):NEXT
8220 POKES,0:PRINT"*****SPC(8)"
*****
8230 PRINTSPC(8)"I I I I I I I I I I
I I I I I I I I I I I I I I I I I
8240 PRINTSPC(8)"*****
*****
8250 FORX=0TO4:PRINTTAB(8)"X+
*****:M$(X)TAB(30-FNL(X
))":M$(X)
8260 SYSKC:NEXT:TW=1200:GOTO8020
8300 POKEC2,6:FORX=50TO0STEP-2:P
OKEV,Y:SVSY:GOSUB1:SYSKC:NEXT
8310 PRINT"*****SPC(19)"*****:SYS36884:
FORX=1TO39:PRINTPR$;NEXT
8320 PRINTP15X$"*****TAB(27)T15
8340 POKES,1:FORX=80TO0STEP-1:P
OKEV,X:POKES,8+(XAND4)/2
8350 SYSKC:PRINTP15L$((XAND8)/8)
:NEXT
8360 POKES,3:FORX=0TO80:POKEV0+
2,X:PRINTP15L$((XAND8)/8):SYSKC:
NEXT
8370 PRINTP15L0$:FORX=80TO0STEP-
2:POKEV0+2,X:SYSKC:NEXT
8380 POKES,1:FORX=0TO80:POKEV0,
X:POKES,9+(XAND4)/2:SYSKC:NEXT
8390 PRINT"*****:TW=400:GOTO8020
8400 FORX=1TO25:GOSUB1:SYSKC:NEX
T:PRINT"*****
8410 FORX=1TO39:PRINTPR$;NEXT:M
L=FF-CD
8420 PRINT"*****TAB(10)T15"*****TA
B(28)T15
8430 POKES,2:POKEV0+29,2:POKEV1
,150:POKES,3
8440 FORX=0TO340STEP4:POKEV0+16,

```

(listing continued on page 83)



**The Commodore 128.
When you look at the facts
they do seem to weigh rather
heavily in our favour.**

When you add it up, the Commodore 128 is really three computers in one.

It can run 64K, 128K and CP/M software. Giving it the largest range of computer software in the world. Making it as efficient in business as it is entertaining at home.

That's why Commodore has become the world leader in microcomputers.

And why, on balance, the Commodore 128 has no equal.





BBC English

Speech without a speech chip. David Hoskins explains how to do it.

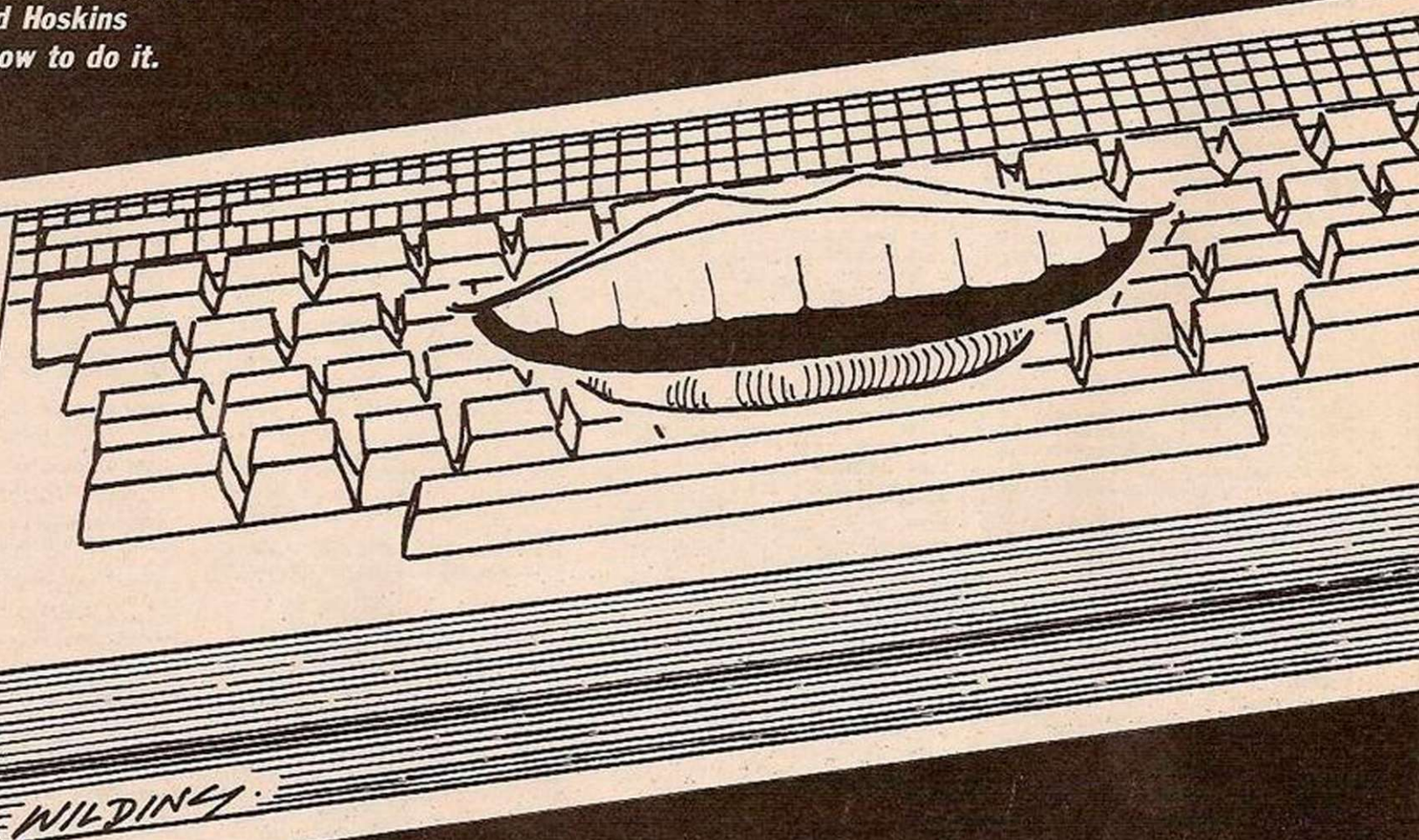

The BBC has very easy to use and versatile sound facilities. The envelope command enables you to change the pitch and volume of any sound played. But there is one draw-back, you cannot change the actual waveform of the sound. So you always get that spikey, tinny kind of sound that's always recognisable as a BBC.

Digitise speech

About six months ago I was very impressed by some speech on a Commodore 64 game, and wondered if it was possible to do it on the BBC. The first problem — and quite a big one — was to find a way of encoding a waveform so I can literally play from the BBC speaker! I will briefly explain how this can be achieved.

First, set the sound chip to its highest possible frequency, which is inaudible to the human ear. The more channels used the louder the waveform will be. The waveform which varies in amplitude from 0 to 15 is then sent nibble by nibble to the

volume control of each channel. The fastest speed the BBC can do this is about 10000 times a second, the faster you go the clearer the sound will become. What was needed now was the waveform data to feed the program. To do this I used the Interbeeb module from DCP Microdevelopments which sampled — recorded — data at a rate of 10000 times per second, this was perfect for the job. After many weeks of frustration and fiddling I eventually had a result . . .

"It worked!" I exclaimed and ran downstairs to tell everyone. The scope for experiment was awesome. I spent a long time recording and playing sounds, at different speeds, backwards, with an echo, while mixing with other sounds, making drum beats, and even playing tunes with samples like some £280000+ synthesisers!

I had digitised about five seconds of music at a high sample rate, and it was now playing through the BBC's speaker under complete software control!

To digitise speech I use a sampling rate of about 5.5KHz and a filter to cut out any unwanted sounds above that frequency. I speak the words into a microphone which are then converted from analogue form to digital by the Interbeeb, and sent to the BBC which in turn stacks the data in memory. The data can then be saved and played back any time without using any hardware.

A phoneme solution

Since then I have been developing a program called Speech! which is being marketed by Superior Software. This system allows the user to type in English or phoneme phrases (explained later), which are then spoken by the program, e.g. *SAY Hello I am a speech synthesiser. The above command can be typed directly to the computer or put into a program. Speech! will translate this command and speak it through the BBC's speaker.

This program, like a few hardware systems on the market, has an unlimited voca-

bulary. So how did I manage to digitise every word in the English language in 32K?

The answer is in phonemes: the sounds that we string together in order to make speech. Take the words "mat" and "cat" for example, they both use exactly the same "a" sound. So in the sentence "The cat sat on the mat" all the "a" sounds can be just one block of speech data. The same thing applies to the "t"'s, "th"'s, "e"'s, and so on until you have covered as many phonemes needed for understandable speech. In Speech! I have used 49 different phonemes, which are merged to form whatever word or sentence you like.

Unfortunately to convert English phrases into phoneme data is a little more complicated. The trouble with the English language is that it is occasionally very illogical. For instance, the word "laughter" almost completely changes pronunciation when an "s" is prefixed to make "slaughter". Why is the word "rough" different from "bough" and

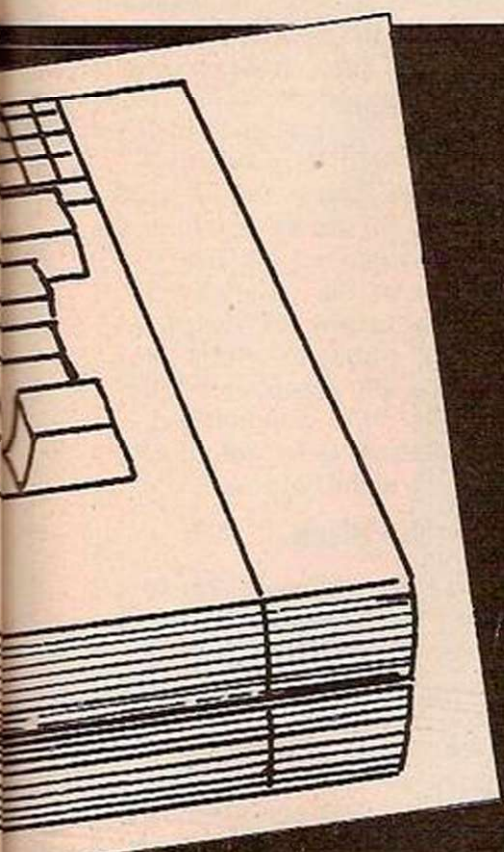

could handle I found that I could get the waveform to repeat every 128 samples. Unfortunately it is very difficult to remember and keep a steady pitch of voice throughout the recordings and it took many hours to complete the voiced — glottal pulse phonemes — sounds.

Voiced fricatives

Explosive sounds like "P" or "D" as in "Dear" never repeat so the 128 sample waveform is only played once. But this is not all. Before we make the explosive sound air pressure is built up behind the lips, making a slight pause before pronunciation. This pause was reconstructed just before playback of the phoneme. Similarly, because

a relatively small sample of the sound was taken a small pause was also needed after the phoneme as well.

The biggest problem with sampling and repeating waveforms is that it does not work with fricatives. These are phonemes which use "white noise" or resonated hiss e.g. "S" as in "Salt". Voiced fricatives use the resonant hiss but are also overlaid by a glottal pulse waveform. You cannot use the BBC's own white noise generator because it has only one set sound and doesn't resemble any of the phonemes.

To get around this problem I digitised 128 samples of spoken fricative, which fitted nicely into the rest of the data and could be easily tabled. To play the frica-

tive Speech! picks a random number between 0 and 127 along the data of the sound and then plays a waveform block of 16 samples from that point. The process is then repeated by choosing the random number again. This is continued until the desired time of the phoneme is over. The result is quite an accurate reproduction of the original fricative. The only problem left (soundwise) was the voiced fricatives.

No white noise

I found that it was possible to say these phonemes and not actually sound the white noise into the microphone. After digitising and tabling this sound I worked out that the fricative

(continued on next page)

"tower" different from "mower" merely because of the prefixing consonant? The reason why we know the differences and exceptions in the English language is because we have had years of training. The computer hasn't, and all it has to rely on is logic. Basically there can be at least 400 rules for text/speech conversion with a few thousand exceptions! Obviously to fit Speech! into 7.5K I have cut down on the exceptions, but any mispronounced words can be easily altered with a little thought.

Glottal pulse

To digitise each phoneme sound that uses the vocal chords for speech, i.e. "OO" not "S" I prolonged the sound (like when the doctor says "Say aaahh") into the microphone and sampled a small section of it. On analysis it can be seen that there is a close repetition in the waveform, every time the vocal chords produce what is known as a glottal pulse. By changing the pitch of my voice with the highest sample rate my program

```

10 REM      Waveform Encoded strange sounds program
20 REM      (C) 1985 DAVID J. HOSKINS
30 REM      for YOUR COMPUTER
40 REM      line 110 inserts sinewave into waveform table
50 REM      this can be changed to create any sound
60 REM      once data is in memory line may be skipped
70
80 MODE4
90 PROCinit
100 MOVE0,448
110 FORA%=0TO255:Y%=7.9+8*SINRAD(360/256*A%)
120 DRAWA%*4,Y%*64:A%?table=Y%:NEXT
130 CALLstart
140 END
150
160 DEFPROCinit      :REM assemble code
170 temp=&71:table=&4000:sped=&70
180 tim=&72:coun=&74
190 FOR pass=0 TO 2 STEP2:P%=&4100
200
210 OPT pass
220
230.start
240
250 SEI
260 LDA #193:JSR in:LDA #0:JSR in      \ set up sound channels
270 LDA #129:JSR in:LDA #0:JSR in      \ " " " "
280 LDA #161:JSR in:LDA #0:JSR in      \ " " " "
290 LDA #0      360 STY coun
300 STA tim      370
310 STA tim+1    380.loop2
320 STA sped     390 LDA table,Y
330              400 AND #15
340.loop         410 JSR send
350 LDY #0

```

(listing continued on next page)

BBC English

(continued from previous page)

(listing continued from previous page)

```
420 LDA tim 700
430 AND #127 710 EOR #15
440 CLC 720 STA temp
450 ADC #1 730 ORA #208
460 TAX 740 JSR in
470 wait 750 LDA temp
480 DEX 760 ORA #144
490 BNE wait 770 JSR in
500 TYA 780 LDA temp
510 CLC 790 ORA #176
520 ADC sped 800 JSR in
530 TAY 810 RTS
540 CLC 820
550 ADC #3 830 in
560 STA tim 840
570 DEC coun 850 LDX #255
580 BNE loop2 860 STX &FE43
590 LDA sped 870 STA &FE41
600 AND #7 880 INX
610 ADC tim+1 890 STX &FE40
620 ADC tim 900 LDA &FE40
630 STA sped 910 ORA #8
640 INC tim+1 920 STA &FE40
650 BNE loop 930 RTS
660 CLI 940
670 RTS 950é
680 960 NEXT
690 send \ send 970 ENDPROC
    wave form
    to sound
    chip
```

sound could be added to the waveform after it has played one section of about 100 samples. For example, in the phoneme "Z" as in "ZEBRA" SPEECH! plays about 100 samples of the wave (without the hiss) and then it plays 28 samples of the fricative "S". The reason why "S" was used in the phoneme "Z" was because it's sharp and loud, whereas "V" would need a mellow and quiet sound like "H" — as in "House".

Vary the pitch

The user of Speech! can also control the overall pitch of the voice and individual phonemes. Inserting full-stops and question marks vary the pitch of the voice towards the end of the sentence. To change pitch Speech! simply plays back the phoneme at different speeds. But . . . the problem was that when you change pitch of the voice in the phrase it suddenly changes where it should vary slowly. Also, after a voiced phoneme was played it suddenly jumped into the next one usually making it very hard to understand at the best of times! What was needed was some kind of merging technique which will slowly change one waveform into another while they are playing.

Fairly accurate

With the phonemes "AA" in "Yard" and "EE" as in "Feet", the merging was achieved as follows. When the "AA" phoneme starts, 128 samples are played and then 0 samples of "EE". Then 127 samples of "AA" are played and 1 of "EE". This continues until the end of the "AA" phoneme when 0 samples are played of "AA" and 127 of "EE", you see! This merge is timed to finish exactly when the first phoneme has completed its cycle, no matter how long it is played. The result is a gradually varied and fairly accurate reproduction of speech.

An example of Speech! can be heard on two games from Superior Software: Citadel and Repton 2. Speech! and six programs and utilities can be bought at £9.95 on tape and £11.95 on disk. ●

TAKE A TRIP
INTO THE
PLEASURE GAME

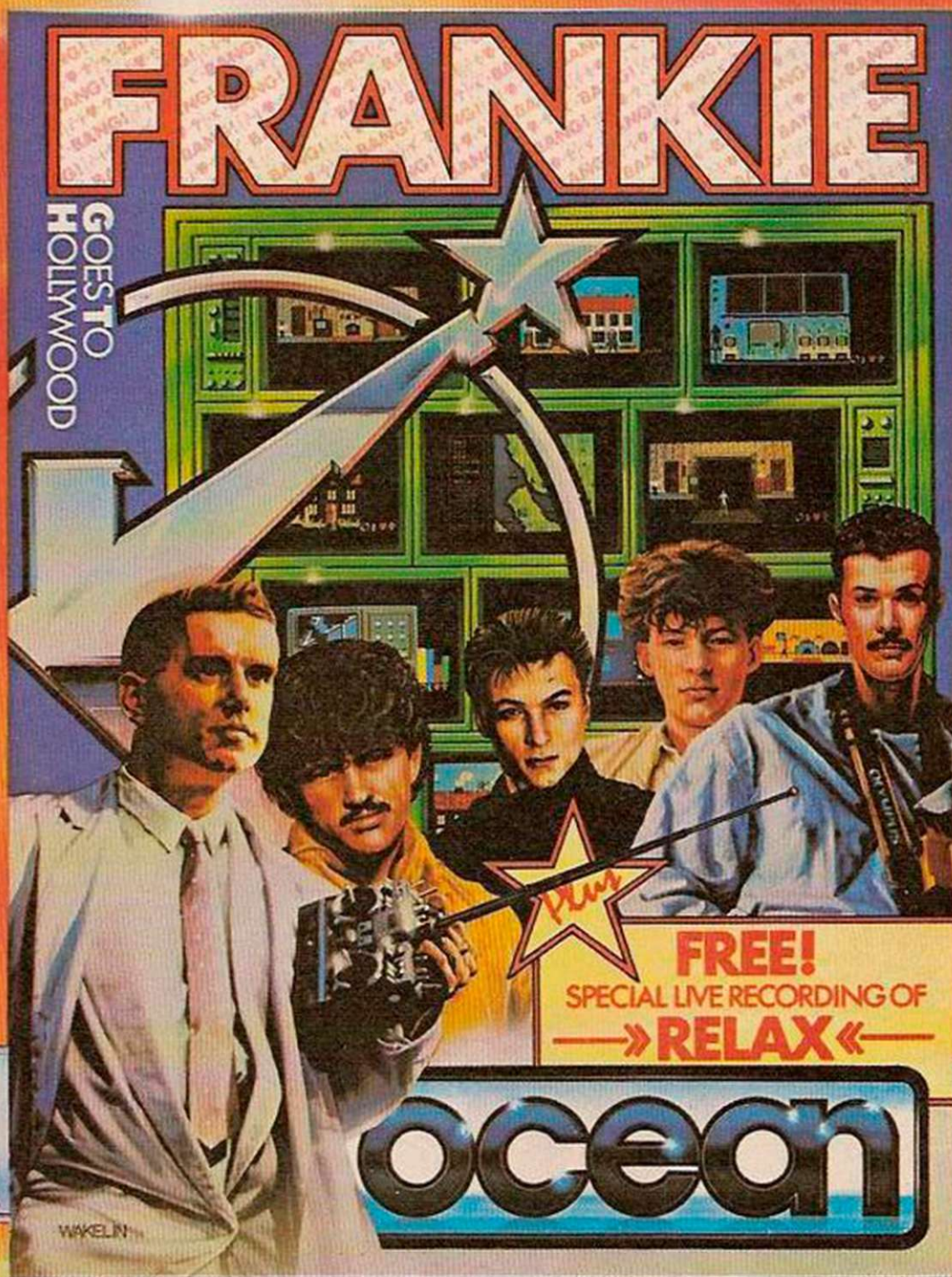

AVAILABLE
NOW

FOR THE

SOME ALREADY HAVE...

**YOUR
COMPUTER**

... innovative mix of ideas and excellent graphics ...

CRASH

Variety is certainly the key word in this highly unusual game which has surely gone far beyond what anyone ever expected.

CLASSIC

... a beautiful program, an adventure of great imagination, with some superb programming techniques ...

**COMPUTER
GAMES**

It's nice to see a game that can match the quality and the style of the group.

— action and strategy — and there are a number of slick touches that will keep you on your toes.

SPECTRUM 48K

Ocean Software Limited

6 Central Street, Manchester M2 5NS

Telephone: 061-832 6633 Telex: 669977 Oceans G

9.95

COMMODORE 64

Ocean Software is available from:  WHSMITH,

John Menzies, **WOOLWORTH**, LASKYS, Rumbelows, Greens

Spectrum Shops and all good software dealers.

The Standard by which others will be judged.

This is Hardball from Accolade. The first in a new generation of game software that sets the standard for others to beat; if they dare! With graphics so large and lifelike and sound effects so real, you'll believe you really are at the ball park - yes, you can almost smell the hot-dogs!

Sorry, we can't supply the hot-dogs; you'll have to bring your own - but everything else is here to recreate the atmosphere, tension and excitement of big time baseball on your own small screen.

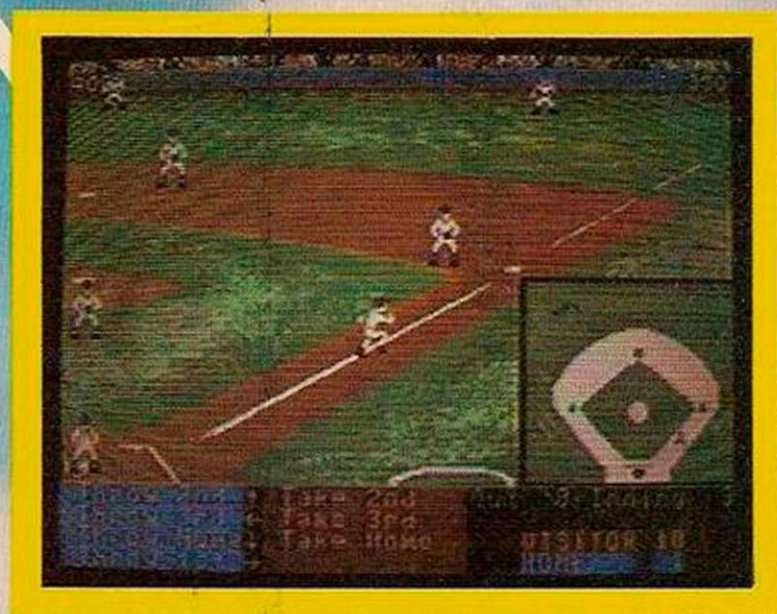
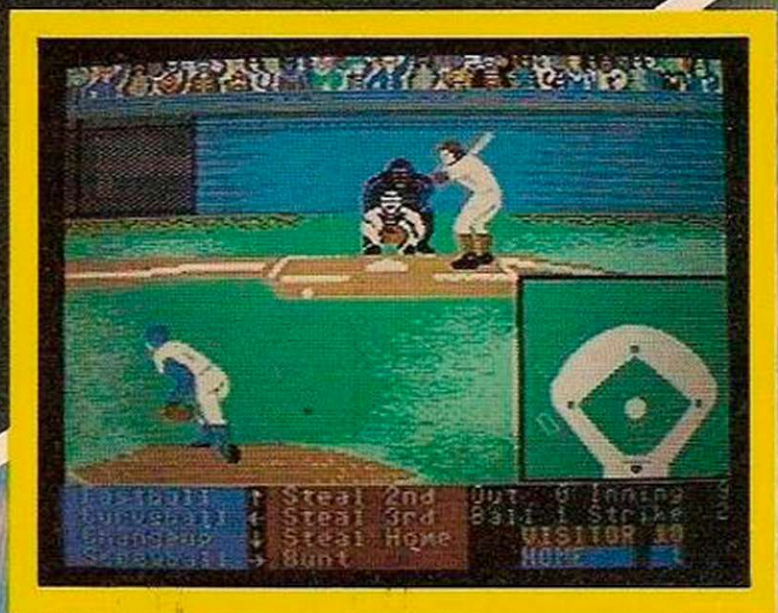

Accolade, Inc.

ALL-STAR	1	2	3	4	5	6	7	8	9	EX	10
ALL-STAR	B	28	283								
Allen	CF	279									
Jose	CF	285									
Miller	CF	274									
Craven	CF	275									
Lorenzen	CF	281									
Flaws	CF	288									
Gautista	CF	271									
Warrten	CF	268									
Doggett	CF	268									
P. Frisina	R	3.55	Rep	P. Euler	L	1.3	Rep				

CHAMPS	1	2	3	4	5	6	7	8	9	EX
CHAMPS	B	28	283							
McCall	CF	279								
DeSoto	CF	285								
Conoto	CF	274								
Barnes	CF	275								
Nyden	CF	281								
Horra	CF	288								
Hills	CF	271								
Quarion	CF	268								
McCall	CF	268								
Euler	R	3.55	Rep	P. Euler	L	1.3	Rep			

SUBSTITUTE	0	1	2	3	4	5	6	7	8	9	EX
Player	Position	Bat	AB	HR	RBI	SB	AVG				
Dennis Hannu	OF	Rt	283	12	31	1	.291				
Dennis Hannu	CF	Sw	105	2	11	1	.190				
Warrten	CF	Lf	381	21	31	3	.271				

HardBall!

By Accolade

For Commodore 64

Cassette - £9.95

Disk - £14.95



Harvey Smith



For the best entry to this competition we're giving away a full Sanyo midi stereo system. And the top 30 runners-up will each receive a copy of Software Projects' new game Harvey Smith Showjumper.



COMPETITION RULES

- The winners of the competition will be the people who, in the view of the editor, come up with the most interesting or amusing designs for a home computing obstacle course.
- The names of the winners will be printed in the March issue of *Your Computer*.
- All entries must arrive at the *Your Computer* offices by the last working day in January 1986.
- Each person may enter the competition only once.
- Entries to the competition cannot be acknowledged.
- No employees of Business Press International or their relatives may enter the competition.
- The decision of the editor is final.
- No correspondence on the result of the competition will be entered into.
- Business Press International assumes no responsibility or liability for any complaints arising from this competition.

To enter the Software Projects Harvey Smith competition what we want you to do is send us your designs for a home computing obstacle course. You can submit your entry as a written description or drawing.

HARVEY SMITH COMPETITION

Don't forget to enclose this coupon, or a photocopy of it, when you send in your entry to Harvey Smith Competition, *Your Computer*, Room L221, Quadrant House, The Quadrant, Sutton, Surrey SM2 5AS.

Name _____

Address _____

ONLY THE BRAVEST FLY....

TOMAHAWK

New, from the author of Fighter Pilot... a stunningly realistic helicopter simulation that puts you in command of an Apache Advanced Attack helicopter. You will learn to take off, to land, to manoeuvre and locate and destroy enemy tanks using Hellfire anti-tank missiles. You will experience authentic battlefield conditions as you endeavour to carry out your mission and return safely to base.

BY D.K. MARSHALL
48K SPECTRUM

Digital Integration would like to thank
McDonnell Douglas for all their help and technical support.

£9.95
inc. p&p & VAT



Spectacular 3D cockpit view with over 7,000 ground features.
Authentic aerobatic performance.
Ground attack and air-to-air interception, with laser guided missiles, rockets and 30 mm. gun.
Doppler navigation and target tracking.
Day/Night vision systems.

Cloudy, Crosswinds, Turbulence.
Pilot ratings — Trainee to Ace. Pilots Notes.
Impressive sound effects. Twin Joystick Option.

FREE HELICOPTER FLIGHT Competition
Entry forms & full details inside every pack.
2 First Prizes of a trip in a helicopter.
20 Runner-up Prizes of Apache model kits.
Closing date Feb. 15th. 1986.

- SPECTRUM**
- Tomahawk 48K £9.95
- Night Gunner 48K £6.95
- Fighter Pilot 48K £7.95
- COMMODORE 64**
- Speed King Disk £12.95
- Speed King Cassette £9.95
- Fighter Pilot Disk £14.95
- Fighter Pilot Cassette £9.95
- AMSTRAD CPC 464**
- Fighter Pilot £8.95
- Fighter Pilot Disk £13.95

Cheques payable to Digital Integration Ltd
I enclose a cheque/P.O. for _____ Total

Name _____
Address _____

Or debit my Access Account No. _____

Tele Sales (0276) 684959

Please send to **DIGITAL INTEGRATION**

Trade and Export enquiries welcome. Lifetime Guarantee.

Watchmoor Trade Centre,
Watchmoor Road,
Camberley, Surrey
GU15 3AJ



VAT and p. & p. inclusive within UK (Overseas inc. 55p. per cassette)

Hot Shots

SPECTRUM POKES

Android 2 inf/Lives	Load Game. When asked for keyboard or Joystick. Press Cap and Break. Enter POKE 52249,24:POKE 52250,32:POKE 53897,0. Enter Cont.	Freez Bees Pyramid Tutankhamun Wheelie	POKE 34610,0 POKE 44685,0 POKE 27783,0 Codes, 1. Witty 2. Shark 3. Bebop 4. Xenon 5. ZX83B 6. 2MQL3 7. HRME2.
Arcadia inf/lives Cookie Defenda Fall Guy	POKE 23776,0 or POKE 25776,0 POKE 26197,0 Stops the Rubbish. POKE 35730,52 10 CLEAR 24100 11 LOAD "" CODE 12 RANDOMISE USR 65100 13 LOAD "" CODE 14 POKE 44204,0 15 RANDOMISE USR 41200 Type in and Run then play tape.	Helicopter Booty	Passwords. Show. Forever. Restart. Clear. Type in and Run. The Start Tape. 10 BORDER 0: PAPER 0: INK 0 20 CLEAR 26870 30 LOAD "" SCREENS 40 LOAD "" CODE 26880 50 RANDOMISE USR 26880 60 POKE 58294,0 70 RANDOMISE USR 52500
Frank N Stein	Type in and Run. 10 BORDER: INK 0: CLEAR 24750: LOAD ""SCREENS: PAPER 0: PRINT AT 0,6: :LOAD ""CODE: POKE 28287,X: RANDOMISE USR 27890. (X=No of Lives) POKE 28277,0: POKE 28278,0 inf/lives. For no title screen POKE 34124,0 inf/lives with title screen.	Wizards Lair Spectral Invaders Short Fus	Codes for lift. 1. HAWLO 2. CAIVE 3. VAULT 4. LIAYR 5. DUNGN 6. CRYPT 7. LYONS. POKE 25062,254 Codes 1. 000 2. 367 3. 157 4. 049 5. 281
Ground Attack Horace Goes Skiing	POKE 29063,0 POKE 29270,0 removes traffic. POKE 30027,0: POKE 30644,0 no charge for skis.	Fantastic Voyage Cauldron	Type in and Run to load the code. 10 CLEAR 30791: LOAD "VOYAGE" CODE: POKE 54492,167: BORDER 0: PRINT USR 53248. Type in and run, start tape just past screen. 10 CLEAR 24599: FOR f=23296 TO 23309: READ a: POKE f,a: NEXT f. 20 LET L = USR 23296: POKE 40060,0: LET L = USR 24600. 30 DATA 221,33,24,96,17,232,159,62,255, 55,205,86,5,201.
Hunchback Jet-Pac	POKE 26888,0 POKE 25020,0 inf/lives Poke 26075,0 1 fuel pod to launch rocket.	Sky Ranger	Codes 1. Enter 2. Magic 3. Pilot 4. Stomp 5. Paris 6. Event 7. Recap POKE 33420,0 player 1 POKE 33452,0 player 2 POKE 48825,255 POKE 31683,0: POKE 31684,0 POKE 34695,183 Add to line 30 before the Rand USR command POKE 28032,255: POKE 28087,8: POKE 29243,8: POKE 30543,8 POKE 27662,2 POKE 27150,0 POKE 24786,0 POKE 37319,201 POKE 54065,0
Kokotoni Wilf	Type in and run the load tape. 10 CLEAR 24100: LOAD""CODE 20 RANDOMISE USR 65100: LOAD""CODE 30 POKE 42214,X : PRINT USR 41200 (X=No of Lives)	River Rescue Zaxxon Cavern Fighter Black Hawk A View to a Kill	POKE 26075,0 1 fuel pod to launch rocket. Type in and run the load tape. 10 CLEAR 24100: LOAD""CODE 20 RANDOMISE USR 65100: LOAD""CODE 30 POKE 42214,X : PRINT USR 41200 (X=No of Lives) POKE 36212,0 Alter Line 335 to POKE 56693,0 enter Goto 9999 and restart tape POKE 36965,0 inf/lives POKE 37999,201 no enemies 10 POKE 23693,0: CLS: LOAD "" SCREENS:LOAD""CODE 24756: POKE 42404,255: Print USR 26624. POKE 39754,0 inf/lives POKE 37035,201 no enemies in the air POKE 42654,195 immortality. POKE 33501,0 skip first screen POKE 33693,0 inf/lives POKE 54933,0 gives 2556 lives POKE 46441,0 POKE 24984,0 POKE 25446,0 POKE 24743,0:POKE 32692,0 POKE 36519,0 inf/lives. First Merge"" POKE 23756,1, Enter, list, then put in inf/lives Poke.
Kosmic Kanga Lazy Jones	POKE 36212,0 Alter Line 335 to POKE 56693,0 enter Goto 9999 and restart tape	Project Future Road Racer Ah Diddums Orion Zip Zap Jet Set Willy 2	POKE 48825,255 POKE 31683,0: POKE 31684,0 POKE 34695,183 Add to line 30 before the Rand USR command POKE 28032,255: POKE 28087,8: POKE 29243,8: POKE 30543,8 POKE 27662,2 POKE 27150,0 POKE 24786,0 POKE 37319,201 POKE 54065,0 Type in and Run then start tape. 10 CLEAR 64999 20 LET obj = 150 30 LET room = 32 40 For n = 65000 To 65047:READ a:POKE n, a: NEXT n 50 PAPER 0: INK 0: BORDER 0: CLS 60 RANDOMISE USR 65000 70 DATA 221,33,0,64,17,56,185,62,255, 55,205,86,5,243,48,240 80 DATA 33,6,254,17,197,100,1,59,0,237, 176,195,0,95 90 DATA 62,255,50,67,117 100 DATA 62,obj,50,126,135 110 DATA 62,room,50,75,117 120 DATA 195,0,112
Lunar Jetman	POKE 36965,0 inf/lives POKE 37999,201 no enemies		
Moon Alert	10 POKE 23693,0: CLS: LOAD "" SCREENS:LOAD""CODE 24756: POKE 42404,255: Print USR 26624.		
Other Pokes	POKE 39754,0 inf/lives POKE 37035,201 no enemies in the air POKE 42654,195 immortality.		
Mr Wimpy	POKE 33501,0 skip first screen POKE 33693,0 inf/lives		
Mutant Monty Piballed PSSST TranzAm Zzoom Atic Atac	POKE 54933,0 gives 2556 lives POKE 46441,0 POKE 24984,0 POKE 25446,0 POKE 24743,0:POKE 32692,0 POKE 36519,0 inf/lives. First Merge"" POKE 23756,1, Enter, list, then put in inf/lives Poke.		
Black Crystal	Map References. 1. 512661220 2. 1126690200 3. 1126671220 4. 3126641220 5. 2126671220 6. 1126290200		

Make it live

James Hartley shows you how to control six adventure characters.

In last month's instalment I showed you one way of programming tree structures in Basic. This month, in order to show you the system working on a rather larger scale, we've provided a listing that uses it to control six characters.

Margaret Thatcher, Ronald Reagan, Catherine the Great of Russia, Hamlet, Count Dracula, and Godzilla are all guests at the Hotel Horrabelle. They can discuss their favourite subjects with one another; pick up, drop, and give objects; and indulge in other less conventional activities. To see them in action, simply enter the program and Run it.

Controlling characters in this way is only one aspect of the vast subject of "data structures" and their use in programming. The "trees" we have built are really only a type of linked list which enable items to be stored in memory in some relation to each other that enables them to be sorted and processed by a simple algorithm. If you're serious about programming then you could try getting a book on the subject and your programming will benefit enormously.

The Hotel Horrabelle example is not as efficient as it could be for a number of reasons. First, it's written in minimal Basic and sacrifices the good features of most machines for the standard features they all share (with one or two exceptions). Second, it's rather slow in execution since it's been written with more attention to ease of compre-

hension than to speed.

It's worth noting that this method of handling characters is in fact even better suited to machine code than to Basic, and machine code programmers would find it very easy to program the tree traversal algorithm in lines 1070 to 1210 together with the tree data to

gain obvious benefits in speed.

Large areas of program could also be condensed, in particular by putting sub-messages in data statements and then using either string functions or sub-routines to compile the statements. Perhaps the most practical solution of all, if you wish to make serious use of this technique

without getting into machine code, is to condense the program as much as possible and then compile it, though of course you could only do this if there is a suitable compiler available for your machine.

This approach is adopted by at least one adventure software company I know.

c(c,n) = Character Data Array

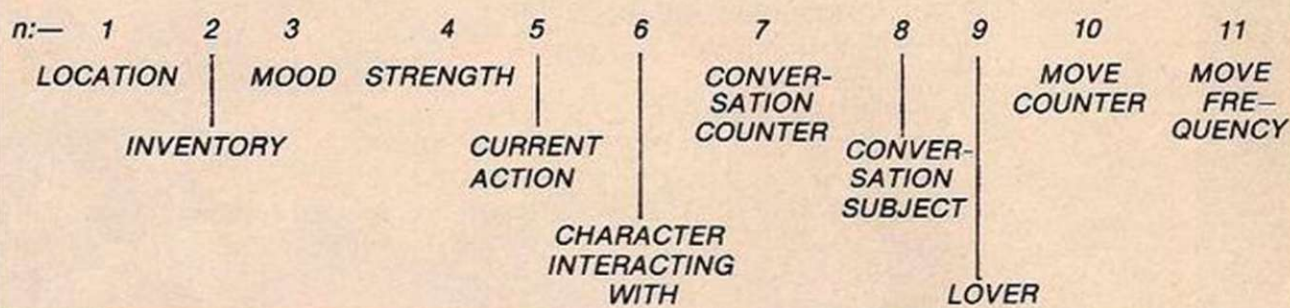

CHOICE	t(t,n,1) 1	t(t,n,2) CONDITION NUMBER	t(t,n,3) BRANCH IF FALSE	t(t,n,4) BRANCH IF TRUE
ACTION TERMINAL	2	ACTION NO.	∅	∅
RANDOM/MULTIPLE CHOICE	3	CONDITION NUMBER	RND NO RANGE	BASE NODE
PROCEDURE	4	PROC NO	∅	∅
RANDOM BRANCH TO ONE NODE	5	∅	RND NO RANGE	NODE TO JUMP

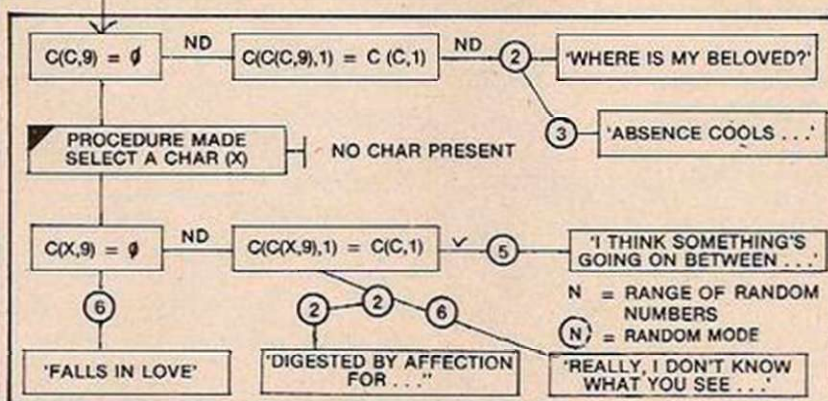

Main variables.

c — current character
x — character interacting with
d(n) — conditions
c(c,n) — character data
a — player's position
v\$(n) — location descriptions
b\$(n) — object descriptions
t(tree no., node no., data) — the arrays

Program Notes.

The program allows the user to input numbers 1 to 4, which will select different locations. You can then see what's going on in that location. Messages are only printed on the screen about the characters in the location you are currently viewing. If you'd like to know what's going on in all the rooms, just delete line 750.

The program as written will run unaltered on the Amstrad range of computers. However, other micro users may have to make some minor corrections. Spectrum

owners will have to alter the string dimension statements, giving the maximum length of the elements involved. They will also have to replace the ON...GOTO/GOSUB statements with the following construct:
RESTORE (line number);
FOR N=1 to (branch variable): READ D: NEXT N:
GOTO D
(line number) DATA ... list of line numbers ...

BBC owners will also have to make slight alterations to the syntax of the random number routine in line 1330 and Commodore owners will

also need to alter the CLS routine in line 1270. The input routine in line 450 may also need minor alteration for some micros.

The program sets up five trees as described in the previous issue's article. Each node has four data values associated with it — a node type, followed by three parameters. The node types are (1) a simple choice node (2) an action terminal node (3) a multiple choice node (either a random choice or as dictated by a condition) (4) a 'procedure node' which exits the tree and then re-enters it and (5) a

random node that branches to a given node only if a specified number is returned from the random number generator.

You could experiment with adding your own trees if you wished. The program is designed to call one of seven trees at random, but only five are implemented. Trees six and seven could be introduced by altering line 2700 and adding the data, action routines, and procedure routines to the different tables. A diagram of the 'falling in love' tree is shown as an example.

Lord of the Rings must be the prime example of an adventure using interactive characters. Anything you can do, they can do, and possibly better.

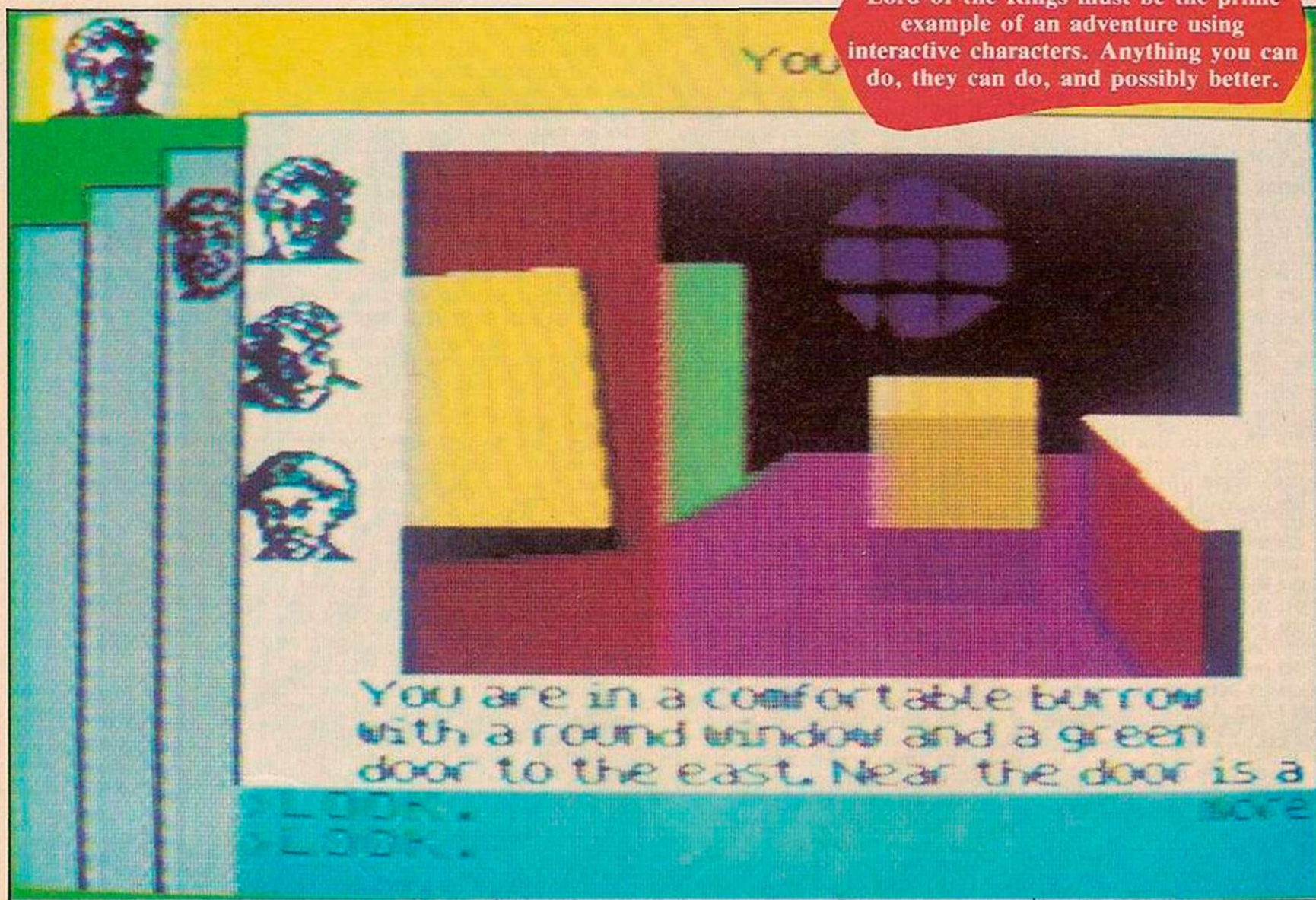

```

18 REM Welcome to the Hotel Horrabelle!
20 REM
30 REM Initialise
40 REM
50 GOSUB 1278
60 PRINT "Welcome to the Hotel Horrabelle ..."
70 PRINT "The guests include Margaret Thatcher, Godzilla, Hamlet, and others"
80 PRINT "Please wait while I call them from their rooms..."
90 DIM r$(4),r(4,4),b$(10),b(10),c$(6),c(6,11),t(7,35,4),d(50)
100 DIM s$(6)
110 DEF FN$(f$,g$,h$)=CHR$(34)+h$+CHR$(34)+f$ says "f$" to "g$"
120 DEF FNq$(f$,g$)=CHR$(34)+g$+CHR$(34)+f$ says "f$"
130 REM read in data
140 FOR n=1 TO 4: READ r$(n): FOR m=1 TO 4: READ r(n,m): NEXT m: NEXT n
150 FOR n=1 TO 10: READ b$(n),b(n): NEXT n
160 FOR n=1 TO 6: READ c$(n): FOR m=1 TO 11: READ c(n,m): NEXT m: NEXT n
170 FOR n=1 TO 6: READ s$(n): NEXT n
180 REM tree one
190 FOR n=1 TO 13: FOR m=1 TO 4: READ t(1,n,m): NEXT m: NEXT n
200 REM tree number two - object manipulation
210 FOR n=1 TO 27: FOR m=1 TO 4: READ t(2,n,m): NEXT m: NEXT n
220 REM tree number three - conversation
230 FOR n=1 TO 35: FOR m=1 TO 4: READ t(3,n,m): NEXT m: NEXT n
240 REM tree number four - love

```

```

250 FOR n=1 TO 21: FOR m=1 TO 4: READ t(4,n,m): NEXT m: NEXT n
260 REM tree number five - actions
270 FOR n=1 TO 31: FOR m=1 TO 4: READ t(5,n,m): NEXT m: NEXT n
280 REM
290 REM main loop
300 REM
310 a=1
320 GOSUB 1260: REM clear the screen
330 GOSUB 490: REM print location
340 GOSUB 510: REM print objects
350 GOSUB 600: REM print characters
360 GOSUB 450: REM check for keypress
370 IF p=0 GOTO 390: REM no keypress so carry on
380 a=p: GOSUB 1350: GOTO 330: REM change player location
390 GOSUB 2660: REM call the character handler
400 GOTO 360: REM carry on
410 REM
420 REM high level subroutines
430 REM
440 REM input
450 i$=INKEY$: IF i$="" THEN p=0: RETURN
460 IF (ASC(i$)<49) OR (ASC(i$)>52) THEN p=0: RETURN
470 p=ASC(i$)-48: RETURN
480 REM print location description
490 PRINT r$(a): GOSUB 1350: RETURN
500 REM print visible objects
510 n=0
520 FOR n=1 TO 10
530 IF b(n)<>a THEN GOTO 560
540 IF n=0 THEN PRINT "You can see: a "; b$(n): n=1: GOTO 560

```

```

550 PRINT " a ";b$(n);
560 NEXT n
570 IF n=0 THEN RETURN
580 GOSUB 1350: RETURN
590 REM print visible characters
600 n=0: FOR n=1 TO 6
610 IF c(n,1)<>a THEN GOTO 640
620 IF n=0 THEN PRINT "Also present: ";c$(n): n=1: GOTO 640
630 PRINT " ";c$(n);
640 NEXT n
650 IF n=0 THEN PRINT "There's no-one here..."
660 GOSUB 1350: RETURN
670 REM move a character
680 y=0:r=5: GOSUB 1330: IF r(c(c,1),r)=0 THEN GOTO 680
690 IF c(c,1)=a THEN n=c$(c)+ " leaves the room...": l=1: GOSUB 750: y=1
700 c(c,1)=r(c(c,1),r)
710 IF c(c,1)=a THEN n=c$(c)+ " enters the room...": l=1: GOSUB 750: y=1
720 IF y=1 THEN GOSUB 600
730 RETURN
740 REM print a message if player present
750 IF c(c,1)<>a THEN n$="": RETURN
760 PRINT n$: IF l=1 THEN GOSUB 1350
770 l=0: n$="": RETURN
780 REM select a random character from a location
790 x=0: n=0
800 FOR n=1 TO 6
810 IF n=c THEN GOTO 850
820 IF c(n,1)<>c(c,1) THEN GOTO 850
830 r=6: GOSUB 1330: IF r=5 THEN x=n: n=6

```

```

840 n=1
850 NEXT n: IF n=0 THEN RETURN
860 IF x=0 THEN GOTO 880
870 RETURN
880 REM select a random object from a location
890 b=0: n=0
900 FOR n=1 TO 10
910 IF b(n)<>c(c,1) THEN GOTO 940
920 r=5: GOSUB 1330: IF r=4 THEN b=n: n=10
930 n=1
940 NEXT n: IF n=0 THEN RETURN
950 IF b=0 THEN GOTO 980
960 RETURN
970 REM check if object owner present
980 x=0: p=0: IF (c(c,2)=0) OR (c(c,2)>6) THEN RETURN
990 IF c(c(c,2),1)=c(c,1) THEN p=1: x=c(c,2)
1000 RETURN
1010 REM check if owned object present
1020 p=0: IF b(c)=c(c,1) THEN p=7: RETURN
1030 FOR n=1 TO 6
1040 IF (c(n,2)=c) AND (c(n,1)=c(c,1)) THEN p=c: n=6
1050 NEXT n: RETURN
1060 REM sort a tree
1070 j=1
1080 ON t(t,j,1) GOTO 1090,1110,1150,1180,1210
1090 j=t(t,j,(ABS(d(t(t,j,2))+3)): IF j=0 THEN RETURN
1100 GOTO 1080
1110 IF t(t,j,2)=0 THEN GOTO 1130
1120 GOTO 1460

```

(continued on next page)

Make it live

```

1130 IF t(t,j,4)=0 THEN RETURN
1140 m$=m$(t(t,j,4)): l=1: GOSUB 1410: R
RETURN
1150 IF t(t,j,2)=0 THEN GOTO 1170
1160 j=t(t,j,4)+ABS(d(t(t,j,2))): GOTO 1
000
1170 r=t(t,j,3): GOSUB 1330: j=r+t(t,j,4
): GOTO 1000
1180 IF t(t,j,2)=0 THEN GOTO 1200
1190 GOSUB 2340: GOTO 1000
1200 m$=m$(t(t,j,4)): l=1: GOSUB 1410: j
=t(t,j,3): GOTO 1000
1210 r=t(t,j,3): GOSUB 1330: IF r=1 THEN
j=t(t,j,4): GOTO 1000
1220 RETURN
1230 REM
1240 REM low level subroutines
1250 REM
1260 REM clear screen
1270 CLS: RETURN
1280 REM beep
1290 PRINT CHR$(7);: RETURN
1300 REM test for a keypress
1310 i$=INKEY$: RETURN
1320 REM generate a variable random numb
er
1330 r=INT(RND(1)*r): RETURN
1340 REM print a blank line
1350 PRINT: PRINT: RETURN
1360 REM convert first letter of word to
caps
1370 IF ASC(LEFT$(p$,1))<97 OR ASC(LEFT$(
p$,1))>123 THEN oops=6175: GOTO 3050
1380 a$=LEFT$(p$,1): b$=RIGHT$(p$,LEN(p$
)-1): z$=CHR$(ASC(a$)-32)
1390 p$=a$+b$: RETURN
1400 REM print a message regardless
1410 PRINT m$: IF l=1 THEN GOSUB 1350
1420 l=0: m$="": RETURN
1430 REM
1440 REM action jumpblock
1450 REM
1460 ON t(t,j,2) GOTO 1500,1530,1540,155
0,1560,1580,1600,1610,1640,1660
1470 ON (t(t,j,2)-10) GOTO 1600,1690,171
0,1730,1740,1760,1770,1790,1810
1480 ON (t(t,j,2)-19) GOTO 1830,1850,187
0,1910,1930,1940,1960,1990,2010
1490 ON (t(t,j,2)-28) GOTO 2030,2050,207
0,2090,2110,2150,2170,2230,2250,2270
1500 c(c,10)=c(c,11): IF c(c,7)=0 GOTO 1
520
1510 m$=c$(c)+ " loses interest in the co
nversation and walks off.": GOSUB 750
1520 c(c,7)=0: c(c,8)=0: c(c,6)=0: GOSUB
600: RETURN
1530 t=2: RETURN
1540 c(c,7)=0: c(c,8)=0: c(c,6)=0: t=2:
RETURN
1550 r=5: GOSUB 1330: t=r+3: RETURN
1560 GOSUB 890: IF b=0 THEN RETURN
1570 c(c,2)=b: b(b)=0: m$=c$(c)+ " picks
up a "+b$(b): l=1: GOSUB 750: RETURN
1580 m$="I think this is your "+b$(c(c,2
))
1590 m$=FN$(c$(c),c$(c,2)),n$: l=1:
GOSUB 750: RETURN
1600 m$=c$(c)+ " is carrying a "+b$(c(c,2
)): l=1: GOSUB 750: RETURN
1610 m$=c$(c)+ " drops a "+b$(c(c,2)): b(
c(c,2))=c(c,1)
1620 c(c,2)=0: l=1: GOSUB 750
1630 RETURN
1640 m$=c$(c)+ " has got the "+b$(c(c,2))
+ " belonging to "+c$(c): l=1
1650 GOSUB 750: RETURN
1660 c(x,2)=c(c,2): c(c,2)=0: m$=c$(c)+
" gives the "+b$(c(x,2))+ " to "+c$(x)
1670 l=1: GOSUB 750: RETURN
1680 m$=c$(c)+ " is arguing with "+c$(c(
c,5)): l=1: GOSUB 750: RETURN
1690 m$=c$(c)+ " is winning an argument w
ith "+c$(c(c,5)): l=1: GOSUB 750
1700 RETURN
1710 m$=" sees "+c$(x)+ " talking to "+c$

```

```

(c(x,5))+ " and fumes with jealousy"
1720 m$=c$(c)+m$: l=1: GOSUB 750: RETURN
1730 m$=c$(c)+ " tries to interrupt "+c$(
x): l=1: GOSUB 750: RETURN
1740 m$=c$(c)+ " gazes lovingly into "+c$(
x)+"'s eyes...": l=1: GOSUB 750
1750 RETURN
1760 m$="Love blossoms between "+c$(c)+
" and "+c$(x): l=1: GOSUB 750: RETURN
1770 m$=FN$(c$(c),c$(x),"Why don't you
talk about "+c$(c))
1780 l=1: GOSUB 750: RETURN
1790 m$=FN$(c$(c),c$(x),"You're talking
nonsense")
1800 l=1: GOSUB 750: RETURN
1810 m$=FN$(c$(c),c$(x),"Ridiculous, bu
t I agree entirely")
1820 l=1: GOSUB 750: RETURN
1830 m$=FN$(c$(c),c$(x),"I think "+s$(c
)+ " is more important")
1840 l=1: GOSUB 750: RETURN
1850 m$=c$(c)+ " tries to join in the dis
cussion between "+c$(x)
1860 m$=m$+ " and "+c$(c(x,5)): l=1: GOSU
B 750: RETURN
1870 m$=c$(c)+ " talks to "+c$(x)+ " about
"+c$(c(c,8)): l=1: GOSUB 750
1880 IF c(c,8)=c THEN GOTO 1900
1890 m$=c$(c)+ " however, does not appear
to be enjoying the conversation"
1900 l=1: GOSUB 750: RETURN
1910 m$="A brisk discussion begins betwe
en "+c$(c)+ " and "+c$(x)
1920 m$=m$+ " on the subject of "+s$(c(c,
8)): l=1: GOSUB 750: RETURN
1930 m$=c$(c)+ " and "+c$(x)+ " talk about
"+s$(c(c,8)): l=1: GOSUB 750: RETURN
1940 m$=c$(c)+ " desperately tries to att
ract the attention of "+c$(x)
1950 m$=m$+ " by indulging in small talk"
: l=1: GOSUB 750: RETURN
1960 IF c(x,9)=c THEN RETURN
1970 m$="I think there's something going
on between "+c$(x)+ " and "
1980 m$=m$+c$(c(x,9)): m$=FN$(c$(c),m$)
: l=1: GOSUB 750: RETURN
1990 m$=c$(c(x,9)): m$=FN$(c$(c),c$(x),
"I don't know what you see in "+m$)
2000 l=1: GOSUB 750: RETURN
2010 m$=c$(c)+ "s affection for "+c$(c(x
,9))+ " dampens the ardour of "+c$(c)
2020 l=1: GOSUB 750: c(c,9)=0: RETURN
2030 m$=c$(c)+ " is suddenly overcome wit
h love for "+c$(x): l=1: GOSUB 750
2040 c(c,9)=x: RETURN
2050 m$=c$(c(c,9)): m$=FN$(c$(c),"Where
is my beloved "+m$)
2060 l=1: GOSUB 750: RETURN
2070 m$=c$(c)+ " goes down before "+c$(c(
c,9))+ " and pleads everlasting love..."
2080 l=1: GOSUB 750: RETURN
2090 m$="Absence cools the passion of "+
c$(c)+ " for "+c$(c(c,9))
2100 l=1: GOSUB 750: c(c,9)=0: RETURN
2110 m$=c$(c)+ " suddenly jumps upon "+c$(
x)+ " and sinks his teeth into "
2120 IF (x=3) OR (x=4) THEN m$=m$+ "her "
: GOTO 2140
2130 m$=m$+ "his "
2140 m$=m$+ "neck": l=1: GOSUB 750: c(x,4
)=c(x,4)-1: RETURN
2150 m$=FN$(c$(c),"Alas, poor Yorick...
"): m$=m$+ " holding up the skull"
2160 l=1: GOSUB 750: RETURN
2170 m$=c$(c)+ " thinking she is back ho
me, threatens everyone with exile"
2180 m$=m$+ " to Siberia.": l=1: GOSUB 75
0: m$="The room empties rapidly..."
2190 l=1: GOSUB 750
2200 FOR n=1 TO 6: IF n=3 THEN GOTO 2220
2210 c(n,10)=0
2220 NEXT n: RETURN
2230 m$=c$(c)+ " swayed by the logic of t
he Iron Lady, agrees to buy."

```

```

2240 l=1: GOSUB 750: c(x,2)=c(c,2): c(c,
2)=0: RETURN
2250 m$=FN$(c$(c),"This hat is my proud
est possession!"): l=1: GOSUB 750
2260 RETURN
2270 m$=FN$(c$(c),"Urk...Grunk...Banana
!!"): l=1: GOSUB 750: RETURN
2280 m$=c$(c)+ " collapses from loss of b
lood.": l=1: GOSUB 750
2290 m$="The hotel staff rush in and rem
ove the body...": l=1: GOSUB 750
2300 c$(c)=" the body of "+c$(c): c(c,1)
=0: RETURN
2310 REM
2320 REM procedure jumpblock
2330 REM
2340 ON t(t,j,2) GOTO 2360,2370,2390,242
0,2440,2460,2470,2480,2500,2530
2350 ON (t(t,j,2)-10) GOTO 2550,2570,259
0,2610
2360 c(c,10)=c(c,10)-1: j=6: RETURN
2370 c(c,7)=c(c,7)-1: IF c(c,7)=0 THEN G
OSUB 1210
2380 j=13: RETURN
2390 IF c(c,7)=0 THEN GOTO 2410
2400 m$=c$(c)+ " is discussing "+s$(c(c,8
))+ " with "+c$(c,6): l=1: GOSUB 750
2410 j=11: RETURN
2420 GOSUB 980: IF p=0 THEN j=9: RETURN
2430 j=10: RETURN
2440 IF c(x,2)=0 THEN j=24: RETURN
2450 j=26: RETURN
2460 c(c,3)=(c(c,3)-1) MOD 5: j=4: RETUR
N
2470 c(c,3)=(c(c,3)+1) MOD 5: j=7: RETUR
N
2480 GOSUB 790: IF x=0 THEN j=10: RETURN
2490 GOSUB 2760: j=11: RETURN
2500 c(c,5)=x: c(x,5)=c: r=3: GOSUB 1330
: c(c,7)=r+1: c(x,7)=r+1
2510 IF d(11) THEN c(c,8)=c: c(x,8)=c: j
=29: RETURN
2520 c(c,8)=x: c(x,8)=x: j=29: RETURN
2530 GOSUB 790: IF x=0 THEN j=21: RETURN
2540 GOSUB 2760: j=3: RETURN
2550 GOSUB 790: IF p=0 THEN j=8: RETURN
2560 j=9: GOSUB 2760: RETURN
2570 GOSUB 790: IF p=0 THEN j=14: RETURN
2580 j=15: GOSUB 2760: RETURN
2590 GOSUB 790: IF p=0 THEN j=19: RETURN
2600 j=21: GOSUB 2760: RETURN
2610 m$=c$(c)+ " in order to further pri
vatization, tries to sell "
2620 m$=m$+ "the "+b$(c(c,2))+ " to "+c$(x
): l=1: GOSUB 750: RETURN
2630 REM
2640 REM character handler
2650 REM
2660 FOR c=1 TO 6: REM process each char
acter
2670 IF c(c,4)=0 THEN GOSUB 2200
2680 t=1: REM start with tree one
2690 GOSUB 2760: z=t: GOSUB 1070: IF z=t
THEN GOTO 2730: REM endif no transfer
2700 IF t<6 THEN GOTO 2720
2710 GOTO 2730
2720 GOSUB 2760: GOTO 2690: REM traverse
next tree
2730 NEXT c
2740 RETURN
2750 REM conditions
2760 d(1)=(c(c,1)=0): d(2)=(c(c,4)=0): d
(3)=(c(c,10)=0): d(4)=(c(c,7)=0)
2770 d(5)=(c(c,2)=0): d(6)=1: d(7)=(c(c,
2)=c): d(8)=(c(c,8)=c)
2780 d(9)=(c(x,7)=0) AND (c(x,7)/c): d(
10)=(c(c,9)=x): d(11)=(c(c,4))c(x,4)
2790 d(12)=(c(x,9)=c): d(13)=(c(c,9)=0):
d(14)=(c(x,9)=0)
2800 d(15)=(c(c(x,9),1)=c(c,1)): d(16)=
c(c(c,9),1)=c(c,1)
2810 d(17)=c-1: d(18)=(c(x,2)=0)
2820 RETURN
2830 REM

```

```

2840 REM data
2850 REM
2860 REM location descriptions
2870 DATA "The Lobby. Guests crowd round
the reception desk...",0,4,2,0
2880 DATA "The Restaurant. There are a
number of empty tables...",1,3,0,0
2890 DATA "The Bar...propped up by numer
ous travelling salesman.",4,0,0,2
2900 DATA "The Reading Room. Newspapers
everywhere and a haze of tobacco smoke"
2910 DATA 0,0,3,1
2920 REM object descriptions
2930 DATA "coffin",0,"skull",0,"sword",0
,"dole cheque",0,"cowboy hat",0
2940 DATA "banana",0,"carving knife",3,"
bloody Mary",4
2950 DATA "bottle of Bull's Blood",4,"pi
nt of bitter",4
2960 REM character descriptions
2970 DATA "Count Dracula",1,1,5,5,0,0,0,
0,0,10,10
2980 DATA "Hamlet Prince of Denmark",4,2
,5,5,0,0,0,0,6,15
2990 DATA "Catherine the Great",4,3,5,5,
0,0,0,0,0,5,14
3000 DATA "Margaret Thatcher",1,4,5,5,0,
0,0,0,0,8,19
3010 DATA "Ronald Reagan",2,5,5,5,0,0,0,
0,0,12,15
3020 DATA "Godzilla",3,6,5,5,0,0,0,0,2,
0,8
3030 DATA "leeches", "the meaning of life
", "Russian history"
3040 DATA "politics", "cowboys", "grape pi
cking"
3050 GOSUB 1290: PRINT "Error in line ";
oops: STOP
3060 REM tree number one
3070 DATA 1,1,2,0,1,2,3,0,1,3,5,4,2,1,0,
0,4,1,0,0,1,4,12,7,4,2,0,0
3080 DATA 2,2,0,0,2,2,0,0,4,3,0,0,2,2,0,
0,2,3,0,0,3,0,2,0
3090 REM object tree data
3100 DATA 3,0,2,2,2,4,0,0,1,5,7,5,1,6,0,
0,5,0,3,6,2,5,0,0,1,7,0,15
3110 DATA 4,4,0,0,5,0,3,13,3,0,4,11,1,6,
0,0,2,6,0,0,3,0,2,22,3,0,3,19
3120 DATA 5,0,2,16,3,0,2,17,2,7,0,0,2,0,
0,0,2,9,0,0,1,6,0,0,4,5,0,0
3130 DATA 1,6,0,0,2,0,0,0,5,0,2,25,2,10,
0,0,5,0,4,27,2,11,0,0
3140 REM conversation tree
3150 DATA 1,4,9,2,1,8,3,6,4,6,0,0,5,0,4,
5,2,11,0,0,4,7,0,0,5,0,4,0
3160 DATA 2,12,0,0,4,0,0,0,1,6,0,0,1,9,1
2,15,1,10,16,13,2,13,0,0
3170 DATA 4,9,0,0,1,10,14,18,1,11,23,17,
2,14,0,0,1,12,33,19,3,0,3,20
3180 DATA 2,15,0,0,2,16,0,0,1,6,0,0,3,13
,0,24,2,17,0,0,2,18,0,0
3190 DATA 2,19,0,0,2,20,0,0,2,21,0,0,3,0
,3,30,2,22,0,0,2,23,0,0
3200 DATA 2,24,0,0,3,0,2,34,1,6,0,0,2,25
,0,0
3210 REM tree number four - falling in l
ove
3220 DATA 1,13,14,2,4,10,0,0,1,14,4,12,1
,15,7,5,5,0,4,6,2,26,0,0
3230 DATA 3,0,2,0,5,0,6,10,5,0,2,11,2,27
,0,0,2,20,0,0,5,0,4,13
3240 DATA 2,29,0,0,1,16,15,18,3,0,2,16,2
,30,0,0,5,0,3,20,5,0,6,19
3250 DATA 2,31,0,0,2,32,0,0,1,6,0,0,0
3260 REM tree number 5 - actions
3270 DATA 3,17,0,2,4,11,0,0,1,7,11,12,4,
12,0,0,1,5,18,17,1,7,26,27
3280 DATA 1,7,29,30,1,6,0,0,5,0,5,18,2,3
3,0,0,1,6,0,0,5,0,3,13
3290 DATA 2,34,0,0,1,6,0,0,5,0,3,16,2,35
,0,0,1,6,0,0,5,0,3,20,1,6,0,0
3300 DATA 4,13,0,0,1,18,22,23,1,6,0,0,4,
14,0,0,5,0,2,25,2,36,0,0
3310 DATA 1,6,0,0,5,0,3,28,2,37,0,0,1,6,
0,0,5,0,3,31,2,38,0,0

```

QUEST CORNER

SEAS OF BLOOD

► Various • £9.95 • Adventure International

Our man with the brass lamp and the key to a thousand mysteries sheds light on new adventure programs. Lost? Never fear, Hugo North is here.

The Fighting Fantasy (FF) gamebooks of Steve Jackson and Ian Livingstone have been a huge success. Two of these books were later used as the bases for computer games.

The first adaptation, Warlock of Firetop Mountain, was very disappointing, being an arcade game with little connection with the book. The second, The Forest of Doom, and released by Penguin books themselves, was excellent. This was virtually a straight conversion of the book's contents and in my opinion deserved far greater success than it actually achieved.

Now comes a third adaptation, Seas of Blood, from Mike Woodroffe and Brain Howarth whose earlier Gremlins and Robin of Sherwood have proved very popular.

The game is in the usual



text and graphics style of Adventure International, plenty of attractive pictures, locations (over 300) and puzzles.

A new element is the addition of a combat system, capturing more of the flavour of the book. This involves

attributing various aspects — strength, stamina, etc — to you and your opponent and determining the outcome of combat by throwing dice.

The plot concerns Tak, a city chock-a-bloc with cut-throats, thieves, pirates and assorted dregs.

WINNIE THE POOH

► Commodore 64Z/128 • Disc £14.95 • U.S. Gold

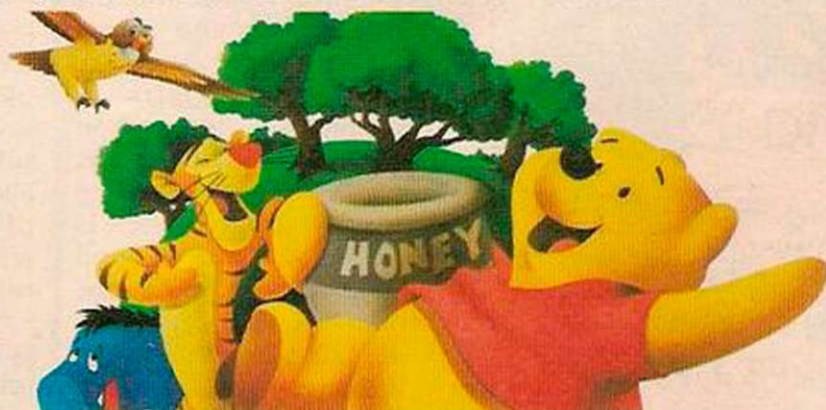

Manufactured under license by US Gold from Walt Disney Productions, this is a very good children's adventure. Pooh has attractive graphics, is different each time it's played and is simple to use. For example, the game is

controlled by selecting one course of action from several displayed on the screen at each decision point.

When the blustery wind whistles through Hundred Acre Wood, it blows objects about. The player's task is to find all the lost articles and return them to their rightful owners, including Pooh, Rabbit, Eeyore and Piglet. The player must take care — Tigger is bouncing around, the mist sometimes comes down and another wind could start blowing again at any moment.

Although the game is marred by a screen glitch along the bottom border of the picture, Pooh is still a delightful adventure.

A HELPING HAND

Russell Deitch of London and Tim O'Neill of Dublin have asked for assistance with the brilliant Hitch Hiker's Guide To The Galaxy: Can't get the babel fish!

1. KOOH NONW OGTU P
2. NIAR DREV OLEW OTTU P
3. LENA PFOT NORF NILE HCTA STUP
4. LEHC TASO NLIA MKNU JTUP
5. NOTT UBSS ERP

Want a hint to prove your intelligence to the door?

AETO NDNA AETH TIWT
NEMI REPX E

Craig Coomber of Aberdeenshire is troubled by The Count and Voodoo Castle.

Can't use the dumbwaiter?

TIRE WOLR OESI ARNE
HTRE TIAW BMUD OG
Where is the safe combination?

EUQA LPEH TNOG NITI
RWSU ONIM ULYN ITEH
TDAE R

Zork 1 fans, want a smashing, alternative way of dealing with the Cyclops?

MIGT ASDUE SSYD OTUO
HS

Your is Perils and Pickles
Hugo North

THE CRYSTAL BALL

The marvellous Infocom have released Spellbreaker, the third in the Enchanter series. It's available on disc for Commodore, Atari, Apple, IBM and others.

If you're lucky enough to own an Atari ST, you'd be well advised to buy A Mind Forever Voyaging, Infocom's 128K blockbusting adventure for this new machine.

Soul of Darkon, a text and graphics adventure from Tasket, is now available for Amstrad owners. BBC B owners might care to sample Star of the Void, a new text adventure from Black Knight Computers of Chislehurst, Kent.

Transdisc

Fast, flexible efficient file copying from Geoff Hatts for CBM-64 disc-drive fans. Up to 58.4K can be transferred from one disc to another.

This program runs on a Commodore 64 with the 1541 disc drive connected and allows you to transfer files up to 58.4 Kbytes — 236 blocks — long from one disc to another. What makes this program special compared to simple file copying programs

is both the presentation and the ability to change the file's parameters once the file has been loaded into the computer.

The program can copy sequential (SEQ), program (PRG) and user (USR) file types — but not relative files — and can intelligently convert from one type to another in memory. The new file can then be re-saved on disc.

The program supports a screen directory which also shows the total number of files which are displayed to the screen. A disc command facility is also included and the disc drive status can be read whilst in the main menu and is automatically updated after disc I/O.

The whole program has been designed to be extremely simple to use and is entirely menu driven with a powerful "pop-up" menu system. To select an option use the vertical cursor keys to control the cursor position and type Return.

When the program prompts for filenames and start addresses, the last entry or address which was entered is remembered and displayed on the input line. This allows simple modification of existing filenames and start addresses. If the last entry was not required then it may be removed in one keystroke by holding down the shift key and typing return. The new filename or address can then be entered.

After running the program you are presented with the main menu. The following describes

each option in detail. Remember, to select an option, use the vertical cursor control keys to position the cursor and type the return key.

When you select the Load File option you are presented with a sub-menu which asks which program type you wish to load — sequential, program or user. When this has been selected, enter the desired filename followed by pressing the return key. The program will now attempt to load this file into memory. A bell sounds to indicate that the loading process has been completed.

If the disc error status — shown in the bottom display box — is OK then your file has been loaded correctly. If it says Out of Memory then the file which you attempted to load was greater than 58.4 Kbytes — 236 blocks — long. If the status line says File not Found then the file does not exist on disc — use the Directory command in the main menu to check the disc contents.

With the file loaded into memory, use the Same File option as often as required to save copies of the file to disc. A sub-menu is presented which allows you to create a new copy of the file on disc, or it allows replacement of an existing file with the same filename.

When the program is asked to replace an existing file on disc, it first erases the old copy and then creates the updated version from the file stored in memory.

This overcomes a slight problem using the @0: replace

Transdisc

```

10 REM *****
20 REM **
30 REM ** TRANSDISK V2.0 **
40 REM **
50 REM ** (LOADER) G.HATTO '85 **
60 REM **
70 REM *****
80 :
90 :
100 PRINT
110 PRINT" PLACE DESTINATION DISK IN DRIVE"
120 PRINT
130 PRINT" TYPE THE RETURN KEY WHEN READY."
140 :
150 GET CR$:IFCR$<>CHR$(13) THEN 150
160 PRINT:PRINT:PRINT" SAVING CODE TO DISK - PLEASE WAIT."
170 :
180 OPEN B,B,B,"TRANSDISK V2.0,PRG,W"
190 :
200 READ ADDRESS
210 BEGIN = ADDRESS
220 MAXNUMBER = 458
230 :
240 PRINT#B,CHR$(ADDRESS AND 255);
250 PRINT#B,CHR$(ADDRESS / 256);
260 :
270 DEF FN LINENUMBER(A) = PEEK(63)+PEEK(64)*256
280 :
290 PRINT
300 FOR COUNT=1 TO MAXNUMBER:GOSUB 400:READ CHECKSUM
310 IF SUM<>CHECKSUM THEN PRINT"CHECKSUM ERROR IN ";FN LINENUMBER(0):GOTO620
320 L = FN LINENUMBER(0):PRINT L
330 IF ADDRESS<L+B THEN PRINT"LINE NUMBER";L;" NOT IN ORDER":GOTO620
340 NEXT COUNT
350 CLOSE
360 PRINT:PRINT:PRINT" EXECUTABLE FILE CREATED."
370 END
380 :
390 :
400 SUM = 0
410 FOR I=1 TO B:READ ENTRY#
420 GOSUB 400
430 PRINT#B,CHR$(ENTRY);
440 ADDRESS = ADDRESS+1:SUM = SUM+ENTRY
450 NEXT I
460 RETURN
470 :
480 IF LEN(ENTRY#)<>2 THEN 570
490 A$ = RIGHT$(ENTRY#,1):GOSUB 530:ENTRY = V
500 A$ = LEFT$(ENTRY#,1):GOSUB 530:ENTRY = ENTRY+V*16
510 RETURN
520 :
530 IF A$<"0" OR A$>"F" OR A$>"9" AND A$<"A" THEN 570
540 V = ASC(A$)-48+7*(A$>"9")
550 RETURN
560 :
570 PRINT"DATA ERROR IN ";FN LINENUMBER(0)
580 :
590 :
600 REM ***** DATA ERROR DETECTED *****
610 :
620 CLOSE B
630 OPEN 15,B,15,"B:TRANSDISK V2.0"
640 CLOSE 15
650 PRINT:PRINT:PRINT" EXECUTABLE FILE DELETED."
660 END
670 :
680 :
690 DATA 2049
700 :
2049 DATA 2E,08,C1,07,9E,32,30,39,567
2057 DATA 36,3A,14,14,14,14,14,14,232
2065 DATA 14,14,54,52,41,4E,53,44,500
2073 DATA 49,53,48,20,56,32,2E,30,493
2081 DATA 20,20,28,47,2E,48,41,54,442
2089 DATA 54,4F,29,00,00,00,20,249
2097 DATA 84,FF,20,0A,FF,20,E7,FF,1330
2105 DATA 20,31,12,A9,0F,0D,20,D0,664
2113 DATA 8D,21,D0,A9,0D,20,D2,FF,1061
2121 DATA A9,92,20,D2,FF,A9,8E,20,1156
2129 DATA D2,FF,A9,08,20,D2,FF,A9,1308
2137 DATA 01,8D,3C,03,20,52,08,A0,498
2145 DATA 0F,A9,00,19,41,03,88,10,429
2153 DATA FA,C9,00,F0,03,20,3B,08,796
2161 DATA D0,0C,8D,3D,03,8D,3E,03,631
2169 DATA 8D,3F,03,8D,40,03,20,25,484
2177 DATA 08,20,52,10,04,92,A0,06,585
2185 DATA B9,01,08,99,F9,FF,08,10,1211
2193 DATA F7,A9,0F,AS,A2,08,20,8A,987
2201 DATA FF,A9,00,20,8D,FF,20,C0,1124
2209 DATA FF,80,34,20,87,FF,D0,2F,1208
2217 DATA A9,08,20,34,11,A9,00,A2,609
2225 DATA 08,86,C6,20,7F,10,AA,8D,866
2233 DATA CA,08,48,8D,C3,08,48,A9,915
2241 DATA 08,60,E4,88,6D,03,A2,D6,986
2249 DATA 3F,08,09,08,0D,0E,0E,147
2257 DATA 48,F9,FF,F9,FF,F9,FF,48,1648
2265 DATA A9,0F,20,C3,FF,20,CC,FF,1157
2273 DATA 68,4C,F9,E0,AD,3C,03,A2,1051
2281 DATA 05,20,7F,10,C9,03,00,05,597
2289 DATA A9,00,4C,80,08,4B,A9,06,676
2297 DATA 20,34,11,20,3B,08,20,67,338
2305 DATA 0F,68,A4,87,F0,EA,8D,3C,1141
2313 DATA 03,20,25,0B,20,0B,0B,A9,306
2321 DATA 08,A2,08,8B,20,8A,FF,A5,984
2329 DATA 92,A2,41,A0,03,20,8D,FF,1912
2337 DATA 20,C0,FF,80,59,A9,00,8D,1054
2345 DATA 3D,03,8D,3E,03,A2,08,20,472
2353 DATA C6,FF,80,4A,A9,0F,20,34,971
2361 DATA 11,AD,3C,03,C9,01,00,0E,677
2369 DATA 20,CF,FF,80,39,8D,3D,03,932
2377 DATA 20,CF,FF,8D,3E,03,20,CF,939
2385 DATA FF,80,2B,20,AD,09,20,14,740
2393 DATA 08,80,38,20,87,FF,F0,EE,1183
2401 DATA 38,A5,22,E9,4A,85,22,A5,894
2409 DATA 23,E9,16,85,23,18,A5,22,681
2417 DATA 6D,3D,03,8D,3F,03,A5,23,580
2425 DATA 6D,3E,03,8D,40,03,A9,08,559
2433 DATA 20,C3,FF,20,CC,FF,A9,00,1142
2441 DATA 4C,A3,0E,A9,0E,20,34,11,537
2449 DATA A9,08,20,C3,FF,20,CC,FF,1150
2457 DATA 20,43,12,AD,3D,03,AE,3E,590
2465 DATA 03,8D,3F,03,8E,40,03,A9,588
2473 DATA 03,4C,80,08,78,AD,34,84,727
2481 DATA 01,A0,00,91,22,AD,37,84,687
2489 DATA 01,38,60,20,89,0A,80,0F,683
2497 DATA A9,00,20,7F,10,C9,00,F0,785
2505 DATA 37,C9,02,00,05,A9,00,4C,716
2513 DATA B0,00,A9,11,20,34,11,A2,633
2521 DATA 0F,20,C9,FF,80,1F,A9,53,962
2529 DATA 20,D2,FF,80,18,A9,3A,20,956
2537 DATA D2,FF,A5,92,F0,0F,A0,00,1191
2545 DATA B9,41,03,20,D2,FF,80,05,931
2553 DATA C8,D4,92,D0,F3,20,CC,FF,1484
2561 DATA A2,0F,20,C9,FF,80,0C,A9,1022
2569 DATA 10,20,34,11,A9,49,20,02,601
2577 DATA FF,90,20,20,CC,FF,4C,A6,1138
2585 DATA 0A,20,CC,FF,A4,92,A9,2C,1024
2593 DATA 99,41,03,99,43,03,AE,3C,678
2601 DATA 03,8D,80,0A,99,42,03,A9,769
2609 DATA 57,99,44,03,A9,88,A2,08,658
2617 DATA A0,08,20,BA,FF,18,A5,92,976
2625 DATA 69,04,A2,41,A0,03,20,8D,720
2633 DATA FF,20,C0,FF,80,52,20,0C,1244
2641 DATA 0C,18,8A,69,4A,85,35,98,691
2649 DATA 69,16,85,36,20,08,08,A2,530
2657 DATA 08,20,C9,FF,80,3A,A0,00,890
2665 DATA A0,3C,03,C9,01,00,13,AD,838
2673 DATA 3D,03,20,D2,FF,80,29,20,810
2681 DATA B7,FF,D0,24,AD,3E,03,20,952
2689 DATA D2,FF,20,FD,0A,20,D2,FF,1256
2697 DATA 80,16,20,87,FF,D0,11,20,925
2705 DATA 14,08,80,0C,A5,23,C5,36,670
2713 DATA 90,88,A5,22,C5,35,90,02,1195
2721 DATA A9,08,20,C3,FF,20,CC,FF,1150
2729 DATA A9,37,85,01,4C,A3,0E,53,694
2737 DATA 50,55,45,52,53,51,47,52,653
2745 DATA BA,48,A0,00,A2,06,89,41,788
2753 DATA 03,D0,E8,0A,F0,0C,CA,10,939
2761 DATA F8,C8,C4,92,90,EE,68,AA,34,84,727
2769 DATA 18,60,48,A9,15,20,34,11,481
2777 DATA 68,20,F2,0A,09,80,8D,74,782
2785 DATA 07,20,43,12,68,AA,A9,02,569
2793 DATA 38,60,3A,3F,2A,2C,3D,40,484
2801 DATA 24,48,0A,68,29,3F,90,02,472
2809 DATA 07,40,60,78,A9,34,85,01,644
2817 DATA A0,00,81,22,A0,37,84,01,719
2825 DATA 58,60,A9,4A,A2,16,85,22,778
2833 DATA 86,23,60,E6,22,D0,02,E6,969
2841 DATA 25,A5,29,C9,FF,D0,04,A5,1068
2849 DATA 22,C9,F8,60,A2,0F,8D,00,945
2857 DATA 02,9D,41,03,CA,10,F7,AA,856
2865 DATA 87,00,11,90,0C,A0,10,84,846
2873 DATA 82,60,20,52,08,A6,92,86,813
2881 DATA 87,F0,0A,CA,8D,41,03,9D,1049
2889 DATA 00,02,CA,10,F7,20,E3,0E,757
2897 DATA 60,A9,00,85,B7,A2,27,A9,951
2905 DATA 20,9D,00,02,CA,10,FA,60,755
2913 DATA BA,48,A9,08,20,34,11,A9,668
2921 DATA 12,20,16,E7,A9,9A,20,16,680
2929 DATA E7,18,A2,07,A0,04,20,F0,860
2937 DATA FF,AE,3D,03,AD,3E,03,20,763
2945 DATA CD,8D,18,A2,08,A0,04,20,787
2953 DATA F0,FF,AE,3F,03,AD,04,03,975
2961 DATA 20,CD,8D,18,A2,0F,AE,84,791
2969 DATA 20,F0,FF,20,FD,08,A9,0C,1024
2977 DATA 20,34,11,A9,98,20,16,E7,707
2985 DATA 20,3B,08,20,30,10,68,AA,472
2993 DATA A9,03,20,7F,10,AA,8D,C6,904
3001 DATA 08,48,8D,C2,08,48,A9,00,718
3009 DATA 60,C9,EA,11,AF,08,08,0C,757
3017 DATA 08,A9,06,20,34,11,20,3B,375
3025 DATA 08,20,67,0F,A4,87,F0,03,751
3033 DATA 20,25,08,A9,03,A2,02,4C,572
3041 DATA 61,08,18,A2,16,84,14,4C,492
3049 DATA F0,FF,AD,3C,03,A2,04,20,929
3057 DATA 7F,10,8D,3C,03,A9,04,A2,682
3065 DATA 02,4C,61,08,AE,3C,03,8D,612
3073 DATA 80,0A,20,16,E7,8D,83,0A,849
3081 DATA 20,16,E7,8D,86,0A,4C,16,744
3089 DATA E7,A9,09,20,34,11,A9,12,697
3097 DATA 20,16,E7,A9,81,20,16,E7,868
3105 DATA 18,A2,16,84,1C,20,F0,FF,923
3113 DATA AE,3D,03,AD,3E,03,20,CA,713
3121 DATA 8D,20,52,08,A0,88,89,08,659
3129 DATA 01,F0,06,99,00,02,C8,D0,810
3137 DATA F5,18,A2,16,84,1C,20,F0,913
3145 DATA FF,A9,05,20,79,0F,A9,3A,824
3153 DATA A4,87,F0,8D,99,00,02,A9,1100
3161 DATA FF,A2,01,85,7A,86,78,20,962
3169 DATA 7F,0C,80,AD,20,79,00,D0,849
3177 DATA AB,A5,62,A6,63,85,22,86,997

```

command provided by the disc drive, which saves the updated version first and then scratches the old version. This can result in a Disc Full error when updating a file on a disc which only has a few blocks free.

If a Disc Full error should occur when using the save option do not scratch the now starred file — as it appears in the directory — or you will stand a chance of corrupting the disc. You should always validate a disc when a starred file appears in the directory. Use the Send Disc Command option in the main menu to issue a validate command. Note — this point also applies in general when saving a Basic program using the 1541 disc drive.

Use the Change File option to vary the file parameters, i.e. the program name, start address and file type. It is quite useful to be able to change the file from one type to another or a program's start address — in decimal. For example, a sequential file stored on disc can be converted by loading it into the Transdisc program and storing it back on disc with a different file name and as a program file with a start address.

This allows you to load to file straight into memory where you can inspect the contents. Remember, Basic programs are tokenised, and so not much is gained by converting them to sequential or user files. This

(continued on next page)

FED UP WITH WAITING FOR THE 'SPIN-CYCLE' BEFORE OVERTAKING.....



AMSTRAD 3" DISC SYSTEM

THE KIT CONSISTS OF:-

1. RELIABLE, COMPACT, AMSTRAD 3" DISC DRIVE UNIT.
 2. HIGH TENSION BELT
 3. HIGH RATIO GEAR (FIXES TO REAR SPINDLE)
- MAKE YOUR ECLAIR C5 REALLY GO.**

Nicholas Card's entry was runner-up in our September 6128 competition.

3185 DATA 23,20,DC,0C,20,EC,0C,A9,748
 3193 DATA 03,A2,02,4C,61,0B,A9,00,520
 3201 DATA 05,62,85,63,20,73,00,20,642
 3209 DATA A9,0C,90,1B,E9,30,48,20,737
 3217 DATA 03,0C,68,80,0C,65,62,85,815
 3225 DATA 62,A5,63,69,00,85,63,90,843
 3233 DATA E3,A9,00,85,62,85,63,60,955
 3241 DATA C9,30,90,05,E9,3A,30,E9,978
 3249 DATA C6,60,48,06,62,26,63,80,783
 3257 DATA 20,A5,62,85,64,A5,62,85,925
 3265 DATA 65,06,64,26,65,80,12,06,546
 3273 DATA 64,26,65,80,0C,65,62,85,791
 3281 DATA 64,85,62,85,65,65,85,930
 3289 DATA 63,68,60,38,AD,3F,03,ED,831
 3297 DATA 3D,03,AA,AD,40,03,ED,3E,773
 3305 DATA 03,AB,68,A5,22,8D,3D,03,671
 3313 DATA A5,23,8D,3E,03,18,8A,65,669
 3321 DATA 22,8D,3F,03,98,65,23,8D,670
 3329 DATA 40,03,60,A9,00,85,D4,20,709
 3337 DATA 7F,10,C9,02,F0,6D,A2,04,861
 3345 DATA 86,96,A2,24,8E,29,02,A2,829
 3353 DATA 30,8E,2A,02,A2,3A,8E,2B,639
 3361 DATA 02,A2,2A,8E,2C,02,C9,00,595
 3369 DATA F0,37,A9,0A,20,34,11,18,599
 3377 DATA A2,16,A0,10,28,F0,FF,A9,1056
 3385 DATA 12,20,16,E7,A9,1F,20,16,557
 3393 DATA E7,20,52,0F,A9,14,20,79,698
 3401 DATA 0F,A4,87,F0,14,A0,22,89,1001
 3409 DATA 00,02,99,2C,02,88,10,F7,600
 3417 DATA 18,A5,87,65,96,69,FF,85,1116
 3425 DATA 96,20,81,0D,A9,00,85,C6,824
 3433 DATA 20,E4,FF,F0,FB,29,7F,C9,1375
 3441 DATA 03,F0,F5,A9,93,20,16,E7,1089
 3449 DATA 4C,A3,0E,A9,00,4C,80,08,682
 3457 DATA A9,FE,85,02,A9,8D,A2,00,910
 3465 DATA A0,00,20,BA,FF,A5,96,A2,1110

3473 DATA 29,A0,02,20,8D,FF,20,C0,903
 3481 DATA FF,80,71,A2,0D,20,C6,FF,1204
 3489 DATA 80,6A,20,CF,FF,20,CF,FF,1270
 3497 DATA 20,CC,FF,A9,69,A0,0E,20,971
 3505 DATA 1E,AB,A5,D6,C9,18,D0,05,1018
 3513 DATA AD,8D,02,D0,07,20,16,0E,599
 3521 DATA A5,90,D0,08,20,E1,FF,D0,1245
 3529 DATA E9,E6,02,18,A9,0D,20,C3,898
 3537 DATA FF,20,CC,FF,A9,0D,20,16,982
 3545 DATA E7,20,16,E7,20,16,E7,20,833
 3553 DATA 16,E7,20,34,11,18,A2,16,562
 3561 DATA A0,0C,20,F0,FF,A9,12,20,918
 3569 DATA 16,E7,A9,9C,20,16,E7,A6,1029
 3577 DATA 02,E0,C8,90,02,A2,00,A9,903
 3585 DATA 00,20,C0,8D,A9,8E,A0,0E,911
 3593 DATA 20,1E,AB,68,48,A9,0D,20,615
 3601 DATA C3,FF,68,38,60,A2,0D,20,913
 3609 DATA C6,FF,20,59,0E,20,59,0E,723
 3617 DATA E0,02,A9,20,20,D2,FF,20,962
 3625 DATA D2,FF,20,D2,FF,20,59,0E,1097
 3633 DATA 85,63,20,59,0E,85,62,20,630
 3641 DATA D1,8D,A9,20,20,D2,FF,20,1128
 3649 DATA 59,0E,A2,01,86,D4,C9,00,813
 3657 DATA F0,0E,20,D2,FF,4C,40,0E,897
 3665 DATA 20,CC,FF,A9,0D,4C,D2,FF,1214
 3673 DATA 20,CF,FF,A6,90,00,01,60,1109
 3681 DATA 68,68,68,68,18,4C,CD,0D,734
 3689 DATA 00,93,0D,1F,20,20,20,55,385
 3697 DATA 53,45,20,53,48,49,46,54,566
 3705 DATA 20,48,45,59,20,46,4F,52,528
 3713 DATA 20,4E,4F,2D,53,43,52,4F,545
 3721 DATA 4C,4C,0D,00,00,20,46,49,353
 3729 DATA 4C,45,20,53,29,20,44,49,482
 3737 DATA 53,50,4C,41,59,45,44,2E,576
 3745 DATA 0D,00,A9,07,20,34,11,18,314
 3753 DATA A2,16,A0,03,20,F0,FF,A9,1043

3761 DATA 98,20,16,E7,A9,12,20,16,678
 3769 DATA E7,A2,0F,20,C6,FF,80,13,1088
 3777 DATA 20,CF,FF,20,16,E7,20,87,994
 3785 DATA FF,F0,F5,20,CC,FF,20,43,1330
 3793 DATA 12,A9,00,4C,80,08,20,CC,683
 3801 DATA FF,A9,1F,A0,0F,20,1E,AB,863
 3809 DATA 20,CF,FF,C9,0D,F0,20,C9,1181
 3817 DATA 20,F0,F5,48,C9,4E,F0,22,1142
 3825 DATA A2,0F,20,C9,FF,80,10,68,961
 3833 DATA 20,D2,FF,20,CF,FF,C9,0D,1205
 3841 DATA F0,05,20,D2,FF,90,F4,A9,1299
 3849 DATA 93,20,16,E7,20,CC,FF,4C,999
 3857 DATA A3,0E,20,57,0F,F0,D9,68,872
 3865 DATA 20,CC,FF,4C,08,0F,1F,0D,634
 3873 DATA 93,0D,0D,45,4E,54,45,52,555
 3881 DATA 20,44,49,53,48,20,43,4F,509
 3889 DATA 4D,4D,41,4E,44,20,53,54,564
 3897 DATA 52,49,4E,47,0D,00,20,362
 3905 DATA 57,0F,F0,0A,A9,08,20,34,613
 3913 DATA 11,A9,00,4C,00,00,A9,0F,630
 3921 DATA 20,C3,FF,4C,E2,FC,A9,12,1223
 3929 DATA 20,34,11,20,43,12,20,E4,478
 3937 DATA FF,F0,FB,C9,59,60,A9,1F,1332
 3945 DATA 20,16,E7,A9,12,20,16,E7,757
 3953 DATA 20,30,10,20,E3,08,A9,10,551
 3961 DATA 85,97,20,52,10,84,02,38,684
 3969 DATA 20,F0,FF,84,C9,86,CA,18,1220
 3977 DATA 98,65,02,AB,A2,16,20,F0,879
 3985 DATA FF,A9,00,85,CC,20,42,F1,1100
 3993 DATA F0,FB,C9,8D,00,06,20,02,1081
 4001 DATA 10,4C,96,0F,C9,0D,F0,3E,773
 4009 DATA C9,8D,F0,E9,C9,94,F0,E5,1633
 4017 DATA C9,83,F0,E1,C9,14,D0,11,1243
 4025 DATA A6,02,F0,D9,A9,20,CA,86,1162
 4033 DATA 02,9D,00,02,A9,14,4C,D5,639
 4041 DATA 0F,A6,02,E4,97,F0,C6,9D,1157

4049 DATA 00,02,E6,02,85,CC,05,D4,916
 4057 DATA A2,00,86,CF,20,5F,10,A9,815
 4065 DATA 00,86,CC,4C,96,0F,20,52,693
 4073 DATA 10,C0,00,84,87,A2,00,86,819
 4081 DATA CF,86,D4,EB,86,CC,A9,20,1324
 4089 DATA 20,5F,10,A9,0D,20,16,E7,610
 4097 DATA 68,20,52,0B,A9,00,85,02,525
 4105 DATA 38,20,F0,FF,C4,C9,F0,1E,1250
 4113 DATA A9,00,85,D4,A9,9D,20,16,894
 4121 DATA E7,A9,20,20,16,E7,20,16,771
 4129 DATA E7,A9,9D,20,16,E7,20,16,896
 4137 DATA E7,85,D4,4C,09,10,60,A0,933
 4145 DATA 00,89,00,02,C9,0D,00,02,611
 4153 DATA A9,3F,C9,8D,00,02,A9,3F,1016
 4161 DATA A2,01,86,D4,20,16,E7,CB,994
 4169 DATA C4,87,90,E5,A9,00,85,D4,1266
 4177 DATA 68,A0,10,89,FF,01,C9,20,946
 4185 DATA D0,03,88,D0,F6,60,C9,14,1118
 4193 DATA F0,03,4C,16,E7,A9,00,85,874
 4201 DATA D4,A9,9D,20,16,E7,A9,20,1024
 4209 DATA 20,16,E7,20,16,E7,A9,9D,896
 4217 DATA 20,16,E7,4C,16,E7,48,8A,824
 4225 DATA 20,34,11,20,52,11,BE,73,537
 4233 DATA 12,20,D5,11,20,D2,11,E6,769
 4241 DATA 8B,00,02,E6,8C,A0,00,81,1056
 4249 DATA 8B,C9,8C,F0,07,CA,D0,EF,1424
 4257 DATA 68,A9,00,68,A9,00,85,14,691
 4265 DATA 68,C5,14,F0,0B,E6,14,48,894
 4273 DATA 20,08,11,68,80,F3,C6,14,798
 4281 DATA 20,8D,10,60,A0,00,A9,3C,722
 4289 DATA 91,88,A0,5A,A2,00,48,68,872
 4297 DATA CA,D0,FB,20,E4,FF,D0,0C,1396

(listing continued on next page)

Transdisc

(continued from previous page)

option is more useful on data files or source code from assemblers, etc.

If the file in memory is not a program file then the start address is set to zero and the end address is actually the number of bytes in the file. To find the number of bytes in a program file, subtract the displayed start address from the end address.

Use the Directory option to display the disc contents to the screen. If you ask for a match, enter the match when prompted and use wild cards — stars and question marks — where appropriate. See your disc drive manual for more information on wild cards.

When the directory display has finished, type any key to return to the main menu.

The Disc Status allows you to inspect the disc drive status when you are at the menu. The disc status is displayed on the bottom display box.

Disc CMDS allows you to send disc commands to the disc drive to do "house-keeping" jobs, such as deleting unwanted files and for validating and formatting discs. A conformation sub-menu is provided to help prevent accidental formatting of your favourite disc containing your best programs!

Sometimes, the disc drive can get confused. If at any point you feel the disc drive is not behaving correctly, issue a U; disc command which will reset the drive. For example, continual Drive not Ready messages can sometimes occur after failing to put a disk in the

drive when saving a file on the first attempt.

Reset 64 resets the computer — performs a cold start. Note — the file in memory and the program are both lost after execution.

To get a copy of this program on disc, type in the program listed and save it. Now place a disc in the disc drive to receive the executable copy of this program and type run. If all is well, then the program will have saved an executable copy of the program on disc. If not, then the reported errors in the Data statements must be corrected and the listing re-saved ready for another attempt.

The program may be reloaded and executed when required by typing:

LOAD "TRANSDISK V2.0",8

This program has not been

designed to transfer a large quantity of files from one disc to another — better to use a program specifically designed for batch copying. It does come into its own, however, when you wish to copy a file, but also to change or inspect all of the file parameters in the process.

Text is not destroyed

It should be noted that all of the individual functions selected from the menus do not affect the file loaded in memory, i.e., using directories, disc functions etc.

Even if the disc drive produces an error when attempting to save a program, the text in memory is not destroyed. In fact, once in memory the program can be saved as many times as required on different discs. ●

(continued from previous page)

4337	DATA	CB,E6,14,4C,BD,10,C9,91,1080	4753	DATA	14,04,0D,17,0A,00,00,69,175	5601	DATA	45,20,4F,4E,20,44,49,53,514
4345	DATA	D0,C2,20,23,11,90,8D,C6,1017	4761	DATA	14,02,13,11,01,00,00,91,204	5609	DATA	4B,2E,2E,2E,2E,00,45,52,410
4353	DATA	14,4C,BD,10,AS,14,60,A0,742	4769	DATA	14,06,25,01,15,00,00,DC,305	5617	DATA	41,53,49,4E,47,20,45,58,559
4361	DATA	50,98,18,65,8B,A9,00,65,766	4777	DATA	14,0C,25,01,15,00,00,ED,328	5625	DATA	49,53,54,49,4E,47,20,46,564
4305	DATA	88,D0,F3,B1,8B,49,80,91,1249	4785	DATA	14,0E,25,01,15,00,00,F9,342	5633	DATA	49,4C,45,20,4F,4E,20,44,507
4313	DATA	88,4C,C3,10,48,A0,00,A9,827	4793	DATA	14,08,25,01,15,00,00,1B,114	5641	DATA	49,53,4B,00,41,52,45,20,479
4321	DATA	BC,91,8B,68,C9,00,F0,1C,1058	4801	DATA	15,06,25,01,15,00,00,34,138	5649	DATA	59,4F,55,20,53,55,52,45,604
4329	DATA	C9,11,D0,0A,20,08,11,90,637	4809	DATA	15,0E,0D,02,04,00,00,41,119	5657	DATA	3F,20,20,2D,20,54,59,50,457
4369	DATA	8C,C9,08,18,F0,0B,B1,0B,940	4817	DATA	15,0C,25,01,15,00,00,7D,217	5665	DATA	45,20,27,59,27,20,4F,52,461
4377	DATA	18,C9,BC,D0,04,20,D2,11,884	4825	DATA	15,04,25,01,15,00,00,8E,226	5673	DATA	20,27,4E,27,00,22,20,22,288
4385	DATA	38,60,20,EB,11,A0,00,B1,773	4833	DATA	15,02,25,01,15,00,00,97,233	5681	DATA	20,4E,4F,54,20,41,4C,4C,522
4393	DATA	8B,C9,BC,38,F0,04,20,D2,1070	4841	DATA	15,0C,25,01,15,00,00,B9,277	5689	DATA	4F,57,45,44,20,49,4E,20,518
4401	DATA	11,18,60,48,20,52,11,89,525	4849	DATA	15,0C,25,01,15,00,00,D3,303	5697	DATA	46,49,4C,45,4E,41,4D,45,577
4409	DATA	78,12,BE,79,12,85,14,86,754	4857	DATA	15,0C,25,01,15,00,00,EF,331	5705	DATA	00,00,00,00,00,00,00,00,0-
4417	DATA	15,B9,7E,12,8D,86,02,B9,800	4865	DATA	15,02,25,01,15,00,00,00,95	5801	DATA	00,53,41,56,45,20,20,53,450
4425	DATA	73,12,85,8F,20,76,11,68,680	4873	DATA	16,02,25,01,15,00,00,2E,129	5809	DATA	45,4C,45,43,54,49,4F,4E,595
4433	DATA	60,20,6F,11,18,A9,00,79,570	4881	DATA	16,4D,41,49,4E,20,53,45,499	5817	DATA	0D,43,52,45,41,54,45,20,481
4441	DATA	74,12,85,8B,A9,04,69,00,684	4889	DATA	4C,45,43,54,49,4F,4E,0D,539	5825	DATA	46,49,4C,45,2E,2E,20,3C,472
4449	DATA	85,8C,BE,75,12,F0,06,20,876	4897	DATA	4C,4F,41,44,20,46,49,4C,539	5833	DATA	0D,52,45,50,4C,41,43,45,521
4457	DATA	D5,11,CA,D0,FB,60,48,0A,1066	4905	DATA	45,2E,2E,2E,20,3C,0D,53,395	5841	DATA	20,46,49,4C,45,2E,20,3C,458
4465	DATA	0A,0A,AB,68,60,A5,8B,85,825	4913	DATA	41,56,45,20,46,49,4C,45,540	5849	DATA	0D,4D,41,49,4E,20,4D,45,484
4473	DATA	BD,AS,8C,29,03,09,08,85,848	4921	DATA	2E,2E,2E,20,3C,0D,43,48,382	5857	DATA	4E,55,2E,2E,2E,2E,20,3C,439
4481	DATA	8E,A0,00,A9,00,20,15,12,702	4929	DATA	41,4E,47,45,20,46,49,4C,534	5865	DATA	00,43,48,41,4E,47,45,20,454
4489	DATA	C4,8F,90,F9,20,D5,11,20,1026	4937	DATA	45,2E,20,3C,0D,44,49,52,443	5873	DATA	46,49,4C,45,20,50,41,52,547
4497	DATA	9F,11,D0,FB,A0,01,A9,00,965	4945	DATA	45,43,54,4F,52,59,2E,2E,562	5881	DATA	41,4D,53,0D,46,49,4C,45,526
4505	DATA	BD,86,02,4C,F9,11,A0,00,779	4953	DATA	2E,20,3C,0D,44,49,53,48,450	5889	DATA	20,4E,41,4D,45,2E,2E,2E,459
4513	DATA	A9,A0,20,15,12,20,15,12,471	4961	DATA	20,53,54,41,54,55,53,2E,562	5897	DATA	2E,2E,2E,2E,20,3C,0D,46,359
4521	DATA	A2,00,A1,14,E6,14,D0,02,803	4969	DATA	20,3C,0D,44,49,53,48,20,436	5105	DATA	49,4C,45,20,54,59,50,45,572
4529	DATA	E6,15,C9,00,F0,0A,C9,0D,916	4977	DATA	43,4D,44,53,2E,2E,2E,20,465	5113	DATA	2E,2E,2E,2E,2E,2E,2E,20,354
4537	DATA	F0,06,20,15,12,4C,A9,11,579	4985	DATA	3C,0D,52,45,53,45,54,20,492	5121	DATA	3E,0D,53,54,41,52,54,20,503
4545	DATA	48,20,F9,11,20,D5,11,A0,792	4993	DATA	43,36,34,2E,2E,2E,20,3C,403	5129	DATA	41,44,44,52,45,53,53,2E,564
4553	DATA	00,20,F9,11,20,D5,11,68,664	5369	DATA	54,52,41,4E,53,44,49,53,616	5137	DATA	2E,2E,20,3C,0D,4D,41,49,412
4561	DATA	60,20,D5,11,18,A5,8B,69,791	5377	DATA	48,20,56,32,2E,30,20,20,401	5145	DATA	4E,20,4D,45,4E,55,2E,2E,511
4569	DATA	28,85,8B,85,8D,A5,8C,69,996	5385	DATA	20,20,20,20,20,20,20,2E,309	5153	DATA	2E,2E,2E,2E,2E,2E,20,3C,322
4577	DATA	00,85,8C,29,03,09,08,85,675	5393	DATA	48,41,54,54,4F,20,27,38,511	5161	DATA	44,49,53,4B,20,44,49,52,554
4585	DATA	8E,60,38,A5,8B,E9,50,85,1044	5401	DATA	35,00,45,4E,54,45,52,20,467	5169	DATA	45,43,54,4F,52,59,2E,0D,529
4593	DATA	8B,AS,8C,E9,00,85,8C,60,1046	5409	DATA	4E,45,57,20,53,54,41,52,580	5177	DATA	4E,4F,20,4D,41,54,43,48,554
4601	DATA	A9,A0,20,15,12,C4,8F,90,883	5417	DATA	54,20,41,44,44,52,45,53,551	5185	DATA	2E,2E,2E,2E,2E,2E,20,3C,0D,335
4609	DATA	F7,AD,86,02,48,A9,00,8D,938	5425	DATA	53,3A,00,45,4E,54,45,52,523	5193	DATA	53,45,4C,45,43,54,20,4D,557
4617	DATA	86,02,A9,A0,20,15,12,68,640	5433	DATA	20,4D,41,54,43,48,3A,00,455	5201	DATA	41,54,43,48,2E,20,3C,0D,439
4625	DATA	8D,86,02,60,AA,98,18,65,820	5441	DATA	53,54,41,52,54,53,20,41,578	5209	DATA	4D,41,49,4E,20,4D,45,4E,549
4633	DATA	8B,A9,00,65,8C,C9,08,80,934	5449	DATA	54,0D,2E,2E,2E,2E,2E,2E,373	5217	DATA	55,2E,2E,2E,2E,2E,20,3C,0D,361
4641	DATA	0D,8A,29,3F,49,80,91,8B,740	5457	DATA	2E,2E,2E,0D,45,4E,44,53,449	5225	DATA	46,49,4C,45,20,54,59,50,573
4649	DATA	AD,86,02,91,8D,8A,C8,60,1029	5465	DATA	20,41,54,20,20,0D,2E,2E,350	5233	DATA	45,0D,53,45,51,2E,2E,2E,453
4657	DATA	48,A9,0F,8D,18,D4,A9,0F,817	5473	DATA	2E,2E,2E,2E,2E,2E,2E,0D,335	5241	DATA	2E,20,3C,0D,50,52,47,2E,430
4665	DATA	8D,05,D4,A9,81,8D,06,D4,1015	5481	DATA	46,49,4C,45,20,54,59,50,573	5249	DATA	2E,2E,2E,20,3C,0D,55,53,411
4673	DATA	68,60,48,8A,48,A9,11,8D,809	5489	DATA	45,0D,2E,2E,2E,2E,2E,2E,358	5257	DATA	52,2E,2E,2E,2E,20,3C,0D,358
4681	DATA	04,D4,A9,30,A2,75,8D,00,853	5497	DATA	2E,2E,2E,00,43,55,52,52,454	5265	DATA	4C,4F,41,44,20,53,45,4C,548
4689	DATA	D4,8E,01,D4,20,69,12,A9,891	5505	DATA	45,4E,54,20,46,49,4C,45,551	5273	DATA	45,43,54,49,4F,4E,0D,53,546
4697	DATA	10,8D,04,D4,20,69,12,A9,697	5513	DATA	20,49,53,3A,00,54,4F,54,493	5281	DATA	45,51,20,46,49,4C,45,2E,516
4705	DATA	00,8D,01,D4,68,AA,68,60,828	5521	DATA	41,4C,20,4F,46,00,4C,4F,477	5289	DATA	2E,2E,2E,20,3C,0D,50,52,405
4713	DATA	A2,00,20,B3,EE,CA,D0,FA,1271	5529	DATA	41,44,20,45,52,52,4F,52,559	5297	DATA	47,20,46,49,4C,45,2E,2E,483
4721	DATA	60,05,12,01,02,00,00,12,140	5537	DATA	3A,20,2A,2A,2A,20,4F,55,412	5305	DATA	2E,2E,20,3C,0D,55,53,52,447
4729	DATA	13,06,13,0A,00,00,00,8A,192	5545	DATA	54,20,4F,46,20,4D,45,4D,520	5313	DATA	20,46,49,4C,45,2E,2E,2E,458
4737	DATA	13,08,16,10,04,00,00,CA,271	5553	DATA	4F,52,59,20,2A,2A,2A,00,408	5321	DATA	2E,20,3C,0D,4D,41,49,4E,444
4745	DATA	13,0E,13,0D,08,00,00,29,114	5561	DATA	4C,4F,41,44,49,4E,47,20,542	5329	DATA	20,4D,45,4E,55,2E,2E,2E,479
			5569	DATA	53,45,4C,45,43,54,45,44,585	5337	DATA	20,3C,0D,45,4E,54,45,52,474
			5577	DATA	20,46,49,4C,45,2E,2E,2E,458	5345	DATA	20,46,49,4C,45,20,4E,41,495
			5585	DATA	2E,00,53,41,56,49,4E,47,502	5353	DATA	4D,45,3A,00,57,4F,52,4B,527
			5593	DATA	20,4E,45,57,20,46,49,4C,517	5361	DATA	49,4E,47,2E,2E,2E,2E,00,406

THOUGHTS & CROSSES

37 MARKET STREET, HECKMONDWIKE, WEST YORKS

COMPUTERS

Apricot F1E 128K disk drive	£595
Apricot F1 256K + 720K disk drive	£895
BBC Plus Microcomputer (includes DFS)	£469
Acom Electron (+ £40 FREE software)	£99
ZX Spectrum 48K (+ £50 FREE software)	£99
ZX Spectrum Plus 48K (+ £50 FREE software)	£128
Memotech 512	£129
Commodore 64 (+ £40 FREE software)	£189
Amstrad CPC 464 (green) + £100 FREE software	£199
Amstrad CPC 464 (colour monitor) + £100 FREE software	£299
Amstrad 612B (cool with disk drive)	£399
Amstrad 612B (green with disk drive)	£299
Sinclair QL	£199
Amstrad PCW 8256	£458
Commodore 128	

PRINTERS

Judd 5510	£299
LX80 Tractor Unit	£22
Canon PW1080A with NLQ	£290
Canon PW1156A with NLQ	£395
Panasonic KX-P1091 with NLQ	£315
Smith Corona D100	£215
Epson LX80	£235
Brother AC adapter	£17
Brother HR15 (Centronics)	£375
Brother Cut-Sheet Feeder	£220
Brother Keyboard	£150
Juki 6100 (Centronics Daisy Wheel)	£350
Juki 2200 (Typewriter Daisy Wheel Printer Centronics)	£275
Juki 6100 Tractor Feeder	£129
Juki 6100 Sheet Feeder	£220
Daisy Step 2000 (Centronics Daisy Wheel)	£250
Shinwa CP80 (Centronics)	£189
Mannesman Tally MT80 Plus (Centronics)	£195
Commodore MPS801	£99
Samielco DX85 (State Interface Req.)	£195

PRINTER RIBBONS

Epson MX/FX/RX80	£4
Epson MX/FX100	£8
Seikosha GP100/Commodore 1523	£4.50
Seikosha GP80	£4.50
Microline (group 66)	£2.30
Amadex	£12.50
MPS801	£8.50
NEC8023	£7
Canon/Kaga Taxan	£8
Ritenas CP80/CPA80/MT80/MT80Plus	£8.50
Ritenas A1	£7
Panasonic KX-P110 (MTX)	£9
QUME MS	£4.30
QUME nylon	£6.50
Diablo MS	£4
Diablo Nylon	£4
Diablo SS	£3
Juki 6100/DPS	£2
Juki 6100/DPS	£5
Brother DP44	£2.30
Brother HR5	£2.99
Brother M1009	£3.80
Brother singlestrike HR15/25	£3
Brother correctable HR15/25	£3
Brother multistrike HR15/25	£8
Samielco DX85	£9.50
Amstrad PCW8526	£x.00

Others available, please ask.
Print wheels also available, please ask.

PRINTER LEADS

BBC Centronics printer lead	£10
BBC Serial printer lead	£10
Memotech Centronics printer lead	£10
Dragon Centronics printer lead	£10
Oric Centronics printer lead	£10
Amstrad Centronics printer lead	£10
Einstein Centronics printer lead	£10
Wafadrove to Centronics lead - Spectrum	£10
Spectrados to Centronics lead - Spectrum	£10
ZX Interface 1 to RS232 'D' - Spectrum	£14.95
QL to RS232 lead	£14.95
Centronics to 25-way 'D' lead	£15
Centronics to Centronics lead	£15
RS232 'D' to RS232 'D'	£13.50
IBM to Centronics	£15
MSX to Centronics	£15
Atari 520ST to Centronics	£15

PRINTED INTERFACES

Epson RS232 Interface	£32
Epson RS232 Interface with 2K Buffer	£72
Canon RS232 Interface	£85
Shinwa RS232 Interface with 2K Buffer	£85
Mannesman MT80 RS232 with 2K Buffer	£45
Mannesman MT80 2K Buffer	£10
Juki RS232 Interface	£60
Kempston Interface-E (rom)	£29.95
Kempston Interface-S (cass)	£29.95
Tasman Interface (cass)	£35
QL Centronics Interface	£30
Turbo Print GT Centronics Interface (supports CBM 64 graphics)	£70
IEEE to Centronics Interface for Commodore 4032/8096/70	£70
Tripler Centronics Interface for Commodore VIC 20/64/£50	£70
Apple III Centronics (Aristocrat)	£69
Apple III Serial Interface Card	£69
Electron Plus 1	£58

PRINTER PAPER

1000 Sheets of continuous tractor feed paper	£9
1000 Single/Double tractor feed labels	£8.50

MONITORS

Microvitec 1431 MS (standard res. suitable for BBC etc)	£199
Microvitec 1451 MS (medium res. suitable for BBC etc)	£290
Microvitec 1431 MZ - Spectrum	£245
Microvitec 1451 DQ - Sinclair QL	£275
Microvitec 1451 APMSA	£345
Philips 7502 anti-glare green screen monitor (20MHz)	£210
Commodore 1702	£82
Fidelity TV/Monitor	£210
Fidelity CM14	£170
Fidelity QL Monitor (std res)	£180
Amstrad Modulator	£30
Reguson MM02 green screen (UK made)	£85
Lead for above	£4
Philips 7522 Amber	£95

DISK DRIVES

ZX Microdrive - Sinclair	£45
ZX Interface 1 - Sinclair	£45
ZX Expansion System (includes Microdrive/Interface 1/Password Two/Masterfile/Am Attack/Games Designer)	£95
Commodore 1541 + Easy-Script + 6 programs	£150
Amstrad 3" drive - Amstrad	£99
Electron Plus 3 - Acom	£150
Micro P 3 1/2" disk drive 720K inc disk interface	£220
Micro P 2nd drive	£120
Challenger (Opus)	£20A
Discover 1 (Opus)	£190
Amstrad 3" Disk Drive + Interface	£159

CUMANA DISK DRIVES

CSXL 100 100K 40T	£99
CSX 100 100K 40T	£109
View 3	£129
CSX 2000 200K 40T DS	£149
CSX 400 400K 40/80T DS	£129
CS 100 100K 40T	£129
CS 2000 200K 40T DS	£129
CS 400 400K 40/80T DS	£249
CD 200 2 x 100K 40T	£299
CD 4000 2 x 200K 40T DS	£299
CD 800S 2 x 400K 40/80T DS	£329

OPUS DISK DRIVES

5401 100K 40T	£109
5402 200K 40T DS	£129
5802 400K 40/80T DS	£149
5401P 100K 40T	£129
5402P 200K 40T DS	£159
5802P 400K 40/80T DS	£179
5401D 2 x 100K 40T	£249
5402D 2 x 200K 40T DS	£299
5802D 2 x 400K 40/80T DS	£329
3" 100K 40T	£70

DISKETTES

Parrot Control Data, SM	
S/S D/D 40T 10 for (Wabash only)	£14
S/S D/D 40/10 for	£16
D/S D/D 40T 10 for	£20
D/S D/D 80T 10 for	£26

DYSAN DISKETTES

104/10 S/S D/D 40T Dysan	£18
104/20 D/S D/D 40T Dysan	£26
204/20 D/S D/D 80T Dysan	£32
3" Maxell Amsoft Diskettes - single	£4.50
3" Maxell Packard - 3 1/2" Fuji - single	£3.50
3" Maxell Packard - 3 1/2" Fuji - double	£4.50
3" Maxell Amsoft 10 for	£40
3" Fuji single 10 for	£30
3" Fuji double 10 for	£40

PVC COVERS

Apricot PC	£6.50
BBC	£3.99
Acom Electron	£2.99
BBC Cassette Recorder	£2.00
ZX Spectrum	£1.99
ZX Spectrum Plus	£2.00
Saga Keyboard	£3.99
Sinclair QL	£3.99
VIC 20/64	£2.99
Dragon 32/64	£3.99
Memotech 512	£3.99
Amstrad CPC464	£3.99
Amstrad Monitor (green)	£3.99
Amstrad Monitor (colour)	£4.99
Philips Monitor	£4.30
Microvitec 14"	£4.80
Canon PW1080A	£4.80
Epson FX80	£4.80
Epson RX80 FIT	£4.30
Epson RX80	£4.30
Shinwa CP80	£4.30
Mannesman Tally MT80	£4.30
MPS801	£4.30
Brother HR15	£5.60
Seikosha GP80	£3.50
Seikosha GP100	£3.75
Juki 6100	£5.60

SPECTRUM PERIPHERALS

Slomo (Speed Controller)	£14
Spectrados DDOS	£89
DK Light Pen	£18
Datel Light Writer	£18
DK Spectrum Keyboard	£29
DK3 Channel Sound	£28
Saga Keyboard	£39
Saga 3 Elite Keyboard	£75
Microdrive Library Case	£5.95
Extension to Keyway (ribbon)	£12
Currah Microslot	£8.95
Microdrive Extension Lead	£8
Microdrive Cartridge	£1.99
Pack of 4 Cartridges	£7.50
Currah Microspeech	£20
2 Wafa Cartridges (64K)	£7
VTX 5000 Modem	£89
Interface III	£37

COMMODORE PERIPHERALS

Koala Pad	£75
Slomo (Speed Controller)	£14
Currah Microspeech	£22
Music Maker	£28
Modem 100	£125
CBM Modem	£80
Simon's Basic	£20
Wordcraft (cartridge)	£35
VC20 RAM Pack (3K) 16K switchable	£32

BBC PERIPHERALS

6502 Second Processor	£199
Z80 Second Processor + FREE Software	£367
Music 500	£189
ROM Extension Board	£40
AMX Mouse	£35
Commatr (rom)	£27
Nightingale Modem inc Commatr	£145

JOYSTICKS AND INTERFACES

Voltmace Joysticks Pr. (for the BBC)	£20
Sure Shot Joystick	£15
Formula 1 Joystick	£16.95
DK Tronics Dual Port Interface	£12
Datel Electronics Interface	£9
Budd Interface (+ reset switch)	£12.95
Cambridge Programmable Joystick	£29
DK Tronics Programmable Interface	£14

COMPUTER SOFTWARE

Spectrum - Titles (approx)	£600
Commodore 64 - Titles (approx)	£400
Amstrad - Titles (approx)	£180
Electron - Titles (approx)	£180
BBC - Titles (approx)	£480

All our software is discounted by 10%. Please send for software lists.
Listed below are serious programs for the BBC, Commodore and Spectrum.
In addition we have the largest selection of games software in Europe. Also send for lists of Educational programs.

BBC

Title	Company	
View 3	Acom	£80
View 3	Acom	£80
Database	Acromsoft	£10.70
View Driver Gen.	Acromsoft	£8.95
Viewsheet rom	Acromsoft	£10.70
Acrom Viewstare	Acromsoft	£35
Accounts Payable	Acromsoft	£55
Intersheet	Acromsoft	£23
View	Acromsoft	£55
Discdex	Acromsoft	£23
Discmaster (disk)	Beebugsoft	£16.90
Dumpmaster (disk)	Beebugsoft	£10.80
Exmon	Beebugsoft	£15
Help (rom)	Beebugsoft	£22.50
Harshy Font (disk)	Beebugsoft	£13.50
Muron (rom)	Beebugsoft	£26.90
Paintbox	Beebugsoft	£10
Seuth (rom)	Beebugsoft	£26.90
Spellcheck II (rom)	Beebugsoft	£27.90
Sprite Utilities	Beebugsoft	£9
Sprite Utilities	Beebugsoft	£9
Starter Pack	Beebugsoft	£11.70
Teletext Pack	Beebugsoft	£9
Teletext Pack (disk)	Beebugsoft	£10
Caretaker (rom)	Comp Concep	£30
Disk Doctor (rom)	Comp Concep	£30
Graphics (rom)	Comp Concep	£30
Printmaster (rom)	Comp Concep	£30
Wordwise (rom)	Comp Concep	£40
Wordwise Plus (rom)	Comp Concep	£55
Beta-Base (disk)	Clares	£22
Gradiak (disk)	Clares	£5
Replica II (disk)	Clares	£8
The Key (disk)	Clares	£10.50
Mini Office	Clares	£5
Database	Clares	£5.35
Cashbook Accounts	Gemini	£50
Database	Gemini	£18
Final Accounts	Gemini	£50
Home Accounts	Gemini	£18
Invoices & Statements	Gemini	£18
Mailist	Gemini	£18
Payroll	Gemini	£35
Stock Control	Gemini	£18
Word Processor	Gemini	£18
Editor Printout Library	Island Logic	£11.65
Synthesizer Keyboard Library	Island Logic	£11.65
The Music System (disc)	Island Logic	£2
Basic Ext (rom)	Micropower	£17.95
Machine Code Tutor	New Gen	£13.50
VU-Calc	Paion	£6
VU-File	Paion	£6
Ultracalc 2	BBC	£72

SPECTRUM

Title	Company	
Deus Ex Machina	Betasoft	£9.95
Beta Basic 3.0	Betasoft	£13.50
Masterfile	Campbell	£13.50
Masterfile & MF Print	Campbell	£18
Astronomer	CP Software	£8.95
Floating Point Forth	CP Software	£9.95
Supercode II	CP Software	£6.95
Supercode III	CP Software	£11.65
Leonardo	Creative	£7.15
Main Office	Database	£5.35
The Illustrator	Gilsoft	£13.50
The Quiz	Gilsoft	£22.50
C Compiler	Hisoft	£12.50
Dev Pac 3	Hisoft	£22.50
Pascal	Hisoft	£8.50
Ultrakit	Hisoft	£7.50
Purchase Ledger	Kemp	£7.50
Sales Ledger	Kemp	£7.50
Stock Control	Kemp	£13.50
Melbourne Draw	Melbourne	£12.50
Omnicalc 2	Microsphere	£13.50
Machine Code Tutor	New Generation	£13.50
Lightmagic	New Generation	£13.50
Machine Lighting	Oasis	£17.15
Spec Mac Mon	Oasis	£13.50
White Lightning	Oasis	£13.50
Address Manager Standard	OCF	£3.05
Address Manager Plus 80	OCF	£17.95
Editor Assembler	OCF	£11.65
Finance Manager Standard	OCF	£8.95
Finance Manager Plus 80	OCF	£17.95
Machine Code Test Tool	OCF	£8.95
Stock Manager Standard	OCF	£8.05
Stock Manager Plus 80	OCF	£17.95
VAT Manager Standard	OCF	£8.05
VAT Manager Standard	OCF	£17.95
Editor & Assembler	OCF	£7.85
Spectrum Monitor	OCF	£8.75
Paint Plus	OCF	£8.95
Screen Machine	OCF	£7.40
Trans Express (cass)	Romantic	£3.95
Trans Express (m/d)	Romantic	£9.95
Make A Chip	Sinclair	£5
Musicmaster	Sinclair	£5
Print Utilities	Sinclair	£5
Small Business Account	Sinclair	£5.50
VU Calc	Sinclair	£4.50
Vu File	Sinclair	£4.50
VU 3D	Sinclair	£4.50
ZX Forth	Sinclair	£7.50
Tascopy	Tasman	£8.90
Tasmerge	Tasman	£8.90
Tasprint	Tasman	£8.90
Taswide	Tasman	£4.95
Tasword II	Tasman	£12.50
The Artist	Softk	£11.65
Blast (Compiler)	Oxford	£22.95

SINCLAIR

Title	Company	
QL Pascal	Metacom	£80
Assembler Development Kit	Metacom	£36
BCPL Development Kit	Metacom	£54
Lisp Development Kit	Metacom	£54
QL Assembler	Sinclair	£36
QL Tool Kit	Sinclair	£22
Cash Trader	Sinclair	£23
QL Touch 'n Go	Sinclair	£63
QL Entrepreneur	Sinclair	£36
QL Project Planner	Sinclair	£36
QL Integrated Accounts	Sinclair	£30
Graphic QL	Talent	£31
QL Man	Hi Soft	£18
QL Pascal Development Kit	Metacom	£81

COMMODORE

Title	Company	
Witchhikens Guide to Galaxy	Activation	£35
Music Studio	Activation	£17.50
Activity Centre (desk)	ASP	£13.50
Maggie Database	Audiogenic (disk)	£36.95
Swift Spreadsheet	Audiogenic (disk)	£17.95
Wordcraft	Audiogenic	£22.50
System 150		

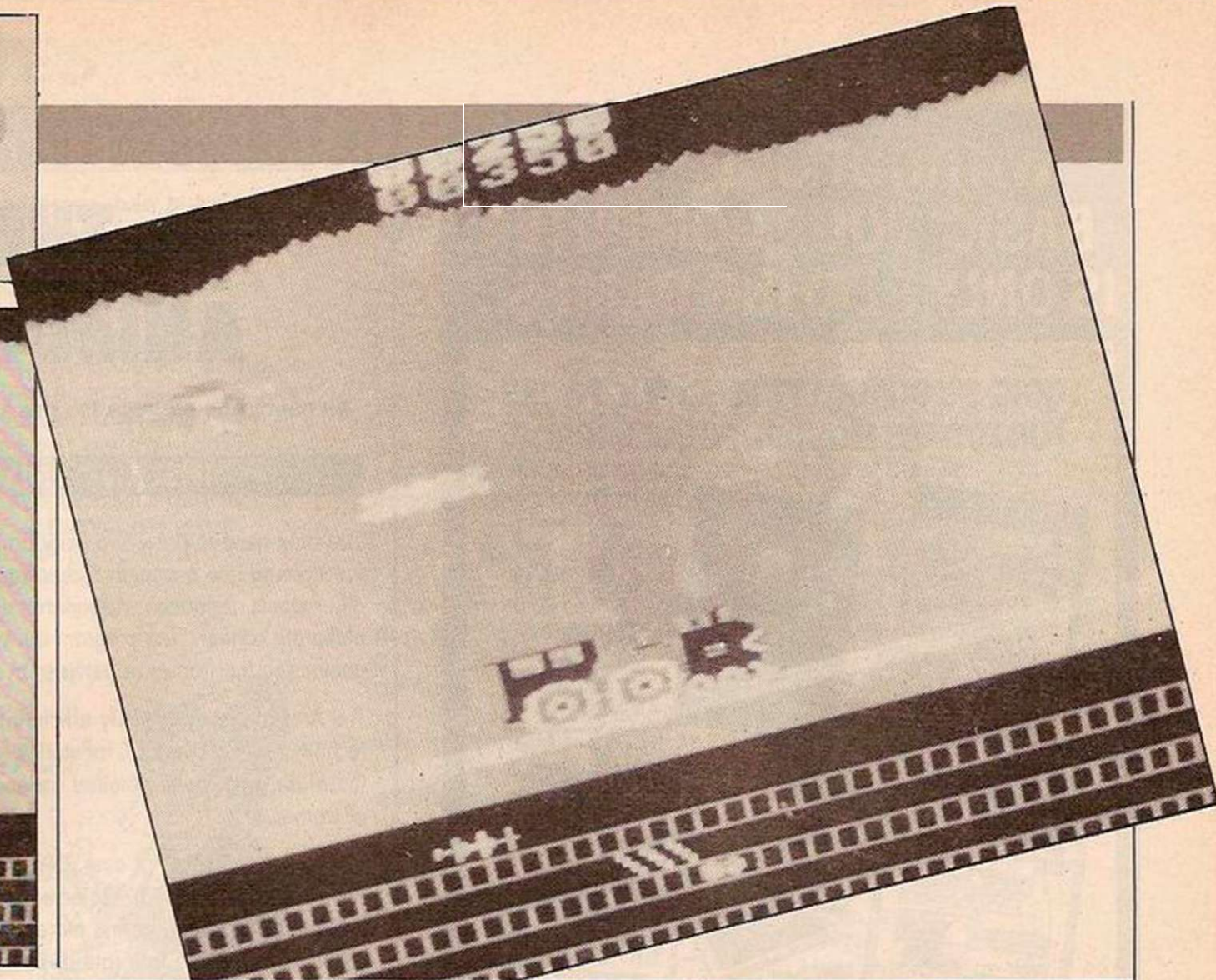
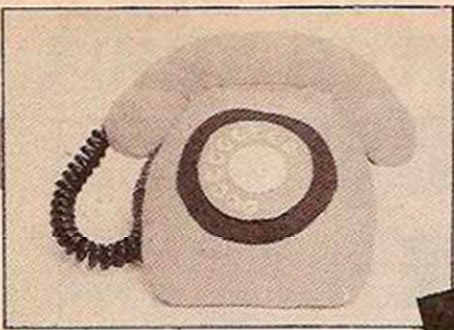

```

520.track INC&C50:LDA&C50:CMF&C52:BNE:CLC:LDA&C52:A
DC#5:STA&C52:CMF#70:BNEBOT:LDA#30:STA&C52:.BOT
530.LDA#0:STA&C50:LDA&C51:DOF#FF:STA&C51:BEQbot:LDA&
C53:INC&C55:LDA&C55:CP#2:BNE:DOF#1:STA&C53:LDA&C53:STX
AC55:R:CLC:ADC#129:YAY:LDA#27:JMP#1:bot:LDA&C54:INC
&C56:LDA&C56:CP#2:BNE:DOF#1:STA&C54:LDA&C56:.S
CLC:ADC#129:YAY:LDA#29
540.pri LDA#17:JSRAFFEE:LDA#3:JSRAFFEE:LDA#31:JSRAFF
EE:LDA#18:JSRAFFEE:TXA:JSRAFFEE:YVA:JMP#FFEE
550.N RTS
560.trpri LDY#0:O LDATA#Y:STA(800):Y:IN:CPY#16:BN
EO:RTS
570.up SEC:LDA&80:SB0#40:STA&4D:LDA&81:SB0#1:STA&4E
LDY#0:LDA(84D):Y:CMF#241:BNEend:DEC&6A:JSRrub:SEC:LDA
&80:SB0#80:STA&80:LDA&81:SB0#2:STA&81:JMP#trpri: end R
TS
580.down CLC:LDA&80:ADC#40:STA&4D:LDA&81:ADC#1:STA&
4E:LDY#0:LDA(84D):Y:CMF#248:BNEend:INC&6A:JSRrub:CLC:L
DA&80:ADC#80:STA&80:LDA&81:ADC#2:STA&81:JMP#trpri: end
RTS
590.rub LDY#0:O LDATA#Y:STA(800):Y:IN:CPY#16:BNQ
E:RTS
600.T4 LDA&40:STA&91:LDA&97:STA&92:T3 RTS: plane1
INC&95:LDA&95:CMF#2:BNET3:LDA#0:STA&95:LDY#0:LDA#240:
T1 STA(891):Y:IN:CPY#16:BNET1:LDA&90:CMF#197:BEOT4:C
LC:LDA&91:ADC#0:STA&91:LDA&92:ADC#0:STA&92:LDA&90
610LDY#0:STY#4A4: T2 LDA#1Y:STA(891):Y:IN:CPY#16:
BNET2:LDA&90:CMF#139:BNIT3:CMF#176:BPLT3:CLC:LDA&96:AD
C#40:STA&4D:LDA&97:ADC#1:STA&4E:LDY#0:TYA: T5 STA(896
):Y:STA(84D):Y:IN:CPY#32:BNET5:LDA&90:CMF#175:BEOT7:
620CLC:LDA&96:ADC#16:STA&96:LDA&97:ADC#0:STA&97:CLC:
LDA&96:ADC#20:STA&4D:LDA&97:ADC#1:STA&4E:LDY#0: T6 LD
Abp#Y:STA(896):Y:IN:CPY#32:BNET6: T6 LDAbp#Y:STA(8
4D):Y:IN:CPY#64:BNET6:LDA#1:STA&94A
630LDA&97:CMF#561:BNETT7:LDA&96:CMF#550:BNETT7:JSRbo
mb: T77 RTS: T7 LDA#80:STA&96:LDA&60:STA&97
640RTS: U3 LDA#70:STA&1:LDA#78:STA&78:STA&78:RTS
650.airship INC&A5:LDA&A5:CMF#3:BNET1:LDY#0:STY#A5:
U2 LDA#240:STA(8A1):Y:IN:CPY#16:BNET2:LDA&A0:CMF#200:
BPLU3:SEC:LDA&A1:SB0#8:STA&A1:LDA&A2:SB0#0:STA&A2:LDY#
0:U4 LDA&A#Y:STA(8A1):Y:IN
660CPY#16:BNET4:U1 LDA&A0:CMF#104:BNIT1:CMF#176:BPL
u1:LDA&94:DOF#1:STA&94:BNET1:CLC:LDA&A3:ADC#40:STA&
4D:LDA&A4:ADC#1:STA&4E:LDY#0:TYA:U2 STA(8A3):Y:STA(84
D):Y:IN:CPY#32:BNET2:LDA&A0:CMF#175:BEQJ3
670SEC:LDA&A3:SB0#8:STA&A3:LDA&A4:SB0#0:STA&A4:CLC:L
DA&A3:ADC#40:STA&4D:LDA&A4:ADC#1:STA&4E:LDY#0:U4 LD
Abp#Y:STA(8A3):Y:IN:CPY#32:BNET4:U4 LD
Abp#Y:STA(84D):Y:IN:CPY#64:BNET4
680LDA&A4:CMF#A5E:BNET1:LDA&A3:CMF#A8B:BNET1:JSRBOB
2:U1 RTS
690.U3 LDA#60:STA&A3:LDA#5F:STA&A4:RTS

```

```

700.HITPL JSR#XX:CLC:LDA&96:ADC#40:STA&4D:LDA&97:AD
C#1:STA&4E:LDY#0:V#1 LDA(896):Y:DOF#4D):Y:AND#N:Y:ST
A(896):Y:LD(84D):Y:DOF#N:Y:AND(896):Y:STA(84D):Y:IN:
CPY#32:BNETV1:JSRdelay
710JSRdelay:JSRdelay
720LDY#0:STY#94A:LDA#240:V#3 STA(891):Y:IN:CPY#16:
BNEV3:LDA#40:STA&91:LDA#47:STA&92:JSRdelay:CLC:LDA&
96:ADC#40:STA&4D:LDA&97:ADC#1:STA&4E:LDY#0
730TYA:V#2 STA(896):Y:STA(84D):Y:IN:CPY#32:BNETV2:
LDA#40:STA&96:LDA#40:STA&97:LDA#201:STA&98:LDA#0:STA
&95:RTS
740.eXX JSR#score:LDA#7:LDA#0#X MOD256:LDY#0#X DIV256
:JMP#AFF1
750.HITAS JSR#XX:CLC:LDA&A3:ADC#40:STA&4D:LDA&A4:AD
C#1:STA&4E:LDY#0:V#1 LDA(8A3):Y:DOF#4D):Y:AND#N:Y:ST
A(8A3):Y:LD(84D):Y:DOF#N:Y:ORA(8A3):Y:STA(84D):Y:IN:
CPY#32:BNETV1:JSRdelay
760JSRdelay:JSRdelay
770LDY#0:STY#94B:LDA#240:V#3 STA(8A1):Y:IN:CPY#16:
BNEV3:LDA#40:STA&91:LDA#47:STA&92:JSRdelay:CLC:LDA&
A3:ADC#40:STA&4D:LDA&A4:ADC#1:STA&4E:LDY#0
780TYA:V#2 STA(8A3):Y:STA(84D):Y:IN:CPY#32:BNETV2:
LDA#40:STA&A3:LDA#47:STA&A4:LDA#200:STA&A0:RTS
790.bomb LDA#1:STA&A0:LDA#40:STA&A1:LDA#63:STA&A2:
BOPRI LDY#0:XX1 LDA#0#Y:STA(8B1):Y:IN:CPY#16:BNEXX
1:RTS
800.Bom INC&B3:LDA&B3:CMF#3:BNEXX2:LDA#0:STA&B3:JSRb
Rub:CLC:LDA&B1:ADC#40:STA&B1:LDA&B2:ADC#1:STA&B2:JSRb
OPRI:LDA&B2:CMF#A70:BNEXX2:LDA&B1:CMF#A50:BNEXX2:LDA#0
:STA&B0:LDY#AFF:RTS:XX2 LDY#0:RTS
810.bRub LDY#0:TYA:XX1 STA(8B1):Y:IN:CPY#16:BNEXX
1:RTS
820.BH1 LDA#0:STA&B0:JSR#XX:LDY#0:XX1 LDA(8B1):Y:EO
ROF#Y:AND#N:Y:STA(8B1):Y:IN:CPY#16:BNEXX1:JSRdelay2:J
MP#Rub
830.delay2 LDY#100:AA LDY#100:BB DEY:BNEXB:DEX:BN
EAA:RTS
840.BOMB2 LDA&B4:DOF#1:STA&B4:BNEXZ1:LDA#1:STA&B6:LD
A#38:STA&B7:LDY#A61:STA&B8:BNP12 LDY#0:Z#2 LDA#0#Y
:STA(8B7):Y:IN:CPY#16:BNEXZ2:Z#1 RTS
850.Bom2 INC&B9:LDA&B9:CMF#4:BNEXY2:LDA#0:STA&B9:JSR
BUB2:CLC:LDA&B7:ADC#40:STA&B7:LDA&B8:ADC#1:STA&B8:J
SRBPR12:LDA&B0:CMF#A70:BNEXY2:LDA&B7:CMF#A30:BNEXY2:LD
A#0:STA&B6:LDY#AFF:RTS:Y#2 LDY#0:RTS
860.BrUB2 LDY#0:TYA:Y#3 STA(8B7):Y:IN:CPY#16:BNEXY
3:RTS
870.BH2 LDA#0:STA&B0:JSR#XX:LDY#0:XX1 LDA(8B7):Y:
DOF#N:Y:AND#N:Y:STA(8B7):Y:IN:CPY#16:BNEXX1:JSRdelay
2:JMP#BUB2
880.aA5 CLC:LDA&65:ADC#30:STA&65:LDA&66:ADC#1:STA&
66:RTS:clive1 LDY#0:JSR#CRUB:SEC:LDA&65:SB0#8:STA&65:L
DA&66:SB0#0:STA&65:LDA&64:CMF#157:BEQ#A5:LDY#0:AAZ

```

```

LDAC111:Y:STA(865):Y:IN:CPY#16:BNEXA2
890LDA&66:CMF#A6A:BEQ#A3:LDA&66:CMF#A6A:BPLU#up:BNIDdo
:AA3 RTS
900.Up SEC:LDA&65:SB0#38:STA&6D:LDA&66:SB0#1:STA&4
E:LDY#0:LDA(84D):Y:CMF#248:BNEBB1:JSR#CRUB:SEC:LDA&65:
SB0#80:STA&65:LDA&66:SB0#2:STA&66:DEC&6B:BB01 RTS
910.D0 CLC:LDA&65:ADC#48:STA&4D:LDA&66:ADC#1:STA&4
E:LDY#0:LDA(84D):Y:CMF#241:BNEBB2:JSR#CRUB:CLC:LDA&65:
ADC#80:STA&65:LDA&66:ADC#2:STA&66:INC&6B:BB02 RTS
920.CRUB LDY#0:AA1 LDATA#Y:STA(865):Y:IN:CPY#16:
BNEXA1:RTS
930.CLLI SEC:LDA&64:SB0#130:TAX:LDA#0:STA&EE:STA&EF:
E#E1 CPX#0:BEQ#E2:CLC:LDA&EE:ADC#16:STA&EE:LDA&EF:AD
C#0:STA&EF:DEX:JMP#E1:E#E2 SEC:LDA#A10:SB0#EE:STA&F2
:STA&56:LDA#72:SB0#EF:STA&F3:STA&57
940CLC:LDA&F2:ADC#32:STA&60:LDA&F3:ADC#0:STA&61:CLC:
LDA&60:ADC#40:STA&62:LDA&61:ADC#1:STA&63:LDY#0:E#E3
LDA#0:STA(860):Y:STA(862):Y:IN:CPY#16:BNEXE3
950LDY#0:E#E3 LDAC12:Y:STA(8F2):Y:IN:CPY#32:BNEXE
E3:CLC:LDA&F2:ADC#40:STA&F0:LDA&F3:ADC#1:STA&F1:E#E5
LDAC12:Y:STA(8F0):Y:IN:CPY#64:BNEXE5:RTS
960.HISI JSR#XX:JSRdelay:JSRdelay:JSR#CRUB:CLC:LDA&56
:ADC#40:STA&4D:LDA&57:ADC#1:STA&4E:LDY#0:TYA: I#11 ST
A(856):Y:STA(84D):Y:IN:CPY#32:BNEXI1:LDA#0:STA&6C:ST
A&64:LDA#30:STA&65:LDA#7C:STA&66:LDA#2:STA&6B:RTS
970.score CLC:LDA&6C:ADC#5:STA&6B:CMF#10:BNESHOW:LDA
#0:STA&6C:INC&6C:LDA&6C:CMF#10:BNESHOW:LDA#0:STA&6C:IN
C&C:LDA&6C:CMF#10:BNESHOW:LDA#0:STA&6C:INC&6C
980.show LDA#31:JSRAFFEE:LDA#7:JSRAFFEE:LDA#1:JSRAFF
EE:LDA#17:JSRAFFEE:LDA#3:JSRAFFEE:LDY#4:K#1 CLC:LDA&
CA:Y:ADC#48:JSRAFFEE:DEY:CPY#A5F:BNEXK1:RTS
990.IN LDA#830:STA&70:LDA#70:STA&71:CLC:LDA&70:ADC#
224:STA&72:LDA&71:ADC#0:STA&73:LDA&72:ADC#224:STA&74:L
DA&73:ADC#0:STA&75
1000LDY#0:Y#11 LDAB7#Y:STA(870):Y:IN:CPY#96:BNET11:
Y#12 LDAB7#Y:STA(872):Y:IN:CPY#192:BNET12:Y#13 LDAB
7#Y:STA(874):Y:IN:CPY#96:BNET13
1010CLC:LDA&74:ADC#0:STA&74:LDA&75:ADC#1:STA&75:LDY#0
:Y#14 LDAB7#256:Y:STA(874):Y:IN:CPY#32:BNET14:RTS
1020.eni LDY#8F:LDA&8D:STA&7C0:Y:LDA&8D:STA&7C0:Y
:LDA&8D:STA&7D0:Y:LDA&8D:STA&7D0:Y
1030LDA&8E:BNENANU:INC&8F:LDA&8F:CMF#4:BNENANU:LDA#1:ST
A&8E:en1 JMP#2:ANU DEC&8F:LDA&8F:CMF#0:BNENANU:LDA#
0:STA&8E
1040.an2 LDY#8F:LDA&8F:LDA&7C0:Y:STA&8D:TXA:STA&72
C0:Y:LDA&72C0:Y:STA&8D:TXA:STA&72C0:Y:LDA&72D0:Y:STA&
D52:TXA:STA&72D0:Y:LDA&72D0:Y:STA&8D:TXA:STA&72D0:Y:R
TS
1050:NEXT:IF INKEY=256<0 AND INKEY=256<-1 THEN A#
"Electron":S=40 ELSE A#="B":S=100
1060PRINTAB(40-LENA#)/2,S):A#TAB(15,7):"Version .2
":delay71:S:CHAIN"

```

```

320SOUND:1,5,10;FORJ%=0TO9:VDU19,2,1,0;:FORK%=0TO20
0:NEXT:VDU19,2,0,0;:FORK%=0TO200:NEXT,
340ENDPROC
350DEFPROC instructions:CLS
360PRINTTAB(15,0);"Locomotion"
370PRINTTAB(14,1);STRING$(12,CHR$(28));
380PRINT"" In this game you are in charge of a r
unaway steam locomotive in which the brakes have fai
led and there is no hope of stopping.However there are
still moresetbacks to your journey."
390PRINT" From the air you are constantly being att
acked by aeroplanes and airships while back on the
rails some one has unleashed a TRAIN SEEKING C-5!"
400PRINT"Luckly your train has an early warning rad
ar system displayed on the bottom of the screen,it sho
ws you what is ahead onthe tracks or in the air.You mi
ght thinkthat such a train would be defenceless"
410PRINT"not on your nelly,it's fitted with a har
poon gun at the front to deal with the C-5 and radio
active smoke to cope with the planes.To fire the har
poon simply press the space bar the smoke, howev
er takes getting used to."

```

```

420PRINT" Firstly you can have upto three pie
ces of smoke in the air at one time but secondly,and
more importantly,the longer you hold the fire button
down thehigher the smoke goes,flying to the left of th
e screen once released."
430PRINTTAB(1,30);"PLEASE PRESS THE SPACE BAR TO CON
TINUE"
440REPEAT:UNTILINKEY=99
450CLS:PRINTTAB(15,0);"Locomotion"
460PRINTTAB(14,1);STRING$(12,CHR$(28));
470PRINT""The keys to use in this game are :-"
480PRINT""A <-> UP space <-> FIRE"
490PRINT""Z <-> DOWN return <-> SMOKE"
500PRINTTAB(1,30);"PLEASE PRESS THE SPACE BAR TO CON
TINUE":FORG=0TO300:NEXT:REPEAT:UNTILINKEY=99:CLS:ENDPR
OC
510DATA52,64,52,72,52,92,52,100,52,112,52,120,52
520DATA36,84,132,28,124,56,104,52,100,36,84,24,52,11
2,92,104,84
530DEFPROC key:PRINTTAB(5,24);"Locomotion"
540REPEAT:UNTILINKEY=99
550ENDPROC

```

WITHOUT OUR 'LEARN BASIC' YOUR COMPUTER IS ONLY PLAYING GAMES...

LOGIC 3's COMPLETE TEACHING PACKS FOR TODAY'S MOST POPULAR MICROS



Based on the teaching methods developed by Professor Andrew Colin of Strathclyde University, Logic 3 is the most comprehensive guide to Basic programming currently available.

Logic 3 is designed for people who want to keep abreast of the computer age, for people who realise that understanding computers is a key to future success at work, at school and as a parent.

If you are thinking of buying, expecting a present, or already have an Acorn Electron, BBC, Sinclair Spectrum 48K, Dragon 32/64 or Amstrad CPC 464/664 you need Logic 3 'Learn Basic' too.

Each Logic 3 pack contains a 190 page work-book, 2 cassette tapes containing 20 programs plus a flow-chart stencil.

QTY	COMPUTER	PRICE	TOTAL
	SINCLAIR SPECTRUM 48K	14.95	
	ACORN ELECTRON	14.95	
	BBC	14.95	
	AMSTRAD CPC 464/664	17.95	
	DRAGON 32/64	14.95	
	CHEQUES/P.O. PAYABLE TO: LOGIC 3 LTD.	TOTAL	

NAME: _____

ADDRESS: _____

TEL NO: _____

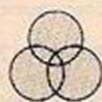

LOGIC 3
THE KEY
TO THE
WORLD OF
TOMORROW

PLEASE TICK BOX IF MORE INFORMATION IS REQUIRED

Logic 3 Ltd,
165 Garth Road, Morden, Surrey SM4 4LH, UK. Telephone: 01-330 0101,
Telex: 28704 MMH VANG, Facsimile: 01-337 5532

ABCDE

Agents/distributors required outside UK. Export enquiries welcome.

THE ANIMATOR

An animation package for the Amstrad 464/664/6128

INSTANT ANIMATION

You only need to draw two "key frame" pictures to see them transformed into a smooth flicker-free animation sequence. In other words, a cartoon. Add more key frames to make a more elaborate cartoon. The program does the work for you by generating the frames in between.

The Animator uses a highly efficient screen compaction technique. With over 30K for storing your animation (64K on the 6128), even quite detailed cartoons can run over hundreds of frames.

Animation sequences of over 750 frames are possible — double that on the 6128. Projected at 12 frames per second, this means a cartoon lasting more than a minute. You can speed up the action to a rate of 25 frames per second; or replay it backwards; or freeze frame it.

- Choice of number of key frames
- Joystick or keyboard control
- Rubberbanding
- Colour facility
- Standard or stippled colour fill
- Edit frames
- Copy frames
- Rotate frames
- Polygon draw
- Save and Load frames
- Choice of Modes 1 and 2
- Variable speed of animation
- Demo mode
- On-screen memory counter

See us on Stand 74 at the Amstrad User Show on January 11th and 12th.

The Animator costs £8.95 on tape, £13.95 on disc, p&p included.

Send cheque/postal order to:

WOOLF
GRAPHICS

8 Sterndale Road
London W14 0HS
01-603 4064

BUFFERS' GUIDE TO MICROS

Starting out in home computing? First Bytes is for you. Just write to *Your Computer* with any hardware or software problems, no matter how small or simple.

Every jargon has phrases which cause non-initiates to glaze over. Automobile hobbyists used to plunge families into catatonia by intoning the awful words, "Differential Gear". Computer addicts have a wider range of conversation killers: one forms our tasteful topic for today. Even those who've dabbled in Basic can turn pale at the far-off cry, "Control Structures!"

There's a chap in one of Moliere's plays who is

delighted to find he's been *talking prose* all his life without knowing it. Similarly with Basic: if you've used an If-Then statement or a For-Next loop, then without knowing it you've been talking control structures. They're just methods of executing program statements in a controlled — conditional or repetitive — way.

Often Basic users have to lash together their own control structures, using the dreaded Goto statement. Saying Goto will cause upmarket programmers not to glaze over but to show snobbish disdain by hitting you in the mouth. For example, you may not know how many times your program needs to go around a loop. If it's supposed to count the full stops in *Robinson Crusoe* — somebody once did this — you want a loop structure with a conditional exit, like this:

```
10 GOSUB 1000 : REM find
  next full stop
20 STOPS = STOPS + 1
30 IF NOT ENDOFTEXT THEN
  GOTO 10
```

Subroutine 1000 contains the hard bits, and sets Endoftext as true when it at last reads the words "The End".

Basic is cruelly short of control structures; high-class languages usually offer three extra-powerful ones, called While, Repeat and Case.

The Crusoe example above is a home-made Repeat-Until

loop. In Pascal it would look like this:

```
Repeat
  FindNextStop;
  Stops := Stops + 1
until EndOfText;
```

Pascal lets you write a Procedure called FindNextStop, which does the same as our old subroutine at line 1000. In this form the program chunk's much easier to understand — and the bug becomes visible. Suppose we've got a duff copy of *Crusoe* without any full stops? The routine still says there's one: anything inside a Repeat-Until is always executed at least once. Really we should be using a While loop. In Microsoft Basic it looks like this:

```
10 GOSUB 1000
20 WHILE NOT ENDOF TEXT
30 STOPS = STOPS + 1
40 GOSUB 1000
50 WEND
```

Here Wend is to While as Next is to For. The extra Gosub at line 10 checks the input before the loop: if "The End" is reached without finding any full stops, the While-Wend loop statements are never executed.

This is the point of powerful control structures and — pause for another turn-off phrase — "structured programming". It's not that they're upmarket and favoured by the Royal Family: just that the programs are easier to read and debug. Most of us still have to toil along with Basic, but one day ...

I was Provoked, officer. He said GOTO!

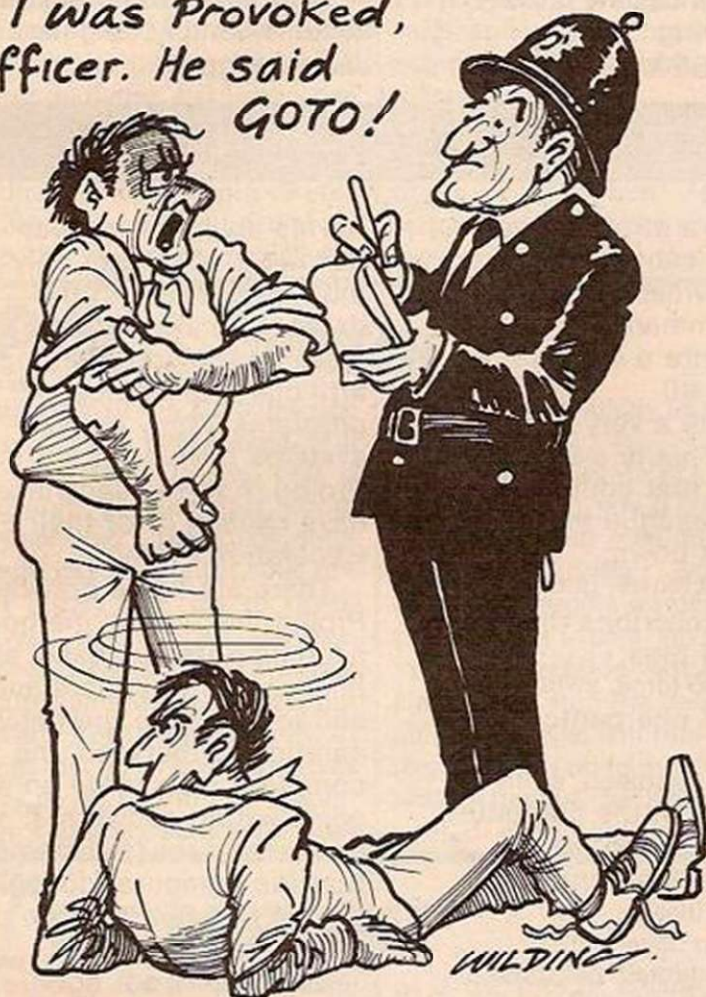

DISPLAY HANDLING

The aspect of microcomputing in which machine-code routines are of greatest use is probably display handling, i.e. drawing, moving and animating graphics.

There exists in the Sinclair operating system several routines to facilitate this process, and the easiest way to manipulate the display from machine code is to use them. The Scroll routine, for example, will allow you to scroll not only the entire screen upwards, but any number of lines on it. You just have to know how to access this potential.

This feature of the Scroll routine allows you to effectively set up two separate "windows" in the display. The assembly language routine to scroll the lower five lines of the screen only is as follows:

```
LD B,5
CALL OEOO
RET (calls up Rom routine for Scroll)
```

To write out the entire routine — see pg 43, *The Complete Spectrum Rom Disassembly*, Dr I. Logan — would take time, patience and computer memory.

The computer must now be told to carry out these

instructions. Each command in machine code corresponds to a number between 0 and 255. It is these numbers which the computer "understands" and can operate upon. The program must, therefore, be translated from "mnemonics" — above — to this code — below. Taking our previous example this code would be:

```
6
5
205
0
14
201
```

(continued on next page)

DISPLAY HANDLING

(continued from previous page)

...where 6 corresponds to LD B, etc. Substituting the 5 for another number changes the no. of lines to be scrolled.

To persuade the computer to look at these codes from Basic, they must first be programmed into an area of memory. A program to do this is shown below.

```
10 CLEAR 30000
20 DATA 6, 5, 205, 0, 14, 201
30 FOR X=0 TO 5
40 READ Y
50 POKE 30000 + X, Y
60 NEXT X
```

The aptly named command,

Poke puts the number in Y into the memory location specified where it remains. Note that Clear 30000 reduces the amount of memory available to the Basic user, but the program caters for 16K as well as 48K. If you do not wish to use up so much memory, and have 48K, 30000 may be replaced by 60000.

When you enter the program and run it, nothing will happen. But the machine code is now in memory. To use it, you need to give the machine code equivalent of Run; in this case it is USR 30000. Typing RANDOMISE USR 30000 will

now scroll up the bottom five lines of the screen — you will, of course, see nothing if you have written nothing there to scroll. You can now incorporate the routine in your own program, if you wish to use a split screen for, say, graphics in the top part and text in the bottom.

This series of articles, over the next few months, sets out to give you routines such as this one, which you can include as part of your own Basic program to enhance its speed or extend its function — without knowing anything about assembly language.

James Higgo

PROLOG

If you are familiar with programming in Basic, you will know what a bind it is to write database-type programs: programs that store sets of data, and allow users to update the data, and retrieve it in various ways. Basic's named variables and arrays are primitive tools, and its handling of disc and cassette files is poor in many versions.

There are many alternative languages which make this type of job simpler. Most of the list-processing school of languages — Lisp, full Logos and so on — concentrate on fitting the data into flexible structures, some of which let you describe specific relationships between the data items. Prolog, however, goes one step further. It concentrates on different ways of *retrieving* data.

In a session working with Prolog, you don't write a program: you set up, enhance or interrogate a database. The Prolog interpreter does most of the hard work of

setting up a structure into which you can fit your data. It also provides you with search commands. You never need to write a search routine at all!

Let's take a very simple example. This is a Prolog statement that could be taken to describe the eating patterns of cows:

food (cows, grass)

This one describes the appetite of pigs:

food (pigs, swill)

and this of one particular animal:

food (Napoleon, swill)

Store these in the computer, and then you can ask, in simple one-line phrases, questions like:

what do cows eat?
which animals eat grass?
do pigs eat swill?

These are the Prolog statements (they vary slightly from dialect to dialect) which do that:

?— food (cows, X)
?— food (Y, grass)
?— food (pigs, swill)

Type these in, and the computer will answer:

X = grass
Y = cows
Yes

It's as easy as that. Prolog can go further, though. You can also include in your database *rules* like:

if an animal eats grass,
then it is a herbivore

if an animal eats swill,
then it is a pig and the interpreter will then be able to answer questions like:

is a cow a herbivore?
is Napoleon a pig?

This ability to answer questions that have only indirect answers in the database makes Prolog an ideal language for writing artificial intelligence programs. Many expert systems have been written in Prolog. And the Japanese have chosen it for their Fifth Generation Project.

There are some drawbacks. Prolog has a fixed method of searching its database, and it is essential to understand it and to structure the database carefully. Otherwise, the computer may come up with some wrong answers. It's also important to remember that the computer doesn't in any way understand the data that is fed in.

Its answers are not necessarily right: they are only logical deductions from the data, right or wrong, that is available.

Finally, in Prolog a "no" answer doesn't mean "That's wrong": only "That isn't provable from the database".

Big expert systems need big computers, of course: but mini Prolog interpreters are available for most home computers, and they can be put to real uses. As well as providing an easy way of setting up "intelligent" databases, they give the programmer a very rigorous training in thinking logically. That's one reason why Prolog is a great educational language.

Susan Curran.

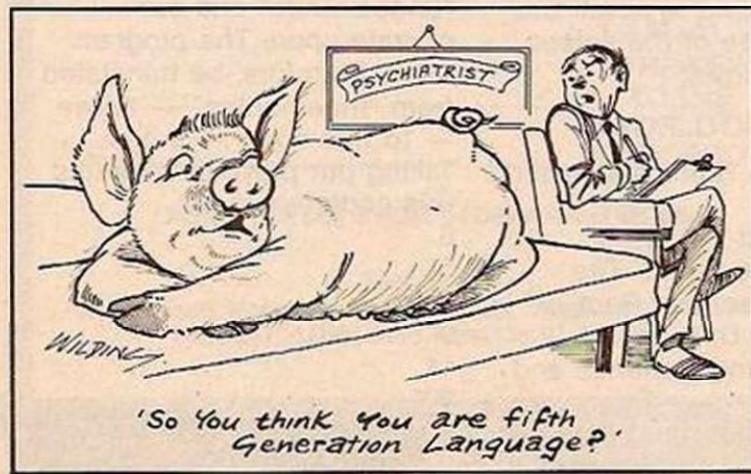

'So you think you are fifth Generation Language?'

Competition results

MUD CHALLENGE

For the MUD competition in our September issue, we asked you to design a game which could be run using the MUD system. In particular it had to exploit the interactive nature of the system. Another problem with running a game on MUD is that it must be playable with only a small number of players or with many participating, and people must be able to come and go more or less at will.

Ideas ranged from the mystic past to the distant future. A common theme was interactive Elite. Dungeons and Dragons-type themes kept coming up, including one from Peter Luckham who suggested that, like the board-game, players

should attempt to become skilled in one area, i.e., develop a certain number of spells, so that co-operation between these different types would be necessary.

The other runner-up was Per Landberger from Sweden who wanted to base his game on the suitably Scandinavian theme of the Vikings being generally unpleasant all over Europe. Players would take part in the raids and gather plunder and acquire status within their village.

The winner, however, found inspiration in the recent space opera *V*. Stephen Jetley's scenario involved players joining resistance bands and going

on various assignments. This would seem to suit the system well. The type of raid generated would depend on the number of players logged on, and people could enter the party at will. Obviously more experienced

players would know the system better and therefore the other players would look to them for guidance.

So Stephen Jetley will go forward as YC's champion to the great MUD challenge.

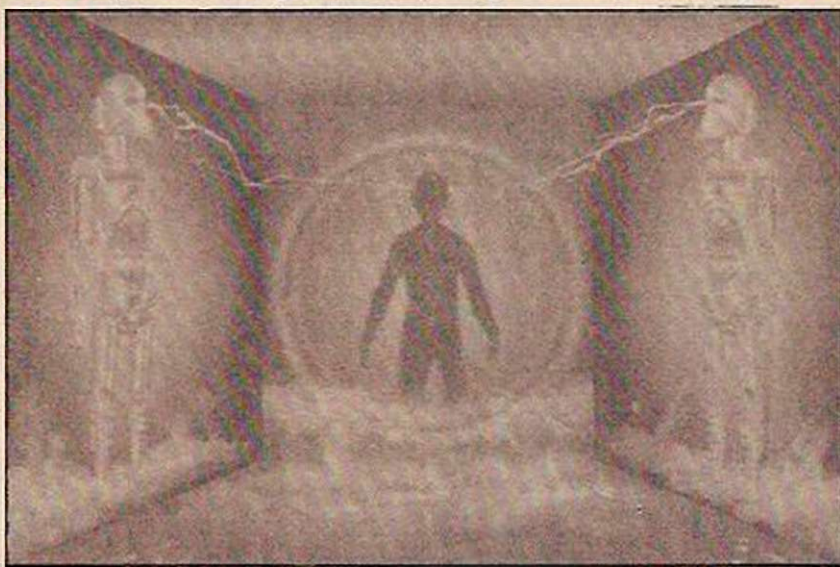

PHILIPS MONITOR

This competition attracted one of our largest ever entries, well over a 1000 of them. This is probably because just about anyone who's got a computer would like a monitor, but few can justify the cost to themselves, parents or spouses. Indeed, domestic bliss was one of the commonest reasons put forward for wanting one. It seems that many computer users have to fit in Elite or Doomdark's Revenge between Wogan

and Dallas, inevitably leading to ructions.

I'm afraid that we're a heartless crowd here, you'll just have to sort out your own domestic problems. Another common theme was people wanted a set that couldn't pick up Terry Wogan. Laudable though this aim is, I'm sure the indefatigable Mr Wogan will find a way to get himself on to monitors as well. After all, he has monopolised every other form of

electrical equipment, and there is even talk that you can get him on some microwaves.

Some complained that while their computer was state of the art, their TV was a little over the hill. The best of these was Kevin Lowe, who claimed John Logie Baird wanted his set back. Foremost in the slogan market was Mr JW Smith from Shetland who claimed that "Philips packs pixel power".

And so we come to the winners. Runner ups were Andrew Callister from Douglas, Isle of Man. A Philips monitor

to him meant no more trouble with the Fuzz — presumably he won't get done for license evasion again. Another runner up was R Laskey from St Albans. He claimed that "dedication was so hard to find nowadays." However, winner by a clear pixel from all the thousands of entries was Mark Bentall from Sheppey, Kent: I asked my computer, a BBC B, What make of monitor it would most like to see.

With a clunk and a whirl and a giggle of glee. It just be a Philips CM -8533.

TOUR DE FRANCE

October's Tour de France competition asked you to redesign the circuit for Activision's bicycle racing game. 20 copies of the game together with a Tour sweatshirt were on offer for the runners up; and for the winner we threw in a Commodore 64 to play the game on.

Most entries wanted to make the course longer and tougher —

as if the present circuit wasn't gruelling enough already. They also thought to change the venue. Thus we had Tours of Australia, Europe, Sweden, Atlantis, Saturn's Rings, and, from a Yugoslavian reader, a nicely illustrated Tour of America. Other suggestions included a race round the coast of France on hydro bikes, and a circuit based on Birmingham's

Spaghetti Junction twisted into the shape of a Mobius band.

First prize goes to Neil Marsh, 25 Oxford Road, Orrell, Wigan, Gr. Manchester. As his extract from the Bike-Rider's Guide to the Galaxy points out, the most demanding circuit in the universe is located in the Rof mountains on the planet Orhim. Due to a freak rift in the fabric of space, the entire circuit is uphill.

Copies of the game and sweatshirts to the following: E. Cook, Cwmbran; O. Sjostrand,

Sweden; A. Aldrick, Coventry; M. Shillaker, Corsham; S. Whitehouse, Halesowen; R. Sheppard, Chingford; R. Stesevic, Yugoslavia; M. Mobarak, Milton Keynes; T. Chapman, Ashwell; H. Sandhar, Wolverhampton; L. Porsklev, Sweden; R. Fleuty, Eastbourne; M. Roberts, Burgess Hill; M. Whaley, Knutsford; S. McRae, Inverurie; M. Woods; M. Lockwood, Huddersfield; J. Williams, Stoke; P. Holland, Wirral; A. Ennis, Herne Hill.

SUMMER OF GAMES II

£100 of sportswear plus a copy of Summer Games II, was the prize in October's competition based on US Gold's hit game. We asked you to come up with a new event for the game. S. Jardine, 108 Barrowby Road, Grantham, Lincs., wins the prize for a Trapeze event: points would

be awarded for smooth landings, artistic interpretation, number of somersaults, and so on, while timing would be absolutely crucial. Among the other entries, fishing and C5 racing were suggested, but were rejected on the grounds that they would be too slow.

30 copies of the game go to the following runners up: J. Green, Radlett; A. Ennis, Herne Hill; J. Williams, Stoke-on-Trent; C. Fyre, Codnor; J. Tunstall, Hartlepool; A. Shaw, Nailsea; P. Croxall, Farby; C. Broad, Oldham; W. Sonner, Folkestone; R. Stewart, Tinsley; F. Turra, Bologna; K. Young, Coventry; P. Cheesbrough, Keswick; M. Hatton, Morpeth; S. Ahmad,

Crawley; J. Morris, Poole; P. Williams, Rushton; S. Whitfield, Beverley; P. Barker, Battersea; D. Constable, Upminster; J. King, Belgium; A. Charles, South Anston; C. Macaskill, Alloa; A. Brett, Broadmeadows; D. Johnson, Stockport; T. Wells, Stourbridge; S. Davies, Wyrley; J. Norris, Beckenham; J. Salfarlie, Mitcham; P. Sandell, Sweden.

A black and white halftone illustration of a hand holding a camera. The camera's LCD screen displays the following information: 'M' (Mode), '2000' (Shutter Speed), '5.5' (Aperture), 'FILM 5' (Film Type), and 'S C S.T.' (ISO/ASA). The hand is positioned on the right side of the camera, with the thumb near the controls. The background shows a building with a window.

THE USER-FRIENDLY MAGAZINE FOR CAMERA PEOPLE EVERYWHERE

News, pictures, advice, weekly camera tests and regular big prize competitions ... they're all in Amateur Photographer—and it's the leading market place for cameras and photographic equipment.

Amateur Photographer

At your newsagent every Tuesday 65p

IT MAKES DRUMMING SOUND LIKE HARD WORK

SYNDROMIC MUSIC

SYNTRON DIGIDRUM

The Syntron Digidrum is an exciting professional digital drumcomputer designed to operate with the Commodore 64.

Using 'live' digital sound samples which are encoded onto software the user has a programmable drum machine with a sound quality many times the price.

Easy visual grid programming, hear the sounds you enter, 51 patterns available in memory plus 10 songs linking 100 patterns together are possible with full copy, insert and delete functions.

Whether you want to play along to it, do demo's and record with it, sing along and dance to it or just enjoy programming it — The Syntron Digidrum — Get It!

The Syntron Digidrum comes complete with a hardware user port connector, audio out, trigger out, easy to follow user's guide, software with the first eight digital samples including Crash Cymbal, Snare Drum, Bass Drum, Floor Tom, Hi Tom, Med Tom, Open Hi Hat, Closed Hi Hat and programming functions. The software contains a complete set of demonstration patterns and songs — All this for just £65.00 Inc VAT.

There is already a new sound sample set in preparation which will contain over 40 new samples including Syn Drums, Latin percussion, Hand Claps and many more for only £16.50! All purchasers of the Syntron Digidrum will receive details of the new sound samples as they become available plus a FREE subscription to the SYNDROMIC USERBASE which includes a membership card and a FREE quarterly newspaper on computer music and computer musicians written by leading music and computer journalists. Please fill out and return the coupon below.



THE BBIG BBBLACK BEAT BBBOX

I would like further information on the Syntron Digidrum

I would like to order my Syntron Digidrum(s)

NAME

ADDRESS

Syntron Digidrum — Disk version @ £65.00 Inc. VAT

— Cassette version @ £65.00 Inc. VAT

Please add £2.50 for packaging/postage/insurance.

I enclose a cheque/postal order — made payable to SYNDROMIC MUSIC — to the value of £.....

All orders should be sent to SYNDROMIC MUSIC, 35A Grove Avenue, London, N10 2AS

SYNDROMIC MUSIC GUARANTEE

Not to Bank your monies until the Goods are ready for Dispatch.

Please allow 21 days for delivery

digi ever hear such a sound?

MAIL ORDER PROTECTION SCHEME

If you order goods from Mail Order advertisements in this magazine and pay by post in advance of delivery, *Your Computer* will consider you for compensation if the Advertiser should become insolvent or bankrupt, provided that:

- (1) You have not received the goods or had your money returned; and
- (2) You write to the Publisher of *Your Computer* summarising the situation not earlier than 28 days from the day you sent your order and not later than two months from that day.

Please do not wait until the last moment to inform us. When you write, we will tell you how to make your claims and what evidence of payment is required.

We guarantee to meet claims from readers made in accordance with the above procedure as soon as possible after the Advertiser has been declared bankrupt or insolvent.

This guarantee covers only advance payment sent in direct response to an advertisement in this magazine not, for example, payment made in response to catalogues etc., received as a result of answering such advertisements. Classified advertisements are excluded.

C & F ASSOCIATES

BBC	RRP	Our price	SPECTRUM	RRP	Our Price
ENTHAR 7 (80 TR).....	16.95	14.95	A VIEW TO A KILL.....	10.99	7.25
BANJAX (80 TR.).....	11.95	10.95	WIZARDS LAIR.....	6.99	5.50
BLUE RIBBON GAMES			COMBAT LYNX.....	8.95	6.75
DISK 1 (40 TR).....	9.95	7.50	THAT'S THE SPIRIT.....	7.95	5.20
DISK 2 (40 TR).....	9.95	7.50	ATIC ATAC.....	5.50	4.50
BANJAX.....	9.95	8.25	UNDERWURLDE.....	9.95	7.25
WORM IN PARADISE.....	9.95	7.25	MONTY ON THE RUN.....	7.95	5.95
COMBAT LYNX.....	8.95	6.75	WORM IN PARADISE.....	9.95	7.25
BOFFIN.....	9.95	7.25	NIGHTSHADE.....	9.95	7.25
GHOULS.....	7.95	2.50	KNIGHT LORE.....	9.95	7.25
RUBBLE TROUBLE.....	7.95	2.50	ROCCO.....	7.95	5.95
KNIGHT LORE.....	9.95	7.25	RED MOON.....	6.95	5.50
BUMBLE BEE.....	7.95	2.50	AQUAPLANE.....	6.95	1.95
FELIX & THE FRUIT			SAM STOAT SAFEBREAKER.....	6.95	5.25
MONSTERS.....	7.50	2.50			
SABRE WULF.....	9.95	7.25	AMSTRAD		
RED MOON.....	6.95	5.50	ALIEN-8.....	9.95	7.25
CASTLE QUEST.....	12.95	8.95	COMBAT LYNX.....	8.95	5.95
SWOOP.....	7.95	1.95	RED ARROWS (AM DISC).....	12.95	7.50
FELIX & THE EVIL WEEVILS.....	6.95	2.50	RED ARROWS.....	8.95	5.75
ATIC ATAC.....	7.95	5.95	WIZARDS LAIR.....	8.95	6.75
ALIEN-8.....	9.95	7.25	PROJECT FUTURE.....	8.95	6.95
KILLER GORILLA.....	7.95	2.50	RED MOON.....	6.95	5.50
			DUN DARACH.....	9.95	7.25
ELECTRON			BRIAN BLOODAXE.....	8.95	5.95
RICK HANSON.....	9.95	8.25	KNIGHT LORE.....	9.95	7.25
BOFFIN.....	9.95	7.25	ROCCO.....	8.95	6.25
NIGHTMARE MAZE.....	2.50	2.25	TASWORD 464 (CASS).....	19.95	16.95
CASTLE ASSAULT.....	2.50	2.25	TASWORD 464/664 (D).....	24.95	19.95
COMBAT LYNX.....	8.95	6.75	TASWORD 6128 (D).....	24.95	19.95
SPECTRUM			COMMODORE 64		
THE ARTIST.....	12.95	9.95	IMHOTEP.....	9.95	6.25
WANTED: MONTY MOLE.....	6.95	5.25	NODES OF YESOD.....	9.95	6.25
MONTY IS INNOCENT.....	6.95	5.25	RED MOON.....	6.95	5.50
RED ARROWS.....	8.95	5.75	RED ARROWS.....	8.95	5.75
HARRIER ATTACK.....	5.95	4.50	WANTED: MONTY MOLE.....	7.95	5.25
STARQUAKE.....	7.95	5.95	BLACKWYCHE.....	9.95	6.25
MARSPOUT.....	9.95	6.90	WIZARDS LAIR.....	8.95	6.25
FAIRLIGHT.....	9.95	7.25	HARRIER ATTACK.....	5.95	4.50
DUN DARACH.....	9.95	7.25	ENTOMBED.....	7.95	6.25
ALIEN-8.....	9.95	7.25	THING ON A SPRING.....	7.95	5.95
ABU SIMBEL.....	7.95	5.95	COMBAT LYNX.....	8.95	6.75
NODES OF YESOD.....	9.95	6.25	WIZARDRY.....	9.95	7.25

PLEASE NOTE: BBC DISC SOFTWARE GUARANTEED FOR ACORN DFS ONLY
ALL PRICES INCLUDE VAT & P&P
(overseas orders add £1.00 per item)

Cheques payable to:

C & F ASSOCIATES

and send to:

C & F ASSOCIATES (PCW), PO BOX 2, BIDEFORD EX39 3RE

RESPONSE FRAME

POINTER PROBLEMS

Do you have a problem related to your micro? Our team will do their best to help. Please include only one question per letter and mark it "Response Frame". Alternatively, perhaps you have an idea you'd like to pass on to others. Why not write to us with your top tips?

● I am developing a drawing program for the Amstrad. How can I move a pointer around the screen without overwriting the background? Also, could you tell me how to incorporate pull-down menus.

*Simon Modi,
Prestel Mailbox.*

Although it is not well explained in the manual, the Amstrad has four different "ink modes" which determine how a pixel or a line interacts with colours already on the screen. Ink mode 1, XOR, the exclusive

OR option provides a simple solution to your problem. In this mode, drawing a line or printing a character twice has the effect of restoring the original picture.

You can set the XOR mode by including a fourth parameter at the end of a plotting command such as Plot or Draw; or by Printing control character 23. The following program illustrates the technique. Lines 10 to 30 create a background, Line 80 simply causes a delay.

```
10 FOR N=1 TO 1000
20 PRINT "M";
```

```
30 NEXT
40 PRINT CHR$(23) + CHR$(1)
50 TAG
60 MOVE 50,100
70 PRINT "TEST";
80 FOR D=1 TO 1000:NEXT
90 MOVE 50,100
100 PRINT "TEST";
```

If you want to include pull-down menus, I am afraid you will have to learn machine code. You'd need first to store part of the screen, print the menu, and then reprint the original screen data.

Doing this from Basic would be too slow.

Jim Taylor.

SIMULATING A PAUSE

● I have been delving into the depths of machine-code for a while now and have met with a problem. How do I simulate the pause function but only allow one key to continue the operations? For example: If one was to save chunks of code headerless one after the other, how would I go about making the system wait for, say, Capsift to be pressed, thus continuing with the save?

*Mark Plumett,
Thetford,
Norfolk.*

The principle of pausing in machine code is fairly similar to Basic. Consider the following:

```
10 LET I$ = INKEY$
```

```
20 IF I$ = " " THEN GOTO 100
30 GO TO 10
40 STOP
```

100 REM continue with program

The way to do this in machine code is to read the keyboard and keep doing so in a continuous loop until such time that the key depressed is the one required. So if you want to save two blocks of headerless code with a pause 0 equivalent in between, use the following:

```
LD HL, START OF SAVE
LD DE, LENGTH OF CODE
LD A, 255 (LENGTH OF LEADER)
SCF
CALL 04C2 (SAVE BYTES)
LD A, CODE OF KEY
```

```
LOOP IN A, (254)
RRA
JR C, LOOP
LD, HL, START OF SAVE
LD DE, LENGTH
LD A, 255 (LEADER)
SCF
CALL 04C2 (S/B)
RET.
```

This routine works on all of the outside keys. Here are their values.

```
1 — 247
0 — 239
Q — 251
P — 223
A — 253
ENTER — 191
CAPS — 254
BREAKSPACE — 127
Craig Rawston
```

WHICH COMPILER?

● In the June issue of *Your Computer* you answered a letter about a compiler for the Spectrum.

You advised Softek's FP-Compiler, as it is the best you know. Please could you give me a little more information on this compiler, like what sort of speed increase it has, how much user memory it provides and how much it costs.

*S Smith,
Minster Lovell,
Oxon.*

Basically the Compiler Pack is made up of two separate compilers F.P. and I.S. The "Floating Point" version supposedly speeds up your programs by 10 times (about right) and the Integer version between 200 and 500 times.

To be realistic the latter is more like 5-10 time average.

Obviously the more complicated the program is

the slower the compiled code will be. Both programs fit fairly high up in the memory so a large chunk is available to the user.

Although most operations are catered for I would disagree with Tim Hartnell and say that 'Blast' from Oxford Computer Systems Ltd is far superior, but then for £24.95 it should be. FP will set you back around £19.95 and is available in the shops whereas Blast is only available by post. The less extensive but faster Softek Computer, I.S., costs £9.95.

Oxford Computer Systems Ltd — 0993 812700; The Edge — 01-240 1422/7877.

Craig Rawston.

TOP TIPS

This short piece of machine code — 179 bytes — which will list the current variables in memory. It works on any Spectrum. Type in the program below and run it. If there are no errors it will then save the machine code it creates to tape.

The routine is leaded by LOAD "" CODE but first reserve memory with CLEAR 59999. To call LVAR from Basic enter. RANDOMISE USR 60000.

Non-printable characters are handled by + CHR\$(n) +, where n is a character from 0 to 32.

Anant Modi

```
10 DEF FN A(AS)=CODE AS-40-T(1
AS:9)-32+(AS:Z)-DEF FN H(AS
FN A(39(1))+15-FN A(39(2))
20 LET A=60000:FOR X=100 TO 1
20 STEP 10
30 READ AS:LET (AVAL AS) TO S
LET AS=AS:6 TO )
40 POKE A,FN H(AS):LET 1st-PE
EK AS:LET 399+
50 LET 399+10 TO 1:IF AS(1)
THEN GO TO 40
60 IF 1 THEN PRINT AT 16,0:ER
FOR IN LINE :STOP
70 NEXT X:PRINT AT 16,0:RLL
OK - Saving code"
```

```
80 SAVE "LVAR" CODE 60000,179
100 DATA "10004453402c0118294b
5c7e480c8e6e0fe40227afe60205d7e
2c0a05ebf800c303bf6e0c30c0e78e0c
7f62085d73e24973e3d73e22d7e120
442348e8d1130923c8041a7e203818e0
d87d1c1130d027e
110 DATA "0909110703e22d73e05d7
e1c09e4c0e0c0e0c0e0c0e0c0e0c0e0c
2d7c4e32d93e2d70e2218d57e473e3d
c7237e2208e23e850c4e234e03e8c4e0e23
c4e02d12c0e7e4e40e7237e4e00/e0020
047e4723747e4e00
120 DATA "0108e2718d0235e235e23
19c3e9e11120019c3e9e100"
```

Software File

SYNTHESISER

►David Walker • Amstrad
• Knighton, Powys

After typing in the listing and successfully running it several inputs will have to be made before you can make the program play music.

Programs for Software File should be fairly compact and sent on a cassette. Please include clear instructions and say what computer it's for. We pay between £6 and £36 for programs published. They must be double-checked and submitted to *Your Computer* exclusively.

You will input the octave number. The attack rate — how fast the sound reaches its peak volume.

The lower the number the faster this happens. The decay rate — how fast the sound drops to its

constant volume.

The release rate — how fast when you have released the key the sound decays away. The tone effect. You can experiment with all the preset sounds in lines 600-700 and alter them if you wish. After these inputs your keyboard will be live.

Synthesiser.

```
1 REM David Walker 1985
2 REM Synthesiser
10 GOSUB 370
20 EVERY 4,3 GOSUB 250
30 EVERY 4,2 GOSUB 290
40 EVERY 4,1 GOSUB 330
50 FOR x=1 TO 13
60 IF INKEY(k%(x))=0 AND x<>c1 AND x<>c2 AND x<>c3 THEN GOSUB 90
70 NEXT x
80 GOTO 50
90 IF c1=0 THEN GOSUB 100 ELSE IF c2=0 THEN GOSUB 150 ELSE IF c3=0 THEN GOSUB 200 ELSE RETURN
100 IF x<>0 AND x=c2 OR x=c3 THEN RETURN
110 SOUND 129,p%(x),0,0,1,tone
120 SOUND 129,p%(x),10000,12,0,tone
130 c1=x
140 RETURN
150 IF x<>0 AND x=c1 OR x=c3 THEN RETURN
160 SOUND 130,p%(x),0,0,1,tone
170 SOUND 130,p%(x),10000,12,0,tone
180 c2=x
190 RETURN
200 IF x<>0 AND x=c1 OR x=c2 THEN RETURN
210 SOUND 132,p%(x),0,0,1,tone
220 SOUND 132,p%(x),10000,12,0,tone
230 c3=x
240 RETURN
250 IF c1=0 OR INKEY(k%(c1))=0 THEN RETURN
260 SOUND 129,p%(c1),0,12,2,tone
270 c1=0
280 RETURN
290 IF c2=0 OR INKEY(k%(c2))=0 THEN RETURN
300 SOUND 130,p%(c2),0,12,2,tone
310 c2=0
320 RETURN
330 IF c3=0 OR INKEY(k%(c3))=0 THEN RETURN
340 SOUND 132,p%(c3),0,12,2,tone
350 c3=0
360 RETURN
370 DEFINT a-z
380 DIM p%(13),k%(13)
390 FOR x=1 TO 13
400 READ k%(x)
410 NEXT
420 MODE 1
430 INPUT"octave (1-5)";o
440 IF o=1 THEN RESTORE 770
450 IF o=2 THEN RESTORE 780
460 IF o=3 THEN RESTORE 790
470 IF o=4 THEN RESTORE 800
480 IF o=5 THEN RESTORE 810
490 FOR x=1 TO 13
500 READ p%(x)
510 NEXT
520 MODE 1
530 INPUT"attack rate (0-5)";attack
540 INPUT"decay rate (0-5)";decay
550 INPUT"release rate (1-10)";rel
560 ENV 1,5,3,attack,2,-1,decay
570 ENV 2,12,-1,rel
580 MODE 1
590 INPUT"Which tone effect (1-15)";tone
600 ENT -1,3,1,1,3,-1,1
610 ENT -2,3,2,1,3,-2,1
620 ENT -3,6,1,1,5,-1,1
630 ENT -4,6,2,1,6,-2,1
640 ENT -5,5,1,1,10,-1,1,5,1,1
650 ENT -6,2,1,1,4,-1,1,2,1,1
660 ENT -7,2,2,1,4,-2,1,2,1,1
670 ENT -8,2,1,2,4,-1,2,2,1,2
680 ENT -9,5,1,1,2,-1,1,5,1,1,8,-1,1
690 ENT -10,3,5,1,3,-10,1,3,5,1
700 ENT -11,1,1,1
710 ENT -12,1,-1,1
720 ENT -13,20,1,1,10,-2,1
730 ENT -14,5,10,1,10,-5,1
740 ENT -15,5,1,1,6,-1,1
750 RETURN
760 DATA 71,60,63,61,62,55,52,54,44,46,45,38,39
770 DATA 956,902,851,804,758,716,676,638,602,568,536,506,478
780 DATA 478,451,426,402,379,358,338,319,301,284,268,253,239
790 DATA 239,225,213,201,190,179,169,159,150,142,134,127,119
800 DATA 119,113,106,100,95,89,84,80,75,71,67,63,60
810 DATA 60,56,53,50,47,45,42,40,38,36,34,32,30
```

PILE-UP

►David Judge • BBC
• Surbiton, Surrey

This is a strategy game for the BBC model B — with OS 1.2 — for two players. It is played on a 10 by 10 board. Each player takes it in turn to place a counter of his or her colour onto a square on the board.

To place a counter on the board, you simply move the cursor — a cross on the board — to the desired

square, using the cursor keys, and press the space bar. You may also use joysticks.

When there are more than five counters "piled up" onto a single square, that square explodes, and throws counters into the surrounding squares. If there are any of the opponent's counters in these squares, then they are wiped out.

The object of the game

(continued on next page)

File

(continued from previous page)

is to take over the entire board with your own coloured counters.

The strategy of the game is more complex than it at first appears. For instance, one strategy is to build up a chain of squares each containing five counters, until you consider that it is the right time to set off the chain. Another strategy

is to explode squares as soon as possible, in order to take over a lot of the board quickly.

The game is in two parts. The first part gives the game instructions, while the second part is the game itself. Type in listing 1 and save it onto the start of a cassette. SAVE "PILE" <RETURN> Then enter listing 2 and save that after listing 1 on the same cassette.

SAVE "PILE2" <RETURN> Then rewind the cassette and run the game by typing:

CHAIN "" <RETURN>

The game as written will run on disc-based machines without the need for a downloader, as there is sufficient memory for the program to run with Page set to &1900.

The program has not been tested on an Electron. However, if all

references to Mode 7 are removed, the program should run.

Listing 1 can, in fact, be left out altogether.

If anybody would like to play the game without having to type it all in, a cassette of the program is available for £3.00 from me. Please send a cheque or postal order for £3.00 to: David Judge, 39 Warren Drive North, Tolworth, Surbiton, Surrey.

Listing 1.

```
10MODE 7
20PROCintro
30CLS
40PRINT
50FOR J=1 TO 2
60PRINTTAB(12);CHR$(131);CHR$(131);CHR$(157);CHR$(1
32);CHR$(141);"Pile up ";CHR$(156)
70NEXTJ
80PRINT""
90CHAIN "PILE2"
100DEFPROCintro
110CLS
120PRINT
130FOR J=1 TO 2
140PRINTTAB(12);CHR$(131);CHR$(131);CHR$(157);CHR$(1
32);CHR$(141);"Pile up ";CHR$(156)
150NEXTJ
160PRINT
170PRINT" This is the game ofPile up"
180PRINT"The game is for two players. Each player";
190PRINT"takes it in turn to place one of their"
200PRINT"counters on the 10 * 10 board. "
210PRINT"When their are more then 5 counters on "
220PRINT"a space, this space explodes and throws"
230PRINT"counters into the surrounding squares."
240PRINT"These squares will then take on the same";
250PRINT"colour as the exploding square."
260PRINT"One player is blue, the other is red."
270PRINT"The object of the game is to convert the";
280PRINT"whole board to your own colour."
290PRINT"There is an option for either joysticks"
300PRINT"or keyboard play. If the keyboard option";
310PRINT"is selected, then use the cursor keys to";
320PRINT"move and the space bar to pick a square."
330PRINT" HIT ANY KEY TO CONTINUE ";
340A$=GET$
350CLS
360PRINT
370PRINT"The rules:-"
380PRINT"1) You can only place a counter in an"
390PRINT"empty square, or one already "
400PRINT"occupied by one of your counters."
410PRINT"2) With the joystick option, it is "
420PRINT"necessary to have one joystick for"
430PRINT"each player."
440PRINT"There are 3 options for the length of"
450PRINT"each game, either short, medium or long."
460PRINT" HIT ANY KEY TO CONTINUE ";
470A$=GET$
480ENDPROC
```

Listing 2.

```
1REM LISTING 2
10ON ERROR MODE 3:REPORT:PRINTERL:END
20DIM B(11,11)
30VDU23,240,255,255,255,255,255,255,255,255
40FOR J=1 TO 11
50FOR K=1 TO 11
60B(J,K)=0
70NEXT K
80NEXT J
90PROCstart
100TIME=0
110MODE2
120VDU 23;8202;0:0:0
```

```
130movs=0
140PROCscreen
150PRINTTAB(15,1);"MOVES"
160PRINT TAB(15,6);"TIME"
170FOR JX=1 TO 10
180FOR JY=1 TO 10
190IF B(JX,JY)<>0 THEN PROCsquare
200NEXT JY
210NEXT JX
220REPEAT
230PRINTTAB(15,3);STR$(movs);
240PROCtime
250PROCplay1
260PROCcheck
270PROCplay2
280PROCcheck
290movs=movs+1
300PROCboard
310UNTIL FALSE
320
330DEFPROCscreen
340CLG
350VDU29,0,112;
360VDU19,1,7;0:0:0;
370VDU19,2,1;0:0:0;
380VDU19,3,4;0:0:0;
390GCOL 0,1
400FOR J=0 TO 800 STEP 80
410MOVE J,0:DRAW J,800
420NEXT J
430FOR J=0 TO 800 STEP 80
440MOVE 0,J:DRAW 800,J
450NEXT J
460ENDPROC
470
480DEFPROCplay1
490PROCdisp(1)
500flag1=1
510IF key THEN PROCkeys ELSE PROCjoy1
520B(JX,JY)=B(JX,JY)+1
530PROCsquare
540ENDPROC
550
560DEFPROCplay2
570PROCdisp(2)
580flag1=-1
590IF key THEN PROCkeys ELSE PROCjoy2
600B(JX,JY)=B(JX,JY)-1
610PROCsquare
620ENDPROC
630
640DEFPROCjoy1
650JX=1:JY=1
660REPEAT
670PROCtime
680PROCcross
690A1=ADVAL(1)
700A2=ADVAL(2)
710A3=ADVAL(3)
720A4=ADVAL(4)
730F0=ADVAL(0) AND 3
740IF F0=1 THEN PROCcross:GOTO 820
750IF ((A1>30000 AND A1<35000) AND (A2>30000 AND A2<
35000)) THEN 690
760IF (A1<1000 AND JX=10) OR (A1>60000 AND JX=1) OR
(A2>60000 AND JY=10) OR (A2<1000 AND JY=1) THEN 690
770PROCcross
780IF A1<1000 JX=JX+1
```

File

```
790IF A1>60000 JX=JX-1
800IF A2<1000 JY=JY-1
810IF A2>60000 JY=JY+1
820UNTIL F0<>0
830 IF B(JX,JY)<0 THEN 660
840ENDPROC
850
860DEFPROCkeys
870JX=1:JY=1:FX15
880REPEAT:PROctime:PROCcross
890A=GET
900IF A=32 THEN PROCcross:GOTO 980
910IF A<136 OR A>139 THEN 890
920IF (A=136 AND JX=1) OR (A=137 AND JX=10) OR (A=13
8 AND JY=1) OR (A=139 AND JY=10) THEN 890
930PROCcross
940IF A=136 THEN JX=JX-1
950IF A=137 THEN JX=JX+1
960IF A=138 THEN JY=JY-1
970IF A=139 THEN JY=JY+1
980OSCLIA=32
990IFB(JX,JY)<>0 AND SGN(B(JX,JY))<>flag1 THEN 880
1000ENDPROC
1010
1020DEFPROCcross
1030CX=((JX-1)*80)+40
1040CY=((JY-1)*80)+40
1050GCOL3,1
1060MOVE CX-20,CY
1070DRAW CX+20,CY
1080MOVE CX,CY-20
1090DRAW CX,CY+20
1100ENDPROC
1110
1120DEFPROCioy2
1130JX=1:JY=1
1140REPEAT
1150PROctime
1160PROCcross
1170A1=ADVAL(1)
1180A2=ADVAL(2)
1190A3=ADVAL(3)
1200A4=ADVAL(4)
1210F0=ADVAL(0) AND 3
1220IF F0=2 THEN PROCcross:GOTO 1300
1230IF ((A3>30000 AND A3<35000) AND (A4>30000 AND A4<
35000)) THEN 1170
1240IF (A3<1000 AND JX=10) OR (A3>60000 AND JX=1) OR
(A4>60000 AND JY=10) OR (A4<1000 AND JY=1) THEN 1170
1250PROCcross
1260IF A3<1000 JX=JX+1
1270IF A3>60000 JX=JX-1
1280IF A4<1000 JY=JY-1
1290IF A4>60000 JY=JY+1
1300UNTIL F0<>0
1310IF B(JX,JY)>0 THEN 1140
1320ENDPROC
1330
1340DEFPROCboard
1350chk=0
1360FOR J=1 TO 10
1370FOR K=1 TO 10
1380IF B(J,K)=0 THEN 1400
1390IF B(J,K)<0 THEN chk=chk-1 ELSE chk=chk+1
1400NEXT K
1410NEXT J
1420IF chk=100 OR chk=-100 THEN PROCend
1430ENDPROC
1440
1450DEFPROCcheck
1460change=0
1470FOR J=1 TO 10
1480FOR K=1 TO 10
1490IF B(J,K)>-6 AND B(J,K)<6 THEN 1590
1500IF B(J,K)<=-6 THEN flag=-1 ELSE flag=1
1510FORJ1=J-1 TO J+1
1520FORK1=K-1 TO K+1
1530IF RND(1)<.8 THEN PROCchange
1540IF J1=J AND K1=K THEN PROCchange
1550NEXT K1
1560NEXT J1
1570change=1
1580SOUND 0,-15,5,10
1590NEXT K
1600NEXT J
1610IF change=0 THEN ENDPROC
1620PROctime
1630PROCboard
1640GOTO 1460
1650ENDPROC
1660
1670DEFPROCchange
1680IFJ1<1 OR K1<1 OR J1>10 OR K1>10 THEN ENDPROC
1690JX=J1:JY=K1
1700IF J1=J AND K1=K B(J,K)=flag:PROCsquare:ENDPROC
1710IF SGN(B(J1,K1))<>flag THEN B(J1,K1)=flag:PROCsquare:
ENDPROC
1720B(J1,K1)=B(J1,K1)+flag
1730PROCsquare
1740ENDPROC
1750
1760DEFPROCtime
1770T1=INT(TIME/100)
1780T2=T1 DIV 60
1790T3=T1 MOD 60
1800T2$=""
1810IF T2<10 THEN T2$="0"+RIGHT$(STR$(T2),1) ELSE T2$
=RIGHT$(STR$(T2),2)
1820T3$=""
1830IF T3<10 THEN T3$="0"+RIGHT$(STR$(T3),1) ELSE T3$
=RIGHT$(STR$(T3),2)
1840T4$=T2$+" "+T3$
1850PRINTTAB(15,8):T4$
1860ENDPROC
1870
1880DEFPROCend
1890IF chk=100 THEN COLOUR 2 ELSE COLOUR 3
1900REPEAT
1910PRINTTAB(15,12):
1920IF chk=-100 THEN PRINT"BLUE": ELSE PRINT"RED "
1930FOR K=1 TO 1000:NEXT K
1940PRINTTAB(15,12):" "
1950FOR K=1 TO 1000:NEXT K
1960UNTILFALSE
1970
1980DEFPROCsquare
1990VDU5
2000JX1=((JX-1)*80)+10
2010JY1=((JY-1)*80)+60
2020MOVE JX1,JY1
2030IF B(JX,JY)>0 THEN GCOL 0,2 ELSE GCOL 0,3
2040IF B(JX,JY)>=5 THEN GCOL 0,9
2050IF B(JX,JY)<=-5 THEN GCOL 0,12
2060PRINTCHR$(240):
2070GCOL 0,1
2080MOVE JX1,JY1
2090PRINTCHR$(ABS(B(JX,JY))+48):
2100VDU4
2110ENDPROC
2120
2130DEFPROCstart
2140CLS:PRINT
2150PRINT"Do you want sound (Y/N)":
2160REPEAT
2170A$=GET$
2180UNTILA$="Y" OR A$="N"
2190IF A$="Y" THEN 2220
2200*FX210,1
2210GOTO 2230
2220*FX210,0
2230PRINT""
2240key=FALSE
2250PRINT
2260PRINT"Would you like a :- 1 Keyboard game"
2270PRINT" 2 Joystick game"
2280REPEAT:A$=GET$:UNTILA$="1" OR A$="2"
2290IF A$="1" THEN key=TRUE:FX4,1
2300PRINT""
2310PRINT"Would you like a :- 1 long game"
2320PRINT" 2 medium game"
2330PRINT" 3 short game"
2340REPEAT
2350A$=GET$
2360UNTILA$="1" OR A$="2" OR A$="3"
2370IF A$="1" THEN ENDPROC
2380IF A$="2" THEN max=40 ELSE max=80
2390FOR J=1 TO max
2400X=INT(RND(1)*10)+1
2410Y=INT(RND(1)*10)+1
2420IF B(X,Y)<>0 THEN 2400
2430val=INT(RND(1)*4)+1
2440IF RND(1)>.5 THEN val=val*-1
2450B(X,Y)=val
2460NEXTJ
2470ENDPROC
2480
2490DEFPROCdisp(p)
2500IF p=1 THEN COLOUR 2 ELSE COLOUR 3
2510PRINTTAB(0,0):"PLAYER ";p;" "
2520COLOUR 1
2530ENDPROC
```

File

LABELS

► M Payne • Spectrum
• Milton, Stoke-on-Trent

This program allows labels to be used on the Spectrum. It is written in such a way that it may be used with a line renumberer thus adding

greater versatility to program development. By using meaningful labels you can forget about line numbers and settle down to writing some readable, structured programs. Points to note:

- A label is stored as a variable containing the value of the line number on which it appears.
- A label is defined by a

Rem statement followed by an asterisk followed by the label name.

- No other text may appear with a label — each label must have a line of its own.
- This program must precede any program using labels.
- Labels must not be longer than 20 characters.

The program is searched for label declarations, and

when found, the label name is poked into the Let statement on the second line. This statement is then executed and the search continues until the end of the program. Note — the Go Sub statement, and the For z=0 TO 0 Step 0 statement are methods of avoiding direct jumps involving line numbers.

Labels.

```

1 LET pointer=0
2 LET payney =PEEK (pointer+1)+256*PEEK pointer: IF
pointer<>0 THEN RETURN
3 LET start=26+PEEK 23635+256*PEEK 23636
10 LET pointer=start-26
20 LET nextaddr=pointer
25 FOR z=0 TO 0 STEP 0
30 LET pointer=nextaddr
40 LET nextaddr=pointer+PEEK (pointer+2)+256*PEEK (pointer+3)+4
50 IF PEEK (pointer+5)<>CODE "*" THEN GO TO 100
55 LET length=PEEK (pointer+2)+256*PEEK (pointer+3)-3
60 IF length>20 THEN PRINT "label error - line ";PEEK (pointer+1
)+256*PEEK pointer,stoprun
62 FOR n=1 TO length
65 POKE start+n-1,PEEK (pointer+5+n)
70 NEXT n
75 FOR n=length TO 19
80 POKE start+n,32
85 NEXT n
90 GO SUB 1+PEEK (start-25)+256*PEEK (start-26)
100 IF pointer<PEEK 23627+256*PEEK 23628 THEN NEXT z
110 REM
120 REM -----
130 REM Payney 1984
140 REM -----
150 REM
1000 REM next line is a label
1005 REM *example1
1010 PRINT "example1=";example1
1020 REM *error: REM label must apper on its own line

```

SQUIGGLE

► Robert Bain • Spectrum
• Dorset

Squiggle is about 8K long. the game has no machine code. When first run, it may look simple but in reality it is fairly complex and many hours of fun can be obtained from it.

The idea of Squiggle is to complete a continuous line from the top left-hand corner of the board to the bottom right-hand corner, or to force your opponent off the edge of the board.

All the player is required to do is input the letter of the piece he/she wishes to place at the end of the line and the computer will do the rest.

As the first piece is placed to the right of the start square placing piece Y will automatically lose the player the game.

A running score is kept of how many games each player has won and if different players want to play the names can be changed and the scores reset.

Squiggle.

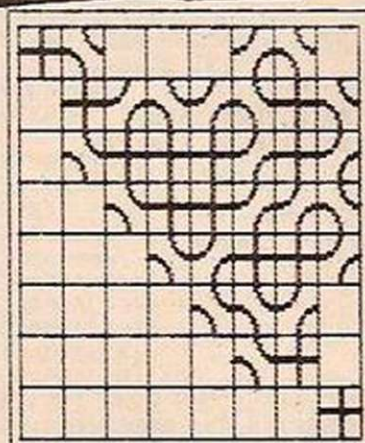

X Y Z

YOUR MOVE :-
ROBERT

MOVES MADE 30
FAR = 33

SQUIGGLE

```

10 REM ***** SQUIGGLE FOR THE
SPECTRUM & SPECTRUM+ *****
20 REM ***** BY ROBERT BAIN ©
15 JUNE 1985 *****
30 BORDER 1: PAPER 1: INK 7: C
LS : POKE 23855,8
40 GO SUB 9000: GO SUB 8000: G
O SUB 7000
50 CLS : PRINT AT 9,0: FLASH 1
:P$(START);AT 11,0:"STARTS THIS
TIME"
60 PRINT #0: INVERSE 1: INK 5;
"PRESS A KEY TO PLAY,"
70 IF INKEY$="" THEN GO TO 70
80 PRINT #0:AT 1,0;"
LET PLAYER=START
85 LET MVES=0: LET AX=1: LET A
Y=2: LET X=1: LET Y=3: LET X1=1:
LET Y1=1: FOR A=1 TO 8: FOR B=1
TO 8: LET A(A,B)=0: NEXT B: NEX
T A: LET A(1,1)=1: GO SUB 6000
90 PRINT AT 5,18: INK 5;P$(PLA
YER): BEEP .1,10
100 OVER 1: LET Z$=INKEY$
110 IF Z$<"X" OR Z$>"Z" THEN GO
TO 100
120 IF Z$="X" THEN PRINT AT X,Y
:A$(1);AT X+1,Y:A$(2): LET A(AX,
AY)=1
130 IF Z$="Y" THEN PRINT AT X,Y
:B$(1);AT X+1,Y:B$(2): LET A(AX,
AY)=2
140 IF Z$="Z" THEN PRINT AT X,Y
:C$(1);AT X+1,Y:C$(2): LET A(AX,
AY)=3
150 OVER 0: GO TO 5000
160 IF PLAYER>2 THEN LET PLAYER
=1
170 PRINT AT 8,26: INVERSE 1;MU
ES
180 GO TO 90
3000 REM FILES
3020 PRINT AT A,B: INK 0;" 50.
UIGGLE
3030 RETURN
3040 RESTORE 3050
3045 READ A: READ B: IF A=255 TH
EN RETURN
3050 PRINT AT A+1,B+3: INK 0;"■"
: PRINT AT A,B+2: INK 0;"■"
3055 GO TO 3045
3060 DATA 6,0,6,1,6,2,7,0,8,0,8,
1,8,2,9,2,10,0,10,1,10,2,7,4,7,5
,7,6,8,4,8,6,9,4,9,5,9,6,10,5,11
,6,12,6,12,7,7,8,7,10,8,8,8,10,9
,8,9,9,9,10
3070 DATA 5,12,7,12,8,12,9,12,7,
14,7,15,7,16,8,14,8,16,9,14,9,15
,9,16,10,16,11,14,11,15,11,16,7,
18,7,19,7,20,8,18,8,20,9,18,9,19
,9,20,10,20,11,18,11,19,11,20
3080 DATA 5,22,6,22,7,22,8,22,9,
22,9,23,6,25,6,26,6,27,7,25,8,25
,8,26,8,27,9,25,10,25,10,26,10,2
7,25,25
4000 REM END OF GAME
4010 CLS
4020 PRINT AT 0,10:P$(PLAYER)
4030 IF WIN=1 THEN PRINT AT 2,0;
INK 4:"LOSSES THE GAME BY GOING
OFF THE BOARD."
4040 IF WIN=2 THEN PRINT AT 2,0;
INK 5:"WINS THE GAME IN ";MVES;
" MOVES"
4050 IF WIN=1 THEN LET PLAYER=PL
AYER+1: IF PLAYER>2 THEN LET PLA
YER=1
4070 LET S(PLAYER)=S(PLAYER)+1
4080 PRINT AT 8,0: INK 3:"GAMES
WON SO FAR"
4090 PRINT AT 10,1: INK 5;P$(1);
" ";S(1): INK 6;AT 12,1;P$(2);"
";S(2)
4100 PLOT 0,95: DRAW 120,0: DRAW
0,-25: DRAW -120,0: DRAW 0,25:
PLOT 88,95: DRAW 0,-25
4110 PLOT 0,83: DRAW 120,0
4120 PRINT #0: FLASH 1;" PRESS
<SPACE> TO PLAY AGAIN."
4130 IF INKEY$<>" " THEN GO TO 4
130
4140 PRINT #0:AT 1,0;"ARE THE PL
AYERS THE SAME?"
4150 LET Z$=INKEY$
4160 IF Z$="Y" THEN LET START=ST
ART+1: IF START>2 THEN LET START
=1
4170 IF Z$="Y" THEN GO TO 50
4180 IF Z$="N" THEN RUN
4190 GO TO 4150
5000 REM MOVE CHECK
5010 BEEP .5,30
5020 GO TO 4990+A(AX,AY)*40
5030 IF X1<X THEN LET X1=X: LET
Y1=Y: LET AX=AX+1: LET X=X+2: GO
TO 5150
5040 IF X1>X THEN LET X1=X: LET
Y1=Y: LET AX=AX-1: LET X=X-2: GO
TO 5150
5050 IF Y1<Y THEN LET X1=X: LET
Y1=Y: LET AY=AY+1: LET Y=Y+2: GO
TO 5150
5060 IF Y1>Y THEN LET X1=X: LET
Y1=Y: LET AY=AY-1: LET Y=Y-2: GO
TO 5150
5070 IF X1<X THEN LET X1=X: LET
Y1=Y: LET AY=AY-1: LET Y=Y-2: GO
TO 5150
5080 IF X1>X THEN LET X1=X: LET
Y1=Y: LET AY=AY+1: LET Y=Y+2: GO
TO 5150
5090 IF Y1<Y THEN LET X1=X: LET
Y1=Y: LET AX=AX-1: LET X=X-2: GO
TO 5150
5100 IF Y1>Y THEN LET X1=X: LET
Y1=Y: LET AX=AX+1: LET X=X+2: GO
TO 5150
5110 IF X1<X THEN LET X1=X: LET
Y1=Y: LET AY=AY+1: LET Y=Y+2: GO
TO 5150
5120 IF X1>X THEN LET X1=X: LET
Y1=Y: LET AY=AY-1: LET Y=Y-2: GO
TO 5150
5130 IF Y1<Y THEN LET X1=X: LET
Y1=Y: LET AX=AX+1: LET X=X+2: GO
TO 5150
5140 IF Y1>Y THEN LET X1=X: LET
Y1=Y: LET AX=AX-1: LET X=X-2: GO
TO 5150
5150 IF X<1 OR X>16 OR Y<1 OR Y>
16 THEN LET WIN=1: BEEP 1,-25: G
O TO 4000
5160 IF X=15 AND Y=15 THEN LET W
IN=2: GO TO 4000
5170 IF A(AX,AY)<>0 THEN GO TO 5
020
5180 LET MVES=MVES+1: LET PLAYER
=PLAYER+1
5190 GO TO 160
6000 REM DRAW BOARD
6010 OVER 0: CLS : FOR A=7 TO 13
5 STEP 16: PLOT A,39: DRAW 0,128
: NEXT A
6020 FOR A=39 TO 168 STEP 16: PL
OT 7,A: DRAW 128,0: NEXT A
6030 PLOT 3,35: DRAW 137,0: DRAW
0,137: DRAW -137,0: DRAW 0,-137
6040 PRINT AT 1,16:"X ";A$(1);"
Y ";B$(1);" Z ";C$(1): PRINT AT
2,20;A$(2);" ";B$(2);" ";C$(
2)
6050 FOR A=159 TO 239 STEP 40: P
LOT A,151: DRAW 16,0: DRAW 0,16:
DRAW -16,0: DRAW 0,-16: NEXT A
6060 PRINT AT 4,18: INK 5;"YOUR
MOVE :-"
6070 PRINT AT 7,19: INK 6;"MOVES
MADE SO";AT 8,22;"FAR = ";MVES
6120 PRINT AT 1,1: OVER 1;A$(1);
AT 2,1;A$(2);AT 15,15;A$(1);AT 1
6,15;A$(2)
6130 LET A=19: LET B=4: LET C=4:
LET D=10: GO SUB 300
6140 RETURN
7000 REM INSTRUCTIONS
7010 CLS : LET C=4: GO SUB 3040
7020 PRINT AT 15,3: INK 5; FLASH
1;"Do you want instructions?";
7025 IF INKEY$="N" THEN GO TO 71
50
7026 IF INKEY$="Y" THEN GO TO 70
30
7027 GO TO 7025
7030 LET A=0: LET B=4: CLS : GO
SUB 3000: PRINT AT 3,4: INK 0;"■"
7035 PRINT "" The idea of SQUIG
GLE is quite simple. All you ha
ve to do is complete a continu
ous line from the top left hand
corner of the board to the botto
m right hand corner, or force y
our opponent off the edge."
7040 PRINT "" There are three pi
eces which may be placed they
are :-
7050 PRINT "X ";A$(1);" Y ";B$(
1);" Z ";C$(1): PRINT " ";A$(
2);" ";B$(2);" ";C$(2)
7060 PLOT 15,23: DRAW 16,0: DRAW
0,16: DRAW -16,0: DRAW 0,-16
7070 PLOT 63,23: DRAW 16,0: DRAW
0,16: DRAW -16,0: DRAW 0,-16
7080 PLOT 111,23: DRAW 16,0: DRA
W 0,16: DRAW -16,0: DRAW 0,-16
7090 PRINT #0: FLASH 1: INK 2; P
APER 5;" Press any key to cont
inue."
7100 IF INKEY$="" THEN GO TO 710
0
7110 CLS : PRINT "" As the first
piece will be placed to the
right of the startsquare, placin
g piece 'Y' will automatically
lose the game for you."
7120 PRINT "" When you play the
game all you have to do is tell
the computer which piece you wou
ld like to place and the compu
ter will do the rest."
7130 PRINT #0: FLASH 1: INK 2; P
APER 5;" Press space to pla
y."
7140 IF INKEY$<>" " THEN GO TO 7
140
7150 INPUT "YOUR NAME PLEASE PLA
YER 1 ";P$(1)
7160 INPUT "YOUR NAME PLEASE PLA
YER 2 ";P$(2)
7170 FOR A=1 TO 2: IF LEN P$(A)>
10 THEN LET P$(A)=P$(A, TO 10)
7180 NEXT A: CLS : RETURN
8000 REM VARIABLES
8010 DIM A$(2,2): DIM B$(2,2): D
IM C$(2,2): DIM A(8,8): DIM S(2)
: DIM P$(2,10)
8020 LET A$(1)="1": LET A$(2)="
"
8030 LET B$(1)="J": LET B$(2)="
"
8040 LET C$(1)="I": LET C$(2)="
"
8050 LET S(1)=0: LET S(2)=0
8070 LET START=1
8998 RETURN
9000 REM USERS
9010 RESTORE 9030: FOR A=USR "A"
TO USR "L"+7
9020 READ B: POKE A,B: NEXT A
9030 DATA 0,1,1,1,1,1,1,255,0,12
8,128,128,128,128,128,254
9040 DATA 255,1,1,1,1,1,1,254,
128,128,128,128,128,128,128
9050 DATA 0,1,1,3,3,6,26,248,0,1
28,128,0,0,0,0,6
9060 DATA 224,0,0,0,0,1,1,1,30,5
6,96,192,192,128,128,128
9070 DATA 0,1,1,0,0,0,0,224,0,12
8,128,192,192,96,56,30
9080 DATA 248,26,6,3,3,1,1,1,6,0
,0,0,0,128,128,128
9090 RETURN
9997 STOP
9998 RANDOMIZE USR 15363: REM :
ERASE "SQUIGGLE"
9999 RANDOMIZE USR 15363: REM :
SAVE "SQUIGGLE" LINE 10

```

CHARACTER DESIGNER

◆ RA Mason • CBM-64
 ● Alton, Hampshire

This is a utility program to help in the design of a new character set.

It uses all eight sprites,

an interrupt routine to give three character sets on the screen at once, several short machine-code routines, and allows for saving and loading of character sets.

There are three choices at the start of the program, to copy all the Commodore characters

and then customise them, to start with a blank set, or to retain the set already in memory — the memory area used for the new characters is 12288 — 16384 or \$3000 — \$4000.

The section of the character set which may be re-designed is the alpha-numeric area of

upper/lower case, a total of 128 characters.

As the character is designed the corresponding character on screen is changed. The green set is to select the symbol to be changed, the black set beneath is the new set. The program requires the use of a

(continued on next page)

File

(continued from previous page)

joystick in port two.

Once the new set has been saved to tape or disc it may be loaded into any future program by LOAD "name",device,1. As the new

set is in the area normally used by Basic it must be protected by POKE52,48:POKES56,58. This will reduce the amount of memory available to the Basic user. To switch the

Commodore set out and the new set in the following command is necessary: POKE53272,28 then select upper/lower case by CHR\$(14) or pressing Commodore/Shift

keys.

I advise saving the program after typing it in as the program relies heavily on pokes, and just one mistake might cause a crash if run.

Character designer.

```

1 REM [CHARACTER-SET DESIGNER BY R.
A.MASON (1985)]
2 :
3 :
4 REM [MACHINE CODE ROUTINES:
]
5 REM [SYS49152(4C800) = INTERRUPT
]
6 REM [SYS49272(4C07B) = PLOT
]
7 REM [SYS49301(4C095) = ZERO SET-
DATA
]
8 REM [SYS49394(4C8AC) = MOVE COMM
ODORE SET
]
9 REM [SYS49397(4C0F5) = TURN INTE
RRUPT OFF
]
10 REM [SYS49430(4C116) = INPUT
]
11 REM [SYS49451(4C128) = SAVE
]
12 REM [SYS49472(4C140) = LOAD
]
13 :
14 :
19 REM [SPRITE AND MACHINE CODE LDA
DER]
20 POKE52,46:POKE54,46
30 POKES3280,0:POKES3281,0
40 GOSUB900
50 PRINT:PRINT"PLEASE WAIT..."
60 GOSUB570
70 FORC=0T07:POKE12280+C*(33+255)+C
,0:NEXT
99 REM [MAIN PROGRAM]
100 GOSUB1000
110 GOSUB1100
120 GOSUB1200
130 ONAGOSUB1300,1700,1750,1900
140 IFKP=1THENR=0:GOTO130
150 IFEN=1THENSYS49397:END
160 IFRS=1THENSRS=0:CLR:GOTO100
170 GOSUB1205
180 GOTO130
499 REM [SPRITE DATA]
500 DATA252,0,0,252,0,0,252,0
501 DATA0,252,0,0,252,0,0,252
502 DATA0,0,252,0,0,252,0,0
503 DATA0,0,0,0,0,0,0,0
504 DATA0,0,0,0,0,0,0,0
505 DATA0,0,0,0,0,0,0,0
506 DATA0,0,0,0,0,0,0,0
507 DATA0,0,0,0,0,0,0,0
508 DATA255,0,0,126,0,0,60,0
509 DATA0,24,0,0,0,0,0,0
510 DATA0,0,0,0,0,0,0,0
511 DATA0,0,0,0,0,0,0,0
512 DATA0,0,0,0,0,0,0,0
513 DATA0,0,0,0,0,0,0,0
514 DATA0,0,0,0,0,0,0,0
515 DATA0,0,0,0,0,0,0,0
516 DATA128,0,0,192,0,0,224,0
517 DATA0,240,0,0,240,0,0,224
518 DATA0,0,192,0,0,128,0,0
519 DATA0,0,0,0,0,0,0,0
520 DATA0,0,0,0,0,0,0,0
521 DATA0,0,0,0,0,0,0,0
522 DATA0,0,0,0,0,0,0,0
523 DATA0,0,0,0,0,0,0,0
524 DATA252,0,0,132,0,0,132,0
525 DATA0,132,0,0,132,0,0,252
526 DATA0,0,0,0,0,0,0,0
527 DATA0,0,0,0,0,0,0,0
528 DATA0,0,0,0,0,0,0,0
529 DATA0,0,0,0,0,0,0,0
530 DATA0,0,0,0,0,0,0,0
531 DATA0,0,0,0,0,0,0,0
532 DATA0,0,0,0,0,0,0,0
533 DATA0,0,0,0,0,0,0,0
534 DATA0,0,23,255,232,46,30,244
535 DATA46,252,244,46,62,244,46,254
536 DATA244,110,252,118,111,255,246
,112
537 DATA15,206,111,255,246,96,0,6
538 DATA96,0,6,0,0,0,0,0
539 DATA0,0,0,0,0,0,0,24
540 DATA0,0,0,0,0,0,0,0
541 DATA0,0,0,0,0,0,0,0
542 DATA0,0,23,255,232,46,28,244
543 DATA,251,116,46,62,244,46,251
544 DATA116,110,252,246,111,255,246
,112
545 DATA112,14,111,255,246,96,0,6
546 DATA96,0,6,0,0,0,0,0
547 DATA0,0,0,0,0,0,0,24
548 DATA0,0,0,0,0,0,0,0
549 DATA0,0,0,0,0,0,0,0
550 DATA0,0,23,255,232,46,24,116
551 DATA46,251,244,46,56,116,46,255
552 DATA116,110,248,246,111,255,246
,112
553 DATA15,206,111,255,246,96,0,6
554 DATA96,0,6,0,0,0,0,0
555 DATA0,0,0,0,0,0,0,24
556 DATA0,0,0,0,0,0,0,0
557 DATA0,0,0,0,0,0,0,0
558 DATA0,0,23,255,232,46,24,116
559 DATA46,255,116,46,62,244,46,253
560 DATA244,110,251,246,111,255,246
,115

```

```

561 DATA131,206,111,255,246,111,255
,246
562 DATA111,255,246,111,255,246,0,0
563 DATA0,0,0,0,0,0,0,24
564 DATA24330
570 FORC=0T0511:READD:POKE11776+C,D
:T=T+D:NEXT
575 READD:IFD<>TTHENPRINT:PRINT"ERR
OR IN DATA (PART 1)":STOP
599 REM [MACHINE CODE DATA]
600 DATA169,127,141,13,220,169,32,1
41
601 DATA20,3,169,192,141,21,3,169
602 DATA170,141,18,208,169,27,141,1
7
603 DATA208,169,129,141,26,208,96,2
34
604 DATA169,1,141,25,208,173,18,208
605 DATA201,170,240,21,201,210,240,
38
606 DATA201,255,240,47,173,13,220,4
1
607 DATA1,240,3,76,49,234,76,188
608 DATA254,169,13,141,32,208,141,3
3
609 DATA208,169,23,141,24,208,169,2
18
610 DATA141,18,208,208,223,234,169,
30
611 DATA141,24,208,169,255,141,18,2
08
612 DATA208,210,234,169,0,141,32,20
8
613 DATA141,33,208,169,21,141,24,20
8
614 DATA169,170,141,18,208,208,189,
234
615 DATA32,250,174,32,158,183,138,7
2
616 DATA32,253,174,32,158,183,138,7
2
617 DATA32,247,174,184,168,184,170,
24
618 DATA32,240,255,96,234,169,0,168
619 DATA133,251,162,48,134,252,162,
16
620 DATA145,251,208,208,251,230,252
,202
621 DATA208,246,96,234,128,169,127,
141
622 DATA13,220,173,14,220,41,254,14
1
623 DATA14,220,165,1,41,251,133,1
624 DATA169,0,168,133,251,133,253,1
62
625 DATA208,134,252,162,48,134,254,
162
626 DATA16,177,251,145,253,208,208,
249
627 DATA230,252,230,254,202,208,242
,145
628 DATA1,9,4,133,1,173,14,220
629 DATA9,1,141,14,220,169,129,141
630 DATA13,220,88,96,234,169,127,14
1
631 DATA13,220,169,0,141,26,208,32
632 DATA21,253,169,129,141,13,220,1
69
633 DATA0,141,32,208,141,33,208,169
634 DATA21,141,24,208,96,234,160,0
635 DATA32,207,255,201,13,240,6,153
636 DATA0,194,200,208,243,152,141,1
6
637 DATA194,96,234,32,75,193,169,0
638 DATA133,251,169,48,133,252,169,
251
639 DATA162,0,160,64,32,216,255,96
640 DATA32,75,193,169,0,170,160,32
641 DATA213,255,96,169,1,166,2,160
642 DATA1,32,186,255,173,16,194,162
643 DATA0,160,194,32,189,255,96,0
644 DATA72562
650 FORC=0T0551:READD:POKE49152+C,D
:T=T+D:NEXT
655 READD:IFD<>TTHENPRINT:PRINT"ERR
OR IN DATA (PART 2)":STOP
899 REM [TITLE]
900 PRINTCHR$(147)CHR$(30)"CHARACTE
R DESIGNER":RETURN
999 REM [SET SELECTION SCREEN]
1000 SYS49152:POKES3269,0
1005 GOSUB900
1010 PRINT:PRINT"SELECT:"
1015 PRINT"COPY COMMODORE CHARACTER
S - C"
1020 PRINT"ZERO CHARACTER DATA
- Z"
1025 PRINT"RETAIN EXISTING SET
- R"
1030 GETA#:"IFA#<>"THEN1050
1035 FORC=0T06:P1=1104+C:P2=PEEK(P1
)
1040 IFP2>128THENPOKEP1,P2-128:NEXT
:GOTO1030
1045 IFP2<128THENPOKEP1,P2+128:NEXT
:GOTO1030
1050 IF(A#<>"C"AND(A#<>"Z"AND(A#<>"R"
)THEN1030
1055 IFA#="C"THENSYS49324
1060 IFA#="Z"THENSYS49301
1065 SYS49152

```

```

1070 Y1=88:X1=172:Y2=82:X2=178
1075 RETURN
1099 REM [COMMODORE AND DESIGN CHAR
ACTERS]
1100 PRINTCHR$(30):C=32:X=16:Y=0
1105 FORFLAG=0T01
1110 FORV=0T03:FORH=0T031:SYS49272(X
+V,Y+H):PRINTCHR$(C)::C=C+1:NEXT:N
EXT
1115 X=21:C=32:POKE646,0:NEXT
1120 PRINTCHR$(153)CHR$(19)
1125 RETURN
1199 REM [MODE SELECTION SCREEN]
1200 RE=0:FORC=0T0159:POKE1104+C,32
:NEXT
1205 PRINTCHR$(151):SYS49272(2,1):F
ORC=0T07:PRINTCHR$(175):NEXT:PRINT
1210 FORX=0T07:PRINTCHR$(170):FORX
=0T07:PRINTCHR$(186):NEXT:PRINT:NE
XT
1211 PRINTCHR$(30)CHR$(32):FORC=0T
07:PRINTCHR$(100):NEXT:PRINT"ZEROD
ATA"
1212 PRINTCHR$(32):FORC=0T07:PRINT
CHR$(100):NEXT:PRINT"COMPLETE"
1213 IFR=1THENPRINTCHR$(151):RETUR
N
1215 SYS49272(3,25):PRINT"SELECT:"
1220 SYS49272(4,25):PRINT"DESIGN"
1225 SYS49272(5,25):PRINT"SAVE SET"
1230 SYS49272(6,25):PRINT"LOAD SET"
1235 SYS49272(7,25):PRINT"END"CHR$(
151)
1240 C=0:FORCC=0T0145STEP2:SY(C)=532
40+CC:SX(C)=53249+CC:C=C+1:NEXT
1245 POKES3287,11:POKES3288,11:POKE
53289,11:POKES3290,11
1250 FORC=0T03:POKE2040+C,188+C:NEX
T
1255 Y=40:FORC=0T03:POKESY(C),Y:NEX
T
1260 POKESX(0),72:POKESX(1),82:POKE
SX(2),92:POKESX(3),102
1265 POKES3264,15:POKES3269,15
1270 GETA#:"IFA#<>"THEN1275
1272 FORC=0T06:P1=1169+C:P2=PEEK(P1
)
1273 IFP2>128THENPOKEP1,P2-128:NEXT
:GOTO1270
1274 IFP2<128THENPOKEP1,P2+128:NEXT
:GOTO1270
1275 A=ASC(A#):IF(A<133ORA>136)THEN
1270
1280 A=A-132
1290 RETURN
1299 REM [DESIGN SCREEN]
1300 SYS49272(3,25):FORC=0T06:PRINT
CHR$(32):NEXT
1305 POKES3287,13
1315 POKES3291,0:POKES3292,0:POKES3
293,0
1320 POKESX(4),X1:POKESY(4),Y1:POKE
SX(5),X2:POKESY(5),Y2
1321 POKESX(6),X2+40:POKESY(6),Y2
1325 POKESX(6),X2+40:POKESY(6),Y2
1330 POKE2044,185:POKE2045,186:POKE
2046,186
1335 POKES3269,127
1340 GOSUB2000:IFKP=1THENRETURN
1345 IF(J#="U"ANDVP>0)THENVP=VP-1:X
2=X2-8:GOTO1370
1350 IF(J#="D"ANDVP<3)THENVP=VP+1:X
2=X2+8:GOTO1370
1355 IF(J#="L"ANDHP>0)THENHP=HP-1:Y
1=Y1-8:GOTO1370
1360 IF(J#="R"ANDHP<23)THENHP=HP+1:
Y1=Y1+8:GOTO1370
1365 IFJ#="F"THEN1395
1370 IFY1>255THENY1=255:POKES3264
,31:GOTO1380
1375 IFY1<255THENY1=POKES3264,15
1380 POKESY(4),Y:POKESY(5),Y2:POKES
X(6),X2+40
1385 FORT=1T030:NEXT
1390 GOTO1340
1395 POKES3291,5:POKES3292,5:POKES3
293,5
1400 PX=3:PY=1
1405 AS=32+VP*24+HP
1410 SD=INT(AS/32)
1415 IFSD=1THENSND=AS:GOTO1430
1420 IFSD=2THENSND=AS-64:GOTO1430
1425 IFSD=3THENSND=AS-32:GOTO1430
1430 P=14336+8*SD
1435 FORL=0T07
1440 B1=128
1445 FORR=0T07
1450 IF(PEEK(P+L)ANDBI)=BITHENSYS49
272(PX+L,PY+R):PRINT"(RVS)"
1455 BI=BI/2
1460 NEXT:R=1
1470 SX=74:SY=32:LI=0:RO=0
1475 LI=0:RO=0
1480 B=128
1485 FORC=0T07
1490 BI(C)=B:B=B/2
1495 NEXT
1500 POKE2047,187
1505 POKES3294,1

```

```

1510 POKESX(7),8X:POKESY(7),SY
1515 POKES3269,255
1520 GOSUB2000
1525 IFKP=1THENRETURN
1530 IF(J#="U"ANDLI>0)THENLI=LI-1:S
X=SX-8
1535 IF(J#="D"ANDLI<9)THENLI=LI+1:S
X=SX+8
1540 IF(J#="L"ANDRO>0)THENRO=RO-1:S
Y=SY-8
1545 IF(J#="R"ANDRO<7)THENRO=RO+1:S
Y=SY+8
1550 POKESX(7),SX:POKESY(7),SY
1555 IFJ#<>"F"THEN1520
1560 IFLI=0THENPOKES3269,127:FORC=0
T07:POKEP+C,0:NEXT:RE=1:GOSUB1205:G
OTO1500
1565 IFLI=9THENRE=1:GOSUB1205:GOTO1
300
1566 IFLI=9THENRE=1:GOSUB1205:GOTO1
300
1570 IF(PEEK(P+LI)ANDBI(RO))=BI(RO)
THEN1585
1575 POKEP+LI,(PEEK(P+LI)+BI(RO))
1580 SYS49272(PX+LI,PY+RO):PRINT"(R
VS)":GOTO1600
1585 POKEP+LI,(PEEK(P+LI)-BI(RO))
1590 SYS49272(PX+LI,PY+RO):PRINT"(S
H)":GOTO1600
1600 FORT=1T0150:NEXT:GOTO1520
1699 REM [SAVE SCREEN]
1700 POKES3269,0:SYS49397
1705 GOSUB900
1710 PRINT:PRINT"SAVE ROUTINE...":P
RINT
1715 GOSUB1800:IFA#="A"THEN1790
1720 SYS49451:IFST=0THENGOTO1790
1725 GOSUB1860
1730 IFA#="A"THENGOTO1790
1735 GOTO1700
1749 REM [LOAD SCREEN]
1750 POKES3269,0:SYS49397
1755 GOSUB900
1760 PRINT:PRINT"LOAD ROUTINE...":P
RINT
1765 GOSUB1800:IFA#="A"THEN1790
1770 SYS49472:IFST=64THENGOTO1790
1775 GOSUB1860
1780 IFA#="A"THENGOTO1790
1785 GOTO1750
1790 RE=0:KP=0:RS=1:RETURN
1799 REM [MAIN I/O ROUTINE]
1800 PRINT"PRESS 1 - CASSETTE"
1805 PRINT"2 - DISK"
1810 PRINT"3 - ABORT"
1815 GETA#:"IFA#<>"1"AND(A#<>"2"AND(A
#<>"3")THEN1815
1820 IFA#="1"THENRETURN
1825 POKE2,VAL(A#)
1830 PRINT:PRINT"ENTER CHARACTER SE
T NAME":SYS49430
1835 IFPEEK(49680)>16THENPRINT:PRIN
T"NAME TOO LONG...":FORT=1T0500:NEX
T:GOTO1830
1840 PRINT:PRINT"PREPARE DEVICE..."
1845 PRINT"THEN PRESS R"
1850 GETA#:"IFA#<>"R"THEN1850
1855 RETURN
1860 PRINT:PRINT"DEVICE ERROR!!!"
1865 IFPEEK(2)=1THENGOTO1880
1870 OPENB,0,15:INPUT#1,A#,B#,C#,D#
:PRINT#1,"1":CLOSE
1875 PRINTA#;" ";B#
1880 PRINT"PRESS A - ABORT"
1885 PRINT"R - RE-TRY"
1890 GETA#:"IFA#<>"A"AND(A#<>"R")THE
N1890LIST1700-1790
1895 RETURN
1899 REM [END ROUTINE]
1900 FORC=0T03:POKES3287,11:NEXT:SC
=2:POKES3290,SC
1905 FORC=0T050
1910 GETA#:"IFA#<>"THENC=50
1915 NEXT
1920 IFA#="CHR$(136)THENPOKE800,237:
POKES3269,0:PRINTCHR$(147):EN=1:RET
URN
1925 IFA#<>"THENEN=0:RE=0:RETURN
1930 IFSC=11THENSND=2:GOTO1940
1935 SC=11
1940 POKES3290,SC:GOTO1905
1999 REM [JOYSTICK ROUTINE]
2000 J=PEEK(56320)
2005 FR=JAND16
2010 J=15-(JAND15)
2015 IFFR<>16THENJ#="F":GOTO2050
2020 IFJ=0THENGETA#:"IFA#<>"THENGOT
02855
2025 IFJ=1THENJ#="U":GOTO2050
2030 IFJ=2THENJ#="D":GOTO2050
2035 IFJ=4THENJ#="L":GOTO2050
2040 IFJ=8THENJ#="R":GOTO2050
2045 GOTO2000
2050 RETURN
2055 A=ASC(A#)-132:IF(A>BAND(A<5)THE
NKP=1:GOTO2050
2060 GOTO2000

```

Electric Dreams

An amazing new concept in software presentation, Electric Dreams will bring you two exciting games in one double size cassette package at the superb value for money price of **ONLY £9.95 on cassette and £12.95 on disk.**

Some of the world's most ingenious minds will be recruited to bring you entertainment and excitement beyond your wildest dreams.

Buy this title as the first of many to complete your range of Electric Dreams.

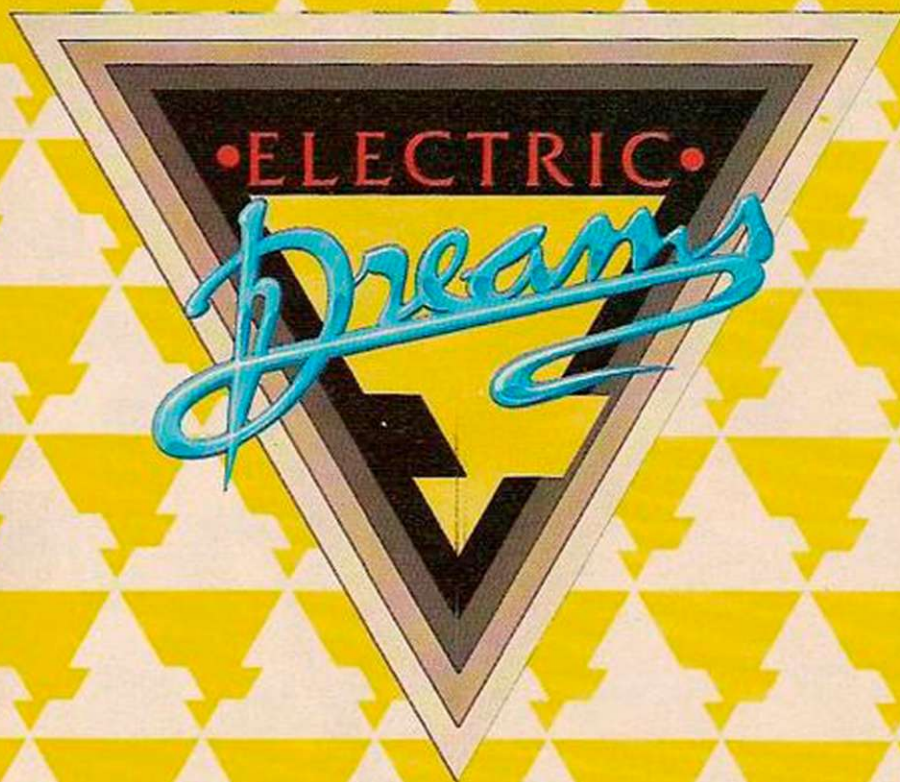

Digital dexterity and devious deduction are only two of the skills you'll require when you take on the nasty bad men in these two episodes from the world's most intriguing espionage story.



Spy's Demise



Spy Strikes Back

Available on Commodore 64 and Atari

THE ULTIMATE UTILITY FOR THE BBC MICRO

SPEECH!

**NO HARDWARE
REQUIRED**

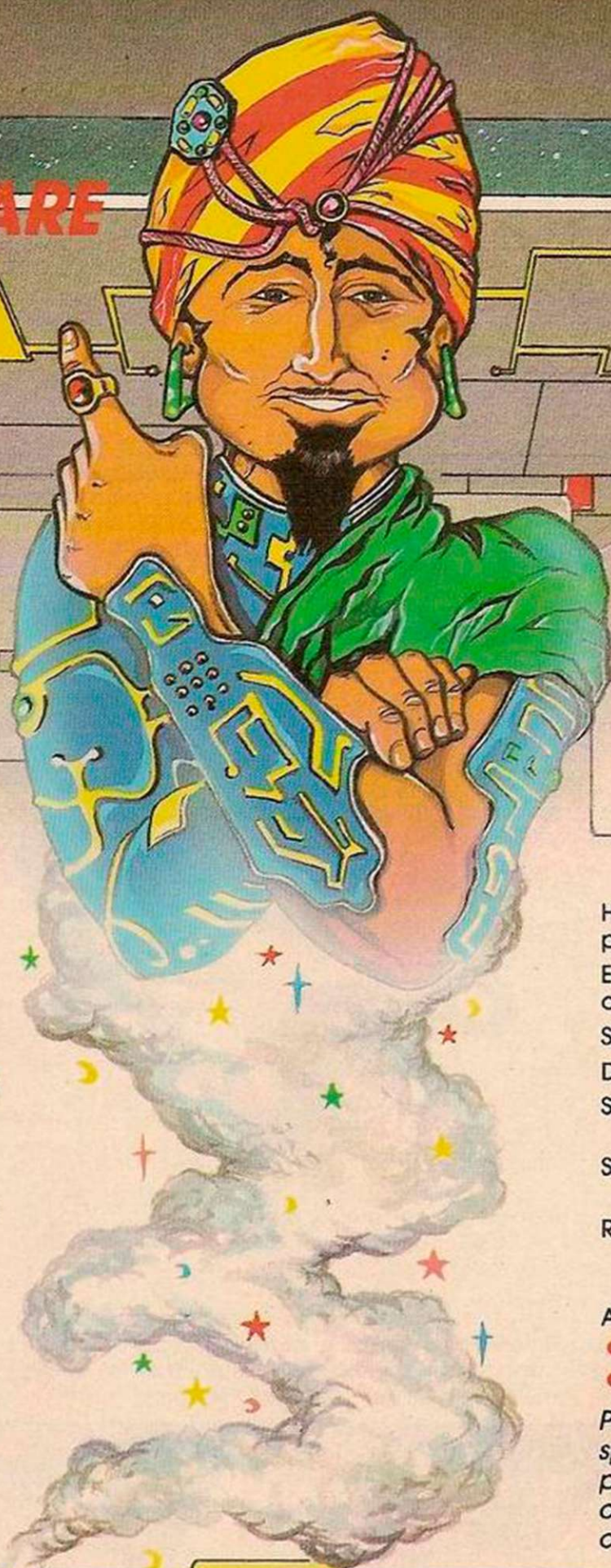

At last, speech synthesis at a price you can afford. SPEECH! works entirely in software, taking up only 7K of RAM: no hardware whatsoever is required. Unlike other systems, SPEECH! has an unlimited vocabulary: it will say anything you want it to, and is simplicity itself to use. Simply type in: ***SAY I am a talking computer, as easy to use as 1 2 3...** and the computer speaks.

Adding a question mark to the end of a word pushes the pitch up (*SAY How are you?) and a full stop pushes it down (*SAY I am really unhappy.) You can even change the overall pitch by using the ****PITCH** command.

SPEECH! has a built-in parser which translates English words into 'phonemes' or speech particles. There are 45 different phonemes, and 8 different pitch settings for vowel sounds. These phonemes can be used directly by using the ****SPEAK** command (e.g. *SPEAK HEH4LOW4), so stress or intonation can easily be added wherever desired. You can even say foreign languages.

Hear SPEECH! for yourself in the loader programs of REPTON 2 and CITADEL.

Every copy of SPEECH! comes complete with 5 programs:

- SPEECH! — the 7K program
- DEMO — shows off all the features
- SPELL — a simple educational program
- SAYFILE — says WORDWISE, VIEW files etc.
- RELOCATE — moves SPEECH! around in memory, onto Sideways RAM, etc.

Applications in:

- games
- business
- education
- utilities

Previously, to get this quality of speech you would have had to pay at least £30. SPEECH! costs only £9.95 on cassette or £11.95 on disc.



SUPERIOR SOFTWARE LTD.

Dept. AU13, Regent House,
Skinner Lane, Leeds LS7 1AX.
Tel: 0532 459453.

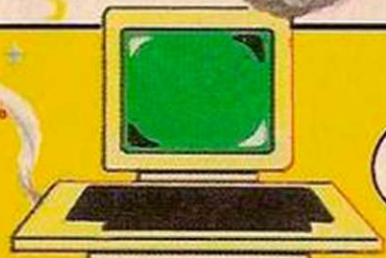

OUR GUARANTEE

- All mail orders are despatched within 24 hours by first-class post.
- Postage and packing is free.
- Faulty cassettes and discs will be replaced immediately.



WE PAY UP TO 20% ROYALTIES FOR HIGH QUALITY PROGRAMS

AMSTRAD 48-95
ZX SPECTRUM 128
COMMODORE 64/75

WORLD SERIES BASEBALL



**NOW RELEASED ON
C16 and PLUS 4
£7.95**

THE BIG BIG HIT!

Join in the big pitch excitement and atmosphere of the World Series championship with:
***RUNNER STEALS*HOME RUNS*PITCHER STEALS**
and many more authentic fun features of real American Baseball.



ULTIMATE PLAY THE GAME

48K SINCLAIR SPECTRUM/AMSTRAD

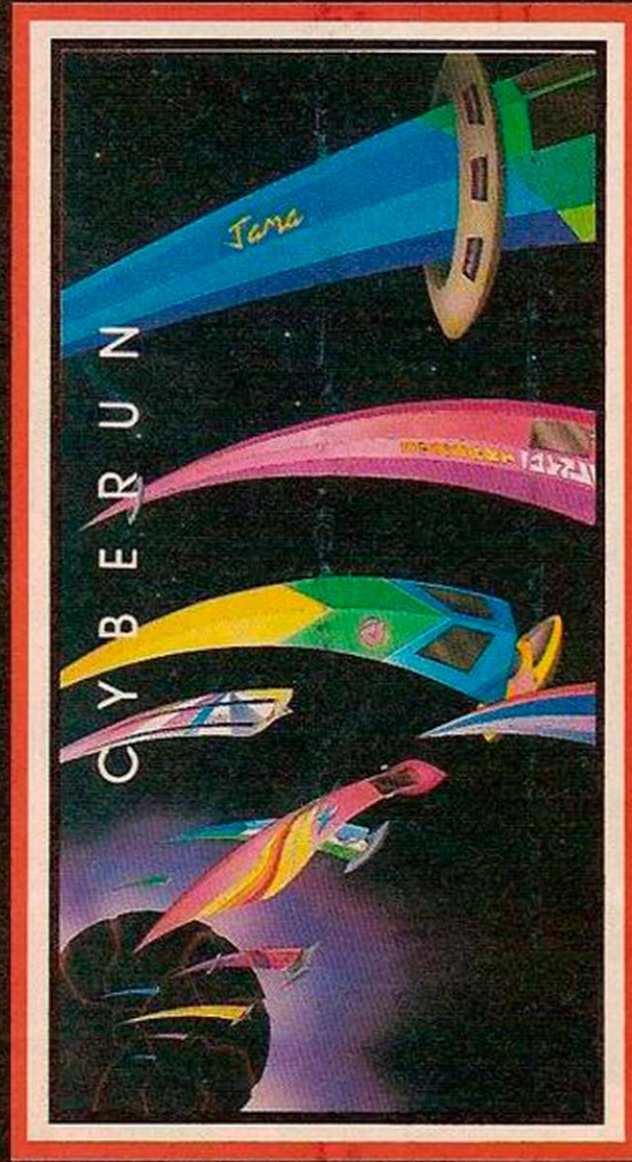

COMMODORE 64



COMMODORE 64



48K SINCLAIR SPECTRUM
AMSTRAD

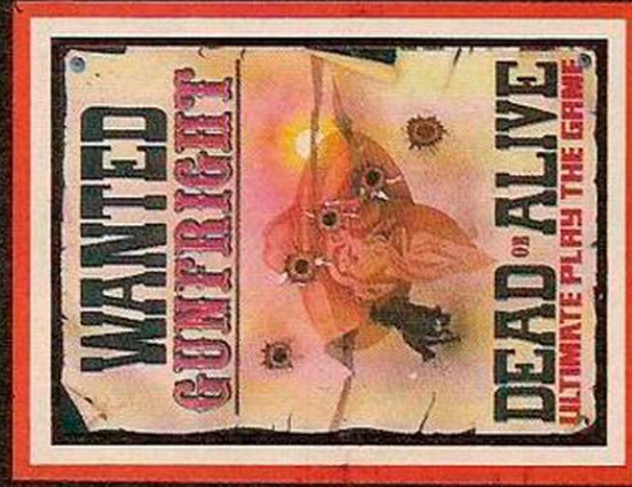

COMMODORE 64



48K SINCLAIR SPECTRUM
AMSTRAD



COMMODORE 64



"CYBERUN", "GUNFIGHT", "PENTAGRAM", "DRAGONSKULLE", "OUTLAWS", "BLACKWYCHE", "ENTOMBED" recommended retail price £9.95 inc VAT. Available from W.H.SMITHS, BOOTS, J.MENZIES, WOOLWORTHS and all good software retail outlets. Also available from ULTIMATE PLAY THE GAME, The Green, Ashby-de-la-Zouch, Leicestershire LE6 5JU (P&P are included) Tel: 0530 411485

AT LAST
YOU CAN REALLY
FLY!!!



The ultimate AIR COMBAT EMULATOR
You will feel the thrill of flying a high
performance combat aircraft.

ACE-EXPERIENCE IT NOW!



Cascade Games Ltd.
1-3 Haywra Crescent
Harrogate HG1 5BG
England

Available for C64,
C16, C128, VIC 20
(+8K RAM Exp),
Amstrad and
48K Spectrum.



ACE - The Air Combat Emulator by Cascade Games. Available from Boots, W. H. Smiths, H.M.V., Virgin, House of Frazer, J. Menzies, Woolworth, Lasky's and all good software retailers or send cheque or postal order for **£10.95** (£9.95 C16 and VIC 20 + 8K RAM Expansion) to Cascade at the above address. You may order by ACCESS or VISA via our 24 hr hotline call **0423 504663** (be sure to state type of computer and game required).

THREE NEW TITLES FROM

REALTIME GAMES LIMITED SOFTWARE

...THE PROGRAMMERS OF STARSTRIKE

7.95 Tape

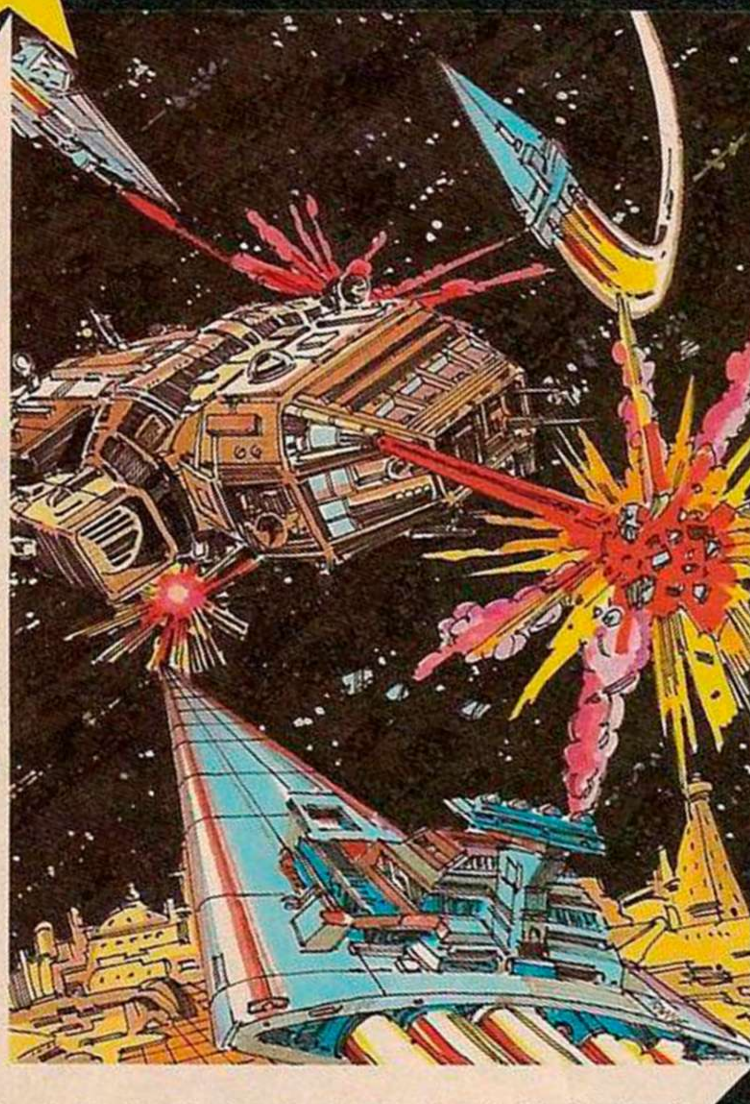

**SPECTRUM + 48K
STARSTRIKE II
SHADED 3D**

Forget just vector graphics. Now you can have real shaded 3D, solid objects that pass behind one another.
A space shoot-em-up which is more addictive, has more game and has more powerful graphics than starstrike.
ALL ACTION ARCADE GAME

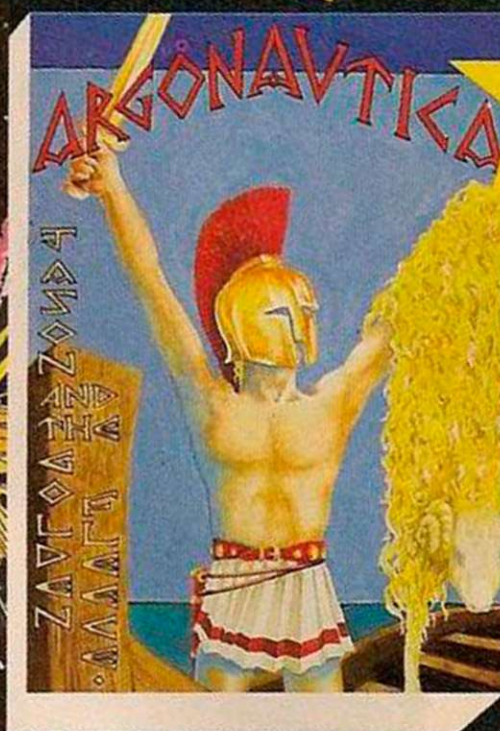

7.95 Tape

**CBM 64
ARGONAUTICA**

Arcade adventure from ancient Greece. Large colour sprites. Highly detailed graphics and game play.

(Unlikely to be available before Christmas)

14.95



Microdrive

**SINCLAIR QL
KNIGHT FLIGHT**

- ★ ADDICTIVE ARCADE ACTION
- ★ CONTINUOUS MUSIC AND SOUND EFFECTS
- ★ UP TO 21 MOVING FULL COLOUR SPRITES
- ★ ONE OR TWO PLAYER GAME OPTION
- ★ JOYSTICK/KEYBOARD

Real arcade action for your QL. Surreal adventure. A knightly quest astride a powerful mount over uncertain terrain.

Available soon:
★ Starstrike II (Amstrad)
★ Argonautica (Amstrad/Spectrum)

Don't just take our word for it
SEE FOR YOURSELVES!

I enclose cheque/P.O. for £..... payable to:
Realtme Games Software Ltd., Prospect House, 32 Sovereign St. Leeds LS1 4BT 0532 458948

Rush me: Knight Flight (QL) £14.95 Starstrike II (Spectrum) £7.95
 Argonautica (CBM 64) £7.95 Starstrike (Spectrum) £5.95
 Starstrike (Amstrad) £6.95

Please debit my Access No. _____

Name.....
Address.....

ATARI

64



The Gates of Apschai loom before you. Many adventurers have stood here and pondered their fate. Will you plunder the grand treasures of the Apschai priests? And live to learn the secret of the Sphinx? Did the wily Innkeeper wheedle his profit from your meagre purse? Or do you go forth equipped with the finest swords and armour leaving him muttering oaths and swearing you stole the food from the mouths of his babies?

Once inside the Temple you know why the Legends of Apschai

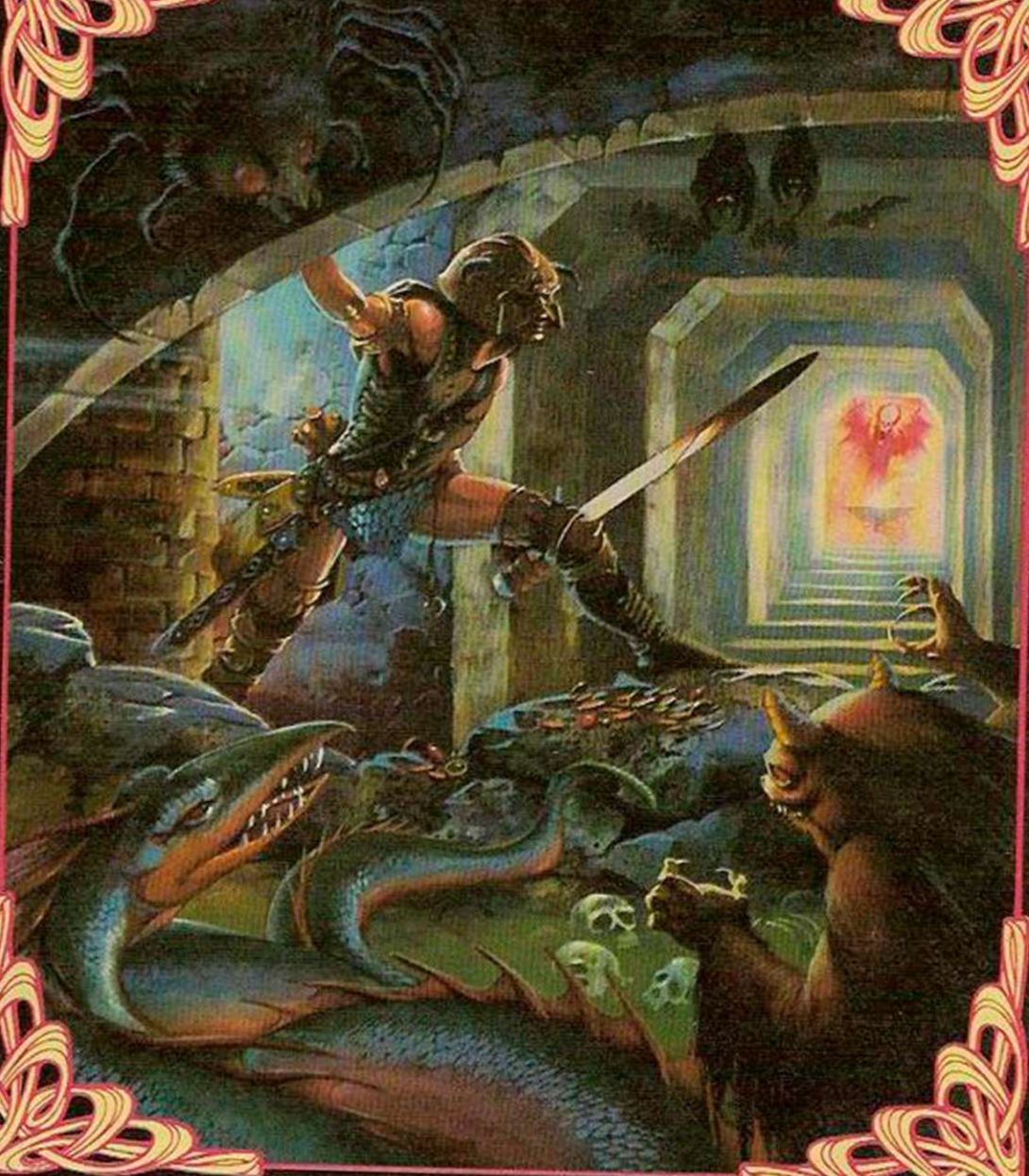

speak of Magic. You will need more than a character of strength and intelligence and the keen nose of intuition to overcome the evil and power of the Curse of Ra. The monsters roam about - Zombies, Ghouls and the terrifying minions of Apschai the Insect God. Giant mosquitos, wasps, ants and beetles suddenly attack, biting and clawing. This my friend is adventure - classic adventure from the Dunjon Masters at Epyx. Welcome to the Temple of Apschai Trilogy...you're just in time for lunch!

THE TEMPLE OF APSCHAI TRILOGY

- ▶ The Complete Temple of Apschai Trilogy: Temple of Apschai, The Upper Reaches of Apschai and The Curse of Ra.
- ▶ 12 Levels, 568 Rooms With 37 Terrifying Monsters!
- ▶ New Graphics, Enhanced Sounds, Faster Play! ▶ One Player.
- ▶ Classic Cast of Characters - The Inn-keeper, The Dwarf, The Magic User and The Cleric and more!

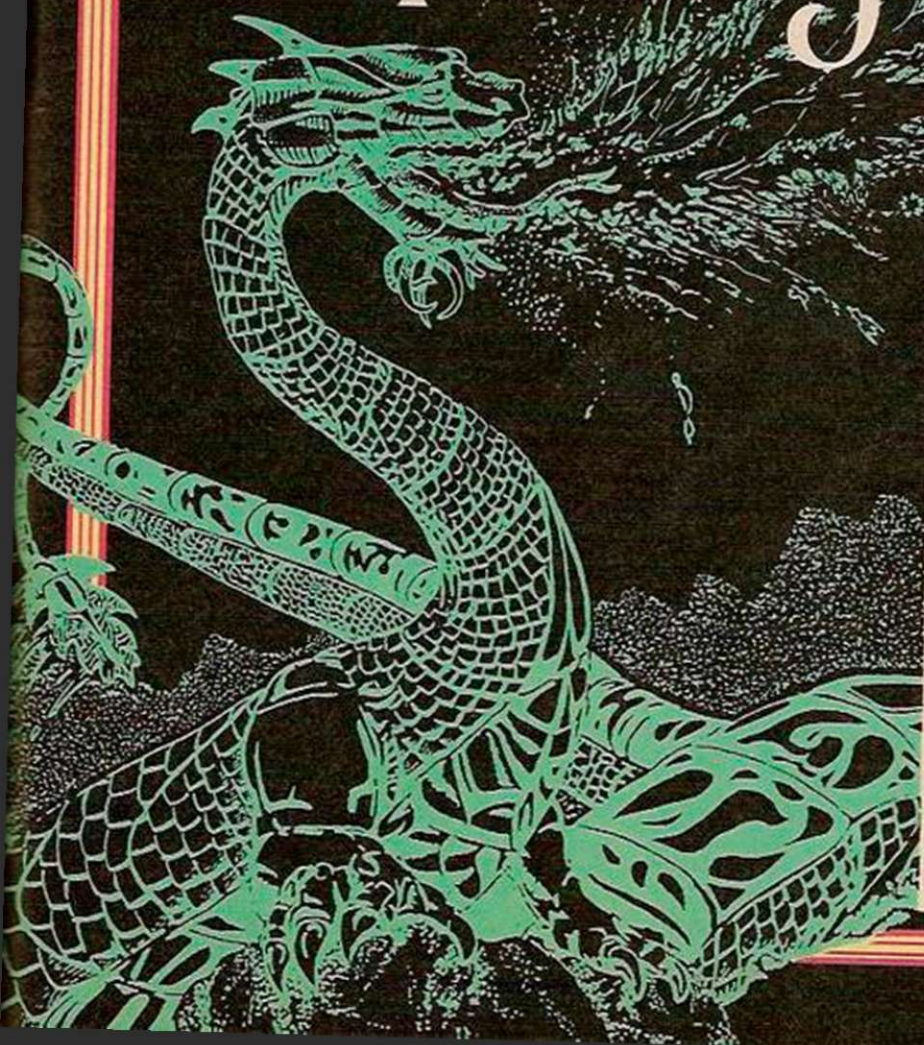

* Screens from Commodore 64 version of game

EPYX
 COMPUTER SOFTWARE

"Products worth shouting about from Cumana!"



DISK DRIVES

Cumana, Europe's leading supplier of floppy disk drives and the first manufacturer to win BEAB approval to BS415 for electrical safety, now have an even wider product range than ever before – whether for the BBC, Spectrum, QL, Amstrad, Apple, Enterprise, Dragon, Tandy, Electron, Oric Atmos, Cumana have the best quality drives available.

UPGRADE

But Cumana's range now covers much more than just disk drives; there's a growing range of exciting new

computer products designed to uprate and extend the uses of the most popular micros. Products like the Cumana Upgrade – a major expansion to the BBC and QL micros, enabling real-time minicomputer performance with .5Mb of RAM and high level applications software. 10Mb and 20Mb Winchester systems are available for both the QL and BBC using Upgrade.

TOUCH PAD

There's the new, improved Touch Pad graphic input device with powerful Screen Artist software – an infinite variety of graphic design or artistic

uses for the home, business or education, taking you another step towards the professional league. Ask us about the new Touch Pad library!

SOFTWARE

Also new and exclusive to Cumana is Pocket Wordstar – a full implementation of Wordstar & Mailmerge, the industry standard word processing package. Thanks to Cumana, it's now available to you, at a price within every users pocket.

Cumana the very best name in memory.

"And so are the prices!"

CUMANA COMPUTER PERIPHERALS – THE VERY BEST QUALITY AT THE MOST COMPETITIVE PRICES.



3", 3½" + 5¼" disk drives for the BBC, Spectrum, QL, Dragon, Apple, Amstrad, Enterprise, Electron, Tandy, Oric Atmos prices from £89.95 to £255.95 inc. VAT.



Cumana Upgrade including software suite for the BBC + QL from £795.95.

QFS (double density disk interface for BBC-B) £79.95.



Cumana Touch Pad only £49.95 inc. VAT.

Additional Touch Pad Software from £4.95.

Pocket Wordstar £119.00.



5¼" double sided double density diskettes (10) £13.95.

3½" double sided double density diskettes (10) £29.95.

Cumana disk interface for the Electron (double density) £74.95.

All prices are inclusive of VAT.

CUMANA DISTRIBUTORS

CEM Micro Computer Services (Belfast) 0232 24411,
Silicon Express (Leicester) 0533 374917
Thompson Cook (Birmingham) 0527 25000,
J.S. Simnett (Kingston-upon-Thames) 01-541-1495,
Microworld (Edinburgh) 031-557-4196,
Hugh Symonds (Bournemouth) 0202 26535,
Eltec (Bradford) 0274 722512.

CUMANA[®]
The best name in memory

CUMANA LTD., PINES TRADING ESTATE, BROAD STREET,
GUILDFORD, SURREY, GU3 3BH. TEL: (0483) 503121

Save £20 on the MT80+ printer

QUALITY PRINTING FOR AROUND £199



From Europe's leading matrix printer manufacturer

- 80 column, 100 cps optimised bi-directional print
- Expanded, compressed and bold print plus italics
- Dot addressable and line graphics
- Friction and tractor feed
- Quick tear facility
- Easy change cassette ribbon

Now the MT80+ from Mannesmann Tally is even better value-for-money! Simply cut the voucher and hand to your nearest dealer upon purchase to claim your £20 discount (inc. VAT). Full information on the amazing MT80+, plus the name of your nearest stockist is available by ringing the number below.



(0734)
791533/791619



MANNESMANN TALLY

£20

THIS VOUCHER ENTITLES THE BEARER TO £20 OFF THE MT80+

Please complete all sections below in block capitals. One voucher per printer. Offer ends March 31st 1986.

Name _____ Address _____

Printer Serial No. _____ Signature _____

Date _____ Computer used _____

Dealer conditions Mannesmann Tally guarantee £20 (inc VAT) refund upon receipt of voucher and copy of proof of sale. Send to MT Direct, Mannesmann Tally Ltd, Molly Millars Lane, Wokingham, Berks RG11 2QT. Vouchers must be received at Mannesmann Tally by April 30th 1986. Don't forget your own name and address. Further information available from MT Direct on (0734) 791533/791619. VAT NO. 199-667973

FREE!!!
ATARI
TOUCH TABLET
with a
130XE Computer

Compumart

Mega Deals

Best Price for ATARI HARDWARE in the U.K.

- Atari 130XE Computer
(with a FREE ATARI TOUCH TABLET!!!) **£159.** ⁹⁵/_{+ £3 p&p}
- Atari 1050 Disk Drive
(with FREE Home File Manager, Payoff
Adventure & Demo Disks) **£169.** ⁹⁵/_{+ £3 p&p}
129
- Atari 130XE & 1050 Disk Drive
(with FREE Home File Manager, Payoff
Adventure, Demo Disks &
10 Blank Disks FREE) **£259.** ⁹⁵/_{+ £3 p&p}
- Atari 130XE, 1050 Disk Drive
& 1027 Letter Quality Printer
(with FREE Atariwriter & 10 Blank Disks) **£344.** ⁹⁵/_{+ £3 p&p}

Goods despatched : SAME DAY — PARCEL POST
12 Month Warranty : ANY PRODUCT FOUND TO BE DEFECTIVE WITHIN 12 MONTHS OF
PURCHASE WILL BE REPLACED — FREE OF CHARGE

Best Prices for BLANK DISKS in the U.K.

Top Quality 5 1/4" Bulk Packed Disks
(Hub-Ringed and in White Envelopes with a Lifetime Warranty)

- FREE!!!** Plastic Library Case worth £2
when you buy 10 Disks
- FREE!!!** Perspex Disk Storage Box worth
£10 when you buy 50 Disks
- 10—5 1/4" Single Sided/Double Density
Blank Disks (with FREE case) **£9.** ⁹⁵/_{+ £1 p&p}
- 10—5 1/4" Double Sided/Double Density
Blank Disks (with FREE case) **£13.** ⁹⁵/_{+ £1 p&p}
- 50—5 1/4" Single Sided/Double Density
Blank Disks (with FREE Storage Box) **£49.** ⁹⁵/_{+ £2 p&p}
- 50—5 1/4" Double Sided/Double Density
Blank Disks (with FREE Storage Box) **£69.** ⁹⁵/_{+ £2 p&p}

GOODS DESPATCHED : Same day 1st Class Post
MONEY BACK GUARANTEE : If you are not completely
satisfied with your purchase we will either exchange
your disks or give a FULL REFUND — that's the
Compumart Guarantee.

Please send cheques/postal orders to :
Compumart, (Dept YC)
71 Gracedieu Road, Loughborough
Leics. LE11 0QF

Compumart...HOTLINE...HOT
0509-262259

GET IN THE PICTURE WITH BEEBUG

JOIN BRITAIN'S LARGEST COMPUTER USER GROUP TO GET THE MOST FROM YOUR BBC MICRO

JOIN BY SENDING £11.90 FOR 1 YEAR MEMBERSHIP (10 MAGAZINES)

OR £6.40 for 6 MONTHS MEMBERSHIP (5 MAGAZINES).

OR SEND £1.00 FOR A SAMPLE ISSUE (UK ONLY)

UK ONLY — OVERSEAS PRICES ON APPLICATION

MAKE CHEQUES PAYABLE TO BEEBUG DEPT YC2 PO BOX 109 HIGH WYCOMBE BUCKS.

NEW RELEASES FROM "THE HOUSE"

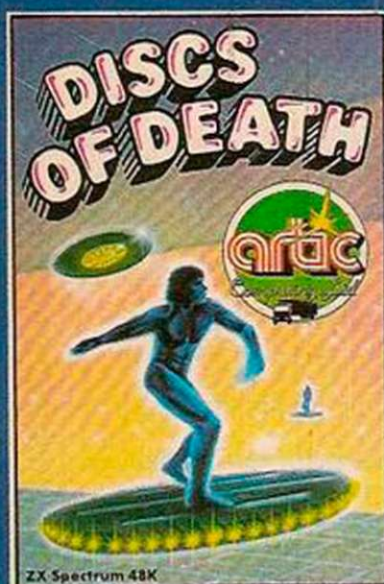

DISCS OF DEATH

Can you retain the title of Disc Warrior Champion? Or will you, like so many before you, die by the disc. Excellent 3-dimensional graphics test your skill to the limit.

Popular Computing Weekly 1/11/85

ZX SPECTRUM 48K
£6.95

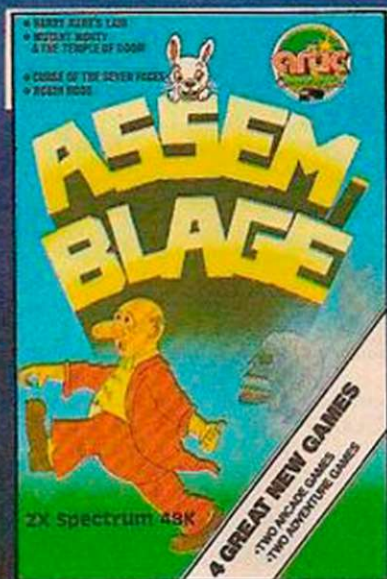

ASSEMBLAGE

Four new and original games on this big value tape! As Harry the Hare, can you outwit Farmer Giles to eat his carrots? Then explore the temple of doom as Mutant Monty. Then rack your brains over two excellent adventure games.

ZX SPECTRUM 48K
ONLY £8.95

ALADDIN'S CAVE

In this exciting arcade/adventure you must overcome the evil wizard by collecting objects and spells which allow you to transform into different lifeforms. Explore the strange caverns in your various bodyforms; as a man, a bird, a dolphin, a monkey or even a genie.

SPECTRUM 48K **£6.95**
AMSTRAD 464 **£7.95**



INTERNATIONAL RUGBY

You can play for any of the Home International Teams – playing for the triple crown or even the grand slam! Includes every feature you would expect from this excellent arcade simulation rugby game.

SPECTRUM 48K **£7.95**
AMSTRAD 464 **£7.95**

WEB WAR

Flying at incredible speed, you must save the people of the 'black widow' from the tyranic aliens.

BBC/ELECTRON **£4.95**

BIG BEN STRIKES AGAIN

The world-famous reporter, Ben of the Chronicle, has been sent to the Houses of Parliament to piece together a big story that is about to break. To obtain his story he must approach the politicians, exchanging gifts for the leaked information. Can you recognise Maggie Lurking in 'the house', or Geoffrey Howe, or the many other celebrities here to haunt you. The game includes a screen kit with which you can totally re-design your own screens!

SPECTRUM 48K **£6.95**

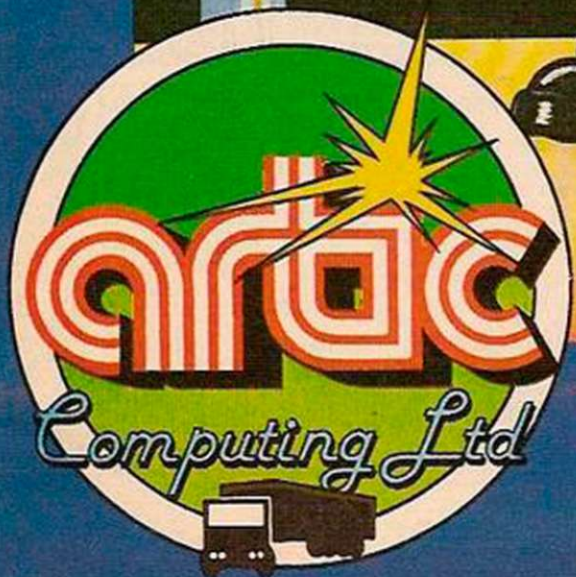

ARTIC SOFTWARE

is available from all good stockists – or direct from
Artic Computing, Main St., Brandesburton, Driffield, YO25 8RL
DEALER ENQUIRIES WELCOME – TEL: 0401 43553

YOUR COMPUTER CLASSIFIED

01- 661 3036

Contact: Ian Faux

ADVERTISEMENT RATES

Copy Date December 20

Linage: 60p per word
(Min 20 words)

Box No: £7.00 extra

Linage advertisements are prepayable and the order form published in this section should be completed and returned with remittance. Credit Card facilities are available.

RATES QUOTED BELOW ARE SUBJECT TO THE ADDITION OF 15% VAT.

Display — rates per scc (Min. 2scc)

One insertion	:	£10.00
Three insertions	:	£9.70
Six insertions	:	£9.50
Twelve insertions	:	£9.00

Display advertisers should preferably reserve space by phone.

Closing date for Classified advertisements is the 20th Dec. for the Feb issue.

Post to
Your Computer, Classified
Department, Room H211,
Quadrant House, The Quadrant,
Sutton, Surrey SM2 5AS.

Britain's Biggest Selling Home Computer Magazine

SPECTRUM MACHINE CODE SYSTEM

ASSEMBLER, DIS-ASSEMBLER, TESTER/DEBUGGER, ON-LINE LEARNING AID with teach yourself machine code booklet.

Options include using microdrive, printer, hex or decimal numbers
"A different approach giving a highly usable package... the most impressive part is the test/debug features... invaluable guide to the secrets of the Z80 (Spectrum CPU)" — PC Today July 85
"It seems to have absolutely everything you could possibly want for machine code... much care is taken in the manual in making the code as Basic-like as possible." — PC Weekly 21 Mar 85

Cassette £7.95, Microdrive Cartridge £9.75, Overseas + £1
Orders with PO/cheque to ROYBOT, Dept. YC4, 45 Hullbridge Road,
Rayleigh, Essex SS6 9NL. Write or tel: 0268 771663 for leaflets. 611

SENSATIONAL postal software bargains for Amstrad, Atari, BBC, Commodore (all formats), Electron, Spectrum. For free list send SAE or phone Teletex Cleckheaton 0274 875299.

COMET shows the sky at anytime from anywhere, stars, planets, Halley's comet shown. 48K Spectrum £4.95. Astro Programmes, 4 Park Lane, Haughton, Stafford.

LETTA-HEAD PLUS

An ENTIRELY ORIGINAL utility program for the 48k Spectrum to design and print your own business and personal stationery; letterheads, orders, receipts, labels and posters. The PLUS version now includes:

- * Library of 25 different fonts!
- * Fast, compiled, font editor.
- * Proportional spacing.
- * 81 different character sizes.
- * Block scroll, inverse and erase.
- * Variable thickness box function.
- * Improved graphics for logo design.
- * Special cassette label option.
- * 18 different print sizes.
- * Many more features!

Price: £9.00 cassette, £10.50 cartridge; Updates from original LETTA-HEAD £2.00.

Both LETTA-HEAD and DUMPY drive Epson type printers (Brother, Star, M-T, Shinwa, Smith Corona, Centronics, etc.) via Hilderbay, Kempston, S & E, Tasman, Morex, Wafadrive, Interface 1, ZX LPrint III, and Opus interfaces.

DUMPY

All the screen dumps you will ever need! No need to understand assembler, just follow the menu and DUMPY creates the machine code, relocates it and saves it for you!

- * Creates code to suit any program
- * Prints any portion of the screen.
- * Up to the full 24 lines!
- * Single, double or quad density.
- * Nine widths and three heights of output.
- * Plain black and white copy.
- * Or shaded colour representation.
- * Tab to any position on paper.
- * Many more features!

Price £7.50 cassette, £9.00 cartridge.

Bradway Software (YC), 33 Conalan Avenue, Sheffield S17 4PG

WDSOFTWARE

FOR THE QL

Utilities (3rd ed) (base £5.50)
PRINT 60-file Directory or view it on one screen, one-key LOAD, COPY or PRINT 60 files with one key (allows for namesakes). Multiple FORMATTING to prevent corrupting by stretching of tape. TOOLKIT to give dated, numbered modules in program development. PRUNE old files to release space (one key DELETES a file). Full instructions in QUIL file. Use up to 6 EXTRA MICRODRIVES (add on your Spectrum ones!)

WD Utilities for CST Q-Discs (2nd ed) (base £8)
As above, with extra utilities; 100-file capacity, for CST/Computamate disc systems AND up to four extra microdrives. User-friendly timesavers. Update 1st ed for 25p (£1.25 outside Europe).

Ref QL (5th ed) (base £5)
900 useful QL references in an ARCHIVE file (too long to share cartridge with other software). Also ARCHIVE 2 search program.

FOR SPECTRUM/QL/BBC/ELECTRON
WD Morse Tutor (base £4)
From absolute beginner to beyond RYA and Amateur Radio receiving. Adjust pitch. Set speed to your test level (4-18 wpm). Learn from single characters, via groups with wide spaces to random sentences; decrease spacing to normal. Write down what you hear, then CHECK on Screen or Printer (or speech for Spectrum with Currah Microspeech). Also own message, random figures, letters or mixed.

FOR SPECTRUM 48K

Wordfinder (microdrive/disc only) (base £8)
For CHEATING at crosswords. Finds m-ss-g letters, solves anagrams of shingle words, 13,000 word vocabulary. 10-letter word ending in ATE? No problem!

Tradewind (base £4)
Sailing/trading strategy game with graphic surprises.

Jersey Quest (base £4)
Test adventure with Bergerac and the Dragon. Based on genuine folklore of the Island of Jersey. (Not on SPDOS)

PRICES (incl. Europe postage — elsewhere add £1).
Cassettes — base price only. QL or Spectrum Microdrives — £2/cartridge plus base price; 5 1/4" floppies £2.31/floppies £4 plus base (SPDOS/Beta/OPUS discs for Spectrum). State required format when ordering. ACCESS/Mastercard welcome (over £4).

Two or more programs on one medium — pay medium + base, e.g. WD Utilities and Morse on microdrive for £11.50, but IMPOSSIBLE to mix QL/BBC/Spectrum programs on one medium. Send YOUR cartridge and base price, but FORMAT it FIRST six times like us for reliability.

WDSOFTWARE (YC),
Hilltop, St Mary, Jersey
Tel: (0534) 81392 708

SUSS BOX



£49.95
-VAT
incl. carriage
CWO please
pocket size

The DUPLEX SUSS-BOX has been designed to enable the less skilled computer user to have a better understanding of the correct working connection between a computer and a peripherals, such as a printer. This is achieved by using the commonly used signals (wires) of the RS232C serial data cable specification, a matrix-block and special connector pins. By inserting the connector pins into the SUSS-BOX's matrix-block at the axis of two incoming signals the user can quickly establish a firm connection. The signals are routed into the SUSS-BOX by two 25 way D type connectors; 1xfemale, 1xmale. The SUSS-BOX also provides a lamp for each signal to show iuts condition when connected in line, ie high or low. SUSS-ADAPTOR & CABLES available.

OCTET/HERMIT

Typewriter interfaces

ADD ON TO THE
OLIVETTI ET121
OR HERMES TT21
ELECTRONIC
TYPEWRITER
AND HAVE THE
BENEFITS OF
THESE FEATURES



•Ideal for
TELECOM GOLD
•New LOW prices

- A DAISY WHEEL PRINTER for your computer
- A COMPUTER TERMINAL (True KSR)
- A TELEX TERMINAL using the Duplex DIAL-TEXT modems
- A COMMUNICATING TYPEWRITER (DIAL-TEXT Compatible)
- A REMOTE PRINTER using DIAL-TEXT modems

DUPLEX
COMMUNICATIONS (UK) LTD
2 Leire Lane, Dunton Bassett, Nr Lutterworth,
Leicestershire LE17 5JP
Tel: 0455 202154 778

FOR SALE. BBC model B system — £12.00 including disc drive, 6502 2P, colour monitor, printer, software. Details on (0256) 464889.

CLASMA SYSTEMS

For consultancy, advice, systems sales, customised software, training, support and maintenance.

CLASMA SYSTEMS LIMITED,
10 BARLEY MOW PASSAGE,
LONDON W4 4PH. ENGLAND.
TEL: 01-994 4395 TELEX 8811418.

LAS AMSTRAD "TOUCHTYPE"

Addictive trainer — educate your fingers. Tape £5.90. Disc — £8.90. Send SAE for special offers, list, Lingfield Advance Software, Plaistow St, Lingfield, Surrey RH7 6AU. Tel: 833960. Telex: 95596 Bosun G.

HOME ACCOUNTS. Put your house in order! Probably the best home use for your computer! Comprehensive coverage of bank accounts, credit cards, HP, etc. Inbuilt accuracy check for all transactions. Project cashflow for any period ahead. Available for CBM 64 or VIC-20 £8.45 or free details from: DISCUS SOFTWARE, FREEPOST, Windmill Hill, Brixham TQ5 9BR. Tel: 08045 55532. 477

THE BEST SPECTRUM TAPE UTILITY

NEW! SUPERUTILITY SU+ NEW!

This ADVANCED tape utility has the following features:

- Deals with the MAJORITY of "ordinary" programs.
- Deals with High Baud Rate programs — converts them to normal speed ready for transfer to microdrive.
- Deals with single or multiple part programs all in one run.
- Deals with normal and for headerless files.
- Contains INTERGRAL HEADER READER.
- Deals with VERY LONG files (up to 64000 bytes!)

UNBEATABLE VALUE AT ONLY: £5.95 (inc. P+P)

IF YOU ARE REALLY SERIOUS ABOUT TAPE TO MICRODRIVE TRANSFER — THIS IS THE UTILITY YOU MUST HAVE! SUPERB VALUE AT ONLY: £5.95 (inc. P+P).

NEW! SL2 ADVANCED SUPER SPEEDLOADER NEW!

Tired of waiting for your cassette program to load? Then try our NEW ADVANCED SUPER SPEEDLOADER. With this indispensable utility, your cassette based programs will load up to THREE times faster than normal, e.g. "THE HOBBIT" takes 115sec! (267 sec). "MANIC MINER" takes 84sec! (194sec). It comes with 12 useful programs to help you, and it will convert even the latest programs. Complete with FREE HEADER READER/HEADERLESS BLOCK LENGTH READER AND FULL instructions. EXCELLENT VALUE AT: £5.95 (inc. P+P)

Send cheque/P.O. to: "KOBRAHSOFT", "Pleasant View", Hulme Lane, Hulme, Nr. Longton, Stoke-on-Trent, Staffs, ST3 5BH. (Overseas: Europe add £1 P+P PER ITEM, others £2).
UPDATES: For your latest version — send old cassette + large S.A.E. for £2 saving on above prices — please mark envelope "update" Send S.A.E. for full catalogue of all our Spectrum utilities — please mark envelope "ENQUIRY". 825

**DUST COVERS SETS FOR
AMSTRAD CPC 6128, 464, 664
£6.95**

*Matching proofed nylon, treated with anti-static inhibitor. Red/Green/Blue piping on monitor cover, AMSTRAD CPC on keyboard cover.
*Please state model, colour or mono.

Cover for Tatung-Einstein £7.50

Proofed pale grey nylon piped in Red with name on keyboard.

Cover for other computers

Matching proofed nylon with toning piping and name on keyboard: BBC, DRAGON £4.95, COMMODORE, GOLDSTAR, SANYO, SONY, TOSHIBA £3.95. In black but unlined: SPECTRUM Plus £2.50, QL £3.50.

Matching covers for Printers

Amstrad DMP-1, Canon PW 1080A, Commodore MPS 801, Epson FX-80, RX-80, LX-80, Mannesmann MT-80, Shinwa CP-80, CPA-80, Tatung TP100, Taxan KP810 £4.50. Brother HRS £3.50 and Juki 6100 at £5.50. For full range, including business machine covers, please ring or send S.A.E. Prices include UK delivery. Europe at 50p, abroad £2 (Airmail).

BBD COMPUTER DUST COVERS
39 MANSE AVENUE
WRIGHTINGTON WN6 9RP
Telephone 0257-422968
TRADE ENQUIRIES WELCOME 711

**NOTICE TO
ADVERTISERS**

In view of legislation which has been introduced, 'Your Computer' will not publish advertising for copiers or other equipment which may encourage copyright theft.

1986 Games

Games for the Amstrad, BBC and Acorn Electron.

Inu... Kill your opponents to be the only survivor.....£3.50
The Heist...Fast cars, explosives, money or jail. Can your rob a bank.....£3.50
Both Games.....£5.00

Send cheque/PO to:
MRJ, 64 Reva Road,
Broadgreen, Liverpool

Spectrum Repairs

£16.95 inclusive of labour, parts + p&p. Fast reliable service by qualified engineers. Average repair 24 hrs. 3 mths guarantee. For help or advice ring:

HS Computer Services,
2 The Orchard, Warton,
Preston, Lancs. PR4 1BE.
Tel: 0772 632686

BLANK CASSETTES

	C10	C15	C20	C30
10	3.80	4.00	4.15	4.15
20	7.00	7.20	7.35	7.50
50	15.00	15.20	15.35	15.50
100	27.00	28.00	29.00	29.00

Fully inclusive (COD 65p extra)
Superior Tapes. Don't Settle for Less!

5 1/4" DS/DD DISKS

Manufactured by Memorex. Reinforced Centres.
10 for £13.50 inc. Plastic Storage Case

RING US NOW! (0793) 695034
UK HOME COMPUTERS (Dept YC)
82 CHURCHWARD AVE,
SWINDON, WILTS SN2 1NH 706

**FREE MEMBERSHIP
SOFTWARE HIRE**

- VIC-20 • COMMODORE 64 •
- SPECTRUM •

SAE FOR YOUR HIRE KIT

VSH (YC), PO BOX 65,
NOTTINGHAM NG1. 647

PLEASE STATE MICRO

A M S T R A D

**AMSTRAD CPC 464/664/6128
DISCOVERY**

THE SERIOUS TAPE TO DISC TRANSFER PROGRAM

- ★ PROVIDES a quick and easy way of transferring software onto disc
- ★ DISPLAYS program name and header details
- ★ ALTER program names before saving
- ★ ADD relocators to programs that overwrite the disc area
- ★ RENAME and erase programs, easy to use

Only £7.95 on tape £11.95 on disc
Please add £1.00 for overseas orders

SIREN SOFTWARE (Dept YC)
76 Bridge Street, Manchester M3 2KJ
Tel: 061 796 6874 794

A M S T R A D

IF YOU LIVE IN

SWEDEN
FOR ALL YOUR COMPUTERS NEEDS
NIMAX

DROTTNING KRISTNAS VÄG 13,
114 28 STOCKHOLM SWEDEN

08/102703

796

**FIVE SUPER
GAMES FOR C64
FOR ONLY £12**

Boxing for the C64, Car Racer, Space Run, Space Target, Battleship.

Five Super Games for only £12 on Cassette. Don't loose this Super opportunity.

Payment must be made in Sterling. Send Cheque or Postal Order to: Joseph Muscat, "Lourdes" Fisher Rd., Mgarr-Malta. 782
Payment includes also Postage and packing.

**FREE XMAS GIFT
WITH EVERY CATALOGUE**

Send £1 cash for our catalogue of the best software for the Amstrad, BBC and Spectrum.

We'll send you the catalogue, with detailed reviews, what the critics say, load times and screen shots of the software we have selected as the best of its kind. PLUS a voucher for £1 off you first order and a FREE Xmas gift. (It will help you write your order!)

Satisfied customers in 64 countries. Send £1 to: SPEEDY SOFT (YC), 37 Church Road, London SW13 9TQ 824

PROFESSIONAL REPAIRS

The complete Sinclair service centre

- ZX-81.....£13.95
- ZX 16K RAM.....£13.95
- ZX Interface 2.....£13.95
- ZX Interface 1.....£17.95
- ZX Microdrive.....£17.95
- ZX Spectrum.....£17.95
- ZX Printer.....£17.95
- Sinclair QL.....P.O.A.
- 16K to 48K Upgrade.....£26.95

Also BBC, C64, ORIC, DRAGON, ATARI & AMSTRAD
Ring 0234-213645

- * Av 3-4 day turnaround * 6 month warranty
- * All inclusive price * Free estimates

ZEDEM COMPUTERS LTD
2 Kimbolton Road, Bedford,
MK40 2NR.

(Trade and overseas enquiries welcome). 758

IMPORT/EXPORT - TRADE ONLY

we stock all well-known brands all the time

HOME-COMPUTERS : Commodore, Atari, Spectrum, etc.

PERIPHERALS : printers, monitors, disk drives, etc.

ACCESSORIES : diskettes, joysticks, interfaces, ink-ribbons, etc.

and we are always looking for import/export connections.

IF YOU WANT TO SELL OR BUY, PLEASE CONTACT US 746

ECTRON
Handelmaatschappij b.v.

Kruiswaal 3 - 1161 AL Zwanenburg
Holland - telephone (31) 2907 7102
telex 10246 ectro nl

**ASTROLOGY
for beginners
only £11.50**

A Starter Pack comprising a simple program to calculate a horoscope, an introductory booklet & 2 self-teaching programs (how to interpret the horoscope).

**No previous
knowledge required**

Spectrum, BBC/Electron, Oric, Dragon, Tandy/Genie, Commodore 64/PET, Atari, Sharp, Amstrad/Schneider, Colour Genie, MSX, IBM, Apricot, etc.

many more programs for experienced astrologers also other micros

Cash with order (add 50p outside UK) or large sae for free catalogue to: -

ASTROLCALC (Dept YC)
67 Peascroft Road,
Hemel Hempstead, Herts HP3 8ER
Tel: 0442 51809

BLANK CASSETTES

Guaranteed top quality computer/ audio cassettes at great budget prices. Packed in boxes of 10 with labels, inlay cards and library case.

Prices include VAT, post and packing.

- (C5) £3.35
- (C10) £3.40
- (C12) £3.45
- (C15) £3.75
- (C30) £4.70
- (C60) £5.30
- (C90) £7.00

BASF FLOPPY DISCS

- Prices of boxes of 10
- 5 1/4 Single side/Double density £19.95
- 5 1/4 Double side/Double density £21.85
- 5 1/4 Double side/Quad density £28.75

MICRO FLEXI DISCS

Price per unit
□ 3 1/2" Single side £4.00 each
□ 3 1/2" Double side £4.75 each
Indicate quantity of each product required in boxes Free delivery UK only. Cheque/PO. Enclosed for £

NAME.....
ADDRESS.....

**PROFESSIONAL
MAGNETICS LTD** 741

Cassette House, 329 Hunslet Road, Leeds LS10 3YY
FREEPOST Tel: 05321 706066

SPECIAL OFFER

from

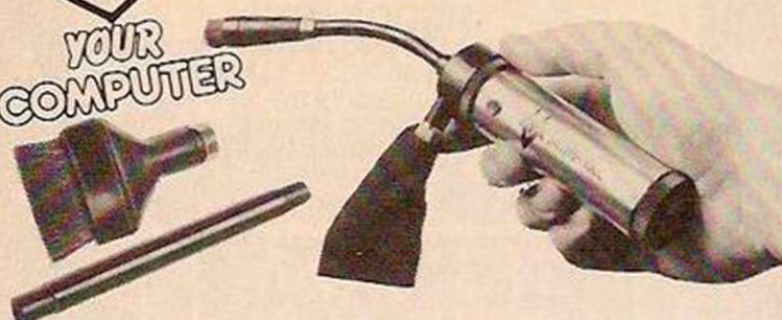
YOUR COMPUTER**BEAT THE DUST PROBLEM**

The Mini-Vac is a vacuum cleaner in miniature. It fits in the hand and comprises a chrome plated metal body, which contains a surprisingly powerful motor driven by a PP3 size battery (not included). There is a choice of two tubular nozzles on which can be fitted a large or a small soft bristle brush and a dust collection bag with Velcro flap for emptying. When used as a vacuum cleaner it was found to be ideal for dust removal from the inside of computers and peripherals, or around keyboard and screens. By removing the dust bag and putting one of the nozzles in its place it can also be used for blowing.

Has many other uses: for blowing or removing dust from stereo and video equipment, cameras, lenses and enlargers.

OFFER PRICE £8.99 incl. 15% Vat and UK p&p

Order from Your Computer Mini-Vac Offer, 48 Beauchamp Place, London SW3 1NX using coupon or copy or plain paper. Allow up to 28 days for delivery. UK addresses only. Closing date 31.12.85. Cheques should be made payable to Your Computer Offers. If Vat receipt is required, it is essential to say so when ordering.

Coupon to: YC Mini-Vac Offer, 48 Beauchamp Place, London SW3 1NX
Please send Mini-Vacs @ £8.99. Cheque enclosed £.....

Name

Address

Postcode 85/183

BUSINESS PRESS INTERNATIONAL LTD.

Registered in England No. 151637. Regd Office: Quadrant House, The Quadrant, Sutton, Surrey SM2 5AS.

**WET ZONE** BBC(B)classical arcade action
— fast, addictive, skilfulonly on **micronet 800**
or by mail orderSend **£4.95** cheque,
cash or postal order to**EVERISS SOFTWARE**
37 Linkway, Denham Green,
Uxbridge, Middlesex UB9 5NL**NEW! A.F.I. LISP**for the 48K Sinclair spectrum (and Plus).
Specifications include: 4K/5K cells, external
oblist and p.d. stack, over 70 functions, 64-col
full-screen integral editor, Interface-1 and
Microdrive compatible.Plus full documentation with a turtle graphics
example. For only £15.00 inc.

(+ £1.00 for Export) from:

A.F.I. Software

P.O. Box 149, London SW17 9LB

SPECTRUM TAPE UTILITY 007Your shaking specky driving you dotty? Would
you like a firmer sharper display? Our dot crawl
suppressor fits inside case two solder joints,
clear simple instrs, fully guaranteed 7-14 days
delivery only £5.50 inc. Cheque/PO to, A
Baldwin, 11 Willoughby Ave, Lenton, Nottm,
NG7 2EP.**AMSTRAD * ATMOS * ORIC-1
SOFTWARE CLUB**Hundreds of titles available — Excellent
selection. Also, popular accessories and
utilities for the Amstrad available for sale
at discount prices.**SEND SAE STATING COMPUTER**
26 Beechley Drive, Cardiff CF5 3SN.MOTORIZED gearbox — two motors, clutch
and housed in a plastic case £9.50 +
information to control each motor via
computer e.g. CBM 64. Wheels £120 each.
Unisoft, 31A Church Road, Burton Joyce,
Nottingham.The Publishers take all
reasonable care to
ensure that classified
advertisements are
genuine, but readers
must satisfy them-
selves that they will be
obtaining what they
require before entering
into transactions, parti-
cularly if they involve
large sums of money.

128/128

**SELL IT WITH
YOUR
COMPUTER****CLASSIFIED
ORDER FORM****Classified Rates**Linage: 60p per word (Min 20 words) —
prepayableLinage advertisers should complete the form
provided in **BLOCK CAPITALS**. Phone number
counts as 2 words. Name and address to be
paid for if used in advertisement. Box Number
if required is £7.00 extra.**Display — rates per scc (Min 2scc)**One insertion : £10.00
Three insertions : £9.70
Six insertions : £9.50
Twelve insertions : £9.00Display advertisers should provide separate
copy and preferably reserve space by phone
(01-661 3036).**Method of Payment**Cheques etc. should be made payable
to Business Press International Ltd, and
crossed. I enclose herewith
cheque/PO forPlease debit my Access/Visa Barclay
Card/American Express/Diners Club Int/
as below

.....

SIGNATURE**Post to:**Cut out the order form and return
together with your remittance to:
Classified Department, Your Computer,
Room H211, Quadrant House, The
Quadrant, Sutton, Surrey SM2 5AS.
(01) 661 3036

Please insert the following advertisement in Your Computer Classified Section

					LINAGE	PLUS 15% VAT	TOTAL
					£12.00	£1.80	£13.80
					£15.00	£2.25	£17.25
					£18.00	£2.70	£20.70
					£21.00	£3.15	£24.15
					£24.00	£3.60	£27.60
					£27.00	£4.05	£31.05
					£30.00	£4.50	£34.50

No. of insertions required Box No. required YES/NO

NAME (Please include initials)

ADDRESS

Payment by credit card please state address card is registered

Daytime tel. no

THIS FORM SHOULD BE RETURNED BY DEC 20 FOR THE FEB ISSUE

Company Registered Number: 151537 (England) Registered Office: Quadrant House, The Quadrant, Sutton, Surrey SM2 5AS.

FAST COMPUTER REPAIRS

VIDEO VAULT INTERNATIONAL 10★ REPAIR SERVICE

ACCESS
WELCOME

THE NO. 1
REPAIR CENTRE
IN THE U.K.

24 HOUR
TURNAROUND



SPECTRUMS REPAIRED for only £19.95
including PARTS · INSURANCE and P & P.
NO HIDDEN EXTRAS

We don't give you a between price and let you guess the bill, we give you a 100% fixed price NO extras. We don't need to boast about our service, we have 1000's of customers from all over the world highly delighted with our service and help. Only 20 minutes from Manchester Centre. BBC, Commodore 64, Vic 20, also repaired call us for details.

Don't wait weeks for your repair, we turn around all computers in 24 hrs. All repairs carry a full 3 month guarantee, plus on every Spectrum we repair, we send you a free game worth £5.95 for your enjoyment and pleasure.

- While you wait service by Professional Computer Engineers.
- 3 month written guarantee on all repairs.
- International Repair Company. We repair computers from all over the world.
- All computers sent by Mail Order turned around in 24 hrs.
- Most Spectrums repaired within 45 minutes.
- All Micros insured for return journey.
- Keyboard faults only £8.95
- School repairs undertaken - discount available.
- Free software with each Spectrum repaired.
- Over 8 years experience working with computers. All computers fully tested.

HOW TO SEND YOUR COMPUTER

Just parcel your computer in suitable wrapping enclosing £19.95 for Spectrum repairs, please do not send power supplies. Commodore computers, just send £1.75 (U.K. Eire, I.O.M. C.I.) or £6.50 (Europe/Scandinavia) with your address or phone number and we will contact you same day by phone or letter with quote, if you prefer, please call us and we will give you a quote over the phone, we aim to please. That's what made us the most reliable service centre.

TRADE
REPAIRS
most
welcome

BEST SERVICE - BEST PRICES!

COMMODORE 64 * NOW REPAIRED *

Call us for details or purchase the I.C.'s from our D.I.Y. section

WE ONLY USE SINCLAIR
SPARES. FITTED BY OUR
QUALIFIED STAFF!

THE
LOGICAL
CHOICE

*SPECIAL KEYBOARD UPGRADE



Why not upgrade your Spectrum into a new keyboard. We can upgrade your old Spectrum into a new D.K. Tronics keyboard

for only £31.50
which includes fittings + return P. & P. and V.A.T
Normal retail price £39.95 without fitting

ORDER
NOW!

SPECIAL OFFER!

YOU CAN'T REFUSE

16K to 48K Upgrade

Upgrade your 16K Spectrum to 48K Spectrum for only £19.95 fitted including V.A.T. and P.&P.

(Limited offers while Stocks Last.)
Makes a great Christmas present.
To order the Upgrade Kit,
(only £17.95.)

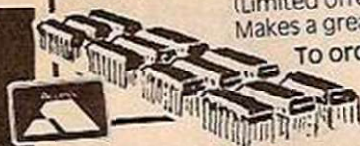

P.S. We would like to wish all our customers past and present a very Merry Christmas and a Happy New Year.

THERE'S
NOBODY QUICKER
IN THE BUSINESS AT PRICES
THAT CANNOT BE
BEATEN

VideoVault D.I.Y. CORNER

We regret we cannot show all the components available. Just give us a call and we can quote you over the phone, delivery by return.

Spectrum Parts

Z80A CPU	3.00
4116 Rams	0.95
ZTX 650	0.60
Service Manuals	20.00
ULA 6C001	9.50
Transistor ZTX 213	0.30
Transistor ZTX 313	0.50
Keyboard Membrane	3.00
Keyboard Template	3.00
Keyboard Mat	5.00
Power Supply Units	7.95
Feet (Each)	0.25

Commodore 64 Chips

6526	23.00
6510	23.00
6581	23.00
901227-03	23.00
901226-01	23.00
901225-01	23.00
6569	23.00
4164 Rams	3.00
Power Supply Units	29.00
All prices + P.&P.	£1.50
But include V.A.T.	

TRADE
ORDERS
WELCOME

VIDEOVAULT HEALTH WARNING!!!

Sending your computer to any other Repair Centre can seriously Damage its Health

STOP
PRESS

VIDEOVAULT LTD will shortly be opening their New Branch in Manchester City Centre for while you wait computer repairs, watch this space for details of Special opening offers.

OPEN
7
DAYS
A
WEEK

VideoVault Ltd.

Telephone: Glossop (STD 04574) 66555/67761
140 High St. West, Glossop, Derbyshire, England

FREE GAME WORTH
£5.95 WITH
EACH SPECTRUM
REPAIR.

Special Reader Offer!

£17.95
INCLUDES POST,
PACKING &
VAT

...the Duraplug
Mains Filter
Adaptor...

The Duraplug Mains Filter Adaptor is an essential, yet inexpensive, item for any user of sensitive electronic equipment in the office or home. Plugged into an ordinary wall socket it provides adequate protection against distortions in the mains supply, 'laundering' noise and spikes out of the current and preventing digital circuits from misbehaving.

...the end of the
line for spikes!



To: Your Computer Offer, Room 807, Quadrant House, Sutton,
Surrey SM2 5AS

Please send me the following:

Quantity.....Duraplug Mains Filter Adaptor(s) @ £17.95 each
incl. p&p and VAT.

I enclose my cheque value £..... made payable to
YOUR COMPUTER OFFER.

NAME.....

ADDRESS.....

EXPORT

AND OVERSEAS VISITORS

ALL MAKES OF MICRO
COMPUTERS, PRINTERS,
PERIPHERALS AND SOFTWARE
SUPPLIED AT DISCOUNT
PRICES.

AMSTRAD • ORIC • SINCLAIR
• BBC MICRO • ATARI •
COMMODORE • APRICOT •
STAR • BROTHER AND ALL
POPULAR MAKES

MICROGOLD

UNICOM HOUSE
182 ROYAL COLLEGE STREET,
LONDON NW1 9NN
TELEX: 295931 UNICOM G
TELEPHONE: 01-482 1711

A		L	
ABC Electronic	32	LCL	50
Africa Online	106, 107		
Alligata Software	34		
Amstrad	6, 7, 9	M	
Amstras Ahaw	32	Mannesman Tally	4, 123
Anirog	10	Micro-X	26
Atari	76, 77	Microgold	130
Artic Computing	125	Micronet 800	47
		Micropower	17, 19
		Miracle Technology	22
B		O	
Beebug	124	Ocean Software	11, 70, 87
Beta-Soft	34	Opus Supplies	60, 61
C		R	
Cascale Games	5, 119	RSD Connections	50
Commodore	36, 82	Realtime Games	120
Compumart	124	Romantic Robot	28
Computer Link	50		
Computers by Post	26	S	
Cumana	122, 123	Selec Software	28
		Silica Shop	79
D		Spectravideo	102
Dennison	I.B.C.	Superior Software	116
Digital Integration	90	Swanley Electronics	28
Durell Software	8		
E		T	
English Computer Shop, The	34	Tandy	65
		Thoughts & Crosses	99
G		U	
Gremlin Graphics	55	US Gold I.F.C., 12, 13, 14, 15, 43, 66, 67, 88, 115, 121	
		Ultimate	16, 18, 118
H		V	
Hi-Voltage	24	Virgin Games	40
I		W	
ICS	26	Woolf Graphics	102
Imagine	117, Back Cover		

MORE ELEPHANTS TO TRUST

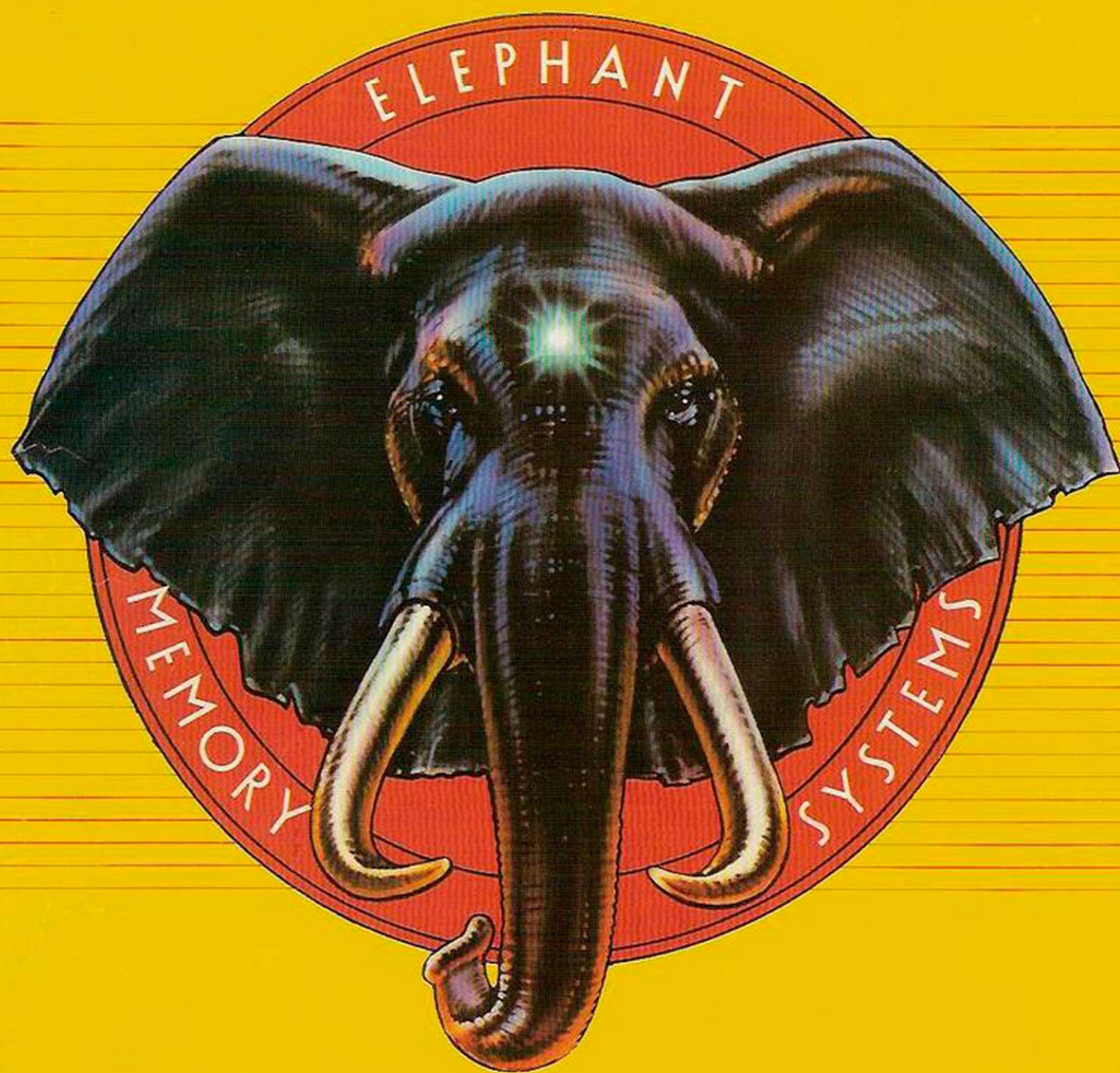

ELEPHANT printer ribbons, head cleaning disks and computer cleaning kits are now added to the ELEPHANT family to provide you with a total computer supplies package. Together with ELEPHANT MEMORY SYSTEMS disks – certified 100% error free and problem free and guaranteed to meet or exceed every industry standard – ELEPHANT is now more than ever the trusted brand that gives you the best from your computer.

Dennison

ELEPHANT NEVER FORGETS

Dennison Manufacturing Co. Ltd.

Colonial Way, Watford, Herts WD2 4JY, Tel: Watford (0923) 41244, Telex: 923321

France: Soroclass, 45, rue de l'Est - 92100, Boulogne.

Tel. Réseau de Distribution: 605 98 99. Administration des Ventes: 605 70 78. Telex: EMS 206 436 F

Germany: Marcom Computerzubehör GmbH, Podbielskistr. 321, 3000 Hannover 51, Tel: (0511) 647420, Telex: 923818

Italy: King Mec SPA, Via Regio Parco 108 BIS, 10036 Settimo, Torinese, Tel: (011) 800 93 93, Telex: 211467 KIN MEC-I

Other Countries: Dennison International Company, 4006 Erkrath 1, Matthias-Claudius-Strasse 9, Telex: 858 6600

AMSTRAD 16-95
SPECTRUM 4-95
COMMODORE 64 13-95

YIE AR KUNG-FU

THE ARCADE SMASH COMES HOME!

Also
for the
BBC Micro
9.95

Imagine

...the name
of the game

Konami

Imagine Software is available from:  WHSMITH,  John Menzies, WOOLWORTH, LASKYS, Rumbelows, Greens, Spectrum Shops and all good dealers.

Imagine Software (1984) Limited • 6 Central Street • Manchester M2 5NS • Tel: 061 834 3939 • Telex: 669977