

FREE INSIDE - YOUR COMPUTER COURSE PART 5

Your COMPUTER

► JULY 1986 VOL. 6 NO. 7

BRITAIN'S BIGGEST-SELLING HOME COMPUTER MAGAZINE

SUPERCHARGE YOUR AMSTRAD

DIY 8256 RAM UPGRADE

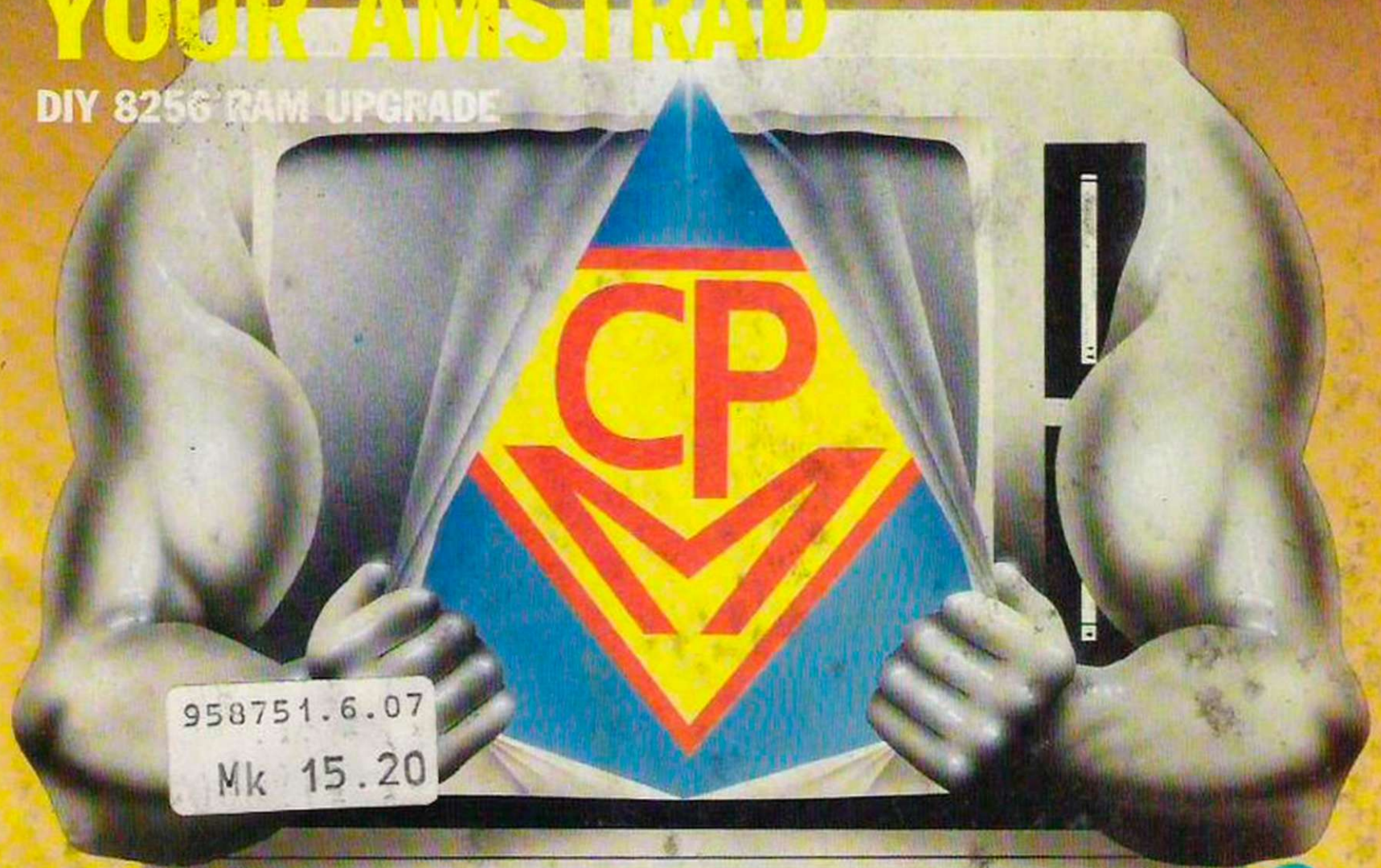

£1	Denmark	DKr.	36.00
	France	Fr.	52.50
	Germany	DM.	9.50
	Greece	Dra.	360.00
	Holland	DFI	8.90
	Italy	L.	4300
	New Zealand	NZ\$	3.70
	Spain	Pts.	425.00

DATA PROTECTION ACT:
DO YOU NEED TO REGISTER?

**BUYERS' GUIDE
TO PRINTERS**

WIN A VIDEO DIGITISER

HINTS & TIPS ★ SOFT FILE ★ CLUBS ★ NEWS ★ SOFTWARE PREVIEWS

**FOUR-PAGE
COMMODORE
SUPPLEMENT**



Colleen Music Compendium



Incredible Integrated Music Package for the Atari and Commodore Range of Computers
Suitable for beginners and advanced users alike!



£49.95

THIS DOUBLE DISKETTE CONTAINS — SIDE ONE: NO BLUES FILE!

MUSIC THEORY: This computer help package in music enables you to understand the fundamentals of music.

GUITAR TUTOR: Teach yourself guitar from the comfort of your own home. Covers all the chords found in today's popular music charts.

SOUND CHIP TUTOR: All you need to know about programming the sound chip in your computer — explained in such a way that even a novice can understand.

SIDE TWO:

PLAY ALONG: Amaze your family and friends by providing real time accompaniment to the songs of your choice. Provides backing in four musical styles in every key!

DRUM MACHINE: Program your own drum patterns with the help of this exciting utility. Drum away for up to two hours — but mind the neighbours!

COLLEEN MUSIC CREATOR: Specifically designed to create super efficient complete machine code music programs. Tunes created and run independently of the creator which in turn can be marketed without ANY restrictions. This could be your chance to make money!

Tunes are played back using multi-tasking features normally associated with 16-bit machines — this means you can have two programs running together.

JUST LOOK AT SOME OF THE FEATURES:

- Joystick controlled ■ Icon driven ■ Full synthesiser control over each and every note from a 2000 note sequencer using any combination of voices
- Full editing facilities with an option of super-imposing sound effects over your polyphonic music
- Full after-sales support and comprehensive manuals provided ■ Special conversions for the disabled.

cheques or postal orders (payable to COLLEEN LTD) to:
COLLEEN LTD., Colleen House, 18 Bishop Street,
Penygraig, Tonypany, Mid Glam CF40 1PQ

I enclose cheque/postal order for £

Signature

Name

Address

Post Code

Any other information required about COLLEEN LTD,
write to the above address or telephone (0443)
43 5709/434846

TANTALUS

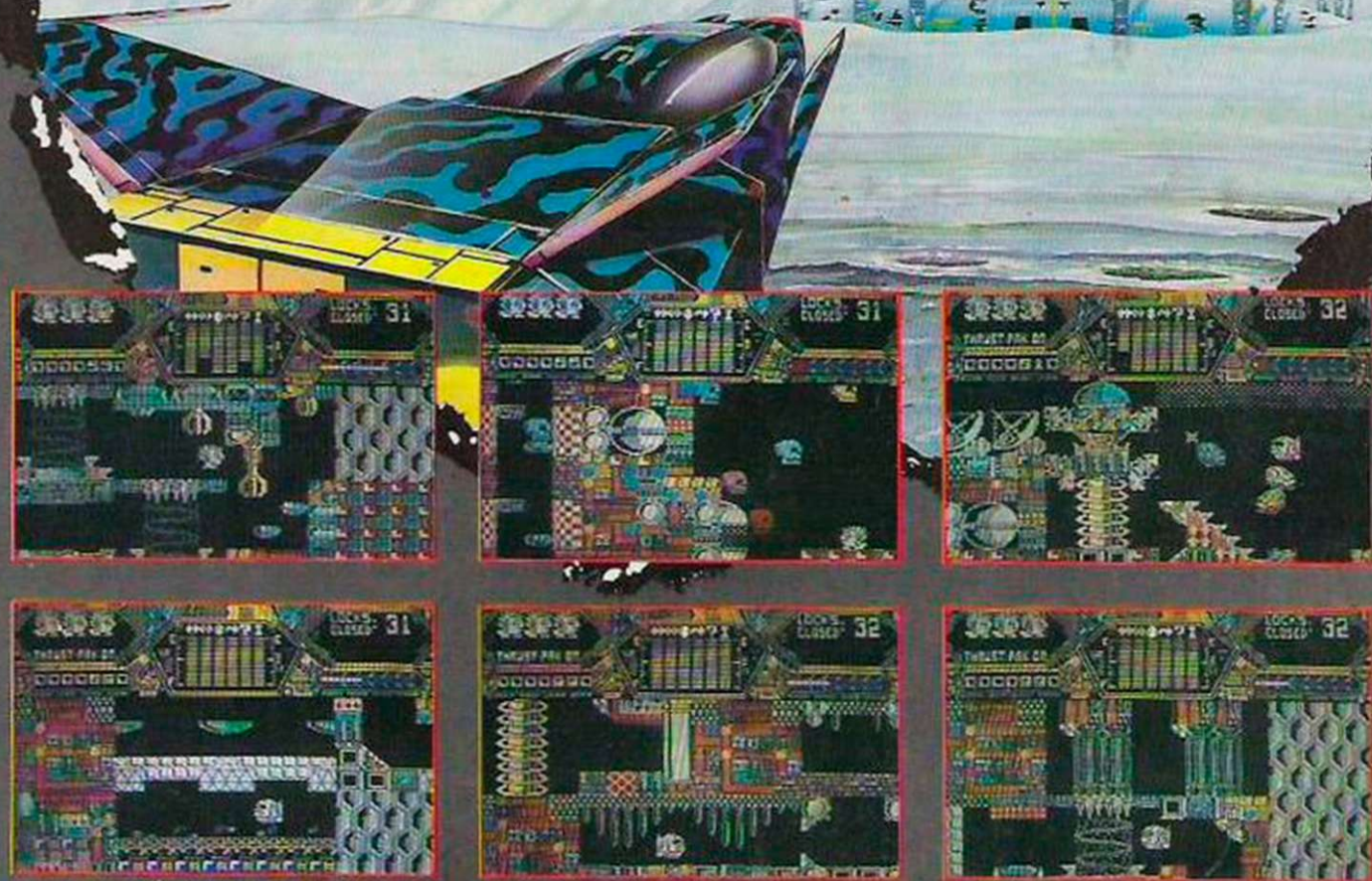

Famed for their fighting prowess the Punkoids are sent on the most important mission of their inhuman lives — to assassinate the last deviant human being on this side of the anti-matter curtain.

Tantalus is a full colour, hyper-graphic, super arcade style adventure. You have the chance to affect the final outcome — life or death for the Last Deviant in the Universe!

Spectrum 48/128 £8.95

QUICKSTEVIA

Liberty House, 222 Regent Street
London W1R 7DB
Telephone 01-439 0666

Editor

Gary Evans

Software Editor

Lee Paddon

Staff Writer

Anthony Thompson

Sub Editor

Harold Mayes MBE

Production Editor

Jim McClure

Production Assistant

Nick Fry

Editorial Secretary

Sheila Baker

Designer

Chris Winch

Editorial 01-222 9090**Group Advertisement Manager**

David Lake

Advertisement Executives

Ian Faux

Jeremy Kite

Classified

Paul Monaf

Advertising 01-222 9090**Publisher**

Paul Coster

Financial Director

Brendan McGrath

Managing Director

Richard Hease

Cover

Mark Tyler

**Your Computer,
79-80 Petty France,
LONDON SW1H 9ED**

ISSN 0263 0885

© 1986 Focus Investments Limited.
Printed by The Riverside Press, England.
Typeset by Time Graphics Ltd., Northampton.
Member of the Audit Bureau of Circulation.

Reasonable care is taken to avoid errors in this magazine but no liability is accepted for any errors which may occur. No material in this publication may be reproduced in any way without the written consent of the publishers. The publishers will not accept responsibility for the return of unsolicited manuscripts, listings, data tapes or discs.

We will assume permission to publish all unsolicited material unless otherwise stated. We cannot be held responsible for the safe return of any material submitted for publication. Please keep a copy of all your work and do not send us original artwork.

Unfortunately we are unable to answer lengthy enquiries by telephone. Any written query requiring a personal answer MUST be accompanied by a stamped, self-addressed envelope; please allow up to 28 days for a reply.

Subscriptions: UK £14 for 12 issues. Overseas (surface mail) £22.50 - Airmail rates on request. Please make cheques/postal orders payable to Focus Investments. (Please allow 5 weeks from order receipt of first subscription copy). Send orders to Your Computer Subscriptions, Oakfield House, Perrymount Road, Haywards Heath, RH16 3DH. Telephone (0444) 459188.

January to April 86 back issues of the magazine are available for £1.50 from the Back Issues Department, 79-80 Petty France, London, SW1H 9ED.

Distributed by Business Press International, Quadrant House, Surrey, SM2 5AS. Telephone 01-661 3239.

CONTENTS

**TURN TO PAGE 83 FOR THE START OF THE
YOUR COMPUTER COURSE****26**

COMMODORE SUPPLEMENT

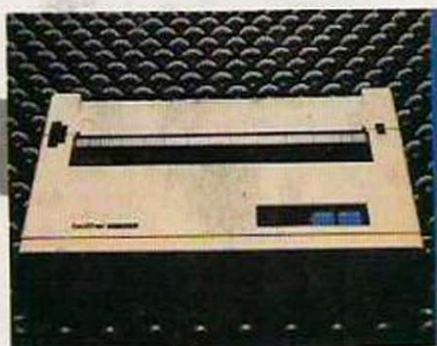
Buyers' guide to hardware and software for the world's favourite home computer.**32**

GETTING INTO PRINT

Our guide to the best buys in printers.**39**

AMSTRAD UTILITIES

Reviews of two top Amstrad programming tools.**46**

DATA PROTECTION

Do you need to register under the Data Protection Act? We have the answer.**50**

ADVENTURE REVIEWS

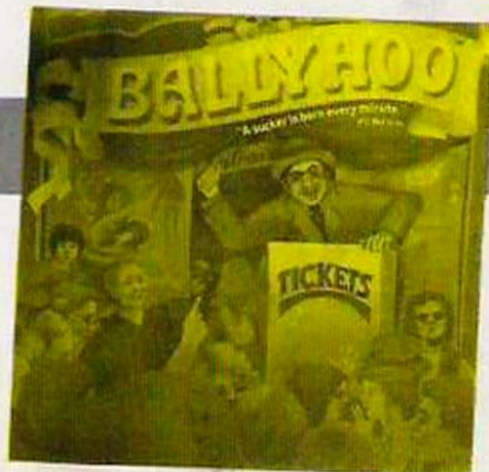
Our guide to the best of the latest adventure games.**PCW82****Turn to page 34 for
best-selling Amstrad**

8256/8512 Special

34 for the start of four pages devoted to the Amstrad computers



55

DR LOGO

It is a mistake to dismiss Logo simply as a language to control turtles, as Mike James reveals.



58

SPECTRUM 128 PROGRAMMING

Continuing our guide to the inner working of the Sinclair – sorry Amstrad – 128K computer.



75

NEXUS COMPETITION

Win a digitiser in this month's competition with code-breaking as the aim.



76

ADVENTURE WRITING GUIDE

Part two of our series showing how to construct your own adventure game.

NEXUS

NEWS

12 Alan Sugar's millions.

COMMUNICATIONS NEWS

15 Prestel to follow the French example?

CHARTS PAGE

17 A new format this month.

SOFTWARE PREVIEWS

18 Games in the pipeline.

SOFTWARE NEWS

19 Charting the software scene.

DREAM MACHINE

20 Big Blue's blockbuster.

COMPANY PROFILE – ELITE

23 We preview tomorrow's chart-toppers.

PROFILE

25 Commotion, the robot makers.

HARDWARE REVIEWS

31 Thomson's monitor and a joystick with 4 or 5 way movement

SOFTWARE SHORTLIST

41 The best of this month's games.

LETTERS

61 Give vent to your feelings.

SOFTWARE EXCHANGE

62 Our new software supermarket.

EDUCATION

64 Computers with a touch of class.

CAREERS

65 Could you be a Mr. Fix-it?

CLUBS

67 The scene in Scotland.

PROGRAM FILE

70 Let your fingers do the programming.

It does accounts, projections, v



No wonder people are racing out to buy Amstrad's new CPC 6128 computer.

Not only does it answer all your business needs, it's also compatible with nearly 200 arcade and adventure games. So it can either speed you through your income tax returns or whizz you round a simulated Silverstone.



On the business side we start you off with a free disc

which introduces you to the Amstrad CPC 6128's impressive range of capabilities, and the best ways to exploit them.

You'll discover how its massive 128k memory can open the door to over 8,000 CP/M* applications.



Programs like 'Wordprocessing' and 'Database' will file and index records, produce standard letters, mailing lists and even compile reports.

There's a series of business control programs which form a complete invoice, stock control and statement system.

In other words it's easy to choose the software you need to take the big problems out of your small business.

But even if you don't own a business there are plenty of good reasons for owning an Amstrad CPC 6128.

It makes short work of the problems we all face. Like keeping track of rates, mortgage and H.P. payments.

However even software packages as comprehensive



word processing and 180mph.



as Amstrad's are only as good as the hardware they're loaded into.

You need a complete system.

That's why the Amstrad comes complete with a built-in disc drive as well as a monitor (green screen or full colour). So it's ready to go to work as soon as you get it home.

And if you want to go further additional disc drives, printers and joysticks are all available to ensure that your computer can grow with your growing needs.

Finally there's one feature of the Amstrad CPC 6128 that's both good business and a pleasure: the price.

With Green Screen around **£299**

With Colour Monitor around **£399**



Tell me more about the Amstrad CPC 6128

Name _____

Address _____

Amstrad CPC 6128 with 128k memory

Who says business and pleasure don't mix?

Amstrad P.O. Box 462, Brentwood, Essex CM14 4EE

*CP/M is a trademark of Digital Research Inc.

RUMBELOWS · SUPREME DISCOUNT STORES · TANDY · VALLANCES · W.H. SMITH · WIGFALLS · AND GOOD INDEPENDENT COMPUTER STORES

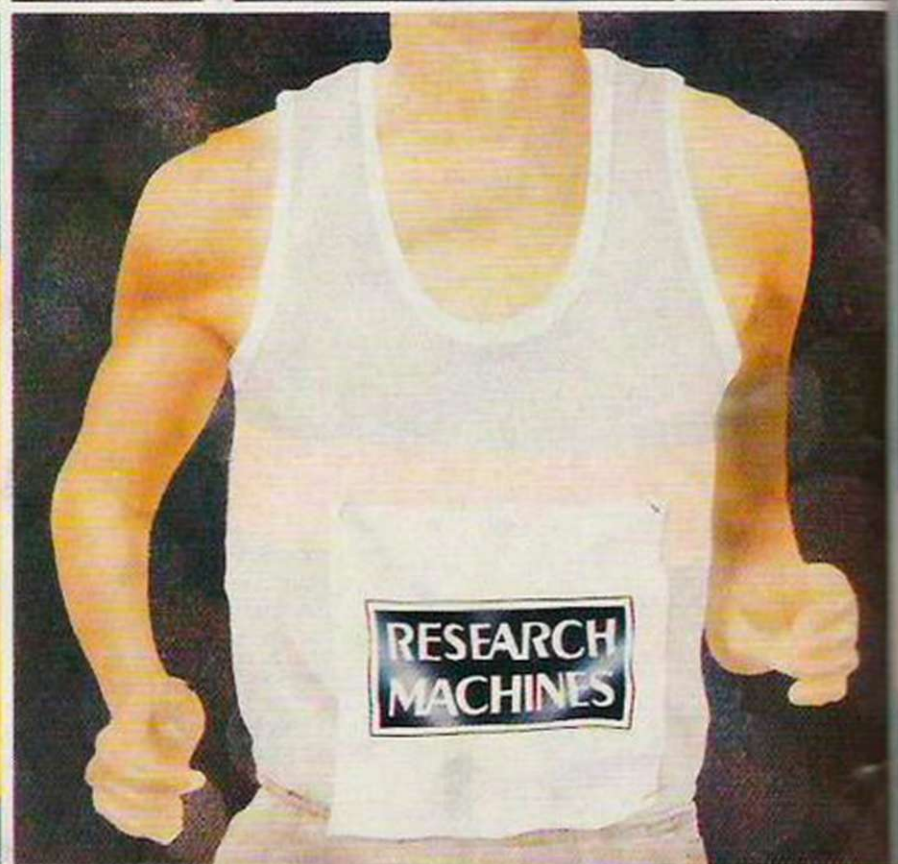
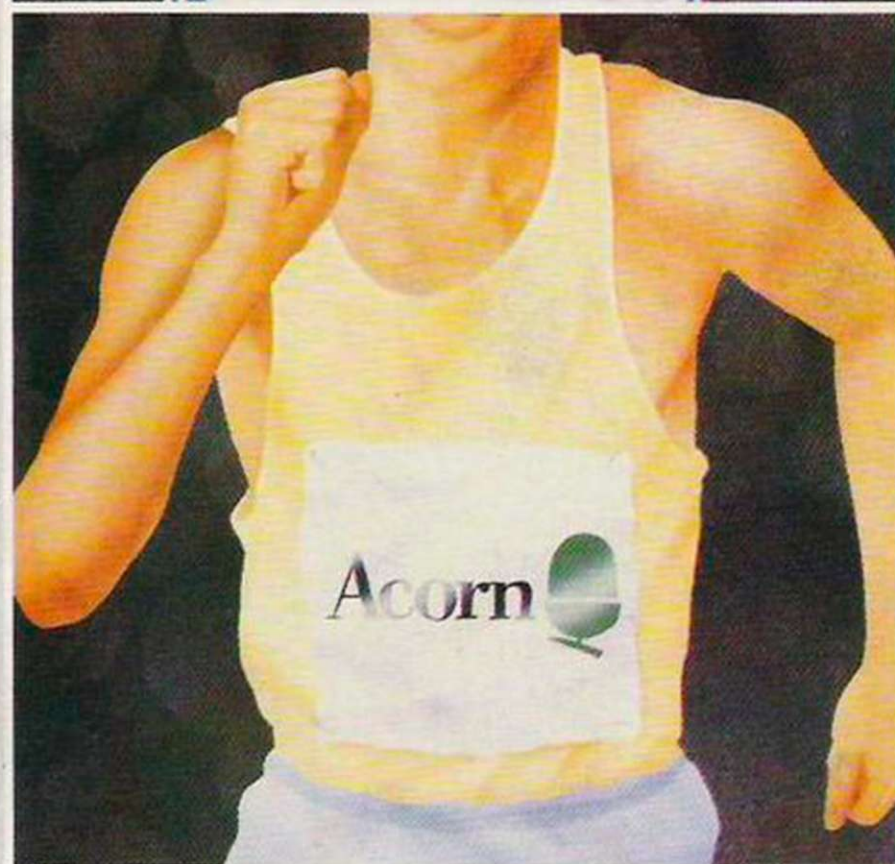
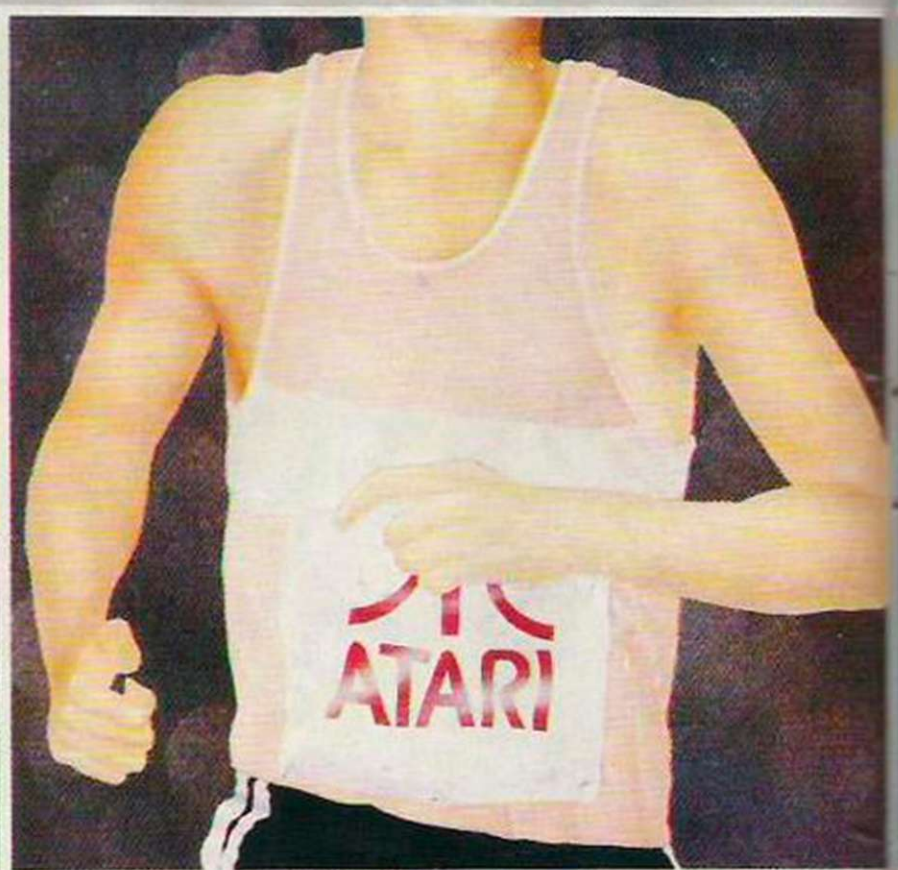

Join the front runner

The main event in the personal computing calendar has got to be the PCW Show at Olympia. It's the largest event of its kind held under one roof. And this September we're proud to be celebrating our 9th year.

Once again you've the golden opportunity to see all the famous names in the business battling for top positions alongside fresh, talented newcomers.

At your leisure you can pick and choose

the ideas that will profit you best.

And with an extensive range of hardware, software and peripherals on show, you can be certain there's something of interest for everyone. Whether you're a seasoned professional, a teacher or an enthusiast.

There's also a line-up of services and facilities to help you make the right decisions. Like the Application Advisory Service and consultancy area, our Product Locator system,

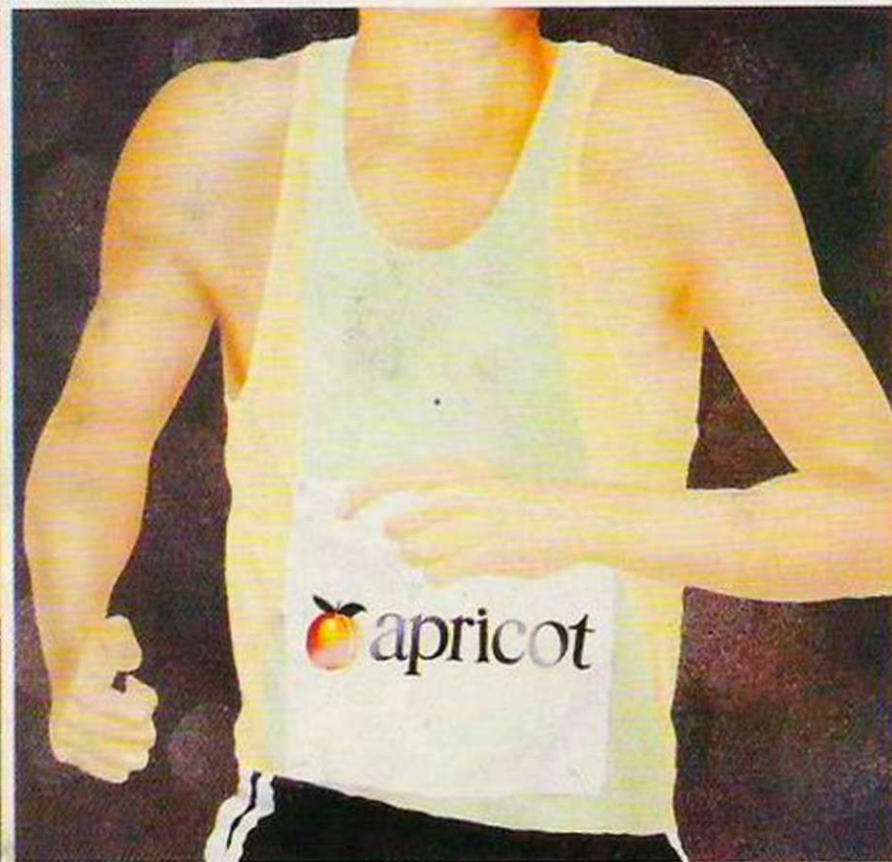
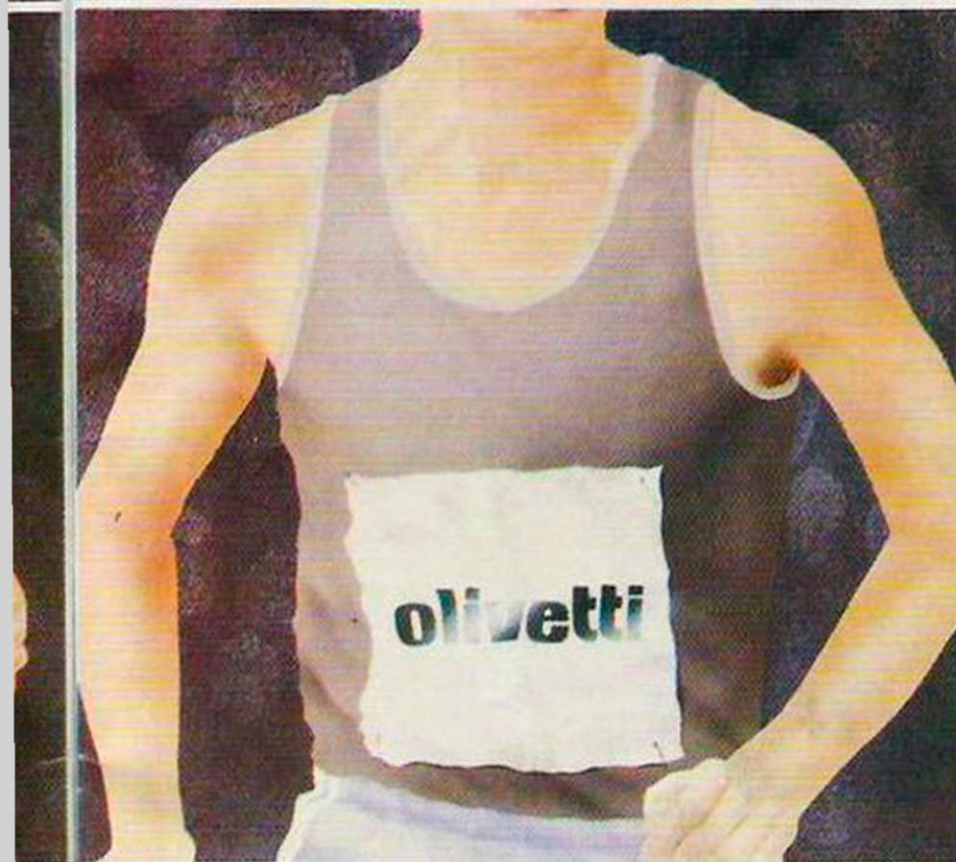
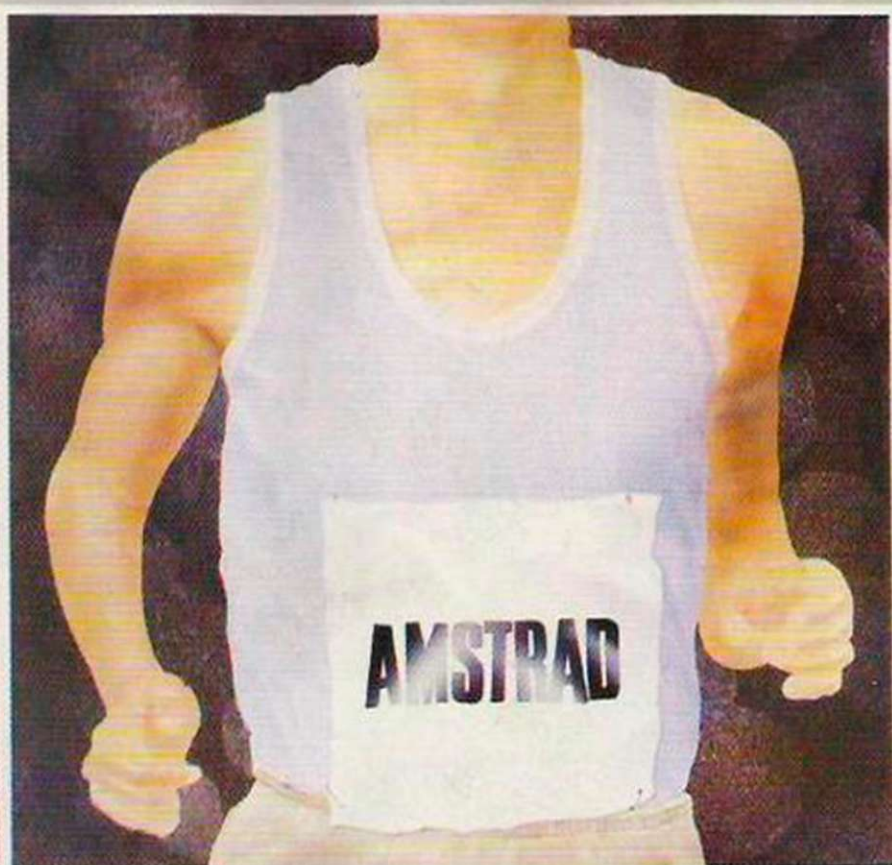

ers at the main event.

the new PCW Show Education Centre and the Association of Computer Clubs.

All offering help and advice with your computing problems. So how will the stars fare against the smaller specialist suppliers this year? Get set for the main event when all will be revealed.

The stadium is London's Olympia. The dates 3-7 September 1986. Send



3-7 SEPTEMBER 1986
OLYMPIA LONDON

Sponsored by Personal Computer World

for your tickets now. [Business, professional and trade only days 3-4 September].

For advance tickets at £2.00 each ring the PCW Show ticket office on 01-487 5831 with your Access or Barclaycard number. Or send a cheque to PCW Show Tickets, 11 Manchester Square, London W1M 5AB.

Organised by Montbuild Limited 11 Manchester Square London W1M 5AB

OFF THE HOOK

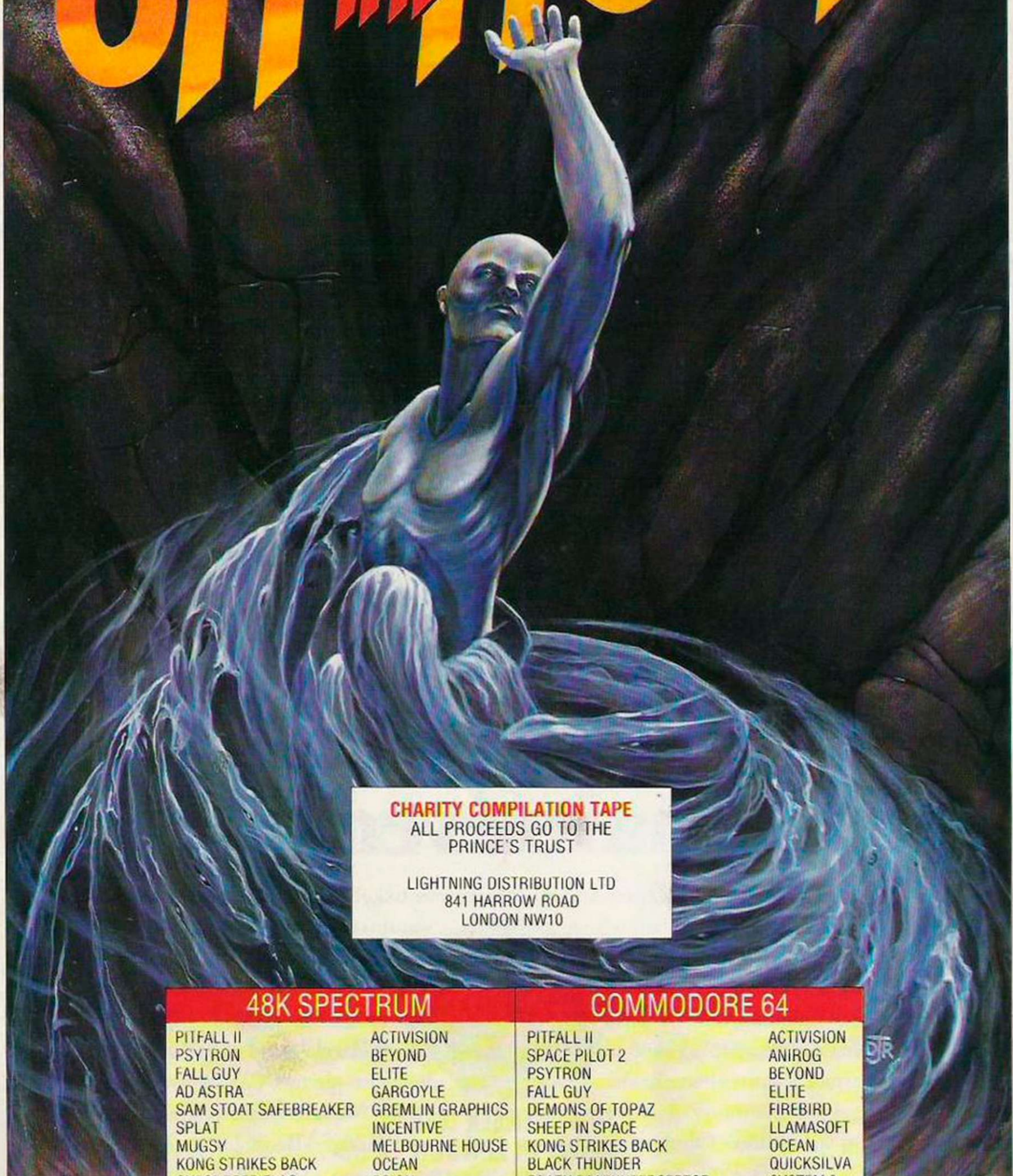

CHARITY COMPILATION TAPE
ALL PROCEEDS GO TO THE
PRINCE'S TRUST

LIGHTNING DISTRIBUTION LTD
841 HARROW ROAD
LONDON NW10

48K SPECTRUM

PITFALL II	ACTIVISION
PSYTRON	BEYOND
FALL GUY	ELITE
AD ASTRA	GARGOYLE
SAM STOAT SAFEBREAKER	GREMLIN GRAPHICS
SPLAT	INCENTIVE
MUGSY	MELBOURNE HOUSE
KONG STRIKES BACK	OCEAN
CHEQUERED FLAG	PSION
BLUE MAX	U.S. GOLD

COMMODORE 64

PITFALL II	ACTIVISION
SPACE PILOT 2	ANIROG
PSYTRON	BEYOND
FALL GUY	ELITE
DEMONS OF TOPAZ	FIREBIRD
SHEEP IN SPACE	LLAMASOFT
KONG STRIKES BACK	OCEAN
BLACK THUNDER	QUICKSILVA
DEATH STAR INTERCEPTOR	SYSTEM 3
TALLADEGA	U.S. GOLD

TIMETRAX



TIMETRAX

Just after the Holocaust you wouldn't think anything else could go wrong now would you? There you were sitting peacefully in your cellar, trying to have the nervous breakdown you've earned and the next thing you know you're setting out through the Portals to stop the Evil One rending asunder the fabric of Creation. Some days nothing goes right...

An amazing, all-action, animated adventure across the ages of Man to save civilisation. You'll be able to start playing it in minutes but you mightn't finish it for years!

WARNING: This game could damage your social life. TIMETRAX is an addictive habit.

COMMODORE 64, SPECTRUM or AMSTRAD: £9.95.

In case of difficulty this game is available from Argus Press Software.



The Argus Press Software Group,
Liberty House, 222 Regent Street,
London, W1R 7DB.
Telephone: (01) 439 0666.

MIND GAMES

A significant percentage of the articles in a typical issue of *Your Computer* are concerned with reviewing the latest hardware and software launches. When preparing product reviews, a reviewer is under a number of constraints, not least of which is the short time available to prepare an assessment of the equipment or software being examined. In the case of, for example, a shoot-'em-up game or joystick, the fact that a review will be based on an immediate evaluation of a product is not a disadvantage; the attractions of that type of hardware

COMMENT

or software are essentially immediate in nature. When reviewing items which are more complex in nature, however, a reviewer can face a number of problems.

Take for example the task of reviewing a newly-launched comprehensive database program. To meet the requirement of keeping readers up-to-date with the latest developments in computing there is a need to mention the new software as soon as possible. To test a database thoroughly requires that it be used for a period in a variety of applications. Clearly the latter requirement conflicts with the first, thus the reviewer's dilemma.

At *Your Computer* we think we have found a solution to the problem. In future, when reviewing complex software packages we will prepare initially a review which sets out to describe the overall facilities offered by the product, making no pretence to assess the package in-depth. That review will be followed two months later by a further assessment based on our experience of using the product for a period.

The first software to be subjected to this form of review will be a database package. We shall be using it, among other things, to process the many hundreds of replies we received to our recent reader questionnaire. By combining those two approaches to the problem of reviewing new products, we hope to be able to give readers the best of both worlds.

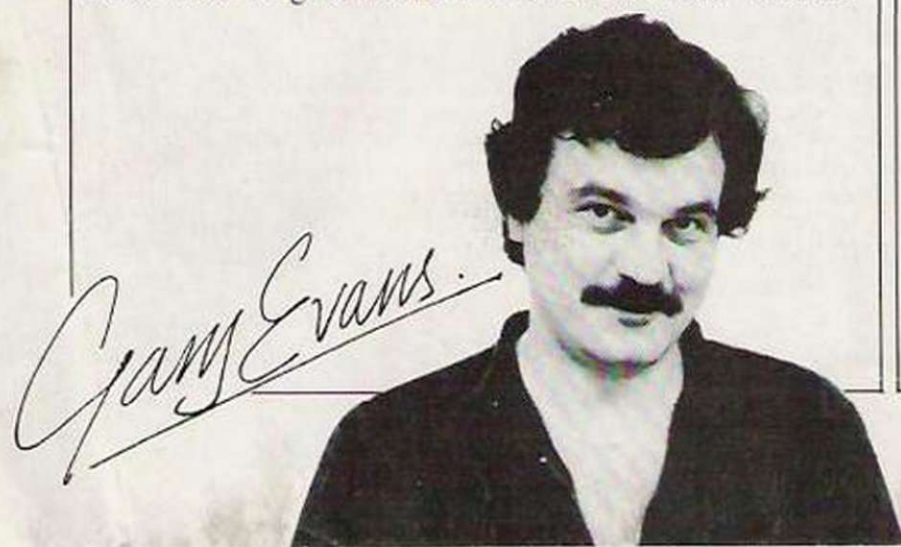

Heavy loss at Commodore

Hot on the heels of the Commodore announcement of the final official launch of the Amiga in the U.K. follows the news that the company is showing a pre-tax loss of \$36.7 million in the first quarter of this year on sales of \$182.3 million world-wide.

Commodore U.K. head man Chris Kaday says that despite announcements of the poor financial showing, there are many people still wanting Commodore products and that owners of 64s, 128s *et al* need not worry about their favourite computer company. He is particularly optimistic about the Amiga, announced in May as a £1,500 business machine with colour monitor and built-in disc drive.

"We are recruiting dealers for the Amiga," he says. "We have about 50 dealers and they are applying thick and fast. All the dealers we have so far recruited have made their first orders. I would say we are cautiously optimistic about the product."

Kaday also spoke about the much-mooted IBM compatibility add-on for the Amiga. "It is only of short-

term importance. Once the software becomes available in true Amiga form, people will not want PC software for it."

He is a little more guarded when talking about Commodore 64s and 128s. The word in the industry is that Commodore will soon be unveiling a version of the 64 with an enhanced graphics interface and 128 casing but it is not surprising that the company wants to keep as tight-lipped about that as possible while it is busy moving present stocks of the machine.

The new man at Commodore was, however, more forthcoming about the company's Amstrad-killer, the Commodore 128-D. The machine previewed exclusively in *Your Computer* in March, includes monochrome monitor, detachable keyboard and full 64 compatibility and Commodore says it will be pushing the machine heavily in advertising during the summer. Although Commodore says there will be no reductions to the £499 price of this bundle, summer promotions have been known to include price cuts.

RAM upgrades

Elsewhere in this issue of *Your Computer* is an article describing the installation of an extra 256K bank of RAM to the PCW8256 computer. Having upgraded the RAM disc of the machine, the next obvious step is to install an additional disc drive.

Doing that the Amstrad way is a rather expensive option and many owners may well balk at the cost of the official disc upgrade kit. Enter Citadel Products, a London-based company which offers a complete disc and memory kit for only £189.95. The kit

includes all the necessary metalwork and instructions and the price is inclusive of VAT and post and packing. We plan to review the disc upgrade in the near future.

Another company in the business of supplying RAM upgrade kits is Silicon City. It offers a set of RAM ICs together with instructions at the price of £32.50.

Citadel Products, 50 High Street, Edgware, Middlesex HA8 7EP. Tel: 01-958 1848.

Silicon City, Mithian, St. Agnes, Cornwall TR5 0QE. Tel: 087255 21123.

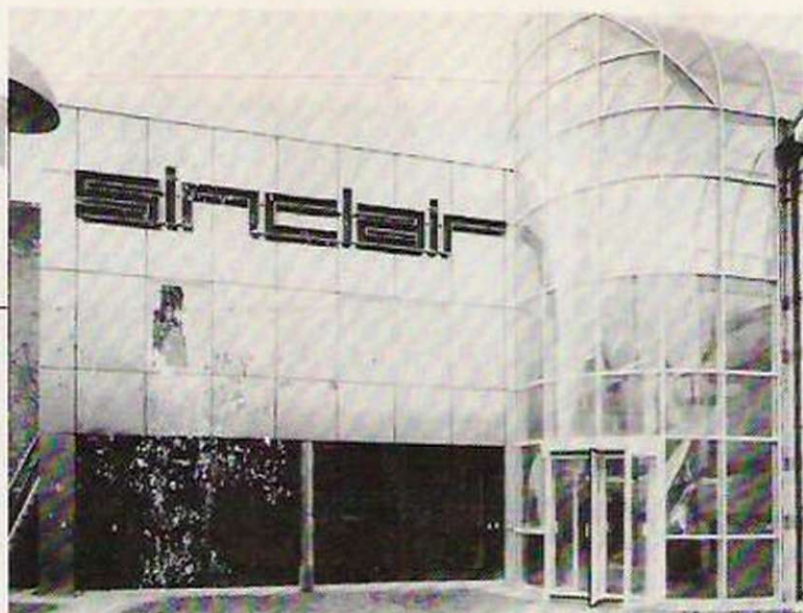

Sir Clive backs WSI

There is life after death, at least if you are a brainchild of Sir Clive Sinclair. While Amstrad figures indicate just how many tape recorders and monitors it wants to add to the Spectrum and how quickly it can dump the QL, those behind Sir Clive's Metalab braintrust have been working quietly to get one of his most innovative projects to date back on its feet.

The Wafer Scale Integration project to produce a new breed of high-capacity and highly-reliable chip has occupied the minds of Metalab for many months. Most of the people on the Sinclair WSI project had been working on WSI research for some 12 years when the news came that life at Milton Hall in Cambridge would no longer be populated by Microdrives and Spectrums.

It should have been no surprise, then, that the idea, together with the people working on it, has now been moved to a new Sinclair-owned company which does not

contain the name of the famous silicon-knight.

Establishment of the Cambridge-based Anamartic company is a deliberate move by Sir Clive and the people working on the WSI project to take away attention from his past consumer interest and focus on the more up-scale chip manufacturing project which might help Sir Clive make his next major financial comeback.

There is no doubt that a successful WSI project could do that.

A successful completion of the WSI project would be a bitter pill for many QL owners, who had been told originally that their machines would be the first to benefit from this ground-breaking technology in the form of a WSI half-megabyte RAM expansion for the machine. Although many companies have since moved to fill the gap, they are not exactly offering wafer scale.

More low-cost PCW software

Software for the PCW range became even cheaper last month as First Software and Publishing announced its plans to sell the Ashton-Tate dBase II for the Amstrad, Commodore 128 and Atari ST range for less than £150.

That is a considerable reduction from the previous price of up to £500 – still the price for the similar Ashton-Tate IBM PC product. It is expected that other major software firms with CP/M versions of their software will soon follow.

Amstrad users should also be comforted by the news that Amstrad has now officially

supported the Pace Nightingale modem for use with its computers, a move which should make the communications market for the PCW machines, currently dominated by the Sagesoft Chit-Chat package, a good deal more competitive.

The standardisation around the new Amstrad communications pack could also improve the tricky business of selling downloadable software on communications services such as Micronet 800, which greeted the news of the Amstrad modem with enthusiasm.

Oops . . .

As part of our Sinclair Special published last month we stated that the FE Electronics Doodler light-pen was available only for the Spectrum 128 computer. We have been asked to point out that the light-pen is available in a version compatible with the Spectrum Plus.

We also stated that the software accompanying the Doodler did not support picture reduction/enlargement. That is also incorrect, as the package allows users to add fine detail

to pictures created with the light-pen.

Oops II . . .

In our guide to I/O devices published in the May issue, we suggested that the Voyager modem was awaiting BAPT approval. In fact, the Modem House Voyager modem has been granted a BAPT certificate of approval and we apologise to Modem House for the error in our report. We can state, without reservation, that the Voyager modem represents excellent value.

MAN LOGIC

IN A WORLD OF HI-TECHNOLOGY IT IS ASSUMED THAT THE COMPUTER IS A CREATION OF TODAY. HOWEVER, IN THE BEGINNING THERE WAS 'MAN' AND HE LONGED FOR A KNOWLEDGE OF THE HEAVENS, A KNOWLEDGE WHICH ONLY A MACHINE COULD GIVE HIM. A LOGIC MACHINE! AND SO HE SET ABOUT CREATING SUCH A MACHINE, A MACHINE WORTHY OF THE ATTENTION OF THE GODS! IT IS AT THAT MOMENT OF FULFILMENT OUR STORY BEGINS AS THE FIRST QUESTION IS ASKED OF THIS MONUMENT TO TRUE ENLIGHTENMENT..



By NEIL BRADLEY

MEET MAN LOGIC

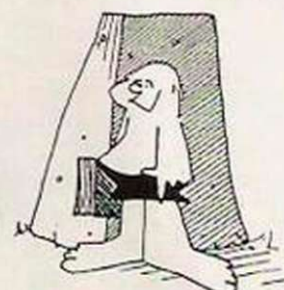

IN THE BEGINNING..

MAGIC DISK KIT



Why pay repair bills when you can solve or prevent most of your 1541 and 1570 disk drive problems for only £19.95

Every time you use your disk drive the protection on your software bangs your playing head, eventually knocking it out of place. Now with our very easy to use Magic Disk Kit with a clear book of tips you can remedy head alignment faults and give simply maintenance to your machine to give better performance and longer life.

Available from good computer shops or:-

Robtek

Robtek Ltd, Unit 4, Isleworth Business Complex
St. John's Road, Isleworth, Middx. TW7 6NL
Telephone: 01-847 4457

MERCENARY
ESCAPE FROM TARG

A NEW DATASET FOR
COMMODORE 64
& ATARI

THE SECOND CITY

THE TOUGHEST CHALLENGE YET
FOR MERCENARY ENTHUSIASTS.

NOVAGEN CASSETTE £5.95 DISK £9.95
NOVAGEN SOFTWARE - SALES: 142 ALCESTER ROAD
BIRMINGHAM B13 8HS 021-449 9516



ENFAB of EYNHAM

E Computer Workstations **E**

workstations from £57.50 inc VAT
amstrad workstations from £64.40 inc VAT
enfab also offer worktables; printer stands; custom built tables;
filing trolley's etc. - carriage extra

for more information write to:-

ENFAB of EYNHAM

9 Tilgarsley Road, Eynsham, Oxford OX8 1PP.

please enclose a S.A.E.

OR Telephone: 0865 881561

Cheap Hayes a Miracle?

A mysterious new modem from Miracle Technology was advertised in last month's issue of *Your Computer* and various other June issue magazines. That was strange, because issues of Miracle press releases are usually an abundant and familiar component of our mail, yet there had been no mention of a WS4000.

It appears that the ever-efficient Miracle marketing people had jumped the gun in the advertisement department; the new WS4000 was not supposed to be launched until mid-June.

Now we have gleaned some technical aspects of the WS4000, there are some good reasons why Miracle has gone

slightly 'over the top' to bring it to our attention - at £149.95 plus VAT the WS4000 must be one of the cheapest Hayes-compatible smart modems around.

For WS4000, read "stripped-down basic version WS3000". Missing from the WS4000 specifications list are the £295 WS3000 call monitor, user-programmable in/out port and battery back-up for its telephone number store. The 4000 can be upgraded via modules from its basic V21/23 specification - 300 and 1,200 baud - to V22 and even 2,400 baud V22bis, the latter of which could be put to good use on the new Prestel Vasscom interface - see elsewhere.

Spectre modem for 128

Undergoing pre-production beta testing is the Spectrum 128 modem hinted at in last month's *Your Computer*. For £79.95, Spectrum 128 owners will be able to buy a custom modem, the Spectre, from a company which rose from the ashes of OEL Ltd, which designed and manufactured the famous VTX5000 modem, among others.

Spectre Communications, run by ex-OEL engineer Lawrence Cook, has done a deal with Tandata to use part of the Tandata Qcom QL modem system in its Spectre package. Spectre uses the modem section of the modular Qcom system - an ex-OEL product - replacing the software module with its own. Sinclair owners will be delighted to hear that Dave Gorski, who contributed major enhancements to the old VTX5000, was enlisted to write the Spectre terminal.

Full scrolling text and viewdata standards will be catered for as standard and although the Spectre modem is restricted to 1,200 baud, an on-board RS232 interface enables the user to link to more exotic modems, something virtually unheard of previously even on the original Spectrum. Gorski's software has full off-line mailbox capabilities, user-to-user and 300 baud configuration options.

As the boxes for the QL-based Qcom system were designed to match the QL, they also match the Spectrum 128, punctuating its attractiveness as the modem finally to release Spectrum users into the full world of comms.

Official Amstrad modem to stimulate Comms?

The Amstrad modem will cost £99 and, connected via a suitable RS232 interface, can be used with any proprietary Amstrad terminal software, e.g., the Pace Commstar package.

Amstrad claims to be

shipping around 70,000 micros a month, the majority being the PCW8256/8512 type. From that there are optimistic expectations of up to 20,000 new Amstrad comms users by the end of the year.

Yellow pages walks down the line

Let your keyboard do the walking? BT and Prestel have made a low-key announcement that some telephone users will be able to use Prestel, via a gateway interface to BT mainframes, as an electronic Yellow Pages telephone directory.

There was no mention of ordinary telephone subscribers' numbers being accessible on the system - only

business numbers. Also the system will feature only London, Guildford and Reading numbers for the time being.

Let us hope that is the thin end of the wedge. In France there are almost three million users of the French electronic telephone directory system, Teletel. That is several orders of magnitude ahead of us in good old Blighty.

Vaunted Vas to boost Prestel

One of the worst-kept secrets in comms this year was the privately much vaunted Prestel Vasscom network. VAS stands for Value Added Systems and Vasscom will permit a host of new Prestel network access options later this year.

Oddly enough, one of the advantages of Prestel over some of its international rivals, speed of display, is a source of one of its main criticisms from some quarters. Prestel does not use time-costly error-checking for ordinary display of information pages, making the system convenient to use. Information Providers when updating their pages remotely, will now be available to end-users.

BABT gives nod to internal modems

At last the news that, after a wait of many months, several budget modems have finally received BABT approval. BABT has seemingly proved that its approval process is being speeded with the announcement from Miracle Technology that its Commodore 64/128 Multimodem has been granted a green sticker.

Ironically, there were many pundits who predicted that the C64 Multimodem might not gain BABT approval because of its plug-in cartridge design. "The Commodore 64 will have to be approved, too", was a familiar saying but now that the Multimodem has been approved there must be a good chance that other integral modems, like those from Pace and Modem House for the BBC Master, will gain approval without great difficulty.

ACTION! ACTION! ACTION!



Biggles

Packed with all the action and atmosphere of the movie, Biggles is a multipart game that'll keep you on the edge of your seat right to the end of your mission.

Spectrum · Commodore 64 ·

Amstrad CPC £9.95 tape

Commodore disk £12.95 · Amstrad disk £14.95

Biggles t-shirts, pilot's scarves, button badges and stickers available too – ask your retailer or call us direct.

DYNAMITE DAN II

Dynamite Dan's back – and how! There's 200 screens of challenging gameplay, simply crawling with intelligent aliens out to trap you, to keep you on your toes (which will be tapping like mad to the amazing music, too!)

Spectrum £7.95 tape

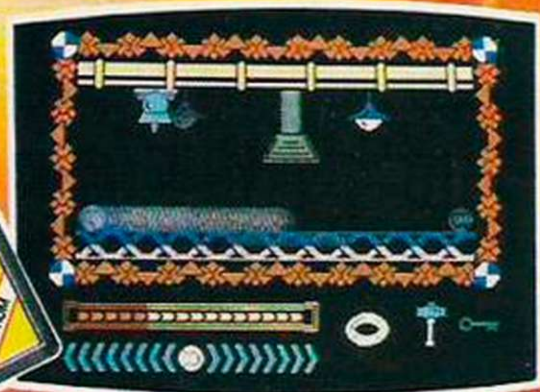
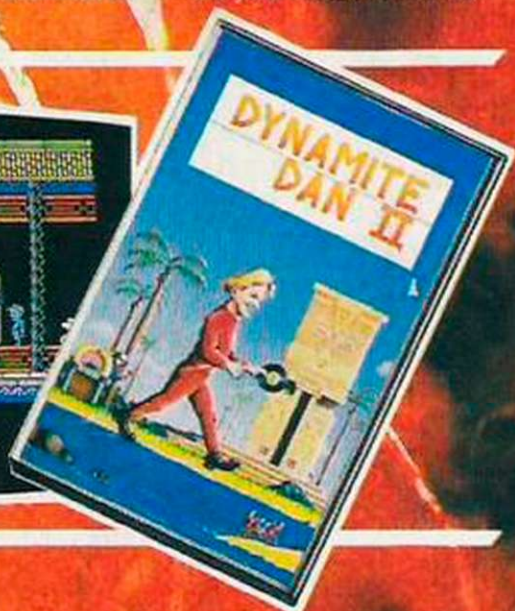

ACTION REFLEX

The brand-new, all action, Medusa label launches out with a real smasher! It's a frantic, multilevel. Beat the clock ball game – and where did you see that red-and-white chequered ball before...?

Spectrum £7.95 tape

STRIKE FORCE HARRIER

Fly by the seat of your pants at the controls of the Harrier, one of the world's most exciting combat aircraft. But beware of enemy ground and air attack as you battle your way to your ultimate target.

Spectrum · Amstrad CPC · BBC/Electron £9.95 tape
BBC disk £12.95 · Amstrad disk £14.95

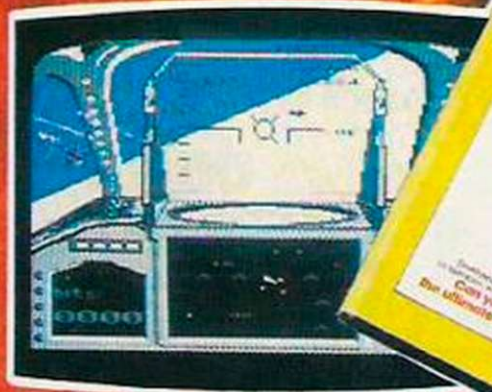

MIRRORSOFT

Purnell Book Centre, Paulton, Bristol BS18 5LQ Tel: (0761) 413301

This chart is based on the MicroScope chart as compiled by Gallup.
MicroScope GALLUP
 MicroScope is the weekly trade paper of the microcomputer industry. If your computer store doesn't display the latest MicroScope chart, ask the manager to call Mark Salmon on 01-631 1433 - we'll send a copy every week.

THE CHARTS

TOP 20

1	BATMAN	OCEAN
2	SPINDIZZY	ELECTRIC DREAMS
3	COMMANDO	ELITE
4	INTERNATIONAL KARATE	SYSTEM 3
5	BOMB JACK	ELITE
6	THEY SOLD (2)	HIT SQUAD
7	WORLD CUP CARNIVAL	U.S. GOLD
8	WAY OF THE TIGER	GREMLIN GRAPHICS
9	GREEN BERET	IMAGINE
10	COMPENDIUM OF HITS 10 VOLUME 2	BEAU JOLLY
11	SUPERBOWL	OCEAN
12	V	OCEAN
13	BOUNDER	GREMLIN GRAPHICS
14	ROCK 'N' WRESTLE	MELBOURNE HOUSE
15	TURBO ESPRIT	DURELL
16	HEAVY ON THE MAGIK	GARGOYLE GAMES
17	STARSTRIKE 2	REALTIME
18	PSI-5 TRADING COMPANY	U.S. GOLD
19	QUAZATRON	HEWSON CONSULTANTS
20	SABOTEUR	DURELL

BUDGET TOP TEN

1	THRUST	FIREBIRD
2	KIK START	MASTERTRONIC
3	FORMULA ONE SIMULATOR	MASTERTRONIC
4	SPELLBOUND	MASTERTRONIC
5	VEGAS JACKPOT	MASTERTRONIC
6	LAST V8	MASTERTRONIC
7	ONE MAN AND HIS DROID	MASTERTRONIC
8	ACTION BIKER	MASTERTRONIC
9	FINDERS KEEPERS	MASTERTRONIC
10	HEKTIK	MASTERTRONIC

BUBBLING UNDER

CAULDRON 2	PALACE
GOLF CONSTRUCTION SET	ARIOLASOFT
KNIGHT TYME	MASTERTRONIC
BIGGLES	MIRRORSOFT
NINJA MASTER	FIREBIRD
BUMP SET SPIKE	MASTERTRONIC
SEABASE DELTA	FIREBIRD
GET DEXTER	PSS
PRICE OF MAGIK	LEVEL 9
ALTER EGO	ACTIVISION

STOP PRESS

SHOGUN

► Amstrad, Commodore ● Virgin ● Arcade Adventure ● Ian Nicol

Deep in the land of the rising Sony, things are stirring. Nobles and Samurai battle with bandits, peasants and servants in a desperate struggle to reach the exalted rank of *Shogun*.

Inspired by James Clavell's best-selling novel of the same title, the game attempts to re-create the atmosphere of feudal Japan in the early 17th century, complete with peasant revolts, non-stick rice and lotus blossom.

To become a Shogun, 20 devoted followers are needed. Depending on which of the game's 32 characters you choose to play, that can prove to be a very difficult or fairly difficult task, but making friends in the midst of a land filled with violent political conflict is never easy.

Nobles begin life with large amounts of money and several followers to their advantage but they lack fighting ability

and a surprise attack from a peasant may bring the game to an early end.

Samurai are blessed with great fighting ability but little else; many regard them as 'riff raff' and will not let them enter certain areas. No matter which character you choose, the others continue their own travels and disputes. Should you take too long, another may become Shogun, which will end the game. Messages telling of conflicts and battles in other parts of the country flash across the screen, so such an occurrence can be avoided. It adds to the feeling of realism if you sit cross-legged at your computer and eat stir-fry vegetables while playing.

GRAPHICS



SOUND

None

PLAYABILITY



VALUE FOR MONEY



OVERALL

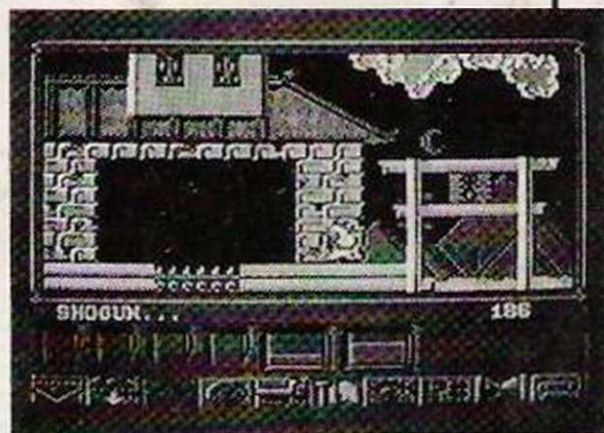

TIGERS IN THE SNOW

► CBM64 ● U.S. Gold ● Wargame ● Lee Paddon ● £9.95 Cass/£14.95 Disc

Unfortunately, *Tigers in the Snow* is very unbalanced – the Germans usually win. You can handicap the game to make it more difficult but the essential pre-requisite of a good wargame is absent. The game was written by SSI, one of the leading U.S. simulation companies. The method of resolving combat during each move is complex, relying on such diverse factors as supply, combat readiness, strength, artillery support, weather and terrain. Despite all that, the game is reasonably easy to learn to play, and strategy game veterans will have little difficulty.

GRAPHICS



SOUND



PLAYABILITY



VALUE FOR MONEY



OVERALL



Another criticism is that the historical strategy should be disregarded. You

must prevent the Germans gaining ground. There is also no regard for roads, an important historical factor. The scale of the game is large – the whole battle area is only 11 hexes wide.

The battle, and the campaign in general, is probably better simulated by *Crusade in Europe*, also from U.S. Gold, but this is still a reasonable strategy game, with some real decisions to make, and several factors to balance when making a decision. Despite that, it shows its age when compared to more up-to-date games like the Microprose series, or the latest CES wargames.

SOFTWARE NEWS

U.S. Gold makes World Cup substitution

World Cup Carnival from U.S. Gold has been unmasked. It is, apart from two "new" features, just the Artic Software *World Cup* with a free wallchart and sticker, costing £9.95.

The first hint of trouble occurred when U.S. Gold was extremely reticent about giving review copies to

computer magazines. The excuse was: "The demand was so high we had to ship all copies to distributors and thus had none left for the magazines."

Obviously that means that the whistle will not be blown by magazines until the July issues appear, after the World Cup competition has finished

and thus peak sales.

If you must have a copy of this rather tired old title, either pick it up for around £2 flying under its original Artic colours, or buy it on the *Now Games II* compilation; or, better still, buy the vastly superior *Match Day* from Ocean, which has also acquired a new 128K Spectrum version.

Creative Sparks rekindled

Snodgits is one of a batch of six budget titles released on a range of machines by Creative Sparks. They cost £1.99 and the other titles are *Danger Mouse in Double Trouble*, *White Viper*, *Mad Doctor* and *Tower of Evil*. The label is called Sparklers and represents the re-launch of Creative Sparks as a software publisher after a long silence.

Mercenary gets new world and guidebook

Novagen has announced several new products for Mercenary fans. For players already hooked on the game, Novagen has produced *The Second City*. It costs £5.95 on cassette and £9.95 on disc.

You must have *Mercenary - Escape from Targ* to use the program and it provides you with a new city to explore and a new set of puzzles which Novagen believes will be a tough challenge for even the

most streetwise man about Targ.

There is also a *Targ Survival Kit*. It consists of a short story which follows the plot of *Mercenary*, a map of the city and the underground complexes, and drawings of the ships. On the conversion front, a Commodore +4 version is on release and an Atari ST version is planned for July.

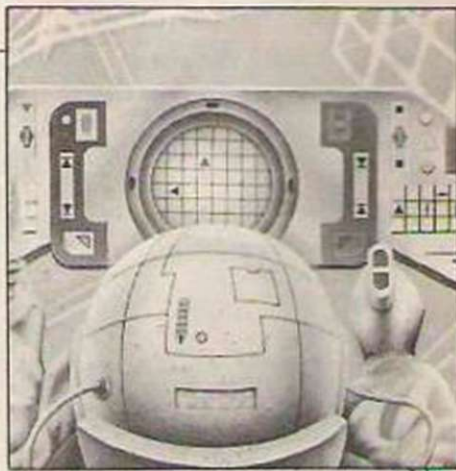

Trinity will go down a bomb

Trinity is the name of the new adventure game from Infocom. It should be available soon from Activision on CBM128, ST, IBM and Apple computers and is written by Brian Moriarty, author of *Wishbringer*, a recent Infocom hit.

You take the part of an American tourist on a vacation in London. Unfortunately, your vacation is to be ruined by someone dropping a bomb on Kensington Gardens while you are walking there. Fortunately, you find a doorway into an alternative reality in the odd nanosecond you had while waiting to be vapourised. What other people in The Gardens and the surrounding area did with their nanoseconds we are not told.

This alternative reality allows you to arrive at the site of atomic explosions throughout time a few minutes before the big firework. You might think "seen one population vapourised, seen 'em all" but there is more to this tale than genocidal voyeurism.

Eventually you can work your way back to the granddaddy of them all - you reach the *Trinity* test site in the New Mexico desert. What do you do? Moriarty hastens to explain that this is not a political diatribe - "It is more philosophical. All I can reveal about the ending is that it surprised all the people who play-tested it."

Budget Bonanza

Software houses are falling over themselves in their haste to launch budget ranges. With the cry "There's money in that low-priced stuff", the likes of CRL, Artic, Interceptor and Creative Sparks are all following Firebird, Mastertronic and U.S. Gold into the bargain basement.

The CRL label is called Alpha Omega. *Nocturne* and *Wrath of Olympus* will be available on the Amstrad, *Jet Strike Mission* is on the

Commodore, and *Captain Slog* is on the Spectrum.

Artic, the BBC specialist, has two games, *The Great Wall* and *Woks*, for its favourite machine, as well as *The Master on the Spectrum* and *Voodoo Rage* on the Amstrad.

Interceptor has launched a label called Players. There are six titles launched for a range of machines. The Creative Sparks range is called Sparklers and has five titles,

some re-launched full-price games such as *Danger Mouse*, and some new.

Mastertronic is not resting on its market-leader laurels. It has launched two more labels, Entertainment U.S.A. and Mad Chrome. The Entertainment U.S.A. label, naturally, will feature games written in the States. It also has a major project, *Flash Gordon*, planned for the Autumn.

Solo flight speaks out

U.S. Gold has a new version of *Solo Flight* available on Commodore and Atari computers. It is a multi-layered game which takes you all the way from practising landings through doing circuits of an airfield to planning mail runs.

The new version has several enhancements. The instrument panel has been re-arranged, you have twice as many maps to fly around, and you have a night-flying option. The Commodore version also features high-quality software speech synthesis. That means you receive constant verbal instructions during your first few intrepid steps into the sky, as well as radio messages about changing weather conditions.

If you want to fly a high-performance jet fighter, do aerobatics and shoot things, look elsewhere, but

this game is a pleasant mix of strategy, quick thinking and technique. At the expert levels you have to cope with

instrument or even engine failure, and wind changes, as well as suddenly finding the target airfield fogbound.

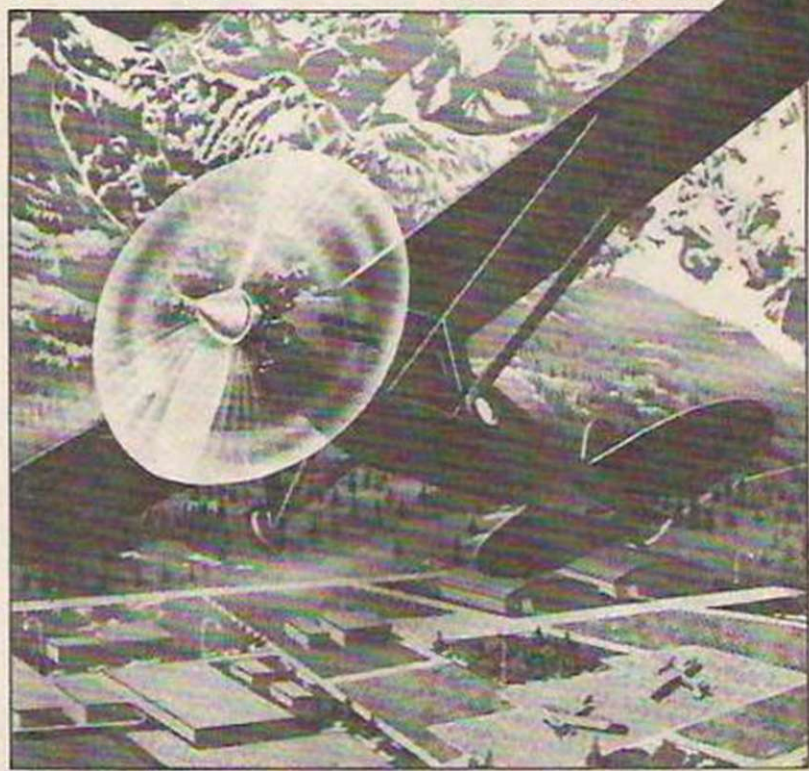

Big Blue, as International Business Machines is known in the computer business, is not the company name which springs to mind automatically when you start dreaming about the perfect computer. The first IBM foray into the business micro-computer market was the boring, unexciting but very popular IBM PC and its XT hard-disc variant. It was followed by two massive flops, the IBM Portable and the ill-fated PC Junior, which gave the corporate giant some considerable humbling and earned it a good deal of criticism from the computer industry.

It was something of a sur-

prisingly beefier version of the IBM PC, costs a mere £3,600, and includes 256K of RAM as standard.

It also incorporates the latest in locking protection devices via a large key on the left-hand side of the machine to prevent prying fingers reaching the information on your hard disc. That begs the question of whether or not the burning issue among the nation's wealthier home users will turn from "Dad, can I borrow the keys to the car?" to "Dad, can I borrow the keys to the AT?"

The AT keyboard is a good deal bigger than most you will find on home machines and even that of the PC is not a

latter can read and write information in either the AT high-capacity 1.2MB format or in the standard PC 360K format. Unfortunately, software houses and users alike have not been particularly smitten with the 1.2MB drives and little software has been released to take advantage of the extra capacity.

Many dealers report that a vast number of AT users go out of their way to get standard 360K drives installed in their machines instead of the 1.2MB disc drive. Another wrinkle has been introduced recently to the floppy picture with the addition of an optional 3.5in. 720K micro-floppy disc which can be



used in the new IBM PC Convertible lap-top machine – and many other new PC lap-tops.

Two main types of display are offered for use with the AT – monochrome and colour –

Geof Wheelwright dreams of an IBM Advanced Technology computer.

Big Blue and the AT

prise, however, when IBM finally released its new generation of PC – the IBM PC AT (Advanced Technology) – that the machine was powerful, innovative and really broke some new ground in business computing terms. It is expected to lead existing IBM PC users to a new and faster standard of business computer, using the better grade of computer processor, more RAM and greater disc storage.

The machine looks like a



patch on it. There is a large and welcoming ENTER key which makes touch-typing much simpler and indicator lights to tell you when the CAPS, SCROLL and NUM locks have been activated.

All in all, IBM seems to have taken into account all the major criticisms made of the PC keyboard when it designed that of the AT. Even small details such as the length of the detachable keyboard cable have been attended to. There will be no great struggling with the keyboard to move it to where you want to do.

Storage is the only really controversial area of AT design. Although the flexible nature of the storage device configuration in the machine means that you can hold both twin floppy disc drives and a hard disc in the main cabinet, the most common set-up includes a 20MB hard disc and a 1.3MB floppy disc drive. The



added externally to allow AT users to read the small discs

offering the same resolution as the IBM PC. Like the PC, the AT can also use the IBM – or that of anyone else, so long as it is compatible – Enhanced Graphics Adaptor card to bring the colour display to the specification needed to run computer-aided design applications and high-resolution graphics applications such as Microsoft Windows in colour.

The AT nominally will take expansion cards developed for the PC, although its own 16-bit slots mean that more powerful AT-specific expansion cards can also be used.

When, for example, you add extra memory, a dedicated mouse card and a Hayes-compatible internal modem you could run applications which make the machine run like a Macintosh, communicate like a mainframe and use integrated applications like the best of small minicomputers.

The AT will run much but

not all of the software written for the IBM PC. It runs that software a good deal faster than a standard PC. The extra speed is crucial to graphics-based programs such as Microsoft Windows and the Digital Research Graphics Environment Manager which make the AT feel and look like the Apple Macintosh.

The software with which it has difficulty is timing-dependent applications which are too fast to run properly. That can cause serious problems when using games. I tried playing a standard version of *Centipede*, creatively known as Fuzzy Worm, on the machine, only to find that the worm had virtually reached the bottom of the screen before I had fired my first shot.

I have seen *Flight Simulator* running on other 'fast PCs' previously at such a rate that you might think it was Concorde, rather than a small aircraft, of which the program was supposed to put you in charge. I suspect, however, in any dreams that feature use of the AT you would not be attempting to turn it into a star games machine.

Sharing information

The AT really shines when you use it to drive a network. The speed and capacity of the AT mean that with the addition of some very cheap clone PCs, which now cost less than £500, and some network cabling and software, you can have a system which permits a number of users to share and exchange information easily.

If your business dreams are grandiose and include empire-building, that aspect of the AT's operation should fit very well. The high capacity of both RAM and hard disc could prove particularly important, with 40MB or more of hard disc available and several megabytes of RAM.

Although you might dream about using the IBM version of the AT, it is much more likely to be one of the clones of the machine which you can afford. AT clones are now available for less than £2,000 and the price is still falling.

There can be no doubt that



We could not find a picture of the IBM AT; instead we show one of the many clone machines.

within a year or two the current craze for inexpensive PC clones will be replaced by an equal number of similarly-priced AT-specification machines. Even now there are accelerator cards available for existing PCs which piggy-back the AT 80286 processor through an expansion card to a standard PC.

The advantages offered by the AT hard disc capacity are also under threat with the advent of internal hard cards for the PC which now allow you

to add up to 30MB, using the new Mountain 30MB hard card, to a standard PC without an external or up-rated power supply.

Until Amstrad makes available its much-touted sub-£500 PC-compatible or one of the clone manufacturers has a big enough distribution system to make a difference, that upgrade route from PC to AT specification will be as much of a dream as the AT.

With a large software base – almost all the titles written for

the IBM PC along with a growing number of AT-specific titles for single- and multi-user configurations – and a big range of hardware support products from peripheral manufacturers, the dream of AT ownership is likely to be dangled before home and small business micro owners for some time. The ever-downward price spiral should ensure that a few can grasp of the real thing. • *The cartoon characters shown are from an IBM brochure.*

DIRECT MAIL DISCOUNT

5.75 SPECTRUM

GREEN BEET
HEAVY ON THE MACHIC
ID
MOUNTAIN IS INNOCENT
MURDER'S REVENGE
NOW GAMES 2
PHYSICS 800
QUAZATON
ROCK N' WRESTLE
ROCKY HORROR SHOW
ROTHSCHILD FOOTBALL QUIZ
SABOTEUR
SAMANTHA FOX
SKY FEM
TUBES ESPRIT
VAT MANAGER
WAY OF THE EXPLODING FIAT
6.99
FOOTBALL MANAGER
7.29
ADVENTURE LAND & SECRET MISSION
BATTLE OF THE PLANETS
CASH CONTROLLER
CLASSIC 3 PACK
CLUEGO
COMPUTER KITS 10 GAMES
CRASH SMASHES
CYRUS-18-CHESS 823/S
DABUSTERS
DEZERT RATS
DOODLEBUGS REVENGE
ENDGAME FORCE
FAIRLIGHT
GOLDEN
GREENLING
GYMOK
HALL OF FAME
HERBERT'S SUFFY RUN
HOTSPOTS
HUMAN TORCH
KINGSTON
KONPLEX
LORDS OF MIDNIGHT
MACHINE CODE TEST TOOL
NARS PORT
PACER TOOL KIT
MAX HEADROOM
MONOPOLY
OPERATION CARETAKER
PENTASMAN
PRINT UTILITIES L3/S
PUNTER
KEEL PLANET
ROBIN OF THE WOOD
ROBIN OF SHERWOOD
SEAS OF BLOOD
SEA FRENZ
SHODDITS
SPIDERMAN/4X TWIN PK
SPIFFIRE 40
SUPERSONIC
GAMES AND SORcery
TAU CEI
THEIR FINEST HOUR
THEY SOLD A MILLION
THEY SOLD A MILLION II
THREE WEEKS IN PARADISE
TIN-NA-HOO
TORANAK
VOLAC COMPUTER KITS
WAY OF THE TIGER
WINTER SPORTS
WINTER SPORTS
GRAHAM GOUGH CRICKET
SORDERONS SHADOW

7.65
EVERYONE'S A WALLY
SABRE WOLF
UNDERMURDER
WORDGAMES PW RH
ALIEN 8
7.99
ART STUDIO
CHEMISTRY
COMPUTER STUDIES
GEOGRAPHY
HENRY PART I
MATHS
MERCHANT OF VENICE
PHYSICS
9.50
ARTIST
MACHINE CODE EDITOR/ASSEMBLER
WORDMANAGER
10.75
ART STUDIO
BIOLOGY
CHEMISTRY
ELITE
FRENCH
LASER BASIC
MATHEMATICS
PHYSICS
ECONOMICS
11.50
LORDS OF THE WINDS
13.99
ADDRESS MANAGER + 80
FINANCE MANAGER + 80
STOCK MANAGER + 80
PAY MANAGER + 80

Spectrum 128

5.75
BALL BLAZER
TECHNICIAN TED
6.50
I.C.U.P.S.
SAMANTHA FOX
7.29
ZARRY HOOVERMAN BOXING
NICKY
BORED OF THE RIBS
DEZERT RATS
EYE OF THE HASK
GLADIATORS
LOGIC RUNNER
MUSIC BOX
MUSIC BOX
NODES OF YEBOD
ROBIN OF SHERWOOD
ROCKY HORROR SHOW
SPITFIRE
SWEEPSTAKES
WINTER GAMES
7.99
THREE WEEKS IN PARADISE
15.99
ART STUDIO 2

199

BAT ATTACK
CONQUEST
ESPIONAGE ISLAND
FLIPPIT
HALAGA
INCA CURSE
MAGNETS
PADNET
PLURNET
REVERSI
SHIP OF DOOM
STONKERS
TAFY TURNER
TILER
ZIP ZAP
2000
ABC LEFT-OFF
AQUARIUM
ARABIAN NIGHTS
ARCADIA
ARENA/ALEX SWARM
BACKPACKERS
BEAKY AND THE EGG SNATCHERS
BLACK HOLE
BOY BOA
BVS BLASTER
COSMIC CRUISER
CENTRO PODS
CHESS PLAYER
CITY
CLUB RECORD CONTROLLER
COLLECTORS PACK
COSMIC CRUISER
COSMIC DEBRIS
COUNT ABOUT
DEATH STAR
DIMENSIONAL DESTRUCTORS
DOWNDAY CASTLE

199

CANELS
HELLGATE
HOOPER BOYVER
LATER ZONE
3-D HYPERMATHS
AMERICAN SAFARI
ARK
ARCADIA
ASH THE FAMILY
ASTRAL ATTACK
AUTOPHANIA
B C BILL
BIG MASTERING
BEAKY AND THE EGG SNATCHERS
BIG TOP BARNEY
BODY
BREAK FEVER
BURSTER TIME
CARMEN'S NEW 12 TAPES
CARRIERS OF BILLYCANT
CENTRO PODS
CHOCIA MINER
COSMIC CRUISER
COSMIC CRUISER
COSMIC CRUISER
CRYSTALS OF CARUS
CUDLY CURVIT
CYCLONER
CYLU
DAREDEVIL DENNIS/FIOLA
DATA MUSIC
DEFENDER 44
ELECTION TRAIL
EMPIRE OF BARRON
ESCAPE MFP
FACE MAKER
FARE GUEST
FIRST MOVES (CHESS)
FROXY FOX
FRONT LINE
GANDOLF THE SOCCERER
GEOGRAPHY
GET OFF MY GARDEN
GLUS DUS
GO MICRO
GRAPHIC EDITOR
GUZZLER
HERCULES
HEROES OF KARN
LEVELS OF BABYLON
KNOW YOUR 1,0
LANEY LORDS
LAZY JONES
LET'S COUNT (12 TAPES)
LESBRATOR
PIZZA MANIA
MAZE MASTER (12 TAPES)

ROAD RACERS
ROBOT RUNNER
ROCK'N'ROLL/DRACULA
SAM SPAZE
SCUBA ATTACK
SHUFFLE
SHOOTER
SPACE ISLAND
SPACE STATION ZEMRA
SPECTRUM CHESS
SPECTRUM SAFARI
SPELLBOUND
STYX
SUR SCRITCHER
TACHYON COMMAND
THE ISLAND
THE PYRAMID
TIME BOMB
TOOTH PASTE/COLORIZ
VIOLENT UNIVERSE
WU-20
WALL-CALC
WARLORD
WILD WORDS
WORLD CUP FOOTBALL
2.50
ALBERTA
ATOMS AND MOLES
BALLBOUNCE
CAR JOURNEY
CASTLE BLACKSTAR
CUP AND BOWL
DEVIL RIDES IN
ENGLISH SKILLS II
FAIR SHARE
FIRST NUMBERS
FORM AND COPP
GAMES WRITER

GETSET
INTRO TO TRIANGOMETRY
KNOW YOUR TABLES
NUMBER FUN
NURSERBY RHYME
O LEVEL BIOLOGY
O LEVEL CHEMISTRY
O LEVEL MATHS
O/A LEVEL PHYSICS
PASSINGTON'S GARDEN GAME
PASSINGTON'S EARLY VISIT
PASSINGTON'S DISAPP. IJK
PUNCTUATION PETS
PYTHAGORAS
SHOPPING
SPECIAL AGENT
STARTER PACK 2
STARTER PACK 1
TABLE BUNS
THE GREAT SPACE RACE
VALHALL
WHAT'S THE TIME?
WORD BANK
WORDSPELL
2.95
A VIEW TO A HILL
CODENAME MATT II
COMPUTER CARE KIT
FIRE ON THE WATER (1800)
FLIGHT FROM THE DARK (1800)

3.50
BRIGHT BOB STRIKES BACK
FANTASIA ZIANDHO
FRIDAY THE 13TH
GOLD RUSH
QUICK THINKING
VOLCANIC PLANET
ZODIAC MASTER

4.95
ELURKA
BALAKHAN
MR. PACMAN
PEYTRON
TAPPER
5.95
30 HOUR BASIC
HYPERSPORTS
LORDS OF MIDNIGHT
PACMAN
SELECT 1 (12 GAMES)
6.95
HAREBRaiser
ZORRO
7.90
PLUS 80 ADDRESS MANAGER
PLUS 80 VAT MANAGER

20p per title P&P

C-64

MISSILE COMMAND
MR. T.N.T. (12 TAPES)
REORDER
STELLA DODDER
STING 44
SUPER GRIPPER
SUPER SCRAMBLE
TABLE SUP
WHAT'S THE TIME
2.95
A VIEW TO A HILL
BEST OF FCV 125 GAMES
BOOSABO
CODENAME MATT II
DESIGNER PENCIL
DID DUG
DRESS
EMPIRE
ESCAPE
FALCON PATROL
FRED
GOLF
GROB'S REVENGE
GYRODOPE (12 TAPES)
HENRY'S HOUSE VOL 2
HENRY'S HOUSE VOL 1
MATCHMAKER
MISSION 2
MUSIC STUDIO
OMEGA RACE
PINBALL SPEC (PART)
RADAR RAY RACE
SCRAMBLE
SEE SAW
STAR RANGER
SUPERBASIC 44
TITANIC
TODIN INVADERS
TRAFFIC
WEB DIMENSION
3.50
BEACH HEAD
SQUIDY BOB STRIKES BACK
TODIN'S NIGHT OUT (12 TAPES)
CAGESIE THE CAT
CHUCKIE EGG
CHUCKIE EGG II
CLONES
COMBAT LEADER
CONGRATS
DODDY BOY
FRIDAY THE 13TH
PRODIGER
SILLIGAN'S GOLD
STAR CROSS
HUBERT'S SUFFY RUN

LIMITED INCOME-DEFERRED STOCK

CIG+4

LIMITED INCOME-DEFERRED STOCK

ELECTRON

2.95
A VIEW TO A HILL
BUZZ OFF
CHUCKIE EGG
HUNCHBACK
3D BOMB ALLEY
ADVENTURE
HUP HIEKESSEN FET
BLITZKRIEG
BLUMBLEBEE
CATERPILLAR
CYBERTON MISSION
DANGER ONE
ELECTRON INVADERS
ESCAPE MOCHBASE ALPHA
FELIX AND FRUIT MONSTERS
FIRST MOVES (CHESS)
FIRST-1-A-SIDE BOCCER
FRENZY
GALACTIC COMMANDER
GOLF
GUNSMOKE
HIPPER DRIVE
INVADERS
MAHAZEE
MODWAIDER
PHAROSAN'S TOMB
POSTITON
PUSSIBLE TROUBLE
STRATO BOMBER
SUPER POOL
TALES OF ARABIAN NIGHTS
THE HINE
VORTICE

3.50
CHUCKIE EGG
CRIME & DETECTION 12
CYCLONE ATTACK
DATING GAME 12 TAPES
SREALINE
HISTORY QUIZ 12 TAPES
HOPPER (ROM)
I DO 12 TAPES
MUSIC QUIZ 12 TAPES
PCW BANKS COLLECTION
ROYAL QUIZ 12 TAPES
SCIENCE QUIZ 12 TAPES
SMOOTHER
THEATRE QUIZ 12 TAPES

4.95
ROBOTHON
2.95
CRAZY GOLF
CURBIT
HAMMYBEE
MATHY
PUNCHY
ZARL WOOD

Dragon
1.99
CELLS AND SERPENTS
CRIBCO
DENON KNIGHT
DETECTIVE
LEBOUT
- MOVIE PRODUCER 3D
PETITISKY'S STORY
PUZZLER
QUIZ
PERISCOPE
2.95
ADVANCED BASIC TUTORIAL
BASIC TUTORIAL
BEST OF FCV (125 PROG)

AMSTRAD
PCW8256
37.96
BRAINSTORM
SHARTY KEY
42.0
SCATCH PAD PLUS
MEMO INQUIRY/SPECIMEN
CENTRO COMP PROGRAMME GUIDE FOR 124
COMMODORE 84 MANUALS
COMMODORE C16 THE WORKMACHIE
16.99
CHIT CHAT CONBO
POPULAR ACCOUNTS
THE ELECTRONIC CARD INDEX
127.5
POPULAR ACCOUNTS PLUS
167.99
CHIT CHAT COMMUNICATIONS PAC

BOOKS 2.50

PROGRAMMING YOUR 286 SPECTRUM
VERY BASIC BASIC EPISODES
PUTTING YOUR COMMENTS TO WORK
INSTANT ARCADE GAMES FOR THE COMMODORE
COMMODORE 64 DISC COMPANION
COMMODORE 64 SHOOTING TECHNIQUES
COMMODORE 64 SOUNDS BOOK
COMMODORE 64 WORDGAMES
COMMODORE 64 ADVENTURE GAMES
COMMODORE 64 EDUCATIONAL GAMES
30 OUTSTANDING GAMES FOR THE VC 20
VC 20 EDUCATIONAL GAMES
VC 20 BANKS BOOK
86C MICRO REVEALED
36 CHALLENGING GAMES FOR THE 86C MICRO
PUTTING YOUR 86C MICRO TO WORK
INSTANT ARCADE GAMES FOR THE 86C
DYNAMIC GAMES FOR YOUR ELECTRON
WORD SEARCH
VERY BASIC BASIC ELECTRON
ELECTRON INSTANT ARCADE GAMES
ELECTRON BEST OF FCV
ELECTRON ADVENTURE GAMES
ELECTRON GAMES MASTER
ELECTRON 27 GAMES
FCW GAMES COLLECTION AMSTRAD
BEST OF FCV 125 PROG FOR THE 86C
AT&T BOOK OF GAMES
BOOK OF GAMES WITH THE QL
WORD PROCESSING WITH THE QL
DATABASE MANAGER ON THE QL
MACHINE CODE PROGRAMMING ON THE QL
ANGLAR ODDS COMPANION
SINGULAR QL ADVENTURES
THE WORKING QL
EXPLORE THE SMALL QL
PRACTICAL IDEAS FOR WHEN YOUR COMPUTER IS HOME
NOW TO COMPUTERS & BUSINESS SUCCESSFULLY
HOW TO APPLICATIONS ON YOUR MICRO
MI AND MY MICRO
BEYOND THE ARCADE
CREATING ADVENTURE GAMES ON YOUR 86C
MICRO INQUIRY/SPECIMEN
CENTRO COMP PROGRAMME GUIDE FOR 124
COMMODORE 84 MANUALS
COMMODORE C16 THE WORKMACHIE
16.99
CHIT CHAT CONBO
POPULAR ACCOUNTS
THE ELECTRONIC CARD INDEX
127.5
POPULAR ACCOUNTS PLUS
167.99
CHIT CHAT COMMUNICATIONS PAC

BBC

1.99
B.C. BILL
BATTLEZONE 2000
BISHARCK
CARLLE BLACKSTAR
CHERRY
CYRILLIS
COSMIC CRUISER
CROSSWORD PUZZLER
CYBERTON MISSION
DAREDEVIL DENNIS
DESELETOR
DIBBER
EMPIRE
FELIX & THE FRUIT MONSTER
FELIX & THE EVIL HEVELLS
FRENZY
FRULLY
GALAXY RAIDERS
JET BACK
MCHASHER
MR. T. MEASURING GAMES
MR. T. MEETS HIS MATCH
PENGU
PLUCK WALK
PROTECTOR
ROMAN EMPIRE
RUBBLE TROUBLE
SHADOPAF
SPACE ADVENTURE
STOLEN LAMP
SVOOP
TEN LITTLE INDIANS
TIME MACHINE
ULTRON
WARLORDS OF DOOM
WIZARD
WIZARD OF AZKYZ
WIZARDS CHALLENGE
2.50
ATOMS AND MOLES
ZODIAC AND SHUN

2.50
ARRIV OF DEATH
BOMER
BUSINESS GAMES
CASTLE OF WIDDLES
CIRCUS
CREATIVE GRAPHICS
DESK DIARY
EARLY VISIT
ESCAPE FROM PULSAR 7
FIRE NUMBERS
FORTH
GOLDEN SATON
GRAPHS AND CHARTS
JET BODY JACK
KNOW YOUR TABLES
LISP
NE AND MY MICRO
O LEVEL CHEMISTRY
O LEVEL MATHS
O LEVEL BIOLOGY
O/A LEVEL PHYSICS
PASSINGTON'S SHOPPING MIX
PASSINGTON'S DISAPP. IJK
PAUL DANIEL'S MUSIC SHOW
PERSEUS AND ANDROGHEA
PERSONAL MONEY MANAGE
PHILOSOPHER'S BUST
PLANET 10
SUNSHOE
STARSHIP COMMAND
STARTER PACK 2
STARTER PACK 1
SUPER FASCAL
TEN LITTLE INDIANS
TIME MACHINE
TREE OF KNOWLEDGE
WAX WORKS
WHAT'S THE TIME?
WIZARD OF AZKYZ
WORKSHOP

AMSTRAD

1.99
ESPIONAGE ISLAND
ENCA LENSE
EYE OF THE OCHS (DARTS)
PLANET OF DEATH
SHIP OF DOOM
2.95
3D INVADERS
A VIEW TO A HILL
BEST OF FCV 125
ANDSOOL
ANIMATED STRIP POKER II
ASTRO ATTACK
ATOM SHOOTER
BALLBOUNCE
CLASSIC ADVENTURE
CLIMB IT
CODENAME MATT II
CODENAME MATT I
CUBIT
ELECTRO FREDDY
FOREST AT WORLD'S END
GALACTIC PLAGUE
GATCOBRAGER
HARRIER ATTACK
HAUNTED HOGGES
HEROES OF KARN
JETS OF STADIUS
JET BOG JACK
JEWELS OF BABYLON
LASER WARR
LUCKY FRUITS
MUNCH
MURPHY
RESCUE
RELAND OGS ESSIONS
SPACE WAARS
SPANNERMAN
SPECIAL OPERATIONS
SPLAT
STOCK MARKET
SULTAN'S MAZE
TALES OF ARABIAN NIGHTS
WAXLINS

2.50
BIG OY
CANNIBALS
FRIGHTER PILOT
GOLF
MR DID
PEWSON
TUTTI FRUTTI
2.95
ARRIV OF DEATH
CHUCKIE EGG
CIRCUS
ESCAPE FROM PULSAR 7
GOLDEN SATON
PERSEUS & ANDROGHEA
TEN LITTLE INDIANS
TIME MACHINE
4.95
ENERGY CDAR
GRAPH 11
STATES & CAPITALS CARD.
BLUE MAX (105C)
SHELLS (105C)
PAYOFF/PULLING/DEMO (105C)
QUADRUPLE (105C)
WILDLYNES (105C)
6.95
ZAKRON
7.90
AER RAID (105C)
ALLEN ROG (105C)
ATTAK (105C)
AVALANCHE (105C)
BARRL (105C)
BLUE MAX 2001
CONVERSATION ITALIAN
CONVERSATION GERMAN
CONVERSATION PERMAN
CONVERSATION SPANISH
COUNTER (105C)
DANGER IN DRINKING (105C)
DATESTONE OF RYM (105C)
DOWNHILL (105C)
PARTS CASH FLOW (105C)
WELF THE WARRIOR (105C)
JUGLES RAINOW
JUGLES HOME
LOOK AHEAD (105C)
MEMOTAP (105C)
RUSHING (105C)
OUTLAW (105C)
PAY OFF (105C)
PERSONAL FITNESS (105C)
PHOTOS (105C)
PRESIDENTS OF USA (105C)
REVERSI (105C)
SALMON RUN (105C)
SLEAZY ADVENTURE (105C)
SPACE CHASE (105C)
STAR WARRIOR (105C)
THE WISE (105C)

3.50
3-D STUNT RIDER
ALEX HIGGINS WORLD POX
ALIEN
AMERICAN FOOTBALL
BOBBY BOB STRIKES BACK
CHOPPER SOLDI
CHUCKIE EGG
FRIDAY THE 13TH
FU KUNG IN LAS VEGAS
HOME RUNNER
HUNCHBACK
HUNTER KILLER
KLEBER (105C)
MASTER CHESS
MESSAGE FROM ANDROGHEA
MY COMMAND
SURVIVOR
TRIPODS
4.95
ALLEN 8
GRAND PRIX DRIVER
WAXE WOLF
WARRIOR

**lots more for...
AMSTRAD C16/+4 BBC
ATARI 400 800XL
FREE ELECTRON
SEND FOR OUR
CATALOGUE**

To: AGF, Unit Q, Ashgrove Industrial Park, Bognor Regis, West Sussex.
Please send me _____
I enclose my cheque/PO. for £ _____ Please make cheques payable to AGF Direct Mail Discount. I wish to pay by: Access [] Visa []
My credit card numbers: _____ ADD 20P PER TITLE FOR P&P

NAME _____
ADDRESS _____
POSTCODE _____
SIGNATURE _____ DATE _____ 24 hrs (0243) 823337

STATE WHICH MACHINE

QL

9.50
ROUNDER
ADVENTURE
JASSER
SUBOIDS
11.50
GAVENB
DICTIONARY
MATCH STORM
12.46
COSBOS
KNIGHTFLIGHT
MATCH POINT
S ZRAB
SCARBLE
STEVE DAVIS SHOOTER
TEXT
12.99
CARTRIDGE DOCTOR
HYPERTRIVE
16.20
BRIDGE PLAYER 2
SUPER MONITOR DISASSEMBLER
QL ARCHIVER
16.60
HOME ACCOUNT MANAGER
Q SPELL
17.20
CHESS
PASH
SUPER ASTROLOOER
23
GARDNER
RIFE FINANCE
ICE
MONITOR (SOFTWARE)
TOOL KIT
TOUCH "N" 80
PAINT

30
TALLER LEDGER
TRANACT
GRAPHIDL
FORTH
36
ASSEMBLER
DECISION MAKER
ENTREPRENEUR
PROJECT PLANNER
53
SUPER CHARGER
ICPL DEVELOPMENT KIT
LISP DEVELOPMENT KIT
67
CASH TRADER
77
INTEGRATED ACCOUNTS
PASCAL DEVELOPMENT KIT
86
C COMPILER

LIMITED INCOME-DEFERRED STOCK

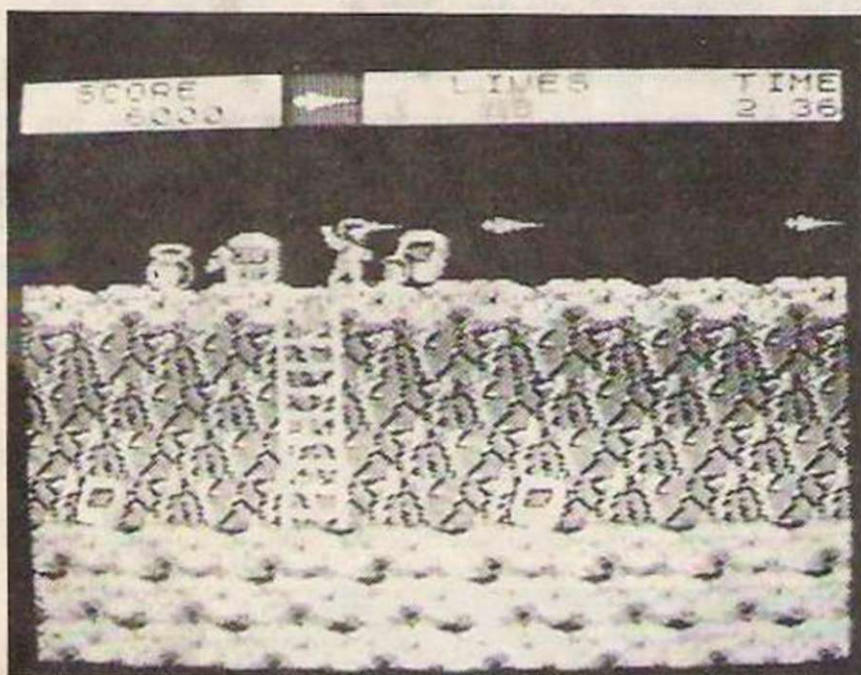

Ghost and Goblins, chart bound.

Eliteism

Who had the most games in the top twelve best-sellers of 1985? U.S. Gold? — wrong. Melbourne House? — wrong again. Elite Systems, a small company from near Birmingham beat all the mega-buck companies with three titles. *Frank Bruno*, *Airwolf* and *Commando*. So what is the secret of its success and how does sales director, Steve Wilcox plan to repeat the success in 1986?

"We write to a formula. We have gained a reputation for accurate conversions of the games on which youngsters have become hooked in the arcades and we give them that authentic feel," he says.

Wilcox is unrepentant about producing the computer industry's equivalent of the disco record. "You do not have to read a 15-page instruction manual to play one of our games. We write programs for people who are enthusiastic about games. They have played it in the arcades, they want to buy it, load it and play it. After a short time they will get fed up with it, go out and buy another one. Our games sell in big numbers for a month or so and then drop out of the charts."

So far this year the formula has given Elite chart success with *Bomb Jack*, a simple dodge around arcade conversion. All four versions, on

Spectrum, Commodore, Amstrad and C16, did well. *Ghost and Goblins* is a big hit in the arcades and the imminent Elite adaptations of it should put the company back at the top of the charts.

Superficially, it is a simple platforms-and-ladders game. Various ghosts and ghouls try to come between you and your loved one, whom you must rescue from the evil clutches of the wizard. Scenes include a graveyard, forest, village and labyrinth. You dodge, jump and shoot your way through each screen with the usual combination of timing, technique and reflexes.

"We think it has a very authentic feel and has certainly generated more interest than *Bomb Jack*," according to Wilcox.

Paper boy

Following that is another coin-op conversion, *Paper Boy*, an everyday story of news-delivering folk. You have to lob papers at the houses of your readers, trying to avoid breaking the windows, except those of people not on your rounds — you can wreak as much havoc with their bijou dwellings as you wish. On the higher levels, manic drivers and suicidal pedestrians will try and run you off the road.

"If we have a weakness, it is that we cannot write anything

Steve Wilcox talks about Elite's plans to stay king of the coin-op converters.

original of any great consequence," Wilcox admits. In an attempt to rectify that, Elite has teamed with Gargoyle Games, which is to write the Spectrum version of the long-awaited *Scooby Do* game. Elite will then handle the conversions.

Gargoyle Games might seem an unlikely bedfellow for Elite. Its reputation is planted firmly on complex games of great depth such as *Marsport* and *Tir No Nog* but for *Scooby Do* Gargoyle is producing a game far more in the Elite tradition.

The game follows our cartoon hero through one of those bizarre haunted adventures, certainly more like the recent Gargoyle humorous hit, *Sweevo's World*. After that, there are some more coin-op conversions on the way.

According to Wilcox, "I can't say anything definite but just look at the games Capcom has in the arcades and you will

have some idea of the kind of thing we are likely to produce."

There is also some more original material on the way. Although Elite has no in-house programmers, one of its two designers is busy working on the graphics for a new game, provisionally called *Ninja Warrior*. It promises to be another martial arts game but with a fair dollop of plot overlaying the usual flying feet and fists.

It will start life on the Commodore, possibly at Christmas-time, and will transfer to other machines. "We will probably be launching between 10 and 20 products in the remainder of this year — it is as uncertain as that. In this fashionable market, where tastes seem to change from month to month, you have to be prepared to move fast. With 40 or so freelance programmers at our disposal, we can turn an idea into a finished game in a few months," says Wilcox.

"As I see it, computer games come from two routes. The adventure-type strategy games arose from computer games written on mainframes. Arcade shoot-'em-ups can trace their pedigree all the way back to *Pong* and the home video consoles. I think there is room in this industry for both kinds — we just happen to know the kind at which we are best."

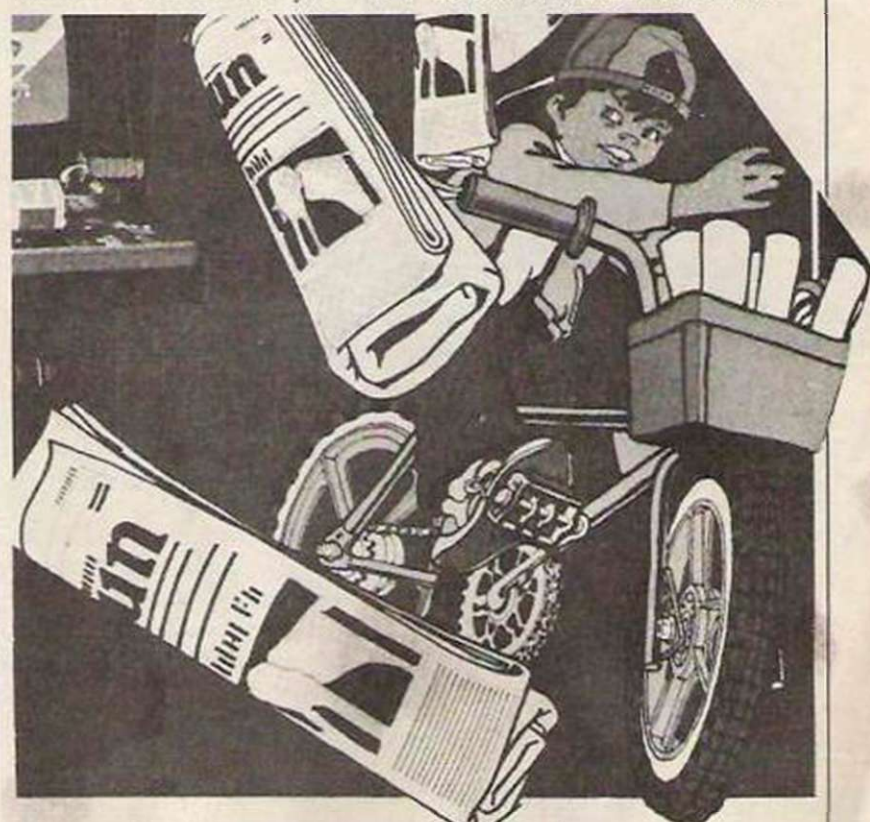

Can the arcade megahit do as well on micros?

DISCOVERY CRUSHES THE COMPETITION

NOW
ONLY **£99.95** + VAT

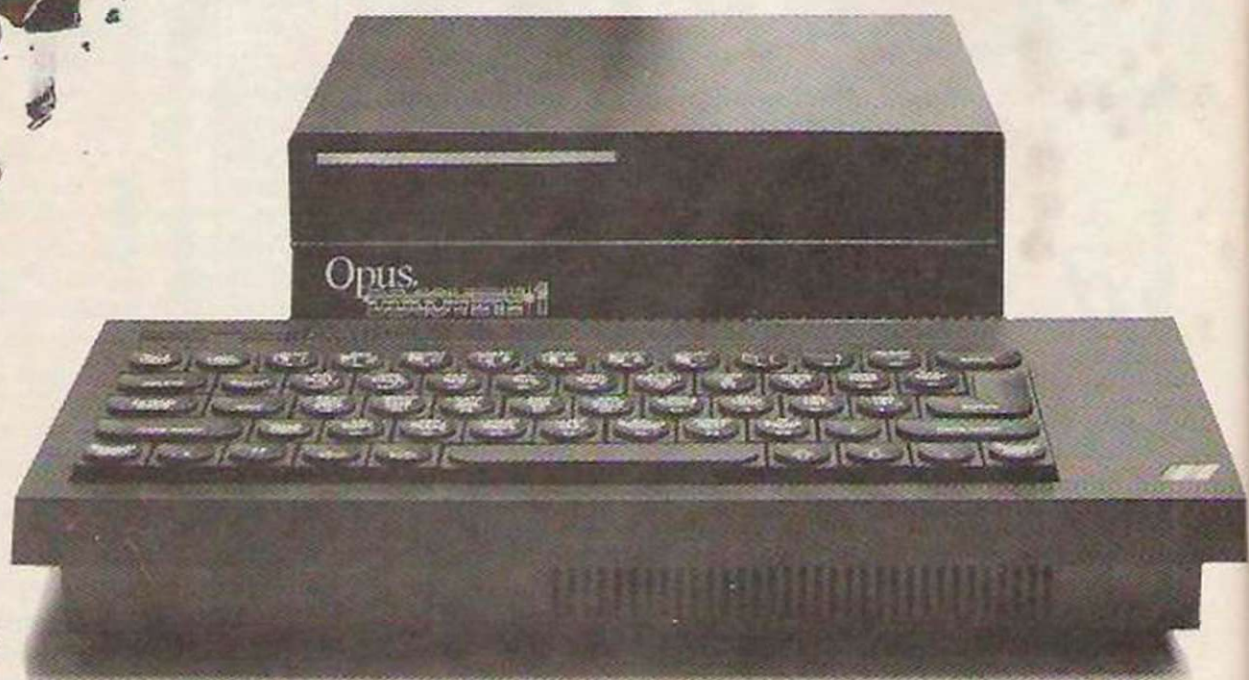
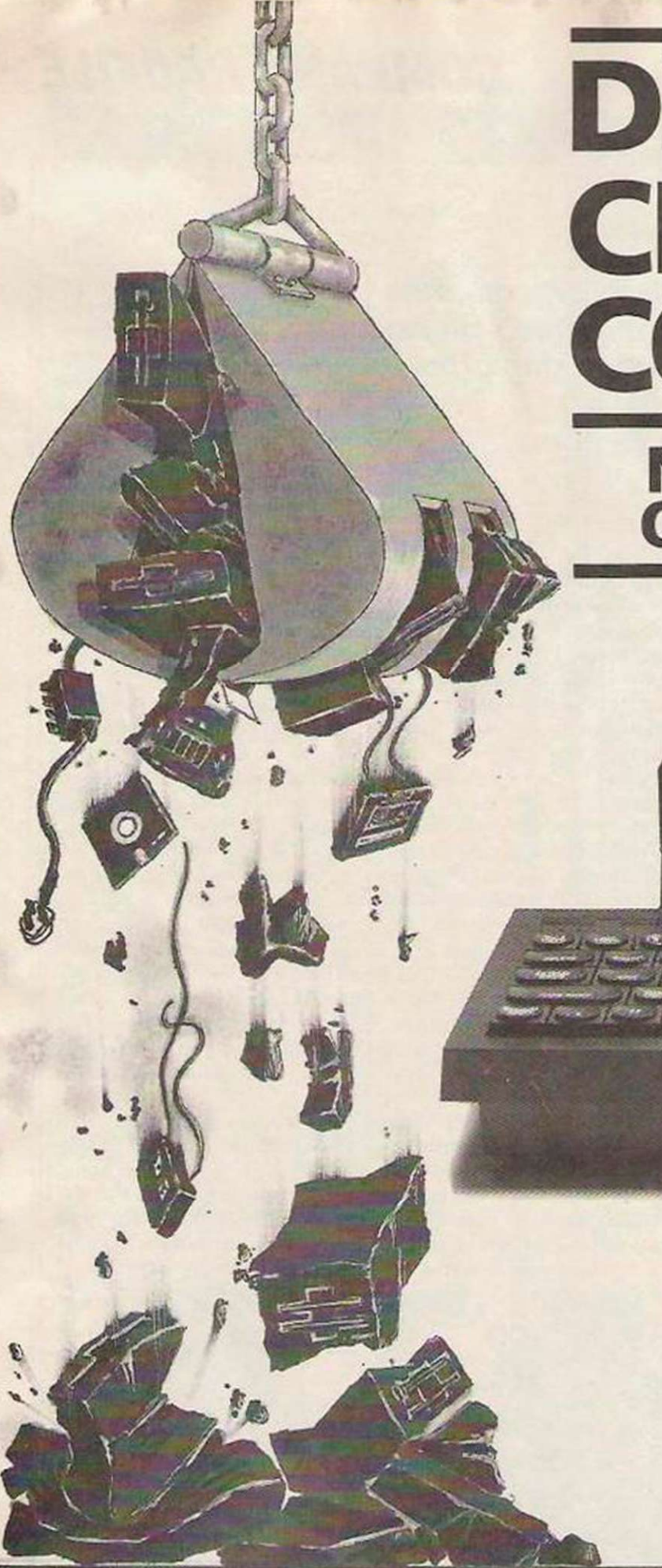

All this for only £99.95. And now there's even more!

- * FREE TRANS-EXPRESS UTILITY PROGRAM — TRANSFERS YOUR FAVOURITE TAPE SOFTWARE TO DISC
- * CHOICE OF DISCOVERY FOR THE 48K OR 128K SPECTRUM
- * FULL 12 MONTH WARRANTY
- * COMPREHENSIVE USER MANUAL
- * OPUS DELIVERY PLEDGE

At an amazing £99.95 Discovery deals a crushing blow to every Spectrum disc drive system on the market. Now it's not just the best equipped disc drive you can buy, it's also the cheapest.

Choose Discovery and you'll find a system packed with brilliant features:

- 3½" 250 K DISC DRIVE
- DOUBLE DENSITY DISC INTERFACE
- JOYSTICK INTERFACE
- PRINTER INTERFACE
- VIDEO MONITOR INTERFACE
- RAM DISC FACILITY
- BUILT-IN POWER SUPPLY FOR DISCOVERY AND SPECTRUM
- SIMPLE ONE-POINT CONNECTION

The Opus package is unbeatable value. We guarantee you delivery within 72-hours of receiving your order and it's absolutely FREE.

To order your Discovery call the Opus Sales Hotline now on 0737 65080 or post the coupon. Dealer and Education enquiries welcomed. Special export rates available.

To: Opus Supplies Limited, 55 Ormside Way, Holmethorpe Industrial Estate, Redhill, Surrey.
Please rush me the following: (PRICES INCLUDE VAT AND CARRIAGE)

DISCOVERY unit(s) at £114.94

I enclose a cheque for £ _____ or please debit my credit card account with the amount of £ _____

My Access Visa no. is:

MY COMPUTER IS: 48K SPEC.+ 128K (tick box) YC

NAME _____

ADDRESS _____

TELEPHONE _____

Opus.

Tim Coote, Commotion managing director.



Commercially, it was a silly idea. A travelling representative for Ripmax, the hobby model company, spent an hour or so in late 1982 with an inventor in Cambridge, drinking coffee and playing with two servo motors strapped to two pieces of plywood. The inventor, Peter Miller, called it a robot arm and kept it on his desk until such time as it could take its part in educating future generations as a computer-operated, problem-solving device.

Tim Coote, Ripmax representative, was impressed. As a result, the contraption, suitably groomed and christened The Beasty, made its debut in public at the 1983 Acorn show as the first product on offer from Commotion - COMPUTER-OPERATED MOTION. At that stage, it was little more than an interface for a computer, used to power whatever the end-user envisaged for it.

"If I had been a little wiser, I would never have done it, but it was a passion," says Coote, founder, managing director and packing operative for his Enfield firm. It was not, however, a passion which gripped too many visitors to the Acorn show that year. "We had an enormous stand, which I spent hours building, with doors which opened in every direction, and I stood there with Beasty saying, 'Isn't this amazing?' and everyone walked by, saying, 'Yes, but I don't want to buy it.' So I thought there could be a disadvantage here - it is good fun, but it's costing money."

Try and try again

He decided to try again, approaching schools and colleges direct, learning what they needed, collecting information on what else was available and arriving rapidly at the conclusion that his product as it was would not sell. Miller's sister obligingly designed something for the Beasty to run and Coote took delivery of the Beasty arm as Commotion's first real robot.

"The schools said we like it, it's cheap and it's cheerful and we can do things with it." The company was under way, with

one product and its first customers, including Kodak, which used the Beasty in its film processing laboratories to signify end stops on a gangplank system. For the first year, Commotion scraped by with Beasty and its arm, but Coote's researches revealed a number of companies attempting to market robotic devices, starting much as Commotion had done.

"It became very obvious it was a bit of a shambles, no mar-

worst thing you can do in business - nine different price lists and thousands of widgeits and wodgeits. It was a tester to see who wanted what and we realised that the retail market, although very interested in robotics, was going through a very difficult phase, and anyway it was £100 for a robot arm..

"At the end of the day, you can't do anything useful with a £100 robot arm from a home use point of view but from an

What a Commotion!

Mary Sargent writes of a company with a one-stop technology centre as its aim.

keting, some of the stuff complete rubbish and over-priced. There was some reasonably good equipment but the wrong people were trying to do something with it. Inventors can't run companies. If you rely on inventors, you never get anything to sell, because they never stop improving the product."

So Commotion became a distribution company, with the aim of providing as many computer-controlled peripherals as possible to offer schools the choice they needed to spend capitation on allowances effectively.

In 1983-4, the first Commotion catalogue appeared. At the time, many people were convinced that robotics would be the next big seller in the microcomputer world.

"The catalogue tried to please everyone, the retail market, the schools market and the trade market. It's the

educational view you can achieve a great deal; but you need the enthusiasm to explain the potential and retailers are not interested in that. For them, it's boxes off shelves, so it had to be the schools market, in particular the area where the large, boring companies weren't going."

Two years of talking, demonstrating, mailing literature and attending shows, with a steady increase in the number of products on offer, has brought Commotion to its present position of comparative affluence. The company has more than 700 items for sale in its current catalogue - aimed to please only one market - is poised to make a sensible profit this year and has recently opened its first Technology Centre at its Enfield headquarters.

That is designed to encourage teachers to see what is available to them and to discuss

problems, ideas and requirements with Roger Jones, Commotion technical manager, with Coote or with sales manager Laura Coyte. Commotion has expanded into the area of design in technology and the Centre offers not only manufactured products but also various Heath Robinson constructions designed by Jones to demonstrate the versatility of the various materials available to do-it-yourselfers.

Helping hand

"It doesn't matter whether we sell a £5 kit or a £10,000 arm," says Coote. "We're here to help. Any teacher can telephone and we will give honest advice. We are not biased to any particular system, because teachers must have something they can use, and the Centre gives them the chance to try things they may have seen only in catalogues."

He admits he could make more money doing almost anything else but the passion remains. He thinks British education needs an overhaul - "There's no unity in the school system" - which means exchange of information between schools is inhibited; he believes teachers "are an unfortunate bunch. They've been very unlucky to have technology forced on them, whether they wanted it or not" and there is too little information and too little time to enable them to meet the challenge adequately; and he is sure that robotics, at least in the educational environment, will come of age rapidly.

His current ambition is to turn Commotion into a "one-stop technology centre" for anyone who wants to know about computer control. His long-term ambition is to continue his company's forward movement. "As the new advances happen, we will react to them and move with them. We will re-educate ourselves, change the products we sell, change our attitudes. We're as flexible as the technology itself."

Commotion can be contacted at 241 Green Street, Enfield EN3 7SJ. Tel: 01-804 1378.

Commodore 64 - Born in the USA

**Chris Jenkins and Richard Sargent
report on the games and peripherals
that make the CBM64 what it is today**

Once upon a time, when Sinclair was promoting "Britain's best-selling computer", when one of the pioneers of the micro revolution was already in receivership, and when Apples could be found in electrical as well as green-grocery shops, an American corporation made a bid for the British business computer market.

Although much the same description could apply to early 1986, that was 1981. The Sinclair market leader was the ZX-80, Nascom had already been taken over by a company fated to follow it into insolvency, and Commodore launched the Pet series, sold complete with substantial keyboards, disc drives and green-screen monitors at a price of almost £1,500 for 32K of memory.

They were bought in quantity and received local authority seals of approval when they infiltrated schools and colleges, council offices and various other bureaucratic strongholds, as well as small businesses generally. The launch of the Vic-20 followed shortly, as Commodore attempted similar success in the home market. That micro, too, displayed healthy sales figures, even though it required a datacorder rather than a standard cassette recorder, which increased the overall price. Its "real" keyboard persuaded many potential buyers of its innate superiority over the Sinclair rubber versions and the Vic laid a firm launch platform for the bigger and better Commodore 64.

Memorable for one of the neatest advertising campaigns for any computer, the 64 was heralded for its reliability, availability and realistically-decreasing price, and became known in the U.K. as a superior games machine. Elsewhere, in places like Scandinavia, it had a more serious image as an educational micro but, either way, it spelt substantial success for the company. The best thing about it was that it sold for substantially more than the Vic-20, while costing Commodore substantially less to manufacture.

Then 1985 arrived, with declining markets for all. Rumours of the Amiga made not only the opposition but Commodore products look outdated and unexciting, but neither the micro nor its price has yet reached viable market proportions. For Christmas 1985, the 64 was re-packaged and promoted as a music micro, in a campaign which lacked the instant appeal of the original elephant and which failed to revive Commodore fortunes.

The C16 and the Plus 4 suffered the dubious distinction of being bought as job lots by Dixons, almost as soon as they reached these shores from the U.S., and the 128, launched in response to apparent market demand for extra memory, has made little or no impression. By the end of the year, Commodore had levelled its own score, with three successful micros and three also-rans.

The tale from there is depressingly familiar. Will the new all-singing, all-dancing, 16-bit, super-amazing Amiga arrive in time to restore Cinderella's fortunes, or will the company's invitation to the ball be withdrawn? Time, as they say, will tell.

Inevitably, any look at Commodore add-ons must concentrate on the 64, with the occasional side-glance at the 128 and Vic-20. Whatever their success in the States, neither the Plus 4 nor the C16 reached the homes of sufficiently significant numbers of enthusiasts in the U.K. for the peripherals industry to show much interest in them.

In Britain, the most impressive showing of the 64 was as a games machine and it is scarcely surprising, therefore, that joysticks and trackballs feature high on the list of available peripherals. Companies like Kempston, Spectravideo, Cheetah and Atari vie with names such as Vulcan, Meedmore, Cookridge and CBM U.K. to supply the youth of the nation with the fastest and most efficient weaponry for zapping aliens.

Models with titles such as Sureshot, the inevitable Quickshot, Hotshot, Gunshot, SpeedKing and even Zipstick spell destruction in figures ranging from about £8 to slightly less than £20, but among so much publicity, the Lightwave product, The Stick, has certain modest appeal, not least for its £12.99 price.

Joysticks, however, are very much a matter of personal preference. It would be brave to attempt to recommend such things to aficionados and I do not intend to try it, but if you find yourself with a joystick which has a slower reaction time than your adrenalin die-

tates, or you cannot see the wretched pixels anyway, there is always the Robtek Game Killer. That small black cartridge slots into the cartridge port at the back of a 128 or 64 and proceeds to corrupt the signals from arcade-style games - or at least those which use sprite collisions to determine a player's fate - by some undisclosed process which disables sprites and turns little green men into sitting ducks.

Music micro

Whether that will be regarded by inveterate games players with the enthusiasm the makers expect remains to be seen but, for £14.95, you can decide for yourself.

Because of the attempt to relaunch the 64 as a music micro, the machine is well-supported with noise-making commodities ranging in price from £10 to £250. Keyboards, synthesizers, synchronisers and be-your-own-Beethoven packages abound. One of the more prolific companies in this area, Music Sales, offers a keyboard emulator and various music-generating packages. Prices range from £9.99 for Playalong Albums to the £100 Sound Expander which claims to increase the already good range of sounds on the 64 and 128.

Syndromic supplies a drum-emulating kit, with a complementary package expanding the original drum rhythms by 50 "new samples". The supplementary disc promises a "full selection of tom-toms, sweep,

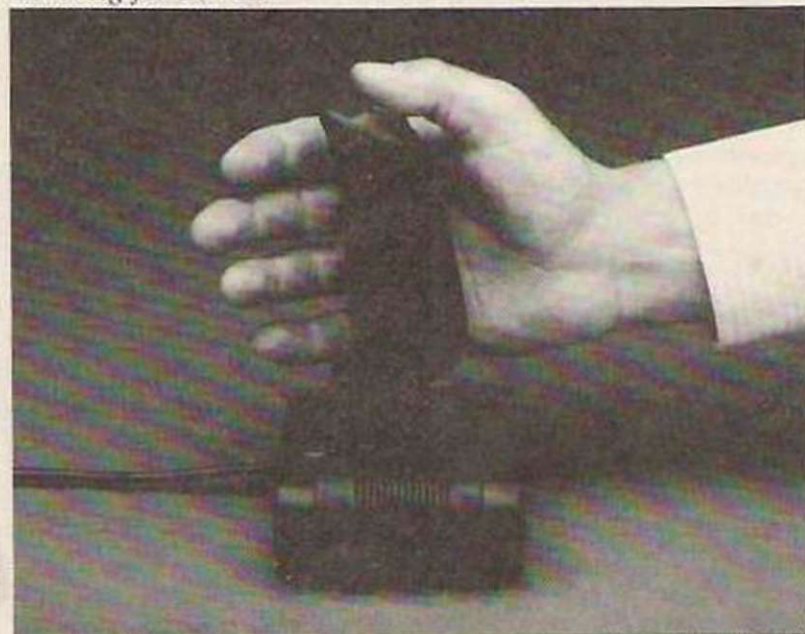

Putting it in writing.

pitchbend toms, cymbals, hi-hats, Latin effects and syndrum effects". It does not, however, promise ear-muffs. Thereafter, the company indulges itself and more dedicated music enthusiasts with a four-octave keyboard for £125 and a Sound Buggy, with Midi facilities, for £99.

Most of the Commodore music add-ons are directed at the more dedicated. You need to be serious to pay £239 for the Rosetti RMS 6h Midi master synchroniser, £245 for the equivalent from Joreth Music, or £165 for the Autographics Digital Music System, even if it promises the ability to create complex sound as well as pitch-

printer paper, and they are slower in execution than their bigger competitors.

The Brother HR-5 is a good example of this sector of the market, since it is a thermal printer which prints a full 80-column width of paper and costs £110. Commodore, of course, markets printers which are specifically compatible with its computers and they cover the full price range from £100 for a plotter, up to the DPS1101 daisywheel letter-quality printer for £399.99. If, however, you want a full-facility printer at rather less than Commodore prices, you will have to investigate the world of printer interfaces, of which

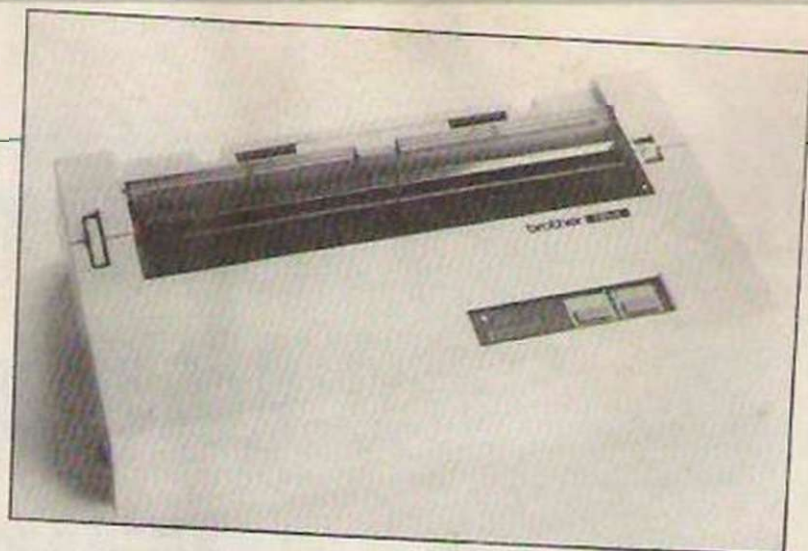

parallel port given manufacturers of interfaces plenty of work. Perhaps that is the real dynamic behind that timeless mystery of non-standardisation of micros? Perhaps the various producers all want to give work to each other?

dealt with are of much assistance, of course, unless you have a monitor and again Commodore supplies a 14in. colour monitor which, not surprisingly, is said by many to give the best colour range and clearest definition from any Commodore home micro. You will pay £230 for the privilege, which is not expensive when you consider that the Sony KX14CP1 14in. screen hi-res video input, with all connectors necessary to tune into the stars and beyond, will cost £462.50.

Hardware roundup

testing samples. In this gathering, Datel sells its Sampler for £50.

Still with the entertainment aspect of the Commodore in mind, the modem market is well represented by several companies. Prominent among them is Miracle Technology, which offers an RS232 serial interface with each of its models, thus avoiding the perennial difficulties of the Commodore non-standard link. Commodore has the Communications Modem, which sells for around £100 and includes a year's free subscription to Compunet. Buy a Modem House product, for example its Modem 1000 which costs £100, and Miconet is available free, but only for three months. You will not find a serious modem for less than the cost of these but if you are really committed you could pay as much as £650 for the Miracle WS 3000 V22 bis.

You might like something left in the bank to buy a printer or a monitor. All the usual names cater for the 64, Vic-20 and 128, with Brother, Epson, Rotronics and Star competing with Commodore to supply dot matrix printers and plotters. It is possible to buy a small printer for less than £100 but they tend to be thermal, which means buying special paper costing more than standard

there are more than a dozen designed specifically to take the Commodore micros back into the world of standard peripherals. SMC sells a software package and cable which links a 64 to any Centronics printer for £19.95.

More sophisticated

More sophisticated versions include printer buffers with parallel interfaces and printer test routines, as in the Connection from Tymac, which sells for £79.95, unless you insist on an Epson printer, in which case you pay £89.95. The less complex 92000 interface/buffer from FCC costs £47.50 and is compatible with the Plus 4 and C16, as well as the 64 and 128.

Just as the Spectrum's lack of a joystick facility gave rise to a whole section of the

peripherals market, so has the Commodore non-standard

Another example of this kind of symbiosis is the existence of a fair number of speedloaders, whose existence is more than justified by the slow disc and tape systems for the Commodore machines. Names to look for include Ram, whose 1541 Express is designed for business software and costs around £35; Centresoft, which markets the Robcom Turbo range for prices between £25 and £40; and MPS, whose Warp 5 combines speed loading with patriotic fervour, in the shape of a utility which enables the disc drive to render God Save the Queen on demand. At £9.95, it would seem you are not charged extra for gracious living.

Few of the peripherals so far

Keeping ahead

Microvitec, Philips, Fidelity and Thomson are other names to conjure with, although you will inevitably pay more for Microvitec - colour monitors only - and Philips, whose green screen and amber mono models are several pounds dearer than the equivalent for other micros. It is difficult to know whether this reflects Philips or Commodore pricing policies.

If you feel sated by all those add-ons essential to make the most of the CBM 64, consider some of those that will keep you ahead of the Joneses. A digitiser or robot arm perhaps? Such devices are now readily available for the computer - at a price.

Commotion Ltd,
241 Green Street,
Enfield EN3 7SJ.
Tel: 01-804 1378.
Cheetah Marketing Ltd,
1 Willowbrook Science
Park,
Crickhowell Road,
St Mellons, Cardiff.
Tel: 0222 777337.
Ram Electronics (Fleet)
Ltd, Unit 16,
Redfields Industrial
Estate, Redfields Lane,
Church Crookham,

Aldershot,
Hampshire GU13 0RD.
Tel: 0252 850031.
Kempston
Micro-Electronics Ltd,
Singer Way, Kempston,
Bedford MK42 7AW.
Tel: 0234 856633.
Philips Electronics,
City House,
420-430 London Road,
Croydon,
Surrey CR9 3QR.
Commodore Business
Machines U.K. Ltd,

1 Hunters Road,
Weldon, Corby,
Northamptonshire
NN17 1QX.
Tel: 0536 205252.
Datel Electronics,
Unit 8,
Fenton Industrial Estate,
Dewsbury Road, Fenton,
Stoke-on-Trent.
Tel: 0782 273815.
FCC Systems Ltd,
The Lodge,
Moorlands Road,
Merriot,

Somerset TA16 5NF.
Tel: 0460 73442.
Epson (U.K.) Ltd,
Dorland House,
388 High Road, Wembley,
Middlesex HA9 6UH.
Tel: 01-902 8892.
Miracle Technology
(U.K. Ltd),
St. Peter's Street,
Ipswich IP1 1XB.
Tel: 0473 216141.
Atari (U.K. Ltd).
Tel: 0753 33344.

Nothing beats the Commodore 64 as a games machine. With its large memory, 16 colours, sophisticated sound chip and sprite routines, it has played host to some stunning games programs.

For technical brilliance, graphic sophistication and sheer arcade excitement, probably the best yet is *Uridium*. Andrew Braybrook's hard-edged metallic graphics and incredibly smooth animation routines combine to create the nearest thing yet to a "cabinet" game on a home computer.

Like all the best games, the plot is simple. Fly over 15 alien motherships in your Manta fighter, blasting surface features and defence ships, then land and play through a quick reaction test for bonus points—*Defender* multiplied to the nth degree, a truly awesome computer game guaranteed to give you sleepless nights.

Commodore 64 – the unbeatable arcade games machine

More sedate in some ways, yet equally violent, is the marvellous *Way of the Exploding Fist* from Melbourne House. *Fist* has given rise to a host of imitators but remains the best of the

Superb software has made the CBM64 the number one home computer for the last few years. Chris Jenkins reports.

"chop'n'kick" games. With one- or two-player options, featuring beautifully-detailed oriental backgrounds and stunning sampled sound effects, this kung-fu killer is simple to play yet difficult to master.

With 16 moves at your disposal, from chops and kicks to jumps and flips, it demands an almost Zen-like concentration to defeat opponent after opponent and reach the rank of Shaolin Monk. Design and animation are excellent and at the time of its release it rated as the best game available for the 64.

More esoteric is the exceptional *Deus ex Machina* from Electric Dreams. It is not so much a game – more an experience. Accompanied by a synchronised audio tape sound-track of voices, electronic music and narration, it tells the story of a rebel lifeform in a totalitarian society. Your task is to help that life-form develop,

through a series of simple arcade-type reaction tests, into a complete entity.

Though it sets no new standards for programming excellence, the sheer imaginative power of *Deus* is overwhelming; it is a perfect example of what can be achieved with home computers in the proper hands.

Equally unusual in some ways is the surreal *Spindizzy*, another Electric Dreams title. Paul Shirley's strange artificial backgrounds or ramps, dips, drops, aircraft, towers and causeways form the backdrop for a brilliant challenge of co-ordination and timing. You control the *Spindizzy*, with which you must map the confusing dimension in which you find yourself.

Comparisons with *Marble Madness* are obvious, as the *Spindizzy*, an inverted pyramid, teeters and totters through the bizarre landscape. Brilliantly colourful, full of unusual ideas and challenging thought-puzzles, *Spindizzy* is the ultimate trip for map-makers, joystick-bashers and puzzle freaks alike.

Returning to the popular theme of mindless violence, *Rocketball* from IJK is in many ways a tougher version of the Commodore *International Soccer*. Based on the James Caan film *Rollerball*, it pits two teams of five roller-skating sportsmen against each other

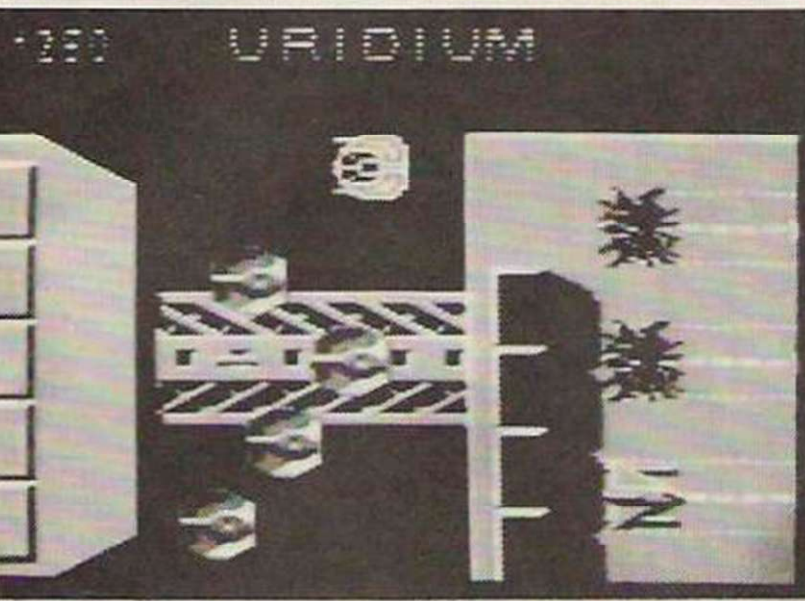
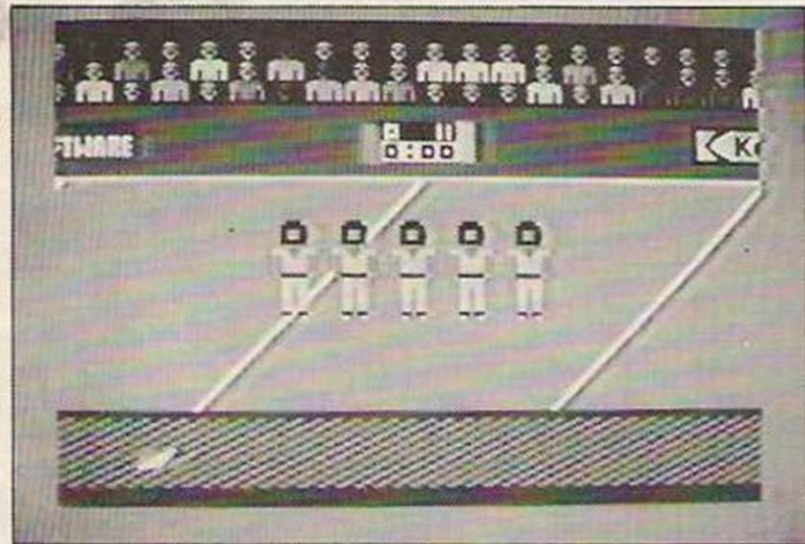

on a circular track. As the display scrolls round to show the whole circuit, you must control your men to clobber the opposition, gain possession of the ball, race round the track, leap at the enemy goal and slam the ball in.

The joystick controls speed, passing, punching, ducking, leaping and shooting, and all that is missing is the motorbikes. Great crowd atmosphere, choice of teams and good animation make Rocketball a favourite.

Hyper-fast action

It would be remiss not to include one of the many Llamasoft games which repeat Jeff Minter's themes of hyper-fast action, amazing sprite-handling, whacky characters and bizarre game play. In *Ancipital* a shaggy, horned anthropoid must master 100 chambers of hallucinogenic action to defeat the evil Zzyaaxians. With strange gravity effects, weird sprites such as flying coke signs, bananas, hamsters and goats, it is a challenge to find the six Key Camels and the five

Goats of Power, decide how to escape from each chamber and defeat the enemy.

A kind of adventure for shoot-'em-up fans and to be recommended, along with *Sheep in Space*, *Mama Llama*, *Batalyx* and the other shaggy games.

Even stronger on strategy but no slouch with graphics, is *Zoids* from Martech. Featuring sophisticated window and icon graphics, the most advanced Rob Hubbard music, and a complex game system, *Zoids* is a remarkable game based on the popular Tomy monster-machine toys.

Robot combat

Zoids casts you as a lone Earthman caught in a battle between rival robots. You must find the hidden pieces of the Blue Zoid leader Zoidzilla, controlling weapons systems, communication, radar jamming and shields through a system of windows and icons. The enemy Red Zoids must be avoided or fought in sophisticated combat routines if you are to succeed in your quest. One of the most

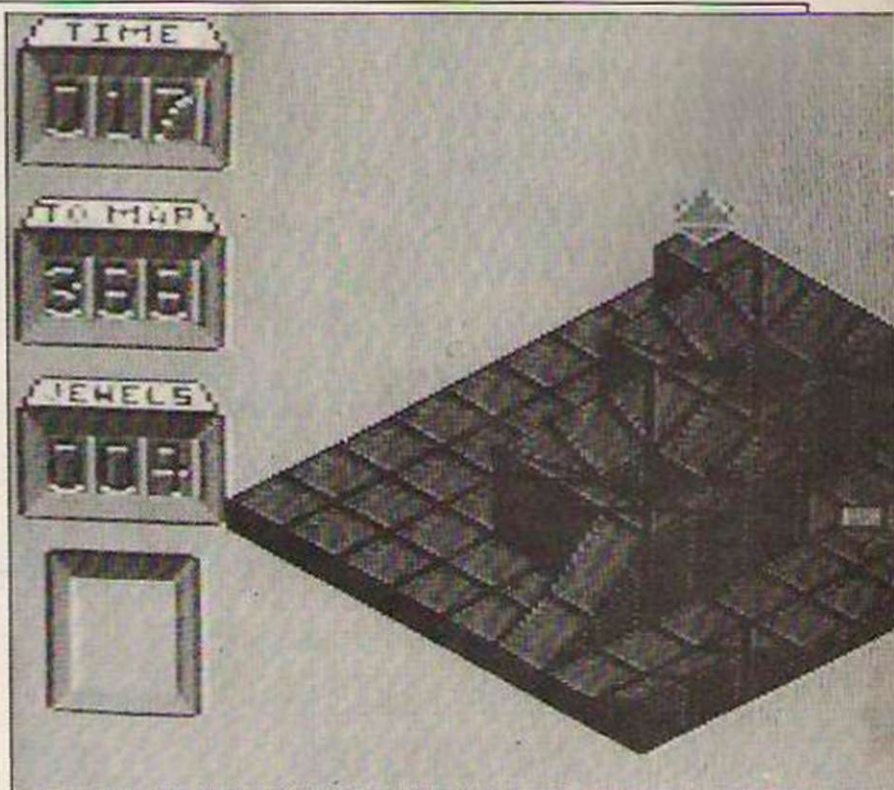

impressive CBM 64 games yet, though certainly one which will take many hours of play to complete.

Equally stunning is the *Novagen Mercenary*, an adventure requiring you to amass credit and find hidden objects to escape from the planet Tarq. You move through a complete 3D vector graphic representation of the world, with almost complete control over the objects and vehicles you encounter, because of the amazing world-design system of programmer Paul Woakes.

Best of all

Full of subtlety and jokes, such as gigantic 3D advertisements for Novagen and saucy responses from your on-board computer, *Mercenary* gives a much better impression of interaction with a real-world system than any text adventure, combining flight simulator, arcade game and adventure in one amazing package.

If I were to choose one real golden oldie it would have to be *Guardian* from Alligata. The single immaculate version of the original Williams *Defender* – miles better than the official Atari cartridge, it features all the familiar elements – humanoids, landers, fast-moving mutants, bombers, pods, swarms and

the dreaded baiters.

Guardian may no longer be remarkable graphically but it captures the thrill of the first video game to take the industry beyond the realms of *Space Invaders*. Some sophisticated multi-sprite routines and reasonable sound effects make it a must but you will probably need a rapid-fire joystick if you are not to die in hyperspace.

How about the game many players regard as the best yet, on any machine, *Elite* from Firebird? Combining space battles in 3D vector graphics with the complexities of a trading game and the subtleties of an adventure, *Elite* is truly a cult. Complete with spacecraft recognition chart, keyboard overlay, control key booklet, introductory guide and a scene-setting novella, it is also the best-packaged game to emerge from a U.K. software house.

If you have not experienced the excitement of battling the Thargons, jumping through hyperspace, docking – without a computer – and fighting off pirates, you should try *Elite* immediately.

The good thing about the Commodore 64 is that every time games players think the machine has been stretched to its limit, something even more stunning appears.



LONDON'S LARGEST DISPLAY OF PRINTERS MONITORS COMPUTERS AND PERIPHERALS

DON'T TAKE A CHANCE

—COMPARE BEFORE YOU BUY

OVER 40
PRINTERS ON
DISPLAY — MOST ON
DEMONSTRATION

HI VOLTAGE London's Largest Computer Shop

CITIZEN 120D
NLQ Dot Matrix Printer
120 c.p.s., 4K Buffer,
Friction/Tractor, Epson/
IBM Compatible

£179.90 inc VAT

**COMMODORE
AMIGA**

In Stock Now

Phone for Details

**AMSTRAD NETWORK
AND 20mb HARD DISK**

Connect upto 100 Amstrad
computers together.
On demonstration now.
Distributor for South
London

ATARI 1040 STF
Including Mono Monitor
and 1mb Disk Drive
Plus FREE 1 year
on site Maintenance

£899.95 inc VAT

ALL PRICES INCLUDE VAT

EXPORT

Contact our specialist export department on 01-686 6362

DOT MATRIX PRINTERS

Brother HR5	£89.95
Brother 1509NLQ	£482.95
Epson P40 Thermal AC/DC	£59.95
Epson LX80NLQ	£229.95
Epson GX80NLQ	£229.95
Epson FX85NLQ	£425.95
Epson FX105NLQ	£549.95
Epson LQ800NLQ	£579.95
Epson LQ1000NLQ	£769.95
Epson JX80 Colour	£519.95
Canon PW1080A NLQ	£309.95
Canon PW1156A NLQ	£419.95
Panasonic KP1091 NLQ	£299.95
Oki-Mate 20 Colour	£252.95
Shinwa CPA80 plus NLQ	£195.95
Micro P. 165 NLQ	P.O.A.
Seikosha GP50A	£79.95
Seikosha GP500A	£105.95
Seikosha SP1000NLQ	£229.95
Seikosha SP1000VC NLQ CBM	£229.95
Seikosha MP1300A NLQ 300 cps	£459.95
Star NL10 (IBM) NLQ inc I/F	£279.95
Star SG10CNLQ (CBM I/F)	£229.95
Star SG15NLQ	£379.95
Star SD10NLQ	£379.95
Star SD15NLQ	£469.95
Star SR10NLQ	£459.95
Star SR15NLQ	£579.95
Kaga Taxan KP810NLQ	£279.95
Kaga Taxan KP910NLQ	£439.95

DAISYWHEEL PRINTERS

Brother HR15 (P)	£359.95
Brother HR25	£699.95
Brother HR35	£849.95
Epson DX100	£279.95
Juki 6000	£229.95
Juki 6100	£299.95
Juki 2200 Typewriter Por S	£265.95
Commodore DPS1101	£279.95
Quen Data DWP1120	£199.95
Uchida DWX305	£199.95

All popular interfaces, cables, etc. available from stock. Custom cables made to order.

Let our experts match your computer to the printer of your choice.

Printers — All models parallel-centronics interface Serial RS232C available at same or slightly higher prices.

MONITORS

Microvitec Colour	
1431 DS STD RES RGB	£209.95
1431 MZ STD RES Spectrum	£229.95
1451 DS MED RES RGB	£264.95
1451 DQ MED RES QL	£264.95

1451 APDS MED RES	£333.95
1441 DS High RES RGB	£449.95
Philips Monitors (Monochrome)	
BM7502 Green	£86.95
BM7522 Amber	£91.95
BM7542 Paper white	£98.95
Philips Monitors (Colour)	
CM8501 RGB STD RES	£209.95
CM8524 Comp/STD	£259.95
CM8533 RGB/IBM/MED	£289.95
1114 Monitor/TV	£199.95

COMPUTERS

Amstrad	
PCW8256 256K 1 x D Drive	£454.95
FD2 1 Mb Second drive	£172.95
CPS Serial/Parallel I/F	£68.95
Full range of business software	PHONE
CPC6128 Green Monitor	£298.95
CPC6128 Colour Monitor	£398.95
CPC464 Green Monitor	£198.95
CPC464 Colour Monitor	£298.95
FD1 Second drive including cable	£106.95
DMP2000 NLQ Printer	£159.95
MP2 Modulator	£29.95
Atari	
520STROMO.S.	£344.95
520STM	£389.95

SUPERDISKS per box of ten				
Add 80p for P&P per order	SSDD	DSDD	SS96TP1	DS96TP1
	40TR	40TR	80TR	80TR
BASF 5 1/4"	£11.50	£18.20	£20.00	£22.00
3M 5 1/4"	£15.50	£22.50	£22.90	£27.50
VERBATIM 5 1/4"	£14.00	£17.50	£17.50	£22.90
DYSAN 5 1/4"	£15.80	£20.70	£20.70	£27.50
TDK 5 1/4"	£18.30	£16.70	—	£33.90
SONY 3 1/2"	£26.30	£37.80	MAXELL 3"	P.O.A.

PRINTER RIBBONS Single prices, deduct 10% for 5+					
Brother HR15 Corr	£3.40	CBM1525	£5.20	Juki 2200	£4.40
Brother HR15 MS	£6.50	CBMDPS1101 MS	£4.40	Kaga KP810	£6.80
Brother HR5	£3.40	Daisystep 2000	£4.50	Mannesman MT80	£7.50
Brother EP44	£3.40	Epson LX80	£4.60	Seikosha GP50	£7.90
Brother M1009	£4.50	Epson MX/RX/FX80	£4.00	Seikosha GP100	£5.20
Canon PW1080A	£6.80	Epson 100 Series	£5.20	Seikosha GP500	£7.90
CBM801	£7.90	Juki 6100SS	£2.20	Seikosha GP700	£21.50
CBM802/1526	£7.50	Juki 6100MS	£4.40	Shinwa CP80	£7.50
				Star/Oki	£2.20

1040STF 1MB + D.D. + Col. Mon.	£1149.95
500K ST Disk Drive	£142.95
1MB ST Disk Drive	£195.95
ST Colour Monitor	£389.95
ST 10MB Winchester Hard Disk	£829.95

BBC	
New Master Series	PHONE
Commodore	
CBM128/CPM Compatible	£259.95
CBM128D inc 1571	£499.95
CBM128D + Monitor	£599.95
CBM1541 Disk Drive for 64	£164.95
CBM1571 Disc Drive for 128	£259.95
CBM64	£159.95
MPS1000 NLQ Printer	£269.95
1901CRGB Colour Monitor	£289.95
PC10 IBM Comp. Green	£1259.95
PC10 IBM Comp. Colour	£1719.95
PC20 IBM Comp. Green	£1839.95
PC20 IBM Comp. Colour	£2295.95
Commodore Amiga	PHONE
Sanyo	
MBC555 128K 2x160K	£499.95
Sinclair	
QL	£159.95
Spectrum PLUS	£109.95
NEW Spectrum 128K	£134.95

Mail Order + Export + Trade Hot Line Phone 01-686 6362



Delivery by Securicor (4 day) please add £5.75 per item.
Delivery by Securicor 24 hour please add £9.95 per item.



Send off or order by phone quoting your Access, Visa No. Phone 01-686 6362.
Immediate despatch on receipt of order or cheque clearance. Or Telex your order on:
946240 Attn 19001335. EXPORT CUSTOMERS SUPPLIED TAX FREE.

OPEN MONDAY - SATURDAY 9 AM - 6 PM

OPEN MONDAY - SATURDAY 9 AM - 6 PM

ALSO VAST RANGE OF DISK DRIVES, JOYSTICKS, DISK BOXES, INTERFACES, SHEETFEEDERS, ETC.

HI VOLTAGE 53-59 High Street, Croydon, Surrey CRO 1QD. Tel: 01-681 3022

Prices correct at copy date. Subject to change without notice due to currency fluctuations etc. E. & O.E.

Giving it some stick

Joysticks are the first line of defence in the game-players' battle to outwit the computer.

The joystick used can seriously affect the way the game is played and many joysticks are available for various types of game. For quick action shoot-'em-up games, a large robust stick with a conveniently-placed firing button is a good choice. For arcade games requiring a softer touch, a microswitch joystick which has greater sensitivity should be considered.

Auto gunshots

Vulcan manufactures the popular Gunshot 1 and 2 joysticks. They feature sturdy designs with four suction cups attached to the base, permitting you to fix the stick on a firm base for one-handed control. Unless you have sufficient room on your table or desk to accommodate both keyboard and this space-consuming peripheral, however, it is scarcely a

A good joystick is the key to success in many shoot-'em-up type games.
Anthony Thompson reviews some top models from Vulcan.

feature worth buying.

Both joysticks have two firing buttons, one on the left-hand side of the base and the other on top of the pistol grip. Both buttons have a slight tendency to stick as they are pressed, which could slow you in games which demand rapid bursts of gunfire. The second fire button is designed to allow the joystick to be held in the hand if no space is available to mount it. When it is used in that way the four suction cups make it slightly

uncomfortable.

The Gunshot 2 model is identical to the Gunshot 1 but it has the additional feature of an auto-fire button. That can be useful in some games where you have to shoot aliens while flying round obstacles but it can be a real disadvantage. Most games allow bullets to be fired only at set intervals and that is the rate dispersed in the auto-fire mode. If you miss a shot through concentrating on your movement, you may lose a life waiting to fire again. The Gunshot 1 costs £7.95 and the Gunshot 2 with auto-fire £9.95.

At £12.95, the Kraft joystick, new from the Vulcan workshops, seems over-priced when first compared to its bigger cousins. Its small, dainty size and plain appearance are somewhat disappointing but its range of capabilities more than compensates.

Interesting feature

The most interesting feature is a flick switch which allows the operating mode of the



joystick to be changed from four-way to eight-way. That, the manufacturer claims, gives the Kraft the ability to attack every type of game - from platforms and adventures to graphics and action.

Light control

The control is very light, allowing for small and precise adjustments to be made with ease. Although the structure seems solid enough, one wonders how well the sensitive mechanism would withstand the repeated stresses generated by an over-excited user in the midst of a shoot-'em-up massacre.

The stick is short, restricting control to the fingertips. The single fire button on the left of the base has a smooth and easy action, something sadly lacking from the larger and more robust Gunshot range.

The Kraft joystick is a worthwhile buy for the games player and would be an ideal addition for someone with a stubborn model who would prefer a little more sensitivity.

VM1302 hi-res monitor

Market research would tend to indicate that major motivation behind the purchase of many home computers has more to do with their game-playing potential than any more serious application, writes Michael Graham. Having installed the computer at home, though, many users use their machines, in conjunction with some of the excellent applications software available, to undertake a variety of non-game tasks.

It is when using a computer as, for example, a word processor or database, that the limitations of the TV set which so many people use as a

monitor become all too apparent. In particular, the resolution of a colour TV set is too low to resolve adequately the characters of any display exceeding a 40-column by 24-line format. It is no coincidence that that is the Teletext display specification, being the maximum number of characters which can be transmitted and displayed by typical broadcast TV equipment.

To obtain a satisfactory, high-resolution display it is necessary to add a monitor to the list of essential peripherals for your computer. When

The Thomson VM3102 is one of the latest monitors to

reach the market and is available with either green or amber phosphor. The VM1302 accepts a composite video signal via a phono socket at the rear of the set. Make sure that

The VM1302 has a display quoted as 35MHz. To put that figure in perspective it is some six times that of a typical TV set. As may be expected from the bandwidth and resolution figures, the Thomson monitor produces a crisp, easy-to-read display.

A comprehensive range of controls means that the display can be adjusted to suit the personal tastes of the user. The monitor features an internal audio amplifier, the input to

which is again via a phono socket at the rear of the unit. The VM1302 is a well-built unit and is worth considering if you intend to make use of your computer in applications demanding that a great deal of text-based information is to be displayed on-screen.

At a glance

CRT	12in. diagonal
Phosphor	Green or amber
Video Bandwidth	35MHz
Resolution	1,000 lines
Input	Composite video, negative sync.



The Honeywell 32 range – good but pricey.

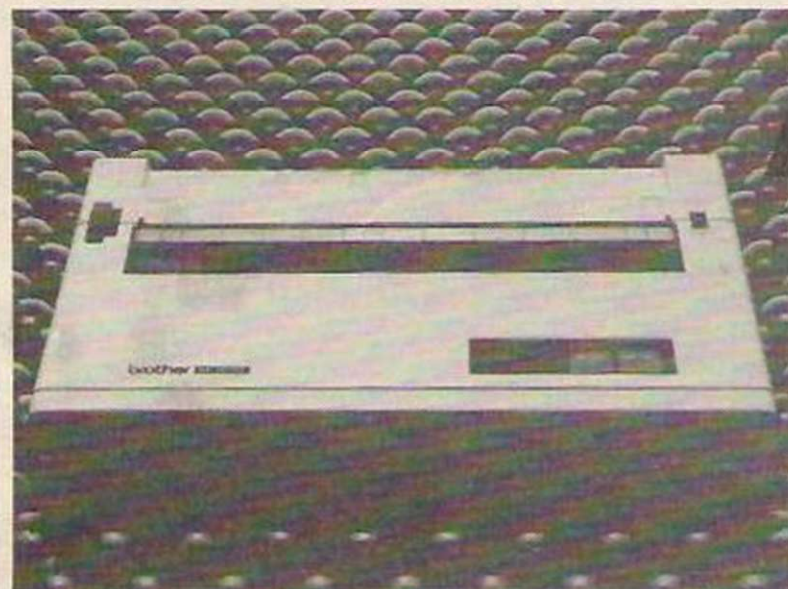

An all-rounder from Brother.

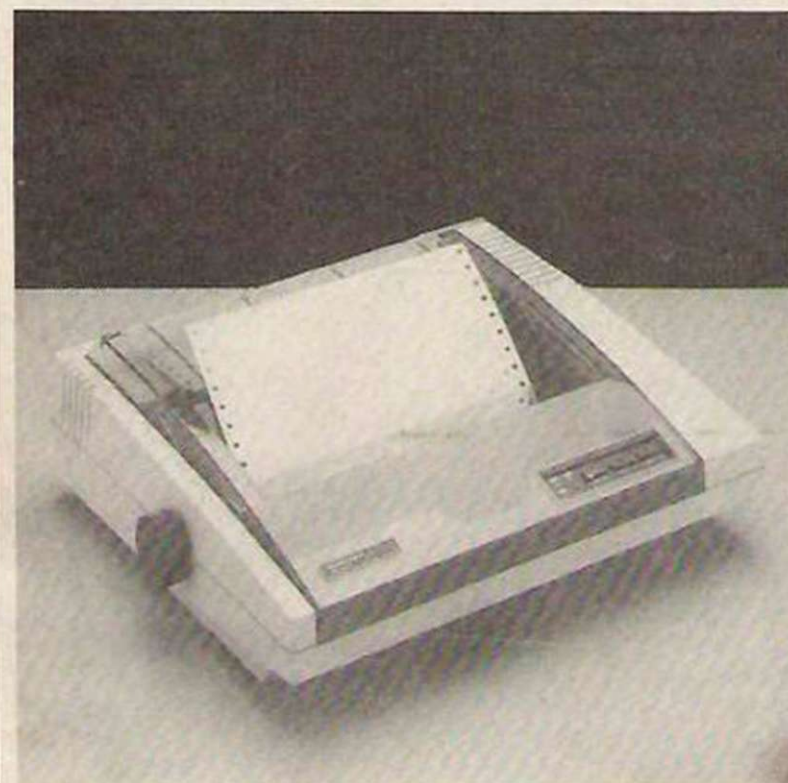

Competitive features at a competitive price.

Making a good impression

There are many different types of printer available on the market today. Deciding which to buy depends on what you intend to use it for.

Many people who are buying new home computers are offered printers at no extra cost. That reflects not only the intense competition in the market, with manufacturers struggling to make their products as attractive as possible, but also seems to make the point that a printer is an essential part of any computing system.

For those wishing to expand or update their own hardware, there is no shortage of potential purchases. There are many models available of varying size, speed and quality. The best buy for any particular person depends on the intended usage.

Printers can be split into three main groups. The dot matrix is the most popular and the most versatile, permitting draft quality printing at very high speed. Most dot matrix models offer near letter quality printing. In this mode speed is greatly reduced as each character is printed twice, the second time with the printhead slightly displaced.

Prime requisite

That helps to disguise the fact that the characters are formed by many dots and produces a darker finish. Anyone who wants to use a micro for word processing should regard NLQ as a prime requisite.

Another advantage of the dot matrix system is the ability to print complex graphics

figures, graphs and screen dumps. Some models use multi-coloured ribbons, permitting reproduction in full colour.

Daisywheel printers produce very high quality text but have no graphics capability. They are a great deal slower than the draft speed of dot matrix machines and few can match their reduced speed when in NLQ mode. They tend, however, to be cheaper and prices are falling all the time. They are not so versatile as their spotty cousins. It is possible to alter the print style but that normally involves removing the printwheel to replace it.

Cheapest of all

Thermal printers are the cheapest of all. They use a special paper which requires no ribbon but that can be expensive and difficult to obtain. If you intend to use your printer only to produce copies of your listings for your own use, a thermal model is probably the best choice.

Buffers are extremely useful, especially with the slower daisywheel models. A buffer stores the text to be printed, allowing you to continue programming while the printer continues to operate. If you have several pages to print and your letter-quality speed is around 20cps, you would have to wait a considerable time before you could use your computer if you did not have a buffer.



A heavy duty daisywheel from Juki.

Daisywheel printers generally use carbon ribbons which cost around £4 each, while dot matrix machines use fabric ribbons which are slightly cheaper and last a little longer.

For those with extra cash to spend, the Twinwriter from Brother gives the best of both worlds. Its two printing heads, one dot matrix and the other daisywheel, permit the user to produce high-quality text and graphics characters on the same page.

It is worth noting that many computer manufacturers now produce their own-name printers and although many of them are re-badged versions of other makes, they are often good value and definitely worth considering.

Name	Price	Type	NLQ?	Draft Speed	NLQ Speed	Colour Capability	Graphic Capability
HR-5	£99.95	Thermal	No	30	—	No	Yes
DWP 1120	£139	Daisywheel	Yes	—	20	No	No
801	£129 + vat	Dot Matrix	No	100	—	Yes	Yes
DMP 2000	£160	Dot Matrix	Yes	100	20	No	Yes
M1009	£169	Dot Matrix	No	50	—	No	Yes
<u>Citizen</u>	<u>£175</u>	<u>Dot Matrix</u>	<u>Yes</u>	<u>120</u>	<u>25</u>	<u>No</u>	<u>Yes</u>
Kaga KP810	£199	Dot Matrix	Yes	160	—	No	Yes
1101	£199 + vat	Daisywheel	Yes	—	20	No	No
LX-80	£225	Dot Matrix	Yes	100	16	No	Yes
Star NL-10	£229	Dot Matrix	Yes	120	30	No	Yes
MT80+	£229	Dot Matrix	No	100	—	No	Yes
<u>Juki 5520</u>	<u>£399 + vat</u>	<u>Dot Matrix</u>	<u>Yes</u>	<u>180</u>	<u>30</u>	<u>Yes</u>	<u>Yes</u>
HR-15	£399 + vat	Daisywheel	Yes	—	20	No	No
Juki 6100	£399 + vat	Daisywheel	Yes	—	20	No	No
S32	£595 + vat	Dot Matrix	Yes	150	60	No	Yes
Juki 6300	£899 + vat	Daisywheel	Yes	—	40	No	No
Twinwriter	£1,295	DM + DW	Yes	140	30	No	Yes

Increasing the memory of the PCW8256 to 512K is a straightforward DIY job, as Gary Evans reveals.

Fattening the Joyce

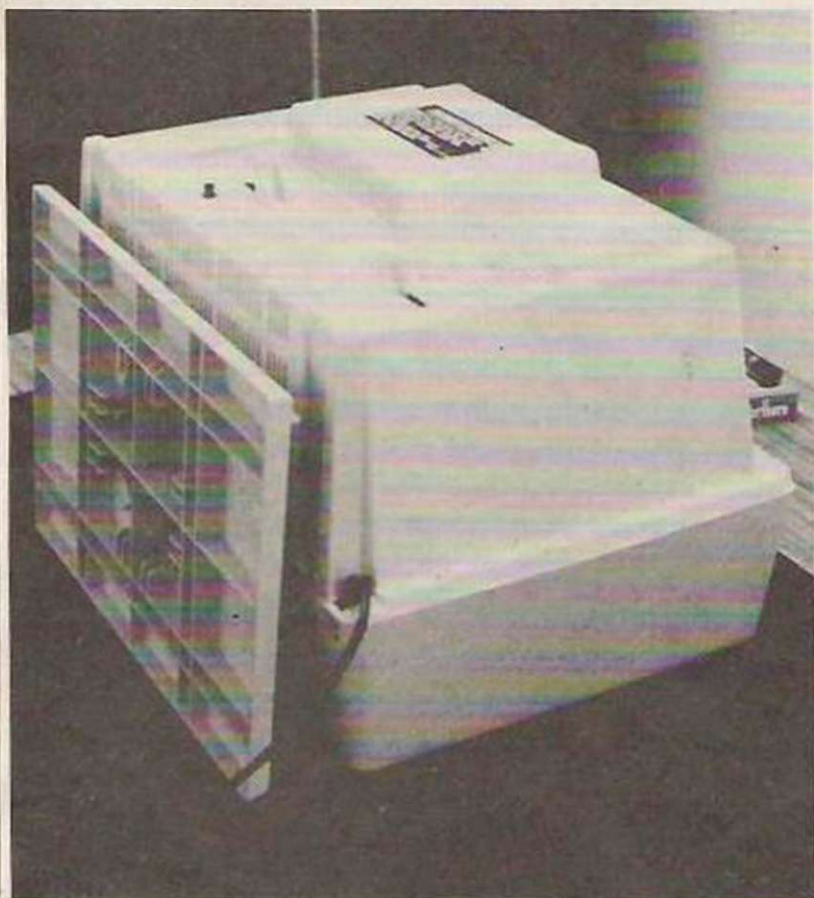

Six screws hold the rear cover of the PCW8256 in position.

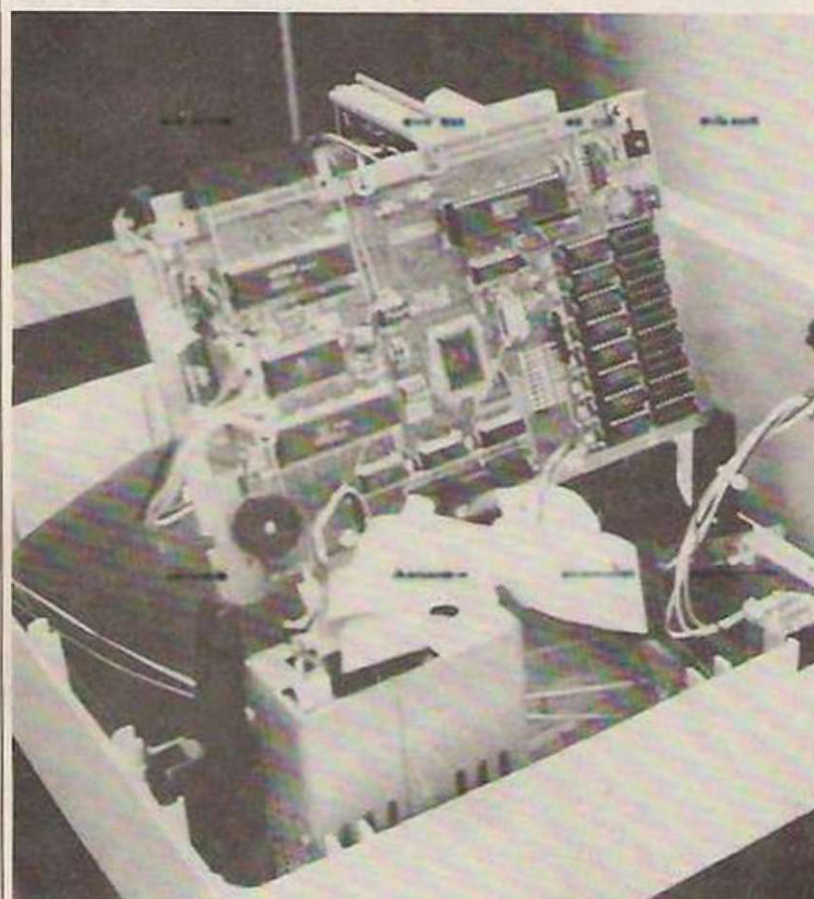

The main PCB of the computer; note the eight vacant sockets along the lower edge of the board.

To judge by the advertising copy which accompanies promotions for the two models comprising the Amstrad PCW range, the memory of the PCW8512 is massive, while that of the 8256 is huge. It is the 256K difference in the size of the memory of the computers which earns each the appropriate adjective. There is a well-known phrase, though, which goes something along the lines of it is not the size which is important, it is how you use it – in the case of the PCW8512 the extra memory is put to very good use indeed.

The 256K memory of the 8256 computer, according to whether the machine is operating under Locoscript or CP/M, is mapped to provide the various areas of working memory necessary to support operation of the software, in addition to supplying RAM for the silicon disc – a drive m – which complements the 3in. mechanical drive of the computer.

The size of the RAM disc differs between Locoscript and CP/M but in either case has a maximum size of 112K. The extra memory of the PCW8512 is mapped to that RAM disc, increasing its size, when running under CP/M, to 368K – more than the total capacity of a single FD1 format disc. While those who use the PCW exclusively with Locoscript are unlikely to appreciate the significance, those who have had occasion to use CP/M applications software will realise the implications.

The advantages of the large RAM disc fall into two areas,

depending on the particular application program in use. Some software, to function correctly, requires more than the 112K RAM disc of the PCW8256. Using such software on the unexpanded machine inevitably means some compromise in performance. In practice, that often means an irritating number of disc swaps as data is loaded and discarded from the RAM disc.

Question of size

The 368K RAM disc will provide sufficient space for even the largest applications software. For example, when using NewWord, the NW.COM file plus all system overlays and the entire The Word spell check suite can be loaded to RAM disc. With a data disc in drive a, the WP and spell check can be used without the need to swap discs.

The second type of applications software to benefit from the increased RAM disc will be packages which require a large amount of data storage capacity. Spreadsheets, for example, will be able to make good use of the increased RAM space. In that instance the applications program will reside in drive a while drive m will contain any data files.

The user will have to ensure that any data file does not exceed the 170K limit of the physical drive a, but working in RAM disc usually will lead to a considerable increase in the speed of operation of a program. That is because RAM disc access is virtually instantaneous.



Having explained the benefits to be gained from the large disc drive of the PCW8512, the good news is that 8256 owners can upgrade to enjoy all the benefits of the larger RAM disc.

Warning: Removing the rear cover of a PCW computer will invalidate any warranty in force on the computer. *Your Computer* can accept no responsibility for any damage which may occur to any reader's machine as a result of undertaking the modification described.

Down to work

To undertake the memory upgrade you will require a cross-head screwdriver and eight 256K x 1 dynamic RAM ICs. The ICs used in our conversion were NEC-type D41256 with 150ns access time, available from Technomatic at £3.50 each plus VAT.

The first step in the conversion is to remove the rear cover of the computer. Six screws hold the cover in place, two at the top of the computer, two at the base, and two smaller screws adjacent to the expansion port. To remove the cover, place the computer face down on a soft surface to give easy access to the screws. Having removed all the screws and put them in a safe place, the cover of the machine can be removed.

The next stage is to ease the main computer circuit board back slightly to gain access to

the eight vacant RAM sockets which can be seen at the lower edge of the PCB. To accomplish that it may be necessary to remove both the keyboard and video connectors.

Next insert the RAM ICs, re-connect any connectors and slide the PCB home into its mounting hardware.

Going for a DIP

The final stage of the conversion is to alter the setting of the DIP switches which can be seen at the centre of the PCB. That is necessary to signal to the PCW operating system software that the additional memory is in place. The switches to alter are marked A and B. To effect the conversion, the position of the switches must be reversed; in other words, switch A which is towards the rear of the PCB must be switched forward, while switch B must be switched towards the rear of the PCB.

Finally, re-assemble the computer, switch on and boot CP/M. If all is well you will be greeted with a sign-on message which indicates that the RAM disc is 368K in size.

Undertaking the above conversion will, at a cost of less than £35, increase the power of the PCW8256 dramatically. Having undertaken the conversion we can report that, with the larger RAM disc, most users will find that there is little need for a second physical disc drive.

Before installing RAM.

A: show M: (drive)

```

M: Drive Characteristics
890: 128 Byte Record Capacity
112: Kilobyte Drive Capacity
64: 32 Byte Directory Entries
0: Checked Directory Entries
120: Records / Directory Entry
6: Records / Block
120: Sectors / Track
3: Reserved Tracks
120: Bytes / Physical Record
  
```

After the RAM is installed.

A: show M: (drive)

```

M: Drive Characteristics
2,944: 128 Byte Record Capacity
360: Kilobyte Drive Capacity
120: 32 Byte Directory Entries
0: Checked Directory Entries
256: Records / Directory Entry
10: Records / Block
120: Sectors / Track
3: Reserved Tracks
120: Bytes / Physical Record
  
```

The CP/M SHOW command with the [drive] option shows the effect of the modification.

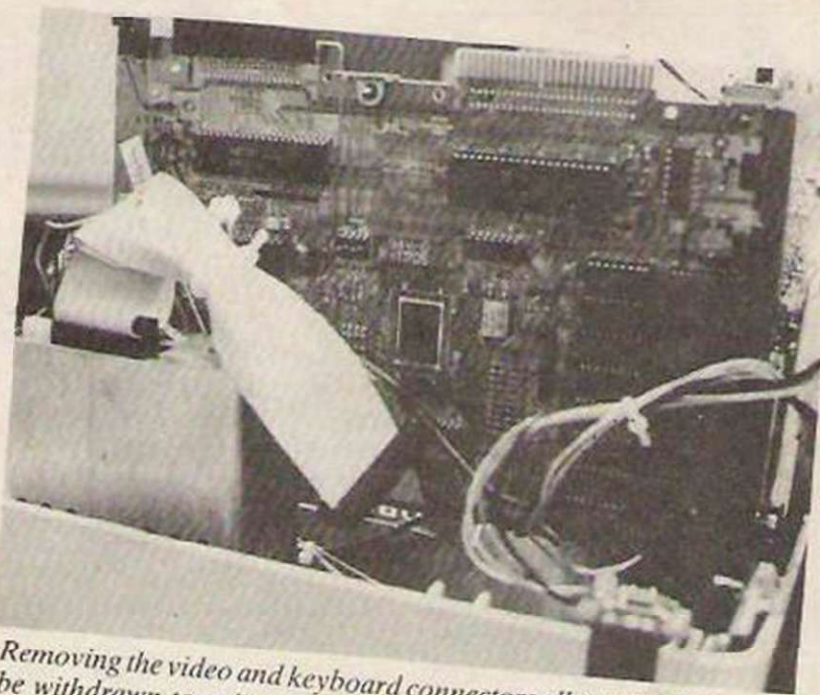

Removing the video and keyboard connectors allows the PCB to be withdrawn to gain access to the RAM sockets.

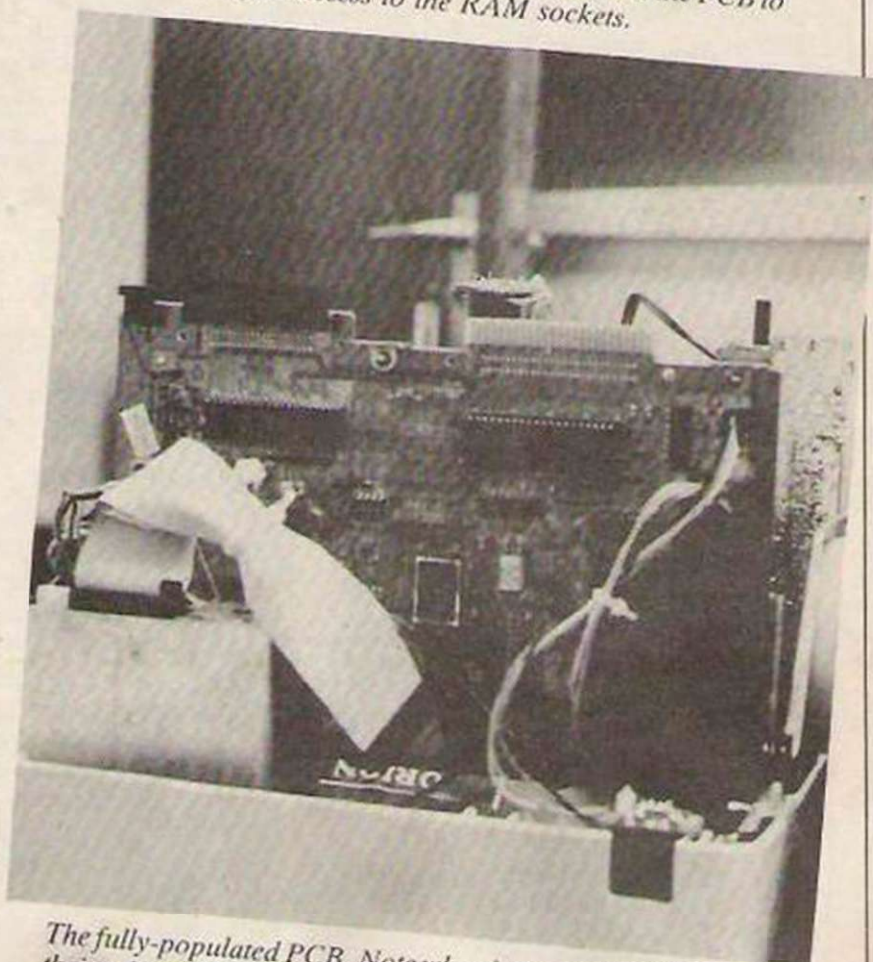

The fully-populated PCB. Note when inserting the RAM ICs that their orientation should correspond to that of the original devices.

PCW software — beyond Locoscript

Amstrad PCW computers are supplied with a wealth of free software. First, and arguably foremost, is the Locoscript word processing package which earns the system its Personal Computer Word Processor badge. In addition, a very respectable implementation of Basic and the DR Logo language are provided. As if that were not sufficient, Amstrad also supplies the CP/M Plus operating system, together with a comprehensive selection of utilities. The provision of CP/M means that the PCW owner has potential access to a vast range of both public domain and commercial applications software.

The success of the PCW computers has meant that

those companies with good-quality, reasonably-priced software for the computer have had somewhat of a sales bonanza since the start of this year. As new owners discover that, given appropriate software, the computer is capable of wider use than basic word processing, sales of PCW-compatible spreadsheets, databases and comms software have soared.

One of the companies to recognise the potential of the PCW system at an early stage was NewStar, the Brentwood-based distributor established by William Poel, former general manager of the Amstrad computer division. NewStar supplied *Your Computer* with some of the best PCW software for the purposes of this review.

In the first of a regular review of PCW software, Peter Luke reviews NewWord, an alternative to Locoscript, and Bridge Player for those who want a little relaxation.

Why spend £70-odd on a word processor when the PCW computer is supplied complete with Locoscript? The answer is that for many business users of the computer Locoscript is too limited in the facilities offered.

There is, for example, no provision to merge text documents with data files, an essential requirement for the printing of individually-addressed mail shots. Locoscript lacks other features many WP operators would require; a word count option and spell check program are two such functions.

Aside from those major omissions from the repertoire of Locoscript functions, the word processor, while adequate for the production of letters and small text documents, can become tiresome to use on larger — more than five-page — documents. The reason is that Locoscript can be slowed to a snail's pace when manipulating large files. Add to that the fact that cursor control is limited when compared to some other WPs and the need for a more sophisticated WP can be appreciated.

NewWord is just such a product, providing a powerful word processor which compensates for many of the deficiencies of Locoscript. NewWord is a WordStar lookalike, which means that its operation will be familiar to a considerable number of people who have used one of the best-established WP programs.

Building on WordStar

NewWord is supplied on a single 3in. disc, both sides of which contain a full complement of software. Side one of the disc contains the NewWord COM and OVL files, in addition to some installation software and example data files, while side two contains The Word, a generic CP/M spelling checker.

The software is supplied with a set of three manuals, a

NewWord Reference Card



Opening Menu

- D** Create a new document, or Revise an existing document
- N** Create or revise a non-document
- P** Print a file
- M** Merge print one or several files
- L** Log onto a different diskette/drive
- X** Exit from NewWord
- O** Copy a file
- Y** Erase a file
- C** Protect/unprotect a file
- E** Rename a file
- R** Run a program (COM file)
- J** Help with Opening Menu

Cursor Movement

- CTRL E** Up one line
- X** Down one line
- S** Left one character
- D** Right one character
- A** Beginning of word to left
- F** Beginning of word to right
- I** Next tab stop (same as TAB)
- Q E** Upper left corner
- Q X** Lower right corner
- Q S** Left end of line
- Q D** Right end of line
- Q R** Beginning of document
- Q C** End of document

Editing and Erasing

- CTRL G** Erase character under cursor
- H** Erase character left of cursor
- T** Erase word right of cursor
- Y** Erase whole line under cursor
- Q H** Erase line left of cursor
- Q Y** Erase line right of cursor
- K Y** Erase block
- Q D** Insert blank line after text
- RETURN** Insert additional blank lines
- B** Align single paragraph
- Q B** Align to end of document
- U** Undo or Unerase
- J** Help with Edit & other menus

Margins, Lines, & Tabs

- CTRL O L** Set left margin
- O R** Set right margin
- O X** Margin release
- O I** Set tab (# before column number means decimal tab)
- O N** Clear tab
- O** Set tab, non-document
- I** Move cursor to tab (same as TAB)
- O G** Temporary indent
- O C** Center text between margins
- O S** Set line spacing
- O T** Ruler display on/off
- O F** Read ruler line from text
- O O** Write ruler line into text
- R R** Automatic ruler line (no need for CTRL key)

Scrolling

- CTRL W** Up one line
- Z** Down one line
- R** Up one screenful
- C** Down one screenful

Saving

- CTRL K D** Save, return to Opening Menu
- K S** Save and resume edit
- K O** Abandon changes
- K X** Save and exit from NewWord

Typing Features, On/Off

- CTRL O W** Word wrap on/off
- O J** Right justify on/off
- O H** Hyphen help on/off
- O E** Insert soft hyphen
- O D** Print controls display on/off
- O T** Ruler line display on/off

Special Printing Effects

- CTRL P B** Bold
- P D** Doublestrike
- P S** Underline
- P X** Strikeout
- P T** Superscript
- P V** Subscript
- P A** Alternate pitch
- P N** Standard pitch
- P H** Overprint character
- P RETURN** Overprint line

CUT PRICE SOFTWARE

Spectrum	OUR RRP PRICE	OUR RRP PRICE	OUR RRP PRICE
Elite	14.95 10.00	Zoids	8.95 6.50
Bomb Jack	7.95 5.80	Rock And Wrestling	9.95 7.25
Battle of Planets	9.95 7.25	Uridium	8.95 6.50
Yie Ar Kung Fu	7.95 5.50	Winter Games	9.95 7.25
Hypersports	7.95 5.50	Max Headroom	9.95 7.25
Mike	7.95 5.50	Laser Basic	14.95 11.00
Zoids	7.95 5.50	Laser Basic (D)	19.95 14.00
Rambo	7.95 5.50	Freeze Frame	39.95 35.95
"V"	7.95 5.50	Time Tunnel	9.95 7.25
Superbowl	9.95 7.25	Lord Of The Rings	15.95 11.00
Rock & Wrestling	8.95 6.50	The Force	9.95 7.25
Spindizzy	9.95 7.25	PSI-5 Trading Co	9.95 7.25
The Planets	9.95 7.25	FA Cup Football	7.95 5.50
Movie	7.95 5.50	Dragon Skull	9.95 6.00
Spitfire 40	9.95 7.25	Ad Music System (D)	39.95 32.95
Sabatour	8.95 6.50	Superman	9.95 4.99
Turbo Esprit	8.95 6.50	Fairlight	9.95 7.25
Winter Games	7.95 5.50	The Elidon	9.99 7.45
Max Headroom	9.95 7.25	Desert Fox	9.95 7.25
Gunfight	9.95 7.25	Basidon Bond	9.95 5.25
Cyberun	9.95 7.25	Space Dout	8.95 6.50
Pentagram	9.95 7.25	Empire	9.95 7.25
Lord Of The Rings	15.95 11.95	Green Beret	8.95 6.50
Laser Basic	14.95 11.00	R.M.F. Titanic	9.95 7.25
Enigma Force	9.95 7.25	Silent Service	9.95 7.25
Mugsy's Revenge	8.95 6.50	International Karate	6.50 5.00
Sam Fox's Strip Poker	8.95 6.50	Amstrad	
Hot Shots	9.95 7.25	Strike Force Harrier	9.95 7.25
The Price of Magic	9.95 7.25	Way Of The Tiger	9.95 7.25
Batman	7.95 5.50	Elite	14.95 10.00
Heavy on the Magic	9.95 7.25	Elite (D)	17.95 13.95
		Rambo	8.95 6.50
		Laser Basic	14.95 11.00
		Laser Basic (D)	19.95 14.00
		Mini Office II	16.95 12.95
		Mini Office II (D)	19.95 14.95
		Sorcery + (D)	13.95 10.95
		Cyrus II Chess (D)	13.95 10.95
		Tau Ceti	9.95 7.25
		Tau Ceti (D)	14.95 11.00
		BBC	
		Elite (D)	17.95 13.95
		Yie Ar Kung Fu	9.95 7.25
		Explosion Fist	9.95 7.25
		Southern Belle	7.95 5.50
		Mini Office 2	14.95 11.00
		Mini Office 2 (D)	10.95 13.95
		Strike Force Harrier	9.95 7.25
		Commando	9.95 7.25
		Match Day	9.95 7.25
		Repton 2	9.95 7.25
		Speech	9.95 7.25

Large Range Amstrad disk s/w available. Blank Amstrad Disks £39.95 per 10. Overseas orders please add 75p per tape. Access and Visa orders welcome. Please make cheques payable to C.P.S. Sorry Mail Order Prices only.

**CUT PRICE SOFTWARE (YC), 4 Slacksbury Hatch,
Harlow, Essex, CM19 4ET.**
Telephone: (0279) 24433 (24hr Ansaphone)



MIDLAND COMPUTER LIBRARY

ATTENTION Computer Users

- * OVER 8000 different titles available for hire for the **COMMODORE, SPECTRUM, ELECTRON, BBC, AMSTRAD, ATARI,** and **MSX** computers
- * **ARCADE, ADVENTURE, EDUCATIONAL** and **BUSINESS** software too.
- * **HIRE PRICES** from only 75p **INC. P&P.**
- * **20% DISCOUNT** off all purchase software.
- * **LIFE MEMBERSHIP £6.00**
- * **FREE CATALOGUE.**
- * **FREE HINTS AND TIPS.**
- * **FAST RETURN OF POST SERVICE** (if reserves are given).
- * **ALL GAMES** manufactured **ORIGINALS** with full documentation.
- * **OVER 25,000** satisfied members.
- * **EUROPEAN** members welcome.
- * Full computerised system keeps track of your order. We pride ourselves in being the most professional Hire Library in the United Kingdom, with staff of 14 who know what the word service means. Backed by our own software company and programmers.

MIDLAND COMPUTER LIBRARY

28 College Street, Worcester WR1 2LS Tel: 0905 611072

Send now for free catalogue stating which computer

Name:

Address:



THE TOP PEOPLES CHOICE

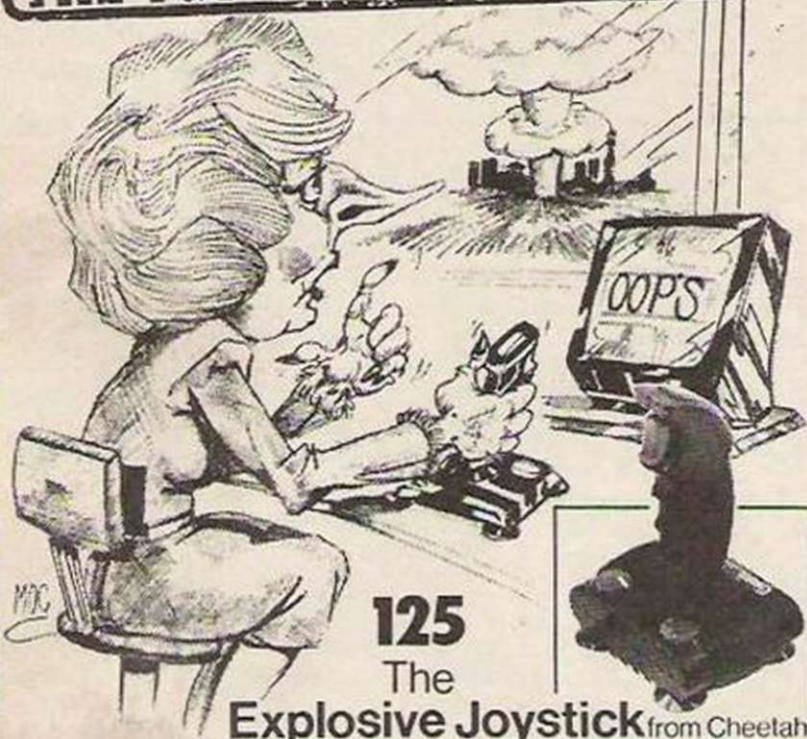

125
The
Explosive Joystick from Cheetah

Compatible with ZX Spectrum, Commodore 64, Vic 20, Amstrad, Atari, MSX, etc.

- Four extremely sensitive fire buttons.
- Uniquely styled hand grip.
- Auto fire switch.
- 12 months warranty.

ONLY £8.95



High Quality Low Price! Single fire joystick for Spectrum 48/128. Includes all standard parts. Great Value at **£9.75**

Prices include VAT postage & packing. Delivery normally 14 days. Export orders at extra cost. Dealer enquiries welcome. Cheetah products available from branches of...

Cheetah
Marketing

DEPT Y06, CHEETAH MARKETING LTD.
1 WILLOWBROOK SCIENCE PARK
CRICKHOWELL ROAD, ST MELLONS, CARDIFF
TEL: CARDIFF (0222) 777337 TELEX: 497455

FREE SOFTWARE* FREE 15 MONTHS MEMBERSHIP

A great new home computer club now under way!! Savings on software & books from 25% and up to 40% off R.R.P. originals only. You're never committed to any makes for software or books nor are you committed to buy. Every two months you get a software update, free software & game playing tips. Savings on hardware from 15% and up to 30% off R.R.P. not just joysticks but a wide range of peripherals for your computer. Normally membership is £15 for 12 months but for a limited period only membership is FREE for 15 months when you buy a program with a R.R.P. of £7.95 or more through us, choose one of the emphasised programs as your free bi-monthly software. Our club is designed for all Amstrad CPC, ZX, Spectrum 48K & +, Commodore 64 and 128.

SPECTRUM	AMSTRAD	COMMODORE
Lord of the Rings £15.95	Lord of the Rings £15.95	Lord of the Rings (D) £15.95
Elite £14.95	Elite (D) £14.95	Elite (D) £14.95
Enigma Force £9.95	Ace £10.95	Ace £10.95
Ace £10.95	Spitfire 40 (D) £9.95	Spitfire 40 (D) £9.95
Back to the Future £9.95	Back to the Future £9.95	Enigma Force (D) £9.95
Arc of Yesod £8.95	Skyfox £9.95	Skyfox (D) £9.95
Battle of the Planets £9.95	Bored of the Rings £9.95	Back to the Future £9.95
Three weeks of Paradise £9.95	Bomb Jack (D) £8.95	Hardball (D) £9.95
Tau Ceti £9.95	They sold a Million (D) £9.95	Arc of Yesod £8.95
They sold a Million £9.95	Rock 'n' Wrestling £9.95	Time Tunnel (D) £9.95
	Sabre Wolf £9.95	Fighter Pilot (D) £9.95

One of these Mastertronic games is FREE when you buy one of the above programs restricted to R.R.P. Please state computer.

*One man and his Droid Spec/Com *Formula One Sim. Spec/Am *Finder Keepers Spec/Am
*Caves of Doom Spec/Am *Last V8 Com *Action Biker Spec/Com

Who said anything about you don't have a choice in software?

* BUSINESS * UTILITIES * EDUCATION * ARCADE *

* ADVENTURE * ARCADE ADVENTURE * SIMULATION * STRATEGY *

These are just a few hardware prices which are exclusive to our club members:
AMX Mouse Designer £54.45 Opus Discovery 1 £122.50 Comm 1900C Col. Mon. £254.95
Brother HR5 Printer £84.95 Opus Discovery 2 £254.95 Comm 1900 M Mono Mon £122.50
Epson RX80 Printer £212.50 Saga Elite Keyboard £59.45 Comm 1541 Disk Drive &
Sinclair Expansion Pack £84.95 Seiko wrist Terminal £169.95

Our complete price list is much bigger than this, for any enquiries that you may have please ring 0376 45639 24 Hrs (it's much quicker than writing).

Please make cheques/postal orders payable to **T. L. DAVIS COMPUTING**. All priced items include postage & packing except hardware items below £100, also are correct when going to press. **Disk prices are different**

Post to: **THE T. L. DAVIS HOME COMPUTER CLUB, Dept. YC,
286 WOODBRIDGE ROAD,
IPSWICH,
SUFFOLK,
IP4 2QU.**

PYRADEV

► Various ● Gremlin Graphics/DISCOVERY

Gremlin Graphics, better-known for its arcade games, is moving into the more serious software market. *Pyradev* is the first of a series of software tools for the Amstrad range of machines – 464, 664, 6128 – which is being released under the Discovery logo.

Pyradev is a set of five programs which will enable the user to write, compile, edit, modify, housekeep and manage files all from one disc. The disc arrives in a video cassette-sized case but that is mainly for the benefit of the manual which packs a good deal of information in its 32 pages – actually 72 but it is written in French as well. It is extremely well-documented and is easy to follow, with screen shots displayed to help.

The first thing the manual advises the user to do is to copy the programs and make a working disc, keeping the original as a master disc; in the event of problems, it can be accomplished using *Pyradev*.

The five main programs are Screen Editor, Macro Assembler, Monitor, Disc Nurse and File Utility; there is also the Systems Menu and three program files for the user to practise.

On loading, the Systems menu is displayed. You can then access any of the five main programs, the menu being returned after you have finished, assuming that you have the *Pyradev* disc resident.

The first of the five programs is the Screen Editor, which allows the user to create or input any type of file which can then be modified, altered, checked or merged with other files before either saving or outputting to a printer. The types of file which can be written using

the editor are varied, including Basic programs which can then be saved and run, Assembly programs which can be saved and then assembled to binary using the Macro Assembler or, because of its extensive features, used as a mini word processor. They include tab setting, delete block, search system, move block, and so on. There is full screen help mode available at all times.

The next program is the Macro Assembler, which takes any assembly program file and turns it into a binary file.

It will access files from two disc drives and up to 992K of source code can be processed at 40,000 characters a minute on 64K machines, which is very

OVERALL



impressive by any standards. Additional RAM packs may be added and used to increase the Assembler performance further.

The Monitor, when loaded, can be re-located and will load, trap, step, modify and save code to disc. The user can select and study any additional ROMs which may be resident but, be warned, it is not a program for the inexperienced user as it would be easy to lose or change files if one is not careful.

The last of the programs is the File Utility, a standard type of program for re-naming, deleting, cataloguing and, of course, copying disc programs.

Pyradev uses one disc to give the Amstrad a complete set of utility programs, which most software houses produce separately; the front cover shows it as a rainbow which, of course, is produced from one light source.

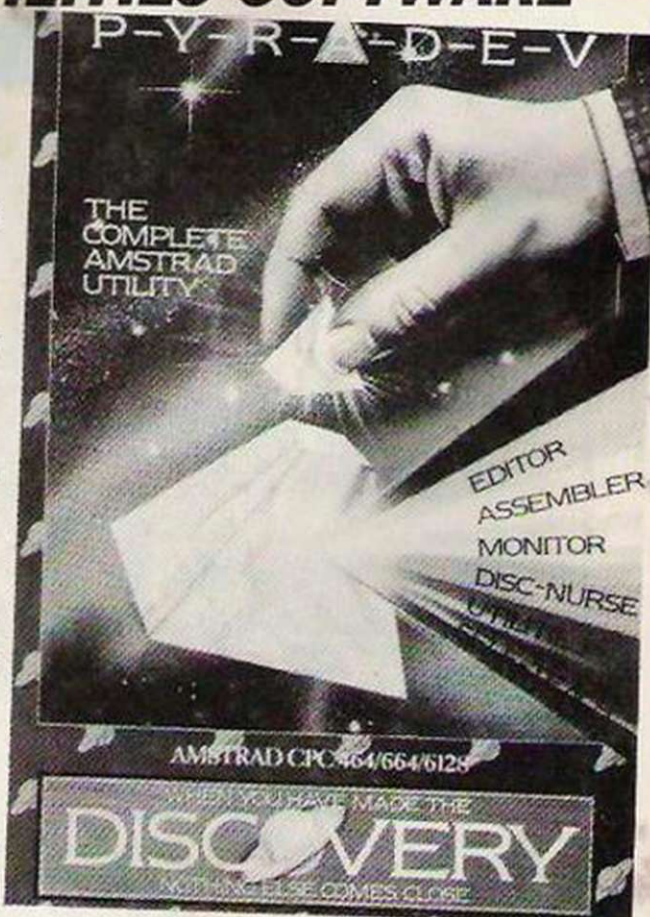

The programs are well-documented with numerous help pages for the user to access when necessary, although it is advisable to read the manual carefully at first to learn the basics of the programs.

Pyradev will not turn the amateur programmer into a professional overnight but will most certainly help to improve programming skills; for the professional it must compare to the best of the utilities on the market for the Amstrad.

One criticism is that displayed on the System Menu screen is Zap*.BAK which erases all back-up files on pressing the 'Z' KEY, which is rather easy to press accidentally, thus erasing files needed by the user.

LASER BASIC

► Amstrad CPC 464/664/6128 ● Ocean ● Utility ● Ian Duerden ● £14.95

Laser Basic from Ocean, which, according to the advertisements, claims to "turn your computer into a professional games-writing machine for fun and profit," looks at first sight to be able to plug that apparent gap.

The package, although rather big and bulky, is colourful and gives the impression of being able to do what it claims. Inside there is a 132-page manual, printed in black on blue paper in an attempt to prevent piracy, and two cassettes. The first contains the Basic Extension Program on one side and a demonstration on side two. The second cassette contains the Sprite Generator and Sound Generator, plus a couple of pre-programmed sprites.

After loading, the extension leaves around 15.5K available to play with but you get more than 200 new commands

The commands are loaded as RSX – Resident System Extension – and require the '!' bar (sifted @) to be placed in front of the command name. It is possible, using Laser Basic, to move sprites in any direction – up, down, forward, backward, sideways, behind screens, in front of screens and move them along pre-determined paths all within any pre-determined limits. You can also detect collisions, expand, shrink, rotate, inverse, duplicate and reflect any sprite without corrupting the background or foreground display. There are commands for setting windows, colours, modes, inks and, on the sound side, you can generate any type of sound you wish and associate any sound with any particular sprite character.

The program, although mainly for

sprite manipulation, allows you to create complex backdrops for your characters to wander round, as you will see when you use the demonstration program. Like any new language, Laser Basic takes some getting used to but there are plenty of worked examples listed in the manual.

OVERALL



The Sound and Sprite Generators are a little more advanced than those I have seen elsewhere. Both are menu-driven and user-friendly. One disadvantage to Laser Basic is that it needs to be resident in the machine while running, so if you are considering seriously writing and marketing programs, Ocean is producing a Mini Laser Basic which has most of the facilities of its bigger brother but leaves more memory available.

Your key to communications!

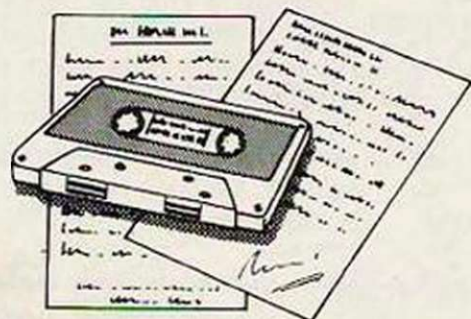
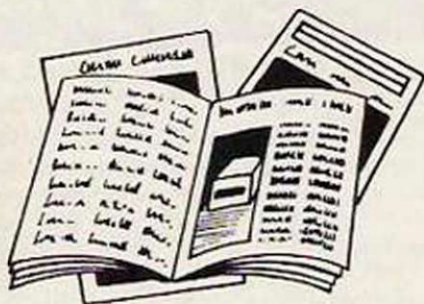

PRESTEL

FREE Electronic Mail . . . International Telex . . . 10 National Chatlines (Interactive Bulletin Boards) . . . 70,000 users across the UK . . . Teleshopping . . . Multi-User Interactive Strategy Games

Instant computer news . . . Hardware and software reviews . . . Technical features . . . Hints and tips

FREE and discounted quality software to download direct to your micro - **24 hours a day**

300,000 pages of information on the huge Prestel database

for just 20p a day

Micronet 800-
The ultimate peripheral

Micronet 800
8 Herbal Hill, London EC1R 5EJ
Telephone: 01-278 3143

To: Micronet 800, 8 Herbal Hill, London EC1
Please send me a brochure on Micronet 800

Name _____

Address _____

_____ Telephone No _____

Age _____ Micro _____

YC7.86

GUIDE TO THIS MONTH'S REVIEWS

AMSTRAD

Classic Invaders
Toad Runner
Winter Games
5th Axis

COMMODORE 64

Biggles
Jump Jet Spike
Leader Board
Psi 5 Trading Co
Shamus
The Young Ones

COMMODORE C16

Return Of Rockman

SPECTRUM

Action Reflex
Helicopter
Molecule Man
Splitting Images
Stainless Steel
The Planets
The Young Ones
Toad Runner
Biggles

Software Shortlist

Each of the games reviewed in Software Shortlist has been reviewed extensively by our team of reviewers.

We do not include reviews of unfinished products in this section of *Your Computer*; they are the games you can buy now or in the near future.

See the Software News and Preview features for advance news of games being developed.



Watch for the *Your Computer Software Star*. They are awarded to games which, in our opinion, offer outstanding value.

LEADER BOARD

► CBM64 ● U.S. Gold ● Sports Simulation ● Peter Luke ● £9.95



Hot on the heels of the Ariolasoft *Golf Construction Set* is *Leader Board*, another game designed to appeal to the armchair golfer. The game casts the player in the role of a golfer out on the fairway of one of four what can best be described as aquatic courses – water rather than the rough awaits any errant shots.

Leader Board can be played by between one and four players, each of whom can select an ability level from novice through amateur to professional. Each course is of 18 holes, though there is an option to select matches of anything up to 72 holes by mixing and matching the courses.

In play, the game is delightfully simple. Control is by way of a joystick and, having selected the appropriate club – the manual provided maximum and minimum expected ranges for each –

and aimed the on-screen cursor at the distant hole, the stick's fire button is held down to start the player's swing action; the longer the button is held the more power will be transferred to the ball. Pressing the button again, having determined the power of the shot, affects the snap; that will decide whether the ball goes straight ahead or is either hooked or sliced.

When within 64 feet of the hole the game will automatically select a putter for the player. The professional level built in means that any shots will be affected by the prevailing wind, further adding to the realism of the simulation.

Good graphics give this excellent simulation a realistic feel and the straightforward design mean that *Leader Board* scores highly in terms of playability.

5TH AXIS

► Amstrad ● Activision ● Arcade ● Lee Paddon ● £9.95

You may have the impression that there are only four dimensions, or axes, but Professor Chronos discovered a fifth – probability. Having done so, he proceeded to mess up the other four by hot-rod-ding it round the universe of time and space, making it less and less likely that time would exist at all.

While zipping round in the old time machine, he took one of those nasty probability curves with his toe to the floor, which left pieces of his time machine all over the place. You must re-assemble the old jalopy and re-assemble time. You do so by going round a series of platforms, picking up artefacts and kicking the hell out of a bunch of robots in the old prof's lab.

That part of the game is great fun. You

can walk, run, leap and kick. The robots are a variety of shapes and sizes and all have different fighting styles. The best way to trash the beasts is to boot them down the nearest hole in the floor, whereupon they will emit a sound not unlike a recently-trodden-on cat. You move up platforms on elevators, and can drop through holes in the floor. That

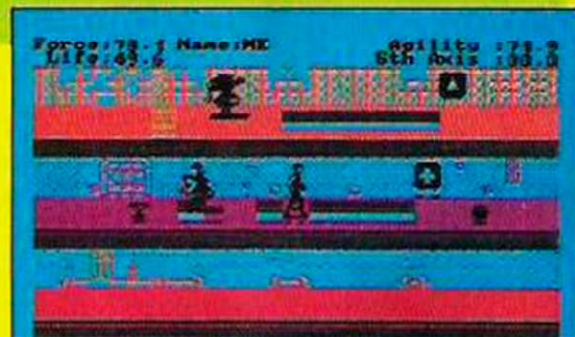

section is fast furious and fun.

After collecting all the artefacts, you move to a screen where various objects attempt to impale themselves in you. You must leap, duck and punch your way through them and then it is back to the laboratory for more of the same. With a good sound track throughout and impressive graphics, it is certainly an impressive debut for the Loriciels and Activision tie-up.

BIGGLES

► CBM64 ● Mirrorsoft ● Arcade Adventure ● Lee Paddon ● £9.95

Well, here is the computer game for which all you fellows have been waiting. Based on the old film of the same name, *Biggles* follows the exploits of our brave chums as they battle their way through to foil the dastardly Hun and destroy the secret sound weapon. In reality, this was



just an early recording of Sique Sique Sputnik but, in the wrong hands, that kind of thing could be nasty.

The game is in two parts, The Sound Weapon and the Timewarp – all together now, "Let's do the Timewarp again." The better you do in the Timewarp section, the easier it will be to complete the other section.

Timewarp is divided into three sections. You switch between them whenever you lose a life in one section, to simulate the sections in the film where, when his "timetwin" was in mortal danger, characters would fly through time. There is a Green Beret type scenario, coupled to a biplane shoot-em-up which has elements of *Scramble* in it, and a leap over buildings with a single stride bit completing the trio.

The Sound Weapon consists of



zipping around the Somme in a helicopter – I kid you not – picking up your chums, finding objects and clues, and generally giving the old Hun a difficult time.

Certainly not the most original of games but the combination of pleasant graphics and a great rendition of the film sound track makes the reappearance of some old favourite themes easier to accept.

SPLITTING IMAGES

► Spectrum ● Domark ● Arcade Adventure ● Ian Nicol ● £7.95



This game belongs to that rare breed of adventures which, at the outset, seem very simple to complete but in practice prove to be tricky. You have to form pictures of politicians, the Royals, pop stars and other famous personalities from the jumbled pieces of jigsaw appearing on the screen. A spinning

cursor allows you to move off the screen to dip into a unseen store of pieces to place on the screen. Do not take too long, though, as the cursor will explode after a few minutes.

What makes the game really difficult are the items mixed with the jigsaw. They include diamonds, matches, pistols, bullets, dripping taps, flags and several other mystery items. You cannot finish the picture with those items on the screen, so to get rid of them you can either push them through holes which appear from time to time in the playing area or, better still, combine two to make a pair – e.g., pistols and bullets – and win bonus points.

Watch for the bombs which appear on the screen. Unless you get rid of them



quickly they will explode and cause you to lose one of your lives. Once all the pieces are on the screen and all the unwanted items have been dealt with, all that remains is to move them into their correct positions to form the completed face before you run out of time.

If you have seen the TV series, read the book and sung the song, you will probably enjoy the computer game as well.

ACTION REFLEX

► Spectrum ● Mirrorsoft ● Arcade Adventure ● Ian Nicol ● £7.95

With hundreds of new games entering the market each week and software houses struggling to meet the rising demand for new games, it seems inevitable that, eventually, programmers will run out of names for their creations.

That would explain why the first game from the new Mirrorsoft Medusa label has the unlikely title of *Action Reflex*. Even though it sounds like a medical term for a muscle spasm, the game is very enjoyable.

It involves guiding a bouncy ball through a maze of screens filled with everything from green monsters and spiked gloves to wall speakers and vacuum tubes. At various intervals along the floor of the maze there are certain



places which, should you roll or bounce on them, will lead to your doom. Only trial and error will identify the safe areas, so making a map as you proceed is a very good idea.

The idea of the game is to complete the maze. As you progress deeper and deeper, obstacles such as glass walls and lakes are encountered. Only by collecting certain objects along the way can they be overcome. A counter on the screen records your progress. If you lose a life, a time penalty is imposed, reducing the chance of completing the game.

There are three skill levels with 25 screens on each level, a real challenge for those who can face the embarrassment of going into a software shop and saying "Action Reflex, please".

TOADRUNNER

► Amstrad & Spectrum ● Ariolasoft ● Arcade Adventure ● Lee Paddon ● £9.95

You have had a bad day. The wizard Stone Master has turned you into a frog – a letdown for a Prince. So, to get out of the tight spot, you have to find a Princess with a penchant for puckering-up to amphibians. On the way you should dispose of the Wizard, plus many assorted hazards around the maze.

Although the 2D maze consists of a mere 60 screens, the vast amount of to-ing and fro-ing involved in solving the various problems makes it seem far bigger. It is all done against a limit of 75 toad time units or you dry out and go to that great lily pad in the sky.

Your toad is equipped with four pockets in which to put the various objects needed to solve the problems.

GRAPHICS
●●●●●
SOUND
●●●●●
PLAYABILITY
●●●●●
VALUE FOR MONEY
●●●●●
OVERALL
●●●●●

They often involve the combination of two objects at once. You have five lives, various objects drain your energy, but you can fight back, hacking things to pieces with your axe.



The game is very colourful, with plenty of pleasant animation – like snoring dragons or berserk bees. Just solving the problems will be difficult and it will take you a great deal of practice to be able to solve them quickly enough to complete the quest.

WINTER GAMES

► Amstrad ● U.S. Gold ● Simulator ● Ian Nicol ● £9.95 (Tape) £14.95 (Disc)

With British summers having a notorious reputation for being bitterly cold and wet, it seems sensible that U.S. Gold should be releasing a simulation based on the Winter Games.

You are invited to compete in skating events, bobsleigh, ski jumps and the biathlon and, using the Amstrad joystick, two people may compete at the same time.

Each event is scored according to

official Olympic rules. Points are deducted for awkward movements or falls and even for failing to complete a set number of moves.

The tape version is supplied on four cassettes containing two games on each side. As they can take some time to load the additional cost of the disc version is easily justified.

For all the games, the competitor is controlled by the joystick, moving it from left to right to control a skater's legs or in any one of eight directions to perform stunts and flips. At first those movements can be a little difficult, causing your skier to nose-dive or skater to topple but, with a little practice, it is possible to create performances which would rival those of Torvill and Dean – when bound hand and foot.

In the biathlon, a counter records pulse rate as you struggle over

GRAPHICS
●●●●●
SOUND
●●●●●
PLAYABILITY
●●●●●
VALUE FOR MONEY
●●●●●
OVERALL
●●●●●

snow-covered hill and dale. At the shooting stage the gun sights rise and fall in time with your pulse rate, making it difficult to shoot accurately and causing you to lose time as you rest.

Overall, the games are very enjoyable, the only brickbat on the tape version being the delay in loading individual sections. If you are one of those people who watch the Olympics and say "I could do that", this is one way to find out without getting a soggy backside.



STAINLESS STEEL

► Spectrum ● Mikrogen ● Shoot-'em-up ● Lee Paddon ● £9.95

GRAPHICS
●●●●●
SOUND
●●●●●
PLAYABILITY
●●●●●
VALUE FOR MONEY
●●●●●
OVERALL
●●●●●

Not saving the world again, you sigh as you climb aboard your ground skimmer and prepare to do battle with the nasty robotic hordes of the evil professor. The old prof, naturally enough, is indulging in the time-honoured pastime of blowing-up the world. The fuze is burning and

only you stand between it and the future of mankind.

You have to get through five long and complex screens. You have to shoot the robots, helicopters and aircraft while picking up fuel and avoiding colliding

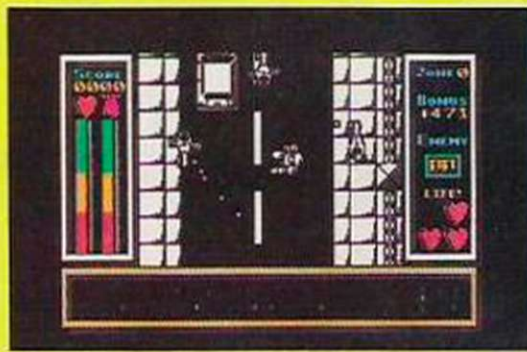

with the usual deadly debris.

The graphics are crisp and stylish, with our hero picked out in fine detail. The landscape scrolls very smoothly top to bottom, with a radar screen giving you advance warning of impending trouble. There is virtually a gratuitous amount of graphic detail scattered around the screen. Desert landscapes, highways with parked cars and toll booths – it all adds to the atmosphere. The graphics and the way the skimmer moves are in many ways reminiscent of Uridium on the Commodore – it is that good.

Although just a simple shoot-'em-up, the smoothness of the graphics and the sensitivity of the controls makes it the kind of game which will get you hooked very quickly.

THE YOUNG ONES

► Various ● Orpheus ● Arcade Adventure ● Lee Paddon ● £7.95

Orpheus brings anarchy to your computer with *The Young Ones*. You take the part of one of the quirky quartet. Your object is to gather your belongings and get out of the house before the whole rotting edifice crashes round your ears or, worse still, someone asks for the rent.

It is an arcade adventure in the *Wally* tradition. Your large animated character wanders round picking up things and solving problems, such as how can Vyvian pick up SPG, the assassin hamster, without losing more of his arm than he can spare safely.

Most of the solutions to the problems will be obvious to aficionados of the TV series and the game relies heavily on re-creating the chaos of the small screen.

GRAPHICS
●●●●●
SOUND
●●●●●
PLAYABILITY
●●●●●
VALUE FOR MONEY
●●●●●
OVERALL
●●●●●

It does so by using the other three characters in the house to get in the way generally and make things awkward. You also have to identify which things in the house are yours. That is a combination of remembering the series, by gaining



clues from the other characters and by using the talk command.

That, in many locations, admits you to the tortured workings of your chosen character's "mind". Fans of the series will love the game. Even if not a follower of the frenetic foursome, it should provide you with a few laughs.

PSI 5 TRADING COMPANY

► CBM64 ● U.S. Gold ● Strategy ● Frank Mahoney ● £9.95

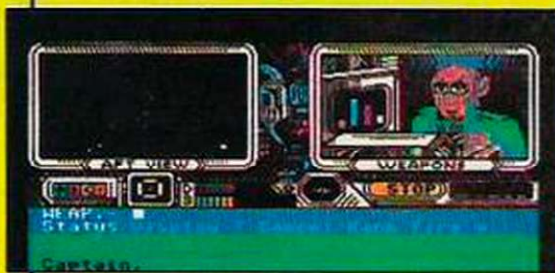

The PSI 5 Trading Co. is in the business of making a fast buck by running supplies to the Parvian frontier. Why is this business so lucrative? Well, the Parvian frontier is not exactly the safest place in the world. There are six candidates for each post – weapons, scanning, navigation, engineering and repairs. A personal file is provided for

each prospective crew member which gives details of their skill and experience. The secret at this stage is to pick a crew which will work together as a team.

You give the orders and everyone else does the dirty work. Commands are issued to the crew by a joystick-controlled menu. You must give the orders to scan, lock and destroy enemy ships, carry-out damage repairs, divert power to engines or shields, take evasive action, and so on.

As with any good strategy game, it is much more complicated than it seems. The secret of success is to keep your eye on 100 things at once and anticipate impending disaster.

The graphics are worthy of mention.

GRAPHICS
●●●●●
SOUND
●●●●●
PLAYABILITY
●●●●●
VALUE FOR MONEY
●●●●●
OVERALL
●●●●●

They are superbly implemented and add to the atmosphere, rather than distracting you, which is more often the case with this kind of game. PSI 5 is thoroughly absorbing and highly recommended to anyone looking for a challenge more demanding than being clever with a joystick.

THE PLANETS

► Spectrum ● Martech ● Strategy ● Lee Paddon ● £9.95

GRAPHICS
●●●●●
SOUND
●●●●●
PLAYABILITY
●●●●●
VALUE FOR MONEY
●●●●●
OVERALL
●●●●●

Just as you thought you had seen your very last lunar lander game, *The Planets* proves that what can be programmed into a 1K ZX-81 and use two keys can be produced as a multi-load Spectrum game with icons, umpteen keys and plenty of pretty but ultimately meaningless graphics.

The Planets challenges you to explore the solar system – wot, no galaxy? – in a bid to save the earth from imminent destruction, not from any aggressive

aliens but from a cocktail of acid rain, radioactivity and other gunk.

Alien capsules have landed on the planets; you must recover them and



decipher their contents. Then, as the game instructions put it enigmatically, you will know what you must do to save the world.

What that all boils down to is landing on the various planets, walking round until you find the capsule, zapping a few nasties. Landing on the planet is done in the time-honoured fashion. Your spacecraft falls free until you use the retros to slow it. You must land within certain speed limits. When your unmanned explorer has recovered the capsule, it must then rejoin the mother ship. Once again, high-speed docking is not to be recommended.

When landed on the planet, you get a graphic display out the window – different for each planet. They also all have different gravity and rotation periods. Despite the superficial chrome, it will not really provide the games player with much into which he can get his teeth.

C CLASSIC INVADERS

► Amstrad ● Bubble Bus ● Shoot-'em-up ● Ian Nicol ● £2.99



Platform games may come and go. Trends such as bouncing or rolling return to haunt us every so often but invader games will be here forever.

Just when you thought it was safe to return to the software shop, they are there again – not daleks or little green slimy things but those multi-coloured

dancing blobs which march in time across the skies above your laser base.

Classic Invaders, a great value and truly classic game, contains all the elements of the originals which started the computer games revolution all those years ago but it also contains a new dimension of danger.

OVERALL ● ● ●

H HELICOPTER

► Spectrum ● Firebird ● Dodge about ● Lee Paddon ● £1.99



Another one of those hoary old plots which refuses to expire like any respectable theme. You have to use your helicopter to rescue things. Naturally, there are many other things trying to zap your chopper and stop your mission of mercy.

Pleasant graphics, fast and wacky game play – have you ever bombed a duck? Well, now is your chance – prevents it from being intolerably dull. The whole thing is against the clock, you have five lives and 23 screens of little chaps to rescue.

OVERALL ● ● ●

M MOLECULE MAN

► Spectrum ● Mastertronic ● 3D Maze ● Lee Paddon ● £1.99



Once again the topical theme of defusing radioactive places rears its ugly head. In this 3D isometric maze you have to guide your hero around various non-fatal obstacles. You must pick up 16 circuits and thus save the planet. To get the circuits you have to pick up coins to buy bombs from the handy bomb-vending

machines. That allows you to clear the way to the circuits.

You can also use coins to buy iodine pills to stave off the affects of radiation. On the flip side of the tape is a maze designer if you become bored with the one supplied. Pleasant graphics and touches of humour make it challenging.

OVERALL ● ● ● ●

S SHAMUS

► CBM64 ● Americana ● Arcade Adventure ● Peter Luke ● £2.99

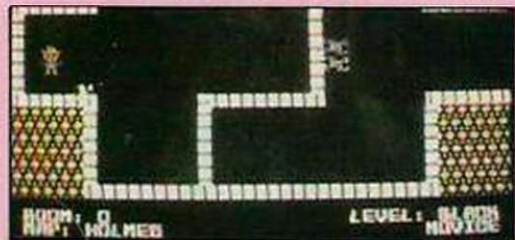

The instructions for *Shamus* are arguably more interesting than the game. *Shamus*, a mixture of a weak arcade action game interwoven with a tenuous adventure element, is of limited appeal – lasting or otherwise.

The object of the game is to guide your

character through a series of 32 rooms, picking up objects and blasting away at enemy vapourisers as you go. The aim is to reach an arch-villain and ultimately to discover his secret. A budget game with an appeal which is strictly budget in nature.

OVERALL ● ● ● ●

B BUMP, SET, SPIKE!

► CBM64 ● Entertainment USA ● Simulation ● Peter Luke ● £1.99



Get in the mood for your summer holidays with this game which transports you to a sun-kissed beach for a game of volleyball. Control of players is straightforward, making the game instantly playable. Two options allow you to play either against the computer, which at least for novice players is

virtually unbeatable even at the lowest of the three skill levels, or against a human opponent. The winner is the first to reach 15 points with a clear lead of at least two points.

Simple but effective graphics and a suitably tropical music track make it a very enjoyable game.

OVERALL ● ● ● ●

R RETURN OF ROCKMAN

► C16 ● Mastertronic ● Arcade ● Peter Luke ● £1.99



There is a suggestion that the Gallup top ten chart for the C16 computer should be re-named the Mastertronic chart. That company's dominance of the charts will surely be consolidated with the release *Return of Rockman*.

The game owes more than a little to the highly popular *Boulderdash*. It

involves guiding Rockman through a series of 10 caves. On the way he must pick up diamonds and other point-scoring items. The difficulty is that in hewing his way through the caverns, he loosens rocks which are liable to fall on his head. It is the mixture of strategy and arcade action which makes it stand out.

OVERALL ● ● ● ● ●

Do you realise that you could already be a lawbreaker? Under the terms of the Data Protection Act, which came into force on May 11, 1986, all microcomputer users have to be careful about how they use their micros and the type of information they hold on cassettes and floppy discs. Anyone holding personal information about anyone else on their cassettes, Microdrives or floppy discs could, theoretically, be breaking the new law if they and their data are not registered with the Data Protection Registrar as a data user.

The Act is designed to allow people access to any information held about them on a computer. Under the terms of the Act, anyone handling such personal information is a data user and thus liable to the rules, regulations and penalties. Failure to register yourself as a data user can lead to fines of up to £2,000 on summary conviction before a magistrates' court or unlimited fines on conviction in a trial before judge and jury in a Crown court.

If the Act does not sound like something you would expect from a 'laissez-faire' Conservative government, that is largely because it is not. The Act is the result of a directive from the EEC, which will bring the U.K. into line with data protection legislation in the rest of Europe.

The Act was introduced to Parliament in 1983, was held up when the General Election writ was issued that summer, and



THE DATA PROTECTION REGISTRAR

returned to the Order Paper in 1985. Shortly after the Act became law, the Government set up the Data Protection Registrar to administer it and laid down the May 11, 1986 deadline for user registration.

The key to whether or not you need to pay the £22 registration fee is in two definitions – personal data and data user.

Personal data is defined by the Act as "information which relates to a living individual who can be identified from the information – or from that and other information in possession of the data user – including any expression of opinion about the individual but not any indications of the intentions of the data user in respect of that individual." That covers data containing information such as addresses and telephone numbers, as well as data containing names.

A data user is someone who holds data – controls its contents and use. That does

Do you need to register under the Data Protection Act?



not necessarily mean the user who carries out the processing – it could be done by a bureau.

Anybody with a home micro is definitely a data user, unless they only play games and never generate their own information; the real question is whether or not the information on their machines is personal data. A few examples from the Data Protection Registrar's recent

Question and Answers pamphlet shed a little light on the problem:

"A computerised list of authors, of the title of their books and of the numbers of books sold would constitute personal data relating to those authors who are still alive. Even if the names of the authors were removed from the computer, the data would continue to be personal data so long as the data user, from other information in his possession, could identify the author to whom a particular book title and sales figures related."

The list may form part of a bookseller's stock list. The fact that the information



THE DATA PROTECTION REGISTRAR

relates to the authors may be immaterial to the purpose for which the list is processed. If the bookseller processes the data only to determine the number of units sold against each stock item, he is not processing by reference to the authors and is not holding personal data.

If the bookseller processes the data to provide information about a particular author – for example, to identify the books which he has written or to determine the popularity of his work – the processing is by reference to the author. Where the bookseller processes or intends to process in that way he is holding personal data relating to the authors and must, therefore, register under the Act.

As it relates to people who use their

micros for lists of names and addresses, whether it be the parish council or the local computer club, the Data Protection Act allows exemptions but they are exacting. If you are exempt, you have to be very careful about who sees the exempt data. Listen to this question and answer exchange from the Data Protection Registrar's recent brochure:

Question: What disclosures of personal data may be made by a data user who relies on the exemption for data held by an incorporated members' club or for data held only for distribution purposes?

Answer: Preambled by reference to pages 24, 25 and 26 of the Data Protection Registrar's Guideline No. 1 booklet. In addition, the data user may disclose the



THE DATA PROTECTION REGISTRAR

personal data of the data subject, or a person acting on his behalf, if he has requested or consented to the disclosure. Consent may be given either generally or in the circumstances in which the disclosure in question is made.

It would, therefore, be sensible for data users to identify the circumstances in which they may wish to make disclosures and to consider whether those disclosures

are expressly permitted. If not, they may wish to obtain the consent of the data subjects. In the case of a club, those disclosures might include, for example, the publication of a list of members of the club, disclosures to affiliated clubs or societies, or other disclosures for the purposes of the club which may be deemed necessary by its governing body. Those consents might be incorporated in membership application forms or in a rule of the club.

While the Act will give the general public far easier access to personal data held about them in computer systems, there is some evidence to suggest that even highly-reputable companies are taking steps to avoid making disclosures under the Act. The key point is that disclosure of information can be compelled under the Act if that information is held on computer.

In some cases companies are de-computerising at least some of their information systems, transferring more sensitive data to a manual system which is then run in parallel to a computer system.

While information held on the computer is available to an individual, that does not give a true picture of the information record of the person; the company is under no obligation to disclose the contents of a paper record system, nor even to disclose the fact that one exists.

At least one national company, when the scope of the Act became known, sent a memo to all middle managers in its organisation. That suggested that any computerised personnel records should be examined closely and that any sensitive information concerning an employee should be transferred to a manual filing system. Such information might have included comments on an suitability of the individual for promotion and reliability.

Such manouvres by even large institutions are within the terms of the Act, though certainly not within the spirit. If larger public companies are prepared to go to those lengths to protect their more



THE DATA PROTECTION REGISTRAR

sensitive data from exposure, one can only ponder on the likely reaction of some smaller organisations.

As you can see, the business of finding whether or not you are exempt from the Data Protection Act is complex and the Data Protection Registrar advises anyone who is in doubt to part with £22 and register, or to at least write for more information at the Office of the Data Protection Registrar, Springfield House, Water Lane, Wilmslow, Cheshire SK9 5AX.





COLLEEN

the complete computer service



Training Full training facilities

Business A range of Business Software for most micros

Music See our latest releases –

Colleen Music Compendium Disk (£49.95) See the reviews in *Your Computer* A double sided disk full of the most powerful and fun to use music and utilities.

Side one contains Music Theory Tutor a Guitar Tutor a Sound Chip Tutor plus Keyboard tutor

Side two contains Playalong:- Turns the computer into a sophisticated musical accompaniment tool giving you hours of fun for the absolute beginner.

Drum Machine:- Learn all about Rhythm and have fun all at the same time.

The Creator:- No programming skill needed to create professional quality music that can be used and marketed in your own programs. The Creator Utilises the full power of the sound chip with user friendly on screen instructions allowing you to multitask your program.

The Combiner:- Up to three music files can be combined, giving a choice of three tunes at any one time.

The Sound Effects Master:- Gives an unlimited range of user defined sound effects fully compatible with the music creator and combiner.

THE FOLLOWING PACKAGES ARE AVAILABLE SEPARATELY

Colleen Music Creator **Disk (£19.95) Tape (£14.95)**

Colleen Keyboard Playalong Tutor **Disk (£12.95) Tape (£10.95)**

Colleen Guitar and Drum Machine **Disk (£12.95) Tape (£10.95)**

Colleen Music Programming Tutor **Disk (£12.95) Tape (£10.95)**

OTHER PACKAGES

MYSTERY VOYAGE:- An exciting adventure game with superb music, sound effects plus voice. Over 200 locations a must for any adventurer. **Disk (£10.95) Tape (£8.95)**

Software Support

If your problem be business, music or basic programming, this service is a must. Available up to 9.00 p.m., 7 days a week, over the electronic mail services, providing a rapid answer to your problem.

cheques or postal orders (payable to COLLEEN LTD)
to: COLLEEN LTD., Colleen House, 18 Bishop Street,
Penygraig, Tonypany, Mid Glam CF40 1PQ

I enclose cheque/postal order for £

Signature

Name

Address

.....

..... Post Code

BALLYHOO

► CBM64/128/Atari XL/XE/ST ● Infocom (Import) ● Text Adventure ● R. Garrett ● £33

GRAPHICS
Text Only
SOUND
None
PLAYABILITY
●●●●●●●●
VALUE FOR MONEY
●●●●●●●●
OVERALL
●●●●●●●●

Roll up, roll up for all the fun of the fair. Step this way; visit Andrew-Jenny, half-man, half-woman and have a two-sided conversation; see the clowns; marvel at the wild beasts; hold your breath at the sight of our high wire acts; so step this way for the show of a lifetime.

After the show is over you decide to stay for a time, hoping to catch a glimpse of the glitter and glamour behind the scenes. Instead, you are plunged into a mysterious underworld where crime and corruption occupy centre stage.

Playing the part of a young, small-town circus-goer, accidentally you overhear a

whispered conversation. You learn that the circus owner's young daughter has been kidnapped and, seeing that the hired Private Eye is a bit of a wino, decide to investigate.

Not only will you need your wits about you but you will also have to perform various circus acts; walking the tightrope is great fun but make sure you have the proper equipment before you do.

As in any Infocom game, text descriptions are superb and build the correct atmosphere for an adventure as intriguing as this one. It is not an original idea but, given the Infocom treatment, by far the best adventure using a circus as the environment.

The excellent packaging for which Infocom is now famous includes a souvenir program, well-detailed instruction book and even a ticket for the show. Once again, Infocom has proved that imaginative text cannot be beaten and this game is another amazing example of its work.

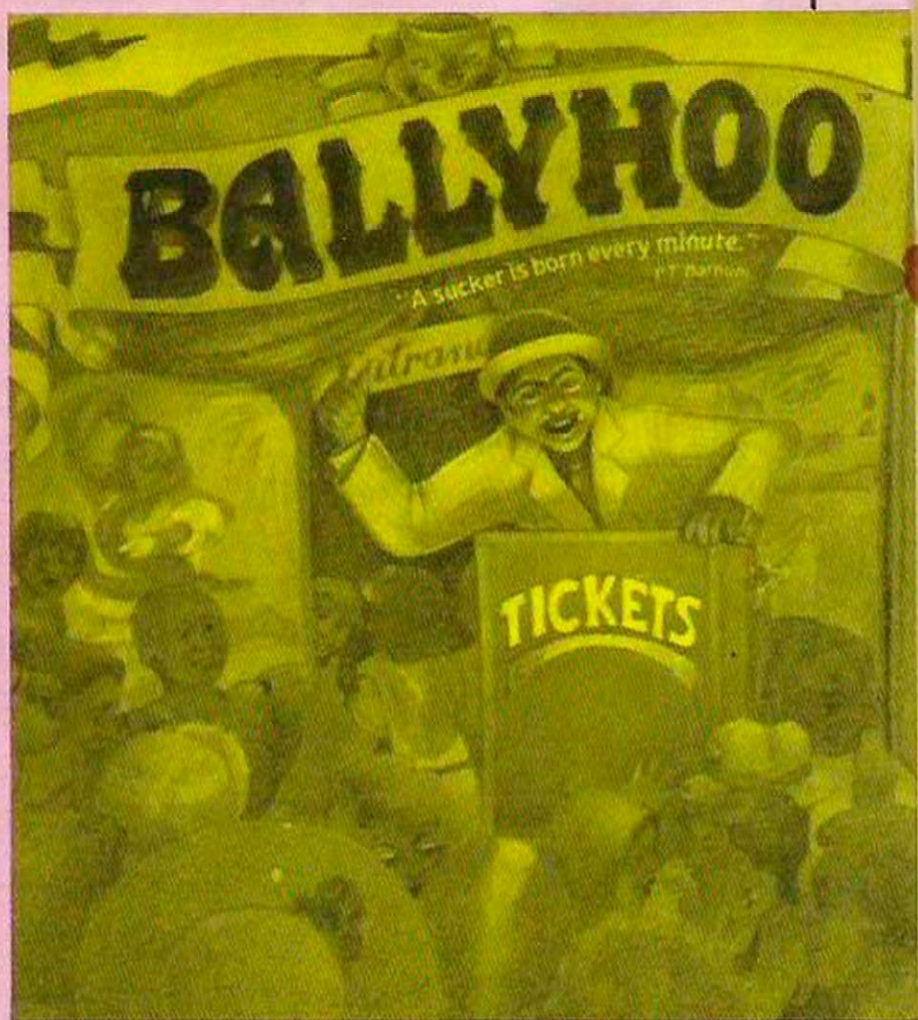

ALTER EGO

► CBM64 Disc DR ● Activision ● Adventure ● R. Garrett ● £24.95

The greatest adventure is life and, as we all know, it can be the most challenging adventure of all. How many times have we made a decision and then, on reflection, wondered what

would have happened if the situation had been handled another way? In a real-life situation it is sometimes difficult to make or feel you have made the proper choice but in the world of the

GRAPHICS
●●●●●●●●
SOUND
None
PLAYABILITY
●●●●●●●●
VALUE FOR MONEY
●●●●●●●●
OVERALL
●●●●●●●●

answering various questions, make up your own.

Beginning at any one of seven stages, from birth to old age, you are presented with different situations to which you must react in any way you feel. The computer, acting like a Freudian psychoanalysis, monitors your answers and slowly your personality/ego begins to develop. All answers are relevant to how you will cope in later life.

I found the game very entertaining and after going through the early stages of my development I soon became highly-involved in trying to become a millionaire. My one mistake was trying to get married before establishing a proper relationship with my intended, which resulted in being left at the altar.

Overall the game is very clever and should appeal to most people. Not an adventure in the true sense of the word but still highly enjoyable and it should keep you involved for a long time.

computer anything is possible. We can make outlandish decisions, be cunning, be brave or foolish. We can change our basic personalities in many ways, safe in the knowledge that no harm is being done to ourselves or anybody else.

The latest Activision release allows you to replay your life over and over again, each time with a different personality development and with new chances to react and respond to the endless possibilities confronting you. To begin the game you have the choice either of allowing the computer to pick a personality for you or, by

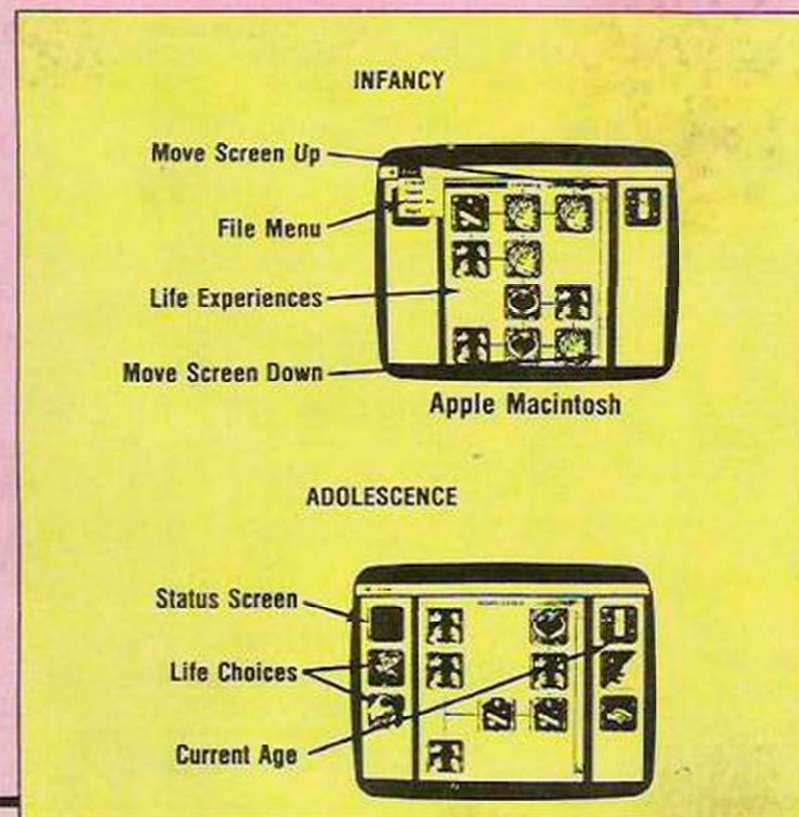

TERRORS OF TRANTOSS

► Spectrum 48K ● Ariolasoft ● Graphic Adventure ● R. Garrett ● £7.95

GRAPHICS
●●●●

SOUND
None

PLAYABILITY
●●●●

VALUE FOR MONEY
●●●●●

OVERALL
●●●●●

The latest game from Ariolasoft has been written by

the people who wrote *Valkyrie 17*, recently re-released, the Ram Jam Corporation. It certainly scored with its first game and *Terrors of Trantoss* looks as if it could be equally successful. The plot is the usual find-the-evil-wizard-and-in-doing-so-restore-order type of adventure, including all your old-time favourites, such as Orcs,

mysterious runes which need to be translated, the obligatory key, deserted villages – everything for which the adventurer could wish.

Where the game differs is in the interplay between the two main characters, who are brothers called Lobo and Scarn, a kind of a Laurel and Hardy double act. Using the swap command – I wonder

where I have seen that previously? – you interchange between the two.

The graphics are well-detailed and I liked particularly the shading effect used on the mountains. My only criticism about an otherwise excellent game was the slow response times – it took up to four seconds, which is annoying when one wants to press on.

THE PRICE OF MAGIK

► Most popular makes ● Level 9 ● Adventure ● R. Garrett ● £9.95

To say I am one of thousands who await every new release by Level 9 would not be an understatement. Level 9 has for the last few years led the field in cassette-based adventures, founded on wonderful text descriptions which fired the imagination. To me it could do no wrong but since it introduced graphics I noticed a distinct lack of rich narratives and many more locations. It seemed that Pete Austin and his brothers were trying to put as much into the cassette as possible but one thing now begins to stand out glaringly. There is a general lack of atmosphere through poor text

descriptions. I never thought I would see the day when I would write about a Level 9 game and call it boring but with the release of *The Price Of Magik* I have.

Magik is the sequel to *Red Moon*. Once again you must take up the challenge, this time to defeat Myglar, who is using the power of the Red Moon for his personal use. To win you will need to find and learn how to use 18 spells, plus keeping your hit level at a reasonable figure.

There are moments when the imaginative Austin genius shines and those moments are like the sun breaking through on a cloudy day.

Unfortunately they are very rare. In fact, the most interesting item to read is the appendix on the cover inlay.

The parser also played some very strange tricks on me. For instance, after finding a Prism I typed-in the command "Look through Prism" and was rewarded

with the answer "You can't see the Wraith. Likewise when inputting "Attack Werewolf with Dagger" the game responded with "You can't see the poniard" doing a quick inventory.

Other strange things also seem to happen on examining various objects. To say it is disconcerting is an understatement.

My opinion is that Level 9 should look closely at what it is doing. To release games with more than 200 pictures and 1,000-word parsers is satisfactory but adventurers do not want to see poor, unatmospheric text coupled with mediocre graphics.

GRAPHICS
●●●●

SOUND
None

PLAYABILITY
●●●●

VALUE FOR MONEY
●●●●●

OVERALL
●●●●●

HEAVY ON THE MAGICK

► Spectrum 48K ● Gargoyle ● Adventure ● R. Garrett ● £9.95

Axil the Able, more commonly known as Axil the Absolute Average, surveyed his surroundings with a deep sense of misgiving. Only a few fleeting seconds ago he had been engaged in his favourite pastime of wizard-baiting. Just as he was about to finish the story, who should appear but that old buffoon Therion, after a severe telling off, about which Axil was not too amused. Being told you look and eat like a Graumerphy goat is not funny. Therion raised his left index finger, muttered something under his breath, and Axil was transported several hundred leagues across Graumerphy into the stinking, dismal dungeons which stagnated below Collodon's Pile.

The first item Axil noticed was a mouldy old book which,

on closer scrutiny, revealed that it was a spell book. So, armed with the book and little else but an indefatigable spirit, Axil set about finding his way out. That is where you come in. The latest Gargoyle game will have you enthralled from the start. Controlling and guiding Axil through the dingy dungeons is a joy to watch. Animation of the various characters is excellent and there are certainly many characters in the program, all created in large cartoon-style graphics.

Axil is a marvellous hero who shrugs his shoulders when unable to do anything, throws his arms in the air when casting spells, and even waves his fist at you when in the process of dying. I felt like explaining to him, in certain circumstances, that I did not

mean to make that fatal move.

As in any D&D/RPG, stamina, luck and skill play an important part. Running into monsters and doing battle can have fatal results if your stamina is not what it should be, but searching round the dungeon and finding bread helps build this essential part. *Heavy on the Magick* will appeal to all gamers, young and old.

GRAPHICS
●●●●●

SOUND
●●●●

PLAYABILITY
●●●●

VALUE FOR MONEY
●●●●●

OVERALL
●●●●●

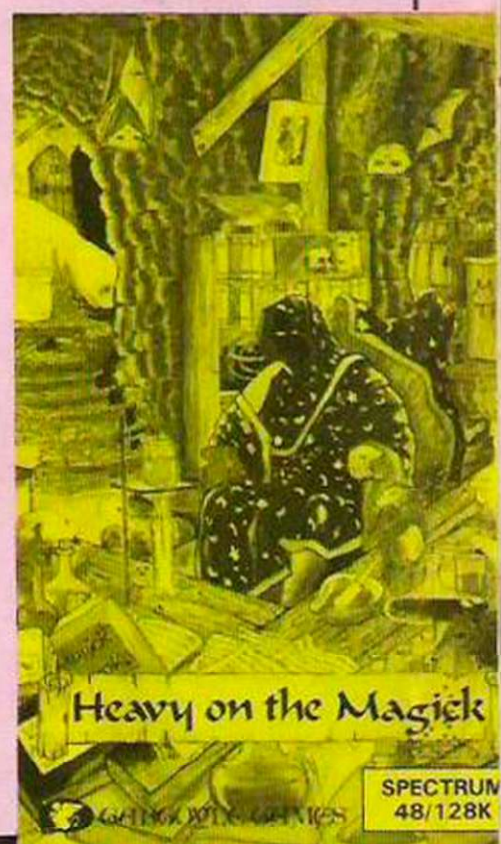

A picture is worth a thousand bytes. That phrase, a technological update of the old cliché, aptly sums-up the function of a video digitiser. A digitiser must accept as input a video signal, which is analogue in nature, and convert it into a stream of digital data which must then be stored in an area of computer memory. What follows is an explanation of how a video digitiser performs that conversion.

To understand the operation of a digitiser, it is necessary to appreciate the way in which an image is formed on the screen of a television set. At the heart of the cathode ray tube which produces the visual image of a TV set or computer monitor is an electron gun. It emits a stream of electrons which strike the rear surface of the CRT screen. That is coated with a phosphor which converts the energy of the electron beam into light. It is that we see when we look at the front surface of the tube. If it were the end of the story, the only image a TV would be capable of producing would be a bright spot at the centre of the display tube.

The first step to producing a

Computer images – worth a thousand bytes

picture from the single beam of electrons is to arrange that the beam scans the entire surface of the CRT. To accomplish that, a pair of electromagnets are mounted on the neck of the tube. Basic physics can show that if those magnets are fed with appropriate electric currents, the beam can be made to move to any point on the front surface of the tube.

In practice, the beam is moved in such a way that it forms a series of lines across the tube. The pattern is such that the beam first moves from the top left of the tube in a

Video digitisers convert video signals into a computer-readable form. Ken Alexander explains.

straight line to the top right in a U.K. standard TV which takes some 64µs. Having reached the right-hand edge of the screen, the beam then flies back to the left-hand side. In plain English, that means that the beam is moved back rapidly to its starting position.

The beam is then moved again from left to right, though this time at a position slightly lower down the screen. The process is repeated, so that after a short time the beam has traced a series of parallel lines over the entire surface of the screen. Having scanned the whole screen, the beam is then moved back quickly to its starting position at top right, where it begins another series of scanning lines.

Shades of grey

The process of scanning by itself would simply produce an even illumination over the surface of the screen, an effect familiar to owners of Amstrad PCW computers which produce such a display when first switched on. To produce an image, the intensity of the beam must be varied during the scanning process to produce the shades of grey which make up a monochrome picture.

The electrical signal which

controls the intensity of the display will, in general, be derived from a TV camera. A camera can, simply, be thought of as a TV set which happens to operate back to front. The camera contains the same scanning beam as a TV set, although this time light striking the camera face causes a photosensitive layer on the face of the camera tube to undergo a physical change. That change has the effect of altering the electron beam current, any changes being converted into voltage variations by the electronic circuits of the camera.

Getting in sync

We still are not at the end of the story for, given that both the TV and the camera are scanning, it is obvious that there must be some way of synchronising the actions of the two. To achieve that, sync pulses are added to the video signal at the camera. One set of sync pulses – line sync – indicates that the camera is about to start scanning a line while a second set – frame sync – indicates that the camera has finished a series of line scans and is about to return to the top left of the screen to begin another sweep.

In the time it has taken for you to read this explanation of the operation of a TV, thousands of scans would have taken place in a TV set. The speed of operation is governed by the physiology of the human eye. It can be shown that if a series of discrete images is presented to the eye so that each is shown only for a period



of less than 1/50th of a second, the eye will be unable to distinguish between the images; that is why animated cartoons appear to produce continuous movement from a series of still pictures.

Thus to produce the illusion of movement from a TV, scanning must take place 50 times per second. Given that figure and the fact that to achieve the required level of definition, $312\frac{1}{2}$ lines $-625/2-$ are required in each frame scan, it can be shown that the bandwidth of a video signal – a measure of the amount of data within a signal – is in the region of 5MHz. That figure is more likely than the clock speed of many micros, leading to the obvious conclusion that a typical computer will be unable to process a video signal directly. Enter the video digitiser.

Some sacrifices

TV companies use equipment which can digitise a picture with no degradation in image quality. Those digital frame stores cost many thousands of pounds. Digitisers designed for use with home computers must make considerable sacrifices in terms of the resolution of the stored image. The size of each individual picture element – pixel – and the number of levels of grey reproduced are reduced dramatically in a home computer digitiser. Typically only 16 grey levels are stored in a home computer, as opposed to the many hundreds present in a broadcast-quality frame store.

How, then does a digitiser designed for operation with a home computer perform the conversion of the analogue video signal into a pattern of bytes which can be stored in the limited memory of a typical computer. The secret lies in the fact that a digitiser does not convert frames in real time – it will take several seconds to read a frame into the computer memory. For that reason it is usual to convert only static video frames; attempting to digitise a moving scene will lead to considerable distortion of the digitised image.

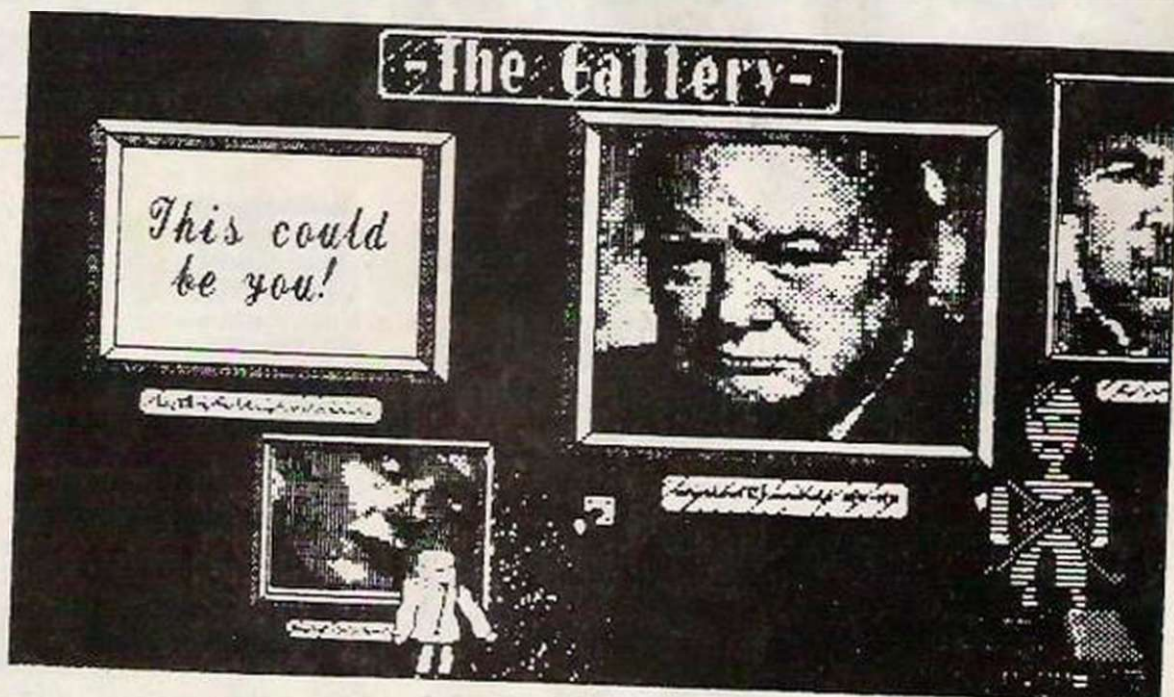

A digitiser operates by sampling the video signal level at a particular point on each successive line of the image. As each such point will be separated by a period of 64µs, there is sufficient time for a low-cost analogue-to-digital converter to sample the analogue signal and convert it to a digital value. Initially, the digitiser will sample the signal at the leftmost point on each line. On the next frame the sample point is advanced slightly along the line. The digitiser thus takes a series of vertical slices through the image, building the digitised picture over a period of several seconds.

The hardware necessary to achieve that consists of the A/D IC which forms the heart of the circuit, plus additional control electronics which govern the point at which the converter samples the signal. That usually takes the form of a variable delay circuit, either analogue or digital, which is triggered by the line sync pulse, the period of delay being increased on detection of the frame sync pulse.

Essential software

The hardware of a digitiser must be complemented by suitable software; it is the software which will determine the ultimate performance of the system. The software is responsible for accepting the digital information output from the digitiser and storing it in the computer memory.

Having stored the picture information, most systems will allow the user to perform basic image-processing operations

on the image file. For example, false colours may be assigned to the discrete levels of grey stored in the system to enhance an image. Some systems will allow the computer to zoom-in on the picture and to rotate and stretch the digital picture.

In a future issue of *Your*

Computer we will look at some of the digitisers available for home micros and evaluate some of the graphics applications packages which allow images captured in digital form to be manipulated to produce high-quality graphics displays.

The image-sensing equipment at the heart of the majority of TV cameras is still essentially a CRT tube in reverse, as described in the main feature. In the next few years, though, the vacuum camera tube will have been replaced by CCD image sensors. A Charge Coupled Device sensor is an integrated circuit which offers a number of advantages over the traditional camera tube. The major benefits to be gained by using a CCD include very low power consumption and rugged construction.

A CCD device is made up of a large number of individual semiconductors arranged in a matrix. The image to be scanned is focused on to a transparent lid on the top of the IC – the lid is rather like that of an EPROM – and thus on to the matrix. The amount of light falling on each of the cells in the matrix affects the level of charge held in any particular cell.

At the end of a scan the charges present on each of the cells which make up a row are read out by a serial shift register; data from each row is then collated and output by a further shift

register. Note that unlike the majority of ICs used in a computer, the CCD is an analogue device and a video digitiser is still required if the image produced by a CCD is to be used by a computer.

Until recently, CCDs were able to produce only very low-resolution images because manufacturers were unable to fabricate devices with a dense enough matrix of cells – resolution is directly proportional to the number of cells on the imaging surface of a CCD. There were also difficulties in reading-out the charge packets at a fast enough rate to eliminate picture lag. Those problems have now been overcome and the latest generation of home video cameras have adopted CCD technology.

For the home computer user, the advent of low-cost CCD devices means that high-resolution camera and digitiser units should soon be available at low cost. If high resolution is not an essential requirement, a CCD-based system, the EV1, designed for use with the BBC micro, is available from Commotion.



MICRO MAIL

53 FENNEL STREET
MANCHESTER M4 3DU
TEL: 061 834 2808

COMMODORE

	RRP	OUR PRICE
Music Systems (includes Commodore 64)	£329.99	£309.99
Currah Speech	£21.95	£19.95
1570 Disc Drive	£199.99	£179.99

SOFTWARE ON DISC

Textpro - Wordprocessor -	£12.95
Datapro - Database -	£12.95
Zork I	£11.95
Zork II	£11.95
Zork III	£11.95
Hitch Hikers Guide	£24.95
Gemini - Home Accounts	£24.95
Database	£24.95
Cashbook	£64.95
VAT File	£24.95
Final Account	£64.95
Superbase - 128	£99.95
Superscript	£79.95

If the title you want is not listed all you have to do is send your cheque or P.O. for the retail price less our 10% Discount and state whether disc or cassette.

ALL DISC AND CASSETTE TITLES

10% OFF.

JUST TELL US WHAT YOU WANT!

COMMODORE

	RRP	OUR PRICE
Commodore 64	£199.95	£185.00
Commodore 128	£269.95	£250.00
Commodore 128 D	£499.00	£470.00
Commodore 128 D & Monitor	£631.00	£545.00
Music Expansion	£150.00	£140.00
1541 Disc Drive	£159.95	£149.95
1571 Disc Drive	£299.95	£279.95
Modem	£79.95	£69.95
Mouse	£69.95	£59.95
Light Pen	£29.95	£24.95
Sketch Pad	£49.95	£44.95
Speech Synthesiser	£24.95	£21.95
Blank Discs - Sony SS Box of 10	£12.95	£10.95
DS Box of 10	£16.95	£12.95

GENERAL

	RRP	OUR PRICE
Cheetah 125 Joystick	£8.95	£7.95
Pro 5000 Joystick	£18.95	£16.50
Comdrum Tape or Disc	£29.95	£26.95
Sound Sampler - Commodore	£49.95	£44.95
Data Recorders for all Commodores	£39.95	£33.95

Post and Packing: **FREE**. ALL Computers ADD £6 for value UNDER £250

All payments cheque or P.O. to: MICRO MAIL.

SHOWROOM NOW OPEN

GAMES PROGRAMMERS

A leading software development group require experienced assembler programmers to work freelance or salaried.

Please write stating experience and give samples of previous work.

The company would also be interested to view completed projects with a view to marketing.

All replies to Box No. 102, Your Computer,
79-80 Petty France, London SW1H 9ED

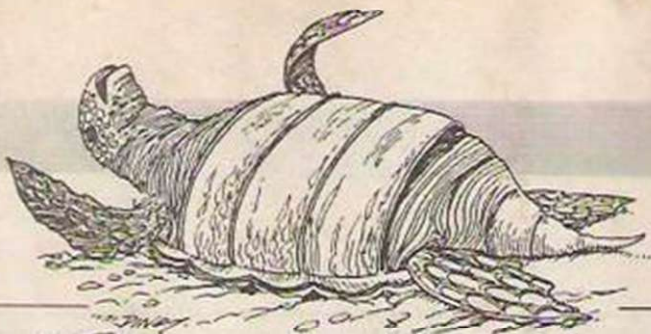

DR LOGO

Putting the Turtle through the loop

There are two ways of writing any program — using iteration and using recursion — and there are programmers who believe that only one of the ways is correct. That belief often is held so strongly that the argument often verges on warfare. Put simply, iteration is doing things using loops and recursion is doing things by subroutines or procedures which call themselves.

Most Basic programmers find recursion a strange and often difficult idea because most Basics do not allow recursion and an unfamiliar idea is always difficult. On the other hand, Logo is so keen on recursion some versions of Logo do not allow you to use any form of iteration apart from the REPEAT statement.

Fortunately Dr Logo is not so single-minded and it allows the programmer to choose whichever method suits the problem in hand. In this article we look at the uses, rather than the dogma, of both iteration and recursion, for the truth seems to be that each has its role to play.

Mind-boggling

In programming languages recursion refers specifically to the situation where a subroutine or procedure can call itself. At first sight it is a mind-boggling idea. Certainly in other walks of life examples of recursion are thought of as curiosities. For example, when a TV camera is pointed at the monitor to which it is connected we have an example of a physical recursion in that the picture displayed must include itself. The result is, of course, an echo of images rather like that seen in two mirrors set facing each other.

Because recursion is of practical value it is important that programmers learn to be neither frightened nor seduced by it. For that reason the newer teaching languages such as Logo include recursion in the hope that early familiarity will make it as natural to the programmers of the future as iteration.

Following that line of thought suggests that the best way to explain recursion is in combination with the familiar ideas of iteration.

The fundamental concept of iteration is the loop or perhaps, more accurately, the infinite loop. Consider the problem of printing the word HELLO on the screen repeatedly. Most programmers would solve the problem in Basic using something like listing one.

Dr Logo, though not all versions of Logo, allows a similar solution using the label and go statements in listing two.

After defining that procedure, typing `print_hello1` causes the screen to be filled with the repeated printing of HELLO until the program is halted by the user pressing ESC or by the power being disconnected. The only real difference from the Basic program is that the Logo program transfers back control to the position in the list of instructions marked by the label statement referred to by the go instead of using line numbers. The same problem can be solved using recursion by defining a procedure which prints HELLO and then calls itself to print another HELLO and so on, as in listing three.

Similarities

This second, infinite recursion version of the program has many similarities with the infinite loop but many programmers tend to panic at the sight of the `print_hello2` occurring in the middle of what they think of as the definition of `print_hello2`. If you type `print_hello2` this version of the program will also print HELLO repeatedly on the screen and in principle

Mike James looks at two ways to construct a Logo program. The choice between the two verges on warfare.

the only way you can stop it is by typing ESC or pulling out the plug but in practice you will find that there are physical limitations on the number of times a recursion can repeat.

That is due to the real difference between iteration and recursion. When executing an iterative loop you are carrying-out the same

screen n times, most programmers would find the iterative solution very easy as in listing four.

where the variable n is being used as a loop counter which is decremented each time through the loop until it is zero — i.e., the loop ends when n is zero. That can, of course, be done more simply using REPEAT `:n [pr "HELLO]` but this is nothing more than a shorthand form and it hides what is really happening in the loop. The equivalent recursive solution is shown in listing five.

This recursive method of repeating something has much in common with the previous looping program. It has a counter, in the form of variable "n" which is updated by make "n :n - 1 just before each repetition; it also has an if statement which controls when the repetition should end.

In circles

The difference is that that looping program achieves its repetition by transferring back control to the start of the program and the recursive program says "do it all again" by transferring control to a completely new copy of the procedure `nonloop :n`. The difference can be seen more clearly if you try to follow the path through each program with your finger.

In the case of the iterative solution you will find that you really go round in circles but in the case of the recursive solution you have to write a completely new copy of the procedure for each repeat. For example, the path for `nonloop` for n equal to 2 is shown in listing six.

Notice that at the point

Listing 1.

```
10 PRINT "HELLO"  
20 GOTO 10
```

Listing 2.

```
to print_hello1  
  label "loop  
  pr "HELLO  
  go "loop  
end
```

Listing 3.

```
to print_hello2  
  pr "HELLO  
  print_hello2  
end
```

section of program over and over again but each time through a recursion you are carrying-out a new copy of that section of the program. The new copy idea will be explored in more detail later.

Infinite recursion is no more useful than the infinite loop and so it is not surprising that the next idea we have to examine is finding some way of limiting it. If we wanted to print the word HELLO on the

Continued on page 56

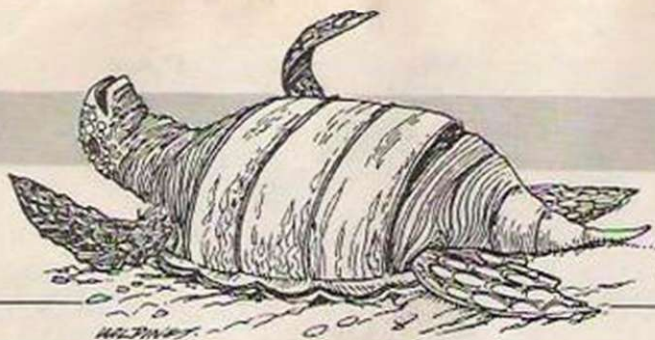

Continued from page 55

when the repetition ends – when $n=0$ – the latest copy of nonloop ends and passes back control to the copy before it and so on all the way back to the first copy. You can think of this as unwinding the recursion.

Procedure

The type of recursion described is particularly simple because nothing extra happens during the unwinding of the recursion. It is of the form shown in listing seven and when the condition is false, all the copies of the

involve doing something during the unwinding are more complicated and difficult to understand.

One of the conditions which has to be satisfied for recursion to work is that each time you call a procedure a completely new copy is brought into existence. For example consider the listing nine of the recursive HELLO program:

In principle, that should print "HELLO" during the forward part of the recursion and then, when n is zero, the unwinding of the recursion should print 0,1,2... If you try this program, however, you

Listing 4.

```
to loop :n
  label "prnloop
  pr "HELLO
  make "n :n - 1
  if (:n = 0) [] [go "prnloop]
end
```

Listing 5.

```
to nonloop :n
  pr "HELLO
  make "n :n - 1
  if (:n = 0) [] [nonloop :n]
end
```

procedure just end one after the other without doing anything. You can use this unwinding phase of a recursion to produce some interesting results. For example, try listing eight.

After entering this, typing backwards 10 will cause the machine to pause for a moment and to print-out 0 HELLO, 1 HELLO, 2 HELLO etc up to 9 HELLO. You should find that a little puzzling as the value of n decreases by one each time a new copy of the procedure is called, yet values printed-out increase.

The reason is that the printing-out is done during the unwinding phase of the recursion and this takes you back through existing copies of the procedure in the reverse order to the one in which they were created, hence the increasing value of n . In general, recursions which

will find that it prints "HELLO" the correct number of times but it then prints 0, 0, 0... The reason is that in its present form each new copy of the procedure inherits the original version of the variable n – a new variable n is not created along with each new copy of the procedure.

Listing 6.

<pre>Copy 1 (n=2) v to nonloop :n pr "HELLO make "n :n-1 (n=1) if (:n=0) [] [nonloop :n] --> end-----<-----end </pre>	<pre>Copy 2 v to nonloop :n pr "HELLO" make "n :n-1 (n=0) if (:n=0) [] [nonloop :n] end</pre>
--	---

Listing 7.

```
Do something
if condition then do something
end
```

Listing 8.

```
to backwards :n
  make "n :n-1
  if (:n=0) [] [backwards :n]
  pr :n
  pr "HELLO
end
```

Listing 9.

```
to nowork
  pr "HELLO
  make "n :n-1
  if (:n=0) [] [nowork]
  pr :n
end
```

That means that when the recursion unwinds there are no other copies of variable n to return to and hence all the procedures print 0, the final value of n . When n is passed to each new version of the procedure as a parameter a new copy of it is created but ordinary variables are not re-created anew each time a procedure is called.

To ensure that an ordinary variable is created anew when a procedure is called it has to be named in a local statement. For example:
(local "a "b)
at the start of a procedure will cause it to bring new copies of the variables a and b into existence each time the procedure is used. Variables like a and b are called local

variables because they are created by, and in this sense belong to, a single procedure rather than the whole program. To ensure that recursive procedures work properly it is essential to name all the variables used, apart from those passed as parameters, as local.

Simple solutions

Most examples of recursion are about solving problems which contain a clearly recursive element, for example working out factorial n as $n!=n*(n-1)!$ or drawing recursive patterns. There are many important problems which are not clearly recursive but have simple and powerful recursive solutions. One of the most surprising is the

Quicksort method of sorting a list into order.

Most obvious sorting methods are incredibly inefficient and require a great deal of unnecessary moving about of data. Quicksort is the best sorting method of which we know and it is fascinating in that at first sight it is difficult to see what connection the method has with sorting. The fundamental operation in Quicksort is the partitioning of a list into two parts, one larger and one smaller than a given value. The given value is often called the "key".

Partitioning

The partition is achieved by scanning the list from the left-hand side until it finds a value smaller than the key and then scanning from the right-hand side until it finds a value larger than the key and then it swaps the positions of those values. The scanning from the left and right and swapping values continues until the two scans meet. At that point the list is divided into two parts; everything to the left of the meeting point is larger than the key and everything to the right is smaller than the key. The key is usually chosen as a value in the list. For example, consider the list:

2 5 3 6 1

If 3 is picked as the key, then scanning from the left, 5 is the first number bigger than 3 and scanning from the right 1 is the first value smaller than 3 and so they change position, giving:

L R

2 1 3 6 5

The scan continues from the positions shown by L and R. The left scan stops at the 6 - the first value bigger than the key - but the right scan meets the left scan before finding a value smaller than

the key, giving:

LR

2 1 3 6 5

and the list is then partitioned into the part to the left of the LR which is smaller, or equal to the key and the part from the LR to the end of the list which is larger than the key.

After partitioning in that way, the list is definitely not sorted but if each partition is itself subject to a partition - using a new key, and so on until we reach a partition of one item, that will produce a sorted list. This is clearly a recursive process.

The reason that produces a completely sorted list is difficult to explain but if you watch the demonstration Quicksort program at work - add `pr:klist type:i:j` to the end of the swap procedure - you should be able to see what happens. The reason it works is connected with the fact that once you have partitioned a list, sorting the entire list into order cannot involve moving values between the two parts of the list and so you can concentrate on putting the partitions into order independently of one another. The program will work on both Logo V1 and V2.

Into order

Procedure `recsort` sets up a random list in `K_list` which procedure `sort` then sorts into order. Procedure `swap :i :j` swaps the positions of items `:i` and `:j` in `K_list`. It is this swap routine which is the main source of inefficiency in the program; can you find a better way of swapping two elements in a list? The variables `l` and `r` are used to mark the left and right positions of the scan and to avoid confusion of `l` with `1` it has been printed as `L`.

Next month: Property lists and databases.

QuickSort

```
to recsort
  (local "k_start "k_num "k_item)
  make "k_start 1
  make "k_num 10
  make "k_list [1]
  repeat :k_num - 1
    [make "k_item random 50
     make "k_list fput :k_item :k_list
    ]
  pr :k_list
  sort :k_start :k_num
  pr :k_list
end

to sort :L :r
  (local "i "j "key "a "b)
  make "i :L
  make "j :r
  make "key int ((:L + :r) / 2)
  make "b item :key :k_list
  label "part
  label "left
  make "a item :i :k_list
  if not (:a > :b) [go "left_out] []
  make "i :i + 1
  go "left
  label "left_out
  label "right
  make "a item :j :k_list
  if not (:b > :a) [go "right_out] []
  make "j :j - 1
  go "right
  label "right_out
  if not (:i > :j)
  [swap :i :j
   make "i :i + 1
   make "j :j - 1
  ]
  []
  if not (:i > :j) [go "part] []
  if (:L < :j) [sort :L :j] []
  if (:i < :r) [sort :i :r] []
end

to swap :i :j
  (local "s_list "si "temp "s_len "w "v)
  make "s_len count :k_list
  make "s_list []
  make "w item :i :k_list
  make "v item :j :k_list
  make "si :s_len
  repeat :s_len
    [make "temp item :si :k_list
     if (:si = :i) [make "temp :v] []
     if (:si = :j) [make "temp :w] []
     make "s_list fput :temp :s_list
     make "si :si - 1
    ]
  make "k_list :s_list
end
```

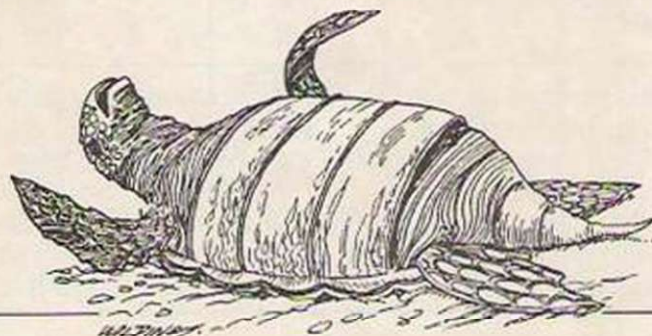

The 128 keypad is an optional extra designed to function as a calculator pad and as a screen editor. As a calculator pad, there is not really much to say about it. The new Spectrum has a built-in calculator function which leaves the result of a calculation on the screen in such a manner that it can be incorporated in a further calculation if you wish. All that is available from the normal keyboard; what the keypad allows you to do is to type sums such as $4*(3+1)-(9/3)$ without having to press the SHIFT key to get *, +, (and).

In screen-editor mode, the pad is rather more useful. It allows you to wander round a screen listing, moving the cursor in increments of whole words, or jumping directly to the start or finish of a line. Word deletions and line deletions are also possible, as is the useful "delete forward" which supplements the backwards delete of the standard keyboard.

None of the Sinclair keys is user-definable, which is a pity. As a keypad, there is little reason to suppose it is anything other than a Sinclair gimmick; as an 18-element input device it might be well worth its price. Removing the back of the pad, by unscrewing six screws, reveals that a no-solder guarantee-preserving modification is possible.

Intriguing

The circuit of the Sinclair keypad is not a straightforward design but its physical construction is simple and it should be possible to modify it to double as a real-world input device - for example, reading and switching sensors such as thermostats. The question of how information from the 18 contacts of the keypad is transmitted to the computer along four wires of the connecting lead is intriguing, especially since two of the wires are +5V and Ground respectively.

The link is bi-directional, according to the technical manual, so one wire is an input and one is an output. The port

As a calculator pad there is little to say about the 128K Spectrum numeric pad - in screen-editor mode, however, it is rather more useful. Dick Sargent explains.

128K Spectrum keypad in action

involved with the keypad is an 8-bit I/O belonging to the AY-3-8912 sound chip. This port also handles the computer RS232 interface. The eight lines can be configured as inputs or outputs but it is not possible to set some bits as inputs and some as outputs. So, as usual, some crafty work is being done by the keypad components; there is one solitary chip inside the keypad, marked as GI 8532, and an assortment of diodes, capacitors and resistors.

Socket positions

Fortunately for would-be users, it is not necessary to know how the keypad transmits its information. The 18 keys are on a 4-by-5 matrix and are terminated in an in-line socket. Removing the matrix is easy - it just pulls out - and different sensors can be plugged into place. Diagram one shows the socket positions and also which Row to connect to which Column to cause the computer to respond to the new sensor.

For example, any mechanical switch, such as the contacts of a relay, can be wired to connect an R socket to a C socket. Connect R4 to C3 and when the relay contacts close, the computer will think that key 9 has been pressed. Seventeen other switches may similarly be connected; R3 to C4, R3 to C3, R3 to C2 would represent another three, seen as keypresses +, 6 and 5.

In Basic the INKEY\$ function will detect 18 keypad

keys. Use IF INKEY\$="9" THEN PRINT "Sensor on key 9 is active" to decode the small keys and zero key and use IF CODE(INKEY\$)=13 THEN . . . and so on to decode the large enter/= key. Attempting to read a shifted key, or a shift-key simulation using relays, fails using the INKEY\$ method. To gain access to the shifted keys, it is necessary to know something of the mechanism by which the Editor ROM scans the keypad.

Spectrum's read their keyboards 50 times a second using a ROM routine called by the Z-80 maskable interrupt. When the normal 48K Spectrum ROM (ROM 1) is active, the keypad is scanned using new routines which reside in the 386EH-3FFFH area. Notice that, very sensibly, the computer has determined that the keypad is connected and has set BIT4 of FLAGS to indicate that it is present and needs reading. The code is:

```
PUSH IX
BIT 4,(IY+1) ;look at FLAGS
JR Z 3879H ;skip keypad-scan if BIT4=0
CALL 3A42H ;scan keypad
CALL 02BFH ;scan keyboard
POP IX
RET
```

That piece of code at least supplies the address of the keypad scan routine, 3A42H. When ROM 0, the Editor ROM, is active, a call to 0118H will also cause the keypad to be scanned. Routine 0118H

seems reasonably well-documented and machine-coders are advised to experiment with this one first, before tackling 3A42H.

The entry conditions for calling KPSCAN - EDITOR ROM 118H are:

- 1) Page-in ROM 0.
- 2) Disable interrupts.
- 3) Save all register except IY and E.

The routine may then be called. On exit the conditions are:

- 1) Bytes 5B88, 5B89 and 5B8A hold a bit-map image of keypad keypresses.
- 2) The Zero flag. If it is clear (non-zero) the keypad scan failed. If it is set (zero) the keypad scan succeeded.
- 3) Register E holds 10H if no key was pressed. If a key was pressed, register E holds an intermediate key code.

The bit-map of the keypad is an interesting place to start investigations, since it can be inspected without having to

write any machine code at all. These three bytes, called ROW01, ROW23 and ROW45, represent a snapshot of the keypad immediately after a scan has taken place. If a key is pressed, a BIT is set

Bit3 /	Bit2 *	Bit1 (Bit0)	of byte 5B88H key legend
Bit7 7	Bit6 8	Bit5 9	Bit4 -	of byte 5B89H key legend
Bit3 4	Bit2 5	Bit1 6	Bit0 +	of byte 5B89H key legend
Bit7 1	Bit6 2	Bit5 3	Bit4 =	of byte 5B8AH key legend
Bit3 0	Bit2	Bit1	Bit0	of byte 5B8AH key legend

in the map, which looks like that above.

The useful thing about key bit-maps is that they reflect accurately whatever happens to the keyboard - no key or key-combination is disallowed at this level of operation. As proof, the program in listing one is most instructive.

Run the program and press keypad key "8". The display shows, with some mental decimal-to-hex conversion, the map shown as listing two, and line 10 is needed only to remind you which key you pressed. Delete line 10 and the program still works. Turn the keypad upside down and press

all keys down - the bit-map turns into 20 "1"s, with decimal 15,255,255 showing on the screen. Reading the bit-map bypasses the "only press two keys at once" rule imposed by Basic and would prove useful if you were to use the keypad port to read 20 sensors. It seems that a Sinclair Spectrum could now, in its final flowering, genuinely run a home central heating system.

To complete the information on the KPSCAN ROM routine, which machine code practitioners will need if they intend to call 118H, the intermediate codes returned by the E register are listed in

Diagram 1.

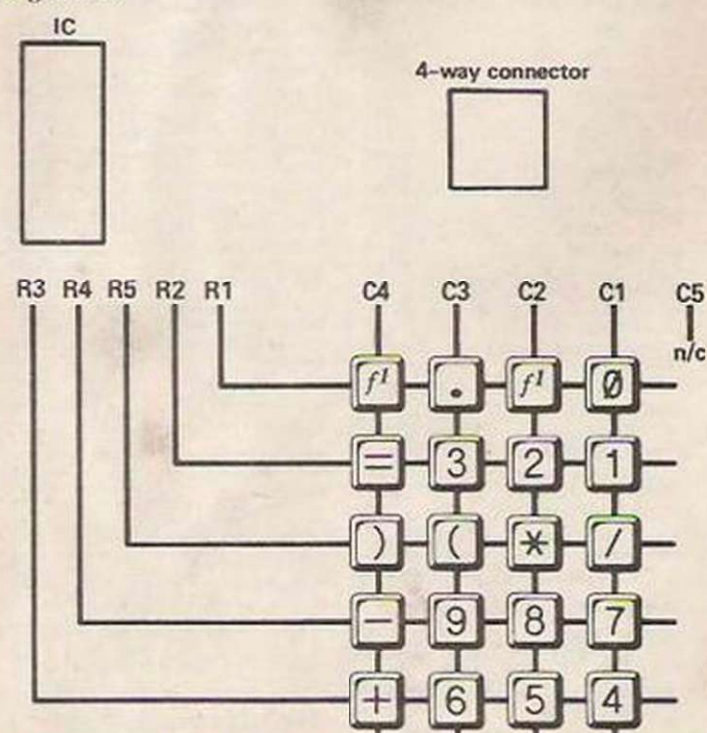

diagram two. Notice that they bear no relation to the ASCII codes of the keys concerned.

If this month's look at one specialised piece of Spectrum 128 equipment seems to be of little relevance to owners of other Spectrums, do not forget that every Spectrum has a key-scan routine and a key bit-map. The normal keyscan

occurs 50 times a second or, if interrupts have been switched-off, it can be scanned specifically in machine code by calling 0038H. Alternatively, the "big keyboard" bit-map is at 23552 to 23559 inclusive, so PEEKing these bytes in a program similar to that used for the keypad will reveal information of a similar nature.

Diagram 2.

Keypad legend	Code	Code if SHIFTeD
0	6C	--
.	5B	6C
=	5C	6E
3	5D	6F
2	5E	70
1	5F	71
)	60	72
(61	73
*	62	74
/	63	75
-	64	76
9	65	77
8	66	78
7	67	79
+	68	7A
6	69	7B
5	6A	7C
4	6B	7D

Listing 1.

```

5 PRINT AT 1,1
10 LET a$=INKEY$: PRINT "key=";a$
12 PRINT "row1 ";(PEEK(23432))-240;" "
14 PRINT "row23 ":PEEK(23433);" "
16 PRINT "row45 ":PEEK(23434);" "
17 PRINT " "
18 GO TO 5
    
```

Listing 2.

```

key=8                               BitMap
row1 0.....0H...0000
row23 64.....40H.....4H...0100
      :.....0H...0000
row45 0.....00H.....0H...0000
      :.....0H...0000
    
```

Computers by Post

Export Enquiries Welcome

PRINTERS			
Epson LX80	£195	Amstrad 464 Colour	£257
Epson FX85	£349	Amstrad DMP2000 Printer	£138
Epson FX105	£459	Apricot FIE	£499
Epson LQ800	£479	Apricot FI	£699
Brother HR15	£312	Atari 520STM	£325
Brother HR35	£699	Atari 520ST (ROM O.S.)	£299
Commodore DPS1101	£247	Atari 1040 STF Mono	£699
Canon PW1080	£234	Atari 1040 STF Colour	£899
Canon PW1156	£355	Commodore C64	£138
Citizen 120D	£152	Commodore C128	£219
Kaga Taxan KP810	£195	Commodore C128D (inc 1571)	£429
Kaga Taxan KP910	£355	Commodore 1541 Disk	£145
Juki 6000	£199	Commodore 1571 Disk	£225
Juki 6100	£259	Commodore PC10	£1099
Queen Data DWP1120	£189	Sinclair QL	£138
Smith Corona Fasttext 80	£109	Sinclair Spectrum Plus	£95
Star N110	£239	Sinclair Spectrum 128K	£119
Shinwa CPAB0 plus NI Q	£155		
COMPUTERS		MONITORS	
NEW Amstrad PCW8512	£494	Microwitec 1431DS	£175
Amstrad PCW8256	£394	Microwitec 1451DS	£219
Amstrad 6128 Colour	£344	Microwitec 1451DQ (QL)	£226
Amstrad 6128 Green	£257		
Amstrad 464 Green	£170		

4 Day Insured Delivery £7 + VAT 24 Hour Insured Delivery £10 + VAT

CREDIT CARD HOT-LINE



01-760 0014

All prices exclude VAT
Export Enquiries Welcome

Galaset Ltd, 30 Bayford Road,
Littlehampton, West Sussex.

BETA BASIC 3.0

SPECTRUM 48K

SINCLAIR USER, JAN. 85 (ABOUT RELEASE 1.8) "HAS ESTABLISHED ITSELF AS THE STANDARD EXTENDED BASIC FOR THE SPECTRUM...TURNS SINCLAIR BASIC FROM A GOOD VERSION OF THE LANGUAGE TO A FANTASTIC ONE." NOW, WITH RELEASE 3.0, BETA BASIC BECOMES PROBABLY THE MOST POWERFUL BASIC AVAILABLE ON ANY 8-BIT MICRO!

- PROCEDURES - a terrific implementation that lets you extend your Basic! No PROC keyword is needed, e.g. you can use commands like: swap a,b or draw box 10,20,5 or addup b1,sum. With parameter passing by value or by reference (including arrays), LOCAL variables and recursion.
- Up to 128 WINDOWS with their own attributes and character size.
- ANY CHARACTER SIZE (giving from 1 to 64 or more chars/line).
- LISTINGS with optional automatic indentation of loops, procedures, IF, etc. Works on existing Spectrum Basic programs too!
- KEYWORDS (including the Spectrum Basic ones) can all be entered by typing them in full, or by the "single entry" method, or both in the same line.
- A full range of TOOLKIT commands. * EXCEPTIONAL ARRAY and STRING handling.
- Many powerful GRAPHICS commands. * EXCELLENT EDITOR - fast and convenient.
- MICRODRIVE commands are improved and much easier to use.
- OTHER FEATURES, new or improved, are too many to fully list! DO - LOOP structure with WHILE, UNTIL and EXIT IF; ALTER, AUTO, BREAK, CLEAR, CLOCK, CONTROL CODES, DEF KEY, DPOKE, DRAW TO, EDIT, ELSE, FILL, GET, JOIN, KEYIN, multi-LET, LIST a slice, LIST DATA, ON, ON ERROR, OVER 2, POKE strings, POP, READ LINE, REF, ROLL, SCROLL, SPLIT, TRACE, USING, Faster GOTOS, GOSUBS and FOR-NEXT loops.
- 26 POWERFUL FUNCTIONS: AND, OR, XOR, DEC, HEX\$, BIN\$, fast SINE, COS\$, RNDM, CHAR\$, NUMBER, DPEEK, EOF, FILLED, INARRAY, INSTRING, ITEM, LENGTH, MEMORY\$, MEM, MOD, SCRNS\$, SHIFT\$, STRINGS\$, TIMES\$, USINGS\$.
- Spectrum Basic compatible - you can run existing programs. Transferable to Microdrive, Wafadrive and other special versions available.
- Comprehensive A5-size manual, more than 80 pages, packed with examples.
- To show you the power of Beta Basic's excellent procedures, we include on each tape a FREE TURTLE GRAPHICS package!
- Upgrades to Release 1.8 customers: If you bought direct from us, there is no need to return your cassette - just quote the (approximate) original purchase date with your order; otherwise return your cassette and name your supplier. The upgrade price of £8.95 (£7.50 overseas) includes a new manual. Release 1.8 remains available, at a reduced price of £8.95 (£9.50 overseas).
- TRANSFORM your Spectrum with BETA BASIC 3.0 for just £14.95 inclusive! (£15.50 overseas). Or if you want to know more about the program, send us an S.A.E.

(TICK AS APPROPRIATE.) PLEASE SEND ME:

- BETA BASIC 3.0. PAYMENT OF £14.95 (OR £15.50 OVERSEAS) IS ENCLOSED.
 BETA BASIC 3.0 UPGRADE. PAYMENT OF £6.95 (£7.50) IS ENCLOSED.
 BETA BASIC 1.8. PAYMENT OF £8.95 (£9.50) IS ENCLOSED.
 MORE INFORMATION ON _____, I HAVE/DO NOT HAVE RELEASE 1.8 ALREADY.
 A STAMPED ADDRESSED ENVELOPE IS ENCLOSED.

BETA SOFT

92 OXFORD RD.
MOSELEY
BIRMINGHAM
B13 9SQ



MICRO MAIL

53 FENNEL STREET
MANCHESTER M4 3DU
TEL: 061 834 2808

AMSTRAD

	RRP	OUR PRICE
CPC 6128 - Colour	£399	£379
CPC 6128 - Green	£299	£284
PCW 8256	£459	£439
PCW 8512	£574	£549
RS 232 for 464/664/6128	£49.95	£44.95
RS 232 for PCW 8256/8512	£69.95	£59.95
DMP 2000	£159.95	£149.95
SSA1 Speech Synthesiser	£29.95	£26.95
MP2 - Modulator	£29.95	£26.95
JY2 - Joystick	£14.50	£12.50
Modem -	£136.85	£126.00
PCW 8256 Modem & Sage Software	£189.95	£172.00
CF23" Discs	£3.99	£37.50
CF2003" Discs	£5.99	£55.00
FDI - 2nd Disc Drive	£89.95	£84.95
DDI - Disc Drive	£159.95	£149.95

AMSTRAD CPC6128/PCW 8256/ PCW 8512 SOFTWARE

Personal Assistant	£94.95	Touch 'n' Go	£24.95
Pocket Wordstar	£99.95	Mastercalc 128	£34.95
(please state whether for 6128 or 8256)		Pyradev	£29.95
Flexifile/Flexiwrite	£49.95	Protext	£26.95
Supercalc 2	£49.95	Promerge	£24.95
3D Clock Chess	£19.95	Prospell	£24.95

SHOWROOM NOW OPEN

SAGESOFT

Pop. Accounts	£99.99
Pop. Accounts/ Payroll	£149.95
Pop. Accounts Plus	£149.95
Payroll	£69.95
Invoicing/Stock Control	£69.95
Database	£69.95
Chit Chat E. Mail	£69.95
Chit Chat Viewdata	£69.95
Magic Filer	£69.95
Retrieve	£69.95
Accounts Super Combo	£199.95
HISOFT	
Pascal 80	£39.95
Devpac 80	£39.95
"C"	£39.95

Keyboard Tutor	£24.95
Pocket Cash	
Trader	£99.95
Masterfile II	£33.00
Microfile/ Microword	£49.95
Bridge Player	£19.95
Hitch Hikers' Guide to the galaxy	£28.95

CAMSOFT

Stock Control	£49.95
Payroll	£49.95
Invoicing	£49.95
Database	£49.95
PSIS Stock, Inv. & Sales	£99.95
PSIL Stock, Inv., Sales, Pur, Nom.	£149.95

CAXTON

Cardbox	£99.99
Scratchpad Plus	£69.95
Brainstorm	£49.95
Touch 'N' Go	£24.95
Smartkey	£49.95

DIGITAL RESEARCH

DR Draw	£49.95
DR Graph	£49.95
Basic Compiler	£49.95
Pascal MT +	£49.95

Printer Extension Cable 8256/8512	£12.95
Covers	
8256/8512 set	£12.95
6128 set	£12.95
464 set	£12.95

256K Expansion kit for 82556	£49.95
---------------------------------	--------

**DEDUCT 10% DISCOUNT WHEN ORDERING SOFTWARE
JUST SEND YOUR CHEQUE OR P.O. WITH A NOTE STATING
WHICH TITLE YOU WANT.**

Post and Packing: **FREE.** ALL Computers ADD £6 for value UNDER £250
All payments cheque or P.O. to: MICRO MAIL.

ALL PRICES INCLUSIVE OF VAT



High price of the hard disc

Acting on the recommendation of *Your Computer* and other micro magazines, recently I bought an Amstrad CPC6128 computer. I considered the purchase very carefully, opting for the green screen version of the system – the money saved buying that rather than the computer plus colour monitor combination going towards the purchase of a dot matrix printer. I intend to use the computer to play games and for more serious applications, including word processing, and to set up a database of information about the members of a bridge club of which I am chairman.

I am very pleased with my purchase and have already started work on building the database. I was shocked, however, when I tried to buy some 3in. discs for the computer. My local shop would sell me the discs only in boxes of 10, the cost being almost £50. Even my limited mental arithmetic skills can determine that this means that each disc costs £5. A friend has a BBC micro with a 5¼in. disc drive and pays a fraction of that price for his discs. Can you tell me why Amstrad discs are so expensive?

P E Hickling,
London SE5

Editor's reply: Amstrad discs are expensive for two interlinked reasons. The first is the law of supply and demand,

the second being economies of scale at the manufacturing stage. Amstrad is the only volume computer manufacturer of note to have adopted the 3in. disc format. On a global scale that means that, when compared to the other formats, 5¼in. and 3½in., the market for 3in. discs is comparatively small. That, in turn, means that disc manufacturers are reluctant to commit their production lines to the production of Amstrad format discs. Inevitably that leads to a shortage of discs and, enter the law of supply and demand, to the premium price charged for them.

For the record, our information is that Amstrad buys discs at £1.25 each and sells them to the wholesale trade at £2.25. Mark-ups at that stage by the retail outlets takes the price to the £5 mark you quote in your letter.

Mail order misery

This letter is written as a warning to people who may buy software with a seven-day unconditional money-back guarantee. I recently purchased a program on disc which cost slightly less than £12 with such a guarantee. Two days later I returned it with an explanatory letter

saying that I was not satisfied and would like my money returned.

After waiting a few weeks, I contacted the supplier and was told that my letter had not been received. Looking back now, I can see that sending a registered or recorded parcel would have been a very wise course as the parcel appears to have been lost in the post. I hope others may benefit from my experience.

J Pieroux,
Wiltshire.

The end of the Einstein?

The following is an extract of the editorial from the March edition of the UKEUG (United Kingdom Einstein User Group) Newsletter.

Some of you may have seen advertising for an Einstein show due to take place at the end of April. This show had to be cancelled due to the lack of interest shown by the commercial side of the computer industry. In fact only three companies bothered to reply to the invitations to take part. Does this mean that the computer industry in general and the manufacturer in particular has decided to try to kill off the Einstein? We hope not. Tatung (UK) have over 6000 registered users and there are two to three times more who have not registered, all these people require support of some kind.

Another show will be organised in the near future and invites will again be sent to the commercial sector, if the

response is as bad second time around the show will still go on but behind closed doors. No commercial companies will be involved on a basis of – if they won't help us, we will help ourselves.

K. Stokes,
Secretary, UKEUG.

Keep us informed

I have been reading the *Your Computer* magazine since April 1982. Before you changed the format of the magazine in December 1985 you used to have a regular space giving the readers details of any forthcoming computer shows and exhibitions on the second from last page. I have been unable to find any similar section since the change in form and wonder if you will be reintroducing it.

P. K. Attwood
Jersey.

Editor's reply: Thank you for your letter. We understand the need for such a feature in order that our readers may support such events and keep up with the latest developments in the computer industry. For this reason we will be printing such an item once again, in its usual place, starting this month.

**Write to: Your Letters,
Your Computer,
79-80 Petty France,
London, SW1H 9ED.
Tel: 01-222 9090
Our Prestel mail box
number is 01-9991 800.**

MAN LOGIC

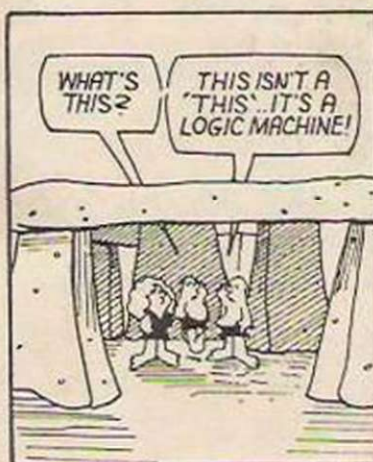

By NEIL BRADLEY

»Software Exchange«



Offering high quality software at bargain basement prices is the aim of Software Exchange – a new service for *Your Computer* readers.

Each tape features two programs, either games or utilities, and each has been extensively tested by our staff.

At only £1.99 per tape, each program costs under one pound – cheaper than the cheapest budget software!

Spectrum

TAPE: SP05

CASHFLOW STATEMENT

Machine: Spectrum 48K
Program Type: Home use
Author: A. Mehmood

This program will allow you to keep track of all your money – just what we all need. Full details of your cashflow are kept as a series of dated transactions, which can easily be added, deleted or amended. They may also be sorted by date, amount or transaction type, and printed-out in the form of a complete statement.

POOL

Machine: Spectrum 48K
Program Type: Pool simulation
Author: A. Mehmood

Do you fancy a dip? Well, you will find it difficult, because this is a *Pool* table simulation. Rather than a two-player game, the program gives you a certain number of shots in which to try and clear the table. By the use of only a few keys you can simulate eight types of spin, speed and direction.

TAPE: SP06

ROADRUNNER

Machine: Spectrum 48K
Program Type: Arcade
Author: C. D. Harden & R. Blundell

This is nothing to do with a certain character being chased across the American plains by Wily Coyote. The object of *Roadrunner* is to drive your car, the Wally ZX, for 500 miles in a time-trials race avoiding hay bales – and every other driver mad enough to enter.

WINDOWS

Machine: Spectrum 48K
Program Type: Programming Utility
Author: Paul Rhodes

Windows is a utility for Spectrum 48K owners, allowing up to 14 separate windows – individual mini-screens – showing simultaneously. They are accessed from Basic PRINT statements and an extended command set.

Features include pixel scroll and pan, window position and size – double-height characters, extended LIST, attribute pan, scroll, clear-screen and fill commands, extended graphic areas for each window and fast filled and open circles.

CBM 64

TAPE: CBM05

MISSION XZ1

Machine: CBM-64
Program Type: Arcade
Author: John Storer

Hordes of descending aliens are hell-bent on destroying your ship. You will need very quick reactions and a fast trigger finger if you want to survive in this very fast machine code game.

In addition to the normal options, you can choose the size of the aliens and whether or not there will be any wreckage round which to navigate.

80-COLUMN SCREEN

Machine: CBM-64
Program Type: Programming Utility
Author: Roger Kinkead

This utility will give your Commodore 64 an 80-column display, just like all the other micros such as the BBC and Amstrad. Included with the machine code routine to produce the display are some demonstration programs, showing how best to use it.

INSTRUCTIONS FOR USE

Software Exchange tapes are not supplied with any paper documentation – all instructions relating to the use of the software are provided as text files at the start of the programs.

To load the software the following instructions should be followed unless otherwise stated within the description of the software.

AMSTRAD CPC

Press CTRL – control key – while at the same time holding down the ENTER key.

CBM64

Press the SHIFT AND RUN/STOP keys.

SPECTRUM

Type LOAD"" then press the ENTER key.

BBC

Type CHAIN"" then press the RETURN key.

»Software Exchange«

CBM 64

TAPE: CBM06

SPACE AMBUSH

Machine: CBM-64
Program Type: Arcade
Author: Michael Solomon

Navigating through deepest space, you find yourself under attack by marauding aliens. This unusual variation on the alien-bashing theme includes dual-turreted guns, alien attack patterns and asteroid storms. All the movement routines are written in fast-action machine code.

VID BASIC

Machine: CBM-64
Program Type: Programming Utility
Author: J. Dakin

One of the major problems with the CBM-64 is its lack of Basic commands for handling the excellent sound and graphics facilities. *VID Basic* changes all that by offering a staggering 33 extra commands, accessible either in direct command mode or from your Basic programs.

The normal screen is split into three sections and you can access each individually – in hi-resolution, extended background mode or multi-colour mode, or any mixture on the screen. You can have eight sprites per screen section, giving a total of 24 sprites on the screen simultaneously, and you can even use different character sets in different sections of the screen.

The new commands give Basic access to all those facilities, plus hi-res plotting, plus Sprite manipulation commands, plus full sound facilities.

Amstrad

TAPE: AMS03

SCREEN EDITOR

Machine: Amstrad CPC-464
Program Type: Utility
Author: Stephen White

Though written in Basic, the *Screen Editor* is a professional-looking monochrome drawing package, allowing you to create and save your own screen pictures. Commands include freehand drawing, line drawing, fill-any-shape, circles, text, and a copy/flip picture. Instructions are included to show how to use those saved pictures in your programs.

PWS ASSEMBLER

Machine: Amstrad CPC-464
Program Type: Programming Utility
Author: Peter Slade

It is not often you find a programming utility of this quality at this price. The *PWS Assembler* allows you to assemble up to 4,999 lines of source code at any time, though obviously you could link object code programs for even larger programs.

This two-pass assembler will compile all standard Z-80 code, plus a number of pseudo-ops – ORG, EQU, DEFB, DEFM, DEFS and DEFW – and will handle up to 100 infinite-length label names.

The Basic assembler is written in the high line numbers, and your source code, plus any comment lines, are written in REMark lines, shown by an apostrophe at the start of each. That gives you full use of the standard Basic editor for modifying your source lines.

TAPE: AMS04

HI-RES DRAW

Machine: Amstrad CPC-464
Program Type: Drawing Utility
Author: Peter Wylie

Hi-Res Draw is a graphics utility which will allow you to create, save and load your own screens for use in your own programs.

Most of the package is concerned with the on-screen drawing, which can be in either screen mode zero or one, with the appropriate choice of colours. In addition to the colour choice keys, the cursor keys will either move or plot at the graphics cursor – shown on the screen and given as X,Y co-ordinates – and the finished screen may be saved to tape with the built-in save function, for later loading back into the *Hi-Res Draw* program or as a screen on one of your own games.

SUPERBANDIT

Machine: Amstrad CPC-464
Program Type: Fruit Machine Sim.
Author: Kevin Weaver

Playing fruit machines can be great fun but very costly. With *SuperBandit*, you will not win anything but neither will you lose your shirt. This excellent simulation has all the features of the best machines, including spins, trebles, holds, nudges, nudge gamble, spin-a-win, and much more.

It is essential for those days when you are miles from the nearest pub, even further away from the closest arcade, and have no change anyway.

ORDER FORM

Please send me the following Software Exchange tapes (print tape reference number clearly).

I enclose a cheque/Postal Order value £ (please remember to add 40p p&p per tape).

NAME _____

ADDRESS _____

Send orders to Software Exchange, 79-80 Petty France, London SW1H 9ED – please allow 28 days for delivery.

The University of Cambridge is the picturesque setting for our final update on computers in education. Cambridge has played an important part in the development of computers and its computing department is one of the best in the country. It is also one of the oldest, established as the Mathematics Laboratory in the late 1940s by professor Maurice Wilkes. We visited the laboratory, where we spoke to Richard Stibbs, user services manager for the computing service.

In 1949, working with a few bright undergraduates and using mercury delay line storage, Wilkes completed one of the first store programming computers ever built, which he called Edsac 1. The department soon changed its name to the Computing Laboratory and has since been one of the fastest-growing departments in the university, expanding into two adjacent buildings connected by a bridge on the second floor.

Edsac 1 continued to operate through into the 1950s until it was superseded by Wilkes' second computer, called

ambitiously Edsac 2. During those early years no more than two dozen people had either the intelligence or reason to use the computer but Wilkes realised its potential and much thought went into the theory of computing during those early years.

By that stage manufacturing

two sections, the teaching/research department and the computing service. The former is directly responsible for computer research and development groups and those undergraduates whose primary subject is computing, while the computing service maintains and updates the immense array

approximately 1,000 terminals – including IBM PCs, Apple Macintoshes and BBC micros – in every department of the university, supporting at least 8,000 users from Cambridge and other universities throughout the country.

Any time, any place

Those users, who must be registered, can access information stored on the mainframe at any time from any place; all they need is a terminal and a modem. Security is extremely important and the university has developed some powerful methods of restricting mainframe access only to registered users.

The research group, run by Professor Roger Needham, has been responsible for some well-known developments in the computing industry, in particular the Cambridge Ring Local Area Network which his department developed and now uses. It is also responsible for several other high-performance systems, including expert systems, artificial intelligence and the development of the C programming language.

Using MicroVax and Xerox

Cambridge University

companies were developing computers as a commodity and it was a subsidiary of Ferranti, Atlas Computers, which provided the necessary parts for the department's next computer, Titan. Built and in operation during a 10-year period – 1963-73 – Titan was one of the first multiple-access computers in Europe.

In 1986, the Computing Laboratory looks very different. It is organised into

of hardware and software in the Computer Laboratory and, to a certain extent, throughout the university's many colleges.

The university's main source of computing power is an IBM 3081D mainframe computer which contains 32MB of main storage – 32,000 times the memory of a BBC – as well as 32,000MB of storage on fixed disc and 10,000MB on streamer tape. That is linked directly through a network to

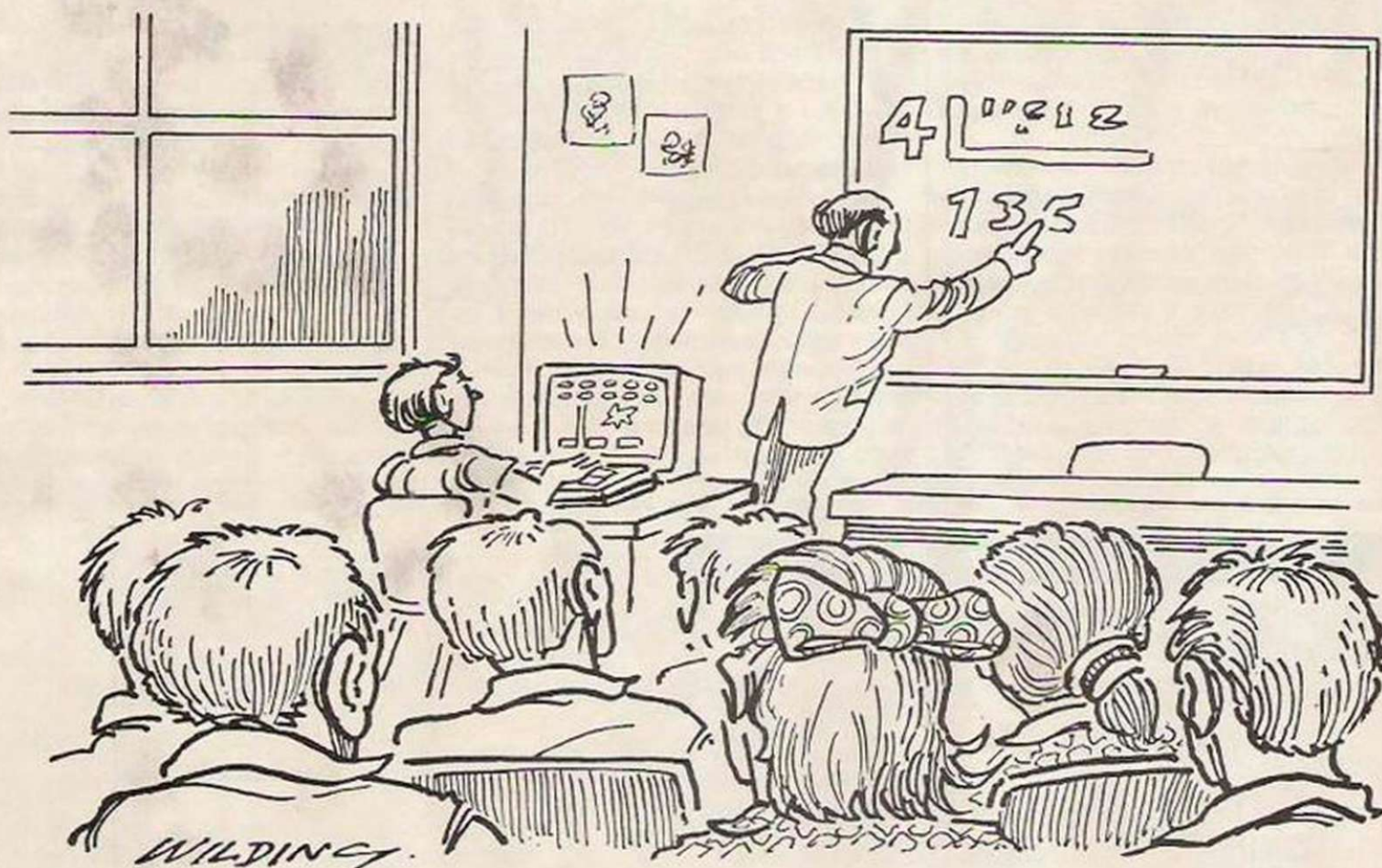

workstations. Needham's department teaches some 200 students about programming languages and other subjects related directly with computers, such as graphics. He also lectures to some 1,500 undergraduates from other disciplines who make use of the computers in their work.

Most departments also own a number of stand-alone computers which do not rely on the computing power of the mainframe. Stibbs believes that as those computers become more powerful and less expensive, so other departments will use the mainframe less and less for computing but more and more as a source for storing and retrieving information through the university and metropolitan data networks.

The computing service, directed by Dr David Hartley, has been directly responsible for the development of the Computer Laboratory and the growth of computers in other departments. Students and teachers in all subjects use the computers and often the Computing Service needs only to offer advice on the purchase of equipment and software, which it will install if necessary.

The biology department, for instance, used its computers and those of the laboratory to help the discovery of a double helix in DNA, an important step towards understanding genetic deficiency.

The library also makes good use of the mainframe, keeping records of all books and serials since 1979. That allows any authorised student from any university in the country to check for articles or books relevant to his subject.

Electronic messaging

An increasing number of undergraduates and teachers now use the computers for preparing essays, reports and manuscripts, since it allows them to edit text and print it out in any format. That can be done either using the computers in their own colleges or departments, or the computers at the main Laboratory, which are available 24 hours a day, almost all the year round.

Messaging is also popular,

with students and teachers using the terminals to send notes or articles to each other confidentially and instantaneously.

An undergraduate can even send his work to the library, where it will be printed on the laser printer and stored ready for collection.

More and more undergraduates have bought computers, often taking advantage of significant discounts offered by manufacturers such as Apple. An office has been set up, devoted to advising people on the computers and software which might best suit them.

BBC still popular

The BBC micro is also still popular, since it offers inexpensive computing power with programs such as View and Wordwise, and it can also be used as a terminal utilising the power of the mainframe.

Much of the early BBC design took place in the university, which may account for its continued support. Anyone who requires more processing power than a BBC or Macintosh might choose an IBM or one of its many compatibles. Other machines are bought rarely, since academic software is so specific - far more so than business software - it is available only for a few computers.

Perhaps the most interesting point about computers and their role at Cambridge is that, unlike primary, preparatory, secondary and public schools, it is not just a few people who make use of computers but everyone from language students to administration staff. That can probably be attributed to the early Cambridge involvement in computers but without doubt it indicates the invaluable importance of computers in schools today.

So great has the development been that it led to the Cambridge Phenomenon, the development of more than 300 computer-related companies, including Sinclair Research, Acorn Computers, Apple, DEC and, more recently, IBM, each working in close collaboration with the university. - Jason Ball.

Could you be a Mr Fix-it?

There are few guarantees in the business of job-hunting, even when you look in the fast-moving electronics business. Yet if there is one area where you are reasonably certain to find some work, it is in the business micro sector.

One of the hottest trends in the business micro industry is the proliferation of cheaply-made IBM PC clones or imitators. The clone machines are usually almost identical to the PC inside and outside, can run almost all PC software, and cost as little as one-third the recommended price of the real thing.

There is one area, however, where inexpensive replicas of the PC find it difficult to compete and that is in offering after-sales support and service for the machines. To secure a low price and make a reasonable amount of money, distributors of clone machines cannot afford to offer expensive guarantees or a good deal of technical help when buyers leave the showroom.

We need you

That, as they say, is where you figure. A large business is growing to provide support and service for the increasing numbers of inexpensive PC-compatible machines and those businesses will need qualified people to work for them.

What you will need is a working familiarity with the machines which are the most popular purchases by business. At the moment, the biggest success stories are the IBM PC design and its hundreds of imitators and the Amstrad PCW range, a big hit among small businesses. Although Amstrad provides service and support, it is only for the guarantee period and many

businesses may well want more back-up than that.

The support and service of successful PC clone manufacturer Walters International, will offer a two-year contract either to replace or repair one of its PCs within 24 hours, for the cost of only an extra 12 percent on the purchase price of the machine. When that machine costs about one third of what you might pay for IBM, the extra 12 percent will be very attractive.

Getting to business

With that kind of incentive, it is certain that many businesses will accept support and service contracts. It is equally certain that qualified and reliable staff will be needed.

On the IBM front, there are several areas you could research to get into the PC repair business:

The Intel 8088 processor used by the PC; have a working familiarity of machine language with that processor.

The bus expansion slot system; many internal problems which arise in the PC can be traced to expansion cards installed by users. You should be familiar with the most popular cards and what they do.

The 360K disc drives; many of the data retrieval problems experienced by users start with faulty drives. Familiarity with standard disc drive technology, such as that used on the BBC micro will make you much more qualified in this area.

In short, there is a growing market for technicians who can repair PCs and if you can convince some of the people who count that you are qualified, you may well be on your way to a well-paid, full-time job. - Geoff Wheelwright.

ATARI COMPUTERS



The 1040STF Computer, 5205TM and 5205TM+ come with tos and gem in rom and logo, basic, neochrome, firstword, db master one, doodle and megaroids. 1040STF with disc drive, mouse and monitor: monochrome £836 (E839) £916, colour £1046 (E1046) £1156. Atari 520 STM Computer (512K version) £343 (E336) £376. Atari 520 STM+ (1 Megabyte version) £426 (E416) £456. 1 megabyte upgrade for the Atari 5205TM £99 (E99) £109. Cumana economy 1000K disc drives for the 5205TM: single £148 (E148) £170, dual £239 (E239) £271. Atari 500K ST disc drive £130 (E132) £152. Atari 1000K ST disc drive £173 (E172) £192. Atari 5T monochrome monitor £136 (E146) £194. Economy Fidelity ST colour monitor £199 (E204) £264. Atari 14" medium resolution ST colour monitor £354 (E349) £399. 20 Megabyte ST hard disc £730 (E699) £769. Atari 130XE computer + game £115 (E121) £141. 130XE computer + cassette recorder + software £148 (E147) £172. 130XE computer + disc drive + software £234 (E233) £263. 130 XE computer + disc drive + 1027 printer + software £307 (E309) £369. Atari 1027 £116 (E122) £148. Atari 1050 £116 (E122) £148.

SINCLAIR COMPUTERS



Sinclair Spectrum 128 £136 (E138) £158. Sinclair pocket TV £197 (E195) £101. Sinclair QL Computer £194 (E196) £229. QL Floppy disc interface (See Cumana disc section below for suitable disc drives) £86 (E84) £94. Sinclair Spectrum Plus Computer 48K £96 (E98) £119. Spectrum Plus Computer + cassette + 4 games + joystick with interface £139 (E139) £169. Kit to upgrade the Spectrum to Spectrum Plus £40

(£40) £56. Microdrive £49 (E50) £60. RS232 interface £49 (E50) £60. Special offer: Microdrive + interface £1 + 4 blank cartridges £97 (E99) £107. Blank microdrive cartridges £2.50 (E3) £4. Spectrum floppy disc interface (See Cumana disc section for suitable disc drives) £107 (E99) £109. Interface 2 £29-45 (E20) £24. Spectrum Centronics printer interface £46 (E42) £47.

COMMODORE COMPUTERS

Commodore 128 £250 (E249) £279. New Commodore 128 Compendium Pack £279 (E275) £310. Commodore 128D £466 (E460) £510. 1571 Disc drive £257 (E250) £270. Commodore 64 + recorder + musicmaker keyboard + software £191 (E195) £235. Converter to allow most ordinary mono cassette recorders to be used with the Commodore 128 and the Commodore 64 £9-78 (E9) £11. Centronics printer interface for Vic20 and the Commodore 64 £45 (E41) £46. MPS803 Printer £138 (E145) £175.

AMSTRAD AND ENTERPRISE COMPUTERS

New Amstrad PCW8512 £564 (E575) £675. Amstrad PCW8256 £449 (E450) £550. Amstrad 464 Colour £297 (E322) £402. Amstrad 464 Green £197 (E230) £310. Amstrad 6128 Colour £397 (E420) £500. Amstrad 6128 Green £297 (E322) £402. Amstrad DMP2000 printer £156 (E159) £191. Extra disc drive for Amstrad 6128 £99 (E103) £133. Enterprise 64 £110 (E116) £156. Enterprise 128 £159 (E163) £203. Enterprise disc drive interface (See Cumana disc drive section for suitable disc drives) £84 (E80) £85.

CUMANA DISC DRIVES

To suit disc interfaces of Sinclair QL, Spectrum Enterprise and BBC B 80 track double sided, cased with power supply: single 3.5" £134 (E134) £156, dual 3.5" £224 (E224) £256, single 5.25" £172 (E172) £201, dual 5.25" £310 (E310) £350.

PRINTERS

New Epson LX80 £249 (E249) £262. Tractor for LX80 £20 (E20) £30. Brother HR5 £148 (E152) £184. Brother M1009 £201 (E203) £234. Shinwa CTI CPA80 £193 (E192) £228. Taxan KP810 £218 (E219) £269. Cannon PW1080A £309 (E306) £356. Microperipherals MP165 £223 (E223) £263. Brother EP44 £224 (E220) £240.

SWANLEY ELECTRONICS
The Computer Export Specialists
Dept. YC, 32 Goldsel Rd., Swanley, Kent BR8 8EZ, England
Tel: SWANLEY (0322) 64851

Official orders welcome. UK prices are shown first and include post and VAT. The second price in brackets is for export customers in Europe and includes insured airmail postage. The third price is for export customers outside Europe (including Australia etc) and includes insured airmail postage.

RSD Connections Ltd

MONITOR LEADS	RIBBON CABLE (price per ft)	SPECTRUM EX. LEADS
FIDELITY (Suit to: BBC QL/COMMODORE/SONY/SPECTRUM 128/AMSTRAD) £4.95	Grey Rainbow 3 way £0.13 £0.24 10 way £0.15 £0.28 14 way £0.18 £0.32 15 way £0.20 £0.36 16 way £0.22 £0.40 20 way £0.30 £0.50 24 way £0.36 £0.60 25 way £0.40 £0.65 26 way £0.45 £0.70 34 way £0.60 £0.80 37 way £0.65 £0.85 50 way £0.70 £0.90 60 way £0.95 £1.25 60 way £1.10 £1.40 64 way £1.25 £1.50	6 inch extension cable M to F £10.50 6 inch F to 2M's £14.75 12 inch extension cable M to F £10.75
FERGUSON to BBC/COMM 64/MSX QL/SPECTRUM 128/AMSTRAD £2.50	HITACHI to BBC/COMM 64 QL/SPECTRUM 128/AMSTRAD £2.50	AMSTRAD EXPANSION PORT EXTENSION LEADS
SONY KAGA to BBC £5.95	Green Screen to: Comm 64/BBC £2.95 Green Screen to: QL £1.50 Green Screen to: COMM 128 £4.95 Phono to Phono £1.25 PHILIPS to BBC/COMM 64 £2.95	NEW! 8" Single F to M £10.50 Double F to 2M's £14.75 Suitable for 664 & 6128 The easy way to connect your add-on's
36-way plug £4.95	36-way socket £5.95	AMSTRAD MONITOR EXTENSION LEADS
36-way plug (Isolder type) £4.95	36-way plug (Isolder type) £4.95	To 664, 1m. £5.50 To 664 & 6128 £7.50
DUAL DISK DRIVE LEADS	EDGE CONNECTORS	AMSTRAD PRINTER LEADS
Dual disk drive power lead £4.50	2 x 23 way (ZXB1) £1.85 2 x 28 way (Spectrum) £2.10	1 metre £10.75 2 metres £12.50
Dual disk drive lead 1m £10.25	DOUBLE SIDED PLUG BOARD	AMSTRAD 2nd DRIVE LEAD
Single disk drive power lead £2.75	ZX-B1 23-way £1.25 Spectrum 28-way £1.50	Suitable 664 & 6128, 1m £6.95
Single disk drive lead 1m £2.25	ADDITIONAL IDC	AMSTRAD 8256
Disk drive extn lead 1m £7.25	56-way Card Edge for Extension Lead £4.25	1m. Printer Extn. lead £9.50 PCW Intraface to Printer (1.5m lead) £15.20
COMMODORE Serial Lead £2.75	D CONNECTORS	MISCELLANEOUS
BBC to cassette £2.25	Solder Ratchet Male Female 8 way £0.75 £1.00 15 way £0.95 £1.50 25 way £1.50 £1.90 37 way £2.40 £3.25	TV Aerial Leads 1.2m £1.25 2m £1.50 3m £1.75 4m £2.00 'Y' place Switched TV Splitter, TV & Aerial leads plugged in without loss of signal £1.95 Spectrum Power Supply replacement lead £2.50
Dragon to cassette £2.20	TELEPHONE CONNS	IDC D CONNECTORS
Spectrum to cassette £1.25	Surface master jack socket £3.75 Surface extn socket £2.50 Dual outlet adaptor £4.25 Line jack cord 3mtr £1.85 4 core cable per metre £0.15 DT Plug £0.48	9 way Male Female £2.70 £3.20 15 way £3.20 £3.70 25 way £3.80 £4.45 37 way £5.90 £6.80
BBC to Agom cassette £2.25	CONNECTIONS IDC	ANY COMBINATION OR LENGTH OF LEADS MADE TO ORDER
MSX to Cassette £2.50	Card Edge PCB Socket 10 way £1.20 £0.95 £0.80 14 way £1.20 £0.90 16 way £1.60 £1.20 £1.00 20 way £1.90 £1.35 £1.20 26 way £2.40 £1.60 £1.45 34 way £3.10 £1.95 £1.60 40 way £3.40 £2.00 £1.85 50 way £3.85 £2.25 £2.00 60 way £4.80 £2.60 £2.25	
BBC to cassette £2.25	Printer Leads	
Dragon to cassette £2.20	ALL 1 METRE LENGTH	
Spectrum to cassette £1.25	BBC £9.95	
BBC to Agom cassette £2.25	BBC serial £8.95	
MSX to Cassette £2.50	SPECTRUM 128 £10.75	
	MEMOTECH £12.75	
	EINSTEIN £12.75	
	IBM PC £15.75	
	SPECTRUM interface one to RS 232 £9.75	
	ATARI 520 1040 £15.25	
	MSX £13.95	
	APRICOT £15.20	
	DRAGON £9.95	
	QL £10.75	

Please enclose SAE with all enquiries for FREE advice.
TRADE ENQUIRIES WELCOME
75p P&P IN UK. Access & Visa accepted. Add 15% VAT to all orders
Cheques made payable to:
RSD Connections Ltd, Dept YC7,
PO Box 1, Ware, Herts.
Tel: 0920 5285



MICRO MAIL

53 FENNEL STREET
MANCHESTER M4 3DU
TEL: 061 834 2808

COMMODORE

	RRP	OUR PRICE
Music Systems (includes Commodore 64)	£329.99	£309.99
Currah Speech	£21.95	£19.95
1570 Disc Drive	£199.99	£179.99

SOFTWARE ON DISC

Textpro - Wordprocessor -	£12.95
Datapro - Database -	£12.95
Zork I	£11.95
Zork II	£11.95
Zork III	£11.95
Hitch Hikers Guide	£24.95
Gemini - Home Accounts	£24.95
Database	£24.95
Cashbook	£64.95
VAT File	£24.95
Final Account	£64.95
Superbase - 128	£99.95
Superscript	£79.95

If the title you want is not listed all you have to do is send your cheque or P.O. for the retail price less our 10% Discount and state whether disc or cassette.

ALL DISC AND CASSETTE TITLES
10% OFF.
JUST TELL US WHAT YOU WANT!

COMMODORE

	RRP	OUR PRICE
Commodore 64	£199.95	£185.00
Commodore 128	£269.95	£250.00
Commodore 128 D	£499.00	£470.00
Commodore 128 D & Monitor	£631.00	£545.00
Music Expansion	£150.00	£140.00
1541 Disc Drive	£159.95	£149.95
1571 Disc Drive	£299.95	£279.95
Modem	£79.95	£69.95
Mouse	£69.95	£59.95
Light Pen	£29.95	£24.95
Sketch Pad	£49.95	£44.95
Speech Synthesiser	£24.95	£21.95
Blank Discs - Sony SS	Box of 10 £12.95	£10.95
DS	Box of 10 £16.95	£12.95

GENERAL

	RRP	OUR PRICE
Cheetah 125 Joystick	£8.95	£7.95
Pro 5000 Joystick	£18.95	£16.50
Comdrum Tape or Disc	£29.95	£26.95
Sound Sampler - Commodore	£49.95	£44.95
Data Recorders for all Commodores	£39.95	£33.95

Post and Packing: **FREE.** ALL Computers ADD £6 for value UNDER £250
All payments cheque or P.O. to: MICRO MAIL.
SHOWROOM NOW OPEN

Since only a minority of our readers live in London, it is only fair this month to move out of the capital to a club elsewhere. Going to extremes as usual, Scotland was chosen as the ideal location.

Finding a computer club north of the border proved to be almost as difficult as sighting the mythical aquatic inhabitant of Loch Ness. Even the Association of Computer Clubs, which has been extremely helpful to this column in the past, was unable to provide much information about the killed computer fraternity. In fact, the first time we telephoned it had its bulletin board modem attached to the telephone line and we could not obtain much information from a continuous beep.

When eventually we made contact, it was suggested that we refer to the best source of up-to-date information, Prestel. Taking heed of the advice, we retrieved an excellent list of seven Scottish clubs, each with a telephone number and contact name.

Closed club

The first man we contacted from this newly-discovered fountain of Scots club information admitted that he had not attended his computer club in Carlisle for more than a year, much less had anything to do with running it. He said the club had ceased to exist, together with several other such groupings in the area.

Undeterred, however, we went to the top, Derek Young of the Scottish Amateur Computer Society, extension 2586. "Sorry, love", said the secretary at the end of the line, "he left this job almost 18 months ago and no-one knows where he went". Perhaps the same way as the Carlisle clan?

Three other people were either no longer living at that address, away on holiday, or did not reply. Finally, we managed to contact Jim Cook of the Kingsway Amateur Computer Club at Kingsway Technical College, recently rechristened Dundee College of Further Education, and

Computer Clans - Over the Border

There is a legend that Scottish computer clubs are as rare as Scotch mist. Jason Ball investigates.

persuaded him to talk to us between tutorials with his examination students.

It transpires that amid the gloom and doom affecting some Scottish computer clubs, Cook's Kingsway club is a comparatively thriving organisation. He says the club has a membership of more than 50, offers a wide appeal to students at the college, and has its own meeting room, power and lighting donated by the college.

Subsidised Spectrums

The membership fee of only £1 reflects a keen desire to see a wide range of people attending the club meetings every Thursday evening. Members take their own machines, many of them Spectrums, bought at an advantageous price from the nearby Timex factory in Dundee where the machines were made and many of the

younger members also take games. Despite the local fame of the Spectrum and its importance to the local economy, there is also a sprinkling of Oric, Dragon, BBC, Commodore 64 and Atari ownership among the Kingsway fraternity.

Pet doorsteps

Unlike some other clubs, however, the Kingsway group does not restrict itself to weekly meets and swapping of games software. It also conducts demonstrations of new software and hardware and has recently organised several club outings. "They have gone down rather well", says club president Cook.

Although the group is based on the college, it tries not to use the college computers, preferring instead to develop expertise further on their own machines. The odd college-

owned Commodore Pet, largely a doorstop at the college anyway, is called into service occasionally, they are largely redundant.

Lack of lasses

The general membership is young and the club has so far had no success in recruiting female members. Cook adds that older members tend to be more fair-weather attendees than the younger set.

He is, however, optimistic about the future. Despite a high turnover - few members stay for more than a year - and fluctuating attendance, he says that with a low membership fee, full co-operation of the college in providing the facilities for meetings, and the wider range of club activities, the Kingsway Amateur Computer Club is not likely to become another of Scotland's misty legends.

Stars before the eyes

I would like to give you details of my new viewdata/bulletin board called Prometheus. The system has been primarily set up with astronomy as its central theme, although many of the systems' features prove to be of genuine use to serious amateurs. I intend the system to be of real interest and educational value, particularly to the young. The database has been constructed with sections that appeal more readily to junior stargazers and more are planned.

Prometheus is currently

open from 8pm to midnight every night and will soon be in operation for twenty-four hours each day.

B. J. G. Spencer
Sysop Prometheus,
01-300 7177

Atari force in Fife

I am forming an Atari user group in Fife. I hope that this will encompass both the eight-bit machines and the ST.

There is virtually no software back-up in my area for the Atari user, even the major stores who retail the 800XL do not support the machines. If there are any

Atari users in or around the area who are interested in joining such a group, give me a call on (0592) 714887.

L. Singer, Fife.

Glenrothes Computer Club

Based in the new town to Glenrothes in Fife. Two software libraries are open to members. Although they hold only programs for Commodore and Amstrad machines, all types of computer are welcome. For details of meeting times and venues, call the chairman, Alan Donaldson, on 0592 758746 after 6.30 p.m.

POOLSWINNER

THE ULTIMATE POOLS PREDICTION PROGRAM

- **MASSIVE DATABASE** Poolswinner is a sophisticated Pools prediction aid. It comes complete with the largest database available - 22000 matches over 10 years. The database updates automatically as results come in.
- **PREDICTS** Not just SCOREDRAWS, but ALWAYS, HOMES and NO SCORES.
- **SUCCESSFUL** SELEC guarantee that Poolswinner performs significantly better than chance.
- **ADAPTABLE** Probabilities are given on every fixture - choose as many selections as you need for your bet. The precise prediction formula can be set by the user - you can develop and test your own unique method.
- **SIMPLE DATA ENTRY** All team names are in the program. Simply type in the reference numbers from the screen. Or use FIXGEN to produce fixture list automatically (see below).
- **DISC/MICRODRIVE COMPATIBLE** Tapes supplied with conversion instructions.
- **PRINTER SUPPORT** Full hard copy printout of data if you have a printer.



Boxed, with detailed instruction booklet

AVAILABLE FOR Spectrum (48K), Commodore 64, VIC 20 (+16K), AMSTRAD, BBC B, Atari (48K), ZX81 (16K), Dragon, Apple II, ELECTRON

PRICE £15.00 (all inclusive)



FIXGEN 85/6

AT LAST! No more struggling for hours to get the fixture list into the computer. FIXGEN has been programmed with all English and Scottish fixtures for 1985/6. Simply type in the date, and the full fixture list is generated in seconds. Fully compatible with Poolswinner.

POOLSWINNER with FIXGEN £16.50 (all inclusive)



COURSEWINNER V3

THE PUNTERS COMPUTER PROGRAM

You can develop and test your own unique winning system by adjusting the analysis formula, or use the program in simple mode. Coursewinner V3 uses statistical analysis of major factors including past form, speed ratings, course statistics, prize money, weight, going, trainer and jockey form etc. etc. It outputs most likely winners, good long odds bets, forecasts, tricast etc. The database includes vital course statistics for all British courses. You can update the database - never goes out of date.

AVAILABLE FOR Spectrum (48K), Commodore 64, BBC (B), AMSTRAD, Atari (48K), Apple II

PRICE £15.00 (all inclusive) includes Flat AND National Hunt versions.

NOT JUST A TIPSTER PROGRAM, Coursewinner V3 can be used by experts and occasional punters alike.

Send Cheques/POs for return of post service to...



phone 24 hrs



SOFTWARE



phone 24 hrs

37 COUNCILLOR LANE, CHEADLE, CHESHIRE. ☎ 061-428 7425

(Send for full list of our software)

Leading computers in Belgium

ATARI ACORN COMPUTER

commodore

sinclair

Schneider AMSTRAD

The English Computer Shop

Willem Ogieplein 2
B 2000 Antwerp
Tel. 03/233 59 06

Rue Grétrystraat 31
B 1000 Brussels
Tel. 02/218 60 26

THE VOLEX TELETXT-TELESOFTWARE ADAPTOR

FOR USE WITH SPECTRUM, BBC & AMSTRAD MODELS

FREE COMPUTER PROGRAMS INSTANT SPORTS RESULTS CONSTANT T.V. UPDATE
A WORLD OF INFORMATION AT YOUR FINGERS

TELETXT

Extra information available day or night whilst television transmitters are on air and without any charge can now be enjoyed without the need of having a special Teletxt T.V. set. All you need is to plug in your VOLEX ADAPTOR to receive 4-Tel from Channel 4, CEEFAX or ORACLE services.

TELESOFTWARE

Telesoftware is the name for computer programs which are broadcast on Teletxt. Thus they may be loaded OFF AIR into the appropriate micro computer instead of being loaded from say TAPE or DISC. Both Channel 4 and BBC are broadcasting Telesoftware, however there are the following limitations:-

- Spectrum Adaptor:- All Teletxt Channels but Channel 4 Telesoftware only.
- BBC Adaptor:- All Teletxt Channels but BBC Telesoftware only.
- Amstrad Adaptor:- All Teletxt Channels, Channel 4 Telesoftware programs and BBC Telesoftware data files including the Education Newsletter.

*Channel 4 is currently expanding its Telesoftware programs particularly CP/M based material.

Because of the special nature of Teletxt these programs are frequently updated-So you will not see the same thing each time you run the program.

STORING PAGES

With the Volex Adaptor it is possible to send received pages to your printer or to disc or cassette for storage and later recovery.

EASY TO SET UP AND USE

A simple procedure tunes the Volex Adaptor to your local teletxt channels. All loading of Telesoftware is via an index page which the Adaptor will automatically find and display for you. Absolutely no modification is necessary to T.V. or Computer.

- *User friendly-built in disc/tape and printer routines.
- *Comprehensive User Guide included.
- *2nd Processor Compatible. (BBC Version).
- *Incorporates Custom gate array and Crystal controlled Data Slicer.
- *Free Power Supply included.



Simply write out your order and post to
VOLEX ELECTRONICS, STOWELL TECHNICAL PARK,
ECCLES NEW ROAD, SALFORD, M5 2XH. TEL: 061-736 5822.

I enclose cheque/PO, payable to VOLEX ELECTRONICS
OR charge my ACCESS/BARCLAYCARD/VISA number.

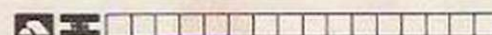

NAME _____
ADDRESS _____

- £99.99 (SPECTRUM) 16-48K
 £114.99 (BBC) Model B
 £125.00 (AMSTRAD) 464.664.6128

VOLEX ELECTRONICS
A DIVISION OF VOLEX GROUP p.l.c.

PROGRAM LISTINGS

H

```
5 L=828:N$=""
10 PRINT "{CLR}{RED}":POKE53280,7:POKE53281,
7
20 FORI=1TO8
30 PRINT "{HOME}{DOWN}{DOWN}{DOWN}{DOWN}{DOW
N}{DOWN}{DOWN}{DOWN}{DOWN}{DOWN}{DOWN}{RIGH
T}{RIGHT}{RIGHT}{RIGHT}{RIGHT}{RIGHT}{RIGHT
}{RIGHT}{RIGHT}{RIGHT}{RIGHT}{RIGHT}STOP TH
E TAPE":FORN=1TO200:NEXTN
50 PRINT "{HOME}{DOWN}{DOWN}{DOWN}{DOWN}{DOW
N}{DOWN}{DOWN}{DOWN}{DOWN}{DOWN}{DOWN}{RIGH
T}{RIGHT}{RIGHT}{RIGHT}{RIGHT}{RIGHT}{RIGHT
}{RIGHT}{RIGHT}{RIGHT}{RIGHT}{RIGHT}
":FORN=1TO200:NEXTN
60 NEXTI
70 PRINT "{CLR}"
80 PRINT "{DOWN}{DOWN}";TAB(10);"HEADER READ
ER"
90 PRINT "{DOWN}";TAB(15)"{BLK}BY"
100 PRINT "{DOWN}";TAB(8);" {BLU}STEPHEN ELME
R 1985"
110 PRINT "{DOWN}{DOWN}{DOWN}{PUR}INSERT TAP
E TO BE READ AND ":FORI=1TO300:NEXTI:OPEN 1
120 D=PEEK(L):SA=PEEK(L+1)+256*PEEK(L+2):EA
=PEEK(L+3)+256*PEEK(L+4)
130 FORI=L+5TOL+20:N$=N$+CHR$(PEEK(I)):NEXT
I
140 CLOSE1
145 IFN$=""THENN$="NO NAME FOUND"
150 IFD=1ANDSA=2049THENA$="BASIC":POKE53280
,12:POKE53281,12:GOTO200
160 POKE53280,1:POKE53281,1
170 A$="MACHINE CODE"
200 PRINT "{CLR}TYPE OF PROGRAM: ";A$
210 PRINT "{DOWN}{DOWN}{RED}FILE NAME: {BLK}
";N$
215 GOSUB400
220 PRINT "{DOWN}{DOWN}{RED}START ADDRESS: {B
LK} ";SA;"{RED} HEX{BLK} ";Q$
230 SA=EA:GOSUB400
240 PRINT "{DOWN}{DOWN}{RED}END ADDRESS : {B
LK} ";EA;"{RED} HEX{BLK} ";Q$
250 PRINT "{DOWN}{DOWN}{DOWN}{DOWN}{DOWN}{DO
WN}{DOWN}{DOWN}{DOWN}{DOWN} PRESS ANY K
EY TO CONTINUE."
260 GETA$:IFA$=""THEN260
270 POKE53280,7:POKE53281,7:PRINT "{RED}":N$
="":GOTO70
400 Q$="":Q=SA:FORI=1TO4
455 Q=Q/16:QQ(I)=INT((Q-INT(Q))*16)
460 NEXT:FORI=4TO1STEP-1
470 IFQQ(I)>9THENQ$=Q$+CHR$(QQ(I)+55):GOTO4
80
475 Q$=Q$+RIGHT$(STR$(QQ(I)),LEN(STR$(QQ(I)
))-1)
480 NEXT:RETURN
```

◆ Commodore 64 ● Stephen Elmer

This short utility program reads the headers of slow-loading cassette tapes. It can be very useful if you cannot remember the name of the type of program which you have saved on to a tape. *Header Reader* displays the name of the program, its type, and gives the addresses in decimal and hexadecimal.

Whoops!

The program *Egg Head*, printed in the last issue of *Your Computer*, contained a few errors. The following lines need to be changed to allow the program to work properly:

```
20 V=53248
30 POKEV+21,31
60 FORN=12288TO12350:
READQ:POKEN,Q:NEXT
70 FORM=12352TO12414:
READW:POKEM,W:
NEXT
80 FORZ=12416TO12478:
READE:POKEZ,E:NEXT
90 FORX=12480TO12542:
READR:POKEX,R:NEXT
```

Also, the lines beneath 120, 140 and 160 should be re-numbered 130, 150 and 170 respectively.

We called this magazine *Your Computer* precisely because we welcome your views, programs, hints and even your criticisms of machines and software in general.

Letters can be hand-written but if you want to submit a program, a listing would be of great assistance to us. Please indicate on what machine the program runs and enclose a loaded version on cassette or disc.

We regret that we are unable to return any submissions sent without stamped addressed envelopes.

MICRO MARKET

WDS Software

FOR THE SINCLAIR QL:

JOSS £15 on mdv or 5 1/4" flp, £17 on 3 1/2" flp
Forget syntax errors and mistyped names in file commands! Just move a cursor and press SPACE. Cursor keys or joystick allow access to up to 8 microdrives and all the discs your interface will handle, with up to 150 files on each. Scroll & print directories, COPY, DELETE or PRINT any file, select TV or Monitor mode before LOADING/RUNNING a program. Use keyboard only to set date or label a medium. Easy to use with Psion or other software. No silly icons to learn - JOSS will tell you what it's doing! Mass copying/printing utilities and programmer's toolkit. Specify disc size, tracks and interface (CST, Cumana, PCML, MicroPeripherals) or microdrive only.

RefQL7 £11 on 2 mdvs or 1 3/2" flp, £9 on 5 1/4" flp
For use with ARCHIVE 2, contains 1300 useful QL references and a search/print program. Find programs, articles and reviews buried in the magazines on your shelf! Cheap updates of earlier editions.

Mdv Extension Cable (8") £5.50
Add ZX Microdrives to your QL.
Joystick Adaptor £4.99

FOR THE QL, SPECTRUM (ALL), BBC & ELECTRON:

WD Morse Tutor £4 cass, £6 mdv or 5 1/4", £8 3 1/2"
Teach yourself to read Morse Code. From absolute beginning to 18 words/minute. Feedback on screen or printer. Random letters, numbers or mixed, 100 random sentences, many helpful features include phonetic speech via Currah Micro-Speech (Spectrum). Discs unsuitable for BBC B+.

FOR THE SINCLAIR SPECTRUM (48/128K):
Wordfinder 2 £8 on cassette
16,000 word vocabulary, 3 to 10 letters long.

Wordfinder 3
£10 on mdv or 5 1/4" disc, £12 on 3 1/2"
19,000 word vocabulary, 3 to 12 letters long. Solves anagrams and missing-letter words. Very fast machine code. Update Wordfinder 1 for £2.
Spectrum Disc Versions are Opus, TR (Beta) and SPD1.

We export hardware and third-party software. Ask for lists.

Payment: In advance, in STERLING on British bank branches, International Giro, Postal Order or ACCESS/MasterCard. Add £1 outside Europe for AIRMAIL.

WDS Software (YC), Hilltop, St Mary, Jersey, C.I. Tel: 0534 81392



◆ Commodore 64 ● Grant Robson

This program is of great use to all budding adventure programmers who use either Basic or machine code. It allows you to enter location descriptions which are then stored away from the Basic program space, allowing you to create bigger and better adventures.

When typing-in

descriptions, the computer creates spaces automatically after commas, semi-colons and colons and also produces capital letters after full stops. To start a word with a capital letter, use 'PS'. Locations are saved by pressing 'F7' and can be re-loaded using 'F5'. 'F8' allows you to see any location by entering its

number.

When you have all the locations you desire, simply break out of the program and type 'NEW'. Then, to see a location, type:
**POKE 254, [LOCATION]
SYS (49243)**
Up to 200 locations can be entered.

```

100 rem *****
110 rem ***   adventure   ***
120 rem ***   utility    ***
130 rem *** BY GRANT ROBSON ***
140 rem *****
150 t=49152:1=0:if Peek(49152)=162then190
160 read9:if9=-1then180
170 l=1+3-Poke(9):t=t+1:goto160
180 if1<38968thenPrint"error in data-check through lines":Print"730-980":end
190 dima$(255):Poke49700,0:Poke51600,0
200 a$(250)="":a$(251)="":a$(252)="":a$(253)="":a$(254)="":a$(255)="":
210 Poke53281,6:Poke53280,6:Printchr$(14)" ":x=1:it=1:r=49701:f=51601
220 Print"Location number "x:Print"Memory for sentences left":53248-f
230 Print"Memory for words left "":51599-r
240 Print"You are "":gosub490:b$=b$+" "":ifa$=":"then300
250 t=1
260 ift>len(b$)then290
270 ifmid$(b$,t,1)=" "thena$=left$(b$,t-1):b$=mid$(b$,t+1):t=1:gosub360:goto320
280 t=t+1:goto260
290 Pokef,0:f=f+1:Poke254,x:Print"YOU are "":sys49243:Print"|| "":x=x+1:goto220
300 Poke780,0:Poke781,1:Poke782,1:sys65466:Poker,0:Poker+1,0:Poker+2,0
302 Pokef,0:Pokef+1,0:Pokef+2,0
305 Poke251,0:Poke252,192:Poke781,0:Poke782,208:Poke780,251:sys65496
310 goto220
320 ifi=itthena$(i)=a$:it=it+1:gosub340
330 Pokef,i:f=f+1:goto280
340 for s=1 to len(a$):Pokes+r-1,asc(mid$(a$,s,1)):next s:r=r+len(a$):Poker,0
350 r=r+1:return
360 i=0
370 i=i+1:ifi=itthen400
380 ifa$=a$(i)thenreturn
390 goto370
400 ifa$(255)=a$theni=255:return
410 ifa$(254)=a$theni=254:return
420 ifa$(253)=a$theni=253:return
430 ifa$(252)=a$theni=252:return
440 ifa$(251)=a$theni=251:return
450 ifa$(250)=a$theni=250:return
460 return
470 end
480 b$=""
490 geta$:ifa$=""then490
495 ifa$=":"then672
497 ifa$=":"then1000
500 ifasc(a$)=13thenPrint:return
510 ifa$=":"thenPrint:return
520 ifasc(a$)=20then620
530 c=0:ifa$=","thenb$=b$+" , ":goto600
540 ifa$="."thenb$=b$+" . ":goto600
550 ifa$="-"thenb$=b$+" - ":goto600
560 ifa$=":"thenb$=b$+" : ":goto600
570 ifa$=";"thenb$=b$+" ; ":goto600
580 ifa$=":"thenb$=b$+" "":a$=":"goto600
590 iflen(b$)+len(a$)>255then490
595 b$=b$+a$
600 Printa$
610 goto490
620 a=len(b$):ifa=0then490
630 iflen(b$)>2then650
640 b$=left$(b$,a-1):Print"|| ||":goto490
650 a$=right$(b$,2):g=asc(a$):a$=chr$(g)
660 ifa$=","thena$=",":ora$=",":ora$=":":ora$=":"then680
670 goto640
672 Print:input"Which location "a:ifa=0ora>255then672
674 Poke254,sys49243:Print:Print"You are "":goto490
680 b$=left$(b$,len(b$)-3):Print"|| ||":goto490
730 data 162,0,72,169,194,133,252,169,96,133
740 data 251,160,0,177,251,240,9,230,251,208
750 data 2,230,252,76,13,192,104,133,253,72
760 data 232,228,253,144,238,104,230,251,208,2
770 data 230,252,160,0,177,251,240,9,200,208

```

SAVE £££ SAVE £££ SAVE £££ SAVE £££

"NEW RIBBONS FOR OLD"

Why pay £££s for a new fabric ribbon cassette when we can re-ink your old one at A THIRD OF THE PRICE?

Post cassette, stating printer make and model and enclosing one third of the price of a new one (minimum £1), to:

**ALADDINK, (Dept. YC),
4 Hurkur Crescent,
Eyemouth, Berwickshire,
TD14 5AP**

SAVE £££ SAVE £££ SAVE £££ SAVE £££

```

780 data 249, 152, 72, 56, 32, 240, 255, 104, 133, 253
790 data 152, 24, 101, 253, 201, 38, 144, 5, 169, 13
800 data 32, 210, 255, 160, 0, 177, 251, 240, 6, 32
810 data 232, 192, 200, 208, 246, 169, 32, 32, 210, 255
820 data 96, 162, 0, 169, 201, 133, 159, 169, 144, 133
830 data 158, 160, 0, 177, 158, 240, 6, 230, 158, 200
840 data 2, 230, 159, 200, 244, 232, 228, 254, 144, 243
850 data 230, 158, 208, 2, 230, 159, 160, 0, 177, 158
860 data 240, 99, 201, 255, 240, 37, 201, 254, 240, 33
870 data 201, 253, 240, 29, 201, 252, 240, 80, 201, 251
880 data 240, 21, 201, 250, 240, 17, 234, 234, 234, 234
890 data 234, 32, 0, 192, 230, 158, 200, 2, 230, 159
900 data 76, 126, 192, 72, 169, 157, 32, 210, 255, 104
910 data 201, 255, 240, 15, 201, 254, 240, 35, 201, 251
920 data 240, 15, 201, 250, 240, 19, 76, 164, 192, 169
930 data 44, 32, 210, 255, 76, 164, 192, 169, 58, 32
940 data 210, 255, 76, 164, 192, 169, 59, 32, 210, 255
950 data 76, 164, 192, 169, 46, 32, 210, 255, 76, 247
960 data 192, 96, 166, 2, 240, 7, 24, 105, 128, 162
970 data 0, 134, 2, 32, 210, 255, 96, 169, 1, 133
980 data 2, 76, 164, 192, -1
1000 Poke780,0:Poke781,1:Poke782,1:sys65466
1001 Poke780,0:sys65493
1002 t=49700:m=0
1004 k=peek(t):ifk=0thenm=m+1:t=t+1:goto1010
1006 a$(m)=a$(m)+chr$(k)
1008 t=t+1:goto1004
1010 ifpeek(t)=0orm>255then2000
1020 a$(m)="":goto1004
2000 r=t:it=m
2002 s=51600:m=0
2004 k=peek(s):ifk=0thenm=m+1:s=s+1:goto3000
2006 s=s+1:goto2004
3000 ifpeek(s)<0then2005
3002 f=s:x=m:goto220
    
```

ready.



◆ Spectrum ● Alan Crowe ●

Menu routines can be rather tedious to organise, with each item usually requiring a PRINT statement to put it on the screen. This short program overcomes this problem. It

can be placed at the start of a Basic program and only lines 80 to 97 need to be saved separately and merged into the program which is to be menu-driven.

In the printed version, the lines from 1100 onwards

illustrate how the routine can be used. Up to 10 items can be displayed on a particular menu; more items should be split into sub menus. Alterations are carried-out by adding or deleting the two DATA variables for each item.

```

1 REM Main Menu Items
2 DATA "Cartridge Catalog",200
3 DATA "SubMenu 1",10
4 DATA "SubMenu 2",20
8 DATA "Save ""run""",9999
9 DATA "CROWE",PI
10 REM SubMenu 1 Items
11 DATA "Routine 1",1100
12 DATA "Routine 2",1200
13 DATA "Routine 3",1300
19 DATA "CROWE",PI
20 REM SubMenu 2 Items
21 DATA "SubMenu 1",10
22 DATA "LOAD ""Prog 1""",2100
23 DATA "LOAD ""Prog 2""",2200
29 DATA "CROWE",PI
30 REM SubMenu 3 Items
39 DATA "CROWE",PI
80 LET HS="MAIN MENU": LET LN=1
81 REM PRINT OUT MENU
82 RESTORE LN: LET NI=0: CLS
83 PRINT AT 2,16-LEN HS/2; BRIGHT 1;HS; BRIGHT 0
84 READ I$: READ I: IF I=PI THEN GO TO 89
85 LET NI=NI+1
86 PRINT AT NI+4,7;".....";AT NI+4,6;I$:AT NI+4,26;CHR$(47+NI)
87 GO TO 84
89 IF LN<>1 THEN PRINT AT NI+5,6;"MAIN MENU..... "; INVERSE 1;"ENTER";
INVERSE 0
90 REM CHOOSE ITEM IN MENU
91 PAUSE 0: LET M=CODE INKEY$
92 IF LN<>1 AND M=13 THEN GO TO 80
93 IF M<48 OR M>47+NI THEN GO TO 91
94 RESTORE LN
95 FOR N=1 TO M-47: READ HS: READ LN: NEXT N
96 IF LN<80 THEN GO TO 81
97 GO TO LN
200 CAT 1: PRINT FLASH 1;"Hit a key"; FLASH 0: PAUSE 0: GO TO 1
1100 CLS: PRINT "A Basic Routine would start here";"Hit a key to get back to
MENU": PAUSE 0: GO TO 1
1200 CLS: PRINT "A Basic Routine would start here";"Hit a key to get back to
    
```

HUMAN INTERFACE MICRO COMPUTER SUPPORT



COMPLETE RANGE

from

SHAPWICK BLAISE Ltd.

FULLY ADJUSTABLE COMPUTER
and PRINTER STANDS from UNDER £100
LIGHTING AND COPYHOLDERS
DISC BOXES

Unit 46B, St. Michaels Trading Estate,
Bridport, Dorset DT6 3RR
Telephone: Bridport (0308) 23946

ALL IN STOCK S. P. ELECTRONICS BBC SPECIALISTS

Amstrad 6128 Green	£299.00	Colour	£399.00
Amstrad 8256			£458.00
CPA 80 Printer (inc. cable)			£199.00
Disc Operating System BBC			£96.00
Full Cumana range		From	£89.00
ACORN 1770 DFS			£49.95
G3 WHO RTTY PROGRAM (TAPE)			£7.50
G3 WHO RTTY PROGRAM (EPROM VERSION)			£20.00
Circuit board for RTTY decoder Mk 3 (inc. instructions)			£7.00
CANNON Dot Matrix 160cps NLO			£299.00
Joysticks (pair) self centering + analogue		From	£17.95
Printer Cable (Centronics)			£12.90
Speech Synthesis			£55.00
Disc Doctor			£33.00
WORDWISE Word Processor			£39.00
Cumana CD800S 40/80 psu			£250.00

FULL REPAIR SERVICE AVAILABLE
Wide selection of software, books, leads, plugs, etc.
SAE for full list. All available Mail Order
All prices apply while stocks last — carriage extra

48 Linby Road, Hucknall, Notts.

NG15 7TS

Tel: 0602 640377

All prices include VAT

COMPUTER REPAIRS

ALL MACHINES DESPATCHED
WITHIN 72 HOURS OF RECEIPT

For example:

Spectrum Plus	£17.00
16-48 RAM Upgrade	£25.00
ZX81	£12.50
Interface 1	£18.00
ZX Microdrive	£16.50
BBC B (not D.F.S.)	£25.00

(All prices include: parts, VAT, labour, return postage insured, and full warranty)

For a fast and reliable service send machine, brief description of fault and cheque or PO for relevant amount to the experts:

CAPITAL COMPUTER SERVICES

Dept P

Unit K2, Cardiff Workshops

Lewis Road, East Moors

Cardiff CF1 5EG

Tel: Cardiff (0222) 461801

We also service Acorn, Dragon, Commodore, Lynx and Oric systems.
Please telephone for a quote.

YOUR PERSONAL CENTRONICS PRINTER



- DRAFT MATRIX PRINT
- NEAR LETTER QUALITY
- SUBSCRIPT SUPERScript
- GRAPHICS
- OPTIONAL TRACTOR
- CONDENSE EMPHASIZE

● 96 CHAR + 48 EURO + 16 MATHS

128 Station Rd Glenfield
Leicester
LE3 8BR

TEL: (0533) 313531 **ROCK HALL**

COMPUTER REPAIRS

ALL MACHINES DESPATCHED
WITHIN 72 HOURS OF RECEIPT

For example:

Spectrum Plus	£17.00
16-48 RAM Upgrade	£25.00
ZX81	£12.50
Interface 1	£18.00
ZX Microdrive	£16.50
BBC B (not D.F.S.)	£25.00

(All prices include: parts, VAT, labour, return postage insured, and full warranty)

For a fast and reliable service send machine, brief description of fault and cheque or PO for relevant amount to the experts:

CAPITAL COMPUTER SERVICES

Dept P
Unit K2, Cardiff Workshops
Lewis Road, East Moors
Cardiff CF1 5EG
Tel: Cardiff (0222) 461801

We also service Acorn, Dragon, Commodore, Lynx and Oric systems.
Please telephone for a quote.

SCREENMASTER is a family of advanced graphics programs that give full access to the code, so you can adapt them for your own special needs. Use them individually or together (eg on disc).

SM1 - Powerful character generator. Create single character. Create single character blocks, 2x2 character blocks (sprites) and 8x8 blocks (pictels). Novel scrolling window design grid. Cartoon animate sprites. Paint coloured pictels. Pick up blocks from a screen file.

SM2 - Creative art & drawing. Rubber-banded line, circle, ellipse, polygon & arc drawing. Freehand draw & erase. User defined brushes & fill patterns. Multi-size text. Character, sprite & pictel handling. Alter, move, copy & paint areas of screen. Kill incorrect commands.

SM3 - Advanced graphics compiler. Store pictures in highly compressed form. Run-time routines to reconstruct pictures can be included in user programs. Edit & redraw at any time (we find this incredibly useful). Rubber-banded drawing as in SM2. Create macro commands.

Spectrum (48K & Plus) tape £4.50 each. SPECIAL OFFER 2 for £7.95 or 3 for £9.95.

DOCUMENTATION PACKAGES - detailed info including expanded, commented listing. £1.95 per program.

CAR CURE - EXPERT SOFTWARE to help diagnose faults on your car. Covers 300 symptoms & 900 faults.

Spectrum (48K --- +) and Amstrad CPC464 tape £9.95. BBC disc £11.95. Amstrad 464/664/6128 disc £13.95.

Please send S.A.E. for information pack.
Add £1.50 for airmail outside Europe.

SIMTRON
PROGRAMS TO HELP YOU

4 CLARENCE DRIVE, EAST GRINSTEAD WEST SUSSEX RH19 4RZ
Tel: 0342 28188

Continued from page 71

```

ENU": PAUSE 0: GO TO 1
1300 CLS : PRINT "A Basic Routine would start here"; "Hit a key to get back to M
ENU": PAUSE 0: GO TO 1
2100 CLS : PRINT "Routine to LOAD another program starts here"; "Hit a key to go
to MAIN MENU": PAUSE 0: GO TO 1
2200 CLS : PRINT "Routine to LOAD another program starts here"; "Hit a key to go
to MAIN MENU": PAUSE 0: GO TO 1
9998 STOP
9999 ERASE "M";1;"run": SAVE "M";1;"run" LINE 1: CAT 1: PRINT FLASH 1;"Hit a k
ey": FLASH 0: PAUSE 0: GO TO 1
    
```



◆ Amstrad ● Paul Park

This short program allows the user to create graphics characters. A grid is displayed

on the screen and you then have the option either to deposit a block or leave a space as you move round and build your character. When

you have finished, the data items for the character are displayed.

```

10 GOSUB 630
20 GOSUB 510
30 DIM A(20)
40 MODE 0
50 LOCATE 1,1:PRINT"GRAPHICS DESIGNER BY ";
:PEN 3:PRINT"
   PAUL PARK"
60 PEN 1
70 FOR T=8 TO 15:FOR X=6 TO 13:LOCATE X,T:P
RINT".":NEXT:NEXT
80 LOCATE 6,7:PRINT N1$
90 LOCATE 7,7:PEN 2:PRINT N2$
95 PEN 1
100 LOCATE 1,22:PRINT"[X]-ERASE MISTAKE"
110 PRINT"[C]-LEAVE SPACE"
120 PRINT"[SPACE]--LAY BLOCK"
130 PEN 1
140 SYMBOL AFTER 33
150 SYMBOL 42,255,255,255,255,255,255,2
55
160 ON ERROR GOTO 370
170 GOSUB 420
180 FOR T=8 TO 15
190 FOR X=6 TO 13
200 LOCATE X,T
210 IF COPYCHR$(#0)="*" THEN 270
220 NEXT X
230 LOCATE 15,T:PRINT V
240 A(T)=V
250 V=0
260 NEXT T
270 IF X=6 THEN V=V+128
280 IF X=7 THEN V=V+64
290 IF X=8 THEN V=V+32
300 IF X=9 THEN V=V+16
310 IF X=10 THEN V=V+8
320 IF X=11 THEN V=V+4
330 IF X=12 THEN V=V+2
340 IF X=13 THEN V=V+1
350 GOTO 220
360 LOCATE 1,15
370 REM
380 SYMBOL 35,A(8),A(9),A(10),A(11),A(12),A
(13),A(14),A(15)
390 LOCATE 1,17:PEN 2:PRINT"CHARACTER CREAT
    
```

PROGRAM LISTINGS

```

ED:":PEN 1:PRINT CHR$(35)
395 LOCATE 1,25:PRINT"[S]-RESTART"
400 R$=INKEY$:IF R$="" THEN 400
410 IF R$="S" THEN SYMBOL AFTER 232:RUN ELSE
E 400
420 X=6:Y=8
430 LOCATE X,Y:PRINT"*"
440 R$=INKEY$:IF R$="" THEN 440
450 IF R$=" " THEN LOCATE X,Y:PRINT"*":X=X+
1:IF X=14 THEN X=6:Y=Y+1
460 IF Y=16 THEN RETURN
470 IF R$="C" THEN X=X+1:IF X=14 THEN LOCAT
E 13,Y:PRINT".":X=6:Y=Y+1 ELSE LOCATE X-1,Y
:PRINT".":GOTO 490
480 IF R$="X" THEN X=X-1:IF X=5 THEN X=13:Y
=Y-1:LOCATE 13,Y+1:PRINT".":LOCATE 6,Y+1:PR
INT".":LOCATE X,Y:PRINT"+" ELSE LOCATE X+1,
Y:PRINT".":LOCATE X,Y:PRINT"+"
490 LOCATE X,Y:PRINT"+"
500 GOTO 440
510 SYMBOL AFTER 35
520 SYMBOL 36,183,149,149,183,165,165,183,0
530 SYMBOL 37,117,69,69,119,81,81,113,0
540 SYMBOL 38,119,17,17,119,20,20,119,0
550 SYMBOL 39,92,80,80,92,84,84,92,0
560 SYMBOL 40,56,40,40,56,40,40,56,0
570 SYMBOL 41,40,40,40,56,8,8,8,0
580 SYMBOL 42,56,8,8,56,32,32,56,0
590 SYMBOL 43,16,16,16,16,16,16,16,0
600 N1$="$ & (" *"
610 N2$="% ' ) +"
620 RETURN
630 MODE 1
640 PRINT" GRAPHICS DESIGNER"
650 PRINT
660 PRINT"THIS PROGRAM IS FOR THE PROGRAMME
R WHO DOES NOT WANT TO WASTE MUCH TIME WHE
N PLANNING CHARACTERS SO THIS PROGRAM
ENABLES YOU TO DESIGN A CHARACTER. IF YOU MA
KE A MISTAKE THEN IT IS POSSIBLE TO ERASE
THAT MISTAKE WITHOUT RE-STARTING."
665 PRINT"AFTER YOU HAVE FINISHED YOUR CHAR
ACTER THEN HOLD DOWN [C]."
670 PRINT
680 PRINT"THE KEYS YOU USE ARE....."
690 PRINT
700 PRINT"LAY DOWN A BLOCK.....[SPACE]"
710 PRINT
720 PRINT"ERASE PREVIOUS BLOCK...X"
730 PRINT
740 PRINT"LEAVE A SPACE.....C"
750 PRINT
760 PRINT"AFTER YOU HAVE FINISHED THE CHARA
CTER THE DATA WILL BE PRINTED OUT. YOU CAN
THEN PRESS [S] TO DESIGN A NEW CHARACTER"
770 PEN 3
780 PRINT" WHEN READY PRESS A KEY"
790 R$=INKEY$:IF R$="" THEN 790
800 RETURN
    
```

DUST COVERS

AMSTRAD PCW 8256 £11.95

Light grey 3 piece set, monitor and printer piped in green, name on keyboard.

AMSTRAD CPC 6128/464/664 £6.95

Matching proofed nylon, treated with anti-static inhibitor. Red Piping on monitor cover. AMSTRAD CPC on keyboard cover. Please state model, Colour or Mono.

Tatung Einstein £7.50

One piece cover for monitor and keyboard in proofed light grey nylon. Piped in red with name on keyboard.

BBC MASTER £5.95

Made from beige proofed nylon, piped in brown, with BBC MASTER hot-foil printed on keyboard.

Matching covers for Printers

DMP2000 Amstrad, Brother HR5, M1009, Canon PW 1080A, Epson FX 80, RX 80, LX 80, Mannesmann MT-80, Shinwa CP 80, CPA-80, Taxan KP810, Tatung TP100, All £4.50. Brother HR15, Juki 6100 at £5.50. Large range of other covers also available on request.

Dept YC

BBD COMPUTER DUST COVERS

THE STANDISH CENTRE, CROSS STREET,

STANDISH, WIGAN WN 9RP

Telephone: 0257 422968



**COMPUTER
REPAIRS
BY THE
SPECIALIST**



Walkers will repair your computer at a realistic price. You send a cheque not to exceed £40.00 your computer will be repaired and returned the same day or send for a free quotation. Most repairs will be in the range £15.00-£40.00 subject to machine.

For information Telephone - 021 622 4475

or simply send your computer together with the coupon below

Thomas Walker & Son Ltd, 37-41 BISSELL STREET
BIRMINGHAM B5 7HR

PLEASE TICK

Cheque Enclosed Free Quote Access Card

Name

Address

Access No: □□□□□□□□□□□□□□□□

Telephone No:

WDSOFTWARE

FOR THE SINCLAIR QL

JOSS £15 on mdv or 5 1/4" flo, £17 on 3 1/2" flo
Forget syntax errors and mistyped names in file commands! Just move a cursor and press SPACE. Cursor keys or joystick allow access to up to 8 microdrives and all the disk's interface will handle, with up to 150 files on each. Scroll & print directories, COPY, DELETE or PRINT any file, select TV or Monitor mode before loading/printing a program. Use keyboard only to set date or label a medium. Easy to use with Picon or other software. No silly icons to learn - JOSS will tell you what it's doing! Mass copying/printing utilities and programmer's toolkit. Specify disc size, tracks and interface (DS1, Cumana, PCML, MicroPeripherals or microdrive only).

ReQL7 £11 on 2 mdvs or 1 3/4" flo, £9 on 5 1/4" flo
For use with ARCHIVE 2, contains 1300 useful QL references and a patch/print program. Find programs, articles and reviews buried in the magazines on your shelf! Cheap updates of earlier editions.
Mdx Extension Cable (8") £5.50
Add ZX Microdrives to your QL.
Joystick Adapter £4.99

FOR THE QL, SPECTRUM (ALL), BBC & ELECTRON:
WD Morse Tutor £4 cass, £6 mdv or 5 1/4", £8 3/4"
Teach yourself to read Morse Code. From absolute beginning to 18 words/minute. Feedback on screen or printer. Random letters, numbers or mixed, 100 random sentences, many helpful features include phonetic speech via Carfax Micro-Speech (Spectrum). Discs unsuitable for BBC B+.

FOR THE SINCLAIR SPECTRUM 148/128K:
Wordfinder 2 £8 on cassette
16,000 word vocabulary, 3 to 10 letters long.
Wordfinder 3 £10 on mdv or 5 1/4" disc, £12 on 3 1/2"
19,000 word vocabulary, 3 to 12 letters long. Solves anagrams and missing letter words. Very fast machine code. Update Wordfinder 1 for £2.
Spectrum Disc Versions are Dops, TR (beta) and SPD1.

We export hardware and third-party software. Ask for lists.

Payment: In advance, in STERLING on British bank branches, International Giro, Postal Order or ACCESS/MasterCard. Add £1 outside Europe for AIRMAIL.

WDSOFTWARE (YC), Hilltop, St Mary,
Jersey, C.I. Tel: 0534 81392

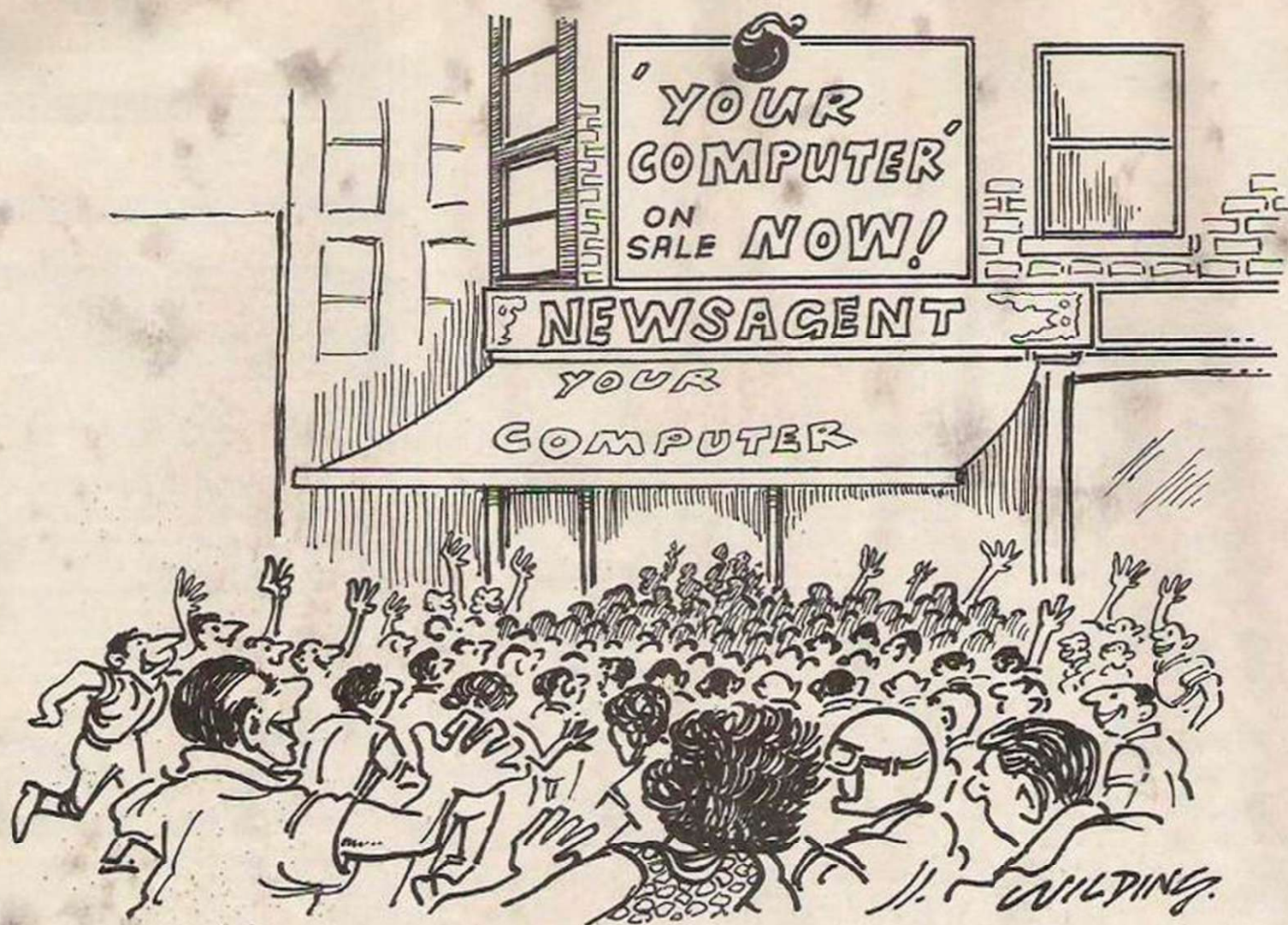

Stay ahead of the crowd subscribe to *Your Computer*

While the scenes at your local newsagent are unlikely to be so frantic as those depicted in our cartoon, it is a fact that copies of the latest issue of *Your Computer* disappear fast from the shelves. If you cannot go to the shops on our publication date, you could miss the mixture of news and practical features which make *Your Computer* one of the most popular home computer magazines.

The only way to avoid possible disappointment is to take a subscription to the magazine. In that way a copy will drop on to your doormat each and every month. Copies are sent direct by our printer

so by subscribing you should receive the magazine even before it reaches newsagents.

A subscription also makes an ideal present for a friend or relative. If you know someone who takes computing seriously, why not make them a present of a subscription?

To subscribe to *Your Computer*, complete the form and send it, together with cheque or postal order for £14, to the address shown. Do not delay. Send your order now and relax in the knowledge that you will never again miss a copy of *Your Computer*.

Your Computer
(Subscriptions)
Oakfield House,
Perrymount Road,
Haywards Heath,
RH16 3DH

Name _____

Address _____

Postcode _____

WIN A VIDEO DIGITISER PLUS 24 RUNNERS-UP PRIZES OF NEXUS

PRESENTED IN CONJUNCTION WITH NEXUS

Nexus, the game, makes novel use of digitised images which enable players to recognise the various characters featured in the game. Now *Your Computer*, in conjunction with Nexus, the company, is offering a video digitiser as first prize in this month's free-to-enter competition. The video box will allow video images to be captured and manipulated by computer, perhaps as part of a game as in Nexus.

In addition, 24 runners-up prizes of copies of the game – in Spectrum, Amstrad or Commodore 64 format – are on offer.

HOW TO ENTER

Nexus is set inside the HQ of an evil drugs ring. The player takes the part of an investigative journalist. His objective is to survive long enough to gather the elements of a scoop story which will expose the drugs barons.

During the mission our intrepid hero stumbles on the computer printout shown. It contains a jumble of letters which the journalist believes has useful clues which will aid him in his mission. Your mission, should you decide to accept it, is to locate and circle the words which make up a sentence relevant to the game. Good luck.



This is where you will find your hidden words. You can move forward, backwards, horizontally, vertically or diagonally, as long as it is in a straight line and all the letters are in adjoining boxes.

The hidden sentence is: "Transmit story from transmission room."

COMPETITION RULES

- * The three first prizes and 25 runners-up prizes will be awarded to the people who send an all-correct entry with, in the opinion of the judges, the most appropriate tie-break sentence before the closing date of the competition.
- * The names of the winners will be announced in the August issue of *Your Computer*.
- * All entries must arrive at the *Your Computer* offices by the last working day of June, 1986.
- * Each person may enter the competition only once.
- * Entries to the competition cannot be acknowledged.
- * No employees of Focus Investments nor their agents or close relatives may enter the competition.
- * The decision of the Editor in all respects of the competition will be final.
- * No correspondence with regard to any aspect of the competition will be entered into.
- * Focus Investments assumes no responsibility or liability for any complaints arising from this competition.

J	V	A	L	S	T	O	C	T	M	E	V	A	K
I	F	B	E	M	L	Q	D	A	P	W	L	H	I
N	Y	R	Y	A	C	O	T	X	B	K	E	T	R
C	Y	Z	O	X	E	F	R	W	B	R	J	W	Z
I	O	D	E	M	Y	F	A	P	D	U	A	H	V
J	Q	Z	J	C	K	X	N	U	H	D	G	F	I
F	R	O	M	K	V	B	S	V	R	H	S	H	G
C	X	O	K	C	U	D	M	Z	S	T	O	R	Y
N	O	T	W	F	G	L	I	M	O	N	V	H	U
R	P	E	M	T	F	B	S	J	T	O	P	G	L
F	N	S	T	R	A	N	S	M	I	T	I	R	A
B	Q	P	K	Q	M	F	I	M	J	R	U	M	E
X	L	Y	O	N	C	V	O	S	N	A	T	W	R
Q	A	O	L	K	Z	S	N	D	T	G	S	G	J

NEXUS COMPETITION

Name _____

Address _____

Should you win one of the runners-up prizes, please state which version of the game you would require _____

Do not forget to enclose coupon, or a photocopy of it, when you send your entry, marked Nexus Competition, to the *Your Computer* editorial offices at 79-80 Petty France, London SW1H 9ED

Write your own adventures

Listing 1.

```
10REM Adventure Shell No 2

251DIM OBJ$(5),OBJ(5),OBJDE$(5)
252FOR N=1 TO 5
253READ OBJ$(N),OBJ(N),OBJDE$(N)
254NEXT
255F2%=5:L%=0

285F2%=F2%-1:IF F2%<0 AND L%=0 THEN PRINT"It is too dark to
see":GOTO 300

294F1%=0
295PRINT"You can see "':FOR N=1 TO 5:IF OBJ(N)=LOC THEN PRINT
OBJDE$(N):" "':F1%=1
296NEXT
297IF F1%=0 PRINT"nothing else"

330GOTO 285

370A=0:A$=A$+" "
375S=INSTR(A$," "):O$=MID$(A$,S+1,LEN(A$)-(S+1)):A$=LEFT$(
A$,S-1)

435IF A>18 THEN GOSUB 1000:RETURN
440GOSUB800:RETURN

570DATA ON,OFF

740DATA BOTTLE,1,a mysterious green bottle
750DATA LAMP,1,an old rusty lamp
760DATA DOG,3,a small corgie
770DATA MAP,5,an ancient map
780DATA TREASURE,6,a mountain of valuable treasures
790:
800REM Verb Sorter
805O=0
810FOR N=1 TO 5
820IF O$=OBJ$(N) THEN O=N
830NEXT
840IF O=0 THEN PRINT"Sorry, I don't understand":RETURN
850IF A=13 GOSUB 900:RETURN:REM Take
860IF A=17 GOSUB 930:RETURN:REM Drop
870PRINT"You can't do that yet":RETURN

900IF OBJ(O)=LOC THEN OBJ(O)=(0):PRINT"You take the
":OBJ$(O):RETURN
910PRINT"I don't see a ":OBJ$(O):" here.":RETURN
930IF OBJ(O)=0 THEN OBJ(O)=LOC:PRINT"You drop the
":OBJ$(O):RETURN
940PRINT"You don't have a ":OBJ$(O):RETURN

1000IF OBJ(2) <>0 THEN PRINT"You can't do that":RETURN
1010IF A=19 THEN PRINT"The lamp is on":L%=1
1020IF A=20 THEN PRINT"The lamp is off":L%=0
1030RETURN
```

A somewhat limited program accompanied the first in the series of articles outlining the basic principles and structure of an adventure game.

If you do not wish to type-in the program listings for this month they will be available in the Download Section of NBBS Clyde on 041 880 7863 (300 baud). When you are logging on, please include "YC" in your City i.e., "LONDON YC" so that the SYSOP will know who you are.

We will add some useful verbs to the command analyser and add a few objects.

Objects: The program has to know where each object starts, where it is at present, if it is visible and if it is carried. Also a description of each object is preferable. Compare "You have a bottle" to "You have a dark green bottle, half-filled with a mysterious glowing orange liquid." It is obvious which description gives feeling and atmosphere, the things which make a good adventure game.

Command analyser

The other problem we have to solve is that at the moment our command analyser understands only one-word input. To separate the input sentence we need first to find the space between the two words and then to separate the input string into two pieces. Unfortunately different computers all use different methods for handling strings.

Light: No good adventure would be complete without a rusty lamp or a candle. Darkness helps the mood and is yet another problem with which the adventurer can struggle.

Load the previous program and add, or change, the lines in listing one for your computer to the first program. Line 375

The secret to creating your own adventures is a shell program. David Williams explains.

will cause a few problems for some computers. If your computer does not understand this line - BBC and Amstrad readers will have no difficulty - call the Adventure Helpline. If any reader could tell me how it was done on his machine, a telephone call to me would be appreciated.

As the programs become more complicated so, too, will the problem of maintaining compatibility with a wide range of micros. I shall include program notes from now so that if there are any difficulties, or you wish to add new features, changing them for your computer will be made a little more simple.

Waving the flag

You may have noticed the word 'flag' and think that a flag is something which flies on the mast of a ship but these are a little different. Your computer

uses flags all the time. Is the printer on? What mode are we in? and so on. Those I am using are the program's way of keeping track of what is happening. You could also refer to them as status registers. Their uses are:

L% will be 0 if the lamp is off and 1 if the lamp is on.

This is a flag in its simplest form.

F1% is the same type, set to 0 at the start, but becomes 1 if there is an object at your current location.

F2% is a little more complicated. It starts with a value of 5 and at line 285 it is decremented by 1 each time.

Line 285 could be translated to read IF it is dark (F2%<0) AND the lamp is off (L%=0) THEN PRINT "It is too ..."

Professional look

In the next article I will be showing how to develop a routine to print text without splitting words, which will have its uses in many other kinds of programs you may choose to write, as well as giving your adventure game a much more professional look.

We will also add some more verbs and introduce a few problems for the player to cope with and give them a purpose for starting on their quest.

For assistance.

You are in a clearing in the middle of a large forest.
You can see a mysterious green bottle and an old rusty lamp. What now?
?TAKE LAMP
You take the LAMP
You are in a clearing in the middle of a large forest.
You can see a mysterious green bottle.
What now?
?UP
You go UP
You are on top of a small hill south of a castle.
You can see nothing else.
What now?
?NORTH
You go NORTH
You are standing at the imposing gates of a castle.
You can see nothing else.
What now?
?QUIT
>

How listing 1 works.

Line 10 is a simple change
Line 330 is a simple change
Lines 251 to 254 set up the object arrays
Lines 294 to 297 handle the printing of visible objects
Line 375 splits the Input String into two pieces
Lines 740 to 780, the object data statements
Lines 800 to 870 check the VERB/NOUN statements
Lines 900 to 940 handle TAKE and DROP
Line 255 adds a 'flag' for daylight and a 'flag' for the lamp
Line 285 checks the 'flags' to see if you can see
Line 294 adds a 'flag' for objects
Lines 1000 to 1030 handle the light/lamp

ADVENTURE HELPLINE

The Helpline is at present running only on Sundays from 2 p.m. to midnight on 041 770 9599. Do not despair if the number is always engaged. I am answering the problems as fast as I can and I will extend the hours again as soon as circumstances permit.

The Graphics Adventure Creator from Incentive is now available for the BBC, Spectrum and Commodore and looks the most promising Adventure writer yet.

These were the most-asked questions on the Helpline last month.

BORED OF THE RINGS

The pepper can be found at the top of the mountain.

To get the rope, say HOG.

CASTLE BLACKSTAR

To raise the portcullis, turn the wheel in the equipment room.

The sticks are dynamite.

CLASSIC ADVENTURE

CIRCUS

Dig in the field with the shovel.

ESCAPE FROM PULSAR7

Examine the couch carefully.

ENCHANTER

For the sacrifice look for the OZMOO spell in the gallery.

EUREKA

Stuck in the curser? Wait until the third move then USE PUMP E.E.U.W.JUMP.

EYE OF BAIN

Drop the post before examining the altar.

FUNHOUSE

Music will help someone sleep.

THE HELM

The key is to sieve the flour.

HITCHHIKERS

The vending machine can be adjusted to give real tea.

MORDEN'S QUEST

To find the king of the jungle, examine the map. Keep the octopus in the dark.

Underwater, take the pearl on the return journey if you are running out of air. Create a smoke screen to win in combat.

QUEST

The NIC knight kneeds(?) pink shubbery

ROBIN OF SHERWOOD

Hang around the bushes to find an accomplice.

SPIDERMAN

You will need a hand to defeat Electro.

SUBSUNK

To get the key, jump on the mattress.

TEMPLE OF VRAN

You can swing across the quicksand.

WORM IN PARADISE

Try saying ON in the home locations.

If you are confused, call Helpline.

Your COMPUTER CLASSIFIED

01- 222 9090

Contact: Paul Monaf

COPY DATES: AUGUST ISSUE: July 1st; SEPTEMBER ISSUE: July 31st

ADVERTISEMENTS RATES QUOTED BELOW ARE SUBJECT TO THE ADDITION OF 15% VAT.

Lineage: 60p per word
(Min 20 words)

Box No: £7.00 extra

Lineage advertisements are prepayable and the order form published in this section should be completed and returned with remittance.

Display — rates per scc (Min. 2scc)

One insertion £10.00

Three insertions £9.70

Six insertions £9.50

Twelve insertions £9.00

Display advertisers should preferably reserve space by phone.

Post to:

Your Computer,
Classified Department,
79-80 Petty France,
London SW1 9ED.

Britain's Biggest Selling Home Computer Magazine

COMPUTER BROKEN

Have it repaired and working again in no time. All machines repaired and guaranteed by our fully skilled staff.

Sinclair repairs at fixed prices e.g.

SPECTRUM/PLUS £17.00

Other makes — BBC/ELECTRON, COMMODORES, AMSTRADS and DRAGONS.

All at very competitive prices.

So send or bring your computer for free no obligation estimate.

MICRO:MEND

The Old School, Main Street, FARCET, Peterborough PE7 3DB.

Telephone: (0733) 241718

NEW TAPE and DRIVE SPECTRUM and AMSTRAD UTILITIES

Yes LERM, famous for our SPECTRUM programs, now has vital utilities for AMSTRAD owners. We also offer on ALL our products:

- ★ A FULL MONEY BACK GUARANTEE
- ★ FULL MANUALS
- ★ AN UPDATE SERVICE to get the latest version at a reduced price.

★ ★ S P E C T R U M ★ ★

TUB — ALL SPECTRUM OWNERS NEED this specialist tape utility.

Send SAE for FULL DETAILS of this AMAZING program for Tape back-up and drive transfer.

- ★ Simple operation. Manages the seemingly impossible including fast/clicky/none standard tone leaders etc.
- ★ Manages 100% accurately MOST 48K plus programs.
- ★ Includes TONE and Baud rate (speed) measurer.
- ★ Clicky/Jerky leaders can be converted COMPLETELY to normal.
- ★ Handles Headerless parts etc. etc.

TUB ON TAPE £6.99 (or £7.99 on m/drive cartridge)

TAPE to DRIVE transfer for SPECTRUM OWNERS

Transfer Pack 2 — A sophisticated package of programs INCLUDING TUB, other utilities, allows drive transfer of many programs.

- ★ includes header reader, bytes chopper, bytes mover.
- ★ Extra utilities (REM kill, VAL creator, RUN program for m/drive owners).
- ★ 5 information sheets giving details on drive transfer 40 popular programs.
- ★ Manages virtually all jerky/clicky leaders to drive.
- ★ Full manual, sample transfers, technical information.

GIVE NAME of your drive system (eg m/drive, Wafa, Opus)

ONLY £11.99 (£12.99 on m/drive cartridge)

Information sheets — up to no. 12 available — £1 each includes MANY top 20 hits!

MICROTRANS — 2 programs for m/drive owners. FAST and EASY DRIVE to DRIVE and TAPE to DRIVE (does NOT convert programs!) Plus multiple erase program (inc true CAT, printer output) etc. etc.

ONLY £4.99 on tape, £5.99 on cartridge — AMAZING!

THE PRICES QUOTED ARE ALL INCLUSIVE EXCEPT overseas: add £1 within Europe, £1.50 others. SAE for more information

LERM, DEPT YC, 10 BRUNSWICK GDNS, CORBY, NORTHANTS NN18 9ER

★ ★ A M S T R A D ★ ★

TAPESPEED TWO (TS2) — ESSENTIAL FOR ALL AMSTRAD OWNERS

Convert your slow loading software from 1000 to a max of 3600 baud. Stop and study programs.

- ★ AMAZING — now manages MOST of the clicky leaders — some will now run on the 064/6128 for 1st time!
- ★ Fully automatic. It loads in continuously up to 44K.
- ★ Save at range of 9 speeds.
- ★ Permanent display of HEADER plus STATUS information.
- ★ Motor on/off. Insert PAUSE. Removes protection.
- ★ Handles HEADERLESS files, and PULSED/clicky leaders.
- ★ Handles AMSTRAD programs with Spectrum loaders. Speed (Baud rate) detector.
- ★ VERY SIMPLE TO USE — FULL MANUAL

PRICE ONLY £6.99 — state 464, 664, or 6128

DISC MANAGER ONE. — for ANY AMSTRAD

Essential to help you manage your AMSTRAD drive. No risk — try it and see how useful it can be.

- ★ Does a CAT which can then be used to do repeat ERASURES very easily. Gives disc type. Memory free/used.
- ★ 2 Disc editors — edit or study sectors of a disc.
- ★ Recover ERASED files.
- ★ Simple and fast whole disc or sector BACKUP copier.
- ★ Send outputs to printer (CAT, sector contents, etc)
- ★ Unsecured for easy adaption/drive transfer.
- ★ Menu driven — FULL manual.

PRICE only £5.99 — amazing!

THE BEST SPECTRUM UTILITIES

NEW! SUPERUTILITY SU+ NEW!

This ADVANCED tape utility has the following features:

- Deals with the MAJORITY of 'ordinary' programs.
- Deals with High Baud Rate programs — converts them to normal speed ready for transfer to microdrive.
- Deals with single or multiple part programs all in one run.
- Deals with normal and/or headerless files.
- Contains INTEGRAL HEADER READER.
- Deals with VERY LONG files (up to 64000 bytes!)

UNBEATABLE VALUE AT ONLY £8.95 (inc. P&P)

IF YOU ARE REALLY SERIOUS ABOUT TAPE TO MICRODRIVE TRANSFER — THIS IS THE UTILITY YOU MUST HAVE! SUPERB VALUE AT ONLY: £5.95 (inc. P&P).

NEW SUPER INTERFACE FL1

Convert your programs to FAST LOADERS quickly and automatically. £29.95 + £1.50 P&P

NEW SUPER INTERFACE MD1

TRANSFER your programs to microdrive quickly and automatically. £29.95 + £1.50 P&P Send cheque/P.O. to: "KOBRAHSOFT", "Pleasant View", Hulme Lane, Hulme, Nr. Longton, Stoke-on-Trent, Staffs. ST3 5BH. (Overseas: Europe add £1 P&P PER ITEM, others £2).

Send S.A.E. for full catalogue of all our Spectrum Utilities.

NEW! SD2 ADVANCED TAPE TO M/D UTILITY NEW!

Now you can transfer virtually ANY of your programs to microdrive, with this advanced but user friendly utility. It features:

- Uses the semi-automatic method for best results.
- A large collection of superb programs to help you.
- Many hints and tips and information on transfer techniques.
- FULL Technical Section to help you understand more clearly the best way to approach each transfer.
- LARGE number of examples of programs being transferred to microdrive — all fully explained.
- FREE Header Reader and Headerless Block Length Reader.
- FULLY documented, user friendly instructions.

PROFESSIONAL REPAIRS

Home Micro Service Centre

Amstrads	£34.95
BBC (up to £5 parts)	£34.95
Commodore	£34.95
Electron	£24.95
Sinclair QL	£45.95
16K to 48K Upgrade	£26.95
ZX Spectrum	£19.95

Ring 0234-213 032

★ Av 3-4 day turnaround

★ 6 month warranty

★ Free telephone diagnostic service

ZEDEM COMPUTERS LTD

2 Kimbolton Road
Bedford MK40 2NR
(Trade and overseas enquiries welcome)

SPECTRUM CODE CRACKER

ASSEMBLER, DIS-ASSEMBLER, TESTER

DE-BUGGER, ON-LINE LEARNING AID and

TEACH YOURSELF MACHINE CODE BOOKLET

"A different approach giving a highly usable package ... most impressive test/debug features ... invaluable guide to QTY" *PC Today* July 85

Introduced 1984; customers in 12 countries

Write new programs. De-bug code that will not work. Single step/trace/display any code. Use direct input/dynamic displays to learn/teach. Tape only £7.95, Microdrive £9.75

ROYBOT YCS, 45 HULLBRIDGE ROAD

RAYLEIGH, ESSEX SS6 9NL

Write or tel: 0268 771663 for leaflets.

SPECTRUM MICRODRIVE RANDOM FILES

OPEN files for reading and overwriting. MOVE file pointer directly to any position. SPEED operation with memory buffering and prefetching. Files can be LEMed, UPDated and SPOLed. SPECTRUM programs can be sent over the NET for IMMEDIATE loading by a Q1!

£14.95 including instruction manual and P&P from: R.J. Osborough, Windwhistle, Uxott, Oatley, Winkfield, Devon, EX14 8PG

ORIG 1 & ORIG ATMOS SOFTWARE

OVER 100 TITLES AVAILABLE

ALL AT DISCOUNT PRICES, e.g. AIR ATTACK compatible £4.95, Arena 3000, Kibum Encounter, Skramble, Snow Jumping, Wayfar, Pilare Dash, Hangman etc. £5.50, Cabbage, Riggle Commander, Super Fruit, £5.95, Chess, E. Dagger, Defence Force, Dribbles Revenge, Dribbles, Guardians, Hammer Attack, Helion, Land of Illusion, Ice Giant, Warlord, Mr Wimpy, Mushroom Maria, Patsy's, Park, Flat Sled, Scuba Dive, Spooky Mansion, Special Ops, Trouble in Stone, Ultima Zone, Johnny Reb, Paras, £5.50 Attack Cybernet, Backgammon, Chopper, Draughts, Ghost Gobbler, Invaders, Probe 3, Triclist, Zebbie, Gubbis, Playground 21, £5.95 Category, Classic Racing, Maniac Miner, Space Shuttle, 4 Games Children, £7.50 Don Juan, Trans At 1, Atmos Extended Basic, Zenon II, £7.95 View to a Kill, £11.50 Author, Account Book, Orig Calc, Orig Mon, Orig FORTH, Orig Base, Orig Assembler, Orig Spreadsheet, £14.95 The Quest Adventure Writing System.

Dust Cover £2.95, On Off Reset Switch £4.50, Disc Drive £17.95 (Disc Software Please Call) CHFD's To: O. J. SOFTWARE Prices incl U.K. P&P 273 Mossy Lea Rd., Wighton, Wigan, Lancs, WNE 8RN Tel: (0257) 42915

Overseas Please Add 50p, Europe £1. Others per item Write or Phone for FREE List 704

LONDON COMPUTER REPAIR CENTRE

★ Spectrum, Commodore, BBC, Atari, Amstrad etc.

★ Low cost repairs from £12.00

★ Collection & delivery optional

★ Used Micro's bought, sold, exchanged.

Call NIGEL: 01-863 7166

MICRO SUPPORT
Unit 3, 15 Springfield Road,
Harrow, Middx, HA4 1QF.

ASTROLOGY for beginners only £11.50

A Starter Pack comprising a simple program to calculate a horoscope, an introductory booklet & 2 self-teaching programs (how to interpret the horoscope).

No previous knowledge required

Spectrum, BBC/Electron, Oric, Dragon, Tandy/Genie, Commodore 64/PET, Atari, Sharp, Amstrad/Schneider, Colour Genie, MSX, IBM, Apricot, etc.

many more programs for
experienced astrologers
also other micros

Cash with order (add 50p
outside UK) or large sae for free
catalogue to: -

ASTROLCALC (Dept YC)
67 Peascroft Road,
Hemel Hempstead, Herts HP3 8ER
Tel: 0442 51809 537

Spectrum Repairs

£14.90 inclusive of labour, parts
+ p&p. Fast reliable service by
qualified engineers. Average repair
24 hrs, 3 mths guarantee. For help
or advice ring:

HS Computer Services
2 The Orchard, Warton
Preston, Lancs. PR4 1BE
Tel: 0772 632686 327

ATARI SOFTWARE

RRP	Our Price
£7.95	£6.95
£9.95	£8.50
£12.95	£10.95
£14.95	£12.75

Any Atari title. Cassette or Disk
Payment by cheque/PO/Access

Send to:
SUNARO SOFTWARE (YC)
PO Box 78, Macclesfield,
Cheshire SK10 3PE
Telephone: 0625 25228

VELDA PUBLISHING

THE SPECIALISTS PRODUCING THE
CLEAREST ENGLISH W.P. GUIDES

LOCOSCRIPT WORDSTAR NEWWORD
CARDBOX

All at £5.00 each (thousands sold)
Printed or Audio versions same price

1 LANDSEER ROAD, WESTBOURNE,
BOURNEMOUTH, DORSET BH4 9EH
Telephone: 0202 762401

A.F.I. LISP for the Sinclair Spectrum (and Plus).
Specifications include: 4K/5K cells, external oblist
and p.d. stack, over 70 functions, 64-col full-screen
integral editor, Interface-1 and microdrive com-
patible. Plus full documentation with a turtle
graphics example.

For only £15.00 inc. (+ £1.50 Export) From:
AFI SOFTWARE, PO Box 149, London SW17 9LB

BLANK CASSETTES

Guaranteed top quality computer/
audio cassettes at great budget prices.
Packed in boxes of 10 with labels,
inlay cards and library case.

Prices include VAT, post and packing.
 IC5) £3.35 IC30) £4.70
 IC10) £3.40 IC60) £5.30
 IC12) £3.45 IC90) £7.00
 IC15) £3.75

BASF FLOPPY DISCS

Prices of boxes of 10
 5 1/4 Single side Double density £19.95
 5 1/4 Double side Double density £21.85
 5 1/4 Double side Quad density £28.75

MICRO FLEXI DISCS

Price per unit
 5 1/4 Single side £4.00 each
 5 1/4 Double side £4.75 each
 Indicate quantity of each product
 required in boxes Free delivery UK only.
 Cheque/PO. Enclosed for £

NAME _____
ADDRESS _____

**PROFESSIONAL
MAGNETICS LTD**

741

Cassette House, 529 Hunslet Road, Leeds LS10 3YJ
FREEPOST Tel: 0532 706066

HOME ACCOUNTS. Put your house in
order! Probably the best home use for your
computer! Comprehensive coverage of
bank accounts, credit cards, HP, etc. Inbuilt
accuracy check for all transactions. Project
cashflow for any period ahead. Available
for CBM 64 or VIC-20, Commodore,
Spectrum and Amstrad £8.45 or free details
from DISCUS SOFTWARE, FREEPOST,
Beach Approach, Brixham, Devon TQ5 8BR.
Tel: 08045 55532.

477

PRE-SCHOOL, PRIMARY, JUNIOR



Education

By a Teacher, Tested by Pupils
Approved by Parents and Schools
For Home use on all CPC and
BBC models

£6.00 Per Set

Choice of more than FIFTY programs.

SAE for Lists to: Dept YC1
ARC (ACU1) 53 Bentley Street, CLEETHORPES,
Stn. HUMBERSIDE DN35 8DL (0472) 699632

For Small Software Houses

CASSETTE DUPLICATION
50-1,000 load tested
Copyright holders only

SOUNDS GOOD
04946 (Beaconsfield) 5900

ORIC 1/ATMOS/ELECTRON USERS

Software/Hardware/Books/Repairs/Upgrades + New DUAL
MEMORY ONIC

Contact - W. E. (Software)
Foley Bank, Worcester Road, Great Malvern,
Worcestershire WR14 4DW
Telephone: Malvern (06845) 69059

SPECTRUM ELITE Editor. Define nearly
every feature including special missions,
cash, weapons, cargo, cloaking device,
E.C.M. Jammer £1.99 D.D.S, 49 Beaumont
Road, Halesowen, West Midlands.

SUSS BOX



£49.95

- VAT

incl. carriage
CWD please
pocket size

The DUPLEX SUSS-BOX has been designed to
enable the less skilled computer user to have a
better understanding of the correct working
connection between a computer and a peripheral,
such as a printer. This is achieved by using the
commonly used signals (wires) of the RS232C
serial data cable specification, a matrix-block and
special connector pins, by inserting the connector
pins into the SUSS-BOX's matrix-block at the axis
of two incoming signals the user can quickly
establish a firm connection. The signals are
routed into the SUSS-BOX by two 25 way D
type connectors: 1xfemale, 1xmale. The SUSS-
BOX also provides a lamp for each signal to
show its condition when connected in line, in
high or low. SUSS ADAPTOR & CABLES
available.

OCTET/HERMIT

Typewriter Interfaces

ADD ON TO THE
OLIVETTI ET121
OR HERMES TT21
ELECTRONIC
TYPEWRITER
AND HAVE THE
BENEFITS OF
THESE FEATURES



Ideal for
TELECOM GOLD
New LOW prices

- DAISY WHEEL PRINTER for your computer
- A COMPUTER TERMINAL (True KSR)
- A TELEX TERMINAL using the Duplex DIAL-TEXT modems
- A COMMUNICATING TYPEWRITER (DIAL TEXT Compatible)
- A REMOTE PRINTER using DIAL-TEXT modems

**DUPLEX
COMMUNICATIONS (UK) LTD**
2 Leire Lane, Danton Bassett, Nr Lutterworth,
Leicestershire LE17 5JP
Tel: 0455 202154 778

CPC464 tape magazine 'Amsmag' contains
50K of reviews, competition, game etc.
issue 1: £2.50 from Bellsoft, Seventy, Park
Avenue, Shoreham, W. Sussex.

23 GAMES on disc for the CBM64 + to the
first 200 purchasers a FREE Graphic
Adventure. Only £6.95 + 50p p&p to: Mike
Smyth, Edenderry Lodge, Banbridge BT32
3BS Tel: 08206 24506.

ZX SPECTRUM UTILITIES

Huge range of discount tapes including

TASWORD TWO	£12.50	TASPRINT	£8.90
TRANS-EXPRESS	£8.95	TASCOPY	£8.90
GRAPHMATE Bar Line & Pie charts			£5.95
MASSIVE CONTROLLER 1 key commands			£5.95
MAILING LIST with label printer			£5.95
HOME BUDGET	£5.00	BANK ACCOUNT	£5.00
PRINT & INPUT 64 CHARS PER LINE			£4.00
FLEED FLEER	£5.95	SPEEDYLOAD	£3.95

SAE/IRC Catalogue or £1 (refundable)
for detailed V.I.C.E.T. cassette (PC version)

SD MICROSYSTEMS (DEPT YC)
P.O. BOX 24, HITCHIN, HERTS, UK

ROGER COMPUTER SOFTWARE

AMSTRAD CPC, SHARP M2-700
CBM 64, MSX, ELECTRON, BBC
Educational, Business and Games software
Send a SAE for details stating micro to -
ROGER COMPUTER SOFTWARE
2 RIVERWAY GARDENS, THE MEADOWS,
NOTTINGHAM NG2 3LL
Trade Enquiries Welcome

FOR DETAILS

on
**CLASSIFIED
ADVERTISEMENTS**

Contact
PAUL MONAF
on
01-222 9090



FLOPPY DISCS 100% GUARANTEED ERROR FREE

5.25"		Disks available only in multiples of 10	3.5"	
10+	100+		10+	100+
SS/DD	63p 60p		SS	2.00 1.90
DS/DD	69p 65p		DS	2.20 2.10

p&p £1.00

File for 50 Discs
£9.95

**WE RESERVE THE
RIGHT TO LOWER
PRICES WITHOUT
PRIOR NOTICE AND
REFUND THE
DIFFERENCE OR
QUANTITY AT OUR
PREFERENCE.
Please ask for our
Price List for IBM®
PC compatible
systems & add-ons
including a simple
kit £499 complete**

IBM® is a registered trade mark of International Business Machines Ltd.

**FROM
60p**

8" ON APPLICATION

Send your order now
to:

**ART Dept YC
UNIT 1
5 MILLBROOK
IND. ESTATE
CROWBOROUGH
E. SUSSEX
TN6 3DU**

Trade enquiries
welcome on
(08926) 65606

LETTA-HEAD PLUS

An ENTIRELY ORIGINAL utility program for the 486 Spectrum to
design and print your own business & personal stationary,
letterheads, orders, receipts, labels & posters. The PLUS version
now includes:

- Library of 25 fonts including foreign sets.
- Fast, compiled, editor to create new fonts.
- All characters are proportionally spaced
- 81 different character sizes
- Scroll, inverse & erase any screen portion
- Variable thickness box function
- Improved graphics for logo design
- Or use SCREENS from any other source
- Print headings in 18 different sizes
- Design any size label up to 4x2"
- Special cassette label option
- Many more features!

Price: £9.00 cassette, £10.50 cartridge;
Updates from original LETTA-HEAD £2.00.

All Bradway Software programs drive Epson type printers (Brother, Star, M-T, Shinwa, Centronics etc) via Hilderday, Kempston, Tasman, Morex, Wafadrive, Interface 1, ZX I/Print III, and Opus interfaces.

P.S. Need just a few labels but no-one will sell less than 1000? Send an sae for details of Bradway Software "QUIDSWORTH" service!

Bradway Software (YC), 33 Conalan Avenue, Sheffield, S17 4PG

DUMPY

All the screen dumps you will ever need! No need to understand
assembler, just follow the menu. Unlike other screen dump soft-
ware, DUMPY is a screen dump generator. It creates the machine
code, relocates it and saves it ready for you to use in your
programs.

- Creates code to suit any program.
- Definable start column, start & end lines.
- Or automatic screen area determination
- Prints any portion of screen up to 24 lines.
- Single, double or quad density
- 9 widths and 3 heights of output
- Plain black and white copy
- Or shaded colour representation
- Tab to any position on paper
- Many more features!

Price £7.50 cassette, £9.00 cartridge.

LINE-O-TYPE

NEW! Turns your Spectrum and printer into an electronic type-
writer, superb for addressing envelopes or filing in forms, and a
text file formatter: print those Tascard files out professionally

- Full WYSIWYG line editor
- Library of 25 fonts including foreign sets
- Fast, compiled, editor to create new fonts
- Single or double size characters
- Easily switchable underline
- True proportional spacing and justification
- Loads files from any storage device
- Prints files as found, or allows editing
- Double density print, so NI G
- Printing multi-tasked with keyboard use
- Many more features!

Price £8.50 cassette, £10.00 cartridge.

THE REPAIR MAN

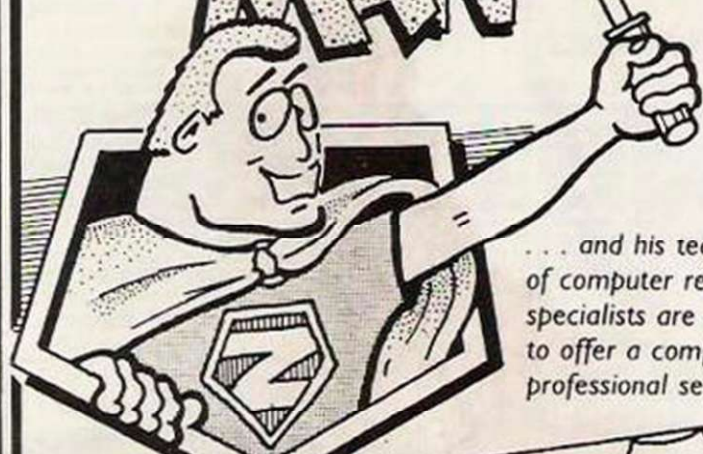

... and his team of computer repair specialists are here to offer a complete professional service.

FREE
£15 cartridge with every Commodore 64 repair

Spectrum £17.99
Commodore 64 £29.95
BBC £29.95
(including parts & p/p)

FREE
software with every Spectrum repair

We also repair Amstrad, Oric, Atari, Vic 20, Printers, Disc drives etc.

- ★ WHILE-U-WAIT SERVICE
- ★ FAST TURN AROUND
- ★ 3 MONTH GUARANTEE
- ★ FREE SOFTWARE
- ★ DIY COMPONENTS

ZEDEM
COMPUTERS LIMITED

2 Kimbolton Road
Bedford MK40 2NR

Call (0234) 213645/213032 7 days a week 24 hr. answering service

FACULTY ENTERPRISES

AMSTRAD	OUR RRP PRICE	COMMODORE	OUR RRP PRICE	SPECTRUM	OUR RRP PRICE
Rambo	9.95 6.75	Superowl	9.95 6.75	Sold A Million II	9.95 6.75
Sold A Million II	9.95 6.75	Sold A Million II	9.95 6.75	World Cup	7.99 1.99
Friday 13th	9.95 4.25	Friday 13th	8.95 6.75	Friday 13th	8.95 4.25
Ship of Doom	7.25 2.25	Missile Command	7.25 1.99	Ship of Doom	6.50 1.75
Planet of Death	7.25 2.25	Pilot 64	7.25 1.99	3D Ret Attack	6.50 1.75
Space Hawks	8.99 3.25	Automania	7.25 3.25	Flight in Dark	7.95 3.25
3D Invaders	8.99 3.25	View To A Kill	8.99 3.25	Cosmic Cruiser	7.25 3.25
Harrier Attack	8.99 3.25	Flyer Fox	0.00 0.00	Black Hole	7.25 3.25
View To A Kill	8.99 3.25	Speech	7.99 1.99	View To A Kill	7.25 3.25

P + P INC. PLEASE MAKE CHEQUES PAYABLE TO:

FACULTY ENTERPRISES

29 RUTLAND COURT, PONDERS END,
ENFIELD, MIDDLESEX Tel: 01-805 8054

PROFESSIONAL ELECTRONICS TECHNICIANS

Short re-training courses (3 week)
VCR SERVICING
MICROCOMPUTER SERVICING
(ONCROND/MNC also available in modules)
★ MSC GRANT AID to EMPLOYERS/ TRAINEES ★
Television/Video/CCTV/
MICROELECTRONICS
Information Technology/CAD/CAM/ATE
MICROPROCESSORS/Computers/ CONTROL
Dept (VIC)
LONDON ELECTRONICS COLLEGE
20 Pennywell Road, LONDON SW9 9SU
Telephone: 01-373 8721
Next Course Starts 21 July

SCOTLAND'S No 1

for home and personal computer repairs
specially fast Spectrum service.

- ★ Same day for most faults
 - ★ 1 hour if delivered personally
 - ★ Free estimates
 - ★ Upgrades, Membranes and P.S.U.'s
 - ★ 3 mth. warranty on work done
 - ★ Open 6 days a week
- Also BBC/CBM/ORIC and PERIPHERALS

MICRO-SERV

95 Deerdrykes View
Westfield Industrial Estate
Cumbernauld
Tel: Cumbernauld 02367 37110
Trade, schools and club discount given.

SELL IT WITH

Your
COMPUTER

CLASSIFIED ORDER FORM

Classified Rates

Linage: 60p per word (Min 20 words) —
prepayable

Linage advertisers should complete the form
provided in BLOCK CAPITALS. Phone number
counts as 2 words. Name and address to be
paid for if used in advertisement. Box Number
if required is £7.00 extra.

Display — rates per scc (Min 2scc)

One insertion : £10.00
Three insertions : £9.70
Six insertions : £9.50
Twelve insertions : £9.00

Display advertisers should provide separate
copy and preferably reserve space by
phone (01-222 9090)

Method of Payment

Cheques etc. should be made payable
to Focus Investments Ltd., and
crossed. I enclose herewith
cheque/PO for

£

Post to:

Cut out the order form and return
together with your remittance to:
Classified Department, Your Computer,
79-80 Petty France, London SW1 9ED.

Please insert the following advertisement in Your Computer Classified Section

	LINAGE	PLUS 15% VAT	TOTAL
	£12.00	£1.80	£13.80
	£15.00	£2.25	£17.25
	£18.00	£2.70	£20.70
	£21.00	£3.15	£24.15
	£24.00	£3.60	£27.60
	£27.00	£4.05	£31.05
	£30.00	£4.50	£34.50

No. of insertions required Box No. required YES/NO

NAME (Please include initials)

ADDRESS

Daytime tel. no

**THIS FORM SHOULD BE
RETURNED BY JULY 1st
FOR THE AUGUST ISSUE
OR BY JULY 31st
FOR SEPTEMBER ISSUE**

NEW TAPE and DRIVE SPECTRUM and AMSTRAD UTILITIES

Yes LERM, famous for our SPECTRUM programs, now has vital utilities for AMSTRAD owners. We also offer on ALL our products:

- ★ A FULL MONEY BACK GUARANTEE
- ★ FULL MANUALS
- ★ AN UPDATE SERVICE to get the latest version at a reduced price.

★ ★ S P E C T R U M ★ ★

TUB - ALL SPECTRUM OWNERS NEED this specialist tape utility.

Send SAE for FULL DETAILS of this AMAZING program for Tape back-up and drive transfer.

- ★ Simple operation. Manages the seemingly impossible including fast/clicky/jerky standard tone leaders etc.
- ★ Manages 100% accurate MOST 48K plus programs.
- ★ Includes TONE and Baud rate (speed) measurer.
- ★ Clicky/Jerky leaders can be converted COMPLETELY to normal.
- ★ Handles Headerless parts etc. etc.

TUB ON TAPE £6.95 for £7.99 on m/drive cartridge)

TAPE to DRIVE transfer for SPECTRUM OWNERS

Transfer Pack 2 - A sophisticated package of programs INCLUDING TUB, other utilities, allows drive transfer of many programs.

- ★ includes header reader, bytes chopper, bytes mover.
- ★ Extra utilities (REM kit, VAL creator, RUN program for m/drive owners).
- ★ 5 information sheets giving details on drive transfer 40 popular programs.
- ★ Manages virtually all jerky/clicky leaders to drive.
- ★ Full manual, sample transfers, technical information.

GIVE NAME of your drive system (eg m/drive, Wafa, Opus)

ONLY £11.99 (£12.99 on m/drive cartridge)

Information sheets - up to no. 12 available - £1 each includes MANY top 20 hits!

MICROTRANS - 2 programs for m/drive owners. FAST and EASY DRIVE to DRIVE and TAPE to DRIVE (does NOT convert programs!) Plus multiple erase program (inc true CAT, printer output) etc. etc.

ONLY £4.99 on tape, £5.99 on cartridge - AMAZING!

THE PRICES QUOTED ARE ALL INCLUSIVE EXCEPT overseas; add £1 within Europe, £1.50 others. SAE for more information

LERM, DEPT YC, 10 BRUNSWICK GDNS, CORBY, NORTHANTS NN18 9ER

★ ★ A M S T R A D ★ ★

TAPE SPEED TWO (TS2) - ESSENTIAL FOR ALL AMSTRAD OWNERS

Convert your slow loading software from 1000 to a max of 3600 baud. Stop and study programs.

- ★ **AMAZING** - now manages MOST of the clicky leaders - some will now run on the 664/6128 for 1st time!
- ★ Fully automatic. It loads in continuously up to 44K.
- ★ Save at range of 9 speeds.
- ★ Permanent display of HEADER plus STATUS information.
- ★ Motor on/off. Insert PAUSE. Removes protection.
- ★ Handles HEADERLESS files, and PULSED/clicky leaders.
- ★ Handles AMSTRAD programs with Spectrum loaders. Speed (Baud rate) detector.
- ★ VERY SIMPLE TO USE - FULL MANUAL

PRICE ONLY £6.99 - state 464, 664, or 6128

DISC MANAGER ONE. - for ANY AMSTRAD

Essential to help you manage your AMSTRAD drive. No risk - try it and see how useful it can be.

- ★ Does a CAT which can then be used to do repeat ERASURES very easily. Gives disc type. Memory free/used.
- ★ 2 Disc editors - edit or study sectors of a disc.
- ★ Recover ERASED files.
- ★ Simple and fast whole disc or sector BACKUP copier.
- ★ Send outputs to printer (CAT, sector contents, etc)
- ★ Unsecured for easy adaption/drive transfer.
- ★ Menu driven - FULL manual.

PRICE only £5.99 - amazing!

SPECTRUM — AMSTRAD — COMMODORE

NOBLES COMPUTER REPAIRS

* Repairs carried out by our own engineers on site.
* All repairs carry a 4 MONTH GUARANTEE
For estimates phone or send your computer to NOBLES.

Spectrum Plus £16.95 inc parts
post and pack
Commodore 64/VIC 20 from £9.95 plus
parts
BBC from £18.95 plus
parts

Also repair specialists for Amstrad and MSX computers

NO HIDDEN CHARGES

★ SPECIAL OFFER

5 FREE GAMES WORTH £25

with each Spectrum repair Trade/School and Club discounts arranged.

*For free, no obligation estimates phone or send your computer to NOBLES for the fastest, cheapest repairs in ESSEX.

NOBLES

14-17 Eastern Esplanade
Southend-on-Sea

Essex

0702 63377/8

63336/7/8/9

(Ask for Norman)

7 days a week, 24-hour Answering Service

SPECTRUM — AMSTRAD — COMMODORE

DIARY

This is our new diary page. If you know of any events or exhibitions linked to computing in your area, please write to us.

The University of Manchester's Institute of Science and Technology is playing host to the 1986 APL (A Programming Language) conference from July 7-11th. This year's theme is APL in Action and more practical demonstrations will be provided than ever before. The conference should be of interest to beginners and experts alike and, should you not want to attend all the lectures, a major exhibition will be running nearby.

Further details from: Conference Department (APL86), The British Computer Society, 13 Mansfield Street, London W1M 0BP.

The 9th Personal Computer World show is due to be held at Olympia from September the 3rd to the 7th. Over 63,000 people visited last year's show and this year, it is hoped that the attendance will be even greater. As well as personal computers, software, peripherals and complete business systems will be on display.

The Computer Training and Education Centre are running several courses in business microcomputing. These run for between one and five days and are held in London and Manchester. The subjects taught include WordStar programming, Introductions to Assembler code and Advanced Basic.

Details are available from CTEC's head office on 01 583 2322.

At Southampton University, September 10-12, Software Engineering '86 will be held. It will be the first of a series of annual conferences on software engineering and has been organised jointly by the British Computer Society and the Institution of Electrical Engineers in conjunction with the Alvey Directorate.

The subjects to be discussed include the practical application of software engineering and teaching and training methods.

Special Features

ATARI SUPPLEMENT

The latest in hardware and software for the Atari ST series of computers, together with a round-up of the best software for the 8-bit 130XE model.

PCW DATA BASES

Reviews of two database programs for the Amstrad PCW computers. One of them makes use of Jetsam, the keyed record system built into PCW Basic.

ARGUS SOFTWARE

A profile of a software company with more varieties than Heinz.

INTO THE ARCADES

Postponed from this month, this is our look at the latest games to be found in the arcades.

MAKING SPECTRUM MUSIC

A collection of programs demonstrating the techniques involved in using the Spectrum 128 Programmable Sound Generator.

PLUS

The final instalment in the *Your Computer Course*. Concluding our guide to programming for beginners.

NEWS ● REVIEWS ● HINTS & TIPS ● CLUBS ● SOFTWARE GUIDES

Contents subject to late revision

August issue on sale July 28, 1986

EXPORT

AND OVERSEAS VISITORS

ALL MAKES OF MICRO COMPUTERS, PRINTERS, PERIPHERALS AND SOFTWARE SUPPLIED AT DISCOUNT PRICES.

AMSTRAD ● ORIC ● SINCLAIR
● BBC MICRO ● ATARI ●
COMMODORE ● APRICOT ●
STAR ● BROTHER AND ALL
POPULAR MAKES

MICROGOLD

UNICOM HOUSE
182 ROYAL COLLEGE STREET,
LONDON NW1 9NN
TELEX: 295932 UNICOM G
TELEPHONE: 01-482 1711

ADVERTISERS INDEX

A	MICRONET	40
AGF	MICROGOLD	82
AMSTRAD	MIDLAND	38
ARGUS		
	N	
B	NOVAGEN	14
BETASOFT		
BUDGET SOFTWARE ..	O	
	OCEAN	92
C	OPUS SOFTWARE	24
CHEETAH SOFT		
CUT PRICE SOFTWARE ..	P	
COLLEEN	PCW SHOW	8, 9
E	R	
ENGLISH	RSD	66
ENFAB	ROBTEK	14
G	S	
GALASET	SELEC	68
	SILICA SHOP	91
H	SWANLEY	66
HI VOLTAGE		
	T	
J	THOUGHTS & CROSSES ..	49
JETSOFT	T L DAVIS	38
M	V	
MIRRORSOFT	VOLEX	68

Your COMPUTER COURSE

JULY 1986

A COMPREHENSIVE GUIDE TO PROGRAMMING - PART 5

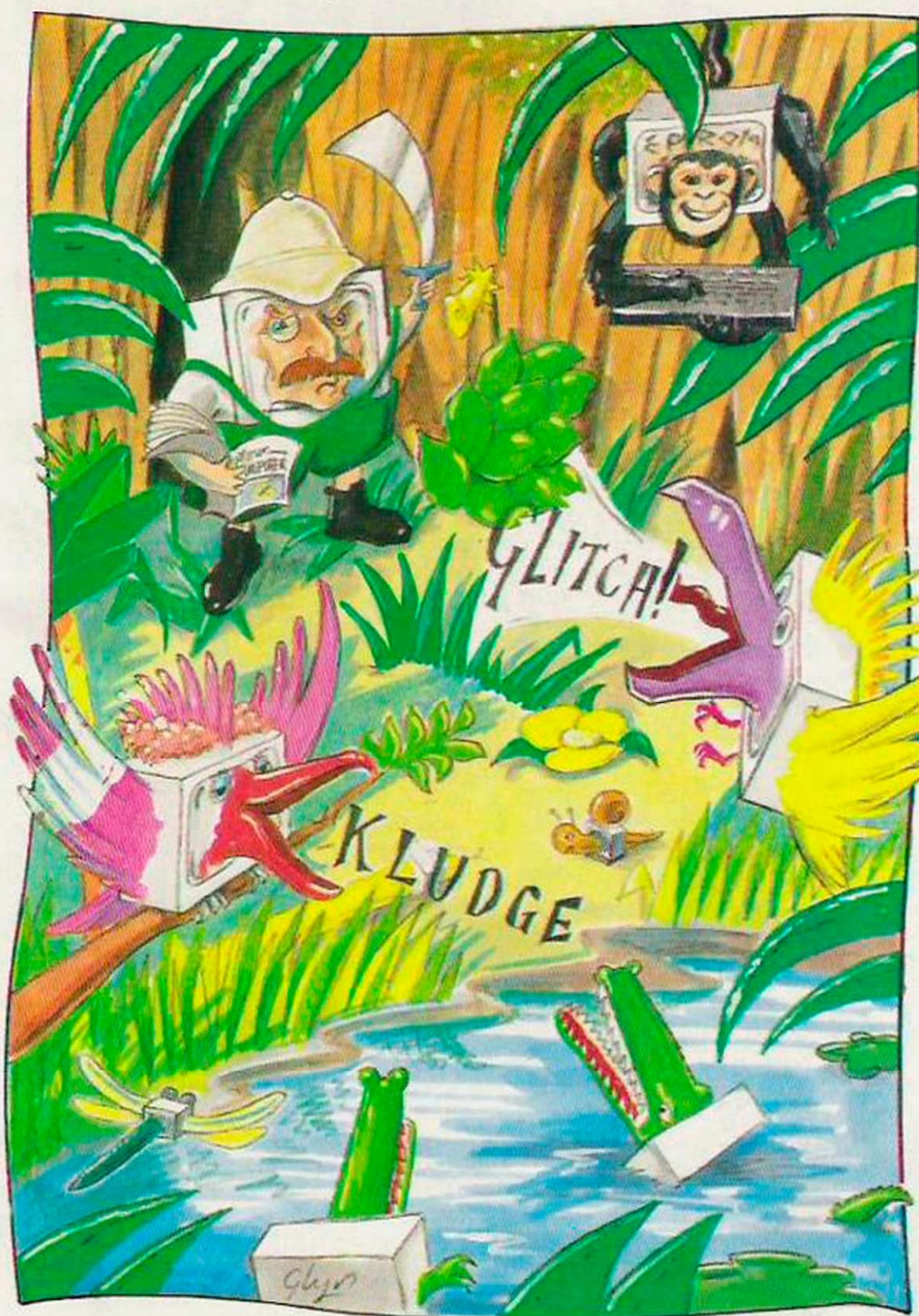

HACKING THROUGH THE JARGON JUNGLE

OUR GLOSSARY SHOWS
YOU THE WAY

SPEAKING THE BBC LANGUAGE

AN INTRODUCTION TO
6502 MACHINE CODE
PROGRAMMING

GETTING TO GRIPS WITH GRAPHICS

MOVING IMAGES
ON-SCREEN

FORCED TO SUBMIT

THE CPM SUB-COMMAND
EXPLAINED

The short but intensive *Your Computer Course* is almost at an end. This month's instalment is the penultimate part of the six-monthly series designed to introduce the fundamentals of computer programming.

The mix of articles this month follows that established in earlier parts of the course, with a range of subjects encompassing all aspects of the programming art.

We begin with further exploration of the techniques of computer graphics. In particular, the Basic UDG program for the CBM64, as published last month, is modified to increase its flexibility.

The *Your Computer Course* glossary has been a major feature in previous parts and this month is no exception. John Lettice nears the end of the alphabet; it is surprising how many computing terms begin with the letters from Q to S.

The third of this month's articles introduces 6502 machine coding programming. While not one of the latest 16-bit wonder MPUs, the 6502 is the workhorse at the centre of many leading micros, including the BBC computer.

Finally this month we return to the subject of computer operating systems with a detailed look at the powerful CP/M submit utility.

INDEX

Computer Graphics 34

Glossary (Q-S) 36

6502 programming 38

CP/M Submit 40

Contributors:

Ken Alexander

John Lettice

Peter Turcan

Geof Wheelwright

Computer- animated design

Geof Wheelwright explores putting surreal graphics into motion.

Animation is the cornerstone of all good arcade games on home micros, giving the player the feeling that they are really there in whatever fantasy-scape the game planner has designed. To round off the taster on animation techniques you will need to write your games, we will run over the program example we gave you last time, giving you the information you need to finish the rock-collecting game and suggesting improvements you might make on it.

The first thing you need to resolve is the question of smooth movement across the screen. As you will know by now, the simplest method of moving something across the screen is to use the PRINT statement to place the character on the screen; then to use the CLS statement to clear the screen of what you have printed, and then to use a PRINT statement to print the character one place further than last time.

That method of animation works but is both slow and clumsy. It also causes a good

deal of screen flicker as the whole of the screen is being cleared every time you want to move the character, not just the space where the character had previously been printed.

To make your animation truly smooth, you need to arrange things so that when you move a character from one spot to another - whether it is a number, letter or part of a user-defined graphic - the place it has just come from is clear. As you will want to move your character up and down as well as back and forth, that means ensuring that the business of blanking-out the previous position of the character will have to be handled in two dimensions, not just one.

The exact method by which you set about identifying the two-dimensional position of a character is different from machine to machine. Many just use x and y co-ordinates to allow you to specify the exact position of a character of pixel, while others map the screen from the top left-hand corner to the bottom right-hand corner.

On computers which use the latter technique such as the Commodore 64 and 128, you will need to determine the exact single-number screen locations which correspond to where you want to print your character and where you want to print a blank space in place of where it had been. On those which use the x,y placement, you need only

subtract or add to the value of x and y, depending on where in the screen to which you have moved the character.

Once you have mastered this concept, it is a relatively short leap to achieving full cursor control of the character. All you have to do is have the value of the 'Y' co-ordinate to increase when you press the up key or move the joystick upwards - and conversely get it to decrease when you move the joystick down or press the down key - and tie the X value to the press of the left and right keys.

In the Commodore 64 program example, you can see how the variable 'Q' is used to define the position of the character in our rock-collecting game.

Only one variable is needed because the screen positions of characters and pixels on the Commodore 64 are not of the X,Y type. They are at the top left-hand corner of the screen with one number, and increase until you reach to the bottom left-hand corner of the display.

Recognition must be achieved

For the necessary cursor control to play the game, you see how we need to take into account what happens if each of the four up, down, left and right keys (CHR\$(145),CHR\$(17), CHR\$(157) and CHR\$(29)) are pressed. You will also see that because the on-screen man is made up of not one, but four,

special characters that each of the characters has to be rePOKED to the screen every time the man is moved.

The other major game component you will notice is the counter in line 3000. At the moment, it is only really set up as a timer, giving you only 125 presses of the keyboard to complete all collection of the on-screen rocks. You could make this a count instead by typing: *FOR T=125 TO STEP-1* at line 3000 instead, which would start the countdown of your keypresses at 125 and move down to 1.

The alternative, is to score only when a rock is collected. To do that, however, you would need to write a routine which found where each of the randomly-placed on-screen rocks finished and match that constantly against your current position. When it detected a match - or what we in the game business call a collision - you would score and the place which had contained the rock would be blanked-out.

Modularity and structure

To make the game more sophisticated, you could then draw a series of more complex backgrounds in which the hero could move and then perhaps some animation sequences - i.e., walking or picking up a rock - which could be invoked at certain points in the program.

Remember that the most important thing in any program is modularity and structure, so that as you move round and improve and change one piece of the program the next is not affected. In the rock-collecting program, for example, the keyboard input section is all one module and could be replaced by a joystick input section.

To allow for joystick input, read the values of the joystick port instead of the keyboard and use the same incrementation for when the cursor is moved to gain the necessary control to play the game.

Finally, to our little secret about how to solve that little problem in the game you saw last time. I will not tell you at once where the change is but suffice it to say that you will see it between lines 10 and 230.

```

4 PRINT CHR$(147)
10 POKE 56334, PEEK (56334) AND 254: POKE 1, PEEK(1) AND 251
20 FOR I=0 TO 63
30 FOR J=0 TO 7
40 POKE 12288+I*8+J, PEEK(53248+I*8+J)
50 NEXT J: NEXT I
60 POKE 1, PEEK(1) OR 4: POKE 56334, PEEK(56334) OR 1
70 POKE 53272, (PEEK(53272) AND 240) + 12
80 FOR CHAR=60 TO 63
90 FOR BYTE=0 TO 7
100 READ NUMBER
110 POKE 12288+(8*CHAR)+BYTE, NUMBER
120 NEXT BYTE: NEXT CHAR
130 FOR L=40 TO 78
140 PRINT CHR$(147) TAB(1) CHR$(60);
150 PRINT CHR$(61) TAB(L) CHR$(62) CHR$(63)
160 FOR H=1 TO 10: NEXT H: NEXT L
200 DATA 7,7,7,1,1,31,3,3
210 DATA 224,224,224,128,128,248,192,192
220 DATA 1,2,4,8,16,32,64,128
230 DATA 128,64,32,16,8,4,2,1
1000 PRINT CHR$(147)
1500 PRINT CHR$(5)
2000 Q=1484
2100 FOR I=55296 TO 56295: POKE I, 1: NEXT I
2600 FOR U=1 TO 12: X=INT(RND(1)*1000)+1024: POKE X, 35: NEXT U
3000 FOR T=1 TO 125
3100 GET B$: IF B$="" THEN 3100
4000 IF B$=CHR$(17) THEN Q=Q+40: POKE Q-40, 32: POKE Q-39, 32: POKE
Q, 32: POKE Q+1, 32
5000 IF B$=CHR$(145) THEN POKE Q, 32: POKE Q+1, 32: POKE
Q+40, 32: POKE Q+41, 32: Q=Q-40
6000 IF B$=CHR$(157) THEN POKE Q, 32: POKE Q+1, 32: POKE
Q+40, 32: POKE Q+41, 32: Q=Q-1
7000 IF B$=CHR$(29) THEN POKE Q, 32: POKE Q+1, 32: POKE
Q+40, 32: POKE Q+41, 32: Q=Q+1
8000 POKE Q, 60: POKE Q+1, 61
8200 POKE Q+40, 62: POKE Q+41, 63
9000 PRINT T: PRINT CHR$(19): PRINT CHR$(32): NEXT T
9500 PRINT CHR$(147)
9700 POKE 53272, 21
10000 FOR G=1 TO 23
11000 PRINT "....."
TIME'S UP....."
12000 NEXT G: GOTO 10000

```



■ **Qwerty:** Used by manufacturers in advertising blurb for their computers, as in "has full qwerty keyboard". Beware of non-qwerty keyboards.

■ **Qdos:** DOS stands for disc operating system, therefore Qdos is the operating system for the Sinclair QL, launched without discs. In this case the D obviously has to stand for something else, but please don't write.

■ **QL:** Machine launched in 1984 by Sinclair Research, reputedly with more operating system versions than machines sold. Sir Clive said it stood for Quantum Leap; the full name of the machine is now known to be Quiche Lorraine.

■ **Quinkey:** Five-key single-handed word processing system used on the Microwriter. Beware of non-qwerty keyboards - see qwerty.

■ **Quadrant:** Part of Sutton where computer journalists rub shoulders with esoteric titles dealing with supermarkets, travel agents and other publications.

■ **Queue:** What you had to do initially if you wanted to buy a QL. Also refers to an ordering of data awaiting processing.



R

■ **RAM:** Random Access Memory. Not, as you might

think, a medical condition involving forgetfulness but a kind of memory used in computers which allows you to access any part of it, from any point, at any time.

■ **ROM:** Read Only Memory. The microcomputing equivalent of the Bourbons, who learned nothing and forgot nothing. ROM is a kind of memory which can be read but cannot be erased and so cannot be changed, usually used to contain the "personality" of a computer.

■ **REM:** Short for remarks and used by programmers to annotate programs with comments explaining a listing. Computers ignore those unco-ordinated and misleading burlblings just as you, if confronted by a programmer, would do.

■ **Random access:** The entryphone's broken. Also used of disc drives, which generally allow the read head to jump to any part of a disc at any time, as opposed to tape drives which, because they have to read through all matter preceding the required entry, use sequential, or serial, access.

■ **Raster:** The little dot which scans across the TV screen to make up the picture. First rose to prominence in Bob Marley's seminal TV repair concept album "Raster Scan Vibrations."

■ **RUN:** 1, Basic command used to execute a program after it has been written. 2, Basic action taken by programmers to avoid execution after a program has not been written.

■ **Real number:** The profit figures of a normal computer company, as opposed to the profit figures of IBM, which are absolutely unreal. Also all sensible numbers which people can comprehend, consisting of positive, negative, zero and fractions.

■ **Real-time clock:** A software device, sometimes built into a computer ROM, which gives you progressively more misleading information about the time of day the longer the computer is turned on.

■ **Reciprocal:** The reciprocal of a number is one divided by that number and relates in the same way to that number as a normal computer company's

Your COMPUTER

The jargon which pervades the computer language is more than a tool to effective communication. By following John Lettice's guide you can be fluent in the hi-tech parlance.

profits relate to those of IBM.

■ **Record:** The number of operating system versions the QL has had. Alternatively, a collection of data items or a subdivision of a file.

■ **Recursion:** The repetition of a series of operations, which may include an operation that calls itself. See bug.

■ **Redundant:** Duplication of functions; description of a function no longer needed; what dictionary authors are when they reach Z.

■ **Refresh:** To re-write data into an area, often used describing the updating of a screen.

■ **Register:** What you should have done by May 11 if you keep data on people and you do not want to be nicked. Also a temporary storage area within memory.

■ **Re-locatable:** A program which can be placed in different areas of memory is re-locatable. So are other things. If price and quality of current manufacturers of Sinclair machines does not suit Alan Sugar, production is re-locatable to Korea.

■ **Report generator:** Usually part of another program, e.g., an accounting suite, which pro-

duces printed output.

■ **Reserved word:** A word which cannot be used as a variable, often because it is a Basic command.

■ **Re-set:** What you have to do when your program crashes. There are three kinds - soft re-set, which re-sets the machine through software; hard re-set, which involves switching it off; and very hard re-set, the hammer which returns the machine to its pre-manufactured state.

■ **Return:** Computer key used to execute Basic commands, sometimes also known as Enter.

■ **Right-justified:** Speech by Norman Tebbit, or hard copy where text is aligned on the far right. As I said, speech by Norman Tebbit.

■ **Round:** Rounding is the process of chopping-off the twiddly bits at the end of long decimal numbers, thus causing a rounding error.

■ **Routine:** Short for subroutine.

■ **RS232:** A standard interface designed to facilitate communications. It is important to make sure you have the correct standard, as they are all different.

ER COURSE

puter industry seems more like a foreign communications for those who are not in the e's guide to computer-speak you, too, variance spoken by computer people.

■ **Source code:** The language in which a program is written initially.

■ **Spooling:** Involves writing data to a disc for later output to a printer.

■ **Start bit:** A bit preceding the data bits in a character code during communications to identify the first data bit. A stop bit identifies the last one.

■ **String:** A series of characters.

■ **Structured programming:** A method of programming based on neat flowcharting and intended to be elegant – good structured programmer word, this – and easy to understand. Structured programmers can be recognised by their willingness to discourse on esoteric program languages and occasionally by their Pascal T-shirts.

■ **Subscript:** Sometimes refers to illegible printer output, or rejected BBC radio plays, but really means those dinky little letters which reside just below the real thing.

■ **Subset:** A collection of related data which is part of, and completely encompassed by, a larger collection of data, or set.

■ **Syntax error:** A typical piece of computer output.

■ **Systems analysis:** A method used by consultants to persuade you to pay inordinate amounts to give a recommendation as to where your business problems lie, and how you can solve them. The answer is invariably that you need more money.

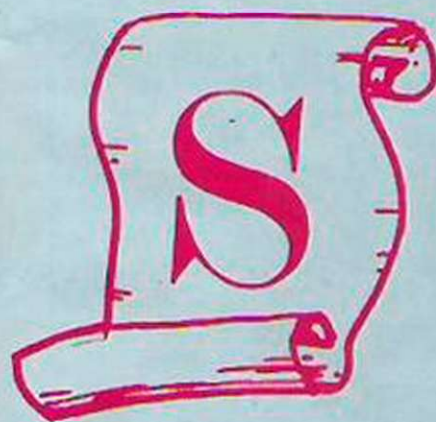
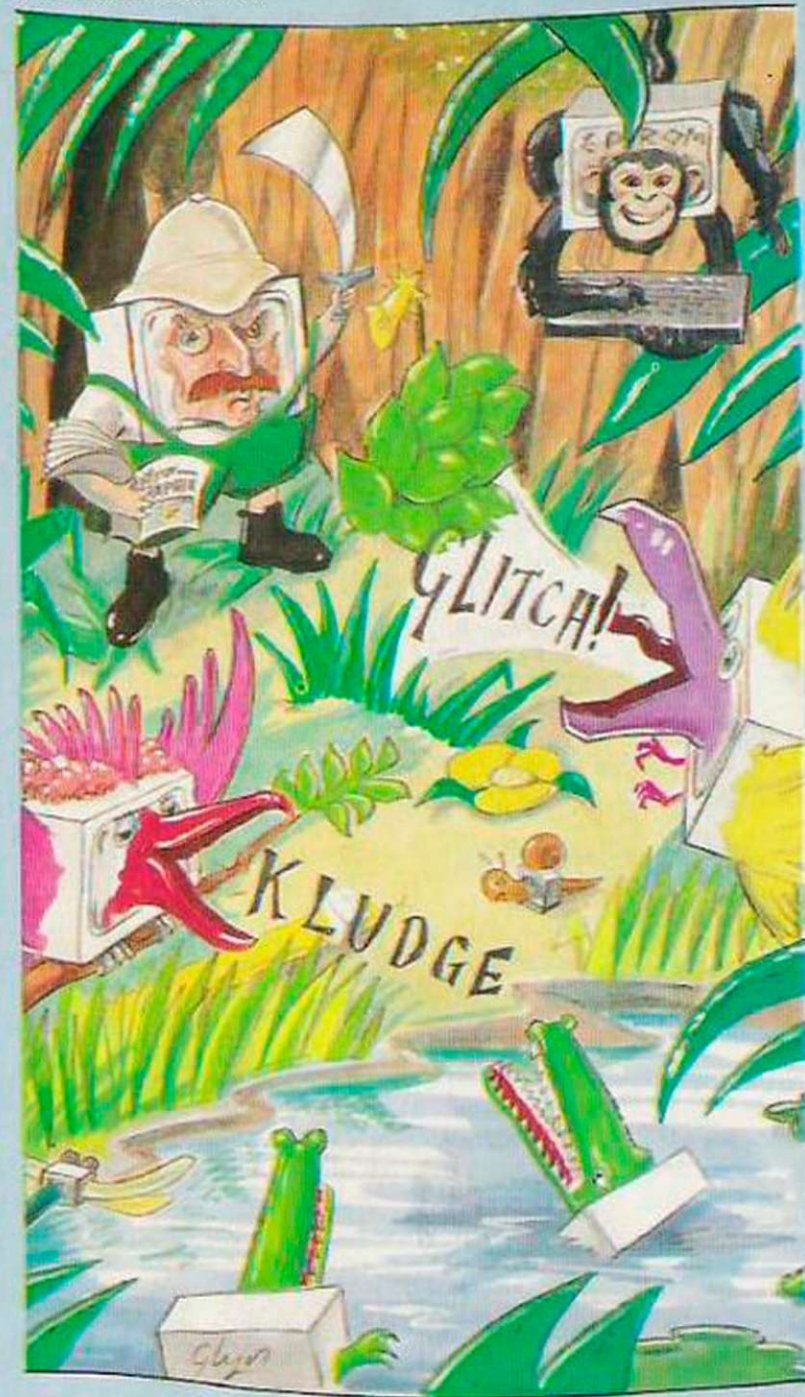

■ **Scrolling:** Any text moving up the screen faster than you can read comfortably is scrolling.

■ **Search:** A search checks data for the presence of a given value.

■ **Segment:** Computer component – see re-set. Alternatively a division of memory.

■ **Semiconductor:** London Transport trainee, or an alternative expression for an integrated circuit.

■ **Sequencer:** A device which can arrange data in a particular order, i.e., a London Transport signalman.

■ **Serial:** A kind of data transmission which involves the elements to be sent lining-up conga fashion, rather than parallel, which involves them holding hands and jumping.

■ **Shared resources:** Items of hardware which can be used by more than one micro, pioneered unsuccessfully by Widgit Data Products with its One Per Building concept.

■ **Shift:** A key which alters the case or mode of a micro, or to move data in a register to the left or to the right.

■ **Signal:** An electrical impulse carrying information between machines.

■ **Sign-on:** Action followed to gain access to a remote computer, synonymous with log-on. Also see **redundant**.

■ **Simulator:** A device, also known as an emulator, which simulates another device, generally not very accurately or quickly.

■ **Sinclair:** Term used to describe mail order problems. Now obsolete.

■ **Sink:** What happens to micro makers after a bad Christmas. A method of dissipating heat generated by circuitry.

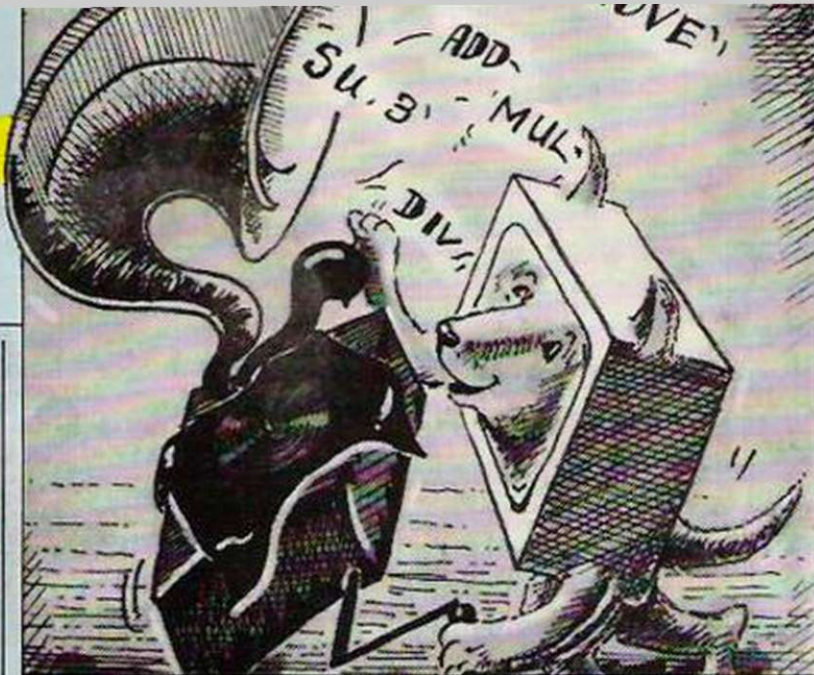

The 6502 has proved to be a workhorse of a processor. At the centre of the Apple II, Commodore 64, BBC and many other successful microcomputers, the 6502 has developed a momentum which is keeping it alive, even in the days of impressively-powerful processors such as the 68000. One of its main advantages is that it is comparatively easy to program – easier, in our opinion, than the Z-80 – so getting to grips with it does not take too much time.

Every processor has a range of instructions it can interpret – the full range is called the instruction set – and a program written in those instructions is usually called a machine code program. It is possible to add short machine code sections to a Basic program by using PEEK and POKE commands to load the data and instructions into various memory locations.

The reason is simple – speed; Basic is slow, machine code is very fast. Another reason is that a machine code program uses a minimum of memory space, whereas Basic or any other high-level language is comparatively greedy.

Adding machine code to Basic is usually something of an error-prone performance. The instructions sometimes need to be translated into hex before being POKEd into memory, a slow, tedious and unrewarding operation. On some computers

Machine code made easy – Peter Turcan tackles the 6502

such as the BBC, however, that is not necessary as there is a built-in assembler.

An assembler translates what are called mnemonics which a human can understand into numeric codes the processor understands. The process of developing a machine code program is to create a file, usually called a source file, and to use an editor to type-in the instructions in mnemonic form, run an assembler program to create a second file containing those instructions in numeric

Figure 1.
Convention for writing a machine code subroutine

```

SUBRTN PHA      / save off A,X and Y on the stack
        TXA
        PHA
        TYA
        PHA
        *
        <body of subroutine>
        *
        PLA      / restore A,X and Y
        TAY
        PLA
        TAX
        PLA
        *
        RTS
  
```

Beginners' guide to the 6502

form, return to the editor to correct any syntax errors, re-run the assembler, and finally run as a program the output from the assembler, usually called a binary or object file.

That basic loop is then repeated many times as faults in the program are found. A further extension of the loop is to develop a large program in several more manageable positions, called modules, assemble them separately but run them all together by using what is called a linker. A reasonable size for any module is 500 lines, so becoming familiar with a linker can be left until you are familiar with the main business of writing machine code programs in assembler.

For anyone considering entering the world of 6502 machine code, I would recommend obtaining a good assembler package and a good reference book on the 6502. The

other main piece of documentation needed is a detailed reference guide to the computer memory – a memory map. With those three things machine code programs of great size and complexity can be tackled. Without any one of them you may well fall on the first fence.

Figure 2.
Adds N1 to N2, leaving the result in N2

```

ADD16  SAVE      / save registers
        CLC      / clear the carry flag
        LDA  N1L  / A register = low byte of first number
        ADC  N2L  / add the low byte of second number
        STA  N2L  / store in low byte of second number
        LDA  N1H  / A register = high byte of first number
        ADC  N2H  / add the high byte of second number
        STA  N2H  / store in high byte of second number
        RESTORE  / restore registers
        RTS
  
```

The most fundamental unit of any program is the subroutine, sometimes called a procedure, without which programming would be almost impossible. Before leaping into a program,

it is important to work out conventions to handle subroutines and then stay with them through thick and thin. The instruction to call a subroutine in 6502 is JSR <xxxx>, where <xxxx> is the address of that subroutine in memory or, more usefully, a name associated with an address.

JSR is a good example of a mnemonic – it stands for Jump to SubRoutine. When that instruction is done the computer remembers where it finished by placing a return address on a stack. A subroutine is left by using an RTS instruction – Return from SubRoutine – which picks up the return address and processing continues with the next instruction in sequence after the JSR <xxxx>.

A stack is like a machine gun cartridge – the first bullet in is the last out. That method is used so that if one routine calls another, that calls a third, that calls a fourth, and so on, then the RTS instructions will pick up the return addresses in reverse order, so the fourth subroutine will return to the third, the third to the second and finally back to the first.

A processor contains a number of registers – see the computer course in the May issue of *Your Computer* – called the A, X and Y registers. There is also a stack pointer (SP) and program counter (PC) in the processor but if your programs are well-behaved and conform to good conventions, you will not need to concern yourself too much with them. Another register, the processor status (P) con-

tains single bits, called flags, which are set independently to give information on the results of comparisons and the like.

When a subroutine is called it is a good idea to save the

A, X and Y registers, in case they contain useful information the calling routine does not want to be corrupted by the subroutine. That gives us our first convention, a subroutine should look like figure one. Whenever the subroutine SUBRTN – that could be any name – is called by a JSR, the registers are saved on the stack before anything is done and restored at the end of the routine before returning.

The five statements which save and restore registers can, in many assemblers, be grouped into what is called a macro. A macro is a definition of any number of instructions and prevents having to type them every time; the assembler program will include them when it encounters the macro. In future

You need an assembler, a reference book and a memory map

examples we will assume there are two macros, SAVE and RESTORE, which save and restore the A, X and Y registers respectively.

The 6502 operates on units in byte quantities. There is an add and a subtract instruction but many programs will require additions and subtractions of numbers larger than eight bits. If we wish to add two 16-bit integers, that is done in 6502 instructions by adding each half at a time and detecting whether there is anything which should be carried from one addition to the other. Figure two shows the program.

The program in figure two shows how the carry flag – one of the bits in the P register – is useful. That flag is first set to 0 but the addition of the two low bytes may set it to 1 if that addition overflows. If it is set to 1, the ADC command – ADd with Carry – in the second addition ensures that overflow is taken into account. The other instructions in that subroutine should be reasonably obvious; LDA loads the A register with the contents of the memory location specified, STA does the reverse.

Many 6502 programs will

contain a large number of fundamental routines which perform 16- and 32-bit addition, subtraction, multiplication and division. Fortunately there is no need to re-invent those wheels by determining all the overflows for yourself; instructions for all those routines will be found in most 6502 programming books from which they can be copied.

Our example addition exposes another problem, that of addressing. The numbers N1 and N2 are passed as parameters to the subroutine by first loading the values into four bytes of memory. Figure three shows how this subroutine would be called to multiply 300 by 125.

In figure three, the instruction LDA £1 loads register A with the number 1. That is called immediate addressing. In figure two the instruction LDA NIL loads the register A not with a number but with the contents of the byte pinpointed by the name NIL. That is called absolute addressing. Immediate and absolute are called addressing modes and there are 13 addressing modes recognised by the 6502 processor.

Addressing modes

Another example is LDA (LOC),Y. That loads the accumulator with the byte which is Y bytes away from the address held by the location LOC in memory. This is an example of indirect indexed addressing; the Y register is used to provide the index and the brackets round LOC mean that the contents of LOC are required and not LOC. The latter form of addressing is called indirection and is very useful in writing machine code programs.

Although addressing is crucial, learning the addressing modes is a little like learning English tenses in grammar; it is often easier to learn by example and ignore the theory. Ploughing through text on indirect, indexed, immediate, absolute, implied and the other modes of addressing is sufficient to send any newcomer running for the Basic Interpreter. Addressing, however, is nothing like so daunting as it looks at first and the initial horror can quickly be overcome by getting on with the

job. So learn addressing as you proceed – do not attempt to swallow it all at once.

Another crucial concept surrounds the use of a special 256 bytes of memory called Zero Page. That is the first 256 bytes of RAM, and is special as the first two hex digits of any of those bytes addresses is 00 – hence the name Zero Page. To take advantage of that there are special addressing modes for Zero Page which have the advantage of being faster than the rest, as a shorter address has to be interpreted by the processor.

The address is shorter since the processor knows the first byte of the address is zero and so ignores it. That means that data can be stored and retrieved in zero page faster than in any other area of memory and so that page becomes prime real estate for storing frequently-used variables.

Machine code programming is often easier if the algorithms are written in advance in a well-structured language such as Pascal or possibly Basic. That is because major program flaws are often difficult to find in an assembler listing and also because translating downwards to assembler is straightforward.

The statement IF C = D THEN PROC-ONE ELSE PROC-TWO is translated in figure four; note how the high-level language can be used as comments. OUT and P2 are labels used by the unconditional jump instruction JMP and BNE – branch if equal flag not set. Gotos, case statements, FOR loops, WHILE loops and so on can be translated just as easily into assembler.

The few examples should indicate what programming in 6502 might be like. It is true that many more lines of code are needed to translate single lines of a high-level language but with good conventions the extra size should not be too difficult to cope with. Each instruction – there are 56 – usually takes between two- and four-millionths of a second to complete.

Speed of that kind is hopelessly unobtainable in high-level languages and is certainly the main attraction of machine code programming but also there is the feeling that you are really in control of the computer, as machine code instructions are usually easy to understand, perform exact operations and have no side effects.

Figure 3.
Setting-up parameters for the 16-bit addition,
/ Data bytes set up in memory

```
N1L  HEX 00
N1H  HEX 00
N2L  HEX 00
N2H  HEX 00
/
LDA  £1      /A holds 1, not the contents of location 1
STA  N1H    /high byte, so value is 256
LDA  £44
STA  N1L    /low byte contains 44 as 44+256 = 300
LDA  £0
STA  N2L    /high byte of 125 is 0

LDA  £125
STA  N2L    /low byte contains 125
JSR  ADD16  /performs the addition
```

Figure 4.
Translation of if . . then . . else

```
LDA  C
CMP  D      /IF C = D . . . . .
BNE  P2
JSR  PROC-ONE /THEN PROC-ONE . . .
JMP  OUT
P2:  JSR  PROC-TWO /ELSE PROC-TWO
OUT:
```

Between the twin extremes of programming in a high-level language like Basic and low-level coding in an MPU native machine language there is a third level of programming – programming in the operating system of a computer. It is more like using a high-level language yet the degree of control it affords the user over the computer system is more akin to that achieved when using machine code.

CP/M, the most widely-used 8-bit operating system, has a wealth of transient program utilities available to the user, though most people make little use of them. Amstrad, for example, supplies a comprehensive range of CP/M utilities with the PCW and CPC computers yet, with the exception of the disc copy commands, few users will make use of them. At least one of the commands can make using most PCW software, in particular, far easier. That command is SUBMIT; the COM file for this utility is supplied on side two of the PCW system software.

The SUBMIT utility allows a sequence of instructions stored previously within a data file to be executed one by one as if they were entered at the keyboard. To appreciate the significance of

Submit is only one of a range of powerful CP/M utilities.

this command, consider this example. The PCW computer is to be used in conjunction with a word processor which requires a COM file and associated overlay files to be copied to the PCW RAM disc so that it may operate most efficiently.

To achieve that without the use of the SUBMIT utility would require the following series of commands to be entered at the keyboard. First, with side two of the computer system software in drive a, the CP/M Peripheral Interface Program would be called with the command PIP. The disc in drive

a would then be removed and the word processor work disc inserted in its place. Then the line `m:=a:wp.com <return>` would be entered, followed by, for example, `m:=a:wpmsgs.ovl <return>` and `m:=a:wpprint.ovl`.

Those commands would then be followed by a single return to exit the PIP utility and then the line `M:<return>` to log on to drive m, then the command

Having created that file on the word processor working disc and copied the PIP.COM and SUBMIT.COM files from side two of the system disc, to load and run the software it is necessary only to type the single command SUBMIT USEWP. The computer will then read in each line of the SUB file and execute each in turn, duplicating the entry of each via the keyboard.

The SUBMIT command has an additional sophistication

can be incorporated as part of a SUBMIT file. The SET-KEYS.COM and associated KEYS file could, for example, be used as part of the submit process. That would allow the keyboard of the computer to be re-configured so that the keys associated with word processing functions – the cursor control keys, EOL, copy, cut and the like – would generate the appropriate sequence of commands.

The SUBMIT command, if used correctly, can ensure that when the CP/M software is loaded the computer is configured for immediate use. SUBMIT, though, is only one of the commands which can be used to personalise the PCW computer to meet the requirements of a particular user. Browsing through the CP/M section of the PCW manual will reveal many more useful utilities.

The CP/M submit utility allows users both to personalise their systems and to prevent keying repetitive sequences of commands at the keyboard. Ken Alexander introduces the command.

WP to run the word processing software. That time-consuming series of commands would have to be entered at the start of every session with the word processor; clearly there must be an easier way. The SUBMIT utility provides that easy way out of the problem.

In the foregoing example, the user would create a file called USEWP. The file type would be set to SUB. Within the file the sequence of commands shown in listing one would be entered. This file could be created with the CP/M ED utility or by Locoscript using the create a simple ASCII file option, having entered the lines of text.

which operates when the CP/M operating system is first booted. As part of the boot process, CP/M looks for a special file, PROFILE.SUB. If that file is present on the disc which holds the CP/M EMS file, the commands contained in the file will be executed automatically.

To create a boot disc which will allow the WP software to be loaded from a cold start the CP/M operating system software would have to be copied to the WP work disc and the file in which listing one is stored be re-named to PROFILE.SUB. A directory of the WP work disc would thus produce the output shown in listing two.

Many other CP/M commands

Listing 1.

```
PIP
<m:=a:wp.com
<m:=a:wpmsgs.ovl
<m:=a:wpprint.ovl
<
<m:
<wp
```

Note that the above could be shortened by use of the CP/M wild card option, by replacing the three lines transferring the WP files to the RAM disc with a single line of the form `m:=a:=wp*.*`

Listing 2.

```
J14CPM3.EMS
PIP.COM
SUBMIT.COM
PROFILE.SUB
WP.COM
WPMSG.SOV
WPPRINT.OVL
```

Note that the CP/M software may have a slightly different reference from that shown above but will be the only file to have the EMS extension.

NEXT MONTH

MASTERING INTERRUPTS

Many programs use interrupts to speed their operation. We explain the concept of interrupt-driven software, with some specific examples.

FURTHER READING

Is there life after the *Your Computer Course*? We list some suggestions for additional reading.

AND SO TO Z . . .

. . . With the final part of our glossary.



ATARI ST

Power Without The Price!

FREE SOFTWARE

When you buy one of the new Atari ST computers from Silica Shop, you will receive a large and varied software package free of charge. This package covers several applications and comprises a total of nine titles. All ST's now have TOS/GEM on ROM, and the total list of free software is as follows:

- 1) GEM - DR Desktop environment with WIMP (in ROM)
- 2) TOS - Tramiel Operating System (in ROM)
- 3) 1st WORD - Word Processor by GST using the GEM environment and multiple windows
- 4) BASIC - Personal Basic by DR (with manual)
- 5) LOGO - Logo language by DR (with manual)
- 6) DOODLE - Simple paint/doodle drawing package (works on mono or colour systems)
- 7) MEGARIDS - Asteroids type game by Megamax
- 8) NEOCHROME - A powerful colour paint and graphics package (only useable with colour systems)
- 9) CP/M EMULATOR - Allows the use of DR's Z80 C/P/M software to run on any ST system

3rd PARTY SUPPORT

The power and potential of the ST range of computers is causing a flood of new software titles, peripherals and accessories from third party manufacturers. Titles range from word processing to spreadsheet programs, from graphics and games to database management - all with those easy drop-down menus and windows. With the list of companies producing ST software including dozens of top names, you can expect some first class titles for the new ST range. The following includes a selection of the third party manufacturers who have developed, or are working on, products for the ST range:

ABACUS	EXTENDED S/W	MICRO-ED INC	ROBINSON SYS
ACADEMY	FIDELITY	MICROPRO	SCARBOROUGH
ACCOLADE	FIRST BYTE	MICROPROSE	SIERRA ON LINE
ACTIONSOFT	FIRST PUBLISH	MICROPRO ENG	SM SOFTWARE
ACTIVISION	FLIP 'N' FILE	MIGRAPH INC	SOFTEX
ADVENTURE INT	GLENTOF PING	MILES COMP	SOFTLABS
ANTIC	GST SYSTEMS	MIRACLE	SOFTLOGIK
AMERICAN COVERS	HABA	MIRAGE	SOFTWARE COMS
ARTWORK	HAYDEN	MIRRORSOFT	SECS
ASHTON TATE	HIPPO	MONARCH DEV	SOFTWARE PUNCH
ATI	HISPOFT	MOSAIC	SOFTWARES
AUDIO LIGHT	INFOCOM	MULTIFORM	SPRINKLER
AZTEC	INSIGHT	MULTIMATE	SST SYSTEMS
BATTERIES INC	INSOFT	OCEAN	STONEWARE
BAYVIEW	ISLAND LOGIC	ODIN	SURLOGIC
BECKEMEYER	KNOWLEDGWARE	OMNITREND	SUNDATA SERVICES
BETTER WORKING	KUMA	OSS	SUNSHINE BOOKS
BLUE CHIP	LASERSOFT	OTHER VALLEY	SUPPLEMENTAL
BOS	LEHRNER	OXII	SYSTEMATICS
CASHLINK	LEVEL 9	PAPERLOGIC	TALENT
CHANG LABS	LIONHEART	PARADOX	TDI
CHELTIX SYST	LLAMASOFT	PENGIN	TELLARIUM
CHIPSOFT	LONGMINSTER	PHILON	TK COMPUTER PRO
COMPUTE!	MAINTHINK CORP	PLANNER	TOP EXPRESS
CROSSBOW MUSIC	MAP COMPUTERS	PLANTIR	TOWNGATE
DATABENCH	MARK OF UNICORN	PROGRESSIVE	TYNESOFT
DATACODE SYS	MARK WILLIAMS	PROSPERO	UNISON
DATA SYSTEMS	MARTIN CONSU	PRIORITY	WASON MICROCHIP
DELTRON	MCGRAW HILL	PSION	WHITENDALE
DILITHIUM PRESS	MEGAMAX	PSYGNOSIS	WHITCHAM CLASSICS
DRAGON GROUP	MEMOREX	QUICKVIEW SYS	WORD OF GOD COM
DUROSO PUBLISH	METACOMCO	RAINBIRD	XLENT
ELECTRONIC ARTS	MICHTRON	REGENT	
EXECON	MICRODEAL	RISING STAR	

520ST-M

NEW 512K 520ST-M KEYBOARD: The new 520ST-M keyboard costs only £346.96 (+VAT £399) and is yet another price breakthrough for Atari Corporation. The keyboard now includes both an RF modulator and cable, allowing you to connect it to an ordinary domestic television set. In addition, the keyboard is supplied with 512K RAM, a mouse and a free set of 3 1/2" disks containing applications software. The TOS operating system and the GEM graphics package are now supplied on 192K ROM chips which are already installed in the keyboard. This means that the operating system will automatically boot in when you switch the power on. In addition to the keyboard, you will also need to purchase either a 1/2Mbyte disk drive (RRP £130+VAT) or a 1Mbyte disk drive (RRP £174+VAT). Either disk drive will provide you with fast information retrieval and a vast amount of storage space. If you prefer not to use your own TV set, you may connect your ST to a monitor. You may purchase the Atari SM124 monochrome monitor (RRP £130+VAT), or one of Atari's two Thomson colour monitors. Alternatively, you may choose one of the many third party colour monitors which are available.

NEW 1024K 520ST-M* KEYBOARD: In addition to the standard 520ST-M, we have a new keyboard which we are calling the Atari 520ST-M*. The M* is a 520ST-M keyboard which has been enhanced by a third party RAM upgrade to 1 megabyte of memory. The 520ST-M* is available from Silica at a retail price of only £433.91 (+VAT £499). This product will provide you with an alternative to the 1040ST-F, but at a lower price. Additionally, it features the advantage of the 520ST-M's built in modulator.

£347

1040ST-F

For the businessman and the more serious home user, Atari has introduced the 1040ST-F, a low cost powerhouse which can be introduced to a business environment as a stand-alone system, or can support a mainframe computer as a terminal. The new one megabyte 1040ST-F enhances Atari's 'value for money' reputation in the marketplace as it is the first personal computer available with one megabyte of memory for less than £800. You can purchase the 1040ST-F as a monochrome or colour system. The price of the monochrome system is £799 (+VAT - £918.85), with the colour system at only £999 (+VAT - £1148.85). The new 1040ST-F not only features twice as much memory as the 520ST-M, but also includes a one megabyte double sided disk drive and mains transformer, both built into the console to give a compact and stylish unit with only one mains lead. The 1040ST-F is also supplied with a free software package. Unlike the 520ST-M, the 1040ST-F was manufactured solely with business use in mind and as such is supplied with a monitor. It does not include the RF modulator or lead. We now have stock of the 1040ST-F at all four branches of Silica Shop. Call into your nearest branch for a demonstration.

1-4 The Mews, Hatherley Road, Sidcup, Kent, DA14 4DX
117 Orpington High Street, Orpington, Kent, BR6 0LG
Lion House (1st floor), 227 Tottenham Court Rd, London, W1
Selfridges (1st floor), Oxford Street, London, W1A 1AB

£799

THE ATARI EXPLOSION!

If you read the specialist computer press, you will have noticed that there is one company which is getting a large slice of editorial space at the moment, that company is Atari Corporation. Atari have been making the news since the launch of their new 16/32 bit range of ST computers. Led by the powerful figure of Jack Tramiel and under the banner 'Power Without The Price', Atari are manufacturing new computers at unheard of prices, with the power to challenge firmly established market leaders. With the introduction of IBM compatibility, a CP/M emulator, a powerful networking system and a communications package for their new low cost powerhouses, it doesn't look as if it will be long before there is an explosion of the magnitude which will see Atari placed firmly besides such names as IBM and Olivetti in the personal computer marketplace. Read on for more details of what Atari are doing, and how they are putting their 'Power Without The Price' computers beyond the reach of the competition.

FREE CP/M EMULATOR

This newly announced CP/M Emulation Package, will enable software written under Digital Research's Z80 CP/M operating system to be run on the ST family of computers. There are several thousand applications written for CP/M in the UK alone, and several of the major CP/M software development houses may convert their programs to 3 1/2" disk format for the ST range. The CP/M emulation package is supplied FREE OF CHARGE by Silica Shop with all ST computers.

IBM COMPATIBILITY

To make the ST available to those businesses who currently run IBM systems and are looking for a low cost expansion method, Atari have announced a co-processing unit for ST computers. This processor will open the ST range to all IBM or IBM compatible software applications. The unit, which attaches to the ST computers via the DMA (Direct Memory Access) port, contains an Intel 8088 processor with 512K of RAM and will accept a 5 1/4" disk drive. In it's ST mode, the unit will also act as a second disk drive, offering the user an additional 500K of memory. The IBM co-processing unit should be available in late Summer 1986. If you would like to be informed when it is released, please complete and return the coupon below. We will send you further details as soon as we have them.

20Mbyte HARD DISK

£739

The new Atari hard disk for the ST range has just been released. All ST computers already have a hard disk interface built into them so there is no external interface required. The memory size of the disk is a massive 20 megabytes (unformatted) with a data transfer rate of 1.33 Mbytes per second. At a price of £739 (+VAT £849), the 5 1/4" hard disk offers massive storage with fast access at a very reasonable price.

NEW ST SOFTWARE PACKAGES

There are now hundreds of software packages which have been announced for the Atari ST range. Titles available now include DB Man, a DBase 3 clone as well as H&D Base, a DBase 2 clone. In addition, PC Intercomm is a VT 100 emulator which enables you to use any ST keyboard as a terminal connected to a mainframe or mini. Other programs include a Lotus 1-2-3 clone (see paragraph below).

VIP PROFESSIONAL - LOTUS 1-2-3™ CLONE

This is probably the most impressive program to have been released so far for the ST range. VIP Professional is an extremely easy to use, integrated spreadsheet, database and graphics program which is identical both in features and commands to Lotus 1-2-3™. The same spreadsheet analysis, information management and extraordinary business graphics are all combined in one easy to learn, affordable package. What's more, VIP Professional not only has all the features of 1-2-3™, you can also type the same commands to do the same things. Probably the most surprising feature of VIP Professional is not its total compatibility with Lotus 1-2-3™, nor its ease of use, but its price. Lotus 1-2-3™ for the IBM PC/AT costs £395 (+VAT £454.25), whereas VIP Professional for the ST is a mere £169 (+VAT £194.35). That's less than half the price! If you would like further details, of VIP Professional, please return the coupon below.

SILICA SHOP LTD, 1-4 The Mews, Hatherley Road, Sidcup, Kent, DA14 4DX
SEND FOR FREE ATARI ST LITERATURE

SILICA SHOP

ATARI WE ARE THE UK'S No1 ATARI SPECIALISTS ATARI

At Silica we have been successfully dedicated to Atari ever since their products first appeared on the UK market. We can attribute our success largely to the Atari specialisation which we practice and to the user back-up we provide. Rest assured that when you buy a piece of Atari hardware at Silica you will be fully supported. Our mailings giving news of software releases and developments will keep you up to date with the Atari market and our technical support team and sales staff are at the end of the telephone line to deal with your problems and supply you every need. With our specialist bias, we aim to keep stocks of all the available Atari hardware, software, peripherals and accessories. We also stock a wide range of Atari dedicated books and through us, the owners on our list can subscribe to several American Atari dedicated magazines. We can provide a full service to all Atari owners and are now firmly established as the UK's NUMBER ONE Atari specialists. Here are just some of the things we can offer to our customers:

- * FREE POST & PACKING ON MAIL ORDERS
- * FREE NEXT DAY DELIVERY
- * INFORMATION MAILING SERVICE
- * TECHNICAL SUPPORT TEAM
- * HIGHLY COMPETITIVE PRICES
- * AFTER SALES SUPPORT SERVICE
- * REPAIR SERVICE ON ATARI PRODUCTS

If you would like to be registered on our mailing list as an Atari computer owner, or as a person interested in buying an Atari machine, let us know. We will be pleased to keep you up to date with new Atari developments free of charge. So, return the coupon today and begin experiencing a specialist Atari service that is second to none.

SILICA HOTLINE  01-309 1111

To: Silica Shop Ltd, Dept YC 0686, 1-4 The Mews, Hatherley Road, Sidcup, Kent, DA14 4DX

PLEASE SEND ME FREE LITERATURE
ON THE NEW RANGE OF ATARI ST COMPUTERS

Mr/Mrs/Ms: Initials: Surname:

Address:

Postcode:

Do you already own a computer
If so, which one do you own?



**Quasimodo's ding-dong
derring dos rattle the rafters
in...**

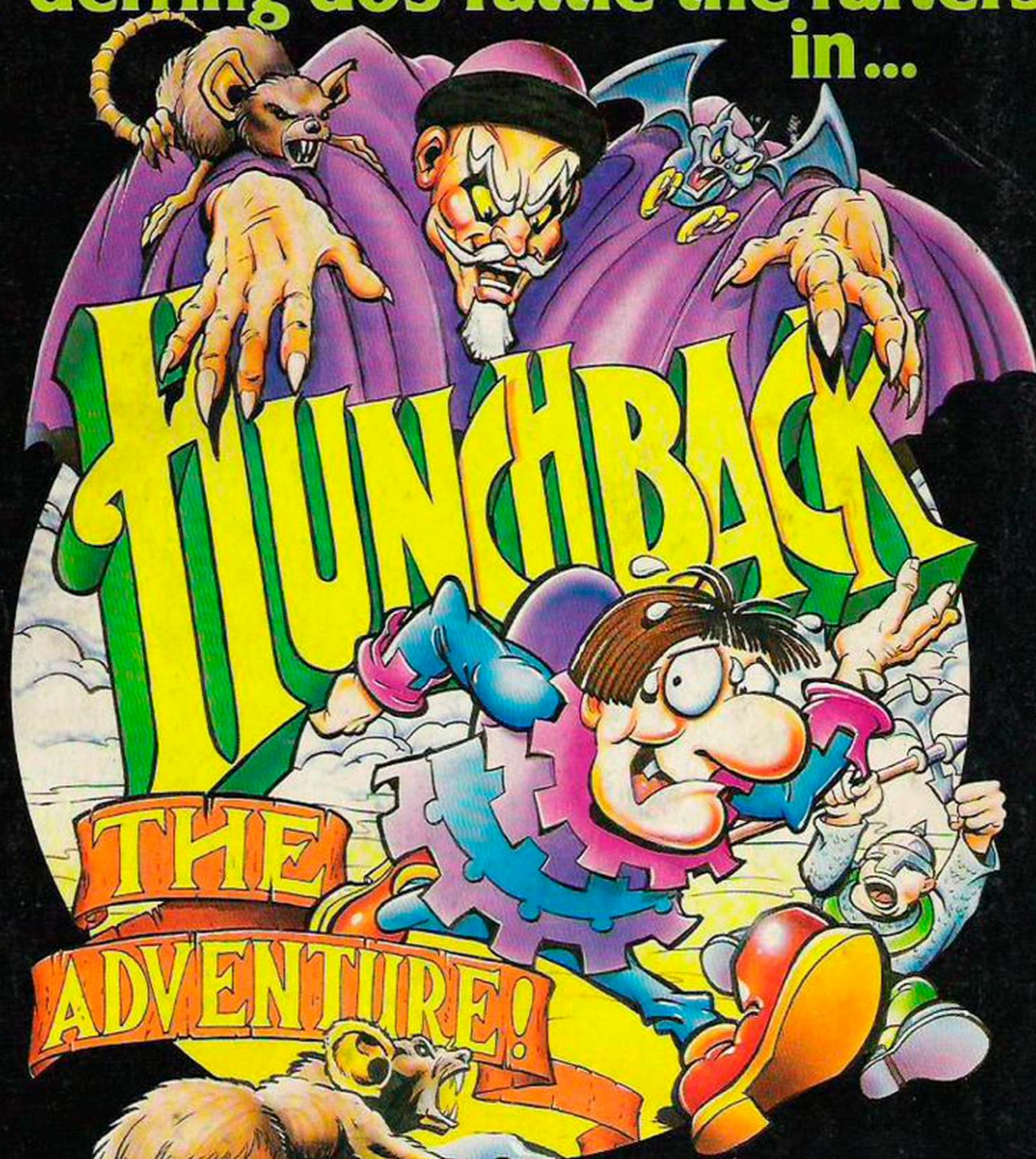

**...a text-teaser
world where
no 'modo has left before!
Go on... take a swing at it!**

£7.95 £8.95 AMSTRAD COMMODORE 64

Ocean Software is available from selected branches of:
 WHSMITH /  John Menzies  WOOLWORTH LASKYS Rumbelows
 Greens Spectrum Shops and all good software dealers. Trade enquiries welcome.

ocean

Ocean Software Limited
 Ocean House · 6 Central Street · Manchester · M2 5NS · Telephone 061 832 6633 · Telex 669977 Oceans G